

STILL  
£2.30

WORLD  
HI-FI

# HI-FI WORLD

JANET SHAW  
P Jones

AUGUST 1997 £2.30

For the love of music

## BACK TO DAC

### GROUP TEST OF FIVE DACs AT £600-£1000



**SCOOP!**

**ABC**  
fastest growing  
hi-fi magazine

**PIONEER  
A-300R  
PRECISION  
AMPLIFIER**



**KEF'S  
NEW Q55  
SPEAKERS**



**Predictable start.**



**Spectacular finish.**



Every loudspeaker manufacturer has the basics. The cones, coils, crossovers and cabinets. The woofers, tweeters, magnets and faceplates. But only one really knows how to put them together. The proof, Celestion's new i Series.

Built with 70 years experience of pioneering development in loudspeaker technology, this range blows your mind. It combines the highest level of audio fidelity with outstanding dynamic range. So you fully enjoy the true power of contemporary music and film recordings. Time and time again.

But don't just take our word for it. Take it from Hi-fi World. "Powerful, dynamic, musical and convincing", the i Series "shows just how strong British loudspeaker engineering really is".

Spectacular praise, you might think. But where Celestion's involved, it's almost predictable.



Celestion Consumer Division, Eccleston Road, Tovil, Maidstone, Kent, ME15 6QP U.K. Tel: 01622 687442. Fax: 01622 687981.  
Celestion Industries Inc., 89 Doug Brown Way, Holliston, MA 01476, USA. Tel: 508 429 6706. Fax: 508 429 2426

**CELESTION**



# THIS MONTH'S WORLD

- Can Roksan build on the success of their Caspian integrated amp with the new £900 matching Caspian CD player? Jon Marks provides the answer.
- Having taken a shine to KEF's lively Q15 stand mounters back in February '97, we were looking forward to listening to their bigger brothers, the £500 Q55 floor standers. Did they excel or disappoint?
- UK tweaked Special Editions have been around for a while now. Jumping on the bandwagon are Pioneer with their A-300R Precision integrated amplifier, which had Eric Braithwaite reaching for his wallet.
- There's good news for you, if your main source of music is the airwaves. Sony's ST-SE700 tuner sports impressive sound quality, LW reception and a skimpy price tag of £180, Ketan Bharadia discovered.

**B**ack in August we took a look at Teac's rather tasty £2500 P-30 transport and were wowed by its rock solid and supremely natural sound. But for most people, CD spinners are more likely to consist of a transport like Audiolab's 8000CDM at £1200 and a DAC at £600-£1000. So this month, we take a look at the best converters under £1000 with hopefuls from DPA, Marston Audio Research, Arcam, Audiolab and Monarchy Audio and find a bright future in store for DAC upgrading.

Looking over the other side of the replay fence is David Price. With copies of second-hand original LPs becoming ever more expensive, he discovers what modern reissues offer analogue audiophiles with pressings from Blue Note, Castle Communications, EMI and Classic Records. And if your money is positively scorching a hole in your pocket, make sure you take a look at September's Hi-Fi World for a comprehensive list of all the best places to buy new and used LPs.

Jon Marks, Editor

## TEST EQUIPMENT



- Hi-Fi World has its own advanced test laboratory and acoustically treated listening room. No other hi-fi magazine has the benefit of such facilities.
- Hi-Fi World has a dedicated in-house team of experienced listeners, and uses selected freelance professionals. We review thoroughly by extensive auditioning, rather than by quick-fire group listening tests.
- Hi-Fi World's engineering team designs a wide range of products in-house. No other hi-fi magazine is so expert and dedicated.

## LISTENING ROOM

(TREATED BY RPG ACOUSTIC TOOLS)



## IN THE SEPTEMBER ISSUE

Here's a selection of the quality components we hope to bring you in the next issue:

### DENSEN DP DRIVE MC PHONO STAGE

Most manufacturers rely on regulators, chunky transformers and hefty reservoir capacitors to ensure that variable mains quality doesn't adversely effect sound quality. Densen take a different route though, running their DP Drive phono stage from solar cells powered by Light Emitting Diodes. We find out if light is right.

### JAMO CONCERT II

In the June issue we reviewed the stand mounted Concert 8s and loved them.

Next month we listen to their big brothers, the mighty Concert 11s, to see if bigger means even better.

### REL Q100E

If you really want to feel those seismic lows which most 'speakers only hint at, then a subwoofer could well be the answer. Does the REL Q100E have what it takes to deliver in the quality and quantity departments?

### AUDIO ANALOGUE PUCCINI SE VS PRIME DESIGNS A100

The £600-£700 integrated amplifier

market is crowded but new manufacturers Audio Analogue and Prime Designs think their amps stand out. We pitch the Puccini and A100 head-to-head to find out if either is the new king of the amp castle.

### CYRUS PRE/POWER AMPLIFIERS

The Cyrus range just keeps on growing, wearing its customary half-width casework. This latest Pre/Power combination offers stylish looks, flexibility and remote control, but is sound quality sacrificed in return?

**AUDIO PUBLISHING LTD**  
64 CASTELLAIN ROAD,  
MAIDA VALE,  
LONDON W9 1EX.

### CONTACT NUMBERS

10am - 6pm  
Tel: 0171-289 3533  
Fax: 0171-289 5620  
Email: edit@hi-fiworld.co.uk  
Individual queries cannot  
be answered by telephone.

### MAIL ORDER

Tel: 0171-266 0461  
(24 hour answerphone)

### SUBSCRIPTIONS

See page 97 or our web  
site: www.hi-fiworld.co.uk  
for details.

Editor  
**Jon Marks**

Assistant Editor  
**Ketan Bharadia**

Contributors  
**David Price**  
**Eric Braithwaite**  
**Douglas Floyd-**  
**Douglass**  
**Dominic Todd**

Music Reviewers  
**Peter Herring**  
**Simon Hopkins**  
**Jon Clarke**  
**Simon Cooke**  
**Viv Craske**  
**Martin Rae**

Production Editor  
Designer  
**Joseph Fernandes**

Photography  
**David Noble**

Advertising Manager  
**Caroline Knott**  
Tel: 01245 443555

Marketing Manager  
**Jon Dolan**

Technician  
**Nick Lucas**

Accounts  
**Kevin Huggett**  
**Ken Heath**

Publisher  
**Noel Keywood**

Distributed by:  
Marketforce Ltd, 245  
Tottenham Court Road,  
London, W1P 0AU  
Tel: 0171 262 5555

Printed by:  
Southernprint, Poole, Dorset.  
Tel: 01202 622226

All unsolicited submissions are  
made at the owners risk. We  
accept no responsibility for such  
submissions, nor do we undertake  
to return them.

No material may be reproduced  
from this magazine without the  
publisher's written permission.  
© Audio Publishing Ltd

**ABC**  
CONSUMER PRESS

## THIS MONTH'S REVIEWS

### AMPLIFIERS

#### LINN LK240 vs MERIDIAN 505 35

If you're on the lookout for a pair of monoblocs and have £750-£800 to spend, should you go the



Linn or Meridian route? Eric Braithwaite has the answer.

#### PIONEER A-300R PRECISION 65

Will Pioneer's new UK tweaked A-300R Precision integrated have audiophiles queuing around the block? Eric Braithwaite thinks so.

### VINYL

#### DENON DL-103M 59

Eric Braithwaite finds a long lived cartridge for your long players with Denon's 34-year-old DL-103M MC.

### COMPACT DISC

#### £600-£1000 DAC GROUP TEST 12

We take a look at some of the best DACs out there to find what sound quality your money can buy these days.



#### ROKSAN CASPIAN 57

Following hot on the heels of the superb Caspian integrated amplifier comes the £900 Caspian CD player. Is it a chip off the new Roksan block?

### LOUDSPEAKERS

#### KEF Q55 31

Proudly sporting the same Uni-Q dual-concentric as the Q15 stand mounter we took a shine to in February, the Q55 adds a bass driver to great effect.



#### MISSION 732i 39

Can Mission extend their long line of respected loudspeakers with the new £200 732i? Dominic Todd finds out.

#### PARADIGM MINI MONITORS 53

We cross the Atlantic to discover what Canadian Paradigm has to offer with the £280 Mini Monitors. Ketan Bharadia makes the trip.

### TUNER

#### SONY ST-SE700 41

Budget tuners are better now than ever, as Ketan Bharadia finds with Sony's £180 ST-SE700 tuner.



### WORLD VERDICT



**OUTSTANDING** - Superb sound, something we'd use ourselves.



**GOOD** - Has strong merit. Well worth an audition.



**ADEQUATE** - Mediocre in several areas. May be worth auditioning.



**PCOR** - Seriously flawed. Not worth considering.



## REGULARS

### NEXT ISSUE

You don't have to wait for the mists of time to clear to see what's coming up next month - just have a peek at this page.

### NEWS

News so hot off the press you can cook an egg on it.

### READERS' LETTERS

System problems or audio theory, it's all here in our six pages of letters.

### HI-FI WORLD LIBRARY

Information on every hi-fi topic is at your finger tips thanks to Hi-Fi World's extensive library.

### COLUMNS

55, 61, 67, 73

The thoughts and opinions of World gurus Haden Boardman, Dominic Todd, David Price and Noel Keywood.

### SPECIALIST HI-FI DEALERS

The people you can trust to help you make the right component decisions.

### MEET YOUR MAKER

How to get in contact with the manufacturers that make all the hi-fi equipment in your rack.

### HI-FI WORLD KITS

If you've ever felt like having a go at making your own components, these pages are a good place to start with our top quality kits.

### DIAL-A-DEALER

If you want to find the closest specialist dealer to you, take a look here.

### MEASURED PERFORMANCE

All this month's reviewees take a medical to see if Doctor Keywood pronounces them fit and able to do their duties.

### WORLD BUYING GUIDE

This is the roll call of star products that we've taken a shine to over the last few years.

### OLDE WORLDE

The second-hand star of this month's hi-fi retrospective is Technics' battleship direct drive deck, the SL-1000.

### READERS' CLASSIFIEDS

Six pages crammed to the hilt with hi-fi bargains galore.

## FEATURES

### VINYL OLD VS VINYL NEW

David Price compares modern reissues of classic LPs with the originals to find out what sonic progress vinyl has made in the last 20 years.

### CAPABLE CABLES

Douglas Floyd-Douglass gets connected with three loudspeaker cables from £16/m to £25/m.

### READERS' SYSTEMS

Roving news hound Jon Marks tracks down an active system built around drivers and electronics from every walk of hi-fi life.

## COMPETITION - PAGE 28



Up for grabs this month is a superb £2000 system made up of Celestion's A1 stand mounters, Audio Analogue's Puccini SE integrated amp and Trichord's Genesis CD player.

## MUSIC

### ROCK AND POP

#### RECORD OF THE MONTH:

Ragga and the Jack Magic Orchestra, Ragga and the Jack Magic Orchestra

### DANCE/AMBIENT

#### RECORD OF THE MONTH:

Various, Ministry of Sound - Classics

### JAZZ REVIEWS

### CLASSICAL REVIEWS

#### RECORD OF THE MONTH:

Monteverdi, Quinto Libro de' Madrigali

# COMPETITION

# DeNova™

DENMARK

## Stage 3 Home Theater System



## AV-3 Surround Receiver



DOLBY SURROUND  
PRO • LOGIC

DENOVA AUDIO (DK) ApS  
BRANSAGVEJ 16-18 DK-9490  
PANDRUP DENMARK  
Tel: +45 (98) 24-6766  
Fax: +45 (98) 24-6765

- AV 3 Main Functions:
- DOLBY Pro-Logic Surround
  - DOLBY 3 Stereo
  - DSP (Digital Sound Processor) with 5 modes
  - Motorised Volume Control
  - 400w total power output makes it no nonsense movie machine



**HI-FI SALES UP - SORT OF!**

According to a recent Verdict report on consumer spending patterns, there will be growth in spending by 25-35-year-olds over the next six years, and a corresponding decline in spending by under-25s. Since the older group has more disposable income and is prone to spend it on, or in, the home rather than hedonistic pursuits, sales of hi-fi are expected to increase. With CD sales at a record high, there's obviously no shortage of interest in listening to music. Disposable incomes and leisure time are steadily increasing in most major Western economies so the trend is stable and long term, but it's had a stronger impact in Britain than elsewhere since Britain's CD sales-per-head are second only to the USA.

Whilst Verdict predicted a rosy future, The Business Book for the electrical retail market in Britain (1997) apparently thinks otherwise. It opines, "It is hard to see the separates market halting the decline in volume". At 835,000 pieces, sales for 1996 were up 4% over the previous year, their figures show. However, against an overall downward trend it is difficult to tell whether this is an anomaly or the start of an up-turn. Verdict see it as the latter, but The Business Book takes the opposite view, plausibly explaining that secondary brands are moving out of the separates sector to concentrate upon the larger audio systems market. The Japanese giants have managed to persuade people that all-in-one systems are hi-tech hi-fi, free from techno-babble and religion, and coming in at a fantastic price. It will be interesting to see whose prediction for the future is right.

Meanwhile, in a curious but perhaps natural law of the market, as the volume of sales went down, average purchase price went up, The Business Book explaining it thus. Those continuing to purchase real hi-fi are increasingly well informed and buy on quality rather than price. Specialist manufacturers are slowly taking a larger share of the remaining market and their prices are higher, pushing up the average unit price. The change was relatively modest though, price rising just 2% (£4) to £224, so we are not talking Krell prices here.

The hi-fi separates market was valued at £207million for 1996, healthily up on earlier years, all of which were below the £200m mark. By way of comparison, the audio systems market (midis, minis, micros) was valued at £528million, but the unit price was a measly £247.50 - for a complete 'hi-fi' system!

Although the independent retail sector is in decline in Britain according to Philips' market data, it is still very large by European standards. The Business Book says single-store independents account for 89% of sales of hi-fi separates, the rest being taken by multiples.

So where is the hi-fi market going? Whilst UK economic and social demographic conditions are all set fair at present, The Business Book does make the point that there is little in the way of technical progress to entice people into making a purchase or buying a replacement. In fact, it could be said that hi-fi is technically moribund, recent failures like DCC acting as a deterrent to those who might want to innovate.

Only MiniDisc appears to be the exception, with a firm sales base in Japan and a programme of development. With a newly revised ATRAC system due out soon, MD now truly meets stringent hi-fi standards. With no real competition, it may start to take off in popularity, becoming a de facto recording medium standard in future, much as cassette has been in the past. This is probably going to be gradual, though, and is unlikely to have much impact upon separates sales overall. Although MiniDisc is more durable and convenient than CD, it offers no improvement in sound quality and The Business Book suggests that it belongs to the portable market. However, cassette started off in this fashion, as a portable dictation medium which ended up in the Nakamichi Dragon.

It could well be that DVD, with its huge storage capacity and potential to become an 'ultimate' source, will some day replace audio CD, but that is some time off. DVD standards have yet to be sorted out, but there is a lot of serious discussion going on about a new, advanced audio coding standard to replace CDs, which was conceived in the late 1970s. But whilst DVD may offer this prospect, people are likely to stay with CD for a long while yet. The Consumer Electronics business is very nervous about destabilising

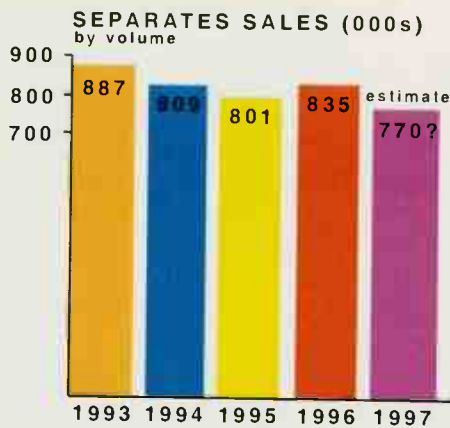

Source: The Business Book

**WORLD VERDICT** 

The Concert 8s are superbly clean, crisp and transparent. Beware their revealing nature though - they'll show up any source shortcomings.

**WHAT HI-FI?**

**WHAT HI-FI?**

April 1997

May 1997

Concert 8

Concert Center

★★★★★

★★★★★

# Concert



**The Jamo Concert Series.  
HEAR...SEE...RELAX & ENJOY...**

Advanced technology, innovative design and refined workmanship is not always the perfect recipe for success, we believe a little more is required.

The Concert series has enabled Jamo to produce a range of loudspeakers which will reproduce music that is clean and neutral. The dynamic range transparency and sound stage are all raised to a higher dimension.

The successes attained by the Jamo development team is the result of efforts to design high quality loudspeaker components which are critically matched to one another.

It's an honour for us to introduce this new generation of loudspeakers to you...

... **Jamo Concert 11, Jamo Concert 8 and Jamo Concert Center.**

**THE SOUND OF EXCELLENCE** - Made in Denmark.

**Jamo**® "THE SOUND OF EXCELLENCE"

JAMO UK Ltd, 5 Faraday Close, Drayton Fields, Daventry, Northants NN11 5RD Phone: 01327 / 301 300, Fax: 01327 / 300 511  
International enquiries: JAMO A/S, P.O. Box 220, DK-7870 Glyngøere, Denmark, Phone: +45 99 76 76 76, Fax: +45 97 73 20 75  
Web page: <http://www.jamospeakers.com> E-mail: [speakers@jamo.dk](mailto:speakers@jamo.dk)



people's confidence in a product when it is doing well. When CD sales start to level out, then we might get to hear more about DVD audio, but until that time, it is likely to remain in the lab. The Business Book notes that, "the music industry has little enthusiasm for junking CD yet".

Of Digital Audio Broadcasting (DAB) The Business Book says, "The format will not have much impact if it simply offers more of the same. . . The initial target market will be in-car use. . . It would be a brave person who predicted the short term demise of analogue radio". None of this sounds very promising, but few would disagree with it.

The Business Book view of the hi-fi separates market concludes that, "while the separates market may be contracting in volume terms, it is still a sizeable sector and, more importantly, showing some growth in value terms."

**The Business Book 1997**  
**for the electrical retail market - £90**  
**Chalvington Publishing**  
**Hampshire GU33 6JD**  
**Tel: 01730 894059**

**A NEW BABY ARRIVES**

Heybrook has proudly announced a new baby 'speaker joining its 'Hey' range. The Heylette measures only 300mm high by



195mm wide and 213mm deep. It shares the family traits of stylish beaded cabinet edges and a shaped grille. The Heylette has two rear-facing ports and a claimed sensitivity of 88dB. Costing £269, the Heylette is available in either Black or Rosewood.

**Heybrook Hi-Fi**  
**Clevo Road,**  
**Liskeard,**  
**Cornwall PL14 3NH**  
**Tel: 01579 342866**

**LIGHT THE WAY**

Bill Beard Audio (BB Audio) has released a new integrated amplifier called the 30/60. This is a 30watt all-valve line level integrated which, once a simple user adjustment is made, can



be run as a 60watt monobloc power amplifier. Also incorporated into the design is a monitoring circuit for each valve which uses a bi-colour LED. If the LED is showing green then operating conditions are normal, red signifies that the valve needs replacing and no light at all means that the valve is faulty.

The 30/60 uses eight Russian Sovtek EL84s in the output stage and four ECC88s in the driver stage. All valves are guaranteed for a year and the amplifier itself has a five-year warranty covering parts and labour. The 30/60 is available in Black or Brazilian Mahogany and costs £1295.

**BB Audio**  
**98A Oaklands Grove,**  
**London W12 0JB**  
**Tel: 0181 749 4258**

**NOW HEAR THIS**

High End Audio Recherché (HEAR for short) is a Belfast based importer who specialises in ultra high-end equipment like Purist Audio Design cables which offer some interesting solutions to cable problems. All the cables make use of a fluid filled outer jacket which isolates the conductors from the effects of airborne and mechanical noise as well as helping to filter out radio frequency (RF) interference, PAD say.

Cheapest of the PAD cables is the Elementa, which utilises OFC copper conductors in a twisted configuration with a polyurethane dielectric. The cost for a terminated metre length is £150 with an additional £25 for every extra 1/2 metre. At the other end of the range is the Dominus RLS, a snip at £6155 per metre with each additional 1/2 metre costing £305.



**High End Audio Recherché**  
**11 Camden Street,**  
**Belfast,**  
**Northern Ireland BT9 6AT**  
**Tel: 01232 319148**

**MORE MISTRAL**

Essex based hi-fi specialist LFD has just announced a new addition to its Mistral range of components with the new £999 Mistral CD player. During the design of the player, special attention was paid to power supply isolation and regulation. This has resulted in

Clearly  
better.



When one of the best loudspeaker engineering teams in the world advances its state-of-the-art technology, you'd expect the result to outperform the competition.

It does.

KEF's new Q Series, with its distinctive clear cone Uni-Q® drivers, delivers a more precise stereo image, over a wider listening area, than any conventional loudspeaker can. This latest advance in KEF's patented technology delivers even smoother midrange response and clarity that's simply stunning.



From bookshelf to 3-way floorstander, the entire range is magnetically shielded for Home Theatre use. And because aesthetics are integral to good design, the two largest models incorporate KEF's new 'racetrack' bass unit. With the performance of an 8 inch driver in the space of a 6 inch, it preserves the slim, elegant Q Series design.

With the new Q Series, the competition have been decisively out-classed.

The difference is clear.

**Q**  
SERIES



The experience  
of sound





the digital and analogue sections running from separate supplies. Quality of passive components, internal wiring and effective earthing were also priorities. The Mistral CD player is available in two finishes, Stainless Steel/Gold and Black/Gold, the latter carrying an extra £20 tariff.

**LFD Audio**  
**7 Lancaster Gardens West,**  
**Clacton-on-sea,**  
**Essex CO15 6QG**  
**Tel: 01255 422533**

## "I" FOR IMPROVED

Goodmans Loudspeakers Limited have just launched improved versions of their Imagio speakers and introduced two new models. The IC50i is a small sealed box bookshelf model which, like the rest of the range, makes use of a modified version of GLL's ICT (Inductive Coupling Technology) 2-way driver. This allows a tweeter to be mounted in the centre of the mid/bass unit's cone and driven from the field generated by the mid/bass driver's voice coil - no crossover is needed.

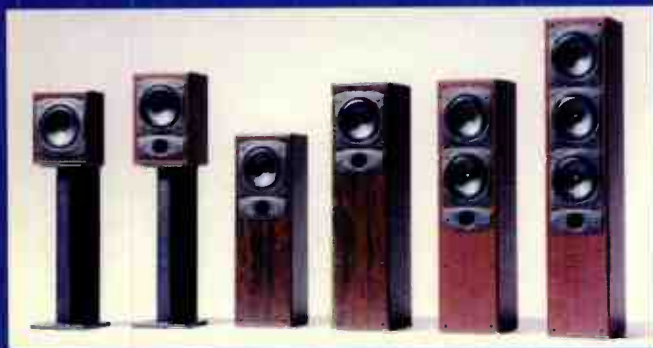

The other new speaker is the IC115i, which is a floor standing ported design with a claimed sensitivity of 88dB and a frequency response of 40Hz - 20kHz. Prices are still to be announced.

**GLL**  
**Unit 1A,**  
**Lakesmere Road,**  
**Hazleton Industrial Estate,**  
**Horndean,**  
**Hampshire PO8 9JU**  
**Tel: 01705 492777**

# trade winds

## NEW NAIM, OLD FACE

Naim Audio have upgraded their entry level CD player, the CD3, to CD3-5 status. This £1000 player uses a VAM 1205 transport, which is a high quality variant of the well known Philips CDM12. On the main circuit board sit 14 regulated power supplies while another separate supply for the servo control board is mounted in the loading tray. The CD3-5 also differs from its predecessor in that it can be connected to any of Naim's external power supplies to power the analogue circuitry. Doing this is claimed to improve sound quality significantly.

**Naim Audio**  
**Southampton Road,**  
**Salisbury,**  
**Wilts. SP1 2LN**  
**Tel: 01722 332266**

## PARTY ON, PEARL

Obviously a company that just loves to party, Mordaunt-Short has just released yet another 'speaker to celebrate their 30th anniversary. Following hard on the heels of the Pearl version of the MS10i is the MS20i Pearl. This sells for £199.99 and features a new MCS5 Technology cone and surround. MCS5 Technology is basically a new cone material which improves the stiffness-to-mass ratio, making the cone behave in a more pistonic manner while increasing the overall sensitivity of the drive unit. To accommodate the driver change the crossover has been modified to produce a more refined and detailed treble performance. The Pearl version supersedes the current MS20i and is available in Black Ash and Rosewood finishes.

**Mordaunt-Short**  
**3 Ridgeway,**  
**Havant,**  
**Hampshire PO9 1JS**  
**Tel: 01705 407722**

## AE100: THE NEXT GENERATION

Acoustic Energy's diminutive AE100 has been revised and relaunched as the AE100i (no prizes for original suffixes here). Though the drivers remain the same, the crossover has been realigned and its components upgraded. The internal wiring has also been improved to 'audiophile' quality OCC copper. These changes are said to result in greater transparency and better integration between the two drivers. The AE100i is now an easier load than their predecessors and the modifications have also marginally increased sensitivity. The price remains unchanged at £199.95.

**Acoustic Energy**  
**16 Bridge Road,**  
**Cirencester,**  
**Glos. GL7 1NJ**  
**Tel: 01285 654432**



trade winds

group  
test

# CONVERSION THERAPY

**Jon Marks and Ketan Bharadia  
get to grips with five  
converter hopefuls to  
find the best of DACs  
at £600-£1000.**

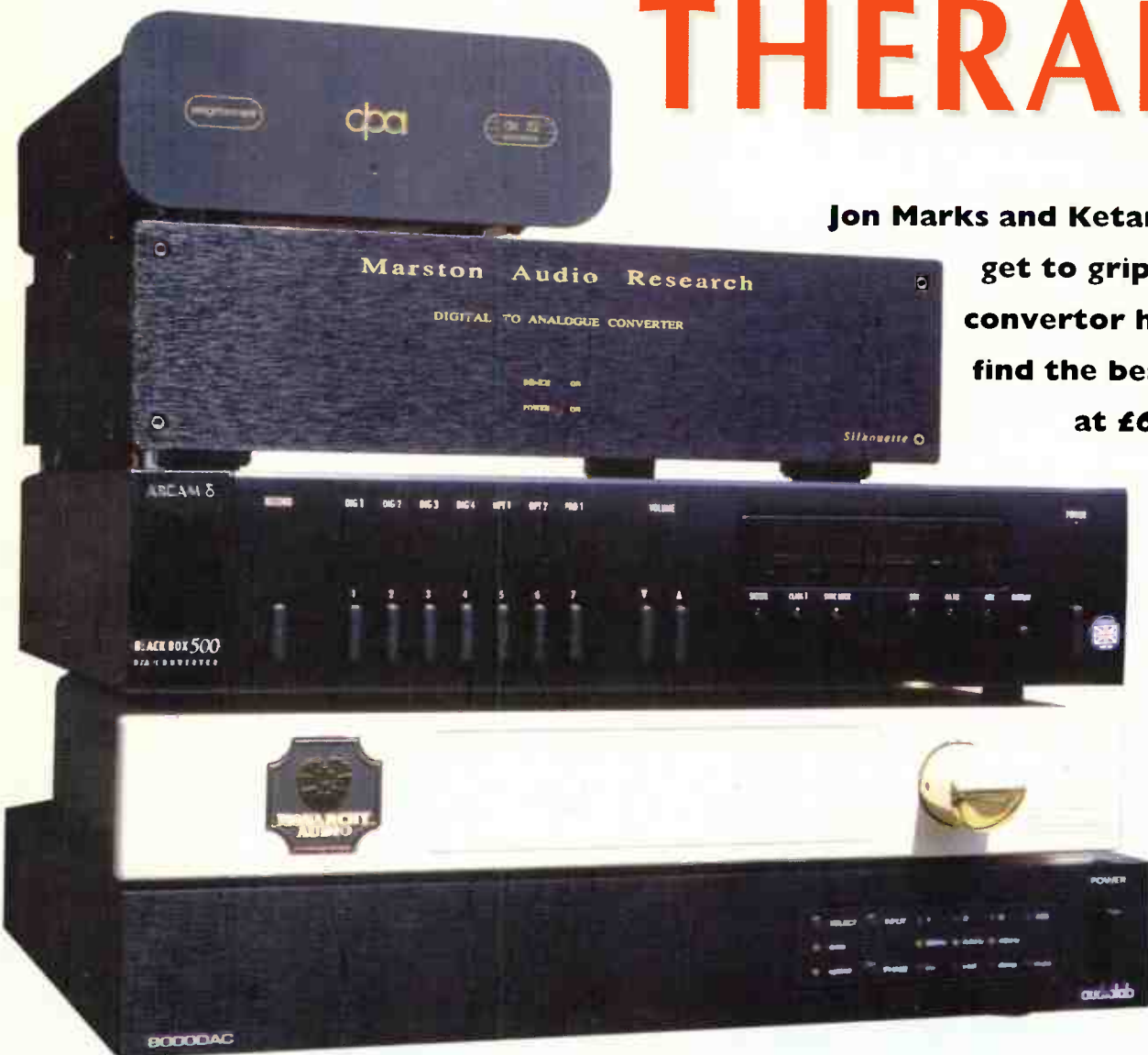

**T**he pressing question facing most digiphiles with £1000 to spend is: "Do I go the one-box or transport/DAC route?" At this kind of price the only real reason to go the second way is to keep your upgrade options open because there are some stonking integrated players around (Marantz CD-63 mkII KI-Signature, Trichord Genesis and Revelation for instance). As price rises, though, the playing field starts to level as transports and DACs come increasingly into their own as more money gets spent on the beefy power supplies, regulators and high quality components necessary to get the best from CD. But if you've already got a transport and budget

converter, which DAC should you go for if you've got up to £1000 to spend?

We've assembled a group of five contenders to answer this question. There's the £825 Enlightenment from DPA, famous for their radical and effective in-house decoder designs and love of miniature 'surface mount' components. Another DAC following a non-standard design route is the £750 Black Box 500 from well known and respected manufacturer Arcam. The third British manufacturer in the test is Audiolab, represented by their £900 8000DAC, partner to the 8000CDM transport we use here at Hi-Fi World towers, alongside the more expensive Teac P-30 (both of which were hooked

up to the DACs here). Next comes Marston Audio Research with their £650 Silhouette and £300 optional matching power supply unit. Finally, we have the sole overseas contender in the form of the £600 Model 18 Delux from American company Monarchy Audio.

All the DACs were connected to the transports via co-ax cables - using the optical inputs invariably produced a rather dynamically squashed sound with blurred detail. And while each DAC was being auditioned all the others were removed from the system and switched off. If this wasn't done, the result was a hard, grainy sound from whichever DAC was being tested.





## TECHNOLOGY

DPA have always done things a little differently from most and it shows in this DAC. The Enlightenment uses DPA's proprietary 1-bit dx32 processor (eight of which are used in the amazing £6000 1024 DAC) built up from the discrete components in the two white-outlined boxes on the circuit board. This carries out the filtering normally done in the analogue domain in the digital domain. As a result, the analogue circuitry is simpler and has shorter signal paths than would normally be the case, which improves sound quality, making it more transparent, say DPA.

The DAC takes its power from a single transformer mounted directly on the PCB, the various sections being fed through six LM317/337 variable positive and negative

voltage regulators. These are mounted flat on the PCB and surrounded by a mix of standard and surface mount ICs. This reduces Radio Frequency interference which DPA say adds a coarse, gritty coloration to the sound.

On the back panel of the Enlightenment's somewhat non-standard size case sit the single co-ax and optical inputs, along with another optical socket for the Deltran signal which synchronises DAC and transport to reduce jitter.

## SOUND QUALITY

Listening started with the Dave Brubeck Quartet's Time Out CD. Cymbals shimmered and decayed with great realism, only a hint of brightness at the highest frequencies tainting the sound. Both sax and piano had richly natural texturing courtesy of the

DPA's wide ranging tonal colour -

the only thing grey about the DPA is its casing. Plucked double-bass amply demonstrated the fact that the Enlightenment has a deep and hard hitting bass (second only to the Monarchy Audio Model 18), although I can imagine it might cause problems in

an already bass heavy system. Where the DPA equalled the PSU'd Silhouette and drew ahead of the other DACs was in sound staging and image focus. Instruments had body and presence rather than sounding like two dimensional cut-outs as they can often do.

Chaka Demus and Pliers made their way to the CD tray next. Here the DPA proved its pedigree - even with the drum machines and synthesisers working overtime the Enlightenment kept a track of everything, never sounding confused or overwhelmed. All hi-fi aspects of the sound were present and accounted for, with deep, powerful bass, translucent midrange and fast, clean treble. Even more of a sound for sore ears than all this was the sense of cohesion that the DPA gave to music, with images knitted into a spacious acoustic. Admittedly the DPA was pipped in the detail stakes by the Marston DAC and matching PSU but this didn't detract from the enjoyability of its performance.

Wagner and Otto Klemperer continued the proceedings. The Enlightenment produced a wide, deep sound stage for the orchestra to fill, its various sections clearly defined. And once again the DPA pulled off a convincingly organic performance. Tonally it was rich and full although that hint of brightness at the highest frequencies was still present.

The DPA Enlightenment is a very musical DAC which is highly enjoyable to listen to. But care must be taken in system matching to ensure its powerful bass and slightly emphasised high treble don't cause any problems.

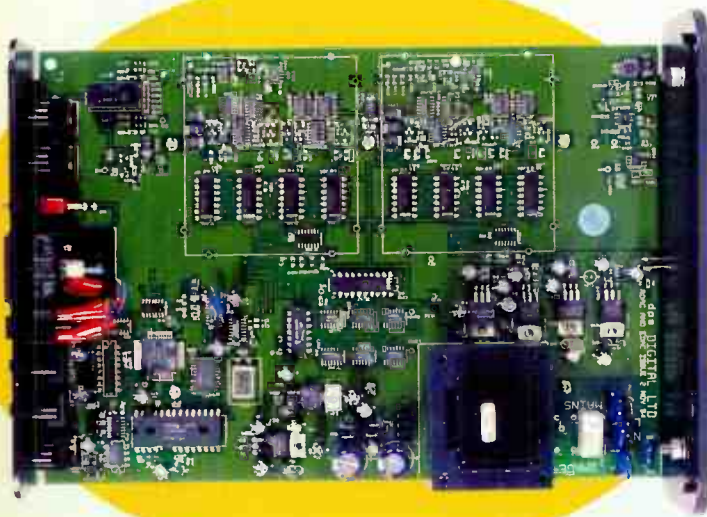

# INTRODUCING THE SOUTH WEST'S NEWEST HI-FI DEALER...

**J&A**  
**CAMERAS**  
PHOTOVIDEO

**AT LAST!** - Somewhere near to home to hear those products the magazines rave about! (As long as you live in the west country!)

**THRILL!** - To friendly, unbiased advice from the staff that bought you the south west photo/video + Hi-Fi exhibition!

**CHEER!** - As we don't talk jargon, we don't supply coffee, we don't even have free parking (sorry!) - We just try to offer exceptional service and competitive prices!

Agencies include: Arcam, B&W, Tannoy, Castle, Marantz, Cable Talk, JVC, Aura, Yamaha, NAD, Audioquest, Onkyo, Sonneteer, Sony

*P.S. We also stock loads of cameras too!*

**J&A**  
**CAMERAS**  
PHOTOVIDEO

Hi-Fi Centre  
85 Boutport Street  
Barnstaple  
North Devon EX31 1PE  
Tel: 01271 75037



Group Test



## TECHNOLOGY

Arcam have decided not simply to buy in a DAC chip set from an outside manufacturer as most companies producing DACs do. Instead, like DPA, they've plumped for an in-house convertor in a screening can which uses discrete surface mount components and multiple power supplies to achieve near 20-bit resolution, Arcam say. The DAC is hooked up to a Philips 1307 (DAC 7) filter chip.

Aiding sound quality are the separate power supply transformers, one for digital and one for analogue sections. There's also a smattering of industry standard 5V and LM317T variable voltage regulators for the various ICs.

The Black Box 500's rear panel is a real socket-fest. All inputs are catered for, with a pair each of optical, co-ax and BNC

sockets along with a single AES/EBU. Like the Audiolab, there are two pairs of analogue outputs. Setting the Arcam apart is another pair of optical connectors to allow the BB500 to sync-lock to an Arcam transport to reduce jitter. And like the Monarchy DAC, the BB500 comes with a volume control (so it can be used straight into a power amp), although the Arcam's is digital where the Monarchy's is analogue.

## SOUND QUALITY

The Arcam is one of the best DACs I've heard in a long time. The way it handled Tori Amos' Boys For Pele allowed all the nuances and rhythmic drive to shine through in what was a superbly engrossing performance. And it pulled this feat off whether music was strolling along at a relaxed tempo or going hell for leather at 125bpm.

Where the Arcam also scored was for its smooth, grain-free midrange and treble. Tori Amos' singing was powerful, as was her harpsichord playing, but both had the tonal colour to sound realistic and natural. Switching off the Black Box 500's display helped here, removing a slight fuzziness from the music to

give crisper dynamics and more detail.

These qualities stood the Arcam in good stead when it faced up to the Chemical Brothers' 'Setting Sun'. This recording sounds like it was mixed with an industrial sander - saying it has a few rough edges is putting it mildly. Through the Arcam, its heinously addictive heavyweight rhythm remained intact and its upper registers were just as they should be - raw and powerful but not painful. Convertors like the Marston did, however, pull ahead in bass extension and sound stage width, instruments and samples having more room to breathe where they could sound rather cramped on the Black Box.

An EMI digital remastering of Wagner's Flying Dutchman (Philharmonia orchestra, Klemperer conducting) proved this DAC has no problems dealing with complex orchestral works. The full range of tonal colour here contrasted with the Audiolab's rather greyer rendition, putting the Arcam on a par with the DPA. Sound stage depth was good, as were dynamics, although again the '500 produced a smaller scale picture than the DPA. That said, the DPA could sound almost unnaturally dynamic at times.

The Arcam Black Box 500 works well with whatever you throw at it, whether it's Janis Joplin or Bach. It doesn't have the overtly warm balance which used to characterise Arcam's components. Instead, it has a smooth but even-handed delivery. While a slightly bigger sound stage and greater bass extension wouldn't go amiss, the Arcam is still a good all rounder.

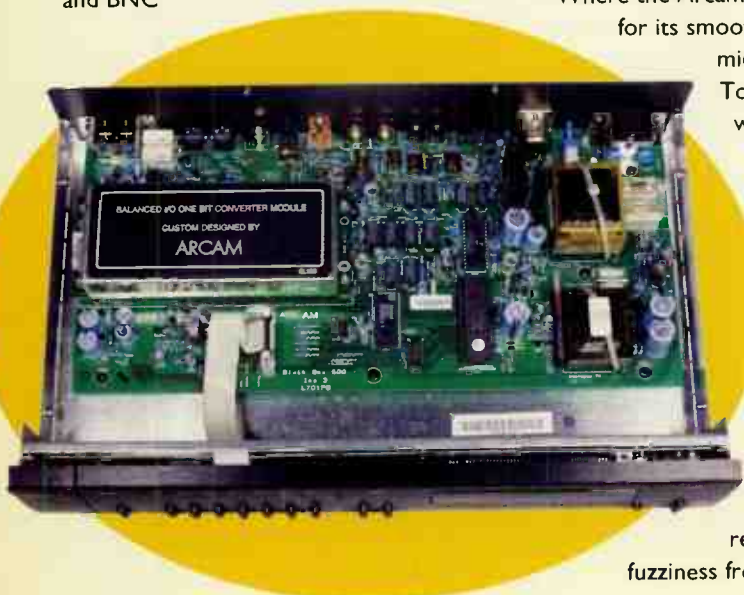

# FLEXIBILITY



Audiolab 8000DAC  
Audiolab 8000CDM  
Audiolab 8000C  
Audiolab 8000P  
Audiolab 8000S  
Audiolab 8000T



Audiolab 8000Q  
Audiolab 8000M  
Audiolab 8000T



Audiolab 8000S

The Audiolab 8000A Integrated Amplifier, 8000C Pre-amplifier and 8000P Power Amplifier have earned an unrivalled international reputation for outstanding sound quality, engineering excellence and flexibility.

They are the basis of many fine Hi-Fi and AV Systems and they also play your LPs – *that's real flexibility.*

For more information and details of your Audiolab dealer call or write.

Cambridge Systems Technology Ltd  
Spitfire Close, Ermine Business Park  
Huntingdon, Cambs PE18 6XY  
Telephone 01480 415600  
Fax 01480 52159







## TECHNOLOGY

Audiolab have opted for Philips chips inside their 8000DAC. The convertor is the TDA7350 20-bit noise-shaping IC with 384 times oversampling which passes its output on to a TDA1547 20-bit filter. Both of these are contained in a screening can to reduce Radio Frequency interference. Power for both digital and analogue sections comes from a total of 11 separate regulators; reservoir and decoupling capacitors are by Elna. Dealing with analogue filtering and outputting the analogue signal are three pairs of the well known and much used 5534 op amps.

The Audiolab takes the opposite approach to input sockets

from the Marston Silhouette. On the 8000DAC's back panel are three optical, three BNC and one AES/EBU electrical inputs, but no RCA co-ax sockets.

## SOUND QUALITY

Getting the Audiolab ball rolling with Stravinsky's *The Rite of Spring*, I found the 8000DAC civilised in a way many of this company's components have been thanks partly to a lack of roughness across the midrange and treble. Also playing its part is a treble roll-off which could be heard on whatever music I was listening to, with the 8000DAC setting up a sound stage (good width but slightly curtailed depth next to the DPA and Marston) behind

the front plane of the loudspeakers rather than on a level with it. In this way, it was actually reminiscent of the Arcam Black Box 500 with its display left on - missing out on a little incisiveness and projection.

With Tori Amos' *'Marianne'* from her *Boys For Pele* CD the Audiolab spread images across one of the broader sound stages in this group

test. The images themselves, though, didn't have the transparency of the DPA or the outright detail of the Marston Audio Research Silhouette, coming across as slightly out-of-focus by comparison. And the 8000DAC could start to get a bit confused when things got busy, as this song proved with instruments starting to blend together on crescendos. In spite of this, the Audiolab showed that it could muster a fair spread of tonal colour and the bass control to give the pounding rhythms of *'Caught a Lite Sneeze'* the power they need.

The 8000DAC seemed happier with the simpler electronic arrangements of Chaka Demus and Pliers' *Tease Me* album. *'She Don't Let Nobody'* strolled along with precise timing and smooth vocals, as did the whole of this CD. Other beneficiaries were the sparse vocals and percussion of *'Never Be Mine'* from Kate Bush's *Sensual World* CD where the 8000DAC picked up brownie points for punchy upper bass and the disconsolate opening to *'This Woman's Work'*.

The best way to sum up Audiolab's 8000DAC alongside the other convertors in this group test is 'inoffensive'. Where the DPA can sound almost over-dramatic at times the 8000DAC takes a more measured approach. Where the Marston Audio Research Silhouette can be a little clinical at times in its basic form the Audiolab was smoother and less artificial. But at the end of the day, the Audiolab lacks the involvement and natural flow of the DPA, Marston and Arcam convertors.



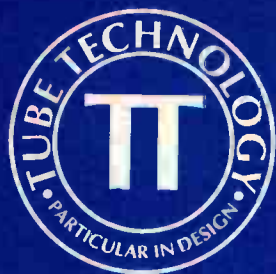

*Glowing at*



Prophet & Genesis Signature  
Pre-Power Combination



# COOL BRITANNIA

The finest of British valve amplification is now on permanent demonstration - just a stone's throw from Covent Garden Tube.

Acclaimed by audiophiles the world over, British Tube Technology amplifiers and preamplifiers simply have to be seen and heard to be believed.



*The Synergy PPS - Single Chassis Pre Power System*

*"...pure Vistavision, wide and deep and stretching out as if the room had no boundaries."*

*"This amp makes music with body, with mass, with foundation, and yet it's never overbearing... a perfect example of Why We Love Valves."*

*Hi-Fi News, June 1995*

0% APR

Cash Price £6900  
Deposit £2100  
Balance £4500  
36 months  
£125 p/m

Experience Tube Technology in the relaxed surroundings of Musical Images' award winning Covent Garden store, where our professional team can guide you through every aspect of this remarkable tube equipment. If you want to discover Britain's hottest tubes, you owe it to yourself to visit the nation's coolest A/V retailer.

18 Monmouth Street Covent Garden London WC2H 9HB Tel: 0171 497 1346



**OPEN SUNDAYS**



Other Stores at ~ Edgware 0181 952 5535 Hounslow 0181 569 5802 Beckenham 0181 663 3777

Interest free credit subject to status. Written Quotation on request. E&OE. email: sales@musical images.co.uk



GROUP TEST

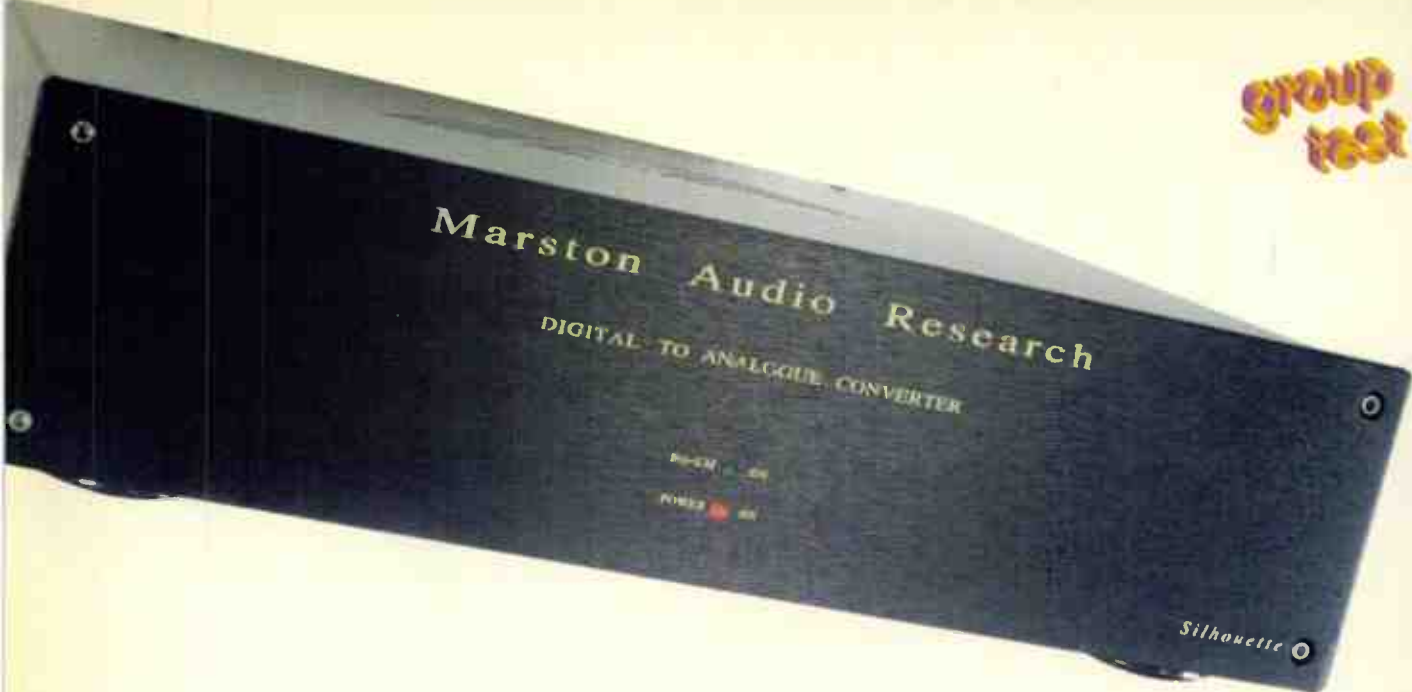

## TECHNOLOGY

Lurking beneath the Marston's unassuming black casework is a surprisingly small Printed Circuit Board sparsely populated. Marston, like DPA, have decided to travel the surface mount component route which gives shorter signal paths than standard resistors and capacitors. The heart of the Silhouette is a Crystal Semiconductors 4328 18-bit DAC. This, along with the rest of the digital section, draws its power from three regulators, while the analogue stage relies on no fewer than five.

To prevent contamination by Radio Frequency interference, all ICs are screened with aluminium foil and heat-sensitive chips have heat sinks bonded to them. Taking care of passing the signal on to the amplifier are current

feedback op amps chosen for their high slew rates. And if you decide to partner the DAC with the outboard power supply (£895 for the DAC and PSU if bought together, £295 if the PSU is bought on its own), basically what you get is a hefty 500VA toroidal transformer like you'd expect to see in a beefy power amplifier. This supplies the analogue stages of the DAC, leaving the on-board transformer powering the digital sections. As far as socketry goes, the Marston will only accept co-ax plugs, eschewing both optical and BNC inputs.

## SOUND QUALITY

The first CD in to the Teac P-30 transport's tray was Chaka Demus and Pliers. My immediate impressions were of an extremely clean and clear sound.

The dynamic duo's vocals were well focused and easy to follow, the rhythm section in full flow as my tapping feet demonstrated. There was a good dose of detail present as well, all the way from the powerful basslines up to the complex percussion.

The ever-present Dave Brubeck Quartet followed with Time Out. Here the Marston was equally impressive.

Cymbals sounded suitably realistic, shimmering and decaying in a believable manner and sax was rich and smooth. The piano imaged well forward out of the right-hand 'speaker as it should and had a realistic timbre to boot.

It wasn't quite ten out of ten for the Silhouette though. Plucked double-bass was less prominent in the mix than it should have been and sounded a bit lightweight. There was also an artificial hardness present on some of the more heavily struck piano notes but this wasn't unpleasant enough to become a problem.

Turning to Wagner's Rienzi overture performed by the Philharmonia Orchestra and conducted by Otto Klemperer I once more found a clean, clear sound. Strings flowed well, never sounding aggressively sharp and horns had real, brassy power. The Marston managed to capture the full scale of the piece without coming across as 'loud' or harsh.

Switching to the optional power supply made a significant difference, all of it for the better. Most notable was the improved weight to the sound, especially at the bass end. Stereo width broadened significantly although stage depth, which was already very good, didn't benefit to the same extent. All in all, the Silhouette sounded much more natural thanks to the loss of the clinical edge that the DAC possessed when used on its own.

Marston Audio Research's Silhouette DAC on its own is really rather good, only a few minor blemishes blotting its copy book. With its optional power supply the good bits get even better.

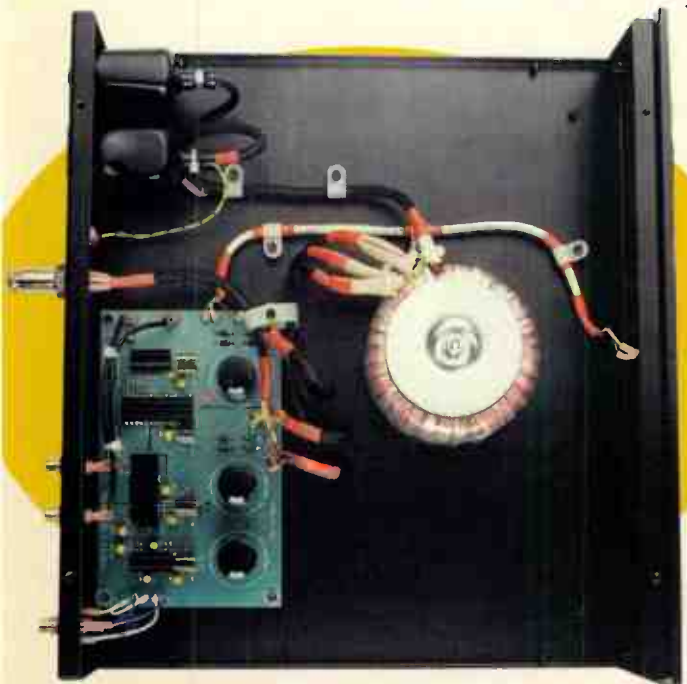

Group Test



**TECHNOLOGY**

The Monarchy is the only DAC in this group test to rely on multi-bit convertor technology (Analog Devices' AD1860N). The other DACs, like most these days, use 1-bit processing. Monarchy say they went this way because of the better perceived dynamic range provided by multi-bit filters. There's a separate DAC in left and right channels, each of which is individually trimmed for best performance.

Like Arcam, Monarchy use two mains transformers for analogue and digital sections, the former getting a potted toroidal, the latter an IE core type. Five regulator ICs also put in an appearance.

Unusually, the Delux 18's electrical inputs are transformer coupled which, Monarchy say, suppresses jitter and maximises signal transfer. Alongside the AES/EBU socket are single co-ax and optical inputs. Outputs come in two flavours, one fixed and one variable thanks to the analogue volume control from Noble. This allows the DAC's output to be connected direct to a power amp - no pre-amp is necessary.

**SOUND QUALITY**

Despite being the cheapest DAC of the group the Model 18 Delux feels the most sturdily built. Much of this impression is due to the heavy gauge casing and thick front panel which left the other DACs in this test feeling like

biscuit boxes.

In the company of Chaka Demus and Pliers the Monarchy excelled. Bass rhythms were pumped out with real force and authority - this aspect of its sound was unequalled by any other DAC in the test. Not only was the bass powerful, it was also well defined and had enviable get up and go. This meant the Monarchy conveyed the pace and timing of these songs very well. Transient attack was similarly eye-brow raising and made for highly enjoyable listening with any sort of music which is rhythm driven.

As with most things in life the Monarchy isn't perfect though. It's not as transparent as the better DACs in this test, sounding slightly veiled by comparison. Vocals lacked body as well and consequently sounded a little flat. But this was all in keeping with the Monarchy's smaller price tag.

Dave Brubeck was up next. Cymbals came across as rather thin and dry, lacking the harmonics and resonances captured in the recording. With this CD it became apparent that while the Model 18's sound stage width was OK, depth was limited. And a lack of tonal colour portrayed the sax, which should be rich, textured and flowing, as flat, thin and hard edged. On the other

hand, double-bass was doing its job well with power, weight and definition readily apparent.

Listening to Wagner's Rienzi the constrained sound stage was apparent in the diminished size of the acoustic. Within this space though the various sections of the orchestra were well focused and easy to identify. Orchestral crescendos were a little squashed because the Monarchy didn't quite have the dynamic headroom to do them justice but this DAC maintained the music's flow where the Audiolab 8000DAC sounded rather uninvolved.

The criticism levelled at the Monarchy might seem damning but given the fact it's up against competition costing at least £50 more, it does pretty well for itself. And a rhythmic performance and superb bass welly ensure that with a lot of music it remains highly enjoyable.





## CONCLUSION

The DACs in this test seem to fall into two fairly well defined sonic groups. The first of these consists of DPA's Enlightenment, Arcam's Black Box 500 and Marston Audio Research's Silhouette (with power supply). The second is made up of Monarchy Audio's Model 18 Delux and Audiolab's 8000DAC.

What sets the first group apart from the second is a mix of ingredients which taken together make these DACs a great way to spend a lot of time listening to music. The DPA, Arcam and Marston all have rhythm - there's no way music through these DACs is going to sound uninvolved or lacklustre. This is backed up by a natural ebb and flow to their presentation which enables you to ignore the fact that you're listening to hi-fi and just get on with immersing yourself in the music. The last part of the puzzle is a transparency which lets you hear deep into the music, all its delicate subtleties revealed. This makes music so much more convincing and involving because all the nuances which

shape the music are there to be heard.

While the Audiolab and Monarchy Audio are streets ahead of the kind of DACs that were around four or five years ago, next to the threesome above they have a slightly old-fashioned sound. This comes through most obviously as a lack of acoustic space and transparency.

The Audiolab 8000DAC is the more culpable of the two here as it costs a good deal more than the Monarchy's £600. Its treble roll-off serves to remove some of the music's sparkle, leaving in its wake a rather warm, soft-focus sound that can come a-cropper on busier passages. The Audiolab lags behind the group leaders in the rhythm stakes too, where it fails to set your foot tapping and your heart pounding.

At £600, the Monarchy with its multi-bit DAC actually looks like pretty good value. It may not be quite as engrossing a listen as the Marston, the DPA or the Arcam but it doesn't offend and its multi-bit convertor chip packs a mighty bass punch. Another plus is its on-board analogue volume potentiometer which means a pre-amp isn't necessary to set volume levels.

Build quality is very good too, with a reassuringly hefty weight and solid casework.

So which is best, the DPA Enlightenment, Arcam Black Box 500 or Marston Audio Research Silhouette with matching PSU? Well, as is ever the case with good hi-fi, the choice is yours. If it's edge-of-the-seat excitement, bass punch and unbeatable rhythm, then the DPA is the one to go for. On the other hand, if detail is high on your list of priorities and you look for a more forceful, harder-edged presentation then the Marston looks like the best bet. For a more measured but by no means less engaging sound there's the Arcam which will doubtless fit snugly into many systems thanks to its smooth but not rolled-off treble and easy-going rhythm. And at £750 it's very good value too.

I'd hesitate to say that the best of modern convertors at £600-£1000 have a more 'analogue' sound than those of old - vinyl and CD have very different sounds and never the twain shall meet. But good modern DACs can sound very natural and make listening to the silver disc true audiophile fun ★

## Manufacturers

### Audiolab

Spitfire Close,  
Ermine Bus. Park, Huntingdon,  
Cams. PE18 6XY  
Tel: 01480 52521

### Monarchy Audio

(distributed by Wollaton Audio)  
134 Parkside,

Wollaton,  
Notts. NG8 2NP  
Tel: 0115 928 4147

### Marston Audio Research

PO Box 89,  
King's Lynn,  
Norfolk PE30 5SH  
Tel: 01553 772875

Arcam  
Pembroke Avenue,

Denny Ind. Centre,  
Waterbeach,  
Cams. CB5 9PB  
Tel: 01223 440964

DPA Digital  
Units 7 & 8,  
Willowbrook Lab Units,  
Crickhowell Road,  
St Mellons,  
Cardiff CF3 0EF  
Tel: 01222 795621

# SUGDEN

HAND CRAFTED



FAIT À LA MAIN

## PURE CLASS A FROM £599

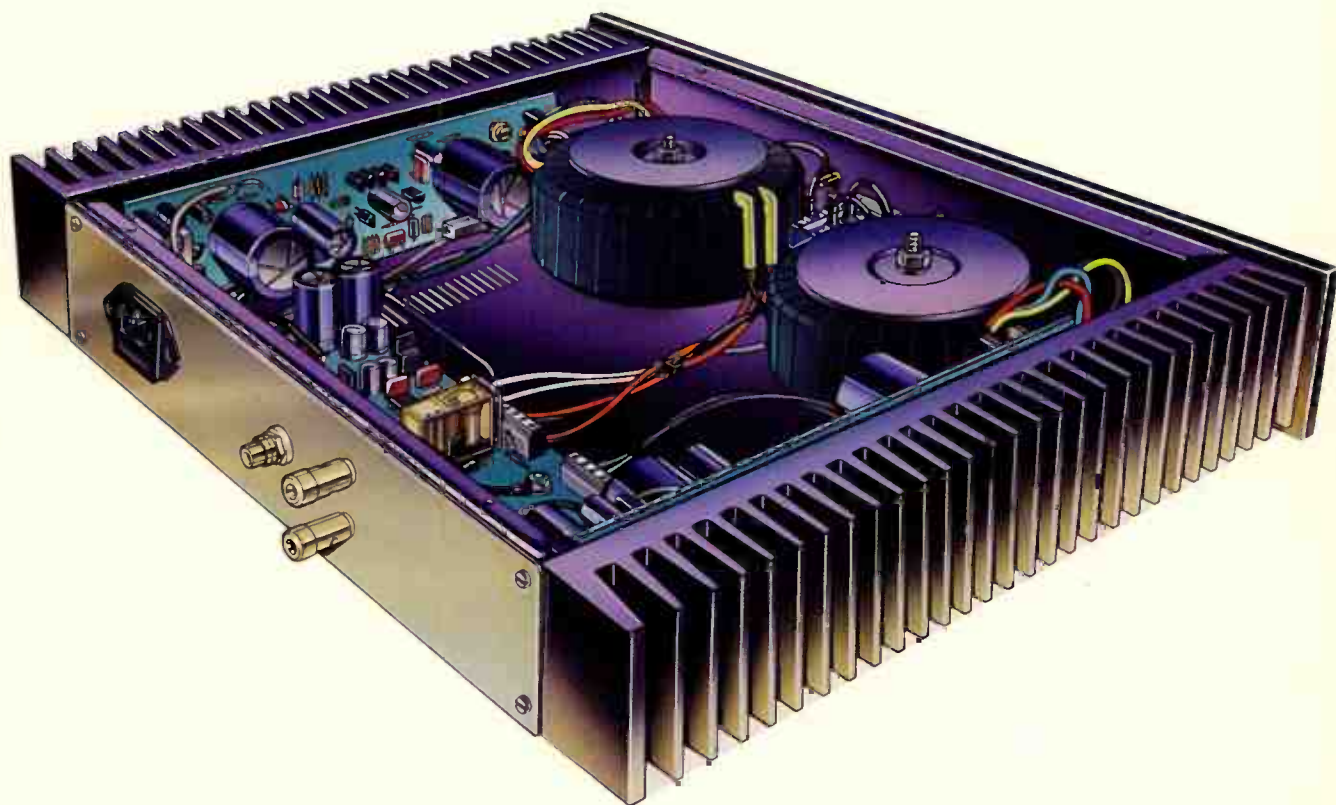

**INDIVIDUALLY HAND CRAFTED  
REFERENCE SOUND QUALITY  
SENSIBLE RETAIL PRICES  
PURE CLASS A OPERATION  
THE ORIGINAL AND BEST**

**DESIGNERS AND MANUFACTURERS OF REAL AUDIO EQUIPMENT**

**J.E. SUGDEN & CO.LTD**

Valley Works,

Station Lane, Heckmondwike,

West Yorkshire WF16 0NF

Tel: Heckmondwike 01924 404088/9

Fax No: 01924 410069



# THE WAX FACTOR

**David Price investigates the record industry's latest money spinner - the vinyl LP!**

**F**or the last five years the major record companies' refusal to press vinyl has been tantamount to throwing money away. There is still a great demand for black plastic, as the rising prices of second-hand discs prove. Now, at last, the likes of EMI, Blue Note, Impulse, Castle, Classic Records, RCA and Testament are pressing vinyl again and openly talking about a 'vinyl revival'.

Finally realising how desirable a commodity vinyl can be, all these reissues come on premium vinyl with original-style packaging and most sell for between £7 and £15 - the same as a standard CD.

So why all this sudden interest in a format the record companies once tried to kill? Well, conspiracy theorists will be sad to hear that it's the simple expedient of money. Nowadays, LPs rather than CDs are the rarities enthusiasts want. So the record companies, famous for their interest in their customers' cash, have found themselves another nice little earner. Not that they'd put it so bluntly of course, preferring to spin the story bathed in vast amounts of nostalgia.

EMI's Steve Davis told *Hi-Fi World* that, "People have an abiding affection for vinyl" and, "People want another chance to buy the real thing". To wit, EMI has released the Centenary series of 20 classic Rock titles, with everything from Peter Gabriel's *Sledgehammer* to The Beach Boys' *Pet Sounds*.

The albums have been kept "as

authentic as possible", with original artwork and no tacky 'bonus' tracks added. The response has surprised EMI, with all 40,000 180gm audiophile pressings snapped up by dealers, and Steve says, "we'd like to think we'll do another 20 later this year".

Castle's Mick Carpenter believes reports of vinyl's death were "premature and exaggerated", saying there's still a great demand. He thinks LPs are particularly useful because of their attractive packaging, hence Castle's superb recreation of the original artwork on The Small Faces' classic *Ogden's Nut Gone Flake* LP. The circular sleeve, designed to resemble a tobacco tin, was an essential part of the album's artistic concept that you just can't replicate with CD. Again, Mick says that Castle are contemplating more reissues if the project goes well and all

the signs are that it has.

But it isn't only Rock titles that are finding their way back to black plastic. Impulse have just reissued no less than 20 classic Jazz waxings from the likes of John Coltrane, Quincy Jones and Sonny Rollins on 180gm audiophile vinyl. And Blue Note have followed suit with 22 more titles ranging from Herbie Hancock to Dexter Gordon on similarly high grade LPs.

Meanwhile, Testament Records, a small label with an exclusive licence to reissue EMI's vast Classical catalogue, are offering a number of titles with meticulous analogue mastering, all cut at Abbey Road and quality checked on a *Michell Orbe/Wheaton/Transfiguration* MC front end. Pressing is carried out by EMI to Testament's specification on 180gm virgin vinyl from lacquers rather than Direct Metal Masters.



Nick Webb, the cutting engineer at EMI's Abbey Road Studios, monitoring a Direct Metal Master being cut.

Behind the scenes, vinyl's resurgence has surprised many industry professionals. EMI's record pressing boss at the Hayes plant, Bob Bailey, says that business has undergone a transformation in the last five years. The huge drop in demand for vinyl in 1992 looked like the writing on the wall for the format - EMI was anticipating it surviving only a further six to nine months. But the Dance music boom in the early Nineties kept the 12in single presses rolling and then audiophile vinyl appeared on the scene, sparking a fresh demand for premium quality LPs. Bob told Hi-Fi World, "Vinyl didn't die, it changed. Rather than cheap 7in singles, the future looks like a new, higher quality LP. Now we're flat out 16 hours a day."

## HOW DO THEY SOUND?

We decided to sample some of the latest reissues to find out just how well they'd been produced. Listening took place through a highly revealing system comprising Michell Orbe/SME Series V/Ortofon MC15 Super II source, Mistral amplification and Mission 752F loudspeakers. Where possible, comparisons were made with original UK or Japanese pressings.

## EMI CENTENARY SERIES £14.90

This series is made up of 20 titles Direct Metal Mastered onto 180g virgin vinyl. Generally original analogue masters have been used but on some titles, digital remasters were chosen. EMI refused to comment but it's rumoured that Pink Floyd stipulated that digital masters should be used on their reissue. The vinyl is pressed at EMI's Hayes facility.

## KATE BUSH - THE KICK INSIDE

Against a mint 1978 Japanese pressing, the EMI LP turned out to be rather good. The Japanese disc had an



extremely smooth, musical sound with superb sound staging. By contrast the EMI lacked some of the reference's sweetness and imaging, but had stronger bass, a clean, detailed midrange and crisp treble, albeit rather 'chrome-plated'. Overall though, an excellent result considering the EMI disc's relatively low price and non-audiophile aspirations.

## WORLD VERDICT



## CASTLE COMMUNICATIONS £12.90

Castle offer various classic Kinks, Small Faces and Iron Maiden titles on numbered limited edition (10,000) LPs, with plans to release more. The discs themselves are Direct Metal Mastered on 160gm virgin vinyl and the original packaging is reproduced in its entirety, complete with superb additional sleeve notes. Packaging and disc quality is excellent, but unfortunately Castle have used the digital CD masters.

## THE SMALL FACES - OGDEN'S NUT GONE FLAKE

Compared to an original UK pressing the Castle reissue felt heavier and better made but was a bit of a let down on audition. Obviously digitally remastered, the album had a DAT-like quality to it - clean and crisp but fairly cold and uninviting. Bass was lighter, the midband closed in and treble sounded like it was coming straight from a CD player. Still, noise, hiss and vinyl roar were low and the album was perfectly listenable, just rather inferior to the

original analogue mastered LP.

## WORLD VERDICT



## BLUE NOTE £6.90 - £12.50

Two reissue series are currently being run by Blue Note - Connoisseur and Rare Groove. The former has premium 180gm pressings with original thick card jackets, the latter standard 120gm



pressings with less substantial packaging at nearly half the price. Both types are Direct Metal Mastered on to virgin vinyl at EMI Hayes.

**REUBEN WILSON - LOVE BUG**

Compared to an original 1970 pressing, this Rare Groove reissue sounded promising considering its low price. The original was superb, with extremely low noise and vinyl roar and a very relaxed, musical sound. By contrast, the reissue had more vinyl roar, but also a stronger bass, brighter treble and plenty of detail. Sound staging was better on the original



but the reissue was still good in this respect. Another impressive showing by EMI Hayes and excellent value for money. **WORLD VERDICT**



**CLASSIC RECORDS £25**

An American label, Classic have reissued some seminal Jazz titles on high quality 180gm virgin vinyl, all meticulously mastered

using original analogue masters. Classic's reissue of Miles Davis' Kind of

Blue has opened a few eyes - it comes on two discs, the first taken from the original master tapes, while the second replicates the CBS LP which after three decades was found to have been mastered at the wrong speed! Standards are very high all round, with excellent packaging using laminated card jackets and polythene inners.



**TIME OUT THE DAVE BRUBECK QUARTET**



**DAVE BRUBECK QUARTET - TIME OUT**

Compared to a vintage Columbia pressing, the Classic was noticeably cleaner and supremely quiet. Sound was sharper and more up-front with almost holographic imaging, while the standard pressing had a smoother, more relaxed quality - not unwelcome as the Classic was a touch bright and hard. A fine reissue but modest value considering its high £25 price.

**WORLD VERDICT**



**NEXT MONTH: WHERE TO SHOP FOR THE BEST IN NEW AND USED VINYL.**

*Mastering Mayhem*

**B**eware - today's reissued LPs aren't quite the same as the original Sixties' and Seventies' pressings. Why? Well, some companies use the digital remasters made for their CD reissues which have a cold, flat sound. So always avoid reissues with 'digitally remastered' hidden in the sleeve notes' small print.

Even if the original analogue masters are used, modern reissues still won't sound quite the same because

they're cut on modern lathes using digital delay lines. Rather than using analogue tape loops to drive the control electronics, the latest lathes (such as the Neumanns used at EMI's Abbey Road studios) use 20-bit, 48kHz digital delay lines to achieve efficient groove spacing. Although the quality of the digital convertors is very high - far superior to CD - they can still introduce slight digital coloration.

Finally, there's the vexed question of Direct Metal Mastering. Unlike Sixties' and Seventies' vinyl, most modern pressings use DMM because

it's relatively simple and gives superior measured performance. However, many audiophiles feel that traditional lacquer mastering gives a warmer, more involving sound - high-end vinyl specialists Mobile Fidelity swear by it. So if it's absolute originality you want, even the cream of today's vinyl reissues may not suffice. That said, most of them still sound really good - far superior to even the latest gold-plated, SBM or HDCD digital discs. Whatever modern production processes have done to vinyl, its intrinsic musicality still shines through!



# 28 Branches Nationwide



## STAFF WANTED

A Career in Hi Fi?

Please write to the personnel department at Sevenoaks Head Office including a recent photograph and CV.

Vacancies available at several locations.

At Sevenoaks Hi Fi you will find a wide range of products on show with the emphasis on quality combined with unbeatable value for money.

Everything in stock is on display and available for audition in our dedicated Hi Fi and Home Cinema demonstration rooms.

Our friendly and experienced staff will be happy to assist you through every step of your purchase to ensure total listening satisfaction.

**Sevenoaks Hi Fi - there is no better place to buy.**



## 28 SEVENOAKS HI FI BRANCHES NATIONWIDE

- SEVENOAKS 01732 459555  
109-113 London Road
- ABERDEEN 01224 587070  
491 Union Street
- BARROW-IN-FURNESS 01229 838757  
46 Cavendish Street
- BEDFORD 01234 272779  
29-31 St Peters Street
- BIRMINGHAM 0121 233 2977  
12 Queensway Arches, Livery Street
- BRIGHTON 01273 733338  
55 Preston Street
- BURY ST EDMUNDS 01284 753776  
47 Churchgate Street
- **new** CARLISLE 01228 590775  
3 Earls Lane
- CHATHAM relocated to Maidstone
- CHELSEA 0171 352 9466  
403 Kings Road, SW10
- CHELTENHAM 01242 241171  
24 Pittville Street
- CROYDON 0181 665 1203  
373 London Road
- ENFIELD 0181 342 1973  
7 Genotin Road
- ESSEX 01376 501733  
1 The Grove Centre, Witham
- GUILDFORD 01483 536666  
73b North Street
- KINGSTON 0181 547 0717  
43 Fife Road
- **new** LEEDS 0113 245 2775  
112 Vicar Lane
- LEICESTER 0116 255 7518  
94 Granby Street
- MAIDSTONE 01622 686366  
96 Week Street
- NORWICH 01603 767605  
29/29A St Giles Street
- OXFORD 01865 241773  
41 St Clements
- **new** PETERBOROUGH 01733 897697  
36 Park Road
- READING 0118 959 7768  
3 & 4 Kingswalk
- **soon** SHEFFIELD 0114 255 5861  
Old Sheffield Savings Bank, Heeley Bottom
- TUNBRIDGE WELLS 01892 531543  
28-30 St Johns Road
- WATFORD OPEN SUNDAY 01923 213533  
478 St Albans Road
- WOOLWICH 0181 855 8016  
162 Powis Street
- WORCESTER 01905 612929  
2 Reindeer Court

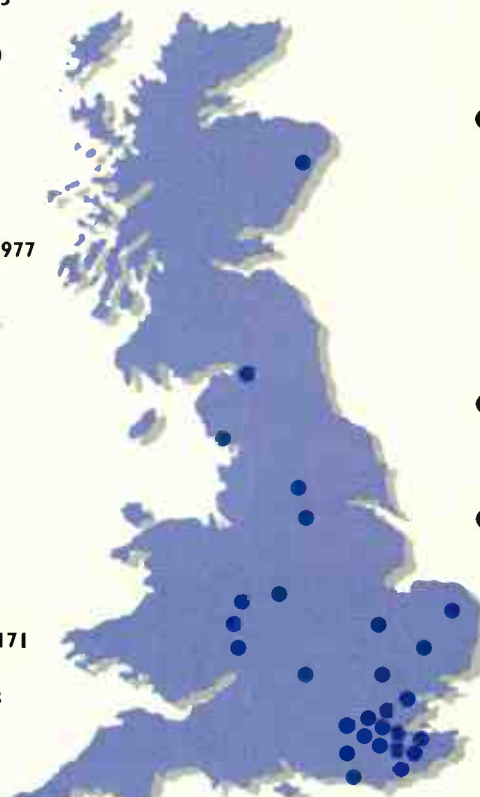

Mail Order 01732 458985

## WE LOOK FORWARD TO SEEING YOU AT ONE OF OUR 28 BRANCHES NATIONWIDE

SEVENOAKS 01732 459555  
 ABERDEEN 01224 587070  
 BARROW-IN-FURNESS 01229 838757  
 BEDFORD 01234 272779  
 BIRMINGHAM 0121 233 2977  
 BRIGHTON 01273 733338  
 BURY ST EDMUNDS 01284 753776

CARLISLE (NEW) 01228 590775  
 CHATHAM SEE MAIDSTONE  
 CHELSEA 0171 352 9466  
 CHELTENHAM 01242 241171  
 CROYDON 0181 665 1203  
 ENFIELD 0181 342 1973  
 ESSEX 01376 501733

GUILDFORD 01483 536666  
 KINGSTON 0181 547 0717  
 LEEDS (NEW) 0113 245 2775  
 LEICESTER 0116 255 7518  
 MAIDSTONE 01622 686366  
 NORWICH 01603 767605  
 OXFORD 01865 241773

PETERBOROUGH (NEW) 01733 897697  
 READING 0118 959 7768  
 SHEFFIELD (SOON) 0114 255 5861  
 TUNBRIDGE WELLS 01892 531543  
 WATFORD 01923 213533 OPEN SUNDAY  
 WOOLWICH 0181 855 8016  
 WORCESTER 01905 612929



# Quality at



ACOUSTIC ENERGY



Award winning Loudspeakers



# ARCAM



Award winning Components

## MUSICAL EXPRESSION PRODUCT SELECTION

### AMPLIFIERS

Arcam Alpha 7		£ 249.95
Arcam Alpha 8		£ 349.95
Arcam Alpha 9		£ 499.95
Arcam Alpha 8P	Power	£ 249.95
Arcam Alpha 9P	Power	£ 399.95
Audiolab 8000A		£ 499.95
Audiolab 8000S		£ 699.95
Audiolab 8000P	Power	£ 749.95
Audiolab 8000M (each)	Mono	£ 799.95
Audiolab 8000PPA	Phono	£ 899.95
Audiolab 8000C	Pre	£ 549.95
Audiolab 8000Q	Pre	£ 1099.95
Cyrus SL		£ 399.95
Cyrus III		£ 599.95
Cyrus	Pre	£ 649.95
Cyrus XPA	Power	£ 299.95
Cyrus	Power	£ 499.95
Cyrus PSXR	Power Supply	£ 329.95
Exposure	P.O.A.	£ 229.95
Marantz PM66SE		£ 399.95
Marantz PM66 KI Signature		£ 794.95
Meridian 55 I		£ 694.95
Meridian 501.2	Pre	£ 1294.95
Meridian 502	Pre	£ 894.95
Meridian 556	Power	£ 1399.95
Meridian 557	Power	£ 794.95
Meridian 505 (each)	Mono	£ 349.95
Micromega Minium		£ 399.95
Pioneer A300R Precision		£ 699.95
Quad 77 Ex Remote		£ 849.95
Quad 77 Inc Remote		£ 599.95
Quad 77	Power	£ 799.95
Quad 707	Power	£ 849.95
Quad 77 Inc Remote	Pre	£ 694.95
Roksan Caspian		P.O.A.
Talk Electronics		

### HOME CINEMA

A/Energy AE107C	Centre	£ 149.95
Arcam Xeta Two	Processor	£ 649.95
Arcam AV50	Amplifier	£ 699.95
B&W C100	Centre	£ 129.95
B&W CC3	Centre	£ 149.95
B&W CC6	Centre	£ 229.95
B&W S100	Surround (Pr)	£ 129.95
B&W DS6	Surround (Pr)	£ 399.95
B&W PB100	Sub	£ 349.95
Castle Keep	Centre	£ 249.95
Cyrus AV Master	Processor	£ 699.95
Kef 20B	Sub	£ 349.95
Kef 30B	Sub	£ 499.95
Kef 60S	Surround (Pr)	£ 199.95
Kef 70S	Surround (Pr)	£ 299.95
Kef Q95C	Centre	£ 199.95
Kef 90	Centre	£ 259.95
Kef 100	Centre	£ 359.95
Meridian	Stocked	
Mission 75C (Blk)	Centre	£ 249.95

Polk CS250	Centre	£ 249.95
Polk M2	Surround (Pr)	£ 179.95
Polk RTFX	Surround (Pr)	£ 349.95
Polk L5FX	Surround (Pr)	£ 449.95
Polk RMS300	Package	£ 999.95
Ruark Dialogue One	Centre	£ 289.95
Yamaha APD1	Demodulator	£ 99.95
Yamaha DDP2	AC3 Decoder	£ 349.95
Yamaha DSPE492	Processor	£ 249.95
Yamaha DSPE1000	Processor	£ 699.95
Yamaha DSPA492	Amp	£ 249.95
Yamaha DSPA592	Amp	£ 329.95
Yamaha DSPA1092	Amp	£ 849.95
Yamaha DSPA3090	Amp	£ 1499.95
Yamaha NSC60	Centre	£ 59.95
Yamaha NSC105	Centre	£ 79.95
Yamaha NSC150	Centre	£ 109.95
Yamaha NSE60	Surround (Pr)	£ 79.95
Yamaha NSE105	Surround (Pr)	£ 109.95
Yamaha YSTS40	Sub	£ 139.95
Yamaha YSTS40	Sub	£ 179.95
Yamaha YSTS40	Sub	£ 279.95

### SPEAKERS

Acoustic Energy AE100		£ 199.95
Acoustic Energy AE109		£ 349.95
Acoustic Energy AE120		£ 499.95
B&W DM601		£ 199.95
B&W DM602		£ 299.95
B&W DM603		£ 499.95
B&W DM302		£ 149.95
B&W DM305		£ 249.95
B&W CDM1		£ 599.95
B&W P4		£ 674.95
B&W P5		£ 874.95
Castle Isis	(Deluxe extra)	£ 229.95
Castle Tay	(Deluxe extra)	£ 329.95
Castle Severn	(Deluxe extra)	£ 539.95
Castle Avon	(Deluxe extra)	£ 699.95
Castle Harlech	(Deluxe extra)	£ 849.95
Castle Howard II	(Deluxe extra)	£ 1199.95
Epos ES12		£ 499.95
Epos ES22		£ 1184.95
Kef Reference		P.O.A.
Kef Q15		£ 199.95
Kef Q35		£ 349.95
Kef Q55		£ 499.95
Mission 751f	(Deluxe extra)	£ 349.95
Mission 752f	(Deluxe extra)	£ 579.95
Mission 753f	(Deluxe extra)	£ 799.95
Mission 754f	(Deluxe extra)	£ 1299.95
Monitor Audio Monitor 1	(Blk)	£ 249.95
Monitor Audio Monitor 2	(Blk)	£ 299.95
Monitor Audio Monitor 3	(Blk)	£ 399.95
Monitor Audio Monitor 4	(Blk)	£ 499.95
Monitor Audio 700PMC	(Blk)	£ 599.95
Monitor Audio 702PMC	(Blk)	£ 699.95
Monitor Audio 703PMC	(Blk)	£ 799.95

Monitor Audio 705PMC	(Blk)	£ 1399.95
Monitor Audio Studio 25E	(Blk)	£ 599.95
Monitor Audio Studio 12	(Blk)	£ 999.95
Monitor Audio Studio 20SE	(Blk)	£ 2199.95
Monitor Audio Studio 50	(Blk)	£ 3999.95
Monitor Audio Studio 60	(Blk)	£ 5999.95
Polk RT3		£ 199.95
Polk RT5		£ 249.95
Polk RT8		£ 399.95
Quad 10L		£ 599.95
Ruark Icon		£ 359.95
Ruark Templar MkII		£ 559.95
Ruark Sceptre		£ 599.95
Ruark Talisman II		£ 749.95
Ruark Prologue One		£ 799.95
Ruark Crusader II		£ 1599.95

### TUNABLES

Michell Gyrodec/RB300		£ 967.95
Project 0.5		£ 159.95
Project 1		£ 199.95

### TUNERS

Arcam Alpha 7		£ 229.95
Arcam Alpha 8		£ 279.95
Audiolab 8000T		£ 799.95
Cyrus FM7		£ 399.95
Meridian 504		£ 694.95
Micromega Minium		£ 299.95
Quad 77		£ 699.95

### CD PLAYERS

Arcam Alpha 7		£ 319.95
Arcam Alpha 8		£ 519.95
P.O.A.		
Audiolab 8000 CD		£ 999.95
Audiolab 8000 CDM-96		£ 1399.95
Audiolab 8000 DAC-96		£ 899.95
Cyrus DAD3		£ 599.95
Cyrus DAD3Q		£ 899.95
Exposure CD		£ 1049.95
Marantz CD67SE		£ 349.95
Marantz CD63II KI Signature		£ 499.95
Marantz CD17 KI Signature		£ 1299.95
Meridian 506 20 bit		£ 1094.95
Meridian 508 20 bit		£ 1684.95
Meridian 500 Transport		£ 1244.95
Meridian 566 DAC		£ 1094.95
Micromega Minium		£ 349.95
Micromega Stage 4		£ 399.95
Micromega Stage 5		£ 749.95
Micromega Stage 6		£ 949.95
Micromega Drive 3 Transport		£ 999.95
Micromega DAC		£ 749.95
Pioneer PDS505 Precision		£ 459.95
Pioneer PDR05 Recording CD		£ 999.95
Quad 77 Bns		£ 699.95
Quad 77 Powered		£ 899.95
Roksan Caspian		£ 894.95

Please telephone to verify price and availability before travelling. Offer valid until at least the end of July 1997. E&C ©

## 0% FINANCE

Spread the cost of buying selected quality hi fi separates and loudspeakers with our 0% finance terms. Up to 24 months interest free.

Written details on request. 0% APR. Subject to status

**OPTION 1**  
A minimum balance of £400 after a 10% deposit, followed by 6 equal monthly payments.  
Example, Cost: £1000 Deposit: £100, followed by 6 equal Monthly Payments of: £150

**OPTION 2**  
A minimum balance of £400 after a 25% deposit, followed by 9 equal monthly payments.

**OPTION 3**  
A minimum balance of £400 after a 50% deposit, followed by 12 equal monthly payments.

**OPTION 4**  
A minimum balance of £1000 after a 20% deposit, followed by 18 equal monthly payments.

**OPTION 5**  
A minimum balance of £2000 after a 20% deposit, followed by 24 equal monthly payments.

0% Finance not available on price match.

**BADA** THE ULTIMATE IN SOUND ADVICE

**ad** authorised DEALER  
WE ONLY SELL PRODUCTS FOR WHICH WE ARE AUTHORISED DEALERS

Mail Order- 01732 458985

## WE LOOK FORWARD TO SEEING YOU AT ONE OF OUR 28 BRANCHES NATIONWIDE

SEVENOAKS 01732 459555  
ABERDEEN 01224 587070  
BARROW-IN-FURNESS 01229 838757  
BEDFORD 01234 272779  
BIRMINGHAM 0121 233 2977  
BRIGHTON 01273 733338  
BURY ST EDMUNDS 01284 753776

CARLISLE (NEW) 01228 590775  
CHATHAM SEE MAIDSTONE  
CHELSEA 0171 352 9466  
CHELTENHAM 01242 241171  
CROYDON 0181 665 1203  
ENFIELD 0181 342 1973  
ESSEX 01376 501733

GUILDFORD 01483 536666  
KINGSTON 0181 547 0717  
LEEDS (NEW) 0113 245 2775  
LEICESTER 0116 255 7518  
MAIDSTONE 01622 686366  
NORWICH 01603 767605  
OXFORD 01865 241773

PETERBOROUGH (NEW) 01733 897697  
READING 0118 959 7768  
SHEFFIELD (SOON) 0114 255 5861  
TUNBRIDGE WELLS 01892 531543  
WATFORD 01923 213533 OPEN SUNDAY  
WOOLWICH 0181 855 8016  
WORCESTER 01905 612929



competition

# WIN BASED WO



**Making up this month's competition prize we've got Trichord's Genesis CD player, Audio Analogue's Puccini SE integrated amp and Celestion's AI stand mounters.**

than the normal Class AB.

When Douglas Floyd-Douglass reviewed the Genesis he concluded his article by awarding it four globes and writing, "I have no hesitation in commending the Genesis as one of the most enjoyable players I've heard. It is excellent value and sounds dynamic, bold and inspiringly musical". At its price of £549 it is undoubtedly one of the best.

The output from the Trichord feeds into Audio Analogue's new £595 Puccini Special Edition integrated amplifier. Audio Analogue is a young Italian company (they're only two years old), whose components are imported into this country by UKD. To show their love of music, all their amps and CD players are named after great Italian composers.

The 50W Puccini is dual mono in construction, using two toroidal mains transformers, one for each channel. Completing the power supply section is almost 40,000uF of high grade smoothing capacitors which ensure that the supply output is steady and smooth. Other technical highlights are a high quality Alps Blue volume pot and 0.1% tolerance metal film resistors in critical areas, along with polypropylene and polystyrene capacitors.

Completing the system we have the

junior member of Celestion's new A series. The £899 AI is a two-way stand mount design which features a 25mm titanium dome tweeter and a 175mm woofer. Both units are specially made for the A series of speakers. The tweeter was designed using finite element analysis methods to give a smooth response and is Ferrofluid cooled. The bass unit has a die-cast aluminium chassis which helps heat dissipation from the voice coil and thus improves power handling. And its injection moulded cone is specially strengthened around the voice coil to improve dynamics and detail.

If you would like a chance to win this system all you have to do is answer the following questions and complete the tie breaker. Send in the entry form on the back of a sealed envelope or postcard to reach us before August 4th to:

**August System Competition  
Hi-Fi World magazine,  
64 Castellain Road,  
Maida Vale,  
London W9 1EX**

Don't forget to include your name, address and telephone number if possible so we can contact the winner promptly ●



**F**ronting this month's system is Trichord's Genesis CD player which so impressed Douglas Floyd-Douglass when he reviewed it in the July 1996 issue.

The Genesis is based on the Pioneer PD-S504 which uses Pioneer's Stable Platter Mechanism and their Legato Link digital processing system in the DAC section. The basic PD-S504 is reworked by Trichord, who install their well known Clock 2 modification. The Clock 2 reduces jitter by improving the accuracy of the master clock which controls the timing of the digital data. In order to lower noise, the Clock 2 comes with its own power supply regulator.

This isn't all Trichord do to the player, though, as the output stage also comes in for revision, with a change of biasing so it works in Class A rather



# A CD SYSTEM BIRTH

competition

Over £2000

## COMPETITION ENTRY QUESTIONS

- 1) What does Trichord's Clock 2 reduce?  
 A. Frequency range    B. Jitter    C. Bass    D. Weight
- 2) What are Audio Analogue's components named after?  
 A. Mushrooms    B. The Seven Dwarfs  
 C. Italian composers    D. Days of the week
- 3) How many mains transformers does the Puccini have?  
 A. 5    B. 1    C. None    D. 2
- 4) What material does the AI use in its tweeter?  
 A. Silk    B. Aluminium    C. Titanium    D. Polypropylene
- 5) What size is the AI's mid/bass unit?  
 A. 45mm    B. 5mm    C. 175mm    D. 350mm

### TIE BREAKER (obligatory)

Complete the following in less than 30 words

There's musicality and rhythm to set the soul alight,  
 With detail aplenty and dynamics to delight,  
 It's the Puccini that amplifies and the Genesis that's grooving,  
 In an AI system that'll get your booty moving,

.....  
 .....  
 .....

Name: .....  
 Address: .....  
 .....  
 Post Code: ..... Tel No.....

Please do not add my name to your mailing list.

## COMPETITION WINNER

### JUNE ISSUE COMPETITION

In our June edition we offered one fan of the silver disc a chance to win Teac's stunning £2500 P-30 transport. And the lucky person turning all at Hi-Fi World green with envy is:

**J. R. SPENCE**

of St Albans in Hertfordshire.

**Congratulations!**

### COMPETITION RULES AND CONDITIONS

- [1] Only one entry per household. Multiple entries will be automatically disqualified.
- [2] In the event of more than one entrant submitting all-correct answers, the winner will be picked from the tie-breaker by the Editor. We will endeavour to publish the results in the second issue following the closing date.
- [3] Purchase of the magazine is not a precondition of entry.
- [4] No correspondence will be entered into; the Editor's decision is final.
- [5] No employees of Audio Publishing Ltd. or of any companies associated with the production or distribution of the prizes may enter.

If you would prefer *not* to receive details of new products or special offers please tick the box.  
 Hi-Fi World magazine is published by Audio Publishing Ltd.





# START

review

# Q-ING?

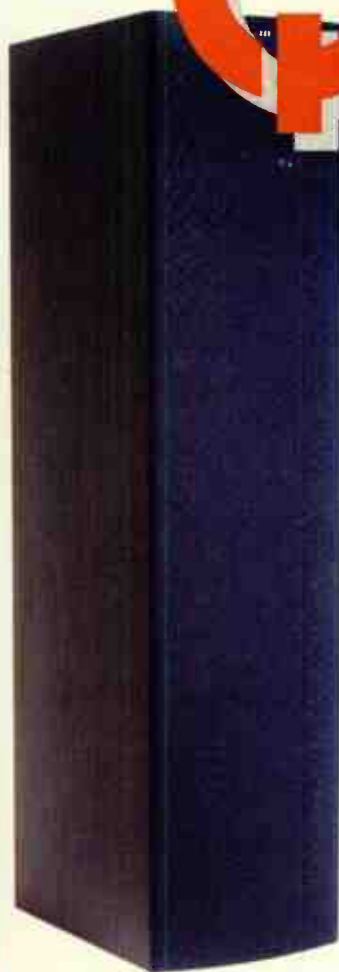

**Jon Marks has an audience with KEF's £500 Q55 floor standers complete with Uni-Q point-source driver technology.**

**B**ack in February of this year, a diminutive £200 stand mounter arrived from KEF. It was called the Q15. Built into the front ported cabinet was a latest generation Uni-Q point-source driver with its polypropylene mid/bass cone and soft dome tweeter. And not to put too fine a point on it, the Q15 sounded great. So when a chance came to listen to the £500 Q55 with its Uni-Q driver, allied to a 6.5in mid/bass unit in a floor standing cabinet, we jumped at the chance.

The Q55's design boils down to a Uni-Q driver in its own front ported enclosure which sits atop a separate enclosure housing the second mid/bass driver (the output of the two mid/bass units overlaps so this is more of a two-and-a-half-way design than a true three-way). This second driver is also reflex

loaded, its port firing rearwards.

Grabbing my attention as well as recent headlines were The Spice Girls and their Spice CD. 'Say You'll Be There' proved instantly that the Uni-Q had lost none of its imaging skills moving from the Q15 to the Q55.

Voices were pinpointed in a broad, cohesive swathe of sound that stretched between the 'speakers. Lovers of bass will find themselves drawn to the Q55s for their great downward extension, which handled the drum machine on 'Say You'll Be There' with almost disdainful ease.

Following hard on this number's heels was 'Two Become One'. Here a couple of the Q55's less amenable character traits started to show up. First of these was a slightly recessed lower midband which could make vocals sound rather distant at times. This was compounded by a slightly raised upper midrange which gave a little extra prominence to sibilance.

Trait number two was a blurring in the bass which could take the edge off a song's rhythmic drive, though it never left it sounding stodgy. Confirmation came in the form of Tori Amos' Boys For Pele CD, where the congo on 'Talulah' was looser and 'plummier' than

it should really be.

As ever, the proof of the pudding with 'speakers is Classical music. On an HDCD encoded recording of Stravinsky's The Rite Of Spring, there was no doubting the KEFs' ability to capture the emotional intent of the music. The 'speakers' bass extension lent a helping hand here, giving timpani tremendous power if not precision.

In spite of their imaging skills and great bass reach, I have to say that the Q55s still ended up sounding like they've been engineered to shout for attention in the showroom, with their peaked bass and treble. This style of presentation might appeal to home-cinema goers and ardent bass heads, but if you're after finesse to match power, better bets would be Castle's £450 stand mounting Edens or B&W's £350 DM305 floor standers which have most of the KEFs' depth combined with a wonderfully transparent midrange •

**KEF Q55**

**£499**

**KEF Audio  
Tovil,  
Maidstone,  
Kent ME15 6QP  
Tel: 01622 672261**

## WORLD VERDICT



The Q55s look rather expensive at £500 with their 'boom and tizz' presentation.

**Measured Performance  
see p103**

# The Cartridge Family



# ortofon

# 01753-889949

DISTRIBUTED BY HENLEY DESIGNS LIMITED



## WIRE & INSULATION

introduce **DESKADEL** Products

731/733 Ormskirk Road • Pemberton  
Wigan • Lancashire • England • WN5 8AT  
Tel: 01942 224040 Fax: 01942 887171

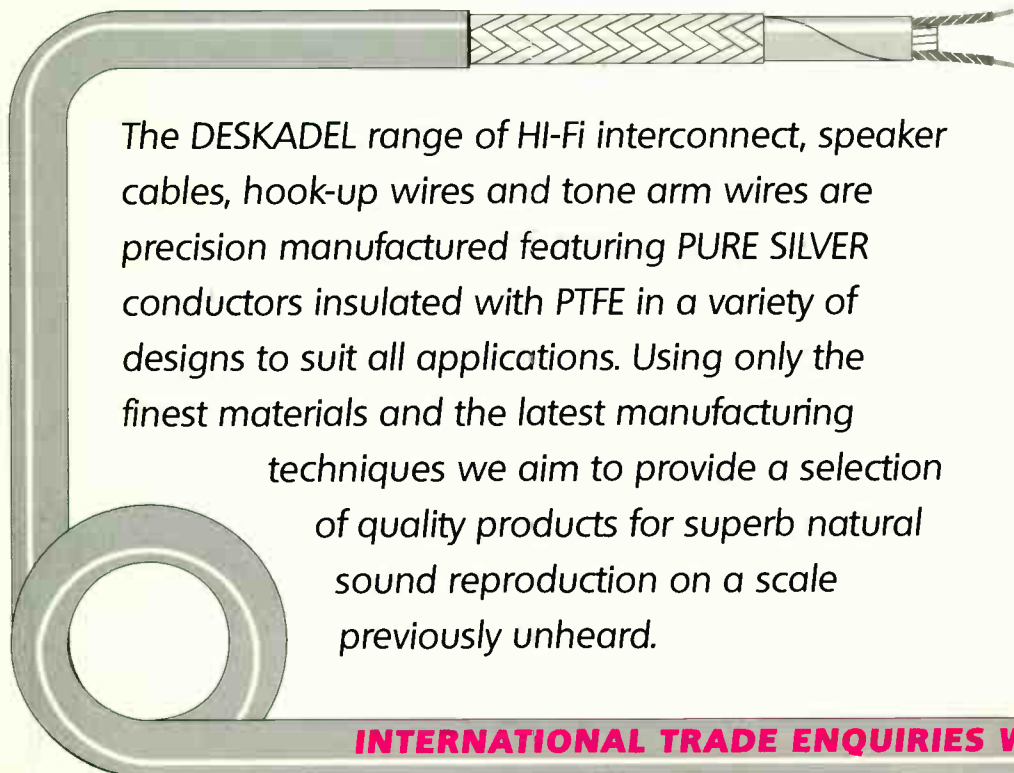

The **DESKADEL** range of Hi-Fi interconnect, speaker cables, hook-up wires and tone arm wires are precision manufactured featuring **PURE SILVER** conductors insulated with **PTFE** in a variety of designs to suit all applications. Using only the finest materials and the latest manufacturing techniques we aim to provide a selection of quality products for superb natural sound reproduction on a scale previously unheard.

**INTERNATIONAL TRADE ENQUIRIES WELCOME**

### DISTRIBUTORS:

France:  
HIFI-MEDIA X  
MARSEILLE  
Tel: 91-49 80 65  
Fax: 91-49 76 03

Greece:  
LOCATION SOUND  
ATHENS  
Tel: 30-1-3646155  
Fax: 30-1-3642983

South Africa:  
LOWVELD AUDIO  
WHITE RIVER  
Tel: 27-1311-31485  
Fax: 27-1311-50457

Belgium:  
DESKADEL INTERNATIONAL BVBA  
Tel: 03-899-04-11  
Fax: 03-889-32-07

Switzerland:  
ARBELOS-BASEL  
Tel/Fax: 41-613 616 466

United Kingdom:  
AUDIO SYNTHESIS  
NOTTINGHAM  
Tel: 0115 9224138  
Fax: 0115 9229701



# ABLE CABLES

This month, Douglas Floyd-Douglass takes a look at three more contenders for top loudspeaker cable.

## Pentacone Grade 1

(£176.25 for 3m bi-wire terminated)



Rock music provided swift proof of the Pentacone's control and speed, with a very taut, fast sound. Jazz was presented in a similar manner, with treble in particular crisp but free from excessive brightness. Dance had a better time of it with the Pentacone which was less ruthlessly revealing than the Apollo.

As with the Apollo, though, it was Classical recordings that really gave this cable a chance to strut its stuff. With its bass depth, speed and articulation it reminded me of studio rather than hi-fi quality sound. The Pentacone is the most natural and uncoloured cable out of the three here and looks like very good value even though it's the costliest.

## Apollo Fathom

(£99.80 for 3m bi-wire terminated)



I tried the Fathom first with some Choral music (Canterbury College and Choir of Westminster Cathedral).

Here, the Apollo showed an impressive openness, particularly on vocals. Bass was well rounded, if slightly rich as orchestral recordings demonstrated. The Fathom's detailing could be a little overzealous at times in a slightly up-front way - this side of the cable's performance made the hard, artificial sound of processed electronic music obvious.

This is a top cable for Choral and most Classical music but it's too revealing (and unforgiving) for synthesised Dance and similarly engineered Rock works.

## Nordost Flat Four

(£89.70 for 3m bi-wire terminated)



Dealing with the Classical music that the Apollo and Pentacone thrived on, the Flatline seemed rather less at home. While it was transparent and sound staged well, there was a kind of glassy hardness to the treble that was at odds with the Pentacone's natural smoothness. This did help the Nordost dredge up bags of detail, though, and bass was never less than controlled.

Where the Flatline really came into its own was with Rock. Powerful guitars and punchy bass produced extremely atmospheric results - this is not a cable that leaves you uninvolved. And Dance music was so convincingly up-beat and rhythmic the Nordost should convince the Ministry of Sound to rewire their entire PA rig.

As Jazz showed, the only fly in the ointment was a slightly hard, bright midrange and treble. But then, as the cheapest cable of the three, the Flatline still makes financial sense.

# the AUDIO CONSULTANTS

## Digital

		RRP	
Parasound CDP 1000	Ex-dem	(£749)	<b>£525</b>
Monrio Privilege CD	Ex-dem	(£995)	<b>£700</b>
DPA TI transport/Kinshaw DAC	2nd Hand	(£1400)	<b>£700</b>
Parasound DAC 1600HD	Ex-dem	(£1449)	<b>£999</b>

## Analogue

Nottingham Analogue Spacedeck	2nd hand/mint	(£1200)	<b>£750</b>
Michell Gyrodec with RB300 arm	2nd hand/3 mnths use		<b>£650</b>
Project 5	2nd hand		<b>£275</b>
Moth Alamo	2nd hand/4 mnths use		<b>£150</b>

## Pre-amps

Graaf WFB Two	Ex-dem		<b>£850</b>
Cary SLP-74 including phono-stage	Ex-dem	(£1900)	<b>£1330</b>
Trilogy 901 with phono-stage mercury finish			
	2nd hand/mint	(£1095)	<b>£650</b>
Gamma Era standard	Ex-dem	(£999)	<b>£699</b>
Art Audio VP-1 old style facia	2nd hand		<b>£400</b>
Parasound PLD 2000-XLR in/outputs full remote control			
	Ex-dem	(£1495)	<b>£1050</b>
Trilogy 904 phono-stage	Ex-dem	(£375)	<b>£265</b>

## Amplifiers

		RRP	
Trilogy 948 stereo amplifier-50wpc mercury finish			
	2nd hand	(£1695)	<b>£1020</b>
Audio Note Quest monoblocks 300SE			
	2nd hand/mint	(£2750)	<b>£1650</b>
Audion Silver Knight-18wpc		(£2449)	<b>£1499</b>
Gamma Aeons 211 SE monoblocks	Ex-dem	(£5000)	<b>£3500</b>
Parasound HCA2200 stereo power amp-250wpc			
	Ex-dem	(£1795)	<b>£1250</b>
Monrio MC-250 Integrated-80wpc	Ex-dem	(£1545)	<b>£1050</b>
Gamma Rhythm 211 Integrated	Ex-dem	(£2500)	<b>£1750</b>

## Speakers

Opera Terza	Ex-dem	(£999)	<b>£699</b>
Opera Callas II	Ex-dem	(£950)	<b>£650</b>
Gamma Epoch V	Ex-dem	(£3500)	<b>£2100</b>
Impulse Lali	Ex-dem	(£1850)	<b>£1150</b>
Ensemble Reference Silver	2nd hand/mint	(£4500)	<b>£2750</b>

**In addition, we also have our usual large selection of equipment to choose from.**

Demonstrations by appointment only 0171 380 0866 CAMDEN TOWN, NW1 FAX:0171 383 5028 E.MAIL:101650,2424@compuserve.com

You could get, oh,  
£1 each for  
your records.

Or you could listen  
to them.



HENLEY PHONO STAGE



**HENLEY**

**01753-889949**

DISTRIBUTED BY HENLEY DESIGNS LIMITED



# POWER BLOCKS

**Eric Braithwaite misses his customary aerobics class to try body-building with some heavyweight monoblocs from Linn and Meridian.**

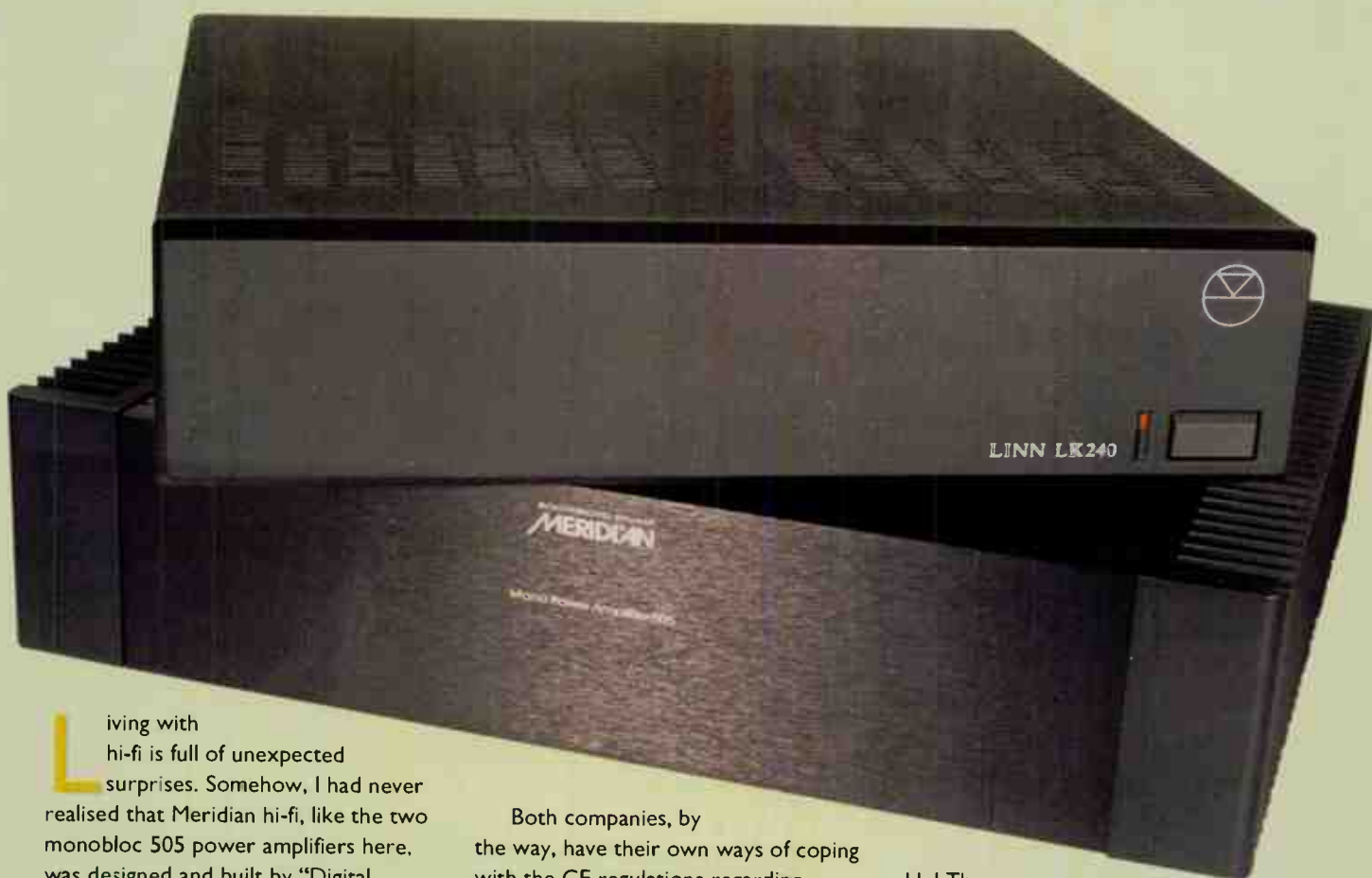

Living with hi-fi is full of unexpected surprises. Somehow, I had never realised that Meridian hi-fi, like the two monobloc 505 power amplifiers here, was designed and built by "Digital Gramophone and Wireless Ltd." How quaint. A digital wireless, what with Digital Audio Broadcasting with us, I can just about get my head around. A digital gramophone, though?

Given that Linn once vehemently derided all things digital, the manual for the LK240 monobloc power amplifiers was inspected suspiciously just to see if they had become the "Scottish Analogue Wireless and Gramophone Company". But no, that is not where Linn's particular verbal ambush lies. Each individual LK240 is a "Single Speaker Amplifier". There are terminals enough on the back of each to bi-wire two or single-wire four two-way 'speakers.

Both companies, by the way, have their own ways of coping with the CE regulations regarding loudspeaker terminals. Meridian fit fully plastic-shrouded screw terminals, into which some sprung banana plugs can be forced (just). Linn, however, opt for a strange split screw with a gold-plated collet. Don't like 'em. They are very close together so you daren't leave any spare wire hanging out.

Not having a digital gramophone I plugged an ordinary analogue Gyrodec with a Koetsu Black cartridge into an Iso and an Argo HR pre-amp and the whole lot into the single 'speaker amplifiers. Oops, I mean monoblocs.

They were also driven direct from various CD players via a passive pot. The interconnects, I discovered, need to be watched with the Linns. Van den

Hul The Second, surprisingly, was ruinous and flattened the sound from the LK240s. No wonder Linn supply their own cables, though low-capacitance cables worked just as well. The Meridians were less fussy, but sounded bleak straight out of the box and took some time to settle in.

Putting the Beautiful South's 0898 album on the platter demonstrated two quite different styles. With the Linns, it was as though this multi-tracked recording had a kind of balloon of sound between the 'speakers. The two (male and female) vocalists found themselves at the outer central edge of the balloon, as it were, with the music tracks packed tightly around them.



## VIBRATION CONTROL PLATFORMS AND THE MODULAR AUDIO SUPPORT SYSTEM

**MUCH MORE THAN JUST A STAND!**

As a piece of functional furniture the BASE Racks and platforms together are a work of art - Dave Wiley, Audiophile Magazine.

It's refreshing to find a complete isolation system that values aesthetics as highly as it does sonic benefits -  
Mr P M Rodwell, Cornwall.

Thanks!! The improvement is astonishing and after hearing and trying other audio stands, the performance of BASE is second to none -  
Mr M Slattery, Sussex.

*"The Audiophile support brings the sound I hear at home one step closer to the sounds we create in the concert hall. Bravo".....Dr. K Murphy (Classical Musician)*



### WORLD VERDICT

OUTSTANDING - Superb Sound, something we'd use ourselves.

### WORLD VERDICT

Great Build and finish, and it sounds great too.

Audiophile Furniture Ltd  
The Square  
Forest Row  
East Sussex  
RH18 5SE.



For more details and a product portfolio please contact:  
Tel: 01342 826262  
Fax: 01342 824845

**DANGER!**  
**Diamond Mine**

ortofon  
Rohmann

**ortofon** 01753-889949

DISTRIBUTED BY HENLEY DESIGNS LIMITED

**DON'T MISS THE PEAKS! CR328 200 Watts RMS per Channel**



TEL: 44 (0) 1702 469055  
FAX: 44 (0) 1702 601883



Through the Meridians, the mix flattened out between the 'speakers more, the multi-tracking less amorphous and more clearly separated. Now the Meridians' flatter layering was truer to the technicalities, but the Linns made for more immediacy. On vocals, the LK240s added their own ingredients to the midrange: baritone voice had a slightly more muscular diaphragm, soprano voice greater crispness than is entirely truthful.

It was a listening session with some samples of Sony's 'Legacy' collection, all Jazz and Blues 20-bit SBM-remastered from the Columbia back catalogue (highly recommended) which really confirmed the fundamental differences between the Linn and Meridian styles. If the latter painted a Mondrian between the 'speakers, the former was more of a Miró. Miles Davis' trumpet-playing on 'Springsville' had more style via Linn, more technique on Meridian. The drumkit was much more spacious via Meridian, more bunched together on the Linn. In terms of bass, there wasn't much to choose: more of a good solid whack from kick-drum on the LK240s, more sense of the drummer having to stretch a bit to reach the snares on the 505s.

Where people will seriously part company with one or other of the presentation styles is over something like the Klemperer Brahms No 1 on an original Columbia stereo LP. The orchestra had greater scale and substance on the Linns, while there was far more detail and a broader swathe of sound between the 'speakers on the

Meridians. At times, for all that the cellos and violas had more drive in the Linn version, first violins at the top didn't seem numerous enough, almost down to a solo violinist at times. Some string vibrato was distinctly grating, too.

Conversely, though the 505s got this right, they didn't make as much of dynamic climaxes, which seemed mildly compressed against the Linns. A spell with an early Renaissance piece confirmed the Linns made a much livelier, more danceable sound. But neither amp could be said to be perfect; why true stage depth appears increasingly to be off the (transistor) amplifier agenda these days I don't know.

The 160W 505s had a distinct flavour which Meridian owners would recognise instantly. Most auspicious was the broad lateral spread of the recorded image, stretching rather wider than is usual from left to right. That doesn't mean the in-fill between was vague; individual instruments or voices were clearly defined and precisely located. Equally, the 125W LK240s were interested more in an overall 'big picture' and the pre-eminence of tunes in the scheme of things than the finer points of instrumental tone colour and pin-sharp individual images. This is all very likeable, quite impressive, and with some people it would go down a storm.

Having been spoilt by such amplifiers as those from Chord, Michell and Sugden at prices in roughly the same band, I couldn't entirely forgive the Meridians'

comparatively squeezed dynamics and stage depth. They were a little too light in body; lithe, yes, but muscularly, the impression stuck that they were a bit under-developed. On the other hand, the LK240s' occasionally curt dismissal of imaging precision took some of the

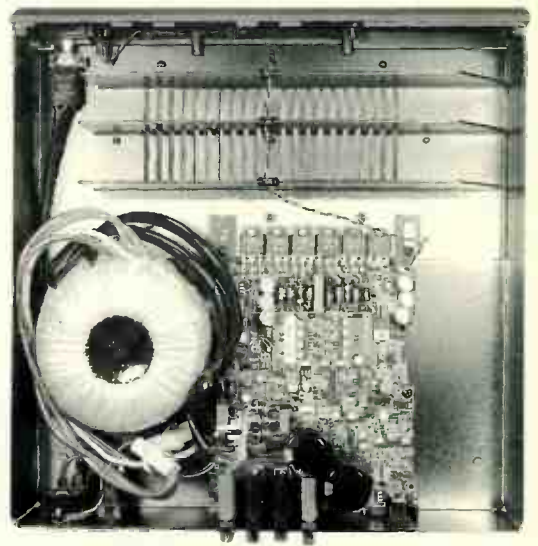

shine off them, too. It's a marked case of "Yer pays yer money. . ."

By the way, it's taken all this time to click. You don't suppose 'digital gramophone' is Fenlands dialect or Cambridgeshire-speak for a CD player do you? Just a thought ●

**Meridian 505** £795 each  
**Linn LK240** £750 each

**Meridian Audio**  
**Stonehill,**  
**Huntingdon,**  
**Cambs. PE18 6ED**  
**Tel: 01480 434334**

**Linn Products**  
**Floors Road,**  
**Waterfoot,**  
**Eaglesham,**  
**Glasgow G76 0EP**  
**Tel: 0141 307 7777**

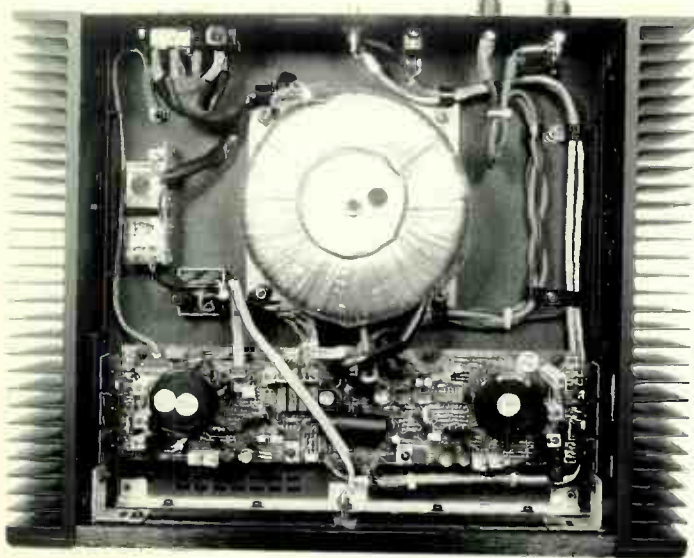

## WORLD VERDICT

### MERIDIAN 505

Crisp, clear images are set in a broad spread between the 'speakers but the 505 lacks stage depth and grunt.

### LINN LK240

It's no surprise the LK240 plays tunes well. Tonal colour and image precision are not its fortes though.

**Measured Performance**  
**see p 103**

## UPGRADEABLE HI-FI.



### WHATEVER WILL WE THINK OF NEXT?

You've thought long and hard about choosing the right sound system. You think you've found what you're looking for. It looks great. It sounds even better. And it's within your budget. So how come you still have that niggling doubt in the back of your mind? Simple. Before you make your final decision, you want to be sure that a few years down the line, you're not going to regret it. Unlike most hi-fi manufacturers, we understand completely. We've already set the standard by offering legendary sound

quality in every price category. Now we've completely rewritten the rules. Because practically every piece of Arcam equipment now comes with something that will radically change the way you buy hi-fi. A set of pre-defined upgrade paths that allow you to upgrade your sound system just as soon as technology (or your wallet) allows. If you'd like to hear more about Arcam's revolutionary upgradeable components, call now on **(01223) 203203.**

*Please send me the name of my nearest authorised dealer, and information on:*

**Arcam amplifiers  Arcam CD players & DACS  Arcam tuners  Arcam home theatre  all Arcam products**

Title First Name(s)

Surname

Address

Postcode

In Australia: Stolmack Audio Pty. Ltd., P.O. Box 162, Lindfield, N.S.W., 2070. Tel: (612) 9416 4799.

In Canada: Emerald Audio Resources, R.R.1, Palgrave, Ontario, LON 1P0. Tel: (905) 880 7170.

In New Zealand: Avalon Audio, 587 Mount Eden Rd., Auckland. Tel: (09) 369 9000.

In South Africa: Hi-Fi Specialists, Durban Road 155, Bellville. 7535. Tel: (021) 946 1441.

In USA: Audiophile Systems Ltd., 8709 Castle Park Drive, Indianapolis, Indiana 46256. Tel: (317) 849 7103.

Clip the coupon and return to Arcam, Pembroke Avenue, Cambridge CB5 9PB, England. Or telephone: (01223) 203203. Or e-mail us at: [custserv@arcam.co.uk](mailto:custserv@arcam.co.uk)



# Silk route

**Dominic Todd finds that the new Mission 732i with its new silk dome tweeter succeeds where its predecessor failed.**

**M**ission have launched a new version of their 732 loudspeaker, the 732i.

As with the original 732, it uses a medium size cabinet with a moulded front baffle, the driver layout inverted to improve imaging. The polypropylene bass driver remains, but it's now partnered with a silk dome tweeter. The tweeter was a weak point with the original design, so this looks like it could be money well spent by Mission. Also new are bi-wireable terminals, bringing the 732i fully up to speed with the competition.

A Mission forte has always been a vibrant and upbeat character and the 732i lived up to expectations here. Divine Comedy's 'Everybody Knows' set the ball rolling. Electric guitar was superbly portrayed in a bold and energetic fashion, accompanied by a spot-on sense of timing. Only a slight looseness in the bass marred the proceedings and the fact that, ultimately, the 732i didn't go quite as low as some of their rivals. Balancing this was an articulate mid-range which gave vocals expression and separation from instruments. While all of these characteristics were present in the original 732, where real progress has been made is higher up the frequency spectrum.

Previously, stringed instruments could sound grainy and harsh. Now there is a smoother, more cohesive balance, which means high volume levels can be enjoyed rather than endured.

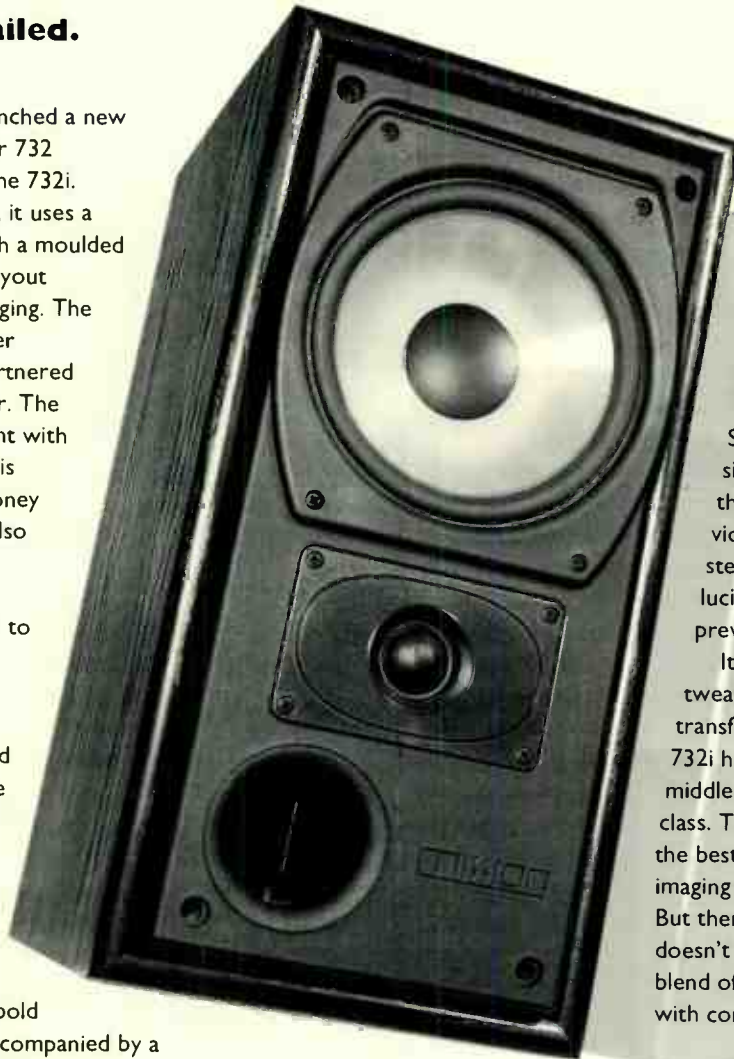

'Suffocated Love' by Tricky gave the Missions' mid/bass drivers a good work out, the powerful synthesised bass line underpinning the track. Vocals were impressively open and transparent, as was the 732i's presentation generally for a 'speaker of this price. Fine sound stage depth allowed for a layering of instruments and gave the track a sense of atmosphere.

The sound stage wasn't quite as holographic as some smaller contenders, such as B&W's 601 or the System Audio I005. But it was broad enough to avoid boxiness and possessed decent depth of sound.

Classical music has not been a strong point with budget Mission 'speakers, so I was prepared for disappointment with Philip Glass's 'The Low Symphony'. Whilst it would be true to say that the Missions didn't quite have the finely etched and studied qualities of Heybrook's Solos, the 732i is still a significant improvement upon their predecessors. As before, violins that had once sounded steely were now imbued with a lucidity and smoothness alien to the previous 732.

It's often amazing what a few tweaks here and there can do to transform a product. The Mission 732i has leapt from being an erstwhile middle-ranker to one of the best of its class. This doesn't necessarily mean it is the best. Slightly loose bass, narrow imaging and lack of analysis see to that. But then show me a £200 'speaker that doesn't have flaws. I can see the 732i's blend of pace and excitement mixed with control appealing to many people.

**Mission 732i**

**£199.90**

**Mission Group  
Huntingdon,  
Cams. PE18 6ED  
Tel: 01480 451777**

## WORLD VERDICT

If you've got £200 with 'loudspeaker' written on it, then the 732i should be on your shopping list.

**Measured Performance  
see p103**

# ABSOLUTE ANALOGUE

CLASSIC RECORDINGS  
for  
AUDIOPHILES



CLASSIC RECORDINGS OF 1957-1961  
£77.50



CLASSIC RECORDINGS OF 1962-1966  
£77.50



CLASSIC RECORDINGS OF 1959-1960  
£77.50



CLASSIC RECORDINGS OF 1964-1968  
£77.50

## INTRODUCTORY OFFER! Any 2 for £30

These records are all Premium Grade 180g pressings produced from short run stampers and strictly limited to an edition of 2000 for each title. Cut from original master tapes by Ray Staff, they represent the best available vinyl records of these seminal works by great musicians.

Available from:  
Vinyl Demand, PO Box 1592, Fordingbridge, SP11 1SE  
Tel: 01425 654545 Fax: 01425 654400  
and selected specialist record shops.

European Distributors please contact Absolute Analogue  
Fax: 0181 459 8113

## MAKE YOUR REGA SOUND AS GOOD AS A LINN

FibreLam plinth kits, Megabearings, power supplies and Rega tonearm rewires from £70 and upwards. There's a lot of potential upgrading in your deck - telephone or e-mail for info pack.

## MAKE YOUR LP12 SOUND AS GOOD AS A MANTRA

FibreLam subchassis with Megabearing and motor rebuild, power supplies and tonearms from £330 upwards. Manticore Mistral *System Integrity* wired phono stage now available.

## MAKE YOUR MANTRA SOUND EVEN BETTER

Take your Mantra up to Magister level. And then spend your money on vinyl. Over 4,000 pre-enjoyed vinyl records in stock from £3 and upwards. Amplifier and CD upgrades a speciality.

## MANTICORE AUDIO VISUAL

MAV Shareholders Ltd, The Old Tinsmith's, Shortmead Street, Biggleswade, Bedfordshire, SG18 0AP, United Kingdom

Tel: 01767 318437 Fax: 01767 318462  
Visa, Mastercard, Delta, Switch, cheque and wonga taken  
E-mail: [manticore@dial.pipex.com](mailto:manticore@dial.pipex.com)

Web: <http://dialspace.dial.pipex.com/manticore/>



# SMOOTH SIGNALS

**Sony's £180 ST-SE700 should be high on any audiophile's tuner shopping list reckons Ketan Bharadia.**



Most people go through life listening to the airwaves with nothing more than a box full of air populated by the usual ICs hooked up to a piece of skimpy cable. And most of these boxes put out a thin, hard, uninvolved sound that's perfect for encouraging background listening rather than serious ear-to-the-dial enjoyment. Lately, though, a fresher, more enjoyable sound has been heard from certain companies' tuners, Sony amongst them. So we decided to find out what audiophiles on a budget can expect for £180 with the ST-SE700.

This Sony is a rare tuner in that it possesses LW in addition to FM and MW. There's also RDS (Radio Data System) and EON (Enhanced Other Networks) for those seeking text information and traffic news. There are even two FM aerial inputs which allow you to connect up the Sony to a signal from a roof aerial or cable company. And when tuning into a station the Sony's meter actually worked usefully instead of showing full strength at the merest hint of a signal as many others do.

Right from the off it was obvious the Sony stood out from the tuner crowd. Listening to a news broadcast

on Radio 2 I was pleasantly surprised. Normally on budget tuners voices possess a chesty coloration and a sibilant edge. With the Sony this coloration was barely apparent.

Following the news was 'New York, New York' by Frank Sinatra. Ol' Blue Eyes was as smooth as ever but this didn't stop the accompanying trumpets rasping as they should, although they never became harsh or aggressive. The overall impression was of a smooth, sweet, enjoyable sound.

Switching to Classic FM I caught the London Symphony Orchestra playing Haydn's Symphony No 101 in D. The sound of the orchestra ebbed and flowed naturally, the interplay between the various instruments easy to follow. Sound staging had a depth to match its width and image precision was similarly impressive. The only small whinges were that orchestral dynamics were subtly restricted and higher frequencies a little rounded off. But to be honest, in the face of the ST-SE700's music making capabilities these flaws paled into insignificance.

Listening to MW and LW proved that both were better than average for tuners in this price range, sounding relatively clear and listenable. If it's the

BBC's World Service you're after as well as Radio 3, this is one of the few budget tuners that will fit the bill.

Sony's ST-SE700 joins NAD's 412 in the ranks of high quality budget tuners. Both of these two have transparency and imaging abilities that leave most of the competition standing. The NAD may have the edge in terms of clarity but the Sony's sweet, smooth character is going to win it a lot of friends ●

**Sony ST-SE700 £179.99**

**Sony UK**  
**The Heights,**  
**Brooklands,**  
**Weybridge,**  
**Surrey KT13 0XW**  
**Tel: 01932 816000**

## WORLD VERDICT

The Sony ST-SE700 is one of the best at this price. LW reception is a welcome bonus.

**Measured Performance**  
 see p103

# World Mail

**WRITE & WIN  
WITH  
HI-FI WORLD!**

Every letter we print  
wins a superb prize!

Vivante audiophile  
LFs,  
Chord Co.  
interconnects,  
Electronics Made  
Simple books and a  
FREE subscription  
to Hi-Fi World  
for the best letter  
of the month!

Please write, fax or  
E-mail to  
Hi-Fi World Mail  
(with prizes)  
64 Castellain Rd  
Maida Vale,  
London W9 1EX  
Fax: 0171 289 5620  
E-mail:  
edit@hi-fiworld.co.uk



The writer of the  
'Letter of the Month'  
wins a free subscription  
to Hi-Fi World

## LETTER OF THE MONTH

### BI-AMP FAN CLUB NO1...

I'd just like to say thanks for an excellent article in last month's issue on bi-amping with the two NAD 310 amps. I tried the same arrangement with my two Kenwoods, a £200 KA-3020SE and KA-1030 which cost me £60 second-hand. While not exactly high-end audio, when they were set up in the way you suggested the results were amazing.

Dire Straits' Making Movies album on vinyl sounded tremendous - the sound stage opened up a good two feet either side of my 60litre home-made floor standers. I could put my finger on the instruments in the room the imaging was so precise. I've had problems with the sound stage through my floor standers, which use Audax 8in paper cone mid/bass drivers and Fane horn tweeters. They lack the subtlety of more famed 'speakers, but bi-amping did the trick.

But I have a complaint, only one mind. The system demonstrated by you doesn't allow for different players to be used, as you have to go behind the amps and switch the Tape Out lead to say Phono or Tape depending on what source you want to use. So after much trial and error, I found the following worked well (see diagram).

The Kenwood KA-3020SE now serves both left and right woofers while the Kenwood KA-1030 serves the tweeters. Silver interconnects run from Tape 2 Out on the '3020SE to the CD input on the '1030. The sound stage narrowed a slight amount but still gave a fantastic

result all for a total system price of £680.

**Nigel Purdy  
Beccles,  
Suffolk.**

*Thanks for the positive feedback. The world of tweaking is probably one of the few areas in hi-fi where some feedback is better than no feedback at all!*

*As you said, with a relatively cheap second-hand amp to make up the numbers, bi-amping can offer massive improvements*

*example, is to use one amp for both tweeters and one for both woofers as you've tried (diagram No1). But as you say, our June NAD arrangement isn't the most convenient of layouts when it comes to switching sources.*

*The main restriction in hooking up the amps was the fact that neither had Pre-Amp Out/Power Amp In sockets or mono switches. Very few amps at £100 do.*

*With separate Pre and Power sockets, we could*

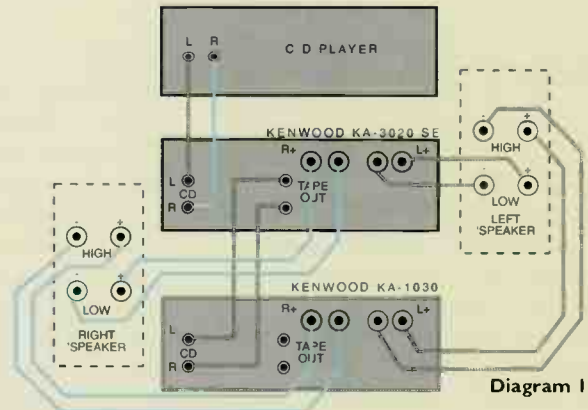

This diagram shows how to bi-amp your system when you have two different amps and want to control source switching from one amp (Rec Out Select and Input Select are turned to the chosen source). This way, one amp powers both left and right tweeters while the other deals with left and right mid/bass units.

*in sound quality for very little outlay.*

*We decided to go for the set-up with the NADs in June because we wanted to get the very best sound quality out of the system and because bi-amping with the amplifiers dedicated to separate channels is a relatively unexplored avenue for upgrading. The standard approach, which we've followed in the past with John Shearne's amps for*

*have used a pair of Y-connector cables. One end of each of these would run to the Pre-Amp Out sockets on the first amp. The other ends would be connected to the Power Amp In sockets of the respective amps, with one amp handling only the left channel and one only the right. This would mean only one volume pot. and one source selector to control the whole system (diagram No2).*



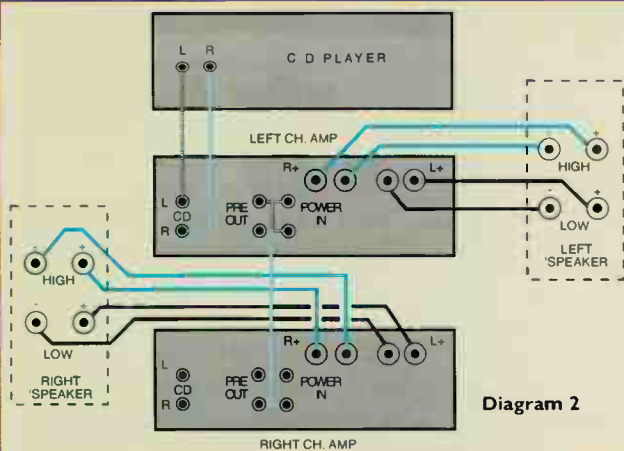

Diagram 2

**If you have two amps of the same type you can use one to power the left channel and one the right. Using two different amps for this will give different sound qualities from each 'speaker. Wired up in this way, amps which have separate Pre-Amp Out/Power Amp In sockets can be used to bi-amp and control volume level and source switching from one amp.**

The mono alternative involves using both amps in mono mode and simply feeding one with the left channel and one with the right channel from each source (diagram No3). This leaves you with two volume controls (which I personally prefer - it renders unnecessary the balance controls that often introduce crosstalk and ruin the sound stage) and two source selectors but no re-wiring. JM

### ... AND NO2

Until recently I had thought that the trend towards bi-amping was probably more to do with getting us all to buy yet one more piece of equipment! However, articles and letters published in HFW (which I trust more than some of your competitors) encouraged me to experiment with my spare A&R A60 amplifier.

As one of my two A60s is the AP model with split pre and power sections, I first tried taking a lead from the Pre-Amp Out socket to the AUX input on the other amp. One amp fed the treble and the other the mid/bass drive units. Next I tried feeding each channel of the source into each amp. As there is a mono mode on the A60 I didn't need to run a lead from the Tape Out socket to the other CD input.

I can't say that I was overly impressed by the first arrangement but

my findings with the other set-up concur very much with yours with the two NAD 310 amps - ie, improved low level signals, better ambience and a wider and more defined sound stage.

So far so good, but as we all know there is no such thing as a free lunch. The first drawback is that of making up new cables as the A60 uses the dreaded DIN sockets. I hope

to convert my A60s

to phonos and so get over this problem. More inconvenient is the fact that altering volume levels involves not one but two volume controls. With the high gain of the A60 this can involve several attempts to get the correct balance. An evening's listening can take a lot of fiddling with the volume control and I live in a terraced house so I don't want to fall out with my neighbours.

Accepting that using one amp for each 'speaker gives the best sound, I would like to know if I can take a line from the Pre Out socket of the A60/AP amp and feed that into the power section of the second A60 (assuming that it is converted to AP spec). This would mean that only one volume control is needed but would I need to run the second A60 in mono mode or supply the incoming signal to both left and right channel inputs?

I hope you can answer these questions as I am now converted to bi-amping. This is a realistic option for many audiophiles as they merely need to find

another amplifier of the type they are using.

In the case of the A60, NAD amps and other popular models, these can still be found second-hand at reasonable prices making this a very cost-effective upgrade providing that they can be properly connected.

Thank you for an excellent publication. For many of us, reviews of new and expensive equipment are of little more than academic interest. Where HFW scores is with its realistic upgrading tips and DIY projects which are of interest to a much wider audience. Long may you continue!

**Nick Whetstone  
Burnham-on-sea,  
Somerset.**

*If you take a look at our diagrams, you'll find that the goal you're aiming for can be achieved with the connections detailed in diagram No2. This allows both A60 amps' power sections to be run effectively in mono from a stereo pre-amp. Pressing the mono button on your A60/AP would mono the pre-amp as well as the power amp, rendering the pre-amp useless for bi-amping. And not running your A60/AP's power section in mono would mean you couldn't use one amp for each 'speaker - you'd have to go for one amp doing woofer duty and one doing tweeter duty for both left and right channels. JM*

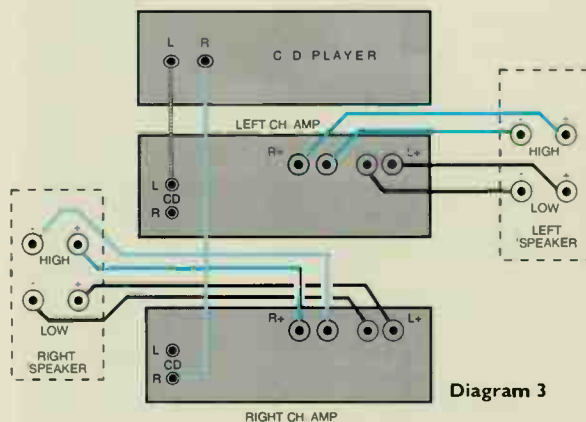

Diagram 3

**This set-up allows amps which lack Pre-Amp Out/Power Amp In sockets but which have Mono switches to be used for bi-amping. Volume level and source selection need to be set with one control on each amp.**

## Stand and Deliver!



No Name Acoustics (NNA), a small Norfolk based company, have just launched a bright new range of Audio Equipment supports, the NNA 500 series.

Constructed of bright mild steel sections, the stands are silk powder coated and fired at 200°C to produce a black sheen finish.

The free-standing shelves are available in 15mm MDF and 10mm clear float glass. These can be isolated from the stands themselves using adjustable 8mm stainless steel spikes. To guarantee precision levelling the shelves also utilise a unique ball-bearing and

brass disc levelling system, and all units come complete with Allen keys and a bullseye spirit level to enable setting-up.

The 500 Series consists of an isolation platform, wall mounted shelf and range of free-standing supports with two, three, four or five tiers. These can all be upgraded with additional isolation stages. The isolation platform is priced at £175, the wall mounted shelf £350, with the multi-tiered stands starting at £250. All equipment comes in standard sizes, but the company can, on request, build supports in a range of colours and designs to cater for specific customer requirements.

No Name Acoustics  
3 Ber House  
158 Ber street  
Norwich NR1 3EN

Tel: 01603 615817 Fax: 01603 626936



## SOUND CONNECTIONS

TEL/FAX: 01244 401280  
E-Mail: [sound.connections@dial.pipex.com](mailto:sound.connections@dial.pipex.com)

Mail Order  
Suppliers of  
Quality Hi-Fi  
Accessories

CHORD CO  
VAN DEN HUL  
DNM RESON  
SONICLINK  
NORDOST  
AUDIO QUEST

CARDAS

KIMBER

QED

XLO

SENNHEISER

STAX

ORTOFON

LYRA

AUDIO ALCHEMY

BLACK DIAMOND

STANDS UNIQUE

TARGET

WBT

MUSICAL FIDELITY

- and many more



Soniclink Violet offers excellent value and is available to audition through our home trial service

Tel/Fax/E-Mail  
For Our Latest  
Product & Price List.

52 Green Lane,  
Great Sutton,  
South Wirral,  
Cheshire L66 4LE.



Mon - Fri 9.30 a.m. - 8.00p.m. (Sat to 1p.m.)

## Don't read the Gramophone - listen to it

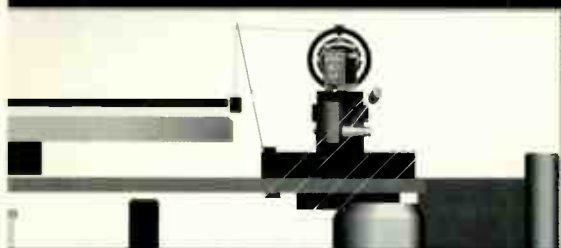

PROJECT  
AUDIO SYSTEMS

01753-889949

DISTRIBUTED BY HENLEY DESIGNS LIMITED

## replay

UDIO COMPANY

- ▶ ALCHEMIST
- ▶ AUDIO GEM
- ▶ AVI
- ▶ HEYBROOK
- ▶ LFD
- ▶ MICHELL
- ▶ MUSICAL FIDELITY
- ▶ NEAT
- ▶ ORIGIN LIVE
- ▶ PINK ▼
- ▶ ROYD
- ▶ ROKSAN
- ▶ SONNETEER
- ▶ TOTEM
- ▶ TRICHORD



"THE EXCELLENT LFD  
MISTRAL RANGE  
NOW AVAILABLE"

For more information or a copy of our latest newsletter/pricelist, telephone or fax:

Chester 01244 401290

e-mail [replay@dial.pipex.com](mailto:replay@dial.pipex.com)



## ICING THE SYSTEM CAKE

My current system comprises a Teac T1 transport, QED Digiflex, DPA Enlightenment convertor, Chord Cobra



One loudspeaker candidate well worth considering is DNM's smooth, transparent Reson.

comparison with cables at twice the price is DNM's Reson at £6.95/m. This solid core cable has a smooth, colourful sound and impressive dynamics

and should fit into your system nicely. In addition to the DNM you could try a 1m length of the Chord Co's Cobra balanced interconnect at £65.

Changing the pre-amp's volume pot

is a simple and effective way of boosting sound quality. The best known replacement option would be a pot from Alps - either their Blue or Black models. Prices here are about £15 for the former and £30 for the latter. Better still is Panasonic's For Audio pot at £64, available from Audio-Links, tel: 01724 870432. KB

Newnes Tel: 01865 310366

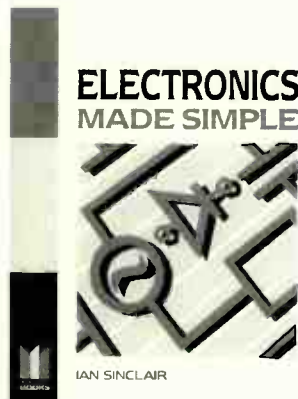

Help get your DIY career off to a good start with a copy of Electronics Made Simple.

### A CALL TO ARMS

My system comprises a Linn LPI2/Lingo/Trampolinn/Akito /van den Hul MC-One or Audio Technica ART 1,



If you're after a phono stage with fully adjustable MC input impedance, Audiolab's 8000PPA is one of the few that will suit.

Audiolab 8000Q pre-amp with Electrocompaniet ECP-I phono stage and four Audiolab 8000M power amps driving Monitor Audio Studio 10 'speakers.

It seems to me the weakest link is the Akito tone-arm so I'd like to replace this. Obvious contenders are the Linn Ekos and Naim ARO. Should I consider other arms? One dealer tells me that with the Naim arm it's impossible to adjust the pickup because there are three mounting holes only. Will I be able to use my van den Hul or my Audio Technica (or any other pickup for that matter)?

I'm not satisfied with the imaging and sound stage of my phono stage so I would like a new phono stage, but which one? Should I consider the Audiolab 8000 PPA, the Naim Prefix or Michell Iso? It's also important that the MC input impedance is adjustable in small steps from 10-100 ohms to suit different pickups. Your advice would be highly appreciated since I find I agree on most of your conclusions about different equipment which means I trust you more than any dealer.

**Vidar Pedersen Norway.**

*Naim's ARO has three mounting holes which allow no forward or back adjustment of cartridges for alignment. It suits only Linn cartridges as far as*

*achieving correct alignment goes. This means only other cartridges with Linn-style overhangs will be correctly aligned in the ARO. Incorrect alignment has a very big effect on cartridge sound quality so I'd forget the ARO and go for the Ekos instead.*

*Your choice is pretty much limited to one of the phono stages mentioned by the fact that input impedance needs to be adjustable for MC cartridges - Audiolab's £899.99 PPA. The unit comes factory set at 100Ω but this can be changed to almost any value down to 10Ω by adding resistors in parallel to the input. There's a series of slots on the back of the PPA where these resistors can be inserted. Audiolab supply a table of values but not the recommended 1% metal film resistors themselves. Maplins (tel: 01702 554000) stock a wide range though. KB*

Vivante. Tel: 0181 891 4195

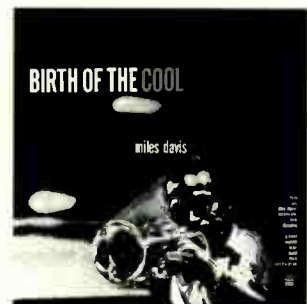

Enjoy a fresh audiophile pressing through your new phono stage.

If you do not want your e-mail address published, please let us know

edit@hi-fiworld.co.uk

www.hi-fiworld.co.uk



For a second-hand CD upgrade try Linn's Karik III if you decide on an integrated player.



### THE GOOD SOLDIER

Up to now I have completed all the missions you've set me. I have bought the recommended Audiolab 8000S, matched it with the Mission 752 'speakers (cables are van den Hul bi-wire and Music-cord Interconnect Transparent).

But there is one more element in the way of victory: the CD player. My current CD is a NAD 502 which I think has a little bit less resolution than suits my system.

So which digital canon shall I take to the war? Arcam's Alpha 8, Marantz's CD-63mkII KI-Signature, the Mission dAD3 or the Trichord Genesis? (Linn Karik s/h is also available). Or should I equip myself with a DAC like the kit HDCD DAC or the Arcam BB5? Our platoon listens to Jazz, soft Rock, Classical and Ethnic music.

Can you please also specify what the differences are (if they exist) between an

expensive one-box CD player (£500-£1000) and a cheaper transport and DAC at the same price.

I'm counting on you to help me finish this long upgrade battle.

**Eyal Lovton**  
lovtone@  
smtplink.indigo.co.il

*If you want to go the single-box route and you are happy to buy second-hand, I'd go for the Linn Karik, if it's MkIII specification. David Price was very impressed by the level of enjoyment and involvement this player offered when he reviewed it back in July 1995. He ended up concluding, "It's difficult to fault this player." Given its price of £1600 when originally reviewed, the Karik will happily outperform the other players you list.*

*There are very few DAC/transport combinations around at £1000, let alone at £500. Teac's T1/D-T1 (£1050, reviewed October 1996) and Rotel's RDD/RDP-980*

(£900, reviewed July 1996) spring to mind. The Teac is the better of the two transports and partnered with the Assemblage DAC-2 kit would offer superb sound quality, outstripping the Karik III. That said, the Assemblage is a) a kit, so it doesn't suffer the same kind of cost penalties that ready-made components pay, and b) it is exceptionally good anyway.

*There are some superb one-box players around at £500-£1000, most of which you mention yourself. Going the DAC/transport route offers greater upgradability although in sound quality terms there's little to recommend a DAC/transport over an integrated player at this kind of price. JM*

Newnes Tel: 01865 310366



Find out more about the inner workings of CD with a copy of Electronics Made Simple.



### GETTING TURNED ON

I know that with valve amps, it is generally better for the sound (and for the valves) to leave them switched on all the time. Does it make any difference with solid-state amps?

**Mark Harvey**  
mharvey@csfp.co.uk

*If sound quality is your priority then leaving components on all the time will save you having to wait for them to warm up although I've yet to come across the component which gets better the longer it's left on.*



Valve amps can be left on all the time but it will shorten the valves' working lives.

*Leaving valve amps on saves the valves from potential damage at switch-on where the anodes can be stripped because the High Tension supply reaches the anode before the heaters have reached their proper working temperature. Increasingly, though, these days amps are fitted with HT delay circuits to minimise this problem.*

*Valves have relatively short lives when compared to transistors and leaving valve components on all the time will drastically shorten their useful listening life, especially in power amps where the valves are worked hardest.*

*Some solid-state amps benefit from long warm-up periods but it varies from one component to another, as it does with valve amps. But with the greater longevity of transistors there's less danger of shortening the life of a solid-state amp. JM*



Chord Co. Tel: 01722 331674



Here's a set of the Chord Co's Siren interconnects to use with your amplifiers.



### STEP UP TO A DREAM SYSTEM

Just thought I would drop you a line and say hello. I'd like to thank the team at Hi-Fi World for their advice over the last several years. I originally started off with a midi system many years ago. What changed it all? A friend of mine introduced me to the vagaries of high-fidelity and a brand called NAD. I knew I was hooked there and then.

Over the years I have read your magazine and learnt a great deal about this thing called hi-fi. I am now able to come home from a hard day at work and relax, listening to pure, delightful music. What a feeling! The majority of my friends do not understand why I am so happy to pay large sums of money for my hi-fi. Little do they realise the improvements in clarity and musicality just increase the pleasure of listening to music as a recreational pastime.

For the record my system is as follows: DPA Little Bit 2 DAC and Teac P-500 transport, Audiolab 8000C and 8000Ms for the amplification, a Nakamichi CR5e tape deck, NAD 401 tuner and dedicated aerial mounted topside. For vinyl I have a

Systemdek IIX turntable with a Rega RB300 tone-arm and a Lyra Clavis cartridge. My 'speakers are an Australian brand called Richter (Paladins). Interconnects are either Tandy Gold Patch or Dick Smith Silver Plated.

As you can imagine this system sounds wonderful, although the upgrade bug is forever biting. I am intending to update the 'speakers to the likes of Sonus Fabers, etc, as well as upgrading the DAC to a DPA PDM2 Series 3. I am also looking at purchasing an SME 309 tone-arm to improve the vinyl front end. Any suggestions?

Your magazine is the only one I read regularly as I find nothing of interest in the others. Yes I am a vinylholic!  
**David Pastern**  
dpastern@vir.idx.com.au

*Other 'speakers to consider alongside the Sonus Fabers are the £1500 Jamo Concert 8 (reviewed in the June issue) which*

*were rated very highly by everyone who heard them at World Towers. If you don't mind floor standers then have a good listen to KEF Reference Ones, Epos ES 25s and of course Heybrook Sextet IIs.*

*DAC-wise the DPA PDM2 is excellent but no longer in production. A replacement DAC called the XS 128 is to be released soon, although we haven't heard it yet. Judging by DPA's track record I'd expect it to be seriously good. Don't ignore the Pink Triangle Da Capo which we use in our reference system. This possesses a good deal of grace, smoothness and detail which make listening a pleasure. Also think about changing your transport to something better - the Audiolab 8000CDM comes to mind. If you end up using the DPA convertor it is well*

*worth having the transport sync-lock modified by DPA as this gives significant improvements.*

*The SME 309 is an excellent match for the Systemdek and would be a significant upgrade on the RB300. As for being a vinylholic, join the club!*  
KB

Vivante. Tel: 0181 891 4195



A fix fit for a vinylholic - a heavyweight audiophile LP from Vivante.



### LOOKING FOR TRANSPORT

In trying to improve some audio qualities of a Sony CDP-333ESD integrated CD player (no optical o/p) I acquired a Meridian 203 convertor but the result was very disappointing. A couple of years later I obtained a second-hand Cambridge CD1 player and haven't listened to the Sony/Meridian system since. The tonal qualities of the CD1 were immediately convincing and, as a friend put it, the difference was like "chalk and cheese".

Can HFW, or any reader suggest a better marriage for the 203 that can improve on the Cambridge CD1. Otherwise they may be up for sale.

The rest of my modest system is: Linsley Hood 300 series 45W



Components for a dream system - Jamo's Concert 8 loudspeakers and Pink Triangle's Da Capo DAC.

# The Sound Organisation London

Hot Summer Sale Starts 1st July

## Analogue

Roksan Xerxes s/h, reconditioned players with Rega arm, only £469, with Tabriz-zi, only £749.

Ex-dem items include SME 20.2A and Rega players and cartridges from Ortofon, Sumiko and Denon.

## Digital

Roksan DP1 classic transport, s/h mint, only £649.

Arcam Alpha + integrated, s/h, vgc, one only £179.

Ex-dem items include Arcam Alpha 7 and 8, Copland CDA277 and CDA288, Micromega Stages and Naim CD3 and CD2.

## Amplifiers

Art Audio Quintet valve power amplifier, s/h, mint, was £1300+, but no box, hence only £549.

Concordant Exhilarant line level all triode pre-amp, Groove tubes, s/h, vgc, but no box, hence £449.

Copland CTA501 valve power amp with volume and two line inputs, was £1750, one only £1295.

Copland CSA303 latest spec valve hybrid pre-amp, was £1155, one only £899.

Copland CTA505 valve power amp, latest model, 65wpc, was £2099, one only £1699.

Ex-dem items include Arcam Alpha 7, 8 and 9, Delta 290P, Audio Research LS7, LS15, D130, Copland CSA8 and CSA14, Densen Beat, DM10, Naim Nait 3, various Naim Pre-power amps.

## Loudspeakers

Heybrook Sextet in black ash, burr walnut trim, little used demonstrators, were £1130, only £749.

Castle Howard Mahogany s/h v.g.c. £849

Naim SBL walnut, s/h, vgc, boxed, only £795.

Spica TC50 unusual wedge shape, s/h, £199.

Ex-dem items include most Castle models, Epos ES12, ES22, Naim SBL, Credo and Intro, Neat Critique and most Mordaunt Short Ms series.

All ex-dem items are 15-25% off normal prices.  
Phone for full sale list.

Real Hi-Fi in the City

**4** Pickfords Wharf  
Clink Street  
London S.E.1  
**0171 403 2255**

AE  
Atacama  
Audiolab  
B&W  
Cable Talk  
Copland  
Cyrus  
Hamman-Kardon  
JBL  
KEF  
Kenwood  
Krell  
Marantz  
Martin-Logan  
Mendian  
Michell  
Mission  
Monitor Audio  
Musical-Fidelity  
Pickering  
Pink Triangle  
Pioneer  
Quad  
REL  
Rogers  
Ruark  
SME  
Sonus-Faber  
Spendor  
Systemdek  
Tannoy  
TDL  
Thorens  
Yamaha  
& lots more...

**York...**  
a great place for...

- Widest choice in the area
- Independent advice
- Qualified staff
- Comfortable dem rooms
- Superb showrooms
- Main road location
- Major car parks nearby
- Insurance estimates
- Over 30yrs experience
- Service Dept.
- Delivery & installation
- Part Exchange
- Open 10:30-5:30 6 days

Up to 3 yrs.  
Interest Free  
Credit

deposit only 20% of  
£500+ for 12 months  
£1500+ for 24 months  
£3000+ for 36 months  
subject to status

PS. if you're making a special trip...  
it's best to book weekdays.



**24 Gillygate, York**  
**Tel. 01904 629659**  
High Fidelity Specialists est. 1967

CYRUS

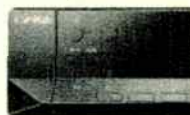

AUDIOLAB



The very best  
in Hi-Fi and  
Home Cinema...

MARTIN-  
LOGAN



KRELL

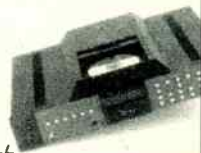

MONITOR-  
AUDIO



# AUDIO GALLERY



LISS NEAR PETERFIELD HAMPSHIRE

TELEPHONE - 01730 895194

main AUDIO-NOTE DEALER ON THE  
SOUTHCOAST

Come and see the "NEW VALVE AN-CD2 CD  
PLAYER" devastating

All the Audio Note range available by appointment  
I

Klipsch all of these very efficient loudspeakers from  
98dB to 104dB

LaScala

KLF 20 new speakers are amazing come and listen  
and you will never forget

I

TEAC Reference VRDS MINI system and VRDS CD  
players

I

LEIDER CABLES

AUDIONOTE CABLES

I

COME AND SEE US FOR A FRIENDLY AND VERY RELAXED LISTEN  
• WE GIVE YOU TIME AND GOOD ADVICE





At £550 Teac's TI transport with its VRDS mechanism offers impressive digital performance at a bargain price.

MOSFET amp (Hart Kit),  
Rogers LS7, Systemdek  
II/Rega RB300/Linn K9.

George Evans  
gevansl@clara.net

The most obvious match with the 203 convertor is Meridian's 200 transport. These were literally 'made for each other' and so would make an ideal couple. The 200 is out of production now though, so if you wanted to go for that option, it would have to be second-hand - expect to pay in the region of £300-£450 for a good sample.

Another option to think about is the Teac T1 transport (reviewed in Oct '96) which costs £550 and makes use of the highly regarded VRDS mechanism. This solidly built transport sounds superb for the price. If, after trying any of these combinations, you still prefer the CD1, don't worry - just enjoy its sound! KB

Chord Co. Tel: 01722 331674



Your next system upgrade - a set of the Chord Co's excellent Siren interconnects.



### BOTTLES AND CANS

Firstly, may I say thank you to all at Hi-Fi World for stimulating my interest in hi-fi again for the first time since the early 1980s. It's great to

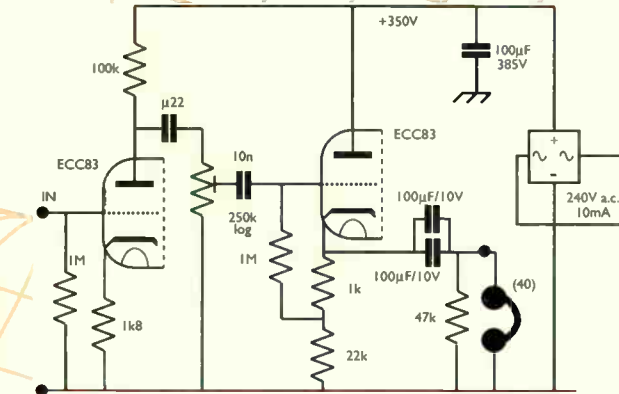

This circuit is based on a pre-amp design and should work with headphones of about 40ohms' impedance.

look forward every month to a magazine so obviously produced by enthusiasts after the overt consumerism of the magazines produced during the 1980s where hi-fi became a lifestyle product. In the last two years, I have radically changed, and more importantly built, my system due to your enthusiasm for valves and all things DIY.

My system now consists of a Source/RB300/Ortofon MC 25FL record player, Teac TI/Cambridge DACMAGIC CD player, KLPP1, EAR 859 monoblocs bi-wired with Maplin's silver-plated 'speaker cable to KLS3s, plus an old Nakamichi 582 tape deck and a Leak Troughline 3. In building these amps I have yet to suffer a belt from the HT

but sitting on my left hand is definitely a good safety procedure - I shouldn't tempt fate!

My long term project is to build a pair of single-ended 211 or 845 monoblocs or parallel single-ended 300B monoblocs, if I don't electrocute myself or the cat in the process. What about a design based on your existing 300B converted to parallel single-ended operation?

My main reason for contacting you is to ask if you have any plans for publishing a design in your DIY supplement for a valve headphone amplifier to complement your excellent pre-amplifiers. If you don't, could you direct me to a suitable design? I know that

the Musical Fidelity X-Cans are now available but I would prefer to build one myself.

John Murray  
106114,1546  
@compuserve.com

We don't have plans for a valve headphone amplifier, nor valve circuits for same. However, the circuit shown, conceived in Hi-Fi World towers, should work. The first stage, one half of an ECC83 double triode, has a high input impedance and useful gain. Output is coupled to a 250kΩ log. volume control through the 0.22µF DC blocking capacitor.

The cathode follower output stage has a low and substantially resistive

output impedance. Most headphones are a 40ohm load. This will load down the output but frequency response will remain flat. The main problem is preventing bass roll-off in the output coupling (i.e. DC blocking) capacitor.

This must be 200µF for a -3dB point at 20Hz, practically achievable by strapping two 100µF reversible (non-polarised) electrolytics in parallel. Maplin stock these. They also stock a suitable mains transformer (Order Code XP27E). You will need a 240V AC secondary that can deliver 30mA or more, plus 6.3V for the heaters, at 1A. Remember, this circuit shows one channel only; you will need to use two ECC83s for stereo.

For lower impedance headphones I suggest an output step-down transformer is used. Maplin's Line Transformer with 8ohm tapped output should do (Order Code DH49D), coupled in the same manner as the headphones.

Note that we have not built and validated this circuit, as we usually do. However, it has been derived from a working pre-amp design, with a few mods for headphone use, and should be fine. The parts cost is very low; I suggest building a quick single channel prototype first. Have fun. NK

Newnes Tel: 01865 310366

**ELECTRONICS  
MADE SIMPLE**



IAN SINCLAIR

Here's a little something to help you on your way - a copy of Electronics Made Simple.



## VALVE BOOKS

### The Williamson Amplifier -

D.T.N. Williamson. Offers practical advice on how to build and set up the amplifier for best results.

£9.95 + £1 p&p  
Code: 1040

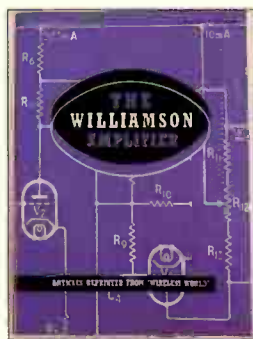

### Principles of Electron Tubes - Herbert J Reich.

A textbook for beginners starting with the basics of how a vacuum tube actually works. Shows how a simple circuit is designed including amplifiers, transformers and power supplies. A must for both enthusiasts and hobbyists.

£27.95 + £2 p&p  
Code: 1010

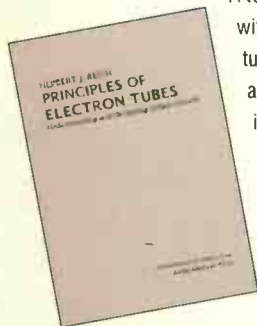

### An Approach to Audio Frequency Amplifier Design -

Seventeen circuits from 5 to 1100watts - General Electric Co.

High quality amp. designs using KT66s, KT88s, DA100s etc. Includes two valve pre-amps complete with phono stages.

£19.95 + £2 p&p

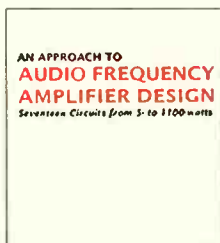

Code: 1020

### Mullard Tube Circuits for Audio Amplifiers

- Includes full designs for eleven power and control amps, including 5-20, using valves. Begins with a four chapter tutorial on getting the best sound from valve amplifiers.

£13.95 + £2 p&p  
Code: 1030



## 70 Years of Radio Tubes and Valves

- John W. Stokes.

Outlines the evolution of radio receiving tubes and the part they played in the domestic radio receiver. A reference for those

interested in the history and development, and collectors alike.

£19.95 + £2 p&p  
Code: 1050

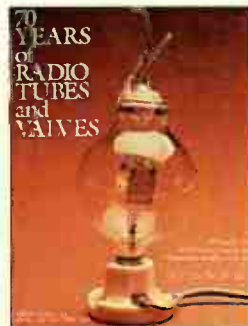

## LOUDSPEAKER BOOKS

### Electronic Universal Vade-Mecum - Piotr Mikolajczyk & Bohdan Paszkowski.

This Data book comprises 5693 valves divided into 442 groups. A comprehensive book which contains connection details, operating parameters, load lines and example circuits.

£49.95 + £6 p&p  
Code: 1060



### Quick & Easy Transmission Line Speaker Design

- Larry D. Sharp. Practical approach to designing and building your own transmission line loudspeaker.

Includes design examples, equations and a computer disk (Lotus123) for the maths! £10.95 + £2 p&p  
Code: 1130

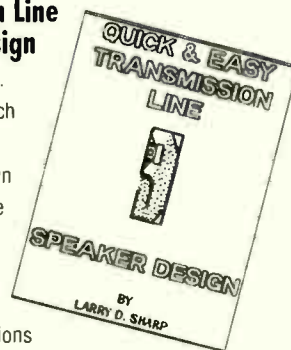

### Loudspeakers: The Why and How of Good Reproduction -

G.A. Briggs. An easy to understand book on building loudspeakers, using

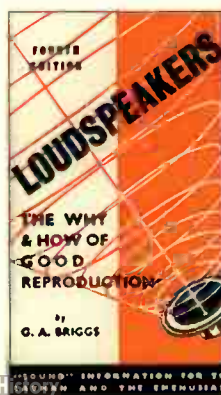

empirical techniques that pre-date computer analysis. Strong recommendation for beginners.  
£10.95 + £1 p&p  
Code: 1070

### Bullock On Boxes

- Robert M. Bullock III. Using Thiele-Small parameters clearly, it offers lots of helpful tables and graphs to get to grips with the sizing of the box and port of a reflex loudspeaker.

£12.95 + £2 p&p  
Code: 1100

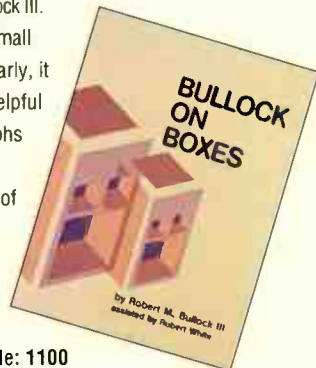

### Electrostatic Loudspeaker Design and Construction

-Ronald Wagner. Step by step guide to the design and construction of a full range electrostatic loudspeaker, including basic operating principles. Strongly recommended for those wanting to either build, repair and/or restore or who are just interested in electrostatics.

£16.95 + £2 p&p  
Code: 1080

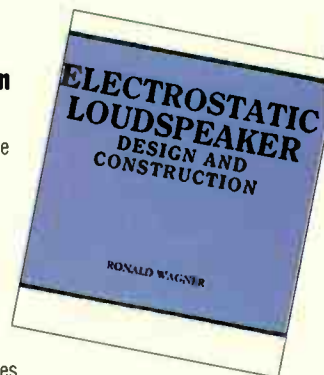

### The Loudspeaker Design Cookbook, 5th edition -

Vance Dickason. This best seller offers up-to-date design information for the home constructor. It uses modern Thiele-Small theory and parameters.

£22.95 + £2 p&p  
Code: 1090



### Theory and Design of Loudspeaker Enclosures -

J. E. Benson. Covers infinite





baffle, reflex, passive radiator etc. in great detail with a highly mathematical approach making it unsuitable for beginners but highly authoritative to experienced designers.

£23.95 + £4 p&p Code: 1140

**Acoustics** - Leo L. Beranek.

This book ranges from analogous electrical circuits, (important for modelling) to microphones, then loudspeakers (sealed, ported and horn) showing how theory influences practice in drive units. In addition it describes the behaviour of sound in rooms.

£39.95 + £4 p&p Code: 1120

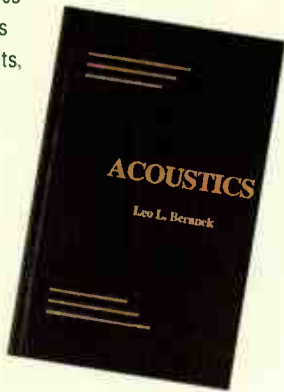

**AUDIO ANTHOLOGIES**

**Audio Anthologies - When Audio Was Young**

Six volumes to collect, covering one of the most exciting and important eras of hi-fi. The Audio Anthologies contain many ground breaking circuits and theory articles of all aspects of hi-fi design. A must for true enthusiasts.



**Volume One: May'47 to Dec'49**

Contents: 9.5W, 5W and 6.5W 6AS7G amps., 30W 300B amp., valve FM tuning indicator, 30W 211 power amp., cathode follower amp. using 6V6, an adaptation of the Williamson amp., valve phono pre-amp., several horn and reflex loudspeaker designs.

£14.95 + £2 p&p Code: 1150

**Volume Two: Jan'50 to Jul'55**

Contents: Ultra linear 6L6 design and operation of the Williamson, a direct coupled amp., Williamson type amp using 6A5s, 40W 845 push-pull amp., valve phono and line pre-amps., valves and loudspeaker damping, design and construction of reflex and horn loudspeakers.

£14.95 + £2 p&p Code: 1160

**Volume Three: Aug'52 to Jun'55**

Contents: Simple valve phono stage, transformerless amplifier using 6082, 20W 5881 amp., 10W 6V6 amp., stereo valve pre-amp., high quality valve phono stage, a pre-amp for the Williamson, low distortion tone control pre-amp., binaural or stereophonic, transistor phono amp., corner horn loudspeaker, concrete horn loudspeaker.

£14.95 + £2 p&p Code: 1170

**Volume Four: Jul'55 to Dec'57**

Contents: 18W 5881 amp., 4W single-ended tweeter amp., budget 11W amp., versatile bass/treble control, transistor theory, transistor pre-amp., transistor techniques, battery powered transistor phono pre-amp. and loudspeakers explained.

£14.95 + £2 p&p Code: 1180

**Volume Five: Jan'58 to Dec'59**

Contents: Stereo valve multiplex decoder, 7W EL84 amp., valve active crossover and 20W treble amp./50W bass amp., monaural, binaural,

monophonic and stereophonic explained, heterodyne FM multiplex adapter, transistor pre-amp., 60W EL34 amp., high power audio amps, hi-fi loudspeaker enclosure.

£14.95 + £2 p&p Code: 1190

**Volume Six: Jan'60 to Dec'61**

Contents: Transistor pre-amps., feedback techniques, the coming of FM stereo, FM multiplex adapters, Tape recorders; distortion, frequency response and noise, 120W 6550 amp., loudspeaker efficiency.

£14.95 + £2 p&p Code: 1200

**SOLID STATE ELECTRONICS**

**The Art of Electronics**



- P. Horowitz & W. Hill. An ideal book for beginner through to engineer. Each chapter takes you from the basic first principles through to full design and practical circuits. £35.00 + £5.50 p&p. Code: 1210



**For overseas orders, please telephone (+44) 171 289 3533 or fax (+44) 171 289 5620 for postage rates.**

**P&P rates are for UK only**

**ORDER FORM**

Please Send (Code No.) \_\_\_\_\_ (enter codes clearly)

I Pay: World Audio Publishing Ltd. £ \_\_\_\_\_ or debit my Mastercard/Visa card (Card No): \_\_\_\_\_

Exp date \_\_\_\_\_ Name \_\_\_\_\_ Signed \_\_\_\_\_

Delivery Address: \_\_\_\_\_

Tel (Day) \_\_\_\_\_ Please return to: W.A.P. Ltd, 64 Castellain Road, Maida Vale, London W9 1EX, ENGLAND

**CREDIT CARD ORDERS TELEPHONE: 0171-266-0461**  Tick if you do not want to be added to our mailing list

Please contact us for overseas P&P charges. Allow 28 days for delivery. All orders subject to availability. If further space is required please attach separate sheet.

# THE SUPER ANALOGUE DISC IS HERE!

CLASSIC DECCA RECORDINGS PRESSED ON DELUXE HIGH QUALITY VINYL

THESE SUPERB LIMITED EDITION RECORDINGS ARE MASTERED BY AKIRA MAKINO AT KING RECORDS IN JAPAN, PRESSED ON 180G VINYL AT RTI IN AMERICA, AND AVAILABLE IN THE UK FOR THE FIRST TIME



Brahms: Symphony No. 3 Op. 35  
Herta: The Vienna Philharmonic  
Orchestra conducted by Pierre Monteux  
KDC 9186 Price: £21.95



Ravel: Daphnis & Chloe, Louis Mureel  
conducts the Cleveland Orchestra and  
Chorus, KDC 9187 Price: £21.95



New Year's Eve Concert 1977: The Music Of Josef  
Strauss, The Vienna Philharmonic Orchestra  
conducted by Willi Boskovsky, KDC 9188  
Price: £21.95

Other titles in the series:

- KDC 9165 - Mascagni Cavalleria Rusticana (LP 4004)
- KDC 9172 - The Vienna of Johann Strauss - Von Kammer VPO
- KDC 9174 - The Music of Debussy - Maritime Academy of St Martin-in-the-Fields
- KDC 9176 - Beethoven Piano Concerto No. 5 "Empire" - Vladimir Spivakov/CHO
- KDC 9183 - Wagner: Die Walkure Complete - SUP 9183/4/5
- KDC 9189 - Music Of Gioacchino Rossini - Munchinger/Suttgart Chamber Orchestra

- KDC 9171 - Shostakovich The Isle Of Spring - Marmel VPO
- KDC 9173 - French Overtures - Assoluto/Silber-Romande
- KDC 9175 - Mozart: Serenade No. 13 in D major - Boskovsky
- KDC 9178 - Backhaus Brilliant Record - Wolfgang Backhaus
- KDC 9185 - Brahms' Symphony No. 1 in C minor - Marmel VPO

Imported and distributed in the UK by Vivante London, 74 Heathfield North, Twickenham, TW2 7QW. Tel: 0181 891 4195 Fax: 0181 891 5433  
Available by Mail order from Vivante London, or from the following vinyl stockists:

Beckenham Record Centre  
44 Beckenham Road  
Beckenham  
SE18 4LJ  
Tel: 0181 598 1864

Disque Vinyl  
25 Upper Oak Street  
Notting  
Canon 4PP 108  
Tel: 0181 221 841

Deans Hill  
Cannons Road  
1000 New North Road  
London N1 2DB  
Tel: 0171 226 2901

The Den  
44 Cambridge Street  
Kingsly  
W14 9NS  
Tel: 0181 604 476

The Record Shop  
41 Fife Road  
Kingsly  
London E11 1RD  
Tel: 0181 346 4000

## campaign audio design



Getting a better, more involving sound often means spending a lot of hard earned money. It's such a waste, because every system can benefit from our cables and accessories, at a fraction of the cost of some new "black box". Here are some of the ways we can help.

We have Linear Crystal Oxygen Free Copper interconnects (£12.48) up to High Purity Silver cables (£89.00) and high definition loudspeaker cables in Silver Plated Copper or Pure Silver. Our mains cables add weight, power and scale, and with non-inductive RF filtering (£10.00) and over-voltage protection (£3.00) enhance performance still further. Gold plated AV cables, both RF (£17.95) and OFC Scart (£19.21), help bring picture quality in line with NICAM sound resolution.

Valves, capacitors and transistors are all microphonic. They cannot perform optimally if vibrated. Our set of three brass isolation cones (£5.00) are worth their weight in gold - revealing low level resolution and dynamics hitherto hidden beneath electronic noise. We also have a cure for your noisy fridge or central heating motor (£3.50), enabling you to throw away your big mains noise suppressor, which has been giving you that "sat upon sound" for years. There's lots we can do to bring you closer to the emotion and energy of the performance. So confident are we, that we offer a 14 day money back guarantee.

Ring or write for details:-

**CAMPAIGN AUDIO DESIGN**  
Llandudno Road (HW)  
Cardiff CF3 8PG  
Tel:- 01222 779401



Trade and International Enquiries Welcome.

# MARSTON AUDIO RESEARCH

are pleased to announce the

## Silhouette Series

### Digital to Analogue Converter & External Power Supply Upgrade



## Rediscover the true nature of audio

For further details contact:  
Marston Audio Research  
17 Queens Avenue  
Kings Lynn PE30 5LR  
Tel: 01553 772875  
e-mail: marston@planetweb.co.uk  
www.planetweb.co.uk/marston  
Credit cards accepted





# SHOWROOM SAVVY

**Ketan Bharadia finds out whether Paradigm's £230 Mini Monitors can survive in the budget 'speaker jungle.**

Play a word association game with almost anyone and mention the word, "Canada" and you'll probably get an immediate response of, "Mounties". But there's more to this huge country than men and women in red uniforms on horseback. For example, there's the 'speaker manufacturer Paradigm, who, having built up a strong following on the other side of the pond, are now turning their attention to Britain with designs like the Mini Monitor.

While the Mini Monitors aren't especially large they look chunky thanks to their deep enclosures, which, after a bit of experimentation, were positioned about 30cm from the rear wall and toed in. The 'speakers sat on Atacama SE24 stands which were a good match in terms of height.

The single-wire Mini Monitors were thrown in at the deep end with some demanding high-power organ music from the compilation CD *Bach is Back*. Immediately impressive was the weighty bass on the organ's lowest notes considering the size of the cabinet - the clear polypropylene mid/bass driver was certainly working hard for its living.

On higher notes a sharpness was apparent from the tweeter which gave it a slightly edgy sound. The Paradigms also suffered from a lack of midrange projection because of a not-so-subtle 'loudness contour' effect (see measured performance). The raised treble and bass that cause this tend to impress in

the showroom but become fatiguing after long listening.

Next up in the Teac's CD tray was Tori Amos with her *Boys For Pele* album. Vocals were presented well, the Paradigms managing to capture a large percentage of her quirky accentuation accurately. Stereo focusing, though, was a touch vague, making it difficult to pinpoint her voice. Piano notes also came across as rather dry and wooden, as though their harmonics were somehow being suppressed. Having said that, it was still an enjoyably rhythmic performance.

Tchaikovsky's *Symphony No6* performed by The Royal Philharmonic Orchestra illustrated the good and the bad in the Paradigms. On the credit side, double-bass was substantial and there was a good sense of scale to the music courtesy of spacious sound staging. On the debit side, the Mini Monitors made violins especially sound screechy and sharp. They also turned the shimmering cymbals on *Time Out* by the Dave Brubeck Quartet into a thin, dry imitation of their normal selves.

The Paradigms are pretty good 'speakers at heart, but their high frequency performance lets the side



down by sounding sharp and edgy. The lack of midrange projection is also a disappointment. The Paradigms' problem is that at about £30 less there are products from the Big Gun loudspeaker manufacturers which are capable of shooting the Mini Monitors down.

**Paradigm Mini Monitors £229.95**

**Richer Sounds  
Richer House,  
Hankey Place,  
London SE1 4BB  
Tel: 0171 940 2222**

## WORLD VERDICT

The Paradigms have a generally enjoyable sound but treble is sharp and midrange recessed.

**Measured Performance  
see p103**

### Living Voice Auditorium.

"I had expected these speakers to be hot on tone and dynamics...I wasn't disappointed. Vocals were superb, instrumental timbre was beautifully resolved and any life that could be found in the music was there to walk into. What I hadn't expected was the nimbleness. The fine sense of timing especially in the bass where so many speakers fall down was quite a surprise...you don't often get bass of this quality from a speaker of this driveability and price. In fact I've not encountered this combination; usually this degree of bass resolution costs more money or less sensitivity. Consummate performance at an affordable price."

Hi Fi Choice March 97.

Size 1.0m. x 28cm. x 22cm. Sensitivity 93 dB/w. Amplifiers from 12 watts. £1300. Ring for UK dealer list.

### Living Voice Airscout/RW24 Bass Bin.

"...don't expect to find a better speaker system".

Hi Fi Choice Feb 97.

Sensitivity 108 dB/w.

100 watt power handling.

Recommended amplifier power - 3 watts upwards.

Airscout £14,750. RW24 Bass Bin £9,500.

# DEFINITIVE AUDIO

DIFFERENT BY NATURE.  
BETTER BY DESIGN.

#### USED ITEMS

	LIST	SALE
Stax SR30 headphones	£180	£80
Wilson Benesch ACT 2 T-arm LV lead	£1400	£900
Audion Sterling power amp. Cherry	£600	£450
Monarchy Audio M18 DAC. Excellent. New.	£800	£500
Monarchy Audio DIP.	£250	£200
Acoustic Energy AE109.	£330	£220
Impulse H2,5 6, 7		£ Ask
Heybrook Quartet.	£800	£400
Audio Note Quest monos. 300B.	£2750	£1800 pr
Audio Note M2. Line pre-amplifier.	£1000	£675
Audio Note ANSPX s/c, ANV i/c, ANVX i/c, ANVX s/c		£ Ask
Castle Chester Yew	£900	£600
Wilson System V. Black. As new.	£15,000	£10,000
Audio Innovations L2 preamp	£700	£450
RARE AND HARD TO FIND		LIST
Vitavox AK157 15" Alnico bass unit x2	£800	£450
Vitavox S2 Alnico pressure driver x2	£1800	£900
Vitavox RH 330 4 cell midrange horn x2	£960	£500
Gauss 1702 H.F. units (serious) x2	£880	£400
Solatron SR 152 Valve regulated power supply		£250
600v / 200mA		
Lord Lucan	200 Rand	
Shergar	175 Punt	

### Hørning Loudspeakers

Unusual and remarkable Danish loudspeaker systems. These enduring and strikingly original designs reproduce music with a freedom and naturalness that give meaning to the term high fidelity. Challenging music programmes are recreated without the sense of mechanical process and sluggishness that characterises today's popular high end speakers.

97dB/watt. Acoustic crossover. 3 way. 8 ohm load. Amplifiers from 9 watts. From £2500

### Border Patrol PSU

This outboard power supply unit replaces the existing power supply in your current valve amplifier. It provides a profound improvement in sound quality that cannot be gained by making other changes to your system. Depth of tone, breadth of dynamic expression, quietness of background, vivid tone colour. Money back if your expectations are not exceeded. £595 fitted. Ring for further details.

### SJS Electroacoustics

Arcadia. The Line Pre Amp. Outstandingly intelligent design. Beautiful execution.

A breath of fresh air for high end audio.

This is clearly the best line pre amp available anywhere - irrespective of cost. £1000.

DEFINITIVE AUDIO  
Where High Fidelity Happens  
IMPORT/EXPORT  
0115 981 3562

All of the above and other interesting, useful and unusual things. For the best in service, advice and hardware from budget to very high end. Appointments only. Visa Amex Mastercard. No credit. Export facilities. Secondhand items. Fax or phone for details. (+44) [0] 115 981 3562.

Vitavox • Living Voice • Wadia digital • Art Audio • EMT • Nottingham Analogue • Border Patrol • Lowther

10/12 Chapel Place  
Tunbridge Wells, Kent

## Sounds Of Music

Tel: 01892 547003  
Fax: 01892 547004

Quad  
Audion  
B.A.T.  
Exposure  
Marantz  
D.A.C.  
Audio Note  
X.T.C.  
Micro Mega  
Michell  
Roland  
Krell  
Transfiguration  
Nottingham An/Lg  
and many more

#### SPEAKERS CORNER

We have one of the most comprehensive ranges in the South East. Here is a small selection.

**Jamo Concert II** A surprise to us all. They really are quite incredible at their price range. Detailed and controlled.

**Cadence Dynamics?** You had better hear these.

**KEF Reference** A very welcome product from one of the finest manufacturers.

**Spendor** Another great name. You should hear the SP3/1 with the Woodside valve integrated.

**Dunlavy** Slim Tall and very transparent and detailed.

**Martin Logan** We have managed to get a pair of SL3s into our dem room - wow!

**Quad ESL 63** A reference standard and still one of the best ever.

**Lumley L/M 2 STD & SIG** One of our long time favourites. Very dynamic and detailed but musical too.

**Ruark Excalibur** Something special we are told. Report to follow.

Klipsh \* Totem \* Musical Technology \* Lumley \* Audio Note \* A.T.C. \* A.V.I. \* Von Schweikert \* Sonus Faber \* Pro-Ac \* Neat \* B&W \* Harbeth \* Acoustic Energy \* Promenade \* Chario \* Tannoy \* Alon \* R.E.L. \* Magnaplanar \* Genesis \* Etc. Etc.

\* 1 months trial exchange \* Good prices & free delivery \*  
\* The widest range of equipment \* Systems from £500 - £100k \* Valve and vinyl specialist \*

A.V.I.  
Audio Research  
Copland  
Magnum  
Lumley  
Thorens  
Teac  
Audio Synthesis  
Eikos  
C.A.T.  
Townsend  
Graham  
Wadia  
Trichord  
and many more



NEW LUMLEY NEW  
SILVER 10/4  
BI-WIRE CABLE - FANTASTIC

CALL US OR WRITE FOR OUR  
SPECIAL RECOMMENDED SYSTEMS LIST

NEW EIKOS NEW  
CD PLAYER  
BEST UNDER £2K





Recently, I've discovered some fascinating hi-fi sites on the Internet, which I'll mention here, but one in particular has caught my attention with a great idea that drives a coach and horses through high-cost commercial audio measurement systems.

Matthias Brennwald, a Swiss physics student, has noticed that Macintosh computers come with an audio input and 16-bit A/D converter as standard. He has written a programme that turns a Mac into a spectrum analyser for loudspeakers, complete with digital test-signal source. A PowerMac suitable for this task costs around £800, not including the monitor, oodles less than a dedicated commercial analyser - and you get a powerful computer free!

This is a fantastic idea, great for all serious DIYers, engineers, students and small audio companies. Up till now audio measuring systems have cost a lot; Hi-Fi World's totals around £15,000. Anyone already possessing a Mac gets a near equivalent almost free, needing only a measuring microphone and the necessary software of course. The Internet being what it is, even this comes free in demo form, complete with an impressively well written and laid out user manual.

It's so good that I need say little more about the technicalities here. It's best if you yourself go to: <http://home.sn.no/~rpd/speaker/software/>

This is The Speaker Building Page, one of the best Net sites I've found dealing with loudspeakers. The programme is called simply MacSpeaker and takes up 1Mb on disc. It comes as a 176k BinHex archive (.hqx) that takes about 1min. to dump down and must be unstuffed by StuffIt Expander™ from Aladdin Systems Inc. I've listed the names so you can find the sites through a search engine like AltaVista.

# kaleidoscope

## Mysteries from Noel Keywood



The demo is a full working version, but it will not save results to disc. Matthias asks only \$45 for his efforts, which strikes me as extraordinary. There's a lot of maths and programming in this sort of thing and a dedicated commercial analyser costs £5k-£15k. You need to be able to sort out a good microphone. Matthias uses a German Monacor

around 60 programmes listed.

The programme I have reviewed in this month's Supplement, LspCAD, will not only do this, but it can analyse your room acoustics too. Most engineering software is written for PCs, not Macs. I believe I am right in saying you will need a sound card with A/D converter to run a PC as an audio analyser.

quoted as 20Hz-17kHz (+/-2dB), but the measuring system can equalise out response errors using a calibrate routine. The 603e PowerPC processor with integrated Floating Point Unit this computer uses has no problems handling such audio programmes. This isn't a plug for Macs, by the way. I'm looking forward to the day when a computer will run anything and am putting my money on the forthcoming CHR standard.

Being relatively new to the Internet, I am more than a bit impressed by what it has to offer audio buffs. But what a pity that when it comes to computers and audio engineering, the two being evermore tightly linked (and yes, you can get CAD/CAM for valves on the net - try Intusoft!), America seems to be light years ahead of the UK and much of Europe.

At the end of the day, what I am talking about here amounts to engineering technology as it is today, with enormous implications for tomorrow. Things are moving very fast, but Britain doesn't appear to be much of a player any more. This will have an adverse affect on employment in an area of electrical engineering where we really should, at least by historical precedent, be participating more strongly ●



MCE-2000, cost around £4! Old Colony Sound Labs, through their magazine Speaker Builder, can supply a Mighty Mike (e-mail them at: [audioidiy@top.monad.net](mailto:audioidiy@top.monad.net)) for 'speaker measurement, or you could contact Bruel & Kjaer and have a heart attack instead! I hope to review MacSpeaker in more detail soon.

Of course, the same computer can be used to run a loudspeaker design programme - see Software and Hardware for Speaker Design at: <ftp://graphics.cornell.edu/pub/rahe/software/> where you will find

I have never bothered to inspect a Mac's audio input specs. but the Motorola StarMax 3180 clone I use has a "sound generator capable of driving audio equipment", which acts as a source of digitally generated test signals, like impulses. Motorola claim "CD quality 16-bit stereo, 44.1kHz sampling rate, in and out". Input line level 0dB is 2V peak-to-peak (0.7V rms) into 6.5kohms, noise is lower than 86dB down "with no discrete tones" and distortion is claimed to be "less than 0.1% at full level".

I notice though that the audio bandwidth is

# Make the sound decision with May Audio...



...the Distributors of note!

## Totem Loudspeakers

"Wonderfully communicative miniature; loads of fun"

SOUND QUALITY  
★★★★★  
Hi-Fi Choice



"Whatever sort of music you enjoy, if you're in the market for small speakers, you'll find the refined but invigorating Totems are poles apart from masses of more mundane miniatures"

MITE ..... £495.00    MODEL 1 ..... £1195.00  
TABU ..... £2195.00    MANI 2 ..... £2995.00

## Sequence Loudspeakers

"The SW12 subwoofer produced more extension of the listening experience than I expected. The sound was warmer, more solid and involving."

"...this subwoofer is remarkably self-effacing in appearance and easily accommodated in any room situation."

Gramophone

"...a natural sounding system that impressed from first listening and continued to provide musical enjoyment over an extended listening."

"...the Sequence 400s thus gain an enthusiastic recommendation."

Hi-Fi NEWS & RECORD REVIEW



MODEL 200 ..... £200.00    MODEL 400 ..... £330.00  
MODEL 300 ..... £250.00    SUBWOOFER ..... £250.00  
TRI-MOUNT RIGID SPEAKER STAND ..... £50.00

## LFD Amplifiers

"It's a diamond necklace in a world of plastic - but without the Tiffany price tag."

Eric Braithwaite, Hi-Fi World

"Clearly then, these LFD components are of an outstanding quality."

Jimmy Hughes, Audiophile

"The result was music making without the Hi-Fi intruding."

Peter J Comeaux, Hi-Fi News

"Spirolink I, Spirolink II and Digilink Copper"

Hi-Fi Choice Recommended

"Airoflex. ★★★★★ rating" What Hi-Fi

Integrated Zero ..... £500.00    Phonostage MMO ..... £400.00  
Integrated Zero LE ..... £800.00    LSB Linstage ..... £2000.00  
Linstage LSO ..... £500.00    Power PA2M ..... £2000.00  
Powerstage PAO ..... £500.00    DAC D to A ..... £2800.00



## Jecklin Float Headphones

"Speaker-like sound...  
...it's in the cans!!!"

"To call these transducers 'headphones' is to do them an injustice 'headspeakers' would be a more accurate appellation."

Audiophile

"...the sound quality is more akin to a pair of speakers than most other headphones we know."

What Hi-Fi



JECKLIN FLOAT TWO £99.00

JECKLIN FLOAT  
ELECTROSTAT £399.00

## Classical • Jazz • Blues • Big Band... the very best on Compact Disc

Our current C.D. catalogues feature some of the finest recordings of their genre and also offer unique repertoires to delight lovers of music and audiophiles alike.

- ORGAN ■ SOLO VOCAL ■ CHOIR ■ ORCHESTRA & OPERA
- CHAMBER MUSIC/ENSEMBLES ■ SOLO INSTRUMENTS
- JAZZ/FOLK MUSIC ■ TEST DISCS ■ LASER DISCS

proprius

≡ PROPHONE ≡



For literature please indicate your interests by ticking the relevant boxes-

- TOTEM LOUDSPEAKERS     L.F.D. AMPLIFIERS     SEQUENCE LOUDSPEAKERS  
 JECKLIN FLOAT HEADPHONES     ERGO HEADPHONES     SONNETEER CAMPION  
 CLASSICAL C.D.     JAZZ C.D.     BLUES C.D.     BIG BAND C.D.

NAME \_\_\_\_\_ ADDRESS \_\_\_\_\_

MAY AUDIO MARKETING, ARESIDE MILLS, CONONLEY, KEIGHLEY,  
WEST YORKSHIRE, BD20 8LW • TELEPHONE 01535 632700 • FAX 01535 632887

## NEW SONNETEER CAMPION AMPLIFIER



"Campion is one of those very rare amplifiers that puts everything together and a tingle in all the vertebrae, especially the ones that keep a listener fully upright on the edge of the seat" HI-FI WORLD January 1996

ERGO HEADPHONES...  
"Swiss precision made in sound"  
ERGO 1...£119.00    ERGO 2...£139.00  
ERGO AMT...£POA



# SEEING GREEN

Jon Marks spins the silver disc with Roksan's new £900 Caspian CD player.

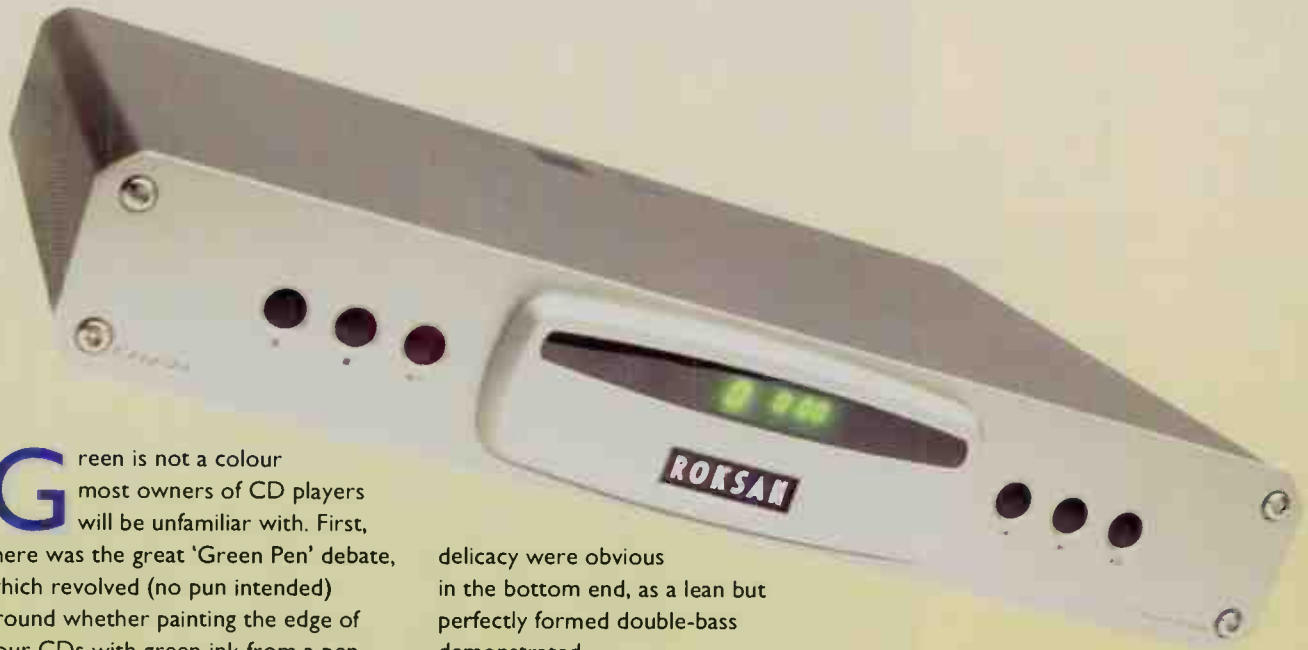

**G**reen is not a colour most owners of CD players will be unfamiliar with. First, there was the great 'Green Pen' debate, which revolved (no pun intended) around whether painting the edge of your CDs with green ink from a pen improved the sound. Then came green self-adhesive linings to put on the tray of your CD player. There were also rubber damping rings that fitted around the outside of a CD which came in a breathtaking shade of, yes, green. Now Roksan are putting green back on the agenda with their Caspian CD player.

Sitting next to the laser inside the Caspian CD is a green light. Roksan say this shines onto the disc and helps the laser to focus on the disc, reducing data reading errors and improving laser tracking. Roksan were a bit vague as to exactly how this system works because there's still some patent work going on. Suffice it to say, the green light and the fact that this player comes from the same stable as the Caspian integrated we use as a £700 reference whet my ears' appetite.

The Dave Brubeck quartet showed what the Caspian was capable of in the treble, with great resolution of detail that wasn't due to an in-your-face forwardness, just an extremely revealing presentation. With cymbals on this album, almost all the delicate tonal gradations were obvious, where many players only manage a monotonal version of events. Similar focus and

delicacy were obvious in the bottom end, as a lean but perfectly formed double-bass demonstrated.

Janis Joplin's Pearl album on a Master Sound Super Bit Mapping CD found the Caspian no slouch when it came to rhythm. That said, it wasn't quite as gripping a listen as DPA's Renaissance, which had a more adrenal outlook on music. Atmospherically, though, the Roksan got the slower moving 'A Woman Left Lonely' pretty much spot on - I could almost smell the sweet smoke filling the studio as the recording was made.

With Robert White's Sacred Music for Choir CD (Voces Sacrae, director Judy Martin), 'smooth' was the operative word. Voices had power as well as a complete freedom from excessive sibilance and harshness across the midrange. And the way the acoustic came through the Caspian meant I could just close my eyes and 'see' the interior of St Martin's church in East Woodhay. Beethoven's symphony No 1 had the same openness, the Caspian not holding back any of the spaciousness caught on this HDCD disc. The Roksan thrived on whatever musical diet it was fed, avoiding the twin perils of tubby bass and skinny, insubstantial midband and treble.

The Caspian is a very smooth, even

performer blessed with plenty of rhythmic drive. It may not be quite as funky as DPA's Renaissance but it does make the DPA sound a bit ragged and uneven. While the DPA also loses out in detailing as well as bass control, it has a lucidity the Caspian can't quite equal. It looks like going green is a good idea sonically for the Caspian. I can see the competition following suit, although they'll be going green with envy ●

**Roksan Caspian CD £895**

**Roksan**  
**St Peters Road,**  
**Huntingdon,**  
**PE18 7DB**  
**Tel: 01480 433777**

## WORLD VERDICT

The Caspian CD impresses like the Caspian integrated did. This is a very capable player and well worth £900.

**Measured Performance**  
**see p103**

# DAC Attack!

Following in the path of the original and extremely well received Assemblage DAC-1, the DAC-2 appears to be another big hit with customers and reviewers alike. The DAC-2 builds on the strengths of the original DAC-1, with its dual Burr-Brown PCM 1702 20 bit DACs, Crystal CS8412 input receiver, toroidal power transformer and Analog Devices based output stage, but adds HDCD capability with the PMD-100 digital filter chip, an extra co-ax digital input on a BNC jack, a phase invert switch, three more power supply regulation stages with greatly increased power supply capacitance, and improved parts quality in the analog output stage. The best news is that all these improvements come with a very small price, the DAC-2 digital processor kit is \$499.00 U.S.! Of course, the DAC-2 also comes with our 30 day satisfaction guarantee, two year limited warranty, AND our assembly guarantee (If you can't get it to work, we will!).

For those of you with the upgrade bug, we also have a parts upgrade kit available for the DAC-2. This kit includes Caddock resistors and MultiCap capacitors for the analog output stage, Kimber silver and Illuminati hook-up wire, EAR and Soundcoat isolation and damping materials, Linear Technology voltage regulators, and more parts that make a significant improvement in the performance of the stock DAC-2. The parts upgrade kit is available at a special package price of \$149.00 U.S., which makes it even more good news!

**At today's exchange rates, the DAC-2 will cost approx. £329 including VAT and shipping (10-14 day delivery).**

For more information on any of our products, please Call, Write, Fax or E-mail us and we will be happy to assist you.

## A few of the positive comments from the press:

*"...for the price of \$499.00, it produces remarkably excellent sound. This is a really good kit for the DA converter beginner."*

Mitsuru Yoshioka, MJ Magazine (Japan) Dec. 1996

*"Putting on Steven Stills' Manassas (Atlantic 82808-2) - a bona-fide, re-mastered-from-the-original-master-tapes, HDCD-badge-wearing, High Definition Compatible Disc-was much better. The resemblance in quality to what I'd been hearing that day in the recording studio, listening directly to my own master tapes, was uncanny"*

*"The DAC-2 is the best D/A I've ever had in my system, revealing musical details on familiar recordings that I was previously unaware of."*

Muse Kastanovich, Stereophile, Vol. 20 No. 1, January 1997

*"The DAC-2 is another well-engineered product from Sonic Frontiers. The unit had better bench performance than many more expensive processors. In particular, the DAC-2 had low crosstalk, very low noise, good linearity, and excellent reproduction of low-level signals"*

Robert Harley, Stereophile, Vol. 20 No. 1, January 1997

Subscription Info: Stereophile - (800) 334-8152.  
MJ Magazine (Japan) - 011 - 81-03-5999-5121

**THE PARTS CONNECTION**

A DIVISION OF SONIC FRONTIERS INC



## Now Available!

The Parts Connection's Catalog and Resource Guide Volume 3 is here! Packed with our regular selection of quality component parts, tubes, wire and cable, connectors, audio books, and more, as well as our valuable resource section, we have also added many new products. We have new wire and cables from Goertz, Kimber Kable, and DH Labs, new isolation products from EAR, vacuum tubes from Svetlana and Sovtek, and a greatly expanded list of audio books, including many foreign titles. The Parts

Connection's Catalog also includes info on our new Assemblage DAC-2 digital processor kit, and preliminary info on several upcoming Assemblage kits.

To order your own copy of The Parts Connection's Catalog and Resource Guide Vol. 3, please call, write, or E-mail us at the address and numbers listed below. The \$10.00 cost of the catalog includes surface mail anywhere in the world, as well as a coupon good for \$10.00 off your first order over \$150.00, or \$20.00 off your first order of \$300.00 or more.



Visit our newly redesigned Web Site: <http://www.sonicfrontiers.com/TPC>



2790 Brighton Road, Oakville, Ontario, Canada L6H 5T4 Telephone (905) 829-5858 Facsimile (905) 829-5388  
Toll Free Order Line 1-800-769-0747 (U.S. & Canada only) E-Mail: [TPC@sonicfrontiers.com](mailto:TPC@sonicfrontiers.com) Web Site: <http://www.sonicfrontiers.com/TPC>



# DIAMONDS ARE FOREVER

**Eric Braithwaite salutes Denon's spring-chicken DL-103M MC cartridge, which is now 34 years young.**

It's bargain time. For one thing, this is a review of a cartridge whose price has increased by no more than a pound a year in the last ten years. For another, it's two reviews in one. This is the first review in *Hi-Fi World* of Denon's DL-103M Moving Coil cartridge and it's by way of a review of a vintage cartridge as well.

Historically, this is one of the great cartridges of all time. It first saw the light of day in, would you believe, 1963, when Denon created it for the Japanese broadcaster NHK (the equivalent of the BBC). It's not been out of production since, making it one of the world's oldest living MCs and due for a telegram from the Queen - well, since it's Japanese, Emperor then.

There is a certain vintage aspect to the 103M in looks at least, with its square and squat appearance. It harks back to the Sixties in other ways, too. Output is on the lower end of what is now average and it tracks at what, to modern eyes, is a fear-inducing 2.5g, though there is in reality nothing wrong with that.

As far as the speck of diamond on the end of the cantilever goes, there's no fancy 'line', 'wedge' or 'Geiger' profiling. This is a simple, no-nonsense old-fashioned conical shape. That's not necessarily bad either. For all that more esoteric shapes are generally reckoned to track better, it has to be said the 103M didn't falter, even at the tell-tale end of the LP side. Nor, rather surprisingly, did it emphasise LP hiss, the groove staying very quiet.

When we measured this cartridge it tracked superbly. Frequency response was flat, with slight treble lift - just enough to brighten the sound a little. Treble loss on inner grooves was

modest at 2dB or so, just enough to cancel the lift out, giving good balance overall. So the DL-103M measures well.

Now, it could be that knowing the Denon was originally relaying LPs over the airwaves may have coloured my judgement. Yet if a character made itself felt consistently, it was that the 103M made LPs sound as though they were a live broadcast performance. That's not to say it has an FM bandwidth - it doesn't. It's more subtle than that. It was a little while before it dawned, listening to Cotrubas in the Kleiber *La Traviata*, that her voice, and Domingo's, were just a little sharper-edged, a little brighter than normal.

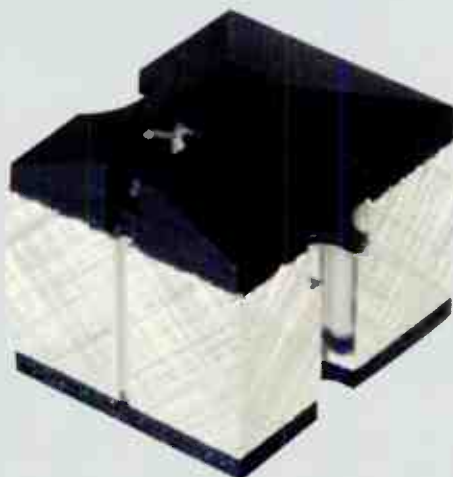

Meanwhile, the string tone was particularly sweet, brass quite forthright and images very solid. So much so as to produce that very 'live' illusion of Cotrubas really walking across space

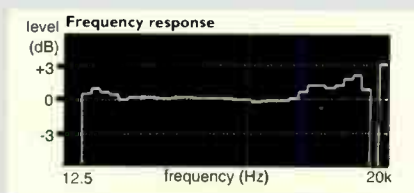

from one side of the stage to the other. Decent stage depth helped here too; the off-stage orchestra sounded properly distant.

There is, if one is looking for a disadvantage, a bloom that is a little overdone when it comes to the lower midrange. Pick on a solo horn in either Mozart's or Strauss's horn concertos and it is a little too laid back. That's a minor drawback, because otherwise this cartridge doesn't have the slightest problem with blazing dynamics when the band gets busy.

The 103M is beautifully balanced in tone, free from exaggerations, clear in the presence region, spot-on tight with imaging and rhythmical to boot - no wonder it's lasted this long. Personally, I can't think why people struggled with Deccas to achieve a much wilder and far less groove-friendly variation on what the Denon does. And the price? Well, exchanged for your old LP-chewing MC it's a mere £110. You don't often see a bargain like this and get to buy a piece of history at the same time ●

**Denon DL-103M**

**£109.95**

**Hayden Laboratories  
Chiltern Hill,  
Chalfont St Peter,  
Bucks. SL9 9UG  
Tel: 01753 888447**

**WORLD VERDICT** ●●●●●  
At the age of 34 years the 103M sounds mature and sure-footed rather than over the hill.

s of hi-fi ...the academics of hi-fi ...the academics of hi-fi ...the ac

# if you've an eye for quality

From interconnects through to the very latest specialist Audio Visual equipment, Our three Hi-Fi Studios and Large Screen Theatre are here for you to make the most of the very best in sound and vision Technology.

Based near Walsall with over 17 years experience, Sound Academy have Hi-Fi & Home Cinema for the beginner, the enthusiast and the audiophile. Accessible by the M6, only five minutes from junctions 10 & 11, and just 15 minutes from Birmingham.

- free unbiased advice 
- superb range of equipment 
- home cinema specialists 
- free demonstrations 
- part exchange welcome 
- delivery and installation 
- interest free credit on selected items   
(subject to status. written details available on request)
- service department 

## look no further



A C A D E M Y

### for the midlands

152a High Street, Bloxwich, nr.Walsall, West Midlands, WS3 3JT

01922 493499/473499







WE ARE HERE









...the academics of hi-fi ...the academics of hi-fi ...the academics of hi-fi ..the



audiophilia

David Price



“Journalists,” as G. K. Chesterton once wrote, “work harder than any other lazy people in Britain”. True to this maxim, I find myself constantly endeavouring to push forth the boundaries of hi-fi hackery, never ceasing in my search for that ultimate upgrade, that transcendental purchase to spirit me to audio heaven. But the problem is, all those years of ‘final upgrades’ have left funds distinctly depleted - money’s too tight to countenance, let alone mention. I’ve had to slash back on the hi-fi habit, go cold turkey on the upgraditis and find a way of keeping my system rolling without breaking the bank.

How? Well, there is a way, but it involves rethinking some of your most basic assumptions. What you’ve got to do is deprogramme yourself, challenge hi-fi’s natural laws and go against what so many dealers and magazines tell you. You have to accept that new isn’t necessarily better. This done, you’ll discover loads of great hi-fi around at knock-down prices on the second-hand scene. If ever you needed proof, just look at Hi-Fi World’s classifieds.

You don’t believe me? Well, five years or so ago there was yours truly, sitting at home lamenting the loss of my much loved Nakamichi BX100 cassette deck. It had been rendered deceased by a hapless removal man who’d dropped it down two flights of stairs. The Nak, already in what antiques dealers would call a ‘distressed’ condition (although not as distressed as I was), wasn’t worth much, and the insurance company was particularly adamant about this fact. How could I replace such a wondrous recording device with the paltry sum I got back from

Grabbit and Stingy? Not by buying the latest entry-level plastic biscuit box in the High Street, that’s for sure

Imagine my surprise then, when I happened across my local paper,

locked direct drive motors and more metal than a Sherman tank. Unbeknown to the seller, my name was written all over it.

Feigning indifference, I ‘reluctantly’ arranged a

recording machine I’d once thought, because the RT707 trounced it in every respect. I couldn’t believe 50 spondoolicks could sound as good as this, but there it was, bending the Target hi-fi rack on which I’d perched it, sounding in fine fettle.

Old high-end equipment seems to survive the rigours of age better than more recent budget stuff - the Pioneer didn’t put a foot wrong. With that huge sound stage, fantastic clarity and near inaudible hiss, even someone with silly putty for brains would’ve known they were on to something good.

But is buying second-hand really a practical, viable

proposition? Is the Pope a Catholic? Does a giraffe have a long neck? You’d be surprised how good a lot of old hi-fi sounds, providing it’s been properly looked after. Ignore the unbelievers who sneer from the sidelines and put ‘classic’ hi-fi’s popularity down to ‘nostalgia’. And take with a sack full of salt some magazines’ assertions that the latest is automatically the greatest. Buy well preserved examples from a reputable manufacturer that still supports its products and you’ll be laughing. And with all that money you’ve saved, there’s all the more cash to spend on new stuff!

*“I’ve had to slash back on the hi-fi habit, go cold turkey on the upgraditis and find a way of keeping my system rolling without breaking the bank.”*

where, sitting inconspicuously between the flotsam and jetsam of hi-fi’s past, was a ‘reel to reel recorder’ for 50 quid. Chances were it was no better than the ‘Jewel record deck’ [sic] or Tandy CD between which it lay, but what the hell, it was worth a try. Which particular open reel would it be I wondered - an ancient Philips portable or a clapped out Akai? Well, it was hardly likely to be a mint Revox G36, because I knew my luck too well. Or so I thought. When I dialled the number I found out it was a Pioneer RT707, a wondrous confection of glass crystal heads, quartz

dem later that evening. Braving February blizzards that would have made Nanouk of the North think twice, I coaxed the car into life and set out on a great adventure. Several hours later I was on the return journey, sliding through the snowdrifts in a distinctly lopsided vehicle - my mere twelve stones in the driver’s seat couldn’t compete with the Rock of Gibraltar-like reel to reel crushing the passenger footwell carpet.

Having properly cleaned, demagnetised and set up the Pioneer in my system, I soon discovered that my Nak wasn’t the ultimate

## LONDON



**WHERE DREAMS COME TRUE**  
**EXPERIENCE THE BEST IN HOME THEATRE**  
 starring DTS and AC3

Supported by: **ANGSTROM, DWIN DENON, HARMAN, KRELL, LEXICON, MARTIN LOGAN, NMT, ONKYO, PIONEER, REL, RCE, THETA, YAMAHA**

Other participants include: **AUDIO RESEARCH, ARCAM, AUDIOLAB, BOSE, B&W, B&O, CASTLE, COPLAND, DENON, JADIS, MICHELL, MICROMEGA, MARANTZ, MERIDIAN, MONITOR AUDIO, MUSICAL FIDELITY, PROJECT TURNTABLES, QED ROOMLINK, ROTEL, SONIUS FABER, SONY, TANNOY, TDL, WILSON**  
 Interconnect cables, hi-fi stands, speaker cables, headphones all supporting the above brands stocked, please call.

**OPENING HOURS MON-SAT 10am-5.30pm**  
 All major credit cards accepted. Low cost and 0% finance available, subject to status. Written details on request. Personal overseas orders welcome, competitive shipping quotes. UK Mail Order available (£3 per item) (mainland only).

**422 RICHMOND ROAD**  
**EAST TWICKENHAM**  
**MIDDLESEX TW1 2EB**  
 at the foot of Richmond Bridge

Tel: 0181 892 7613  
 Fax: 0181 892 7749

Visit our site on the Worldwide Web  
<http://www.riversidehifi.co.uk>  
 email us on [soundadvice@riversidehifi.co.uk](mailto:soundadvice@riversidehifi.co.uk)

## SOUTH con't



**UNILET**  
 Sound & Vision

*Best place in town for Hi Fi and Home Cinema*

- \* Six demonstration rooms
- \* All leading brands
- \* Interest Free Credit
- \* Free Parking
- \* Open 10-4 every Sunday

**UNILET SOUND & VISION**  
 35 HIGH STREET, NEW MALDEN,  
 SURREY, KT3 4BY

Tel: 0181 942 9567 Fax: 0181 336 082

## AUDIO CONCEPTS

**27 BOND STREET, EALING**  
**LONDON W5 5AS**  
**TEL. 081 - 567 8703**

AMC, Acoustic Energy, Aura, Audiolab, Audio Innovations, B&O, B&W, Cannon, Castle, Cyrus, Denon, Dual, Evolution, JPW, KEF, Marantz, Micromega, Mission, Monitor audio, Musical Fidelity, NAD, Nakamichi, Onix, Onkyo, Quad, REL, Rogers, Rotel, Systemdek, Target, Teac, Thorens, Van den Hul.

10 - 6 pm Mon., Tues., Friday, & Sat.  
 Late night Thur., closed Wed.

Two demonstration rooms.  
 Free local delivery and installation.  
 Repairs and Services



79/81 Fairfax Road  
 Swiss Cottage  
 London NW6 4DY  
 071 624 8855/6  
 Mon-Fri 10-7 Sat 10-6

## HI-FI EXPERIENCE

Arcam • Audiolab • Audioquest • Bang & Olufsen • Chord • Cyrus  
 Denon • KEF • Marantz • Meridian • Mission • MF • NAD • Quad  
 REL • Rotel • Spondor • Tannoy • TDL • Yamaha • Sony

Award Winning Hi-Fi from stock - Sales or Service - WE CAN HELP

Tel: (0171) 580 3535  
 Fax: (0171) 436 4733



Britain's Top Specialist Hi-Fi Stores

227 Tottenham Court Road,  
 London, W1P 0HX.

Send or call for your FREE Magazine and Catalogue. BADA Bonded

**"One of the 5 best hi-fi shops in the world"**

**GRAHAMS HI-FI**

Canonbury Yard, 190a New North Road  
 London N1 7BS, ☎ 071-226 5500  
 Ring for a chat, an appointment and a map!

BADA



INSTANT 0% FINANCE AVAILABLE SERVING LONDON FROM BATTERSEA

**ORANGES & LEMONS**

Juicy fruit from London's newest, freshest hi-fi/home cinema retailer. Telephone demonstrations or just pop in. All the usual, i.e. friendly and efficient service, free home installation + credit cards.

THE INNOVATIVE AUDIO/VISUAL HI-FI RETAILER. ARCAM, CABLETALK, CHORD CO, DENON, EPOS, MARANTZ, NAD, NAIM, REGA, ROKSAN, ROTEL, ROYD, RUARK, SOUNDSTYLE, STANDS UNIQUE, YAMAHA.

NOW IN OUR THIRD TANGY YEAR.  
 0171- 924 2040

61/63 WEBBS ROAD, SW11

**Front End Problem?**

contact

**The Cartridge Man**

It doesn't have to cost an arm and a leg to get the best - listen to my Koetsu - and Decca -eater.

Also agents for Croft, Sugden, Thorens, Pentachord Speakers & Nottingham Analogue.

plus cartridge re-tipping service

0181 - 688 6565

## SOUTH

## SPALDINGS

THE SOUTH EAST'S LEADING HI-FI COMPANY

3 DEM ROOMS A.V.  
 HOME DEMS., 0% CREDIT  
 FREE INSTALLATION

**LINN . NAIM . QUAD . AUDIO LAB**  
**DENON . MARANTZ . RUARK**

MON TO SAT 9.00 to 6.00, TUE 9.00 to 8.00

**SEVICE DEPT**

325-354 Lower Addiscombe Road, Croydon, Surrey CRO 7AF

Telephone: 0181 654 1231/2040 Facsimile: 0181 655 3922

Stockists of: **ARCAM • CREEK • EPOS HEYBROOK • MICROMEGA • NAIM AUDIO NEAT • REGA • ROKSAN • ROTEL • ROYD TEAC • YAMAHA**

**Infidelity**  
 indecently good hi-fi

9 High Street, Hampton Wick, Kingston upon Thames, Surrey KT11 4DA. Tel: 081-943 3530  
 Open Tues - Sat 10.30am - 7.00pm.

## WORTHING AUDIO

20 Treville Gate, W.Sussex BN11 1UA  
 (0903) 212133

The friendly shop with the best sound system in the South.  
 Talk Electronics - Friendly Advice - 3 Year Guarantees  
 Easy Parking - Open Mon-Sat. 10am-6pm.  
 Late Night Wed 7.30pm.

Agencies include: Arcam, Exposure, Kinshaw, Naim, Audio, Marantz, Ruark, Audio Technica, Target, Tripod, JPW, TDL, Oreille, and many more.....

## SOUTH WEST

### QUAD 33 CONVERSION

A re-designed rear panel incorporating gold phono sockets and up-dated selector boards installed into your Quad 33. Free Ixos leads supplied with conversion. Other Quad modifications available. Also repairs to:

**QUAD, LEAK, LOWTHER, BOSE, etc**

ACADEMY SOUND (CORNWALL).

BANK HOUSE, ST AGNES, CORNWALL, TR5 0QW.  
 TEL (OFFICE) 01872 553317 (WORKSHOP) 01209 711612

## SOUTH EAST



hi-fi for grown-ups

ipswich 01473 622866

## NORTH WEST



**WHERE THE MUSIC MATTERS**

**CHESTER**  
 86-90 Boughton,  
 Chester CH3 5AQ  
 (01244) 345576

**PRESTON**  
 131 Friargate  
 Preston, PR1 2EE  
 (01772) 253057

**TUESDAY - SATURDAY 9.00 - 5.30**  
**CLOSED MONDAY**

## NORTH

## HI-FI EXPERIENCE

Arcam • Audiolab • Audioquest • Bang & Olufsen • Chord • Cyrus  
 Denon • KEF • Marantz • Meridian • Mission • MF • NAD • Quad  
 REL • Rotel • Spondor • Tannoy • TDL • Yamaha • Sony

Award Winning Hi-Fi from stock - Sales or Service - WE CAN HELP

Tel: (01325) 481418  
 Fax: (01325) 382982



Britain's Top Specialist Hi-Fi Stores

17 Coniscliffe Road,  
 Darlington DL3 7EE.

Send or call for your FREE Magazine and Catalogue. BADA Bonded



# NORTH (Con't)

## THE hi-fi ROOM

50 BRIDGE STREET, MANCHESTER M3 3BN. TELEPHONE: 0161-832 0888/0161-835 1366

*An Oasis of Sound*

EXCLUSIVE HI-FI AND AUDIO VISUAL SYSTEMS

GLASGOW EDINBURGH NEWCASTLE LEEDS  
0141 248 2857 0131 220 0909 0191 230 3600 0113 242 7777

## SERIOUS KIT

The finest range of Hi-Fi in the north. Stockists of Audionote, Sugden, Impulse. Pro-Ac, Harbeth, Holfi, Stempfart, Target, etc etc

Open 10-6pm Mon-Fri  
10-5pm Sat  
10-2pm Sun

Phone: 0161 796 6656  
Fax: 0161 767 9080

273 Bury New Rd  
Whitefield  
Gtr Manchester

## MIDLANDS



*SOUND*  
ACADEMY

Audio Equipment from leading and specialist brands for you to listen to and choose from.

Tel: 01922 493499/473499

- 3 Hi-Fi Studios
- Home Trials
- Home Cinema Theatre
- Audio Visual Equipment
- Inhouse Service Department
- Mail order available
- Interest Free Credit (On Selected Items. APPRO\*6-written details on request)

Hi-Fi for those with an eye for Quality



WE ARE HERE

Sharing the ASDA Carpark with ample free parking. Off High Street, Bliswich, Nr. Walsall, West Midlands. Open 6 Days, 9am - 6pm. Late night Friday.

ARCAM AUDIO LAB CHORD NAIM KESWICK AUDIO RESEARCH ALSO-AROLLO A.T. AUDIO ALCHEMY AUDIO QUEST B&W BOSE BEYER CABLE TALK CHORD COMPANY CYRUS CELESTION DPA EPOS EXPOSURE KEF REFERENCE KENWOOD MARANTZ MICHELL MORDANT/SHORT MERIDIAN MICROMEGA MISSION MOTU MUSICAL FIDELITY NAKAMICHI ORTOFON PROJECT QUAD ROKSAN ROGERS ROTEL SENNHEISER SONY SUMIKO SYSTEMOEK TARGET TDL TUBE TECHNOLOGY VAN DEN HUL YAMAHA

MUSIC MATTERS

**NEWS**

### LATEST ARRIVALS...

CHORD SPA3200 & SPM1200B PRE-POWER, MERIDIAN DSP6000 SPEAKER SYSTEM, 565AC-3 SURROUND PROCESSOR, 557 POWER AMP, 518 DIGITAL PROCESSOR AND 566 20-BIT DAC.

ALCHEMIST MAXIM NEMESIS AND FORSETI AMPLIFIERS, DYNAUDIO RANGE OF SPEAKERS, EPOS ES22, SPENDOR AND PRO-AC SPEAKERS, ROYD SQUIRE & DOUBLET SPEAKERS, QUAD 77 RANGE.....

### CLEARANCE & SECOND HAND SALE

OUR VERY SUCCESSFUL SALE NOW MEANS WE HAVE A NEW LIST. PLEASE SEND A N.S.A.E. FOR AN UPDATE OF THE NEW BARGAINS AVAILABLE.

### PLEASE NOTE OUR NEW OPENING TIMES

TUESDAY TO SATURDAY 10am TILL 5.30pm, LATE NIGHT THURSDAY TILL 7pm.

### Branches at:

■ Birmingham : 363 Hagley Road, Edgbaston, Tel: 0121 429 2811

■ Solihull : 93-95 Hobs Moat Road, Tel: 0121 742 0254

■ Stourbridge : 156/157 Lower High Street, Tel 01384 444184

~Demonstrations By Appointment~

## FRANK HARVEY

### Hi-Fi EXCELLENCE

163 Spon Street, Coventry, CV1 3BB Tel : 0203 525200.  
Mon to Sat 9.30 till 5.30. Closed Thursday

MUCH MORE THAN HI-FI

WE ARE A

BADA DEALER

Audiolab · Audio Alchemy · Arcam · Alphason · Bose · Bang & Olufsen · Celestion · Cyrus · Denon · Dual · Foundation · Kef · Marantz · Monitor Audio · Mission · Musical Fidelity · Nakamichi · Nad · Quad · Rega · Rogers · Rotel · Target · Tmpod · Tannoy · Thorens · Van Den Hul · Yamaha

MAILORDER - EXPORT - HOME TRIALS

3 Floors. 3 Dem rooms. 3000 sq feet in the pursuit of Hi-Fi Excellence



## CREATIVE AUDIO

9 DOGPOLE, SHREWSBURY, SHROPSHIRE

Tel: (01743) 241924

Closed Mondays

- Comfortable listening rooms
- Home demonstrations available
- Part exchange welcome
- Free home installation
- Interest free credit

Authorised retailer for:

A&R ARCAM, AUDIOLAB, CELESTION, CYRUS, DENON, DUAL, MERIDIAN, MISSION, MONITOR AUDIO, QUAD, REVOLVER, ROKSAN, ROTEL, YAMAHA, EPOS, NAIM, KEF, NAD

## THE LEAMINGTON HI-FI COMPANY

THE LEADING HI-FI SPECIALIST

ARCAM AUDIOLAB QUAD MERIDIAN MARANTZ DENON PIONEER YAMAHA NAD MICROMEGA MISSION KEF CELESTION ATACAMA TECHNICS TRICHORD TDL REL IXOS SINGLE SPEAKER DEM ROOM WE DO NOT USE ANY COMPARETORS WE ALSO HAVE FULL DEMONSTRATION OF PROJECTION TV WITH LASERDISC AND FULL PRO LOGIC SYSTEMS PART EXCHANGE WELCOME PLEASE PHONE OR E-MAIL FOR PRICES WE HAVE IN STOCK OVER 2000 LASERDISCS CALL FOR OUR LATEST CATALOGUE

THE LEAMINGTON HI-FI COMPANY  
23a Regent Street, Leamington Spa, Warwickshire CV32 5EJ  
Phone: 01926 866644 Fax: 01926 867486 E-mail: h.brown@btncs.org.uk

To Advertise in Hi-Fi World's "Specialist Hi-Fi Dealer" Section Please Telephone Me... Caroline !!! on (01245) 443555



specialist hi-fi dealers

## WEST & WALES

audio excellence **BADA**  
THE ULTIMATE IN SOUND ADVICE

### WHERE THE MUSIC MATTERS

<b>Bristol</b>	<b>Cardiff</b>
65 Park Street	134/6 Crwys Road
Bristol BS1 5PB	Cardiff CF2 4NR
(01179) 264975	(01222) 228565
<b>Gloucester</b>	<b>Swansea</b>
58 Bristol Road	9 High Street
Gloucester GL1 5SD	Swansea SA1 1LE
(01452) 300046	(01792) 474608

### Exeter

156 Sidwell Street, Exeter, EX4 6RT  
(01392) 491194

**TUESDAY - SATURDAY 9.00 - 5.30**  
**CLOSED MONDAY**

## EIRE

Hearing is Believing

**CLONEY**  
*Audio*  
30 years of Excellence

55 Main Street,  
Blackrock,  
Dublin.

Tel: (01) 2889449/2888477

Open: Tues - Sat 10 am to 6 pm.  
Thur - Fri 10 am to 6 pm.

**Arcam**  
**B&W**  
**Audiolab**  
**Castle**  
**Meridian**  
**Classé**  
**Rega**  
**Marantz**  
**Epos**  
**Technics**  
**Sony**  
**REL**

## VALVES & TUBES



**CHELMER VALVE COMPANY**  
for  
High Quality Audio Valves

Buy CVC PREMIUM Hi-Fi valves direct from us.  
All valves processed for improved performance.

We also have Stock of MAJOR BRAND types  
including :MULLARD, GEC, BRIMAR, RCA, GE, etc  
130, New London Road, Chelmsford, Essex, CM2 0RG  
Tel: 01245 265865 Fax: 01245 490064

## SERVICES & CONSULTANTS

### STUDER REVOX

SALES, SERVICE, SPARES  
SERVICE & REPAIR OF  
A77, B77, A700, PR99 &  
36 SERIES

HI-FI SPARES TO ORDER  
SERVICED MACHINES IN  
STOCK  
APPROVED CONVERSIONS  
E.M.A.S.  
TEL: 01246-275479  
FAX: 01246 550421

## SERVICES & CONSULTANTS

### REVOX SERVICE

Fully Guaranteed Service and Repair  
Insured Carriage arranged  
Free Estimation

Also: Tape Supplies  
Second User Reconditioned Machines  
Spare Parts orders welcome  
Free Advice

### Ram Tek

Tel: (0181) 207 6159

Fax: (0181) 953 1118

Kinetic Centre, Theobald Street,  
Borehamwood, Herts. WD6 4SE

### LORICRAFT AUDIO

Required Garrard 301/401, Thorens TD124,  
Goldring GL75 any condition or any parts  
from new to completely used

Tel/Fax/Answer phone -  
**01488 72267**

### atv

- Service & Repairs
- Valve & transistor amplifiers
- Vintage valve Radios
- Hi-Fi VCR's
- Valves Tested

ATV SERVICES  
LEATHERHEAD  
01372 456921

### RESTORATION OF CLASSIC EQUIPMENT

Electronics engineer (Degree/MAES) with  
over 40 years experience and specialist  
knowledge of Quad, Radford, Leak, Rogers  
and Armstrong, etc. Extensive facilities enable  
original standards with detailed reports of  
work carried out. Apparatus is demonstrated  
prior to clients departure. Available 7 days a  
week. Valve testing a speciality.

Circuit Data of Classic Equipment on offer...

PLEASE ENQUIRE

Electronics Engineer and Consultant  
Tel: 0181 504 5467 Woodford, Essex

For a great sounding Hi-Fi room

### Room Acoustics Services

provide a computerised postal  
Hi-Fi room acoustics consultancy

Full details from:-

ROOM ACOUSTICS SERVICES

3, Queen Elizabeth Way, BARTON-upon-HUMBER,  
South Humberside, DN18 6AJ. Tel: (01652) 635523



To Advertise in Hi-Fi World's  
"Specialist Hi-Fi Dealer" Section  
Please Telephone Ms.  
Caroline Hill on (01246) 443555

## REPAIR & DIY



Shocked by the cost of really  
good sounding Hi-Fi ?

The Russ Andrews Solution

Don't change it - upgrade it!

By improving the quality of crucial components and  
wiring in your equipment you can achieve results that  
will astound you...and for a fraction of the cost of  
buying a new model

Our Catalogue contains the definitive selection of  
the World's best Hi-Fi components.

Our Upgrade Kits provide instructions on how to  
carry out a vast range of upgrades.

Our Unique after-sales technical support ensures  
you have access to our expertise should you have any  
queries.

We think you'll be pleasantly surprised!

To receive our latest information and upgrading advice  
- just mail, phone or fax the following address:  
Russ Andrews Ltd., Edge Bank House, Kendal, Westmorland  
LA8 9AS, ENGLAND. Tel: 01539 823247 Fax: 01539 823317

### Lockwood Audio

THE  
Authorised **TANNOY** Specialist

SPARES AND REPAIRS

DEALERS IN VINTAGE AND USED  
EQUIPMENT AND RECORDS



Callers welcome by  
appointment



Imperial Studios Maxwell Road  
Borehamwood Herts. WD6 1WE  
Phone: +44(0)181 - 207 4472  
Fax: +44(0)181 - 207 5283

### TECHNICAL & GENERAL

THE ORIGINAL TURNTABLE SPECIALIST

for the Great Classical Turntable, Arms, Cartridges, Styli

CONNOISSEUR • GARRARD • GOLDRING •  
LENCO • ORTOFON • SHURE • S.M.E. •  
THORENS • WATTS

All available Genuine spares and our own  
re-manufacture of obsolete parts

NO ILLUSORY 'IMPROVEMENT' NO  
DUBIOUS OR HARMFUL 'MODIFICATIONS'

Cartridges and styli, correct radius diamonds, for early  
recordings - 78s & Lps

TECHNICAL & GENERAL

P.O.Box 53 Crowborough, East Sussex TN6 2BY  
Tel: 01892 65 45 34

### GT AUDIO

GUARANTEED TOP QUALITY REPAIRS AND  
SERVICING ON ALL TYPES OF VALVE AUDIO  
EQUIPMENT. SYMPATHETIC UPGRADING  
CARRIED OUT USING THE FINEST  
COMPONENTS AVAILABLE.

Also agents For:-CROFT, G.A.T.E., GRAAF, LEAK  
TROUGHLINE TUNERS. MONRIO,  
NOTTINGHAM ANALOGUE, POSSELT, UKD  
OPERA, UNISON RESEARCH, YAMAMURA  
CHURCHILL ACCESSORIES

**TEL: 01895 833099**



# FOR OUR EARS ONLY

**Eric Braithwaite joins the burgeoning fan club of Pioneer's new A-300R Precision amp, specially tweaked in Britain.**



No-one goes to visit poor old Karl Marx's grave in Highgate cemetery any more, apparently. The few who do no doubt hear whirling noises from below as those states that supported his principles decide they're simply not as true as they used to think. "History repeats itself", he wrote once, "the first time as tragedy, the second time as farce." Well, Pioneer is attempting to repeat history. Remember the run-away success of the A-400 amplifier? Now there is a "British tweaked" version of the A-300R, surnamed the "Precision".

The revisions were planned by Tom Evans responsible for the acclaimed 'GTE' version of the A-400. Pioneer have used specially-sourced and hand-matched ICs from California in the gain stages of the pre-amp and the front-end of the power amplifier. And three capacitors in each channel are military-spec and expensive non-electrolytic types, chosen for their high frequency characteristics.

Wiring up a pair of Jamo Concert 8 loudspeakers which have an exceptionally clean, clear and detailed tweeter, proved the changes really work. To hear every drummer's stroke on perfectly distinct and separate cymbals is unexpected from any amplifier, let alone a £400 one. Neither is it normal to hear such silvery bells

listening to Mozart's Ein Musikalischer Spass. This is a lively piece at the best of times and the combination of Concert 8s and A300-R Precision made it a real sprinter thanks to the amp's quite remarkable rhythmic grasp.

Somehow, transistor amplifiers that portray depth and an overall acoustic seem to have become rarer these last couple of years. The Pioneer proved particularly good in this area, with a definable acoustic that extended to full-scale orchestral recordings like the Adagio from Mahler's Ninth played by Barbirolli and the BPO.

Though the Precision has grown in stature over a mere A300-R, it hasn't quite achieved high-end giant-killer status. Showing up on Faure's Elegy, there was a certain amount of muddling. With the best amplifiers at £600-£1000, there's more discrimination between the points at which double-basses and cellos meet and more clarity in woodwind. Yet for one will put up with a lot more than that for the dynamic strength and power of an amplifier like this.

The moving-magnet only phono stage remains untweaked. Switching between phono and CD while the Barbirolli/Mahler was playing showed that whatever has been done to the pre

and power stages has brought out more here than anyone would credit. True, the dynamic envelope of the BPO was a little compressed by comparison with the line

stages and the Faure Elegy's high violin notes were less clear, as though the upper harmonics had been cut off. But for what is still a budget phono stage, this was a very good overall sound.

It has often been said that Yorkshire women have outstanding complexions, something which has been attributed to the quality of the water. Pioneer's A-300R has benefited from its time in Castleford, Yorkshire, just as much. Perhaps other hi-fi companies would gain by moving up to Yorkshire, too. Relocation grant, anyone?

**Pioneer A-300R Precision £399.99**

**Pioneer Hi-Fidelity  
Hollybush Hill,  
Stoke Poges,  
Slough,  
Berks. SL2 4PQ  
Tel: 01753 789789**

**WORLD VERDICT** 

A bargain at £400, pure and simple. Outclasses the competition in every area.

**Measured Performance  
see p103**



# A REFERENCE GUIDE TO BRITAIN'S MANUFACTURERS AND DISTRIBUTORS.

**ACOUSTIC ENERGY LTD.** 16 Bridge Road, Cirencester, Gloucester, GL7 1NH. Tel: +44 (0)1285 654422. Fax: +44 (0)1285 654430. In 1988, a year after the birth of Acoustic Energy, the AEI was launched amidst worldwide acclaim. Acoustic Energy Ltd went on to develop their Reference Series Loudspeakers, also with great success. It was this success that brought about the 100 Series, a range of loudspeakers aimed at the more volume-orientated 'mid-fi' market. The immediate success of this Series has produced significant growth for A.E. and the Company continues to expand and re-invest.

**ALCHEMIST PRODUCTS.** Call us and allow us to transform your life with products from an acclaimed range of Amplifiers, CD's and Pre/Power combinations including such models as 'Kraken' and 'Forster's' right through to our award winning 'The Alchemist' range (Winners 1996 C.O.T.Y. Japan) Unit 1, Furze Wood House, Cranborne Ind. Estate, Potters Bar, Herts. EN8 3JN. Tel: 01707 664607 (for enquiries). Tel: 01753 889949 (for UK Sales). Fax: 01707 664207 (for enquiries). Fax: 01753 889636 (for UK Sales).

**ALEMA UK LTD.** 25 Montrose Road, Hove, BN1 1RD. Tel: 01273 202637. Audion<sup>®</sup> Edson<sup>®</sup> Anderson<sup>®</sup> (Trade enquiries welcome for our newly extended range).

**ALPHASON DESIGNS LTD** Unit D2, (2), Moss Industrial Estate, St Helens Road, Leigh, Lancs. Tel: 01942 678000. Fax: 01942 609913. Fully modular television and hi-fi systems to suit individual requirements. If you would like to receive further information of our full product range, or wish to know details of your local stockist, please telephone us now.

**APOLLO.** The UK based designers and manufacturers of high quality speaker stands and equipment racks have now added to their comprehensive range a modular system ideal for housing audio visual products and CD storage. Please send for our free brochure to Zenith Crown Ltd, Tipton Rd, Dudley, West Midlands, DY14 Tel: 0121 520 5070. Fax: 0121 522 2055. All export trade enquiries welcome.

**ARCAM.** Pembroke Ave, Denny Industrial Centre, Waterbeach, Cambridge, CB5 9PB. Tel: 01223 409694 or Fax: 01223 863384. Digital FM Tuner. The Delta 290 Amplifier and the Delta 280 Digital FM Tuner. The two together produce a sound that has been described as "subtle and intriguing" and that provide "real class" - discover this for yourself. For information on not only these products but also the Arcam CD Players, Speakers, Cassette Decks etc., phone or write in to request a brochure - The pleasure is all yours!

**ATACAMA AUDIO SUPPORTS** from Sambell Engineering Ltd, Winston Avenue, Croft, Leicester, LE19 3QG. Tel: 01455 283251. Fax: 01455 283908. We are the sole manufacturers of the 'SE' range of speaker stands, consisting of an 8", 12", 16", 20" and the award winning 24" high stand. Also three specialist models for the Tannoy 'Sires' Loudspeakers.

**AUDIOMIC (UK)** Component Suppliers. 25 Wallowtree Gdns, Saundersfoot, Pembrokeshire. SA69 9DE. Tel: 01834 814036. AudioCom are suppliers of the Premium Grade components, including Alps, BNC, Burr Brown, Cinescript, Danish Audio Centre, JBL, Holco, Linear Technology, MIT, Mullerax, Nicholson, MUSE, Silver Wire (99.99% Au), Symco Ocean, Sernice, Visway, WBT plus many more products at very competitive prices. New 1997 Audiophile Parts Catalogue is priced £1.50 (Incl. P&P) redeemable on your first order of over £10.00. Overseas send large SAE.

**AUDIO ECLAT** Manufacturer of S.O.T.A. Power supplies for most equipment i.e. Nam Preamp £200 Monarchy D.I.P. £200, Radford S22 (£150) Custom Valve Pre Amps from £400, Silver in Oil/Teflon interconnects £75 mtr pair, Silver Speaker Cable £15 metre, mains cables from £25. Amplifiers Upgrades Valve and Solid State. Previously owned valve equipment always in stock. Tel: 01642 559543. Fax: 01642 535655.

**AUDIOPHILE FURNITURE LTD** The Square, Forest Row, East Sussex RH18 5ET. Tel: 01342 826262. Fax: 01342 824845. Manufacturers of the patented BASE VIBRATION CONTROL PLATFORMS AND THE MODULAR AUDIO SUPPORT SYSTEM. These products are endorsed by Hi-Fi World. Also newly introduced are the RESONANCE CONTROLLED HI-FI CABINETS which are multi level modular design and available in various sizes and wood finishes. Please telephone for more details and a product portfolio.

**AUDIOLAB** Cambridge Systems Technology Ltd, Spitfire Cross, Ermine Park, Huntingdon, Cambs, PE18 6XY. Tel: +44 (0)1480 415600. Fax: +44 (0)1480 52159. The Audiolab amplifiers, CD players and tuners are internationally acknowledged for their sophisticated, modern design, combined with outstanding sound quality and flexibility. There are now 10 Audiolab models which range from the famous 8000A Integrated Amplifier through to the new 8000CD Integrated CD Player. For full information and details of your Audiolab dealer, please phone or write.

**AUDIO PARTNERSHIP** The Audio Partnership plc owns several of Britain's leading quality hi-fi brands, including Cambridge Audio, Gale Loudspeakers, Audio Innovations and Anston. All products are designed and engineered in the UK, and our reputation for innovation, reliability and exceptional value for money has resulted in the Audio Partnership being at the forefront of British manufacturers. All products are exclusively available through Richer Sounds stores around the UK, and for further information please call free on 0800 181355, or drop us a line at the address below. The Audio Partnership plc, Cattery Court, Haverhill, Cambs, Cambs, CB23 9LQ.

**AUDIOPHONICS** The UK's Sound Reproduction. Bespoke design and manufacture of audio systems including Loudspeakers with metal cone drivers; CASO fiberoptic speakers in hand carved marble with matching B5150 Bass. New Athene range coming soon. Amplification; Zeus semiconductor zero feedback push-pull or single ended output transformer monoblock power amplifiers and pre-amplifiers. 3 Melrose Close, Surbiton, Surrey KT5 9HQ. 0181 390 6480. Email: info@apnax.demon.co.uk

**AUDIO ILLUSION** 23 Langley Broom, Langley, SL3 8NB. Tel: 01753 542761. Fax: 01753 772532. Distributors and Consultants for the World's Finest Audio Equipment - Classé Audio - Solid State excellence in amplification design and now their new breakthrough digital components Enlightened Audio Designs - Hi-End Digital featuring hi-End Digital Flywheel and Dolby AC3™. Korea - Trade Valve Amplification - Integrated amps from £1795. Mirage® The Original Bipolar Loudspeakers™ - Full range of Loudspeakers and Subwoofers from £185.

From **AUDIO SYNTHESIS** manufacturers of the outstanding DAX digital to analogue converter, comes DAX-2, a new Hi-End reference converter able to dig deeper into the digital source than ever before! A new addition to the superb PASSION series of all Vishay controllers has just been introduced in the form of PASSION 8 - a fully remote controlled uniquely transparent passive preamplifier, the perfect match for DESIRE. By word of mouth our DESIRE power amplifier is rapidly convincing listeners, whether passive or active! New for 1997 is TRANSCEND a state of art CD transport with AES, coaxial, AT81 glass and Toslink outputs. Audio Synthesis, PO BOX 50 Northampton, NN9 1DN. Tel: (444) (0)15 922 9370. Fax: (444) (0)15 922 9370.

**CABLE TALK UNIT** 12, Farmborough Business Centre, Ecton Road, Farmborough, Hampshire, GU14 7XA. Tel: (444) (0)1252 373434. Fax: (444) (0)1252 371818. Designers and manufacturers of British made high quality, value for money,

interconnect and speaker cables. Phone or fax for a free full colour brochure on our What Hi-Fi? star rated products. **CAMPAIGN AUDIO DESIGN.** Llandudno Road, Cardiff CF8 2PG. Tel: 01222 779 401. Supplies / manufactures major, high purity silver interconnects, loudspeaker cables, internal wires and bespoke mains cables. Generous two week trial period.

**CANFORD AUDIO PLC.** Crowther Road, Washington, Tyne & Wear, NE39 6BW. UK Sales 0191 415 0205. Admin: 0191 417 0057. Fax: 0191 416 0392. UK's leading manufacturer and distributor of professional audio equipment 9000+ products are detailed in a bi-annual catalogue which is available free of charge to professional users. Next day deliveries when possible.

**CHELMER VALVE CO.** "Valves/Tubes/Transformers". 130 New London Road, Chelmsford, Essex CM2 0RG. Tel: 0245 265865. Fax: 0245 490064. Supplier of premium range of audio valves, other valves and components also available. Please see our ad on outside back cover of this supplement.

**CHORD ELECTRONICS LIMITED.** 3 Bower Mount Road, Maidstone, Kent, ME16 8AX. Telephone: 01622-764874. Fax: 01622-888480. We have recently complemented our highly acclaimed SMP1 range of power amplifiers with 2 superb pre-amps - the CPA 2800 & CPA 4000s well as the BBC qualified LS512A loudspeaker & LS512 best extension system. Call us for copies of reviews that will leave you wanting details of your nearest retailer.

**CREEK AUDIO LTD** 2 Bellevue Road, Fern Barret, London N11 3ER. Tel: 0181 361 4133. Fax: 0181 361 4136. Manufacturers of the 4240SE Integrated Amp, A42 Power Amp, P42 Pre-Amp, CD42 Compact Disc Player, OBH-M Mono Pre-Amp, OBH-R MC Phono Pre-Amp OBH-10 IR Remote Volume Control OBH-11 Headphone Amplifier, OBH-12 Remote Passive Pre-Amp. New range launched Spring '97.

**DBS AUDIO P.O.** Box 91, Bury St Edmunds, Suffolk, IP30 0NF. Tel: 01284 828 926 Fax: 01284 828 026. DBS Audio supply quality loudspeakers designed by Dave Berman. The DBS 6, features a custom-built 8-inch cast-chassis woofer with high-power voice coil, Morel high-power tweeter, and reassembled crossover with Van den Hul cable ICW 630V polypropylene capacitors and bi-wired with gold-plated terminals by popular demand DBS41 is now upgraded to MKII (upgrade kit available). New designs are planned. Also, UK distributor for the CIUO professional quality (but easy to use) PC-based audio measuring system. Access/Visa accepted.

**ECA DISTRIBUTION** Resulting from our own research and development, The ECA Design Team, has achieved the award winning Vista S/Lectern S Pre-Processor combi (Best Buy Hi-Fi Choice) and the Vista HD/Lectern HD Pre-Processor combi (Gramophone Audio Choice 1996 Award). Closely followed by our ECA A2 True Ribbon Speakers and Prisma Phono Amp for "the naturally neutral chain". The barest minimum of wiring in the amps, super symmetry in the circuits and vacuum integrated air coils custom made for the speakers. P.O. Box 3023 London NW2 7RW. Tel: 0181 998 1086.

**ELECTROFLOIDS.** 27 Froumer Street, Spitalfields, London E1 4QE. Tel: 0171 247 0813. Makers of the acclaimed Sonolith loudspeaker series and Monolith 2020 cable. Mineral polymer enclosures, controlled - flexure alloy - cone drive units, ultra - low impedance wide - band feeds extraordinary clarity, control and resolution.

**EMF.** 24 Bellevue Road, Fern, Barret, N11 3ES. Tel: 0181 361 6734. Manufacturer of Sequel 50w integrated amplifier and the Crystal D22A converter/amplifier and DAC. Please write in for details.

**EMINENT AUDIO** Distributor of Croft Valve Amplification. Tel: 01902 656517. Fax: 0121 681 8772. Mobile 0956 921740. UK Stockists are: Classicque Sounds (Leicester) GT Audio (London) Wylf Nottingham Analogue, Pursat Audio, The Cambridge Man (Len Gregory - Croydon), call for overseas distributors.

**FALCON ACUSTICS LTD.** Tabour House, Norwich Road, Mulbarton, Norwich, Norfolk, NR14 8JT. Tel: (01508) 57872. UK distributors of FOCAL drive units and SOLEN (chateaux) polypropylene capacitors and the largest inductor manufacturer in the UK. Comprehensive range of DIY Speaker Parts and Kits, Sub-Bases and Electronic Filters. "Everything but the wood". Enquiries should be accompanied by a 30p stamped addressed envelope.

**FULLERS AUDIO.** 20 Tunbridge Road, Southend on Sea, Essex SS2 6LT. Tel: 01702 612116. Fuller's audio produce a range of innovative products: Amplifier - a10 single ended class A sem-conductor power amplifier - £1200, 370 a magnet power amplifier of high standard - £599, pre1 and pre1+ matching pre-amplifiers - £299/£449, gen1 phono stage for mm and mc cartridges - £599. Loudspeakers - Pharaoh system, upgradeable from 1 pair of cabinets to 3 pairs for truly extended bass, passive/active options £649-£2499, Sphinx x 3 way floor standing unit £849, Sultan H.E., 98db sensitivity £439, matching Sub Woofer £595, Sultan, 91.5db sensitivity £309.

**IAN EDWARDS** The Old Chapel, 282 Skipton Road, Harrogate, Yorks. Tel: 01423 500442. Somebody Somewhere must make better storage units for CDs, Music, LPs, Hi-Fi: Books, etc. than Ian Edwards. BUT will he appears, why not send for the brochure showing a selection of HAND MADE units. To do this please send 3 x 2nd class stamps.

**EM DISTRIBUTION (FI RAX)** Springfield Mills, Spa Street, York, Wafefield, WY5 0AH. Tel: 01754 277632. Fax: 01754 270759. FI-RAX offers a new dimension in audio visual tracking. High quality aluminium construction. Finishes available to your choice. Fully adjustable 6mm glass shelving sound insulation on shelf/flex. Custom created to suit your system. Free delivery throughout the UK. For further information or a free brochure contact: EM Distribution.

**JORDAN WATTS ACUSTICS LTD.** Cyntra Place, 201 Mare Street, Hackney, London E8 3QE. Tel: 0181 985 1646. Jordan Watts Acoustics for Sight AND Sound.

**KESWICK AUDIO RESEARCH.** 54 Coach Road, Outwood, Wakefield, W Yorks, WF1 3EX. Tel/Fax: 01924 870606. "I'd say that the Figaro is the best miniature speaker I have heard" Audiophile March 1993. Write in or call for details on our full product range and your nearest stockist.

**KRONOS DISTRIBUTION.** 53 Farthing Road, Dunnington, N. Ireland, BT71 4DU. Tel: 0161868 748632. Kronos is the UK distributor of some of the finest Hi-Fi products in Europe. These include Audiomega digital products and turntables: Lieder silver speaker and interconnect cables; Pro-Ject turn-tables and amplifiers; Triangle speakers and electronics; and YBA amplifiers. We also handle Frameworks equipment tables; Arion valve amplifiers and main filters and Essex Audio digital products from the UK. Please telephone or write for product details and dealer lists.

**LAREX SUPPLIES LTD.** 1, Mayo Road, Croydon, Surrey. CR0 2QP. Tel: 0181 684 1166. Fax: 0181 684 3056. One of the largest distributors of electronic valves, tubes and semiconductor in the UK, and USA manufacturers. Stock and we specialise in obsolete types including original UK and USA made valves. Telephone or fax for an immediate quotation.

**LFD AUDIO.** 7 Lancaster Gardens West, Clacton-on-Sea, Essex CO15 6QG. Tel: (01255) 422533. Fax: (01255) 210699. Manufacturer of High Quality Amplifiers, CD Players, D/A Converters, copper & Silver Cables. Hand built to the highest standards to give stunning performance & classie looks. No gimmicks just pure sound. High End Audio has never been so affordable. **NEW** Mystral range for those who want an

alternative to mass produced products. Top quality looks & sounds at surprisingly reasonable prices. **LINN PRODUCTS LTD.** Floors Road, Waterfoot, Glasgow, G76 0EP, Scotland. Customer Helpline 0500 888990. LINN Hi-Fi faithfully captures the source signal, nurturing and protecting it through every stage of the playback chain. All you have to do is listen to decide for yourself how good a sound you want. Call the LINN Customer Helpline for further information on LINN Hi-Fi and LINN RECORDS, or to find your nearest retailer.

**LORICRAFT AUDIO.** "Vintage DIY". 4 Big Lane, Goose Green, Lambour, Berks. RG16 7SQ. Tel: 01488 72267. Specialist restoration of 301's and 401's using genuine spares and re-manufactured parts to original pristine standards in our newly built work shops designed primarily for these purposes.

**MARSTON AUDIO RESEARCH** PO Box 89, Kings Lynn, Norfolk, PE30 5SH. Tel: 01553 765 930. WEBSITE: <http://www.planetweb.co.uk/marston> E-MAIL: [Marston@planetweb.co.uk](mailto:Marston@planetweb.co.uk) Marston Audio Research are proud to announce The Silhouette Series Digital To Analogue Converter and External PSU Combination. All Marston Audio Research products are covered by a full 2 year warranty. Modifications also available to pre-amp, power amps, tuners and cassette players. Contact Marston Audio Research for further details.

**MAY AUDIO MARKETING U.K. LTD.** Areside Mills, Cononley, Keghley, West Yorkshire, BD20 8LW. Tel: 01535 632700. Fax: 01535 632887. Distributors of High Quality audio products from Linn products, Reference Loudspeakers, Reference Recordings, Jeklin Float Headphones, Sequence Loudspeakers, Sonneteer amplifiers and quality recordings from Proprius, Phono, Opus, MAP and Swedish Society IF IT'S MUSIC YOU LOVE. TELEPHONE OR WRITE FOR LITERATURE.

**MICHELL 2** Theobald Street, Borehamwood, Herts, WD6 4SE. For full information on our full range of excellent products including the Gyrodex, Alecto, Iso, Argo and others please telephone us on 0181 953 0771. Michell - Symbol of Precision

**MORGAN AUDIO SYSTEMS LTD.** A range of equipment has been built in the UK, consisting of a CD player / D.A. converter / integrators & pre-amp amplifiers. The integrated amplifiers are designated 125/250/600. Priced at £249/399/£999. Pre-pro versions of the 250/600 are priced at £799/£899. The CD player @ £579 & DAC @ £399 offer outstanding performance and complete the 250 range. For further info please call: 0151 236 7667.

**MUSITUBE** Prma Links, Yew Tree, Stone House Lane, Peckforton, Tarporley, CW9 2JT. Tel: 01829 260503. The manufacturer of PINK LINK interconnects would like to thank Hi-Fi World for their excellent review in their February edition. All interconnects are made from high conductivity silver plated copper PTFE insulated, and are uniquely conditioned. For mail order details of full range please contact us on: 01829 260503.

**NO NAME ACOUSTICS** 3 Ber House, 158 Ber Street, Norwich NR1 3EN. Tel: 01603 615817. Manufacturers of distinctive Hi-Fi and audio visual equipment supports. Some products look great but do they improve the sounds? Others sound great but look like a welder's bench. Our stands not only look stunning, but they deliver unbeatable sound quality. The range includes multi-tiered stands, isolation tables, wall mounted shelves and speaker stands all available in 4 striking finishes. A sight for sore ears.

**NOTTINGHAM ANALOGUE STUDIO** Tel: 01773 762947. Design and manufacture of quality analogue music. We're in the business because we realise how important music is. Our turntable arms and cartridges sell the world over a commitment to providing all our customer's with the best of analogue we have to offer.

**PENTACONE** 4 Cross Bank Road, Batley, W Yorks. WF17 8PJ. Tel/Fax: 01924 445039. Naturally recorded music on CD & LP. Three dimensional, Dynamic & Live. Plus dynamic equipment to play it on, including a concrete turntable and speakers. linear tracking arm, unique cabling system and valve amplifier.

**OPTIMUM INTERNATIONAL 2000** "A beautiful and stunning range of support systems for both hi-fi and audio visual equipment. Manufactured in the UK for the new millennium. Comprising stylish toughened safety glass and stainless steel support rods, these products provide both visual and sound performance. The new Premier range is totally modular and therefore totally flexible, suiting the needs of all customers. All models are fully spiked and flat packed for ease of transportation. Please call for further details. Tel: 01274 563249.

**PLATFORM 7** High density marble ISOLATION PLATFORMS for all makes of equipment RACKS/STANDS. An elegant way to UPGRADE. Improves clarity; better BASS control. 3 Abbots Drive, North Wembley, Middlesex HA8 3SB. Tel: 0181 904 2646. Also NEALGAR DISTRIBUTION Tel/Fax: 01296 24756.

**P.M. COMPONENTS LTD** Are the specialist component company for high end audio enthusiasts. Also carbon tube valves. Major stockists for Golden Dragon, Mullard, GEC & Technic valves plus a vast archive of vintage tubes.

**PREMIER MARBLE LIMITED** Uncover the true sound quality and potential of your system. Use the natural benefits of granite as your marble. These natural materials offer better base definition, clarity, and natural sound staging capabilities. CD/Turn-table platforms, custom made stands, shelves or anything you desire cut and polished to any shape or size required. Tel: 01603 721 995

**QUANTUM AUDIO LTD.** PO Box 26, 1 Oliphant Drive, Kilmarnock KA3 7JA. Tel: 01563 71122 Fax: 01563 71133. Quantum's craftsmen produce the £899 99 MINISTREL 30 Watt Ultra Linear, zero feedback correction, integrated, line level, valve amplifier. Don't buy any old fashioned valve amplifier before hearing the unique improvements modern technology provides to valve sounds. An audition will immediately convince the listener of the Ministrel's superiority.

**REL ACOUSTICS**, North Road, Bridgnd Ind. Est. Bridgnd, Mid Glamorgan, CF31 3TP. UK. Tel: 01656 768 777. Fax: 01656 766 993. international +44 656 766 993. The UK's only specialist sub-bass speaker manufacturer. "The only one that works". Get your dealer to give you a home demo and find out what the fuss is all about.

**REL HARMAN AUDIO**, Unit 2, Borehamwood Ind. Park, Rowley Lane, Borehamwood, Herts. WD6 5PZ. Tel: 0181 207 5050. Fax: 0181 207 4572. Sub Base Systems - Rel Strata, Stadium, Stentor, Studio.

**RDE TANDBERG HI-HI SERVICES**, Holly Tree House, The Green, Fulden, YORK YO4 1HW. Tel: 01759 327795. The service, overhaul and reconditioning of all Tandberg hi-fi products regardless of age.

**RICHARD ALLAN AUDIO**, Bradford Road, Gomersal, Clackheaton, W Yorks. BD19 4AZ. Tel: 01274 872442. Fax: 01274 869935. Manufacturers of very high quality loudspeaker enclosures and drive units. Examples being the £220 RAB series 2 as supplied to the BBC and the 5' reviewed Minista 2 & £120. **RINGMAT DEVELOPMENTS** Ringmat Developments, PO Box 200, Brentwood, Essex CM15 9FB. Tel: 01277 201 210 Fax: 01277 201 225. Ringmat is the first support for a record on a turntable player to be properly designed and is now the leading

turntable mat for the discerning listener. It can be used on almost all turntables. It even sounds great with 78's! RINGMAT 330 was born in 1992 and it's still successsor in 1994. They have both been acclaimed around the world by record lovers and hi-fi and record reviewers for their outstanding performance and cost-effectiveness. The NEW LK1 VERSION of the 330 MkII at £47.50, improves performance still further!

**SELECT SERVICES (PERFECT PITCH MUSIC)**, Heathrow Trading Estate, Hampton Road West, Feltham, Middlesex, TW13 6DH. Tel: 0181 893 8662. Fax: 0181 893 4318. We manufacture the Franconstein CD enhancement system, The Dacia DAC and Perfect Digital and Analogue interconnects. Perfect Pitch also provide freelance design, manufacture, prototyping and test, also valve and solidstate specials. Trade enquiries welcome.

**SEQUENCE DESIGN LTD.** 83 Main Street, Burley-in-Warfield, Yorkshire. LS29 7BU. Tel: 0171 495 0775. Fax: 0171 495 0281. Slim loudspeakers which stand close to a wall or hang like pictures. "Likely to cause a glint in the audiophile's eye" (Audiophile). "the answer to a prayer... a bargain in the extreme" (HiFi News). Available with light or dark grilles and various solid wood finishes. From £1995 a pair. Call or write in for an information leaflet.

**SHEARNE AUDIO P.O.** BOX 12, Sevenage, Hertfordshire, SG8 8H. England. Tel: 01438 740953. Following the highly acclaimed Phase 2, integrated, by adding the Phase 3 power amplifier and Bi-amping, Shearne Audio are continuing the design philosophy of an upgradable system through the range. Introducing the Phase 6, a superbly musical, specialised pre-amplifier allowing owners of the Phase 2 or 3 or both to upgrade their systems to highly specialised levels, also the introduction of the Phase 5, 100 watt Monoblock. These along with the phase 6 pre-amplifier can be used via Phono inputs or baniced much given ever greater versatility.

**SONICLINK** The Derwent Business Centre, Clarke Street, Derby, DE1 2BU. Tel: +4401 332-361390 Fax: +4401332-298986. SALES HOTLINE: 0700-CABLE(0700-32233) "Make the World's Finest Hi-Fi Cabinets from the Highest Quality Materials. SonicLink SILVER PINK SONICLINK VERNILLION Interconnect. SonicLink AST200 2 & BiWire Speaker Cable Sonic Link VIOLET Interconnect. Plus many more. Please ring for details.

**SOUND IMAGE UK LTD.** 52 Milton Road, London SW14 8R. Tel: 0181 255-8688. Importers and distributors of the finest audio equipment, featuring the stunning Boulder 2.000 series and the complete range from Norwegian manufacturer Electrocompaniet.

**SPECTRA DYNAMICS** Tel: (01745) 360070 Fax: (01745) 360086. Spectra Dynamics make a range of products to suit the connoisseur and DIY enthusiast. Products include DeTefex Acoustic Panels, the simplest and most cost effective way to upgrade your existing system. Isolation Feet, Damping Sheet, Sealing Strip, Gaskets etc. For a FREE information pack and details of other products please telephone or fax.

**J.E. SUGDEN & CO. LTD.** Valley Works, Station Lane, Heckmondwike, West Yorkshire, WF16 0NF. Tel: 01924 404088. Manufacturers of hand crafted audio products. "A world of Music". Call or write in for information on our SDA-1 Digital to Analogue Converter, S-DT-1 CD Player, A21a Class "A" Amplifier, A25B Integrated Amplifier, A48 Integrated Amplifier, Au51c Pre-Amplifier, Au51p Power Amplifier and more.

**TARGET AUDIO PRODUCTS PLC.** Britannia House, Leagrave Road, Luton, LU3 1R. The Audio equipment, rack and speaker stand specialist. For information on our products please telephone or write.

**TECH-LINK** distributes some of the best performing hi-fi and hi accessories currently available in the UK. These include: PureSonic, best known for its range of high performance interconnects and connectors, and cable adapters for a wide variety of hi-fi and av applications in its range. Tech-Link's own brand Switch Boxes are the perfect solution to multiple applications - for example, its highly acclaimed TAS-1 is a very practical and inexpensive way of switching your speakers between hi-fi and home cinema systems; and Shark - a range of very exclusive high quality cables, interconnects and connectors. For more information, contact Tech-Link at Units 1/2, 76a Farley Road, London, SE25 6NX. Tel: (0181) 771 8388. Fax: (0181) 771 1840.

**TEAC** 5 Marlton House, The Crossley Centre, Watford WD18 8YA. Tel: 01923 819630. Fax: 01923 226290. Teac has already established a virtual world-dominance in the manufacture of precision recording equipment and data storage products and the company is now turning its attention to its core hi-fi and audio related products. The Tokyo Electro-Acoustic Company (hence TEAC) was formed in 1956. Over the years TEAC has produced some of the world's most outstanding recording equipment, including many excellent affordable home cassette decks (for which the name TEAC became almost synonymous) and by the time of the dawn of the digital age at the beginning of the 1980's it was internationally acknowledged as a world leader in audio technology with a string of high fidelity firsts to its name. 1997 saw a significant turning point for TEAC with the launch of a superb new mini-system, a newly developed VRDS mini CD player and a British designed CD player.

**TRICHORD RESEARCH LIMITED** Following on from the highly acclaimed CD clock oscillator modifications the Pulsar Series One digital to analogue converter. This unique design is part modular and part bespoke to give absolute linearity over an extremely wide dynamic range. Switchable between 18 or 20 bit resolution this converter will compare the standard for CD replay. For details telephone 01684 573524.

**WILMSLOW AUDIO.** 50 Main Street, Broughton Astley, Leicester LE9 6RO. Tel: (01455) 286603 Fax: (01455) 286605. "Extensive range of Drive Units and over 30 different designs of self-sealment kit. Drive units include those from KEF, Dynaudio, Seas, Peerless, Scanspeak and Morel. Everything required for the loudspeaker Builder, and facilities to listen to the kits in built up form."

**SERVICES & CONSULTANTS**  
**R. J. FLETCHER AUDIO VISUAL** Tel: 01209 612260. Tel: 01209 710777. AK-G, Audio Innovations, Audio Analysts, Atacama, Audio Mech, Audioroute, Audioguest, Audio Technica, Beyer, Cable Talk, JBL, Focall, Focallon, Goldring, Harman Kardon, Impulse, DEN, IPW, Klipsch, Micromega, Monitor Audio, Musical Fidelity, NAD, Nakamichi, Onkyo, Ortonic, Precepcon, Project, QED, S.D. Accessories, S.ME, Sonic Link, Soundsystem, Sugden, Target, TDL, Teac, Trangle, Trichord, Vivanco.

**STYLI**  
**MUSONIC UK LTD** Specialist manufacturer & supplier of replacement & original styli for more than 40 years. Over 600 types stocked with many obsolete - 78 versions available. Also pick - up cartridges, record, tape, CD accessories. Why not try us & hear the difference!! Trade-Export enquiries welcome. Tel/Fax/e-mail your requirements to: Unit 2, Second Way, Witley, Middlesex, HA5 0YS. Tel: 0181 903 7067. Fax: 0181 903 4607. e-mail: 00544.3301@compuserve.com

meet your maker



# Vintage Virtues

by Haden Boardman

As a spotty youth I was interested in getting crazy power ratings from solid-state amps - the more Watts the better. My mother's front room became filled with hi-fi construction projects: 100watt, 500watt and the ultimate 1.25kilowatt per channel monster that would occasionally take out the mains' circuit breaker when switched on.

I had read about valve amps and was curious as to how something with less than 100watts on tap could possibly cut the mustard. I can remember reading rantings about them from one reviewer, at a time when only about three or four new valve amp makers existed in England.

Perhaps he aroused my interest. It was a week before my 18th birthday when I purchased my first real hi-fi valve amp, a Radford STA25 Series 3 complete with matching SC22 pre-amplifier.

A chance find at a local hi-fi shop, the poor thing wasn't working - it kept blowing its mains fuse. One IN4007 diode saw my amplifier back in operation. It had a couple of other minor faults but it was alive and kicking. An audition beckoned. My Castle Howard IIs were hooked up and a CD player plugged in. After about 20 seconds of warm-up, music emerged into the front room.

My jaw hit the deck. This thing seemed to have endless power and life. The sound stage was simply glorious compared to my beloved 1.25kilowatt lump. For a digital-loving, solid-state

hugging, future-friendly teenager of the eighties, this was quite a shock.

Historically, the Series 3 Radfords were out of step. Everyone else was looking at transistors in the mid-1960s when the range was launched. Nothing in the Series 3 is ground-breaking technology - the circuit is a development of the classic Mullard 5-20 circuit, using Dr Bailey's triode/pentode phase splitter circuit. But the overall package was splendid.

Radford made their own transformers rather than sourcing them from people like Partridge or Parmeco. The finish on the power amplifier is superb, giving it a feeling of quality not matched by any other English vintage power amplifier. And the SC22 pre-amplifier was beautifully styled, with a heavy chromed fascia, machined control knobs and beautiful detailing.

Inside, the circuitry was a little more innovative than in the power amp. The phono stage was a hybrid, using both triode valves and silicon transistors. The line stage was pure tube and featured filtering circuitry and tone controls.



Both the pre and power amplifiers were supplied with comprehensive instructions and data sheets. These included claims about the longevity of the amplifier and the minimum life expectancy of all the components, as well as useful servicing data.

Altogether there were four power amplifiers in the range; MA15, MA25, STA15 and STA25. Surprisingly enough, "MA" referred to mono amplifier and

## CD UPGRADE

Why go out and buy a new CD player at great expense for only minimal improvement in performance? Trichord's highly renowned 'Clock 2' and dedicated 'Clock 2 Power Supply' modifications will dramatically improve the sound quality of your existing CD player, or CD transport. Hear the potential that the CD medium really has to offer.

- ♦ High accuracy (5 ppm) low jitter performance master clock.
- ♦ Up to five times reduction in data related jitter.
- ♦ Increased transparency, resolution and sound staging.
- ♦ Greater dynamics and sheer listening pleasure.
- ♦ Can be fitted to most players or transports regardless of price. The level of improvement is just as significant with expensive transports as it is with inexpensive players.

These modifications can be carried out by Trichord Research Ltd, or by your local Trichord dealer. Also available in kit form with instructions for the technically competent.

We are so confident in these upgrades that we offer a complete refund and return your player back to its original state if not satisfied.

Clock 2 Trichord or Dealer fitted	£141.00 inc. VAT
Clock 2 Kit for self fit	£ 95.00 inc. VAT
Clock 2 Power Supply Trichord or Dealer fit	£ 80.00 inc. VAT
Clock 2 Power Supply Kit for self fit	£ 55.00 inc. VAT

for more information:

### Trichord Research Limited

Tel: (01684) 573524 Fax: (01684) 577380

FOR THOSE WHO ARE TRULY SERIOUS ABOUT THEIR MUSIC

73 CHURCH STREET, MALVERN, WORCS, WR14 2AE

SOUNDS PERFECTION  
LOOK  
TO THE WEST  
FOR THE BEST



AUDIO NOTES PREMIER DEALER IN THE WEST

GIVES YOU THE REMARKABLE OTO SE AND DAC 1  
SPEAKERS FROM AN-K'S TO AN-E SILVERS.

**HEAR THE MAGICAL MICHELL ORBE AT  
SOUNDS PERFECTION**

MONITOR AUDIO'S SUPERB PMC RANGE

ALCHEMIST UNIQUE STYLING AND EXCELLENT SOUND

HERE IN STOCK:-  
MUSICAL FIDELITY'S  
MUST" X-10D  
SUPERB" X-DAC  
X-LP & L-PSU

REL SUBWOOFERS  
GIVE YOURSELF THE EXTENSION YOU ALWAYS WANTED  
FROM Q100 TO STENTOR II

ALSO STOCKISTS OF:  
ANALYSIS, MICHELL, MYRYAD, NORDOST, ORTOFON,  
PROJECT, PARASOUND, SME, SONIC LINK, TRIANGLE,  
STANDS UNIQUE & SOUND STYLE

**CONTACT NIGEL  
TEL/FAX 01326 221372  
MOBILE 0468 754353**

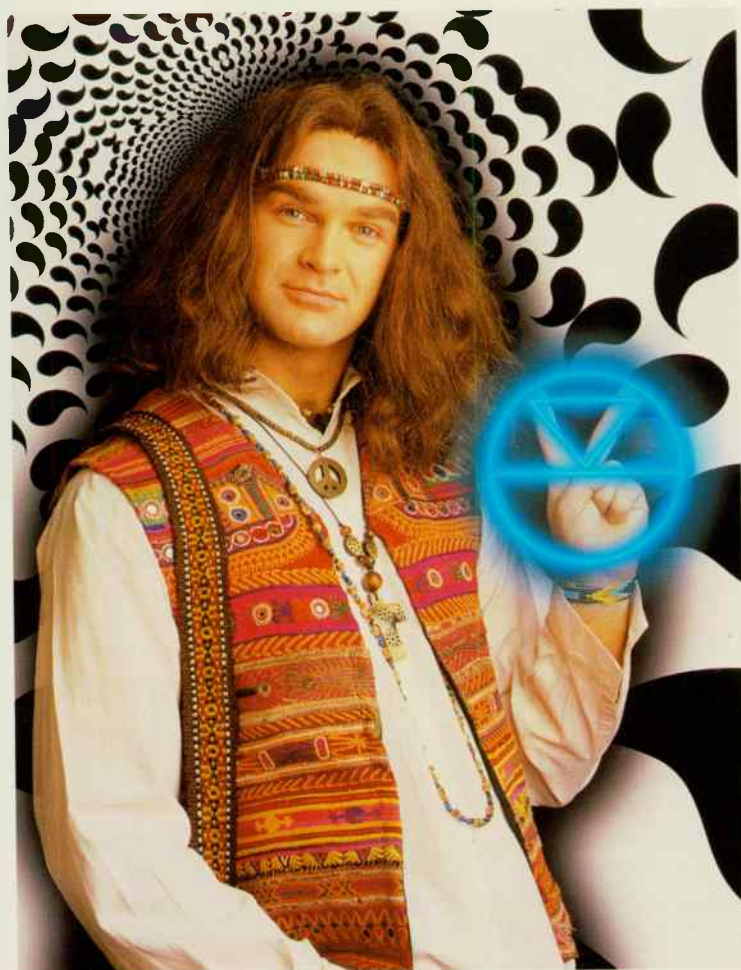

You didn't call  
your son  
Hongo Ishi  
after all.  
Another very  
wise choice.

 **LINN** *the only sound™*

DISCOVER THE MEANING OF LINN ON 0800 33 55 44  
<http://www.linn.co.uk/linn>





The CS22 pre-amp uses valves throughout apart from its phono stage which is a hybrid design that uses transistors alongside valves.

“STA” to stereo amplifier with either 15watt or 25watt outputs from a pair of EL34s per channel operated in ultra-linear/distributed load mode. Prices for the STA15 and STA25 in 1965 were £40 and £50 respectively.

Underneath, the amplifier is built using military grade printed circuit boards, one per channel. The '25 has an additional board to carry the extra power supply components. All variants can be considered semi-hard wired - the valves sit on the chassis, not directly on the PCB. This form of construction can make servicing a pain, especially with the more complicated STA25.

The '25 operates the output EL34 pentodes in fixed grid bias, an additional power supply giving the negative voltage that sets current through the valve. This has to be user set via four presets and four test points on the rear of the chassis. Any serious errors can result in damage to either the output or the mains transformers.

For correct operation, it's necessary to check the voltage at the test point is bang on two volts. As the valve ages, it will pass more current and the negative voltage at the grid must be adjusted to

compensate. Obviously, when fitting a new set of output valves (I recommend you change all four at once) this bias needs to be reset. The '15s are simpler beasts. Their cathode autobias system is more reliable and less affected by user errors. The basic audio circuit is identical,

though, so these amplifiers sound similar.

Both have a very warm character. The STA15 is rather loose in the bass where the STA25's negative grid bias helps maintain control. The output transformers add their own sonic signatures with a somewhat limited low frequency response. But then these amplifiers are really about midrange and treble.

It's hard to put your finger on what is so special about a Radford's midrange. It possesses real emotion and power along with a sense of timing and delicacy that very few amplifiers on the planet come close to. The treble is a little recessed, but it balances the bass end nicely and isn't necessarily a bad thing with some digital sources.

The SC22 pre-amplifier can't quite equal the power's quality - the line stages have a slightly veiled feeling. The phono stage offers reasonable results with higher output

cartridges though and the '22 will work with a CD player and most other modern ancillaries.

It's good news as far as servicing is concerned. Woodside Sound Engineering (01994 448271) can supply replacement transformers for Radfords, so it is possible to get even

the most derelict example back into full health.

When looking to buy a Radford, try to get the cleanest, most original example you can. They either turn up almost untouched or in a very sorry state, suffering from misguided modification. If it's a '25, check the bias voltages. Also remove the bottom cover and check for added components which shouldn't be there.

A clean Radford set can fetch upwards of £500, so make sure you are buying a good one. If it's a bit rough but working, around £300 will be enough. Generally, '15s and '25s change hands for the same amount of money. Both amplifiers are conservatively rated, so the difference in usable loudness levels is relatively small.



The STA25 uses a pair of relatively cheap, easily obtainable EL34 pentodes in its fixed bias output stage.

Arthur Radford wasn't one of the industry greats. His circuits were well developed but not very original. Radford amplifiers never dropped to low price levels like the Quad II or Leak Stereo 20 though. They were always held in high regard and still are to this day.

In a modern system, that glorious midrange can still show today's amplifiers up, making these Series III amplifiers a good bet for anyone looking for openness, if not outright authority. For the sound quality, prices aren't high and the amps are very reliable if looked after correctly. Happy hunting!



For the STA25 to work properly, the output valves need a bias of 2V, which is set with four potentiometers on the amp's back panel.



FI Magazine **"The Alon V MkII proved to be an unusually realistic transducer....These speakers are all but impossible to audition."** Arthur S Pfeffer

Stereophile **"...provides the potential for sound that is very near the state of art."** Russell Novak

Stereophile **"...extraordinary expressive... accurate & precise,"** Wes Philips

***Alón***

**Sound Image UK Ltd**

52 Milton Road London SW14 8JR

Tel 0181 255 6868 Fax 0181 255 6869

Range from the Alon Petite at £995 through to the formidable Alon V MkII at £4995 & the flagship Phalanx at £19000





ELECTROCOMPANIET

Hi Fi Choice **"The ECI-1 is one of the more important intergrated amplifiers out there in hi fi land."** Alan Sircom  
England June 95

Hi Fi Choice  
**"Electrocompaniet's cheapest amp is the one to beat."** Alvin Gold  
England May 96

Hi Fi News & Record  
Review **"AW100DMB combined with the EC-4 preamplifier is recommended for amplifier combinations over £2000"** Alvin Gold  
Nov 96



ELECTROCOMPANIET

**Sound Image UK Ltd**

52 Milton Road London SW14 8JR

Tel 0181 255 6868 Fax 0181 255 6869

Prices from £500 ECP-1 phono stage through ECI-2 intergrated at £995 to the AW 250 DMB @ £3995

# Audio Masters

We are very pleased to announce that  
**Audio Masters**  
are now a main **Audio Note** stockist!

We have on permanent dem the remarkable OTO Phono SE integrated Class A Amplifier (£1499) along with other superb AN products such as the utterly amazing and seriously under priced DAC 1 (Only £675!) The DAC 1 d/a converter is 20bit/8 times oversampling with a valve output stage. People are always asking me why we constantly harp on about valve output stages on DAC's. Well if you hear the Audio Note DAC 1 you will see why!!

Also we have on dem the **Audio Note K/L Speakers**. These loudspeakers match the OTO amplifier to a tee and are available in many different finishes.

The Audio Note range is from well under £1000 to well over £200,000.00!

Yes two hundred thousand pounds!

Call now for more details on these and other Audio Note products.

## X.....The true sound is out there...

The Musical Fidelity X-Series just gets bigger and better. The latest product to roll off the production line is the X-ACT an inexpensive 18 bit Dac. At under £130 it's a real bargain! And certainly re-writes how a budget dac should perform.

If you want to upgrade your cd player without having to visit your bank manager this is the only real option.

The X-ACT opens up the sound of any budget CD player and gives you the detail and warmth you would expect from a Musical Fidelity product.

Only **£129.00 P+P FREE**

Call or write to order or for more details

### Audio Masters Analogue Cleaning Kit

1X Discwasher D4 Cleaning System 1X Goldring Exstatic Brush

1X Discwasher SC2 Stylus Cleaner 1X Exstatic Sleeves (25)

Usual Price **£48.00 OFFER PRICE £40.00 + £1.50 P+P**

### Audio Masters Digital Cleaning Kit

1 X CD Lens Cleaner & Fluid 1 X Bib Electronic CD Cleaner

1 X Kontak Cleaner

Usual Price **£45.95 OFFER PRICE £38.95 + £1.50 P+P**

### Odds and Ends

Super Extatic Carbon Brush	£8.95
Exstatic Record Sleeves (25)	£9.95
Discwasher D4 Cleaning System	£18.00
Discwasher SC2 Stylus Care System	£10.00
Michell Record Clamp Black	£21.00
Shure Cartridge Scale	£19.95
Sorbothane CD feet	£29.95
Michell banana plugs 4 gold	£10.00
Bib electronic CD cleaner (Absolute bargain!)	£16.00
Perfect sound gold cones (8)	£38.50
CD Lens Cleaner	£15.00
Anti-static t/table mat	£10.00
Goldring 1022 Cartridge	£99.00
Greydo SR60 Headphones	£79.00
Maxview FM rod areial	£13.50
Permaclean Kit (LP)	£12.00
Focalpods (4)	£15.00
Zerostat Anti-static Pistol	£25.00
Powerlink remote extender	£59.99
Strobe Disc	£3.95
Sumiko Oyster Cartridge	£29.99
Sumiko Blue Point	£99.99
Sumiko Blue Point Special	£249.00

## Now Demonstrating

Come and listen in comfortable, informal surroundings to:

Myryad MI 120 R/c 60w integrated amp

Myryad MC Compact Disc Player

Musical Fidelity A2 Class A Amplifier

Musical Fidelity A2 Compact Disc Player

Audio Note Otto se phono Amplifier

Audio Note K-L Speakers

Audio Note Turntable One

Audio Note Arm Two

Plus The Musical Fidelity X Series

& Much More

Call us now to arrange your appointment!!

## At Last, Something to Write Home About!

If we said that there was a dac that had optical as well as coaxial inputs was HDCD compatible and was built by Musical Fidelity. You would probably say "so what!"

If we told you it was under £300 you might see what all the fuss is about.

**A HDCD Dac for only £299.95 !!!**

*We even pay the postage!*

## The Musical Fidelity X-Dac

Call now to place your order, stocks are going fast!

We stock far too many products to fit into this page so please write or call for our latest price list.

### SECOND HAND & EX/DEM CABLES

MAGNAN interconnects 1mtr (£150) ..... £80.00

MIT MH 750 loudspeaker interface cables (Puppy Tails) £295

XLO 0.5mtr type 1 ref intercon ..... £100.00

### SECOND HAND EQUIPMENT

Musical Fidelity F15 Power Amp ..... £1100.50

Magnaplaner MG2.5R VGC ..... £1200.00

Audio Note Model K ex-dem. .... £450.00

Thorens TD180 T/Table (inc. cart) ..... £125.00

## How To Pay

By Post:- Please make cheques or Postal orders payable to:

**AUDIO MASTERS.**

We accept VISA, MASTERCARD and SWITCH

Telephone: **01608 644954**

Facsimile: **01608 645954**

E-Mail: **-sales@audio-masters.demon.co.uk**



from  
**Dominic Todd,**  
*our man in  
 retailing*



It seems to be impossible to go through daily life without being asked about your business. And if you happen to be having your haircut, the question, "So what line of business are you in?" is an inevitability. There's no getting away, either. Like it or not, you're stuck in that chair for a good twenty minutes or so, taking on an ambassadorial role for your career. When I mention I'm "in" hi-fi, the response usually takes one of two forms. Either I'm asked, in detail, the merits of a 3-D super woofer and quizzed as to whether it is Technics or Bang & Olufsen who make the best hi-fi in the world. Or, I'm met with an "Oh" and a blank face.

The latter was the case the other day, when it was my turn to take the barber's chair. His response was, "I don't really listen to music, I just have the radio on in the background". My heart sank. I wanted to say, "Why not? Music can be incredibly healing and invigorating, and whether live or pre-recorded, is one of life's best experiences!" But, I didn't. Instead, it was my turn to mutter an apathetic, "Oh". Without meaning to patronise, there's a lot of people out there who really don't

know what they're missing out on. And, no doubt, they're the same people who appear totally incredulous when you mention someone's decided to buy a decent hi-fi rather than having the latest status symbol parked on their drive.

way towards explaining the success of 'chic' lifestyle mini systems sold at out-of-town electrical super stores. They may not sound especially good, but they make the right statement, and are often seen as an accessory. Just look at

taking the opportunity to cash in their wind fall and go on a shopping spree. Some of this money has found its way into purchasing decent hi-fi separates, surely something the hi-fi industry could never have dreamed of when the first building societies announced their intentions to merge and become banks!

Maybe this is just an economic blip, but there are signs of hope from another quarter. You only have to look at the numerous adverts for semi-pro equipment to see a flourishing market. Whether you like it or not, the Dance culture has seen a rise in the numbers of young people actually getting involved with music.

Budding DJs usually begin with a package of two turntables, a pair of headphones and a mixer to put through their midi system. Yet, often through peer group pressure, this leads to the purchase of a decent separate amp and pair of 'speakers, with possibly a cassette deck to record work on and a CD

player too.

Before you know it a full hi-fi separates system has grown up. And as most of us know, once we've heard how good a decent system can sound it's difficult to go back to a midi. Furthermore, the area in which this trend is thriving is amongst students. So, even if Dance DJing is just a passing trend, there will be a whole generation brought up with decent quality hi-fi components.

Whilst we may never again see the likes of the Seventies, when hi-fi had its heyday, a levelling out and gradual strengthening of the market are quite possible. Until then, does anyone know of a decent audiophile barber out there?

*"Despite what is usually a quiet time of year for the hi-fi industry, many stores are showing improvements in sales."*

I recall a Linn advert from a year or so ago, which ran something like, "He has a top job in the City, a country house, and takes several exotic holidays a year. He is the most boring old fart you'll ever meet". The ad obviously implied he placed no emphasis whatsoever on music or hi-fi. It was bold and perhaps rather crude, but it struck a chord with me.

The problem that hi-fi faces is that it's not a particularly visible sign of wealth so it doesn't impress, for want of a better phrase, society at large. And as society has changed over the last 20 years or so, visible wealth and aspiration have become more important. This probably goes some

how many general interest magazines feature them as such, rather than as a means to relay music. I think this has had a lot to do with why hi-fi has slipped from third to eighth on the list of major purchases made by people in the past 20 years.

The question is, are there any signs of this trend reversing? Despite what is usually a quiet time of year for the hi-fi industry, many stores are showing improvements in sales. Yet there have been recent events that have, I think, affected the situation.

With so many investors benefiting from building society pay-outs and the resulting stock market buoyancy, people are

# KITS HAVE NEVER

## K5881 MkII VALVE AMPLIFIER KIT

A 20watt, Class A power amplifier that uses reliable Russian 5881 output valves, a military version of the American 6L6, designed for low distortion audio work.

Now with a super shunt regulated push-pull (SRPP) input stage K5881 offers amazing sound quality. It can be used with a simple passive pre-amp or one of our own pre-amplifiers, and it matches modern loudspeakers well.

MkII with SRPP input stage!



£395



£650

## K5881PSE VALVE AMPLIFIER KIT

An audiophile parallel-single-ended valve amplifier at an affordable price. K5881PSE uses the reliable Russian 5881 output valve. Its 17watts is enough to drive most loudspeakers, making high-end sound quality and design available to everyone. Can be easily monoblocked to give 32watts.

## 300B VALVE AMPLIFIER KIT

This is a specialised 28watt amplifier based on the highly linear 300B triode valve. Our 300B runs in Class A, giving one of the most sweet, open and neutral sounds possible today. Matched with good loudspeakers, it is unsurpassed. All parts are included in the kit, except valves since different 300B makes are available.



£850

### KL53 THREE WAY CARBON-FIBRE DRIVER LOUSPEAKER

KL53 uses extremely light and stiff carbon-fibre cone drive units for a fast, accurate sound. A dedicated 4inch carbon-fibre midrange drive unit provides the clean, smooth and detailed midrange characterised by superb projection. Its high 90dB sensitivity and near flat 8ohm impedance make it one of the easiest loudspeakers to drive. An ideal loudspeaker for high-end valve amplifiers.

Drive Unit & Crossover kit etc £350  
Drive Unit Pack £230

### KL54 TWO WAY CARBON-FIBRE DRIVER LOUSPEAKER

A two way standmounter using stagger-tuned reflex loading for good bass, plus light and fast carbon-fibre drivers

Drive Unit & Crossover kit etc £230  
Drive Unit Pack £120

### KL57 TWO WAY CARBON-FIBRE DRIVER FLOORSTANDER

Compact and affordable two way reflex loudspeaker. KL57's slim dimensions make it easy to accommodate, but it uses top quality

carbon-fibre drivers, so performance isn't compromised. An audiophile bargain.

Drive Unit & Crossover kit etc £195  
Drive Unit Pack £110

### KL58 TWO WAY HIGH SENSITIVITY

With a sensitivity of 94dB, KL58 needs very little power. Its 10in. professional bass driver and horn loaded tweeter give it a BIG sound. Ideal for low power amplifiers. Provides high level listening without fatigue!

Drive Unit & Crossover kit etc £260  
Drive Unit Pack £175



# BEEN SO GOOD!



**£495**

## KLPP1 VALVE PHONO PREAMPLIFIER

KLPP1 has five line inputs, a tape input with monitor, and a unique low noise valve MM/MC phono stage. There is a switchable subsonic filter to prevent output transformers of valve amplifiers saturating. The line stage has gain, so it will drive any power amplifier. Audio grade components are used and many parts are custom made for highest quality. KLPP1 has a super clear sound, sweet and detailed through line and phono inputs.



**£345**

## KLP1 VALVE LINE PREAMP

The KLP1 line level preamp uses one an elegant cathode follower line drive circuit to give a sound of remarkable clarity and detail. The components are all high quality and include Alps volume control, Sovtek valves, silver plated wire etc. With a gain off x1, it matches our sensitive power amplifiers. Beautifully built, with solid machined alloy fascia and gold anodised knobs, it looks compact and elegant in the home.

## UPGRADE KITS

**K5881 MkII** **£35**  
 Upgrade your pre November '96 K5881 amplifier to MkII status for just £35. Includes new 7025 double triode input stage in place of the original EF86 pentode.

**KLS3 Gold** **NEW LOW PRICE - £385**  
 Upgrade your KLS3s to Gold status. Includes latest oval gold dome piezo tweeter and all components

**Beginners. Go for this one and blow your mind!!**



**KLS9 TWO WAY FLOORSTANDER**  
 Here's a storm for you - KLS9, with its BB4 alignment bass cabinet and Audax High Definition Aerogel 8in bass/midrange unit. Designed by Noel Keywood to possess optimal bass damping and a clean step response. Aided by a teensy bit of bass lift, KLS9 really thunders; it will re-arrange your furniture. But it does not waffle, falling silent when there's no bass in the music. Aided by a high power 1in fabric dome tweeter, KLS9 is detailed, evenly balanced and images superbly. It is an easy 12ohm load and is 88dB sensitive. For amps up to 60W. Easy to build and great for beginners. 93cms high.

Drive units, crossover parts, wool, etc **£230**  
 Drive unit pack **£160**



**KLS3 Gold ADVANCED TECHNOLOGY THREE WAY LOUDSPEAKER**  
 KLS3 Gold uses the latest version of Audax's innovative oval gold dome piezo electric tweeter, giving it the sweetest and most extended treble. Married to a 4in. carbon fibre cone midrange driver for neutral and clear reproduction, and a powerful 8in. bass driver for superb depth, this is our top-of-the-line reference 'speaker'.  
 Drive Unit & Crossover kit etc **£765**  
 Drive Unit Pack **£630**

# *The Caspian Collection*



*...even better British Hi-Fi!*

by

**ROKSAN**

t: 01480 433777

f: 01480 431767

E-mail: [info@roksan.co.uk](mailto:info@roksan.co.uk)



**WARNING**

THESE ARE EXPERT KITS, NOT FOR THE INEXPERIENCED. YOU MUST BE ABLE TO SOLDER AND READ A CIRCUIT DIAGRAM. THE VALVE KITS CONTAIN LETHAL VOLTAGES. WE CANNOT BE HELD RESPONSIBLE FOR ANY ERRORS ARISING FROM THE CONSTRUCTION OF THESE KITS.

**ORDER FORM**

Please send your completed order form to: WORLD AUDIO PUBLISHING, 64 Castellain Road, Maida Vale, London W9 1EX

**Tel: 0171 289 3533**

**Fax: 0171 289 5620**

240/120 option - delete the voltage NOT required. Valves included except where otherwise stated.

IF YOU WOULD LIKE A DATA SHEET ON ANY OF THE KITS, PLEASE WRITE A 'D' IN THE QTY BOX

WARNING - World Audio Publishing Ltd accept no responsibility for kits, parts or modifications made or supplied by third parties.

DESCRIPTION	ORDER No.	QTY	UK (inc VAT & carriage)	OVERSEAS (exc. VAT)
<b>AMPLIFIER KITS</b>				
NEW K5881 MkII 20W push-pull valve amplifier	K5881-K240/120	<input type="checkbox"/>	£395	£350
NEW K5881 MkII Built	K5881-B240/120	<input type="checkbox"/>	£595	£550
K5881PSE 17W single-ended amplifier	K5881PSE-K240/120	<input type="checkbox"/>	£650	£555
K5881PSE Built	K5881PSE-B240/120	<input type="checkbox"/>	£850	£725
300B 28W valve power amplifier (Not inc. Valves)	300B-K240/120	<input type="checkbox"/>	£850	£725
300B Built	300B-B240/120	<input type="checkbox"/>	£1150	£950
KLP1 line level pre-amplifier	KLP1-K240/120	<input type="checkbox"/>	£345	£295
KLP1 Built	KLP1-B240/120	<input type="checkbox"/>	£545	£465
KLPP1 valve phono pre-amplifier	KLPP1-K240/120	<input type="checkbox"/>	£495	£425
KLPP1 Built	KLPP1-B240/120	<input type="checkbox"/>	£695	£595

**LOUDSPEAKER KITS**

KLS3 3-way carbon-fibre driver floorstanding loudspeaker				
Drive Units + Crossover kit etc	KLS3-C	<input type="checkbox"/>	£350	£300
Drive Units	KLS3-D	<input type="checkbox"/>	£230	£200
NEW KLS3 Gold 3-way carbon-fibre driver floorstanding loudspeaker with piezo tweeter				
Drive Units + Crossover kit etc	KLS3-C	<input type="checkbox"/>	£765	£655
Drive Units	KLS3-D	<input type="checkbox"/>	£630	£540
KLS4 2-way carbon fibre driver standmounting loudspeaker				
Drive Units + Crossover kit etc	KLS4-C	<input type="checkbox"/>	£230	£200
Drive Units	KLS4-D	<input type="checkbox"/>	£120	£105
KLS7 2-way carbon fibre driver floorstanding loudspeaker				
Drive Units + Crossover kit etc	KLS7-C	<input type="checkbox"/>	£195	£170
Drive Units	KLS7-D	<input type="checkbox"/>	£110	£95
KLS8 2-way high sensitivity standmounting loudspeaker				
Drive Units + Crossover kit etc	KLS8-C	<input type="checkbox"/>	£260	£225
Drive Units	KLS8-D	<input type="checkbox"/>	£175	£150
NEW KLS9 2-way HDA driver floorstanding loudspeaker				
Drive Units + Crossover kit etc	KLS9-C	<input type="checkbox"/>	£230	£200
Drive Units	KLS9-D	<input type="checkbox"/>	£160	£140

**AUDAX DRIVE UNITS (P&P Extra - please add £5.75 for individual units or tweeter pairs, otherwise add £10.)**

**High Definition Aerogel Drivers**

3inch midrange, 93dB	HM100Z0	<input type="checkbox"/>	£35	£30
4inch midrange, 92dB	HM130Z0	<input type="checkbox"/>	£45	£40
6.5inch bass/mid, 91dB	HM170Z0	<input type="checkbox"/>	£50	£45
8inch bass, 91dB	HM210Z0	<input type="checkbox"/>	£60	£55
10inch bass, 90dB	PR240Z0	<input type="checkbox"/>	£75	£65

**Carbon Fibre Drivers**

4inch midrange, 90dB	HM130C0	<input type="checkbox"/>	£40	£35
6.5inch bass/mid, 90dB	HM170C0	<input type="checkbox"/>	£45	£40
8inch bass, 90dB	HM210C0	<input type="checkbox"/>	£55	£50

**Paper Cone Drivers**

10inch paper cone bass, 95dB	PR240M0	<input type="checkbox"/>	£60	£55
13inch paper cone bass, 97dB	PR330M0	<input type="checkbox"/>	£145	£125

**Fabric Dome Tweeters**

25mm 92dB for 2 way systems	TW025M0	<input type="checkbox"/>	£15	£13
25mm 92dB for 3 way systems	TW025M1	<input type="checkbox"/>	£16	£14
25mm horn loaded 97dB	PR125T1	<input type="checkbox"/>	£24	£21
34mm 93dB - powerful sound	TW034X0	<input type="checkbox"/>	£25	£22
Oval Gold Piezo electric dome tweeter, 89dB	HD-3P	<input type="checkbox"/>	£225	£195

NAME: \_\_\_\_\_  
 ADDRESS: \_\_\_\_\_  
 \_\_\_\_\_  
 COUNTRY: \_\_\_\_\_  
 POST CODE: \_\_\_\_\_  
 TEL: \_\_\_\_\_

I enclose cheque/postal order for £ \_\_\_\_\_ made payable to

World Audio Publishing Ltd.

I wish to pay by Access/Visa. Please debit my account no:

Expiry Date: \_\_\_\_\_

Signature \_\_\_\_\_



**OVERSEAS PRICES AND DETAILS**

Please allow for your own local import taxes (customs duties) and for carriage charges, which must be added to the net price. Telephone or Fax for a quote. METHODS OF PAYMENT International money order in Sterling, Visa, Access.

CREDIT CARD ORDERS TEL: 0171 266 0461 (24 HRS)

feature

# READERS' SYSTEMS

**Jon Marks describes an unusual but interesting system built up over the years by reader Ted Hay.**



It looks as though once the hi-fi upgrade bug bites, it bites for life.

Ted Hay has been an ardent audiophile since 1937 and is still searching for the hi-fi holy grail in his 70s. We decided to pay Ted a visit, having recently received a letter from him detailing his intriguing system.

Heading up the source ranks is the familiar Linn LP12 turntable matched with an Ittok arm and the fantastic Audionote lo MC cartridge (bought second-hand from the local undertaker).

The lo's tiny output is stepped up through a Denon AU-320 MC step-up transformer before being handed on to an Aragon 24K pre-amp. Alongside the Linn sit a Philips CD 650 CD player, Sony TC-K45 cassette deck, Pioneer F-91 Reference

tuner and a Teac quarter-inch reel to reel tape machine. So far, so conventional. It's from here on in though that things start to differ from the norm.



Ted's main source is an LP12 turntable with an Ittok arm and Audionote lo MC cartridge.

Once the line level signal exits the Aragon pre-amp, it's fed into a three-way active crossover (Rane AC23) which splits the Aragon's full range signal into three bands with

12dB/octave roll-offs; bass (from about 40Hz to 180Hz), midrange (180Hz to 3.5kHz) and treble (3.5kHz and up).

This arrangement means three stereo power amps are needed to run the loudspeaker drive units. Handling treble duties is the venerable Quad 405-2 power amp which caters to the Motorola piezo pressure driver with Acoustilens horn and the Pioneer ribbon tweeter. Ted chose both of these units because they have very low masses and give superfast transients. The Pioneer in particular stands out because it has a huge





Seen here sitting on top of the Pioneer F-91 tuner is the Rane AC23 active crossover at the heart of the system. To its right is the JVC power amp, while above it are a second pre-amp (from JVC again) and the Denon AU-320 MC step-up transformer.

magnet assembly that endows it with a high efficiency of 95dB/W and because its claimed response runs right up to 100kHz. The Japanese are especially keen on wide bandwidth loudspeakers and the Pioneer certainly scores from this point of view.

Dealing with the Westrex 2090 pressure driver firing into a ten-cell Altec 1003B horn and the mid/bass units in a pair of Leak Sandwich cabinets is a JVC 3030M power amp. This was designed as a studio amp and turns out 100W per channel in Class B. JVC didn't skimp on the build quality - there are two hefty power supplies with their own transformers on the chassis, one dedicated to the output stage and one the driver and input sections.

Finally a Haffler XL600 power amp is used to drive two pairs (one in each channel) of Morel MW266 double-magnet woofers aided and abetted by a Tannoy Monitor Gold dual-concentric with its tweeter disconnected. This is fitted to an open baffle and acts as a kind of fill-in between the Morels and the Leak Sandwich woofers.

At first glance it might look as though a system like this, made up of such an assortment of drivers, would have a hard time sounding cohesive. In fact, it has one of the

most cohesive sounds I've come across. Setting it apart were two factors.

One is that a single driver, the Westrex pressure unit with its Altec horn, covers a large chunk of the midrange where the ear is most sensitive to crossover phasing and response anomalies. The second is that this is an active set-up.

The net result is a well balanced, superbly dynamic delivery with a focus and punch in the bass that loudspeakers with passive crossovers can't match. Missing out on the great lengths of wire that make up crossover inductors really does pay dividends. Inductors also

reduce an amp's damping of a driver, meaning it has less control over the cone. And with the whole caboodle fronted by the LP12 with an MC of the lo's calibre, the sound was always transparent and revealing.

Talking with Ted as we went through his record collection, I asked him why he had gone the active route:

**TED HAY** "It gives you a great deal of control over how the drivers work. It's a near approach to how I think a good 'speaker should be. I think the first real breakthrough in loudspeakers came when Peter Walker of Quad made his first electrostatic. There were no really good 'speakers before that time in my view. Peter actually showed us what hi-fi should be like. The ELS 57 wasn't perfect at all, but it was a reference for all other 'speakers.

**JON MARKS** I know there are people who still regard the ELS 57 as a reference.

**TH** What makes a good 'speaker for me is balance.

**JM** And when you say balance, you mean a flat frequency response?

**TH** Yes, that's right. And from a subjective point of view as well. You know, you might balance it objectively - it might measure flat - but you can find out subjectively it still might not sound good. As you know, you've got to do a bit of tweaking here and there.

I've also been disappointed by a lot of two-way 'speakers because many have a midrange peak which pushes vocals up-front and putting the crossover in the presence region can ruin the sound. Some people seem to mistake this forwardness for detail and transparency.

**JM** So you prefer to cross the midrange driver over quite low down?

**TH** Yes, at about 200Hz. I use a series capacitor for the ten-cell horn and a choke for the Leak Sandwich bass driver.

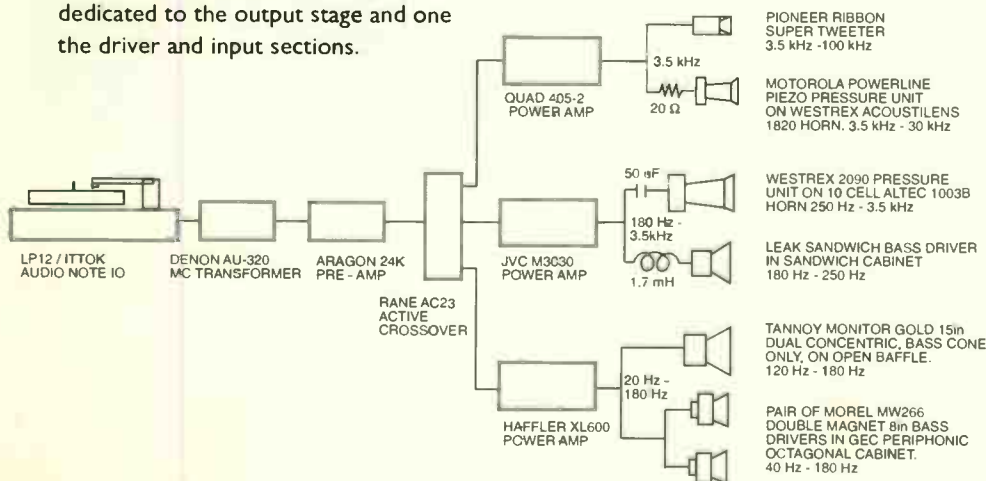

**JM** I suppose the point of using an active crossover is that you don't need to use the large capacitors and chokes found in passive crossovers.

**TH** Well, sometimes you still do - it can pay to use them to tweak the sound slightly but mods like this should be kept as simple as possible. The more elements you put in a crossover, the more you dirty the sound.

**JM** Companies like Epos tend only to use simple crossovers. In their two-way designs like the ES12 they use a single capacitor to roll in the tweeter and the mid/bass unit is actually run full range.

**TH** I think there's a lot to be said for that sort of approach. You need a hell of a good bass/midrange driver for that though. But I think no one driver can ever handle the full bandwidth satisfactorily. I tried that quite a while ago.

**JM** What kind of drivers did you use?

**TH** Vitavox first - they were good units. Goodmans as well but I didn't like those much in the early days.

**JM** Did you listen to Goodman's Axioms as well?

**TH** Yes, those too. They were good actually. But before then the drivers were a bit duff. I didn't think much of the early Wharfedales either.

**JM** I had a pair of Wharfedale's 12in dual concentrics a year or so ago. They had huge Alnico magnets for the paper mid/bass cone and a metal dome tweeter. They sounded quite good, although efficiency was only 86dB/W and power handling limited to about 20W.

**TH** Some of the best sounds I heard in those days came from mains energised 'speakers. They were incredible. The one I had was an Epoch. It had a horn a foot long and 8in wide at the mouth. The driver's voice coil was 3in in diameter and the surround was made of pigskin.

**JM** Pigskin?! I can't see vegetarian audiophiles going for that!

**TH** I used to drive it straight off my valve amp's output valves - the driver's impedance was about 100ohms.

**JM** You didn't use an output transformer then?

**TH** No. And the transients this set-up produced were incredible. Unfortunately it blew up one night at a party.

**JM** So many loudspeakers go to the great junk shop in the sky because of parties!

**TH** Out of all the other drivers I've lived with, I thought the Westrexes were some of the best, although some are better than others. But in the midrange, even they are

really bettered by electrostatics like the Quads and Martin Logans. Getting hold of replacement film for the old '57s is pretty much impossible unfortunately.

Then there was the Ionophone tweeter which used plasma, I think. People reckoned that was bad for your health though.

**JM** Yes, it used to discharge quite a lot of ozone, which isn't a good thing at ground level.

**TH** What I look for is a truly transparent midrange. Sir Thomas Beecham, the conductor, said he wanted to hear every instrument playing in the orchestra. He didn't want eight of the musicians going to sleep and the person listening to the recording not noticing. He wanted to be able to hear everything."

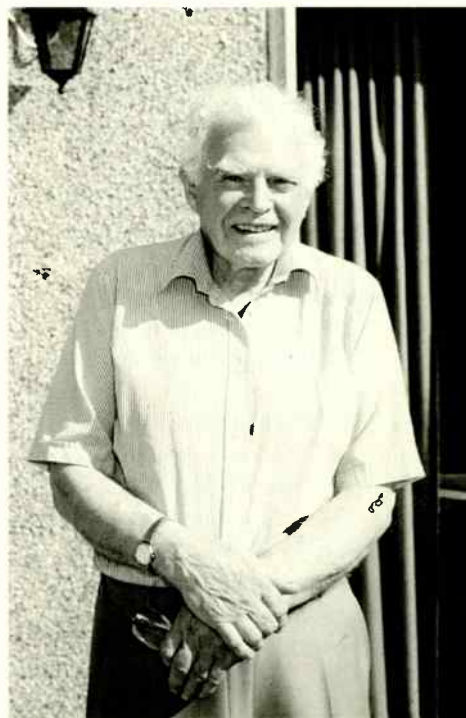

Life-long audiophile, Ted Hay.

Ted's system is always changing. The next step is a crossover for the Westrex which equalises its response at the top end so it can cover the entire midrange. There's also the possibility of an upgraded turntable and CD player. Like all dedicated audiophiles, Ted's journey towards hi-fi nirvana is never-ending. Bon voyage!



System No2 consists of Quad 22/11 valve pre/power amps driving Tannoy Cheviot 'speakers. The source is an Audionote step-up transformer fed from a Goldring-Lenco GL88 turntable for playing 78s, with arm and cartridge by Wilkin and Wright. The cartridge is an early Moving Coil (vintage 1946) and uses replaceable steel needles instead of a diamond stylus.





# MUSIC REVIEWS

## I N D E X

**ROCK & POP** .....81

Martin Rae  
Jon Clarke

**DANCE & AMBIENT** .....84

Viv Craske

**JAZZ** .....87

Simon Hopkins  
Simon Cooke

**CLASSICAL** .....93

Peter Herring

rock & pop reviews

## Martin Rae



**BIM SHERMAN**  
**IT MUST BE A DREAM**

MANTRA MNT CD1005

This is a re-mix of last year's *Miracle*, with the subtle, cool Sherman singing just a single dB or so louder than Whispering Bob Harris. It's almost after-dinner Reggae, as smooth and suckable as an eight o'clock mint, as slick with its Techno synths and wibbly Palm-Court Orchestra (Shepherd's Hotel, Cairo, around 1928) strings as Nat King Cole's hairstyle. I mean, who could believe 'Solid as a Rock' could come out as a gentle ganja-scented Rasta anthem from the Blue Mountains? But this is a very tenderly assembled and

superbly crafted album. It grows on you. Just inhale deeply, hold it in, relax. Aaah, lovely.

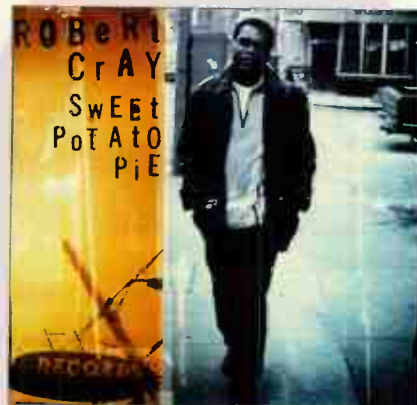

**ROBERT CRAY**  
**SWEET POTATO PIE**

MERCURY 534 698-2

Mr Cray, they say in some quarters, has soul. My hindquarters say different. Live, yes, he's clever and slick, and he can persuade you for a while. As the songs get soulful after track 1 the words become increasingly mawkish and the music (especially the gettar, but the ailment spreads to keyboards and drums, too) increasingly simple, countrified and unoriginally Bluesy. The

man's just treading water.

Much is made of the reappearance of the Memphis Horns, but they sound as though they just nipped in to record a few lazy bars to be bounced onto any track that was a bit lacking in emotion, drive, nay, even sincerity, which, alas, is pretty well all of them.



**SPIRITUALIZED**  
**LADIES AND GENTLEMEN WE  
ARE FLOATING IN SPACE**

DEDICATED DEDCD 034

I loved the first album or more accurately the two 12in 45s that were

called Spiritualized back in 1990. Trouble was, no-one else seemed to. What main man Jason Pierce has been doing for the last two years, though, ain't quite like 1990. Where that album used real instruments, for 1997 Mr P has borrowed the London Community Gospel Choir, Memphis horns, jazzy drumming, keyboards and a harmonica played like it's a Hammond organ. These ingredients are blended in a wall-of-sound of textures, rhythms and melodic improvisations that add up to

Soul-Psychedelia for the turn of the century.

Describe it track-by-track and it's crazy, from the Elvis oldie 'Can't Help Falling in Love' treated as a kind of electronic singing-round, to the mournful 'Broken Heart' that's lush, near-Nelson Riddle strings confronted with a Michael Nymanesque melody. There's a psychedelic fuzzied wash that could be the Pink Floyd allied to vocals that could be Roger Waters circa The Wall, with a backing from the gospel

chorus. And what begins like a typically swampy Louisiana Dr John (yes, it is him playing) is suddenly interrupted and overtaken mid-way on this 16-minute track by raucous Seattle Garage guitar.

But it's very together, to be taken whole, all 70-odd minutes. It's a complex and continually surprising album. If this is the direction Rock is going in the late '90s in Britain, let it roll. Ladies and Gentlemen, it's like Rock has acquired a Hubble telescope to see the future.



## rock & pop record of the month

RAGGA AND THE JACK MAGIC  
ORCHESTRA  
**RAGGA AND THE JACK MAGIC  
ORCHESTRA**  
M4M CD ED 1 101

No, no, no, not that kind of Ragga, or not altogether at least. This is an Icelandic singer. No, no, no, not like Bjork. You can understand the words and they're interesting words, too, lyrics even. And what a singer: Elaine Paige at one moment, Patti Smith another, P J Harvey somewhere else and maybe a spot of P J Proby on a dubbed chorus. She has a versatility (she popped up on 808 State's 'Mooz', by the way) befitting a graduate from LAMDA, which along with the Guildhall has been turning out some hellishly good Jazz musicians of late. Just to prove she could be one too, there's a splendid little Jazz-Funk track, 'Shot', due out as a single.

Ragga and the JMO are enormously inventive. In fact, they've invented post-modernist Rock. The boring old pastiche and tribute-to-the-'60s (or '70s or '80s) stuff should stop here, dead. These Icelandic geezers have stuffed it.

The album is driven by a clamorous percussive beat which track-to-track

plays variations on itself from Trip-Hop to R 'n' B, using "mucked up domestic appliances" (except they don't write it with an 'm'). I swear they use a washing-machine-drum, a screwed up food-mixer and a dying

This album is damn near impossible to describe. Just call it 'total sound theatre'. There are 'doo-wah' horns that might be on a Supremes track led by clangy percussion which all suddenly metamorphose into a syncopated tune that stumbles, slows and then catches itself up again just as you cop the disparity between the balladesque tune and the deceptively coy words which turn out to be about being stalked by a guy with a gun.

Then there are the whale noises and bubbly gurgles supporting the mystical vocals of 'Underwater'. There's another track which can only be described as 'musical Chinese New Year Dragon meets hieroglyphic riff from the Desert Song meets Garage/Grunge'. And to top it all, the drum machine beats hand over quite unexpectedly to a track made up of acoustic instruments in a way

Pentangle might have done it if they were new in '97 instead of '67.

Indescribable, truly, but I haven't had so much fun since. . . Well, we'll skip that. Not since Les Negresses Vertes, anyway. And Ragga and the Jack Magic Orchestra make them sound twopenny-halfpenny cafe-buskers. Weird. Wonderful. What's Icelandic for 'Wow!'?



tranny radio tuned to the howls between Radio Albania and Radio Free Uzbekistan. All this counterpoints melodies on keyboards and organ from one Jakob Magnusson, lately the Icelandic Cultural attaché, would you believe? Even now we've a guitarist as PM, I can't quite see Her Britannic Maj's rep. in Washington getting up to this sort of thing.





**COLD KRUSH CUTS**  
COLDOUT VS DJ KRUSH  
ZEN CD26

Cold Krush Cuts is an intriguing head to head turntable battle between futurist Japanese DJ Krush and the pioneering figureheads of the highly rated Ninja Tunes groove collective, Coldcut.

Think of this album in terms of a game show, with both competitors getting a stockpile of records, in this case label Ninja Tunes' back and front catalogue, and then throwing them on in whatever order they deem best. The result is the two teams both do a nice line in mixing, scratching, cutting and pasting.

So have Coldcut met their Pearl Harbour?

Kicking off the proceedings they do a superb job with 23 tracks, each of which has that unmistakable experimental feel thanks to a vague Dance/Trance beat. This is a diet of mashed up beats, orchestral guests and turntable mayhem.

Using a series of their own tracks in the hour-long mix, Coldcut also mix in a range of tracks from highly rated peers, particularly DJ Food and Funki Porcini.

The Dub concoctions, such as DJ Vadim's 'The Breaks', include some startlingly good Jazz motifs and run the usual gamut of Hip-Hop, Drum 'n' Bass, Jungle, Trip-Hop and the odd freaky noise. If there are any vocals they fit in comfortably with the general ambience.

Most of the tracks merge into each other leaving a flavoursome mix. However, 'Get Your Head Down' by Luke Vibert and 'Naked Leaves' by Coldcut are particular standouts.

DJ Krush takes over on Side B with a similar assortment of tracks, concentrating especially on those by DJ Vadim and the London Funk Allstars.

Although with DJ Krush there is a vague sense at times of repetition, this is another impressive journey into modern Dance by Ninja.



**THE CHEMICAL BROTHERS**  
DIG YOUR OWN HOLE  
XDUSTCD1

If there's anything to entice an old man like myself back onto the dancefloor, it's the Chemical Brothers.

Techno's equivalent of the Gallagher brothers have followed their promising debut album Exit Planet Dust, released two years ago, with one of the most cocksure albums to be heard thus far in '97. It has even managed the incredible twin feats of pushing the Spice Girls off the Number One slot and rocking straight into the American Top 20, putting British Electronica very much on the world map.

Forget the timid Ambient sounds often now associated with ecstasy fuelled Techno/Dance - this album is a Dance contradiction. It's a full-on head-bursting assault on the senses driven by the dirtiest and nastiest of rocking beats.

Dig Your Own Hole is a Dance album you can Rock to and a Rock album that will even get the unlikely of retroheads reaching for their Dancing shoes, Noel Gallagher for one.

Starting off as a bunch of gawpy Manchester students, who had a couple of wacky records they liked to spin to their assembled group of mates at the odd club, the Chemical Brothers grew from humble beginnings.

With an aptitude for business and a knack for getting people onto the dancefloor, they built up their empire to the point where, two years ago, they started Heavenly Social Sunday, one of

the capital's most famed clubs. It was to put their stamp on a city obsessed by innovations and good music.

Dig Your Own Hole is testament to this originality. It kicks off with the riveting 'Block Rockin' Beats', a tune that sums up the whole album - brutal machine riffs, funky basslines and wailing sirens. The nearest comparison would be The Prodigy's 'Firestarter' - less insane perhaps, but a whole lot meaner.

Like the brilliant Prodigy, listening to the Chemicals is a bruising, almost combat-like experience. And it just gets better. Backing up the opener are the stunners 'Dig Your Own Hole' and 'Elektro Bank'.

Moments of respite are few and far between but worth the wait. There's 'Setting Sun', the collaboration with our Noel which uses The Beatles' 'Tomorrow Never Knows' as its template. In the same vein are the soft, mysterious psychedelic trip 'Where Do I Begin?' (vocals provided by Beth Orton) and the total, blissful meltdown of the last track, 'The Private Psychedelic Reel' which verges on the transcendental at nine and a half minutes long.

Overall Dig Your Own Hole has a sort of amateurishness that is appealing in a raw Hip-Hop kind of way. The Americans have names for this type of music - they call it Digi-Rock or Electronica. They can keep the names, we'll keep the band. This is music to scare middle-England. Lock up your children, or they might just flip out. ●





## Viv Craske



VARIOUS  
**THE LOVE GROOVE DANCE PARTY - VOL 5&6**  
 METROPOLE LGCD3

My, my, doesn't time fly! Either that or Danny Rampling's really knocking out those mix CDs. Still, you can't go far wrong with Danny.

This third time around for the flashily packaged Rampling mix series, the format once again offers a bit of everything. The Glitterball Mix sees Rampling in a sequined dress with a vocally, Garagey, Housey mix. From Byron Stingly (the Aled Jones of Dance) with his gospelly vocal thang to Morales' pumping mix of U2's 'Discotheque' and Angel Morales's sexy Garage of 'I Like It', Rampling warms up the glamour pussies like a king.

But the real action is reserved for the Spacey Trance Mix, a royal feast of beats to CD One's Lentil Casserole. Easing into the fray with Oakenfold's mix of Olive's refreshing 'You're Not Alone', the choices soon get interesting. El Diablo's 'Fuego' laps up the Latino vibes before the ominous 'Nightmare' from Brainbug kicks in

with those scary string arrangements. Quickly moving into Techno/Trance territory, DJ Misjah whips up a storm with the momentum kept through choice cuts from Chris Liberator and Astral Projections. Like all good meals, this one is finished off with a nice dessert and a little burp - Terra Firma's luscious 'Lunar Sunrise' and BBE's 'Flash'. See, that's what a DJ should do - take you on a musical journey (despite the cliché). Cheers.

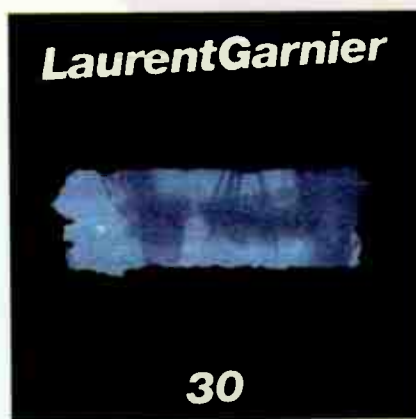

LAURENT GARNIER  
**30**  
 F COMMUNICATIONS F053CD

Laurent Garnier's first studio album has been a long time coming, so you'll excuse the fact that it's taken this long to get around to reviewing it. Thanks.

Well, by now you may have heard the first 12in to be released, 'Crispy Bacon'. If not, then it's worth a listen. It's a slab of fine French Techno, which maintains a minimalist approach while cramming in a lot of content. 'Crispy Bacon' has a Techno'd funkiness married to a hypnotic bassline. I know

that may not make much sense but go with it.

Released on Laurent's label, F Communications, the cover shot shows Laurent looking all Cantona. But not to worry - inside there are 14 tracks nestled together as a whole album, a real listening experience (if you'll forgive my pretension).

However, in this case the flow of the album makes it a nice 'home listening' CD, so there's very little in the way of club stormers. There's 'Crispy Bacon', but what else? 'The Hoe' is pretty average, while 'Kault' is a tad to weirdybeaty to really make it on most floors. 'Flashback' cuts the mustard, though, in a retro, funky, Acid Electronica way, with its Techno beat and sumptuous, squealing Acid building through the track.

And, perhaps, that's why some of the reviews of 30 were a touch on the dismissive side. Laurent Garnier's DJing is a superb mix of good tunes, perfect timing, dancefloor oomph and crowd control savvy. At a time when many Techno DJs play within their little sub-genres and decide to 'educate' the crowd, Laurent's out there stuffing party beasts into your ears.

Maybe we all expected the album to be a hard-edged Techno monster, resting on heavy bass and grating metallic grooves. But that's not what Laurent's made here. 30 is closer to a mellow chill-out compilation than that. Just listen to the dreamy flow of 'Midsummer Night' or the Jazz leanings of 'Theme From Larry's Dub' or 'Le Voyage De Simone' with its subtle touches, affectionate bass and ethereal singing.

It's a big thumbs up, I say. Just don't stick it on in the middle of a party.





THE AMALGAMATION OF SOUNDZ  
**THE AMALGAMATION OF  
 SOUNDZ**

FILTER FILT O20CD

First in a series of special-price CDs to be released on Filter Records, this instalment brings together two EPs from the Amalgamation Of Soundz from the last few months.

Opening with the apparently Iranian flavoured 'Tears For Yazd', it sounds very much like walking down Haringey High Street on a Saturday afternoon. 'Tears For Yazd', like the rest of the CD, fuses melodies with AOS's own take on Breakbeat while crossing the globe taking in ethnic styles from all over the shop.

Next up is 'Maternal Blues', a coffee shop Hip-Hop nodder, laden with innocent melody and swaggering like it's

caught the sun a little. Later, 'Fiesta De Castellon' takes us on a Latino tip moving away from Breakbeat and towards House.

What this CD provides is that oft-lacking ingredient of musical talent and spirituality - a journey through Jazz and Hip-Hop sensibilities, or the lusty modernity of Breakbeat and the slow smokiness of the down-tempo tracks.

From the first note to the last, this is a pleasure to listen to. Not too clever, not too simple, but just right on mood.



VARIOUS  
**CLUBLAND**  
 TELSTAR TCD2912

My customary reaction to compilation CDs called things like 'Clubland' on labels like Telstar is "Oh dear". But

then we're all wrong sometimes. There are 34 tracks drawn from a broad musical range, with a few fillers. Oh, and the lettering on the inside sleeve is rather groovy, which is nice.

As I said, the strength here is in the ground covered. OK, it's all Housey Housey, but they've done better on the track listing front than many big label compos.

You've got the big hits - Sash!'s 'Encore Une Fois', Olive's 'You're Not Alone', BBE's 'Flash' and Rosie Gaines' 'Closer Than Close'. Then there are the small scale chart hits - Sneaker Pimps' '6 Underground', Casino's 'Sound Of Eden', Red 5's 'I Love You... Stop' and The Space Brothers' 'Shine'. Nice. Add to that the dream House of Disco Citizens' 'Footprint', Candi Staton and Robert Owens' re-releases, some Funky Green Dogs, Basement Jaxx and the big beaty coolness of Slacker's 'Scared', and you're on the way to a very fine review of House from the last few months.

Of course, there's always going to be one or two aberrations on a 34-track CD. There's a below-par mix of The Fugees and DJ Prof-X-Or, who's made a career out of creating awful mixes from his Seventies' back catalogue. And personally, I don't believe Lisa Stansfield will ever sound cool, even if she does blueprint her remixes on those of Tori Amos.

Still, very nice indeed.

**dance & ambient record of the month**

VARIOUS  
**MINISTRY OF SOUND -  
 CLASSICS**  
 MINISTRY OF SOUND CLACD1

Ministry Of Sound surge forward once again, barely getting sips of tea in between prolific album releases. However, I think if I'm not careful, 'prolific' may become synonymous with 'arse'. It's not that I have a personal vendetta or any kind of bias - hey, I'm a pretty open-minded kinda guy. It's just that with every MOS release at the moment I seem to have some little grudge or whinge against it.

So what are we up against this time around? Well, a pretty fine double CD actually. Over the two discs you get a range of MOS sanctioned classic tracks (the name gives it all away really). And joy of joys, there's Mr Judge Jules, that radio-friendly sweetie pie and DJ, causing people to salivate as soon as Disc One kicks in.

So what kind of flavour are we talking here? Well, that's the magic. Jules cuts across the House spectrum to pull together star tracks from a glittering firmament. Jam & Spoon's 'Stella' melts into those much imitated kickdrums of Joey Beltram's 'Energy Flash'. Then Armand van Helden offers up his own 'Witchdoctor' before wee Jules skips sideways to take in



Aftershock's 'Slave To The Vibe'. And slapped on top is the nostalgia of DJ Duke's 'Blow Your Whistle', MD X-Press' 'God Made Me Phunky' (note retro spelling) and Ce Ce Penniston's anthem 'Finally'. Nice.

Now you've got the idea. CD Two offers up a couple of obvious but necessary additions - A Guy Called Gerald's 'Voodoo Ray', Lil' Louis' 'French Kiss', Nightcrawlers' 'Push The Feeling On' and Clivilles and Cole's emotion-fest 'A Deeper Love'. Then for the finale Jules goes all Indie-Dance on us with 'Progen' from the funky-trousered Shamen and the Stone Roses' 'Fool's Gold'.

And petty whinges? No. Minor gripes at musical contents? No. Lack of value for money? No. Opportunistic marketing? Well, maybe. Or perhaps everyone really is gagging for another nostalgia-fest in the wake of Biology and The Hacienda getting in on the act. Just a thought ★

THE  
NEW

# C.A.T. SL1 SIGNATURE

MK2 PRE-AMPLIFIER

is Here

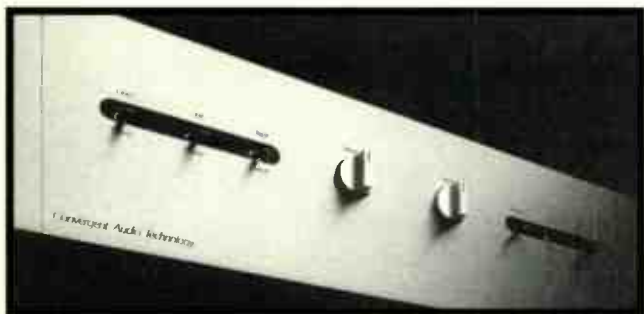

## The Convergent Audio Technology

SL1 has been the worlds No.1. Pre- amplifier for the last 10 years.

The New SL1Signature Mk11 takes performance to new heights

*"There is no alternative"*

Call us now for your nearest dealer

## AUDIO REFERENCE

Distributors of : Graham Tonearms, Transfiguration Cartridges and Magnum Dynalab Tuners  
Telephone 01483- 575344 or Fax 01483- 301412



## ORANGES & LEMONS

Juicy fruit from London's freshest hi-fi / home cinema retailer.

Free home installation + credit cards,

**0% credit finance available**

**(subject to status).**

ARCAM, B&W, CABLETALK, CHORD CO, DENON, EPOS, KEF, MARANTZ, MICROMEGA, NAD, NAIM, NEAT, QUAD, REGA, ROKSAN, ROTEL, ROYD, RUARK, SOUNDSTYLE, STANDS UNIQUE, YAMAHA

Now in our third tangy year

*THE INNOVATIVE*

*AUDIO RETAILER*

0171-924 2040

61/63 WEBBS ROAD, CLAPHAM, SW11

## p l a t f o r m p r o d u c t s

Diamond Polished Plinths for Turntables, CD Players & Amps

# THE TALOS™

*isolation platform*

THE TALOS INVASION IS HERE!

THE TALOS is the best isolation platform you can buy.



Incredible soundstaging, focusing, and stability is brought about by its massive 15kg solid granite plinth.

The Talos is the key to unlock the hidden depths of your hi-fi.

Ask yourself, whats missing ? £165 for a standard 14"x18.75" Talos

Currently over 2225 Talos Sold. Also Available Talos Reference & Speaker Platforms



"The Talos Standard"  
Treat your source to a rock solid foundation

Tel/Fax 01285 862002 for colour brochure and order form

Coming Soon

The Talos Super Stand ( 3-5 Shelf Multi Levelling Granite Hi-Fi Racks)

Platform Products, Unit R, The Old Brickyard, Ashton Keynes Swindon, Wilts SN6 6QR  
It's So Good, It's Scary.

## THE listening rooms

SALE NOW ON.	RRP	SALE	
<b>CD PLAYERS</b>			
PIONEER PDS904 CD	299.00	149.00	D
QUAD 77 CD (BUS)	595.00	416.00	D
THETA DATA CD/LD TRANSPORT	3290.00	1699.00	D
QUAD 66 CD	-	150.00	
MERIDIAN 606 DAC	-	295.00	S/H
MICROMEGA STAGE ONE	549.99	379.00	D
MICROMEGA STAGE TWO	699.99	459.00	D
MERIDIAN 207	-	295.00	S/H
MERIDIAN 203 DAC	-	195.00	S/H
AUDIO RESEARCH LS3 PRE	1997.00	1095.00	D
TRICHOORD PULSAR I DAC	1395.00	895.00	
MERIDIAN 506 18 BIT	995.00	695.00	
MERIDIAN 500 TRANSPORT	1245.00	875.00	
<b>AMPS</b>			
QUAD 77 INT	650.00	455.00	D/N
QUAD 77 PREAMP INC REMOTE	849.95	595.00	D
QUAD 77 POWER AMP	599.00	420.00	D
MUSICAL FIDELITY PRE 3A	-	99.00	S/H
MUSICAL FIDELITY P150	-	120.00	S/H
HARMON KARDON AVR30	-	-	
PRO LOGIC RECEIVER	1000.00	750.00	D
BEARD P50 PWR AMP	-	395.00	S/H
MOD. SQUAD DE-LUXE	995.00	295.00	S/H
AURA AU100 AMP	350.00	219.00	D
ANGSTROM HOME THEATRE DIRECTOR	3495.00	2200.00	D
<b>LOUDSPEAKERS</b>			
QUAD 101L CHERRY	595.00	416.00	D
MISSION 754 OAK	1498.00	999.00	D
B&W 805	995.00	646.00	D
B&W DM305	349.00	249.00	D
KEF CODA 9	299.00	219.00	D
EPOS ES22	1185.00	999.00	D
MONITOR PMC 703	799.90	649.00	D
APOGEE CENTAUR	-	795.00	D
TANNOY D500	1500.00	850.00	D
TANNOY 637	499.90	349.90	D
TANNOY 636	419.90	295.00	D
LINN KABERS	-	1000.00	D
<b>TUNERS</b>			
QUAD 77 TUNER	699.90	499.00	
AURA TU50	259.90	179.00	D

D=ExDem S/H=Second Hand N=New

161 OLD BROMPTON ROAD, LONDON, SW5 0LJ  
TEL: 0171-244 7750 / 59 FAX: 0171 370 0192



# Jazz

Simon Hopkins

jazz record reviews



DEREK BAILEY/PAT METHENY/GREGG BENDIAN/PAUL WERTICO  
**THE SIGN OF 4**  
KNITTING FACTORY WORKS KFW197

Well, on the face of it this has to be one of the unlikeliest Jazz records of 1997, and unless Lee Ritenour teams up with Sonic Youth later this year, *The Sign of 4* is likely to remain that way.

I've gone on at length here in the past about British improvising guitarist Derek Bailey, and of late Pat Metheny has turned up in this column with surprising regularity.

Bailey is a legitimate musical phenomenon. A key player in the small but influential British Jazz avant-garde of the '60s, he has spent the 30 years since resolutely not selling out, treading his own, highly individual path. Along the way he's organised regular Free Music festivals, written an extensive history of the practice of improvisation in many areas of the world's musics, run a highly influential independent record company and, of course, developed one of the most singular guitar techniques on the planet, a technique which has gradually earned him a loyal if highly disparate following.

But what's truly remarkable about Bailey is the renaissance he's enjoyed over the last couple of years or so. Now in his mid-60s, he has recently recorded what are not just among the most astonishing records of his own career, but some of the landmark albums of the decade. *Arcana's The Last Wave* saw him alongside bassist Bill Laswell and the late, great Jazz drummer Tony Williams - one of the finest examples of a true power trio ever. He has recorded with Japanese prog-Rockers Ruins (and for that matter, performed with them in London very recently as I write - one of the shows of this hack's life). And on *Guitar, Drums and Bass* he pitted his guitar against Jungle break beats - essentially an extension of his home improvisations to North London pirate radio stations - and turned in one of the most lauded albums of 1996.

Not bad for a musician who, when asked by *The Wire* magazine for his take on 1996, replied that he was still trying to figure out 1956. At a time when any minor tweaking of musical practice is heralded as a major stylistic innovation, Bailey remains a genuine ground breaker.

American guitar player Pat Metheny, of course, is a very different matter, but is also, in his own way, very much a phenomenon. Probably the most bankable Jazz musician alive, he has maintained an improbable balance between, on one hand, a large, adoring international audience, won over by a 20-year succession of highly accessible, lushly orchestrated group recordings, and, on the other, a series of adventurous live and recorded projects which has more seriously addressed his love of both Hard Bop and Free Jazz.

Unlikely as it may be, *The Sign of 4* brings together Bailey and Metheny

with percussionists Gregg Bendian and Paul Wertico (a regular member of Metheny's group for over a decade). A reasonably priced triple CD, the package presents two shows performed last December by the quartet at New York's famed home of New Music, The Knitting Factory, and studio sessions recorded over two days around the same time. It's to the Knitting Factory's own imprint that we owe the release of this record, and all respect to them for pulling off what I imagine was a tricky business proposition.

This is, in many ways, a meeting of two very different worlds. Metheny, renowned for his championing of guitar synthesisers, obviously brought to the live shows a lot of electronics. Bailey brought his electric guitar and maybe a wah-wah pedal.

No matter. Metheny's trademark lush ambience is nowhere to be heard here. Instead, he produces a vast canvas of constantly shape-shifting sounds through which Bailey improvises some of the most hair-raising music of his career. Wertico and Bendian, too, perform some of the most adept, sensitive percussion I've heard of late, turning from clattering drum mayhem to spindly, angular textures on a vast array of tuned and non-tuned percussion.

In a perfect world, a whole army of Metheny fans would be won over by this record and the critical fringes who normally support Bailey vigorously would put aside their prejudices about the younger musician. But then in a perfect world this group would have a weekly residency in my local. Until Utopia arrives, we have *The Sign of 4*, which I can't see being surpassed - in quality or invention - by any Jazz record this year ●

# Simon Cooke

# Jazz

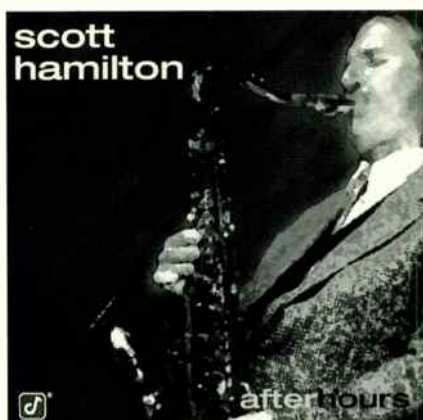

SCOTT HAMILTON  
**AFTER HOURS**  
CCD-4755-2

Scott Hamilton is back on Concord, although the consistent pace of his new releases renders the concept of him ever having been away somewhat laughable. This time the release also features Tommy Flanagan on piano, Bob Cranshaw on bass and Lewis Nash on drums, and is recorded with Concord's usual panache, emotion and space in abundance.

The CD consists of ten tracks including Flanagan's own 'Beyond The Bluebird', Gillespie's 'Woody 'n' You', Carter's 'Blues In My Heart', and Parker's 'Steeplechase'.

Some time ago I commented on the lack of sparkle in Hamilton's recent playing when compared to his earlier releases. I felt that he was settling into a routine - a rut - and perhaps losing some of his style and charm. He then comprehensively demonstrated otherwise in his last release and continues in this vein with *After Hours*. Having also seen him play live a short time ago I can confidently report that, while the set was perhaps not up to the standards of some I have seen him play, Hamilton is still as surprising and interesting a player as ever.

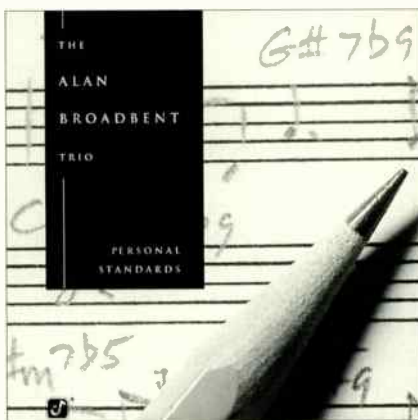

THE ALAN BROADBENT TRIO  
**PERSONAL STANDARDS**  
CCD-4752-2

Another Concord release, this one puts the clarity of the label's recording technique at the disposal of Alan Broadbent.

Here, Broadbent fronts a simple trio with Putter Smith on bass and Joe Labarbera on drums. This kind of soft, even sound seems to translate to CD almost as well as a solo performance. It would take an extremely critical ear and a top-flight hi-fi to find fault with this recording in my opinion.

For your money you get nine tracks, eight of which are written by Broadbent and one by bassist Smith.

Broadbent's work is presented without the perspective of chronology or theme, simply as an insight into the music of a composer who gestates his art slowly, producing (in his words) one or two tunes in a year, at most. This does not, when listening to the tunes, come across as a struggle but more of a gentle maturing into a modernist mainstream mould, rather like the ageing of a good wine. This may be a rather worn simile to use, but it does serve to counterpoint the fact that the music is fresh, vibrant, and heartily recommended.



GARY BURTON AND FRIENDS  
**DEPARTURE**  
CCD-4749-2

Last, but far from least, comes an offering from vibraphonist Gary Burton. With this album there is a slight feeling of *deja vu*. Is it me or is there a tendency for vibraphonists in particular to use that '... and Friends' suffix when coming up with their album's title? Surely professional musicians are the kind of people who turn up to record CDs like this in a studio session, while friends are those you jam with after a few beers in the back room just to see what kind of spontaneous sound evolves?

Titular quibbles aside, *Departure* has musical substance in the form of Burton's vibes, Peter Erskine's drums, Fred Hersch's piano, John Schofield's guitar and John Patitucci's bass. Together they run expertly through ten tracks including Silver's 'Ecaroh', Wells/Torme's 'Born To Be Blue', Coreia's 'Japanese Waltz' and Phinnessee/Miller's 'Tossed Salads And Scrambled Eggs', which is enjoying something of a renaissance as the theme from *Frasier*.

Well played, well recorded, and well recommended if you're a fan of the vibraphone.



## AVON

**AUDIO EXCELLENCE** 65 Park Street, Bristol. Tel: (0117) 9264975 All that's best in Hi-Fi carefully selected and demonstrated by friendly knowledgeable staff, at prices to suit all budgets. Delivery and installation, home dems, part exchange, in-house workshops, full credit facilities with interest free on selected items. Tues-Sat 9.00-5.30. Closed Monday.

**AUDIO EXCELLENCE** 65 Park Street, Bristol BS1 5PB. Tel: 01179 264975 Fax: 01179 251327. All that's best in hi-fi carefully selected and demonstrated by friendly knowledgeable staff, at prices to suit all budgets. Delivery and installation, home dems, part exchange, in-house workshops, full credit facilities with interest free on selected items. Tuesday - Saturday 9.00 - 5.30. Closed Monday.

**THE RIGHT NOTE** Tel: (01225) 874726. Give your ears a new reference point for the best sounds at any price. Forget reviews and trying to put together a system like a patchwork quilt with the "best" bits around. It's our job to do the assessing, you judge the results. Come here, or we'll come to you, and plan a system for the future, even if you spread the purchases. Leave "upgrade-itis" behind, save money and enjoy music. Just listen, and you'll know. Ask also about our ex-dem and mint used items if you must! Our credentials - CD: Accurus, Audio Synthesis, Classé, Enlightened Audio Design, Meracus, Orelle, Wadia, XTC. Vinyl: Basis, Graham, Mitchell, Sumiko. Amps: Arcam, Audio Sculpture, CAT, Classé, DNM, Kora, Lumley, Meracus, Mitchell, Orelle, Sirius, Sonneteer, XTC. Speakers: Audio Aristry, Audio Physic, Ethos, Harbeth, Lumley, Magneplanar, Mirage, NEAT, Spondor, Totem. Tuners: Fanfare, Magnum Dynalab. Cables: Chord, DNM, Silver Sounds, SonicLink, Tice

## BEDFORDSHIRE

**RICHARD'S AUDIO VISUAL** 4 Greyfriars Bedford. Tel: 01234 365165. Stockists of: Arcam, Audioquest, Beyer, B&W, Bose, Cable Talk, Celestion, Cyrus Denon, Heybrook, Marantz, Mission, Moth, Nakamichi, Ortofon, Pioneer, Pro-Ject, Quad, REL, Rotel, Royd, Ruark, Sennheiser, Sound Style, Systemdek, Target, Teac, Thorens, van den Hul & more! Expert friendly service • Listening room. Pioneer Reference Point. Visa / Access.

## BERKSHIRE

**AUDIO T** 4 Queens Walk, Broad Street Mall, Reading. (0118) 958-5463. Great Value on Acoustic Energy, Arcam, Audioblab, B&W, Cyrus, Denon, Dynaudio, Linn, Marantz, Micromega, Mission, Naim, Nakamichi, Quad, Rega, Rotel, Royd, Trichord Research, Yamaha & many more. Tues-Sat 9.30-5.30. 3 year Hi-Fi guarantee. Free delivery & installation. 30 day free upgrades. Home demonstrations. PX. Selected Interest Free Credit. Listening room. BADA Bonded.

**J & A HI-FI CENTRE**, 85 Boutport St., Barnstaple. Tel: (01271) 24384. Open Mon-Sat 9.00 to 5.30. Arcam, Atacama, B&W, Cable Talk, Castle, JVC, Sony, NAD, Marantz, Tannoy, Yamaha, Sonneteer, Target. Private listening room for Hi-Fi and Surround Sound. Also large selection of Video Camcorder and editing equipment. Expert advice in a quiet relaxed atmosphere.

**J & A CAMERAS Ltd.**, Gammon Walk, Barnstaple. Tel: (01271) 75037 and 53 Mill St., Bideford. Tel: (01237) 421791. Open Mon-Sat 9.00 to 5.30. All major brands of cameras, lenses and equipment stocked. Large darkroom section. Slide projectors, digital cameras and scanner. Probably the most comprehensive range in the South West of England

**SEVENOAKS HI-FI** 3 & 4 Kingswalk, Reading. 0118 959 7768. Open Mon-Sat 9.30am-5.30pm. Acoustic energy, aiwa, akai, Alphason, Arcam, Atacama, Audioblab, B&W, Cable Talk, Castle, Denon, Ferguson, Harman Kardon, Kef, Kef Reference, Kenwood, Marantz, NAD, QED, REL, Sony, Teac, Yamaha and many more.

## BUCKINGHAMSHIRE

**HAZLEMERE AUDIO CONSULTANTS** To hear how realistic music can sound please call for an appointment (day or evening). Objective advice, comfortable listening, home demonstrations, free installation, part exchange, repairs and superb service. Acoustic Precision, Air tangent, ATC, Audiomeca, Basis, Classe, EAD, Fanfare, Henley, Magnaplanar, Mirage, Monrio, Mute, Nottingham Analogue, Opera, Ortofon, SD, Sirius, Straightwire, Trice, Triangle, Trilogy, VPI. Based in High Wycombe. Please call: 01494 437892.

**TECHNO SOUND/ AUDIO INSIGHT** 7 Granville Square, Wilen, Milton Keynes, MK15 9JL. Tel: (01908) 604949. Audiophile Hi-Fi and Home Cinema Specialists. All major brands stocked from Arcam to Yamaha. Meridian Digital Home Theatre dealer. Custom home cinema and multi room installation. 4 dem rooms and expert advice. Audiophile CDs, LPs and LaserDiscs to buy. Open late on Fridays.

**NORTHWOOD AUDIO** 98 Cambridge St, Aylesbury, Bucks HP20 1BA. Tel: 01296 28790. Selected sounds from Acoustic Energy, Alchemist,

Arion, Audio Meca, Audio Note, Aura, Boston, B & W, Cabeltalk, Castle, Celestion, DNM Virtual Reality, Denon, DPA, Epos, Exposure, Gyrodek, Harman Kardon, Heybrook, Kef, Marantz, Micromega, Monitor Audio, Moth, Musical Technology, Myrrad, NAD, Nakamichi, Neat, Pioneer, Proac, Rega, Rel, Rose, Rotel, Royd, Ruark, Spondor, Systemdek, Tannoy, Teac, Talk Electronics, Thorens, TDL, Triangle, Tube Technology and a range of quality pre-used equipment. Export orders welcome. 2 Dem rooms. Credit facilities available.

## CAMBRIDGESHIRE

**THE AUDIO FILE** 41 Victoria Road, Cambridge. Tel: 01223 68305. 'For the best in British Hi-Fi and Home cinema entertainment'. Visit or call to arrange a dem with products from: Audioblab Arcam, Mission, Linn, Naim, Rega, Cyrus, Absolute Sounds, Kef, Sony, Yamaha, Rel, Quad, Ruark, Denon.

**AUDIO VISION** 228 Lincoln Road, Millfield, Peterborough, PE1 2NE. Tel: 01733 352752. B&W, Beyer, Cabeltalk, Exposure, Grado, Harmon Kardon, JVC, Marantz, Micromega, Mordaunt Short, NAD, Pioneer, Projects, QED, Rel, Ruark, soundstyle, Tannoy, Teac, TDL and more. All major credit cards accepted. finance arranged. demonstration facilities, open 9.30 - 5.30 Monday - Saturday

**THE HI-FI COMPANY PETERBOROUGH** The region's largest range of enthusiast hi-fi. Arcam, Audioblab, B&W, Cyrus, Denon, Kef, Kenwood, Krell, Marantz, Martin Logan, M&K, Meridian, Mission, NAD, NAIM, Pioneer, Quad, REL, Rotel, Yamaha and many more. Excellent hi-fi and A/V demonstration facilities. Part exchange welcome. Huge selection of top quality, carefully used equipment, telephone for mailing list. 35-42 COWGATE, Peterborough. Phone: (01733) 341755 Fax: (01733) 358141.

**UNIVERSITY AUDIO** 1-2 Peas Hill, Cambridge. 01223 354237. Mission-Cyrus, Arcam, Rotel, Denon, Meridian, Ruark, ATC, AVI, Quad, Linn. £ dems, 1 single speaker. Home trial, free install, Service Dept. VISA, ACCESS, AMEX. Credit Terms. Open 9-5.30

## CHESHIRE

**ACOUSTICA** 17 Hoole Rd., Chester CH2 3NH Tel: 01244 344227. All that's best in hi-Fi from Epos, KEF, Teac, Royd, Linn, Rega, Naim, Arcam, Audioblab, Ruark, Rotel and many more. Multi room systems from Linn Kneks. Superb demonstration facilities, home demonstrations and installation a pleasure. We offer the best products, the best service and the best sounds. Open Tuesday to Saturday, evenings by appointment.

**THE AUDIO COUNSEL** 14 Stockport Road, Cheadle, Cheshire. Tel: (0161) 428 7887 and 12 Shaw Road, Oldham, Manchester OL1 3JQ Tel: (0161) 633 2602. Linn, Arcam, Naim, Audio Research, Martin Logan, Yamaha, Creek, Nakamichi, denon, JPW, Marantz, Royd, Lexicon. 3 dem rooms, free install. VISA/ACCESS Full multi-room and A.V. installation 10:00 - 5:30pm Mon-Sat, till 8:00 Thursdays.

**AUDIO EXCELLENCE** 86/90 Boughton, Chester, CH3 5AQ. Tel: 01244 345576. All that's best in hi-fi carefully selected and demonstrated by friendly knowledgeable staff, at prices to suit all budgets. Delivery and installation, home dems, part exchange, in house workshops, full credit facilities with interest free on selected items. Tuesday - Saturday 9.00 - 5.30. Closed Monday

**CHRIS BROOKS AUDIO** 29 Gaskell Street, Stockton Heath, Warrington, Cheshire, WA4 2UN. Tel: (01925) 261212. Tues-Sat 10.00-6.00. 2 dem rooms. credit facilities. All credit cards. Established 1978. Total absence of bulls\*\*t. Linn Specialist.

**DOUG BRADY HI-FI** Kingsway Studios, Kingsway North, Warrington, WA1 3NU Tel: 01925 828009 Fax 01925 825773. Visa, Mastercard, Lombard Tricity. 2 dem rooms, home trial; Agencies include: Arcam, Audioblab, Castle, Chord Electronics, DPA, Exposure, Harbeth, Heybrook, Krell, LFD, Mitchell, Mission, Naim, Orelle, Origin Live, Pink Triangle, ProAc, Roksan, SME, Spondor, Wilson Benesch and many more.

**PRACTICAL HI-FI** 88 Bridge Street, Warrington, WA1 2RF. Tel: 01925 632179. See our main entry under Preston, Lancs.

**REPLAY AUDIO CONSULTANTS** Tel/Fax Chester (01244) 401290. Cheshire's alternative hi-fi specialists. Honest advice and personal service. We can demonstrate Alchemist, AVI, Henly, Heybrook, LFD, Mitchell, Moth, Musical Fidelity, NAD, Neat, Origin Live, Ortofon, Pink Triangle, Royd, Sonneteer, Totem, Trichord. Demonstrations by appointment in Chester or in your own home. Delivery & installation available. Mastercard, Visa, Swtch, Delta

**SWIFT HI-FI** St. Annes Parade, Wilmslow. 01625 526213. Aura, B&W, Denon, Kenwood, Marantz, Nad, Pioneer, Rotel, Systemdek, Tannoy, Revolver, J.P.W., M. Short, Mission, Celestion, Technics, Audioblab, Castle. Open 9.30-6. Dem rooms. No pressure. BADA member.

## CLEVELAND

**ACTION ACOUSTICS** 155-157 High St., Redcar, Cleveland TS10 3AN. 01642 480723. Audio Innovations, Audio Note, Denon, Harman Kardon, JBL, Michell, Musical Fidelity, Pink Triangle, Rogers, Sugden, SonicLink, Townsend, TDL, Thorens etc. Dem room appointment nec. Home Trial, Free installation, service dept. Int. free credit facility. Access, Visa & HP. Open 9.15-5.30

## CORNWALL

**SOUNDS PERFECTION** 'Cornwalls most exclusive audio retailer'. Agencies include: Audiomecca, Analysis, Audio Spectrum, Audionote, Cadence, Harmon Kardon, Impulse, Konnekt Cables, Michell, Ortofon, Parasound, Project, Phylosophy Cables, Rel and SME. Home Demonstrations by Appointment. Tel/Fax. 01326 221372 Mobile 0468 754353

## CUMBRIA

**MISONS SOUND & VISION** Viaduct House, Victoria Viaduct, Carlisle, CA3 8AN. Tel: (01228) 22620. Exposure, Heybrook, Aura, Bang & Olufsen, B & W, Castle, NAD, Quad, Rotel, Sony, Sugden, Yamaha, Demo Suite. No appts nec. Home trial facilities. Free installation. Service Department Mon - Sat, 9 - 5.30

**PETER TYSON** 6 Abbey Street, Carlisle, Cumbria, CA3 8TX. 'Cumbria's premiere hi-fi centre'. Part exchange welcome. (01228) 46756. Audioblab, Linn, Mission, Pioneer, Marantz, Denon, Philips., Technics and more. Dem Rooms. Dems without obligation. Home trial. Free installation. In-house service dept. Access, Visa, HP. 9-5.30pm

**PRACTICAL HI-FI** 106 English Street, Carlisle, CA3 8ND Tel: 01228 44792 See our main entry under Lancaster.

## DEVON

**AUDIO EXCELLENCE** 156 Sidwell Street, Exeter EX4 6RT. Tel: (01392) 491194 All that's best in Hi-Fi carefully selected and demonstrated by friendly knowledgeable staff, at prices to suit all budgets. Delivery and installation, home dems, part exchange, in-house workshops, full credit facilities with interest free on selected items. Tues-Sat 9.00-5.30. Closed Monday.

**CHELSTON HI-FI** 38 Walnut Road, Chelston, Torquay, Devon. TQ2 6HS. Tel: (01803) 606863 Where you can compare a range including Acoustic Energy, Bose, Castle, Celestion, Creek, Denon, Heybrook, JPW, Kenwood, Marantz, Musical Fidelity, Pioneer, Rotel, Sony ect. Two dem rooms (including AV room 25 x 18ft). Free installation. Free delivery up to 15 miles. Access, Visa, Amex, Diners, Credit facilities. 9.30-7.30. Mon-Fri. 9.30-6.00 Sat.

**THE HI-FI ATTIC** 58 New George St., Plymouth, Devon. PL1 1RR. 01752 669511. We stock most leading brands including Linn, Arcam, Denon, Pioneer, Musical Fidelity amongst others, and have an expert enthusiastic staff. Premises include attractive hi-fi and home cinema demonstration rooms. We offer free installation and credit facilities (written details on request) also a fully equipped service department. We can also provide a mail order service for all your LaserDisc requirements. We accept Visa, Access, Amex.

**J & A CAMERAS Ltd.**, Gammon Walk, Barnstaple. Tel: (01271) 75037 and 53 Mill St., Bideford. Tel: (01237) 421791. Open Mon-Sat 9.00 to 5.30. All major brands of cameras, lenses and equipment stocked. Large darkroom section. Slide projectors, digital cameras and scanners. Probably the most comprehensive range in the South West of England.

**J & A HI-FI CENTRE**, 85 Boutport St., Barnstaple. Tel: (01271) 24384. Open Mon-Sat 9.00 to 5.30. Arcam, Atacama, B & W, Cable Talk, Castle, JVC, Sony, NAD, Marantz, Tannoy, Yamaha, Sonneteer, Target. Private listening room for Hi-Fi and Surround Sound. Also large selection of Video Camcorder and editing equipment. Expert advice in a quiet relaxed atmosphere.

## DORSET

**MOVEMENT AUDIO** 588 Ashley Road, Poole, Parkstone, Dorset BH14 0AQ. Tel: (01202) 730865. Arcam, Audioblab, B&W, Castle, Cyrus, Denon, KEF, Marantz, Meridian, Michell, Micromega, Pioneer, Ruark, Shearpe Audio. 2 Dem rooms. Listen to the available choice and decide at your leisure - no pressure, no obligation. Our staff enjoy music, with our choice of products, you can too! Service Department. Free installation. Home trial facilities. Access, Visa, Amex, Diners Card. Credit facilities available. Open Mon-Fri 10-6. Sat 9-6

**MOVEMENT AUDIO** 336 Wimborne Road, Winton, Bournemouth, Dorset. BH9 2HH. Tel: (01202) 529988/520066 Arcam, B&W, Denon, KEF, Marantz, Meridian, Mission, Pioneer, Sony, Yamaha. Full dem facilities available, also home dem. Friendly expert advice. Service Department. Free installation. Home trial facilities. Access, Visa, Amex. Open Mon-Fri 9-5.30

**DAWSONS OF WESTBOURNE** Home Cinema Specialists. Main agents for Bang & Olufsen, Harman Kardon, JBL, REL, Mordaunt Short, Sony, Technics and TDL. Demonstration facilities include our unique Dolby pro-logic system comparator for the ultimate way to choose the perfect system. Also on demonstration large screen televisions from Thomson, Sony and Ferguson with video projectors from Sharp and Seleo. Dawson's, 23 Seamore Road, Westbourne, Bournemouth 01202 764965

**SUTTONS HI-FI** 18 Westover Road, Bournemouth. Tel: (01202) 555512. Linn, Arcam mission, Quad, Audioblab, Rotel, Yamaha, Denon ect 2 siingie Speaker Listening Rooms. Home Demonstrations. Free Installation. Open Mon-Sat 9-5.30. Call for details.

**WEYMOUTH HI-FI** 33-35 Maiden Street, Weymouth, Dorset DT4 8BA. Tel: (01305) 785729. Arcam, Aura, B&W, Denon, Kenwood, Marantz, Micromega, Musical Fidelity, Panasonic, Quad, Sony, Technica, Yamaha. Dem room. Friendly professional advice. Only quality hi-fi dealer in Weymouth area. Service Department. Free installation. Home trial facilities. Access, Visa, Amex. Switch, Delta Mastercard. Interest free credit. Instant credit. Open Mon-Fri 9.30-5.30 Sat - 9.30-5.30

## ESSEX

**AUDIO T** 442-444 Cranbrook Road, Gants Hill, Ilford. (0181) 518-0915. Great Value on Acoustic Energy, Arcam, Audioblab, B&W, Cyrus, Denon, Jamo, KEF, Linn, Marantz, Mission, Micromega, Monitor Audio, NAD, Quad, Rotel, Technics, Trichord Research, Yamaha & more. Tues/Thurs/Fri 10-7. Wed/Sat 9.30-5.30. 3 year Hi-Fi guarantee. 30 day free upgrades. PX. Selected Interest Free Credit. 2 Listening rooms. BADA Bonded.

**GRAYSTON SOUND & VISION** 33 Sir Isaac's Walk, Colchester. (01206) 675682. Akai, Arcam, B&W, Boston Acoustics, Denon, Grundig, Infinity, KEF, Linn, Loewe Opta, Meridian, Nokia, Philips, Pioneer, Quad, Rotel, Ruark, Sennheiser, Spondor, Thorens. Superb demo rooms, free regional delivery and installation. Regular musical and surround evenings, home demonstrations. Excellent credit facilities.

## GLOUCESTERSHIRE

**AUDIO EXCELLENCE** 58 Bristol Road, Gloucester, GL1 5SD. Tel: 01452 300046 Fax: 01452 310680. All that's best in hi-fi carefully selected and demonstrated by friendly knowledgeable staff, at prices to suit all budgets. Delivery and installation, home dems, part exchange, in house workshops, full credit facilities with interest free on selected items. Tuesday - Saturday 9.00 - 5.30. Closed Monday.

**AUDIO T** 40-42 Albion Street, Cheltenham. (01242) 583960. Great Value on Acoustic Energy, Arcam, Audioblab, Denon, Dynaudio, KEF, Linn, Marantz, Meridian, Micromega, Mission, NAD, Nakamichi, Naim, Pioneer, Quad, Rotel, Technics, Trichord Research, Yamaha & many more. Tues-Fri 9.30-6. Sat 9.30-5.30. 3 year Hi-Fi guarantee. 30 day free upgrades. Home demonstrations. Part exchange. Selected Interest Free Credit. Listening room. BADA Bonded.

**THE RIGHT NOTE - BATH** for specialist advice and home demonstrations. See Avon.

## HAMPSHIRE

**AUDIO GALLERY** Nr Petersfield Hampshire 01730-895194 Valve Specialists on a superior level. Home dem. For Opening hours and appointments please ring 9.30am-7pm.

**AUDIO T** 4 Feathers Lane, Basingstoke. (01256) 24311. Great Value on Acoustic Energy, Arcam, Audioblab, Cyrus, Denon, Dynaudio, Linn, Marantz, Micromega, Mission, Naim, NAD, Nakamichi, Quad, Royd, Rotel, Technics, Trichord Research, Yamaha & many more. Tues-Sat 9.30-5.30. 3 year Hi-Fi guarantee. Free delivery & installation. 30 day free upgrades. Home demonstrations. PX. Selected Interest Free Credit. Listening room. Home Cinema. BADA Bonded.

**HAMPSHIRE AUDIO Ltd.** 2-12 Hursley Road, Chandlers Ford, Hants, SO53 2FU. Tel Southampton (01703) 252827/265232. 3 Hi-Fi and 2 Home Cinema/Dolby Surround Sound Demonstration Rooms, one with Projection TV and an 8' x 6' screen. Brands stocked include ARCAM (incl. Xeta), Audioblab, Audioquest, Celestion, Cyrus, Denon, Gradient, Infinity, KEF, Marantz, Meridian, Mission, Polk, Quad, Rotel, Seleo, Sennheiser, Soundstyle, Tannoy, Target Audio, Thorens, & Yamaha. Established 1969, we offer a 2-year Guarantee covered by our own well-equipped Service Dept. We have a large FREE car parking facility and we are located within 3 miles from Junction 14 (M3/M27 Interchange) and Junctions 13 (M3) and 5 (M27). Closed Mondays, except in December. Late Night: Thurs to 8pm. BADA Founder Member. All deposits fully covered by BADA Bonding.

dia-a-dealer



NOW THATS HI-FI 32 Arundel Street, Portsmouth Tel: (01705) 811230. Pioneer, Yamaha, Marantz, Kenwood, Mission, TDL, REL, Atacama and much more. Laserdisc and AC3 specialists. Accessory center at 24 Arundel Way, Portsmouth. Tel: (01705) 811618

SOUTH COAST SPEAKERS Ltd 326 Portswold Road, Southampton, Hampshire. Tel: 01703 559312. Hand made Loudspeaker Systems! Tailored to your individual tastes. Many real wood veneers. Any colour finish available. U.K. suppliers of Driver Units for: SEAS, VOLT, MORE, VISION, RCL, SCAN-SPEAK & MORE. Home builder kits always on demo. High quality accessories/components, comfortable listening area. ample free parking, friendly advice.

HEREFORDSHIRE

ENGLISH AUDIO 37 Whitecross Road, Hereford, HR4 0DG. (01432) 355081. Arcam, A.T.C., Audiobal, HR4, B&W, Castle, Celestion, Cyrus Centre, Denon, Exposure, KEF, Marantz, Michi, Micromega, Mission, Musical Technology, NAD, Nakamichi, Pink Triangle, Pioneer, REL, Rotel, Ruark, John Shearne, SME, Stax, Systemdek TDL, Yamaha. Single speaker dem room, home trial facilities, free installation, service dept, Access/Visa, Credit arranged. Open Mon-Sat. 9.30-5.30pm. BADA members.

HERTFORDSHIRE

ACOUSTIC ARTS LTD 101 ST. Albans Road, Watford, Herts. Tel: (01923) 245250. Fax: (01923) 230798. Apogee, Audiobal, Audio Research, B&W, Bose, Castle, Celestion, Chord, Classe, Copeland, Denon, KEF, Magneplanar, Marantz, Martin Logan, Michell, Micromega, Orelle, PS Audio, Professional Motor, Roksan, Ruark, SME, Sonus, Faber, Sonic Link, TDL, Theta, Thorens, Wilson. 4 demonstration rooms. Purpose built AV studio. Credit available. 100 yards from Watford Junction station. Open Tues-Sat 10.5-3.0 (Thursday open until 8pm)

THE AUDIO FILE 27 Hockerill Street, Bishops Stortford Herts. Tel: (01279) 506576. Please see main ad under Cambridge

DARBY'S OF ST. ALBANS. 6 Market Place, St Albans, Herts. Tel: (01727) 851596. Herefordshire's premier Hi-Fi/Audio Visual specialists established 1946. Full Home Cinema demonstration suite. Whether your needs are large or small, we stock it all; Arcam, Yamaha, quad, Denon, Musical Fidelity, Sony, Bang & Olufsen, Pioneer, Nokia, REL, JVC, JBL, TDL, KEF, Mission, Ruark, Celestion, Polk, and many more. Free planning service. Free Delivery and basic installation. Full workshop facilities. Open 9-6 Mon-Sat.

HAILEY AUDIO LTD 328 Ware Road, Hailey, Hereford, SG13 7PG. Tel: (01992) 442425. Fax: (01992) 448387. Enjoy choosing your system in one of our three listening rooms. Relax with coffee or something from the bar. Demonstrations include Lexicon CP3 with THX surround sound with the guaranteed deepest, tightest bass available. Choose your hi-fi (top valves and MOSFETS), LD, CDi etc in a realistic domestic environment. Brands include: REL, AC Magnum, CR Devs, Rotel, Celestion, Micromega, Lumley, Reference, Acoustic Energy, royd, JPW, Sonic Link, Harmon etc. We deliver anywhere in the UK for home audition, or mail order. Access. Visa etc.

STUDIO 82 82 High Street, Harpenden, Herts AL5 2SP. 01582 764246. Fax 01582 467022. ATC, AVI, Arcam, Aura, Audiobal, B&O, Bose, Castle, Denon, Marantz, Mission, Musical Technology, NAD, Naim Audio, Quad, Roberts Radio etc. Quiet single speaker dem room. Appts nec. Home trial, Service dept. Visa, Amex. Access and finance terms. 9.5-3.0 Mon-Sat.

HUMBERSIDE

ZEN AUDIO 35 George Street, Hull Tel: 01482 587397. "Comfortable listening rooms: Home dems; Personal, friendly service; Free installations. Agencies include: Arcam, Audiobal, Atacama, Audio Innovations, Audio Note, Audion, Alchemist, B&W, Cable Talk, Chord CO, DPA, Densen, Denon, DNM, EAR, Exposure, Fi-Rax, Harbeth, Heybrook, Impulse, KAR, KEF, Michell, Micromega, Monitor Audio, Musical Technology, Myrrad, NAD, NAIM, Pioneer, REL, Rehdeko, Rotel, Royd, Ruark, Shearne Audio, Stands Unique, Sugden, Spondor, Sonic Link, TEAC, TDL, Tube Technology, Vivanco and many others.

KENT

ASHFORD SOUNDCRAFT HI-FI 40 High Street, Ashford. Seeking music lovers, male or female, any age, to share common interest in musical Pro-aktiv Hi-Fi Systems, Multi Room of Home Cinema. Attractive unusual equipment in unusual setting, your place or ours, we guarantee lasting pleasure. Open Mon-Sat. Appointment Service or just pop in. Tel (01233) 62441

DOVER HI-FI 43 High Street, Dover. Tel: 01304 207562. Suppliers of quality hi-fi equipment including: Arcam, Akai, Aura, B&W, Denon, Jamo, JPW, Mordaunt Short, NAD, Panasonic, ProAc, Quad, Rotel, Ruark, TDL, Technics, Tannoy. Part exchange. Listening room. Service and repairs. Credit facilities. Access/Visa. Open 6 days 9-5.30.

ELECTRICAL DISCOUNT CENTRE 138 Peilham Road Gravesend, Kent DA11 0JH. Tel: 01474 569601. Pioneer, Marantz, Technics, Akai, JVC, Jamo.

ELECTRICAL DISCOUNT CENTRE 109 The Broadway Bexley Heath Kent DA6 7JH. Tel: 0181 298 7880. Pioneer, Marantz, Technics, Akai, JVC, Jamo.

THE LINN STUDIO Sondex LP12\* knekt\* Karik\* Kairn\* Klout\* Kremlin\* Keltik\* Kaber\*Keiledh\* Numerik\* Tukan\* Wakonda\* Majik\* Mimik\* LK100\* Ekos\* Kudos\* Arkiv\* Brilliant\* Lingo\* Yalhalla\* Sekric\* Aktiv\*...Dream systems for everyone from £2,000 to £30,000+. A new dealership from a specialist family business, established in 1948. Outstanding service and facilities. Multi-room specialist. 123 Snargate Street, Dover, Kent. CT17 9AP. Tel: 01304 201525, Fax: 01304 240135.

KIMBERLEY HI-FI 193 Broadway, Bexleyheath, Kent. Tel: 0181 304 3272. Sep dem rooms, Denon, Technics, Kenwood, AiW, NAD, Dual, Wharfedale, Mission, Marantz, Tannoy, Castle, Monitor Audio, Heco, Jamo, Cerwin Vega and many more.

PROGRESSIVE AUDIO 2, Maryland Ct, Rainham, Kent, ME8 8QY. Tel. 01634 389004. Agencies include: Audio Innovations, Audion, Audionote, Audio Mecca, Audio Systems, Audio Stax, Audio Technica, Chord Amps, Cogan Hall, Conrad Johnson, Convergent, Denon, Goldring, Impulse, Koetsu, Levinson, LFD, Lyr, Moch, Nordost, Origin Live, Pink Triangle, Proac, SD Acoustics, Silversounds, SME, Sugden, Sumiko, Systemdek, Snell, Target, TDL, Transfiguration, Townshend, Tube Technology, Unison Research, UKD., Voyd, VPI, etc. Dems by appointment.

V.J. Hi-Fi 29 Guildhall St. Folkstone Kent Tel: 01303-256860. Stockists of: Mission, Tannoy, J.B.L., Pioneer, Philips, Aiwa, Marantz, Musical Fidelity, Quad, Yamaha, Denon and much more besides. Full audio and home cinema demonstration facilities. Fully bonded BADA members. Interest free credit available (subject to status). Open Mon-Sat 9:00-6:00

LANCASHIRE

AUDIO EXCELLENCE 131 Friargate, Preston, Lancs PR1 2EE Tel: (01772) 253057. Fax: (01772) 562731. All that's best in Hi-Fi carefully selected and demonstrated by friendly knowledgeable staff, at prices to suit all budgets. Delivery and installation, home dems, part exchange, in-house workshops, full credit facilities with interest free on selected items. Tues-Sat 9.00-5.30. Closed Monday.

CLEARTONE 235 Blackburn Road (1/2 mile from city center on the A 666 Blackburn Road) Bolton, Lancs BL1 8BH Tel: (01204) 531423. Bolton's biggest Hi-Fi superstore. Every top brand & all the best buys at guaranteed unbeatable prices. Aiwa, Akai, Arcam, Audiobal, B&W, Bose, Castle, Celestion, Denon, Hitachi, Infinity, JBL, JVC, KEF, Kenwood, Marantz, Meridian, Mission, Mordaunt Short, NAD, Panasonic, Pioneer, Rotel, Sony, Tannoy, TDL, Technics, Toshiba, Yamaha. 2 dedicated Hi-Fi Demo rooms and 2 AV Demo rooms, no appointments necessary. Service department, free installation, home trial facilities, free parking, Access, Visa, Amex, Diners. Interest free credit. Open Mon-Wed 10.00-6.00. Thurs-Fri 10.00-7.00. Sat 9.00-6.00. Sun 11.00-5.00

MARTON MUSIC 5 Masterson Ave., Read, Burnley, BB12 7PL. Tel/Fax: (01282) 773198. Hear demonstrations of stereo an AV systems in a large comfortable lounge using MIRAGE dipole speakers and the latest BRYSTON pre/power amps (20 yr guarantee), with YAMAHA DSP surround sound and equipment from AVI, RUARK, MARANTZ, TANNAY, SEQUENCE and more, plus a range of custom built Transmission Line and other speakers. Home demo's encouraged for complete satisfaction. Main agent for LIBERTY INSTRUMENTS AUDIOSUITE loudspeaker testing system, BOXMODEL, TLBOXMODEL and other PC based design packages. Ring anytime for an appointment, free advice or a chat...we never close.

ORPHEUS AUDIO Standish, Lancs Tel: 01257 473175 See our main entry under Greater Manchester.

PRACTICAL HI-FI 43 Friargate, Preston. Tel: 01772 883958. The audio visual specialist, expert advice, instant demonstrations, best prices, instant free credit, part exchange welcome. Extended warranty. Stockists of Yamaha, Kenwood, Denon, Sony, Technics, Onkyo, Marantz, Pioneer, Mission, Kef, Jamo, Celestion, B&W. Also stockists of LaserDiscs.

PRACTICAL HI-FI 84 Penny Street, Lancaster, LA1 1XN Tel: 01524 39657 - See our main entry under Lancaster.

PRACTICAL HI-FI 33/35 Knowsley Street, Bolton, Lancs Tel: 01204 395789 - See our main entry under Lancaster.

PRACTICAL HI-FI 81 Whitegate Drive, Blackpool, FY3 9DA Tel: 01253 300599. See our main entry under Lancaster.

LEICESTERSHIRE

CLASSIQUE SOUNDS "Vintage Hi-Fi Specialist". Stockists of: Garrard 301/401, Thorens, Quad, Leak, Rega, Shirley Labs, Spondor, Wharfedale, Rogers, Arcam, SME, Decca, Pioneer, UKD, Sugden, Musical Fidelity, + much more." Tel/ Fax Paul Greenfield on UK + 0116 283 5821 or 0802 213 740 (mobile) any - time Classeque Sounds, Classique House, 61 Aylestone Drive, Leicester, LE2 8QE.

CYMBIOSIS 6 Hotel Street, Leicester, LE1 5AW. Tel: (0116) 2623754 Fax: (0116) 262 3758. Arcam, Audiobal, Denon, Epos, KEF, Linn Hi-Fi, Linn AVS1, Loewe Televisions, Micromega Classique, Micromega Rega, Mordaunt Short, Myrrad, Projekt Furniture, Stax, Rotel & Royd. Multrroom Design & Installation. Four listening lounges. Finance available. Open 6 days 10am-5.30pm

ENCORE! Mr. Melton Mowbray. Tel. 01664 823282. Sugden, Densen, Unison, Tube Technology, Ruark, UKD Opera, Keswick Audio Research and Fi-Rax. As you can see from our agencies, we are open-minded and able to present diverse options for your appraisal. Unbiased and unhurried demonstrations by appointment incl. evenings and weekends.

LEICESTER HI-FI CO 6 Silver Walk, St Martins Square, Leicester LE1 5EV. Tel: (0116) 2539753. Fax: (0116) 2626097. Alchemist, Arcam, Aura, B&W, Copland, Haran Kardon, KEF, Marantz, Michell, Mission, Cyrus, Musical Fidelity, Pink Triangle, Quad, Roksan, Rotel, Sonus Faber, Technics, Yamaha and more too numerous to mention. 2 Dem room. We can demonstrate, deliver and install. Credit facilities. All cards taken. Open 6 days 9.30-5.30

STEREO SHACK 1-3 Guildhall Lane, Leicester. Tel: (0116) 2530330. Fax: (0116) 2626097. Yamaha, Kenwood, NAD, Mission, Teac, Aiwa, Cerwin Vega, Pioneer, TDL, Thorens, JBL, Rotel, Celestion, Jamo & many more. We are A.V. specialists, 2 dem rooms. We can demonstrate, deliver and install. Credit facilities and all cards taken. Open 6 days 9.30-5.30

LINCOLNSHIRE

COTTAGE AUDIO 17 Bridge Street, Saxilby, Nr Lincoln. LN1 2PZ. Tel: (01522) 702834. Evenings: (01522) 696708. ATC, AVI, Chord amplifiers, Harbeth, LFD, Michell, Origin Live, Kinshaw, QED, Royd, Sansui. Sequence, Something solid, Sonic Link, etc. Demonstration rooms. Home trial facilities. Free installations and above all a personal, friendly service.

STAMFORD HI-FI, 9 Red Lion Square, Stamford, Lincs. PE9 2AJ. Tel: (01780) 62128. Aiwa, Denon, KEF, Kenwood, Marantz, Mission, NAD, Pioneer, Quad, Technics, Yamaha, Plus all major speaker manufacturers. Expert advice and comparator demonstrations, on two floors. Part exchanged hi-fi purchased for cash. No appointments necessary. Home trial facilities, free installation and service dept. Mastercard, Visa and Credit Charge Finance available. Mon - Sat 9.5-3.0 pm. Closed Thursdays.

LONDON

ALPHABET LTD 392 Finchley Road, London, NW2 2HR. Stockists of Bose, Boston, Clifford, Denon, Jamo, JVC, Grundig, KEF, NAD, Onkyo, Panasonic, Sony, Vivanco and Yamaha. Specialists in Multi-Room Installations. Full service facilities. Credit terms available. Open Mon-Sat 10am-6pm. Thurs 10am-1pm. Tel: 0171 431 9133

AUDIO CONCEPT 27 Bond Street, Ealing, W5 SAS. Tel: (0181) 567 8703. Acoustic Energy, Audiobal, Aura, B&O, B&W, Boston Acoustics, Canon, Castle, Denon, Dual, Evolution, Infinity, JPW, KEF, Marantz, Mission, Monitor Audio, Musical Fidelity, NAD, Nakamichi, Onix, Quad, Revox, Rogers, Rotel, Systemdek, Target, Teac, Thorens, Van den Hul. Two dem rooms. Interest free credit, free local delivery & installation, service department. "Hi-Fi Specialists without the attitude"

AUDIO T 190 West End Lane, West Hampstead. (0171) 794-7848. Great Value on Acoustic Energy, Arcam, Audiobal, B&W, Denon, Linn, Marantz, Meridian, Micromega, Mission, NAD, Proac, Quad, Rotel, Technics, Trichord Research, Yamaha & many more. Tues-Sat 10-6 Late Thurs until 8.00. 3 year Hi-Fi guarantee. 30 day free upgrades. Home demonstrations. PX. BADA Bonded.

AUDITORIUM 119 Middlesex Street, Bishopsgate, London E1 7JF. Tel: 0171 247 5000 Fax: 0171 247 0990. Friendly and honest advice on all your hi-fi and multi-room requirements, full range of equipment from Arcam, Bang & Olufsen, Cyrus, Denon, Epos, Kef, Micromega, Mission, Naim, Neat, Ortofon, Rega, Ruark, Shahinian and Xlo. Opening hours: Mon-Fri 10.30am-7.00pm; Sat 11.00am-4.00pm; Only two mins walk from Liverpool Street Station.

BABBER ELECTRONICS SERVICE CENTRE 15B Uxbridge Road, West Ealing, London, W13 8SB Tel: 0181 579 6315 Akai, Aiwa, A&R, Celestion, Dual, Goodmans, Harman Kardon, JBL, JVC, Kenwood, Marantz, Panasonic, Sennheiser, Sony, ES range, Tannoy, Technics, Wharfedale, Yamaha and many more. Auth. Service Dept. Credit Facilities. Open 10.30 - 5.30 Mon-Sat.

BILLY VEE SOUND SYSTEM 248 Lee High Road, Lewisham, London SE13 5PL. Tel: 0181 318 5755/0181 852 1321. Arcam, Denon, Marantz, Linn, Mission, Cyrus, Naim, nakamichi, Quad, Rega, etc. 2 domestic style listening lounges. Appts required, service dept, home trial facilities, Inc. free credit card, instant credit access, Visa. Opened Mon-Sat 10-6.30, Closed Thursday.

CHOICE HI-FI Tel. 0181 392 1959. Specialist dealers in high end quality second-hand equipment. All main brands in stock including Krell, Audio Research, Wadia, Mark Levinson, Sonus Faber, Linn, Naim, SME & many more. Generous price given on trade-in. Part exchange welcome. Also dealers for Trichord, SME, Gamma, Trilogy, Lumley, Boulder & many more.

INFIDELITY 9 High Street, Hampton Wick, Kingston-upon-Thames. Tel: (0181) 943 3530. for full details see entry under SURREY

HIFI EXPERIENCE 227 Tottenham Court Road, London W1. 0171 580 3535. Arcam, Audiobal, Mission, Cyrus, Quad, Celestion, Kef, Meridian, Rogers, Tannoy, Yamaha, TDL, Thorens, Marantz, Nakamichi, Musical Fidelity and many more. Open 10.00-7.00 Mon-Fri. 9-6 on Sat. Service dept. Credit facilities, delivery and free installation.

K J WEST ONE 26 New Cavendish St., London W1M 7LH. 0171 486 8262/63. Fax 0171 487 3452. Two hi-fi & two home cinema dem studios. Appts pref. Home trial. Installation by arrangement. Service dept. Major credit cards. Interest free credit on selected items. Major brands stocked: Arcam, Audio Alchemy, Audion, Audiobal, Audio Research, B&W, Castle, Chord, Copeland, DPA, Epos, Graaf, Harbeth, KEF, Klipsch, Krell, Lexicon, Marantz, Martin Logan, Meridian, Michell, Micromega, Mission, Musical Fidelity, Nitty Gritty, Pink ProAc, Quad, Rel, Rotel, Orelle, Sonus Faber, Stax, Tannoy, Theta, Unison Research, Wilson Benesch. Open 6 days.

THE LISTENING ROOMS 161 Old Brompton Road, London SW5 0LJ. (0171) 244 7750/59. Fax (0171) 370 0192. Linn, Quad, Meridian, Nakamichi, Arcam, Audiobal, Acoustic Energy, SME, Audio Research, Krell, Wadia, Theta, Apogee, Martin Logan, Pioneer, Tannoy, Systemdek, Stax, Pink Triangle, Michell, Monitor Audio, Yamaha, Marantz, Kef, Bose, Celestion, Epos, Mission, Denon, Neat Petite. Mon-Sat 10-6pm.

ORANGES AND LEMONS 61-63 Webbs Road, Batterssea, sw11. Tel: 0171 924 2040. Juicy fruit from London's freshest Hi-Fi / Home Cinema retailer, now in our second year. Telephone demonstrations, or just pop in. All the usual, i.e. friendly and efficient service, free home installation, credit cards, 0% credit finance available (subject to status), plus...all the very best from Arcam, Cable Talk, Castle Acoustics, The Chord Co., Denon, Epos, Kef, Marantz, Micromega, NAD, Naim Audio, Neat, Quad, Rega, Roksan, Rotel, Royd, Ruark, Soundstyle, Stands Unique, Yamaha and more.

THOMAS HEINITZ LTD 35 Moscow Road, Bayswater, London, W2 4AH. Tel: 0171 229 2077. Fax: 0171 727 9348. Nearest tube stations are Queensway and Bayswater. Plenty of parking meters available. Demonstration room available by appointment. Stockists of B&O, NAIM, REGA, Micromega, Cyrus, Denon and Epos. Payment Via, Access, Visa, Cheques, Cash and interest free credit facilities (details on request) Open 10.30am-6.00pm, Tue-Sat.

TIME & TUNE For T.V. video, Hi-Fi, and in-Car Hi-Fi, we are dealers of: Aiwa, Bose, Hitachi, Jamo, Kenwood, Marantz, Mitsubishi, NAD, Panasonic, Pioneer, Sony, Technics. For these and more come and see us at Time & Tune, 218-220 Whitechapel Rd, London, E1 1BJ. Or call 0171 377 2000

UNIQUE AUDIO Tel: 0181 4507384. Specialists in our field of high end, high Fidelity Audio Products incl: Audiosynthesis, LFD, VPI, Audiophysics, Yamayuru, Pink Triangle, QLN, Townsend, Credco, XLO, Rockport, Michell. Impulse to name just a few! We are also valve and vinyl experts and can offer ex-dem and 2nd hand equipment too. 9.00am-7.00pm Mon-Sat.

GREATER MANCHESTER

AUDIO COUNSEL, 14 Shaw Road, Oldham, OL1 3LQ. Tel (0161) 633 2602 Fax (0161) 633 2502. Linn, Naim, Rega, Arcam, Rotel, Royd, Mission, Micromega, Marantz, Shahinian, Celestion, Nakamichi, Dymavector. Free installation. Record Club. Major credit cards and credit facilities. Open Tuesday-Saturday 10.00- 5.30, 8pm on Thurs.

ORPHEUS AUDIO...Passion for Total Fidelity... Authorised Dealer for: Arion Acoustics, Art Audio, Audio Alchemy, Audiomeca, Audio Physic, Audio Synthesis, Boulder, Burmester, Cabasse, Croft, E.A.R., Electrocompaniet, Forsell, Fullers, Gamma Acoustics, Graaf, Klipsch, Living Voice, Lowther Voigt, Magnum, Meracur, OCM, Orelle, Ortofon, Papworth, Projekt, Pentachord, Purist, QED, Sequence, Stax, Teac, Triangle, Trichord Research, Totem, Unison Research, Yamamura Churchhill, YBA and others. Custom made stands & support from marble, solid



brass & 10mm glass. Free delivery/installation. Call for list of part ex. bargains. Demonstrations by arrangement in Standish (J27 off the M6), or in your own home without obligation. Tel: 01257 473175 (evening calls welcome).

**PRACTICAL HI-FI** 65 Bridge Street, Manchester M3 3BQ Tel: 0161 839 8869 See our main entry under Lancaster

**SWIFT OF WILMSLOW**, 4-8 St. Annes Parade Wilmslow, Tel (01625) 526213. Aura, B&W, Denon, Kenwood, Marantz, NAD, Pioneer, Rotel, Tannoy, Revolver, JPW, Open 9.30-6.00pm. 2 dem. rooms. No pressure!

### MERSEYSIDE

**ACOUSTICA** 17 Hoole Rd., Chester CH2 3NH Tel: 01244 344227. All that's best in hi-Fi from Epos, KEF, Teac, Royd, Linn, Rega, Naim, Arcam, Audioblab, Ruark, Rotel and many more. Multi room systems from Linn Knekt. Superb demonstration facilities, home demonstrations and installation a pleasure. We offer the best products, the best service and the best sounds. Open Tuesday to Saturday, evenings by appointment.

**WIRRAL HIFI** (Audio Consultants) 17 Shore Bank, Wirral, L62 1DB Tel/Fax: 0151 645 4621. We believe in value for money. That's why we only stock audio equipment that has been carefully selected for its price, build, & most important excellent sound quality. The following manufacturers offer all this DPA, Gamma, Klyne, Magnum, Monarchy, Orelle, Rose, Teac, Tube Technology, XLO, Audio Synthesis, Audio Alchemy, Audioemca, Audio Valve, Arion, Alon, Base, Bolter, Carver, Cary Audio, Castle, Dynaudio, Electroacompianet, Golden Tube, Grado, Heybrook, Lyr, Parasound, SD Acoustics, Shun Mook, Sound Lab, Stax, Sumiko, Triangle. For friendly advice, free local delivery & installation, demonstration facilities by appointment.

### MIDDLESEX

**AUDIO T** 159a Chase Side, Enfield, (0181) 367-3132. Great Value on Acoustic Energy, Arcam, Audioblab, Celestion, Cyrus, Denon, Kenwood, KEF, Linn, Marantz, Meridian, Micromega, Mission, NAD, Nakamichi, Quad, Rotel, Trichord Research, Yamaha & many more. Tues-Fri 9.30-6. Sat 9.30-5.30. 3 year Hi-Fi guarantee. 30 day free upgrades. PX. Selected specialist. 2 listening rooms. Home Cinema specialists. BADA Bonded.

**MUSICAL IMAGES** 45 High Street, Hounslow, Middlesex. Tel (0181) 569 5802. Fax: (0181) 569 6353.

**MUSICAL IMAGES** 173 Station Road, Edgeware, Middlesex. Tel (0181) 952 5535. Fax: (0181) 952 5535. Most brands available - see full page advert. Interest free credit, ask for details. Demos only. Repairs & Service. Sunday opening - Open all week. A Home Cinema Specialist. Mail order. Part exchange.

**RIVERSIDE HI-FI LTD.** 422 Richmond Road, East Twickenham, Middx TW2 2EB. Tel: 0181 892 7613. Fax: 0181 892 7749. E-mail: soundadvice@riversidehifi.co.uk. Internet: http://www.riversidehifi.co.uk/ "Where dreams come true". Experience the ultimate in home theatre. Starring DTS and AC3 supported by Angstrom, Bank & Olufsen, Owlin, Denon, Harman, Krell, Lexicon, Martin Logan, NHT, Onkyo, Pioneer, REL, RCF, Yamaha, TV and projection systems, 2 screen home cinema complex. 0% finance available countrywide (subject to status). Professional home installation and design consultancy. Open Monday to Saturday 10am-5.30pm

### NORFOLK

**BASICALLY SOUND** The Old School, School Road, Bracon Ash (Nr. Norwich), Norfolk NR14 8HG. Tel: (01508) 570 829. Stockists of the following leading Hi-Fi: Arcam, Audioblab, Audio Alchemy, Denon, Naim, Epos, Micromega, Heybrook, Nakamichi, Rotel, Royd, TDL, Beyer, Grado, Sennheiser, Dynavector, and more. Bada members. 2 comprehensive demo rooms.

**ZEROTH AUDIO** GT Yarmouth. Tel: (01493) 443693. Audio analyst and consultant, supplier of quality new and second user audiophile equipment for Norfolk and Suffolk. Authorised stockist of Trichord Research, Orelle/XTC, Bandor, CableTalk etc, please phone for full list. Computer aided reports on your current system, advice updates etc. Appointments only.

### NORTHAMPTON

**CLASSIC HI-FI** At Classic Hi-Fi we cover the best in quality sounds. Be it a question of taste, a question of balance or a question of price, we're the ones to help. We stock: Marantz, Nad, Pioneer, Aura, Yamaha, Heybrook, LFD, Sugden, Rotel, Kenwood, B & W, Kef, Rogers, Monitor Audio, JPW, Shearpe Audio, Royd, Audio Alchemy, Teac and many more. For more details call: 01536 310855

**LISTEN INN** 32 Gold Street, Northampton, NN1 IRS. Tel: (01604) 37871 Fax: (01604) 601 430. Linn, Rega, Audioblab, Naim, Denon, Arcam, KEF, Marantz, Royd, Micromega, Mission, Rotel, Myrrad, Epos, and more. Open 10am-5.30pm (closed Thursday).

### NOTTINGHAMSHIRE

**CHANTRY AUDIO** 18-18a Eidon Street, Tuxford, Nr Newark, Notts. NG22 0LH. Tel. 01777 870372. Pink Triangle, Absolute Sounds, Micromega, DPA, Alchemist, CD developments, SME, Meridian, Ruark, Rotel/Michi, Audion, Monitor Audio + much more. Three demo rooms incl. Home Cinema, home trial, free installation, service dept. Access, visa, credit facilities. Mail order, Mon-Sat 9.30-6.00, Sun and evenings by appointment.

**DEFINITIVE AUDIO** serves the first time purchaser and the seasoned audiophile with the same high level of care and interest. Our aim is long term customer satisfaction. We achieve this with quality impartial advice, quality back up and service and genuine interest in your needs. We have an established reputation for achieving sound quality benchmarks with innovation. We have an extensive range of carefully selected agencies. We are open Mon-Fri 9.30-6.30, Sat 10.00-1.30. Visa/Mastercard/Amex. Deliveries nationwide and worldwide. Extensions second hand stock, components from £10.00 to £75000. Call for more information. Tel/Fax (0115) 9813562

**NOTTINGHAM HI-FI CENTRE** 120-122 Alfreton Road, Nottingham. Tel: 01602 786919. Over 25 years experience, superb demo rooms, extensive range, free parking. Mon-Sat 9.5-30

### OXFORDSHIRE

**ASTLEY AUDIO LTD** 3 Marketplace, Wallingford (midway between Oxford and Reading). 01491 839305. Aura, B&W, Technics, Panasonic, Pioneer, Kenwood, Sony, Yamaha, Denon, Dual, Marantz, Mission, Tannoy, Kef, Mordaunt Short. One Listening and one Home Cinema room. Home trial, free installation. Service department. Access. Visa, Amex. Diners. Instant credit. Tues-Fri 9.5-30, Sat 9.5. Records & CDs stocked.

**OVERTURE HI-FI**, 3 Church Lane, Banbury, OX16 8LR. Tel (01295) 272158. Arcam, Bose, Denon, Heybrook, KEF, Linn Products, Mission, NAD, Naim Audio, Quad, Yamaha. For sensible unbiased advice, call Oxfordshire's audio experts. Superb demo facilities. No appts. necessary, service dept. free install, home trial. Access/Visa, instant credit. Mon-Fri 10-6, Sat 9.30-5.30.

**AUDIO T** 19 Old High Street, Headington, Oxford (01865) 65961. Great Value on Acoustic Energy, Arcam, Audioblab, Cyrus, Denon, KEF, Linn, Marantz, Meridian, Micromega, Mission, NAD, Pioneer, Quad, Rotel, Technics, Trichord Research, Yamaha & more. Tues-Fri 10-6. Sat 9.30-5.30. Thurs until 8.00. 3 year Hi-Fi guarantee. 30 day free upgrades. PX. Selected Interest Free, 2 listening rooms. Home Cinema specialists. BADA Bonded.

**OXFORD AUDIO CONSULTANTS**, Cantay House, Park End Street, Oxford OX1 1JE. Tel (01865) 791665. Quad, Denon, Spondor, Aura, Micromega, Ruark, B&W, Pink Triangle, Roksan, Krell, Sonus Faber, NAD, Rotel, Musical Fidelity, Pioneer, Marantz, Rogers, TDL, Demo room, Home trial and free installation. Instant credit. Access. Amex. Visa. 10-6 Mon-Sat.

**WESTWOOD & MASON** 46 George Street, Oxford. Tel/Fax: 01865 247783. Open 10.00am-5.00pm. Closed all day Thursday. Demonstration by appointment if possible. Spacious demonstration lounge. We stock: Naim, Rega, Arcam, Mission, Marantz, Denon, Yamaha, Klipsch, Royd, B&W, Ayra, Rotel, Chord Co., Infinity, KEF, etc.

### SHROPSHIRE

**ADAMS & JARRETT** Hi-Fi and Home Cinema Specialist. Phone or visit us at 6-18, Norman Road, St. Leonards-on-Sea. E.Sussex. (01424) 437165/432398. Stockist of quality equipment including: Audio Innovations, Meridian, KEF, Ruark, Marantz, NAD, JBL, Royd, Dali, Jamo, Onkyo, REL, Traget, Cable Talk, Technics, TDC, Yamaha, Kenwood. Air conditioned listening rooms, on site service and repair facilities

**SHROPSHIRE HIFI** St Michael Street, Shrewsbury, Shrops. SY1 2ES. Tel. 01743 232065. Stockists of Musical Fidelity, Mordaunt Short, Sony, Kenwood, Pioneer, Rotel, Denon, B&W, Proac. Audio Visual. Products available. Open 9.30 - 5.30pm Mon-Sat.

### SUFFOLK

**ANGLIA AUDIO** The Street, Hessest, Bury St Edmonds, Suffolk. IP30 9AZ. Tel. 01359 270212. "Hi-Fi and speaker centre dedicated to quality hi-fi since 1971. Open 10-6. Closed Weds and Sundays. Evening and Sunday Demos by appointment.

**AUDIO IMAGES** 7 All Saints Road, Pakefield, South Lowestoft, Suffolk. NR33 6JL. Tel/fax: 01502 582853. Quad, Triangle, Arcam, Castle, Rotel, Moth, JPW, Sugden, Mission, Project, Denon, Yamaha surround sound. Audio Innovations, plus the amazing ROTHWELL range. Separate dem room, no appts nec. 10-6.30 Tues-Thurs, 7pm Fri. 6pm Sat.

**EASTERN AUDIO** 41 Bramford Road, Ipswich, Tel. 01473 217 217. Fax 01473 215705. Quad, Arcam, Audioblab, Meridian, Mission, Denon, Rotel, Marantz, NAD, Sony, Rogers, Nakamichi, Systemdek, Technics,

Celestion, B&W, Tannoy, Morel Thorens and Top Tape. Also stock a wide range of accessories. usual credit facilities. A BADA dealer.

### SURREY

**INFIDELITY** 9 High Street, Hampton Wick, Kingston upon Thames, Surrey, KT1 4DA. Tel 0181 943 3530. Stockists of: Arcam, Creek, Epos, Heybrook, Micromega, Naim Audio, Neat, Rega, Roksan, Rotel, Royd, Teac, Yamaha. Open Teues - Saturday, 10.30am - 7.00pm.

**ROGERS HIFI** 13 Bridge Street, Guildford, Surrey, (01483) 61049. B&W, Castle, Denon, Dual, JBL, Harmon Kardon, Kenwood, Marantz, Micromega, Mordaunt Short, Moth, Myriad, Musical Fidelity, Pioneer, Rel, Royd, Ruark, Systemdek, Tannoy, TDL, Teac, Thorens. Dem facilities available, no appts necessary, free installation, service dept. Access/Visa. Instant credit upto £1,000 subject to status. Monday-Saturday, 9.30-6pm, later by appt.

**SPALDINGS HI-FI** 352-4 Lower Addiscombe Rd., Croydon, Surrey. CR0 7AT. 0181 654 1231/2040. 3 dem rooms and home dem. Free installation/credit. Meridian, Linn, Naim, Quad, Arcam, Audioblab, Mission, Denon, Tannoy, Marantz, Ruark. Mon-Sat 9-6, Tues 9-8. Service dept. (3 Dem rooms incl. A.V. 0% credit).

**SURREY HIFI** 45 High Street, Godstone, Surrey, RH9 8LS. (01883) 744755. Demonstration rooms & Free parking available. "Home Cinema on Demonstration." Arcam, Audioblab, Kef, Kef Reference, Rogers, TDL, Thorens, Denon, Bose, Marantz, Yamaha, M&M Sub-woofers, Musical Fidelity, Cable Talk, Quads, Stands Unique, Alphonson, Target, Partington, Atacama Stands, Bayer Headphones, Sennheiser. 0% interest. Credit Cards, Free installation service dept. Closed all day Wednesday.

**ZEBRA** 18-24 Brighton Road, South Croydon, Tel: 0181 - 688 2093. The UK's First and Finest Home Cinema Store. 3 Demonstration Rooms. Laser Disc CRT and Projection TV Centre. Many brands stocked including Arcam, Audioblab, Meridian, Lexicon, Kef, Pioneer, Rotel, Yamaha, REL and Panasonic. Mon-Sat 9.30-6.00pm. All major credit cards accepted. Finance available. Evening demonstrations by appointment.

### SUSSEX (EAST)

**ADAMS & JARRETT** Hi-Fi and Home Cinema Specialist. Phone or visit us at 6-18, Norman Road, St. Leonards-on-Sea, E.Sussex. (01424) 437165/432398. Stockist of quality equipment including: Audio Innovations, Meridian, KEF, Ruark, Marantz, NAD, JBL, Royd, Dali, Jamo, Onkyo, REL, Traget, Cable Talk, Technics, TDC, Yamaha, Kenwood. Air conditioned listening rooms, on site service and repair facilities.

**THE POWERPLANT** "Brighton's Leading Hifi Shop". 66 North Street, Brighton, Tel. 01273 775978. Comfortable listening rooms. Knowledgeable and approachable staff. Roksan, Micromega, Exposure, Audioblab, Epos, Rotel, Marantz, Cyrus, Regal, Arcam, Mission and more.

### SUSSEX (WEST)

**AUDIO DESIGNS** 26 High Street, East Grinstead, West Sussex RH19 3AS. Tel/Fax (01342) 314569. Hi-Fi, Home cinema + multi room specialists. Authorised specialists of: Arcam, Audioblab, Castle, Cyrus, Epos, KEF, Linn (inc AVSI), Marantz, Mission, Naim, Pioneer (inc LaserDisc), Quad, Rel, Rotel, Sony, Soundstyle, Stands Unique, Target, Thorens, Yamaha & more. 3 dedicated demonstration rooms - Hi-Fi & Home cinema. Service dept 0% finance available 9.30-6.00 Mon-Sat. Late by appointment.

**DEFINITIVE AUDIO** Tel/fax Brighton 01273 276716. We specialise in the assembly of natural sounding dynamic audio systems which use high quality valve amplification and high efficiency loudspeakers. If dynamic, effortless sound with natural bite appeals to you give us a ring. If you prefer small strained wearing transistor sound don't bother. If you are a first time buyer bewildered by the amount of choice and opinion give us a ring anyway. Selected components from: Arcadia, Audio Innovations, Audio Note, Border Patrol, Bravura, Goldring, Living Voice, SMC, Voyd. Relaxed demonstrations in comfortable home environment. Appointments only please. Visa/Access. No Credit

**HEATHERDALE AUDIO LTD** 202 Findon Road, Worthing, Sussex. Tel: 01903 872288 or 0860 660001 eves. Three comfortable demonstration lounges where you can audition; Audionote, Krell, Audio Research, Klipsch, Martin Logan, Apogee, Sonus Faber, Theta, S.M.E. Copland, Voyd, Magnephan, E.M.F., Lumley Reference, Creek, Rotel, Heybrook, Clearaudio. Phone for used stock list. 'We are the South Coast's Premier Hi-Fi Specialist'

### TYNE & WEAR

**FERROGRAPH SPARES & SERVICES** Reel to reel tape recorder servicing facilities, spare part and refurbished equipment suppliers. Main brands supported: Ferrograph and Revox. In total, around 90% of the entire range of Ferrograph spare parts are still available from stock. Our service department also covers all Ferrograph recorders from the range. Call today for further information. Suite 7, Cookson

House, River Drive, South Shields, Tyne and Wear, NE33 1JX. Tel: 0191 427 7774 Fax: 0191 427 5566 E-mail lee@ferrograph.win-uk.net

### WARWICKSHIRE

**THE LEAMINGTON HI-FI CO** 23a Regent Street, Leamington Spa, Warwick CV32 5EJ. Tel: 01926 888644. Fax: 01926 887486. E-mail: k.browne@bbcnc.org.uk. Arcam, Audioblab, Quad, Meridian, Marantz, Denon, Pioneer, Yamaha, NAD, Micromega, Mission, Kef, Celestion, Atacama, Technics, Trichord, TDL, REL, Ixos. Single speaker dem room. We do not use any comparators. We also have full demonstration of Projection T.V. with Laserdisc and full Pro Logic systems. Part exchange welcome. Please phone or E-mail for prices. We have in stock over 200 Laserdiscs. Call for our latest catalogue.

**SOUNDS EXPENSIVE** 12 Regent St, Rugby, Warwick CV21 2QF. Tel: 01788 540772. Agents for: Arcam, Audioblab, B&O, Castle, Celestion, Denon, Dual, Kef, Mission, Marantz, Meridian, Pioneer, Quad, Rotel, Sony, Tannoy, Yamaha & many more. 2 year warranty on all hi-fi separates. 2 Demonstration rooms, Home Trials, All Major Credit Cards Accepted, Mail Order Welcome. Ring Now For Keenest Prices. Open Monday - Saturday 9.5-30. Closed Wednesday. If We Haven't Got It It's Probably Not Worth Having.

**STRATFORD HI-FI** 10a Chapel Street, Stratford upon Avon, Warwickshire. Tel: (01789) 414533. Arcam, B&W, Bose, Cyrus, Denon, KEF, Marantz, Micromega, Mission, Monitor, Audio, NAD, Panasonic, Onkyo, Pioneer, Rotel, Sony, Technics, Yamaha. Demonstration room. Service facilities. Mail order, interest free credit. Open 9.30-5.30 Monday to Saturday, all major credit cards.

### WEST MIDLANDS

**AMADEUS SOUND & VISION** 10 Boldmere Road, Sutton Coldfield, West Midlands. Tel. 0121 354 2311. Audio Innovations, B&O, Castle, John Shearn, QED, Rotel, Wharfedale. Single speaker demo, appts preferred, service available, installations, B&O link install, home trials, Access/Visa, interest free credit available subject to status. 9.30-6.00pm 6 days.

**FRANK HARVEY HI FI EXCELLENCE** 163 Spon Street Coventry Tel: 01203 525200 Fax: 01203 631403 Audioblab - Audio Alchemy-Atacama Aura - Arcam - Audio Quest - Alphonson - Apollo - Bang & Olufson - Bose - Castle - Canon - Cable Talk - Celestion - Chord - Cyrus - Denon - Dual Definition - Heybrook - IXOS - Kef Reference - JBL - JPW - Jamo - Kenwood - Laser Disc Marantz - Meridian - Monitor Audio - Micromega - Mission - Michell Gyrodek Monster - Morduant Short - Musical Fidelity - Nakamichi - NAD - Ortofon - Onkyo - Panasonic - Pioneer - Polk Audio - Quad - QED - REL - Rega - Revolver - Rogers - Rotel - Royd - Sennheiser - Systemdek - Target - Teac - Technics - Tannoy - Thorens - TDL - Van Den Hul - Wessex - Yamaha Much Much More In Store on 3 Floors 4000 SQ Feet with 3 Dedicated Hi Fi Demo Rooms of the very Best Hi Fi Plus 2 A/V Demo Rooms. Nice staff nice coffee. Appts Nec. Service Dept. Free Install & Home Trial. All Credit Facilities. Plus Interest Free Credit. Open 9.30am to 5.30pm Monday to Saturday.

**GRIFFIN AUDIO** 94 Bristol St., Birmingham, Tel. 0121 622 2230/0121 692 1359. Tues-Sat 10 am-6 pm. Enjoy music at home with a system from Griffin Audio. We demonstrate and install the very best hi-fi, with systems from £500 to £25,000. Ask for Bob, Tim or Alex. Linn, Naim, Shahinian, Quad, Arcam, Rega, Denon, Marantz, Rotel.

**SOUND ACADEMY** For the West Midlands. 152a High Street, Bloxwich Nr Walsall, W. Mids. Next to the ASDA shopping centre. Tel: (01922 493499/473499. Established in 1981. Now hosts 3 private studios including a home theatre cinema with '3-Tube' and 'LCD' projectors. The best in Hi-Fi on 2 floors from Naim, Arcam, Audioblab, Chord, Keswick and so many more. So...if you've taken the time to read this, please let us make you welcome. Phone 01922 493 499 or call in to browse our exciting display of hi-fi and home cinema equipment. Mail order available. Interest free credit S.T. Status. Open 6 days, 9am-6pm. Late night Friday. Expert Advice. Cable Dressing and Free Installation.

### WILTSHIRE

**AUDIO T** 60 Fleet Street, Swindon, (01793) 538222. Great Value on Acoustic Energy, Arcam, Audioblab, Cyrus, Denon, KEF, Linn, Marantz, Meridian, Micromega, Mission, NAD, Naim, Nakamichi, Quad, Rotel, Technics, Trichord Research, Yamaha & many more. Tues-Sat 9.30-6. 3 year Hi-Fi guarantee. Free delivery & installation. 30 day free upgrades. Home demonstrations. PX. Selected Interest Free Credit. 2 listening rooms. Home Cinema specialists. BADA Bonded.

**SALISBURY HI-FI LTD.** 15 Catherine Street, Salisbury, Wiltshire SP1 2DF. Tel (01722) 322169. Arcam, B&W, Celestion, Denon, KEF, Kenwood, Marantz, Meridian, Micromega, NAD, Ruark, Sony, Yamaha, 2 Dem rooms. Friendly, relaxed atmosphere. Professional advice. Home dem available. Service department, Free installation. Home trial facilities.

dial-a-dealer



Access, Visa, Amex. Interest free credit, instant credit. Open Mon-Sat 9-5.30.

**THE RIGHT NOTE** - See under AVON heading

## WORCESTERSHIRE

**COLORAMA HI-FI** 27 Kingfisher Walk, Kingfisher Centre, Redditch, Worcs B97 4EY (01527) 597260. Marantz, Rotel, Harman Kardon, Ixos, Sennheiser, Teac, NAD, Onkyo, TDL, Polk Audio, B&W. Full Pro-logic products. In-store integrated dem facilities. No appts required, service dept. Access, Visa. Open 9-5.30, closed Thursdays.

**MIDLAND AUDIO EXCHANGE** 181, Franche Road, Kidderminster, Worcs, DY11 5AD. Tel. 01562 822236 mobile. 0421 605966. Open seven days a week 9.30am to 6.30pm. By appointment. Evening demos arranged. 2 demo rooms, home demos. Part exchange always welcome, service facility, free delivery. Analogue Hi-End specialist. Agencies include Rokan, Rega, Audionote, Audio Alchemy, Apogee, Proceed, B&W Tech, Heybrook, Sonic link, Q.L.N. and many more. Access, Visa and Switch, finance on request.

**SPAINS HI-FI 2 & 2a** New rd, Bromsgate Worcs's Tel: 01527 872460. Aura, Apollo, Audioquest, b&w, Denon, Harmon Kardon, jbl, jvc, Kef, Kenwood, Marantz, Mission, nad, Nakamichi, Onkyo, Pioneer, qed, ref, Revolver, Rotel, Sennheiser, Sony, Tannoy, Thorens, etc. 2 Demonstration Rooms, Home Cinema Specialists, 0% Finance available on selected products, Part Exchange welcome, on site service dept, wide range of television, video, mini systems etc. in stock.

**WEST MIDLANDS AUDIO** 158 Ombersley Road, Worcester WR3 7HA. Tel 01905 458046. Fax. 01905 457585. Naim, Rega, Rotel, Marantz, Nakamichi, NAD, Audiobal, Roksan, Meridian, B&W, Audio Research, Krell, Martin Logan, Arcam. 9-5.30 Mon-Sat, eve's by appt only.

## YORKSHIRE (NORTH)

**CLARITY HI-FI PHONE MIKE** ON 01723 503432 Friendly polite new business, free estimates/advice, no VAT. All work guaranteed specialist in Repairs, Servicing. All makes including Valve Equipment, Audio upgrades V.C.R.S. All work considered. Plugs, sockets, tapes, headphones, microphones, etc. Brand names like Q.E.D., Goldring, Demion, Audio Quest etc. To find out more feel free to phone between 9.00am/9.00pm Mon to Sat.

**HARROGATE HI-FI**, 15 Commercial Street, Harrogate, N.Yorks. Tel (01423) 504274. One of the best ranges of quality hi-fi in the North of England, including Lumley valve amplification, Audio Research, Musical Fidelity, Martin Logan, Sonus Faber, Castle, Orelle, Michell, Ruark, Stax, Copland, Tannoy, NAD, Onkyo, Rotel, Meridian, Lexicon, Project, Silver Sounds, Cogan Hall, DNM. Home Cinema dems. Home dems. (appts. not always required). Service Deptt. All major credit cards accepted. Credit facilities available. Open 10-6. Why? Because music matters.

## YORKSHIRE (SOUTH)

**HIFI STUDIOS DONCASTER** The best range of quality hi-fi in the north of England - Unison valve amps and phono stages, Michell Gyrodec and Orbe - Alchemist amplifiers, Electrocompaniet, Sugden, John Shearpe amplifiers, TDL, Audio Alchemy, Proac, Ruark, Castle, Teac, Impulse Horns, Densen Amplifiers, Apogee, Stemofoort, Kinshaw, Pink Triangle, Morel Speakers, Heybrook, Monitor Audio, Harbeth, Keswick Audio Research Speakers, AMC, CR Developments (Valves), Art Audio (Valves), REL Subwoofers, Exposure, Target, Sonic Link, Chord, Audio Quest + Yamaha & Klipsch Home Cinema Demonstrations. BADA members. Phone Jeff or Neil on 01302 781387

**MOORGATE ACOUSTICS** 8 Westgate Chambers, Rotherham Tel: 01709 370666, 184 Fitzwilliam Street, Sheffield Tel: 01142 756048 - Audio Alchemy, Atacama, Arcam, Audio Lab, Audio Quest, Beyer, Bose, Canon, Castle, Cyrus, Celstion, Denon, Jamo, John Shearn (Amplifiers), Linn, Marantz, Mission, REL (Sub Woofers), Rogers (Speakers & Amplifiers), Royd, Sennheiser, Spendor, Tannoy "D", T.D.L., Technics, Yamaha. Demo rooms (6), Home Cinema, Access, Visa, Switch, Interest free credit (details available upon request), up to 5 years guarantee.

**SOUNDWAVE AUDIO** 22 Lord Mayor's Walk, York, YO3 7HA. Tel. 01904 646309. Hi-Fi sales incl. NAD, Onkyo, Dali, Cerwin Vega, Teac, Kenwood, Ortofon, Alchemist, Jamo and many others. In-house workshops for repairs and svcs. on all makes. Dem-room incl. Home Cinema. No pushy sales staff!! Just good equipment and a friendly atmosphere.

**SOUND ORGANISATION** YORK, 2b Gillygate, York YO3 7EQ. Tel (01904) 627108. Carefully chosen Hi-Fi and AV equipment including Arcam, B&W, Denon, Linn, M&K subwoofers, Naim, Rega, Rotel, Royd, etc 3 dem rooms incl. Home Cinema and Multi-room facilities. Service Department. Home installations. Instant Credit and major credit cards. Closed Mondays. Phone for chat and more details.

**VICKERS HI-FI** 24 Gillygate, York. Tel: (01904) 629659. There's a lot we could say - but it's all there already in our ad in this issue. (See Main ad index on page 130 to find Vickers) ...Why not look at the whole picture?

## YORKSHIRE (WEST)

**AUDIO PROJECTS** 45 Headingley Lane, Leeds Tel: (0113) 230 4565. Eve. Tel: 0973 834 724 'Linn HiFi, Linn AV, Arcam, Myriad, Castle, Musical Technology, Loewe, Creek, Kef Custom, etc. Installations a speciality. Home Trials. Linn & QED multiroom systems on demonstration. Tues-Fri 9.30-6.00, Sat 10.00-5.00

**HUDDERSFIELD HI-FI CENTRE** 4 Cross Church St, Huddersfield. (01484) 544668. B&W, Cyrus, Kenwood, Denon, Rotel, Arcam, Musical Fidelity, Quad, Audio Lab, Marantz, Mission, etc. Dem facilities - appointment reqd. Mon-Sat 9-5.30, Thurs 9-8. Closed Wed. Free installation, credit facilities. Access, Visa

**PREMIER AUDIO** Wakefield (01924) 255045. A brand new company offering a range of exciting Audiophile products carefully selected and professionally demonstrated. Equipment includes Audio Synthesis, Chord Company, Classe, cable Talk, DPA, EAD, Exposure, Harbeth, Kora, Mirage, Myriad, Orelle, Trichord and many others. demonstration facilities, Home demonstrations & Free installation. Part Exchange & used equipment Available. telephone for details and opening offers.

## SCOTLAND

### CENTRAL

**COLIN MACKENZIE'S HIFI CORNER** 52 Gordon Street Glasgow 0141 248 2840. Rose St Edinburgh 0131 220 1535, 1 Haddington Place, Edinburgh 0131 556 7901 and 44 Cow Wynd, Falkirk 01324 629011. Audiobal, Cyrus, Sound-Bytes, Meridian, etc. Most major Brands stocked. Free five year guarantee on all loudspeakers, keen prices. JAMES KERR & Co., 145 Bath St, Glasgow 0141 226 5711. Glasgow's oldest established hifi specialist, now at new larger premises

### LOTHIAN

**LOUD & CLEAR** 520 St Vincent Street, Finniestone, Glasgow G3 8XZ. Tel: (0141) 221 0221 - not just another hi-fi shop, combining friendly advice with specially selected products and the keenest prices. Three dem rooms and full service installation facilities. Interest Free Credit available on selected products. Naim, Exposure, Alchemist, Marantz, Denon, Rotel, Teac, Systemdek, Aiwa, Kef, Tannoy, TDL, Mordaunt Short, Royd, Epos. Mon-Sat 10.00am - 6.00pm. Thursdays 10.00 am - 7.00pm. Complimentary parking at PC World, Finniestone Street.

**COLIN MACKENZIE'S HIFI CORNER** 52 Gordon Street Glasgow 0141 248 2840. Rose St Edinburgh 0131 220 1535, 1 Haddington Place, Edinburgh 0131 556 7901 and 44 Cow Wynd, Falkirk 01324 629011. Audiobal, Cyrus, Sound-Bytes, Meridian, etc. Most major Brands stocked. Free five year guarantee on all loudspeakers, keen prices. JAMES KERR & Co., 145 Bath St, Glasgow 0141 226 5711. Glasgow's oldest established hifi specialist, now at new larger premises

**MUSIC MILL** 72 Newhaven Road, Edinburgh EH6 5QG. Tel: 0131 555 3963 Fax: 0131 555 3964. Audio Research, Copland, Naim Audio, Krell, Roksan, Marantz, DPA, AVI, Martin Logan, Pro-Ac, Wilson Audio, Theta Digital, Transparent Audio, Alchemist, AVI, Quadraspire, Stands Unique. Listening Rooms, Free Parking, Full Workshop, Delivery and Installation. Open Mon-Sat 10-6.00 pm. Please phone for a map or contact Al, Fraser, Mark, or Mike.

### GRAMPIAN

**HOLBURN HI-FI** 441 Holburn Street, Aberdeen. Tel: 01224 585713. Arcam, Audiobal, B&W, Celestion, Denon, Dual, Epos, Heybrook, ION, Kenwood, Creek, Marantz, Meridian, Mission, Cyrus, M.S., NAD, Nakamichi, Pioneer, QED, Quad, Revox, Rotel, Ruark, Tannoy, Technics, Whatfedale, Yamaha. 9.30-5.30 Mon-Sat.

### AYRSHIRE

**THE SOUND FOUNDATION** The Sound Foundation, 22 Nelson Street, Kilmarnock, Ayrshire. KA1 1BA. (01563) 574185. Equipment by Sugden, Audio Note, ProAc, Harbeth, Michell, Castle, Voyd, Trichord Research, Firax and Stands Unique. Full credit facilities available, all major credit cards accepted

### STRATHCLYDE

**COLIN MACKENZIE'S HIFI CORNER** 52 Gordon Street Glasgow 0141 248 2840. Rose St Edinburgh 0131 220 1535, 1 Haddington Place, Edinburgh 0131 556 7901 and 44 Cow Wynd, Falkirk 01324 629011. Audiobal, Cyrus, Sound-Bytes, Meridian, etc. Most major Brands stocked. Free five year guarantee on all loudspeakers, keen prices. JAMES KERR & Co., 145 Bath St, Glasgow 0141 226 5711. Glasgow's oldest established hifi specialist, now at new larger premises

**STEREO STEREO** 278 St Vincent Street, Glasgow. Tel: 0141 248 4079 E mail Stereo @ cix.compulink.co.uk We will supply the most musical sound for your budget and if you take the time to visit us we will take the time to return the compliment with free installation of your chosen equipment. Open 10-6.00pm closed Sunday, Tuesday Installation Nation-wide Interest free credit available

## WALES

### NORTH WALES

**ACOUSTICA** 17 Hoole Rd., Chester CH2 3NH Tel: 01244 344227. All that's best in hi-fi from Epos, Kef, Teac, Royd, Linn, Rega, Naim, Arcam, Audiobal, Ruark, Rotel and many more. Multi room systems from Linn Knekt. Superb demonstration facilities, home demonstrations and installation a pleasure. We offer the best products, the best service and the best sounds. Open Tuesday to Saturday, evenings by appointment.

**ACTON GATE AUDIO** 4 Ruabon Road, Wrexham, North Wales, Tel.01978 364500. Audio Visual Specialists, Aiwa, Arcam, Aura, Bose, B&W, Beard, Canon, Celestion, Castle, Denon, Jamo, Marantz, Michell, Mission, Mordaunt Short, Pro-ject, Musical Fidelity, NAD, Nacamichi, Micromega, QUAD, Radford, Rotel, Rega, Ruark, Tannoy, Thorens, UKD, Yamaha, DSP Club Member, Demo Room, installation service. Easy Parking and Motorway access. All major credit cards accepted. 9.30 - 5.30 daily. Closed Weds pm.

**ELECTRO TRADER** 19 Colwyn Crescent, Rhos on Sea, Colwyn Bay, Clwyd, Wales. LL28 4RN. (01492) 548932. NOW APPOINTED SUGDEN DEALER FOR THE NORTH WEST. Rotel, Yamaha, NAD, Harman, Kardon, Teac, Alphason, Heco, Infinity, Kef, JBL, Sugden, Tannoy, Rotel Michi, Haybrook, Acoustic Research, Ruark and Soundstyle tri-pod racks etc. Dem room appts. preferred. Home trial. Free install. Access, Visa. Open 9.30 - 1.00, 2.00 - 5.30 Mon-Sat.

### GLAMORGAN (SOUTH)

**AUDIO EXCELLENCE** 134-6 Crwys Road Cardiff CF2 4NR. Tel. 01222 228565 Fax. 01222 398201. All that's best in hi-fi carefully selected and demonstrated by friendly knowledgeable staff, at prices to suit all budgets. Delivery and installation, home dems, part exchange, in house workshops, full credit facilities with interest free on selected items. Tuesday - Saturday 9.00 - 5.30. Closed Monday.

**SOUND DR. JULES SWANSEA**, 01792280 061. Call now for price list, UK or overseas. Hi end new and pre-owned hi-fi at an affordable price. Home trial prior to purchase. Reliable courier service and repair service. Friendly and enthusiastic advice, day or evening seven days a week. A service to suit you.

### GLAMORGAN (WEST)

**AUDIO EXCELLENCE** 9 High Street, Swansea, SA1 1LE. Tel. 01792 474608 Fax. 01792 645087. All that's best in hi-fi carefully selected and demonstrated by friendly knowledgeable staff, at prices to suit all budgets. Delivery and installation, home dems, part exchange, in house workshops, full credit facilities with interest free on selected items. Tuesday - Saturday 9.00 - 5.30. Closed Monday.

## IRELAND

**CLONEY AUDIO** 55 Main Street, Blackrock, Dublin, Tel.289449/2888477 Fax. 2834887. Products include: Arcam, Classe, Philips, Rogers, Epos, B&W, Naim Audio, Meridian and others. Open Tues/Sat 10am-6pm. Thurs/Fri 'till 9pm Closed Mondays.

**DUBLINN HI-FI** 38 Augier Street, Dublin 2. Tel: (00 353) 1 4785205. Fax: (00 353) 1 4785219. We have two ears and one mouth - use them accordingly. We only stock the best products, based on performance and reliability - not reviews or sales patter. Call Mark or drop in for a listen. Three single speaker demo rooms. Free delivery and installation. Full service department. Open Mon-Fri 10-7, Sat 10-6

## VINYL / RECORD MAIL ORDER

**AUDIOPHILE INTERNATIONAL** PO Box 303, Chobham, Surrey, GU24 8YP. Specialists in high quality vinyl & CD. Telephone Order: 01276 855530/855578. Fax Order: 01276 855580. E-Mail: sales@audiophile.u-net.com. Order your own free copies of Audiophiles Update Catalogues and get the most informative guide to the latest vinyl and audiophile releases 12 times a year.

**DIVERSE MUSIC** 12 Upper Dock Street, Newport, Gwent, NP9 1DF. 9am-5.30pm Mon-Sat, Internet site http://www.diverse-music.co.uk. Phone/fax 01633 259661 / 256261. E-mail:- sales@diverse-music.cix.co.uk. Catalogues available. Mastercard, Visa, Amex, Switch, JCB. New and forthcoming releases: Blue Note 180gm LPs - re-issued on 14th April (very

limited) also large current and back catalogue stock selection. P&P £1.00 1st LP, additional LPs 50p each (max £3.50) Please contact us for more details and catalogues.

**LIONEL'S VINYL** PO Box 22, Biggleswade, Beds, SG18 87B. Tel: 01767 314936 Fax: 01767 318462. E-Mail: mafe34@dial.pipex.com We stock a large range of quality assured secondhand vinyl, covering the whole musical spectrum. All purchases are fully guaranteed, and we will professionally clean records prior to posting, if requested. All albums are priced to sell quickly (from £1.00/LP.), and Worldwide Export is a speciality. Send A4 S.A.E. or Phone 01767 314936 now for free catalogue.

**SILVERNOTE** PO Box 158, Cheshunt, Herts, EN7 6UH Always wanted: Vintage and Modern Equipment, Records & CD's. Tel/fax Steve on 01992 620905

**VINYL DEMAND** Stockists of VPI record cleaning machines and the widest range of audiophile vinyl in the UK - at the best prices. Living Stereo, Verve, Mobile fidelity, Decca, Absolute Analogue, Testament, MCA, DCC. Also a vast range of analogue accessories. Phone 01425-654545 or Fax 01425-654400 for orders or catalogues.

**VIVANTE** - LONDON 74 Heathfield North, Twickenham TW2 7QW. Tel: 0181891 3433. One of the UK's largest importer and distributor of audiophile and conventional vinyl is now operating a mail order service specialising in jazz and classical reissues. Labels include Decca, London, Deutsche Gramophon, Arhivo, EMI, Telefunken, Testament, Verve, MPS, Milestone, Fantasy, Pablo and more. Extensive catalogue available. Access/Visa accepted.

## VINTAGE

**AUDIO CLASSICS** Audio Classics / Mellotone Acoustics Co. P.O. Box 67, Wigan, Greater Manchester, WN2 3AG. Tel: 01942 257525. Fax: 01942 525861. Mobile: 0585 476574. E-mail: mell@one-u-net.com. Hi-Fi bought, sold, repaired and renovated. Mail order and vintage specialists. Please see our main ad (look under the ad index to find) for further information.

## EX DEMONSTRATION

**AFFORDABLE AUDIO** (Northampton) Pre-Owned Hi-Fi Specialists. 168 Wellingborough Road, Northampton, NN1 4DU. Tel: (01604) 231261/714900. Mobile: (0585) 710992. Urgently required: compact disc collections, hi-fi separates, especially Linn products, Naim Audio, Cyrus Electronics, Musical Fidelity, Quad Electronics, almost anything British/American. Cash waiting, part exchange welcome. We also stock lots of audio accessories, compact discs, vinyl, Naim video recorders, DAT players. Single speaker dem room. All equipment is sold with warranties. All Credit Cards accepted. Please phone anytime for stock update.

**AUDIO CLASSICS** Audio Classics / Mellotone Acoustics Co. P.O. Box 67, Wigan, Greater Manchester, WN2 3AG. Tel: 01942 257525. Fax: 01942 525861. Mobile: 0585 476574. E-mail: mell@one-u-net.com. Hi-Fi bought, sold, repaired and renovated. Mail order and vintage specialists. Please see our main ad (look under the ad index to find) for further information.

**CHOICE HI-FI/Hi-Fi** Exchange Open 10am-8pm, 7 days by appt. Tel: 0181 392 1959/1963. Fax: 0181 392 1994. Agents for Acoustic Energy, Alon, ATC, Boulder, Bryston, Chord, Forsell, Gamma, Van den Hul, Lumley, Rockport, SME, Soundstyle, Straight Wire, Target, Trichord, Triology, VPI, XLO and many more. We offer: generous part exchange, your equipment purchased, show room/dem room, single speaker dem room, trade in policy, credit card facilities, mail order, export service, finance available.

**HAZELMERE AUDIO**. To hear how realistic music can sound, please call for an appointment, (day or evening). Objective advice, comfortable listening, home-demonstration, free installations, part exchange, repairs and superb service. Acoustic Precision, Air Tagent, ATL, Audiomeca, Basis Classe, EAD, Fanfare, Henley, Magneplanar, Mirage, Monrio, Muse, Notts, Analogue, Opera, Ortofon, SD, Sirius, Straightwire, Tice, Triangle, Triology, VPI. High Wycombe (01494) 437892

**THE HI-FI CLEARING HOUSE**. Good quality Hi-Fi and home cinema kit bought, sold and part exchanged. Please offer us your unwanted quality kit and let us know your requirements. We specialise in ex demo and secondhand equipment. Mail order facilities. Switch, Delta, Visa, Mastercard. Callers welcome but by appointment only. Contact Paul Walton. Tel: 0161 432 4245. Fax: 01161 442 1375



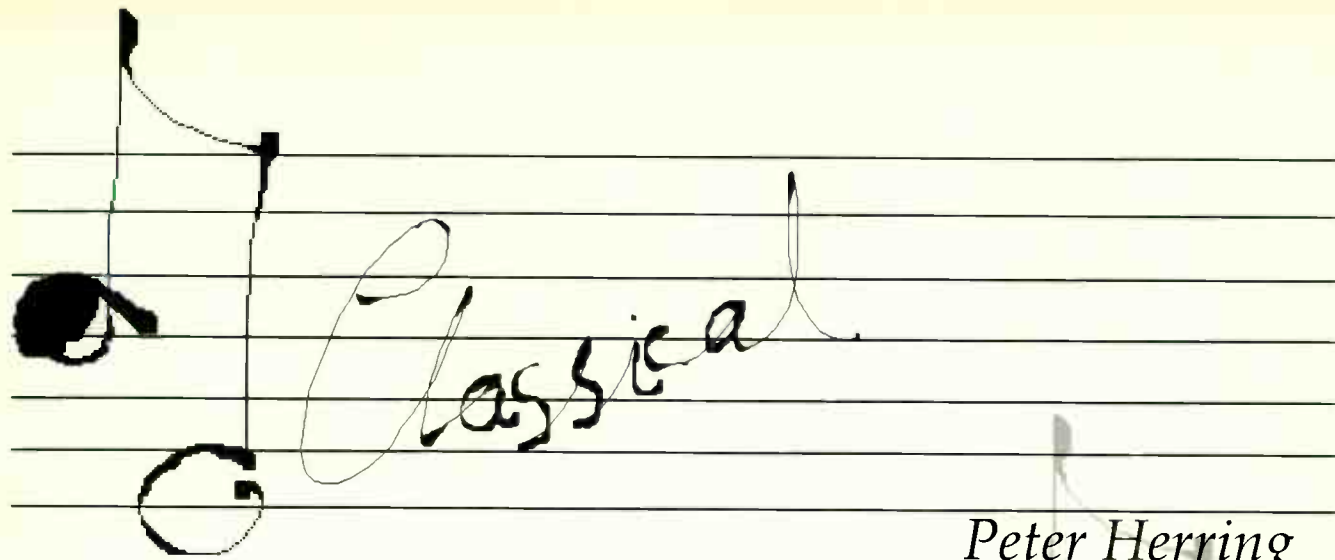

Peter Herring

**We are accustomed to great music originating from south of the Alps - Mantua's Claudio Monteverdi amply testifies to that with a new recording of madrigals. The Alpine slopes of Switzerland though have proved much less musically fertile. At least that's the impression until you encounter the work of the decidedly un-Swiss sounding Frank Martin.**

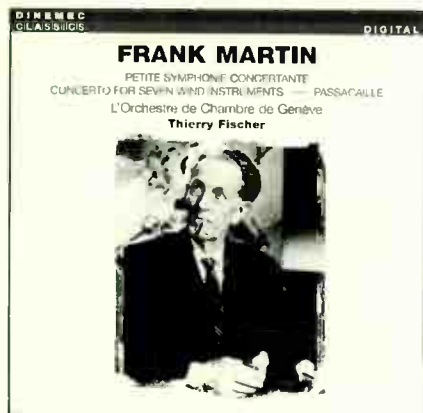

FRANK MARTIN

**Petite Symphonie  
Concertante/Concerto for  
Seven Wind  
Instruments/Passacaille  
L'Orchestre de Chambre de  
Genève; conductor, Thierry  
Fischer**

DINEMEC CLASSICS DCCD012  
(DDD/55.53)

Born in Switzerland in 1890, the son of a Calvinist minister, Frank Martin had already taken his first tentative steps in composition when, at the age of ten, he heard a performance of Bach's St Matthew Passion. It was to leave a deep and permanent impression, but it was another four decades before Martin's own musical language reached its full flowering.

He dabbled in twelve-note techniques, most notably in his First Piano Concerto (1933-34) and then added Bela Bartok to a list of

influences that, aside from Bach, already embraced Debussy, Schoenberg and Hindemith. Martin's first indisputable masterpiece was an oratorio on the Tristan legend entitled *Le Vin Herbe*. He went on to write a number of other choral and operatic works, both sacred and secular.

However, the work which finally established Frank Martin's reputation was orchestral rather than vocal, the brilliant *Petite Symphonie Concertante* of 1944-45. The work was written to a commission from his fellow-countryman and incomparable supporter of new music, Paul Sacher, and was given its first performance in Zurich in May 1946. That same year, Martin revised the piece for full orchestra, dropping the 'Petite' prefix in the process. He believed the unusual scoring of the original would deny it concert exposure. He was to be proved wrong. The *Petite Symphonie* with its glittering, transparent sonorities and arresting percussive effects has become one of the most frequently heard of Martin's compositions.

Three years later, Martin again turned to the concerto grosso form, at least in its modern guise. The *Concerto* for seven wind instruments, timpani, percussion and strings is an altogether sunnier and more relaxed work than its predecessor, whose nervous energy perhaps betrays the anxious mood prevailing everywhere at the time of its composition. In the

*Concerto*, only the second movement, with its hypnotic and unsettling 'tick-tock' ostinato pulse betrays a sense of foreboding.

Both of these modern, yet immediately accessible masterpieces are superbly performed by musicians from the city of Frank Martin's birth, Geneva. There is virtuosity a-plenty from this top notch chamber group, which was only formed some five years ago, and their ensemble playing in the *Passacaille* which concludes the programme is of a similar standard.

Here Martin pays homage to his original and most lasting inspiration Bach, using a form beloved of the German master, the *passacaglia*. It is a work of sustained and affecting nobility, clearly possessed of great depth of feeling - I was reminded of Richard Strauss's heart-achingly poignant *Metamorphosen* from the same period (1944-45).

This welcome and enriching introduction to the orchestral music of Frank Martin also benefits from a recording of the highest quality - wide-ranging, vivid yet atmospherically balanced. And if you want to find out how it's done, the accompanying booklet tells you how, right down to providing a diagram of Dinemec's mobile recording truck! I earnestly hope that this Swiss-based label will continue to explore the music of a composer who, alongside Arthur Honegger, brought true musical status to the land of the cuckoo clock.

# SOUNDS UNREAL!

## DISTRIBUTOR'S BLOW OUT SALE

An opportunity to purchase some of the world's finest audio equipment at rock bottom prices!



**"From top to bottom this is a remarkably well engineered valve amplifier . . ."**  
*Noel Keywood, Hi-Fi World*

### TUBE TECHNOLOGY

	LIST £	SALE
Seer Line Level Pre Amp	935	395
Seer Phono Pre Amp	1,000	435
Unisis Integrated Line	2,300	935
Unisis Integrated Phono	2,400	995
Unisis Power Amp	1,900	795
Genesis Mono Block Power Amps (pair)	4,700	1,935
Electronic Bias Meter for alignment	-	50

### Pink Triangle

	LIST £	SALE
DaCapo (base unit only, requires filter)	1,400	700
BNC/BNC Hi-Q interconnect cables for DaCapo		25
BNC Re-clock input module for DaCapo	-	49
Toslink input module for DaCapo	-	69
Cordinal CD Player (includes 18 bit filter)	1,680	840
18 bit filter	-	99
Ventricle Speakers (Cherry) pair	1,170	585



**"The sense of realism it confers to music is quite simply the stuff dreams are made of"** *Audiophile*



**"An award winning range of products designed and built to the highest standards"**

### Spendor SPEAKERS in pairs

	LIST £	SALE	
Spendor 2010 Centre Speaker (single)	249	124	<p>"the deliciously smooth and beautifully projected vocals, delicately performed treble and rich and fruity bass were a real treat."  <i>Dominic Baker, Hi-Fi World</i></p>
Spendor 2020 Bookshelf Speaker	399	199	
Spendor 2030 Floor Stander	599	299	
Spendor 2040 Floor Stander	899	449	
Spendor 2030 AV System (2010, 2020 & 2030)	1,247	599	
Spendor 2040 AV System (2010, 2020 & 2040)	1,547	749	



Prices include VAT and are subject to carriage/insurance. Payment by Access and Visa credit cards welcomed.

**Tel: +44 (0)181 460 7299 or Fax: +44 (0)181 460 0499**



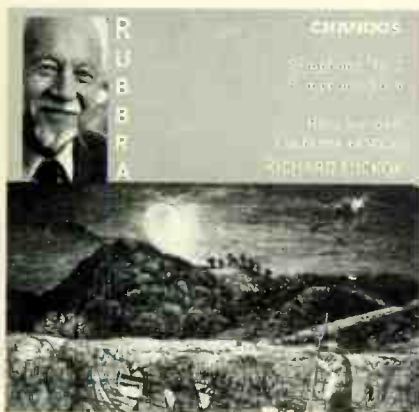
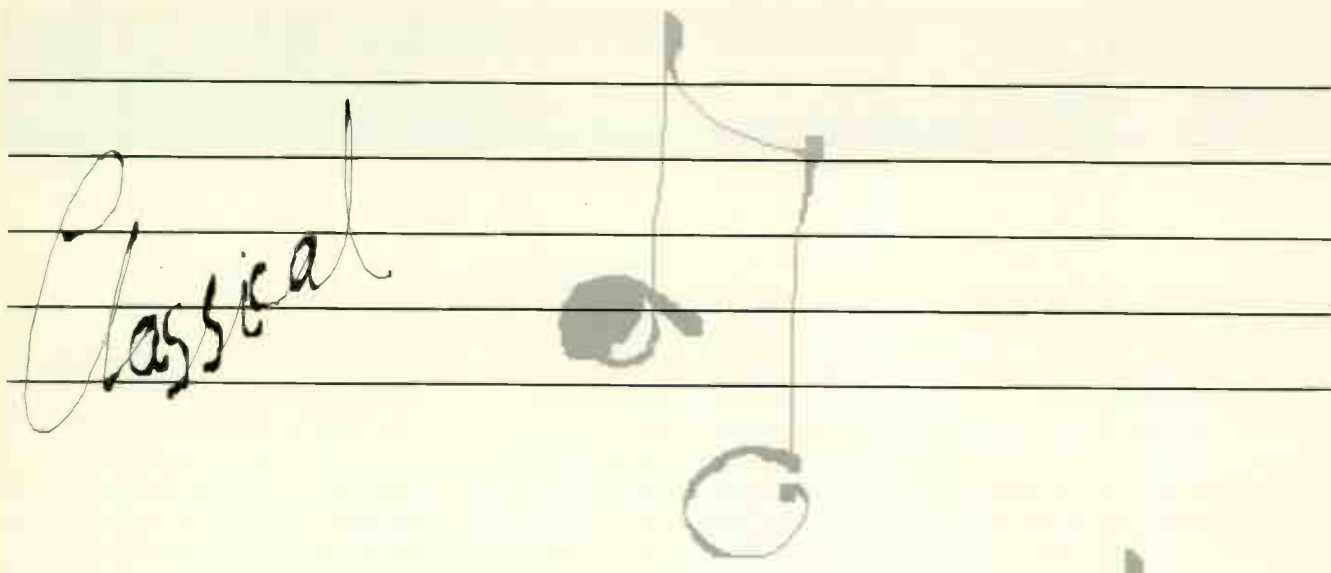

EDMUND RUBBRA

**Symphony No2  
Op45/Symphony No6 Op80  
BBC National Orchestra of  
Wales; conductor, Richard  
Hickox**

CHANDOS CHAN9481 (DDD/67.32)

For decades, the responsibility for championing the music of Edmund Rubbra was shouldered more or less single-handedly by Richard Terrier's Lyrita label. Several of its important recordings of the symphonies conducted by the likes of Sir Adrian Boult, Vernon Handley and Norman del Mar have been reissued on CD, and very fine they still sound. Nevertheless, the appearance of a new symphonic cycle from Richard Hickox, of which this is the third instalment, has been warmly welcomed by all admirers of Rubbra's music. Moreover, to date these Chandos issues have lived up to and, in some cases, most notably the glorious Ninth Symphony, surpassed expectations.

But I may be jumping the gun; there will be those for whom Rubbra is merely an entry in the record catalogue

and his music an unknown quantity. Suffice it to say, therefore, that Edmund Rubbra was born in 1901 in Northampton but did not begin serious musical studies until the age of nineteen after some four years' employment as a railway clerk. He gained a music scholarship at Reading University and, the following year, a scholarship in composition at the Royal College of Music. Among his teachers were Gustav Holst and Ralph Vaughan Williams.

In a career spanning almost seven decades, Rubbra composed well over one hundred works including concertos, chamber music, choral compositions, songs, madrigals and a Mass for double choir. But it is his symphonies that lie at the heart of this considerable output, and justifiably so. They are works that combine craftsmanship and invention with a sublime beauty and deeply felt sincerity.

Rubbra's is English music that doesn't wear its Englishness on its sleeve; there is nothing here of the 'cowpat school', as Constant Lambert scathingly termed it. Instead, there is something of a Nordic grandeur to Rubbra's symphonies, with echoes of Sibelius and, in their robustness and forcefulness, Nielsen. Above all, though, it is Rubbra's individuality and unwavering spiritual conviction that shine through in music that, in many respects stoutly traditional, is no pastiche.

In this latest issue in his Rubbra series, Richard Hickox offers superlative performances of the Second and the Sixth Symphonies, compositions undertaken some seventeen years apart. The former

dates from 1937 (although its orchestration was substantially revised in 1950) and is a work of arresting directness and strong musical unity. Almost every detail contained in its four tightly knit movements derives from the opening unison string line, yet there is no lack of expansive lyricism - witness the serene adagio which offers repose between the tautly energetic scherzo and the dance-like rondo finale.

The Sixth Symphony, composed between 1953 and 1954, contains what many commentators believe is the finest single movement in any of Rubbra's symphonies, the song-like second movement marked *Canto: largo e sereno*. The playing here is spellbinding, demonstrating just how fine an ensemble the BBC's Welsh orchestra has become. It is equally satisfying in the other three movements of a work which, like its companion, derives virtually all its material from a single sequence, in this case a four-note (E, F, A, B) 'motto' heard on cor anglais at the opening of the finale. The reason this kernel occurs here is simply that this was the first movement Rubbra composed, intending it to open the symphony before coming round to the view that it was better suited as its conclusion.

It has been said that Rubbra's music is "not of our time, but could not have been written at any other" and, hearing Richard Hickox's eloquent and committed performances of these two symphonies, that observation falls into place. And Chandos's spacious, full sound - recorded using a 20-bit system - is ideally suited to Rubbra's richly detailed scores.

CLAUDIO MONTEVERDI

**Quinto Libro de' Madrigali  
(Fifth Book of Madrigals)  
Concerto Italiano; director,  
Rinaldo Alessandrini  
OPUS 111 30-166 (DDD/65.19)**

Claudio Monteverdi was responsible for the original operatic masterpiece, *Orfeo*, first performed at the court of Mantua in February 1607. It was in a different league from any of the six *dramma per musica* which had preceded it, beginning with Jacopo Peri's *Dafne* of 1598. But to those familiar with Monteverdi's musical progress, *Orfeo* was no 'bolt from the blue'. Rather it was the inevitable consequence of his genius as a composer of madrigals, the first collection of which had appeared in 1587 when Monteverdi was just 20.

The fifth collection (or 'book') of madrigals predates *Orfeo* by less than two years, having been published by Riccardo Amadino in Venice in July 1605. It was to prove a turning point for its composer.

Monteverdi's unorthodox style, particularly in matters of harmony, had already come in for fierce criticism from certain more conservative members of the musical establishment in Italy, most notably the theorist and composer Giovanni Maria Artusi, canon of San Salvatore in Bologna. Artusi had found much that was not to his taste in the fourth book of madrigals, which Amadino had published two years earlier.

In the dedication to the fifth volume, Monteverdi seizes the opportunity to rebut Artusi's criticisms. He comments that the modern composer, in choosing his musical devices and method of composition, above all "... builds upon the foundations of truth", concluding with the succinct exhortation, "Live happily."

Artusi's adverse remarks clearly cut little ice with the audience for

Monteverdi's music: the fifth book was reprinted by Amadino on no less than six occasions in the ensuing ten years and a seventh reprint appeared in Antwerp in 1615 (Italian merchants had strong trading links with this northern European port).

With the fifth book, arguably the most integrated and coherently assembled of the madrigal collections, Monteverdi's stature and reputation were secured. Equally importantly, it was a major turning point in his career. In this collection of nineteen miniature

translations employed in this excellent production by the French Opus 111 label are first-rate.

Alongside its bold use of harmony and strong melodic lines, the fifth book of madrigals is also distinguished by its varied instrumental accompaniment (deemed essential in the last six pieces but optional elsewhere). Coupled with the demands of the vocal parts, this would indicate strongly that this collection was not intended for amateur performance. For its aristocratic audience, appreciation would have to come from listening not, as it had been accustomed to, playing.

When it comes to the expressive nuances which permeate these madrigals, Rinaldo Alessandrini's *Concerto Italiano* start with a self-evident advantage over rival ensembles. As was displayed in their recordings of the second and fourth books of madrigals (again for Opus 111), nothing can surpass the instinctive, idiomatic response of singers for whom the sound and feel of the vocal lines is inbred. That aside, the nine soloists of *Concerto Italiano* are uniformly outstanding in their

technique, flexible, ever attentive to detail, and sensitive in their tuning.

Just as important in conveying this music to a modern audience is their dramatic understanding, bringing alive what might initially appear an archaic genre. The range of emotions - passionate, pessimistic, joyful, lachrymose, even gently ironic - with which Monteverdi puts flesh on the bones of Guarini's verse is given full rein in these scrupulously prepared but far from detached interpretations. Moreover, the warmth, intensity and fidelity of the performances is beautifully caught by the cleanly balanced recording, produced and engineered by the proven team of Yolanta Skura and Laurence Heym in the appropriate venue of the *salone della musica* of an Italian villa ★



dramas, the genre is taken to the limit of its expressive potential; the previously prescribed emotional boundaries are pushed to breaking point. Though possessing sufficient originality to indicate a new stage in the development of the madrigal, Monteverdi himself would henceforth require an altogether grander vehicle for his ideas. That vehicle was opera.

The texts for the collection are taken from the *Pastor Fido* (Faithful Shepherd) of Gian Battista Guarini, published in 1590 and one of the madrigalists' 'bibles', the other being Petrarch's *Canzoniere*. The dramatic and poetic power of Guarini's words are tellingly reflected in Monteverdi's music, which makes a familiarity with the texts essential. Thankfully, the



# INTERNET

Visit our site

**UPDATED REGULARLY**  
**News; DIY; valve amps/pre-amps; speaker kits; reviews**  
**+ lots more information not published in the magazine.**

**www.hi-fiworld.co.uk**  
**or Email: edit@hi-fiworld.co.uk**



## SUBSCRIBE

★ For the love of music

1 year's subscription only £25 (£2.09 per issue!), and we mail it to you free.

★ Get to our amazing classified ads first and grab a bargain. ★ Run by dedicated hi-fi engineers and enthusiasts, HI-FI WORLD has become famous for its informative reviews and radical kit designs.

### OVERSEAS SUBS RATES

Surface Mail	£38
Airmail Europe	£48
Airmail Middle East & South East Asia	£58
Airmail USA, Canada, Australia, Japan, Korea and China	£68

- Airmail
- Surface mail



**By telephone:** Contact John Dolan **Credit card hotline:** (44) 0171 289 3533  
**Fax:** (44) 0171 289 5620 (Please fax form below)  
**By post:** To pay by cheque or postal order send in an envelope marked **Hi-Fi World, FREEPOST LON3478, LONDON, W9 1BR**

## HI-FI WORLD SUBSCRIPTION CARD

**PLEASE REGISTER ONE YEAR'S SUBSCRIPTION FOR HI-FI WORLD**

DEBIT MY MASTERCARD/ACCESS/VISA ACCOUNT NO:

EXPIRY DATE:

SIGNATURE \_\_\_\_\_

Credit AUDIO PUBLISHING LTD the sum of £25.00 (UK ONLY)

NAME \_\_\_\_\_

ADDRESS \_\_\_\_\_

DAYTIME TEL NO \_\_\_\_\_

# XTC

CDT-1  
DAC-1  
PRE-1  
POW-1

CD transport, FRTB clock, silver cable  
DAC 18bit x8 o/s, twin transformers  
Preamplifier, Class A, system remote  
Power amplifier, 4 channels at 175W

£1250  
£1000  
£1000  
£2000



The ultimate listening experience. Indulge yourself. . . call 0181 810 9388

## van den Hul

## Carbon Cables

### Speaker cables

Skytrack Hybrid (biwire)

£4.99/m

The Snowtrack (biwire)

£9.99+/m

The Cleartrack (biwire)

£12.99/m

The CS122 Hybrid

£11.99/m

Teatrack Hybrid (biwire)

£21.99/m

The Wind Hybrid

£39.98/m

### Interconnects

The Source

£49.99 (0.8m)

D102III Hybrid

£59.99 (0.8m)

The First

£199.99 (0.8m)

### Cartridges

from £3450 to £250

Re-tips from £210



For further  
information call

(01388) 66 32 73

P O Box 31  
Bishop Auckland  
DL14 7YX



# SLATE AUDIO



*Linking The Past, Present & Future*



## THE SPEAKERSTAND®

*The best speaker supports in the world.*

State of the art in both performance and design. custom made to suit any loudspeaker. solid slate, supremely rigid and totally stable.

"Immaculately finished, sublimely rigid, on a par with the best stands I've used." Ken Kessler, Hi-Fi News R/R. "An astonishing degree of instrumental separation, stable and holographic, with great precision and remarkable poise. The ultimate in high fidelity supports." David Prakesel, Hi-Fi Answers. "Superbly finished, the sound quality was considered to be first rate." Martin Colloms, Hi-Fi News R/R. "The sound quality when using the Slate Audio stands proved to be a revelation, something special." Paul Messenger, Hi-Fi Choice. "The finish is excellent, the sound quality magnificent and breathtaking." Tom Bryant, The Telegraph. "The Slate stand is unusual and expensive, but if you are after an exceedingly neutral stand it's the leading contender. This stand offers an exceptionally neutral platform for speakers; highly transparent sound leads to musical performances with real insight." SOUND QUALITY: ■■■■■ Malcolm Steward Hi-Fi Choice.

## SLATE AUDIO GARRARD 301 and 401

*The most musical record players in the world.*

Our researched Solid Marble Plinth System® advances the state of the art and brings the Garrards into the 21<sup>st</sup> century. All wooden plinths produce unacceptable levels of coloration, microphony and feedback, with poor signal to noise ratios. When dealing with a thoroughbred you must respond with a firm hand, as anybody who has heard the transformation will testify.

No other plinth system can claim to improve the performance of these superb players.

*Dear Mr. Soper,*

*Thanks for sending me the plinth for my Garrard 401. I must confess, that I was a bit sceptical about it, when I ordered one - after all, I bought it, without the possibility of listening to it first. But the results I get are really unbelievable. There is no rumbling, instead deep, deep bass and an authority, I never heard before from my records. And believe me, I tried some of the best turntables around (Linn LP 12, Roksan Xerxes). Now I'm waiting for the forthcoming power-supply. The day I place my order for it, I will do so without being a bit sceptical. Thanks again for a marvellous piece of art.*

MR TEILINGNER - AUSTRIA



*Nothing sings like a diamond*



## THE GLASSMAT®

*The finest platter mat in the world.*

The Glassmat® was developed to improve the performance of the Garrard 301 and 401 record players. However it also gives astonishing results when used on other turntables. So effective is its performance, we have now made it available as a universal replacement mat. In all cases other mats introduce colorations of their own, robbing the music of large amounts of detail and ambience. In order to achieve maximum information retrieval with optimum damping, a hard and unyielding material is required. Glass is ideal in every respect, damping is complete, the playing surface being quite simply sublime. In terms of detail resolution and sheer three dimensional ability, no other mat comes close. But then you still have to consider the absolute clarity, precision and solidity of the presentation. This is the ultimate platter mat.

**THE POWERHOUSE OUR QUARTZ REFERENCED GARRARD 301/401 TD124 AND UNIVERSAL POWER SUPPLY. "KILLER" K.K.**  
**THE TABLESTROBE QUARTZ REFERENCED STROBE GUN DESIGNED SPECIFICALLY FOR THE GARRARD 301 AND 401.**  
**THE HANDSTROBE QUARTZ REFERENCED HAND HELD STROBE SUITABLE FOR ANY TURNTABLE WITH SPEED ADJUSTMENT.**  
**STORMFORCE SOLID MARBLE ENCLOSURES® FOR ALL TANNYO DUAL CONCENTRICS. STRUCTURAL DAMAGE MAY OCCUR!!!**  
**HUMDINGER ELEVATE YOUR EARLY SME 3009S2 TO 1997 STATUS. BREATHES NEW LIFE INTO A GREAT CLASSIC.**  
**BACKLASH SUPERB SME 3009 & 3012 GOLD PHONO SOCKET CONVERSION, INCLUDING OFC LEADS; BRILLIANT? YES.**  
**BRAZEN UPGRADE YOUR V15III WITH OUR ALLOY RE-BODY AND MICRO RIDGE STYLUS; INSANE? NO.**  
**SOLID MARBLE PLINTH SYSTEMS® ALSO FOR EMT AND THORENS TD124.**

SLATE AUDIO GARRARD 301 AND 401 ARE AVAILABLE COMPLETE OR MARBLE PLINTH SYSTEM® ONLY.

SME CELEBRATION ARMS WITH SPECIAL GRAPHICS "GARRARD 301 OR 401 CELEBRATION" AND "THORENS TD124 CELEBRATION" 309 • 312 • IV • V.

THE TONEARM OUR SPECIAL VERSION OF THE FAMOUS REGA R8300, FITTED WITH GOLD PHONOS.

SME 3009S2 (1997 VERSION) A PERFECT MATCH FOR OUR V15III BRAZEN AND THE NEW SHURE V15V x MR. "STILL CRAZY AFTER ALL THESE YEARS".

THE SPIKEKIT SPECIALLY DEVELOPED TO FIT DIRECTLY TO FLOOR STANDING LOUDSPEAKERS OR ANY WOODEN SUPPORT ADJUSTABLE AND VERY SIMPLE TO FIT.

**BE BRAVE FACE YOUR FEARS LIVE YOUR DREAMS**

SHURE STYLUS PRESSURE GAUGE • GARRARD 301 SWITCH SUPPRESSOR • TURNTABLE SERVICING • GARRARD 301 LEVER SET • GARRARD 301 FIXING BOLT SET  
STROBE DISC • GARRARD 401 CONTROL PANEL SET • GARRARD 301 MOTOR PULLEY • FULL RESTORATION OF GARRARDS TO ORIGINAL CONDITION

**ALWAYS WANTED, GARRARD 401, GARRARD 301 AND THORENS TD124 RECORD PLAYERS, PLEASE PHONE**

**47 GEMINI CLOSE, LEIGHTON BUZZARD, BEDS, LU7 8UD.**



TEL/FAX: 01525 384174 MOBILE: 0421 624429



# GAMMA ACOUSTICS

"This amplifier possessed a seductive vitality, a marvellous sense of communication with the heart of the music. Vocals were most communicative, subtle dynamic contrasts were portrayed very well, and the music bounced along with a fine sense of rhythm. This amplifier was seriously transparent, showing great clarity, fine stereo depth and very fine presentation of space and ambience in the sound stage."

"It sounded quick, direct, uncomplicated, with an ability to resolve subtle textures in instrumental scoring. Taken overall, the sound quality score (on my usual subjective listening test scale) was an impressive 23 points."

*Martin Colloms*  
HI FI NEWS / RR March 97

The Rhythm presentation as a whole could be described as clean and powerful, in an appealing natural way."... "Whether it was the string quartets of Ravel or Debussy, Alanis Morissette or Joni Mitchell being fed into the Rhythm, what emerged always impressed with its natural, easy power and control. For those in search of an alternative to the 300B, one which couples the organic feel of valve amplification with a rather un-valve-like ear-opening bass extension and control, the Rhythm is definitely worth audition."

*Jon Marx*  
HiFi World July 1996

## WORLD VERDICT

Partnered with sensible 'speakers of good bass depth, the Rhythm is capable of impressive performance.

## WHAT HI-FI? says

sound ★★★★★

facilities ★★★★★

build ★★★★★

verdict ★★★★★

*Dan Houston*  
WHAT HI-FI May 1997

**Tel: 01753 526939**

**Fax: 01753 532262**

Ivy Lodge, 81 Sussex Place, Slough, Royal Berkshire, SL1 1NN, England.



RHYTHM 211/VT4C LINE INTERGRATED £2499

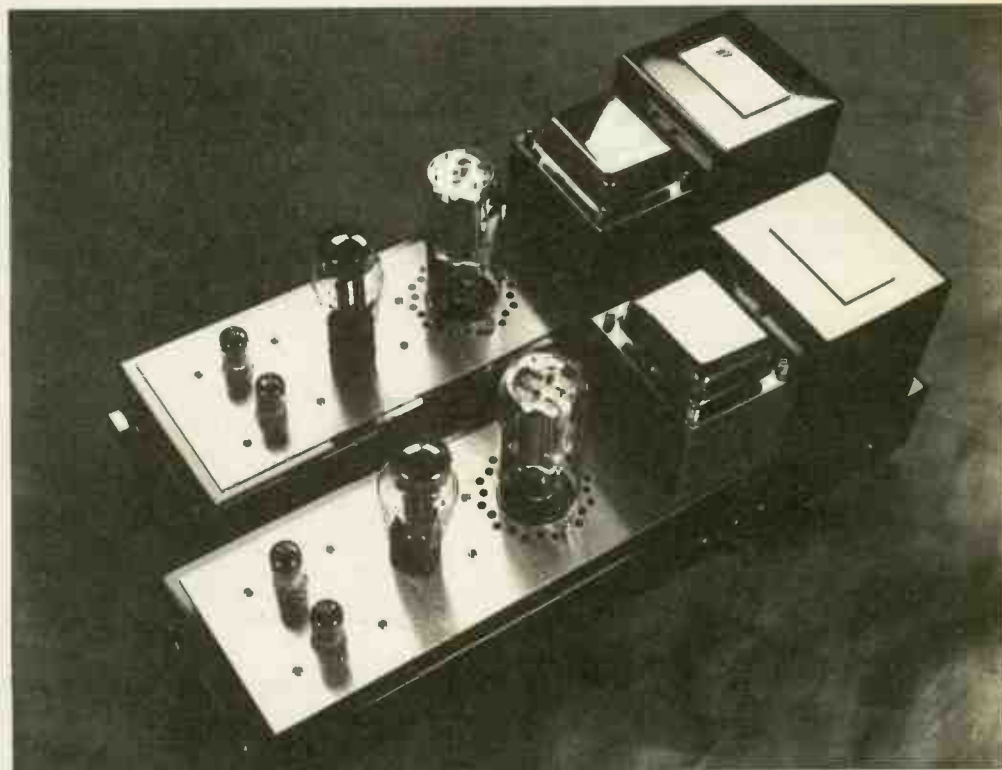

NEW AEON MONO BLOCKS £4999 A PAIR

## Clearance List

	RRP	XD S/H		RRP	XD S/H
We have a number of Gemini line integrated S. Ended triode amplifiers with the original old front panels on at £399.00 a saving of over £300 on a superb acclaimed product, very limited stock.					
Epoch Reference Five spk FABULOUS Piano Bl. New Marked	£2999	£1400	AEON new marked	£4999	£2500
RHYTHM 211/VT4C Phono New return. slight paintwork chip/ mint in all aspects	£2499	£1350	AEON ex review	£4999	£4000
As above New blemished	£2499	£1600	Era Std. phono MM preamp New marked New	£999	£399
RHYTHM LINE Ex review/as new marked	£2499	£1750	SPACE REFERENCE mk1 300B S. Ended power/line Integrated S/H All new tubes.	£3999	£850
			Epoch loudspeakers EX Demo slight marks	£1499	£699
			Voyd Bl pu SME4 silteck wired / Audionote I.O. A.I 100m.c.t bargain	£4700	£2600





## DENYS TRICKETT'S HI-FI CURIOSITY SHOP

Why pay £500 for a vintage valve rebuild?  
Why indeed!

Leak power amps + preamp £100.

Quad 2 x II and 22 pre £120 for a  
standard rebuild - polyprops + carbon.

Special components at cost.

All guaranteed 2 years.

We buy sell and exchange all valve  
vintage and classic Hi-Fi: Quad, Leak,  
Radford, McIntosh, Fisher what have you.

Other Classic Hi-Fi. Buy-sell-exchange-  
repair all Quad models 33/303 34/44/405.  
ELS, Tannoy, Lowther, Altec, Revox,  
McIntosh, Fisher, Nakamichi, Garrard  
301, 401, 4HF, Thorens 124, 135, 160,  
125, 126, 224

Mastercard: Visa: Amex 23 Bell Street  
London  
NW1 5BY



Tel/Fax: 0171 723 8545

## R.J.F. AUDIO VISUAL

**HIGH END  
AUDIO FOR  
DISPOSAL AT  
GIVE-AWAY  
PRICES!**

84 PNDARVES STREET, TUCKINGMILL, CAMBORNE  
CORNWALL TR14 8NJ 01209 710777

EQUIPMENT	List £	Clearance £
QED Digit Reference DAC	450.00	269.00
QED Digit Plus	199.00	129.00
QED Super Dac Pac	139.00	99.00
Kinshaw Overture DAC	239.00	199.00
Meridian 200/263/Tri chord II	used	650.00
Micromega Stage 1	549.00	400.00
Micromega Mirium CD	350.00	299.00
Micromega Mirium FM	300.00	249.00
Micromega Mirium AMP	350.00	249.00
Micromega Mirium Speakers	300.00	249.00
Impulse H6 Speakers	used	700.00
Micromega Leader	used	275.00
Kinshaw Perception Monoblock Amps (£1500 new)	used	999.00
Kinshaw Perception pre-amp	459.00	359.00
Arcam Alpha Plus	used	275.00
Heybrook TT2/Linn Basik LV X	used	200.00
QED Digit Plus	old stock	150.00
QED DAC PAK	old stock	120.00
Exposure X Integrated amp (when new £725)	used	200.00
Revox A77, V.G.C.	used	400.00
Aiwa XA-003	ex-dem	185.00
JBL Music One subs/sats	ex-dem	200.00
QUAD 33/303	used	175.00
Technics SH-11P3 / Mission 774 / Grado F1	used	400.00
Technics SL-110 motor unit	used	220.00
Acos Lustre arm	used	130.00
Roxan ROK-DA1	used	250.00
JBL Music 2 Sub-bass powered 100 watts	550.00	400.00
Rotel RT935AX tuner	150.00	130.00
Rotel RT950BX	250.00	200.00
Grado SR60 phones	79.00	60.00
Grado SR125 phones	150.00	120.00
Beyerdynamic DT511 phones	106.00	85.00

Also consult us for your high (or low) end repairs / mods, CD re-clocking, etc.

## MUSICAL FIDELITY

### X-SERIES



#### X10-D "THE MISSING LINK"

Designed as an upgrade for budget to mid  
priced CD players this tube line stage has a  
very high input impedance so that your CD  
player works into an easy load, the X10-D then  
easily drives the amplifier input giving clearly  
audible improvements in dynamics and bass  
response. Can also be used with other line level  
sources or between pre and power amps etc.

£119.99



#### X-CANS

A high-end Class A triode tube headphone  
amplifier for the serious headphone listener,  
used with good quality headphones the results  
are truly breathtaking.

£129.99



#### X-DAC

Upgrade your existing CD player to the  
latest technology the X-DAC is fully  
HDCD compatible for great sound with  
your existing discs and the new HDCD  
encoded discs. Compatible with CD, DAT  
and broadcast digital standards with both  
coaxial and optical inputs.

£299.99

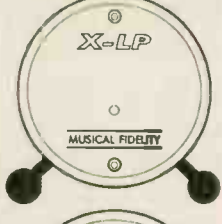

#### X-LP

For lovers of vinyl who either don't have or  
want to upgrade their phono input. Caters for  
both MM and MC cartridges. This low noise,  
high quality phono stage will get the very  
best from your record collection.

£129.99

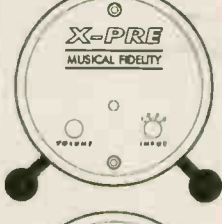

#### X-PRE

A very high quality Class A triode tube pre-  
amp which will find numerous uses, for  
instance adding extra inputs to a system or  
upgrading the performance of integrated  
amplifiers or simply as a high quality pre-  
amp.

£199.99

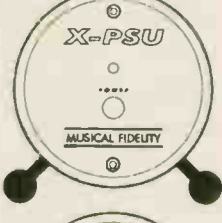

#### X-PSU

Upgrades and powers up to four X-series  
units. The X-PSU even further improves the  
performance of the X-Series units.

£129.99



#### X-TONE

Tone control module with separately  
selectable and defeatable bass and treble roll  
off frequencies. Allows subtle tailoring of  
system sound to adjust for system deficien-  
cies, room resonances etc. without disturbing  
the midrange tonality.

£129.99

For more details or to order any of the above, please call:-

*Audio Masters*

Tel:- 01608 644954

Fax:- 01608 645954

e-mail:- sales@audio-masters.demon.co.uk

1 Dunthorp Farm Cottages, Heythrop, Chipping Norton, Oxon, OX7 5TJ

5 Rocks Lane Barnes  
London SW13 0DB

Tel: 0181 876 3355

Fax: 0181 876 3399

**Don't cheat yourself...  
...Treat yourself  
to the world's finest audio fidelity equipment**

We specialise in:

Audio visual interior design • Multi-room installations • 'Life-style' systems  
Systems from £300 to over £30,000

### CLEARANCE BARGAINS

	Was	NOW
AVI S2000 MP Pre-Amp (SH)	£949	£549
AVI S2000 250W Pwr Amp (SH)	£2500	£1500
AVI S2000 ref CD Player	£1400	£1099
B+W CDM1	£600	£479
B+W 602	£300	£239
Chario Hiper 1000 Tower	£800	£499
Chario Academy 1	£1300	£975
DPA 200S Pre (SH)	£495	£339
DPA 200S Pwr (SH)	£775	£399
KEF Reference Model One	£1200	£899
Linn Axis/Basik (s/h)		£199
McIntosh MC500 Pwr	£8000	£5499
McIntosh C712 Pre-amp	£1500	£1125
McIntosh MC7100	£1400	£1050
Michell Gyrodec	£825	£659
Project 6 - MC15	£450	£379
Roksan Rok One	£645	£515
Tannoy 632 Plus	£199	£159
Tannoy Mercury M2	£140	£115
Tesseract Audio T amp 60 (Pr)	£7700	£3999
TDL RTL 3	£399	£299
TDL RTL 2	£279	£209
Teac AR 500	£250	£199
Teac TI Transport	£550	£439
Thorens TD180	£190	£145

### NOW DEMONSTRATING

AVI Pre-amp + Monoblocks - *awesome*  
 ANTHEM Integrated/Pre/Power-Amplification -  
*best of Canadian valves*  
 CYMBOL - *HDCD at £1299 - Unreal*  
 CYMBOL - *New Integrated amp at £499*  
 ELECTROCOMPANIET - *Class A Perfection from Norway*  
 GAMMA ACOUSTICS RHYTHM - *single ended integrated*  
 LINN - *LP12, HI-FI + Multi Room solutions*  
 MARANTZ - *CD63SE, CD63 K.I.Sig*  
 MERIDIAN - *500 Series*  
 MAGNUM DYNALAB - *Ultimate reference tuners.*  
 MICROMEGA STAGE/DRIVE - *Vinyl like CD - so natural*  
 ROKSAN - *Caspian Amp + CD*  
 RUARK - *Icon, Sceptre, Broadsword - monitor heaven*  
 RESTEK - *The Germans have landed - Challenger II, Concret CD "Battleship hi-fi" - Trully remarkable*  
 SONIC FRONTIERS SFCD1 - *HDCD - Heaven*  
 SONNETEER CAMPION - *The best*  
 SONNETEER ALABASTER - *The best gets better*  
 SYSTEMDEK - *RM1 and RM2 bookshelf monitors - Beyond words, simply breathtaking*  
 TOTEM Model 1 - *We dare you*  
 TOTEM MANI 2 - *Our best loudspeaker*  
 TRICHORD - *Revelation and Genesis CD Players*

AVI, ALCHEMIST, ANTHEM, BOSE, BOULDER, CABLETALK, CHARIO, ELECTROCOMPANIET, EXPOSURE, FINAL, GAMMA ACOUSTICS, GENESIS, HEYBROOK, JAMO, KEF, LINN, LUMLEY, MAGNUM DYNALAB, MARANTZ, MCINTOSH, MERIDIAN, MICHELL, MICROMEGA, MYRYAD, PRECIOUS METALS, PROJECT, ORTOFON, QUAD, REVOX, ROKSAN, RUARK, SEQUENCE, SOUNDSTYLE, SONNETEER, SONICLINK, SENNHEISER, SONIC FRONTIERS, TDL, TEAC, TOTEM, TRICHORD, TANNOY, TARGET

Showroom open 10.00 to 6.00 Monday to Saturday

All Major Credit Cards Accepted • Finance Arranged • 2 Demonstration Rooms

Try Me & See - Mail Order Worldwide

Tel: 0181 878 0066

Fax: 0181 876 3399



# MEASURED PERFORMANCE

## CD

### ARCAM BLACK BOX 500

The BB500 is the latest in a long line of Arcam DACs, their experience in this field obvious from this DAC's test performance.

The BB500 has a very flat frequency response with very little roll-off at higher frequencies. Most manufacturers roll treble off more than this to ensure smoothness but as long as all else is well this won't be problematic. Distortion figures are good but at -30dB there are traces of non-harmonic distortion present which could lead to a slightly grainy or gritty quality to the sound. Dynamic range is good at 109dB and output is accurate at 2V. **KB**

Frequency response	4Hz-21kHz		Separation (dB)	left	right
Distortion (%)	left	right	1kHz	106	109
-6dB	0.006	0.005	20kHz	81	83
-30dB	0.019	0.019	Noise		-95dB
-60dB	0.48	0.41	with emphasis		-96dB
-90dB	30.3	29.5	Dynamic range		109dB
-90dB dithered	16.6	15.5	Output		2.0V

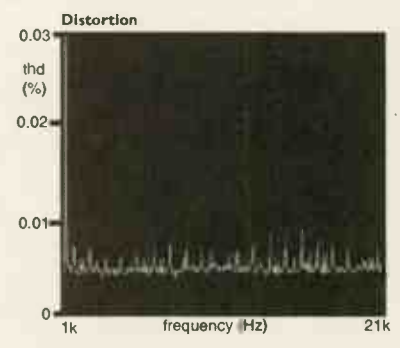
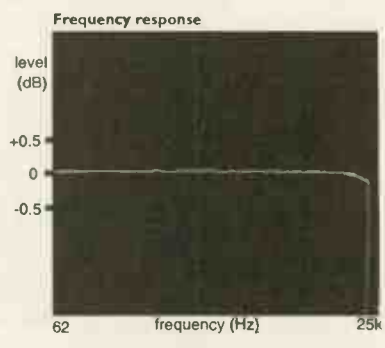

### AUDIOLAB 8000DAC

Audiolab's latest 8000DAC produced some impressively low distortion results. At -30dB only the slightest amount of second harmonic distortion is visible which, because it is an even-order distortion, is innocuous to the ear. At such a low level it is unlikely to colour the sound. Even at -60dB the distortion figure is only 0.35% which is the lowest of the group. The frequency response shows a subtle bass lift and a gentle rolling off of at the top end, so I'd expect strong basslines and a smooth treble. Output is spot on Philips' standard at exactly 2.0V. This is a well engineered DAC. **KB**

Frequency response	4Hz-21kHz		Separation (dB)	left	right
Distortion (%)	left	right	1kHz	121	120
-6dB	0.005	0.005	20kHz	99	97
-30dB	0.006	0.006	Noise		-105dB
-60dB	0.35	0.35	with emphasis		-105dB
-90dB	28.3	28.6	Dynamic range		111dB
-90dB dithered	13.2	13.8	Output		2.0V

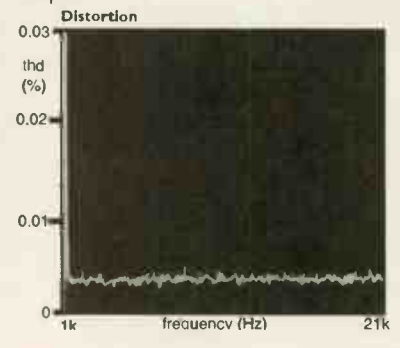
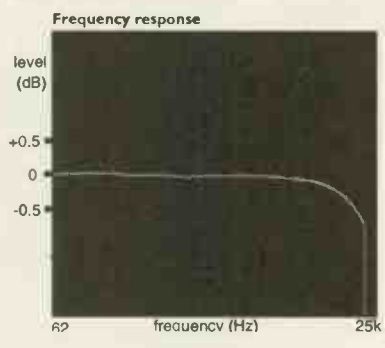

### DPA ENLIGHTENMENT

The Enlightenment uses DPA's in-house designed dx32 one-bit digital-to-analogue convertor which gives worse than average distortion figures at all levels. At -30dB you can see that not only is the harmonic distortion figure on the high side but also present is a large amount of non-harmonic distortion. This, when combined with the rising treble in the frequency response, may well give a sharp edge to the sound. Only listening will show whether this will prove a problem or not. Having said that, previous experience of DPA's 1024 and an earlier example of the Enlightenment show that there may well be benefits to DPA's discrete design that outweigh the poorer than average distortion performance. **KB**

Frequency response	4Hz-21kHz		Separation (dB)	left	right
Distortion (%)	left	right	1kHz	85	78
-6dB	0.027	0.022	20kHz	74	77
-30dB	0.041	0.074	Noise		-96dB
-60dB	1.1	1.58	with emphasis		-101dB
-90dB	42.8	49.9	Dynamic range		100dB
-90dB dithered	41.3	54.1	Output		2.1V

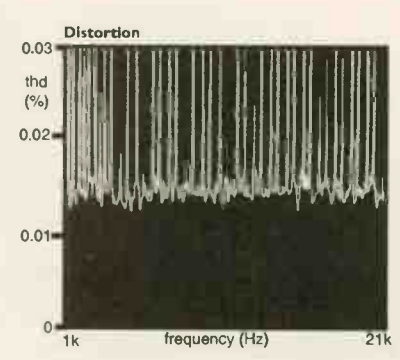
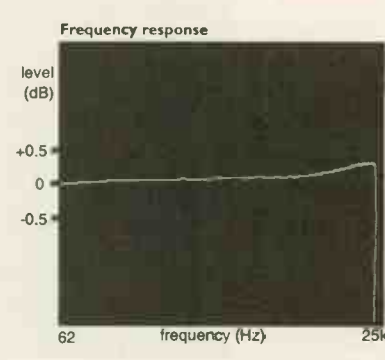

**The Hi-end**  
Barnes  
London  
tel.0181 876 3355

**London Hi-Fi**  
**Services**  
North London  
tel.0171 263 1015

**Amadeus Sound**  
**& Vision**  
W.Midlands  
tel.0121 354 2311

**J & A Cameras**  
Barnstaple  
Devon  
tel.01271 24384

**WORTHING**  
**AUDIO**  
W.Sussex  
tel.01903 212 133

**The Right Note**  
Bath  
tel. 01225874 728

**Olivia Audio**  
Essex  
tel. 01702 585 865

**May Audio**  
**Marketing (UK)**  
Ltd.  
W. Yorkshre  
tel.01535 632 700

**BIL AUDIO**  
Northumberland  
tel.01670 788671

**Replay**  
Chester  
tel. 01244 401290

# Campion and Alabaster

by

# SONNETEER

"...utterly gripping" "...on its own amongst its class." "...exceptional value for money." "most attractive sounding..." "sounds greater than the sum of its parts." "almost too good to be true." "a liquid flow of musical delight." "great vocal subtlety..truly powerful dynamics." "The best..." ".....and it gets better and better." Extracts from Hi-Fi World and Hi-Fi News and Record Reviews Jan '96, Sept '96, Dec '95 and May '97.

Hand Crafted In the U.K. by F.T.M. Marketing Limited.

PO Box 163c, Esher, Surrey. KT10 0YH.

Tel.01372 468676 or Fax.01372 470053

Mobile 0956 600 306

## Haden Boardman's mellotone

	<b>Loudspeakers</b>	
Tannoy 633, mint condition,		£200
Quad Electrostatics (ESL57s), working fine		£300
Magneplanar Timpani		£1800
Castle Conway III, matching stands, teak, mint		£450
Leak Sandwich Speakers, originals, various pairs		£50-£100
Tannoy ILLZ Golds,		P.O.A.
Tannoy Lancaster, 12" Golds		P.O.A.
	<b>Turntables:</b>	
Thorens TD224, mint & fully working		£275
Thorens TD125/II, mint		£120
Thorens TD166, brushed aluminium plinth		£75
Thorens TD520, mint, with Ortofon MC15.		£275
Harman Kardon / Rabco ST8 turntable		£120
Decca FFSS, various in stock		please call.
	<b>Recorders:</b>	
Revox A77, half track, amps & speakers		due in
Revox A77, half track, last version		due in
Revox G36, half track, valve		£200
Sony TCD D3 portable D(r)AT, boxed		£350
Nakamichi DRAGON cassette		£1200
Fostex E-16, 1/2", 16 track with remote & full loom, mint		£1700
	<b>Amplifiers:</b>	
H.H. VX1200, 600w + 600w pro power amp		£750
Quad 33, preamp		£55
Fisher X-100, mint valve amp, wooden case, best ever		£325
McIntosh C28, pre-amp		£675
McIntosh C26, pre-amp		£875
McIntosh 2105, power amp, 105wpc		£875
Leak STEREO 20, serviced, working perfect, with pre		£220
Leak STEREO 20, full perfect phase modifications, stunning sounding		£300
Leak TL25 + monoblock, just a single, original		£200
BTH/AEI A1, 20w valve mono, works, but untidy		£100
Sugden A48, original		£75
Scott integrated valve amp		£170
Westrex amplifiers, various		details on request
	<b>Tuners:</b>	
Beam Echo Avantic BM611, AM/FM Tube mono.		£75
Armstrong AM/FM tube tuner		£25
Leak Troughline II, with TdP FM decoder		£300
Leak Troughline I		£50
Troughline STEREO, modified high output, serviced		£150
Leak Troughline III, with TdP FM decoder		£300
Yamaha T2, outstanding FM tuner		£300
	<b>Misc:</b>	
Marantz HiFi rack, glass front & top, as new condition		£75
Alphason Atlas turntable power supply		£250
Slax Lambda Ear speakers, upgraded,		call for details
Soundtracks Topaz Project 8 desk, PC Windows automation, virtually unused		£2250+VAT
	<b>Hi-Fi Bought/Sold/Repaired &amp; Renovated</b>	
	<b>Demonstration facilities</b>	
	<b>Mall order speciallist. Part Exchange welcomed.</b>	
	<b>mellotone.</b>	
	The mellotone Acoustics Company,	
	P.O. Box 67, WIGAN, Grt. Manchester. WN2 3AG	
	TEL: 01 942 25 75 25	
	Fax: 01942 525861	
	E Mail: mell@tone.u-net.com	

## MUSONIC STYLI

Manufacturers and Suppliers of Replacement Styli for the following Cartridges

A&R	GENERAL ELECTRIC	RADIOHM
ACOS	GLANZ	RCA
ADC	GOLDRING	REALISTIC
ADMIRAL	GRACE	RESON
AIWA	GRADO	REUTER
AKAI	HAFÉ	RIGONDA
AKG	HITACHI	ROCK-OLA
AMSTRAD	HMV	RONETTE
ARCAM	HW	ROTEL
ASTATIC	ISKARA	SANSUI
AUDAK	JELCO	SANYO
AUDIO DEVELOPMENTS	JVC	SCHUMANN MERULA
AUDIO TECHNICA	KENWOOD	SCOTT
AUE	KS	SEEBURG
BANG & OLUFSON	KSMU	SHARP
BELLELEX	LENCO	SHURE
BRAUN	LESA	SIGNET
BROTHER	LINN	SINGER
BSR	LUSTRE	SONIC
CEC	LUXMAN	SONOTONE
CHUO DENKI	LUXOR	SONOVOX
CLARVILLE	MAGNAVOX	SONY
COIN	MARANTZ	STANTON
COLLARD	MARLUX	SUPLEX
COLLEL	MASTERCRAFT	SUPRAPHON
COLUMBIA	MICRO	TANNOY
CONER	MISSION	TEAC
CORAL	MITSUBISHI	TECHNICS
COSMO	NAD	TECHTRON
CRONOTON	NAGAOKA	TELEDYNE
DECCA	NATIONAL	TELEFUNKEN
DENON	NEAT	TELETON
DIGITRAK	NEC	TENOREL
DUAL	NIVICO	TENSAI
EAGLE	ONKYO	TEPPAZ
EDEN	ORTOFON	TETRAD
ELAC	OSAWA	THOMSON
ELECTRO VOICE	PANASONIC	TOSHIBA
EEI	PATHE MARCONI	TRIANETTE-REUTER
EMI	PERTUUM EBNER	TRIO
EMPIRE	PHILCO	UNITRA
ERC	PHILIPS	VACOVARCO
EUPHONICS	PICKERING	VEB
EXCLLARD	PIEZO	VICTOR
FISHER	PIONEER	WEGA
FONICA	PLESSEY	YAMAHA
FUJI DENKI	POWER POINT	ZENITH
GARRARD	PYE	

For prices tel/fax/e-mail your stylus/cartridge details. Versions for 78 rpm records supplied in many types. Original styli and cartridges also available. Trade enquiries welcome.  
Suppliers of extensive range of accessories (full list available on request):  
Compact Disc - Cleaners, Storage, Replacement Cases, PVC and Card Sleeves.  
Record - Antistatic Fluid, Nagaoka Inner Sleeves, Storage Cases, Cleaners, PVC/ Card/Paper Inner/Outer Sleeves, Head Shells, Turntable Slipmats.  
Tape - Cleaners, Storage, Replacement Cases, Cardboard Sleeves, Reel-To-Reel, Cassettes.  
Cables - Full range for Audio, Video and Computer.  
**MUSONIC (UK) LIMITED**  
Unit 3 Second Way Wembley Middlesex HA9 0YS  
Telephone: 0181-903 7067 Fax: 0181-903 4607 e-mail:musonic@compuserve.com

# AMADEUS

Audio Gem, Aura,  
AVI, B&W,  
Castle Acoustics,  
Heybrook, Marantz,  
Musical Fidelity,  
NAD, Pioneer,  
Rotel, Sequence,  
Shearne Audio,  
Sonneteer, Teac,  
Technics.

## SOUND & VISION

10 BOLDMERE ROAD  
SUTTON COLDFIELD, WEST MIDLANDS  
Tel: 0121 - 354 2311



**MARSTON AUDIO RESEARCH SILHOUETTE**

The Marston Silhouette DAC measures extremely well. It's frequency response is flat and the distortion measurements at all levels are very low. At -30dB the trace shows barely any harmonic distortion at all, a good result. Noise performance was also commendable, going down to -114dB with emphasis. Output was spot on standard at 2.0V. **KB**

Frequency response 4Hz-21.1kHz

Distortion (%)	left	right
-6dB	0.007	0.007

-30dB	0.072	0.075
-60dB	0.71	0.70
-90dB	31.6	32.0
-90dB dithered	22.3	22.4
Separation (dB)	left	right
1kHz	110	110

20kHz	89	88
Noise		-113dB
with emphasis		-114dB
Dynamic range		105dB
Output		2.0V

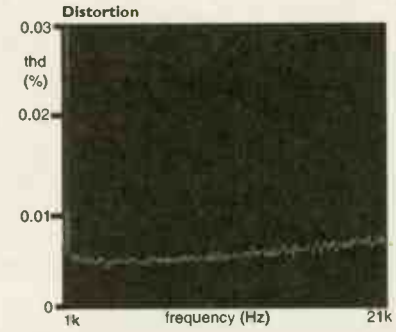
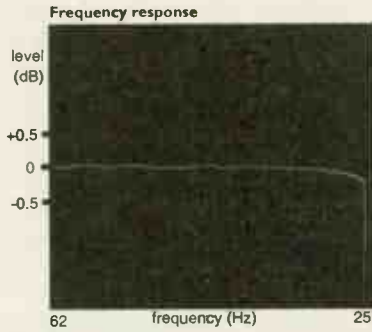

**MONARCHY AUDIO MODEL 18**

The Monarchy frequency response has a very shallow down turn which becomes a plateau at a lower level. The effect is probably subtle subjectively. What is likely to be noticeable are the relatively high levels of harmonic distortion present at -30dB. Fortunately these are predominantly even-order and while they may colour the sound are unlikely to have a sonically unpleasant effect. Out-of-band spurious products were not well suppressed, measuring -31dB. Output was very high at 2.7V. **KB**

Frequency response 4Hz-21kHz

**ROKSAN CASPIAN CD**

The Roksan Caspian delivered a fine frequency response with some gentle rolling off at the top end which should help it sound smooth. The distortion figures were good, though in the -30dB trace there are higher orders of both odd and even harmonics present. As their levels are fairly low I wouldn't expect them to have a noticeable effect on the sound. Dynamic range is satisfactory at 106dB and output is close to standard at 2.1V. **KB**

Frequency response 4Hz-20kHz

Distortion (%)	left	right
-6dB	0.009	0.010
-30dB	0.04	0.07
-60dB	1.15	1.96
-90dB	37.2	42.3
-90dB dithered	21.7	27.1

Separation (dB)	left	right
1kHz	117	119
20kHz	96	98
Noise		-98dB
with emphasis		-101dB
Dynamic range		104dB
Output		2.7V

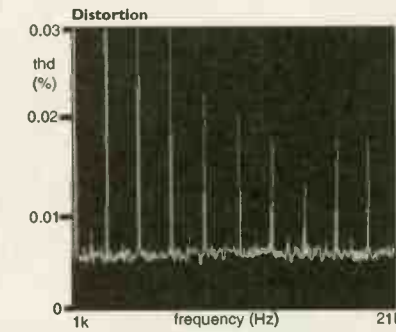
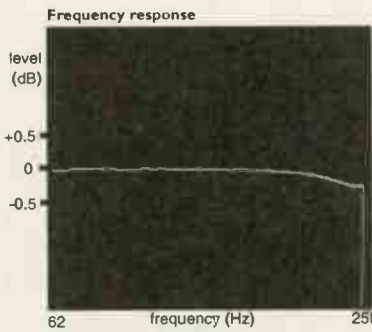

Distortion (%)	left	right
-6dB	0.007	0.007
-30dB	0.025	0.026
-60dB	0.467	0.532
-90dB	28.7	29.1
-90dB dithered	16.8	17.5

Separation (dB)	left	right
1kHz	111	106
20kHz	89	81
Noise		-103dB
with emphasis		-104dB
Dynamic range		106dB
Output		2.0V

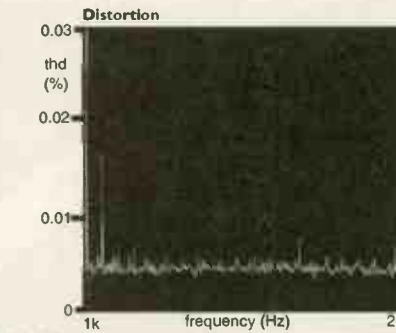
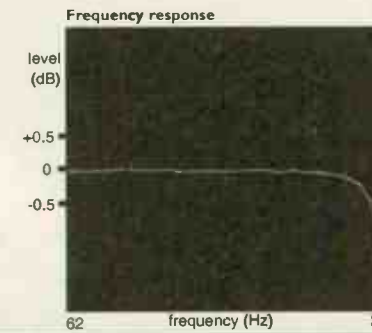

**TUNER**

**SONY ST-SE700**

The ST-SE700 displays flat audio response from 5Hz up to 15kHz (-1dB). Lack of spurious pilot and sub-carrier ensures the Dolby system of cassette decks will not have its action blocked. Distortion was low at 0.13%, comprising a little second and third harmonic.

The extra cost of this tuner translates into lower hiss (-75dB), about 3dB better than usual, and a wide range signal strength meter with analogue indicator and digital readout (dB relative to 1µV). It has an upper readout limit of 70dB (3mV) but the highest sector on the analogue

indicator lit at 5mV, high enough to show whether full quieting has been achieved.

The ST-SE700 measured well. **NK**  
 Frequency response 5Hz-15kHz  
 Stereo separation 48dB  
 Distortion (50% mod.) 0.13%

Hiss (CCIR)	-75dB
Signal for minimum hiss	1mV
Selectivity (at 0.4MHz)	80dB
Sensitivity	
mono	2µV
stereo	25µV
Signal strength meter (µV):	
20, 50, 63, 80, 125, 1000, 4000, 5000.	

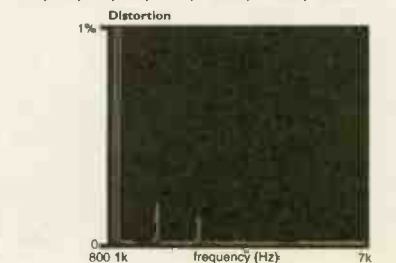
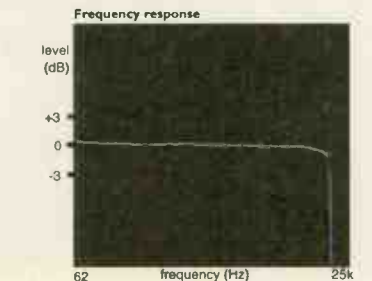



# SOUND-BYTES

High Density Filler for Speakers and Stands

There is no doubt, that for maximum speaker performance, your stands or mass loadable floorstanding speakers must be filled with a suitable mass loading material. Our small diamond shaped steel chips are designed to almost completely eliminate pillar and cabinet resonance that would normally adversely effect speaker performance.

But don't just take our word for it, independent recommendations from the stand and speaker manufacturers listed below speak for themselves as do the glowing reviews from the Hi-Fi press. In addition we have just celebrated a record breaking sales figure of 25 TONNES of material sold throughout the UK over the last 12 months. All these sales and not a single complaint - only letters of thanks from satisfied customers!



## FOR MASS LOADING, THERE IS NO SUBSTITUTE!

### WHAT THE EXPERTS SAY:

"Not only was the bass tighter and better defined, but midrange became better focused and treble more precise."

Dominic Baker.  
Hi-Fi World

"Listening tests proved conclusively to my mind that SOUND-BYTES are thoroughly effective"

Jonathan Kettle.  
CYBERFi

"It'll improve your unfilled stands, budget or dear" Ken Kassler.  
Hi-Fi News

### RECOMMENDED BY THE FOLLOWING MANUFACTURERS:

APOLLO, ATACAMA AUDIO, B&W, KLH, KUDOS, MISSION, MONITOR AUDIO, PARTINGTON, REVOLVER, RUARK, SOUNDSTYLE, SOUND ORGANISATION, TARGET

### AVAILABLE MAIL ORDER FROM

**Colin Mackenzie's  
HI-FI-CORNER**

Scotland's No.1  
Hi-Fi Company

Tel: 0131 556 7901

ONLY £19.95 + £5.00 P&P

## Colin Mackenzie's HI-FI-CORNER

Scotland's No.1  
Hi-Fi Company

MAIL ORDER FROM  
HI-FI-CORNER SELECT  
1 HADDINGTON PL  
EDINBURGH  
TEL: 0131-556-7901

### MORE OUTLETS AT:

52 GORDON STREET  
GLASGOW  
TEL: 0141-248 2840

121 ROSE STREET  
EDINBURGH  
TEL: 0131-220 1535

44 COW WYND  
FALKIRK  
TEL: 01324-629011

<http://www.virtual-publishing/cyberfi/hifishop/>



PURE  
DEAD  
BRILLIANT

MISSION 731i  
SPEAKERS AT  
HALF PRICE!\*

\*Buy 2 or more Mission 731i speakers and get a pair of Mission 731i speakers at HALF PRICE!

Available while stocks last.

THIS GREAT OFFER IS ALSO AVAILABLE  
TO SASSENACH'S!

Arcam  
Audiolab  
Audiquest  
Beyer  
Bose  
B&W  
Castle  
Collection  
Denon  
Dorcen  
Harman  
Kelvin Cables  
Kenwood  
Micromega  
Mission  
NAD  
Onkyo  
Panasonic  
REL  
Ruark  
Sennheiser  
Sound-Bytes  
Soundstyle  
Tannoy  
Target  
TDL  
Teac  
Technics  
Thorens





# LOUDSPEAKERS

## MISSION 732I

The 732i peaks a little in the bass - not unusual - to give it speed and enthusiasm. Our analysis shows the lift in output this gives around 130Hz. The bass -6dB point is a low 50Hz, but this is not the low frequency limit of the 'speaker, for the port goes down further. Across the rest of the audio band the Missions were very flat, as our analysis shows. This was the case over a wide range of forward angles, so the 732is have good dispersion and the drivers are well integrated in phase terms. The treble unit rolls off smoothly above 10kHz, but this is not necessarily a bad thing. It ensures there's no sharpness or

sting, but the 732i will not dull the sound.

Sensitivity was good at 87.5dB for one nominal watt of input (2.84V). Overall impedance measured 9ohms, the impedance curve never dropping below 6ohms across the audio band. This means

the Missions will not draw much current and, with smooth slopes indicating low values of reactance, they are an easy enough load.

The 732is are well engineered all round and will be easy to drive. **NK**

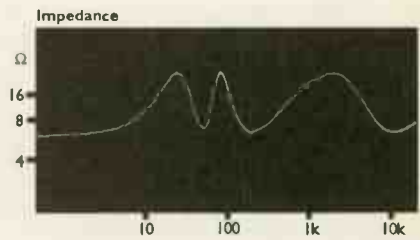
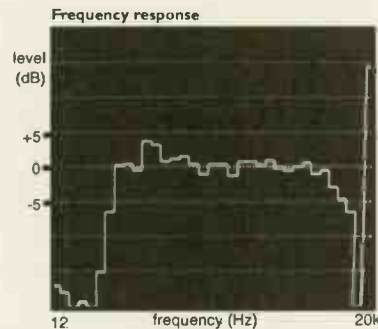

## WILMSLOW KEVLAR I

The Kevlar I uses a Kevlar bass/midrange unit and a fabric dome tweeter. Kevlar is both light and tough, forming a strong cone with controlled high frequency properties. Wilmslow have exploited it well: the Kevlar I has a smooth upper midband response and integrates with the tweeter well. The tweeter itself has a smooth response, giving the overall system an even looking characteristic right across the audio band. A small amount of lift in the midband will aid vocal projection and there is just a little humping in the bass,

enough to give a lively sound. The lower limit was 50Hz, below which the port cuts in, so the Kevlar I goes as low as commercial loudspeakers of the same size.

Sensitivity was a normal 87.5dB SPL at

1m for one nominal watt of input (2.84V). Overall impedance measured 8.6ohms and the impedance curve was smooth, showing the Kevlar Is are an easy load.

This loudspeaker has been well engineered in every respect and will give good results. **NK**

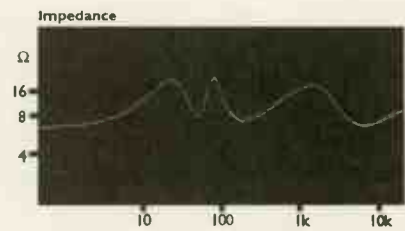
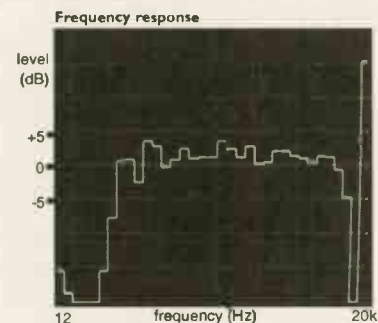

## KEF Q55

This is an unusually configured loudspeaker, comprising what looks like a Q15, complete with front port, that works over the entire frequency range. It has been allied to a bass/midrange driver in its own reflex chamber that reaches up to 800Hz. It also has a port on the rear panel. Because the uppermost Uni-Q driver comprises two units in one, this is a three-way loudspeaker. It gave a reasonably even response over the audio band, but with significant lift in output at 120Hz. This took forward radiation down to 50Hz and both ports reached down very low, so the Q55 will produce a lot of bass. Splitting

the load between two drivers increases both power handling and maximum output.

A low impedance of 5.3ohms overall caused the Q55s to draw current and hence power. I wasn't surprised therefore

to find they were sensitive at 90dB Sound Pressure Level (SPL) for one nominal watt (2.84V) of input. This will make the Q55s seem louder than most other 'speakers, but in truth they are working the amplifier harder. Ideally, they should be used with a gutsy amp.

The Q55s are bassy and strong power handlers. The Uni-Q unit sounds sweet, so I'd expect a good sonic result. **NK**

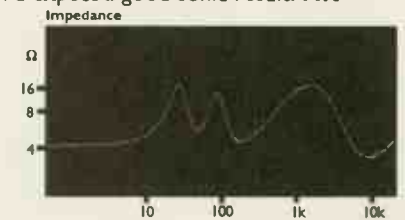
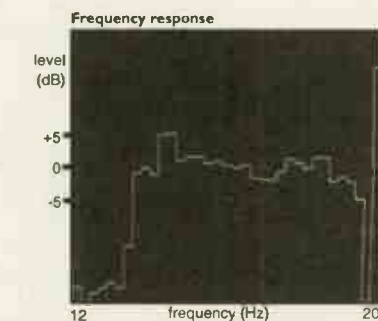

## PARADIGM MINI MONITOR

The Paradigms hail from Canada and are designed from a differing outlook. Accuracy has been balanced against effect, with both bass and treble lift characterising the frequency response. There's +6dB of bass lift at 150Hz and +5dB of treble lift at 16kHz. The tweeter is peaky in itself, so a phase plate has been fitted, which inserts a sharp dip at 12kHz, as our analysis shows. Whilst this reduces treble energy, it isn't enough to tame excessive high frequency output. Presumably, Paradigm have engineered this in to add 'sparkle'.

Listeners should beware though. With CD in particular this may be quite unpleasant.

The overall impedance was a little low at 6.6ohms, giving a standard sensitivity value of 87dB. The impedance curve was

normal enough though, as our analysis shows.

The Paradigm has been engineered for sonic effect. It is best to listen carefully with wide ranging programme material to judge its qualities. **NK**

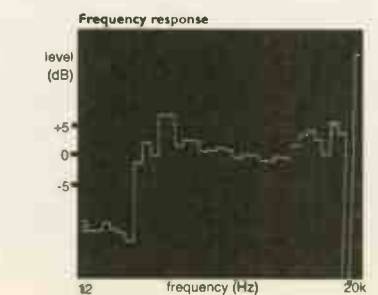

## aanvil audio

*Music from the Sound Foundry!*

Suppliers of: **[Audio Physic]:** loudspeakers, **Adyton:** amplifiers, **Meracus:** CD transports, players, DAC's pre and power amplifiers, **Yamamura Churchill:** cables and accessories, **ART:** Accessories

We have a large selection of CD's, accessories and cables that we can supply by mail order. Here are some examples:

ART Q-Dampers, set of 3 £54.95, set of 4 £69.95  
ART CD Mat £64.95, ART Q-Ring ferrite ring £12.99  
ART LP/Contact cleaner £17.99, ART CD Cleaning/coating oil £11.99

CD's: (Stereophile's Records to Die for)  
The Spendour of Al Andulus, Calamus, MA Recordings £16.99  
Salterio, Begonia Olivide, MA Recordings £16.99  
Sins Svale Band, Blackbird, Son Label £17.50  
Los Rivelse and Gate ved Gate, Kari Bremnes £14.99

### Cable Stock Clearance:

ART Monolith 1.5m mains cable was £210 now £149  
ART Supermains 1.5m mains cable was £410 now £285  
ART Monolith 1m digital cable was £220 now £149  
ART Monolith 3.0m loudspeaker cable was £650 now £455  
Yamamura Churchill Millennium 5000 0.5m digital was £275 now £175  
Yamamura Churchill Millennium 5000 1m interconnect was £695 now £485  
Yamamura Churchill Millennium 5000 3m speaker was £1295 now £840

Phone or fax for further details and ex-demo hardware offers  
Most major credit cards accepted

Tel/Fax 01359 240687 Mobile 0467 404874



## PROGRESSIVE AUDIO



NEW PRODUCTS IN THIS MONTH AND ON PERMANENT DEMONSTRATION:-

CADENCE ES LOUDSPEAKERS- NOW MUCH NICER LOOKING AND SOUNDING BRILLIANT!

ULTIMATE CD PLAYER BY DIGITAL ANALOGUE COMPANY AS REVIEWED IN WHAT HI-FI (FIVE STARS)

ALON V LOUDSPEAKERS - VERY SPECIAL PRICES ON ALL ALON PRODUCTS - CALL FOR DETAILS .

AUDIO SYNTHESIS DESIRE POWER AMP

PINK TRIANGLE NUMERAL, LITERAL CD PLAYERS AND BRAVA PARALLELL TRACKING TONE ARM.

AUDIONOTE M3 PRE-AMP- STAGGERING PERFORMANCE AT A SENSIBLE PRICE.

TUBE TECHNOLOGY SYNERGY SIGNATURE P.P.S AMPLIFIER - LOOKS AND SOUND TO MATCH.

COMING SOON Y.B.A. EQUIPMENT.

PLUS ALL THE REGULAR ITEMS FROM:- PROAC AUDIONOTE, AUDION, C.J, UNISON RESEARCH, CADENCE, ORIGIN LIVE, SD ACOUSTICS ANALYSIS, CALLAS, SUGDEN, MOTH, PINK TRIANGLE, MICHELL, AUDIO SYNTHESIS, LYRA, ORTOFON, SME, ALON, GRAAF ETC. ETC.

FOR SALE:- EX DEM:- IMPULSE TA'US £1950

IMPULSE LALI £1250

FOR SALE:- SECONDHAND KRELL KST £100(MINT) £1350

FOR MORE INFORMATION OR TO BOOK A DEM.  
CALL DAVE ON 01634 389004 ANYTIME

# Cymbiosis

## Audio & Visual Solutions

*Arcam~Audiolab~Chario~Denon  
Epos~Heybrook~KEF~Linn Hi-Fi  
Linn AV51~Loewe TV~Micromega  
Mordaunt Short~Myryad~Projekt  
Rega~Rotel~Royd*

**In harmony with  
music lovers everywhere**

**6 Hotel Street ~ Leicester ~ LE1 5AW  
Telephone 0116 262 3754  
Facsimile 0116 262 3758**

## Pure Sound

Call us to hear the excellent **Audiophysic** range of speakers. These sensitive and dynamic speakers have received rave reviews and are also very easy on the eye.

Talk to us about the current favourites from the **Audiomeca** range, the **Mephisto**, **Kreatura**, and **Damnation**, all available with **Trichord** clock options, *plus* the new products just coming out!

A selection of our used and ex-dem bargains:

Counterpoint SA-4 monobloc valve OTL power amps	£3,250
Convergent Audio Technology CAT SL1 Mk II phono/line preamp	£2,150
Arion Acoustics Electra Export chrome, line level integrated valve amp (perfect)	£780
Aragon 24K phono mm/mc (and line) preamp, excellent	£425
Marantz MA22 power amps and matching SC22 line pre gold	£1,455
Marantz CD12 / DA12 two box player	£1,595
Lumley Reference passive preamp (chrome)	£250
Technics SP10 II, Turntable Obsidian plinth	£1,200
Spectral preamp, phono	£1,250
Alchemist Kraken integrated amp	£225
Futterman OTL valve power monoblocs, 120Watt, pair	£2,995
LFD DAC 3	£2,250
Wadia 3200 DAC	£650
Technics ST-9600 (one of the superb analogues, AM/FM)	£625
Audio Physic Virgo (90db, and no horns! - Ex dem, reduced!)	£2,450
Vandersteen 2CI Speakers, with stands	£550
Sound Labs Electrostatics - large, tall panels, integral bass unit	£1,550
Ensemble PL1 Reference	£1,995
Triangle Altinis (beautiful speaker, sensitive for low power valve amps)	£1,499
Lumley Reference 4s - bookshelf speaker - amazing value	£250

**07000 750 160    01784 458176**

(London, West)



# AMPLIFIERS

## PIONEER A-300R PRECISION

Distortion was a meagre 0.02%, mainly second harmonic, with a bit of third at higher levels. Have Pioneer reduced feedback, in true Brit. style, hoping to open up the sound of this amplifier?

Perhaps. Bandwidth was unusually wide though, stretching up to 138kHz (-1dB) which suggests not. Only listening tests can tell. The A-300R Precision also goes down low, to 5Hz.

Otherwise, producing 50watts into 8ohms and 80watts into 4ohms, the A-300R Precision has plenty enough grunt to handle modern loudspeakers.

The phono stage was also a wide bandwidth design, its response stretching

from 10Hz up to 110kHz. Unfortunately, this isn't too clever, since disc warps will flap the cones of a reflex loudspeaker.

There was very little hiss and no hum.

The A-300R Precision has been well designed, showing small signs of a differing design approach, but nothing too radical.

**NK**

Power	50watts
CD/tuner/aux.	
Frequency response	5Hz-138kHz
Separation	83dB
Noise	-97dB
Distortion	0.03%
Sensitivity	250mV
DC offset	1.1/1.4mV

Disc	
Frequency response	10Hz-110kHz
Separation	68dB
Noise	-79dB
Distortion	0.04%
Sensitivity	4mV
Overload	120mV

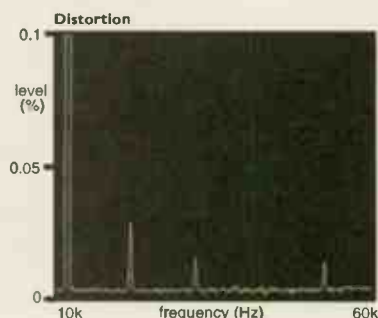

## LINN LK240 MONOBLOC

The LK240 produced 112watts into 8ohms, increasing to 200watts into 4ohms, plenty enough power for most situations. Power supply regulation was very good, as I would hope for a monobloc. This helps give good, solid bass.

The Linn produced a distortion spectrum comprising mainly odd-order components, as our analysis shows. Third and fifth order harmonics reached almost 0.1% at high outputs. I would expect this to add some sharpness or hardness to the sound.

Bandwidth was sensibly set to reach

CD's lower limit of 5Hz. Higher up the LK240 rolled off smoothly above 40kHz, safely above the audio band.

At 1.2V input sensitivity was low, meaning a pre-amp with gain is needed. Noise was very low, mainly because of low gain.

The LK240 measured well, but is likely to sound a little hard or edgy. **NK**

Power	112watts
Frequency response	4Hz-40kHz
Noise	-122dB
Distortion	0.012%
Sensitivity	1.2V
DC offset	0.1mV

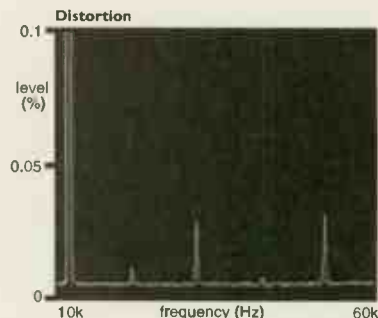

## MERIDIAN 505 MONOBLOC

The Meridian is a real powerhouse, producing 150watts into 8ohms and no less than 256watts into 4ohms, more than enough for insensitive loudspeakers or big rooms. It has very good power line regulation, suggesting effective subjective bass control.

The distortion spectrum possessed extended odd-order harmonics, especially into low loads. I would expect a hard or perhaps glassy edge to the sound from this phenomenon. It was surprising to see such a characteristic, but the Linn LK240 suffered much the same.

Sensitivity was low at 1.3V, so the Meridian will need a pre-amp with gain. Bandwidth measured 4Hz-41kHz (-1dB), sensibly wide and enough for CD and other sources, whilst not accepting supersonics.

The Meridian is well engineered but is likely to sound a little glassy or hard. **NK**

Power	150watts
Frequency response	4Hz-41kHz
Noise	-110dB
Distortion	0.01%
Sensitivity	1.3V
DC offset	0.4mV

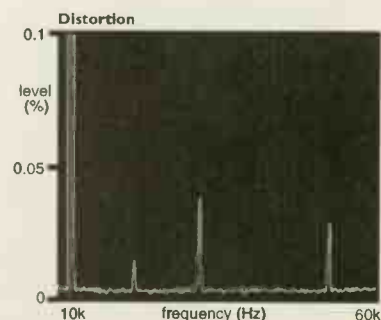

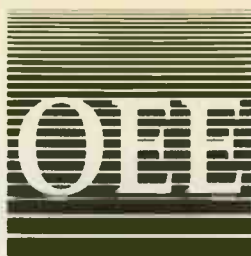

OMEGA Electronic Equipment (Europe) Ltd, New Road Business Estate, Ditton, Maidstone, Kent, ME20 6AF  
 Tel : 01732 848268 Fax : 01732 848289

## World Class Sounds Don't Have to Come From Boring Black Boxes.

### High Quality Audio Products ... Mail Order ... 0% Finance ... (Good Looks Thrown in FREE )

OEE specialise in the supply of quality audio components and enhancement products that not only sound out of this World, but also happen to look stunning !!. Our comprehensive and entertaining product guide and full price list are available **FREE** on request. We appreciate that real quality and style costs money, so offer you the facility to own the products that you really want with our flexible 0%, deferred and low rate finance plans. All products are despatched carriage free within mainland UK. Call for details on our Monthly **SPECIAL OFFERS** and **STAR FEATURE PRODUCTS**.

**Special Opening Offers - and extra special STAR FEATURE offer.**



**Anthem**



**Sennheiser Lucas**



**Sequence**



**Arion**



**UKD Opera**

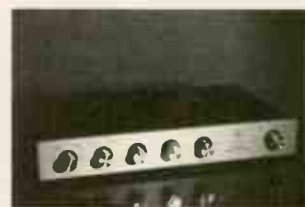

**Monrio**



**New Audio Analogue**



**New Musical Fidelity**

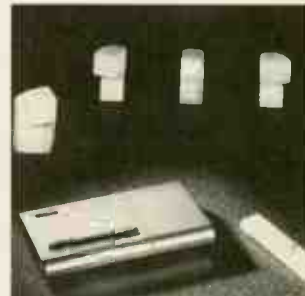

**Bose**

*The Prime Source for ...* Arion, Audio Gem, Audio Analogue, Audiomeca, Audiocarpet, Audiophile BASE, Bose, Ergo, Grado, Jecklin Float, Kabelwerk, LFD, Mistral, MIT, Monrio, Musical Fidelity, Neolith, Partington, Precious Metals, Ringmat, Sennheiser, Sequence, Shure, Silver Sounds, Sonic Frontiers, Sonic Link, Sonneteer, Sound Organisation, Soundstyle, Stands Unique, Stax, Totem, Townshend, Triangle, UKD, WBT ...



# IAN HARRISON HI-FI

TEL: 01283 702875

9am-9pm  
INCLUDING SUNDAYS

TRADE IN YOUR OLD MOVING COIL CARTRIDGE  
& SAVE UP TO 45% OFF THE RRP.

CARTRIDGES & STYLUS	TONEARMS	CASSETTE DECKS	COMPACT DISC
DENON SHURE AUDIO TECHNICA GOLDRING AUDIOQUEST TRANSFIGURATION LONDON (DECCA) ARCAM STANTON GRADO B & O TECHNICS ROKSAN VAN DEN HUL ORTOFON	ROKSAN SME MOTH ZETA  <b>TURNTABLES</b>  SME TECHNICS STRATOSPHERE & OTHERS	PIONEER TEAC SONY DENON YAMAHA MARANTZ TASCAM  <b>DAT</b>  PIONEER TEAC TASCAM SONY FOSTEX	PIONEER TEAC SONY DENON YAMAHA MARANTZ QUAD PHILIPS CREEK  <b>TUNERS</b>  SONY DENON PIONEER YAMAHA MARANTZ QUAD PHILIPS
LOUDSPEAKERS	HIFI FURNITURE	MINI DISC	AMPLIFIERS
HARBETH ATC QUAD SONY ROYD	APOLLO SOUND STYLE PROJEKT SOUND ORGANISATION	SONY  <b>CDR</b>  PIONEER	QUAD DENON MARANTZ PIONEER YAMAHA MARANTZ PHILIPS & OTHERS
HEADPHONES	CABLES	REEL-REEL	
SENNHEISER BEYER SONY AKG GRADO AUDIO- TECHNICA	SONIC LINK AUDIOQUEST AUDIO- TECHNICA VAN DEN HUL GOLDRING OED	STUDER TASCAM	
TEST CASSETTES TEST CDS TEST RECORD DEMO CDS *PHONE OR WRITE FOR DETAILS	BLANK TAPES / DISCS TDK SONY MAXELL BASE 353	ACCESSORIES DISC/WASHER MILLY OED GOLDRING TDK	MAXELL SONY ANTIFERRENC MAXVIEW PIVOTELLI

PLEASE PHONE TO CONFIRM PRICE & AVAILABILITY PRIOR TO ORDERING. GOODS ARE NOT SUPPLIED ON APPROVAL. SORRY, NO GENERAL CATALOGUES. PLEASE PHONE OR WRITE FOR SPECIFIC REVIEWS, BROCHURES OR PRICES.

MAIL ORDER ONLY FROM: IAN HARRISON, 7 MILL HILL, REPTON, DERBY, DE65 6GO. TEL: 01283 702875. 9am - 9pm INCLUDING SUNDAYS.

## PHASE 3 HIFI

PLEASE READ THE FOLLOWING  
VERY CAREFULLY

Offers in excess of £1000 are invited for the following

TANNOY MANSFIELD 385 15" Dual Concentric speakers.  
Teak finish, original packaging. Purchased new in 1975.

Immaculate condition. This is a once in a lifetime  
opportunity to purchase a pair of speakers from the  
'Golden Age' of Hi-Fi.

MARANTZ 2245 90wpc AM/FM Receiver	£ 295.00
MARTIN LOGAN AERIUS Speakers	£1200.00
REVOX G36 4track	£ 395.00
MERIDIAN 602 CD	£ 625.00
MERIDIAN DSP 50000 RWOOD	£2795.00
SME 3009HE	£ 80.00
SPENDOR SP2/2	£ 350.00

## PHASE 3 HIFI

215 Tarring Road, Worthing, West Sussex BN11 4HW

(01903)245577: FAX (01903)505824: E-MAIL pearl@MSN.com

# Oxford Audio Consultants HI-FI SPECIALISTS



Our superb service is the same,  
regardless of price.

## NOW DEMONSTRATING

AUDIO RESEARCH - DO NOT UNDERESTIMATE THIS COMPANY, THEY ARE RIGHT AT THE TOP - WE LOVE THEIR PRODUCTS  
WILSON AUDIO CUBS - an astonishing new baby from this top class company !!  
- WITH US AT LAST !!

KRELL - WE HAVE NOW GOT THE AWESOME FPB600 ON DEMO  
TOGETHER WITH THE BRAND NEW 300 CD PLAYER & NOW THE NEW 300 PRE & POWER

TEAC P30 CD TRANSPORT - ASTOUNDING PERFORMANCE AND BUILD QUALITY

SONUS FABER CONCERTO GRAN PIANO - AT LAST A FLOOR STANDER

FROM ONE OF OUR FAVOURITE COMPANIES, THEY ARE JUST BRILLIANT!!! - hang on for the exciting new products just around the corner

THETA PEARL CD TRANSPORT - WITH A CHROMA THIS MAKES A KNOCK-OUT COMBINATION!

MARTIN LOGAN - THE SL3 IS STILL A WORLD BEATER

COPLAND CD288 & 277 CD PLAYERS - STILL CLASS LEADERS

AUDIO RESEARCH CA 50 INTEGRATED AMPLIFIER - JUST IN AND OH SO GOOD

PROAC RESPONSE TWO POINT FIVES / TABLETTES / STUDIO 150 - A NEW LINE FOR US & A WORTHY COMPETITOR

GENISUS DIGITAL LENS - MUST BE HEARD !!

EXPOSURE AMPLIFIERS - A NEW AGENCY - AND VERY GOOD THEY ARE TOO

UNISON RESEARCH 845 MONO BLOCKS - ITALIAN DESIGN AT ITS BEST WITH SOUND TO MATCH THE LOOKS

MUSICAL FIDELITY X10D RANGE - NOW ALSO A DAC/PHONO STAGE AND HEADPHONE AMP & NEW POWER SUPPLY UPGRADE

## EX DEM & P/EX BARGAINS

REGA ELA SPEAKERS WALNUT	£450
ATC SCM50 ACTIVE LOUDSPEAKERS BLACK	£1995
AURA VA100 AMPLIFIER	£195
CYRUS 2 AMPLIFIER	£195
AUDIO RESEARCH LS22 REMOTE	£3495 S/H
STAX LAMBDA NOVA SIGNATURE SYSTEM	£950 SH
RUARK TALISMAN ROSEWOOD	£450
LFD MC 1 PHONO STAGE	£495
B&W THX SPEAKER SYSTEM. EX DEM	£2950 XD
RCF LS5001 PROJECTOR WIDESCREEN. EX DEM	£4250 XD
AUDIO RESEARCH VTM120 SE PRIVATE SALE	£3995
AUDIO SYNTHESIS PASSION	£895
AUDIO RESEARCH LS5 MK1	£1995 XD
KRELL KPS30 CD PLAYER	£4250 XD
B&W SILVER SIGNATURES INC STANDS	£2995 XD
TUBE TECHNOLOGY UNISYS AMPLIFIER	£1000 XD
AUDIO RESEARCH LS2B MK2	£2295 XD
MICROMEGA TEMPO 1 AMPLIFIER EX DEM	£499
PIONEER CLD2950 LASERDISC PLAYER	£499 XD
MICROMEGA STAGE ONE	£350
TDL NFM2 NEW BOXED	£99.95
TDL NUCLEUS SATELLITE/SUB SYSTEM	£225
ROYD MINSTRELS NEW BOXED	£199.95
ROGERS LS33 SPEAKERS NEW BOXED	£199.95
MISSION 753 SPEAKERS	£449
CASTLE DURHAM 900 SPEAKERS LIGHT OAK NEW	£225.00
ROTEL RCD970BX	£249.95
RUARK TEMPLAR SPEAKERS	£299.95
MICROMEGA DUO BS DAC	£399.95
MUSICAL FIDELITY E20/E30 PRE POWER	£699.95
ROTEL 956 6 CHANNEL POWER AMP	£265.00
NAD 901 A/V PROCESSOR	£99.95
ONKYO TA6210 CASSETTE DECK	£99.95
PIONEER VSP200 SURROUND SOUND PROCESSOR	£175.00

## 0% INTEREST FREE CREDIT

Licensed Credit Broker

Agencies include: Air Tangent, Apogee, Audio Alchemy, Audiogram, Audio Research, Audio Technica, Aura, B&W, Bose, Cable Talk, Castle, Copland, Demon, DPA, Dynaco, Goldring, Harman, Haybrook, Jadis, Koetsu, Krell, Lyra, Marantz, Martin Logan, Michell, Micromega, Monro, Musical Fidelity, NAD, Onkyo, Orelli, Ortolon, Pink Triangle, Pioneer, Proac, Proceed, Projekt, QED, QUAD, REL Subwoofers, Rogers, Rotel, Ruark, Seismic Link, Sennheiser, SME, Sonus Faber, Spendor, Stax, Target, T.D.L., TEAC, Theta, Thorens, Transparent Cables, Unison Research, van den Hul, Wilson.

TAX-FREE EXPORT SERVICE  
MAIL-ORDER AVAILABLE ON MANY ITEMS

Open Mon-Sat 10am-6pm

# Oxford Audio Consultants

Oxford Audio Consultants, Cantay House, Park End Street Oxford OX1 1JE  
Telephone: Oxford (01865) 790879 Facsimile: Oxford (01865) 791665





# M MIDLAND A AUDIO X EXCHANGE

Suppliers & Installers of High  
Quality Audio Systems  
Roksan - Rega - Michell - D.P.A.  
Audio Note - ProAc - Ortofon - Path  
Premier - Deva - Alchemist - Kef - Ruark

181 Franche Road  
KIDDERMINSTER  
WORCS  
DY11 5AD  
Telephone: 01562 822236  
Mobile: 0421 605966

## Roksan

With the continued success of the new Caspian CD player and amplifier, we will soon have the matching tuner in stock. Retailing at £695 it will incorporate the latest FM technology available, with manual and preset tuning, and a remote control compatibility. Also arriving soon will be the Digital to Analogue converter and power amp, so biamping could not be any easier. Rated at 70 watts per channel, it will give an astounding improvement in dynamic range, control and depth of image. The Rok-One loudspeaker system will also see an upgrade to 1.5 spec within a few months.

Only a few Xerxes X Upgrades left now. Still at an unbelievable price of £950 including XPS 3.5 + DSU. The only parts used off the existing turntable are the inner and out platter, everything else is brand new. So in effect you get around £600 back on your old Xerxes! Don't forget MAX has the whole range of Analogue and Digital products from Roksan on permanent demonstration.

Turntables: TMS/Xerxes/Radios  
Tonearms: Artemis/Tabrix/Zi  
Cartridges: Shiraz/Corus  
Amplifiers: Caspian L2.5/L1.5/S1.5/M1.5  
Arterxes X: Stunning  
CD Players: Caspian/Atessa DP3 CD/DP3T/DAC  
DA2/DS5/DS1.5  
Speakers: Rok-One/Ojan 3/Ojan 3X

## Michell Engineering

Becoming one of the most popular analogue manufacturers in the UK at the moment, these beasts never fail to impress, both with Awesome Orbe and Superb Gyrodeck. Always a good selection of tonearms and cartridge combinations available to hear on these formidable machines

## Products on full demonstration

The Orbe inc SME V/Ortofon Rohmann  
The Gyrodek inc RB300/MC20 Supreme  
The Gyro Power QC psu  
The Iso phono stage inc Hera psu  
Please ring now to book your demonstration on any Michell products

## ProAc Loudspeakers

Quite a new range at MAX but these are the reference at which all other speakers need to beat.

Tablette 50 Available in Teak, Oak, Black, Mahogany, Walnut at £600, More exotic finishes to order and price difference.

Tablette 50 Signature Our favourite small monitor at any price, coupled with Target R4 stands, there's not much around to

touch this! Being a Signature Series Version means that exotic finishes come as standard, i.e. Ebony, Yew, Maple etc. £995

## ProAc Response 1SC

Utilises a new bass/mid range driver with an innovative copper magnet and phase plug assembly, which gives amazing dynamics for a speaker of this size. Also available in many finishes. Prices start at £1199.

## Response 2.5

Well, what can we say? One of the best speakers of it's kind on the planet. It incorporates slim and elegant styling with an astonishing sound quality and pin point imagery. At £2700 per pair they deliver the goods!

## New Products

Midland Audio Exchange are pleased to announce the arrival of 'Electrocompaniet' range of high quality amplifier and speaker systems. The EC1-2 affordable high end quality integrated amplifier at £995 a must to hear. If no compromise is necessary then the EC1-1 integrated amplifier which is rated at 100w per channel and gives 80 AMPS! peak to peak (Awesome) £2195

The ECP-1 which is a dedicated phone pre amplifier amazing value at £495.

## Orelle Digital

Now famous for their SA100 integrated amplifier, have a range of upgradable CD players. CD100e Class A £649. And a SA version at £999. A valve output version will be available soon. Price TBC

Here is a list of current LP's in stock and are recommended by ourselves:

Yello	Pocket Universe (import)	£18.90
Ben Harper	Will To Live	£15.90
Michael Brook	Abino Alligator	£10.90
Cassandra Wilson	New Moon Daughter	£19.95
Van Morrison	Healing Game	£12.90
Monty Alexander	Live At Montreux 180gm	£19.95
Ricki Lee Jones	Pop Pop 180gm	£17.90
Eagles	Hell Freezes Over	£17.90
EMI	EMI 100 Years 180gm	£14.90

Always a fine selection of cartridges available to listen to before you buy. Don't just accept advice, hear it, then you know.

Midland Audio Exchange will buy British or American used hi-fi for cash. Please ring John Roberts for prices on 01562-822236 Get that MAX factor.



## Clearance Items For August 97

	Was £	Now £
Naim 82 preamp inc K boards	2300	1395
Naim HiCap new style	650	450
Rega Radio Tuner	230	170
Micromega Stage 3 CD player	999	575
Ear 802 preamp	1750	795
Ear 'The Head'	450	195
Roksan L2 preamp	995	450
Roksan S1 power amp	1495	695
Roksan DSU power supply	150	75
Rotel RB965 BX 6 channel amp	279	175
DPA DSP 200 pre/power	1500	625
Audio Synthesis Pro Passion/inc Switcher	695	325
Restek pProlog phono stage	800	450
LP12/Itok/Asak turntable	1700	595
LP12/Basik Plus/K9 turntable	750	375
LP12/Ekos/Klyde/Avondale psu	2700	995
Audio Alchemy Pro Drive III	699	499
Audio Alchemy Digital Decoding Engine 3	900	600

Aura VA80 amplifier	280	149
Aura CD100 CD player	400	199
Roksan Rok-One speakers (clearance)	650	
Revox A77 1/2 track (domestic use only)	795	350
Project 6.1 SA (new boxed)	995	650
Kef Coda 8 speakers	189	129
QLN Cubic 111	199	95
QLN Cubic 122	279	150
QLN Cubic 222	350	225
Theta Data II PAL/CD player	3800	1995
Theta Gen III balanced converter	4250	1995
Heybrook HB1 inc stands	400	120
Klark Teknik DN 15 preamp	900	250
Ion Systems MA600 monoblocks	1699	650
Hitachi DE27 cassette deck	100	35
Rotel RC 970 BX (new)	175	145
Rotell RB 970 BX (new)	225	175
Yamaha KX 580 cassette deck (new)	250	195
Various stands and cables from £25 to £100 to clear.		

# Grandix

Sound & Vision

71 HIGH STREET, NEW MALDEN,  
SURREY, KT3 4BT. ENGLAND.

TEL: 0181 336 0012

FAX: 0181 336 2703

FULL DEMONSTRATION FACILITIES AVAILABLE FOR...

- ATC ● AVI ● AURA ● ALCHEMIST ●
- B&W ● CABLE TALK ● CASTLE ● DPA ● DUAL ●
- EXPOSURE ● HARBETH ● HARMAN KARDON ●
- JBL ● LINN ● MARANTZ ● MICHELL ●
- MARK LEVINSON ● McINTOSH ●
- MUSICAL FIDELITY ● NORDOST ●
- PIONEER incl. PRECISION ● PROCEED ●
- PROJECT ● REL ● RUARK ● SENNHEISER ●
- SONY ● SYSTEMDEK ● TANNOY ● TEAC ●
- TDL ● TECHNICS ●
- AND MANY MORE

## CLEARANCE BARGAINS

	WAS	NOW
ATC SCM20T ROSEWOOD	£2650	£1999
AVI S2000 MP PRE	£ 850	£ 720
B&W P6	£1095	£ 849
McINTOSH C712 PRE	£1500	PHONE
McINTOSH C40 PRE	£3500	FOR
McINTOSH M.C.7100 POWER	£1400	BEST
McINTOSH MC150 POWER	£3200	PRICES
MUSICAL FIDELITY E101	£ 500	£ 399
PIONEER A400X	£ 300	£ 245
PIONEER 605R	£ 400	£ 325
PIONEER PDS904	£ 400	£ 325
REL Q50	£ 375	£ 299
REL Q50 / JBL TLX AV5	£ 750	£ 579
SYSTEMDEK 2X2/RB300	£ 681	£ 579
TEAC VRDS 10 se	£ 850	£ 679
TDL T LINE 2 R/W	£ 600	£ 429
TDL T LINE 3 R/W	£ 750	£ 499

## SPECIALS ★ SPECIALS ★ SPECIALS

	WAS	NOW
MUSICAL FIDELITY F25 PRE	£1500	£1199
MUSICAL FIDELITY F16 POW	£2500	£1999
MUSICAL FIDELITY F19 POW	£4000	£3199

★ ALL BRAND NEW STOCK ★

TANNOY WESTMINSTER ROYAL  
THESE INCREDIBLE LOUDSPEAKERS ARE ON  
DEMONSTRATION

## NEW ARRIVALS

### MARK LEVINSON



EXPERIENCE SUPERB MUSIC REPRODUCTION

CALL INTO OUR  
SHOWROOMS OR USE OUR  
WORLDWIDE MAIL ORDER  
SERVICE

# AUDIOJUMBLE

## "97"

FIFTH  
YEAR

NEW  
LARGER  
VENUE

ANNUAL SALE OF VINTAGE AND MODERN HI-FI  
EQUIPMENT AT:- THE ANGEL LEISURE CENTRE

TONBRIDGE, KENT

SUNDAY 27TH JULY 1997

10.30AM - 4.30PM

STALLS £20.00 ADMISSION £2.00

BOOKINGS/ENQUIRIES 01892-540022

LARGE CAFETERIA SERVING HOT AND COLD

MEALS ALL DAY. MAIN LINE RAILWAY

STATION WITHIN WALKING DISTANCE

\*VALVE AMPS \*TUNERS \*RECORDS

\*SPEAKERS \*COMPONENTS \*BOOKS

\*CASSETTE DECKS

\*TAPE RECORDERS\*

## Cable Talk

Interconnects & Speaker Cables

1994



Best Speaker Cable

1995



Best Interconnect & Highly  
Recommended Speaker Cable

1996



Best Interconnect &  
Best Speaker Cable

Interconnects Speaker Cables

Doesn't Your System Deserve The Best?

FOR FURTHER INFORMATION

Please telephone, fax or write to  
Cable Talk, Unit 12, Farnborough Business Centre,  
Eelmoor Road, Farnborough, Hampshire, GU14 7XA.  
TEL: (01252) 373434 FAX: (01252) 371818

Please quote HFW 08/97



## DANISH AUDIO CONNECT

### CT1 AUDIO ATTENUATOR

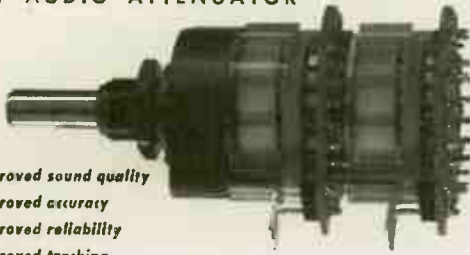

- Improved sound quality
- Improved accuracy
- Improved reliability
- Improved tracking

### THE IDEAL VOLUME CONTROL

*In high quality hi-fi and professional audio equipment  
Precision attenuator for measuring & test equipment  
Passive volume control*

5 times shorter signal path than conventional designs	Available in 10, 20, 50, 100 and 250 kOhm log
50 MHz bandwidth	Available in versions for
Reduced distortion	balanced equipment (4 gang)

#### World-wide sales office

Danish Audio Connect (Thailand) Ltd.  
Unit 1561/3 Ban Chang Glas Haus Bldg.  
1 Sukhumvit Rd. Soi 25  
Bangkok 10110, Thailand  
Tel: (+66 2) 240 6072  
Fax: (+66 2) 240 6071  
E-mail: vifadact@loxinfo.co.th

#### UK distributor

AUDIOCOM  
2 Swallowtree Gardens  
Saundersfoot  
Pembrokeshire  
SA69 9DE, U.K.  
Tel. (01834) 814660  
Tel/Fax (01834) 814036

#### International Distributors Welcome

Designed and manufactured in Denmark Audio Connect A/S, Copenhagen

## AudioCom (UK)

Suppliers of the World's Finest Components

### Price Preview On Selected Popular Values

#### Nichicon MUSE KZ Premium Grade Electrolytic's (Made For Audio Featuring Low Distortion, OFC Wire Lead-Outs)

VALUE (µF)	PRICE(£) 1+	PRICE(£) 5+
25V/100	1.05	0.95
25V 470	2.00	1.85
25V 1000	3.20	3.00
50V/1000	7.10	6.60

#### Pure Silver Wire 99.99% (4N) Fully Annealed

Dia.(mm)	PRICE(£)1.0Mtr	PRICE(£) 5+ Per Mtr
0.45	3.45	3.22
0.71	5.30	4.72
1.0	8.98	8.05

#### DNM Slit Foil Electrolytic Capacitors

VALUE(µF)	TYPE	PRICE(£)
50V/10000	PIN	18.50
63V/15000	TAG	20.50
63V/22000	TAG	26.00

**Other Products Include:** Alps, BHC AEROVOX, Burr Brown, Caddock, Danish Audio Connect CT1 Attenuators, Elma, Elma, Evox, Holco, Linear Technolgy, MIT MultiCap, Sanyo OS-CON, Suflex, Sfernice, Vishay, all at fair prices.

#### Friendly Service . Prompt Dispatch

For a free copy of our 1997 Illustrated Audiophile Parts Catalogue, contact us at:-

#### AudioCom (UK)

2 Swallowtree Gardens, Saundersfoot, Pembrokeshire, SA69 9DE.  
Tel. (01834) 814660 Tel./Fax (01834) 814036  
(Business Hours: 9:30 to 5:30 from Mon-Fri, 10:00 to 2:00 on Sat)

The Roksan Caspian system has quickly established itself as one of our favourites. Both the CD player and the amplifier sound fantastic and look fabulous too! The amplifier is certainly one of the most solidly made products under £1000, and yet sells at only £695.

The similarly-priced LFD Mistral CD player and amplifier have also been making great sounds especially with the Neat Mystique speakers (remarkably good value at £650 in Cherry finish).

Despite the recent price increase, A.V.I. products remain good value, particularly the integrated amplifier (£999) and the CD player (£1400). The sound is very smooth and uncoloured and works with a wide range of loudspeakers, not least A.V.I.'s own new model, the Positron.

The remarkable Totem Model One speaker has recently undergone some revisions to its design, and now sounds even better than before. People are always surprised at the huge soundstage that these tiny boxes can produce. At £1250, they are not inexpensive, but they do sound stunning!

We still have a few ex-demonstration and second-hand items at reduced prices, including:

Pink Triangle Export GT1/RB300	£699 (new price £1339)
A.V.I. S2000MT tuner	£499 (new price £599)
Aura VA100 amplifier	£179 (new price £349)

If you are interested in any of these products or would like any advice generally, please call us on the number below.

tel / fax CHESTER 01244 401290  
e-mail : replay@dial.pipex.com

## APOLLO CABLES

Our wide range of interconnect and speaker cables feature, semiconductor technology to eliminate noise, and carefully designed strain relief systems to protect the venerable solder joints. Our top of the range Azure interconnect also utilises the highest quality LC-OFC conductors, giving state of the art performance at a very reasonable price. With an emphasis on stylish design and solid build quality, coupled with a 14-day money back guarantee and rave reviews from the press, you can't go wrong with APOLLO CABLES

Azure 1m gold plated phono - phono	£49.99
Black Velvet 1m gold plated phono - phono	£29.99
Black Velvet 1m 5-pin DIN - 5-pin DIN	£29.99
Black Velvet 1m 4-pin DIN - 4-pin DIN	£29.99
Black Velvet 1m 2 phono - 4-pin DIN	£29.99
Black Velvet 1m 2 phono - 5-pin DIN	£29.99
Black Velvet 1m 4 phono - 5-pin DIN	£39.99
Fathom Speaker Cable 2m pair with gold plated 4mm plugs	£48.00

When ordering DIN cables please give the required pin configuration and directionality for phono to DIN.

**"The Black Velvet's unusually atmospheric sound proved engrossing over the long term. There was great insight into performances, thanks to an uncanny retrieval of low level subtleties."**

(Noel Keywood - HiFi World magazine January 1997)

**For more information send for a free catalogue.**  
Payment by cheque, postal order, credit or debit card in UK£ Sterling.



Credit Card facilities now available for fast delivery



P&P £1.50 UK mainland. £5.00 international.

Apollo Cables, 11 Fishers Mead, Puckeridge, WARE, Herts, SG11 1SP

24 hour Telephone/FAX: 01920 823 208

the Summer Silly

# SALE

at..

## mike manning

*the hi-fi specialists* **audio**

**AMPLIFIERS:**

ARCAM ALPHA 7  
MYRIAD MC120  
PIONEER A605R  
ROTEL RC/RB970  
ION NEXUS PRE/POWER

SAVE UP  
TO 25%

**CD PLAYERS:**

MYRIAD MC100  
ROTEL RCD970  
MARANTZ 63 SE & KI Sig  
ARCAM ALPHA 8

SAVE UP  
TO 30%

**SPEAKERS:**

CASTLE HOWARD  
TDL RTL 2 & 3  
ATC-10  
HEYBROOK HEYLO

SAVE UP  
TO 40%

**RECORD DECKS:**

ROKSAN XERXES - Phone

**DAC CONVERTERS:**

PINK TRIANGLE ORDINAL  
DAC IN A BOX  
QED DIGIT

SAVE UP  
TO 50%

### PLEASE PHONE FOR FULL DETAILS & PRICES

*Most sale items are either new or ex demonstration models and are covered by our full one year guarantees.  
Full Servicing Facilities - 2 Year Guarantees - Mail Order - Instant Credit Facilities - Access - Visa - Switch*

110, Middle Street, Yeovil, Somerset

01935-479361

CLOSED ALL DAY MONDAYS

# CROFT



**"Against similarly priced competition, the Crofts will take some beating."**

Haider Bahrani HI-FI WORLD JUNE 1996

Tel: +44 (0)1902 656517  
Mobile: +44 (0)956 921740  
Evenings: +44 (0)1902 659150  
Ans. Machine: +44 (0)121 373 1442  
Fax: +44 (0)121 681 8772

## Bravura

*...horns for music lovers*

Some people think that horn loudspeakers all 'honk' or sound 'cuppy'...others have listened to our new Virtuosos and they *know* that's not true. You love music, you want to hear your power amplifier give of its best - *these are the speakers for you.*

Highly sensitive and fast, their high average impedance and smooth (as these things go) impedance curve makes them exceptionally easy for an amplifier to drive and control - and you don't need megawatts to bring them to life.

The Virtuoso is an affordable true horn speaker, has the fine resolution needed to unveil the unique timbre of each individual instrument, and to place it accurately in the sound stage. Superb dynamics and depth of image combine with every last lingering echo from the recording venue to create an immensely satisfying sense of space, of reality, of being there. *This is the system upgrade you've been looking for!* Prices from £2995

### *Virtuosos make music real!*

*Bravura speakers are designed and manufactured by*  
Thomas Transducers  
White House Hall, Hadlow Road, Tonbridge, Kent TN11 0AJ, UK  
T: +44 (0)1732 851408 F: +44 (0)1732 850315

# b



# AUDIO CRAFTS FAYRE

at: - Ringwood Hall, Brimington, Chesterfield  
Clearly Signposted - only 4 miles from M1 Motorway Junction 30 - HEAD west on the A619  
SATURDAY 25th & SUNDAY 26th OCTOBER 1997 (9am-5pm)

A great Hi-fi weekend for everyone!

- \* Over Twenty Sound System Demonstration Rooms - Come & Meet the Experts \*
- \* Loads of Components, Kits, Spares, Cables, Audio Publications etc \*
- \* Visit the Great Bazaar - Used Equipment & Vintage Kit Calore \*
- \* Tons of New and Secondhand Vinyl - Many Special Show Offers \*
- \* Popular Bring and Buy Section - we'll Sell your Surplus Equipment \*
- \* Super Collectors Corner for that Rare Bargain - Audio Society Stands \*
- \* Our Fabulous Free to Enter Draw with over £1000 of Prizes...!! \*
- \* Good Food and Drink available All Day - Ample Free Car Parking \*

Entrance & showguide - £5.00 on The door - SO Don't be late...!!

Organised by: Avondale Audio & The Chesterfield Hi-Fi Show Ltd. PO Box 50, Chesterfield S40 4YU  
24 Hour Computerised Voice Information & Faxback Service: 01-246-207240

We've been busy for  
the last two years....

...designing the  
most exciting collection  
of audio products  
you'll ever see in one place..!!

Over 80 pages of modules and components to  
enable you to easily build state of the art kit &  
for you to upgrade your system to perform better  
than anything you could ever buy in the shops.

Exclusive, mouth watering products not obtainable  
elsewhere are waiting for you in this unique manual.

PLUS.... a wealth of 'insider information' from the  
World Leaders in Audio Upgrading Techniques.  
(Described as the finest reference manual in the business)

Published on 1.44MB discs to browse or print from your PC  
(Includes Acrobat reader to run in Windows™ 3.1 or higher)

Order your personal copy today...!!

\*The first 250 qualify for a valuable discount voucher\*

Just £5.00 Post Free From:

**Avondale Audio**

PO Box 50 Chesterfield England S40 4YU  
Credit Card Hotline: 01-933-461058

## Sound Investment

If you have invested expertise and money in building up a sound system to your own unique specifications, then why compromise with indifferent housing units?

Fi-Rax offers a new dimension in audio visual racking - from a range of standard designs to the flexibility to custom create a unit to suit your particular sound system and lifestyle.

- \*High quality aluminium construction.
- \*Finishes available to your choice.
- \*Fully adjustable 6mm glass shelving.
- \*Sound isolation on shelving/feet.
- \*Custom created to suit your system.
- \*Free delivery throughout the UK.

Fi-Rax - a sound investment for those who want the best from their equipment.

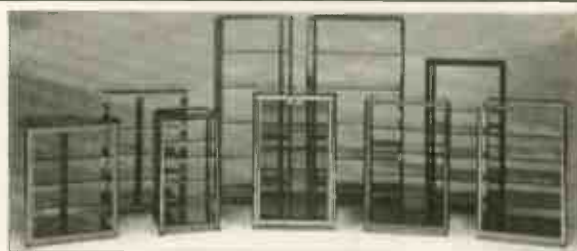

Audio Visual Furniture

For further information or a free brochure contact: JEM Distribution,  
Springfield Mills, Spa Street, Ossett Wakefield WF5 0HW.  
Tel: 01924 277626 Fax: 01924 270759

HORN LOUDSPEAKERS

# Klipsch®

IMMORTAL SOUND FORESIGHT

Hear KLIPSCH for yourself in: Bucks 01296 28790. Cheshire 01625 264666. Cornwall 01209 710777. Devon 01803 606863. Eire 01-288 9449. Hants 01730 895194. Herts 01727 855577. Hunts 01733 341755. Lancs 01257 473175. Leics 01162 571414. London 0171 486 8262, 0171 431 7423. Oxon 01865 247783. Somerset 01935 79361. Suffolk 01502 582853. Sussex 01903 872288. Wales 01978 364500. W. Midlands 0121 455 0667, 0121 429 2811, 0121 742 0254. Wores 01384 444184. Yorks 01302 781387

KLIPSCH THX  
WEST END STYLE



WEST END HOME THEATER  
KJ WEST ONE 0171 486 8262

# CLASSIQUE SOUNDS (LEICESTER) VINTAGE HI-FI SPECIALIST

## WANTED

THE FOLLOWING HI-FI EQUIPMENT. WORKING OR NOT  
TOP PRICES PAID. FREE COLLECTION OR CARRIAGE PAID.

### VALVE AMPLIFIERS

QUAD, LEAK, RADFORD, ROGERS, AVANTIC, LOWTHER, BEARD,  
AUDIO INNOVATIONS, CHAPMAN,  
CROFT, EAR, AUDIONOTE, LUMLEY, REVOX, WESTERN ELECTRIC ETC.

### SPEAKERS

QUAD ELECTROSTATIC, LOWTHER, TANNOY, VITAVOX, IMF ETC.

### TURNTABLES

GARRARD 301, GARRARD 401, THORENS 124/224 ETC.

### VALVES

MULLARD, OSRAM, BRIMAR, GEC, KT66, KT88, EL34, EL84, GZ32/34, 300B, PX4, PX25 ETC.

### RECORDS

CLASSICAL, JAZZ, BLUES ETC. FULL OR PART COLLECTIONS.

### OLD CAMERAS

WORKING OR NOT

### MISCELLANEOUS

HI-FI YEAR BOOKS. OLD CAPACITORS. OLD CARBON RESISTORS.

### ALSO WANTED

QUALITY MODERN/TRANSISTOR HI-FI EQUIPMENT. SPEAKERS,  
RECORD DECKS, AMPLIFIERS, TUNERS ETC.

### FOR SALE

#### NEW SILVER WIRE

99.99% PURE SILVER WIRE @ £4.95 PER METRE  
SUITABLE FOR AMPLIFIERS/SPEAKER REWIRE

#### TRANSLUCENT INTERCONNECT CABLE

99.99% PURE SILVER  
DOUBLE SCREENED. PSEUDO BALANCED  
QUALITY GOLD PLATED RCA PLUGS

5 METRE - £60.00, 1 METRE - £80.00, - ADD £20.00 PER HALF METRE FOR LONGER LENGTHS  
7 DAY MONEY BACK GUARANTEE IF NOT BETTER THAN YOUR EXISTING CABLE.

#### MAF STANDS

FOR QUAD ELECTROSTATIC SPEAKERS  
ESL 57 £175.00 ELS 63 £275.00

#### 301/401/124 POWER SUPPLIES

SUPPLIED BY F&S TRADING. AMAZING VALUE AT ONLY £99.00 EACH

#### NEW EAR EQUIPMENT/YOSHINO EQUIPMENT

EAR 834P MOVING MAGNET/MOVING COIL PHONO STAGE WITH VOLUME CONTROL - £499.00  
AUDIO INNOVATIONS FIRST AUDIO 7.5 WATTS TRIODS SOUNDS GORGEOUS ONLY  
EAR 834P MOVING MAGNET ONLY PHONO STAGE WITHOUT VOLUME CONTROL - £349.00  
EAR 834L ONLY VALVE PRE-AMPLIFIER. AMAZING VALUE - £449.00

#### NEW TRIANGLE SPEAKERS

TITUS TZE £379.00 COMETE TZE £525.00  
ZEPHYR E £799.00 ANTAL £1099.00

#### LEAK MAINS AND OUTPUT TRANSFORMERS

RE-WOUND TO ORIGINAL LEAK SPECIFICATIONS IN EXISTING HOUSING  
SUPPLIED AND FITTED FROM £90.00

#### GARRARD 301/401/124 PLINTHS

READY TO VENEER/PART VERY HEAVY - £175.00  
VENEERED AND FINISHED IN ROSEWOOD - £275.00

#### FOR SALE. USED

##### PRE / POWER AMPLIFIERS

KRELL KSA80 CLASS A POWER AMPLIFIER. A REAL MONSTER FOR ONLY £1595  
PAIR PYLE HF25 AMPLIFIERS IN EXCELLENT CONDITION. VERY RARE £1000  
KEFF RYEWLAND MODEL ONE POWER AMPLIFIER. EXCELLENT CONDITION £1495  
ROKSAN L2 PRE-AMPLIFIER WITH DSU POWER SUPPLY. MINT BOXED SILVER £850  
AUDIO INNOVATIONS FIRST AUDIO 7.5 WATTS TRIODS SOUNDS GORGEOUS ONLY £4000  
PAIR LUMLEY M75 MONO BLOCK AMPLIFIERS. HUGE POWERFUL BEAST EX COND £790  
PAIR RAY LUMLEY M100 VALVE MONOBLOCKS. EXCELLENT CONDITION £1095  
EAR 859 SINGLE ENDED AMPLIFIER GOLD TRANSFORMER TOPS SILVER WIRED £1195  
MUSICAL FIDELITY MA65 CLASS A AMPLIFIERS. PAIR. MINT BOXED £1095  
PAIR LEAK TL12 + AMPLIFIERS FINISHED IN GOLD IN NEED OF OVERHAUL £649  
CLARKE + SMITH 1010 INTEGRATED £170 SUGDEN A21A + PHONO STAGE. MINT £525  
LINN LK1 PRE-AMP. REMOTE CONTROL £249 SUGDEN A48 MK1 GOOD COND £149  
SUGDEN P51 50W POWER AMPLIFIER £175 SUGDEN C51 STEREO PRE-AMPLIFIER £399  
ROGERS CADET POWER £POA ROGERS CADET 3 £POA  
QUAD L2 PRE-AMP + POWER SUPPLY £495  
LEAK TL12+ AMPS VARIOUS £POA PAIR ROGERS JUNIOR AV COND £POA  
LEAK STEREO 20s VARIOUS £POA ROGERS CADET MONOS PAIR £225  
AUDIO INNOVATIONS S400 AMP £349 LEAK STEREO 50 AMP RESPRAYED £400  
ROGERS JUNIOR STEREO POWER AMP £POA BEAU DECCA RADIOGRAM RARE £POA  
AUDIO INNOVATIONS S800 PRE-AMP £249 ROGERS HG88 MK3 TEAK FINISH £150  
BEARD P500 VALVE PRE-AMPLIFIER £250 A/INNOVATIONS S700 7 MONTHS OLD £695  
PAIR LEAK TL10s NICE CONDITION £POA DNM 2A PRE-AMP & 2 \* 2A P/SUPPLY £695

##### TURNTABLES

GARRARD 301/401 CHASSIS VARIOUS £POA GOLDRING GL99/ALPHASON ARM/PLINTH £150  
SYSTEMDECK X2 WITH SNE SERIES 3 ARM AND GOLDRING 1042 CARTRIDGE £250  
GARRARD 301 GREY & SME 2000 PLINTH SYSTEM C/W SME 3009 TONE-ARM £POA

##### SPEAKERS

PAIR B+W DM70 HYBRID LOUDSPEAKERS. GOOD CONDITION £495  
ANOTHER PAIR B+W DM70 ELECTROSTATIC LOUDSPEAKERS £495  
CELESTION 5000 + STANDS RIBBONS £399  
PAIR ROGERS LS77 SPEAKERS. BLACK £249  
B&W DM6 EXCELLENT CONDITION £250  
SPICA ANGELUS COST £1300 £495  
WHARFEDALE AIREDALE CORNER UNITS £295  
MUSICAL TECHNOLOGY HARRIER G/C £199  
QUAD ESL 57s PAIR £POA  
CALLAS OPERA MINT BOXED £379  
£299

##### OTHER ITEMS

NEW GEC KT66s £80 USED TESTED GEC KT66s £40 USED TESTED GEC KT88s £60  
USED TESTED PX4 £75 LOTS OF OTHER RARE / UNUSUAL VALVES. PLEASE RING  
REVOX 877 REEL TO REEL RECORDER. HIGH SPEED IN EXCELLENT CONDITION £695  
SONY TCD-D7 DAT WALKMAN RM-D3K ADAPTOR KIT WITH REMOTE. MINT BOXED £300  
SONY WMD-6C PROFESSIONAL WALKMAN DOLBY B AND C GOOD CONDITION £150  
QUAD RACK AND PEDESTAL FOR 66306/66CD MINT BOXED £100  
SUGDEN R51 STEREO TUNER. EX COND £125  
STAX LAMBDA BASIC SYSTEM IHPHONES £299  
SUGDEN R21 TUNER. MINT TEAK SLEEVE £100  
REVOX G36 QUARTER TRACK £350  
LOWTHER PM3A DRIVE UNITS MINT £690  
DENON DCD1520 CD PLAYER £175  
LEAK THROUGHLINE 2/3 VARIOUS £140  
LENTKE MC CARTRIDGE PRE-AMP £50

TEL/FAX PAUL GREENFIELD ON UK +0116 2835821 OR 0802 213740 ANYTIME  
CLASSIQUE HOUSE, 61 AYLESTONE DRIVE, AYLESTONE, LEICESTER, LE2 8QE

## EX DEMONSTRATION EQUIPMENT

	NEW	SALE
CYRUS XPA Power Amplifier	£298	£225
CYRUS DACMASTER D/A Converter	£950	£395
EPOS ES25 Walnut loudspeakers	£1655	£1250
MICROMEGA MINIMUM Integrated Amplifier	£400	£295
MICROMEGA MINIMUM Loudspeakers (As New)	£300	£195
PROCEED PRE Pre Amplifier	£1995	£1550
PROCEED POWER Power Amplifier	£1995	£1650
PRO AC STUDIO 250 Loudspeakers (Cherry)	£2249	£1995
REGA ELLICIT Integrated amplifier	£730	£550
RUARK PALADIN loudspeakers (Rosewood)	£1099	£850
TRICHORD GENESIS CD Player inc. base	£930	£495

## QUALITY USED EQUIPMENT

AUDIOLAB 8000P Power Amplifier	£750	£525
CYRUS DAD7 CD Player (As New)	£900	£575
MISSION 73PS Sub Bass (Boxed as new)	n/a	£95
PRO AC TABLETTE II Loudspeakers (Teak)	n/a	£375
SONY MDP850D Laser Disc Player	£700	£375
TDL RTL3 Loudspeakers (Black)	£400	£285
QUAD 77 Integrated Amplifier (6 weeks use)	£700	£495
SPENDOR BCT Loudspeaker (Teak)	n/a	£275

## SPECIAL PURCHASE NEW BOXED EQUIPMENT

YAMAHA KX580 Dolby S Cassette Player	£250	£199
YAMAHA RXV 590RDS Pro Logic Receiver	£450	£325
YAMAHA DSP A590 Pro Logic Amp	£350	£275

## THE

# powerplant

66/67 Upper North Street Brighton BN1 3FL

Tele: 01273 775978 Fax: 01273 748419

Email: [email@powerplant.co.uk](mailto:email@powerplant.co.uk)

ATC, AVI, Audiobab, Arcam, B&O, B&W, Cyrus, Exposure, KEF, Linn, Micromega, Marantz, Mission, Mark Levinson, Pro Ac, Proceed, Rega, Roksan, Slax, Trichord and other quality equipment.

Mail order and Worldwide Export service available

## MANTRA AUDIO

- HI-FI/VIDEO ACCESSORIES
- MAIL ORDER DIRECT 1-10 DAYS
- COMPETITIVE PRICES (Inc P&P)

MAKE	MODEL	CARTRIDGE	STYLUS	SWISS QUALITY DIAMOND STYLUS	PRICE
Arcam	777 D7 Mg	N/A	£18.00	AOC DLW 30 R0 3/4	£9.00
	E77 E77 Mg	N/A	£36.00	R20 XE OLM 34/36 XLM III	£13.50
	P77 P77 Mg	N/A	£48.00	AN 5/11/30/60/8745	£9.00
Audio Technica	AT 95E	£21.00	£12.50	AN 2/50/70/77/0/4932/8743	£11.00
	AT 110 E	£25.00	£13.00	RS 33/35/38/84/85/90	£9.00
Denon	DL 110	£110.00	£210.00	SP 80/12A	£25.00
	AT 120/ET	£45.00	£31.50	ST 14/15/16/17/19/21	£3.00
	AT 440 ML	£81.00	£63.00	Dual DN 145/155/165/E DN 149 S	£13.50
	AT 150	£63.00	£33.00	G800/820/850 (D110/D120/D130)	£11.00
	ATML150	£187.00	£128.00	G800 Sup E	£13.50
	DL 110	£70.00	£55.00	Hitachi DS-ST 7/12/14/15/26/30/35/102	£9.00
	DL 304	£190.00	£160.00	DS-ST 5/16/23/24/25/55/103/104	£11.00
	1006	£53.00	£34.00	DT 33/35/36/45/55/60/65, DT 21 S	£9.00
	1012 GX	£70.00	£46.00	N 47/48/51/53/60/61/63/66/72	£9.00
	1022 GX	£90.00	£57.00	N 36/37/43/45/56/59/62/67/69	£11.00
Grado	1042	£105.00	£70.00	EP5 23/24/25/30/33/51 CS/270 D	£9.00
	ERDICA (LX/H)	£100.00	£65.00	EP5 43/52/57/61/STSD. P30/33 D	£9.00
	ELITE	£187.00	£122.00	P30 (upgrade). EP5 205/207 E	£13.50
	Prestige black	£44.00	£24.00	P30 (upgrade). EP5 205/207 E	£13.50
	Prestige green	£53.00	£29.00	Ortofon FF 15V/M5 10/20 EIL OMP/2 E	£9.00
	Prestige Blue	£62.00	£34.00	GP 371/400/780/400 H/III	£9.00
	Prestige Red	£90.00	£49.00	GP 330/370/401/401 H/412 II	£11.00
	Prestige Silver	£107.00	£59.00	PN 210/220/240/6/5/250/295T	£9.00
	Prestige Gold	£134.00	£74.00	EP5 27/28/29/33/43/47/41/50/80/101	£9.00
	Ortofon OM/OMP 5 E	£20.00	£16.00	ST 80/100/150/66/613	£6.00
Shure	OM 10	£28.00	£20.00	ST G 8/9/10 ST 28/29/35/37/40 D	£9.00
	510	£32.00	£22.50	STY 104/111/116/117/118/123/124	£9.00
	520	£59.00	£45.00	N 75-60/6 N 91 G SS 35 C	£9.00
	530	£95.00	£68.00	STY 104/111/116/117/118/123/124	£11.00
	MC 1 Turbo	£70.00	£58.00	N 55 E N 95 ED/EJ N 97/105 ED	£13.50
	MC 3 Turbo	£124.00	£105.00	VN 15E VN 35E (V 15 III E)	£16.50
	MC 10 Super	£78.00	£78.00	N 95/97 HE VN 35 HE	£22.00
	MC 15 Super II	£120.00	£102.00	ND 133/134/142/150/155/200 G	£9.00
	MC 25 E	162.00	138.00	ND 115/143/148/153/220/250 G	£11.00
	MC 25 FL	£210.00	£178.00	N 53/55 80 DY N 62/292 N 71/290	£9.00
Stanton	MC 20 Supreme	£263.00	£224.00		
	MC 30 Supreme	£330.00	£280.00		
	Rohmann	£392.00	£333.00		
	SC 35 C	£29.00	£29.00		
	V 15 III	N/A	£80.00		
	V 15 V XMR	£265.00	£134.00		
	500 AL Disco	£30.00	£18.00		
	680 ALX Disco	£46.00	£36.00		
	680 ELX Disco	£57.00	£41.00		
	Trackmaster	£99.00	£41.00		

**NO CREDIT CARDS PLEASE. EARLY SUPPLIER PRICES. WE WILL MATCH ANY CURRENTLY ADVERTISED PRICES SUBJECT TO AVAILABILITY. OVERSEAS CUSTOMERS PLEASE ADD £5.00 TO ORDERS OVER £50 IN VALUE TO COVER INSURANCE.**

\*\*\* Over 500 titles in stock \*\*\*

Exchange any 2000 Value Kit

Full manufacturers guarantees applicable to all above items  
MANTRA AUDIO (HFW), 22 GARTH AVENUE, NORTH DUFFIELD, SELBY, NORTH YORKS YO8 7RP



## COMPACT DISC PLAYERS

### QUAD 67 second-hand

One of Quad's best products for a long time, the 67 is warmer and smoother than most, yet is highly musical and revealing. Good enough to frighten many rivals.

### DENON DCD-315 £150

Real hi-fi and real music for a mere £150. Achieves a good semblance of orchestral dynamics and acoustic space.

### NAD 510 £200

A competent all rounder with lifelike soundstaging and impressive treble clarity.

### ARCAM ALPHA 7 £320

This British built player is extremely good value. An upfront, punchy nature suits Techno and Rock particularly well.

### MARANTZ CD-63MKII KI-SIGNATURE £500

Similar to the CD-63SE but more powerful bass and an all-round smoother sound.

### TRICHORD GENESIS £549

Conveys music in a powerful and dramatic fashion. Smooth and sweet, with a good sense of depth. A little soft sounding though.

### DPA RENAISSANCE £895

Words cannot describe its infinite variety, but suffice to say you'll love it or hate it. Highly emotional, involving presentation with not a hint of self-doubt.

### ROKSAN CASPIAN £895

The Caspian has a smooth, even sound with some of the clearest treble in the business. Very engaging, dynamic character.

### LINN KARIK 3 £1600

Superb one-box player. Its supremely rhythmic, musical sound with delicacy and finesse puts it up with the best of the rest.

### NAIM CDI £1600

This single box 16-bit player sounds very engaging compared to your average bitstreamer. Has that vital tingle factor of the larger, two-box CDS.

### MCINTOSH CDM7009 £2635

A thoroughly inspiring machine. One of the most musical CD players around; sweet, open and detailed.

## COMPACT DISC TRANSPORTS

### TEAC VDRS-T1 £550

Not as substantially built as its chunky looks suggest, the T1 is nevertheless a good entry-level transport with a warm, expansive sound.

### AUDIOLAB 8000CDM £1300

Beautifully built and finished, the CDM is packed with sensible features and performs superbly, day-in day-out.

### TEAC P-30 £2500

Cheap it isn't, but then it sounds like a million digital dollars. Nothing short of superb.

## CD CONVERTORS

### DPA LITTLE BIT III £300

A lot more weight at frequency extremes than the II and far better control. For £300 there's nothing to beat it.

### THORENS TDA2000 £700

Used with the TCD2000 as a transport, the TDA2000 produces a sound that is focused, detailed and spacious. Good value.

### DPA ENLIGHTENMENT £795

Some believe this to be the best convertor around. A truly charismatic performer, it dives into Rock music with rare passion.

### PINK TRIANGLE DA CAPO £1450+

Offers a choice of filter modules, all up there with the best. The Da Capo is superb in many respects, but can sound a touch polite on rock.

### DPA 1024 £6000

Proof positive that today's CDs needn't sound CD-like! Uses an in-house discrete convertor, and DPA haven't skimped on the build either!

## TURNTABLES

### GARRARD 401 second-hand

In a decent plinth with an arm of SME309 calibre, the 401 has a highly authoritative overall sound with the most solid, expressive bass in the business. Very musical, but treble isn't up to modern standards.

### THORENS TD124 second-hand

One of Thorens' best-ever turntables. Needs a modern plinth to give of its best. Duly installed, it's good enough to face off the Garrard 401, swapping some of its bass power for a more delicate, incisive treble.

### SYSTEMDEK IIX900/RB250 £330

A fine all rounder and easy to upgrade. Brings more depth and breadth than a Rega 3.

### SYSTEMDEK 2X2 £499

Although tuneful, bass isn't as deep as some rivals. More than makes up for it though with neutral and precise midrange and treble.

### RESON rsI £600

A lean, yet vibrant sound quality that really draws the listener in. With good detail and rhythmic integrity this is an impressive turntable package.

### MICHELL GYRODEC £800

Stunning looks, build and engineering, and don't underestimate the sound. Standard PSU and Rega arm gives a detailed, architectural, if undynamic sound. With QC PSU and SME V, its scale and insight kills the competition at the price.

### PRO-JECT 6.1SA £999

The Pro-ject places the listener in the best seat in the control room. Outrageous dynamics and a punchy, seriously deep bass. Comes with Sumiko arm and Ortofon MC30 Supreme.

### LINN SONDEK LP12 £840 - £1530

Cirkus bearing puts it back up with the best. Superbly beguiling, rhythmic sound that plays Jazz like few others, but lacks the Gyrodec's detail or imaging. You'll forget CDs were ever invented.

### PINK TRIANGLE ANNIVERSARY £2495

One of the finest-sounding turntables around, the Anniversary takes the listener nearer the recording studio than almost any other deck. Works with Rega, Linn and SME arms alike.

### ROKSAN XERXES X £1295

DSU or XPS 3.5 power supply £150/170 extra. Excellent pitch stability from a new Swiss motor and outboard power supply. Very tight bass, fine dynamics and revealing clarity.

### MICHELL ORBE £1950

The Darth Vader of analogue, the Orbe builds on the strengths of the Gyrodec. An ultra-tuneful, expansive sound.

### SME MODEL 20 £2495

Including the excellent SME V tonearm, the Model 20 is possibly the last great turntable, unless you've got £11,000 for the Model 30, that is.

## TO NEARMS

### REGA RB300 £130

Supremely capable at the price, but not quite humankind's salvation as has been suggested. Detailed, tight, rhythmic sound but tonally rather grey and cold-sounding.

### SME 3009SII £375

This Paleolithic device doesn't bother with frequency extremes or detail, but its legendary serviceability makes it a cult in Japan. Oh death, where is thy sting?

### SME309 £570

A down-market version of the IV and V with aluminium armtube and detachable headshell. Tight, neutral sound with good tonality, but lacks the IV's pace and precision.

### SME V £1235

A masterpiece of precision engineering with a cohesive, ultra-transparent sound. A dream to set up and use.

### LINN EKOS £1400

A thunderous battleship of an arm, with a very impressive sound, masses of detail and dynamics, but lacks the SME V's cohesion and musicality.

## CARTRIDGES

### ORTOFON VMS-2E £110

Warm, full-bodied, punchy and fast. Not to be sniffed at for a tenner. Can be upgraded with a better stylus at a later date.

### GOLDRING 1012GX £60

An accomplished MM with a solid bass, slightly forward midband and clean transients. £20 buys the faster, more dynamic 1022GX.

### GOLDRING 1042 £100

The best moving magnet available. Has an extremely cohesive sound that's warm but highly involving. Deliciously delicate treble and strong, powerful bass.

### SHURE V15VXMR £295

The Shure produces a warm, dynamic sound which has great detail and impact. Far superior to earlier V15s.

# World favourites guide

## ORTOFON SUPREMES £225-£450

The MC10, MC20 and MC30 Supremes all offer superb sound and value for money, with a distinctively rich, smooth and detailed musical performance. The valve brigade love them.

## ORTOFON MC2000 £650

We came across this one in an SME IV on a Garrard 401; it duly gave one of the best results we've ever heard.

## ORTOFON ROHMANN £1000

In a way it's MC2000 meets MC7500 with the tonal strengths and dynamo sound Ortofon have been putting into their moving-coil cartridges of late.

## LYRA LYDIAN £649

A truly musical, sophisticated device that makes most other MCs sound frigid.

## VAN DEN HUL MC-10 £840

Fluid bass, finely etched treble and highly tuneful in between. The MC-10 is honey, pure and simple.

## ORTOFON MC7500 £2000

Conclusive proof that there's hope for humankind. Makes music of enormous scale and vibrancy. CD lovers would die if they heard it.

## INTEGRATED AMPLIFIERS

### NAD 3020 second-hand

Classic sweet sounding, punchy budget super-amp with strong phono stage. Able to embarrass many modern budget amps.

### NAD 310 £130

A real hi-fi amplifier at a bargain price. Forms the heart of a separates system that will murder any midi system at twenty paces. No phono stage, but you can't have everything at this price.

### NAD 312 £200

Smooth, clear and dry. Fine detailing with little to complain about at the price. Good facilities.

### ROTEL RA-970BX £250

With its smooth and powerful sound, the Rotel sings a seductive song with all types of music. Powerful enough for most 'speakers too.

### AURA VA-80 £280

The VA-80 is superb for the price with a confident, powerful sound. One of the smoothest around, it is capable of embarrassing more up-market competition.

### ARCAM ALPHA 9 £500

A detailed and open sound lends great atmosphere to music. Wide range of facilities too, including optional MM/MC phono stages.

### AUDIOLAB 8000A £500

A jack-of-all-trades whose facilities, build, power and top-rate phono input make it a steal. Sound is good, but less involving than the Naim Nait 3.

### NAIM NAIT 3 £500

A taste of high-end audio. The most involving, musical design at the price, but low power. Superb phono stage is £100 extra.

### MISSION CYRUS 3 £500

Superb engineering, a solid cast chassis and a clear, spacious sound. Phono stage could be better.

### SONNETER CAMPION £579

An amplifier that delivers near studio definition along with exemplary timing. Utterly gripping.

### DPA RENAISSANCE £595

Rich and smooth, the Renaissance is one of the sweetest amps around, if lightweight

### AUDION STERLING ETSE £600

Economically but well built single-ended valve amplifier. Wonderful clarity with vocals. £600 with 1 line input, £800 with 5.

### SUGDEN A21a £640

Class A transistor amp. Rich, crisp, deep, tight sound and it images well too. Wonderful.

### MERIDIAN 551 £795

Beautifully-built integrated with a sweeter, clearer sound than mid-price alternatives. Plenty of facilities and remote controllable.

### UNISON SIMPLY 2 £995

This single-ended valve amplifier is smooth, sweet and open. An extremely musical performer.

### UNISON SIMPLY 4 £1495

Sonically similar to the Simply 2, but with more power and control.

### AUDIONOTE OTO SE £1500

Ten watts of the sweetest sound around. Use sensitive speakers though, because it's unlikely to crack windows or trigger earthquakes.

### McINTOSH MA6800 £3735

The MA6800 not so much plays music as takes control of it, with effortless bass drive and a three-dimensional sound stage.

## PRE-AMPLIFIERS

### QED DISCSAVER £35

A true bargain that offers a cohesive, musical sound. Avoid using it in thin sounding systems though.

### ROTEL RQ-970BX £130

Superb value entry-level phono stage with audiophile quality components and clear sound.

### TECHNICS SU-C1000 £350

At its price, this battery powered pre-amp is difficult to beat. Weak points are lightweight build and average phono stage.

### DPA DSP200S £495

Not quite the 50S, but there's little to match it at this price if outright sound quality is your priority.

### ROSE RV23-S £495

This interesting valve/transistor hybrid has a smooth, rich, spacious sound.

### AUDIOLAB 8000C £520

Versatile with superb phono input. Can sound sterile, but latest version is much improved.

### MICHELL ISO/HERA £530

This phono stage has fine midband and treble detail, with taut bass. The £850 ISO/HR brings more of everything, and for many people is the last word on the subject.

### AUDIO INNOVATIONS P2 £749

Fantastic bass and super insight make this one of the best phono stages around. One for vinyl lovers.

### AUDIOLAB 8000Q £995

Excellent line-level only pre-amp, greatly improves on 8000C with a more fluid, musical sound and greater grip. Remote control.

### MERIDIAN 502 £1295

Transparent, detailed sound with good tonal range and a neutral presentation. Flexible and remote controlled too.

### MARANTZ MODEL 7 PRE-AMP £3500

A '60s reissue, the Marantz pre-amp still sounds superb. Has a great phono stage.

## POWER AMPLIFIERS

### QUAD II second-hand

Classic valve monoblock with many thousands still in use around the world. Archetypal warm, smooth valve sound, although not the last word in detail or dynamics.

### LEAK STEREO 20 second-hand

The Stereo 20 can sound impressively up-to-date, although power and detail are ultimately limited.

### QUAD 405II second-hand

Solidly built, but lifeless sounding, power amp which can be substantially improved by a Quad factory service.

### ARCAM ALPHA 9 £400

With 70watts on tap, the 9P will drive most loudspeakers with a spacious and detailed sound. Good bass drive too.

### MISSION CYRUS POWER £450

This power amplifier is a honey. Rich and smooth, but with a firm grip; a fine blend of properties.

### ROSE RP190 £495

Used with the partnering pre-amp it gives 70watts of smooth, relaxing sound.

### SUGDEN AU41P £530

Extremely competitive at the price with 100VV of unusually smooth, full-bodied sound.

### SHEARNE PHASE 3 £619

A neutral, highly dynamic and thoroughly exciting amplifier. A sonic bargain.

### QUAD 606II £675

Quad's latest 140W powerhouse is smooth and civilised, but engagingly musical. Legendary back-up service.

### DPA DPA200S £750

Better than anything else at the price. Not as dry as the 50S.

### NAIM NAPI80 £900

Partnered with a NAC82, this has classic Naim control, making for a superbly rhythmic presentation. A touch lean for some tastes.

### MICHELL ALECTO STEREO £1300

A refined transistor amplifier with valve-like transparency and a full, warm, easy-going sound. The £1800 Alecto monoblocks have rare lucidity and three dimensional realism.



# World favourites guide

## **MERIDIAN 557** £1400

Great control and dynamics allied to seductive smoothness. A rare combination of power and delicacy.

## **MARANTZ MODEL 9** £8000

Authentic reproduction monoblocs which still more than cut the sonic mustard. The sound lives up to the powerhouse appearance and combines ergonomics with great tonal colour and expressiveness.

## **TUNERS**

### **LEAK TRUGHLINE** second-hand

Our favourite way of listening to the wireless. A deliciously smooth, mellifluous sound that will have you junking your transistor radio in seconds. Ergonomics are crude, and you'll need a decent aerial and stereo decoder.

### **NAD 412** £190

The 412 is remarkably musical and natural sounding. Rich sound and full bass are a rarity. Unbeatable at the price.

### **KENWOOD KT-6050L** £300

Very, very tuneful and as clear and detailed as CD. Tuners like this have you sitting in your seat wondering at the sheer wealth of music out there.

### **MISSION CYRUS FM7** £300

Clear and lucid sound that puts it up with the best regardless of price. Superb build and superior ergonomics to the NAD.

### **ROTEL RT990BX** £500

High quality Michi-based tuner with a sophisticated, forward sound with great imaging and soundstage. Sensible facilities and remote control.

### **NAIM NAT03** £500

The NAT03 is further proof of Naim's proficiency with tuners, with a warm, easy sound and a good sense of atmosphere.

### **FANFARE FT-1** £1350

In its native US the FT-1 is no mere tuner but a 'broadcast monitor' no less, a task at which it acquires itself well, with a clear and powerful sound.

### **NAIM NAT01** £1380

The best solid-state tuner available. For better radio, live in the studio.

## **CASSETTE DECKS**

### **AIWA AD-S750** £150

Sonically a very decent machine. For the price there's nothing better. With Dolby B, C and S.

### **KENWOOD KX-3080** £160

A simple deck, but high quality head and transport give an unusually high level of performance at this price. Not to be missed.

### **DENON DRM-650S** £230

Forget metal tapes, but sound quality with ferrics and chromes makes it a bargain.

### **AIWA AD-S950** £300

A stable transport, superb head and Dolby S make this an excellent recorder.

### **PIONEER CT-S740S** £430

A great piece of engineering from Pioneer, a bit complex, but a first rate sound on playback and recording. Dolby S included.

### **NAKAMICHI DR2** £600

Where serious cassette decks start. The DR2 pushes recordings to the limit, remaining unflustered at all times.

### **NAKAMICHI DR1** £850

Better still than the DR2, with manual head azimuth adjustment to boot.

### **NAKAMICHI CR7** £1500

Kills every other cassette deck and stamps on their graves.

## **LOUDSPEAKERS**

### **MISSION 731i** £130

A truly worthwhile improvement on the old 731s, sounding faster, stronger, tighter and more subtle. Able to take on all comers.

### **MISSION 731 LE** £149

An extensive reworking of Mission's entry level 'speaker, much tighter on transients and more refined treble. Neutral and revealing.

### **KEF Q15** £199

These stand mounters offer impressive bass and excellent clarity but need a powerful amplifier to perform at their considerable best.

### **HEYBROOK HB1 S3** £269

Fine tonal resolution through midrange and a smooth and extended treble make the HB1s ideal for Classical/acoustic music. Bass is a little boxy and constrained though.

### **CELESTION IMPACT 23** £299

Smooth and even handed. Clear and well extended treble and deep, tight bass. Midrange is focused and pure with plenty of detail and speed.

### **B&W DM 602** £300

Deep and strong bass, pure, projected and uncoloured midrange. Treble quality a little metallic, but imaging precise. A lively, enjoyable sound.

### **REL Q-BASS** £350

Few subwoofers match the Q-Bass at the price. The tuning controls can be a bit of a fiddle, but once set up the rest is pleasure.

### **CASTLE EDEN** £450

Impressively vice-free 'speakers that offer great transparency and involvement. Unbeatable at the price.

### **EPOS ES12** £495

Strong, punchy bass is allied to detailed and articulate midrange and treble. Above all, these 'speakers are thoroughly musical.

### **REL STRATA** £500

The Strata is not a toy. Offers superb, true hi-fi bass depth and power.

### **MISSION 752 Freedom** £600

Use advanced High Definition Aerogel bass/midrange and silk dome tweeter. Dynamic, punchy and musical, yet refined like few others at the price. Not as soft as the original 752s.

### **TANNOY D100** £650

This small dual-concentric loudspeaker produces believable three dimensional imaging.

### **CASTLE AVON** £700

Taut, dry bass and lucid midrange from their carbon fibre driver, but need warm ancillaries to avoid sounding bright.

### **HARBETH HL-P3ES** £799

A fine example of good loudspeaker engineering. The top of the mini-monitor league.

### **HARBETH HL-K6** £975

Clean, musical and classy - Harbeth have done themselves proud again.

### **KEF REFERENCE SERIES ONE** £995

The KEFs combine pin-point imagery and detail with a smooth and polite balance. Good, agile bass too.

### **HEYBROOK SEXTET 11** £1129

Heybrook have retained the strengths of the original Sextet, improving on bass extension and smoothness. Treble and imaging still excellent.

### **MISSION 754 FREEDOM 5** £1299

Highly articulate and informative sound with fine imaging and tight, deep bass extension. Uses silk dome tweeter, HDA midrange and 8" bass driver.

### **JAMO CONCERT 8** £1500

With their inch-thick cabinets and fabulous drive units, the Concert 8s are the most transparent stand mounters around. They don't suffer poor sources gladly though.

### **EPOS ES25** £1505

Epos' best. Combines near-uncoloured tonality with characteristic fireworks in the rhythm department. Superb by any other name.

### **SPENDOR SP7/1** £1970

This big Spendor is very appealing thanks to its lucid sound and valve-friendly load.

### **TANNOY AMS8** £2700

Bold sounding professional active monitor with solid bass, clearly focused midrange and delicious treble. Built-in amplification.

### **QUAD ESL-63** £2860

A reference against all other loudspeakers, with superb imaging qualities and genuine transparency. Earlier ESL model is a fine second-hand buy.

### **KEF REFERENCE SERIES FOUR** £3099

Superb bass and near-electrostatic soundstaging make these involving loudspeakers a reference to others. Need a strong amplifier though.

### **JBL S2600** £3500

Smooth, detailed and spacious with great dynamics and fine imaging. Capable of producing a superb performance when used in a big room.

### **TANNOY WESTMINSTER ROYAL** £10,000

An incredibly dynamic, detailed full-range horn design with a rich sound. Its high sensitivity predisposes it to valve amplification.

## **MINIDISC PLAYERS**

### **SONY MDS-JE500** £300

An impressive sound and unmatched convenience make this MiniDisc player an excellent buy.

### **KENWOOD DM-7090** £500

Both replay and recording quality are superb through this Kenwood. Nakamichi owners should start getting worried - at last there's

# ▲ WILMSLOW AUDIO LTD ▼

**The name in loudspeakers for over 30 years**  
**Quality sound to rival the best**

To coincide with various acquisitions made by ourselves including **Kord Audio** (Nottingham), we have a surplus of fully finished empty loudspeaker cabinets, ideal for the DIY enthusiast wishing to obtain a high quality aesthetically appealing unit to compliment the sound of their loudspeaker kit. We are offering these cabinets whilst stocks last at these incredibly low prices!

**Kord Audio "Tornado" cabinet**  
**Fully finished in Walnut veneer**  
**Size: 600x270x290mm**  
**Only £40 pair**

**Kord Audio "Vulcan" cabinet**  
**Fully finished in Walnut veneer**  
**Size: 510x270x260mm**  
**Only £40 pair**

The above cabinets will each take a Volt BM220.8 and Scan-speak: D2010 drive units  
Special offer price for the 4 drivers £265

**2 -way cabinet**  
**Finished in Black Ash or**  
**Walnut**  
**Size 420x270x270mm**  
**Only £20 pair**

**2 -way cabinet**  
**Finished in Black Ash or**  
**Walnut**  
**Size 440x240x210mm**  
**Only £20 pair**

**2 -way cabinet**  
**Finished in Black Ash or**  
**Walnut**  
**Size 440x240x210mm**  
**Only £20 pair**

The above cabinets will each take a combination of the following drive units  
RCL 80758, Peerless 832556, Volt LS201 and Seas H202  
Special offer prices for 4 drivers for 2 way cabinets:-

**RCL 80758**  
**Seas H202**  
**£65 per set**

**Peerless 832556**  
**Seas H202**  
**£110 per set**

**Volt LS201**  
**Seas H202**  
**£120 per set**

The 3 way uses 2 of the 8 inch bass drivers and 1 tweeter  
We also have a quantity of Vifa **C17WG-69** 8 ohm Bass/Mid drivers at **ONLY £8 each !!!**



**Wilmslow Audio** have a range of 25 DIY loudspeaker kits from £140 - £3800 on demonstration and are able to offer a crossover design service as well as the supply of 1000s of high quality products. These include Binding Posts, Capacitors, Cables, Connectors, Grill Cloths and Foams, Inductors, Ports, Resistors, Spikes and much, much more.

We are the UK's largest distributor of replacement drive units and accessories for the trade and DIY speaker builder. Our stock range includes

**ATC, Coles, Dynaudio, KEF, Morel, Peerless, Scanspeak, Seas, Volt.**

Wilmslow Audio Ltd  
50 Main Street  
Broughton Astley  
Leicester LE9 6RD  
England

Phone for your Free catalogue

Tel: 01455 286603  
Fax: 01455 286605  
Email:  
wilmslow.audio@dial.pipex.com



## New arrival at Wilmslow

Wilmslow Audio are pleased to introduce the latest addition to their range of loudspeaker kits, which will approximately be called the **Elegance**.

The **Elegance** is a slim two way tower combining simple but stylish aesthetics with stunning tonal reproduction. This new speaker reflects the Wilmslow Audio philosophy of accurate, well balanced, natural sounding units without the necessity of exaggerated bass or accentuated treble.



This highly efficient 4ohm speaker has been designed with the usual care and attention to detail synonymous with the name of Wilmslow Audio. The slim cabinet styling enables the **Elegance** to be integrated in almost all living accommodations without being obtrusive or over powering and yet despite its diminutive size does not compromise on sound reproduction.

Wilmslow have used the latest drive units from Peerless, incorporating the new Composite Sandwich Cone (CSC) technology, which improves accuracy and consistency of sound reproduction over the

entire frequency range, creating a more 'musical' driver. This woofer is coupled with a Peerless 25mm dome tweeter featuring a wide angle face plate, which controls its directivity, eliminating unwanted omnidirectionality in the low end and over bearing high end directivity.



Wilmslow Audio are offering this new kit to readers of Hi-Fi World at a special introductory price of only:-

**£299.00** excluding postage and packing.

**Proving once again that at Wilmslow Audio even the prices sound good!!**

# ELVIS IS ALIVE!

AT

## AUDIOPHILE INTERNATIONAL

### DCC BRINGS ELVIS BACK!

**ELVIS PRESLEY: ELVIS IS BACK! (180 GM HQ LP OR 24 KT GOLD CD)** Released in 1960, Elvis is Back! hit the record stores within weeks of The King's discharge from the army and was his first ever album recorded in stereo. Featuring classics like *Soldier Boy*, *Such A Night and Fever*, *Elvis Is Back!* hit as high as no.2 on the Billboard charts and remained on the charts for over a year. Now you can enjoy *Elvis Is Back!* as it makes its first appearance on 180 gm high quality vinyl. Remastered by Steve Hoffman from the original master tape, be prepared for a shock as you hear Elvis as never before!

180 gm HQ Vinyl or 24kt gold CD £25

### OTHER GREAT DCC NEW RELEASES

**JETHRO TULL: AQUALUNG (180 GM LP OR 24 KT GOLD CD)** Hear Aqualung as you have never heard it before! DCC have gone to great lengths in locating Ian Anderson's personal copy of the original master tape of *Aqualung*. Steve Hoffman has performed his magic on this album to reveal inner details previously unheard on this all-time classic.  
(180 gm HQ Vinyl or 24 kt gold CD) £25

**JEFFERSON STARSHIP: RED OCTOPUS (180 GM HQ LP OR 24 KT GOLD CD)** £25

**JEFFERSON AIRPLANE: SURREALISTIC PILLOW (180 GM HQ LP OR 24 KT GOLD CD)** £25

**MILES DAVIS: ALL STAR QUINTET & SEXTET (24 KT GOLD CD)** £25

**JOHN COLTRANE: LUSH LIFE (180GM HQ LP OR 24 KT GOLD CD) SPECIAL OFFER!** £20

**BADFINGER: NO DICE (24 KT GOLD CD)** £25

WE ARE THE EXCLUSIVE UK DISTRIBUTORS FOR DCC DEALER ENQUIRIES WELCOME

### CLASSIC RECORDS 180 GM HQ VINYL

<b>HI FI A LA ESPANOLA (MERCURY SR 90144)</b>	£28
<b>MILES DAVIS: KIND OF BLUE (2LP INCLUDING UNRELEASED ALTERNATE TAKE)</b>	£39
<b>BRANFORD MARSALIS: THE DARK KEYS (2LP) 165 GM HQ SPECIAL OFFER</b>	£25
<b>DEAD MAN WALKING (SOUNDTRACK AND SCORE) 3LP BOX FEATURING RY COODER-SPECIAL OFFER</b>	£35
<b>WALTON: FACADE (RCA LSC 2285) AGOULT, ROYAL OPERA HOUSE ORCH. - VERY SPECIAL OFFER</b>	£15
<b>BORODIN: SYMPHONY NO.2 (RCA LSC 2298) MARTINON, LSO - VERY SPECIAL OFFER</b>	£15
<b>MILHAUD: LA CREATION DU MONDE (RCA LDS 2625) MUNCH, BSO-VERY SPECIAL OFFER</b>	£22

### VISIT US ON THE WORLDWIDE WEB

<http://www.audiophileusa.com>

WE ARE THE U.K.'S LEADING SUPPLIER FOR ALL YOUR VINYL AND CD NEEDS. JOIN OUR WORLDWIDE DATABASE IN BOTH THE U.K. AND THE U.S. TO RECEIVE FREE MONTHLY CATALOGUES OF NEW RELEASE LPS, CDS, ACCESSORIES AND SUPERB LISTS OF 1000'S OF MINT, USED LPS.

**JOIN OUR FREE U.K. MAILING LIST AT:**  
**P.O. BOX 303, CHOBHAM, WOKING, SURREY, GU24 8YP.**  
**TEL: (01276) 855578/855530, FAX: (01276) 855580**  
**E-MAIL: SALES@AUDIOPHILE.U-NET.COM**

**JOIN OUR FREE U.S. MAILING LIST AT:**  
**P.O. BOX 1672, FAIR OAKS, CA. 95628, U.S.A.**  
**TEL (001) 916 863 6748, FAX: (001) 916 863 6749**

### WE BUY RECORD COLLECTIONS





# Sussex Surplus

13 STATION ROAD, HORSHAM, WEST SUSSEX RH13 5EZ

Telephone: (01403) 251302 Fax: (01403) 270339

Test Equipment • Components • Accessories  
Electromechanical • Mechanical • Engineering

## VALVES

G237 Mullard	£7 ea
G233 Mullard	£15 ea
G232 Mullard	£15 ea
GSN7GT S.T.C.	£8 ea
5R4GY S.T.C.	£10 ea
5U4G USA	£10 ea
6L6G USA	£25 ea
6L6WGB USA	£15 ea
6B4G USA	£35 ea
L63 GEC	£12 ea
HG3 GEC	£12 ea
KT61 GEC	£25 ea
A2900 GEC	£20 ea
GCC81 Mullard	£8 ea
GCC82 Mullard	£8 ea
GCC83 Mullard	£12 ea
G88CC Mullard	£10 ea
GCC88 Mullard	£8 ea
EF86 Mullard	£10 ea
EL86 Mullard	£6 ea
EF37A Mullard	£8 ea
GSL7 GT STC	£8 ea
3A/108A STC	£20 ea
3A/110A STC	£20 ea
3A/110B STC	£25 ea
3A/109B STC	£25 ea

AVO CT160 VALVE TESTER	
TESTED AND WORKING WITH	
DATA BOOKS	£150 ea

## VALVE SOCKETS AND PLUGS

6 way QUAD 2 plug	£4 ea
Mains plug QUAD 2	£4 ea
Octal Free plug	£3 ea
Octal Free Skt	£3 ea
B9A Skt Chassis	£1.50 ea
B9A Skt Skirt Chassis	£1.50 ea
Octal Ceramic McMurdo	£3 ea
Octal Bacolite McMurdo	£2 ea
UX4 Bacolite McMurdo	£2 ea
B4 Bacolite McMurdo	£5 ea
B4 Paxolin Single Wafer	£2 ea
B5 Bacolite McMurdo	£4 ea
UX5 Ceramic McMurdo	£3 ea
Octal Ceramic Marconi	£4 ea
DA100 Bacolite Base UK made	
(100% Vintage) Ex equipment	£45 ea

## MISCELLANEOUS ITEMS

P.T.F.E. Silver plated wire, various

sizes, colours	50p per metre
Silicone rubber sleeving Bore 1mm	
Wall-5mm 25mtrs	£3.00
Cable wrap 1/8" Dia 5mtr	£1.00

Meter 2.5" Dia Dual Scale Ferranti	
Sealed Ex equipment	
0-600 volts	£15 ea
0-150 milliamps	£15 ea
Meter 2.5" Dia sealed Brand new	
Scaled 0-10	£15 ea
Meter 2" Dia Dual Scale Ferranti	
made 1944 Brand new boxed	
0-15 volts	£25 ea
0-600 volts	£25 ea
Meter 1.5" Dia GEC Brand new bxd	
0-75 milliamps	£10 ea
Meter 2.5" Dia Ernest Turner	
Bacolite ex equipment	
0-200 milliamps	£20 ea
Vintage Bulgin Ball end switch	£5 ea

**P&P £5 PER ORDER**

**17.5% VAT TO BE ADDED TO TOTAL ORDER**



## HEATHERDALE AUDIO LTD.



202 FINDON ROAD, WORTHING, WEST SUSSEX. BN14 0EJ  
TEL: 01903-872288 OR (AFTER HOURS) 0860 660001 FAX: 01903-872234  
e-mail: heatherdal@aol.com http://members.aol.com/heatherdal/heatherd.htm

### HEATHERDALE PRE-OWNED GUARANTEED EQUIPMENT EXPORT FACILITIES AVAILABLE

KRELL KSA 200B Power Amplifier	£2750
VENETA RESEARCH Dual Mono Phono Stage	£1495
STAX EL-5-F81X Full Range Electrostatics	£3995
VOYD Stancard Turntable, Mint	£1500
MARK LEVINSON 28 2-box pre-amp with phono	£2495
HELIUS Silver wired tonearm	£995
AUDIO RESEARCH LS2 Hybrid Line Pre-amp	£1695
AUDIO NOTE 10 Limited cartridge & PSU	£2750
LUXMAN D-500Xs CD Player MINT/BOXED (£3495)	£1795
NAKAMICHI ZXL1000 Tape Deck - B&W Serviced	£2195
SME 10 Silver Wired Tonearm Ex Dem	£750
AUDIO NOTE ANS7 Step-up Transformer	£3000
AUDIO RESEARCH Litz Link Intercon 2.5mtr	£295
MICROMEGA T-Drive CD Transport AES/EBU	£595
CALIFORNIA AUDIO LABS Alpha DAC bal input	£1200
TD WINSHENO Seismic Sink Large Heavy Duty	£195
LUMILEY VTA 1030 Valve Power Amplifier	£395
AUDIO RESEARCH Ex-Dem V160 Valve Power Amp	£1995
ARCAM Alpha 3 Integrated Amp with Phono	£165
MERIDIAN CD50 Remote CD Player	£110
MERIDIAN 203 DAC Good Condition	£295
BUARK Swordsman Plus Loudspeakers	£175
SUGDEN AU51 Pre-Power with phono (£2100)	£75

PRO-AC 2 Loudspeakers 2-way Teak	£395
AUDIO NOTE Kassa Silver Amplifier	£1995
STUDER A725 Pro CD Player balanced output	£1250
MISSION 782 Loudspeakers with stands	£250
REF 104 Loudspeakers	£450
NAIM 250 Power Amplifier Mint/Boxed	£295
ORELLE CD160 CD Player Boxed	£295
AUDIO NOTE M7 Silver Signature pre-amp	£700
SONUS FABER Ex-Dem Minuetto (£898)	£750
LUXMAN T-4 Accutouch CLL AM/FM Tuner	£450
ARCAM Delta Black Box II DAC Boxed	£195
VOYD Reference Turntable (Large Motors)	£4695
AUDIO NOTE AN/SE Loudspeakers silverwired	£4000
AUDIO NOTE DAC 4 MINT/Boxed	£395
B&W 808 Loudspeakers	£1995
ION SYSTEMS Nexus SP1 pre & X-PAK 2 psu with	
ION SYSTEMS Nexus SAM 40 Stereo Power Amp	£595
STUDER A807 Pro. tape recorder MINT	£3750
HEYBROOK Quartets & stands Ex Dem (£840)	£585
AUDIO RESEARCH LS2b Hybrid Line Pre (£3398)	£2195
SOLSTICE AAD speakers with stands	£850
APOGEE Centaur Minor Loudspeakers	£495
SILTECH 2x2.4 Interconnect 0.75mtr set	£175
TRANSPARENT Ref. interconnect 15 st pair	£1595
GENESIS Model III speakers MINT	£495
JADIS Dely 7 stereo amp, mint	£395
PRO-AC Response One S (ex demo)	£795

PRO-AC Tablette 50 (rosewood)	£550
LUXMAN MQ 3680 KT88 stereo power amplifier	£1295
ROGERS LS71 speakers Black ash	£350
SNELL K Loudspeakers with stands	£295
SPENDOR SP1 Loudspeakers	£250
STANDSIGN Speaker stands new/unused	£95
LUMILEY 120 Valve Mono Power Amps (NEW)	£2795
LUMILEY Promenade SP1 Loudspeakers (NEW)	£250
QUAD 34 Pre-Amp Ex Dem Mint / Boxed (£388)	£275
QUAD 66 Pre-Amp Ex Dem with remote (E842)	£395
QUAD 306 Power Amp Ex Dem Mint / Boxed (E341)	£249
QUAD 306 Power Amp Ex Dem Mint / Boxed (E673)	£395
QUAD 77 Integrated Amplifier Ex-Dem (E699)	£595
TECHNICS SL030 Turntable	£195

### VARIOUS EX-DEM & PRE-OWNED CABLE AVAILABLE

\*\*SPECIAL OFFERS ON UNUSED/BOXED CARTRIDGES\*\*

	Approx Cost	New	Our Price
KISEKI Blackheart	£1995		£1500

### \*\*SPECIAL OFFER\*\*

Part Exchange your old Krell KSA for the new

FPB 300 and be amazed by our generous allowance

\*\* We are proud to announce that we have been newly

appointed Sonic Frontiers dealers for the South

**DON'T MISS OUT ON THAT BARGAIN! FOR AN UP-TO-THE-MINUTE LIST:**  
<http://members.aol.com/heatherdal/heatherd.htm>

ALL USED CARTRIDGES  
ARE CHECKED UNDER A MICROSCOPE  
BEFORE BEING OFFERED FOR SALE.

VISA - SWITCH - MASTER CARD - DINERS CLUB WELCOME.  
WE TAKE PART EXCHANGE ON NEW & USED STOCK AND BUY IN FOR CASH

# Are you making the right connections?

Send for Britain's biggest catalogue of specialist cable and connections.

All available by mail order.

Phone 0181-942 9124 or clip the coupon for your Free copy

## CUSTOM CABLE SERVICE

PO Box 4007, London SW17 8XG

Please send me your FREE Custom Cable Catalogue

Name \_\_\_\_\_

Address \_\_\_\_\_

Postcode \_\_\_\_\_

NO FURTHER INFORMATION REQUIRED

Send to: Custom Cable Service  
PO Box 4007  
London SW17 8XG

HFV 8/97



# PERFECT TECHNIQUE

**Jon Marks tips his hi-fi hat to a classic turntable which has yet to receive its due respect - Technics SL-1000/II.**



**H**ave you ever heard the old chestnuts, "The Japanese only turn out mass market hi-fi dross" and, "I wouldn't touch a direct drive turntable with a barge pole, they're no good"? Well, Technics disproved both these statements two decades ago with their superb SL-1000/II turntable.

Selling back in 1978 for a whopping £1100 (when an LP12/Ittok cost half as much), the SL-1000/II was made up of the SP-10MKIIIP motor unit, SH-10B3 plinth (powdered obsidian in resin cast to produce a gorgeous plinth the size of a sideboard and weighing almost 20kgs) and EPA-100 tone-arm with titanium nitride arm-tube.

The SL-1000/II obviously went down well with cognoscenti because the BBC used it as their studio turntable of choice. And this is where many of the examples you can pick up come from. If you're worrying about reliability, don't. The SP-10MKIIIP's direct drive motor packs a massive 6kg torque punch, spinning the 2.9kg platter up to 33rpm in less than a

quarter of a second. And the build quality makes most modern decks look like they're made from balsa wood.

The old myths of "direct drive decks can't hold their speed" and "direct drive decks are noisy" also bite the dust when faced with the SP-10 and matching plinth. The motor unit has a claimed wow and flutter figure of 0.025% which easily betters most belt drive turntables and the plinth soaks up any noise from the motor and the outside world.

So how does it sound? Fitted with an SME Series V tone-arm and DNM Aciore MC the Technics sounded as solid as it looked. Bass is deep and well controlled, midrange open and treble free from harshness. In fact the Technics and the SME seem almost to have been made for each other.

While the Technics' standard

performance is good, it can be a little uninvolved with Rock music. There's a very easy cure for this though. Fitting inexpensive 5V regulators to the ICs in the crystal oscillator section of the power supply costs about £5 if you DIY and brings about a huge improvement

in sound quality. With this modification (which we hope to cover in a future supplement) bass becomes superbly extended and powerful, while midrange and treble have a smoothness and transparency that makes a lot of other decks sound harsh by comparison. Speed stability also benefits, and the deck becomes wonderfully taut and rhythmic regardless of the type of music it's playing.

Prices obviously vary depending on condition, ranging from about £275 up to £375 for the motor units and £150+ for the plinths. Original EPA-100 tone-arms go for about £150 as well and stand comparison well with more up-to-date arms. If you're a fan of superb engineering and like to get the most from your vinyl, Technics' SL-1000/II is definitely a golden oldie worth hunting down ●



# Hi-Fi World Classified Ads

PRIVATE

WANTED: ROTEL RB 980 power amp. Tel: 01795 430254

SPENDOR SPI/2 SPEAKERS & M.A.F. Stands £650 (£1500) or exchange for solidstate or valve amps, Audio Innovations 1st Audio, AVI SM2000MM, DPA, ART Audio, Unison Research SIMPL-4, Audionote OTE SE. Tel: 0181 531 5979

PROAC STUDIO 100's with Target RS2 stands, good condition, boxed £590. REL Strata sub as new, boxed £296. Tel: Dave 01992 628848 (Cheshunt)

DEFINITIVE TECHNOLOGY BP10 Bi Polar Reference HiFi/AV speaker. 6 months old boxed immaculate (due to upgrade) £1095. Pioneer CT93 Reference cassette deck, Dolby S, built like a battleship, hardly used £395. Meridian 263 DAC £195. Tel: 01869 278249

LINN LP12, Ittok, Asak (new cantilever and stylus) £395, Quad FM4 £200. Sony ST80F FM/AM tuner £50. Spendor BCI speakers and stands £200. Tel: 01993 883523

MISSION 753 LOUDSPEAKERS black ash £400. Arcam Delta 90.2 integrated amplifier £150. Excellent condition. Tel: 01686 626530 Dave (Mid Wales)

MORDAUNT SHORT DECODER One TV Surround sound amplifier list £300, £135ono. Mana shelf (£130) £70. B&W centre speaker DM600IFS (£180) £85. Naim SNAIC4 £15. Various interconnects half price. All equipment two years old, mint, boxed can demonstrate/post. Tel: 01702 582986 (evenings)

NAIM CD2 as new £1500. Naim NAPI80/NAC72 (latest spec) £900. Castle Harlech speakers as new £600. Mission 752 Freedom speakers as new £400. Tel: 01303 240862 (Folkestone)

TANNOY 607 LOUDSPEAKERS 50x32x23 cms 88dB sensitivity 8 ohms impedance, bi-wirable. Hexagonal cabinets, v. good condition £85 ono. Tel: 01273 676805 (Brighton)

**ARION ADONIS VALVE AMP (Chrome) £500. Trichord Genesis CD Player £350. Triangle Titus TZXe speakers £250. Stax Lamba Nova electrostatic headphones £250. All hardly used, mint condition, can demonstrate. Tel: 0181 684 0188 anytime**

LINN LP12/Lingo/Ittok LVII/K18, black, mint condition and boxed £995. Tel: 01453 758322 (6-9pm)

LINN LP12/TITOK LV II Supex SDX 1000 M/C. Excellent condition £495. Tel: 0121 628 2437

FOR SALE: NAKAMICHI CR5 cassette deck (magnificent CR7 sound quality without auto calibration remote control). Pristine condition. Also Snell J speakers on back breaking Pirate Sounds. Tel: 01753 879468 (day) 01753 529926 (eve) Steve, Berks.

CR DEVELOPMENTS Romulus integrated valve amplifier, 35 wpc, 1yr old, as new. Cost £1189, £750 ono. Tel: 01205 750314

MICHELL ARGO PRE-AMP with Hera power supply, mint condition and boxed, will demonstrate. Superb sound £450. Tel: 01732 461561 Mike (Wenlocks)

**CHARIO ACADEMY I Speakers. Solid walnut, boxed, mint 6 months old £800. Target K. Series stands. Filled and spiked. Boxed, new £100. Tel: 0181 642 6470 (Cheam, Surrey)**

HARBETH HL-K6 SPEAKERS, as new £595. ATC stands for SCM10 speakers £95. Tel: 01892 536919 (W. Kent)

AUDIO RESEARCH LS3 (black) £1000, Rowland Model Three monoblocks (black) £2000, Audio Research DAC1 £1000, Target TT4 £60, Audiotech wall shelf £60. All boxed in excellent condition. Tel: 01628 34109 (Julian)

NAIM CD3 £650. Nait 3 £425. 2x5M NACS £25. Tel: 01993 811480

FOR SALE: LINN KARIK 3 £1250. Wakonda pre-amp, LK100 power amp £450 each, boxed. World Audio Design KLS6 floor stander speakers £1000. Sell fantastic sounding system complete £3000. Tel: 0181 797 7670 after 6pm (John)

HI-FI CABLES. Various cables, some unused, still boxed including Audioquest, XLO Reference, Masterlink, Van Den Hul, all excellent condition and at bargain prices due to upgrading. Tel: 01425 477515

LOUDSPEAKERS: Italian Chario Hiper II's in light walnut on walnut stands, bi-wirable, superb! (weeks old) £450. B&W, DM3's, refurbished and regilled. Great with valves! £150. Preamp: Nytech CPI12 (MM) a classic! £75. Tuner: Sony ST70 £25. Tel: 01462 678158

MERIDIAN 506 CD Player £540, NAD 916 & 917 DPL amplifiers & tuner £525. KEF 705 speakers with KEF stands £185. All mint condition, under 2 years old, with boxes and manuals. Tel: 01245 381810 (Essex)

FOR SALE: KEF Concerto's, fitted with Canon XLR connectors and extra tweeter unit. Ex-small recording studio monitors £110. Wanted: Quad 303. Tel: 01923 212044 days (David)

PAIR OF STACKED ELECTROSTATICS beautifully constructed magnificent sound £500. Tandberg 3600xD reel to reel tape deck £100. Tel: 01279 718325 after 5.0/c weekdays

MERIDIAN DSP 5000 Active loudspeaker system, rosewood with MSR 12 months old, immaculate boxed £2450 ono. Tel: 01454 250193 after 6pm or Fax: 0117 9354115

LINN KAN 2 SPEAKERS & K2 Stands £230. Cyrus III amp, new £395. Sony SS86E speakers £35. Arcam Alpha 7 CD Player £235. Mission 760i speakers £40. All mint condition. Tel: 0171 794 3843 (Robin)

WANTED: SONY TC229SD, TCK8B, CDPX303ES, Sansui SR222, Michell Gyropower PSU, old HiFi mags. Tel: 016974 78537

CYRUS TWO Amplifier with PSX power supply, excellent condition £290. Systemdek turntable with Moth arm, Goldring G800 cartridge as new £170. Tel: 01792 369582 (evenings) 01792 703139 (day, Swansea)

WANTED: NAIM CD, amp and speakers plus Linn LP12 Ekos Lingo etc. Tel: 0121 783 8227

NAIM CD3 new Dec 96 (£970). Perfect boxed with receipt. Will accept £750. Tel: 01247 274451 (N. Ireland)

PAIR DUAL POSITION Lowther Acoustas PM7A drive units £400 ono. Can be demonstrated. Studer Revox A77 2 Track £375 ono can be demonstrated. Tel: 01705 321494 after 6pm

**RUSS ANDREWS thinks his Rata Excel Plus is one of the finest sounding CD players around. Listen to mine, judge for yourself and buy for £995 ono. Tel: 01423 528256 (Harrogate)**

DAT Sony DTC77 four head recorder £450, Revox A77HS £325, Marantz SD62 three head cassette recorder £110, B&W 620i Speakers black £250. Tel: 01787 247243 (Dick Histed, Suffolk)

2 W.B. STENTORIAN H.F. 816 Speaker units £40 pair. 1 professionally built column speaker (no unit) £40. Decca FF55 arm (minus cartridge) £40. ACOS Hi-light arm (Deram cartridge) £50. Tel: 01429 298956 (Hartlepool)

MUSICAL FIDELITY F22 pre-amplifier, phono-stage £600. Yamaha DSP-1 digital soundfield processor £125. Pioneer VSA-730 pro-logic amplifier £195. N.T.S.C. to PAL converter for PAL televisions £80. All excellent condition. Tel: 0121 705 1142 (Rod)

MARANTZ SM11 Stereo power amplifier. Fantastic build & sound £750 (1500). Marantz SC1000 pre £450 (1000). Amcron ES224 electrostatic speakers & subs. Awesome £1750. Metaxus Icarus integrated amp £400 ono. Tel: 0121 459 9616

WANTED: SNELL TYPEK Speakers. Must be Mk1, in good condition. For sale: Transcriptors Hydraulic Reference Turntable, fluid arm, sweep arm, stylus brush £300. Tel: 01935 702643 (day) 01935 432417 (eve)(Chris)

LINN KABER Loudspeakers; passive, black ash. 2x6m lengths K600. Boxed, immaculate, 3.5 years old £850 ovno. Tel: 0161 429 0963 evenings/weekend (Nick, Stockport)

ACOUSTIC ENERGY AE2 Speakers plus stands (now £2000+) superb sound and looks. Reluctant sale £750 ono. Rega Planar 3 £100. Nytech CA252 amp £90. Tel: 01633 254673 (Nick)

KRELL KSA 100 Power amplifier. One owner from new, as new £1250. Tel: 0161 904 8081 or fax 904 8082 (Manchester)

**AMERICAN POWER AMP. MUSE 160, 50 hours use. Musicality with definition, as new. £2400 new, accept £1100. Tel: 01246 590452**

J.P.W. AP3 SPEAKERS, oak veneer + JPW stands vgc £150 or swap Pioneer A400 amp. Meridian 103 power amps + power supply £60. Tel: 01765 600450 (N. Yorks)

NAIM NAPI40/NAC72 MM boards £850, Flat Cap (new), NAC72 £425, SEAS T25-001 tweeters £85 pair, MkII Talisman tweeters £25 pair, Nytech Pre/power £200, all items immaculate and boxed. Tel: 0181 668 8983

WANTED: WHARFEDALE 708 speakers. Selling Leak TL10 £150, Williamson amp £170, Garrard 301 £170. 1950s Wharfedale open baffle speaker £50, Quad mono pre and tuner £10 each GL75 £10 Ortofon Fonofilm Cartridge and linear tracking arm £25, CTC mono valve tuner £25. Large selection of new/used valves send SAE for list. A. Cavender, 288 Hexham Rd, Throckley, Northumberland NE15 9QX. Tel: 01661 852874

PINK TRIANGLE EXPORT GT1 with SME 309 and Corus Black; Perception Phono Stage; Air Pod Supports (3); VDH First interconnect 1m. All sensible offers considered. Tel: 01685 385898 eves./weekends.

ROGERS E20a Integrated amplifier, 18 Watts per channel Class A with a phono output 7 months, mint condition. £700 ono. Tel: 0161 764 8136

**I SOURCE TURNTABLE including R.P.G. One Odyssey arm and the 3 dimensional power supply, excellent condition £650 ono. Tel: 01623 646543**

KEF 107 REFERENCE Speakers, rosewood with cube £1200. Yamaha digital processor/amp DSP E1000 £300. Technics VC4 200 Watt amp £150. Nakamichi BX300E cassette deck £200. Arcam Delta stereo TV tuner £50. Thorens TD 321 turntable. Linn BSK arm, Gldrg G1042 Cart £150. Tel: 0385 791744

ATC SCM50A active loudspeakers in black ash, tri-amplified, 300W, with stands and cable. Immaculate condition, only 24 months old. Ono £2850. North London. Tel: 0181 340 3832/ 0973 313 819

# 1 NEW ♦ EX-DEM ♦ USED ♦ VINTAGE HI-FI BOUGHT & SOLD CASH ♦ PART - EXCHANGE ♦ COMMISSION SALES

# And WHAT'S NEW?

**SELLING OR CHANGING YOUR HI-FI?**  
You will want to know that  
**THE HI-FI COMPANY**  
has the most flexible approach to  
ensure you get your best price - quickly.

## WANTED URGENTLY

We always require top-quality hi fi  
and can offer **INSTANT CASH** for your  
carefully used equipment.  
Currently we have customers waiting to  
purchase the following items:

YAMAHA CT7000 Tuner, VALVE amps,  
NAIM amps & power supplies, REVOX tape  
decks, all ELECTROSTATIC loudspeakers,  
Nakamichi, Sequerra, all MICHELL Turntables  
QUAD FM3 / FM4 / 67CD / 66 Series  
Quad owners note: Extra Special Upgrade  
p/x allowances to Latest Quad 77 Series

**TRADE ENQUIRES VERY WELCOME**

## COMMISSION SALES

Difficulty selling your specialist hi-fi?  
Then, allow us to sell it for you on a  
commission basis.  
And, for mint condition items, boxed, or  
with owner history, we can advance up  
to 50% of agreed selling price, with  
balance payable (less commission)  
immediately on sale of goods.

## THE 'WISH' LIST

Looking for something specific?  
New or used, there's a good chance we  
can obtain what you want, at the best  
price - and we can always find a new  
home for your old equipment too!

## PART-EXCHANGE

We promise **UNBEATABLE** allowances  
against items from our extensive range  
of **NEW** and **USED** hi-fi equipment.  
Use your P/X as the deposit on your new  
purchase (available on **INTEREST FREE  
CREDIT**) or ask for a '**CASH-BACK**'  
if you prefer to pay any other way!

ALL USED EQUIPMENT IS FULLY TESTED  
AND SOLD WITH WARRANTY.  
**CALL FOR UP-TO DATE LIST.**

**CREDIT CARD CALLERS**  
NEXT DAY DELIVERY GUARANTEED

TURNTABLES / ARMS		
Grado Tonearm / Signature 8 (both Unused)	£1000	£495
Linn LP12 / Akito / Audio Tech OC3	£1500	£595
Linn LP12 (Blk) / Ekos / Lingo / K9	£3500	£1295
Linn Axis / Black Pearl cartridge	£595	£295
Manticore Mantra / Magician / MB6 with power supply and Ortofon MC3000	£3200	£1195
Rega Planar 3 / RB 300 / Ortofon Q	£349	£249
Roksan Xerox (Black) / Rega RB300	£1175	£595
Slate Audio 401 (Never used) Cut for SME 309	£1600	£750
Trio L 07D Direct Drive (Extremely rare)	£2250	£750

CASSETTE DECKS / REEL TO REEL / TUNERS		
Nakamichi 480Z	£425	£275
Nakamichi 700 Tr Tracer	£1750	£495
Nakamichi 583	£695	£395
Nakamichi 600	£500	£195
Stax Omega headphones inc power supply	£3000	£1695
Pioneer CT91a (Reference)	£795	£395
Revox B77 1/2 track	£2500	£695
Naim NAT101	£1250	£495

AMPLIFIERS		
Albary APS1 / PSU / DMP 1 / M408	£1400	£600
Arcam Delta 110 / 120 Pre-power	£1250	£745
Arion Electra (New) Integrated	£1400	£875
Audiolab 8000M (X2) Ex-show stock	£1600	£1125
Audio-Note Otto phono pre-amp (Valve)	£1500	£750
Audion Sterling (Silver wired power)	£599	£495
Audio Research LS3 (Blk) Pre	£2000	£1195
AVI S2000MI (Ex-dem)	£899	£699
Classe Audio DR9 Class A Power amp	£3699	£1800
Concordant Express	£1295	£695
Exposure 7 Pre / 8 Power	£1100	£575
Incatech Claymore (Finished in Gold) Unused	£575	£425
Jeff Rowland Model 3 Monoblocks	£4000	£2250
John Shearpe Phase 2 (Integrated)	£595	£395
LFD PA1 / MC1 / 2 X Monoblocks	£4500	£2700
Linn Majik 1 (Inc MM Phono stage)	£890	£395
Linn LK1 / Dirak PS / 2 X LK280	£2500	£1000
Linn Kaim / LK100	£2350	£1495
Magnum 330 Pre/power (Chrome)	£1120	£895
Meridian 562 Pre (Ex-dem)	£995	£795
Meridian 565 AC3 / 519	£3150	£2350
MicroMega Tempo 2 (Integrated)	£950	£650
Mission Cyrus 2	£395	£175
NAD 208 (THX Power)	£1100	£799
Naim 92 / Flat Cap / 90 (As new)	£1260	£900
Naim 32 / 160 (Scratched)	£1495	£495
Naim 160 (X2) (Modified)	£660	£595
Pioneer A91D (Reference)	£1250	£595
Quad 77 (Inc remote - New)	£849	£649
Quad 34 / 306	£715	£495
PS Audio IV / HCPS (Pre-amp)	£695	£295
Rappaport Pre-2 (Pre-amp)	£595	£395
Sonographe FET (Pre)	£1250	£495
Sugden A21a Integrated amp	£695	£495
Sumo Alhena (Pre) + 9 (Power)	£1900	£995
Threshold S300 Power amp	£5500	£1950
YBA 2 (Pre)	£1700	£875

CD PLAYERS		
Arcam Delta 70 / Black Box 3	£1100	£675
Audio Alchemy V3 DAC	£700	£495
Audiolab 8000 Transport & DAC (Ex-show)	£2200	£1500
Carver TL3220	£500	£295
Linn Karik 3 (As new)	£1850	£1295
Meridian 206B Delta Sigma	£795	£395
MicroMega Stage 3	£900	£595
Naim CD3 (1 month old)	£997	£797
Parasound 1600 DAC	£1450	£995
Quad 77 CD (unused)	£850	£650
Roksan Artessa Mk2 Trans / DAC / Pwr Sup	£2200	£1295
Sony CD-P701ES	£795	£295
Teac VRDS10	£800	£595

LOUDSPEAKERS		
Acoustat Model X (inc valve power amps)	£3500	£1750
Acoustic Energy AE2 + Stands	£1545	£695
Apogee Stage (Ribbons)	£2995	£1295
ATC SCM10 (Black)	£1100	£595
Celestion SL700	£1495	£650
Epos ES14 (New)	£675	£475
Harbeth HL-P3	£799	£599
Impulse H6 (Horns)	£1495	£875
Linn Sara (Teak)	£700	£295
Magnaplanar SMG-CSE	£990	£675
Meridian M30 (Active)	£1000	£575
Mission 754 (Oak) Ex-dem	£1498	£1198
Proac Response 1	£1200	£850
Proac Studio 100 (Rosewood)	£650	£495
Quad ESL57 (Black)	£1500	£395
Quad ESL63 (Rosewood)	£3500	£1495
REL Sentour	£1800	£995
Rogers Studio 1	£499	£349
Spendor S100	£2125	£995
Spendor BC3	£1250	£495
Tannoy Berkeley 15" HPD (Walnut)	£750	£495
Tannoy Lancaster 15" Gold (Circa 1960)	Offers over	£395
Yamaha NS1000 (Black) Ex-studio	£1399	£695
Yamaha NS1000 (Ebony) Very rare	£1999	£895

Most of the hi-fi bargains you'll see listed on the left have come into stock when customers have chosen to up-grade components or systems at The Hi-Fi Company. Generous trade-in allowances are just one of the benefits enjoyed by our customers because - we really want your old hi-fi equipment! And, most importantly, we back up our **Easy Up-Grade** facility with the most appetising stock of hi-fi equipment at any price level.

As well as virtually every justifiably 'award winning' component and system featured in the serious hi-fi press, we always keep a wide range of equipment which we consider to have outstanding or unique qualities and characteristics, regardless of budgetary constraints or that invidious 'sound for your pound' journalese espoused by 'popular' hi-fi magazines, and which so demeans the aspirations of more discriminating enthusiasts!

In fact it is obvious to us that most of our customers have quite individual and specific expectations, often not met by the 'vanilla' favourites of the popular press! For them (and hopefully, you) we keep right up-to-date with the very latest, and most interesting hi-fi components and systems available for your assessment.

Amongst several exciting new products that have found favour in our demonstration studios in the last few weeks are the following:

- ♦ **SONUS FABER**  
Concerto Grand Piano £2299
- ♦ **MICHELL ORBE** with  
SME Series IV / Lyra Lydian £3445
- ♦ **AUDIOLAB**  
8000 CD Player £1000
- ♦ **NAIM Credo**  
Loudspeakers £1060
- ♦ **KRELL KAV 250 P/A**  
Pre and power £5280
- ♦ **COPLAND CDA 277**  
CD Player £1799
- ♦ **MERIDIAN 565 (7.1)**  
DTS/AC3 Dig. Processor £2850
- ♦ **M&K 150 THX (5.1)**  
Studio Monitor Spkr System £5000
- ♦ **QUAD 77 Remote Control**  
CD / Tuner / Amp system £2250
- ♦ **YAMAHA DDP-2**  
AC3 Processor £350
- ♦ **MAGNEPLANAR**  
MG - 0.6 SE Speakers £1370
- ♦ **MARTIN LOGAN CLS II**  
Full Range Electrostatics £4555

Phone for our latest newsletter or for details about any of these fabulous new products.

## PLEASE CALL

We are open 9.30am - 5.30pm  
Tuesdays - Saturdays (Inc)  
CLOSED MONDAYS  
Answerphone all other times

# The HiFi Company

**TRADING STATION**

35-42 COWGATE PETERBOROUGH PE1 1LZ

BUYING OR SELLING : (01733) 555514

'WHAT'S NEW': (01733) 341755



# Hi-Fi World Classified Ads

## PRIVATE

NAIM 250, old style £550. Sony TCK6115 Dolby S cassette deck, little used £120. Leak Variaslope stereo pre-amp, excellent condition £30. Quad FM1 tuner £10. Toshiba Aurex FM tuner £20. Tel: 01276 65054

SILVER SOUNDS 1/2 2x4 mtrs £150. Denon 250 MkII £60. Denon 250 MkIII £80. MAD 304 as new £85. Mullard 3 Watt Single Ended Monoblocks £150. Leak Stereo 60 (new chassis) rebuilt £200. Tel: 0114 2215271 or 2723621

ARCAM ALPHA 5 PLUS as new boxed with manual, accept £250. Quick sale. Looking for Marantz CD635E must be in good condition, boxed with manual. Tel: 0161 232 1431 after 6pm.

ROKSAN DPL5 CD Transport £600, DPA PDM 1 MkII DAC £300, both excellent condition, single-owner and recent manufacturer service; Moth Passive Pre, Audioquest Video 2 1m digital interconnect, Audion Pure Silver 0.5m, Deltec Black Slink 1m, Deltec Slink 0.75m stereo interconnects, Chord Flatline Gold 2x3m speaker cable, offers. Tel: 0151 526 5344

MARK LEVINSON 27 £1500. Apogee Centaur Minors with stands £500, mint boxed. Origin-Live table £100 (equivalent of Mana). 1-metre Cardas AES/EBU digital £100 (£190). 1/2-metre Siltech HF6 digital £60 (£110). Tel: 01442 877853

GRANT G50A valve amplifier £600. Pair Rogers Studio 3 speakers £300. Pair 22" Huygens speaker stands £100. Pair 16" Target stands £30. Akai x 2000 reel to reel tape deck £100 plus tapes. Tel: 01709 510588

LINN SONDEK, Mission 774 arm. (NOTLO) Linn Asak, low hrs, mint £450 ono. KEF Transmission Line Speakers 102x47x34cm, 3070 200 Watts, hand crafted in black, new tweeters worth £100, rewired. Superb sound, perfect condition £450 ono. Audition next to Linn, Valhalla, Circus, Ittok, KEF 105/3s, 140 Watt amp. Come and listen! Tel: 0958 210836 (B/Ham)

QUAD BRONZE ESL speakers all six driver panels renewed by Quad, 10 hours use since, £500. Beard BB 100 integrated line amp 50W+50W £600. The Cartridge Mans AKG, few hours use only £50. Tel: 0181 393 4265 day 01737 362 899 eve

SHUN MOOK CD Clamp (£600). Not one ever existed in UK. Full-bodied, detailed, sweet sound, ultimate turntable upgrade. KSA 300S (£5500). Immaculate, boxed, still so close to the FPB. Enquiries welcome. Tel: 0131 668 3389

MISSION 754 Freedom 5s black, 2 months old mint condition boxed £875. Projekt Audio Rack designed to fit Naim slim series, 80mm spacing, 8 shelf, black ash veneer, fully modular, 2 months old mint condition (new £485) accept £200. Tel: 01295 250000 evenings (Christian)

NAIM NAC 82 pre-amp, absolutely superb, mint with manuals, remote + box, receipts cost £2056, asking £1350. Also Sonus Faber Electras together with own dedicated iron/wood stands, breathtaking £1200. Tel: 0171 242 1214 day or 0181 882 8792 eves (George)

LINN NAIM ACTIVE SYSTEM, Isobariks one of last models Active/Passive. Naim 3x250s, 3 way x-over, HiCap, 32.5, 2xLK 600 cable £3250 may split. Tel: 01904 490796

WANTED: SPENDOR SP2 original Mk 1 speakers. Tel: 01274 817035

WANTED: BATTERY Power supply for Pink Triangle DAC. For sale: pair Acoustic Energy AE1s £250 ono. Tel: 0131 661 6040 (Edinburgh)

ROTEL RC970BX Mk II Pre-amp £100. RB970 BX MkII power amplifier £140. Mission- Pair 780SE speakers £140. Target HS20 stands £35. As new- boxed. Tel: 01444 413782

LINN LP12, Ittok LVIII arm, Ortofon MC10 Supreme Cartridge £650. Alphason turntable stand (grey) £75. Ruark Templar speakers, rosewood £275 (boxed). Denon UPAF10 amplifier/Denon UDRF10 cassette (remote control) £300. Tel: 01954 232056

EXPOSURE 14 Pre-amp, 9 power supply and 4 power amp all in good condition £2000. Tel: 01252 843391 (North Hampshire)

PINK TRIANGLE CARDINAL and Decap. HDCD. Re-clock, HIQleads, 3 months old £1395. Meridian 200 Transport £250. Roksan Darius MkII speakers £695. AVI 2000 Pre. +2 power amps £1095. Tel: 01582 454246 (Luton)

LINN LP12 Ekos Lingo Circus Trampolin Arkive Cartridge 3 years old £1500. Naim CD1 CD player with remote £1050. Tel: 01904 490796

KEF Q55 as new, boxed and with remainder of warranty- (8 months ) £395. Rotel RA935BX mint condition- boxed £135. Tel: 01732 355143 (Tonbridge)

FOR SALE: Nakamichi 1000ZXL computing cassette deck very rare £1595, Nakamichi 1000 Tri-Tracer, rack mounted deck £495, Nakamichi CRSE cassette deck £595. Tel: 0181 942 6553 (London, Surrey)

MERIDIAN 200 TRANSPORT, 203 DAC £485. Mod Squad, American passive pre-amp £240. All mint, boxed with manuals. Tel: 01883 349298 (Surrey)

JBL L20T Monitors £200. Rotel RA820BX2 £55. Tandberg TCD320 £125. NEAL 302 studio cassette deck £550. Rega RB250 £45. Audio Technica AT24 £60. Goldring G1042 £50. Denon DL103 £40. Tel: 01474 704382

**ROGERS STUDIO 3 Speakers, black ash with heavy custom stands. Very Good Condition, transparent sound, well reviewed. £295 or near offer. Tel: 0171 273 4436 (day) 01727 855003 (eve) (Herts)**

LINN LP12, Akito arm, K9, Valhalla, black, pristine £1100. Naim NAP90, NAC72 amp, pristine £695. Nakamichi Cassette Deck I, pristine £295. Alpha Arcam CD, pristine £130. Tel: 0115 9558603 (Matthew)

**SPEAKERS, Original B&W Black Technopods, c/w wall brackets, cost £1300, accept £600. Black 613 Tannoys with bases, cost £690 accept £250. All excellent condition, view West London. Tel: 0171 266 4781**

QUAD ELS63 (black) £1600. Gradient SW63 £700. Also Mordaunt-Short M52H £100. All as new. Tel: 0161 427 4744 evenings (Manchester)

NAIM CD3 1 month old £675. 72, 160, £795 (160 upgraded to new spec inside, + new style case). Mission 752 Freedom £375. Tel: 01293 416022 (Colin, Crawley)

LINN ISOBARIK SPEAKERS, Panelled stands, upgraded Kelik tweeters, Active/Passive, black £850 Linn Activ crossover + Dtrak £550. Linn LK280 Spark £500. Linn AY5120 Centre Speaker 2 months old £500. Cyrus AV Master 2 months old £550. Tel: 01474 833697

PASSION PASSIVE CONTROLLER latest vishay type excellent condition £350. Musical Fidelity MA 100 monobloc amps class A £500. KEF Reference 107 loudspeakers black ash with cube equaliser £1050. Tel: 01228 21533 (Carlisle Cumbria)

LINN KARIK CD player £950. KEF 104/2 Raymond Cooke specials £950. ATC Active 100 speakers £4200. Quad 34/405II Pre Pwr £350. Quad 66 Pre-Amp £480. Tel: 01977 643629

ROKSAN XERXES with Artemis Arm £595. Tel: 0181 452 1452 (eves)

MONITOR AUDIO STUDIO 505E in piano ebony half price £2495 (4950). Immaculate condition. Martin Logan SL3- light oak £2600 (3400). Tel: 01797 253673 (East Sussex)

QUAD PAIR SERIES 2 valve power amplifiers, 22 control unit, matching stereo tuner installed in period GKD cabinet with Garraad 301 turntable, SME 3009/2 £645 onvo. Further details Tel: 01842 812895

BANG AND OLUFSEN BEOMASTER 3300. Complete system. Receiver, Gram, CD, Recorder, 2037 active aerial, remote control, pair Beovox S75 speakers. Mint condition £600 Tel: 01243 552061 (West Sussex)

LINN KAIRN PRE AMP boxed as new £800 ono. DPA Bigger Bit DAC MkII £300. Arcam Alpha 6 CD 12 months old, boxed as new (600) £400 ono. AR EB101 turntable c/w AT95E £100. Denon DRS 810 cassette deck (310) £130. Meridian 200/203 DAC 7 £550. Tel: 01792 280061 (Jules)

SOW NT mini digital tape recorder. Perfect for musicians. Full kit including manual plus 20 cassettes £275. Tel: (+353) 87 230 5958 (Mick)

SPENDOR BCI SPEAKERS teak finish. Excellent condition. Plus Target stands £240. Tel: 01708 767478 (Romford)

AUDIO INNOVATIONS P2 £600 Zeta (rewired Manticore Cardas) £600 Yoyd Valdi £400 Goldring Excel YX £290 Bantor 150MM 852 x2 unused £150 Townshend Seismic Sink £75. Tel: 01942 202360 (anytime)

AUDIOLAB 8000C Pre-amp late 96 spec £375. Audiolab 8000Q £695. Musical Fidelity pre-amp II 4 line MM/MC £120. Ixos 101 new £60. Wanted: Denon POA 4400/6600 monoblocks/Pro-Ac Response 3. Tel: 01634 387686

DENON AVC 1530 Prologic amp + Canon SC10 Centre Speaker £150. Cost £600. TDL Studio 0.5 £150. Cost £500. Tel: 01203 383845 (Nick, Warw.)

WANTED: PRO-AC STUDIO TOWER speakers, may consider Response 2.5/3.5. Cash waiting for night pair. Tel: 0171 409 5789 (weekdays)

MISSION 753 SPEAKERS Rosewood £400 as new. Royd Eden speakers £120. Musical Fidelity E600 CD player £300 boxed as new. JBL MR Centre £70 new boxed. Tel: 0181 363 4963

HEYBROOK SEXTET II spks, special walnut finish, 7 months old, highly recommended in Hi-Fi World £780 ono (1200); Arcam Alpha 5 CD player, excellent condition £200 ono (500); Tel: 01689 855063

ORELLE DA188 DAC (£499) mint condition £250. Pandoras box (£180) power conditioner, DAC/Pre upgrade £90. Both for £325. Custom BNC to Phono (£120) digital lead £60. Tel: 01823 334275

MISSION ARGONAUT SPEAKERS £320 Dual 505 turntable £50, Akai 4000DS £90, Naim NAC 32 pre-amp £125. Sherwood 18 band equaliser £50. Spendor speaker stands £45. Meridian 101 pre-amp £85 Quad AM tuner £50 all vgc Tel: 0181 686 7996 (Croydon anytime)

DPA LITTLE BIT 2 DAC good cond £180 ono. Monster 400 interconnects £20- Mordaunt Short M25i spks + Cable Talk 3 Bi-wire cable £200 ono. Tel: 0161 368 4105 (Colin)

ACOUSTIC RESEARCH EB101, Mission 774, A&R C77, £145; Cyrus PSX power supply £50; mint pair Heybrook HB2 (teak) £125; Marantz PM-445E amplifier £115. All as new. Tel: 01244 335194 (Chester, evenings)

TOWNSHEND GLASTONBURY II speakers £800 ono. 150 Watt monoblock amps £450 ono. Meridian 203 DAC £190. Yamaha 710 tuner £35. Aiwa F770 cass. deck £80. Tel: 01392 874746

MICHELL ARGO HR. Superb sound. Boxed £695 ono. Moth phono preamp with 100VA power supply. Boxed. £165 ono. Tel: 0118 954 7758

"HI-FI CHOICE", 33 copies early comprehensive editions (Martin Colloms) 1976-1985 and Hi-Fi Yearbook 1978 £175. 30 1970's HiFi Magazines £50. Tel/Fax: 00 3531 4591432

**CYRUS 2 AMPLIFIER & PSX P/supply £150 each. Linn LP12B Ekos Lingo K9 £1500 & Yamaha CDX390 £80. Good condition. Oxon. Tel: 01993 850439 (evening) Andy**

# MS

Mordaunt Short

<http://www.mordaunt-short.com>

LOUDSPEAKERS

## Silvernote

Handcrafted Amps, Speakers and Cables  
PO Box 100, Chesham, Bucks, UK, MK37 0JH  
Tel: 0494 600000 Fax: 0494 600000  
proprietor Steven Mason

NEW - DIY Quarterly magazine - **Ultra High Fidelity** - covering DIY project rebuild vintage Hi-Fi etc - Out Now!  
Handcrafted clear Perspex lids to fit Slate Audio and Loricraft turntables - £99  
Also made to measure to any design or make of turntable from £99

Coppemote leads £99 per meter  
Silvernote leads £499 per meter  
Strong Steel Chassis for your amp projects - made to measure £75

NEW Svetlana 572 Vacuum Tube  
Coming Soon Slate, Granite, Marble and Glass Isolation supports Lowther Drive Unit  
Lecson amp, Speakers, Tuner

**Wanted:**  
Quad EL5 57 bronze must be mint  
Old Hi-Fi magazines  
Hi-Fi year books  
Worldwide distributors and agents

**Wanted:**  
**FOR SALE:**

Audionole Ongaku M7 Phono ANS 7C Silver transformer £25000, Vayd reference .5 with super cyaleen £2500

Nakamichi 1000 cassette decks, £800 each.

Lecson AC1 / AP3 MK2 Mini Boxed £450, TVA 1 Amp £1500,

Conrad Dohnson £1500, Quad II Boxed POA

Decca International Box £150, Linn Sara POA, Studer B62 £400, Revox G36 £200 £350, Akai Reel to Reel POA, Magnifying Glass £5 each.

# INACCESSIBLE ACCESSORIES ~~ BY POST ~~

cartridges :

denon, goldring, lyra\*,  
ortofon, roksan, sumiko

**\*new lyra parnassus dc out now  
30% allowance for your old one**

cables :

audioquest, cable talk, chord company,  
heybrook, ixos, kimber, kontak, lfa,  
nordost flatline, ortofon, qed, sonic link,  
trichord, van den hul, xlo

stands :

alphason, apollo, frameworks, heybrook,  
sound organisation, something solid,  
soundstyle, stands unique, target

headphones :

beyer, creek, earmax, grado,  
jecklin, sennheiser, stax\*

**\*new stax SR0001 in ear electrostatic  
package £279 in stock**

accessories :

audioquest, blb, creek, densen demagic,  
discwasher, goldring, hunt, ixos, kontak,  
michell, milty, monarchy, moth, musical fidelity,  
nordost, pixall, qed, rms, rata, shure, trichord, zerostat



featuring cool  
cables from...



phone, fax or write for  
price list / newsletter

## DEALS, DEALS, DEALS

**Naim 62** preamplifier, current style,  
mint, s/h ..... **£175**

**Rogers LS33** loudspeakers ex  
display, boxed, perfect ..... **£175**

**Naim 140** power amplifier, current  
style, as above ..... **£395**

**Denon DL304** cartridge. Only 50  
hours use, perfect, boxed ... **£110**

**Unison Research** simply two inte-  
grated single ended valve  
amplifier, perfect, (rrp £999) ... **£675**

**Royd Squire** loudspeakers.  
Compact slim floorstanders in  
walnut veneer (£390) ..... **£185**

**Pro-Ac** studio 100 loudspeakers,  
walnut, boxed, excellent (£700)  
work exceedingly well with the  
above Unison Research amplifier  
..... **£425**

**Pink Triangle** DaCapo DAC with  
HDCD filter and BNC connection  
absolutely perfect, six months old  
cost over £1800 ..... **£975**

**Pro-Ac** studio 100 loud-  
speakers, mahogany,  
boxed, slight damage,  
hense..... **£325**



**Audiovector 5** loud-  
speakers finished in  
black lacquer, very  
(very very) dynamic  
with astonishing bass  
quality and extension.  
Best in a big room. Very  
efficient but 4 ohm  
load. x/d (£2500) ..... **£1425**

**John Shearne** phase 2  
amplifier with MC  
phono stage, excellent,  
s/h ..... **£350**

DEMONSTRATIONS WITH PLEASURE BUT BY APPOINTMENT PLEASE  
a t c a u d i o m e c a a u d i o v e c t o r

a u d i o s y n t h e s i s b e y e r c r e e k d e n s e n g r a a f  
g r a d o h a r b e t h j e c k l i n l y r a m i c h e l l  
m u s i c a l f i d e l i t y n o r d o s t o r t o f o n a l n  
r o g e r s r a k s a n r o y d s e q u e n c e s u g d e n s u m i k o  
t e a c t h o r e n s t r i c h o r d u n i s o n r e s e a r c h  
**i p s w i c h ( 0 1 4 7 3 ) 6 2 2 8 6 6**  
s i g n a l s m a r t l e s h a m h e a t h  
i p s w i c h s u f f o l k I P 5 3 U A  
e m a i l : s i g n a l s @ d e m o n . c o . u k  
h t t p : / / w w w . s i g n a l s . d e m o n . c o . u k /

HAVE YOU EVER WISHED.....  
that your speakers gave you more?

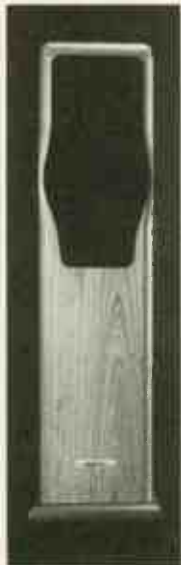

Well now they can!

Discover the full heart and passion  
contained within your music.

Origin Live speakers will fulfill the  
highest musical aspirations in  
exemplary fashion. With their  
stunning good looks they are  
intended for those who desire  
something special.

These speakers have that rarest of  
all qualities - the ability to bring  
music to life, effortlessly,  
gracefully, and utterly  
convincingly.

Don't miss auditioning a pair of Origin Live Speakers at  
one of our specialist dealers.

For further information and complete list of Origin Live  
dealers contact:-

**Origin Live, 87 Chesel Crescent, Bitterne,  
Southampton, SO19 4BT**

**Tel: 01703 442183 / 671237 Fax: 01703 398905**



# Hi-Fi World Classified Ads

## PRIVATE

Q.E.D. MA34 Passive Pre-amp, as new £30. For CD Campaign Audio Silurian Digital 75 ohm 1 mtr lead, as new £25. Integrex NRDC Ambisonic surround sound decoder circuit details and review, boxed, good condition £20. Quad 306 power amp, booklet, boxed, overhauled by Quad, excellent condition £165. Tel: 01903 247779 (Sussex)

QUAD ESL63 Electrostatic speakers + stands + Kimber mains cable £1200. Tel: 01843 584030. Please leave message if answerphone.

NAIM NAP250 Poweramp, new style- mint boxed £795. TEAC P-10 CD Transport (£1500)-£650. Wadia X32 20bit DAC Coax and optical I/P's (£2200)- £695. Tel: 01394 460281 (Woodbridge)

MARTIN LOGAN AERIUS speakers, bi-wire black finish. Purchased May 1995 from Absolute Sounds dealer, balance of warranty, owners manuals and purchase invoice - as new condition £1400 (2400). Tel: 01733 892228 (eve) 01733 310819 (day)

WANTED; HAFLER XL280 and XL600 poweramps, Tannoy 12" Superduals, S300s and single 15" Dual Concentric. Tel: 01203 460723

**KEF 107/2 RAYMOND COOKE Special Edition Series Ref speakers, genuine Santos rosewood, 15 hour's use extremely rare, significant upgrade to the standard 107/2 IE finish, crossovers wiring. Complete with certification manuals, boxes mint cond £3400 ono. Tel: 0121 742 2015 (Ralph)**

VALVE RECEIVER (Pioneer) 40 wpc. vgc (£195). Proac Super E.B.T. speakers (£175). Meridian 101B, MM input (£70). Denon DR171 cassette (£50). Dual S05-1 (£45) Glass platter mat (£10). Tel: 01621 772884

ROGERS LS3/5A Loudspeakers black mint condition £380. Monitor Audio R852/MD Kenyan black mint condition with stands £350. Epos ES14 walnut, mint condition with stands £400. Tel: 01634 828010 or 0181 657 2171 (evenings)

**PROAC EBSs (black ash) £1195, Counterpoint SA-100 Hybrid poweramp £995, Sony Esprit TAE901 preamp £995, Sonus Faber Electas £1295, Sony CDP333ESD £395, Krell: KSA100S £3995; KRC3 £2495; KPS30i £3995. Tel: 01628 789115(h); 01793 883299(w)**

IMPULSE H2 Horn speakers 94dB sensitivity, rosewood, vgc £1450 (£2500 new). Orelle DA 180 DAC £295. Wanted: pair of Celestion DL 8 speakers. Tel: (00 33) 320-35-91-19. 18.00-21.00 or weekend.

NAIM AUDIO CDS CD Player £1600. Tel: 01454 418997 evenings

VINTAGE FOR SALE: EMT948 Broadcast Turntable. EMT arm/Cart £700. Chapman 30S valve stereo + preamp + tuner £350. Connoisseur HQ20 valve amplifier + preamp/tuner £375. Pye HFS/8 valve monoblocks £425. Symphony Stereo £200. McIntosh MC30 monoblocks £900. Westrex valve amplifier. Western Electric Triode amp 300B + speaker. EMG valve amplifier using KT66s + preamp + tuner Goodsel, Williamson, PX25s. Tannoy double triode amplifier. Decca Triode amplifiers. Offers. Tannoy LSU speakers + Vitavox D/Concentric. Offers. Tel: 0171 262 9419 or 0958 607613

SONUS FABER ELECTAS walnut with Audio Dimensions stands (£300 new) mint, both £1150. Lumley ST70 black Triode/Pentode switch as new £1150. Audio Research SP9 Mk 2 silver mint £800. Tel: 01834 814311

LINN LP12, Valhalla, Ittok LVII, K9, mint condition £400. Tel: 0191 384 7871

IPL S3TL Mk3s Mahogany run in only £180. Musical Fidelity A1 £50. New Tannoy 625 Alf subwoofer £300. Pair boxed Seas 25 FEWRX mounted unused £60. Wanted: Quad IIs. Tel: 01494 874381 (Bucks)

MYTECH 102 Preamp/Tuner and 602 power amp £150. Tel: 01484 654309 (Huddersfield) anytime

LEAK STEREO 20, Hadan Boardman rebuild, great sound and condition £250 ovno. Concordant Exhilarant valve preamp, excellent £395 ono. Tel: 0181 670 6796 (Jim)

MUSICAL FIDELITY 180 CRPS £650. MYT III £495. Ekos II £650. Jordan Watts spkrs £275. Tandy Lineaums £80. Decca arm £45 P/Ex considered. Tel: 01323 726110

LINN LK100 (new) £450. Linn Mimik (new) £575. Linn Kabers (rosenut) £950. Linn Karik/Numerik (new) £1125/£950. Grado SR60 headphones £40. Mission 733 speakers (new). Tel: 01952 502097 (Telford)

MERIDIAN DSP 5000 Digital Active speakers (rosewood) mint boxed, very powerful dynamic sound (£3300) £2000 with MSR remote. Meridian 602 Transport also excellent boxed with remote £600 ono. Tel: 01273 601272 (Brighton)

**BLACK LP12, Lingo, Ekos, Cirkus, Blue Point Special as new (mint). 10 hours use £1950 ovno. Naim CDI (mint) £1250. Naim Hi-Cap, 140, 72 (K Boards) £1500. All boxes and instructions. Tel: 01252 518136 or 0468 791404 (Keith)**

LINN LP12 VALHALLA. Ittok LVII, Troika. Recent service £650. DPA Little Bit Mk1 (£356) £155 and associated RF Noise mains filter (£123) £45 all incos. Pioneer PD5703 CD Player 1 year £140. Package. DAC. Filter CD £300. Tel: 01526 320513

WANTED: STAX SRM1 or similar line energiser for non pro headset, also Metcalc PC crossover design software complete. Tel: 0121 777 5497 (Les)

CHORD 1200B Power, 2800 Pre. boxed with guarantee £4250. A.T.C. 20SL bi-wire monitors £1250. Sumo Nine Plus Class A power £500. Adcom Pre £150 (excellent together). Wanted: Gale 401 Chrome any condition. Tel: 01226 710605 (Yorkshire)

B&W P6 SPEAKERS and specialist stands, 18 months old and boxed £695. Arcam Black Box 2 £110; S.M.E. IIs arm plus spare carrier, boxed £115. Bolivar 18 speakers £175. Tel: 0802 717680 (John Humphreys, Birmingham)

LINN NUMERIK D to A converter- boxed, as new, latest spec £950. Linn Kairn Pro Pre Amp- boxed, with remote and interconnects, as new, latest spec £900. Tel: 01753 866042 after 8pm (Peter)

NAIM PRE-POWER 125/225 (from New Zealand) £300 ono. Walker CJ55 turntable with A/T 1120 tonearm (Ultra Low Mass) £65 ono. Wharfedale S05/11 speakers in black (boxed) £75 ono. Cambridge P40 integrated amp (a true classic) boxed £85 ono. May P/Ex. Tel: 0191 422 3415

AUDION SILVER NIGHT 300B Monobloc valve power amps, and 2 box single ended preamp with phono input, worth over £4000 for sale for £2100. Tel: 01403 711778

MISSION 752 FREEDOM speakers, black 20 hours use as new boxed £400 ono. Tel: 01444 413782

LINN SONDEK LP12 in walnut with Valhalla power supply complete with Ittok arm and Klyde cartridge (cartridge- boxed) £1000. Tel: 01206 331540

NAD 402 TUNER £100. Aiwa ADF 810 cassette £90. Sony TA-E88B pre £150. Nakamichi 582 cassette £225 TDL Studio 1 + stands £450. Technisat Tuner + dish, offers. Tel: 0181 390 8169 evenings

KEF 'CONCERTO' floor standing speakers, 3 way including renowned B139 13 inch elliptical woofer 30-20,000 Hz. 4-8 ohms. Teak with black grills. 28"Hx17Wx12D. Superb sound. Tel: 01342 301273 (East Grinstead, eves)

MISSION 753, black ash excellent, boxed £375. Michell ISO MC phono stage mint £240. Nordost Fladine Gold Bi-wire 2x4m £45 (£120 new). Tel: 01371 850665 Essex

CYRUS DAD7 CD £550. Cyrus preamp + power with system commander £700. Cyrus FM7 £200. Epos ES22 speakers £850. Interconnects, cable + stand £200. All mint and boxed still under guarantee, will not split. Tel: 01252 350582 or 01252 514535 (George)

TECHNICS SLP2000 Reference CD (1100) £425. Origin Live O.L.2 small oak floorstanders (600) £240. Orelle DA180 DAC (550) £225. Woodside ISA230 integrated line amp (1000) £440. Excellent condition. Tel: 01707 321878 (Herts)

NAIM NAP180 (93) Immaculate, boxed with manuals £575. Tel: 01545 571262 (evenings)

CLASSIC SONY Reel To Reel 7" TC-651 4 Track Auto Reversing stereo tape deck. Tape speeds 7 1/2 ips/ 3 3/4 ips, mint little use £280 (buyer collects). Celestion Ditton Speakers £80 (buyer collects) Tel: 01203 313109

**YAMAHA NS1000M Speakers A1 condition £600 ono. Tel: 01179 505836 (eve) 01179 768005 (day) Keith, Bristol area**

NAIM 42.5 + 140 AMPLIFIER, MC and MC Boards £450. Tel: 01992 444951 (evenings)

NAIM NAP180 Power amp for sale 3 years old very little used boxed £650 ono. Tel: 01202 570675 (Bournemouth)

MUSICAL FIDELITY A370 MK1 Power amp. Big heavy, effortless power, drive anything. Krell upgrade forces sale. Serious offers. California Audio Labs Aria CD player, valve output, rare import £200. Tel: 0121 628 9247

WANTED: Electric diagram of Armstrong 127 stereo tuner amplifier for Quad 22 preamp, a suitable stereo adaptor for moving coil cartridge. Rodolfo Ruvalo, Via Baleari 298, 00121 Ostia, Italy. Fax: 00 39 6 5674735

QED Digit DAC with two Positron power supplies and Coaxial interconnect £140 (cost over £300). Mission Cyrus speaker cable 2x5m terminated lengths £10 (cost £30). Tel: 01626 891950 evenings (Devon)

LINN SONDEK LP12, Ekos arm MkII Lingo, Troika (200 hours) Cirkus upgrade, excellent cond't £1250. Naim 32 pre amp £130. Shure V15 Type IV £80 new. Tel: 00 3531 2954076

AUDIO ALCHEMY DAC-IN-BOX, bargain upgrade for CD players, boxed, only £95. Tel: 01276 411328 (W), 0118 973 1958 (H)

**ROKSAN ATT-DP2/ATT-DA2/ATT-DSS wanted. Another good CD Player considered. Tel: 0171 359 3050 (day) 01992 524276 (eves) Martin**

RUARK TEMPLAR II loudspeakers. Rosewood finish. New model, 4 months old, boxed and in perfect condition £425 ono. Tel: 0171 454 3530 (days), 0181 529 9913 (eves)

MISSION 733 Floorstanding speakers mint £140, Marantz PM44SE amplifier £60. Tel: 01793 613238 (Swindon)

MERIDIAN 201 Pre-amplifier with remote £250 ono; Two Denon PNA4400A monoblock power amps. 150W £250 ono the pair; Deltac One Little Bit D/A converter £125 ono. Tel: 01234 713198 (Milton Keynes)

MISSION 760iSE speakers £100. Audiolab 8000A £300. Arcam Alpha 5 Plus CD £275. TDL RTL3 speakers £200. Garrard SB86 turntable £50. Tel: 01473 412823 (Ipswich)

PAIR HARBETH HL-K6 Speakers month old £530. Denon 810 CD player £95. Rotel 820BX amplifier £80. Yamaha stereo cassette deck £60. Yamaha Digital tuner £50. Haffler pre-amplifier £75. Pair Philips bookshelf speakers £15. All VGC. Tel: 0181 681 1054 (Croydon)

# BETTER OFF DEAD

no vibrations dead sounds perfect

## Fi FOCULPODS

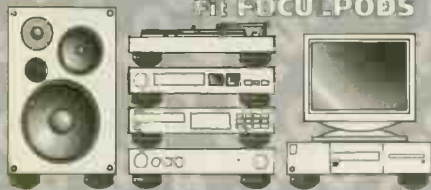

### WHAT THE PRESS HAVE TO SAY

"...I thought they worked very well on some low-cost CD players I had Knocking About..."

Hi-Fi Choice July 1995

**FOCULPODS & POLIPODS** are high performance vibration absorbing supports designed to be placed under Compact Disc Players, Turntables, Amplifiers, Loudspeakers and all other Audio & Video equipment. Designed using computer modelling techniques the spherical surface provides even contact and uniform energy distribution

**4 FOCULPODS** will support a maximum of 20 Kilos

## NEW POLIPODS

Designed to support a pair of bookshelf speakers or 2 items of lightweight Hi-Fi equipment



50 mm dia. x 20 mm



40 mm dia. x 14mm

**£14.95** per pack 4

available from most good Hi-Fi dealers

**WHAT THE PRESS HAVE TO SAY**  
"...We found they worked best with CD players, allowing the transport to run more smoothly to give a more open and natural sound, and better stereo imaging..."

WHAT HI-FI - 1996

**£14.95** per pack 8 - **YES 8!!**

available from most good Hi-Fi dealers

For a **FREE** information pack and details of other products from **SPECTRA DYNAMICS**

Tel (01745) 360070 Fax (01745) 360086

Unit A1, Ffordd Derwen Industrial Estate, Rhyl, Denbighshire, LL18 2YR



# Border Patrol

## Valve Amplifier Power Supply Upgrade

£595.00

Off board valve rectified, choke input filter power supply for Valve Amplifiers. This upgrade reduces distortion, increases resolution and strengthens bass performance and dynamics. If you like the sound of your valve amplifier but would like to tighten the bass and strengthen the overall dynamics, this is what you need. Versions available to suit everything from vintage Leaks to modern Audio Innovations, Audio Note and Art Audio designs. If you are unsure about the suitability for your amp please telephone us.

"In every instance the Border Patrol effect was nothing short of a transformation. Bass solidified, imaging became significantly more three-dimensional and substantial, and the power supplied amp made the regular version sound, quite literally a mess."

"With the Border Patrol back on the music regained its composure. Instruments not only sounded more natural and realistic, but seemed much more musically coherent in many respects it was like taking the good things about transistor amps and adding them to the natural strengths of valves - a remarkable blend."

...Jason Kennedy Hi-Fi Choice April 97

# definitive audio

Tel/Fax Brighton 01273 276716

# DEFLEX<sup>®</sup> By SPECTRA Dynamics

Deflex material is a specially formulated low resilience polymer with exceptional shock absorbing properties. Loosely grouped molecules within the material rub together and transfer vibrations into heat. In its soft form the material has a texture similar to plasticine but with a high memory characteristic, the mechanical properties of the material guarantee to reduce unwanted noise.

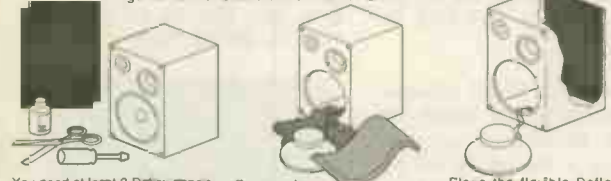

You need at least 2 Deflex panels for a pair of small bookshelf speakers, 4 panels for a pair of Tannoy 6's and at least 6 panels for larger cabinets.

Once you have gained access to the inside of the cabinet, remove foam and/or wool damping from the inside of the speaker (if fitted).

Flare the flexible Deflex panel thru the speaker cut-out and stick to the inside of the cabinet using the recommended adhesive.

## DEFLEX ACOUSTIC PANELS

The simplest and most cost effective way to upgrade your existing system

Deflex panels seemed to give greater tightness and control, improved internal clarity, and pitch definition - all without deadening the sound in any way.  
Audio Video - January 1995

...the result was sharper imaging, wider dynamics and a more natural sound...  
Hi-Fi Choice - January 1991

### CHOICE VERDICT

Sound Quality **★★★★**  
Value for money **★★★★**

...a marked improvement was obvious from the first few bars of REM's Automatic for the people album...  
Hi-Fi News & Record Review - March 1994

But one thing for sure - the Deflex panels are no gimmick. They work.  
Audio Video - December 1994



New sit back and listen to the extra detail in sound, and far less distortion when played loud.

### PANEL PRICES

Standard Panel	£7.95	(28cm x 21cm)
Medium Panel	£6.95	(28cm x 18cm)
Small Panel	£5.95	(24cm x 13cm)
Sub-Woofer Panel	£14.95	(34cm diameter)
Adhesive	£3.50	Delivery £5.00

"The only world acclaimed flexible acoustic damping pad for lining loudspeakers"  
(UK PATENT N° GBPT 2277038)

For a **FREE** comprehensive information pack & details of other products from **SPECTRA DYNAMICS**  
Tel. (01745) 360070  
Fax. (01745) 360086

Unit A1, Ffordd Derwen Industrial Estate, Rhyl, Denbighshire, LL18 2YR, UK

# AUDIO ILLUSION

23 Langley Broom  
Langley Berkshire SL3 8NB  
TEL: (01753) 542761 FAX: (01753) 772532



Introducing...  
**EUPHONIA Resonance Isolation Devices from France**

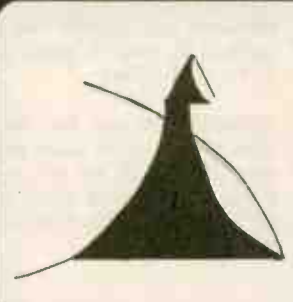

- Processed from mass of numerical lathes allowing for greater precision.
- The density of the steel allows faster evaluation of vibrations and echo.
- Very strong point able to resist heavy weights without being worn or deformed.
- Use under even the heaviest loudspeakers.
- Use under all electronic apparatus: CD Players, preamplifiers, power amplifiers, converters, etc.

Secondhand and Ex Demo Bargains available:-

	Now	Sale Price
Thorn Cobalt 307 DAC	Ex Demo £ 700	£ 475
EAD CD 1000 High Resolution CD Player with HDCD	Ex Demo £2000	£1495
Audio Research ES3B Balanced Line Preamplifier	Ex Demo £2250	£1495
Audio Research LS22 Linestage Pre-amplifier (A few hours use)	£4200	£3295
Mag Levonson No. 27.5 Power Amplifier (Still Under Warranty - A. New)	S/Hand £5400	£3495
Mirage M-290 2-way Audiophile Compact Monitor	Ex Demo £ 400	£ 250
Mirage M1-3 Reference Bipolar Radiators	1x Review £6900	£3495
Mirage M5-3i Bipolar Loudspeakers	Ex. Review £2000	£1495

Information available on the following -

**acurus**  
Classe Audio  
Enlightened Audio Designs

FOR APPLICATION  
**Mirage® Bipolar™ Loudspeakers**

For your nearest stockist contact **AUDIO ILLUSION**



# Hi-Fi World Classified Ads

PRIVATE

THE ELECTROCOMPANET 2 Channel Preamp with matching power amp, Class A and a classic £495. Exposure 6, 7 and 8 preamp, power supply and power amp (£1300+) offers around £550. Royd Merlin walnut speakers, very little use £220 (£300). Koetsu Black-recently retipped at cost of £225 by the Cartridge Man £350. Tel: 0171 613 0136

CD PLAYERS: Linn Karik (£595); Meridian 506 (£600); Marantz CD10 (£575). Amplifiers: Linn Wakonda/LK100 (£735); Meridian 551 (£450). Speakers: Linn Kellidhs + stands (rosenut) £450; Epos ES11 + stands (mahogany) £275. Tel: 0113 2943863

EPOS ES14 speakers, Epos stands, walnut, later type, boxed, excellent condition £325. Lovely speakers, just need something smaller. Tel: 0131 310 2144 daytime, 0131 310 2299 evenings (Edinburgh, Hugo)

QUAD 77 PREAMP, 77 power amp (new carbon finish) including remote console. Both components just 3 months old, cost new £1450 asking £800. Tel: 01296 437314 (eves) Aylesbury

M/FIDELITY F19, new £4000, asking £2700. P/Triangle Cardinal II, new £850, asking £500. P/Triangle DaCapo, new £1750, asking £1100. Meridian 518 processor, new £950, asking £550. Tel: 01296 437314 (eves) Aylesbury

CRIMSON 1708 Pre + Power amps. 170 Watts £180. Tel: 01296 22668

APOGEE STAGE loudspeakers c/w 4x2.44 metres SYMO Cable for biwiring, excellent condition, boxed £1199 o.b.o. CLASSE DR 9 Stereo Power Amplifier, mint £1000 o.b.o. Tel: 00 353 21 841576 (evenings) (Ireland)

BARGAIN HI-FI! Ortofon MC20 Supreme Cartridge £195 ono (£420 new). Ruark Talisman II speakers. Perfect in oak £300 ono (£700 new). Tel: 0121 706 0376

MARTIN LOGAN AERIUS speakers £1200, Yamaha CX2/MX2 Pre Power Amps £700, A.V.I. Pre Amp £460, Linn Index speakers £100, Sony 228ES CD Player £250, Marantz CD10 £530, Spondor SP9 speakers £1900. Tel: 01977 643629

ACT10 Speakers yew (new £1200+) £700, Quad 606 II Amp £450, Denon cassette deck DR M34 HR £200, all less than 2 years old, hardly used, mint condition - baby forces sale. Tel: 01202 487090 (Bournemouth)

TRICHORD RESEARCH Digital Turntable CD Transport inc base platform cost £800 bargain £445. Michel Argo HR with latest Tom Evans mod + Alecto Monos cost £3400 bargain £1995. Tel: 07050 095911 (NW London)

THORENS 147 JUBILEE record deck including cartridge £120 ono. Graphic Equalizer Technics SH-8066 £100 ono. Yamaha Tuner CT600 silver colour facia £30 ono. Tel: 01773 608045

WANTED: Hart Linsley Hood 80W Power Amp. Tel: 01242 820920 (Glos)

RARE ORIGINAL LEAK TL12 Point-One amp and preamp (one of each) ideal for rebuild. Best offer secures. Marantz SX-72 Scratch noise suppressor, as new £175 ono. Tel: 01474 708631 (Kent, near Brands Hatch)

**EXPOSURE XV AMPLIFIER, MM Phono stage. Valve upgrade forces sale. Very good condition £400. Tel: 0171 628 8657 (City)**

FOR SALE: Rogers Studio Sevens (slightly blemished) £500. Sonneteer Champion amp boxed as new £420. Also large Rogers speaker cabinet with 11" polypropylene driver + spare driver £200. Tel: 01546 603592

MERIDIAN 551 AMPLIFIER 18 months old mint cond can demo boxed bargain £300. Kenwood CD Player cost £240 new, £70. Tel: 01795 430254

AUDIOLAB 8000S, 6 months' old £450, Audiolab 8000P £400, Quad 606 Power amp £300, all mint condition and boxed, no offers please. Tel: 01634 365153 (Kent)

EXPOSURE MONO 8 Power Amplifiers, excellent condition £475. Tel: 01296 87191 (Bucks) after 6pm

LINN INTEK integrated amp and Powertek power amp (Bi-Amping) immaculate boxed £450. Dac-in-a-Box, with Ixos digital interconnect, again immaculate condition £130. Tel: 01908 321885

MICHAELSON AUDIO ODYSSEUS valve amplifier boxed, mint condition- 45 Watts R.M.S. (8 EL34's) cost £1000 accept £575. Tel: 01432 275203 (Hereford)

AUDIOLAB 8000A, superb sound, excellent condition, with box, can demonstrate £300. Tel: 01483 894659

LEAK STEREO 30 £30. Pair KEF T27 £30. Pair KEF T52 £50. Grundig valve radio £50. Rock Lid/Plinth £60. Armstrong 521 Int/Amp £35. Marantz Model 1530 Receiver £55. J.R. 25 Watt Amp/70 Hz X/Over for sub bass £35. Tel: 01474 708631 (Kent)

TRICHORD PULSAR DAC + PSU £950. Audiomeca Kreatura Trans £650. Meridian 518 Anti-jitter + DSP £500. Tel: 01604 766124

QUAD 63's (10483/4), rosewood/brown + low spiked stands, £1050. Quad 405 2, £190. Quad 405, £140. Tel: 0113 258 3061 (Leeds)

SPENDOR SP1/2 + M.A.F. stands quick sale £550 (£1500) or exchange for any quality valve amp, or will trade Spondor SP1/2 + cash for valve amps Copland CTA 501 ECT. Tel: 0181 531 5979

NAIM PRE-POWER-HICAP: NAC 72, NAP 140, 3 years old £1200. Naim tuner NAT 02, under 3 years old £600. Tel: 0171 415 8101 (work) or 0181 220 8527 (home)

NAIM 62/140 Pre/Power amplifier, m/c phono boards, manual, all cables and interconnects with 2x3.75m lengths NAC AS speaker cable. Mint condition £575 ono. Tel: 01639 814628 (Richards)

211 SINGLE ENDED Integrated amp, line, phono, superb £595. Magneplanar SMGA Panels, mint £270. Lecson horns £190. Musical Fidelity X10-D £90. Troughline Mono £60. Plus other small items. Tel: 01895 446713 (Paul)

FOR SALE: Conrad Johnson P.V.10AL (Special Edition) 2 yrs old, boxed as new. Major sonic gains over standard Conrad. Reason for sale upgrading (£1300 new) £995. Tel: 01886 821577

MUSICAL FIDELITY F22 Pre-Amp mint condition boxed, remote £550 ono. Tel: 01752 775887 (Plymouth) After Six P.M

MUSICAL FIDELITY E100 Amplifier, 90 WPC remote control, mint condition, boxed £400 ono. NAD 533 T/Table inc. Goldring Electra cartridge, mint, boxed £150 ono. Tel: 0191 234 2397

WANTED: AUDIO INNOVATIONS 1000S monoblock amplifiers, might consider another make. Pre-amp also required. Tel: 0171 359 3050 (Martin) Mon-Sat 9am-6pm

NAIM 72 PREAMP Moving coil boards, new style, mint £450. Tel: 01986 895631 (Suffolk)

MERIDIAN 508 20 Bit CD Player c/w MSR immaculate condition less than 6 months old £1295. I.0m Audioquest Quartz 3 Balanced £100 (£180). Siltech HF6 digital interconnects £50. Tel: 01703 283191 (So'ton)

LOOK!!! PAIR SEAS P17REX woofers and Morel MDT30 tweeters worth £200+. Superb quality as new, £125 ono. Two pairs 3/4 metre pure silver interconnects £95 ono. Excellent sound. Tel: 01492 879244 anytime (Adrian)

ARCAM 170.3 + Black Box 5 CD/DAC, new cost £1200, mint £450. Tel: 0976 918983 'Pop'

ACOUSTIC ENERGY AE1's black, bi-wire + dedicated stands, mint, genuine reason for sale £550 ono. Tel: 0113 2608656 (eves) No Dealers! Robert (Leeds)

NAKAMICHI CASSETTE DECK 2, little use, excellent condition £230. Linn LK400 bi-wire cable, 7 metre pair £90. Tel: 01455 213406

AUDIOLAB 8000Q £750 and 8000P £350 virtually unused boxed as new both for £1000. Also Kinshaw Perception phono stage with separate power supply boxed as new £250. Tel: 01708 344334 (Essex)

LOWTHER ACCOUSTA's new PM6C drive units good order £350. Also Ariston RD 80 record deck. Linn Basic Plus arm with Nagaoka MP11 plus original Linn Basic arm. All in good order and with original box and handbook £100. Tel: 01379 384043

KOETSU BLACK mint boxed and in storage last three years. Recent inspection by Absolute Sounds guarantees condition £650. Revox B710 cassette deck. Recent service beautiful build quality £450. Tel: 0171 681 7221 (Laurence)

MUSICAL FIDELITY A100 £160. NAD 402 Tuner £85. NAD 304 amp £90. Denon 250 MkII £80. Goodmans Axioms in cabinets £80. Silver Sounds 12/2 - 2x4mtr £160. Tel: 0114 2215271 or 2723621

QUAD 77CD (Mains) £500. 77Pre and System controller £450. 77 Stereo power amp £350. Quad ESL63's, as new £1800. Divorce forces very reluctant sale. Tel: 01733 51881

CASTLE CHESTER S2 Speakers, cherrywood finish, excellent condition cost £700. 3 yrs warranty, can demo £395. Tel: 01795 590227 (Kent)

**WANTED: CRIMSON ELECTRIK power amplifiers Model CK1100, any condition, also SME IV tonearm and Marantz CD-63 MkII KI-Signature. Tel: 0181 746 8103 day or 0181 746 1250 evn. (John Stewart)**

AUREX (TOSHIBA) Micro components. Magnificent build quality and performance. Cost £1000 in 1980. Amp-preamp-tape deck-Adres unit-tuner. £20 per item. Tel: 01886 880 754

QED Vector, remote control passive/active preamp £90. Rotel RQ970BX MM/MC turntable preamp £85. Both highly reviewed, in good working order, can demo. Tel: 01530 831357 (Leics) or 0831 565010 (mobile)

**WANTED: AUDIOLAB 8000Q 8000M 8000P. Cash waiting. Tel: 01747 852640**

MERIDIAN 555 AMP £550. Latest Meridian 508 (20 Bit) £1350. Both 2 months only. Meridian 551 Int. Amp £495. Meridian 504 Tuner £445. Both under G'Tee. Heybrook Quartets + stands £495. Retired owner. Tel: 01202 470789

WADIA 2000 Decoding computer. WT 3200 Transport. AT&T. Latest specification, little use, as new. Leads, manuals, boxed. Change of priority forces reluctant sale £2495. Tel: 01953 789562 (Norfolk)

CROFT SERIES 30TL Power Amp £595 as new (£1200). Pair of Wilmslow Audio Decca Volt speakers £275 (new £550). Tel: 01727 766601 (St Albans)

QUAD 2, Immaculate black rebuilt power amplifiers £300 per stereo pair. Bi-Amp with two at £575 with free matching horn speakers. Partex SME 5, Ekos/Troika, Spacedeck? Tel: 01924 870361

WADIA WT-3200 CD Transport, remote control, X-32 digital convertor, 20 bit resolution, electrical/optical I/O, 1m ST optical fibre, latest specification, superb sound, mint, boxed £1395 (£4200 new). Tel: 01449 676335

**UNUSED NAIM NAXO 3-6. Brand new fascia. List price £638, will sell for £400 ono. Tel: 00 353 1 2853860 (Dublin)**

AUDIO ALCHEMY D.I.T.B./Power Station One £140. Audio Innovations valve pre-amp £200. Thorens TD125/2, SME 3009 £175. B&W DM620 floorstanders £220. NAD 3130 amplifier £110. Yamaha CDX730E £75 cassette £65. Tel: 01424 433736

# THE EMPORIUM

28 St Nicholas Street, Diss, Norfolk IP22 3LB  
Tel/Fax: 01379 650744

## FOR SALE

<b>CD &amp; DAC's</b>			
LUXMAN D-173 CD Player	£200	Pair with 1000 resistor	£475
MICROLOGIA Microdac	£200	TANNOI Canterbury/Ten/DM Pairs	£200
MISSION DACS	£100	LEWTECH TPI Original Type A Pair	£2000
REWOOD DP 89010 transport	£200	ACOUSTIC ENERGY AE1's Pk 1	£400
DELTEC Lites hot DAC	£150	SPRINGOR AE1's (new)	£100
MISSION DAC (5 case £200 new)	£100	WANTED: Pro-Mac, L32A, TANNY 15" + 12" EREL SUNI SONS FABER, MARTIN	£100
DESHAW OPERATIVE DAC	£100	LOGAN, QUAD, HUBBARD, VOLT ENERGISED DRIVERS, PTE DECS, WPI CANTATA	£100
HOTEL MCP 945 80	£100		
AGALY DELTA 1012	£400		
MERIDIAN 307 CD + Image	£100		
AUDIOLAB 8000 CD Player, 6 months old	£100		
WANTED: CD Transports + Good DAC's			
		<b>TURNABLES/CARTRIDGES</b>	
<b>VALVE-AMPS</b>			
AUDIO CONCEPTS Second Audio with new modified			
Octon of Golden Dragon 283	pair £1200	SPE 3012 based	£200
STERNS HULLARD 5-10 with partridge + Parrot transformer	pair £250	Black Linn LP12 (LIMGO), (LIMUS, E405	£1400
ACQUETRA 1945's with ELP7 pair 70 (Pre-QUAD 10)	£100	SPE 3009 II	£60
ROGERS CASEY III	£150	NADCOCK LIMPPOFF 210 New, new remanufactured	£110
ROGERS HGB88H	£150	Garrard 451, SPE 3009 II on SPE Phonic	£250
GAMMA BIRTHBY 211	£1400	GARRARD 301 press bearing ring	
AUDIO RESEARCH CLASSIC 30	£1200	GARRARD 401	
ROGERS CASEY IV	£100/150	PHONORS TD124 II	£200
AUDIO INNOVATIONS 200 Pre amp (phone amp)	£200	TONYBEND BOKER II with AB150	
AUDIO INNOVATIONS 500 Ph III Pre amp	£400	ALFA PLAKMA 2 & 3 turntables available secondhand	
LEAF Integrated	£150	LINN BAKUMATO	£235
COURTESY 647 valve pre with high level input	£150	PIKE TROUBLE TUNABLE with Back plus arm	£250
HELIOS 222 Tone box Tannet high and hybrid valve pre-amp,	£1400	TRICHERY TD 1600 + SPE 3009 II	£100
200mV/100mV PE input. Don't be a wimp, try it!		YQD with light phase PSU, Audiozone Arm	£1300
BEARD P100 Ph II Power amp, the big black ugly beast,		SYSTEMSOL No 900 / Linn Basic Plus	£175
100w to 100w price		GARRARD 301	£150
AUDIO RESEARCH 07H	£150	RETROSCOP T2	£200
AGALY HINCHATHURS 080 Integrated amp with PPI	£1450	WANTED: GYROSCOPE, SREZA, OLBE, SREFF, V, 3012, NAIN, AAD, DECENT PCL, LUMI	
ACQUETRA QUEST - Amazing 3000! single ended		LP12, TITON, E405, AAD	
monoblocks, massive old + 100V			
BEARD 08A 1 100 line level integrated amplifier	£650	<b>FOR SALE</b>	
CO-ORDINATE EQUIPMENT (two level only)	£900	MICROSCAN 205 Monoblocks	£500
BEARD 3003 single ended monoblock valve amp	£150	LINN LEO Preamp	£150
As a to-be price		BAILEY 101 Pre	£100
LEAF TL12 + gold very good	£1550	DECCA P55 heads	£100
A PAIR OF HULLARD 5-10 monoblocks	£250	DECCA London Heads	£100
Orange Pre Amp	£350	SPINNO BLUEPOWER (LASTING) (new)	£70
Genl Super Heats with Dr. Purpura HE Transformers	£200	MUSICAL FIDELITY 81	£100
Gamma Gamma single ended integrated	£350	YELLEMAN digital pre-amp	£75
LEAF STENO 20	£150	QUAD 33 pre-amp	£75
HIREAS SHARDON pair	£350	RELFOR LARS Machine Zero line pre + PE stage (year)	£250
MSD 1940 can 1945's, P54 gold push amp pair of monoblocks	£1000	MUSICAL FIDELITY E100 Shiny + Phonic	£400
MSD 1072 12 Signature Pre Amp	£400	LEAF THROUGHLINE STEREO	£100
LEAF TL12 12 painted black one only	£400	QUAD P11 minor working	£40
		QUAD 33/303 (used)	£150
		MICROSCOP 400/400 AMP	£160
		MURDO World small ugly (but like NAIN)	£150
		PROBAC CD 1000 Tones Amp - wooden sleeve bezel	£200
		HACATECH CLAYMORE	£100
		LEAF Throughline Stereo	£100
		MUSICAL FIDELITY TYPHOON pair	£300
		QUAD 34, 44, 44S, 304,	£200 each
		YQD DOMESTIC, COASTER BOKERS with PVEA	£2500
		NAH 72 pre with PE board	£450
		NAH Back Up Old Style	£350
		HYA 50 wst monoblocks and pre's	£300
		NAD 7150 Tannet	£120
		MUSICAL FIDELITY The Preamp (1980's one)	£100
		RADIO INNOVATIONS Passive Pre	£100
		REVAL G24 2 track	£300
		PIONEER A3000	£100
		ROCKWOOD SCALP/SL50	£200
		NAH FLATCAP	£200
		MUSICAL FIDELITY TYPHOON	pair £100
		HALKENCOR GP 345 line Pre-amp	£100
		QUAD T7 Bus Co, AMP & System	Remove all heard
			£1100

WANTED ALL YOUR VINTAGE GEAR.  
PHONE WITH THE PRICE YOU WANT OR WE CAN MAKE YOU AN OFFER. ALSO GOOD USED EQUIPMENT WANTED

# diverse vinyl

12 Upper Dock Street Newport Gwent NP9 1DF 9am-5.30pm Mon-Sat.  
Internet site <http://www.diverse-music.co.uk>  
phone/fax 01633 259661 / 256261 E Mail : sales@diverse-music.clx.co.uk  
-Mastercard - Visa- Catalogues available -Amex-Switch-JCB-

## New and Forthcoming Releases

Can	Tatogamo/Cannibalism-each	£12.50
Can	Monster Movie/Ege Bam-each	£10.90
Eels	Beautiful Freak	£9.90
Faith No More	Album Of The Year	£12.90
Monaco/Peter Hook	Music For Pleasure	£10.90
Paul Weller	Heavy Soul	£11.90
Prodigy	Fat Of The Land	£9.90
Radiohead	OK Computer - 2 LP	£14.90
Spiritualized	Ladies And Gentlemen We Are	£17.90
	<b>Recent Releases</b>	
Art Blakey	Moanin-180gm	£12.50
Bentley Rhythm Ace	Bentley Rhythm Ace	£11.90
Broadcast	Work And Non Work	£6.90
Decca Classical Vinyl	180gm Reissues	£19.90
Dexter Gordon	Go-180gm	£12.50
Foo Fighters	Colour And the Shape	£12.50
Geneva	Further	£9.90
Guided By Voices	Mag Earwhig	£9.90
Horace Silver	Song For My Father-180gm	£12.50
Koko Taylor	The Earthshaker	£7.90
Lard	Pure Chewing Satisfaction	£8.90
Lee Morgan	The Sidewinder-180gm	£12.50
Misfits	American Psycho	£9.90
Nanci Griffith	Blue Roses From The Moons	£11.90
Nina Simone	Sings The Blues-180gm	£19.90
Pink Floyd	Pulse (Ltd Price)	£25.00
Rickie Lee Jones	Pop Pop 180gm	£19.90
Santana	Santana	£7.90
Seahorses	Do It Yourself	£9.90
Silver Apples	Silver Apples-Reissue	£16.90
Silver Sun	Silver Sun	£8.50
Son Volt	Straightaways	£9.90
Sukia	Contacto Espacial Con	£11.90
Sun Ra	Heliocentric World Volume 2	£7.90
Sun Ra	Nothing Is	£7.90
T-Rex	Electric Warrior Sessions	£8.90
Wu Tang Clan	Wu Tang Forever	£17.50
	<b>Coming Soon</b>	
Genesis	TBA - Sept	£TBC
Oasis	Be Here Now - August	£TBC
Rolling Stones	TBA - Sept	£TBC
UB40	Guns In The Ghetto - July	£TBC
Verve	TBA - Sept	£TBC

P and P £1.00 1st LP additional LP's 50p each (max £3.50)

# AUDIBLE ELEGANCE

All of the following high end manufacturers products are on permanent demonstration

- Source
- Trichord Research ★ Loricraft Audio / Garrard
- Nottingham Analogue
- Amplification
- Art Audio ★ Beam Echo
- Gamma Acoustics ★ Tube Technology
- Speakers
- Gamma ★ J M Labs
- Cables
- Art Audio ★ Silver Litz
- Accessories
- Sovereign Valves ★ Groove Tubes
- Target Supports

Demonstrations by appointment only  
Canterbury, Kent. CT6 6RP  
Phone/Fax: (01227) 742928  
Mobile: 0976 402779



Hi-Fi & Audio Consultants  
Sales and Service

## EX DEM CASTLE LOUDSPEAKERS VARIOUS WOOD VENEERS AVAILABLE

ISIS	BOOKSHELF	£ 230.00	£ 10-15%
TAY	BOOKSHELF	£ 330.00	£
EDEN	STAND MOUNTER	£ 450.00	£ OFF
SEVERN	FLOORSTANDER	£ 540.00	£
AVON	FLOORSTANDER	£ 700.00	£ RETAIL
HARLECH	FLOORSTANDER	£ 850.00	£
HOWARDS	FLOORSTANDER	£1200.00	£ PRICES
ARCAM DELTA 290 P	POWER-AMPLIFIER	S HAND £ 400.00	£ 250.00
BANG & OLUFSEN CENTURY	BEOSOUND	EX DEM £1075.00	£ 950.00
CELESTION 9'S	LOUDSPEAKERS	EX DEM £ 289.00	£ 175.00
CELESTION MP 1'S	LOUDSPEAKERS	EX DEM £ 200.00	£ 120.00
DENON D-77 W	MINI SYSTEM	NEW £ 700.00	£ 550.00
DENON D-99 W	MINI SYSTEM	NEW £ 900.00	£ 700.00
HEYBROOK HEYSTACK	LOUDSPEAKERS	NEW £ 500.00	£ 250.00
MARANTZ SM 500	POWER AMP	EX DEM £ 400.00	£ 200.00
MERIDIAN 500	CD TRANSPORT	EX DEM £1245.00	£ 950.00
MERIDIAN 541	PROCESSOR	EX DEM £1095.00	£ 895.00
MERIDIAN 551	AMPLIFIER	NEW £ 795.00	£ 695.00
MERIDIAN 555	POWER AMP	EX DEM £ 695.00	£ 545.00
MERIDIAN 565	PROCESSOR	EX DEM £2250.00	£1750.00
MERIDIAN 565 + AC-3	PROCESSOR	EX DEM £2750.00	£2250.00
MICROMEGA MICRODAC	DAC	S HAND £ 500.00	£ 150.00
MISSION 732	LOUDSPEAKERS	EX DEM £ 200.00	£ 150.00
MISSION 733	LOUDSPEAKERS	EX DEM £ 250.00	£ 330.00
NAD 501	CD PLAYER	EX DEM £ 190.00	£ 100.00
PHILIPS CD 960	CD PLAYER	S HAND £ 400.00	£ 120.00
PIONEER PDS 901	CD PLAYER	S HAND £ 400.00	£ 175.00
REL STORM	SUBWOOFER	EX DEM £ 695.00	£ 595.00
ROTEL RA 930 AX MKII	AMPLIFIER	EX DEM £ 150.00	£ 120.00
ROTEL RC 970 AX MKII	PRE AMPLIFIER	EX DEM £ 175.00	£ 125.00
ROTEL RB 970 BX	POWER AMPLIFIER	EX DEM £ 225.00	£ 175.00
SONY CDP 710	CD PLAYER	S HAND £ 250.00	£ 120.00
TDL NUCLEUS	CENTRE SPEAKER	EX DEM £ 150.00	£ 75.00
YAMAHA KX 580	CASSETTE DECK	NEW £ 250.00	£ 175.00
YAMAHA RXV 390 RDS	PROLOGIC RECEIVER	NEW £ 300.00	£ 150.00
YAMAHA DSPE 390	PROCESSOR	EX DEM £ 250.00	£ 150.00

## STAR BUY OF THE MONTH 'MERIDIAN 565 PROCESSOR + AC-3' £2250

All items are in perfect condition and fully guaranteed  
MAIL ORDER SERVICES MAJOR CREDIT CARDS ACCEPTED  
CALL 01788 540772  
OR WRITE TO 12 REGENT STREET, RUGBY, WARWICKSHIRE.



# Hi-Fi World Classified Ads

## PRIVATE

MERIDIAN 557 Power Amp guaranteed for two years £1050 ono (£1400). Audiolab 8000M Monoblocks boxed, immaculate £950 ono (£1600). Rus Andrews silver-wired passive preamp £175 ono (£375). Silver Sounds cables. Tel: 0131 228 9070 (Salman)

NAGRA IVS PROFESSIONAL RECORDER. PSU case £1250. Nakamichi Tritracer cassette £325. Revox B77/2 HS2T £495. Revox B291 Turntable £295. Accuphase T100 Tuner £395. Thorens 124/2 Turntable £195. Roksan Artemiz £395. Shiraz £495. XPS3/DSV £195. Everything vgc+. Wanted: Nakamichi Dragon/S05. Tel: 01747 853372 (Dorset)

NEW 2X QUAD 67 £450 each, 66 preamp remote £450; 2x 606 £350 each; 44 preamp + MM/MC Boards best example £250. The lot £2000, or split 66/67/606 £1250; 44/67/606 £850 inc/p+p. New YBA integrate with phono, best integrated in the world? Tel: 01482 842740

**D.P.A. (DELTEC) Gortex Black Sixteen Loudspeaker cable 10ft pair terminated with W.B.T. lockable 4mm plugs, excellent condition £295 ono. Tel: 01900 826400 daytime. 0831 323111 anytime**

LINN AXIS TURNTABLE complete with Akito arm & K9 Cartridge excellent condition £250. Tannoy DC2000 speakers plus dedicated stands powerful sound £140. Tel: 01436 674507 (Glasgow)

LINN KEILIDH Loudspeakers finished in cherrywood with Linn plinths mint condition, first £495 secures, demonstration a pleasure. Tel: 01904 763157 (York)

NAIM 32.5 £195. Naim Hi-Cap £295. Naim 250 £595. Linn LP12 with Ittok LV3 2 years old £850. All boxes, manuals etc. Tel: 0121 783 8227

KRELL KSA 250, just serviced, mint £2999. Audio Research LS 2B MkII 18mths old £1999, serious bargain. Tel: 01623 871950

PRO-AC RESPONSE 2.5. Walnut, mint, 1 year old, £1700 no offers. Wanted, Martin Logan SL3. Tel: 01902 786818 (Midlands)

GARRARD 401, Two Decks, one with U.S. Motor, SME arm £175. Quad 303 amp £85, Mamiya 645, 1.9 lens camera, accessories £395. Exchange Quad Main Amp 306, 405, 606. Tel: 01384 296519

FOR SALE: REVOX B710 Mk 1 cassette deck, 3 head £350. Revox B750 Mk 1 amplifier 60 wpc £225. Wanted Revox B202 I/R remote receiver for B791/795 Turntable. Tel: 01604 762142 after 7pm (Northampton)

AUDIOLAB 8000C preamp. Very good phono stage. Mint (£280). Krell KSA300S, boxed, remote, manual. Mint, bargain (£4750). Shun Mook CD Clamp, ultimate upgrade for toploading transport (£450). Tel: 0131 668 3389

ROTEL RB970BXII- Two power amps boxed 1 year old as new £260. Linn Saras + stands £140. SME 3009 IMP £20. Tel: 01263 512815

MISSION CYRUS II Amplifier and PSX power supply £200 each. Superb quality combination in excellent condition (very late models). Tel: 01626 774564

PRO-AC RESPONSE 4, mint condition £7995. Michell Argo H.R. pre amp. Michell ISO H.R. (High Resolution) phono stage both units mint condition both with Hera P.S.U. £1250 ono. Pro-Ac Studio 50 Tablette, walnut, mint condition £450 ono. Tel: 0181 854 6738 or 0378 876116

**NAIM NAC 82 PRE-AMP wanted. £1300 cash paid for mint boxed example. Will collect. Tel: 01536 744812**

SONUS FABER REFERENCE EXTREMAS in real walnut, complete with original six pillar SVF stands, excellent condition, boxes, reviews, will demonstrate, may P/Ex smaller Sonus Faber £3700. Tel: 01895 820191 (London)

VALVE OUTPUT TRANSFORMERS, 200 Watts, superb with ultra-linear screen grid winding and super low impedance secondaries + 1KW HT Transformer + choke. £200 the lot, worth £600 easily. Tel: 01608 684694 (Eves)

AUDIO RESEARCH SP14 high end preamp black £675. Marantz CD10 Trichord O/P £450. Micromega Duo Pro2 DAC £575. All vgc boxed. Tel: 01603 633451

ARCAM 5 CD Player £200 ono. Marantz SD45II cassette player £110 ono. Both items were part of secondary system, therefore little used and in very good condition. Tel: 01934 624404

QUAD 44 recently serviced £180, Beyer DT990 headphones £90, Can Opener £30, QED disc saver £25, SME 3009/II renovated by SME £100. Wanted Quad ESL57's black grilles, Quad 67 CD, SME V. Tel: 01274 667882 (Bradford)

CASTLE CONWAY III with custom stands, sounds amazing with tremendous bass extension (£1200) £490 for very quick sale. Townsend seismic sink, makes any CD Player sound better (£170) £70. Tel: 0121 705 4859

800W CONTINUOUS can be delivered by my Chameleon Ruby power amp worth £1000. Looks and sounds stunning too. £400 for very quick sale. Sony graphic equaliser (£100) £40. Tel: 0121 705 4859

NAKAMICHI 582 CASSETTE, immaculate, rare opportunity £650. Audio Innovations Series 300 £250. Linn LP12 Cirkus, Ekos, Troika £1100. Linn Keilidh active system (latest) £2250 for details Tel: 01952 502097 (Telford)

AUDIOLAB 8000A, boxed, mint £225. Rega Planar 2, RB250, BIAS, £85. Quad 405 £160. Quad 33 £60. Albarry M408 monoblocks £350. Akai 4000D £50. Wanted: Koetsu, Lydian, Quad IIs. Tel: 01604 38961 0976 943793

**KEF Model Four, Black ash £2500, Meridian 557 Power Amplifier £990, 2x Meridian 555 Power Amps £490 each, Meridian 541 Surround sound processor £850, Meridian M60C Active centre channel £850, Pioneer CLD-925 AC-3 Laser disc player £495. All as new, boxed, manuals, guarantees, four months old. Tel: 01622 746863 or 0973 899651**

CELESTION DITTON 44- One pair of these handsome, fine sounding loudspeakers in good condition. Best offer over £150 secures. Tel: 01732 461313

KRELL KSA 100 Mk2 boxed £1100. Acoustic Energy AE1's black on Slate Audio Stands, boxed £500. Wanted: DNM amplification. Tel: 01652 636086 (North Lincs)

MERIDIAN 200/203 DAC with Tri-Chord clock mod £500. Dynaudio "Twin" speaker kit, complete £375. Tel: 01295 780363

YOYO "THE YOYO" Turntable Rega RB300, Goldring Elite MC (£2000) £1200. Sugden A21A MC/MM (£825) £580. Sugden A40MkII (recent factory service) £120. Tel: 01203 551536

PURE SILVER INTERCONNECTS with gold plated phonos, any length, eg half metre pair £55. One metre £80. Suitable for digital link, eg half metre £35. Tel: 01744 811447

ROKSAN XERKES X Turntable, DSU and XPS 3.5 PSU's, SME 309 arm, Ortofon MC25FL cartridge, new, competition prize £1600. Linn Kaber speakers, latest spec, polymer stands, absolutely mint condition £780 ono. Naim NAC 62 (modified) £85. NAC 32.5 mint condition £175. Hi-Cap PSU £275. All items boxed. Tripod spiked stand sections, the best! Various sizes including record box's, offers. Naim speaker cable 6x6m NAC 05 £85. Tel: 0116 2716132 (Leicester)

FOR SALE Quad 33 preamp, Quad 405 power amp (both boxed and mint condition) and pair of Lowther Acoustas (good condition) £475 ono. Tel: 01634 240481

**QUAD VALVE STEREO, preamp & Quad tuner, Wharfedale speakers, all housed in original solid hardwood cabinetry £495. Move forces reluctant sale. Tel: 01564 782278 (after 7pm)**

AUDIO INNOVATIONS Series 200 power amplifier £249. Series 200 phono MM preamplifier £225. Both as new with new valves. Owner upgrading. Tel: 01834 860 681

LINN WAKONDA pre-amp with MM/MC phono stage and remote, LX100 power amp. Mint, with long warranty £850. Harbeth HL4 monitors, with stands, superb sound £350. Tel: 01858 464771 (Leics)

WANTED: SONY TA-N88B Class D power amplifier for my matching TA-E88B pre-amp. Also Technics SST-1 horn speakers. Tel: Jon 0181 992 8952 eves & w/ends

LUMLEY REF ST 70 Power amp, Triode mode (£2125) £1100. Ex cond, spare tubes, boxed etc. N.Y.A. Soundpipes 4x1m pairs £50 each. Tel: 01772 314151

AVI REFERENCE CD player £899, LFD LS2 preamp £650, NVA A80 monoblocs £550, ATC SCM 10 loudspeakers £599, Origin Live OLI loudspeakers £250. Tel: 01522 696708 (evenings)

PARASOUND. 1600HD Digital to Analogue converter latest specification. Four inputs including balanced also balanced output. Burr-Brown PCM 63-K DACs. Three transformers, silver wiring. Superb sound £1450 new will accept reasonable offer. Tel: 01208 872316 (Bodmin)

NAIM 03 TUNER in perfect condition £350, NAD 7150 Receiver £125, Garrard 401 with SME arm and Shure Stylus £150. Tel: 0181 681 6849

ELECTROCOMPANET EC1/1 (KAY300i beater) £1350. Art Audio Quintet Mk2 £750. Orelle CD107/DA180 Mk2 £650. Mirage M890i bipolar £650. 5 mtrs Madrigal HF10C speaker cable £80. Half price records. Tel: 01902 892613 (Roy)

ROKSAN L2 & S1 pre & power amp + DS1 power supply, Roksan Attessa CD player, Linn Kaber Passive speakers tri-wired with K400 cable. Offers considered, mint condition. Tel: 01708 440947 (Essex)

MICROMEGA DRIVE I CD Transport plus Arcam Black Box 3 £425. Roksan Radius, Tabriz, ATOCs £375. Musical Fidelity A1000 Amplifier £795. Roksan Ojan loudspeakers, black £350. All items are less than 3 years old and in new condition. Tel: 0161 432 6120 (Stockport)

LUMLEY ST 70 AMP Triode/pentode switching, pearl coolers, recently overhauled hence warranty. Boxed as new £950. Conrad Johnson PV10 AL line pre-amp, as new, boxed £595 or £1500 the pair. Tel: 01734 412987

CAMBRIDGE AUDIO R50 Transmission Line speakers. Very good condition. Original boxes and users handbook. Reluctant sale due to move to smaller house £400. Tel: 01423 521705

YBA MC MOD for YBA 11 £350 mint condition. Compact cass/player Pioneer 7171 £50. Tel: 01286 678112

WANTED NON-WORKING QUAD 405/405-2 or 606/606-2 amplifier. Anything considered. Tel: 01357 520049

NAKAMICHI DR2 £385. Castle Durhams (yew) £175. Neat Peites £265. NAD 402 tuner £85. NAD 501 CD £100. Cyrus tuner £85. All mint & boxed. Tel: 01753 684887 (Slough)

classified ads



# more CHOICE

## AGENTS FOR:

ACOUSTIC ENERGY, ALON, ATC, BOULDER, BRYSTON, CHORD, FORSELL, GAMMA, LUMLEY, ROCKPORT, SME, SOUNDSTYLE, STRAIGHT WIRE, TARGET, TRICHORD, TRILOGY, van den Hul, VPI, XLO and many more.

- generous part exchange
- your equipment purchased
- show room/dem room
- trade in policy • credit card facilities
- mail order • export service
- the hi-fi exchange

## SOME OF OUR CURRENT SECOND HAND STOCK

### POWER AMPLIFIERS

Mark Levinson 20.5 monoblocks	Mint S/H £5500.00	Ruarik Icon & Stands	Mint S/H £ 295.00
Audio Research D125 balanced	Mint S/H £1995.00	Musical Fidelity MCS	Mint S/H £ 395.00
Audio Research M300 monoblocks	Mint S/H £4995.00	Wilson System Y	Mint S/H/CL10995.00
Jadis JA500 monoblocks	Mint S/H £2795.00	Snell JII's	Mint S/H £ 695.00
Jeff Rowland Model 3 monoblocks	Mint S/H £2395.00	Sonus Minima Amators & Ironwood Stds	Mint S/H £1395.00
Lumley Ref 120 monoblocks	Mint S/H £1695.00	Martin Logan CLS II & Kinergetic Subwoofer	Mint S/H £5995.00
Audio Research D 200	Mint S/H £1995.00	Magneplanar SMG 3	Mint S/H £ 895.00
Conrad Johnson MF 2300	Mint S/H £1995.00	AMC B1 - 20 Subwoofer	Mint S/H £ 350.00
Audio Research VT 60	Mint S/H £1995.00	Dalquist DQ12	Mint S/H £ 595.00
Michell Alecto Monoblocks	Mint S/H £1495.00	Sonus Faber Extrema+Stnds	Mint S/H £4250.00
Unison Research Smart 845	Mint S/H £2250.00	Magneplanar SMG CSE	As New £ 695.00
Audio Research D70 mk II	Mint S/H £ 895.00	Shahinian Arc	Mint S/H £ 895.00
Naim Nap 180	Mint S/H £ 750.00	ATC SCM 100A	Mint S/H £3695.00
Jadis DA 30	Mint S/H £2500.00	Mission 753	Mint S/H £ 450.00
Musical Fidelity F16/£22 Pre/Power	As New £2295.00	•••••	
Audio Innovations 2 Audio	Mint S/H £1395.00	•••••	
Art Audio Quintet	Mint S/H £ 995.00	•••••	
Albarray PPI	Mint S/H £ 295.00	•••••	
Conrad Johnson Prem 8a	Mint S/H £7995.00	•••••	
Boulder 500 AE	Mint S/H £3295.00	•••••	
MELOS 402 Monoblock	As New £4950.00	•••••	
LFDA PA1/LS1	Mint S/H £ 895.00	•••••	
Audio Research D79/SP10 mkII	Mint S/H £ P.O.A.	•••••	
Musical Fidelity A1000	Mint S/H £ 995.00	•••••	
Exposure XVIII	Mint S/H £ 295.00	•••••	
Krell KSA 50 S	Mint S/H £2495.00	•••••	
Mark Levinson No 27	Mint S/H £2250.00	•••••	
Naim Nap 250	Mint S/H £1295.00	•••••	
Mission Cyrus II + psx	Mint S/H £ 395.00	•••••	

### PRE AMPLIFIERS

Audio Research LS3 Silver	Mint S/H £1195.00	Wadia 16	Mint S/H £5995.00
MC Cormack TLC-1	As New £ 695.00	Krell Studio 2	Mint S/H £1795.00
Exposure 19 pre amp	Mint S/H £ 395.00	Mission Cyrus Discmaster	Mint S/H £ 595.00
Tesseract Tala	Mint S/H £ 795.00	Roksan DP-1 Transport	Mint S/H £ 695.00
Jeff Rowland Consumate & Phono	Mint S/H £4995.00	Krell SBP 64X	Mint S/H £3500.00
DNM 3A & Twin Pack	Mint S/H £ 850.00	P.S. Audio Ultralink	Mint S/H £ 895.00
DNM 3 & 6 Pack	Mint S/H £ 995.00	McCormack DAC-1	Mint S/H £ 695.00
Boulder LSAE	X-Dem £2250.00	Wadia 22/26	As New p.o.a.
Linn Wokanda	Mint S/H £ 495.00	EAD 9000 Series III HDCD Balanced/Gold	Mint S/H £4500.00
Michell Argo HR/HERA	Mint S/H £ 895.00	Musical Fidelity FCD	Mint S/H £ 895.00
Audio Research LS2B mk II	Mint S/H £2250.00	Acuphase DP70	Mint S/H £2250.00
Audio Research LS7	Mint S/H £1395.00	Aura CD100	Mint S/H £ 295.00
Audiolab 8000 Q	Mint S/H £ 795.00	Acuphase DP90/91	Mint S/H £995.00
Naim 42.5 Avondale	Mint S/H £ 250.00	Mark Levinson 30.5 / 31.5	Mint S/H/£14995.00
Conrad Johnson Prem 7B	Mint S/H £5995.00	Krell 30 i	Mint S/H £3250.00
Linn Kaimir pre/phone	Mint S/H £ 795.00	Forsell Air Ref Transport mk II	Mint S/H £7995.00
Audio Research SP11 mk II	Mint S/H £1595.00	Forsell Air Ref dac	
Audio Research LS2B mk II	Mint S/H £2195.00	Micromega Duo 3.1/Pro Dac	Mint S/H £1895.00

### SPEAKERS

Apogee Diva + Dax	Mint S/H £3995.00	Basis Ovation	As New £3495.00
Infinity IRS Beta	Mint S/H £4995.00	Pierre Lurme JVSLS	Mint S/H £2250.00
Apogee Scintila	Mint S/H £ 895.00	Audio Note AM-SI	Mint S/H £ 150.00
Ensemble PAI Silver - bi wire	As New £1995.00	Tesseract phono stage mm/mc	Mint S/H £ 795.00
Tannoy D700 (Definition, Rosewood)	Mint S/H £1495.00	Koetsu Urushi	Mint S/H £1295.00
Quad ESL 63 (Rosewood) & Stnds	Mint S/H £1695.00	Kuzma Stabi/ Stogi reference	Mint S/H £1495.00
Quad ESL 63 (Rosewood) & Stnds	Mint S/H £1795.00	Lynx Tuner	Mint S/H £ 295.00
Duntech Crown Princes	Mint S/H £1995.00	YPI TNT Wheaton III	Mint S/H £1995.00
B & W Silver sig & Stnds	Mint S/H £3995.00	Pierre Lurme JJ/Sowther mk III	Mint S/H £2250.00
Apogee Caliper	Mint S/H £ 795.00	Musical Fidelity TI Tuner	Mint S/H £ 195.00
Alon IV mk II	Mint S/H £3495.00	Sony Tuner STS 261	Mint S/H £ 150.00
		AR Cambridge Cassette RD06	Mint S/H £ 150.00
		Musical Fidelity FT Tuner	Mint S/H £ 495.00
		Audio Technica ART I	Mint S/H £ 595.00
		Stax SR Omega and Stax SRM TIW Valve Energiser	Mint S/H £1995.00
		Transparent Music Link Ultra 1mr bl	As New £1200.00
		Rega Planner 3/RB 300	Mint S/H £ 295.00
		Clear AudioGamma 24 CT Gold Coil	As New £ 495.00
		Nakamichi 1000 ZXL	Mint S/H £1595.00
		Sony TCD D7 DAT/RH/B3K	As New £ 450.00

### C.D. PLAYERS & DACS

### TURNTABLES / ANALOGUE / VARIOUS



## HIGH END AUDIO BOUGHT/SOLD EXCHANGED

		Sale	List
Krell MD10 CD turntable last version	mint	£3995	s/h £7990
Krell Studio DAC balanced AT+T ect	mint	£1995	s/h £4450
Meridian 508 20 bit CD player latest	mint	£1295	e/d £1685
Meridian 506 Mk2 CD player	mint	£ 595	e/d £ 995
Linn Karik/Numeric CD/DAC latest	mint	£1695	s/h £2572
Micromega 21 CD + Duo Pro 2 DAC latest	mint	£2500	s/h £4000
Micromega T. Drive transport	mint	£ 695	s/h £1200
Audiolab 8000 CDM transport + 8000 DAC	mint	£1695	s/h £2300
Accuphase 80-81L trans/DAC digital vol. rare	vgc	£3995	s/h £10000+
Accuphase DP70 CD player bal/AT+T	vgc	£1895	s/h £6000
Meridian 208 CD preamp phono board MRS	vgc	£ 795	s/h £1665
Meridian 200/203 CD/DAC Trichord	vgc	£ 795	s/h £1660
Audio Research CDT 1 transport	mint	£1795	s/h £3290
Cal Tempest 2 CD player valve	mint	£1295	s/h £3900
Stax Lambda Signature headphones + valve energiser	mint	£ 895	s/h £1450
Teac V80305 cassette deck 3 head	mint	£ 395	s/h £ 650
Oracle Delphi Mk3 turntable/Sumiko The Arm	mint	£1595	s/h £3400
Oxford Crystal Reference turntable wall mount rare	mint	£1495	s/h £2500
Well tempered classic turntable silver wired arm	mint	£ 995	s/h £2500
Alphason Symphony turntable + arm + p/supply	mint	£1295	s/h £2700
Krell KSL Mk2 preamp balanced	mint	£1295	s/h £2300
Krell Pam 1 dual mono preamp superb	as new	£ 995	s/h £1998
Gryphon Limited Edition preamp No. 1	mint	£3500	s/h £8000
Gryphon XT preamp	mint	£2395	s/h £5500
Audio Research L55 Mk2 preamp latest	mint	£2995	s/h £5690
Audio Research LS3B preamp remote black	mint	£1895	s/h £3025
Audio Research LS7 preamp silver	mint	£1295	s/h £1698
Audio Research SP11 Mk2 preamp silver	mint	£1895	s/h £5350
Audio Research SP8 Mk2 preamp silver	mint	£ 995	s/h £2180
Audio Research SP14 preamp silver	mint	£1495	s/h £3298
Audio Research PH2 phono stage bal silver	mint	£1895	s/h £2898
Levinson 12A preamp + p/supply MM/MC	mint	£ 995	s/h £2400
Threshold FET 10E phono/line balanced	vgc	£2395	s/h £4920
Threshold FET 10 phono/line 'E' supplies	mint	£1895	s/h £4250
Burmester 838/846 phono/line chrome bal	mint	£1295	s/h £3250
Cary CAD 5500 CD preamp analogue pro	mint	£ 595	s/h £1200
Krell KSA 200S power amp balanced	mint	£4795	s/h £7987
Krell KSA 100S power amp balanced	mint	£3500	s/h £5843
Krell KSA 250 power amp balanced	vgc	£3295	s/h £6600
Krell KSA 100A power amp Class A	mint	£1695	s/h £3450
Audiolab 8000 mono power amps latest	mint	£1195	s/h £1600
Rowland Model 5 power amp balanced	vgc	£2295	s/h £5250
Goldmund Mimimis 3 power amp balanced	mint	£1995	s/h £5150
Counterpoint SA12 power amp black	vgc	£ 595	s/h £1200
Levinson ML3 Dual mono power amp 'The Best'	vgc	£3500	s/h £8500
Cary 2A3 triode stereo power amp chrome	mint	£ 895	s/h £1495
Audio research V70 power amp balanced	mint	£1995	s/h £4400
Lumley ST70 valve power amp chrome	vgc	£1495	s/h £2645
Densen Beat int amp	new	£1485	new £2300
Beard P100 Mk2 power amp KT88 valves	mint	£ 450	s/h £ 650
Tandberg A3009/Mk2 power amp monoblocks	vgc	£ 595	s/h £1430
Sonus Faber Guameri Ltd Ed speakers + stands	mint	£ 995	s/h £2195
Sonus Faber Extrema speakers + stands	mint	£4495	s/h £6200
Sonus Electra speakers	mint	£3895	s/h £6890
B+W 800 Matrix speakers Blackash rare	mint	£ 995	s/h £1790
Meridian DSP 5000 digital active speakers	vgc	£5500	s/h £10000
Ensemble Prima Donna speakers superb	as new	£2550	e/d £3460
Ensemble PA1 speakers	vgc	£3500	s/h £10000
Proac Response 3.5 Burr Oak latest	mint	£1295	s/h £2950
Monitor Audio 20SE speakers + plinths Rosewood	mint	£3500	e/d £5000
Heybrook Sextet speaker Rosewood	mint	£1695	s/h £2400
Martin Logan CLS Z2 speakers + stands	mint	£ 595	s/h £1100
Apogee Stage speakers + stands	mint	£1995	s/h £4550
Alon 4 speakers Black	mint	£1495	s/h £3450
		£1689	s/h £3800

### New This Month

B+W 801 Matrix Mk2 speakers Maughan x/overs Sound	mint	£2750	s/h £5000
Anchor stands full hoods stunning sound Black	mint	£1995	s/h £5350
Burmester 850 mono power amps rare	mint	£1495	s/h £3500
Burmester 838/846 phono/line gold plated	mint	£4500	s/h £6949
Krell KRC HR remote preamp latest	mint	£1495	s/h £2000
Naim CD2 CD player (6 weeks old)	mint	£2495	s/h £3400
Naim 82 preamp + 2 HiCaps (6 weeks old)	mint	£2495	s/h £3280
Naim 135 mono power amps (3 weeks old)	mint	£1395	s/h £3450
Krell Pam 3 preamp	mint	£ 995	s/h £2500
Nakamichi CA7 preamp remote	mint	£ 995	s/h £1800
Nakamichi PA7 poweramp (Threshold 200 watt)	mint	£1395	s/h £3277
Martin Logan Sequel 2 speakers b/w/ire	new	£ 995	new £1799
Kef 104.2 Raymond Cook special edition speakers	new	£ 495	new £ 820
Celestion SL600SI speakers + stands	mint	£ 695	s/h £1000
TDL Studio 1M speakers + stands (Rosewood)	mint	£3995	s/h £9000
TNT Mk2 turntable/Air Tangent 2B auto arm + stand	vgc	£ 695	s/h £1555
Koetsu Red Signature cartridge	vgc	£ 495	s/h £1000
Linn Achieve cartridge	mint	£ 550	s/h £1000
Nakamichi RX 505E auto reverse cassette deck	mint	£2295	s/h £4995
Snell A2 loudspeakers Walnut	mint	£ 150	s/h £ 230
Arcom Alpha 7 tuner AM/FM tuner 6 weeks	mint	£ 495	s/h £1000
Micromega Duo 3 CD transport	vgc	£ 250	s/h £ 900
Marantz CD94 DAC balanced			

### Summer Clearance

Apogee Mint Grand speakers stand subwoofers	mint	£2995	s/h £8595
Apogee DAX x/over	mint	£1095	s/h £4400
Hales Signature 2 speakers Rosewood superb	mint	£2500	s/h £6600
Muse 18 active subwoofer Walnut	vgc	£1595	s/h £4000
Primare 201P/202 pre/power amps s/steel rare	mint	£5995	e/d £13800
Sota cosmos Vacuum turntable SME arboard	mint	£1595	s/h £4400
Audiophonie Konzert speakers Black	mint	£ 595	s/h £1750
Ben Duncan Amp 01 preamp balanced (giveaway)	vgc	£ 295	s/h £ ???
Cambridge CD1 CD player (still great)	vgc	£ 500	s/h £1500
Rock original table (rare)	vgc	£ 500	s/h £ ???
Wharfedale Option 1 active speakers (very rare)	vgc	£1500	s/h loads
Spendor SP2.2 speakers + Slate stands	vgc	£ 395	s/h £ 850
Snell A3 loudspeakers Walnut (stunning)	mint	£3295	s/h £6950
Adcom GFA565 mono power amps balanced	mint	£ 995	s/h £2000

ALL MAJOR CREDIT CARDS ACCEPTED  
RING FOR DETAILS AND DEMONSTRATION

01438 714038

10.00am - 7.00pm MON - SAT • 10.00am - 1.00pm SUN  
NOTE: ALL ITEMS IN STOCK AT TIME OF PRESS  
WE ARE NOT AGENTS

CHOICE  
10am-8pm  
7 days by appt.

Tel 0181 392 1959  
0181 392 1963  
Fax 0181 392 1994





# advertisers' index

<b>a</b>		Hi-Fi Corner	106	Roksan	76
Aanvil Audio	108	Hi-Fi Curiosity	101	<b>s</b>	
Amadeus S&V	104	<b>j</b>		Sevenoaks	26/27
Apollo Cables	115	J&A Cameras	14	Signals	130
Arcam	38	<b>k</b>		Silvernote	130
Audio Consultants	34	KEF	10	Slate Audio	99
Audio Elegance	134	<b>l</b>		Sonneteer	104
Audio Gallery	48	Linn Hi-Fi	60	Sound	
Audio Illusion	132	Listening Rooms	86	Connections	44
Audio Masters	101	<b>m</b>		Sound	
Audio Reflections	86	Mantra	118	Organisation	48
Audiolab	16	Marston Audio	52	Sounds	
Audiophile		MAV	40	Expensive	134
Furniture	36	May Audio		Sounds Of Music	54
Audiophile		Marketing	56	Spectra Dynamics	132
International	124	Mellotone	104	Sugden	22
<b>c</b>		Michael Stevens &		Sussex Surplus	125
Campaign Audio		Partners	94	SW Litho	86
Design	52	Michel	60	<b>t</b>	
Choice Hi-Fi	136	Mike Manning	116	TEAC	30
Classique		Mordaunt Short	130	The Emporium	134
Sounds	118	Musical Images	18	The Hi-Fi	
CR Developments	36	Musonic	104	Company	128
Croft	116	<b>n</b>		The Power Plant	118
Custom Cables	125	No Name		Thomas	
Cymbiosis	108	Acoustics	44	Transducers	116
<b>d</b>		<b>o</b>		Trichord	
Definitive Audio		Oranges &		Research	92
(Notts)	54	Lemons	86	Try Me & See	102
Definitive Audio		Origin Live	130	<b>v</b>	
(Sussex)	132	Ortofon	32,34,36,44	Vickers	48
DeNova	6	<b>p</b>		Vinyl Demand	40
Diverse Vinyl	134	Progressive		Vivante	52
Dynamics	136	Audio	108	<b>w</b>	
<b>g</b>		<b>r</b>		Wilmslow Audio	
Gamma Acoustics	100	Replay Audio			122/123
<b>h</b>		Consultants	44,115	Wire & Insulation	32
Heatherdale	125	RJF Audio	101		







the best...



WHAT HI-FI?  
★★★★★

March '97

731



731



731



731



731



731



731



731



731



731



732



733



733



733



733



734



734



734



734



734



735

...just got better...



MISSION

seven  
three



SERIES

listen and believe...