

# Hi-Fi WORLD SUPPLEMENT

No. 18 NOVEMBER 1995

**AFFORDABLE, HIGH  
PERFORMANCE 35W  
INTEGRATED VALVE  
AMPLIFIER**

**WE SHOW YOU HOW  
TO GET A TOP  
QUALITY FINISH ON  
YOUR DIY SPEAKER  
CABINETS**

**BOOK REVIEWS -  
BULLOCK ON BOXES  
70 YEARS OF RADIO  
TUBES AND VALVES**



**DESIGNING A TOP CLASS  
HEADPHONE AMPLIFIER**

**FREE D.I.Y. SUPPLEMENT No. 18**



## THE HI-FI LAW OF DIMINISHING RETURNS

Ask a Hi-Fi dealer to upgrade your system, and he'll sell you ever more expensive bits of hardware, giving you a constantly changing sound, new solutions producing more problems which can only be solved with more expensive equipment. The harder you try, the more it costs and the less satisfying the results. This is the well known Hi-Fi law of diminishing returns. We have an alternative:

## THE RATA LAW OF INCREASING RETURNS

Why buy new equipment when it makes more sense to realise the full potential of your existing equipment. Don't replace it, upgrade it; it's cheaper. Most equipment can be transformed by us for the cost of a dozen CDs. Magic? No - logic! To find out how we do it, ask for our 1994/95 Catalogue; it provides discussion, analysis and a definitive resource of audiophile components and advice on the art of recreating music in the home.

# Russ Andrews Audiophile Catalogue

Includes :

- CD Players, Preamplifiers, Disc Preamplifiers, Power Amplifiers
- Loudspeakers
- Kimber Kable
- Upgrading Services and Guides
- Audiophile Kits and Components
- Accessories
- Reviews

# 1994/95 CATALOGUE

### Russ Andrews

Edge Bank House, Skelsmergh, Kendal  
Westmorland. LA8 9AS  
England

**Tel: 01539 823247**

Fax: 01539 823317

To receive your copy of our 1994/95 catalogue just mail, phone or fax the address above.

# D.I.Y. Supplement

## Contents

All rights to the designs are reserved by World Audio Design Ltd. They are published for single use by private individuals. They are not to be used for commercial gain without prior permission from World Audio Design Ltd.  
Audio Publishing Ltd and World Audio Design Ltd accept no responsibility for accident or injury arising from the construction or use of any of the designs published.  
All of the projects in this supplement have gone through rigorous listening and test procedures. The performance and specification of these projects can only be guaranteed on kits bought directly from World Audio Design Ltd.

### KIT NEWS

All the latest developments from the world of Hi-Fi kits and components.

5

### K6L6 35W INTEGRATED VALVE AMPLIFIER

Another unique design from the World Audio Design stable. This one's a high performance integrated with an output of 35watts and a price under £300.

7

### HEADPHONE AMPLIFIERS

Looking to get the best sound from your headphones? We take a look at what goes into the design of a high quality headphone amplifier.

16

### A TOP QUALITY FINISH FOR YOUR CABINETS

We show you how to get a professional finish on your DIY loudspeaker cabinets, be it glossy paint or real wood veneer.

19

### BOOK REVIEWS

#### 70 YEARS OF RADIO TUBES AND VALVES

A historical look at the birth of the vacuum tube and the people and companies associated with it up to the present day.

23

#### BULLOCK ON BOXES

Everything you need to know about designing vented and sealed loudspeaker enclosures. An ideal book for those without a computer, since it shows how to tackle the maths.

25

### DIY LETTERS

Our team of experts set about answering your DIY hi-fi design queries. Write to us for practical advice and help with your DIY projects.

27

# BILLINGTON GOLD VALVES/TUBES

Long known as specialists in rare tube brand: Billington Export provides a line of premium-grade valves to fill the increasing demand for hard-to-find tubes! BILLINGTON GOLD features specially tested valves selected for long life, low microphony and low noise. Versions with gold plated pins are available. BILLINGTON GOLD brand comes from a variety of countries around the world. We have carefully chosen the best manufacturer for each type, with an emphasis on the highest audio quality and product reliability. We stock one million valves including: BRIMAR, GE USA, GEC UK, MAZDA, MULLARD, RCA, RUSSIAN/SOVTEK, SYLVANIA, TESLA, TUNGSRAM and other rare brands, as well as sockets and CRTs.

## BILLINGTON GOLD

2A3	15.50
6L6GC	6.45
12AX7	5.25
300B	60.00
811A	12.00
845	33.00
6550A	11.50
E81CC	5.25
E81CC-01	9.50
E82CC	4.50
E82CC-01	8.50
E83CC-01	8.50
E88CC	7.50
ECC81	5.25
ECC82	4.50
ECC83	5.25
ECC88	6.90
EL34	9.95
EL84	3.60
KT66	9.50
KT88	18.50

## SOVTEK

5U4G	3.60	ECC83/12AX7WB	3.50
6L6WGC	6.00	EF86	POA
6SL7GT	2.50	EL34G	6.20
6SN7GT	4.95	EL84	1.99
12AX7WA	3.50	GZ34	5.40
12AX7WB	3.50	GZ34/5Y3GT	2.90
5881/6L6WGC	6.00		

## RUSSIAN

6AS7G	4.50
6B4G	27.00
ECL82	2.25

Try us for ALL Russian Valves

## CHINESE

300B Silvertone	60.00
ECC88	3.90
EL34	7.00

## OTHERS

6CG7 Yugoslavian	6.75	6336A Penta USA	58.50
6X4W Raytheon USA	3.60	ECC85 Tungstram	3.30
5751 (USE ECC83)		ECL86 Tungstram	3.45

## RARE BRANDS

3AMP1A Tungstram Hungary	32.40
5C-450A STC UK	259.35
5R4GY USA	POA
5Y3GT RCA	3.90
6BH6 RCA	2.48
6L6WGB Sylvania	15.00
6V6GT STC UK	POA
12BH7A GE	11.40
12E1 STC/ITT UK	POA
13E1 STC UK	135.00
85A2 Mullard	5.93
807 USA	POA
5687WA RCA	6.45
6550A GE USA	33.00
CV4003 Mullard UK	POA
CV4004 Brimar UK	POA
CV4024 Mullard UK	POA
DG7-32 Tungstram Hungary	32.48
ECC81 Mullard UK (CV4024)	POA
ECC82 Mullard UK (CV4003)	POA
ECC83/ECC803S Tesla	13.13
EF86 GEC UK (CV4085)	POA
GZ32 Mazda	8.00
GZ37/CV378 Mullard UK	POA
KT90 Yugoslavian	45.00
PL519 ECG Philips	5.95

## SOCKETS

Jumbo 4-Pin for 211, 845 etc	11.50
Jumbo 4-Pin, Gold Plated, for 211	24.00
UX4 for 2A3, 300B, 811A, etc.	2.25
UX4 Large Locking Type for 300B	6.00
B5 UK	POA
UX5 McMurdo UK for 807	3.60
B7A for 6C33CB	3.23
B7G McMurdo UK, chassis, skirted	0.72
813 Ceramic	15.00
Octal McMurdo UK	1.20
Octal PCB, nylon	2.70
Octal PCB, foreign	1.20
B9A for ECC83, EL34, EF86, etc, suitable for pre-amps: -	
- Ceramic, skirted, chassis, screening can;	
Chinese	1.20
Russian	0.90
- PCB, gold pins	2.40
B9D Magnoval, chassis, for PL519	2.25

We supply sockets for all valves listed in this advertisement

## TOPCAPS

For 2C34, 807, etc	1.20
For 12E1, 5B-254M PL519	3.60

## MATCHED TESTING

£2.00 Per Valve (£4.00 per pair)

All items in stock at time of going to press. Prices in GB Pounds and subject to fluctuation: please check before placing your order. We stock over 3000 valve types and 400 types of CRT. Please ask for our free 50 page catalogue of valves and/or our CRT catalogue.

Payment is accepted by:

ACCESS, AMERICAN EXPRESS, DEBIT CARD, JCB, MASTERCARD, VISA, Bankers Draft, Bank Telex, Eurocheque and Cheque (UK only)  
MINIMUM ORDER: UK £50.00 + VAT & Carriage. Export £100.00 (US \$150.00) + Carriage

# BILLINGTON

EXPORT LIMITED



1E GILLMANS TRADING ESTATE

BILLINGSHURST

WEST SUSSEX RH14 9EZ UK

TEL: (0)1403 784961 FAX: (0)1403 783519

VISITORS STRICTLY BY APPOINTMENT PLEASE

# KIT NEWS

## TOP AUDIO ANALYSER FROM KENWOOD

Kenwood have announced a new audio analyser, the VA2230. Priced at £4800 it isn't cheap, but it combines several instruments into one to reduce the amount of equipment and test leads normally found on a test bench (anyone who's seen our test bench with over twenty measuring instruments and miles of cabling will understand the benefits of this). The VA2230 Audio Analyser combines an audio generator (5Hz-100kHz), AC/DC electronic voltmeter, wattmeter, distortion meter, frequency counter and signal-to-noise meter. It can also be linked to a PC for computer controlled analysis and there is optional software for frequency response graphs etc. All in all, it looks an impressive piece of kit, and we hope to bring you a short test in one of our future supplements.

**Trio-Kenwood UK**  
Kenwood House,  
Dwight Road,  
Watford,  
Herts. WD1 8EB  
☎ 01923 816444

## PM COMPONENTS

PM components are continuing to expand their range of modern-manufacture vacuum tubes. New this month is the EL34M. Produced using an original Mullard EL34 as a reference when designing the component parts, PM Components hope to have faithfully reproduced this classic British valve to the highest standard. Price is £25/pair.

There is also a new EL34 Super, priced at £25/pair. It is a more rugged EL34 for longer life span. Features include a bottom getter for cooler running and higher current operation, and it is made using a lower temperature process to reduce ionization in manufacture. This, combined with a high vacuum, should make the EL34 Super a very efficient valve.



We saw an early sample of the EL156 several months ago. Production units are now available from PM Components. The EL156 is a high power - 50watt anode dissipation - beam tetrode for audio output stages. It was designed and made (originally) by Telefunken of Germany. However, instead of the original and unusual German base, PM have opted to use the more widely available International Octal base, making it easier to implement. Price is £75/pair.

**PM Components**  
Selectron House,  
Springhead Enterprise Park,  
Gravesend,  
Kent.  
DA11 8HD  
☎ 01474 560521

## NEW TRANSFORMERS AND CABLES

Audio - Links are pleased to announce that they are now able to offer a custom transformer winding service to customers. Audio - Links can wind transformers for original designs such as the Mullard 5-20 and Western Electric WE-91, as well as helping with custom designs for your own project. They can also take the failed transformer from your vintage valve amplifier, analyse it

and wind a modern, high performance replacement to give it a new lease of life. Call for a quote.

Also new is a kit version of Audio - Links' "The Green" interconnect. Using silver plated OFC copper wire insulated with PTFE, The Green usually retails for £75. In kit form, including silver loaded solder, it is available for £50, a worthwhile saving for anyone equipped with a good soldering iron and a keen eye.

**Audio - Links**  
7 Fairmont Crescent,  
Scunthorpe,  
North Lincolnshire.  
DN16 1EL  
☎ 01724 870432

## NEW CATALOGUE FROM PV

PV Tubes have just produced a new catalogue, containing a listing of all of the valves they stock as well as other components for audio, including a range of capacitors. This 50page catalogue is available for 50p, which should be sent with a large SAE to:

**PV Tubes**  
104 Abbey Street,  
Accrington,  
Lancs. BB5 1EE  
☎ 01254 236521

## SPECIAL OFFER SINGLE-ENDED HEADPHONE AMP

A special offer to Hi-Fi World readers. Hart electronics are reducing the price of their Chiara single-ended headphone amplifier and associated Adante power supply from £198.53 to £184.92 in kit form for any orders placed before Christmas. It is also available fully built and tested for £284.74.

**Hart Electronic Kits**  
Penylan Mill,  
Oswestry. SY10 9AF  
☎ 01691 652894

# Vintage Audio

## Valve Data Book

FED UP WITH TRYING TO FIND THOSE ELUSIVE VALVE DATA BOOKS.??? SO WERE WE!!!!

THE SIMPLE FACT IS THEY DON'T EXIST ANYMORE.

THAT'S WHY WE PRINTED OUR OWN

NOT ONLY THAT WE DECIDED TO TAKE IT A STAGE FURTHER, AND INCLUDED SCHEMATIC DIAGRAMS OF AMPLIFIERS FROM 3 WATTS TO 500 WATTS, PUSH PULL TO SINGLE ENDED. POWER SUPPLIES FROM 150 VOLT TO 1500 VOLTS STABILISED. ALL THE DATA YOU NEED IS IN THIS BOOK

THIS BOOK IS INVALUABLE FOR THOSE INTERESTED IN THE DESIGN AND BUILDING OF VALVE AMPLIFIERS.

Vintage  
Audio



Amplifier Tube Manual

TO ORDER YOUR COPY  
@ £15 PLEASE CALL OR FAX US ON  
**(01239) 891448**

c/o THE POST OFFICE  
EGLWYSWRW, CRYMYCH,  
DYFED, WALES. SA41 3UJ  
(DO NOT SEND ANY MONEY)  
LIMITED QUANTITY PRINTED

**SOWTER**  
TRANSFORMERS

Sowter Transformers have been used by the Professional Audio Market throughout the world for at least the last twenty - five years.

Using modern technology and Computer Aided Design we are now able to offer a complete design and manufacture service.

Our current lists show a range of over 50 output, 70 power transformers and nearly 30 chokes.

**E.A. SOWTER LTD**  
P.O. BOX 36, Ipswich IP1 2EL  
SEND S.A.E. FOR DETAILS  
Tel: 0473 252794. Fax: 0473 236188

# Connect the dots.



Introducing The Parts Connection's first complete DIY kit: the Assemblage DAC-1 Digital Processor.

It comes in a small package (24cm x 5cm x 18cm chassis), but packs a big punch and a very musical sound. Designed for the rookie or first time kit builder, the only tools required are a pencil tip soldering iron, a screw driver, a wrench, a pair of electronics pliers, and a wire stripper or hobby knife. With only 21 solder joints and a handful of nuts and bolts, this kit goes together in one evening (typically about an hour). It's as easy as connecting the dots.

The parts quality is top notch. The board comes assembled and tested, implementing the Burr Brown 1702 DAC, a Crystal 8412 input receiver, an NPC 5813 digital filter, Analog Device's AD844 and 847 op amps and a custom potted toroidal power transformer.

At \$449 US, the Assemblage DAC-1 offers an outstanding value in digital conversion and comes with a *Satisfaction Guarantee* (return it with-

in 30 days of purchase for a full refund) and an *Assembly Guarantee* (if you can't get it running, we will!). We challenge you to find a DAC anywhere near this price with better measured performance, component quality, and most importantly, sound quality. Call us for more specific information on the performance or construction features.

To order the DAC-1 kit or to order The Parts Connection 1994 Catalog (for £3), full of a lot of other exciting stuff (including a \$10 US discount coupon good on your first order over \$100 US), send us your request and mailing address - or call with credit card information.

**ASSEMBLAGE**

**THE PARTS CONNECTION**  
A DIVISION OF SONIC FRONTIERS INC

2790 Brighton Road, Oakville, Ontario, Canada L6H 5T4  
Telephone 0101-905- 829-5858 Facsimile 0101-905-829-5388

Toll Free Order Line 1-800-769-0747 (U.S. & Canada only)

# K6L6 VALVE AMPLIFIER

by Noel Keywood



**T**his amplifier was conceived in direct response to your requests for an inexpensive design. But we failed - to make it cheap, that is! A cheap cheapy means performance compromise, which contradicts the basic thrust of high fidelity, a pursuit of perfection. So here's a 35watt per channel integrated valve amplifier that as a kit costs £295, but as an amplifier is quite specialised.

Our basic design brief demanded the use of inexpensive valves of course. The tried and trusted 6L6 was our preference. This is a beam tetrode, designed by RCA for audio use. It delivers good power and excellent audio performance, but costs little, so replacement after a few years carries no fear. Russia and China manufacture them today in quantity, so availability is not a problem either.

To match a good range of modern commercial 'speakers, including ones of mediocre sensitivity, power output needed to be 30watts or more, we felt. Pure Class A was out, because at this power the amplifier would stream heat and transformer costs would rise if we were to meet our usual criterion of cool-ish running in the tropics (our kits are popular in Singapore, Hong Kong and Malaysia). So the new K6L6 amplifier is a Class A/B push-pull design running substantially in Class A. Although nominally rated at 35watts, this is conservative. It hits 40watts at a few percent distortion.

A moderate amount of feedback has been used to keep output impedance low, again to ensure good speaker matching. Also, as usual we've optimised performance at around 6Ω, giving good

power transfer and low distortion to a large majority of 8ohm loudspeakers. In the mid-band, distortion hovers around 0.02%; this is a low distortion amplifier.

There's no point in making a budget power amp., 'cos then the preamp will hike the overall system cost, so K6L6 had to be integrated, with input selector and volume control. This amplifier has a lot of gain, so it has a high input sensitivity of 220mV - low enough to match any signal source. Anyone wanting to use a record deck will need to add an external phono stage.

A lot of the cost of a valve amplifier - any amplifier in fact - lies in the casework and transformers. All the same, we didn't consider offering an unpunched chassis for the sake of cheapness. We expect our kits to have a professional finish, not look like battered

Cocoa tins. A lot of cost saving lies in a new form of chassis construction devised for K6L6 that's simple to manufacture, yet strong, safe and neat in appearance. It's a two-part "clamshell" design that dispenses with welded & buffed corners. Most of the circuit is built onto a printed circuit board with component positions printed on, to simplify assembly.

The chassis comes powder coated for durability and longevity; powder coat is baked on in an oven, dispelling moisture, so it survives better in humid climates than plating or paint. As always, we have used heavy 16 gauge steel, and the chassis comes screen-printed front and rear, so it looks and feels professional. The bottom section ensures high voltages cannot be touched, but bear in mind that the output valves run hot enough to cause a burn, so young children and pets shouldn't be allowed close.

The ever important power supply uses a toroidal transformer for cool, efficient running and low external hum field. This feeds a bridge rectifier built from fast diodes, which give cleaner

switching free from sharp transition glitches. The bridge feeds a reservoir capacitor of 500 $\mu$ F, comprising stacked 1000 $\mu$ F units to give 800V working, fitted with bleed/balancing resistors. This gives such a quiet H.T. line that hum and noise come mainly from the input valves, because of the large amount of gain that follows them. To get hum right down to negligible levels we found it essential to use a d.c. supply to the input valve heaters.

We took note of a new ruling by the E.C. against the use of 4mm loudspeaker plugs, because they can be inserted into European mains outlets. It would be more sensible if others used the British shuttered 13A socket, because children can't poke wire, metal knitting needles or heaven knows what else into them, but since rewiring Europe would probably be more expensive than German reunification, it's hi-fi amps and 'speakers that must change.

We've opted to use XLR 'speaker connectors, female on the amp so the output terminals cannot be touched. They're not dangerous, swinging just 20V or so, but because amps of 100W

or more must in future have protected outputs (E.C. rules again) we thought we'd fall in line. The 'speaker cable must have a sheathed male plug at the amplifier end. Ideally, a female XLR plug should be used at the other end, but I suspect most U.K. DIYers will use 4mm plugs, because all speakers are so equipped.

Talking of safety, do remember that anything over about 100V is potentially lethal. K6L6, like any valve amp, runs at a very high 500V and is potentially hazardous during the final testing stage (it meets BS415 safety requirements). If you do not know about safety precautions or are at all uncertain of your abilities, then we do not recommend you build it - it's as simple as that! Get someone experienced and knowledgeable to build it or at least test it. Electricians are a good bet, as is your local TV repair man. Speak to them first to agree costs though, since building will take 8-12 hours, testing 1 hour or so, but fault finding and rectification unspecified hours!

## K6L6 THEORY OF OPERATION by designer, Andy Grove.

The K6L6 circuit is straightforward, similar to the ubiquitous Mullard 5.20, but with some refinements to improve performance.

The input valve, V1, is a 6AU6 low noise R.F. pentode. It is configured as a high gain, single-ended amplifier stage with R5 as its anode load and R7/C3 as part of the H.F. compensation to maintain feedback stability. The input grid (g1) is connected via a grid stopper R2 (to prevent parasitic instability). VR1 is the volume control with R1 as a precautionary measure to ground g1 in case VR1's wiper contact fails. The screen grid (g2) is supplied by R6 with C2 to bypass any audio signal to the

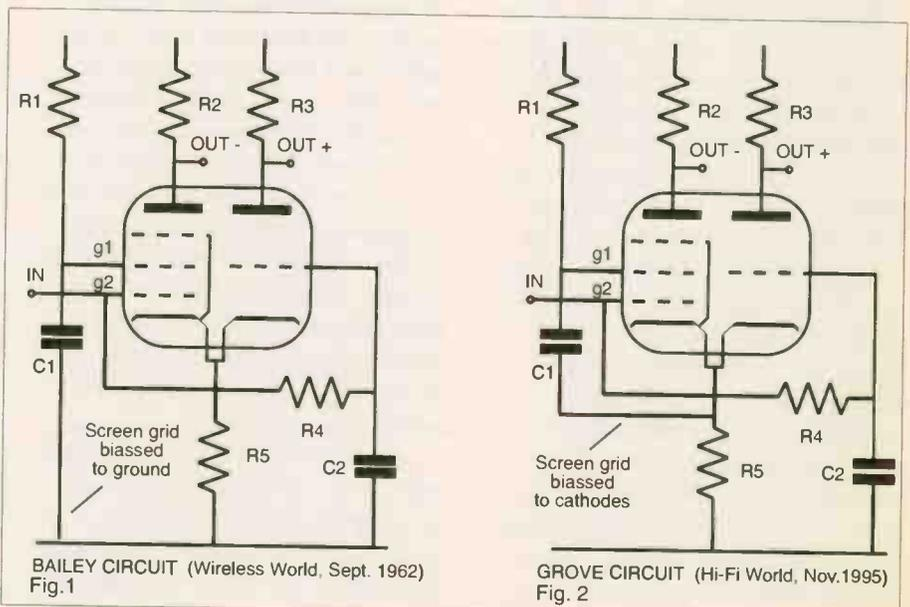

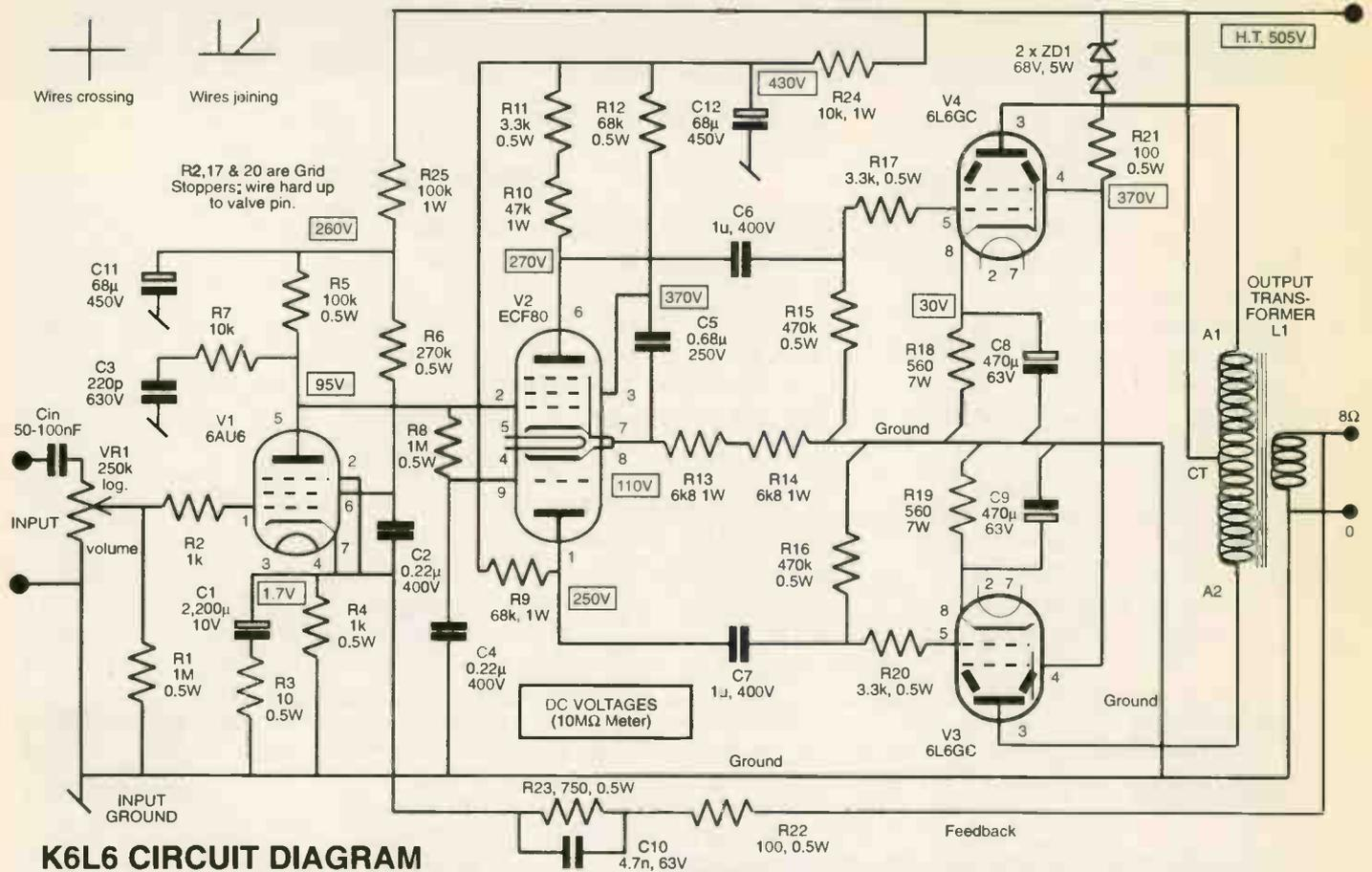

K6L6 CIRCUIT DIAGRAM

cathode. R4 is the cathode bias resistor and C1/R3 are LF feedback compensation components.

The second stage and phase splitter (V2) is an ECF80 triode pentode valve with the pentode section (V2a) direct-coupled to V1's anode, at approximately 95V D.C. under quiescent conditions. The triode section's (V2b) input grid (g1) is connected to V1's anode via R8 but all audio signals are bypassed to ground by C4, effectively holding it at around 95V D.C. V2a's and V2b's cathodes are connected together and to ground by R13 and R14 which define V2's total cathode currents. V2b's anode load is R9 with R10 and R11 in series to give the correct load for V2a for accurate A.C. balance. R12 supplies V2a's screen grid (g2) and C5 A.C. couples to the common cathode connection.

Capacitors C6 and C7 block D.C. and couple the audio signal via grid stoppers R17 and R20 to the grids of the 6L6 beam tetraode output valves, V3 and V4. Resistors R15 and R16 hold the

grids to ground at D.C. Resistors R18 and R19 are V4 and V3's cathode bias resistors which are bypassed by C8 and C9 with regard to A.C. ZD1 (2) causes a voltage drop of 2x68V from the main H.T. line for safe operation of the screen grids of V3 and V4, and R21 is a common stopper resistor to prevent parasitic oscillation. The anodes of V3 and V4 are connected to the output transformer and feedback is taken from the secondary via R22, R23 and C10, which are compensation components.

The main power supply uses a capacitor input filter and R24, C12, R25 and C11 lower the voltage from the raw supply and filter it further for the low level stages.

The heater supply is a normal 6.3V A.C., except for the input valves, which are fed D.C. to minimise hum.

There are some unusual features in this amplifier which need some extra explanation. Firstly the phase splitter circuit is somewhat unconventional but bears some similarity to the Radford type designed by Dr. A.R. Bailey. It uses

a triode-pentode valve for improved electrical performance, in place of the Mullard 5.20's double-triode. The problem with the conventional double-triode phase-splitter is its high input capacitance caused by the Miller effect. This causes H.F. loading on the input valve and reduces bandwidth, making it very difficult to use appreciable amounts of negative feedback without instability due to the phase shifts incurred. A pentode has a very low input capacitance and high gain due to the shielding effect of the screen grid. This means that the loading on the input valve is greatly reduced, increasing bandwidth and decreasing troublesome phase shifts.

In the original Bailey/Radford circuit a pentode replaces the first triode of the Mullard type cathode-coupled phase-splitter, but its capabilities are not fully exploited. Fig 1 shows the Bailey circuit. Here the screen bypass capacitor C1 is connected to ground. This means that the drive voltage for the triode section (which appears at the common cathode

# LANGREX SUPPLIES LTD

DISTRIBUTORS OF ELECTRONIC VALVES, TUBES AND SEMI-CONDUCTORS AND I.C.S.

PHONE  
0181 684 1166

1 MAYO ROAD • CROYDON • SURREY CR0 2QP  
24 HOURS EXPRESS MAIL ORDER SERVICE ON STOCK ITEMS

FAX  
0181 684 3056

A selection of our stocks of New Original Mullard - Brimar audio types made in UK.

STANDARD TYPES			SPECIAL QUALITY TYPES			
ECC81	MULLARD	6.00	E88CC - GOLD PIN MULLARD	8.50		
ECC82	MULLARD	6.00	E88CC SIEMENS GOLD PIN	8.50		
ECC88	MULLARD	6.00	E188CC - GOLD PIN MULLARD	8.50		
ECH81	MULLARD	3.00	ECC81 - M8162 / CV4024 MULLARD	6.50		
ECL82	MULLARD	3.50	ECC81 - 6201 / GOLD PIN MULLARD	8.50		
EF86	MULLARD	10.00	ECC82 - M8136 / CV4003 MULLARD	6.50		
EL33	MULLARD	10.00	ECC83 - M8137 / CV4004 BRIMAR	6.50		
EL84	MULLARD	6.00	<b>AMERICAN TYPES</b>			
GZ32	MULLARD	8.50				
GZ33	MULLARD	6.00	5 R4GY RCA	6.00	12BY7A GE	7.00
GZ34	MULLARD	15.00	6 FQ7/6CG7 SYL	7.50	6146B GE	15.00
6SL7GT	BRIMAR	4.50	6L6GC GE	12.50	6550A GE	20.00
6SN7GT	BRIMAR	4.50	6L6WGB SYL	10.00	7027A GE	17.50
6V6GT	BRIMAR	4.25	12AX7A GE	7.00	7581A SYL	15.00

MANY OTHER BRANDS AVAILABLE

THESE ARE A SELECTION FROM OUR STOCK OF OVER 6000 TYPES. PLEASE CALL OR FAX FOR AN IMMEDIATE QUOTATION ON ANY TYPES NOT LISTED. WE ARE ONE OF THE LARGEST DISTRIBUTORS OF VALVES IN THE UK. SAME DAY DESPATCH VISA/ACCESS ACCEPTABLE. OBSOLETE TYPE A SPECIALITY.

VISA

OPEN TO CALLERS MON.-FRI. 9AM - 4PM. CLOSED SATURDAY

P&P 1-3 VALVES £2.00, 4-6 VALVES £3.00 ADD 17.5% VAT TO TOTAL INC P+P

Access

## The AP ELECTRONICS Route to Musical Happiness

### EXPERIMENT

With different interconnecting and loudspeaker cables  
With Sonelink custom designed mains cables  
By changing resistors and capacitors  
With large power supplies  
By applying simple modifications to improve your circuits  
By bypassing high value capacitors with higher quality lower values  
With mechanical damping of mechanical parts and electrical circuits

#### LEARN

From your experiments  
The features which give the best sound quality.  
From knowledge gained through reading AP PERFORMANCE AUDIO

#### MODIFY

Use the knowledge gained from experimentation  
And from tips published in AP PERFORMANCE AUDIO  
To rebuild your own amplifiers  
To improve the sound quality of your system  
To get greater enjoyment from your favourite music.

#### BUILD

Build your own hi-fi equipment  
From the excellent range of AP ELECTRONIC kits

#### DESIGN

Design the equipment of your dreams  
Make your dream come true with parts purchased from AP ELECTRONICS

### AP ELECTRONICS

Audiophile Parts at Affordable Price  
1995 CATALOGUE now available - £4.95  
(or FREE with your next £40 + order)

### AP PERFORMANCE AUDIO

The Journal of High Performance Audio Construction  
1995 Subscription (4 issues) - £5 (overseas £10)  
Please make cheque payable to "AUDIOKITS"



CREDIT CARD TELEPHONE ORDER HOTLINE: 01332-674929  
(messages recorded when unattended - please give full details)  
HOTLINE FOR FREE TECHNICAL ADVICE - TEL: 01332-674929  
9-10am Mondays-Sundays

Derwent Business Centre, Clarke Street, Derby DE1 2BL  
Tel: +44-1332-674929 Fax: +44-1332-298836

## TECHNICAL & GENERAL

THE ORIGINAL TURNTABLE SPECIALIST

for the Great Classical Turntable, Arms, Cartridges, Styli

CONNOISSEUR GARRARD GOLDRING LENCO  
ORTOFON SHURE S.M.E. THORENS WATTS

All available Genuine spares and our own re-manufacture obsolete parts  
Servicing and Overhauls, to original technical specifications.

NO ILLUSORY 'IMPROVEMENT' NO DUBIOUS OR  
HARMFUL 'MODIFICATIONS'

Remedial Services available

Cartridge and styli, correct radius dismond, for early recording - 78s & Lps

**TECHNICAL & GENERAL**

P.O. Box 53 Crowborough, East Sussex TN6 2BY  
Tel: 01892 65 45 34

## Falcon Acoustics Ltd

Incorporating Falcon Electronics Falcon Components

Send for our FREE price list PL24: Just send a large S.A.E. (36p stamp) or \$2 bill (air) overseas. Europe - \$1 bill or 3 International Reply Coupons (IRC)

New and updated FOCAL 'State of the Art' Kits  
FOCAL 'In-car' & JMLab Speaker Systems.

Increased range of SOLEN 400 & 630v Polypropylene capacitors.  
DRIVE UNITS: by FOCAL, and a pick of the best from other manufacturers.

CROSSOVER NETWORKS - Active & Passive Components, Accessories, Large range of Capacitors + Falcon Custom-wound Inductors.

AUDIO AMATEUR PUBLICATIONS

Loudspeaker Design Cookbook, Recipes' Book, Mullard Valve Circuit, and many more - list in P/L.  
Back year sets of Speaker Builder, Audio Amateur & Glass Audio, plus the Audio Anthology Set.  
COMPUTER PROGRAMS

Large selection of Programs available from the very comprehensive Liberty AudioSuite test program  
via AJRR and LoudSpeaker Ver.6, to the basic Bullock/White Boxresponse.

Also the IMP FFT Test Kit and the Miley Mic Kit

Full details from

(Dept HFW) Tabor House, Norwich Road, Mulbarton, Norwich,  
Norfolk. NR14 8JT Tel. (01508) 578272

connection) causes not only feedback into g2 but also increases the input capacitance, because g2 is grounded to A.C. but g1 is not.

To overcome these drawbacks I have connected the capacitor to the cathode connection (see Fig 2). This means that g2 and the cathodes now have the same A.C. voltage on them. This removes the unwanted feedback mechanism, increasing gain, but it also

reduces the capacitance between the input g1 and g2, widening bandwidth and reducing phase shifts. This allows substantial feedback to be applied without instability, even with highly capacitive loads like electrostatic speakers.

Feedback was tried at various levels, both for measured performance and audio quality. It was found that, in this design, greater feedback at high

frequencies, as long as good stability and square-wave performance could be maintained, gave a cleaner and sweeter quality. This could be due to the decrease in distortion and better transient response. The special LF feedback networks gave a cleaner and faster bass quality.

The H.F. compensation networks R7/C3 and R23/C10/R22 are quite ordinary, but the L.F. compensation is

somewhat unusual. At medium to high audio frequencies the reactance of C1 is negligible so the feedback is determined by R3. As the frequency decreases the reactance of C1 increases, increasing the feedback at L.F. but maintaining stability. This gives the amplifier excellent control over the speaker at low bass frequencies and reduces bass distortion. A.G.

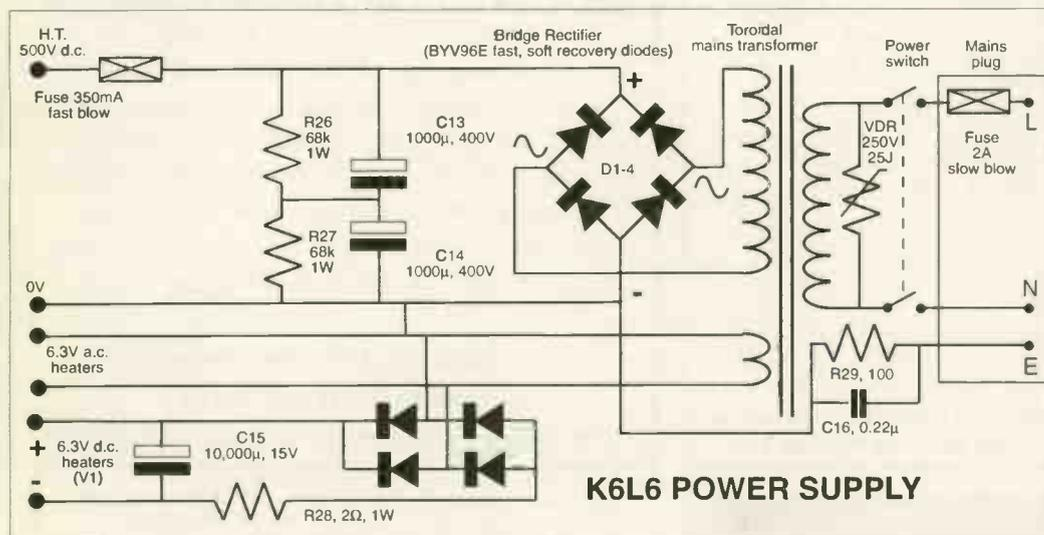

## BUILDING K6L6

Home constructors making their own amplifier from our transformer set and board will face the task of constructing a chassis. Those buying a complete kit get a fully punched, finished and printed 16 gauge steel chassis that meets normal industry standards, except that it is less flimsy than most.

Key points to bear in mind, especially for those that build their own chassis, are safety, thermal behaviour and hum susceptibility. An earthed metal chassis should be used, ours conforming to BS415 requirements to ensure live parts are not accessible from outside. Remember that the 505volt H.T. line is potentially lethal and poses a threat during final tests. This is the time to be very cautious.

Copious top and bottom venting should be used to ensure a good flow of air through the amplifier. In particular,

the cathode resistors run hot, although they dissipate only 1.8watts in this design, so not very hot. We put vents above and below as a matter of good practice to ensure thermal convection take place, preventing heat build up inside the chassis. The large toroidal mains transformer runs relatively cool.

Our experience has shown that high gain valve amplifiers are incredibly sensitive to hum fields. The input valve's entire operating environment needs to be considered and hum fields must be kept well away from it - any closer than 4in for a A.C. cable is too close!. For example, in V1 even the input valve heater feeds introduced hum, so we used D.C. heaters to eliminate it. Star earthing should be used and hum loops avoided. Avoid sharing earths, especially the returns used for the bridge rectifier and the output valve cathodes, both of

which carry heavy signal currents.

The input capacitor C<sub>in</sub> is for d.c. blocking and also for subsonic roll-off below 20Hz. The 50nF value will introduce attenuation below 20Hz (-3dB at 13Hz) and is the best choice for clean bass. No valve amplifier can swing large subsonic signals, distorting instead, so it's best to block them in this fashion. It is also wise not to assume sources will be free of D.C. on their output.

We have biased the output stage to accept inexpensive Russian Edicron 6L6GC valves. If Golden Dragon 6L6s are used it is possible to get a little more power by removing one of the zener diodes (ZD1). Voltage drop across R18/19 should rise to 35V or so.

There are differing views about the use of grid stoppers to prevent instability. Ideally, they should be left out, but in practice this can result in

the new

## CRICKLEWOOD ELECTRONICS

Very Interesting CATALOGUE

### ASTRONOMICAL RANGE AT DOWN TO EARTH PRICES

- TRANSISTORS + ICs + SEMICONDUCTORS
  - RESISTORS + CAPACITORS + INDUCTORS
  - SURVEILLANCE + SECRECY + SECURITY
  - PLUGS + SOCKETS + LEADS + CONNECTS
  - TV & VIDEO SPARES (inc Video Heads)
  - HIFI + DISCO + HIFI GADGETS + SPEAKERS
  - AUDIOPHILE COMPONENTS (inc Capacitors)
  - IN CAR AUDIO + SPEAKERS (inc Bass tubes)
  - COMPUTER ACCESSORIES + BOARDS
  - TOOLS + TEST EQUIPMENT + BENCHMARK
- & much much much more (over 10,000 lines).

SEND TODAY FOR THE VERY INTERESTING CATALOGUE

Pay by PO, Cheque, Credit Card or tape Coin to Paper

Please send me ..... copies of the 1995 Cricklewood Catalogue.  
I enclose £2.50 per copy (UK & Europe). £5.00 overseas

Name: .....

Address: .....

.....

.....

.....

Please Charge my Credit Card No. ....

Expiry Date.....Tel No.....HFW

Cricklewood Electronics Ltd, 40-42 Cricklewood Broadway  
Lindon NW2 3ET Tel 0181 450 0995 Fax 0181 208 1441

**IMPROVED**

## STEREO DECODER FOR MONO VALVE TUNERS

Now with revised impedance matching, for wider separation, fuller bass and extended treble.

Experience REAL stereo from your Troughline, Quad, RCA, Rogers, etc. Just connect this great sounding decoder to the multiplex output from your mono tuner. Available as a mains powered boxed unit, or an easily assembled kit of parts, or a fully aligned module only. No special tuner alignment needed.

**Complete unit £48.50. Kit £28.50.  
Assembled module £12.50. (Inc. P&P)**

**STUDIO 12** Nanjivey Terrace, St Ives, Cornwall,  
TR26 1BQ. Tel: (01736) 798393

### RESTORATION OF CLASSIC EQUIPMENT

SUITABLY QUALIFIED ELECTRONICS ENGINEER (DEGREE/ MAES)  
WITH OVER 40 YEARS EXPERIENCE AND SPECIALIST KNOWLEDGE  
OF QUAD, RADFORD, LEAK, ROGERS, AND ARMSTRONG, ETC.  
EXTENSIVE WORKSHOP FACILITIES ENABLE ORIGINAL STANDARDS  
ACCOMPANIED BY DETAILED REPORTS OF WORK CARRIED OUT.  
CLIENTS WILL HEAR THEIR APPARATUS DEMONSTRATED PRIOR TO  
THEIR DEPARTURE. AVAILABLE 7 DAYS PER WEEK

**CIRCUIT DATA ON OFFER  
(SEND SAE FOR LIST)**

**TEL 0181 504 5467 WOODFORD, ESSEX**

# AUDIO LINKS

**SUPPLIERS OF HIGHEST  
QUALITY COMPONENTS**

**NEW PRODUCTS**

**CUSTOM WOUND TRANSFORMERS &  
CHOKES**

- Exceptionally high quality item for valve and solid-state designs at realistic prices.

**AUDIO - LINKS, "THE GREEN" INTERCONNECT  
CABLE**

- Now available in kit form. All the parts you need to make your own reference interconnects at a fraction of the cost.

**TEL: 01724 870432/764804**

Mon. to Sat. 10am - 7pm

**AUDIO LINKS**

**7 Fairmont Crescent, Scunthorpe**

**North Lincolnshire, DN16 1EL**

## SERVICE MANUALS

We have what is probably the largest range of Service Information available anywhere. From the Earliest Valve Wireless to the Latest Video Recorders Colour Televisions, Test Gear, Audio, Computers, Amateur Radio in fact practically anything. Write Fax or Phone for immediate Quote.

Originals or Photostats as available

Also available. Our FREE catalogue detailing Hundreds of Technical Books and Repair Guides available.

**STOP PRESS**

Now Available. Our Service Manuals Index on P.C. Disc (3.5") for use on your Computer. Just £3.50 with FREE everlasting Updates. Order MP-285.

**MAURITRON TECHNICAL SERVICES (HFW),  
8 Cherry Tree Road, Chinnor, Oxon, OX9 4QY.  
Tel: 01844-351694. Fax: 01844 352554.**

Please forward your latest catalogue for which I enclose 2 x 1st Class Stamps or £3.50 for the Technical Books Catalogue plus Manuals Index on PC Disc(s)

NAME .....

ADDRESS .....

.....

POSTCODE .....

If you do not wish to cut your magazine photocopy this coupon or use a separate sheet

oscillation with some particular samples of a valve. For safety we use them, but home constructors may like to experiment with their removal.

There are some common and recurrent build difficulties. Any channel that 'motorboats' (low frequency instability that produces a very loud drone) has its feedback the wrong way around. Reverse the feedback connection on the output transformer secondary. When checking remember that the amplifier is stable without feedback and should not motorboat in

this state, although it will have excessive gain and seem to have hum and noise until feedback is connected.

Poor soldering and wire layout are not uncommon too, we find. Keep all high level signal lines in the output stages away from input lines to prevent mutual induction and possible instability. All input lines on this amp must be kept away from mains and heaters; they are unusually sensitive, being of high impedance, and must be screened. Beware of running cables alongside each other or in looms - they may interact.

Watch out for dry joints when soldering, another common problem. A joint might appear made, but in fact it will 'dry' and be making poor or no contact, because of movement whilst the solder was cooling. Inspection, continuity testing and pulling at wires have to be used to spot this mistake. Finally, electrolytic capacitors must be inserted the right way around and their polarity marking correctly identified. Usually, can is negative, black end positive and negative is the pole identified on the side. **NK**

## SOUND QUALITY

K6L6 is a high feedback design, and shows all the hallmarks of this in its sound quality. The sound stage is tightly defined and well ordered, images sounding clean and free of grain. Where K6L6 scores is in clarity and detail. It has all of the openness through the midrange and sweetness of treble that any good valve design should be capable of.

Bass is tight and powerful, unflustered by strong dynamics, shown well by the powerful bass guitar on Soundgarden's 'The Day I Tried to Live'. The notes really punched out, underpinning the track with a firm foundation. K6L6 copes with awkward loads well too, an advantage of feedback, driving a wide variety of loudspeakers and always producing stable and tuneful bass.

Where K6L6 shows its best colours though, is with female vocals and strings, where its dry and analytical nature urges detail to the fore. The Cranberries' Dolores really shone on 'Daffodil Lament', vocals clear and forward pushing out into the room. Valves just can't be matched.

**DB**

## K6L6 PARTS LIST

### RESISTORS

R1	1M, 0.5W
R2	1k, 0.5W
R3	10, 0.5W
R4	1k, 0.5W
R5	100k, 0.5W
R6	270k, 0.5W
R7	10k 0.5 W
R8	1M, 0.5W
R9	68k, 1W
R10	47k, 1W
R11	3.3k, 0.5W
R12	68k, 0.5W
R13, 14	6k8, 1W
R15, 16	470k, 0.5W
R17	3.3k, 0.5W
R18, 19	560, 7W
R20	3.3k, 0.5W
R21, 22	100, 0.5W
R23	750, 0.5W
R24	10k, 1W
R25	100k, 1W
Power supply	
R26, 27	68k, 1W
R28	2Ω, 1W
R29	100Ω, 1W
VR1	250k, dual, log.
Cin (D.C. block)	50n/63V
C1	2200μ, 10V

C2	0.22μ, 400V
C3	220p, 630V
C4	0.22μ, 400V
C5	0.68, 250V
C6, 7	1μ, 400V
C8, 9	470μ/63V
C10	4.7n, 63V
C11, 12	68μ, 450V
C13, 14	1000μ, 400V
C15	10,000μ, 15V
C16	0.22n, 250V
2 x ZDI	zener diode, 68V,5W
H.T. Bridge Diodes	4 x BYV96E
Heater Bridge	1A, 50V
V1	6AU6
V2	ECF80
V3,4	6L6GC

L1	toroidal output transformers
L2	toroidal mains transformer

### K6L6 SPECIFICATION

Class A/B, push-pull stereo power amplifier using 6L6GC output valves.

Power	35W/ch.
Distortion	0.02%
Separation	60dB
Noise (CCIR)	-103dB
Sensitivity	220mV

**FOR FURTHER INFORMATION ON K6L6 AND ORDERING DETAILS, PLEASE SEE PAGE 82 IN THE MAIN ISSUE.**

# AUDIO NOTE

The increase in interest in all things single-ended, especially the triode non-feedback variety is now so great that even the mainstream valve manufacturers are about to follow suit. So if you are looking for a single-ended product before it becomes a false prophet, who speaks of things he does not believe in, until it falls financially expedient or downright necessary to have a single-ended amplifier in the program. So whether you are building a single-ended amplifier yourself, or looking to buy a manufactured single-ended product, please remember that it was **AUDIO NOTE**, who, in the face of the usual industry hype about continual "progress", brought this technology to the attention of press, public and general audio industry alike, not because it would lend a quick buck to the purse, but because we firmly believe that it is a superior way of amplifying any musical signal, and therefore deserves to be resurrected as the preferred technology for anyone who want the genuine aesthetics and beauty of real music reproduced in their home.

Now that we stand on the boundary of this, the brave "new" world of 1920's circuitry, we note with interest the number of manufacturers who have manufactured valve amplifiers for many years, but who only now have "discovered" the value of the single-ended stage, and who in the past have been the strongest proponents of the high power "high quality" valve amplifier, which are, as they now, for commercial gain embrace the world of high loudspeaker efficiency and single-ended triode amplification and then draw your own conclusions about their sincerity and competence in overall knowledge of the technology of Audio **AUDIO NOTE** were first and remains the last word in sonic quality if you appreciate music properly reproduced.

To enhance your ability to design and manufacture your own special version of any of the single-ended circuits being discussed, whether old or new, we will continue to expand on what is already the most extensive range of ultra high quality components that the discerning "do-it-yourself" valve amplifier enthusiast can use to construct any single-ended (or share on your!) push pull amplifier, whether triode or pentode. All of these parts are used in various models of the manufactured line of the **AUDIO NOTE** amplifiers. These components include mostly specially made items like ceramic valve bases with either silver or gold plated pins, paper in oil aluminium foil signal capacitors, copper & silver foil signal capacitors, Black Gate graphite electrolytic capacitors, acid/corrosive-free silver solder, copper and silver wired audio transformers, non-magnetic tantalum resistors, non-magnetic RCA and speaker terminals, valves and many other useful bits and pieces for upgrading old or constructing new valve amplifiers.

All prices are excluding UK VAT at 17.50%, which, if you live inside the EEC, UK VAT will be added to your purchase, after the addition of postage and packing costs.

We accept **VISA, Mastercard, Access, Dinners, and Amex**, to pay this way, we will need your address, card no. with start and expiry dates, you can also pay by bankers draft, Euro cheque or cheques drawn on a UK bank account. Please note that there is a minimum charge on credit card transactions of £20.00.

Delivery is normally about 14 days from receipt of cleared funds, but please allow up to 60 days for some items, if not stock at the time or order.

If any of you reading this have possession of any books which contain information relevant to the subject of Audio Design and which would be useful to share with others, please let us know either by fax or telephone, there is an award of £20.00 (payable in valves or other bits, postfree) to anybody who sends us a book which contains useful information about valve amplifier design or theory.

## CIRCUITS, VALVEDATA & BASIC TECHNICAL INFORMATION.

If you would like some suggestions which to base a future project around, then we shall be happy to provide you with a circuit pack containing good circuits like **ONGAKU, KEGON/KASSAI, NEIRO, GAKU-ON** plus several other power amplifier circuits and the **M7T** pre-amplifier, which is the best pre-amplifier circuit we have come across. Just send a stamped self addressed A4-size envelope, together with 5.00 pounds in small denomination UK stamps, or if you live outside the UK US\$ 15.00 in \$ bills will do, please do not send Bankers Drafts in US, International Response Coupons or International money orders, as they cost more to cash than their value.

We have a large number of requests for the circuits of the **AUDIO NOTE** UK-made amplifiers, like **OTD Phono SE, M1 Phono, MEISHU, SORO** etc., and since we (unlike the majority of our talented competitors) do not have any secrets in this department, and are only too pleased to help extend the envelope of knowledge in this much maligned field, we shall be happy to send you or any existing or prospective competitor, one or more circuit diagrams, they cost £5.00 each, or you can buy for example all phono-integrated amplifiers, for £30.00 (\$ 50.00), or all Line-integrated amplifiers for £25.00, all pre-amplifiers for £20.00 (\$ 35.00), or simply a complete circuit pack for £50.00, (\$ 80.00) All can be paid either by credit card, cash, bankers draft or cheque drawn on a UK bank, the cost includes postage.

We can also supply a set of data sheets for the most commonly used valves, **ECC82, ECC88/6922, 12AY7/6072A, 7025/12AX7WA/ECC83, 6SN7, 300B, 211/V74C, 845, EL34/6CA7, 2A3, 6X4, 5U4G, GZ34/SAR4, EL84/6B05, 6VE6GT, 6L6G, 58B1/6L6WG/C/KT66**. Again send a stamped self addressed A4 envelope together with £4.00 in small denomination stamps or if outside the UK another US\$ 15.00 will suffice.

Since nothing really exists which gives a reasonable background to the subject of valve amplifier circuit design, Guy Adams and I have written and assembled a number of articles and extracts from old books which give some background to the subject, do not expect to become an instant expert, but it will serve as a useful reference, for the beginner as well as the more advanced, we have expanded this info-pack to include even more useful information, so if you have already bought the old pack, just send £2.00 or US\$ 5.00, for the full pack a small charge is required, this time £7.00, in small denomination stamps with a stamped self addressed envelope, or outside the UK, please send US\$ 25.00.

We do accept a UK cheque or bankers draft in Pound Sterling for the above charges as well, just convert the US\$ amounts to Sterling at \$ 1.70 to the Pound, after you have rounded up to nearest \$ 5.00

## SOUND PRACTICES

If you are seriously interested in the subject of valve amplifier design, without the usual preconceived notions of what is "good" amplifier design and technology (the traditional view, which has brought us the blessings of the transistor amplifier, has obviously disfigured itself quite monumentally!), then **SOUND PRACTICES** is the magazine to read, here you will find articles about design parameters, DIY articles for amplifiers and speakers, reviews of new and old, in other words the very subjects that none of the self-serving, advertising led traditional press will touch as they do not enhance the business of their normal advertisers. You can buy **SOUND PRACTICES** from us at £5.00 per copy (there are currently 5 issues available) or by subscription from **SOUND PRACTICES P.O.**, Box 180562, Austin, TX 78718, USA. A regular modern world bargain, and there are practically none of those in Audio today. With enough subscription support **SOUND PRACTICES** may just bring about the "sound practices" that the hi-fi industry has abandoned for so long. So get a subscription!

By the time you read this **SOUND PRACTICES** issue 8 should be here, so this should keep you off the street for the next weekend! Buy a copy for £5.00 + postage (or self addressed envelope with order if you live in the UK), contains the following articles, Blue Thunder - DIY TAD and Focal Horn System from Zurich, The Lowther-Voigt Legacy, Join the Club, Lowther Clubs by Joe Roberts, The Reichert 300B Amplifier, by none other than Herb Reichert, Homebrew Gallery, Photos of Readers Projects and Systems, Rejuvenating Old Triodes, New Russian Triodes, A Screen Drive Driver Stage, A Cathode Follower/Bridge Amplifier, and much more!

Much good and informative reading as usual, again £5.00 + an A4 size, stamped self addressed envelope if you live in the UK or US\$ 10.00 and a self addressed envelope if you live abroad.

## POSITIVE FEEDBACK

This is one type of feedback that we are not entirely against! Positive Feedback is the club magazine for the Oregon Triode Society with aspirations towards greatness, not unlike the great underground magazines of the 1970's. It is a quarterly publication of zany, controversial commentary, by in-house writers, members, as well as various industry doyens on the subjects of music, audio, technology and the quest for musical satisfaction. I for one think it is an excellent read and provides a good alternative view to most of the established press, which tends to view the world in the context of what new products is available right now, without giving much perspective backwards. Positive Feedback latest issue is just off the press and is available at £6.00 per issue.

## AUDIO NOTE OUTPUT TRANSFORMERS

We are in the process of building up four separate ranges of Audio Note output transformers, in order to offer the best possible outputs at different pricepoints, they will fall into four categories.

A.) Economy range, where the price/quality relationship is carefully calculated to ensure audio quality in a compact package, initially we will only be offering 3 single-ended output transformers in this range, push-pull outputs are under development, but do not expect to see any on this side of August 1995.

B.) Mid-price range, which are the output transformers already on offer, we have made a couple of additions to this range, since the last list.

C.) High Quality range, this will be a range of double C-core outputs for single-ended circuits exclusively, no push-pull outputs will be offered, unless demand requires it. Again 3 offerings initially.

D.) Super High Quality range, all-silver wired outputs of the best possibly quality, when I say best possible, I do not mean to say that these silver outputs will be as good as the silver output transformers handwound by Audio Note in Japan, they won't, but then again they do not carry the price tag either!

The quality criteria for group A are 20Hz to 20KHz -1 to -1.5dB, they are IE cored with silicon steel laminations and are supplied with frames and solder tabs, which will allow good audio quality at the cost. The main cost saving being the use of a smaller core, specified to the exact power level required, rather than overspecifying by 50 or 100%, as we do on Group B, the winding quality and copper wire is the same.

Group B are typically 20Hz to 20KHz minus 1.5dB, IE cored with high quality silicon steel laminations, wound with oxygen-free copper wire and supplied with either belt-ends or frames always with flying leads.

Group C are typically 12Hz to 70KHz minus 1.5dB, stripwound double C-cores made from the best available silicon steel lamination, these outputs will compare more than favourably with the best available types from days gone by and from other current sources like Partridge, Tango, Tamura etc.

Group D use **Audio Note** silver wire, need I say more??

### Specifications.

PP = Push-Pull, PPP = Parallel Push-Pull, SE = Single-ended, PSE = Single-ended Parallel, UL signifies 43% ultrafine taps, as a general rule we do not condone the use of UL-taps, as we consider these detrimental to sound quality. \* Dynaco replacement.

All primary impedances are calculated for Class A operation, with the main consideration given to maximum dynamic power transfer ability and minimum distortion, rather than meaningless steady state sine- or squarewave conditions.

All our single-ended output transformers are airgapped, and the maximum standing current allowed before saturation is shown in column 5.

All our output transformers are tested to insulation levels of minimum 3,000 volts, all 211/845 outputs are insulated to 5Kv flash, every transformer is tested to this level of insulation.

We generally overspecify our transformers by 50% power in Push-Pull (which means that a transformer stated as 25 watts will allow about 35-38 watt peaks, our single-ended outputs are

generally over specified by 100%, which means that they will instantaneously allow peaks of double the given maximum power through undistorted, this is necessary due to the better clipping behaviour of the single-ended stage.

We do not give any further technical information on our output transformers, as we do not wish to take part in technical competitions, our products are designed to criteria which are and will be understood once they are listened to!

In addition to the output transformers offered below, we offer a design service, where we can supply almost any requirement for wideband transformers, whether for microphones, moving coil cartridges, line input, phase splitter, interstages, driver or power output, we design and manufacture prototypes in-house, the cost for the paper design is £200.00, prototype cost is calculated on a per case basis. We can also produce production quantities.

Sizes are given as Width/Height/Depth, where depth is the depth of the coil itself and width is the length of the core.

## AUDIO NOTE AUDIO QUALITY OUTPUT TRANSFORMERS

Group A	Single-ended Outputs	Primary Voltage	Sec. Sec. Imp.	Sec. Resist.	Core Const.	Price Ex. UK
211A/845	15 watts	145 - 410 0 Ohms	1000 Ohms	1000 Ohms	1000 Ohms	44.50
211A/845	20 watts	145 - 410 0 Ohms	1000 Ohms	1000 Ohms	1000 Ohms	74.50
211A/845	25 watts	145 - 410 0 Ohms	1000 Ohms	1000 Ohms	1000 Ohms	104.50
211A/845	30 watts	145 - 410 0 Ohms	1000 Ohms	1000 Ohms	1000 Ohms	134.50
211A/845	35 watts	145 - 410 0 Ohms	1000 Ohms	1000 Ohms	1000 Ohms	164.50
211A/845	40 watts	145 - 410 0 Ohms	1000 Ohms	1000 Ohms	1000 Ohms	194.50
211A/845	45 watts	145 - 410 0 Ohms	1000 Ohms	1000 Ohms	1000 Ohms	224.50
211A/845	50 watts	145 - 410 0 Ohms	1000 Ohms	1000 Ohms	1000 Ohms	254.50
211A/845	55 watts	145 - 410 0 Ohms	1000 Ohms	1000 Ohms	1000 Ohms	284.50
211A/845	60 watts	145 - 410 0 Ohms	1000 Ohms	1000 Ohms	1000 Ohms	314.50
211A/845	65 watts	145 - 410 0 Ohms	1000 Ohms	1000 Ohms	1000 Ohms	344.50
211A/845	70 watts	145 - 410 0 Ohms	1000 Ohms	1000 Ohms	1000 Ohms	374.50
211A/845	75 watts	145 - 410 0 Ohms	1000 Ohms	1000 Ohms	1000 Ohms	404.50
211A/845	80 watts	145 - 410 0 Ohms	1000 Ohms	1000 Ohms	1000 Ohms	434.50
211A/845	85 watts	145 - 410 0 Ohms	1000 Ohms	1000 Ohms	1000 Ohms	464.50
211A/845	90 watts	145 - 410 0 Ohms	1000 Ohms	1000 Ohms	1000 Ohms	494.50
211A/845	95 watts	145 - 410 0 Ohms	1000 Ohms	1000 Ohms	1000 Ohms	524.50
211A/845	100 watts	145 - 410 0 Ohms	1000 Ohms	1000 Ohms	1000 Ohms	554.50
211A/845	105 watts	145 - 410 0 Ohms	1000 Ohms	1000 Ohms	1000 Ohms	584.50
211A/845	110 watts	145 - 410 0 Ohms	1000 Ohms	1000 Ohms	1000 Ohms	614.50
211A/845	115 watts	145 - 410 0 Ohms	1000 Ohms	1000 Ohms	1000 Ohms	644.50
211A/845	120 watts	145 - 410 0 Ohms	1000 Ohms	1000 Ohms	1000 Ohms	674.50
211A/845	125 watts	145 - 410 0 Ohms	1000 Ohms	1000 Ohms	1000 Ohms	704.50
211A/845	130 watts	145 - 410 0 Ohms	1000 Ohms	1000 Ohms	1000 Ohms	734.50
211A/845	135 watts	145 - 410 0 Ohms	1000 Ohms	1000 Ohms	1000 Ohms	764.50
211A/845	140 watts	145 - 410 0 Ohms	1000 Ohms	1000 Ohms	1000 Ohms	794.50
211A/845	145 watts	145 - 410 0 Ohms	1000 Ohms	1000 Ohms	1000 Ohms	824.50
211A/845	150 watts	145 - 410 0 Ohms	1000 Ohms	1000 Ohms	1000 Ohms	854.50
211A/845	155 watts	145 - 410 0 Ohms	1000 Ohms	1000 Ohms	1000 Ohms	884.50
211A/845	160 watts	145 - 410 0 Ohms	1000 Ohms	1000 Ohms	1000 Ohms	914.50
211A/845	165 watts	145 - 410 0 Ohms	1000 Ohms	1000 Ohms	1000 Ohms	944.50
211A/845	170 watts	145 - 410 0 Ohms	1000 Ohms	1000 Ohms	1000 Ohms	974.50
211A/845	175 watts	145 - 410 0 Ohms	1000 Ohms	1000 Ohms	1000 Ohms	1004.50
211A/845	180 watts	145 - 410 0 Ohms	1000 Ohms	1000 Ohms	1000 Ohms	1034.50
211A/845	185 watts	145 - 410 0 Ohms	1000 Ohms	1000 Ohms	1000 Ohms	1064.50
211A/845	190 watts	145 - 410 0 Ohms	1000 Ohms	1000 Ohms	1000 Ohms	1094.50
211A/845	195 watts	145 - 410 0 Ohms	1000 Ohms	1000 Ohms	1000 Ohms	1124.50
211A/845	200 watts	145 - 410 0 Ohms	1000 Ohms	1000 Ohms	1000 Ohms	1154.50
211A/845	205 watts	145 - 410 0 Ohms	1000 Ohms	1000 Ohms	1000 Ohms	1184.50
211A/845	210 watts	145 - 410 0 Ohms	1000 Ohms	1000 Ohms	1000 Ohms	1214.50
211A/845	215 watts	145 - 410 0 Ohms	1000 Ohms	1000 Ohms	1000 Ohms	1244.50
211A/845	220 watts	145 - 410 0 Ohms	1000 Ohms	1000 Ohms	1000 Ohms	1274.50
211A/845	225 watts	145 - 410 0 Ohms	1000 Ohms	1000 Ohms	1000 Ohms	1304.50
211A/845	230 watts	145 - 410 0 Ohms	1000 Ohms	1000 Ohms	1000 Ohms	1334.50
211A/845	235 watts	145 - 410 0 Ohms	1000 Ohms	1000 Ohms	1000 Ohms	1364.50
211A/845	240 watts	145 - 410 0 Ohms	1000 Ohms	1000 Ohms	1000 Ohms	1394.50
211A/845	245 watts	145 - 410 0 Ohms	1000 Ohms	1000 Ohms	1000 Ohms	1424.50
211A/845	250 watts	145 - 410 0 Ohms	1000 Ohms	1000 Ohms	1000 Ohms	1454.50
211A/845	255 watts	145 - 410 0 Ohms	1000 Ohms	1000 Ohms	1000 Ohms	1484.50
211A/845	260 watts	145 - 410 0 Ohms	1000 Ohms	1000 Ohms	1000 Ohms	1514.50
211A/845	265 watts	145 - 410 0 Ohms	1000 Ohms	1000 Ohms	1000 Ohms	1544.50
211A/845	270 watts	145 - 410 0 Ohms	1000 Ohms	1000 Ohms	1000 Ohms	1574.50
211A/845	275 watts	145 - 410 0 Ohms	1000 Ohms	1000 Ohms	1000 Ohms	1604.50
211A/845	280 watts	145 - 410 0 Ohms	1000 Ohms	1000 Ohms	1000 Ohms	1634.50
211A/845	285 watts	145 - 410 0 Ohms	1000 Ohms	1000 Ohms	1000 Ohms	1664.50
211A/845	290 watts	145 - 410 0 Ohms	1000 Ohms	1000 Ohms	1000 Ohms	1694.50
211A/845	295 watts	145 - 410 0 Ohms	1000 Ohms	1000 Ohms	1000 Ohms	1724.50
211A/845	300 watts	145 - 410 0 Ohms	1000 Ohms	1000 Ohms	1000 Ohms	1754.50
211A/845	305 watts	145 - 410 0 Ohms	1000 Ohms	1000 Ohms	1000 Ohms	1784.50
211A/845	310 watts	145 - 410 0 Ohms	1000 Ohms	1000 Ohms	1000 Ohms	1814.50
211A/845	315 watts	145 - 410 0 Ohms	1000 Ohms	1000 Ohms	1000 Ohms	1844.50
211A/845	320 watts	145 - 410 0 Ohms	1000 Ohms	1000 Ohms	1000 Ohms	1874.50
211A/845	325 watts	145 - 410 0 Ohms	1000 Ohms	1000 Ohms	1000 Ohms	1904.50
211A/845	330 watts	145 - 410 0 Ohms	1000 Ohms	1000 Ohms	1000 Ohms	1934.50
211A/845	335 watts	145 - 410 0 Ohms	1000 Ohms	1000 Ohms	1000 Ohms	1964.50
211A/845	340 watts	145 - 410 0 Ohms	1000 Ohms	1000 Ohms	1000 Ohms	1994.50
211A/845	345 watts	145 - 410 0 Ohms	1000 Ohms	1000 Ohms	1000 Ohms	2024.50
211A/845	350 watts	145 - 410 0 Ohms	1000 Ohms	1000 Ohms	1000 Ohms	2054.50
211A/845	355 watts	145 - 410 0 Ohms	1000 Ohms	1000 Ohms	1000 Ohms	2084.50
211A/845	360 watts	145 - 410 0 Ohms	1000 Ohms	1000 Ohms	1000 Ohms	2114.50
211A/845	365 watts	145 - 410 0 Ohms	1000 Ohms	1000 Ohms	1000 Ohms	2144.50
211A/845	370 watts	145 - 410 0 Ohms	1000 Ohms	1000 Ohms	1000 Ohms	2174.50
211A/845	375 watts	145 - 410 0 Ohms	1000 Ohms	1000 Ohms	1000 Ohms	2204.50
211A/845	380 watts	145 - 410 0 Ohms	1000 Ohms	1000 Ohms	1000 Ohms	2234.50
211A/845	385 watts	145 - 410 0 Ohms	1000 Ohms	1000 Ohms	1000 Ohms	2264.50
211A/845	390 watts	145 - 410 0 Ohms	1000 Ohms	1000 Ohms	1000 Ohms	2294.50
211A/845	395 watts	145 - 410 0 Ohms	1000 Ohms	1000 Ohms	1000 Ohms	2324.50
211A/845	400 watts	145 - 410 0 Ohms	1000 Ohms	1000 Ohms	1000 Ohms	2354.50
211A/845	405 watts	145 - 410 0				



# HEAD FOR QUALITY

**A lot of you loved Richard Brice's Class A headphone amplifier. Here are some interesting follow-on suggestions, given consideration by designer Andy Grove.**

## HEADPHONE AMPLIFIER COMPATIBILITY

I was fascinated to discover Richard Brice's design for a Class A single-ended headphone amplifier in your DIY Supplement.

About 18 months ago I came up with a very similar design for my own set of Jecklin Float Model 2s (the 'phones photographed in the article). In my case I used just two transistors per channel, and a common emitter gain stage and emitter follower (TIP121) driver, and no op-amps. Power was supplied via 78 series regulators and the thing sounded pretty good as far as I could tell. A bit light in the bass department perhaps, probably due to 100uF output caps rather than 220uF as specified by Mr Brice.

One thing that intrigued me was the lack of mention of compatibility with different types of 'phones. I believe the Floats have a relatively high impedance

(approx. 200Ω) making them an easy load for the single transistor. I wonder how the circuit would cope with low impedance 'phones, say 8-16 ohms. Any comments?

Out of interest, I have recently been playing with an op-amp that seems well suited to exacting audio applications, the OP27. This is a reasonably low noise, high slew rate device that performs well in voltage gain stages in power amps as well as the active part of RIAA preamps. In fact, it may well get incorporated into a Mk2 version of my headphone amplifier.

**Peter Withers  
Pershore,  
Worcestershire.**

*Unfortunately the headphone amplifier as it stands will not satisfactorily drive low impedance headphones, due to the fact that the quiescent bias current in the output*

*transistor and supply voltage are optimised for high impedance types.*

*For 100mW into 200Ω, 4.5Vrms (6.3Vpeak) and 22.5mA rms (32mA peak) is needed. The supply voltage is 15V and the quiescent current is around 50 mA, so no problems.*

*For 100mW into 8Ω 0.9Vrms (1.26Vpeak) and 113mA rms (160mA peak) is needed, with the standard circuit the quiescent current is just too low and asymmetrical clipping will result even at reduced levels.*

*To optimise for low impedance headphones, reduce the supply voltages to +/-5V and change the 150Ω emitter resistor to 8.2Ω, this will increase the quiescent current while keeping the transistor's dissipation sensible. The 220μF output coupling capacitor will have to be increased to 4700μF as well. Also, the biasing resistors may have to be modified slightly to get maximum power from the available supply voltage. Alternatively, use the Direct Coupled circuit with +/-5V rails and a 15Ω emitter resistor for even better results, the transistor will now need a small heatsink (10 deg. C/Watt) though. Either circuit should then perform satisfactorily with headphones of 8Ω to 16Ω.*

*The OP27 is widely used in professional audio equipment such as mixing desks, mic preamps and so on. There are, however, some real hot-rodded op-amps, designed specifically for audio, such as the AD743 and AD797 from Analogue Devices. Burr Brown and Linear Technology also make audio types so check with them as well, but be prepared to pay premium rates for these specialist chips. Whether the 2N3055 will be as sought after as a Western Electric 300B we'll just have to wait and see! AG*

## AN AMP FOR YOUR EARS

After building the headphone amplifier I can honestly say it has elevated the sound quality of my headphone listening to a level I would not believe possible from such a modest pair of 'phones. I would actively encourage anyone else who uses headphones to build this

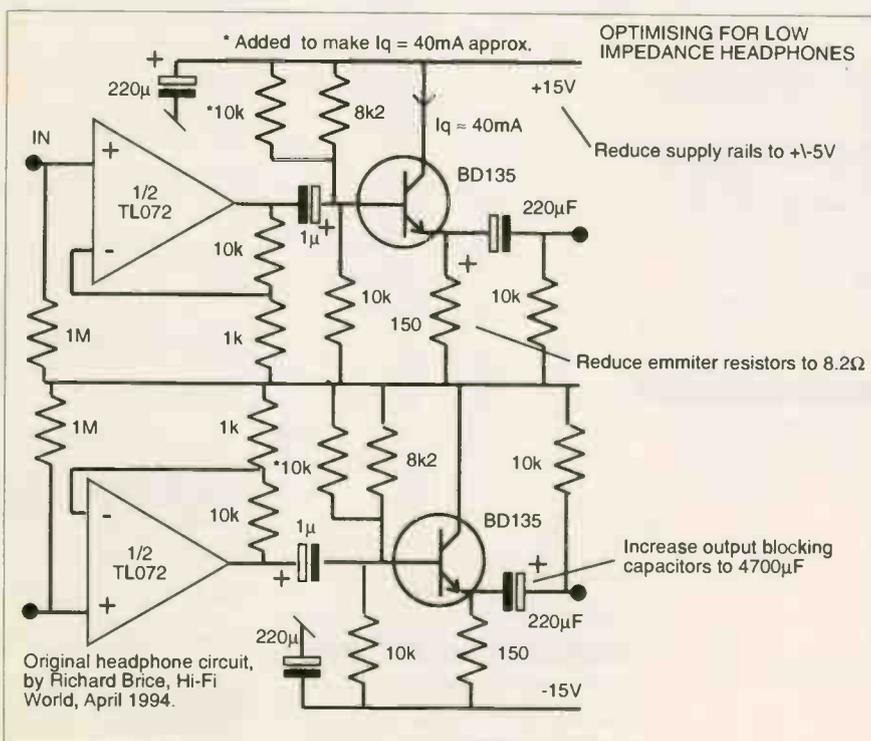

design, sit back and enjoy!

Having built this design and listened to it for a considerable time I would like to pass on some hints and modifications that your readers may be interested in.

Firstly, the choice of components. All resistors in the amplifier I have built are 1% metal film types, these are good quality but inexpensive and so do not add to the cost. The decoupling and output coupling capacitors are all low-ESR electrolytics, as intended for use in switch mode power supplies, and again are easily available at modest cost. The coupling/d.c. blocking capacitor between

completely star earthed, star supply layout, with every component having its own p.c.b. track back to a central earth or supply point. I am powering mine from a 2.5A +/-15V power supply that I had lying around (very convenient) and I have taken the sense wires from the power supply to the star points on the p.c.b so that any voltage drops in the power cables are compensated for. For readers who do not have such a power supply conveniently lying around I would suggest building a basic d.c. power supply and placing an integrated

regulator close to the amplifier. LM317/337T adjustable I.C. regulators would be ideal for this purpose, possessing good regulation and a low output impedance at audio frequencies.

Finally, to add fuel to the low/high feedback amplifier argument I intend to build another amplifier, using the same basic components, but

including the output transistor in the feedback loop of the op-amp. For interested readers this means eliminating the 1µF capacitor and the two/three base bias resistors in the original design and taking the 10k feedback resistor to the emitter of the transistor (instead of the output of the op-amp). This now means that the base bias for the transistor has to be supplied by the op amp, so a small d.c. level will have to be applied to the input of the op-amp (it will be amplified by the op-amp) from a potential divider, via a

stand-off resistor. Since there is now d.c. present on the input of the op-amp, a d.c. blocking capacitor will have to be added. Comparing the sound quality of the two will prove very interesting! See enclosed diagram for details.

The only other area for experimentation is in the choice of op-amp, but to experiment in any detail a dual mono p.c.b layout will be required as there are no other high quality, audio grade op-amps available in a dual package.

**Andrew Weeks**  
Sevenoaks,  
Kent.

### ANDY GROVE SAYS:

*Your modified circuit is interesting, although I think you made an error in your calculations for the biasing network at the op-amp input. The op-amp has loop feedback which sets its gain at 11. The required voltage at the transistor's emitter is 7.5V, the base-emitter voltage drop is inside the feedback loop and will be corrected for by the feedback. Therefore we need  $7.5/11=0.68V$  at the op-amp input. I have added some values to your circuit to supply this.*

*I have also taken another step and sketched a fully DC coupled amp which eliminates the input and output coupling capacitors, replacing them with one in the feedback path which provides 100% feedback at DC, keeping the output at 0V. This circuit however requires full +/- split supplies for both the op-amp and the output transistor. The latter may require a heatsink unless the supply voltage is reduced from the original +/-15V. It may be worth trying a high grade stereo op-amp, the LM833. Why not split the*

*two channels and use two separate supplies and high quality op-amps? You can even cascade the voltage regulators, i.e. regulate to +/-15V then regulate again to +/-12V this allows the regulator supplying the audio circuit to work from a fairly clean supply to start with, reducing ripple and noise. Keep experimenting! AG.*

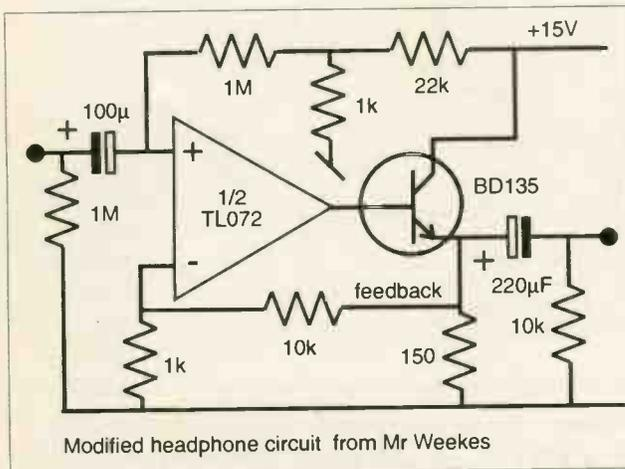

the output of the op-amp and the base of the transistor has been through several iterations in my amplifier. I started with a 1µF tantalum capacitor in this position and, after some listening, changed it to a 1µF metallised polyester film. The tantalum capacitor had a more relaxed sound whilst the film type had a sharper, but maybe harsher quality.

After some more listening I felt that the low frequency response was rolling off too early, and since the 1µF capacitor, in conjunction with the impedance presented by the base of the transistor, is the primary reason for this early roll-off I changed the 1µF capacitor for a 10µF tantalum. This resulted in an even more extended bass response and the effect was very noticeable! I have now settled for a 100µF tantalum in this position and the bass extension is now superb. Your readers would be advised to experiment with this value to find a response that suits their own headphones.

My headphone amplifier was built on a p.c.b. of my own design using a

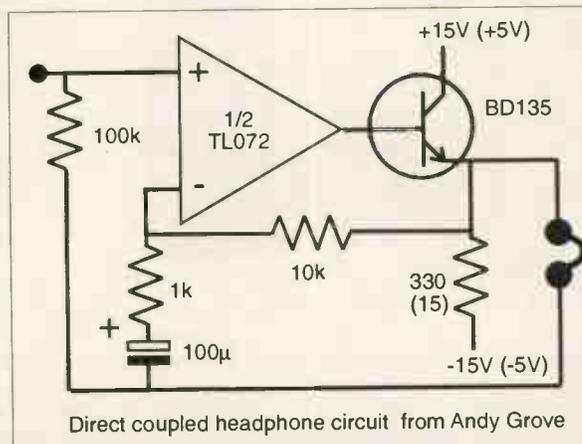



## Vacuum Tubes for Audio Are Back!

*Glass Audio* brings together yesterday's tube with today's improved components, voltage control, and the exciting new Soviet tubes, to make smooth sound in your livingroom possible again!

# YES!

Please send my first issue of *Glass Audio*. I'll pay just \$45.00 for six issues (1 year); \$80.00 for 12 issues (2 years) of the best information on tubes to be found anywhere. I understand that my satisfaction is guaranteed!

Name \_\_\_\_\_

Street & Number \_\_\_\_\_

City \_\_\_\_\_ Postal Code \_\_\_\_\_

Country \_\_\_\_\_

REMIT IN US \$ DRAWN ON A US BANK ONLY PRICE GOOD THROUGH DECEMBER 31, 1995.

We Accept MC/VISA.

## Glass Audio

PO Box 176, Dept. HFWS, Peterborough, NH 03458-0176 USA  
Phone: (603) 924-9464 or FAX 24 hours a day (603) 924-9467

# SPEAKER KITS FROM IPL ACOUSTICS

Over a 8 year period I.P.L. ACOUSTICS have developed a range of high quality speaker kits, using the best units from SEAS, MOREL, AUDAX, and I.P.L. and have produced a comprehensive range of speakers which will compete with the most expensive of commercial designs.

All speakers have biwired crossover kits containing high quality components and terminals.

**S5TL  
TRANSMISSION LINE**



PLUS KIT .....£331.00  
TOTAL KIT .....£446.00

**FIVE  
TRANSMISSION  
LINE KITS**

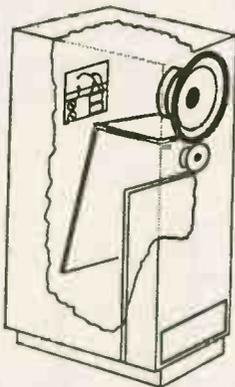

TRANSMISSION LINE  
PLUS KITS .....£166.00 -  
.....£331

**M3TL  
TRANSMISSION LINE**



PLUS KITS .....£166.00  
TOTAL KIT .....£225.00

**A2 H.D.A.  
AEROGEL KIT**



PLUS KIT .....£185.00  
TOTAL KIT .....£250.00

**S3TLM METAL  
TRANSMISSION LINE**



PLUS KIT .....£216.50  
TOTAL KIT.....£289.50

PRE-VENEERED CABINET KITS NOW AVAILABLE. Carriage charge extra on all kits.

If you would like further details please send large SAE with 36p stamp for PAGE SPEAKER BUILDING CATALOGUE, comprising VALUABLE ADVICE on DESIGNING, BUILDING, and TESTING speakers and full technical specifications including response curves of eight kits, drive units, and details of SPECIALIST CABLES and ACCESSORIES. KITS FOR A.V. USE NOW AVAILABLE.

**I.P.L. Acoustics, 2 Laverton Road, Westbury, Wiltshire, BA13 3RS. Tel: 01373 823333**

# A TOP FINISH FOR YOUR DIY SPEAKERS



◀ . . . or how to make your kit loudspeaker cabinets look as good as these, by Dominic Baker.

**B**uilding your own loudspeakers is great fun; it gives tremendous pride of ownership. We've noticed that constructors like to pay attention to choosing and applying a good finish, but this isn't so easy, so here's some guidance with help from industry experts.

Nowadays, the most common material for loudspeaker cabinet manufacturing is MDF (medium density fibreboard). This is a very workable material, being easy to saw and sand, and not prone to warping. It has good acoustic properties too, making it near-ideal. This article concentrates on MDF and how to finish cabinets made from it.

## INITIAL TREATMENT OF MDF

So you've built up your cabinets and they're reasonably square and neat. Make sure there are no overlapping edges or depressions where screws or panel pins have been used, filler can be used to rectify this. MDF is a very workable material, so I'd suggest a rough grade sandpaper, say 80 grade, and a wood block to ensure that you are sanding the surface flat.

Once the cabinets are in a reasonable state, with smooth edges and

surfaces, sand with 150 grade paper and then more carefully with 280 grade paper to get rid of surface defects. A quick wipe down with a lightly dampened cloth will then help remove any fine surface dust which would otherwise show up in the applied finish.

## PRIMER/SEALER

Once the cabinets have been prepared, a primer coat can be applied. It is always better to apply two or more light coats, sanding them smooth in-between, than one thick gloopy coat full of lumps and dribbles.

Primer serves two purposes, it seals the wood, especially the end grain which would otherwise soak up the top coat, giving an uneven finish. It also provides a good base for the top coat to ensure that you get a smooth, even finish.

Once the primer coat has dried, sand it very gently with 400 grade paper to remove the surface dust and grit that will have dried on. This will gently key the surface and prepare it for the finish coat.

## TOP COAT

The finish coat can either be painted on with a brush, rolled on with a roller, or sprayed on.

A paint brush will leave lines but is quick and easy, and if carefully done can look superb. A roller gets around the 'hand painted' look and can give the top coat an interesting pattern that will look quite professional. You can check what kind of pattern you will get from different rollers on a spare piece of MDF.

Spraying potentially gives the finest finish. I say potentially, because in the wrong hands it can be a disaster. You need a clean environment, plenty of space and mountains of patience. Spray in fine coats, don't try and completely cover a surface in one go. I find that spraying on to vertical panels works best. Don't spray downwards onto a surface; drips of paint from the nozzle have an annoying tendency to drip onto the wet paint just as you finish.

## GLOSS OR PIANO FINISHES

These follow essentially the same procedure as above, but remember, at each stage any imperfection will show up that much more. So, if the bare MDF is uneven, or you leave a bit of grit in the primer coat, it's going to be seen. It takes a great deal of work to get gloss finishes perfect and it is well worth at



**Get on our list -  
to get closer to this list.**

- MIT MultiCap • Wonder Cap • Kimber Kap • Solo • Hovland MusiCap • Solen • Siemens
- Wima • Holco • Rel-Cap • Draloric • IRC • Allen-Bradley • Jensen • Resista • Vishay • Mills
- Caddock • Matsushita • TKD • Noble • Cardas • Kimber Kable • van den Hul • Discovery
- Audioquest • MIT • Alps • Bourns • Shalco • Elma • Electros witch • Nichicon • Gold Aero
- RAM • Mallory • Panasonic HFQ • Nichicon • Elna • N.O.S. • Ruby Tubes • UltraAnalog
- Burr-Brown • Crystal • Linear Technology • Analog Devices • Edison Price • Motorola • UCC
- International Rectifier • Hitachi • MagneQuest • Sonic Frontiers • Pearl • Tube Sockets
- WBT • Neutrik • Sound Coat • Curcio Audio Engineering • Assemblage and other kits

And it's growing and growing. To order The Parts Connection 1995 Catalog & Resource Guide, send £7 and mailing information. You'll also receive a Discount Coupon worth \$10 off a purchase over \$100 or \$25 off a purchase over \$250\* as well as *The Breadboard* bulletin to keep you updated on our latest news, information and growth spurts.

\*or \$10 US, or credit card information  
\*catalogue discounts are in US Dollars

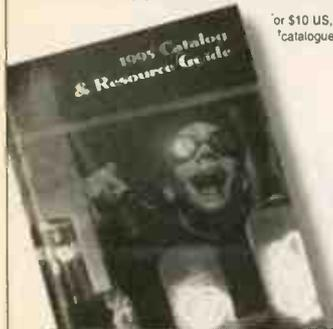

**THE PARTS CONNECTION**

A DIVISION OF SONIC FRONTIERS INC

2790 Brighton Road, Oakville  
Ontario, Canada L6H 5T4

Toll Free Order Line 1-800-769-0747  
(U.S. & Canada only)

Tel (905) 829-5858 Fax (905) 829-5388

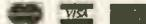

**KEF CONSTRUCTOR  
SERIES**

**Wilmslow  
▼ Audio ▲**

KEF Uni-Q Technology, the unique KEF driver design that delivers a sharply focused sound stage throughout a room, is now available to the home constructor.

KEF's Constructor Series of loudspeaker drive units and dividing networks, may be used in systems of your own design, or by following the KEF kit plans below:

**KEF Kit 60** - A two-way bookshelf/stand-mounted loudspeaker using a single 8" Uni-Q drive unit in a compact 18 litre reflex loaded enclosure. The DN60 dividing network allows bi-wiring/bi-amping.

**KEF Kit 80** - An 8" Auxiliary Bass Radiator augments the output of the main 8" Uni-Q driver used with a DN80 bi-wireable dividing network. This is a floorstanding loudspeaker with exceptional bass response.

**KEF Kit 90** - An 8" dedicated bass unit, 8" Uni-Q and DN90 bi-wireable dividing network give this three way floorstander extended bass output down to 35 Hz (-6dB).

KEF have designed a range of drive units and dividing networks which, with simple D.I.Y skills, can be transformed into State-of-the-Art loudspeakers capable of giving years of truly high-fidelity performance.

Kit	60	70	80
Boxed	£215	280	370
Total	£290	370	460

Free DIY speaker catalogue  
export £3.50



**KEF Kit 60**  
2-way bookshelf/  
stand-mounted



**KEF Kit 80**  
2-way floorstanding



**KEF Kit 90**  
3-way floorstanding

**Dept. HFW**  
**Wellington Close, Parkgate Industrial Estate,**  
**Knutsford, Cheshire WA16 8XL**  
**Tel: 01565 650605**  
**Fax: 01565 650080**

Open Tuesdays to Saturdays  
4 demonstration rooms

**ACCESS VISA  
AMEX**

Phone/Fax

+44(0)1706 823025

interstage  
output  
chokes  
mains

**SJS Electroacoustics**

for retail  
catalogue  
send SAE  
38p/2IRCs

*Hand Wound  
Transformers*

International suppliers OEM,  
trade and retail clients.  
Design and consultancy service.

**SJS Electroacoustics**  
**Ben-Dor, Lumb Carr Rd, Holcombe,**  
**Bury, Lancs. BL8 4NN**

**Renhold**

cures  
his  
jitters!

...thanks to  
the Audio  
Technology  
'Sorcerer  
DAC'

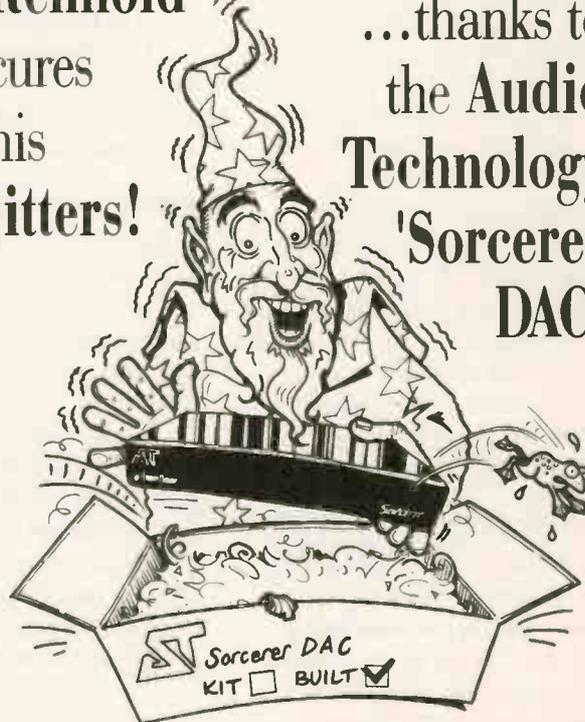

20 Bit Colinear DAC • 24 Bit Floating Point Digital Filtering  
Full Kits • Sync-Lock for Zero Jitter • Precision Case  
Modular • Silver Wired/Soldered • Audiophile Components

For details of this and other kit/built products, send A4 SAE to:  
**AUDIO TECHNOLOGY LTD, PO Box 147, BEDFORD, MK41 8PR**

least one practice run on a spare piece of MDF first.

From the primer stage onwards, it is important to have the cleanest possible atmosphere for a good finish. If you have a garage, it is worth building a simple plastic tent, so wind can't blow grit, leaves, grass cuttings and what have you, onto the cabinets. The high gloss finish is achieved by applying a good quality clear lacquer, which is then hand finished with a burnishing cream. This kind of finish takes a lot of work, but when carefully done is among the most professional.

## PRE-VENEERED BOARD

One of the easiest ways to get a real wood veneer on your cabinets is to use pre-veneered MDF. This is MDF with a machine applied veneer, so it is just about perfectly flat and needs very little further sanding or finishing before a varnish or polish can be applied. Pre-veneered MDF is more expensive though. An 8x4ft sheet of plain 25mm MDF costs around £40, whereas pre-veneered board ranges from £85 for Ash and Oak for example, to around

£95 for more exotic woods such as Cherry and Maple.

The drawback is that the edges are bare MDF. Fortunately, there is a simple and very effective solution used by many top loudspeaker manufacturers, including KEF on their Reference Series. Radius all of the edges where there is bare MDF, as shown in the diagram below. This can be done with a plane to remove the bulk of the material, and then sanded smooth, 150 grade followed by 280 grade, followed by 400 grade.

The bare edges then need to be stained to match the veneer in colour. This finish will be more successful with dark wood finishes or Black Ash finishes, because it is a lot easier to achieve a good colour match. These bare edges will be very porous, so you will need to keep applying the stain until it dries to leave an even top colour.

From here onwards finishing is relatively easy. Seal the cabinets with a coat of sanding sealer and then finely sand smooth using 400 grade paper. Several coats of light varnish or polish should give you a super finish ●

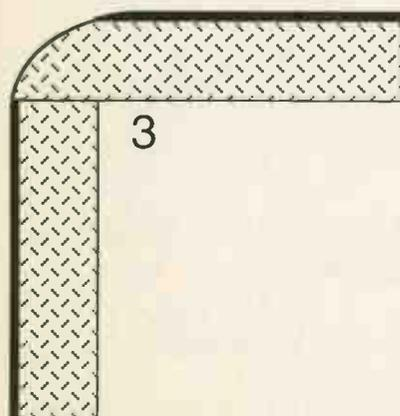
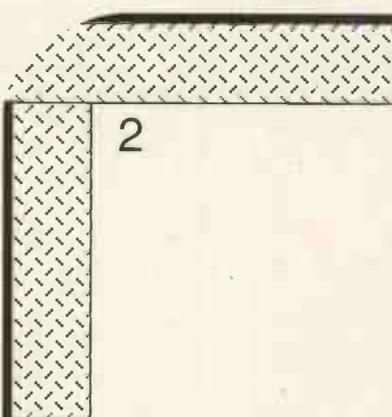
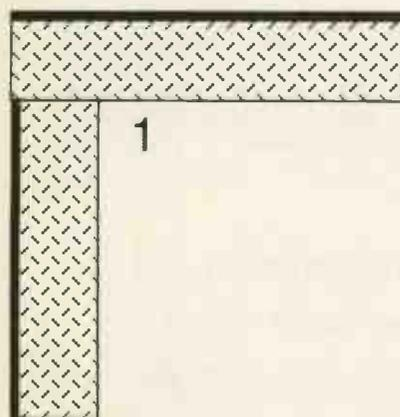

Three easy steps to finishing the ends of pre-veneered MDF. Radius the corners and then stain them to match the veneer. With darker finishes a very good colour match is possible, and once the whole cabinets have been varnished the effect is very professional.

## Recommended paints etc. by Foxell & James

### Pre-cat Lacquer Paints

981 Clear Basecoat £4.61/ltr  
(won't affect tone of top coat colour)  
Coloured top coats £5.38/ltr (black)

### Aerosol Spray Paints

Plasticote colours £5.30/500ml  
Plasticote Clear Acrylic £5.30/500ml

### Sanding Sealer

Mylands 2000 Shellac Basecoat £5.99/ltr

### Varnish

Mylands No.8  
Matt £8.06/ltr  
Semi £7.17/ltr  
Gloss £6.46/ltr

### Wax Polish

Mylands (various types) £3.27/450ml

### Lacquers

Use clear Pre-cat Lacquer or Mylands Gloss varnish

### Burnishing Cream

Mylands Glossoid £2.35/500ml

### Wood Filler

Mylands Nitrofilla £14/4kg

Prices are not inclusive of VAT.

Foxell & James stock the paints etc. mentioned above recommended by Moss and Co. timber merchants. This is just a small selection of what they can offer. Give them a call and they will be able to supply exactly what you need for a professional finish.

Our thanks also go to the following for their help with this article:

Harry Bolton of Castle Acoustics

Moss & Co. (Timber Merchants)  
Dimes Place,  
104 King Street, Hamersmith,  
London W6.  
☎ 0181 748 8251

Foxell & James (Finishing specialists)  
57 Farringdon Rd,  
London EC1M 3JBP.  
☎ 0171 405 0152

# DIGITAL STORAGE OSCILLOSCOPE

**\$230.**

The O-SCOPE is a pocket-size module that plugs into a PC's printer port and turns it into a DSO, Spectrum Analyzer, Freq. Counter, DVM and Data Logger. Accepts standard probes.

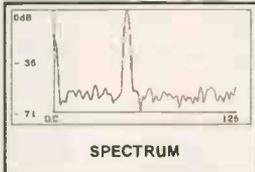
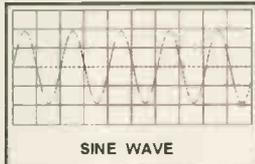

Operating parameters easily adjustable and continuously displayed. Bandwidths to 22 KHz for the O-Scope I and to 250 KHz for the O-Scope II which also features phase measurement and external trigger capabilities. DOS print screen or log to disk.

O-Scope I, Single Trace \$230.  
O-Scope II, Dual Trace 390.  
Probe, x1, x10 30.  
Sound Level Meter 55.

Prices include software, cables, power supply, instructions and U.S. Airmail shipping cost.

**ALLISON TECHNOLOGY CORP.**  
8343 Carvel Tel: 713-777-0401  
Houston, TX. Fax: 713-777-4746  
77036 U.S.A. BBS: 713-777-4753

Pay by VISA, MasterCard, American Express or Bank Wire Transfer.  
Satisfaction Guaranteed.

## TECHNICAL & GENERAL

Some Necessities - From the Original Classic Turntable Specialists

Connoisseur		P&P
	BD1/2 Drive Belt	9.85 1.85
	BD1/2 Motor Suspension kit	13.75 2.25
	SAU.2 Headshell	16.75 2.55
	SAU.2 Connecting lead	15.95 3.55
Garrard	Standard Models	
	Wired arm tubes	from 12.75 2.55
	Cartridge carriers (sliders)	9.25 1.85
	Idler Wheels	9.85 2.25
	301/401 Transcription Models	
	Original Thrust pad assembly	9.80 2.25
	Original Idler tension spring	2.95 1.85
	Original Speed control disc - 401	13.75 2.20
	Xeroxcopy Owners Manual 301 incl. full size mounting template	7.35 1.85
	Xeroxcopy Owners Manual 401 incl. full size mounting template	5.20 1.85
	Replacement Intermediate drive wheel	19.95 2.85
	Replacement 301 control knobs On-Off/Speed select	pair 20.25 2.55
	Replacement 301 suppressor unit	5.65 2.25
	Replacement 301 motor pulley (-2%), (-1%), (Std), (+1%)	each 12.65 2.25
	Replacement 301 Chrome plated mounting bolts	set 3.70 1.85
	Recommended Lubrication set - early 301 or 301/401 (specify)	5.20 1.85
Goldring/Lenco		
	Idler wheel (lock-nut or clip fixing)	19.95 2.85
	Arm Pivot bearings with instructions	7.85 1.85
	Spindle/Main bearing assembly complete	22.85 3.85
	Headshells	from 21.95 2.55
	Instruction books	from 4.20 1.85
Thorens		
	TD.124 series	
	Idler wheel	19.95 2.85
	Drive belt	9.85 1.85
	Chassis spring suspension (replaces mushrooms')	13.85 2.55
	150/160 series	
	Drive belt	9.85 1.85
	Suspension springs (-1%), (Std), (+1%)	set 10.85 2.55
	Suspension bushes	set 12.50 2.25
	Armboards for most models	from 16.90 2.55

Cecil Watts Dustbuds/Parastats/ (spares incl. Preener wicks)  
Cartridges and styli for 78s & Mono LPs in addition to current Stereo LP

TECHNICAL & GENERAL PO Box 53. Crowborough,  
E.Sussex. TN6 2BY Tel:- 01892 654534

# AUDIO ENGINEERING

**6 KILO SINGLE- ENDED OUTPUT TRANSFORMERS  
ALL BUILT ON A 2 1/2 " STACK OF IMPERIAL E & I 120  
LAMINATIONS**

**TOP SHROUDED, DROP THROUGH, INCORPORATING  
ANTI- MAGNETIC INSULATORS COMPLETE WITH FIXING  
BOLTS AND AMPLIFIER CIRCUITS WHERE POSSIBLE.**

2200 / 8Ω @ 16.58 TO 1 TURNS RATIO  
2300 / 8Ω @ 17 TO 1  
2500 / 8Ω @ 17.6 TO 1 KT88  
2700 / 8Ω @ 18.5 TO 1  
3000 / 8Ω @ 19.36 TO 1  
3200 / 8Ω @ 20 TO 1  
3500 / 8Ω @ 21 TO 1  
4000 / 8Ω @ 22 TO 1  
5000 / 8Ω @ 25 TO 1 PX25  
2200 / 15Ω @ 12 TO 1  
2300 / 15Ω @ 12.4 TO 1  
2500 / 15Ω @ 13 TO 1  
2700 / 15Ω @ 13.4 TO 1  
300 / 15Ω 14 TO 1  
3200 / 15Ω @ 14.5 TO 1  
3500 / 15Ω @ 15 TO 1  
4000 / 15Ω @ 16 TO 1  
5000 / 15Ω @ 18 TO 1

PRICE £170 PER PAIR

TYPE IS OXT. PRICE £180 PER PAIR  
MAINS HT TXS. 2V-0-2 @ 2 AMPS & 50V + 50V @ 10 MA £25 EACH  
3.15-2V5-OV-2V5-3.15 @ 4 AMPS  
6V3 @ AMP, 6V3 @ 1 AMP, 25V DRIVER BIAS  
100V OUTPUT STAGE BIAS, 25V DELAYED HT WINDING  
AND HT TAPPED TO PROVIDE 0-400-450-500-550-600-650 VDC  
AT 150 MA, APPROX 8 KILO. PRICE £120 EACH.

We now manufacture chassis to order in any quantity and in any size, in 1.5mm steel or BRASS, all our CHASSIS have welded and ground corners, and a 12mm underside flange. They are very good quality and one of the best value. Prices start at around £30. We can also make TOP COVERS and base plates, and can work from a rough sketch if need be, and can advise on drilling and finishing, without our customers having to take out a second mortgage. Please send in a sketch for a quote.

## ANCILLARY COMPONENTS (WHILE STOCKS LAST)

VT105 (ML6) BOXED, NEW, MILITARY DRIVER VALVES  
B5,PIN £20 EACH.  
ONLY 20 LEFT (DIRECTLY HEATED 6V3 TRIODES,  
PORCELAIN BASED)

19 X 25 SILVER PLATED COPPER PTFE,  
MIL SPEC, £1.50 PER MTR

2200 UF @ 450V BY ITT, BLACK 51/2" X 3"  
DIAM £40 EACH (20 OFF)

330UF @ 450V BY BHC BLACK £7 EACH  
150 + 200 + 200uf @ 300v PLESSY £5 EACH  
800 uf @ 250v ITT £5 EACH  
SOLID PLATED COLOURED WIRE PACK 11 COLOURS 15 METERS, IDEAL FOR AMPLIFIER £5 PER PACK  
B9A NYLON VALVE HOLDER BY VACTITE £0.80 EACH

ALL ITEMS INC. P.P. + INS. PLEASE SEND S.A.E.  
FOR FURTHER DETAILS, TO P J PERRY  
AUDIO ENGINEERING  
57 LYNDHURST DRIVE, LEYTON LONDON E10 6JB.

# 70 Years of Radio Tubes and Valves

by John W. Stokes.

Reviewed by Andy Grovè.

Here is a historical survey of valve evolution. Author John W. Stokes starts at the very beginning with Edison's original discovery of the unidirectional current flow from a heated filament and how this discovery led Fleming to the first commercial detector diodes. De Forest's addition of a grid to the diode to form the "Audion" (triode) and the first commercial Audions are covered next. These, first two chapters are a brief history of the discovery of the valve as we know it. There are quotes from the inventors and pictures of the original prototypes and early commercial versions, which were basically modified light bulbs! The reader is led forward in time to WWI and the valves and respective numbering systems used by the armed forces at that time.

The valves start to become a little more recognisable with the introduction of the British R valve

(French derived) and similar types. American valve development after WWI is next with the politics behind the formation of RCA as well as the other giants AT&T, Western Electric and ITT, and their valves. The early independent American companies are introduced in a separate chapter, a lot of these were either absorbed by the giants or just faded away. There are names like Moorhead, Myers, Schickerling and so on, probably familiar to valve collectors but totally new to me.

Screen grid valves (tetrodes) are next on the historical trail. Most of the manufacturers of this type of valve are European, with familiar names like Mullard and Philips, because the tetrode was invented by Schottky while working for Siemens of Germany. Unusual double-ended RF tetrodes are described as well. Chapter 7 introduces valves intended for use on AC mains power, where previous valves needed a battery supply for the filaments. Next is the pentode, designed by Philips to overcome the problems associated with tetrodes, together with pictures and details of the very first types. However, the tetrode underwent further development and beam tetrodes such as the 6L6 (RCA) and KT66 (GEC) are described in the following chapter.

Multiple filament valves which led to multi-element valves are covered in Chapter 10. Chapter 11 returns us to the diode with a short description of the developments which took place in detectors.

The radio theme is continued into the next chapter, all about frequency changers for heterodyne receivers. These valves had multiple grids, hexodes, heptodes and octodes, the type numbers will be recognisable to vintage radio collectors.

The author, having detailed the basic valve types, continues his survey in the next few chapters with the development of the different basing and bulb arrangements. Metal tubes come first and then the familiar Octal base. All-glass envelopes, which aided mass production, come next together with the politics surrounding their introduction. Chapter 15 describes a variety of power rectifier valves and their evolution to Tungar and Mercury vapour types as well as the later indirectly heated rectifiers such as the GZ34.

Chapter 21 returns the reader to the American independent companies, but this time the names are more familiar, Sylvania and Tung-Sol for example. Then the Australian and Canadian manufacturers are followed by a return to large British companies like Ediswan (Mazda), Marconi and Brimar. The smaller, independent British companies are in the following section: Ekco, Cossor, Hivac, Lissen and so on, all familiar to British set owners. Some more unusual manufacturers are also described. Following this is a chapter dedicated to Philips and their valves.

Valve development in the USA after WW2 is the subject of the penultimate chapter, also covering the American manufacturers' attempts at cheapening valve production by manufacturing in Chile and Brazil. The final chapter is about valve collecting as a hobby.

This chronological look at valve evolution up to just after the Second World War has many monochrome pictures showing some really unusual valves, packaging and vintage advertisements. It is also interesting to read how now-familiar brand names came about, as well as the manufacturers that didn't make it in such a big way but were important historically. This book seems to be aimed at set owners and valve collectors more than hi-fi enthusiasts, but if you are interested in valve history it's for you ●

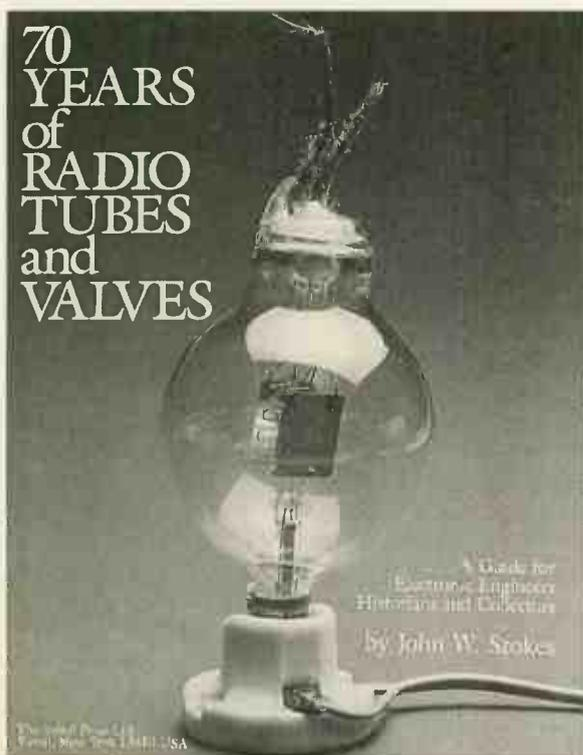

# HART

## Hart Audio Kits - Your Value for Money Route to Better Sound

2 Penylan Mill, Oswestry, Shropshire, UK. SY 10 9AF  
Phone 01691 652894 Fax. 01691 662864

Hart Audio Kits and factory assembled units use the very best audiophile components in circuit designs by the renowned John Linsley Hood to give you unbeatable performance and unbeatable value for money.

We have always led the field for easy home construction to professional standards, even in the sixties we were using easily assembled printed circuits when Heathkit in America were still using tagboards! Many years of experience and innovation, going back to the early Dinsdale and Bailey classics gives us incomparable design expertise in the needs of the home constructor. The current range of Hart kits is designed to give you all the components for a matching ensemble of audio excellence.



### K1100 AUDIO DESIGN 80 WATT POWER AMPLIFIER.

This fantastic John Linsley Hood designed amplifier is the flagship of our range, and the ideal powerhouse for your ultimate hi-fi system. This kit is your way to get EX performance at bargain basement prices. Unique design features such as fully FET stabilised power supplies give this amplifier World Class performance with startling clarity and transparency of sound, allied to the famous HART quality of components and ease of construction. Useful options are a stereo LED power meter and a versatile passive front end giving switched inputs, with ALPS precision Blue Velvet low-noise volume and balance controls. Construction is very simple and enjoyable with all the difficult work done for you, even the wiring is pre-terminated, ready for instant use! All versions are available with Standard components or specially selected Super Audiophile components at £29.60 extra per channel, plus £2.40 if you want to include Gold Plated speaker terminals.

K1100B Complete STANDARD Amplifier Kit	£385.21
A1100B Factory Assembled	£499.21
K1100SC Complete SLAVE Amplifier Kit, £	£333.62
A1100SC Factory Assembled	£422.52
K1100M Complete MONOBL DC Amplifier Kit	£261.20
A1100M Factory Assembled	£329.20
RLH10 Reprints of latest Amplifier articles	£4.50
K1100CM Construction Manual with full parts lists	£5.50

**K1400 AUDIOPHILE PREAMPLIFIER.** A versatile ultra high quality preamp with no less than seven inputs, all switched by sealed high quality relays. Separate tape output selection Class 'A' headphone output for two phones. Lo-Z long line drive facility.

Standard Kit	£343.49
K1400T Kit with Tri-range tone controls	£396.41



### "CHIARA" SINGLE ENDED CLASS "A" HEADPHONE AMPLIFIER.

First Module to appear in our new "2000 Range" of kits. This unit provides a high quality phone output for those many amplifiers that do not have one. Easily installed with special link-through facility the unit draws its power from our new Andante Ultra High Quality linear toroidal supply. Housed in the neat, black finished, Hart minibox it features the wide frequency response, low-distortion and 'musicality' that one associates with designs from the renowned John Linsley Hood. Pre-terminated interconnecting leads and PCB mounted sockets prevent supply polarity reversal and on-board diagnostics provide visual indication of supply line integrity. Volume and balance controls are Alps 'Blue Velvet' components. Very easily built, even by beginners, since all components fit directly on the single printed circuit board and there is no conventional wiring whatsoever. The kit has very detailed instructions, and even comes with a roll of Hart audiograde silver solder. It can also be supplied factory assembled and tested. Selling for less than the total cost of all the components, if they were bought separately, this unit represents incredible value for money and makes an attractive and harmonious addition to any hi-fi system.

K2100 Complete Kit	£109.50
K2100SA Series Audiophile version with selected audiophile components	£112.46
A2100SA Factory Assembled and Tested "Chiara"	£149.46



K3565 "Andante" Audiophile Power Supply Kit to suit	£85.42
A3565 Factory Assembled and Tested "Andante"	£128.42
Special Offer, Both Units in Kit Form together, with SA version "Chiara" with mains and DC Supply lead	ONLY £184.92
Factory Assembled and Tested	ONLY £267.88

**K1450 MAGNETIC PICKUP PREAMPLIFIER KIT** features a totally discrete component implementation with the superior sound of the Shunt Feedback concept. High quality components fitting to an advanced double sided printed circuit board make this a product at the leading edge of technology that you will be proud to own. Nevertheless with our step by step instructions it is very easy and satisfying to assemble. The higher current consumption of this unit means that it is best powered by our new **Andante** Audio Power Supply, itself an advanced piece of technology in a matching case. This supplies the superbly smoothed and stabilised supply lines needed by my sensitive preamplifier and features a fully potted Hi-grade toroidal transformer along with a special limited shift earthing system for hum free operation. The K1450 is suitable for all moving coil and moving magnet transducers this unit is especially recommended for, and will extract the very best from the modern generation of low output high quality moving coil transducers.

This magnificent kit, comes complete with all parts ready to assemble inside the fully finished 228 x 134 x 63mm case. Comes with full, easy to follow instructions as well as the Hart Guide to PCB Construction, we even throw in enough Hart Audiograde Silver Solder to construct your kit!

K1450 Complete Kit	£111.58
K1450SA Audiophile Kit	£133.94

Why not buy the reprints and construction manual for the kit you are interested in to see how easy it is to build your own equipment the HART way. The FULL cost can be credited against your subsequent kit purchase.

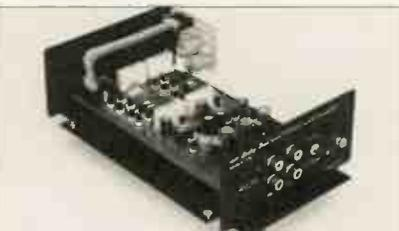

### ALPS "Blue Velvet" PRECISION AUDIO CONTROLS.

Now you can throw out those noisy ill-matched carbon pots and replace with the real hi-fi components only used selectively in the very top flight of World class amplifiers. The improvement in track accuracy and matching really is incredible giving better tonal balance between channels and rock solid image stability.

### MANUAL POTENTIOMETERS

2-Gang 100K Lin	£15.67
2-Gang 10K, 50K or 100K Log	£16.40
2-Gang 10K Special Balance, zero crosstalk and zero centre loss	£17.48

### MOTORISED POTENTIOMETERS

2-Gang 20K Log Volume Control	£26.20
2-Gang 10K RD Special Balance, zero crosstalk and less than 10% loss in centre position	£26.98

### SOLDERING

The size of modern components makes the right soldering equipment essential for good results. Everything we offer we actually use in our own workshops! See our Lists for the full range.

845-820 XS240 ANTEX 240W 25w Soldering Iron. This is the ideal Multi-purpose iron as the bit is designed to totally surround the element giving the best heat transfer. This excellent design also means that although it is small and handy enough for modern components its heating capacity is better than larger irons of conventional construction. Excellent Value	£9.93
845-080 ST4 Lightweight Soldering Iron Stand. This has provision for the classic damp sponge for bit wiping	£3.95

### HART SUPER AUDIOGRADE SILVER SOLDER.

Hart Super Audiograde Silver Solder has been specially formulated for the serious audiophile. Not only does it give beautiful easy-to-make joints but it is designed to melt at normal soldering temperatures avoiding the possibility of thermal damage to components or the need for special high temperature irons. A very low residue flux makes perfect joints easy but eliminates the need for board cleaning after assembly.

845-007 3mtrs 22SWG in Hart Mini Tube	£3.90
845-008 100g Real Special Valve Grade, 20swg	£12.90
845-009 100g Precision PCB Grade, 22swg	£14.75
845-110 100g Real Superfine 24swg for ultra precise control and easy working	£21.45

### PRINTED CIRCUIT BOARD SOLDERING PRACTICE KIT.

Unsure whether you can construct a HART kit?, this is your chance to try! Your HART Printed Circuit Board Soldering Practice Kit comes with a range of modern components, a typical Hart quality PCB, a roll of the correct grade of solder and full instructions. It enables the enthusiast who is uncertain of his, or indeed her, ability to put together and solder a printed circuit to try their hand at minimum cost. The instructions explain the right technique and guide even an absolute beginner through the seemingly daunting, but in fact very simple, art of making a good soldered joint.

Excellent value for money at only	£4.99
Super Version with Hart Silver Solder	£6.95

### TECHNICAL BOOKSHELF

**NEW! "AUDIO ELECTRONICS"** And now, hot off the press, yet another classic from the pen of John Linsley Hood. Following the enormous ongoing success of his "Art of Linear Electronics" the latest offering is the all-new edition of "Audio Electronics", now entirely re-written by the master himself!

Underlying audio techniques and equipment is a world of electronics that determines the quality of sound. For anyone involved in designing, adapting or using digital or analogue audio equipment understanding electronics leads to far greater control over the reproduced sound.

The subjects covered include tape recording, tuners, power output stages, digital audio, test instruments and loudspeaker crossover systems. John's lifetime of experience and personal innovation in this field allow him to apply his gift of being so familiar with his subject that he can write clearly about it and make it both interesting and comprehensible to the reader. Containing 240 pages and over 250 line illustrations this new book represents great value for money at only

£18.99*
---------

### "THE ART OF LINEAR ELECTRONICS."

The definitive linear electronics and audio book by the renowned John Linsley Hood. This 300+ page book will give you an unparalleled insight into the workings of all types of audio circuits. Learn how to read circuit diagrams and understand amplifiers and how they are designed to give the best sound. The virtues and vices of passive and active components are examined and there are separate sections covering power supplies and the sources of noise and hum. As one would expect from this writer the history and derivation of audio amplifier circuitry have an entire chapter, as does test and measurement equipment. Copiously illustrated this book is incredible value for the amount of information it contains on the much neglected field of linear, as opposed to digital, electronics. Indeed it must be destined to become the standard reference for all who work, or are interested in, this field. Latest reprinted edition with extended index.

1394 344 Pages 247 x 190. 1kg 0-7506-0868-4	£16.95*
---	---------

### "DIGITAL AUDIO AND COMPACT DISC TECHNOLOGY"

0-7506-0614-2 £17.95\*

### INTRODUCING DIGITAL AUDIO CD, DAT AND SAMPLING.

ISBN 180775 22 8 £7.95

"THE ART OF SOLDERING" 0-85835-324-3, 0 £3.95

### "TOWERS' INTERNATIONAL TRANSISTOR SELECTOR"

0-572-01062-1 £19.95\*

"AUDIO" F.A. Wilson, BP111 £3.95

"HOW TO USE OSCILLOSCOPES & OTHER TEST EQUIPMENT" R.A. Penfold BP267. £3.50

"THE LOUDSPEAKER DESIGN COOKBOOK" Vance Dickason (4th Edn.) 0-9624-191-7-6 £22.95\*

ELECTROSTATIC LOUDSPEAKER DESIGN AND CONSTRUCTION Ronald Wagner BKT6 £18.95

"AN INTRODUCTION TO LOUDSPEAKERS & ENCLOSURE DESIGN"

V. Capel BP256 £2.95

"LOUDSPEAKERS FOR MUSICIANS" BP297 £3.95

"THE HART PRINTED CIRCUIT BOARD CONSTRUCTION GUIDE." This is included FREE with all complete kits but is available separately. £2.50

### VALVE & EARLY CLASSIC BOOKS

THE VTL BOOK David Manley BKV1 £17.95

LOUDSPEAKERS; THE WHY AND HOW OF GOOD REPRODUCTION. G. Briggs 1949 0-9624-1913-3 £8.95

MULLARD TUBE CIRCUITS FOR AUDIO AMPLIFIERS

BKAA27 £13.95

"THE WILLIAMSON AMPLIFIER" 0-9624-1918-4 £6.95

AN APPROACH TO AUDIO FREQUENCY AMPLIFIER DESIGN GEC 1957, 1-882580-05-2 £18.95

AUDIO ANTHOLOGIES, articles from Audio Engineering Six volumes covering the days when audio was young and valves were king! BKAA371 to 6. All £13.95 each

"A SIMPLE CLASS A AMPLIFIER" J.L. Linsley Hood M.J.E.E. 1969 RLH12 £2.50

Postage on all books, unless stated, is only £1.50 per book, maximum £4.50 for any number, any size! Stamped items are heavy books costing £2.50 to send. No waiting! All listed books are normally in stock!

Ordering your HART kit is easy, simply post, telephone or fax your order anytime. Let us know what you require, with your name, address, cheque or credit card number and expiry date. Your daytime phone number is useful in case we need to get back to you. If you need further information on our kits just ask our FREE lists. Overseas order are welcome and we can send anywhere in the World. **Post on UK orders up to £20 is £1.50, over £20 - £3.50. Express Courier £10.**

QUALITY  
AUDIO KITS

24hrs SALES LINE  
01691 652894

ALL PRICES  
INCLUDE  
UK/EU VAT

# HART

# BULLOCK ON BOXES

by Robert M. Bullock III

reviewed by Dominic Baker

**B**ullock on Boxes is a collection of articles printed in *Speaker Builder* from 1980 onwards by author Bob Bullock. Although a professor of Applied Mathematics at Miami University, Bob Bullock's explanations of vented and closed box systems are written in an informative, down to earth style with the emphasis on practicality.

But who will this book interest? Nowadays a lot of the basic box design for a loudspeaker is done on a PC. Simple box modelling packages are cheap and easy to use, giving fast and accurate results. But if you don't have access to a PC, it doesn't mean you can't design your own loudspeaker cabinets. All manufacturers give Thiele-Small parameters with their drive units these days, and applying these with a few simple formulae will give you all of the design information you need, it just takes a little longer.

Bullock on Boxes gives you these equations and shows exactly how to manipulate them for the design you want. There are even design examples, textbook style, which clearly show how to manipulate the maths, calculate the data you need and interpret it.

The first chapter gives the reader a grounding in Thiele-Small parameters, without getting into heavy maths; ideal for the keen amateur who doesn't need to plough through lengthy equations. A useful part of this first chapter is the description of Thiele's work in determining a specific vented speaker system alignment for a given driver. This basically shows you what kind of bass response you get from a driver with a given  $Q_{ts}$ , which varies from 0.2 to around 0.65 for quality drivers. With a  $Q_{ts}$  of 0.38 it is possible to tune for a Butterworth 4th order alignment (B4), which gives the flattest response possible in the pass band. With a  $Q_{ts}$  above 0.38 the response will show some ripple

before it rolls off (these are normally better suited to sealed enclosures where a flatter response is possible). Below 0.38 bass rolls early which would give light bass. This is useful stuff, showing that to get good bass and a flat response, the right driver parameters must be matched to the right type of cabinet alignment.

In the next article, Bullock describes in detail a method and the equipment needed to measure the Thiele-Small parameters for yourself. The method is fairly standard, and similar procedures can be found in *The Loudspeaker Design Cookbook*, amongst others. For most readers it will not be necessary to make these measurements, nearly all manufacturers supply a full set of Thiele-Small parameters for their drivers nowadays. In Chapter 3 Bullock takes the vented box a stage further. There is a lot of useful practical advice here, well worth knowing before you buy your drivers. For example, he draws attention to the fact the higher  $Q$  drivers need a larger cabinet volume for a given bass response than low  $Q$  drivers. So if you are aiming to design a compact enclosure with good bass,  $Q_{ts}$  should be low.

In places Bullock makes valid points, but they are not necessarily important in practical designs. He suggests that if you arrive at a given volume for a loudspeaker cabinet, the volume that the driver, port, bracing and so on take up should be allowed for. In practice this tends to be a very small percentage of the total volume, and leakage and absorption losses will further complicate things.

In other areas the author is very practical though, describing his method for making a removable baffle for experimentation. He goes on to describe a process of fine tuning, and which

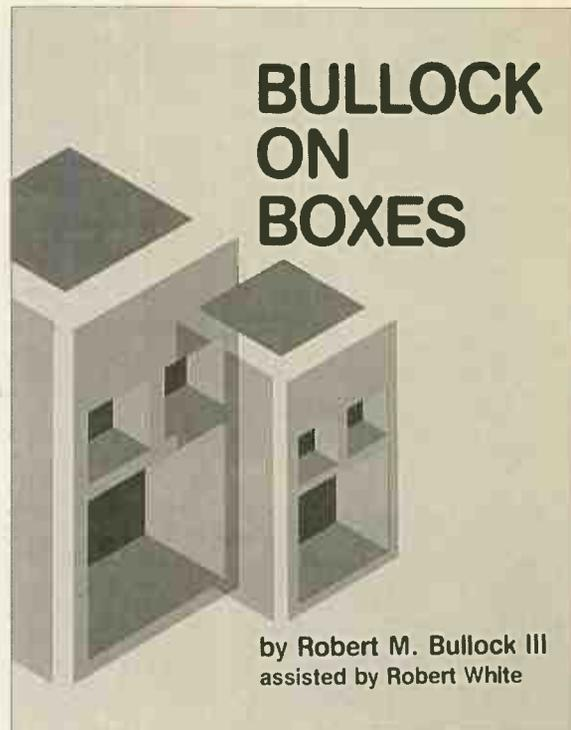

parameter; box volume, port size, etc. to vary to get the effect you want.

These first three chapters give the home constructor just about everything they need to competently design and tune their own loudspeaker cabinets. Chapter 4 goes on further to discuss alternative alignments and how they can be used to get specific response shapes. This is really for those with a perverse quest for knowledge, and isn't necessary for DIYers just looking to design a good loudspeaker for themselves. It is useful information, but goes further than most will need.

The remainder of the articles, with the exception of Chapter 9 which discusses 6th order alignments (more for the boffins), concerns Boxresponse and Boxmodel, computer aided design packages that do a lot of the maths for you. But I suspect that this book will be of more interest to readers without access to a PC.

Last of all, Chapter 10 contains updates and correspondence from *Speaker Builder* readers, where many questions are raised and answered by Bullock, for example: how to apply Thiele-Small parameters when two drivers are used in the same box. All in all, *Bullock on Boxes* is a very comprehensive, readable and practical guide to all aspects of vented and sealed cabinet design, a must for enthusiast loudspeaker builders ●

# KIT & COMPONENT SUPPLIERS

## LOUDSPEAKER KIT SUPPLIERS

### Falcon DIY Speakers

Falcon Acoustics Ltd. Tabor House, Norwich Road, Mulbarton, Norfolk NR14 8JT. Tel. 01508 578272  
UK distributors of FOCAL drive units, Kits, In Car and JMLab speaker systems plus SOLEN (SCR - Chateauroux) polypropylene capacitors and the largest audio inductor manufacturer in the UK. Stocking Audio Amateur Publications and Computer software. Comprehensive range of D.I.Y. Speaker kits, Parts, Accessories and Books.  
Please send large SAE (36p) for free price list.  
"Everything but the wood"

### The Speaker Co.

Unit 9, Waterside Mill, Waterside, Macclesfield, Cheshire. SK11 7HG. Tel: 0625 500507  
The largest range of speaker drive units and accessories stocked for the speaker builder. Plus a range of speaker kits designed exclusively for The Speaker Company. MLSSA test facility available, phone for an appointment. Our prices can not be beaten.

### Audiocab

9 Skew Bridge Close, Wootton Bassett, Swindon, Wilts. SN4 7DW. Tel: 0793 848437.  
Loudspeaker cabinet kits are the speciality of "AUDIOCAB". Whether you are prototyping your own loudspeakers or working to a design published in Hi-Fi World, including the KLS3, "AUDIOCAB" will produce a bespoke kit to your specification. "Biscuit jointing" is used to ensure perfect alignment of adjacent panels and cabinets are dry assembled and sanded before dispatch. David Barfield, proprietor, says "no prior experience of woodworking will be required to build our kits and achieve a professional finish". Kits will normally be supplied in 25mm unfinished MDF but any finish is available and designs are usually enhanced by the use of mouldings to escape from the normal "square box". Ready built cabinets can also be specified. Professional, trade and retail enquiries are invited.

### Wilmslow Audio

Wellington Close, Parkgate Trading Estate, Knutsford, Cheshire WA16 8DX  
Tel. 0565 650605 Fax. 0565 650080  
Extensive range of drive units and over 30 different designs of self-assembly kit. Two 'ATC' kits now available. Drive units include those from KEF, Dynaudio, Audax, SEAS, Peerless, Scanspeak and Morel. Everything required for the loudspeaker builder and four dem rooms to listen to the kits in built-up form. Two new kits from Morel - one 3 litre, magnetically shielded, one 11 litre book shelf.

### IPL Acoustics

2 Laverton Road, Westbury, Wilts BA13 3RS. Tel. 0373 823333  
IPL supply a range of eight speaker kits using drive units from SEAS, Morel, Audax, Visaton etc. including four transmission lines to suit all room sizes. We also supply a full range of drive units, capacitors, and cabinet accessories as well as silver plated P.T.F.E. insulated cables.

### DBS Audio

PO Box 91, Bury St Edmunds, Suffolk IP30 0NF. Tel. 0284 828926  
Sole authorised supplier of DBS loudspeaker kits designed by Dave Bennman. The acclaimed DBS6 kit includes Morel tweeters and custom built woofers, plus top quality pre-assembled crossover and components.

### UPLIFTING SOUNDS - Tel: 0121 777 4196

Offers assistance in the design and construction of loudspeakers and audio furniture. From innovative to stylistic talk through your ideas with an enthusiast and choose your own level of involvement.

## VALVE AND OUTPUT TRANSFORMER SUPPLIERS

### P.V. Tubes

104 Abbey Street, Accrington, Lancs. BB5 1EE  
Tel. 0254 236521/232611 24 hrs a/p. Fax. 0254395361

For all your electronic components. Valves are new in branded boxes and matched pairs are available. Pls call for types and prices. We are closed all day Wednesday.

### Vintage Valves,

PO Box 147, Station A, Vancouver B.C. Canada, U6C 2M3. Fax (604) 876 5876.  
Dynaco, Sherwood, Scott, The Fisher, McIntosh, Eico, Harmon Kardon, Heath, Altec, Stromberg- Carbon. Many vintage parts and equipment available on request.  
**Wilson Valves**  
28 Banks Ave., Golcar, Huddersfield, West Yorks HD7 4LZ.  
Tel. 0484 654650/420774. Fax. 0484 655699.  
Mail order. Call us to find out more about our extensive range of valves. Over 1,000 different types stocked. S.A.E. for list. (Please mark for Dept. HFV).

### Langrex Supplies Ltd

1 Mayo Road, Croydon, Surrey CRO 2QP  
Tel. 081 684 1166 or fax. 081 684 3056  
One of the largest distributors of electronic valves, tubes and semi-conductors in the UK by original UK and USA manufacturers. Obsolete types are a speciality. Telephone or fax for an immediate quotation.

### Billington Export Ltd.

1E Gillmans Trading Est., Billingshurst West Sussex RH14 9EZ  
Tel. 01403 784961 or Fax. 01403 783519  
Billington Export Ltd. holds large stocks of audio valves including many obsolete brands such as Mullard, GEC, Bnmar etc. as well as Sovtek, Thermionic Gold Brand and the recently introduced Billington Gold range. Also Cathode Ray Tubes (eg. used in Marantz tuner 10B). 50 page catalogue available, tel or fax for a quotation. Minimum order £50.00 UK, £100 export.

### PM Components

Springhead Enterprise Park Springhead Road, Gravesend, Kent DA11 3HD. Tel. 0474 560521 P.M. Components Ltd are the specialist component company for High End Audio enthusiasts. We have a design and manufacturing base for audio valves and associated products and have a capability to produce custom tubes for major manufacturers. Our 70 page catalogue is available at £2.50 including U.K. postage. P.M. Components are major stockists for Golden Dragon, Mullard, GEC and Teonex valves and have a vast archive of vintage tubes gathered from every manufacturer in the world.

### Chelmer Valve Company

130 New London Road, Chelmsford, Essex CM2 0RG. Tel 0245 265865 Fax. 0245 490064.  
Supplier of premium range of audio valves, other valves and components also available. (Please see our ad on outside back cover of this supplement).

## RESTORATION

GT Audio 5 Upper Road, Higher Denham, Bucks UB9 5EJ. Tel. 0895 833099  
Professional repair/restoration of all hi-fi including classic and vintage equipment. Supplier of very high quality electronic components, in particular types which are difficult to source. Original valves available, i.e.. Mullard, Bnmar, GEC, GE, RCA, Sylvania etc.

## COMPONENT SUPPLIERS

Hart Electronic Kits Ltd Penylan Mill, Oswestry, Shropshire SY10 9AF  
24 Hr sales/enquiries. Tel. 0691 652894  
A range of Audiophile kits for 80 watt Power Amplifiers, Tuners, Pre-Amps and Moving Coil/Moving Magnet RIAA Pickup Preamps. All kits are fully engineered, with our thirty years design experience, for easy constructions from circuits by John Lindsey Hood, the most respected designer in the field. Send for lists.

J.J. Components, Electronic Component Distributors, 63 The Chase, Edgware, Middx. HA8 5DN UK.  
Tel: 0181 952 4641 Fax. 0181 381 1700  
Television - Video - Hi-Fi and Computer components at a very keen prices. Video Head, Belt Kits, Pinch Rollers, Repair Kit, Television, Transformers On-Off Switches Semi-conductor IC's Computer Hard Drive, Floppy Drive, cases, Drums, Keyboards, Monitors, Mouse all under one umbrella. Ring for our latest catalogue & price lists.  
Most credit cards accepted.

### V.R.R.

30 Melbourne Ave, Worthing, BN12 4RT. Tel: 01903 501158  
Vintage Radio Restoration

We can provide mains transformers, chokes and single-ended or push/pull output transformers as well as silver cable, paper-in-oil capacitors and other goodies all at reasonable prices. Our 30w monoblock short kit is only £299!

### AP Electronics

20 Derwent Centre, Clarke Street, Derby, DE1 2BUT  
Check out the AP ELECTRONICS 1994 catalogue. It's free with every order of over £40.00 or can be purchased for a £4.95 cheque payable to 'AUDIOKITS' Over 80 pages include pre and power amplifier kits, high grade audiophile resistors, capacitors and semiconductors, audio and mains cables, gold and rhodium plated connectors and COMPONENT NOTES on using high grade parts. A quarterly newsletter 'AP PERFORMANCE AUDIO' has been recently launched and your first issue is free.

### RushAudio

126 Station Rd., Tempsford, Sandy SG19 2AY. Tel. 01767 640779 Fax. 01767 640617

RushAudio stock high quality British made polypropylene capacitors (630V dc) ideal for PSU applications. 30uF (100mm x 50mm dia.) £22; 40uF (100 x 63) £27; 50uF (100 x 63) £32; 100uF (125 x 76) £55. Cabbage: 1 capacitor £2; 2 - £4; 3 or more - £6. Unfortunately VAT is extra on total of goods plus carriage. Cheque with order appreciated for prompt delivery.

### Audio-Links

7 Fairmont Crescent, Scunthorpe, North Lincolnshire DN16 1EL  
Tel. 01724 870432 / 764804  
CUSTOM WOUND TRANSFORMERS & CHOKES  
- Exceptionally high quality items for valve and solid state designs at realistic prices  
AUDIO - LINKS, "THE GREEN" INTERCONNECT CABLE  
- Now available in kit form. All the parts you need to make your own reference interconnects at a fraction of the cost.  
Vast range of highest quality electronic components and accessories for the D.I.Y. enthusiast. VAT incl. prices, mail order and a friendly service. Open Monday to Saturday 10am - 7pm

### Chassis Company

PO Box 36, Letchworth Hertfordshire SG6 2UR  
Tel/Fax: 01462 671594  
Suppliers of high quality classic style welded Aluminium chassis, designed for DIY Audiophile constructors. Our modular chassis is also very suited to semiconductor pre/power amplifier applications. Check out our PTFE sheet at £24 inc per sheet 150x30x5mm. Please send 38p A4 SAE for details.

### Russ Andrews Audiophile Components

Edge Bank House, Skelsmergh, Kendal, Westmorland. LA8 9AS  
Tel. 01539 823247 Fax. 01539 823317  
World leading supplier of the highest quality premium grade components. If you want the very best sounding resistors, capacitors, inductors, volume controls, wire etc. send for our 1994/95 catalogue. We also have a range of our own design of amplifiers, pre-amps, speakers and CD players built with our components. To receive your copy of our 1994/95 catalogue just mail, phone or fax the address above.

## VINTAGE DIY

### Loricraft Audio

4 Big Lane, Goose Green, Lambourn, Berks RG16 7SQ. Tel. 0488 72267  
Specialist restoration of 301's and 401's using genuine spares and re-manufactured parts to original pristine standards in our newly built workshops designed primarily for these purposes.

## CLASSIC TURNTABLES

### Technical & General

P.O. Box 53, Crowborough, East Sussex TN6 2BY. Tel. 0892 654534.  
The original specialist source of spares, restorations and overhauls for the classic turntables. Years of actual experience and comprehensive range of parts (originals and re-manufactures), manuals, ancillaries. No dubious 'improvements' - no harmful 'modifications'. Our specialities: Connoisseur, Garrard; Goldring; Lenco; S.M.E.; Thorens; Watts; Ortofon; Shure; Cartridges and styli for 78s, Mono LPs, Stereo LPs.



# D.I.Y. Letters

## DIY DAC KIT?

Congratulations and thanks for the feature on preamp valves in the DIY section of the April issue. It was very clearly written and pitched exactly at the right level for a reader like myself, who has built three of the World Design kits by following the 'recipe' but who seeks a bit of real 'understanding' of what the components are doing. I expect that you will produce a similar piece on power valves soon, and I for one will look forward to reading it. One thing that interested me about your feature was that, despite your initial mild reproof of your friend's approach of 'just plugging in and listening', your final comments about each of the valves were concerned with their sonic qualities. But how else could these be ascertained except by taking your friend's advice?

I would be tempted to get out my soldering iron again if you could produce a DAC kit, because then I could claim to have built everything from

front end through pre and power amps to speakers. But I note your (actually NK's) reservations about the cost savings in digital circuit assembly. So if that is not on the stocks, what about a circuit for a single channel with variable components and headphone output, so that we could all 'plug in and listen' and also fiddle around with the component values to try and get a deeper understanding of the influence of each on the sound.

In any event, thanks again and keep up the high standard. It's a real pleasure to read HFV each month.

**Don Dougall**  
East Nempflar,  
Lanark.

*Feature on power valves? Now that's a good idea, one so obvious we hadn't thought of it!*

*Digital convertors*

*work at up to 30MHz and can be very difficult things to design, especially in their mechanical layout. Philips Labs at Eindhoven, Holland, are quick to complain that their DAC chips often didn't work properly in commercial products because of board layout problems arising from unsatisfactory design. If manufacturers can't get it right, we're doubtful that DIYers without test equipment can manage, making us reluctant to feature such things.*

*Ironically, the very fact that layout is such a problem has spurred chip makers to produce "evaluation boards" (examples of how you should do it), which DIYers can buy. Crystal evaluation boards are available from Electromail, for example. These demonstrate that*

*even the electronics alone are not cheap.*

*We have tentatively discussed designing a valve one-bit convertor, but the development costs and problems are too much for us at present. NK*

## BUILDING A LOWTHER SPEAKER

A few weeks ago I ordered two drive units from Lowther, their PM7s.

As I have no experience with Lowther, and can't find tests in the leading Hi-Fi press, except in the latest issue of Hi-Fi World in form of the Thomas Tranducers Brio, my imagination ranges from very positive to scepticism. The idea is as follows. There were (I don't know if they still exist) a few models in the past, all big (large) transmission line or horn loaded TP, Acoustica, Audiovector etc. that used Lowther drivers.

As I have no idea about the size and proportions, can you describe those models? Or if there are some drawings or tests from some Hi-Fi mags that can be of help before I decide which plan to purchase for building. So please describe for me the sound of each kit enclosure for Lowther drivers and if you can draw some connection with the new Bicolor range.

I know it is a lot to request from you, but if I choose the wrong model to build, it's financial and musical disappointment for me.

**Marjan Vacev**  
Skopje,  
FYR Macedonia

*If you contact Lowther on Tel: 0181 300 9166, they have a large range of cabinet drawings available to suit your drivers. If you let them know what kind of thing you're after, what size your listening room is etc. they will be able to supply suitable plans for around £25. DB*

## IMPROVING K588 I

I want to make some notes to improve the design of your K588 I amplifier.

1) The supply of the EF86 input valve should be stabilised with three 68V/1.3W zener diodes. This not only improves the dynamic response of the amplifier, it helps also to solve another problem: if the amplifier is turned on, the potential on the grids of the ECC83s will rise up to 450volts (or more) until the tubes are warmed-up. In the original Mullard design this problem never existed, because the GZ34 rectifier valve delayed the plate voltage until the other valves are warmed-up.

2) Every electrolytic capacitor should be bypassed with a small polypropylene or polyester capacitor (rule of thumb: 1 percent of the capacity of the electrolytic). This improves not only the treble response, it also improves the quality of the "room reproduction" (paper-in-oil capacitors may work also for this, but I never tried.)

3) The power supply capacitors C12 - C15 should only be high quality types with screw terminals used. This will not only perform better (lower ESR), it will also last for many years.

4) If an output transformer with 4 and 16 ohms secondary taps is used, you can connect the 4 ohm tap to ground and use the 0 and 16 ohm taps for cathode feedback of the output valves. This not only improves control on the bottom end, it also improves coupling between the primary and the secondary of the output transformer. This will result in better submission of the resonant peak of the output transformer and greater bandwidth of the whole amplifier.

5) UL Taps should be offered as an option. The problem here is that 43% taps do not always work best. For example, the first commercial amplifier with ultra linear feedback (as described in Jean Hiraga's "Initiation aux Amplis a Tubes") invented by Hafler and Keroes used 18.5% UL taps for an output stage with two 6L6s very similar to the K5581. In my experience it works best if both UL taps and cathode feedback used together.

**Karl Stephan  
Frankfurt,  
Germany.**

*Many vintage amplifiers were built to a standard only found in the very best of modern day equipment. As you say, for the non-enthusiast, the expense of buying and restoring an old Leak or Marantz*

*amplifier may come to a substantial amount of money and most would, at a basic practical level, be better off with a solid-state integrated. The restored vintage amplifier, however, is likely to outperform anything in the same price range, and then there is the pride of ownership commonly lacking in today's characterless products.*

*Regarding your comments on the K5881 amplifier, I am afraid to say that you overestimate the capabilities of zener diodes, especially high voltage types (avalanche operation). A quick look at the specification for the 1.3W 68V zener you mention reveals it has a slope resistance of around 130ohms, so three in series would add up to 390 ohms.*

*Compared to the reactance of the decoupling capacitor at all but very low frequencies the zener's effect on the supply impedance would be negligible.*

*Also, as these high voltage "zener" diodes are actually avalanche diodes, noise is likely to be another problem. Generally, in my experience, avalanche diodes need to be treated with care in audio circuits, including solid -state; glow tubes are a better device.*

*A simple regulator, similar to that used in KLPP-1 could be used to greater effect though. The higher than usual voltage on the ECC83 grid does not cause any damage to the valve, but we do use delayed H.T. in the more*

# Letter of

## DIY CD CONVERTOR

I have just finished the construction of a DAC using a Crystal CDB4328 evaluation board supplied by RS Components referred to in your June DIY supplement. I have recorded some notes that may be of interest to anyone who intends using the board as the basis for a DAC.

1. Obtain the application notes for the CS4328 chip from RS as it gives some valuable information that is not included with the evaluation board.

2. Before working on the board, observe the precautions for avoiding static discharge by making sure that you and any tools that you use are connected to earth. I use simple croc

clip pads attached to my metal watch strap, soldering iron etc the other end of which is connected via a resistor to earth.

3. The board requires two power supplies analogue +/- 15V and digital +5V. I chose to use two mains transformers (supplied via a 1amp mains filter) for this, one toroidal O-9/0-9v for the analogue supply and a small 6V PCB mounted one for the digital supply. The board already has filtering and regulation for the analogue supply and only requires a rectifier and smoothing capacitors to be included in your circuit. For the digital supply a +5V supply can easily be constructed using a 7805 regulator. (You can also wire across from the analogue supply patch area,

if you wish)

4. I used a black slimline case from RS to house the unit, they're quite expensive but give a professional look to your project and exactly match the width and finish of some commercial hi-fi. I had to remove the binding posts from the board so that it would fit in the case, I suggest that you keep these in place during initial testing and then solder all connections later.

5. Jumper configuration caused some problems, but eventually I arrived at these settings: JP1 can be left as is, it only affects the on-board LED error display. JP2 should be set to 0. DIF1 (next to JP2) should be set to 1 (away from CS4328) and DIF0 to 0 (towards

expensive 300B project.

Bypassing electrolytic capacitors is considered good practice in some circles and bad in others. It seems that bypassing can cause a change in the tonal colour of the amplifier when going from one frequency extreme to the other and for those who want absolute tonal consistency this is not acceptable. I find it is best to use a single very high quality unit, except possibly in the main power supply. In my personal projects, where commercial cost constraints don't exist, I use only Black Gate (available from AudioNote) and BHC ALS20 electrolytic capacitors. The super high quality screw-terminal can types you mention (such as BHC ALS20 or Philips

GRADE ONE) are better than the smaller axial types but are much larger and much more expensive, precluding their use in a budget design.

The K5881 amplifier is ideal for experimentation and owners may wish to try bypassing their electrolytics and assess the sound. Use 630V or 1000V rated units on the H.T. lines, available from Maplin. In fact, it would be possible to replace the smaller value electrolytics with polypropylenes from their range (if you can find room!). Expect a more open sound but, depending on which type of capacitor is used, also an increase in overall brightness and possibly aggressive treble.

The problem with using the impedance taps of an output transformer for

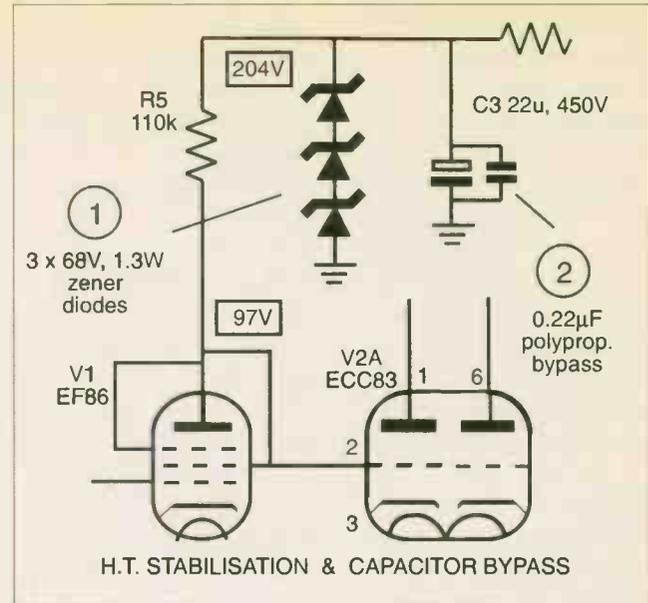

cathode feedback is that they may not be symmetrically coupled to the primary. In most transformers they won't be. This could lead to asymmetrical operation of the output valves at high

frequencies, causing distortion and/or instability.

Also, using the taps in the manner you suggest only allows you to use 16 ohm speakers for fully balanced operation. Some amplifiers use this type of local feedback, such as the Quad II and MacIntosh amplifiers. Here though, the output transformers were specially designed with cathode feedback in mind. The MacIntosh used a unity coupled transformer with a bifilar winding, injecting 50% of the primary voltage into the cathodes. Some modern day American super-amps use linearising cathode feedback in the output stage, but with no global feedback.

Similar difficulties arise with Ultra Linear taps. The transformer needs to be designed around them because the taps must be very tightly coupled to the primary to avoid instability and H.F. distortion. This makes the transformer much more expensive, and as you say the commonly quoted 43% taps (which I believe came into being in the application notes for the KT66 and EL34 valves) are not always ideal. The optimum ratio must be calculated first, and then

# The Month

CS4328). I found that setting DIF0 to 1 connected 5V direct to ground causing havoc! JP3 should be set to the 8412 position.

6. The digital input is configured for AES/EBU with a 110ohm resistor, to use an SPDIF input you should, strictly speaking, change this to 75ohm. In practice this wasn't necessary.

7. Mount the board as far away from your mains input as possible and keep input and output leads as short as possible.

8. Having observed all of the foregoing you should now have a working DAC. The great thing about the CDB4328 is its almost limitless tweakability which enables you to experiment

with differing modes of power supply, inputs, clocking etc. I intend to try battery power supplies soon.

For me, the effort was well justified by the sound quality and resolution of detail which is nothing short of superb. I have since spent many happy hours revisiting my CD collection!

**Peter Johnson**  
Essex.

Thank you for passing on your experiences with the Crystal CDB4328 CD converter, I'm sure they will be helpful to many of the keen DIYers out there. As you have found, it provides a relatively straightforward project for those with experience of digital electronics, and sounds good too! DB



**WIN A MAPLIN  
SOLDERING IRON KIT  
COMPLETE WITH A  
LENGTH OF SILVER  
SOLDER**

The writer of the most interesting DIY letter each month will receive a superb Maplin soldering iron, stand, booklet on good soldering practice and a length of high quality silver solder. Write in to: Hi-Fi World DIY letters, 64 Castellain Rd, Maida Vale, London W9 1EX.

experimentally optimised.

Regulated power supplies, super components, cathode feedback and Ultra Linear taps would make K5881 into a different, possibly better, but definitely more expensive amplifier. The basic kit can be used as it is or as a platform on which to try these and other modifications at minimum expense. A.G.

This sort of debate raises an important basic consideration of design outlook. My experience strongly suggests that elegant simplicity gives the best results. With K5881 I quite deliberately simplified and honed the circuit during development; a lot of components in the original circuit ended up on the floor.

Simple inspection of this sort of circuit doesn't reveal much, which might disappoint you and arouse a desire to bolt on goodies. You can, of course, do so and certain mods, mainly component substitution, do yield improvement. But most of the ideas you suggest are likely to be unnecessary and possibly retrogressive.

Most commercial valve amps operate with a 400V H.T. line, set purely by the 450V limit of electrolytic

capacitors and the steep rise in cost of using stacked series caps. if this limit is to be exceeded.

K5881 runs with a special 500V power supply electrolytic, which gives a 460V line. The output valves see a higher load impedance in consequence and operate more linearly.

The output transformers were load matched using an FFT to give optimum performance at all frequencies (not just one spot frequency) giving optimal power transfer into a 6Ω nominal load (8Ω tap). Distortion falls at higher load values, giving unusually linear behaviour, helped by very high quality output transformers. Speaker matching is therefore excellent (the 4Ω tap is optimised to 2Ω and there's even a 16Ω tap).

You talk about applying more feedback, but in truth it doesn't need it. Ultra-linear taps were tried and abandoned. This form of feedback skewed the transfer characteristic,

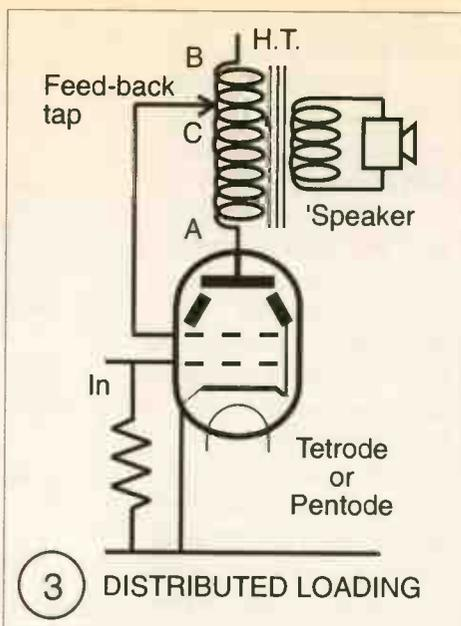

If the tap is affixed to point A the stage behaves as triode, and if B as a normal tetrode. If the screen is tapped at intervals from B to A there will be progressive inclusion of load impedance in the screen circuit and a progressive change from tetrode to triode characteristics. It is not essential to use a tap. An additional winding tightly coupled to the primary may be used and has the advantage that the screen supply then may differ from the anode, for best results.

modulating the distortion pattern to make third harmonic dominant at higher outputs. My findings were in line with Peter Walker's (Quad) and D.T.N. Williamson's observations on Hafler and Keroes claims (Amplifiers & Superlatives, J.A.E.S., Vol 2, No2, April 1954: "With up to 30% of the winding common to screen and anode the reduction in distortion is greater than the reduction in gain. This "something for nothing" is small however and can be lost or reversed if there is any appreciable unbalance". "Departure from ideal (in the output transformer) may mean that at high frequencies the

thickness of insulants and in the positioning of windings". "The possibility of pitfalls is greatest in the output transformer and increases rapidly with the number of windings when all these must be close coupled". See our digram (3) and explanation from the AES paper.

Hafler & Keroes 1951 claims for originality were refuted by Quad, by the way, who stated that a similar technique had appeared in Wireless World, April/May 1947 and that the Quad II amplifier contained a better variant, cathode coupled feedback. As it stands, because of the design approach adopted, K5881 produces just 0.02% pure second harmonic at 1W/1kHz and this rises smoothly but slowly as output power increases, a very benign characteristic. It's better as it is.

Feedback is an attempt to make a silk purse from a sow's ear. Where it exists in audio, by definition the basic circuit is not, at a most fundamental level, adequate for its purpose, the reproduction of music. If it is, then why are we trying to make it better using feedback? N.K.

circuit is not all it would appear and the effective sense of the coupling may be reversed, producing oscillation. "Even with transformers of the same nominal specification, in performance at high frequencies may occur owing to minor variations in the quality and

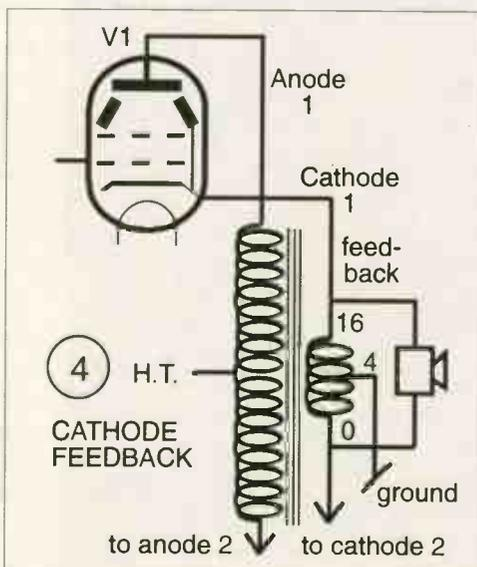

The basic circuit of the Quad II power amplifier with cathode feedback (also used by McIntosh).



# CHELMER VALVE COMPANY

for  
High Quality Audio Valves

We offer below a selection of our CVC PREMIUM range of audio valves. These CVC BRAND valves are from selected world wide sources, processed in our special facility to provide low noise/hum/microphony PRE-AMP valves and POWER VALVES burnt-in for improved stability and reliability. Use this sheet as your order form. If you require matched pairs, quads or octets etc. Please allow £1.00 extra per valve for this service and mark alongside the valve type number 'M2,M4, M8' etc as required.

## Price list and Order Form for CVC PREMIUM Audio Valves

PRE-AMP VALVES				RECTIFIERS																							
	Unit Price	Qty	Total Price		Unit Price	Qty	Total Price																				
ECC81/12AT7WA	5.00			EZ80	4.00																						
ECC82/12AU7WA	4.50			EZ81	4.25																						
ECC83/12AX7WA	5.00			GZ32	7.00																						
ECC85	5.00			GZ33	7.00																						
ECC88	4.50			GZ34	6.00																						
ECF82	5.00			GZ37	6.00																						
ECL82	5.00			5U4G	5.00																						
ECL86	5.00			5V4GT	4.00																						
EF86	4.50			5Y3GT	3.50																						
E80F Gold Pin	9.00			5Z4GT	3.50																						
E81CC Gold Pin	6.20																										
E82CC Gold Pin	6.20			SOCKETS ETC																							
E83CC Gold Pin	6.20				Unit Price	Qty	Total Price																				
E88CC Gold Pin	7.20			B9A (Chassis or PCB)	1.60																						
6EU7	6.00			B9A (Ch or PCB) Gold	3.00																						
6SL7GT	4.00			Octal (Ch or PCB)	1.80																						
6SN7GT	4.50			Octal (Ch or PCB) Gold	4.20																						
6922	5.00			4 Pin (For 2A3, 300B)	3.30																						
7025	6.20			4 Pin Jumbo (For 211 Etc.)	11.00																						
				4 Pin Jumbo Gold (For 211 Etc.)	15.00																						
POWER VALVES																											
	Unit Price	Qty	Total Price	5 Pin (For 807)	3.00																						
EL34/6CA7	7.50			7 Pin (For 6C33C-B)	4.50																						
EL34 (Large Din)	8.50			Screening Can (For ECC83 Etc.)	2.00																						
EL84/6BQ5	4.00			Anode Connector (For 807 Etc.)	1.50																						
E84L/7189A	5.50			Anode Connector (For PL519 Etc.)	1.60																						
KT66	9.20			Retainer (For 6L6WGC Etc.)	2.00																						
KT77	12.00																										
KT88	12.50			MATCHING CHARGES																							
KT88 (Gold Special)	19.80				£																						
2A3 (4 or 8 Pin)	14.50			POST & PACKING (UK)	£3.00																						
211	22.00			TOTAL EXC VAT	£																						
300B	50.50			VAT @ 17.5% (UK/EEC ONLY)	£																						
6C33C-B	27.00			TOTAL TO PAY	£																						
6L6GC	6.50																										
6L6WGC/5881	8.00			Please make cheques payable to:																							
6V6GT	5.00			'CHELMER VALVE COMPANY' or pay by																							
6080	12.00			ACCESS/MASTERCARD/VISA Please give details:																							
6146B	10.20			<table border="1" style="width: 100%; height: 20px;"> <tr> <td></td><td></td><td></td><td></td><td></td><td></td><td></td><td></td><td></td><td></td><td></td><td></td><td></td><td></td><td></td><td></td><td></td><td></td><td></td><td></td> </tr> </table>																							
6336A	46.00			SIGNATURE: ..... EXP. DATE: .....																							
6550A	11.00			NAME: .....																							
6550WA	13.50			ADDRESS: .....																							
6550WB	13.50			.....																							
7581A	11.00			.....																							
807	8.00			..... Post Code: .....																							
811A	10.50																										
812A	34.00																										
845	30.00																										
Total carried forward ...																											

**VALVE AMPLIFIERS SOUND BETTER STILL WITH CVC PREMIUM VALVES!**

130 New London Road, Chelmsford, Essex. CM2 0RG. Tel: 01245 355296/265865 Fax: 01245 490064



McIntosh

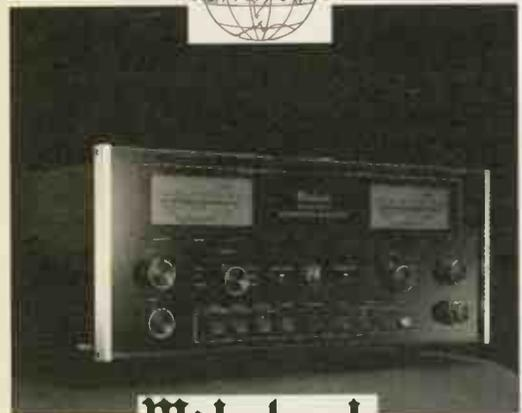

McIntosh

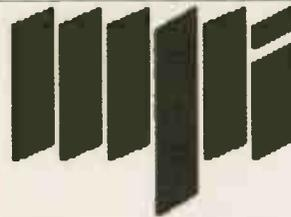
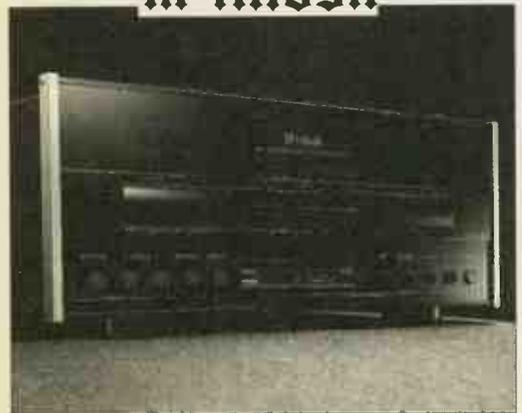

• mpi electronic •

13 weston road  
guildford  
gu2 6au  
tel: 01483 454 993  
fax: 01483 454992

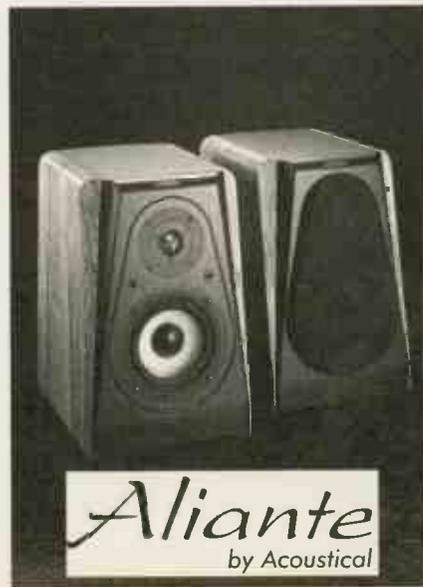

*Aliante*  
by Acoustical



 SONIC FRONTIERS  
INCORPORATED

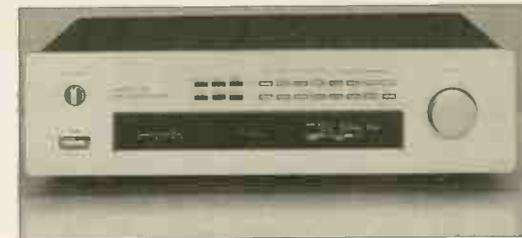

*Accuphase*



*Accuphase*

