

11

Will be Completed in Three Handy Volumes

1<sup>s</sup>/<sub>3</sub><sup>d</sup>

# HARMSWORTH'S WIRELESS ENCYCLOPEDIA

## For Amateur & Experimenter

FIL-GEN

CONSULTATIVE EDITOR

**SIR OLIVER LODGE, F.R.S.**

THIS PART CONTAINS

187 New "Action" Photos & Diagrams  
Many 'How-to-Make' Articles

FOUR-VALVE SET  
FRAME AERIALS  
FRAME AERIAL SET  
GALVANOMETERS  
GAUGES

ALSO AN IMPORTANT ARTICLE

**THE FLEMING VALVE**

By Prof. J. A. Fleming, F.R.S., D.Sc.

*SPECIAL PHOTOGRAVURE PLATE:*  
**FRAME AERIAL RECEIVING SET**

*J. LAURENCE PRITCHARD, F.R.Ae.S., Technical  
Editor, with expert editorial and contributing staff*

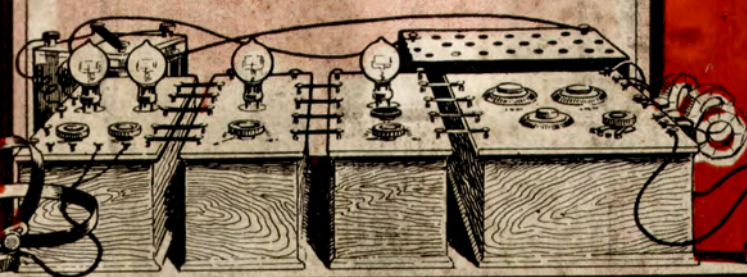

The Only ABC Guide to a Fascinating Science-Hobby

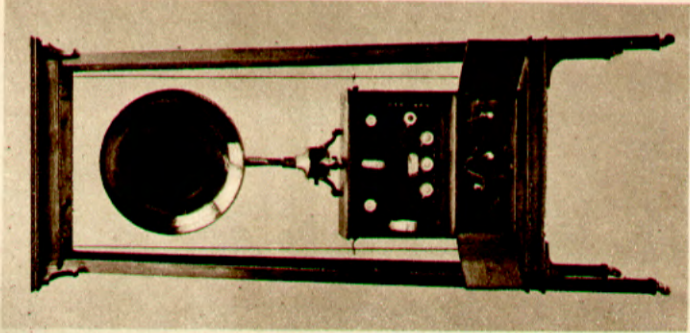

Fig. 5. Complete set, front view, showing coils and batteries

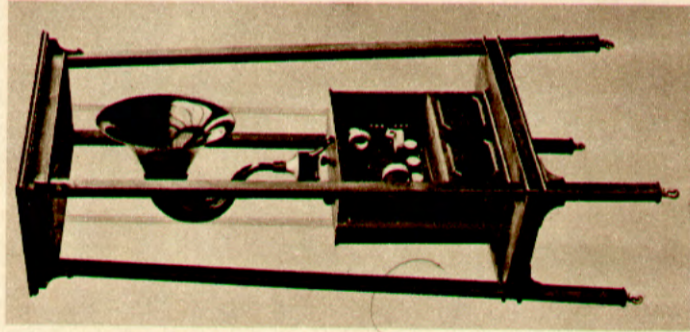

Fig. 6. Partial side view showing wires of frame aerial

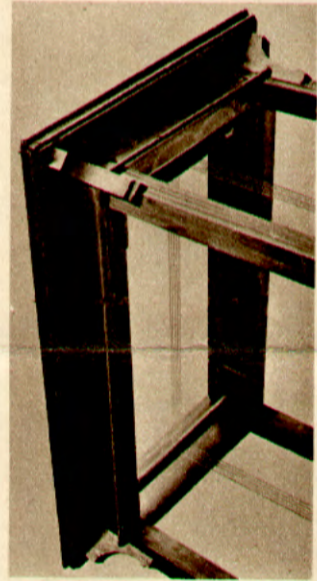

Fig. 7. Top of stand complete, showing construction and ebonite cross bars

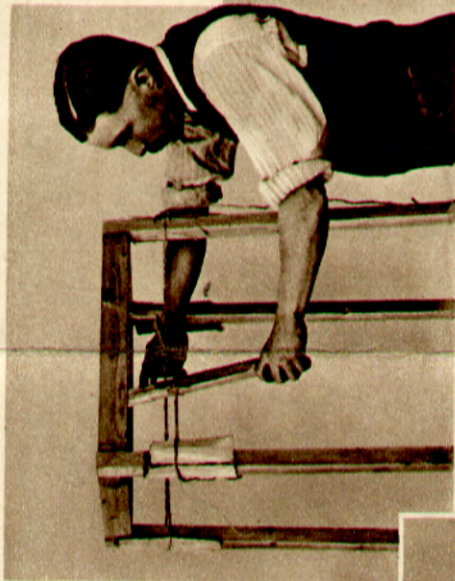

Fig. 8. Applying tourniquet to joints at top of frame after glueing

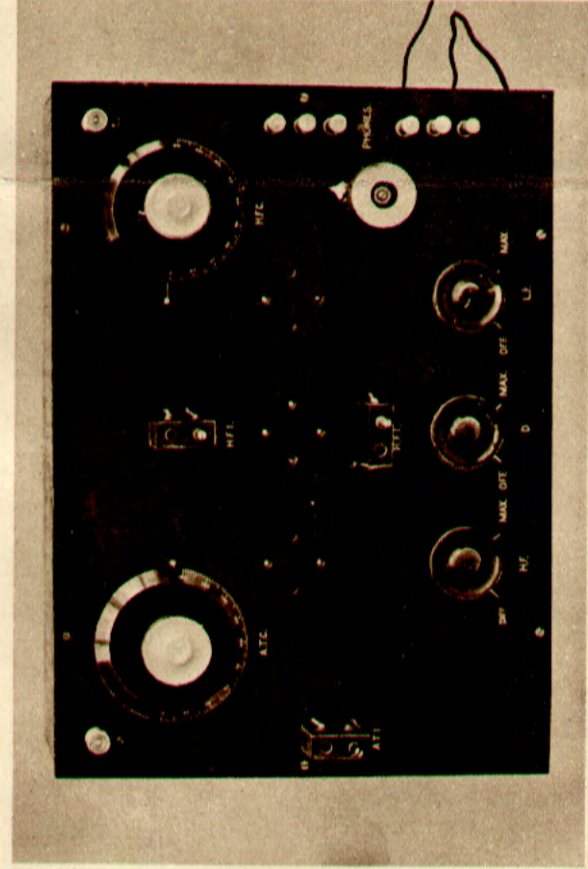

Fig. 9. (Above) Layout of panel receiver. Fig. 10. (Right) Interior of set from the back with battery connections

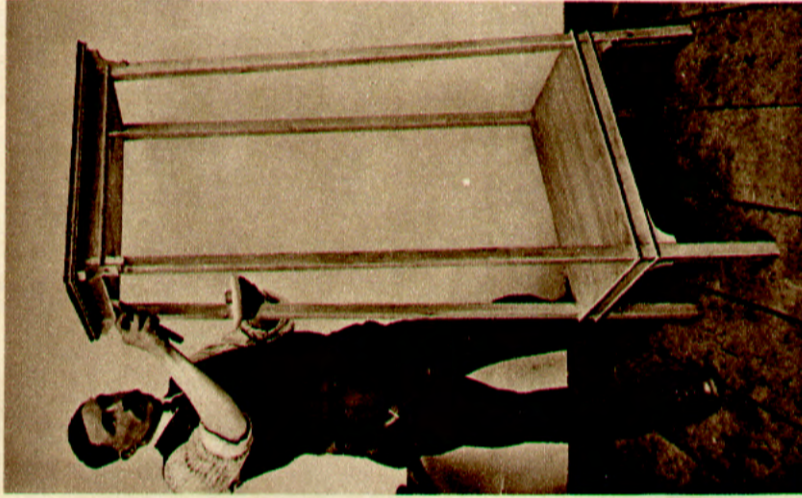
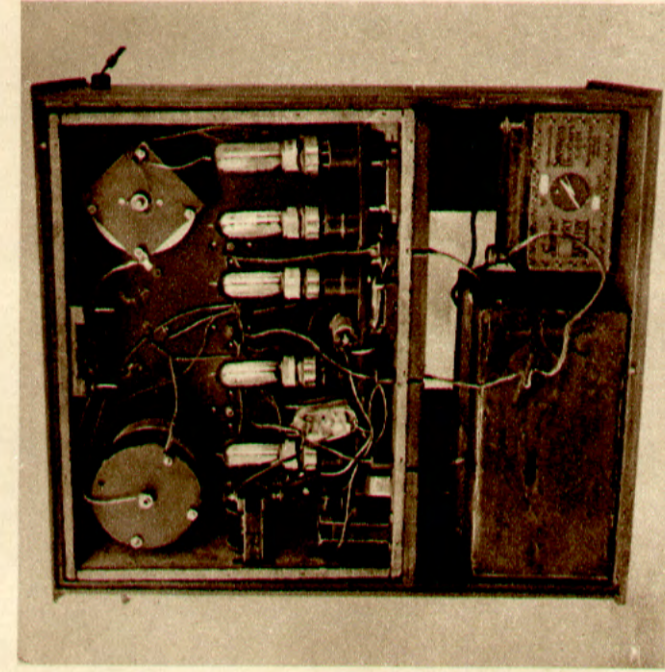

Fig. 13. The stand completed, nail holes being stopped with beeswax

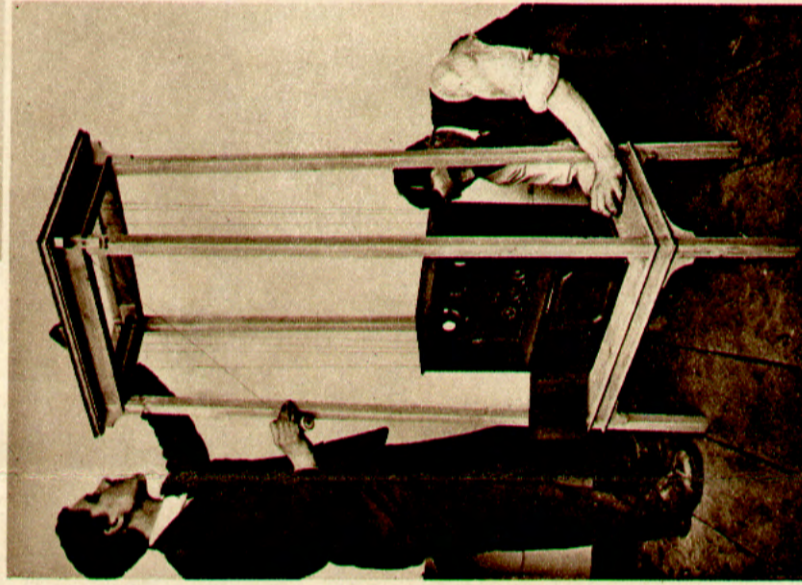

Fig. 14. Receiver in place, aerial wires being strung on ebonite rods

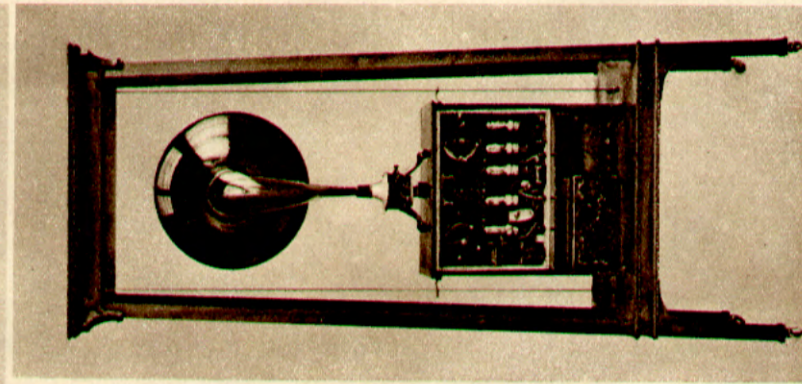

Fig. 15. Set complete with loud speaker, back view

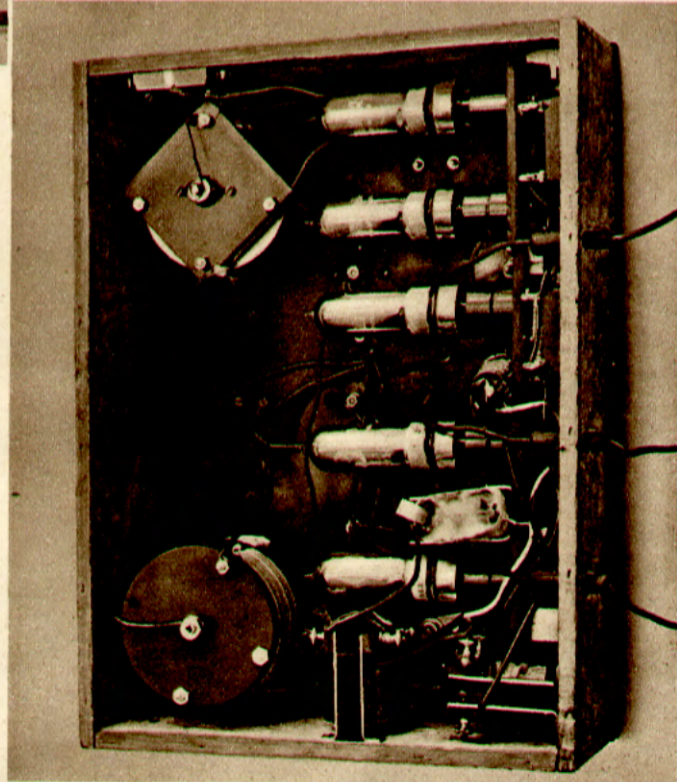

Fig. 11. Interior view showing wiring, dull-emitter valves, grid batteries, and tuning condensers

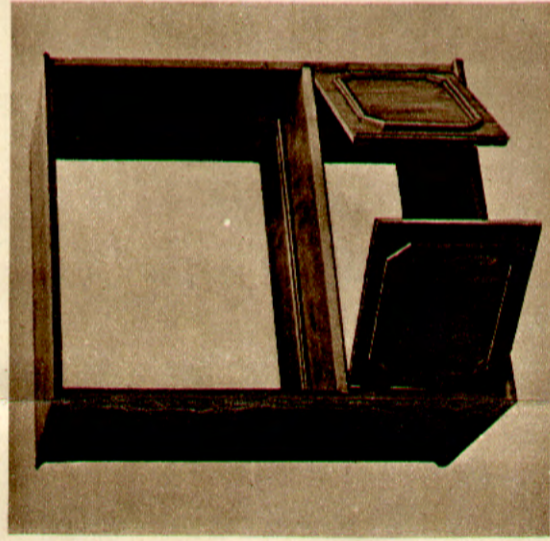

Fig. 12. Cabinet for the receiving set completed, before staining

**FRAME AERIAL RECEIVING SET: SELF-CONTAINED RECEIVER WITH INTERNAL BATTERIES AND NO EXTERNAL CONNEXIONS, GIVING LOUD-SPEAKER RESULTS UP TO 200 MILES**

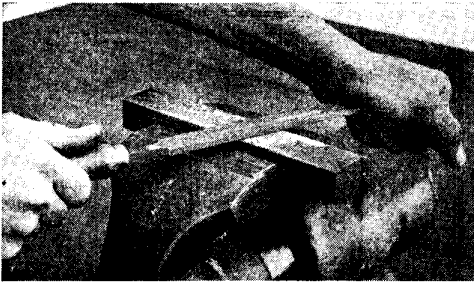

Fig. 2. Flat filing is in operation, and the photograph shows the correct position for the hands. The filing in this case is coarse

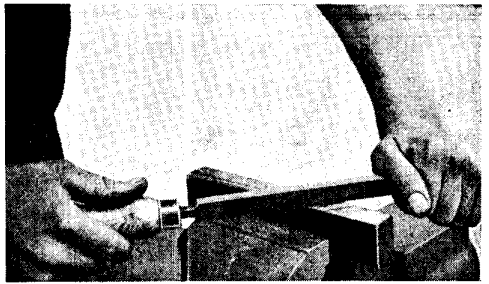

Fig. 3. At the commencement the rough edge of the file is used in this way to remove quickly the surface of the metal



Fig. 4. When casing out a hole with a round file the worker's hands appear as shown here

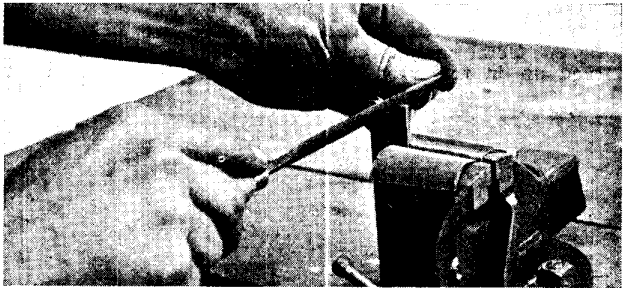

Fig. 5. Concave surfaces are made by using a half-round file

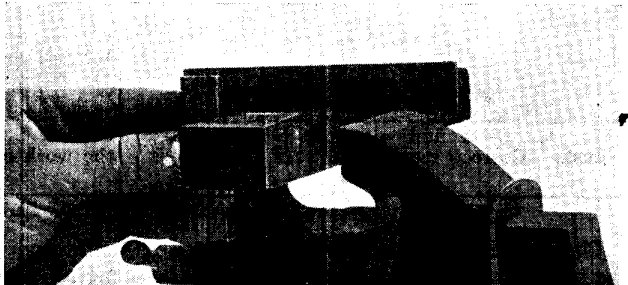

Fig. 6. Flat surfaces should be tested after filing with a steel square. A line of light shows a hollow place across the work

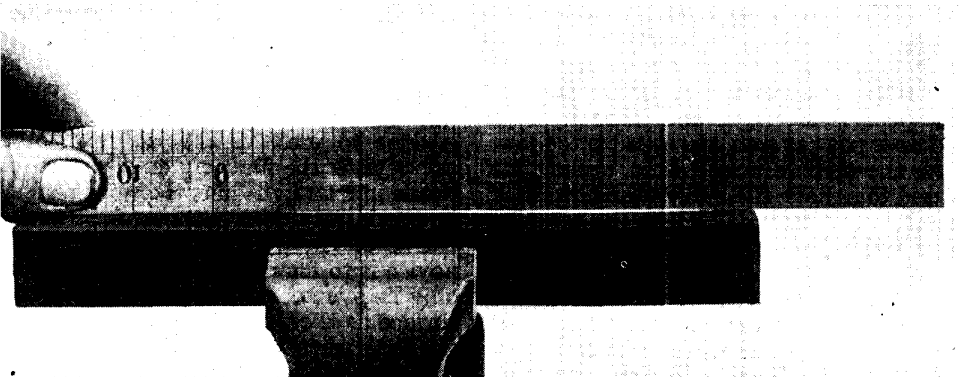

Fig. 7. Testing should be carried out in two ways when a flat surface is filed. A steel rule or straight-edge is used as illustrated to find the uneven places along the work, as compared with a square across the work as in Fig. 6

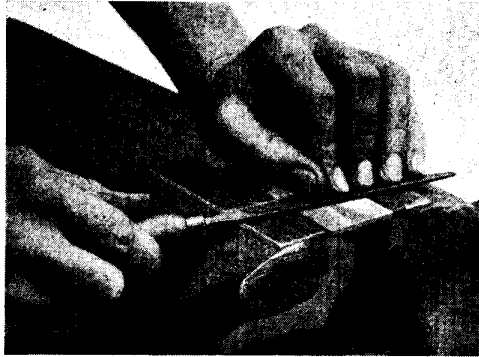

Fig. 8. Metal surfaces can be flattened and trued up in this way. The work must be firmly held

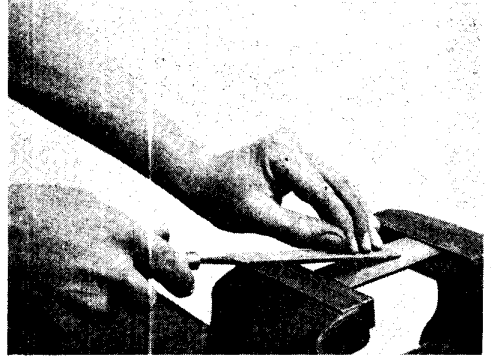

Fig. 9. One way to remove a defect or high piece on the surface is illustrated. This is known as local filing

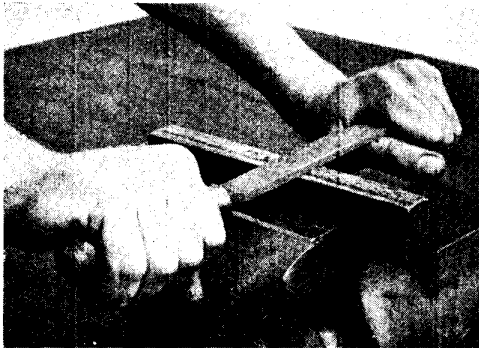

Fig. 10. Draw filing produces a fine surface finish. Correct manipulation of the file is shown

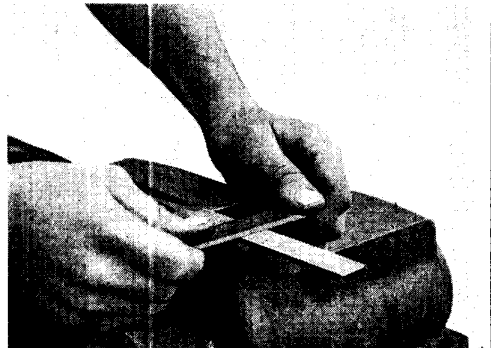

Fig. 11. Small articles can be filed by pushing the work over the file held in a vice, instead of handling the file

#### CORRECT MANIPULATION OF FLAT FILES

The speed of the file is also important, the novice having a tendency to work too quickly. The file ought to make about 25 to 30 strokes per minute on average work, cutting only on the forward stroke. The best guide for the beginner is to study the chips. If these come away freely and easily, there is nothing much amiss, but if the file skates or slips over the surface, the speed is too high, and when it drags and does not cut well, the speed is too low.

At the start a rough or a milling file is used to remove the bulk of the unwanted metal. Another wrinkle is to use the edge of an ordinary hand-flat file in the manner shown in Fig. 3, but in this case file diagonally across the work, first in one direction and then in the opposite. The smaller files, such as those of 6 in. length, are more readily controlled by gripping the point between the finger and thumb. The position of the hands as they appear to the worker when using a round file is shown in Fig. 4, where the file is shown

enlarging the hole through a piece of metal.

Half-round files are chiefly used for filing concave surfaces, and to do this they are held as in Fig. 5, and the filing accomplished with a compound movement. The file is pushed forward bodily and at the same time is swept round, or slightly twisted between the fingers, so that it travels across and along the work. This is done to preserve the fair form of the curve, as if the file were only pushed outwards in a straight line, the work would be in a series of ridges.

One of the greatest difficulties for the novice is to file a flat surface, and this can only be overcome by careful testing of the surface as the work proceeds. One of the simplest ways to do this is to apply the edge of a straight steel rule to the work, as shown in Fig. 7, and to look across the surface, when the hollow places will be revealed by the presence of a line of light. Another plan is to use a steel square, as

shown in Fig. 6, when the errors are similarly revealed. The latter test should always be applied when attempting to file one edge square, or at right angles to another.

When either of these tests reveals the high spots, they should be noted and the filing localized to them. There are several wrinkles that the novice can adopt, and one is to hold the file flat on the work, as shown in Fig. 8, and to work the file to and fro over the metal with a short stroke, keeping the fingers of the left hand pressing on the file while on the cutting stroke and releasing the pressure on the return stroke.

Another plan, especially useful when the work is comparatively long, is shown in Fig. 9, and consists of employing only the extreme end or point of the file, and making very short strokes with it. In the ordinary way the work is started with a rough file, further smoothed and trued up with a second file, and finished with the finest files.

A method of getting a nice finish is to adopt the plan known as draw-filing, illustrated in Fig. 10. This is accomplished by grasping the file in both hands, and while standing so that the file can be worked along the surface, the file is pushed along it. Thus the teeth do not cut quite so quickly, and the surface is more or less grained in appearance when the work is completed.

A method that is sometimes adopted successfully is to grip the file in the vice, as shown in Fig. 11, and to push the work

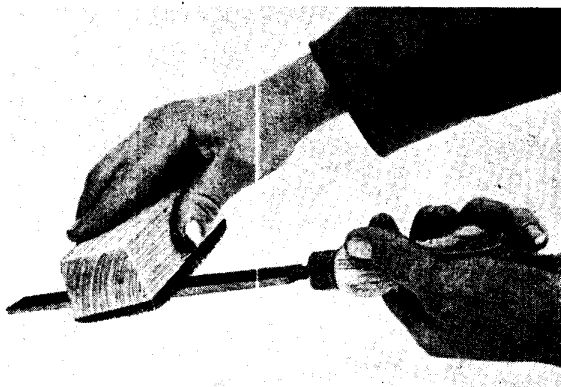

**CLEANING A FILE WITH A FILE CARD**

Fig. 12. When a file becomes clogged with particles of the material worked upon, a file card is used as illustrated. The movement is made in the direction of the grooves in the file

over the file. The sense of touch will readily show when the work is held flat on the file, and the result on small pieces is generally quite satisfactory.

Rounded edges are often needed by the wireless worker, especially on the bases of ebonite blocks, and the way to manipulate the file for this work is shown in Fig. 13. The left hand is depressed and the right hand raised simultaneously, while the file as a whole is pushed forwards, thus producing a rounded edge on the work, which can be trued up occasionally during the process by filing longways on the edge.

Round bars are best filed in a lathe, and the way this is done is illustrated in Fig. 14, by clucking the work and revolving the lathe at the customary speed for the material as if turning it. The file is held as shown, and worked forwards over the surface as it revolves, pushing it somewhat slowly.

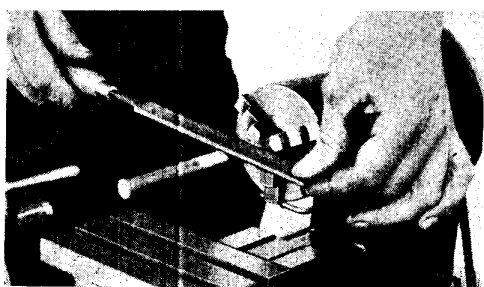
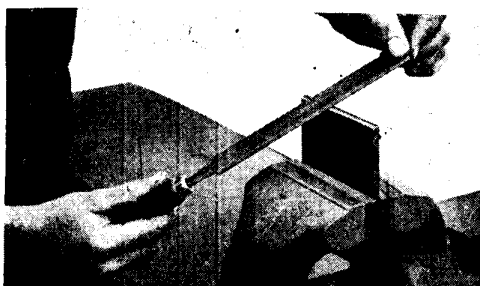

**CORRECT METHODS FOR FILING ROUND SURFACES**

Fig. 13 (left). Round edges are produced by filing in this way. The operator is standing as near side-ways as the bench will allow, and a combined sweeping or rolling and a pushing motion is made.

Fig. 14 (right). Round rods are conveniently filed while revolving in a lathe

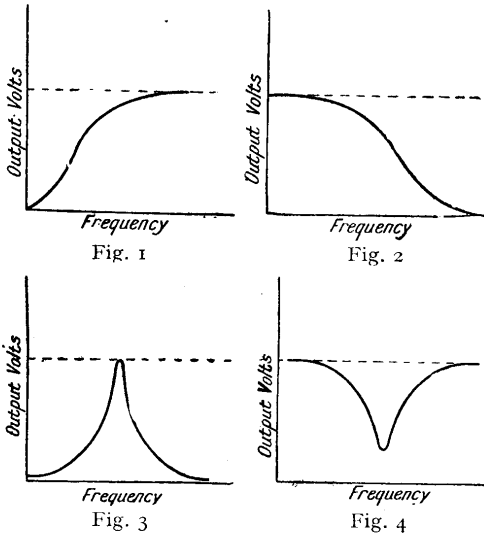

**CHARACTERISTIC CURVES FOR FILTER CIRCUITS**

Fig. 1. Resistance capacity is represented in this curve. Fig. 2. In this case the curve shows resistance inductance. Fig. 3. Resistance-inductance capacity is here represented. Fig. 4. This curve shows modified values of Fig. 3

After a file has been in use for a while the teeth become clogged with particles of metal, and these must be removed without delay, as they cause scratches on the work. A file card is used for this purpose, and is brushed sideways across the file while it is held at an angle on the bench, as illustrated in Fig. 12. Preventives for clogging are to rub the teeth with French chalk, especially when filing copper or aluminium.

To obtain the best results from files, always use new files on brass or soft metals, and keep the worn files for use on steel or iron; the worn files cut the steel faster than new ones, and do not choke up so readily. Files, when not in use, should be kept in a rack and not allowed to rub or touch each other, as this only damages the teeth. As files are made of a good grade of hard-cast steel, when they are no longer useful as files they may be thoroughly annealed and cut up into pieces for other tools—drills and the like—and subsequently re-hardened and tempered.

**FILTER CIRCUITS.** The purpose of a "filter" is to exclude currents of a definite frequency from any selected part of a circuit without, however, preventing the free passage of currents at other

frequencies. The filter, in other words, acts as a selective conductor which will pass through signals of one frequency better than it does any others which may be undesirable.

A filter may be aperiodic, that is, having no natural period of its own, which is the case when it consists of resistance and inductance, or resistance and capacity. Or it may be periodic, in which case it will contain inductance and capacity and possess a natural period of oscillation of its own. Different arrangements of filters will have different characteristics, which can be represented by Figs. 1, 2, 3, and 4. In reading these figures it is supposed that a signal of a certain fixed amplitude is impressed upon the input terminals of the filter circuit, and the voltage resulting at the output terminals is then plotted against the frequency.

Fig. 1 shows the characteristic of a filter containing only resistance and inductance. Fig. 2 represents the characteristic obtained with resistance and capacity in the filter circuit. Fig. 3 is the result of combining resistance, inductance and capacity, and Fig. 4 a different combination of the same factors. The so-called "band" filters pass a certain range of frequencies by correctly proportioning the values, while attenuating all other signals lying outside such ranges.

Any combination of inductance and capacity taken at random will oppose currents of one frequency in particular; and the value of this will depend principally upon the values chosen for the inductance and capacity. In order, therefore, to make the filter effective against currents of a certain chosen frequency, the capacity and inductance of the filter

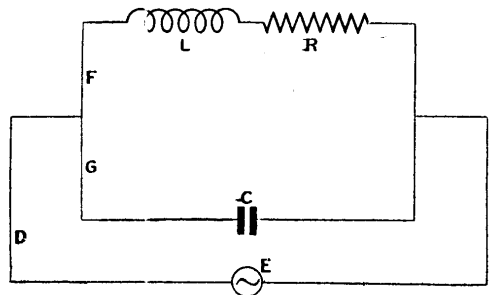

**PRINCIPLE OF PARALLEL RESONANCE**

Fig. 5. Experiments can be carried out with a circuit arranged as above, by inserting three ammeters, at D, F, and G, and varying the capacity of C

circuit must be adjusted to have a definite relation to the conditions of reception. This involves a knowledge of the principles of parallel resonance.

In Fig. 5 an inductance coil,  $L$ , is shown in series with a resistance,  $R$ , joined in parallel with a capacity,  $C$ . A current,  $D$ , flowing from an alternating source of electro-motive force,  $E$ , will branch partly through  $F$  and partly through  $G$ , the algebraic sum of  $F$  and  $G$  being equal at all times to that of  $D$ . By introducing suitable ammeters in each of the three circuits  $D$ ,  $F$ , and  $G$ , the following experimental facts can be observed on varying the capacity  $C$ . The currents in the inductance  $L$  and condenser  $C$  may be found at first unequal in value, while that in the main circuit  $D$  is less than either. By varying the value of the capacity, however, the currents in  $L$  and  $C$

which will not prevent the passage of currents at any other frequency than the one to which it has been adjusted.

Instead of tuning the filter by varying its capacity, it would, of course, be possible to obtain resonance by varying the inductance  $L$ . Or, again, resonance might result simply from a change in the frequency.

A filter is generally employed with high-frequency amplifiers for preventing signals from other stations than the one sought being amplified and so interfering with reception. Also it prevents, to a large extent, currents due to "strays" and "atmospherics" from reaching the operator.

A typical filter circuit applied to a high-frequency amplifier is shown in Fig. 6. This type of filter acts as a barrier not only to interference from high-frequency currents, but also to low-frequency static

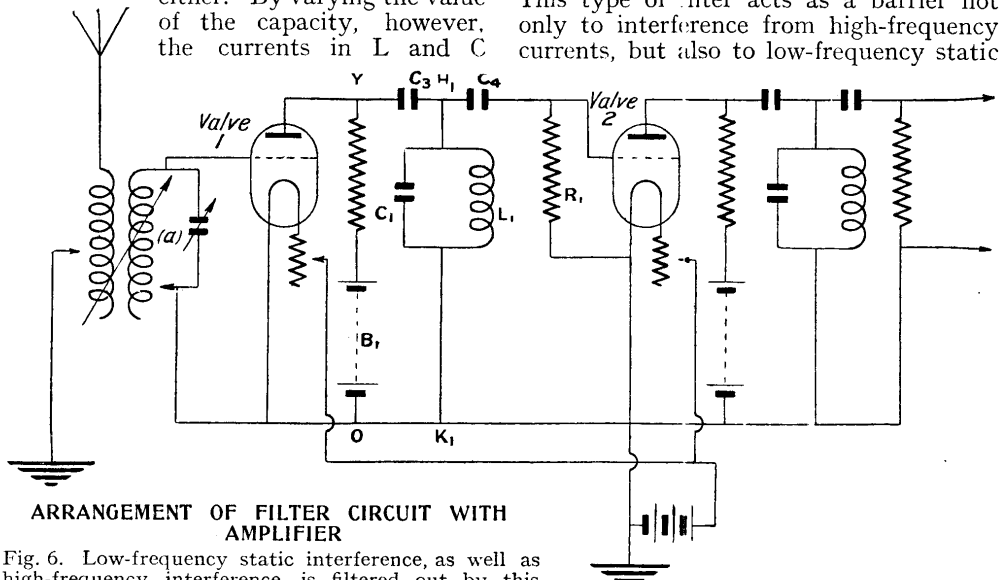

Fig. 6. Low-frequency static interference, as well as high-frequency interference, is filtered out by this means. The tuned receiving circuit is at (a), and the circuit  $C_1, L_1$  is tuned to the frequency to be amplified

may be made to approach equality, and at the same time the current in  $D$  will diminish. There will be found some critical value of capacity where the current in  $D$  almost vanishes, provided the frequency is kept at the same value throughout the adjustments.

The operation of the filter can be gathered from the above phenomena, since a troublesome electro-motive force giving rise to undesirable currents in circuit  $E$  may be practically neutralized by the provision of a suitable value of inductance and capacity coupled in parallel, but

interference. All incoming currents which go past the tuned receiving circuit (a) will produce varying voltages across the grid filament of the first valve, and will be amplified into the plate circuit of this valve. Across the points  $Y$  and  $O$  is connected the circuit  $C_3, H_1, K_1, O$ ; the circuit from  $H_1, K_1$  consists of  $L_1, C_1$  in multiple with the grid condenser  $C_4$ , the leak resistance  $R_1$ , and the grid and filament of the second valve. The condenser  $C_3$  serves the purpose of keeping the battery  $B_1$  from sending any current into the circuit from  $H_1$  to  $O$ , and should be made

quite large, so as to have a low reactance at a low frequency, such as 1,000 cycles or even less. The circuit  $L_1, C_1$  is the one that is tuned to the frequency which it is desired to amplify, and at this frequency it naturally has a very high impedance; while at all other frequencies, higher or lower, it offers much less impedance. The characteristic of such a filter would be similar to that shown in Fig. 3. See Acceptor Circuit; Atmospherics; Franklin Circuits; Rejector Circuit.

**FILTER CONDENSER.** The condenser forming part of a "wave trap" or "wave filter" or filter circuit (*q.v.*). One periodic type of wave filter consists of an acceptor circuit and provides a means for reducing or eliminating local interference.

Such an acceptor circuit offers the greatest resistance to waves of its resonance frequency, so that it absorbs these while permitting other wave-lengths to pass through it. The oscillatory circuit of a wave filter contains inductance, resistance, and capacity. The filter condenser affords a means of adjusting the last and tuning the wave filter to the frequency it is desired to eliminate.

It usually consists of a variable air condenser with a maximum capacity of .0005 mfd., combined with a suitable inductance. Each wave trap only removes one interfering wave, but several filters may be arranged in series. Plug-in coils afford a ready means of approximation to desired wave-lengths.

To use a filter, the filter condenser is varied until the interfering sound is eliminated. Aerial tuning may alter slightly in consequence, and this may require a little readjustment of the aerial tuning condenser. The filter may be either in series with the aerial, or inductively coupled to it.

**FILTER PAPER.** Name applied to a particularly pure form of semi-porous paper used as a means of filtering a liquid. The paper is obtained in circular form and in different diameters. In use the paper is suspended over the neck of a bottle or other suitable receptacle and the liquid to be filtered poured slowly on it. The filtration is better carried out by making a conical-shaped funnel, by forming a pleat in one side of the disk.

The funnel so formed is placed in the neck of a bottle or test tube and the liquid allowed to percolate slowly through the filter paper.

**FILTRON.** Trade name for various wireless accessories. One useful piece of apparatus bearing this name is the Filtron combined grid leak and condenser, shown in Fig. 1. The special feature is the fact that the condenser and the grid leak are

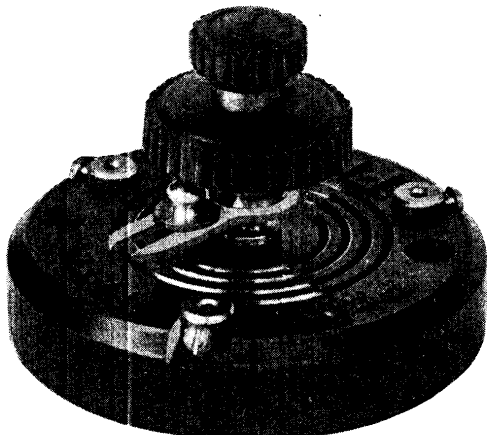

**FILTRON GRID LEAK AND CONDENSER**

Fig. 1. Both the condenser and the grid leak are variable, and are controlled by the two corrugated ebonite knobs

both variable by rotation of the knobs seen at the top of the appliance.

An underside view of the interior is given in Fig. 2, and this shows the two plates of the condenser with connexions to

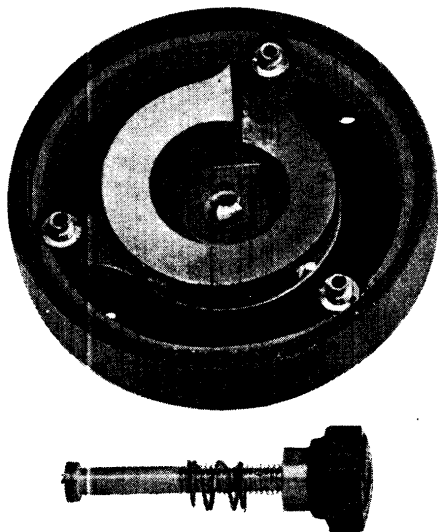

**UNDERSIDE OF FILTRON LEAK-CONDENSER**

Fig. 2. An underside view is given of the interior of the combined condenser and grid leak shown in Fig. 1. The spindle which operates the moving plate of the condenser is shown below



the terminals. The other moving plate of the condenser is a small disk seen at the right of Fig. 3. This is attached to the spindle, seen separately with its knob, which, when rotated, compresses the plates and varies the value of the condenser. The plates are separated by mica sheets.

long lever handle, such as those shown below, which are applicable to anything in the nature of a movable coil holder spindle. It is imperative that the lever be securely attached to the spindle, and that the whole can move smoothly. Under these conditions the lever has much to commend it.

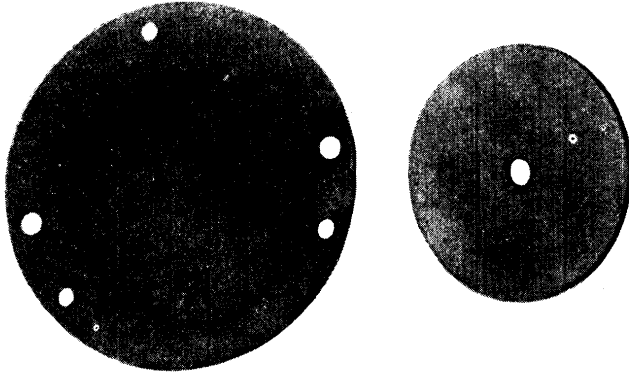

COMPONENTS OF FILTRON CONDENSER

Fig. 3. These are parts of the Filtron grid leak and condenser in Fig. 1. Left is a fibre disk covering the base and right a moving condenser plate

The whole is enclosed within a cavity in the base, and this is covered with a fibre sheet disk seen at the right of Fig. 3.

The variation of the value of the grid leak is obtained by revolving the larger knob seen in Fig. 1, which propels a small pencil of graphite around a spiral groove formed in the base. The current enters the leak by the separate terminal and is tapped at the point where the pencil comes to rest, and is from there conveyed to the circuit by the opposite terminal. There are many uses for this device in receiving circuits.

Fig. 3 shows the connexions for the terminals in two applications. That on the left shows the use of the Filtron for high-frequency capacity-resistance coupling, and on the right in its normal function of variable grid leak and condenser. See Condenser; Grid Leak.

**FINE ADJUSTMENT**

**DEVICES.** Term applied to any apparatus employed for the purpose of making very small adjustments in the relative positions of two pieces of wireless apparatus. The need for fine adjustments in the highly developed receiving sets is very necessary, and one of the simplest ways is to use a

Alternatively, a device as illustrated at the bottom of the photograph can be employed, more especially with the large-diameter dial and knob used on condensers. The device comprises a long ebonite handle. One end is knurled, the other has a small rubber wheel and a projecting spindle. The latter turns in a metal bushing, which has to be fixed into the panel at the side of the rim of the dial. The pencil, when inserted into the bush

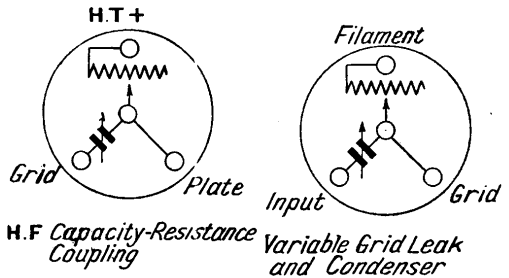

FILTRON LEAK AND CONDENSER CONNEXIONS

Fig. 4. Two applications of the Filtron grid leak and condenser are shown diagrammatically. Connexions are made to the terminals as indicated above

and pressed home, forces the rubber wheel into contact with the dial, and thus by rotating the pencil the dial is moved a very small amount. The finest

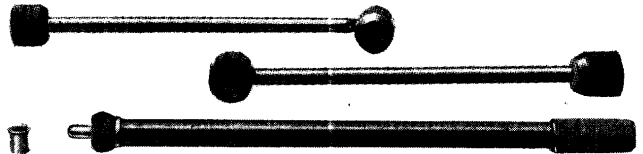

FINE ADJUSTMENT LEVER HANDLE

Long handles with ebonite insulating knobs are used for the fine adjustments necessary on many of the modern receiving sets, which are critical in their tuning. Three examples are illustrated

tuning is possible by a mere pressure with the fingers on the end of the pencil, by imparting the least trace of a twist. One pencil will adjust an unlimited number of dials if all are fitted with bushed panels. A photograph of the device in use appears on page 484.

**FIRMER CHISEL.** Name applied to what is popularly known as a chisel, a carpenter's cutting tool specially adapted for the shaping of wood. A typical pattern is illustrated in use, and comprises a flat steel blade tapered at the upper or working end. The other end is reduced to an approximate octagonal shape with a tang forged upon it. This tang is driven



STERLING FIXED CONDENSER

Fixed condensers are made in many patterns and various capacities. Here is a .00005 fixed condenser with mica dielectric

In the standard example illustrated the condenser plates are separated by mica sheets, and the number of the metal foil condenser plates is arranged in course of manufacture to give the desired values. The alternate plates are connected to the

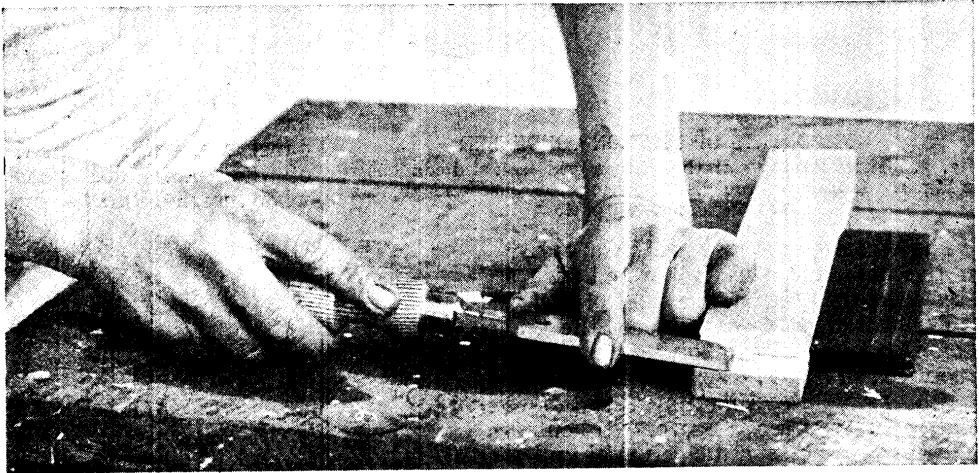

HOW TO USE A FIRMER CHISEL

Many jobs in the course of the construction of wireless apparatus have to be carried out with the aid of a firmer chisel. In the photograph above the operator is cutting a step-shaped section from a piece of wood, and the chisel in use is of the handled firmer type. For the particular job in operation, it is interesting to note how the chisel is held. The left hand is being used to steady and guide the chisel

into the centre of a hardwood handle, which may be shaped to any convenient form adapted to the need, and strengthened at the upper end with a ferrule of brass or steel.

A convenient range of sizes for experimenters' use is  $\frac{1}{4}$ ,  $\frac{3}{8}$ ,  $\frac{1}{2}$ ,  $\frac{3}{4}$  in. and 1 in. in width. They should always be kept sharp and keen by grinding, and a keen edge maintained by frequent use of the oilstone. See Chisel; Grindstone; Oilstone.

**FIXED CONDENSERS.** A condenser having a known and fixed value. Usually, this class of condenser, as employed in amateur wireless receiving sets, is of the mica dielectric type and comparatively low in value.

strips of metal seen at each side of the moulded composition case. The plates and the dielectric are contained within a cavity in the base, and embedded in wax. Connexions are made by soldering the conductors to the projecting lugs. The two small screws on each plate should not be touched, or the condenser may be damaged. This type of condenser is used extensively in most wireless sets, and ranges in value from .0001 mfd. to .005 mfd. Many other varieties and types are manufactured, suited to all the varying needs of the experimenter. See Block Condenser; Condenser; Mansbridge Condenser.

**FIXED DISCHARGER.** A fixed discharger is a spark gap in which the electrodes are not moved in any way during

discharging. Such a spark gap may be quenched or not, and the width of the gap may be varied as required. See Discharger; Spark Gap.

**FLAME ARC.** An arc produced between carbons impregnated with or having a core of certain chemicals, as calcium fluoride. Calcium salts are most generally used for flame arcs, and are in the core of the electrodes in a solid state when cold, and are insulators, becoming conductors when evaporated. See Arc Lamp.

**FLAME MICROPHONE.** This apparatus, also known as the varying flame photophone, embodies the principle of König's manometric flames with the photo-sensitivity of a selenium cell. König's manometric capsule consists of a thin rubber membrane, dividing a sound box and a gas chamber, leading to a coal gas flame.

Pulsations are set up in this flame when the mouthpiece is spoken into. The alterations in flame height are so rapid that they cannot be seen directly, but a rotating mirror resolves them into repeating forms characteristic of the note sounded. Such flame fluctuations correspond to the modulated continuous waves used in wireless telephony.

In the flame microphone they are rendered audible by a telephone in the battery circuit attached to a selenium cell. This reproduces speech accurately through the conductivity of the selenium varying with the illumination concentrated upon it. This form of microphone has almost been forgotten, owing to the difficulties surrounding the transmission of speech over even a short distance. See Photophone.

**FLASH-LAMP BATTERY.** Name applied to a small primary or storage battery used to light the electric bulbs used in pocket flash-lamps.

In a typical example illustrated the battery consists of three dry cells connected in series with an electro-motive force of about  $4\frac{1}{2}$  volts. They are extensively used in wireless work as the elements of a high-tension or B Battery (*q.v.*), and have applications as grid-biasing batteries. Varieties are made on the lines of small accumulators, which require charging in the usual way. See Dry Battery.

**FLAT BRASS STRIP.** Term used to describe rectangular-sectioned brass bars when the width is greater than the thickness. There are many uses in wireless

work for this material, especially as it can be obtained in a wide range of sizes. For example, strips measuring  $\frac{1}{2}$  in. wide and  $\frac{1}{16}$  in. thick make excellent angle brackets for support of various accessories.

These are simply made by cutting the material to length and filing the ends smooth. Grip the strip in a vice and gently hammer it over as shown in Fig. 1. The bend should not be too sudden, or the metal will very likely crack at the bend, but this is entirely obviated by making the corner slightly rounded, as shown in the illustration. The bulk of the hammering should be concentrated about  $\frac{1}{2}$  in. from the bend.

Thicker strip is better annealed before bending, but the material should never be bent while it is hot, as the strength of brass is practically nil when hot. The thinner strips are excellent for making laminated arms for contact purposes, and one such is illustrated in Fig. 2, where four strips are shown bent over at the ends and secured by riveting them together with a small copper rivet. Two rivets should be used, and when they have been closed the strips can be touched up and trued with the hammer and the contact faces filed flat and smoothed with emery paper.



FLASH-LAMP BATTERY

Batteries used in ordinary pocket flash-lamps, electric torches, and the like, are very useful to the wireless experimenter. These batteries have the advantages of being easily and quickly replaceable, and are inexpensive

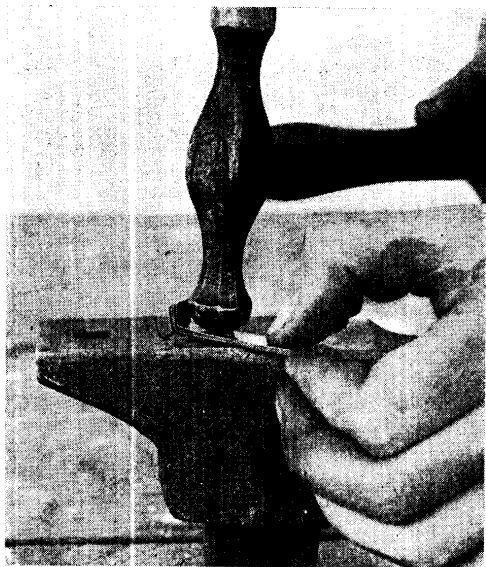

**HOW FLAT BRASS STRIP IS BENT AND RIVETED**

Fig. 1 (left). Brass strip is bent with a hammer, holding the work in a vice. The blows should be delivered gently a small distance from the bend. Fig. 2 (right). Laminations can be riveted together to form a switch arm. The operator is seen flattening the small copper rivet with the round side of the hammer

Other uses include the connecting strips between terminals as bus bars, and for constructional purposes generally. The metal generally used in these strips is a hard-drawn brass, and the surface is, as a rule, sufficiently good not to require any special finishing.

**FLAT CONNECTING TERMINALS.** An arrangement of terminals and a brass or other conducting strip which is used to

connect one or other of two or more terminals.

It is illustrated in a very common application, which shows the flat strip attached to a terminal on the left by a hole through the strip. The other end of the strip has a slot so that the strip can be slipped under the other terminal and both secured by the upper terminal nuts. Such connecting terminals are often employed, where reaction or loading terminals are on a receiving set, for the addition of reaction or loading coils when required. The metal should be clean and smooth, especially at the edges, and the terminal nuts tightened to ensure perfect contact. The connecting strips are removed when the loading coils are put into the circuit. *See Connecting Strips.*

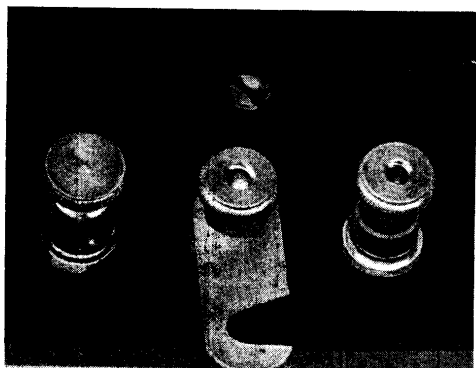

**FLAT TERMINAL CONNECTOR**

Two or more terminals can be connected in this way. Usually only two terminals are used, and the strip connecting them is slotted to allow quick connecting and disconnecting

**FLAT-TOP AERIAL.** This is a term often used for an aerial whose upper portion is parallel to the earth. The ordinary multiple-wire horizontal aerial is a flat-top aerial. *See Aerial.*

**FLAT-TOP WAVE.** A name given to the type of oscillations in the anode circuit of a thermionic valve working between upper and lower saturation points in the characteristic curve of the valve. Since at these bends in the curve the relative value of the plate voltage to

the grid voltage falls off considerably, the conventional or graphic form of sine curve is not followed, but the upper part of the wave crest is lowered or flattened. The illustration shows the deviation of a flat-top wave from the ideal sine curve. See Characteristics of Valves; Curve, etc.

**FLAT TUNING.** The reverse effect to sharp tuning of an oscillating circuit to electric waves of a definite frequency. The circuit is said to be sharply tuned when a slight change in the wave-length produces a marked reduction in induced alternating currents, and flat when this is not the case. See Tuning.

**FLATS.** Portions of a commutator or slip rings which become burnt away or flattened by excessive sparking.

**FLEMING, JOHN AMBROSE.** British wireless expert. Born in Lancaster, Nov. 29th, 1849, he was educated at University College, London, the Royal School of Mines, and St. John's College, Cambridge.

From 1873-74 Fleming was demonstrator at the Royal College of Chemistry, and in 1877 he began work under Clerk-Maxwell at the Cavendish Laboratory, Cambridge. There he carried out a series of experimental researches on the British Association standards of electrical resistance.

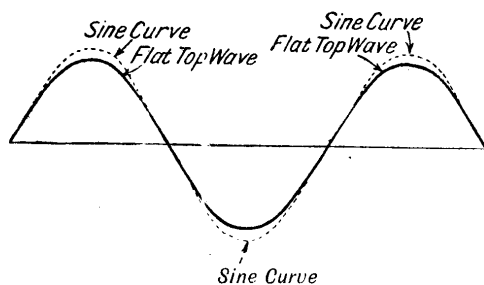

FLAT-TOP WAVE

Two waves are indicated in this curve, an ideal sine wave, shown by a dotted line, and a flat-top wave, shown by a black line departing from the sine wave

In 1881 Dr. Fleming was appointed the first professor of mathematics and physics at University College, Nottingham, but the following year he joined the Edison Electric Light Company, and on the amalgamation of the Edison and Swan Companies he was appointed advising electrician, a post he held for twenty years. In 1885 Fleming was appointed to the newly-founded professorship of electrical engineering at University College, London, and he was entirely responsible for the design and equipment of the new electrical and engineering laboratories which were opened in 1893. In 1892 he was elected Fellow of the Royal Society.

Dr. Fleming has been very closely associated for many years with wireless telegraphy and telephony, and has since 1890 acted as the scientific adviser to Marconi's Wireless Telegraph Company. He is well known as the inventor of the thermionic two-electrode valve, or glow-lamp detector, which was one of the greatest steps forward in wireless telephony.

Fleming has written a very large number of papers and books on wireless telegraphy and telephony, and his "Principles of Electric Wave Telegraphy" is the standard treatise on the subject. He has also published an "Elementary Manual of Radiotelegraphy and Radiotelephony"; "The Wonders of Wireless Telegraphy"; "The Thermionic Valve and its Development"; "A Pocket

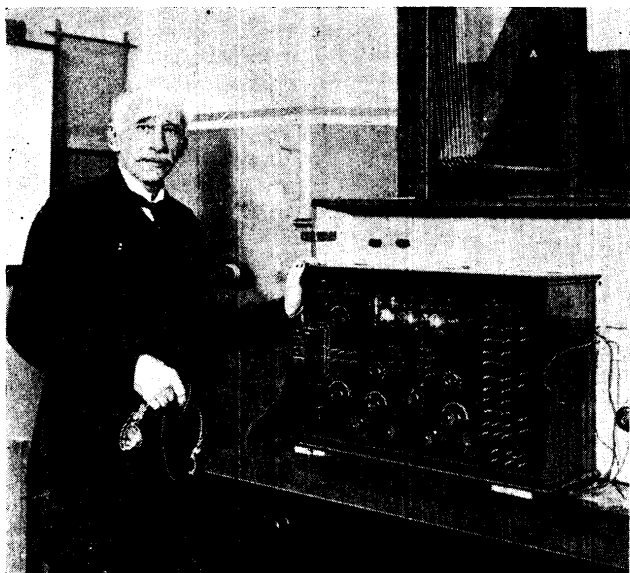

PROFESSOR JOHN AMBROSE FLEMING

Fleming crowned the long series of important discoveries which made wireless practical for the layman by inventing the two-electrode valve which bears his name. Many advances in electrical and radio science have followed his investigations

Book for Wireless Telegraphists," and other books. As a Cantor lecturer at the Royal Society of Arts he has obtained a world-wide reputation for his lectures on electric oscillations and electric waves, Hertzian wave telegraphy, high-frequency measurements, etc. He has given many lectures, too, on wireless at the Royal Institution.

Dr Fleming was awarded the Hughes gold medal of the Royal Society in 1910 as an acknowledgment of the value of his work in electrical science and engineering, and he has twice been awarded the Institution Premium of the Institution of Electrical Engineers, the highest award

for communicated papers, and he is an Albert Gold Medallist of the Royal Society of Arts, awarded to him for the pioneer invention of the thermionic valve.

**FLEMING COHERER.** Form of coherer invented by J. A. Fleming. It consists of two L-shaped pieces of silver, A, A, which are fastened on either side to a thin slip of fibre or ivory, B. In this slip of ivory is cut out a U-shaped depression to form a small cavity, two sides of this cavity being the silver pieces on each side of the ivory slip. In the cavity are placed freshly made nickel filings, and the top of the cavity is closed by a wedge of wood, as shown in the illustration.

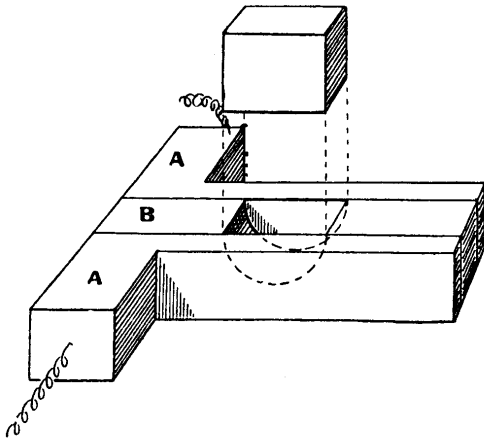

**SILVER AND IVORY COHERER**

Fleming's coherer is represented above. A, A are silver sections and B an ivory or fibre section. Fresh nickel filings are placed in the cavity below the wood block, which is inserted in B

The coherer is attached to the vibrating armature of an electro-magnet. There are two screw stops which prevent too great a play of this armature. In series with the coherer is a relay and a single dry cell. The relay closes the circuit of another cell through the electro-magnet, and also another circuit, that of a large electric bell or Morse printing telegraphic instrument. When an electric wave falls on the coherer the vibrating armature of the electro-magnet restores the filings of the coherer back to a non-conductive condition. This type of coherer is very easy to adjust, and is very efficient in action. See Coherer.

**FLEMING CYMOMETER.** This is a form of wave-meter invented by Dr. J. A. Fleming. It is a direct-reading portable cymometer, which may also be used for the measurement of small capacities, inductances and coefficients of coupling of oscillation transformers. It is described in this Encyclopedia under the heading Cymometer, on page 637. See also Wave-meter.

**FLEMING'S RULE.** A method of visualizing the directional relationships between the lines of magnetic force, the transverse motion of these lines, and the electric force urging an electron along a conducting circuit cut by the expanding pulses of magnetic force. The most complete version by Dr. J. A. Fleming of his rule is as follows:

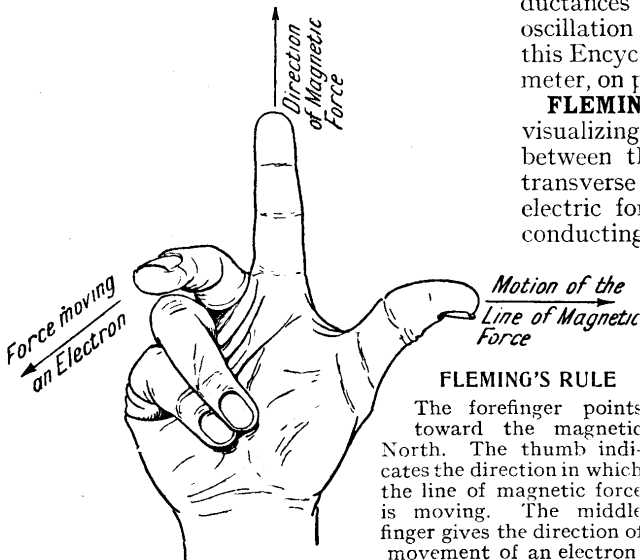

The forefinger and thumb of the right hand are held in the same plane at right angles to each other, and the middle finger at right angles to both. Let the direction in which the forefinger points be the direction of the line of magnetic

force, that means the direction in which the pole of a magnet which points to the earth's North Pole would be moved along it.

Let the direction of the thumb represent the direction in which the aforesaid line of magnetic force is moving trans-

versely to its own direction. Then the direction in which the middle finger points will be the direction in which a negative electron, in a conductor across which this line of magnetic force moves, will be urged by the electric force created by the motion of the line of magnetic force.

## THE FLEMING VALVE: A PIONEER INVENTION

By Professor J. A. Fleming, F.R.S., D.Sc.

Here the well-known scientist and inventor describes his two-electrode thermionic valve, which, as a detector and rectifier of wireless waves, proved itself to be one of the greatest steps forward in the science of wireless communication.

See Detector; Electron; Valve; also the forerunner of the valve, Coherer.

The Fleming valve is an appliance for rectifying high- or low-frequency alternating currents, that is, converting them into unidirectional or direct currents. It is also a detector of electric oscillations and electric waves.

It was invented by the writer of this article in 1904, and has had an enormous influence upon the development of wireless telegraphy and telephony, not only as a new type of detector in itself, but as a very novel departure in a new regime of invention, leading to and inspiring the subsequent invention of the three-electrode thermionic valve amplifier and generator, without which modern wireless telephony as we know it would hardly exist.

It consists of an incandescent electric lamp comprising a filament of carbon, tungsten, or other material, which can be rendered incandescent by an electric current. This filament is sealed in the usual way inside a bulb of glass, silica, or metal and glass, and the bulb is in general highly exhausted of its air. Around the filament is a cylinder of metal which does not touch it, which is attached to a wire sealed through the bulb, and the terminals of the filament and of the cylinder are brought to three binding screws or pins, in a support or socket, as in Fig. 1. Some early types are shown in Fig. 2.

In large valves of this kind the cylinder is generally made of sheet nickel, and is carried on a support, which is clamped to a re-entering tube forming part of the bulb. Valves may be either hard, that is, very high vacuum in the bulb, or soft, that is, low vacuum, or gas-filled with a neutral gas such as argon or helium, at a reduced pressure.

In the case of valves with envelopes or bulbs partly of glass and partly metal, viz., copper sealed to glass, the copper or

metal part of the valve serves the purpose of the metal cylinder or anode.

The mode of operation is as follows. It has long been known that conductors, such as carbon, tungsten, and other substances, when heated to a high temperature emit electrons, or atoms of negative electricity.

These electrons are the free electrons which give electric conductivity to the material. It would be impossible, however, for these electrons to escape in any large number unless three conditions are fulfilled. There must be some source of negative electricity which is connected to the incandescent body, or else the escape of negative electrons from it would leave it with a charge of positive electricity which would prevent any further emission of electrons. Then, again, the electrons which first

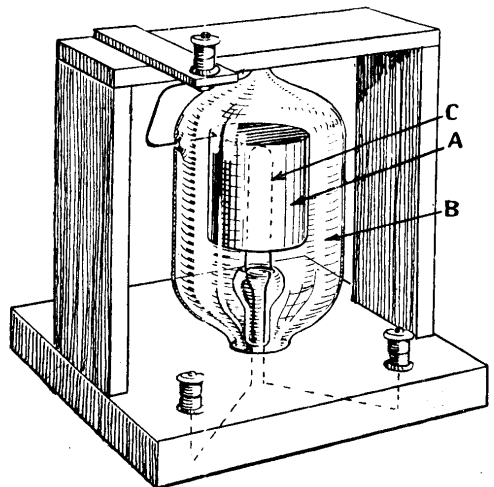

THE FLEMING TWO-ELECTRODE VALVE

Fig. 1. A is the metal cylinder or anode, B the highly exhausted glass bulb. The filament is shown by the dotted loop C

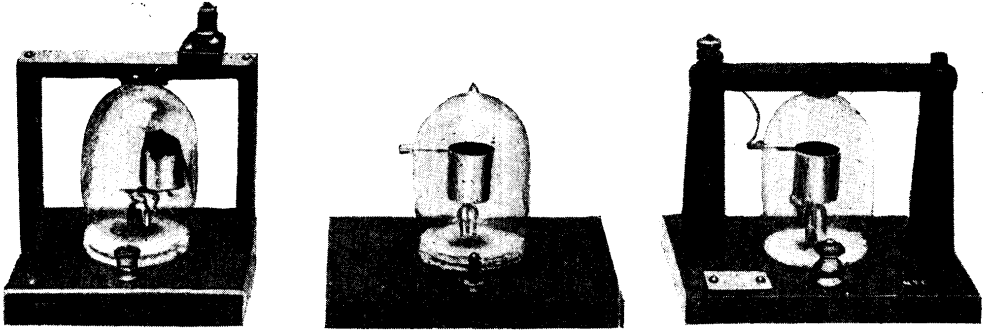

EARLY SPECIMENS OF FLEMING VALVES

Fig. 2. Fleming's two-electrode valve was developed in stages, and some of the early types appear in the above photograph. These were the forerunners of the three-electrode valve that has revolutionized wireless telephony

Courtesy Marconi's Wireless Telegraph Co., Ltd.

escape from a space charge of negative electricity around the filament and by their repulsion for other electrons prevent further emission.

Hence there must be a cylinder of metal around the filament which is kept positively electrified and so continually attracts away the electrons emitted by the filament. Also there must be a good or high vacuum, or else the crowding of air molecules around the filament will prevent the electrons escaping. If, however, we connect the positive pole of a battery to the plate and the negative pole to the filament, and also render the filament incandescent by either direct or alternating current, then electrons will continue to escape from the filament and be drawn

through the vacuous space in the bulb to the cylinder. This electron motion constitutes the thermionic or plate current.

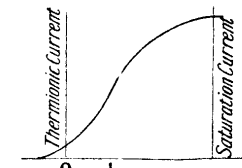
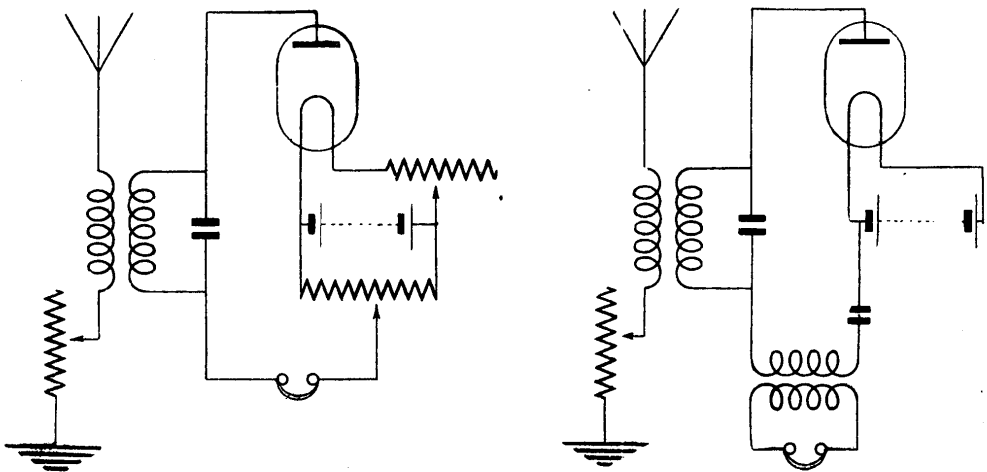

Fig. 3. Potential difference of cylinder and filament is shown in a characteristic curve of a Fleming valve

For every definite temperature of the filament there is a certain maximum rate of escape of electrons per square centimetre of filament surface, and it is clear that the electrons cannot be drawn to the plate faster than they escape from the filament. This maximum thermionic current is called the saturation current for that temperature. Hence for



EXAMPLES OF CIRCUITS EMPLOYING FLEMING VALVES

Fig. 4. Two circuits in which the Fleming two-electrode valve may be employed. Before the grid was added the valve was used as in the two circuits above for some years as the means of detection



every temperature we can plot a characteristic curve for the valve, which is a curve whose abscissae are the potential differences of the cylinder and the negative end of the filament and the ordinates the corresponding thermionic currents, as in Fig. 3. As a matter of fact, this characteristic curve does not start from zero potential difference of plate and filament, but the plate has to be made slightly negative by 0.5 to 1 volt, to make the thermionic current zero.

We can then explain the rectifying action of the instrument, from which its

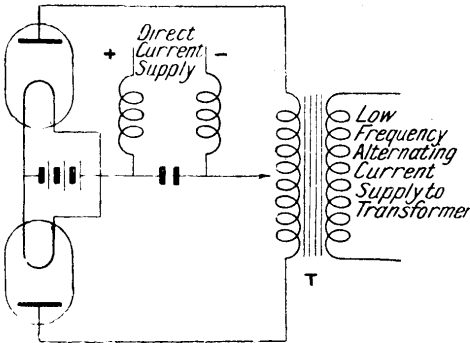

**METHOD OF USING HARD FLEMING VALVES**

Fig. 5. Rectification of both components of an alternating current supplied by a transformer T, by means of two Fleming valves, is produced by a circuit arrangement as in this diagram

name valve is derived, as follows : Suppose the cylinder and filament to be connected outside the bulb by a current which contains some alternating electro-motive force of high- or low-frequency, and also some instrument, such as a telephone or galvanometer, which is sensitive only to direct electric currents. Then, when the electro-motive force is in such direction as to make the cylinder positive, an electron current will be emitted from the filament ; but not when the plate is negative. Accordingly, the electric current through that circuit which includes the vacuous space of the valve will be an intermittent but unidirectional current consisting of gushes of electricity in one direction only.

Hence the galvanometer or other direct current instrument will give an indication. Owing to the high speed at which the electrons move this rectification will take place, no matter how high the frequency of the electro-motive force ; which is not the case with the mechanical or chemical rectifiers

This appliance was therefore used by the writer and patented in all countries as a detector of wireless waves because it enabled the feeble high-frequency oscillations in the receiving circuit of a wireless telegraph plant to be rectified and detected by a galvanometer or telephone. Fig. 4 shows two circuits which may be used with one Fleming valve.

In this manner it was largely used from 1904 to 1910 or 1912 as a wireless detector, until the improvements made by the introduction of the grid caused the so-called three-electrode valve to displace it as a receiving detector.

The chief use of the high-vacuum or hard Fleming valve at present is as a rectifier of high-voltage, low-frequency electro-motive force and current. When so used, two such valves are employed, as shown in Fig. 5, to rectify both phases of the low-frequency alternating current into direct high-voltage current, which is then employed for the plate voltage of three-electrode valves.

In some cases gas-filled valves are employed, as in the so-called Tungar rectifier, to rectify low-frequency alternating voltage for battery charging. If the filament of a Fleming valve is heated with an alternating current, then the electron-stream is made intermittent owing to the magnetic field which surrounds the filament hindering the escape of the electrons.

It is then easily seen that the thermionic current becomes pulsating, and by passing it through a static transformer we can draw off from the secondary circuit an alternating current of double the frequency of the current used to heat the filament. See Tungar Rectifier.

**FLEWELLING CIRCUIT.** The Flewelling circuit is a super-regenerative circuit in which self-oscillation is checked by means of fixed condensers acting upon the grid of the detector valve and so damping it that self-oscillation is automatically regulated. In principle the Flewelling circuit has much in common with the Armstrong super-regenerative circuit. In practice this difference exists :—

In the Armstrong super-regenerative circuit self-oscillation is checked by the use of a special oscillator valve, tuned to such a frequency that it affects the working of the amplifier valve by alternately assisting it towards self-oscillation and then, in the other half-cycle, effectively damping its action. The Flewelling circuit,

however, does not rely on a separate oscillator, the necessary suppression of self-oscillation being effected by means of grid condensers and a variable high resistance to permit the dissipation of condenser charges.

Fig. 1 shows the circuit diagram of the original Flewelling circuit, and reference to this diagram will assist in the comprehension of this simple yet very effective circuit. There are three varieties of current passing through the plate circuit of the valve shown in Fig. 1. The unidirectional anode current supplied from the high-tension battery is present, secondly there exists the pulsating current due to the valve in its capacity as a rectifier, and thirdly, high-frequency oscillations are transferred to this circuit from the grid circuit by the magnetic coupling between  $L_1$  and  $L_2$ .

The steady anode current is restricted to the anode circuit, as a condenser forms an insurmountable barrier to unidirectional current, unless it has sufficient power to break down the dielectric. The bank of condensers represented by  $C_2$ ,

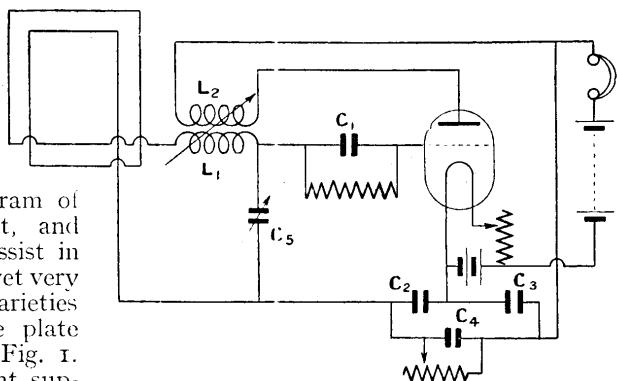

ORIGINAL FLEWELLING CIRCUIT

Fig. 1. This diagram shows that a standard valve-detector circuit can be easily modified to be Flewelling circuit

$C_2$ ,  $C_4$ , and the variable condenser  $C_5$ , offers too high an impedance to the rectified current which is similarly restricted.

The high-frequency currents, however, avoid the high impedance offered by the telephones and the high-tension battery and choose the path of comparatively low impedance through the condensers. At the point where  $C_2$  and  $C_4$  meet two

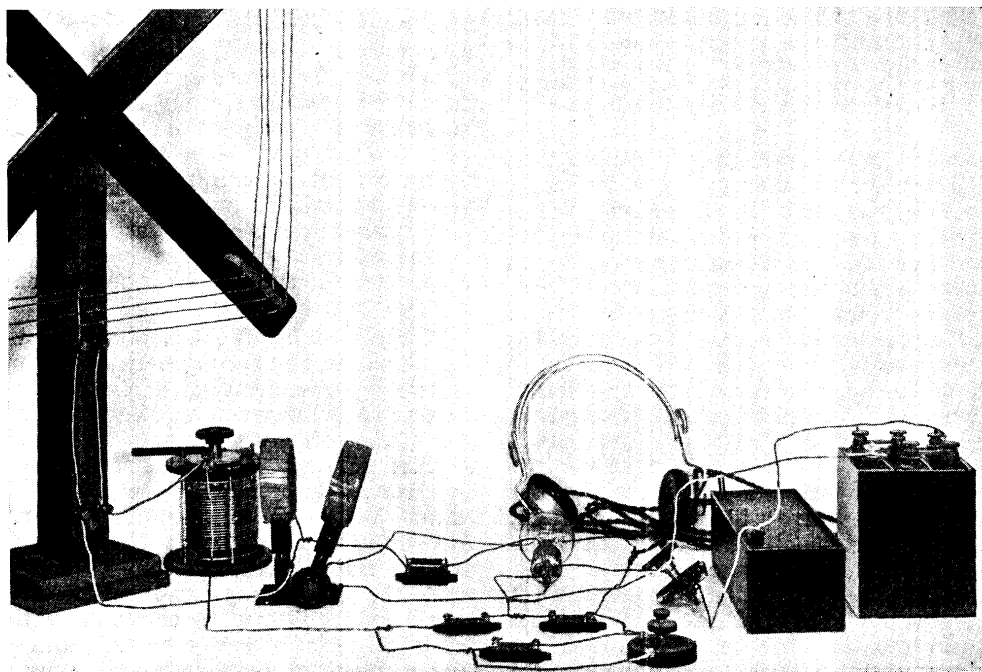

CONNECTED COMPONENTS OF ORIGINAL FLEWELLING CIRCUIT

Fig. 2. Laid out are the components of an experimental Flewelling circuit of the original design. It will be noted from this illustration that the components required for building the set are simple and likely to be already in the possession of the experimenter. A variable grid leak and condenser may be used if preferred



### FLEX OR FINE ELECTRIC CURRENT CABLE

Fig. 1. Many purposes may be served by flex. Connexions from batteries to apparatus may be made by this wire, and telephones may be carried considerable distances from the wireless set by adding double flex, as illustrated, to the existing cords on the carpieces

paths are presented, one through  $C_3$ , and the other through the condensers  $C_4$  and  $C_2$ . Another path for the high-frequency current is through  $C_5$  and  $C_1$ . The bank of condensers represented by  $C_2$ ,  $C_3$ ,  $C_4$ , has definite values, to allow a by-pass through the grid to the filament.

This causes an accumulation of electrons on the grid, which stops the valve from oscillating. This charge is then dissipated through the grid leak, when the valve immediately builds up in oscillations during the positive half-cycle and amplification is present to a large degree. The negative charge is then repeated, with the same effect as before, and a constant cycle is thus formed.

The effect of the high-resistance leak across  $C_4$  is to vary the extent of the by-pass of high-frequency current to the grid. In order to obtain maximum signal strength the ratio between the high-frequency aerial oscillations and the frequency of the damping effect on the grid should be as high as possible. Beyond a certain point distortion will occur.

The great advantage of the Flewelling circuit is the small cost of the components, and owing to the simplicity of the circuit it may very easily be made up in a short time.

An experimental lay-out of this circuit is shown in Fig. 2, where it is used in conjunction with a frame aerial. For broadcast wave-lengths an Igranic No. 50 will be found suitable, with a No. 75 coil variably coupled to it for reaction effect. A list of values for the construction of this circuit follows, the reference letters being taken from Fig. 1.

$L_1$  for broadcast wave-lengths  
Igranic No. 50.

$L_2$  for broadcast wave-lengths  
Igranic No. 75

$C_1$  .0003 mfd.

$C_2$  .005 mfd.

$C_3$  .005 mfd.

$C_4$  .006 mfd.

$C_5$  .0005 mfd.

Grid leak, 2 megohms.

Any type of hard receiving valve will be found suitable, with the anode voltage varying according to the valve used from 50 to 80 volts. See Armstrong Circuit, Igranic Coil; Regenerative Circuit.

**FLEX.** Abbreviation for flexible electric conducting wire. This material consists essentially of a number of strands of wire, usually copper, covered with insulating material, customarily rubber, cotton and a braiding on the exterior.

Two such insulated conductors are generally twisted together and known as twin flex, as shown in Fig. 1. The material is made in various forms, and those chiefly used for wireless are the lighting flex,

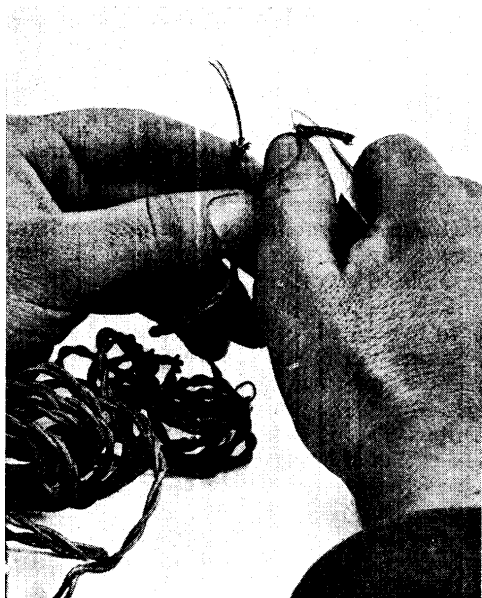

### HOW TO REMOVE INSULATION FROM FLEX

Fig. 2. Flex is usually covered with silk or a sleeving of like material, with rubber beneath, surrounding a number of strands of fine wire. The operator is shown removing the covering of the ends of a piece of flex in order to make contact

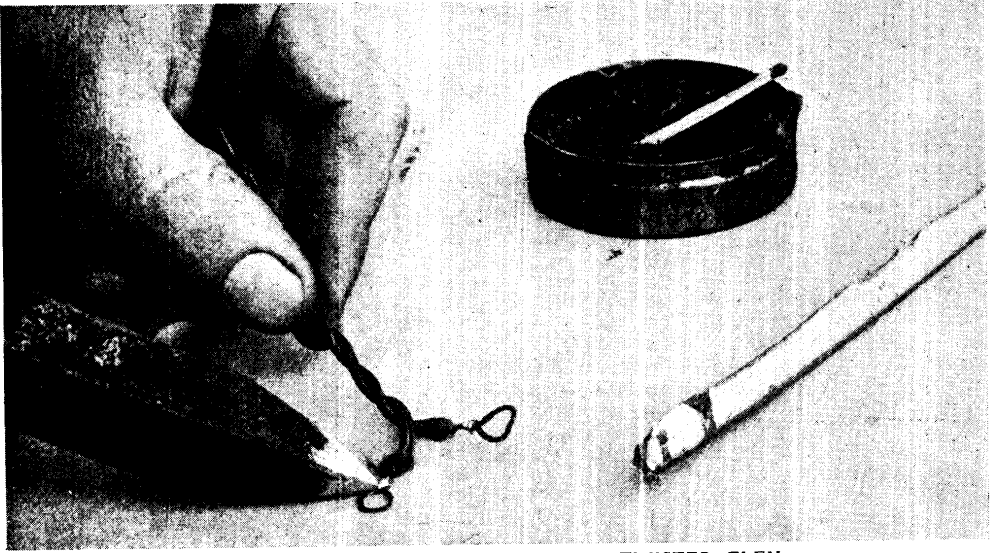

### HOW TO MAKE EYE TERMINALS ON TWISTED FLEX

Fig. 3. Having removed the outer covering and insulating material from the ends, the wire is scraped and thoroughly cleaned. The eyes are made by turning the strands round a nail or pencil according to the size required, and then twisting to take up the spare ends. The joints or necks of the eyes are then soldered as illustrated, by holding the flex on a flat surface and using a well-cleaned soldering iron and the smallest possible amount of solder

miniature flex and workshop flex. The lighting flex is usually composed of fourteen strands, each No. 36 gauge, and sold as 14/36. Smaller sizes are known as miniature flex and are used for electric bell work. Both have many applications in wireless sets, as, for instance, flexible lead-in wires and flexible connexions to plug-in terminals and the like. Similar material is used on telephones. The workshop flexes are covered externally with a waterproofing composition, and are useful for rougher work where the flex is liable to considerable wear.

The greatest difficulty for the novice is to make neat ends to the flexible wires, but this can be accomplished by untwisting the two wires and scraping the insulation from them with the blade of a pocket-knife. This is facilitated by first burning the end of the wires with a match, as this chars the insulation and frees it from the wire, when the whole can be scraped off, as shown in Fig. 2. The ends of the wires are then lightly scraped and brightened, and the strands twisted together. An eye is then turned in the wire and the outer end turned around the main part of the wire, the whole being made good by soldering, as shown in Fig. 3. Neat joints made in this way will well repay the trouble of making them.

**FLUX.** The precise idea attached to this word is that of a numerical coefficient associating the result arising from the application of a magnetizing force with the immediate effect in its neighbourhood. By convention it is usual to regard the space surrounding the magnet pole, for instance, as being filled with a greater or lesser quantity of magnetic "lines of force," the strength of this field being measured by the number of such imaginary lines per unit of area. Although it is convenient in practice to regard the flux in any magnetic field in terms of lines, the convention breaks down if

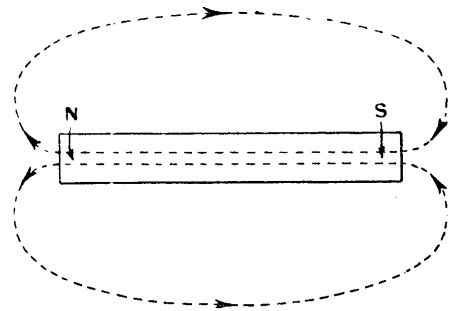

### CONVENTIONAL IDEA OF FLUX DIRECTION

Fig. 1. Illustrated is a magnetic field, and the dotted lines with arrows indicate the assumed direction of lines of force. The flux leaves at the north pole and re-enters at the south

pushed too far, since unless the lines were infinite in number—in which case they would obviously be useless to denote relative strengths of flux—there would necessarily be unoccupied spaces between them where the magnetic influence would not be felt; whereas in practice it is found that the whole region surrounding any magnet is permeated with the so-called flux. It would perhaps convey a better idea to regard a magnetic region as carrying a greater or lesser flux according to its *colour*, a deeper or paler tint indicating the presence of a stronger or weaker flux.

Flux is an effect and must therefore be preceded by a cause. That is to say, before a magnetic field can be established there must be a magneto-motive force at work, just as the presence of an electric current is due to an impelling electro-motive force. The ordinary means of producing a magneto-motive force is to circulate a current of electricity around a coil of wire a number of times, the larger the current and the greater the number of turns of

netizing force is applied in air, or in iron or other material more susceptible to magnetization than air. A definite magnetizing power  $H$  applied to a solenoid with an air core will produce vastly different results from the same value of  $H$  if the solenoid is filled with iron. The flux (designated by symbol  $N$ ) will in the one case have the same value as  $H$ , but in the other case may be increased many hundred times, according to the quality of the iron core and the degree of magnetization to which it has been pushed.

Iron has a property somewhat akin to that of resistance in the electric circuit, by virtue of which it resists the passage of magnetic flux on applying a magneto-motive force; and this magnetic resistance is termed "reluctance." The law of the magnetic circuit may be stated as follows: Magnetic flux ( $N$ ) =

$$\frac{\text{Magneto-motive force (M.M.F.)}}{\text{Reluctance (Z)}}$$

The electrical resistance of a conductor can be calculated from a knowledge of its length, cross-sectional area, and its con-

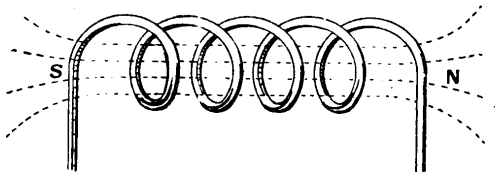
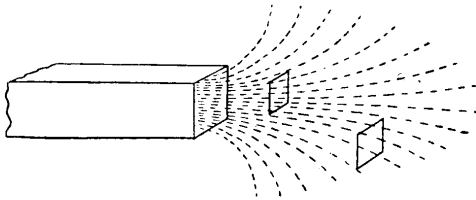

**FLUX DENSITY AND MAGNETO-MOTIVE FORCE IN A COIL**

Fig. 2 (left). Variations in flux density in different regions of the field are illustrated in this diagram. Fig. 3 (right). Magneto-motive force, giving rise to the flux, produced by a current-carrying coil is represented. The flux is equal to 1.257 times the ampere-turns

wire, the more powerful being the effects produced. If current is represented by  $C$  and the number of turns of wire by  $\text{it}$  can be shown that the magnetizing force of a solenoid or current-carrying coil is equal to

$$\frac{4\pi CS}{10}$$

In other words, the magneto-motive force (usually represented by the symbol  $H$ ) is equivalent to 1.257 times the ampere-turns.

It by no means follows, however, that the same magnetizing power invariably produces the same effect as regards the resultant flux, any more than the same electro-motive force gives rise to the same value of current in the electric circuit.

Another property has to be taken into consideration, namely, whether the mag-

ductivity; and the magnetic reluctance of a bar of iron can also be found in the same way, with certain qualifications. The divergence between the two methods lies in the fact that whilst in the electrical case the conductivity is the same both for small and large currents (ignoring the question of temperature coefficients) in the magnetic case the behaviour of the iron is different with a large flux than it is with a small flux.

This variation in behaviour with different values of flux density is known as the "permeability," and the simplest way to regard it is in the light of a multiplying effect upon the magneto-motive force  $H$ . When  $H$  is small the permeability ( $\mu$ ) is high, and up to a certain point it increases still further with every increase of  $H$ . But when a point is reached, known as the

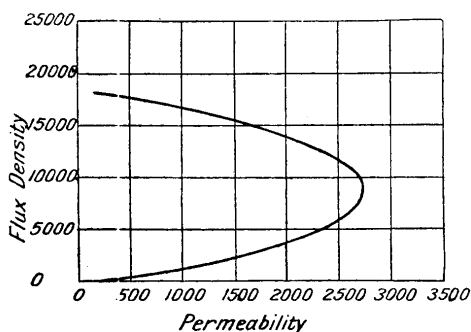
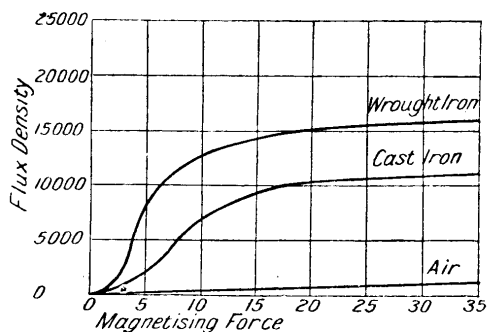

FLUX INCREASE IN IRON AND AIR AND PERMEABILITY CURVES

Fig. 4 (left). Relationship is shown in this curve between magnetizing force and flux when the solenoid is filled with wrought iron, cast iron, and air respectively. Fig. 5 (right). This curve shows the relationship between flux density and permeability. The multiplying effect increases at the early stages, and after reaching the maximum falls off as excitation progresses until the value becomes negligible

practical saturation point, subsequent increases in the value of H do not produce proportionate results in the flux N, and the value of  $\mu$  falls off rapidly at the higher flux densities.

Every imaginary line of force in a magnetic field is assumed to have a closed circuit; by convention the flux leaves at the north pole of a magnet, and re-enters at the south pole. This is illustrated in Fig. 1. By reason of the divergence of the flux lines it is clear that at greater distances from the magnet pole the flux density must fall off, and this may be represented in Fig. 2 by a unit area consisting of a rectangle, of either one square centimetre or one square inch, according to the units chosen, placed close to or at a distance from the actual pole. The number of lines included in such a rectangle are a measure of the flux density, referred to as B when in iron. The magnetomotive force giving rise to the flux can be shown as a current-carrying coil of wire (Fig. 3, denoted M.M.F.), and proportionate to 1.257 times the ampere-turns.

When the solenoid is filled with iron instead of air, the total flux N arising from its exciting power is largely increased.

These facts can be shown in graph form by Fig. 4, which illustrates the way in which the flux increases with a progressive magnetizing force in air, in cast iron, and in wrought iron. The bottom curve, it will be seen, is a straight line, the number of flux lines being in exact proportion to the magnetizing force, which is equivalent to stating that the permeability of air is unity, and it has no multiplying effect on the applied M.M.F.

The middle curve, representing the behaviour of commercial cast iron, shows the gradual increase of B with the first stages of H, and subsequent falling-off as H increases, until the permeability is practically nil, and the increase of B then becomes almost exactly proportionate to the increase in H at the higher stages. The top curve, representing wrought iron and mild steel, conforms in general to the cast-iron curve, but on a higher plane owing to the increased permeability of these materials as compared with cast iron.

Other magnetic materials such as nickel and cobalt, have not sufficient value to be made much use of commercially.

Fig. 5 is a representation of the general character of a permeability curve, and shows how the "multiplying effect" increases at the early stages, arrives at a maximum, and then falls off to a negligible value as the excitation progresses. With the aid of such curves the designer is able to predict with considerable accuracy the flux resulting from a certain application of magnetizing force, information which is of great importance.

**FLUX.** Material used in uniting metals during welding, brazing, or soldering processes. Fluxes vary with the metals to be united. For brass and copper, fluxes include ammonium chloride, rosin, and zinc chloride; for zinc, hydrochloric acid; for silver soldering, borax, etc. The use of fluxes is dealt with in this Encyclopedia in the article Soldering.

**FLUX DENSITY.** The number of lines of force per square centimetre of sectional area of a magnetic path. For practical purposes the flux density is measured by

the relation between the magnetic flux in an electro-magnet and the number of ampere-turns in its coils. The magneto-motive force on a magnetic circuit is equal to the product of the flux and magnetic reluctance of the circuit, or, alternatively,

$$\text{Flux} = \frac{\text{Magneto-motive force}}{\text{Reluctance}}$$

See Flux.

**FLUXMETER.** A moving-coil type of ballistic or "dead-beat" galvanometer in which control torque of coil and air-damping are kept small. The Grassot fluxmeter (shown in the photograph) is

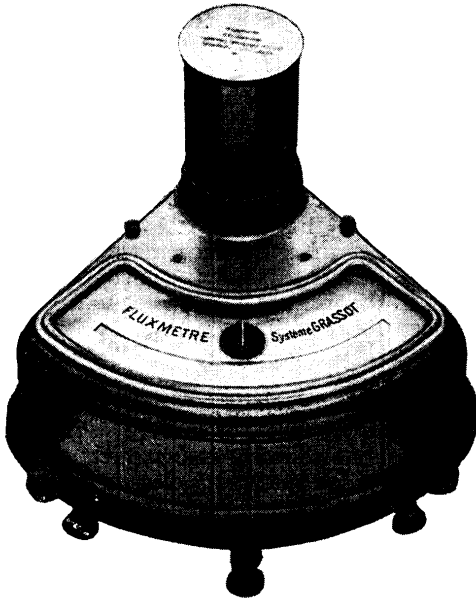

**DEAD-BEAT FLUXMETER**

This is a Grassot fluxmeter, which is a type of ballistic galvanometer having a suspended coil of wire hung on a silk fibre. The movement of the coil actuates a pointer on a calibrated scale

*Courtesy H. Tinsley & Co.*

quite dead beat, *i.e.* the pointer takes up its position in the first deflection and remains stationary until the current changes again. It consists of a fairly large open suspended coil of small cross-section hung on silk fibre with current leads exerting practically no control over the moving system. In consequence the final deflection of the needle does not depend on the rate at which the change of flux flows through the secondary circuit. It is not so sensitive as a ballistic galvanometer. See Ballistic Galvanometer; Galvanometer.

**FOCUS.** Point at which converging lines meet. The term is often used for that point at which the converging rays of light meet, and they are said to come to a focus. In mathematics a focus is a point from which, if lines are drawn to any points on a curve, the lengths of these lines are connected by some law. As an example in the case of a parabola, any point on the curve is equidistant from the focus and a straight line. In optics, heat, etc., where waves are considered, the focus is the point to which the rays are brought after reflection from a curved surface or refraction through a lens.

**FOOT-POUND SYSTEM.** System of units used in mechanics and engineering. In this system the units are based on the British imperial units of length, mass and time. The yard is the British imperial unit of length, and is defined by the Weights and Measures Act of 1878. The foot is one-third of this standard yard. The imperial standard pound is the weight in a vacuum of a platinum cylinder preserved at the Standards Office of the Board of Trade, and the second is 1/86400 part of a mean solar day. See Units.

**FORCE.** Force, in mechanics, is a familiar term which has been much misused, and about which there is even now a certain ambiguity in popular language. Strictly speaking, force is that which one body exerts upon another, and is not a property of any one body alone.

When force is latent and not actually exerted, the latent power is more properly called energy. Thus gun-cotton contains a great deal of energy, and only needs a detonator to bring out its actual force, which it then exerts on all things in the vicinity.

When a single force acts on a body, its state of motion is changed. It is either accelerated or retarded or altered in direction. The amount of change of motion, that is, the mass multiplied by the acceleration, is a measure of the force. This is Newton's Second Law and the foundation of dynamics.

A simple example of an unbalanced force is that applied by a cricket bat or a golf club, and, accordingly, the ball is vigorously accelerated by either; energy being imparted to it, which it has to expend on the air and other obstacles until it comes to rest on the ground—unless a fielder applies an opposition force and checks its motion by his hands, which then receive all the energy that is left.

But it is very easy, and still more common, to have a balanced force; that is to say, a body may be acted on by two equal opposite forces which neutralize each other. In that case no acceleration is produced, and whatever motion the body had continues unchanged. This is Newton's First Law of Motion.

Most things in a room are in that predicament. Gravity is acting on them, but the table or the floor is supporting them. Consequently, they are moving at a steady pace round the sun, along with the rest of the earth, without any interference or interruption. (There is, indeed, a *slight* unbalanced force acting on them, the attraction of the sun, which causes them to move round him once a year.) Balanced forces are sometimes called "static forces," or more properly, "stress." They do not change the motion of a body, but they may change its shape; they may distort it, or even crush it; as when you apply crackers to a nut, or when you pull out a piece of elastic.

One important thing about force is that it is always mutual or reciprocal, always acts between two bodies. Whatever force the sun exerts on the earth, the earth exerts an equal force on the sun. Whatever force the bat exerts on the ball, the ball is equally exerting on the bat, which, in consequence, may get dented in. Whatever force a horse exerts upon a cart, the cart exerts an equal opposite force upon the horse. This is not a case of balanced forces at all. It is not a case of two forces acting on one body, but of a stress between two bodies.

#### Foundation of Conservation of Energy

There is often unnecessary confusion about this. In the case of bat and ball, for instance, only one force acts on the ball and only one force acts on the bat. Consequently, the ball is accelerated, the bat is retarded. When gunpowder explodes in a gun the bullet is propelled one way, the gun the other. And since the two forces are equal, the momenta, or quantity of motion produced in each, are equal. This is Newton's Third Law of Motion, commonly expressed by saying that action and reaction are equal and opposite.

One very important result of this law is the conservation of energy. Whatever energy one body loses, the other body gains; so that the energy is simply

transferred from one to the other. The energy of a strained bow is imparted to the arrow. There is never any generation of energy. It is received by one body, and passed on to another; and the amount is the same, because the forces are the same. One gains and the other loses the same amount, because action and reaction are equal and opposite.

This is sometimes masked, because we do not usually take the ether into consideration. When we wind up a spring, we know that the energy is in the spring, and that it will keep the clock going or do whatever work is wanted in the recoil. But when we raise a weight we are not clear what gravitation is, and forget that we have really done work against the ether, which is in a peculiar condition owing to the neighbourhood of the earth, and forces the weight down again. The energy of the raised weight is not really in the weight, but in the strained ether. When the weight is liberated it receives energy from the ether, moving quicker and quicker under the accelerating force of gravity until it expends the energy on the earth in the form of heat and sound.

**Electro-motive Force.** Force, as ordinarily used, means mechanical force, force applied to matter. But there is also force applied to electricity, which is called electro-motive force, or E.M.F. This it is which puts electricity into motion and is responsible for sustaining electric currents against resistance; just as mechanical force is responsible for the motion of matter against friction. When unbalanced electro-motive force acts, electricity is accelerated. When the propelling and resisting forces are equal, the current continues steady until the resisting forces get the upper hand, when the current begins to die away. The laws governing mechanical and electrical propulsion are quite similar. Resistance represents friction. Inductance represents mass or inertia. Current represents velocity. Electro-motive force represents the propelling force. Voltage corresponds to difference of level, and voltage per centimetre corresponds to slope or gradient.

Mechanical propulsion can be exerted by a difference of level, as when water flows downhill. This is due to the force of gravity, and the magnitude of the force depends upon the gradient. Just so in electricity. You may have a gradient of potential to which the flow of electricity is



due. It is one form of electro-motive force: just as gravity is one form of mechanical force. Mechanical force is measured in pounds or tons weight, or dynes, or any other such unit. Electro-motive force is measured in volts.

Just as you have balanced mechanical force, so you may have balanced electro-motive force. And the result is not a current, but a strain. The charging of a condenser is like the bending of a spring, or the stretching of elastic; and you get from it a recoil, which is called the discharge, analogous to the discharge of a bow when the string is liberated. The elasticity need not be perfect. There is opportunity for some loss here. The dielectric of the condenser may be of poor material, just as a bow might be made of bad wood. Moreover, the condenser may leak, which is analogous to the string being not held tight but allowed to slip carelessly and slowly between the fingers. In this way there can easily be a loss of available or useful energy; although, as Joule showed by direct experiment, there is never any real destruction of energy if the whole of its fragments are collected and accounted for.—*Oliver Lodge, F.R.S.*

**FORCED OSCILLATIONS.** Electrical vibrations imposed upon an oscillatory circuit which are not in time or resonant with the natural wave frequency of the circuit. This is in contrast with the free oscillation when the circuit oscillates at the same frequency on its own account as the frequency of the incoming waves or at one of the harmonics of this frequency. The oscillations are thus forced when the circuit is not suited to them.

Forced oscillations are set up in the first stages of induction of free oscillations, so that both free and forced oscillations can occur in the same oscillatory circuit.

**FORGING.** The art and act of shaping metals by impact, generally while the metal is red hot. The process is a very skilled trade in the more advanced stages, but the experimenter can do all that is needed for the average wireless set with the simplest tools and produce creditable results.

The metals generally used are wrought iron and mild steel, the former for rougher work not liable to excessive strains, the latter for better-class work. Of the steels there are two great classes, so far as the amateur is concerned, the bright

drawn mild steels, and the black or Bessemer steels. The former is, as the name suggests, bright in appearance, as the process of manufacture is a cold-drawing method that leaves the surface clean and bright.

The black or Bessemer steels have a blue-black surface colour, due to the presence of an oxide or scale as a result of the manufacturing methods. All these types of steel and iron are obtainable readily from the metal merchants and in different sizes, such as 1 in. by  $\frac{1}{4}$  in., meaning that the bar is 1 in. wide and  $\frac{1}{4}$  in. thick, the greatest width being stated first. Round stock or bar is sold in sizes from  $\frac{1}{4}$  in. or so in diameter upwards in steps of about  $\frac{1}{16}$  in. in the smaller sizes, and  $\frac{1}{8}$  in. in the larger diameters.

In the normal way the novice can use wrought iron for such things as the stand for a small machine tool, or some parts of the framework of metal masts of the lattice type. Wrought iron may also be used for straps and such-like for the attachment of aerial guy wires to a mast.

The bright mild steels are the best for all-round work that is on the small size. It is very strong, and does not want much time expended on it in the way of filing to a finish, as the surface is naturally good.

Cast and silver steels are seldom forged by the amateur. Their application to wireless is more restricted to the construction of parts of instruments, tool-making, and the like, where the shape can be obtained by filing, turning, milling, and regular workshop processes.

Most forging is done with the aid of a regular smith's forge and fire, and the use of an anvil is essential, as well as some assistance in the way of a striker to manipulate the sledge hammer while the smith holds the fullers and other tools.

Such tools are not usually found in the amateur workshop, but when a powerful paraffin blow-lamp is available, such as that shown in Fig. 1, it is quite possible to do a large amount of practical work, and when a gas-heated blow-pipe is at hand the range is extended.

The first essential is some means of getting the metal red hot, and as most of the parts wanted by the wireless experimenter are small, the use of a brick furnace such as that shown in Fig. 1

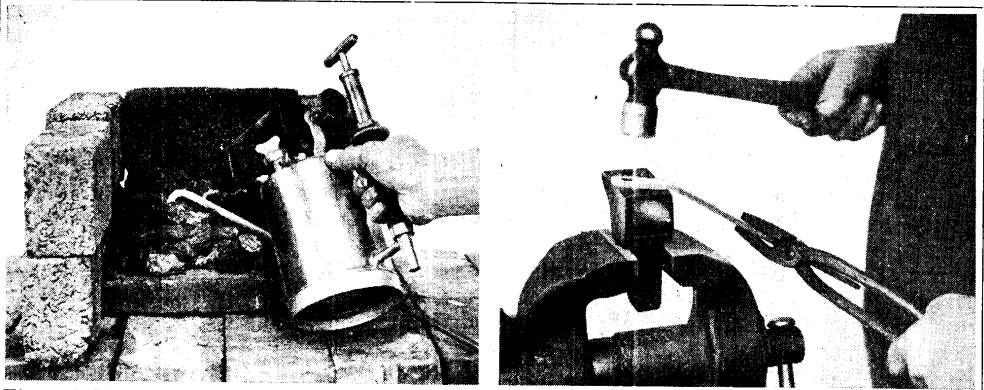

Fig. 1 (left). Forging of small parts is simply arranged as illustrated. The iron to be worked on is heated by a powerful paraffin blow-lamp. In this way the wireless experimenter can do nearly all the forging he is likely to require. Fig. 2 (right). How to make a plain angular bend may be seen from this photograph. The smith's tongs shown are necessary for work of this kind

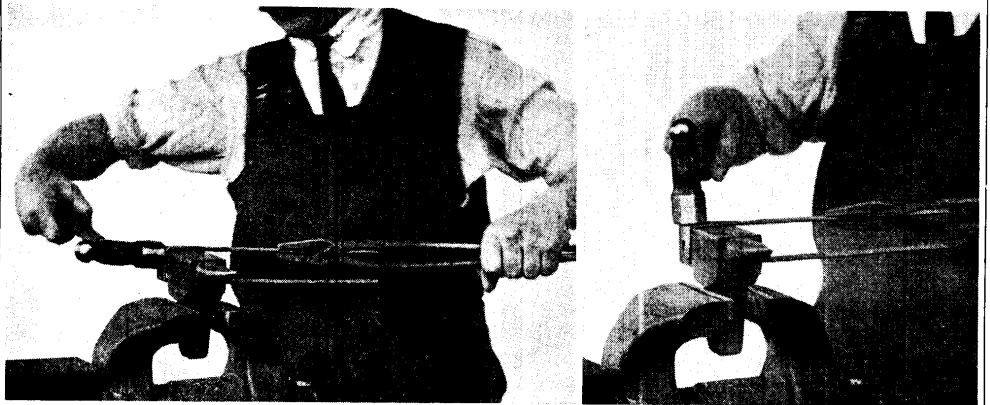

Fig. 3 (left). Corners of a long U-shaped strap are squared by hammering the work on the side of the anvil in this way. Fig. 4 (right). Both sides in turn should be hammered on the top of the anvil to make them square and true after the corners are made

#### METHODS OF FORGING FOR WIRELESS AMATEURS

will answer all requirements if the blow-lamp is in good working order. The bricks should be set up to form a recess, and the space should be filled with coke, fine coal, or even cubes of asbestos, which, by conserving the heat and radiating a certain proportion of it, assist the rapid heating of the metal. The work to be heated is placed in the coke and buried just below the surface. The flame of the blow-lamp is directed on to the work, and the whole raised to a bright red heat, when the work is then taken quickly from the fire, rapped on the side of the brickwork to knock off all adherent matter, and is then dealt with by the hammer.

Successful smithing depends on rapidly but accurately hitting the heated metal at the right place and at the right time,

regulating the blow according to the size of the metal and the nature of the work. The essential tools for forge work of this general simple class are a heavy hammer about  $1\frac{1}{2}$  lb. weight, a lighter hammer, a pair of smith's tongs, such as those illustrated in Fig. 2, a really strong vice, preferably of the leg pattern, a small bench anvil or a stake with a beak, a large centre punch, and a few rough files.

As a preliminary exercise take the case of a flat strap for the aerial guy-rope attachment to a mast. This may be some 8 in. long, 1 in. wide, and  $\frac{1}{4}$  in. thick. One end will have to be set out to an angle of about  $30^\circ$ . Each end will be drilled for the holding bolts and the thimble on the guy respectively. In such a case the novice should cut the metal to length and file the end to shape, drill all the holes,

and then perform the simple forge work of bending the metal to shape. Suppose the bend is to come  $2\frac{1}{2}$  in. from the end. Mark this point with a few centre pops on the side of the work that will be uppermost when the metal rests on the anvil. As the metal is to be worked red hot, it would not be possible to see a line, consequently the centre pops are made, as they will show up when the metal is hot. These centre pops are indentations made with the large centre punch.

The next step is to place the iron in the fire and concentrate the heat of the lamp upon it at the point where the bend is to be made. It is imperative that the metal be hottest at the exact place where the bend is to come, and as the work is heating up it is as well to look at it occasionally and see that the heat is properly concentrated on the centre-popped part of the metal.

When the metal is bright red, take it from the fire with the tongs and, holding them in the left hand, rest the hot metal on the anvil or stake (which can be held in the heavy vice, as shown in Fig. 2), and, with the heavy hammer, strike the metal a few sharp blows just beyond the bend, keeping the hammer blows well over the anvil. This may jar the hand, and the novice would do well to wear a glove.

#### Golden Rules in Forging

The left hand is kept still and in the same position during the whole process, the hammer being employed to flatten the metal on to the face of the anvil, by hammering mostly on the part next to the bend, and flattening it with a few blows on the outer portion, especially towards the finish.

If the hammer is used on the outer part of the metal it will cause the bar to bend and assume a curved shape, which will have to be corrected later. It is important to hold the metal square with the edge of the anvil, otherwise the bent part will not be in line. This is corrected by reheating the work, laying it flat but edge up on the anvil, and flattening it with a few light blows of the hammer.

The forging should not be carried on after the metal has cooled below red heat, as in the state then known as black hot the metal is more liable to crack at the bend and ruin the work.

Golden rules are to heat the work well at the start, have everything ready, and

quickly but certainly strike the hammer blows. Success is certain if the hammer be thought of as a large and powerful hand that will press the metal to the required shape. The metal will always tend to move away from the hammer blow and in the same direction as that of the path of the hammer. The hammer should therefore always be directed in the path that it is desired the metal should take, and, above all, the face of the hammer should fall flat and square on the metal.

A more difficult task is to make two right-angle bends in the same piece of metal, as, for example, the long U-shaped strap required for the attachment of a strainer to take the stake driven in the ground for the support of the lower end of a guy rope. The same general procedure will be followed. The first step is to heat the metal and make the first right-angle bend by continuing the hammering as in the foregoing example, but driving the metal right over the edge of the anvil. In this case a few blows at some distance out will bring the metal over more quickly, and the final shape is then obtained by local hammering near the bend itself. The second bend is made in the same way, but to do this necessitates having the horn or flat end of the anvil clear of obstructions, to allow the metal to pass. The final shaping of the work is accomplished, as shown in Figs. 3 and 4, by striking the work as it rests first on the face and then on the side of the anvil. This will speedily square up the corners.

#### How the Work is Trued Up

When properly bent the metal should lie flat on the work-bench; if it does not, rest it on the anvil and flatten it with a few blows near the bend, but on the edge of the work, and flatten the corners, as at these points the metal will rise somewhat. The metal must be heated over a large area to do this, as the trueing has to be done to several places on the work.

It is not always advisable to do the forging on the anvil, and an example of the way in which a piece of work can be carried out by grasping it in the vice is shown in Fig. 5, which illustrates how the ears of a strap are turned at two different angles to the normal line of the straight part of the bar. The ears are in this example bent simultaneously in two directions by gripping the metal in the

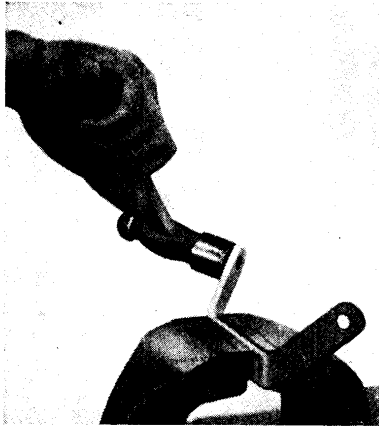

Fig. 5. Ears of a strap for an aerial mast are shown being turned at two different angles while held in a vice

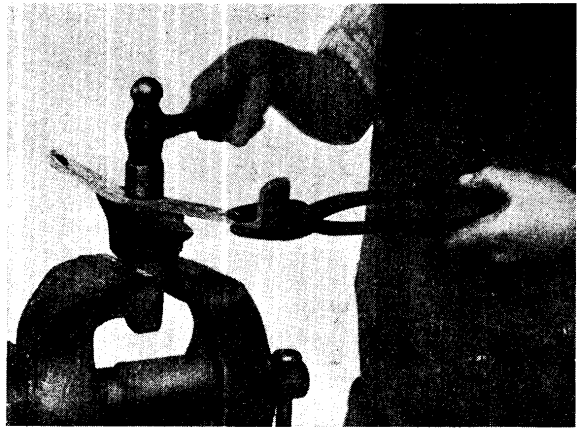

Fig. 6. After making an angular double bend the forged metal can be flattened by hammering on an anvil



Fig. 7. First stage of forming a hook. The heated end of the rod is being hammered round the beak of the anvil

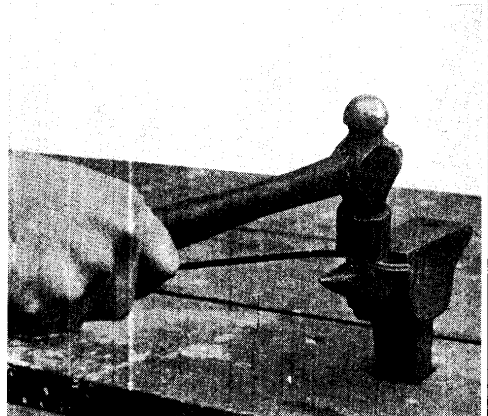

Fig. 8. First steps in making an eyebolt or strainer. The rod is set back for the neck of the eye

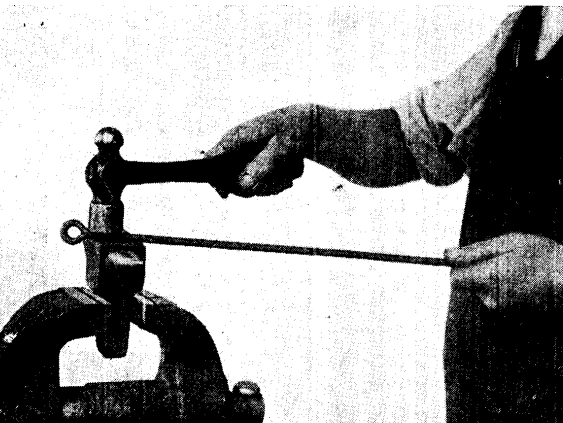

Fig. 9. Finishing the eye in an eyebolt, and trueing it up. The eye is brought into line with the rod



Fig. 10. This photograph shows how to use a large spanner to twist a forged piece of stock

HOW THE AMATEUR MAY FORGE COMPONENTS FOR AERIAL MASTS

vice with the ear projecting and inclined at the desired angle to the top line of the vice. The metal is bent over as far as needed, and the other end treated the same way. Final trueing up is done as shown in Fig. 6, by hammering on the face of the anvil. This example shows that by bending a strip of metal at an angle to the edge the projecting part will point in two different directions. It will incline downwards, as seen from the front, and also point outwards, as seen from the top.

Hooks are often needed for the support of objects, and the first step in forging them is shown in Fig. 7, where the heated rod is shown being hammered around the beak of the anvil. The work is commenced at the top of the anvil, and the bent rod turned under as shown in Fig. 7, and the remainder of the hook shaped as shown.

The method of forming an eye or ring on the end of a rod is shown in Fig. 8, where the rod is seen kinked or set back some distance from the end. This is to form

while the punch remains in place. The punch should have a tapering body to permit of this enlargement of the hole.

There are many other processes in forging work, such as reducing the diameter or bulk at one point, but these are practically impossible without a forge and some necessary dexterity and skill, but the methods outlined will enable the novice to undertake a large amount of work that would otherwise have to be put out, with the consequent delay of the completion of the job.—*E. W. Hobbs.*

See Aluminium; Brass; Lathe; Soldering.

**FORMER.** Name used in several ways to describe a foundation whereon to construct or complete some part of an appliance. Examples are the tubes used

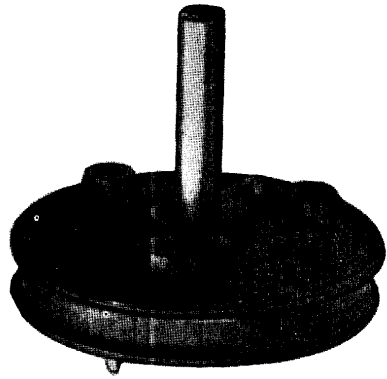
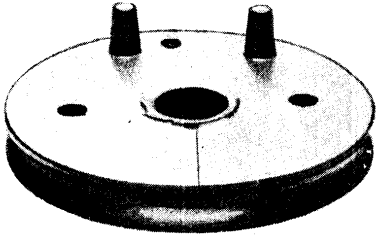

#### MOULDED TYPES OF FILAMENT RESISTANCE FORMERS

Fig. 1 (left). Composition is moulded in this shape to be used as the former of a filament resistance. It serves the double purpose of supporting the resistance and attaching it to the panel. Fig. 2 (right). At the time of moulding this type of former the spindle is incorporated, and so becomes part of the former. Note how the bosses for the screws are included in the design.

the neck of the eye, or that part where the end of the rod will meet the remainder of the stock: the eye is formed by hammering around the beak of the anvil and trueing up as shown in Fig. 9. The joint may be welded or brazed, as desired. When it is desired to twist a piece of stock the method illustrated in Fig. 10 is as good as any for the novice. It consists in gripping the stock in the vice and twisting the projecting portion with a strong spanner.

To make a sharp bend the metal must be very locally heated, the other parts being cooled somewhat by dipping into cold water for a moment. The eye seen at the end of this job in Fig. 9 is formed by punching. This is a method of driving a blunt-ended punch through the hot metal, thus forming a hole. The hole is enlarged by hammering on the sides of the work

as formers in the winding of many inductance coils, the disks whereon the windings of a spider web coil are placed, and the pegged contrivance used in the preparation of basket coils. Another type is illustrated (Fig. 1), and shows the moulded composition former employed as the foundation of a filament resistance. This type of former performs two functions: first, it supports the resistance winding, and, secondly, it acts as the means of attaching the resistance as a whole to the panel.

In some cases it is possible to incorporate some part of the device in the former itself during the process of manufacture, as is shown in Fig. 2, where the stop-pegs are formed integrally with the circular part during the moulding process. This type of former is often made in a

composition akin to ebonite, and when this is done it is possible to incorporate the spindle, or some other metal part, as illustrated in Fig. 2, where the contact arm stud is shown projecting from the centre, as well as bosses for the attachment screws.

More elaborate formers are those used for the construction of a variometer, such as the set shown in Fig. 3. The two halves of the stator are seen at the right and left of the illustration with the rotor between them. In all of these parts there are numerous bosses and projections moulded on, and the whole is a neat and effective

brown positive plate, and grey porous metallic lead on the negative plate. This is effected by connecting the battery with a suitable source of direct current of electricity and by a reversing switch alternately charging and discharging the cells. Formerly it was customary for a battery to increase its charge capacity considerably during use, but modern accumulators have plates fully formed for practical purposes when sent out. The use of pasted plates ensures quick "forming," as well as increasing the porous surfaces or active mass of the plates. See Accumulator; Faure Plate.

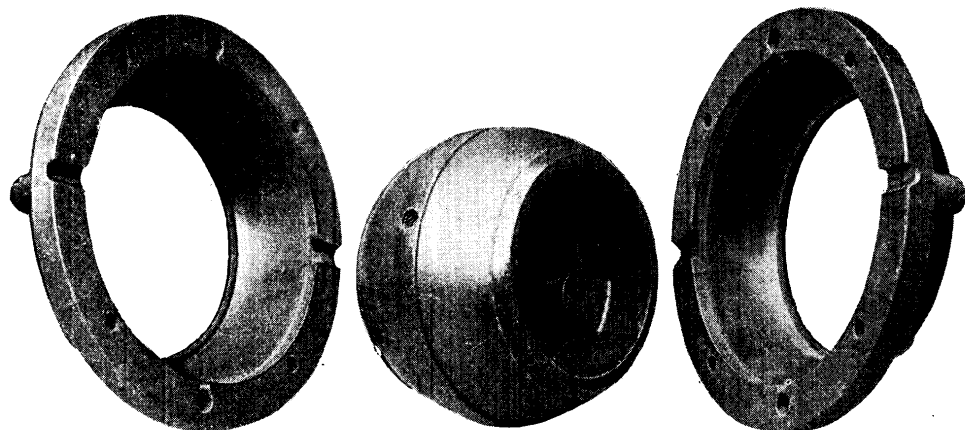

DISSEMBLED COMPONENTS OF A VARIOMETER FORMER

Fig. 3. Elaborate types of formers are sometimes used for variometers, as well as very simple ones which can be made by the skilful amateur. In the above photograph on the right and left are the two halves of a variometer stator, and in the centre is the spherical-shaped rotor. When the two halves of the stator former are put together they enclose the rotor, which turns on a spindle which rests in the grooves seen in the stator halves

piece of work. To wind such formers as the stators requires the use of another former, in shape like the rotor. The wires intended to be wound on the inside of the stator are first wound on the separate former and then transferred to the inside face of the stator by means of a suitable adhesive. This is difficult work calling for an absolutely accurate former, and practically requires manufacturing facilities to carry out efficiently.

Another application of the word former is to a cutting tool with a profiled face or cutting edge, such as those used in milling and turning operations. See Basket Coil; Cardboard Tube: Coil.

**FORMING: In Accumulators.** The process of "forming" in accumulators consists of converting the paste in the grids of the plate into an active mass consisting of lead peroxide in the case of the

**FOSTER BRIDGE.** Resistance bridge devised by Professor Carey Foster to measure the difference between two nearly equal standard resistances. The kind of bridge to which Carey Foster first applied his method was the form known as the Metre Bridge, which consists of a metre scale with a stretched wire of german silver, or other fairly resistant metal, stretched along it, on which is a contact slider with an index or pointer pointing to the divisions of the metre scale, so that its position can be read off correctly. The rest of the bridge consists of brass strips provided with binding screws, in which the resistances to be compared are to be clamped.

From the middle of this interrupted brass strip a wire is led through a galvanometer or battery to the slider, and at the same time a galvanometer or battery is

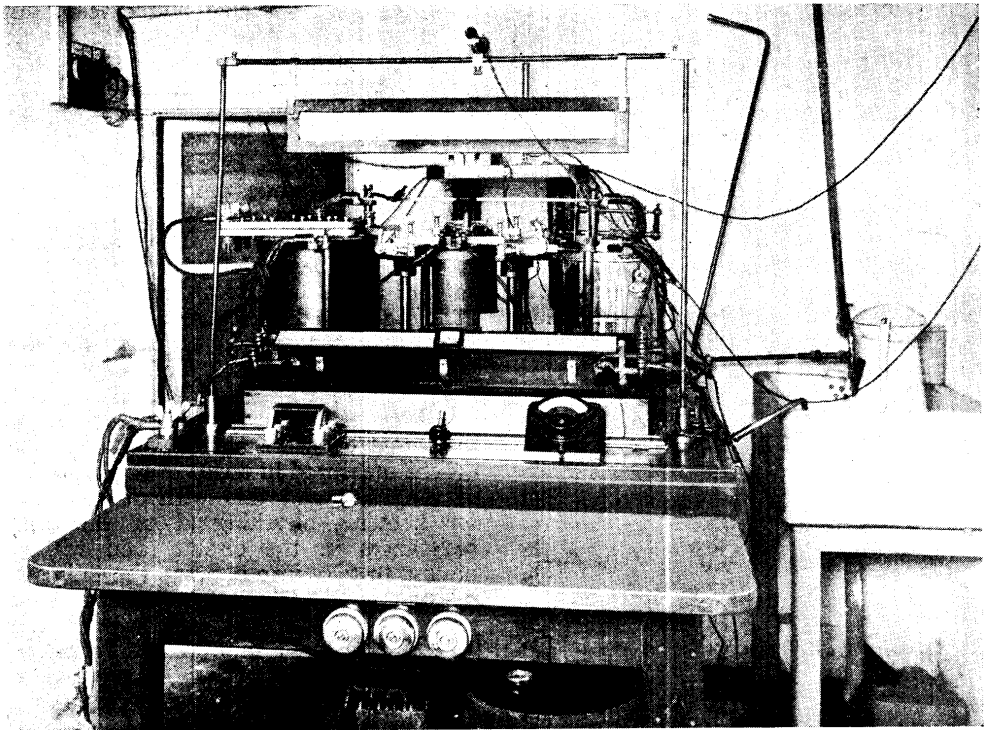

#### MODERN DEVELOPMENT OF CAREY FOSTER RESISTANCE BRIDGE

Fig. 1. Difference between two resistances was measured by Professor Carey Foster by an apparatus which is shown in the above photograph. From the middle of an interrupted brass strip a wire is led to a slider through a galvanometer or battery. Another galvanometer or battery is connected to the ends or terminal screws, to which is soldered german silver wire. Differences are measured by two interchangeable coils. Difference of resistance is equal to the resistance of the german silver wire between the two positions of the slider

connected to the ends or terminal screws, to which the ends of the straight german silver wire are soldered. It does not matter, except for convenience, which branch the battery and which branch the galvanometer is placed in; they are interchangeable. But in order to avoid the uncertainties of a sliding contact, it is rather better to put the battery in the branch attached to the slider, and the galvanometer in the other one.

Naturally, a key is also supplied with the battery, so that it can be put on and off, or else reversed, momentarily. It is undesirable to leave the battery on, because that will heat the wires and produce disturbance; a momentary contact is sufficient to show on the galvanometer. In the ordinary use of the bridge it is assumed that the coils have no inductance, *i.e.* that they are wound, as resistance coils always are, anti-inductively. If they have any perceptible inductance,

and still more if one of them is an inductance coil whose resistance is being measured, it is necessary to have a key in the galvanometer circuit also, and only to close that key *after* the battery key, allowing a second or so interval, necessary to enable inductive effects to have subsided and the current to have reached its steady state.

All this is familiar, and belongs to the Wheatstone bridge proper. The problem now is how to work the bridge so as to measure differences. For that purpose the two coils must be interchangeable, like the method of double-weighing on a balance, when weights and things weighed are interchanged, so as to be sure that there is no inequality in the balance arms, or so as to correct it if there is. That, however, is a precaution that may readily be taken in the ordinary use of the bridge. To get differences requires some further ingenuity.

In practice, when things are properly arranged, all we have to do is to find the position of the slider which gives a balance with the coils in one position, and then the position of the slider when the coils are interchanged. If they were exactly equal, the position of the slider would be the same in the two cases, and the difference would be nothing. But if there is a slight difference between the coils, then there will be a corresponding slight difference in the position of the slider. And the difference of resistance will be equal to the resistance of that bit

is where the two coils are placed, not in the other arms of the bridge at all. The other arms of the bridge are composed of a pair of resistance coils of any convenient magnitude, which are left unchanged and are constant.

The plan, then, is, first to get a balance, then to interchange the two coils which are in series with the measuring rod, and get a new balance. The discrepancy, if any, has been shifted from one side to the other; and accordingly the slider must be shifted an equal amount in the same direction, so as to shift the discrepancy back again. The step of the slider on the measuring rod will now be equal to the discrepancy. Hence the difference of resistance between the two coils is measured in terms of the constants of the rod; and this without any need for knowing anything about the other resistances in the circuit, and without having to take into account the unknown resistances of any of the junctions or clamping screws, or anything of that kind, so long as they remain constant.

The only precaution that must be rigorously taken is that the contacts of the interchanged coils must be perfect and identical, whether they are in one position or in the other; and to that end it is customary to use a mercury joint. For standard coils have thick terminals with flat amalgamated ends, and they make contact by resting flat on amalgamated copper disks or plates, the positions being regulated by holes in ebonite lids, through which the legs or terminals of the coils enter, till they stand fair and square upon the mercury-covered copper below.

To make this description clear, refer to the diagram (Fig. 2). Fig. 1 shows the bridge as developed since by Carey Foster. —*Oliver Lodge, F.R.S.*

See Metre Bridge.

**FOUCAULT CURRENTS.** An alternative name for eddy currents (*q.v.*), which are electro-magnetic currents due to induced current circulating wholly in the mass of the conductor itself. This phenomenon was known many years before Foucault proved by experiment that such eddy currents are wasteful of energy through the production of heat.

Foucault's apparatus included a copper disk capable of being rotated between the poles of an electro-magnet. Little resistance is felt on spinning the disk until an

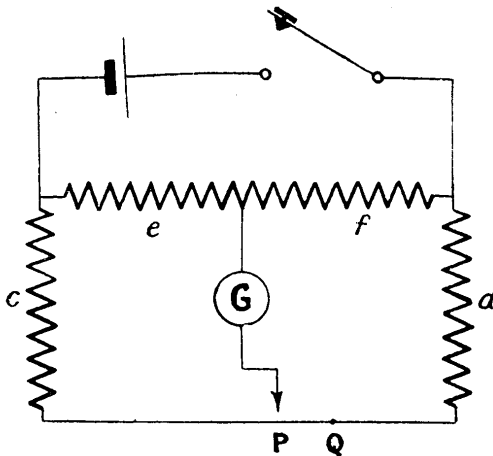

FOSTER BRIDGE CONNECTIONS

Fig. 2. The coils *c* and *d* are interchangeable. A balance is obtained at *P*, then *c* and *d* are interchanged, and the new balance obtained at *Q*. The difference of resistance  $c-d = P Q$ . Resistance is measured in much the same way as weight is measured in a balance

of the german silver wire which lies between the two positions of the slider.

Hence the thicker and better conducting the wire, the longer will this interval be, as measured on the metre scale, for a given small difference between the coils. So in the bridge actually used by Messrs. Nalder for the construction of their standards the german silver wire was replaced by a rod of some alloy, such as platinoid, about a foot long, the resistance of the rod being accurately calibrated and known. But this rod is not by any means the whole of the resistance in that branch of the circuit; it is only its middle portion. The main part of the resistance is in two coils, one at each end of it.

Now these two coils, thus used, may be the two coils to be compared; and in the Foster bridge arrangement that



electric current is sent through the coils of the magnet. Then rotation becomes difficult, or even stopped, but if continued by force, the disk heats up to a remarkable extent. Alternating currents set up eddy currents in masses of metal near them, so that iron cores of transformers must be laminated. Metal sheets act as induction screens by interposing eddy currents between a magnetic field and the apparatus it is desired to shield.

**FOUR-ELECTRODE VALVE.** The standard type of four-electrode valve has one filament, one anode, but two grids. A photograph of a Marconi-Osram four-electrode valve is given in Fig. 1. The bulb in which the electrodes are fitted is the same size and shape as for the V24 valve. In order to reduce the self-

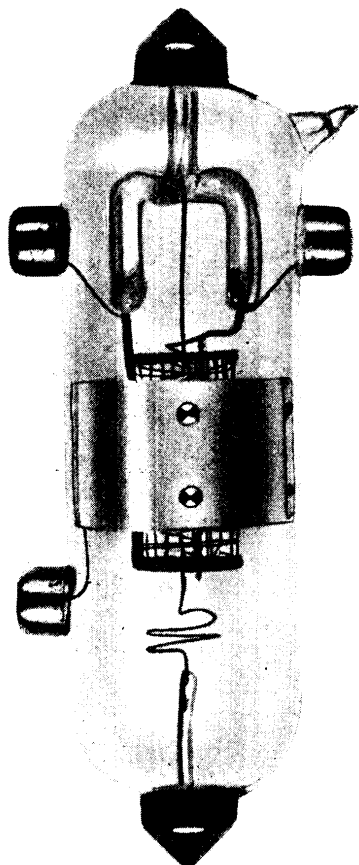

**FOUR-ELECTRODE VALVE**

Fig. 1. Two grids, one filament, and one anode form the four electrodes of this Marconi-Osram valve, which can be used for the three purposes of high- and low-frequency amplifying and detecting, simultaneously

*Courtesy Marconi's Wireless Telegraph Co., Ltd.*

capacity of the valve to a minimum, the four contacts to the electrodes are placed as far apart as possible. Situated at opposite ends of the bulb are the two contacts for the filament. The leads inside the bulb are well carried inside small glass tubes, which also serve the purpose of supporting the electrodes. A short spiral spring may be seen attached to the filament in the lower end of the valve. This automatically keeps the filament straight despite changes in its length due to expansion when heated.

The first grid, the contact for which is situated on the right of the bulb immediately beneath the pip, is of the usual spiral type. This is supported by the right-hand limb of the forked glass tube, which may be seen inside the bulb. The second grid, which the other limb of the fork supports, consists of a fine wire mesh of much larger diameter than the first grid, which it completely surrounds.

An anode of very large diameter is fitted, the connexion to which is clearly shown.

The four-electrode valve may be made to serve the triple purpose of high-frequency amplifier, rectifier, and low-frequency amplifier at the same time. Fig. 3 is a photograph of a marine receiver in which the three functions of this valve are utilized. A circuit diagram of this instrument is given in Fig. 2.

Transformer-coupled high-frequency amplification is used, the transformer having three tappings both on the primary and secondary. The design of this component is such that it will give perfectly even amplification from 500 to 12,000 metres, above which figure there is a slight falling off until 20,000 metres is reached.

The switch controlling the high-frequency transformer may be seen in Fig. 3, in the right-hand corner of the panel. Only the knob is visible, all the contacts being inside the cabinet. The output from the tuner is brought to the first grid and the low-tension negative, the former connexion, however, being via the primary of a closed-core transformer. Connexion from the second grid is taken to the high-frequency transformer.

The anode connexion is unusual in that the current applied to it is taken from a potentiometer across the low-tension battery. One side of the windings of both transformers is connected in series with the potentiometer and the anode.

A high-tension battery of 24 volts is required for this set; the terminals for this supply may be seen in the lower right-hand corner of the panel in Fig. 3.

Low-resistance telephones are used, the telephone transformer being connected between the high-tension positive and one side of the high-frequency transformer.

The simplicity of operation of this set may be

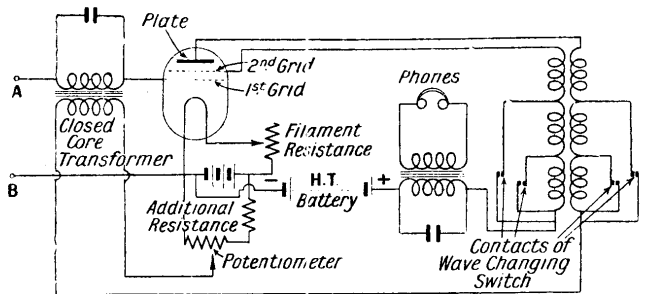
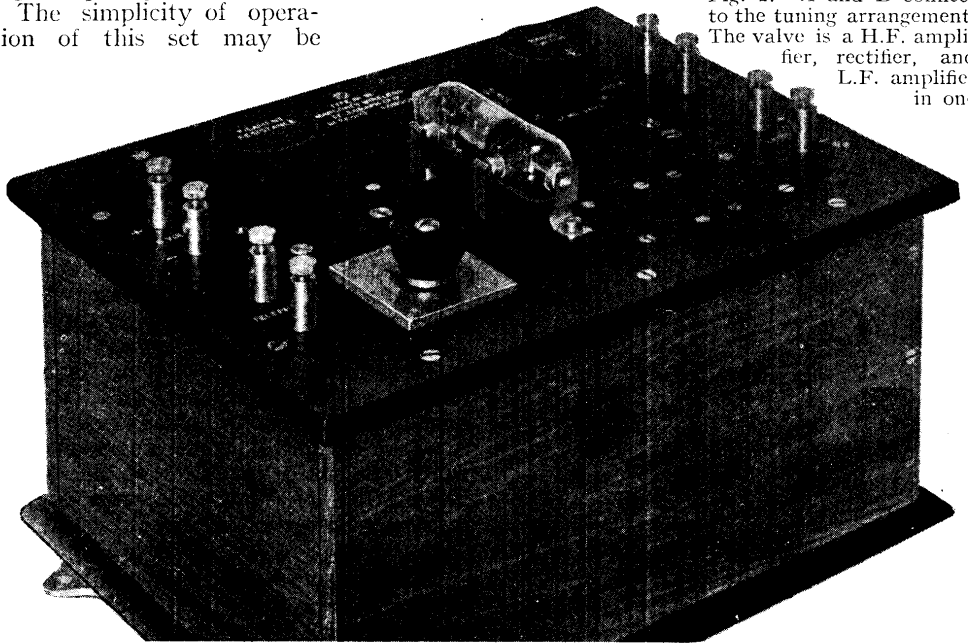

Fig. 2. A and B connect to the tuning arrangement. The valve is a H.F. amplifier, rectifier, and L.F. amplifier in one



**FOUR-ELECTRODE VALVE, MOUNTED**

gathered from the fact that only three controls are necessary, these being the filament resistance, potentiometer and high-frequency transformer tapping switch.

Fig. 3. Contact is made to the four electrodes by the clips which hold it in position. The photograph shows a four-electrode valve mounted on a marine receiver

*Courtesy Maconi's Wireless Telegraph Co., Ltd.*

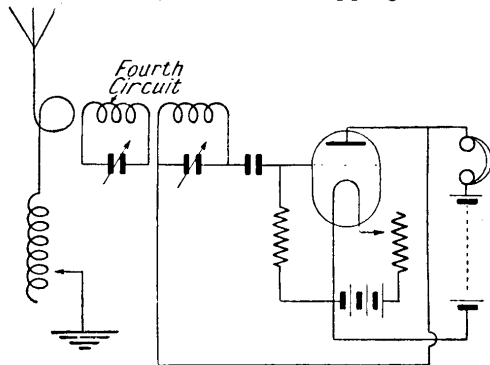

**COCKADAY FOURTH CIRCUIT**

Coupled between the aerial circuit and the grid circuit is a wave trap for controlling self-oscillation. This is known as a fourth circuit

**FOURTH CIRCUIT.**

A method evolved by L. M. Cockaday for controlling the self-oscillation of a thermionic valve consists in coupling a small tuned wave trap between and to both aerial circuit and grid circuit of an oscillating detector valve. This fourth circuit consists of an inductance wound on the same former as the grid coil, while the aerial coupling is very loose, with only a few turns of wire. The mode of operation consists in adjusting reaction until the valve is oscillating vigorously. Then, by varying the filter condenser from zero, energy is subtracted from the grid circuit until the oscillations come under control. See Cockaday Circuit.

## FOUR-VALVE SET: A SIMPLE LONG-RANGE RECEIVER

How to Build an Easily Made Set with a Normal Range of About 520 Miles

This is one of the series of receiving sets referred to on the Broadcasting Map (facing page 282), ranging from the simplest crystal set picking up a local station to this four-valve set, which brings all the British stations within range. See also Crystal Receiver; High-Frequency; Three-Valve Set, and similar general headings

A four-valve set, designed in conjunction with the broadcasting map facing page 282, is shown in Fig. 1. The set is constructed in three parts, which are mounted on a common baseboard. The object of this is to simplify the construction of the set, which would be more difficult to assemble on one large panel. The three panels consist of the tuner, the high-frequency amplifier and detector forming the second unit, while the third unit is built up as a two-stage low-frequency amplifier.

The tuner is of the simplest type, and is the same as was used in the two-valve dull emitter set, described under Dull Emitter, page 762. It consists of an inductance wound on a cylindrical former attached to the back of the panel. Certain modifications have been made in the tuner previously described.

The second or centre unit comprises a high-frequency amplifying valve using transformer coupling, and a valve detector. The primary of the transformer is shunted with a small variable condenser connected to a knob on the panel by a flexible rubber tube. This novel form of coupling has the advantage of enabling the condenser to be placed at the back of the base, where it is free from the moving arm of the filament resistance. The transformer is of the plug-in type, and is seen to the left of this unit in Fig. 1.

The third unit consists of two low-frequency amplifiers, the transformers of

which are placed on either side of the two valves, which occupy a central position on the base.

The tuning inductance is wound with No. 24 S.W.G. enamelled wire on an ebonite former 5 in. long and  $3\frac{1}{4}$  in. diameter. It is secured to the panel by means of valve-holder sockets. These are tapped in the

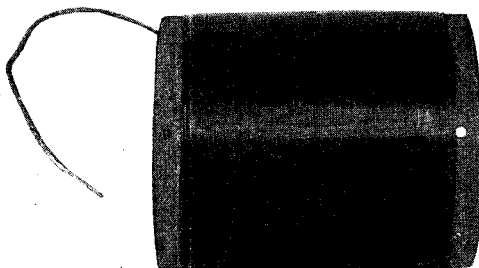

INDUCTANCE OF FOUR-VALVE SET

Fig. 2. On either side of the wiring of the wound inductance of the tuner unit are the holes for attachment to the panel

holes to allow a countersunk screw to hold each in position, one on either side of the tuner. Corresponding holes are drilled, as shown in Fig. 2, at either end of the tuning inductance, through which the screwed legs of the valve sockets pass. The inductance former can now be locked tightly in position by nuts on the screwed legs. Fig. 4 clearly shows the position of these valve legs, and in Fig. 5 the inductance is seen in position. It should

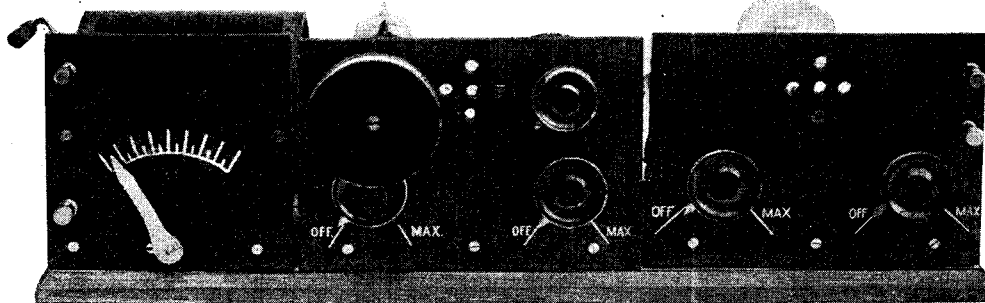

FRONT VIEW OF FOUR-VALVE RECEIVING SET

Fig. 1. In this front view of the four-valve set the plug-in transformer is seen in position on the high-frequency and detector panel. To the right of this is seen the control knob of the variable condenser. The tuner unit is engraved for observing the position of the contact arm for specially required wave-lengths

Fig. 3. Soldered to the main contact arm of the tuner is an additional brass piece to provide more springy contact

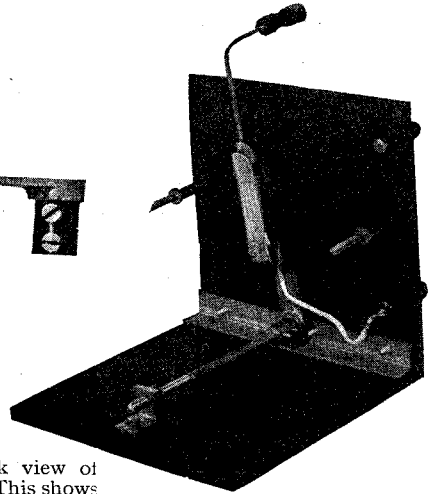
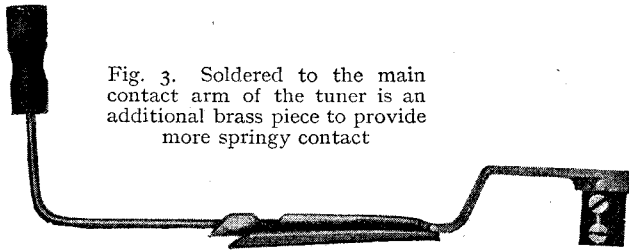

Fig. 4. Back view of tuner unit. This shows the position of the contact arm and spindle, also valve sockets for the inductance former

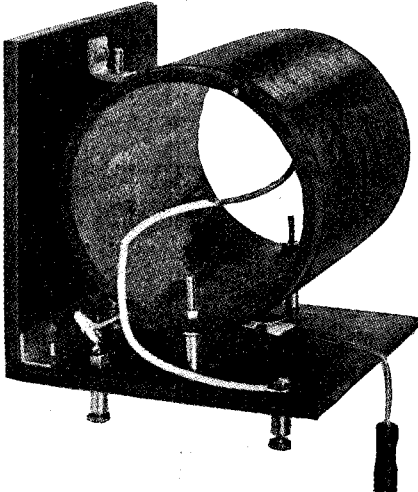

Fig. 5. How the inductance former is secured to the panel is seen in this view of the rear of the completed tuner. Aerial and earth connexions are also shown

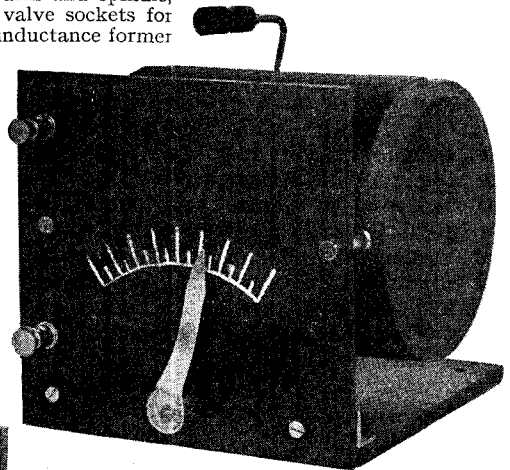

Fig. 6. Pointer and dial are on the face of the tuner panel. The position is arranged in line with the contact arm to indicate position of the inductance

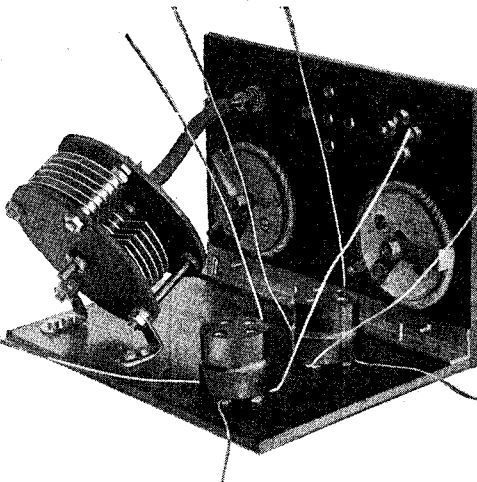
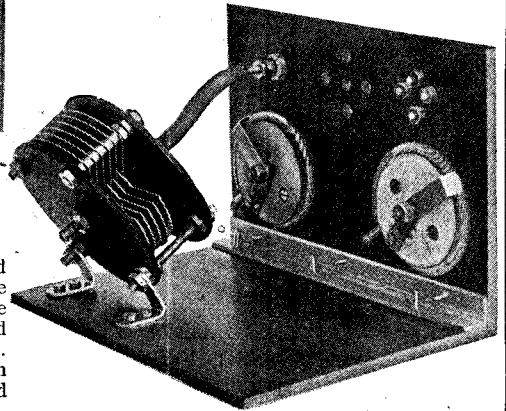

Fig. 7 (above). Short wires will be seen attached to each valve leg. These are attached before assembly to the base. Note the position of the valves. Fig. 8 (right). How the condenser is fixed behind the H. F. and detector panel is shown. On the right will be seen the valve holder in which the high-frequency transformer is plugged



#### COMPONENTS AND STAGES IN BUILDING THE FOUR-VALVE SET

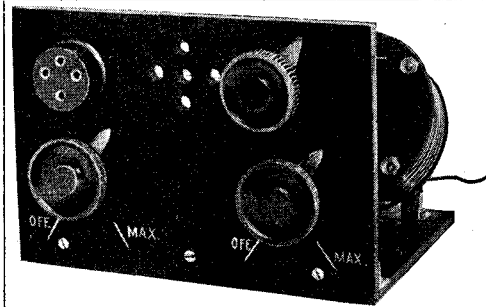

Fig. 9. Finished appearance of high-frequency and detector unit from the front. The valve holder receives the plug-in transformer

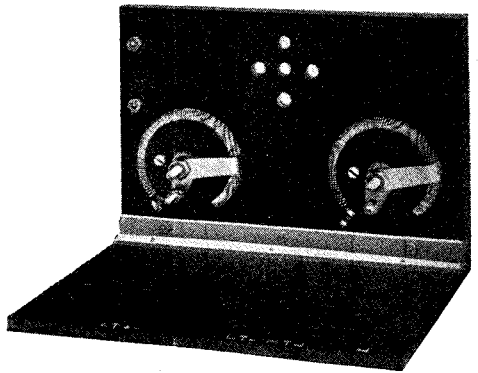

Fig. 10. At this stage of construction of the low-frequency unit the positions of the rheostat, telephone terminals, and holes for the transformer, valve holder and connecting terminals can be seen

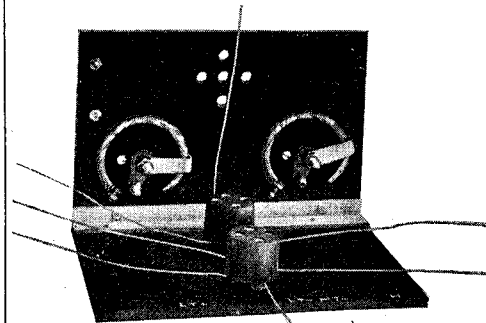

Fig. 11. Valve holders are in position behind the low-frequency amplifier panel with wires soldered before assembly

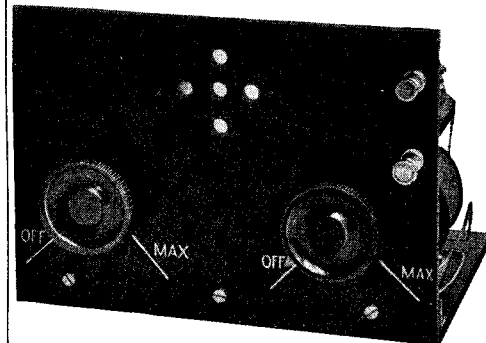

Fig. 13. Front view of low-frequency amplifier. Valve peep-holes are seen, also telephone terminals and control knobs for filament resistances

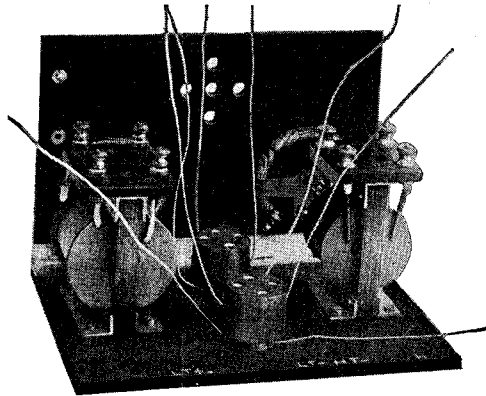

Fig. 12. Preparatory to assembly on a common base the position of the low-frequency transformers is shown on the amplifier



Fig. 14. Three units are mounted on this base, part of which is seen. Note the scooped-out holes, arranged to clear projections on the underside of valve holders

#### CONSTRUCTIONAL DETAILS FOR THE FOUR-VALVE RECEIVER

now be removed until the contact arm, shown in Fig. 3, is made and fixed in position.

This consists of a strip of brass  $\frac{1}{2}$  in. by  $\frac{1}{16}$  in. soldered to a brass bush having a  $\frac{3}{16}$  in. central hole. Two small screws, shown in the bush in Fig. 3, lock the contact arm to a  $\frac{3}{16}$  in. rod, which forms a spindle for the rotation of the moving parts. A brass bush let into the panel forms one

bearing for the spindle, which is supported at the other end by a centre mounted in a brass angle bracket.

The remainder of the contact arm differs from that described in the dull emitter valve set (page 763) in that an additional brass strip is soldered to the strip of  $\frac{1}{16}$  in. brass. The arm is extended above the top of the panel by a  $\frac{1}{8}$  in. diameter brass rod soldered to the thicker of the brass strips.

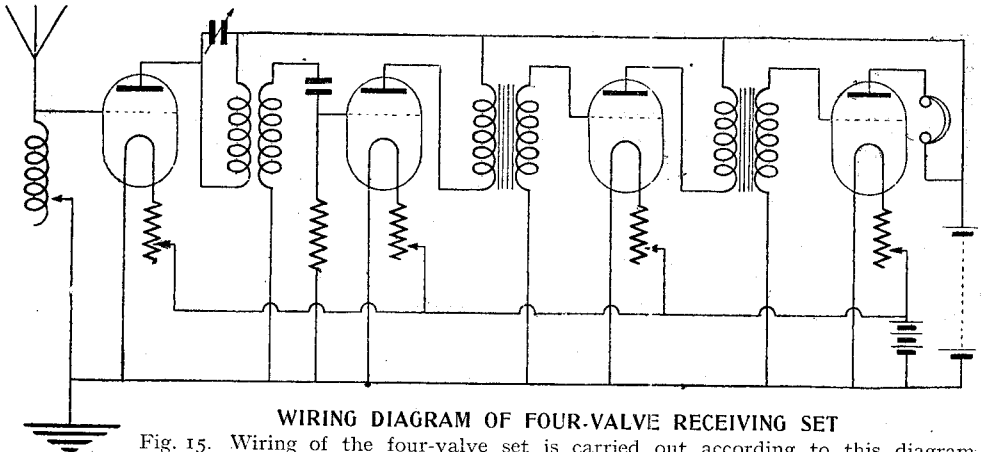

WIRING DIAGRAM OF FOUR-VALVE RECEIVING SET

Fig. 15. Wiring of the four-valve set is carried out according to this diagram. Tuning is extremely simple. The only controls are the aerial tuning inductance and a small variable condenser across the primary of the high-frequency transformer

A convenient-sized handle of ebonite is attached to the free end, which is bent over at a right angle. The spindle is allowed to project a little on the outside of the panel, where a brass pointer is attached so that it comes in line with the contact arm, thus indicating its position on the inductance. When assembled, electrical contact is made between the coil and the moving arm by removing the insulation from the former by means of a piece of emery paper wrapped round the moving arm.

Another point of difference from the tuner described in the dull emitter valve set is that the terminals between tuner and the detector panel are omitted, as the wiring is carried out in one operation, when all components are mounted in position and the three units secured to a common baseboard.

A flexible insulated wire is soldered to the moving spindle, the free end being taken to the lower or earth terminal of the tuner. The aerial terminal may now be connected to the beginning of the inductance coil, which is finally mounted in position.

The tuner, complete with the exception of the wiring, is seen in Fig. 5. The pointer and dial are clearly seen in Fig. 6, which shows the front view of the tuner.

The panel and base of the high-frequency and detector unit is built up in a similar way to the tuner with  $\frac{1}{2}$  in. angle brass, the ebonite panel measuring 7 in. by 5 in., and the base, also of ebonite, cut to the same dimensions. At a convenient distance from the top of the

panel and in the centre of it five  $\frac{1}{4}$  in. holes are drilled for the inspection of the valve filaments. The exact location of these holes is not important, but the same relative positions should be chosen when constructing the low-frequency amplifier. The two filament resistances are screwed to the back of the panel, as shown in Fig. 7. They should be placed as low as possible on the panel, providing the moving contact arm clears the angle brass supporting the panel.

Midway between the valve peep-holes and the left-hand edge of the panel, viewed from the front, a valve holder is attached, the back of which is seen in Fig. 7. A valve holder of the pattern shown in Fig. 11 should be chosen, having screwed legs, four nuts on which secure it to the panel. In a corresponding position on the other side of the valve peep-holes a  $\frac{3}{8}$  in. hole is drilled, into which a flanged brass bush is tightly pushed, so that the flanged edge is to the inside.

The bush has a  $\frac{3}{16}$  in. central hole. An ebonite knob tapped 2 B.A. is screwed and locked with a 2 B.A. lock nut to a screwed rod  $1\frac{1}{2}$  in. in length. The rod is pushed through the bush, with the knob to the outside. A 2 B.A. spring washer is slipped over the rod and the whole adjusted and then locked with two 2 B.A. nuts, so that a free turning motion may be given to the knob and spindle without undue looseness.

The rod protruding must not be cut off, for a flexible rubber tube to the variable condenser is screwed on when the latter has been mounted. This condenser has a maximum capacity of .0003 mfd., and may

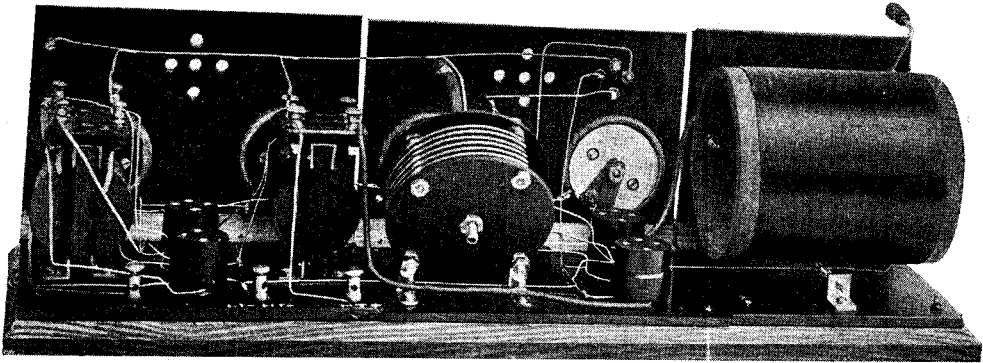

#### GENERAL LAY-OUT OF THE BACK OF A FOUR-VALVE SET

Fig. 16. From this photograph the position of the components of all three units can be seen. The wiring is arranged to give as little inter-action as possible. A common base supports the whole set. On the left is the low-frequency amplifier, and the battery terminals will be seen with their bases engraved

either be purchased or assembled from components. The method of mounting the condenser will depend on the adaptability of the component to be used. A convenient method of mounting a condenser built up of standard parts is shown in Fig. 8. This consists of two brass brackets screwed to the base, and also to two extensions of the rods separating the end plates of the condenser.

A position for the condenser should be chosen where the minimum resistance to turning motion is found. Any convenient method of coupling may be chosen—a thick rubber tube screwed to the end of the condenser spindle and the control spindle will be found very effective. Such a device is shown in Figs. 7 and 8.

Valve holders for the high-frequency and detector valve may be attached to the base, as shown in Fig. 7, in a similar way to that adopted in mounting the valve holder for the plug-in transformer. Short lengths of No. 24 S.W.G.

tinned wire should first be attached to the valve legs before screwing the valve holders to the base. An alternative method is to use valve holders of the flanged or A type, in which case short countersunk screws are used for securing them to the base.

A combined grid leak and condenser of .0003 mfd. is screwed to the base at any convenient position between the valve holders and the variable condenser. This unit, as shown in Fig. 9, is now completed, and may be left until the wiring-up stage.

The low-frequency amplifier unit is also built on the open-frame principle, and consists of two ebonite sheets, each 7 in. by 5 in., bolted together in the same way as the other two units with  $\frac{1}{2}$  in. angle brass. Five peep-holes, drilled to match those in the preceding panel, are placed centrally at the top of the panel, on either side of which the filament resistances are attached. Two telephone terminals will be required, and are placed at the top

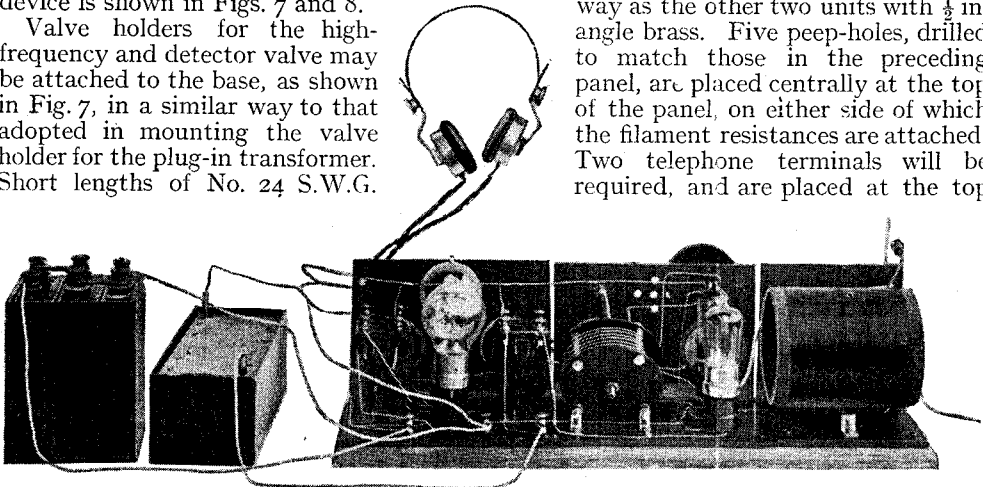

#### COMPLETE FOUR-VALVE SET READY FOR RECEPTION

Fig. 17. Accumulator and high-tension battery are connected to the terminals behind the low-frequency amplifier, and the telephones are connected with their terminal pins visible, where the telephone terminals hold them on the panel, which is seen from the rear. Projecting from the tuner panel, on the right of the illustration, are the aerial and earth leads

right-hand side of the panel. The valve holders are placed across the centre of the base, with one low-frequency transformer on either side. The holes for these components are drilled and tapped in one process, in order that the presence of any component may not interfere with the operation of drilling and tapping any subsequent holes. The valve holders have short leads attached to them before fixing them in position, as shown in Fig. 11 of the back of the unit at this point of the construction. The low-frequency transformers should be of the same pattern and make, to ensure that they will work well together. They are screwed to the base, as shown in Fig. 12, sufficient room being left to permit the insertion of the valves.

The front view of the unit is shown in Fig. 13. All three units are now ready for attachment to a base of  $\frac{3}{4}$  in. mahogany or whitewood. Holes should be drilled in the base, in order to clear any projection that may exist on the underside of the bases of the units. These holes are seen in Fig. 14, which shows the base before assembly of the units. These may now be screwed to the base with  $\frac{3}{4}$  in. round-head screws.

Fig. 15 shows the wiring diagram applicable to the set, which may now be wired up. All joints should preferably be soldered, and wires kept as short and straight as possible.

The appearance of the wiring is shown in Fig. 16, of the back of the completed instrument. The battery terminals are conveniently placed at the back of the low-frequency amplifier. In order to prevent confusion between these terminals, it is best to engrave them; which may be done according to instructions given under the heading Engraving.

In Fig. 17 is seen a back view of the apparatus, showing batteries and telephones connected.

The set will be found extremely simple to operate, owing to the small number of controls. Having ascertained that the set is in working order, "searching" for a signal should be carried out by slowly moving the contact arm backwards and forwards until a signal is heard. Having found the best position for loudness on the tuner, the variable condenser should be turned until the point of maximum loudness is obtained. Finally, the filament resistances should be regulated until the signal is at its loudest.

It is a mistaken idea that the brighter the valve filament, the louder will be the signal. It very often happens that signal strength is greatly increased by decreasing the brilliance of the valves.—*W. W. Whiffin.*

**F.P.S.** This is the abbreviation for the foot-pound-second system of units. See Foot-pound System.

## FRAME AERIALS: THEORY, TYPES AND CONSTRUCTION

### An Important Variety of Receiving Aerial, How it Works and How it is Made

For all kinds of reception the frame aerial has become of increasing importance and usefulness with the advance of radio communication. Here the theory of reception by these aerials is clearly explained, the best types to use described, and full details given for their construction by the wireless amateur. The article is followed by a description of a five-valve frame aerial receiving set. See Aerial; Hanging Set

A frame aerial is a particular type of aerial arranged on a rectangular or polygonal-shaped frame. The aerial, in general, consists of one or more wires arranged in a variety of ways, by means of which electro-magnetic waves can be radiated when high-frequency alternating currents are sent into them; or, conversely, H.F. currents are generated when they come within the influence of radiated electro-magnetic waves from another source.

Generally, the aerial comes under the description of either "umbrella" type, "T" type, "inverted L" type, "fan or harp" type, "multiple-tuned" type, "coil" or "frame" type. They all have

different characteristics, but the frame type is notable for its pronounced directional effect.

Each loop of the aerial receives best when its direction is in the plane of the sending station; and if it should be pointed at right angles thereto, the reception value is practically nil. When it is placed in intermediate positions, the strength of the current signals picked up may be expected to vary as the cosine of the angle existing between the plane of the coil aerial and the position of the sending station.

The radiation of electro-magnetic waves can be studied by a consideration of the accompanying figure, showing how the



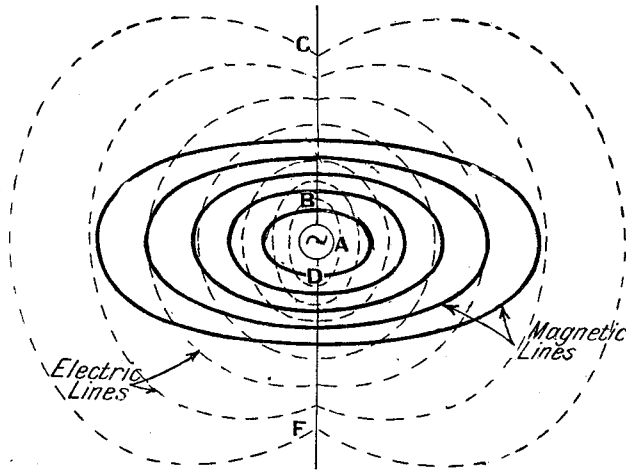

**RADIATION OF ELECTRO-MAGNETIC WAVES**

Fig. 1. Diagrammatic representation is given of a magnetic and electric field around a wire carrying high-frequency current. This should be considered when studying the theory of frame aerial reception

changes taking place in the electric and magnetic fields can be radiated to great distances away from their origin. In speaking of "fields" a vision of "lines of force" is usually conjured up. And while constituting a very convenient means of representing such phenomena graphically for demonstration purposes, it is dangerous to push the analogy too far, since there are no open spaces between the so-called lines. It would convey a more apt mental picture to regard the effect taking place as a kind of "fog," more or less dense according to the strength of the forces at work.

The production of a field, whether electric or magnetic, is accompanied by a strain in the ether, and therefore represents a definite amount of energy expended according to the field strength. An electric field in motion produces a magnetic field, and the converse is equally true, hence the link between radiation and reception. The transmitting station sends rapidly pulsating currents into the aerial, which, in its turn, emits electro-magnetic waves. These waves are caught by the receiving aerial, and are reconverted into pulsating electric currents due to the ordinary laws of electro-magnetic induction. It is impossible that current should actually pass without the presence of a conductor, but there is no reason why the radiated electro-magnetic field should not set up a difference of electric potential

across the intervening space between the two aerials, whether intercepted by a conductor or not. An electric current is really a stream of electrons following one another at a high speed in the same direction, and each one will carry with it an electric field of its own, so that at any point in space near it there will be called into existence a moving electrostatic field.

Referring to Fig. 1, two conductors, BC and DF, are shown connected to a high-frequency alternator, A. Since its electro-motive force is continually changing, both in value and sign, the charges on these two conductors change in a similar manner. The result is that a rapidly changing current is flowing

through the wires accompanied by a similar change in their potential difference. The magnetic field due to the presence of these currents will take the form of lines of force concentric with the wires BC and DF, as shown, having their plane perpendicular to the flow of current; while, in addition to this, an electrostatic field

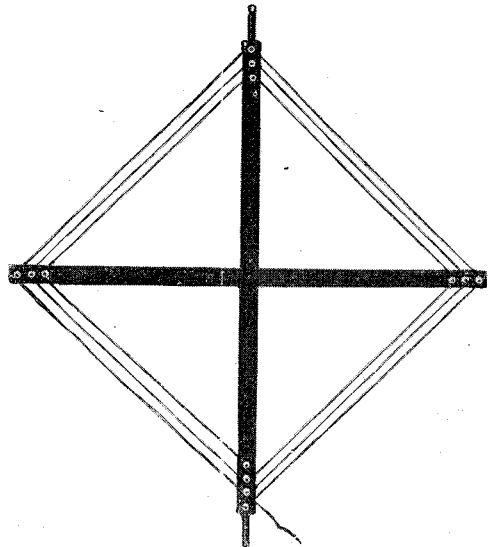

**SIMPLE FORM OF FRAME AERIAL**

Fig. 2. One of the simplest forms of frame aerial is illustrated. This consists of a cross of hardwood, with ebonite plates and china insulators for the wires

will be propagated in the manner shown by the dotted lines. The electric field at a point, P, for instance, will follow the variations of the potential difference between the wires BC and DF, but will take place slightly later owing to the time element in transmitting the strain in the ether from place to place.

At some time, depending upon the frequency, the potential difference across the wires will reach a maximum, which change will be followed after a definite time interval by corresponding changes in the electric field at the same point; the field will then diminish gradually, and at the same time begin to return energy back to the conductors; but, owing to the time lag, not all the energy will have been returned before their potential is again growing towards maximum, and the unspent energy left in the field is unable to return to its origin, because that is now sending out more energy. Consequently, the unreturned balance is forced away and detached from the aerial.

#### Radiation Fields and Frame Aerials

Briefly, it may be said that the space about the aerial may be considered as being occupied by two components of electric and magnetic fields. One of them is continually moving backwards and forwards from the aerial, from which it alternately receives and returns energy. This is known as the stationary component or the induction field. The other component is the one which, having once left the aerial, is prevented from returning to it by the facts explained above, and is urged away from the aerial, travelling outwards with the velocity of light. This component being completely detached is known as the "radiation" field, and represents energy transferred by the aerial to the ether. The radiation field is almost non-existent in L.F. circuits.

One of the great advantages of the frame aerial over the ordinary type of flat-top aerial or inverted L or T aerials, is the ease with which it can be made directional. This property of receiving signals much more strongly from one direction than from another is one which is steadily making the frame aerial more and more popular to cut out interference from stations which are not wanted to be heard.

The principle underlying this can be followed from the previous remarks on the

electric and magnetic fields, and from the well-known fact that before a current can flow in a wire a difference of potential must exist between the two ends of the wire. Before a current can flow in the wire composing the frame aerial a difference of potential, therefore, must exist between two points on the wire.

Now, imagine that the plane of the frame aerial passes through the transmitting station it is desired to receive. Then one side of the frame is nearer the station than the other side, and an electromagnetic wave radiated from the station will cut across the wires of that side of the frame before it does the wires on the other side. This causes the necessary difference of potential, and a current flows in the frame aerial. Alternating currents are set up in the frame aerial which will oscillate at a frequency depending upon the length of the received wave. If the plane of the frame is now turned through a right angle so that it is square on with the wave front, it is clear that both sides of the frame receive currents of equal value which nullify one another, and so no signals are heard. And in between the points of the strongest signals and that where no signals are heard there is an infinite variation of signal strength.

#### Rules for Frame Aerial Wave-Lengths

To obtain the best results from a frame aerial the fundamental wave-length of the frame aerial and that of the received signal should bear some relation to one another. A general rough rule is that the wave-length of the frame should not be greater than one-third of the wave-length of the received signals. The square type of frame aerial is as efficient as any for the small frame aerials suitable for broadcasting reception. The frame is erected with one corner of the square towards the ground in order to reduce the capacity effects between the aerial and the earth.

As a general rule it may be stated that for short-wave reception a large frame with few turns is required, and for long-wave reception a small frame with a large number of turns. The wire used should be of as low resistance as possible, and the turns of the wire should be well spaced. The wires round the frame, too, should be insulated. The two ends of the frame aerial should be connected to the terminals of a variable condenser, which in turn are

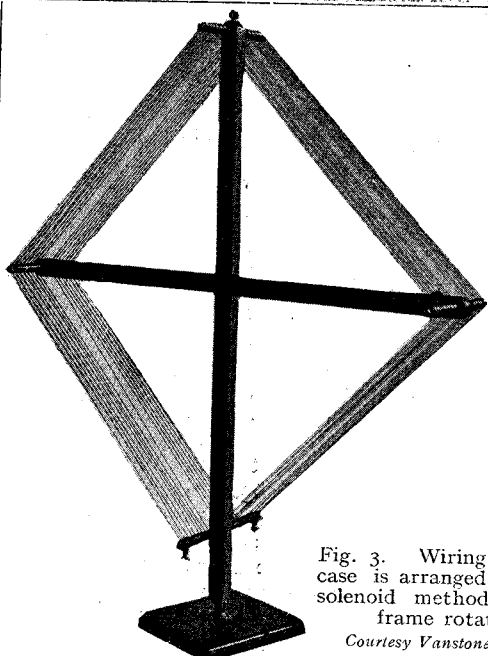

Fig. 3. Wiring in this case is arranged on the solenoid method. The frame rotates  
*Courtesy Vanstones, Ltd.*

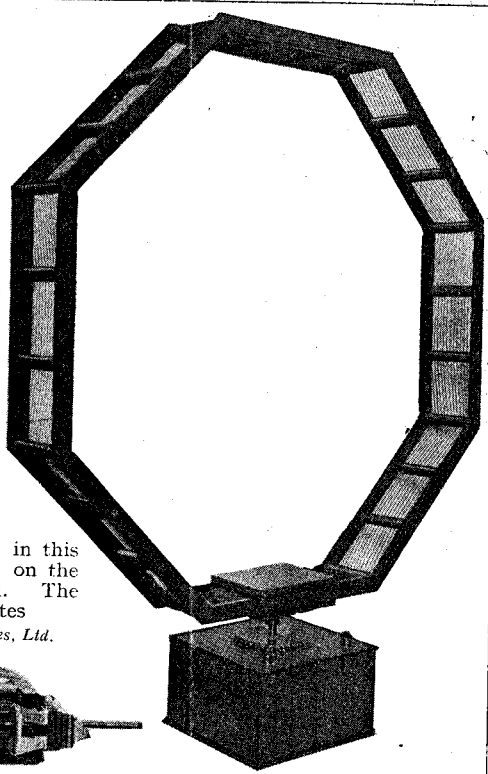

Fig. 4. Wires are wound over ebonite cross-bars on the solenoid principle  
*Courtesy Radio Instruments, Ltd.*

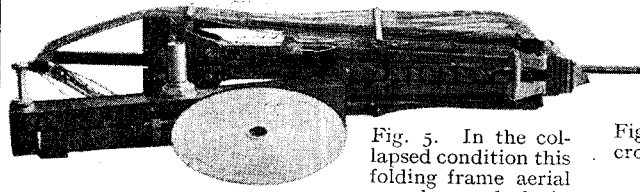

Fig. 5. In the collapsed condition this folding frame aerial can be packed in very small space

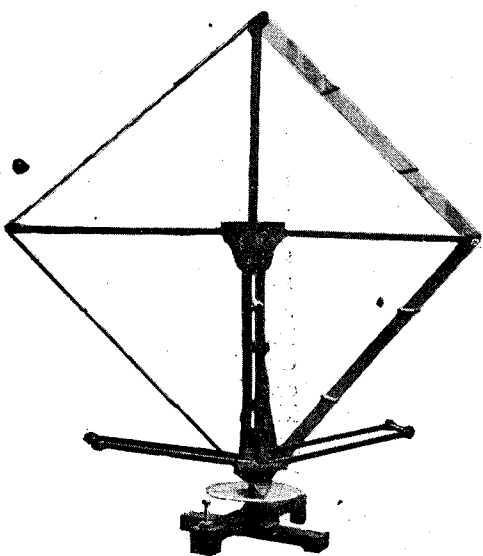

Fig. 6. The collapsible frame aerial in Fig. 5 is here seen erected and ready for use  
*Courtesy Cobb, Webb & Co.*

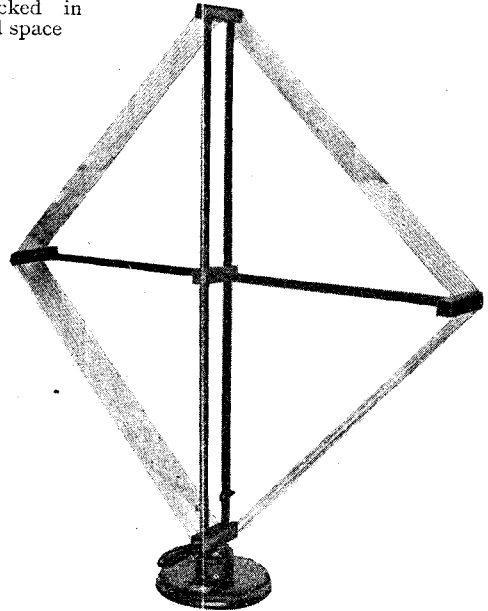

Fig. 7. At the foot of this aerial is a handle for rotation. The wires are wound on ebonite  
*Courtesy Radio Components, Ltd.*

**COLLAPSIBLE AND PERMANENT TYPES OF FRAME AERIALS**

connected to the input terminals of the receiving set. It is best to keep the aerial as far away from the ground as possible.

It will be appreciated that the amount of energy received by a frame aerial is extremely small, and it is indeed only by the use of amplifiers that the frame aerial may be used at all. Crystal sets will only respond with a frame of very large size.

The size of wire employed in winding a frame aerial is not of primary importance, and a very suitable size for all ordinary broadcast reception purposes is 20 or 22 S.W.G. For a frame of 2 ft square the wires should be about  $\frac{1}{16}$  in. apart; for a 4 ft. frame, about  $\frac{1}{8}$  in. apart, and for a 6 ft. frame, about  $\frac{1}{4}$  in. If the wires are placed at a farther distance apart there is a considerable reduction in the inductance, and more turns will be necessary. For broadcast reception, four turns of the wire on a 6 ft. square frame aerial, or six turns on a 4 ft. frame, will generally be found sufficient. These turns must be increased as the wave-length it is desired to receive is increased. On a 4 ft. frame, for example, some twenty turns are required to receive a transmitted wave of, say, 1,750 metres.—*A. H. Avery, A.M.I.E.E.*

**Types of Frame Aerials.** A simple form of frame aerial is shown in Fig. 2, and merely consists of a cross made of hardwood with ebonite plates attached to the face and near to the ends. Small china insulators are attached to these ebonite plates, and the aerial wire wound around them in the form of a square. The end of the wire is attached to an insulator and the wire taken through it to the next arm, and so on, until three complete circuits of the frame have been made.

The loose end of the wire is then fastened to a fourth insulator, and a short end left for connexion to the receiving set. Two circular portions are provided at the top and bottom respectively, and may be used either for mounting the frame on a bracket, or it may be suspended by a ring on the end of the top spindle by means of a cord to the ceiling of the room.

A development of the frame aerial is shown in Fig. 3. This comprises a cross-shaped wooden frame, with ebonite arms projecting on either side near the ends. The frame is mounted on a bearing on a baseboard of sufficient size and weight to hold the frame erect. The frame should rotate bodily on the bearing on the baseboard for directional control.

The wiring is differently arranged, and is known as the solenoid method. It is commenced at one terminal, makes several circuits of the frame, and terminates at the opposite terminal, connexion being made from them to the receiving set.

An octagonal frame aerial wound on the solenoid principle is illustrated in Fig. 4, and is constructed of very light mahogany, with ebonite cross-bars, the wire being wound over them, and terminating within the base. Provision may be made for the use of an inductance or for a variable condenser for tuning purposes.

As frame aerials are of some considerable size, it is desirable to make them collapsible, especially if it is intended to use the set in different rooms, or to take it from one place to another. A neat and efficient collapsible frame aerial is illustrated in Figs. 5 and 6, the former showing the frame erected and ready for reception, and the latter the instrument dismounted and packed into small compass. The framework is made of good bright polished mahogany, and comprises essentially a central support reaching from the base to the centre of the frame. The upper arm is mounted so as to slide in the cross-head in the centre of the frame, while the lower member has bearings and a pointer, together with two extension handles for directional control.

The dial is attached to the bearing, which is fixed to the two arms which form the base of the frame, and a screw is provided so that the frame can be adjusted and stand perfectly firm. This type of aerial is most conveniently orientated to the cardinal points of the compass. The bearings of the different broadcasting stations should be ascertained in relation to the cardinal points and the frame aerial, and the frame should be turned until it points to the required station.

A very simple form of frame aerial is illustrated in Fig. 7, and comprises three long arms united in the centre by a short square cross-piece. The ends of the frame arms are provided with ebonite blocks and the wire wound over them. The lower member is provided with a handle so that the frame can be turned about the spindle bearing on the base.

Frame aerials need not be set in a vertical plane, though this form of mounting is generally adopted in order to obtain the well-marked directional effect. The frame round which the wire is wound may be in

a horizontal plane, and under the heading Hanging Set in this Encyclopedia such a frame is described.

**How to Make Frame Aerials.** In cases where the receiving set is close to a broadcasting station and a powerful set is in use, the simply-made type of frame aerial shown in Fig. 8 can be successfully employed. It consists of two cross-pieces of light wood, known as door stopping, screwed to an upright made from a piece of deal 2 in. square, which is in turn fixed to a base plate made from a piece of thick wood about 6 or 8 in. square.

Four pieces of ebonite are attached to the ends of the arms, and these are slotted to receive the aerial wire, which is wound on the frame in the manner clearly shown in the illustration, the two ends of the wires terminating at the terminals on the base.

A slightly more elaborate frame is shown in Fig. 9. In this case the arms are 4 ft. in length, and made from light pine, 1 3/4 in. wide and 1/2 in. thick, tapering to 1 1/4 in. wide at the ends. The frame is simply screwed together in the centre, as shown in the illustration. The next step is to mount four ebonite rods on the ends of the arms, fitting these tightly into holes drilled in the ends thereof, as shown in Fig. 10. The rods are slotted with a hacksaw, so that the wires can rest in the slots, as is clearly visible in Fig. 10.

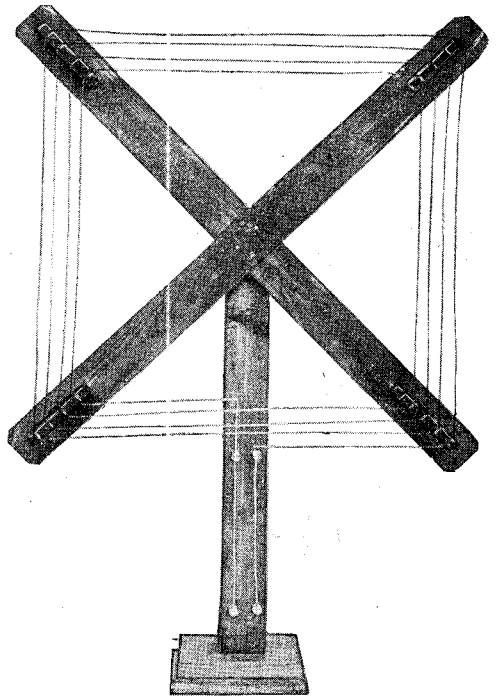

**HOME-MADE FRAME AERIAL**

Fig. 8. Battens are made of ordinary building material or door stopping. This frame aerial is one of the simplest for the amateur to make. It is fixed to the base plate and the whole aerial revolved for directional effects

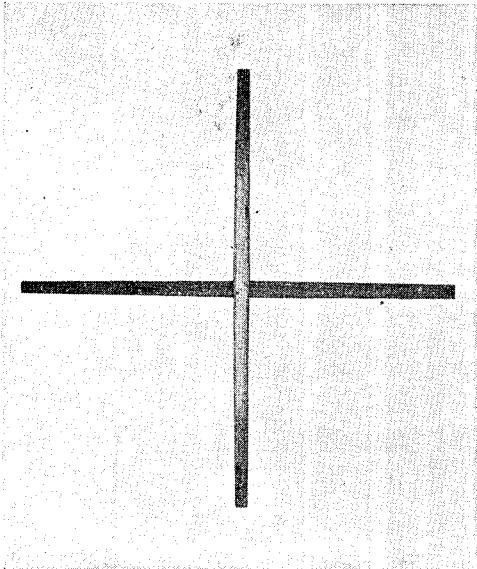

**FIRST STAGES IN MAKING A SIMPLE FRAME AERIAL**

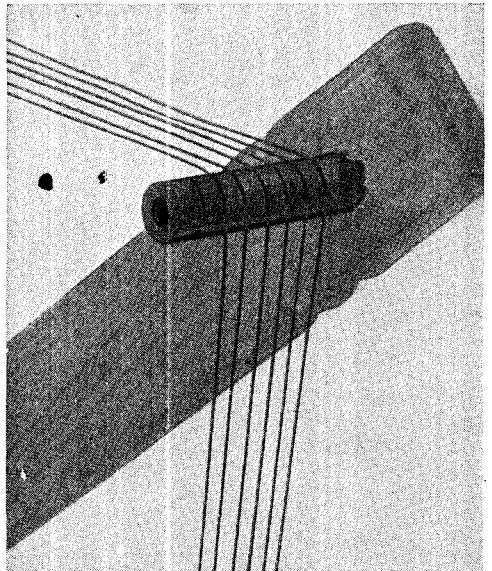

Fig. 9 (left). Cross-bars are first made and joined together to form the foundation. Fig. 10 (right). Pieces of ebonite rod or tube are cut and mounted, slots being made to hold the wires. The ebonite rod must be made to fit perfectly tight in the wooden support to take the strain of the wires

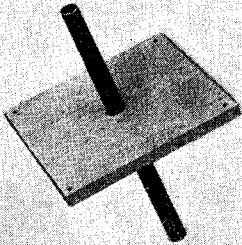
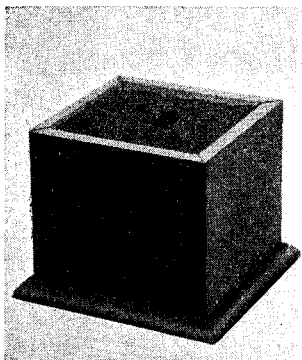

Fig. 11 (above). Sand is placed in the box base to give the frame stability. (Below). The frame is pivoted in a tube held by the lid

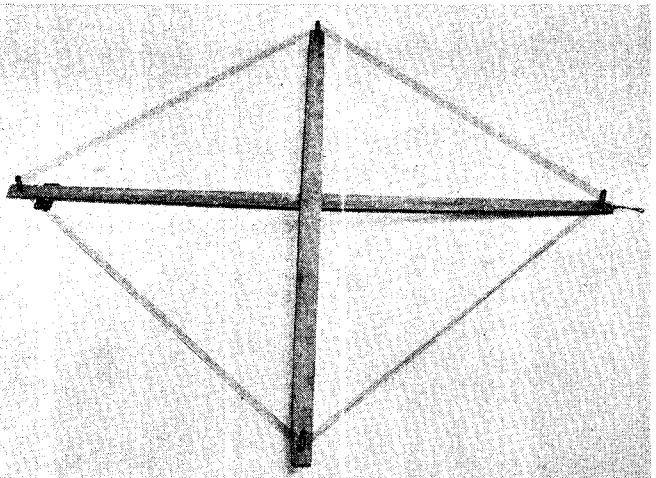

Fig. 12. On the right of the frame in the photograph is the top corner of the frame aerial. An eye loop is fitted to this corner as a means of suspending the aerial from the ceiling by a cord if it is not desired to fit a base for the aerial to stand independently. This shows the complete frame and wiring of the aerial. The base and its fittings, allowing rotation which can be measured, are shown in the other photographs

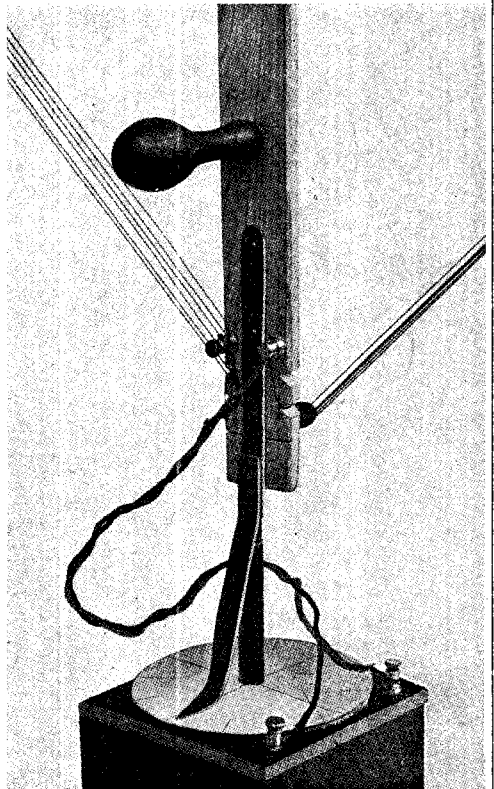
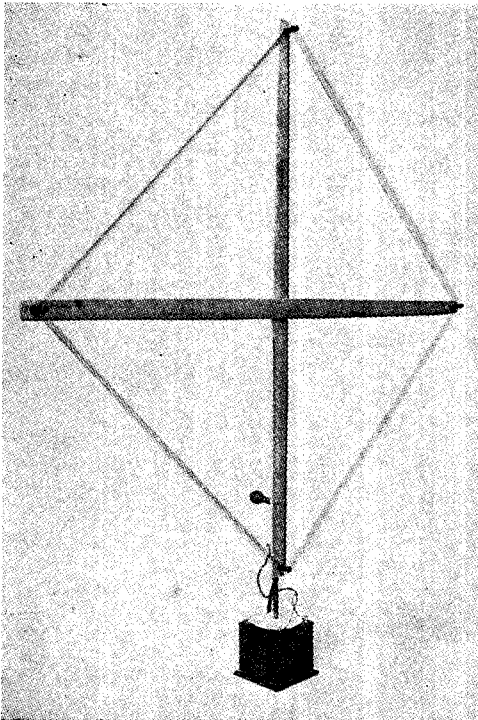

Fig. 13 (left). Details of the complete home-made frame aerial are shown, with the base and handle for rotation. Fig. 14 (right). Fitted to the spindle support is a metal strip, tapered and bent to shape. As the aerial is rotated, the pointer moves over the face of a fixed dial on the base. The dial is marked off in equal divisions

**HOW TO CONSTRUCT A SIMPLE FRAME AERIAL WITH WEIGHTED BASE**

A small tablet with two terminals is attached to one of the arms, a screw eye and loop to the opposite end of the same arm, and the ends of the wires are attached to the terminals. The screw eye is provided with a loop of cord so that the frame may be suspended. This is clearly shown in Fig. 12. Alternatively, a box about 8 in. square may be made up as shown in Fig. 11, and provided with a strong lid which can be screwed to the top of the box. Through the centre of the lid is passed a piece of brass tube which reaches the bottom of the box, where it rests on a small block of hardwood. The box is filled with sand or lead to add to its weight, and the lid screwed firmly in position.

A brass spindle is fitted to the bottom of the frame so that it may turn in the tube and thus act as a bearing. A dial and pointer are fitted respectively to the top of the box and the arm, and a turned hardwood handle also fixed to the frame by means of a screw, so that the frame can be turned in any direction. Details of the pointer and dial are clearly shown in Fig. 14, and the finished appearance

of the completed frame is illustrated in Fig. 13.

The folding frame aerial shown in Figs. 15 and 16 has the advantage of being very easily constructed, efficient in use and occupying very little room when closed. The material required consists of two 7 ft. lengths of planed slate batten  $\frac{3}{8}$  in. wide by  $\frac{1}{2}$  in. thick, 10 yards of ordinary rubber and cotton, or rubber and silk covered twin electric light flex, afterwards separated and a soldered connexion made so that the single insulated flex forms one continuous length of lead; a pair of hinges; a few odd scraps of brass; a few screws, and some pieces of ebonite for insulation.

The folding arrangement will be easily understood from the photographs, the vertical member being in one piece, while the horizontal member is made from two separate lathes, which are hinged to the vertical rod, the release of the clip at the top being all that is required to allow the shorter pieces to fold down. It may be thought that the wires may get mixed, but if they are firmly held between the clamps, there is no danger in this respect.

Cut one piece of batten 5 ft. long, and two pieces 27 in. long. The latter should

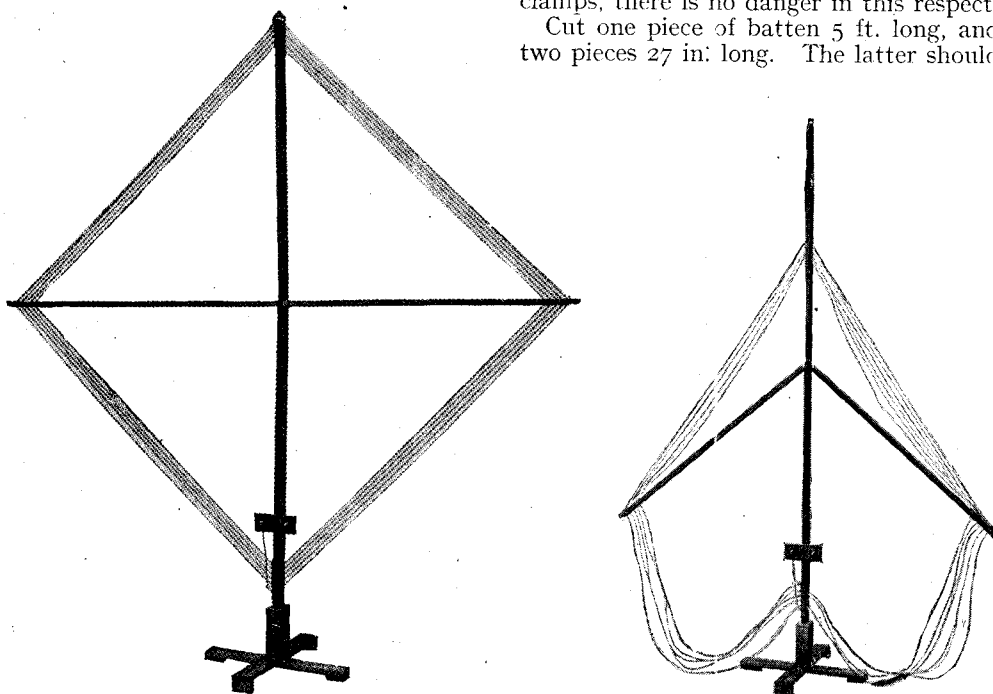

AMATEUR-MADE FOLDING FRAME AERIAL

• Fig. 15 (left). This folding frame aerial is very suitable for amateur construction. The vertical member is in one piece and the horizontal in two, to allow it to collapse. The aerial is shown ready for use. Fig. 16 (right). The two cross-pieces are hinged at the middle of the vertical member, so that when the clamp holding the wires at the top is released they collapse as illustrated

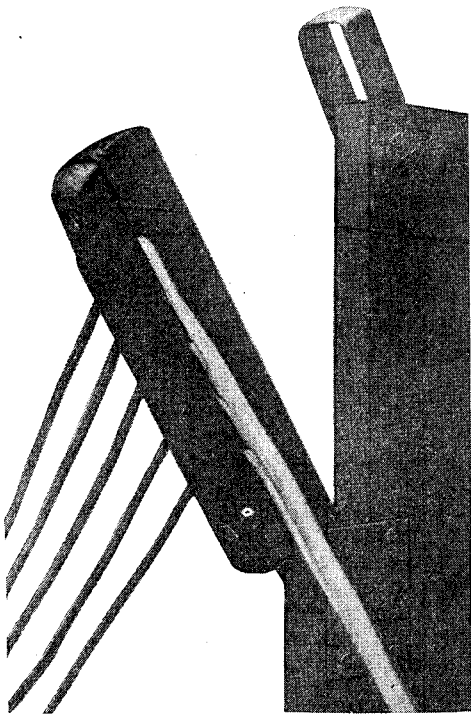

#### FRAME AERIAL REMOVABLE TOP

Fig. 17. Details of the removable top portion are shown. It will be seen that the wires are so clamped that when the catch is raised the whole portion can be removed and the aerial collapses

now be clamped to the vertical member, so that all the ends are level, when fine saw cuts are made, say  $\frac{1}{2}$  in. apart, commencing at 1 in. from the top. The position of the hinged portion should now be marked and one side piece turned over in order that the position of the lower notches may be marked, when they should be cut out as before.

It is now necessary to cut out completely a strip from the top, as shown in Fig. 17, which also shows the method of holding this portion in position. At this

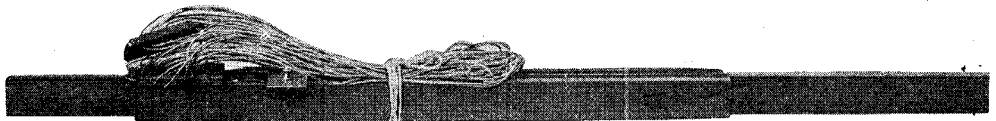
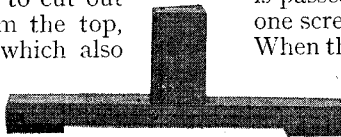

#### HOW THE COLLAPSIBLE FRAME AERIAL IS FOLDED

Fig. 18. At the top of this photograph is one of the footpieces of the structure, and below it the frame aerial, folded. The wires are not disarranged, and when the aerial is opened out they assume their correct position automatically. How the wires are held separately is seen in Fig. 17. The wires in the folded position should be tied to the frame to avoid damage in transit

stage the notched portion at each corner may be removed and pieces of ebonite fitted, using the removed wood as a guide. It will be better to make these pieces of ebonite  $3\frac{3}{4}$  in. long by  $\frac{3}{8}$  in. by  $\frac{1}{2}$  in., which is the size of all the clamping pieces, in which case only two screws in each will be required to hold the wires and ebonite blocks in position. The horizontal members may now be hinged in position.

The clamp at the top is simply a piece of brass bent over and fastened by two small screws. The small square pieces of brass may be any convenient size, and simply serve to prevent the removable portion being pulled out of position by the strain on the wires. The folding foot is made of the remaining battens, in this case 14 in. and 16 in. long respectively, which are provided with feet at the ends in order that, when crossed, the foot may stand evenly upon any flat support.

The foot should be arranged so that the cross members may fold together for compactness. The box, in which the frame may be fitted, is  $4\frac{1}{2}$  in. high, and sufficiently wide to accommodate the vertical member of the frame, and is firmly secured to the top portion of the foot. The terminals are fastened to a piece of ebonite, say 4 in. by  $1\frac{1}{2}$  in., and are screwed in a convenient position upon the vertical post, the ends of the wires being attached to the rear of the terminals in due course.

The wire may now be placed in position. This is best done by placing the frame on the floor in an extended position, fastening the clamping pieces by the inside screw in each case. The wire may now be laid in position in each groove in the ebonite, the top clamping piece being turned over to hold the wire temporarily, as each corner is passed sufficient tension being put on to one screw to prevent the wire slipping out. When the frame has been completely wired, then all the screws may be put in place and the wire worked around until taut. See Aerial.



# FRAME AERIAL RECEIVING SET, SELF-CONTAINED

How to Build a Receiver Working a Loud Speaker up to 200 Miles

This set, which has no external aerial or earth connexions and contains its own dry batteries, is designed to give long-range results without reaction. It includes five valves, two of which are high-frequency and two low-frequency amplifiers, the tuning being extremely simple. The article is illustrated with a special plate in photogravure.

See Frame Aerial; Hanging Set; Loud Speaker, etc.

This receiving set has been designed and made with the object of providing a truly self-contained set that does not need either an aerial or earth connexion, contains its own source of power in the form of batteries for the filament and anode current, is portable, and gives loud-speaker results up to distances of over 200 miles. It was also desired that the set should be simple to tune and reliable and stable in operation, and not call for an obtrusive frame aerial that is always getting in the way.

Numerous experiments pointed to a five-valve set without a reaction coupling as the best for the purpose, consequently the set illustrated on the photogravure plate and in the body of this article was devised. The circuit, shown in Fig. 1, includes two stages of tuned anode high-frequency amplification with a special dual condenser for simultaneous tuning of the two high-frequency stages. The two high-frequency valves are controlled by one filament resistance. The detector valve and two stages of low-frequency amplification are controlled by two separate filament resistances, one for the detector and one for the two low-frequency stages.

The valves used are the D.E. 3, working at three volts and only consuming some .06 ampere per valve. Current for the filament lighting is supplied

from an Ever-Ready dry battery, the high-tension current from an ordinary type of Hellesen dry battery of a minimum capacity of 60 volts.

Potentiometer control of the grids of the high-frequency valve is incorporated, and is essential, as it gives perfect control over the tone qualities, and to a large extent on the receptivity of the set.

Grid-biasing batteries are used on the two low-frequency valves, and add considerably to the signal strength. In actual operation at more than 30 miles from 2 LO (London) the set was tested and tunes easily and brings in 2 LO with ample strength to be heard all over the house, and also brings in Cardiff, Bournemouth, Birmingham and Newcastle at good loud-speaker strength. The set is primarily intended for loud-speaker work, but on head telephones brings in all B.B.C. stations on the frame, with the exception of Aberdeen, from 30 miles south of London.

The whole of the tuning is carried out on the two condensers, and near-by stations tune on the loud speaker, the others on the headphones and the potentiometer. The potentiometer is chiefly to check any tendency to self-oscillation and to control the tonal qualities. Once the stations have been tuned in it is only necessary to note the settings and

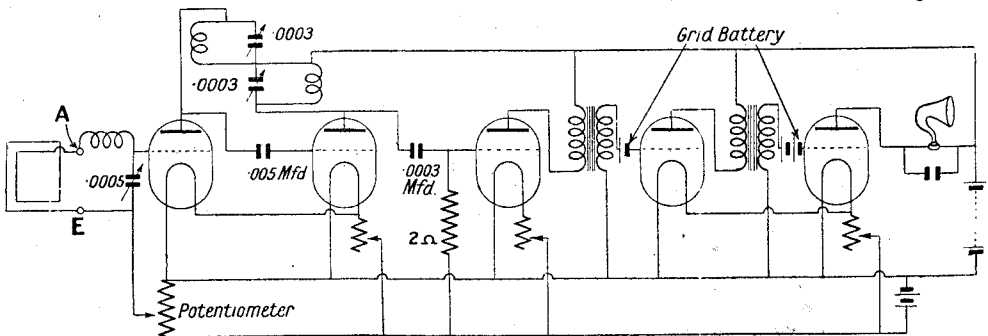

METHOD OF WIRING A FIVE-VALVE FRAME AERIAL SET

Fig. 1. On the extreme left is the frame aerial, which is wired to the two terminals marked A E. These two terminals would, in the event of using an outdoor aerial, connect aerial and earth. A special dual condenser simultaneously tunes the two stages of high-frequency amplification, the two valves for which are controlled by one rheostat. Transformer-coupled to the detector valve are two low-frequency amplifying valves, each of which has a grid-biasing battery

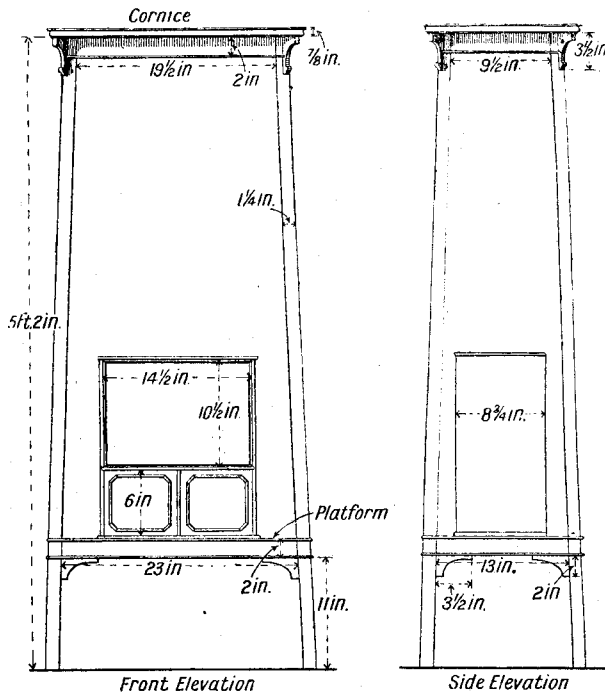

DETAILS AND DIMENSIONS OF STAND FOR FRAME AERIAL SET

Fig. 2 (left). Measurements of the stand are given as seen from the front. The apparatus is seated on a platform. Fig. 3 (right). Dimensions are shown in this partial side view of the main features

the stations can be immediately tuned in again by merely turning the dials to the noted settings and giving a final critical tuning by the slightest movement of the dials and the potentiometer knob.

Directional effects are noticeable but not critical, as the bulk of the aerial wires are disposed in a vertical manner; but as the set is mounted

on castors, it is perfectly simple to move it bodily to the correct direction and thus get the best results possible.

The general aspect of the set is clearly seen from Fig. 5 on the plate facing this page, which is a front view of the set ready for use, and from Fig. 6, a partial side view; the leading dimensions are given on Figs. 2 and 3.

The work involved in the construction of such a set is by no means beyond the abilities of the home constructor. All the joints in the woodwork are simple, and the receiving set is markedly simple for a five-valve set. The panel lay-out is shown in Fig. 9 on the special plate and two views of the interior in Figs. 10 and 11, from which it will be seen that the valves are arranged on a platform of ebonite at the bottom interior of the case. At the left are the two low-frequency transformers, above them is the dual condenser tuning the anode reactance, at the opposite upper corner is the aerial tuning condenser. Grid-biasing batteries are located between the valves and the condensers, and grid leak beneath the valve platform. To avoid interaction effects the transformers are mounted at right angles to each other. The size of the panel is 14 1/2 in. long and 10 1/2 in. wide, and the case measures 4 in. deep.

The set is first made up in this

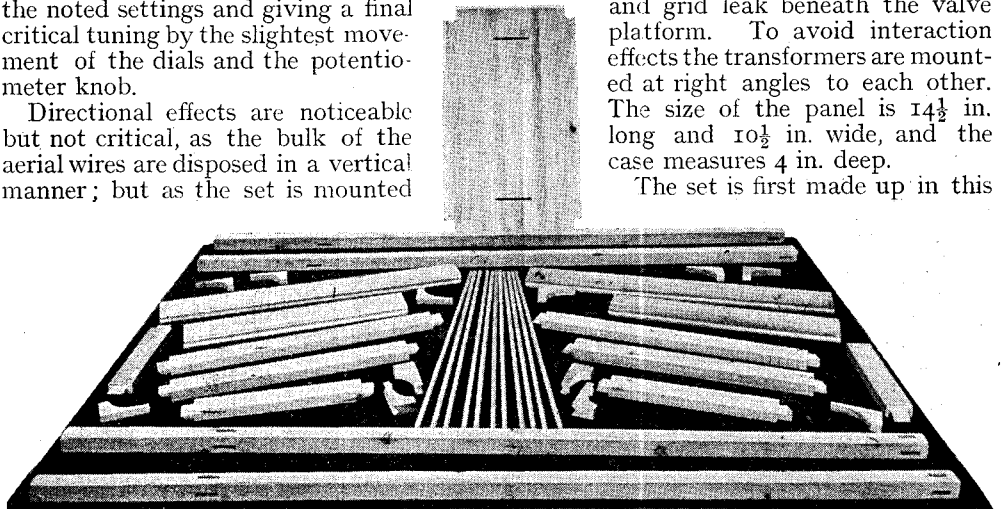

DISSEMBLED COMPONENTS OF FRAME AERIAL SET STAND

Fig. 4. Components of the stand and platform are shown laid out before assembly. These should be made and prepared for construction before actually putting the various parts together. As each part is made it should be compared with its fellow and the joints put loosely together as a test of truth, so that when the whole is complete erection can be carried out satisfactorily

rough case, as shown in Fig. 11, and when everything is perfect is placed bodily into the cabinet, which forms the lower part of the set. The coils used for inductance and reactance purposes plug into ordinary coil holders on the front of the panel. The best results are only obtained by experiment; those successfully and regularly used on the set illustrated being a No. 35 Igranic honeycomb for the aerial-tuning inductance, and two No. 75 Burndept for the tuned anode circuit. The set being available, the real interest of the work then centres on the stand and cabinet.

Full directions for the construction of this part of the work are given in this Encyclopedia under the heading Cabinets (*q.v.*), but the following hints may be helpful to the home craftsman.

The first step is to prepare all the com-

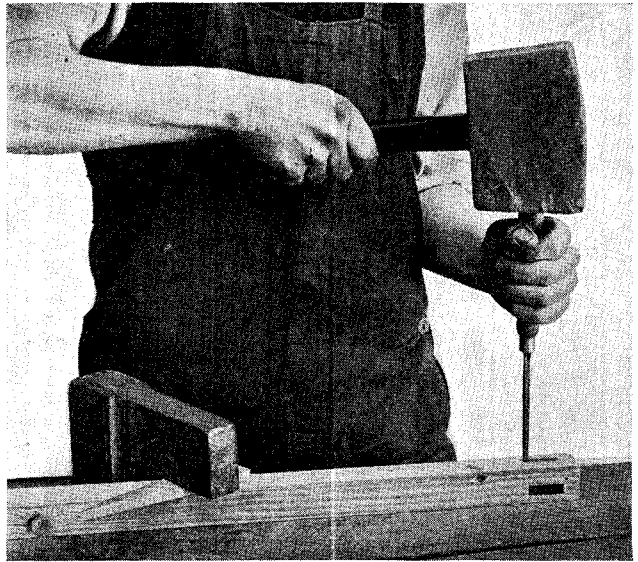

**MORTISING FOR THE TOP CROSS RAIL**

Fig. 16. Joints are made with the top cross rail by mortising, which is carried out correctly in the manner illustrated by using a mortising chisel and mallet

the home

ponents of the stand, as shown in Fig. 4, and to mark out and cut the various mortise and tenon joints. Those for the top of the side supports are shown in course of construction in Fig. 16, and the mode of shaping and fitting the top rail to the side pieces in Fig. 17. Note that the tenon is mitred. The second cross rail is similarly fitted, and it is important

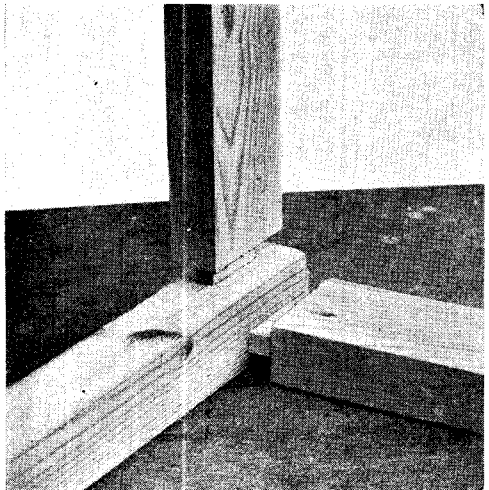

**MAKING JOINTS IN THE FRAMEWORK OF THE FRAME AERIAL SET STAND**

Fig. 17 (left). How the corner joints are made may be seen in this illustration, which shows the mitred tenon being inserted into the mortised hole. Fig. 18 (right). Corner posts and side rail are fitted into the mortised slots in the end of the cross rail. The photograph shows the joints loosely made so that the fit can be seen.

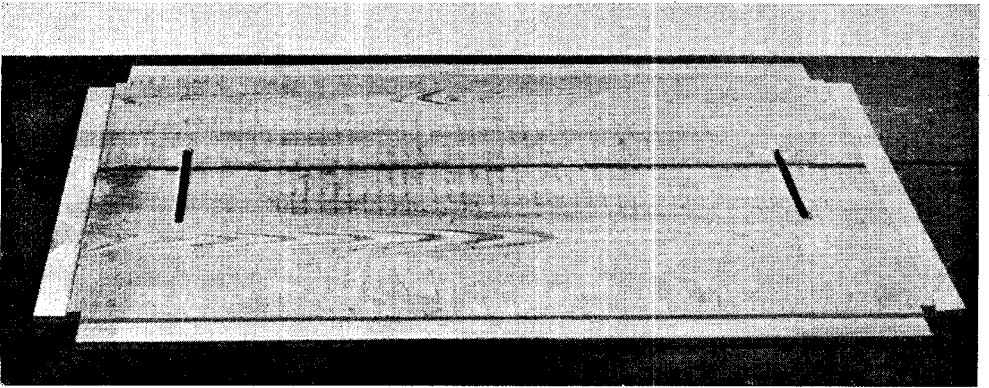

#### HOW TO CLAMP THE PLATFORM OF THE FRAME AERIAL SET STAND

Fig. 19. Half-inch material is used for the platform. Slots are cut for the passage of the aerial wires. The joint is glued and clamped together by means of battens nailed to the work bench, as shown in the photograph

that all these rails fit very nicely and quite square with each other as in Fig. 18. Note particularly that the sides or shoulders of the tenons on the cross rails are not at right angles to the top edge, but at the corresponding angle of the corner posts. The lower set of cross rails are similarly fitted, and the whole structure assembled and the joints glued up.

In the absence of proper clamps, the joints can be drawn tightly together, as shown in Fig. 8 on the plate by stretching strong cords from corner post to corner post. Place some packing between the cords and the posts and tighten the cords with a strip of wood, turning it like a tourniquet. While the framework is drying, prepare the platform from  $\frac{1}{2}$  in. boards, cut the two

slots for passage of the aerial wires, and glue the joint and clamp it together with battens nailed to the work bench as shown in Fig. 19. When the glue is thoroughly dry, plane the surfaces smooth and true, as illustrated in Fig. 20, and fit it to the lower cross rails, finishing this part of the work by fitting the small beads and the corner brackets. The top of the stand is ornamented with a moulded cornice, which has to be neatly mitred. A perfect fit can be obtained by careful planing, as shown in Fig. 21, and repeatedly testing by trying the joints as illustrated in Fig. 22.

The cornice is supported at the corners by four specially fitted brackets shaped and dimensioned as shown on Fig. 24,

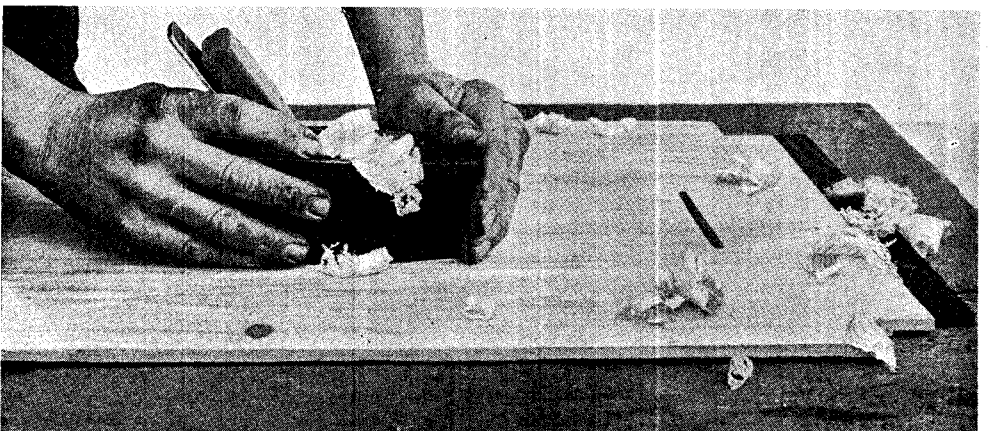

#### PREPARING THE PLATFORM OF THE STAND FOR THE FRAME AERIAL SET

Fig. 20. Having made quite sure that the joint which has been glued is firmly set, the platform for the frame aerial set stand is smoothed off with an ordinary carpenter's smoothing plane. The fit to the lower cross rails should be checked

and fitted as illustrated in Fig. 26, and secured with glue and fine brads. To complete this part of the work, a small half-round bead is planted on the face of the lower edge of the cross rails, as illustrated in Fig. 28, which clearly shows how by offering up the bead and

respectively. The doors are simply plain wood with feathered edges, the moulding is planted on and secured with glue and fine pin points. A small moulding is fitted to cover the joint between the panel and the sides of the cabinet and is visible in Fig. 12 on the plate facing page 976.

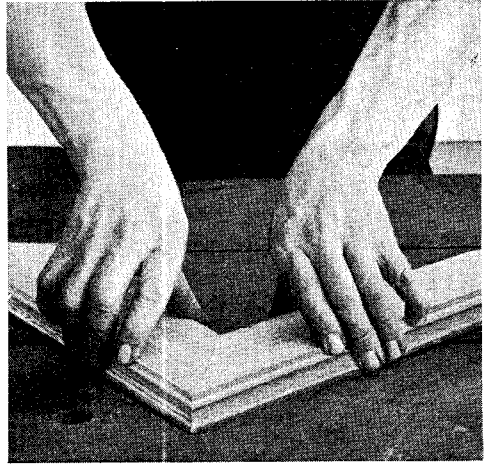
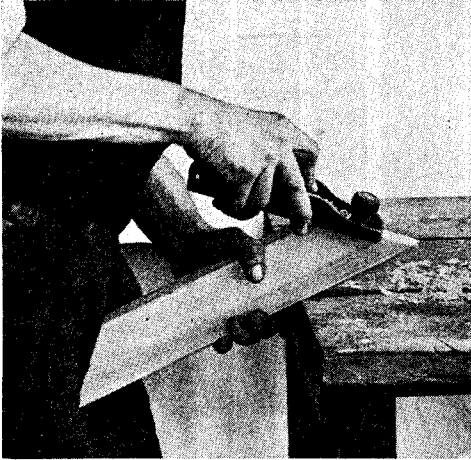

**MAKING A MITRED JOINT FOR THE STAND OF THE FRAME AERIAL SET**

Fig. 21 (left). Careful planing is necessary in making the joint of the mitred corner in the moulded cornice at the top of the stand. A perfect fit should be made, as this is one of the most obvious points in the construction, and defective workmanship would be particularly noticeable. Fig. 22 (right). The corner is here shown being fitted together, to ensure a perfect joint. This should be done frequently when the corner is being made, until the effect is satisfactory

marking the correct angle on it with a pencil, subsequently cutting the bead to size and fitting it with a chisel.

The next proceeding is to fit up the wooden brackets and the ebonite cross-bars whereon to mount the aerial wires. Those at the top are clearly shown in Fig. 7 on the plate. The ebonite rods are  $\frac{3}{4}$  in. diameter and are mounted in flat brackets screwed to the inner side of the top frame. Those for the lower part are supported on two runners of wood that span the platform. The ebonite is fitted to holes drilled in the runners, as shown in Fig. 23, which also shows the saw cuts to keep the wires in place and a small screw for the termination of the winding. These screws are only fitted to the lower bars.

The work at this stage is shown in Fig. 13, which indicates that all the nail holes should be well stopped with beeswax or hard stopping before the final sandpapering and staining.

The cabinet for the receiving set is shown in Fig. 12, and in Fig. 25 the mode of cutting grooves in the sides and the base to take the shelf and side pieces

The storage batteries are placed in the lower compartment of the case, and the connecting wires are taken through ebonite bushes shaped as shown in Fig. 27, made from ebonite rod  $\frac{1}{2}$  in. diameter and 1 in. long. Similar bushes are fitted near

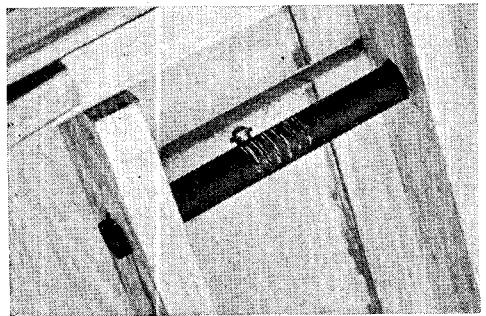

**EBONITE CROSS-BAR FOR AERIAL**

Fig. 23. Underneath the platform are runners and ebonite cross-bars. Saw cuts are made in the bar illustrated, and a terminal screw is provided for the aerial wires

the top of the case, and act as lead-in insulators for the short wires connecting the aerial loop wires to the set. The

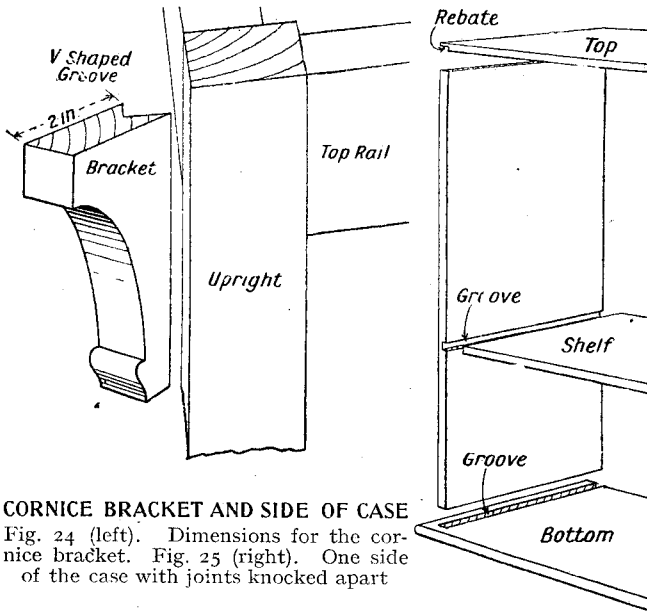

**CORNICE BRACKET AND SIDE OF CASE**  
 Fig. 24 (left). Dimensions for the cornice bracket. Fig. 25 (right). One side of the case with joints knocked apart

used on the top of the case to permit of removal or temporary disconnection while the telephones are in use for tuning purposes. A front view of the set with the cabinet doors open is given in Fig. 5, which shows the connexions between the set and the aerial wires. A back view of the set with the back of the cabinet removed is shown in Fig. 10 on the plate, which should serve to make the arrangement and disposition of all the components clear.

While in operation the loud speaker should normally remain in the centre as shown, as under some conditions of reception there may be loss of signal strength if the loud speaker be turned too near to the aerial wires—*E. W. Hobbs.*

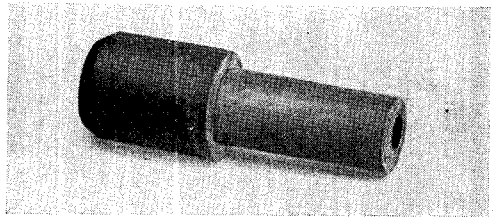
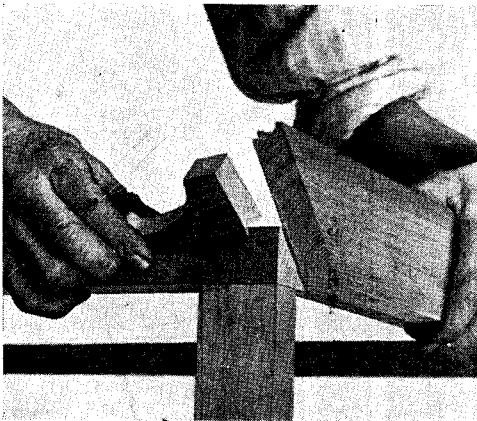

**FITTING CORNICE AND BRACKET**

Fig. 26 (left). How the cornice moulding and the corner bracket are fitted to the top of the frame aerial set stand is illustrated. Fig. 27 (right). One of the ebonite bushes used in the frame aerial set stand

aerial wire with No. 24 enamelled copper wire, and consists of eight turns spaced  $\frac{1}{8}$  in. apart. An assistant is needed to guide the wire through the slots and over the top cross-piece. This operation is pictured in Fig. 14 on the plate. The cabinet is simply screwed to the top of the platform, the receiving set placed within it and the aerial wires connected to the set. The loud speaker illustrated is a standard Ethovox and is connected in the anode circuit of the last valve in the usual way. A plug-in connector is

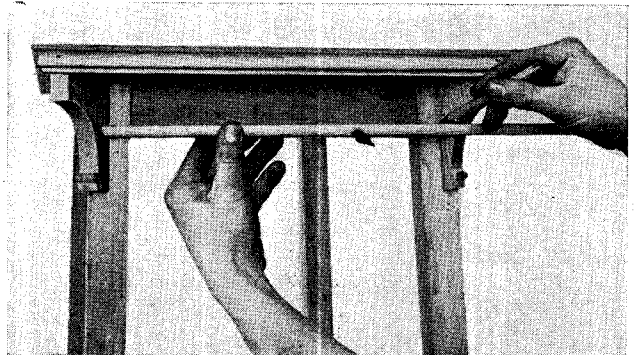

**HALF-ROUND BEAD FOR CROSS RAIL**

Fig. 28. Cornice moulding or beads complete this section of the top of the stand for the frame aerial set. A portion of half-round bead is being marked off for the front edge

**FRANKLIN CIRCUITS.** Various receiving and transmitting circuits invented by C. S. Franklin.

The importance of these circuits in wireless lies in two facts. One is that Franklin was one of the first to realize the importance of reaction, and the second that, by his system of aerials, he improved greatly on the various directional systems, which may ultimately lead to something approaching secret wireless, and also to the elimination of interfering signals. The latter is one of the most important steps in wireless, and from it important results may follow, particularly in commercial wireless. Franklin has been for some years in the service of Marconi's Wireless Telegraph Company, and much of his work has been done on their behalf.

Fig. 1 shows a circuit, a patent for which was taken out on June 12th, 1913. The filament K is heated in the usual way by the current obtained from the battery,  $b$ , whilst a series resistance,  $r$ , is provided for adjusting the filament brilliancy.

The grid circuit, M, L, C, is tuned, as is also the anode circuit, N, O, F. Rectification is obtained by means of a crystal  $q$  having a separate battery and potentiometer  $P_1$  provided for adjusting the rectification point.

The principle of reaction was clearly understood, and both electrostatic and electro-magnetic coupling between the two circuits, which react on one another, are mentioned.

Franklin mentions that although the circuit shown and described is arranged for high-frequency oscillations, the system may be arranged for tuning to the spark frequency of a wireless telegraph transmitter, or to the note obtained in a wireless telegraph receiver when using the interference method of receiving continuous oscillations, or generally in any case where sharp tuning is required.

His claims for the circuit are that when used for a receiving system for electrical oscillations, and magnifying the oscillations, the circuit in which are set up the magnified oscillations reacts on the circuit in which occur the oscillations to be magnified.

Fig. 2 shows a method of combining the effects of four or more frames for directional reception and described in a patent for which Franklin made application in September 1919. These are four frame aerials arranged in a line, and forming a line pointing towards the distant station from which it is desired to receive signals.

The aerials are A, B, C, D. They are coupled or combined through the tuned circuits E, F, G, and H, each one of which is properly screened to prevent interference, except from the aerials.

Each of these circuits is provided with inductance coils at each end and a tuning condenser. These circuits E, F, G, and H are again in their turn combined through the circuits O and P, each of which is provided with an inductance coil at each end and a tuning condenser.

The receiver or amplifier is then finally coupled to both the circuits O and P by means of the coil S.

By correctly tuning each of these circuits it is possible so to phase the oscillations in each system, that the resultant will be an addition to each of their effects of a wave coming in from one direction along the line of the frames. The combined systems will receive best from the direction A D, and will give zero reception from directions 90 degrees, 120 degrees and 180 degrees from A D, whilst the maximum receiving power of the system in any

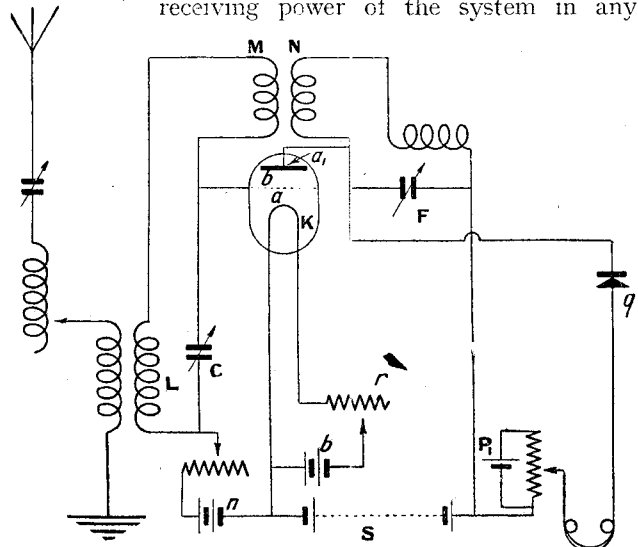

ONE OF THE EARLIEST CIRCUITS WITH REACTION

Fig. 1. Reaction was used in the set invented by C. F. Franklin in 1913, of which the above is the circuit diagram. Both grid and anode circuits are tuned, and rectification is by crystal, which has a separate battery and potentiometer

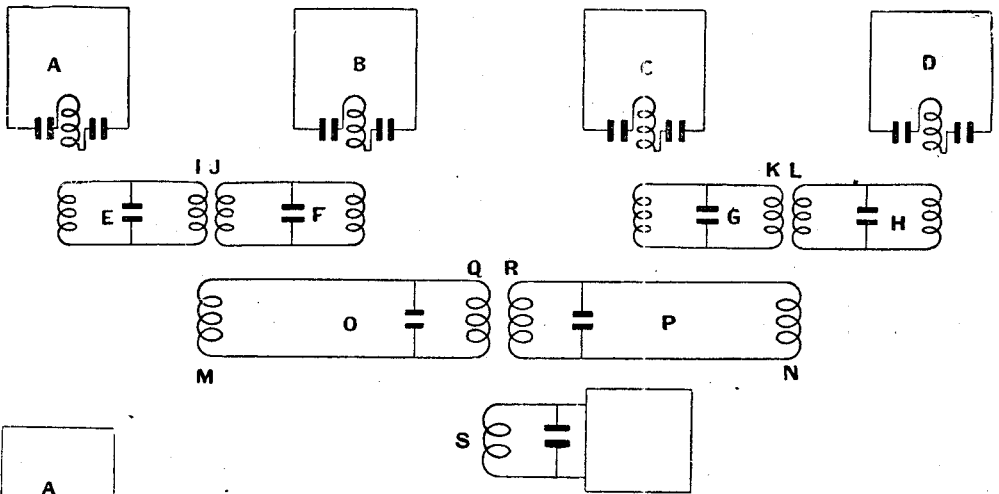

**DIRECTIONAL RECEPTION BY USE OF FOUR AERIALS**

Fig. 2. Four frame aeriels, A, B, C, D, are used in this arrangement, which is a method of using Franklin circuits for directional reception

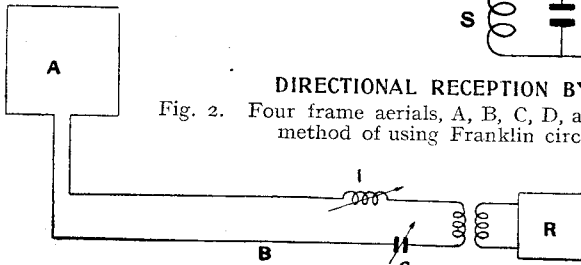

**INCREASING SIGNAL STRENGTH**

Fig. 3. A is a frame aerial, B one of the two long parallel wires joining the frame to the receiver through a transformer. I is a tuning inductance, C a tuning condenser, and R the receiver

direction at the back of the station is only 1.65 per cent of the receiving power in the direction A D.

Franklin points out that in place of each single frame, two frames may be employed, mounted at right angles, and that these frames may be connected to radiogoniometers, and that by suitable phasing the system can be given

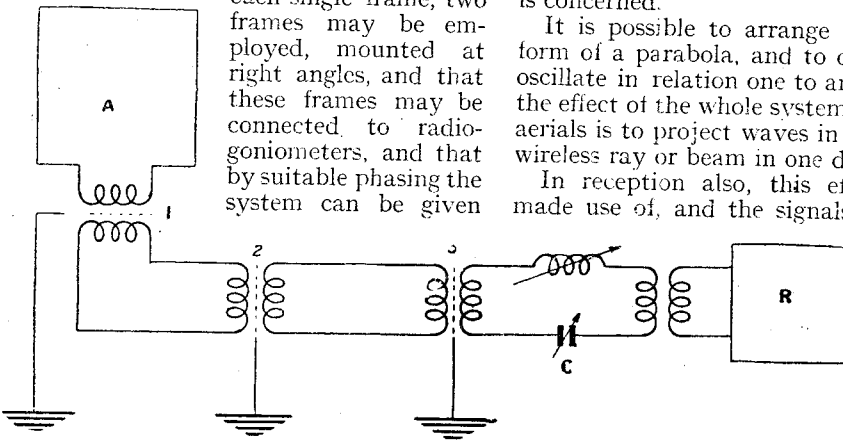

**FRANKLIN CIRCUIT WITH EARTH SCREENS BETWEEN TRANSFORMER WINDINGS**

Fig. 4. In the above diagram 1, 2, 3 are coupling transformers having earthed screens between their windings. This circuit is for use with a number of aeriels to increase the effect in the telephones and to make the set directional

zero receiving power in six directions, which are under control.

A great amount of work on special aeriels has been carried out by Franklin. His systems have been employed, both for directional reception and transmission, by correctly spacing aeriels and adjusting their circuits, so that the oscillations in each aerial have a definite phase relationship to the oscillations in other aeriels of the system. It is possible to add the effects of each aerial, or to make the oscillations in one aerial cancel those in another, as far as their effect on a receiver is concerned.

It is possible to arrange aeriels in the form of a parabola, and to cause these to oscillate in relation one to another so that the effect of the whole system of oscillating aeriels is to project waves in the form of a wireless ray or beam in one direction only.

In reception also, this effect may be made use of, and the signals received on



many aerials may be added together in their effect on one receiver, whilst these aerials may be so arranged that they will receive only from one or more desired directions.

Franklin has devised many systems of interlinking these aerials, and in August, 1919, made application for a patent to cover one of these improvements in aerial systems. In this patent he emphasises the desirability of having the tuning of all the aerials under control at one central place.

He shows how this may be accomplished by bringing a pair of parallel wires connected to each aerial to the central place and having all the necessary tuning condensers and inductances located at that point (Fig. 3). He states that this method is sometimes objectionable, as the aerials, when so connected to the long wires, oscillate in undesirable ways, one of which is that the aerial A and the wires B have a strong tendency to oscillate as a long horizontal aerial, and so to impair the directional properties of the frame aerial.

According to his invention, instead of connecting the horizontal wires B directly to the aerial A, he connects the aerial A to one winding of a transformer, and the wires B to the other winding of the same transformer, whilst, preferably, these transformers are constructed with an earthed shield interposed between their two windings (Fig. 4).

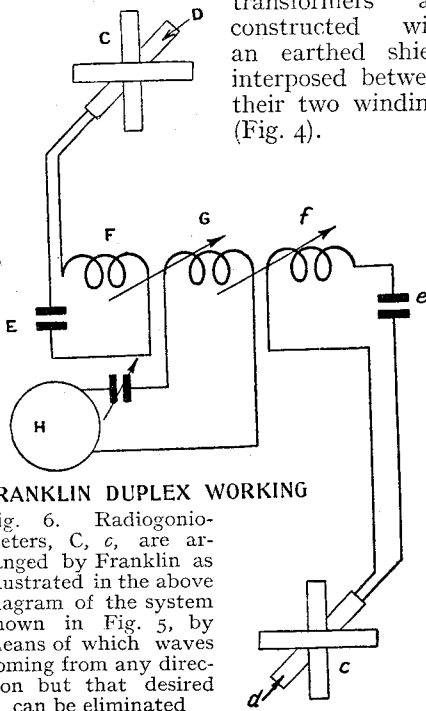

Fig. 6. Radiogoniometers, C, c, are arranged by Franklin as illustrated in the above diagram of the system shown in Fig. 5, by means of which waves coming from any direction but that desired can be eliminated

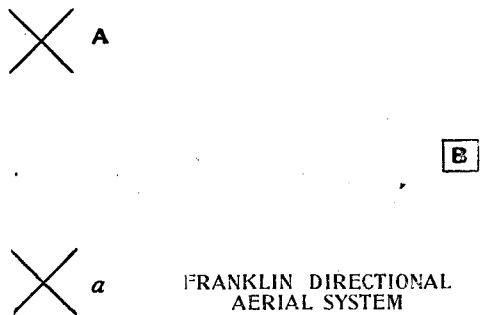

Fig. 5. Two similar directional aerial systems, A, a, are arranged so that the distance between each and B, the transmitting station, is equal. B is the system used for duplex telephony. Details of the apparatus are given in Fig. 6

In some cases the transformers, one at each end of the wires, will suffice, whilst in others the wires may have to be broken up into three or more sections.

The transformers should be so constructed that they have small capacity between the windings and between the windings and earth screen, also their leakage must be small, whilst the inductance of all transformer windings should be high in comparison with the inductance of the aerial.

Fig. 5 shows another aerial system due to Franklin, the object of which is to provide an improved means of reception for a receiving station, used in conjunction with a transmitting station, and separated from it, for duplex working.

Frame aerials are used at right angles to one another, in conjunction with a radiogoniometer. The best reception is obtained from the directions which are opposite to one another, whilst it is possible to eliminate signals from any two opposite directions at right angles with the first-named ones.

Franklin employs two similar directional aerial systems erected so that the distance between each and the transmitting stations is approximately equal, as shown in Fig. 5.

Where A, a are the receiving aerials and B the near-by transmitting station, these two aerial systems are so placed and adjusted that the oscillations induced in them from the near-by transmitter at B are equal and in phase. The oscillations can therefore be made to produce no effect on the receiving apparatus.

Waves coming in from the distant transmitter, which is on the line of the aerial systems, will not produce this

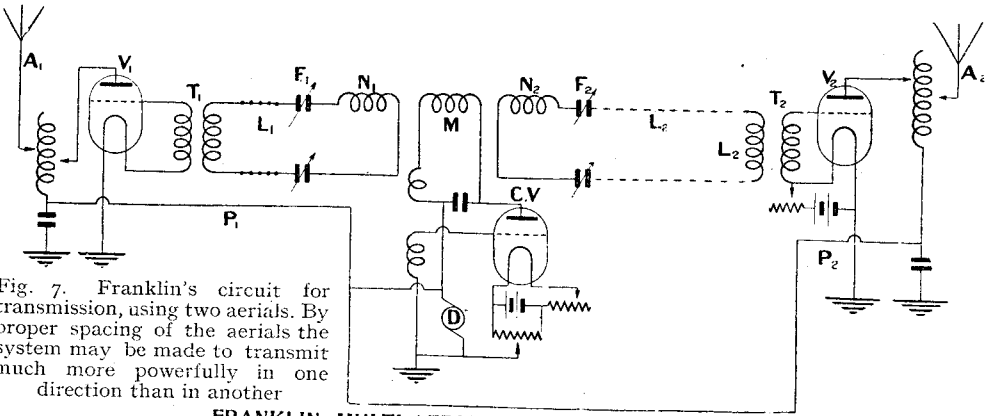

Fig. 7. Franklin's circuit for transmission, using two aeri-als. By proper spacing of the aeri-als the system may be made to transmit much more powerfully in one direction than in another

FRANKLIN MULTI-AERIAL TRANSMITTER CIRCUIT

opposing effect, and provided the circuits are correctly adjusted, the signals from the distant station may be made to affect the receiving apparatus.

By adjusting the position of the radiogoniometer coils to any particular angle, waves coming from any direction besides that of the transmitting station can be eliminated.

The arrangement of the apparatus is illustrated in Fig. 6, and consists of two radiogoniometers C, c, having their fixed coils connected in the usual manner to aeri-als. The radiogoniometer moving coils D, d are connected through the condensers E, e to the coils F, f. A coil G is then connected to the receiver H, and so arranged that it may be coupled simultaneously to both coils F, f. The necessary tuning arrangements being provided for in the circuit HG.

Considering the effect of the incoming wave from the near-by station B, it will be seen that as both the directional receiving systems are equidistant from B, it is clear that, provided both these systems are correctly tuned, the oscillations produced in them will be equal in magnitude and in phase with one another. Under these conditions the incoming signals from the near-by station will produce no effect on the receiver H, whilst at the same time other waves coming from a direction appreciably different from that to or from B will produce unequal effects in the two aerial receiving systems, because the resultant oscillations in A, a, will not be in phase.

To eliminate signals from any desired direction other than B, it is only necessary to set the coils D, d respectively to the

angle at which the oscillations produced in the frame aeri-als of each system A, a, neutralize each other in their effects upon those coils.

The construction of this receiving system is such that the receiver will not be affected by waves coming to it from four directions, two of which are fixed, and two of which are controllable.

Another use of this system is that it will enable two distant transmitting stations, which are situated in opposite directions, to be read, without mutual interference, whilst at the same time the near-by transmitter may be in use.

This is effected in the following manner :

Suppose the radiogoniometer coils are adjusted so that the signals from the station B are eliminated. Now, if the two aerial systems A, a are separated by a distance equal to a quarter wave-length, then signals coming from a direction on the line pointing A, a will set up oscillations in the two circuits joined to the radiogoniometers, oscillations which are 90 degrees out of phase with one another. The two circuits must now be mistuned so that in one case the phase of the oscillations in that circuit is advanced 45 degrees, whilst in the other it is retarded by the same amount.

Under these conditions waves coming from one direction will produce oscillations in the circuits which oppose, whilst those coming from the other direction will produce oscillations which are in phase.

If the radiogoniometer circuits are now coupled to two receivers, and the couplings are so adjusted that the oscillations in phase with each other in the two circuits oppose as regards one receiver and add as

regards the other, it will be seen that one of the receivers will respond to waves coming from one direction, whilst the other will respond to those coming from an opposite one. This same construction may be employed for a transmitting station; it is only necessary to employ radiogoniometers which are capable of dealing with the necessary power, and to supply the high-frequency current to the two moving coils of the radiogoniometers.

Such a system will not radiate in the two directions at right angles to the line joining the two systems  $A, a$ , whilst there will also be two other directions in which it will not radiate, these directions being determined by the setting of the moving coils of the radiogoniometers.

Fig. 7 shows the arrangement of the circuits employed by Franklin in a multi-aerial type of transmitter, in which  $A_1$  and  $A_2$  represent two aerials, which are so placed that the distance separating them is any desired fraction of the wave-length which is to be used.  $V_1$  and  $V_2$  are two power-oscillator valves,  $D$  the dynamo which supplies power to the two valves by the wires  $P_1, P_2$ . It may, if desired, be arranged to employ a separate dynamo on each valve.

The control valve is shown at C.V. It may be a smaller valve than the two oscillator valves. The control valve is arranged to generate oscillations of the desired frequency, and preferably equidistant from the two aerials.

$M$  is a coil joined to the anode of the control valve, and coupled to the two coils  $N_1$  and  $N_2$ , which are connected through tuning condensers  $F_1, F_2$  by means of the lines  $L_1, L_2$  to the transformers  $T_1$  and  $T_2$ , which are joined to the grids of the two valves  $V_1$  and  $V_2$ . The valve C.V. thus controls the frequency, whilst the phase is determined by the tuning of the circuits comprising the primaries of the transformers  $T_1, T_2$ , the lines  $L_1, L_2$ , and the condensers  $F_1, F_2$ , as well as the coils  $N_1, N_2$ .

The phases may also be controlled by the tuning of the aerials  $A_1$  and  $A_2$ .

In arranging the twin leads  $L_1$  and  $L_2$ , care must be taken that the waves radiated from  $A_1$  and  $A_2$  affect them equally and produce no reaction effect on the valves  $V_1, V_2$  or C.V.

One of the very useful effects which may be produced by two or more aerials so arranged is directional transmission, for if the two aerials are so spaced that

the distance separating them is equal to half the wave-length which will be employed, then if the two aerials are caused to oscillate in phase and with the same intensity, the system will radiate powerfully in the direction at right angles to the line joining the two aerials, and there will be no radiation along the direction of the line joining the two aerials.

With the above arrangement, if the oscillations generated the two aerials are made to be opposite in phase, but equal in intensity, then the radiation is most powerful in the direction of the line joining the two aerials, whilst it is zero in a direction at right angles to this.

Again, by spacing the two aerials a quarter of a wave-length apart, and by generating in them oscillations which are 90 degrees different in phase and equal in intensity, then the system will radiate powerfully in one direction along the line joining the two aerials, but will not radiate in the opposite direction along the same line.—*R. H. White.*

See Bellini-Tosi Aerial; Direction Finder; Frame Aerial; Goniometer; Reaction.

**FREE A.C.** Free A.C. is the name given to the current which would be produced if a single impulse of electricity were applied to an oscillatory circuit.

It should be noted that an oscillatory circuit must necessarily contain inductance and capacity, and may contain a series condenser through which direct current would not pass. A simple oscillatory circuit would contain a source of electrical supply, say, an alternator, and a series condenser. If, now, one impulse only were produced in that alternator and impressed upon that circuit, it would charge up that condenser and then immediately discharge, run round the circuit, and charge up in the opposite direction. This process would continue, the condenser charges being gradually damped out as time went on, until finally the current would be all dissipated in the form of heat.

**FREE ELECTRONS.** The name given to the outer or valency electrons of atoms which become detached in various chemical transformations and take part in many electrical phenomena. This is in contrast with the bound electrons of the positive core or nucleus of the atom, which are only emitted when the atom is disrupted by radio-active changes.

The normal atom contains just sufficient negative particles of electricity (or electrons) external to its central nucleus to neutralize the positive charge thereon. Electrically substances are classified as good or bad conductors of electricity according to whether the constituent atoms readily part with electrons or these are removed with difficulty.

The flow of an electric current through a good metallic conductor would appear to be a handing on of electrons from atom to atom rather than an actual passage of free electrons. Metals in general have few electrons in their outermost electron orbit or shell, and in solids these apparently form a lattice of electrons, the sharing of electric forces holding the atoms together into a coherent non-fluid mass. Such lattice electrons are mobile and readily respond to the forces causing the motions of electrons so as to move them bodily as electric currents. The emission of electrons from the heated filament of a thermionic valve is a true production of free electrons, discrete particles of electricity being ejected into highly evacuated space. Such free electrons often move with sufficient speed to remove electrons from neutral molecules of gases which, when thus ionized, become conductors of electricity.

On the ultra-modern view all manifestations of energy are due to change in motion of particulate electricity, which sets up ether waves. The changes on the plates of a condenser represent excess or deficit of free electrons. Inductance is regarded as a consequence of the inertia of electronic flow. Conduction of electricity is transference of mobile electrons. The free electron itself is the carrier of the definite charge associated with each electron, but with ionized gases the current of electricity may be due to electrons or ions. The latter may be positively charged owing to loss of one or more electrons, or negatively charged, due to an electron in excess of neutrality. See Electricity; Electron.

**FREE MAGNETISM.** All magnetism that exists externally to any magnet is known as "free magnetism." Probably the most familiar form of "free magnetism" is that which is emitted from the magnetic poles of the earth, and to which we are indebted for the directional properties of the magnetic compass. The earth's magnetic field is also responsible for the

phenomenon of the dipping needle. If a magnetized needle is suspended accurately about its centre of gravity and allowed perfectly free movement in all directions, not only will it point due magnetic north and south, but it will also be displaced from the horizontal and place itself parallel with the magnetic meridian.

All magnets, whether permanent or electro, and any current-carrying conductor of electricity, sets up a magnetic field in the surrounding ether, this field being limited in size by the power of the magnet which is responsible for it. This magnetic field or free magnetism is of fundamental importance in electrical engineering, and without it magnetic induction would be an impossibility.

Unfortunately, however, the field surrounding a magnetic appliance is frequently a nuisance, and has to be neutralized. The most notable instance of this in wireless work is in the case of two or more inter-valve low-frequency transformers, which are grouped in close proximity to one another. Quite strong magnetic fields of force are set up by such transformers, and these are likely to cause interaction between them, with consequent losses and distortion.

One remedy for this is to surround the transformers completely in an iron shield or case, which should preferably be earthed. Iron is an absorbent of free magnetism, and forms a very effective shield which lines of force cannot penetrate. Any eddy currents (*q.v.*) set up within it, however, should be run straight to earth. See Lines of Force; Magnetic Field; Magnetism.

**FREE OSCILLATIONS.** A free oscillator is one that is left completely to itself, without being hampered by connexion to anything else and without having to be driven. A piston of a steam engine is by no means a free oscillator; it is a forced oscillator. It is driven by steam, and it has to propel a flywheel or do other work.

The pendulum of a clock is to a small extent a forced oscillator, too. It is driven by the weights or mainspring through the escapement. But it is very slightly forced and nearly free. In the best and most accurate clocks an attempt is made to leave the pendulum quite free, giving it a sustaining impulse only as it passes the middle point, for at that point it can receive energy without having its oscillations or time of swing interfered

with. The freer it is, the better it keeps time, for if it is forced, its rate of oscillation will depend a little on how vigorous the force is that drives it.

The oscillations of a tuning-fork are nearly free, once it has been excited; for the prongs are massive. If mounted on a sound-board or sounding-box, their energy is used in emitting waves, which tends to damp them down rather more quickly.

The oscillations of a Leyden jar or condenser circuit, completed through an inductance coil of low resistance, are nearly free, and therefore continue for many swings before they are damped out by resistance. The oscillations of an open circuit like an aerial are much less free, especially if it is earthed as usual. The resistance of the earth damps them out; but the main damping is due to their emission of waves, by which at every swing they lose some of their energy.

This, of course, is what the oscillations are for, and therefore that kind of damping is not to be deprecated. Aerial or antenna oscillations may be maintained by coupling to a suitable valve, or to a Poulsen arc, or by other devices, whereby we get the emission of continuous waves (*q.v.*). But that is manifestly a case of forced oscillation. How much it is forced and how much it is free depends on a compromise, as in the case of the pendulum.

**Coupling of Oscillators.** If a pendulum be coupled to another pendulum of nearly the same period—as it might be by a slight connecting thread near its upper part, or by being suspended from the same not quite rigid support—a very curious and instructive action goes on. One pendulum being excited, it will swing for a time, but will gradually transfer its energy to the other and come to rest; while the other takes up its swing. Then this same energy will be transferred back again from the second pendulum to the first. And this alternation of swing will go on several times.

A very curious model has been made by Professor Wilberforce, of Liverpool, to illustrate this. A weight suspended by a spiral spring from a rigid support has two distinct methods of oscillations. It can oscillate up and down, thus stretching and relaxing the spring; or, without any vertical movement, it can oscillate round and round, rotating first in one direction and then in the other. These

two kinds of swing will have in general quite different periods, and no relation with each other. But by adjusting the shape and size of the weight it is possible to bring them into very near synchronism, so that they both take the same time. In that case any energy imparted to the weight will take first one form and then the other. For, say, half a minute it will be moving mainly up and down; for another half minute it will mainly be rotating. And in the next half minute it will move up and down again. And so on. There will be instants when the up-and-down motion entirely ceases, and there will be other instants when the rotatory motion entirely ceases; so that the behaviour of a thing like this can be made to look quite curious.

**Electrical Application.** These things are mentioned here because they are typical examples of two coupled oscillating circuits of nearly the same period. For if two condenser circuits, each with an inductance, are put in each other's neighbourhood, so that lines of force from one inductance thread the other, they are no longer free, but coupled; and we shall have the curious alternation above described, waxings and wanings of the swing. In the mechanical case we can follow it with the eye. How can we detect it in the electrical case? By remembering that waxings and wanings like this correspond to the phenomenon of "beats" in sound, which are produced by two notes nearly in tune. Accordingly, if two coupled circuits emit waves or are connected to a detector of waves—as they are in wireless work—we shall detect not one set of waves, but two; two swings of slightly different frequency, a double wave, in fact; so that tuning cannot be very precise. We shall have not one peak to deal with, but two peaks—a phenomenon well known to wireless experts. Hence the preference they have for loose coupling, as opposed to tight coupling.

Tight coupling introduces the double wave when both of the oscillators are or would be otherwise free. If, however, one of the circuits is of very high resistance—as it is when it contains a valve or crystal rectifier—that circuit is not free, but very much damped; and in that case there will be hardly any interference with the really free oscillations of the other circuit, and the double wave will not appear.

The use of a free oscillator has great advantages in wireless, for if it is accurately tuned its surgings will work up to a surprising extent under a continued stimulus of the same frequency.

**Algebraic Expression for Oscillations.**

As to the equations which represent these things, it must suffice to say here that a free oscillation is represented by

$$x = a \sin pt$$

where  $a$  is the amplitude and  $p2\pi$  is the frequency. These are sometimes called sinuous oscillations, because they are represented by a sine or a cosine, and if not damped at all would go on for ever.

A damped oscillation is represented by

$$x = ae^{-kt} \sin pt$$

where  $k$  is the logarithmic decrement; since this gives the rate at which oscillations die out, in geometrical progression, while time goes on, as usual, in arithmetical progression. These are sinuous oscillations of decreasing amplitude; the amplitude at any instant being  $ae^{-kt}$  where  $t$  is the time that has elapsed since they started.—*Oliver Lodge, F.R.S.*

See Oscillation; Wave.

**FREEZING POINT.** Temperature at which a liquid assumes a solid form. The freezing point of water—that is, the point at which it turns into ice, is one of the fixed points on the Centigrade and Fahrenheit scales. Some liquids have no very definite freezing point, or, to put it another way, some solids have no very definite melting point. Glass, for example, slowly changes from the liquid state into the solid state. Most liquids, too, have their freezing points changed by pressure. The greater the pressure on water, for example, the lower the freezing point, though the reverse is the case in the freezing of paraffin wax.

**FRENCH VALVE.** Name of a valve largely developed for the French military services and extensively used in France and elsewhere. The appearance of a general purpose French valve is illustrated.

The arrangement of the electrodes and the shape of the bulb are similar in general lines to the Marconi-Osram, and the spacing of the valve legs follows standard British practice.

These valves are useful for amplification and rectification or detection; the normal anode voltage is 60 volts and the filament 4 volts, although some considerable

latitude is generally possible with these values. As a rule the valves are very stable, are uniform in action, and reliable. In use it is as well to try the effect of

varying the values of the anode and grid currents, and to adjust carefully the filament resistances to get the best results. See Valve.

**FRENOPHONE.**

The Frenophone is a combined amplifying and loud-speaking instrument developed and marketed by S. G. Brown, Ltd. It is interesting in that its amplifying properties are obtained in a very novel manner, namely, by utilizing the frictional effect between a small disk of cork held

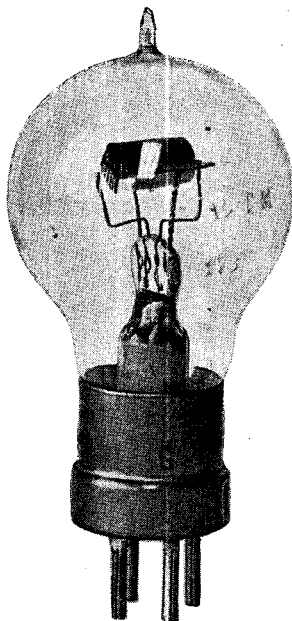

FRENCH VALVE

Thermionic valves of this type were first largely developed for the French military services. The valve is very similar to the Marconi-Osram valve

stationary and a smooth disk of glass which rotates beneath it.

A general view of the Frenophone is given in the photograph (Fig. 1), and in Fig. 2 is an enlarged view of the mechanism. Reference to Fig. 1 will show that the instrument is contained in two cabinets. The lower and larger cabinet contains the clockwork motor, the winding handle of which may be seen projecting from the right-hand side. Another handle, terminating in a knob, projects through a slot in this cabinet, this being for the brake. Glass windows are fitted to the upper cabinet, through which the mechanism of the Frenophone may be seen. The horn is the standard Brown large type of loud-speaker horn. An ordinary Brown A type reed telephone earpiece, from which the diaphragm and its supports have been removed, is suspended face downwards upon a hinge, which allows it free movement in a vertical plane. In place of the

diaphragm is a small metal stylus bar attached to the reed. This is perfectly straight, and approximately  $\frac{1}{2}$  in. thick.

A thick glass disk is placed beneath the telephone, situated in such a position that the stylus bar is about  $\frac{1}{4}$  in. from the inside of the rim of the disk when the earpiece is in its correct position. The glass disk is driven at a very slow speed by a clockwork motor, which will drive it for 30 minutes when fully wound. A small disk of cork rests between the glass and the stylus, the point of the latter resting in the centre of the cork, which is roughly  $\frac{3}{8}$  in. in diameter.

The cork is held in position by reins of a special fibre in the manner indicated in Fig. 3. It is held on both sides by two reins, which meet at their other extremities, each pair forming two sides of a triangle. The junction of one pair is attached to an adjustable screw fixed in a rigid pillar, the latter being screwed to the base of the instrument. The reins on the other side of the cork are fixed to the centre of the diaphragm, which is situated at the base of a curved horn.

It will be seen, therefore, that any movement which is imparted to the cork will be transferred via the reins to the loud-speaker diaphragm. The electrical impulses which are received in the earpiece cause the reed to vibrate. These vibrations are transferred to the cork by the stylus bar which rests upon it. The glass disk, which is rotated away from the large diaphragm, tends always to pull the cork in the same direction, for the normal friction is assisted by the application

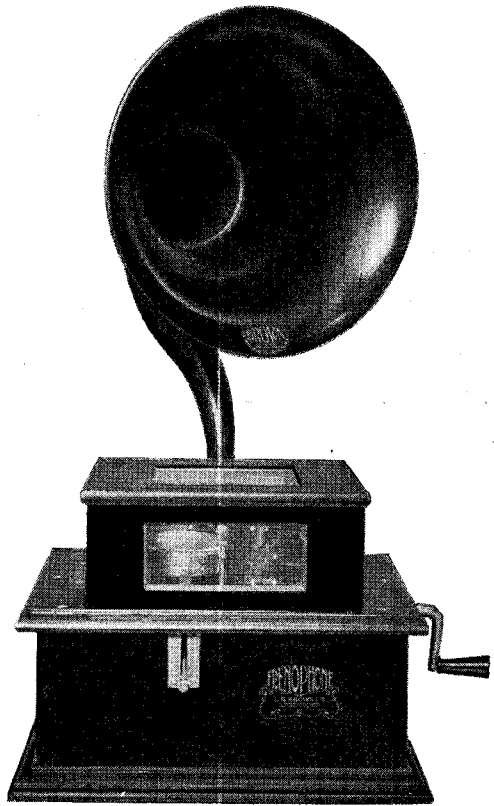

**FRENOPHONE AMPLIFIER AND LOUD SPEAKER**

Fig. 1. Combined in the one apparatus in the photograph is a loud speaker and amplifier made by S. G. Brown, Ltd. Amplification is obtained by using a disk of cork held stationary on a disk of glass which rotates

of a special sticky "dope," which is periodically applied. As the stylus bar vibrates with the reed in the earpiece, it will be seen that the pressure of the cork upon the glass is



**INTERIOR OF FRENOPHONE LOUD-SPEAKER AMPLIFIER**

Fig. 2. Beneath a telephone is a thick glass disk which is revolved by clockwork. Between the glass and the stylus point is a small cork disk held in position by fibre (see Fig. 3). Movement is transferred from the telephone by electrical impulse via the cork and fibre reins to the diaphragm of the loud speaker

*Courtesy S. G. Brown, Ltd.*

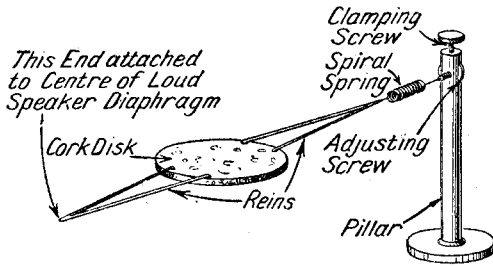

**FRENOPHONE AMPLIFIER CORK DISK**

Fig. 3. How the cork disk in the Frenophone loud-speaker amplifier is held by reins of fibre is seen in this diagram. Vibrations are conveyed by this means from the telephone to the loud-speaker diaphragm

always changing in accordance with these vibrations. Therefore the pull of the reins upon the diaphragm is varied exactly proportionally. A large amount of amplification occurs, however, due to the manner in which the vibrations are increased in amplitude at each transference of motion between the reed and the stylus, the stylus and the cork, and the combined pull of the cork and the diaphragm.

The makers claim that no trouble is experienced with the instrument and that no distortion is evident. The Brown "A" type reed telephone receiver is well known for its sensitivity, and it is claimed that the value obtained is approximately equal to that of two stages of low-frequency amplification.

**FREQUENCY.** In wave motion the number of complete cycles per second is called the frequency of the wave.

When the particles of any material or medium perform successively any kind of movement or displacement, by which they start from and come back to a given point, a wave motion is constituted. The most familiar example of wave motion is that shown by water waves, with their alternate crests and hollows, and many of their properties are common to all kinds of waves.

The wave-length of a wave is the shortest distance between successive crests or successive hollows, and the greatest displacement from the position of rest that any point undergoes is called the amplitude of the wave. If in a wave train any particular point is watched, it will be found that a crest, say, appears at that point a definite number of times in any given interval of time. The numbers so appearing in one second give the frequency of the wave. It is clear that if we multiply

together the length of one wave and the frequency, we obtain the rate at which the wave is moving forward, or in other words, the wave velocity. This is a very important relation in wave motion, for if we know the velocity of propagation of a wave and its length, we can immediately calculate its frequency, or if we know its frequency and its velocity we can calculate the wave-length.

Now it is well known that the velocity of electric waves is the same as that of light waves, 300,000,000 metres per second. Thus when we say that a broadcasting wave-length is 300 metres, it is equivalent to saying that the wave motion in question has a frequency of one million cycles.

The following table gives the frequencies of the most important waves or rays:—

Wave or Ray	Frequency
Gamma rays . . . . .	$3 \times 10^{19}$
X-rays . . . . .	$4.7 \times 10^{15}$
Ultra-violet rays . . . . .	$3 \times 10^{15}$
Violet rays . . . . .	$8.33 \times 10^{14}$
Blue rays . . . . .	$6.6 \times 10^{14}$
Green rays . . . . .	$6.1 \times 10^{14}$
Yellow rays . . . . .	$5.1 \times 10^{14}$
Orange rays . . . . .	$4.6 \times 10^{14}$
Orange-red rays . . . . .	$3.8 \times 10^{14}$
Red rays . . . . .	$2.7 \times 10^{14}$
Wireless waves . . . . .	$6 \times 10^6$ to $2 \times 10^4$

See Amplitude ; Wave Motion.

**FREQUENCY CHANGERS.** Instead of using specially constructed alternators which will supply currents of a sufficiently high frequency to be employed direct on the aerial circuit, which necessitates a highly complex and expensive type of machine, it is possible to substitute a lower frequency alternator and step-up the frequency to the desired value by means of a frequency changer or transformer.

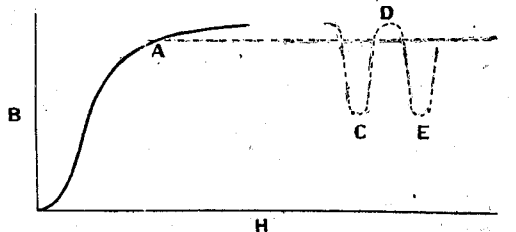

**MAGNETIZATION CURVE OF IRON**

Fig. 1. Illustrated in the form of a curve is the action of alternating magnetic force impressed on a saturated iron core to illustrate the principles of a frequency changer



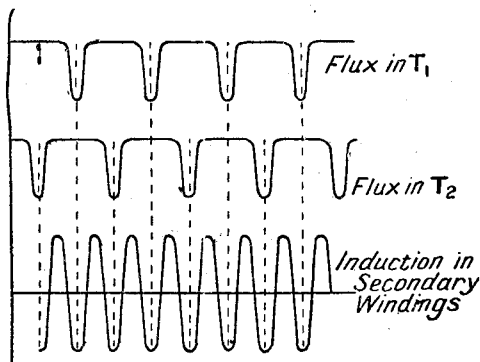
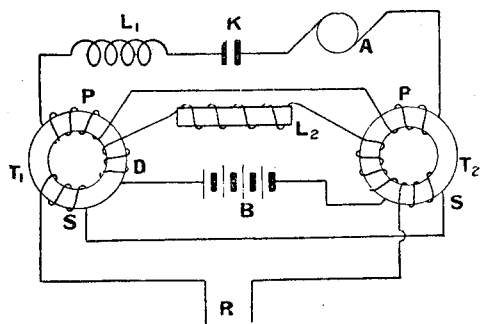

TELEFUNKEN FREQUENCY CHANGER AND STEP-UP EFFECT

Fig. 2 (left). Two transformers are shown at  $T_1, T_2$  with their iron cores magnetized by coils, D, supplied from a constant current source. The primary current at the secondary terminals, R, is doubled. Fig. 3 (right). Step-up effect of the apparatus in Fig. 2 is shown in these curves, which represent the result in the two transformer cores and their secondary windings

Frequency changers have been designed by M. Joly, A. M. Taylor, M. Plohl, and others. The desired effect is brought about either by the use of static transformers, or by rotating elements. One of the simpler types utilizing the rotating element system consists of two rotors and two stators, the rotors being mounted on a common shaft; one of the rotors acts as a synchronous motor, while the other generates as an alternator. A supply of current at ordinary

commercial frequencies, such as 25 or 50 cycles, can by this means be raised to a frequency of 10,000 cycles per second or even greater, and this can again be stepped up by the use of a static transformer frequency changer.

The fundamental principles upon which the latter operate are nearly always the same, and depend upon the asymmetrical variation of flux with magnetizing force in a saturated iron core. The normal magnetization curve of iron is shown in Fig. 1. On passing a direct current through the magnetizing coil the resultant magnetomotive force  $H$  causes the rise in magnetic flux  $B$  to assume the proportions more or less indicated by the thick line in the early part of the curve A. After a certain value of  $H$  has been reached the increase of  $B$  becomes negligible owing to the iron having arrived at a "saturated" condition. If one coil in an iron transformer core is energized from a direct current source to such an extent as to bring the condition of the iron to the point A, marked on this

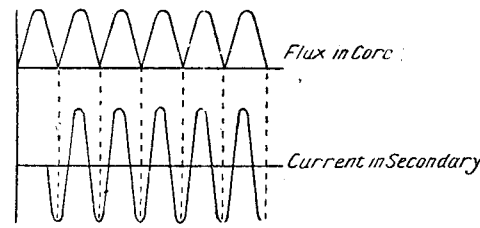
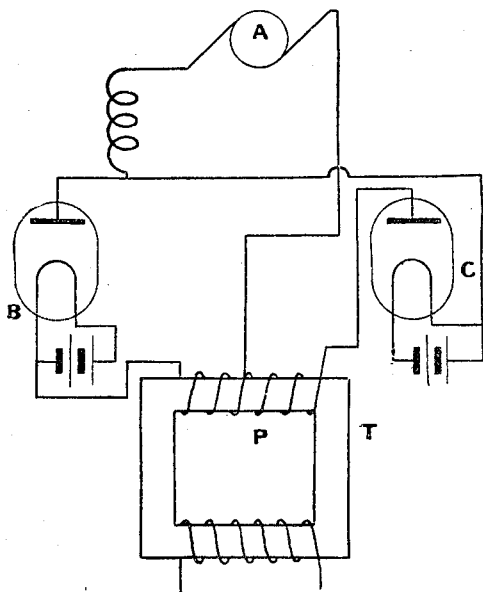

FREQUENCY CHANGING BY VALVE RECTIFIERS

Fig. 4 (left). Frequency can be doubled by the use of valve rectifiers in an arrangement such as that shown in this diagram. An alternating current generator is connected through the valves to the primary of the transformer. Fig. 5 (right). The result of frequency changing by the apparatus in Fig. 4 is shown in the curve, which represents the flux in the core and the current in the secondary of the transformer

curve, and an alternating current is then caused to flow round a second coil on the same iron core, the resulting magnetization, when the alternating magneto-motive force is superimposed on the steady magnetizing effect due to the direct current coil, will be represented by the dotted part of the curve C, D and E.

The practical application of this principle is made use of by the Telefunken Company in the manner shown by Fig. 2. There are two transformers,  $T_1$  and  $T_2$ , which have their iron cores magnetized practically to saturation point by means of the coils D, D, supplied from a constant current source, such as the battery B. The primary current from an alternator A is led to the two primary windings, P, P, on the transformer core, which are wound in opposition to one another, and can be connected either in series, as shown, or in parallel, as circumstances require. The secondaries, S, S, of the two transformers are connected in series.

On an alternating current being passed to coils P, P, the direct and the alternating currents will assist one another during one half-cycle of the alternating wave in one of the transformers,  $T_1$ , but will act in opposition to one another on the other transformer,  $T_2$ . When aiding one another the flux will not rise appreciably, as the iron core is already at the saturation point; but when the two currents are in opposition the magnetic flux will fall as a result of the two opposing magneto-motive forces. The result in the two transformer cores and in their secondary windings is shown in Fig. 3, and the net effect is to double the frequency of the primary currents at the secondary terminals, R.

The purpose of the induction coil,  $L_1$ , and the condenser, K, is to help to tune the primary circuit to resonance, while coil  $L_2$  prevents any high frequency from flowing round the direct current exciting coils.

If the secondaries were connected so as to assist instead of opposing one another, the resulting frequency would be three times that which is impressed on the primary.

A method of doubling the frequency by the use of a valve rectifier is illustrated in Fig. 4. An alternating current generator, A, is connected through the valve rectifiers, B, C, to the primary, P, of the transformer, T. During the positive wave of any cycle valve B allows a current to pass, but valve C opposes it. The current through

B therefore transmits a pulse of magnetization to the iron core of T. On the reverse wave of current A, valve B will oppose, but valve C will pass the pulse of magnetization.

The current is now in the reverse direction, but since the coil winding on T is also reversed the result is that the net magnetization remains the same as before, rectified impulses being produced at regular intervals. If the secondary is connected to a circuit tuned to twice the frequency of the primary current, oscillations will therefore flow round this circuit at double the original impressed frequency, and the result becomes as depicted by Fig. 5.

Undamped high-frequency oscillations may also be obtained by the use of multi-gap generators, wherein by properly timing the discharge periods of related spark circuits each discharge may be made to act inductively on a secondary circuit common to all. A number of rotating disk dischargers are brought into correct relation for discharge intervals, and the sparks ensured at the exact sequence and instants by means of an auxiliary toothed disk acting as a "trigger," and causing the main discharge to take place at exactly the right instant. This device is not used to any very great extent, but is an interesting example of synchronizing a series of short period damped waves occurring at timed intervals, the resultant of which becomes virtually an undamped wave train arising from a series of isolated spark discharges. See Alternator; Transformer.

**FREQUENCY METER.** Instrument for determining the number of complete cycles per second of an alternating current. Measurements relating to the frequency of alternating or oscillating electric currents can be carried out in a variety of different ways, depending on the nature of the apparatus, and whether the alternations are of low frequency or high frequency.

The usual practice adopted in measuring the frequency of commercial low-frequency alternating currents is by means of a tuned vibrating reed device. In the Hartmann and Braun frequency meter, Fig. 1, there are two parallel rows of steel reeds, all tuned to respond to different frequencies, and acted upon by a single alternating current magnet with a girder-shaped core. When this is excited by a current sent round the windings, alternating magnetic effects cause a strong vibration of that particular

reed nearest in sympathy with the frequency of the circuit. The ends of the reeds may be marked with the figure representing definite frequencies, and when in action one figure disappears, indicating the periodicity at a glance. The Frakm frequency meter is another form of tuned steel reed instrument, and it has the advantage that its indication is independent of voltage, changes in wave form and external magnetic fields.

The induction frequency meter makes use of the fact that the current in a circuit which is connected to a constant voltage alternating supply will itself be constant at any frequency if the circuit contains only non-inductive resistance. If, however, it contains inductance, the resistance being

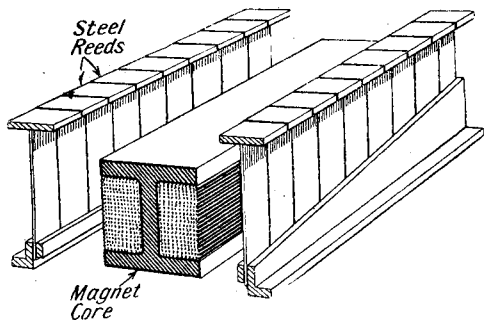

**HARTMANN AND BRAUN FREQUENCY METER**

Fig. 1. This diagram illustrates the principle of the Hartman and Braun frequency meter. Two parallel rows of steel reeds tuned to respond to different frequencies have between them an alternating current magnet

negligible, the current will become inversely proportional to the frequency. This principle is shown in the diagram, Fig. 2. A and B are two coils with their axes at right angles to one another and are connected in parallel in such a way that the independent influence of current flowing in either coil is to cause a deflection of the needle N in opposite directions. The inductance coil L is connected in series with A and a non-inductive resistance in series with B, their respective values being chosen so that when a current of a definite frequency is passed through the combination, the position of needle N will be on zero. For any other frequency the current through coil A will be less or greater than through B, consequently the needle will then take up a position to one side or other of zero, and can be calibrated to read direct in cycles per second.

The Westinghouse is another type of frequency meter that may be compared

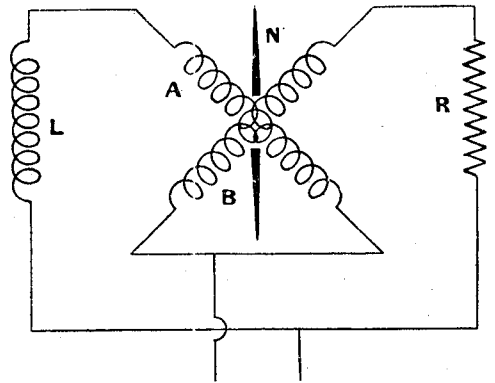

**CONNEXIONS OF INDUCTION FREQUENCY METER**

Fig. 2. Two coils at right angles are connected in parallel, so that current flowing in either deflects a needle mounted centrally

with the last example, although differing in certain respects. The diagram, Fig. 3, shows two electro-magnets  $M_1$  and  $M_2$ , in place of the coils A and B, while an aluminium disk, V, floating between the poles of the magnets, takes the place of the needle, N. Rotation of the disk is caused by the reaction due to the eddy currents set up in it by the alternating flux from the magnets,

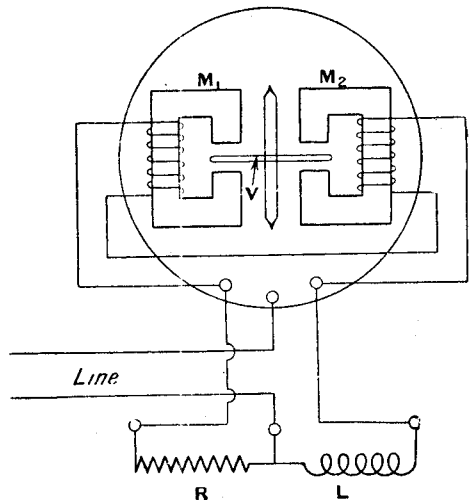

**WESTINGHOUSE FREQUENCY METER**

Fig. 3. Comparing this instrument with that in Fig. 2, it will be seen that two electro-magnets take the place of the coils, and a floating aluminium disk is inserted between the poles of the magnets instead of a needle.

one magnet winding being in series with an inductance coil, L, and the other in series with a non-inductive resistance, R. The torque resulting in movements of the disk depends thus on the difference in the

field strengths of the two magnets, one of which will be more affected by frequency changes than the other. To prevent the disk from being continually rotated under the influence of this constant torque, it is so shaped as to move out of the field as it revolves, and so come into a position of equilibrium.

The Weston frequency meter has a particular arrangement of circuits which results in giving a particularly open scale, though in principle it does not differ materially from the last example.

The Duddell oscillograph can be employed to measure frequency if fitted with two vibrators. One is connected to an alternating supply of known frequency, and the other vibrator to the supply whose frequency is unknown. The relative frequencies are then easily compared, either by observation on a rotating mirror or by the customary photographic means.

Measurements of the frequency of spark discharges or oscillation trains can be carried out in three different ways. A tape record of spark frequency was obtained by Professor Fleming in the manner indicated by the accompanying diagram, Fig. 4. The tape is run at a known and steady speed through the jockey pulleys, D, between two spark balls, S, connected to the secondary of a small oscillation transformer, T, which is included in the high-frequency circuit. Every time a spark occurs at S the tape is punctured; so that the distance between the punctures, taken in conjunction with the known tape speed, is a measure of the frequency of the spark discharges. Instead of puncturing the tape, a series of dark marks can be produced on it at every discharge if the paper is first saturated with ferrocyanide of potassium. The method just described has only a limited application, up to a

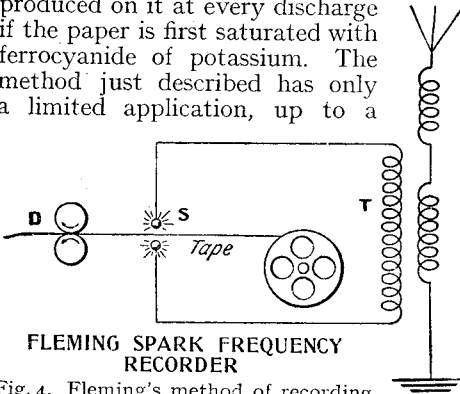

Fig. 4. Fleming's method of recording spark frequency was by means of a tape which passed between electrodes of a spark gap. As the tape passed and the spark occurred punctures were made

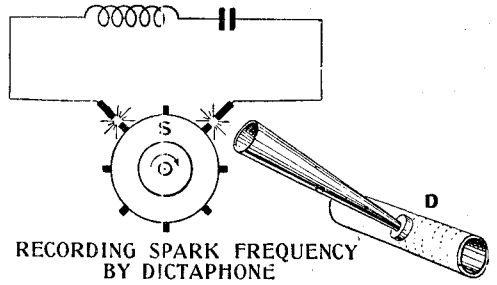

Fig. 5. Spark frequency, up to 2,000 per second, can be recorded by the arrangement illustrated, which shows a Marconi dictaphone receiving the reports made by the spark discharge

spark frequency of about 50 per second, as the highest practical speed for the paper tape is about 17 ft. per minute.

A much greater range of frequency measurement is obtained in the Marconi "Dictaphone" method shown in the further diagram, Fig. 5. The cylinder of the dictaphone, D, runs at a high speed in the close neighbourhood of a spark discharger, S, which is arranged to give a note within the range of audibility. The recording style attached to the vibrating disk of the dictaphone trumpet records its impressions upon the wax cylinder beneath, the speed of which is noted. The record having been obtained, the telephone transcriber is then substituted for the stylus, and the cylinder run at a low speed in order to count the number of spark impressions recorded. The actual spark frequency is then obtainable by dividing the number of spark impressions per second multiplied by the recording speed by the transcribing speed. The wax cylinder can be satisfactorily run up to a speed of 1,000 revolutions per minute, and a definite record is countable if the spark impressions are not less than  $\frac{1}{16}$  in. apart. Hence this arrangement serves to measure all working frequencies up to 2,000 per second.

Fleming also produced a photographic spark counter, in which the image of the spark is passed through and concentrated by a camera lens on to a four-sided revolving mirror, driven by clockwork, inside a light-tight box. The spark image is reflected and focused on to the surface of a sensitized plate, which falls in front of a slit opening in one side of the box. Four series of spark images are thus projected on to the photographic plate for every revolution of the mirror, and they are prevented from superposing by the falling

motion of the plate. It can be shown that the spark frequency per second is equal to twice the mirror speed in revolutions per minute multiplied by  $2\pi$  times the distance in inches between the axis of the mirror and that of the plate, divided by sixty times the mean distance between the spark images on the plate.

The counting of oscillation frequencies calls for more refined methods than any of those previously discussed, owing to the excessively high rates of oscillation. The photographic method has so far been the only means found successful. Each spark image must be spread out as much as

tions per minute. The mirror is concave, in order that its reflections may be focused accurately upon the photographic plate, and the sparking electrodes are made of cadmium, which is a metal that gives a spark strong in actinic rays. The speed of the mirror depends upon the frequency of the spark train, and is adjusted until the train is spread out to a sufficient width to distinguish individual sparks.

This is first ascertained by inspection, using the ground glass screen as in the ordinary camera. The photographic plate is then inserted in the carrier, and caused to slide over the aperture at a slow and uniform speed, recording by successive bands on each line the result of successive spark trains of high-frequency oscillations.

The frequency meter illustrated in Fig. 7 is of the vibrating reed type, with a double element. The small square disks shown opposite the numbers on the instrument face one of the heads of the reeds. These reeds are situated in close proximity to an alternating current electro-magnet. The shape and size of these reeds are such that they will naturally vibrate at a certain known predetermined periodicity.

In this instrument there are nine reeds

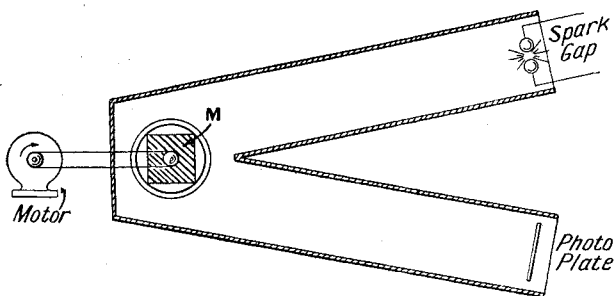

**PHOTOGRAPHIC FREQUENCY RECORDER**

Fig. 6. Two arms at an angle are equipped with a revolving mirror at the apex, a spark gap at the end of one arm and a photographic plate at the end of the other. The mirror reflects the spark to the plate

possible in order that its oscillatory character can be examined accurately, and it will have a banded appearance due to the rapid variations in brightness. The delicacy of the methods necessary may be gathered from the fact that instead of dealing with phenomena recurring at a few hundreds of oscillations per second, the oscillation frequency of a spark discharge may well amount to a figure in the order of millions per second.

The spark counter employed by the National Physical Laboratory consists of a long V-shaped camera (Fig. 6), having the sparking electrodes at the extremity of one arm, and a slide at the extremity of the other. This slide moves in front of a slot, and carries either a ground glass screen or a falling photographic plate, the complete apparatus being rigidly mounted on a heavy base. A rotating mirror, M, is situated at the junction of the two arms, and is driven by a vertical spindle electric motor. A heavy balanced flywheel is fitted to ensure steadiness in running, and the rotating element is carefully balanced, as the speed may amount to 5,000 revolu-

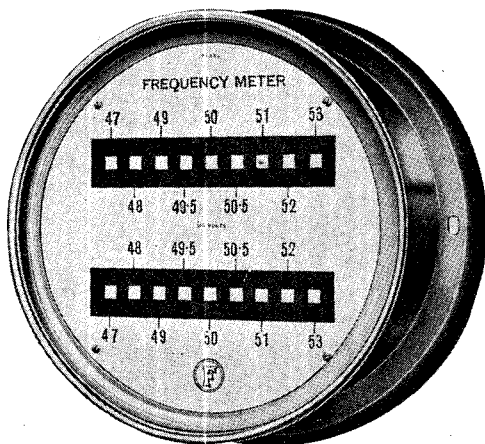

**VIBRATING REED FREQUENCY METER**

Fig. 7. Small square disks are opposite the heads of the reeds, which are close to an A.C. electro-magnet. The reeds vibrate naturally at certain known periodicities

*Courtesy Ferranti, Ltd.*

to each element, whose natural periodicity, or vibrations per second, varies between 47 and 53 inclusive. The electro-magnets, of which there are two, one to each element, are placed either directly across the mains, or through a suitable step-down potential transformer. Thus the magnet is energized at the same frequency or periodicity as the mains.

By the natural law of resonance, providing the frequency of the mains is somewhere between 47 and 53 in this instance, one of the reeds will vibrate in sympathy with the main's frequency. Thus one reed only will move, while the others remain stationary, or very nearly so. The moving reed will show up as a blurred rectangle, and thus indicate the frequency of the applied current.

The instruments are made so that the centre reed is the one which vibrates at the natural frequency of the circuit. The two reeds adjacent to this vibrate at frequencies one per cent above and below normal, while the remainder are arranged in steps of two per cent variation.

Should it happen that the current frequency is not exactly at one of the indicated frequencies, then two or three reeds will vibrate at once, but the one whose natural frequency most nearly corresponds to the circuit frequency will vibrate through a greater amplitude than the others, and is thus readily distinguished.

With experience one may differentiate between variations of 0.25 per cent. by observing the different amplitudes of adjacent reeds. The double element type of instrument, such as here shown, may be used for the purpose of synchronizing two A.C. machines, if suitably connected. The two elements are, of course, entirely separated from each other. Such instruments can only be satisfactorily made for frequencies below 100. Above that, the manufacture of the reeds becomes commercially impossible. Their use is therefore restricted to ordinary A.C. power supply frequency.

**FULLER CELL.** Trade name of a variety of storage batteries made by Messrs. The Fuller Electrical Co., Ltd. A 6 volt accumulator is illustrated, and is typical of the class of wireless storage battery of the portable type. In the example illustrated each cell is composed of three negative and two positive plates. Three such cells are provided in a transparent celluloid case, which is divided

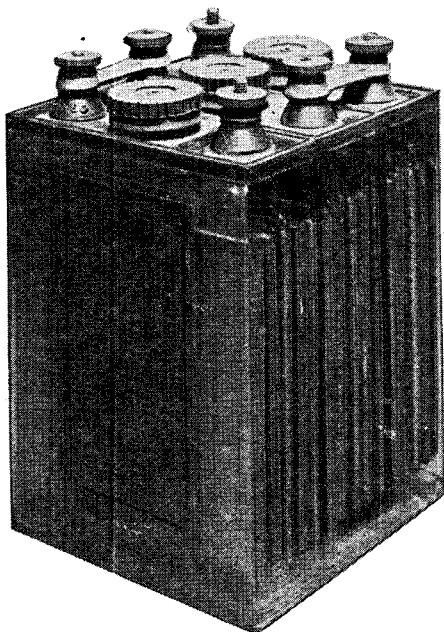

EXAMPLE OF FULLER CELL

Storage batteries of this kind are well known and largely used in wireless work. The photograph shows a 6 volt battery, which may be connected up in various ways to give a lesser number of volts

*Courtesy Fuller's Electrical Co., Ltd.*

into three in the usual way. Each cell has separate terminals, enabling the accumulator to be connected in various ways according to the most convenient voltage needed at the time. Large vents and plug combined are a notable feature of this type of accumulator.

Perhaps the best-known type of Fuller cell is that known as the Fuller Block, so called because of the construction of the plates. This type is illustrated on page 10. See Accumulator; Storage Battery.

**FUNDAMENTAL UNITS.** Term often used for the absolute system of units, the centimetre-gramme-second system. See C.G.S.; Foot-pound System

**FUNDAMENTAL WAVE.** A term derived from acoustics in which the fundamental is a pure sound wave or note. This will combine with other frequencies which are a whole multiple of the fundamental to produce an harmonious note; hence these constituents of multiple frequency are termed harmonics.

By analogy, the fundamental natural frequency of an oscillatory circuit is the longest electro-magnetic wave which will set up free oscillations therein. Such a

circuit will also oscillate to any periodic vibration containing the fundamental and its harmonics. Theoretically, there are an infinite number of fundamental waves whose frequency, wave-length, and amplitude can be represented graphically by a sine curve.

**FURRING.** Expression used in connexion with accumulators, and referring to the growth of a furry or spongy-like formation on the negative plates, probably due to impurities in the electrolyte.

**FUSE.** Device incorporated into a circuit to prevent some of the apparatus there being damaged by the action of the current. Very low value fuses, for protecting filament circuits in a receiving set, are known as filament fuses (*q.v.*). In a commonly used construction the ordinary fuse is of the cartridge type, as illustrated in Fig. 1, so named from its shape.

It consists, in its essence, of an exterior carton or container, the interior of which may be packed with sand or some insulating material, through the centre of which runs a fine wire, the ends of which are connected to suitably shaped contact plates, slotted for attachment to the fuse holder. This type of fuse is suitable for comparatively low value currents.

Another form of fuse, useful for controlling circuits from a small generator, is illustrated in Fig. 2, and is known as the wedge type. In this class of fuse an insulated handle supports two contact plates, between which the fuse wire is extended. The contact plates effect connexion between two springy contact blades mounted on an ebonite or other insulated base. Normally, both plates make connexion, and the fuse wire therefore completes the circuit.

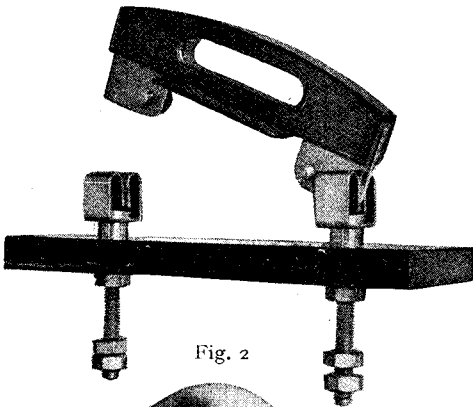

Fig. 2

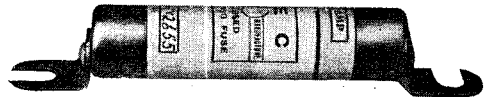

Fig. 1

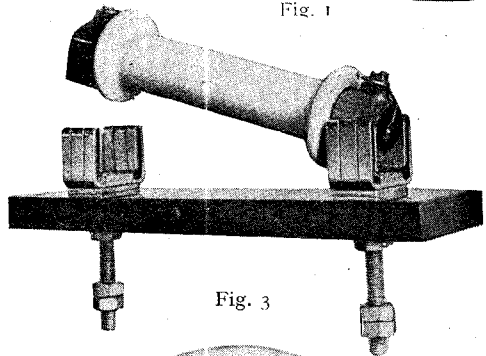

Fig. 3

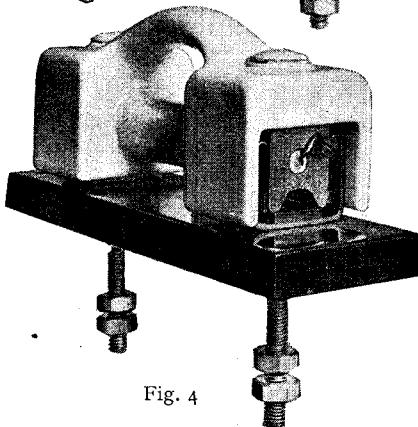

Fig. 4

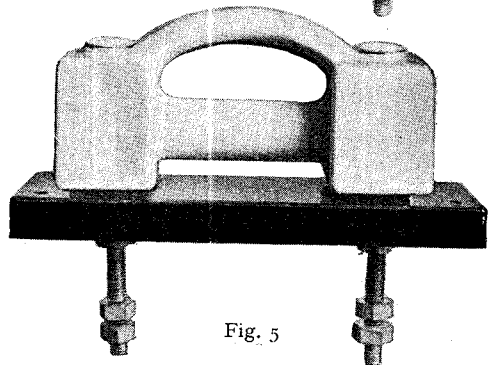

Fig. 5

**FUSES USED IN VARIOUS BRANCHES OF WIRELESS WORK**

Fig. 1. Running through a packing of sand or insulating material is a fine wire. This is a cartridge fuse. Fig. 2. Wedge fuses of this kind are used for controlling circuits from small generators. Fig. 3. This is a bobbin fuse, used for large currents. Fig. 4. Handguard porcelain fuses prevent accidents when handling. The fuse wire is seen at the end. Fig. 5. Another view of the fuse in

Fig. 4, showing the heavy insulation

*Courtesy General Electric Co., Ltd.*

When it blows, the fuse holder may be removed, the wire replaced, and the whole put back into position without the necessity of cutting out the current as a whole.

In the bobbin type of fuse, illustrated in Fig. 3, the grip is made of vitreous porcelain, or some similar material. The fuse wire passes through the centre of it, and is embedded in other insulating material. Contact is effected at either end by substantial springy blades. Such fuses are capable of dealing with considerable current.

To prevent any chance accident when dealing with high-voltage current, the handguard type of fuse, illustrated in Fig. 4, can be employed. This consists of a vitreous porcelain, or similar, handle to a separate hand-grip, the fuse being disposed through the centre of the circular part in a somewhat similar manner to the previous examples and making connexion in much the same way. The arrangement of the china insulated portion is such that practically the whole of the device is protected by insulating material when it is in position, as can be appreciated by Fig. 5.

It is important in all fuses that the fuse wire should be of suitable capacity for the circuit it is to protect, and it is always advisable to have a good supply of spares at hand, in case of emergency. In the handguard type, and also some of the other patterns, the fuses are often incorporated in a cast-iron casing to protect them from injury, and this may be sealed to prevent their being tampered with.

Other varieties are made with water-tight connexions to protect them from dampness and consequent chance of earthing. In general, when this class of fuse is used, it is necessary that the circuit arrangements, cut-outs, and fuses be designed to comply with the Home Office regulations for the use of electricity, and also to meet the requirements of the insurance companies.



**GAEDE PUMP.** There are two kinds of Gaede pump, both used for producing a vacuum such as is necessary in the manufacture of thermionic valves. The Gaede rotary mercury pump, which, until about fifteen years ago, was the apparatus

generally employed for obtaining a high vacuum, depended on the production of the vacuum at the top of a narrow tube, like that used for barometers, by compression of the extracted gas.

Owing to their failure to deal with traces of residual vapour, these pumps were not wholly satisfactory, and a step forward was made by the introduction of the Gaede molecular pump, in which a drum rotates at such high speed that any drifting gas molecules are summarily cleared out. The latter pump is still in use, but for the production of very high vacua it has largely been superseded by the Langmuir "diffusion" or mercury vapour pump, to which, however, it is often employed as a subsidiary. See Vacuum; Valve.

**GALENA.** Name of a crystal used for rectification purposes. The chemical symbol is PbS. Galena is an ore of lead, known as lead sulphide, is lead-grey in colour, and when fractured in cubical form exhibits a brilliant metallic lustre.

The mineral usually contains traces of silver, selenium, gold, copper, and other metals, and is generally found in lead mines or in districts where lead mining is carried on.

Galena is of wide distribution, and found in Great Britain in Derbyshire, Cornwall, and elsewhere.

It is widely used in wireless receiving sets, and may be used with a cat's-whisker or in combination with another mineral. When used with the cat's-whisker it is usual to employ a fine brass wire, but better results are claimed for the use of tellurium wire.

Experimental investigation shows that different combinations have different effects on the results, as the current can flow more freely in one direction than another. For example, the combination of galena and zincite is more efficient when the zincite is negative.

Galena and galena is another combination that gives good results, as does the combination of galena and graphite. In this arrangement the graphite may take the form of a pencil pressing firmly but lightly on the galena. To be successful in getting the very best results, it is, as a rule, necessary that the cat's-whisker be very lightly adjusted to the galena, and the sensitive spots are often a little difficult to find. Adjustment is therefore often rather critical.



Galena possesses unilateral conductivity, hence its use as a detector and rectifier, a property remarked by F. Braun as long ago as 1874. To render the mineral more sensitive as a rectifier, it is often treated in the course of preparation for market, the difference in appearance being seen by the changed nature of the surface.

A good specimen of ordinary galena is shown in Fig. 2, which clearly exhibits the natural cubical cleavage of the mineral, resulting in the bright facets on the mineral. The treated galena shown in Fig. 1 exhibits a larger number of smaller bright

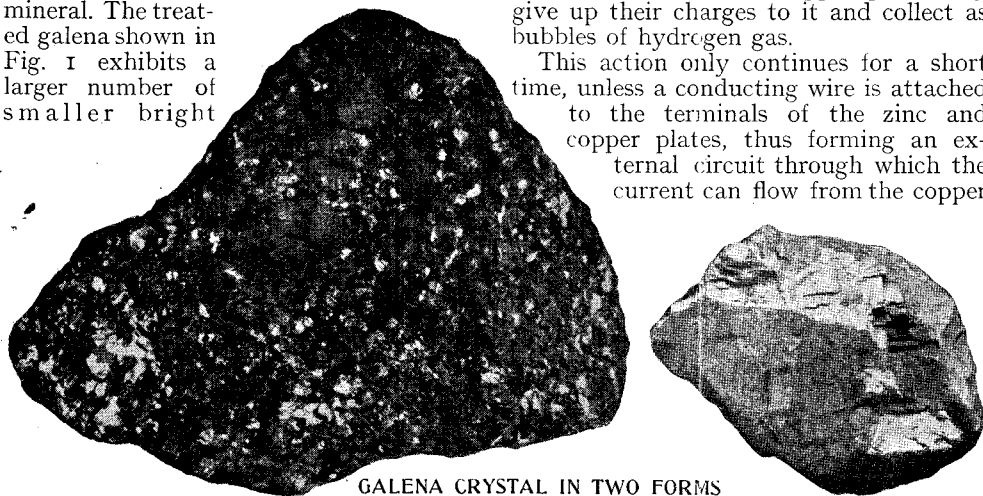

GALENA CRYSTAL IN TWO FORMS

Fig. 1 (left). Here the galena has been treated so that the surface is broken up into a large number of small parts, which increases the number of sensitive spots. Fig. 2 (right). This is a standard specimen of galena crystal with comparatively large smooth surfaces which should be compared with the treated specimen in Fig. 1

*Courtesy Will Day, Ltd.*

facets, and often has a greater number of sensitive spots. Specimens vary in their sensitivity, and the experimenter having a good specimen should take care to preserve it, keeping any spare pieces in a closely covered box or packed in clean cotton-wool. *See* Crystal

**GALVANIC CELL.** Expression used to define all types of primary cells. A simple galvanic cell comprises a container partly filled with a solution known as the electrolyte. Two dissimilar metals are immersed in the solution, with the result that the molecules of the solution are split up into two electrically charged parts known as ions. For example, in a cell composed of plates of copper and zinc in a dilute solution of hydrochloric acid (HCl), the HCl molecules are split up into hydrogen and chlorine ions, the former carrying a positive charge and the latter an equal negative charge, the phenomenon being known as dissociation.

The solution remains neutral or uncharged, as there are equal numbers of positive and negative ions. The zinc plate is, however, attacked by the acid, which pulls zinc atoms into the solution, bringing with them tiny charges of positive electricity.

The solution in the neighbourhood of the zinc plate is positively charged with electricity, which tends to repel the hydrogen ions towards the copper plate. When they reach the copper plate they give up their charges to it and collect as bubbles of hydrogen gas.

This action only continues for a short time, unless a conducting wire is attached to the terminals of the zinc and copper plates, thus forming an external circuit through which the current can flow from the copper

to the zinc plate. The flow of the current allows the cycle of operations to continue until the zinc plate or the solution is exhausted—that is, until the zinc plate has been eaten up or the hydrogen ions all driven out of the solution.

The electro-motive force of a galvanic cell depends on the materials of which it is composed, and not upon the shape or size or the distance apart of the plates. The current supplied by a galvanic cell is directly proportional to the electro-motive force existing in the circuit in which the current flows, and inversely proportional to the total resistances of the circuit. *See* Daniel Cell; Dry Battery; Gravity Cell; Primary Cell.

**GALVANIZED WIRE.** This expression may be applied to any ferrous metal wire which has been treated by a process known as galvanizing to render it damp-resisting. In the galvanizing the iron wire is usually covered with a coating of zinc. Tin and

lead are sometimes used as the coating materials, but they are not so effective. The coating of zinc is applied in a number of ways—by dipping in molten zinc, by electro-plating, or by the vapour or Sherardizing process. The wireless experimenter will mostly use the material in the form of a stranded wire cable for the purpose of staying and supporting an aerial mast, for lashing two spars together, and for such purposes as making up a purchase tackle for lifting some heavy weight. The material is made up in many sizes

and several different forms. In some cases a hemp core is used, the exterior being wound with galvanized wire. In others, seven or more strands are twisted to form a cable. Alternatively, the wire can be purchased from a fine variety suitable for binding small parts together, to a thickness of  $\frac{1}{4}$  in. or thereabouts.

Joints and connexions are best made in the stranded wires by means of splicing, or by some of the patented clips supplied for the purpose and described under the heading Cordage (*q.v.*).

## GALVANOMETERS: THEIR USES AND CONSTRUCTION

### Standard Types of Measuring Instruments and How to Make a Simple Galvanometer

Here every important variety of galvanometer is described and the principles of its construction are explained, with full instructions for making a simple galvanometer which will be of practical value for the experimenter. See also Astatic Galvanometer; Galvanoscope; and under the names of particular instruments such as D'Arsonval; Einthoven, etc.

A galvanometer is an instrument for detecting and measuring electric currents. In its simplest form it consists of a small magnetized iron needle pivoted in the centre of a hollow coil of wire. The needle, being controlled by the earth's field, points north and south when at rest. The application of an electric current, as in the diagram given, causes a deflection of the needle, which is larger or smaller according to the strength of the current, and is to the right or left of the zero position according to the direction of the flow. Such an instrument is called a detector galvanometer, and simple models of it only enable comparatively large currents to be detected without special reference to their value.

Practically all galvanometers depend for their action on the mutual effect of a magnet and an electric circuit, and the first step towards the production of more elaborate and comprehensively serviceable instruments is the elimination to the utmost possible extent of the controlling effects of the earth's magnetism. This is done in several ways, all depending on the same common principle. One method is to have a second magnet attached to the shaft on which the indicator, itself a permanent magnet, moves, and so arranged that its poles are opposite to those of the indicator. The result is that any stray field tending to deflect the indicator is counteracted because it must act in the opposite direction on one magnet to that in which it acts on the other. Sometimes two similar and nearly equal

magnets are rigidly fixed parallel to each other with their poles pointing in opposite directions, one needle being inside the coil of the coil of the instrument, the other either outside or else in a second coil in which the current flows in the opposite direction to the current in the first coil. This is called mounting in astatic pairs, and a galvanometer employing the principle is said to be astatic. Such instruments are commonly made with indicator scales having divisions which enable the strength of a current to be measured with a moderate degree of accuracy.

Of galvanometers in general there are a number of varieties, among which are included the following: Tangent, sine, ballistic, Ayrton-Mather, Thomson, Helmholtz, shielded, torsion, and Einthoven (*q.v.*). A tangent galvanometer is one in which a short magnetic needle is suspended at the centre of a coil of large diameter and small section. The coil is set in the plane of the magnetic meridian; the current is then proportional to the tangent of the angle of deflection, or, put as an equation,  $C = K \tan \theta$ .

The constant  $K$  is termed the reduction factor of the instrument, and is equal to the horizontal magnetic force  $H$  divided by the galvanometer constant (*i.e.* the number by which a galvanometer reading must be multiplied in order to enable the quantity to be read), or  $K = \frac{H}{G}$ .

A galvanometer may be used as an ammeter by shunting it with a suitable low resistance, or as a voltmeter by putting

in series with it sufficient resistance to allow the correct current to pass for a given reading at the measured pressure. Thus a galvanometer taking  $m$  micro-amperes per division would require a resistance  $\frac{V \times 10^6}{m \times 8}$  to read  $V$  volts for a deflection of eight divisions.

An aperiodic galvanometer is one in which the suspended system (needle or coil) is prevented from swinging backwards and forwards after the current has ceased or become steady. This checking, whether by electrical or mechanical means, is called damping, and a ballistic galvanometer is one in which the damping is very slight.

Precision galvanometers enable very accurate readings of very small currents to be obtained, but the use of such instruments, of which the D'Arsonval pattern is a representative type, is confined mainly to the laboratories. The D'Arsonval is sometimes known as a "suspended coil" galvanometer, from the fact that it consists of a coil of thin wire wound on a rectangular silver frame which is suspended in a magnetic field between the poles of a horseshoe magnet by strips of flattened phosphor-bronze wire fixed at the top and bottom of the coil frame.

These strips also act as conductors to the coil. Inside the coil, but not touching it, is a cylinder of soft iron which concentrates the magnetic field from the poles of the magnet through the coil, and thus increases the sensitiveness of the instrument. In some patterns a controlling spring runs from the lower end

of the coil in order both to provide a controlling force for the coil and also to conduct the current away from it. In this case the coil is suspended by a single wire only, fixed to the top of the coil.

A mirror or pointer may be affixed to the coil, the terminals of the instrument being connected respectively to the top and bottom end of the controlling spring. Normally, the plane of the coil, when no current is flowing, is parallel to the lines of force between the magnet poles. When a current is passed through the coil the lines of force due to its magnetic effect will pass through the coil at right angles to its plane. The result will be that the coil will tend to twist round in such a direction, and to such a position, that its lines of force are parallel to, and in the same direction as, the lines of force of the permanent magnet.

The controlling spring, however, will prevent it from turning through  $90^\circ$ , and the angle through which it will turn will depend (1) upon the strength of the controlling force and (2) upon the strength of the deflecting force produced by the action of the two magnetic fields. Inferentially, the angle through which the coil moves is a measure of the current flowing in it.

The sensitiveness of such a galvanometer is specified by its "figure of merit," which indicates the total resistance of the galvanometer circuit through which an applied electro-motive force of one volt will produce unit deflection on a scale placed one metre away. Galvanometers have been constructed of such supersensitiveness that they will detect a current of  $10^{-13}$  amperes, which is so small that it would require centuries to liberate with it a cubic centimetre of hydrogen (J. J. Thomson).

The uses of a simple galvanometer in ordinary wireless practice are not very extended, since, for purposes of measurement, voltmeters and ammeters are more generally serviceable. But a galvanometer may sometimes be employed with advantage to test the direction of currents in the case of doubtful connexions, and of estimating roughly the value of a filament resistance. Again, the use of even precision galvanometers in wireless work is restricted by the fact that in such instruments the necessary mechanical system cannot follow the changes of forces, which recur with extreme rapidity

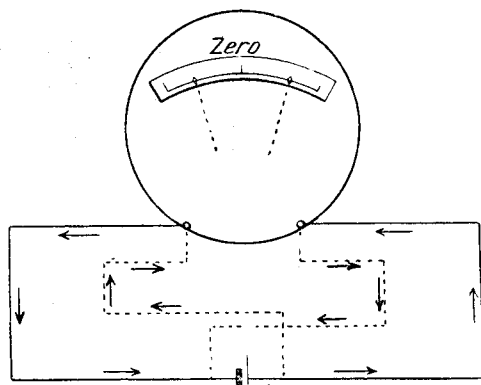

**ACTION OF A GALVANOMETER**

Fig. 1. Change of direction in an electrical current, with corresponding deflection of the galvanometer needle, is explained by the above diagram

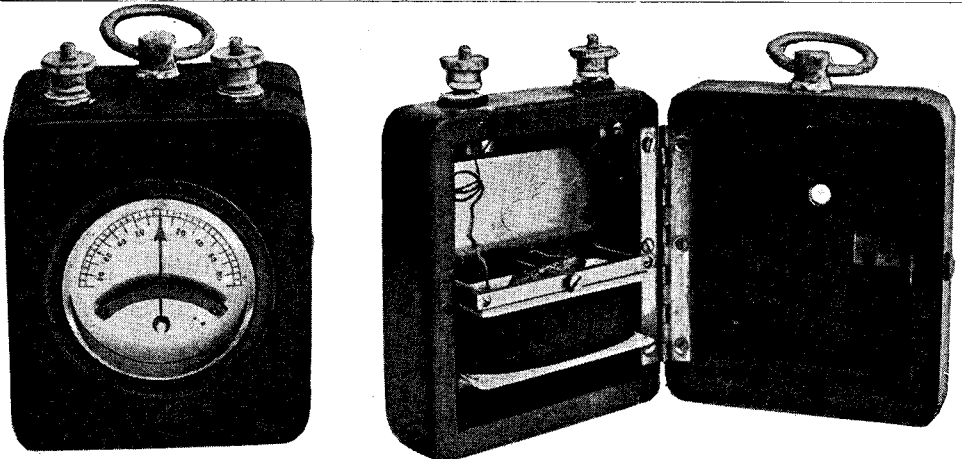

**GALVANOMETER SUITABLE FOR WIRELESS EXPERIMENTS**

Fig. 2 (left). Experimenters frequently make use of a galvanometer of this type, which is largely employed when repairs to telephones or installation work is being carried out. Fig. 3 (right). The galvanometer in Fig. 2 is here shown open, and the coil winding and magnetic bar can be seen. The movement of the magnet actuates the pointer, seen in Fig. 2

even in low-frequency alternating current circuits, to say nothing of high-frequency ones.

Coursey points out that with such instruments the indicating means, which is generally a spot of light reflected from a small mirror, vibrates in synchronism with the current variations, so that the instrumental readings must be gauged, not by a steady deflection from the zero position, but by the amplitude of the vibration on either side of zero. These instruments require to be mechanically tuned to the frequency of the alternating

current, and this generally precludes their use with accuracy in circuits in which the currents are much divergent from the sinoidal form. Galvanometers of no special sensitivity may be used for measuring signal strength in the case of both crystal and valve rectifiers. A galvanometer may also be substituted for a

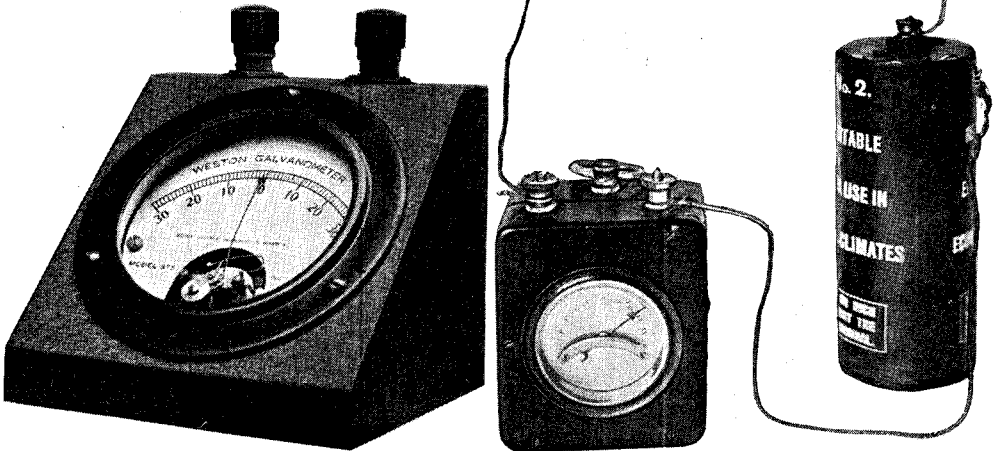

**HIGH-GRADE GALVANOMETER WITH DAMPED ACTION**

Fig. 4 (left). Dead-beat action is applied to this galvanometer, or the needle action is damped to suppress swinging when a reading is taken. This instrument is the Weston Electrical Instrument Company's model No. 375. Fig. 5 (right). How the galvanometer needle deflects to indicate direction of flow of current is indicated in the above photograph. A dry battery is being tested

*Fig. 4, courtesy Radio Communication Co., Ltd.*

milliammeter in determining the characteristic curve of a valve.—*A. H. Avery, A.M.I.E.E.*

Fig. 2 shows the type of galvanometer chiefly used for detecting the presence of current or continuity in a circuit, and also for indicating the direction of flow of the current. It is mounted in a strong wooden box, with terminals and carrying ring on the top of the instrument. Galvanometers of this type are largely used in telephone work, owing to their robust construction and portability.



**GALVANOMETER TEST OF FILAMENT RESISTANCE**

Fig. 6. Placed in series with a battery and valve unit is a galvanometer, which is used to test the continuity of the filament circuit

Fig. 3 shows the inside of the instrument, which consists of a straight-bar magnet finely pivoted between centres. At one end a light balanced pointer is attached, capable of movement over an equally graduated dial. A hollow bobbin of fine insulated wire, into which either end of the magnet is capable of dipping, is placed underneath the magnet. Connexions are made from the bobbin to the terminals on the top of the instrument. When at rest, the needle or pointer is at a zero mark, the graduations of the scale being made on either side. The graduations are purely arbitrary, and are useful only in forming a basis for comparison of current values.

A galvanometer of the dead-beat variety is shown in Fig. 4. The instrument shown in Fig. 4 is suited to the needs of the experimenter if a high-grade galvanometer is required.

The application of the galvanometer for determining the direction of flow of current

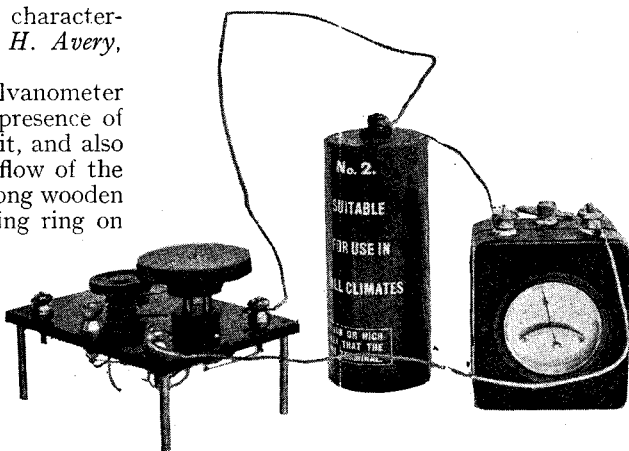

**TESTING A H.F. TRANSFORMER**

Fig. 7. Continuity of windings of a H.F. transformer is tested in this way with a battery and galvanometer. Connexions are taken to grid and anode terminals of an experimental panel

is shown in Fig. 5, where it is desired to test the direction of flow of the dry battery. This is indicated by the needle in a right-hand deflexion.

Another application of the galvanometer is to ascertain if a circuit is continuous. This is shown in Fig. 6. To the left is seen a combined valve holder and filament resistance panel. The valve, when inserted into its holder, does not

light for some cause or other. It is, naturally, inadvisable to test the valve itself without some form of resistance in circuit, or it may be burnt out.

The best method of procedure then is to test the remainder of the circuit, to ascertain if the current is reaching the valve sockets. A suitable battery is connected in series with a galvanometer, and the free ends of wire joined to the filament terminals. A springy piece of wire is connected to both filament sockets, when the needle of the galvanometer should show a deflexion when the arm of the filament resistance is touching the resistance coil.

The trouble may thus be traced to the valve holder if no deflexion occurs. It should be noted that the direction of deflexion is on the opposite side of the scale to that shown in Fig. 5, as the battery connexions have been reversed. Also, the amount of deflexion in Fig. 6 is less, owing to the resistance of this circuit.

In a similar manner, Fig. 7 shows a high-frequency transformer under test for continuity, connexions being made to an experimental panel at the grid and anode terminals, to which one winding of the transformer is taken.

**How to Make a Simple Galvanometer.**

The construction of the simple galvanometer shown in Fig. 8 is not beyond the scope of the home craftsman, and while it may not have the accuracy of the scientifically constructed instrument, it is vet of

considerable service, and is a useful means of studying the principles of the galvanometer and understanding its mode of operation.

The baseboard is cut from a piece of good dry deal or preferably mahogany or hardwood, 1 in. thick and 8 in. square. The edges are chamfered, and the whole given a coat of varnish or polished. Two telephone terminals are fixed as shown in Fig. 9, and three flat strips of brass,  $\frac{1}{2}$  in. wide and  $\frac{1}{16}$  in. thick, cut to a length of

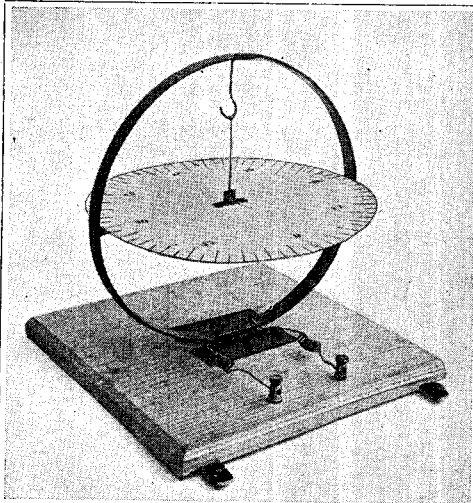

Fig. 8. The home-made galvanometer will be seen to be quite different from the elaborate commercially made instruments; but its usefulness to the experimenter is considerable

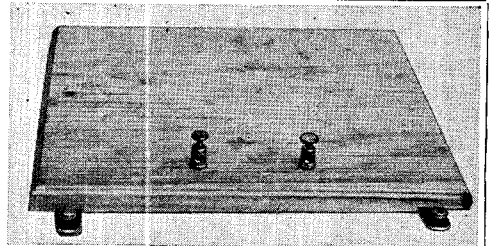

Fig. 9. Terminals and adjusting feet are fitted to a plain wooden base as here illustrated

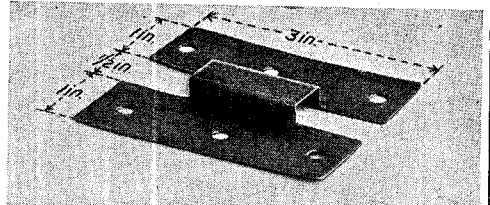

Fig. 10. Cut out of a plate of brass and bent to the shape in the photograph is a base which dimensions are given

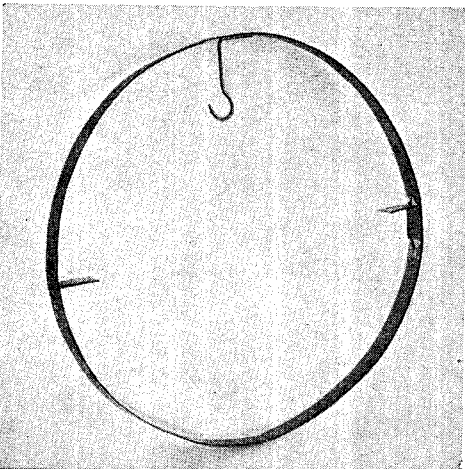

Fig. 11. Soldered together at the ends to form a hoop is a strip of brass with two angle pieces on the inside and a hook attached to the top

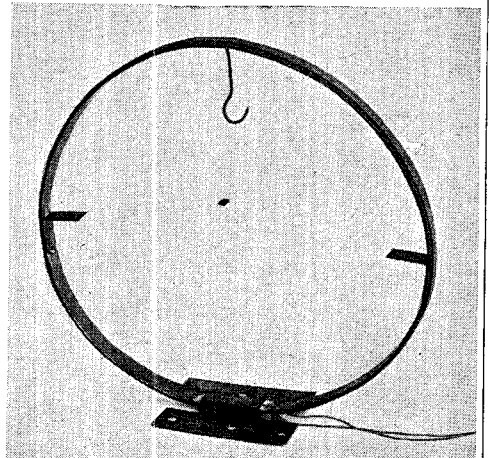
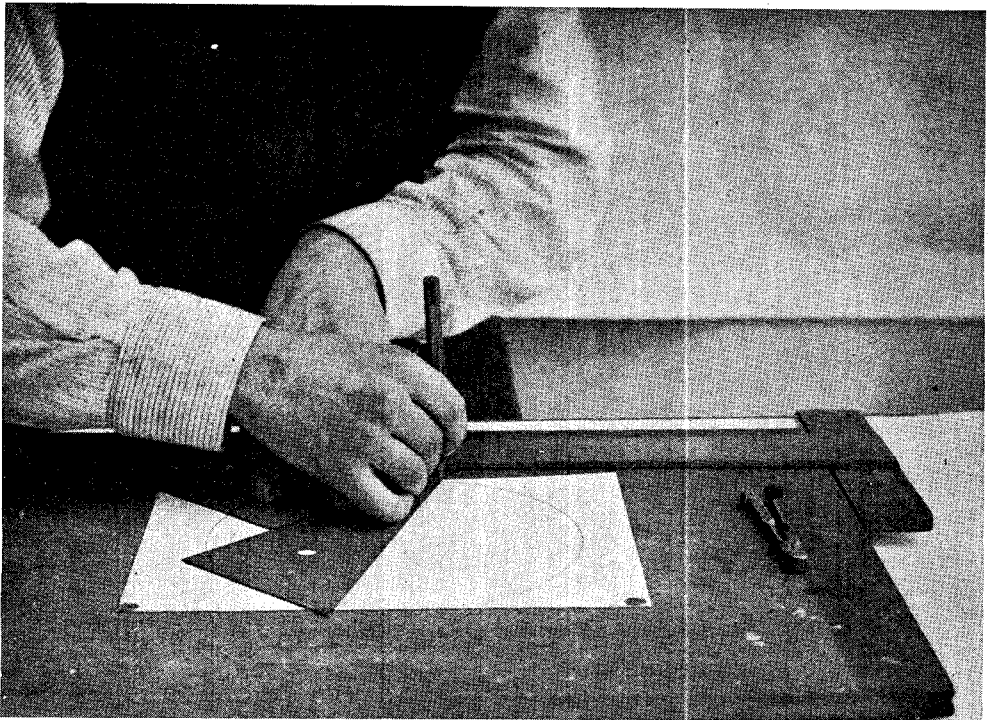

Fig. 12. Half-inch brass forms a hoop 8 in. in diameter, which is attached to the base and wound with wire as shown

**SIMPLE GALVANOMETER AN AMATEUR CAN CONSTRUCT**



PREPARING A DIAL FOR A HOME-MADE GALVANOMETER

Fig. 13. As will be seen in Fig. 8, which shows the complete home-made galvanometer, the dial is suspended from the centre. The calibrations are marked off as illustrated by means of two set squares and a T-square. This is the first stage, and the bisecting lines are being drawn on the square of bristol board which forms the face of the dial. The dial should not be cut to shape until the whole process of marking is complete

$1\frac{1}{2}$  in. and screwed to the underside of the base. Two are fixed at the front corners, and one in the centre of the back. Holes are drilled and tapped through the front part of the strips to take knurled-headed screws as shown, and these are used to level the base, as it is important that when in use the base is perfectly level.

The next step is to take a brass plate,  $\frac{1}{16}$  in. thick, cut and bend it to the shape shown in Fig. 10. The raised portion in the centre stands up  $\frac{1}{4}$  in. above the base, the other dimensions are given on the illustration. Next prepare a long strip of brass  $\frac{1}{2}$  in. wide and  $\frac{1}{16}$  in. thick, cut it to a length of  $25\frac{1}{2}$  in., and bend it around a disk of wood to form a circle 8 in. diameter, and solder the ends together.

Next fix two angle pieces of the same material at exactly opposite points on the circle, as shown in Fig. 11, making them project inwards for  $\frac{3}{4}$  in. Make and fit a hook as shown and solder it exactly midway between the angle pieces on the ring.

Then solder the brass base to the bottom of the ring, and take care that when finished thus far the hook, two angle pieces, and the base are equally spaced around the ring, thus dividing it

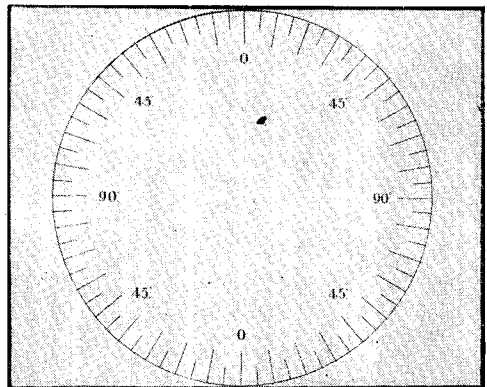

DIAL MARKINGS FOR GALVANOMETER

Fig. 14. Two sets of markings are balanced. The stages are marked off in  $5^\circ$  from zero up to  $90^\circ$ , and then decline to zero at the opposite pole

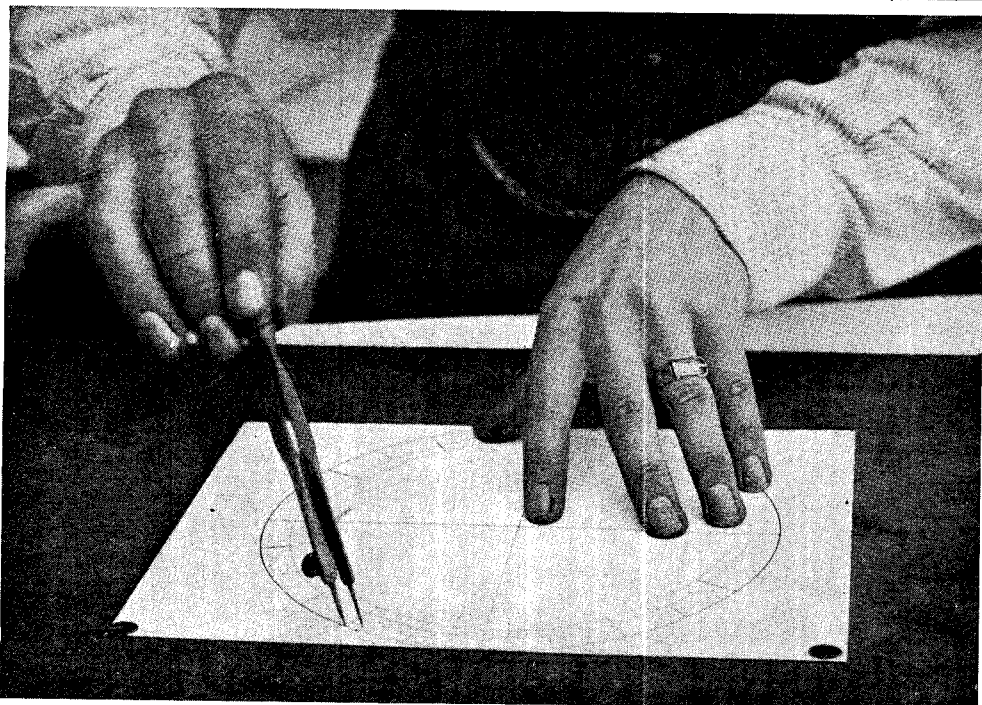

#### GRADUATING A HOME-MADE GALVANOMETER DIAL

Fig. 15. After the outer circle has been made two other circles are lightly drawn on the inside. The  $90^\circ$  bisecting lines and the zero lines give four quarters of the dial, and each of these quarters is marked off in 18 equal divisions with a pair of dividers. Alternate long and short lines are then drawn at these marks from the outer circle to the first and second inner circles. Great care should be taken to ensure accuracy

equally into four parts. The next step is to wind three layers of No. 20 D.C.C. wire around the outside of the ring, and bring out the terminations of the windings at the bottom. The wire is wound continuously and in the same direction. The work at this stage is shown in Fig. 12, and is afterwards screwed to the baseboard.

Prepare a disk of zinc or brass 8 in. diameter, and about  $\frac{1}{16}$  in. thick, flatten it and drill a hole through the centre  $\frac{1}{2}$  in. diameter, and solder it to the two angle pieces on the ring, taking care to get it exactly central. Drop a thin piece of cotton from the upper hook through the hole, and tie a small weight to the end, thus making a plumb line. Adjust the whole so that when the base is quite level the line passes exactly through the centre of the hole in the disk and the latter is also perfectly horizontal.

The next step is to prepare the dial by taking a piece of thin bristol board and marking it out as shown in Fig. 13, noting that the disk is divided into four parts, and each quarter divided into 18 smaller

parts. This is easily accomplished with the aid of a T-square and two set squares on the drawing board, as shown in Fig. 14, manipulating the  $45^\circ$  and the  $60^\circ$  set squares as shown to make the primary divisions. The intermediate divisions are spaced out with the dividers, as shown in Fig. 15.

When the disk is finished it is pasted to the top of the zinc disk, with the  $90^\circ$  marks in line with centre of the ring. The needle is made from a thin fibre of glass by cutting a thin strip about 6 in. long and drawing it out in the flame of a blow-pipe. The needle should be made equal in weight at each side of the centre, as it has to balance on the end of the suspension thread.

The magnetic needle is made from a strip of steel  $\frac{3}{4}$  in. long and about  $\frac{1}{8}$  in. wide and  $\frac{1}{32}$  in. thick. It is magnetized by stroking it with a powerful permanent magnet or by winding a coil of thin insulated wire around it and passing a current of electricity through it for a few minutes.



The next step is to make the holder, as shown in Fig. 16, by bending a narrow strip of thin aluminium,  $\frac{1}{8}$  in. wide, to form a loop, and making two holes through it as shown. The magnetic needle is clipped within the strip by lightly hammering over the aluminium to make it grip the steel. The glass needle is at right

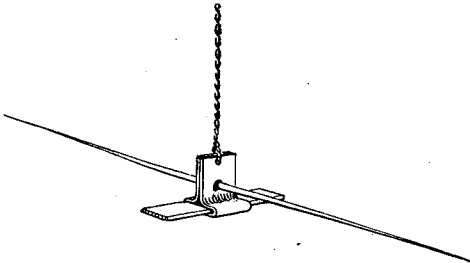

**HOME-MADE GALVANOMETER NEEDLE**

Fig. 16. At right angles to the magnetic needle is a glass needle. Both are held by a strip of aluminium bent to shape and suspended

angles to the magnetic needle, and is passed through a hole punched in the aluminium and secured with seccotine.

The whole is then suspended from the upper hook on the ring by means of a fine silk thread. The instrument has to be adjusted so that the glass needle comes to rest over the zero divisions on the dial when current is not flowing in the coil of wire around the ring. The ends of the windings are connected to the terminals as shown in the first illustration. The whole apparatus is best covered with a large glass shade, to prevent the needle moving in a draught of air.

**GALVANOMETER DIAL.** Name given to the calibrated card used to compare the relative movement of the galvanometer pointer. The dimensions and form of the calibrations and the dial itself are determined by the nature and design of the galvanometer and its particular purpose. The dial may be composed of celluloid, glass, or other appropriate material. Generally, the indications are graded from a central zero mark to permit of determining the deflection of the pointer in either of two directions.

**GALVANOSCOPE.** The galvanoscope is a device which serves to indicate the presence and direction of an electric current by reason of its magnetic effects. This instrument consists essentially of a few turns of wire wound round a former inside which is pivoted a compass needle. Fig. 1 shows the arrangement diagrammatically.

Assuming the current to be flowing in the direction indicated by the arrows, the N pole of the needle will swing towards the reader, the effects of that part of the current in the copper wire combining with those due to the component in the lower conductor to produce this result. A very convenient method for determining the motion of a magnetized needle relative to a current-carrying conductor has been suggested by Ampère. Imagine a man swimming along the wire in the direction of the current flow, always facing the needle. Then the N pole of the latter will turn to his left.

Before any attempt is made to use this instrument, it is essential that it be placed with its plane in the magnetic meridian, so that the needle will be parallel to the windings.

The deflection of the needle is dependent upon a combination of two forces, that due to terrestrial magnetism, which tends to keep it aligned N-S, and that exerted by the field produced by the flow of current in the wires. The relative strength of these two forces is the factor which decides the angle of movement.

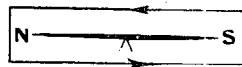

Fig. 1

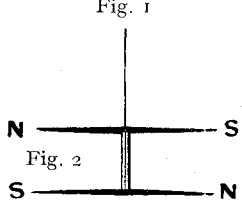

Fig. 2

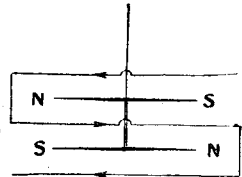

Fig. 3

**PRINCIPLE OF THE GALVANOSCOPE**

Fig. 1. Wound round a former are a few turns of wire, with a needle inside, shown here diagrammatically

Fig. 2. Another method has two needles with poles in opposite directions

Fig. 3. When two needles are used the coils are wound round both in opposite directions

Part of the available energy represented by the current flow is therefore wasted in overcoming the directive force of the earth's magnetism, instead of performing useful work in turning the needle. If some means could be devised for neutralizing this latter force, the instrument would respond to much weaker currents. There are two principal methods by which this is accomplished.

By placing a bar magnet in the magnetic meridian with its N-seeking pole inclined

to N, directly over or under the coil, the compass needle will be caused to reverse its position, and a careful adjustment of the vertical distance between the magnet and the needle will enable the effects of terrestrial magnetism to be balanced out.

A method which has received wider application than the above consists of coupling two compass needles of equal size and strength rigidly together, parallel to one another and with their opposite poles adjacent, as shown in Fig. 2. Whatever effects are produced by the earth's magnetism on the one will be exactly counteracted by the equal and opposite effects it has on the other, so that the pair will remain in whatever direction they are placed, except for any torsional tendencies due to the method of suspension. Actually, however, owing to the difficulty of procuring two needles of exactly similar strength, they will tend to swing to the magnetic meridian. This arrangement is known as astatic and has a very important bearing upon the design of sensitive galvanometers.

The whole of the applied energy is now available for producing movement of the needles. In all cases further sensitivity may be obtained by increasing the number of turns of wire. In the astatic arrangement just described it should be noted that if coils are wound round both needles, the winding must be in opposite directions. A consideration of Fig. 3 in conjunction with Ampère's rule will explain the necessity of this.

The indicated direction of the current is at all points such as to produce a twisting effect on the needles in one and the same way. It should be clearly understood that the galvanoscope is not an instrument for measuring currents, but merely serves to indicate their approximate strength and direction. See Galvanometer.

**GAMMA RAYS.** Ether waves or rays given off by radium or radio-active substances. These rays have a frequency of  $3 \times 10^{19}$  cycles and their presence may be detected by a photographic plate or fluorescent screen. They have the highest frequency of any of the known ether waves, and are therefore at the opposite end of the scale to the wireless waves.

**GAP.** As in air gap, the term applied to that part of any magnetic circuit where the lines of force have to pass through air

from iron to iron. More particularly in dynamos it denotes the space between the armature and magnets, or between the rotor and stator. In electricity a spark gap is the space between two terminals—in some forms of apparatus the latter take the specific form of spark balls—across which an electric spark passes when a sufficient current has been applied.

In oscillating circuits a spark gap is sometimes used as an automatic safety valve. This is the principle underlying some of the appliances for protecting wireless receivers from lightning and other

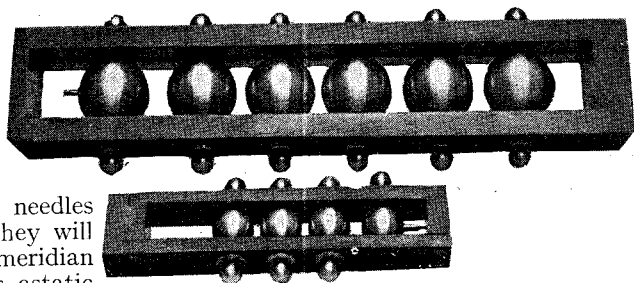

**EARLY MULTIPLE SPARK GAPS**

Marconi used this apparatus in his early experiments. The balls are mounted on an ebonite framework, and the distance between them is adjustable

*Courtesy Marconi's Wireless Telegraph Co., Ltd*

charges that might damage the instruments. In the cases of such excessive charges a conductive spark is formed as soon as the voltage reaches an unsafe point, and this spark, by leaping across the gap, shorts the apparatus in use.

The series of gaps shown in the figure are some that were used by Marconi in his early experiments. The framework surrounding the balls is made of ebonite, and is of heavy construction. A slot runs from end to end of this framework, and in this slot the balls are clamped. The distance between them is adjustable by moving them in the slot. It is possible to see here and there that the balls themselves are pitted by the discharges. Contrary to present-day practice, the electrodes are made of brass. Connexions from the transmitter to them is made by fixing the wires to the smaller balls which project on either side of the ebonite framework. See Spark Gap.

**GASKETS.** Name given to the insulating disks which are used to separate the discharge disks of a quenched spark gap. See Spark Gap.

**GAS RECTIFIER.** General name given to any form of valve which is only partially exhausted of its gas. See Soft Valve; Valve.

**GASSING.** Gassing is the term applied to the free liberation of oxygen and hydrogen which occurs during the final stages of accumulator charging. The chemical changes which occur during a charge are (a) the oxidation of the positive plates, and (b) the reduction of the surface of the negatives to pure spongy lead. As the charge becomes advanced, however, the ions liberated by the charging current are not fully absorbed. The result is that oxygen is freely liberated from the positives, and hydrogen from the negatives. The gases thus given off assume the form of bubbles in the electrolyte, and they rush rapidly to the surface, causing a fine acid spray to arise.

This is the action which is known as gassing. It will be realized that as gassing only becomes apparent towards the end of a charge, the process may be used as an indication as to whether a charge is nearing completion. Those experienced in accumulator charging frequently use this method, and can gauge with reasonable accuracy the condition of a cell and its state of charge by making observations upon the gases evolved.

Unfortunately, the spray which occurs is very troublesome, particularly in open storage batteries, owing to the fact that it is very acid in composition. It will attack metals, other than lead, in its immediate vicinity. For this reason it is essential that all connexions to the cells and all metalwork should be protected by substances unaffected by sulphuric acid. This may usually be done by painting with anti-sulphuric enamel or thick coatings of vaseline or other impervious substance.

It is the practice of some accumulator manufacturers to fit a number of inclined glass plates over the top of the cells in order to reduce the formation of spray. The lower edges of the plates are immersed in the acid, and as the bubbles arise they naturally impinge upon the glass. The surface of the latter being wet, the bubbles immediately burst and turn into a liquid, which runs back into the electrolyte with perfect freedom. It is always advisable for storage batteries to be housed in a room by themselves. This room should be free of metal fittings in order that no damage due to acid splashes or fumes may be caused. See Accumulator.

**GAUGE: The Tool.** The gauge is an instrument for comparing the size, form, or volume of an object with some predetermined standard, the gauge itself being made very accurately in conformity therewith. In the broad sense of the word any measuring instrument is a gauge, but as generally understood a gauge is a small implement employed for determining the relative or actual size of an object as compared with a known dimension or form. The latter is then designated the standard or master gauge, and carefully preserved for reference purposes only. Commercial gauges are as a rule manufactured within certain limits of error, and are therefore reliable. Gauges are more particularly described by prefixes which sufficiently indicate their special purposes. Examples are the pressure gauge, surface gauge, wire gauge and limit gauge. The latter indicates limits of permissible error in an object when gauged with two limit gauges, each differing slightly from the other and from the standard.

In wireless work the gauges mostly used are those for the comparison of dimensions of an object; for example, the diameter of a piece of wire. In the instructions for making up wireless sets, some such expression as "No. 20 gauge wire" or sheet metal constantly occurs. The instrument used to determine such sizes is known as a wire gauge.

There are several forms of this instrument, of which one is in the form of two circular disks of hard steel loosely joined together so that they can be opened out for convenience in working or closed up into a small compass. Each of these disks is pierced with a number of small holes slightly within the rim of the disk. The holes are connected to the outside by slots which form jaws. The distance between these jaws is the measuring dimensions, and is designated by the number placed against it, this number corresponding to that of the particular gauge system, generally the Imperial Standard Wire Gauge.

The pattern illustrated in Fig. 1 is in the form of a long, notched piece of metal which performs a similar function. To use such a gauge the tool is held in the right hand and the piece of wire or other material to be measured is inserted between the jaws, and should just fit between them. It should not be too loose a fit, nor should it have to be forced in. To

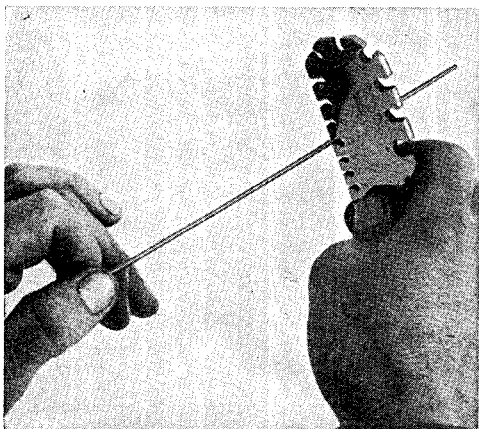

#### HOW TO USE A WIRE GAUGE

Fig. 1. Measurement is made by inserting the wire into the jaws of the gauge, the diameter is given by the number stamped next to the jaw

determine the exact size, it is best to gauge the wire in two or three different positions and try a size larger and a size smaller and to take the wire as being the intermediate size or the one into which it fits most accurately, as shown in Fig. 1.

Another form of gauge is known as a drill gauge, and is shown in Fig. 2. One form comprises a flat, hard steel plate with a series of holes drilled in it, stamped with numbers indicating the gauge number of the hole. The other pattern is similar, and is used as illustrated in the photograph, Fig. 1. In the case of gauges drilled with holes, the material to be measured should just fit in the hole, and to ensure this the end of the wire or rod must be perfectly smooth and free from any suggestions of roughness or burrs, for which reason ordinary wire should be slightly rounded off with a file so that it can slip in easily.

It is often convenient to use this type of gauge for drills and other prepared articles or tools, and to use the former pattern for wires. It should be appreciated that gauges of substantially the same appearance are used for different systems of wire gauges, such as the Birmingham, Whitworth, and S.W.G. It is therefore important to obtain the correct gauge when purchasing.

If intended for use with drills, the numbers are generally in accordance with the

Morse twist drill gauge size. Other drills are gauged according to the Stubbs gauge size, while those for continental appliances or sizes use the millimetre-sized drills and gauge of the metric system.

Screw threads are very difficult to gauge. One of the most useful instruments for this work is illustrated in Fig. 3, and is known

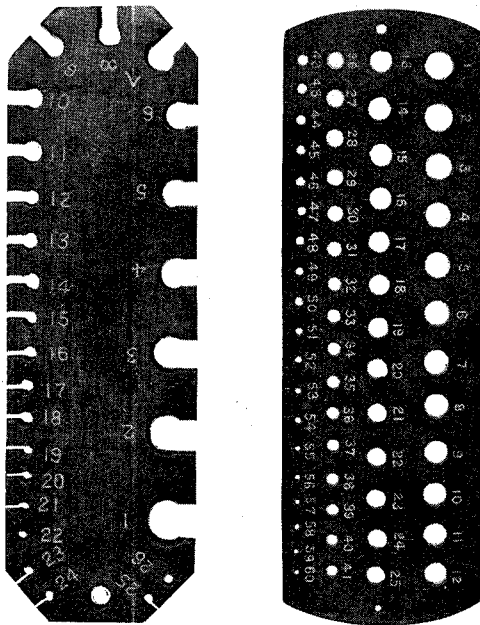

#### TYPES OF WIRE AND DRILL GAUGES

Fig. 2. Two types of gauge are shown. On the left is a wire gauge, used as in Fig. 1, and on the right is a drill gauge. Wire gauges may also be used for sheet metal

*Courtesy G. Buck*

as the Starrett screw thread gauge. Not unlike a penknife in appearance, it comprises a number of movable blades, each with a serrated edge, the serrations being

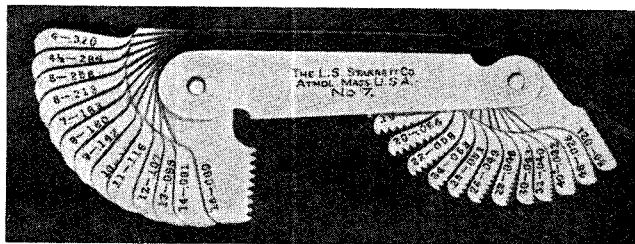

#### SCREW THREAD GAUGE

Fig. 3. Each blade has a serrated edge and each is of different pitch. The gauge of the screw is engraved on the blade of the instrument

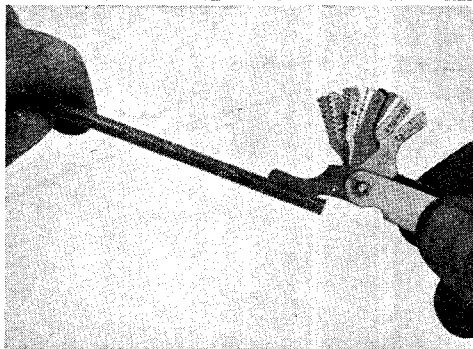

Fig. 4. How to use a screw thread gauge is shown in this photograph. The serrations must fit accurately and naturally

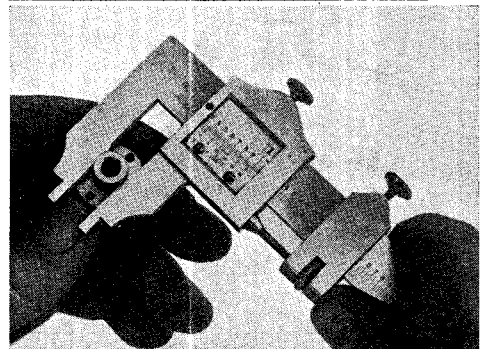
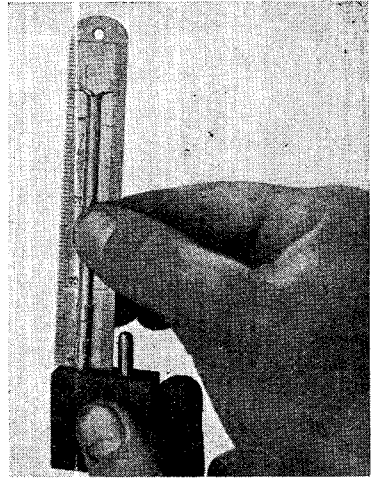
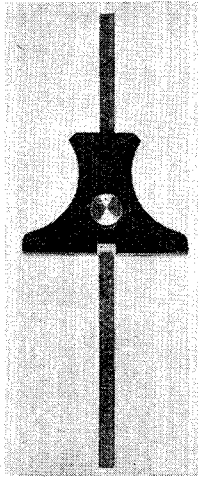
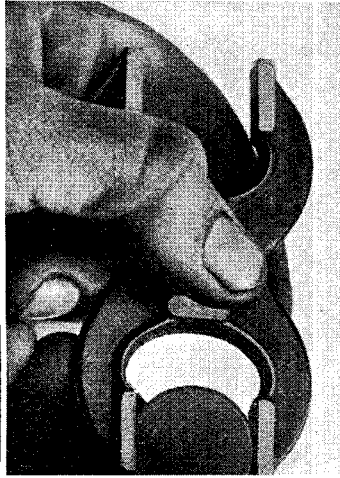
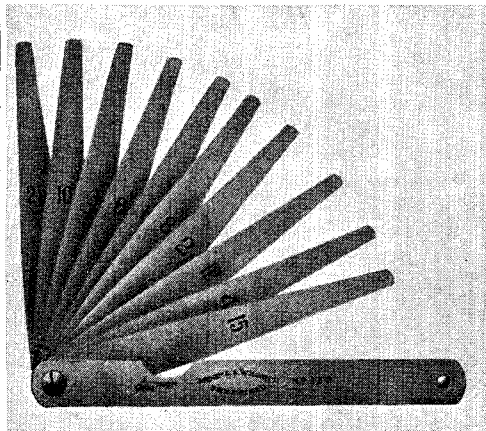

Fig. 5. Vernier caliper gauges are very precise and give fine readings. The outside measurement of a bush is being gauged



*Courtesy G. Buck*

Fig. 6 (left). Limit gauges are usually fixed. This one is seen gauging the diameter of a metal disk. Fig. 7 (centre). This is a depth gauge calibrated in inches and fractions. Fig. 8 (right). Another form of depth gauge is used for testing the sockets of coil holders and similar small holes



*Courtesy G. Buck*

Fig. 9. Feeler gauges, as in this photograph, are inserted into slits to gauge the width. Each blade is of different thickness

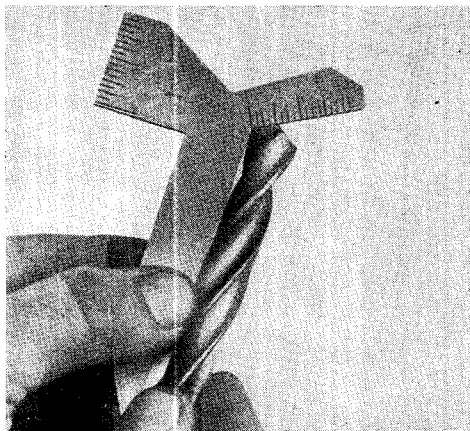

Fig. 10. Universal drill gauges are used in this way to check the cutting edge of drills, especially when the drill has been sharpened

#### TYPES OF GAUGES AND HOW TO USE THEM

accurately formed to correspond with the number of screw threads and pitch per inch for the different sizes of screw threads, such as the Whitworth, B.A., and the like.

In use, the tool is applied in the manner shown in Fig. 4, by comparing the screw threads on the rod with the serrations on the different blades, which have the numbers corresponding to the number of screw threads per inch marked upon them. When the screwed rod is screwed to its gauge size, the serrations on the gauge exactly fit into the holes between the screw threads, but if inaccurate, only the first few threads will appear to fit, the others will not drop into their places.

In such a case the next larger or smaller blade should be tried, to determine the size of the screw thread. Such gauges only measure the number of threads per inch, and are not affected by the diameter of the screwed portion.

To gauge the screw threads for the correct diameter calls for precision measuring methods, but the novice can use a piece of ordinary mild steel plate which has been drilled and tapped with good quality new taps, when the screwed rod should fit closely into the correct tapping hole. Such gauges are procurable, but can be readily made by the experimenter. They should be marked in accordance with the numbers or size of the taps used for tapping the holes.

#### Use of the Vernier Caliper Gauge

To determine the outside diameter of the screw threads, the vernier caliper gauge may be used. In this type of gauge, illustrated in Fig. 5, the blade is usually calibrated one side in inches and the other in millimetres, each system being subdivided. Mounted on the blade are one or two movable jaws, in the pattern illustrated two being used.

The first carries the measuring arm and the vernier, and the second provides a support for a knurled nut which turns upon a screw thread forming part of the movable jaw. In use, the jaws are slipped along the blade by means of pressure of the right thumb until a fairly close adjustment is obtained, as shown by taking the reading on the vernier marking and the calibrations on the blade. The second jaw is locked to the blade by tightening up the set-screw, and final adjustment imparted to the jaws by rotation of the knurled knob.

Good quality vernier gauges of this type will readily measure differences in diameter as small as  $\frac{1}{1000}$  in. The work to be gauged is held by the left hand between the jaws as shown in Fig. 5, and the moving jaw adjusted until the work is just held between them. This type of gauge can be used to determine the diameter of an object. Alternatively, the jaws of the gauge can be set to some predetermined diameter, and the piece of work turned or otherwise prepared until it just fits between them.

The instrument should be very carefully handled, kept greased when not in use, and stored in a small case or box and be kept free from dust, dirt, and any chance of damage, otherwise its measuring powers will be ruined.

#### Limit Gauge for Accurate Measurements

For accurate measurements, especially with a number of parts which have to be substantially alike in size, a limit gauge, such as that shown in use in Fig. 6, may be used. By this system a double-ended gauge, generally made of cast steel and very accurately machined, has one of its jaws made to a dimension slightly larger than the nominal, for example, 1 in. plus  $\frac{1}{1000}$  in. The other end of the gauge is made slightly smaller than the original, for example, 1 in. minus  $\frac{1}{1000}$  in., and the difference between the two is known as tolerance, or the limit of approximate error.

In use, the work is applied to the larger of the two jaws, known as the "go" jaw, or "go end," and is machined or otherwise prepared until it will go between the jaws, as is shown in Fig. 6. This ensures that its diameter does not exceed the nominal amount plus the approximate error. To ensure that the work is not too loose for the nominal plus the approximate error it is placed in the other end, which is known as the "not go," and the work should not enter this end. Therefore the work enters the "go" end but not the "not go" end, when it follows that it must fit to within a very small fraction of absolute size.

The ordinary limit gauges, made to standard tolerance, can readily be procured from any good tool dealer, and their use by the experimenter for such things as gauging the diameter of screwed rods, or making a number of parts of a uniform size, is to be recommended. The system is the basis of modern machinery

manufacturing methods, and will be found in practice to save the novice a great deal of time and trouble.

For measuring the depth of a hole, a depth gauge can be employed, of which one pattern is illustrated in Fig. 7. This comprises a movable stock which rides upon a steel block and movably fixed there by means of a set-screw. The blade is calibrated from zero, usually in inches. The amount that protrudes from the lower end of the stock, measured to the bottom of the blade, is the measuring portion, and is used by inserting the blade into the hole until the stock touches the surrounding material, thus ascertaining the depth of the hole.

To determine whether the hole is deeper than it should be the set-screw is loosened, the stock placed over the hole, and the blade pressed down with the thumb until it touches the bottom of the hole. The reading is then taken as before.

Another type of depth gauge is shown in Fig. 8, and is in the form of a 4 in. steel rule, having upon it a movable rod sliding in a socket formed towards the outer end of the rule. The upper end of the movable rod is bent over to form two pointers. One side of the rule is calibrated into inches and divided into ordinary fractions, and the other side is divided into tenths. The instrument is shown in use in Fig. 8, gauging the depth of a hole in a socket for a coil holder.

The rod is adjusted until it projects the desired amount, in this instance  $\frac{5}{8}$  in., the measurement being indicated by the pointer on the near end of the rod, the projecting portion projecting the amount indicated, and in this instance is inserted into the hole in the socket, to ascertain its depth. The use of this inexpensive tool will facilitate good and accurate work.

Another type of gauge, for measuring the thickness of a slot of small dimensions, is known as the "feeler" gauge, and is illustrated in Fig. 9. This comprises a number of movable steel blades of different thicknesses, indicated by numbers, the numbers being at thicknesses of  $\frac{1}{1000}$  in. of each blade. In use, one of the blades is tried in the slot, the blade which fits it most accurately indicating the breadth of the slot. By using a metal spacing block of known accuracy, slots wider than the total number of blades can be measured.

For example, if a slot is, say, nominally 1 in. wide and the 1 in. gauge be used,

if the block is slack, this slack can be taken up by introducing one or more of the feeler blades, the sum of the number of gauges introduced giving the number of  $\frac{1}{1000}$  in. the slot is wider than 1 in. Other gauge blocks can be used for other dimensions in the same way.

Angular gauges are often used to test the accuracy of the lip angle of twist and other drills, and a useful pattern is shown in Fig. 10, the various angles shown on the gauge being those used for measuring twist drills. The pattern illustrated is for testing the lip angle of a drill, and has a sliding arm calibrated from zero outwards,

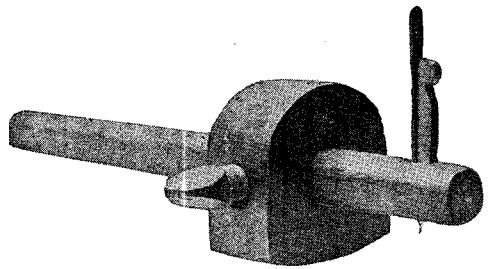

**CUTTING GAUGE FOR WOODWORK**

Fig. 11. Wireless cabinets and other woodwork call for carpenter's tools, which include a cutting gauge, as illustrated, for scribing lines

thus the length of the cutting edge can be measured. When the tool is correctly ground, both edges should be of the same angle and of the same length. The tool is sometimes known as a universal gauge, as it may be used for setting up the slide-rest tool for such purposes as screw-cutting on a lathe.

A type of gauge very useful for woodworkers is shown in Fig. 11, and is known as a cutting gauge. It comprises a hardwood handle with a movable head adjustably mounted upon it, held thereto by a thumb screw. The cutter is a fine steel blade secured in position by means of a hardwood wedge. In use the head bears against one edge of the wood, and the distance from the face of the head and the point of the cutter should be adjusted to the desired amount, when by moving the gauge over the surface of the wood the cutter will mark a line corresponding to these dimensions.

A great many other gauges are made, but those mentioned are those most used by the amateur experimenter. For measuring pressures an altogether different type of instrument is used, known as the pressure gauge. Pattern makers use

a special type of rule or measuring instrument, known as the pattern or shrinkage gauge. In this case the dimensions marked upon it are designated in the ordinary way in inches, but in effect measure a little more than the actual figures, the difference being the customary allowance for shrinkage of the pattern which the gauge is used to measure.

The capacity of a container is gauged by means of an instrument known as a water gauge, consisting essentially of two fittings connected together with a glass tube, the contents of the vessel being indicated by the height of the liquid up the tube. In other forms a float may move a pointer across a dial calibrated in gallons or other measure of capacity or volume.

Plug and ring gauges are used for determining the diameters of rods or holes. They comprise respectively a cylinder of metal of known diameter, or a ring, the bore of which is of known diameter. They are generally used on the "go" and "not go" principle, and marked accordingly.

A scribing gauge (*q.v.*) is a most useful tool used for marking out metal work.

—*E. W. Hobbs, A.I.N.A.*

See Caliper; Scribing Gauge.

**GAUGE: for Wire, etc.** Word used in several senses. In one connexion it refers to a recognized table of dimensions for the comparison and determination of the size of different articles. In wireless work the experimenter is mostly concerned with the wire gauges which are employed for the various wires used in constructional work. Of these the Imperial Standard Wire Gauge is mostly used, abbreviated to I.S.W.G., or sometimes as S.W.G., and is the only legal standard wire gauge in the British Isles.

There are several systems of wire gauge in use, including the S.W.G., the Warrington, Birmingham, Stubbs, and Whitworth wire gauge. Most of them vary from one another slightly, and this sometimes leads to confusion, consequently it is very necessary to be certain which gauge is referred to when ordering material or making calculations. American wire gauges are principally the B. and S., or Browne and Sharpe, also known as the American wire gauge.

The steel wire gauge is based on the gauge sizes of the American Steel and Wire Co., and recommended by the Bureau of Standards at Washington for general adoption in America. In their practice

steel wire is gauged by the steel wire gauge, and copper and brass wires by the B. and S. gauge.

There are some differences between the sizes of corresponding gauge-numbers in all the gauge systems, and these are given in any engineering textbook. When comparing the gauge sizes of wire used, for example, in an inductance as mentioned in American books, it is important to remember the differences with British practice.

With all of these systems the gauge sizes are designated by numbers, the larger diameters commencing from .000,000 to 0, then 1 up to 50, on the usual systems; the higher numbers indicate the thinner wires. The Stubbs gauge sizes rise from 1 to 80, which has a diameter of .013 in. In the Birmingham wire gauge the diameters of the wires differ by so many mils, or thousandths of an inch, as is the case with the Whitworth wire gauge.

Many drills are designated by letter or gauge numbers, and these generally have reference to the makers' dimensions. Of these the "Morse" and "letter drill" sizes are mostly in use.

There are other wire gauges in use, as, for example, for piano wire, a strong steel wire occasionally used for the stays of aerial masts and spreaders. The experimenter is, however, mostly concerned with the I.S.W.G. sizes, as these are used for the insulated wires customarily employed in wireless work. The gauge size refers to the diameter of the wire, and not to the outside size of the insulation. Sheet metal in the smaller sizes is sold according to the same gauge size up to about No. 7, and in larger sizes from  $\frac{1}{8}$  in. upwards by the fractional size, or thickness in inches, or fractions of an inch.

Pipes and tubes are sold by the diameter and a gauge size. For example,  $\frac{1}{2}$  in. diameter No. 16 gauge meaning that the outside diameter is  $\frac{1}{2}$  in. and the thickness of the metal No. 16 gauge by the I.S.W.G. system. See Copper Wire; Wire.

**GAUSS.** Name given to the unit of magnetic force or the intensity of a magnetic field in the C.G.S. system of units. See Units.

**GECOPHONE.** Trade name adapted by the General Electric Co., and applied to an extensive range of wireless apparatus, ranging from small components to complete receiving sets. The crystal set illustrated in Fig. 2 is an example of a complete



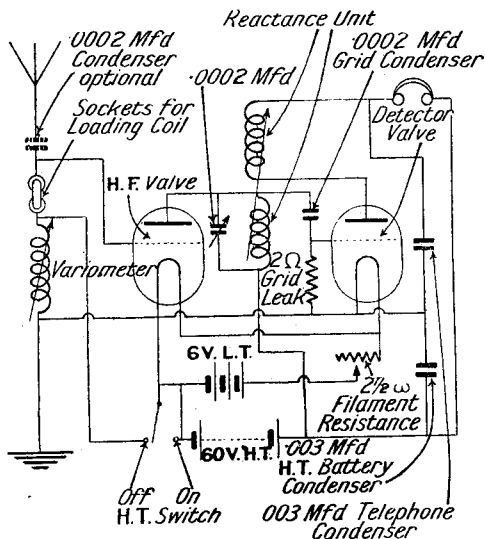

**GECOPHONE CIRCUIT DIAGRAM**

Fig. 1. Capacities and components are given in this circuit diagram of the Gecophone two-valve set self-contained appliance suitable for all broadcast reception when reasonably close to a broadcasting station. The internal arrangements are shown in Fig. 3, and comprise an inductance, variometer and variable air condenser, tuning being effected with the latter, together with the usual fixed

condenser, and plug-in connexions for the telephones and the aerial and earth leads.

The two-valve set illustrated in Fig. 4 shows the appearance with the cabinet open to reveal the position of the two valves and the controls. The low-tension battery is shown on the left, and high-tension battery and telephones on the right. Fig. 5 is a back view of the same set, and shows the plug-in connexions and

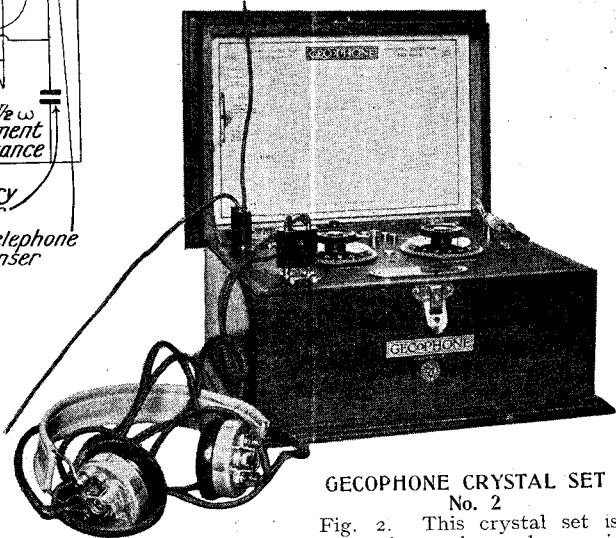

**GECOPHONE CRYSTAL SET No. 2**

Fig. 2. This crystal set is tuned by means of a vario-coupler and a variable condenser. Note the special plug-in telephone lead and aerial and earth leads

*Courtesy General Electric Co., Ltd*

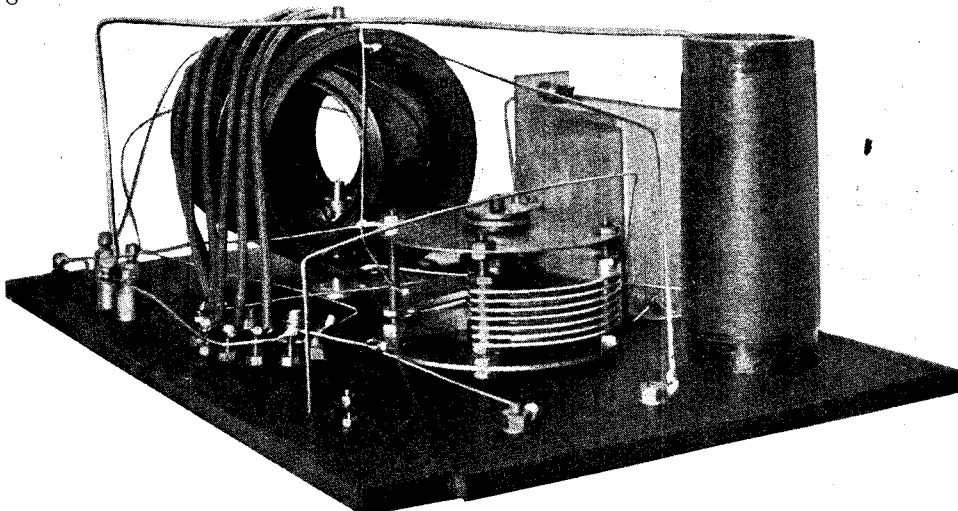

**INTERIOR OF GECOPHONE CRYSTAL SET No. 2**

Fig. 3. Underneath the panel of the Gecophone crystal set in Fig. 2 are the components shown in the above photograph. The vario-coupler and tuning condenser can be seen. Note how the tappings of the stator of the vario-coupler are closely sleeved from the coil to the switch studs

*Courtesy General Electric Co., Ltd.*



Fig. 4. Two valves are employed in this set. On the left is the low-tension battery and on the right the high-tension battery, together with a compartment for the telephones

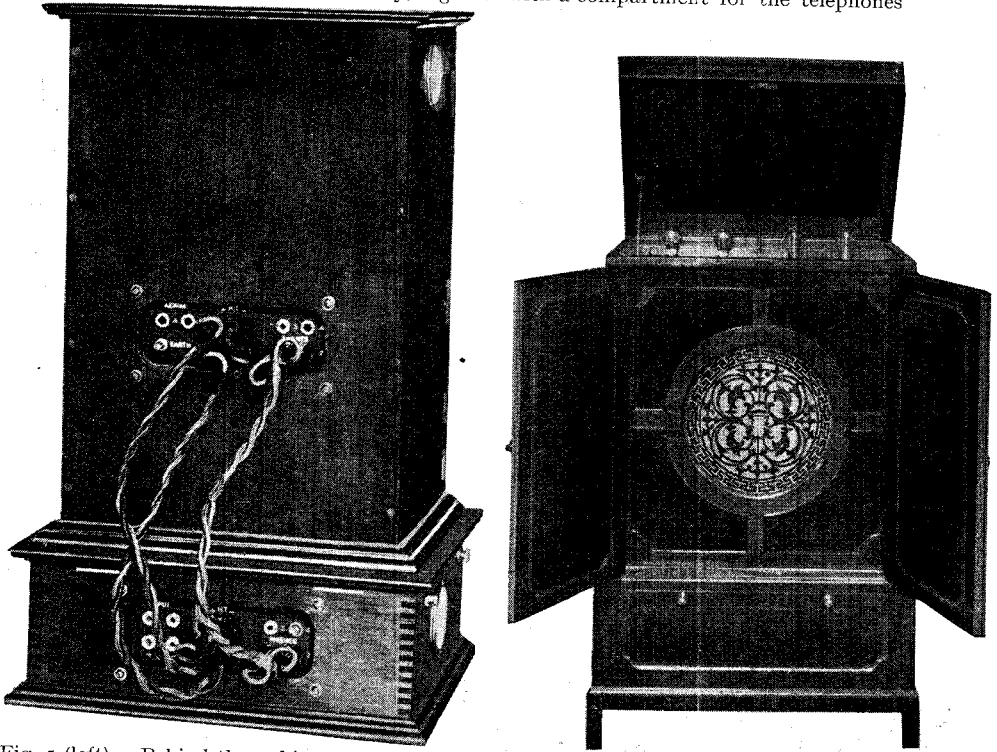

Fig. 5 (left). Behind the cabinet seen in Fig. 4 the connexions, which are all of the plug-in type, can be seen. This set has a range of about 100 miles. Fig. 6 (right). A four-valve cabinet set, a handsome piece of furniture. It has a longer range than the set in Fig. 5, and is worked with a loud speaker

*Courtesy General Electric Co., Ltd.*

#### GECOPHONE CABINET VALVE RECEIVING SETS

also the sockets for aerial and earth connexions and telephones. This set has a normal range of about 100 miles, but under suitable conditions stations at a greater distance will be heard.

A larger set, with a greater range and

power, intended chiefly for use in reception-rooms, is illustrated in Fig. 6, which shows a standard four-valve receiving set of the cabinet variety. The circular ornamental front masks the flare of a loud speaker, and when not in use the

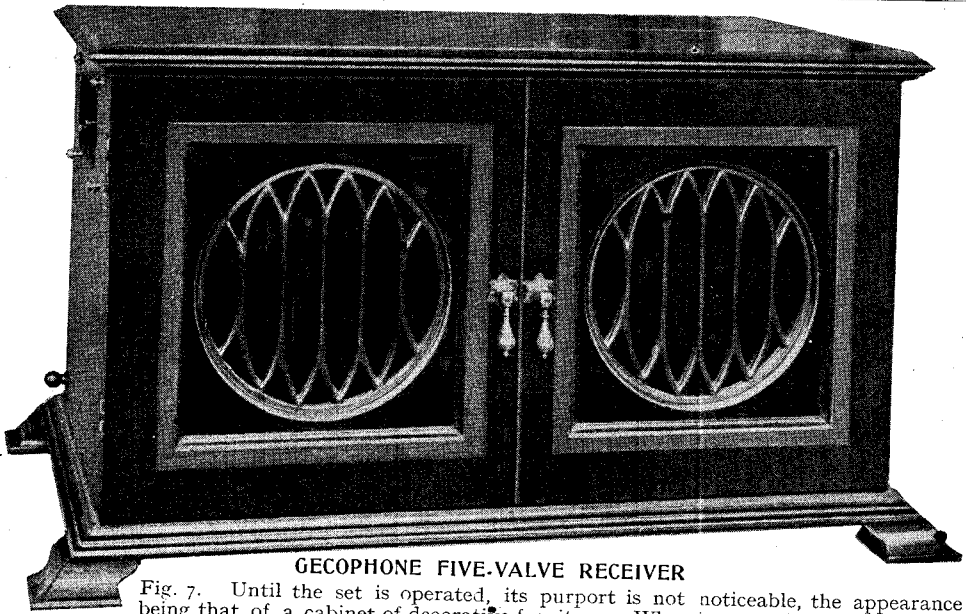

**GECOPHONE FIVE-VALVE RECEIVER**

Fig. 7. Until the set is operated, its purport is not noticeable, the appearance being that of a cabinet of decorative furniture. When in operation the doors may be kept closed

*Courtesy General Electric Co., Ltd.*

hinged doors are closed. The lid is arranged to open to provide access to the valves and controls.

A back view of the same set is shown in Fig. 9, which clearly illustrates the dis-

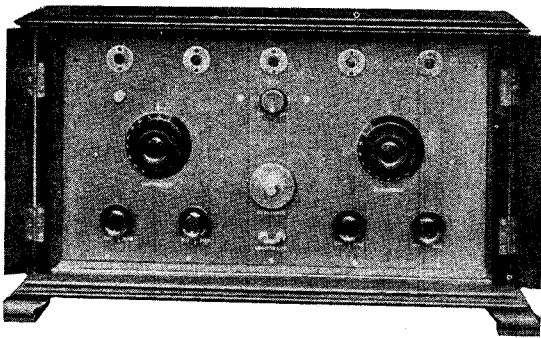

position of the batteries and the loud-speaker trumpet. Another fine table set is illustrated in Figs. 7 and 8. This is a standard five-valve Gecophone receiving set. When closed, it presents the appearance of an ornamental casket. In use, the two doors are opened, the desired station tuned in, and, if preferred, the doors may again be closed. Tuning is effected by means of a variometer and condenser. The valves are located within the panel, and inspection of the filament brightness is possible through the peepholes provided for that purpose in the upper part of the panel.

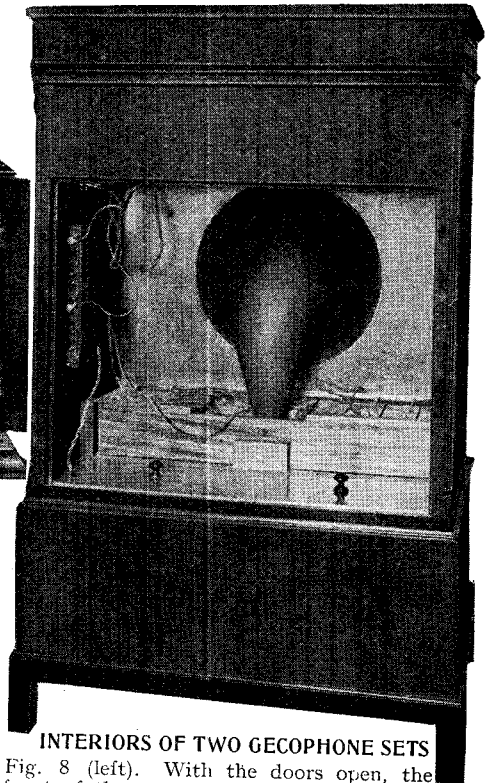

**INTERIORS OF TWO GECOPHONE SETS**

Fig. 8 (left). With the doors open, the front of the set in Fig. 7 appears as in this photograph. Fig. 9 (above). Behind the set in Fig. 6 the loud speaker can be seen. In this set the top is raised to examine the valves

*Courtesy General Electric Co., Ltd.*

**GEISSLER TUBE.** The luminous effects of electrical discharge may best be observed in air or gases which have been rarefied, and for this purpose Geissler tubes, so named after their investigator, furnish a convenient means of studying such phenomena, particularly in partial vacua. Hermetically sealed glass tubes blown into various shapes with a bulbous portion at each end constitute the most usual form. The potential required to operate them may be supplied from an influence machine or an induction coil, and is applied to two platinum electrodes fused into the glass at two points.

A tube containing air at ordinary pressure exhibits no unusual phenomena, a stream of sparks passing between the two electrodes, provided they are subjected to sufficiently high potential difference. Where, however, the air is exhausted to a certain degree the whole tube presents a luminous appearance, a glow of violet-blue light being exhibited at the

The intensity of the light is greatest in constricted portions of the tubes, and provides good opportunities for spectrum analysis. The discharge is susceptible to the presence of external conductors and magnets, and may be caused to alter its position and form inside the tube.

These tubes are sold commercially in multitudinous variety, apparently only limited in design by the skill and inventive genius of the glass blower, and one is shown in the photograph. They are filled with different gases at various pressures, in which beautiful optical effects are capable of being produced. Rarefied nitrogen gives rise to a cathode light of pale blue and an anode brush of red or rosy tint. In hydrogen the negative electrode exhibits the discharge as a blue light, which becomes crimson in constricted portions of the tube. The composition of the electrodes may further modify the colour scheme, the heat generated, particularly at the cathode,

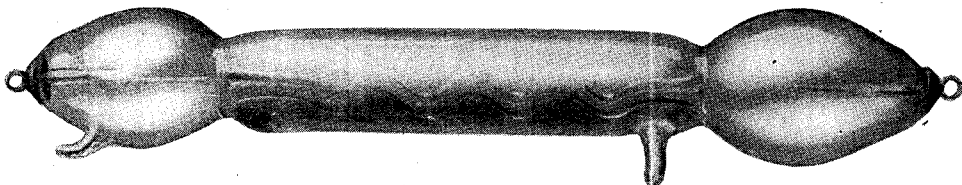

**GEISSLER TUBE FOR OBSERVING ELECTRICAL DISCHARGE**

Various shapes of Geissler tubes are used to study the effects of electrical discharge through air or gases which have been rarefied. The current passes through the two platinum electrodes seen at the ends of the tube

*Courtesy Economic Electric Co., Ltd.*

cathode or negative electrode, while a kind of brush discharge in the form of a bright star of light is observed at the anode or positive electrode.

The glow at the cathode is not immediately contiguous to it, but is separated by a narrow dark space which increases in width with further exhaustion, and in exceedingly high vacua this dark space completely fills the tube. A perfect vacuum is nearly a perfect insulator, so that no discharge can take place in it. At other degrees of rarefaction the luminosity ceases to be uniform, and is broken up into curved patches or layers, called striae, which vibrate backwards and forwards, presenting their concave surface to the anode and the convex portion to the cathode. These striae increase in number up to a certain stage of exhaustion, after which, if the pressure is still further decreased, they become thicker but fewer in number.

being on occasions sufficient to volatilize a portion of the metal composing them.

Advantage is taken of the fact that the rays of light emitted are productive of fluorescence and phosphorescence to provide a further variety of luminous effects. Fluorescence is the absorption of light of certain colours and its radiation in another form. Phosphorescence is the self-luminosity of certain substances which is retained after the exciting cause has been removed.

Compound tubes, constructed with an outer jacket filled with a solution of quinine, or a simple tube of uranium glass, may be used to evoke the characteristic pale blue fluorescence of the former and the green effects of the latter. The phenomena of phosphorescence require a higher degree of rarefaction than usual, and at certain stages the glass walls of the tubes themselves acquire this property. Sulphides of barium, calcium and strontium are particularly useful in this respect.

**GELL KEYBOARD.** Apparatus used in high-speed wireless transmission and reception. In general appearance it resembles an ordinary typewriter and punches a perforated strip of paper which

is afterwards passed through a Wheatstone automatic transmitter. The Gell keyboard is fitted on many of the bigger ships for high-speed work, and enables an operator to deal with 240 words a minute.

## GENERATORS FOR TRANSMISSION & OTHER PURPOSES

By A. H. Avery, A.M.I.E.E.

Here are described the principles and uses of generators of all kinds, whether direct current dynamos or alternators, with particular reference to their use in radio communication. The amateur transmitter is told how to use a direct current generator in place of a high-tension plate battery. See also Alternator ; Disk Discharger ; Dynamo, etc.

Electric generators, in the ordinary significance of the term, are power-driven machines wherein the rotation of a system of conductors by mechanical means in an intense magnetic field sets up an electro-motive force of either a direct or alternating nature. In the one case they are termed direct or continuous current dynamos, or simply D.C. machines, and in the other they are known as alternating current generators, A.C. generators, or simply alternators. The underlying principles of both machines are the same, but the design and construction varies so much in different requirements as to be scarcely recognizable at times.

There are still other types of machines and appliances which also come under the rather loosely applied term of generators, but these are intended for high-frequency continuous-wave signalling, and can be omitted from the present consideration, as they are treated under their respective headings specially. Such apparatus includes the Poulsen arc, special high-frequency alternators, synchronized spark-trains, and oscillating valves.

Except for very small transmitting sets and emergency equipment generally, the power for a radio set is obtained from a generator of either the continuous or alternating current type. The employment of high-tension batteries for the plate-voltage supply of transmitting valves, although very convenient, has certain drawbacks. Not only are the batteries expensive in the first instance, but they require frequent renewals, which are not always easy to procure in isolated places, and they are greatly affected by climatic conditions.

Fig. 1 shows how a plate battery may be replaced by a high-tension direct current generator, G, which is shunted by a condenser, C, of one to two

microfarads capacity, in order to wipe out any inequalities or voltage ripple in the supply current to the valve which would cause noises in the telephone at the receiving station. This ripple is caused by slight pulsations in the voltage arising as the commutator segments pass under the collecting brushes, the frequency of which may be about 1,000 cycles per second, and although very small, amounting perhaps to not more than one per cent in a well-designed machine, they have an appreciable effect in reception unless smoothed out. This ripple effect is a constantly recurring trouble which must be compensated for in some such way as this.

It will be noticed in this diagram that a fixed battery voltage is applied to the grid. Two methods of adjustment are possible in order to bring the valve to the required working position of its "characteristic"; one is to alter the filament current, which shifts the position of the top bend of the characteristic, but leaves the lower bend

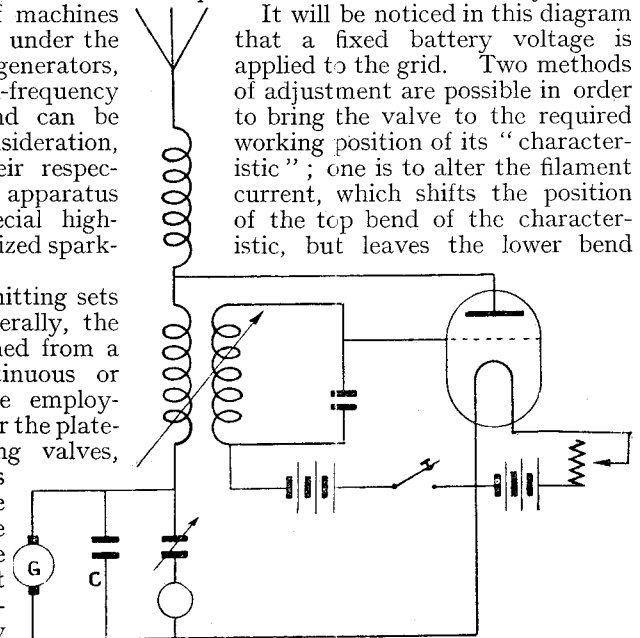

GENERATOR IN PLACE OF PLATE BATTERY

Fig. 1. Instead of using a plate battery the arrangement as shown in the above circuit makes use of a high-tension direct current generator

practically unaltered, and the other method is to alter the plate voltage, which shifts the characteristic bodily without altering its shape.

The use of alternating current supply is shown in its application to a wireless telephone transmitting circuit in Fig. 2. Here the alternator, G, supplies current to the primary, P, of a static transformer, which can be conveniently drawn upon for a multiplicity of purposes. Thus the secondary winding, S, provides a low-tension heating current for the filament of a rectifying valve, R, having two electrodes.

A high-tension secondary winding, S, having one of its ends earthed, supplies a potential of 6,000 to 9,000 volts to the plate of the rectifying valve, R, and on completing this circuit a rectified current passes between the plate and the filament. At O is represented the oscillating three-

electrode valve, the plate-filament circuit being directly in series with the plate and filament of the rectifying valve, R; but the current in flowing from one to the other has to pass through a series of inductance coil and condenser combinations,  $L_1, C_1$ , and  $L_2, C_2$ , etc., which have the effect of filtering or wiping out the fluctuations in the current supply.

A fourth coil,  $S_2$ , on the transformer core supplies heating current for the filament of the oscillating valve, and one end of this circuit, as well as one end of the high-potential circuit, is earthed. The only battery in the complete transmitting circuit therefore is the one shown at B, which supplies the microphone.

In general it may be stated briefly that the distinguishing feature between a direct current and an alternating current generator is that the former is provided with a "commutator," which is a series of metal contacts arranged in cylindrical form upon which the brushes which collect the current press, whereas the latter has "slip-rings" or continuous unbroken metal rings and brushes for the same purpose. Every dynamo is really an alternator in the first place, in that it generates alternating electro-motive force in its windings when at work, but in the one case these alternating directions of current are commuted or rendered unidirectional by the action of the commutator, whilst in the other case they are left to pulsate naturally to and fro, and are collected at the slip-rings as alternating current.

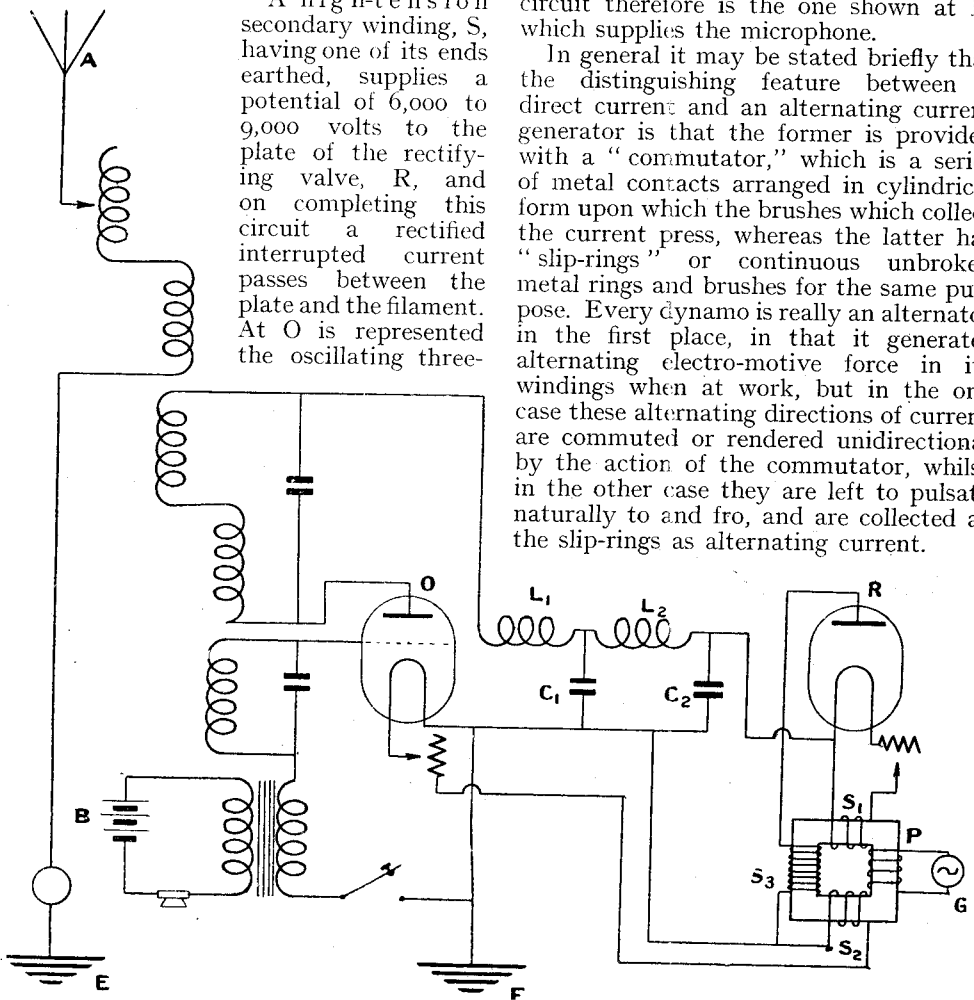

ALTERNATING CURRENT GENERATOR IN TRANSMITTING CIRCUIT

Fig. 2. Current is supplied from G, which is the generator, to a static transformer, the low-tension current being drawn from the secondary winding to supply the two-electrode rectifying valve, R. Oscillations are set up by a three-electrode valve, O, the filament circuit of which is in direct series with the plate and filament of the rectifier

Whether alternating or continuous, the machine does not actually generate current. What it does is to generate a potential difference, either in one or both directions, at its terminals, whereby a direct or alternating current is enabled to flow from one to the other when the external circuit is closed in a suitable manner.

The current is the result of an applied potential difference to a conducting circuit, and it is the function of the generator to maintain this potential difference, whatever the value of the current flowing may be, according to the circuit conditions prevailing at the time. The origin of this potential difference lies in the electromagnetic reaction between a revolving electric circuit and a magnetic field, or vice versa, and the extent of the potential generated is a function of the number of conductors, strength of field, and speed of rotation; the current-carrying capacity of the machine, however, is determined solely by the cross-sectional area of the

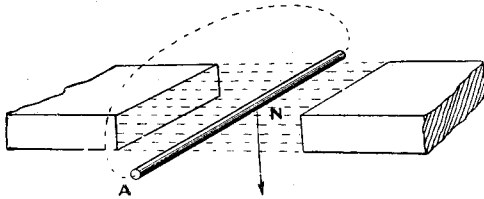

**ELECTRO-MOTIVE FORCE IN A GENERATOR**

Fig. 3. Generation of potential difference between the ends of a conductor moving through a magnetic field is shown in this diagram

conductors and their specific conductivity, and has nothing to do with either speed, flux, or number.

A dynamo may be generating its full voltage, and yet be delivering no current at all by virtue of the external circuit being discontinuous; and although by convention dynamos are universally referred to as direct current and alternating current generators, it would be more correct that they should be designated alternating or direct voltage generators.

The laws which govern the production of an electro-motive force in any generator may be briefly stated as follows: Any conducting body, such as the wire A in Fig. 3, if moved across an intense magnetic field, N, at a good speed, will experience an inductive effect, causing a difference of potential between its two ends.

So long as the circuit remains incomplete no power is taken up in moving the

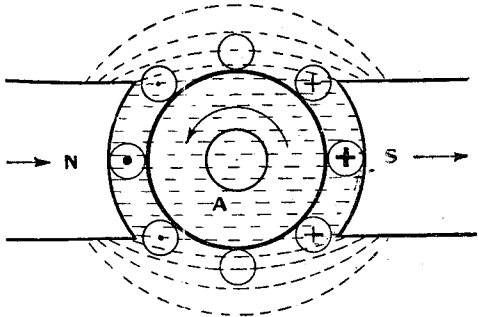

**ARMATURE ROTATING IN MAGNETIC FIELD**

Fig. 4. This diagram shows how an armature and surface conductors rotate in a magnetic field

conductor, except the ordinary frictional losses and air resistance; but if a circuit is made by joining the two ends of this wire, as shown by dotted lines, current will immediately begin to flow, and will continue flowing so long as the motion and the magnetic field are maintained.

According to well-known laws of electromagnetic induction the direction of current along the circuit will be such as to tend to oppose the motion which gives it being, hence resistance to movement will be felt and power will be absorbed in creating it. This is partly the reason that a dynamo takes mechanical power to drive it. Whether the conductor is moving and the magnetic field stationary, or the conductor is at rest and the field moving, makes no difference in the result, so long as there is the same relative movement between the two.

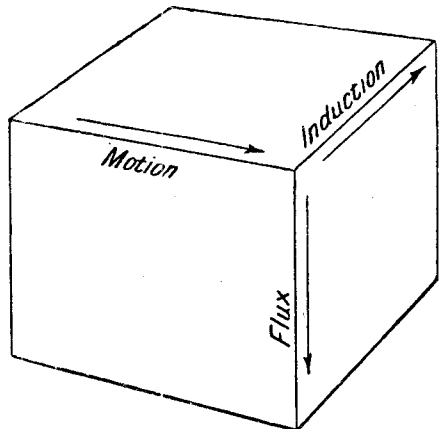

**DIRECTION OF MAGNETIC FLUX**

Fig. 5. This diagram represents the relationship between flux, motion and induced electro-motive force in a generator

The converse of this simple fact also holds true: an electric motor derives its power from the reaction between the current supplied to its armature conductors and the magnetic field under whose influence they lie; the conversion from mechanical to electric and from electric to mechanical power is thus interchangeable.

In practice the field of a generator is provided by the electrically excited magnets, the driving power is provided by an engine or other prime mover, and the electric circuit takes the form of a system of conductors wound upon an iron core termed the armature. In its simplest form all this is illustrated by the diagram in Fig. 4.

As the motion imparted to the electric circuit is usually one of rotation, the natural shape for it to assume is the circular form represented at A. The relationship existing between flux, motion, and electro-motive force is best exemplified by reference to Fig. 5, after which reference can again be made to Fig. 4 in seeking an explanation of the changes in condition which each conductor on the rotating armature encounters during its orbit. In Fig. 5 is represented a box, any three sides of which meet at one corner, forming three co-ordinate axes, each one at right angles with the other two. If these three axes are respectively associated with ideas of motion, flux direction, and induced electro-motive force, a mental picture can always be recalled of the

actual effects taking place in any moving conductor which comes under the influence of a magnetic field, such as the armature in Fig. 4.

For instance, the direction of the magnetic flux from the poles N and S is indicated by the straight arrows—that is, it leaves the north pole and enters the south. The direction of the arrow on the cube in Fig. 5 representing flux is then brought into correspondence with this by turning the diagram round. At the same time the motion of the conductor under consideration is made to correspond with the axis representing motion on the cube, and when these two functions have been brought into agreement the third and unknown quantity is at once given by the axis representing induction in Fig. 5.

Since the first two axes are parallel with the plane of the paper and the last axis is at right angles, it is customary to indicate the "up" or "down" direction by either a dot or a cross in the section of the conductor, representing the point of an arrow coming towards the observer, or its retreating tail, according to the circumstances of the case. Assuming the conditions of flux and motion to be as shown in Fig. 4, the changes that will be undergone by any conductor during its course around one complete revolution will be indicated by the dots and crosses indicated.

It will be noticed that there are two positions in which the conductor is unmarked, indicating the absence of any inductive effects when in such relation to the field flux that it is "sliding" along the lines of force momentarily before it commences to cross their path. In other

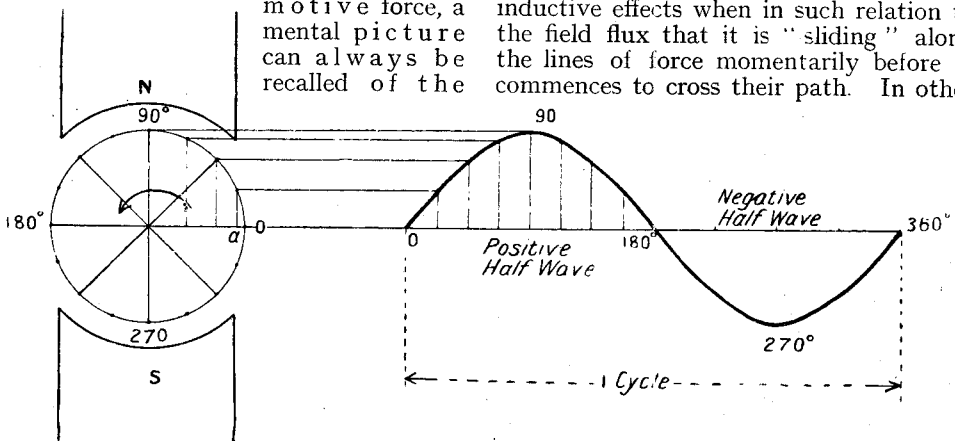

RISE AND FALL OF POTENTIAL IN A CONDUCTOR

Fig. 6 On the left of the diagram is a rotating armature between two pole pieces, N, S, and on the right is the curve which is produced as a record of the rise and fall of potential. From zero it will be seen that in one quarter of a cycle the curve has reached 90°, and at three-quarters of a cycle the curve declines to a point of equal amount in the opposite direction, the first half of the cycle representing the positive half-wave and the second half-cycle the negative half-wave



words, in order that there may be an induced electro-motive force it is necessary that the conductor should cross the field at an angle, and the less acute the angle the greater will be the induced electro-motive force for a given strength of field and length of conductor. It naturally follows that the electro-motive force in any conductor will vary not only in direction, but in extent according to its momentary position in the field; in fact, the generation of electro-motive force follows the sine law when rotating in an evenly distributed field at a steady rate of motion.

In Fig. 6 a succession of points is plotted out in graph form illustrating the growth and decay of electro-motive force in any single conductor during one revolution of 360 degrees in a two-pole magnetic field. On the left-hand side of the figure is a diagram of the armature; with the conductor *a* shown at successive stages of rotation. On the right-hand side of the figure the circumference of the circle is developed into a straight line, and the successive sine values corresponding to each stage of angular progression are plotted out as ordinates.

#### How E.M.F. Grows in a Magnetic Field

Starting at zero, the growth of electro-motive force continues until a point is reached where the conductor is cutting the field at the most rapid rate, that is, at 90 degrees; from this point onward the rate of cutting diminishes, until at 180 degrees it is sliding along the field for the moment, and, consequently, the induction falls to zero value. A moment after the conductor emerges into a new position and commences to cut the field once more, but this time in the reverse direction; consequently, the direction of the induced electro-motive force is also reversed, grows to maximum, and then dies away as in the previous half-rotation. Having arrived at the starting point, or 360 degrees, one "cycle" of operations has been accomplished, and successive revolutions merely give rise to the same set of operations repeated in an exactly similar manner.

The sine curve obtained by this construction serves to illustrate the theory of alternating electro-motive force as generated by a good modern alternator, but the actual wave shape is liable to be distorted by conditions in the external circuit giving rise to harmonics or ripples. In dealing with alternating values, whether

of electro-motive force or current, it is the "virtual" or "mean," or "root-mean-square" values that are of importance.

Since the instantaneous values of volts or amperes are continually changing according to the angle of rotation that has been traversed with regard to the zero point, it is obvious that the mean or effective values will be less than the maximum points on the curve of sines in Fig. 6. When these harmonic variations follow the true sine law it can be shown that the effective value is only .707 times the maximum or peak value of the wave; or, to put it another way, the reciprocal of this (1.415) represents the required peak value to give a mean effective value of 100. If, an alternator is giving a reading of 100 mean volts, therefore, the maximum value of the peak electro-motive force, if it follows the sine law, will be 141.5 volts. If, on the other hand, the peak value is only 100 volts, the mean value will be 70.7 volts.

The output of a direct current generator is reckoned in watts—that is, volts multiplied by amperes. That of an alternating current generator must be measured in volt-amperes, which is not quite the same thing, since, in pulsating currents, the two-power components, volts and amperes, may not be "in step"; the wave of current may lag behind the voltage wave if there is self-induction in the circuit, or it may even be in advance of the electro-motive force wave if there is capacity present.

#### Essential Parts of a Generator

The only true power conveyed is when the volts and amperes are joining forces, so to speak, and acting in the same direction. If one wave is growing while the other is decreasing, a point will come when one wave reverses its direction in respect of the other and power is lost to the outer circuit, though still absorbed by the engine or prime mover. The theory of alternating current phenomena is dealt with under the headings Alternating Current and Alternator. It is necessary, therefore, to turn to the more practical details of construction, with representative examples.

The essential and important parts of any generator are: 1, the field magnet, which provides the magnetic flux; 2, the armature carrying the system of conductors wherein the electro-motive force is generated; 3, and the collecting gear,

which collects and transmits the current. Item 1 comprises a frame or casing containing the field magnet poles excited by current-carrying coils of wire, and the end frames or brackets, with bearings for the armature shaft.

Item 2 includes a laminated iron core of circular section, generally provided with

Item 3 consists of an assembly of "brushes," usually of carbon, which are kept in close contact, by spring pressure, with the commutator or collector rings. In the former case they would be usually mounted on a rocking arm, in order that the exact point of contact may be adjusted for purposes of "commutation" or sparkless collection of the current.

Generators may be constructed with rotating armatures and stationary field magnets, or the reverse; so long as there is relative motion between the magnetic field and the system of conductors, the choice between the two methods is merely one of mechanical design.

There are even cases where both field and armature are stationary and the field flux is caused to oscillate across the armature system by means of a revolving "inductor," which takes the form of an iron star-shaped element which alternately screens and exposes the conductors from the influence of the flux during its rotation. In the case of very high speed machines this method is the only one to adopt.

In general, it may be said that the field magnets of a direct current generator remain stationary, while the armature revolves. In alternating current generators the opposite is frequently

the case, since alternators are generally used for the production of very much higher voltages than are customary for direct current work, hence it is easier to insulate them efficiently when the coils are stationary than otherwise. The terms "rotor" and "stator" are generally employed to indicate the revolving and stationary parts of an alternating

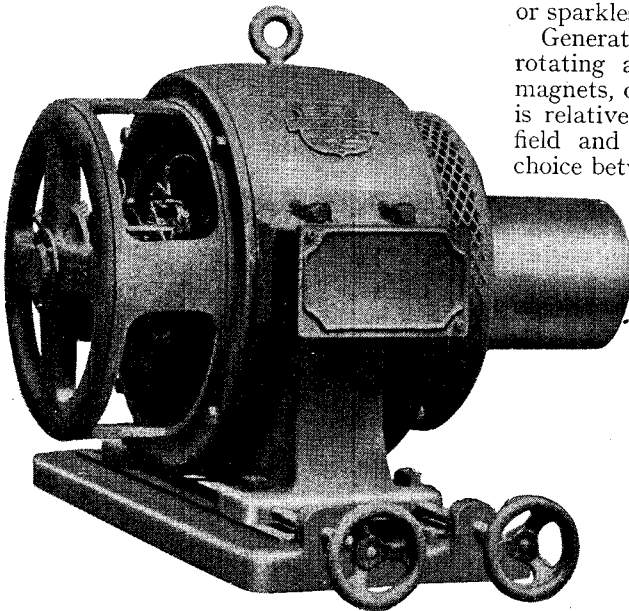

**DIRECT CURRENT 3 KW. GENERATOR**

Fig. 7. This is a direct current generator of the multipolar type. The yoke or frame of all modern multipolar generators is circular in outline. A large eyebolt is usually attached at the top of the frame as in this case, for the purpose of lifting the generator into position

slots in which are embedded the insulated copper conductors carrying current to the collector rings in the case of an alternator, or to the commutator in the case of a direct current generator. These are mounted rigidly on a steel shaft which runs in bearings of either the self-oiling or ball-bearing type, supported by the end frames on the field-magnet casing.

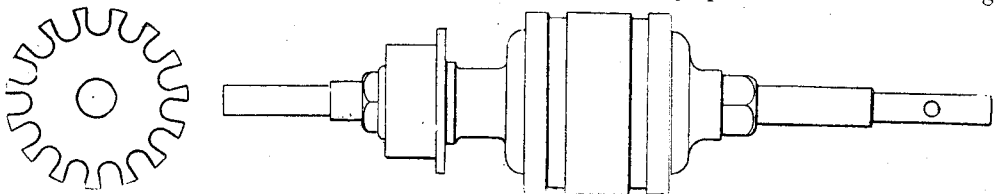

**ARMATURE CORE AND COMMUTATOR. WITH END VIEW OF DISK**

Fig. 8. Mounted on the shaft is the armature core complete, with its commutator. This diagram gives the position in sequence of the various components. On the left is an end view of the armature core disk without the other parts. Armature disks are not always of this design, and several other patterns are illustrated on p. 1025

# CONTENTS OF PARTS 1—10

OF

## Harmsworth's Wireless Encyclopedia

*This list of the more important articles which appear in back numbers of "Harmsworth's Wireless Encyclopedia" is published for the convenience of readers who may wish to refer to particular subjects. It also shows the comprehensive nature of the work and gives an indication of its outstanding value to both amateur and experimenter as the only encyclopedic work of reference in an entirely new science.*

*The first 10 parts of the "Wireless Encyclopedia" here listed include the striking total of nearly 750 articles and 2,000 photographs and diagrams, all of which have been specially prepared for the "Wireless Encyclopedia" and are now published for the first time.*

### Part 1

- WIRELESS AND OTHER WAVES  
By Sir Oliver Lodge, F.R.S., D.Sc.  
WIRELESS THEORY FOR AMATEURS  
By Dr. J. A. Fleming, F.R.S.  
RADIO WONDERS OF THE FUTURE  
By Dr. N. W. McLachlan  
ACCUMULATORS: CHOICE, CHARGING & REPAIR  
with 36 photos and diagrams  
AERIALS: TYPES, THEORY & CONSTRUCTION  
with 50 photos and diagrams, and photogravure plate

### Part 2

- AMPLIFIERS: PURPOSES & CONSTRUCTION  
with 51 photos and diagrams, and photogravure plate  
ANODE CIRCUIT: PRINCIPLES & COMPONENTS  
with 20 illustrations  
ANTI-CAPACITY SWITCHES: HOW TO MAKE  
with 15 illustrations  
ARMSTRONG CIRCUITS & RECEIVERS  
with 27 illustrations

### Part 3

- AUDIO-FREQUENCY TRANSFORMERS  
with 15 illustrations  
BANK-WOUND COILS: HOW TO WIND  
illustrated by "action" photographs  
BASKET COILS, FORMERS & HOLDERS  
with 37 photos and a photogravure plate  
BATTERIES & BATTERY SWITCHES  
with 18 illustrations

### Part 4

- BOX MAST: HOW TO MAKE  
with 8 "action" photographs  
BROADCASTING: PRINCIPLES & PROBLEMS  
by Richard Twelvetrees and Captain P. P. Eckersley  
with large broadcasting map in three colours  
CABINETS FOR WIRELESS SETS  
with 67 new "action" photos and diagrams  
CALL SIGNS: PUBLIC & AMATEUR  
comprehensive lists covering the world's important stations and British amateur transmitters

### Part 5

- CAPACITY: THEORY & CALCULATION  
a series of 6 important articles  
CHARGING BOARDS: HOW TO USE AND MAKE  
with 12 photos and diagrams  
CIRCUITS: THE FUNDAMENTAL PRINCIPLES  
explanations of the general systems for transmission and reception  
COCKADAY CIRCUIT: A REMARKABLE RECEIVER  
with 13 photographs and diagrams  
COILS: TYPES, USES & THEORY  
with 16 photos and diagrams

### Part 6

- COILS: HOW TO MAKE & WIND  
with 43 photos, including a three-folder plate  
COIL HOLDERS: USES & CONSTRUCTION  
with 24 photographs  
CONDENSERS: THEORY & CONSTRUCTION  
with 74 photos and diagrams, and a photogravure plate  
CONTROL BY WIRELESS  
by Major Raymond Phillips, I.O.M.

### Part 7

- Special "Crystal" Number  
CRYSTALS: TYPES & HOW TO USE THEM  
CRYSTAL CIRCUITS: PRINCIPLES & PRACTICE  
with 14 diagrams  
CRYSTAL DETECTORS: THE BEST TYPES  
with 21 photographs  
CRYSTAL DETECTOR UNIT  
with 6 illustrations  
CRYSTAL RECEIVERS: (1) STANDARD SETS & THEIR USE  
with 14 photographs  
CRYSTAL RECEIVERS: (2) HOW TO MAKE SIMPLE SETS  
with 66 "how-to-make" photographs  
CRYSTAL RECEIVERS: (3) ADDING AMPLIFYING VALVES  
with 30 illustrations, including three-fold plate in full colours

### Part 8

- DEAD-END SWITCH: HOW TO MAKE  
with 10 photos  
DETECTOR PANELS & DETECTOR UNITS  
with 30 illustrations, including plate in photogravure  
DIRECTIONAL WIRELESS  
with 20 special photographs and diagrams  
DISK CONDENSER  
with 10 new photographs  
DISTORTION PROBLEMS IN RADIO RECEPTION

### Part 9

- DRILLS & DRILLING  
with 18 photos  
DUAL AMPLIFICATION: THEORY & CONSTRUCTION  
with 17 photos and diagrams  
DULL EMITTER VALVES & A RECEIVER  
with 18 photos, including a photogravure plate  
DUPLEX WIRELESS TELEPHONY  
with 13 special photos  
EARTHS: CAPACITY, CONNEXIONS, LEADS & SWITCHES  
series of 7 articles with 20 photos  
EBONITE: HOW TO WORK AND USE IT  
with 21 "action" photos  
EIFFEL TOWER STATION  
special description, with 10 unpublished photos  
ELECTRICITY: ITS CHARACTERISTICS & MODES OF ACTION  
by J. H. T. Roberts, D.Sc., F.Inst.P. An extraordinarily clever and simple article with remarkable illustrations

### Part 10

- THE ELECTRON IN THEORY & PRACTICE  
by Sir Oliver Lodge, F.R.S., D.Sc.  
ELECTROSTATIC CAPACITY & HOW TO CALCULATE IT  
by Sir Oliver Lodge, F.R.S., D.Sc.  
THE ETHER: MODERN THEORIES  
by Sir Oliver Lodge, F.R.S., D.Sc.  
FAULTS IN RECEIVERS & HOW TO FIND THEM  
with special three-fold photogravure plate



**SAGAMAN.**—One of the most primitive of all story-tellers, the Sagaman delighted our Viking ancestors with his tales of prowess and adventure.



**JONGLEUR.**—In the Age of Chivalry, the Jongleur wandered from Castle to Castle, telling the Ladies in their bowers and the Knights at their feasting, marvellous tales of bravery, love and romance.



**SCHEHERAZADE.**—The famous Queen of Arabia who prolonged her life from night to night by telling the wonderful tales of the *Arabian Nights*.



**TOLSTOY.**—The great Russian reformer, idealist and novelist famous for his fearless courage and sincerity.



**DICKENS.**—The immortal novelist of London life, creator of Mr. Pickwick, Little Nell, Oliver Twist, Mrs. Gamp, Mr. Micawber.

# “Tell me a Story”

The Cry of Humanity throughout the Ages.

FROM the child devouring fairy tales to the business man who relaxes at home over a book, stories throughout our lives are the magic carpet that carries us away to Adventure and Romance. The art of the Story-Teller annihilates the centuries, and gives you not the dry bones of historical fact, but men and women in their habit as they lived. It brings you the knowledge of strange lands, vivid emotions, great deeds.

If you live in the Country, it keeps you in touch with the wider kingdom of thought and imagination. If you are a Town worker, it lifts you clear of the monotony of your daily occupation, and transports you into a world thrilling with passion and drama.

beautiful with the visions of the lover and the artist. And here is your opportunity to get the world's greatest Story-Tellers to practise their art for you; to tell you in your own home the tales that have made them immortal. Write to-day for particulars of

## The Masterpiece Library of Short Stories.

20 magnificent volumes containing 1,000 best short stories of all nations and centuries, selected by a Board of the most eminent critics and writers of the day.

Read in them the marvellous tales of love and intrigue told 4,000 years ago in the sacred walled cities of China, and in the palaces of the Egyptian Pharaohs. Read the dark stories of medieval Italy, stories of poison and murder and feud; real original contemporary documents which no Grand Guignol thrill can rival. Read the splendid stories of old Scandinavia, of Spain and Portugal, and the gorgeous Courts of France. Read the work of Victor Hugo, de Maupassant, Pierre Loti, Flaubert, Tolstoy, Turgeneff, Dostoyevsky Maeterlinck, Jokai, d'Annunzio. Read the 3 volumes of American stories, by such writers as Mark Twain, Thomas A. Burke.

O. Henry, Jack London, Irvin S. Cobb. Read the stories of Ireland and Scotland; stories by Hardy H. G. Wells, Galsworthy, Zangwill, Anthony Hope, John Buchan, W. W. Jacobs, Boyd Cable, Stephen McKenna, Alec Waugh and the most brilliant short-story writers of Canada, Australasia, and South Africa.

This collection is a library indeed! All the best is here. The best stories by the best authors in the world, and enough to last you a lifetime. If you were to read a different story every day, it would take you nearly 3 years to finish these 20 volumes—and then you would want to begin all over again.

### Write for the FREE BOOKLET

Do not miss the chance of acquiring this incomparable Library for your very own. It will repay you its cost again and again in the absorbing interest of the hundreds of stories it tells.

Send a postcard now, mentioning Part 11 of “Harmsworth's Wireless Encyclopedia” to the Educational Book Company, Ltd., 17, New Bridge Street, London, E.C.4, for the Free Art Booklet, which gives you full details of the finest collection of stories the world has ever known, and of the simple way in which you can pay for the work after it is delivered to you complete, by monthly subscriptions of a few shillings each.

SOUTH AFRICAN readers should apply to Central News Agency, Ltd., P.O. Box 1033, Johannesburg, and AUSTRALIAN readers to Gordon & Gotch (Australasia), Ltd.