

4

To be Completed in about 20 Fortnightly Parts

1<sup>s</sup>/<sub>3</sub><sup>d</sup>

# HARMSWORTH'S WIRELESS ENCYCLOPEDIA

## For Amateur & Experimenter

BOO—CAL

CONSULTATIVE EDITOR

**SIR OLIVER LODGE, F.R.S.**

THIS PART CONTAINS

77 Practical and Theoretical Articles

WITH

215 New "Action" Photos & Diagrams

Many 'How-to-Make' Articles

BOX MAST — BRACES AND BITS — BRASS  
AND BRASS WORKING — BUZZERS AND  
THEIR USES — CABINETS FOR WIRELESS  
SETS — CALIBRATING AND CALIBRATION

**SPECIAL COLOUR MAP OF  
BROADCASTING IN GREAT BRITAIN**

*J. LAURENCE PRITCHARD, F.R.Ae.S., Technical  
Editor, with expert editorial and contributing staff*

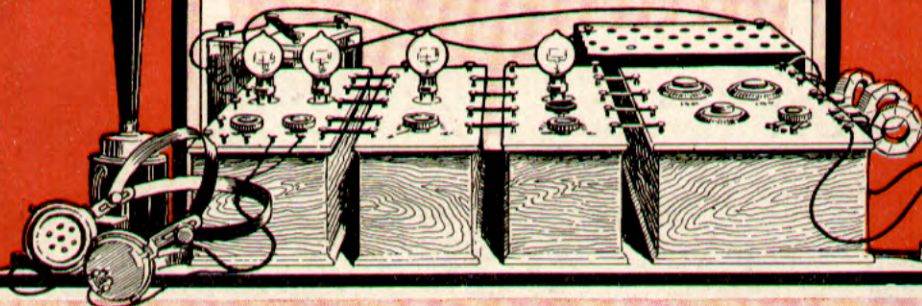

The Only ABC Guide to a Fascinating Science-Hobby

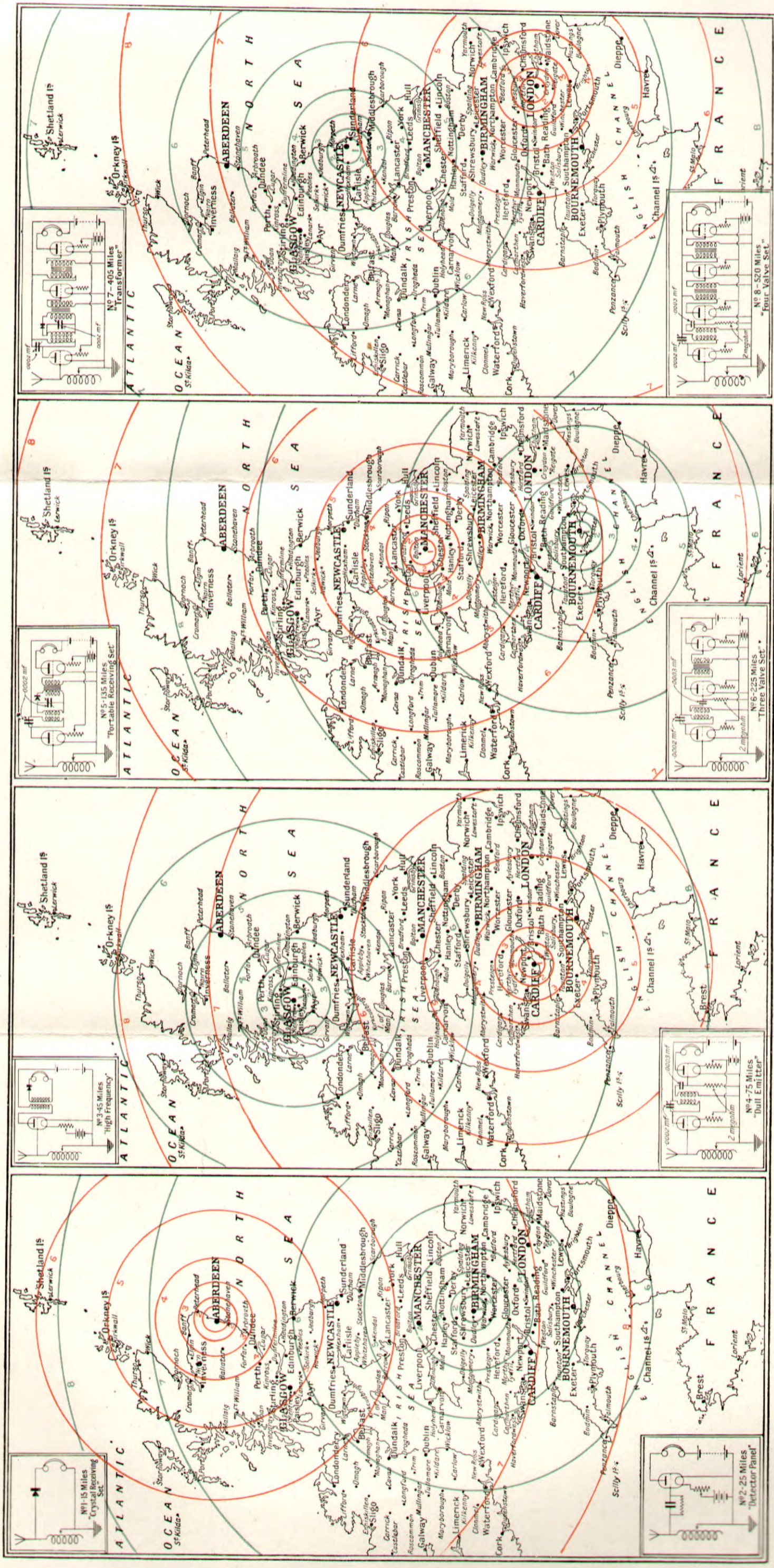

**BROADCASTING: SERIES OF MAPS OF THE BRITISH ISLES SHOWING THE APPARATUS REQUIRED TO HEAR ANY STATION AT ANY DISTANCE**

The eight stations of the British Broadcasting Company are covered in four maps, distances of from 15 to 520 miles being indicated by coloured circles with numbers indicating the receiving set required. Thus, in the first map numbered circles in green show the distances from Birmingham; red circles show the distances from Aberdeen. The second map covers Cardiff and Glasgow. The third Manchester and Bournemouth, the fourth London and Newcastle. For places falling inside circle 5 and outside circle 4, for instance, a No. 5 receiving set, consisting of two valves and a crystal, will be required to make certain of good results. The circuit diagrams of the eight receiving sets are inset at the top and bottom of the maps and the title given in each inset diagram is the heading under which description and construction of the particular set will be found in this Encyclopedia. The ranges of the sets are purposely quoted at a somewhat low figure to allow for local conditions and poor aeriels. Under really good conditions considerably greater ranges will be achieved by most of the sets.

*Specially prepared for HARSWORTH'S WIRELESS ENCYCLOPEDIA*

In wireless work there are many ways in which nuts and bolts are used, and there are likewise many different types of bolt and nut. A few of those most generally useful to the amateur experimenter are illustrated. There is no such thing as an ordinary bolt and nut, as the requirements of different industries call for certain qualities. An engineer would place the engineer's bright bolt and nut with hexagonal heads as the standard bolt and nut, an example of which is illustrated.

In building work, and such industries as coach building, and generally for all kinds of woodwork, a "coach" bolt with a head that is rounded on the top and flat on the underside, and having a square-shaped piece beneath it, is used in conjunction with a square nut. It is a type of bolt and nut that is preferable in woodwork, as the square under the head grips the timber it passes through and prevents the bolt rotating. A similar type of bolt used with a flynut is also shown in the illustration. The flynut can be rotated by hand between the finger and thumb, and is useful for making temporary connexions, or for any purpose when a clamping action under the control of the hand is sufficiently strong.

In wireless work the requirements are so diverse that all types of bolt and nut are employed. For example, on the power plant the bolts and nuts would be of the engineer's type, but on an aerial with a wooden mast the coach bolt is the correct type to use. When a bolt is needed to act as a means of attachment for a rope or wire or the like, it is often formed with an eye at one end and a screwed portion at the other. An eyebolt with a short shank may be used in wireless—for example, on the top of a dynamo field magnet casting as a means of moving it about by attaching a rope to the eye. When the eyebolt has a long screwed shank and is equipped with nuts, it can be employed as a strainer for an aerial guy wire. Two such bolts are shown in the illustration, one a long one for straining wire, and the other a smaller variety used for a similar purpose.

In the construction of wireless apparatus the bolts and nuts used are comparatively small, and usually made of brass or

some non-magnetic material. The average receiving set is built up with set-screws, often termed bolts. The essential difference between them and a true bolt is that the bolt is only screwed for a portion of its length, whereas the set-screw is screwed for the entire length. The B.A. system of screw threads is extensively adopted in commercial sets. The usual engineer's bolts are threaded on the Whitworth system, as are the coach bolts. Many other types or shapes of bolt are made, and there are several patterns of nut, but those of greatest interest to the wireless experimenter are the foregoing.

The various kinds of nuts used in wireless work, for placing on terminals and the like, and for making connexions on panels, are described under the heading Nut.

**BOOSTER.** The purpose of the booster is to change the potential between two points locally, in a direct current system, without affecting the difference of potential at the generating end of the line. It is particularly useful when it is required to overcome the effect of volt-drop due to

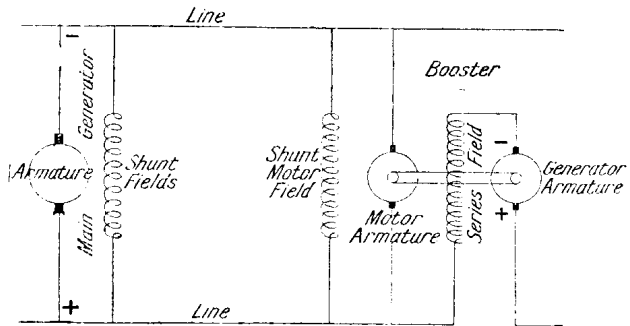

CIRCUIT DIAGRAM OF A BOOSTER

Fig. 1. When a local change of potential is necessary in a direct current system, or it is desired to raise the voltage locally, an arrangement such as that represented above is used, and is known as a booster

line resistance, also in cases where the accumulators are being charged and their counter electro-motive force rises towards the end of the charge to such an amount that it practically balances the voltage of the charging dynamo and reduces the charging amperes to a negligible amount.

There are other cases where the line volts may require to be reduced locally, in which case the booster is applied in the reverse sense, and, instead of "boosting," is arranged to have a "bucking" effect by giving a negative boost. In appearance the booster resembles a double unit motor

generator, the motor being shunt wound, with its armature shaft rigidly coupled to the armature of the generator. The generator fields are series wound, and both field windings and armature are in series with the line it is required to boost. The generator armature, therefore, has to carry full line current, but as a usual thing it only has to provide a relatively low voltage, namely, the difference between line volts due to the main generator supplying it and the extra volts required locally for some purpose or another.

The circuit is shown in diagram in Fig. 1, and the boosting effect is more or less automatic in action, since if the generator armature is driven at constant speed by the shunt motor, the volts it will add to the line will depend upon the excitation of its own field circuit, which, being in series with the line, will again depend upon the current in the line for the time being. A small line current results in a small volt

drop, and at the same time, the generator field being only partially excited, the generator armature only adds a relatively small electro-motive force to the line volts.

If, however, a heavy current is flowing in the line, the volt drop will be correspondingly heavy, and the demand for more volts to be added will be automatically met by the fact that the series field of the generator will now be more heavily excited by the line current which passes through its coils.

For accumulator charging a different arrangement would be better, since the conditions are changed by the fact that as the main current in the line decreases the added volts should increase in order to compensate, by maintaining the same charging rate. To meet this condition the booster could either be arranged as in Fig. 1, but with its armature polarity opposed to that of the main charging circuit ("bucking" the line), in which case the booster volts would drop as the line current diminished, allowing the volts from the main generator to rise at the accumulator terminals; or usually the booster would be arranged with a shunt

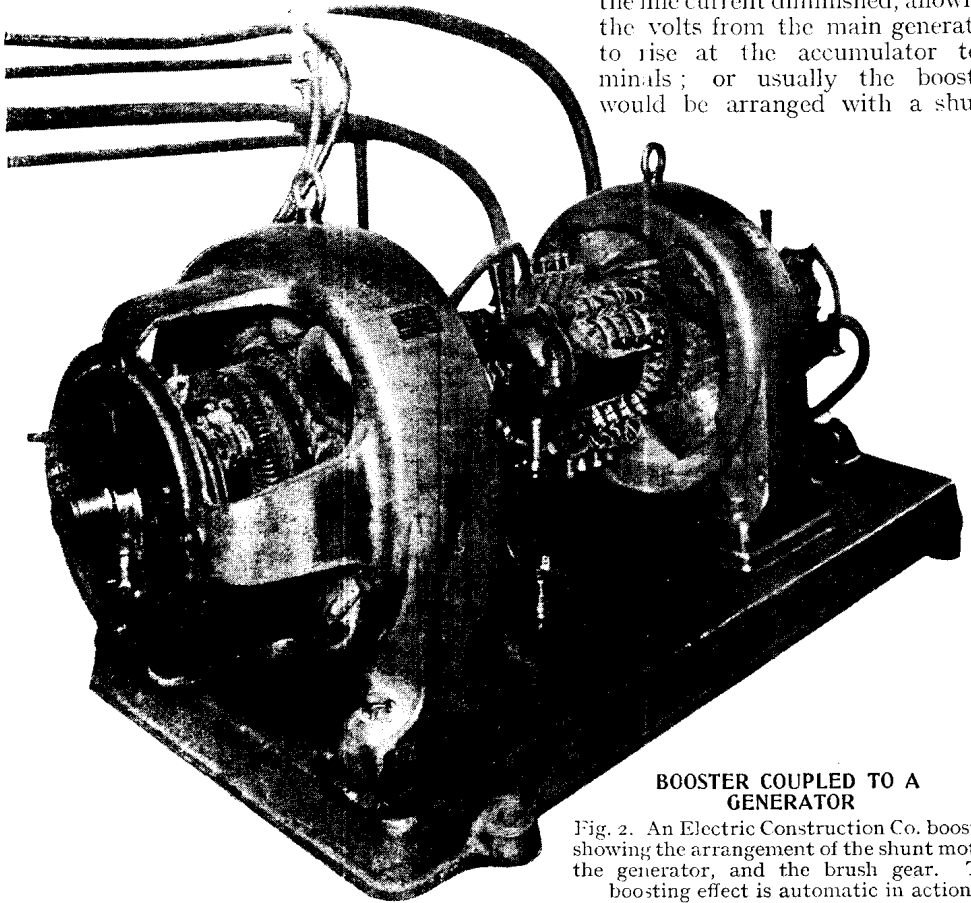

**BOOSTER COUPLED TO A GENERATOR**

Fig. 2. An Electric Construction Co. booster, showing the arrangement of the shunt motor, the generator, and the brush gear. The boosting effect is automatic in action

field to both the motor and the generator side, the latter field circuit being also in series with an adjustable field rheostat, so that the amount of "boost" to the volts could be hand-controlled as necessary. This would eliminate any automatic features. Fig. 2 shows a typical booster.

**BOREAL POLE.** This is a French term which is occasionally used to denote the north pole of a magnet. See Magnet.

**BORNITE.** Crystal rectifier. Bornite is a native sulphide of iron and copper. It has a metallic, crystalline, blue lustre, and is also known as erubescite or variegated copper ore. The blue lustre is due to exposure to the air. When freshly cut it has a coppery or bronze colour. Bornite is used as a crystal rectifier in combination with zincite or with copper pyrites. The combination often gives a better result with a small battery, but it is not necessary.

Fig. 1 shows the characteristic curve for a bornite-zincite crystal. It will be seen that for a positive voltage the resistance is

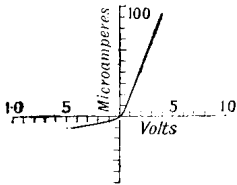

**BORNITE-ZINCITE CURVE**

Fig. 1. A bornite and zincite crystal combination gives a characteristic curve as here shown

low, but for a negative voltage the resistance increases very rapidly. The combination of bornite-zincite makes a sensitive detector, but the contact must be a very delicate one, accurately adjusted, and may be upset by strong atmospheric effects.

**BORON.** One of the non-metallic elements. Its chemical symbol is B, atomic weight 11.0, and specific gravity 2.6. Boron has a strong affinity for oxygen, and is therefore an excellent deodorizer. Boron is used in wireless in the T.Y.K. arc, forming one of the electrodes of the arc. See T.Y.K. arc.

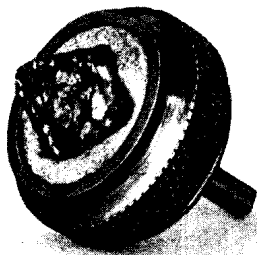

**BORNITE, MOUNTED**

Fig. 3. Bornite crystal mounted in Wood's metal

**B.O.T.** This is the usual abbreviation for Board of Trade Unit, 1,000 watt-hours, approximately one and a third horse power for an hour. See Board of Trade Unit.



**SPECIMEN OF BORNITE**

Fig. 2. High-frequency currents are in many cases rectified by means of a bornite crystal

**BOUCHERISING.** A chemical method of preserving timber, especially poles, from rotting. The method consists of injecting a solution of copper sulphate into the grain of the timber by forcing it through the pole as if it were a pipe. The treatment is claimed to preserve such erections as a pole mast for an aerial from the effects of dampness.

**BOUTHILLON, LEON.** French wireless expert. Born in 1884, he studied at l'Ecole Polytechnique, Paris, and entered the government service in the department of Posts and Telegraphy, in which department he became engineer in 1908, and became attached to the wireless section. In 1911 he became director of the wireless telegraphy department of the Posts and Telegraphy, and directed the construction of wireless coast stations in France. In 1920 he became the Engineer-in-Chief of the department, and since 1913 he has been Instructor of Physics at the Polytechnic School in Paris. In 1920 he was awarded the Herbert Prize of the Academy of Sciences at Vienna for his many publications in wireless. In addition to a large number of articles contributed to various scientific journals, Bouthillon wrote "Theory and Practice of Radio Communication," in 8 vols., and "Wireless Telegraphy," the latter in collaboration with G. E. Petit.

**BOX AERIAL.** This is an alternative name sometimes used for a frame aerial. See Frame Aerial.

**BOX MAST.** A mast for supporting an aerial, built up from planks of wood nailed or screwed together at their joints, and strengthened by cross-pieces or membranes of wood. This type of mast is very suitable for amateur construction, as when finished it is stiff and strong. It does not present any great difficulties in erection, and the procedure may follow that detailed in the article on Aerial.

As an example of construction, take the case of a mast 40 ft. above the ground. This would be made in three separate sections, the timber for each of which would be 15 ft. in length. This allows for 1 ft. depth of joint between the joints in the mast, and 2 ft. or so for letting into the ground at the bottom. The bottom section, or main mast, is made from 9 in. by 1 in. prepared deal planks, one end of which is sawn to a taper, so that the smaller end is of such a size that the intermediate section of the mast can fit snugly into it. This will necessitate cutting off 1 in. or so on the upper end of the main mast, tapering outwards to nothing about the middle.

The edges of the planks should be planed up smooth and true, and the components can then be screwed or nailed together at the joints. The planks are arranged so that the edge of one fits on to the top of the

in place. Similar membranes may be fitted about the middle of the length of the mast and at the bottom, a third piece fitted flush to the ends of the planks, after which the remaining side plank is screwed or nailed into place.

To strengthen the structure, hoop iron should be wrapped tightly around and secured with nails or screws. The hoop iron should be fitted, as shown in Fig. 2, at each place where a membrane is fixed, as this will bind the whole together and make it perfectly rigid. The mouth of the lower mast is then reinforced by attaching strips of batten about 2 in. wide and 1 in. thick, these being nailed in place, and ultimately reinforced with a piece of hoop iron, which is clearly shown in Figs. 3, 6, 7 and 8. The hoop iron may, when the mast is finished and before it is erected, be protected by a good coat of paint, since it rusts very easily and therefore deteriorates rapidly.

The next section of the mast is made up in the same way. The bottom of it fits into a socket formed on the top of the main mast, and a similar socket is made on the top of the intermediate mast for the top mast to fit into, as in Fig. 4. The intermediate section can be conveniently made of material about 6 in. wide and  $\frac{7}{8}$  in. thick. It will also have to be tapered at one end as described for the main mast, so that the size of the terminal socket will be of such dimensions that the topmast can fit nicely into it.

The topmast can be made from 4 in. wide prepared deal,  $\frac{3}{4}$  in. in thickness, and should taper to about 3 in. square at the top. It is nailed or screwed, and reinforced with membranes as before. The sizes given are nominal; and when purchasing the material it will be found that the 9 in. by 1 in. prepared board will only actually measure about  $8\frac{3}{4}$  in. wide and about  $\frac{7}{8}$  in. thick. Consequently, it is best to obtain all the material at the start, and temporarily

tack the four pieces of each of the sections of mast together. The absolute outside measurements should be taken and the sockets prepared so that the inside size is exactly the same as the outside size of the next mast section, in order that one may fit into the other.

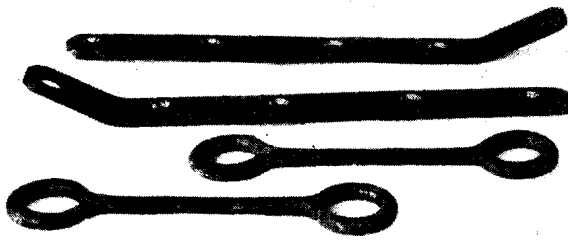

**IRONWORK FOR BOX MAST**

Fig. 5. Wrought iron double eyes and iron straps for fixing on the guy ropes supporting the mast are here illustrated

next, their disposition being clearly shown in Figs 1 and 2. When the three of them have been nailed or screwed together to form a trough-like structure, cross pieces of similar material should be cut and fitted across at about a foot or so from the end of the mast, these being screwed or nailed

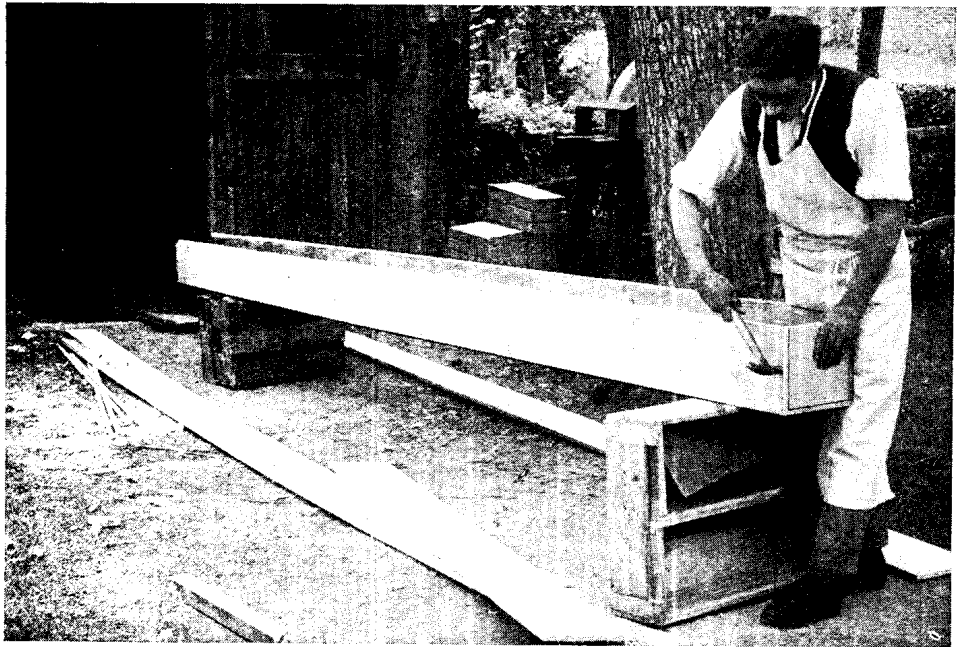

Fig. 1. General construction of a three-part box mast shown in progress. The lowest section has sides of 9 in. by 1 in. deal planks and is 15 ft. long



Fig. 3. Fitting the iron hoops to strengthen the joint at a section

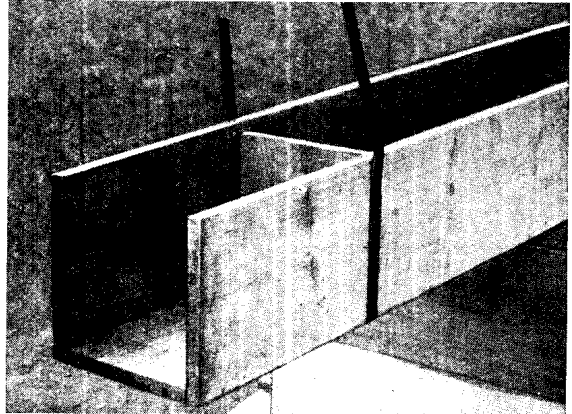

Fig. 2. Membranes are fitted inside the box, and hoop-iron reinforcement added outside

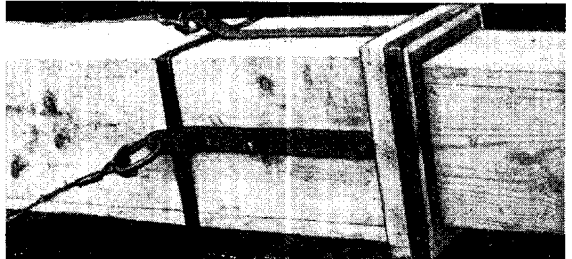
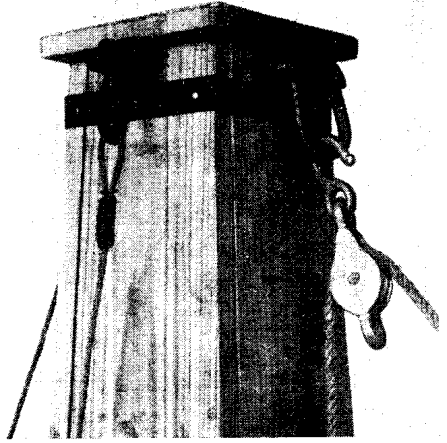
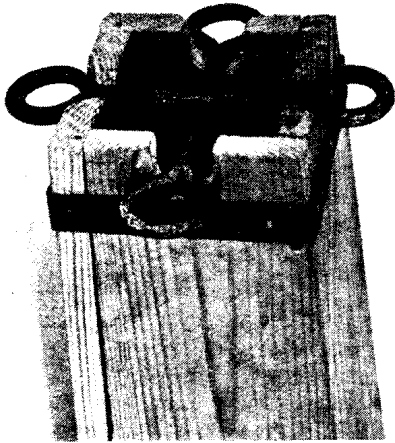

Fig. 4. Shows how one section fits into the next, also position of straps and supporting battens

BOX MAST FOR AN AERIAL IN PROCESS OF CONSTRUCTION



#### STAY-ROPE ATTACHMENTS FOR BOX MAST

Fig. 6 (left). Double-ended eyes are fitted in this manner into slots at the top of the mast, to take the strain of the support ropes or wires. Fig. 7 (right). Double-ended eyes are now seen engaged. Three of the four hold stay ropes, and the fourth is attached to the aerial halyard.

Having made all three sections in the manner described, they may be finished by painting, or by thoroughly well brushing with creosote, solignum, or any good wood preservative. The ironwork, Fig. 5, should be well painted with brunswick black or some similar good quality paint. The top

of the mast is finished by cutting four slots, one in the centre of each plank, as in Fig. 6, making these slots about  $\frac{1}{2}$  in. wide and  $\frac{3}{4}$  in. deep. Two wrought iron double-ended eyes must then be obtained, and these are rested in the slots in the manner clearly shown in Fig. 6; after which a band of hoop iron is fixed around the outside of the mast immediately beneath the termination of the slots. The top is then enclosed by a square piece of wood, screwed or nailed in place.

The result is that there are four eyes, placed one on each side of the mast, and one of these is used for the attachment of the aerial and the other three for the side and back stays. This is shown in Fig. 7. The joints between the sections of the mast have also to be steadied by stays, and for this purpose four wrought iron plates, as shown in Fig. 8, should be prepared. Each plate may be about  $1\frac{1}{4}$  in. in width and  $\frac{3}{16}$  in. in thickness and 12 in. long, with at least four screw holes drilled and countersunk in it.

When the plates are secured in this way the screws may pass through both sections of the mast, and this to some extent helps to secure the whole. The primary purpose of these plates is, however, for attachment of the ends of the guy wires. This type of mast, if strongly made in the manner described and erected as indicated in the article on aerial, should give entirely satisfactory results. See Aerial; Frame Aerial; Lattice Mast.

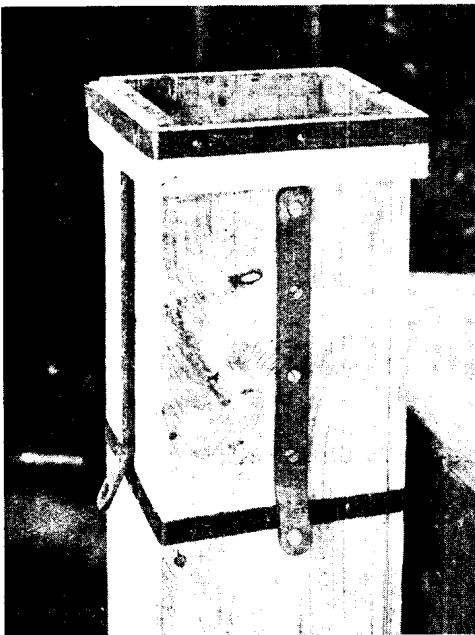

#### STAY ATTACHMENT AT JOINT

Fig. 8. Iron strips are screwed on to the box mast, as shown in this photograph, at the joints, and to these are attached stay ropes.



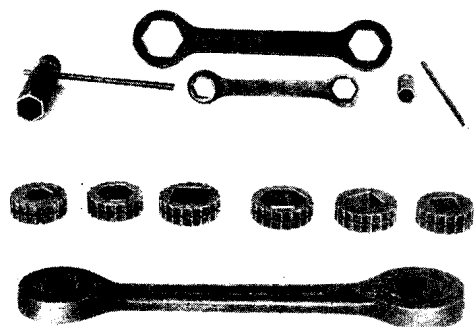

#### EXAMPLES OF BOX SPANNERS

Fig. 1 (top). Two tubular pattern box spanners with tommy bars, and two other types are included in this group. Fig. 2 (bottom). For employment in awkward positions this ratchet type of box spanner is very useful

**BOX SPANNER.** Any spanner which when in operation embraces all the sides or flats of the nut simultaneously. The particular advantage of the box spanner is the continuity of the operating part or jaws. These are always so shaped that each flat on the nut is reproduced on the spanner. Thus if the nut has six sides, *i.e.* is hexagonal, the spanner will have a six-sided hole in it, similar to the examples illustrated in Fig. 1. The spanner is made of good tough steel, and may be shaped from flat steel, the ends may be bossed to form an extra thick part around the jaws, or the tubular type may be adopted. Each has its merits and disadvantages.

The wireless experimenter is usually faced with the difficulty of dealing with nuts and bolts in somewhat awkward positions, as, for instance, on the mast of some aerials. In such a case the nuts are difficult of access and the hands will be partly occupied in holding on to the mast.

The box spanner is then very useful, as it only has to be rotated, and by its natural tendency to slip off the nut.



Fig. 4. The complete home-made box spanner

Another type of box spanner that is equally useful under such conditions is the ratchet. In one form, as shown in Fig. 2, the ratchet is located in the body of the spanner, and the nut is manipulated by a circular steel jaw piece having a hole of appropriate size and shape through it. When this jaw is placed on the nut and the ratchet is in place, the handle part of the spanner is worked to and fro, the ratchet driving the nut in one direction and not in the other. To unscrew a nut the jaws and the ratchet pawl are reversed.

Small box spanners are readily made from steel tube, provided it be of suitable diameter. As a rough guide the diameter of the tube should be equal to the diameter of the nut; that is the width across the flats. The method of making a small spanner for temporary use is to take a piece of hexagonal metal rod and drive it into the end of the tube. To do this easily it is best to taper the end of the hexagonal rod. The next step is to work the jaws flat and get them to exact size, this being accomplished by simply placing

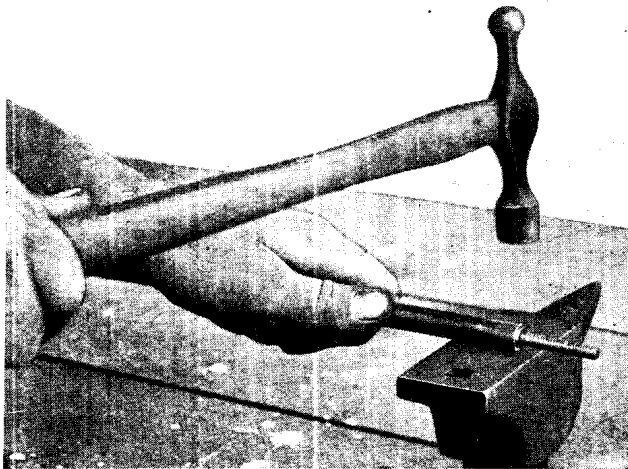

#### MAKING A TUBULAR BOX SPANNER

Fig. 3. Home-made box spanners are easily constructed, as this photograph shows. A metal tube is hammered to shape over a hexagonal rod, and a small hole bored at the other end to take a turning rod or tommy bar

the head of a bolt or set-screw into the end of the spanner and holding it flat on the anvil (Fig. 3). Flatten each side of the jaws separately, gradually working the head of the bolt into the tube until the lower side of the head is flush with the edge of the spanner. The tube is cut to length, a hole drilled at right angles through it, and a steel tommy bar inserted, as shown in Fig. 4.

The bar can be fixed or removable, as desired. As a rule if the spanner is wanted for regular use on ordinary open work it is best to fix the bar, as it cannot then be mislaid. For awkward jobs, such as tightening the nuts at the back of a panel, the length of the spanner tube can be reduced to a minimum, little more than the thickness of the nut, and the bar used as before. When a very difficult nut has to be placed, it can be put into the jaws of the spanner and the bar fixed so that it comes immediately behind the inner side of the nut. By this method the nut can be put on to the bolt and so started. When space is restricted, as it so often is at the back of a panel, the spanner body should have a series of tommy bar holes drilled in it, so that the nut can be gradually tightened by removing the bar and inserting it into the next hole and turned again as far as it will go and the bar again moved and inserted into the next hole. One or two sizes of tubular box spanners so drilled to take a tommy bar in almost any position of the spanner will be found to be one of the most useful tools in the equipment of the wireless experimenter. There are numerous makes of box spanner adapted to specific operations and for dealing with the particular problems of different industries, but those mentioned are most useful to the wireless experimenter. See Bolt; Nut; Screw.

**BRACE AND BIT.** A brace is a device for actuating a bit or drill, and comprises a hand-grip, crank, and drill or bit holder. A brace and a selection of bits are essential to all wireless experimenters. By their aid holes up to  $1\frac{1}{2}$  in. diameter or thereabouts can be made in wood, and, if suitable bits be used, in metal and ebonite, as well as in other materials.

#### The Ratchet Brace and its Uses

The simplest form of the tool is shown in Fig. 1, which illustrates a plain brace with a solid steel crank or bow, a solid hand-grip, a plain head, and a tapered hole in the end of the bow for reception of the bits. These are secured by the set-screw, which pinches the end of the tapered shank of the bit.

A superior type is the ratchet brace shown in Fig. 2, which has a ball-bearing hand-grip, an adjustable drill chuck, a ball-bearing head, and a ratchet action at the bottom of the crank. The chuck is operated by gripping the hexagonal body

with the left hand and rotating the crank with the right. The bit is then placed in the space between the jaws, and the rotation of the crank in the opposite direction closes and tightens the chuck on the bit.

The ratchet is actuated by rotation of a knurled ring which, when turned to the right, sets the ratchet so that the bit is rotated in a clockwise direction, thus driving the bit into the work. If the ring be turned the other way the bit is rotated in the opposite direction. When the ring is midway the brace is in effect a solid one, and the bit is driven with the crank. This feature is invaluable when working in restricted places, as the crank can perhaps only be turned, say, a quarter of a turn, but by repeated movements the bit is driven gradually into the work.

#### Methods of Working With the Brace

When working in an horizontal position the left hand grips the head of the brace, the right rotates it, and the pressure needed to force the bit into the work is applied from the top of the thigh, as shown in Fig. 6. When a vertical hole has to be dealt with, the position is as shown in Fig. 3, where the brace is used to drive a countersink to take the head of a screw for the corner of a valve panel. Note that two nails are driven into the bench to prevent the work rotating.

This is a necessary precaution, as should the work slip the bit may jump and scratch the surface of the work. It is imperative to hold the brace perfectly upright when drilling vertical holes or making countersinkings, otherwise the hole will be out of truth and the result look very slovenly.

When it is desired to bring great pressure on the bit, as when drilling a hole in metal, a considerably increased drive is easily obtained in the manner illustrated in Fig. 4, where a piece of board is used as a lever. The method is to place a block of wood on the floor immediately behind the lever, and fix it with a couple of stout nails. The head of the brace can be tied to the lever with a thin cord, and the pressure applied from the shoulder to the top of the lever. By this method the labour of drilling is greatly reduced, and the hole is bored more quickly than would be possible by the more ordinary methods of holding the brace.

Some useful bits are illustrated in Fig. 5, and, from left to right, these are known and used as follows: A rose-head

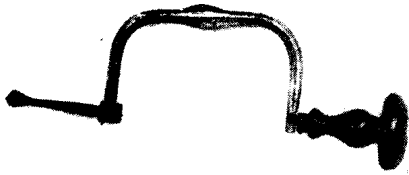

Fig. 1. Common type of brace for drilling metal or ebonite



Fig. 2. Better type of brace with ratchet motion and drill cluck



Fig. 3. How to hold the brace when countersinking a screw hole is illustrated

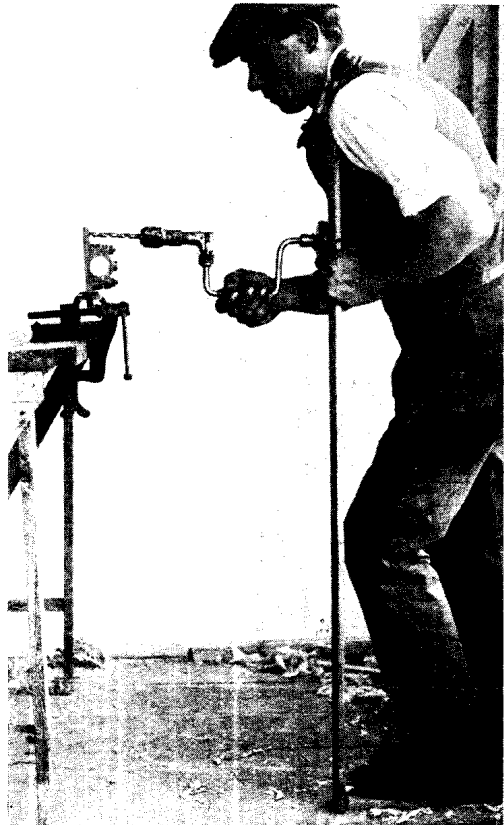

Fig. 4. Increased power is obtained in this manner. The vertical board increases pressure on the bit.



Fig. 5. Various examples of bits described on p. 264

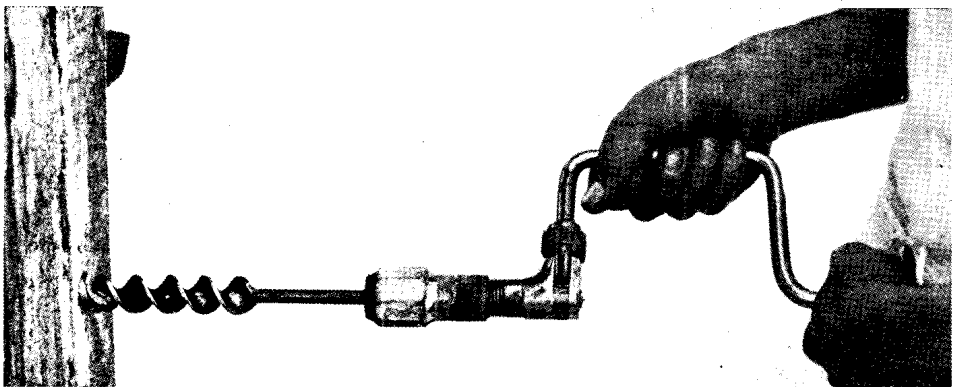

Fig. 6. Manipulation of the brace when boring in an horizontal position is accomplished by holding the tool as shown, applying the pressure from the hip

countersink for recesses for countersunk screw heads; screwdriver bit, used to drive screws (a brace is an invaluable help when many screws have to be driven, as it is quicker than working with the ordinary type of screwdriver); bung borer or taper bit, employed in making tapering holes; Jennings' pattern auger or twist bit, the best type for all woodwork. The Jennings bits are made in many sizes, and are indispensable to the experimenter. The point of the bit is cut as a screw, so drawing the bit into the wood. The cutting edges of the auger are chisel-shaped, and if kept sharp the bit will cut freely and quickly. This type of bit will not work well if a smaller hole has already been made, as then there is nothing for the screw point to grip into, and much of the directional and driving power of the bit is lost.

The next drill is a twist drill with brace shank, used for drilling holes in metal. Generally, this is not practical with drills of over  $\frac{1}{2}$  in. diameter. An expanding bit for drilling large-diameter holes in sheet metal is shown next to this. The central drill acts as a pivot, and the cutter at the end of the arm cuts a circular path through the metal. It is adjustable to different diameters by the thumb screw. This bit will often prove handy in making circular grooves in wood for the subsequent reception of a tube, as when fixing the end of a tube to the cheeks of an inductance coil.

The nose bit is used for boring holes in the end grain of wood, and the shell bit for general woodwork. A reamer is used to enlarge slightly the front of a hole drilled in metal, ebonite, or other material. The centre bit comprises a central point and a projecting fang known as a nicker, and the cutting part, or scoop. The centre point guides the bit, the nicker cuts across the fibres of the wood, and the cutter removes the bulk. On the extreme right is shown a flat drill used for making holes in metal, generally in sheet metal.

A similarly shaped bit is known as an iron countersink, but either are very handy for taking the burr or rough edge off a hole after it has been bored. The cutting edges of all bits should be kept sharp, and the bits ought to be stored so that their cutting parts cannot come into contact with anything likely to damage them. A good plan is to use a divided tool roll made of baize or leather. Alternatively the brace may be suspended

from a hook on the wall or ceiling and the bits housed in a wooden block or rack, with holes for each separate bit. The cutting points ought to be downwards, to avoid accidents. To guard against rust, wipe the brace and all the bits with an oily rag after use.

When boring with a brace and bit keep the bit in line with the centre of the desired hole, turn the brace with a regular and steady motion, and exert only just sufficient pressure to make the bit cut. The rate of cutting is best judged by the appearance of the chips or shavings. If these come away freely and cleanly the speed and pressure are about right; if not, see if the edges are sharp, and try varying the speed and the pressure. When in good order a bit should cut quickly and freely, and produce a clean hole. When boring with a centre bit or an auger or twist bit, work from the face side until the point of the screw is just peeping out at the back, then withdraw the bit and finish by boring from the back. This produces clean holes. Another plan is to clamp an odd piece of wood to the back of the work, as this gives the fibres of the wood a support, and prevents them giving way and causing a ragged hole or tearing at the edges.

**BRADFIELD INSULATOR.** Type of lead-in insulator. The insulator is shown in Figs. 1 and 2. A long steel rod, one end, A, of which may be seen in Fig. 1,

passes through the ebonite tube, B. The usual diameter for the steel rod is  $\frac{1}{2}$  in., and for the ebonite tube  $1\frac{1}{2}$  in. The rod is threaded at each end, and the lower end is fitted with a brass socket, C, and a wing nut, D. On the upper end is fitted a shackle head and lock nuts. A feature of the insulator is the zinc cone E, which fits over the steel rod and is held by lock nuts. An asbestos washer is fitted to render the joint watertight. This cone serves to keep part of the

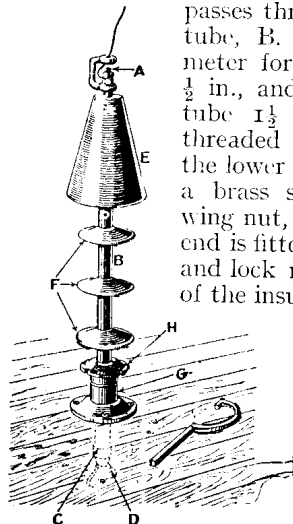

Fig. 1. Parts of Bradfield insulator. E is a zinc cone, B an ebonite tube, C a brass socket and D a wing nut

insulator dry in bad weather and to distribute the potential gradient.

Another striking feature of the Bradfield insulator is the three ebonite anti-spark disks, F, fitted at intervals over the ebonite tube. These disks help to prevent sparking over the surface in wet weather. They give, in fact, a longer insulating or leakage path.

This form of insulator is largely used on board ship, and at the lower end is fitted with a stuffing box, G. The flanged cap, H, screws over the top of this box, and is made tight by means of the key shown in Fig. 1. A series of asbestos washers are fitted inside the box, and the flange H is screwed firmly home to fix the insulator on the roof or side of the cabin, the stuffing box being held by four coach bolts to the planking.

The aerial leads are fastened round the shackle head, led through the eye, and held firmly by means of the lock nuts. See Lead-in.

**BRANDES' TELEPHONES.** A type of telephone receiver in extensive use in America and elsewhere. A typical example is illustrated, from which it

will be seen that double headbands are used, with an extension arm and universal joints for the adjustment to the head. One of the ear pieces is shown with the cover removed, and the internal arrangement of the magnets and pole pieces is clearly visible. The metallic diaphragm is adjusted and both the receivers are matched for tonal qualities. The electromagnetic properties are also matched, so that very pure reproduction is the result.

**BRANLY, EDOUARD.** French wireless expert. Born at Amiens, France, Oct. 23, 1844, he was educated at Paris and afterwards became Fellow of the University,

doctor of physical science, and doctor of medicine.

Branly early made a study of electromagnetic waves, and in 1890 and 1891 patented methods of operating a local relay circuit from a distance by means of

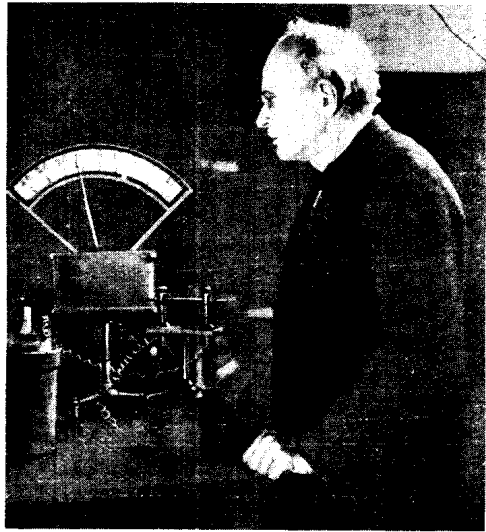

**DR. EDOUARD BRANLY**

Discoverer of the varying resistance of filings and metallic powders to electric waves and originator of the filings tube as detector, or coherer

wireless waves. In 1900 he was awarded the Grand Prix by the International Jury of Superior Precept Instruction for his exhibition of radio-conductors.

In 1890 Branly published an account of his very extensive series of observations on the electrical conductivity of loosely

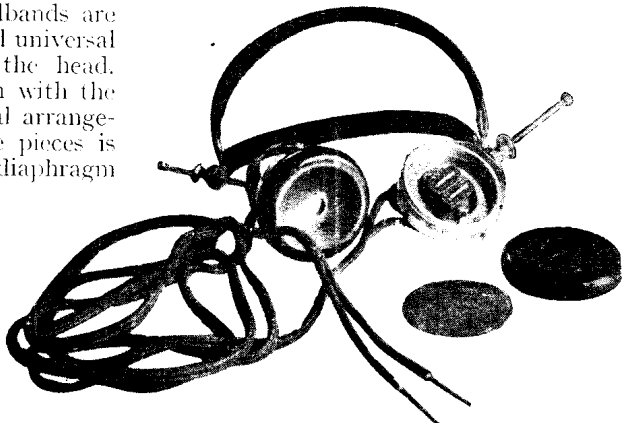

**BRANDES' TELEPHONES**

Headphones fitted with universal joints to allow the ear pieces to adjust themselves naturally



**BRADFIELD INSULATOR**

Fig. 2. Insulators of this kind are used extensively in wireless sets on ships. The cone helps to keep the insulator dry in wet weather

packed metal filings, and he made the extremely important observation that an electric spark at a distance had the power of suddenly changing the electric conductivity of loose masses of powdered conductors. To Branly is due the coherer named after him.

**BRANLY COHERER.**

Detector of electro-magnetic waves. Prof. E. Branly published in "La Lumière Electrique," in 1891, a very exhaustive account of researches he had made on the subject of the detection of electro-magnetic waves. He observed that an electric spark—the origin of the waves—could alter the conductivity of many loosely-packed conductors. The conductivity in some cases was increased, and in others decreased by the action of the waves.

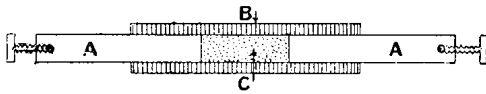

**FORM OF BRANLY COHERER**

Fig. 1. Professor Branly's invention is shown diagrammatically. A A are two metal plugs in a tube B. Between the plugs iron filings, C, are packed loosely

Branly invented a detector in the form of a tube containing loosely packed iron filings between, and making contact with, two metal plugs. Fig. 1 shows the form of Branly's coherer, and Fig. 2 a photograph of an early type. Under normal conditions the conductivity of the filings

is very low, but under the action of a spark the conductivity is greatly increased.

Branly demonstrated these effects by connecting in a circuit the coherer, a



**EARLY BRANLY COHERERS**

Fig. 2. One of the earliest types of coherer, packed with loose metal filings, was constructed as the two examples in the above photograph

Courtesy of Marconi Wireless Telegraph Co.

single cell, and a current detecting instrument. If the iron is in the form of a powder, the resistance of the coherer will be so high that no current will be detected. If now a Leyden jar be discharged at some distance from the coherer, then immediately the galvanometer needle is deflected, thus indicating a current in the circuit. The conductive state will persist until the tube is disturbed.

Not only did Branly use various metals in powder form, but he also used mixtures in paste and solid form. Of the former type, mixtures of colza oil and iron or antimony filings, of ether and aluminium were used. Of the latter type, a mixture of iron filings and melted Canada balsam was poured into the tube, the mixture solidifying when cold. This mixture was very efficient, the original resistance of several hundred ohms being reduced to a few ohms by the action of the spark. See Coherer.

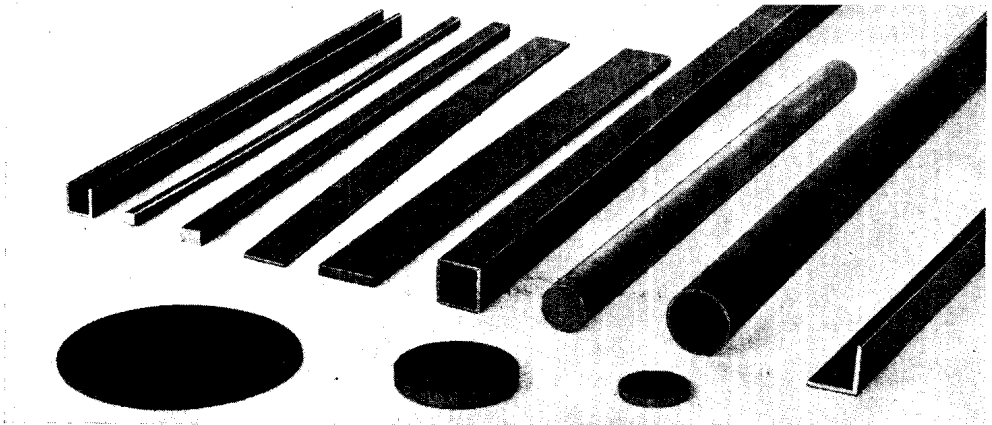

**BRASS MATERIAL USED BY WIRELESS WORKERS**

Fig. 1. Some of the many forms in which brass is supplied to the wireless worker, both amateur and professional, are shown in this photograph; rod brass is represented, also strip, tube, angle, trough-shaped, and sheet, all of which are used for numerous purposes, in all thicknesses

## BRASS AND BRASS WORKING

### How to Select, Use and Work this Important Metal

Brass is one of the most important metals for the amateur wireless experimenter, and in this chapter are described the various methods of working it. Related articles which should be consulted are Aluminium; Drills and Drilling; Lathe Work. See also under the names of various tools and metal processes, as Brace; File; Taps and Dies, etc.

Brass is a yellow-coloured metallic alloy. It is one of the most useful metals to the wireless experimenter, as by its aid numerous parts of the apparatus can readily be made. The composition varies, but the alloy consists mainly of copper and zinc, with traces of iron and lead. Ordinary brass as used for many industrial purposes contains about 30 to 40 per cent of zinc. The greater the proportion of copper the redder the colour of the brass, and when there is a percentage of nickel the colour is very like silver. Brass as used by the wireless experimenter is easily worked, takes a good polish, can be soldered or brazed, files easily, and is, in general, one of the most satisfactory metals for the amateur. The electrical conductivity is good, and the mechanical strength ample for all ordinary purposes to which it is likely to be put by the experimenter in the construction of wireless apparatus.

#### Strengths of Brass Alloys

The strength of brass varies with its composition. Brass wire containing about 65 per cent of copper and 35 per cent of zinc has a tensile strength ranging from 40,000 to 80,000 lb. per square inch. Cast brass has a tensile strength of about 24,000 lb. per square inch, but rolled or drawn brass may have a tensile strength in the neighbourhood of 45,000 lb. per square inch. The tensile strength increases with the proportion of zinc up to a maximum of 40 per cent of zinc. It then decreases, and when as much as 50 per cent of zinc is present, the resulting alloy is quite fragile. The specific gravity of brass varies from 8.2 to 8.6, the melting point ranging from 1,700° to 1,850° F.

Brass is obtainable for wireless purposes in the form of sheet, rod, tube, and various special sections, of which a few typical and useful examples are illustrated in Fig. 1. Some of these are obtainable in different forms—that is to say, the ordinary round rod is obtainable with a rough surface, and is composed of cast brass. It is then only nominally round and approximately of the dimensions stated. For

example,  $\frac{1}{2}$  in. diameter cast brass rod, when not machined up to a bright true surface cannot be so finished much over  $\frac{1}{16}$  in. in diameter. As previously stated, the strength of such material is not so great as in the case of drawn brass rod.

The latter is manufactured by special machinery, which virtually pulls the metal into shape by forcing it through a circular die. The result is that this class of drawn or rolled material has a clean, bright surface and holds up very closely to the stated size. The experimenter will do well always to purchase the drawn or rolled brass, in preference to the cast for wireless purposes.

The ordinary commercial sizes of this material range in tubes from very small size, about  $\frac{3}{32}$  in. outside diameter, up to several inches in diameter. The tubing is obtainable in different thicknesses or gauges, and is sold according to the outside diameter. As a rough guide in selecting the thickness of tube, it may be mentioned that No. 16 gauge is for all practical purposes  $\frac{1}{16}$  in. in thickness. Consequently a tube 1 in. outside diameter and No. 16 gauge will have a bore of very closely  $\frac{7}{8}$  in.

#### Rods and Tubes and Their Uses

This can be obtained in two forms in most of the sizes. First the solid brass or seamless tube, which is manufactured without a joint of any kind, and the brazed tube, which is made from sheet metal rolled to shape and the joint brazed. The joint runs along the length of the tube. When a specially good face is wanted with brass tube, it is best to use the best solid brass or seamless quality as this is much truer and is more easily finished.

In the case of rods, there is a wide selection of sizes, both in the cast and drawn qualities. Square tube is very useful for some experimental purposes, and convenient sizes, such as  $\frac{1}{2}$  in.,  $\frac{3}{4}$  in., and so on, are generally obtainable. The size is measured across the flats. A great many different sections of brass strip can

be obtained, from the small pendulum or clock brass, measuring, for example,  $\frac{1}{8}$  in. wide and something like  $\frac{1}{16}$  in. thick, up to a thick bar several inches in width and  $\frac{1}{2}$  in. or more in thickness. Most of the metal warehouses will generally supply the experimenter with odd pieces which are very convenient for sawing out various shapes in the manufacture of different classes of apparatus.

The L-shaped sectioned metal, known as angle brass, is obtainable in various sizes from about  $\frac{3}{8}$  in. upwards. It is measured across the flat, from the corner or angle, to the extreme end of the metal, and may be uniform, or one side may be longer than the other. In this case the brass is sold as, for example,  $\frac{1}{2}$  by  $\frac{3}{4}$  in., meaning that one side is  $\frac{1}{2}$  in. wide and the other  $\frac{3}{4}$  in.

#### Rods, Disks, Castings and Plates

Hexagonal rod and tube is also available, and is extensively used in the manufacture of nuts and bolts and other parts where it is desired to use a spanner for tightening. In this case the metal is measured by the width across the flats. Another handy material is known as channel brass. This has a three-sided, trough-like section, and has many applications in the construction of special wireless apparatus for experimental purposes.

Circular disks, known as brass blanks, may also be obtained, and range in size from, roughly, 1 to 4 in. in diameter and from  $\frac{1}{16}$  up to  $\frac{1}{4}$  in. or so in thickness. These are generally punchings from brass sheet, and are very useful for all manner of experimental purposes.

A number of stock brass castings, such as those for bushings, pipe fittings, and so on, are generally obtainable from metal merchants, and can be pressed into service by the experimenter. Sheet brass is generally sold either in rolls from 12 in. wide and upwards, or in sheets measuring approximately 3 ft. by 2 ft. Two qualities are usually available—soft brass, particularly adapted for bending and hammered work; and the hard, or spring brass, more useful for flat plates and other purposes where a perfectly flat surface is needed. The thickness varies from a little more than the thickness of ordinary note-paper, upwards, to  $\frac{1}{8}$  in. or more, which is usually the limit of the experimenter's requirements.

It is generally possible to purchase a certain range of sizes of brass plates already flattened and planished, intended particularly for use in engraving of name tablets and so forth. On account of the flatness of the plate, however, it is very handy for the experimenter.

Brass wire in various sizes, and circular, half-round, square, or hexagonal in shape, is obtainable, and often saves a great deal of trouble in the construction of amateur wireless apparatus. Brass wire can be used for making up small, stiff springs. They can be coiled up in the lathe, when this is available, or as shown in Fig. 2, with the aid of an ordinary small polishing head. The method is to grasp in a chuck a piece of steel rod slightly smaller in diameter than that of the intended spring, and to turn the polishing head backwards while coiling the brass wire on to the rotating steel rod. Any length of spring can be made in the same way, and the ends bent to shape with round-nosed pliers in the manner illustrated in Fig. 3. This is typical of the way in which brass wire can be bent to all manner of shapes with the aid of ordinary pliers.

Brass is generally sold at so much per pound, the price varying with the market fluctuations, and also varying according to the size or nature of the material. For example, cast brass is generally cheaper than the drawn. Some dealers supply small quantities of brass at so much per foot run, which is a convenient method when only small quantities are required.

#### How to Work in Brass

The experimenter will find that brass is a very convenient material to work with. It cuts readily with a hack-saw, especially if one with fine teeth be used and a fresh saw be employed. A good plan is to use new hack-saw blades for brass, and after they have been dulled somewhat set them aside for use when iron or steel is to be cut. As a rule, there is no need to lubricate the teeth of the hack saw unless a very deep cut is to be made, in which case a little machine oil applied to the saw cut and some on the saw blade will help to keep the latter cool.

The filing of brass is best accomplished with new files, especially with those of medium and fine cut. The files should be used for brass work only, and not used for steel or any other material, as if used



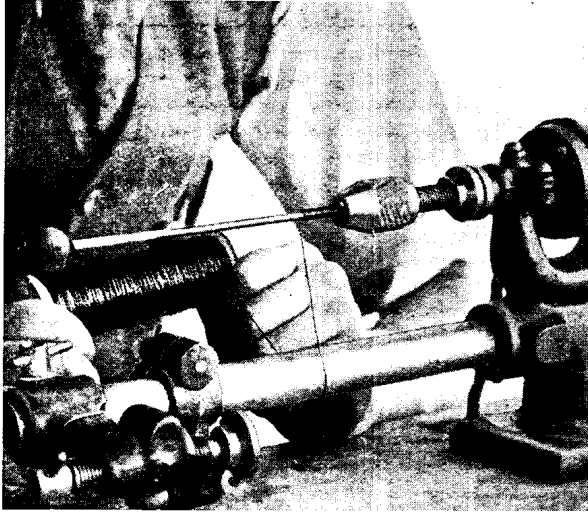

Fig. 2. Brass wire is being wound with the aid of a small rod rotated in a lathe to make a small coil spring

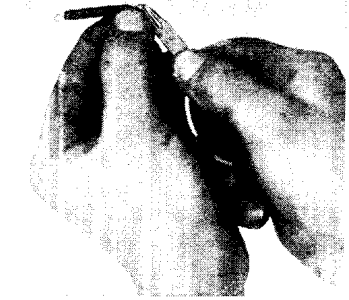

Fig. 3. Eyes are made in the end of a coiled brass wire spring with round-nosed pliers

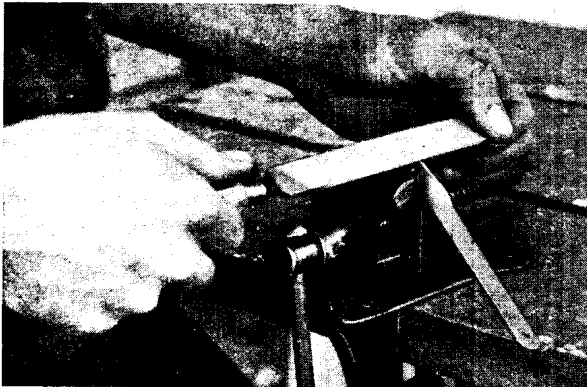

Fig. 4. When filing brass components an ordinary 8 in. second cut file held as shown is best for the purpose



Fig. 5. Small articles made by the wireless experimenter can be drilled with a hand drill stock

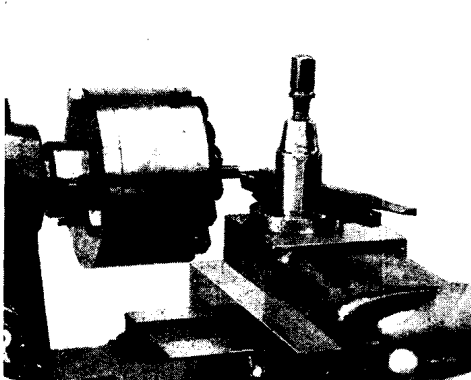

Fig. 6. Brass turning is best accomplished with a lathe with a slide rest. A piece of brass is being turned while held in a three-jaw chuck

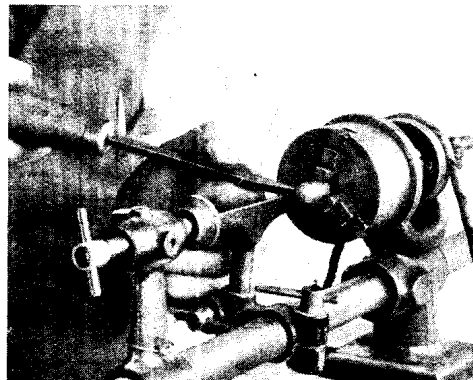

Fig. 7. Another method of turning easily is with a hand tool using a small bench lathe with a T rest

**BRASS WORKING IN THE CONSTRUCTION OF WIRELESS COMPONENTS**

indiscriminately the teeth are speedily blunted and the file cuts the brass very sluggishly. The best plan is to follow the same lines as with the hack-saw and reserve the new files for use on brass, and after they have been dulled turn them over to general work. For small work on brass, such as is illustrated in Fig. 4, an ordinary 8 in. file is quite satisfactory. For general work a rough or coarse file should be used, finishing the work off with a fine file, and finally working up any grooves or other fine surfaces with the aid of a small file. The teeth of the file should be lubricated with French chalk to facilitate the working and to prevent them from being clogged with brass filings.

For drilling brass, especially the small parts used in wireless apparatus, the ordinary hand drill with a twist bit such as that illustrated in Fig. 5 will generally answer all ordinary requirements. The drill should be run at a fair speed, and there is seldom any need to lubricate it unless a deep hole is being drilled, in

It is generally possible when using a small hand drill to feel the point of the drill break through the surface of the brass, and at this stage, instead of pressing on the drill to keep it in cut, the pressure should be removed and the drill stock held firmly, with a tendency to hold the drill back while still rotating the crank handle. The fluting of the drill will cut its way through, but the action of holding the drill back will prevent it running and turning up a big burr.

The use of a flat or diamond-point drill or straight-fluted drill is preferable in this respect, as there is no tendency for either of these to run.

Brass can be readily turned in the lathe, and Fig. 6 shows a typical piece of work held in a three-jaw chuck with the tool set up on the slide rest. For brass turning the tools should be keen, and generally most of the running down work is done with a simple, sharp, round-nosed tool either in the slide rest or by a hand metal-turning tool such as that illustrated in Fig. 7. A small amount of top rake is an advantage.

Brass can be soldered with ordinary tinman's soft solder if a hot, well-tinned iron be used and the brass thoroughly well cleaned and tinned. The methods of soldering are fully dealt with in the article on solder and soldering (*q.v.*).

The brazing of brass calls for particular care on the part of the operator, as if the heat is excessive the brass itself is melted, and if insufficient, a faulty joint is the result. The difference between the melting points of the brass and the spelter, or brazing brass, is not much more than 100° or so. For most amateur purposes the use of silver solder is preferable. The process is akin to brazing, and is sometimes known as hard soldering. It consists essentially of uniting the parts by

flowing a film of silver between the surfaces, using crushed or ground borax as a flux.

The polishing and lacquering of brass is an important item in wireless work. Fortunately, however, brass is readily polished, and an excellent surface can be

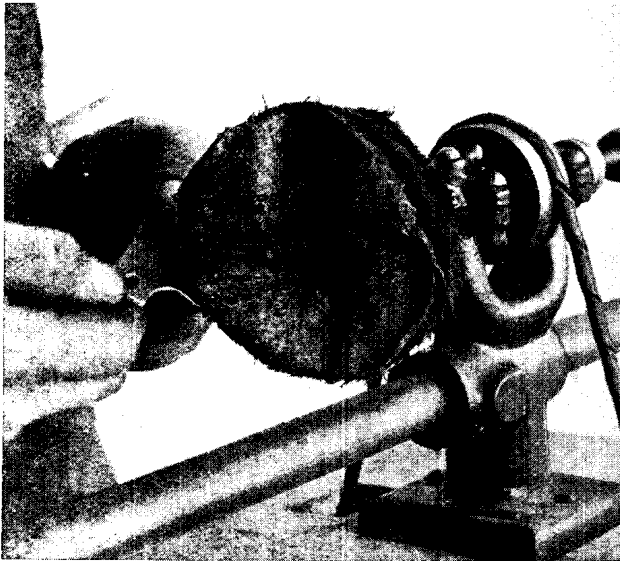

**BRASS POLISHING**

Fig. 8. Polishing small brass articles may be carried out with a calico mop and a small inexpensive polishing head. The operator is seen holding the brass article in position ready to engage the polisher

which case light machine oil or soapsuds can be used. With the ordinary twist drill there is a tendency for the drill to run just as it emerges through the brass. This is checked by holding the drill back just as it is about to emerge.

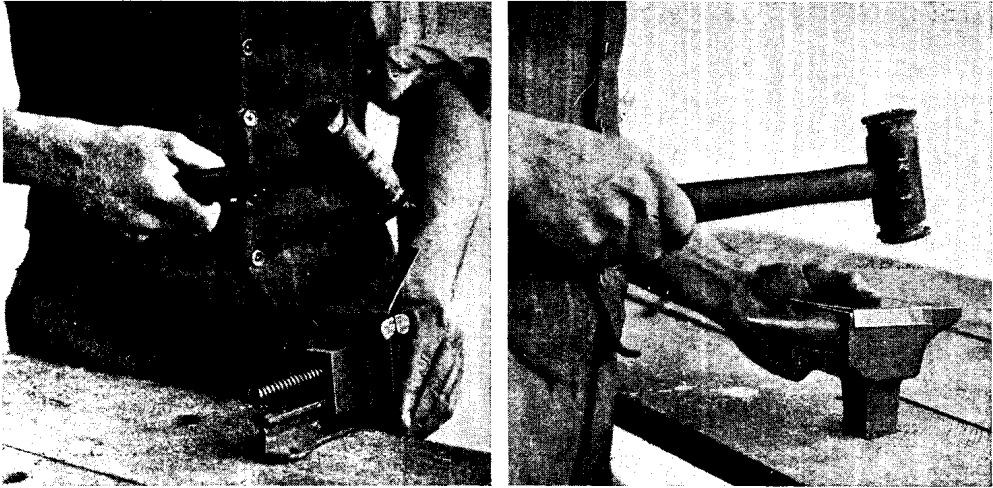

HOW BRASS ANGLE PIECES MAY BE BENT

Fig. 9 (left). Bending a brass strip. A hide-faced hammer is used to prevent the surface being bruised, as would be the case if a steel hammer were used. Fig. 10 (right). Completing the bending of a brass angle piece with a hide-faced hammer on a bench anvil

worked up either in the lathe with a calico mop, as in Fig. 8, or by hand with the use of very fine emery papers of a quality known as blue backs. The final polishing is effected by the use of rotten stone and oil, tripoli, and the usual polishing compounds.

Brass may be coloured with the aid of chemicals, which impart to it a deeper colour somewhat akin to gold, or very pleasing results may be obtained by the use of a blue-black bronzing acid which turns the brass a delightful bluish-grey colour. The process is dealt with under the heading bronzing (*q.v.*).

Brass when exposed to the air tarnishes readily, and consequently it must be protected in some way. The best method is a coating of lacquer. Discoloured or dirty brass can be cleaned with the aid of a weak solution of nitric or sulphuric acid, in water. The metal is dipped into the solution for a few minutes until it assumes a bright colour. It is then removed and thoroughly washed in clean water.

Among the miscellaneous operations on brass may be included metal piercing, which consists of cutting or fretting patterns out of sheet brass, the internal work being accomplished by merely sawing to shape with a fine metal piercing saw held in a saw frame, or by drilling a hole through the metal, threading the saw blade through the hole, attaching it to the saw frame and working internally.

The amateur is frequently called upon to bend brass, as, for example, to make an angle plate. The physical and mechanical properties of brass render it fairly ductile, and it can often be hammered to shape if reasonable common-sense methods be adopted. Brass should always be worked cold, and with the soft brasses the metal can be bent considerably before it fractures, and the hammering can be continued for considerable periods if the metal be annealed from time to time. The annealing process consists of heating the brass and maintaining it at a high temperature for some time, and then allowing it to cool off very slowly. The latter is the most important part of the operation, and should on no account be scamped. Hard rolled brass, such as strips, is a little more difficult to bend without breaking, and it is advisable to always make a slight curvature at a corner, rather than attempt an absolutely abrupt right-angle bend.

Possibly the best method for the amateur to adopt in making a right-angle bend in, for example, brass  $\frac{1}{2}$  in. wide and  $\frac{1}{4}$  in. thick, is to grasp it in the jaws of a vice. A pair of copper clamps is interposed between the jaws and the metal, and the latter is pressed over with the hands as far as possible, and finished by gently hammering it down with a hide-faced hammer as flat as possible, as in Fig. 9, and finally beating on the surface of a small bench anvil. For very important

work the first part of the bend can be made, the work then annealed, and the bending completed afterwards. Usually brass is most easily bent by hammering it over a shaped block of wood or metal. To avoid bruising the surface use a hide-faced hammer, such as that shown in Fig. 10, where a typical bending process of this nature is seen in an advanced stage.

Screw threads can be cut in brass with great ease, either in the lathe or with the ordinary type of screw-cutting tool, or struck up by hand with a chaser, or by the use of ordinary small stocks and dies. The latter are used for cutting screw threads on the outside of the rods, as in Fig. 11, while taps are used for making threads on the inside of holes. The hole

and nuts, terminals, connectors, and so forth, all of which are dealt with under their specific headings in this Encyclopedia.—*E. W. Hobbs, A.I.N.A.*

**BRASS CONNECTORS.** A term used to describe a variety of different methods of attachment used to connect the terminals of a battery or other pieces of electrical apparatus. Brass is generally used for such fittings, as it is tough and a good conductor of electricity. The connectors are dealt with in this Encyclopedia under their respective headings. *See* Connector; Spade Terminal.

**BRASS FOIL.** The name of a very thin brass sheet used for such electrical purposes as the construction of condensers, and for mechanical purposes, as the packing between the joints of some types

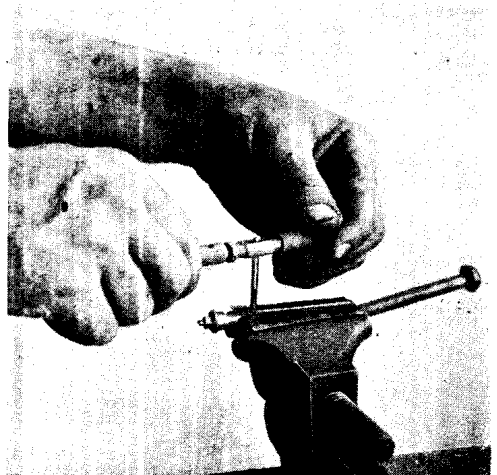

**BRASS SCREW CUTTING AND TAPPING BY HAND**

Fig. 11 (left). External screw threads are cut in this manner by the amateur with the aid of a small die and stock. Fig. 12 (right). Tapping a hole is here being carried out with a small hand tap, rotated by the tap wrench, held carefully between finger and thumb

is smaller in diameter than the screw to be inserted into it. The correct size for the tapping hole is most easily and accurately ascertained by referring to the standard drilling and tapping gauges, which may well form a part of every experimenter's tool kit.

Tapping is accomplished in the ordinary way by careful rotation of the tap, as in Fig. 12, which should be withdrawn frequently to clear the hole of any chips. If these accumulate excessively the tool will have a tendency to strip the threads and so ruin the whole job.

A great variety of manufactured components are made of brass, such as bolts

of bearing. It is so thin that it can easily be cut with a strong pair of scissors.

**BRAUN, FERDINAND.** Professor at the University of Strassburg and one of the leading world authorities on wireless transmission. As early as 1899 Braun was granted a patent for closed oscillating systems with an inductively coupled antenna. The system was claimed by Braun to possess a much greater efficiency than the directly coupled systems. The Braun transmitting set, as manufactured by Siemens and Halse, consisted of a large coil worked into an electrolyte interrupter, a set of Leyden jars, enclosed spark gap, oscillation transformer wound with

insulated wire placed in oil, and for the receiving set the standard type of coherer, relay and Morse register.

In 1899 Braun established communication between Cuxhaven and Heligoland, using aerial wires 90 feet high, and the inductive coupled aerial connexion for transmitting. In 1903 Braun joined with Slaby, von Arco, and Siemens to form the Telefunken system of transmission. Professor Braun was awarded the Nobel prize, with Marconi, in 1909, for his work in wireless.



**PROF. FERDINAND BRAUN**

Professor at the University of Strassburg, and a leading authority on and pioneer in wireless transmission

Braun has devised a method of directional wireless which depends upon the interference of electric waves travelling in the same direction but different in phase. Three simple vertical wire aeri-als are set up in positions corresponding to the angular points of an equilateral triangle, and oscillations are created in these which differ from one another in phase.

In 1897 Professor Braun published a description of his cathode ray tube, and afterwards pointed out, in 1902, how such a tube could be used to trace the forms of alternating current waves. *See Cathode Ray Tube; Oscillograph.*

**BRAZING.** Method by means of which metal parts are united by the use of a film of material known as spelter, an alloy of brass, or by the use of soft brazing wire. All metals are not united by this

means, as cast iron is much better treated by autogenous welding, but such metals as steel, wrought iron, copper, and brass are more usually united in this way. The process consists essentially in heating the metal to be joined, applying the flux, and following it with the spelter. The whole is then heated until the spelter melts or runs, so that when the object cools the surfaces of the metal will be firmly united. To ensure this result it is imperative to have the joint faces perfectly clean, a state of affairs that must be brought about mechanically by the aid of an abrasive such as emery paper or by the use of acids.

The apparatus required for such an operation is, first of all, a brazing blow-lamp or gas blow-pipe, the latter supplied with air by means of a foot or other bellows. Secondly, a good stout iron pan, preferably provided with legs and partially filled with cubes of asbestos or coke, is required, together with the necessary brazing material, which may be in the form of wire or in granular form, something in the nature of brass filings. A flux, such as borax powder, and some means for holding the work while the operation is being carried out are necessary.

#### How Spelter is Used

It will generally be found that the brazing material is more easily handled if in the form of wire. The latter is generally square in section, and obtainable in rolls. If spelter is used in the granular form, it is mixed with an equal proportion of ground or powdered borax and applied to the joint with a metal rod. The success of the operation depends a great deal on cleanliness at the start, and for this reason the surfaces of the parts to be jointed should be polished with emery cloth or a fine file. Other items that will be found useful are a packet of brazing pins and some soft iron wire, which will often be required to hold the joint together while the operation is in progress, so that the parts remain firm and do not move while the brazing is being carried out.

As an example of brazing applied to wireless construction, take the case of a light tubular steel mast to which it is desired to attach a flange plate of steel for support of the guy wires. This would be made first in the form of a sheet, and, after preparation, bent around the mast. The

whole of the steel tube adjacent to the joint and the parts of the flanged plate must be thoroughly and mechanically cleaned. To do this it must either be dipped into pickle, such as a dilute solution of sulphuric acid, and afterwards thoroughly washed in hot water, or, more conveniently, have wiped off any trace of dirt and grease by the use of turpentine. The parts should then be rubbed up with coarse emery paper until the surface of the metal is perfectly clean and bright. The least trace of grease or dirt on the work is absolutely fatal to the success of the operation, as when the metal is heated the grease will burn and leave a deposit and make it impossible for the flux to flow properly.

The next step is to prepare the borax solution by taking a piece of lump borax, moistening it with water, and then grinding it to a paste on a piece of clean slate. A kind of creamy froth will work up as the result of this operation, and this is applied to the whole of the joint surfaces by means of a clean brush or a little

stick of wood. The plate is then placed in position on the steel tube and held there by binding around the outside with a piece of soft iron binding wire.

Some spelter and some of the borax is then built up around the outside of the joint, somewhat in the manner illustrated in Fig. 1. The job is then placed in the brazing pan, and coke or asbestos cubes built up around it to prevent loss of heat by radiation. These parts should not, however, come actually in contact with the work, otherwise the dirt from them will spoil the job. The work has to be heated first with a kind of stroking motion of the hot flame of the blow-lamp. This will cause the borax to bubble and turn quite white. Directly this is noticed the flame should be turned on to the joint, which should be heated as uniformly and as rapidly as possible, keeping a close watch meanwhile that the bubbling of the borax does not displace the spelter. As soon as this is seen to happen, a fresh supply of spelter and borax should be applied from the end of a piece of iron wire which has been beaten out to form a crude type of spoon.

If the work is watched closely the spelter can be seen in the molten state flowing over the surface of the metal, and to cause it to flow right through the joint it is necessary to remember that the molten brass will always follow the heat. If the metal should be hotter on the upper part of the job, the molten metal will flow an appreciable distance upwards. It is best, however, to follow the natural course of things and work downwards. For this reason the metal should first be heated on the upper part and the heat gradually drawn down as the spelter melts.

If properly done there will be a complete film of brass uniting the whole of the joint surfaces, and in this condition, practically speaking, the flange plate can be considered as being solid with the tubular part of the mast itself. Directly the brass has been observed to flow through the

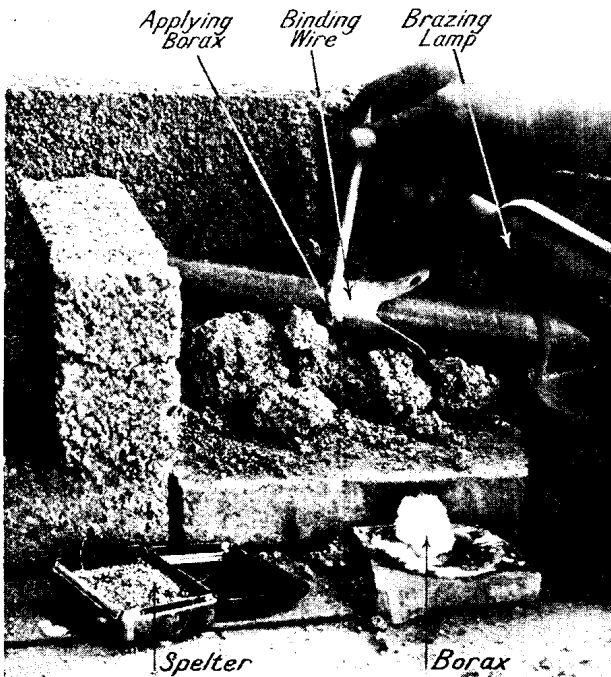

PREPARATION FOR BRAZING

Fig. 1. Before the actual operation of brazing is carried out the parts are secured with binding wire and the two joint surfaces painted with the flux. This should be done as above while the objects to be brazed are in position

joint the heat should be removed and the job left undisturbed until it has cooled down to a black heat.

It is necessary in such brazing work to get the steel to a dull red heat for the spelter to run freely. It must not, however, be overheated, or the brass itself will be burnt. This is evidenced by a bluish-coloured flame appearing on the surface of the work, and this should not be confused with the normal blue colour of the heating flame.

Directly the job has cooled down to below black heat it should be removed from the pan, using a pair of gas-tongs or the like, and brushed with a stiff steel wire brush. This will remove the bulk of the scale, especially if it be done at the right moment—that is, when the brass is set and the scale still in a plastic condition. The job should not be cooled by pouring water on to it, but should be left to cool down gradually, after which the work is cleaned up by filing with old rough files and finished with emery paper in the usual way.

An alternative method is illustrated in Fig. 2, which shows the use of a paraffin blow-lamp in the brazing of a collar on to a tube.

With any paraffin blow-lamp operations the difficulty is that unless a large lamp be used the heat is only just sufficient for the purpose, unless the work is well protected. In the example illustrated the brazing material is in the form of soft brass brazing wire. Ground borax is applied as previously described, the job brought up to a red heat, and the end of the stick of brazing wire brought into the flame of the lamp, when it will speedily melt, and can be flowed on to and around the joint, after which it is worked through by manipulation of the flame as previously described.

Some prefer to use the borax in a dry state, in which case it is simply applied to the work after it has been slightly warmed up. An iron wire spoon is brought into the flame of the lamp and thereby heated, and plunged into a tin full of crushed borax, when a quantity will adhere to the spoon. This is then applied to the joint

surfaces, and as it heats it will flow on the metal and remain. With this system there is more chance of the inexperienced experimenter getting trouble, because the surface of the metal will oxidize if any other part of the flame than the hot point be applied and the inner part of the blow-lamp flame allowed to play upon it. The whole purpose of using borax, or any other flux, is to prevent the surface of the metal oxidizing, and also to act as a vehicle for the molten brass.

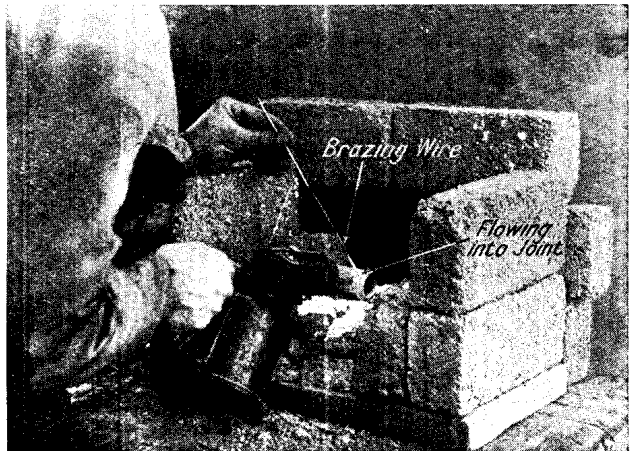

USE OF FIRE-BRICKS IN BRAZING

Fig. 2. Brazing wire is being applied to the heated metal while the collar is being brazed to a tube with the aid of a paraffin blow-lamp. Loss of heat by radiation and draughts is prevented by the built-up fire-bricks

Several excellent brazing compositions are on the market, such as Boron Compo. This is used in the same way as the borax, but is not so liable to scaling, and if brushed vigorously just as the job is cooling off, practically the whole of the compo can be brushed off, thus saving labour in filing up and finishing.

Quite small brass and copper parts can be brazed in the same way, but in this case very soft brazing wire, or soft spelter, must be used, and care taken not to melt the brass or copper object. A better plan is to use silver solder (*q.v.*).

To protect the steel work from the effects of the scale, it can be coated with any of the proprietary brands of anti-scale. Aluminium can be brazed by the use of the proprietary fluxes and brazing mixtures specially made for the purpose, and by the most strict adherence to the makers' instructions. Essentially, by many processes, the edges of the joints are bevelled.

A brazing composition is introduced in the bevel and the whole heated until the composition melts, when it is then worked into position with a hot copper soldering bit or with a steel wire brush. See Aluminium; Brass.

**BREAKDOWN VOLTAGE.** The voltage necessary to break down a dielectric. The subject is of some importance to the wireless experimenter, especially as regards transformer and telephone winding insulation, or any apparatus liable to a sudden rush of high-tension current. The ability to resist breakdown is a necessary quality in a dielectric or insulating material. The relation between the breakdown voltage and the dielectric strength is given by the following formulae, due to Baur:

Let  $d$  = the thickness of the dielectric in millimetres,

$V$  = the potential difference in volts,

$c$  = a constant representing the potential difference in volts necessary to break down a sample of the dielectric 1 mm. thick,

Then  $V = cd$ .

Typical values of  $c$  are, for dry air 3,300 volts, Empire cloth 12,500 volts, mica 58,000 volts. See Dielectric Strength.

**BREAKING IN.** Term used to indicate the interrupting of a transmitting station during transmission. The aerial circuit of a transmitting and receiving set contains a long-break heavy insulated switch to change over the apparatus from transmitting to receiving, *i.e.* breaking in. The same result is obtained with the Marconi earth arrester, which consists of two heavy plates separated by a thin mica washer. The oscillating currents in the aerial spark across during transmission, but are unable to do so during reception. See Earth Arrester.

**BRIDGE.** Term used in wireless for various forms of measuring instruments. One of the best known bridges is the Wheatstone bridge, an arrangement of conductors used for measurement of resistance. The main principle of all bridges is that there are a number of points joined by wires to form a set of closed circuits which are interconnected. When an electromotive force is applied to the system currents are set up in the conductors and the relationship between the currents is expressed by Kirchoff's corollaries of Ohm's law. By these corollaries the algebraic sum of the currents at any junction is zero, and the algebraic sum of

the products of the currents in each conductor and its resistance is equal to the algebraic sum of the electro-motive forces of the circuits. Expressed in equation

$$\begin{aligned}\sum(C) &= 0 \\ \sum(CR) &= \sum(E)\end{aligned}$$

In the simple Wheatstone bridge there are six wires. Four form resistance arms arranged in a rectangle or lozenge-shaped diagram. A fifth wire joining two opposite corners with a galvanometer in it is called the bridge wire, and the last wire joins the other corners of the resistances to a battery. It is shown in the article Wheatstone bridge how, if three of the resistances are known, the fourth can be calculated.

The Anderson bridge is a form of Wheatstone bridge which enables small inductances as used in radio-telegraphic work to be calculated. An important

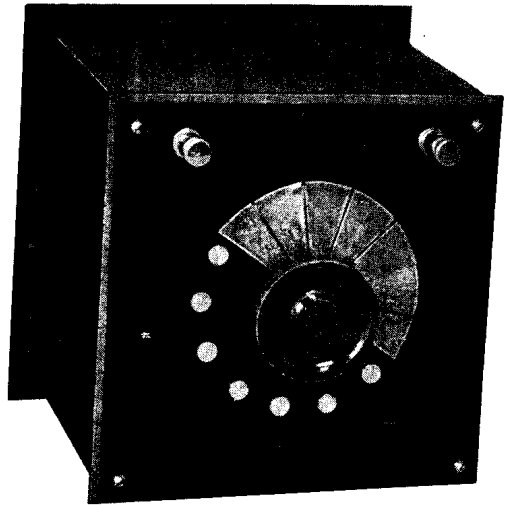

**BRIDGING CONDENSER.**

Increase of range of a variable air condenser is obtained by means of a bridging condenser, which is a form of variable condenser, as shown above. This has a multi-contact brush

bridge for the measurement of the mutual inductance of two coils is the Carey Foster bridge.

A barretter or bolometer bridge is a Wheatstone bridge containing a fine wire which is heated by high-frequency currents, so increasing its resistance and enabling the high-frequency currents to be measured. See Anderson Bridge; Foster Bridge; Wheatstone Bridge; Bolometer.

**BRIDGING CONDENSER.** A form of variable condenser consisting in a typical example of a subdivided condenser with a mica dielectric. The condenser has a



number of taps which are connected to the appropriate stud contacts. The sections are of unequal capacity. At the minimum values the taps are closer together than at the maximum end. They are brought into action as required by the movement of a multi-contact brush contact arm, as shown in the illustration. The construction of the condenser calls for good workmanship, as the plates ought to be well impregnated and carefully insulated to guard against leakage and to maintain a constant capacity value under all normal conditions of service. It is used to increase the range of a variable air condenser, or as a bridging condenser when a continuously variable value of capacity is not essential.

**BRIDLE.** A short rope with a thimble or eye worked at each end and a similar thimble in the middle or bight of the rope. It is used to support a spreader for an aerial. The illustration shows one way of arranging a bridle. In this case it is made of rope  $1\frac{1}{2}$  in. in circumference and 10 ft. in length. The thimbles are the ordinary galvanized iron pattern, and are worked into the ends of the rope by turning the rope around the groove in the thimble and either splicing the rope together or laying the rope alongside the other part of it immediately where it leaves the thimble, and seizing or binding it firmly together with copper wire or strong, thin cord. It is better to use copper wire, as this is more durable and is not so susceptible to atmospheric conditions and changes.

In this case the binding is applied by first placing the end of the copper wire between the two ropes where they are to be jointed, at their junction with the thimble, and then turning the wire abruptly at right angles and twisting it round and round the two ropes, drawing each turn as tightly as possible. Continue binding for several inches. The end of the wire must be laid in the direction of the rope and bound away from the thimble, so that when the binding is in place it will hold the copper wire firmly in position.

The end of the binding is finished in a somewhat similar manner, by cutting it off so that about 6 in. or so remain. This end is then tucked down under the last three turns, brought up between them, tucked down again, and then drawn tight. If desired, the end of the wire can

be further secured by soldering. The eye in the bight of the rope is seized in the same manner. It is important to draw the two parts of the rope very tightly together with the binding wire, as a great deal of strain falls upon this particular part.

The ropes used for a bridle should be of good quality, of galvanized iron wire

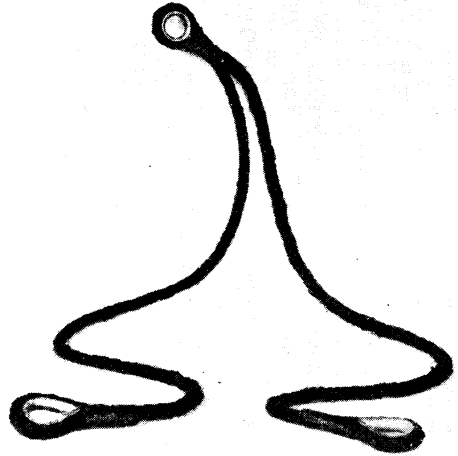

**BRIDLE FOR A SPREADER**

This form of bridle is frequently employed for wireless aeriels. Note the thimbles at each end and the manner in which the rope is bound

or of hemp, and may be tarred, or purchased ready for use prepared in that way. For usual amateur purposes an excellent bridle can be made from an ordinary standard scaffold cord. This measures about 12 to 16 ft. in length and  $1\frac{1}{2}$  to 2 in. in circumference, is supplied ready tarred, and is probably the most convenient way for the amateur to obtain the requisite supply of rope.

**BRITISH BROADCASTING COMPANY.** Company formed in 1922 for the purpose of instituting and conducting the broadcast wireless service in Great Britain. The capital of the company is £100,000, and is guaranteed by the British Thomson-Houston, the Marconi, the General Electric, the Metropolitan Vickers Electrical, the Radio Communication, and the Western Electric Companies. Membership of the British Broadcasting Company is open to British manufacturers of wireless apparatus on the taking up of one or more shares.

The company operates under licence from the Postmaster-General, who undertook to issue licences for receiving sets only to those who buy their wireless sets from members of the company. Each such set must bear the B.B.C. seal, royalties from which provide the company with part of its revenue.

The British Broadcasting Company has stations operating in London, Birmingham, Manchester, Newcastle, Cardiff, Bournemouth, Aberdeen and Glasgow, and a system of relay stations is planned, enabling the owner of a crystal set to listen in any part of the country. See *Broadcasting; Transmission*.

**BRITISH SYSTEM OF UNITS.** One of the two fundamental systems of units, the other being the C.G.S. system. In the British system of units the foot and the pound are the standards, and the system is sometimes referred to as the foot-pound-second system. In the C.G.S. system the

centimetre and gramme are the standards of length and mass, and the system is also known as the metric system. The fundamental unit of time is the same in both systems, and is the mean solar second. In the British system the unit of force is the poundal, that force which in one second retards or accelerates the velocity of a mass of one pound by one foot per second.

The corresponding unit, used largely by engineers, is "the weight of one pound," the force equivalent to the attraction of the earth on a mass of one pound. This unit, though a practical one, varies with the place of observation. The practical unit of work is the foot-pound, the absolute, the foot-poundal. The unit of power is the horse-power. The unit of heat, known as the British Thermal Unit, is the amount of heat required to raise one pound of water through one degree Fahrenheit. See *Units*; also under the names of the various units.

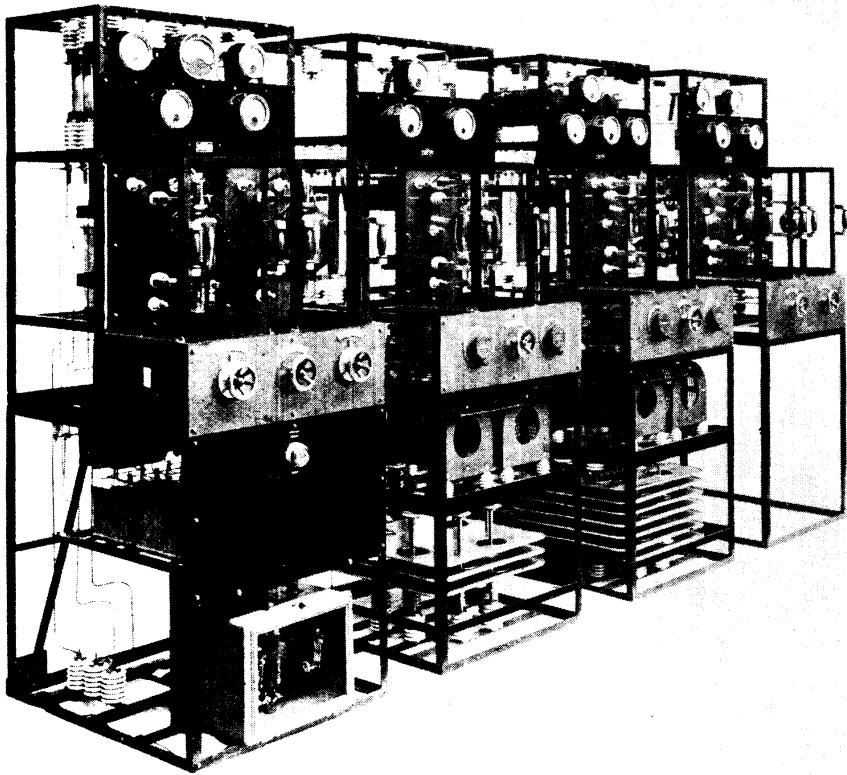

STANDARD TRANSMITTING APPARATUS FOR BROADCASTING

Fig. 1. British broadcasting stations transmit their daily programmes to the general public by means of apparatus of which the above is a typical example, such as is used at the London station, 2 LO

## BROADCASTING : (1) GENERAL PRINCIPLES AND METHODS

By Richard Twelvetrees, A.M.I.Mech.E.

Here is given a general account of the methods of Broadcasting, which is followed by a second dealing with the engineering problems that arise. Almost every article in this Encyclopedia is related to the subject, but particularly the reader is referred to articles under the names of the various broadcasting stations, e.g., London, Manchester, the Hague, etc. See also Crystal Receiver; Licence; Transmission; etc.

To give a fairly accurate idea how broadcasting takes place, it is necessary to outline a few of the broad principles upon which wireless transmission is based. The basic principle is that the electric circuit, having the properties of capacity and inductance, is capable of producing electric oscillations of definite frequency.

To explain the propagation of light and other forms of energy, the hypothesis of the existence of ether has been formulated, a medium which is supposed to permeate uniformly through all space and matter. Any electric disturbance that takes place sets a series of electrical waves in motion in this medium, and these waves spread out in all directions. Now an electrical circuit, such as the one described, possesses the property that whenever it is oscillating, waves are set up in the surrounding ether and propagated in all directions with the same frequency as that of the oscillations in the circuit. All wave propagation in the ether takes place with definite velocity, namely, the speed of light, 186,000 miles per second, or 300,000,000 metres per second, and the connexion between the wave-length and frequency is given by

$$\text{Wave-length in metres} = \frac{300,000,000}{\text{Frequency per sec.}}$$

The strength of the electric waves, in simple terms, depends on the extent of the circuit, and it therefore follows that if the condenser is replaced by an aerial system in which one plate is represented by the earth and the other by wires suspended high in the air, we shall obtain a system capable of giving a large amount of radiation for a definite amount of power.

### Importance of a High Aerial

It also follows that the higher the aerial can be fixed, the greater is its efficiency—a point that is widely recognized by wireless experimenters. Having considered the influence of a good aerial system, it becomes necessary to supply the aerial with continuous oscillations of a definite frequency. There are several methods of supplying the aerial in this manner, but at the present time the most widely adopted is that of

employing the high-power three-electrode valve, or thermionic tube, as a generator of sustained electrical oscillations of constant magnitude.

It is essential that for good radiation very high frequencies be employed, the result of practical experience indicating that the wave-lengths used in wireless work vary from 50 metres up to 20,000 metres, the larger power stations usually working on the highest wave-lengths.

In this country all control of wireless communication is in the hands of the Postmaster-General, and for general broadcasting purposes a band of from 350 metres to 425 metres has been allotted. These wave-lengths are particularly suitable, because within these specified ranges very efficient transmitters can be operated. From the formula previously given, a simple calculation shows that the frequency used in ordinary broadcasting operations is in the neighbourhood of 750,000 per second. This high frequency or radio-frequency of the actual transmission must not be confused with the low frequency of speech waves in the air, the latter being of a totally different order, within the rough limits of from 20 to 4,000 per second.

### Purpose of the Microphone

To understand how wireless telephony is transmitted, we have to consider the method of supplying the aerial system with high-frequency oscillations. Suppose we have a wireless signal of constant strength and known frequency, say 150,000 per second, radiated into space and the strength of these oscillations is varied at low frequency, say about 2,000 per second, we get a musical note radiated at the latter frequency.

By means of the microphone we can convert sound and speech, *i.e.* air pressure waves, into variations of electric current, and then by suitable amplifying apparatus vary the strength of the electric waves radiated to correspond electrically to the acoustic variations of the air pressure in front of the microphone. The constant strength wave thus sent out is called the

carrier wave, the variation of its strength being called "modulation." Full modulation means a variation of the carrier wave from zero to twice its original value. Variations above this degree result in breaking up the oscillations, and thus destroying the character of the signals transmitted. The main point to observe at this point is that the carrier wave oscillations take place at high frequency, and the modulation or variations in the carrier wave at low frequency, or at that of ordinary speech.

When electric waves pass by an oscillatory circuit which is tuned to the same frequency, currents are induced in it varying exactly in proportion to the currents in the transmitting aerial, though of much less magnitude. By including the receiver circuit condenser in the aerial and earth system, the reception can be improved, but even in this case the currents are very small and the most sensitive indicator of these small currents is a combination of the telephone receiver and the

directional impulses, which register a definite low-frequency motion in the diaphragm of the telephone. This latter action produces low-frequency sound waves corresponding exactly with the modulations of the transmitter.

The above describes the main outline of transmission and reception of wireless telephony, which brings us to a consideration of some of the details of the various apparatus used to produce the results described, beginning with the microphone. The actual conditions surrounding the microphone have been the subject of much technical controversy. At the present time most of the broadcasting studios are thickly draped with sound-resisting materials so as to eliminate all possible chances of echo. Until certain concerts were transmitted from large halls with a pronounced echo effect, the arrangement appeared quite satisfactory.

The type of microphone generally employed is of the carbon granule variety. In practice, the rule is to develop quality of production in the microphone at the expense of sensitivity if needs be, and so with some forms of instrument eight or nine stages of amplification are adopted. The main difficulty of the broadcaster is to get a perfectly even reproduction throughout the whole range of sounds falling upon the microphone, so that no particular notes or tones predominate or develop resonance, and this point presents numerous problems. The shape of the instrument and its case, the nature and dimension of the diaphragm, and many other similar technical points call for close attention, the matter being finally treated with a sort of compromise, whereby the most satisfactory average results are secured.

The characteristics of the amplifier also present a complicated problem, because the necessary use of transformers in connexion with the apparatus produces some kind of resonance, which is more or less bound to become emphasized at some particular range of sound unless the design is worked out with the most minute care.

Whilst an actual transmission is taking place, very careful note must be taken of the strength of the music or speech as heard at the end of the speech amplifier. The maximum strength allowable to operate the transmitter without loss of quality is known, and there is always an operator on duty at this point to regulate the control of the apparatus. Part of the duty of this

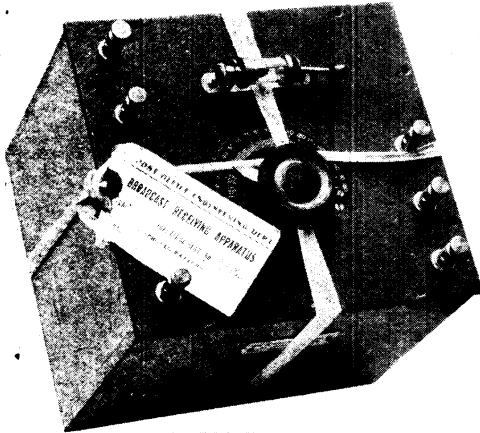

G.P.O. SEAL ON B.B.C. SET

Fig. 2. Approval of the Postmaster-General of the pattern of a wireless set for broadcast reception having been obtained, the model is closed and sealed. Copies of it may then bear the B.B.C. stamp

human ear. Unfortunately, the telephone will not respond to the high-frequency oscillatory currents used in wireless transmission, the currents collected by the aerial being essentially of high frequency, though modulated to low frequency. This difficulty is overcome by using a rectifier in series with the telephones, the action of the rectifier being to convert the high-frequency oscillatory currents into uni-

operator is to control the musical balance of an orchestra, to see that the sound of no one instrument predominates.

Coming now to the transmitter proper, the present British broadcasting stations produce a carrier wave by means of an oscillating valve which requires an amount of electrical energy amounting to  $1\frac{1}{2}$  kilowatts. In some cases, to ensure the constancy of the wave-length, an independent drive valve is used, which varies the grid potential of the oscillating valve to the correct frequency, and the system used for modulating the carrier wave in all cases is by means of choke control.

The amplified speech currents from the microphone are applied to the grid of a control valve (or bank of valves in parallel) giving large variations in the control valve anode current. The control or oscillating valves are fed from the same high-tension current through a very highly inductive choke coil, which ensures a constant flow of current to the two anodes. Hence, when the control valve takes a larger amount of current than it does normally, the strength of the current to the oscillating valve decreases, thus affecting the carrier wave in a similar manner. The power valves used in transmission stations require a great amount of current, varying from between 5,000 and 10,000 volts. At the Manchester broadcasting station the energy is supplied by a direct current dynamo giving out 5,000 volts. At London the main alternating current supply is stepped by means of transformers, and is then rectified by large valves and smoothed out, giving a direct current of 8,000 volts.

The last parts of the transmitting apparatus consist of the aerial and earth, the former consisting of the cage type, giving large capacity and small resistance. The earth connexion, which should appear to be quite a simple thing to effect, is a troublesome problem at many of the more important transmitting stations. Sometimes, when the instruments are housed

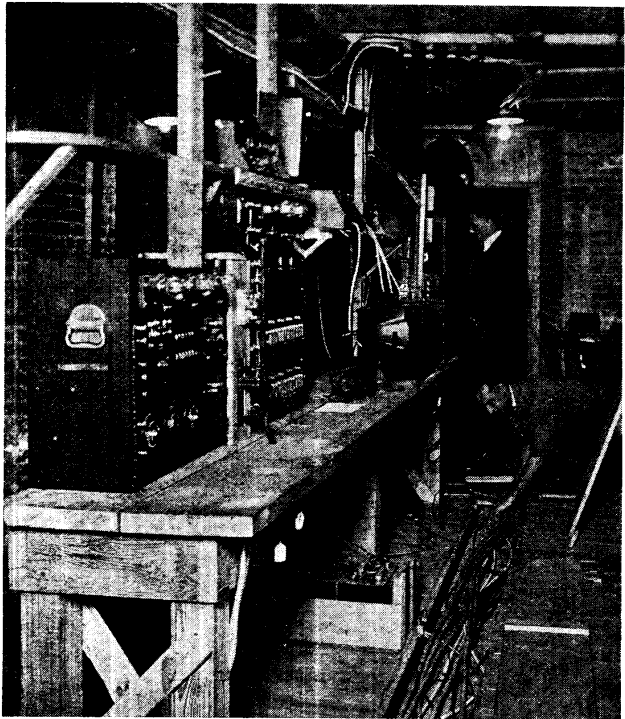

#### SOUND AMPLIFYING FOR BROADCASTING

Fig. 3. Broadcasting by land-line relay is carried out by using an apparatus of this kind. Here the instruments for amplifying are seen installed beneath a theatre

in steel frame buildings, the structural metal is found to give excellent results when used as an earth, and by way of contrast it has been discovered that large masses of metal sunk at the bottom of a canal have not at all come up to expectations in this respect.

If we now assume that the microphone is giving out the very best results and that no kind of fault exists in any part of the transmitting apparatus, and finally that suitable receiving apparatus is installed, it might be well supposed that the troubles of the broadcaster are at an end. Such, however, is not the case, for the real difficulties, in point of fact, only begin after the waves have left the transmitter.

The receiving apparatus will have to conform with certain definite conditions. The essential parts are the earth and aerial system, the tuning circuit rectifier, and telephones. The simplest class of instrument is the crystal set, which, though cheap, can be made to give excellent results over a comparatively limited range of operation.

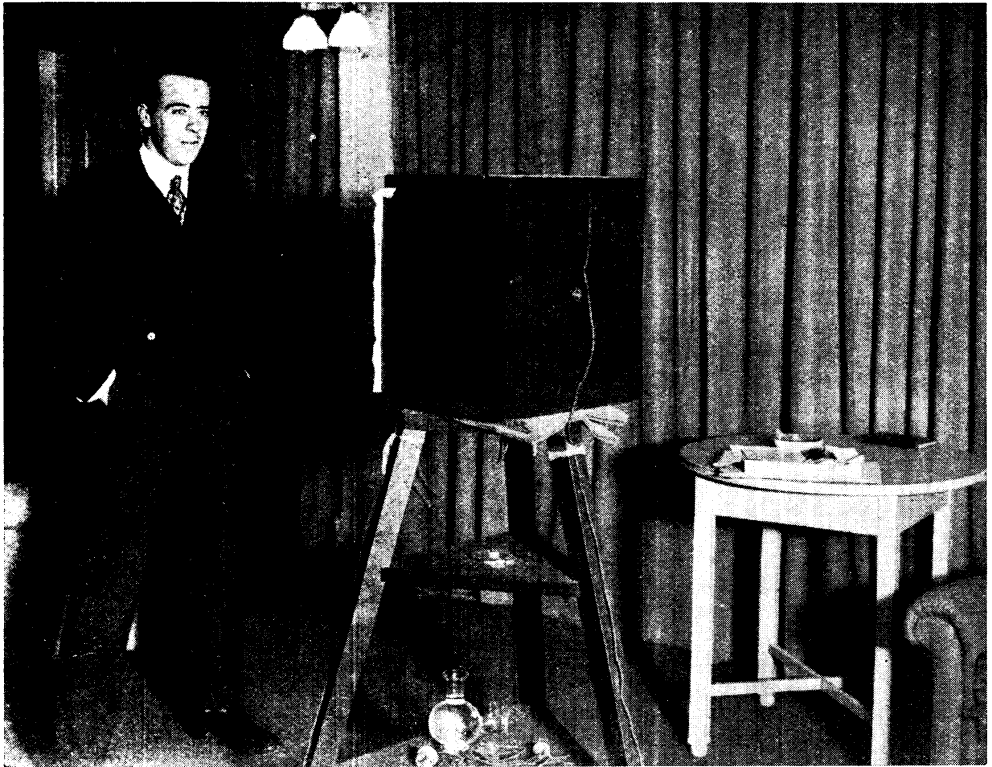

#### CHIEF ENGINEER OF THE BRITISH BROADCASTING COMPANY AT THE MICROPHONE

Captain P. P. Eckersley in the studio at the London station, 2 LO, which is situated at Savoy Hill, by the Thames Embankment, and right in the heart of London. As Chief Engineer, Captain Eckersley is responsible for the mechanical operation of broadcasting from all B.B.C. stations throughout the country. His name is associated with the well-known experimental station at Writtle, which, before broadcasting became general, transmitted concerts regularly

In the more complicated valve sets the valve can be used as a rectifier, with additional valves for the amplification of the high frequency before and low frequency after rectification. Very good results can also be obtained by using the ordinary form of crystal detector with valves for the purpose of amplification in the same manner as is adopted in valve rectification sets.

In transmission, a modulated carrier wave is propagated over the surface of the earth and into all space with the speed of light. During the daytime the waves become ionized, due to the action of the sun. This means that minute particles of gas, which, considered electrically, are normally neutral, become charged with positive and negative current. The ionization is very small near the earth's surface, but increases considerably at different distances from the surface. Electric waves can only travel

with great difficulty through an ionized atmosphere, and become absorbed, or, in other words, the waves are said to "fade."

Thus during the daytime the waves sent out from the broadcasting station are practically confined to the surface of the earth. When the sun sets, the particles of air become neutral again, starting from the earth upwards, and this results in raising the layer of ionization to a certain height, where it remains until the next morning. The under side of this layer reflects electric waves, so that at certain distances from the transmitting point two separate waves are received, that is, the surface of the wave and the reflected wave, and these may combine to give very loud signals, or, conversely, oppose each other so as to reduce the signals to a degree of inaudibility. These waves may also combine so as to produce remarkable distortion, in which case ordinary speech becomes unintelligible.

In addition to the effects produced by fading and distortion, signals may be subject to considerable interference from other electrical discharges, such as Morse signals sent out from ships or from discharges known as atmospherics. These latter are produced by magnetic and electrical disturbances all over the surface of the earth, and the only remedy for these adverse conditions seems to be that of increasing the power of the waves sent out from the transmitting stations, so that they may subdue atmospheric interferences by sheer electrical force.

Another problem is the interference set up by the action of local valves used in private receiving sets, for the result of faulty adjustment in a valve set is to convert the aerial into an element of a transmitter. The oscillations thus being sent out are generally powerful enough to interfere seriously with the reception of listeners for a range of several miles round. In a very large number of cases the offenders are quite unconscious of the trouble they are causing.

The organization of a broadcasting concern is a matter which involves a large amount of technical as well as administrative ability, especially when one considers the vast amount of influence the transmission of information may have upon moulding public thought into certain directions.

The question of relaying or transmitting simultaneously from a central station is one that opens up a very large field of usefulness. In this case the various stations are linked up with headquarters by Post Office trunk lines, but one development that may be expected is that of relaying by wireless and not by land lines. Stations may be erected near the towns where the main transmission is picked up and after amplification the waves sent out again for local short-range receivers.

It is obvious that broadcasting is not confined to the amusement and entertainment of the public, for recent experiments in connexion with transmission and reception as applied to moving automobiles open up a remarkably valuable field. The London police authorities have not been slow to realize how wireless can aid them in tracking down criminals, and by a system of transmitting code messages in wireless and the use of portable transmitting and receiving sets the whole country can be linked up so that simultaneous communication can be set up all over the country. It is actually possible to transmit and receive messages and deliver instructions to the officers on cars that may be travelling at forty miles an hour, from which it will be seen that broadcasting has peculiar adaptations in the interest of public safety.

## BROADCASTING : (2) THE ENGINEERING PROBLEMS

By Captain P. P. Eckersley, Chief Engineer, British Broadcasting Co., Ltd.

Our contributor, who is well known to "listeners-in" throughout the British Isles, discusses the technical difficulties that face the engineer in carrying out the broadcasting of popular musical and vocal programmes by wireless telephony. Mainly, he is concerned with the question of quality of reproduction

To rid oneself of catchword formulae and to come to real essentials, what is the ultimate aim of the engineer-in-charge of a broadcast scheme? The answer at first sight is obvious, and is: "To ensure that every single one of the subscribers is easily able to receive a popular broadcast." But, strangely enough, human nature being what it is, there must be a rider to this dealing with the man who wishes not only to hear a local station, but is interested in long-distance work. So the question might be answered: "To ensure that every one of the subscribers is easily able to receive a popular broadcast, and has also the possibility of 'tuning in' to distant telephony stations."

Were it a question of simply fulfilling the conditions of the first answer, and had the engineer no worries as to the enthusiast who wishes to tune in distant stations, the solution of the problems would be extraordinarily simple. The erection of two stations in the British Isles, one in London and the other in the heart of the industrial north, each using a power of 20 kilowatts to the aerial on a wave-length of 2,000 metres, would satisfy the conditions admirably.

But what of the dweller in North London who wanted to hear the northern station? Would he be able to tune out London? Probably not, unless the wave-lengths were widely separated.

If one station worked on 2,000 and the other on 1,000, perhaps the conditions might be fulfilled, and crystal reception at ranges up to hundreds of miles might be possible.

Two stations of this power and wave-length in England would, however, blot out a very considerable number of other commercial stations, so the whole scheme would never be sanctioned by authority—and quite rightly

Thus a shorter wave-length must be chosen, since the undesirable "broadness of tuning" becomes practically less at shorter wave-lengths.

**Difficulties with Short Waves**

Short wave-lengths have, however, the undesirable quality of being easily absorbed, even though the radiation efficiency of small aerials is largely increased by their use. Thus, at small ranges short-wave stations are relatively very powerful, but their power falls off very quickly with increasing distance. The phenomenon of fading is largely manifest with shorter waves; and one may sum up by saying that short waves serve small areas very well. Increasing power to increase the range is, to my mind, uneconomical and unnecessary, and furthermore—and this is important—it stops the possibility of listeners tuning out their local stations in order to experiment on distant reception.

The problem is, therefore, solvable by dividing up the country to be exploited into areas, and using about 500 to 1,000 watts in the aerial for these main areas.

It will, however, be found even then that reception over 30 miles is really not much good (true, a lot can be heard, but it is confused with "mush," and the listener is at the mercy of jamming and local interference), and the remaining areas should be served by other smaller stations or relay stations, mainly "repeating" the main station broadcast, until the ideal of reception anywhere from a relatively powerful transmitter by a robust receiver is attained.

This, to my mind, constitutes the real solution of the engineer's problem as regards the disposition of the stations, their power, and so on.

The only problem remaining is that of good quality (meaning thereby the faithfulness of reproduction). It is most elusive, but it must be our constant aim to find it. Sound frequencies, or the frequencies

of sound detectable by the human ear, range from 50 a second to about five to six thousand a second for all practical purposes.

The ear's response to a particular amplitude and frequency is a purely arbitrary factor, but it is a good basis to assume that the ear apprehends the same amplitude at all audible frequencies equally. This is probably not true, but it serves as a basis first of all.

Thus, if we could obtain a microphone (which is the instrument that converts sound into electrical energy) that gave for the same amplitude of sound at all sound frequencies the same amplitude of electrical energy, we should have achieved a basis.

Not only should we have achieved an arbitrary basis, but also a practical basis for the following reason.

Whatever frequency is considered, there is a limiting amount of amplitude that a broadcast transmitter will stand; obviously one can over-control. Now, suppose that the microphone gives a maximum response of 10 to a frequency of 1,000, but only a response of 2 to a frequency of 200, and perhaps of 1 to 6,000, then, obviously, the thousand frequency limits the amount of overall control that can be given to the set. With a "straight line" microphone or one which gives equal electrical amplitudes for equal sound amplitudes, no single frequency will limit the overall control.

This is made clear from the diagram. A, B in Fig. 1 is the limiting amount of amplitude that the set will stand, and the cross-hatched area is the overall amount of control with a resonant microphone.

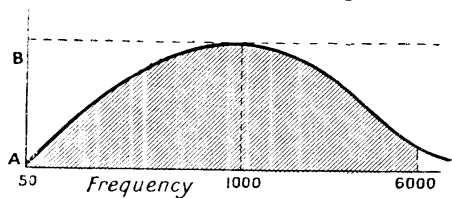

Fig. 1. Limiting amount of amplitude is represented by AB, and the overall amount of microphone control the cross-hatched area

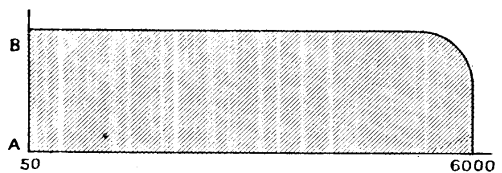

Fig. 2. In this diagram the cross-hatched area being larger than in Fig. 1, the aperiodic microphone gives a larger overall control

**MICROPHONE CONTROL**



In Fig. 2 it will be seen that the aperiodic microphone gives the maximum possible overall control, since the cross-hatched area is larger in Fig. 2 than in Fig. 1.

Thus, as a basis, it would seem desirable to have an aperiodic microphone.

But it has been said that the ear's response to various frequencies may not be uniform, and the "audition curve" may take a purely arbitrary shape. If correction be needed, therefore, it should be done (obviously, from the above argument, overall control being an essential quality for practical considerations) at the receiver and not at the transmitter.

Thus, if we send out the arbitrary basis, the ordinary cheap receiver will get fairly faithful reproduction: the perfect receiver will be only within reach of the comparatively rich. This is a good point politically, as it gives the manufacturer a better chance to compete with the home maker.

#### Don't Overwork Your Valves

As a fundamental and guiding principle, I would earnestly advise those who are looking for really faithful reproduction to remember that too much magnification per valve is the greatest fault. Beware of the man who receives and boasts of receiving a distant station on few valves. He is being misled by the catchword efficiency; he can worship only noise. Ninety per cent of the troubles of quality come about because people will use too few valves, and work their valves far past the distortionless limit.

From what has been said previously, obviously the function of the microphone is to convert the sound waves existent in the adjoining air from variations of air pressure to variations of electrical pressure. Furthermore, it is necessary to have an arrangement whereby equal amplitudes of sound at *any* frequency gives equal amplitudes of electrical potential.

There are two types of microphone in use in England to-day that merit serious consideration, each embodying different ways of obtaining the desired aperiodicity.

The Western Electric Co.'s gear consists essentially of a diaphragm instrument with carbon buttons, and the diaphragm is so tightly stretched as to have a resonance at some 10,000 a second, thus possessing *no* resonance below this period. But in doing away with resonance the sensitivity of the arrangement

is largely decreased, and hence it is necessary to use an amplifier to bring the speech up to the correct strength for the in-put to the wireless telephone control system proper. The magnification of the amplifier is controllable on the instrument itself, so that the operator can avoid giving too much or too little control energy to the transmitter.

The Marconi Co. have developed a microphone for use with broadcast, and this embodies an entirely different system. A flat coil wound in a single layer making an annular ring lies freely in a magnetic field. The sounds impinging on this coil cause it to move. By suitable suspension the coil approximates to a free mass in space. Applying ordinary dynamical laws, it is found that the voltages induced at various frequencies of impulse vary inversely as the frequency of such impulses. In other words, the lower tones are then given proportional predominance over the high tones.

To correct this undesirable quality a correction circuit is applied whereby the voltages applied to the main amplifier are proportional to the frequency of the alternating currents set up in the coil. Since the voltages in the coil are inversely proportional to the frequency, while the voltages, thanks to the correction circuits applied to the amplifier, are proportional to the frequency, the resultant amplified voltages are equal for equal impulses of any frequency—the desired result.

#### Seven Stages of Amplification

The movements of the coil being so small and the electrical energies so feeble, it is necessary to use an amplifier, which, again, has its sensitivity controllable.

The Marconi amplifier embodies resistance capacity magnification in nine stages (with correction valve) maximum, but the normal setting uses about seven stages.

The wireless transmitters are largely of the same type, and basically consist of an oscillation generator using valves and circuits for controlling the output in sympathy with the applied variations of electric energy driving from the microphone amplifier output.

Usually a coupled circuit has been employed because the loading coils in the aerial circuit are very small for maximum aerial efficiency. In the Marconi equipment a "master oscillator" system is employed wherein a circuit is made to

oscillate in synchrony with the natural time period of the aerial circuit, and the impulses from this circuit are given to the grid of the main valve.

Undoubtedly this is a good method. The circuit can never stop oscillating due to over-control, and breaking is avoided. Furthermore, aerial sway cannot change the tune of the emitted broadcast.

The control system universally used is called choke control. Here a "choke" or iron-cored inductance is connected in series with the H.T. supply to the oscillating valve. By connecting a valve from the end of the choke remote from the H.T. supply to earth, the currents through the choke are made to vary according to the extent of the impulses given by the microphone and associated amplifier to the grid of the valve. This valve is known as the control valve. The variation of current in the choke causes fluctuating potentials

at the end of the choke, and hence the applied voltage to the oscillation generator is varied sympathetically with the impulses on the control valve grid, and so back through the chain to the amplifier and microphone.

This arrangement makes for strict proportionality between applied impulse and resulting variation of emission from the aerial, but if over-control occurs this proportionality fails and distortion steps in.

A meter shows when over-control is present, and the engineer on duty watches this meter and prevents as far as he can over-control. In most stations it has been found easier to calibrate a tell-tale meter at the studio end to act in sympathy with the over-control meter in the wireless transmitter, and therefore fine control is done at the studio end, the engineer on duty at the wireless transmitter doing only coarse control.

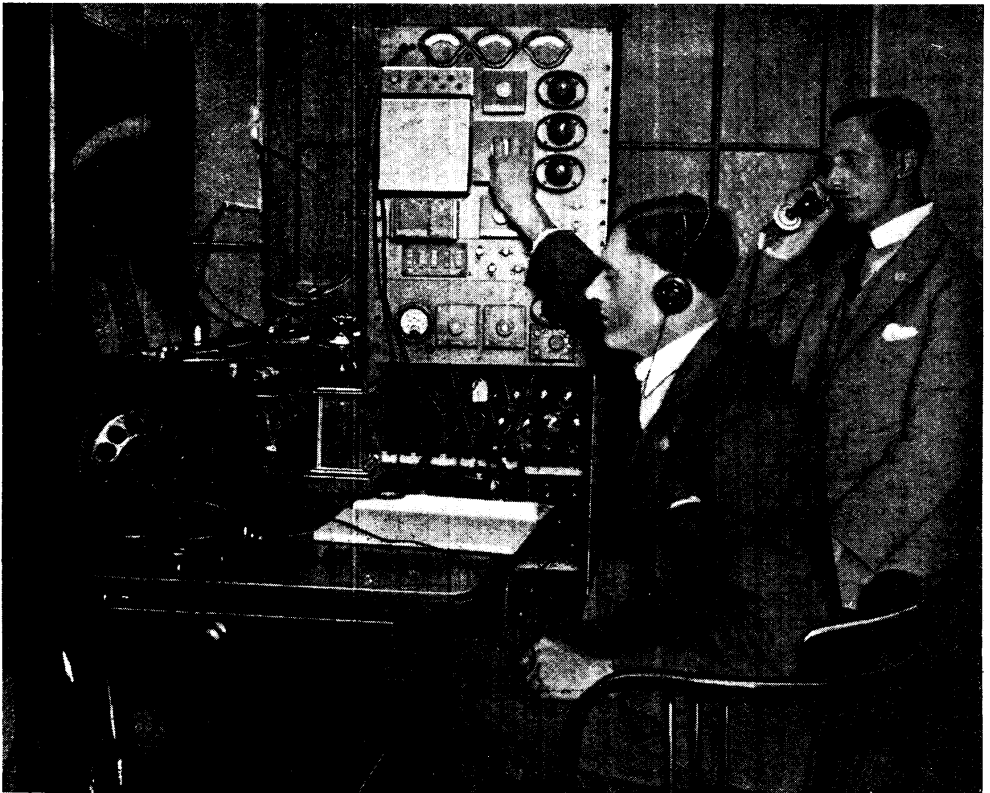

#### MODULATION AND SIGNAL CONTROL WHILE BROADCASTING

Broadcasting stations have a room specially equipped for the purpose of modulation and the control of output. Above will be seen apparatus in use, in a station in course of erection, by means of which the operators can tell whether the receivers listening-in are having broadcast to them correct signals or otherwise. In this way transmission is rectified until the public are given perfect reception

**BROAD TUNING.** Term used in two ways. When the secondary coil of a vario-coupler is separated from the primary coil, the operation is known as loose coupling, or sharp tuning, and when the coils are placed closer together as close or tight coupling, or broad tuning.

In transmitting, an aerial tuned to a given wave-length may actually be compelled to radiate on other wave-lengths, and this is also known as broad tuning.

**BRONZE.** An alloy composed chiefly of copper and tin. Other varieties have some traces of zinc, antimony, phosphorus, and other constituents. An average sample of bronze should have a specific gravity of 8.8. Its weight is about 0.32 lb. per cubic inch, and melting point in the neighbourhood of  $1675^{\circ}$  F. The allied alloys of bronze are known under such names as manganese-bronze and phosphor-bronze. Silicon-bronze, another alloy, is used in some types of aerial wire or tape. Bronze is also used for contact arms and other small parts of wireless apparatus. Phosphor-bronze is a hard and durable metal, and is used extensively for the bearings of revolving shafts. Another use for bronze is in the form of thin strips arranged on to one another to form laminations for springs, or in single thicknesses as spring contacts. See Brass.

**BRONZING.** Method of colouring brass and other non-ferrous metals by the application of a chemical. The process is simple and one that is helpful to the wireless experimenter. By its aid some very pleasing colours are readily obtained, especially on many brass parts. For example, terminals and other metal attachments for panels can be bronzed, and produce a particularly neat and harmonious appearance, contrasting well with the ebonite and the polished wood of the cabinet. The chemical used is best purchased by the amateur ready for immediate use, and, on this assumption, the general procedure as applied to small brass parts is as follows:

First obtain a supply of bronzing acid. This is poisonous and has an oxidizing effect on metals. It must, therefore, be kept in a glass or earthenware container, securely corked and in a safe position. The only other essential requirements are some cotton-wool and an old pair of gloves. The parts to be burnished must be perfectly clean, and for this work nothing less than

absolute mechanical cleanliness is of any use. That is to say, the work must either be dipped into a solution of nitric acid in water, sulphuric acid and water, or boiled in strong soda water, and afterwards rinsed in hot, clean water, and then dried off in warm, dry sawdust.

Alternatively, the work may be cleaned up by the use of fine grade emery paper, and after the cleansing process the work must not be touched with the bare fingers, or at any rate, those parts which are to be bronzed. The bronzing acid can be obtained to produce various colours, but the most useful is that known as blue-black, which imparts a delightful silvery-grey to black colour.

In the case of long objects such as a flat strip of brass, some of the acid is poured out into a small glass or earthenware container and wiped on to the work with a pad of cotton-wool. It is a wise precaution for the amateur to wear gloves while handling the pad and cotton-wool, as the acid is distinctly unpleasant on the fingers. Its effects are neutralized by washing in soda water, or applying any alkaline solution.

Having brushed the bronzing acid on to the work, it will be found to change the colour very quickly, but to get a regular, even colour the pad must be worked something in the nature of a rubber, and the acid flowed over the whole of the surface as uniformly as possible. After a certain stage, if more acid is applied to the work with the rubber, it will only destroy the colour already obtained, and in such a case the work must be thoroughly cleaned and commenced afresh.

Directly the desired colour is obtained, thoroughly well wash the object in hot, clean water, allow it to dry off in hot sawdust, and finish by lacquering (*q.v.*). Small objects can be bronzed by wiring them together and immersing them in a bath of the bronzing acid. In this case a few minutes' immersion will suffice to bring them up to a good colour.

The surplus acid may then be shaken off and the parts thoroughly well washed, dried off in sawdust, and lacquered. Steel and other metals can be bronzed by other treatment.

**BROOKITE.** A brownish-black coloured dioxide of titanium. The chemical symbol is  $TiO_2$ . It is used to a small extent as a crystal rectifier.

**BROWN, SIDNEY GEORGE.** Born in Chicago, U.S.A., in 1873, of English parents, he was educated at Harrogate and London University. An early study was made by him of the subject of submarine telegraphy. During these investigations he invented the magnifying relay for cables. Another important invention was the cable drum relay. In the year 1898



S. G. BROWN, F.R.S.

Vice-President of the Radio Society of Great Britain

*Photo, Elliott & Fry*

he invented the magnetic shunt. Since that time many of his activities have been directed to the solution of problems in telephony and wireless telegraphy. In particular the wireless experimenter will know the telephone receivers bearing his name and the important developments of the microphone relay. In the field

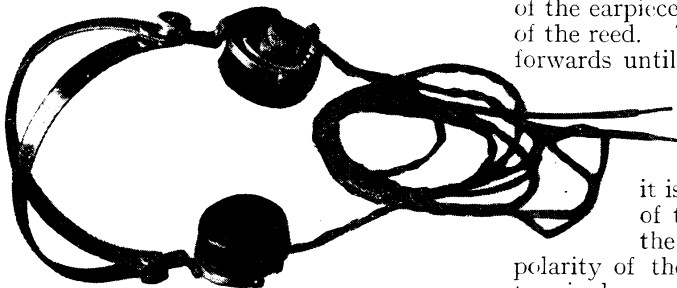

**BROWN'S TELEPHONES**

Fig. 1. Aluminium headbands with sliding adjustments are fitted to Brown's telephones, the external appearance of which may be seen from the above example

of land telegraphy and telephony his activities have resulted in the invention of such items as the carbon telephone relay system, which is largely used on land trunk lines for the transmission and reception of telephony.

He is a Fellow of the Royal Society and Vice-President of the Radio Society of Great Britain. His writings on technical subjects are extensive, and numerous valuable patents have been taken out by him, including the vacuum oscillation generator in 1916 and ionic electric relays, 1918.

**BROWN'S TELEPHONES.** The trade name of a sensitive head-telephone used for wireless telephony and telegraphy invented by S. G. Brown.

The electrical construction of this make of telephone receiver varies somewhat from general practice in so far as an iron reed, which can be tuned to a suitable note, has attached to it a cone-shaped aluminium diaphragm.

The external appearance of the telephones is shown in Fig. 1. The headbands are made of light aluminium with a double swivel motion, together with the usual sliding adjustment for the size of head. The interior of a single earpiece is shown in Fig. 2. The reed with the little coned washer which holds the diaphragm is clearly visible, the diaphragm having been removed.

The diaphragm is shown in Fig. 3, and comprises the inner coned member and the outer case or ring to which the coned part is attached by a thin membrane. The whole is slipped on to the body and the diaphragm secured with the screw and coned washer, and enclosed with an ebonite cap in the usual way.

A milled head screw, which will be seen in the illustration (Fig. 1), on the outer side of the earpiece is provided for adjustment of the reed. This is turned backwards or forwards until the position of maximum sensitiveness is found.

As the receiving coils are wound on to the poles of a permanent magnet, it is desirable that the polarity of the current flowing through the winding be correct for the polarity of the permanent magnet. The terminals are marked + and -, and care should be taken to see that they are connected into the circuit accordingly. Several types of these telephones are manufactured.

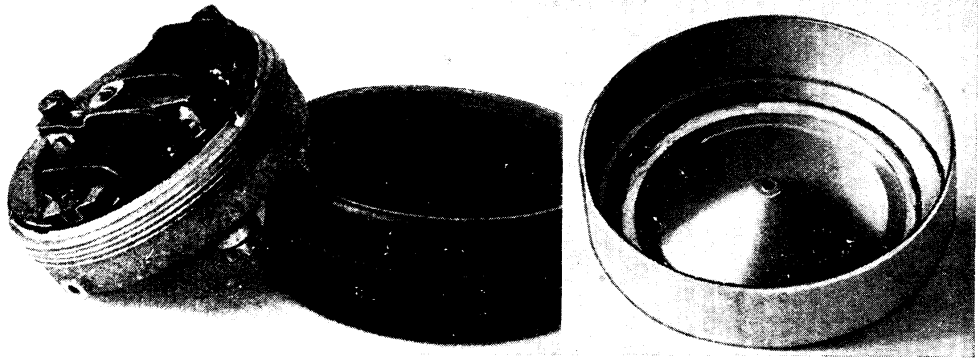

INTERIOR AND CONSTRUCTION OF BROWN'S TELEPHONE

Fig. 2 (left). Adjustment is made to the vibrating reed by the screw seen in this interior view. This screw may be recognized by the little coned washer which holds the diaphragm. Fig. 3 (right). Connecting the coned aluminium diaphragm to the outer ring or case will be seen a membrane. The whole is slipped on to the body of the earpiece, and the diaphragm secured with the screw and coned washer.

**BRUNET TELEPHONES.** A French telephone adapted for the reception of wireless telephony and telegraphy. These telephones, illustrated below, are of the flat disk type. The diaphragm, secured by the screwed ebonite case, is held between two internal rubber bands. The magnets are set as shown, at right angles, and the general internal arrangements are clear from the illustration, where one of the cases has been removed to show the interior. A simple swivel type of adjustment in conjunction with double slide

just beyond the actual sparking distance, a peculiar phenomenon takes place known as a "brush discharge." Seen in a darkened room it is often a very striking sight, commencing with a number of faint blue specks on the surface of the terminals, which, as the applied voltage is increased

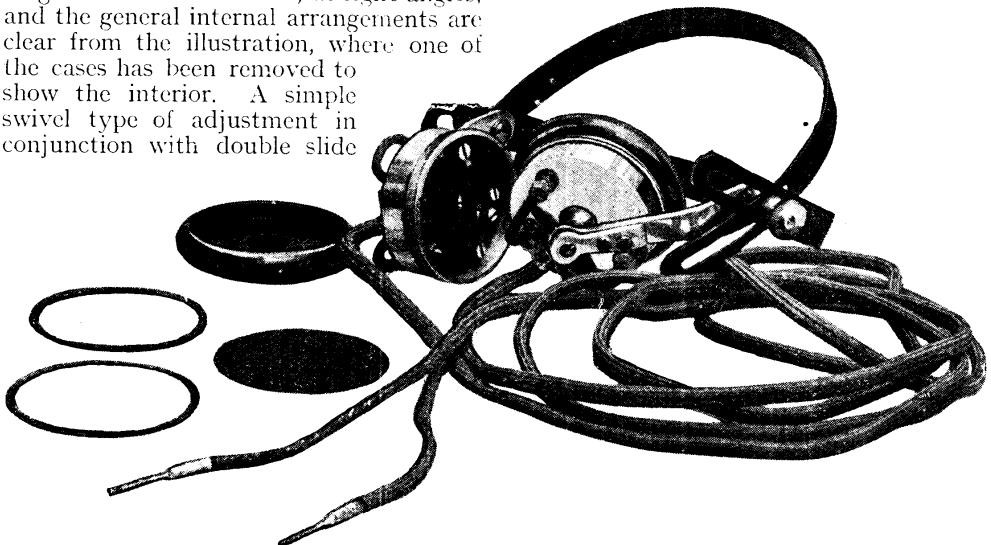

BRUNET FRENCH TELEPHONES FOR WIRELESS RECEPTION

One of the earpieces has been partially disassembled in this pair of Brunet telephones to show the internal construction. These headphones are of the flat disk type, the diaphragm being secured by the ebonite case

adjustment is provided on the headbands, so that the receivers can adapt themselves to the head.

**BRUSH DISCHARGE.** When two terminals are connected up to some high-potential source of electricity and separated

or the terminals moved nearer to one another, send out active streamers and feathery discharges, almost silent but often accompanied by a slight hissing sound. The colour of these silent brush discharges is usually intensely blue.

The brush discharge may be ascribed to dissipation of the static charge existing on the terminals by electrified particles of dust and air being torn off from the surface and violently repelled by the parent terminal on the principle of "like repels like." The brush discharge serves to illustrate another well-known law regarding the dissipation of a static charge by the action of points. On every particle of dust or rough edge of metal the static charge accumulates from the fact of mutual repulsion between similar charges repelling it to the maximum possible distance, and eventually the surface density of the charge becomes so great that it is blown off into space either as a charge residing on a detached particle of dust or as a stream of electrified air.

A point-shaped electrode will discharge across a much smaller gap than a ball electrode, other things being equal, owing to the natural dissipation effect of the

accumulated charge upon the point. The temperature and pressure of the surrounding air, and degree of humidity or otherwise, has also a great deal to do with the formation of a brush discharge, which it may always be assumed is the preliminary to a disruptive spark.

**BRUSHES AND BRUSH HOLDERS.** In electrical work, a brush is generally a metallic or other conducting component which sweeps a contact, or series of contacts, and picks up a current, according to the exact nature of the device. The holder is the device that supports the brush. In the case of a dynamo or motor, the contacts, *i.e.* the commutator segments, are moving, and the brushes are stationary.

For a resistance or regulating switch the brush may be devised so that it can move over a set of contact studs in the adjustment operation and be brought to rest on any one contact as desired.

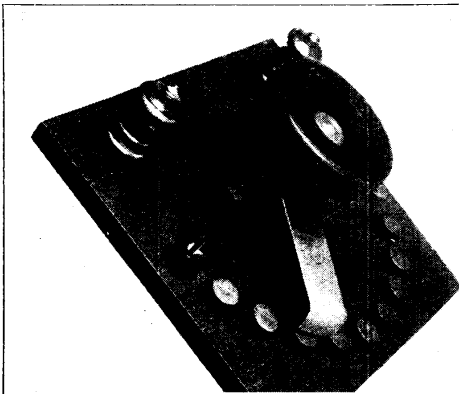

Fig. 1. Simple brass or copper brush made of a strip of spring metal. Contact with one stud is made before breaking contact with the other



Fig. 2. Multi-contact switches such as this, with pivoted and handled brushes, act directly on the contacts. The brushes are laminated for ensuring adequate contact surfaces

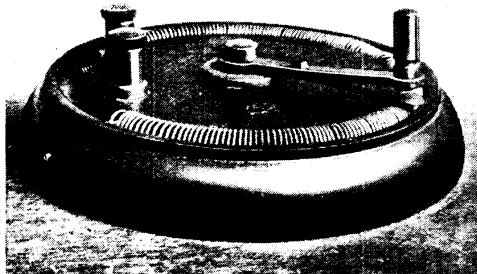

Fig. 3. Example of rigid arm and flexible brush used in a regulating resistance for the A battery circuit of a valve set

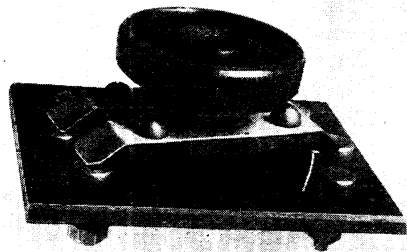
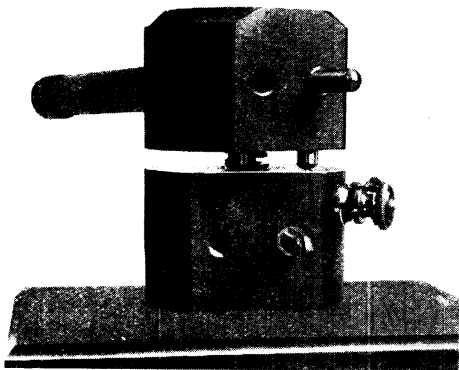

Fig. 4. For commutation purposes this type of double-brush switch is used. The brushes bear simultaneously on opposite contact studs

#### EXAMPLES OF BRUSHES AND BRUSH HOLDERS

Brushes may slur over the contacts, not leaving one until it is on the other. This arrangement, as shown in Fig. 1, is only possible where the electrical circuits are such that no dangerous short-circuiting can occur when the contacts are bridged by the moving brush blades. Continuity of current is ensured by this method, and it is chiefly adopted where the contact studs are connected to the steps in a regulating resistance. It is desirable that the current should not be broken and sparking result.

For reversing or commutating a current, or changing over from one source of power



to another, it may be necessary to break definitely the circuit in passing from one stud to another. Dead contacts, *i.e.* studs which are not connected to any part of the circuit and are insulated from all, are therefore employed. The brush slides over the idle stud and thence to the next live one. An example of this type is shown in Fig. 4, where two brushes are employed to commutate or change over a current. The brushes are double-ended and bear simultaneously on opposite contact studs.

When circumstances require that the hand lever arm of the brush shall be of stiff material, it is necessary to provide a lightly resilient contact between the stud and moving arm. In this case the actual brush may consist of a thin blade riveted or screwed to the lever arm, as in the case of some resistance switches used for regulating the value of

the currents supplied to the valve filaments of a wireless receiving set. This device is illustrated in Fig. 3.

Where the current to be transmitted through the brush and contact is small in

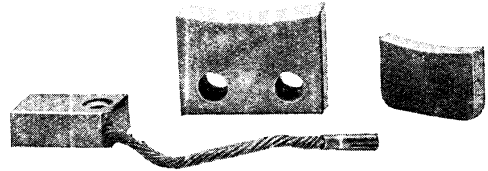

#### COMPOUND BRUSHES

Fig. 5. Highly efficient results are obtained with compound brushes as shown when used for dynamo and motor work. The compound consists of copper, carbon, and graphite

amperage, the former may be a simple strip of metal or a solid plunger with a strip of springy metal keeping it down on the contacts. Further, the contacts may be of brush form, *i.e.* of thin resilient sheet metal, shaped like a brush, the contact being of a solid, non-flexible character in ordinary tumbler switches.

Large currents require a relatively larger area of metal in the brush. As the necessary amount would make the brush

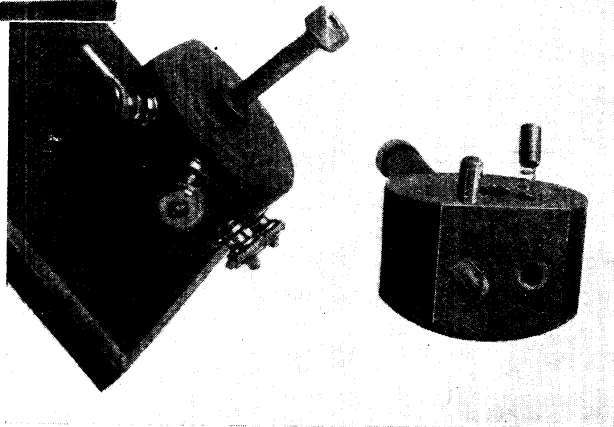

#### SPRING-LOADED BRUSH

Fig. 6 (top, left). Spring-loaded brushes are applied to effect connexion between the moving face of a coil holder and the face of a fixed coil holder. Fig. 7 (below). The movable coil holder is pivoted, and the spring-loaded brush makes contact by pressure of the spring with a contact ring

unyielding in its passage over the contact studs, and also tend to increase the resistance at the point of contact, such brushes are laminated, as shown in Fig. 2. Each leaf then makes its own contact and ensures as many contacts as there are

blades. With a solid brush, a slight ridge in the contact stud would lift the whole brush, and the area of contact would not be greater than that of the excrescence. With separate spring blades, the surface will readily conform to the shape of the contact. Laminated brushes of this kind are made with hard leaves of rolled copper strip.

For dynamos and motors, conditions are varying. As a rule, all the larger machines,

folded up and soldered on. Where the unyielding block is fitted, it is better to saw the brush into longitudinal strips to ensure a more perfect contact throughout the whole length of the commutator. Another method of arranging flat brushes for small motors and dynamos is to solder on a strip of folded-up gauze to a solid metal bush.

Small plunger brushes, made by rolling up strips of gauze, are often fitted to small motors. These are held in pieces of brass tube with an adjustable spring load on the top.

An example of the use of spring contact brushes is that found in Bond's adjustable coil holder, shown in Fig. 6. The brushes are used to maintain contact between the two parts of the holder. The upper or moving part turns on a central pivot, and the brushes slide over separate contact rings sunk into the upper part of the lower element. This is clearly visible in Fig. 7, which also shows the arrangement of the spring-loaded brushes.

It is at all times best to fit plunger brushes in brass tubular guides, and to electrically connect the guide to the terminal. The spiral spring should not be relied on to carry the whole current. It may not have sufficient area of metal in the wire of which it is formed to conduct the amperage and voltage impressed upon it. This is even more important in cases where carbon rods are used as brushes in place of the rolled wads of gauze.

A simple arrangement of a single solid brush with an independent spring to impart the necessary contact pressure is shown in Fig. 8, the end of the lever having been cut away to reveal the construction. This type of brush contact is quickly made by the experimenter, and comprises an ebonite lever pivoted in the centre. One end is fashioned as a handle, the other is drilled and a short piece of brass rod passed through it. The ends of the brass should be rounded and quite smooth. The pressure is imparted by the flat brass strip on the top of the lever. This is regulated by the round-headed screw located about the

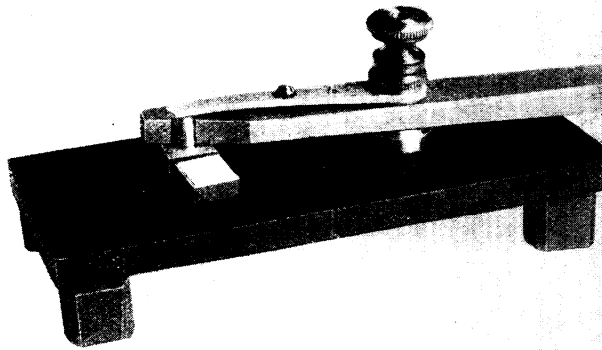

**SINGLE SOLID BRUSH**

Fig. 8. Sectional photograph showing how to make a simple distributing switch with a plunger brush. The end of the lever has been cut away to show construction

*i.e.* above  $\frac{1}{4}$  h.p., are fitted with carbon brushes. The old style of brush for big machines was always made of copper gauze, wrapped up into slabs and used as if it were a solid bar. Copper brushes running on the copper commutator segments wear very rapidly, and except in tiny machines have been replaced by blocks or rods of soft carbon. The conducting properties of carbon are not as good as copper, and therefore in designing motors and dynamos slightly longer commutators to accommodate brushes of large cross-sectional area are fitted. To minimize this defect a composite brush is made in the example illustrated in Fig. 5. The compound is of copper, carbon and graphite, the combination of these materials ensuring a practical measure of good conductivity with the advantages of minimum sparking and efficient self-lubrication.

Simple machines and small instruments need brushes made of small strips of hard brass. Sometimes these spring brushes are clubbed at the ends with small blocks of brass, or pads of copper gauze are



centre of the contact blade. It is a method that can be employed when desiring to divert the path of a current. The connexions in the example illustrated (Fig. 8) are from the negative to the apparatus direct. The positive is connected to the centre terminal or pivot, and leads taken from the contact plates to the desired parts of the apparatus.

Carbon for dynamos and motor bushes has the advantage of reducing the friction and wear and tear on the commutator. Dissimilar materials are generally to be desired in parts rubbing against each other. For large machines, numerous designs of holders for carbon blocks are in common use. Fig. 9 illustrates one type. The block must be readily removable for replacement and repair purposes.

Brush holders for dynamos and motors are frequently made adjustable, for adjustment on the periphery of the commutator. They are attached to bush rockers which swing concentrically with the armature shaft for electrical reasons, dynamo brushes being advanced in the direction of rotation of the machine and motor bushes retarded. In large machines several bushes are arranged to lie side by side to obtain a more perfect contact over the whole length of the commutator, and each brush has its separate spring. Small motors usually have fixed brushes, as the electrical disturbances set up by the moving armature and varying loads are not sufficiently serious to need a fine adjustment in the position of the brushes.

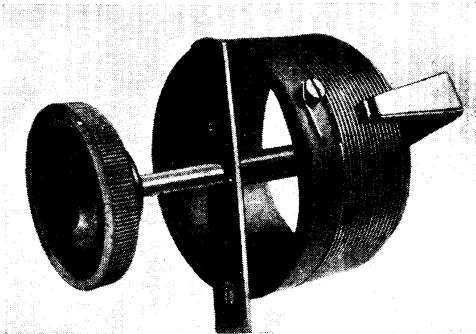

**TUNING BY BRUSH AND HOLDER**

Fig. 10. Combined brush and holder for coarse and fine tuning. This method is applied to inductance, or for reactance regulation. The handle is pushed in or out for coarse tuning and turned for fine tuning

In an instrument which must have a brush with a very small area of contact and engage with a very light pressure,

it may be necessary to tip both the contact and brush with platinum. This metal is sparingly used because of its high cost, but as it does not oxidize, any sparking which occurs does not affect the area of contact and reduce its efficiency as a conductor. Platinum may be soldered in position, but where heat is likely to be

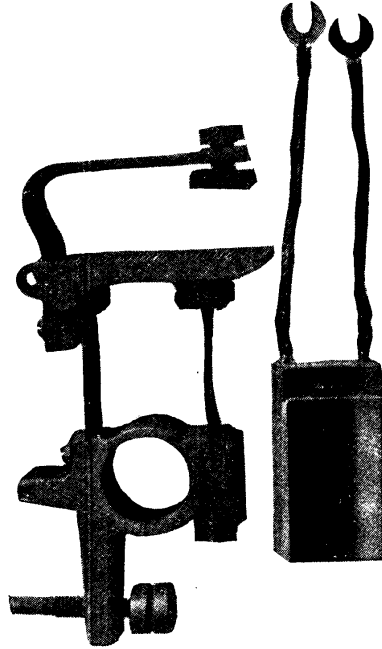

**DYNAMO BRUSH AND HOLDER**

Fig. 9. Numerous designs, of which the above is one, of brushes and brush holders are in use for dynamo work. Attachment of the brush is so effected that replacement is easily carried out when necessary

generated, plugs of the metal should be fixed by riveting.

The wireless experimenter is often in need of a quickly adjustable contact brush, and one solution of the difficulty is shown in Fig. 10, where the brush and the holder are so combined that they together act as a fine and a coarse tuning device. The brush is bent over at right angles, and makes contact with the bared surface of the coil of wire. The control handle is arranged so that it can slide in the central bush and can also be rotated therein. For coarse tuning the handle is simply pushed in or pulled out. The final fine tuning is obtained by a partial rotation of the handle. This causes the brush to sweep around on the coil of wire and thus allows of a very delicate and continuously variable adjustment.

**B.S.F.** Abbreviation for British Standard Fine, a series of screw threads and their tolerances. See Screw Thread.

**B.T.H.** The initials of the British Thomson-Houston Co., Ltd. The wireless experimenter will come across these initials on many different examples of electrical apparatus, including the wireless receiving sets bearing them. Several models are manufactured, of which three are illustrated. In Fig. 1 is seen a crystal receiving set which embodies duplex crystals controlled by a change-over switch. Both crystals are enclosed in a transparent case to protect them from dust and damp. A double range-tuning device allows the set to receive on a considerable wave-length range.

A similar set with the addition of a valve is illustrated in Fig. 2, and has a greater range and volume than the simple crystal set.

A cabinet receiving set with two valves is shown in Fig. 3; the case having folding doors, enables the same to be entirely closed when the set is not in use. The valves are set behind the panel, and inspection holes enable the brightness of the

filaments to be judged and regulated as required by the lower left-hand knob. Separate compartments are provided for storage of batteries and telephones.

**B.T.U.** The abbreviation for British thermal unit. This is the British unit of heat, and is the quantity of heat needed to raise the temperature of one pound of pure water one degree Fahrenheit. The equivalents of a British thermal unit may be expressed in other forms of energy

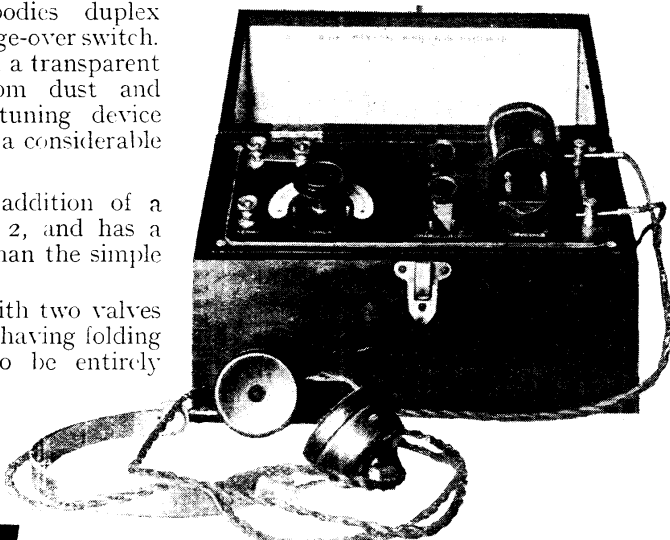

**B.T.H. CRYSTAL RECEIVING SET**

Fig. 1. Two crystals are used in this set. Both are enclosed in a transparent dustproof case, and are controlled by a change-over switch

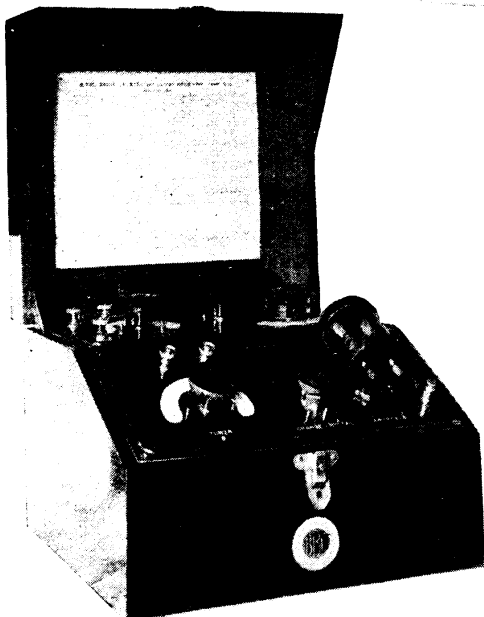

**CRYSTAL AND VALVE B.T.H. SET**

Fig. 2. Greater range and volume are given to this set by the addition of a valve, otherwise the appearance is very similar to that shown in Fig. 1

as follows: 1 B.T.U. = 1,052 watt-seconds; 778 foot-pounds, or 0.252 calorie.

**BUCKLING.** As applied to accumulator plates refers to a bent condition, the plates being distorted. The general cause of buckling is charging after excessive discharging. Suppose a cell to be short-circuited. This sets up a heavy chemical action in the plates, and the paste of the positive plates undergoes a violent chemical and electrical change. This is apparently accompanied by a change in bulk, and the mechanical stress set up thereby forces the plate out of shape. The positive plates are the first to be affected, and the action may in some cases be so bad that the negative plates are simply forced out of shape somewhat as shown in the illustration. A remedy is to gently press the plates flat after removing them from the cell. The best cure is, however, to remove the cause by never

discharging below 1.8 volts per cell and never subjecting a cell to a greater strain, electrically or chemically, than it has been designed to withstand. See Accumulator.

**BUILDING ACTS.** A building Act is an Act of Parliament, but in practice includes all the regulations made under powers conferred upon the local authorities by such Act, as affecting the mode of construction and nature of any building. The wireless experimenter should become familiar with the various Acts or the local building by-laws to ascertain the nature of any legal restrictions (if any) on the erection of some contemplated structure, such as an aerial mast or experimental workshop.

**BULB HOLDER.** Small holder or support for a test



#### BUCKLED PLATES

Buckling of the negative plates has occurred in this case as the result of failure of the positives

lamp being the same as the intended voltage to be applied to the filament of the valve. For this purpose a simple device can be made by the experimenter by cutting a plate of ebonite, about  $1\frac{1}{4}$  in. long,  $\frac{1}{2}$  in. wide, and  $\frac{1}{4}$  in. thick, and drilling two holes through the ends to take a

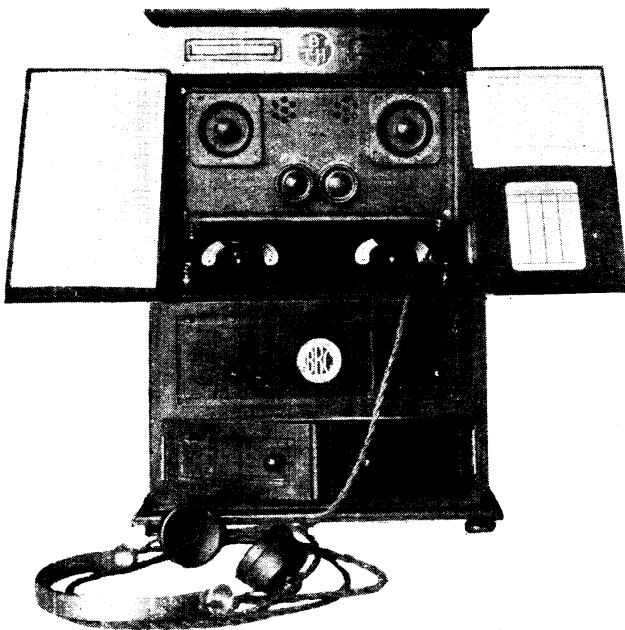

#### R.T.H. CABINET SET

Fig. 3. Folding doors enable the whole set to be hidden from view, when the cabinet becomes outwardly an ordinary article of furniture

lamp. Its use in wireless is practically restricted to the preliminary testing of the filament circuit of any receiving set using a valve. Such a test is especially valuable when the set has been wired on a new or experimental circuit, and it is desired to be certain that the valve will not be endangered by an excessive voltage.

The principle adopted is to insert a small lamp in the filament circuit, the voltage of the

pair of standard valve legs. These are held to the plate by the nuts which screw on to the legs. One is located on the underside, and the other on the top of the plate. The bulb holder is removed from an old flash-lamp case, and soldered to a small brass plate, one end of which is bent up at right angles and soldered to the side of the holder as shown in the illustration, Fig. 1.

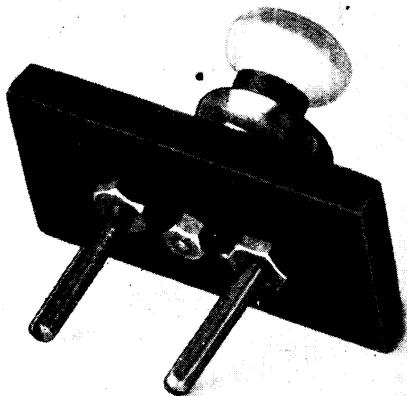

#### PLUG-IN BULB HOLDER

Fig. 1. Contact between the centre connexion and the valve leg is visible in this underside view

A hole is drilled in the end of the plate and one of the valve legs passed through it and secured with the nut. The centre contact is made by fitting a countersunk screw into the centre of the ebonite plate in the middle of the bottom part of the holder, as shown in Fig. 1. Contact is made from this screw to the other valve leg by means of a short length of copper wire. One end is attached to the

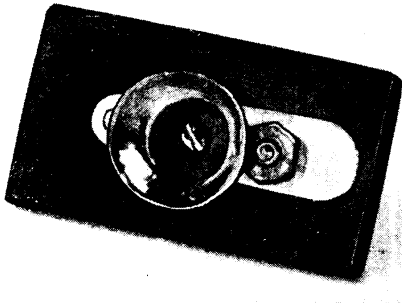

**BULB HOLDER FOR VALVE TESTS**

Fig. 2. In this view the centre contact screw is seen, also the flat plate on right to which the holder is joined. How the contact screw is connected to the valve leg on the underside is seen in Fig. 1

projecting end of the screw and held fast by the nut. The other is similarly held by the nut on the valve leg, as shown in Fig. 2, which also illustrates the general arrangement of the device.

In use it is simply placed in the filament sockets of the valve holder, as the valve legs are fixed the same distance apart (that is  $\frac{3}{8}$  in.) as the centres of the filament terminals of a standard valve holder. The filament current is then switched on, and the lamp should light up and continue to burn steadily. The high-tension current is then switched on, and the lamp should continue to burn as before, but if there is any fault in this part of the circuit the lamp will burn out. This is evidence that the high-tension wires are incorrect, and the cause must be ascertained and remedied.

Such a simple test is well worth while, as the loss of an expensive valve is many times the cost of a device of this character. Various commercial types are available

for those who do not wish to make their own. The term bulb holder is sometimes applied to the brass ring that supports the glass bulb of a valve.

**BULL TRANSMITTER.** A selective system of wireless telegraphy based on mechanical principles, developed by Anders Bull. This device, worked on a synchronized system, includes both transmitter and receiver. The transmitter consists of an open-circuit oscillator, supplied with energy by the usual transformer or spark coil, which operates through an apparatus termed the disperser. The receiver had, in the original form, an open circuit resonator actuating a number of registers through a collecting mechanism.

The disperser is shown in diagram at Fig. 1. A is connected by gearing with the motor B, which is in series with a variable resistance for regulating the speed. An electro-magnet, D, automatically controls a disk making a specific number of contacts and sending out a similar and predetermined number of waves or oscillations. When it is desired to send a message, the key L is depressed and closes the circuit, which includes the battery and the electro-magnet 2, which in turn attracts an armature attached to a clutch carrying a pin.

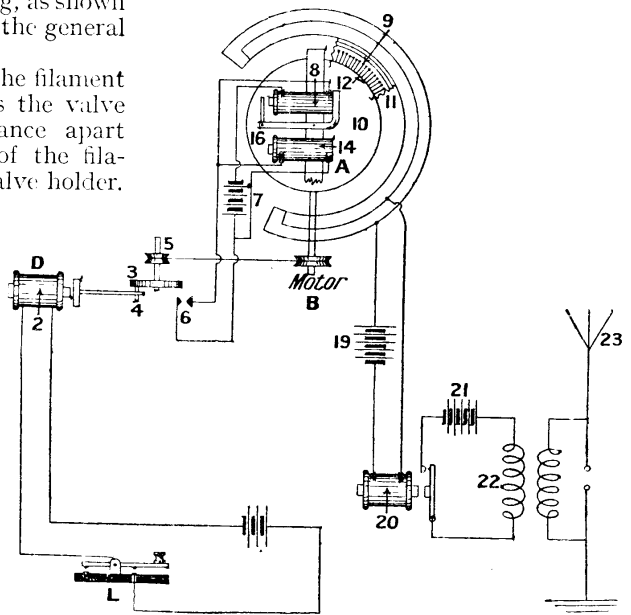

**BULL TRANSMITTER WORKED ON MECHANICAL PRINCIPLES**  
 Fig. 1. Operation of the spark coil in the old Bull transmitter was conducted through a disperser, the arrangement of which is seen in the above diagram

The function of the armature, magnet, and switch is shown more clearly in Fig. 2, which is a sectional view of Fig. 1. When the armature is drawn to the magnet, 2, disk 3 is released by the clutch, 4, and then revolves at a speed of about five revolutions per second. At every revolution of the disk contact is made by the springs, 6, and the circuit, which includes the battery, 7, and electro-magnet, 8, is closed. The disperser itself consists of 400 steel springs, 9, attached at right angles to the disk and near its periphery. These long vertical springs have their ends free and pass through slots in a stationary upper disk, 10. The springs are thus able to move in a radial direction only. A brass ring forming a groove, 11 (shown in part in Fig. 1), is attached to the framework, and guides the springs so that with each revolution of the disk, which occurs once in every second, they either slide in the groove, 12, or within its inner circumference.

The bronze arc, 13, takes the place of a section of the brass ring, 11, and has a finger projecting toward the centre of the disk; as the vertical steel springs come in contact with it they are forced towards the magnet, 14. Attracted by this magnet, the springs then slide along until released at the edge of 15, where they are again drawn into the groove or return to the

inner part of the ring by their own elasticity, according to whether the magnet is energized or not.

When it is required to send a dot signal, the key is depressed for less than one-fifth of a second, which is the time required for disk 3 to complete one cycle, and the current flows through the circuit as a single

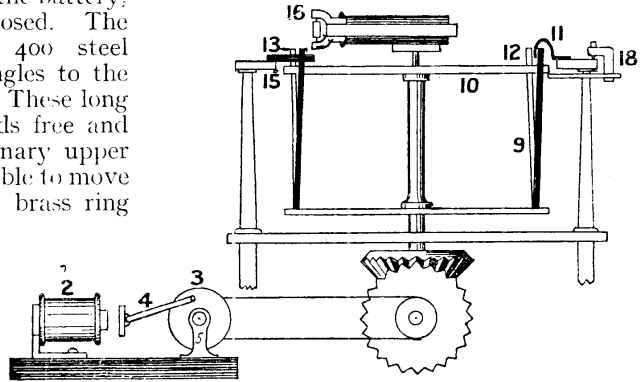

DETAILS OF BULL TRANSMITTER

Fig. 2. Sectional view of Fig. 1. From this will be seen more clearly the function of the armature, magnet, and switch. The magnet is at 2, disk at 3, and clutch 4. The disk revolves when the armature is drawn to the magnet

impulse. When transmitting a dash signal, the key is held in contact long enough for disk 3 to revolve a number of times, consequently a corresponding number of electric impulses, at intervals of one-fifth of a second, flow through the circuit, causing the springs to make contact at regular intervals by means of the contact points, 18, and thus closing the circuit in which the battery, 19, and magnet coil, 20, form a part.

As there are a number of these contact points arranged round the frame at prescribed intervals, it is clear that the number of series of electric waves emitted will be equal to the number of contact points, and by varying the distance between these points, any combination or series of waves may be sent out through the medium of the electro-magnet key, 20, battery, 21, spark coil, 22, and oscillator circuit, 23.

The collector is similar to the disperser, except that receptive devices are employed instead of emitting devices in the circuit. Fig. 3 is a plan view of a receiver. The coherer is connected in

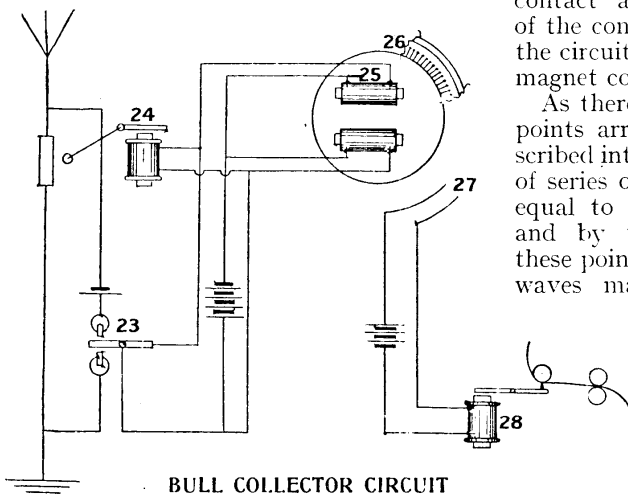

BULL COLLECTOR CIRCUIT

Fig. 3. Except that, instead of emitting devices, receptive devices are used in the above circuit, the collector is similar to the disperser. A coherer was included in a local circuit with a relay in series with a battery

the open circuit resonator in the usual manner, while the relay, 23, in series with a battery, is included in a local circuit with the coherer. The tapper, 24, is in parallel with an auxiliary circuit formed by the armature of the relay in series with the magnet, 25.

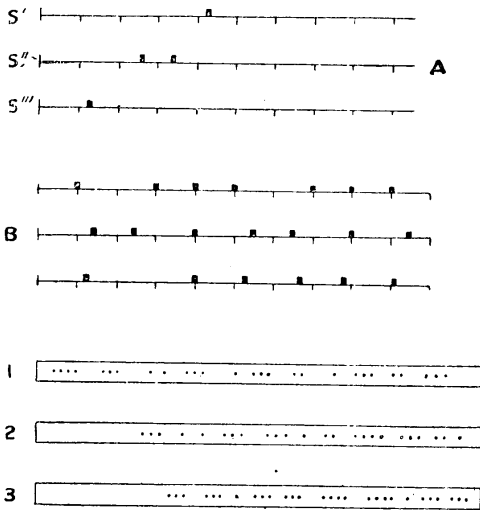

RECORDING TAPE FROM BULL RECEIVER

Fig. 4. Three Morse registers were operated in Bull's experiments, and examples of the three methods of recording are given. These represent the result of early experiments to obtain selective reception

For every series of electric waves that impinge upon the resonator system one of the vertical steel springs slides into the groove, 26, of the ring. The revolving disks of the transmitter and the receiver, or, as they would be termed, disperser and collector, revolve synchronously so that the angular distances of the springs sliding in the grooves will be proportional to the time constant between the series of waves impinging on the aerial.

Since the points are arranged in the same relative positions in both transmitter and receiver and are operated synchronously, contact in both is made simultaneously. The points, 27, are connected in series with the Morse printing register, 28. A prearranged series of electric waves will cause the springs to make contact at the same instant when the local collector battery operates the register.

In Bull's experiments one disperser and one collector were used, and these were arranged with three sets of contact points, thus permitting any one of three Morse registers to be operated at will. In Fig. 4,

three series of waves are shown, by the dotted lines S', S'', and S''', the horizontal line being taken as time and the wave series by the heavy vertical strokes. In Fig. 4, B, is represented the way in which the wave series is registered when the key of the transmitter is kept closed; 1, 2, and 3 are the type from three Morse registers operated independently of one another. The transmitters and receivers may be set up in different localities and at varying distances with equally good results. This system was a serious attempt to obtain selective reception.

**BUNSEN CELL.** Type of primary cell notable for its steady and powerful current. The electro-motive force varies between 1.9 and 2.0 volts. One type of the Bunsen cell is illustrated, and consists of an external pot or container made of earthenware or some similar material. Within this is a porous pot which contains strong nitric acid. Immersed in the acid is a square carbon rod having a terminal at the upper end. Surrounding the porous pot is the zinc plate, also provided with a terminal. The carbon is in this case the negative element and the zinc the positive.

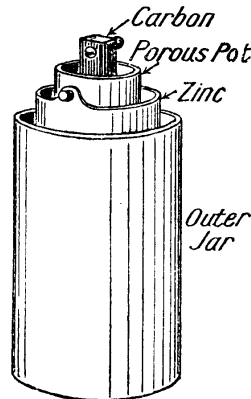

BUNSEN CELL

Primary cells of this type are useful for experimental purposes, having low internal resistance and large current

The outer container is filled with a solution of sulphuric acid and water in the proportions of 1 of acid to 10 of water. The Bunsen cell has a low internal resistance, gives a large current, and is suitable for experimental and laboratory use. It is also of service in the recharging of small accumulators. Several cells may have to be connected in series to give sufficient voltage according to that of the accumulator to be charged.

**BURNDEPT COIL.** Trade name of a patented multi-layer coil extensively used for tuning purposes. The general appearance is well shown in Fig. 1, which illustrates a No. S2½ Burndept coil, as used for aerial tuning inductance purposes.

These coils are made by Burndept Ltd. in a wide range of sizes, with various inductance values. In essence, they consist of a base or holder made of ebonite and provided with non-reversible plugs; one is in the form of a projecting prong with spring contact pieces, the other is

are the multi-layer coils, and cover the wave-length range from about 750 to 25,000 metres.

The windings have been arranged to give inductance values that will cover a full wave-length range with the minimum number of coils. It is necessary to use a variable condenser with a value of 0.00075 mfd. in parallel with each coil in order to attain something over the minimum of the next larger coil.

Although it is possible to cover a wider range with a larger condenser, this course is inadvisable, as there is

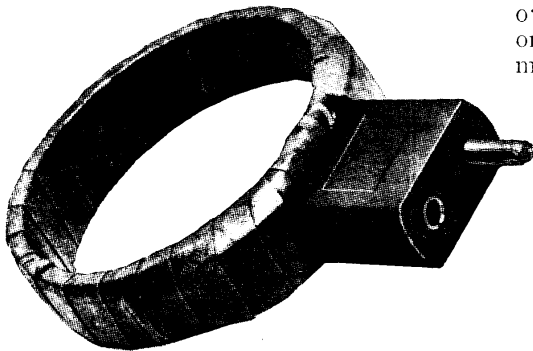

**BURNDEPT MULTI-LAYER COIL**

Fig. 1. Aerial tuning inductance is a common function of this well-known coil. The photograph is of a No. S2½ coil, widely used for the broadcasting range

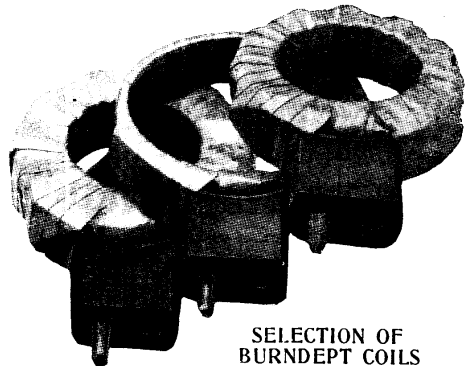

**SELECTION OF BURNDEPT COILS**

Fig. 2. Burndept coils are in various sizes. Those illustrated are, left, No. 300, centre, No. S1, and right, No. 150. These coils are extensively used in tuned anode circuits

a socket. On the inner end they are connected to the two ends of the coil winding, one end is attached to the prong, the other to the socket. By this arrangement there is no possibility of reversing the direction of the windings, as is the case when the prongs are duplicated. The smaller sizes are simply single coils of wire wound upon a former and attached to the holder, the larger are multi-layer coils. The following table, issued by Burndept Ltd., gives useful data on these coils, and will prove helpful to the experimenter when constructing a new circuit.

The special construction of these coils is such that an ample air space is secured between the windings, thus reducing the distributed capacity to a low value. Coils Nos. S1 to S4 are single-layer coils wound on ebonite, and are specially designed for the reception of broadcasting. They cover the wave-length range of 150 to about 800 metres when used with the average type of amateur aerial. The coils Nos. 75 to 1500

are a considerable loss of signal strength. The middle coil in Fig. 2 is a No. S1, that to the right a No. 150, and to the left a No. 300. In use they are plugged into a coil holder (*q.v.*), the circuit wires

**TABLE OF INDUCTANCE VALUES AND WAVE-LENGTH RANGES**

Coil No.	Induction in Microhenries	Primary Tuning with Average P.M.G. Aerial and Burndept Condensers or Tuners				Secondary Tuning with Burndept Condensers or Tuner	
		Condensers in Series		Condensers in Parallel		Condensers in Parallel	
		min.	max.	min.	max.	min.	max.
S1	35	160	260	310	380	135	330
S2	50	175	290	350	470	170	420
S2½	—	—	—	370	500	—	—
S3	100	210	360	430	640	230	575
S4	200	270	470	600	900	340	810
75	350	350	570	700	1100	450	1000
100	600	450	750	950	1450	600	1340
150	1250	650	1050	1300	2100	830	1900
200	2400	900	1450	1900	3000	1200	2700
300	5000	1250	2000	2600	4100	1600	3840
400	10500	1750	2900	3700	5800	2300	5400
500	22000	2600	4300	5500	9000	3500	8100
750	52300	4000	6600	8500	13500	5400	12500
1000	109000	6000	10000	12500	21000	7900	18000
1500	190000	Coil order	only.	16500	28000	10000	25000

are connected to the terminals of the holder, and thus it is possible to vary the wave-length range of the set by merely changing the coil.

To listen-in to the Paris concerts, for example, all that has to be done is to select a coil of the appropriate wave-length range according to the table, and adjust the condenser, and the signals will come in immediately if the set be sufficiently powerful.

**BURNETIZING.** The name given to a process of preserving timber from rotting. The method consists essentially in immersing the timber in a solution of chloride of zinc in such a way that the timber absorbs as much of the solution as possible, the amount depending upon the duration of immersion and the absorptive power of the timber. The method is chiefly applied in wireless work to the preservation of aerial masts. The amateur will find it more convenient to employ some of the commercial solutions that can be brushed on, as this avoids the necessity of constructing an immersion trough.

**BURNING OUT.** The destruction of a part of a conductor due to electrical overloading. In wireless work, for instance, when the filament of a valve is supplied with too great a voltage, the filament wire is overheated, the material, in effect, is fused, and the valve is said to be burnt out. Examples of burning out are found with all manner of electrical conductors, and so far as the wireless experimenter is concerned the matter is chiefly associated with the use of high-tension batteries and low-tension accumulators. There are two chief practical ways of guarding against burning out, the first is to provide all conductors of sufficient capacity to carry the maximum electrical pressure that can possibly be brought upon them, the other is to introduce a protective fuse. This has the property that it will burn out at some predetermined voltage, and if this be lower than the remainder of the circuit conductors, it will automatically burn out, and thereby sever the circuit and stop the current flow, before the rest of the circuit is affected. *See Fuse.*

**BURNISHING.** The art of producing a brilliant lustre on the surface of metals and other material by rubbing with specially prepared implements called burnishers. Essentials of the operation are to prepare the surface of the metal as neatly and smoothly as possible, and to

burnish by rubbing the surface with the burnisher, the lustre being produced by the slight surface hardening and closing up the pores resulting from the application of the burnisher.

The whole process is really an art, and one which is only acquired by experience. It calls for manipulative skill and dexterity and is a process which is very difficult to describe in words. As suggestions for the amateur experimenter, two illustrations are given. Fig. 1 shows the ordinary type of bent burnisher in use on a small brass plate intended for attachment to the exterior of a panel. Fig. 2 shows a double-handed burnisher in use burnishing a bar of metal. In the first case, the tool is manipulated with both hands and turned and twisted in various directions and moved to and fro with a regular, steady movement. The degree of pressure must be governed by circumstances and it is impossible to lay down any hard and fast rules.

The test is whether or not the metal is taking on a bright appearance. If it is not, the pressure is probably insufficient. Should the surface work up bright in one part and not in another, it indicates that the pressure is uneven. If scratches appear on the surface, it suggests that either the burnisher is imperfect and requires re-polishing or, when too great pressure has been exerted, the surface of the metal is turned up.

Some operators prefer to work without a lubricant, others advocate the use of various lubricants, among which are ox gall, vinegar, and argol water. The object of all of them is the same, to keep the working surface of the burnisher as cool as possible and to reduce surface friction. The object is to have the burnisher glide easily over the surface so as to compact it.

Burnishing is sometimes done in the lathe, especially for circular objects that can conveniently be chucked and rotated. Burnishers vary in shape and size, two typical examples being illustrated in Figs. 1 and 2, and these are made of very hard, close-grained steel, highly polished. Others have an agate, or bloodstone end, and are known respectively as agate and bloodstone burnishers. They are used in much the same way.

**BUS BAR.** A term used to describe a single conductor employed to connect a number of pieces of apparatus. The example illustrated shows a bar in a power



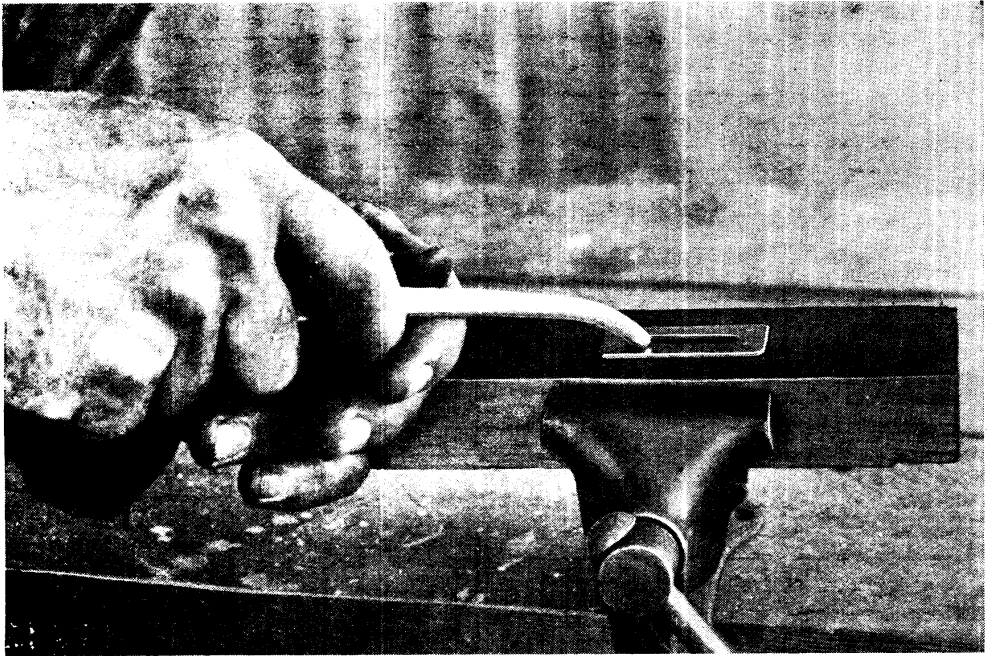

#### BURNISHING A SMALL WIRELESS COMPONENT

Fig. 1. Small articles such as the brass plate in the picture are given surface gloss by using a bent burnisher. The article is to be used for the outside of a panel, and where finished appearance is important burnishing provides the necessary lustre

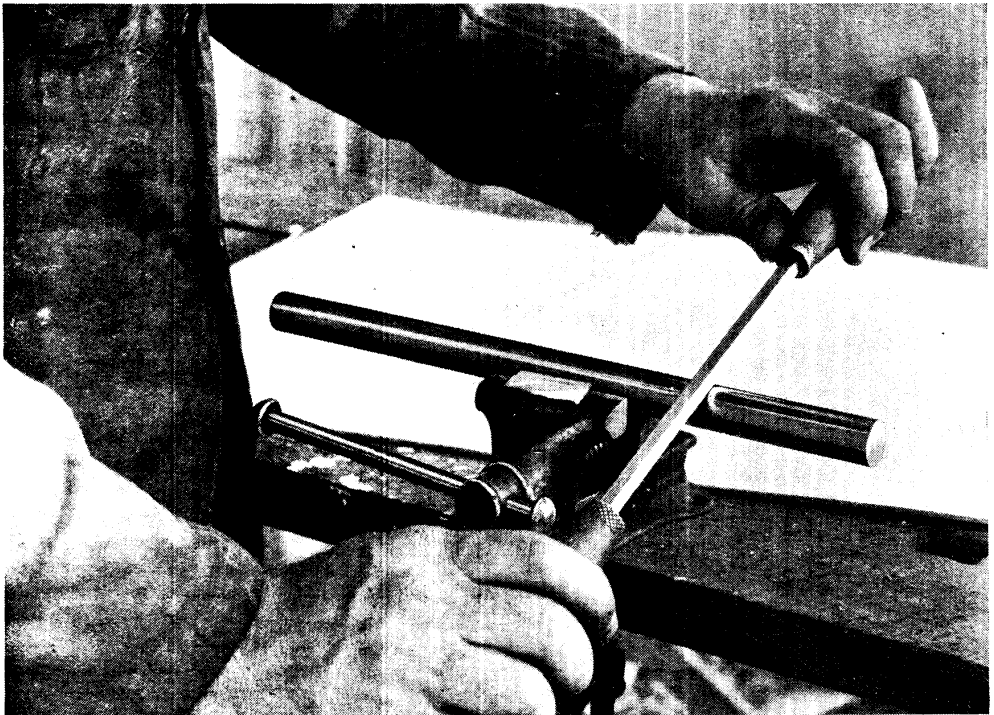

#### HOW TO USE A DOUBLE-HANDED BURNISHER

Fig. 2. Burnishing a bar or any similar object which cannot be laid flat may be accomplished by using a double-handed burnisher. The work is held in a vice and operated upon as shown in photograph

plant used to supply electric light, but similar bus bars are found in many other pieces of apparatus. For example, a bus bar may be used on a distribution board, or on the back of a panel in a wireless receiving set to obviate a multitude of loose wires.

In the latter case the bus bar could take the form of a strip of brass or copper, say  $\frac{1}{4}$  in. wide and  $\frac{1}{16}$  in. thick. This is fixed to the panel near to one of the edges, and common earth connexions are made to it by means of wires attached to terminals soldered to the bus bar. The current-carrying capacity of a bus bar is important, and should be such that the maximum currents of all the circuits attached to it are well within the safe loading capacity of the bus bar. With the average amateur wireless sets this does not entail anything very serious, but when the question is one of the power distribution of a generating

set it calls for care and attention. The matter is really one with the design of a suitable conductor, and if treated as such, the calculations may be based on the same assumptions. See Conductor; Current; Fuse; Resistance.

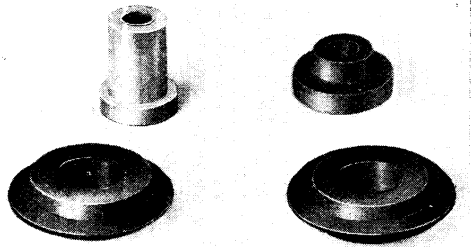

#### BUSHES FOR WIRELESS APPARATUS

Ebonite bushes extensively used in wireless. The three types illustrated are particularly useful as bearings for spindles of variometers, rheostats and other turning components. The fourth type (top, left) is a brass bush

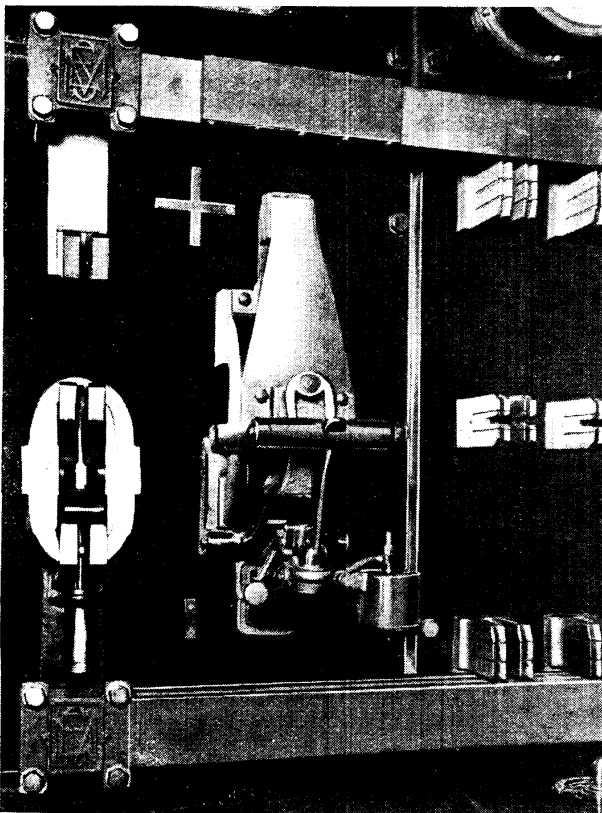

#### BUS BAR OF POWER GENERATING PLANT

Similar bus bars to the one shown are used in wireless apparatus for connecting a number of wires, or conductors, to a common electrical path. The bus bar must in all cases have carrying capacity equal to the sum of all charges meeting at that point

**BUSHES.** Circular liners for a hole. Their purpose is to strengthen the material around the hole, or to provide a better bearing or more resistant material locally, as, for example, a metal bush in which a metallic spindle can turn. The metal is better able to resist the wear occasioned by the constant or intermittent movement of the spindle. Other bushes are used for their insulating qualities—for example, those used to bush a hole in metal when it is desired to pass a conductor through the hole. In such a case the bush would be made of ebonite or other insulating material.

A few typical examples of bushes are illustrated above to show the general appearance of some that are useful to the amateur wireless experimenter. The long bush is turned from brass, and is suitable for such things as the top of a bichromate battery, as a guide for the zinc lifting rod. It may also be used for spindle bearings. The three in the foreground are made of ebonite and used as insulators. There are many types used for one of the essential purposes mentioned.

**BUSHINGS.** A lining inserted into a piece of material to make the latter more suitable for some particular purpose. Examples are the brass bushes inserted into an ebonite panel for the support of a spindle, the use of insulating bushes to

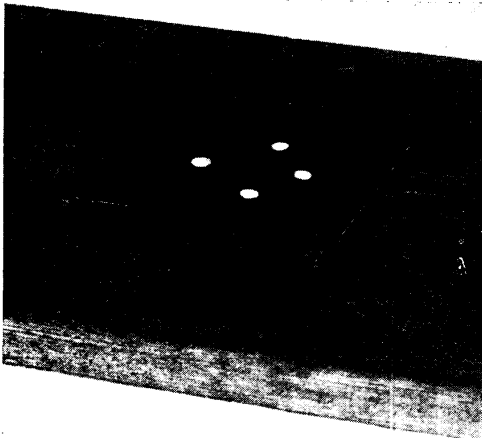

**EBONITE BUSHING FOR WOOD PANEL**

Fig. 1. Bushings are inserted in this manner in order to support a valve or other component in wood or other non-insulating panel

protect a conductor, and the insertion of a block of some comparatively expensive material into a cheaper variety to secure the combination of efficiency and low cost.

An example of this class of bushing is illustrated in Fig. 1, and shows a block of ebonite inserted into a hardwood panel. The ebonite is secured by recessing it into the wood and leaving a projecting edge or rebate on the edges of the wood to act as a support for the ebonite, which is secured by means of fine brass screws or pins. In such a case the ebonite should stand

slightly above the normal surface of the wood, as this assists the insulating qualities. The example illustrated shows the ebonite panel marked out ready for drilling the holes for the valve legs.

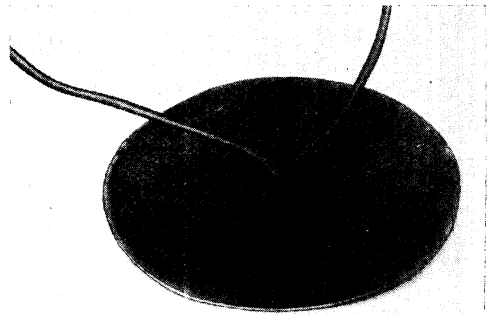

Fig. 3. Bushing in ebonite is often carried out as above. A brass bush forms a bearing for a turning spindle

An example of the use of a bushing to insulate a conductor is that shown in Fig. 2, where a brass disk is insulated in the centre with a circular bush of ebonite. This is fixed in place by making it a tight fit in the hole drilled in the brass plate and securing

it with a trace of insulating compound. This is possible, as there is no tendency for the bush to come out, and as the plate is thin the bush can be screwed in with a twisting movement. This causes the ebonite to bite on the edge of the hole in the brass, and helps to keep it firm. A better method is to make a double bush and screw the two parts together, thus pinching the plate between them. When a moving part such as a brass rod has to pass through a material such as ebonite it is desirable to bush the hole with a metal, as brass, and one way of doing this is illustrated in Fig. 3, where a bush is shown attached to a plate of ebonite by means of two round-headed screws passed through the flange on the bush. This type of bush is much allied to a small bearing, and may often be used in that way on small wireless apparatus.

**BUTT OF MAST.** The bottom part of a solid pole which is used as an aerial mast. The butt is an important consideration when choosing a pole for an aerial mast, as it is that part that has to be embedded in the ground, and is, in consequence, subject to considerable stresses. Moreover, it has to withstand



**EBONITE BUSHING**

Fig. 2. Insulation of a brass disk by means of an ebonite bush, through which the connecting wires are passed

the constant changes of the soil due to rain and drought. For these reasons it is desirable that the butt be as solid and of as great dimensions as possible.

In most cases a pole is chosen for its straightness and even taper, but it is no detriment if the butt be somewhat bent over at the end or if it has a projection such as that left when a branch has been lopped off. The added weight of the butt due to the increase in local bulk helps to keep the pole erect.

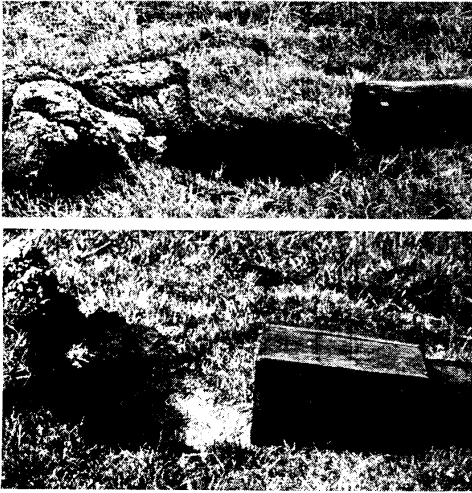

BUTT OF MAST

Fig. 1 (top). Preparation has been made for erecting a typical mast, the butt of which is in position for insertion into the hole. Fig. 2. Wooden cheeks have been added to the butt of the mast in this case as a means of reinforcement

The treatment of the butt to protect it from rotting is dependent on the nature of the wood. When this is oak the bark should be removed and the butt allowed to dry off, when the mast can be set up without further treatment. If, however, it is soft wood, as is generally the case with a scaffold pole or the like, it is preferable to peel off the bark and set the butt in a pail or tub filled with creosote or

some good wood preservative, such as solignum. Allow the butt to remain immersed for several days, and thereby give the fibres time to absorb the preservative. The mast is then set up by digging a hole in the ground, placing the butt in it, and well ramming the earth around it, piling up the earth around it to allow for the shrinkage of the ground.

A typical butt ready to be placed in position is illustrated in Fig. 1. When a prepared timber mast is used the butt is generally somewhat larger in size than the pole, and is squared. Another plan sometimes adopted is to add cheeks of wood to a pole mast (Fig. 2), the foot of the latter having been roughly squared. The cheeks are simply four stout pieces of timber screwed or bolted to the flats. These parts ought to be thoroughly well creosoted or treated with tar, to render them as damp-resisting as possible. With either of the latter arrangements the top of the squared portion or the cheeks may project about a foot above the ground.

**BUTTON INSULATOR.** A small insulator made of porcelain or similar material, and so named because of its general form and size, as indicated by the illustration. Button insulators are used for the support of a conductor, and as feet or supports for small base-boards. See Insulation.



Porcelain button insulator

## BUZZERS AND THEIR USES FOR EXPERIMENTERS

### How to Make and Use these Test Instruments

In this section the amateur is told how a buzzer works, how to make one for testing the receptivity of his crystal set, and how to use it both for this purpose and practice in sending and receiving messages in Morse. See also Crystal; Morse; Tikker

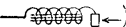
A buzzer (symbol ) is a low-power generator of damped oscillations used for tuning radio circuits.

Buzzers do not form a necessary part of a receiving circuit. They are a very useful adjunct in testing the efficiency of various crystals, and in the wave-meter the buzzer also plays an important part. The buzzer works on exactly the same principle as an electric bell, the only difference being that the buzzer has an extremely light armature. This allows of much more rapid vibration, the hum of which is alone responsible for the sound.

The essentials of a buzzer consist of an electro-magnet (or magnets, *a, a*, Fig. 1), a light armature of soft iron, *b*, rigidly

fixed at one end and supported near the electro-magnet in such a position that it obtains the maximum influence from the lines of force of the magnet. A metallic stop (*c*, Fig. 1) rests against the spring when it is not being influenced by the magnet. Fig. 2 shows a theoretical diagram.  $T_1$  and  $T_2$  represent terminals attached to the battery operating the buzzer. Supposing  $T_2$  is connected to the positive terminal of the battery, then the current will flow from  $T_2$  to *c*. As the armature is normally resting against the post, *c*, and making electrical contact with it, the current flows on through the magnets and to the negative terminal of the battery.

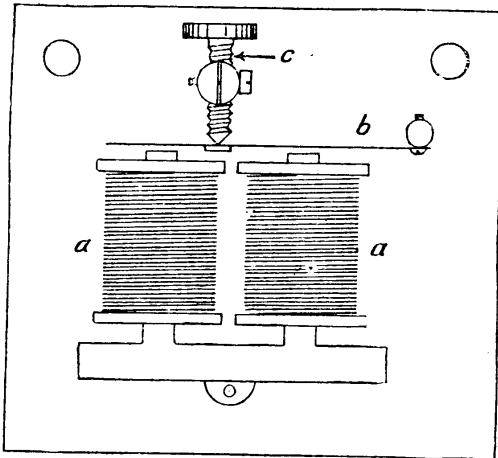

ESSENTIALS OF A BUZZER

Fig. 1. Construction of an ordinary common buzzer is represented in the above diagram, *a a* being the magnet coils and *b* the soft iron armature

The circuit is thus complete, and causes the armature to leave post *c* owing to the attraction of the field magnets. Immediately on leaving post *c* the circuit is broken and the magnets cease to pull the armature, which, owing to its springiness, returns to post *c*. Once more the circuit is completed, the magnet attracts the armature, and so the cycle continues until the battery circuit is permanently broken. The frequency of these vibrations will depend upon the weight of the armature and the distance of its movement. The heavier the armature the slower it will vibrate, and vice versa.

When the armature breaks the buzzer circuit another important change takes place. Energy is retarded in the buzzer

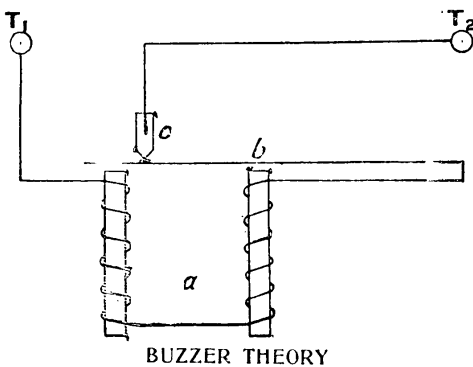

BUZZER THEORY

Fig. 2. To appreciate the action of a buzzer, this circuit diagram should be studied. The current operating the buzzer is supplied from a battery connected to the terminals  $T_1$ ,  $T_2$ .

coils owing to their high inductive value, and feeble oscillations take place. Although these oscillations are very feeble they are sufficiently powerful to be registered on a wireless receiving set. We have, therefore, in effect a small transmitting station, to which the crystal or other detector can be adjusted for its best point of contact or receptive power.

In a large buzzer having a high inductive value the energy released on the circuit being broken by the armature is so large that it will jump across the gap where contact is made and broken in the form of a small arc. For this reason a fixed

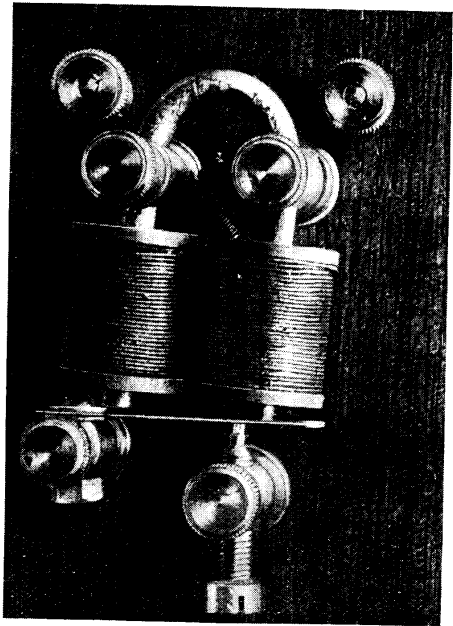

SIMPLE HOME-MADE BUZZER

Fig. 3. This instrument, simply and easily made, is a thoroughly efficient accessory to a crystal set. It is employed for testing receptivity of the crystal

condenser is placed across the gap. This has the effect of holding the charge until the armature once more makes contact. This sparking tends to burn and pit the conductors at their point of contact. Partly for this reason, and partly to prevent bad contact from oxidation, these points of contact are made of platinum. The platinum is usually riveted on, but occasionally it is soldered.

**How to Make a Buzzer.** In the construction of the buzzer shown in Fig. 3 such a refinement will be unnecessary. The materials needed are to be found

in the scrap material of any wireless enthusiast. The buzzer is of robust construction, and if care be taken in its manufacture it should stand up to considerable service and even rough usage.

Materials required:

- 4 telephone terminals.
- 1 block of hardwood,  $3\frac{1}{2}$  in. by  $2\frac{1}{2}$  in. by  $\frac{1}{2}$  in.
- $\frac{1}{4}$  lb. of 26-gauge D.C.C. wire.
- 4 in. soft iron rod,  $\frac{3}{16}$  in. diameter.
- 2 small terminals.
- 1 strip of thin, soft iron,  $1\frac{3}{4}$  in. by  $\frac{3}{8}$  in.
- 1 contact screw and 2 nuts.
- 1 clamp-screw and nut.
- 2 2 B.A. brass washers.

The parts are shown in Fig. 4.

Take first the base, of any hardwood—beech, oak or mahogany will be suitable. Ebonite may be used if to hand. Square

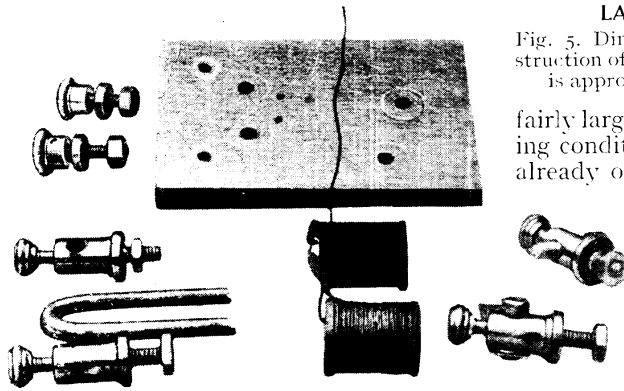

PARTS REQUIRED FOR BUZZER

Fig. 4. Complete set of parts necessary for constructing the simple buzzer illustrated in Fig. 1. An ebonite panel may be used instead of hardwood.

this up to size,  $3\frac{1}{2}$  in. by  $2\frac{1}{2}$  in. Now drill the four holes as marked in Fig. 5. This should be done with great care, as upon the position of these four holes depend the positions of the armature strip to the magnets and the contact screw to the armature strip. The design of this buzzer lends itself, however, to adaptation through inaccuracies of workmanship.

No definite size can be given for these holes, as they depend upon the diameter of the screw holding down its terminal. In buying the terminals those having a 2 B.A. stem should be obtained, when only a  $\frac{3}{16}$  in. diameter drill will be necessary. The two small terminals need not be any special variety. They are merely binding posts to connect the buzzer to the battery.

The selection of the four large terminals is, however, much more important. They

must be of the telephone pattern—that is, the type of terminal having a hole in it to clamp the wire. Select a terminal with sides parallel to each other—if not all the way down, then at least parallel near the hole (see Fig. 6). The terminals should be

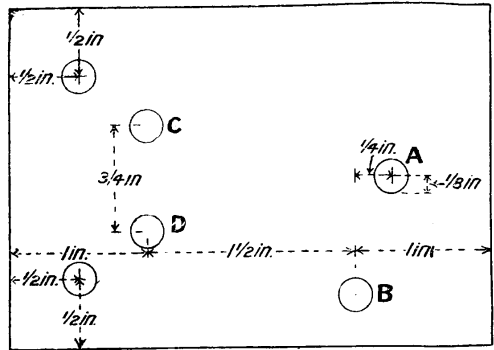

LAY-OUT OF BUZZER PANEL

Fig. 5. Dimensions are here given for the construction of the panel of the buzzer. This diagram is approximately three-quarters actual size.

fairly large, complying with the two following conditions: (1) That if the hole is not already of  $\frac{3}{16}$  in. diameter, it is capable of being drilled out to that size without weakening it. (2) That the distance from the centre of the hole to the base, when mounted, is not less than  $\frac{1}{2}$  in.

The reader is recommended to visualize the design of the buzzer, and by understanding the purpose of each part he will be able to use more individual discrimination. It is

very important to get terminals that match in every particular.

If the base is intended to stand on a table by itself, all holes on the underside must be countersunk. The easiest way is to screw the buzzer on to a shallow box or tray, or to glue or screw on four strips of wood on the underside of the base.

Before fixing terminal B (Fig. 6), one side should be filed flat in order that the iron strip may be properly bolted on to it (Fig. 3). This terminal, and also terminal A, has a short length of wire attached under the tightening nut or screw.

The soft iron strip is the next item to consider. This is  $1\frac{3}{4}$  in. long and  $\frac{3}{8}$  in. wide. At a distance of  $\frac{1}{16}$  in. from one

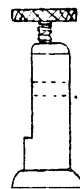

Fig. 6. How the terminal is cut

end a hole is drilled in the middle of the strip of such a size as to enable it to be bolted on the flattened side of terminal B. Before final assembly this strip should be polished bright with a fine grade of emery paper. This should be done on a perfectly flat bench or plate in order to minimize the risk of buckling the strip, which would be fatal to its efficiency.

The strip should be bolted on and the terminal mounted. The hole in terminal A need not be enlarged. A screw having a large diameter knurled head should be found to fit. If it is possible to tap a thread into the terminal hole and screw the knurled screw, so much the better. If facilities for this are not available, the fit should be as nearly as possible perfect, and final setting can be effected and rigidity obtained by tightening down the knurled screw on the head of the terminal. A little lead paper packing may be found useful in fixing this screw. A short length of wire is attached to the underside of this terminal.

For the magnets take a piece of soft iron rod of  $\frac{1}{16}$  in. diameter. This is bent at the centre into a horseshoe shape, with the exception that the sides are kept parallel (Fig. 7). The distance between the centres of this rod should be  $\frac{3}{4}$  in. An easy way of making this certain is to bend it over a former of hardwood slightly less than  $\frac{5}{8}$  in. in thickness. Now file the ends quite square and smooth and rub them bright with emery paper. Put the two remaining large terminals in the holes made for them, and

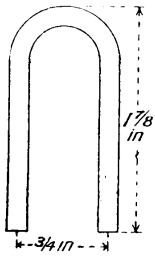

Fig. 7.  
Dimensions of  
horseshoe mag-  
net

adjust the iron magnet to slide in and out of the terminals without undue friction. The terminals are left on and the knurled terminal tops tightened.

Cut four circles of  $\frac{5}{8}$  in. diameter from thick cardboard and drill  $\frac{1}{16}$  in. holes in their centres. Slip one over the end of each of the magnets until it stops at a distance of 1 in. from the outer end. Cover the straight shanks of the magnet with shellacked paper to within  $\frac{1}{8}$  in. of the outer end and slide on the remaining two

disks, thus forming a bobbin; or bobbins may be bought as seen in Figs. 3 and 8.

Give the paper and cardboard several coats of shellac and allow to thoroughly harden. Now wind on the wire, keeping even layers and applying a coat of shellac after each layer. Having filled one bobbin, do not break the wire.

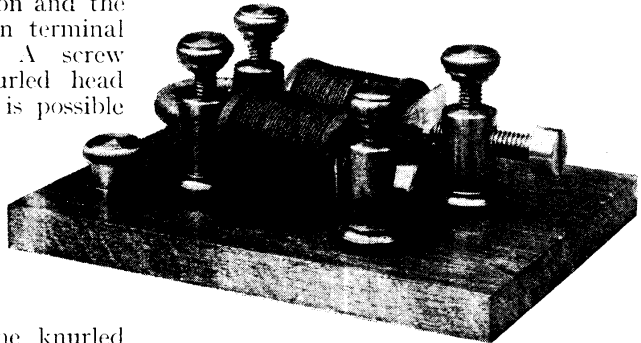

COMPLETED BUZZER SUITABLE FOR WIRE-  
LESS TESTS

Fig. 8. Tests are frequently necessary to determine the most sensitive spot on a crystal before broadcast reception begins, and the buzzer described and here shown complete is very suitable for this and other purposes. It is not difficult to make and very inexpensive

Commence winding the second bobbin, taking care to start winding in the opposite direction. This is important, as if the second bobbin is wound the wrong way one magnet will neutralize the other.

Continue winding the second bobbin until the same amount of wire has been put on. Both bobbins should now be protected with shellacked paper. The whole magnet may now be placed in position about  $\frac{1}{16}$  in. in front of the armature. The small terminals can now be fixed down and the wiring completed. The wire clamped under terminal A, Fig 5, is taken to either small terminal. Either free end of the magnet windings is taken to the remaining small terminal and the other free end is bolted under the nut and screw of the armature strip.

Connect up the battery and adjust the knurled screw. If the armature sticks to the magnet ends the terminal supporting the armature strip can be slightly slackened and slewed round, giving greater clearance. On the other hand, the armature strip may be pressing too hard against the contact screw. If this is so, correction can be made by turning the post in the other direction.

**Other Types of Buzzers.** If an electric bell is available it can very easily be altered into a buzzer by removing the complete armature and substituting an iron strip similar to the one just described. A small steel strip will be found on the bell armature. This can be removed by carefully filing off the rivet heads and riveting it on the buzzer armature. The best way of effecting the alteration is to use the bell armature as the jig for making the new one. This ensures getting the platinum point on the small steel strip registering with the platinum point of the adjusting contact screw.

A simple type of commercial buzzer constructed on these lines is shown in Fig. 9; the armature is of the bell pattern, with a small steel spring having a contact at one end and at the other mounted on a short post. Attached to this spring is

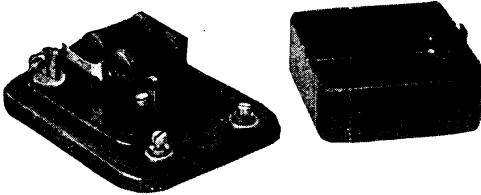

**SMALL COMMERCIAL BUZZER**

Fig. 9. Commercial buzzers, such as the above, present a neat appearance and are suitable for permanent inclusion in wireless sets. They are usually similar in principle to the home-made buzzer described on preceding pages

an iron armature located in front of the poles of the magnet cores. Tension of the spring is variable by the small screw seen at the end near the support. The contact screw turns in a vertical post and varies the time at which contact is made. With these two adjustments the vibration rate and the note can easily be varied.

The buzzer shown in Fig. 10 is a laboratory type of instrument and has several special features; the note can be varied by the movement of a cam, and has a range of three octaves. It is mounted on an ebonite base, and the apparatus is enclosed in a brass case with a glazed top to facilitate observation of the action.

The three terminals are fitted so that a telephone can be introduced into the circuit when desired. A single magnet is used, and to obviate sparking at the contact, points a small graphite rod is provided which can be shunted across

the coil, across the contacts, or cut out by movement of a contact arm.

The experimenter desirous of learning the Morse code and acquiring the needful skill in operation to acquire a transmitting

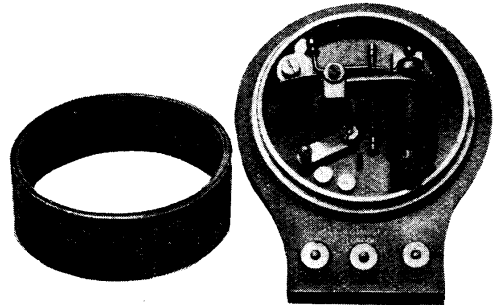

**NAROH TUNING BUZZER**

Fig. 10. Specially constructed buzzer made to give three distinct octaves. It is tuned by means of a cam adjuster

*Courtesy A. W. Gamage, Ltd.*

licence or to enable the numerous messages that are transmitted in the Morse code to be read, can well use a combination instrument such as that shown in Fig. 11, illustrating the combination of a buzzer, Morse tapper or key, and a flash lamp. This can be operated anywhere when suitably connected to a battery, and the signals can be read by another student from a distance by observation of the

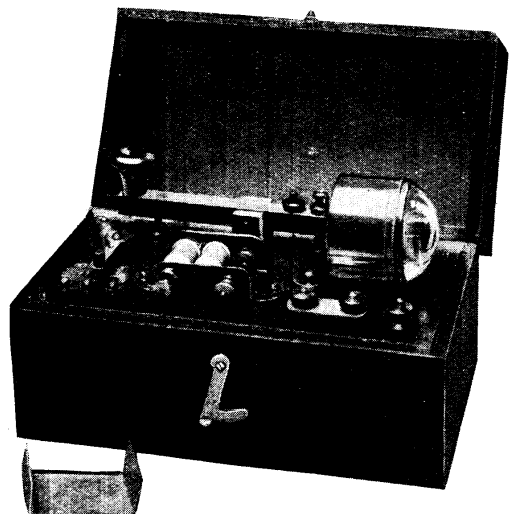

**FLASH LAMP AND BUZZER**

Fig. 11. Morse code may be learned by means of a combination of buzzer and flash lamp; this instrument is specially constructed for such a purpose

*Courtesy A. W. Gamage, Ltd.*



intermittent flashes from the lamp. The instrument can be used singly in this way or in conjunction with a similar station connected by wires.

**Buzzer Tests for Crystal Sets.** The amateur will find the greatest use for a buzzer is in finding the most sensitive spots on a crystal. By its aid the set can be tuned to maximum receptivity, at least as far as the crystal is concerned. The ordinary run of crystals have one or two fairly passable points which give signals, but there is generally one particular spot that is by far the most superior.

To find this while a broadcast concert is in progress is unsatisfactory for several reasons. In the first place there is the natural desire to hear the music. In the second there is the difficulty of correctly judging the sensitivity of the crystal, as it may happen that tuning is carried out at a time when a band is playing and the signals seem to be strong. The next item may be a song with considerable variations of tonal qualities and changes in the volume of sound.

The difficulties are all overcome when a buzzer is available, as the tests can be carried out before the broadcasting begins. There are several ways in which the buzzer can be used. For example, it may be permanently incorporated into the cabinet and used as required by simply pressing the contact switch. By another method the buzzer is placed in some remote position, so that it cannot be heard except through the telephones of the set. A third variation is the use of a buzzer unit which may be operated in proximity to the set.

This is possibly the best arrangement for the experimenter, as it is then available for the testing of various parts of the apparatus. For example, it can be used to test the electrical continuity of a tapped inductance coil. The buzzer is simply placed in series with the coil and a low-tension battery. When the contact arm is on any of the studs the buzzer should sound, as the circuit is or should be complete through the buzzer, as shown in Fig. 12, which illustrates the application of a buzzer to a test circuit for a tapped inductance.

The note of the buzzer will vary according to the resistance of the coil, or that part of it which is in the circuit at the time, and should this resistance be excessive

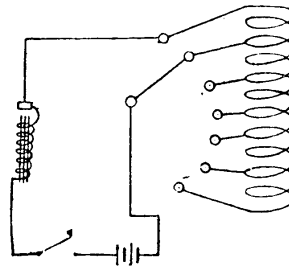

**BUZZER TEST**

Fig. 12. The windings of an inductance coil and its tapings may be tested with the aid of a buzzer by this arrangement

the buzzer may cease to sound unless additional battery power be forthcoming. Should, however, no sounds be heard when the contact arm is on a particular stud, it means that the particular tapping is faulty, probably due

to a poor connexion, the presence of insulation between the coil winding and the tapping point, as may happen when enamelled wire is used.

The general principle of using a buzzer for testing a crystal is that the buzzer, when in operation, becomes a tiny transmitting station operating with one note and at a high frequency. Consequently high-frequency pulses of energy are radiated from a wire forming part of the buzzer circuit and these waves can be impressed on the receiving set. When the crystal is correctly adjusted the sound of the buzzer will be clearly heard in the telephones, although the sound of the buzzer itself may be inaudible to the ears.

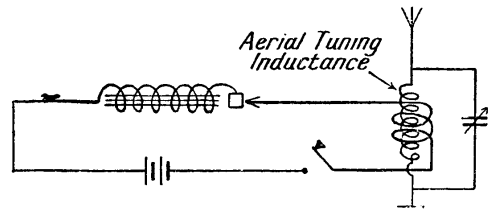

**TESTING CRYSTAL SENSITIVITY**

Fig. 13. Weak oscillatory waves from the buzzer impressed on the receiving set by the above arrangement enable tests to be carried out to find the most sensitive spot on a crystal

One way of impressing the buzzer waves on the receiving set is to make one or two turns of the wire around, say, the inductance coil of the aerial tuner. The energy passing through the buzzer wire sets up a magnetic field around it and this induces a corresponding current in the receiving set, thus providing the requisite means of tuning.

The circuit diagram, Fig. 13, shows one example of this type of test. Another way,

shown in the form of a circuit in Fig. 14, consists in placing the buzzer wire near to the receiving set and picking up the signals in exactly the same way they would be from a full power station.

Still another way is to connect the buzzer in the usual way to a battery and to connect a wire from the interrupter to the earth lead of the receiving set, as in Fig. 15. When a tuned buzzer, as for example one having a resistance shunted across the magnet windings, is used the circuit may take the form illustrated in Fig. 16. The shunted buzzer battery and sounding key or press are connected in series. One end of the series is connected to the earth side of the tuner and the other end to the aerial tuner in such a position that the buzzer circuit is completed when the key is depressed. The buzzer circuit cannot be completed if one part of it be connected to the aerial side of an aerial tuning condenser, as the latter is not a conductor of direct current.

Another use for a buzzer is in conjunction with a condenser which, when the buzzer is in operation, can be readily charged up to its discharging voltage. If an oscillating circuit be connected across the make and break of the buzzer, as in Fig. 17, and the latter connected to a source of direct current, the discharge of the condenser will

set up high-frequency oscillations in the circuit. The method is extensively used to energize a short-range transmitting oscillator or for testing the receiving circuit of a crystal detector.

Another application of the buzzer is to render an ordinary crystal set capable of receiving continuous wave signals. This is accomplished in one method by combining two buzzers, one to actuate the other in such a way that the current flows through both coils of the buzzers. When the contact maker of the second buzzer is disconnected, only interrupted direct current flows through the second coils. The contacts of the second buzzer are connected into the circuit in place of the crystal, so that the armature of the second buzzer, as it vibrates, interrupts the continuous wave signals and renders them audible. This phase of the use of the buzzer is more particularly dealt with under the heading Tikker.

**B.W.G.** Abbreviation for Birmingham Wire Gauge. It is one of the oldest of the wire gauges, and is an empirical method of measuring wires in contrast to the geometrical method of the Imperial Standard Wire gauge. See Gauge; Wire.

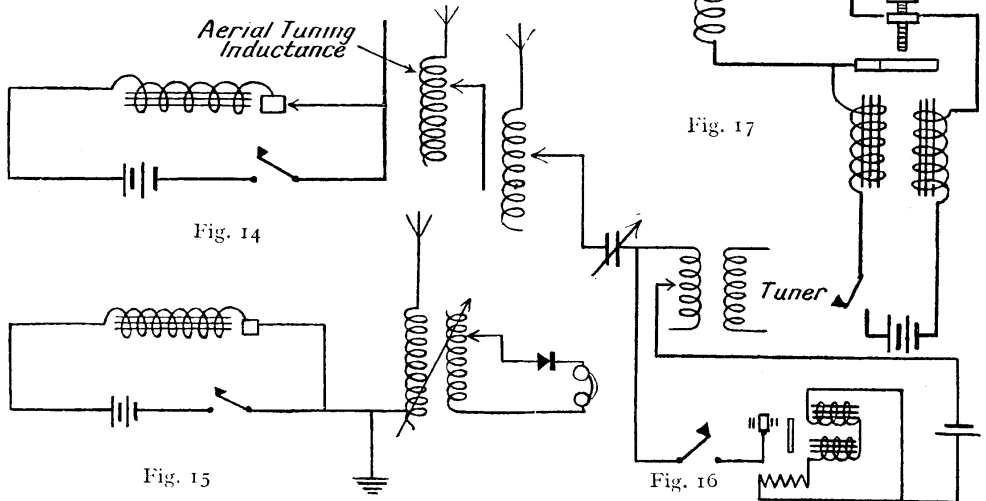

#### BUZZERS AND THEIR USES IN WIRELESS CIRCUITS

Fig. 14. Radiation tests can be carried out in this manner: A lead from the buzzer is placed near the aerial induction coil to enable buzzer waves to be picked up in place of signals, as in ordinary reception. Fig. 15. Direct excitation test. The buzzer is connected with an interrupter and battery to the earth lead. Fig. 16. Circuit connexions are made in this test with a buzzer having a resistance shunted across the magnet windings. Fig. 17. High-frequency oscillations can be produced in a circuit by using a buzzer and condenser, the latter being charged up to its discharging voltage

**BY-PASS CONDENSER.** A by-pass condenser is a fixed condenser placed in such a position, relative to an inductance, that it prevents a steady direct current from passing, but at the same time offers practically no resistance to high-frequency or modulated current.

Perhaps the best-known applications of a by-pass condenser in wireless receivers are a condenser of, say, .002 mfd. across the H.T. battery, and one of, say, .004 to .005 mfd. in series with a choke, and both placed across a loud speaker.

The ordinary dry-cell H.T. battery offers great resistance to high-frequency or speech-modulated currents, and therefore when working a set of more than one or two valves, fairly large currents begin to be taken from this battery, and for that reason a large condenser is placed across it. Direct current of constant potential is completely stopped by such a condenser, but, as is well known, alternating or oscillating currents are not. By this means, then, we have the ideal arrangement for H.T. batteries, namely, a means of almost eliminating their resistance to modulated currents, and at the same time having no loss of current through unavoidable discharge.

Loud-speaker work is really very little understood by many experimenters; indeed, many consider they have done everything possible by merely substituting the loud speaker for the telephones. This, however, is not good practice, and great

In this circuit L is an iron-cored inductance or choke coil, while C is a Mansbridge or other condenser of 4 mfd. Reference to the article on choke coils will disclose full instructions for making a choke for this purpose. It will be seen that the arrangement shown in the above circuit fulfils all the conditions necessary for good results with loud speakers, and tends to minimize distortion.

The condenser, C, allows the speech-modulated currents to pass through it

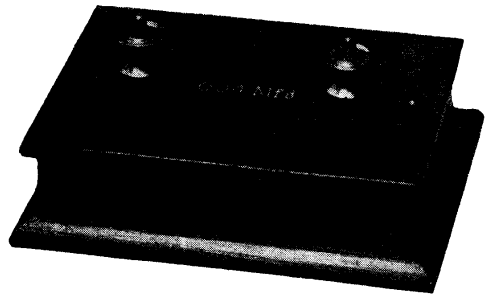

**BY-PASS CONDENSER**

Fig. 2. A by-pass condenser is a larger variety of the ordinary fixed condenser. A common use for it is the protection of the loud speaker windings from direct currents

easily, but prevents the plate current from doing so, thus protecting the loud-speaker windings. On the other hand, the choke, L, offers a very high impedance to the speech current, but provides a ready path for the steady plate voltage.

It might be thought that by preventing the anode current from going through the loud speaker a loss of volume would accrue; this is not the case, however, for it is the modulated current solely which operates the loud-speaker diaphragm. The anode or plate current has no such effect, but simply heats the windings. Fig. 2 shows an ordinary form of by-pass condenser of .004 mfd. capacity. See Choke Coil; Condenser; Loud Speaker.

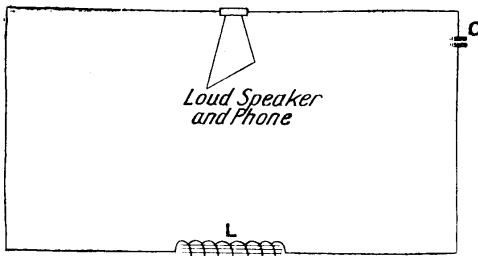

**THEORY OF BY-PASS CONDENSER**

Fig. 1. Speech-modulated currents are allowed to pass the condenser C, but not the plate current. High impedance is offered to the speech current by the choke L, which provides a steady plate voltage and improves the tone in the loud speaker

improvements can be obtained by using a filter-feed circuit. The safeguarding of the loud-speaker windings is also accomplished at the same time. Fig. 1 is a circuit employing this device.



This usually represents the chemical symbol for carbon. It is also the standard symbol in electricity for coulomb and, in italics, the international symbol for capacity. See Abbreviations; Capacity; Carbon; Coulomb.

**Ca.** Chemical symbol for calcium, one of the metallic elements. See Calcium.

## CABINETS FOR WIRELESS RECEIVING SETS

### Design and Construction of Twelve Types Fully Illustrated

Here are given full instructions, illustrated with a large number of photographs and diagrams, showing how the amateur can make his own cabinets, whether of the simple type suitable for a modest crystal set, or the elaborate article intended for a multi-valve set. The reader should also consult such cognate subjects as Amplifier ; Bench ; Brace and Bit ; Glue. See also Ebonite ; Panel

The word cabinet includes in its meaning the great variety of pieces of furniture and other articles of domestic utility, but to the wireless experimenter it refers to the case or container for the receiving or transmitting set.

The great advantage of a cabinet is that it provides a convenient way of protecting the apparatus from damage. In its simplest form it is nothing more than a box, but there are numerous examples of well-designed pieces of furniture suitable for any room in the home. All of them come under the same heading, and their essential purpose is the same—to provide a secure container for the wireless set. The enthusiastic experimenter may be inclined to scoff at the highly polished cabinet sets and to assert that a cabinet is of little utility to those who prefer to build up and try out a variety of different circuits. There is no reason why such experiments should not be made in a cabinet designed for the purpose, and it is probable that the apparatus then would be better treated.

#### Important Considerations in Design

There are several points that should be borne in mind in the design or selection of a cabinet, as, for instance, that of including the low-tension accumulator within the cabinet itself. There is always a certain amount of fumes from an accumulator, and these should not be imprisoned within the cabinet, as, sooner or later, they will adversely affect the metalwork of the apparatus.

Another point to consider is the position of the valves. In some cases these are placed on the exterior of the set, and although in this position they are readily accessible they are equally exposed to damage, and modern practice tends to locate the valves within the cabinet and to provide a window for the inspection of the filament. When only a small cabinet is used there are the questions of the proximity of the parts to consider. For example, it is wrong to jumble up the inductances with the transformers and

resistances, as there is then bound to be a serious interaction between them.

It is best, therefore, to provide adequate space for all the pieces rather than crowd them together. Many cabinet sets are made that only incorporate the receiving apparatus and do not include an accumulator and H.T. battery, but if a cabinet set is to be made it is just as well to provide a place for them, but to keep them from the other parts.

#### Making the Simplest Cabinet

In the following pages are given details of the construction of several typical sets, and any desired modifications can readily be made, as the details of the construction of a cabinet are common to all. For instance, the construction of a housed joint for a small case is the same when it is used in an elaborate cabinet.

The simplest type of cabinet is the plain flat box as shown in Fig. 1, where the top is composed of a sheet of ebonite on which are mounted the various instruments.

The case is shown in Fig. 2, and comprises five separate parts—the bottom, two ends, and two sides. These are jointed at the corners with the kind of dovetail joint generally known as combed. The bottom has a moulded edge and is merely screwed to the framework. The essentials of such a construction are that the corners be perfectly square and the top surface level. If it is not the ebonite top may be cracked right across when the holding-down screws are tightened.

It is customary to measure this class of case by the outside dimensions; consequently, in the construction, prepare the timber accordingly. Cut two pieces slightly longer than the exact length of the sides, and two others for the ends. Plane the ends by placing the timber crosswise on a shooting board, so making the ends square and true, and finish them slightly on the long side rather than too short. The other edges are then planed true and parallel and the joint prepared.

The details of the joint are clearly shown in Fig. 3. The depth of the slots

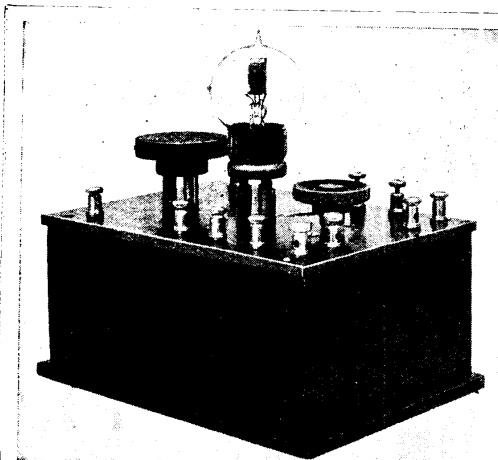

Fig. 1. A neat and simple cabinet without decoration or elaborate design

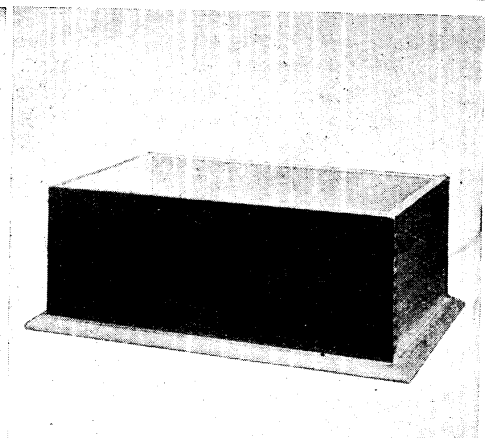

Fig. 2. Similar to the cabinet in Fig. 1, this example is made with combed dovetail joints

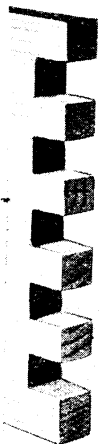

Fig. 3. Dovetail corner before the two sections are joined

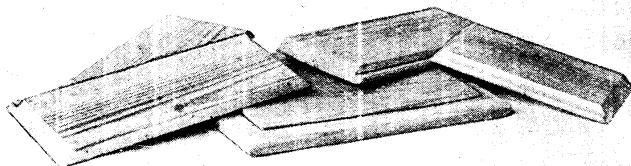

Fig. 4. An alternative method is to make mitred joints, cutting a rebate round the top edge of the base to support the side pieces

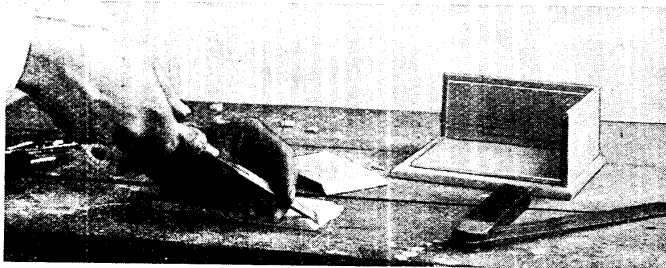

Fig. 5. Working on one of the side pieces. Two sides of a cabinet made in this way are seen erected

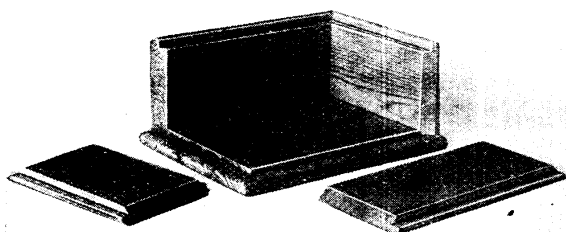

Fig. 6. Before permanently assembling the parts, the whole construction should be put together loosely as a test of truth

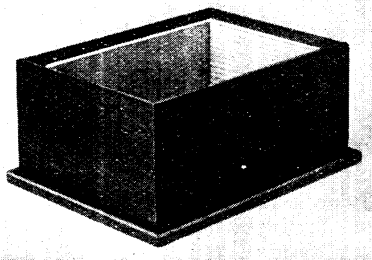

Fig. 7. The completed cabinet, stained and polished

PLAIN AND SIMPLE CABINET FOR WIRELESS SET

should be equal to the thickness of the timber, and the width about the same. Success in construction is more a matter of accurate marking out than anything else, and of sawing to the waste side of the line—that is, the part that will ultimately be cut out. The saw to use is a small tenon saw, and the cuts are made downwards while the wood is held in a vertical position in the vice.

When all the cuts have been made the intermediate pieces of wood are cut out with a paring or firmer chisel, preferably the width of the slot or slightly less. The preliminary cuts may be made by driving the chisel with a mallet, but the final fitting is done with the chisel driven by hand, carefully working the slots until all fit closely together.

An alternative way is to mitre the corners as shown in Fig. 4, and to cut a rebate or recess around the top edges of the base to act as a support for the side pieces. The method of cutting the mitres is clearly shown in Fig. 5, and all that has to be done is to prepare the timber to exact length and chisel the end grain to an angle of 45 degrees. This is done with the aid of a bevel square, seen on the workbench in Fig. 5, where two of the side pieces are shown in position on the base and the other part on the bench.

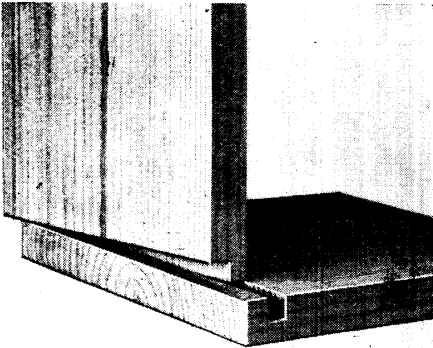

#### HOUSING JOINT FOR CABINET

Fig. 8. Strength and simplicity are combined in the housing joint. This kind of joint is simple to make and is recommended to the amateur

In this case the panel of ebonite that is fitted to the top is housed in a rebate, and the method of making it is described later. To assemble the case, first fit one corner, as shown in Fig. 6, by screwing the base to the side pieces after they have been secured at the corners with glue and fine

pins driven into the corners. The remaining two sides are then glued at the corners and pinned, and then glued to the others that are already fixed. The result is a strong and neat case as shown in Fig. 7.

An easily made joint that is also a strong one is shown in Fig. 8, and is known as a housing. It consists of a groove cut

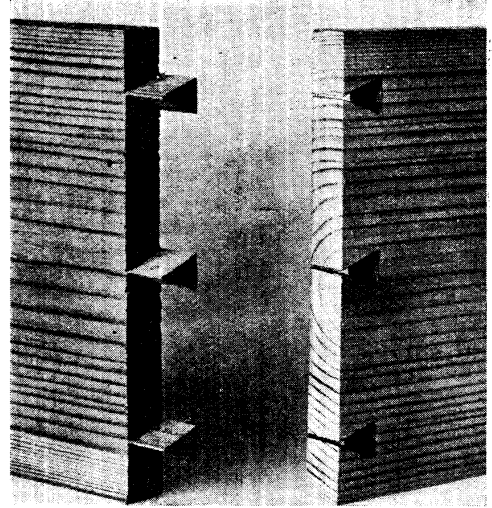

#### DOVETAIL JOINT

Fig. 9. This is a very rigid form of joint which can only be taken apart in one way. It is largely used in professional work

across one part with the aid of the tenon saw and the timber cut out of it with a narrow chisel. The other part is partly cut away on one side of the end, either with a saw or with a rebate plane. The resulting projection or tongue is then fitted to the groove by careful chiselling.

The dovetail joint, Fig. 9, is another that is extensively used and is there clearly shown. The special feature is that the joint can only be taken apart in one way, as the shape of the projections prevents it moving in the other direction. These joints call for a considerable degree of skill to make nicely, but the work itself consists simply of marking out the joint accurately and then sawing along the sides of the V-shaped parts and afterwards cutting away the wood with chisels.

With all these classes of joints, such as the housed and the dovetail, the usual custom is to fit them so that a small portion of the joint projects, and when the case is finished to plane them smooth and finish by sandpapering. This usually results in a good close-fitting joint.

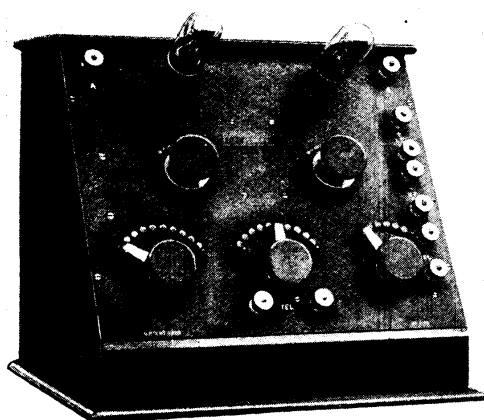

Fig. 10. Commercially-made cabinets, as well as those constructed by the amateur, are frequently made with a sloping front

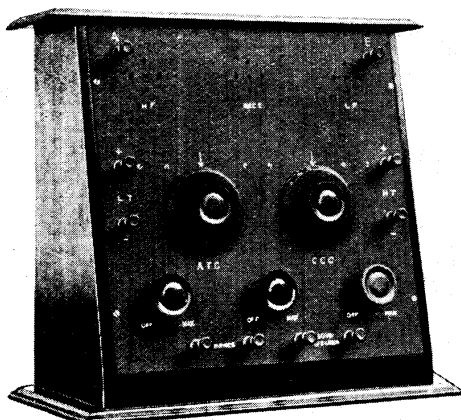

Fig. 11. Cabinets are designed according to purpose, bearing in mind that separate units should be uniform in appearance

*Courtesy Economic Electric Co., Ltd.*

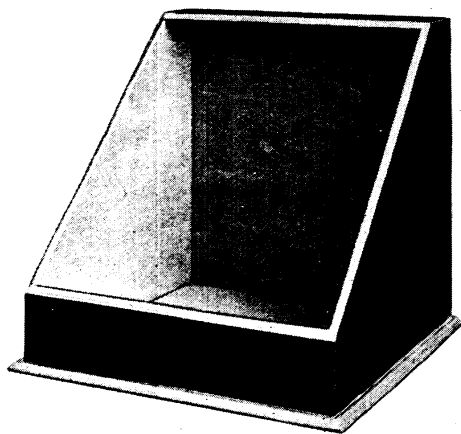

Fig. 12. Sloping front cabinets are pleasing in appearance and suited to hard wear. They require care in arranging the components

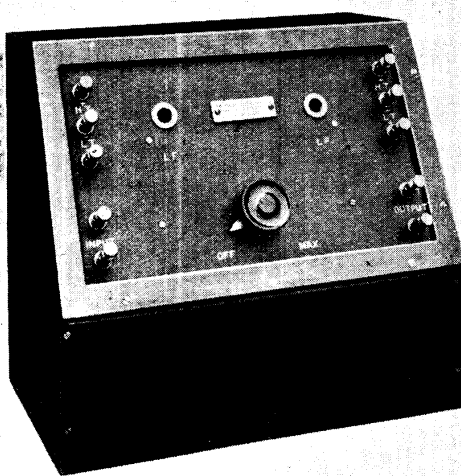

Fig. 13. Cabinets of the sloping front type are very suitable for housing complete sets. The above is a two-valve amplifier with hinged back

**WIRELESS CABINETS WITH SLOPING PANELS**

The natural development of the flat case is the upright inclined type as shown in Fig. 10; the construction is similar to the foregoing, with the exception that the sides are taller and tapered. In the model illustrated the valves are exposed on the outer side of the panel. A better plan is to enclose them as shown in Fig. 11, a three-valve receiving set by the Economic Electric Co., Ltd.

The appearance of the cabinet for this kind of set is shown in Fig. 12, from which it will be seen that it is simply an inclined case, the sides and back, together with the

low front piece, being the equivalent of the side pieces of the simple flat type. The back and top are jointed in the same way and the bottom screwed in place. Such cabinets are very strong. With this type of cabinet it is sometimes difficult to accommodate the apparatus, especially when it is desired to place, say, the transformer on the baseboard. It is then better to utilize the pattern illustrated in Fig. 13, where the front part is increased in height for this purpose. The cabinet illustrated houses a two-valve amplifier and the back is hinged as shown

in Fig. 14, to enable the valves to be reached or replaced.

Another variety of cabinet is that with hinged top of the type shown in Fig. 15, which shows a single-valve set. To operate this class of receiver the hinged lid is opened, the valve placed in position, and the tuning carried out in the usual way after the batteries have been connected. This is not so convenient as the former type, as the valve has to be removed before the lid can be shut and all the connecting wires have to be disconnected. On the other hand, when portability is a consideration the design has much to commend it, as it closes up into compact compass and a carrying handle on the top is an aid in this direction.

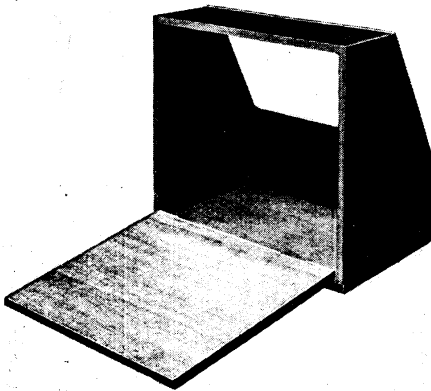

**CABINET WITH HINGED BACK**

Fig. 14. Facilities for replacing valves and examination of the working of the set are provided in a sloping front type of cabinet by hinging the back

The construction of a hinged lid cabinet as shown in Fig. 16 is simple. The material used is ordinary building deal obtained from the timber yard and nicely planed up true. The side pieces are made the full height of the box and the lid, the corners mitred as previously described and the base screwed in place.

Before this is done, grooves are cut across the inner faces of the side pieces for the partition seen in Figs. 18 and 19. The top is cut from material 1 in. thick. This finishes when planed only about  $\frac{7}{8}$  in. thick. It is then glued and pegged to the top of the sides with little pegs made from match sticks. When the glue has set the corners are rounded off with a plane and the whole of the exterior planed up.

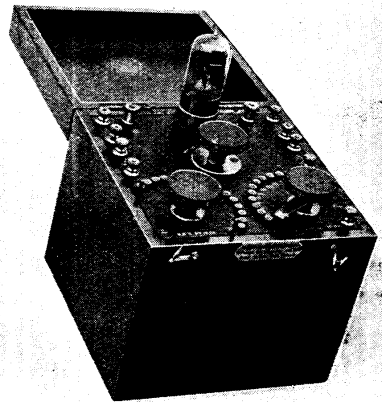

**HINGED TOP CABINET OPEN**

Fig. 15. Square box cabinets with hinged tops as here shown are well known among wireless enthusiasts

*Courtesy Economic Electric Co., Ltd.*

The box is now in the form of a complete structure enclosed on all sides, top and bottom, and the next step is to draw a line around it where the lid is to fit to the case, and it is then sawn asunder as shown in Fig. 17, using a fine-toothed tenon saw and following the line very carefully. Commence sawing at one corner and work from corner to corner, as this tends to accuracy. The appearance of the case immediately after sawing off the lid is shown in Fig. 18.

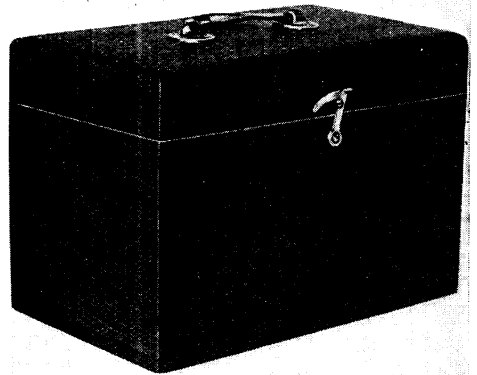

**AMATEUR-MADE HINGED TOP CABINET**

Fig. 16. The construction of this cabinet in planed deal is illustrated in the photographs on the opposite page. It is made portable by the addition of a handle



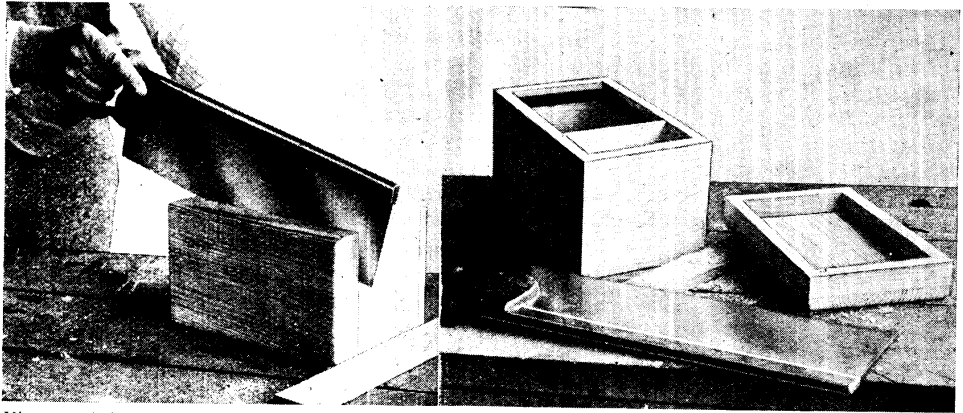

Fig. 17 (left). After the box has been made, all sides, top and bottom being glued together, the corners of the top are rounded and the lid is formed by sawing clean through the structure. Fig. 18 (right). Before assembling the box, two sides have grooves cut in them to accommodate a partition, seen above. Note the lid, which has been cut off as in Fig. 17

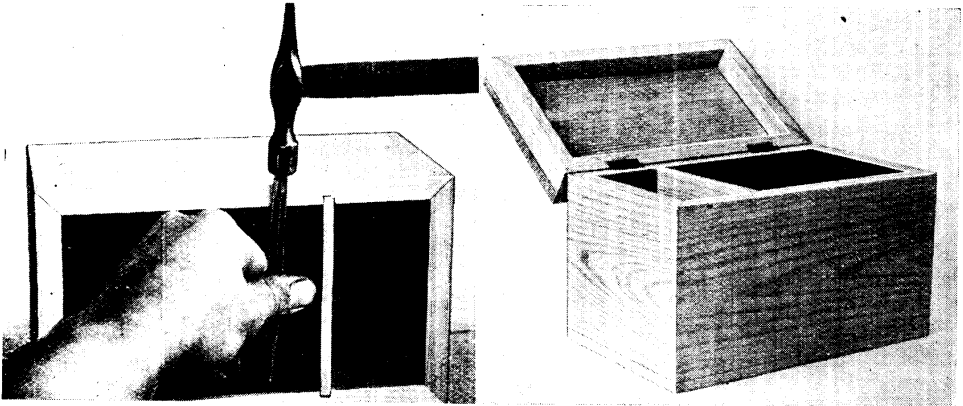

Fig. 19 (left). Brads are inserted to secure the panel filets, these are punched home to avoid their contact with any part of the apparatus. Fig. 20 (right). Butt hinges are used in the construction of the hinged top cabinet. In this photograph the ebonite panel is shown in position fitted flush with top

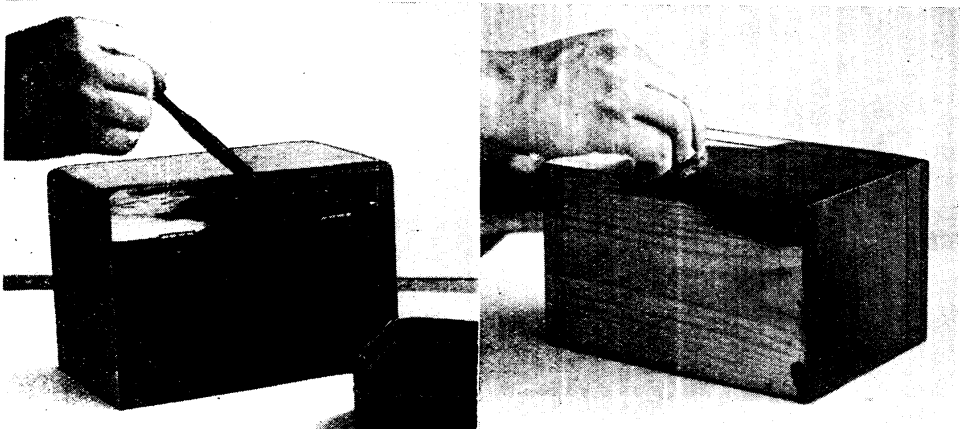

Fig. 21 (left). Staining the completed cabinet should be done before the handle and hook-and-eye are attached. The stain may be brushed on in the manner illustrated. Fig. 22 (right). An alternative method is application with a rag. This gives a more even colour, and the process is quicker

#### CONSTRUCTION OF A HINGED TOP CABINET

The partition is in place, having just been put in position by sliding it into the grooves already cut for that purpose. The joint is then planed up so that the lid can fit down flat and true. The panel is in this case supported by fillets of wood secured to the inner faces of the main portion of the case. This is accomplished by the use of a nail set or punch, as shown in Fig. 19. The fillets are set about  $\frac{1}{4}$  in. below the top, so that the ebonite panel can fit down into it nicely, as shown in Fig. 20, which also shows the butt hinges recessed into the wood so that the lid can close properly.

A carrying handle and hook and eye for keeping the lid shut are fitted and removed again. The exterior can then be stained by using any of the recognized brands of wood stain, applying it with a brush, as in Fig. 21, or preferably with a rag, as illustrated in Fig. 22. This tends to ensure a better and more uniform colour. If a specially good finish is desired the wood should first be well sandpapered with very old paper, the grain filled with a wood filler or with a little whiting and linseed oil well rubbed in, and the surface again sandpapered. After the stain has dried finish with french polish or varnish.

Quite a different class of cabinet is illustrated in Fig. 23, which is based on the unit expanding principle. The illustration shows another amateur produc-

tion, and two of the units assembled and connected together. The unit on the right is the tuner, and on the left a detector and L.F. amplifier, but the principle is the same whatever the type of set.

The great feature is that all the units are the same height and width and are connected by dowels so that any combination of units can be assembled. The construction is simplicity itself, and may be carried out by any amateur without any knowledge of woodwork. The timber is ordinary building deal and known as  $\frac{1}{2}$  in. by  $\frac{3}{4}$  in. prepared board.

The first step is to saw off two pieces to the desired length, say, 9 in., and to round off their top edges. Clean up the end grain with a plane or sandpaper and cut two other pieces to the desired height for the ends. Prepare two cross battens and nail them to the underside of the bottom piece or baseboard. Then screw the ends to the bottom and the top to the upper part of the ends as shown in Fig. 24, taking care to countersink the holes so that the screws will sink in flush with the surface.

Next prepare a drilling jig by nailing three pieces of batten together, as shown in Fig. 25, and then marking the location of the dowel holes on the end and drilling the holes into the end grain of the top and baseboards, as shown in Fig. 25. The jig assures that the holes will all be sufficiently uniform to ensure interchangeability. The jig should be preserved.

To one end of the units six pegs of brass about  $\frac{1}{8}$  in. diameter by driving them into the holes and leaving a short piece projecting, as shown in Fig. 26, where the next step is also illustrated. This is to cut and fit the ebonite panels so that they fit nicely into the opening, and secure them to little angle pieces of wood glued and pinned into the corners. The back is enclosed with a panel of three-ply wood, which fits into a groove made by nailing a narrow strip of wood to the base and a second piece just within the opening, so that the panel can drop into the space between them, as in Fig. 27. Two strips of brass are provided near

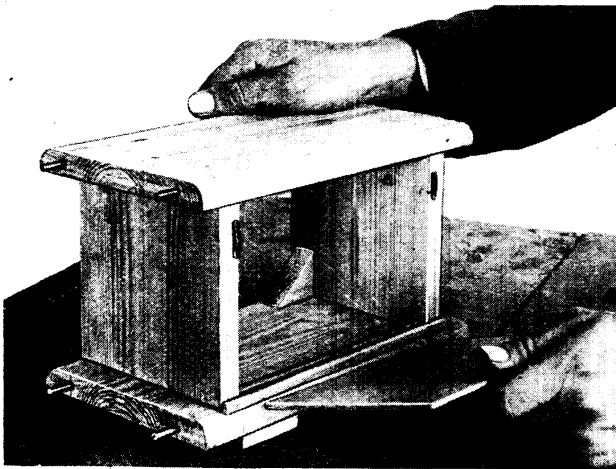

**EXPANDING CABINET WITH THREE-PLY BACK**

Fig. 27. Cabinets for expanding unit sets, as in Fig. 23, have three-ply panel backs. These are removable to allow the interior of the cabinet to be examined. As will be seen above, the back is held in position in grooves by two brass holding pieces

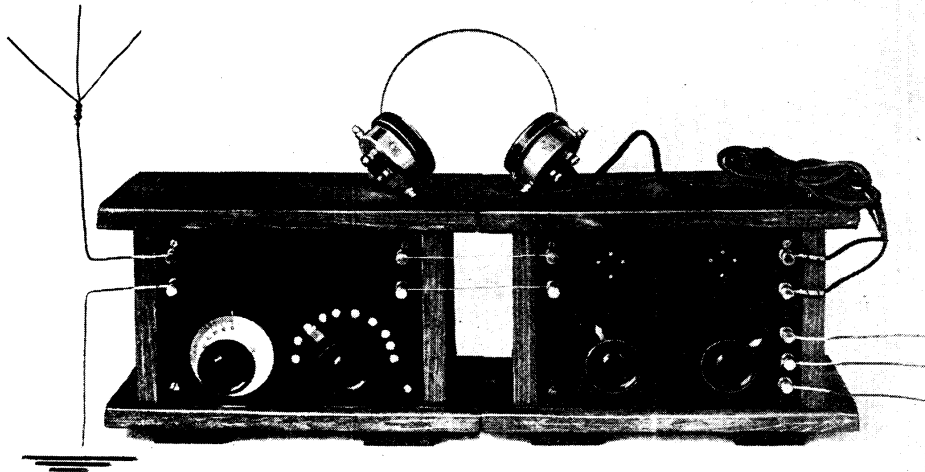

Fig. 23. When high- and low-frequency units are added to a set, cabinets suitable for the purpose may be made as here illustrated. The two units are uniform in design and dimensions

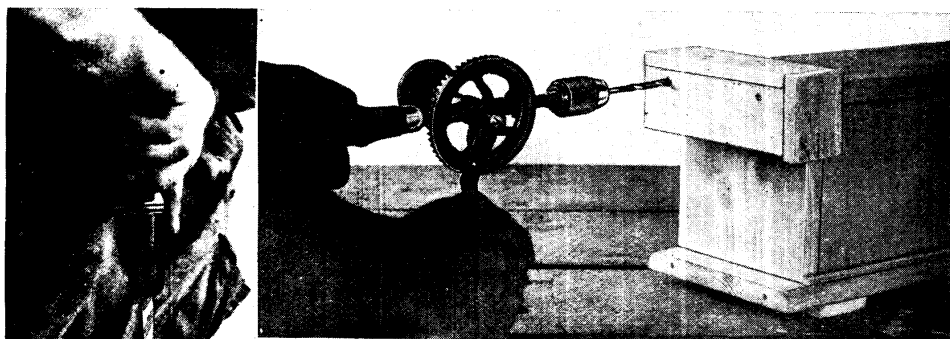

Fig. 25. Dowel holes are bored with the aid of a drilling jig. This ensures that the dowels are uniformly spaced for every unit

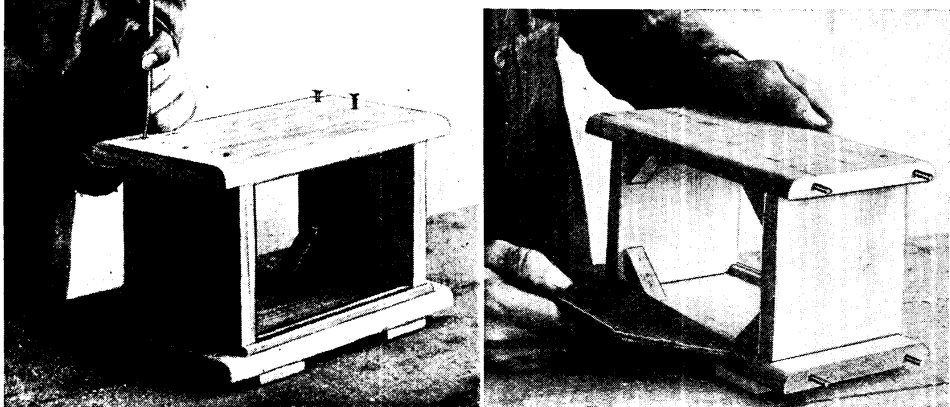

Fig. 24. Top and bottom of the separate cabinet are screwed together. The screw holes should be countersunk. Fig. 26. Brass pegs or dowels are here shown in position for connecting the separate cabinets. The ebonite panel is being fitted in position

#### MAKING A UNIT EXPANDING CABINET

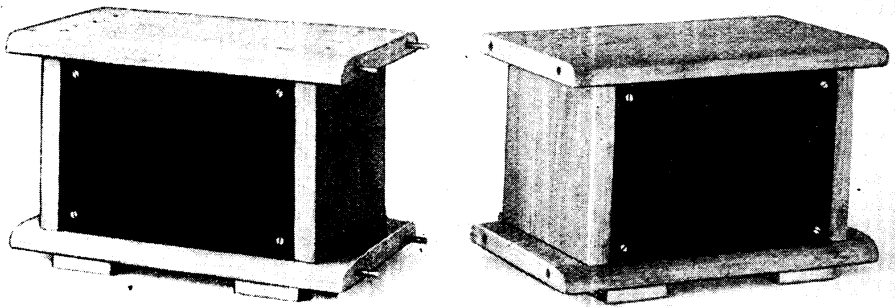

Fig. 28. Two units of the cabinet are here assembled ready for putting together. The way the ebonite panels are screwed on to the back may be seen, and also the dowels and dowel holes

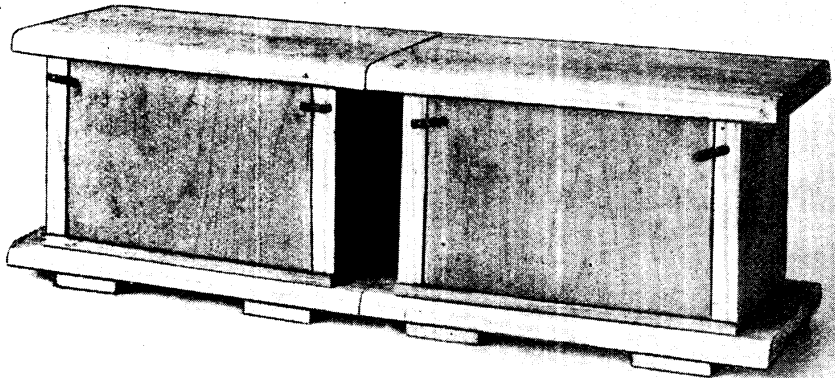

Fig. 29. On the reverse side the back panels are seen in position. The two units are now joined, and are held in position by the dowels

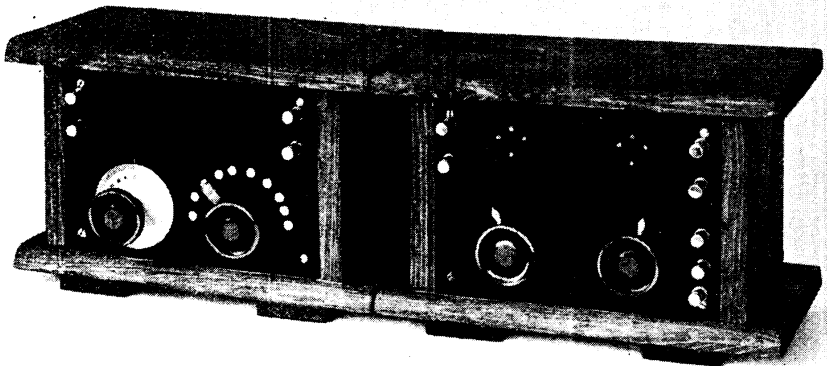

Fig. 30. Staining and polishing having been carried out, the cabinet is complete. The control and instruments are placed in position, and the finished result is as seen in this photograph

FINISHING THE UNIT EXPANDING CABINET

the top and linged with small screws, one through the upper part of each.

Two units made in this way are shown in Fig. 28, and the utility of the dowels is very apparent, also the screws that secure the ebonite panel to the angle pieces within. A back view is shown in Fig. 29, and how the two are put together, also the way the strips are turned to hold the removable back in place. The exterior is then stained and polished, and the panels finished by mounting the apparatus as in Fig. 30, some of which can be attached to the baseboard if this is more convenient. The removable back and the case with which the panels can be removed by withdrawing four screws make this cabinet system particularly valuable to the experimenter.

**Standing Cabinet in American Whitewood.** A more pretentious cabinet is illustrated in Fig. 32, and the working drawings for it in Fig. 31. This is intended to receive the accumulator and batteries in the lower compartment with the hinged doors. The upper contains the receiving set, and the drawer is a convenient place for the telephones. The sizes given are suitable for the average four-valve set. When the experimenter has the requisite skill the cabinet can be made on the regular cabinet-making lines, but as many wireless enthusiasts are more familiar with working in metal and ebonite the construction has been simplified. The material can be American whitewood or ordinary building deal. Mahogany or oak could be used and would be preferable, but their expense is considerable and more appropriate to the regular cabinet-making methods as detailed later.

The first step is to cut two pieces of material for the two sides and then to saw out the space between the legs, as shown in Fig. 33. The hand-saw for this part of the work should be used in the manner illustrated. The first finger points down the handle. The wood is cut out between the saw-cuts with the aid of a chisel, as in Fig. 34, and the result should be as shown in Fig. 36.

Now mark out the location on the shelves, and cut the housing joints into which the shelves are fitted. The groove for the housing does not go right across the board, but terminates about  $\frac{1}{2}$  in. from the front. The groove is made by first chipping out a recess with a chisel at the stopped end, as in Fig. 35, and then sawing along the waste side of the lines with a tenon saw, as shown in Fig. 37, after which it is easy to chisel out the groove. The outside is next planed up true and flat, as shown in Fig. 38. The shelves are cut to length and a corner cut back to fit into the housing or grooves. They are fixed in place by nailing through from the outside, as in Fig. 39, or by the preferable method shown in Fig. 40.

Here the nails are driven at a small angle through the shelves into the side pieces as shown, as by this method they do not spoil the external appearance, but the nails should not incline too much or they may break through.

The top is simply screwed on to the side pieces, and is therefore longer than the shelves by twice the thickness of the side pieces. The top is finished by nailing a

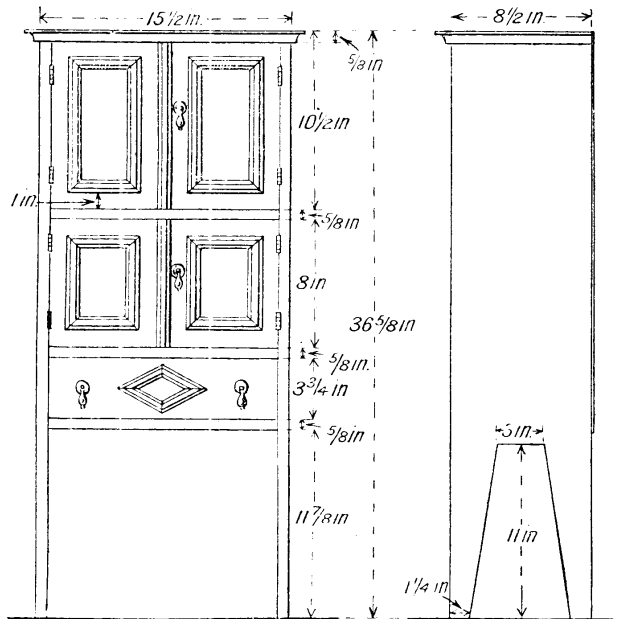

STAND CABINET TO CONTAIN COMPLETE APPARATUS

Fig. 31. Dimensions are given for the construction of a cabinet with a drawer and hinged doors designed to accommodate an entire receiving set, including batteries. The finished appearance may be seen in Fig. 32

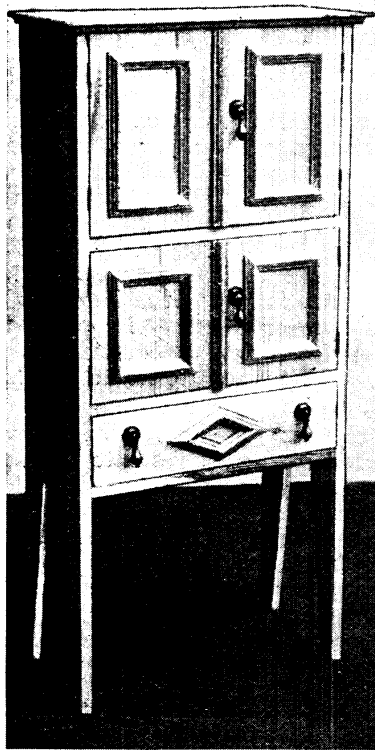

Fig. 32. The amateur can make this cabinet from the description and diagrams. It is here seen in the white

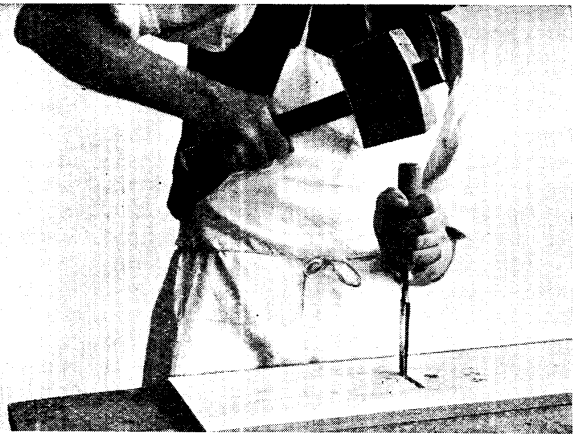

Fig. 34. After making the two saw-cuts, the material between the legs is removed by chisel and mallet

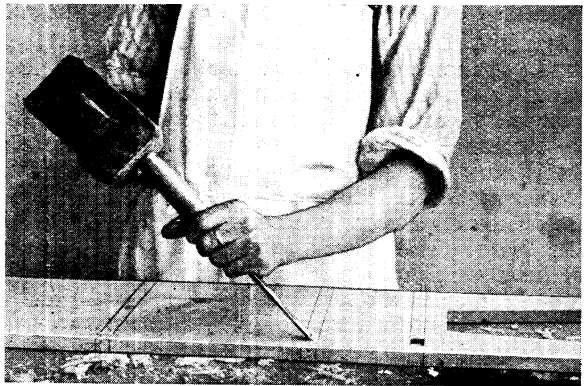

Fig. 35. Accommodating the shelves by cutting housing grooves; chipping out a recess at the stopped end



Fig. 33. Side pieces are cut out first and the legs made by sawing out a blunt V-shaped piece of the material. Fig. 36 (top, right). Legs for the cabinet may here be seen more clearly. A complete side is shown with the outside uppermost. Fig. 37. Grooves are sawn for the shelves, as illustrated. One groove is completed, one is sawn but not chiselled out, and one is being sawn

HOME-MADE WIRELESS CABINET AS AN ARTICLE OF FURNITURE

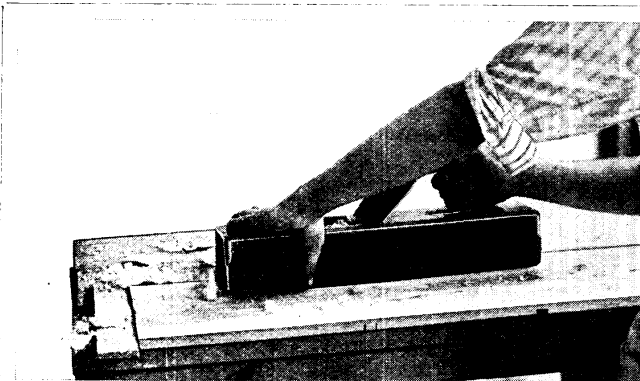

Fig. 38. Planing up the outside of the side. Note the method of holding the plane

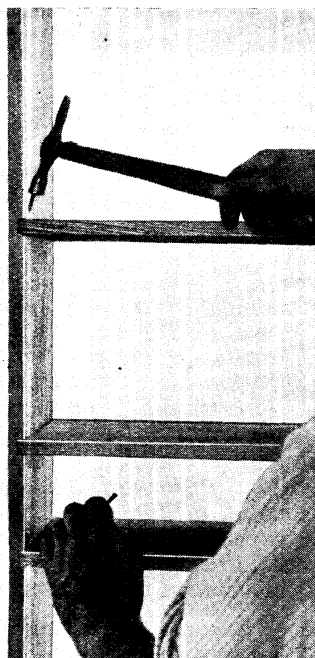

Fig. 39. Fixing shelves by nails driven through from inside. This keeps them rigid in their housing

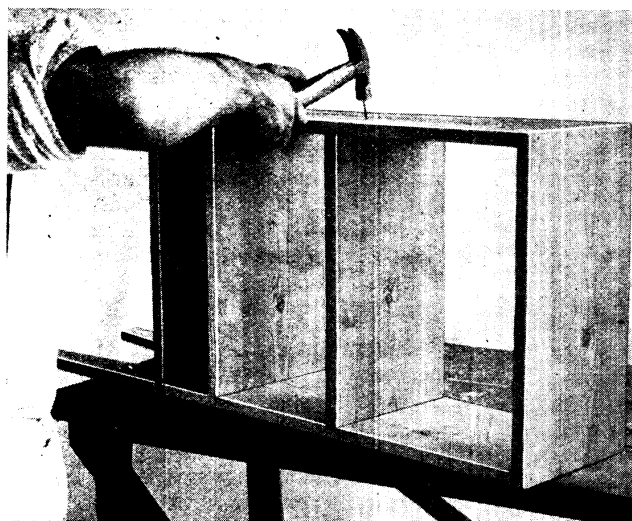

Fig. 40. A neater method than that shown in Fig. 39. Nails are driven through ends of shelves at an angle

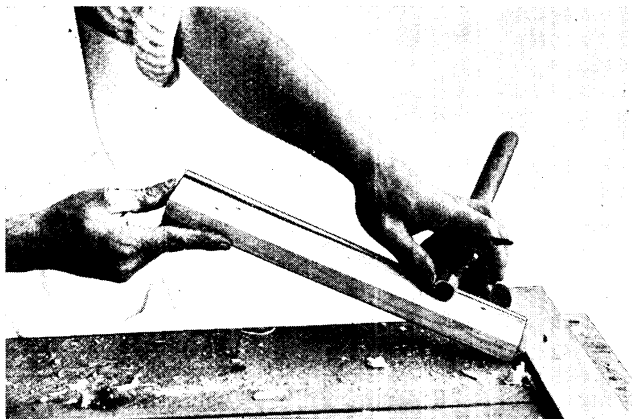

Fig. 41. Cutting out a rebate. The operator is using a cutting gauge

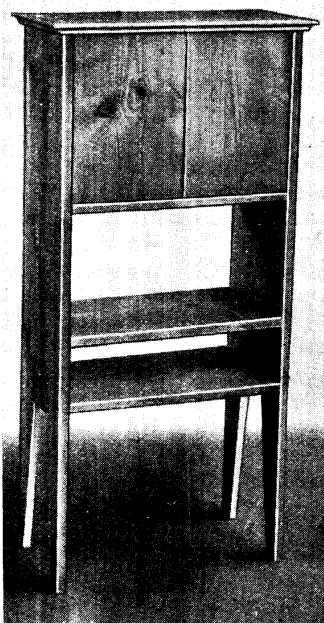

Fig. 42. Carcase and doors of cabinet assembled

MAKING THE STAND CABINET FOR A FOUR-VALVE SET

a simple moulding to the edges, mitring the corners as if it were a picture frame. The doors are then cut to size and fitted to the openings, as shown in Fig. 41. This is the simplest way, but it is preferable to clamp the edges or to make a proper frame with mortised and tenoned joints, and to fit the panels to a rebate or into a groove cut in the edge of the frame.

One simple way of making the rebate is shown in Fig. 42, where an ordinary carpenter's cutting gauge is used. This is done by simply cutting a slip out of the edge of the frame, working in the manner illustrated (Fig. 42), first on one side and then on the other. The use of a rebating plane for the same work is illustrated in Fig. 43. These planes are not expensive, and one of them is very useful in the experimenter's tool kit, for it is in constant use in panel construction.

#### How to Use the Plough Plane

The use of the plough plane for making grooves in wood is clearly illustrated in Fig. 44, and is the only practicable plan when long narrow grooves have to be made. The operation and appearance of this plane are clearly shown in the illustration. The corners of frames are conveniently joined with a haunched mortice and tenon joint, as shown in Fig. 45. It will be seen that the joint is made by cutting the tenon to shape with a tenon saw and then making a rectangular hole in the other piece of the framework, as shown in Fig. 46. The chisel is in this case driven into the wood with a mallet and then the chip is cut out by working cross-wise, but cutting in the direction of the grain. This removes a wedge-shaped chip of wood, and the process is repeated until the hole is cut out about half-way through.

The work is then turned over and the same procedure gone through until the hole is pierced through the wood. The walls are then chiselled to shape and the tenon fitted to it by careful chiselling of the sides both of the tenon and of the mortice until they fit nicely together. This type of joint is the strongest for the purpose, but has to be made accurately, or the result will be a twisted door that will never be flat.

The panel must be fitted to the rebate or to the grooves, whichever system is adopted. In the case of the rebate the

panel can be fitted after the frame is finished, but the groove would be inaccessible and, consequently, the panel must be fitted to the groove while the frame is in pieces and prior to gluing and pegging the joints.

When the door is finished it is fitted in place by planing the edges, and the surface should be cleaned up with a smoothing plane. If the doors are made from the solid, as at first suggested, the panel effect is conveniently obtained by cutting strips of some small moulding and securing them to the face of the door with fine brads. All the corners ought to be mitred as for a picture frame.

The arrangement of the moulding can follow individual taste, but one effective design is shown in the working drawings, and the appearance when finished is quite good. The drawer is shown in Fig. 47. The front of the drawer is rebated as shown and the side pieces nailed to it. The end is nailed to the sides and the bottom similarly attached. The division is then cut to size and fixed in place, as shown in Fig. 47.

#### Making and Fitting the Drawer

When making the drawer it is very important to keep everything square or the drawer will not run smoothly, and slight adjustment can be made by planing off the edges until the drawer works freely. The doors should be fitted with hinges and provided with handles and a bolt or lock as desired. Drop handles look well on this type of cabinet, as if it is finished with a dark brown stain and dull polished it has the appearance, shown in Fig. 32, of the popular Jacobean type of furniture.

The back is enclosed with three-ply wood panels. One is screwed to the back so that it covers the upper part from the top to the first shelf, enabling the contents to be examined easily. The rest of the back is closed in with a fixed panel of the same material. An ebonite panel can be fitted towards the front or at the back, as may be most convenient, or the apparatus can be mounted on bars of ebonite fixed at convenient distances from one side of the cabinet to the other.

**Jacobean Bureau Cabinet in Oak.** This style of cabinet is a compromise between the simple case and the regular furniture type of cabinet made with proper joints and framed up in the regulation manner.



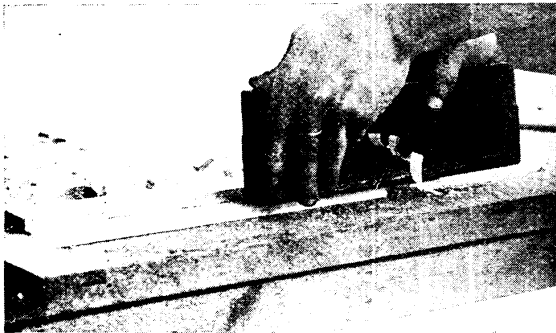

Fig. 43. Rebates for fitting the door panels for the stand cabinet are being made. The tool used is a rebating plane

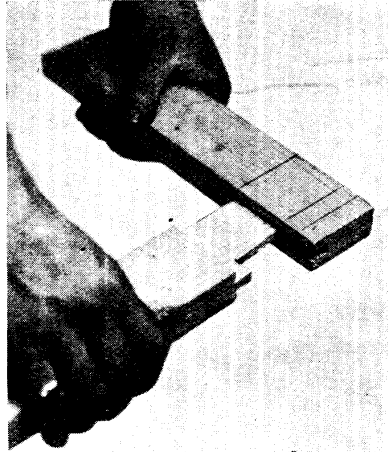

Fig. 45. Doors and other parts of the cabinet have haunched mortice and tenon joints at the frame corners. Note the outside marking

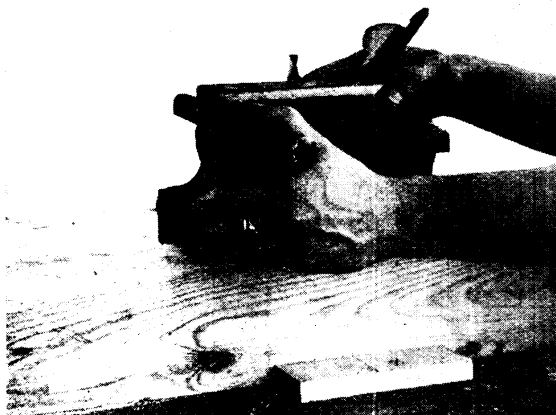

Fig. 44. Grooves are made with the plough plane. This is the best tool for making long, narrow grooves

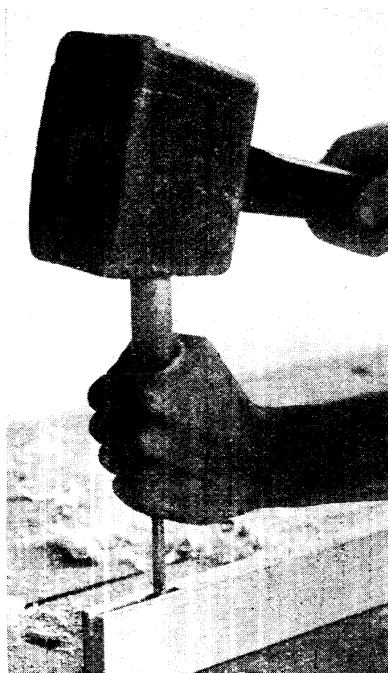

Fig. 46. Cutting out a mortice for a framework. The chisel is driven with a mallet

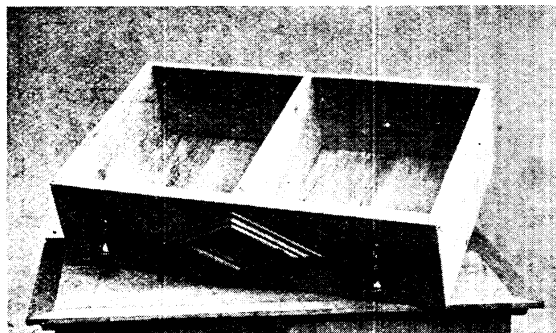

Fig. 47. Telephone drawer of the cabinet completed

**METHODS AND TOOLS USED IN CONSTRUCTING THE STAND CABINET**

A superior piece of work is illustrated in Fig. 48, which shows a bureau cabinet of Jacobean design suitable to be made in oak or in one of the softer woods stained to represent oak. The panel is contained within the fall in the place usually

occupied by the stationery nest in an ordinary bureau. It is so hinged that it can be raised in a similar manner to the fall, so that the parts of the set can be easily reached without the trouble of withdrawing the screws by which it is

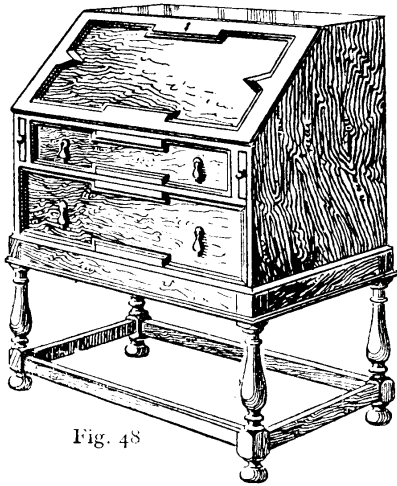
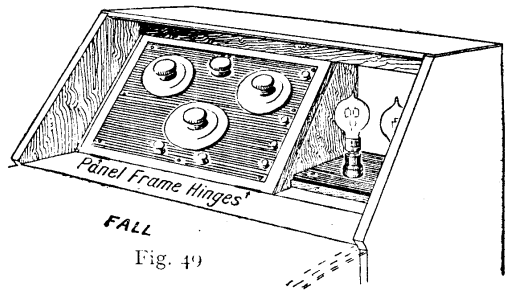

Fig. 48



FALL

Fig. 49

Fig. 48. Resembling an ordinary article of household furniture, this wireless cabinet is designed to take its place with the other pieces of a suite

Fig. 49. Inside the fall front is a panel of ebonite upon which are mounted the tuning knobs and terminals of an ordinary receiver

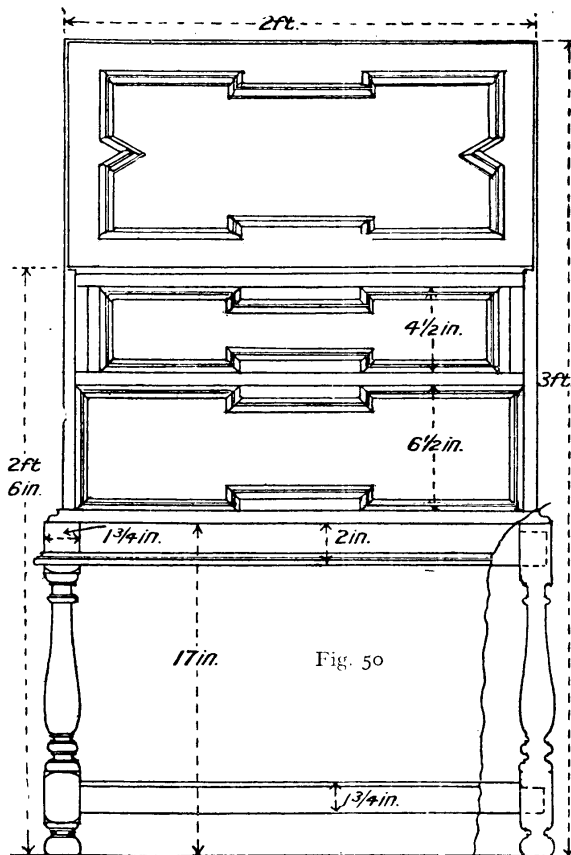

Fig. 50

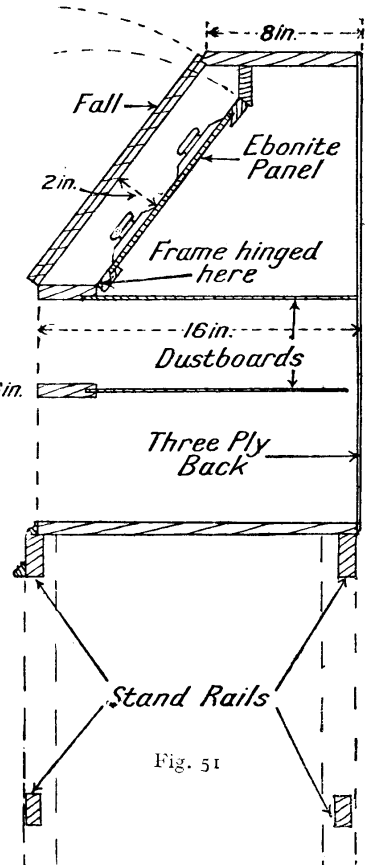

Fig. 51

Fig. 50. Working diagram for the main body in two parts, the lower portion being a stand upon which is mounted the main body. The stand should be made first. Fig. 51. Details of the main body, with side dimensions. Dotted lines indicate the direction of fall of the cabinet sloping front and of the ebonite panel, both of which are hinged at the bottom

JACOBAN STYLE OF WIRELESS BUREAU CABINET

fastened down; a view of the panel is shown in Fig. 49. The cabinet is of the usual bureau size, and is provided with two drawers in which headphones and spare parts may be kept.

The whole piece is constructed in two portions, consisting of a stand upon which is mounted the main body, the latter being made first. The two ends of the main body are first prepared, to the sizes given in Figs. 50 and 51, from  $\frac{3}{4}$  in. material, allowance being made for the small lapping left on the top piece (see Fig. 52). It is really advisable to set the job out on paper to the full size and work always to this. Next cut out the top and bottom from the same thickness stuff, and having squared them up, cut a rebate at the bottom of each end and at both ends of the top. All the rebates will be equal in depth to the thickness of the

wood, so that a level and flush joint occurs, as shown in Fig. 52.

It will be noticed that the front edge of the top is bevelled off in both directions, and this should be done previous to gluing the job together. The upper bevel should be made first in accordance with the slope of the cut-away portion of the ends, and the lower bevel cut at right angles to this. The position of the two drawer rails is now marked on both ends and the position of the mortices for these gauged in. The two rails are then prepared also from  $\frac{3}{4}$  in. stuff and the tenons marked out, the exact length being obtained by marking it off from the top.

Mortices are also marked out on these to receive the two small upright dividing rails at each side of the drawer (Fig. 53). Fig. 51 shows a sectional end view of the work, and it will be noticed that the upper rail is rebated at the back lower edge and the lower rail is grooved to take a dust board. Both the rebate and the groove must be worked before they are fixed. All joints being cut, the carcass may be glued up. Glue the dividing rails to the drawer rails first and then these into the ends, putting in the top and bottom last.

These latter are also nailed, using oval brads for the top. The nails are put in through the sides into the top and should slope slightly towards each other to so obtain a dovetail grip. All nails should then be punched in and the hole filled in with wax coloured with powdered burnt umber. Before proceeding further with the upper part it will be as well to make the stand, as it is more convenient to fix the interior parts when on the stand.

This latter projects about  $\frac{5}{8}$  in. from the carcass, and is surmounted with a moulding behind which the carcass fits. The stand is mortised together, the mortices being cut sufficiently

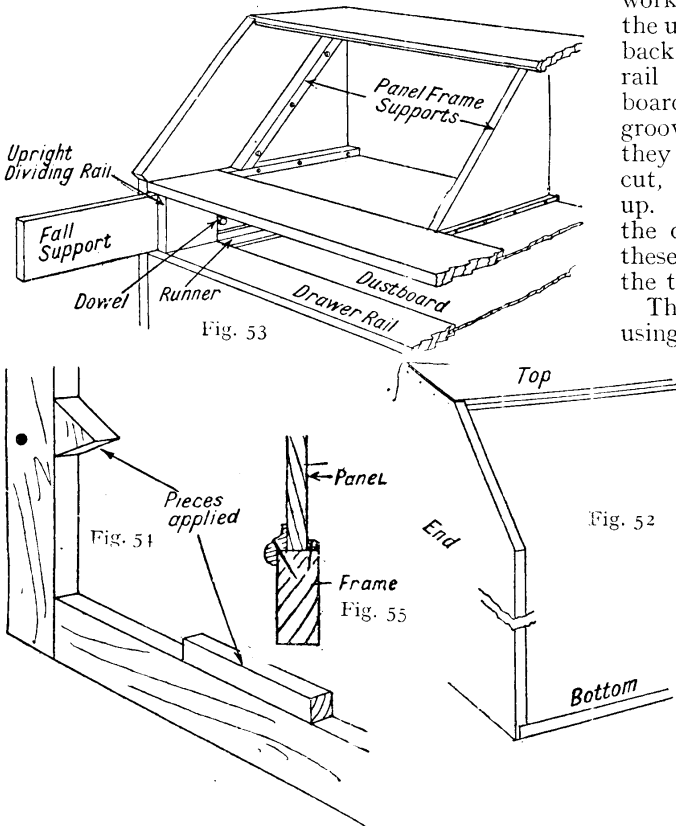

**CONSTRUCTIVE DETAILS FOR JACOBEN CABINET CONSTRUCTION**  
 Fig. 52. Flush joints at the top of the main body of the cabinet. Fig. 53. Parts for the top of the cabinet and the arrangement for the accommodation of the panel. Fig. 54. Shaping is formed in this manner, and small blocks are glued to the frame before attaching the moulding. Fig. 55. Back panel beading attachment

deep so that they meet. It is advisable to cut and fit all joints before having the legs turned, to avoid bruising them. When gluing the stand up, glue two opposite sides separately first and allow to set before gluing the remainder.

Having glued the whole, clean up the joints and mitre the lower moulding round and place the main carcass in position on top and mitre the top moulding round on the top of the stand to so form a kind of rebate in which the carcass will fit (Fig. 51). The two may be screwed together through the bottom into the rails of the stand.

The drawer runners are now fixed, only two being necessary. These must be sufficiently wide to cover the distance occupied by the fall supports and to reach under the drawer. They are of exactly the same thickness as the drawer rails and are grooved to take the dustboard. They are fixed by cutting a small stub tenon at the front to fit into the groove in the rail and are screwed to the ends at the back, being cut off at an angle at the back to facilitate screwing.

Fig. 53 shows the arrangement for the accommodation of the panel. A slip  $\frac{3}{4}$  in. square is screwed to the left-hand end, parallel to the slope of the fall and sufficiently deep so that the knobs will comfortably clear. Another slip is screwed horizontally below this, as shown, to form a runner for the fall support. A dustboard is screwed or nailed to this (this of course fits into the rebate in the front rail) and the right-hand panel support fixed as shown.

A simple rebated frame is now made to take the panel, and this hinged to the back edge of the rail. Notice that this framework does not reach to the top, a cross rail being secured below the top, as shown in Figs. 49 and 51. This rail is, of course, necessary, as otherwise the top would prevent the panel framework from opening. The right-hand space is occupied by the valves, the holders being mounted on a piece of ebonite screwed to a block of wood, shown in Fig. 49.

The drawers are now made, using either  $\frac{1}{2}$  in. or  $\frac{3}{8}$  in. stuff for the sides and backs and  $\frac{3}{4}$  in. for the fronts. They are either dovetailed or rebated together in a similar way to the jointure of the top with the sides of the work. If dovetailed, the dovetails may run right through, as the mouldings will cover the joint. It should be

remembered that the moulding will only project slightly, so that the drawer fronts will actually be recessed slightly. When mitreing the mouldings round, small filling pieces are glued in where the projection occurs. The fall consists of a mortised frame, the rebate for the panel of which is formed by the moulding, which is rebated to fit over the edge of the frame. Fig. 54 shows how the shaping is formed by gluing small blocks to the frame before attaching the moulding. The panel is then beaded in from the back (Fig. 55). The fall supports should fit hand tight and a dowel is put in near the back to prevent it from being pulled right out.

A back of three-ply is screwed to the fall, the edges being rounded over, though this should not be finally fixed until after the job has been polished.

CUTTING LIST FOR OAK BUREAU WIRELESS CABINET.

Allowance of about  $\frac{1}{4}$  in. in length and  $\frac{1}{8}$  in. in width extra.

	Length ft. in.	Width ft. in.	Thick- ness in.
2 ends .. .. .	2 1	1 4 $\frac{1}{8}$	$\frac{3}{4}$
1 top .. .. .	2 0 $\frac{1}{2}$	8 $\frac{1}{8}$	$\frac{3}{4}$
1 bottom .. .. .	2 0	1 4 $\frac{1}{8}$	$\frac{3}{4}$
2 drawer rails .. .. .	2 0	3 $\frac{3}{8}$	$\frac{3}{4}$
2 divisions .. .. .	5 $\frac{1}{2}$	3 $\frac{3}{8}$	$\frac{3}{4}$
1 back .. .. .	2 1	2 0	3 ply
2 fall supports .. .. .	1 2	4 $\frac{5}{8}$	$\frac{3}{4}$
FALL			
2 rails .. .. .	2 0	2	$\frac{3}{4}$
2 rails .. .. .	1 3	2	$\frac{3}{4}$
1 panel .. .. .	1 9	11	$\frac{3}{4}$
DRAWERS			
1 front .. .. .	1 9	4 $\frac{5}{8}$	$\frac{3}{4}$
1 " .. .. .	1 11	6 $\frac{5}{8}$	$\frac{3}{4}$
2 sides .. .. .	1 3	4 $\frac{5}{8}$	$\frac{3}{4}$
2 " .. .. .	1 3	6 $\frac{5}{8}$	$\frac{3}{4}$
1 back .. .. .	1 9	4 $\frac{1}{4}$	$\frac{3}{4}$
1 " .. .. .	1 11	6 $\frac{1}{4}$	$\frac{3}{4}$
STAND			
4 legs .. .. .	1 5 $\frac{1}{4}$	1 $\frac{3}{4}$	1 $\frac{3}{4}$
2 rails .. .. .	2 1	2 $\frac{1}{2}$	1
2 " .. .. .	2 1	1 $\frac{7}{8}$	1
2 " .. .. .	1 4	2 $\frac{1}{8}$	1
2 " .. .. .	1 4	1 $\frac{8}{8}$	1
Mouldings various.			

Mahogany or Stained Bass Wood Cabinet.

Fig. 56 is another type of cabinet suitable to be made in either mahogany or in bass wood. The latter is a very useful wood for imitating mahogany, as it takes stain evenly and well and is fairly close in the grain. The cabinet is opened by the two lids at the top, the decoration of the front, in imitation of two doors, being sham. As will be noticed, the inner sides of both lids are cut away so that the

head-phones, which are stored in the right-hand compartment, need not be disconnected when the cabinet is not in use, the wires passing through the space formed by the cut-away portion.

The cabinet is made in two portions, as in the previous example, the only difference being that the moulding surmounting the stand is about 2 in. wide and is planted on the top of the stand, the main body of the cabinet resting directly on this (Figs. 58 and 59). This main portion is made first, and consists of a box-like structure, the corners being joined as in Fig. 60. A rebate is worked at both ends of the short sides and the front and back glued and nailed into this.

Before putting it together, all four pieces are rebated to take the bottom (see the sectional drawing, Fig. 59). When the whole is glued up, screw the bottom into the rebate and size up a piece of wood for the inside division and nail it in.

It will not matter about the nail holes, as these will be covered by the applied decoration. This latter consists of two parallel pieces of moulding worked to a section, as in Fig. 60, and mitred round to resemble

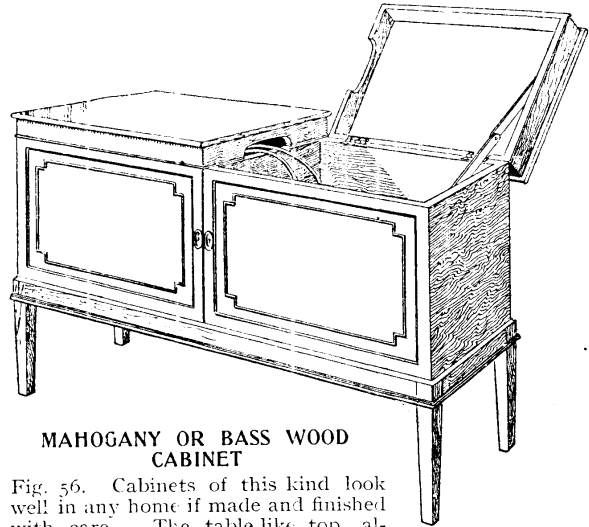

MAHOGANY OR BASS WOOD CABINET

Fig. 56. Cabinets of this kind look well in any home if made and finished with care. The table-like top, although in two parts, adds to its value as an article of furniture, while as a wireless cabinet its capacious interior makes it suitable for almost any kind of receiver

doors, as in Fig. 58. They are glued and pinned in position, and will thus hide all the large nail holes made in the main structure of the job. The two lids are then made from 1/2 in. wood, the corners being joined in a similar way to the main box. It should be noticed that the tops project on three sides only, finishing flush with the sides

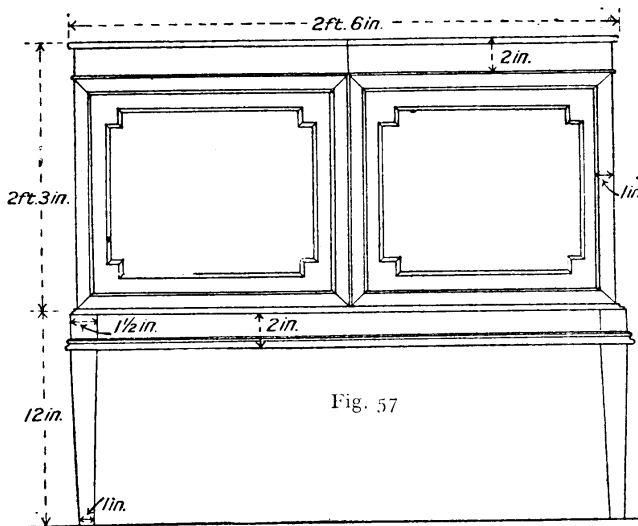

Fig. 57

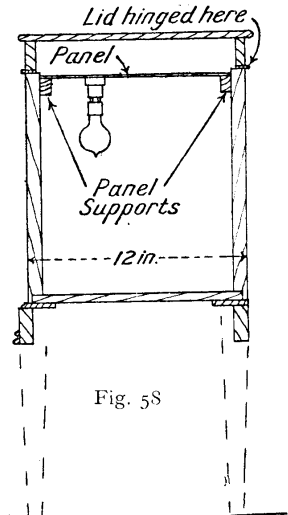

Fig. 58

CONSTRUCTION OF FLAT-TOP CABINET

Fig 57. Dimensions are here given for the cabinet shown in Fig. 56. The material may be mahogany, but bass wood, being more easily worked and suitable for staining and imitating mahogany, may be used instead. Fig. 58. End elevation is shown, and the valve panel represented diagrammatically. In order to provide for the maximum space beneath the panel, the valve is inverted

where they meet at the centre. The tops should not be glued on, as this will render them liable to split if any shrinkage occurs, but are screwed on as in Fig. 60, the screw holes being made fairly large to allow a little play. A small bead is mitred round the bottom of the slides of the lid, and this should exactly equal in thickness that of the butts by which the lids are hinged. Figs. 58 and 62 show how the panel is supported, a fillet being screwed all round, to which the panel may be screwed.

the moulding up into the bottom. When hinging the lids, sink the butts into the lids only, so that they form a continuous line with the bead, as in Fig. 62, as otherwise the bead will bind when the lid is opened. A jointed stay is fastened to each lid, as in Fig. 56, to prevent them from opening too far, and thus straining the butts. Two oval brass handles are secured to the front of the job to add reality to the false doors.

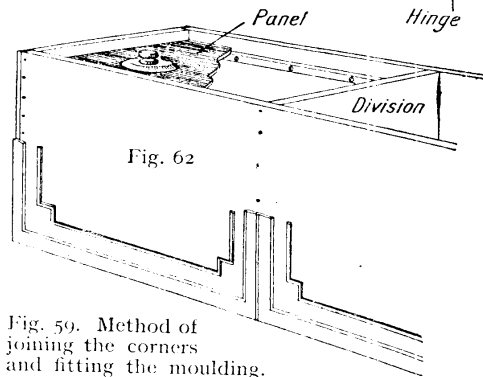
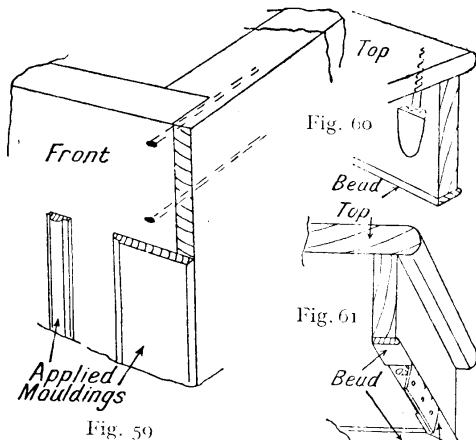

Fig. 59. Method of joining the corners and fitting the moulding. Fig. 60. How the tops are screwed on. Fig. 61. Sides, top, and bottom of lid. Note bead on latter equal to thickness of the hinges. Fig. 62. Fillets can be seen in this diagram screwed on the inside wall of the cabinet for the support of the panel

The stand is made in a similar way to the previous example, except that the legs are tapered instead of being turned. The tenons should meet to obtain the maximum strength. When marking out the rails, be sure to allow for the moulding, which is to be placed on the top. The two portions are screwed together through

CUTTING LIST FOR MAHOGANY WIRELESS CABINET

Allowance of about 1/4 in. in length, and 1/8 in. in width, extra

	Length ft. in.	Width ft. in.	Thick- ness in.
2 long sides .. ..	2 6 1/4	1 1 1/8	3/4
2 short sides .. ..	1 0 1/4	1 1 1/8	3/4
1 bottom .. .. .	2 6	1 0	3/4
1 division .. .. .	11	1 1 1/8	3/4
2 tops .. .. .	1 3 3/4	1 1 1/4	1 1/2
4 rails for top .. ..	1 3 1/4	1 5/8	1 1/2
4 rails for top .. ..	1 0 1/4	1 5/8	1 1/2
STAND			
4 legs .. .. .	1 0	1 1/2	1 1/2
2 rails .. .. .	2 6 1/2	2 1 1/8	1
2 rails .. .. .	1 0 1/2	2 1 1/8	1
Mouldings various.			

A particularly handsome example of the type of cabinet shown in Fig. 56 is illustrated in Fig. 64. It is the No. 4 Lyrian, manufactured by the Radio Instrument Co., Ltd. The cabinet work has quartered panels and handsome mouldings and carved enrichments. The use of an enclosed book-form aerial is a feature of interest, as the set is entirely self-contained, neither aerial nor earth wires being required.

An upright cabinet made by the same firm is illustrated in Fig. 66, and is known as the No. 2 Lyrian. The disposition of the valves and the arrangement of the aerial are interesting points in this model.

A compact model on the same lines is shown in Fig. 65, adapted for table use, and including a built-in loud speaker, the outlet or mouth of which is provided with louvres, seen near the top of the instrument. A very complete cabinet set is shown in Fig. 63, and illustrates one of the Radio Communication Co., Ltd.'s seven-valve sets, complete with loud speaker. This type of cabinet is suited to the needs of institutions and large buildings, and is an ornament in any smoking-room or lounge.

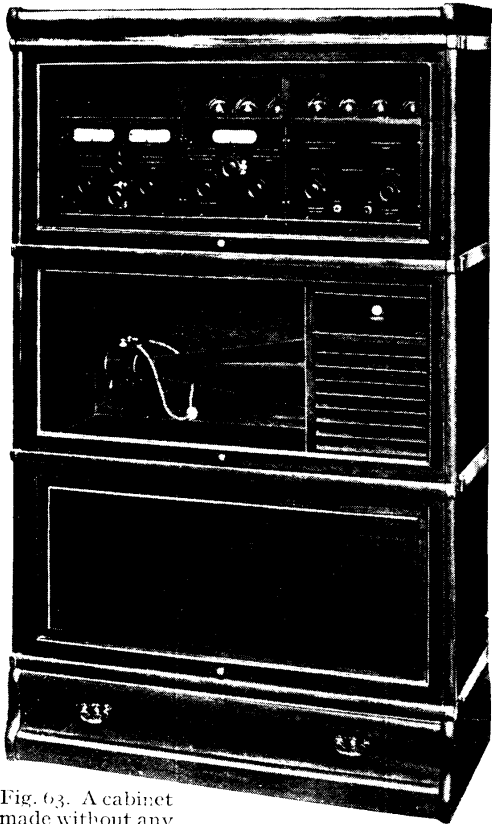

Fig. 63. A cabinet made without any attempt to conceal its purpose, while possessing the appearance of first-class furniture. It contains a seven-valve set and loud speaker

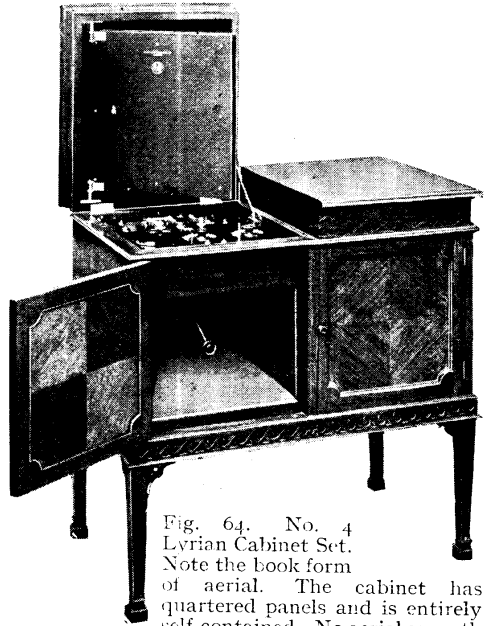

Fig. 64. No. 4 Lyrian Cabinet Set. Note the book form of aerial. The cabinet has quartered panels and is entirely self-contained. No aerial or earth wires are needed

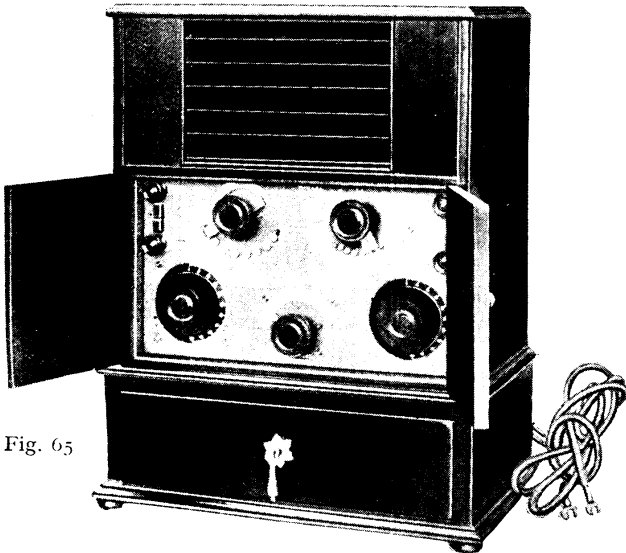

Fig. 65

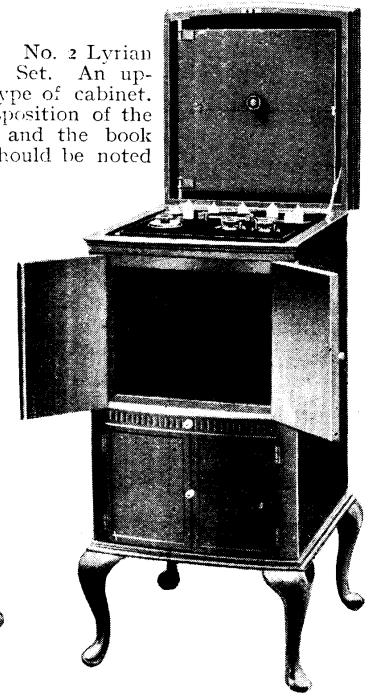
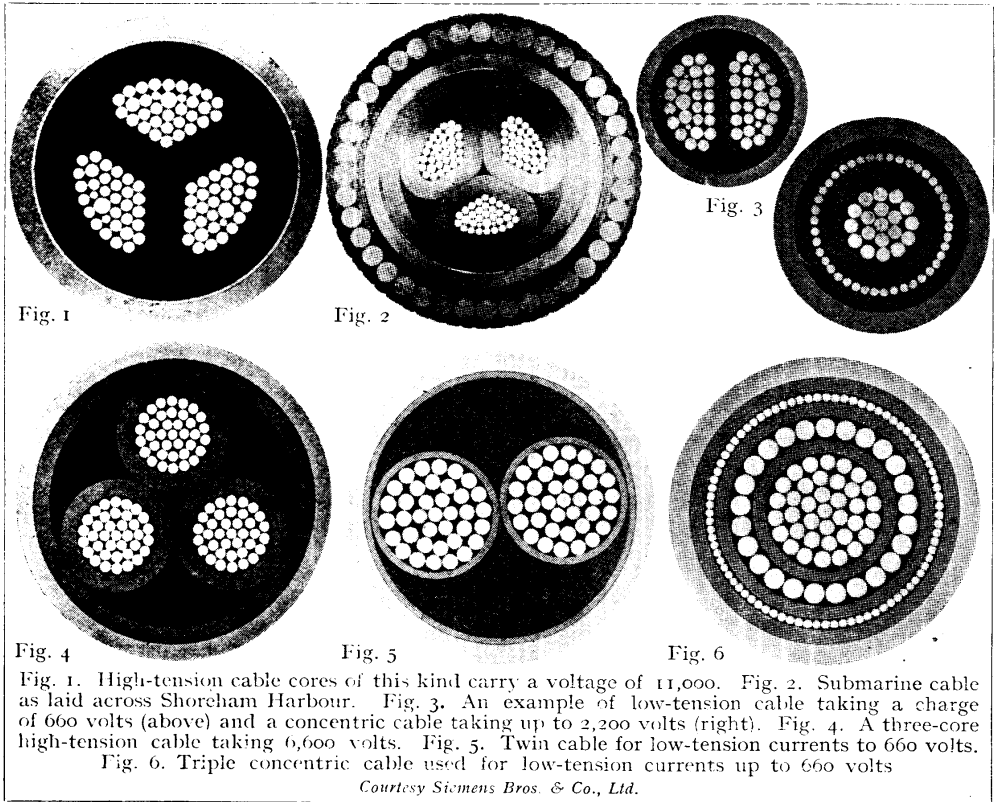

Fig. 66. No. 2 Lyrian Cabinet Set. An upright type of cabinet. The disposition of the valves and the book aerial should be noted

Fig. 65. No. 1 Lyrian Cabinet Set. A loud speaker is enclosed in this cabinet, which is designed for table use

CABINETS-DE-LUXE FOR MULTI-VALVE SETS

Fig. 63 by courtesy of Radio Communication Co., Ltd.; others Radio Instruments, Ltd.



#### CABLE CORES FOR TRANSMISSION OF HEAVY CURRENTS

**CABLE.** The word cable is a general term usually applied in electrical engineering to a conductor composed of a group of wires twisted together and insulated on the exterior. It may also be applied to a combination of conductors which are insulated from one another.

Another application of the word cable is to a stranded rope made of manilla, hemp, or wire, and twisted together from a number of separate strands.

Cables are used in wireless work to a considerable extent for conducting electric current from a source of power, as for example a generator, to some part of the apparatus. They have also a considerable application for land lines, such as those connecting an opera house to the broadcasting station. In some cases a cable carries a number of separate currents, in others only one. The latter is generally the method adopted for transmission of currents of considerable strength. On

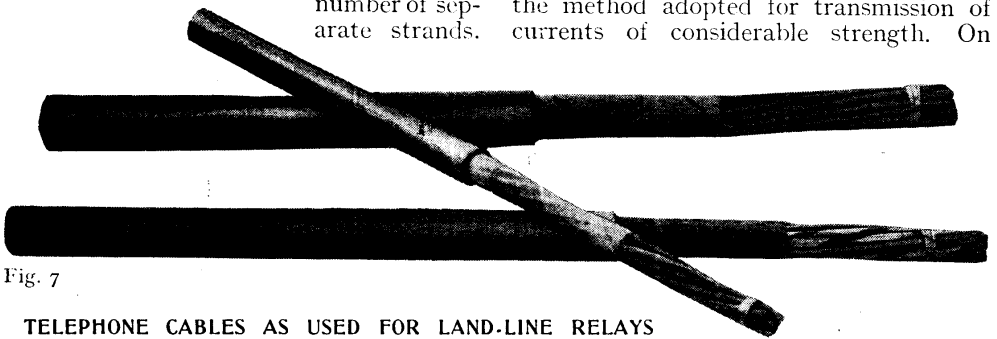

#### TELEPHONE CABLES AS USED FOR LAND-LINE RELAYS

Fig. 7. Each cable consists of a number of wires separately insulated by paper, fibre, rubber or other material, and the whole sheathed with lead. The insulation has been partly removed to show different layers



underground systems the cable is heavily insulated, and often protected with an external covering of lead.

An example of the former is the telephone cable illustrated in Fig. 7. This consists of many wires, each separately insulated from one another with paper, fibre, rubber, or other material; the strands are twisted and covered with an insulating wrapping and sheathed with lead.

A three-core high-tension cable is illustrated in Fig. 1, and is suitable for currents up to 11,000 volts. It is composed of three groups, each of thirty-three separate strands, surrounded with an insulating material; the whole of the three cores are embedded in insulating material and sheathed with metal. When a cable is laid under water or in a particularly damp and exposed position, it is often composed of a three-core cable, as Fig. 2, and the insulation covered with jute and asphalt, and reinforced with steel wires or strands. An example of this type is shown in Fig. 2, a submarine cable by Messrs. Siemens Bros. & Co., Ltd.

Fig. 3 shows two types of cable, the upper a low-tension twin cable for voltages up to 660, the lower a concentric cable up to 2,200 volts. The latter is a multi-strand central-core cable well insulated from the outer helical-laid cable, and the whole insulated on the exterior.

A three-core high-tension cable for voltages of 6,600 volts is illustrated in Fig. 4, constructed on similar lines to the others. An example of a twin-cable for low-tension currents is shown in Fig. 5, and is composed of two separate cables embedded in jute or other material and sheathed. A triple concentric cable, also for low-tension purposes, is illustrated in Fig. 6, comprising a central core of many separate strands again insulated, and then again surrounded with a series of strands smaller in diameter but greater in number, and the whole insulated and sheathed. Three-conductor concentric cables are frequently used for conducting alternating currents.

The experimenter has little use for large cables, but benefits by their application by public supply companies for power-transmission purposes. The choice of the best cable for any particular duty calls for careful consideration and calculation, but is chiefly a matter of the current-carrying capacity of the con-

ductor or the strands of which it is composed. The values for cables in common use for wireless purposes are given in the article on Wire. The class of cable used for the support of an aerial is dealt with under the headings Guy and Rope.

**CADMIUM.** One of the metallic elements. Its chemical symbol is Cd, and atomic weight 112.4. It resembles zinc, with ores of which it is generally associated. Cadmium is a white metal with a bluish tinge. The metal is useful from its property of uniting with other metals to form fusible alloys, that is alloys with a low melting point. One such alloy consists of 50 parts of bismuth, 25 parts of lead, 12.5 parts of tin, and 12.5 parts of cadmium, and melts at the low temperature of 140°F. This alloy expands on cooling, and it is therefore useful in wireless work for the setting of crystals in crystal cups, making a firm, close contact. The low temperature at which the alloy melts does not affect in any way the sensitiveness of the crystal.

The specific gravity of cadmium is 8.56, increased by rolling to 8.67. Its electrical conductivity is 24.4 (silver 100). Cadmium sulphate is used in the making of standard electric cells, as, for example, the Weston cell.

**CAGE AERIAL.** Form of receiving or transmitting aerial. Fig. 1 shows the general form of a cage aerial and Fig. 2 a cage aerial of the T type as used by the Birmingham Broadcasting station (*q.v.*). Three cages are used, two of them

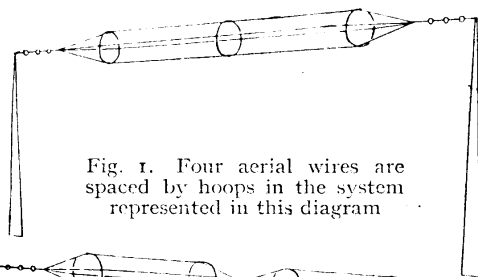

Fig. 1. Four aerial wires are spaced by hoops in the system represented in this diagram

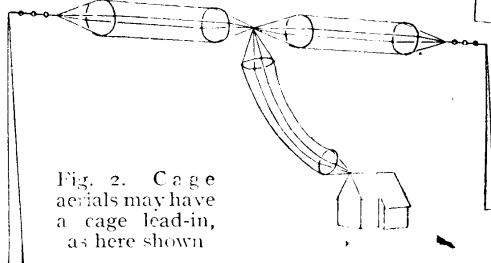
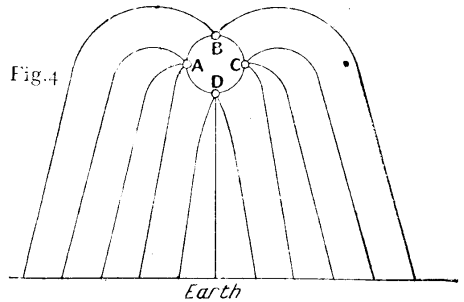
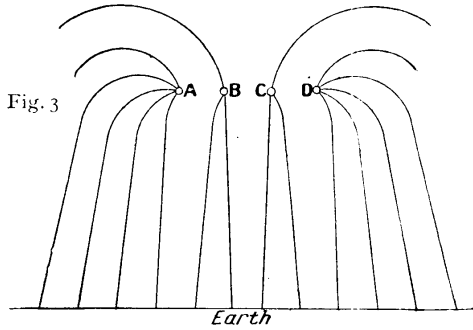

Fig. 2. Cage aerials may have a cage lead-in, as here shown

TYPES OF CAGE AERIALS



**ELECTROSTATIC LINES OF FORCE IN CAGE AND FLAT AERIALS**

These diagrams are rough representations of the electrostatic lines of force proceeding from the aerial wires A, B, C, D in two types of aerial, the flat wire (Fig. 3, left) and the cage aerial (Fig. 4, right). The lines of force are seen to be more evenly distributed in the cage aerial than in the flat-topped aerial, and greater efficiency is therefore achieved

for the aerial and the third to serve as a lead-in. In the cage aerial, instead of the usual spreaders, the aerial wires are supported on hoops or rings, and the wires are arranged on these hoops to form a round or cage-like aerial. The wires are taken to a point, as seen in Fig. 1, and insulated and supported in the usual way.

The cage aerial has a number of advantages over the ordinary flat-top aerial for transmission work. It is more constant in its electrical characteristics and more efficient. Figs. 3 and 4 will explain how the cage aerial is more efficient than the

flat-topped aerial. In Fig. 3, A, B, C, D, are sections of the wires of a four-wire flat-topped aerial. Lines of force radiate from these wires, and there are more of these lines of force in the outer wires than in the inner. There is a greater current in A and D than in B and C.

In Fig. 4, A, B, C, D, as before, are sections of wires of a four-wire cage type of aerial. The lines of force are more evenly distributed, leading to greater efficiency.

The capacity of a four-wire cage aerial has been calculated by Professor Howe.

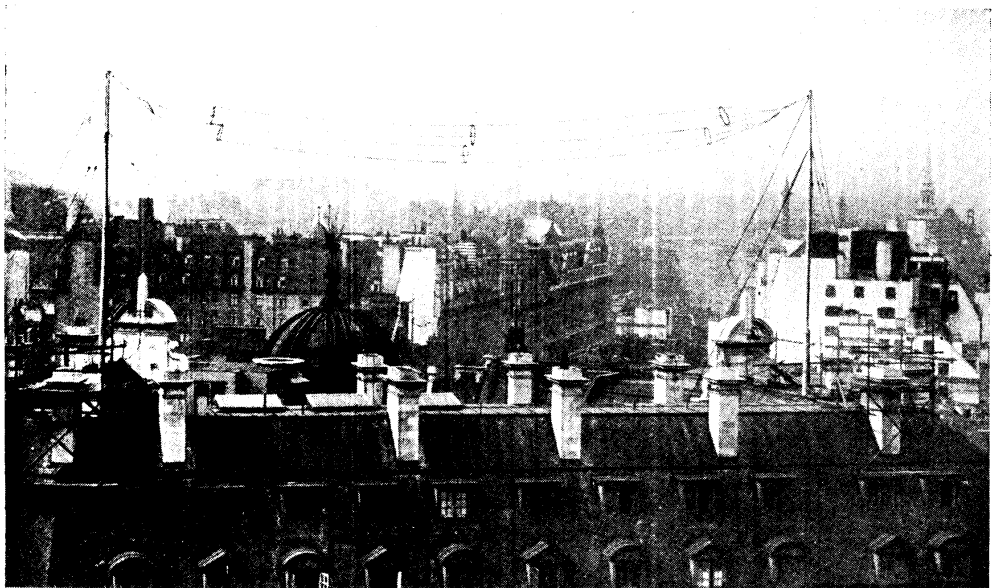

**CAGE AERIAL AS USED BY 2 LO, THE LONDON B.B.C. STATION**

Fig. 5. This cage aerial, situated on the top of Marconi House, is that from which the daily transmissions of the British Broadcasting Co., Ltd. radiate. It should be noticed that there are twin cages, but the span is not unusually great

The wires are arranged actually on the four corners of a square. Then if  $a$  be the length of the side of the square, measured in centimetres,  $l$  the length of any wire, and  $r$  its radius and  $\sigma$  the potential of any wire due to its own charge, then the average potential of the wire, and therefore of the whole aerial, is given by  $\gamma = 4\pi a \sigma \{ \log (l/r) + \gamma \}$  where  $\gamma$  is a expression depending upon  $l/a$ . The following table gives the value of  $\gamma$  for various values of  $l/a$ :

$l/a$ .	$\gamma$ .
20 .. ..	7.58
50 .. ..	10.22
100 .. ..	12.26
150 .. ..	13.48
200 .. ..	14.33

Fig. 7 gives a curve of  $l/a$  plotted against  $\gamma$  to allow of the interpolation of values.

The construction of a cage aerial follows the same general lines described under aerial. In preparing the wires, however, it is advisable to place them on the ground and cut them to equal lengths rather than to measure them. For a four-wire cage aerial, for example, the four lengths should be placed on a level piece of ground and soldered one by one to the supporting loops to ensure absolutely correct adjustment. The loops may be made from hard copper wire bent into a circle of about 12 in. to 20 in. in diameter

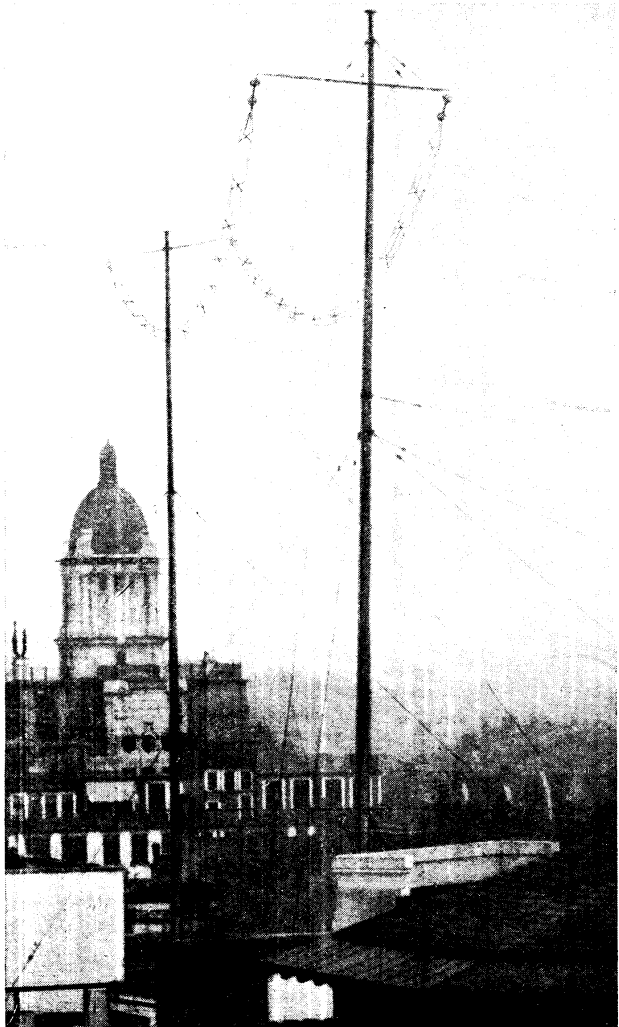

**CAGE AERIAL USED BY AIR MINISTRY**

Fig. 6. The aerial in this photograph is erected over the chief office of the Air Ministry, in Kingsway, London. Twin cages are the main feature. Note the natural curve which the wires are allowed to take, so as to avoid undue tension

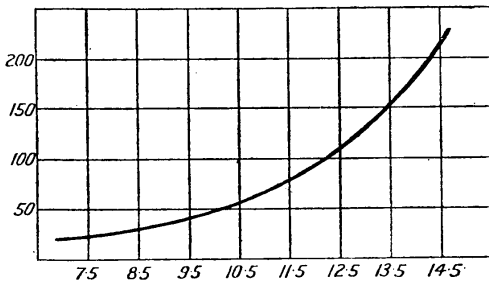

**CAPACITY OF A FOUR-WIRE CAGE AERIAL**

Fig. 7. This diagram is a plotting of the table given on this page; vertical readings give the values of  $l/a$  and horizontal readings of  $\gamma$

and soldered. A loop should be made every 12 to 15 ft. In an aerial of 50 ft. in length there should be, for example, five such loops, three supporting loops in the central part of the aerial and the two end loops. These loops should be all marked before the wires are soldered on to them to ensure that the wires are all uniformly spaced. The four wires, after soldering on the end loops, should be evenly twisted together and fastened to insulators. For transmission insulation should be plentiful. See Aerial; Transmission.

**CALCIUM.** One of the metallic elements. Its chemical symbol is Ca, atomic weight 40.1, specific gravity 1.57, and electrical conductivity 21.8 (silver 100). It has a light yellow colour, is hard as gold, and very ductile.

One most important use of calcium is in the form calcium carbide, used in the making of acetylene. Calcium carbide may be bought in  $\frac{1}{2}$  lb. and 7 lb. tins, and in drums holding 28 lb. to 2 cwt. Acetylene is used in wireless in some forms of arc generators, particularly the Colin-Jeance arc generator, in which a mixture of acetylene and hydrogen is used for the arc atmosphere.

**CALIBRATED RESISTANCE.** As its name implies, a calibrated resistance is a resistance every part of which has been compared with standard resistance. Sufficiently accurate resistances are supplied in the Post Office Box and other forms for convenient use as a Wheatstone Bridge.

Externally a resistance box appears to be a cabinet with ebonite top, upon which are mounted a number of solid, heavy section brass blocks in close proximity to

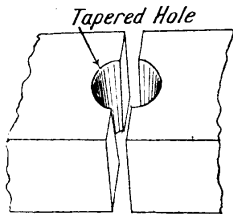

Fig. 1. Brass blocks used in calibrated resistance device

one another. At the end of each block, centrally situated, is cut away a portion of a taper hole. Fig. 1 will make this clear. Inserted in this hole, and making an accurate ground-in fit with it, is an ebonite-capped brass key or pin. Terminals, of a type which will conveniently allow of more than one piece of wire being inserted, are also fitted, and occasionally a key switch or button, which will allow circuit to be closed or broken at will. Connected between each of the brass blocks is a coil of resistance wire, one end of which is connected to one block and the other to its neighbour; thus it will be seen that the insertion of a key short-circuits the resistance coil, cutting that particular resistance out. The sectional area of the brass blocks is large enough to render their resistance negligible.

It will be gathered from the foregoing that resistance is brought in circuit by pulling the plugs out. The last two blocks on the box have usually no connexion or

resistance at all between them, thus obtaining an infinity reading.

The actual values of the individual resistances fitted is arranged so that any desired resistance—usually from 1 ohm to infinity—can be obtained. This is not so difficult as it might seem, for in a box containing resistances from 1-10,000 ohms the following number would be probably fitted: 1, 2, 3, 5, 10, 15, 20, 50, 100, 200, 400, 500, 1,000, 2,000, 4,000, 5,000. Some of these would not actually be required, but would probably be fitted for convenience. Should a resistance of, say, 4,897 ohms be required, the following combination of plugs would be drawn:

4,000, 500, 200, 100, 50, 20, 15, 10, 2 = 4,897 ohms.

It is quite clear that any required resistance can be plugged in in this manner, and this forms a very convenient method of varying a resistance accurately to some known or required resistance.

These resistances are made and calibrated very accurately indeed against laboratory standards, and are correct at a certain fixed temperature. In order to bring the highest resistances within reasonable limits as to size, very fine wire has to be used; and

great care must be exercised not to allow too much current to be used in conducting experiments, otherwise the coils may overheat, and the resistance will increase. In order to minimize the effects of self-induction in

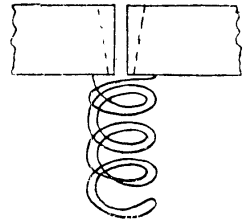
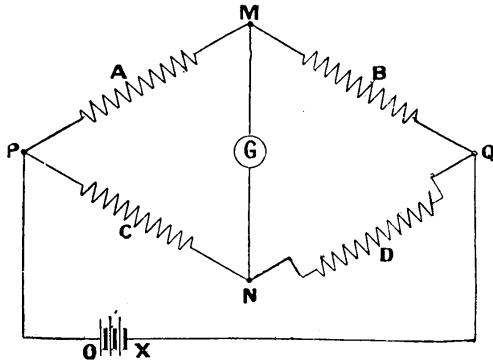

Fig. 2. Fine wire coil bridging brass blocks in calibrated resistance

the coils, they are wound in the manner indicated in Fig. 2. As will be seen from this illustration, the wire is wound back upon itself, having always really two wires side by side. It will thus be seen that the self-induction in one direction will be met by an equal and opposite self-induction, and therefore the two will counterbalance one another and neutralize the effect. The circuits employed, their use, and the methods employed with calibrated resistances in conducting experiments are given below.

The particular type of box chosen for the purpose of these illustrations is the Wheatstone Bridge. The circuit employed in the bridge is given in Fig. 3. Reference

to this diagram will show that the current flows from point O (the battery) to P, where it is split up into two parts. The potential at point P will be at a certain value fixed by the battery and the lead resistance of OP.



WHEATSTONE BRIDGE FOR CALIBRATING RESISTANCE

Fig. 3. Resistance may be calibrated with the Wheatstone Bridge, of which the above is a circuit diagram. Current from the battery is split at P, and the two sides of the bridge are balanced when the resistances are equal

From P the potential in the upper arm will fall to a smaller value at M, and a still smaller one at Q. An exactly similar state exists in the lower arms of the bridge. It will thus be seen that if M is the same resistance distance along the arm as N, or, to put it in a different manner, if the arm A is the same ohmic value as the arm C, the potential value will be the same at both M and N. Again, if the resistances A and B are of the same value as the resistances C and D; and if M and N are in the same resistance-ratio in each, the potential value at M and N will be equal. It will follow, therefore, that if a galvanometer is connected between points M and N, and if those points are at equal potentials *no reading* will be visible on that galvanometer. Should they, however, be at different potentials, a deflection of the galvanometer needle will result.

In actual practice, then, we have in the box of the bridge three sets of resistances, say, A, B and C. The resistance of which the value is unknown will naturally be D. In order to ascertain what this resistance will be, it is necessary to balance the bridge to it, or, in other words, to pull out plugs on the box until the resistances in the known arms of the plugs are equal. The right values, when found, are indicated by the galvanometer showing no deflection.

To quote an example :

If D is the unknown resistance, then  $D = BC/A$ .

A = 20 ohms.

C = 200 ohms.

B = 30 ohms.

Then D = 300 ohms.

A further type of calibrated resistance in common use is the metric bridge.

This is an exceedingly simple device. Upon a long board approximately 3 ft. 8 in. long are mounted two brass clamps, the inner checks of which are exactly 1 metre long. Fixed to the clamps, but away from the inner faces, are terminals of any convenient type.

A piece of resistance wire is stretched fairly tightly between the clamps. Underneath this wire is a scale, graduated in centimetres and millimetres. Provision is made whereby a tapping can be taken any distance required along the wire.

The bridge works on the principle that, given a resistance of unvarying thickness and constant resistance-value, such as a piece of wire, the potential of an electromotive force flowing along that wire will vary in direct proportion to its length. It will be seen, therefore, that an accurate measurement of resistance may be made by merely measuring the length of wire used. For instance, if 1 metre of wire has a resistance of 1 ohm, then 50 centimetres will have a resistance of 0.5 ohm; 25 centimetres, 0.25 ohm, etc. For measurements of fairly limited resistances, therefore, the metre bridge is a very accurate, cheap, and useful instrument. See Anderson Bridge; Bolometer; Campbell Bridge; Wheatstone Bridge.

**CALIBRATING.** The art of marking divisions on a dial or other plate or surface.

To calibrate measuring instruments properly it is necessary to know the rate of variation between the zero and maximum markings. For example, given a plain clock or watch dial, it is known that the minute hand will in one revolution register one hour, which is divided into 60 equal parts. The circular dial is therefore marked out into 60 equally spaced divisions around the edge. The hour hand goes round once in twelve hours; each fifth of these markings is therefore emphasized and marked, from 1 to 12.

For the one calibration two readings are possible, which become with constant use so familiar that a child can express

the readings in words at a glance at the dial. Such an arrangement is possible because the speed of the clock is constant, and the pointer or hand moves through a regular distance in a given time.

When the speed of the pointer is not regular the divisions will not be uniformly spaced to show correspondingly equal amounts. For instance, a centrifugal device will vary in its divisions on the "square law." That is, 1, 2, 3, will be represented as  $1^2$ ,  $2^2$ ,  $3^2$ , or 1, 4, 9.

In wireless work, however, the instruments, such as condensers and the sliders on an inductance coil, can conveniently space the divisions in regular order. The actual marking out will be determined by the facilities available, and when a lathe with a division plate is at hand it enables all manner of dials and knobs, as well as long slider bars, to be quickly calibrated.

In the case of the dial for a condenser, this can be calibrated as follows: Presuming the lathe has a division plate with rows of holes more or less unlimited in scope—*i.e.* contains multiples of all

the smaller digits, say 1 to 9, and all the odd numbers from 10 to 19 inclusive, practically any system of measuring out a dial is readily accomplished. When the lathe has only one row of, say, 60 holes, as the J. R. lathe illustrated in Fig. 1, only spaces that are equal multiples of 60 can be cut in one revolution of the mandrel.

Should this not be suitable, or there be no division plate available at all, the change wheels of a screw-cutting lathe can be pressed into service and treated as a division plate. The plate or the wheel is mounted firmly on the headstock mandrel, and the spacing effected and controlled by a simple arm or pointer, as shown in use in Fig. 1.

The use of change wheels or other gearing adversely affects the accuracy, but for such things as condenser dials this is sufficient for all purposes. The method of mounting a circular plate or dial is shown in Fig. 2, and consists in screwing a smooth and flat piece of wood to the faceplate. The dividing plate is set by placing the pointer in any of the holes.

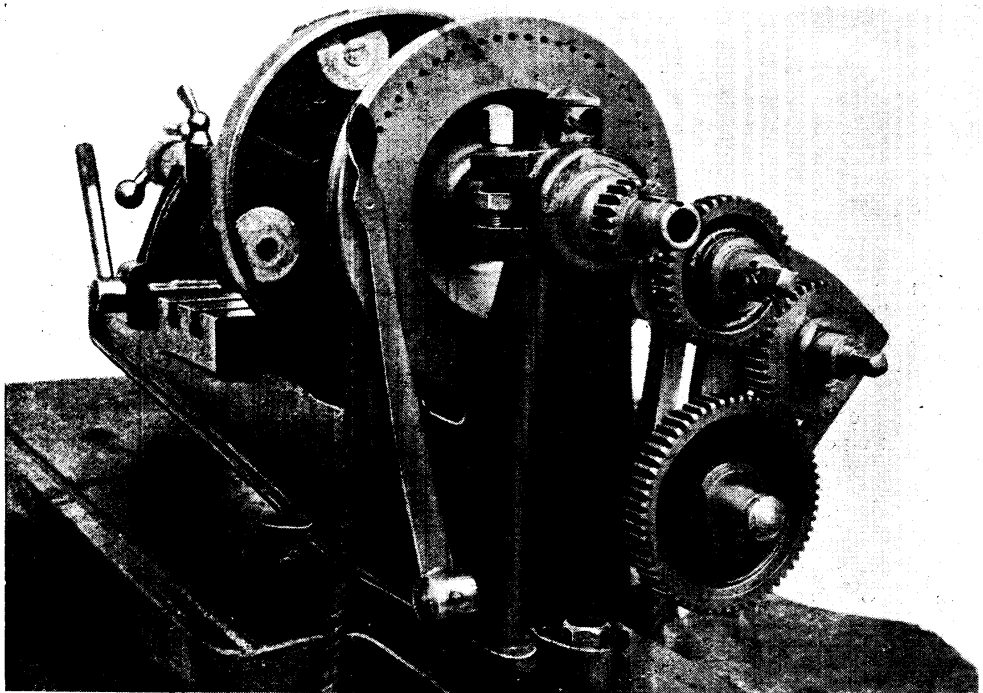

**DISK CALIBRATING WITH A LATHE**

Fig. 1. Calibrating disks for condensers and other wireless apparatus is carried out with a device as seen on the J. R. lathe above. This consists of a 60-hole division plate incorporated in the mandrel pulley of the lathe. The pointer is in position

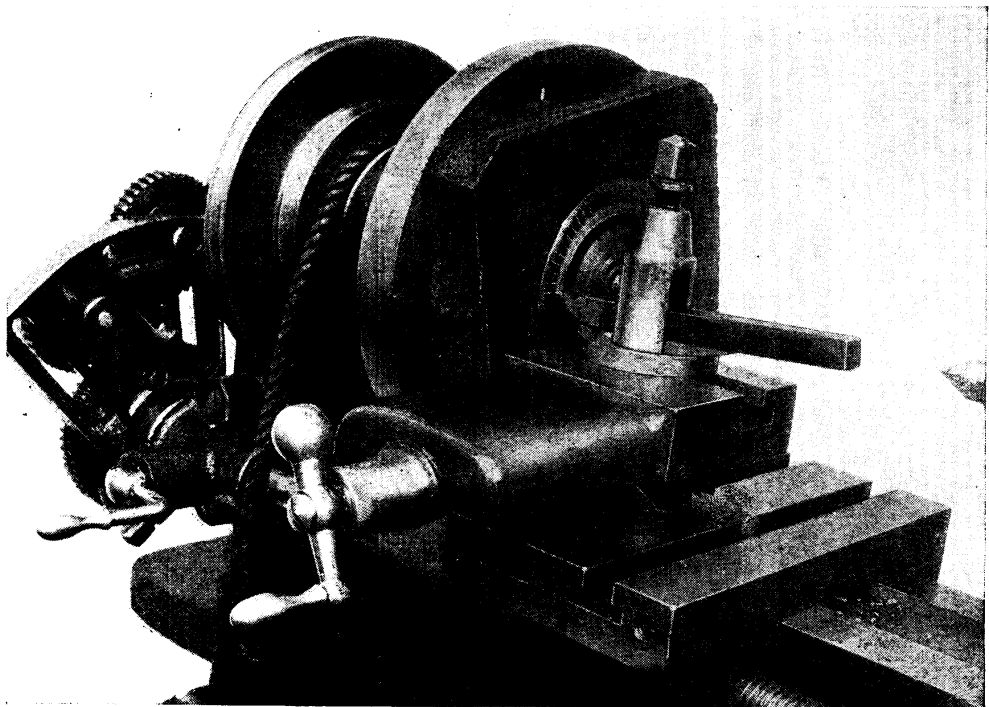

Fig. 2. Condenser dials may be calibrated by hand in this way. The wooden block to which the dial is attached is screwed to the face plate of the lathe. Note how the tool is disposed in the tool holder in the top side of the slide rest

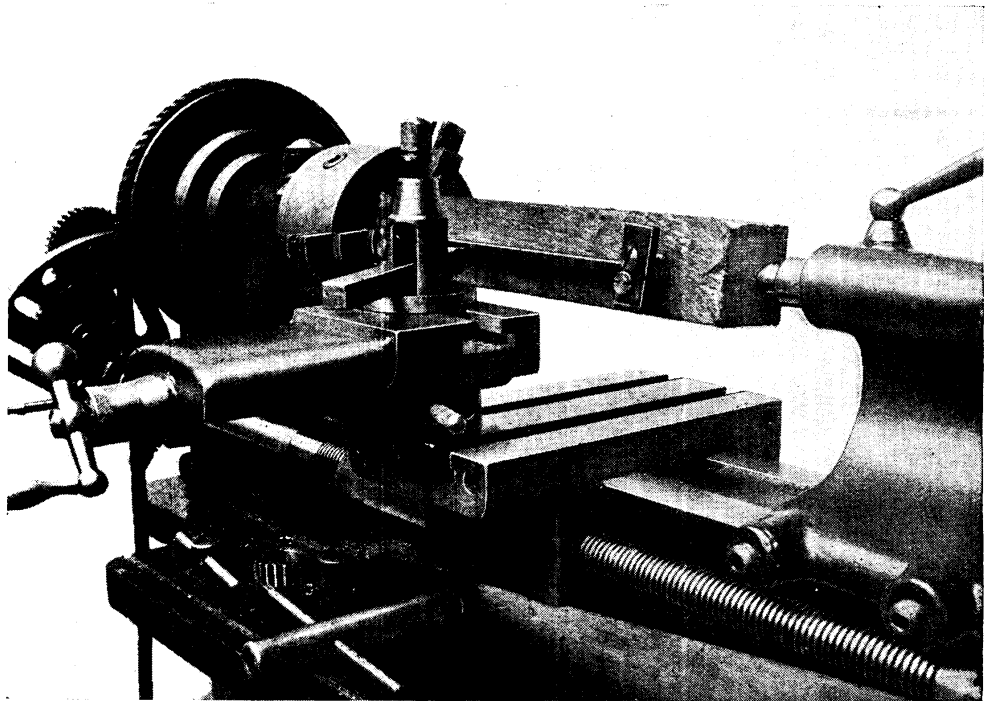

Fig. 3. Attached to the wooden bar is a slider bar for an induction coil, which is being calibrated by hand. The spacing is effected by operating the slide rest lead screw

**METHODS OF CALIBRATING INDICATORS FOR WIRELESS APPARATUS**

A sharp-pointed tool is mounted on its side in the tool post of the top slide. The tool is brought into cut and traversed across the face of the dial by rotating the handle of the top slide lead screw.

When several dials have to be calibrated it saves time to remove the lead screw and rig up a lever handle to push the top slide to and fro. When one division has been marked the pointer is withdrawn from the division plate, the lathe turned by hand to the next hole on the division plate to give the desired spacing, the pointer replaced, and another cut made as before, and so on until all have been cut.

To graduate a long bar, such as a slider bar for an inductance coil, the lead screw of the lathe is rotated to effect the spacing desired. The bar may be attached to a block of wood held in the chuck at one end and supported by the tailstock at the other, as shown in Fig. 3.

The lead screw can be rotated in equal divisions if it has a graduated feed, as on the lathe illustrated. The incisions are made by bringing the point of a sharp tool into engagement with the face of the bar and then rotating the mandrel by hand so that it swings across the bar. When the lead screw is rotated the tool is fed along, and at the desired spot another cut is made, and so on to the end.

**Finishing Off the Calibrated Bar**

When the bar is very narrow and is well supported by the wood, the graduating can be carried out in one operation by setting up the desired change wheels as for screw cutting. For instance, if the divisions are to be  $\frac{1}{8}$  in. the wheels would be set up for an eight thread per inch screw.

The tool is brought into cut and the lathe rotated by hand when the divisions are at all widely spaced. The dividing lines will be slightly inclined, but when this is no detriment, as is generally the case for such things as slider bars, quite fine divisions of the order of 40 to the inch are readily and fairly accurately cut. The method of arranging the lathe for this class of operation is clearly illustrated in Fig. 3.

Having made the incisions, they are filled with a contrasting colour, to accentuate the markings. The exact procedure and the materials to use depend on the nature of the material used for the index or dial. On black fibre or ebonite, white or red paint may be used in the grooves. The

article is covered with the paint, and as it is setting the paint on the face is wiped off with a clean rag held firmly in the hand. The work is set aside to dry before it is handled again. On polished brass or plated surfaces the cuts can be filled with black or red wax.

Lettering and numbering may be accomplished by engraving, or by punching the figures or letters with suitable letter and number punches. These are purchasable tools and made up in sets in various styles and sizes. Instead of engraving the calibrations with the cutting tool, the dial or plate can be coated with wax and the lathe or other tool used to scratch lines through the wax.

The plates can then be etched with acid. Any desired figuring will have to be scratched by hand with the point of a sharp scriber. Glass can be engraved with calibrations, if the surface be first coated with bituminous paint. This is scratched off by one of the methods previously described and the glass permanently engraved with fluoric acid. When using this material, however, avoid inhaling the fumes, as they are pungent and poisonous. See Condenser; Ebonite; Engraving.

**CALIBRATION.** Before any of the commercial measuring instruments, such as galvanometers, voltmeters, ammeters, etc., can be turned to practical account, the readings or indications of their needles on the dial or scale must be given a definite meaning in terms of current,

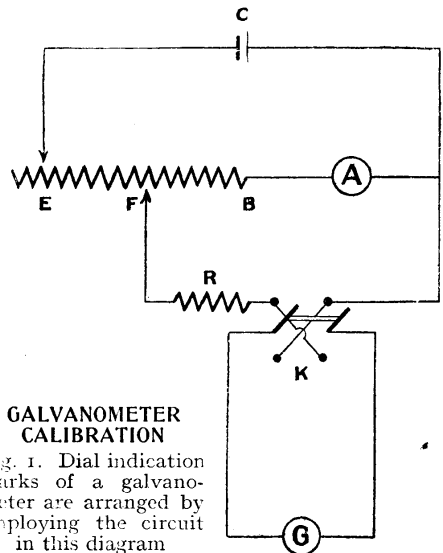

**GALVANOMETER CALIBRATION**  
 Fig. 1. Dial indication marks of a galvanometer are arranged by employing the circuit in this diagram



quantity, or electro-motive force; in other words, they must be "calibrated."

The process of calibrating an ordinary reflecting galvanometer will first be described, and a diagram of the connexions for calibrating is to be found in Fig. 1. Storage batteries or lead accumulators are generally more useful than primary batteries for supplying the required current, owing to their greater constancy of electro-motive force. The single cell C, therefore, in the diagram represents the source of current. This cell is connected through the low-resistance galvanometer A to a resistance B E, which should be not less than 10,000 ohms.

The galvanometer G, to be calibrated, is connected through a reversing switch K, and a variable resistance R across a part of B E, with the galvanometer A included in circuit. Thus the galvanometer G is receiving current at only a fraction of the total electro-motive force of C, since the potential will drop steadily between B and E.

#### Calibrating a Galvanometer

During the experiment the deflections of A must be kept quite constant by slightly varying the resistance between B and E. Since the current along B E is unvarying, and the resistance B E is also of constant value, it follows that the electro-motive force across B F must also be constant, and therefore the current through the galvanometer G is inversely proportional to the sum of the resistances of G and R. If  $r$  is the resistance of the galvanometer, the current will be

$$\frac{I}{R + r}$$

Thus, starting with a fairly large value for R and a correspondingly small deflection on G, a reading is taken of the deflection and a note made of the value of R. With the same value of R, a deflection is then taken on both sides of zero by means of the reversing key K. The next step is to decrease slightly the value of R so as to increase the deflection of G, and again take a reading on both sides of zero. A series of readings is obtained in this manner.

The deflections on both sides of zero are then plotted separately against the reciprocal of the sum of the resistances  $r$  and R. A calibration curve is thus obtained which may, if desired, be converted into current readings in the following manner. First measure the voltage across

B F by a standard voltmeter or by any of the methods to be described later, and divide this by the sum of the resistances  $r$  and R, and by Ohm's law this will at once give the direct value of the reading in amperes. To ensure great accuracy both resistances R and  $r$  must be corrected for the temperature at which the calibration curve was taken, unless they consist of some special alloy wire possessing a negligible temperature coefficient, which is usual in modern instruments. The distance of the scale from the mirror, the length of the scale division, and the period of vibration should all be noted and kept for reference.

A method of galvanometer calibration with an iodine voltmeter due to Herroun depends upon the liberation of iodine at the platinum electrode by electrolytic action when current passes, the amount of iodine so liberated depending upon the coulombs of electricity which have passed during a certain period in seconds, which can be reduced to current terms by dividing coulombs by seconds.

There is a distinction between the "relative" and the "absolute" calibration of any instrument. The first refers to the law connecting the various deflections with the relative strength of the currents required to produce them, and the second relates to the absolute value in amperes of the currents required to cause any particular deflection in scale divisions on the dial.

#### Earth Coil Method of Calibration

In calibrating a ballistic type of galvanometer, used in the measurement of transitory currents such as condenser discharges, the first swing of the needle is a measure of the energy imparted to it, and the simplest method of calibrating a galvanometer of this type would be by means of an "earth coil."

This consists of a carefully constructed coil of wire of a known and preferably large number of turns, and also of a large area. To obtain the true mean diameter of the coil it should be measured up, layer by layer, as it is constructed, and the figures recorded.

This coil is connected to the terminals of the galvanometer and placed with its axis vertical. The spot of light from the galvanometer mirror having come to rest on the scale, the earth coil is quickly turned over, that is, through

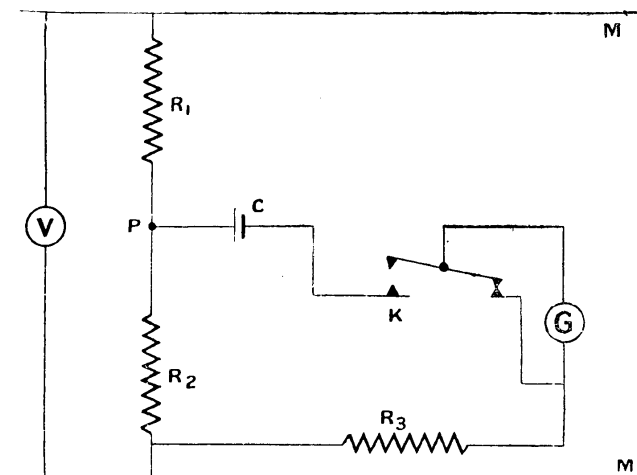

**CIRCUIT FOR CALIBRATION OF A VOLTMETER**

Fig. 2. Voltmeters are calibrated by the employment of an arrangement of which the above is the theoretical diagram. This method is principally a comparison with a standard cell, C

one hundred and eighty degrees, so that it is lying on its other face with its axis again vertical, having twice cut the vertical component of the earth's magnetic field during its motion. The resulting scale deflection from the galvanometer mirror is then noted, and a calculation made as follows:

If A is the mean area of the earth coil in square centimetres,

If v is the vertical component of the earth's field,

If s is the number of turns in the earth coil,

Then M represents the total cutting of lines, and is equal to  $2\lambda vs$ .

If R is the sum of the resistances of the galvanometer and the earth coil, and Q the quantity of electricity,

$$Q = \frac{M}{10^8 R} = 2 \frac{\lambda vs}{10^8 R}$$

As in the calibration of most other instruments, the simplest method is, of course, that of direct comparison with another already calibrated and of a known percentage accuracy. It is not always that such an instrument is available; some other expedient must be resorted to. A voltmeter, for instance, can be calibrated in various ways, one of which is shown in Fig. 2.

Some outside source of potential is necessary and the main leads M, M are represented supplying current at a sufficient pressure to cause the voltmeter

needle to deflect over its full range. C is a standard cell, such as a Fleming or Clark cell, which will give an exact potential difference at a known temperature. P is a subdivided resistance connected across M, M which enables current at a pressure suited to the range of the voltmeter being calibrated to be taken at any lower value than the potential between M and M, if necessary, by shifting the tapping point. R1 is a resistance of 10,000 ohms, R2 a resistance of 1,000 ohms capable of adjustment, and connected in series with R1.

At R3 is a further resistance permanently in the circuit with the galvanometer G,

and for the purpose of protecting the latter from any excessive currents during the preliminary adjustments, when want of balance may give rise to a comparatively large potential difference across the galvanometer terminals. A sensitive mirror-type galvanometer should be employed, and resistance should be at least 500 ohms.

A Morse key at K short circuits the terminals of the galvanometer when at rest, and when depressed it connects the galvanometer in series with the standard cell C across the terminals of R2. The voltmeter V is connected as shown across the ends of R1 and R2, which are always in series. The method of calibration is that of balancing the fall of potential down R2 by the counter electro-motive force of the standard cell C, the galvanometer indicating when this balance has been obtained by giving no deflection on depressing the key.

Being a "null" method, the test is extremely accurate. The electro-motive force of the standard cell must of course be opposed to the potential difference down R2, otherwise it will be impossible to get a balance on the galvanometer. The current

flowing in circuit R2 is equal to  $\frac{V}{R_1 + R_2}$ ,

V being the voltage across the voltmeter terminals. The fall of potential, therefore, down R2 is equal to the above current multiplied by the resistance of R2 (that is the  $C \times R$  drop), and when balance

has been obtained by adjusting the value of  $R_2$ , it indicates that the two opposing electro-motive forces are equal and opposite, that is, the fall of potential is 1.072 volts if the Fleming standard cell is used as a comparison. Expressed in symbols

$$\frac{V}{R_1 + R_2} \times R_2 = 1.072$$

or

$$V = 1.072 \left( \frac{R_1 + R_2}{R_2} \right)$$

A simple, and if carefully carried out a perfectly accurate, method of calibrating high-resistance voltmeters is that illustrated in Fig. 3, which is based upon

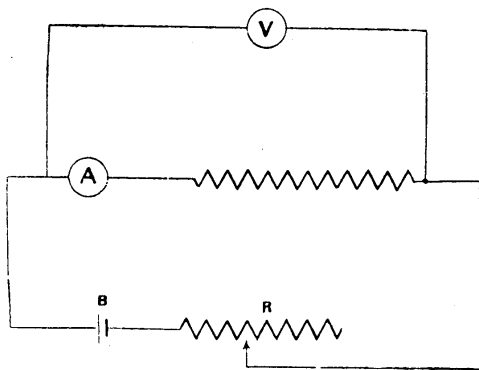

**CALIBRATING A VOLTMETER**

Fig. 3. Calibration of high-resistance voltmeters is sometimes carried out in this manner. Accuracy depends on extreme care in this case

the elementary law that the potential difference between the two ends of a wire carrying current is proportional to the current multiplied by the resistance. If the resistance is standard and of a known amount, and an accurate ammeter is available, it is simply necessary to take a few readings with definite values of current, which can be varied by the series resistance  $R$ , and note the voltmeter deflections.

The ammeter readings are afterwards converted into the equivalent volt-drop readings by multiplying them by the fixed resistance in ohms. In the diagram  $A$  is the ammeter,  $B$  the battery supplying current,  $R$  a resistance for varying the value of the current passing, and a standard resistance is shown above.  $V$  is the voltmeter being calibrated. This may be termed the potentiometer method.

A very rough and ready method, which is adopted for cheap commercial instruments where a high percentage of accuracy is not essential, is to use a battery of

small accumulators in a partly discharged condition, which will have an electro-motive force of almost exactly 2 volts per cell. With a multiple switch, as at  $S$ , Fig. 4, any number of cells can be grouped in series, and the resulting voltmeter deflections,  $V$ , are marked at 2-volt steps, intermediate stages being estimated.

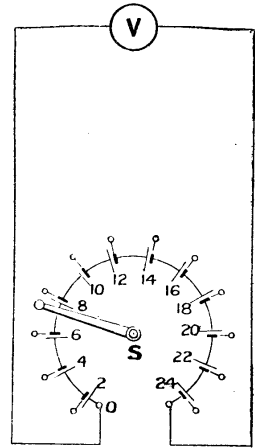

**ROUGH CALIBRATION**

Fig. 4. Voltmeters may be calibrated by the above arrangement, employing a battery of accumulators

The converse of the method described in Fig. 3, namely, that of passing a measured

current through a known resistance, and calculating the volts by multiplying together the two known factors, is equally applicable to the calibration of an ammeter. Instead of the arrangement shown in Fig. 3, however, the relative functions of the ammeter,  $A$ , and the voltmeter,  $V$ , are reversed,  $V$  being already calibrated and  $A$  having a blank scale. In the voltmeter calibration the volts  $E$  were calculated by  $E = C \times R$ , whereas in the ammeter calibration the current will be found by dividing the known value of the volts  $E$  as read on  $V$  by the known value of the resistance  $R$ ,

that is  $C = \frac{E}{R}$ . The current is adjusted as

before by means of the variable resistance  $R$  until a series of definite voltage readings are collected on  $V$ , the ammeter needle deflections being noted for each voltage reading on  $V$ .

The corresponding current values are then plotted from the simple expression  $C = \frac{E}{R}$ .

In cases where no standard ammeters or voltmeters are available, the copper voltmeter method of calibrating ammeters is the one generally used and is very reliable. The points to be observed to secure accuracy are to carefully avoid fingering any part of the copper plates which are immersed in the copper sulphate solution, and to avoid either too high or too low a current density. About 20 amperes per square foot gives very good results.

If two pure copper plates are immersed in a solution of copper sulphate and current passed from one to the other, it is well known that copper will be deposited on one plate at the expense of the other, at the rate of 0.0003268 of a gramme for every ampere that flows for one second. Consequently the gain in weight of one plate, or, better, the difference in weight between the two, at the end of a definite interval of time, will be an accurate measure of the quantity of electricity which has been passing in ampere-seconds, and if the rate of current flow has been kept perfectly steady the amperes can readily be calculated by dividing the weight by the electro-chemical equivalent above-mentioned.

The solution in which the copper plates are immersed consists of 15 oz. of re-crystallized copper sulphate dissolved in 100 oz. of distilled water, to which is added first 5 oz. of sulphuric acid and 5 oz. of alcohol. The copper plates are thoroughly cleansed with fine glass paper, rinsed in dilute potassium cyanide and swilled in clean water, after which they are immediately plunged into the

copper solution and the current at once started and kept at a steady value for sufficient time to ensure a good even deposit of copper, which will be of the characteristic salmon-pink colour associated with pure copper.

Immediately current has ceased the plates are removed, thoroughly rinsed, and dried as quickly as possible in filter paper. The difference in weight between the two plates at the start will now be found to have altered, owing to one plate having gained copper (the cathode) and the other plate (the anode) having lost metal. A comparison of the two differences of the weights in grammes will give the weight of actual metal transferred, which, as stated above, if divided by the electro-chemical equivalent 0.0003268 gives the ampere-seconds, and the latter divided by the seconds gives the final result directly in amperes. When a standard ammeter is available for calibration purposes, all that is necessary is to connect the two instruments in series with one another and with a battery and variable resistance for varying the deflections over the required range.

## CALL SIGNS: (1) BROADCASTING AND PUBLIC STATIONS

### Identifying Calls for British, Foreign and American Stations

Here follows a selected list of Broadcasting and Public Service Transmitting Stations in the British Isles, on the Continent and in America, which may be heard by amateurs. A list of signs for amateur transmitters in the British Isles and France is given separately

CALL SIGN	STATION	WAVE-LENGTH	MILE-AGE RANGE	SERVICE	CALL SIGN	STATION	WAVE-LENGTH	MILE-AGE RANGE	SERVICE
<b>BRITISH ISLES</b>									
B Y D	Aberdeen, Scotland	3,300 (C.W.)		Admiralty	B Y Q	Corkbeig ..	600		Admiralty
2 B D		495		B.B.C.	G F C	Cranwell ..	1300	250	Training Stn.
B Y A	Admiralty		300	Admiralty	B Y P	Cromarty, Black Isle			Admiralty
G F A	Air Ministry, London	900, 1210, 1400, 1680	300	Air Ministry	G X O	Crookhaven		600	Post Office
A C A	Aldershot ..	4100, 1600 (C.W.)			G E D	Croydon Radio	900	400	Civil aviation
G F I	Andover, Hants				B Y M	Culver Cliff	1000	200	Admiralty
G F B	Balldonne ..				G C C	Cullercoats	600	250	Post Office
B Y G	Berwick, Admiralty	45		Admiralty	G K U	Devizes Radio	1800-3000	1000	Ditto
5 I T	Birmingham	420		B.B.C.	G E M	Didsbury ..	900	200	Civil aviation
6 B M	Bournemouth	385		B.B.C.	G F K	Donibristle	1300 (C.W.)	250	
B Y R	Bunbeg, Donegal	1000	230	Admiralty	B V J	Felixstowe ..			Admiralty
G C S	Caister - on - Sea, nr. Yarmouth	1750		Post Office	G R L	Fishguard Radio	600	200	Post Office
G F L	Calshot ..	1300	150		B V N	Flamborough Admiralty	450		Admiralty
5 W A	Cardiff ..	353		B.B.C.	5 S C	Glasgow ..	415		B.B.C. Stn.
M U U	Carnarvon ..	14200		Marconi Co.	B Y C	Horsea, Portsmouth	6000		Admiralty
B V Z	Carnsore ..	450			G I Z	Howden ..	1300	250	
G F M	Cattewater	1300	250		B Z A	Inchkeith ..	600		Admiralty
M Z X	Chelmsford	3800		Marconi Co.	B V E	Ipswich ..	2400		Admiralty
B Y B	Cleethorpes Radio	3000-5200	1000	Gale warn-ings; civil aviation	B W K	Kingstown ..	2080		Admiralty
M F T	Clifden Radio	6000	2000	Marconi Co.	G B L	Leafield ..	8750-9400		Post Office
					G I W	Lea - on - Solent	900	250	Under construction
					B V Y	Lizard ..	450		Admiralty
					2 L O	London ..	363		B.B.C.
					2 Z Y	Manchester..	370		B.B.C.

CALL SIGN	STATION	WAVE-LENGTH	MILE-AGE RANGE	SERVICE
<b>BRITISH ISLES (contd.)</b>				
5 N O	Newcastle	400		B.B.C.
G L A	(a) North Weald, Essex	3800		Marconi Co.
G L B	(b) " "	2900		"
G L O	(c) " "	4350		"
G K B	Northolt	6890		Post Office
G L A	Radio Ongar	2400		Marconi Co.
G L B	" "	3950		"
G L O	" "	4350		"
G B L	Oxford Radio	8750-12300		Post Office
B Y F	Pembroke	2080, 2400		Admiralty
B Y P	Plymouth	4800		Aircraft
M P D	Poldhu	220	(not yet open)	B.B.C. Experimental
B Y N	Portland Bill	600, 800		Admiralty
G P K	Port Patrick Radio, Scotland	600		Post Office
B Z C	Portsmouth Signal School			Admiralty
G E P	Pulham	900	150	D.F., Civil aviation
B W Q	Queenstown Ramehead	600	250	Admiralty
G E R	Renfrew	600, 800	250	"
B Y H	Radio Rosyth	900		Civil aviation
G L V	Seaforth	1000	150	Admiralty
B Y K	Sheerness	600		Admiralty
G F O	Shotwick	1300	250	Admiralty
G S W	Stonchaven	3000, 5000	900	Post Office
G C A	Radio Tobermory	300	180	"
G C K	Radio Valentia	600	250	"
G K R	Wick	600		"
2 M T	Writtle	400		Experimental Marconi Scientific Inst. Co.

<b>BELGIUM</b>				
B A Y	Brussels	1400, 1680		Army Aviation
O P O	" Royal Met. Inst.	1500		"
O P V O	Ostende Aerodrome	1400, 1500, 1680		Aviation
O S T	" Radio	300-1800	1250	Government

<b>CANADA</b>				
V A L	Barrington Passage	1600, 2200	3500	Dept. of Marine and Fisheries
G B	Glacc Bay	4200	4000	Marconi Wireless Tel. Co. of Canada
V A S	Louisberg, Nova Scotia	7925		"

<b>CZECHOSLOVAKIA</b>				
P R G	Prague	4000, 4100, 10000	2000	Government

<b>DENMARK</b>				
O X B	Blaavand Radio	300-1800	800	Government
O X A	Copenhagen	300, 600, 1800	600	"
O V C	Schults-Grund	600	300	"
O U B	Shavens Rev.	600	300	"
O X J	Thorsham (The Faroes)	600	300	State " Telegraphs

<b>EGYPT (Nr. Cairo)</b>				
S U C	Abu Zabal Radio	10000	4000	British Post Office

<b>FRANCE AND ALGIERS</b>				
I A	Basse-Lande, nr. Nantes	2800	2000	Weather
F N B	Bayonne	1200	800	

CALL SIGN	STATION	WAVE-LENGTH	MILE-AGE RANGE	SERVICE
<b>FRANCE (contd.)</b>				
F N X	Bordeaux, T.S.F.	300, 600, 1300, 1500	500	Postal Administration
L Y	Bordeaux	2340c	1000	General transmission
F F B	Boulogne-sur-Mer, T.S.F.	300, 600	300	Postal and Telegraph Administration
F N B	Bourget, Le	900, 1400, 1680	500	Aviation
F F X	Bouscat	300, 600	300	Government
F F K	Brest	600	300	"
F E X	" La Trinite	450, 2100		D.F. (Direction Finding)
F U C	Cherbourg	450, 600, 800	400	State Telegraph
F F C	" Rouge Terres	800	400	Navy
F F I	Dieppe	400	250	State Railways
F F O	Dunkirk	600	1000	Navy
F L	Eiffel Tower (Paris)	2200, 2600, 6500	3000	Telephony, Weather, Sports, etc.
F E N	Gris Nez	600	250	Navy
F F H	Hadre, T.S.F. (Le)	600	250	Postal Authorities
F U N	Louent	600	350	D.F. and Aviation
Y N	Lyons	1500, 8100, 15200, 15500, 1680	3000	"
F N M	"	1680	500	Aviation
F U E	Meugam, nr. Brest	600-2400	1000	Navy
F R X	Nantes (Basse Lande)	2700	1000	"
V A	"	2650, 9000, 13800	3000	Navy
F F N	Nice	600	250	Postal
F F U	Ushant, T.S.F.	300, 600, 750	500	"
F U Q	Porquerolles	450, 600, 800	1000	Navy
F F R	Rochefort	300	500	"
U F T	Sainte Assise	1500		"
F N G	St Inglevert	900, 1400, 1680	750	"
F N S	Strasbourg	1400, 1720, 2500	800	Aviation
F U T	Toulon Mourillon	450, 1350	1500	Navy
F N T	Valenciennes	1200, 1400	1800	Aviation

<b>GERMANY</b>				
D K	Berlin	2000, 3200, 3700, 8100	3000	
L P	Bulle, F.S., Kiel Bay	3200, 3700, 600, 820	2000	Government
K B K	"			"
K C X	Cuxhaven	300, 600	800	"
O H D	Deutsch Altenburg	3100, 3500, 4000, 4250, 5000, 5670	3000	"
D F	Dusseldorf	1200	1000	"
F M	Frankfurt-on-Main	1200, 1850	1000	"
O U I	Hanover	9700		"
K A H	Heligoland	300	250	Ministry of Posts and Telegraphs
L P	Konigs Wusterhausen	5250	3000	"
P O Z	Nauen	3900, 4000, 4700, 9100, 12500	5000	"
K A Y	Norddeich	600, 800	1000	Government
K B Q	Nordholz, F.R.A.	600, 800	500	Navy
K R N	" F.S.	600, 1250	1000	Government
K A N	Wilhelms-haven	600, 800	500	State Marine
K A N	" F.S.	600		Aviation

CALL SIGN	STATION	WAVE-LENGTH	MILE-AGE RANGE	SERVICE	CALL SIGN	STATION	WAVE-LENGTH	MILE-AGE RANGE	SERVICE
<b>HOLLAND</b>					<b>SPAIN</b>				
P C A	Amsterdam ..	400, 600, 1800, 2800		Government	E A A	Araujiz ..	300-6700	1000	C.N.T.H.
P C D	Flushing ..	600			E A B	Barcelona ..	300-2300	1000	"
P C C	" (Bufler)	400				Radio			
P C G G	Hague ..	1050		Telephony	E G E	Barcelona ..	600-1600	1000	Army
P C B	Helder, P C B	600		Concerts	E S H	Bilbao ..	600-1600	1000	"
P C C	Helder, P C C	600		Government Reserve Station	E A C	Cadiz ..	2500	1500	C.N.T.H.
P C G	Kootwijk-Sanbeek	6650, 13250			E A S	Calomajor ..	300-1800	1000	"
P C B	Nieuwediep	17750			E A F	Finisterre ..	300-1800	1000	"
R T	Rotterdam	1000, 3000			E A L	Las Palmas ..	300-2540		"
R O M	"	900		Aviation	E A T	Tenerife ..	Ditto		"
P C H	Scheveningen	600	400	Government	E G G	Valencia ..	600-1600		Army
S T B	Sterberg	1400	600	Aviation	E A Y	Vigo ..	300-2900		C.N.T.H.
R D M	Waalhanen ..	900	500	Rotterdam Municipality					
<b>HUNGARY</b>					<b>SPITSBERGEN</b>				
H B ..	Csepel .. ..	4700	1500		L F G	Spitsbergen ..	300-1600		Norwegian Government
<b>ICELAND</b>					<b>SUDAN</b>				
T F A	Reykjavik	600	750	Government	S U L	Khartoum ..	1500		
<b>ITALY</b>					<b>SWEDEN</b>				
I C S	Spezia .. ..			Army	S A E	Gottland Radio	300, 600, 2000		Marine Dept.
I D O	San Paulo (Rome)	1850, 11000		Public Service	S A H	Härnösand Radio	Ditto		State Telegraphs
I C D	Centocelle ..	11500, 2500			S A J	Karlsborg Radio	2500-4200		
<b>MALTA</b>					<b>SWITZERLAND</b>				
B Y Y	S. Angelo ..	600	900	British Admiralty	H B B	Berne .. ..	3400		Federal Dept. of Posts and Telegraphs
V P T	Malta Island	2800, 3300	1000	British Admiralty					
B Y Z	Kinella ..	2700, 4200	1000	"					
<b>MOROCCO</b>					<b>UNITED STATES OF AMERICA</b>				
C N W	Rabat .. ..	600	650	French Government	N S S	Annapolis ..	7900, 10110, 10510	5000	Navy
C N W	Tangier ..	600	500	"	K E T	Bolinas Ket	1331	4000	Radio Corporation of America
<b>NORWAY</b>					<b>W Q L</b>				
L G N	Bergen Radio	600	1500	Government		Coram Hill ..	300, 600, 1900	4000	"
L C H	Christiania ..	4100-8000	2000		W R Q	Marion ..	13900	4000	"
L D F	Elekkeroy ..	600		Station	W I I	New Brunswick	15600	4000	"
L E I	Ingoy Radio	600, 1600	500		W R T	Ditto .. ..	11500	4000	"
L C M	Stavanger ..	12000			K D U	Point Reyes	12100	4000	"
<b>PANAMA</b>					<b>W O K</b>				
N B A	Balboa .. ..	1600-17145	5000	U.S. Navy		Saint James	16465	4000	"
<b>PHILIPPINE ISLANDS</b>					<b>W G G</b>				
N P O	Cavite .. ..	5000	6000	U.S. Navy		Tuckerton, N.J.	15900	4000	"
<b>POLAND</b>					<b>W J Z</b>				
P S O	Poznan (Posen)	800-10000	5000			Newark ..	405-600		Westing-house Electric Co.
W A R	Warsaw ..	2000	1000						"
<b>PORTUGAL</b>					<b>W B Z</b>				
P G L	Lisbon .. ..	1000	800			Springfield, Mass.	337	750	"
C R P	Oporto .. ..	600	700	Government	W D Y	Roselle Park, N.J.	600		Soc. Ind. T.S.F.
P O T	Terceira Radio	1000	800	"	W H I	New York	600		J. Wanamaker
<b>RUSSIA</b>					<b>W M E</b>				
M S K	Moscow ..	5000-6700	2000			Rockland, Maine	425-600	300	S.I. and Rockland Radio
<b>SANDWICH ISLANDS</b>					<b>W E Y</b>				
K I E	Kahuku ..	9145, 16975	4000	Radio Corporation of America		Wichita, Kansas	360-485	150	Cos Radio Co.
<b>SEYCHELLES</b>					<b>W B Y</b>				
B Z H	Seychelles ..	5300				Lima, Ohio ..	1700	250	Illinois Pipe Co.
					<b>W O A F</b>				
					<b>W O A C</b>				
					<b>W G Y</b>				
					<b>K Y W</b>				

Note: Wave-lengths given for stations of the British Broadcasting Co., Ltd., are liable to alteration, having been allotted temporarily

## CALL SIGNS: (2) AMATEUR TRANSMITTING STATIONS

Compiled by Leslie McMichael, M.Inst.R.E., Hon. Secretary, Radio Society of Gt. Britain

In this list the call signs of nearly all the amateur transmitting stations in Great Britain are given so that the amateur may identify the calls he hears. A certain number of signs are not for publication and others are necessarily subject to alteration. The reader is therefore advised when binding the volume to bind in one or two leaves of writing paper, so that alterations and additions may be made from time to time

2AA	Radio Commun. Co., Ltd., Slough	2DU	W. D. Norbury, 57, Chilwell Rd., Beeston	2HC	F. M. J. White, Winchcombe Lodge, Bucklebury, nr. Reading
2AF	A. R. Taylor, 49, Idmiston Rd., W. Norwood, S.E. 27	2DX	W. J. Aiford, Rosedene, Camberley	2HF	W. G. Gold, Rosedale, Belwell Lane, Four Oaks
2AG	T. Moor, Castlemaine, Leth- bridge Rd., Southport	2DY	F. H. Haynes, 5, Regent Sq., W.C. 1	2HG	T. Boutland, Sur., Ashington, Northumberland
2AJ	Radio Commun. Co., Ltd., Barnes, S.W. 13	2DZ	F. H. Havnes, 26, Avenue Rd., S. Tottenham, N. 15	2HH	T. Boutland, Jnr., Ashington, Northumberland
2AL	W. Halstead, Briar Lane, Thornton-le-Fylde	2FA	F. G. Bennett, 16, Tivoli Rd., Crouch End, N. 8	2HK	A. A. Campbell Swinton, F.R.S., 66, Victoria St., S.W. 1
2AM	A. Pearl, 5, Sharon Rd., Chiswick, W.	2FB	W. Ison, A.M.I.R.E., 80, Harnham Rd., Salisbury	2HL	A. A. C. Swinton, F.R.S., 40, Chester Sq., S.W. 1
2AN	A. W. Sharman, Kelvin Lodge, 1, Morella Rd., Wandsworth	2FC	D. Sinclair, 19A, Ladbroke Gardens, W. 11	2HO	H. C. Woodhall, 10, Holborn House, E.C. 1
2AO	O. N. Rely, Stratton, De Roos Rd., Eastbourne	2FG	L. McMichael, 32, Ouxer Rd., W. Hampstead, N.W. 6	2HP	A. W. Fawcett, 11, Leigh Rd., Clifton, Bristol
2AQ	Davis, Thornton Heath, Lon- don, S.W.	2FH	T. I. Rogers, 2, Park Hill, Moseley, Birmingham	2HQ	F. O. Read & Co., Ltd., 13-14, Great Queen St., King'sway, W.C. 2
2AR	E. Gaze, 3, Archibald St., Gloucester	2FJ	W. J. Fry, 22, Thirsk Rd., Lavender Hill, S.W. 11	2HR	G. W. Hale and R. Lyle, 36, Dagnall Park S. Norwood, S.E. 25
2AT	Mr. Beresford, Birmingham	2FK	F. C. Grover, 20, Rudland Rd., Ilford	2HT	R. H. Klein, 18, Creditor Hill, W. Hampstead, N.W. 6
2AU	A. C. Bull, 25, Fairland Rd., West Ham, E. 15	2FL	C. Wilcox, 21, George St., Warminster	2HV	H. Beresford, Wyde Green, Birmingham
2AV	D. H. W. Swiney, 18, South- church Rd., Southend	2FM	V. Coreih, 41A, Grove Rd., Eastbourne	2HW	H. Beresford, 213, Bull St., Birmingham
2AW	H. H. Burbury, Crigglestone, Wakefield	2FN	L. M. Baker, Ruddington, Notts	2HX	F. A. Love, Ivydene, Guildford Park Rd., Guildford
2AX	G. Sutton, 18, Melford Rd., E. Dulwich, S.E. 22	2FP	F. Foulger, 74, Jerningham Rd., S.E. 14	2IB	W. Bemrose, Four Winds, Littleover, Derby
2AY	D. F. Owen, Limehurst, Sale	2FQ	Buridept, Ltd., Aerial Works, Blackheath, S.E. 3	2ID	E. S. Firth, 5, Manor Rd., Harrow
2AZ	Wm. Le Queux, M.I.R.E., St. Leonards-on-Sea	2FR	S. Rudeforth, 54, Worthing St., Hull	2IF	S. W. Blight, 2, North Lane, Canterbury
2BC	D. F. Owen, Limehurst, Sale	2FU	E. T. Manley, Jnr., 491, Arthur Rd., Wimbledon Park, S.W. 19	2IH	C. G. Bevan, Technical Coll., Cathays Park, Cardiff
2BM	J. H. A. Whitehouse Hamp- stead, N.W. 3	2FW	Rev. D. Thomas, St. Paul's B.P. Scouts, Bournemouth	2II	Southport Wireless Soc., Queen's Hotel, Southport
2BO	Marconi Co., Writtle	2FX	H. C. Binden, 32, Oxford Rd., Bournemouth	2IJ	County High School for Boys, Altrincham, Cheshire
2BP	Daimler Motor Co., Kelvinside	2FZ	Manchester Wireless Soc., Houldsworth Hall, Deans- gate	2IK	H. R. Goodall, Fernlea, Win- chester Rd., Bassett, South- ampton
2BZ	B. Davis, The Pavilion, Marble Arch, W. 1	2GA	Rev. J. A. Gibson, 15, Daniel St., Bath	2IL	J. E. Fish, Thornley, Station Rd., Thornton-le-Fylde
2CA	J. H. Reyner, 69, Station Rd., Chingford	2GD	Birmingham Wireless Experi- mental Club, Digbeth Insti- tute, Birmingham	2IQ	W. A. Ward, 26, Marlborough Rd., Sheffield
2CB	W. E. Cooke, 29, Empress Av., S. Chingford	2GF	J. V. Newson, 139, Ormside St., S.E. 15	2IS	Rev. W. H. Doudney, St. Luke's Vicarage, Bath
2CD	Burton-on-Trent Wireless Soc. (Hon. Sec.), 66, Edward St., Burton-on-Trent	2GG	R. H. Kidd, Marlborough House, Newbury	2IT	G. A. E. Roberts, Twyford, Winchester
2CH	Science Soc., The School, Oundle	2GI	L. Johnson, Ilinde House Lane, Pisnmoor, Sheffield	2IV	L. F. White, 10, Priory Rd., Knowle, Bristol
2CI	R. B. King, Widcombe, Taun- ton	2GJ	" " " " "	2IW	G. R. Marsh, Mallards Close, Twyford, Winchester
2CK	City and Guilds (Engin.) Coll., Exhibition Rd., S. Kensington	2GK	" " " " "	2IX	S. G. Taylor, Littleover, Derby
2CM	N. D. B. Hyde, 92, Littledale Rd., Egrement	2GL	W. J. Henderson, 2, Holly- wood Road, S.W. 10	2IY	J. Briggs, 61, High St., Manchester
2CO	J. C. Elmer, 14, Gordon Sq., Birmingham	2GO	L. B. Flag, 61, Burlington Rd., Bayswater, W. 2	2JA	A. S. Atkins, St. Malo, Beau- champ Rd., Upper Norwood, S.E.
2CP	" " " " "	2GP	H. W. Nunn, 49, Leigh Rd., Highbury Park, N. 5	2JB	P. H. Dorte, Downside School, Stratton-on-the-Fosse, nr. Bath
2CW	B. Hipsley, " Ston, Easton Park, Bath	2GQ	1st Taunton Scouts, Parish Buildings, Wilton, Taunton	2JC	I. H. Storey, Escowbeck, Caton, Lancaster
2CX	A. L. Rockham, 114, Beau- champ Rd., Upper Nor- wood, S.E.	2GR	T. Forsyth, Wenslea, Ashing- ton, Northumberland	2JD	I. H. Storey, White Cross Mills, Lancaster
2CZ	C. Atkinson, 17, Beaumont Rd., Leicester	2GS	" " " " "	2JF	C. G. Williams, 22, Scholar St., Sefton Park, Liverpool
2DC	M. Child, 60, Ashworth Mans., Maida Vale, W. 9	2GT	G. Irvine, 12, Treberth St., Liverpool	2JG	W. A. Seed, Crigglestone, nr. Wakefield
2DD	A. C. Davis, 105, Brynland Av., Bristol	2GU	Halifax Wireless Club, Clare Hall, Halifax	2JH	C. A. Barrand, Stefano, Wel- lington St., Slough
2DF	R. E. Miller, 65, Malden Rd., New Malden	2GV	Rev. W. P. Rigby, St. Law- rence Vicarage, Bristol		
2DG	W. Burnet, 10, Coverdale Rd., Sheffield	2GW	A. Cash, Foxley Mount, Lynn, Cheshire		
2DH	" " " " "	2GZ	A. L. Megson, Talbot Rd., Bowdon, Cheshire		
2DI	" " " " "	2HA	" " " " "		
2DJ	A. T. Lee, The Court, Alveston, Derby	2HB	L. H. Lomas, Highfield, Sum- mersseat, nr. Manchester		
2DR	S. R. Wright, 14, Bankfield Drive, Nab Wood, Shipley				
2DT	Barrow and Dist. Wireless Assoc., Market Tower, Bar- row-in-Furness				

2JJ	C. Worthy, 4, Riversdale Rd., Egretnont, Wallasey	2LQ	J. A. Henderson, 18, Elm Hall Drive, Moseley, Liverpool	2OD	E. J. Simmonds, Meadowlea, Queen's Way, Gerrard's Cross
2JK	P. R. Coursey, Stamford House, Marchmont Rd., Richmond, Surrey	2LR	J. Scott-Taggart, 6, Beatyville Gardens, Ilford	2OF	H. C. Trent, Secondary School, Lowestoft
2JL	G. G. Bailey, The Beeches, Cowley, Middlesex	2LT	A. F. Battle, St. Cyres, 5, Coleraine Rd., Blackheath, S.E.3	2OG	A. Cooper, 16, Westworth Rd., York
2JM	G. G. Blake, 10, Onslow Rd., Richmond, Surrey	2LU	W. A. Appleton, Wembley, Park	2OI	C. Baine, 51, Grainger St., Newcastle-on-Tyne
2JN	H. B. Burdekin, Bilton, Rugby	2LV	W. R. H. Tingay, 22, Leinster Gardens, W.7	2OJ	E. A. Houghton, 52, First Avenue, Hove
2JO	J. W. Whiteside, 30, Castle St., Clitheroe, Lancs	2LW	Tingey Wireless Ltd., 97, Queen St., Hammersmith, W.6	2OK	H. D. Butler & Co., Ltd., 222, Great Dover St., S.E.1
2JP	M. C. Ellison, Huttons Ambo Hall, York	2LY	H. H. Thompson, 59, Redlands R.I., Penarth, Glam	2OL	H. D. Butler, Trebarwith, S. Hutfield, Surrey
2JQ	H. B. Dent, 25, Church St., Leatherhead	2LZ	F. A. Mayer, Silemans, Wickford, Essex	2OM	H. S. Walker, A.M.Inst.R.E., Park Lodge, Brentford
2JS	H. B. Dent, 25, Church St., Leatherhead	2MA	P. S. Savage, 14-16, Norwich R.I., Lowestoft	2ON	Major H. C. Parker, 56, Sthernhall St., Walthamstow
2JU	E. J. Pearcey, 115, Woodland Rd., Handsworth	2MB	E. H. Jaynes, 67, St. Paul's R.I., Gloucester	2OP	Capt. G. C. Price, 8, Lansdown Terrace, Cheltenham
2JV	A. G. Robbins, Station Rd., Epping	2MC	H. J. Dent, Albion, Fleetwood Av., Westcliffe-on-Sea	2OQ	D. P. Baker, Crescent House, Newbridge Crescent, Wolverhampton
2JW	J. R. Barrett, Westgate Court, Canterbury	2MD	C. Chipperfield, Victoria Rd., Oulton Broad, Lowestoft	2OS	Amersham
2JX	L. Vizard, 12, Seymour Gardens, Ilford	2ME	Marconi Scientific Instrument Co., Ltd., 21-25, St. Anne's Court, Dean St., W.1	2OT	Ilford and District Radio Soc., Sec., L. Vizard, 12, Seymour Gardens, The Drive, Ilford
2JZ	R. D. Spence, Craighhead House, Huntly, Aberdeenshire	2MG	C. C. Millar, Arndean, Bearsden, nr. Glasgow	2OU	Dr. Ratcliffe, 22, Wake Green Rd., Moseley, Birmingham
2KA	Brighton and Hove Radio Soc., 68, Southdown Avenue, Brighton	2MH	A. Lawton, Brwnedee Vicarage, Stoke-on-Trent	2OX	Capt. E. J. Hobbs, 4th Tank Batt., Wareham, Dorset
2KB	W. E. Earp, 675, Moore Rd., Mapperley, Nottingham	2MI	L. McMichael, Ltd., StagWorks, Providence Place, Kilburn, N.W.6	2OZ	Worcester Cadet Signal Co., R.C. of Signals, Junior Technical School, Sansome Walk, Worcester
2KC	H. T. Longchaye, 96, Barnmead Rd., Beckenham	2MK	A. W. Hambling, 80, Brondesbury Rd., N.W.6	2PA	G. Z. Auckland & Son, 395, St. John St., E.C.1
2KD	Denison Bros., Experimental Station, Wainhouse Tower, Halifax	2ML	R. C. Clinker, Bilton, Rugby	2PB	D. E. O. Nicholson, 383, Upper Kennington Rd., Lambeth
2KF	J. A. Partridge, 22, Park Rd., Colliers Wood, Merton, S.W.	2MM	C. A. Hines, Watley, Twyford, nr. Winchester, Hants	2PC	A. G. Davies, Redcott, Park Rd., Timperley, Cheshire
2KG	A. E. Hav, Glendale, Abernant, Aberdare	2MO	F. O. Read, 26, Flanders Rd., Bedford Park, Chiswick	2PD	W. Harvey-Marston, The Manor, Willenhall, Staffs
2KH	Ashley Wireless Telephone Co., Ltd., Renshaw Rd., Liverpool	2MS	R. H. Reece, Fasketts, Birchington	2PF	R. B. Jefferies, Lynn Dene, Mount Hill, Kingswood, Bristol
2KK	Hutchinson & Co. (F. Pinkerton), 101, Dartmouth Rd., Forest Hill, S.E.23	2MT	Marconi Scientific Instrument Co., nr. Chelmsford Station, for specially authorized transmissions to amateurs	2PG	B. Hesketh, High St., Chalvey, Slough
2KL	F. Pinkerton, 50, Peak Hill, Sydenham, S.E.26	2MV	R. Wallis, Dehn de Lion, Westgate-on-Sea	2PH	L. Dove, 139, Milcote Rd., Bearwood, Smethwick
2KM	C. Stainton, 155, Escourt St., New Bridge Rd., Hull	2MY	H. M. Hodgson, Clifton House, Hartford, Cheshire	2PI	Loughborough College, Leicestershire
2KN	A. B. Day, Finchley	2MZ	J. Mavall, A.M.I.E.E., Burfield, St. Paul's Rd., Gloucester	2PJ	Major L. N. Stephens, O.B.E., R.A., Haddon House, Bridport Harbour, Dorset
2KO	C. S. Baynton, 48, Russell Rd., Moseley	2NA	H. Frost, Longwood, Barr Common, Walsall	2PL	C. J. Pratt, 332, Upper Richmond Rd., Putney, S.W.
2KP	F. A. Bird, 13, Henrietta Rd., Bath	2NB	J. W. Barnaby, Sylvan House, Broad Rd., Sale	2PP	J. Knight, Clark's Hill Nursery, Prestwick, Manchester
2KQ	H. Taylor, The Lodge, Tettenthall Wood, nr. Wolverhampton	2NC	J. Goodwin, Crown St., Duffield, Derbyshire	2PQ	G. E. Mortley Sprague & Co.'s Test Station, Nelson Rd., Tonbridge
2KR	E. Edmonds, 2, Yew Tree Rd., Edgbaston	2ND	E. H. Pickford, 6, Wilson Rd., Sheffield	2PR	A. E. Whitehead, Hollingwood, King's Ride, Camberley, Surrey
2KS	C. C. Beakell, Mill Bank, Church St., Preston	2NE	G. S. Whale, Whale's Wireless Works, Colwyn Bay	2PS	J. H. Gill, 18, Fourth Avenue, Sherwood Rise, Nottingham
2KT	J. E. Nickless, 83, Wellington Rd., Snaresbrook, E.11	2NH	O. R. C. Sherwood, 41, Queen's Gate Gardens, S.W.7	2PT	J. Jardine, Hall Rd, West, Blundellsands, Liverpool
2KU	A. J. Selby, 66, Edward St., Burton-on-Trent	2NI	Dartford and District Wireless Soc., Sec., E. C. Deavin, 84, Hawley Rd., Wilmington, Dartford	2PU	C. R. W. Chapman, Nirvana, 44, Chopin Rd., Wembley
2KV	W. J. Crampton, Weybridge	2NK	P. Priest, 174, Woodside Rd., Lockwood, Huddersfield	2PV	G. Smith Clarke, Glenroy, Waverley Rd., Kenilworth
2KW	W. R. Burne, Springfield, Thorold Grove, Sale	2NL	F. J. Hughes, A.M.I.E.E., 129, Wells Rd., Bath, Somerset	2PW	J. Matthews, 33, Capel Rd., Forest Gate, E.7
2KX	W. Stanworth, Fern Bank, Blackburn	2NM	G. Marcuse, Coombe Dingle, Queen's Park, Caterham	2PX	H. H. Lassman, 429, Barking Rd., East Ham, E.6
2KY	L. Pollard, 209, Cunliffe Rd., Blackpool	2NN	Brig.-General Palmer, Hill Crest, Epping	2PY	H. Carter-Bowles, 51, St. Gunterstone Rd., W. Kensington
2KZ	B. Clapp, A.M.I.R.E., Meadowmoor, Brighton Rd., Purley	2NO	H. R. Adams, Crescent Cabinet Works, Sutton Road, Walsall	2PZ	A. E. J. Symonds, 12, Addison Av., Holland Park, W.11
2LA	H. F. Yardley, Victoria Rd., Headingley, Leeds	2NP	H. G. Treadwell, Middleton Cheney, Banbury	2QA	Dr. H. W. Estgarth-Taylor, 320, Humberstone Rd., Leicester
2LB	H. F. Yardley, 6, Blenheim Terrace, Leeds	2NQ	R. J. T. Morton, 14, Woodside Rd., Kingston-on-Thames	2QD	J. Ayres, 10th Wimbledon B.P. Scouts, 18, Seaforth Av., New Malden
2LD	R. J. Cottis, 4, Crondace Rd., Fulham, S.W.6	2NR	J. Knowles-Hassell, Mount Pleasant Works, Wooden Box, nr. Burt-on-Trent	2QC	J. S. Alderton, 1,542, Stratford Rd., Hall Green, Birmingham
2LF	P. Harris, Chilvester Lodge, Calne, Wilts	2NS	M. Burchill, 30, Leighton Rd., Southville, Bristol	2QH	C. Hewins, 42, St. Augustine Av., Grimsby
2LG	H. H. Whitfield, The Glen, Primrose Lane, Hall Green, Birmingham	2NT	H. Littley, Lodge Rd., West Bromwich		
2LI	C. H. Wilkinson, 14, Kingswood Avenue, Brondesbury, N.W.6	2NW	J. N. C. Bradshaw, Bilsboro', nr. Preston		
2LJ	Worcester Cadet Signal Co.	2NY	J. N. C. Bradshaw, Bilsboro', nr. Preston		
2LK	S. Kniveton, Brooklands, Normanton	2NZ			
2LL	A. W. Knight, 26, Stanbury Rd., S.E.15				
2LP	A. W. Knight, 26, Stanbury Rd., S.E.15				



CALL SIGNS

CALL SIGNS

2QI Hurst & Lucas, 3, Mayford Rd., Balham, S.W.12  
 2QJ R. Walton, 17, Moorfield Rd., Penlwith, Manchester  
 2QK J. Bever, 85, Emm Lane, Bradford  
 2QL R. J. Hibberd, Grayswood Mount, Haslemere  
 2QN A. Hobday, Flint House, North-down Rd., Margate  
 2QO P. Pritchard, Blenheim House, Broad St., Hereford  
 2QP L. C. Grant, 3, Langhorn St., Newcastle-on-Tyne  
 2QQ Burndept, Ltd., Blackheath  
 2QR F. W. G. Towers, 12, Mayfield Rd., Handsworth  
 2QS S. Ward, Ravenswood, 339, Brixton Rd., S.W.9  
 2QT C. C. Barnett, Lower Farm, Nether Compton, Sherborne  
 2QU Lucas & Hurst, 199, Lais-down Rd., Blackheath, S.E.13  
 2QV Altricham, Wireless Soc., Brezzer Cest., Plane Tree Rd., Hale, Cheshire  
 2QY London, N.W.6  
 2QZ Brian H. Colquhoun, 3, Eastbrook Rd., Blackheath, S.E.3  
 2RB H. B. Grylls, Ironay, Fawton, Carew Rd., Eastbourne  
 2RD G. W. Fairall, 27, Newbridge St., Wolverhampton  
 2RF Technical College, Bradford  
 2RG E. W. Scammell, 147, Solihull Rd., Sparkhill, Birmingham  
 2RH H. A. Pound, 101, High St., Broadstairs  
 2RJ Major F. S. Morgan, E. Fair-leigh, Kent  
 2RK A. E. Blackall, 7, Maple Rd., Surbiton  
 2RM S. Cross, 3, Norman Rd., Heaton Moor, nr. Stockport  
 2RN D. Richards, Mumcety House, Contemacwood Terrace, Tackwiss, Glam  
 2RP F. W. Emerson, 178, Heaton Moor Rd., Heaton Moor  
 2RQ E. Strong, 119, Church Lane, Handsworth  
 2RR W. V. Waddopp, 56, Welling-ton Rd., Handsworth Wood  
 2RS Thomas Hesket, 42, Castle Hill Av., Folkestone  
 2RT North Eastern Instrument Co., Durham Rd., Low Fell, Gateshead  
 2RU North Eastern Instrument Co., Rowlands Gill, nr. New-castle-on-Tyne  
 2RV A. Rawlings, 162, Burnt Ash Hill, Lee, S.E.  
 2RW Merton Park, S.W.20  
 2RY D. Hanley, Forbury, Kint-bury, Berks  
 2RZ D. T. Woods, Denley Villa, Parker Rd., Bournemouth  
 2SA Sir Hanbury Brown, Newlands, Crawley Down, Sussex  
 2SD John Mayall, Burfield, St. Paul's Rd., Gloucester  
 2SF C. Midworth, Sumia, Ridgeway Rd., Osterley  
 2SH F. L. Hogg, 37, Bishop's Rd., Highgate, N.6  
 2SI L. C. Holton, 112, Conway Rd., Southgate, N.14  
 2SK K. Graham Styles, 43, New Oxford St., London, W.C.1  
 2SL K. Graham Styles, Kitesoot, 52, Bower Mount Rd., Maidstone  
 2SM R. J. Bates, 34, Abbeygate St., Bury St. Edmunds  
 2SO T. Geeson, Alder Cottage, Peel St., Macclesfield  
 2SP L. Mansfield, Cregneish, Ley Hey Park, Marple, Cheshire  
 2SQ A. J. Spears, 25, Rawlings Rd., Bearwood, Smethwick  
 2SS Bradford Technical College  
 2ST L. Lambert, 46, Church Rd., Holland Park

2SX F. B. Baggs, 24, Westhorpe St., S.W.15  
 2SY H. Stevens, 25, Oaklands Rd., Wolverhampton  
 2SZ Wireless Soc., Mill Hill School, N.W.7  
 2TA H. Andrews, 8, North Grove, Highgate, N.6  
 2TB H. W. Sellers, 18, Edgerton Grove Rd., Huddersfield  
 2TC  
 2TF Edinburgh and District Radio Soc., Sec., W. Winkler, 9, Ettrick Rd., Edinburgh  
 2TG Dr. T. F. Wall, Dept. of Applied Science, University, St. George's Sq., Sheffield  
 2TH  
 2TI H. Bevan Swift, 49, Kingsmead Rd., Tulse Hill, S.W.2  
 2TJ Burndept, Ltd., George St., Leeds  
 2TL V. Martin, 128, Daisy House Rd., Derby  
 2TM L. H. Mansell, Woodfield, Madresfield Rd., Malvern  
 2TN C. E. Stuart, Lyndon Lodge, Polesworth, Tamworth  
 2TO F. T. G. Townsend, 46, Grove Lane, Ipswich  
 2TP C. W. Andrews, Radioville, 26, Melody Rd., Wandsworth Common, S.W.18  
 2TQ T. C. Macnamara, 31, Rollscourt Av., Herne Hill, S.E.24  
 2TR F. O. Sparrow, 8, North Drive, Swinton, Manchester  
 2TV E. W. Wood, 79, Colwyn Rd., Northampton  
 2TW  
 2TX A. R. C. "Johnston," 87, Twyford Av., Acton, W.3  
 2TX S. Scott, Field Villa, Norton, Maltot  
 2TZ E. Jones, Newholme, Hemp-shaw Lane, Offerton, Stockport  
 2UA S. B. P. Barnes, 38, Avenue Rd., Highgate, N.6  
 2UC E. J. Winstone, 55A, Gunter-stone Rd., W. Kensington  
 2UD E. W. Smith, 77, Grove Lane, Camberwell, S.E.5  
 2UF H. Bailey, 51, Manchester Rd., Denton, nr. Manchester  
 2UG W. H. Burton, 103, Portland Rd., Nottingham  
 2UI A. R. Ogston, 41, Broomfield Av., N.13  
 2UJ L. R. Richards, 25, Cholmeley Park, Highgate, N.6  
 2UK Cotteridge Day Continuation School, King's Norton, Birmingham  
 2UM H. Lloyd, 3, Ventnor Place, Sheffield  
 2UN 14th Cardiff Lord Mayor's Own Troop of B.P. Scouts, Y.M.C.A., Boys' Dept., Cardiff  
 2UQ H. F. Abell Sanderson, H.A., 23, Palace Rd., Llandaff  
 2US Radio Society of Highgate, Highgate 1919 Club, South Grove, Highgate, N.6  
 2UV W. Corsham, 104, Harlesden Gardens, N.W.10  
 2UX A. T. Headley, 255, Galton Rd., Warley, Birmingham  
 2UY W. Fenn, Holly Cottage, Pole-worth, Tamworth  
 2UZ C. V. Stead, 29, Sholebrooke View, Chapeltown, Leeds  
 2VB Shooter's Hill  
 2VC A. S. Gosling, 63, North Rd., West Bridgford, Nottingham  
 2VD Captain Crowe, Juniper, Rough Hardes, nr. Canterbury  
 2VF H. A. Blackwell, Whyte House, Bispham, Blackpool  
 2VH S. E. Payne, Bush Hill Park, Enfield  
 2VI H. Curtis, 26, Upper Hall Lane, Walsall  
 2VJ B. J. Axten, Ravenscourt, 78, Ealing Rd., Wembley

2VK Burndept, Ltd., Aerial Works, Blackheath, S.E.3  
 2VL Mitchell & Co., McDermott Rd., Peckham, S.E.15  
 2VM J. Lipovsky, 614, Old Ford Rd., Bow, E.3  
 2VN M. H. Drury-Lavin, Old House, Soining, Berks  
 2VO Alan C. Holmes, 60, Aire View, Cononley, Keighley  
 2VP P. G. A. Voigt, Bowdown Mount, 121, Honor Oak Park, S.E.23  
 2VQ H. B. Old, 10, St. Jude's Av., Mapperley, Nottingham  
 2VR H. J. Jackson, 8th Waltham-stow Boy Scouts  
 2VS W. K. Hill, 79, Beulah Hill, S.E.19  
 2VT  
 2VV Southampton  
 2VW E. H. Robinson, 125c, Ade-laide Rd., N.W.3  
 2VX H. H. Thompson, 44, North-umberland Rd., Coventry  
 2WA J. Pigott, Manor Farm, Wolver-cote, Oxford  
 2WB G. W. Jones, 8, Rosebery St., Wolverhampton  
 2WD C. W. Clarabut, Bedford Radio Soc., Beechcroft, Beverley Crescent, Bedford  
 2WI C. Munday, 37, Leat St., Tiverton, Devon  
 2WJ R. L. Royle, Southwold, Alderman's Hill, Palmer's Green, N.13  
 2WK G. R. Lewis, 10, Lansdowne Rd., Ashton-on-Mersey, Man-chester  
 2WL F. J. Cripwell, Lonk Hill, Thorpe, Tamworth  
 2WM J. W. Pallett, 111, Ruby St., Leicester  
 2WN A. H. Wilson, 67, Broad St., Hanley, Stoke-on-Trent  
 2WO J. H. Brown, Redbrook, Baguley, Cheshire  
 2WQ C. H. Gardner, Amblecote House, Brierley Hill, Staffs  
 2WR L. W. Burcham, Gaucezout, Chestnut Av., Oulton Broad, Norfolk  
 2WS H. Squelch, Jr., 35, Crown Lane, Bromley Common, Kent  
 2WT H. Chadwick, 9, Raimond St., Halliwell, Bolton  
 2WU Capt. C. Bailey, Charlacre, Moun-ton Rd., Cheshport  
 2WZ Capt. A. H. Hobson, 32, Wil-bury Rd., Hove, Sussex  
 2XA Rev. C. H. Townson, Wilts Farm School, Warminster  
 2XB G. Z. Auckland & Sons, 35, Douglas Rd., Highbury, N.6  
 2XC H. Johnson, Avondale, Chest-nut Glade, Worcester  
 2XD H. R. Gladwell, London Rd., Abridge  
 2XF E. T. Chapman, A.M.I.R.E., Hillmorton, Ringwood Rd., Newtown, Dorset  
 2XI R. H. Wagner, 6, Maresfield Gardens, N.W.3  
 2XJ Dept. of Applied Science, Sheffield and District Wire-less Soc., Sheffield  
 2XK Sheffield and District Wireless Soc., Sec., L. H. Crowther, 18, Linden Av., Sheffield  
 2XL Capt. Edward Davis, Pavilion, 122, Lavender Hill, Clapham Junction, S.W.11  
 2XM P. H. Dorte, Downsides Wire-less Soc., Downsides School, Stratton-on-the-Fosse, nr. Bath  
 2XN  
 2XP J. F. Payne, 22, Shakespeare Crescent, Manor Park, E.12  
 2XR J. F. Haines, 36, Zetland St., E.14  
 2XT W. E. Philpott, Appledore, Kent  
 2XW H. A. Woodyer, 118, Bucking-ham Rd., Heaton Moor, nr. Stockport

- 2XX** D. F. Young, 23, Holcombe Rd., Hford  
**2XY** H. T. Littlewood, Esholt, Wedgewood Drive, Roundhay, Leeds  
**2XZ** L. T. Dixon, 4, Haythorp St., Southfields, S.W.18  
**2YA** R. A. Miles, 4, Cambridge Green, New Eltham, S.E.9  
**2YF** J. R. Clay, Upper Longbottom, Luddendenfoot S.O., Yorks  
**2YG** L. G. Boomer, 42nd Camberwell Troop, B.P. Scouts, 51, Brook St., S.E.1  
**2YH** G. E. Duveen, 40, Park Lane, W.1  
**2YI** W. J. Hewitt, B.Sc., 83, Reddins Rd., Moseley, Birmingham  
**2YJ** Wireless Equipment, Ltd., 90, Charing Cross Rd., W.C.2  
**2YK** T. M. Ovenden, 12A, Elgin Court, Elgin Av., Hampstead  
**2YM** R. W. Piper, 62, Chiltern View Rd., Uxbridge  
**2YN** A. W. Thompson, 32, St. Nicholas St., Scarborough  
**2YQ** W. P. Wilson, 1, Highland Rd., Gipsy Hill, S.E.19  
**2YR** A. K. Pike, 17, Avonwick Rd., Heston, Hounslow  
**2YU** G. W. Hale and R. Lyle, 36, Dagnall Park, S. Norwood, S.E.25  
**2YV** G. M. Whitehouse, Allport House, Canook  
**2YW** J. H. F. Town, 4, Eversley Mount, Halifax  
**2YX** F. E. B. Jones, Hill Crest, Jockey Hill, Birmingham Rd., Wyde Green, Birmingham  
**2YY** O. H. Patterson, 26, Allerton Rd., Stoke Newington, N. 16  
**2ZB** C. R. Small, Broadhurst, Skelmersdale Rd., Clacton-on-Sea  
**2ZC** General Radio Co., Twyford Abbey Works, Acton Lane, N.W.10  
**2ZD** A. Woodcock, 1, Montagu Rd., Handsworth, Birmingham  
**2ZG** W. J. Badman, Orchard St., Weston-super-Mare  
**2ZK** W. L. Turner, Purley, Caddy, West Kirby  
**2ZL** H. W. Gee, 44, Gordon St., Gainsborough, Lincs  
**2ZM** T. H. Isted, Terling, Witham  
**2ZO** L. H. Soundy, 60, Bellevue Rd., Ealing  
**2ZP** G. F. Forwood, West Chart, Limsfield, Surrey  
**2ZR** S. G. Brown & Co., Ltd., 19, Mortimer St., W.1  
**2ZS** F. J. Dinsdale, 14, Highfield View, Stoneycroft, Liverpool  
**2ZT** Benham, Woodbury Rd., New Malden  
**2ZU** T. Eccles, 30, Thackeray St., Liverpool  
**2ZV** E. T. Smith, Rutlands, Felsted  
**2ZZ** Messrs. Fellows, Ltd., Cumberland Av., Park Royal, N.W.10  
**5AA** The Leicester Daily Mercury, Leicester  
**5AC** W. G. Kimber, Catford, S.E.6  
**5AF** J. A. H. Devey, 232, Great Brickkiln St., Wolverhampton  
**5AG** A. E. Gregory, 77, Khedive Rd., Forest Gate, E.7  
**5AI** A. H. Sheffield, 139, Wallwood Road, Leytonstone, E.11  
**5AJ** W. C. Barraclough, 9, Rutland Av., Withington, Manchester  
**5AK** H. Guy Mansell, Cleeve View, Harrington, nr. Evesham  
**5AN** W. J. Joughin, 158, Sumner Rd., Peckham, S.E.15  
**5AO** H. H. Elson, 142, Birchfield Rd., Birmingham  
**5AP** A. J. Hill, Buckhurst Rd., Bexhill-on-Sea  
**5AQ** D. Douet, 10, Ruvigny Gardens, Putney, S.W.15  
**5AS** F. A. Bourne, 10, Linley Rd., Tottenham, N.17  
**5AT** Dabulier Condenser Co. (1921), Ltd., Goldhawk Rd., Shepherd's Bush, W.12  
**5AU** W. H. Goodman, 94, Addison Rd., Holland Park, W.14  
**5AV** R. W. Harvey, 25, Shakespeare Av., Portswool, Southampton  
**5AW** F. Hough (Soutport), Ltd., 60, Sussex Rd., Southport  
**5AY** T. F. Crowther, 29, North Drive, St. Annes-on-Sea, Lanes  
**5AZ** F. Charnley, 43, Reads Av., Blackpool  
**5BA** Capt. Steven, Chase Motors, Ltd., Newcastle  
**5BB** Messrs. Vickers, Ltd., Broadway, Westminster, S.W.1  
**5BC** Sir Trevor Dawson, Elstree, Heris  
**5BG** J. B. Kaye, 12, Close Hill, Lockwood, Huickersfield  
**5BI** Bournemouth  
**5BK** W. G. H. Brown, 52, Winstonian Rd., All Saints, Cheltenham  
**5EL** A. E. Vick, 19, Gresham Rd., Hall Green, Birmingham  
**5BM** J. T. Quick, 164, Portland Rd., Edgbaston  
**5BP** R. A. Wells, 59, Compton Rd., Winchmore Hill, N.21  
**5BT** L. V. Clark, 4, Compton Crescent, Grove Park  
**5BV** H. N. Ryan, 88, Home Park Road, Wimbedon Park, S.W.19  
**5BW** A. De Villiers, 161, Westminster Bridge Rd., S.E. 1  
**5CA** N. L. Yates-Fish, Cleveland, Mansfield Rd., Reading  
**5CB** Capt. K. E. Hartridge, 14, Westbourne Crescent, W.2  
**5CC** Bath Electric Plating Works, Foxcombe Rd., Bath  
**5CD** G. Warl Booth, Eastlands, Queen's Rd., Wisbech  
**5CF** F. G. S. Wise, 12, Crouch End Hill, N.8  
**5CJ** J. Balleston, 6, Clough Ter., Barnoldswick, Colne  
**5CK** L. H. Pearson, c/o Messrs. Pearson Bros., 54-56, Long Row, Nottingham  
**5CP** D. V. L. Fellows, 20, North Common Rd., Ealing, W.5  
**5CS** G. R. Garratt, 35, Abben Rd., St. John's Wool, N.W.5  
**5CU** J. A. Walshaw, Garnett Villa, Otlev, nr. Leeds  
**5CV** R. J. Harrison, Seaton, Walton-on-Thames  
**5CW** A. H. S. Colebrooke, 82, High St., Harborne  
**5CX** A. Higson, 161, Cotton Tree Lane, Colne, Lanes  
**5CY** L. Gordon, 133, Old St., Ashton-under-Lyne  
**5DA** G. Gore, 24, Brucegate, Berwick-on-Tweed  
**5DB** C. H. P. Nutter, 243A, Selhurst Rd., S.E.25  
**5DC** W. T. Aked, Kasauli, Devonshire Rd., St. Annes-on-Sea  
**5DD** Capt. M. Barnes, Akals, Ainsdale, Southport  
**5DG** C. H. Stephansen, Penn Manor, Wolverhampton  
**5DH** Pollis Hill  
**5DI** C. J. Matthews, Havering, nr. Romford  
**5DJ** E. A. Reeves, 5, Crescent Av., Plymouth  
**5DM** A. N. J. Ley, Grove House, Albert Grove, Nottingham  
**5DN** Capt. L. A. K. Ha comb, South Denc, 106, Mill houses Lane, Sheffield  
**5DO** E. J. Watts, 6, Ashley Rd., Salisbury  
**5DP** Sea Scouts' Headquarters, Clacton-on-Sea  
**5DS** A. W. Fittian, 51, St. James' Rd., S.W.17  
**5DT** Hutchinson & Co. (F. Pinkerton), 101, Dartmouth Rd., Forest Hill, S.E.23  
**5DV** D. Whittaker, 56, Park Rd., St. Annes-on-Sea  
**5DY** Chelmsford Radio Engineering Co., Ramsford End, Chelmsford  
**5DZ** Devises  
**5FA** F. L. Devereux, 11, Clifton Villas, Maida Vale, W.9  
**5FF** H. Anson, 13, Nottingham Place, Marylebone, W.1  
**5FH** L. H. Lee, 155, Rosefield Rd., Snaithwick, Staffs  
**5FI** H. D. Webb, 59, Bradford St., Walsall  
**5FL** T. W. Pevensey, Lewisham, S.E.  
**5FM** R. Stone, 30, Bushy Hill Rd., Camberwell, S.E.  
**5FR** J. L. Jeffrey, 191, St James' Rd., Croydon  
**5FS** W. A. Andrews, B.Sc., 1, Baimoral Mansions, St. Andrew's Park, Bristol  
**5FU** University Coll., Nottingham  
**5FW** S. I. Holt, 21, Bromley Rd., St. Annes-on-Sea  
**5FZ** Lincoln Wireless Soc., Sec., J. T. James, 126, West Parade, Lincoln  
**5GB** L. Humphries, 61, Geraint St., Prince's Park, Liverpool  
**5GF** H. Stophar, 14, Johnston Ter., Cricklewood, N.W.2  
**5GI** R. Horrocks, 65, Leander Rd., Thornton Heath  
**5GJ** James Bevis, 4, Somerset Rd., Linford Estate, Mucking Ford, nr. Stanford-le-Hope  
**5GL** N. G. Baguley (Hon. Sec.), Newark and District Wireless Soc., The Park, Newark  
**5GP** J. E. Simpson, Baskerville, Epsom Rd., Guildford  
**5GQ** F. W. Nightingale, Pickford Schools, Northampton  
**5GT** E. S. Dobson, Lorne House, Ilkley, Yorks  
**5GX** P. D. Tyres, 30, Mildred Av., Watford  
**5GY** C. Horwood, 557, Lordship Lane, E. Dulwich, S.E.22  
**5HA** R. Watson, 35, Fairview Rd., Oxtou, Birkenhead  
**5HC** J. A. Beveridge, Dunelm, 8, Cluny Drive, Edinburgh  
**5HD** Henry St. John Ward, N.E. Coast W. Co., Ltd., 1, Crowtree Rd., Sunderland  
**5HI** L. W. Birch, 30, Limesford Rd., Waverley Park, S.E.15  
**5HJ** F. A. Sleath, 31, Archery Rd., Leamington Spa  
**5HL** G. W. Vowles, St. Leonards, Hooley St., Sherwood, Nottingham  
**5HP** Cunningham, Ltd., 169, Edgware Rd., W.2  
**5HQ** E. A. Pollard, Spring Bank, Limefield, Blackburn  
**5HW** National Physical Laboratory, Teddington  
**5HX** C. H. Gardner, Electrical Disposal Syndicate, 6, Market Place, Oxford Circus, W.1  
**5HY** Baynham Honri, Cromwell Hall, E. Finchley, N.2  
**5HZ** C. A. Carpenter, 10, Crossley St., Sherwood Nottingham  
**5IB** L. H. & L. W. Corder, 5, Dee-side Parade, W. Kirby, Birkenhead  
**5IC** F. E. Harvey, Fairmead, Sunset Av., Woodford Green  
**5ID** P. D. Coates, 55, Ennismore St., Burnley  
**5IF** H. Featherstone, 3, Cumberland Gardens, Tunbridge Wells

# The **AUTHORITATIVE** **Wireless Magazine**

**E**VERYONE who is interested in "Wireless" from a more scientific point of view than the average "listener-in" should read WIRELESS REVIEW. This fine weekly magazine is an invaluable guide to every new radio development. Accurate, reliable, and absolutely authoritative, it deals fully with the technical side of wireless work—both theoretical and practical—giving explanatory articles by the leading experts only, and being exceptionally well illustrated by photographs and diagrams. Sir Oliver Lodge, F.R.S., D.Sc., acts as Scientific Adviser-in-Chief, and the editorial board includes many of the most notable personalities in the world of wireless.

# **Wireless Review**

**AND SCIENCE WEEKLY.**

Every **3<sup>D.</sup>** Tuesday.



**SAGAMAN.**—One of the most primitive of all story-tellers, the Sagaman delighted our Viking ancestors with his tales of prowess and adventure.



**JONGLEUR.**—In the Age of Chivalry, the Jongleur wandered from Castle to Castle, telling the Ladies in their bowers and the Knights at their feasting, marvellous tales of bravery, love and romance.



**SCHEHERAZADE.**—The famous Queen of Arabia who prolonged her life from night to night by telling the wonderful tales of the *Arabian Nights*.



**TOLSTOY.**—The great Russian reformer, idealist and novelist, famous for his fearless courage and sincerity.



**DICKENS.**—The immortal novelist of London life, creator of Mr. Pickwick, Little Nell, Oliver Twist, Mrs. Gamp, Mr. Micawber.

# “Tell me a Story” —

The Cry of Humanity throughout the Ages.

FROM the child devouring fairy tales to the business man who relaxes at home over a book, stories throughout our lives are the magic carpet that carries us away to Adventure and Romance. The art of the Story-Teller annihilates the centuries, and gives you not the dry bones of historical fact, but men and women in their habit as they lived. It brings you the knowledge of strange lands, vivid emotions, great deeds.

If you live in the Country, it keeps you in touch with the wider kingdom of thought and imagination. If you are a Town worker, it lifts you clear of the monotony of your daily occupation, and transports you into a world thrilling with passion and drama.

beautiful with the visions of the lover and the artist. And here is your opportunity to get the world's greatest Story-Tellers to practise their art for you; to tell you in your own home the tales that have made them immortal. Write to-day for particulars of

## The Masterpiece Library of Short Stories.

20 magnificent volumes containing 1,000 best short stories of all nations and centuries, selected by a Board of the most eminent critics and writers of the day.

Read in them the marvellous tales of love and intrigue told 4,000 years ago in the sacred walled cities of China, and in the palaces of the Egyptian Pharaohs. Read the dark stories of medieval Italy, stories of poison and murder and feud; real original contemporary documents which no Grand Guignol thrill can rival. Read the splendid stories of old Scandinavia of Spain and Portugal, and the gorgeous Courts of France. Read the work of Victor Hugo de Maupassant, Pierre Loti, Flaubert, Tolstoy, Turgeneff, Dostoyevsky Maeterlinck, Jokai, d'Annunzio. Read the 3 volumes of American stories, by such writers as Mark Twain, Thomas A. Burke,

O. Henry, Jack London, Irvin S. Cobb. Read the stories of Ireland and Scotland; stories by Hardy H. G. Wells, Galsworthy, Zangwill Anthony Hope, John Buchan, W. W. Jacobs, Boyd Cable, Stephen McKenna, Alec Waugh and the most brilliant short-story writers of Canada, Australasia, and South Africa.

This collection is a library indeed. All the best is here. The best stories by the best authors in the world, and enough to last you a lifetime. If you were to read a different story every day, it would take you nearly 3 years to finish these 20 volumes—and then you would want to begin all over again.

### Write for the FREE BOOKLET

*Do not miss the chance of acquiring this incomparable Library for your very own. It will repay you its cost again and again in the absorbing interest of the hundreds of stories it tells.*

*Send a postcard now, mentioning "Harmsworth's Wireless Encyclopedia" to the Educational Book Company, Ltd., 17, New Bridge Street, London, E.C. 4, for the Free Art Booklet, which gives you full details of the finest collection of stories the world has ever known.*

SOUTH AFRICAN readers should apply to Central News Agency, Ltd., P.O. Box 1033, Johannesburg, and AUSTRALIAN readers to Gordon & Gotch (Australasia), Ltd.

Printed and Published every alternate Tuesday by the Proprietors, The Amalgamated Press (1922), Ltd., The Fleetway House, Farringdon Street, London, E.C.4. Sole Agents for South Africa: Central News Agency, Ltd.; for Australasia: Messrs. Gordon & Gotch, Ltd.; and for Canada: The Imperial News Co. (Canada), Ltd. Subscription Rates: Inland and Abroad, 1s. 5d. per copy. December 18th, 1923.