

THE WIRELESS ENGINEER

VOL. XVIII.

SEPTEMBER, 1941

No. 216

The Dimensions of Physical Quantities

AFTER the exhaustive treatment of this subject in Lanchester's "Theory of Dimensions" in 1936 and in O'Rahilly's "Electromagnetics" in 1938, it was not surprising that it should be given a rest. It is a subject, however, that can never rest long, and in the current number of the Proceedings of the Physical Society (Vol. 53, p. 418 and p. 432) two papers are published, one entitled "A New Treatment of the Theory of Dimensions" by Dr. Burniston Brown and the other "The Dimensions of Physical Quantities" by Dr. W. E. Duncanson. Dr. Brown maintains that there are only two direct measurements, viz., those of length and time, and these are obtained by pointer readings and counting. As for the rest, "mass is a coefficient invented by Newton, force is a hypothetical cause of change, and potential is a pure Western-European myth. None of them could, therefore, be measured directly." Even the measurements of length and time are not independent since the first involves the second, due to the time taken for light to travel the length of the scale. Dr. Brown objects, however, to "the velocity of light" on the grounds that "nothing observable has ever been shown to travel at all"; he calls c the "constant of interaction." We cannot say that we are impressed by the argument, but so long as one remembers that his constant of interaction is "the velocity of light" no harm is done, especially as he admits that $c = 3 \times 10^{10}$ cm per second.

Since time and length are the only two possible direct measurements, Dr. Brown maintains that the dimensions of any

physical quantity should be expressed in terms of T and L , or, since $L = cT$, in terms of c and T . By putting force = $\frac{M^2}{L^2}$, i.e.

assuming the gravitational constant to be dimensionless, in addition to the usual formula, force = ML/T^2 , we find that $M = L^3/T^2$ and by substituting this for M in all the usual dimensional formulae, they are obtained in terms of L and T alone. This is not a new idea; as Dr. Brown states, Maxwell mentioned the possibility of doing it, but did not seem to favour it; Kelvin also discussed it and especially the striking result that the dimensions of force are L^4/T^4 , i.e. the fourth power of linear velocity. Dr. Brown apparently regards the standard of length as being dimensionless, for he says, "The length of an object in *exact* science is not something given directly in consciousness. It is a number obtained by a conventional process called measurement. Now the standard is not got by measurement but by *definition*, and so it is correctly represented dimensionally solely by unity. The length of a rod measured by it is, say, $10.L$. On forming the ratio we have, therefore, that the ratio of the length of the rod to that of the standard is $10.L$." Surely science can be exact without necessitating such queer arguments; its exactness will not suffer by regarding the standard of length as having the dimensions of a length. The process of measuring merely determines the numerical ratio between two lengths, one of which is the standard.

When he considers electric and magnetic quantities Dr. Brown simply regards both

κ and μ as dimensionless constants. He emphasises that "they are what we define them to be, and not in some mysterious way indicative of the 'physical nature' of electricity and magnetism." He thus obtains for each quantity two different dimensional formulae, one for the electrostatic system and the other for the electromagnetic system. This does not worry his *exact* scientist who sees in the dimensions nothing beyond the pointer readings involved in the measurement but it does worry those who see in the dimensions the fundamental constituents, as it were, of the quantity, apart from details of its measurement or the system of units adopted.

In a section headed "a dark-room experiment," he points out that one could determine the ratio of the capacitance of a condenser on the e.s. and e.m. systems in a dark room, reading the galvanometer by touch, and using a metronome as a clock. "After a period of practice, the observer produces the result $(3 \times 10^{10} \text{ cm/sec})^2$. . . as all light has been carefully excluded, and as no measurement of any velocity of any radiation has been made, it would require considerable temerity to assert that what has been measured is the velocity of light." As an alternative we would suggest the determination of the density ρ of air and its adiabatic elasticity E in dead silence in a sound-proof room, and the calculation of $\sqrt{E/\rho}$. After a period of practice, which, as he would not be working in the dark, need not be so very long, the observer would produce the result 34,000 cm/sec. Although all sound had been excluded and no measurement of a velocity had been made, it would surely not require much temerity to suggest that what had been determined was the velocity of sound.

The paper by Dr. Duncanson is a wider review of the subject from the more generally accepted point of view. He takes L , M and T as the indefinables for the mechanical properties but says that when we turn to other branches of physics it may be necessary or desirable to introduce further indefinables, but, on the other hand, with increasing knowledge it may be possible to reduce the number of indefinables, and he expresses the hope that ultimately only one indefinable will be necessary. He emphasises the close relationship between the dimensions and the definition of a quantity. "If there is any

doubt concerning the dimensions of a quantity this means, not that there is some hidden mystery as to the complete nature of that quantity, but merely that the quantity concerned has not been unambiguously defined." Dr. Duncanson gives reasons for taking Q as the fourth indefinable in electromagnetic quantities. He points out that those who claim that κ and μ have no dimensions do not really treat them as dimensionless quantities but as indefinables. Rucker pointed out fifty years ago that

putting $\kappa = 1$ in the equation $f = \frac{q_1 q_2}{\kappa r^2}$

did not do away with its dimensions, although it made it easy to forget them. Dr. Duncanson also considers the expression of the dimensions of mechanical and thermodynamical quantities in terms of L and T only, but unlike his colleague he retains Q in the electromagnetic quantities.

We recommend a careful study of these two papers to all those who are interested in this subject.

G. W. O. H.

Ferrocart

IN April, 1933, we published an article by Alfred Schneider describing the manufacture of a type of finely divided ferromagnetic core due to Hans Vogt in which the fine rod-shaped particles were mixed with a liquid and applied to a thin paper strip which then passed through a coil producing a magnetic field of sufficient strength to align the particles during the drying process. The core was then built up of these paper strips. At the time, the author, a manufacturer in Berlin, sent us a sample core, a solid-looking structure which we put away in a cardboard box. On recently opening the box for the first time since 1933 we were surprised to find that the core had completely disintegrated into a loose heap of paper and what appears to be rust. During the whole eight years the core had been in a cupboard in a dry laboratory. Our object in writing this note is to discover if any of our readers have coils with "Ferrocart" cores, the inductances of which were accurately measured when new, in which case it would be very interesting if the inductances could be redetermined and compared with the original values.

G. W. O. H.

D.C. Amplified A.V.C. Circuit Time Constants*

By K. R. Sturley, Ph.D., A.M.I.E.E., and F. Duerden, B.Sc.

(Marconi School of Wireless Communication)

SUMMARY

A theoretical examination of a D.C. amplified A.V.C. system with filter circuits in the grid and cathode of a valve showed that the overall time constant is very nearly equal to the sum of the time constants of the two circuits when the two time constants are widely different, i.e.

$$T = R_g C_g + \frac{R_k R'_a}{R_k + R'_a} C_k$$

where the suffixes g , k and a refer to grid, cathode and anode circuits respectively, and R'_a is the sum of the valve slope resistance and any external anode circuit resistance (a valve used for audio-frequency as well as D.C. amplification may have an anode load resistance). The actual time constant has greatest departure (+ 7 per cent.) from the formula given above when grid and cathode time constants are equal.

Experimental investigation with a triode and pentode D.C. amplifier indicated that errors occur in practice due to variations of the valve slope resistance R_a and amplification factor over the working range. A more correct expression for overall time constant is

$$T = KR_g C_g + \frac{R_k R'_a}{R_k + R'_a} C_k$$

where K is a correction factor dependent on the variation of μ and R_a in R'_a the average value of valve slope resistance over the operating range; methods of calculating K (it is less than 1 for discharge and greater than 1 for charge) and R_a are given.

IN a previous paper† one of the authors investigated the time constants of non-amplified A.V.C. filter circuits, but the examination was not extended to cover D.C. amplified A.V.C. circuits, in which the filter circuits are separated by a valve. It has been stated elsewhere‡ that the total time constant of two R.C. circuits separated by a valve is the sum of the time constants of each circuit. A theoretical investigation and experimental check by the authors showed, however, that the above statement needed modification.

Theory

A typical circuit for a D.C. amplified A.V.C. system is shown in Fig. 1a. The filter, $R_g C_g$, in the grid circuit prevents the R.F. ripple voltage across the detector load resistance being applied to the grid of the combined D.C. and A.F. amplifier valve V_1 . In the theory which follows the terms

“charge” and “discharge” imply rising and falling cathode voltage respectively and it is important to note that charge of the cathode circuit means decreasing negative voltage in the grid circuit, i.e. it is discharge for the grid circuit. For the cathode charge condition it is assumed that C_g and C_1 are both initially at a voltage $(-E_1)$, determined by the D.C. component of the R.F. carrier voltage applied to the A.V.C. detector and that owing to fading of the R.F. carrier the voltage across R_1 falls eventually to $-E_2$. During this time the A.V.C. diode is non-conducting and the equation for the voltage across C_g is

$$E_g = -E_1 + (E_1 - E_2)(1 - e^{-\frac{t}{\alpha}})$$

where $\alpha = C_g(R_g + R_1) + C_1 R_1$

(see reference 1 below)

= the time constant of the grid circuit.

The change of grid voltage across C_g is therefore

$$\Delta E_g = (E_1 - E_2)(1 - e^{-\frac{t}{\alpha}})$$

and the circuit of Fig. 1a can now be replaced by a generator of open circuit voltage

$$-\mu \Delta E_g = E(1 - e^{-\frac{t}{\alpha}}), \text{ where } E = \mu(E_2 - E_1)$$

* MS. accepted by the Editor, April, 1941.

† Time constants for A.V.C. Filter Circuits. K. R. Sturley, *Wireless Engineer*, Sept. 1938.

‡ Time delay in Resistance Capacity Circuits. E. W. Kellogg and W. D. Phelps, *Electronics*, Feb. 1937.

with an internal resistance of $R'_a = R_a + R_o$ supplying a load consisting of the cathode resistance R_k and capacitance C_k in parallel, as shown in Fig. 1b.

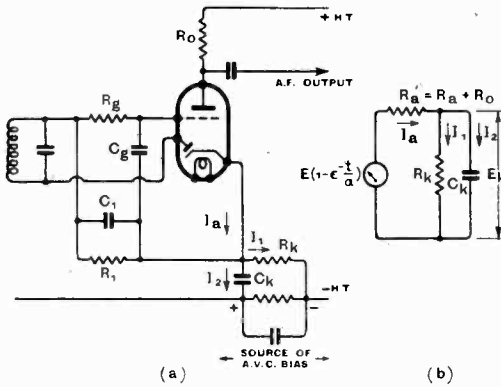

Fig. 1.—(a) Typical D.C. amplified A.V.C. circuit. (b) Equivalent circuit for (a).

R_o is the audio-frequency load resistance when the valve is used for A.F. as well as D.C. amplification purposes. The current and voltage equations for Fig. 1b are as follows:

$$I_a = I_1 + I_2 \quad \dots \quad (1)$$

$$I_1 R_k = \frac{\int I_2 dt}{C_k} \quad \dots \quad (2)$$

$$E(1 - \epsilon^{-t/\alpha}) = I_a R'_a + \frac{\int I_2 dt}{C_k} \quad \dots \quad (3)$$

Combining these two equations

$$E(1 - \epsilon^{-t/\alpha}) = \left[\frac{\int I_2 dt}{R_k C_k} + I_2 \right] R'_a + \frac{\int I_2 dt}{C_k} \quad \dots \quad (4)$$

$$\begin{aligned} &= \left[\frac{q_2}{R_k C_k} + \frac{dq_2}{dt} \right] R'_a + \frac{q_2}{C_k} \\ &= q_2 \left[\frac{R'_a + R_k}{R_k C_k} + D R'_a \right] \end{aligned} \quad \dots \quad (5)$$

where $q_2 = \int I_2 dt$

and $D = \frac{d}{dt}$

Multiplying 5 by $\frac{R_k C_k}{R'_a + R_k}$

$$\frac{E R_k C_k}{R'_a + R_k} (1 - \epsilon^{-t/\alpha}) = \left[1 + \frac{R'_a R_k}{R'_a + R_k} \cdot C_k D \right] q_2 \quad \dots \quad (6)$$

Replacing $\frac{E R_k}{R'_a + R_k}$ by E' and $\frac{R'_a R_k}{R'_a + R_k}$ by R , equation 6 becomes

$$E' C_k (1 - \epsilon^{-t/\alpha}) = (1 + R C_k) q_2 \quad \dots \quad (7)$$

The solution to 7 is

$$\begin{aligned} q_2 &= E' C_k \left[1 - \left(\frac{\epsilon^{-t/\alpha}}{1 - \frac{RC_k}{\alpha}} + \frac{\epsilon^{-t/RC_k}}{1 - \frac{\alpha}{RC_k}} \right) \right] \\ &= E_k C_k \end{aligned}$$

∴ the voltage across the capacitor C_k is given by

$$E_k = E' \left[1 - \left(\frac{\epsilon^{-t/\alpha}}{1 - \frac{\beta}{\alpha}} + \frac{\epsilon^{-t/\beta}}{1 - \frac{\alpha}{\beta}} \right) \right] \quad (8)$$

where $\beta = R C_k$

To determine the time constant of the circuit it is necessary to find the value of t which makes $E_k = E'(1 - \epsilon^{-1})$

$$\text{i.e. } \frac{\epsilon^{-T/\alpha}}{1 - \frac{\beta}{\alpha}} + \frac{\epsilon^{-T/\beta}}{1 - \frac{\alpha}{\beta}} = \epsilon^{-1} \quad \dots \quad (9)$$

where T = time constant of the circuit.

Replacing $\frac{\alpha}{\beta}$ by n and $\frac{T}{\beta}$ by λ , 9 may be rewritten as

$$n \epsilon^{\frac{1-\lambda}{n}} - \epsilon^{1-\lambda} = n - 1 \quad \dots \quad (10)$$

If the time constant of the complete circuit were given by the sum of the separate time constants, T would equal $\alpha + \beta$ and the relation between λ and n would be

$$\lambda = n + 1$$

It is therefore necessary to investigate the graph of λ against n from expression 10 to find how far it differs from the straight line $\lambda = n + 1$. A method of solving equation 10, developed by S. Millington (Marconi Research Department), gives the relationship between λ and n shown in Fig. 2. The curve at first diverges from the straight line $\lambda = n + 1$, the maximum divergence occurring between $n = 1$ and $n = 2$, but after $n = 2$ it approaches the straight line.

Another way of expressing the result is to plot $\frac{\lambda}{1+n}$, i.e. $\frac{T}{\alpha + \beta}$ against n and this has the advantage of indicating the ratio error

between the actual time constant and the sum of the two time constants ($\alpha + \beta$).

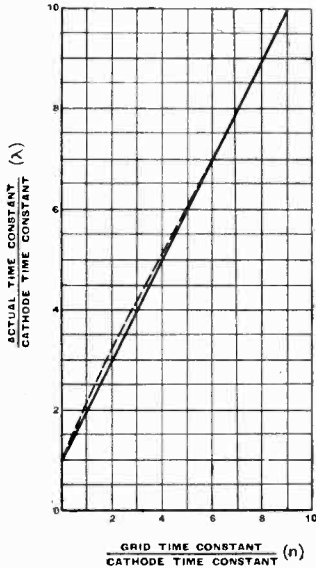

Fig. 2.—Ratio actual/cathode time constant for different values of grid/cathode time constant.

This is plotted in Fig. 3 and three important points arise from the curve :

(1) The error is always positive, i.e. the time constant is greater than $\alpha + \beta$, though when $\alpha \gg \beta$, or vice versa the error is very small.

(2) Maximum error (+ 7 per cent.) occurs at $n = 1$.

(3) The error for a particular value (n_1) of n is the same as for its reciprocal $\frac{1}{n_1}$. This may be proved from equation 10 by replacing λ by $K(n_1 + 1)$ where K is the correction ratio.

Thus for $n = n_1$ equation 10 becomes

$$n_1 \epsilon^{1 - \frac{K(n_1 + 1)}{n_1}} - \epsilon^{1 - K(n_1 + 1)} = n_1 - 1 \quad (IIa)$$

whilst for $n = \frac{1}{n_1}$, $\lambda = K(\frac{1}{n_1} + 1)$ and equation 10 is

$$\frac{1}{n_1} \epsilon^{1 - K(\frac{1}{n_1} + 1)n_1} - \epsilon^{1 - K(\frac{1}{n_1} + 1)} = \frac{1}{n_1} - 1$$

$$\epsilon^{1 - K(n_1 + 1)} - n_1 \epsilon^{1 - \frac{K(n_1 + 1)}{n_1}} = 1 - n_1 \quad (IIb)$$

which is identical with IIa.

When $\alpha = \beta$, ($n = 1$) equation 10 fails and must be replaced by

$$\epsilon^{-1} = \left(1 + \frac{1}{\alpha}\right) \epsilon^{-\frac{1}{\alpha}}$$

An equation similar in form to (8) is obtained by taking the discharge condition and then

$$E_k = E' \left[\frac{\epsilon^{-\frac{1}{\alpha}}}{1 - \frac{\beta}{\alpha}} + \frac{\epsilon^{-\frac{1}{\beta}}}{1 - \frac{\alpha}{\beta}} \right] \dots \dots (12)$$

In the above analysis an ideal valve having constant values of μ and R_a has been considered and the error in assuming the overall time constant to be the sum of the separate time constants of the grid and cathode (including the valve resistance) circuits is shown to be small when the two time constants are far from equal and is + 7 per cent. (the maximum) when the two are equal. An experimental check was next undertaken and the method of procedure and results are given below.

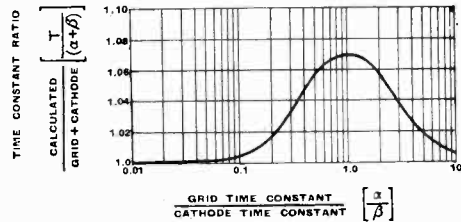

Fig. 3.—Ratio calculated/grid + cathode time constant for different ratios of grid/cathode time constant.

Experimental Check

The method employed was a visual one by means of a cathode ray tube and a diagram of connections is shown in Fig. 4. A curve of anode current against cathode voltage was traced and the control electrode of the cathode ray tube was modulated at 50 c/s, so that the spot was extinguished at regular time intervals giving a series of dots spaced at 1/50 second. The A.C. load resistance R_0 in Fig. 1a was omitted since as far as the cathode circuit was concerned it could be considered as included in the valve resistance. By its omission the curve traced out was an $I_a E_a$ locus line of operation and the general performance could therefore easily be checked with reference to the

"static" valve curves. It was not, of course, necessary for the time constant measurement to have vertical anode current deflection since the dotted horizontal cathode voltage line gave all the required data for time constant measurement. Valuable information on the behaviour of the circuit was,

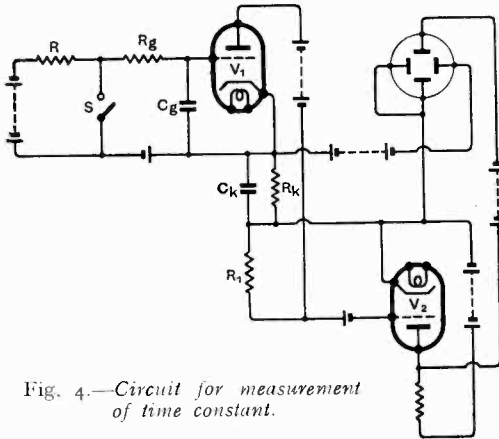

Fig. 4.—Circuit for measurement of time constant.

however, obtained by employing anode current deflection. A resistance R_1 (1,000 ohms) was used to develop the anode current deflecting voltage, which was amplified by the D.C. amplifier valve V_2 before applying to the vertical deflection plates of the cathode-ray tube. Exponential charge and discharge grid voltages were produced by opening and closing switch S . Resistance R' prevented shorting of the battery but had little effect on the grid circuit time constant being never $> R_g/100$. Photographs of the trace were taken, and, after enlarging, the time constant was measured by counting the number of dots in 63 per cent. of the horizontal (cathode voltage) length of the trace from the starting point of charge or discharge.

Preliminary tests using an RC circuit

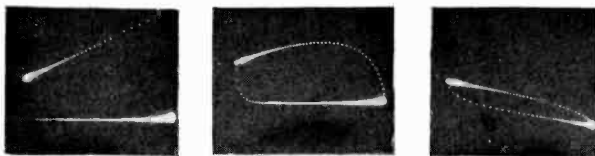

Fig. 5.—Photographs of traces on the cathode-ray tube screen for a triode valve. (a) $R_g C_g = 0$; (b) $R_g C_g < R C_k$; (c) $R_g C_g \approx R C_k$.

without a valve confirmed the accuracy of the method.

Two separate tests were performed (for different values of α/β and grid voltage charge and discharge limits) the first with a triode (MHD₄) and the second with a pentode (MSP₄) as the D.C. amplifier valve V_1 . The total time constant had to be kept within 0.2 and 0.8 seconds to obtain satisfactory photographs with well-defined dots.

Results

I. Triode D.C. Amplifier

Preliminary experiments were made with a grid circuit of zero time constant, an H.T. voltage of 230 and a grid voltage variation of -0.5 to -3 volts for different values of cathode resistance and capacitance. For a

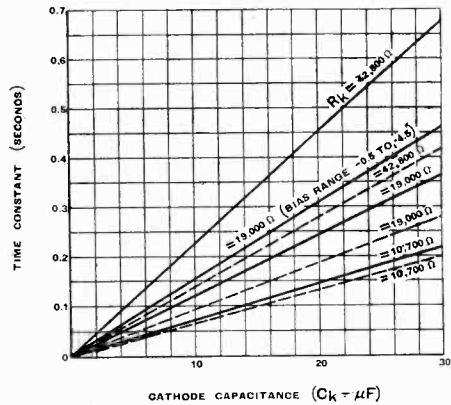

Fig. 6.—Time constant/cathode capacitance curves for a triode valve. Full line—discharge, broken line—charge. H.T. = 230 volts; bias voltage limits -0.5 to -3 (except where stated otherwise); $R_g = 0$; $C_g = 0$.

cathode resistance of 19,000 Ω , a grid voltage range of -0.5 to -4.5 was also taken. A photograph of a typical trace is shown in Fig. 5a. The measured time constant is plotted in Fig. 6 against cathode capacitance for different values of R_k . As was to be expected the relationship between T and C_k is linear and the equivalent value of the valve resistance may be calculated from

$$T = \frac{R'_a R_k}{R'_a + R_k} C_k \dots \dots (13)$$

The values of R'_a for the different conditions are tabulated below.

R_k		R'_a (calculated from Fig. 6)	R'_a measured from the chord to the $I_a E_a$ curve.
42,800Ω	Discharge ..	48,200Ω	65,000Ω
42,800Ω	Charge ..	20,800Ω	21,000Ω
19,000Ω	Discharge (-0.5 to -4.5 volts) ..	65,500Ω	122,000Ω
19,000Ω	Discharge (-0.5 to -3 volts) ..	33,800Ω	40,900Ω
19,000Ω	Charge ..	19,600Ω	19,500Ω
10,700Ω	Discharge ..	23,600Ω	31,200Ω
10,700Ω	Charge ..	17,800Ω	17,800Ω

The cycle of operations can be more readily followed by reference to the $I_a E_a$ curves of the test valve, which are drawn out in Fig. 7 for the three grid bias voltages of -0.5, -3 and -4.5 volts. The load line corresponding to $R_k = 42,800\Omega$ is represented by AB , drawn from an H.T. voltage of 230 volts; thus for a grid bias of -3.0 volts the point C gives the current through R_k . If the bias is suddenly changed from -3 to -0.5 (this is the cathode charge condition for no grid time constant) the anode current rises vertically and instantaneously to point D and then falls back exponentially with regard to time along the bias line $E_g = -0.5$ volts coming to rest at point F , the intersection of AB and the bias line. The locus CDF is the charge line, and the voltage across the capacitor C_k has risen from AH to AJ .

For discharge (E_g is reduced again to -3 volts) the current changes instantaneously to G , and then gradually rises to its starting point C . Since the change from C to D and F to G is instantaneous, only D to F and G to C are visible on the trace in Fig. 5a.

It is clear from Fig. 7 that the charge time is very much faster than the discharge, for the resistance of the valve at -0.5 volts bias is much less than at -3 volts. The charge locus occurs over a part of the $I_a E_a$ curve which is almost straight, so it is to be expected that the valve resistance R_a measured from the slope of this line FD would be very close to that calculated from the time constant. The value of R_a so measured is tabulated above and is very

close to that calculated. For discharge the locus line is curved and the equivalent value of R_a is difficult to assess. In the table above the measured value of R_a is calculated from the slope of chord GC and agreement is not very good, the measured value being greater than the calculated.

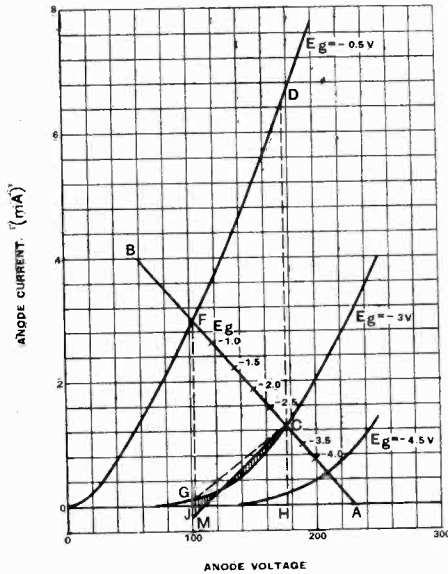

Fig. 7.— $I_a E_a$ curves and cathode resistance load line for $R_k = 42,800\Omega$, H.T. = 230 volts.

The discrepancy is still more marked as the curvature of the locus line is increased as for $E_g = -4.5$ volts. The discharging effect of the current between the chord and the curved bias line must of necessity decrease the time constant and a better approximation to the equivalent valve resistance would be obtained by measuring the slope of a line CM drawn to intersect the bias line GC such that the two shaded areas are equal. The slope of the line CM , drawn approximately to fulfil this condition on Fig. 7 for $R_k = 42,800\Omega$ gives $R_a = 51,000\Omega$ a value quite close to that calculated from Fig. 6 (see the first line of the above table).

The effect of including a grid circuit time constant is shown in photos 5b and 5c. The latter has the larger grid time constant. The grid circuit time constant prevents the instantaneous change of anode current from C and D and causes the locus line to be continuously curved. In the limit when the cathode time constant is zero, the locus lines

for charge and discharge are coincident in CF though, owing to the variation in valve amplification factor (μ), the time constant for discharge will always be faster than charge. This is due to the fact that at C , from which point charge begins, μ is least, whereas at F , the beginning of discharge, it is greatest, i.e., E_g varies exponentially but owing to its non-linear relationship to E_a , the voltage across the cathode resistance R_k does not vary exponentially. For the particular valve taken the ratio of charge to discharge time constant for $R_k = 42,800\Omega$ and a grid bias variation of -0.5 to -3 was constant at 1.18 for all values of $R_g C_g$. The ratio was increased to 1.42 for a bias variation of -0.5 to -4.5 volts.

The effect on the time constant of variation of μ may be calculated for charge and discharge by plotting a curve of cathode voltage against grid bias voltage. Such a curve obtained from the $I_a E_a$ curves of Fig. 7 is shown in Fig. 8 for $R_k = 42,800\Omega$; the cathode voltage values are given by the difference between the H.T. voltage and the

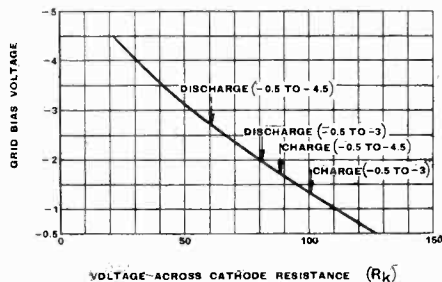

Fig. 8.—Cathode voltage|grid bias curve for triode valve. $C_k = 0$; $R_k = 42,800\Omega$; H.T. = 230 volts.

intercepts of AB with the appropriate bias lines in Fig. 7. For a bias change of -0.5 to -3 , the cathode voltage change E_k is 128 to $53.5 = 74.5$ volts. The increase in E_k for charge is $74.5 \times 0.632 = 47.1$ volts and the time constant value is therefore $53.5 + 47.1 = 100.6$ volts, which corresponds to a grid voltage of -1.35 volts. The initial grid voltage is -3 volts so that the change is $3 - 1.35 = 1.65$ volts; the maximum change is $3 - 0.5 = 2.5$ volts and hence the ratio of grid bias change giving the time constant cathode condition is $\frac{1.65}{2.5} = 0.66$. Referring this to the ex-

ponential charge curve 1 in Fig. 9, the time constant is seen to be $1.08 R_g C_g$. Similarly for discharge the cathode voltage falls from

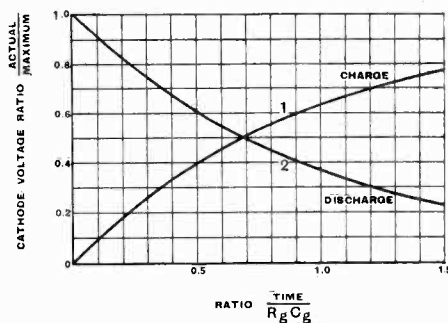

Fig. 9.—Charge and discharge curves for an R.C. circuit.

128 volts by 47.1 volts, corresponding to a grid voltage of -2 volts. The ratio is therefore $\frac{1}{2.5} = 0.4$ and from the exponential discharge curve 2 (Fig. 9) the discharge time constant is $0.92 R_g C_g$. The ratio of charge to discharge time constant is 1.175, a value comparing favourably with that (1.18) obtained by measurement. A similar process gives the ratio as $\frac{1.15}{0.8} = 1.44$ for a bias change from -0.5 to -4.5 volts and this is in good agreement with the measured value of 1.42.

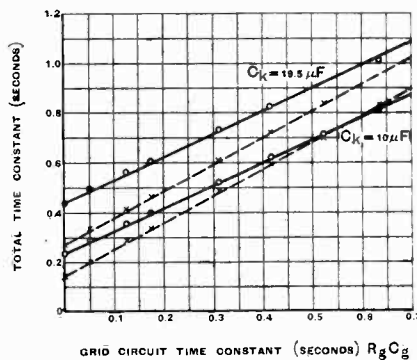

Fig. 10.—Time constant curves for a triode valve for different values of $R_g C_g$. Full line—discharge, broken line—charge. H.T. = 230 volts, $R_k = 42,800\Omega$, bias voltage limits -0.5 to -3 volts.

Tests were next made with different values of $R_g C_g$ for $R_k = 42,800\Omega$ and two values of C_k , 10 and $19.5\mu F$, over a bias range of

- 0.5 to - 3 volts and the results are given in Fig. 10. The straight lines on this figure are drawn from the measured time constant point for $R_g C_g = 0$ and are corrected for the variation in μ over the bias range. Thus for the charge condition the increment in total time constant is $1.08 R_g C_g$ whilst for discharge it is $0.92 R_g C_g$. The measured points are indicated with respect to each of these lines and in every case they are quite close to the straight lines, thus indicating that the total time constant is very nearly equal to the sum of the cathode circuit

region of high R_g and the time constant of the cathode circuit tends to rise as $R_g C_g$ is increased.

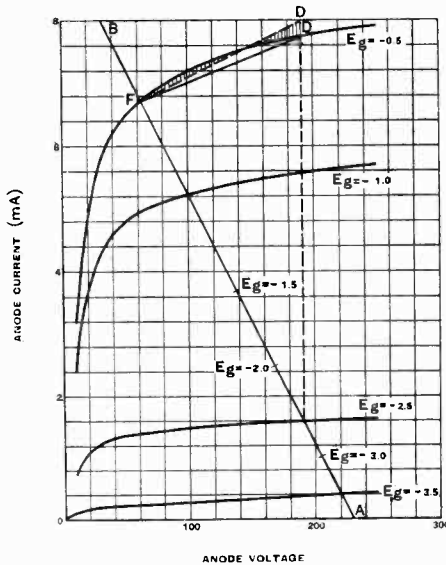

Fig. 11.—Pentode $I_a E_a$ curves and cathode resistance load line. $R_k = 25,000 \Omega$; $H.T. = 230$ volts.

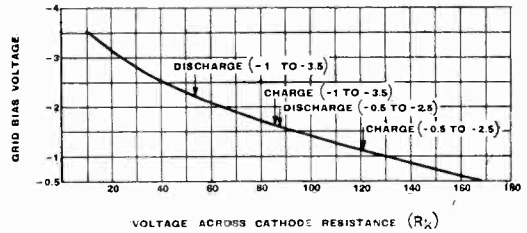

Fig. 12.—Cathode voltage/grid bias curve for a pentode valve. $C_k = 0$; $R_k = 25,000 \Omega$; $H.T. = 230$ volts.

2. Pentode D.C. Amplifier

The $I_a E_a$ characteristics of the pentode valve used in this experiment are shown in Fig. 11. The screen voltage was maintained at 100 volts and the cathode resistance and capacitance at 25,000 ohms and 10 μF respectively throughout the tests, which were carried out for various values of grid circuit time constants over two grid bias voltage ranges, - 0.5 to - 2.5 and - 1 to - 3.5 volts. The value of 25,000 Ω for R_k gave approximately the maximum cathode voltage for $E_g = - 0.5$ volts without entering the low R_a part of the $I_a E_a$ characteristic.

A curve of cathode voltage against grid bias voltage taken from the load line AB in Fig. 11, is shown in Fig. 12 and by following the same procedure as for the triode, the effect of the variation of μ on the grid circuit time constant is found to be

Bias Voltage Range	Charge	Discharge
- 0.5 to - 2.5	1.2	0.8
- 1 to - 3.5	1.42	0.65

Three photographs of typical traces for

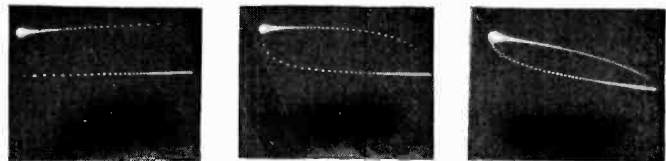

Fig. 13.—Photographs of traces on the cathode-ray tube screen for a pentode valve. (a) $R_g C_g = 0$; (b) $R_g C_g < RC_k$; (c) $R_g C_g \approx RC_k$.

time constant and the grid circuit time constant multiplied by a factor compensating for the change of μ . A point to be noted is that the contribution by the cathode circuit to the total time constant changes as $R_g C_g$ increases because the effective value of R'_a in Eq. 13 depends on the operating locus. The effect should be most pronounced for discharge for the locus line approaches CF (Fig. 7), leaving the curved region of high R_a . Hence R_a decreases and so also does the discharge time constant of the cathode circuit. For charge the locus line leaves the

$R_g C_g = 0$, an intermediate value and a value comparable with RC_k are given in Figs. 13a, b and c and it is clear that the mode of operation is similar to that for the triode.

Results of time constant measurement for the two grid bias ranges and different values of $R_g C_g$ are plotted in Fig. 14. The straight lines are drawn (as in Fig. 10) from the measured value of cathode time constant with $R_g C_g = 0$ and have a slope equal to the μ correction factor given above. The

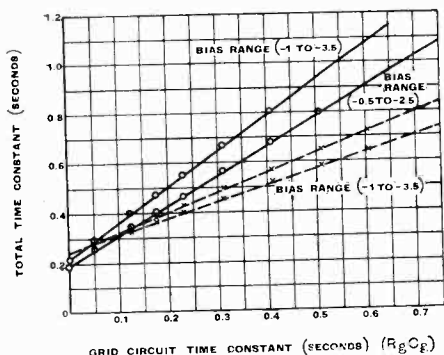

Fig. 14.—Time constant curves for a pentode valve for different values of $R_g C_g$. Full line—discharge, broken line—charge. H.T. = 230 volts; $R_k = 25,000 \Omega$; $C = 10 \mu F$.

measured points are indicated and the agreement between them and the lines is good, thus justifying the use of the correction factor:

The measured value of cathode circuit time constant for $R_g C_g = 0$ allows the equivalent valve resistance to be calculated and this is tabulated below together with

and this is due to the curvature of the $I_a E_a$ characteristic at -0.5 volts. A value nearer to the measured value of R_a could be obtained by measuring the slope of a line FD' drawn from F to cut the characteristic so that the two shaded areas are equal, as described for the triode D.C. amplifier. R_a , from FD' , equals $80,000 \Omega$, a value which is very nearly that measured for $R_g C_g = 0$.

Conclusion

The overall time constant of a D.C. amplifier with an RC circuit in both grid and cathode is given theoretically very nearly by

$$T = R_g C_g + \frac{R_k R'_a}{R_k + R'_a} C_k$$

The correct value of T has its greatest departure from that calculated by this formula when

$$R_g C_g = \frac{R_k R'_a}{R_k + R'_a} C_k$$

when it is 7 per cent. higher.

In the practical case errors occur due to variations in R_a and μ over the working range and a more correct expression is

$$T = K \cdot R_g C_g + \frac{R_k R'_a}{R_k + R'_a} C_k$$

where K is a correction factor dependent on the variation of μ and obtained from the graph of E_k against E_g for a given value of R_k . This factor is less than 1 for discharge and greater than 1 for charge. R_a in R'_a is the average value of the valve slope resistance over the operating locus line.

Grid Bias Range	Measured R_a		R_a from Chord DF	
	Charge	Discharge	Charge	Discharge
- 0.5 to - 2.5	79,000 Ω	700,000 Ω	100,000 Ω	715,000 Ω
- 1 to - 3.5	220,000 Ω	1,250,000 Ω	263,000 Ω	1,000,000 Ω

the value calculated from the slope of the chord DF (Fig. 11).

The results are reasonably satisfactory except for charge on the first grid bias range,

Acknowledgment

The authors are grateful to the Marconi Company for permission to publish these results.

Coupling Circuits as Band Pass Filters. Part 1*

By E. K. Sandeman

INENTIONALLY, or unintentionally, ever since the inception of the radio art, it has been the custom to use impedance matching or coupling circuits for connecting together circuits of different impedance level. A number of typical examples are shown in Figs. 1A to 1J.

Quite apart from the advent of television, other techniques involving apparatus to pass wide bands of frequencies, require a precision method of design of such structures to work between definite impedances and to pass definite frequency bands. Such a method is provided by the application of straight filter theory.

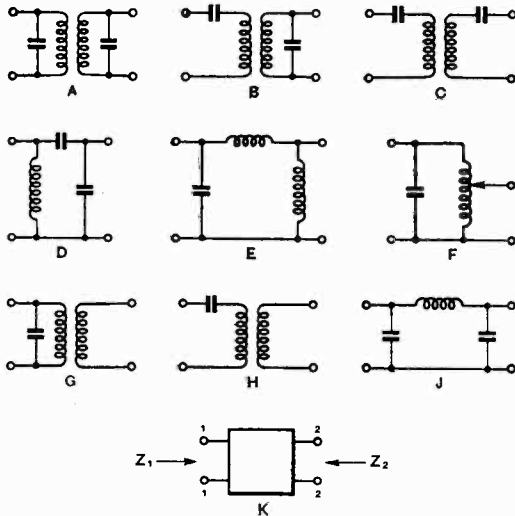

Fig. 1.—(A) Double parallel tuned mutual coupling; (B) series parallel tuned mutual coupling; (C) double series tuned mutual coupling; (D) capacitance top coupling circuit; (E) inductance top coupling circuit; (F) tapped inductance coupling circuit; (G) single parallel tuned circuit; (H) single series tuned circuit; (J) series inductance parallel capacitance π coupling circuit.

With varying degrees of deliberation these circuits have been designed by rule of thumb so as to pass a band of frequencies sufficiently wide for whatever purpose was in hand. For instance, a rule which has served a useful purpose in the past is that which sets a limit to the kVA/kilowatts ratio of the circuit. This can be expressed alternatively as the resistance to reactance ratio of the circuit.

At best this is a rough rule subject to some possibility of misinterpretation, and of limited application.

Any structure of loss-free reactances can, within limits, have such values assigned to its elements that, when terminated by appropriate impedances, it will pass certain bands of frequencies without attenuation, and will attenuate other bands. The frequencies at the ends of the pass bands are called cut-off frequencies. In one class of filter the conditions which limit the performance of the filter are largely those set by the size of the filter elements which is physically realisable. In another class of structure there is a form of limitation which appears as a functional relationship between the ratio of input and output impedances, and the ratio of the cut-off frequencies.

Only structures designed to pass a single band of frequencies are here under discussion. The structures at D, E, F and J of Fig. 1, are subject to the last-named limitation: if the cut-off frequencies are determined the ratio of output to input impedances is determined, while if the ratio of output to input impedance is determined the ratio of the cut-off frequencies is determined. In the structures at A, B, C, G and H, this limitation is absent: the ratio of the cut-off frequencies is independent of the ratio of input and output impedances, and vice versa.

It is useful here to explain exactly what is meant by the term "image impedances."

If the image impedances of the structure in Fig. 1K are Z_1 and Z_2 , respectively observed at terminals 1,1, and 2,2, then Z_1 and Z_2 must satisfy both the following conditions simultaneously:

When the structure is terminated at 2,2 with Z_2 the impedance observed looking into 1,1 is Z_1 .

When the structure is terminated at

* MS. accepted by the Editor, April, 1941.

1,1 with Z_1 the impedance observed looking into 2,2 is Z_2 .

The image impedances of a filter structure are pure resistances inside the pass bands and pure reactances outside the pass band. At the cut-off frequencies they are either zero or infinity.

Inside the pass band of a filter the magnitudes of the image impedances are not constant but variable, and reach zero or infinity at the cut-off frequencies. (Zero frequency is not a cut-off frequency).

The design of filters to pass a single band of frequencies is determined and defined in terms of the image impedances at the geometric mid band frequency. If f_1 and f_2 are the cut-off frequencies of the pass band in question, then the geometric mid-band frequency is $f_m = \sqrt{f_1 f_2}$.

As already indicated, the cut-off frequencies of a filter define the limits of the pass band. The pass band is the region in which the structure is free from attenuation, while at the cut-off frequencies the attenuation begins to rise as the frequency is varied away from the cut-off frequency. In the types of structure which are shown in Fig. 1 the attenuation continues to rise progressively until either infinite or zero frequency is reached. There are other types of structure in which this does not happen, but in which the attenuation rises to a maximum and then falls away again. These, however, are outside the scope of the present discussion. f_1 is used to define the cut-off frequency of lower magnitude and f_2 the cut-off frequency of higher magnitude.

Since the image impedances of a filter vary within the pass band it follows that a filter structure which, when terminated with its image impedances, possesses no attenuation inside its pass band, will have loss at all frequencies except one, when terminated in any value of physical resistance whatever. If for instance it is terminated in resistances respectively equal to the image impedances at frequency f_m , then at frequency f_m the structure will introduce no loss, but at every other frequency, over the remainder of the pass band there will be a loss rising throughout the pass band as the cut-off frequencies are approached from the mid-band frequency f_m . In the case of filters with one cut-off frequency, or in the case of filters with image impedances, both of which rise to infinity,

or both of which fall to zero at the cut-off frequencies, the transition loss at the ends of the pass band can be reduced at the expense of an increase in the middle of the band, by terminating the filters in resistances which are greater or less than the mid-band image impedance: greater for impedances which rise towards cut off, and less for impedances which fall towards cut off.

It is at this point that art and experience have to step in and aid science. For most purposes, however, entirely satisfactory results can be obtained by terminating such structures in impedances equal to their mid-band image impedances.

In the discussion which follows, the image impedances at the geometric mid-band will be termed R_1 and R_2 . The ratio between R_1 and R_2 will be termed the impedance ratio of the structure.

Fig. 2 shows two of the above matching circuits shown in Figs. 1A and 1B respectively, together with the values of their elements in terms of their cut-off frequencies f_1 and f_2 , and R_1 and R_2 . The resistances R_1 and R_2 shown opposite the terminals of the networks are merely a symbolical indication of the ends of the network at which R_1 and R_2 are observed. In the case where the network is to be terminated in its mid-band image impedances they may be regarded as representing the terminating impedances.

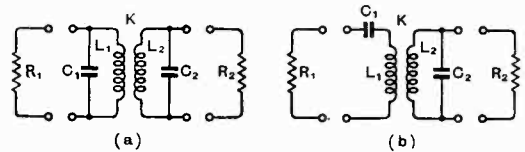

Fig. 2.—(a) Double parallel tuned mutual coupling; (b) Series parallel tuned mutual coupling. (Impedance ratio and cut-off frequencies independent).

The purpose of this paper is to derive the design formulae given immediately below for the two circuits at (a) and (b) in Fig. 2.

(a)—Double Parallel Tuned Mutual Coupling;
Coupling Factor = k^\dagger .

$$L_1 = \frac{R_1(f_2 - f_1)(f_1^2 + f_2^2)}{4\pi f_1^2 f_2^2}$$

† The coupling factor k is defined as the ratio $\frac{M}{\sqrt{L_1 L_2}}$ where M is the mutual inductance between L_1 and L_2 .

$$L_2 = \frac{R_2(f_2 - f_1)(f_1^2 + f_2^2)}{4\pi f_1^2 f_2^2}$$

$$C_1 = \frac{I}{2\pi R_1(f_2 - f_1)}$$

$$C_2 = \frac{I}{2\pi R_2(f_2 - f_1)}$$

$$k = \frac{f_2^2 - f_1^2}{f_1^2 + f_2^2}$$

$$\frac{f_2}{f_1} = \sqrt{\frac{1+k}{1-k}}$$

(b)—Series Parallel Tuned Mutual Coupling:
Coupling Factor = k .

$$L_1 = \frac{R_1}{2\pi(f_2 - f_1)(1 - k^2)}$$

$$L_2 = \frac{(f_2 - f_1)R_2}{2\pi f_1 f_2}$$

$$C_1 = \frac{f_2 - f_1}{2\pi f_1 f_2 R_1}$$

$$C_2 = \frac{I}{2\pi(f_2 - f_1)R_2}$$

$$k = \frac{\phi - 1}{(\phi^2 - \phi + 1)^{\frac{1}{2}}} \text{ where } \phi = \frac{f_2}{f_1}$$

$$\frac{f_2}{f_1} = \frac{2 - k^2 + \sqrt{4k^2 - 3k^4}}{2(1 - k^2)}$$

In the proofs of the above sets of formulae given below, L_1 , L_2 , C_1 and C_2 are respectively called L_a , L_b , C_a and C_b to avoid confusion with the symbols occurring in the basic filter formulae taken from Shea.

From the last formula for $\frac{f_2}{f_1}$ in terms of k for each of the above structures, it will be found that the band width possible with the series parallel tuned mutual coupling is much greater for a given coupling factor than is the case with the double parallel tuned circuit.

Using a series parallel tuned mutual, the author found no difficulty in realising a pass band extending from 6 to 20 megacycles with an impedance ratio of 800 to 100 ohms, the high impedance being on the parallel tuned side. The loss of the mid-band was about 1 db. and at the ends of the band about 2 db. An air core coil was used with a diameter of $\frac{1}{4}$ in. and about 1/16 in. separation between windings which were about half an inch wide.

Recently a core ring was obtained from The Telegraph Construction and Maintenance Co., which when wound gave a coupling factor at a megacycle of about 0.995. This corresponds to a value for f_2/f_1 equal to 101, e.g., it would be possible to make a transformer section going from 10 kc/s. to a megacycle. In practice, with certain types of coil, owing to the fall in permeability at high frequencies it is possible to realise still greater bands.

Derivation of Formulae for the Double Parallel Tuned Mutual Coupling (Fig. 1a)

Equivalent π for unity ratio mutual coupling.

In the two circuits of Fig. 3, L_a and L_b are two equal inductances of magnitude L and coupling factor k : P and S are inductances of magnitude P and S respectively.

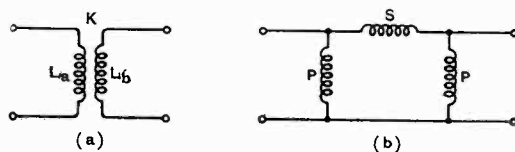

Fig. 3.

The two circuits are equivalent when the short circuit and open circuit impedances are respectively equal, i.e., when

$$(1 - k^2)L = \frac{PS}{P + S} \quad \dots \quad (1)$$

$$\text{and } L = \frac{P(P + S)}{P + S + P} \quad \dots \quad (2)$$

$$\therefore \frac{1}{L} = \frac{1}{P} + \frac{1}{P + S} = \frac{1}{P} + \frac{(1 - k^2)L}{PS}$$

$$\therefore P = L + \frac{1}{S}(1 - k^2)L^2 \quad \dots \quad (3)$$

Substituting (3) in (1)

$$\therefore (1 - k^2)LS + (1 - k^2)[L + \frac{1}{S}(1 - k^2)L^2]L = SL + (1 - k^2)L^2$$

$$\therefore (1 - k^2)S^2 + (1 - k^2)LS + (1 - k^2)^2L^2 = S^2 + (1 - k^2)LS$$

$$\therefore S^2k^2 = (1 - k^2)^2L^2$$

$$\therefore S = \pm \frac{(1 - k^2)L}{k} \quad \dots \quad (4)$$

$$P = L \pm \frac{k}{(1 - k^2)L} \cdot (1 - k^2)L^2 = (1 \pm k)L \quad \dots \quad (5)$$

Since S must be a real inductance the positive sign must be taken.

Solving for L and k in terms of P and S .
From (4) and (5)

$$\frac{P}{S} = \frac{k}{1 - k} \dots \dots \dots (6)$$

$$\therefore k = \frac{P}{S} - k \frac{P}{S} = \frac{P}{1 + \frac{P}{S}} = \frac{P}{S + P} \quad (7)$$

From (5)

$$L = \frac{P}{1 + k} = \frac{P}{1 + \frac{P}{S + P}} = \frac{P(S + P)}{S + 2P} \dots \dots (8)$$

Now consider the filter structure shown in Fig. 4a and the double parallel tuned mutual inductance circuit in Fig. 4b. The former

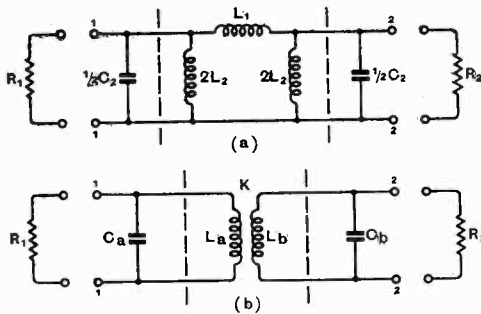

Fig. 4.—In circuit (b) $L_a = L_b = L$ and $C_a = C_b = C$.

is a section of a type III₃ filter terminated at mid-shunt when

$$L_1 = \frac{R}{\pi(f_1 + f_2)}, \quad L_2 = \frac{(f_2 - f_1)R}{4\pi f_1^2}$$

and $C_2 = \frac{1}{\pi(f_2 - f_1)R}$

and $R = R_1 = R_2$.

(See "Transmission Networks and Wave Filters," by T. E. Shea, page 316).

The structures between the chain dotted lines are equivalent when $P = 2L_2$ and $S = L_1$.

Hence the two structures in Fig. 4 are equivalent when the following relations hold :

(i) $k = \frac{P}{S + P} = \frac{2L_2}{L_1 + 2L_2}$

$$\begin{aligned} &= \frac{2(f_2 - f_1)R}{4\pi f_1^2} \\ &= \frac{R}{\pi(f_1 + f_2)} + \frac{2(f_2 - f_1)R}{4\pi f_1^2} \\ &= \frac{(f_2^2 - f_1^2)}{2f_1^2 + f_2^2 - f_1^2} = \frac{f_2^2 - f_1^2}{f_2^2 + f_1^2} = \frac{\phi^2 - 1}{\phi^2 + 1} \end{aligned} \quad \dots \dots (9)$$

where $\phi = \frac{f_2}{f_1}$

(ii) $L = \frac{P(S + P)}{S + 2P} = \frac{2L_2(L_1 + L_2)}{L_1 + L_2}$

$$\begin{aligned} &= \frac{2(f_2 - f_1)R \left[\frac{R}{\pi(f_1 + f_2)} + \frac{2(f_2 - f_1)R}{4\pi f_1^2} \right]}{\frac{R}{\pi(f_1 + f_2)} + \frac{(f_2 - f_1)R}{\pi f_1^2}} \end{aligned}$$

$$= \frac{R}{4\pi} \left[\frac{2(f_2 - f_1)[1 - \frac{f_2^2 - f_1^2}{2f_1^2}]}{f_1^2 + f_1^2 - f_1^2} \right]$$

$$= \frac{R}{4\pi} \left[\frac{(f_2 - f_1)(2f_1^2 + f_2^2 - f_1^2)}{f_1^2 f_2^2} \right]$$

$$= \frac{R}{4\pi} \frac{(f_2 - f_1)(f_1^2 + f_2^2)}{f_1^2 f_2^2} \dots \dots (10)$$

$$= \frac{R(\phi - 1)(\phi^2 + 1)\phi}{4\pi f_1} \dots \dots (10a)$$

(iii) $C = \frac{1}{2}C_2 = \frac{1}{2\pi(f_1 - f_1)R} \dots \dots (11)$

The above equations define the performance for a unity ratio structure, i.e. when the inductances each side of the mutual are equal.

When the two inductances are unequal, let one be equal to $L_a = L$ and the other equal to $L_b = n^2L$, the coupling factor k being unchanged.

Then $M = k\sqrt{L_a L_b} = k\sqrt{n^2 L_a^2} = nkL$.

The condition that the attenuation through the filter shall be unchanged, by change of L_b , from equality with L_a will be satisfied if the impedance presented at terminals 1, 1 is unchanged.

Try putting $R_2 = n^2 R_1$ and $C_b = \frac{1}{n^2} C_a$

When $L_b = L_a, R_2 = R_1, etc.$

Unit current through L_a generates an e.m.f. $Mj\omega$ in $L_b = kLj\omega$ and a secondary current flows of magnitude $j \frac{kL\omega}{Z}$ where Z is the total secondary series impedance.

This induces an e.m.f. into L_1 of magnitude and sense

$$= - \frac{k^2 L^2 \omega^2}{Z}$$

When $L_b = n^2 L_a$, $R_2 = n^2 R_1$, etc.

Unit current through L_a generates an e.m.f. in $L_b = nkLj\omega$ and a secondary current flows of magnitude

$$j \frac{nkL\omega}{n^2 Z} = j \frac{kL\omega}{nZ}$$

This induces an e.m.f. into L_1 of magnitude and sense

$$= - \pi kL \cdot \frac{kL\omega}{\pi Z} = - \frac{k^2 L^2 \omega^2}{Z}$$

Hence the impedance facing the input to the structure remains unchanged if the impedance of all elements on the secondary side is changed in the same ratio as L_b is changed.

It follows that to design an inequality ratio circuit, each side can be designed independently of the other: for the value of R in equations (9), (10) and (11) the value of R_a is substituted to determine the value of the primary impedance elements, and the value of R_b is substituted to determine the secondary impedance elements.

Derivation of formulae for the Series-Parallel Tuned Mutual Coupling Circuit.

For this purpose it is convenient to use another alternative circuit for the mutual coupling. This is shown in Fig. 5.

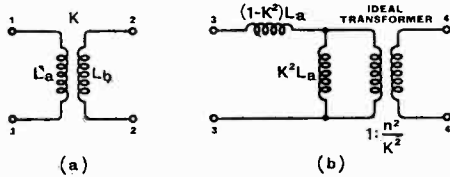

Fig. 5.

These two circuits are equivalent if the short circuit and open circuit impedances looking into both circuits at both ends are equal, i.e., if $Z_{11} = Z_{33}$ and $Z_{22} = Z_{44}$ for short circuit and open circuit conditions of the other terminals.

Check—

Open circuit condition

$$\begin{aligned} Z_{11} &= L_a \\ Z_{22} &= n^2 L_a \\ Z_{33} &= (1 - k^2)L_a + k^2 L_a = L_a \\ Z_{44} &= \frac{n^2}{k^2} \cdot k^2 L_a = n^2 L_a \end{aligned}$$

Short circuit condition

$$\begin{aligned} Z_{11} &= (1 - k^2)L_a \\ Z_{22} &= n^2(1 - k^2)L_a \\ Z_{33} &= (1 - k^2)L_a \\ Z_{44} &= \frac{n^2}{k^2} \cdot k^2 L_a (1 - k^2)L_a = n^2(1 - k^2)L_a \end{aligned}$$

Now consider the filter structure shown in

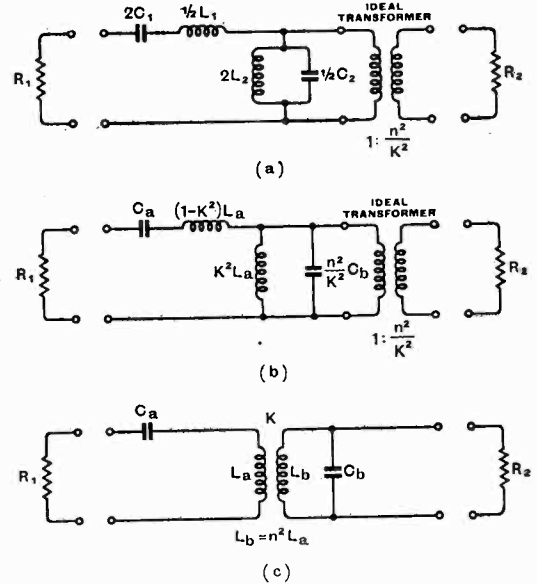

Fig. 6.

Fig. 6a, neglecting the ideal transformer associated with it. This is a half section of Shea Type IVk (see Shea, p. 315) when

$$\begin{aligned} L_1 &= \frac{R}{\pi(f_2 - f_1)}, \quad C_1 = \frac{f_2 - f_1}{4\pi f_1 f_2 R} \\ L_2 &= \frac{(f_2 - f_1)R}{4\pi f_1 f_2}, \quad \text{and } C_2 = \frac{1}{\pi(f_2 - f_1)R}. \end{aligned}$$

The structure is evidently identical with that shown in Fig. 6b if corresponding elements are equal. While, from the principle of equivalence established immediately above, the structures in b and c are also equivalent. Evidently b can be derived from c by replacing the coupled circuit in c by the equivalent structure as shown in Fig. 5b and transferring C_b from one side of the ideal transformer to the other, changing its magnitude in the ratio of the ideal transformer.

Fig. 6c is evidently in the form of the series-parallel tuned mutual coupling. Suf-

fixes a and b are used instead of 1 and 2 to distinguish the elements from those of the half section of Shea Type IVk filter shown at 6c.

It is immediately possible to determine the values of the circuit elements in Fig. 6c as follows, taking advantage of the fact that in a Type IVk filter, at the geometric mid-band frequency, the mid-shunt image impedance is equal to the mid-series image impedance. These are both represented by the symbol R in the Shea equations immediately above.

By inspection of Fig. 6 a, b and c, it can be seen that

$$C_a = 2C_1 = \frac{f_2 - f_1}{2\pi f_1 f_2 R_1} \dots \dots (I2)$$

Also $(1 - k^2)L_a = \frac{1}{2}L_1 = \frac{R_1}{2\pi(f_2 - f_1)}$

$$\therefore L_a = \frac{R_1}{2\pi(f_2 - f_1)(1 - k^2)} \dots \dots (I3)$$

Further,

$$k^2 L_a = \frac{k^2}{n^2} L_b = 2L_2 = \frac{(f_2 - f_1) \frac{k^2}{n^2} R_2}{2\pi f_1 f_2}$$

$$\therefore L_b = \frac{(f_2 - f_1) R_2}{2\pi f_1 f_2} \dots \dots (I4)$$

Finally,

$$\frac{n^2}{k^2} C_b = \frac{1}{2} C_2 = \frac{1}{\pi(f_2 - f_1) \frac{k^2}{n^2} R_2}$$

$$\therefore C_b = \frac{1}{\pi(f_2 - f_1) R_2} \dots \dots (I5)$$

Determination of Relation between k and Cut-off Frequencies

By inspection of Figs. 6a and 6b :

$$k^2 L_a = 2L_2 = \frac{(f_2 - f_1) R_1}{2\pi f_1 f_2} \dots \dots (I6)$$

From (I3) and (I6)

$$\frac{k^2}{1 - k^2} = \frac{(f_2 - f_1)^2}{f_1 f_2} = \frac{(\phi - 1)^2}{\phi}$$

$$\therefore \phi k^2 = \phi^2 - 2\phi + 1 - \phi^2 k^2 + 2\phi k^2 - k^2$$

$$\therefore (\phi^2 - \phi + 1) k^2 = \phi^2 - 2\phi + 1 \quad (I7)$$

$$\therefore k = \frac{\phi - 1}{\phi^2 - \phi + 1} \dots \dots (I8)$$

and alternately from I7

$$\phi = \frac{f_2}{f_1} = \frac{2 - k^2 + \sqrt{4k^2 - 3k^4}}{2(1 - k^2)} \quad (I9)$$

Chart for rapid Determination of Values of Elements of Double Parallel Tuned Mutual Coupling.

This chart, which is shown on Fig. 7, gives values of filter elements plotted against percentage band width for a filter structure having a value of $\bar{f} = \frac{1}{2}(f_1 + f_2) = 10^6$ c/s. and designed to work between equal impedances

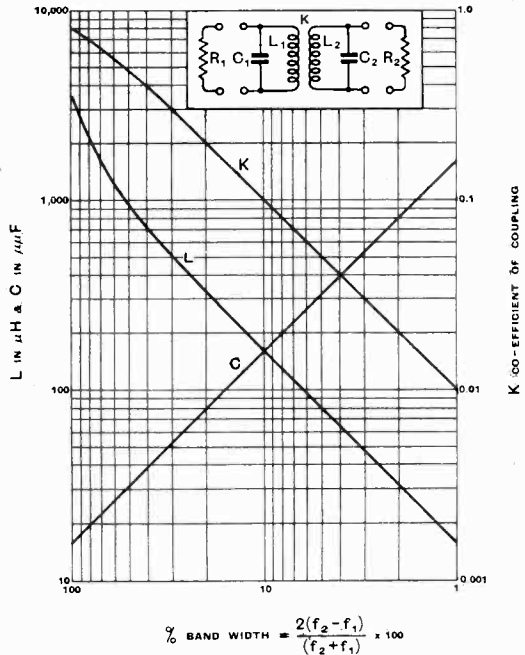

Fig. 7.—L, C and K against % band width for $R_A = R_B = 10,000 \Omega$, and

$$\bar{f} = \frac{1}{2}(f_1 + f_2) = 10^6 \text{ c/s. } L = \frac{R}{4\pi} \cdot \frac{(f_2 - f_1)(f_2^2 + f_1^2)}{f_1^2 \cdot f_2^2};$$

$$C = \frac{1}{2\pi R (f_2 - f_1)}; K = \frac{f_2^2 - f_1^2}{f_2^2 + f_1^2}$$

of 10,000 ohms where f_1 and f_2 are the cut-off frequencies. The percentage band width is defined as $100 \frac{f_2 - f_1}{\bar{f}}$.

By means of this chart it is possible rapidly to design filters to operate between any impedances, and for any band width for which the required value of coupling is realisable.

Owing to the presence of pure mutual coupling, the band width is independent of the impedance ratio, and each side of the filter can be designed independently of the other side.

Example

To design a double parallel tuned mutual coupling circuit with impedance ratio 1,000 : 100Ω, $f_1 = 400$ kc/s., $f_2 = 600$ kc/s.

$$\therefore \bar{f} = \frac{1}{2}(400 + 600) \text{ kc/s.} = 500 \text{ kc/s.}$$

Per cent. band width

$$= 100 \frac{f_2 - f_1}{\bar{f}} = 100 \frac{200}{500} = 40 \text{ per cent.}$$

Design for filter on chart, reading direct from chart, the values of L, C and k corresponding to 40% band width.

$$L = 700 \mu\text{H}, C = 38 \mu\mu\text{F}, k = 0.39$$

The value of k is then 0.39, but the values of L and C have to be transformed for frequency and impedance.

Transforming to 1,000 ohms : To find the elements on the 1,000 ohms side :

$$L = 1400 \times \frac{1,000}{10,000} = 140 \mu\text{H}$$

$$C = 76 \times \frac{10,000}{1,000} = 760 \mu\mu\text{F}$$

Similarly the values of the elements on the 100 ohms side are :

$$L = 14 \mu\text{H} \quad C = 7,600 \mu\mu\text{F}$$

Chart for Determining Values of Elements of Series Parallel Tuned Mutual Coupling.

This is shown in Fig. 8, the method of use being identical with the above except that L_1 and L_2 involve separate readings from the chart as do C_1 and C_2

Conclusion.

The double parallel tuned mutual coupling will have been recognised as the prototype network for basic transformer design.

In this connection it is necessary to state the relation of a previous paper by the author to the present discussion. See "Transformers as Band Pass Filters," in *Electrical Communication*, April, 1929. Here the problem was attacked by deriving the equivalent T of a transformer and then lumping the whole

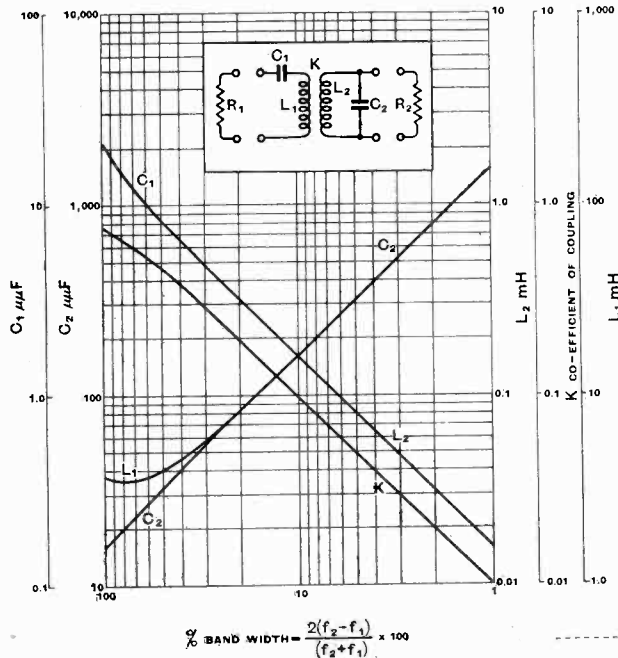

Fig. 8.— L_1, C_1, L_2, C_2 and K against % band width for $R_1 = R_2 = 10,000\Omega$ and $\bar{f} = \frac{1}{2}(f_1 + f_2) = 10^6$ c/s.

$$C_1 = \frac{f_2 - f_1}{2\pi f_1 f_2 R}; \quad C_2 = \frac{1}{2\pi R_2 (f_2 - f_1)};$$

$$L_2 = \frac{R_2 (f_2 - f_1)}{2\pi f_1 f_2}; \quad L_1 = \frac{R_1}{2\pi (f_2 - f_1) (1 - K^2)};$$

$$K = \sqrt{\frac{1}{1 + \frac{f_1 f_2}{(f_2 - f_1)^2}}};$$

$$\frac{f_2}{f_1} = \frac{2 - K^2 + \sqrt{4K^2 - 3K^4}}{2(1 - K^2)}$$

Transforming for frequency : the values of the elements are changed so that their reactances remain constant.

$$L = 700 \times \frac{10^6}{0.5 \times 10^6} = 1,400 \mu\text{H}$$

$$C = 38 \times \frac{10^6}{0.5 \times 10^6} = 76 \mu\mu\text{F}$$

leakage inductance in one arm : this introduced a measure of approximation which, however, is quite good enough for all practical cases that may occur.

The present treatment, however, is quite rigid, and, as the results are as easy, or easier, to apply, it completely replaces the previous discussion.

Wireless Patents

A Summary of Recently Accepted Specifications

The following abstracts are prepared, with the permission of the Controller of H.M. Stationery Office, from Specifications obtainable at the Patent Office, 25, Southampton Buildings, London, W.C.2, price 1/- each

ACOUSTICS AND AUDIO-FREQUENCY CIRCUITS AND APPARATUS

534 599.—Construction of a microphone utilising the magnetostriction effect.

Cie Generale de T.S.F. Convention date (France) 22nd March, 1939.

534 716.—Extending the linear response and stabilising the operating conditions of an amplifier utilising negative feed-back.

Akt. Brown, Boverie, et Cie. Convention date (Switzerland) 2nd November, 1938.

534 760.—Amplifying circuit for handling a complex of currents, including components of different frequency but uniform amplitude, particularly for carrier telephony.

Ericsson Telephones and F. W. Hopwood. Application date 13th November, 1939.

534 779.—Construction and arrangement of the speech coil and diaphragm of a loudspeaker.

A. H. Blue and R. D. Wood. Application date 17th November, 1939.

AERIALS AND AERIAL SYSTEMS

534 945.—Fixed aerial and counterpoise system for an aeroplane with a metal fuselage.

Marconi's W.T. Co. and C. S. Cockerell. Application date 6th October, 1939.

535 055.—Short-wave tube aerial of "stepped" contour and means for coupling and matching it to a transmission line, particularly for television signals.

The General Electric Co.; T. A. Julian; and H. J. Shaw. Application date 24th July, 1939.

535 127.—Aerial circuits for signalling systems in which the carrier wave is transmitted on one channel and the side-band frequencies on a separate channel.

Marconi's W.T. Co. (assignees of D. G. C. Luck). Convention date (U.S.A.) 30th December, 1938.

RECEIVING CIRCUITS AND APPARATUS

(See also under Television)

534 400.—Shock-absorbing mounting for the chassis of a wireless set installed in a motor car.

The General Electric Co. and F. Clark. Application date 8th November, 1939.

534 457.—Direct or galvanic coupling-circuit, for sound or television, designed to ensure an automatic limiting action for "noise" as compared with a desired level of signal strength.

A. A. Thornton (communicated by Philco Radio and Television Corp'n.). Application date 8th June, 1939.

534 603.—Means for sharpening the cut-off effect to undesired frequencies in a wave filter of the composite type.

Standard Telephones and Cables (assignees of R. A. Sykes). Convention date (U.S.A.) 2nd June, 1939.

534 631.—Remote tuning and operating control for a car wireless set.

Philco Radio and Television Corp'n. of Gt. Britain and C. A. Laws. Application date 7th September, 1939.

534 723.—Wireless receiver for frequency- or phase-modulated signals with means for compensation for any casual amplitude modulation.

Telefunken Co. Convention date (Germany) 20th December, 1938.

534 988.—Stabilised tuning system for a wireless receiver in which back-coupling is combined with a selectivity which can be varied from a broad to a sharp response.

Hazeltine Corporation (assignees of J. F. Farrington). Convention date (U.S.A.) 1st February, 1939.

535 313.—Variable band-pass or tuning circuit in which the band of frequencies admitted, at any setting, is of uniform width and symmetrical with relation to the mean or carrier frequency.

Hazeltine Corporation (assignees of M. Cawein). Convention date (U.S.A.) 23rd November, 1938.

535 500.—Tuning arrangement for a superhet receiver in which a correcting member is provided to ensure a constant difference between the pre-selector and local-oscillator circuits.

Philips Lamps. Convention date (Netherlands) 23rd March, 1939.

TELEVISION CIRCUITS AND APPARATUS

FOR TRANSMISSION AND RECEPTION

534 750.—Means for "locking" the synchronising generator in a television transmitter with the frequency of the mains supply.

Marconi's W.T. Co. (assignees of K. R. Wendt). Convention date (U.S.A.) 26th October, 1938.

534 774.—Saw-tooth oscillation generator forming part of a time-base unit, the main discharge valve being highly evacuated and connected in series with an auxiliary tube.

Standard Telephones and Cables; D. S. B. Shannon; and P. K. Chatterjea. Application date 15th September, 1939.

534 839.—Separating the picture signals from the synchronising impulses in a television receiver and deriving a biasing voltage dependent upon amplitude.

A. A. Thornton (communicated by Philco Radio and Television Corp'n.). Application date 8th June, 1939.

534 906.—Wide-band amplifying and modulating system, using negative feed-back, particularly for television.

The British Thomson-Houston Co. Convention date (U.S.A.) 12th November, 1938.

534 973.—Means for indirectly illuminating the screen of a cathode-ray television receiver in order to avoid eye strain.

A. H. Cooper. Application date 24th August, 1939.

535 078.—Television receiver which is tunable over a wide range of frequencies whilst maintaining a uniform band width.

Hazeltine Corporation (assignees of H. A. Wheeler). Convention date (U.S.A.) 29th October, 1938.

TRANSMITTING CIRCUITS AND APPARATUS

(See also under Television)

534 820.—Single-stage oscillator including a 180° phase-change filter, particularly for generating audible and sub-audible frequencies.

Marconi's W.T. Co. and O. E. Keall. Application date 18th August, 1939.

534 955.—Method of phase or frequency modulation in which a master oscillation is heterodyned with a frequency-modulated oscillation, and a derivative is subsequently changed in phase.

D. Weighton and Pye. Application date 22nd December, 1939.

535 086.—High-frequency modulator in which the floating carrier principle is applied to separate peaks of the wave.

The British Thomson-Houston Co. Convention date (France) 5th November, 1938.

536 383.—Frequency-modulated system of radio transmission specially modified for intercommunication between the individual ships of a fleet at sea.

The British Thomson-Houston Co. Convention date (U.S.A.) 12th November, 1938.

CONSTRUCTION OF ELECTRONIC-DISCHARGE DEVICES

534 465.—Automatic means for preventing defocusing during the magnetic deflection of the electron stream of a cathode-ray tube.

A. D. Blumlein and F. Blythen. Application date 28th July, 1939.

534 474.—Electrode system for controlling the secondary emission in an amplifier of the electron-multiplier type.

F. J. G. van den Bosch and Vacuum-Science Products. Application dates 23rd and 29th August, 1939.

534 558.—Means for "fixing" the residual gases in the manufacture of photo-electric cells.

The Mullard Radio Valve Co. Convention date (Germany) 13th March, 1939.

534 576.—Selectively-operated electron "switch" utilising a valve of the kind in which secondary emission takes place.

Standard Telephones and Cables; D. S. B. Shannon and P. K. Chatterjee. Application date 6th September, 1939.

534 627.—Focusing system for the electron stream of a cathode-ray tube designed to prevent "cross-over."

L. F. Broadway. Application date 7th September, 1939.

534 696.—Electron-discharge device of the kind in which an electron stream is modulated or "bunched" between successive resonant systems.

Standard Telephones and Cables and D. H. Black. Application date 13th September, 1939.

SUBSIDIARY APPARATUS AND MATERIALS

534 283.—Switching system for distributing a number of broadcast programmes fed on over-land lines to a central point where they are to be sent out to different transmitting stations.

Standard Telephones and Cables; R. A. Meers; and F. G. Filby. Application date 1st September, 1939.

534 567.—Low-frequency transformer with a metal-powder core of graded cross section to ensure minimum hysteresis.

Automatic Telephone and Electric Co. and H. R. F. Carsten. Application date 14th March, 1940.

534 649.—Photo-electric relay suitable for supervising the operation of a petrol filling station.

Photoswitch Incorporated. Convention date (U.S.A.) 2nd May, 1939.

534 758.—Electrode system and mounting for a piezo-electric oscillator of the multiple-plate or "flexing" type.

Brush Crystal Co. (assignees of A. L. W. Williams). Convention date (U.S.A.) 14th November, 1938.

534 767.—Electrode system and mounting for a piezo-electric unit vibrating in the so-called "thickness mode."

Marconi's W.T. Co. (assignees of H. W. N. Hawk). Convention date (U.S.A.) 28th November, 1938.

534 802.—Symmetrical wave-filters suitable for use at the terminals of a multiplex carrier telephone system.

Standard Telephones and Cables (assignees of H. W. Bode). Convention date (U.S.A.) 9th March, 1939.

535 124.—Automatically adjusting the gain of amplifiers in accordance with varying line conditions in a carrier signalling system.

Automatic Telephone and Electric Co. and T. B. D. Terroni. Application date 11th December, 1939.

535 181.—Network or circuit for coupling two or more currents of different frequencies to a common input which presents an optimum impedance to each.

Marconi's W.T. Co.; C. D. Colchester; and A. T. Starr. Application date 31st August, 1939.

535 384.—Signalling system utilising trains of impulses having a time function which is characteristic of the sound or other signal to be transmitted.

Standard Telephones and Cables; W. A. Beatty; and C. T. Scully. Application date 6th October, 1939.

Abstracts and References

Compiled by the Radio Research Board and reproduced by arrangement with the Department of Scientific and Industrial Research

For the information of new readers it is pointed out that the length of an abstract is generally no indication of the importance of the work concerned. An important paper in English, in a journal likely to be readily accessible, may be dealt with by a square-bracketed addition to the title, while a paper of similar importance in German or Russian may be given a long abstract. In addition to these factors of difficulty of language and accessibility, the nature of the work has, of course, a great influence on the useful length of its abstract.

	PAGE		PAGE
Propagation of Waves	370	Directional Wireless	381
Atmospherics and Atmospheric Electricity	373	Acoustics and Audio-Frequencies	381
Properties of Circuits	373	Phototelegraphy and Television ...	382
Transmission	375	Measurements and Standards ...	384
Reception	376	Subsidiary Apparatus and Materials	386
Aerials and Aerial Systems ...	377	Stations, Design and Operation ...	389
Valves and Thermionics	379	General Physical Articles... ..	390
		Miscellaneous	390

PROPAGATION OF WAVES

2333. COUPLED RADIATION FIELDS IN THE CYLINDRICAL TUBULAR CONDUCTOR.—Buchholz. (See 2402.)

2334. THE ATTENUATION OF VERY SHORT ELECTRIC WAVES IN THEIR PASSAGE THROUGH CLOUDS AND MIST [Short Survey of Knowledge].—K. Franz. (*Hochf.tech. u. Elek. Akus.*, May 1940, Vol. 55, No. 5, pp. 141-143.)

From the Telefunken laboratories. The attenuation is due practically only to drops of liquid water and not to water vapour. The action of a sphere of known dielectric constant and conductivity was fully calculated by Mie (*Ann. der Physik*, Vol. 25, 1908, p. 377): energy is removed from the wave by scattering (in the form of diffraction waves) and by heat generation inside the drop. The curves of the constants of liquid water are known in principle from the Debye theory of dipole liquids (see section 11, and Hettner, 252 of 1938) and in detail from measurements such as those of Esau & Báz (252 of 1938). As for the combined action of a large number of drops, it may be stated simply that n drops remove n times as much energy as a single drop: the effect of multiple scattering only comes in, according to Trincks (2177 of 1935), when the average distance between the drops is small enough to be comparable with their radius, a condition not obtaining in clouds or mist.

A careful examination of Mie's results (section 11) shows that for the over-all attenuation the total quantity of liquid water is the determining factor, and not its distribution between drops of different size. This is because the component particles of cloud and mist are small compared with the wavelengths: the removal of energy is due practically only to heat production and not to diffraction. Calculated attenuations in nepers/km for a water content of 1 gm/m^3 are given: they range from 2.8×10^{-4} for a 20 cm wave, through 4.9×10^{-3} for a 5 cm wave and 3×10^{-2} for a 2 cm wave, to 0.12 at 1 cm, 2.3 at 0.2 cm, and 9.0 at 0.03 cm.

"The above data are free from uncertainties in their derivation. There is only lacking a statement as to the maximum amount of liquid water existing in cloud and mist. According to meteorological measurements (admittedly old) such a maximum may be from 5 to 8 gm/m^3 [see section 1v]. Thus the attenuation of a wave of about 1 mm would be very serious, so that its unrestricted practical use would appear questionable." A 1 km path through a cloud with a water content of 1 gm/m^3 corresponds to a homogeneous layer of water 1 mm thick: by calculating the penetration of a wave into such a homogeneous layer by the formula $d = \lambda/4\pi\epsilon\kappa$, the curve of Fig. 4 is obtained, which shows that this 1 mm thickness would be just penetrated by a wave of about 3 cm. A comparison of this result with the data given above shows that the attenuation due to a quantity of water distributed in drops is much smaller than that due to the same amount of water concentrated into a layer.

2335. THE ABNORMAL-E LAYER OF THE IONOSPHERE AND AN UNUSUAL LONG-DISTANCE ACTION OF ULTRA-SHORT WAVES [5-12 m. over Distances of Some Hundreds of Kilometres].—H. A. Hess. (*E.T.Z.*, 24th April 1941, Vol. 62, No. 17, pp. 401-405.)

The main part of the paper is based on the writer's 1936/7 observations at Saarow-Pieskow (already dealt with in 2600 of 1938 & back reference) and on the American results (from 1935 onwards) of Hull, Pierce, and others (see the writer's paper dealt with in 3030 of 1939). Although the data on these abnormal ranges are admittedly scanty, an attempt has been made to compare the results for the three years 1935, 1936, and 1937. "The comparison led to the striking result that the phenomenon evidently tends to recur on the same days or groups of days of the different years. In the records for August of these years this is shown quite obviously, as is seen from Fig. 6 [it seems doubtful whether any North American results are

embodied in this: only German observations (1936/8) are mentioned in detail, and it is later remarked that such 5 m American ranges have been, up to the present, predominantly in May and June. The derivation of the 1935 plot is therefore left rather uncertain]. The striking recurrence between 8th & 15th August of the years 1935/7 may well be connected with . . . the passage of the Perseid meteors": see Skellett, 1736 of 1935 [and 1752 of 1938] and Leithäuser, 1753 of 1938. Attempts, not further specified, to connect the occurrence of these abnormal ranges, and of the abnormal-E layer with which they seem to be connected (unlike the frequent ranges of several thousand kilometres in the case of television transmissions, which are due to special conditions in the F_2 layer) with sunspots, chromospheric eruptions, magnetic storms, or aurora, have all failed. Data are badly needed on the simultaneity (or otherwise) of the abnormal ranges at different parts of the globe, and on long-distance short-wave direction-finding difficulties and other sudden short-wave phenomena, which also seem to be connected with the abnormal-E layer. Among such phenomena are sudden changes in the best working hours, changes which "cannot be correlated with the appearance of aurora or with Dellinger fade-outs. . . . At certain times unusually good transmission conditions are found to exist. . . . In winter, at night, unexpectedly short skip distances occur suddenly on the short waves used in transoceanic service, and in summer even by day particularly long distances can be covered with longer short waves." This part of the paper is preceded by a short discussion of the abnormal-E layer, the uncertainty regarding its formation-mechanism, and its effects: the results of Crone & others (3974 of 1936) are quoted as indicating the action of wandering ion clouds: the reflecting power of the abnormal-E layer is often considerably greater than that of the F_2 layer. "During the appearance of this layer, in the summer months, unusual ultra-short-wave ranges have been noticed": and this leads to the principal thesis.

2336. TRANSATLANTIC FREQUENCIES [Considerations on the Highest Frequencies actually received and Those predictable from Ionospheric Data: and the Smallest Skip Distance for 50 Mc/s].—T. W. Bennington. (*Wireless World*, July 1941, Vol. 47, No. 7, pp. 193-194.) See also pp. 194-195, and August issue, p. 218.
2337. MEASUREMENTS OF THE VELOCITY OF WIRELESS WAVES [by Pulse Retransmission Method: Measured Velocity in Line of Sight "practically Same as That of Light"].—Colwell, Atwood, & others. (*Science*, 16th May 1941, Vol. 93, Supp. p. 12.) In the same issue, Bessey Smith writes to point out that the total fall in the values obtained for the velocity of light from the 1849 value to that of Anderson (2081 of August) is 4.32%: "why always downward?" It seems improbable that all the errors of measurement were on the same side. For another summary see *Phys. Review*, 1st June, p. 935.
2338. FIELD EQUIPMENT FOR IONOSPHERE MEASUREMENTS [for Automatic Recording of Virtual Heights & Critical Frequencies: Frequencies 790-14 000 kc/s: Record every Minute for Four Hours without Battery-Recharging].—T. R. Gilliland & A. S. Taylor. (*Journ. of Res. of Nat. Bur. of Stds.*, May 1941, Vol. 26, No. 5, pp. 377-384.)
2339. "DIE AUSBREITUNG DER ELEKTROMAGNETISCHEN WELLEN" [Book Review].—B. Beckmann. (*E.T.Z.*, 10th April 1941, Vol. 62, No. 15, p. 384.) First volume of a series edited by Zenneck ("Library of High-Frequency Technique").
2340. "ELEMENTE DER OPERATORENRECHNUNG MIT GEOPHYSIKALISCHEN ANWENDUNGEN" [such as Electron Motion & Wave Propagation in the Ionosphere, Harmonic Waves in Water, etc.: Book Review].—H. Ertel. (*Physik. Zeitschr.*, 15th Aug. 1940, Vol. 41, No. 16, p. 393.)
2341. THE RECOMBINATION LAW FOR WEAK IONISATION [Test of Equation implying Linear Law].—Nolan. (See 2368.)
2342. THE IONOSPHERIC STORM OF THE 25TH AND 29TH MARCH 1940 [with Data on Short-Wave Signals from New York, Cairo, Beirut, & Shanghai at Malnome, and Breslau Broadcasting Signals at Perugia: Interpretation of the Breslau Results].—I. Ranzi. (*La Ricerca Scient.*, June 1940, Vol. 11, No. 6, pp. 397-402.)
- "Particularly interesting is the depression in intensity of the Breslau signals. The following hypotheses may be formulated to explain it: (1) that the maximum electronic density of the ionosphere was so lowered as to reduce the critical frequency for the Breslau/Perugia path below the Breslau frequency (950 kc/s), or (2) that at a comparatively low level (50-70 km) there was formed a strongly ionised layer strongly absorbent to the medium wave; or that, in consequence of irregular stratification of the ionosphere, the coefficient of reflection was considerably lowered, the critical frequency in either case remaining above the frequency of the Breslau wave.
- "On the first hypothesis . . . we can calculate the value of the critical frequency for vertical incidence corresponding to a critical frequency of 950 kc/s for oblique incidence, for the Breslau/Perugia communication." The writer carries out this calculation, with 950 km as the distance between the stations and an assumed virtual height of 500 km (taken as the maximum for stable reception) giving an angle ϕ (defined as between the ray and the normal at the point of departure) of 47° (misprint for 43° ? The 47° is repeated at the end of the paper, but the value of the secant there given again indicates 43°). This leads to a critical frequency at vertical incidence, to correspond with a critical frequency of 950 kc/s on the Breslau/Perugia path, of 690 kc/s. "When one considers the curve [of F_2 critical frequencies] of Fig. 1, and that the reflection of the Breslau wave received at Perugia occurs at a latitude higher than that of Rome, the first hypothesis seems worthy of attention."

2343. IONOSPHERIC RECORDINGS DURING MAGNETIC STORM OF 1ST MARCH 1941 [Severe Ionospheric Disturbance beginning with Development of Ionised Region at 160 km, falling to 130 km with Trebled Ion-Density (Not a Simple Sporadic-E Ionisation) : etc.].—H. W. Wells. (*Terr. Mag. & Atmos. Elec.*, June 1941, Vol. 46, No. 2, pp. 245-246.)
2344. THE DAILY VARIATION OF IRREGULAR DISTURBANCES OF THE EARTH'S MAGNETIC FIELD AT BOMBAY.—R. Narayanaswami. (*Terr. Mag. & Atmos. Elec.*, June 1941, Vol. 46, No. 2, pp. 147-162.)
 "It is suggested that the maxima of disturbance-variation at Bombay at about noon and the afternoon are associated with the maxima of ion-density in the E and F₁ layers [in low latitudes] and in the F₂ layer, respectively. The late evening maximum is presumably due to fluctuations in the F₂ layer caused by electrified particles from the sun concentrating on the night side of the earth on account of the deflecting action of its magnetic field."
2345. LIGHT OF THE NIGHT SKY AND TERRESTRIAL MAGNETISM [Experimental Evidence (Lick Observatory) of Intimate Connection between Measures of Luminous Activity and Those of Magnetic Disturbance, previously Suspected but Not Established].—D. R. Barber. (*Nature*, 19th July 1941, Vol. 148, pp. 88-89.)
2346. THE LIGHT EMITTED DURING THE THERMAL DECOMPOSITION OF OZONE, AND THE LIGHT OF THE NIGHT SKY [Investigation of the Former under Laboratory Conditions imitating Those in the Atmosphere: No Help in Interpretation of Mechanism of Latter].—V. H. Regener. (*La Ricerca Scient.*, May 1940, Vol. 11, No. 5, pp. 356-357.)
2347. AFTERGLOWS IN NITROGEN RARE GAS MIXTURES [with Possible Application to Excitation Processes in Aurora].—J. Kaplan & S. M. Rubens. (*Phys. Review*, 1st March 1941, Vol. 59, No. 5, p. 476: summary only.)
2348. THE CORONIUM [New Explanation of Problem of Green Line (attributed to Iron Atoms Thirteen Times Ionised by Unidentified Radiation) and Other Lines: Coronal Matter similar in Chemical Composition to Meteorites: Indication of Very Short Ultra-Violet Rays from Sun, perhaps affecting Ionosphere].—B. Edlén. (*Science*, 16th May 1941, Vol. 93, Supp. p. 10.) News from Sweden. See also *Sci. News Letter*, 10th May 1941, p. 291-292.
2349. HELIOGRAPHIC SURVEY CHARTS FOR THE REPRESENTATION OF SPOT AND FACULA GROUPS ON THE SUN FOR THE ROTATION PERIODS OF 1938, WITH DEVELOPMENT TABLES FOR THE SPOT GROUPS.—W. Brunner. (*Hochf. tech. u. Elek. akus.*, May 1940, Vol. 55, No. 5, pp. 157-159.) Long description, by Zenneck, of this Zurich publication.
2350. FINAL RELATIVE SUNSPOT-NUMBERS FOR 1940.—W. Brunner. (*Terr. Mag. & Atmos. Elec.*, June 1941, Vol. 46, No. 2, pp. 219-221.)
2351. THE SUN AS A PRODUCER OF ENERGY [Part of Kelvin Lecture "The Sun and the Ionosphere"].—S. Chapman. (*Nature*, 28th June 1941, Vol. 147, pp. 792-794.) See also 2054 of August.
2352. 27-DAY RECURRENCE TENDENCY IN NORTH AMERICAN PRECIPITATION.—J. W. Mauchly. (*Phys. Review*, 1st March 1941, Vol. 59, No. 5, p. 469: summary only.)
2353. RECURRENCE PHENOMENA IN COSMIC-RAY INTENSITY [in Colorado: Secondary Pulses at about 28-Day Intervals before & after Primary Pulse: Doubt as to These Pulses & Chree's Magnetic Pulses having Different Origins: etc.].—J. W. Broxon. (*Phys. Review*, 15th May 1941, Vol. 59, No. 10, pp. 773-776.)
2354. CORRELATIONS BETWEEN COSMIC-RAY INTENSITIES AND METEOROLOGICAL CONDITIONS OVER WASHINGTON FOR 1939 [Variation depends 15% on Total Air Pressure, 40% on Air-Mass Distribution, only 10% on World-Wide Magnetic Changes, 30% Unaccounted for: etc.].—N. F. Beardsley. (*Phys. Review*, 1st March 1941, Vol. 59, No. 5, p. 470: summary only.)
2355. FURTHER EVIDENCE FOR A SINGLE COMPONENT IN THE PRIMARY COSMIC RADIATION [supporting Writer's Contention that Mesotrons are Secondary to Primaries (which contain No Electrons), that the Only Electrons in the Atmosphere are Secondary to the Mesotrons, etc.].—W. F. G. Swann. (*Phys. Review*, 15th May 1941, Vol. 59, No. 10, p. 836.)
2356. ON THE PRODUCTION OF MESOTRONS [Suggested Simplified Quantitative Model of Process], and DISTINCTION BETWEEN LONGITUDINAL AND TRANSVERSE MESONS.—J. F. Carlson & M. Schein: M. Kobayasi. (*Phys. Review*, 15th May 1941, Vol. 59, No. 10, p. 840: pp. 843-844.)
2357. STEADY-STATE SOLUTIONS OF TRANSMISSION-LINE EQUATIONS [I—Uniform Line: II—Number of Identical Sections in Tandem].—S. O. Rice. (*Bell S. Tech. Journ.*, April 1941, Vol. 20, No. 2, pp. 131-178.)
 "Often there arises the problem of determining the currents induced in a uniform transmission line by an arbitrary impressed field of some fixed frequency, or of determining the currents produced by generators placed in the branches of the sections if the line is of the second kind. This is the type of problem with which we shall be particularly concerned."
2358. STEADY-STATE DELAY [Phase & Envelope Delays] AS RELATED TO APERIODIC SIGNALS.—Hartley. (See 2459.)
2359. THE OPTICAL PROPERTIES OF TURBID MEDIA [New Treatment avoiding Assumption that Absorption Coefficient of Vehicle is Same as Average Coefficient for Entire Medium].—S. Q. Duntley. (*Journ. Opt. Soc. Am.*, June 1941, Vol. 31, No. 6, p. 463: short summary only.)

2360. THE DEFLECTION OF LIGHT RAYS BY A GENERAL ANISOTROPY [including Deflection of Electron Rays in an Electromagnetic Field].—P. Frank. (*Phys. Review*, 1st March 1941, Vol. 59, No. 5, p. 475: summary only.)
2361. ON THE PROPAGATION OF CYLINDRICAL AND SPHERICAL WAVES IN FRICTION-LESS GASES AND LIQUIDS.—K. Bechert. (*Ann. der Physik*, 11th March 1941, Vol. 39, No. 3, pp. 169–202.) For previous work see 32 of January.
2362. DAMPING OF WAVES BY SURFACE-ACTIVE SUBSTANCES [Oil on Water: Mathematical Analysis].—V. Levich. (*Journ. of Exper. & Theoret. Phys.* [in Russian], No. 11, Vol. 10, 1940, pp. 1296–1304.)
2363. ANOMALOUS PROPAGATION OF SEISMIC WAVES IN ASIA MINOR (EARTHQUAKE OF 27th DECEMBER 1939).—Giorgi. (*La Ricerca Scient.*, June 1940, Vol. 11, No. 6, pp. 403–408.)
2369. ON THE DETERMINATION OF ELECTRIC CHARGES IN THE ATMOSPHERE [Analytical Method of Calculating the Position and Magnitude of a Point Charge from the Values of Its Field measured at Four Stations].—P. Caloi. (*La Ricerca Scient.*, May 1940, Vol. 11, No. 5, pp. 295–297.) Prompted by the graphical method given by Medi, 1827 of 1939 (see also 2923 of 1940).
2370. SOME RECENT DEVELOPMENTS IN METEOROLOGICAL INSTRUMENTS [including Radiosondes: with Discussion of Further Desirable Developments].—F. J. Scrase. (*Journ. of Scient. Instr.*, July 1941, Vol. 18, No. 7, pp. 119–125.)

PROPERTIES OF CIRCUITS

2371. THE REACTANCE AND QUADRIPOLE THEORY OF INHOMOGENEOUS IDEAL LINES.—Eckart. (See 2408.)
2372. THE IMPEDANCE OF LINES WITH PERIODICALLY DISTRIBUTED IRREGULARITIES.—C. Traugott. (*E.T.Z.*, 10th April 1941, Vol. 62, No. 15, pp. 369–371.)
2373. THE CALCULATION OF THE CURRENT DISTRIBUTION IN CYLINDRICAL CONDUCTORS OF RECTANGULAR AND ELLIPTICAL CROSS SECTION.—H. G. Gross. (*E.T.Z.*, 16th May 1940, Vol. 61, No. 20, p. 455–456: summary only, from *Arch. f. Elektrot.*, No. 5, Vol. 34.)
2374. THE INFLUENCING OF THE CURVE FORM OF PROCESSES BY THE DISTORTION OF ATTENUATION AND PHASE.—Strecker. (See 2460.)
2375. THE USE OF QUARTZ CRYSTALS IN WAVE FILTERS [particularly the Separation between Resonant & Antiresonant Frequencies (0.4% of Resonant Frequency) and Its Dependence on Quartz Constant: Consequences in Design of Band-Pass Filters].—R. E. Knox. (*Electronics*, Nov. 1940, Vol. 13, No. 11, pp. 78–80: long summary.)
2376. FILTER DESIGN CHARTS: III [Elements of m -Derived Band-Pass Sections from Corresponding Constant- k Sections].—J. Borst. (*Electronics*, Nov. 1940, Vol. 13, No. 11, pp. 41–42.) Contd. from 718 of March.
2377. THE INPUT ADMITTANCE OF A TWO-CIRCUIT HIGH-FREQUENCY BAND FILTER WITH DAMPING REDUCTION OF THE SECONDARY CIRCUIT.—J. Mühlner. (*Hochf. tech. u. Elek. akus.*, May 1940, Vol. 55, No. 5, pp. 137–141.)
- Further development of the work dealt with in 520 of 1940. The effect of a damping reduction of the primary circuit was shown in that paper to be a displacement of the null-point P (Fig. 7: cf. also Fig. 2A of the present paper) to a position corresponding to the reduced losses in the first circuit brought about by the retroaction: the input admittance is not markedly affected by this. When, on the other hand, damping reduction is applied instead to the second circuit, the input admittance behaves very differently, although so far as the voltage U_2 across the second circuit (Fig. 1) is concerned, it does not matter which circuit

ATMOSPHERICS AND ATMOSPHERIC ELECTRICITY

2364. THE LIGHTNING AND SPARK DISCHARGES [Charge leaving Cloud in Flash to Earth probably 50% Larger than Previous Estimates, but Potential of Cloud Base probably only Few per Cent of Previous Estimates: Proposed Explanation of "Dart"-like Appearance of First Leader Stroke as Sudden Transition of Newly Formed Portions of Advancing Streamer from Glow to Arc Conditions: etc.].—C. E. R. Bruce. (*Nature*, 28th June 1941, Vol. 147, pp. 805–806.) See also E. R. A. Report, Ref. S/T 18a (Bruce & Golde).
2365. CLOUD AND EARTH LIGHTNING FLASHES.—J. A. Chalmers. (*Phil. Mag.*, July 1941, Vol. 32, No. 210, pp. 77–83.)
- A "first approach" to the explanation of the different relative frequency of occurrence of cloud and earth flashes in tropical (and semi-tropical) climates on the one hand and temperate climates on the other, on the supposition that the differences depend on differences in temperature levels and cloud levels.
2366. ON THE NATURE OF GLOBULAR LIGHTNING.—J. Frenkel. (*Journ. of Exper. & Theoret. Phys.* [in Russian], No. 12, Vol. 10, 1940, pp. 1424–1426.)
2367. THE EARTHING SYSTEM AND THE MEASUREMENT OF ITS RESISTANCE.—V. Fritsch. (*E.N.T.*, April 1940, Vol. 17, No. 4, pp. 77–85: Correction to caption, *ibid.*, June, No. 6, p. 139.) Very much on the same lines as the paper dealt with in 153 of January.
2368. THE RECOMBINATION LAW FOR WEAK IONISATION [Test of Equation implying Linear Law (313 of February)].—P. J. Nolan. (*Nature*, 5th July 1941, Vol. 148, p. 26.) In the region ($q = 360$ –120) where the law $q = \alpha n^2$ appears to hold, α comes out at 1.56×10^{-6} , "closer to the values obtained by the earlier workers than to the more recent values such as that of Sayers" [883 of 1939: see also 2136 of 1940].

the damping reduction is applied to. The behaviour is analysed, for this case, on the assumption of two similarly tuned circuits and of a retroactive coupling which is pure in phase, so that the resonance frequency of the damping-reduced secondary circuit does not vary with the back-coupling. Symmetrical curves are thus obtained throughout.

Fig. 3 shows the circuit examined. Eqn. 2, for the input admittance, shows that the diameter of the "retroaction circle" (Fig. 2A) is proportional to the sharpness of resonance ρ_2 of the damping-reduced secondary circuit. Since this damping reduction is practically an increase in the sharpness of resonance, the circle diameter becomes larger as the back-coupling is increased. Fig. 4A shows the calculated vector diagram of the input admittance (for the case of a tight coupling—beyond the critical value—between the two circuits: $k = C_2/C = 2/\rho_1$) for various stages in the damping reduction of the secondary circuit, while Fig. 4B gives the measured frequency characteristics of the input impedance for about the same value of coupling. Thus the vector-diagram input-admittance curve *a* of Fig. 4A (without any retroaction) has a corresponding measured input-impedance characteristic *a* ($\rho_2 = 100 = 1.1\rho_1$) in Fig. 4B. Circle *b*, when the retroaction introduced has about doubled the sharpness of resonance ρ_2 , has its diameter similarly doubled: the more or less corresponding input-impedance characteristic *b* in Fig. 4B (erroneously called *a* in the text) shows a deeper trough and a certain heightening of the maxima. Circle *c* ($\rho_2 = 4\rho_1$) already runs off the page, and in *d*, when all secondary-circuit losses have been abolished by retroaction, the arc of the "retroaction loop" is represented by a twice-traversed vertical straight line: the input admittance, at the middle frequency of the band, jumps suddenly from $-\infty$ to $+\infty$. Correspondingly, the curve *d* in Fig. 4B, which is the measured input-impedance characteristic for this limiting case of damping reduction in the secondary circuit, shows a trough at the mid-band point reaching right down to zero, together with two maxima each of height $\rho_1\sqrt{L/C}$, which is that of the undistorted resonance curve of the first circuit. Thus for the middle frequency of the band the band-filter input acts as an absolute short-circuit, so that a damping resistance connected in parallel with the primary circuit can have no effect whatever, at this frequency, on the secondary voltage. This point is further developed, and confirmed experimentally (Fig. 5).

On increasing still further the retroactive coupling for the damping reduction of the secondary circuit, without rendering the arrangement unstable, the input-admittance circles *e* and *f* of Fig. 4A are obtained, now turned towards the left: the resonance-sharpness of the secondary has passed through infinity to negative values, and the diameter of the circle grows smaller as the retroaction is increased. Since the null point *P* now comes within the loop, an additional phase rotation of 360° appears, so that the total phase rotation of the input admittance now amounts to 540° instead of 180° . Whereas for the "limiting" damping reduction $\rho_2 = \infty$ the filter input behaved to the mid-band frequency as a short-circuit, it now behaves as a negative resistance: self-excitation must occur if an equally

large positive resistance (e.g. generator internal resistance) is connected in parallel to this negative resistance. The measured input-impedance characteristics *e* and *f* of Fig. 4B completely agree with the vector diagram. Further increase of the retroaction causes the vector-diagram loop to contract to curve *g*, and self-excitation sets in when the crossing point of the loop reaches the null point *P*: this occurs when $\rho_2 = -\rho_1$. The last section of the paper deals similarly with the slightly different behaviour of the same circuit with a loose (below-critical) coupling.

2378. A DIRECT-CURRENT AMPLIFIER EMPLOYING NEGATIVE FEEDBACK FOR MEASURING STELLAR PHOTOELECTRIC CURRENTS [Current Amplification of 10^7 with Four Valves—Full-Scale Deflection for 5×10^{-12} A].—Q. S. Heidelberg & W. A. Rense. (*Review Scient. Instr.*, Nov. 1940, Vol. 11, No. 11, pp. 386–388.)
2379. THE CATHODE-FOLLOWER STAGE [developed for Television Amplifiers & now used for Other Purposes, particularly in Detector Circuits: Characteristics & Theory of Operation].—E. Williams. (*Wireless World*, July 1941, Vol. 47, No. 7, pp. 176–177.)
2380. TRANSIENT PROCESSES IN D.C./A.C. INVERTERS [New Treatment, as Switch instead of Valve: Solution of Symbolic Differential Equations with help of Laplace Transformation].—J. Müller-Strobel. (*Arch. f. Elektrot.*, 25th Jan. 1941, Vol. 35, No. 1, pp. 45–65.)
2381. AN OPERATIONAL SOLUTION OF SWITCHING PROBLEMS [Direct Method, without Introduction of Fictitious Potentials].—T. J. Higgins. (*Elec. Engineering*, Nov. 1940, Vol. 59, No. 11, pp. 480–482.)
2382. COMBINATION VACUUM-TUBE SWITCH FOR DOUBLE-TRACE CATHODE-RAY OSCILLOGRAPH, AUDIO-AMPLIFIER, AND MIXER [Square Wave applied to Cathodes of Two High-Mu Pentodes: Alternative Methods of generating the Square Wave—Two-Diode Method, Two-Pentode Method using High-Transconductance Television - Amplifier Valves: Preference for Second].—H. K. Hughes & R. F. Koch. (*Review Scient. Instr.*, April 1941, Vol. 12, No. 4, pp. 183–187.)
2383. AN ELECTRONIC SWITCH AND SQUARE-WAVE OSCILLATOR [Multivibrator (Double-Triode) Wave improved & amplified by Two Sharp-Cut-Off Triodes before application to Switching Circuit (Two 6L7's)], and AN ELECTRONIC SWITCH FOR THE SIMULTANEOUS OBSERVATION OF TWO WAVES WITH THE CATHODE-RAY OSCILLOGRAPH [Similar to 294 of 1936 but with High-Vacuum-Valve Trigger Circuit instead of Thyratrons].—Cosby & Lampson: Reich. (*Review Scient. Instr.*, April 1941, Vol. 12, No. 4, pp. 187–190: pp. 191–192.)

2384. A HARD-VACUUM-TUBE PULSE EQUALISING SHARPENING CIRCUIT [Correction to One Sentence].—Huntoon & Strohmeyer. (*Review Scient. Instr.*, April 1941, Vol. 12, No. 4, p. 215.) See 1491 of May.
2385. THE EQUIVALENT CIRCUIT OF A TRANSFORMER WITH SEVERAL TAPPINGS.—M. Skalicky. (*E.T.Z.*, 9th May 1940, Vol. 61, No. 19, p. 418.)
2386. AUTO-TRANSFORMERS IN MODULATION CIRCUITS [Advantages in High Efficiency & Low Cost: Discussion of Principles applying to R.F., A.F., & Power Transformers, but particularly to Modulators].—T. A. Gross. (*Electronics*, Nov. 1940, Vol. 13, No. 11, pp. 52-58.)

TRANSMISSION

2387. ADDITION TO THE PAPER "THE PHASE FOCUSING OF ELECTRON BEAMS TRAVELLING IN A STRAIGHT LINE" [Velocity-Modulated Oscillators & Amplifiers].—F. Borgnis & E. Ledinegg. (*Zeitschr. f. tech. Phys.*, No. 1, Vol. 22, 1941, pp. 22-23.)

This is the supplementary note on the Fourier analysis of $v(\tau)$ at low depths of modulation, promised at the end of 1638 of June. "The possibility of obtaining a focus of an order higher than the second . . . is shown by the following example . . . By adding the first harmonic to the fundamental, a focusing of the fourth order can be obtained at low depths of modulation". Hollmann has called the writers' attention to his paper dealt with in 2544 of 1940.

2388. THE MODE OF ACTION OF THE FOUR-SLIT MAGNETRON.—I. Runge. (*E.T.Z.*, 10th April 1941, Vol. 62, No. 15, p. 381: summary only, from *Telefunken-Röhre*, No. 18, 1940, pp. 1-17.)

For the explanation of this mode of action, one must be able to survey the combined working of all electrons of whatever direction and phase of emergence. Since the electron paths alter under the influence of the h.f. alternating potential, an exact solution of this problem is not possible. In the present work, therefore, the various influences on the electron paths are considered one by one, in order to be able to synthesise the total action.

The effect of the superposed a.c. field is first calculated for a plane electrode system. In a uniform d.c. field in the y -direction, with a magnetic field at right angles to this, the electron path is the usual cycloid. With an added a.c. field in the y -direction the path becomes a cycloid with varying roll-circle, as it does also with an a.c. field superposed perpendicularly to the y -axis, corresponding to the tangential fields of the magnetron. Additional fields are also considered, acting only at certain points of the space, so that the electron comes under their influence only during its passage through certain parts of its path. For the a.c. field in the y -direction, enlarged and diminished cycloids appear, with the roll-circle slowly increasing. For the a.c. field in the direction perpendicular to the y -axis, the roll-circle radius increases with a downward directrix for a positive direction of field,

while for a negative field-direction the radius decreases with an upward directrix.

In cylindrical systems the electron path in a radial d.c. field combined with a magnetic field can be calculated exactly for certain potential distributions. But to be able to take superposed a.c. fields into account, a simplification is made here, by supposing the tangential a.c. field to be concentrated in a narrow zone at the edge of the circular discharge space. Thus the electron moves over almost its whole path under the influence only of the radial d.c. field, but at the culmination point is given a sudden additional velocity by its passage through a short strong field zone. The change of path produced by this positive or negative additional velocity is calculated. The influence of an a.c. field acting for a longer time on the electron can be deduced. Electrons which are subjected to a radial additional field, so that their culmination points lie in the neighbourhood of the mid-points of the segments, will (as in the case of the plane system) practically only increase or decrease their path-curves: on the other hand, electrons which come into a tangential field at the slits will suffer a deflection of their path direction, an inwards deflection in the case of absorption of energy, an outwards deflection in the case of a giving-up of energy.

The writer then examines how the effects are combined for the whole collection of electrons of all phases and directions of emergence. It is found that a continuous exchange takes place between neutral, out-of-phase, and correctly-phased electrons, so that every electron, originally out-of-phase, at the next revolution is correctly-phased and remains so during several revolutions (multiple damping-reduction). But at each revolution it loses energy, till once more it falls out of step unless it has meanwhile reached the anode. Correct-phase electrons thus proceed gradually outwards, out-of-phase electrons inwards. For these magnetron oscillations ($n = 2$) the efficiency is about 50%. This high value is attributed primarily to the above properties. For the half oscillatory-circuit frequency ($n = 4$) the relations are quite different: correctly-phased electrons become out-of-phase after two revolutions, and the efficiency of 20% represents at most a single damping-reduction.

2389. ON THE ELECTRON MECHANISM IN THE RETARDING FIELD VALVE.—F. W. Gundlach & W. Kleinsteuber. (*Zeitschr. f. tech. Phys.*, No. 3, Vol. 22, 1941, pp. 57-65.)

From the Julius Pintsch laboratories. "As a supplement to a series of papers on the retarding-field valve ["Resotank," 2258 of 1938: Kleinsteuber, 3925 of 1939, 1374 of 1940, and 1861 of July], we give here some mathematical details which have not yet been published. In connection with these, a comparison will be made between new measurements on these valves and calculated values." The work should be of interest with regard to the distinction between the two possible types of mechanism: "which of these two mechanisms, the swinging-to-&-fro or the simple go-and-return of the electrons, is actually responsible for the generation of h.f. oscillations depends above all on the geometrical form given to the grid."

Authors' summary:—"The assumption, often made in the literature and here adopted, that in the retarding-field valve the electron motion is a simple go-and-return, is closely examined, and it is shown that the majority of the electrons entering the retarding-field space (h.f. space) make only a single passage and return and are then absorbed at the grid. This result is obtained by plotting the potential distribution between the valve electrodes in a model test with the electrolytic trough and by the graphical construction of the electron paths in the potential picture thus derived.

"The behaviour of the retarding-field valve depends on the path-time of the electrons for a simple go-and-return journey in the h.f. space, as is shown by the agreement between calculation and measurement. Calculation gives the h.f. conductance between the grid and the retarding electrode for a cylindrical system: in the measurements, the h.f. conductance is determined from the damping or damping-reduction of a h.f. circuit connected in parallel to the grid/retarding-electrode space.

"Multiple swings of a small number of electrons may cause certain deviations in the behaviour of the retarding-field valve: but if it is desired to take, as foundation for the theoretical treatment, the electron transit-time between cathode and reversal-zone (reciprocal of the swing frequency) instead of the transit-time in the h.f. space, a completely different position of the oscillation region must result.

"The comparison between calculation and measurement is carried out over a complete grid potential/retarding-electrode-potential field which stretches over several hundred volts and includes path-time angles between 4 and 25. In this region there are three zones of oscillation and three of damping."

2390. FREQUENCY MODULATION [Theory of Interference: Spectra of Phase & Frequency Modulations: Practical Considerations: etc.].—Everitt. (See 2555.)
2391. THEORY OF RECTIFIER MODULATORS [Comparison with Valve Modulators: Ring-Bridge Modulator (Commutator Theory: More Rigorous Theory, as Resistance-Controlled Passive Linear Network): Other Types: Matching to Load Admittances: R.M. interlinked between Wave Filters: etc.].—S. Kruse. (*Ericsson Technics*, No. 2, 1939, 54 pp: in English.) For a somewhat similar treatment see 1864 of 1939 (Peterson & Hussey).
2392. AUTO-TRANSFORMERS IN MODULATION CIRCUITS.—Gross. (See 2386.)
2393. KEYING THE CRYSTAL OSCILLATOR, AND SOME OBSERVATIONS ON BLOCKED-GRID AMPLIFIER KEYING.—B. Goodman. (*QST*, May 1941, Vol. 25, No. 5, pp. 10-13.) Illustrated by oscillograms.
2394. AN IMPROVED ELECTRON-COUPLED OSCILLATOR: NEGATIVE TRANSCONDUCTANCE CIRCUIT WITH BETTER STABILITY AND OUTPUT-CIRCUIT ISOLATION.—D. F. Metcalf. (*QST*, May 1941, Vol. 25, No. 5, pp. 14-17 and 74.)

2395. A MOBILE POLICE TRANSMITTER [Type A69-1, using New Hytron Valves with Instant-Heating Thoriated-Tungsten Filaments which require No Power during Stand-By and have Low Filament Consumption].—(*Communications*, Nov. 1940, Vol. 20, No. 11, pp. 9-12 and 33, 34.)

2396. SPEECH POWER FOR POLICE COMMUNICATION WORK [Use of 6A6 Valve at Increased (400 v) Voltage as Class B Modulator for 40 Watts Peak Power].—D. Fortune. (*Communications*, Nov. 1940, Vol. 20, No. 11, pp. 15-16 and 34.)

RECEPTION

2397. EFFECT OF ARRIVING ULTRA-SHORT-WAVE SIGNAL ON IONISATION STATE OF GASEOUS-DISCHARGE PLASMA [acting as Dielectric of Tuning Condenser in Circuit constantly excited by Long-Wave Generator] USED FOR RECEPTION.—H. E. Hollmann. (*Hochf.tech. u. Elek.ahus.*, June 1940, Vol. 55, No. 6, pp. 199.) "Sensitivity sufficient even for millimetric waves": Telefunken Pat. No. 686 268.
2398. THE SELECTIVITY OF RECEIVING RECTIFIERS.—O. Tüxen. (*Zeitschr. f. tech. Phys.*, No. 1, Vol. 22, 1941, pp. 1-9.)

From the author's summary:—"For the various types of receiving rectifiers the ratio is investigated in which two modulated oscillations, present simultaneously at the input of the detector, will be demodulated. It is established that this ratio depends on the nature of the rectifier, so that to each type of rectifier can be assigned a more or a less high selectivity, which is not a constant but a definite function (depending on the type) of the ratio of the carrier amplitudes.

"With a square-law detector the l.f. amplitudes (for equal depths of modulation) arising from the two oscillations, and representing their modulations, behave as the squares of the corresponding carrier amplitudes. The demodulation of the one oscillation is not affected by the presence of the other. With the ideal linear detector the ratio of the l.f. amplitudes is, as is found by the investigation of the non-sinusoidal beat [Fig. 3], similarly proportional to the ratio of the squares of the carrier amplitudes (in contrast to the case when the two rectifications are kept separate [when the ratio is directly proportional to the carrier amplitudes]), but the selectivity is about twice as good as that of the square-law detector.

"This selectivity cannot be attained in the diode and audion, even in the linear portion of the rectification characteristic, unless the circuit elements on the h.f. and l.f. sides are so designed that non-linear distortion (and consequently a second rectification) cannot make its appearance. In order to obtain the highest selectivity for the whole arrangement the discharge time-constant of the load condenser [in the l.f. circuit: "C" in the equivalent-circuit diagram of Fig. 5] should be made equal to the time-constant of the input

oscillatory circuit. If on the other hand the discharge time-constant is distinctly larger than that of the h.f. circuit, as well as distinctly larger than a beat period, the ensuing secondary rectification will make the selectivity considerably lower; the l.f. amplitudes may in certain circumstances be directly proportional to the carrier amplitudes.

"With the logarithmic detector the modulation of the weaker signal is completely inaudible, since the deviation of the beat wave from the sinusoidal form is compensated, as regards the average value, by the distortion introduced by the logarithmic detector [the reason why the *linear* rectifier does not almost completely suppress the weak signal, as might be expected from preliminary considerations, is shown on p. 3, l-h column, to be this deviation of the beat wave from the sinusoidal form. As regards the logarithmic detector, this can be obtained approximately by a combination of several audion circuits, or by a single audion with a suitably chosen anode-current/grid-potential characteristic—Telefunken, Roosenstein, German Pat. 618 797. The objection to the logarithmic detector is its comparatively large coefficient of non-linear distortion, which for low degrees of modulation may amount to a quarter of the degree of modulation, as in the case of the square-law detector].

"With the 'multiplicative demodulator' [Telefunken, Urtel, German Pat. 670 585: Fig. 7, in which two control grids, separated by a screen grid, are supplied with the received frequency-mixture and with an auxiliary carrier, respectively] only that oscillation is demodulated in which the auxiliary carrier is multiplicatively mixed with the incoming oscillation. Both the last two types of rectifier must be considered to have infinitely high selectivity" [but the "multiplicative demodulator," in contrast to the logarithmic detector and also to the linear detector in the presence of an interfering signal, has a non-linear-distortion factor of zero for a straight-line characteristic. Whether the additional gear involved will prevent the "multiplicative demodulator," in spite of its theoretical advantages, from supplanting the simple and (when properly designed) really good diode circuit, "remains to be seen"]. For Urtel's work on the mode of action of diode detectors see 1933 Abstracts, p. 623.

2399. THE INFLUENCE OF THE COLOUR OF THE GLAZE ON OVERHEAD-LINE INSULATORS ON THE FLASH-OVER DANGER [especially "Sunrise Flash-Over"].—W. Weber & M. Pfeifer. (*E.T.Z.*, 20th June 1940, Vol. 61, No. 25, pp. 561-564.)

2400. IT WORKS ANYWHERE [Paragraph on American G.E.C. Portable with Many Alternative Supplies].—(*Wireless World*, July 1941, Vol. 47, No. 7, p. 194.)

2401. "TRANSPORTABLE RUNDUNKEMPFÄNGER FÜR DIE REISE UND HEIM" [Book Review].—A. Ehrismann. (*Zeitschr. f. tech. Phys.*, No. 2, Vol. 22, 1941, p. 43.) Down to the smallest "pocket" receiver.

AERIALS AND AERIAL SYSTEMS

2402. COUPLED RADIATION FIELDS IN THE CYLINDRICAL TUBULAR CONDUCTOR [Calculation of Radiation Field of Dipole situated inside a Perfectly Conducting Cylindrical Tube and perpendicular to Tube Axis: the Tangential Dipole & the Radial Dipole, Electric & Magnetic: Application to Some Types of Ring Transmitters].—H. Buchholz. (*Ann. der Physik*, 9th Feb. 1941, Vol. 39, No. 2, pp. 81-128.)

The radiation field both of the radial and of the tangential dipole is quite different from that of an axial dipole such as was dealt with by Weyrich (*Journ. f. reine und angew. Math.*, 1934, Vol. 172, pp. 133-150): the total field is made up of two coupled fields, each of which (considered separately) consists of an infinite number of component fields. This coupling of the fields, due simply to the particular position of the dipole, has nothing to do with the known resistance-coupling of radiation fields such as occurs with an axial dipole in a hollow conducting guide when the surrounding space is not free from resistance (Carson, Mead, & Schelkunoff, 2504 of 1936): in all such cases one of the two fields vanishes as soon as the conductivity of the surrounding material increases beyond a limiting value. The coupling effect considered in the present case, on the other hand, occurs even with a perfectly conducting shell.

The formulae obtained in sections II and III are applied in section VI to three types of "ring" transmitters, in which the circular ring is coaxial with the hollow guide. The simplest type (in theory) is that in which the ring is traversed by a current which is constant in magnitude and phase over the whole free length of the ring; but the necessity for this constancy is avoided in the arrangement shown in Fig. 7 (an American patent) where the ring is divided into four parts joined by four loops so dimensioned that they take up four negative half-waves, leaving each of the four arcs occupied by a complete positive standing half-wave, the effects of the four loops on the external field cancelling out. The last type of ring transmitter considered is that in which the ring is traversed by a progressive wave.

2403. FUNDAMENTAL CONSIDERATIONS ON THE CURRENT AND POTENTIAL DISTRIBUTION ON AERIALS.—O. Zinke. (*Arch. f. Elektrot.*, 20th Feb. 1941, Vol. 35, No. 2, pp. 67-84.)

"With the development of [ultra-] short-wave and decimetric-wave technique and the introduction of television, everything to do with aerials has been put into a state of flux. It is remarkable that among all the mass of papers on new types of aerial, their radiation diagrams and their radiation resistances, certain fundamental problems have been left unsolved—such, for instance, as the nature of the current and potential distribution, the establishment of a strict telegraphic equation for the radiating aerial, and the definition of the dynamic inductance and capacitance per unit of length. With these is connected the calculation of the radiation resistance and reactance of simple and coupled radiators." Both the usual methods of calculating radiation resistance (the distant-field

integration method and the Brillouin-Pistolkors retarded-potentials method) give the same result if the same current distribution is assumed, but both are quite unorthodox compared with the calculation of the impedance of a double line: with the double line the power and impedance are obtained as the product and quotient of the line potential and line current corresponding to current and potential distributions which are perfectly definite for a given terminating resistance. "It must be possible to apply this simple method, usual for long lines, also to aerials, if the true current and potential distribution is known. Hitherto it has been customary, with an aerial whose length is comparable with the wavelength, always to start out from the assumption of sinusoidal distribution and from the law of a pure progressive wave. Actually, for radiating aerials and lines such an assumption for the current distribution should be regarded merely as a first approximation. [In the present work] the current distribution will be determined through the Maxwell field equations in conjunction with the limiting conditions at the aerial ends. The more exact prosecution of the field equations will lead to lucid relationships calculated to close the above-mentioned gaps." The aerials considered have their axes straight: their diameter may vary arbitrarily with their length, but must not attain the order of magnitude of the wavelength—so that the special results of the work are not applicable to horn antennae for decimetric waves.

The treatment is based on the representation of the Maxwell equations in potential form. Author's summary:—"After reducing the field quantities \mathcal{G} and \mathcal{H} to the vector potential \mathcal{A} and a scalar potential ϕ , the telegraphic equations of the radiating aerial are derived in an exact form [eqns. 23, 24] and compared with the ordinary double-line theory. From the ratio of the vector potential to the aerial current at each point on the aerial the concept of the 'characteristic impedance' \mathcal{Z} of the [radiating] aerial is defined. With \mathcal{Z} are also obtained the dynamic aerial inductance and capacitance [per unit length: eqns. 30, 31]. The characteristic impedance \mathcal{Z} represents, as in the case of a homogeneous double line, the ratio of potential to current for a partial wave. For a forward-moving wave train there is a characteristic impedance \mathcal{Z}_+ , which differs from \mathcal{Z} , the characteristic impedance for the backward-moving wave: \mathcal{Z}_+ and \mathcal{Z}_- are, moreover, not constant along an aerial with constant diameter, but vary with place [these properties form two points of departure from ordinary line theory. Both \mathcal{Z}_+ and \mathcal{Z}_- vary in value, also, with the ratio of aerial-length to wavelength] . . ." As is seen in section VII, the solution of the differential equation for \mathcal{A} (eqn. 37) shows that the current consists of a progressing wave and a returning wave, propagating along the aerial with a velocity u' and suffering an attenuation corresponding to the heat developed in the conductor and the radiation losses. Since \mathcal{Z} not only depends on the position along the aerial but also at any point has different values for the progressing and returning waves, the current cannot propagate in a pure sine wave: a sinusoidal distribution is

only possible with a constant \mathcal{Z} . The final equations 41a and 42a, representing the solution of the telegraphic equation of the radiating aerial, taking ohmic loss into consideration, are compared with the corresponding equations for the double line: it is seen that the difference as regards potential distribution merely takes the form of different constants, whereas the current distribution, owing to the variation of \mathcal{Z}_+ and \mathcal{Z}_- with position, differs greatly from the usual form.

2404. ON THE OPTIMUM DESIGN OF TWO-ELEMENT RADIATION-COUPLED DIRECTIVE AERIALS: CORRECTIONS.—Fausten. (*Arch. f. Elektrot.*, 20th Feb. 1941, Vol. 35, No. 2, p. 126.) Thirteen corrections (four due to the old trouble of the typed "1" and "l") to the paper dealt with in 1071 of April.
2405. SUCCESSFUL 56-Mc/s ARRAYS.—E. P. Tilton. (*QST*, May 1941, Vol. 25, No. 5, pp. 23-26.)
2406. COMPUTATION OF ELECTRIC FIELD STRENGTH OF A HALF-WAVELENGTH ANTENNA ABOVE A PLANE EARTH AS A FUNCTION OF THE ENERGY SUPPLIED TO THE ANTENNA PER SECOND: I & II.—K. F. Niessen & others. (*Review Scient. Instr.*, April & June 1941, p. 246 & p. 350: references only, to papers in *Physica*, July & Dec. 1940, Vol. 7, pp. 586-602 & pp. 897-908.)
2407. THE RADIATION RESISTANCE OF A STRAIGHT LINEAR RADIATOR FOR DAMPED PROGRESSIVE WAVES.—W. Jachnow. (*E.N.T.*, July 1940, Vol. 17, No. 7, pp. 141-149.)

From the Telefunken laboratories. For previous work see 3948 of 1939 and 585 of 1940. "Aerials worked with standing waves are as a rule little more than a half-wavelength long and have only low attenuation. In calculating their radiation resistance, therefore, no attention need be paid to the attenuation. This however becomes considerable, and no longer to be neglected, for long-wire aerials which are several wavelengths long and work with progressive waves. With low attenuation the current amplitude can be regarded as constant over the whole length of the aerial, so that in calculating the radiation resistance the latter can be related to this amplitude, but for higher attenuation the question arises to which amplitude among the various values along the aerial the radiation resistance should be referred. For instance, if the amplitude sinks, from the beginning to the end of the aerial, to one half, the radiation resistance with reference to the end current amounts to only a quarter of that referred to the current at the beginning of the aerial. A careful examination of this question forms the subject of this work. On the assumption that exponentially damped progressive sine-waves are formed on the aerial, the radiated power and radiation resistance of a straight linear aerial are calculated. The aerial is assumed to be at such a distance from other conductors that any mutual radiation (coupling) can be neglected [though the method adopted is to start with the aerial running parallel to a second conductor of equal length, and then to reduce the spacing progressively until the two become merged in one].

"For a range covering practical requirements, an approximate formula (eqn. 39) is derived and the possible error involved is estimated (eqn. 40). The radiation resistance, which is now a function of the relative length l/λ and over-all attenuation [transmission equivalent] βl , is plotted in Fig. 3 for various values [from 0 to 0.5] of βl . To obtain the radiation resistance of an aerial it is thus necessary to know the attenuation, which depends on the total line losses and the characteristic impedance of the aerial (eqn. 49 [or, for very low attenuations, eqn. 50]. The thermal losses due to the dissipative impedance R_w are negligible compared to the others until the decimetric-wave region is reached. If, for simplicity's sake, the loss resistance R_s is also neglected, eqn. 49 reduces to $1 - e^{-2\beta l} = R_s/Z$, where R_s is the radiation resistance]). As an example, Fig. 6 shows the characteristic curves of the attenuation as a function of the relative length l/λ , for two aerials with different characteristic impedances: only the radiation losses are taken into account.

"The broken-line curves introduced into Fig. 3 show, as examples, the radiation resistance of these two aerials, to give an idea of the course of the radiation resistance for damped progressive waves": one aerial, of length 5λ and characteristic impedance 500 ohms, shows a value 20% smaller than that for undamped waves ($\beta l = 0$): the other, of the same relative length but of 250 ohms characteristic impedance, shows a difference of 35%. Since only the radiation losses were considered, the actual differences must have been still greater.

2408. THE REACTANCE AND QUADRIPOLE THEORY OF INHOMOGENEOUS IDEAL LINES.—G. Eckart. (*Hochf.tech. u. Elek. Akus.*, June 1940, Vol. 55, No. 6, pp. 173-186.)

"Problems relating to the potential and current distribution on inhomogeneous lines have been dealt with in numerous works, as a glance at the literature references at the end of this paper will show; but hitherto there has been lacking a fundamental investigation of their reactance and quadriple properties. A general theory for these will be developed in the following pages and illustrated by special examples. . . . These examples are so chosen that the differential equations lead to known functions, namely exponential and cylindrical functions. Further examples could of course be adduced, chosen so that our differential equations would yield other functions, such as hypergeometric ones: but such examples will be neglected here, since they would not provide the general theory with anything really new". The lines considered have inductances and capacitances which are functions of place (*i.e.* of distance along the line); they are ideal in that their loss resistance and leakage are zero.

The development of the general theory brings with it proof that the quadriple determinant of the inhomogeneous line is equal to unity, and that the Zobel reactance law (primarily applied to circuits composed of a finite number of reactances) applies also to systems with an infinite number of elements, and thus to systems with continuously distributed inductance and capacitance such as an ideal line in the open- or short-circuited condition.

It also includes section 4 on a special property of the homogeneous line for certain natural frequencies (and the effect of deformation by making the ends converge or diverge), section 5 on the asymptotic distribution of the natural frequencies, and section 6 on the laws of the null points and poles of the open-circuit and short-circuit impedance of reactance quadriple, and their application to the inhomogeneous ideal line.

In Part II, the first example of the application of the general theory is to the exponential transmission line: "Burrows [458 (*see also* 1453) of 1939] has published an investigation of this line dealing with its properties as an impedance transformer and also pointing out its qualities as a filter. For our part we shall choose another aspect of the problem: we shall give the short-circuit and open-circuit reactances, discuss the natural frequencies, and finally consider the filter properties of the 'double symmetrical line of the 1st type'" [made up (*see* Figs. 15/17) of two such exponential lines: section I of Part II]. The second example is that of a line in which the inductance increases with a power n of the length, and which is therefore referred to as a "power" line: the parallel-wire and concentric types are considered. The cases when $n = +2$ and $n = -2$ are discussed briefly.

2409. REGULATIONS CONCERNING OUTSIDE AERIALS IN THE CANTON OF GENEVA [must conform to Standards of Public Security & Aesthetics: etc.].—(*Bull. Assoc. suisse des Elec.*, 25th April 1941, Vol. 32, No. 8, pp. 179-180.)

2410. THE EARTHING SYSTEM AND THE MEASUREMENT OF ITS RESISTANCE.—Fritsch. (*See* 2367.)

VALVES AND THERMIONICS

2411. THE MODE OF ACTION OF THE FOUR-SLIT MAGNETRON.—Runge. (*See* 2388.)

2412. ON THE ELECTRON MECHANISM IN THE RETARDING-FIELD VALVE.—Gundlach & Kleinstauber. (*See* 2389.)

2413. TRAVELLING WAVES IN ELECTRON BEAMS [Non-Mathematical Exposition of Theory involved in Design of Velocity-Modulated U.H.F. Generators].—S. Ramo: Hahn. (*Communications*, Nov. 1940, Vol. 20, No. 11, pp. 5-8 and 24, 25.)

2414. INSIDE THE KLYSTRON [Cut-Away View of Generator made by Westinghouse under Sperry Patents: Output 200 W at 40 cm with about 50% Efficiency].—(*Electronics*, Nov. 1940, Vol. 13, No. 11: front cover.)

2415. ELECTRONIC AMPLIFIER VALVES WITH STATIC SECONDARY-EMISSION MULTIPLICATION [Frequencies up to 100 Mc/s].—W. Flechsig & M. Sandhagen. (*E.T.Z.*, 24th April 1941, Vol. 62, No. 17, pp. 413-414: summary only, from *Mittel. Fernseh.-A.G.*, Vol. 2, 1940, p. 16 onwards.)

Methods are considered for the simultaneous modulation of an electron current and its amplification by secondary-electron multiplication. It is first assumed that the modulation has been accom-

plished and that the modulated current has to be amplified by a fixed amount, independent of the modulating action. In view of the fact that for a given band width the amplifying action of a s.e. multiplier is the better, the larger the ratio slope/output-capacitance, it is seen that for the best results the *relative* slope of the valve, that is the ratio input-slope/input-current, must be made as high as possible: for in a s.e. multiplier the input reposes-current is also amplified, so that if this is large, and overheating is to be avoided, the s.e. electrodes as well as the target must have large surfaces, and this means a large output capacitance. Another reason for making the relative slope as large as possible is in order that the input current should be as nearly as possible completely modulated.

To increase the relative slope, therefore, the working point is placed not in the region of the characteristic governed by the Langmuir equation but in the initial-current region [cf. Weiss & Peter, 1466 of 1939]. Now with a fixed cathode-grid system the initial current can be influenced by the cathode temperature and the grid potential, but in addition to these only by a potential, in the plane of the grid, produced by outer electrodes: the system was therefore surrounded by an additional electrode of suitable diameter. With such an arrangement the initial-current characteristics "a" of Fig. 5 were obtained, for four different voltages on the outer electrode: the diagram also includes a single curve "b" (grid-current curve) which hardly altered at all for the four voltages, so that a single input-impedance curve "c" also serves for the four cases. The values of the relative slope are given by the tangents to the curves "a": "it is seen that the relative slope rises, as the negative grid bias is increased, to a fixed maximum value; further, that among the various equal values of the relative slope for the various parameters there is one at which the current has a max. value: here, therefore, the least s.e. multiplication is needed for the obtaining of a required amplification."

Apart from this method, depending on the displacement of a potential threshold, there is the possibility of controlling the current by displacing the electron trajectories by a modulated field, using a sharp beam deflected with respect to a sharp-edged screen so that more or less electrons are allowed to pass by the edge into the multiplier according to the amount of the deflection. With this arrangement, slopes of 2-4 A/V were obtained for an output current of 10 mA, whereas with the method of grid control in the initial-current region the slopes obtained were only 100 mA/V for the same current or, with a special valve, up to 3 mA/V for an output current of 300 mA. Finally, a third method was tried (Fig. 6) in which the electron paths were so deflected by the modulating potential that the number of electron-multiplying stages brought into action varied with the amount of deflection. The device took the form of a special "gauze"-type multiplier, the successive gauze electrodes each having a sharp edge which was staggered with respect to the preceding edge so that the series formed a set of "steps." If each "step" was 0.2 mm high, a displacement of 0.2 mm of the electron spot on the target electrode would make

the difference of putting into action one s.e. stage more or one less. Actually, the slopes attained by this arrangement were about the same as those with the last-described method. The multipliers were serviceable up to frequencies of 10^8 c/s: "the amplification factors were greater, by one or two orders of magnitude, than those of the latest ordinary amplifier valves, so that a wide-band amplification can still be carried out when ordinary valves fail. The noise level is just about the same as in ordinary amplifier valves."

2416. OPERATION OF ELECTROSTATIC PHOTO-MULTIPLIERS [and Their Applications].—Winans & Pierce. (See 2465.)

2417. TRIPLE-GRID SUPER-CONTROL VALVES [6SG7 & 12SG7 Metal-Type R.F. Amplifier Pentodes: Two Separate Cathode Terminals: particularly for High-Frequency and/or Wide-Band Operation].—R.C.A. (*Review Scient. Instr.*, June 1941, Vol. 12, No. 6, pp. 336-337.)

2418. THE ELECTRON PATHS IN MULTI-GRID VALVES.—J. L. H. Jonker. (*E.T.Z.*, 10th April 1941, Vol. 62, No. 15, p. 381: short summary only.)

"In tetrodes and pentodes the anode current increases strongly with increasing anode voltage and reaches its saturation value for an anode voltage of about 10% of the screen-grid voltage. It is desirable to keep the anode voltage at which saturation occurs as low as possible. This can be done if it is arranged that the electrons are not too much deflected by the wires of the various grids. Such deflection, and its influence on the anode-current/anode-voltage characteristic, is investigated theoretically and experimentally. The following means for reducing the deflection are mentioned: fine pitch of control and screen grids, arrangement of screen-grid wires in the electron shadow of the control grid, coarse pitch of the suppressor grid, and the mounting of this grid close to the anode."

2419. FREQUENCY CHANGING: A NON-MATHEMATICAL APPROACH TO THE THEORY OF THE HEXODE [with Use of Stretched-Rubber-Sheet Models].—J. Greig. (*Wireless World*, July 1941, Vol. 47, No. 7, pp. 172-175.)

2420. "SHOT EFFECT" IN TEMPERATURE-LIMITED DIODES [Derivation of Classical Formula by Method used by Bernamont (1715 of 1937) to derive Johnson-Effect Formula from Theory of Conductivity].—M. Surdin. (*Nature*, 5th July 1941, Vol. 148, p. 27.)

2421. THE "CORRELATION FUNCTION" OF THE CURRENT IN A SATURATED DIODE.—Coutines. (Mentioned in Surdin's letter, 2420, above.)

2422. A SIMPLE METHOD FOR MEASURING STEADY CURRENTS OF BRIEF DURATION [particularly for obtaining Valve Characteristics under Overload Conditions: based on Ballistic Use of Standard Indicating Instruments].—R. D. Bennett. (*Review Scient. Instr.*, June 1941, Vol. 12, No. 6, pp. 332-334.)

2423. THE THEORY OF SECONDARY ELECTRON EMISSION FROM DIELECTRICS AND SEMICONDUCTORS.—A. E. Kadyschewitsch. (*Journ. of Exper. & Theoret. Phys.* [in Russian], No. 12, Vol. 10, 1940, pp. 1384-1391.)

It is pointed out that the secondary emission from dielectrics and semiconductors is in many respects similar to that from metals and that the same theoretical considerations are therefore applicable to both cases. Accordingly, using the methods developed in a previous paper (*ibid.*, Vol. 8, 1939, p. 930; see also 3030 of 1940), in which the secondary emission from metals was discussed, the position of the maximum of the secondary-emission curve and the value of the secondary-emission coefficient are determined as functions of the position of the conductivity zone and of the width of the forbidden and occupied zones. The effect of the work function and internal potential on the secondary emission is also discussed.

2424. THE PHOTOELECTRIC EMISSION FROM THE OXIDE-COATED CATHODE, AND THE EXACT DETERMINATION OF ITS WORK FUNCTION [Experimental Investigation & Discussion of Results].—E. Nishibori & others. (*Proc. Phys.-Math. Soc. Japan*, Jan. 1941, Vol. 23, No. 1, pp. 37-43.) For previous work see 411 of February. "The spectral sensibility curve does not intersect with the frequency axis, but approaches it exponentially. Therefore we must perform a special procedure to get the threshold value. Photoelectric thresholds of BaO and SrO, thus determined, are 1.63 and 2.58 eV respectively, which are greater than the thermionic work functions. The work function of the solid solution of BaO and SrO is almost equal to that of BaO."
2425. VALVES WITH INSTANT-HEATING THORIATED-TUNGSTEN FILAMENTS, FOR MOBILE TRANSMITTERS.—Hytron. (In paper dealt with in 2395, above.)
2426. THE RÔLE OF THE COPPER IN THE TUNGSTEN-COPPER-BARIUM CATHODE [Examination of De-Activation Curves indicates Formation of a Cu-Ba Alloy, into which the Tungsten does Not enter: Measurement of Work Function of the Cathode (1.05 V): No Discontinuity at Melting-Point of Copper].—K. Brüning. (*Physik. Zeitschr.*, 1st/15th June 1940, Vol. 41, No. 11/12, pp. 285-290 and Plate.)
2427. THERMAL CONDUCTIVITIES OF TUNGSTEN AND MOLYBDENUM AT INCANDESCENT TEMPERATURES.—R. H. Osborn. (*Journ. Opt. Soc. Am.*, June 1941, Vol. 31, No. 6, pp. 428-432.)
2428. SPECTRAL AND TOTAL THERMAL EMISSIVITIES OF OXIDE-COATED CATHODES.—G. E. Moore & H. W. Allison. (*Journ. Applied Phys.*, May 1941, Vol. 12, No. 5, pp. 431-435.)

"The comparatively few published measurements [see Blewett, 1028 of 1940] . . . do not seem applicable to the uncombined type of coating now in general use."

2429. CRYSTAL LATTICE MODELS BASED ON THE CLOSE PACKING OF SPHERES [Discussion & Further Application of Langmuir & Nelson Models (102 of January)].—A. L. Patterson. (*Review Scient. Instr.*, April 1941, Vol. 12, No. 4, pp. 206-211.)

DIRECTIONAL WIRELESS

2430. ADCOCK AERIALS WITH WOODEN MASTS: ELIMINATION OF ERRORS DUE TO VARYING CONDUCTIVITIES OF PARTS OF WOOD.—Gothe & Kümlich. (*Hochf.tech. u. Elek.akus.*, June 1940, Vol. 55, No. 6, p. 199.) Telefunken Pat. 688 466.
2431. TESTS OF FREQUENCY MODULATION FOR AIRCRAFT COMMUNICATION [near Schenectady, on 41 & 42.8 Mc/s: Service Range about 50% Greater than with Amplitude Modulation: also Tests on Reception from Two F.M. Stations].—I. R. Weir. (*Electronics*, Nov. 1940, Vol. 13, No. 11, pp. 34-35 and 92.)
2432. 1940 PRIZE COMPETITION OF THE LILIENTHAL SOCIETY FOR AVIATION RESEARCH [Subject is Critical Survey of Work on Propagation of Metric, Decimetric, & Centimetric Waves, and an Examination of Their Practical Possibilities].—(*Hochf.tech. u. Elek.akus.*, June 1940, Vol. 55, No. 6, p. 197.)

ACOUSTICS AND AUDIO-FREQUENCIES

2433. A NEW MICROPHONE PROVIDING UNIFORM DIRECTIVITY OVER AN EXTENDED FREQUENCY RANGE [Combination of M.C. Pressure Element & Improved Ribbon Pressure-Gradient Element, giving Cardioid Characteristic].—R. N. Marshall & W. R. Harry. (*Journ. Acous. Soc. Am.*, April 1941, Vol. 12, No. 4, pp. 481-498.)
2434. MICROPHONE AMPLIFIERS FOR RESCUE PARTIES.—D. W. Aldous. (*Wireless World*, July 1941, Vol. 47, No. 7, p. 194.)
2435. ROOM NOISE SPECTRA AT SUBSCRIBERS' TELEPHONE LOCATIONS.—D. F. Hoth. (*Journ. Acous. Soc. Am.*, April 1941, Vol. 12, No. 4, pp. 499-504.)
2436. FREQUENCY-SELECTIVE FEEDBACK FOR AUDIO SYSTEMS [to counteract Sharp Resonances & Wave-Form Distortion in Loudspeaker or Its Amplifier].—W. N. Brown, Jr., & E. W. Sheridan. (*Elec. Engineering*, Nov. 1940, Vol. 59, No. 11, pp. 460-461.)
2437. A LATTICE-TYPE ACOUSTIC FILTER: II [Adaptation for Low Frequencies (e.g. Cut-Off at 700 c/s) by covering Slats with Plates with Holes or Slits].—H. K. Schilling. (*Phys. Review*, 1st March 1941, Vol. 59, No. 5, p. 469: summary only.) For I see 1411 of May.
2438. NEW RECORDING CHARACTERISTIC: REDUCING THE NOISE LEVEL ["Orthoacoustic Characteristic" System of Pre-Emphasis & Compensation].—(*Wireless World*, July 1941, Vol. 47, No. 7, p. 175.)

2439. A PRECISION INTEGRATING SPHERE DENSITOMETER [primarily for Sound-Track Densities].—J. G. Frayne & G. R. Crane. (*Review Scient. Instr.*, Nov. 1940, Vol. 11, No. 11, pp. 350-355.)
2440. SOUND REALISM AND EXPRESSIONISM: DEVELOPMENTS AT THE STEVENS INSTITUTE OF TECHNOLOGY.—H. Burris-Meyer. (*Sci. News Letter*, 17th May 1941, Vol. 39, No. 20, pp. 314-316.) See also 1447, 3077, & 4329 of 1940, and cf. 1917 of July (R.C.A. "Fantasound").
2441. A NEW ELECTRICAL MUSICAL INSTRUMENT [giving Quality of Any Known Instrument (or of Instruments as yet Unknown) by Superposition, on Fundamental, of Desired Harmonics by Mask Silhouettes projected onto Iconoscope Screen].—Bumstead. (*Science*, 16th May 1941, Vol. 93, Supp. p. 10.) Patent assigned to R.C.A.
2442. THE MODE OF VIBRATION OF A CLARINET REED.—C. S. McGinnis & C. Gallagher. (*Journ. Acous. Soc. Am.*, April 1941, Vol. 12, No. 4, pp. 529-531.)
2443. THE GROWTH OF AN IDEA [that Musical Talent is Subject to Scientific Analysis and Can be Measured].—C. E. Seashore. (*Scient. Monthly*, May 1941, Vol. 52, No. 5, pp. 438-442.)
2444. THE INTENSIVE DIFFERENCE LIMEN IN AUDITION.—F. L. Dimmick & Ruth M. Olson. (*Journ. Acous. Soc. Am.*, April 1941, Vol. 12, No. 4, pp. 517-525.)
2445. ELEMENTARY QUANTITY OF SOUND PERCEPTION [Further Work on "Fluctuation of Hearing Threshold"].—S. Lifshitz. (*Journ. Acous. Soc. Am.*, April 1941, Vol. 12, No. 4, pp. 526-528.) See 662 of 1940.
2446. ENGINEERING REQUIREMENTS FOR PROGRAMME TRANSMISSION CIRCUITS.—Cowan, McCurdy, & Lattimer. (*Bell S. Tech. Journ.*, April 1941, Vol. 20, No. 2, pp. 235-249.) Already referred to in 1104 of April.
2447. INVESTIGATIONS ON THE CAPACITANCES OF PAIRS AND SPIRAL QUADS IN TELEPHONE CABLES [including Measurements on Models & Comparison with Results on Actual Cables], and THE TWO-WIRE CIRCUIT AND SPIRAL QUAD IN A DIELECTRIC LIMITED CYLINDRICALLY.—H. Meinke. (*E.N.T.*, April 1940, Vol. 17, No. 4, pp. 86-91; May, No. 5, pp. 108-115.) Following on previous work, 3081 of 1940.
2448. TIME-DIVISION MULTIPLEX SYSTEMS.—Bennett. (See 2557.)
2449. MEASUREMENT OF PHASE ANGLES BY THE CATHODE-RAY OSCILLOGRAPH [Frequencies 100 c/s to 100 kc/s].—Nijenhuis. (See 2485.)
2450. AUTOMATIC HIGH-SPEED POWER-LEVEL RECORDER.—(See 2524.)
2451. METHODS FOR DETERMINING SOUND TRANSMISSION LOSS IN THE FIELD [for Measurements on Sound-Insulating Efficiency of Wall & Floor Partitions].—A. London. (*Journ. of Res. of Nat. Bur. of Stds.*, May 1941, Vol. 26, No. 5, pp. 419-453.)
2452. THE PROPAGATION OF SOUND IN CYLINDRICAL TUBES [Theory, including Higher Modes].—N. Rochester. (*Journ. Acous. Soc. Am.*, April 1941, Vol. 12, No. 4, pp. 511-513.)
2453. ON THE PROPAGATION OF CYLINDRICAL AND SPHERICAL WAVES IN FRICTION-LESS GASES AND LIQUIDS.—K. Bechert. (*Ann. der Physik*, 11th March 1941, Vol. 39, No. 3, pp. 169-202.) For previous work see 32 of January.
2454. THE DEPENDENCE OF SOUND VELOCITY ON CONCENTRATION, IN A MIXTURE OF DIPOLE AND DIPOLE-FREE LIQUIDS, and SUPERSONIC-WAVE ABSORPTION IN GASES [at Pressures up to 12.87 kg/cm²].—K. Sacher: H. H. Keller. (*Physik. Zeitschr.*, 1st Aug. 1940, Vol. 41, No. 15, pp. 360-363; 15th Aug. 1940, No. 16, pp. 386-393.)
2455. AN ELECTROMAGNETIC SOUND GENERATOR FOR PRODUCING INTENSE HIGH-FREQUENCY SOUND [primarily for Industrial Application of Flocculation of Smoke, Fogs, etc: Frequencies (at present) between 10 & 20 kc/s: Efficiencies up to 30%].—H. W. St. Clair. (*Review Scient. Instr.*, May 1941, Vol. 12, No. 5, pp. 250-256.)
2456. ULTRASONIC ABSORPTION IN WATER [Measurements at 7-50 Mc/s].—F. E. Fox & G. D. Rock. (*Journ. Acous. Soc. Am.*, April 1941, Vol. 12, No. 4, pp. 505-510.)
2457. AN IMPROVED APPARATUS FOR THE DIRECT MEASUREMENT OF THE ABSORPTION OF SOUND IN GASES.—R. W. Leonard. (*Review Scient. Instr.*, Nov. 1940, Vol. 11, No. 11, pp. 389-393.)
2458. PULVERISING OF MACROMOLECULES: AN ATTEMPT TO EXPLAIN THE DEPOLYMERISING ACTION OF SUPERSONIC WAVES.—G. Schmid. (*Physik. Zeitschr.*, 1st/15th July 1940, Vol. 41, No. 13/14, pp. 326-337.)

PHOTOTELEGRAPHY AND TELEVISION

2459. STEADY-STATE DELAY AS RELATED TO APERIODIC SIGNALS.—R. V. L. Hartley. (*Bell S. Tech. Journ.*, April 1941, Vol. 20, No. 2, pp. 222-234.)

"With the development of telephotography and television, the phase characteristic was found to provide a useful index for predicting the overlapping of adjacent picture elements. For these purposes it has been found convenient to express the phase characteristic in terms of phase or envelope delay. These may be called 'steady-state delays' since they are defined and measured in terms of sinusoidal disturbances of adjustable frequency. However, the signals for which they are intended to furnish an index are aperiodic in

nature. It seemed worth while, therefore, to examine more closely the relations existing between 'aperiodic delays', defined in terms of such signals, and steady-state delays . . . The net result of our study is that steady-state phase delay has no direct relation to the particular types of delay of an aperiodic signal which we have chosen to investigate. When the amplitude does not change rapidly with frequency, envelope delay is identical with the delay produced in the maximum value of the envelope of a disturbance corresponding to that part of the signal spectrum which is in the immediate neighbourhood of the frequency in question. The envelope delay, together with the phase shift, determines the delay in the max. absolute value of this disturbance, subject to the uncertainty of half a period. This uncertainty depends on the particular combination of signal spectrum and system characteristic. When the amplitude does change rapidly with frequency, the envelope delay still gives the delay in the max. value of the envelope. However, this maximum is so flat that the interpretation of the results is very difficult."

2460. THE INFLUENCING OF THE CURVE FORM OF PROCESSES BY THE DISTORTION OF ATTENUATION AND PHASE [in Television, etc.].—F. Strecker. (*E.N.T.*, May 1940, Vol. 17, No. 5, pp. 93-107.)

Extension of the work dealt with in 447 of February, where the treatment was deliberately limited to small distortions and the full mathematical development omitted. The present paper fills these gaps, and includes a section on the calculation of the transmission factor necessary to give a desired form of transit-time spectrum: as an example, the calculation of the necessary frequency-dependence of the amplitude factor and phase angle for a low-pass filter, in order that the transient process may "swing" only slightly before and after its rise. The final section discusses the transition to the previously considered problem of small distortions.

2461. THE DEVELOPMENT OF TELEVISION RECEIVING AND PICK-UP APPARATUS IN 1939.—R. Möller & G. Schubert. (*E.T.Z.*, 6th June 1940, Vol. 61, No. 23, pp. 528-529; summary only, from *Hausmitt. Fernseh. AG.*)
2462. A PRE-SELECTOR CIRCUIT FOR TELEVISION RECEIVERS [Constant Gain and Constant Band-Width on All Channels from 50 to 108 Mc/s obtained by Use of Two Tuned Circuits between Aerial and First Valve Grid].—B. F. Tyson. (*Electronics*, Nov. 1940, Vol. 13, No. 11, pp. 23-25.)
2463. CIRCUIT-RIDING THE COAXIAL CABLE [Mobile Testing Laboratory].—G. B. Engelhardt. (*Bell Lab. Record*, May 1941, Vol. 19, No. 9, pp. 280-291.)
2464. ELECTRONIC AMPLIFIER VALVES WITH STATIC SECONDARY-EMISSION MULTIPLICATION [Frequencies up to 100 Mc/s].—Flehsig & Sandhagen. (*See* 2415.)
2465. OPERATION OF ELECTROSTATIC PHOTO-MULTIPLIERS [with Special Reference to Western Electric D-159076: Advantages (over Photocell plus Amplifier) & Applications: Typical

Operating Conditions & Static Characteristics: Fluctuation Noises: Signal/Noise Ratio improved by Cooling: etc.].—R. C. Winans & J. R. Pierce. (*Review Scient. Instr.*, May 1941, Vol. 12, No. 5, pp. 269-277.)

2466. CONTROL ACTION OF A CHARGED PARTICLE IN THE FIELD OF A SECONDARY-EMISSION CATHODE [Light thrown on Various Unexplained Effects in Iconoscope & Other Pick-Up Tubes].—Knoll. (*See* 2509.)
2467. BEHAVIOUR OF THE FOREIGN METAL PARTICLES IN THE COMPOSITE PHOTOCATHODE [Experimental Investigation & Discussion: Ag₂O Films deposited on Activated Cathodes of Cs-Cs₂O, Cs and Ag-(Ag), and Cu Films on Cs-Cs₂O, Cs and Cu-(Cu): Dependence of Sensitivity on Film Thickness: Effect of Reduced Ag Particles: etc.].—S. Asao. (*Sci. Abstracts*, Sec. A, June 1941, Vol. 44, No. 522, pp. 163-164.)
2468. THE APPEARANCE OF A PHOTO-POTENTIAL IN PHOSPHOR CELLS.—F. Goos. (*Ann. der Physik*, 9th April 1941, Vol. 39, No. 4, pp. 281-294.)

Further examination of an effect dealt with in a previous paper on researches on selenium photocells (4588 of 1939), where it was suggested that phosphors could be used as the basic substance in photocells. The present experiments show that a photo-e.m.f. is particularly well obtained with CdSCu phosphors, and reaches the value of that given by a selenium cell. The effect is largely independent of the phosphorescent properties of the substance, though photo-sensitive centres must be present. The photo-e.m.f. is obtainable also with CdS₂ and ZnSCu, as well as with the non-luminescent but photoelectrically sensitive zinc blende crystal (though to a smaller extent), and also with the mixed phosphor ZnSCdSCu. Various properties of a CdSCu cell are examined and compared with those of a selenium cell. Among other points, a rectifying action occurs with the phosphor cell, as it does with the selenium cell. The spectral sensitivity of the phosphor cell extends over the whole visible range and is still quite good in the near infra-red; whereas the curve for the selenium cell reaches zero at 800 mμ. For other papers by the writer, referred to here, see 2714 of 1940.

2469. ON THE NON-ACTIVE PHOTOELECTRIC ABSORPTION OF LIGHT IN CERTAIN SEMICONDUCTORS.—F. F. Wolkenstein. (*Journ. of Exper. & Theoret. Phys.* [in Russian], No. 11, Vol. 10, 1940, pp. 1229-1241.)

It has usually been considered that the non-active photoelectric absorption of light observed in certain semiconductors, i.e. the absorption of light without any accompanying internal photoeffect, could not be explained by the Bloch-Wilson theory. The present paper, however, provides an explanation of this phenomenon within the limits of the theory.

2470. A HIGH-SENSITIVITY PHOTOTUBE CIRCUIT [taking Advantage of Greatly Increased Sensitivity given by Use of Pentode as High-Resistance Load].—H. S. Bull & J. M. Lafferty. (*Electronics*, Nov. 1940, Vol. 13, No. 11, pp. 31-33.)

2471. DOUBLE REFRACTION AND DOUBLE DEFLECTION OF HERAPATHITE SUSPENSIONS IN A FLOW CHAMBER.—H. H. Pfeiffer. (*Sci. Abstracts*, Sec. A, June 1941, Vol. 44, No. 522, p. 143.)
2472. TRENDS IN HIGH-INTENSITY MERCURY LAMPS [Quartz Seals, Thorium Electrodes, New Applications (including Television), etc.].—G. A. Freeman. (*Elec. Engineering*, Nov. 1940, Vol. 59, No. 11, pp. 444-447.)

MEASUREMENTS AND STANDARDS

2473. AN ELECTRODYNAMIC AMMETER FOR ULTRA-HIGH FREQUENCIES [Correction to Abstract 1447 of May 1941].—F. W. Gundlach. (The reference to *Hochf.tech. u. Elek.akus.* should read "June 1940, No. 6".)
2474. THE MEASUREMENT OF SMALL CURRENTS AND VOLTAGES AND SMALL CHANGES IN LENGTH WITH THE BOLOMETRIC COMPENSATOR.—Merz & Niepel. (*See* 2599.)
2475. Q-METER, TYPE 170-A [extending to 200 Mc/s].—Boonton Radio. (*Review Scient. Instr.*, April 1941, Vol. 12, No. 4, p. 231.)
2476. PROPERTIES AND USE OF STANDARD QUALITY-FACTOR COILS AT HIGH FREQUENCIES.—G. Opitz. (*Arch. f. Tech. Messen*, No. 111, 1940, Z.124-2, 4 pp: summary in *E.T.Z.*, 24th April 1941, Vol. 62, No. 17, pp. 408-409.)

Measurements of quality factor often give inconsistent results between the various methods of measurement, largely because the self-capacitance of the coil influences the result differently in different procedures. It is therefore desirable to construct standard quality-factor coils (like standard inductances) in order to check the measuring equipment. Representing such a standard coil by the simple equivalent circuit of Fig. 1, the writer gives correction formulae (not included in the summary) for the various usual measurement-methods, representing the relation between the measured values and the quality factor as defined by $g = \omega L/r$. These formulae contain in particular the ratio of the self-capacitance C_s of the coil to the external capacity C which is necessary to bring the oscillatory circuit into resonance.

The methods dealt with are: (a) measurement of the "half-value" by frequency de-tuning, (b) substitution method (determination of the equivalent resistance by Pauli's method), (c) & (d) measurement of the conductance & susceptance, and of the dissipative impedance & reactance, respectively, and (e) measurement by the "quotient method" (*see* 3271 of 1939). The search for an equivalent circuit for a standard coil to be used arbitrarily in the various methods leads to the circuits of Fig. 3, in which, however, the numerical values are only valid for a particular test frequency. To extend the validity to a definite range of frequencies, the final equivalent circuits of Fig. 4 are recommended. In order that, at will, the plan of Rohde & Schwarz may be adopted and a known resistance added in series in order to obtain a second value for the quality factor, the writer advises that the standard coil (a screened compressed-powder-core coil)

should be provided with a series resistance and three terminals. He gives figures (not included in the summary) for the influence of hysteresis loss on the quality factor, for excessive magnetisation. The variation of the quality factor with temperature is given as 2% per 10^3 C for a standard coil. Changes from 0 to 80% in the relative humidity do not produce more than a 2% change.

2477. THERMOCOUPLE WATTMETERS FOR MEASUREMENTS ON GASEOUS-DISCHARGE LAMPS [and Comparison with Precision & Astatic Types].—J. Kühne. (*E.T.Z.*, 20th June 1940, Vol. 61, No. 25, pp. 567-568.)

2478. THE DEVELOPMENT OF THE THERMAL WATTMETER [Survey].—J. Fischer. (*Zeitschr. f. tech. Phys.*, No. 1, Vol. 22, 1941, pp. 9-14.)

From the Hartmann & Braun laboratories. Among recent developments, Kühne has evolved an instrument for the measurement of the highly distorted wave-forms occurring in gaseous-discharge lamps (2477, above), Pincirolì & Francini have designed a thermoelectric wattmeter for audio-frequencies (2195 of August), and the writer has pointed out the high sensitivity of a special wattmeter circuit and applied it to the measurement of radiated acoustic power, dielectric losses at small voltages, and the frequency-characteristic of rectifier-type meters (2903 of 1939: Maione's work, 2904 of 1939, is not referred to). Besides the practical advantages of the modern thermoelectric wattmeter, the high sensitivity and the independence of frequency of the ohmic circuits, it is worthy of notice that these meters measure fundamentally correctly the powers of periodic currents, since the power is defined by the heat developed: just as the voltmeter correctly measures the electrolytically defined current strength.

The present survey discusses the more important variations of circuit, including those with two and three thermo-converters for the precise simultaneous measurement of power, current, and voltage: *see* for example Bader's two-converter circuit, Fig. 3 (and 1550 of 1936), the three-converter circuit of Fig. 4, and its improvement by Osterman (to be dealt with elsewhere), modifications of which are shown in Fig. 5. Finally, the circuits of Figs. 3 & 4 are investigated with regard to their sensitivity and their internal consumption.

2479. THE CALCULATION AND OPTIMUM DESIGN OF A SIMPLE THERMO-CONVERTER [Combination of Hot Wire & Thermoelement: Current, Voltage, & Power Sensitivities: Influence of Transfer Resistance & Peltier Effect: etc.].—J. Fischer. (*Arch. f. Elektrot.*, 25th Jan. 1941, Vol. 35, No. 1, pp. 23-44.)

2480. PHOTOELECTRIC VOLTAGE-COMPENSATION [Wulff's Circuit for Measurement of Thermovoltages & Other Potentials examined and disparaged as Inferior to a Millivoltmeter].—F. Ender: Wulff. (*Physik. Zeitschr.*, 1st/15th June 1940, Vol. 41, No. 11/12, pp. 297-301: Reply by Wulff, p. 302.) *See* 3120 of 1936.

2481. LOSS ANGLE MEASUREMENTS AT HIGH FREQUENCIES [up to 10 Mc/s: New Bridge eliminating Several Common Sources of

- Error: Accurate within Less than 1×10^{-4} .
—W. Holzmüller. (*Physik. Zeitschr.*, 1st Aug. 1940, Vol. 41, No. 15, pp. 356-360.) The bridge mentioned in 1456 of May.
2482. "PRÄZISIONSMESSUNGEN VON KAPAZITÄTEN, DIELEKTRISCHEN VERLUSTEN UND DIELEKTRIZITÄTSKONSTANTEN" [Book Review].—E. Blechschmidt. (*Zeitschr. f. tech. Phys.*, No. 2, Vol. 22, 1941, p. 43.) No. 2 of a series "Verfahrens- und Messkunde der Naturwissenschaft".
2483. USE OF THE CATHODE-RAY TUBE FOR COMPARISON OF CAPACITIES [applicable also to Resistances: Accuracy within 0.5% in Range 50 kc/s to 2 Mc/s (primarily for Dielectric-Constant Measurements on Polar Liquids): based on Measurement of Slope of Elliptical Trace from Test & Standard Capacities in Series].—R. H. Cole. (*Review Scient. Instr.*, June 1941, Vol. 12, No. 6, pp. 298-300.)
2484. A METHOD FOR THE MEASUREMENT AND AUTOMATIC RECORDING OF THE PHASE ANGLES OF IMPEDANCES AS A FUNCTION OF FREQUENCY.—W. Hübner. (*E.N.T.*, July 1940, Vol. 17, No. 7, pp. 150-167.)
After a short discussion of the five most important methods of measuring such phase angles (of which the method depending on the measurement of the slope of the elliptical trace on a cathode-ray screen is judged to be the least accurate of all) the writer describes his "half-balanced bridge" equipment. This was developed with the special aim of a rapid measurement of the phase angles, as a function of frequency from 30 c/s to 10 kc/s, of a large number of impedances, and is based on the fact that in an imperfectly balanced bridge, in suitable conditions, the voltage across the diagonal is a measure of the phase angle. If the test frequency is continuously varied and at the same time the resistance W in one arm of the bridge (Fig. 1a) is automatically kept equal to the unknown impedance in the adjacent arm, this diagonal voltage will give the phase angle as a function of frequency. Such an automatic adjustment of W can be obtained by making W in the form of an indirectly heated Urdox resistance varied between 200 and 150 000 ohms (Neldel, 500 of 1938) by a valve-regulated control of its heating supply: see p. 152, l-h column. Since W cannot be reduced below 200 ohms and it is not desirable to have several of these resistances in parallel, owing to the increased expenditure in valves, etc., the condition that $R_1 = R_2$ and $W = Z$ first assumed must be departed from if impedances lower than 200 ohms are to have their phase angles measured: the relation $R_1/R_2 = W/Z = m$ is therefore adopted and the relation between the phase angle and the diagonal voltage, no longer given by eqn. 1, has therefore to be investigated (section BII): the general equation is given in eqn. 7, which reduces to eqn. 1 when m is made unity. The calibration of the recording instrument for the three different cases where $m = 1, 2,$ and 4 is dealt with on p. 163. The whole apparatus (a patent for which has been applied for) is discussed in great detail, and Figs. 20 & 21 show specimen phase curves of a resonant circuit and of a filter combination.
2485. MEASUREMENT OF PHASE ANGLES BY THE CATHODE-RAY OSCILOGRAPH.—W. Nijenhuis. (*E.T.Z.*, 24th April 1941, Vol. 62, No. 17, pp. 411-412: summary from *Philips tech. Rundschau*, Vol. 5, 1940, p. 210 onwards.)
Based on the method of frequency measurement described by van der Pol & Addink (1070 of 1940 and back ref.), and suitable for the measurement of phase differences at frequencies 100 c/s to 100 kc/s. The writer of the summary describes it as an interesting solution of the problem (he quotes here Chard's *I.E.E.* paper referred to in 708 of 1939), involving however a considerable expenditure in amplifiers and auxiliary apparatus, and the use of an auxiliary voltage source of the same frequency: "the attainable accuracy, within about 2%, should be sufficient for most purposes". The basis of the method is the obtaining of a circular trace and its division into two semicircles, one bright and the other dim, by modulation of the control electrode at the same frequency as that of the two fixed voltages producing the circular trace. If the two voltages whose phase relations are to be measured are applied one after the other as the modulating voltage, the phase angle between them is given directly by the two different inclinations, to the horizontal, of the dividing line between the bright and dim semicircles. For another method of measuring phase differences see Lyubchenko, 954 of 1940.
2486. TWIN-T IMPEDANCE-MEASURING CIRCUIT [Type 821-A, for Frequencies 420 kc/s to 30 Mc/s].—General Radio. (*Review Scient. Instr.*, May 1941, Vol. 12, No. 5, pp. 280-281.)
2487. RAPID-RECORDING A. C. BRIDGE [operating 24 Hours per Day without Attention, for Power-Factor & Capacitance Measurements during Life Tests, Treating Processes, Series-Production Testing, etc.].—W. Mikelson & H. W. Bousman. (*Elec. Engineering*, Nov. 1940, Vol. 59, No. 11, Transactions pp. 628-631.)
2488. THE PREPARATION OF HIGH-FREQUENCY HIGH RESISTANCES BY MEANS OF CATHODE SPUTTERING [for Measuring Purposes, etc.].—Gössinger. (See 2529.)
2489. A NEW LOGARITHMIC ELECTRONIC VOLT-METER [for Frequencies up to at least 15 kc/s: "Converting Network" of Sections each consisting of Amplifying Triode-Stage and "Compressing" Triode-Stage].—P. J. Selgin. (*Electronics*, Nov. 1940, Vol. 13, No. 11, pp. 40 and 44-52.)
2490. A SIMPLE METHOD FOR MEASURING STEADY CURRENTS OF BRIEF DURATION.—Bennett. (See 2422.)
2491. AN IMPROVED OPTICAL LEVER [Angular Magnification of (*e.g.*) 12 obtained by Repeated Reflections between Moving Mirror & a Second, Fixed Mirror].—P. W. Crist. (*Review Scient. Instr.*, April 1941, Vol. 12, No. 4, p. 214.) For another improved lever see 1718 of June: see also 1462 of May, and 2492, below.

2492. A MODIFICATION OF THE TELESCOPE-AND-SCALE SYSTEM FOR INCREASED ACCURACY IN THE MEASUREMENT OF GALVANOMETER DEFLECTIONS [Addition of Optically Superposed Vernier Scale: Higher Resolution, Readings unaffected by Jarring of Telescope].—B. Vonnegut. (*Review Scient. Instr.*, June 1941, Vol. 12, No. 6, p. 335.)
2493. COMMENT ON THE ELASTIC CONSTANTS OF ALPHA-QUARTZ [Unexplained Discrepancy found by Atanasoff & Hart (1452 of May) removed by taking into account the Forces arising from the Polarisation produced by the Vibration].—A. W. Lawson. (*Phys. Review*, 15th May 1941, Vol. 59, No. 10, pp. 838-839.)
2494. IMAGES PROJECTED FROM ETCHED SURFACES OF QUARTZ CRYSTALS [Development of Technique for Routine Determination of Electric Axes of a Z-Cut Slab within about One Degree].—H. H. Hubbell, Jr. (*Phys. Review*, 1st March 1941, Vol. 59, No. 5, p. 473: summary only.) Continuation of Cady's work, 3126 of 1940.
2495. QUARTZ . . . FROM RAW STOCK TO FINISHED CRYSTAL.—General Electric. (*Electronics*, Nov. 1940, Vol. 13, No. 11, pp. 26-27: photographs and captions.)
2496. TIME STANDARD [Valve-Driven Tuning Fork & Amplifier, Output 0-2.5 Watts: with Various Applications].—American Instrument. (*Review Scient. Instr.*, April 1941, Vol. 12, No. 4, p. 234.)
2497. THE CHRONOSCOPE [Combination of Two Thyratrons and Ballistic Galvanometer for Measurement, within 1%, of Times from 1 to 200 Milliseconds: primarily for Bullet Velocities].—C. I. Bradford. (*Electronics*, Nov. 1940, Vol. 13, No. 11, pp. 28-30 and 60, 62.) See also *Review Scient. Instr.*, May 1941, Vol. 12, No. 5, p. 282.
2498. MEASURING SYSTEM FOR CARRIER CIRCUITS, and MEASUREMENT OF DYNAMIC CHARACTERISTICS OF [Carrier-System] VACUUM TUBES.—Rosen: Maggio. (*Bell Lab. Record*, May 1941, Vol. 19, No. 9, pp. 277-280: pp. 281-285.)
2499. CIRCUIT-RIDING THE COAXIAL [Mobile Testing Laboratory].—G. B. Engelhardt. (*Bell Lab. Record*, May 1941, Vol. 19, No. 9, pp. 286-291.)
2500. A MEASURING EQUIPMENT FOR PERMANENT MAGNETS [and Permanent-Magnet Steels], WITH DIRECT CURVE REGISTRATION.—W. Breitling. (*Arch. f. Elektrot.*, 25th Jan. 1941, Vol. 35, No. 1, pp. 1-23.) Using a "coordinate recorder" with elaborate optical arrangements, combining fluxmeter and loop-oscillograph deflections.
2501. METHOD OF MEASURING HYSTERESIS AND MAGNETIC-VISCOSITY CONSTANTS, INITIAL PERMEABILITY, AND INSTABILITY OF SAMPLES OF SMALL CROSS-SECTION [Quick Procedure, particularly suitable for Researches in Development of New Materials for Low-Loss A.F. Coils].—S. Schweizerhof. (*Zeitschr. f. tech. Phys.*, No. 3, Vol. 22, 1941, pp. 66-75.)

SUBSIDIARY APPARATUS AND MATERIALS

2502. CATHODE-RAY INTENSIFIER TUBE [Type 2529 Series of "Teletrons," for Use where Low Deflection-Plate Capacitance is Essential: with Ring Intensifier (Accelerator) Electrode].—Du Mont Laboratories. (*Review Scient. Instr.*, June 1941, Vol. 12, No. 6, p. 337.) For an earlier note see 2856 of 1939. For Pierce's analysis of post-acceleration see 1965 of July.
2503. AN IMPROVED CATHODE-RAY OSCILLOSCOPE DESIGN [Frequency Discrimination & Other Disadvantages of Usual Attenuator & Gain Control Circuits avoided by Use of Cathode-Coupled Input Stage: Improved Deflection Amplifiers & Positioning Circuits: etc.].—Geohagen. (*Electronics*, Nov. 1940, Vol. 13, No. 11, pp. 36-39.)
2504. A LOW-CAPACITY COUPLER FOR THE CATHODE-RAY OSCILLOSCOPE [to avoid Disturbance of Circuit Conditions by Usual Low Impedance-to-Ground of One Amplifier Input Terminal].—Overbeck & Löf. (*Review Scient. Instr.*, Nov. 1940, Vol. 11, pp. 375-376.)
2505. PAPERS ON ELECTRONIC SWITCHES FOR SIMULTANEOUS OBSERVATION OF TWO WAVES, ETC.—Hughes & Koch, Cosby & Lampson, Reich. (See 2382 & 2383.)
2506. ADDITION TO THE PAPER "THE PHASE FOCUSING OF ELECTRON BEAMS TRAVELLING IN A STRAIGHT LINE."—Borgnis & Ledinegg. (See 2387.)
2507. TRAVELLING WAVES IN ELECTRON BEAMS.—Ramo: Hahn. (See 2413.)
2508. THE DEFLECTION OF LIGHT RAYS BY A GENERAL ANISOTROPY [including Deflection of Electron Rays in an Electromagnetic Field].—Frank. (*Phys. Review*, 1st March 1941, Vol. 59, No. 5, p. 475: summary only.)
2509. CONTROL ACTION OF A CHARGED PARTICLE IN THE FIELD OF A SECONDARY-EMISSION CATHODE [Phenomena observed in Image given by an "Electron Scanner" (1157 & 3037 of 1936 and 4111 of 1939: Moving-Beam Type of Electron Microscope) and Their Explanation by Formation of Local Space Charges: Light thus thrown on Various Unexplained Effects in These & Similar Devices (including Iconoscope & Other Pick-Up Tubes: 216 of 1939): Measurement of Charge-Potential of Insulating Particles on Metal Plate, by Same Technique].—M. Knoll. (*Naturwiss.*, 30th May 1941, Vol. 29, No. 22/23, pp. 335-336.)
2510. THE THEORY OF SECONDARY ELECTRON EMISSION FROM DIELECTRICS AND SEMI-CONDUCTORS.—Kadyschewitsch. (See 2423.)

2511. REPORT ON EXPERIMENTAL WORK ON THE DEVELOPMENT OF THE ELECTRON MICROSCOPE, and OPTICS OF THE ELECTRON MICROSCOPE.—Martin & others. (*Sci. Abstracts*, Sec. A, May 1941, Vol. 44, No. 521, p. 139; p. 139.)
2512. SOME ELECTRON-MICROSCOPIC OBSERVATIONS OF MAGNESIUM-OXIDE CRYSTALS [and Some Hitherto Unnoticed Phenomena].—Kinder. (*Zeitschr. f. tech. Phys.*, No. 1, Vol. 22, 1941, pp. 21–22 and Plate.) Continuation of the work dealt with in 1477 of May. Meanwhile, von Borries & Ruska have reported their similar investigation (1170 of April: see also 1739 of June).
2513. THE EFFECT OF TEMPERATURE ON THE WIDTH OF ELECTRON DIFFRACTION BEAMS.—Zamsha & Kalashnikov. (*Journ. of Exper. & Theoret. Phys.* [in Russian], No. 11, Vol. 10, 1940, pp. 1189–1191.)

During an experimental investigation of the diffraction of slow electrons by silver monocrystals it has been observed that the width and shape of the interference beams is affected by the temperature of the crystals. Experimental curves are shown and the effect is discussed.

2514. THE APPEARANCE OF A PHOTO-POTENTIAL IN PHOSPHOR CELLS.—Goos. (See 2468.)
2515. MISCELLANEOUS OBSERVATIONS ON THE RISE AND DECAY OF LUMINESCENCE OF PHOSPHORS.—de Groot. (*Physica*, May 1940, Vol. 7, pp. 432–446; reference only in *Review Scient. Instr.*, April 1941, p. 243.)
2516. PHOTOELECTRIC INVESTIGATIONS ON LUMINESCENT MATERIALS.—L. Bergmann & F. Ronge. (*Physik. Zeitschr.*, 1st Aug. 1940, Vol. 41, No. 15, pp. 349–355.)

The technique developed by Bergmann for small samples of crystal powders and semiconductors (1932 Abstracts, p. 291, and 2740 of 1936) has been applied successfully to the investigation of fluorescent and phosphorescent materials, including a number of commercial phosphors. Of these substances, the ones which had no after-glow, or only a short one, showed a marked photoelectric effect whose maxima lay at those wavelengths which excited the brightest luminescence. The quenching action of infra-red radiation on fluorescence and phosphorescence also has its parallel in the action on the photoelectric effect.

2517. DIELECTRIC HYSTERESIS PHENOMENA IN PHOSPHORS [CdS-Cu, with Varying Copper Content: Investigation to contribute Information on the Mechanism of Phosphorescence].—Ruffler. (*Ann. der Physik*, 11th March 1941, Vol. 39, No. 3, pp. 203–208.)

In Figs. 2 & 3 the abscissae represent the times after the beginning of the charge of the (previously discharged) condenser with the phosphor as dielectric, while the ordinates represent the ratio ϵ/ϵ_0 of the dielectric-constant values at those times to a fixed value taken 0.01 s after the application of the charging potential. Fig. 2 shows how, for a constant temperature of 20° C, the after-effect for pure CdS is very small, as evidenced by

the very slight rise in the ϵ/ϵ_0 curve during the time of charging (up to 0.7 s). The introduction of a very small amount of copper increases the effect very greatly, the curve for a 0.0001 proportion of Cu/CdS rising to a value of nearly 1.3 for ϵ/ϵ_0 at the end of the charge, indicating a marked increase in the number of carrier dipoles by the formation of light centres. But an increase in the copper content reduces this action, so that for a 0.01 proportion the curve only reaches to 1.1. This agrees with Lenard's result that with an increasing metal content the size of the centres diminishes, so that obviously their orientability in an electric field would increase. Fig. 3 shows how the curves for ϵ/ϵ_0 rise as the temperature is increased from 20° to 50° and 100° C, both for low and high Cu contents: the low-content curve reaches to nearly 2.2 at 100° C, the high-content curve to about 1.85, so that this result does not depend much on the metal content. This is for the phosphor in an unilluminated condition: illumination increases the temperature effect very markedly for a high Cu content, but to a smaller extent for a low content. On the other hand, illumination by itself increases the hysteresis effect very considerably for a low Cu content but much less for a high. Facts of this kind, further examined, should help in the elucidation of phosphor mechanism.

2518. BRIGHTNESS AND ENERGY OUTPUT OF AN X-RAY FLUORESCENT SCREEN [including a Comparison with Rump's Measurements with X-Rays & Cathode Rays].—Widemann. (*Zeitschr. f. tech. Phys.*, No. 2, Vol. 22, 1941, pp. 27–29.)
2519. THERMAL CONDUCTIVITIES OF TUNGSTEN AND MOLYBDENUM AT INCANDESCENT TEMPERATURES.—Osborn. (*Journ. Opt. Soc. Am.*, June 1941, Vol. 31, No. 6, pp. 428–432.)
2520. TRENDS IN HIGH-INTENSITY MERCURY LAMPS [Quartz Seals, Thorium Electrodes, New Applications (including Television), etc.].—Freeman. (*Elec. Engineering*, Nov. 1940, Vol. 59, No. 11, pp. 444–447.)
2521. POINT WELDING OF VERY SMALL PARTS AND FRAGILE MATERIALS [with the Type PHI Machine].—A.E.G. (*E.T.Z.*, 27th June 1940, Vol. 61, No. 26, Advt. p. 11.)
2522. LARGE MOLECULAR PUMPS OF THE DISC TYPE [primarily for Cyclotrons: on Siegbahn's Principle: exceed 70 Litres/Second at 10^{-3} mm Hg].—von Friesen. (*Review Scient. Instr.*, Nov. 1940, Vol. 11, No. 11, pp. 362–364.)
2523. RUGGED QUARTZ-MEMBRANE MANOMETERS OF SMALL VOLUME [as Null Instrument, for Pressures from Few Centimetres of Hg to 50 Atmospheres].—Kenty. (*Review Scient. Instr.*, Nov. 1940, Vol. 11, No. 11, pp. 377–386.)
2524. AUTOMATIC HIGH-SPEED POWER-LEVEL RECORDER [with Many Applications: Scribe (on Waxed-Paper Tape) and Potentiometer Contact carried on Stem of Magnetic

Fork with Prongs sliding on Edge of Magnetic Disc: Paper Speeds up to 50 mm/s].—(*Review Scient. Instr.*, June 1941, Vol. 12, No. 6, p. 338.)

2525. TIME STANDARD [Valve-Driven Tuning Fork & Amplifier, Output 0-2.5 Watts: with Various Applications].—American Instrument. (*Review Scient. Instr.*, April 1941, Vol. 12, No. 4, p. 234.)
2526. THE PLASMA OF A GASEOUS DISCHARGE IN A STRONG LONGITUDINAL MAGNETIC FIELD.—Reichrudel & Spivak. (*Journ. of Exper. & Theoret. Phys.* [in Russian], No. 12, Vol. 10, 1940, pp. 1408-1421.)
2527. THE "GLO-RELAY": A NEW METHOD OF INITIATING VAPOUR DISCHARGES [Applicable also to Other Purposes: Small Glow-Discharge Lamp with Bimetallic Strip as One Electrode, heated when Discharge occurs and making Contact with Other Electrode].—Dench: Westinghouse. (*Elec. Engineering*, Nov. 1940, Vol. 59, No. 11, p. 461: summary only.)
2528. A HARD-VACUUM-TUBE PULSE EQUALISING SHARPENING CIRCUIT [Correction to One Sentence].—Huntoon & Strohmeier. (*Review Scient. Instr.*, April 1941, Vol. 12, No. 4, p. 215.) See 1491 of May.
2529. THE PREPARATION OF HIGH-FREQUENCY HIGH RESISTANCES BY MEANS OF CATHODE SPUTTERING.—Gössinger. (*Ann. der Physik*, 9th April 1941, Vol. 39, No. 4, pp. 308-320.)

In his measurements on electrolytes, especially at high frequencies, Wien required (for use in the barretter circuit, for instance) resistances which could be interchanged without the inductances and distributed capacitances being affected appreciably. This need led to the preparation of thin-film resistances (Wenk & Wien, 1934 Abstracts, p. 281: for later work see 315 of 1935). The present paper deals with later technique in the making of such resistances. Cathode sputtering is substituted for the original sublimation by heat, because it has the advantage that mixtures of two or more metals can be deposited in an easy and reproducible way: this is of importance in connection with the obtaining of the lowest possible temperature coefficient of resistance. The best mixture in this respect was found to be Ag:Pt:Au = 3:4:4 (Fig. 7 and adjacent text). The ageing process has a decisive influence on the temperature coefficient and on the constancy with lapse of time.

The recommended technique for the preparation and ageing is described for a 10^4 ohm and a 10^8 ohm resistance, both on Calan tubes. The former resistance was aged by the step-by-step procedure (reducing zone of Bunsen flame) represented by Fig. 4 and discussed in the adjacent text, and after insertion in its glass container was further aged by being loaded with 3.5 w, reduced after one day to 3 w and after another to 2.5 w, after which the bulb was sealed off. The 10^8 ohm resistance (actually 10^{10} ohm was the highest value made, but this does not represent the limit) used a

longer tube and a thinner layer (Ag:Pt:Au = 3:4:2 was chosen for this): ageing with the Bunsen flame would have injured it, so an oven was employed, at 185°C .

2530. THE EFFECT OF AN ELECTRIC FIELD ON THE CONCENTRATION OF ELECTRONS IN SEMICONDUCTORS.—Kovadlo. (*Journ. of Exper. & Theoret. Phys.* [in Russian], No. 12, Vol. 10, 1940, pp. 1348-1353.)

It has been shown in a paper by A. F. and A. V. Joffe (*ibid.*, Vol. 9, 1939, p. 1428) that the abrupt increase in the electrical conductivity of electron semiconductors when placed in fields of the order of 10^5 v/cm is due to an increase in the concentration of free electrons. At the same time neither this nor any other paper on the subject takes account of the transition of free electrons into the bound state ("sticking" to the crystal lattice) and *vice versa*. Accordingly, the kinetic equation (1) of free electrons is here discussed with particular attention to this factor, and it is shown that the increase in the electron concentration due to it is of sufficient magnitude to play an important rôle in the effect under consideration: thus the number of electrons transferred to the conductivity zone at $E = 10^6$ v/cm is of the order of 10^{15} .

2531. THE DIRECT-CURRENT RESISTANCE OF SYNTHETIC MATERIALS [Difficulties in Measurement: Method & Results for Styroflex Foils, etc.].—Klingelhöter & Jasper. (*E.T.Z.*, 20th June 1940, Vol. 61, No. 25, p. 574: summary only.)
2532. CERAMIC INSULATING MATERIALS [Survey of Composition, Methods of Manufacture, & Characteristics: including Mycalex, Alsifilm, & New Glasses].—Thurnauer. (*Elec. Engineering*, Nov. 1940, Vol. 59, No. 11, pp. 451-459.)
2533. INTRODUCTION OF THE SCHEME DIN VDE 685 "CERAMIC INSULATING MATERIALS" [with Table of Standard Data].—Pfeistorf & Steger. (*E.T.Z.*, 30th May 1940, Vol. 61, No. 22, pp. 494-497.)
2534. NEW ELECTRICAL PORCELAIN ["Prestite", particularly suitable for Intricately Shaped Pieces].—Westinghouse. (*Review Scient. Instr.*, May 1941, Vol. 12, No. 5, p. 288.) See also *Scient. American*, May 1941, pp. 269-270.
2535. THE BEHAVIOUR OF POROUS AND DENSE PORCELAIN INSULATORS IN HIGH-FREQUENCY FIELDS [Method of testing Porosity by Use of Ultra-High Frequencies].—Endres. (*E.T.Z.*, 23rd May 1940, Vol. 61, No. 21, pp. 480-481: summary only.)
2536. BERYLLIUM NOTES [and Possible Applications of Its Alloys & Oxide].—(*Review Scient. Instr.*, May 1941, Vol. 12, No. 5, pp. 286-287.) Regarding beryllia, "the small loss in the presence of h.f. waves is of particular note." Cf. Klug, 2304 of August.

2537. ELECTRICAL BREAKDOWN OF ANODICALLY OXIDISED COATINGS ON ALUMINIUM: A MEANS OF CHECKING THICKNESS OF ANODISED FINISHES.—Compton & Mendizza. (*Bell S. Tech. Journ.*, April 1941, Vol. 20, No. 2, p. 251: summary only.)
2538. ON THE IMPEDANCE OF ELECTROLYTIC CONDENSERS [Correction to Abstract 1503 of May].—Söchting. (The reference to *E.N.T.* should read "April 1940, No. 4".)
2539. ON THE THEORY OF DIELECTRIC LOSS [Establishment of Direct Relations, suitable for Numerical Calculation, between the Two Components of the Absorption Current (One in Phase, the Other in Quadrature with the Voltage) for Sinusoidal Voltages: General Relationship between Dielectric Constant & Dielectric Loss].—Gross. (*Phys. Review*, 1st May 1941, Vol. 59, No. 9, pp. 748-750.) The treatment is also applicable to linear dissipative networks.
2540. THEORY OF INSULATING MATERIALS [based on Picture of Materials as "Compact Dispersed Substances" in sense of Colloid Physics].—Böning. (*Sci. Abstracts*, Sec. B, June 1941, Vol. 44, No. 522, pp. 98-99.) For another paper on this theory see 1771 of June.
2541. ELECTRICAL CONDUCTION IN DIELECTRIC LIQUIDS [Electron Emission concentrated on Sharp Points of Electrode Surface: Support for Cold-Emission Mechanism: etc.].—Dornste. (*Sci. Abstracts*, Sec. A, June 1941, Vol. 44, No. 522, pp. 159-160.) Cf. 1501 of May (Plumley).
2542. LOW-VOLTAGE D.C. MEASUREMENTS ON ELECTRICAL INSULATING OILS [in Investigation of Mechanism of Deterioration].—Oncley & Hollibaugh. (*Elec. Engineering*, Nov. 1940, Vol. 59, No. 11, Transactions pp. 625-628.)
2543. THE LIGHTNING AND SPARK DISCHARGES.—Bruce. (See 2364.)
2544. A THEORETICAL CONSIDERATION OF THE CONTACT BETWEEN A METAL AND A DIELECTRIC OR SEMICONDUCTOR.—Pekar. (*Journ. of Exper. & Theoret. Phys.* [in Russian], No. 11, Vol. 10, 1940, pp. 1210-1224.)
A theoretical investigation is presented of the electrical conditions at the contact between a metal and a non-metallic crystal (dielectric or semiconductor) when a current flows through the contact. The crystal is assumed to possess electron conductivity, although the results obtained are also applicable to the case of "hole" conductivity. Methods are indicated for calculating the electric field, concentration of conduction electrons, and distortion of energy zones in the region of the contact (Fig. 1), as determined by the magnitude and direction of the current. The contact resistance of the crystal when this has a deficiency of conduction electrons is also determined.
2545. THE TRANSITIONAL RESISTANCES IN SEMICONDUCTORS.—Davydov. (*Journ. of Exper. & Theoret. Phys.* [in Russian], No. 12, Vol. 10, 1940, pp. 1342-1347.)
In a previous paper (*ibid.*, Vol. 9, 1939, p. 451) the contact resistance between a metallic electrode and a semiconductor was determined for small values of current. The present paper considers the relationship between the current and the voltage applied to the contact, and the accompanying rectifying effect. The transitional inner resistances in polycrystalline semiconductors are then dealt with. These additional resistances are due to the appearance of surface charges at the crystal boundaries, *i.e.* of ions of the same sign as that of the free volume charges (electrons or "holes") in the semiconductor. It is shown that owing to the redistribution of volume charges these resistances may in certain cases decrease with an increase in the current.
2546. A CERTAIN PROPERTY OF CONTACTS.—Zeldovich & Chariton. (*Journ. of Exper. & Theoret. Phys.* [in Russian], No. 12, Vol. 10, 1940, pp. 1422-1423.)
When an alternating current passes through a contact between two conductors, a d.c. component appears which is due to two factors: (1) thermoelectromotive force due to Joulean heating of the contact, and (2) change in the contact resistance due to Peltier thermal effect. The relative importance of these two factors is discussed.
2547. THE CALCULATION OF CHOKE COILS WITH STRAIGHT IRON CORES.—Scheller. (*E.T.Z.*, 20th June 1940, Vol. 61, No. 25, p. 571: summary only.)
2548. NEW TRANSFORMER STEEL: DEVELOPMENT OF HIPERSIL—GREATER FLUX-CARRYING CAPACITY.—Westinghouse. (*Electrician*, 23rd May 1941, Vol. 126, p. 298.)
2549. X-RAY INVESTIGATION OF THE Al-Co-Fe SYSTEM.—Edwards. (*Sci. Abstracts*, Sec. B, April 1941, Vol. 44, No. 520, p. 49.)
2550. A MEASURING EQUIPMENT FOR PERMANENT MAGNETS [and Permanent-Magnet Steels].—Breitling. (See 2500.)
2551. METHOD OF MEASURING HYSTERESIS AND MAGNETIC-VISCOUSITY CONSTANTS, ETC., OF SAMPLES OF SMALL CROSS-SECTION.—Schweizerhof. (See 2501.)
2552. CRYSTAL LATTICE MODELS BASED ON THE CLOSE PACKING OF SPHERES.—Patterson. (See 2429.)
2553. READING LIST ON RADIO POWER SUPPLY, ESPECIALLY FOR AIRCRAFT, 1930 ONWARDS.—(*Sci. Library Bibliographical Series*, No. 552, 1941.) 17 items.

STATIONS, DESIGN AND OPERATION

2554. TESTS OF FREQUENCY MODULATION FOR AIRCRAFT COMMUNICATION.—Weir. (See 2431.)

2555. FREQUENCY MODULATION [Theory of Interference of Amplitude-Modulated Waves: Angular Modulation—Phase, Frequency, Angular-Acceleration, & nth Order Modulations: Interference of Two Angular-Modulated Waves: Spectra of Phase & Frequency Modulations: Practical Considerations: etc.].—Everitt. (*Elec. Engineering*, Nov. 1940, Vol. 59, No. 11, Transactions pp. 613-625.)
2556. THE FREQUENCY BAND IN WIRELESS PRINTING TELEGRAPHY BY THE IMPULSE PROCESS.—Hudec. (*E.N.T.*, June 1940, Vol. 17, No. 6, pp. 125-139.)
Concluding the series of papers on this process (see 959 of 1939 and 858 of 1940, and back references). The necessary frequency bands for various shapes of impulse are calculated, and parts of the trial equipment described.
2557. TIME-DIVISION MULTIPLEX SYSTEMS [and the Problem of Application to Telephone Channels: General Quantitative Discussion of Factors involved].—Bennett. (*Bell S. Tech. Journ.*, April 1941, Vol. 20, No. 2, pp. 199-221.)
2558. ENGINEERING REQUIREMENTS FOR PROGRAMME TRANSMISSION CIRCUITS.—Cowan, McCurdy, & Lattimer. (*Bell S. Tech. Journ.*, April 1941, Vol. 20, No. 2, pp. 235-249.) Already referred to in 1104 of April.

GENERAL PHYSICAL ARTICLES

2559. ON THE ABSOLUTE DEFINITION OF THE PLANCK QUANTUM (OF RADIATION), and THE POTENTIAL AND THE CHARACTERISTIC CONSTANTS OF PHYSICAL SPACE IN ELECTRIC AND GRAVITATIONAL FIELDS.—Labocchetta. (*La Ricerca Scient.*, May 1940, Vol. 11, No. 5, pp. 354-356; July/Aug. 1940, No. 7/8 pp. 565-568.)
2560. THE CONNECTION BETWEEN THE QUANTUM ENSEMBLE AND THE CLASSIC GIBBS ENSEMBLE: II.—Blokhintzev & Nemirovskij. (*Journ. of Exper. & Theoret. Phys.* [in Russian], No. 11, Vol. 10, 1940, pp. 1263-1266.) For I see 3229 of 1940.
2561. AN EXPERIMENTAL STUDY OF THE RATE OF A MOVING ATOMIC CLOCK: II [Confirmation of Previous Results on Frequency of Light emitted by High-Speed Hydrogen Canal Rays, agreeing with Larmor-Lorentz Prediction].—Ives & Stilwell. (*Journ. Opt. Soc. Am.*, May 1941, Vol. 31, No. 5, pp. 369-374.)
2562. ON THE MAGNITUDE OF ELECTRONIC CHARGES.—Landé. (*Phys. Review*, 1st March 1941, Vol. 59, No. 5, pp. 434-435.) See also *ibid.*, p. 475, and 2279 of August.
2563. ON THE ELECTRON DISTRIBUTION IN THE NICHOLS EXPERIMENT [Attempt to "Centrifuge" the Conduction Electrons: Suggested Improvement of Technique].—Wolf. (*Ann. der Physik*, 9th Feb. 1941, Vol. 39, No. 2, pp. 164-168.) For previous work see 928 of March.
2564. REMARK ON THE TEMPERATURE-DEPENDENCE OF ELECTRICAL RESISTANCE.—Meixner. (*Ann. der Physik*, 6th Dec. 1940, Vol. 38, No. 7/8, pp. 609-614.)
2565. INVESTIGATIONS ON THE TEMPERATURE-DEPENDENCE OF THE OPTICAL CONSTANTS OF SOME METALS [Silver, Gold, & Copper].—Martin. (*Ann. der Physik*, 6th Dec. 1940, Vol. 38, No. 7/8, pp. 615-629.)
2566. THE FOURIER ANALYSIS OF CRYSTALS AND THE DENSITY OF THE METAL ELECTRONS.—Sommerfeld. (*Naturwiss.*, 13th Dec. 1940, Vol. 28, No. 50, pp. 769-777.)
2567. FLUCTUATION OF THE DENSITY IN THE IDEAL BOSE-EINSTEIN GAS.—Galanin. (*Journ. of Exper. & Theoret. Phys.* [in Russian], No. 11, Vol. 10, 1940, pp. 1267-1282.)
2568. THE NATURE OF ELEMENTARY OSCILLATORS AND THE POLARISATION OF PHOTOLUMINESCENCE.—Vavilov. (*Journ. of Exper. & Theoret. Phys.* [in Russian], No. 12, Vol. 10, 1940, pp. 1363-1371.)
2569. THE INFLUENCE OF END EFFECT ON THE THEORETICAL SHAPE OF INTENSITY CURVES IN RADIO-FREQUENCY SPECTRA [in Method of determining Magnetic Moments].—Stevenson: Rabi. (*Phys. Review*, 1st May 1941, Vol. 59, No. 9, p. 767.)
2570. "THE PHYSICAL SOCIETY: REPORTS ON PROGRESS IN PHYSICS: VOL. 7 (1940): [Book Review].—Awbery (Edited by). (*Phil. Mag.*, July 1941, Vol. 32, No. 210, pp. 87-88.)
2571. "ELECTROMAGNETIC PROBLEMS IN ELECTRICAL ENGINEERING": THE PROBLEM OF THE MAGNETIC FIELD DUE TO A LONG STRAIGHT PERMEABLE WIRE IN AIR.—Hague: Higgins. (*Elec. Engineering*, Nov. 1940, Vol. 59, No. 11, pp. 479-480.)

MISCELLANEOUS

2572. "ELEMENTE DER OPERATORENRECHNUNG MIT GEOPHYSIKALISCHEN ANWENDUNGEN" [Book Review].—Ertel. (See 2340.)
2573. "THE THEORY AND APPLICATIONS OF HARMONIC INTEGRALS" [Book Review].—Hodge. (*Phil. Mag.*, July 1941, Vol. 32, No. 210, pp. 86-87.)
2574. "A TREATISE ON ADVANCED CALCULUS" [Logical Treatment after the Study & Acquisition of Technique: Book Review].—Franklin. (*Journ. Franklin Inst.*, May 1941, Vol. 231, No. 5, pp. 504-505.)
2575. ON SOME EXPANSIONS CONTAINING LAGUERRE POLYNOMIALS, AND THEIR EXPRESSIONS IN TERMS OF WHITTAKER'S CONFLUENT HYPERGEOMETRIC FUNCTIONS.—Banerjee. (*Phil. Mag.*, July 1941, Vol. 32, No. 210, pp. 84-85.)
2576. EXPERIMENTS IN APPROXIMATING TO SOLUTIONS OF A PARTIAL DIFFERENTIAL EQUATION [to avoid Solution of Awkward Transcendental Equation given by Operational Treatment].—Bickley. (*Phil. Mag.*, July 1941, Vol. 32, No. 210, pp. 50-66.)

2577. SOLVING A TYPE OF NON-LINEAR SIMULTANEOUS EQUATIONS WITH A MECHANICAL HARMONIC SYNTHESIZER.—Brown & Wheeler. (*Phys. Review*, 1st March 1941, Vol. 59, No. 5, p. 468: summary only.)
2578. THE ELECTRICAL REPRESENTATION OF MATHEMATICAL FUNCTIONS [and Its Application to Their Automatic Solution].—Strobel. (*E.T.Z.*, 27th June 1940, Vol. 61, No. 26, p. 596: summary only.)
2579. "THE ENGINEER'S YEAR-BOOK OF FORMULAE, RULES, TABLES, DATA AND MEMORANDA FOR 1941" ["Kempe": Book Review].—(*Nature*, 28th June 1941, Vol. 147, p. 790.)
2580. "WISSENSCHAFTLICHE VERÖFFENTLICHUNGEN AUS DEN SIEMENS-WERKEN" [Vol. 19, 1940, Nos. 1 & 2: Book Review].—(*Zeitschr. f. tech. Phys.*, No. 1, Vol. 22, 1941, pp. 23-24.)
The papers mentioned include one by Wetter (Wetterer? see 780 of 1940) on a quartz-fibre manometer, one by Müller on the connection between the molecular structures of Styroflexes and their physical properties (for other work by Müller see 310 of 1939), and one by Pätzold on the absorption and focusing of short waves in electrolytes and biological substances (for a paper by Pätzold & Osswald see 3276 of 1940).
2581. "DAS FREIE ELEKTRON IN PHYSIK UND TECHNIK" [Book Review].—Ramsauer (Edited by). (*Zeitschr. V.D.I.*, 7th June 1941, Vol. 85, No. 23, p. 530.) Including sections by Schottky, Rukop, Rothe, and Brüche.
2582. A HINT TO MANUFACTURERS OF RADIO COMPONENTS: THE QUESTION OF CATALOGUES.—Williams. (*Electronics*, Nov. 1940, Vol. 13, No. 11, p. 15.)
2583. WHAT WOULD COMPULSORY PATENT LICENSING MEAN TO YOU?—Nye & Silver. (*Electronics*, Nov. 1940, Vol. 13, No. 11, pp. 76-77: summary only.)
2584. THE PUBLICATION OF PAPERS ON ULTRA-HIGH-FREQUENCY RESEARCH [Appointment of a Reference Committee].—(*Electronics*, Nov. 1940, Vol. 13, No. 11, p. 15: paragraph only.)
2585. COMMUNICATIONS CONTRIBUTES TO NATIONAL DEFENCE [the Defence Communications Board].—(*Communications*, Nov. 1940, Vol. 20, No. 11, p. 3.)
2586. THE DEFENCE SET-UP FOR THE COMMUNICATIONS INDUSTRY [Activities of F.C.C., National Defence Research Committee, National Inventors' Council, etc.].—(*Electronics*, Nov. 1940, Vol. 13, No. 11, pp. 16-17 and 93..100.)
2587. PHYSICISTS NEEDED FOR NATIONAL DEFENCE WORK: MATHEMATICS, THE BOTTLENECK FOR PHYSICISTS.—Williams. (*Science*, 25th April 1941, Vol. 93, pp. 398-400.) See also "Officials foresee serious shortage of physicists," *Sci. News Letter*, 24th May 1941, p. 324.
2588. THE DEFERMENT OF PHYSICISTS [under the Selective Service Act].—(*Review Scient. Instr.*, April 1941, Vol. 12, No. 4, pp. 177-178.) See also Editorial, *ibid.*, May 1941, No. 5, pp. 247-249.
2589. RCA RESEARCH LABORATORY ["World's Largest Radio Laboratories" to be erected at Princeton: Staff Appointments].—(*Review Scient. Instr.*, April 1941, Vol. 12, No. 4, p. 239.)
2590. GENERAL PRINCIPLES OF AUTOMATIC REGULATION, and THE DETERMINATION OF THE MAIN PARAMETERS OF AUTOMATIC REGULATORS [to give a Desired Regulation for a Given Character of Load Variation].—Kulebakin. (*Automatics & Telemechanics* [in Russian], No. 4, 1940, pp. 3-21: No. 6, 1940, pp. 3-24.)
(1) However complicated or diverse the processes of automatic regulation may be, certain general principles can be formulated which must be observed to make regulation possible. An equation (1) representing the regulation process of a system with one regulated parameter is written down, and from an analysis of this equation the necessary conditions are established for (a) static (dependent) regulation, when to each value of the stabilised load there is a corresponding definite value of the regulated parameter, and (b) astatic (independent) regulation when the regulated parameter is maintained constant independently of the load. Fundamental regulating circuits meeting the above requirements are briefly discussed. (2) Further development.
2591. THE PERFORMANCE OF THE AUTOMATIC REGULATOR [and Its Specification, for Most Practical Forms, by "Response Time" and "Compensation Factor"].—Wünsch. (*Zeitschr. V.D.I.*, 10th May 1941, Vol. 85, No. 19, pp. 444-448.)
2592. THE STABILISATION OF REGULATING SYSTEMS EMBODYING VALVE AMPLIFIERS, BY DAMPING OR ELASTIC RESTORING ACTION.—Ludwig. (*E.T.Z.*, 30th May 1940, Vol. 61, No. 22, p. 500: summary only.)
2593. STABILITY INVESTIGATIONS ON INTERMITTENT GOVERNORS, REPRESENTED BY A FRICTION-DRIVEN CONTACT REGULATOR.—Krautwig. (*Arch. f. Elektrot.*, 20th Feb. 1941, Vol. 35, No. 2, pp. 117-126.) With a view to accomplishing, for the intermittent type, what Nyquist and others have done for the continuous-action and average-value types.
2594. REMOTE OPERATION [Survey of Remote Control & Telemetering].—Henning. (*Zeitschr. V.D.I.*, 10th May 1941, Vol. 85, No. 19, pp. 431-439.)
2595. MULTIPLE REMOTE MEASUREMENTS OVER A SINGLE COMMUNICATION CHANNEL.—Tanski. (*Automatics & Telemechanics* [in Russian], No. 4, 1940, pp. 109-122.)
A "pseudo-multiple" transmitting system is discussed in which the transmitters and receivers are connected in turn by two synchronous com-

- mutators at the ends of the line (Fig. 1). One cycle of commutator operation is sufficient for indicating all measured values (as opposed to multi-cycle operation): this is effected by transmitting single impulses whose duration is a function of the deflection of the measuring apparatus (time-impulse as opposed to frequency-impulse transmission).
2596. RECENT DEVELOPMENT IN SUBMARINE TELEGRAPHY [with Data on Some Italian Cables].—Gori. (*Alta Frequenza*, May 1940, Vol. 9, No. 5, pp. 260-277.)
2597. DESCRIPTION OF THE C-5 CARRIER TELEPHONE SYSTEM.—Almquist. (*Bell Tel. System Tech. Pub.*, Monograph B-1264, 20 pp.)
2598. MEASURING SYSTEM FOR CARRIER CIRCUITS, and MEASUREMENT OF DYNAMIC CHARACTERISTICS OF [Carrier-System] VACUUM TUBES.—Rosen: Maggio. (*Bell Lab. Record*, May 1941, Vol. 19, No. 9, pp. 277-280: pp. 281-285.)
2599. THE MEASUREMENT OF SMALL CURRENTS AND VOLTAGES AND SMALL CHANGES IN LENGTH WITH THE BOLOMETRIC COMPENSATOR.—Meitz & Niepel. (*E.T.Z.*, 6th June 1940, Vol. 61, No. 23, pp. 527-528: summary only, from *Wiss. Veröff. Siemens-Werken*.)
- Examples include the recording of propeller shift by a magneto-elastic pick-up with bolometric amplification, and the control of machine tools by the bolometric gauge.
2600. OPERATION OF ELECTROSTATIC PHOTO-MULTIPLIERS [and Their Applications].—Winans & Pierce. (See 2465.)
2601. A HIGH-SENSITIVITY PHOTOTUBE CIRCUIT.—Bull & Lafferty. (See 2470.)
2602. A DIRECT-CURRENT AMPLIFIER FOR MEASURING STELLAR PHOTOELECTRIC CURRENTS.—Heidelberg & Rense. (See 2378.)
2603. PHOTOTUBES AID IN CAMOUFLAGE [Submersible Recording Device used in perfecting Submarine Camouflage].—Utterbach. (*Electronics*, Nov. 1940, Vol. 13, No. 11, p. 72: photograph & caption.)
2604. A PRECISION INTEGRATING SPHERE DENSITOMETER [primarily for Sound-Track Densities].—Frayne & Crane. (*Review Scient. Instr.*, Nov. 1940, Vol. 11, No. 11, pp. 350-355.)
2605. A MODIFIED PHOTONREFLECTOMETER [Reflectometer using Photronic Cell] FOR USE WITH TEST-TUBES IN TURBIDITY DETERMINATIONS.—Libby. (*Science*, 9th May 1941, Vol. 93, pp. 459-460.)
2606. MEASURING METHOD FOR THE DETERMINATION OF SMALL MOMENTS OF FRICTION [on the Photocell Compensation Principle].—Vieweg & Gottwald. (*Zeitschr. V.D.I.*, 3rd May 1941, Vol. 85, No. 18, pp. 417-419.) For instance, in clocks and meters.
2607. A MULTI-PURPOSE PHOTOELECTRIC REFLECTOMETER [using Barrier-Layer Cells: the Choice of the Most Suitable Cell: etc.].—Hunter. (*Journ. Opt. Soc. Am.*, Nov. 1940, Vol. 30, No. 11, pp. 536-559.) With a bibliography of 59 items.
2608. BESSEMER STEEL OF INCREASED UNIFORMITY [by Precise Control of Blow by Photoelectric Recording of Flame].—Work. (*Review Scient. Instr.*, June 1941, Vol. 12, No. 6, p. 339.)
2609. LUMETRON FLUORESCENCE METER [with Balanced Photocells: for Vitamin Measurements, etc.].—(Review *Scient. Instr.*, June 1941, Vol. 12, No. 6, pp. 335-336.)
2610. A PHOTOELECTRIC COLOUR TEMPERATURE METER FOR INCANDESCENT LAMPS [with "Electric Eye" as Indicator, No Valve Amplification].—Sweet. (*Journ. Opt. Soc. Am.*, Nov. 1940, Vol. 30, No. 11, pp. 568-571.)
2611. PHOTOELECTRIC MEASUREMENT [and Recording] OF RELATIVE HUMIDITY.—Strobel. (*E.T.Z.*, 6th June 1940, Vol. 61, No. 23, pp. 515-518.)
2612. THE PROPERTIES OF OPTICAL GLASSES WITH CHEMICALLY TREATED SURFACES.—Schröder. (*Zeitschr. f. tech. Phys.*, No. 2, Vol. 22, 1941, pp. 38-43: Corrections, *ibid.*, No. 3, p. 75.)
2613. SOME OBSERVATIONS ON LOW-REFLECTION EVAPORATED FLUORIDE COATINGS.—Monk. (*Journ. Opt. Soc. Am.*, Nov. 1940, Vol. 30, No. 11, pp. 571-572.)
2614. HIGH-SPEED MOTION PICTURES [including by Use of Polarized Light] AID DESIGN.—Townsend. (*Elec. Engineering*, Nov. 1940, Vol. 59, No. 11, pp. 448-450.)
2615. TRANSMISSION AND REFLECTION OF PLASTICS AND METAL BLACKS IN THE FAR INFRA-RED.—Seifert & Randall. (*Review Scient. Instr.*, Nov. 1940, Vol. 11, No. 11, pp. 365-368.)
2616. THE OPTICAL PROPERTIES OF ALUMINIUM FILMS SUBLIMATED IN HIGH VACUUM [Reflecting Powers in the 500 m μ to 9 μ Range].—Walkenhorst. (*Zeitschr. f. tech. Phys.*, No. 1, Vol. 22, 1941, pp. 14-21.)
2617. CULTURED CRYSTALS [Technique for "growing" Large Single Crystals of Lithium Fluoride, Potassium Iodide, etc.].—Kremers. (*Review Scient. Instr.*, April 1941, Vol. 12, No. 4, p. 235.) See also 3662 of 1940.
2618. AN IMPROVED OPTICAL LEVER [Angular Magnification of 12], and A MODIFICATION OF THE TELESCOPE-AND-SCALE SYSTEM.—Crist: Vonnegut. (See 2491 & 2492.)
2619. THE CHRONOSCOPE [primarily for Bullet Velocities].—Bradford. (See 2497.)