

EXPERIMENTAL WIRELESS & The WIRELESS ENGINEER

VOL. VII.

NOVEMBER, 1930.

No. 86.

Editorial.

Broadcast Receivers—A Modern Need.

SUCH great progress has been made in the design of broadcast receivers during the last few years that one may profitably take stock of the present situation and consider in which directions further improvements are most needed. The introduction of the all-mains receiver has to a large extent removed the limitation of power which was one of the controlling factors in the battery set. This has led to more liberal design in the output stages, since the compromise between power consumption and quality can now be given a much greater bias towards quality. The use of the audio-frequency amplifier for both radio and gramophone reproduction has led to the introduction of tone-correcting devices with frequency characteristics to some extent complementary to those of the record. The same considerations as regards power have also been applied to the detector, and recent articles have shown that even a grid rectifier under proper conditions is capable of giving a large output of high quality. It is on the high-frequency side that the more revolutionary developments have occurred. In this country conditions were such that the super-heterodyne was not viewed with such favour as in America, and attention has been concen-

trated on the development of one, two, or three high-frequency stages, giving high amplification combined with stability, selectivity combined with quality, and simplicity of tuning by means of a single control. The two milestones on the road to the present stage of development were the neutralisation of the inter-electrode capacity of the valve and the perfection of the screen-grid valve making external neutralisation unnecessary. As further refinements we may mention such devices as the switch fitted by at least one German firm, by which one can change over from grid rectification to anode bend when quality is of greater importance than sensitivity—an unnecessary move according to Mr. P. K. Turner's recent work on grid rectification—or the switch on the high-class Lorenz sets, by means of which resistance can be inserted in the high-frequency tuned circuits, so widening their resonance curves and cutting off less of the higher harmonics, or, again, the band-pass filter recently introduced into sets described in *The Wireless World* to attain the same results without picking up anything lying just outside the desired frequency band.

Having reached this stage of development, one may well consider in which direction the

designer or inventor could most profitably turn his attention. From our own personal experience we should feel inclined to give very high priority to the design of anti-fading devices. However sensitive and selective a receiver may be, and however excellent the quality of reproduction, satisfactory reception of relatively powerful stations a few hundred miles away is often quite impossible unless one is prepared to sit beside the set and adjust the volume control almost continuously, thus losing to a large extent the gradations of tone which contribute so much to the quality of the music. It is impossible to enjoy a programme under these conditions. It is very unfortunate that excessive fading is not confined to very distant stations, the reception from which would, in any case, be subjected to other forms of disturbance, but is at its worst for stations within a few hundred miles, the reception from which would otherwise be excellent, and the programmes from which are most likely to be of the greatest interest. As an example, the reception of the London Regional programme in Glasgow often alternates between excessive loudness and inaudibility several times within the course of a few minutes. We do not suppose that any simple solution will be found for the inaudibility, the only known cures for which require several aerials with liberal spacing beyond the powers of the ordinary listener; perhaps something could be done by receiving simultaneously on a vertical and on a horizontal aerial. The limitation of the sensitiveness of the set when the signal exceeds a certain value is a much simpler problem, to which a certain amount of attention has been given, and for which several patents have been granted. The problem is not quite so simple as it may appear at first sight; the device should not interfere in any way with the normal variations in the loudness of music between *ppp* and *fff*, or over as much of this range as a well-trained wireless orchestra is allowed to roam. It is the mean loudness which we require to be maintained at a constant level, and the secret of this discrimination would appear to lie in the differentiating between the carrier wave and the sidebands. The variations of loudness

in the transmitting aerial are represented by variations in the amplitudes of the sidebands, the amplitude of the carrier frequency remaining unchanged, or, for those who prefer it, the variations of loudness cause variations in the depth of modulation without affecting the mean amplitude of high-frequency current. In the ordinary type of receiver it is thus the continuous-current component of the rectifier output which should be controlled and which should, therefore, be used to react upon and modify the sensibility of the high-frequency stages.

One method of doing this was described and patented by H. T. Friis. In a superheterodyne receiver the output of the second detector consists of three components—a direct current with which we are not concerned, an audio-frequency current which goes to the low-frequency amplifier, and the intermediate-frequency current which Friis taps off, amplifies, and rectifies by means of a rectifier with such a large negative grid bias that current flows in its anode circuit only when the input exceeds a certain threshold value. This rectified and smoothed current is passed through a resistance, the drop across which modifies the grid bias of the high-frequency stages of the superheterodyne.

Another method was recently described by H. de Bellecize in *L'Onde Électrique* (June, 1930). A relay is employed, the coils of which carry the direct-current component of the output from the detector of any ordinary receiving set. The armature has three possible positions, viz., on either side or in the middle; the side contacts are connected to tappings to different points of the grid-bias battery of the high-frequency stage. To prevent sudden changes of the grid bias, high resistances and condensers are inserted between the relay and the valve, which have the effect of supplying the grid bias from a large electrical reservoir, the level of which is gradually raised or lowered according to the position of the relay armature. Whether these methods have proved satisfactory in practice we do not know, but they serve to indicate the lines along which the troubles due to fading may be greatly reduced.

G. W. O. H.

The Theory of the Straight Line Rectifier.*

By *F. M. Colebrook (National Physical Laboratory).*

1. Introduction.

BY the term "straight line rectifier" is meant one of which the current-voltage characteristic shows very high (effectively infinite) resistance to currents in one direction and constant resistance to currents in the opposite direction. No existing type of rectifier is exactly of this kind, but one which approximates to it (a triode with a

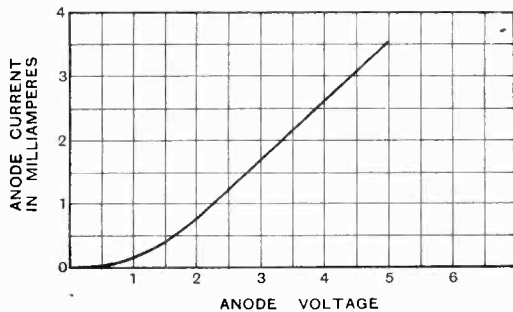

Fig. 1.—PM1 H.F. value $V_g = +10$.

constant positive potential applied to the grid, an arrangement developed by H. G. Kirke) is finding some application in wireless reception (see bibliography at end of this paper). Moreover, certain other types of rectifier (crystal, anode circuit of triode, some forms of power supply rectifiers) can be considered to approximate to the straight line type for large amplitudes of operation.

No comprehensive account of the theory of operation of such rectifiers has so far appeared, and the following brief analysis of the subject may therefore be of some interest and of practical use. The analysis aims at answering in as practical a manner as possible the following questions:—

- (1) What is the effective input resistance of a straight line rectifier?
- (2) What is its effective output frequency internal resistance?
- (3) What is the effective output frequency e.m.f.?

(4) Do the above quantities vary with amplitude and load?

(5) What are the characteristics of such a rectifier from the point of view of modulation frequency distortion?

These questions are obviously of practical importance in relation to design. The answers given are supported by experimental evidence, and it is shown that such a rectifier can be calibrated to a good degree of accuracy by simple d.c. measurements of the static characteristic.

2. Static Characteristic.

Fig. 1 shows the static or d.c. characteristic of a triode valve (PM1HF) with +10 volts on the grid. This will be taken as typical of the approximate straight line rectifier. Notice that the straight line part does not pass through the origin.

For analysis the characteristic will be idealised as shown in Fig. 2, i.e.

$$i = a(e - b) \text{ for } e > b$$

$$= 0 \text{ for } e \leq b$$

3. Response to a Sine Wave e.m.f.

The circuit considered is shown in Fig. 3. Note that a direct voltage e_0 is included. The capacity C is such as to prevent any appreciable fall of input frequency voltage

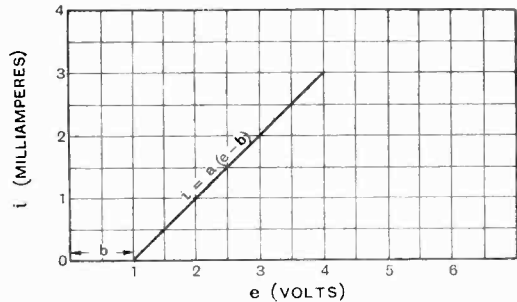

Fig. 2.—Static characteristic of straight line rectifier.

in the load R , a condition which is always desirable from the point of view of rectification efficiency. The current will consist of a complete Fourier series including a

* MS. first received by the Editor October, 1929, and in final form January, 1930.

constant term i_c , which latter will give rise to a back e.m.f. v_c in the load R . Thus

$$i = a(\hat{e} \sin \omega t + e_0 - b - v_c)$$

for all positive values of the quantity in the brackets, and zero for all other values. Taking the mean value of i over a period $T = 2\pi/\omega$,

$$i_c = \frac{1}{T} \int_{t_0}^{T/2 - t_0} a(\hat{e} \sin \omega t + e_0 - b - v_c) dt$$

where

$$\sin \omega t_0 = (v_c + b - e_0)/\hat{e}$$

(since i will be zero outside the above limits). The integration gives

$$i_c = \frac{a\hat{e}}{\pi} (\sin \theta - \theta \cos \theta)$$

where $\cos \theta = (v_c + b - e_0)/\hat{e}$

This is an implicit solution for i_c . No exact explicit solution is obtainable, but the above solution will prove sufficient for most purposes.

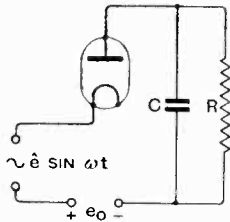

Fig. 3.

It will first be simplified by putting $b - e_0 = 0$

This is obviously a desirable condition for most purposes, and is easily realised in practice. It will be

seen later that only under the above condition will i_c be linear with respect to \hat{e} . (The modification of the analysis for the case $b - e_0 \neq 0$ presents no difficulty.) The importance of this "biasing" the rectifier is shown by Fig. 4, which represents the variation of i_c with e_0 for $b = 1$, $\hat{e} = 1$, and $a = 10^{-3}$. (It is not so important in relation to a modulation frequency output, but is still desirable.) Assuming the correct bias condition we have

$$i_c = (a\hat{e}/\pi) (\sin \theta - \theta \cos \theta)$$

where $\cos \theta = v_c/\hat{e} = Ri_c/\hat{e}$

The factor $(\sin \theta - \theta \cos \theta)$ is shown plotted in Fig. 5.

4. Variation of i_c with \hat{e} and R .

In the first place, if $R = 0$, v_c is 0 and

$$i_c = a\hat{e}/\pi$$

and is thus proportional to \hat{e} . Note that

this is only true if $b - e_0 = 0$. From the curved variation of the factor depending on v_c it might be thought that i_c would not be

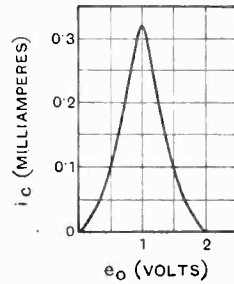

Fig. 4.—Variation of continuous rectified current with bias voltage.

linear with respect to \hat{e} for appreciable values of R , but the following shows that i_c will in fact be proportional to \hat{e} for all values of R . Multiplying the equation for i_c by R/\hat{e} gives

$$v_c/\hat{e} = \cos \theta = (aR/\pi) (\sin \theta - \theta \cos \theta)$$

$$i.e. \cos \theta / (\sin \theta - \theta \cos \theta) = aR/\pi$$

This shows that for a given value of R , $\cos \theta$ is a constant, the value of which can be determined from the curve of Fig. 5a. Calling this constant k

$$\cos \theta = v_c/\hat{e} = k$$

$$i.e. i_c = k\hat{e}/R$$

where k depends only on R . Thus for all load conditions i_c is proportional to \hat{e} , and the variation of i_c with \hat{e} and with R can be exactly determined as shown above. The variation of i_c with R for $\hat{e} = 1$ and $a = 10^{-3}$ is shown plotted in Fig. 6.

(Notice that the above statements will not be true unless $b - e_0 = 0$. For any given value of \hat{e} the variation of i_c with R when

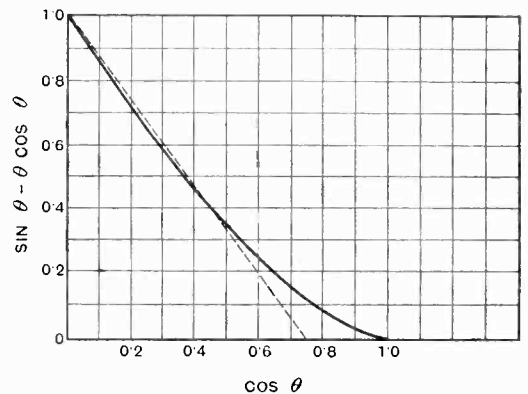

Fig. 5.

$b - e_0 \neq 0$ can be determined by a kind of inverse calculation. Assuming a value for v_c , $\cos \theta$ is known and i_c can be determined

from the curve, and the corresponding value of R is obviously v_c/i_c .

The application of the above to design will be made more apparent by the following transformations of the expression for i_c .

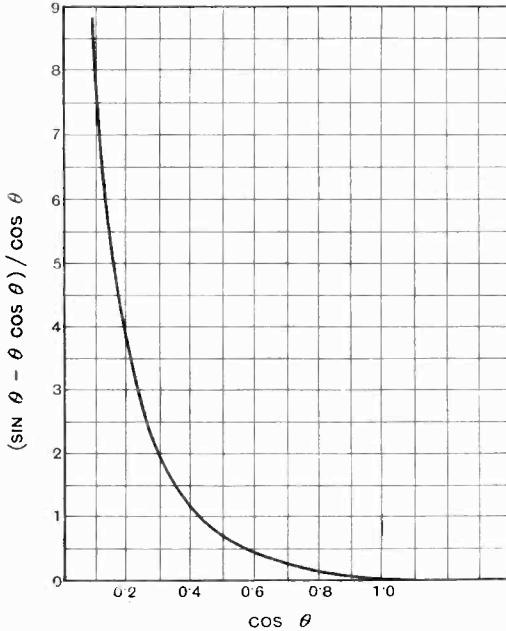

Fig. 5a.—Graph of $\frac{\sin \theta - \theta \cos \theta}{\cos \theta}$

5. Physical interpretation of the expression for i_c .

It is shown in Appendix 1 that i_c can be put in the form

$$i_c = \frac{E_c}{R_c + R}$$

where $R_c = \frac{2}{a}$ and $E_c =$

$$\frac{2\hat{e}}{\pi} \left\{ 1 + \frac{1}{2} \frac{v_c^2}{\hat{e}^2} + \frac{1}{24} \frac{v_c^4}{\hat{e}^4} + \text{etc., etc. ad. inf.} \right\}$$

The quantities E_c and R_c are respectively an effective rectified e.m.f. and an effective internal resistance. The latter is independent of \hat{e} and R , but the former will increase with R from its value $2\hat{e}/\pi$ when $R = 0$.

A simpler approximate form which will be quite sufficiently accurate for most purposes is derived as follows. For values of $\cos \theta$, i.e. of v_c/\hat{e} , equal to or less than 0.5,

$$(\sin \theta - \theta \cos \theta) = 1 - (4/3)\cos \theta$$

correct to better than 5 per cent. Within this limitation therefore,

$$i_c = (a\hat{e}/\pi) \{1 - (4/3)(v_c/\hat{e})\}$$

i.e. $i_c = \frac{E'_c}{R'_c + R}$

where $E'_c = 3\hat{e}/4$

$$R'_c = 3\pi/4a$$

Actually the accuracy with which i_c is determined by the above simple formula is better than the above statement as to its limitation would suggest, probably because i_c appears on both sides of the approximated expression. The curves of Fig. 6 show the comparison between the exact and approximate determinations, for $\hat{e} = 1$ and $a = 10^{-3}$ (giving 2,360 for R_c).

6. Input resistance.

Before considering the application of the above to design it will be well to consider the input resistance of the rectifier. The amplitude of the input frequency component of i under the conditions already specified (negli-

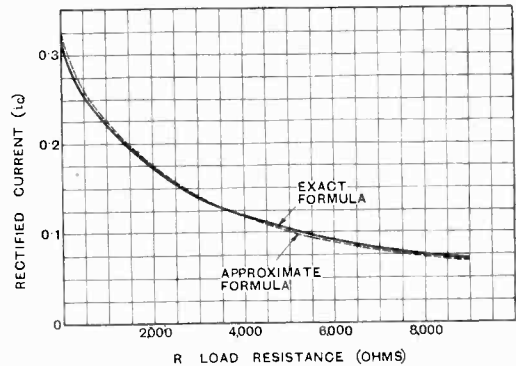

Fig. 6.

gible input frequency back e.m.f. in the load) is given by

$$i_\omega = \int_{t_0}^{T/2-t_0} (a\hat{e} \sin^2 \omega t - a v_c \sin \omega t) dt$$

$$= (a\hat{e}/\pi) (\theta - \sin \theta \cos \theta)$$

where $\cos \theta = v_c/\hat{e}$

Therefore, putting $i_\omega = \hat{e}/R_0$

$$R_0 = \pi/a(\theta - \sin \theta \cos \theta)$$

The variation of $(\theta - \sin \theta \cos \theta)$ with $\cos \theta$ is shown in Fig. 7. By means of this curve the exact value of R_0 for any given value of \hat{e} and R can be determined, since v_c and

therefore $\cos \theta$ can be determined as shown above. The variation of R_0 with R for $\hat{e} = 1$ and $a = 10^{-3}$ is shown in Fig. 8.

The important thing to notice about R_0 is that it depends very much on R , in spite of the fact that no input frequency current flows through R . This is, of course, due to the back e.m.f. v_c which limits the period during which the forward half cycle of the input e.m.f. gives a resultant positive potential on the rectifier. The value of R_0 increases from $2/a$ to ∞ as R increases from 0 to ∞ . (Note that when R is ∞ , $v_c = \hat{e}$ and $i_w = 0$). This variation of R_0 with R has an important bearing on design, which will be considered later.

It should be pointed out that the input resistance as determined above is that due to the rectification action itself. In certain applications (e.g. parallel connection of an input frequency choke) there may be additional terms due to associated circuits.

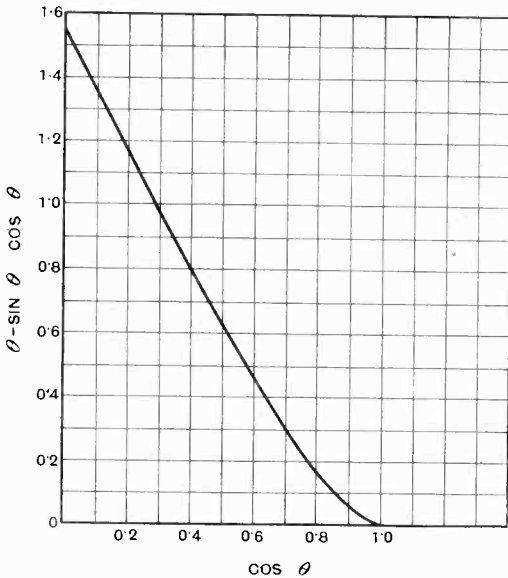

Fig. 7.

These are obviously not included in the above.

7. Experimental confirmation.

The fundamental formula for i_c in terms of a , \hat{e} , and R was confirmed by measurement, using the valve having the static characteristic shown in Fig. 1. The

necessary input voltages were obtained by passing a known current (measured with a non-contact thermo-junction) through known resistances made of very fine wire (No. 47

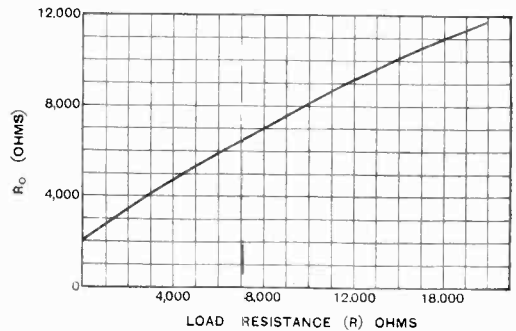

Fig. 8.—Input resistance of straight line rectifier (R_0).

Eureka). The frequency at which the measurements were made was about 100,000 cycles per second, and a repetition at a million cycles showed no appreciable variation with frequency. The measured and calculated values of i_c are shown in Fig. 9 by the full lines and the ringed points respectively. The agreement is sufficiently close to establish the validity of the fundamental formulæ for analytical and design purposes, and shows that a very simple d.c. measurement suffices for the a.c. calibration of this type of rectifier under practical conditions of operation.

8. Application to design. Continuous wave rectification.

(a) *Maximum d.c. power for a given input e.m.f.*

$$\text{Since } i_c = E_c / (R_c + R)$$

the output d.c. power $P_c (= i_c^2 R)$ will reach a maximum with respect to R when $R = R_c$. The variation of P_c with R for $a = 10^{-3}$ and $\hat{e} = 1$ is shown in Fig. 10. From the point of view of output power it is obviously better to err on the large side with the value of the load.

(b) *Maximum output potential difference.*

In many applications it will be $v_c (Ri_c)$ rather than P_c that matters. In all such cases R must be made large compared with R_c . The variation of v_c with R for the example of the preceding paragraph is

shown in Fig. 11. (Remember that for values of R large compared with $1/a$, it is necessary to use the exact formulæ for calculation purposes.)

Since $v_c = \{R/(R_c + R)\} E_c$ the upper limiting value of v_c is E_c , corresponding to an infinite load. Under these conditions $E_c = \hat{e}$. The fact that the upper limit of v_c is \hat{e} is obvious on physical grounds, for, referring to Fig. 3, if R is infinite the condenser will be charged by each successive half wave until it puts a stop to the process by acquiring a back e.m.f. equal to the amplitude. This condition will not generally be realisable in practice, since the reverse conductivity of the rectifier will not be zero. Observe that in general the behaviour with very large loads will be determined mainly by the reverse conductivity and the conductivity at the foot of the characteristic.

(c) Variation of power transformation efficiency with load.

In many cases the ratio of the output d.c. power to the input power (P_0) will be the

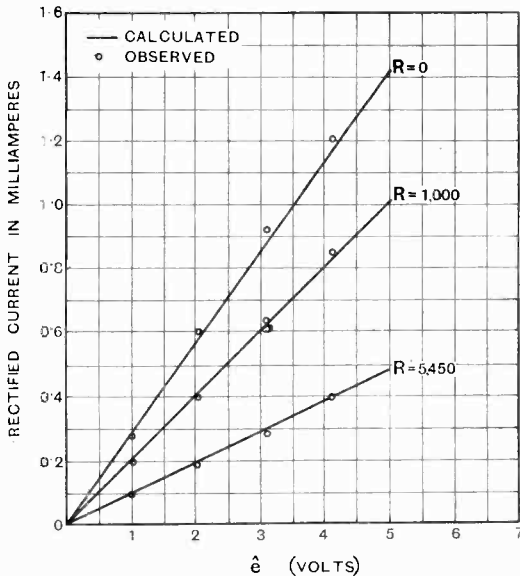

Fig. 9.—Experimental confirmation of theory.

important consideration. The value of this ratio cannot be stated explicitly, but in terms of v_c/\hat{e} it is

$$\frac{P_c}{P_0} = \frac{2(\sin \theta - \theta \cos \theta) \cos \theta}{(\theta - \sin \theta \cos \theta)}$$

This increases with $\cos \theta$ (i.e. with v_c/\hat{e}) right up to its limiting value 1 when v_c/\hat{e} is also 1, i.e. when the load is infinite. The limiting condition will not be realisable in fact,

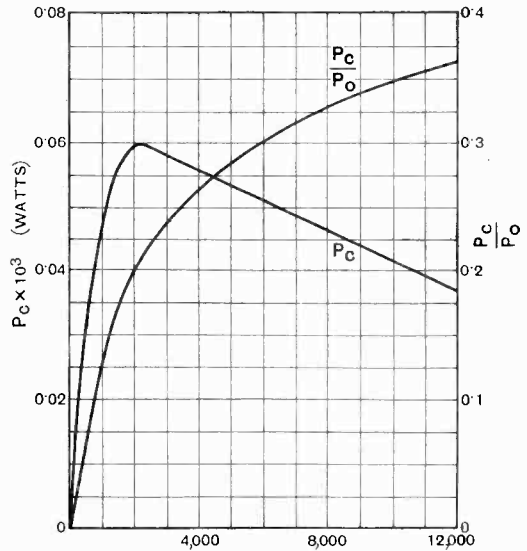

Fig. 10.

and would be of little use if it were, for both P_c and P_0 are then zero. It should be remembered, however, that the power transformation efficiency increases with R , as shown in Fig. 10 for the typical case already considered. This means that when the input amplitude is not maintained, i.e. when the input power is limited (as in all cases where there is in effect an internal resistance in series with the input e.m.f.) there will be an optimum load determined by an energy balance condition, this optimum load being greater than R_c , the optimum for a maintained e.m.f.

It may be mentioned that the above is a very general proposition applicable to all types of rectifier which draw power from the input e.m.f.

(d) Coupling to a tuned circuit.

As distinct from a retro-active valve detector, the detector under consideration will absorb power from the input source. It has in fact a relatively low input resistance. This does not mean that it is an inefficient rectifier. It is on the contrary a very efficient rectifier, as the analysis has already

shown. It does mean, however, that it is very necessary that it shall be rightly associated with a resonant circuit input, if the efficiency of the combination is to be preserved, by obtaining a proper balance of power between the coil and the rectifier. As explained above a relatively high resistance load will be desirable, and further the potential across the coil must be stepped down in some such manner as shown in Fig. 12. The importance of this stepping down of the resonant potential has already been emphasised by Kirke. The best coupling conditions are, of course, calculable, and will be found to correspond to a virtual doubling of the effective resistance of the coil by the load due to the detector. They are, however, more easily determined by trial.

The above are the main design conclusions applicable to continuous wave rectification by a "perfect" rectifier. The more familiar application to the rectification of a modulated wave will now be considered briefly.

9. The perfect rectification of a heterodyned or modulated continuous wave.

The e.m.f.

$$\hat{e} = \hat{e}(1 + m \sin nt) \sin \omega t$$

can be taken as typical of both the above cases, since the heterodyne case can be so expressed if the signal is small compared with the local oscillation, under which condition

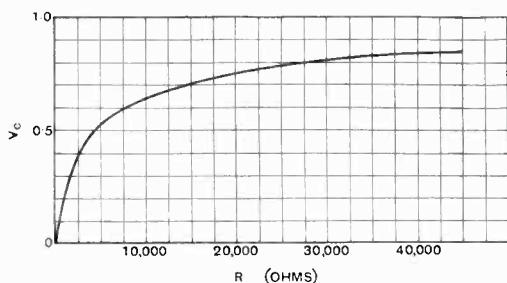

Fig. 11.

the effective modulation percentage (*m*) is the ratio of the two amplitudes, very approximately, and *n*/*2π* is the beat frequency.

Two assumptions will be made :

(a) Negligible fall of radio-frequency potential in the load, which has a d.c. resistance *R* and an operator impedance *Z*(*n*) at the audio-frequency *n*/*2π*.

(b) The modulation or beat frequency *n*/*2π* is so small compared with *ω*/*2π* that if

$$\frac{1}{T} \int_0^T f(\hat{e} \sin \omega t) dt = \phi(\hat{e})$$

where *T* is the radio-frequency period, then to a high degree of approximation

$$\frac{1}{T} \int_0^T f\{\hat{e}(1 + m \sin nt) \sin \omega t\} dt = \phi\{\hat{e}(1 + m \sin nt)\}$$

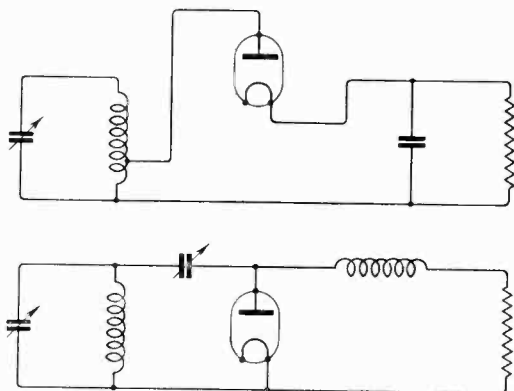

Fig. 12 .

This latter assumption implies that the change in amplitude during a single radio-frequency period is negligible.

With the above reservations the application of the same reasoning as in section 3 will give

$$i_c + i_a = (a\hat{e}/\pi) (1 + m \sin nt) (\sin \theta - \theta \cos \theta)$$

where $\cos \theta = (v_c + v_a)/\{\hat{e}(1 + m \sin nt)\}$

In the above *i_a* is the instantaneous value of an audio-frequency current of fundamental frequency *n*/*2π* and unspecified wave form, and *v_a* is corresponding back e.m.f. in the load. This is the complete solution in implicit form. No exact explicit solution is obtainable in general, though a very important special case can be solved by the same trick as in section 4. With the exception of this special case, considered below it will be found that there is no single frequency solution for *i_a*, showing that even the ideal form of characteristic assumed in this paper will not give ideally distortionless reproduction of modulation in general. Actually the distortion is likely to be considerably less than with most other forms of

rectifier, but it is as well to realise that a straight line characteristic will not necessarily give undistorted reproduction of modulation unless a suitable load is associated with it.

10. The only case in which "perfect" rectification is perfectly distortionless.

If $v_c + v_a = R(i_c + i_a)$
i.e., if the load is a pure resistance independent of frequency, then exactly as in section 4,

$v_a + v_c = R(i_c + i_a) = k\hat{e}(1 + m \sin nt)$
 where k depends only on R and can be determined as already shown. It follows that,

$$i_a = (k \hat{e} m \sin nt) / R$$

and that i_a is a faithful copy of the modulation.

11. General solution in terms of the "rectification characteristic."

Following the general method proposed by David* the rectification characteristics of the perfect rectifier are

$$i_c = (a\hat{e}/\pi) (\sin \theta - \theta \cos \theta) = \phi(\hat{e}, v_c)$$

Then

$$i_c + i_a = \phi\{\hat{e}(1 + m \sin nt), (v_c + v_a)\}$$

and i_n , the fundamental modulation frequency component of i_a is given by

$$i_c + i_n = \phi(\hat{e}, v_c) + m\hat{e} \sin nt \left(\frac{\partial \phi}{\partial \hat{e}} + v_a \frac{\partial \phi}{\partial v_c} \right)$$

i.e.,

$$i_n = m\hat{e} \sin nt \left(\frac{\partial \phi}{\partial \hat{e}} + v_a \frac{\partial \phi}{\partial v_c} \right)$$

where

$$\phi = \phi(\hat{e}, v_c) = (a\hat{e}/\pi) (\sin \theta - \theta \cos \theta); \quad \cos \theta = v_c / \hat{e}.$$

This can obviously be put in vector form

$$i_n = \frac{e_n}{Z(n) + R_a}$$

where e_n is a vector representing the effective modulation frequency e.m.f., of magnitude $R_a(\partial \phi / \partial \hat{e}) m \hat{e}$ and angular velocity n , and R_a is an effective internal resistance of magnitude $-1/(\partial \phi / \partial v_c)$.

The partial differential coefficients can be expressed in terms of θ , *i.e.*, of a and R .

* P. David: "Valve detection." *L'Onde Elect.*, 1928, Vol. 7, pp. 313-359.

This gives

$$R_a = \pi / (a\theta)$$

and

$$e_n = m \hat{e} (\sin \theta / \theta)$$

These results are, of course, approximate to the extent of assuming that i_c is unchanged by the modulation and that the second and higher partial derivatives of the rectification characteristics need not be taken into account. In the case under consideration the approximation will be quite sufficiently close for all practical purposes for all ordinary values of m .

It is interesting to observe as a confirmation of the result that if $Z(n)$ is put equal to R in the above formulae, then we get

$$i_n = (k m \hat{e} \sin nt) / R$$

as already deduced for this special case. As a further confirmation, putting $Z(n) = 0$ gives $i_n = (a m \hat{e} \sin nt) / \pi$, a result which is otherwise obvious.

Note that e_n and R_a both depend on R , the d.c. resistance of the load. Their variation with R for $\hat{e} = 1$, $a = 10^{-3}$, and $m = 10$ per cent. is shown in Fig. 13. The magnitude of e_n varies from $(2/\pi)m \hat{e}$ to $m \hat{e}$. and R_a from $2/a$ to ∞ as R varies from 0 to ∞ ,

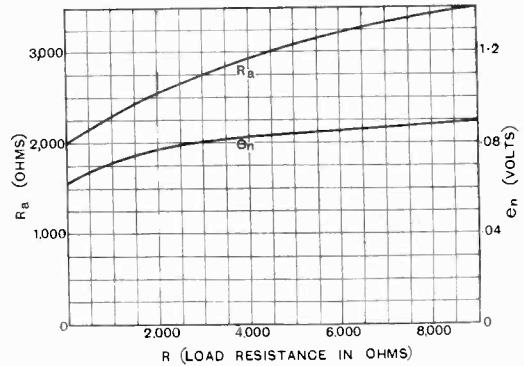

Fig. 13.

This variation is comparatively slow, however, and in most practical cases R_a will be of the order of $2/a$ and the magnitude of e_n in the neighbourhood of 0.7 to $0.9 m \hat{e}$.

12. Application to design.

The possible applications and varieties of circuit involving the rectification of a modulated wave are too numerous to permit of a complete exposition of the subject, though all the information required is con-

tained in the foregoing analysis. The following are the more important general deductions.

(a) *Rectification for modulation frequency power.*

For a given input e.m.f. the optimum value of $Z(n)$ with respect to modulation frequency power is R_a , in accordance with the general internal resistance law. As already pointed out in section 8(c) this load will not give the maximum output power if the input e.m.f. is not maintained against load, the best load in this case being larger than R_a and determined by an energy balance between the source and the rectifier. The discussion already given of the coupling of the rectifier to the source for continuous wave rectification applies to this case also.

(b) *Rectification for modulation frequency potential difference.*

Where v_n is the important output quantity (as in most applications to signal reception) it is obviously desirable that $Z(n)$ shall be large compared with R_a . In respect both of distortion and of efficiency of power transformation the most favourable load is a pure resistance. For given values of m and \hat{e} , v_n with a pure resistance load is proportional to $\cos \theta$ (i.e., to v_c/\hat{e}). The curve of Fig. 11 shows the variation of $\cos \theta$ with R for $a = 10^{-3}$ and $\hat{e} = 1$. (The curve can be generalised by plotting it against aR , which is the essential variable of the case.) It is clear that little is to be gained by making aR greater than 30 or 40 ($R = 30-40,000$). It should be kept as small as possible to avoid frequency variation due to the by-pass condenser.

Observe that if a transformer load is used, the primary impedance need not be as high as for a triode valve used in the ordinary way. Also the rectifier will absorb more power from the source in this case owing to the lower input resistance as compared with that associated with a pure resistance load. The coupling to a tuned circuit input should, therefore, be correspondingly looser.

(c) *Magnitude of the by-pass condenser.*

The condition to be fulfilled is that the radio-frequency impedance of the by-pass condenser shall be as low as possible compared with the effective radio-frequency

input resistance of the rectifier, say not greater than one-tenth of the input resistance. Thus, taking R as 20,000 ohms for the typical case referred to throughout, R_0 will be found to be about 14,000 ohms. Thus the impedance of the condenser at the input frequency should not be greater than 1,400 ohms. This gives C about 150 micro-microfarads for an input frequency of about 1,000,000, and 0.001 microfarad would be quite large enough for the whole broadcast band, though a somewhat smaller value would probably give a slightly more uniform performance with respect to modulation frequency. As in most such cases, the final selection should be confirmed by trial, though the analysis and theoretical design is a valuable guide.

13. Summary.

The following statements refer to a straight-line rectifier assumed to have forward conductivity a and reverse conductivity zero. A triode valve with a constant positive potential on the grid and a small "biasing" potential on the anode approximates to this. A single frequency input e.m.f. is represented by $\hat{e} \sin \omega t$, and a modulated input e.m.f. by $\hat{e}(1 + \hat{m} \sin nt) \sin \omega t$.

It has been shown that the answers to the questions listed in section 1 are as follows:—

(1) The effective input resistance is not a constant but depends on the load resistance R , varying from $2/a$ to infinity as R varies from 0 to infinity. It is discussed in section 5 and illustrated in Fig. 8.

(2) Effective output frequency internal resistance.

(a) For single frequency rectification it is approximately $2/a$, independent of \hat{e} and R . It is discussed in section 5.

(b) For rectification of a modulated or heterodyned input e.m.f., the effective internal resistance to the modulation frequency output depends on the d.c. resistance of the load. It varies from $2/a$ to infinity as R varies from 0 to infinity. For most practical loads it will be of order $2/a$. It is discussed in section 11 and illustrated in Fig. 13.

(3) Effective output frequency e.m.f.

(a) For single frequency rectification it is approximately $3\hat{e}/4$, independent of a and R . Discussed in section 5.

(b) Rectification of a modulated or heterodyned input e.m.f. The amplitude of the effective modulation frequency e.m.f. depends on the d.c. resistance of the load. It increases from $(2/\pi)m\hat{e}$ to $m\hat{e}$ as R varies from 0 to infinity. For most practical loads it will be about 80 per cent. of $m\hat{e}$. It is discussed in section II and illustrated in Fig. 13.

(4) Already answered in (1) to (3).

(5) The straight line rectifier will give undistorted reproduction of the modulation frequency wave form with a pure resistance load. The distortion will probably be very slight in other cases.

In addition the following conclusions have been demonstrated:—

The continuous rectified current is proportional to the input e.m.f. for all values of load resistances. It can be determined as shown in section 4, by means of the curve of Fig. 5a. The power efficiency of rectification increases with load. This, and its application to design, is discussed in sections 8(c) and (d).

This work was carried out as part of the programme of the Radio Research Board and is published by permission of the Department of Scientific and Industrial Research.

APPENDIX I.

$$i_c = \frac{a\hat{e}}{\pi} (\sin \theta - \theta \cos \theta) ; \cos \theta = v_c/\hat{e}$$

i.e. $i_c = \frac{a\hat{e}}{\pi} \phi(v_c/\hat{e})$.

Expanding by Maclaurin's Theorem:—

$$i_c = \frac{a\hat{e}}{\pi} \left\{ \phi(0) + \frac{v_c}{\hat{e}} \phi'(0) + \frac{1}{2} \left(\frac{v_c}{\hat{e}}\right)^2 \phi''(0) + \dots \right\}$$

But $\phi(0) = 1$

and by carrying out the differentiations

$$\phi'(0) = -\pi/2$$

$$\phi''(0) = 1$$

$$\phi'''(0) = 0$$

etc., etc.

Therefore

$$i_c = \frac{a\hat{e}}{\pi} \left\{ 1 - \frac{\pi v_c}{2\hat{e}} + \frac{1}{2} \left(\frac{v_c}{\hat{e}}\right)^2 + \frac{1}{24} \left(\frac{v_c}{\hat{e}}\right)^4 + \dots \right\}$$

Therefore by simple rearrangement

$$i_c = \frac{E_c}{R_c + R}$$

where $E_c = \frac{2\hat{e}}{\pi} \left\{ 1 + \frac{1}{2} \left(\frac{v_c}{\hat{e}}\right)^2 + \frac{1}{24} \left(\frac{v_c}{\hat{e}}\right)^4 + \dots \right\}$

and $R_c = 2/a$.

BIBLIOGRAPHY.

1. "High Quality Reproduction," R. P. G. Denman: *Wireless World*, 1927, Vol. 20, pp. 92-100.
2. "The Distortionless Diode," H. F. Smith: *Wireless World*, 1928, Vol. 23, pp. 783-786.
3. "Diode Rectifier," P. G. Davidson: *Wireless World*, 1929, Vol. 24, p. 23.
4. "The Diode Rectifier," H. L. Kirke; *Wireless World*, 1929, Vol. 24, pp. 32-35.

Book Review.

THE SELENIUM CELL; ITS PROPERTIES AND APPLICATIONS. By G. P. Barnard. xxix+331 pp. with 258 Figs. Constable, 35s.

Selenium was discovered by Berzelius in 1817, but its outstanding property, viz., the variation of its resistance with changes in its illumination was first noticed in 1873 by May, an assistant of Willoughby Smith, who described the phenomenon to the Society of Telegraph Engineers. As the author says in his Preface, fifty-six years of research by separate investigators has produced a need for a connected account of the present state of our knowledge of the subject. The author has attempted to supply this need and we can say unhesitatingly that he has succeeded. Except that it costs thirty-five shillings the book is a model of what such a book should be, well written, well illustrated with excellent diagrams, and supplied, chapter by chapter, with a bibliography and a very complete list of references. Part I consisting of five chapters deals with the properties of selenium, while Part II with four chapters is devoted to its practical applications. Practically every known

type of cell is described and discussed in the second chapter. The various theories which have been put forward to account for the variation of resistance are discussed very fully in chapters IV and V. Every known application of the selenium cell is described in the second part of the book.

We were interested to read in the first chapter, which is historical and chemical, that, when "burning in air, selenium gives off an unpleasant smell of rotten horse-radish." We confess that the analogy goes beyond our experience, but it sounds very unpleasant.

The book is remarkably free from misprints; even the large number of German references appear to have been spared their customary ill-treatment at the hands of English authors. We noticed, however, that in describing Fig. 175 references are made to various letters which do not appear in the figure.

This book will certainly be welcomed by every one who is interested in the applications of the selenium cell.

G.W.O.H.

Olympia, 1930.

A General Impression—and Some Details.

FROM the radio engineer's point of view, the outstanding feature of this year's Radio Exhibition at Olympia lay, not in novelty of design or circuit, but in the sound and careful manner in which the latest advances have been incorporated in commercial receivers. The "power" grid detector has been quite widely adopted, and band-pass tuning has made its appearance in a few of the more ambitious receivers. There was hardly a set which did not appear to owe its final form to close and careful collaboration between the original designer and the production expert to whom the realisation of the designer's intentions in commercial form has necessarily to be entrusted. As a natural result, it can confidently be said that the general level of electrical efficiency to be anticipated from the receivers exhibited this year is very appreciably in advance of that attained in previous years.

Manufacturers have, of course, long since found that the inevitable limitations of commercial production do not stand in the way of high efficiency on the low-frequency side, so that it is the high-frequency stages which show the advances most particularly. One might with fair safety hazard the guess that the average stage-gain is 20 per cent. greater than in last year's models, while selectivity, hitherto a weak point in commercial receivers, has been greatly improved. The regional scheme of twin transmissions has now had a nine months' trial, and the provision of one alternative programme has but whetted the public appetite for more, with the result that the desire to receive foreign stations has begun to return. Attempts have been made to persuade the non-technical that a set which would separate the two Brookmans Park transmissions when used in London was the last word in knife-edge selectivity; it is gratifying to observe that the public are refusing to accept so deplorably low a standard, but expect to receive several foreign stations while the local transmitters are working. There were many sets at Olympia which

would satisfy these new and exacting demands, while the more extended adoption of "one-knob tuning" will go far to free the ordinary listener from the tyranny of the calibration charts which he seldom fully comprehended and almost never used.

The enormous interest taken in radio-gramophones, which were the greatest attraction of the Show, is a sign that the public are at last becoming educated to the possibilities of good quality reproduction at reasonable volume. So long as the wireless set was only used as such, people were content with a small and tinkly noise under the impression that radio reproduction could do no better, although a mechanical gramophone offering the same standard of reproduction would have been scornfully rejected. In the combined instrument the larger output stage and moving-coil speaker which are essential if the equipment is to satisfy as a gramophone, will cause many to realise for the first time that if their wireless programmes are not rendered with fidelity greater than the best the gramophone can achieve, it necessarily follows that the receiver and loud-speaker are not all they should be. As a corollary to this, it follows that the complete disappearance of the battery-operated portable set, which already shows a marked decline in popularity, can only be a matter of time. Though the sheer momentum of its past success will ensure a dwindling market for some time to come, it cannot stand up indefinitely to comparison with receivers possessing an output stage supplied with power adequate for the proper reproduction of music.

The receivers that gave rise to the general—and perhaps erroneous—conclusions that have been set forth were many; the most typical of present tendencies were the Pye "Twintriple" and the Marconiphone Model 560. Both these receivers are built up on a metal chassis which forms a strong structural framework, strong enough and complete enough to make the case a mere ornamental shell and nothing more. At the same time it provides the extensive screening that is

needed by such elaborate receivers, both of which employ two tuned high-frequency stages. A close examination of both these instruments showed that in making the inevitable compromise between the highest electrical efficiency and the insistent demands of manufacturing convenience, little had been lost that could have been retained in a laboratory-built receiver.

In both these sets the tuning-condensers are ganged and driven by a single knob, the inductances being matched in the case of the Pye set by small movable brass vanes on the principle of "spade tuning." The

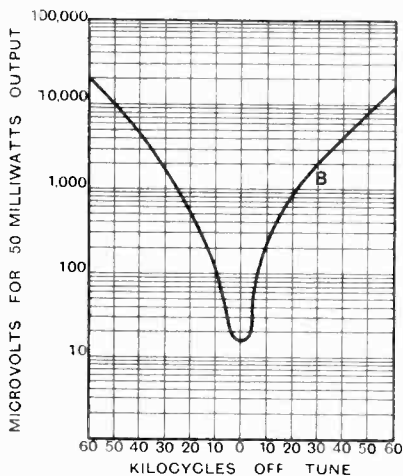

Performance curves of the Pye "Twintriple" receiver, A.C. mains model.

publication of a set of overall performance curves for this receiver is an interesting sign of the times; in taking the curves, which are reproduced here, the loud speaker was replaced by a 4,000 ohm non-inductive resistor.

In the Marconiphone receiver the coils appeared to be matched by the provision of a few turns remote from the bulk of the coil, a small movement of these along the coil-former serving as a fine adjustment of inductance. Another ingenious detail in this set is the ganging of two volume controls. A single knob adjusts both a potentiometer regulating screen-grid voltage and a potentiometer connected across the pick-up terminals. Only one of these is in use at any one time, but it is an appreciable simplification to allow volume to be controlled by the same knob for both gramophone and wireless programmes.

A Marconiphone two-valve set makes use of a novel means of controlling selectivity; the two aerial primaries (one for each wave-band) are in series, and have closely coupled to them auxiliary windings, also in series, which are shunted by a variable resistance. This is taper-wound to provide even control,

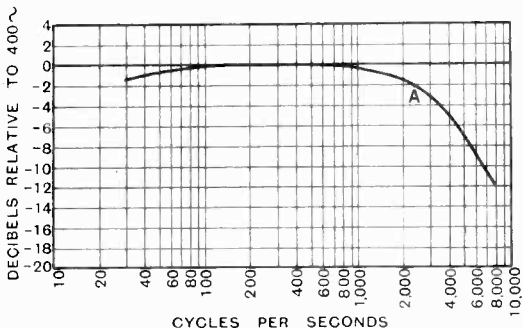
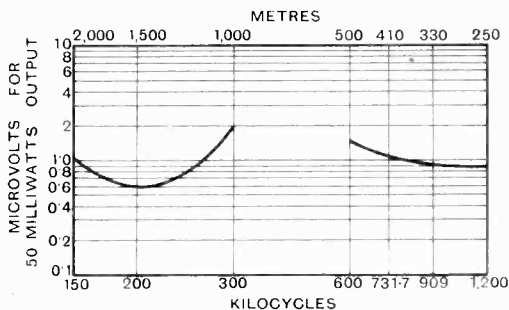

and flattens out the tuning enough to make it possible for even the most inexperienced to find the local stations without difficulty. Reaction is independently controlled in exactly the same manner.

The Burndept three-valve receiver shows some unusually interesting points of detail design. As coupling between the screen-grid valve and the detector a tuned auto-transformer is used; by adopting the circuit shown in Fig. 1 the need for a separate reaction coil has been avoided, which is well worth while in a set covering more than one wave-band. The volume control on this set consists of a differential condenser connected as a static potentiometer in the aerial circuit (Fig. 2), which has the double advantage of controlling the input to the screen-grid valve, so tending to prevent cross-modulation between stations, and of doing so without

appreciably altering the capacity-load thrown by the aerial upon the first tuned circuit, which would upset the ganging.

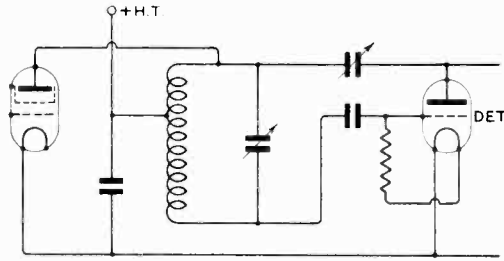

Fig. 1.—Intervalve coupling used in Burndept receiver. This type of auto-transformer does not require a separate reaction coil, and so is exceptionally convenient where switching is needed for several wave-ranges.

The straightforward extension of this circuit to cover the two wave-ranges, as in Fig. 3a, led to the discovery that when receiving on the 1,000–2,000 metre band the circuit ABCE tuned, at certain settings of the differential condenser C, to transmitters on the medium-wave band, bringing these in at considerable strength. It was eventually found that by using the arrangement of Fig. 3b this defect could be avoided, the condenser C₁ moving the resonant frequency of the subsidiary circuit to a position between the wavebands.

The receiver employs a Mazda AC/PEN as output valve, a 2:1 step-down transformer

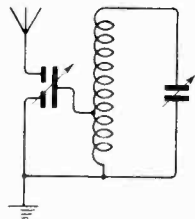

Fig. 2.—Input volume control, using a differential condenser. The perfection of ganging is unaffected by adjustment of this volume control.

coupling the speaker to it. A safety resistance of 10,000 ohms is connected across the secondary of the transformer to provide a permanent output load, thereby both protecting the valve from the development of excessive output voltages and acting as a tone-control preventing undue accentuation of the upper register when a moving-iron speaker is used.

The Radio Gramophone Development Co. have a receiver which is particularly attractive in that a true band-pass filter is used as

coupling between the aerial and the first valve. One of their amplifiers for public address work incorporates the remarkably effective tone-control shown in Fig. 4, which, by rotating a single knob, reduces either the upper or the lower register at will.

In the larger models of the "Parmeko" public-address amplifiers a common difficulty of high-power output stages has been ingeniously overcome. It often happens

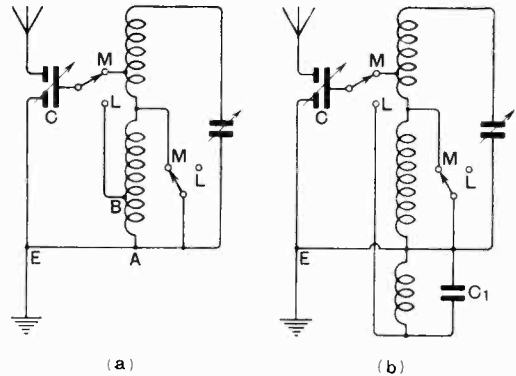

Fig. 3.—(a) The straightforward extension of Fig. 2 to cover both wavebands was unsatisfactory for reasons described in the text. (b) This form of dual-wave circuit has avoided the difficulty that arises in connection with (a).

that a heavy transient or momentary overloading will make the output valve oscillate at some unknown, but very high, frequency. As this oscillation is accompanied by a rise in anode current to five or six times its normal value it is essential, for the sake of the valve, to check it instantly. The circuits of Figs. 5a and 5b, for ordinary and paralleled output stages respectively, show how this is done. The chokes have about

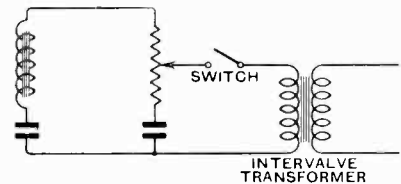
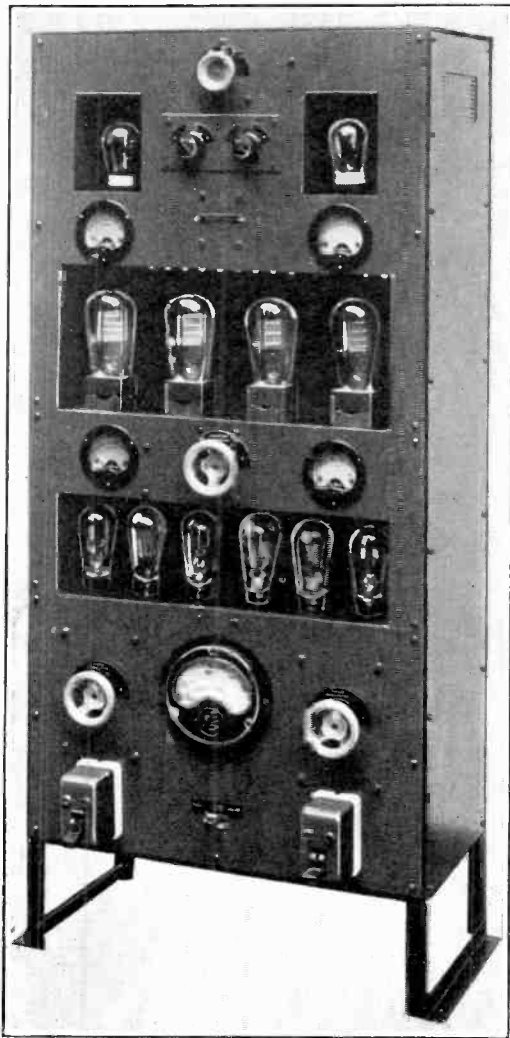

Fig. 4.—A "one-knob" tone control, capable of reducing either high or low notes at will, seen in a public-address amplifier by R.G.D. Co.

20 turns at a diameter of one inch, and tend to prevent the oscillation; if it should start in spite of this first precaution, it can be relied upon to develop a voltage high enough to jump one of the half-inch spark-gaps, and

so automatically quench itself. Exceptional precautions in the insulation of the output transformers must also be taken; in the absence of the spark-gaps half an inch of mica between windings and core is instantly punctured if oscillation should occur.



A "Parmeko" public-address amplifier for cinema and hotel work. There are two independent amplifiers, either of which can be brought into use by the turn of a switch.

In the matter of components, the main feature was a general raising of the standards of quality, though there were a few novelties. Messrs. Radio Instruments have recently developed a series of chokes using gapped

nickel-iron cores; in these high inductance and high current-carrying capacity can be

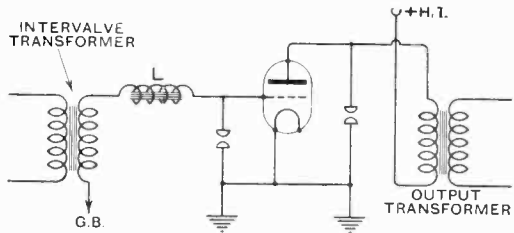

Fig. 5(a).

combined in a remarkably compact instrument. A "mixed" core is used in the new Igranic "Midget" intervalve transformer, with the result that it retains a high inductance even when a comparatively heavy current is passing through the primary. A complete range of constant-inductance chokes on similar cores is also available.

The T.C.C. paper condensers have been re-designed, with the result that the residual inductance has been cut down to such small limits that the 1 mfd. condenser offers a total impedance of less than one-third of an ohm to currents between the frequency-limits of 500 and 1,500 kc. The same firm are offering a new range of electrolytic condensers of very small size, which should find many useful applications. A 2 mfd. 100-volt (working) condenser is contained in the standard case used for the 0.0001 mfd. mica condenser, while others rated at 80

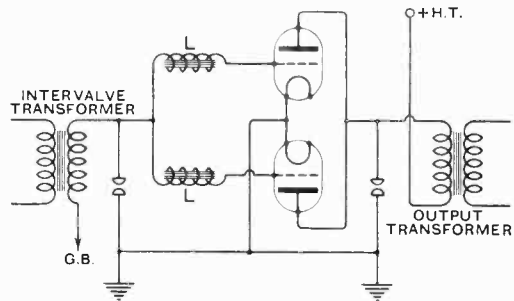

Fig. 5(b).

Figs. 5(a) and (b) show the precautions taken against H.F. oscillation in the output stages of "Parmeko" amplifiers. L are L.F. chokes, of inductance some 5 or 10 microhenrys, while the spark-gaps are set at half an inch. mfd. and 100 volts, and 1,000 mfd. at 12 volts, are put up in the case used for 4 mfd. paper condensers. In addition, there is a new range of laboratory condensers

of exceptionally low temperature coefficient of capacity.

Of new scientific apparatus, the Show brought forth one outstanding example in the new Ferranti electrostatic voltmeter. This is made in six ranges, from 450 volts to 2,500 volts, and is expected to sell at less than £4. For patent reasons, no very intimate details of its construction can be published; we are permitted to say, however, that a safety series resistance is normally incorporated to prevent damage in the event of a flash-over. This does not affect the calibration for D.C. or for A.C. up to the highest audio-frequencies; for radio-frequency work it can be had without the resistance. The meters, which are pivoted instruments identical in general appearance with the well-known range of small meters, are completely insensitive to external electrostatic fields, and are accurate to within two per cent. of full scale reading.

This meter, or any other flush-mounting meter of the Ferranti range, can now be had in the bench mounting illustrated for an extra charge in the neighbourhood of ten shillings, which should still further increase their popularity for laboratory work.

A useful three-range milliammeter, primarily intended for incorporation in a three-valve receiver, was also shown; in this one switch inserts the meter into either of

the three anode circuits, and simultaneously alters the range to suit the current drawn by the valve in question.

For general testing purposes the Gambrell "Multitest" meter, incorporating a number

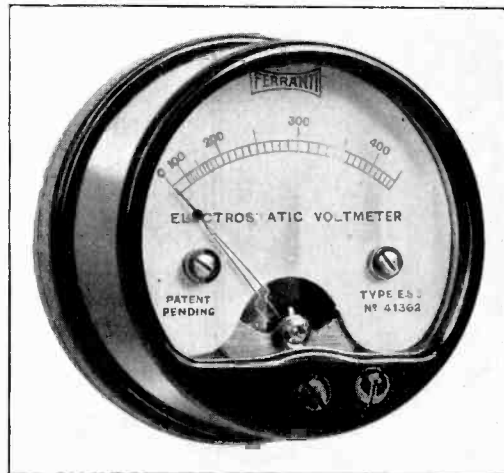

One of the new Ferranti electrostatic voltmeters. Its range can be extended downwards by using it in series with a dry battery of about 200 volts.

of voltage and current ranges in one instrument, attracted attention. Since the accuracy claimed is one per cent. of full scale reading, the instrument may be considered unusual value at £3.

Books Received.

ALTERNATING CURRENT BRIDGE METHODS for the Measurement of Inductance, Capacitance and Effective Resistance at Low and Telephonic Frequencies. By B. Hague, D.Sc.

Second edition revised and enlarged. Pp. 391 + xvi, with 112 diagrams and illustrations. Published by Sir Isaac Pitman & Sons, Ltd., London. Price 15s. net.

KEMPE'S ENGINEER'S YEAR BOOK FOR 1930. 37th Annual issue revised under the direction of the Editor of *The Engineer*.

This standard source of reference for Civil, Mechanical, Electrical, Marine, Mining and other Engineers, which was first compiled in 1894 by H. R. Kempe and W. Hanneford Smith, has been thoroughly revised and brought up to date in its present issue. A new section is devoted to wireless matters, including a short glossary of Technical Terms, Useful Formulæ, Copper Wire Tables, Wavelength-Frequency-and-L.C. Tables, Charts of

Resistance and Capacity, and of Reactance of Condensers at Radio and Audio-Frequencies. Pp. 3040 + xii + xiv. Published by Morgan Bros., Ltd., London, and Crosby, Lockwood & Son, London. Price 31s. 6d. net.

RALPH STRANGER'S WIRELESS LIBRARY FOR THE "MAN IN THE STREET."

No. 8, Wireless Waves. No. 9, Wireless Communication and Broadcasting. No. 10, Modern Valves. No. 11, How to Understand Wireless Diagrams. No. 12, Selection of Wireless Signals. Each number pp. 64, with numerous illustrations and diagrams. Price 1s. Published by George Newnes, Ltd., London.

ERRATA.

On page 540 of October issue, col. 2, read "8. High Pass Filters. Fig. 7." In the last line of same column read ω_a^2 not $\omega^2 a$.

Note on the Relationships Existing Between Radio Waves Modulated in Frequency and in Amplitude.*

By C. H. Smith, B.Sc.

CONSIDERABLE interest has been shown of late, in technical literature, in the possibilities of frequency modulation. Interest has, however, mainly been centred on the transmitter and its behaviour when the oscillating circuit is subjected to simple periodic variations of reactance. Insufficient attention has been paid to the general principles governing the composition of a frequency modulated wave and the relation in which it stands with regard to amplitude modulation.

It is desirable first to fix a definite meaning to the instantaneous frequency of a frequency modulated wave. The frequency of a wave is usually regarded as the number of cycles per second or the reciprocal of the time occupied by one cycle, either of which quantities must be, if variable, discontinuous. If, however, we regard a sinusoidal oscillation as the projection on a line of a point rotating on the circumference of a circle, and define the frequency f of the oscillation as the angular velocity ω divided by 2π , then a periodically variable frequency of oscillation corresponds to a rotating point of periodically varying angular velocity and no discontinuities are involved. It must be noted, however, that if $f = \omega/2\pi$ is the frequency of the oscillation generated by a point rotating with variable angular velocity ω round the circumference of a circle of radius R , the expression for the projection of the point and therefore the oscillation produced is $R \sin \omega dt$.

If, for example, the frequency of the oscillation varies sinusoidally between the limits $f + a$ and $f - a$, q times per second, the expression for the angular velocity of the generating point is $2\pi (f + a \cdot \cos. 2\pi qt)$, but that of the oscillation itself is:—

$$\sin \omega dt = \sin . (2\pi ft + a/q \cdot \sin. 2\pi qt),$$

which, it should be noted, would be more aptly described as a wave of variable phase.

It is shown by B. van der Pol (see I.R.E., July, 1930, page 1,194) that if the reactances of an oscillating circuit are varied in such a manner that $I/\sqrt{LC} = 2\pi(f + a \cdot \cos. 2\pi qt)$ the radiated wave will be given approximately by the expression $\sin . 2\pi(f + a/q \cdot \sin 2\pi qt)$, and that this wave modulated in frequency only is equivalent to a carrier wave of frequency f and an infinitude of sidebands separated in frequency by integral multiples of q , whose amplitudes are given by Bessel functions of increasing orders.

On first thought it appears that such a sideband system, on being applied to a detector, must of necessity produce an audible output of frequency q . Such, however, is not the case, due to the phase relationships which exist between the sidebands, and it can be shown that in the nature of these phase relationships lies the basic difference between amplitude and frequency modulation.

Consider first the simple wave, modulated in amplitude only, given by the expression

$$(1 + a \cdot \sin. 2\pi qt) \sin . 2\pi pt \quad \dots (1)$$

which may be expressed as a carrier wave and two sidebands:—

$$\begin{aligned} &\sin . 2\pi pt + a/2 \cdot \cos . 2\pi(p - q)t \\ &- a/2 \cdot \cos . 2\pi(p + q)t \quad \dots \quad \dots (2) \end{aligned}$$

By reversing the phase of one sideband and writing:

$$\begin{aligned} &\sin . 2\pi pt + a/2 \cdot \cos . 2\pi(p - q)t \\ &+ a/2 \cdot \cos . 2\pi(p + q)t \quad \dots \quad \dots (3) \end{aligned}$$

we obtain the result, by recomposition:—

$$\begin{aligned} &\sqrt{1 + a^2 \cdot \cos^2 . 2\pi qt} . \\ &\sin . (2\pi pt + \tan^{-1} . a \cdot \cos . 2\pi qt), \end{aligned}$$

which, if a is small, so that terms including

* M.S. received by the Editor 6th Sept., 1930.

a^2 are negligible, becomes :—

$$\sin(2\pi pt + a \cdot \cos 2\pi qt) \quad \dots \quad (4)$$

a wave modulated in frequency only at a frequency q .

Consider now the general case of a wave of frequency p modulated both in amplitude and frequency which we will write as :—

$$X \cdot \sin(2\pi pt + Y) \quad \dots \quad (5)$$

X and Y being both continuous functions of periodicity q .

Putting

$$\begin{aligned} X \cdot \sin(2\pi pt + Y) &= F_1 \cdot \sin 2\pi pt \\ &\quad + F_2 \cdot \cos 2\pi pt \\ &= \sqrt{F_1^2 + F_2^2} \cdot \\ &\quad \sin(2\pi pt + \tan^{-1} \cdot F_2/F_1) \end{aligned}$$

$$\text{and therefore } \left. \begin{aligned} X^2 &= F_1^2 + F_2^2 \\ \text{and } Y &= \tan^{-1} \cdot F_2/F_1 \end{aligned} \right\} \quad \dots \quad (6)$$

$$\text{or } \left. \begin{aligned} F_1 &= X \cdot \cos Y \\ F_2 &= X \cdot \sin Y \end{aligned} \right\} \quad \dots \quad (7)$$

Since X and Y are continuous functions of periodicity q , it follows that F_1 and F_2 are continuous functions of the same periodicity theoretically capable of evaluation by Fourier's analysis, and so we obtain the result that any wave modulated in frequency, whether modulated in amplitude or not, is equivalent to two waves of the same frequency modulated in amplitude at the same periodicity, whose phases are perpendicular.

If the wave represented by (5) is modulated in amplitude only we must have

$$Y = \text{constant}; \text{ i.e., } F_2/F_1 = \text{constant},$$

and so the wave is equivalent to : $k \cdot F_1 \cdot \sin(2\pi pt + \theta)$.

If the term of frequency nq in the expression of F_1 is $a \cdot \sin(2\pi nq + \phi)$, the sidebands of frequencies $(p + nq)$ and $(p - nq)$ are given by the expressions $a \cdot \cos(2\pi \cdot \frac{p - nq}{2} \cdot t + \theta - \phi)$ and $-a \cdot \cos(2\pi \cdot \frac{p + nq}{2} \cdot t + \theta + \phi)$, and it is obvious that at the instant when the carrier wave is zero, the sum of these two sidebands is also zero. This relationship exists between each pair of sidebands whose frequencies differ from the carrier wave by the same quantity, and is a necessary and sufficient condition in order that the wave shall be modulated in amplitude only.

The effect in a receiver of a frequency modulated wave will now be considered. The results of detection are not easy to visualise for the resolution into a group of sidebands of a wave modulated in frequency only predicts an audio-frequency output which is not suggested by the envelope of the modulated oscillation. Consider, however, a wave of the form $X \cdot \sin(2\pi pt + Y)$ which may be modulated in amplitude and frequency. Substituting for this expression that for the two amplitude modulated waves $F_1 \cdot \sin 2\pi pt + F_2 \cdot \cos 2\pi pt$, and impressing the sum of these two waves on a parabolic detector, we see that the audio-frequency output is proportional to : $F_1^2 + F_2^2 = X^2$, which is dependent only on the amplitude modulation of the wave and independent of the presence of frequency modulation.

It is well known that it is possible to receive and detect a frequency modulated wave producing an audio-frequency resultant. To do this, however, it is necessary that between the aerial and the detector the frequency modulation shall be converted in some degree to amplitude modulation. This effect is conveniently produced by a tuned circuit whose natural frequency is not the frequency of the carrier wave. The result is to alter the phases and amplitudes of the sidebands relative to the carrier, and either of these effects will tend to change frequency modulation into amplitude modulation and vice versa. The phase changes of the sidebands relative to the carrier wave will be, to the first order, equal and opposite for pairs of sidebands equally spaced from the carrier frequency, in which case modulation will be unaffected. The amplitude changes will be the more important effect. If the receiving circuit is so tuned that the carrier wave lies on the slope of the resonance curve, and pairs of sidebands equally spaced from the carrier wave frequency are amplified by different amounts, the amplitude of the detector output will be roughly proportional to the product of the amplitude of the carrier wave and the difference of the amplitudes of each pair of sidebands, but the efficiency of such a system will vary considerably with the sideband spacing, being a maximum for some value of modulation frequency dependent on the selectivity of the tuned

circuit. In fact, maximum efficiency would occur with a receiver arranged for single sideband reception.

The effect of a heterodyne or super-heterodyne detector is somewhat different. If a local oscillator of the form $A \cdot \cos \cdot 2\pi(\rho - r)t$ is caused to beat with the modulated wave $X \cdot \sin \cdot (2\pi\phi t + Y)$, the detector output will consist of those frequencies in the neighbourhood of "r" contained in the expression:—

$$\{A \cdot \cos \cdot 2\pi(\rho - r)t + X \cdot \sin \cdot (2\pi\phi t + Y)\}^2$$

which we may rewrite as:—

$$\{A \cdot \cos \cdot 2\pi(\rho - r)t + F_1 \cdot \sin \cdot 2\pi\phi t + F_2 \cdot \cos \cdot 2\pi\phi t\}^2$$

$$= \{\sin \cdot 2\pi\phi t(F_1 + A \cdot \sin \cdot 2\pi r t) + \cos \cdot 2\pi\phi t \cdot (F_2 + \cos \cdot 2\pi r t)\}^2$$

and the required terms are given by:—

$$2AF_1 \cdot \sin \cdot 2\pi r t + 2A \cdot F_2 \cdot \cos 2\pi r t \\ = 2AX \cdot \sin \cdot (2\pi r t + Y)$$

which result we see consists simply of changing frequency but leaving undistorted both amplitude and frequency modulation.

If the beat frequency "r" lies in the audible range of frequencies, the detector output provides us with aural indications of the behaviour of a transmitter. If, for example, the reactances of the oscillatory circuit are varied according to the law $1/\sqrt{LC} = 2\pi(\rho + a \cdot \cos \cdot 2\pi q t)$ the radiated wave will be of the form $\sin \cdot (2\pi\phi t + a/q \cdot \sin \cdot 2\pi q t)$ and after heterodyne detection, the audio-frequency will be of the form: $\sin \cdot (2\pi r t + a/q \cdot \sin \cdot 2\pi q t)$. The form of this function suggests if a/q is small, a variable audio-frequency will not be perceptible. It should be remembered, however, that if the variations are slow enough to be followed by ear, the note heard at any moment will be the instantaneous frequency which is given by:—

$$1/2\pi \cdot \frac{d}{dt} (2\pi r t + a/q \cdot \sin \cdot 2\pi q t);$$

i.e. $(r + a \cdot \cos \cdot 2\pi q t)$, the variations of which coincide with the variations of the resonant frequency of the transmitting circuit. It should be practicable to resolve the heterodyned wave by means of an analyser and so conveniently check the results of B. van der Pol's analysis.

General Conclusions.

(1) A complex radiation comprising a carrier wave and associated sidebands will generally represent a wave modulated both in amplitude and frequency. If the sidebands are such that they can be grouped into pairs of equal amplitude and equal frequency difference from that of the carrier, and are so phased that when the carrier wave is zero the sum of each pair of sidebands is also zero, the wave will be modulated in amplitude only.

(2) Any wave, modulated in amplitude and frequency, may be resolved into two waves of the same modulation and carrier frequencies as the original, whose phases differ by 90° .

(3) A wave modulated in frequency only is incapable of producing an audio-frequency output in a parabolic detector.

(4) A wave modulated in frequency only may be made to produce current in a receiver modulated in amplitude also by the effect of a resonant circuit tuned to a frequency not that of the carrier wave, or, more efficiently, by a circuit arranged for single sideband reception.

(5) A frequency modulated wave may be operated upon by a frequency changer without detriment to the modulation.

"The Wireless World" Diary, 1931.

THE 1931 edition of this well-known Diary contains a mass of information useful alike to the experimenter and to the ordinary listener. A new feature is introduced in the form of Practical Hints and Tips for Set Builders and Set Users, intended to smooth over the common difficulties encountered by constructors.

The first pages are devoted to Useful Formulæ, Abacs, and Copper Wire Tables, and those following the Diary portion contain, among other useful information, Practical Notes and Diagrams of Typical Receivers, Coils, and H.F. Transformers, Summary of Regulations controlling Amateur Transmitting and Receiving Licences, Lists of Broadcasting Stations, and a list of valves, with the necessary technical data arranged in tabular form and with a few introductory notes on the choice of suitable valves for any given purpose.

The Diary is strongly bound in leather and is published by Messrs. Iliffe & Sons Ltd., price 1s. 6d. or post free, 1s. 7d.

Practical Experiments in Ultra-short Wave Communication.

By C. C. Whitehead.

(Concluded from page 551 of October issue)

(C) Range Tests and Propagation.

A large amount of "field work" was carried out with the completed apparatus apart from the operating tests mentioned in Sect. (B) of last issue. As the results were consistent throughout, it is only necessary to detail one typical series of tests here.

Early tests had shown that a power of 20 Watts input to the transmitter was ample for the work in hand. This was fortunate, since the valve used in the transmitter was only rated to dissipate 40 Watts and during the tests it had to be kept working continuously for periods of sometimes half an hour or an hour at a time!

The "standard" conditions at the transmitting end during the series of range tests to be described, were:—

H.T. input to transmitter:—400
v.—48mA. = 20 Watts (nearly).

Aerial current:—1.22 A.

Total aerial power:—1.4 Watts
(approx.).

Power radiated:—1.19 Watts
(approx.).

Height of aerial:—7ft. (= 2.14 m. = .765λ).

Wavelength (λ):—2.80 m.

Modulation frequency:—800~(approx.).

As the transmitter was by far the more bulky portion of the equipment, it was decided that this should remain stationary during the test. It was accordingly installed upon a bench on the ground floor of a low building. The feeder was taken through the window to the aerial outside, the aerial being fixed at the top of a wooden pole at a height (to the centre of the aerial) of 7ft. above the ground. The aerial was mounted in such a manner that it could be made to lie at any angle in the vertical or horizontal plane.

The receiver was installed in a light

motor lorry, the aerial being carried upon a wooden pole lashed to the superstructure in a vertical position. As in the case of the transmitter aerial, it was arranged to be capable of being made to assume any angle. The height from the road surface to the centre of the aerial was 9ft.

The ignition system of the motor was not shielded or tampered with in any way. Though ignition noises were audible in the receiver (even from other vehicles passing and at some distance) they were never loud enough to interfere seriously with reception, except at the longest ranges. Up to a radius of 1 mile from the transmitter, telegraphic

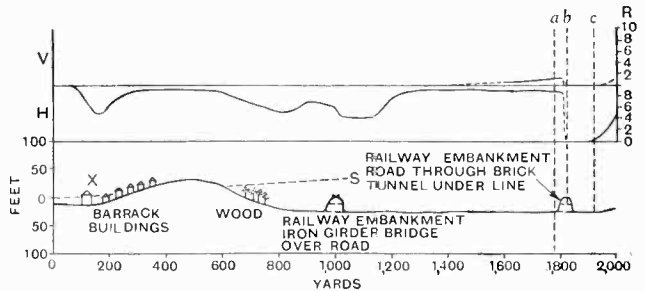

Fig. 7(a).—Wave emitted horizontally. V = receiver aerial vertical. H = receiver aerial horizontal. O = height of transmitting aerial = datum level. S = line of sight (behind hill) to point d, Figs. 7 (b) and (d).

communication was possible with the vehicle on the move, at ordinary road speeds, and telephonic communication up to half this distance under the same conditions.

A remarkable fact noted was that telegraphic signals were invariably of readable (not less than "R.5") strength up to a radius of approximately 1,000 yards from the transmitter, no matter what the local conditions were. Under normal conditions the safe working range of this apparatus was estimated at 1 mile.

In undertaking investigations into the propagation of these waves at ground level

and comparatively long ranges, we are at present greatly hampered by the fact that the field strength present at the receiver is *very small and extremely variable*, according to range and local conditions.

This renders the employment of recording or visual-indicating apparatus at the receiver

receiver was halted at certain selected spots along a chosen route and careful estimations of the signal strength made (according to the above scale) with the aerials in both vertical and horizontal positions.

The presence of "tilt" in the direction of propagation was also sought for. With the apparatus described, this could not be accurately measured, but its presence could be positively affirmed, provided it exceeded about 7° .

The results were plotted on "ground profile" charts (Figs. 7 (a), (b), (c), (d), and tabulated Table II). These charts show relationship between *intervening ground features* and signal strength.

As the result of the above tests, the following inferences were drawn:—

(1) A definite and limited zone exists around the transmitter wherein signals are invariably audible. (They apparently "get through" by "brute force," see (5) below.)

(2) The *horizontally* polarised wave is apparently the more efficient for com-

(so desirable in this class of work) practically impossible at the present stage of development. The old method of estimating the signal strength *orally* was therefore adopted.

This was estimated by means of the "R" scale, long familiar to operators. For the information of those to whom it is not familiar, it is set out in Table I.

In all cases where the signal strength, with telegraphic signals, exceeded "R.5," telephony was clearly intelligible under the same circumstances. The speech quality was remarkably good, considering the simplicity of the modulating arrangement and the type of microphone used.

Whilst the transmitter was in operation, the vehicle carrying the

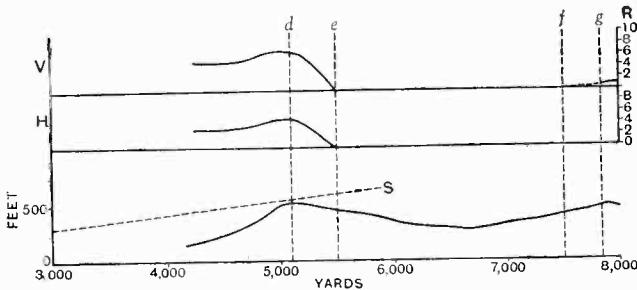

Fig. 7(b).—Wave emitted horizontally. Notation as in Fig. 7(a). S = line of sight from o-d.

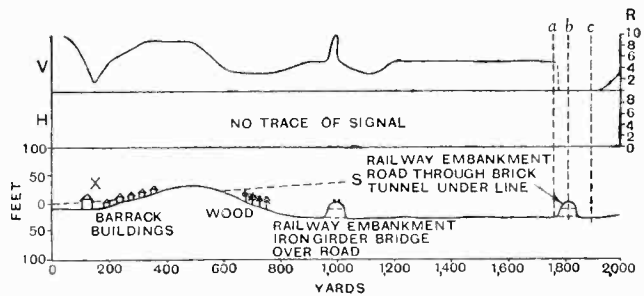

Fig. 7(c).—Wave emitted vertically. Notation as in Fig. 7(a).

TABLE I.

Signal Strength on "R" Scale.	Nature of Audible Signal.
1	Just audible, recognisable as Morse in the absence of interference.
3	Clearly audible, but difficult to "read," except in the absence of interference.
5	A good, readable signal, can be read without difficulty through moderate interference.
7	Strong signal, easily readable through heavy "jamming" and "X's."
9	Very powerful, can be read with 'phones on the table.

munication *within this region*, but not for long ranges. Owing to the influence of the ground, its plane of polarisation becomes changed, rotation taking place, so that (within a wavelength of the ground) it becomes vertical at extreme ranges. (See Table III.)

(3) The *vertically* polarised wave suffers more from attenuation, over difficult ground, than (2), but there is no trace of change in its plane of polarisation under any circumstances or at any range so far

obtained. Ground communication is only possible by means of the vertical wave at long ranges.

(4) The *pure space wave* does not undergo any change in plane of polarisation, *whether emitted horizontally or vertically, or at any range.*

(5) The influence of conditions local to the receiver seems to have more effect upon the strength of received signals than similar conditions local only to the transmitter. (This is entirely consistent with (1), above.) Apparently the radiation is scattered by objects near the transmitter,

TABLE II.

Range, Yards.	Transmitter Aerial. (T.)	Receiver Aerial. (R.)	Signal Strength, "R" Scale.	Local Conditions, and Reference Point and Number of Profile Chart.	Remarks.*
300	V	V	9	Separate test, not charted. Absolutely clear ground between T and R.	No trace of change in plane of polarisation.
		H	0		
	H	V	0		
		H	9		
1,800	V	V†	7	Figs. 7 (a) and (c) point a.	No trace of change in plane of polarisation with <i>vertically</i> emitted wave. Trace of change in case of <i>horizontally</i> emitted wave.
		H	0		
	H	V	1		
		H	9		
1,850 to 1,950	V	V	0	Figs. 7 (a) and (c) between points b and c.	Complete "shadow."
		H	0		
	H	V	0		
		H	0		
2,000	As for 1,800, point a, above.		Rising ground. Figs. 7 (b) and (d) point d.	Emerging from "shadow."	
5,000	V	V	9	HILL TEST: R on edge of plateau, within sight of T, building housing T. One large building (X, Fig. 7(a)) between T and R. Figs. 7(b) and (d), point d.	No trace of change in plane of polarisation in case of <i>vertically</i> emitted wave. Marked circular (or rather, in this case, vertical-elliptic) polarisation in the case of the <i>horizontally</i> emitted wave.
		H	0		
	H	V	7		
		H	5		
5,500 to 7,500	Tests as above, <i>no trace of signal.</i>		Beyond edge of plateau, Figs. 7(b) and (d), points e to f.	Complete "shadow."	
8,000	V	V	3	Figs. 7 (b) and (d), point g.	Reappearance of signal. Apparently <i>vertical</i> component <i>only</i> survives at extreme ranges.
		H	0		
	H	V	1		
		H	0		

Notation: V = Vertical. H = Horizontal.

* Read Paulin, Appendix A (7). † Forward "tilt" of wave-front positive.

so that it can be received provided only that the receiver is not screened also. This is analogous to the case of a powerful light source, the position of which is clearly visible owing to diffused radiation,

Neither, apparently, was any appreciable amount of energy radiated from the feeders. This has some bearing upon the question of "feeder losses," mentioned in Sect. (A), page 547, previous issue.

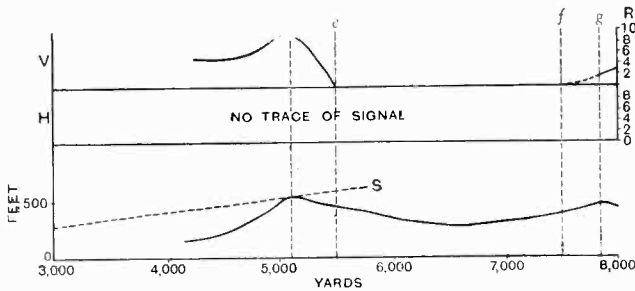

Fig. 7(d).—Wave emitted vertically. Notation as in Fig. 7(a). S = line of sight.

though the source itself is invisible. These tests also showed that no appreciable amount of energy was radiated from the circuits themselves apart from that radiated or absorbed via the aerials.* The result of the propagation tests (Table II) confirmed this, therefore it was not found necessary to screen the circuits specially for the purpose of these tests.

proved very satisfactory indeed, giving a high, clear and pleasant note, with constant depth of modulation on the oscillator.

The schematic arrangement is shown in Fig. 8. The Wheatstone transmitter was operated by means of a message punched on

† In these latter tests, with slight modifications to the apparatus herein described, working ranges up to 10 miles (16 Km.) were obtained, under the same circumstances in regard to location of apparatus.

* Cf. Gerth and Scheppmann, Appendix A (1).

TABLE III.
HORIZONTALLY EMITTED WAVE ONLY.

$\frac{h}{\lambda}$	$\frac{d}{\lambda}$	State of Polarisation of Received Wave.	Remarks.
1.0	100	Horizontal, linear	(No vertical component detected.)
	300	Horizontal	(Trace of vertical component suspected.)
	600	Horizontal-elliptic	(Vertical component clearly present.)
	1,000	Circular (approx.)	(Vertical and horizontal components approximately equal.)
	2,000	Vertical-elliptic	(Vertical component predominant.)
	∞	Vertical, linear (?)	(Vertical component <i>only</i> survives at extreme ranges?)
5.0	1,600	Horizontal (-elliptic?)	(Trace of vertical component suspected.) Special Hill Test. Attempt to receive, as far as possible, Space Wave alone.

Notation :— h = Height of centre of aerial above ground level.
 d = Distance from transmitter.
 λ = Wavelength.

an "endless" tape. This apparatus has been kept in operation without attention for several hours at a time during the progress of tests.

Perhaps not the least interesting fact which it is desired to place on record is that *not a single atmospheric* (or any noise that could be attributed to atmospherics) has so far been heard during the progress of this work, which (up to the time of writing) has

have the marked advantages that they are unaffected by weather conditions and that the speed of communication (*i.e.*, "words per minute") can be as great as that attained in ordinary modern radio-communication practice, including the possibility of "duplex" working.

It remains only to set out the inferences drawn from the results of the above experiments:—

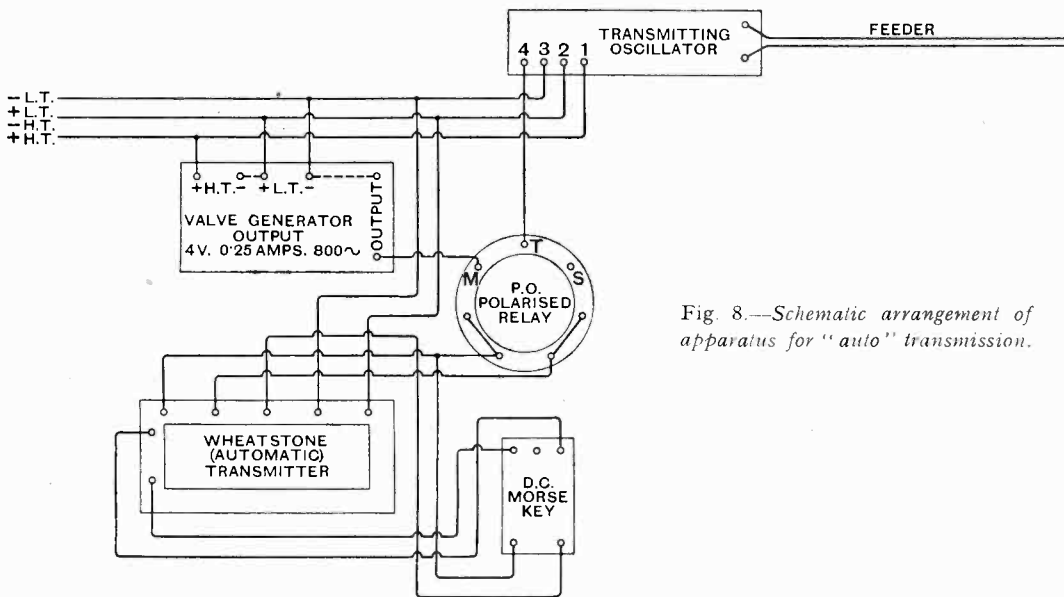

Fig. 8.—Schematic arrangement of apparatus for "auto" transmission.

been carried on for some months in all kinds of weather, including thunderstorms!*

(D) Conclusion.

It would be out of place in the present work to enter into a discussion upon the general characteristics of these waves, as this has been very thoroughly dealt with in those original works mentioned in the Appendix A (1)-(5).

It is sufficient to say that in a great many respects, in regard to propagation, their behaviour is very similar to that of light waves. *Consequently, they can only be employed with maximum efficiency under conditions similar to those required for light-wave communication, over which, however, they*

(1) Whilst it is obvious (taking into consideration all that is so far known about these waves) that this is not their proper sphere of employment, provided only suitable antenna arrangements are developed, is a reasonably economical proposition.

Their use for beacon purposes (aircraft or marine) seems to merit close attention, their immunity from atmospheric interference giving them peculiar advantage in this connection.

(2) Though their behaviour is, in many respects, analogous to that of light waves, it is submitted that the series of experiments detailed herein have served to reveal at least one point which they possess in common with the longer waves in general use for communication purposes.

* Read Mesny, Appendix A (5); also Esau, Appendix A (2).

This is, in regard to the effect of the ground upon their propagation, at comparatively long ranges. (Discussed in Section (C), *i.e.*, the "twisting" of the plane of polarisation, in the case of the horizontally emitted wave.)*

In conclusion, the writer wishes to express his extreme indebtedness to the officer commanding the unit in which he is serving, Lt.-Col. G. G. Rawson, O.B.E., M.C., Royal Corps of Signals, by whose permission the work was undertaken, and who saw that every reasonable facility was afforded to its performance.

APPENDIX (A).

Bibliography.

1. F. Gerth and W. Schepmann: "Untersuchungen uber die Ausbreitungsvorgange Ultrakurzer Wellen." *Zeitschrift fur Hochfrequenztechnik*, Jan., 1929, V. 33, pp. 23-27.
2. A. Esau: "Reichweitenversuche und Dampfungsmessungen im Gebiet sehr kurzer Wellen." Summary in *Electrotechnische Zeitschrift*, 13th Dec., 1929, p. 1816.
3. H. Fassbender and G. Kurlbaum: "Abhangigkeit der Reichweite sehr kurzer Wellen von der Hohe des Senders uber der Erde." *Z. f. H.*, Feb., 1929, V. 33, pp. 52-55.
4. H. E. Hollmann: "Die Erzeugung Kurzester Elektrischer Wellen mit Elektronenrohren." *Z. f. H.*, Jan., 1929, V. 33, pp. 27-30.
5. R. Mesny: "Note au Sujet des Ondes de quelques Metres" ("Note on the Subject of Waves of a Few metres in Length"). *U.R.S.I.*, July, 1928, V. 1, Fascicule 1 (French) or 1 bis (English), pp. 42-44, or 35-37.
6. C. R. Englund: "The Short Wave Limit of Vacuum Tube Oscillators." *Proc. I.R.E.*, 15, 11, pp. 914-927.
7. E. A. Paulin: "Some Polarisation Phenomena of Very Short Radio Waves." *Phys. Review*, Mar., 1929, V. 33, pp. 432-443.
8. E. Green: "The Radiation Resistance and Energy-Capacity of Half-Wave Aerials." *E.W. & W.E.*, Feb., 1928, pp. 82-84.

APPENDIX (B).

(1) Screening of Envelopes of Valves.

(This must not be confused with the practice, long known amongst radio-engineers, of placing a metal-foil "cage" around the glass envelope of the valves to equalise the electric stresses in the glass, and so provide protection against puncturing. In the latter case, it is not essential that the "cage" should be in contact with the glass, as it is in the former.)

The assumed reason for the phenomenon referred to is the following:—

A certain amount of the electron-stream constituting the space-current (or rather which would,

under ordinary circumstances, constitute the space-current) escapes from the control of the electrode potentials owing to the "electron-lag" effect (see (B) 4, below). These "stray" electrons produce a powerful space-charge effect which, since they are outside the normal control of the electrodes, cannot be neutralised by modifying the electrode potentials.

It is not quite clear to the writer, at the moment, in exactly what manner this independent space-charge interferes with the functioning of the valve, but there is no doubt that it exists, and that it is to be blamed for the non-functioning of most glass-enveloped valves below about 4 metres, unless the precaution under discussion is taken.

The effect of the screen is as follows:—

The potential sign of the electron-cloud constituting the independent space-charge is, of course, *negative*. This has the effect of inducing a *positive* charge upon the screen, with the consequence that the electron-cloud is attracted towards the screen, the bulk of it being held against the inner wall of the glass envelope, *away from the electrodes*, where it cannot interfere with the functioning of the valve.

Two further points are worthy of note, namely:—

(a) This effect is only troublesome when the valve is required to furnish considerable power. A valve with low potentials on the electrodes (*e.g.*, a receiving valve, used under normal conditions, as an oscillator) does not exhibit this effect.

(b) The screen must be either connected to a source of considerable positive potential (*i.e.*, H.T.+) or left entirely free. The latter seems preferable.

(2) Asymmetry of Circuit. †

Fig. 9 shows the equivalent circuit. The asymmetry is due to the fact that $C_g f > C_a f$. This could be corrected by means of a small adjustable capacity, C_n , but structural considerations render this inadvisable, as it would also introduce a large amount of superfluous inductance, and unwanted mutual magnetic couplings, *i.e.*, the cure would probably be worse than the disease. L_3 shows the effect of leads necessarily used to connect C_n . There is also probably some magnetic coupling between the grid and filament leads, sufficient to induce considerable H.F. potentials in the latter. (The subscripts have the usual meanings.)

(3) Estimation of Transmitter Efficiency.

Input (for purpose of test): 500 v. 60 mA.
= 30 Watts.

Aerial current, $I = 15$ A. (aerial coupling via feeder).

1875 A. (aerial coupling direct).

Antenna length, $l = 134$ cm.

„ diam., $2r = .945$ cm. (= $\frac{3}{8}$ in.).

„ material = Hard copper tube, for which

“ ρ ” = 1,600 C.G.S. ($\mu = 1$)

* See paper by E. T. Glas, "On the Effect of the Ground on Downcoming Plane Space-Waves." (*E.W. & W.E.*, Dec., 1929, pp. 663-668)

† See also letters by Mr. E. C. S. Megaw and writer, published in *E.W. & W.E.*, Dec., 1929, p. 676, and March, 1930, p. 141.

Resistance of current indicator (thermal ammeter) = 5 Ω.

Main working frequency = 108 mc.
 = 1.08 · 10⁸ (= "f").

(a) *Power Radiated.* Radiation resistance R_a of half-wave dipole, with respect to current I at its centre = 80 Ω, practically. (See Appendix A (8)).

Power radiated = $I^2 \cdot R_a = (.15)^2 \cdot 80$
 = 1.8 Watt = 6 per cent.

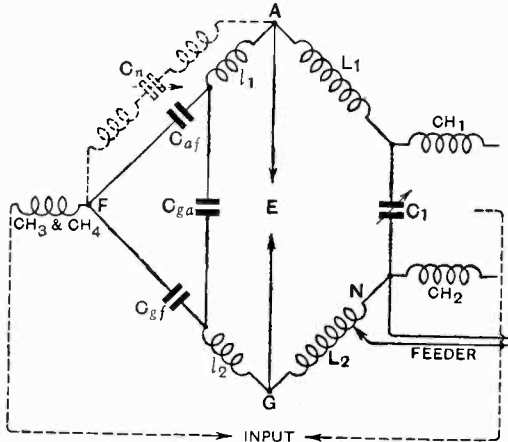

Fig. 9.— E = maximum available output E.M.F. A, F, G = valve terminals. N = nodal point (voltage node) at which feeder is attached.

(b) *Power Lost (H.F. Resistance Losses) in Aerial.* H.F. resistance of aerial (Rayleigh's formula for a straight cylindrical conductor)

$$= \frac{4 \cdot \rho \cdot l}{\pi \cdot d^2} \left(\frac{\pi \cdot d}{2} \sqrt{\frac{f}{\rho} + \frac{\mu}{4}} \right) 10^{-9} \cdot \Omega$$

$$= \frac{4 \cdot 1.6 \cdot 10^3 \cdot 134}{3.14 \cdot (.945)^2} \left(\frac{3.14 \cdot .945}{2} \sqrt{\frac{1.08 \cdot 10^8}{1.6 \cdot 10^3} + \frac{1}{4}} \right) 10^{-9} \Omega$$

$$= 2.44 \cdot 10^7 (1.484 \cdot 260 + \frac{1}{4}) 10^{-9} \Omega$$

$$= 942 \dots 10^{-2} \Omega$$

$$= 9.42 \Omega$$

As the current is not constant along the length of the aerial, but is distributed according to sine law, the mean value of I^2 over the whole length of the aerial

$$= \frac{1}{2} I^2 = .01125d.$$

then loss = $.01125 \cdot 9.42 = .106$ Watt (nearly)
 = .35 per cent.

(c) *Power Lost in Current Indicator (Aerial).*

As the current-meter is situated at the point of maximum current, and can therefore be represented as a "lumped resistance" at this point, power lost in meter = $I^2 \cdot$ (meter resistance)

$$= .0225 \cdot 5 = .1125 \text{ Watt} = .375 \text{ per cent.}$$

(d) *Therefore total Power in Aerial = (a) + (b) + (c)*
 = 1.8 + .106 + .1125 = 2 Watts (practically)
 = 6.66 per cent.

Note.—The use of Rayleigh's formula for calculating the H.F. resistance of the aerial is assumed to be justified, owing to the fact that, whether the

conductor is solid or not, as far as H.F. currents are concerned, it is a tube.

(e) *Losses in Loop.*

(1) *Radiation.* Esau (see Appendix A, above) stated that the radiation resistance of a loop 240 cm.² in area, at a frequency of 10⁸ was 2.4 Ω.

The approximate area of our loop is 120 cm.² the frequency 1.08 · 10⁸ and the current .25 A. Assuming that the radiation is proportional to the product of the area and the square of the frequency, the power radiated will be:—

$$\frac{1}{2} \cdot 1.08^2 \cdot 2.4 \cdot .25^2 = .0875 \text{ Watt}$$

($R_a = 1.4 \Omega$, nearly).

(2) *H.F. Resistance.* The H.F. resistance of the loop was estimated in the same manner as in the case of the aerial, it being practically impossible to measure directly this quantity, since half of the loop consists of the internal structure of the valve itself. The estimated value is approximately 2 Ω. This is the estimated resistance of the loop alone, without taking into account the loading effect of the internal resistance of the valve R_0 . This will be:—

$$\frac{\omega^2 L^2}{R_0}$$

Where L = Inductance of loop.

$$\omega = 2\pi f = 6.78 \cdot 10^8. \quad \omega^2 = 4.13 \cdot 10^{17}.$$

To estimate the inductance of the loop we have an approximate formula (due to Bashenoff):—

$$L = 2l \left(\text{Log}_e \frac{2 \cdot s}{rl} - .15 \right) \text{ cms.}$$

Where l = perimeter of loop = 52 cms.

r = radius of loop conductor (mean equivalent value = .142 cm.)

s = area of loop = 120 cm.² (approx.)

Then $L = 104 \cdot \left(2.303 \cdot \text{Log}_{10} \frac{240}{52 \cdot .142} - .15 \right) \text{ cms.}$

$$= 104 \cdot (3.52 - .15)$$

$$= 350 \text{ cms.} = .35 \cdot 10^{-6} H.$$

$$L^2 = .1225 \cdot 10^{-12}.$$

(2a) The mean value of the internal resistance of the valve, *i.e.*, the mean value of $\frac{dV_a}{dI_a}$ over a cycle, under the actual test conditions was estimated at 8,000 Ω.

Then the equivalent series resistance introduced by the valve* is:—

$$\frac{4.13 \cdot 10^{17} \cdot .1225 \cdot 10^{-12}}{8 \cdot 10^3} = 6.34 \Omega.$$

(Resistance of loop current indicator = 5 Ω).
 Therefore

$$\text{Total resistance of loop} = 1.4 + 2 + 6.34 + 5 = 13.74 \Omega.$$

* It will be observed from this that the valve and its associated circuit are by no means badly matched, which is fortunate, for the use of an "anode tap" device is not a practical possibility, as will be surmised from a little perusal of the elementary considerations set forth in the early part of the text (Section A). It should be borne in mind that the effective impedance of the loop circuit (approximately 14,000 Ω from the above data) will be much reduced by the effect of the aerial load, for which it is impossible to allow.

Total losses in loop = .25² . 13.74 . = .86 Watt
 = 2.87 per cent.

(f) Total power so far accounted for
 = 6.66 + 2.87 = 9.53 per cent.

Total power so far accounted for, including feeder losses "

$$= 2.87 . + \left\{ 6.66 \left(\frac{.1875}{.15} \right)^2 \right\} = 12 \text{ per cent.}$$

(4) Effect of Time of Transit of Electrons Constituting the Space-current.

It is not difficult to estimate, numerically, the effect of this upon the power-conversion-efficiency of the oscillator. Its effect is two-fold, viz. :-

(1) Upon the control exercised by the grid upon the space-current. The practical effect is to reduce the apparent "m" of the valve. This can be counteracted by an increase in the amplitude of the H.F. potential applied to the grid. In a self-exciting circuit (such as the one employed in these experiments) this is compensated for automatically.

It is therefore only necessary to take into account, for practical purposes, its effect :-

(2) Upon the control exercised by the anode potentials, i.e., upon the oscillatory component of the anode-current.

It is evident that only those electrons which have had time to pass from the cathode to the anode, during one half-period of oscillation, will constitute the oscillatory component of the space-current.

Therefore the amplitude of the oscillatory (A.C.) component of the anode current (and therefore the oscillatory energy produced) will be reduced by the amount :-

$$\frac{\text{Transit-Time.}}{\text{Half-Time-Period.}}$$

We have the well-known expression for the final velocity S of the electron, under the influence of an electric field :-

$$S = \left(2 \cdot V \cdot \frac{e}{m} \right)^{\frac{1}{2}} \text{ cm./sec.}$$

(Where V = Potential between electrodes in volts).

$$\frac{e}{m} = \text{Ratio, } \frac{\text{charge}}{\text{mass}} \text{ of electron} \\ = (\text{a constant}) = 1.77 \cdot 10^8.$$

Since S = the final velocity, the mean velocity (which we require to determine the "time of transit") will be S/2.

The transit-time will therefore be :-

$$2 \cdot \times \frac{\text{mean anode-cathode distance}}{S}.$$

Mean anode-cathode distance = .8 cm. approx.
 V = 500 v.

$$\text{Then transit-time} = \sqrt{2 \cdot \frac{.8}{500 \cdot 1.77 \cdot 10^8}} \\ = 3.2 \cdot 10^{-8} \text{ sec.}$$

Half-time period of oscillation at
 "f" = 1.08 . 10⁸ = 4.6 . 10⁻⁹ sec.

Then power lost, owing to "electron lag" :-

$$= \frac{3.2}{4.6} = .696 = 69.6 \text{ per cent.}$$

This percentage is deducted from the already converted energy so, assuming a normal conversion-efficiency of 60 per cent., this accounts for 41.8 per cent. of the input energy.

To sum up, 12 per cent. of the input energy is dissipated in the H.F. circuits and 41.8 per cent. remains unconverted owing to "electron-lag" in the valve, giving a total of 53.8 per cent.

This agrees well (from the practical point of view) with experimental observations, detailed herein.

APPENDIX (C).

(1) **Constructional Details of Transmitter** (see Fig. 4, p. 545, previous issue).

- L₁. Brass strip, ¼ × ⅛ in., 13 cm. long. Drilled with two holes, No. 4 B.A. clearing, 12.5 cm. apart, and bent into "L" shape, 8 × 5 cm.
- L₂. Brass strip, ¼ × ⅛ in. straight, 8 cm. long, drilled two holes (as above), 7.5 cm. apart.
- C₁. "Polar 'Volcon'" variable, .0001μF. max.
- C₂, C₃, C₄. See "special condensers," below.
- Ch₁, Ch₂. Ebonite rod, ⅜ in. diam., 1 ⅜ in. long, screwed 48 threads per inch, wound with 60 turns (1 ½ in.) of No. 36 S.W.G. Eureka wire. (Any covering will do, as the turns are amply spaced.)
- Ch₃, Ch₄. Ebonite rod, ¼ in. diam., ¼ in. long, screwed 8 threads per inch, double thread. Bifilar winding of 26 turns (3 ¼ in.) of No. 18 S.W.G. (enamel covered) copper wire, brought out to two terminals at each end (i.e., 52 turns in both windings, 26 in each groove).
- T. Secondary of "Ford" car ignition coil, primary rewound with 200 turns of No. 24 S.W.G. D.S.C. copper wire, provided with iron wire core, ¼ in. long, ½ in. diam., and suitably mounted.

A small brass slider, with clamping screw and terminal, is made to fit on L₂, to which one of the ends of the feeder coupling leads is secured. The feeder blocking condensers (C₃ and C₄) are secured directly to the shanks of the feeder terminals of the transmitter. The feeder coupling leads run from the other terminals of these condensers to the terminal of C₁ and the slider, respectively.

f₁, f₂. Thin rubber-covered "flex," ¼ in. (10 cm.) long, approx.

The envelope-screen of the valve consists of four strips of tinfoil, each ¼ in. wide, pasted longitudinally upon the valve envelope equidistantly around the circumference, connected together at top and bottom by rings of same material pasted over them.

(2) Constructional Details of Receiver (see Figs. 5 and 6, pp. 548 and 551, previous issue).

- L_1, L_2 . Each coil:—brass wire, No. 18 S.W.G. (bare), 26 cm. long, bent into a two-turn helix, 3.4 cm. diam., turns spaced .5 cm. apart.
- L_3 . Material as above, one turn, 3.4 cm. diam., mounted upon ebonite rod, $\frac{3}{8}$ in. diam., set in hole drilled in wooden baseboard. Arranged co-axially with L_2 and about 1.5 cm. distant from it.
- Ch_1 . Ebonite rod, $\frac{1}{4}$ in. diam., 3 in. long, wound for 2 $\frac{1}{2}$ in. with No. 40 S.W.G. D.S.C. Eureka wire.
- Ch_2 . As above (Ch_1), but wound with No. 44 S.W.G. ditto.
- Ch_3, Ch_4 . Ebonite rod, $\frac{3}{8}$ in. diam., 3 in. long, wound for 2 in. with bifilar winding of No. 24 S.W.G. D.S.C. copper wire, brought out to two terminals at each end.
- C_1 . Small brass variable capacity, constructed integral with valve-holder. One fixed and one moving plate (ordinary semi-circular rotary pattern). Moving plate 1 cm. radius, separation between plates about 2 mm. This condenser is mounted between the grid and anode contacts of the V.24 type valve-holder, in the space between the valve and holder (when valve is in place). The valve-holder is mounted vertically, the control spindle of the condenser emerging from the back.

- C_2 . See "special condensers," below. Mounted upon the valve-holder below C_1 .
- C_3, R_1, R_2 . Of normal pattern, require no description.
- L_4, L_5 . Wound in slotted former of ebonite, 2 $\frac{1}{4}$ in. diam., 1 $\frac{1}{2}$ in. long, in which are turned 4 slots, .1 in. wide and $\frac{3}{8}$ in. deep. L_4 , 1,800 turns of No. 40 S.W.G. D.S.C. copper wire, wound in three of the slots (= 600 turns per slot). L_5 , 300 turns of same wire, wound in remaining slot.
- C_4, C_5 . Of normal pattern, require no description.
- R_3 . 400 Ω McMichael potentiometer. (Used as a variable resistance.)
- f_1, f_2 . Thin rubber-covered "flex," 10 cm. long.

Special Condensers (see sketch, Fig. 10).
 Condensers of the "postage-stamp" type, if available in the capacities stated, might be used.
 A commercial article of the required type is the Metropolitan-Vickers ("Cosmos") "Permacon."

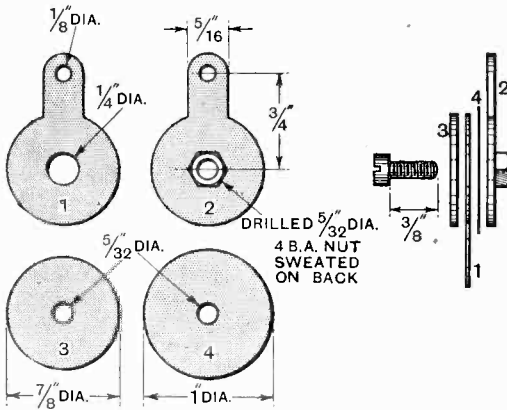

Fig. 10.—Special condenser details. 1 = brass or phosphor-bronze, No. 24 S.W.G., $\frac{3}{8}$ in. dia. 2 = brass or phosphor-bronze, No. 18 S.W.G., $\frac{3}{8}$ in. dia. 3 = brass or phosphor-bronze, No. 18 S.W.G., $\frac{3}{8}$ in. dia. 4 = 0.002 mica, 1 in. dia. 5 = Standard 4 B.A. brass bolt cheese-head, $\frac{3}{8}$ in. long.

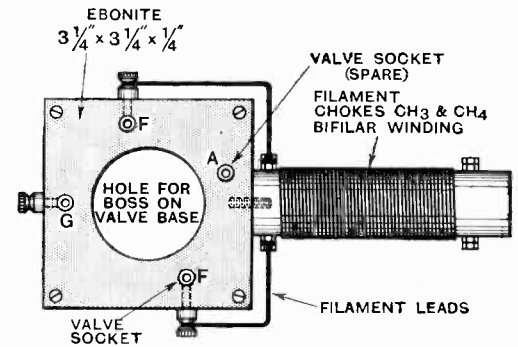

Fig. 11.—Valve base details.

(3) Aerials and Feeders (see Fig. 4(d), p. 547, previous issue).

Aerials.—Two pieces of copper tube, $\frac{3}{8}$ in. diam., 66 cm. long, mounted co-axially in ebonite block, 2 x 1 x $\frac{3}{4}$ in. Inner ends 1 in. apart, provided with terminals for attachment of feeder.

Transmitter Feeder.—7/30 twisted "cab-tyre flex," 3.4 metres long.

Receiver Feeder.—7/30 twisted "cab-tyre flex," 3.8 metres long.

The exact mechanical length of the feeders will depend upon individual circumstances (e.g., method of coupling accounts for difference in length of transmitter and receiver feeders shown above). If the layout and method of construction herein briefly described is followed, the lengths mentioned above should be correct. These correspond electrically to 1 $\frac{1}{2}$ wavelengths.

Abstracts and References.

Compiled by the Radio Research Board and reproduced by arrangement with the Department of Scientific and Industrial Research.

PROPAGATION OF WAVES.

THE REFLEXION OF LONG ELECTROMAGNETIC WAVES FROM THE UPPER ATMOSPHERE [MATHEMATICAL INVESTIGATION].—D. Burnett. (*Phil. Mag.*, July, 1930, Series 7, Vol. 10, No. 62, pp. 1-15.)

Macdonald's solution of the problem of reflexion of electromagnetic waves from the upper atmosphere, in which he assumes the earth to be a perfectly conducting sphere, surrounded by an atmosphere made up of two parts, each homogeneous in itself, separated by a spherical surface concentric with the earth, may be regarded as satisfactory for short and medium wave-lengths but not for very long waves unless in the immediate neighbourhood of the transmitter. In this paper a method is given, analogous to that used by Macdonald in his discussion of the diffracted wave (*Proc. Roy. Soc., A*, Vol. 90, p. 50, 1914), which obtains an exact result for long waves and in which the amount of computation required to get numerical values is not excessive, unless near the transmitter. A table is given, for angular distances from the transmitter up to 25°, of the amplitude of the magnetic force in the diffracted wave from a vertical doublet plus a wave reflected once from the upper atmosphere, expressed as a fraction of the amplitude at the same point due to the same transmitter in free space, when the earth's radius is taken as 6367.4 km., the height of the reflecting surface above the surface of the earth as 100 km., the wavelength as 18,750 metres, the ratio $\frac{\text{dielectric constant of upper atmosphere}}{\text{dielectric constant of lower atmosphere}} = 0.99$, and the earth is supposed perfectly conducting.

REFLECTION OF RADIO WAVES FROM THE SURFACE OF THE EARTH.—L. C. Verman. (*Proc. Inst. Rad. Eng.*, August, 1930, Vol. 18, pp. 1396-1429.)

The full paper, an abstract of which was dealt with in October Abstracts, p. 561.

UNTERSUCHUNGEN ÜBER DIE AUSBREITUNGSDÄMPFUNG ELECTROMAGNETISCHER WELLEN UND DIE REICHWEITEN DRAHTLOSER STATIONEN IM WELLENBEREICH 200-2,000 M. (Investigations on the Attenuation of Electromagnetic Waves and the Ranges of Wireless Stations in the Wave-range 200-2,000 m.).—H. Fassbender, F. Eisner and G. Kurlbaum. (*E.N.T.*, July, 1930, Vol. 7, pp. 257-276.)

Hitherto the planning of wireless links over land has been carried out by rule-of-thumb, while over sea the Austin-Cohen formula gives sufficiently good results. The use of Sommerfeld's theory is impeded by the facts that in practice the average values of the ground constants are not known, and that the theory takes no account of the space wave. The present paper gives the results of a large number of field strength measurements on waves between 200 and 2,000 m., and the writers claim

that the particulars of the propagation of all these waves over land can be calculated more reliably from it than by rule-of-thumb. Since the transmitting stations whose signals were measured were in aircraft, results over varying distances were obtained in rapid succession *with uniform conditions both at transmitter and at receiver*. Curves given show the received field strengths, in microvolts per metre for one metre-ampère at the transmitter, (i) plotted against wavelength for various distances over land, (ii) plotted against distance over land for various wavelengths, (iii) the same over sea, and (iv) perhaps the most useful, the values of Ih in metre-ampères to produce a field strength of 1 microvolt/metre plotted against distance over land, for various wavelengths. The question of the effective heights of aërials is dealt with; for a Zeppelin aerial it is about 25% of the total length of the wire, while for the usual 70-metre trailing aeroplane aerial it is only 10%.

NEGATIVE ATTENUATION OF WIRELESS WAVES.—J. A. Ratcliffe and F. W. G. White. (*Nature*, 21st June, 1930, Vol. 125, pp. 926-927.)

Experiments have been performed to determine whether the "negative attenuation" effect found by Ratcliffe and Barnett (*Proc. Camb. Phil. Soc.*, Vol. 23, p. 300, 1926), on signals of 1,600 m. wavelength from Daventry 5XX is peculiar to these signals, or whether it occurs on all signals of this wavelength. "Attenuation measurements made at Cambridge on a transmitter with a low aerial, working on a wave-length near 1,600 m., showed no sign of the effect," and the writers conclude that it is due to some special conditions at the Daventry site. It is proposed to investigate the attenuation at Daventry using a low transmitting aerial.

Numerical calculations on Sommerfeld's attenuation theory made by Rolf (*cf.* July Abstracts, p. 388) show that for certain values of the conductivity (σ) and dielectric constant (ϵ) of the ground, the "negative attenuation" effect may be expected to occur. The writers find that their experimental curve requires $\sigma = 7 \times 10^{-18}$ e.m.u. and $\epsilon = 80$ e.s.u. Both σ and ϵ may be expected to vary with frequency, and laboratory experiments show that ϵ increases as the frequency is reduced, values of $\epsilon = 45$ being found for a wavelength of 1,600 m., a very different value from that found previously by Ratcliffe and Shaw (*cf.* January Abstracts, p. 29) for a wavelength of 30 m. A possible explanation of the "negative attenuation" effect is thus offered but cannot be made definite until the measurements on a small aerial at Daventry are completed.

THE CALCULATION OF THE SERVICE AREA OF BROADCAST STATIONS.—P. P. Eckersley. (*Proc. Inst. Rad. Eng.*, July, 1930, Vol. 18, pp. 1160-1193.)

Author's summary:—"This paper is a com-

prehensive study of the practical considerations in the determination of the field strength laid down at any distance by a given radio station at any given location. All factors entering into such calculations are considered and practical means of their determination, or estimation set forth. Methods are provided for the evaluation of field strength due to the space ray which should prove of value in further work on this subject. No attempt at extreme accuracy is made, the keynote of the paper being practicability."

The determination of the ground ray attenuation is accomplished from a number of curves derived from Sommerfeld's theory. These are on the basis of $\sigma = 1 \times 10^{-13}$ c.g.s. units, and an abacus is given which serves as a conversion table for other values of σ . For practical purposes, to avoid the necessity of measuring σ for every separate case, the writer gives a table of σ for various degrees of "brokenness" of ground, chiefly based on past B.B.C. tests. Here σ varies from 1×10^{-12} for marshy flat land, through 1×10^{-13} for open pastoral country, 0.5×10^{-13} for hilly and 0.2×10^{-13} for "very broken" country, to 1×10^{-14} for mountainous and 0.75×10^{-14} for "broken" mountainous country. For towns and cities, the value assigned is 0.75×10^{-13} .

The word "brokenness" is used to convey the idea of abrupt changes of level, and the tests led the writer to the conclusion that it is this property which chiefly influences the attenuation. He attaches little importance to the effect of trees, in spite of Barfield's theory (1928 Abstracts, p. 285) according to which σ is dependent on the conductivity of the actual ground and on the number of trees per unit area found on that ground. He agrees that possibly dense forests, larger than can be found in England, may produce greater attenuation, but points out that forests "have a habit of growing on broken ground." The value of σ for towns and cities is given as a result of tests over Greater London on a large number of wavelengths suitable for broadcasting: it was found, again contrary to Barfield's results (1929 Abstracts, p. 262) that σ could be expressed as having "about the same value at every wavelength."

Dealing next with the field strength due to the space ray, the writer makes certain assumptions (e.g., that the maximum strength of ray on leaving Heaviside layer is one-fifth of its strength on entering) and arrives at a rough practical figure for the maximum value of the field due to the indirect ray: "the maximum value of the indirect ray at distances between 100 and 1,000 km. is 0.1 mV. per m. for 1 kW. radiated from the transmitter." He takes, as the outside boundary of "true service," the point where "intolerable fading" begins and the direct ray equals the space ray; the boundary therefore becomes that distance at which 1 kw. radiated produces a direct ray field of 0.1 mv. per m.

If the lower limit of service is represented by 2.5 mv. per m. (for the more northern latitudes) and this is to extend to the above boundary, the radiated power required is $(2.5/0.1)^2$ kw., or 625 kw., *theoretically independent of wavelength*. Some implications of this result are considered: a station forced to use a 200 m. wave in very mountainous country would have the point of intolerable fading at 15-20 miles, and "we should be using 800 kw.

power producing 2.5 mv. per metre indirect ray as an interfering signal over about ten million square miles!" Such high powers are only economic in certain specialised cases, as where the wavelength is long and the territory to be served both wide and densely populated.

The paper then deals with the design of transmitting aerials for broadcast stations, and includes remarks on the effective height [a curious anomaly found in measuring this for T aerials is that if the measurements are taken too close ($d < 10\lambda$) to the aerial the effective height comes out too high—even higher than the physical height] and practical curves for the effect of the aerial on the field strength at a distance. The use of the foregoing analysis in typical cases is illustrated, and the paper ends with a section on the unsuitability of the present wavelengths allocated to the world's broadcast services: "there will undoubtedly be a determined move on the part of European broadcasters to secure more 'long' wavelengths at the forthcoming Madrid Conference."

WIRELESS TELEGRAPHY AND THE IONIZATION IN THE UPPER ATMOSPHERE.—E. O. Hulburt. (*Proc. Inst. Rad. Eng.*, July, 1930, Vol. 18, pp. 1231-1238.)

Author's summary:—A non-mathematical survey is given of the theory of the upper atmosphere and the behaviour of wireless waves. The new physics of the atmosphere based on heating by the sun, cooling at night, winds, gaseous diffusion, etc., the observations of the heights reached by wireless waves, the skip distances, ranges, polarization, etc., led to the conclusion that the ionization in the upper atmosphere was caused by the ultra-violet light of the sun and that the electron density had a maximum value of about 3×10^9 at 190 km. for summer noon. The calculated ionization agreed well with the wireless facts during the day but fell off too rapidly at night. Below the maximum the ionization was not known exactly. The diamagnetic theory of the diurnal variation in the earth's magnetism called for an ion density of about 5×10^9 from about 150 to 190 km. The drift current of the ions, due to the earth's gravitation and magnetism, cause the sunset longitude to be at a potential of about 2,000 volts above that of the sunrise longitude. This voltage, combined with the earth's magnetic field, causes the ions and electrons to rise at night. They move up into regions of lower molecular density where their recombination is less. Their rate of loss at night is about right to agree with the wireless facts. It is pointed out that quantitative experiments with waves between 70 and 400 metres, of which there have been very few, might contribute valuable information about the ionization.

WHISTLING TONES FROM THE EARTH.—H. Barkhausen. (*Proc. Inst. Rad. Eng.*, July, 1930, Vol. 18, pp. 1155-1159.)

After quoting, from his 1919 paper, the part describing the phenomenon of "whistling tones" heard from time to time in the telephones of listening posts during the war, the writer suggests two possible explanations. Both are based on the idea of a remote lightning stroke. The first sup-

poses that the effect is due to multiple reflections between Heaviside layer and earth: qualitatively, this leads to the result—corresponding with observation—of a tone whose frequency decreases very rapidly from a high to a low value; quantitatively, it gives a minimum frequency of 1,500 cycles/sec. (assuming a layer height of 100 km.) and this seems to the writer to be rather high. "A lower frequency would correspond to a greater altitude of the Heaviside layer or to a lower propagation velocity (which is not improbable for higher altitudes)." Another difficulty is that so far as the writer knows these whistling tones have never been observed on high-frequency apparatus, from which he concludes that it is not a question of a series of short high-frequency impulses, as assumed by this explanation, or that at least the high-frequency impulse character must be lost owing to the multiple reflection.

The second suggested explanation depends on the property of certain transmission networks of transmitting the higher frequencies more quickly than the lower. Space waves in the earth travel faster the higher their frequency, but are so strongly attenuated that propagation to 100 km. and more seems improbable (since the whistler lasts almost one second, the difference in time of transit must be almost one second). Space waves through the atmosphere would also probably have the necessary frequency relation if they reached the Heaviside layer and although it is difficult to explain the long time of transit, the long-delay echoes recently observed indicate that such long times do occur. Cf. Eckersley, 1929 Abstracts, pp. 38 and 385.

ON THE ANNUAL VARIATION OF UPPER-ATMOSPHERIC OZONE.—S. Chapman. (*Phil. Mag.*, Aug., 1930, Series 7, Vol. 10, No. 63, pp. 345-352.)

ON OZONE AND ATOMIC OXYGEN IN THE UPPER ATMOSPHERE.—S. Chapman. (*Phil. Mag.*, Sept., 1930, Vol. 10, pp. 369-383.)

"While the foregoing discussion is unavoidably speculative in so far as it involves numerical estimates, two main conclusions stand out as highly probable. The existence of ozone implies a mechanism which will form atomic oxygen by dissociating oxygen molecules; this mechanism is almost certainly, at least in part, ultra-violet radiation, which will be absorbed gradually as it passes through the highest atmospheric strata, there dissociating oxygen. At sufficiently great heights recombination will be slow, so that little ozone will be formed, and atomic oxygen will accumulate; and it will rise by diffusion until (in the absence of hydrogen and helium), together with atomic nitrogen, it becomes the chief atmospheric constituent. On the other hand, as we descend the oxygen atoms will more and more readily attach themselves to oxygen molecules, to form ozone. These, in brief, are the reasons which render it likely that (1) the ozone concentration diminishes rapidly with height above the level of maximum concentration, and especially above the level at which convective mixing is important, and (2) the atomic oxygen concentration increases upwards until it exceeds that of molecular oxygen."

A STUDY OF WAVE SYNTHESIS BY MECHANICAL MEANS.—IV. PART 1. THE PHASE OF CARRIER TO SIDE BANDS AND ITS RELATION TO A SYNCHRONOUS FADING PHENOMENON.—A. W. Ladner. (*Marconi Review*, August, 1930, pp. 25-31.)

In a previous part (February Abstracts, p. 92) the writer investigated the effect of the phase shift of carrier to side-bands in the case of a 100% sine-modulated carrier. It appeared that small shifts of carrier phase resulted in considerable signal distortion; a shift of the order of 90° created distortion taking the form of frequency doubling, and one of 180° reversed the signal. The present part deals with the more practical case of waves with shallow modulation, using signal envelopes (a) of a pure tone and (b) having a complex shape.

A number of records are shown and discussed, leading to the following conclusions:—the effect of phase-shifting the carrier wave of an ordinary amplitude-modulated carrier is to reduce the amplitude modulation and to introduce a frequency modulation; with shallow modulation the change in amplitude may become negligible with a carrier phase-shift approaching quadrature, while a change of frequency will have been introduced which may become fairly considerable. With an ordinary receiving system designed to detect amplitude modulation, the signal will have disappeared, and to obtain intelligence some form of demodulation becomes necessary which will respond to frequency as well as to amplitude-changes.

The writer then discusses whether such phase-shifts can occur in practice. He suggests that the particular type of fading where little distortion occurs and the carrier fading does not synchronise with the modulation fading (sometimes the carrier even strengthens while the modulation weakens or fades right away) may readily be explained by a simple phase-shift of carrier relative to side-bands as the spectrum passes through the ionised regions. Such fading is hard to explain by the more usual picture of the addition of multiple spectra. On the above hypothesis it could, theoretically, be overcome by a receiving system such as that referred to above, "but with present-day apparatus it is very doubtful whether any such receiver would operate, owing to the difficulty of obtaining sufficient frequency constancy. . . . One requires a constancy of one part in 50 million at least before one can hope successfully to operate a system which depends for its action upon the relative phases of the waves comprising the signal." Cf. Heilmann, T. L. Eckersley, under "Transmission."

FIELD INTENSITY MEASUREMENTS AROUND SOME AUSTRALIAN BROADCAST STATIONS: REPLY TO DISCUSSION.—R. O. Cherrv. (*Proc. Phys. Society*, 15th Aug., 1930, Vol. 42, Part 5, pp. 591-592.)

A reply to the discussion on the paper dealt with in July Abstracts, p. 388.

ULTRA-SHORT WAVES FOR LIMITED RANGE COMMUNICATION.—Brown. (See under "Transmission.")

STUDY OF THE EFFECT OF SHORT LENGTHS OF CABLE ON TRAVELLING WAVES.—K. B. McEachron, J. G. Hemstreet and H. P. Seelye. (*Journ. Am. I.E.E.*, Sept., 1930, Vol. 49, pp. 760-763.)

DIFFRACTION.—E. T. Hanson. (*Phil. Trans. Roy. Soc., A*, No. 672, Vol. 229, pp. 87-124.)

CONSTATATION EXPÉRIMENTALE, DANS LE RAYONNEMENT CALORIFIQUE, DE RAYONS ULTRA-ROUGES DYNAMIQUES (Experimental Demonstration of Infra-Red "Dynamic" Rays in Black Body Radiation).—Th. Tommasina. (*C.R. Soc. de Phys. de Genève*, No. 3, Vol. 46, 1929, pp. 133-135.)

The writer claims to have demonstrated the existence of rays which pass through screens impervious to light and heat radiations and make themselves evident by vigorous action on a radiometer.

THE ANOMALOUS PROPAGATION OF LIGHT WAVES IN THE NEIGHBOURHOOD OF A FOCUS.—M. Conti. (*Nuovo Cim.*, No. 1, Vol. 17, 1930, pp. 17-40.)

The investigation by interferometer methods. Among other things, the change of the half period in phase is quantitatively confirmed.

ATMOSPHERICS AND ATMOSPHERIC ELECTRICITY.

GLEICHZEITIGE LUF- UND KABELSTÖRUNGEN (Simultaneous Atmospheric in Wireless Aerials and in Cables).—M. Bäumlner. (*E.N.T.*, Aug., 1930, Vol. 7, pp. 325-330.)

In August Abstracts, p. 469, Wagner is quoted as saying that simultaneous records of disturbances in a wireless receiver and in the Emden-Vigo cable showed that "on short radio waves only a few disturbances coincided, but on the longer waves almost all atmospheric were observed also in the cable." The present paper deals in some detail with these tests, in which the wireless receiver was tuned in turn to waves of 34, 500, 1,400 and 12,000 metres. Records taken on an undulator and also on an oscillograph are given: the latter (owing to the greater sensitivity and freedom from inertia of the instrument) show many more disturbances than the former. Some of the records were taken with a damping resistance in the aerial to make it more similar to the cable: this damping made no apparent difference to the number of impulses recorded.

The records show great agreement between the disturbances in aerial and cable. *There is no suggestion here that this agreement is less on the short waves than on the long.* It is best in those cases when the amplitudes of the aerial disturbances attain a strength as great as that of the cable disturbances. The ratio of amplitudes varies; sometimes the aerial disturbance is stronger than the corresponding one in the cable. In some cases there is a slight difference in time between two otherwise corresponding disturbances: it is appar-

ently concluded from this (though the paper is not clear on this point) that these particular disturbances come from a great distance: earlier tests on two cables, only one of which used permalloy, showed similar discrepancies which are attributed to the different rates of propagation, in the two cables, of impulses arising probably from a distant storm.

EFFECT OF THE EARTH'S ELECTRIC AND MAGNETIC FIELDS ON IONS IN THE ATMOSPHERE.—L. Page. (*Phys. Review*, 1st Aug., 1930, Series 2, Vol. 36, No. 3, pp. 601-602.)

A letter upholding conclusions arrived at by the author (*cf.* 1929 Abstracts, pp. 445, 446) against the criticisms of Hulburt (*Phys. Review*, Vol. 36, 1930, p. 1587). "Ions produced in the portion of the atmosphere which is already ionised should experience no electrical drift relative to the rotating earth. Only those ions which come into the earth's atmosphere from outside or which are produced above the ionised region should suffer the westward drift, and this they should lose in time as a result of collisions."

WIRELESS TELEGRAPHY AND THE IONIZATION IN THE UPPER ATMOSPHERE.—Hulburt. (See under "Propagation of Waves.")

SUR L'OBSERVATION D'UNE AURORE POLAIRE (On the Observation of a Polar Aurora).—P. Helbronner. (*Comptes Rendus*, 15th Sept., 1930, Vol. 191, pp. 449-450.)

After recording his observation, on 3rd September last off the Norwegian coast, of a very brilliant aurora affecting practically the whole visible surface of the sky, the writer refers to the work now being done in Norway under the inspiration of Störmer's researches.

WHISTLING TONES FROM THE EARTH.—Barkhausen. (See under "Propagation of Waves.")

QUELQUES OBSERVATIONS D'ÉLECTRICITÉ ATMOSPHÉRIQUE EN INDOCHINE (Some Observations on Atmospheric Electricity in Indo-China).—A. Yersin. (*Comptes Rendus*, 25th August, 1930, Vol. 191, pp. 366-368.)

Values of the electric field at 1, 2 and 3 m. above the ground are given for various times of the year: observations before, during and after thunderstorms are included.

REDUCTION OF ATMOSPHERICS IN SPACED RECEIVER RECEPTION.—R. C. A. Patent. (See abstract under "Reception.")

EFFECTS OF THE MAGNETIC FIELD ON LICHTENBERG FIGURES.—Magnusson. (See under "Subsidiary Apparatus.")

THE PORTABLE IMPULSE GENERATOR.—E. J. Wade. (*Gen. Elec. Review*, March, 1930, Vol. 33, pp. 180-184.)

Description of two portable impulse generators, one for 400 kv. and the other rated at a million volts.

PROPERTIES OF CIRCUITS.

SYNTHESIS OF ELECTRIC NETWORKS BY MEANS OF THE FOURIER TRANSFORMS OF LAGUERRE'S FUNCTIONS.—Yuk-Wing Lee; N. Wiener. (*Abst. of Sci. & Tech. Pub.*, Massach. Inst. Tech., July, 1930, pp. 82-84.)

Long abstract only: "This thesis presents a new method for the design of electric networks with assigned transfer admittances" [e.g. for wave filters, artificial lines, phase-correction networks]. When either the absolute value or the phase of the admittance function is given, it is necessary to solve the Hilbert transform. If this cannot be done analytically, it can be done by Gray's photo-electric integrating machine developed under Bush [cf. Gray, under "Subsidiary Apparatus"; also Sears, June Abstracts, p. 333]. Two examples are given in the complete thesis: the first is the design of a network having the real part of the transfer admittance function assigned; in the second, the imaginary part is specified. Both problems are carried out analytically, and the required functions are very closely approximated by only three terms of the expansions.

COUPLED VIBRATIONS WITH APPLICATION TO THE SPECIFIC HEAT AND INFRA-RED SPECTRA OF CRYSTALS [Mathematical Investigation applicable to Electrical Wave Filter Problems].—A. B. Lewis. (*Phys. Review.*, 1st Aug., 1930, Series 2, Vol. 36, No. 3, pp. 568-586.)

ZUR THEORIE ZWEIER GEKOPPELTER SCHWINGUNGSKREISE, I. (On the Theory of Two Coupled Oscillatory Circuits—Part I).—V. Petrzilka. (*E.N.T.*, Aug., 1930, Vol. 7, pp. 317-324.)

"Recently, especially in Germany, a number of theoretical and experimental papers have appeared dealing very thoroughly with the problem of coupled circuits; nevertheless a method will be given here which enables the phenomena in such circuits to be handled very easily." The total energy is made up of W_1 introduced into the primary circuit and W_2 into the secondary. W_1 and W_2 are proportional to the squares of the intensities I_1 and I_2 , and are functions of the de-tuning coefficient, the coupling coefficient k , and the dampings d_1 and d_2 of the two circuits. From these relations it is possible to draw resonance curves, which are then discussed on the assumption that the natural frequencies of the two circuits are equal.

Two types of curve are obtained: the simple type with a single maximum, and the double-humped type in which two maxima lie symmetrically about one minimum. The conditions for the production of simple and double-humped curves are represented by diagrams. In the case of resonance with the impressed voltage (de-tuning = zero) W^2 as a function of k passes through a maximum at $k^2 = d_1 d_2$; this is the condition for the greatest energy-transfer in the simple resonance curve region, and may be interpreted as meaning that in resonance the secondary energy W_2 , as a function of k , reaches its maximum value when the resistance induced in the primary by the secondary is equal

to the resistance of the primary. In the double-humped curve region, on the other hand, the condition for greatest energy-transfer is given by $d_1 = d_2$. "These results are not only theoretically interesting but of practical importance."

ELECTRIC OSCILLATIONS IN COILS AND WIRES.—

E. Hallén. (*Uppsala Univ. Årsskrift*, Vol. 1, 1930, 102 pp.)

Science Abstracts describes this as "an important contribution to the mathematical theory of oscillations in coils and wires, using the integral equation method as in Oseen's work."

SOME PROBLEMS IN THE DISTURBANCE THEORY OF LINEAR OSCILLATING SYSTEMS.—S. Schubin. (*Journ. Applied Phys.*, Moscow, No. 2, Vol. 7, 1930, pp. 69-98.)

Russian with German summary. The case of an infinite number of degrees of freedom is treated first, particularly the case where several eigenvalues emerge; formulæ are developed for the calculation of amplitude- and period-corrections, and their use illustrated by concrete examples of electrical oscillatory circuits. Next the paper deals similarly with continuously distributed systems: a stretched string and deformed rectangular and circular diaphragms are taken as examples.

EIN EINFACHER BEWEIS DES REAKTANZTHEOREMS (A Simple Proof of the Reactance Theorem [of Passive Loss-free Dipoles]).—H. G. Baerwald. (*E.N.T.*, Aug., 1930, Vol. 7, pp. 331-332.)

EXPERIMENTELLE UNTERSUCHUNGEN AN SPULEN MIT LEITENDEN KERNEN UND HÜLLEN (Experimental Investigations of Coils with Conducting Cores and Covers).—G. Loos. (*Zeitschr. f. hochf. Tech.*, July, 1930, Vol. 36, pp. 13-24.)

These tests were suggested by problems arising in the use of frame aerials for d.f. purposes in an all-metal aeroplane. Using medium wavelengths (500-1,200 m.), the capacity, inductance and resistance values were obtained for a single-layer coil enclosing, in turn, brass tubes of varying diameter, of varying length, copper rings, constantin rings, slotted tubes of varying diameter, metal strips, etc. The following conclusions are among those reached:—the capacity is not seriously increased by the presence of such cores until the gap between core and winding is very small.

The increase of resistance by these metallic cores is comparatively small for cores which strongly reduce the inductance (e.g., complete cylinders, thick-walled tubes), while cores which have little effect on the inductance may increase the resistance considerably. A maximum increase can be found under certain conditions, e.g., thin-walled tubes of a particular thickness of wall.

SUL FUNZIONAMENTO OSCILLATORIO DEI CIRCUITI A TRIODI FORTEMENTE SMORZATI (On the Oscillating Behaviour of Highly Damped Triode Circuits).—F. Vecchiacchi. (*Nuovo Cim.*, May, 1930, Vol. 7, pp. 172-200 and plates.)

A NOTE ON AN ALTERNATIVE EQUIVALENT NETWORK FOR THE THERMIONIC VALVE.—N. R. Bligh. (*E.W. & W.E.*, Sept., 1930, Vol. 7, pp. 480-481.)

A note to point out the advantages of an alternative equivalent circuit based on the replacement of the usual constant-e.m.f. generator and series resistance by a constant-current generator and shunt resistance.

CAPACITIVE AND INDUCTIVE COUPLING, INCLUDING A METHOD OF MEASURING MUTUAL INDUCTANCE [AND IMPURITY] AT RADIO FREQUENCIES.—R. M. Wilmotte. (*E.W. & W.E.*, Sept., 1930, Vol. 7, pp. 485-492.)

"It is generally accepted that the two kinds of couplings are very similar, but how similar or, alternatively, how they differ, is not usually explained. It will be shown below that one kind of coupling can be replaced by the other, and by using the usual circuital representations of these circuits (*i.e.*, capacities and mutual inductances) formulæ can be obtained for the transformation of one into the other."

ÜBER DIE ANWENDBARKEIT DER ELEKTROSTATIK AUF WECHSELSTROMLEITUNGEN MIT ERDE UND ÜBER DIE ABHÄNGIGKEIT DES KOMPLEXEN GEGENINDUKTIONSKOEFFIZIENTEN VON DER LEITUNGSDÄMPFUNG (On the Applicability of Electrostatic Methods of Treatment to A.C. Lines with Earth Connection, and the Dependence of the Complex Mutual Induction Coefficient on the Line Damping).—F. Pollaczek. (*E.N.T.*, June, 1930, Vol. 7, pp. 247-251.)

O SYNCHRONIZACJI DRGAN RELAKSACYJNYCH (On the Synchronisation of Relaxation Oscillations).—J. Kahan. (*Wiadomości i Prace, Inst. Radjotech.*, Warsaw, No. 4, Vol. 2, 1930, pp. 104-106.)

The tests described show that the synchronised frequency is m/n times the frequency of the synchronising voltage, m and n being whole numbers.

DIE FREQUENZABHÄNGIGKEIT DES WIDERSTANDS-VERSTÄRKERS (The Dependence on Frequency of the Resistance-coupled Amplifier).—H. Wigge. (*Zeitschr. f. hochf. Tech.*, July, 1930, Vol. 36, pp. 24-27.)

According to the writer, in designing such amplifiers the usual aim is to obtain the greatest possible voltage amplification: "the width of the undistortedly amplified frequency band is less considered. Closer consideration shows that the usual normal working conditions are in opposition to the greatest possible widening of this undistorted frequency band." His investigation leads to the following procedure for the calculation of such an amplifier, required to amplify without distortion the band $f_1 - f_2$:—first calculate f_{\max} from the equation $f_{\max}^2 = f_1 \times f_2$. Then determine R_p and C_e (the effective grid leak and intervalve coupling condenser) from the equation

$$f_{\max}^2 = \frac{I}{2\pi R_p R_c C_e}$$

where C stands for

$$C_a + C_{g2} + \frac{C_a C_{g2}}{C_c}$$

and is taken as equal to $50 \mu\mu F$. The equation

$$f_1 - f_2 = \frac{\epsilon}{2\pi R_c C}$$

(giving the breadth of the undistorted band) checks whether the desired band will be amplified without distortion and by how much per cent. the magnification at the limits of the band falls below the maximum magnification; ϵ is to be found from the equation

$$\epsilon^2 = \frac{I}{\left(1 - \frac{P}{100}\right)^2} - I,$$

where

$$P = \left(1 + \frac{C_{g2}}{C_c}\right) \left(\frac{I}{R_t} + \frac{I}{R_a}\right) + \left(1 + \frac{C_a}{C_c}\right) \frac{I}{R_p}$$

The special case of the d.c. amplifier is similarly treated.

TRANSMISSION.

FREQUENCY MODULATION.—B. van der Pol. (*Proc. Inst. Rad. Eng.*, July, 1930, Vol. 18, pp. 1194-1205.)

English version of the paper dealt with in May Abstracts, p. 275.

EINIGE BETRACHTUNGEN ZUM PROBLEM DER FREQUENZMODULATION (Some Considerations regarding the Problem of [unwanted] Frequency Modulation).—A. Heilmann. (*E.N.T.*, June, 1930, Vol. 7, pp. 217-225.)

Author's summary:—In spite of absolute constancy of frequency in the r.f. generator, frequency modulation may occur in telephony transmitters if the modulating processes produce phase changes in the circuits between the generator and the aerial. These phase changes may be particularly great in the case of frequency multiplying circuits; they can be kept small by careful choice of values and dimensions and by the employment of special methods of connection.

The determination of any phase changing present is accomplished by measuring the frequency changes by heterodyne reception and subsequent calculation. A rapid rough way of detecting the presence of frequency modulation is possible by looking for the partial frequencies, arising from the Fourier analysis, by means of an exploring frequency. In certain cases the wave-form of the signals at the receiving station can be obtained from the frequency spectrum, allowance being made for the weakening or strengthening of particular frequencies through selective fading.

In the case of asymmetrical modulation—where the side-bands are asymmetric in phase and magnitude with respect to the carrier frequency—phase changes of the whole complex wave also take place. But since it involves no widening of the frequency band, this type of frequency modulation plays no part as regards interference fading. Cf. Ladner, under "Propagation of Waves," and Eckersley, below.

FREQUENCY MODULATION AND DISTORTION.—T. L. Eckersley. (*E.W. & W.E.*, Sept., 1930, Vol. 7, pp. 482-484.)

A note with the object of offering some explanation of the "almost devastating distortion" encountered in short-wave telephony—even over relatively short distances—unless adequate precautions are taken to prevent any frequency modulation at the transmitter. "A disconcerting feature which may lead one to fail to suspect one's transmitter is that it gives, in general, good if not perfect quality locally, *i.e.*, within a few hundred metres from the transmitter. Nevertheless, there is evidence that the main cause of such distortion is a frequency modulation varying with the amplitude of the oscillation." Obtaining the mathematical expression for an oscillation which is both frequency- and amplitude-modulated, the writer shows that local reception would not be distorted on this account, since although the whole group consisting of carrier and side waves moves to and fro along the frequency axis, the *difference*-frequencies between carrier and side waves remain constant, and it is these which are reproduced in reception. He explains the distortion encountered at greater distances as being the result of inter-action between the direct ray and the space ray arriving after one return from the Heaviside layer or—at greater distances still—after several ricochets between earth and layer; this inter-action producing, superimposed on the normal beat tones between carrier and side waves, other beat tones bearing no relation to the true modulation frequency but varying with a rapidity depending on the amplitude of the frequency excursion on either side of the mean. *Cf.* Heilmann, above.

EINIGE BETRACHTUNGEN ZUM PROBLEM DES GLEICHWELLENRUNDFUNKS (Some Considerations regarding the Problem of Common-Wave Broadcasting).—F. Gerth and W. Hahnemann. (*E.N.T.*, June, 1930, Vol. 7, pp. 226-231.)

Authors' summary:—The properties of synchronised and un-synchronised common-wave transmission are dealt with; these display important differences. In strictly synchronised transmission both linear and non-linear distortions arise, depending on the comparative field strengths of the stations at the points of reception and on the degree of modulation. As regards linear distortion, a field strength ratio of 1:2 is allowable; while the permissible ratio as regards non-linear distortion, for those unfavourable regions in the interference zone where the strength of the carrier wave is at a minimum, depends entirely on the degree of modulation and for a 30% modulation—for example—may also amount to 1:2.

If, however, in a synchronised system r.f. phase-changes and consequently also frequency-changes take place in connection with the modulation, not only is the region affected by non-linear distortion considerably extended but, in addition, non-linear distortion occurs at *favourable* spots where the carrier wave is at a maximum (*cf.* Heilmann, above).

In un-synchronised systems the region of undisturbed reception is very much narrowed by the

occurrence of "wobble" or "quaver" due to the displacements of the interference lines at the receiving point in rhythm with the frequency difference between the transmitters; this trouble only becomes bearable when the field due to one station is at least 10 times as great as that due to the other station.

From these considerations it is concluded that the synchronised system, with all its necessary complications, is only fully justifiable if r.f. phase modulation is kept down to such a point that the resulting frequency modulation is at least no larger than the inconstancy of frequency inherent in un-synchronised systems.

MODULATION OF H.F. CURRENTS BY BRIDGE CONNECTION OF RING TRANSFORMERS.—(German Pat. 496457, Mandelstam and Papaleni, pub. 22nd April, 1930.)

For theoretical and practical diagrams, see *Zeitschr. f. hochf. Tech.*, July, 1930, p. 30.

THE MARCONI SPEECH CONTROL EQUIPMENTS FOR BROADCASTING.—Marconi Co. (*Marconi Review*, Aug., 1930, pp. 8-24.)

SOME POSSIBILITIES OF INTELLIGENCE TRANSMISSION WHEN USING A LIMITED BAND OF FREQUENCIES: DISCUSSION. F. E. Terman; E. H. Felix. (*Proc. Inst. Rad. Eng.*, July, 1930, Vol. 18, pp. 1263-1265.)

Argument on the broadcasting section of the paper dealt with in April Abstracts, p. 212. Felix maintains that synchronised chain broadcasting can only be a minor palliative; Terman defends his position.

SHORT WAVE TRANSMISSION FROM MORE THAN ONE TRANSMITTER ON A COMMON MAST.—(German Pat. 494223, Lorenz, pub. 3rd April, 1930.)

By suitably choosing the distance between the two transmitters, the interference pattern at the surface of the earth can be so arranged as to give maximum strength at a desired receiving station. The radiation can be improved by the use of good conductors (*e.g.*, wire netting) on the ground near the aerials.

"MUSICAL THUNDER" IN SHORT WAVE BROADCASTING WITH 35 KW. (*Sci. News-Letter*, 16th Aug., 1930, Vol. 18, p. 105.)

Before steps were taken to increase the thickness of the wire and to place large hemispheres at its two ends, brilliant corona flashed and wavered round the aerial at Schenectady when the power was raised to 35 kw. and the carrier wave was modulated. The corona started generally about 4ft. from the wires and shot upwards about the same distance; its fluctuations set up air vibrations like thunder which more or less accurately reproduced the music.

DER MECHANISMUS DER BARKHAUSENSCHWINGUNGEN (The Mechanism of the B.-K. Oscillations).—H. G. Möller. (*E.N.T.*, August, 1930, Vol. 7, pp. 293-306.)

Further development of the work dealt with in

March Abstracts, p. 157, in which the writer explained how the unsystematic medley of electrons was brought into a "combined dance" by a sorting-out process at the anode. This "anode sorting" takes place when the anode d.c. potential is zero or slightly positive. B.-K. oscillations, however, may occur with a negative anode, and since at the start the positive anode swing cannot exceed the negative bias, anode sorting cannot be responsible for the setting-in of oscillation under this condition.

The present paper develops, therefore, the idea of a second type of "sorting out" process—phase sorting. In anode sorting the criterion is *energy*; in the second type, which takes place on return to the cathode, it is simply *phase*. The excitation by anode sorting is very much stronger than by phase sorting; as a consequence of this, small valves with poor emission will oscillate only for positive anode voltage. Anode current represents loss; therefore large amplitudes (not to be confused with easy oscillation) are to be expected from negative anode voltage.

Saturation is essential (*cf.* previous abstract); if a strongly emitting valve is oscillating at about 50 v. grid potential, and the heating current is gradually increased, the oscillations at first become stronger but are extinguished as soon as the space-charge zone of the characteristic is reached.

The excitation factor $D = \frac{\text{open circuit voltage}}{\text{output voltage}}$

increases with current, with valve radius and with length of swing of the electrons. If the latter item is reduced by negative anode potential, the oscillations eventually stop. The factor D falls with increasing frequency. The phase excitation factor falls with increasing grid potential, the anode excitation factor with increasing heating voltage (herein lies an advantage in separately heated cathodes).

The effect of the addition of a Lecher wire system is investigated theoretically and the resulting formulae confirmed by experiment. A paper by Helmholtz on the subject of these measurements is promised.

SCREENING ARRANGEMENTS IN ULTRA-SHORT WAVE TRANSMITTERS AND RECEIVERS. (German Pat. 495552, Lorenz, pub. 8th April, 1930.)

The d.c., low- and medium-frequency circuits are housed in a screening box away from the high-frequency valve and circuits, which are carried in a container connected to this screening box by means of a metal flexible pipe or stiff tube which encloses the connecting leads.

MULTI-VALVE GENERATING CIRCUITS FOR SHORT [ULTRA-SHORT?] WAVES. (German Pat. 495968, Esau, pub. 16th April, 1930.)

Patent 444194, to which this is an addition, deals with a transmitter in which the anodes and grids of two valves are inter-connected and the connecting wires bridged by a condenser. Here this arrangement is extended to a number of valves—*cf.* last paragraph of Dennhardt abstract, Sept. Abstracts, pp. 505–506.

TRANSMISSION RADIOTÉLÉPHONIQUE SUR ONDES DE 17 CM. DE LONGUEUR (Telephony on 17 cm. Waves).—C. Gutton and E. Pierret. (*Comptes Rendus*, 18th Aug., 1930, Vol. 191, pp. 313–314.)

The oscillator used was that described by Pierret (1928 Abstracts, p. 465) modulated by means of a transformer inserted in the anode circuit. A TMC valve was employed, with anode voltage -36 v. and grid voltage $+280$ v. The current in the grid circuit was 0.04 A. The aerial, 4 cm. long, lay on the focal line of a cylindrical-parabolic mirror of

focal distance $\frac{5\lambda}{4}$. The height of the mirror was

equal to λ and the opening was 60 cm. wide. The receiver was the quasi-super-regenerative type dealt with rather fully in January Abstracts, p. 43. The quenching frequency corresponded to a 20 m. wavelength. A mirror similar to the transmitter mirror was used.

"Clear and normal" telephony was possible over 6.8 km.; telegraphic signals were not much stronger. At 1.8 km., telephony was very loud and the transmitter mirror could be dispensed with. During these tests the apparatus was never raised more than 1.2 m. above the flat damp ground; the proximity of the ground did not weaken the signals as it does for waves of a few metres. No interference of any kind was found in the reception; an aeroplane in the neighbourhood of the receiver did not produce any ignition interference.

FURTHER EXPERIMENTS ON ULTRA-SHORT WAVES. D. V. Gogate and D. S. Kothari. (*Indian Journ. of Phys.*, No. 5, Vol. 4, 1930, pp. 349–358.)

A special French valve was used for these researches on waves above 3 m.; the usual adjustable parallel wires were employed, one to the grid and one to the anode, their far ends being bridged by a 0.003 μ F. condenser. Measurements were made on an inductively coupled Lecher wire system. For small changes in the length of the oscillatory inductance, the relation $\Delta\lambda/\Delta l \approx 4$ was found. The conditions for oscillation were established as

$r < \frac{L\mu}{(C_1 + C_2)r_i}$, where r is the resistance of the

oscillatory circuit, r_i the internal resistance of the valve, C_1 and C_2 the capacities filament-anode and filament-grid, and μ the amplification factor.

Measurement of Grid-Anode Capacity. An expression is given for determining the grid-anode capacity in terms of the length of the wires of the oscillatory circuit, its capacity, and the measured wavelength. For the valve in question it was 7.9 cm. A second method of determining this grid-anode capacity is to couple two completely identical oscillatory circuits together through this capacity; by this arrangement a shorter wavelength is obtained than by the usual connection—a result which the writers investigate with the help of an equivalent circuit. By measuring this wavelength, and that produced when one of the two circuits is disconnected, the grid-anode capacity can be measured.

ULTRA-SHORT WAVES FOR LIMITED RANGE COMMUNICATION.—W. J. Brown. (*Proc. Inst. Rad. Eng.*, July, 1930, Vol. 18, pp. 1129-1143.)

Experiments on short distance communication on 2 m. waves are described, together with details of the symmetrical two-valve transmitter and the super-regenerative receiver. In the latter, special methods of tuning were employed; a variable condenser, however small, was considered undesirable on account of the wish to keep the L/C ratio as high as possible, and the four parallel wires connecting the two valves were therefore made adjustable by designing each in the form of an elongated upright U. This U consisted of two straight rods with their lower ends dipping into mercury in an ebonite U-tube. The quenching frequency used was 300,000 cycles/sec. The U-form of oscillatory circuit was also employed in the transmitter, to reduce the radiation other than that from the half-wave aerial. The anode supply to the transmitter was at 500 v., frequency 400-500 cycles/sec., the average current being 50 ma.

Very strong (R₀) signals were received over 12 miles across sea—longer ranges could not be tried. In open country the range varied with topographical conditions from 4 to 20 miles. "Contrary to a popular belief, it was not necessary that the transmitter should be visible from the receiver; the average height of the line of transmission and the slope of the ground appeared to be the determining factors. Reception could be carried out even inside sheet-steel structures. . . ."

The effects of a parabolic reflector are described; also tests in a city, where with the transmitter at ground level reception was possible in the streets up to one mile, or two miles when the transmitter was raised 50 ft.; street-car overhead wires had no very serious effect, but street railroad bridges cast a distinct shadow. The paper then deals with various possible applications, great importance being attached to the non-return (assumed from the work of Hoyt Taylor and T. L. Eckersley) of such waves from the Heaviside layer, and the consequent definite limitation of range at will (*cf.* Gerth and Scheppmann, 1929 Abstracts, p. 203). In view of the advantage of raising the transmitter and its aerial (*e.g.*, to the mast-head on board ship), the writer has enclosed the whole transmitter in a copper container of tubular form *which itself acts as the antenna*.

Increase of transmitter power, when using ordinary valves, leads to difficulties in the seals; these have been largely overcome by enclosing the oscillatory circuits in the same evacuated envelope as the valve electrodes; with this arrangement an output of 100 w. has been obtained at 2 m. wavelength.

ÉTUDE DU FONCTIONNEMENT DE L'ARC ÉLECTRIQUE EN GÉNÉRATEUR D'OSCILLATIONS ÉLECTROMAGNÉTIQUES (Study of the Functioning of the Electric Arc as a Generator of Electromagnetic Oscillations).—F. Dacos. (*Bull. de l'Assoc. d. Ing. de l'Inst. Électrot. Montefiore*, March-April, 1930, Vol. 8, pp. 34-59.)

RECEPTION.

SOME MEASUREMENTS ON OPTIMUM HETERODYNE.—J. F. Herd. (*E.W. & W.E.*, Sept., 1930, Vol. 7, 493-499.)

A paper giving and discussing extensive experimental results on optimum heterodyne in c.w. reception (using anode rectification) which are in good agreement with the theory given by Appleton and Miss Taylor. With the optimum value of heterodyne voltage "the audio-frequency output varies linearly with small input signal voltages, while the output from small signals may readily be several hundred times that which would accrue with a heterodyne voltage equal to the small signal. The use of such an optimum heterodyne may tend to equalise the performance, as rectifiers, of valves which appear fairly widely different in details of their rectifying characteristics, while, even with a single valve, the use of optimum heterodyne affords a comparative latitude of adjustment to mean grid potential to the point of rectifying curvature. The advantages quoted above are of practical importance in most applications of the heterodyne principle, *e.g.*, the reception of signals, especially of weak signals, frequency-changing methods generally, including supersonic-heterodyne reception, audio-frequency sources employing the beat principle, etc., and in the homodyne or zero-beat method of reception of modulated signals." When the two-stage audio-frequency amplifier following the detector was of the transformer-coupled type, certain effects were observed (varying with the voltage-ratio of the particular transformer used) "which suggest features of transformer performance that are worthy of further investigation."

LOCATING RADIO INTERFERENCE WITH THE OSCILLOGRAPH.—J. K. McNeely and P. J. Konkle. (*Proc. Inst. Rad. Eng.*, July, 1930, Vol. 18, pp. 1216-1225.)

Authors' summary:—"Certain kinds of radio interference travel many miles over wires and cause trouble in radio reception. Often this interference originates on one system which is coupled to another, and, because of complaints, the interference investigation is started from a point near the second system. The usual methods of locating the trouble are not very effective in such cases. The oscillographic method analyses the interference more exactly, giving its magnitude, frequency, and phase position. It is also shown that various types of interference give characteristic patterns on the oscillogram and a number of oscillograph records are included illustrating common disturbances found in radio reception. It is thus possible to point out when the interference at two widely separated points originates at a common source." Examples given include records of interference caused by a vibrator-type battery charger, a violet-ray appliance, a cut-out with arcing contact, etc.

AUTOMATIC RECORDING OF WAVES FROM BROADCAST STATIONS.—U.S. Bureau of Standards. (*Tech. News Bull., Bur. of Stds.*, July, 1930, No. 159, pp. 67-68.)

Outline of an equipment, in use now for several

months, for making regular continuous measurements of the field intensity due to a broadcasting station.

A fixed vertical untuned aerial picks up the signal, and a superheterodyne receiver changes its frequency to one in the intermediate range and amplifies it. The output of the receiver is automatically measured and recorded on moving scaled paper by a commercial potentiometer recorder used in a triode peak-voltmeter circuit.

In order to include day and night field intensities in the same output scale, a logarithmic relation between input and output is essential. This has been roughly attained by using a single stage of screen-grid amplification in front of the superheterodyne receiver, and by having the potential of the screen grid controlled by the recorder mechanism in such a way as to reduce the amplification of the set as the input voltages are increased. The present calibration of the output scale covers all but the highest signal peaks.

SPACED RECEIVER RECEPTION FOR FADING ELIMINATION: REDUCTION OF ATMOSPHERICS.—(German Pat. 494222, R.C.A., pub. 24th March, 1930.)

In ordinary spaced receiver reception, those receivers which momentarily yield no signals still contribute their full share of atmospherics. The invention obviates this by making each receiver automatically controlled as to amplification by the strength of the incoming signals.

TENDANCES ACTUELLES DANS L'ÉTUDE DES RADIO-RÉCEPTEURS COMMERCIAUX (Lines of Development of Commercial Radio Receiving Stations).—E. M. Deloraine. (*Bull. d. l. Soc. franç. d. Elec.*, Sept., 1930, Vol. 10, pp. 965-972.)

A short survey.

SINGLE VALVE LOUD SPEAKER SET.—W. I. G. Page. (*Wireless World*, 6th August, 1930, Vol. 27, pp. 119-120.)

Describing a suitable circuit arrangement whereby the A.C.-pentode type of valve can be used as a detector-power amplifier, giving approximately 350 milliwatts when fed with a signal of 5 volts, *i.e.*, a power capable of operating a loud speaker.

THE REGIONAL ONE.—W. I. G. Page. (*Wireless World*, 13th August, 1930, Vol. 27, pp. 138-142.)

Constructional description of a batteryless one-valve loud speaker receiver embodying an indirectly heated pentode as power grid detector. A ganged band-pass filter with capacity coupling is employed.

A REMOTE CONTROL TUNING UNIT FOR THE MODERN RADIO RECEIVER.—N. Bishop. (*Rad. Engineering*, Aug., 1930, Vol. 10, pp. 31-32 and 39.)

Illustrated description of a balanced bridge method.

AUTOMOBILE RADIO RECEIVERS.—A. V. Nichol. (*Rad. Engineering*, Aug., 1930, Vol. 10, pp. 23-27.)

Besides the actual receiver, the aerial system is considered carefully, and a long section deals with the elimination of interference from the electrical systems of the car. Resistors (of a special type) in the ignition leads have proved most valuable.

EFFECTIVE SCREENING, PART I.—R. L. Smith-Rose. (*Wireless World*, 27th August, 1930, Vol. 27, pp. 190-192.)

The theoretical reasons for the inclusion of screening in receiving sets.

ALL D.C. THREE.—H. B. Dent. (*Wireless World*, 20th and 27th August, 1930, Vol. 27, pp. 158-162 and 197-202.)

A batteryless receiver for amateur construction in which both filament and anodes derive their current from D.C. mains.

BAND PASS UNIT.—W. I. G. Page. (*Wireless World*, 27th August, 1930, Vol. 27, pp. 186-189.)

Constructional details of a ganged band pass capacity-coupled filter with single-dial control, specially designed for detector-L.F. sets. The filter forms the sole tuning device in the receiver. Curves are given showing the common coupling capacity required to give a constant peak separation of 10 kilocycles.

LE STÉNODE RADIOSTAT (The Stenode Radiostat).—G. Teyssier: W. Reisser. (*QST Franç.*, Sept., 1930, Vol. 11, pp. 38-40.)

An article by the first writer based chiefly on a paper by the second in *Der Deutsche Rundfunk*, dealing with a demonstration given to him in London.

STENODE RADIOSTAT, DAS ENGLISCHE WUNDERGERÄT, IN KRITISCHER BELEUCHTUNG (The Stenode Radiostat, the English Wonder-Worker, Critically Examined).—W. Runge. (*Die Sendung*, 19th Sept., 1930, Vol. 7, pp. 602-604.)

RESPONSE CURVES.—C. F. Jenkin. (*Wireless World*, 20th August, 1930, Vol. 27, pp. 163-166.)

A simple method for measuring experimentally the response curve of a particular receiver. The set is left tuned to a broadcasting station or other transmitter of known wavelength, the tests being conducted when the transmitter is silent. A local oscillation generator is tuned to the same frequency and then detuned by small amounts up and down, milliammeter readings being taken in the plate circuit of the detector. The milliammeter readings are plotted as ordinates and the dial readings of the auxiliary condenser of the generator as abscissæ.

ADAPTATION OF SCREEN-GRID SETS TO USE OF THE PENTODE.—F. S. Huddy. (*Rad. Engineering*, March, 1930, Vol. 10, p. 36.)

THE DEPENDENCE ON FREQUENCY OF THE RESISTANCE-CAPACITY AMPLIFIER.—Wigge.

(See under "Properties of Circuits.")

SHOT AND THERMAL EFFECTS IN RADIO RECEIVERS.—Ballantine.

(See abstract under "Valves and Thermionics.")

A SUPER-REGENERATIVE RECEIVER FOR 2 M. WAVES.—Brown.

(See abstract under "Transmission.")

DESIGN AND USE OF APPARATUS FOR TESTING RADIO RECEIVERS: ENGINEERING CONTROL OF RADIO RECEIVER PRODUCTION.—Farnham and Barber: Graham and Olney.

(See abstracts under "Measurements and Standards.")

PROPOSED STANDARD TESTS OF BROADCAST RADIO RECEIVERS.—Inst. Rad. Eng.

(See under "Measurements and Standards.")

AERIALS AND AERIAL SYSTEMS.

RADIATION FROM A SHORT WAVE VERTICAL AERIAL.—T. L. Eckersley. (*Marconi Review*, Aug., 1930, pp. 1-7.)

The effect of the earth on the vertical polar diagram and on the radiation efficiency of a short wave vertical aerial is discussed. Calculation applied to experimental data obtained with such an aerial leads to a value of only 18.8% for the radiation efficiency. "This is a surprisingly small value, and depends to a certain extent on the assumed values of the earth's inductivity and conductivity. No reasonable alteration of these would materially affect the results, and we may feel confident therefore that in the particular case measured the radiation efficiency is only of the order of 20%. Some doubt as to the generality of this result may be entertained. It is possible, for instance, that there were large local dielectric losses in the wooden masts and support to the measured resistance. A theoretical calculation of the power wasted in the earth is therefore of value as a check." For this, Sommerfeld's analysis forms a starting point for the theoretical analysis, two methods being outlined: they both appear to confirm the previous result.

The analysis of the first method (calculating the electric and magnetic forces at the surface of the earth, forming the product $\frac{1}{4\pi} \cdot E_{\lambda} H_{\lambda}$, and integrating this over the surface of the earth) is not yet complete, "but one result of importance emerges which can be stated without carrying out the full integration. It is that the earth loss decreases with the height of the aerial above the ground. . . . To reduce the loss to one-tenth of its surface value, the aerial must be raised to 3.5 wavelengths above the surface of the earth. With the earth's resistivity increased tenfold the necessary height is 1.1λ, so that in practice between 1 and 3 wavelengths' height is necessary to obtain good radiation efficiency." Certain tests are referred to which confirm these conclusions.

STRAHLUNGSMESSUNGEN AN KURZWELLEN-RICHT-ANTENNEN DER GROSSFUNKSTELLE NAUEN (Radiation Measurements on the Short Wave Beam Aerials of the Nauen High Power Station).—M. Bäumlner, K. Krüger, H. Plendl and W. Pfitzer. (*Zeitschr. f. hochf. Tech.*, July, 1930, Vol. 36, pp. 1-13.)

An account of an experimental investigation into the radiating characteristics of a 64-element system; the field-strength measurements were taken partly on the ground and partly in an aeroplane. The measuring apparatus is described, stress being laid on the elimination of antenna-effect in the frame aerial by a push-pull arrangement and the connection of the point of symmetry of the frame to the filaments. In the aeroplane tests the frame is replaced by a dipole.

The polar diagrams and the rectangular co-ordinate characteristics obtained by these tests are compared with those obtained by calculation. For the horizontal radiation the agreement is good. For the vertical radiation, two limiting cases were calculated, for a non-reflecting and for a completely reflecting earth. The measured characteristics agree well with the second case, and it is assumed from this that the earth's surface under the conditions obtaining at Nauen possesses a very high reflecting power. "The results show that the radiated energy is being sharply concentrated in the desired directions both in the horizontal and vertical planes" [in the latter, the maximum is at 10°].

Similar measurements now being made on a 192-element system already show that this system gives still sharper concentration.

AERIAL SYSTEM FOR TWO BEAMS AT AN ANGLE.—(German Pat. 493877, Telefunken, pub. 12th March, 1930.)

See *Zeitschr. f. hochf. Tech.*, July, 1930, p. 31.

DIRECTIONAL MULTI-AERIAL RECEPTION WITH DELAY NETWORKS ACTING ON AN INTERMEDIATE FREQUENCY.—(German Pat. 494925, Lorenz, pub. 3rd April, 1930.)

For ease of phase-adjustment the high frequency is converted into intermediate frequency by heterodyning.

SPACED RECEIVER RECEPTION FOR FADING ELIMINATION: REDUCTION OF ATMOSPHERICS.—R.C.A. Patent. (See under "Reception.")

VALVES AND THERMIONICS.

COLD VALVES: A PRACTICAL PHOTOELECTRIC VALVE WITH NO FILAMENT.—M. von Ardenne. (*Wireless World*, 3rd September, 1930, Vol. 27, pp. 214-216.)

An article on the second of the two types of cold cathode valve referred to in October Abstracts, p. 571, which has been developed in the writer's laboratories. On account of their minute emission these valves (which at present have a potassium cathode of several square centimetres area, sensitised by hydrogen) only give satisfactory results in conjunction with very high anode resistances. Characteristic curves (anode current/grid voltage)

are given for an anode resistance of 10 megohms, under working conditions; in one case the emission is produced by sunlight (the curve rising from 3-4 μA . to 13-14 μA), in the other by a 50 c.p. lamp (curve rising from 1 μA . to 4 μA .); the failure of the curve to fall to zero is probably due to the grid and anode being contaminated with photoelectric material during the construction of the cathode (cf. Olpin, under "Phototelegraphy.") In spite of this defect, in the first case a voltage amplification of 30, in the second of 10, was obtained per stage; the latter value was improved to 16-17 for a valve constructed by a different process. Grid current curves are also shown; these have a shape which indicates that grid current will have no appreciable influence on amplification. "The results obtained make it quite clear that the use of these cold valves in a low-frequency amplifier is already a very practical proposition."

It was found that a 50 c.p. half-watt lamp fed from the a.c. mains fluctuated in brightness by about 5%; therefore, although such a lamp was quite satisfactory when lit by d.c. mains, for a.c. it had to be replaced by a motor car head lamp bulb, which had so much greater a temperature inertia that its fluctuations were ten times smaller. Experiments were also made with a glow discharge, either in the same bulb or very near to it, as the source of illumination.

A 3-stage voltage amplifier, with its single illuminating lamp, is shown; it gives a magnification of 10 per stage, without valve noise or microphonic ringing. "Although it is not at present intended to produce these valves commercially, it is very possible that, by introducing a more efficient photoelectric cathode (for example, one using caesium) and by developing suitable methods of production, they may become of importance in the future."

The writer ends with a reference to the first type of cold cathode valve referred to in the October abstract. This glow-discharge valve has been developed by G. Seibt.

RÖHREN OHNE HEIZUNG (Cold Cathode Valves).—M. v. Ardenne. (*Die Sendung*, 29th Aug., 1930, Vol. 7, pp. 552-553.)

See above.

GLOW-DISCHARGE COLD-CATHODE VALVE.—G. Seibt. (See end of von Ardenne abstract, above.)

TWO KINDS OF PENTODES [THE EUROPEAN "POWER" PENTODE AND THE NEW "SCREEN GRID" PENTODE].—K. Kenney. (*Electronics*, April, 1930, pp. 40-41.)

In the screen-grid pentode the third grid lies between filament and control-grid, has a positive potential and acts as a space-charge grid increasing the mutual conductance. This pentode cannot be used as a power-output valve, but "it promises to be a very fine audio amplifier and may become a standard detector."

THE POWER PENTODE: ITS CHARACTERISTICS AND APPLICATIONS.—B. V. K. French. (*Electronics*, April, 1930, pp. 12-14 and 58.)

A DRY-CELL SCREEN-GRID TUBE: THE APPLICATION OF SCREEN-GRID TUBES TO RURAL AND SMALL PORTABLE RECEIVERS.—A. B. Du Mont. (*Rad. Engineering*, March, 1930, Vol. 10, pp. 34-35.)

THE PENTODE TUBE; COMPARATIVE CHARACTERISTICS OF THE TRIODE AND PENTODE, AND THE APPLICATIONS OF THE LATTER.—K. Henney and H. E. Rhodes. (*Rad. Engineering*, March 1930, Vol. 10, pp. 25-29.)

The paper is followed by a discussion (pp. 29-30 and 44) in which various speakers give their ideas as to the lines on which this valve should be developed.

THE REVOLVING-GRID VALVE.—A. B. Du Mont. (*Sci. News-Letter*, 30th Aug., 1930, Vol. 18, p. 135.)

Illustrations and brief description of the valve referred to in Oct. Abstracts, p. 571. The cylindrical suspended grid has a series of vertical slots, on the outside of each of which is a small slanting blade; the electrons impinging on these blades drive the grid round. Voltages used are "of the same order as those used in radio equipment."

SPECIAL TRANSMITTER VALVE, WITH ENCLOSED OSCILLATORY CIRCUITS, FOR 2 M. WAVES.—Brown.

(See abstract under "Transmission.")

MEASUREMENT OF GRID-ANODE CAPACITY ON ULTRA-SHORT WAVES.—Gogate and Kothari.

(See abstract under "Transmission.")

SUL CONCETTO DI RESISTENZA INTERNA DI UN TRIODO (On the Conception of Internal Resistance in a Triode).—C. Rimini. (*Nuovo Cim.*, May, 1930, Vol. 7, pp. 167-171.)

FLUCTUATION NOISE [SHOT AND THERMAL EFFECTS] IN RADIO RECEIVERS.—Stuart Ballantine. (*Proc. Inst. Rad. Eng.*, Aug., 1930, Vol. 18, pp. 1377-1387.)

Author's summary:—This paper discusses fluctuation noise in radio receivers due to shot and thermal effects (Schottky) in the radio-frequency circuits. The r-f noise components beat with the carrier when a signal is being received and are transformed to audio components which are heard as a hissing noise.

The mathematical theory for a receiver employing a square-law detector is given, and it is shown that the deflection of a meter measuring the average square of voltage or current due to the noise is proportional to the area under the curve representing the square of the over-all transmission against frequency. The over-all transmission is somewhat analogous to the over-all fidelity of the receiver. This result is similar to the well-known laws for simple linear networks without frequency transformation.

The method of calculating the noise due to the shot and thermal effects is discussed.

Finally a convenient method of measuring the specific noise (noise per frequency interval) in

a radio receiver is described, and results for several typical commercial receivers are given. The method consists in comparing the noise, as referred to the antenna circuit, with the amplitudes of the side bands, mE_0 , in a standard modulated signal.

STUDIES OF ABNORMAL SHOT EFFECT IN GASEOUS DISCHARGES.—J. S. Donal, Jr. (*Phys. Review*, 1st June, 1930, Series 2, Vol. 35, No. 11, pp. 1430-1431.)

Abstract only.

WORK FUNCTIONS AND THERMIONIC CONSTANT "A" DETERMINED FOR THORIATED TUNGSTEN.—W. B. Nottingham. (*Phys. Review*, 15th July, 1930, Series 2, Vol. 35, No. 2, p. 376.)

THERMISCHE ELEKTRONENEMISSION UND THERMOKRAFT (Thermal Electron Emission and Thermoforce).—M. v. Laue and G. Siljeholm. (*Naturwiss.*, 29th August, 1930, Vol. 18, No. 35, pp. 764-765.)

A thermodynamical investigation of the connection between the variations of the thermal electron emission from iron in the neighbourhood of the transition point from β -ferrite to γ -ferrite and the variations of the thermoforce, referred to platinum as the standard, during the change.

ANODE RAYS OF SODIUM, POTASSIUM, CALCIUM AND BARIUM.—A. Poirot. (*Comptes Rendus*, 24th March, 1930, Vol. 190, pp. 735-736.)

SUR L'ÉMISSION POSITIVE DU PALLADIUM (The Positive Emission from Palladium).—M. Wolfke and J. Rolinski. (*C.R. Soc. Polon. de Phys.*, No. 4, Vol. 4, pp. 353-356.)

Chemically clean palladium heated in a vacuum gives at first a strong emission, which falls to zero after 10-30 hours at 1200° C. It can then be reactivated in various ways, a particularly good one being to saturate it with electrolytic hydrogen.

DIRECTIONAL WIRELESS.

AIRCRAFT RADIO RESEARCH.—U.S. Bureau of Standards Notes. (*Journ. Franklin Inst.*, July, 1930, Vol. 210, No. 1, pp. 113-114.)

The use of a short vertical antenna on the central supporting mast of the loop aerials is being developed for the adjustment of the directions of the courses produced by range beacon transmitters to fit airways intersecting at any angles, the aim being to change from the simple 90° or 180° adjustments to other angles without material loss of distance range.

In the development of the radio system for blind landing a runway localising beacon and a high-frequency landing beacon transmitter have been placed at one end of the flying field with the localising beacon course and the landing beam directed along the major runway of the field. A marker beacon is installed at the other end of the field. By adjusting the angle and transmitting power of the high-frequency landing beacon an airplane may be guided along the proper gliding path to the field and may land on the proper point on the runway.

To facilitate the use of the runway localising beacon, a device suitable for automatically controlling the intensity of the receiving set output signals is being developed. The aural type of marker beacon seems preferable.

AIRCRAFT RADIO RESEARCH [CENTRAL ZERO INDICATING INSTRUMENT IN PLACE OF REED INDICATOR: SIMULTANEOUS TELEPHONY AND RADIOBEACON SIGNALS ON SAME CARRIER FREQUENCY].—U.S. Bureau of Standards. (*Tech. News Bull., Bur. of Stds.*, July, 1930, No. 159, pp. 68-69.)

(i) A central zero instrument is being tested against the usual reed indicator for use in connection with the runway localising beacon.

(ii) The carrier power and power for the speech side-bands are supplied in the usual way by a 2 kw. transmitter feeding into an efficient open-type aerial, thus providing plenty of telephony radiation. The master oscillator of the telephony transmitter also serves as master oscillator for the radiobeacon transmitter. The carrier wave is suppressed in the final power stages of the latter, only the side-bands being transmitted by the loop aerials. The carrier necessary at the receiving end for beating with these side-bands is supplied by the open aerial. Since the loop aerials only transmit side-bands, the power amplifier stages of the beacon transmitter may employ 500 w. only (instead of 1 kw. as required in the present system) and still provide plenty of radiation.

MINIMUM POWER REQUIREMENTS FOR RUNWAY LOCALISING BEACON.—U.S. Bureau of Standards. (*Tech. News Bull., Bur. of Stds.*, August, 1930, No. 160, p. 82.)

The required range of about 10 miles is obtained, with some margin to spare, with only 100 w. in each loop aerial. Hitherto 250 w. has been used, and the reduced value considerably simplifies the circuit arrangements and reduces the cost of the installation by fully 25%.

AUTOMATIC VOLUME CONTROL FOR RADIOBEACON RECEIVERS, AND DISTANCE INDICATION BY ITS MEANS.—U.S. Bureau of Standards. (*Ibid.*, same page.)

The control is by rectifying the output voltage and applying the rectified voltage as negative bias on the grids of the r.f. valves, so that increasing input voltages are accompanied by increasing negative bias on the latter. A d.c. milliammeter reading plate-current supply will therefore show smaller deflections as the aeroplane approaches the beacon. Tests show that this device is particularly useful on the runway localising beacon for blind landing, as it tells the pilot at once whether he is approaching or going away from the landing field.

LA "NAVIGATION PHYSIQUE" MARITIME OU AÉRIENNE ("Physical Navigation" for Ships or Aircraft).—L. Lecornu: W. Loth. (*Science Moderne*, April, 1930; summary in *Génie Civil*, 23rd Aug., 1930, Vol. 97, p. 194.)

An article by the first named on the work and proposals of the second named, dealt with in

Abstracts, Jan., p. 47; Feb., p. 104 (2); and April, p. 217. The article ends with a reference to a "fog compass" and a "magnetic look-out," by which all danger of collision between ships would be avoided.

ACOUSTICS AND AUDIO-FREQUENCIES.

ÜBER EINE VOLLAUTOMATISCHE NACHHALMESS-VORRICHTUNG (A Completely Automatic Measuring Apparatus for Reverberation Times).—M. J. O. Strutt. (*E.N.T.*, July, 1930, Vol. 7, pp. 280-282.)

In the final arrangement described, the a.c. voltage from microphone and amplifier is applied to a resistance of 10^4 ohms, and one hundredth part of the voltage is taken off to a three-electrode valve. In addition to this, the whole voltage (about 400 v.) is applied to a second valve. To prevent over-loading of this valve the heating current is diminished. The anode current of the first valve energises a relay which sets a clock going directly the grid voltage sinks below a certain value, while the second valve similarly energises a second relay and stops the clock when its grid voltage sinks below another value. In this way the clock directly indicates the time during which the sound strength falls to one ten-thousandth part of its original value. Cf. Meyer, Sept. Abstracts, pp. 512-513.

ON THE MEASUREMENT OF THE SOUND TRANSMISSION OF A PARTITION.—A. E. Knowler. (*Phil. Mag.*, Aug., 1930, Series 7, Vol. 10, No. 63, pp. 342-344.)

A short description of a method of measuring the sound transmission of a partition separating two rooms *A* and *B* by placing a moving-coil loud-speaker in *A* and reducing the current i_1 through it until the sound is just audible in *B* and reducing the current i_2 until the sound is just audible in the same room. The whole experiment is then repeated with the observer in *A* (currents i_3 and i_4) and the reduction of the wall is found to be given by $10 (\log_{10} i_1 + \log_{10} i_3 - \log_{10} i_2 - \log_{10} i_4)$. Typical experimental results are given.

ÜBER DIE UNTERSUCHUNG VON SCHALLDÄMPFENDEN KÖRPERN (The Investigation of Sound-Damping Bodies).—H. Tischner. (*E.N.T.*, June, 1930, Vol. 7, pp. 236-247.)

In a previous paper (*ibid.*, May, 1930, p. 192) the writer dealt with the damping of sound-waves in tubes, the variation of the sound-pressure at the end of the tube with the length of the tube being determined by a compensation method. He now uses the same method for measuring the effects of a number of sound-absorbing materials arranged first parallel and then normal to the axis of the tube.

CONTACT RESISTANCE AND MICROPHONIC ACTION.—F. Gray. (*Phys. Review*, 15th July, 1930, Series 2, Vol. 36, No. 2, p. 375.)

From the Bell Telephone Laboratories. Abstract only. A mathematical theory is developed to explain the fact that conductivity of a contact between two carbon spheres changes with the

force pressing the spheres together. The relation found between the contact resistance *R* and the contact force *F* is $R = A/F^k + B/F^l$, where *A* and *B* are constants. Surface roughness behaves almost identically with a non-variable, high-resistance film. Higher degrees of roughness increase the exponent of the last term. In the limit it becomes unity and the roughness resistance then varies inversely as the contact force.

CONTACT RESISTANCE AND MICROPHONIC ACTION.—F. S. Goucher. (*Phys. Review*, 15th July, 1930, Series 2, Vol. 36, No. 2, p. 375.)

From the Bell Telephone Laboratories. Abstract only. Previous work (Oct. Abstracts, p. 574), has shown that the conducting portions of contacts between single granules of microphone carbon are of the nature of carbon and that variations in contact area occur when the contact resistance is varied in a reversible resistance force cycle. An experimental study of the slopes of these reversible characteristics both for single contacts and aggregates shows them to be of the form $R = \text{const.} (F)^{-n}$. The exponent *n* varies from cycle to cycle for equal force limits, and the average value depends on the force limits. A maximum mean value independent of the force limits over a wide range is obtained with the aggregates. This value is in agreement with the exponent in the second term of Gray's equation [preceding abstract], which indicates that an aggregate of contacts may, under certain conditions, behave as though it were a single contact between spheres having a rough surface. Values of *n* less than $\frac{1}{2}$ are obtained with both single contacts and aggregates. This is attributed to the effect of cohesive forces, the existence of which was demonstrated by the sticking of contacts.

A CONDENSER-TYPE MICROPHONE USING HIGH FREQUENCY SOURCE, AND THE CHARACTERISTICS OF THE TRIAL SET.—S. Kawazoe. (*Res. Electrotech. Lab.*, Tokyo, No. 282, May 1930, pp. 1-40.)

In Japanese. The outstanding feature is a device which obviates the necessity of tuning or semi-tuning the microphone: consequently operation is not affected by frequency variation at the source. The available frequency band is said to be one to two octaves broader than that of the Marconi-Reisz microphone, the sensitivity to be $1\frac{1}{2}$ times as high, with a current of 3 ma.; fidelity is said to be good.

EFFECT OF CAVITY RESONANCE ON THE FREQUENCY RESPONSE CHARACTERISTIC OF THE CONDENSER MICROPHONE.—S. Ballantine. (*Proc. Inst. Rad. Eng.*, July, 1930, Vol. 18, pp. 1206-1215.)

Author's summary:—"The effect of the cavity before the membrane in the usual condenser microphone is to cause an increase of pressure at the membrane over that which exists in the undisturbed (free) sound-field, particularly at high frequencies.

"An approximate theory of the effect is given and a specimen case is calculated. In this case the pressure ratio reaches a maximum of 2.5 at

3,000 cycles. Experimental values obtained with the Rayleigh disk are compared with the computations and are in general agreement. A modified design for a condenser microphone without a diaphragm cavity, and adapted for spherical mounting, is described.

"The temperature coefficient of sensitivity due to the unequal thermal expansions of a duralumin membrane in a steel mounting was found to be 0.6 per cent. per degree C. The importance of taking the cavity and reflection effects into consideration in the construction of curves showing the overall fidelity of broadcast transmitters is stressed on account of its intimate relation to the design of radio receivers for uniform frequency response." See also Oliver, June Abstracts, p. 349, and Hartmann, same page and March, p. 162.

A COMPARISON OF THE ENGINEERING PROBLEMS IN BROADCASTING AND AUDIBLE PICTURES.—P. H. Evans. (*Proc. Inst. Rad. Eng.*, Aug., 1930, Vol. 18, pp. 1316-1337.)

A paper by the Chief Engineer, Eastern Studios, Warner Brothers-Vitaphone Corporation. Its scope may be indicated by a few extracts:—To a musician with an absolute pitch ear, changes in speed of less than $\frac{1}{5}$ of 1% are readily noticeable, but fluctuations in speed of $\frac{1}{10}$ of 1% or less seem to be satisfactory. Synchronisation was one of the easiest problems; a good frequency characteristic and exceptionally uniform speed were the really difficult problems, and the latter still requires improvement in film reproduction.

Pick-up: some people claim that the best results are obtained with the microphones at about the same distance as the camera, if the sets are given the proper acoustical characteristics: "we feel that the best results are obtained by using the minimum number of microphones possible, preferably one suspended from a long cord and swung above the set by an operator . . . maintaining as nearly as possible a uniform and relatively short distance from the sound source."

Sound Record: Vitaphone uses only discs. "If, at some future date, the results commercially obtainable with film become equal to those obtained with disk, we may change to film." The writer then discusses the frequency-amplitude relations for wax and for film recording, and the effects of these relations: "in film recording, it is essential that the sounds of single frequency be recorded at a relatively low level in order to prevent overloading when complex sounds occur." But he admits that the low amplitudes of the high frequencies in disc recording lead to trouble with surface noises. By reducing, however, the amplitude of the low frequency recording, the high can be recorded at a considerably higher level and thus the ratio of sound to surface noise increased. When this was done, results in the theatre were found to be more pleasing than when the low frequencies were recorded and reproduced in their true proportion; this is due to the acoustics of the typical theatre, of which reverberation-absorption characteristics are shown.

Sound Editing; Re-recording; Improvements Desired:—"Judging from the loud speaker characteristics published by others, their response

does not extend much, if any, outside of the range of reproduction shown [for wax records]. In practice, therefore, under the best conditions it is doubtful whether any sound having frequency much above 5,000 cycles or much below 100 cycles ever reaches the audience from either disk or film recording," and the acoustics of the theatre itself appear to be the limiting factor in realising the best results obtainable with the present equipment. Further difficulties in the way of adding another octave are outlined for disc and for film systems.

TALKING PICTURES.—C. M. R. Balbi. (*Elec. Review*, 20th June, 4th, 11th and 25th July, 1930, Vol. 107.)

Deals particularly with the Vitaphone (disc) and Movietone (film) systems.

PIEZOELECTRIC CRYSTAL SHAPED TO ACT AS RECORDING OR REPRODUCING STYLUS.—(U.S. Pat., 1737253, Linsell and Rad. Corp. America, pub. 26th Nov., 1929.)

MOVING COIL LOUD SPEAKERS.—H. M. Clarke. (*E.W. & W.E.*, Sept., 1930, Vol. 7, pp. 477-480.)

THE NEW "GECOPHONE" MOVING-COIL LOUD SPEAKER.—General Electric Co. (*Electrician*, 8th Aug., 1930, Vol. 105, p. 182.)

TESTING LOUD SPEAKER MAGNETS.—T. A. Ledward. (*Wireless World*, 13th August, 1930, Vol. 27, pp. 143-144.)

A simple method of determining the flux-density of moving-coil loud speaker magnets without the aid of a ballistic galvanometer. The method requires only an ammeter, variable resistance, accumulator and a pair of scales. Use is made of the fundamental principle of the moving coil speaker itself, viz., that if a current passes through a wire placed in a magnetic field the wire will tend to move in a direction at right angles to the field. A coil of a known number of turns is therefore suspended in the gap of the magnet under test from one arm of a balance, a 5- or 10-gramme weight being placed in the opposite scale pan. By determining the pull exerted with a given current the flux density can be calculated. The formula is $H = \frac{9810F}{Il}$, where H = field strength (flux density) in lines per sq. cm., F = force in grammes, I = current in ampères, and l = length of wire in cms.

PRODUCTION TESTS ON LOUD SPEAKERS, INCLUDING ACCELERATED LIFE TEST.—Graham and Olney.

(See abstract under "Measurements and Standards.")

THE CONVERSION OF CURRENTS INTO SOUND BY BI-METALLIC STRIP.—(German Pat. 495899, Siemens and Halske, pub. 11th April, 1930.)

The bi-metallic strip (*cf.* Catterson-Smith, Aug. Abstracts, p. 467) is chosen of metals differing magnetostriictively (*e.g.*, nickel and iron) and is

surrounded by the coil in which the fluctuating current flows.

LOUD SPEAKER PARTS AS CAPACITY AREA, INDUCTIVELY COUPLED TO ACT AS RECEIVING AERIAL.—(U.S. Pat. 1737078, Elliott and Victor T.M. Co., pub. 26th Nov., 1929.)

VIBRATIONS OF A NON-PLANAR MEMBRANE [MATHEMATICAL INVESTIGATION APPLICABLE TO DYNAMICAL THEORY OF LOUD-SPEAKER VIBRATION].—G. R. Stibitz. (*Phys. Review*, 1st Aug., 1930, Series 2, Vol. 36, No. 3, pp. 513-523.)

Author's abstract:—Equations of motion are deduced for a non-planar membrane in small oscillation about any position of equilibrium. Cylindrical and conical membranes are discussed briefly as special cases; with certain types of boundary conditions there is no solution of the problem when stiffness is entirely omitted, and this is particularly true of the cone because of a characteristic singular point in the differential equations.

SUR LES COURANTS D'AIR PRODUITS PAR UNE PLAQUE OSCILLANTE (The Air Currents produced by a Vibrating Diaphragm).—J. G. Roussakoff. (*Journ. de Phys. et le Rad.*, June, 1930, Series 7, Vol. 1, pp. 206-210.)

Studies of the vibrations in the neighbourhood of a telephone diaphragm, by means of lycopodium powder suspended in the air or in water. The results are explained as due to the Bjerknes ponderomotive forces.

THE EFFICIENCY OF THE RICE-KELLOGG LOUD SPEAKER.—E. D. Cook. (*Gen. Elec. Review*, Sept., 1930, Vol. 33, pp. 505-510.)

The efficiency has been generally believed to be about 2% over the whole audio-frequency scale; this figure was obtained by estimating the force developed by the moving coil and the radiation resistance of a plunger in an infinite wall. The careful test analysis described in this paper shows that this value is too low. Two methods of measuring the efficiency are described:—(i) indirect, the quantities being measured entirely in the electrical system by a bridge method and the results checked by measuring corresponding factors in the mechanical system. The procedure is divided into three parts:—impedance measurements with cone freely radiating, the same in a vacuum, and the same with the cone blocked. (ii) The current wave in the cone coil, and the displacement of the cone as a function of time, are photographed simultaneously on a modified oscillograph. Curves are given for 6-inch and 12-inch cones. The two methods are compared in a table showing the radiation resistances obtained at different frequencies by each method: the agreement is "quite satisfactory."

CHARACTERISTICS OF BELL VIBRATIONS.—F. G. Tyzzer. (*Journ. Franklin Inst.*, July, 1930, Vol. 210, No. 1, pp. 55-66.)

EIN WATTMETER FÜR HÖRFREQUENZ (A Wattmeter for Audio-Frequencies).—E. Asch. (*Zeitschr. f. tech. Phys.*, Sept., 1930, Vol. 11, pp. 377-379.)

The principle has been described in a former paper (July Abstracts, p. 400). In the portable instrument now dealt with, suitable for frequencies between 65 and 6,500 cycles/sec., the sensitivity is 0.002 w. per gradation, with a full deflection for 10 w.

SOME PROBLEMS IN THE DISTURBANCE THEORY OF LINEAR OSCILLATING SYSTEMS.—Schubin.

(See under "Properties of Circuits.")

THE SOUNDS EMITTED BY AIRCRAFT AND THEIR RECORDING BY ELECTRICAL METHODS.—J. Obata and Y. Yosida. (*Proc. Phys. Math. Soc.*, Japan, April, 1930, Vol. 12, pp. 80-92.)

PHOTOTELEGRAPHY AND TELEVISION.

ÜBER SPERR- UND PHOTOEFFEKTE AN DER GRENZE VON KUPFEROXYDUL GEGEN AUFGESTÄUBTE METALLSCHICHTEN (On Attenuation and Photoelectric Effects at the Boundary between Cuprous Oxide and Metallic Films Superposed by Spraying).—E. Duhme and W. Schottky. (*Naturwiss.*, 15th August, 1930, Vol. 18, No. 33, pp. 735-736.)

The action of the cuprous oxide rectifier has been shown to be due to the existence at the cuprous oxide-copper boundary of an attenuating layer of ultramicroscopical thickness and resistance depending largely on the applied voltage (*cf.* past abstracts and Pélabon, under "Subsidiary Apparatus"). The question as to the existence of a similar attenuation effect at the boundary between cuprous oxide and thin metallic films superposed on it by pressure, electrolysis or spraying has been solved in the Siemens laboratories. It is found that an attenuation effect is present at the boundary between thick plates of cuprous oxide and all metals superposed either loosely or firmly and also between cuprous oxide and graphite. The attenuation resistance of the boundary is sometimes (*e.g.*, in the case of a mercury electrode on etched cuprous oxide) a thousand times as great as that of the cuprous oxide rectifier; in other cases (*e.g.*, that of a polished cuprous oxide plate with a sprayed gold electrode) it may be a thousand times smaller. It seems that the size of the surface of effective contact is of much greater importance than the material of the superposed electrode in determining the magnitude of the attenuation resistance.

The effect of light on the boundary layer is also found to be similar to its effect on the cuprous oxide rectifier and may reach a value ten times as great. The photoelectric effect in the newly investigated cells occurs, however, at the face of the cuprous oxide directly exposed to the light, in contrast to the effect occurring in the cuprous oxide rectifier. The name "anterior wall effect" (Vorderwandeffekt) is proposed for the new effect and "posterior wall effect" (Hinterwandeffekt) for that already known (V-cell and H-cell). The cell described by B. Lange (*cf.* Abstracts for May, 1930,

p. 283) makes use of the posterior wall effect, as is shown by the direction of the current.

The variation of sensitivity with the frequency of the incident light is completely different for the two effects—though the direction of the photoelectric current is the same. It appears that the photoelectric current in the anterior wall effect as originally produced is more or less independent of the voltage impressed on the cell and that the observed variations with voltage of the photoelectric current which reaches the external circuit can be very largely explained as due to the variation of attenuation resistance with impressed voltage.

The usefulness of the new photocell (V-cell) for technical applications depends on the extent to which the effect is constant as regards time. The cell is sensitive, free from background noise, and depends only slightly on the frequency, so that it seems to fill a gap in the range of applications of photoelectric cells. The effect is being investigated further.

METHOD OF ENHANCING THE SENSITIVENESS OF ALKALI METAL PHOTOELECTRIC CELLS.—

A. R. Olpin. (*Phys. Review*, 15th July, 1930, Series 2, Vol. 36, No. 2, pp. 251-295.)

An account of investigations made at the Bell Telephone Laboratories. Author's abstract:—A technique is described for sensitizing alkali metal photoelectric cells to light by introducing on to the metal surface small amounts of dielectrics, as oxygen, water vapor, sulphur vapor, sulphur dioxide, hydrogen sulphide, air, sodium bisulphite, carbon bisulphite, etc., or some organic compound as methyl alcohol, acetic acid, benzene, nitrobenzene, acetone, etc., or some organic dye as tropaeolin, rosaniline base, eosin, cyanine, kryptocyanine, dicvanine, neocyanine, etc. The marked increase in electron emission from the cathodes of cells so treated is due primarily to an increase in response to red and infra-red light. Vacuum sodium cells have been produced, yielding photoelectric currents as high as 7 microampères per lumen of white light of color temperature 2,848° K. and caesium cells yielding far greater currents.

The response of these cells is proportional to the intensity of the exciting light even for light of longer wavelengths than that to which the cell responded before treatment.

Spectral response curves are similar for all cells using the same metal as cathode. These curves differ from the curves for the pure metal by the appearance of a new selective maximum at lower frequencies. This newly appearing maximum resembles the regular maximum for the untreated metal and is always separated from it by the frequency of a well-known line in the vibration-rotation spectrum of the dielectric molecules, usually the 1.5 μ line so characteristic of oxygen-hydrogen, carbon-hydrogen or nitrogen-hydrogen linkages. The long wave limit shifts an amount agreeing with the separation of the maxima.

With a cell so designed that the cathode could be sensitized in a side chamber and then slipped into its proper place (thus keeping the anode free from light-sensitive materials), stopping potentials were obtained for electrons, liberated by monochromatic light, from a sodium cathode before and

after treating it with sulphur vapor and air. For light of wavelengths ranging from λ 3,500 Å. to λ 8,000 Å. falling on the treated cathode, the electron retarding potentials are found to vary linearly with the frequency of the exciting light, thus establishing the validity of Einstein's photoelectric equation for composite surfaces. From the slope of the straight line depicting this relationship, the value of Planck's constant h is found to be 6.541×10^{-27} , significant to three figures. An almost identical value is obtained for untreated sodium. The apparent stopping potentials, or voltages at which the photoelectric currents become zero, are the same before and after the sulphur and air treatment. The voltage at which the current just saturates is always greater after treatment than before. This is a measure of the change in contact potential of the cathode due to the presence of the sulphur and air. Changes of approximately 0.8 volt are common.

The validity of Einstein's equation precludes the possibility of explaining the new maximum in the spectral response curve for a treated surface by a "Raman shift" of the incident light frequencies, even though the separation of these maxima is equal to certain well-known vibration-rotation frequencies of the dielectric molecules. It may be that the natural frequency of the alkali metal atom is diminished by the vibration frequency of the complex atom in which it is incorporated.

The Lindemann formula for the frequency of the selective photoelectric maximum [$2\pi\nu = (ne^2/mr^3)$], primitive though it seems in the light of modern theory, has always given values for the pure metals in close agreement with experimental determinations. The n term is determined by the valence of the substance, a choice of unity being used for the monovalent alkali metals corresponding to an electron revolving around a singly charged ion. A choice of 2, 3—for divalent, trivalent—substances corresponds to electrons revolving around doubly, triply charged ions.

Under certain conditions the alkali metals manifest different valencies, such, for instance, as those exhibited by the oxide series Na_2O_2 , Na_2O , Na_3O , Na_4O . These compounds can be prepared in vacuum and are light-sensitive. Spectral response curves for such cells exhibit all the selective maxima called for by the Lindemann formula when the value of n is chosen to agree with the valence of the metal. Data are presented showing this condition to be general for the alkali metals, a maximum response to red or infra-red light being dependent upon the formation of a subvalent compound, as a suboxide.

Attention is called to seemingly analogous phenomena in the field of photoelectricity, photography, fluorescence and absorption.

A "WET" PHOTOELECTRIC CELL OR "PHOTOELECTRIC CELL."—Arcturus Company. (*Electronics*, April, 1930, p. 50.)

"The manufacturers report that this cell combines the sensitiveness of the vacuum or gas cell and the ruggedness of the liquid cell. Modulated light tests indicate no appreciable damping or phase difference as high as 10,000 cycles, and

polarisation over light intensity ranges employed in sound reproduction systems is undiscernible."

THE LOCATION OF THE E.M.F. IN THE PHOTO-VOLTAIC CELL.—Lowry.

(See under "General Physical Articles.")

E.M.F., RESISTANCE AND CAPACITANCE PHENOMENA IN PHOTOVOLTAIC CELLS CONTAINING GRIGNARD REAGENTS.—H. E. Hammond. (*Phys. Review*, 15th April, 1930, Series 2, Vol. 35, No. 8, pp. 998-1007.)

PHOTOELECTRIC OUT-GASSING.—R. P. Winch. (*Phys. Review*, 1st Aug., 1930, Series 2, Vol. 36, No. 3, p. 601.)

A preliminary communication of experiments indicating that photoelectrons from gold and silver surfaces, both when ejected and returned to the surface by a reverse field, remove adsorbed gas from the surface.

TEMPERATURE DEPENDENCE OF DIELECTRIC STRENGTH OF LIQUIDS DECREASED BY OUT-GASSING.—Inge and Walther.

(See abstract under "Subsidiary Apparatus.")

ÜBER SYSTEME MIT BESONDERS KLEINER ASYMMETRISCHER AUSTRITTSARBEIT FÜR ELEKTRONEN (On Systems with Particularly Small, Asymmetric Work Functions for Electrons).—W. Ostwald. (*Kolloid-Zeitschr.*, No. 3, Vol. 51, 1930, pp. 370-376.)

The writer calls attention to the striking resemblances, in construction and mode of action, between certain types of rectifier, contacts for heterogeneous catalysis, and photoelectric cells. There are certain systems, as $Cu + Cu_2O$ or $Pt + H_2$, which perform excellently in all three rôles (cf. Lange's photoelectric cell, June Abstracts, p. 342). A special characteristic of such systems is that they are "mixtures" (conductor + semiconductor). Their work functions are particularly small, and are also asymmetrical or oriented.

UNTERSUCHUNGEN ÜBER DEN BECQUEREL-EFFEKT (Investigations into the Becquerel Effect).—I. Lifschitz and S. B. Hooghoudt. (*Zeitschr. f. phys. Chem.*, No. 2, Vol. 146, 1930, pp. 145-172.)

THE NATURAL VIBRATIONS OF PHOTO-ELECTRIC CELLS AND THEIR EXTINCTION BY LIGHT.—E. E. Fournier d'Albe; B. L. Rosing. (*Television*, Sept., 1930, Vol. 3, pp. 281-282.)

A short illustrated summary of Rosing's paper (Sept. Abstracts, p. 515), with comments. The writer remarks that with such feeble illuminations as those mentioned "it is safe to say that no impression has been made on a telephone with a photo-cell before, and even the response of selenium has been inaudible. With this feeble working illumination it should be easy to work signal lamps for audible Morse code."

INHIBITION OF PHOTOELECTRIC EMISSION BY NEAR INFRA-RED LIGHT.—A. R. Olpin. (*Phys. Review*, 15th July, 1930, Series 2, Vol. 36, No. 2, p. 376.)

Communication from the Bell Telephone Laboratories. Abstract only.

THE RELATION BETWEEN THE NUMBER OF ELECTRONS EJECTED PHOTOELECTRICALLY FROM THE CATHODE AND THE TIME LAG OF THE SPARK.—J. A. Tiedeman. (*Phys. Review*, 15th July, 1930, Series 2, Vol. 36, No. 2, p. 376.)

Abstract only.

THE EFFECT OF INTENSE ELECTRIC FIELDS ON THE PHOTOELECTRIC PROPERTIES OF METALS.—E. O. Lawrence and L. B. Linford. (*Phys. Review*, 1st Aug., 1930, Series 2, Vol. 36, No. 3, pp. 482-497.)

From authors' abstract:—The photoelectric effect from thin films of potassium and oxygen on tungsten has been studied as a function of strong accelerating fields. Fields as high as 63,000 volts/cm. were used which shifted photoelectric thresholds towards the red, the shifts being approximately proportional to the square root of the applied fields. . . . From the observations of the variations of the shifts with applied fields calculations of the surface fields were made after the manner of Becker and Mueller. It was found that outside the film of potassium on a thin layer of oxygen on tungsten the field followed closely the Schottky image law in the range 1.5×10^{-6} cm. to 10^{-5} cm. from the surface. The pure potassium film on tungsten exhibited surface fields which were closely image fields between 8×10^{-7} cm. and 1.5×10^{-6} cm. from the surface but which departed from the image law at greater distances. These observed departures were about equal to the image fields and were much smaller than the surface fields at like distances outside thoriated tungsten filaments as recorded by the thermionic measurements of several observers. The surface fields in excess of the image fields are ascribable to inhomogeneity of the surfaces, regions of different work functions having linear dimensions of the order of magnitude of 10^{-5} cm.

Shifts of photoelectric thresholds by strong accelerating fields are of particular theoretical interest for they involve changes of the work function of a surface without alteration of the other important characteristics of the metal. It is found that the form of the photoelectric sensitivity *versus* frequency curve remains unchanged over the range of observations and shifts along with the thresholds in intense fields. Thresholds are not sharp but approach the frequency axis tangentially. These observations are in excellent agreement with the theory of the photoelectric effect based on wave mechanics and the Fermi-Dirac distribution of the electrons in metals worked out by Wentzel and modified by Houston.

PICTURE-TRANSMISSION SCANNING DISC CARRYING SIX STRAIGHT-FILAMENT LAMPS.—(German Pat. 495718, Telefunken, pub. 10th April, 1930.)

BILDTELEGRAPHEN- UND FERNSPRECH-VERKEHR MIT SÜDAMERIKA (Picture Telegraphy and Telephony Services to S. America).—(*E.N.T.*, July, 1930, Vol. 7, p. 292.)

Paragraph giving a few details, rates, etc., of the picture telegraphy service between Germany and the Argentine opened last June.

SCANNING DISC WITH GLASS-BEAD LENSES.—(German Pat. 494779, Telehor, pub. 27th March, 1930.)

These beads are very cheap and very light compared with proper lenses, and require no adjustment in position.

SIMULTANEOUS TRANSMISSION OF PICTURES AND SOUND.—(German Pat. 495349, Telehor, pub. 5th April, 1930.)

The photoelectric circuits and the microphone are alternated so rapidly that their effects appear to be unbroken.

TELEVISION PRINCIPLES APPLIED TO RADIOGRAPHY.—Dauvillier.

(See under "Miscellaneous.")

MEASUREMENTS AND STANDARDS.

PROPOSED STANDARD TESTS OF BROADCAST RADIO RECEIVERS.—Committee of I.R.E. (*Proc. Inst. Rad. Eng.*, Aug., 1930, Vol. 18, pp. 1282-1305.)

A report by the Technical Committee on Radio Receivers and its sub-committees, now being circulated for comment and criticism before being brought before the Committee on Standardisation. It deals in succession with the definition of terms (sensitivity, selectivity, fidelity, etc.); the requirements and characteristics of testing apparatus (audio-frequency and radio-frequency sources, transfer circuit, output measuring circuit); test procedures—input measurements, receiver with and without a self-contained antenna—output measurement, receiver with d.c. in its output, with no d.c. in its output, with extraneous voltages in its output—receiver adjustment, regenerative, stabilised and super-heterodyne—sensitivity and tuning range tests, selectivity, fidelity and additional tests (overloading, sensitivity at maximum undistorted power output, volume control, etc.). The final section deals with Receiver Performance Graph Sheets.

PROBLEMS INVOLVED IN THE DESIGN AND USE OF APPARATUS FOR TESTING RADIO RECEIVERS.—P. O. Farnham and A. W. Barber. (*Proc. Inst. Rad. Eng.*, Aug., 1930, Vol. 18, pp. 1338-1350.)

Authors' summary:—This paper deals briefly with (1) the desirable characteristics of measuring equipment employed in making the usual tests of radio receiver performance and (2) a description of apparatus and technique used in carrying out several special tests. Measuring equipment and methods are discussed with reference to the elements of the receiver, after which are remarks on the usual tests of sensitivity, selectivity, and fidelity.

Under special tests is a discussion of measurements on hum, tube and circuit noise, modulation distortion, intermodulation, audio harmonic analysis, and volume control. Some specimen curves showing results obtained on model receivers are presented.

RECEIVER RESPONSE CURVES.—Jenkin.

(See abstract under "Reception.")

ENGINEERING CONTROL OF RADIO RECEIVER PRODUCTION.—V. M. Graham and B. Olney. (*Proc. Inst. Rad. Eng.*, Aug., 1930, Vol. 18, pp. 1351-1365.)

Briefly discusses a system of receiver production testing and inspection, backed up by "proving" inspections and engineering laboratory checks, which gives close control of production quality to the radio engineering department. Inspection of components is dealt with first (*e.g.*, equipment for detecting shorted turns in small transformer solenoids; testing instruments for measuring the uniformity among the units of ganged condensers); next, the production and testing of loud speakers before installing; the test and inspection of the receiver chassis; "proving" tests of receivers (on certain receivers selected from a number ready to be packed and shipped). In loud speaker testing the system due to Bostwick (1929 Abstracts, p. 275) is used. The over-all characteristics of receivers are also obtained by combining the results of electrical measurements of the receiver chassis and response measurements of the loud speaker mounted in the proper cabinet. Another apparatus shown is for measuring the gap flux density in electrodynamic loud speakers by means of a search-coil fitment. Accelerated life tests are also made on loud speakers, by driving them to the limits of motion of their vibrating systems at a frequency near to fundamental resonance.

TESTING LOUD SPEAKER MAGNETS.—Ledward.

(See under "Acoustics.")

HOCHEMPFFINDLICHES RÖHREN-VOLTMETER (A Thermionic Voltmeter of High Sensitivity).—H. Benecke. (*Zeitschr. f. tech. Phys.*, Sept., 1930, Vol. 11, pp. 361-363.)

Author's summary:—"A valve voltmeter with auxiliary a.c. voltage is described. It possesses a strictly linear calibration curve and allows a.c. potentials of fractions of a millivolt to be measured by means of a pointer instrument. Its employment in a Wheatstone bridge is described." The principle by which the extra sensitivity is obtained is that the grid bias is varied at the frequency of the voltage under measurement and in phase with it. The result is that the a.c. voltage sensitivity is directly proportional to the sensitivity of the d.c. instrument, whereas in the ordinary valve voltmeter it is proportional to the square root only.

A METHOD OF ELIMINATING THE EFFECTS OF MAGNETIC DISTURBANCE IN HIGHLY SENSITIVE GALVANOMETERS.—D. S. Perfect. (*Proc. Phys. Society*, 15th Aug., 1930, Vol. 42, Part 5, pp. 532-540.)

SUL GALVANOMETRO A VIBRAZIONE DI MOLL PER CORRENTI ALTERNATE (The Moll Vibration Galvanometer).—S. L. Straneo. (*Nuovo Cim.*, No. 3, Vol. 7, 1930, pp. 99-116; *Lincei Rendic.*, No. 5, Vol. 11, 1930, pp. 472-477.)

This instrument differs from ordinary vibration galvanometers in having a small mirror carried by the vibrating thread; by means of this, all transverse vibrations of the thread are combined with the torsional and other vibrations.

A RADIO-FREQUENCY POTENTIOMETER.—W. W. Macalpine. (*Proc. Inst. Rad. Eng.*, July, 1930, Vol. 18, pp. 1144-1154.)

Description of an instrument (with two slide wires carrying currents approximately in quadrature) for measuring the amplitude and phase of voltages up to at least one megacycle per second. The method of standardising the instrument is given. The ratio of the currents in the slide wires or dials can be determined to within one per cent., and their phase to half a degree.

THE FREQUENCY ERRORS OF RECTIFIER INSTRUMENTS OF THE COPPER OXIDE TYPE FOR ALTERNATING CURRENT MEASUREMENT.—L. Hartshorn. (*Proc. Phys. Society*, 15th Aug., 1930, Vol. 42, Part 5, pp. 521-531.)

The writer shows that these errors are due to the capacities of the rectifiers and are almost independent of the instrument reading, so that the percentage errors may be very large for small currents. It is possible to compensate them by means of an inductive shunt, the constants of which satisfy a given relation.

THE VARIATION OF THE RESISTANCE OF A RADIO CONDENSER WITH CAPACITY AND FREQUENCY.—R. R. Ramsey. (*Proc. Inst. Rad. Eng.*, July, 1930, Vol. 18, pp. 1226-1230.)

Author's conclusions:—Three methods have been used for the determination of the effective resistance of air condensers at radio frequencies. The coil-elimination method gives results which are high in comparison with the heat method and condenser-substitution method. The extra resistance found in the coil-elimination method is probably due to the equivalent resistance of objects near the circuit. This extra resistance does not appear in the heat method and is eliminated in the condenser-substitution method. The resistance of a variable condenser is a measurable amount and whether or not it can be neglected depends upon the accuracy of results wished and upon the relative value of this resistance to that of the rest of the circuit.

A SCREEN-GRID VOLTMETER AND ITS APPLICATION AS A RESONANCE INDICATOR [FOR LECHER WIRES].—R. King. (*Proc. Inst. Rad. Eng.*, Aug., 1930, Vol. 18, pp. 1388-1395.)

For investigating the shape of resonance curves on Lecher wires, the necessary current or voltage indicator should—ideally—have zero impedance for reading current or infinite impedance for reading p.d., and deflections should reach their full values with as little lag as possible. Vacuum thermopiles

were not found entirely satisfactory, and a thermionic voltmeter (triode with grid leak detection) responded little better to the extremely small p.d.s induced in the wires by a loosely coupled oscillator on frequencies round 100 megacycles. By substituting a tuned input circuit for the usual blocking condenser and grid leak, the relatively high resonance voltage across the grid-filament capacity of the tube was utilised, and very much greater sensitivity obtained. Further, by introducing a screen-grid valve operating at a sensitive point on its plate-current screen-grid voltage characteristic the sensitivity was effectively trebled; readings, moreover, were practically instantaneous.

CAPACITIVE AND INDUCTIVE COUPLING, INCLUDING A METHOD OF MEASURING MUTUAL INDUCTANCE [AND IMPURITY] AT RADIO FREQUENCIES.—Wilmotte.

(See under "Properties of Circuits.")

CECHOWANIE GENERATORA CZESTOTLIWOSCI AKUSTYCZNEJ OPARTE NA JEDNEJ CZESTOTLIWOSCI WZORCOWEJ (The Calibration of an Audio-frequency Oscillator by means of a Single Frequency Standard).—J. Kahan. (*Wiadomości i Prace, Inst. Radjotech.*, Warsaw, No. 4, Vol. 2, 1930, pp. 107-114.)

The writer describes a method in which relaxation circuits are used to obtain multiples and sub-multiples of the one standard frequency. In Polish.

SUR LA MESURE DES SELF-INDUCTIONS PAR LA MÉTHODE DE PIRANI (On the Measurement of Inductances by the Pirani Method).—D. Guindin. (*Journ. de Phys. et le Rad.*, June, 1930, Series 7, Vol. 1, pp. 211-216.)

A paper on an improved version of Pirani's bridge method.

CAPACITY, FREQUENCY, AND OTHER MEASUREMENTS: DEVELOPMENT IN 1929.—Physik. Tech. Reichsanstalt. (*E.T.Z.*, 21st August, 1930, Vol. 51, pp. 1212-1213.)

Among the points mentioned are the following:—an international comparison of frequency standards by means of the department's transversely-oscillating glow resonator showed an agreement within the limits of accuracy of 1×10^{-5} between the three institutions taking part. Extensive research on transversely and longitudinally oscillating resonators has led to constancy of frequency within 5×10^{-8} . Tuning fork generators, on the other hand, showed a frequency increase of 1.6×10^{-6} in a week, probably owing to internal changes in the metal.

For increasing the accuracy of medium frequency measurements, a new set of coils and air condensers was made, specially free from losses. The largest coil (0.1 henry) had a resistance of only 3.7 ohms. For the measurement of small capacities two new standard variable condensers were built, one (10 - 30 $\mu\text{F.}$) of the rotating disc type, the other (5 - 50 $\mu\text{F.}$) with two discs with their gap micro-metrically adjusted. Regarding the measurement of very large capacities (e.g., for interference

elimination in broadcast reception) various special bridges are discussed: a phase-improving condenser (440 $\mu\text{F.}$) showed a loss angle of $\tan \delta = 6.5 \times 10^{-3}$, while two dry-electrolyte condensers for eliminators, about 6,000 $\mu\text{F.}$, showed such high losses ($\tan \delta = 0.9$ and 0.6) that they could almost be regarded as resistances.

Dielectric measurements:—pressbernstein (am-broid—see October Abstracts, p. 583) gave the low loss factor 0.8×10^{-3} , independent of temperature in the practical range. Its breakdown voltage was very high (59 kV. for a thickness of 0.76 mm.). The rectifying effect of thin oil films is mentioned, and piezoelectric methods of measuring rapidly changing pressures, in various connections; also the stroboscopic testing of tachometers, etc., within 1 per thousand, using a glow-discharge tube and tuning-fork combination.

A differential method of measuring initial permeability is described, and some results on nickel-iron alloys are mentioned.

RADIO SIGNAL TRANSMISSIONS OF STANDARD FREQUENCY, JULY TO DECEMBER, 1930.—U.S. Bureau of Standards Notes. (*Journ. Franklin Inst.*, July, 1930, Vol. 210, No. 1, p. 115.)

THE NEW GOVERNMENT FREQUENCY STANDARD HAVING AN ACCURACY BETTER THAN ONE PART IN A MILLION.—S. R. Winters. (*Rad. Engineering*, March, 1930, Vol. 10, pp. 37-39.)

Illustrated article on the U.S. Bureau of Standards national standard crystal-controlled oscillators referred to in September Abstracts, p. 517.

SPECIAL ELECTRODES FOR OBTAINING HIGHER HARMONICS IN QUARTZ CRYSTALS.—(German Pat. 494716, Elektrot. Trust, Leningrad, pub. 29th April, 1930.)

The electrodes are cut away so as to be close to the crystal surface only at the antinodes of the desired oscillation. These projections may be electrically in parallel or in series. They may also be formed by metal strips sputtered on to the crystal faces.

PIEZOELECTRIC TUNING FORK.—(German Pat. 496842, Belin and Holweck, pub. 28th April, 1930.)

This is the invention briefly referred to in July Abstracts, p. 403. Two similar quartz strips are so shaped and combined together as to form a two-ended tuning fork. Where the two strips are thickened to combine to form the central stem, they are metallised and kept apart by two small piezoelectric quartz plates, which when excited drive the forks in transverse oscillations which are practically independent of temperature. The exciting voltage can be very small—it may be provided by a two-grid valve working on 4 v.

NOUVELLES OBSERVATIONS SUR LE QUARTZ (New Observations on Quartz).—R. Weil. (*Comptes Rendus*, 25th August, 1930, Vol. 191, pp. 380-382.)

Continuation of the work referred to in October Abstracts, p. 579.

MICROGRAPHIE DU QUARTZ PIÉZOÉLECTRIQUE (Micrography of Piezoelectric Quartz).—P. T. Kao. (*Comptes Rendus*, 18th Aug., 1930, Vol. 191, pp. 334-335.)

The microphotographs of the positive and negative faces perpendicular to the electric axis, after corrosion by hydrofluoric acid or caustic potash, show entirely different characteristics. The negative face is fibrous, the predominant fibres lying parallel to the optical axis; the positive face is truly crystalline, the predominant form being a parallelogram with two sides parallel to the optical axis.

ELECTROELASTIC AND PYRO-ELECTRIC PHENOMENA.—W. G. Cady. (*Proc. Inst. Rad. Eng.*, July, 1930, Vol. 18, pp. 1247-1262.)

Data concerning (1) Electrostriction—a table of values is given for glass, paraffin, ebonite and rubber, together with references to various publications on the subject; (2) Piezo-electricity—including the constants for each of the 20 classes of crystal possessing the piezo-electric property [see also (3)], together with references to the bibliography; (3) Pyro-electricity—including a list of the substances for which either piezo- or pyro-electric effects have been observed, together with their constants at room temperature; also special sections on tourmaline, quartz and Rochelle salt. Here also references to a large number of publications are quoted. The whole paper is based on the writer's contribution, under the same title, to the International Critical Tables, 1929; additional references have been added to bring the material up to date.

DESIGN OF A PORTABLE TEMPERATURE-CONTROLLED PIEZO OSCILLATOR.—V. E. Heaton and W. H. Brattain. (*Proc. Inst. Rad. Eng.*, July, 1930, Vol. 18, pp. 1239-1246.)

See July Abstracts, p. 404.

THE ANOMALOUS AFTER-EFFECT OF APPLIED POTENTIAL ON QUARTZ.—Saegusa and Shimizu.

(See abstract under "General Physical Articles.")

SUBSIDIARY APPARATUS AND MATERIALS.

NOUVEAUX REDRESSEURS À OXYDE CUIVRIQUE (New Copper Oxide Rectifiers).—H. Pélabon. (*Comptes Rendus*, 1st Sept., 1930, Vol. 191, pp. 402-404.)

Further development of the work referred to in Abstracts, June, pp. 340-347 and Sept., p. 522; here the writer described the existence, in the active layer, of a dissymmetrical condenser formed by electrodes of copper (conducting) and cupric oxide (semi-conducting), separated by an insulating layer of cuprous oxide. He now states that this layer is not of chemically pure cuprous oxide, but is a solid solution, or more probably a solid suspension, of the cupric in a large excess of the cuprous oxide, forming a "semi-insulator."

He has experimented with a number of dissymmetrical condensers of this type, consisting of a conductor, a semi-conductor, and a semi-insulator.

The semi-conductor was provided by a layer moulded from chemically pure cupric oxide rendered more conducting by being kept at a rather high temperature for some time and then cooled, while the semi-insulator was made, by one of various ways, from gold powder in gum lac or collodion deposited on one surface of the semi-conductor. The combination was pressed between two pieces of metal. Such a condenser was found to have a very distinct unilateral conductivity, the larger current flowing when the cupric oxide was positive; the rectifying efficiency, under certain conditions (of moulding pressure for the cupric oxide and the temperature at which it was kept, concentration of the gold powder, etc.), can be very high.

As regards generalising these results and replacing the cupric oxide by other semi-conductors: Tubandt classified these as follows:—substances such as (i) PbS and SnS, showing purely metallic or electronic conductivity, (ii) cubic silver sulphide, having purely electrolytic conductivity (displacement of ions), and (iii) cupric oxide and orthorhombic silver sulphide, with mixed conductivity. Of these, it is found that group (i) form condensers which do not rectify—an important point, since it shows that galena, for example, behaves like a metal poor in free electrons. The rectifying properties which it displays when used in a different way are explained as a metallic contact phenomenon (same writer, 1929 Abstracts, p. 402). Group (ii) is left for further consideration. Group (iii), as shown in the case of cupric oxide, form rectifying condensers; so far as their electrolytic conduction is concerned, polarisation phenomena enter into action: the writer has shown that the e.m.f. of polarisation is much greater when the cupric oxide is negative. He thinks the unilateral conductivity can be explained by unequal polarisation of the two unlike electrodes, in which case the condensers described above would be analogous to the Ferrié electrolytic detector.

STUDIES IN CONTACT RECTIFICATION. II.—THE CUPRIC SULPHIDE-MAGNESIUM JUNCTION.—M. Bergstein, J. F. Rinke and C. M. Gutheil. (*Phys. Review*, 1st Aug., 1930, Series 2, Vol. 36, No. 3, pp. 587-599.)

Paper presented at the Washington meeting of the American Physical Society, April 25th, 1930, Cf. Sept. Abstracts, pp. 522-523.

CONDUZIONE ELETTRICA DI PELLICOLE METALLICHE SPRUZZATE CATODICAMENTE (Electrical Conductivity of Cathode-Sputtered Metallic Films).—E. Perucca. (*Nuovo Cim.*, Feb., 1930, Vol. 7, pp. 50-68.)

Cf. May Abstracts, p. 287.

DRY ELECTROCHEMICAL CONDENSERS.—P. E. Edelman. (*Proc. Inst. Rad. Eng.*, Aug., 1930, Vol. 18, pp. 1366-1371.)

ATTENUATION AND PHOTOELECTRIC EFFECTS AT THE BOUNDARY BETWEEN CUPROUS OXIDE AND METALLIC FILMS SUPERPOSED BY SPRAYING.—Duhme and Schottky.

(See under "Phototelegraphy and Television.")

NEUARTIGE ENTLADUNGSRÖHRE FÜR KATHODENSTRAHL-OSCILLOGRAPHEN (A New Type of [Metal] Discharge Tube for C.R. Oscillographs).—Binder, Förster and Frühauf. (*Zeitschr. f. tech. Phys.*, Sept., 1930, Vol. 11, pp. 379-380.)

The metal tube is of unusually large diameter (300 mm.) in order to minimise the wall effects and—thanks to the large volume—to avoid changes in the vacuum by sudden eruptions of gas. Concentration of the beam is obtained by a Wehnelt cylinder which is not, however, supplied with a potential from outside but is allowed to take up its own potential between that of the cathode and anode but nearer to that of the cathode. The field through which the ray passes is very homogeneous, unlike that of arrangements in which the anode, in tubular form, surrounds the cathode (a reference is here made to the paper by Knoll, Knoblauch and v. Borries—Sept. Abstracts, p. 520). The stability is extremely good even at the highest voltages, and good concentration is obtained without magnetic pre-concentration.

DIE SCHWÄRZUNG PHOTOGRAPHISCHER PLATTEN DURCH ELEKTRONENSTRAHLEN (The Blackening of Photographic Plates by Electron Rays).—M. J. Nacken. (*Physik. Zeitschr.*, 1st April, 1930, Vol. 31, No. 7, pp. 296-306.)

NEW PERMANENT-MAGNET OSCILLOGRAPHS.—M. A. Rusher. (*Gen. Elec. Review*, Sept., 1930, Vol. 33, pp. 491-499.)

DIE SELBSTTÄTIGE AUFNAHME UNWILLKÜRLICHER VORGÄNGE MIT DEM KATHODENOSCILLOGRAPHEN (The Automatic Recording of Uncontrolled Processes with the C.R. Oscillograph).—W. Rogowski, O. Wolff and N. Schäffer. (*Arch. f. Elektrot.*, No. 6, Vol. 23, 1930, pp. 707-710.)

EFFECTS OF THE MAGNETIC FIELD ON LICHTENBERG FIGURES.—C. E. Magnusson. (*Journ. Am. I.E.E.*, Sept., 1930, Vol. 49, pp. 756-763.)

"This paper deals with new forms of Lichtenberg figures produced under the combined stress of dielectric and magnetic fields. The effects produced by the magnetic field may be used for determining whether electrons, positive ions, or protons, are basically the active elements in the formation of the positive as well as the negative figures. The illustrations also show that the presence of the magnetic field greatly extends the range of air pressures within which figures of definite form can be obtained, that figures taken at low air pressures possess structures strikingly different from those hitherto known, and that these figures may prove a key to the mechanism of the electric spark."

A VACUUM-TUBE COMMUTATOR: THE PRODUCTION OF A PERIODIC PULSE OF POTENTIAL OF SQUARE WAVE-FORM.—C. F. Powell and K. H. Manning. (*Proc. Phys. Society*, 15th Aug., 1930, Vol. 42, Part 5, pp. 563-569.)

With a kind of cathode-ray oscillograph tube provided with a grid between cathode and anode,

and with its deflecting plates supplied with an alternating potential, square wave-forms are obtained in which the ratio of the duration of the pulse to the time between pulses is of the order of one to twenty, at a pulse frequency of 1,000. Frequencies at present are not much above 2,000 cycles/sec., but there is no doubt that the method can be employed at considerably higher frequencies.

INSULATORS TESTED: (3) BAKELITE.—W. H. F. Griffiths. (*Wireless World*, 6th August, 1930, Vol. 27, pp. 129-130.)

INSULATORS TESTED: (4) MYCALEX.—W. H. Griffiths. (*Wireless World*, 20th August, 1930, Vol. 27, pp. 167-168.)

PROPERTIES AND APPLICATIONS OF MYCALEX TO RADIO APPARATUS.—W. W. Brown. (*Proc. Inst. Rad. Eng.*, Aug., 1930, Vol. 18, pp. 1307-1315.)

DIE DIELEKTRISCHE FESTIGKEIT VON ENTGASTEN FLÜSSIGKEITEN (The Dielectric Strength of Out-gassed Liquids).—L. Inge and A. Walther. (*Zeitschr. f. tech. Phys.*, Sept., 1930, Vol. 11, pp. 369-372.)

A careful out-gassing largely decreases the dependence of the breakdown voltage on pressure and temperature.

BATTERIELADUNG UND -PFLEGE DURCH NEUZEITLICHE OXYD-GLÜHKATHODEN-GLEICHRICHTER (Battery Charging and Maintenance by the latest Hot Oxide-coated Filament Rectifiers).—W. Germershausen. (*E.T.Z.*, 4th September, 1930, Vol. 51, pp. 1257-1262.)

LEISTUNGSVERSTÄRKER FÜR MESSZWECKE (Power Magnifier for Measuring Purposes).—G. Schützler. (*E.T.Z.*, 11th Sept., 1930, Vol. 51, pp. 1305-1306.)

Description of a power magnifier with a magnification of about $1:10^{12}$, depending on the movement of a screen which controls the flow of air cooling two resistances in the arms of a bridge circuit.

A PHOTO-ELECTRIC INTEGRAPH AND ITS APPLICATION TO MATHEMATICAL ANALYSIS.—T. S. Gray. (*Abst. of Sci. and Tech. Pub.*, *Massach. Inst. Tech.*, July, 1930, pp. 76-78.)

Light from a tungsten filament lamp shines on a mirror on the face of which is a screen or mask cut to the shape of one of the functions to be multiplied or integrated. The reflected beam is moved up and down with uniform reciprocating motion by a special mechanism actuating the mirror, and falls on the face of a second function mask behind which is a large lens. This lens collects all the light which comes through the two function screens and directs it into an integrating sphere which is used in conjunction with a photoelectric cell to eliminate the directional effects of the latter.

A second beam of light from the same source travels through a diaphragm stop, vernier glass-plate device, and a linear shutter to a second photoelectric cell. The two cells are connected in a

circuit which makes use of their saturation characteristics to provide great sensitivity, and which causes an indication of balance between the two light beams to be shown on a meter in the plate circuit of a valve. (The circuit is "of unique character" in that it provides a means of relative light-transmission measurement which is independent of small fluctuations in the source, and that its sensitivity is in theory independent of the light level used). The light in the second or auxiliary optical system can be varied by the linear shutter to balance the light through the function screens. The shutter calibration serves as a relative measurement of the result of the integral for a particular value of t , the upper limit. Cranks controlling the horizontal position of one of the screens, and the opening of the shutter, operate a platen and a pencil on a lead screw, respectively, in such a way that by manual control the machine draws a result curve as a function of the upper limit. For examples of its use, see Yuk-Wing Lee under "Properties of Circuits."

THE EFFECT OF CONDUCTING CORES AND COVERINGS ON COIL CONSTANTS.—Loos. (See abstract under "Properties of Circuits.")

ALLOYS FOR CABLE SHEATHING.—R. S. Dean and J. E. Ryjord. (*Metals and Alloys*, March, 1930, Vol. 1, pp. 410-414.)

"An investigation of the physical properties of lead-calcium alloys of various compositions and heat treatments for use in cable sheathing."

EINE EINFACHE METHODE ZUR BESTIMMUNG DES GÜNSTIGSTEN LUFTSPALTES VON ÜBERTRAGERN (A Simple Method for Determining the Optimum Air-Gap in Transformers).—E. Asch. (*Zeitschr. f. tech. Phys.*, Sept., 1930, Vol. 11, pp. 352-353.)

For any particular kind of iron the air-gap to give maximum self-induction can be determined from a simple geometrical figure.

DAS PERMALLOY C (Permalloy C).—Fischel. (*E.N.T.*, June, 1930, Vol. 7, pp. 251-254.)

ÜBER MATERIALIEN MIT HOHER ANFANGSPERMEABILITÄT (On Materials with High Initial Permeability [Permeability at Low Magnetising Forces]).—E. Gumlich, W. Steinhäus, A. Kussmann and B. Scharnow. (*E.N.T.*, June, 1930, Vol. 7, pp. 231-235.)

A paper on the reversible nickel-iron-manganese alloys (5, 10 and 15% manganese), which not only show a desirably higher resistance than the pure permalloy but depend less for their properties on thermal treatment. Various possibilities are investigated of obtaining a comparatively high initial permeability together with only slight dependence of permeability on the field strength. Two ways have been found practicable: the partial softening [entfestigung] of a suitable cold-worked material, and the alloying of a component [e.g. silver] which is not held in solid solution and thus can be separated out by suitable heat treatment.

U.S. GOVERNMENT SPECIFICATIONS FOR DRY CELLS.—G. W. Vinal. (*Commercial Stds. Monthly*, August, 1930, Vol. 7, pp. 35-39.)

A HIGH FREQUENCY OSCILLATOR FOR GENERAL LABORATORY USE.—S. F. Evans. (*Journ. Scient. Instr.*, Aug., 1930, Vol 7, pp. 261-263.)

A description of an apparatus for producing oscillatory discharges of frequency of the order of 3×10^7 cycles per second.

RÉCENTES ÉTUDES SUR LES RELAIS ÉLECTROMAGNÉTIQUES EMPLOYÉS EN TÉLÉPHONIE (Recent Work on Electromagnetic Relays used in Telephony).—Van Mierlo. (*Bull. d. l. Soc. franc. d. Elec.*, Sept., 1930, Vol. 10, pp. 973-1001.)

THE NEON LAMP AS A GLOW RELAY.—L. Bellingham. (*Nature*, No. 3164, Vol. 125, 1930, p. 928.)

The ordinary Osglim lamp forms a sensitive relay [cf. 1928 Abstracts, pp. 524 and 645] if provided with a third electrode in the shape of a strip of metal foil about 4 cm. broad clipped round the outside of the bulb. The "bee-hive" type is the most suitable, in which the two electrodes are a disc and a conical spiral. If a potential (about 132 v.) is applied to these so that discharge just does not occur, and if a photoelectric cell is connected to the external electrode, illumination falling on this cell will cause a discharge which may be made to energise a magnetic relay. Moreover, the lamp itself will act photoelectrically: if the potential on the external electrode is adjusted so that it just leads to a discharge, the latter ceases when the electrodes are illuminated by (*e.g.*) a gas-filled incandescent lamp.

STATIONS, DESIGN AND OPERATION.

THE OSLO AND BUDAPEST HIGH POWER BROADCASTING STATIONS. (*Telefunken Zeit.*, April, 1930, Vol. 11, No. 54, pp. 7-15 and 37-48.)

CALCULATION OF THE SERVICE AREA OF BROADCAST STATIONS.—P. P. Eckersley.

(See under "Propagation of Waves.")

THE POSSIBILITIES OF SYNCHRONISED CHAIN BROADCASTING.—F. E. Terman: E. H. Felix.

(See abstract under "Transmission.")

CONSIDERATIONS REGARDING COMMON-WAVE BROADCASTING.—Gerth and Hahnemann.

(See abstract under "Transmission.")

RADIOTECHNIK IM FLUGVERKEHR (Radio Technique in Aviation).—F. Benz. (*Elektrot. u. Maschbau*, 7th Sept., 1930, Vol. 48, pp. 822-825.)

A short survey, including a brief description of the Austrian wireless network for aircraft.

WAR DEPARTMENT MESSAGE CENTER.—F. E. Stoner. (*Proc. Inst. Rad. Eng.*, August, 1930, Vol. 18, pp. 1372-1376.)

A short sketch of the new War Department short wave transmitting station WAR at Fort

Myer, Virginia, where beam transmission is being introduced for handling the traffic for the 55 Government bureaux now making use of the facilities of the War Department Message Centre. This centre controls WAR and remotely keys its transmitters.

DICHTE DER KOMMERZIELLEN KURZWELLENSTATIONEN ([WORLD] DENSITY OF COMMERCIAL SHORT-WAVE STATIONS).—E. Quäck and H. Mögel. (*E.N.T.*, July, 1930, Vol. 7, pp. 277-279.)

THE MARCONI SPEECH CONTROL EQUIPMENTS FOR BROADCASTING.—Marconi Co.

(See under "Transmission.")

IMMORTALISING AIR WAVES ["RECORDED" BROADCAST PROGRAMMES].—A. C. Lescarboura. (*Rad. Engineering*, March, 1930, Vol. 10, pp. 31-33 and 44.)

An article on the "recorded" programme system which originated in America in 1928, and has since tended to become unpopular owing to bad recording by mushroom firms quoting low prices. But "the finest developments of recording have been accomplished in the past year," and the radio industry is now "taking the recorded programme to its bosom that it may become an integral part of radio broadcasting." Among the advantages of the system, it means that stations can broadcast much finer programmes than they could otherwise afford; also the programme performance may be repeated several times and the best portions selected for the final record.

GENERAL PHYSICAL ARTICLES.

THE LOCATION OF THE ELECTROMOTIVE FORCE IN THE PHOTO-VOLTAIC CELL.—W. N. Lowry. (*Phys. Review*, 15th May, 1930, Series 2, Vol. 35, No. 10, pp. 1270-1283.)

Author's abstract:—(1) A method was developed to utilise a 4-element vacuum tube to measure small potential differences.

(2) The so-called photovoltaic e.m.f. appears to be a modification of the electrolyte with light, there being no indication of any effect due to the direct illumination of the electrode or the boundary region between the electrode and the electrolyte.

(3) In certain types of experiments with these cells, current measurements cannot be regarded as a quantity proportional to e.m.f.

(4) The e.m.f. of the photovoltaic cell increases with the concentration of the electrolyte.

ON AN ANOMALOUS AFTER-EFFECT OF DIELECTRICS [QUARTZ] IN THEIR APPARENT RESISTIVITY.—H. Saegusa and S. Shimizu. (*Phil. Mag.*, March, 1930, Vol. 9, No. 57, pp. 474-488; *Sci. Rep. Tôhoku Univ.*, No. 1, Vol. 19, 1930, pp. 69-94.)

Joffé has shown that the conductivity of quartz is largely dependent on the height of the previously applied potential; the phenomena involved are now investigated in the case of a quartz plate cut perpendicularly to the optical axis. The influence of the height of the applied potential on the dura-

tion of the after-effect, and on the ratio of the resulting apparent conductivity to the normal conductivity, is studied; a number of allied phenomena are discussed.

THE SCATTERING OF LIGHT BY DIELECTRICS OF SMALL PARTICLE SIZE.—G. F. A. Stutz. (*Journ. Franklin Inst.*, July, 1930, Vol. 210, No. 1, pp. 67-85.)

THE DIELECTRIC POLARISATION OF LIQUID MIXTURES AND ASSOCIATION.—PART I.—N. N. Pal. (*Phil. Mag.*, Aug., 1930, Series 7, Vol. 10, No. 63, pp. 265-280.)

ELEKTRONENAUSTAUSCH ZWISCHEN IONISIERTEN UND NEUTRALEN GEBILDEN (Electron Exchange between Ionised and Neutral Systems).—H. Kallmann and B. Rosen. (*Naturwiss.*, No. 20/21, Vol. 18, 1930, pp. 448-452.)

More on the work referred to in Sept. Abstracts, p. 524.

THE RATE AT WHICH IONS LOSE ENERGY IN ELASTIC COLLISIONS.—A. M. Cravath. (*Phys. Review*, 15th July, 1930, Series 2, Vol. 36, No. 2, pp. 248-250.)

Author's abstract:—The rate of energy loss of ions (including electrons) moving through a gas is rigorously calculated on the assumption that the ions and molecules are smooth elastic spheres with no attraction at a distance, having Maxwellian velocity distributions corresponding to the temperatures T_i and T_m respectively. The result is

$$f = \frac{8}{3} \cdot \frac{mM}{(m+M)^2} \left(1 - \frac{T_m}{T_i} \right),$$

where m and M are the masses of ion and molecule respectively, T_i and T_m are their temperatures, and f is the average energy loss per collision expressed as a fraction of the average ionic energy.

A METHOD OFFERED AS A MEANS OF COMPUTING PLANCK'S CONSTANT WITHOUT INVOLVING THE CHARGE ON THE ELECTRON.—A. Lucy. (*Phys. Review*, 15th July, 1930, Series 2, Vol. 36, No. 2, pp. 367-368.)

THE THEORY OF THE EXTRACTION OF ELECTRONS FROM METALS BY POSITIVE IONS AND METASTABLE ATOMS.—H. S. W. Massey. (*Proc. Camb. Phil. Soc.*, July, 1930, Vol. 26, pp. 386-401.)

ASYMMETRIC SCATTERING OF DOUBLY-REFLECTED ELECTRONS.—E. Rupp. (*Zeitschr. f. Phys.*, No. 34, Vol. 61, 1930, pp. 158-169.)

In a further attempt to detect the polarisation of electronic waves, the writer has used 10, 40 and 80 kv. electrons reflected twice at gold surfaces at grazing incidence. The 40 and 80 kv. beams gave an asymmetric scattering, which is attributed to polarisation of the electronic waves. Contrast 1929 Abstracts, p. 284.

THE MASSES OF THE PROTON AND ELECTRON.—W. Band: H. T. Flint. (*Proc. Phys. Society*, 15th Aug., 1930, Vol. 42, Part 5, pp. 593-594.)

THE ABSORPTION COEFFICIENT FOR SLOW ELECTRONS IN GASES.—C. E. Normand. (*Phys. Review*, 15th May, 1930, Series 2, Vol. 35, No. 10, pp. 1217-1225.)

THE ABSORPTION COEFFICIENT FOR SLOW ELECTRONS IN GASES.—C. E. Normand and R. B. Brode. (*Phys. Review*, 1st June, 1930, Series 2, Vol. 35, No. 11, p. 1438.)

THE LIBERATION OF ELECTRONS FROM METAL SURFACES BY POSITIVE IONS.—PART I—EXPERIMENTAL; M. L. E. Oliphant; PART II—THEORETICAL; Oliphant and Moon. (*Proc. Roy. Soc.*, May, 1930, Series A, Vol. 127, No. A805, pp. 373-387 and 388-406.)

DIE STREUUNG VON STRAHLUNG DURCH GEBUNDENE UND FREIE ELEKTRONEN NACH DER DIRAC'SCHEN RELATIVISTISCHEN MECHANIK (The Diffraction of Radiation by Bound and Free Electrons according to Dirac's Relativistic Mechanics).—I. Waller. (*Zeitschr. f. Phys.*, 7th May, 1930, Vol. 61, No. 11/12, pp. 837-851.)

ON THE RELATION OF ELECTRONIC WAVES TO LIGHT QUANTA AND TO PLANCK'S LAW.—J. J. Thomson. (*Phil. Mag.*, June, 1930, Series 7, Vol. 9, No. 61, pp. 1185-1194.)

THE MOST PROBABLE 1930 VALUES OF THE ELECTRON AND RELATED CONSTANTS.—R. A. Millikan. (*Phys. Review*, 15th May, 1930, Series 2, Vol. 35, No. 10, pp. 1231-1237.)

DISTRIBUTION OF ELECTRIC FORCES IN SPACES TRAVERSED BY ELECTRONS.—E. W. B. Gill. (*Phil. Mag.*, July, 1930, Series 7, Vol. 10, No. 62, pp. 134-139.)

A DIRECT MEASUREMENT OF THE VELOCITY OF CATHODE RAYS.—Charlotte T. Perry and E. L. Chaffee. (*Phys. Review*, 1st June, 1930, Series 2, Vol. 35, No. 11, p. 1437.)

ÜBER DIE WECHSELWIRKUNG DER FREIEN ELEKTRONEN MIT DER STRAHLUNG NACH DER DIRAC'SCHEN THEORIE DES ELEKTRONS UNDER NACH DER QUANTENELEKTRODYNAMIK (The Interaction of Free Electrons and Radiation, according to Dirac's Electron Theory and to Quantum Electrodynamics).—Ig. Tamm. (*Zeitschr. f. Phys.*, 18th June, 1930, Vol. 62, No. 7/8, pp. 545-568.)

MOLECULAR BEAMS IN ELECTROMAGNETIC FIELDS.—D. E. Olshesky. (*Phys. Review*, 15th March, 1930, Series 2, Vol. 35, No. 6, p. 659.)

SULLA CONCENTRAZIONE DI FASCI DI ELETTRONI LENTI (On the Concentration of Rays of Slow Electrons).—I. Ranzi. (*Nuovo Cim.*, June, 1930, Vol. 7, pp. 254-259.)

An interpretation of Thibaud's results (1929 Abstracts, pp. 224 and 645.)

- DEFLECTION OF ELECTRONS BY A MAGNETIC FIELD ON THE WAVE MECHANICS.—L. Page. (*Phys. Review*, 1st Aug., 1930, Series 2, Vol. 36, No. 3, pp. 444-456.)
- ON THE MECHANISM OF THE ELECTRODELESS DISCHARGE.—John Thomson. (*Phil. Mag.*, Aug., 1930, Series 7, Vol. 10, No. 63, pp. 280-291.)
- A simple theoretical investigation of the discharge with external electrodes. Assuming that the high-frequency discharge may be maintained by the ionization produced only by electronic conditions, equations and conditions are derived which are sufficient to explain the mode of variation of the maintenance potential with the pressure, the magnitudes of the gas constants obtained from them being of the correct order. The mode of variation of the maintenance potential with the frequency is not given by the simple equation derived, but other considerations indicate how the experimental facts might be explained. An application of the Tesla Coil transformer to the production of high-tension high-frequency oscillations is also discussed.
- DIE ÄNDERUNGEN DER ELEKTRISCHEN LEITFÄHIGKEIT FERROMAGNETISCHER STOFFE IN LONGITUDINALEN MAGNETFELDERN (The Variations in the Electrical Conductivity of Ferromagnetic Materials in Longitudinal Magnetic Fields).—O. Stierstadt. (*Physik. Zeitschr.*, 15th June, 1930, Vol. 31, No. 12, pp. 561-574.)
- ZUR THEORIE DER WIDERSTANDSÄNDERUNG IN STARKEN MAGNETFELDERN (On the Theory of Variation of Resistance in strong Magnetic Fields).—N. H. Frank. (*Naturwiss.*, 22nd August, 1930, Vol. 18, No. 34, pp. 751-752.)
- UNTERSUCHUNG DES SKINEFFEKTES IN DRÄHTEN MIT KOMPLEXER MAGNETISCHER PERMEABILITÄT (Investigation of Skin Effect in Wires with Complex Magnetic Permeability).—A. Ermolaev. (*Arch. f. Elektrot.*, No. 1, Vol. 23, p. 101; summary in E.T.Z., 11th Sept., Vol. 51, p. 1307.)
- THE MAGNETIC AND MAGNETO-THERMAL PROPERTIES OF FERROMAGNETICS.—E. C. Stoner. (*Phil. Mag.*, July, 1930, Series 7, Vol. 10, No. 62, pp. 27-48.)
- MISCELLANEOUS.**
- ANWENDUNG DER GRUNDLAGEN DES FERNSEHENS IN DER RÖNTGENOLOGIE: DER "RADIO-PHOT" (The Principles of Television applied to Radiography: the "Radiophot").—A. Dauvillier. (*Fortschr. a. d. Geb. d. Röntgenstr.*, No. 4, Vol. 40, pp. 638-654.)
- A scanning disc with two sets of apertures, one transparent to X-rays and the other to light, is interposed between the subject and the source of the X-rays. After passing through the subject the rays fall on a flat "ionisation chamber," the variations of whose current are amplified so as to control a neon lamp (for ocular observation) or a Kerr cell (for projection or for recording on film). The light pulses are synthesised by the second set of holes on the scanning disc. The plan makes it possible to use a tube with a very sharp focus, and practically eliminates dispersion troubles; a low intensity is practicable, giving good pictures without danger to subject or operator.
- PRINCIPLES OF SELSYN EQUIPMENTS [FOR TRANSMITTING ACCURATE ANGULAR MOTIONS] AND THEIR OPERATION.—L. F. Holder. (*Gen. Elec. Review*, Sept., 1930, Vol. 33, pp. 500-504.)
- THE COÖPERATION COMMITTEE [URSI] PROGRAM.—A. E. Kennelly: URSI. (*Proc. Inst. Rad. Eng.*, August, 1930, Vol. 18, pp. 1430-1432.)
- Present daily schedules and future plans for the international exchange of radio-cosmic information are outlined.
- CLASSIFICATION OF RADIO SUBJECTS: AN EXTENSION OF THE DEWEY DECIMAL SYSTEM. (*Proc. Inst. Rad. Eng.*, Aug., 1930, Vol. 18, pp. 1433-1456.)
- The present extension "brings the classification up to date and makes a few changes which use has shown to be necessary."
- RECENT PROGRESS IN ELECTROPHYSICS: ANNUAL REPORT OF THE COMMITTEE OF THE AM.I.E.E. (*Journ. Am.I.E.E.*, Sept., 1930, Vol. 49, pp. 721-729.)
- Includes sections on photoelectricity, thermionics, propagation of electric waves, and electromagnetic theory.
- À PROPOS DU FONCTIONNEMENT DU REDRESSEUR À GALÈNE: POTENTIEL CRITIQUE (On the Mode of Action of the Galena Detector: Critical Potential [dependent on Temperature]).—R. Desoille. (*Rev. Gén. de l'Élec.*, 6th September, 1930, Vol. 28, pp. 345-346.)
- Describes an experiment in which the approach of the hand towards the galena crystal causes a deflection in a galvanometer (sensitive to 5×10^{-10} A.) opposite in direction to that produced by the rectifying action of the crystal. "Everything occurs as if the metal-crystal contact is the seat of an e.m.f. whose value increases very rapidly under the influence of warmth." The writer points out that this phenomenon must be taken into account in quantitative work with such rectifiers.
- THE REDUCTION OF OBSERVATIONS.—A. F. Dufton: H. E. Hurst. (*Phil. Mag.*, Sept., 1930, Vol. 10, No. 64, pp. 465-470; pp. 511-512.)
- The first writer applies a simple graphical method for the reduction of observations to the data given by E. C. Rhodes in his paper on "Reducing Observations by the Method of Minimum Deviations" (Sept. Abstracts, 1930, p. 527). The second writer makes some remarks on the same paper.

MUTUAL INDUCTION IN EARTHED A.C. LINES AND ITS TREATMENT BY ELECTROSTATIC METHODS.—Pollaczek.

(See abstract under "Properties of Circuits.")

CONTACT RESISTANCE AND MICROPHONIC ACTION.—Gray: Goucher.

(See under "Acoustics.")

THE EFFECT OF SHORT ELECTRIC WAVES ON DIPHTHERIA TOXIN INDEPENDENT OF THE HEAT FACTOR.—Mellon, Szymanowski and Hicks. (*Science*, 15th August, 1930, Vol. 72, pp. 174-175.)

DIE FREQUENZABHÄNGIGKEIT DER LICHTSCHWINGUNGEN DES TÖNENDEN LICHTHOGENS (The Dependence on Frequency of the Light Fluctuations in the Singing Arc).—J. Jaumann. (*Zeitschr. f. Phys.*, No. 5/6, Vol. 59, 1930, pp. 386-426.)

An investigation with results of practical importance in connection with photo-telephony.

DISCONTINUOUS CHANGES IN LENGTH ACCOMPANYING THE BARKHAUSEN EFFECT IN NICKEL [HETERODYNE BEAT METHOD FOR MEASUREMENT OF DISPLACEMENTS AS SMALL AS 9×10^{-9} cm.].—C. W. Heaps and A. B. Bryan. (*Phys. Review*, 15th July, 1930, Series 2, Vol. 36, No. 2, pp. 326-332.)

OPTISCH-ELEKTRISCHE ZUGBEEINFLUSSUNG (Optical-Electrical Train Control).—Bäselser. (*E.T.Z.*, 28th Aug., 1930, Vol. 51, pp. 1244-1245.)

Latest results with the system referred to in February Abstracts, pp. 116-117.

A HOT-WIRE AMPLIFIER METHOD FOR THE MEASUREMENT OF THE DISTRIBUTION OF VORTICES BEHIND OBSTACLES.—E. Tyler. (*Phil. Mag.*, June, 1930, Series 7, Vol. 9, No. 61, pp. 1113-1130.)

EIN EINFACHER ELEKTROSTATISCHER VERSTÄRKER (A Simple Electrostatic Amplifier [Water-Dropper]).—H. Greinacher. (*Zeitschr. f. Unterr.*, No. 6, Vol. 42, 1929, pp. 260-264.)

A paper on the use of the well-known water-dropper as a practical amplifying device for such tests as calibrating electrometers, investigating the action of electrolytic rectifiers, testing ionisation currents, etc. By a series connection of two such water-droppers, a self-excited influence machine is obtained.

THYRATRON CONTROL EQUIPMENT FOR HIGH-SPEED RESISTANCE WELDING.—R. C. Griffith. (*Gen. Elec. Review*, Sept., 1930, Vol. 33, pp. 511-513.)

FIN FUNKTECHNISCHER APPARAT ZUR PRÜFUNG DES GANGES VON MASCHINEN (Apparatus using Wireless Technique for Testing the Running of Machines).—A. Gradenwitz. (*Die Sendung*, 25th July, 1930, Vol. 7, pp. 464-465.)

Description of an apparatus, made for a French motor-manufacturing firm by the S.F.R., for measuring the smooth running of various components, ball bearings, etc. It consists essentially of a microphone with a special diaphragm (insensitive to ordinary noises), an amplifier, and indicating instruments.

PIEZOELECTRIC METHODS OF STUDYING THE EFFECTS OF RAM STROKES IN WATER MAINS.—Boullé and A. Langevin. (*Rev. Gén. de l'Elec.*, 16th Aug., 1930, Vol. 28, pp. 507-509 H.)

PIEZOELEKTRISCHER INDIKATOR FÜR SCHNELLAUFENDE VERBRENNUNGSMOTOREN (A Piezo-electric Indicator for High Speed Internal Combustion Engines).—J. Kluge and H. E. Linckh. (*Zeitschr. V.D.I.*, 21st June, 1930, Vol. 74, pp. 887-889.)

THERMIONIC INDICATORS FOR HIGH SPEED MOTORS.—K. Schnauffer. (*Zeitschr. V.D.I.*, 26th July, 1930, Vol. 74, pp. 1066-1067.)

INVESTIGATION OF CUTTING PRESSURES AND OTHER FACTORS IN MACHINE TOOLS BY WIRELESS TECHNIQUE.—C. Salomon. (*E.T.Z.*, 7th Aug., 1930, Vol. 51, p. 1148.)

Methods, using an oscillograph, developed by the Loewe-Gesfürel Company. Cf. below.

ELECTRICAL METHODS OF MEASURING TORSION, CUTTING PRESSURE, ETC. H. Thoma: C. Salomon. (*Zeitschr. V.D.I.*, 28th June, 1930, Vol. 74, No. 26, p. 920.)

This argument as to priority yields a short history and list of the various applications of the principle, and shows the importance attached to it in Germany.

CONSIDERATIONS SUR LE VOL SANS MOTEUR (Considerations on the Subject of Motorless Flight).—A. Lefay. (*Génie Civil*, 21st June, 1930, Vol. 96, pp. 606-607.)

The writer has expounded since 1910 the possibilities of this form of aviation; the present article deals chiefly with his argument that the sense of hearing is of great service to birds in detecting the orientation of air-currents, squalls, etc.; brief preliminary tests on an aeroplane flying with stopped motor, in which the pilot wore telephone headgear connected to two microphones situated symmetrically about 5 m. apart near the following edge of the wings, appear to confirm the possibilities of such a device.

Some Recent Patents.

The following abstracts are prepared, with the permission of the Controller of H.M. Stationery Office, from Specifications obtainable at the Patent Office, 25, Southampton Buildings, London, W.C.2, price 1/- each.

DIRECTION-FINDING SYSTEMS.

Application date, 26th September, 1928. No. 327112.

The transmitting beacon radiates a still-life picture of, for instance, an elongated scale marked with the compass bearings. This may be transmitted from a rotating loop aerial, in which case the part of the scale corresponding to the moment when the loop is at right-angles to the receiver will be missing from the picture as received, thus giving a positive indication of the required bearing. Or the transmission may be non-directional, reception being effected on a rotating frame with a similar result. The advantage of the method lies in the fact that any interfering signal or atmospheric disturbance is readily distinguished as such, and its effect ignored.

Patent issued to J. Robinson.

STYLUS HOLDERS FOR PICK-UPS.

Application dates 28th March and 7th June, 1929. No. 327287.

In order to reduce weight and, at the same time to permit ready removal and replacement, the stylus or needle is mounted in a clip-holder without a binding-screw. Figs. A and B show a two-point support in side elevation and perspective, whilst Figs. C and D are similar illustrations of a three-point support. The needle is held in the two-point support by pressure against the record in the playing position, and by a light spring (or mag-

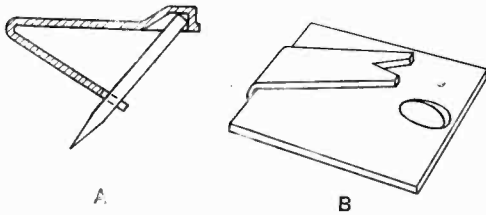

A

B

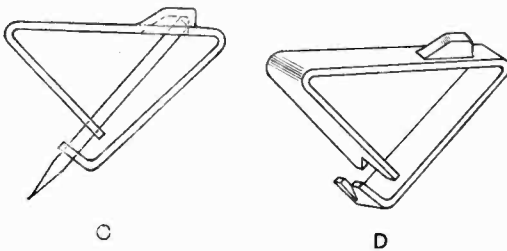

C

D

No. 327287.

netically) when not playing. The three-point support retains the needle in position at all times.

The upper arm of the clip holder constitutes the armature or reed of the pick-up.

Patent issued to The Electramonic Co., Ltd., S. J. and L. N. Tyrrell and D. W. Sayers.

FREQUENCY-DOUBLERS.

Application date, 1st January, 1929. No. 327425.

In order to stabilise the operation of a frequency-doubling installation comprising two valves V_1 ,

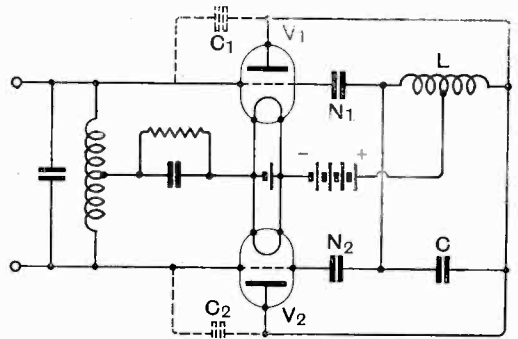

No. 327425.

V_2 fed in push-pull, the grid of each valve is connected through a separate neutralising condenser N_1 , N_2 to the end of the output inductance L opposite that to which the anodes are connected, the high-tension supply being connected to a central tapping as shown. The condensers N_1 , N_2 should be equal to the respective plate-grid capacities C_1 , C_2 (shown in dotted lines). The output circuit LC is tuned to double the frequency of the input, and a common grid leak serves both valves.

Patent issued to S. G. S. Dicker.

SECRET SYSTEMS.

Convention date (U.S.A.), 21st February, 1928. No. 306494.

In order to ensure secrecy in wireless telephony, the signal currents at the transmitting end are passed through inductance-capacity networks designed to introduce different degrees of delay at the different frequencies involved in transmission. Energy loss is compensated by means of attenuation-equalising networks of known form. At the receiving end, the currents are passed through networks which reverse the different degrees of delay so that the signal is restored to its original form. The specification contains design formulae for constructing the required delay networks.

Standard Telephones & Cables, Ltd.

CONSTANT-FREQUENCY GENERATORS.

Application date, 4th March, 1929. No. 327259.

A valve oscillator is maintained at constant frequency, without the use of piezo-electric crystals or similar devices, by adjusting it to work on such a point of its characteristic curve that the direct anode current, as measured by a milliammeter, is the same whether the valve is in the oscillating or non-oscillating state.

Patent issued to S. G. S. Dicker.

DEMONSTRATING PHASE-RELATIONS.

Application date, 16th January, 1929. No. 328010.

Relates to an apparatus for illustrating graphically the instantaneous value of the vectorial product of two sinusoidal variables, e.g., volts and amperes in an AC circuit. The respective graphs of two quantities relative to the axis of the independent variable are marked on two parallel transparent surfaces. On a third parallel surface is marked the graph of the instantaneous values of the product of the first-mentioned quantities. Co-ordinated link-work is used to produce relative movement between the transparent surfaces corresponding to alterations in the phase relation between the variables, and also a simultaneous movement of the third surface, so that the graph on the latter indicates, for example, whether power is being supplied to or by the circuit.

Patent issued to H. E. Dance.

MICROPHONIC AMPLIFIERS.

Application date, 27th May, 1929. No. 327898.

A loud speaker is operated from a crystal detector *K* connected in cascade with two micro-

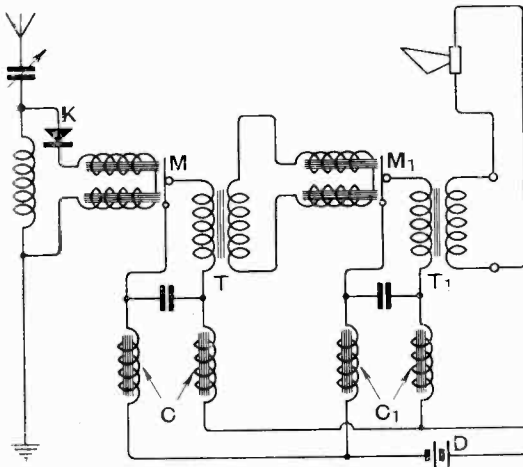

No. 327898.

phonic relays *M, M₁*. Current for both relays is drawn from a common battery *D* through choke coils *C, C₁* shunted by condensers. Both coupling-transformers *T, T₁* have a high step-up ratio: for

instance, the primary may have 700 and the secondary 2,400 turns.

Patent issued to A. M. Newman and J. Suchomski.

AMPLIFYING SYSTEMS.

Application date, 5th November, 1928. No. 327433.

Low-frequency variations are applied through a transformer *T* to the input of an amplifier *V*, the plate of which is connected directly to the H.T.

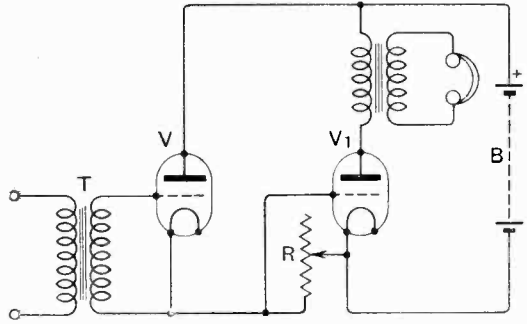

No. 327433.

battery *B*, whilst the filament is connected directly to the grid of a power amplifier *V₁*. A variable resistance *R* is inserted between the two filaments in parallel with the grid and filament of the power amplifier. The output current from the valve *V* thus serves to provide the working grid-bias of the power amplifier, volume control being effected by regulating the value of the resistance *R*.

Patent issued to S. G. S. Dicker.

LOUD SPEAKERS.

Application date, 28th September, 1928. No. 327145.

Relates to the type of loud speaker in which diffraction effects are utilised to ensure unimpaired sound emission directly to an audience located within a predetermined angle. A number of square-apertured horns are arranged in a vertical row so that the total emission area is a comparatively long narrow slot, the width being approximately equal to the wavelength of the highest frequency to be handled. Each horn is separately impulsed from a common feed circuit.

Patent issued to F. W. Lanchester.

Application dates, 5th January and 3rd September, 1929. No. 327689.

The vibrations of a moving-coil or magnetic system are applied to the diaphragm through a series of strings which may be tensioned to the same or to different degrees by separate tensioning-screws. Instead of strings, wire or catgut, or strips of metal or parchment of varying thickness may be used, with or without suitable loading. The strings may be joined together by a transverse member which is impulsed by the magnetic system.

Patent issued to (Miss) R. McDonald.

SHORT-WAVE GENERATORS.

Convention date (Germany), 30th June, 1928. No. 314534.

Relates to short-wave valve transmitters of the kind in which a split tuned circuit is connected in series with a blocking condenser between the anode and cathode, the high-tension supply choke being taken to the side of the blocking-condenser remote from the cathode. In order to prevent the setting-up of spurious oscillations, the high-tension supply is connected to the mid-point of the output inductance through a choke coil connected, not to the blocking condenser, but to a separate condenser arranged in parallel with H.T. supply.

Patent issued to Telefunken Gesellschaft für drahtlose Telegraphie m.b.h.

AMPLIFYING PHOTO-ELECTRIC CURRENT.

Application date, 5th January, 1929. No. 327723.

The operating voltages both for a photo-electric cell and an associated valve amplifier are derived from a common source, preferably the electric mains, through suitable resistances shunted across the supply in series with the valve filament. If the mains are alternating, a condenser of about .0001 mfd. should be connected across the grid and filament of the valve.

Patent issued to General Electric Co., Ltd., and L. B. W. Jolley.

PORTABLE DIAPHRAGMS.

Application date, 20th June, 1929. No. 327642.

A portable diaphragm for a phonograph or loud speaker consists of three triangular sectors

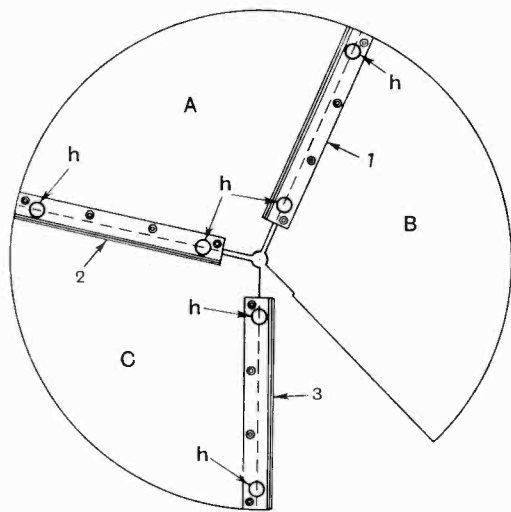

No. 327642.

A, B, C of vulcanised fibre or impregnated paper connected together by elongated spring-clips 1, 2, 3. The clips are evelted on to one edge of each sector, and clip over the edge of the adjacent sector, so as

to form a conical surface when assembled. Holes *h* are pierced in the clip to show when the two edges are abutting.

Patent issued to The Guinea Portable Gramophone Co., Ltd.

MULTIPLE VALVES.

Convention date (Germany), 14th April, 1928. No. 309608.

To permit the use of a multiple-stage valve either for high-frequency or low-frequency operation as desired, certain of the circuit components are housed in re-entrant recesses formed in the bulb, so that they can be readily interchanged. For instance, an additional coupling-resistance *R* can be inserted, as shown, in series with the plate resistance located inside the bulb, when a valve normally designed for high-frequency work is required to function as a low-frequency amplifier.

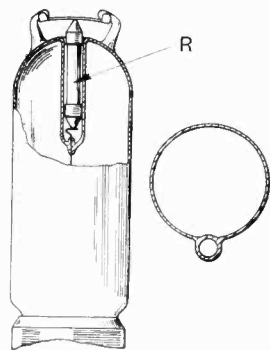

No. 309608.

Patent issued to S. Loewe and E. Romhild.

LOUD SPEAKER SYSTEMS.

Application date, 10th January, 1929. No. 327468

Two loud speakers, preferably of the moving-coil type, are driven simultaneously through separate amplifiers, the output from one speaker being progressively reduced for frequencies between 800 and 3,000 cycles by means of a shunt condenser, so that at the latter frequency the output from the shunted speaker sinks to zero. The combined response is thus doubled for frequencies up to about 700 cycles, whilst above that frequency the output approximates more and more to that given by only one instrument. This ensures a more faithful reproduction of the original high and low notes.

Patent issued to H. J. Round.

PIEZO-ELECTRIC CRYSTAL OSCILLATORS.

Application date, 7th June, 1929. No. 328152.

In order to generate audio-frequency oscillations from a single piezo-crystal of relatively small size, the crystal is cut or ground in "stepped" formation, so that one portion oscillates at one high frequency, and another portion at a second high frequency, the beat or difference frequency between the two constituting the desired low frequency. The effective piezo-electric axes extend along the crystal in the same direction. Alternatively two separate crystals may be selected, each arranged to control independent oscillatory circuits, the desired beat or difference frequency being impressed upon a third circuit.

Patent issued to Kolster-Brandes, Ltd.