

EXPERIMENTAL WIRELESS & The WIRELESS ENGINEER

VOL. VII.

FEBRUARY, 1930.

No. 77.

Editorial.

The Relation Between Electric and Magnetic Fields.

IN a letter which we published in our August number, Captain Curtis drew attention to the ambiguous statements on this subject which appeared in the scientific papers of eminent authorities and which, in his opinion, were extremely apt to mislead students. We have also received other letters expressing the same opinion and suggesting that the subject might be discussed in *E.W. & W.E.* We have written on this subject on many occasions in the hope of removing the fallacious opinions which are so widely held, not only by those who could hardly be expected to formulate clear conceptions on such a complex subject, but also by some of those who write text books on wireless telegraphy.

For the sake of those of our readers—undoubtedly the great majority—whose interest in and knowledge of wireless does not go back twenty-two years, we will explain the origin of the fallacy. In 1908 Professor Fleming (now Sir Ambrose Fleming) published an *Elementary Manual of Radio Telegraphy and Telephony*, in which (p. 125) it was not only stated that the electric and the magnetic fields of an electromagnetic wave were 90 degrees out of phase, but the statement was supported by a fallacious mathematical proof. Instructions were also given for the construction of a cardboard model designed to demonstrate this and impress it on the mind: In a paper which we read before the British Association at the Birmingham meeting in 1913 entitled "The nature of the electromagnetic waves employed in radiotelegraphy

and the mode of their propagation," we drew attention to the fact that "the fourth chapter of Prof. Fleming's *Elementary Manual*, which is devoted to a study of electromagnetic waves, is permeated through and through with this fallacy," but Prof. Fleming pointed out that the mistake had been discovered and corrected in a second edition of the book published before 1913. It is thus seen that the fallacy had a good send off.

In 1919 Stanley's *Test Book of Wireless Telegraphy* appeared, and in reviewing it we expressed our regret that a beautiful colour scheme had been invented for the sole purpose of furthering this same old fallacy. "Imagine," says Stanley, "that we could see the strains in the ether as colours, that an electric strain acting downwards is represented by red, one acting upward by blue, a magnetic strain in one direction by yellow, and in the opposite direction by green. Then a person standing in the ether would see a red colour of electric strain which will grow in intensity and then die out, giving place to a yellowish colour of magnetic strain, which will grow in intensity as the red dies out," and so on. It almost makes one wish that it were true. Stanley was evidently well soaked in Fleming's first edition. Then came the broadcasting boom and in 1925 "All about your Wireless Set" by P. P. Eckersley. In reviewing this for the *Radio Times*, we drew attention to the reappearance of the hoary old fallacy, but served up in real Eckersley style, "Flip! electric strain goes past and

then flip! magnetic strain, and again flip! electric strain, and so on." Launched under such eminent authority, and helped along with cardboard models, colour schemes, and picturesque language, it is small wonder that the fallacy persists in spite of every effort to lay it by the heels.

For the sake of those of our readers who may be wondering what is wrong with the above quotations, we may say that when a wave is passing any point on the surface of the earth, assuming that the earth is a good conductor and that the wave is behaving as long waves are supposed to do, the vertical electric field at the point has its maximum value at the same moment as the horizontal magnetic field, or as Eckersley would say, they both "flip" together, but not first one and then the other.

In his letter Captain Curtis gives several quotations from recent scientific papers which, in his opinion, are ambiguous, but the authors of these papers are not guilty of any attempt to propagate the fallacy just referred to, and in several cases any apparent ambiguity is probably due to a failure on the part of the reader to realise the true facts of the case. It is very necessary to distinguish between the interaction of electric and magnetic fields which constitutes an electromagnetic wave and the action of electric and magnetic fields themselves. It is possible to take any given space and screen it against the electric field of the passing wave so that within the space there will be an alternating magnetic field and no electric field except that set up by the alternating magnetic field. Similarly it is possible to screen a space against the magnetic field of the passing wave so that within the space there will be an alternating electric field and no magnetic field except that set up by the alternating electric field. Although both constituents are essential to a wave, it is thus possible to screen a region against one component. Any wireless receiver inside such a region is not acted on by the wave, but only by the constituent field which has not been excluded. When an aerial is acted upon by an electromagnetic wave, one cannot discriminate between the action upon it of the electric and magnetic fields since each is the result of the other. It is immaterial whether we regard the electromotive force induced in the aerial

as due to the vertical electric field or to the horizontal magnetic field; they are merely two different ways of looking at the same thing.

This applies equally to a vertical wire or to a coil or frame aerial. Which method one adopts for calculation is immaterial, the magnetic flux cutting or linking the wire or turns or the electric flux inducing electric force in the vertical wires or coil sides, they are really one and the same method when analysed.

In a screened space, however, conditions are quite different. It is possible so to arrange copper wires around a cage that the space within is screened from the electric field, but not from the magnetic field of the wave. The electromagnetic wave does not pass through the cage, but sets up an alternating magnetic flux within it. There are, of course, electric forces inside the cage, but they are the forces produced by any alternating magnetic flux, and it would be quite correct to say that a frame aerial situated within the cage was acted upon by the magnetic field and not by the electric field of the wave. Strictly speaking, this is not the whole story, since alternating currents are set up in the wires constituting the screen, and these currents produce a magnetic field which is superposed upon the original field of the wave.

It is also possible to screen a space against the magnetic field of the wave so that anything within the screened space is subjected to an alternating vertical electric field.

It is perhaps convenient and excusable to regard the induction of electromotive force in a frame aerial as due to the magnetic field of an electromagnetic wave without any reference to the electric field, since an alternating magnetic field can produce similar results in the absence of the vertical electric field. Similarly one may be forgiven for regarding the induction of electromotive force in a vertical open aerial as due to vertical electric field without any reference to the horizontal magnetic field of the wave. It is a fallacy, however, to imagine that in either case only one component of the wave is being utilised and that if one could utilise both components one would get double the result. If a mast is 100 feet high when looked at with either eye, it is still only 100 feet high when looked at with both eyes.

G.W.O.H.

Applications of the Method of Alignment to Reactance Computations and Simple Filter Theory.*

By *W. A. Barclay, M.A.*

PART I.

§1. Introduction.

A prominent feature of wireless theory, and one which both tyro and expert will unite to deplore, is the great amount of arithmetical work which is often necessary for the numerical interpretation of formulæ in terms of practical units. Nowhere, perhaps, are these irritating calculations more in evidence than in the estimation of the reactances of capacities and inductances at different wavelengths. To find, for example, the reactance in ohms of .0005 μ F. at 350 metres, it is necessary to evaluate the expression

$$\frac{\lambda}{2\pi \times 3 \times 10^8 \times C}$$

$$= \frac{350}{2 \times 3.1416 \times 3 \times 10^8 \times 0.0005 \times 10^{-6}}$$

Such computations when they occur in any number of occasions the expenditure of no little time and mental exertion, and it is not too much to say that a very natural "mental inertia" in working out numerical data often operates to the discouragement of the student. When, as is generally the case, such reactive components are found in combination, *i.e.*, in series or parallel groups, the arithmetical work is even more complicated, and the difficulties of estimating numerically the performance of such a group as any factor (say wavelength or capacity) is varied are intensified.

There is a real need in wireless work for a means of simplifying the arithmetic with which the subject is encumbered. Fortunately, such a means is to hand. The Alignment Principle, some applications of which to various points of wireless theory have already been contributed by the writer to these pages, is eminently suited for the purpose, and by its use the majority of such petty calculations may be entirely avoided. There can be no doubt that the great facility

for numerical expression which is thus afforded has but to be made known to experimenters for its utility to be appreciated, and that the time will soon come when it will be recognised for what it is—an indispensable aid to wireless calculation. The writer concluded that such an introduction would be best effected by giving a practical example of the automatic nature of the results attainable in one small section of wireless theory, *viz.*, that of reactive filters, omitting for the present any discussion of the mathematical reasoning upon which the diagrams are constructed. By this means readers may judge for themselves of the utility of the new method before embarking upon any detailed study of it. In the execution of this plan, however, the writer found himself handicapped by his inability to find any existing work on Filter Theory which should be at once fairly elementary, accurate, and reasonably intelligible. He therefore decided to work out the subject from first principles, and it is hoped that the results which are embodied in the subsequent articles of this series will commend themselves to readers of *E.W. & W.E.* Such mathematical work as appears in the sequel, therefore, is concerned solely with the subject of Filter Theory. The Alignment Diagrams which are described throughout this series are to be considered as illustrative of the subject of Filters, and the theory underlying their construction is expressly omitted for the reason above stated. The general theory of Alignment Diagrams may, if sufficient interest warrants, form the subject of subsequent articles.

An important property of the Alignment Diagram to which reference was made on a former occasion (see *E.W. & W.E.*, Dec., 1925, p. 937) is the universality with which it may be applied. For example, it may be employed directly to find the reactance of a certain combination at a given wavelength, as well as inversely to find the wavelength,

* MS. received by Editor, March, 1929.

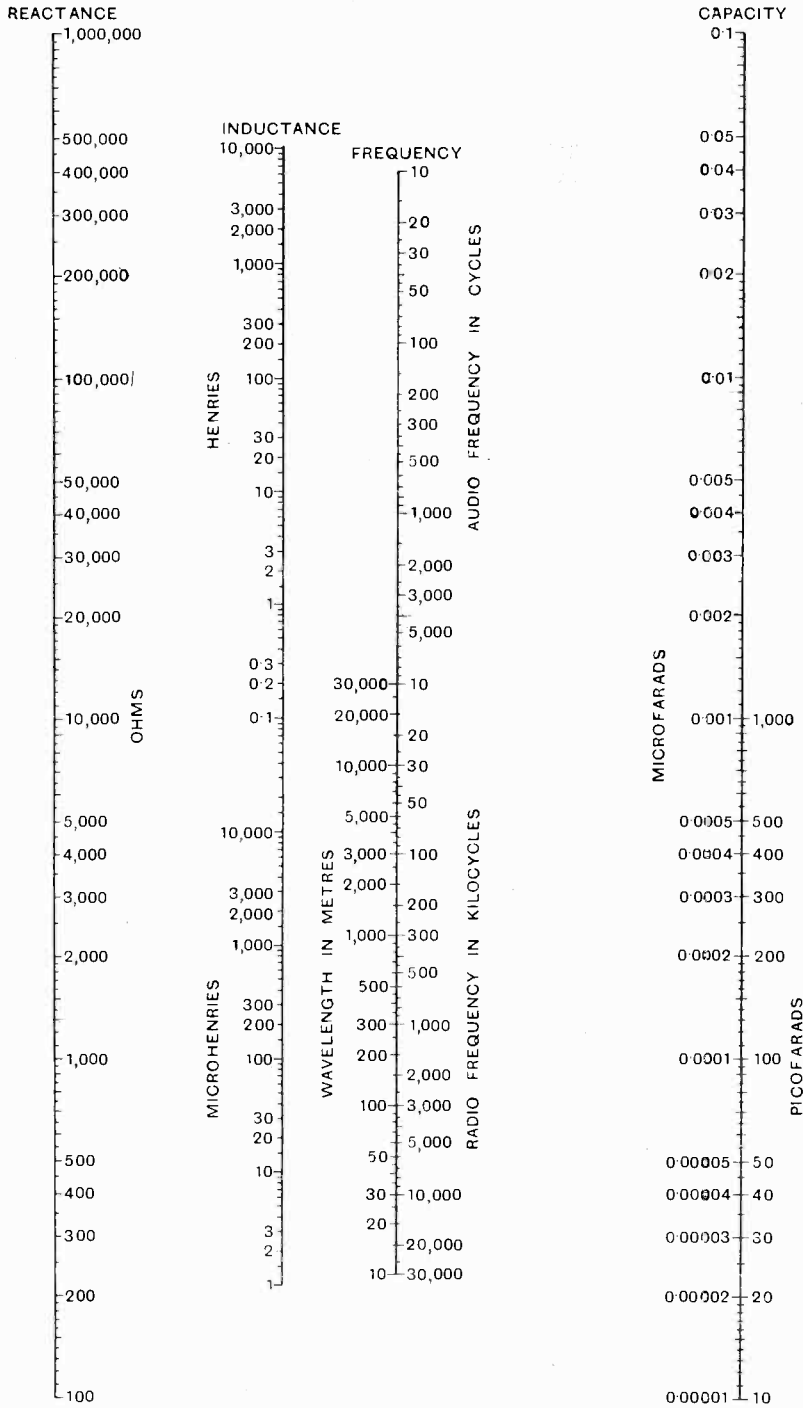

Fig. 1.—Reactance of single capacity or inductance.

Copyright by Author.

etc., to yield a certain reactance. Each of these operations is performed with equal ease. It consists essentially of laying a straight line across the diagram in a position assigned by the known elements of the problem; the line thus found serves as an index from which the values of the unknown

relating inductance and capacity with wavelength according to the formula $\lambda = k \cdot \sqrt{LC}$. The first of our Diagrams, Fig 1, is an extension of this, in which the position of the scales and their graduation have been so arranged as to permit of the inclusion of a fourth scale devoted to values of reactance.

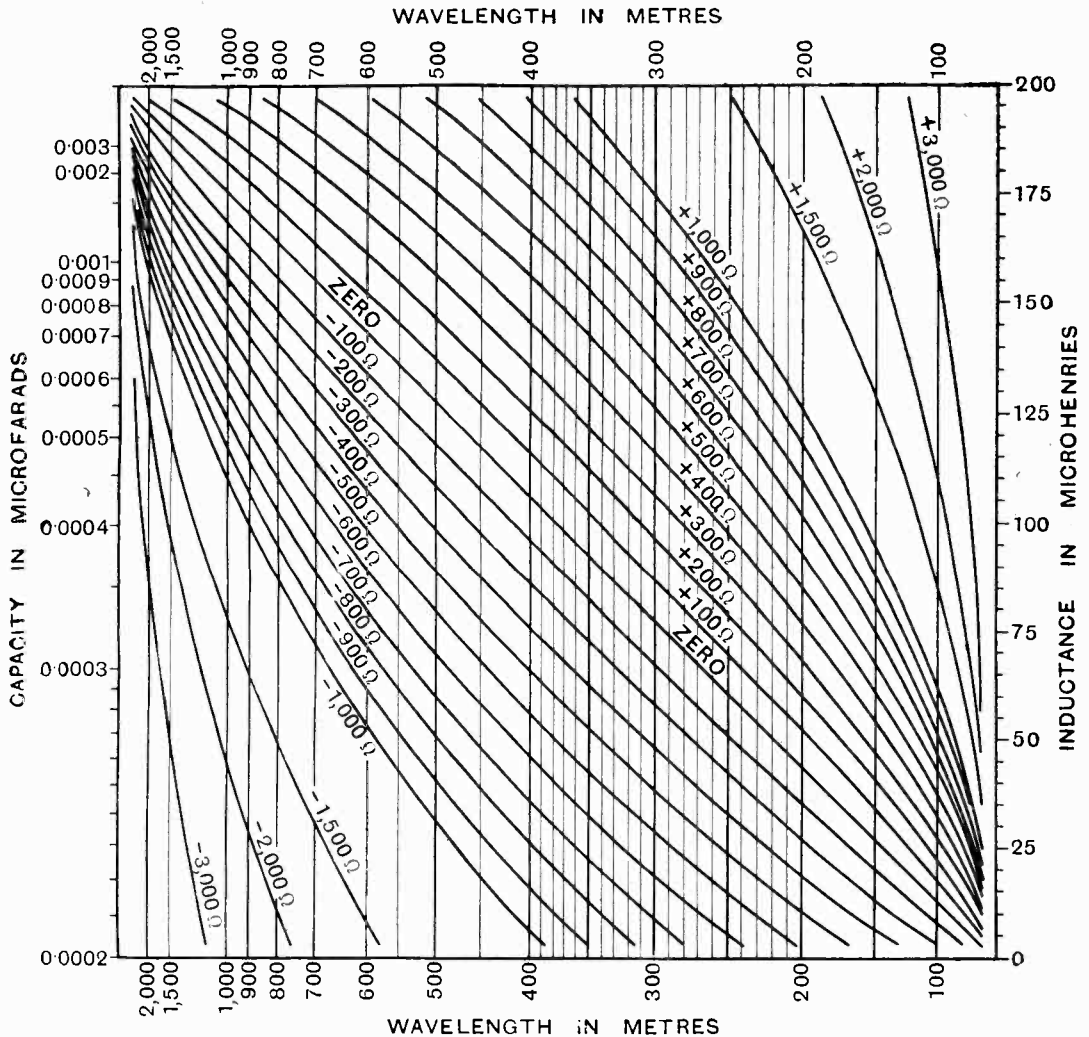

Fig. 2.—Reactance of series combination (radio-frequencies).

Copyright by Author.

elements may be read. The process is thus perfectly general.

§2. Simple Reactance Chart.

Some readers may possibly be acquainted with the simple 3-scale Alignment Diagram

The wavelength scale has further been extended to audio-frequency values, so as to comprise a complete scale of frequency. The scales are all logarithmic in character, that is to say, they are similar to those found on an ordinary slide-rule.

The method of use is extremely simple. A straight-edge or piece of thread placed across the diagram will meet all four scales in corresponding values. For example, the reactance of a condenser is found in alignment with the capacity value and the wavelength, while the value of an inductive reactance is similarly found in alignment with the inductance value and the wavelength. Again, if values of inductance and capacity

of sign) also appears on the reactance scale. We may explain this by noting that, since the diagram has been constructed to illustrate the relations $X = 2\pi fL$ and $X = \frac{1}{2\pi fC}$, it follows that it will also fulfil the relation $X = \sqrt{\frac{L}{C}}$. This reactance value, it should be observed, must not be taken as that of the resonant combination. For a pure

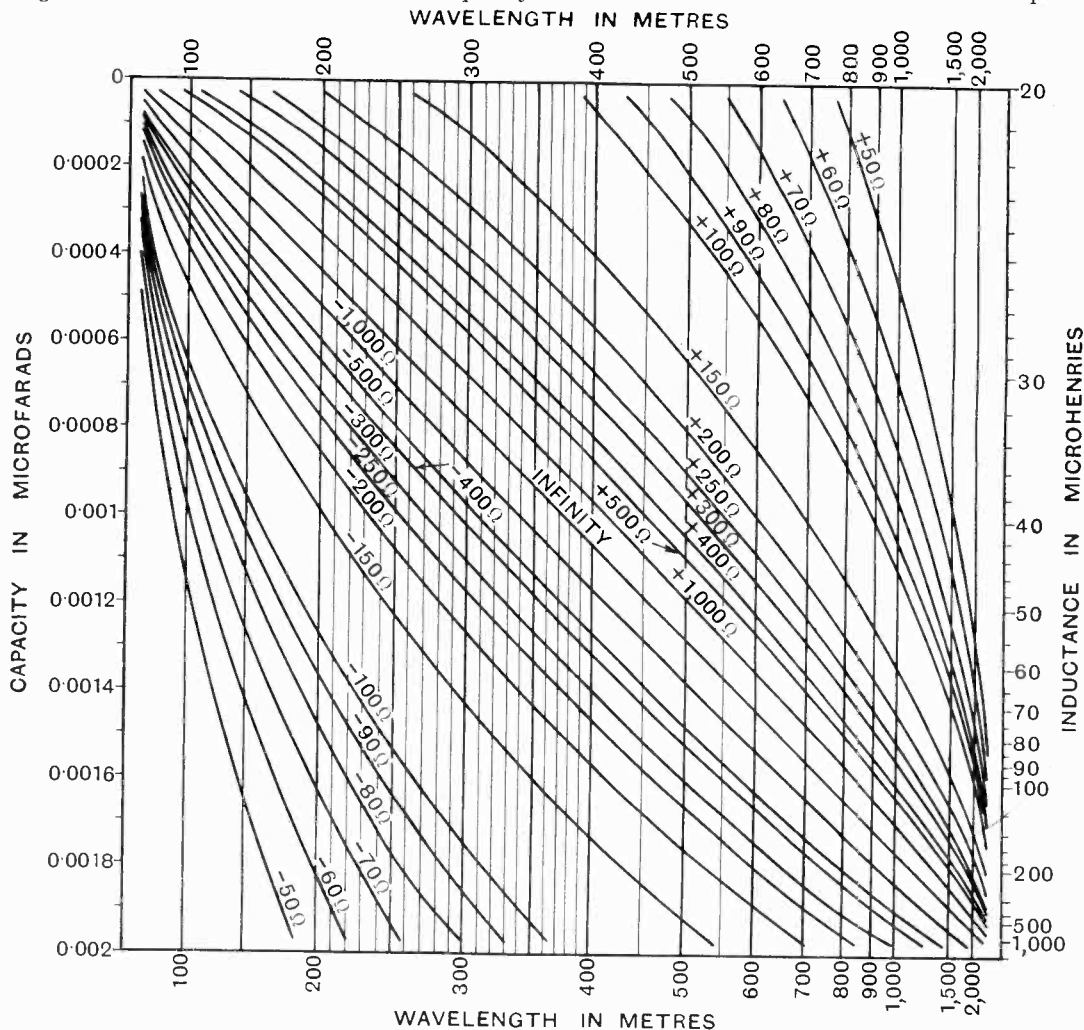

Fig. 3.—Reactance of parallel combination (radio-frequencies). Copyright by Author

be given, the wavelength to which their combination is resonant can be read off, while the reactance offered by each component at the resonant frequency (irrespective

capacity and inductance with no resistance effect, the reactance at resonance is theoretically either zero or infinite, according as they are combined in series or in parallel.

The diagram of Fig. 1 is of considerable utility. Apart from showing at a glance the mutual dependence of the quantities dealt with, and the relations between their variations, we obtain from the chart much useful information respecting the performance of various values of inductance and capacity at different frequencies. For instance, it is

impedes audio while passing radio frequencies, and the larger the condenser the smaller the reactance for any frequency. Thus the relative choke and by-pass effects of coils and condensers at various frequencies are easily and rapidly contrasted. The impedances of valves, choke values, valve capacities, etc., met with in practice may be

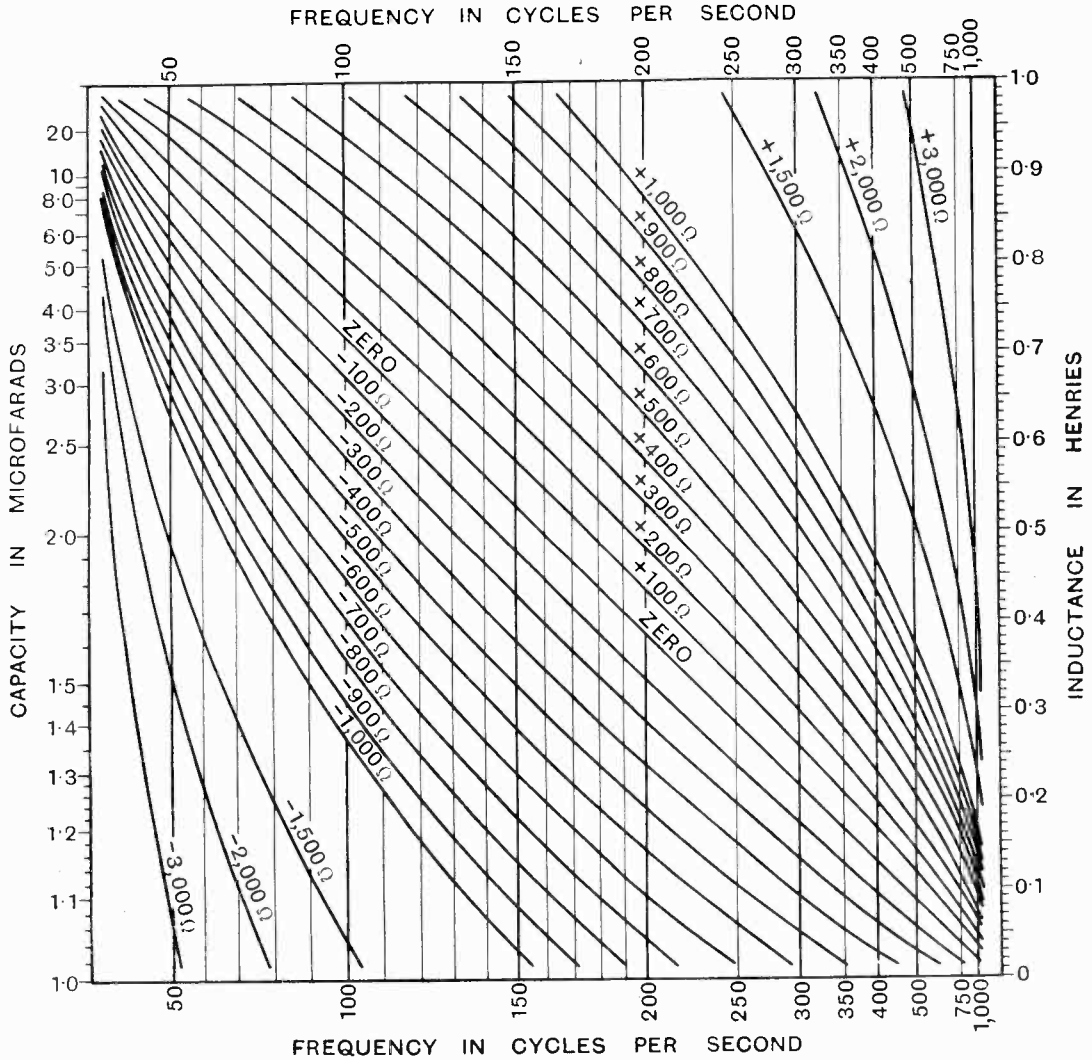

Fig. 4.—Reactance of series combination (audio-frequencies). Copyright by Author.

seen that an inductance or choke impedes radio frequencies more than audio frequencies, and that the larger the choke the larger the reactance it offers. Again a condenser

inscribed on the appropriate scales of the diagram, and the writer would suggest that an enlargement of this chart, with additional data, might be a useful, not to say indis-

pensible, fixture on the walls of the experimenter's "den."

§3. Series and Parallel Reactance Charts.

We now pass on to consider four charts designed to yield at sight the reactances

computed from the following formulæ,

for series combinations, $X = 2\pi fL - \frac{1}{2\pi fC}$

for parallel combinations, $X = \frac{2\pi fL}{1 - 4\pi^2 f^2 LC}$

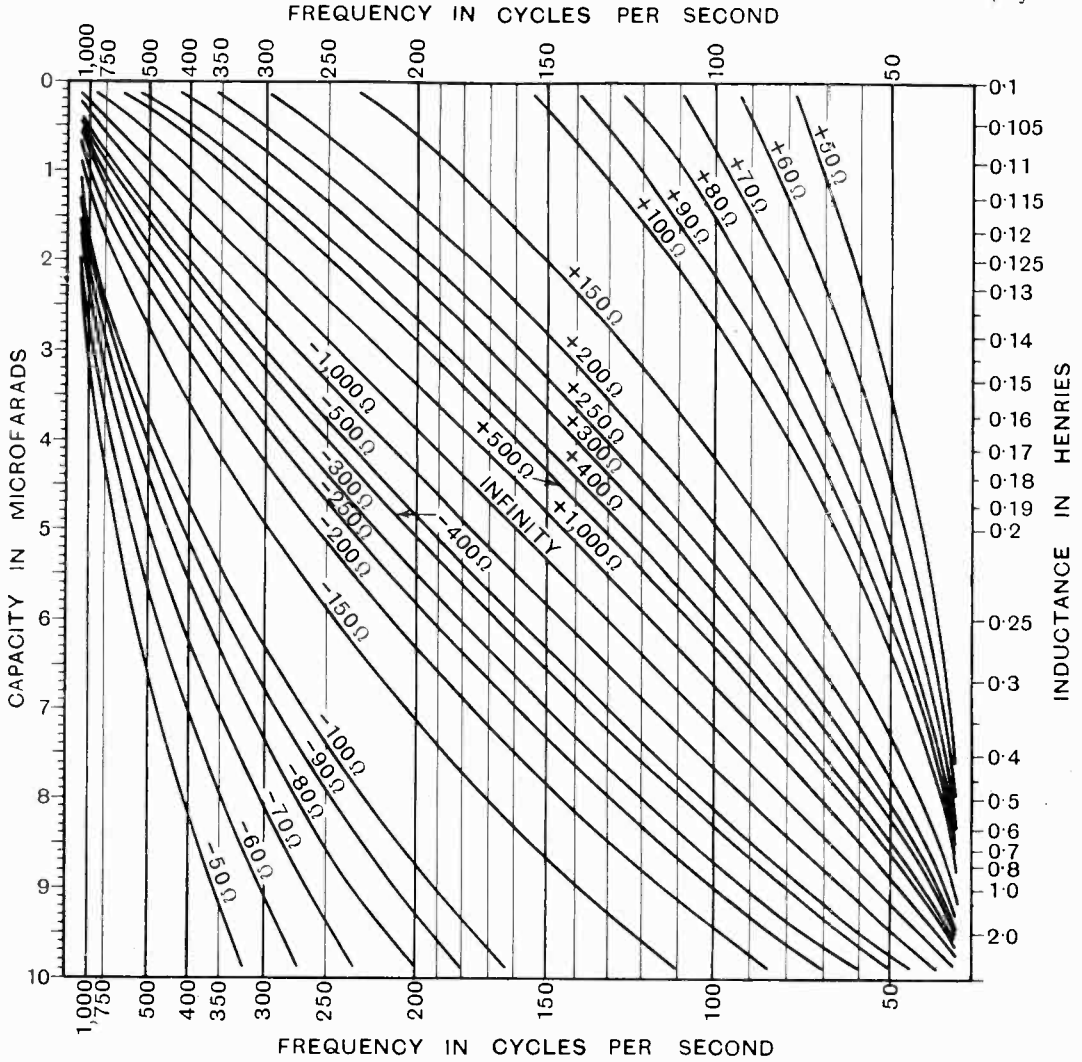

Fig. 5.—Reactance of parallel combination (audio-frequencies). Copyright by Author.

offered at certain wavelengths or frequencies by series and parallel combinations of inductance and capacity, and inversely. The resonant frequency for such a combination may be found from Fig. 1; for any other frequency the same combination will offer a definite reactance which may be

Figs. 2 and 4 are designed to solve the first of these equations, while Figs. 3 and 5 solve the second. The method of use is in all cases the same. The particular values of capacity and inductance being sought on the side (vertical) scales, a straight-edge is placed across them. The line thus found will

intersect the vertical line appropriate to the given wavelength or frequency in a point whose position relative to the network of numbered reactance curves gives a measure of the reactance in question. It will be observed that if any three of the four variables be given, the remaining unknown is at once obtained from the appropriate diagram. Figs. 2 and 3 are constructed for radio frequencies using wavelengths; Figs. 4 and 5 deal with audio frequencies using cycles. For values of frequency and reactance intermediate between the lines and curves given on the charts, recourse must be had to interpolation by eye. On the ordinary scale of these diagrams this is generally sufficiently accurate for most purposes; unfortunately for purposes of reproduction the scale here is necessarily greatly reduced.

§4. Scale Extension Diagram.

In using the five charts given, it may happen that the range of values shown for a particular variable does not contain the actual number which it is desired to use. If, however, the existing range of values were all multiplied by a suitable factor, it could be made to include the desired number. The scale as thus altered can, in fact, be used, on condition that the other scales for the other variables are each multiplied as well by certain other factors which will generally be different for each variable. To indicate various consistent "groups" of such factors, from which we can select the most convenient, is the function of the "Scale Extension Diagram" of Fig. 6.

This chart consists of four parallel lines, one corresponding to each of the variables concerned, and graduated with a series of points lettered $f^2, f, 1, \frac{1}{f}, \frac{1}{f^2}$, etc. Now let f denote an arbitrarily chosen factor by which it is desired to multiply a certain range of values on the original Alignment Chart. Note the point " f " on the line for that variable on the "Scale Extension" Diagram. Then, corresponding factors by which the various other variables may be multiplied will be found on their respective lines in alignment with the original point " f ." Several such possible lines through each " f " point are shown on the diagram, and the most convenient to the case will, of

course, be selected. It will generally be possible to take the value of f as either 10 or .1, so that the factors for the other scales will all be powers of 10, and no arithmetical work beyond shifting the decimal

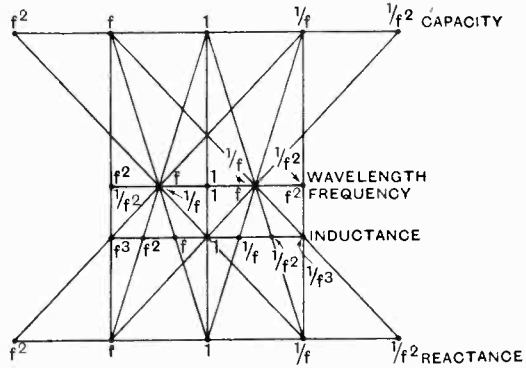

Fig. 6.—Scale extension diagram. Copyright by Author.

point is involved. Where unity is shown as a factor the corresponding scale is, of course, left unaltered. By this device, the range of values covered by any one chart is enormously extended with extreme facility.

Example.

As a practical example of the use of the Scale Extension Diagram, let us suppose it required to find that value of capacity which, in series with $15\mu\text{H.}$, will give a reactance of + 500 ohms at 35 metres. To enable Chart 2 to be used, the wavelengths shown would require to be divided by 10. Take then $f = 10$, and consider the point marked $1/f$ on the wavelength scale of Fig. 6. It will be seen that appropriate sets of multipliers for the other variables are:—

	Inductance.	Capacity.	Reactance.
(1)	$1/f^3$	f	$1/f^2$
(2)	$1/f^3$	1	$1/f$
(3)	$1/f$	$1/f$	1
(4)	1	$1/f^2$	f

Since the inductance in question is $15\mu\text{H.}$, it is seen that the most appropriate set is given by line (3) of the above Table, since the factor $1/f$ or $1/10$ applied to the inductance values of Chart 2 renders them applicable to the case. Therefore we find that the capacity values shown on Chart 2 must also be multiplied by $1/f$ or $1/10$, while the reactance values remain unaffected.

Hence, using Chart 2 as though the values shown by it were all affected by the above factors, a line through the point for $15\mu\text{H.}$ and the point of intersection of 35 m. and + 500 ohms meets the capacity scale at $0.0006\mu\text{F.}$, the required value.

(To be continued.)

A Braun Tube for Direct Photographic Recording.*

By *Manfred von Ardenne.*

Technical Summary.

In the present position of oscillograph technique it is necessary to distinguish between low-voltage and high-voltage oscillographs, corresponding respectively to electron-velocities of 100 to 1,000 volts and 30,000 to 50,000 volts in the tubes. The applications and the methods of observation are entirely different for the two types. The high-voltage oscillograph has from one-tenth to one-fiftieth of the voltage-sensitivity of the low-voltage tube. It is therefore particularly suited to investigations where high voltages are available. There is thus already so much energy available in the high-velocity cathode rays that it ceases to be necessary to produce on the plate standing figures traversed several times by the ray, and it suffices, even at the highest frequencies, if the ray traces out its curve but once. In this type of work it is usual to put the plate

or in the case discussed about 1/10th the velocity of light).

This high-voltage equipment is sharply distinguished from the oscillograph for small currents. It is of the very highest importance that a Braun tube intended for the investigation of small currents should possess the highest possible voltage-sensitivity. This property is inversely proportional to the square root of the anode voltage, and at 500 volts generally amounts to some 2 to 3 mm. per volt. But the decrease in kinetic energy of the electrons results also in a decrease of their direct photographic activity, so that the low-voltage oscillograph is at its best when used with a fluorescent screen. In practice, direct photography of the screen is hardly possible at low voltages, so that if permanent records are to be made it becomes necessary to produce standing figures. No matter whether these take the form of Lissajou's figures, or whether they are depicted, by the aid of synchronised linear deflecting voltages, as wave-form curves, one is restricted to phenomena which are fully periodic for the duration of the exposure.

In the author's laboratory there has therefore been developed a tube which, even with anode potentials between 1,000 and 2,000 volts, permits photography of aperiodic phenomena direct from the fluorescent screen.† The construction of this tube will now be described, and a few photographs taken with its aid reproduced.

Performance of the Tube.

When compared with the low-current tubes available commercially the new tube shows a whole series of characteristic differences. In Figure 1 is shown the base of the bulb, which is in all some 40 centimetres long. The external shape of the bulb is shown diagrammatically in Figure 2, while the bulb as a whole appears in the photograph, Figure 3. The tube is distinguished from all others by its ability to

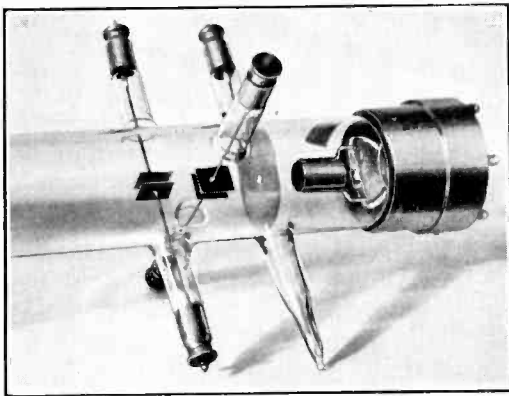

Fig. 1.—The foot of the tube.

directly in the vacuum. Fluorescent screens can seldom be used, for they often cannot stand the considerable local heating. The high-voltage oscillograph is suitable for depicting transients and surges on high-voltage leads and cables, for its short-wave limits are of course extraordinarily low (the electron-velocity is $6.10^7\sqrt{E_a}$ cms. per sec.,

† Head Office: E. Leybold, Berlin, N.W. Luisenstrasse 31. Branch Office: Charlottenburger Motorenengesellschaft, Berlin, Bismarkstrasse.

* MS. received by Editor, October, 1929.

provide brilliance enough for instantaneous exposures. This is fundamentally due to three points :

1. *The Fluorescent Screen.* Instead of the

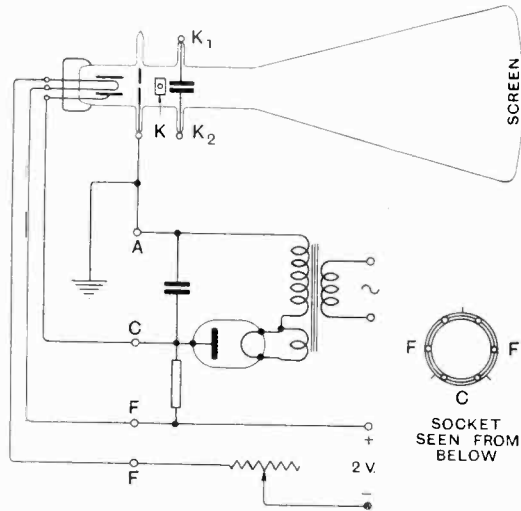

Fig. 2.—Circuit, including rectifier, used with the tube.

usual zinc sulphide, which fluoresces green, a suspension of calcium tungstate ($CaWO_4$) in waterglass is spread in an extremely thin film on the base of the glass bulb. The chief constituent of the fluorescent light emitted

by this substance on irradiation lies far in the violet part of the spectrum, and it therefore possesses a far higher photographic activity than zinc sulphide. The minute thickness of the layer prevents appreciable absorption of the fluorescent light, so that observation and photography become possible from outside the tube, in the direct path of the rays.

2. *Concentrating the Rays.* In order to achieve sufficient brilliance with small accelerating voltages, no loss of energy by screening can be permitted. The rays are concentrated by purely electrostatic means, using a Wehnelt cylinder. This cylinder, surrounding the cathode and coaxial with the path of the ray down the bulb, can be seen in Figure 1. The anode takes the form of a plate, and is situated at a distance from the end of the cylinder. This arrangement of the electrodes ensures that if the cylinder is given a suitable negative voltage with respect to the filament, the lines of force already run homogeneously enough in the direction of the axis of the cylinder to provide good initial concentration. Thus the ray of electrons passes cleanly through the 2-millimetre aperture in the anode without suffering any losses due to screening at this point.

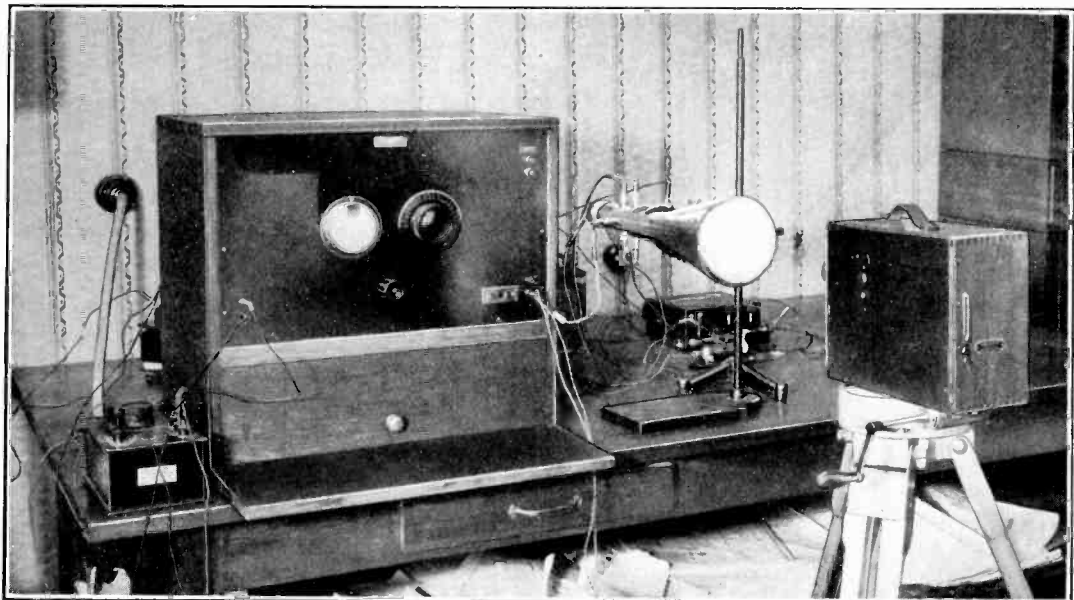

Fig. 3.—Experimental apparatus for photographing modulation-curves of broadcasting stations.

It is next necessary to prevent divergence of the ray after leaving the anode, for which purpose care has to be taken to nullify the space-charge. The presence of a trace of a rare gas, by the ionisation of which a considerable number of positive ions is pro-

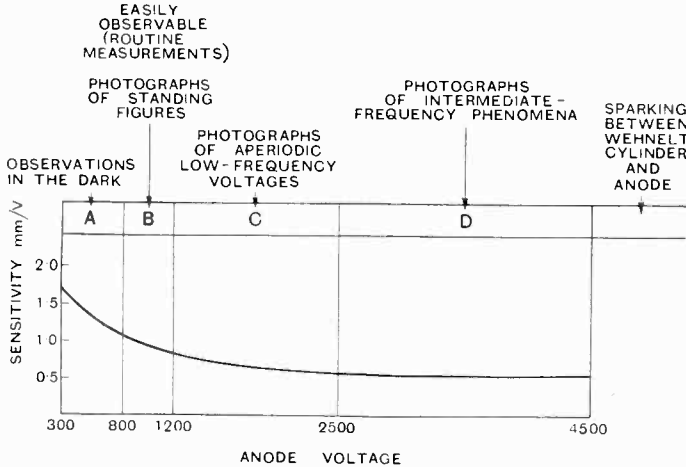

Fig. 4.—Sensitivity and operating voltage of the cathode-ray oscillograph.

duced, causes the electrostatic repulsion due to the space-charge to be outweighed by the electrodynamic attraction of the convection currents moving approximately parallel to one another in the ray. With this arrangement it at once becomes possible, with low anode potentials or from 400 volts upwards, to obtain a bright spot of less than one square millimetre area, and this can be retained up to potentials of some 2,500 volts, the cylinder voltage being kept at about ten per cent. of that on the anode. It is only with still higher voltages, such as are required when unusual brilliance is needed on the screen (for brilliance increases very rapidly with anode voltage) that the use of a control-magnet becomes necessary. The effectiveness of this measure is in any case largely dependent on the condition of the surface of the cathode. Since the ray must necessarily leave the cathode at right-angles to the surface, and since further its intensity is dependent upon the emission per square centimetre from that surface, it is seen to be desirable to coat a small part only of the surface of the cathode with highly emitting oxides, so that only this small region can act as the source of the ray. An oxide-coated cathode of this type combines great efficiency with very long life.

3. *The Anode Potential.* As the brilliance of the illumination rises very rapidly with the anode voltage it is important that the internal insulation of the tube should permit the use of potentials up to 4,500 volts. It is therefore necessary to forgo the convenience of bringing all connections to the socket, even though a separate connection to the anode, such as is shown in Figure 1, adds considerably to the cost of manufacture. Only the connections for the cathode and the Wehnelt cylinder are taken to the socket.

The Sensitivity of the Tube.

The purposes for which the tube was to be used made it desirable to strive for high sensitivity. This was attained by keeping the deflecting plates close together (4 to 5 mm.) while making their length relatively great (10 to 15 mm.). Since the emission of the tube is of the order of 10^{-3} to 10^{-4}

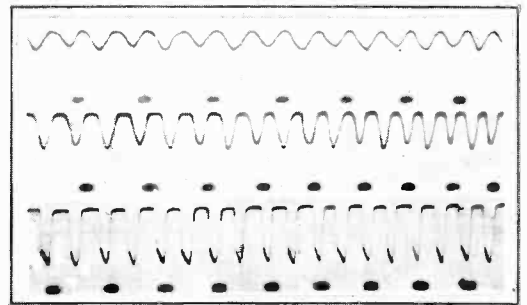

Fig. 5.—Output valve overloaded.

amperes, the high anode voltages were easily obtained by rectification. The circuit of Figure 2 shows a half-wave rectifier, while at the same time the necessary negative bias for the cylinder is obtained by making use of the voltage-drop caused by the passage of the emission current of the tube through the resistance R , of value about 10 megohms. The smoothing of the rectified voltage can be performed by a condenser of capacity 0.02 mfd., for the resistances both of the Braun tube and of the rectifier are very high. The high-resistance rectifier is chosen

for the reason that if its saturation current is, as a maximum, 1 milliampere, the apparatus becomes safe to touch.

In this way a sensitivity of 1.5 per millimetre is attained with an anode voltage of

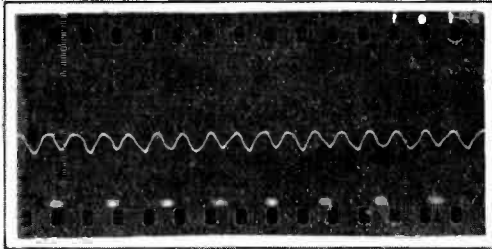

Fig. 5a.—Valve no longer overloaded.

400 volts. If higher voltages are used there is a corresponding drop in sensitivity. At very high voltages, therefore, the use of an amplifier is sometimes necessary in investigating small currents. The arrangement of the deflecting plates is of special importance. It was desired to be able to take oscillograms of high-frequency phenomena. For this purpose it is essential to keep the reactance due to the capacity between the plates, and mutual coupling between the pairs of plates, as low as possible. The leads to the condensers were therefore taken out through the side of the bulb, as Figure 1 shows. The lead-capacity is only some 5 to 6 cms., so that it is possible to make quantitative observations with calibrated aperiodic high-frequency amplifiers preceding the tube even at 300 metres wavelength, and obtain good deflections.

Figure 3 shows the tube in conjunction with a six-stage aperiodic high-frequency amplifier which, with its three multiple valves, permits amplification up to 20,000

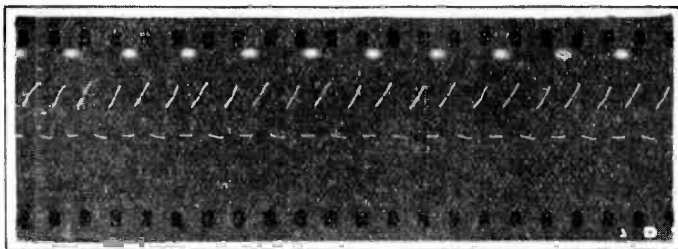

Fig. 5b.—Anode current limited.

times,* the whole being intended for the photography of the degree of modulation of distant broadcasting stations. The film camera can be seen in front of the tube.

A summary of this section is given in Figure 4. In this the various regions corresponding to different anode voltages are shown, together with the purposes for which each can be used. In region A, between 300 and 800 volts, the sensitivity of the tube is at its highest (about 1.5 mm. per volt). A very sharply defined spot of light, which can easily be observed in the dark, is obtained. In region B the brilliance of the spot of light is already great enough for observations in daylight. For photographic exposures only standing figures, for time exposures of 1/10th to 1 second, can be used. The third range, C, is the most generally useful. The brilliance of the spot of light now permits instan-

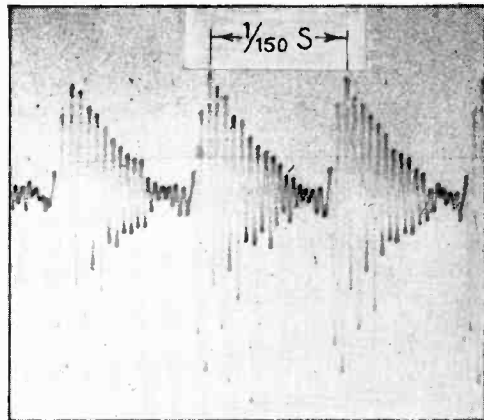

Fig. 6.—The vowel "e."

taneous exposures. These can be taken on super-sensitive plates with a lens working at $f/2.5$, while for film exposures with standard film a faster lens ($f/1.5$) is required.

Using a suitable rate of movement of the film audio-frequency phenomena of 1 cm. amplitude can be photographed up to 4,000 cycles, while by using special film and special methods of sensitising this limit can be pushed up to about 40,000 cycles. The film

* Described in *Jahrbuch f. drahtl. Teleg. und Telephon.*, Vol 32, Part 6, 1928.

must be run continuously; if an ordinary cine-camera is used the intermittent film-feed must be converted so as to feed steadily. The range of highest voltages, range D, is only useful for photographs of very rapid phenomena of appreciable amplitude.

longer overloaded; the sine-wave shape of the voltage applied to the grid is well reproduced. In Figure 5b the anode current is limited in both directions; through grid current in one direction and through the bottom bend in the other.

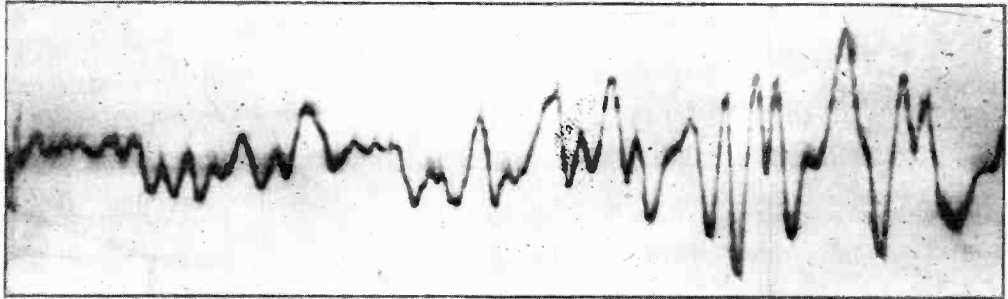

Fig. 7.—The sound of a word.

It should easily be possible to photograph intermediate frequencies up to 20,000 cycles. In general the concentrating of the ray at voltages over about 2,500 offers, as has been said, some difficulties. The use of a concentrating coil, and an amplifier before the tube in order to raise the sensitivity, will be necessary in most cases where high voltages are used. Sparking-over sets a limit to the highest voltage that can be used on the tube; but this does not occur before 4,500 volts.

The uses of the tube will be shown by several oscillograms, taken, some with 1,800 volts on the anode, and some at lower potentials, on Agfa-Normalfilm (Speed 17° Scheiner) with a lens of aperture $f/1.5$. Throughout aperiodic and semi-periodic phenomena are dealt with. That fully periodic

Figure 6 shows the analysis of a vowel-sound; the vowel in question is "e,"* spoken at 150 cycles. The 16th harmonic of the vowel can clearly be seen with a frequency of 2,500 cycles.

Figure 7 shows part of the sound of a word, taken with a carbon microphone and a transformer. As in Figure 6, there is a lack of symmetry between the upper and lower halves of the curve, due to the direct current polarisation of the transformer core.

An interesting oscillogram is shown in Figure 8. This is a direct record of the modulation curve of a broadcast transmitter, and was taken with the arrangement of Figure 3, using an aperiodic amplifier before the tube. It is clear that the amplitude of the high-frequency current is in



Fig. 8.—Modulated high-frequency.

phenomena can be dealt with very easily with this high-illumination tube and time exposures may be taken for granted.

Figure 5 shows the overloading of an output valve supplied with a signal voltage at 300 cycles. A neon lamp, connected to 50-cycle mains, is used to mark time-intervals. In Figure 5a the amplifier is no

places brought right down to zero. Such an equipment, with a revolving mirror and worked with about 1,000 volts, would be suitable for controlling maximum transmitter modulation.

* German pronunciation: the French "é" approximates to it. The English "ay" is a diphthong. (Translator.)

The Problem of Distortion in Sound Film Reproduction.*

By C. O. Browne, B.Sc. (*The Gramophone Company, Ltd.*)

THE object of the following article is to point out where distortion may be introduced into a film recording and reproducing system, and to indicate methods by which it may be eliminated. Little attention will be paid to recording studio technique and to the acoustics of the reproducing auditorium, as these particular problems are met with in other branches of sound reproduction.

Although the general principles of light recording and sound reproduction from film are now well known, it will be convenient

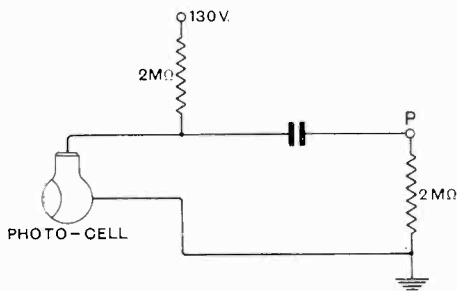

Fig. 1.

first to mention briefly the essentials of a light recording and reproducing system. The photographic film record of sound is an exposed track which, when suitably illuminated, the instantaneous quantity of light transmitted (at a particular part of the record) will be proportional to the corresponding instantaneous value of the microphone current at the time of recording. The light transmitted through the film is allowed to fall on a photo-electric cell, and the resulting photo-electric current is amplified and fed to loud speakers, the reproduced sound being a fair copy of the original.

Whereas in the case of wax recording the sounds are recorded at constant velocity, that is, the amplitude of the recording stylus is substantially inversely pro-

portional to the frequency, the sounds are recorded at constant amplitude in the sound film system. Amplitude and frequency distortion is likely to be introduced in the recording and reproducing apparatus. The former is introduced by working over non-linear portions of the characteristics of recording and reproducing components, and the latter arises from apparatus which responds differently over the frequency range. Apart from the valves used in the system which must not be overloaded, it is essential to preserve linearity between the output current of the recording amplifier and the photo-electric input current of the reproducing amplifier. This necessitates a linear characteristic of the recording element, and in the case of variable density recording, also that the density produced on any part of the sound track should be proportional to the corresponding intensity of the modulated light.

By the use of comparatively simple apparatus it is possible to examine the response of either the recording or reproducing apparatus over the range of audible frequencies. Since the reproducing apparatus is essentially standard for all types of sound film equipment, it will be discussed first, followed by a discussion of the different types of recording apparatus.

Reproducing Apparatus.

A narrow transverse strip (about .001 inch wide) of the film record is illuminated by a steady source of light, and the amount which is transmitted is picked up by a photo-electric cell. It may be assumed that for the small light intensities used in reproducing from film, the photo-electric current is proportional to the quantity of light incident upon the cell.

The cell may be connected in an input circuit such as is shown in Fig. 1. The point P is connected to the grid of the first valve of the amplifier, which may consist of two stages of high voltage magnification coupled

* MS. received by Editor, October, 1929.

to power amplifiers large enough to produce the energy required to work the loud speakers. It will be appreciated that since the impedance of a photo-electric cell under working conditions is of the order of 1,000 megohms, any stray capacity of the input circuit, in shunt with the cell, will lead to considerable attenuation of the higher frequencies. With the values given in the diagram stray

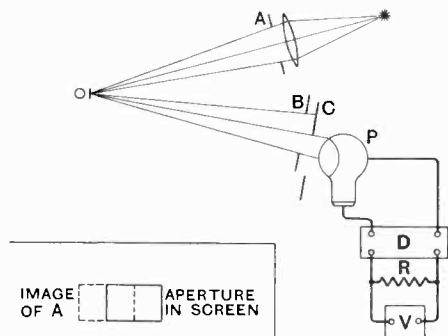

Fig. 2.

capacity of $8 \mu\mu\text{F}$. of the lead to the photo-cell will give rise to 3 T.U.s attenuation at 5,000 cycles per second, even without taking into account the effect of inter-electrode capacity of the first valve. When this circuit is used, the first stages of the reproducing amplifier are therefore placed as close to the cell as possible and low impedance lines are taken to the power amplifiers.

Frequency Characteristics of the Reproducing System.

Before discussing the shape of the frequency characteristics of the photo-electric cell and reproducing amplifier, the method by which these characteristics are obtained will be described.

In order that a frequency calibration of a photo-cell and amplifier may be obtained under working conditions, it is necessary to inject each small input alternating potential to the first valve across the high impedance network associated with the photo-cell, and to measure the corresponding output voltage. It is difficult to improvise a satisfactory network to represent the photo-electric cell, so that this condition is not realised in the usual method of electrical calibration where the input voltage is injected across a high resistance.

The method of calibration is, therefore,

to project on to the photo-electric cell harmonically varying light of selected frequencies at constant amplitude and to measure the corresponding voltages produced at the output of the reproducing amplifier.

A high-frequency type of Duddell oscillograph *O* in conjunction with the optical system shown in Fig. 2 produces the alternating light source. An image *B* of a square aperture *A* is formed by the oscillograph mirror on a screen *C* in which a second aperture is cut having dimensions equal to those of *B*. The image is then displaced half-way across the screen, as shown in the inset diagram. If the double amplitude of the image *B* be limited to the width of the aperture in *C* and be kept constant, it follows that the quantity of light passing through the screen will vary sinusoidally at constant amplitude and with a frequency equal to that of the oscillograph strip. A number of preliminary tests are first made on the wave form of the oscillograph and oscillator supplying it. Usually the errors introduced on this account are not large enough to merit correction.

The photo-electric cell *P* and amplifier *D* are enclosed in a shield and placed behind the screen *C*. The voltage produced across the matching resistance *R* by the incident light on the cell is measured by a Moullin voltmeter *V*.

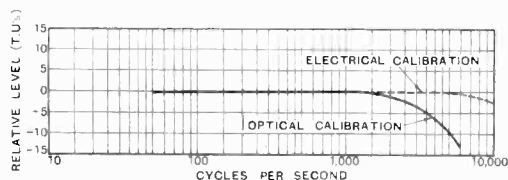

Fig. 3.—Response of reproducing equipment.

The general shape of a response curve of a photo-cell and amplifier is illustrated in Fig. 3, which shows also the corresponding curve obtained by the usual electrical calibration. Both curves can be obtained correct to 1 T.U.

These frequency characteristics indicate considerable attenuation at the higher frequencies, the amount varying considerably with different photo-electric cells, although the same amplifier is used. It is found that the surface noise increases if this attenuation

is reduced and may be practically eliminated by including a filter in the reproducing system to cut off the higher frequencies still further.

Much of the brightness or intelligibility of the reproduced sound will be lost if the response follows a curve such as that in

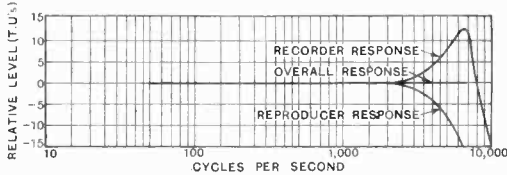

Fig. 4.—“Ideal” characteristics.

Fig. 3. If, however, the recording characteristic be made the mirror image of that of the reproducer over the working range, it would be possible to obtain a complete sound film system having an approximately flat characteristic up to about 5,000 cycles per second, at the same time being tolerably free from surface noise. Fig. 4 gives ideal curves based upon this principle. Overloading may occasionally take place on the film record at the higher frequencies

Recording Systems.

The recording systems may be divided into two groups; the first produces film records of constant density but of variable width, and the second makes constant width records of variable density. These types of records are illustrated in Fig. 5.

A.—Twin Wave Recording.

As a particular example of variable width recording a system producing the twin wave track will be described in some detail. The recording movement in this case is a modified form of Einthoven string galvanometer provided with an optical system to give sufficient magnification of the movements of the strings. The complete recorder is illustrated diagrammatically in Fig. 6. Two metal ribbons constituting the strings of the galvanometer are placed side by side, which are normally .002 inch apart, and are arranged so that the speech currents open and close the space between them. The optical system consists of a light source, illuminating objective *A*, magnifying objective *B*, cylindrical condenser *C* and restricting slit *S*, .003 inch in width. An enlarged image of the ribbons *M* is produced in the plane of the film *F* by

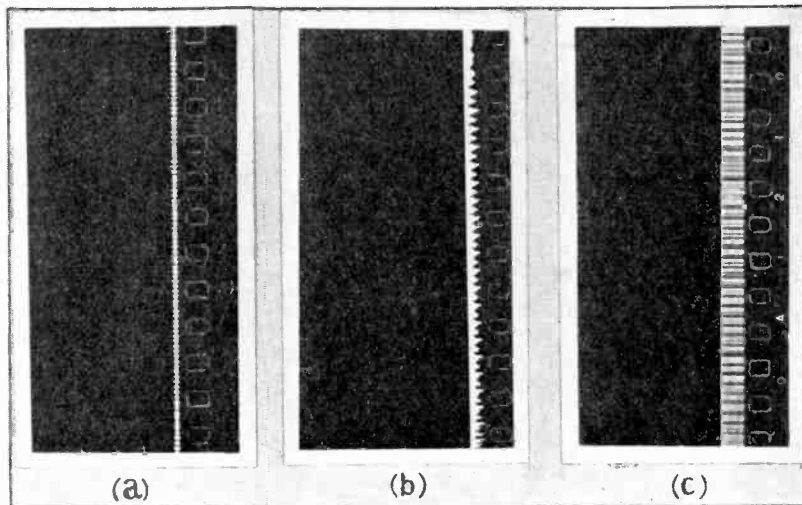

Fig. 5.—Examples of film records. (a) Variable width twin wave; (b) Variable width; (c) Variable density.

due to the increased recording level, but the harmonics of 4,000 cycles per second say, will only be reproduced at a very low level.

the microscope objective *B*, and the position of *C* is so adjusted that an image of the slit condensed in the plane of the paper is also

formed on the film. The resulting composite image is therefore a rectangle .0005 inch wide and having a mean length of .035 inch. The length varies symmetrically about this mean value due to the speech currents between 0 and .070 inch corresponding to maximum modulation.

The Oscillograph Recorder.

Variable width records are also produced by systems embodying some form of Duddell oscillograph. The response of an oscillograph modified for light recording is shown in Fig. 8. The height of the resonance peak can be increased by adjusting the amount

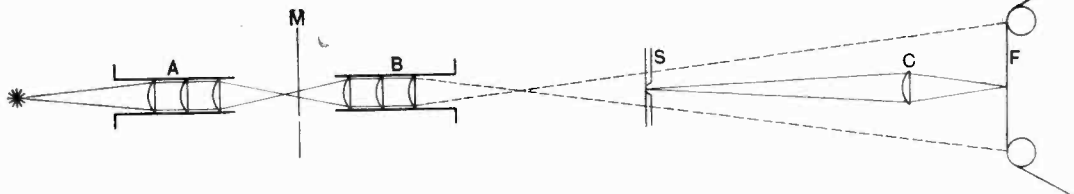

Fig. 6.

In order that the density of the exposed portion of the record should be standard, a preliminary photometer measurement is made on the recording lamp, and the lighting current is subsequently kept constant.

This recorder is calibrated by supplying to it constant energy of various frequencies and measuring the resultant amplitude with a microscope. A typical curve is given in Fig. 7 in which a considerable increase in response in the region of the resonance frequency of the ribbons may be noted. This curve conforms very nearly to the ideal curve shown in Fig. 4.

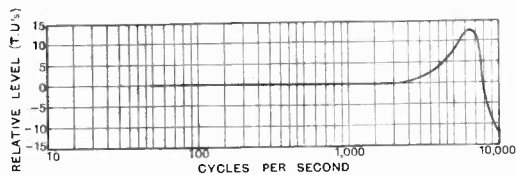

Fig. 7.—Response of twin wave recording movement.

It should be noted that the maximum amplitude recorded by this system is limited by the width of the track of the record, so that excessive amplitude may arise in loud passages in the neighbourhood of the resonance frequency of the recording movement. It has been explained previously that the harmonics introduced by this overloading will not affect the reproduction appreciably, although there is likely to be some attenuation.

of damping so that a fairly satisfactory frequency characteristic can be produced.

B.—Variable Density Recording.

In addition to the various sources of distortion which are present in a variable width recording and reproducing system

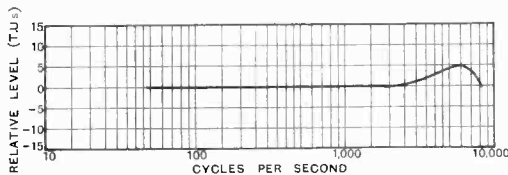

Fig. 8.—Response of Duddell oscillograph modified for light recording.

a further source, viz., photographic distortion, is introduced in the case of variable density records. Fig. 9 is a Hurter and Driffeld curve of a photographic emulsion, which shows the relation between the exposure and the resulting density after development. The density, defined by the log. of the ratio of the incident to transmitted light intensities, is plotted against the log. of the exposure, so that, if we confine our attention to the straight portion of the curve between *A* and *B*, the light transmitted by the developed film will be inversely proportional to the original exposure provided that the slope of the curve or the "gamma" of the developed emulsion is unity. Amplitude distortion will, therefore, be present if we reproduce from a

negative variable density record, so that it is necessary to reproduce from a print taken from the negative, and that the overall "gamma" of the developing and printing processes should be unity.

Referring to the Hurter and Driffeld curve, it will be observed that it is impossible to obtain 100 per cent. undistorted modulation, whereas in variable width records, if the dark portions be assumed opaque and the rest perfectly transparent 100 per cent. undistorted modulation can be realised.

Variable Density Recording Elements.

Types of recording elements which are available for making variable density records may be classified into two groups. The first group includes gas discharge tubes which may be considered as variable light

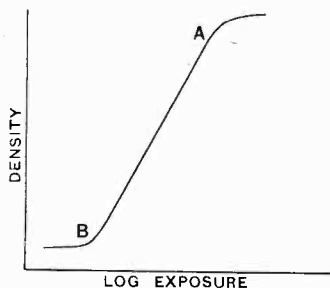

Fig. 9.—Hurter and Driffeld curve.

sources. The intensity of the light emitted by the lamp can be modulated in accordance with the speech currents generated at the microphone. The second group comprises those recording elements which modulate a beam of light emanating from a steady

fields. Two of these recording elements, the glow lamp and the Bell light valve, are described below and their response characteristics discussed.

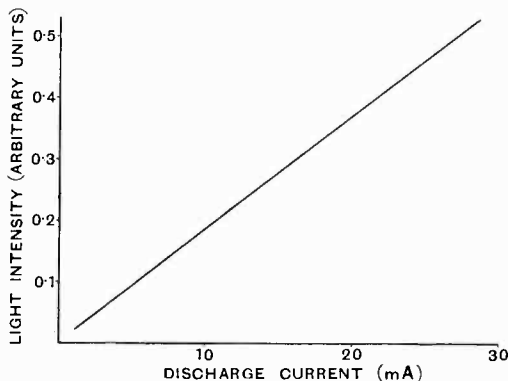

Fig. 10.

The Glow-lamp Recorder.

These lamps are tubes filled with argon, nitrogen or helium at a pressure of a few mms. of mercury. The electrodes are so disposed within the tube that a small source of light of comparatively high intensity is produced, and is modulated by the speech currents about a mean intensity. The curve in Fig. 10 shows that the light intensity/anode current relation is substantially linear. The chief difficulty encountered by using a glow lamp for recording is its small light intensity, but by using the optical system shown diagrammatically in Fig. 11, it is possible to record to a sufficient density on negative film.

The frequency calibration of a glow lamp presents difficulties which are not

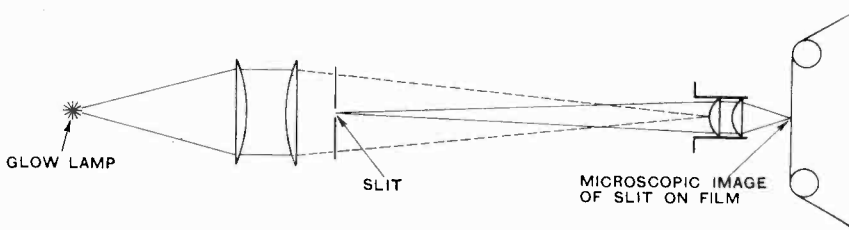

Fig. 11.

source. These light valves include the Kerr cell and various mechanical systems depending upon the movement of oscillograph strips or iron reeds in strong magnetic

experienced in calibrating a mechanical movement. In the case of the latter the amplitude of the vibration at different frequencies may be observed through a

microscope. Glow lamps may be calibrated either by making a number of single frequency records which are subsequently calibrated for density amplitude, or by projecting the modulated light on to the photo-cell and measuring the resulting output voltage of the reproducing amplifier. The first method introduces possible photographic errors, and owing to the fine structure of high-frequency film records their density calibration presents considerable difficulty. Photographic errors are eliminated in the second method, but it is necessary to know the frequency characteristic of the reproducing apparatus before the glow lamp can be calibrated.

The response curve shown in Fig. 12 obtained by the second method is typical, and is level from 50 to 5,000 cycles per second after corrections had been applied

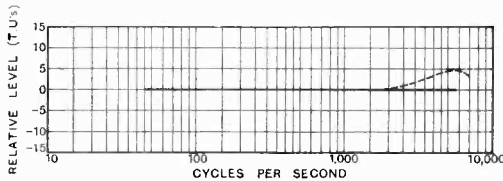

Fig. 12.—Response of glow-lamp recorder ———; response with electrical resonance - - - - -.

for the reproducer response. By including a suitable resonance network in the recording system, this curve can be made to approximate to that shown in Fig. 4. The dotted curve in Fig. 12 is the response when such a network is included.

The Bell Light Valve.*

A number of mechanical light valves have been devised for variable density light recording, all of which comprise an aperture which varies in accordance with the speech currents derived from the microphone. A beam of light is projected through this aperture and after traversing a suitable optical system it impinges on the sensitive film.

The Bell light valve is a particular case of a mechanical recording movement which produces variable density records. Briefly, it consists of two stretched duralumin ribbons *A* and *B*, Fig. 13, which carry the speech currents and constrict a rectangular aperture

C through which the light is passed. A strong magnetic field is applied in a direction perpendicular to the plane of the ribbons causing the latter to be deflected in a direction indicated by the arrows, thus opening

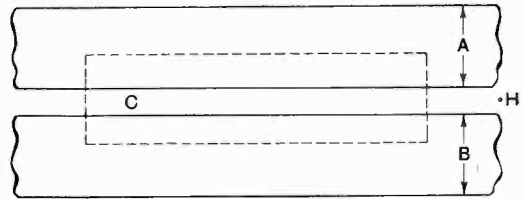

Fig. 13.

and closing the aperture. The slit formed by the two ribbons is illuminated by a metal filament lamp, and its reduced image is focussed on the film by a lens. The mean distance between the ribbons is .002 inch and the image produced on the film has dimensions .001 inch \times .125 inch.

The frequency response of a light valve of this type is obtained by measuring the amplitudes of the ribbons with a microscope; a typical curve is illustrated in Fig. 14. This curve may be subsequently checked by the photo-cell and amplifier method. The resonance in this case is practically undamped, which accounts for the high peak between 7,000 and 8,000 cycles per second. The combined curve of this recording movement and that of the amplifier and photo-electric cell is given in Fig. 15.

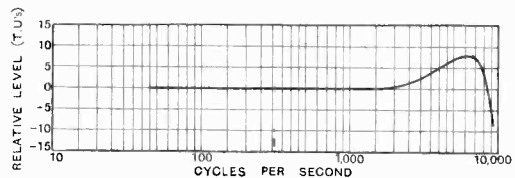

Fig. 14.—Response of recorder of Bell light valve type.

Slit Attenuation.

Thus far the characteristics of the recording element and reproducing system have been considered, but the effect of the finite slit width, by which the film is illuminated, has not been taken into account. The theoretical curve in Fig. 16 gives the attenuation for the ratio of the film speed to the

* *The Bell Technical Journal*, January, 1929.

slit width for a given frequency. In practice the film speed is 90 ft. per min., and the slit width .001 inch, so that the attenuation at 5,000 cycles per second due to both

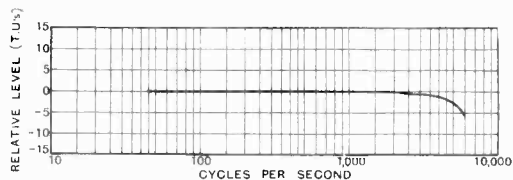

Fig. 15.—Combined curve of light valve (Bell type) and reproducing equipment.

recording and reproducing slits of this magnitude would be 2.5 T.U.s. This attenuation may also be compensated by adjusting the resonance of the recorder.

Summary.

The frequency characteristics of a recording and reproducing sound film system are discussed independently with a view to producing a level combined frequency re-

sponse. At the same time, the reproduction should be tolerably free from surface noise.

Various recorders, and the methods by which their frequency responses can be brought into line with that of the reproducer, are described. Correction can also be made for recording and reproducing slit attenuation.

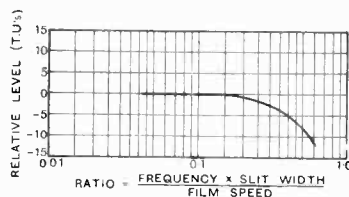

Fig. 16.—Attenuation due to finite slit width.

A recording system producing a twin wave track record of the variable width type is described in some detail, and the essential points of a variable density recording are observed.

Books Received.

RADIO TRAFFIC MANUAL AND OPERATING REGULATIONS. By R. L. Duncan and C. E. Drew.

A handbook primarily intended for the use of operators and amateur transmitters in U.S.A., and comprising instruction in morse; operating rules and regulations of the Radio Marine Corporation of America; International Radiotelegraph Convention of Washington and the Regulations attached thereto; U.S. Radio Act of 1927; Ship Act of July 23rd, 1912, and Regulations governing the issue and renewal of operators' licences in U.S.A. Pp. 187, with 15 illustrations, examples of operators' abstracts, logs, etc. Published by J. Wiley & Sons, Inc., New York, and sold by Chapman & Hall, Ltd., London. Price, 10s. net.

WIRELESS AND GRAMOPHONE TRADER YEAR BOOK AND DIARY 1930.

The sixth edition of this most useful book of reference includes all the features which have proved so valuable in the past carefully revised, enlarged, and brought up to date. The Directory Section contains a full alphabetical list of Manufacturers, Agents, Associations and Publications connected with the wireless and gramophone trades in Great Britain; Wireless and Gramophone Factors; A Classified List of the Manufacturers of Wireless and Gramophone Sets and Accessories and a list of Proprietary Names of various apparatus. The General Information, Trade Information, Technical Data and Gramophone Sections have also been considerably enlarged. Manufacturers and Traders will especially welcome the

abstract of the new provisions of the Marconi Licence. Published by the Trader Publishing Co., Ltd., Salisbury Square, E.C.4. Price 5s. 6d. post free or at a reduced rate to subscribers to the "Trader" journals.

ELECTRICITY, WHAT IT IS AND HOW IT ACTS (Vol. I). By A. W. Kramer, A.M.A.I.E.E.

A simple treatise on the part played by the electron in ordinary electrical phenomena, including its action in diode and triode valves. Pp. 274 + xiii, with 130 diagrams and illustrations. Published by Technical Publishing Company, Chicago, U.S.A. Price \$2 net.

PHOTOELECTRIC CELLS, THEIR PROPERTIES, USE AND APPLICATIONS. By N. R. Campbell and D. Ritchie.

A practical book explaining the theory and use of these cells and their application to Phototelegraphy, Television, Photometry, Absorption of Light, Colour Matching, etc. Pp. 209 with Frontispiece and 41 diagrams. Published by Sir Isaac Pitman & Sons, Ltd., London. Price 15s. net.

THE FUNDAMENTALS OF RADIO. By Prof. R. R. Ramsey, Ph.D., of Indiana University, U.S.A.

A text-book for students, comprising the general theory of electricity and the principles and practice of radio telegraphy and telephony. Pp. 372 + xi, with numerous illustrations and diagrams. Published by the Ramsey Publishing Co., Bloomington, Indiana, U.S.A. Price, \$3.50.

A Method of Measuring the Overall Performance of Radio Receivers.

(Paper by Mr. H. A. Thomas, M.Sc., read before the Wireless Section, I.E.E., on 15th January, 1930.)

ABSTRACT.

THE paper describes work on the above subject carried out at the National Physical Laboratory for the Radio Research Board.

It is pointed out that the overall performance cannot be represented in terms of the product of the performance of the separate parts. The input must be such that the results obtained can readily be applied to practical conditions, and the output must be measured by a method which does not disturb the normal working of the receiver.

An overall performance measurement implies the inclusion of the input tuned circuit, aerial or frame coil. The application of a known e.m.f. to this tuned circuit may be done (i) By mutual inductance, (ii) By capacitive coupling, (iii) By inserting in the tuned circuit a small non-inductive resistance or a small inductance carrying a known current.

The last method has been most employed and is the one described here. Small non-inductive resistances can be made within fairly wide limits and can be used for a wide range of input voltage. Elaborate screening is necessary to prevent direct magnetic and electric induction from the oscillators and potentiometer leads.

audio-frequency and radio-frequency oscillators, is a 6½ ft. cube consisting of a wooden skeleton covered with No. 22 S.W.G. tinned iron sheet. Every joint was carefully soldered over and the completed box hermetically closed, entrance being effected by a mercury-sealed trap-door. The output current leads are taken through seamless steel tubing at *B*.

The radio-frequency potentiometer also requires to be very efficiently screened. For short-wave work, below 40 m., the inductance is not negligible, and it was decided to use a straight screened wire, whose inductance was calculable. The design of such a potentiometer is discussed, and the final arrangement adopted is shown in Fig. 3 (*c*). No. 47 S.W.G. Eureka was used as the resistance wire and No. 40 S.W.G. copper wire was used to connect to the wire *X*, Fig. 2. Six such potentiometers have been made, having resistances of 0, 0.76, 0.96, 5.139, 11.23 and 27.86 ohms respectively, and inductances of 0, 1.39, 3.39, 25.98, 60.45 and 176.5 ($\mu\text{H} \times 10^{-3}$) respectively. The potentiometer is plugged into a bayonet socket, as shown in Fig. 3 (*d*), the thermo junction thus measuring the current within a few inches of where it passes through the resistance wire. This is of importance, since, at

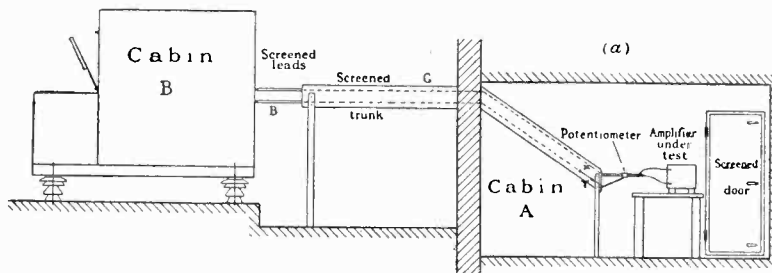

Fig. 2.—Arrangement of screening cabins.

In practice only two factors limit the accuracy of the method: (*a*) The impossibility of measuring the effective impedance of the potentiometer, and the dependence of this value on the calculated value of the inductance; (*b*) the difficulty of measuring the potentiometer current at very high radio-frequencies. At present a non-contact thermo-junction ammeter is used, it being assumed that its d.c. calibration is valid at all frequencies.

Fig. 2* shows the general distribution of the apparatus and the screening arrangements used by the author. The cabin *B*, which houses the

very high frequencies, the current varies along the trunk lead. The two input leads are screened up to the set terminals, and their capacity is insufficient to alter the impedance of the potentiometer even at 30 metres. The zero-resistance potentiometer has a construction identical with that of the 0.76 instrument, but lead *B* is connected to the screen end of the wire. This is used to check whether any electric or magnetic induction effects are present, as no output should be given unless they are. These potentiometers have been used on wavelengths as low as 7 metres.

The circuits of the apparatus are shown in Fig. 5. The radio-frequency input oscillator, of the series-fed Hartley type shown, was found to give best

*The author's original figure numbers are adhered to throughout this abstract.

results. The oscillator in use covers all wavelengths down to 5 metres. A tuned output circuit is employed inductively coupled to the oscillator. Although not so simple to operate, the purity of

Most types of receiver give an output at audio-frequency, and in the early work a vibration galvanometer was used to measure this. This was suitable for small, e.g., headphone-strength, out-

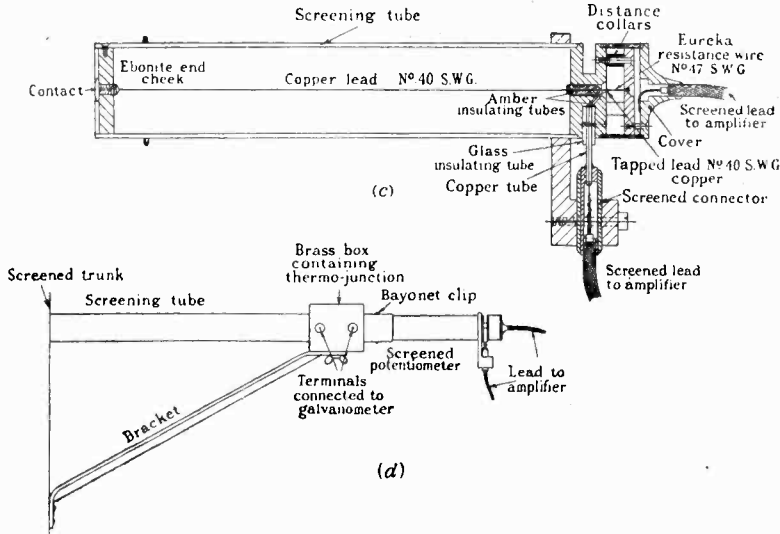

Fig. 3.—Details of screened potentiometer for supplying known potential differences to a wireless receiver.

wave-form so obtained compensates for other difficulties. The audio-frequency oscillator is a push-pull arrangement, with a tuned output circuit in series with the anode feed to the radio-frequency oscillator. The modulation is measured by a valve voltmeter. The output current of the radio-frequency oscillator is sensibly proportional to $(V - K)$ where V is the h.t. d.c. voltage and K

puts, but not for loud-speaker intensity. As the power stage is necessarily a converting mechanism, the amplification must be expressed in terms of the voltage output delivered to the grid of the power stage, with respect to some input voltage. A valve voltmeter was used to measure the input to the power stage, but it was found that the load of the voltmeter made this method unsuitable.

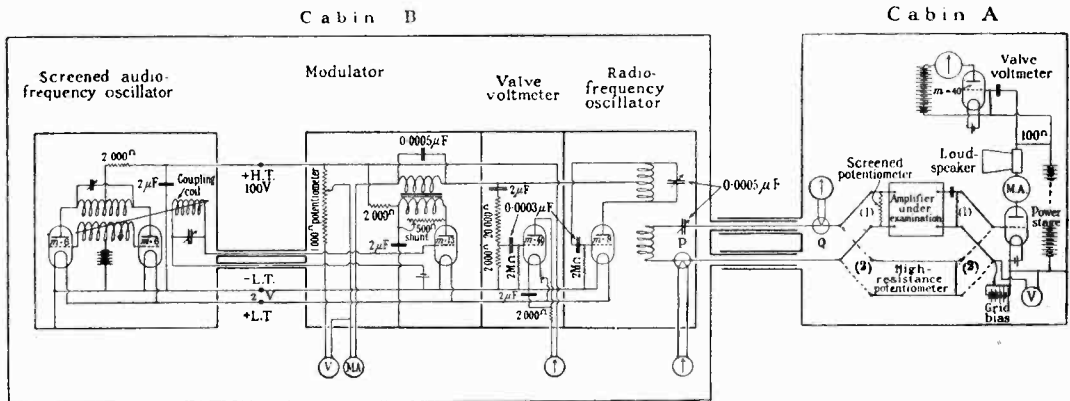

Fig. 5.—Circuit diagram of apparatus for testing the performance of radio receivers.

is an experimental constant. If the R.M.S. voltage of the modulator output is E , the percentage modulation is given by

$$\frac{\sqrt{2}E}{V - K} \times 100\%$$

In all measurements, therefore, the voltmeter was connected across a low non-inductive resistance in the anode circuit, and the power stage was calibrated by supplying an audio-frequency oscillation directly to the grid-filament by means of a

high-resistance potentiometer. By this means the actual voltage on the grid of the power valve can be obtained by noting the deflection of the valve-voltmeter connected in the anode circuit. The resistance referred to is negligible compared to the loud-speaker impedance and its effect in so far as it modifies the circuit is negligible.

The input current is measured at the junction *Q* (Fig. 5), a second junction *P* in cabin *B* permitting the operator to tune. With the switches in cabin *A* at position (1) the input is normally applied to the amplifier and the negative filament leg is connected to the screens and may be earthed if required. At position (2) the power stage is calibrated with an audio-frequency input, by means of a high-resistance potentiometer, as already mentioned. The milliammeter in the anode circuit of the power stage is used as an indicator to obtain the same grid bias under both conditions, the bias voltage being controlled by a potentiometer as shown.

The apparatus is capable of giving an input range of 0.25 to 1,000 mV. at any wavelength from

receiver is shown in Fig. 6, and a large number of result curves are given for this and other receivers, including a commercial short-wave receiver (15 to 60 m.), a screened short-wave receiver (15 to 80 m.), and a supersonic heterodyne receiver (50 to 5,000 m.). The curves show both overall performances and the performances of various parts. An interesting result on a short-wave receiver, using a stage of radio-frequency amplification, is that the amplification of the stage never exceeded 2.1 and was only 1 at 28.5 metres.

The latter portion of the paper discusses suggestions for specifying the performance of receivers.

It is suggested that the characteristic of any receiver can be expressed in terms of three characteristics.

- (a) The input voltage at a definite depth of modulation necessary to produce a definite standard output at all wavelengths within the desired range.
- (b) The sensitivity variation in the neighbourhood of certain fixed wavelengths—this gives the selectivity of the receiver.
- (c) The output variation with constant input

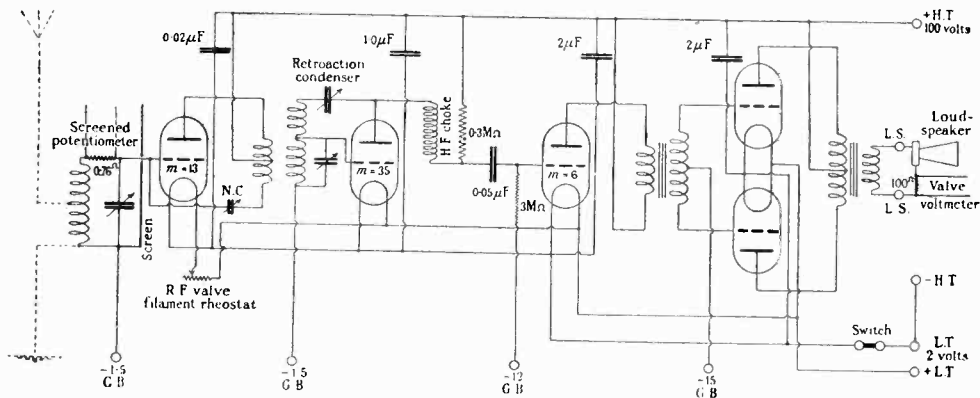

Fig. 6.—Circuit diagram of receiver, showing method of measurement.

5 to 30,000 m. (60 megacycles to 10 kc/s.), and an output range of 20 to 6,000 mV. at any audio-frequency.

The paper then describes tests made with the apparatus. The object of the tests was to demonstrate the utility and range of the apparatus, and although the results show the properties of the different sets tested, no mathematical analysis has been attempted. The results, however, demonstrate the type of overall characteristic likely to be obtained from receivers of a similar type to those employed.

The method of measurement applied to an actual

and depth of modulation but variable frequency of modulation—this gives the frequency distorting properties of the audio-frequency stages.

With a knowledge of the field-strength due to a particular transmitter and of the field-strength/output characteristic of the receiver, a step would be taken towards more scientific classification of types of receiver, and the immediate result would be to improve the design of receivers. In a somewhat similar manner the classification of receivers into various selectivity categories would help towards the correct selection of a receiver for a particular purpose.

The Absorption Method of Capacity and Inductance Measurement.

By A. P. Castellain, B.Sc., D.I.C., A.C.G.I.

IT is probably quite well known that when a tuned circuit is placed near the coils of a valve oscillator having telephones in its plate circuit, a click, or usually two clicks, will be heard in the telephones as the oscillator frequency is made to pass through the natural frequency of the tuned circuit.

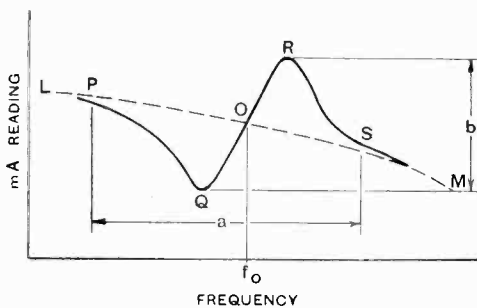

Fig. 1.

These clicks are due to change of plate current in the oscillator valve, owing to power being absorbed by the tuned circuit and thus altering the conditions of oscillation.

Sometimes if the tuned circuit is too near, the valve will stop oscillating altogether and the two clicks will be quite widely separated as the oscillator frequency is varied.

If a milliammeter is inserted in the oscillator plate circuit and the frequency varied as before, then the meter needle will give a curious "N" shaped curve P, Q, R, S in Fig. 1, as the natural frequency of the tuned circuit is passed through.

The width a of the N curve depends on the degree of coupling of the tuned circuit, as also does to some extent the height b , although the latter can only increase in one direction until the plate current reaches the non-oscillating value corresponding to H.T. and grid bias voltages used for the valve.

It can also be shown that the frequency f_0 corresponding to the point where the curve P, Q, R, S cuts the curve L, O, M repre-

sents the normal change of plate current with frequency (*i.e.*, when the tuned circuit is removed) is the natural frequency of the tuned circuit.*

If the oscillator frequency is kept constant and the condenser of the tuned circuit varied then the milliammeter needle will move as in Fig. 2 (a) if the circuit is closely coupled or as in Fig. 2 (b) is loosely coupled. The dotted line represents meter reading when the tuned circuit is removed and C_0 the exact capacity required to tune to the oscillator frequency.

From what has already been said, it will be seen that we now have a means of determining when either the oscillator frequency is exactly equal to the natural frequency of the tuned circuit when the latter is kept constant, or *vice-versa*, and this, as we shall see, leads direct to a measurement of capacity and inductance.

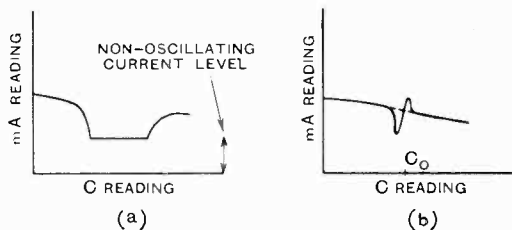

Fig. 2.

In all that follows, by oscillator will be meant a valve oscillator containing a sensitive milliammeter in its plate circuit and oscillating in such a fashion that the mean plate current when oscillating is quite different from the plate current when not oscillating (*i.e.*, with plate coil short-circuited). The latter condition is essential for measurements for reasons which will be obvious after what has been said above, and it may be observed that most ordinary valve oscillators comply with this condition.

* Ref. E. Mallett, D.Sc., M.I.E.E., in *E.W.* and elsewhere.

Measurement of Capacity.

The apparatus required for the measurement of capacity consists of the oscillator, a standard calibrated variable condenser and an inductance suitable to tune with the standard condenser to a frequency in the

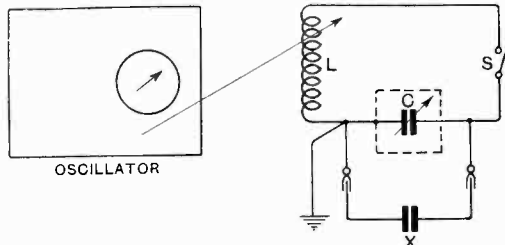

Fig. 3.

range of the oscillator, and, for accurate work, a single-pole switch of the low capacity type.

The circuit is given in Fig. 3, where L is the inductance (whose value need not be known), S the switch, C the standard variable condenser, say of about 1,000 $\mu\mu\text{F}$ capacity at maximum and X the condenser, whose capacity is to be measured. The procedure is as follows:—

Attach the clip connected to the "earth" or screened side of the standard condenser to one tag of X , but leave the other clip about $\frac{1}{4}$ in. or so away from the other tag.

Close S and alter the oscillator tuning until C is somewhere near its maximum capacity when giving the "N" curve on the millimeter and couple L loosely enough to give a curve as in Fig. 2 (b). Adjust C carefully to the centre of this "N" so that the millimeter reading is the same, whether the switch S is open or closed, and note the value of C , say C_1 . At this stage we know that the circuit L, C is tuned exactly to the oscillator frequency.

Now attach the loose clip to the free tag on the condenser C_x , thus adding the value of C_x to the circuit L, C and then retune the circuit to the oscillator frequency by altering C as above—suppose the new value of C is C_2 .

Then since the circuit is tuned to the same frequency both times and the inductance remains the same, the total capacity in both cases must be the same and thus $C_x = (C_1 - C_2)$.

If the standard condenser is well made and

is fitted with a vernier, accuracies up to the accuracy with which it was calibrated may be expected in these measurements. Consistency of results may be checked by taking, say, five readings of C_1 and C_2 and taking $C_x =$ difference of means.

If the capacity of C_x is greater than the maximum value of C , then fixed condensers each of a little less than the maximum value of C (which may be measured as above) will be required in parallel with C to bring the total known capacity greater than C_x . When C_x is inserted, these fixed condensers are disconnected at one end and the final tuning completed as before on C .

It will be seen that this is really a direct substitution method and thus involves no calculation.

Small capacities such as, for example, the inter-electrode capacity of valves or the capacity between loose coupled H.F. transformer coils may be accurately measured by this means. When attempting to measure capacities by this method—or by any other method for that matter—it is of course necessary to realise just exactly what capacity it is that is being measured.

In general, there are three capacities to be considered in connection with any two terminal condensers, namely, what might be called the intentional capacity C_x between the terminals, the capacity C_A of one terminal to earth and the capacity C_B of the other terminal to earth. These are shown diagrammatically in Fig. 4 (a).

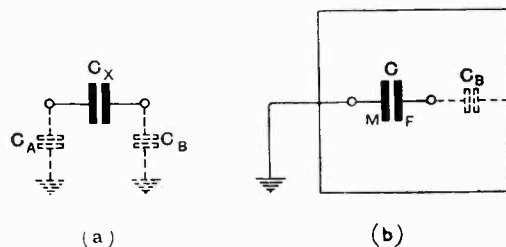

Fig. 4.— $M =$ Moving Plates, $F =$ Fixed Plates.

The capacity C_x is thus effectively in parallel with the capacities C_A and C_B in series, so that the measured capacity under these conditions will be

$$C = \frac{C_A C_B}{C_A + C_B} + C_x$$

between the terminals, assuming no earth or capacity to earth on the measuring device.

By earthing each terminal in turn and measuring the resultant capacities $(C_x + C_A)$ and $(C_x + C_B)$ can be found, while measurement of the capacity between earth and the short-circuited terminals gives $(C_A + C_B)$. These three measured values are sufficient to give C_x , C_A and C_B .

The earth capacities C_A and C_B may be rather indeterminate, so that it is desirable to make them more definite by making the measurements on a bench or table with an earthed metal top, and by connecting one side of the standard condenser to this earthed metal. The standard condenser itself should be in a metal screen which should be connected to the moving plates as shown in Fig. 4 (b). In some cases, where very accurate measurements are not required, C_B may be made very small compared with C_x by suspending the capacity under test well away from the earth plate, using rigid leads to the standard condenser. C_A will be zero, as one terminal will be earthed.

The Measurement of Inductance.

For the measurement of inductance, a calibrated heterodyne wavemeter will be required in addition to the valve oscillator and standard condenser.

Suppose that the unknown coil L_y requires a capacity C_0 to tune to the oscillator frequency which is found by means of the wavemeter to correspond to a wavelength of λ metres. Then we have, by the well-known relation between wavelength, inductance and capacity, that

$$\lambda = 1884\sqrt{L_y C_0}$$

where L_y is the coil inductance in μH and C_0 is in μF

or
$$L_y = \frac{\lambda^2}{1884^2 C_0}$$

assuming that the coil has a negligible self-capacity.

Generally, however, this single measurement may only be used to obtain an approximate idea of the coil inductance, since the self-capacity will not be so small as to be negligible.

Measurement of Self-capacity and Inductance of a Coil.

The method just described enables us to measure the self-capacity of a coil in two ways. First, we might measure the natural wavelength of the coil (*i.e.*, the wavelength corresponding to the circuit formed by the inductance and the self-capacity of the coil) by means of the oscillator and then find the frequency of the latter with the wavemeter. It should be noted here that it is impossible to insert a switch between the inductance and its self-capacity, so that for accurate results readings of the oscillator meter should be taken and plotted against oscillator tuning condenser readings both when the coil is and is not coupled to the oscillator. The oscillator condenser reading corresponding to the natural frequency of the coil can thus be found, and the condenser set to this value for frequency measurement by means of the wavemeter.

Suppose this natural wavelength is λ_n and the inductance of the coil is L_y and its self-capacity c (both the latter being unknown at present) then we have the following relation

$$\lambda_n = 1884\sqrt{L_y c} \dots \dots (1)$$

Now suppose we add a known capacity C in parallel with the coil and measure the new wavelength corresponding to the new natural frequency of the circuit. Let this wavelength be λ_1 . Then we have

$$\lambda_1 = 1884\sqrt{L_y(c + C)} \dots (2)$$

In (1) and (2) we have two equations containing two unknowns, L_y and c , hence we can now find both of the unknowns.

From (1)
$$L_y c = \frac{\lambda_n^2}{1884^2}$$

From (2)
$$L_y C + L_y c = \frac{\lambda_1^2}{1884^2}$$

hence
$$L_y = \frac{(\lambda_1 + \lambda_n)(\lambda_1 - \lambda_n)}{1884^2 C} \dots (3)$$

and
$$c = \left(\frac{\lambda_n^2}{\lambda_1^2 - \lambda_n^2} \right) C \dots \dots (4)$$

At one time the writer was rather doubtful as to whether the self-capacity of a coil at its natural frequency is the same as [its self-capacity when in parallel with a "lump" capacity such as a variable condenser,

owing to the expected different current distribution in the coil in the two cases. Measurements made by him to investigate this point show definitely that these two capacities were the same, within the limits of experimental error, for several coils tested. The writer has since found that this particular query had been answered some years ago by Dr. G. W. O. Howe, who came to the same conclusion after much more exhaustive experiment than he carried out.

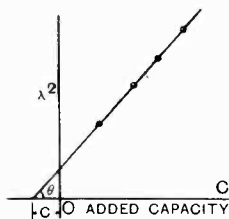

Fig. 5.

The second method of finding c and L_v is to put a calibrated variable condenser in parallel with the coil and to plot condenser capacity against square of corresponding

circuit wavelength, measured as previously described. A curve will be obtained somewhat as shown in Fig. 5, *i.e.*, a straight line.

The slope of the line gives a measure of the inductance and the intercept on the capacity axis is the self-capacity of the coil.

From equation (2) we have generally

$$\lambda^2 = 1884^2 L_v (c + C)$$

$$\therefore \frac{\lambda^2}{c + C} = 1884^2 L_v = \tan \theta, \text{ say} \quad \dots (5)$$

Thus, $\tan \theta$ will be the slope of the line in Fig. 5.

This second method really comes to the same as the first, but is probably rather better insofar as a large number of points on the line may be found and thus any errors in the measurement averaged up automatically in drawing the best line through the points.

It is possible to simplify the measuring apparatus somewhat by combining the oscillator and the heterodyne wavemeter into one instrument by using a meter in the plate circuit of the latter. Also, as long as the coupling between the tuned circuit and the oscillator is weak enough to give an "N" curve of the type shown in Fig. 2(b), then not much error will be introduced, in capacity measurements at any rate, by doing away with the switch S and taking say the top of one peak of the "N" curve as the basis of comparison.

If the resistance of the condenser under test is of the same order as the resistance of the standard condenser (*i.e.*, very low) then very little error will be introduced by this simplification.

Incidentally, the absorption method of capacity measurement will give an *indication* of the order of the effective *resistance* of the condenser under test, in this way. Suppose the plate current of the oscillator is altered by, say, ten divisions on the milliammeter for one peak of the "N" curve when the standard condenser only is used for tuning. Then, if on retuning with the unknown condenser in parallel, the milliammeter reading changes by ten divisions again, the *resistance* of the condenser under test will be of the same order as the standard—*i.e.*, very low—but if the reading changes by only a few divisions, then the resistance of the test condenser must be high compared with that of the standard.

The writer has found that the above described methods of measurement do in practice give extremely consistent and accurate results without a tremendous amount of concentration on the part of the experimenter—a useful point when many measurements have to be carried out.

The Physical Society's Exhibition.

Matters of Wireless and Laboratory Interest.

THE twentieth Annual Exhibition of the Physical Society and the Optical Society was held this year at the Imperial College of Science and Technology on 7th, 8th and 9th January. The Exhibition was—as it has been for some years—a highly interesting one for those concerned with wireless measurements and laboratory work on kindred subjects, while the extraordinary diversity of exhibits was again a testimony to the close relations between scientific development and industrial usage.

Electrical Measuring Instruments.

Electrical measuring instruments (of the voltmeter and ammeter type) were well represented in patterns and sizes for practically every purpose of electrical measurement. The interest of wireless experimenters is perhaps rather in the smaller instruments, and these were present in considerable numbers.

NALDER BROS. & THOMPSON, LTD., exhibited a new range of small-type "Bijou" instruments, in addition to a large number of induction and other instruments of more industrial application.

CROMPTON PARKINSON, LTD., showed a new galvanometer (of 2 mA. and 80 mV. full scale) of considerable laboratory utility, one pattern having even scale divisions, while the other had uneven divisions with wide divisions about zero.

The stand of the WESTON ELECTRICAL INSTRUMENT CO., LTD., is always of interest to wireless workers, and new features this year—in addition to the various instruments for which this firm is already known—numbered a new multi-range D.C. Testing Set and a "Valve Checker" for test of A.C. or D.C. valves.

The firm of ERNEST TURNER had also an extensive show of portable and panel instruments for

ELECTRICAL CO., LTD., are also attractive laboratory adjuncts (especially in the milliammeter class), where their very long scale is of great advantage.

Rectifier instruments were less prominently on view than last year, but a newcomer to this class was a rectifier pattern A.C. Microammeter of the CAMBRIDGE INSTRUMENT CO., LTD., using a Westinghouse Rectifier in conjunction with an "L Pattern Unipivot" movement. The most sensitive of these goes down to 100 μ A.

Laboratory Equipment.

The CAMBRIDGE INSTRUMENT CO. had also their customary large exhibit of laboratory and similar apparatus. A new instrument was the Campbell Precision Condenser Bridge, due to Mr. A. Campbell, while a new Standard Mutual Inductometer due to the same designer was also on view for the first time. Other new items included improved models of the company's Recording Potentiometer and an improved design of Thermo-Junction with insulated heater.

GAMBRELL BROS. had rather less than usual of radio-frequency measurement interest, but showed an extensive range of apparatus for audio-frequency and for low-frequency work, especially in connection with telephone and power cables, and also for d.c. testing in connection with such cables. Two articles of wireless interest were due to Dr. N. W. McLachlan—the Modulated C.W. Wavemeter and the Novotone Compensator, already exhibited at Olympia.

H. W. SULLIVAN, LTD., had an extensive exhibit of laboratory apparatus for all frequencies. A new item was the Lucas-Sullivan Quartz-Crystal Standard and its associated apparatus for standardising frequencies from 10 to 3,000 kc. The Standard Multivibrator Wavemeter (due to Dr. D. W. Dye) was also on view, with its 1,000-cycle fork and a new phonic wheel and amplifier



Isenthal Kerr cell.

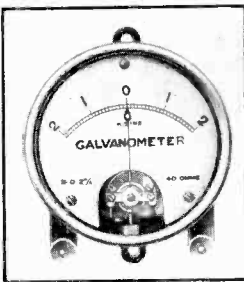

Crompton Parkinson moving coil galvanometer.

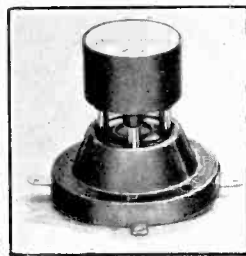

A new type of Vacuo junction, by Cambridge Instrument Co.

wireless purposes, while ELLIOT BROS., LTD.—in addition to instruments of engineering practice—were showing vacuo thermo-junctions of the insulated heater pattern and a robust moving coil galvanometer of useful laboratory application. The "Cirscale" instruments of the RECORD

for standardisation of the fork. Other new items included Sullivan-Griffiths Precision Sub-Standard Wavemeter (100-10,000 m.), and a short-wave Sub-Standard wavemeter for 5 to 100 metres. A large selection of condensers, wavemeters, coils, etc., of standard and sub-standard grade were also shown.

The exhibits of H. TINSLEY & CO., LTD., included a large range of potentiometers, bridges, etc., and of chronoscopes and timing apparatus. Radio-frequency apparatus included Standard Air Condensers and Wavemeters to the design of Dr. Dye.

Wireless Apparatus Accessories, Etc.

As is usually the case, several firms had displays of purely radio interest.

The EDISWAN Co. had a large display of their radio products and those of their associated concerns, the METROPOLITAN VICKERS and B.T.-H. These included gramophone pick-ups, microphones, coils, condensers and other components, loud speakers of various kinds; also several different eliminators, and an extensive range of valves for various purposes of transmission and reception.

The display of the M.O. VALVE CO., LTD., included valves for every purpose, and ranged from large valves of the cooled-anode class down to a full range of receiving valves, including the most modern grid patterns of A.C. valve. An automatic grid-making machine was demonstrated in operation.

Valves of all kinds were also featured at the

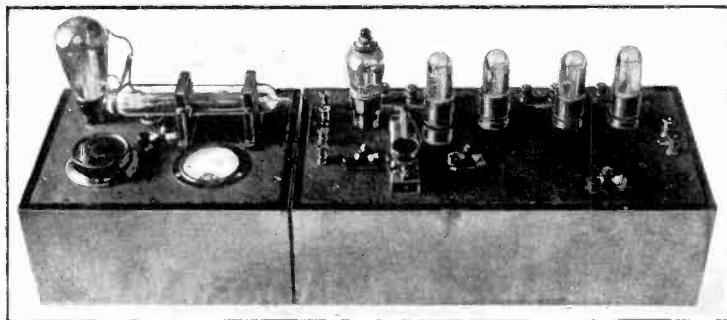

Lucas-Sullivan quartz frequency standardising apparatus.

stand of the MULLARD WIRELESS SERVICE CO., LTD. These included, particularly, examples of mains and power amplifying valves for reception purposes, and a complete range of rectifiers from

30 mA./250 v. to 2 amps./12,000 v. This year's working model was of an audio-frequency amplifier dissected to demonstrate its operation.

The MARCONI Co. had on view a very extensive display of wireless apparatus. Amongst these were Naval and Aircraft direction-finding sets, and a new Marconi d.f. receiver for use with the Adcock Aerial System (*cf. E. W. & W. E.*,

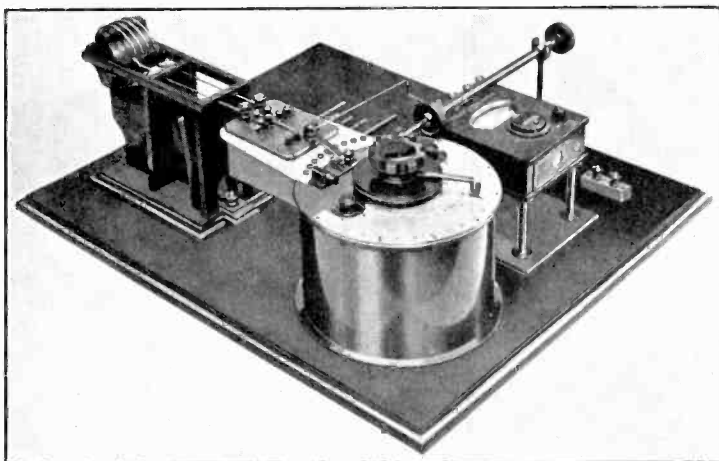

Sullivan short-wave Precision Sub-Standard wavemeter, 5-100 metres.

June, 1926). A new production of testing interest was a beat-frequency l.f. generator, shown in conjunction with a valve voltmeter and attenuation system for application to apparatus under test. Another interesting exhibit was the Tuning Fork Drive and Doubling Circuit. This is intended for the frequency control of broadcasting stations. A fork—of between 700 and 1,400 cycles—gives an output which is passed through a requisite cascade of frequency-doublers to generate radio frequencies of 716.8 kc. to 1,473.6 kc./s., for master drive of broadcast carriers (*cf. E. W. & W. E.*, June, 1929).

Amongst other components of wireless interest should be mentioned the display of condensers of all kinds by the TELEGRAPH CONDENSER CO., LTD. (new-comers to this Exhibition); the products of BAKELITE, LTD., in the form of sheets, rods, insulating varnishes, etc.; a large range of L.T.

and H.T. accumulators by the FULLER ACCUMULATOR CO., LTD.; resistances of large variety by ZENITH ELECTRIC CO., LTD.; photo-electric cells, Kerr cells, glow relays, etc., by ISENTHAL & Co.,

LTD.; and a new d.c. to a.c. machine by the M-L MAGNETO SYNDICATE for the supply of a.c. receivers from d.c. sources. Besides the items already mentioned, GAMBRELL BROS. also had a display of their various mains receivers.

Research and Experimental Section.

A large number of exhibits in this section were connected with radio and acoustical measurements.

The latest display of wireless apparatus was included in the exhibits of the NATIONAL PHYSICAL LABORATORY (WIRELESS DIVISION). Perhaps the most interesting of these was an automatic recorder of bearings from a rotating beacon transmitter, such as that now in operation at Orfordness. Laboratory apparatus included gear for the measurement of resistance and reactance at radio frequencies, and apparatus for measuring the overall performance of radio receivers. Amongst experimental apparatus were various items—transmitters, receivers, oscillators, etc.—for work on waves of 10 metres downwards.

MR. E. B. MOULIN exhibited a new form of small-capacity variable condenser, suitable for precision measurements at very high frequencies, and an absorption wavemeter for use on short waves, and a new directional short-wave transmitter (for 6.04 to 8.65 metres) was exhibited by MESSRS. L. S. PALMER and L. L. HONEYBALL.

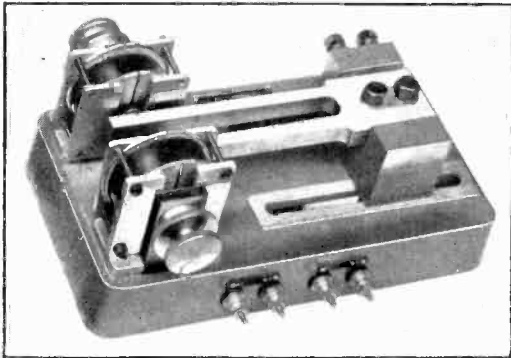

Marconi tuning fork drive.

Interesting exhibits were also to hand from the laboratories of several large industrial companies. Amongst these, the ENGINEERING LABORATORY of the B.T.-H. Co. had a display of mercury vapour devices showing the principle of grid control (as in the three-electrode valve) applied to mercury vapour apparatus.

The RESEARCH LABORATORIES of the GENERAL ELECTRIC Co. showed apparatus for the measurement of sound pressure over the range of 50 to 5,000 cycles per second, and various pieces of apparatus for measuring the performance of telephones and loud speakers.

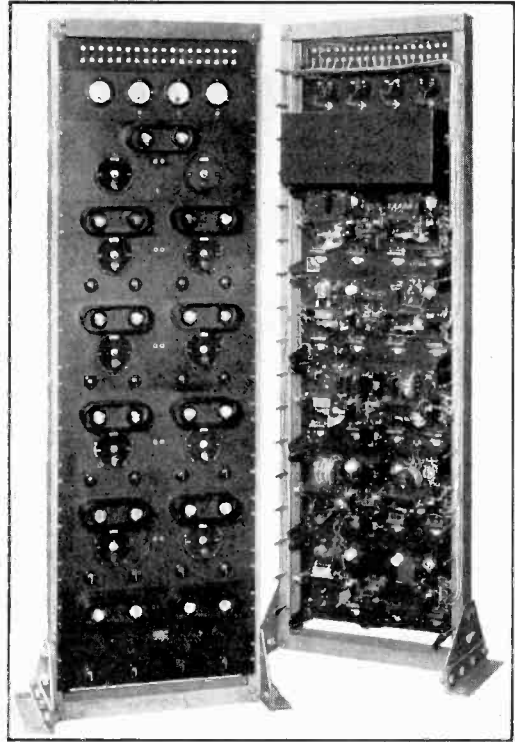

Marconi frequency doubling circuit for tuning fork drive.

The RESEARCH LABORATORIES of the GRAMOPHONE Co. and the MARCONIPHONE Co. were also to hand with exhibits concerned with sound reproduction. These included such items as cinema musical apparatus and a model of a sound-recording system of the photographic type.

Another interesting acoustical exhibit was that of CAPT. B. S. COHEN and MR. R. W. PAUL. This was a new moving coil loud speaker, using pistons of Balsa wood. Specimens were shown, and the apparatus was demonstrated on inputs from a beat-frequency generator and from gramophone test records. Remarkable uniformity of response appears to have been attained.

Some Recent Patents.

The following abstracts are prepared, with the permission of the Controller of H.M. Stationery Office, from Specifications obtainable at the Patent Office, 25, Southampton Buildings, London, W.C.2, price 1s. each

TRANSMISSION SYSTEMS.

Convention date (U.S.A.), 20th July, 1927. No. 294213. Application date, 16th May, 1928. No. 317426.

Relates to means for operating a distant wireless transmitter from a central control office. Usually a direct current is employed, the speed of keying them being limited by the time-lag characteristics of the land line and intermediate relays. According to the invention, the keying means control an alternating current which is used to modulate an intermediate frequency. One side band is selected from the output and is used to modulate a radio-frequency carrier from which, in turn, a single side band is radiated. A frequency "wobble" is preferably introduced with the object of reducing fading effects. Several different messages may be sent simultaneously by using different *A C* frequencies on the keying line.

Patent issued to Marconi's Wireless Telegraph Co., Ltd.

LOUD-SPEAKER DIAPHRAGMS.

Convention date (U.S.A.), 17th August, 1927. No. 295686.

A large disc diaphragm of aluminium-manganese alloy is constructed with equally distributed loading masses consisting of circular brass weights of .5 cm. diameter spaced apart by about 2 cms. and inserted in concentric rings. In effect such a diaphragm may be regarded as a low-pass mechanical filter, the lumped masses corresponding to series inductance, and the intervening portions of the thin diaphragm as shunt capacity. The diaphragm is stated to be an efficient radiator of very low frequencies.

Patent issued to Electrical Research Products Inc.

Convention date (Germany), 1st August, 1927, No. 289406.

Instead of terminating in a single point as usual, a conical diaphragm is bifurcated as shown in the Figure, the driving impulse being applied by separate magnets *M*, *M*₁ to each point. Each part of the cone may be designed to have a different

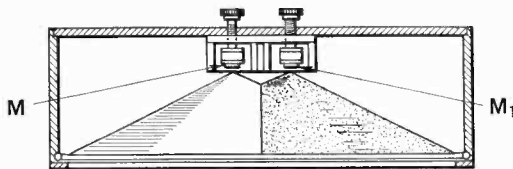

No. 289406.

characteristic response, and the output may be given a corresponding tonality according as one or other or both magnets are switched into circuit.

Patent issued to Rheinische Holzwerke, G.m.b.H.

TELEVISION SYSTEMS.

In reception the image is reproduced upon a surface consisting of a bank of separate small incandescent lamps, each inserted in the output circuit of a valve amplifier. The incoming signal impulse charges up a condenser in the grid circuit of the amplifier, raising the anode current to a value at which the lamp incandesces. According to the invention the light from each lamp is made to persist for a perceptible interval after the signal impact, preferably until the scanning cycle has been completed, this having the effect of increasing the apparent brightness of the image as a whole.

Patent issued to W. E. Beatty.

Application date, 22nd May, 1928, No. 317537.

In order to maintain the analysing and synthesising apparatus at the transmitting and receiving ends of a television system in synchronism, a timing impulse is transmitted once during every revolution of the scanning disc, and is impressed at the receiving end upon a circuit which controls the capacity of a condenser associated with a resonant circuit used to regulate the speed of the local motor. The response of the resonant circuit varies sharply with any slight variations in frequency, and ensures an accurate in-step control.

Patent issued to W. E. Beatty.

LONG AND SHORT WAVE TUNING.

Application date, 11th July, 1928. No. 317956.

In order to facilitate manipulation on the lower readings of the tuning condenser, in a receiver adapted for both long and short wave reception, the condenser is divided into two electrically independent sections. In one position of the wavelength change switch, both condenser sections are connected in parallel across the larger inductance coil. In the other, or short-wave position, only one condenser section is inserted in circuit with the smaller inductance. By so decreasing the relative capacity range, the tuning control is made less critical for the shorter wavelengths, particularly those below 100 metres.

Patent issued to M. G. Scroggie.

WIRELESS RECEIVERS.

Application date, 5th June, 1928. No. 317566.

The output leads from the last valve stage to the loud speaker are back-coupled, either magnetically or capacitatively, to the input of the first valve stage, and so serve as a substitute for the ordinary aerial. If an aerial is used, the back-coupling serves to increase the total pick-up, the magnetic coupling then being so arranged as to prevent the amplifier signals from being fed into the aerial proper.

Patent issued to G. W. Hale and Radio Instruments, Ltd.

A.C. VALVES.

Application date, 28th April, 1928. No. 316350.

In order to reduce A.C. hum in a mains-driven amplifier, the primary and secondary windings of the filament-supply transformer are effectively spaced apart so as to reduce their mutual capacity, and the secondary is tuned by means of a shunt condenser, either to the frequency of the power supply, or to the most pronounced harmonic. An earthed screen is interposed between the windings and the electrical centre of the primary is also anchored to a point of fixed potential. The grid connection is made through a slider from a potentiometer shunted across the secondary winding.

Patent issued to G. M. Wright.

STABILIZING PIEZO-CRYSTAL OSCILLATORS.

Convention date (U.S.A.), 7th June, 1927. No. 291740.

The capacity effect across the electrodes of a crystal oscillator is balanced by means of a compensating condenser inserted in a Wheatstone-bridge arrangement. As applied to a valve generator *V*, three master-control crystals *Q* are

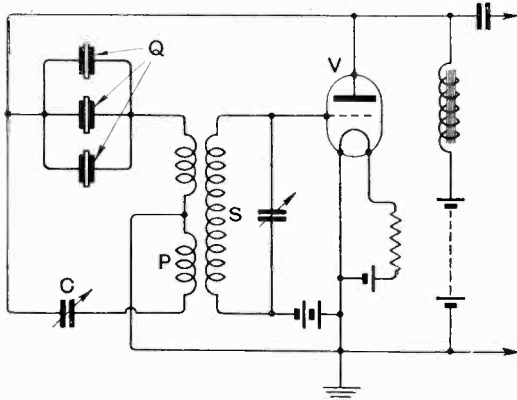

No. 291740.

arranged in the feed-back circuit, their combined inherent capacity being counterbalanced by the condenser *C*. A mid-point tapping on the primary winding *P* is taken to the filament of the valve, whilst the secondary winding *S* is shunted by a condenser tuned to the particular fundamental crystal frequency to be utilised.

Patent issued to Standard Telephones and Cables Ltd.

MULTI-STAGE VALVES.

Convention date (Germany), 5th November, 1927. No. 300124.

A single bulb containing at least two amplifying sets of electrodes is also provided with a unit for rectifying an A.C. supply, so as to furnish direct-current for the plate and filament supply of the amplifying stages. A wave-trap and smoothing-chokes may also be housed inside the same bulb.

Patent issued to Telefunken Ges.

INTER-VALVE COUPLINGS.

Convention date (U.S.A.), 12th July, 1927. No. 293788.

In order to secure a uniform amplification ratio over a frequency range between 30 and 7,000 cycles per second, a transformer or auto-transformer coupling *C, T* is supplemented by a choke-coil *K*

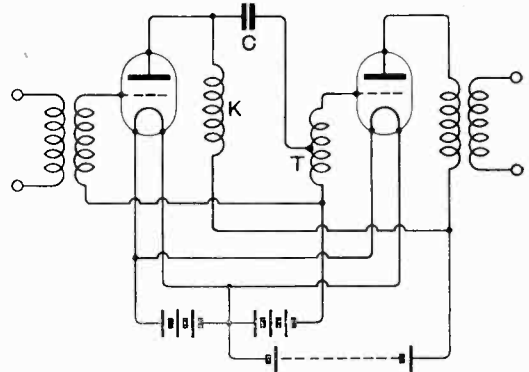

No. 293788.

arranged as shown on the drawing. The necessary values of the inductances *T* and *K* and of the coupling condenser *C* are correlated with the internal resistance of the valve, and are ascertained in a series of mathematical formulæ set out at length in the patent specification.

Patent issued to British Thomson-Houston Co., Ltd.

SECONDARY BATTERIES.

Application date, 27th March, 1928. No. 316328.

A plastic mass for filling the grids of accumulator plates is made by adding to a solution of glycerine diluted with water sufficient sulphate of magnesium or sodium or potassium to make the solution saturated, and then mixing it with lead monoxide to form a stiff paste. A plate filled with this material is porous, has a large capacity, and can be charged and discharged at a high rate.

Patent issued to H. Leitner.

DRY-CONTACT RECTIFIERS.

Convention date (Germany), 2nd July, 1927. No. 293300.

Cuprous iodide is used instead of the oxide in the production of a dry-contact rectifying element. Commercial cuprous iodide is compressed into a thin plate and this is compacted with a thin sheet of copper; or a layer of iodide can be formed upon a copper base by heating the latter in iodine vapour. The prepared metal is then combined with a silver or lead plate similarly coated with iodide to form the complete rectifying unit. The halide is stated to have a superior stability as compared with oxide against the supply voltage its relatively high conductivity allowing the use of a thicker layer.

Patent issued to Patent-Treuhand-G.m.b.H.

LIGHT-SENSITIVE DEVICES.

Application date, 30th April, 1928. No. 316531.

Use is made of the variable light-reflective properties of carbon-dioxide to secure a visible image of an invisible source of radiation. At a temperature of 31° C. and a pressure of 72 atmospheres, carbon dioxide reaches a critical state between gas and fluid, and exhibits the property of opalescence. It is stated that under these conditions very small changes in temperature create pronounced differences in the degree of opalescence present. Thermal radiation, e.g. infra-red waves, from a moving body such as a ship, aeroplane, etc. (which may be otherwise invisible at night-time or owing to the presence of fog), may accordingly be detected and recorded in visible form when focused upon such a carbon-dioxide cell. The cell absorbs energy according to the varying intensity of the focused rays, and reacts to the stimulus so imparted by forming an opalescent image of the unseen radiator.

Patent issued to S. O. Hoffman.

DOUBLE-SCREEN VALVES.

Convention date (U.S.A.), 22nd June, 1927. No. 292563.

An extra screening element G_2 , made in the form of a grid, is located on the outer or opposite side of the plate to the ordinary screening grid G_1 . As shown, the two screening elements are connected in parallel to a point of high potential on the H.T. battery. The ordinary input or control grid is shown at G . In addition extra top and

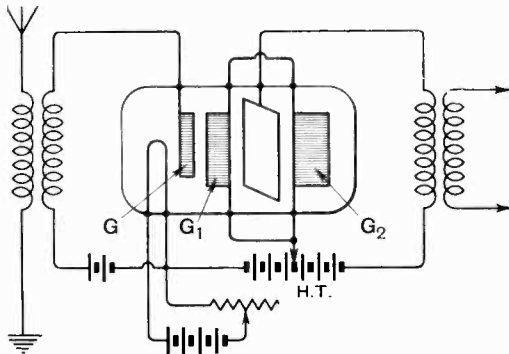

No. 292563.

bottom screens may also be inserted in the form of either solid plates or grids.

Patent issued to British Thomson-Houston Co., Ltd.

AERIALS.

Application date, 21st April, 1928. No. 316115.

For short-wave reception a Hertzian oscillator tuned to the incoming signals is backed by a second similar rod aerial, which is insulated from the ground and spaced away from the first by a distance substantially less than a quarter of the working wavelength. The passive "twin" aerial

is stated to reduce the radiation resistance of the receiving aerial proper, thereby promoting effective reception and increasing the selectivity of the system. The arrangement is differentiated from the known use of reflectors in aerial systems of the Beam type.

Patent issued to Standard Telephones and Cables.

REED-DRIVEN LCUD SPEAKERS.

Convention date (Germany), 30th July, 1927. No. 294877.

One end of the reed R is clamped at X outside the poles P . The other end vibrates between the

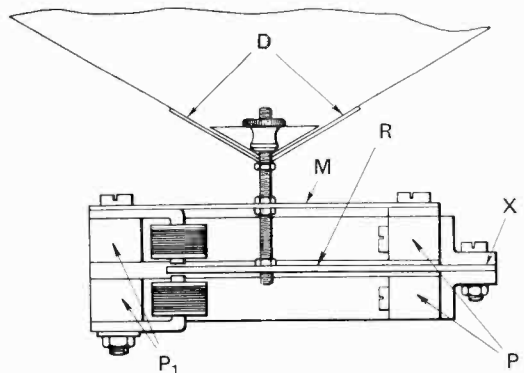

No. 294877.

windings carried by the poles P_1 . A non-magnetic bridge M is secured at both ends to the opposite poles of the magnet and serves to support the connecting-rod carrying the conical diaphragm D . One end of the bridge member M may be carried around the upper pole piece P_1 , and when tensioned by a screw serves to adjust the pitch of the response.

Patent issued to W. Kunze and Radiofrequenz G.m.b.H.

HIGH-POWERED AMPLIFIERS.

Application date, 2nd August, 1928. No. 318720

When a number of H.F. amplifiers are used in parallel, particularly when handling high power, undesirable parasitic oscillations may occur. Also a kind of internal short-circuit, known as the "rocky point" will sometimes set up a heavy discharge sufficient to destroy the valve. In order to prevent these effects, each valve is so coupled that it is isolated from the others, so far as disturbing or parasitic effects are concerned. With this object in view, separate direct-current and alternating-current circuits are provided in connection with each anode, the impedance in the common direct-current circuit between all the anodes and cathodes having a value small by comparison with that of the separate impedance of the direct-current circuit between the anode and cathode of any particular one of the valves.

Patent issued to H. L. Kirke, B. N. MacLarty, and T. C. MacNamara.

Abstracts and References.

Compiled by the Radio Research Board and reproduced by arrangement with the Department of Scientific and Industrial Research.

PROPAGATION OF WAVES.

MESSUNGEN ÜBER DIE AUSBREITUNG ELEKTRO-MAGNETISCHER WELLEN AUF DER ERDE (Measurements on the Propagation of Electromagnetic Waves over the Earth).—M. J. O. Strutt. (*Naturwiss.*, 22nd Nov., 1929, Vol. 17, pp. 919-920.)

The apparatus described in a former letter (1929 Abstracts, p. 623) was used for measurements for solving the following queries:—

(1) With vertical antennæ, are any waves propagated over the earth whose intensity varies with the distance from the transmitter according to the equation $I = R^{-1}e^{-\delta R}$ (cylindrical waves)?
(2) With vertical antennæ, is the radiation along the earth, at several wavelengths' distance from the transmitter, much smaller than that at a finite radiation angle with the earth? The first point deals with the "surface waves" spoken of in Sommerfeld's work on the radiation of vertical dipoles. The second point follows on the writer's theoretical study of antenna radiation (1929 Abstracts, p. 329).

Transmitting and receiving aerials were each about 20 cm. long. The wavelength used was 1.5 m. The first curve shown gives the variation of the logarithm (signal strength \times distance) with the distance (up to 3.5 m.) and is a straight line (the experimental points showing a slight wave on either side of the line, probably due to weak parasitic reflections). "This result constitutes, so far as I know, the first definite proof of the existence of cylindrical waves."

The second curve shows the signal strength as a function of the height above the earth of the receiving aerial, at about 10 wavelengths' distance from the transmitter. Signal strength kept at about 7.5 as the height of the receiving aerial was increased from 0 to 7.5 cm., and then rose steadily, being about 15 at a height of 12 cm., 37 at 22 cm., 57 at 27 cm., 75 at 34 cm.

CONDUCTIVITY OF IONS IN CROSSED ELECTRIC AND MAGNETIC FIELDS.—Leigh Page. (*Phys. Review*, 1st Sept., 1929, Vol. 34, pp. 763-771.)

Author's summary:—The effect of collisions of ions moving through crossed electric and magnetic fields is investigated. (a) Collisions of ions with one another are shown to be without effect, the transverse current at right angles to the fields having the same value neu , where u is the velocity of progression, as would exist in the absence of collisions. (b) Collisions of free ions with neutral particles are investigated for the case where u is small compared to the speed v of thermal agitation. As the mean free path is increased the current parallel to the electric field increases to a maximum and then falls asymptotically to zero, the transverse current parallel to u rising from zero to the limiting value neu for infinite mean

free path. Calculation of the Hall coefficient on the present theory, which differs from the usual theory in that it takes account of long free paths, shows that the coefficient increases with increasing magnetic field.

WIRELESS ECHOES OF LONG DELAY.—P. O. Pedersen. (*Zeitschr. f. Hochf. Tech.*, Oct., 1929, Vol. 34, pp. 152-154.)

A long summary, by Zenneck, of Pedersen's paper (see 1929 Abstracts, p. 565) now published in *Det Kgl. Danske Vidensk. Selskab. Mathem. fysiske Meddel.* IX. 5, 1929, pp. 1-48.

DIE WELLENAUSBREITUNG DES DEUTSCHLAND-SENDERS (The Wave Propagation of the "Deutschland" Transmitter).—F. Kiebitz. (*Zeitschr. f. Hochf. Tech.*, Nov., 1929, Vol. 34, pp. 173-175.)

See 1929 Abstracts, p. 624.

ON THE EFFECT OF THE GROUND ON DOWNCOMING PLANE SPACE-WAVES.—E. T. Glas. (*E.W. & W.E.*, Dec., 1929, Vol. 6, pp. 663-668.)

The writer begins by discussing the various observed results and criticising the various theories regarding the state of polarisation of downcoming waves. He then examines the possibility of attributing the phenomena (e.g., the rotation into a vertical direction of a field horizontally polarised near the transmitter) to the influence of the conducting surface of the earth, at any rate in part. He considers a homogeneous downcoming radiation forming an angle δ with the surface of the earth, assuming the electric field to be originally a pure alternating one. The field above the surface produced by the earth-currents (formed by the rays which are refracted into the earth) is neglected; the calculations deal only with the waves reflected from the earth and their effect in distorting the originally pure field.

For the two cases where the electric field-vector of the downcoming ray is perpendicular to the plane of incidence, and where it lies in that plane, the writer shows that the resulting equation represents an ellipse, the relative position of whose axes, and the axes themselves, can be calculated.

The actual result for a short wavelength (26.5 m.) is given graphically, assuming earth conductivity = 5×10^{-14} e.m.u. "The following conclusions may be drawn from this numerical example: (1) a relatively steep radiation may give narrow ellipses and consequently a pure field. Nevertheless, a nearly grazing incidence will give the same result. (2) The field-component in the plane of incidence is rather pure but somewhat raised or tilted owing to the influence of the ground. Thus the apparent direction of propagation differs from the true one. (3) The state of polarisation of the downcoming

radiation is altered. A steep radiation may be more horizontally polarised, but a radiation the rays of which form a relatively small angle with the surface of the earth will to a certain limit always be more vertically polarised. (4) The resulting field which is generally elliptically polarised is very dependent on the height above ground as regards its intensity, purity and polarisation." The writer shows how this ground-reflection effect may explain the observed variation of the plane of polarisation as the distance from the transmitter increases.

ON THE RELATION BETWEEN LONG-WAVE RECEPTION AND CERTAIN TERRESTRIAL AND SOLAR PHENOMENA.—K. Sreenivasan. (*Proc. Inst. Rad. Eng.*, Oct., 1929, Vol. 17, pp. 1793-1814.)

Author's summary:—It is shown in the paper that there appears to be an inverse relation between long-wave reception on 75 kc. per sec., and the temperatures at the transmitting and receiving stations, when the distance between them is not great. The explanation is offered that the variations in the temperatures and in the signal strength are due to a common source, the changes in the medium between the two places.

If at all, only a direct relationship has been noticed between field intensity and the barometer reading at the receiving station.

There is found to be good correlation between atmospheric ozone in north-western Europe and Bangalore reception, and between the two and sunspots. Little correlation is found between these and terrestrial magnetism as represented by the international magnetic character of day numbers. Analysis of the data on the basis of the 27-day period has yielded very satisfactory agreement between reception and sunspots, with a six-day period in reception for which no explanation is found.

The lag of one to two days between reception and sunspots occasionally occurring has been explained on the basis of the emission of high-speed corpuscles from the sun. Regarding some of the differences between long- and short-wave transmission, the transmission of short waves is attributed to electron movement in the higher regions of the upper atmosphere and that of long waves to less mobile ions below. It is on this basis that the correlation between reception and ozone may be explained.

The paper is in connection with the signal intensity measurements of Madras (Fort) Radio, working on 75 kc. per sec., made at the Radio Laboratory of the Indian Institute of Science, Bangalore, between March 1926 and August 1927, a period of eighteen months.

ON THE VARIATION WITH TEMPERATURE OF THERMAL SEPARATION IN GASEOUS MIXTURES.—J. W. H. Lugg. (*Phil. Mag.*, Dec., 1929, Vol. 8, No. 54, pp. 1019-1024.)

The thermal separations for a single mixture of hydrogen and carbon dioxide have been studied with the cold-bulb temperature at 29 deg. C. and the hot bulb at temperatures between 100 and 464

deg. C. Results indicate that the separations at the higher temperatures are greater than would be expected on the basis of Chapman's formula. The relationship between composition difference and temperature difference is more nearly linear.

L'OZONE ATMOSPHERIQUE (The Ozone of the Atmosphere).—G. M. B. Dobson. (*Journ. de Phys. et le Rad.*, July, 1929, Vol. 10, pp. 241-246.)

Lecture to the French Society of Physics.

ÜBER DIE BILDUNG DES OZONS IN DEN HOCHSTEN ATMOSPHERENSCHICHTEN (On the formation of Ozone in the Highest Atmospheric Layers).—W. Anderson. (*Physik. Zeitschr.*, 1st Aug., 1929, Vol. 30, No. 15, pp. 485-487.)

The writer agrees that the causative factor is a corpuscular radiation of some kind, normal to the earth's surface. He declines to believe that the "cosmic radiation" is concerned: the numerical values he arrives at from various data show that these rays have far too little energy to perform the work. He agrees that the ozone-producing radiation is probably the same that causes auroræ and magnetic storms, but refuses to accept Lindemann's explanation (adopted by various other workers) of an electric field accelerating the descent of the ozone from the heights corresponding to the auroral heights. His own calculations (given in this paper) lead to the conclusion that the maximum ozone-building by the corpuscular radiation goes on at the 40-50 km. height corresponding to the known height of the ozone layer.

FACTORS AFFECTING THE NATURE OF IONS IN AIR.—H. A. Erikson. (*Phys. Review*, 15th Aug., 1929, Vol. 34, pp. 635-643.)

THE RECOMBINATION OF IONS AND OF IONS AND ELECTRONS IN GASES.—L. C. Marshall. (*Phys. Review*, 15th Aug., 1929, Vol. 34, pp. 618-634.)

The full paper, a summary of which was referred to in 1929 Abstracts, p. 625.

THE DIELECTRIC CONSTANTS OF ARGON AND NEON.—A. B. Bryan. (*Phys. Review*, 15th Aug., 1929, Vol. 34, pp. 615-617.)

A STUDY OF WAVE SYNTHESIS BY MECHANICAL MEANS. III AND IV.—A. W. Ladner. (*Marconi Review*, August and October, 1929, pp. 1-12 and 1-9.)

In the August instalment "the phase relationship of carrier to side bands is dealt with and the effects of alteration of their relative phases on the envelope. Examples are given to show what happens when the phases are shifted and what are the effects of frequency alteration. Further, the problem of suppression of one side band as well as the carrier is considered and some peculiarities of this system given." The October instalment investigates beats and allied phenomena, push-pull circuits, and the synthesis of a.c. wave-forms.

MECHANICAL AND ELECTRICAL DEMONSTRATION OF RELATIONS BETWEEN STANDING AND TRAVELLING WAVES.—W. L. Everitt. (*Journ. Opt. Soc. Am.*, Aug., 1929, Vol. 19, pp. 95-100.)

EXPERIMENTELLE UNTERSUCHUNGEN AN WASSERWELLEN ZWECKS HERSTELLUNG VON ANALOGIEN ZU ELEKTROMAGNETISCHEN STRAHLUNGSVORGÄNGEN (Experimental Investigations on Water Waves with a View to Establishing Analogies with Electromagnetic Radiation Processes).—L. Heck. (*Zeitschr. f. Hochf. Tech.*, Oct., 1929, Vol. 34, pp. 121-131.)

Carried out under the auspices of Dieckmann (for whose paper on the plastic representation of interference see 1929 Abstracts, p. 451), these experiments led to very successful results. A number of instantaneous and "time" photographs (the latter obtained by superimposing a number of the former, with the result that the antinodes of the stationary waves are made visible) are given in the paper, and their meanings discussed.

ÜBER DIE AUSBREITUNG DER EBENEN ELEKTROMAGNETISCHEN WELLEN IM KUGELSYMMETRISCHEN GRAVITATIONSFELDE (The Propagation of Plane-polarised Electromagnetic Waves in a Spherically-symmetrical Gravitational Field).—W. Alexandrow. (*Physik. Zeitschr.*, 1st Aug., 1929, Vol. 30, No. 15, pp. 480-484.)

DIE FORTPFLANZUNG VON RECHTECKSIGNALEN IN KABELN (The Propagation of Signals of Rectangular Form in Cables).—H. Edler. (*Arch. f. Elektrot.*, 5th Nov., 1929, Vol. 23, No. 1, pp. 1-18.)

The conditions of propagation of a rectangular-formed wave in a cable are investigated, taking into account the special nature of the dielectric as a carrier of ions possessing a natural frequency of their own. For the purposes of calculation, these ions are replaced by oscillatory circuits connected across the two conductors.

EARTHQUAKE SOUNDS HEARD AT GREAT DISTANCES.—A. Thomson: F. J. W. Whipple. (*Nature*, 2nd Nov., 1929, Vol. 124, pp. 687-688.)

The first writer gives details of the "abnormal audibility" of the sounds of the severe earthquake in N. Zealand (17 June, 1929). Whipple comments on these: abnormal audibility is now believed to be due to return to earth from the high-temperature layers between 40 and 60 km.: the fact that the sounds were heard to the N.E. of the epicentre and not to the S.W. fits in with War-time experience that in Europe the zone of abnormal audibility is to be found to the N.W. of the source of sound in summer and to the S.E. in winter (firing on the Western Front being heard in England in summer and in Switzerland in winter): the earthquake occurred during the N. Zealand winter, and transmission to N.E. in the southern hemisphere is analogous to transmission to S.E. in the northern hemisphere.

BEITRAG ZUR SCHALLAUSBREITUNG IN DER ATMOSPHERE (Contribution to the Subject of Sound Propagation in the Atmosphere).—J. Kölzer. (*Zeitschr. f. Geophys.*, No. 5, 1928, Vol. 4, pp. 250-257.)

By a comparison of recent sound velocity measurements in open air, the writer shows that the most exact measurement possible is required, allowing for the influence of the weather; he suggests the use of Wireless towers to enable the apparatus to be installed at various heights. He gives a mathematical procedure for the construction of velocity curves involving height, temperature and wind components. From the shape of these curves he can deduce the formation of a silence zone.

BEITRAG ZUR THEORIE DES STREUPROBLEMS (Contribution to the Theory of the Dispersion Problem).—F. Sauter. (*Ann. der Phys.*, 26th July, 1929, Series 5, Vol. 2, No. 4, pp. 465-476.)

A mathematical treatment somewhat resembling Wentzel's but of more general application.

THE PRISM WITH AN INDEX OF REFRACTION LESS THAN UNITY.—H. E. Strauss. (*Journ. Opt. Soc. Am.*, Oct., 1929, Vol. 19, No. 4, pp. 167-174.)

SOME PROBLEMS RELATING TO THE MOBILITY OF GASEOUS IONS.—A. M. Tyndall: C. F. Powell. (*Proc. Phys. Soc.*, June, 1929, Vol. 41, No. 4, pp. 248-257.)

H.F. CONDUCTIVITY AND DIELECTRIC CONSTANT OF AQUEOUS SOLUTIONS OF ELECTROLYTES FOR 1 M. AND 5 M. WAVES.—H. Rieckhoff. (See under "Measurements and Standards.")

THE ELECTRICAL SPECTRUM OF WATER, IN THE 2.2 TO 3 METRE ZONE OF WAVELENGTHS.—N. Novosilzew. (See under "Measurements and Standards.")

THE RADIATION FIELD OF A FINITE ANTENNA BETWEEN TWO PERFECTLY-CONDUCTING PLANES.—R. Weyrich. (See under "Aerials and Aerial Systems.")

ATMOSPHERIC AND ATMOSPHERIC ELECTRICITY.

CHAMP MAGNÉTIQUE DU SOLEIL, GÉNÉRAL ET EXTÉRIEUR (The Sun's Magnetic Field, General and External).—H. Deslandres. (*Comptes Rendus*, 16th Sept., 1929, Vol. 189, pp. 413-417.)

The writer recalls his various publications, from 1911 onwards, maintaining the small value of 10^{-7} gauss, opposed to the earth's field, for the mean strength of the general field, based on Meudon observations of the radial velocity of the solar protuberances. Hale and the Mt. Wilson astronomers announced an entirely contradictory value, 25 gauss (diminishing to 10 gauss at 200 km. or less) in the direction of the earth's field, from observations of the Zeeman effect, and apparently

considered Deslandres' suggested value as completely erroneous.

In the present Note, the writer recapitulates his ideas and shows how his various points have been confirmed by later work of others: e.g., his 1913 deduction that the protuberances curved in the direction of rotation contained calcium positive ions was confirmed spectroscopically; Chapman's theoretical work leads to a resultant field of zero or very small value at the upper part of the chromosphere; Störmer, working on his own lines, arrives at a field of the order of 10^{-7} . Evershed's recent work on the protuberances confirms the earlier results.

The writer's idea of the three successive layers, the inner and outer negative and the middle one positive, with a positive resultant, agrees with the existence of the Hale value of field *close to the surface*. His picture of the coronal jets of fast electrons, slightly deviated by the 10^{-7} gauss field in a sense opposed to the rotation, explains the lag of magnetic storms on earth behind the arrival of the sunspot at the central meridian.

LE RÉGIME DES VENTS DANS L'ATMOSPHÈRE, NOTAMMENT LA STRATOSPHERE, AU-DESSUS DES RÉGIONS DE LATITUDE MOYENNE, EN EUROPE (The Régime of Winds in the Atmosphere, particularly the Stratosphere, over Regions of Medium Latitude in Europe).—Peppler. (*Génie Civil*, 21st Sept., 1929, Vol. 95, p. 287.)

Summary of an article in *Zeitschr. f. Flugtech. u. Motorluft.*, 28th June.

MARCH RAINFALL OF NORTH-WEST INDIA AND AGRA UPPER WINDS IN DECEMBER-JANUARY.—M. V. Unakar. (*Nature*, 19th Oct., 1929, Vol. 124, p. 618.)

A correlation coefficient of -0.82 is obtained between the departures from normal of westerly upper winds in a layer 3 km. to 7 km. over Agra, during the second fortnight of December and the first fortnight of January, and the departures from normal of subsequent March rainfall over the plains of N.W. India.

FORTSCHRITTE IN DER DEUTUNG VON WETTERVORGÄNGE UND DIE GRENZEN DER VORAUSGABE (Progress in the Interpretation of the Meteorological Situation, and the Limits of Forecasting).—R. Mügge. (*Naturwiss.*, 6th Dec., 1929, Vol. 17, pp. 952-958.)

TURBULENTE EIGENSTRÖME DER OBERSTEN ERDSCHICHTEN (Turbulent Earth Currents of the Upper Earth Layers).—H. Hunkel. (*Z. prakt. Geolog.*, Nos. 7 and 9, Vol. 36: summary in *E.T.Z.*, 12th September, 1929, p. 1347.)

DISTRIBUTION OF POTENTIAL TEMPERATURE IN THE FIRST 25 KILOMETRES OVER THE NORTHERN HEMISPHERE.—K. R. Ramanathan. (*Nature*, 5th Oct., 1929, Vol. 124, pp. 509-510.)

A smoothed diagram is given showing the latitudinal distribution of potential temperature

in summer and winter of the northern hemisphere. Since lines of equal potential temperature are also lines of equal entropy, this diagram supplies the need mentioned by Napier Shaw (1929 Abstracts, p. 445). Interesting features are pointed out.

EMPIRICAL FACTORS IN WEATHER FORECASTING.—W. Trotter. (*Nature*, 19th Oct., 1929, Vol. 124, pp. 616-617.)

A letter suggesting that perhaps at the present stage of its advancement the art of weather forecasting might with advantage make use of certain unmeasurable tendencies of weather that are to be noticed by mere crude observation of its behaviour. J. S. Dines replies (*ibid.*, 9th Nov., p. 726).

SUN-SPOTS AND RAINFALL.—A. Streiff. (*Power*, 30th April, 1929, Vol. 69, pp. 704-706.)

In connection with forecasting water supplies for hydroelectric developments, the writer shows remarkable correlation between the sunspot period and rainfall and run-off records from widely separated sources, such as Great Salt Lake levels, Nile flood records, rainfall records in Italy, and the annual rings of a giant redwood.

ATMOSPHERIC ELECTRICITY DURING SANDSTORMS.—J. M. Benade. (*Science*, 18th Oct., 1929, Vol. 70, pp. 379-380.)

Results noticed in India. "It has been suggested that this phenomenon is due to triboelectricity, but it is interesting to find that on a perfectly still day when the air is heavily laden with dust, the aerial potential may fluctuate for hours between 5,000 and 10,000 volts, though if earthed through a galvanometer the current amounts only to about one micro-ampere."

THE TIDES OF THE UPPER ATMOSPHERE AND THE HEIGHTS OF METEORS.—J. Egedal. (*Nature*, 14th Dec., 1929, Vol. 124, pp. 913-914.)

Using data on the lowest observed heights of meteors in lat. 56 deg. N., the writer deduces that the mass of air situated above 90.5 km. at flood-tide should be equal to the mass of air situated above 79.5 km. at ebb-tide. The corresponding figures found by consideration of auroræ (*ibid.*, 27th April, 1929) were 106 km. and 100 km. respectively, but these were in lat. 70 deg. N.

ZUR DEUTUNG DES NÖRDLICHTSPEKTRUMS (On the Interpretation of the Spectrum of the Aurora Borealis).—L. Vegard. (*Naturwiss.*, 13th Dec., 1929, Vol. 17, pp. 980-981.)

A criticism of Slipher and Sommer's conclusions (see Jan. Abstracts, p. 35, 2 abstracts).

CONTRIBUTIONS À L'ÉTUDE DE LA MATIÈRE FULMINANTE (Contributions to the Study of Fulminant Matter).—E. Mathias. (*Comptes Rendus*, 7th and 21st Oct. and 9th Dec., 1929, Vol. 189, pp. 512-514, 607-608, and 1049-1051.)

Further development of the writer's theory (1929 abstracts, p. 568). (1) Superficial tension:

division of a globule into several, under the influence of a shock or rebound; (2) Lowering of superficial tension by impurities; (3) The excavating properties of spherical lightning. In the issue of 18th Nov., there is also a note on the "serpentine" forms.

LIGHTNING.—PART I.—F. W. Peek. (*Gen. Elec. Review*, Nov., 1929, Vol. 32, pp. 602-618.)

Characteristics measured in engineering units—laboratory research—lightning generator—high-voltage measurements—waveshapes and polarity—etc. Many photographs, curves, and oscillograph records.

UNSHACKLING THE LIGHTNING ARRESTER.—B. E. Ellsworth. (*Elec. World.*, 9th November, 1929, Vol. 94, pp. 935-936.)

"The entire elimination of lightning troubles is apparently the result of a scheme of arrester connection now in use by the Iowa-Nebraska Light and Power Company. . . . The actual arrester with its connections is designed to give as straight a path to earth as possible (many of the older types have seven or more right-angle turns in the path) but the more important point still is the zig-zagging of the line connecting the transmission line to the sub-station or to the metering equipment, on the far side of the arrester. A zig-zag equivalent to four right-angled turns eliminates practically all the "follow through" of the lightning.

DER GEGENWÄRTIGE STAND DER BLITZSCHUTZFRAGE (The Present State of the Problem of Protection [of High Voltage Lines] against Lightning).—A. Matthias. (*E.T.Z.*, 10th Oct., 1929, Vol. 50, pp. 1469-1474.)

THEORY OF A NEW VALVE TYPE LIGHTNING ARRESTER.—J. Slepian, R. Tanberg, and C. E. Krause. (*Elec. World.*, 14th December, 1929, Vol. 94, pp. 1166-1167.)

"Discharges confined to the interstices of naturally porous material indicate possibilities for development."

ACTUAL LIGHTNING SURGES RECORDED.—J. H. Cox (Westinghouse Co.). (*Elec. World.*, 19th October, 1929, Vol. 94, pp. 776-777.)

1929 results with Norinder-type c.f. oscillographs have been very successful. Some oscillograms are given. "Wave front rise at 100-300 kv. per micro-second. High surges persisted over half voltage for 40 or more micro-seconds." See also same journal, 16th November, 1929, pp. 978-979.

LA TEORIA DI IONIZZAZIONE E LO SPETTRO DELLE MACCHIE DEL SOLE (The Theory of Ionisation and the Spectrum of Sun-Spots).—M. Conti. (*Nuovo Cim.*, July, 1929, Vol. 6, pp. 289-297.)

IONS AND ELECTRICAL CURRENTS IN THE UPPER ATMOSPHERE OF THE EARTH.—E. O. Hulbert. (*Phys. Review*, 15th October, 1929, Volume 34, pp. 1167-1183.)

The Am. Phys. Soc. paper, an outline of which

was dealt with rather fully in 1929 Abstracts, pp. 627-628.

DIE ATMOSPÄRE ALS KOLLOID (The Atmosphere as a Colloid).—A. Schmauss and A. Wigand. (Long review in *Physik. Zeitschr.*, 1st September, 1929, Vol. 30, pp. 556-558.)

PAST CLIMATES.—G. C. Simpson. (*Nature*, 28th Dec., 1929, Vol. 124, pp. 988-991.)

PROPERTIES OF CIRCUITS.

ÜBER ERZWUNGENE SCHWINGUNGEN IN ELEKTRO-NENRÖHRENKREISEN (Forced Oscillations in Valve Circuits).—H. Witte. (*Arch. f. Elektrot.*, 5th Nov., 1929, Vol. 23, No. 1, pp. 84-94.)

For a reaction audion circuit, Ollendorff in 1926 investigated the processes of forced excitation and gave approximate solutions for the resulting differential equations: one, the "forced" solution, of the exciting frequency and the other a "surge" or "beat" solution. The latter is only real if the free oscillating system is capable of self-oscillation, in which case the "forced" amplitude must not exceed a certain maximum. Above this maximum, the "mitnahme" (drawing into tune) zone occurs, and only the forced oscillation is present.

The present paper recalls the writer's investigations (published in 1923) on similar lines, for an intermediate circuit single valve system as well as for the simple circuit: in the latter, the forced excitation was applied directly to the grid, with the oscillatory circuit connected between anode and cathode (whereas Ollendorff applied the excitation to the circuit connected between grid and cathode). Equations were derived for the potentials and currents of the "forced" and "free" oscillations, and for the breadth of the "mitnahme" zone. The intermediate-circuit system gave similar "beat" oscillations, as well as the forced oscillations within the "mitnahme" zone. Thus this system, in spite of its being able to oscillate in one only of the two coupling frequencies, can under certain conditions have its oscillating processes altered by outside excitation.

DÉMONSTRATION DU THÉORÈME D'HURWITZ SUR LES CONDITIONS NÉCESSAIRES À L'EXISTENCE D'UN RÉGIME OSCILLATOIRE (Proof of Hurwitz' theory on the Conditions necessary for Oscillation).—J. B. Pomey. (*Rev. Gén. de l'Élec.*, 5th Oct., 1929, Vol. 26, pp. 519-521.)

EQUIVALENT CIRCUITS OF AN ELECTRON TRIODE AND THE EQUIVALENT INPUT AND OUTPUT ADMITTANCES.—E. L. Chaffee. (*Proc. Inst. Rad. Eng.*, Sept., 1929, Vol. 17, pp. 1633-1648.)

Author's summary:—"This paper is presented in two parts. In Part I two fundamental equivalence theorems concerning a triode and its circuits are rigorously derived. These theorems give the simple circuits which are equivalent to the plate and grid circuits of the triode. These equivalent circuits contain only constant circuit elements and

fictitious electromotive forces, the use of which greatly simplifies the calculation of currents in the triode circuits when the electrical variations are small. In Part II the equivalence theorems are used to obtain the equivalent input and internal output admittances of a triode with its associated circuits."

For the equivalent Plate-Circuit Theorem, the following equation is reached:—

$$r_p \Delta i_p + \Delta e_b = \mu_p \Delta e_g,$$

representing the fact that the small plate current measured from the Q -point [operating or "quiescent" point determined by the steady components of grid and plate potentials] can be calculated assuming an equivalent circuit containing a resistance r_p , an impedance or combination of circuit elements Z_b , and a fictitious voltage $\mu_p \Delta e_g$. If Δe_g is a sinusoidal e.m.f. having an r.m.s. value of ΔE_g , the r.m.s. value of the plate current measured from Q is

$$\Delta I_p = \frac{\mu_p \Delta E_g}{r_p + Z_b},$$

the bold-faced type denoting complex quantities. This therefore is the statement of the theorem for sinusoidal currents and potentials. The corresponding equivalent grid-circuit expression is

$$\Delta I_g = \frac{\Delta E_0 - \mu_g \Delta E_p}{r_g + Z_c}.$$

VLIANIE PARAZITNOI EMKOSTI PRI REZONANSNOM USILENII (The Effect of Parasitic Capacities on Amplifiers using Tuned Circuits).—L. B. Slepian. (*T.i.T.b.p.*, Leningrad, October, 1929, Vol. 10, pp. 427-446.)

In Russian. Investigations on the subject by Beatty (*E.W. & W.E.*, 1928; *Phil. Mag.*, 1927) and Nelson (*Proc. I.R.E.*, 1929) are discussed. Formulae are quoted for calculating the maximum stable amplification with tuned plate circuits, and derived for the case of plate circuits inductively coupled to tuned circuits. A table is prepared showing for both a triode and a screen grid valve operating on various wavelengths (a) the amplification when the maximum output is obtained, inter-electrode capacity being neglected, and (b) the maximum stable amplification calculated from the above formulae. The effect of inter-electrode capacity on multi-stage amplification is also discussed.

CONTROLLING AN ANODE-BEND DETECTOR.—Bertram Hoyle. (*Wireless World*, 27th November, 1929, Vol. 25, pp. 588-589.)

Describing a method of achieving station separation by varying the bias applied to an anode-bend detector and by close adjustment of the plate voltage. By this means a very definite cut-off of all signals below a certain strength can be obtained.

O NEISKAJENOM USILENII SIGNALOV. (On the Distortionless Amplification of Signals).—V. I. Siforov. (*T.i.T.b.p.*, Leningrad, October 1929, Vol. 10, pp. 508-525.)

In Russian. A theoretical discussion of high frequency distortionless amplification, the method

considered being the combination of several amplifiers in such a way that their frequency response and phase shift curves are either added, subtracted or multiplied. A method is given for the construction of frequency response and phase shift curves and for their addition and subtraction. The following two cases are discussed:—(1) Two amplifiers fed in parallel, their output circuits being inductively coupled to two tuned circuits connected in series. In this case, the frequency response curves are either added or subtracted. (2) A cascade amplifier. In this case the frequency response curves are multiplied. The effect of transformer coupling between the amplifiers is reduced to the multiplication of two frequency response curves. The conclusions arrived at have been experimentally checked at the Central Radio Laboratory.

REDUCTION OF DISTORTION IN ANODE RECTIFICATION.—A. G. Warren; P. G. Davidson. (*E.W. & W.E.*, October, 1929, Vol. 6, p. 550.)

Referring to the first writer's paper dealt with in 1929 Abstracts, pp. 569-570, Davidson suggests that the whole point of the method depends on the "straightening effect" of the anode resistance on the static characteristic of the valve, and refers back to papers by Kröncke and Colebrook. In low frequency amplification the effect can be made use of; in the case of an anode bend rectifier with a plain anode resistance the presence of the by-pass condenser vitiates the whole argument, for it is the carrier frequency which must be considered, and for this the anode circuit impedance cannot (in the presence of this condenser) be large compared with that of the valve. Under the actual conditions of operation it is the ordinary static curve which must be taken, and he has come across no valve deviating materially from the simple parabola within the limits of the useful part of the curve; this leads back to the conclusion that the distortion is a function of the percentage modulation only, and cannot be reduced by increasing the input.

It is probably true that the present average modulation is around 20 per cent., but peak values around 80 per cent. occur regularly, and the B.B.C. forecast increasing percentages; in any case the peaks must be provided for if anything like perfection is aimed at. The writer therefore describes his experiments with a tuned circuit in series with the rectifier anode: with this arrangement, for an unmodulated input peak voltage of 7, a modulation depth of 80 per cent. can be dealt with, while the sensitivity for the troughs remains 80 per cent. of that for the peaks; while with a modulation of 40 per cent. the ratio rises to 95 per cent. Better figures can be obtained with increased inputs.

ÜBER NEUE ERSCHEINUNGEN IM KONDENSATORFELDE SEHR SCHNELL SCHWINGENDER STROMKREISE (New Phenomena in the Condenser Fields of Very Rapidly Oscillating Circuits).—K. Heinrich. (*E.T.Z.*, 14th November, 1929, Vol. 50, pp. 1656-1657.)

Using the 300 w., 3 m. transmitter employed in

his previous researches (1929 Abstracts, p. 588), the writer has experimented with the arc-like discharge from a point (forming one plate of a condenser) to a plate (forming the other). The discharge has a very definite core and outer sheath, which preserve their identity even when the point is removed so far from the plate that the discharge cannot reach the latter but "burns" like a candle flame from the point. This flame will burn a hole in a glass plate brought up to it, with brilliant generation of light: it is the core only which does the work, the sheath takes no part and only loosely surrounds the core. If a glass rod is brought near (below) the flame, the core will turn down to it while the sheath—freed from the core—burns upwards. Various other phenomena are described, and explained electronically. The electrons pass right through non-metals, but only move at the surface of metals. Non-metals brought into the condenser-field grow hot and retain their heat long after the field is switched off. But if metals are brought into or near the field, they feel hot to the hand but show no increase in temperature when the field is switched off. "The electrons moving at the surface of the metal appear to hit the skin and produce the effect of heat."

RESONANCE IN CIRCUITS WITH PARALLEL RESISTANCES.—A. Astin. (*Phys. Review*, June, 1929, Vol. 33, No. 6, pp. 1074-1075.)

Jezewski (1929 Abstracts, p. 148) and Doborzynski (1928 Abstracts, p. 342) have shown theoretically that in a resonant circuit with L , C and parallel R the value of C corresponding to the maximum $P.D.$ across the capacity is independent of R . The writer has shown that this is also the case when a non-shunted condenser is in series with a shunted condenser. The above has been verified experimentally for a frequency of 2×10^6 with parallel R down to 100 ohms for the first type of circuit and down to 30 ohms for the second type. The primary importance of the results is in connection with the use of such-circuits for measuring the dielectric constants of conducting liquids.

ZUR QUALITATIVEN THEORIE GESÄTTIGTER EISENDROSSELN (On the Qualitative Theory of the Saturated Iron-cored Choke).—F. Ollendorff. (*Arch. f. Elektrot.*, 19th November, 1929, Vol. 23, No. 2, pp. 162-180.)

Part III. The previous parts appeared in the same journal, 1928, p. 6 and 1929, p. 349.

WAVE FILTERS.—(German Pat. 478866, Wigge, pub. 2nd July, 1929.)

The use of one or more circuits coupled to a circuit in series with the current-path is here dealt with. The resistance for the two coupling waves is very large, while between these there is a very sharp minimum.

INDUKTIVITÄT, ENERGIE UND STROMKRAFT VON SAMMELSCHIENEN (Inductance, Energy and Electric Force in Bus Bars).—W. Steidinger. (*Arch. f. Elektrot.*, 19th November, 1929, Vol. 23, No. 2, pp. 153-162.)

SIMPLE FORMULÆ FOR THE RAPID CALCULATION OF OHMIC RESISTANCE FOR A.C.—A. Levasseur. (See under "Measurements and Standards.")

AN INVESTIGATION OF THE PHENOMENA OF FREQUENCY MULTIPLICATION AS USED IN TUBE TRANSMITTERS.—R. M. Page. (*Proc. Inst. Rad. Eng.*, Sept., 1929, Vol. 17, pp. 1649-1655.)

A paper from the Naval Research Laboratory, relating to the Hoyt Taylor—L. C. Young method (developed there several years ago) of frequency-multiplying to obtain crystal control of high-frequency transmitters. "An experimental study of the operation of the system is made when doubling and tripling the frequency of a 4,000-ke. crystal-controlled oscillator, and comparisons are made with the operation of the same system when balanced and amplifying the fundamental frequency. Relations between d.c. negative grid voltage and r.f. input voltage for maximum efficiency are shown to be critical and nearly constant for any one order of multiplication. Satisfactory operation of the system is shown to depend upon inductive reaction in the grid circuit, which produces regeneration through the grid-plate feedback in the tube" [this accounts for the observed fact that the screen-grid valve is very inferior to the triode for this purpose]. The study is based on circuit efficiencies as measured by the contact pyrometer method (1929 Abstracts, pp. 48-49).

NEGATIVE RESISTANCE IN A DIODE IN A MAGNETIC FIELD.—I. Ranzi. (See two abstracts under "Transmission.")

TRANSMISSION.

OSCILLATIONS IN LOW PRESSURE DISCHARGE-TUBES.—E. W. B. Gill. (*Phil. Mag.*, December, 1929, Supp., No. 53, Vol. 8, pp. 955-960.)

"Many observers have noticed the occurrence of oscillations when direct current discharges pass in gases at low pressures; but as no systematic investigation appears to have been made of the phenomenon the following experiments leading to a simple theory were carried out." Among the conclusions reached are:—the presence of an external condenser is not essential for the production of oscillations, the capacity of the electrodes (magnified by the presence of space charges) being sufficient to produce oscillations. Any discharge-tube is in a state of oscillation provided that the sparking potential is higher than the maintenance potential and that the current is less than that at which the maintenance potential is independent of the current.

Pressures varied from 2 to 85 mm. of mercury. At the higher pressures there was a fair range of currents over which oscillations occurred, but at 2 or 3 mm. they only occurred if the current was a very small fraction of a milliampere. The general effect of a reduction in pressure was a reduction in wavelength, but the variation was not large. The wavelength increased rapidly as the electrode gap was increased, but the greatest effect on the wavelength was exercised by the current. Thus

for $i = 0.5$ mA., $\lambda = 10,400$ m.; for $i = 2.5$ mA., $\lambda = 2,100$ m.; $i\lambda$ is approximately constant. If the parallel capacity C is increased, λ increases linearly, the line not passing through the origin;

combining these results, $\lambda = \frac{k(C + c')}{i}$. Here k depends only on gap and pressure (increasing with either) while " c' is small and depends chiefly on i and decreases [misprint for increases?] if i is increased." The theory is finally represented by the relation $\lambda \propto \frac{(v_1 - v_2)(C + c')}{i}$ where $v_1 - v_2$ is the difference between the sparking potential and the minimum maintenance potential.

FENOMENI DI RESISTENZA NEGATIVA IN UNO DIODO SOTTOPOSTO A UN CAMPO MAGNETICO (Negative Resistance in a Diode subjected to a Magnetic Field).—I. Ranzi. (*Lincei Rend.*, No. 8, 1929, Vol. 9, pp. 652-654.)

In the course of tests on measuring magnetic fields by the anode current of a cylindrical diode, it was found that if the field is slightly inclined to the axis of the electrodes the current is no longer proportional to the changes of field strength, but with increasing strength passes first through a minimum and then through a maximum. If the field is kept constant and the anode voltage varied, at certain values the current decreases with increasing voltage: the diode shows negative resistance, which can be used to produce undamped oscillations.

SUI FENOMENI DI RESISTENZA NEGATIVA IN UN DIODO SOTTOPOSTO A UN CAMPO MAGNETICO (On the Phenomena of Negative Resistance in a Diode subjected to a Magnetic Field).—I. Ranzi. (*Nuovo Cim.*, June and July, 1929, Vol. 6, pp. 249-260 and 310-315.)

Making use of the negative resistance of a diode in the conditions described in a former paper (see above) the writer has obtained persistent oscillations from the lowest acoustic frequencies up to a frequency of about 10^8 p.p.s. He has also obtained Barkhausen-type oscillations (down to 42 cm.), but only when the magnetic field formed a certain angle with the filament. The formation of these latter oscillations is independent of any phenomenon of negative resistance. He finds, for certain values of magnetic field, anode potential and inclination of field, an intense and constant rustling in telephones placed in the anode circuit; this seems analogous to the "small shot" or Schrot effect but is much more intense. This he calls the "granular" effect.

ELEKTRONENSCHWINGUNGEN IN GITTERDIODEN (Electronic Oscillations in the Grid-Diode).—H. E. Hollmann. (*Zeitschr. f. tech. Phys.*, October, 1929, Vol. 10, No. 10, pp. 424-427.)

Author's summary:—"In diodes with anodes of grid form, the electronic oscillations—unlike the B-K oscillations, whose wavelengths decrease with increasing grid potentials—behave in opposition to the Barkhausen relation $\lambda^2 \times V_0 = \text{const}$. This abnormal conduct, as

well as the decrease of wavelength for increasing emission current, is (in this paper) readily explained as the effect of the negative space charge; the anode retarding potential of the triode being here replaced by the retarding potential due to the space charge. In the case of close-meshed grids, electron 'oscillations of higher frequency' occur.

"In view of the results of these tests, experimental deviations from the above-mentioned fundamental relation (derived by making various simplifying assumptions) must not be taken as an argument against the Barkhausen ideas of pure electron oscillations." Thus the writer rejects Kohl's theory of oscillations regulated by an internal LC circuit, supported by his "electron gas" idea (1929 Abstracts, p. 269).

DER ELEKTRONENOSZILLATOR ALS NEGATIVER WIDERSTAND (The Electron Oscillator as Negative Resistance).—H. E. Hollmann. (*Zeitschr. f. Hochf. Tech.*, October, 1929, Vol. 34, pp. 140-143.)

In the B-K retarding potential triode circuit, electron oscillations cause a negative anode current in spite of the anode's strong negative potential; this is due to some of the electrons swinging about the grid receiving "additive kinetic energy" which carries them beyond the plane of zero potential to the anode. An increase of negative anode potential pushes this plane farther from the anode and thus decreases the negative anode current. But when an oscillatory circuit (Lecher wires) is connected to grid and anode, these simple relations no longer hold; the electron motions are complicated by the a.c. voltages induced in the circuit and superimposed on the electrode d.c. potentials. The result is "frequency reaction" (see 1929 Abstracts, p. 571) and an increase in oscillating energy.

The writer here investigates the relations, under these conditions, between anode voltage and negative anode current. In dependence on the tuning conditions, the static characteristic shows a falling slope within a definite zone; consequently, an oscillatory circuit introduced into the anode lead will be set oscillating and will modulate the electron oscillator at any desired frequency. The writer has made use of this modulation effect for the reception of ultra-short waves; supersonic modulation increases the received signal strength very considerably, and the adjustment is not so difficult as might seem likely, for the modulation decreases the selectivity.

Other irregular zones of negative resistance are investigated, due to secondary electrons set free by those electrons which impinge on the anode and form the negative anode current.

ISSLEDOVANIE I RASCHET GENERATORA HOLBORNA NA VOLNU 2.80-3.20 M. (Investigation of the Holborn Oscillator for Wavelengths of 2.8-3.2 Metres).—G. A. Uger. (*T.i.T.b.p., Leningrad*, October, 1929, Vol. 10, pp. 491-507.)

In Russian. As a result of research work at the Leningrad Military School of Communication, a complete study of the Holborn oscillator for ultra-short waves (*Zeits. f. Phys.*, 1921) is presented. Methods are indicated for calculating the resonant

frequency, the distribution of the currents, phase relations, losses, radiation resistance and power output. A description is added of the Holborn oscillator which was used for checking these calculations.

SECURITY IN RADIO-TELEPHONY.—Bell Laboratories. (*Nature*, 30th Nov., 1929, Vol. 124, p. 852.)

Paragraph on a *Times* account of a method of "scrambling" the transmitted speech; "in the course of the transmission the high frequencies are changed to low frequencies and vice versa." Cf. the "wobbling band" method, 1929 Abstracts, p. 102. The paragraph also mentions the Bell Laboratories' new use of talking films for increasing the speed of communication between automatic and manual telephone exchanges.

ELIMINATION OF INTERFERENCE.—(German Pat. 474974, Wiegelmann, pub. 12th July, 1929.)

The telephony transmitter sends out two carrier waves, modulated in opposite phase by a double microphone. A push-pull telephone at the receiving end adds the modulation but cancels the interference.

HOCHFREQUENZSTEUERUNG MIT GITTERSTROM (High Frequency Control by Grid Current: Power Amplification for Quartz-controlled Transmitters).—H. Plendl. (*Zeitschr. f. tech. Phys.*, November, 1929, Vol. 10, No. 11, pp. 500-505.)

The power in the quartz-controlled circuit is necessarily low—of the order of 10 w. The amplification of each stage is limited—averaging about 10 to 1. The writer uses his grid-current control circuit (see 1929 Abstracts, p. 389) to reduce the number of stages, particularly with an eye on the simplification and lightening of mobile stations. He uses a 1.5 kw. valve for the main valve and a power-amplifier valve (RV 24) for the grid control. The wavelength used is 100 m., and the quartz-controlled drive has one valve only—a 10 w. RS 55. The behaviour of the set as regards voltage and current processes, the effect of coupling, etc., are investigated.

Comparison with a self-excited transmitter shows that the power output and efficiency is about equal in the two cases. A figure of 50 per cent. is given for the efficiency. A comparison with a separately driven, neutralised transmitter will be published later.

VALVE TRANSMITTERS.—(German Patent 482448, Ahemo, pub. 14th Sept., 1929.)

One power valve acts simultaneously as high-frequency amplifier and as modulator valve to the control valve. The audio-frequency coupling between the two valves is carried out (e.g.) by a l.f. choke lying in the anode circuits of both valves and short circuited for r.f. by a condenser.

CHOKE COILS FOR TRANSMITTERS.—(German Patent 476063, Telefunken, pub. 14th May, 1929.)

Protecting chokes in the feed circuit have usually to be of high value; according to the invention only comparatively few turns are used, but these are coupled to a coil carrying h.f. in such a way

that a counter e.m.f. is induced which compensates for any h.f. which would otherwise pass through the choke.

TUNED CHOKES IN FILAMENT LEADS OF SHORT-WAVE TRANSMITTER VALVES.—(German Patent 477309, Esau, published 5th June, 1929.)

Owing to the relatively high grid-cathode capacity, the leads carrying the cathode heating current are easily set into oscillation. This is prevented by adjustable inductances in each lead, with or without a tuning condenser.

MARCONI AIRCRAFT TRANSMITTER TYPE A.D.18.—(*Marconi Review*, August, 1929, pp. 13-16.)

A departure from standard aeroplane transmitter practice, in that a drive oscillator is employed to stabilise the frequency of the main transmitting system. $\lambda = 300-1,550$ m.

HIGH POWER VALVE TRANSMITTERS.—(French Patent 652,173, Lorenz, pub. 5th March, 1929.)

To avoid insulation and other difficulties arising from the use of very high anode potentials, two generators in series are here used, each giving half the total voltage; the circuit being so designed that the mid-point between them can be earthed.

FREQUENCY MODULATION.—H. Lauer. (*E.W. & W.E.*, Oct., 1929, Vol. 6, pp. 549-550.)

Continuing the argument referred to in 1929 Abstracts, p. 572 and elsewhere, the writer amplifies his previous letter but maintains that his conclusions remain valid, namely, that the minimum value of the frequency band width (of a constant amplitude, frequency-modulated carrier current) is approximately equal to the frequency-variation k (proportional to the modulating amplitude) plus four times the modulating frequency m ; so that such a transmitter may be imagined replaced by a multiplicity of heavily-damped spark sets having, respectively, frequencies comprised between ω_1 and ω_2 (the limits of the modulation) and operating successively in a given order at a rate of $2m$ sparks per second.

MODULATION METHOD.—(German Patent 476147, Siemens and Halske, pub. 17th May, 1929.)

In a transmitter where the carrier and modulation frequencies are impressed on the same grid, to obtain linearity between amplitude of emitted wave and variations of grid potential, two valves are here used in cascade, the control potential being applied to the grid of each. The amplification factor for such a combination is

$$V = \left(S \cdot R_a \cdot \frac{R_i}{R_i + R_a} \right)^2 \cdot (SR_a)^2,$$

if R_a is small compared with R_i . For the slope of the curve the relation is

$$S = \frac{3}{2} A \cdot (E_g + D \cdot E_a)^{\frac{1}{2}},$$

and from these equations

$$V = \left(\frac{3}{2} AR_a \right)^2 \cdot (E_g + DE_a),$$

from which it is seen that the amplification V varies linearly with the grid potential E_g .

RECEPTION.

FORTSCHRITTE BEIM BAU UND BEI DER ANWENDUNG VON WIDERSTANDVERSTÄRKERN (Progress in the Design and Use of Resistance Amplifiers).—M. von Ardenne. (*Zeitschr. f. Hochf. Tech.*, Nov., 1929, Vol. 34, pp. 161-168.)

I. A reduction of the l.f. resistance-coupled stages to two, made possible by increasing considerably the amplification of the first stage. This is accomplished by obtaining voltage amplification with zero grid bias. Former practice was to consider inevitable the use of a small negative bias, to avoid grid current and distortion. Then, since a "durchgriff" D ($1/\mu$) at least equal to $-E_g/E_a$ was necessary in order to work on a suitable part of the characteristic, if E_a was 100 v. and E_g was -1 v., the best value of μ which could be hoped for was 100. In the latest Loewe two-circuit valves, the first valve has $D = 0.15\%$ for $R_a = 5$ megohms. For an anode voltage of 200 this gives an amplification of 360 for the one stage. A single circuit valve for high anode voltage has also been built on these lines. Here $R_a = 8$ megohms, the anode voltage used is 1,300 v., $D = 0.044\%$ and a stage amplification of 870 is obtained (see Jan. Abstracts, p. 37). The calculation and design of these valves is dealt with, and the distortion factors.

This first section contains also sub-sections on simultaneous anode rectification and l.f. amplification; coupling between r.f. and l.f. stages—an aperiodic coupling is shown in a combined receiver whose diagram is given, which has the advantage of requiring only one variable component. Since two r.f. stages are present, the phase relations allow the reaction coupling to the oscillatory circuit to be made by a little condenser with special screening.

Regarding the high anode voltage valve referred to above, the writer points out the advantage that without appreciable loss of amplification a negative grid voltage (and therefore a higher "entrance" resistance) can be used, so that such a valve can be coupled directly to a r.f. oscillating circuit without [seriously] increasing the decrement of this. Another advantage of the high voltage is that in spite of the high ohmic resistance in the anode circuit, the valve can be used as an oscillator. Yet another is that since the emission is so very small, the necessary high tension can be obtained cheaply by a small cold cathode rectifier. An eliminator circuit is shown, providing heating current, 1,300 v. for the special high voltage valve from a half-wave cold cathode rectifier, and 100-200 v. for the succeeding valve from a full-wave hot cathode rectifier.

II. The reduction of r.f. amplification in resistance-coupled l.f. amplifiers. It is shown that a reduction of r.f. voltage in the ratio 1:15 can be effected, without serious frequency distortion, in a l.f. amplification of about 1,500.

III. Simultaneous amplification of more than one frequency. The great possibilities in this direction, presented by aperiodic amplifiers, seem at present insufficiently appreciated. So long as the straight part of the characteristic is worked on, several frequencies can be dealt with without

mutual interference. By suitable design of the individual stages the necessary condition can be fulfilled, namely, that the sum of the peak voltages of all the frequencies always remains less than the maximum allowable control voltage. An important application lies in the simultaneous amplification of the two wavelengths used in broadcast television-cum-telephony. Even when the picture transmission is on short waves, the aperiodic amplifier is still practicable; for although up to the present no very efficient resistance amplifier has been found for waves under 100 m., the technical limit has not yet been reached in reducing the internal capacities on the lines of multiple valves. Another application is in connection with multiple r.f. amplification at a central receiving station (with directional aerials, etc.) for distribution to a number of simple local receivers (audions with l.f. amplifiers) by means of screened and Pupinised conductors; another, in connection with re-broadcasting from relay stations working on the received radio signals.

RADIO IN FRANCE. (*Wireless World*, 6th November, 1929, Vol. 25, pp. 507-510.)

A review of apparatus on view at the Paris Radio Show. "The universal production of super-heterodyne sets" is the subject of comment, as are the scarcity of portable sets and the non-existence, as a class, of the home constructor. Of more than 120 different receiver models exhibited, probably not more than five per cent were of the mains-operated straight-circuit type. Oxide-coated filaments are now used in most French valves. Moving coil loud speakers are still little in evidence.

RECEIVING SETS OF TO-DAY. (*Wireless World*, 20th November, 1929, Vol. 25, pp. 552-556.)

An analysis of modern set design, with graphical indication of percentage popularity of various characteristics.

FADING-ELIMINATION. (German Pat. 480853, Telefunken, pub. 8th Aug., 1929.)

Signals received simultaneously on a vertical and on a horizontal aerial are rectified separately and the l.f. currents led to a common receiver.

RECEPTION OF ULTRA-SHORT WAVES BY ELECTRON OSCILLATOR GIVING SELF-MODULATION.—H. E. Hollmann (see under "Transmission").

AERIALS AND AERIAL SYSTEMS.

DIRECTIONAL CHARACTERISTICS OF AERIAL COMBINATIONS WHOSE ELEMENTS ARE EXCITED IN HARMONICS.—G. Gresky. (*Zeitschr. f. Hochf. Tech.*, November, 1929, Vol. 34, pp. 178-183.)

Second and final part of the paper dealt with in January Abstracts, pp. 45-46. Combinations of two aerials, excited to the second and third harmonic respectively, are dealt with, the distance between them being given by $d/\lambda = \frac{1}{2 \cos \beta}$; β is so chosen that in the plane $\alpha = 90$ deg. a null point results. Parallel and series connections

display the same differences as those shown by the combinations dealt with in the first part. But in the present case, in the series connection there is no null plane at $\alpha = 90$ deg., but only several null points in this plane which are independent of the ratio d/λ . A way is shown of calculating these null points; with the help of this, a ratio d/λ can be found for obtaining a favourable characteristic. Such a combination can find a useful application where it is desired to radiate horizontally and non-directively, and simultaneously at an angle and directly.

Finally, the paper deals with combinations of three aeriels, as used by Esau (*ibid.*, 1926, Vol. 28, p. 4) to give a unilateral characteristic. For this, the amplitudes in the two outside aeriels must each be half that of the centre aerial and must have an artificial phase difference of $+$ and $- 90$ deg. respectively with regard to the centre aerial. Aeriels excited to the first harmonic only are considered: for these, a maximum for $\alpha = 0$ deg. is obtained with a ratio

$$d/\lambda = \frac{1}{2 \cos \beta_{\max.}} = \frac{1}{2 \cos 35^\circ} = 0.61$$

SINGLE-WIRE TRANSMISSION LINES FOR SHORT-WAVE ANTENNAS.—W. L. Everitt and J. F. Byrne. (*Proc. Inst. Rad. Eng.*, Oct., 1929, pp. 1840-1867.)

Authors' summary:—The versatility of the possible arrangements of short-wave antennas can only be made available through the use of transmission lines. The phenomena of high-frequency transmission lines are discussed with respect to the effect of the low attenuation per wavelength and the influence of the termination on standing waves and radiation, for both an antenna and a transmission line.

The single-wire transmission line is effective when properly terminated. It is the easiest method of feeding the Hertz antenna. The adjustment may be divided into two parts. The frequency which makes the Hertz antenna a pure resistance termination must first be determined. The proper point of connection between the line and antenna must then be found to make the terminating resistance equal to the characteristic impedance of the line. When so terminated, experiment and theory show that radiation from the feeder will be small and that the feeder will act efficiently. Theoretical and experimental curves to show the nature of a horizontal Hertz antenna are shown, since they influence the behaviour of the line under changing conditions.

ÜBER DAS STRAHLUNGSFELD EINER ENDLICHEN ANTENNE ZWISCHEN ZWEI VOLLKOMMEN LEITENDEN EBENEN (The Radiation Field of a Finite Antenna between Two Perfectly-Conducting Planes).—R. Weyrich. (*Ann. der Physik*, 4th Sept., 1929, Series 5, Vol. 2, No. 7, pp. 794-804.)

In an earlier paper (1928 Abstracts, p. 516) the writer dealt with the interference and resonance phenomena involved in the radiation of a Hertz dipole between two perfectly conducting planes. The field thus investigated can be regarded as an

approximation to that of a vertical aerial, if the distance of the observation point from the aerial and the distance between the planes are each large in comparison with the dimensions of the transmitting system and the wavelength.

It, however, the theory thus developed is to serve as a basis for laboratory researches, it requires extension: for the above conditions are not fulfilled, and the finite stretch of the aerial must be taken into consideration. The present paper gives the necessary extension.

THE SCREENING OF FEEDERS.—(German Pat. 480220, Radio Corp., pub. 6th Aug., 1929.)

VALVES AND THERMIONICS.

LES PROPRIÉTÉS D'ÉCRAN DES GRILLES: LES LAMPES ÉCRAN (The Screening Properties of Grids: Screen-Grid Valves).—Y. Rocard. (*L'Onde Élec.*, Aug., 1929, Vol. 8, pp. 347-352.)

The various coefficients of amplification of a valve are, it is well known, derived from a theory which is no doubt only approximate but which nevertheless is useful because it elucidates the manner of action of various circuits employed in practice. The screening properties of the various electrodes as regards each other are less generally known. The writer shows that they are readily calculated by the results of classical theories, and points out how intimately these screening properties are bound up in the coefficients of amplification K .

Starting from Schottky's representation of the electrostatic significance of the amplification coefficient

$$\left(K = \frac{\text{grid/filament capacity } C_g}{\text{plate/filament capacity } C_p} \right)$$

and using Maxwell's treatment of the diminution of induction between two plates produced by the introduction of a grid between them, he shows that the effect of a grid is to reduce the plate/filament capacity (geometrically calculated) by dividing it by K . $\frac{R_p - R_g}{R_p - R_g}$, R standing for radius or half

the thickness. Applying this to screen-grid valves, the effect of the screen-grid is to divide the ordinary plate/control grid capacity by $K_2 \cdot \frac{R_{g2} - R_{g1}}{R_p - R_{g1}}$, K_2 being the value for the triode formed by the suppression of the control grid. For this formula to apply, the screen-grid must exert complete control on the lines of force; it must, therefore, completely surround either the plate (as in Radiotron UX 222) or the control grid (as in Philips E.422), or else it must be extended by electrostatic screens of large dimensions (as in Screen-grid Radiotechnique, R.81).

As an example, the writer takes an E.422: in another article (see below) he calculates that in this valve $K_2 = 645$. Then $645 \cdot \frac{R_{g2} - R_{g1}}{R_p - R_{g1}} = 330$.

Thus the screen-grid divides the plate-grid capacity by 330. Experimentally, the values found were below 0.01 cm. (with screen) and 2.5 cm. (without), the discrepancy being on the side which would be expected.

SUR LE CALCUL THÉORIQUE DES LAMPES À PLUSIEURS ÉLECTRODES (The Theoretical Calculation of Multi-electrode Valves).—Y. Rocard. (*L'Onde Élec.*, August, 1929, Vol. 8, pp. 353-361.)

The usual formula for the amplification coefficient of a triode with cylindrical electrodes is

$$K = 2\pi r_g/a \cdot \frac{\log r_p/r_g}{\log \frac{1}{2 \sin \pi d_g/2a}}$$

The writer shows that for close-meshed grids this is unsatisfactory: if $\sin \pi d_g/2a$ reaches and passes the value $\frac{1}{2}$, K becomes infinite and then negative, which is contrary to the physical facts. The above happens if $d_g \cong a/3$, as occurs particularly in screen-grid valves. Investigating the origin of the discrepancy, the writer finds it in an approximation made in dealing with Maxwell's equation for the potential at a point x from the axis:—

$$v_x = -2q \log 2 \sin \pi x/a + C$$

it is commonly assumed that C is equal to the mean grid potential. Avoiding this assumption, he arrives at a more generally applicable formula from which he derives the following, for cylindrical and plane electrodes respectively:—

$$K = \frac{l_1 \log r_p/r_g}{(1-a)(1-\gamma) \log \left(\frac{1}{2} \sin \frac{\pi a}{2} \right)}$$

and

$$K = \frac{2\pi(r_p - r_g)}{a(1-a)(1-\gamma) \log \left(\frac{1}{2} \sin \frac{\pi a}{2} \right)}$$

where a is the fraction of the grid surface covered by wire, l_1 is the length of wire per cm. of grid, and γ is a numerical factor dependent on a .

A table is given of the values of the various quantities appearing in these formulæ, for values of a from 0 to 1. Experimental confirmation has been limited to indirectly heated valves, to avoid discrepancies due to the cathode not being equipotential. Very good agreement was found, in the case of triodes. The experimental confirmation has been extended to screen-grid and three-grid valves; for a Philips E.442, the calculated value of control-grid K was 3,230: this refers to the whole current emitted, not merely to the plate current "which we cannot at present separate theoretically." By experiment, adding plate current and screen current, the value obtained was roughly 4,000.

CALCULATION OF THE OPTIMUM "DURCHGRIFF" FOR THE VALVES IN A RESISTANCE AMPLIFIER.—H. G. Möller; A. Forstmann. (*Zeitschr. f. Hochf. Tech.*, November, 1929, Vol. 34, pp. 182-183.)

The second writer criticises the first's paper (1929 Abstracts, p. 635). Möller replies, his gist being that the criticism does not affect the theory but only the numerical example, and that even here it is based on the use of "bad" valves whose characteristic slope does not attain the steepness given by Maxwell's distribution of velocities law.

SULLA CAPACITA DELLE VALVOLE TERMOIONICHE (On the Capacity of the Thermionic Valve).—G. Petrucci. (*Nuovo Cim.*, July, 1929, Vol. 6, pp. 298-304.)

The writer investigates theoretically the value of a small condenser between the plates of which a negative space charge exists. He then deals with a cylindrical condenser and applies his results to the two-electrode valve. In an example given, it is calculated that the inter-electrode capacity is 6.20 times smaller than the geometric capacity.

EINE EINFACHE METHODE ZUR BESTIMMUNG DER RÖHRENKONSTANTEN (A Simple Method of Determining the Valve Constant).—M. von Ardenne. (*Zeitschr. f. Hochf. Tech.*, October, 1929, Vol. 34, pp. 143-145.)

So far as work in the space-charge region of the characteristic is concerned, the constant K is of importance: through this, the anode characteristic can be represented in the form $i_a = K(e_g + De_a)^n$, where n is an exponent which is constant over a wide range, equal to $3/2$ for equipotential cathodes and calculable for directly-heated cathodes. On the one hand, K is a useful measure for the merit of a cathode; on the other, it is of importance in calculating the optimum "durchgriff" D ($D = 1/\mu$) on the basis of the emission law. The writer describes a method of determining K without having first to measure D .

The fundamental idea of the method is to introduce a resistance in the anode circuit and thus to reduce the anode potential to very near zero, so that by extrapolation it is possible to determine that point on the characteristic where $e_{control}$ is exactly equal to e_{grid} . The value thus found for $e_{control}$, together with the limiting value of i_a found from $i_{a,lt.} = E_a/R_a$, gives K from the equation $i_a = K \cdot e^{n \cdot control}$. Particulars of the method (for directly- and indirectly-heated cathodes), and the necessary precautions and corrections, are described and illustrated by actual examples.

ON THE EMISSION OF ELECTRONS FROM METALS COVERED BY THIN FILMS, IN INTENSE ELECTRIC FIELDS.—T. E. Stern. (*Proc. Camb. Phil. Soc.*, October, 1929, Vol. 25, Part 4, pp. 454-460.)

In the writer's *Proc. Roy. Soc.* paper with Gossling and Fowler (1929 Abstracts, p. 512) an emission formula was given which extended the original Fowler-Nordheim formula (1928 Abstracts, pp. 400-401) by taking into account the case where the electrons, leaving the metal, must penetrate a thin superficial layer having a lower thermionic work function. The effect of such a film is to increase greatly the electron emission for any given intensity of field. The present paper gives the full mathematical derivation of the new formula, which was not given in the previous paper.

ÜBER DIE EMISSION VON ELEKTRONEN AUS METALLEN BEI BESTRAHLUNG MIT RÖNTGENSTRAHLEN (The Emission of Electrons from Metals under Irradiation by X-Rays).—W. Espe. (*Ann. der Phys.*, 26th July, 1929, Vol. 2, No. 4, Series 5, pp. 381-426.)

DER EINFLUSS VON OBERFLÄCHENSCHICHTEN AUF DIE GLÜHELEKTRONENEMISSION DER METALLE (The Influence of the Surface Layers on the Thermionic Emission of Metals).—C. Zwickler. (*Physik. Zeitschr.*, 15th Sept., 1929, Vol. 30, pp. 578-580.)

Researches on zirconium and hafnium, from which the writer draws certain conclusions regarding the Schottky "dipole-layer" explanation and the Langevin theory of paramagnetism.

ÜBER DIE RICHARDSON-KONSTANTEN VON DESTILLATIONSKATHODEN (The Richardson Constants of [Barium] Distillation Cathodes).—W. Espe. (*Zeitschr. f. Tech. Phys.*, Nov., 1929, Vol. 10, No. 11, pp. 489-495.)

The emergence-work B (in the equation $i_s = O.f.A.T^2.e^{-B_0/T}$) is found to be the same for these "newly-developed" cathodes as for the older paste-cathodes, but the constant $f.A$ is 100-1,000 times greater, for macroscopically equal emission surface.

PHENOMENA IN OXIDE-COATED FILAMENTS.—J. A. Becker. (*Phys. Review*, 15th November, 1929, Vol. 34, pp. 1323-1351.)

A theory of the changes in activity in oxide-coated filaments is proposed. It appears probable that these filaments owe their high activity to absorbed metallic barium. The changes in emission, produced by changes in plate potential and by currents sent into or drawn from the filament, are ascribed to electrolysis of the oxide. When electrons are sent into a coated filament, barium is deposited on the surface and the activity increases until an optimum is reached beyond which the activity decreases. When current is drawn from the oxide, oxygen is deposited on the surface. If the oxygen is beneath the adsorbed barium, it increases the activity; if it is above the barium, it decreases the activity. The theory is tested, confirmed and extended by numerous experiments.

THE PRODUCTION TESTING OF VACUUM TUBES.—P. G. Weiller. (*Rad. Engineering*, Oct., 1929, Vol. 9, pp. 60-61 and 67.)

LIFE OF VALVES IN BROADCASTING STATIONS.—(*Marconi Review*, Nov., 1929, p. 30.)

In the course of an article on the Brookman's Park Station, a quotation from *World Radio* is given concerning the life of Marconi valves at this station, 5XX and 5GB. "6,000 hours is about the average life of the rectifiers; two rectifiers at 5XX recently completed their useful life after both had done over 10,000 hours work. The average for modulators and magnifiers is about 4,000 hours, but two modulators at 5XX have done over 10,000 hours."

PENTODE POSSIBILITIES.—A. L. M. Sowerby. (*Wireless World*, 13th November, 1929, Vol. 25, pp. 546-547.)

"Those who have attempted to design a satisfactory reflex receiver will realise that in the pentode there is available for the first time, a valve that can really 'pull its weight' as dual

amplifier." A reflex circuit is given with crystal detector and a pentode. Powerful loud-speaker signals are obtained.

NEW A.C. VALVES.—Mullard Company. (*Journ. Scient. Instr.*, November, 1929, Vol. 6, p. 360.)

Four types of indirectly heated valves are described:—screened-grid, impedance 1.33 megohms, amplification factor 1,000, mutual conductance 0.75 mA/v., and three triodes with amplification factors of 35, 16 and 10, the last being for use as a power valve in amplifiers of moderate output. Heaters consume 1 ampere at 4 volts, in all types.

LES LAMPES THYRATRONS À TROIS ÉLECTRODES (The Three-Electrode Thyatron Lamps).—(*Génie Civil*, 30th Nov., 1929, Vol. 95, pp. 542-543.)

An article based on Hull's paper dealt with in 1929 Abstracts, pp. 330 and 512.

MICROPHONIC IMPROVEMENT IN VACUUM TUBES.—A. C. Rockwood and W. R. Ferris. (*Proc. Inst. Rad. Eng.*, Sept., 1929, Vol. 17, pp. 1621-1632.)

Authors' summary:—"The paper contains a discussion of the causes and effects of microphonic disturbances in small receiving tubes and the nature of these disturbances, and gives methods of testing for microphonic disturbance whereby the sources of the disturbance may be located and corrected as well as methods of testing tubes as a means of comparison of individual tubes of different types. A new type of tube with low microphonic output but with low filament power for uses where microphonic troubles may be serious [*e.g.*, in aircraft—see Pratt and Diamond, 1929 Abstracts, pp. 210-211] is also described and its characteristics are given."

A discussion on the paper is reported in the October issue, pp. 1899-1902. Among other points, Hoyt Taylor asks if there is any gain in any of the schemes for shielding the valve. The author shows an "adapter," used successfully for a detector directly under a dynamic loud-speaker, which "represents about the extreme possible in a spring-suspended socket with a surrounding acoustic shield." For aircraft, however, it has been found that with such an adapter there is so much motion that trouble from change of tuning and of reaction appears before acoustic isolation is reached.

Hoyt Taylor emphasizes the need for improvement for aircraft purposes, but also stresses the importance for extremely high frequency receivers and for power valves. With a self-oscillating "Gunn" oscillator, he found that while the master oscillator alone gave excellent signal quality with very small frequency ripple, yet when a 750 w. balanced power amplifier was added a great ripple in frequency was produced: this was traced to microphonic disturbance originating (from the plate principally) in the power amplifier valves. He mentions a new type of shielded transmitter valve designed specially for special circuits where piezoelectric control or its equivalent is not used.

Sutherland mentions that he has found that a ribbon type of filament gives less microphonic noise

than the round filament, possibly because it vibrates only in one plane, possibly because of a difference in materials.

DIRECTIONAL WIRELESS.

AU SUJET DU GUIDAGE DES NAVIRES OU AERONEFS PAR ONDES DIRIGÉES (The Guiding of Ships or Aircraft by Directed Waves).—W. Loth. (*Comptes Rendus*, 28th Oct., 1929, Vol. 189, pp. 682-684.)

A navigator learns from a beacon (whether using Wireless, Light or Sound waves) only an alignment: to obtain his position and course he has to take readings from two or more beacons. The writer proposes to co-ordinate the rotation of two beacons in such a way that the beams intersect along the route to be followed. Thus when following the correct route the navigator would receive the two beams simultaneously, while his position on either side of the route would be indicated by his receiving one beam before the other. The law of rotation of the beacons can be so arranged that the distance from the route is proportional to the time-interval between the two receptions. The application of this general idea to Light and Radio beacons is developed.

REMARQUES SUR LE GUIDAGE MAGNÉTIQUE DES NAVIRES (Remarks on the Magnetic Guidance of Ships).—E. Fournier: W. Loth. (*Comptes Rendus*, 21st October, 1929, Vol. 189, pp. 598-599.)

The latest development of the Loth leader cable is to erect, along the coast from which the cable starts, a line on poles (like a telegraph line): one end of this line goes into the sea, as far as possible from the extremity of the cable, while the other is connected to a pole of the generator whose other pole is connected to the cable. In addition to the usual action of the leader cable, there is now the effect of the return currents which spread through the sea from the cable to the furthest point of the line: the horizontal magnetic field produced can be detected (by the same receiver as that used for the cable signals, but with the frame now vertical) at "several tens of kilometres" from the cable-end. By making use of the minimum (frame normal to the currents) the ship can be steered to the extremity of the cable—the entrance of the channel.

In practice, two lines would be erected, to right and left of the cable: these would be connected in turn to the generator (dots on the one and dashes on the other) and the observer would thus be informed which side of the cable he was on. Even apart from the cable, these lines would be of great service on a coast, or run diametrically across an island. Finally, instead of using the frame to receive the magnetic field, the currents themselves may be received by two electrodes at the extremities of the vessel: in this way submerged submarines could receive direction-indications or even Morse signals.

AN AIRCRAFT DIRECTION FINDER: MARCONI TYPE A.D.16.—(*Marconi Review*, Oct., 1929, pp. 10-13.)

"The amplifier [6 h.f., det., oscillator, 2 super-sonic frequency magnifiers, det., one note magni-

fier] has been made extremely selective and sensitive in order to ensure the greatest possible range even when employing the very small frame aeri-als, the use of which is rendered necessary by the all-metal construction of modern aircraft." These aeri-als consist of two rectangular loops, each consisting of several turns of insulated wire, completely screened by streamlined duralumin tubes.

RADIO DIRECTION-FINDING BY TRANSMISSION AND RECEPTION.—R. L. Smith-Rose. (*Proc. Inst. Rad. Eng.*, October, 1929, Vol. 17, pp. 1897-1898.)

A reply to the discussion dealt with in 1929 Abstracts, pp. 636 and 637. Regarding Hoyt Taylor's remarks on errors due to downcoming waves and on the effect of the angle of incidence, the writer says, "The minimum distance at which 'night' or 'atmospheric' errors are experienced will undoubtedly depend upon the wave-frequency, since it is the relative strengths of the ground and atmospheric waves which is the deciding factor. The short ground waves will be attenuated more than the longer waves and so we should expect the errors to begin at shorter distances from the transmitter. I might also emphasize the fact that since, as pointed out by Mr. Dean, the available experimental evidence indicates that the ground conductivity in the United States is lower than in Great Britain, the ground waves will be attenuated more in the former country, and it is therefore to be expected that 'night' errors in America will occur at shorter ranges than in Great Britain at the same frequencies. This probably accounts for Commander Taylor's experience of a 30 deg. error at six miles from a transmitter operating in the broadcast band of wavelengths. This is quite contrary to all our experience in England." Various other points in the discussion are replied to.

SENSE DETERMINATION IN A ROTATING D.F.—(German Pat. 477014, Telefunken, pub. 11th June, 1929.)

To avoid having to rotate the coil through 90 deg. to combine with the vertical aerial for determination of sense, a second coil is provided, at right angles to the d.f. coil, for use with the vertical aerial.

ACOUSTICS AND AUDIO-FREQUENCIES.

ÜBER DIE HÖRBARKEIT VON VERZERRUNGEN (The Audibility of Distortions).—W. Janovsky. (*E.N.T.*, Nov. 1929, Vol. 6, pp. 421-439.)

An investigation of the audibility of non-linear (wave-form) distortion caused by the introduction of overtones and combination tones. Measurements were made on simple notes, combinations of notes, and music, and the limits of audibility determined in each case. The part played by the sensitivity of the ear and its masking phenomena were also investigated. The writer summarises his results as follows:—"Only the 1st D.T. (difference-tone) and eventually also the 2nd D.T. can be distinguished in the distorted sound; on the other hand, in not a single case could the 1st S.T. (summation-tone) be distinguished even when its

strength lay well above the threshold of audibility. This is because the 1st S.T. always lies above the two P.T. (primary tones) and is therefore strongly masked.

"The 1st D.T. can only be distinguished for small intervals, up to the octave; since otherwise it comes between the two P.T.s and is masked by them. The 1st D.T. is particularly audible when it comes in the region of the ear's maximum sensitivity. Its audibility is thus also dependent on the height of the P.T.

"If the ratio of the amplitudes of the two P.T.s is changed but the strength of the 1st D.T. kept constant, the latter is most audible when the two amplitudes are equal. This dependence is due to the greater masking by the louder P.T., and vanishes as soon as the P.T.s are put sufficiently high.

"These four facts belong, according to Waetzmann, to the most striking and important observed results on subjective combination tones. My tests now show that they are explained simply by the effect of the ear's sensitivity, and that no frequency-dependent distortion need be involved. It is only necessary to attribute to the ear a distortion similar to that given to the valve in these researches." The valve in question was in a circuit resembling that of a resistance-coupled amplifier; by working on the lower bend of the curve, the distortions were produced: their magnitude, for constant a.c. grid voltage, depending only on the grid bias and being readily varied in sympathy with this.

MICROPHONES FOR USE IN THE LABORATORY.—E. Simeon. (*Journ. Scient. Instr.*, Sept., 1929, Vol. 6, pp. 280-283.)

Moving coil and electrostatic microphones, when used as very high-quality instruments, are insensitive. For ordinary laboratory use the very highest quality is not always essential; a better sensitivity is then possible, affording the advantage of more stable overall working. The moving coil instrument described has a response placing it in the high quality class, and quite a fair sensitivity; it works direct to the amplifier without a transformer. The capacity microphone described gives better speech than the ordinary carbon transmitter, but has not such good quality as the moving coil instrument; it is, however, more sensitive; with 150 v. between electrodes, one valve with amplification factor 14 brings the volume about level with that from a carbon microphone as ordinarily used, whereas the moving coil instrument requires a further amplification of about 20. Another design of condenser microphone is suggested and illustrated; this has a stretched *annular* diaphragm (0.3 in. wide) which would make it possible to obtain a diaphragm frequency above 10,000 p.p.s. while retaining quite a fair area for picking up sound energy.

PHYSIKALISCHE UNTERSUCHUNGEN AN STREICH-INSTRUMENTEN (Physical Investigations on Bowed Musical Instruments).—H. Backhaus. (*Naturwiss.*, 18th and 25th Oct., 1929, Vol. 17, pp. 811-818 and 835-839.)

A MECHANICAL METHOD OF MEASURING SOUND PRESSURE.—B. E. Eisenhour and F. G. Tyzzer. (*Journ. Franklin Inst.*, Sept., 1929, Vol. 208, pp. 397-404.)

The "Soundmeter" described is purely mechanical in its operation and construction, giving a direct reading of the sound pressure without the use of thermionic valve amplifiers, etc. It depends on the use of a mechanical rectifying valve of so small inertia that it will open and close quickly enough to rectify alternating pressures up to 5,000 d.v. or more per second. Its efficiency is about 20 times that of the Barus "pinhole" rectifiers.

SPEECH POWER AND ITS MEASUREMENT.—L. J. Sivian. (*Bell Tech. Journ.*, Oct., 1929, Vol. 8, pp. 646-661.)

ARTICULATION TESTING METHODS.—H. Fletcher and J. C. Steinberg. (*Bell Tech. Journ.*, Oct., 1929, Vol. 8, pp. 806-854.)

EIN NEUER SCHALLISOLATIONMESSER (A New Apparatus for Measuring Sound-Proofing Material).—E. Meyer and P. Just. (*Schalltech.*, No. 3, 1929, Vol. 2, pp. 33-38.)

Two similar microphones, one in front of and the other behind the partition under test, are switched successively on to a 3-valve amplifier and their output equalised by an attenuator connected to the one. The source need not be constant—a wooden hammer blow is very suitable.

L.F. TRANSFORMER CURVES.—W. Symes. (*E. W. & W. E.*, Oct., 1929, Vol. 6, p. 553.)

Referring, presumably, to the article on the Philips transformer dealt with in 1929 Abstracts, p. 505, and to the widespread publication of frequency response curves, the writer raises the question whether these curves are taken under conditions representing accurately the working conditions: all that he has seen appears to have been taken with a pure resistance load in the anode of the valve on the secondary side of the transformer. "As this load under actual conditions is nearly always a reactive load . . . which is not reasonably constant, it would appear that the input impedance of this output valve is not nearly the constant quantity obtained when a pure resistance load is used. The varying input impedance must therefore affect the transformer characteristic, particularly when the valve capacities are used to promote resonance and keep up the amplification of the higher audio-frequencies." He suggests that it would be very interesting to have the characteristics taken with an actual loud-speaker load in the anode circuit.

THE VIBRATIONS OF STRINGS EXCITED ELECTROMAGNETICALLY: THE INTEGRATION OF EQUATIONS REPRESENTING THE VIBRATIONS OF STRINGS IN A VARIABLE MAGNETIC FIELD.—S. A. Dianin. (*Trans. Elec. Lab. Leningrad*, No. 9, 1929, pp. 5-19 and 20-34.)

In Russian. The results of two years' experimental investigation are given in the first paper. The theoretical and practical possibility of a new

form of electric stringed instrument is shown. The change of timbre by changing the wave-form of the exciting a.c. is involved.

STRUNN CHASTOTOMER (A String Frequency Meter).

A. I. Belov. (*Ti.T.b.p., Leningrad*, October, 1929, Vol. 10, pp. 535-542.)

In Russian. A description of a frequency meter constructed at the State Laboratory of Physics. The current whose frequency is to be determined is passed through an electro-magnet and sets into vibration a taut string. The tension of the string is varied until the condition of resonance is obtained. A microscope is provided in order to increase the accuracy of the observation. When the frequencies which are to be measured lie outside the frequency limits of the string, overtones of the applied frequencies and of the string can be employed. Cf. Harries, 1929 Abstracts, p. 638.

CARBON MICROPHONES IN LONG-DISTANCE TELEPHONY.—R. Fuhrer. (*E.N.T.*, June, 1929, Vol. 6, pp. 214-216.)

Part of a long paper on the Energy Relations in automatic telephone systems.

DETERMINATION OF FREQUENCY CHARACTERISTICS, SENSITIVITY AND RECORD WEAR OF ELECTRICAL PICK-UPS.—G. B. Crouse. (*Rad. Engineering*, October, 1929, Vol. 9, pp. 53-56.)

This final part of a series of articles on gramophone pick-ups describes the measuring methods and gives a number of response curves showing the effects of a transformer of abnormally high or low impedance, a weighted tone-arm, etc. "A correctly-designed tone-arm will impose a weight on the needle-point of not much over four and a half ounces. If a greater pressure than this is required to obtain satisfactory response at low frequencies, the device will cause undue wear on the bottom of the record groove."

THE INTERFERENCE TONES OF THE HIGHER ORDERS: THE OBJECTIVE REPRESENTATION OF MUSICAL MATERIAL.—M. W. Matschinsky. (*Trans. Elec. Lab. Leningrad*, No. 9, 1929, pp. 35-75 & 76-82.)

In Russian.

UNMITTELBARE STEUERUNG DER LUFT DURCH ELEKTRISCHE SCHWINGUNGEN (Direct Control of Air by Electric Oscillations).—Brenzinger and Dessauer; Fleischmann. (*E.T.Z.*, 17 Oct., 1929, p. 1526.)

Attempts to get rid of the diaphragm. See Abstracts, 1928, p. 645; 1929, p. 276.

MOVING COIL LOUD SPEAKERS.—H. M. Clarke. (*E. W. & W. E.*, Nov., 1929, Vol. 6, pp. 602-604.)

In the compensating winding method described in the writer's first article (1929 Abstracts, p. 513), the compensating winding was connected in series with the moving coil. The present paper deals with the case where it is short-circuited so as to obtain its compensating current inductively from

the moving coil. Induced compensation is not so effective in maintaining constant impedance as the series method, but nevertheless keeps the variation down to 250 per cent. for frequencies up to 10,000, and has the advantage that the compensating winding is not in connection with the moving coil, which facilitates the insulation of the latter from the body of the loud-speaker.

In the case of induced compensation, copper cylinders may replace the winding (cf. Branch, 1928 Abstracts, p. 581).

THE MOVING COIL SPEAKER AND ITS EQUIVALENT CIRCUIT.—N. W. McLachlan. (*Wireless World*, 20th November, 1929, Vol. 25, pp. 568-569.)

Discussing (1) the purely mechanical system and (2) the purely electrical system composing the moving coil loud speaker. The interaction between the two systems is traced and a diagram is given by means of which the combined performance can be visualised by aid of an equivalent electrical circuit. For the complete theory on the subject the reader is referred to *Philosophical Magazine*, Supply. No., June, 1929. (1929 Abstracts, p. 513.)

ZUR FRAGE DER FORTPFLANZUNG ULTRA-AKUSTISCHER SCHWINGUNGEN IN VERSCHIEDENEN KÖRPERN (The Propagation of Supersonic Oscillations in Various Bodies).—S. J. Sokoloff. (*E.N.T.*, Nov. 1929, Vol. 6, pp. 454-461.)

An account of experimental investigations and the theory involved. The absorption in solid bodies, the passage through metals (leading to results which suggest an application to the testing of metals for flaws, blow-holes, etc.), and the passage along wires and through tubes are all dealt with.

SOUNDPROOFING OF AIRPLANE CABINS.—V. L. Chrisler and W. F. Snyder. (*Bur. of Stds. Journ. of Res.*, May, 1929, Vol. 2, p. 897.)

L'ISOLEMENT ACOUSTIQUE DES CONSTRUCTIONS ET DES MACHINES (The Acoustic Insulation of Buildings and Machines).—J. Katel. (*Génie Civil*, 16 Nov., 1929, Vol. 95, pp. 480-483.)

THE NEW ACOUSTICS.—W. H. Eccles. (*Proc. Phys. Soc.*, No. 4, 1929, Vol. 41, pp. 231-239.)

Presidential address to the Physical Society.

ERZWUNGENE SCHWINGUNGEN EINER EINGESPANNTEN KREISFÖRMIGEN PLATTE (Forced Oscillations of a Stretched Circular Plate).—G. Franke. (*Ann. der Physik*, 26 Aug., 1929, Series 5, Vol. 2, No. 6, pp. 649-675.)

NEW PHENOMENA IN A SOUNDING DUST TUBE.—E. N. da C. Andrade and S. K. Lewer. (*Nature*, 9 Nov., 1929, Vol. 124, pp. 724-725.)

CONNECTORS IN ACOUSTICAL CONDUITS.—R. B. Lindsay. (*Phys. Review*, 1 Sept., 1929, Vol. 34, pp. 808-816.)

An extension of Brillié's theoretical investigations.

NOTE ON THE THEORY OF ACOUSTIC WAVE FILTERS. R. B. Lindsay. (*Phys. Review*, 15th August, 1929, Vol. 34, pp. 652-655.)

The lumped impedance theory of Stewart and the more recent transmission theory of Mason are compared, and the relation between them pointed out. (*Cf. Stewart and Sharp, 1929 Abstracts, p. 580.*)

ELEKTROAKUSTISCHE ÜBERTRAGUNGSSYSTEME MIT BESONDERER BERÜCKSICHTIGUNG DER TELEPHONIE AUF WEITE ENTFERNUNGEN UND DES KLANGFILMS (Electro-acoustic Transmission Systems, with Special Reference to Long-distance Telephony and Talking Films).—F. Lüschen. (*E.T.Z.*, 21 and 28 Nov., 1929, Vol. 50, pp. 1693-1695 and 1728-1733.)

MESSUNG UND BERECHNUNG VON EIGENFREQUENZEN AN EINEM SYSTEM GEKOPPELTER KONTINUA (Measurement and Calculation of Natural Frequencies in a System of Coupled Continua).—E. Waetzmann and V. Schneeweiss. (*Ann. der Phys.*, 30th October, 1929, Series 5, Vol. 3, No. 3, pp. 314-324.)

PHOTO-TELEGRAPHY AND TELEVISION.

ABBILDUNG UND VERSTÄRKUNG BEI FERNSEHERN (Image Formation and Amplification in Television).—F. Schröter. (*E.N.T.*, November, 1929, Vol. 6, pp. 439-453.)

A theoretical examination of the relations holding in the chain of actions between transmitter and receiver. The resulting equations apply fundamentally to all recording electrical-optical transformations—sound-films, photo-telegraphy, and special forms of light-telegraphy—but are here (in the second half of the paper) applied to the very special case of television. The sections of the first part deal with:—sharpness of contour: the damping of periodically varying brightness: time-constant of amplifier. Of the second part:—geometrical laws: results of these: physical, physiological and psychological factors.

MECHANICAL DEVELOPMENTS OF FACSIMILE EQUIPMENT.—R. H. Ranger. (*Proc. Inst. Rad. Eng.*, September, 1929, Vol. 17, pp. 1564-1575.)

The method of transmitting and receiving across the paper in diagonal directions "corresponding somewhat to the half-tone line pattern of engraving" is described, and its advantages discussed. A new light system for the transmitter is described: four automobile lights are grouped round the pick-up lens which is to analyse the picture. The lenses belonging to the four lights concentrate a very intense illumination on the spot being traced, the pick-up lens carries a picture of this spot back to the slit, "giving a more accurate definition of the

exact spot being considered, and then the light is carried back to the photocell."

Looking forward to the time when it will be feasible economically to "multiplex" picture transmission, arrangements are described for analysing as many as five points simultaneously: very small prisms are used for carrying off the light to five different photoelectric cells.

Photoelectric Cells in Push-Pull:—to surmount the difficulty of getting linear output from cell through the associated amplifiers, a satisfactory push-pull arrangement has been evolved. A rotating glass disc has ground at its edge a circle of very small prisms side by side, which deflect the light first to one cell and then to the other as the analysing pencil comes on to first one and then the other side of these prisms. A further development is to have 3 (say) circles of these prisms, one inside the other, each circle having a different number of prisms: the result is that three analysing points may be picked up from the picture and separated out later by appropriate tone filters. "It should be pointed out that without the push-pull photocell action, the wave form of each tone would be so bad that the filtering would be extremely difficult."

Hot-air recording (1929 Abstracts, p. 514-515) is still being used, a wax-covered paper, inked later by water-ink from a roller, gives much more permanent and pleasing work and sharper definition than the original chemical paper method. Inks of various colours may be used, and the colours may be applied as directed by the transmitting operator—giving a "photoradio in colour."

DAS FERNSEHEN IN DEUTSCHLAND (Television in Germany).—F. Noack. (*Zeitschr. des V.D.I.*, 30th Nov., 1929, Vol. 73, pp. 1703-1705.)

After a short section on standardisation, the writer deals with the three systems at present in use in Germany: Karolus (Telefunken Co.), v. Mihaly-Kramolin (Telehor Co.) and Baird-Loewe-Zeiss-Bosch (German Television Co.). The first firm considers television (with the standardised number of elements) to be unfit at present for broadcasting, and devotes itself to large plants for theatre purposes; the other two firms believe in popularising the art in its present state. The methods of transmission and reception of the three processes are compared.

THE SELECTION OF STANDARDS FOR COMMERCIAL RADIO TELEVISION.—J. Weinberger, T. A. Smith and G. Rodwin. (*Proc. Inst. Rad. Eng.*, Sept., 1929, Vol. 17, pp. 1584-1594.)

Authors' summary:—The basis of a system of television standards suitable for commercial television service, with specific standards, is discussed. The elements considered in this paper are the following: picture proportions, number of scanning elements, number of picture repetitions per second, scanning method and direction, phase of transmitted current.

Synchronising is considered, with possible methods, and also various arrangements for utilising the television channel.

PROGRESS AND FUTURE OF TELEVISION.—(*Elec. World*, 9th November, 1929, Vol. 94, p. 931.)

This short article concludes by remarking:—"As the quality of television transmission and reception increases, synchronism by the power-house frequency will, undoubtedly, become less and less satisfactory, and there are plans under way now to provide a universal frequency standard on the air, to which transmitters and receivers alike can be tuned in order to hold them in exact electrical step."

THE ELECTRICAL TRANSMISSION OF PICTURES AND IMAGES.—J. W. Horton. (*Proc. Inst. Rad. Eng.*, Sept., 1929, Vol. 17, pp. 1540-1563.)

A paper dealing with some of the important principles underlying still picture and television transmission, treating these subjects as special forms of electrical communication, differing from other forms primarily in the nature of the information conveyed. A number of conclusions are reached as to the performance characteristics to be sought in the several elements to be used in picture transmission systems.

CRYSTAL GLOBE MOVING PICTURE RECEIVER.—V. Zworykin. (*Wireless World*, 27th Nov., 1929, Vol. 25, p. 595.)

Paragraph on a *Daily Telegraph* news-item concerning this receiver, employing "a cathode-ray valve which takes the place of the normal glow valve, scanning-disc and motor."

THE DRUM SCANNER IN RADIOMOVIES RECEIVERS.—C. F. Jenkins. (*Proc. Inst. Rad. Eng.*, Sept., 1929, Vol. 17, pp. 1576-1583.)

The ordinary scanning-disc limits the illumination to the light which can pass through a single one of the "tiny" holes, and therefore requires a powerful source of light (*cf.* a pinhole camera). The writer, consequently, always used his "lens-disc" (the name is self-explanatory) instead, but even this is not satisfactory. He therefore devised the drum scanner: such a scanner, 7" in diameter with apertures in six helical turns, gives a 3" picture which when viewed through the magnifying glass appears about 8" x 8". The unmagnified 3" picture is "more than twice the area of any picture possible with a 36" disc." The drum hub, hollow for the length of the drum, encloses a 4-target [this is for a 4-helical turn drum] cathode-glow neon lamp; between this and the periphery of the drum are tiny quartz rods, each rod ending under its particular aperture. The light "flows through the quartz rods as water flows through a pipe: that is, the use of quartz rods may be thought of as avoiding the light loss due to the inverse square law." One of the cathode targets is located under each of the rows of quartz rods, and they are lighted in succession through a 4-segment commutator by current from the output valve of the receiver. Because the movement of the inner ends of the rods is so short, these targets need only be about 3/16 by 1/4 inch in size and require only 3-5 ma. The size of the picture is only limited by the distance between the outer ends of successive

rods: "there is no loss of light in its travel along the quartz rods."

The writer is "still a long way from his ideal"; he is now attacking the problem on the lines of substituting persistence of light for persistence of vision: e.g., in his new model the light of each elementary area persists say 1/10 sec. after the exciting current has passed on. "This same principle applied to picture transmission . . . will be an important contribution . . ."

THE DISTRIBUTION OF LIGHT IN OPTICAL SYSTEMS.—A. C. Hardy. (*Journ. Franklin Inst.*, Dec., 1929, Vol. 208, pp. 773-791.)

The writer derives expressions for the distribution of light within an optical system, based on the conservation of energy principle; he illustrates the method of applying the results to any optical system whatever, by means of a quantitative study of a few special cases (e.g., sound film recording).

TELEVISION RECEPTION USING CATHODE RAYS.—(German Patent 478864, Telefunken, pub. 29th June, 1929.)

The simultaneous control of the cathode ray, for the synthesis of the picture-elements and for the variations in brightness, is not satisfactory; for the control of the light intensity affects the electron speed and upsets the deflections. The present invention suggests that to avoid this, the brightness control should be carried out by a second inertia-free organ—e.g., a Kerr cell.

VIBRATION IN PERPENDICULAR PLANES, FOR PICTURE TRANSMISSION AND RECEPTION.—(German Patent 480365, Ritcheouloff, pub. 2nd August, 1929.)

A spring composed of two portions in series, in planes at right angles to each other, is fixed at one end: the free end therefore can vibrate in these two planes, and is caused to do so by two separate magnets. At the transmitter the free end carries a photoelectric "sensitive point"; at the receiver, the corresponding free end carries a glowing point.

A NEW PHENOMENON CONNECTED WITH THE KERR CELL.—A. Deubner and J. Malsch. (*Physik. Zeitschr.*, 15th Aug., 1929, Vol. 30, pp. 506-508.)

The application, through a water resistance, of 3 to 5,000 v. potential to a Kerr cell results in the splitting up of a line of transmitted light into two lines, spaced unsymmetrically with regard to the original line, with an interval of several millimetres. These two rays are polarised at right angles to each other. The phenomenon is discussed and explained.

ZUR KENNNTNIS DER DISPERSION DES ELEKTRO-OPTISCHEN KERREFFEKTES IM ULTRAVIOLETTEN (On the Dispersion of the Electro-optical Kerr effect in the Ultra-violet Region).—G. Szivessy and A. Dierkesmann. (*Ann. der Physik*, 6th November, 1929, Series 5, Vol. 3, No. 4, pp. 507-535.)

Five different liquids were tested in the visible and ultra-violet parts of the spectrum. It was

found that the quantitative dispersion results were not correctly represented by the Havelock formula

$$B = \frac{h \cdot (n^2 - 1)^2}{n\lambda}$$

SCANNING AND RECEIVING METHODS USING ROTATING PRISMS. (German Patent 479173, Westinghouse, pub. 13th July, 1929.)

A very large number of elements per sec. is obtained without great speed in any moving parts, by the interposition of two prisms, one after the other, rotating at different speeds. The point of light describes a spiral, completing the whole spiral in the time taken for one prism to lag one half turn behind the other.

SYNCHRONISATION. (German Patent 476324, Telefunken, pub. 15th May, 1929.)

The independent synchronous generators at each end are kept at a constant frequency by a valve generator controlled piezoelectrically.

PREPARAZIONE DELLE CELLULE FOTOELETRICHE AL TALLIO (Preparation of the Thallium Photoelectric Cell).—Q. Majorana and G. Todesco. (Summary in *Nuovo Cim.*, May, 1929, Vol. 6, p. XCIII.; see also 1929 Abstracts, p. 158.)

RUBIDIUM OR CÆSIUM PHOTOELECTRIC CELL. (German Patent 477158, Telefunken, pub. 6th June, 1929.)

These cells are to be made more cheaply by substituting a more easily worked potassium or sodium alloy (with at most 3-4 per cent. of caesium or rubidium or a mixture) for the pure metals.

BEHAVIOUR OF HIGH GRID RESISTANCE AMPLIFIERS USED WITH PHOTOELECTRIC CELLS.—W. B. Nottingham. (See last part of abstract under "Measurements and Standards.")

RECENT WORK ON SELENIUM: THE RADIOVISOR BRIDGE.—E. Fournier d'Albe. (*Television*, July, 1929, pp. 233-235.)

A gold grid is fused to a thin glass surface, the interdigitated combs forming the electrodes. The layer of selenium varies in size for different special purposes; the standard size has a surface of 27×50 mm. A standard bridge with a resistance of 4 megohms will give a change between current in darkness and in light of the order of 100-150 microamperes. It will stand up to high voltages—up to a thousand volts.

WASSERSTOFF UND DIE PHOTOELEKTRISCHE EMIS- SION AUS KALIUM (Hydrogen and the Photoelectric Emission from Potassium).—N. R. Campbell. (*Physik. Zeitschr.*, 1st Sept., 1929, Vol. 30, pp. 537-538.)

An interim report on the G.E.C. (Wembley) researches on the sensitisation of the alkali metals by discharge in hydrogen. Results already published were dealt with in 1928 Abstracts, p. 692.

PHOTOELECTRIC THRESHOLDS OF THE ALKALI METALS.—N. R. Campbell. (*Phil. Mag.*, Nov., 1929, Vol. 8, No. 52, pp. 667-668.)

Ives and Olpin (1929 Abstracts, p. 516) have found that the photoelectric thresholds of thin films of the alkali metals are identical with the resonance potentials of their neutral atoms; on this identity they have founded a tentative theory of the photoelectric effect, not easily reconciled with Sommerfeld's theory of the metallic state which Fowler has applied to the photoelectric effect. The writer suggests that their conclusions, though doubtless perfectly valid for the instances examined, may not have the generality that they are inclined to attribute to them. He considers it not yet certain whether the threshold of a thin film of the alkali metals is independent of the surface on which it is deposited, even if the latter be gas-free; and it is definitely certain that if the support is not a gas-free metal surface, but a metal surface deliberately oxidised, the threshold is not identical with the resonance potential of the alkali metal.

NON-LINEARITY OF PHOTOELECTRIC RESPONSE NEAR LONG WAVELENGTH LIMIT.—W. B. Nottingham. (*Phys. Review*, No. 4, 1929, Vol. 33, pp. 633-634.)

Ives and Olpin found the long wavelength limit for thin alkali metal films to coincide with the first line of the principal series. This suggests that the photoelectric current produced by illumination of a wavelength very near this long limit might be a result of the cumulative action of two light quanta for each electron, one producing a state of excitation and the second ionisation. The writer's tests confirm this. A summary only is given.

SOME CHARACTERISTICS OF PHOTOELECTRIC TUBES. L. R. Koller. (*Journ. Opt. Soc. Am.*, Sept., 1929, Vol. 19, pp. 135-145.)

Among the many facts included in this succinct review of our present knowledge are the following:—(1) Where the photo-sensitive surface is apt to be injured by positive ion bombardment, helium may be used instead of argon, as it causes less sputtering; it is not, however, very effective in amplifying the photo-current. (2) The writer has shown that in the case of potassium the maximum sensitivity is obtained from a monatomic film. (3) If a monatomic film of caesium is deposited on a layer of oxygen on a silver background, the maximum is shifted (from $\lambda =$ about 4,850 for monatomic caesium on magnesium, or 5,400 for caesium in bulk) towards the ultra-violet, and the long-wave limit towards the red. If, instead of an oxygen-silver, a caesium layer is formed on caesium oxide, no change takes place in the short-wave maximum, but a remarkable hump appears in the red and the long-wave limit moves out towards the infra-red.

The addition of dielectrics such as sulphur is not referred to.

ÜBER EINE STEUERUNG DES GLÜHELEKTRISCHEN STROMES OXYDBEDECKTER METALLFOLIEN DURCH BESTRAHLUNG MIT ULTRAVIOLETTEM LICHT (On the Control of the Thermionic Current of an Oxide-coated Metal Foil by Irradiation with Ultra-violet Light).—E. Bodemann. (*Ann. der Physik*, 23rd November, 1929, Series 5, Vol. 3, No. 5, pp. 614-628.)

Crew's result, that the photoelectron emission from an oxide-coated foil is increased by a high temperature, is confirmed and explained. In addition to the thermionic current, the light-produced current is about 200 times greater than the photoelectric current from the cold foil; it can be caused to fade away by out-gassing the foil, but returns if the latter is left for several days in dry air and the bulb then re-exhausted. The results are explained as follows:—as the foil gives up its gas, electrons loosely bound to the neutral gas close to the metal surface form a space charge which keeps down the thermionic current. The effect of light frees these electrons, reduces the space charge and increases the current.

MEASUREMENTS AND STANDARDS.

THE COMPARISON OF THE POWER FACTORS OF CONDENSERS.—R. M. Wilmotte. (*E.W. & W.E.*, Dec., 1929, Vol. 6, pp. 656-662.)

A modification of the usual method of measuring the resistance of a circuit containing one condenser and then substituting the other condenser and measuring again. The writer tunes a circuit with each condenser separately and switches rapidly from one to the other, bringing the current to the same value in the two cases by inserting a series resistance, whose value gives the difference between the effective series resistances of the two condensers. The method is particularly useful for high frequencies (where the older method is liable to give inconsistent results); it has been used for frequencies up to 6×10^6 .

A SENSITIVE VALVE VOLTMETER WITHOUT "BACKING OFF" (ANODE CURRENT COMPENSATION).—M. v. Ardenne. (*E.W. & W.E.*, Dec., 1929, Vol. 6, pp. 669-675.)

High sensitivity is obtained without the use of current compensation, so that the time spent in adjustment is small. Damage by overloading is almost impossible. The calibration curve can be made with a medium audio-frequency, since it is independent of frequency for all frequencies above 50 cycles. Within certain limits, the variation with battery voltage is small. Stray capacities amount to not more than $9 \mu\mu\text{F}$. in all.

The above advantages are obtained by the use of two stages: the first (rectifying) stage has a valve of high amplification factor in whose anode circuit is a resistance of several million ohms, bridged by a condenser. The valve of the second stage, which makes use of the change in anode voltage produced in the first stage, must have a grid current small in comparison with the very low anode current of the first stage.

Using as aperiodic amplifier a series of 3 multiple valves, the voltmeter has successfully measured

voltages down to 10^{-5} v.; it has measured directly the voltages produced by distant transmitters in a small frame aerial.

A BRIDGE GRID RESISTOR AMPLIFIER.—J. Razek and P. J. Mulder. (Supplement to *Journ. Opt. Soc. Am.*, October, 1929, Vol. 19, No. 4, Part 2, p. 9.)

Abstract only. Continuing the work referred to in 1929 Abstracts, p. 516, the authors investigate mathematically the conditions to be satisfied for steady galvanometer current at high sensitivity, for the two-valve bridge using grid resistor amplifiers: these conditions are shown to be that the effective characteristics of the valves should be identical in pairs, which is almost impossible to realise. They have therefore developed a circuit in which these conditions are reduced in number, and of such character as to be easily attained. Stability can be realised even if the valves differ considerably. The operating points for maximum stability are rapidly determined by an experimental procedure.

The authors have used the circuit to amplify photo-electric currents in connection with a spectrophotometer. For use in a portable recording and indicating Colour Analyser, it has been arranged to work entirely off a.c. mains (*ibid.*, p. 12).

FORMULES SIMPLES PERMETTANT, DANS TOUS LES CAS, LE CALCUL RAPIDE DES RÉSISTANCES OHMIQUES EN COURANT ALTERNATIF (Simple Formulae for the Rapid Calculation, in all Cases, of Ohmic Resistance for A.C.).—A. Levasseur. (*Comptes Rendus*, 7th October, 1929, Vol. 189, pp. 529-530.)

From purely geometrical considerations applied to Kelvin's results, and from numerical verifications, the writer arrives at the following formula for the ratio of the a.c. to the d.c. resistance of a cylindrical conductor:—

$$K = \sqrt[6]{\left(\frac{3}{2}\right)^6 + \nu^6 + \frac{1}{4}}$$
, where $\nu = \pi a \sqrt{\mu c f}$ (a being the sectional radius). This holds for any value of a , for any substance and any frequency; under the most unfavourable circumstances the error is only 1.15 per cent, usually it is much less. By substituting $s/\rho\epsilon$ for ν , the formula becomes applicable to conductors other than those of cylindrical section: here s is the sectional area, ρ its perimeter and ϵ the thickness of the imaginary shell, calculated by the classical method. Where the approximation for this quantity no longer exists (*e.g.*, for low frequencies) the formula still holds good. It is pointed out that, owing to the form of the formula, the approximation only varies slowly for variations of the radical and index 6: "even for a value of 10, the approximation would remain admissible in certain cases."

A NEW METHOD FOR MEASURING THE DIELECTRIC CONSTANTS OF CONDUCTING LIQUIDS.—A. Astin. (*Phys. Review*, 15th July, 1929, Vol. 34, No. 2, pp. 300-309.)

A modified resonance method in which no correction is necessary for the conductivity of the liquid.

DIREKTE MESSUNG DES MODULATIONSGRADES EINES TELEPHONIESENDERS (Direct Measurement of the Degree of Modulation of a Telephony Transmitter).—M. Büge. (*Zeitschr. f. Hochf. Tech.*, Nov., 1929, Vol. 34, pp. 175-177.)

Two arrangements are given using ordinary indicating instruments—cross-coil or moving coil types. The first arrangement, described at length, appears to be unsatisfactory; the second is apparently satisfactory. A rectifier *V* passes the peak voltage of the signals to a condenser *C* and thence to the grid of an amplifier valve *R*. According to the setting of *C*, either the mean or the instantaneous value of the degree of modulation can be measured.

ÜBER HOCHFREQUENZLEITFÄHIGKEIT UND DIELEKTRIZITÄTSKONSTANTEN WÄSSRIGER ELEKTROLYTLÖSUNGEN (The H.F. Conductivity and Dielectric Constant of Aqueous Solutions of Electrolytes).—H. Rieckhoff. (*Ann. der Physik*, 15th August, 1929, Series 5, Vol. 2, No. 5, pp. 577-616.)

The resistance-measuring method used depends on the damping effect on a tuned circuit; it is a substitution method, *KCl* being chosen as the standard solution. A 1 metre wave was employed. Results conform very well with the Debye-Falkenhagen theory of the dispersion effect (important deviations only occur with solutions containing high-value ions). The temperature effect was also found to conform with the theory.

Conflicting results of various workers as to the dielectric constant of weak solutions of electrolytes in water, as compared with that of the water itself, were investigated by the same method, but a 5 m. wave was necessary for these liquids of small conductivity. The results of Hellmann and Zahn were confirmed and extended: the effect of adding the electrolyte is to *decrease*, but only slightly, the dielectric constant; Walden's results (showing very great decreases) are attributed to a defect in his method.

DURCHLASSBEREICH, PHASENLAUFZEIT UND KLIRRFaktor VON FERNKABELN (Band-pass Zone, Phase-transit Time, and "Klirr" Factor—Measuring Non-linear Distortion—for Long-Distance Cables).—M. Grützmacher. (*E.N.T.*, October, 1929, Vol. 6, pp. 386-395.)

Description of a process for the automatic and continuous recording of the curves representing these three important factors.

SULLIVAN (MCLACHLAN) WAVEMETER WITH AUDIO-FREQUENCY GENERATION. (*Journ. Scient. Instr.*, Oct., 1929, Vol. 6, pp. 327-328.)

A short illustrated description of the instrument referred to in 1929 Abstracts, p. 163.

DIE REGISTRIERUNG VON PENDELSCHWINGUNGEN MITTELS KAPAZITIVER KONTAKTE (Recording of Pendulum Swings by Capacitive Contacts).—H. Mahnkopf. (*Zeitschr. f. Geophys.*, No. 2, 1929, Vol. 5, pp. 49-52.)

A simplified version of Lejay's method (1929 Abstracts, p. 398). Among other differences, a telephone relay gets rid of the use of an oscillograph. For an article on the reaction of the method on the pendulum itself, see Schmehl, same journal, pp. 53-58.

A NEW INERTIA-LESS CHRONOGRAPH.—P. A. Cooper. (*Phil. Mag.*, December, 1929, Vol. 8, No. 54, pp. 1100-1105.)

Gas-discharge lamps of the "Osgilim" type, when used for recording, present the difficulty that there is an uncertain delay before the discharge strikes. Recording, therefore, used to be done by making the event extinguish the lamp: various ionising methods were also tried, to get rid of the lag, without much success. The writer describes a method which successfully reduces the lag to a negligible amount, involving the use of a "pilot circuit": a "pilot leak" (usually 50,000 ohms for the lamps used) passing enough current to keep the gas ionised but not enough to give a photographic record with the film speeds used. The special lamps described and illustrated have an argon filling instead of the usual helium-neon mixture (which needs panchromatic emulsion). The three electrodes, following standard G.E.C. practice, are clean iron plates: the middle plate is the single anode, the outer plates each act as a separate cathode.

METHOD FOR EXACT MEASUREMENT OF TECHNICAL FREQUENCIES.—G. Keinath. (Summary in *Science Abstracts*, Sec. B, 25th October, 1929, Vol. 32, p. 548.)

The writer's frequency recorder, here described, has a range of ± 1 per cent. and gives a 6 mm. movement of the pen for a frequency variation of 0.1 per cent.: one-tenth of this movement is readily readable.

MAGNETOSTRICTION OF SINGLE CRYSTALS OF IRON.—N. Akulov. (See under "General Physical Articles.")

SPECIAL VALVE VOLTMETER FOR PIEZOELECTRIC TESTING OF PRESSURES, ETC.—Kluge and Linckh. (See under "Miscellaneous.")

THE MARCONI TUNING FORK AS A FREQUENCY STANDARD. (*Marconi Review*, Nov., 1929, pp. 16-20.)

"The frequency-spectrum may be divided into the following rough groups, as far as radio purposes are concerned.

(a) 50-3,000 cycles. For this range a tuning fork is generally employed where a stable oscillator is required.

(b) 3,000-10,000 cycles. Magnetostrictive oscillators are useful for these frequencies.

(c) 10,000-75,000 cycles. For reliable oscillations of from 10,000 cycles upwards, stabilised

Inductance Capacity valve oscillators are generally employed.

(d) 75,000–3,000,000 cycles. Either (1) Piezo-electric crystal controlled oscillators or (2) Valve oscillators may be used in this range.

(e) Above 3,000,000 cycles. Valve oscillators are the only form of oscillators which can be practically employed at frequencies above 3,000 kilocycles."

"To cater for the band of frequencies from 50 to 3,000 cycles, the Marconi Company has evolved the tuning fork and associated apparatus" described in this article. It is suitable for purposes for which a constancy closer than 1/100,000 is required. A special grade of very uniform mild steel is ordinarily used, fully annealed in the course of the manufacture of the fork. Later it is mentioned that nickel chrome steels, such as Elinvar, have been used in certain cases for their smaller frequency-temperature dependence, but that these steels have certain disadvantages owing to their peculiar physical properties. "Changes in the physical properties of these steels, resulting from a change of temperature, do not follow the change of temperature immediately. There is a time lag resulting in a slow progressive change in frequency which may be perceptible for weeks."

The special shape of the fork has been designed to obtain exact mechanical balance between the prongs, with the object of reducing to a minimum the reaction of the butt of the fork on its support. The "incubator" temperature is kept constant by a toluene regulator, the adjustment being such that the heating lamps are "on" and "off" for about equal times, the thermostat relay working at intervals of a second or so. The total power taken from the mains is about 250 watts. For the use of the apparatus in the control of transmitter frequencies, see under "Stations, D. and Op."

VISUAL INDICATION OF PIEZOELECTRIC OSCILLATION. (German Pat. 480110, Eberhard, Radiofrequenz, pub. 29th July, 1929.)

A number of methods of combining a piezoelectric crystal with a gas-filled bulb are described and illustrated. Various shapes of bulb are used: sometimes all the electrodes are external, sometimes one or two are internal: in one arrangement there is a third (control) internal electrode.

INDUCTANCES OF HIGH PERMANENCE.—W. H. F. Griffiths. (*Journ. Scient. Instr.*, Nov., 1929, Vol. 6, pp. 354–357.)

See same writer, January Abstracts, p. 52.

BERECHNUNG DER DURCH DIE WINDUNGSISOLATION HERVORGERUFENEN VERGRÖSSERUNG DER INDUKTIVITÄT VON EISENLOSEN DROSSELSPULEN (Calculation of the Increase of Inductance due to the Insulation of the Winding in Air-core Chokes).—J. Hak. (*E.T.Z.*, 3rd Oct., 1929, Vol. 50, pp. 1440–1442.)

THE MUTUAL INDUCTANCE OF TWO PARALLEL CIRCLES.—Chester Snow. (*Bur. of Stds. Journ. of Res.*, Aug., 1929, Vol. 3, pp. 255–273.)

It is shown that the mutual inductance of two parallel circles is identical with the electrostatic potential due to a fairly simple surface charge upon an annular surface. This potential is formulated as a complex line integral, and by deformation of the path its harmonic expansion is obtained for all possible cases.

A NOTE ON THE HIGH GRID RESISTOR AMPLIFIER.—W. B. Nottingham. (*Journ. Franklin Inst.*, October, 1929, Vol. 208, pp. 469–474.)

Referring to Mulder and Razek's paper (1929 Abstracts, p. 516), the writer considers that it does not show clearly the conditions necessary for obtaining the high mutual conductance, without getting also a discontinuous and non-reversible part in the characteristic. The grid current/grid voltage curve is made up from electron current from the filament, leakage current over base of tube and elsewhere, and (most important of all for the case in point) the component depending on the presence of gas in the valve. These three components result in a point of inflection in the characteristic, and the writer analyses the conditions at a part of the curve near this point of inflection; his equations show that the effective mutual conductance can be made very large if R (the resistance in the grid lead) is increased up to a value $1/m$, m being the slope of the curve at the part considered; up to this value the plate current characteristic "has no discontinuity and is stable for all values of V or i_x , as the case may be" (V being the grid potential which is varied when the amplifier is used as a truly "voltage sensitive" device—as with thermo-couples; i_x being the photoelectric current when V is constant and i_x varies, as in photoelectric cell applications). But if $R > 1/m$, there will be a discontinuous region. If the two points of tangency of the slope $1/R$ with the grid current curve are located, the discontinuity will be found between these points. The writer ends with a reference to Rasmussen's paper dealt with in 1929 Abstracts, pp. 647–648: the discussion of the question of gas in a triode is there treated from a different point of view, but the results agree with those of the writer.

UNTERSUCHUNGEN DES ELEKTRISCHEN SPEKTRUMS DES WASSERS MIT UNGEDÄMPFTEN SCHWINGUNGEN IN DEM WELLENLÄNGENBEREICH VON 3000–2200 MM. (Investigations into the Electrical Spectrum of Water, with Undamped Waves of Wavelengths 2.2 to 3 Metres).—N. Novosilzew. (*Ann. der Physik*, 15th Aug., 1929, Series 5, Vol. 2, No. 5, pp. 515–536.)

The apparatus described allows the spectrum to be examined very rapidly but with an accuracy of 0.15 per cent., over the range of 2 to 4 metres wavelength. Particular care was taken to obtain a rapid change of wavelength combined with great constancy when once set. The tests show that the refractive index is represented by a straight line and that there are no streaks of anomalous dispersion in the range considered.

SUBSIDIARY APPARATUS AND MATERIALS.

DIE SCHWÄRZUNG PHOTOGRAPHISCHER SCHICHTEN BEIM KATHODENOSZILLOGRAPHEN (The Blackening of the Photographic Sensitised Layer in Cathode-ray Oscillographs).—W. Rogowski, E. Flegler and P. Rosenlöcher. (*Arch. f. Elektrot.*, 5th November, 1929, Vol. 23, No. 1, pp. 149-152.)

The most convenient method of recording is by camera and lens, using the light from the fluorescent screen. This method is already known to be satisfactory for the most rapid recording speeds if a large electron stream is available, or for moderate speeds (10^{-6} sec.) if only a moderately great electron stream is available.

The present paper shows that such a "light" method can also be used satisfactorily for the most rapid recording with only a moderate electron stream, by pressing the sensitised film against the back of the fluorescent screen. The thickness of the glass plate and that of the fluorescent coating are of importance. Results are "almost as good" as those given by direct electron action, and the method is of course far more convenient.

ÜBER DAS SCHWARZUNGSGESETZ DER PHOTOGRAPHISCHEN PLATTE FÜR ELEKTRONENSTRAHLEN (The Law of Blackening of Photographic Plates by Electron Rays).—W. Seitz and G. Harig. (*Physik. Zeitschr.*, 1st Nov., 1929, Vol. 30, pp. 758-760.)

EISENVERLUSTE VON FREQUENZ-TRANSFORMATOREN (Iron Losses of Frequency Transformers).—M. Osnos: F. Sammer. (*Zeitschr. f. Hochf. Tech.*, Sept., 1929, Vol. 34, pp. 87-91.)

Two papers from the Telefunken Laboratory. Whereas in ordinary transformers, where the iron is only slightly saturated, a sinusoidal magnetising current produces a sinusoidal induction B of the same periodicity, in frequency transformers on the other hand several periodicities exist simultaneously; the iron losses must be dealt with in quite a different manner, since neither B nor the ampere turns per centimetre can be taken as a basis. Moreover in frequency transformers the stopper-circuit has an influence on the iron losses, both as regards its values and its method of connection. The present investigations lead to the discovery that for values of ampere turns per cm. of 10 upwards, the ratio iron loss/transformer kVA plotted against ampere turns per cm. gives a hyperbola, whose constants can easily be calculated and which is quite independent of the size of the stopper-circuit and almost independent of the load. This ratio is nothing else but the damping factor of a coil. A comparison of these hyperbolas (or of the straight lines obtained from the reciprocal ratios) gives a comparison of the merits of different irons: examination of one curve gives the constants of one particular sample; and the approximate absolute value of the iron loss for any frequency transformer can be calculated without even knowing the weight of iron.

SUPERHARDENING HARDENED STEEL BY MAGNETIC MEANS.—E. G. Herbert. (*Nature*, 26th Oct., 1929, Vol. 124, p. 672.)

ELECTRICALLY CONDUCTIVE ANTIMONY MIRRORS ON GLASS.—S. Miller. (*Journ. Opt. Soc. Am.*, August, 1929, Vol. 19, pp. 101-102.)

CONSTRUCTION OF MICRO-THERMOCOUPLES.—D. M. Whitaker. (*Science*, 13th Sept., 1929, Vol. 70, pp. 263-266.)

Describes a method of constructing micro-thermocouples small enough and strong enough to be inserted into small living cells or into tissues: they are small enough to be used in measuring light absorption of a single plastid or for any purpose requiring temperature measurements at minute points. The Taylor method of drawing metals in glass to wires or filaments of exceedingly small size is utilised.

SCHUTZ WISSENSCHAFTLICHER INSTRUMENTE GEGEN ERSCHÜTTERUNGEN (Protection of Scientific Instruments against Shock).—H. J. Menges. (*Zeitschr. f. tech. Phys.*, Oct., 1929, Vol. 10, No. 10, p. 472.)

The use of a partly-inflated inner tube of a motor tyre is recommended, the bedplate of the instrument having four cross-pieces which rest on the tyre.

MECHANISM OF DIELECTRIC BREAKDOWN IN THIN LAYERS [OF IMPREGNATED PAPER].—F. E. Null and J. B. Edwards. (*Phys. Review*, June, 1929, Vol. 33, No. 6, p. 1076.)

NEW GAS-DISCHARGE LAMPS FOR RECORDING.—P. A. Cooper. (See abstract under "Measurements and Standards.")

THE EFFECT OF DRAWING ON THE TEMPERATURE COEFFICIENT OF THE ELECTRICAL RESISTIVITY OF CONSTANTAN.—R. S. J. Spilsbury. (*Journ. Scient. Instr.*, Nov., 1929, Vol. 6, pp. 357-358.)

HOW ELECTRO-PLATING AFFECTS H.F. RESISTANCE.—W. H. F. Griffiths. (*Wireless World*, 6th November, 1929, Vol. 25, pp. 515-518.)

The behaviour of various conductors at radio frequencies and the effect of electro-plating them with certain other metals are discussed and expressed quantitatively. Instances are given of the reduction in the resistance (in comparison with that of copper) of the higher specific resistance conductors at high radio frequencies, including silver, aluminium and phosphor bronze. Curves are given showing the reduction effected in the resistance of different metals at 30 metres when electro-plated with various thicknesses of copper.

A NEW VACUUM THERMOCOUPLE.—Moll and Burger. (*Journ. Scient. Instr.*, November, 1929, Vol. 6, p. 358.)

Equilibrium is reached within two-fifths of a second; 5×10^{-8} cal. per sec. gives 1 microvolt. A strip of constantan and manganin is used, 1 micron thick, 0.1 mm. wide and 2 mm. long,

blackened on one side and mounted in a small, highly evacuated glass bulb.

TAPPED FILAMENT AS POTENTIAL DIVIDER.—Mullard Company. (*Journ. Scient. Instr.*, November, 1929, Vol. 6, pp. 358-359.)

For voltages up to 250, aggregate current 60 ma. 8 intermediate tappings.

ANTI-VIBRATORY PROPERTIES OF RUBBER.—(*Electrician*, Nov., 1929, Vol. 103, p. 671.)

Summary of a report from the Rubber Growers' Association on an investigation primarily undertaken in connection with wireless-set isolation. Among the various conclusions summarised, the best all-round absorption was given by $\frac{1}{2}$ in. thick pads of "cellular or expanded rubber (gas filled)"; perforated samples of sole crêpe rubber rank next, and are recommended for general utility purposes on the score of cheapness. "The proportioning of the diameter and spacing of the perforated holes to the thickness of the material will require investigation."

AN AUTO-CONDENSER.—A. M. Codd. (*Elec. Review*, 29th November, 1929, Vol. 105, pp. 940-942.)

"A compact arrangement that is capable of affording a large number of combinations and, at the same time, effecting a considerable saving of material." The writer describes the use of additional, intermediate plates to give the extra facilities in tapping possessed by the analogous "auto-transformer." The inter-plates may, further, be divided into two equal or unequal parts—the area not affecting the pressure but only the current output, which is proportional to the area. Applications are suggested to filter or smoothing circuits, the independent working of lamps, loud-speakers or other loads of widely different voltage, and other purposes.

ÜBER DEN KERREFFEKT-OSZILLOGRAPHEN (The Kerr Effect Oscillograph).—E. Rostás and P. Selényi. (*Zeitschr. f. tech. Phys.*, Nov., 1929, Vol. 10, No. 11, pp. 483-486.)

The light fluctuations caused by the Kerr cell are made to give interference bands perpendicular to the direction of motion of a photographic film. At present, owing to the feeble illumination, only low frequencies can be recorded, in spite of the inertia-free nature of the arrangement.

ÜBER DIE WEITERE ENTWICKLUNG DER NEUEN, MITTELS ELEKTROSTATISCHER LADUNGEN SCHREIBENDEN KATHODENOSZILLOGRAPH-RÖHRE (The Further Development of the New Cathode-ray Oscillograph recording by Electrostatic Charges).—P. Selényi. (*Zeitschr. f. tech. Phys.*, Nov., 1929, Vol. 10, No. 11, pp. 486-489.)

See 1929 Abstracts, p. 280 and previous references. A concentrating coil encircles the middle third of the tube: the deflecting is electrostatic, the deflecting condenser being formed by the two parts of a magnesium mirror-coating on the inside of the tube. The sharpness of the records is greatly

improved: standing curves are reproduced with "about the same sharpness" as that given by the classic Braun tube: the recording of curves described once only still presents certain difficulties. Examples of records given include the current/voltage characteristic of a valve.

HOCHOHMIGE WIDERSTÄNDE FÜR NIEDERE UND HOHE SPANNUNGEN (High Ohmic Resistances for Low and High Voltages).—F. Krüger. (*Zeitschr. f. tech. Phys.*, November, 1929, Vol. 10, No. 11, pp. 495-500.)

These resistances are made by the cathode sputtering of platinum or gold films on amber or quartz. After $1\frac{1}{2}$ -2 months' ageing a good constancy is attained: the resistance range lies between 10^6 and 10^{13} ohms. For high voltages such as 100,000 to 200,000 v., difficulties with corona and heating-up are overcome by mounting the resistance in a quartz-glass or pertinax tube filled with (e.g.) high-insulation transformer oil.

THE PREVENTION OF IONIZATION IN IMPREGNATED PAPER DIELECTRICS.—S. G. Brown and P. A. Sporing. (*Journ. I.E.E.*, Aug., 1929, Vol. 67, pp. 968-991.)

The full paper, with discussion, a summary of which was dealt with in June Abstracts, p. 340.

FORTSCHRITTE DER VAKUUMTECHNIK (Progress in Vacuum Technique).—H. Ebert. (*Glas u. Appar.*, No. 14, 1929, Vol. 10, pp. 135-136.)

A description of a year's developments relating to pumps, meters and apparatus.

A VOLTAGE REGULATOR FOR GAS DISCHARGE X-RAY TUBES.—F. E. Haworth. (*Journ. Opt. Soc. Am.*, Aug., 1929, Vol. 19, pp. 79-80.)

A device which automatically regulates the voltage across the tube by adjusting a mercury valve between the latter and the pumps, thus controlling the pressure in the tube.

A PRESSURE GAUGE FOR CONTINUOUS READING IN MODERATE VACUA.—M. C. Johnson and G. O. Harrison. (*Journ. Scient. Instr.*, October, 1929, Vol. 6, pp. 305-308.)

Description of the instrument used in the hydrogen adsorption experiments referred to in 1929 Abstracts, p. 402. Pressure differences between $\frac{1}{2}$ mm. and 2×10^{-4} mm. are measurable.

IRON-SILICON-CARBON ALLOYS: CONSTITUTIONAL DIAGRAMS AND MAGNETIC PROPERTIES—THE EFFECTS OF VARIOUS HEAT TREATMENTS.—T. D. Yensen. (*Electrician*, 8th Nov., 1929, Vol. 103, pp. 556-559.)

ÜBER WOLLASTON-DRÄHTE UND -FOLIEN UND IHRE VERWENDUNG ALS WIDERSTANDS-THERMOMETER (ON WOLLASTON-WIRE AND -FOIL, AND THEIR USE AS RESISTANCE THERMOMETERS).—E. Waetzmann, M. Gnielinski and H. Heisig. (*Zeitschr. f. Phys.*, 9th Nov., 1929, Vol. 58, No. 7/8, pp. 449-469.)

DESIGN OF A TRANSFORMER FOR THE FILAMENT CURRENT OF HIGH VOLTAGE RECTIFYING VALVES.—C. L. Fortescue and G. H. Halton. (*Journ. Scient. Instr.*, October, 1929, Vol. 6, pp. 308-310.)

Somewhat on the lines of the Hudson and Blackett transformer (1929 Abstracts, pp. 281-282), the present design provides for a voltage of at least 70,000, providing 8.0 A. at 7.5 v. Each winding is completely surrounded by a copper shield made as smooth as possible in order to reduce the liability to brushing.

STATIONS, DESIGN AND OPERATION.

COMMON-WAVE BROADCASTING, ELIMINATION OF INTERFERENCE ZONES. (German Pat. 480368, Lorenz, published 2nd August, 1929.)

Interference often occurs on the modulation frequencies as well as on the radio frequencies. The former may be caused, for instance, by phase differences due to unequal lengths of connecting lines. The patent deals with the introduction of artificial lines to equalise the linking to the various stations. Cf. Int. Stand. Elec. Corp., 1929 Abstracts, p. 586:—the use of motor-driven phase-adjusters to compensate for phase differences in the synchronising waves.

NAVAL COMMUNICATIONS—RADIO WASHINGTON.—S. C. Hooper. (*Proc. Inst. Rad. Eng.*, Sept., 1929, Vol. 17, pp. 1595-1620.)

Author's summary:—This article describes the radio facilities at Radio Washington. There is included a brief description of receiving equipment and of methods of control of transmitters in use at the Navy Department, Radio Central, and of the transmitting equipment installed at Arlington, Va., and Annapolis, Md.

TELEPHONE CIRCUITS FOR PROGRAM TRANSMISSION.—F. A. Cowan. (*Journ. Am.I.E.E.*, July, 1929, Vol. 48, pp. 1045-1049.)

COMMERCIAL SHORT WAVE WIRELESS COMMUNICATIONS.—H. M. Dowsett. (*Marconi Review*, October, November and December, 1929.)

The full lecture, a summary of which was dealt with in Jan. Abstracts, pp. 53-54.

A CONSTANT FREQUENCY CONTROL FOR BROADCAST TRANSMITTERS. (*Marconi Review*, Nov., 1929, pp. 21-26.)

An article on the use of the Marconi Company's tuning fork apparatus (*see* under "Measurements and Standards") for controlling broadcast transmitters.

SHORT-WAVE TRANSATLANTIC RADIO-TELEPHONY. BELL LABORATORIES. (*Bell Laboratories Record*, July-October, 1929: reprinted in 1 volume, October, 1929.)

Twelve articles "which summarise almost every aspect of the American stations."

DIE ERGEBNISSE DER FUNKTAGUNG IM HAAG (Results of the Hague Wireless Conference [of the CCIR]).—F. Noack. (*Zeitschr. des V.D.I.*, 23rd November, 1929, Vol. 73.)

Among the points decided at this conference (September-October, 1929), the following are mentioned:—Classification of wavelengths: very (ultra) short, under 10 m.; short, 10-50 m.; "border" waves, 50-200 m.; medium, 200-3,000 m.; long, 3,000 m. upwards. Rules relating to amateur transmission (purity of wave, 0.5 per cent. accuracy of wavemeter, only d.c. supply for anode). Broadcasting: no change in the Prague plan was recommended (the consideration of such a change did not come within the province of the Conference), but it was agreed that a stricter watch should be kept on the wavelength constancy (3 to 4 per thousand) of broadcast stations, an accuracy of 0.01 per thousand in the frequency meters employed being stipulated. The breadths of frequency bands were fixed:—for telegraphy, 160-240 cycles; picture-telegraphy, 2,000-10,000 cycles; telephony, up to 6,000 cycles, and broadcasting, 10-20,000 cycles. "Unfortunately no satisfactory limit could be placed to the generally growing powers of broadcasting stations, since those countries which had already begun the construction of giant transmitters voted against any reduction of power. The much too high value of 100 kw. for the maximum antenna power had therefore to be accepted."

THE THIRST FOR POWER.—(*Wireless World*, 27th Nov., 1929, Vol. 25, p. 581.)

Criticism of the recent CCIR decision to consider 100 kw. to be the maximum allowable radiated power for broadcasting stations. "Far from curbing the ambitions of some countries to install giant transmitters, the recent decision at The Hague tends to support this race for power." See also *Nature*, 7th Dec., 1929, p. 885, where the above article is quoted and supported.

GENERAL PHYSICAL ARTICLES.

ELECTRONIC WAVES.—J. J. Thomson. (*Phil. Mag.*, December, 1929, Vol. 8, No. 54, pp. 1073-1092.)

In his former paper (1929 Abstracts, pp. 113-114) the writer considered the electronic waves accompanying an electron moving uniformly in a straight line. In the present paper he considers the waves in a general case, when the electron is under the action of an electric force, so that its velocity and direction of motion are changing. The point of view taken is that the distribution of the sub-electrons in the atmosphere of the electron is affected by the electric force, so that the waves are no longer moving through a uniform medium but one whose properties vary from point to point.

THE CHARGE OF AN ELECTRON.—A. S. Eddington. (*Nature*, 30th Nov., 1929, Vol. 124, p. 840.)

In January, 1929, the writer proposed a theory of electric charge which led to a definite prediction of the numerical value of the constant $hc/2\pi e^2$, namely, 136 (*cf.* Poole, 1929 Abstracts, p. 344). Fuller insight into the problem has led to an improved form of the theory which now makes it

apparent that the "rotation," which was introduced to represent interchange of the two electrons, is not one of the 136 symmetrical rotations of a pair of electrons, but is an antisymmetrical rotation which must be counted in addition. The new value of the constant is consequently 137 [compared with the experimental value 137.2]. The full investigation will be published soon.

THE QUANTISTIC THEORY OF INTERFERENCE FRINGES.—E. Fermi. (*Nat. Ac. Lincei*; summary in *Nature*, 30th Nov., 1929, Vol. 124, p. 862.)

On the basis of Dirac's theory of radiation, a theory of Lippmann's fringes is evolved. The method is applicable generally to the treatment of any interference phenomenon, and the result arrived at coincides with that of the classical electromagnetic theory.

RELATIVITY TRANSFORMATION OF AN OSCILLATION INTO A TRAVELING WAVE, AND DE BROGLIE'S POSTULATE IN TERMS OF VELOCITY ANGLE.—V. Karapetoff. (*Journ. Opt. Soc. Am.*, Nov., 1929, Vol. 19, pp. 253-265.)

NUCLEAR DISINTEGRATION BY PROTONS ACCELERATED ARTIFICIALLY.—G. Breit. (*Phys. Review*, 1st Sept., 1929, Vol. 34, pp. 817-818.)

The writer concludes:—"Even 1500 kv. protons should be of interest for the lighter elements. Experiments with such voltages should not be too difficult to perform." Penetration by a proton inside a light nucleus may not necessarily have a disintegrating effect, but if not, it is reasonable to expect deviations from Rutherford's inverse square law of scattering, giving useful information about the dimensions of nuclei.

THE EFFECT OF RETARDATION ON THE INTERACTION OF TWO ELECTRONS.—G. Breit. (*Phys. Review*, 15th Aug., 1929, Vol. 34, pp. 553-573.)

DIE UNTERSUCHUNG DES SKINEFFEKTES IN DRÄHTEN MIT KOMPLEXER MAGNETISCHER PERMEABILITÄT (Investigation of the Skin Effect in Wires with Complex Magnetic Permeability).—A. Ermolaev. (*Arch. f. Elektrot.*, 5th Nov., 1929, Vol. 23, No. 1, pp. 101-108.)

An investigation based on Arkadiew's theory of the electromagnetic processes in ferro-magnetic materials.

SUR L'ÉTAT DIT "SAMA-ZUSTAND" (The Condition called "Sama-Condition").—E. A. Holm. (*Comptes Rendus*, 30th Sept., 1929, Vol. 189, pp. 483-484.)

More work on the phenomenon referred to in 1928 Abstracts, p. 693.

ÜBER DEN SAMAZUSTAND "ERSTER ART" UND "ZWEITER ART" (On the Sama Effect Types I and II).—W. Anderson. (*Zeitschr. f. Phys.*, 1st Nov., 1929, Vol. 58, No. 5/6, pp. 440-442.)

THE EFFECT OF GASES ON THE ELECTRIC CHARGES DEVELOPED BY HEATED METALS.—D. H. Bangman and D. R. Lewis. (*Journ. Chem. Soc.*, June, 1929, pp. 1140-1149.)

LATENT CARRIERS OF ELECTRICITY IN THE GASEOUS DISCHARGE.—S. A. Ratner. (*Proc. Nat. Acad. Am.*, April, 1929, Vol. 15, No. 4, pp. 318-323.)

ATOMIC THEORY OF FERROMAGNETISM.—N. Akulov. (*Zeitschr. f. Phys.*, May, 1929, Vol. 54, No. 7/8, pp. 582-587.)

A continuation of the work referred to in 1929 Abstracts, p. 338. Actual measurements show that there are no hysteresis losses in single crystals of iron. An action, similar to that of quadruples and perhaps not purely magnetic, must play an important part in ferromagnetism in addition to the action of the magnetic dipoles.

If an iron atom had an electric dipole moment of the order of 10^{-18} , and if its direction could be affected by an external magnetic field, the magnetostriction would be 2,000 times as great as that observed.

ON THE QUANTUM OF COSMIC RADIATION AND THE RELATIVE MASS OF PROTON AND ELECTRON.—A. K. Das. (*Naturwiss.*, 25th October, 1929, Vol. 17, p. 841.)

Taking Fürth's assumption that a photon is composed of a proton and an electron in such a way that the radius of the photon is equal to the sum of the radii of the electron and proton; and, further, accepting Ornstein and Burger's conclusion that the radius of a photon is equal to the wavelength of the associated radiation, the writer arrives at the conclusion that the quantum of Cosmic Radiation is a structure composed of a proton and an electron separated from each other by a distance equal to the radius of an electron. Under this condition the masses of the particles will be less than their masses in the free state. He assumes that Coulomb's Law of force holds good even for a distance of the order of 10^{-13} cm. "Should the above considerations be true, the quantum of Cosmic Radiation would seem to be a miniature hydrogen atom." Cf. same author, 1929 Abstracts, p. 524; also Fürth, p. 645.

MISCELLANEOUS.

ÜBER DEN SCHWINGKRYSTALL (The Oscillating Crystal).—O. Tope. (*Physik. Zeitschr.*, 15th Sept., 1929, Vol. 30, pp. 585-590.)

An extension of the work of Lossow, Seidl, Sixtus and others. The final section deals with the practical applications as a reducer of damping, or for transmitting purposes, in place of the thermionic valve. The experiments are not yet complete, but a circuit has been arrived at, using two crystals, which appears to behave in a stable manner and with an output about doubled.

OPTICAL SIGNALLING FOR TRAINS. (*Nature*, 21st Dec., 1929, Vol. 124, p. 959.)

A paragraph on the system referred to in 1929 Abstracts, pp. 115-116. This "revolutionary

system" is at present working on several hundreds of miles on the German State Railways.

DISTANCE DETERMINATION BY FOGHORN AND WIRELESS TELEPHONE. (*Engineer*, 22nd November, 1929, Vol. 148, p. 551.)

When the foghorn of the Cumbrae lighthouse (on the Clyde) starts sounding, a wireless telephone transmitter beside it begins at once to count "one, two, three . . ." the interval between each word representing the length of time required by sound to travel one mile. The wireless operator can thus obtain the distance by noting which figure was the last before the arrival of the sound of the foghorn.

CAN FOG "CRASHES" BE AVOIDED?—Guggenheim Fund Report. (*Discovery*, December, 1929, Vol. 10, pp. 411-413.)

Extracts from the report just issued. In connection with wireless, it is mentioned that in approaching a beacon station the sound intensity changes at such a rapid rate as to take up too much of the pilot's attention in adjusting the set. "This question of automatic [volume] control is one that has been given consideration and one for which a satisfactory solution will soon be obtained." Regarding ignition interference, the Fund "has found adequate shielding for the ignition wires, but so far has not tested any shielded ignition plugs which were completely satisfactory. Difficulty with plugs tested has been not so much in the absence of shielding, but in improper insulation between the shielding and the high tension wire resulting in poor operation of the motor, especially in wet weather."

As regards transmitting from aeroplanes, the inclination is towards low power short range [short wave] sets. The Radio Frequency Laboratory has produced a light transmitter which does not require a double-voltage generator, the plate voltage being supplied by a Ford spark coil operated on a starting battery. "The whole set, which should be good for transmission up to 150 miles, weighs only 4 lbs."

DETERMINATION OF THE HEIGHT OF AEROPLANES.—L. P. Delsasso. (*Science*, 15th November, 1929, Vol. 70, p. x.)

The sound-reflection method is fairly satisfactory on lengthy craft such as the *Graf Zeppelin*, where the delicate receiver can be mounted far from the noise of the motors. With an aeroplane, however, the noise of operation is so great that the pilot finds it almost impossible to analyse the echo returning from the earth. Latest research by Delsasso indicates that a sound filter will solve the difficulty. In connection with this research, see 1929 Abstracts, p. 637.

ÜBER DIE INDUKTIVE BEEINFLUSSUNG VON SCHWACHSTROMLEITUNGEN DURCH STARKSTRÖME (On the Inductive Effects of Power Lines on Communication Lines).—H. Schüller. (*Arch. f. Elektrot.*, 10th Nov., 1929, Vol. 23, No. 2, pp. 217-225.)

Continuation of the work referred to in 1928 Abstracts, p. 589.

RADIO-TELEPHONY INTERFERENCE: G.P.O. REPORT. (*Elec. Review*, 22nd Nov., 1929, Vol. 105, pp. 924-925.)

Extracts from Radio Report No. 135, issued by the G.P.O., on interference with broadcast reception by tramways at Blackpool and tramways and electric trolley omnibuses at Birmingham. The trailing Dudgeon shoe (bridging the gaps in the wire and the jumps of the collector), or better still the Fischer-plate overhead collector in place of the trolley-wheel, gets rid of the collector trouble, but this is only a small fraction of the total interference. Condensers across the motofs (mid-point earthed in certain cases), stopper circuits in the lead from the collector, transposition of series coils of motors to a position where they act as h.f. chokes between motors and collectors, each of these devices gives an improvement of the order of 10 per cent., except in special cases where it produces abnormally good results. A finally "treated" car, compared with a standard car, reduced the latter's 100 per cent. interference while traversing 800 yards to 50 or 60 per cent. while traversing only 200 yards.

ACOUSTIC SHOCK ABSORBER PROTECTS TELEPHONE USERS.—H. N. Kalb. (*Elec. World*, 23rd November, 1929, Vol. 94, p. 1024.)

Two triodes in push-pull are used as a limiting device to prevent acoustic shock, especially on power company telephone lines where switching and other transient conditions cause particularly severe shocks. Better and speedier service has resulted from the operators being freed from all fear of such shocks.

NOISE FROM AEROPLANES TRAVELLING WITH THE VELOCITY OF SOUND.—(*Engineer*, 11th Oct., 1929, Vol. 148, p. 393.)

Correspondence on the subject. An aeroplane travelling at that speed, approaching an observer in a straight line, would be noiseless until directly overhead. It is suggested that at that moment the "tremendous accumulation of sound of extremely high frequency" (the "ondé-shock") may have a destructive effect on the ear. Also it is suggested that the subject "can be given a turn of intense interest if for the aeroplane we substitute a body emitting light, and re-cast the problem in terms of visibility instead of audibility."

CHARGES ÉLECTRIQUES DÉVELOPPÉES DANS CERTAINS DIÉLECTRIQUES AMORPHES SOUS L'ACTION DE LA PRESSION (Electric Charges developed in certain Amorphous Dielectrics under the Influence of Pressure).—A. Turpain and M. Durepaire. (*Comptes Rendus*, 4th November, 1929, Vol. 189, pp. 739-741.)

This effect was first found by one of the writers when he noticed an electrometer deflection produced when he put all his weight on one foot, his shoes being soled with crêpe rubber. Systematic tests were then made, pressure being applied to various materials by means of a small piston. Ebonite, paraffin wax, glass and paper gave similar but smaller results. According to the spot where the pressure was applied, positive or negative

charges were obtained at the electrometer, but (at any rate with rubber) the spots giving negative electricity were more numerous and of greater extent than those giving positive electricity; "this has to be compared with the fact that rubber becomes negatively charged when rubbed with a cloth." But control experiments convince the writers that the phenomenon is in no way due to contact potentials. The amount of the charges is independent of the nature of the pressing metal.

Inversely, it was shown that the material contracts when the surfaces are charged. The connection between these phenomena and the results of Duter, Righi, the Curies, and Michaud is touched upon.

CONTINENTS AND OCEANS.—G. C. Simpson (*Nature*, 30th Nov., 1929, Vol. 124, pp. 837-838.)

A letter pointing out certain symmetrical characteristics of the present distribution of land and sea, of which the writer says: "I imagine that they have all been noticed before, but I do not remember seeing any discussion of them. . . . If they are not fortuitous but indicate some tendency to symmetrical distribution, that tendency must always have existed, and must be taken into account when discussing shifts of the pole. I do not wish these remarks to be considered to be evidence against the Wegener theory, for I feel more strongly than ever that only by a shift of the continents can the climates of other geological ages be explained." See Holmes, 1929 Abstracts, p. 53; and for Wireless and the Wegener theory, see Vivie, 1928 Abstracts, p. 590.

DIE GEOELEKTRISCHEN UNTERSUCHUNGSMETHODEN MIT WECHSELSTROM (Geo-electrical Prospecting by A.C. Methods).—W. Geyger. (*Zeitschr. f. Hochf. Tech.*, November, 1929, Vol. 34, pp. 184-190.)

First part of a comprehensive survey.

DIE ANWENDUNG DER KOMPLEXEN WECHSELSTROMKOMPENSATORS BEI GEOELEKTRISCHEN UNTERSUCHUNGEN (The Use of the Complex A.C. Compensator in Geo-electrical Explorations).—W. Geyger. (*Arch. f. Elektrot.*, 5th Nov., 1929, Vol. 23, No. 1, pp. 109-118.)

LA PROSPECTION GÉOPHYSIQUE DU SOUS-SOL (Geophysical Exploration of the Sub-soil).—Rothé. (*Génie Civil*, 12th October, 1929, Vol. 95, p. 370.)

Notice of an article by this writer in *Revue Scientifique*, 8th June, 1929, reviewing the various methods.

PIEZOELEKTRISCHE MESSUNGEN VON DRUCK- UND BESCHLEUNIGUNGSKRAFTEN (The Measurement of Compression- and Acceleration-forces by Piezoelectric Methods).—J. Kluge and H. E. Linckh. (*Zeitschr. des V.D.I.*, 14th September, 1929, Vol. 73, pp. 1311-1314.)

The apparatus and its use is described in detail. The maximum sensitivity is 2 mA. per kilogram. With the help of a variable condenser the range can conveniently be extended to 100 kg. Examples dealt with are the measurement of:—the cutting pressure in lathe-work; the starting acceleration of a motor; and the response to shock of a loaded steel wire. Other applications are numerous.

A combination of double-grid input valve and indirectly heated voltmeter valve is used.

The desired freedom from loss of charge is obtained by the use of a "Bernstein" * lead-in for the control grid and by the use of the second grid to keep the grid current practically zero for a small anode voltage and slight filament heating. The result of such precautions (which included the drying of the glass bulb) was that such good insulation was obtained that a charge on the control grid only decreased by 10 per cent. in a minute. The use of the indirectly heated second valve, in which the cathode and heating filament can be at different potentials, enables the two valves to be supplied from a common battery; further, it avoids the return flow of the anode current through the filament, which occurs in a directly heated valve and which for sudden increases of anode current introduces a certain amount of thermal inertia—very undesirable for these purposes. This point does not affect the first valve, where the ratio of filament current to anode current is more than 10^4 . The valves are shielded by enclosure in an earthed metal case.

* Amber?