

EXPERIMENTAL WIRELESS & The WIRELESS ENGINEER

VOL. VI.

MAY, 1929.

No. 68.

Editorial.

Positive and Negative Mutual Inductance.

WHEN two circuits are so placed that a current in one causes magnetic flux to link the other, a change of current in one necessarily induces an E.M.F. in the other, and the magnitude of this induced E.M.F. when the current is changing at unit rate is called the coefficient of mutual induction, or more briefly, the mutual inductance, between the two circuits. By simply moving one circuit relatively to the other it is possible to change the direction of the induced E.M.F., so that the mutual inductance reverses its sign, and it becomes necessary in writing down the circuit equations to adopt some convention as to what is to be called a positive and what a negative mutual inductance. We may say at once that so far as the ultimate result of any calculation is concerned it is immaterial which convention one adopts, so long as one adheres strictly to it, but there is something more to be considered than merely obtaining the correct result, as those engaged in teaching quickly realise. The conventions adopted should always be those which lead to the greatest economy of mental effort in following the various processes represented by our symbols. One could adopt the convention that an applied E.M.F. always produces a current in the opposite direction, and with much justification in the light of our present knowledge, but it would not tend to simplify

the consideration of circuit problems. It is our general experience that articles written by those engaged in teaching are easier to follow than those written by those engaged solely on research work; this is only to be expected, since the obtaining of results to one's own satisfaction is a very different matter to the clear presentation of these results to others.

In electric circuit problems it is necessary to decide which direction around the circuit is to be taken as positive and which as negative. If there is only one circuit, it is quite immaterial which direction is adopted, and this is also the case where there are several circuits, although in the latter case considerations of similarity will often influence one's choice. In a plane network, for example, one would preferably decide that the positive direction in every mesh should be, say, counter-clockwise, rather than clockwise in some and counter-clockwise in others. Having decided upon the direction of current around every circuit which is to be regarded as positive, it is reasonable to regard the direction of the magnetic flux through the circuit produced by positive current as the positive direction of the flux. The opposite convention would lead to the inelegant assumption that a positive current produces a negative magnetic flux. Now comes the question: if a positive current in

one circuit produces a positive magnetic flux through another circuit, is the mutual inductance between them to be called positive or negative? Surely positive, but unfortunately one finds that, although this is the usual convention, several important papers have been published in which the opposite convention has been assumed, to the bewilderment of the reader accustomed to the ordinary convention. It seems unreasonable, and it is certainly inelegant, to suggest that, when a positive current in one circuit produces a positive magnetic flux through another circuit, we should call the mutual inductance negative.

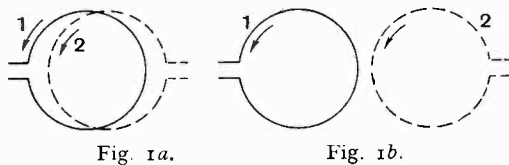

To take a simple example, let two single-turn coils 1 and 2 be placed one on top of the other as in Fig. 1a, or one beside the other as in Fig. 1b. We decide to take the anti-clockwise direction around the circuits as positive. In Fig. 1a a positive current in coil 2 produces a positive magnetic flux through coil 1, *i.e.*, a flux towards us, whereas in Fig. 1b a positive current in coil 2 produces a negative flux through coil 1. We maintain then that with the convention adopted as to currents, the mutual inductance should be called positive in Fig. 1a and negative in Fig. 1b. If one possesses the type of mind which decides to call clockwise currents positive in coil 1 and negative in coil 2, then a positive current in one coil in Fig. 1a will produce a negative flux through the other and the mutual inductance should then, we maintain, be regarded as negative in Fig. 1a and positive in Fig. 1b.

When an E.M.F. e acts on a non-inductive circuit of resistance R , we have $i = e/R$; if the circuit has a self-inductance L and the current is changing, the resultant E.M.F. acting in the circuit is $e - Ldi/dt$ and we have $i = \frac{e - Ldi/dt}{R}$ or $e = iR + Ldi/dt$. The self-inductance L is assumed to be an

essentially positive quantity and the induced E.M.F. is of opposite sign to di/dt . If now there is another circuit in which an increase of current causes an induced E.M.F. in the first circuit in the same direction as would be caused by an increase of current in the first circuit itself—which is only another way of saying that a positive current in the second circuit produces a positive flux in the first circuit—then we maintain that M should be regarded as positive, so that if i_1 and i_2 are both increasing the effects of mutual inductance are in the same direction as the effects of self-induction and are added to them. This gives the equation

$$e_1 = i_1R_1 + L_1 \frac{di_1}{dt} + M \frac{di_2}{dt}$$

It is to be particularly noted that this is true whatever convention one has adopted as to the positive direction of currents in the circuits. If, however, having adopted a given convention as to the directions to be called positive, one then says that a mutual inductance is to be called negative when a positive current in one circuit produces a positive flux in the other circuit, then the above equation would have to be written

$$e_1 = i_1R_1 + L_1 \frac{di_1}{dt} - M \frac{di_2}{dt}$$

This note is written as a protest against this latter form of the convention.

As an example of the peculiar results obtained by those who adopt this unfortunate procedure, we may consider the case of a coil or solenoid tapped at some intermediate point. If the self-inductances of the two parts considered separately are L_1 and L_2 , then instead of the inductance of the whole coil being given by the formula $L = L_1 + L_2 + 2M$ where M is the mutual inductance between the two parts, they are forced to write $L = L_1 + L_2 - 2M$. In this case the effects of mutual inductance are so obviously of the same nature and sign as the effects of self-inductance that it seems very unreasonable to adopt a convention which makes the mutual inductance negative whereas the self-inductance is regarded as essentially positive.

French System of Directional Aerials for Transmission on Short Waves.

By *H. Chireix.*

(Chief Engineer of the Société Française Radio-Électrique.)

THE object of this article is to describe the French system of aerials for transmission by short projected waves such as was achieved by the author at the beginning of 1926, and as is now employed by the Société Française Radio-Électrique in its installations in France and foreign countries.

Theoretical Considerations Recalled.

In a now somewhat old article in "Radio-électricité" (Bulletin Technique of the 25th of July, 1924) the author dealt with the question of directive aerials from a theoretical standpoint, and discussed the diagrams as well as the various practicable combinations of aerial alignments.

This discussion may be recapitulated as follows:—

(1) If vertical aerials are placed in line at equidistant spots, the distance being less

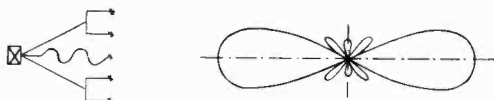

Fig. 1.

than one half-wave length, and if these carry currents of equal value and phase (type 1), the diagram of the resulting field obtained in the horizontal plane will have the form of Fig. 1, that is to say, a sharpened "8" together with small symmetrical loops. The maximum radiation takes place in the two directions perpendicular to the line of aerials, and the greater the developed length of the line the more the principal "8" is sharpened, the greater is the increase in the number of small loops, but the more the importance of these loops is diminished. This case corresponds, in fact, to the limiting case of a parabolic reflector of cylindrical form whose double focus is situated at infinity. (2) If vertical aerials are placed in a row at equal distances, the distance between each being less than one half-wave

length, and if these carry currents of equal value but out of phase by a quantity corresponding to the speed of propagation of electromagnetic waves in air, that is, 180 deg.



Fig. 2.

for each half-wave length (type 2), the resulting diagram in the horizontal plane will have the form shown in Fig. 2, that is to say, of a cardioid together with small loops.

The maximum radiation takes place along the direction of the aerials and in the direction of the phase-lag. In the other direction the radiation is, on the other hand, very much reduced. The greater the length of the row the more the principal part will become sharp, and the more the number of small loops will increase while their size will diminish.

This type of alignment corresponds to the limited case of a cylindrical parabola whose focal distance is zero (an infinitely flattened parabola).

(3) If nevertheless a comparison be made between these two types of alignment, it is found that the alignments of type 1 produce



Fig. 3.

very rapidly, that is to say for a moderately developed length, a very sharp diagram, but that they project equally well the energy in two diametrically opposite directions. On the contrary, the alignments of type 2, for a like developed length, give a much broader diagram, but possess the valuable quality of radiating the energy in one direc-

tion only, even if they are reduced to two aerials situated at a suitable distance apart.

(4) If finally there be combined, according to Fig. 3, suitable parallel and perpendicular alignments such as those of Figs. 1 and 2, we get the advantage of the characteristic features of each of the two types, and thus obtain in the horizontal plane a general diagram which is at the same time sharp and has but a single direction.

In 1924 the author made special experiments with the system shown in Fig. 3, based upon these theoretical considerations.

In order to have the entire diagram, that is to say in the space of three dimensions, it is necessary to take account of the directivity of the system in the zenithal plane, this latter directivity being due on the one hand to the proper directivity of the individual aerials in this plane, and on the other hand to their grouping.

Thus, if in the case of the alignments of type 2 the phase displacement between two consecutive aerials is less than that which corresponds, for their spacing, to the speed of propagation of electromagnetic waves in the air (*i.e.*, below 180 deg. for a spacing of one half-wave length), the maximum radiation will take place for a direction



Fig. 4.

which is inclined with reference to the ground, whereas each individual aerial of the group will have its maximum radiation in the direction of the ground.

Principle of Construction.

In view of these theoretical considerations which will obviously prevail whether currents are brought by power lines or electromagnetically induced, the author undertook to realise in as simple a manner as possible, both from an electrical and a mechanical standpoint, a wave-projecting device adapted both for transmission and reception, and having the following essential features, viz., a sufficiently sharp one-way diagram in the horizontal plane, and only moderately so in the zenithal plane, and projecting or receiving energy along the direction of the

ground, or at will, in a direction which is very slightly inclined from the ground.

According to what precedes, these conditions can be realised by constituting two identical alignments or rows, one behind the other. The aerials opposite one another

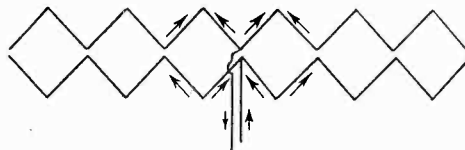

Fig. 5.

will form a row of the second type. In the following description one of the rows will be termed antenna and the other reflector or screen. Since the two rows are identical, either one can obviously serve as an antenna or as a reflector, according to the direction in which the energy is to be transmitted or received. In what follows we shall consider mainly the case of transmission, although the developments and results apply equally as well to the case of reception.

Let us consider a wire developed in zigzag (Fig. 4) with right angles or elbows, and supplied for example at the middle by a feeding wire. If the length of each strand is regulated approximately to a half-wave length, and if the whole device is the seat of stationary waves, the amplitude and instantaneous direction of the current may be shown by the curves and arrows represented on the figure. It will be observed that the aerials 1-2-3-4-5-6 form the first row of half-wave aerials in phase and separated by a half-wave length, and that the aerials 1'-2'-3'-4'-5'-6' constitute a second row of half-wave aerials also in phase between them, but their common phase is in opposition to the common phase of the first row.

The field produced at a distance by each row is separately calculated, and it leads to a diagram of the type shown in Fig. 1. Since the two rows are crossed at right angles, the field due to the vector comprising the two fields, which are equal and at right angles, will be at all points equal to $\sqrt{2}$ times the field due to one row. That is, the diagram due to the combined action of the two crossed rows will still be of the type shown in Fig. 1. It will be readily observed that if the general direction of the wire is

horizontal the resulting electric field will be vertically polarised, as in a vertical antenna. By turning the whole system by $\pi/2$ we evidently obtain a horizontal polarisation. Again, since the several unit elements are of half-wave lengths, the maximum radiation will take place perpendicularly to the plane of the wires, that is to say, horizontally.

This arrangement is of a very simple character and is quite effective in practice. The angles or elbows of the wire coincide with the nodes of the current, and will not cause any reflection of the energy, so that the maximum current will only diminish very gradually from the centre to the ends.

If the system shown in Fig. 4 is doubled as shown in Fig. 5, it will be seen that if the two power supply wires are, for two opposite points, the seat of equal and oppo-

site potentials (Lecher wires), in the first place the feeding line will not radiate energy (the instantaneous currents being in an opposite direction on the two wires), and in the second place, it will be observed (accord-

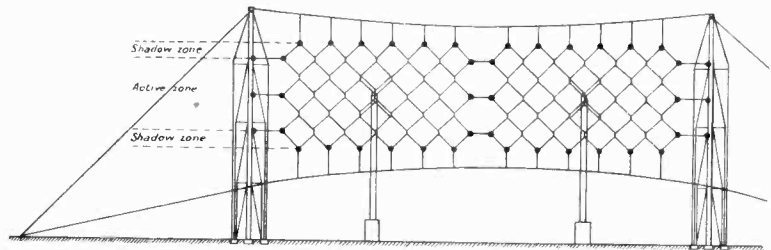

Fig. 6.

ing to the direction of the arrows showing the instantaneous direction of the currents) that the effects of the second system will be added to those of the first system. The whole is now the equivalent of *two rows crossed at right angles*, of unit aerials constituted by two *half-waves in the same direction*. The maximum radiation will thus remain perpendicular to the

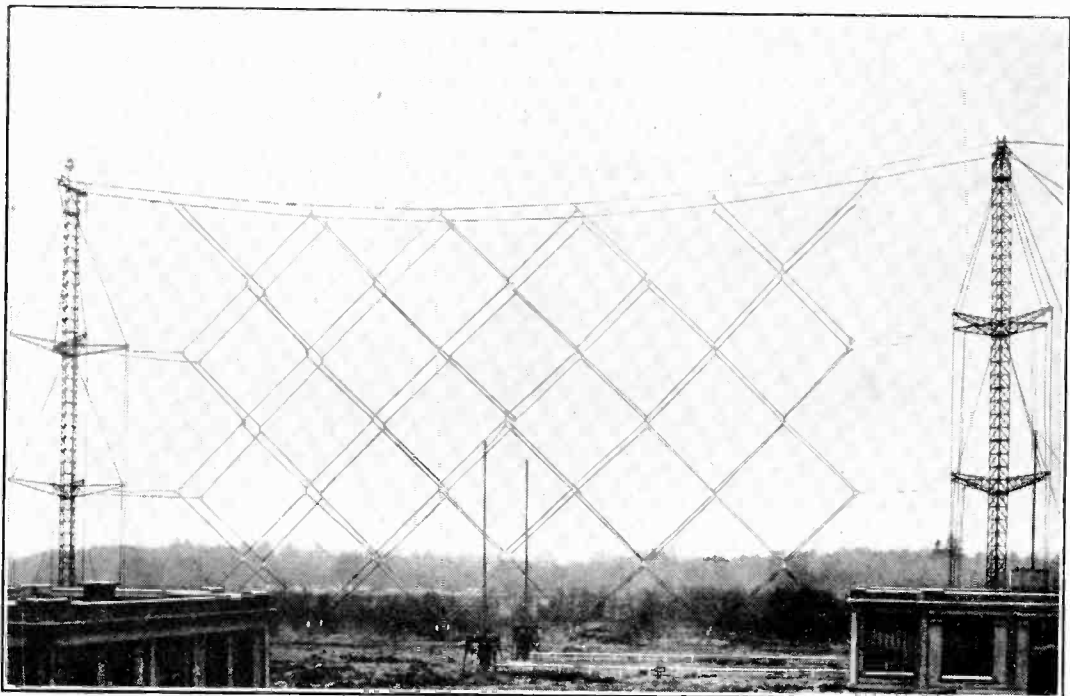

Fig 6(a).

plane of the wire, and will thus be horizontal.

Practical Construction.

By extending Figs. 4 and 5 we obtain the practical construction shown in Figs. 6, 6(a) and 6(b). The aerial and the reflector, which are exactly alike, consist essentially of a sheet of wires having a network disposition, each unit element of the network being in fact a half-wavelength aerial. The arrangement is such that all the elements which are inclined to the right are in phase and form the first row of aerials in phase; all the elements inclined to the left are in phase opposition, and form a second row which is crossed upon the first at right angles. The power is supplied at two central points by two-wire lines (see Fig. 6(c), the detail of the central part). The four middle toothed parts which are superposed form a portion termed active region, and the two extreme toothed parts (upper and lower) form penumbra or shadow regions. These last two parts, of which one is connected to the upper triatic and the other to earth, are not supplied with power,

but nevertheless (due to the electrostatic and electromagnetic induction of the adjacent parts) carry currents whose *direction*

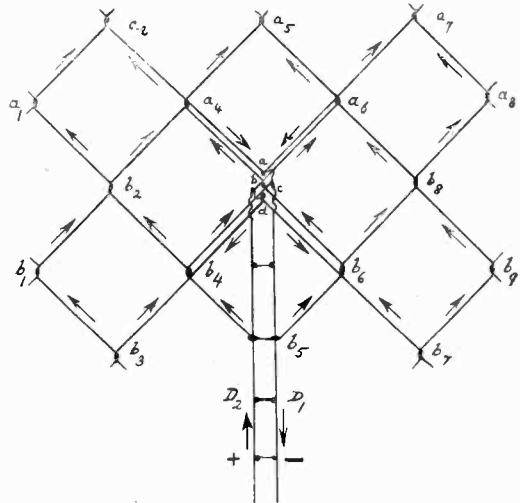

Fig. 6(c).

is such that their action is *added* to that of the active parts. In these conditions the maximum radiation remains perpendi-

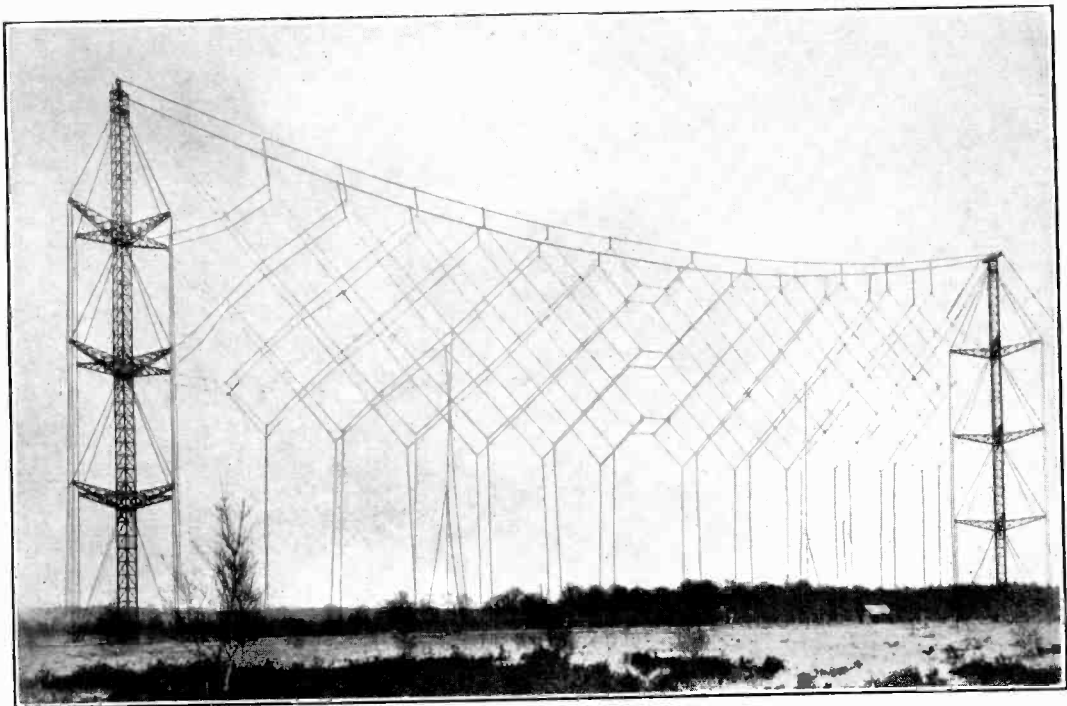

Fig. 6(b).

cular to the plane of the wires; that is, the maximum energy is radiated in a direction parallel to the ground.

The reflector, of identical construction, is placed at about $\frac{1}{4}$ -wave length in the rear of the aerial, and in normal conditions it is not supplied with current. The feeding lines of the reflector instead of being connected to the transmitter are simply short-circuited at a suitable spot, so as to obtain the "general tuning" of the reflector. This tuning consists in exciting in the reflector currents which are leading by $\pi/2$ in advance to the antenna currents. It is easy to verify this by observing that the *back field* is almost entirely absorbed, while it is doubled in front, for a given current in the aerial.

The normal projector constructed by the Société Française Radio-Électrique will practically concentrate all the energy in an angle of 8 deg. to 10 deg. on the horizontal plane.

Principal Advantages.

(1) Owing to their construction, either of the two sheets can serve as an aerial or as a screen, and hence the diagram can be

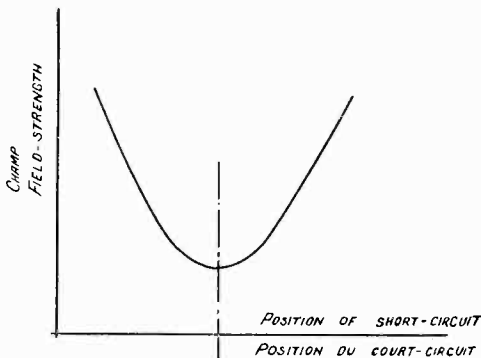

Fig. 7.

readily turned through 180 deg. by suitable switching.

(2) It is an easy matter to tune the screen to the exact wavelength (and to modify this tuning if the wavelength changes) by acting only upon the short-circuiting position of the wires of the screen. Fig. 7 shows the manner in which the back field is modified by the position of the short-circuit. We attain practically the figure 20 for the ratio between the front and back fields.

By slightly modifying this adjustment we may give the beam a slight vertical inclination, as above stated, as we thus change the relative phase of the currents in the aerial and in the reflector.

(3) Similarly, owing to this construction the diagram in the zenithal plane afforded by each sheet will give a maximum effect in the horizontal direction, and this is a very favourable condition, according to tests

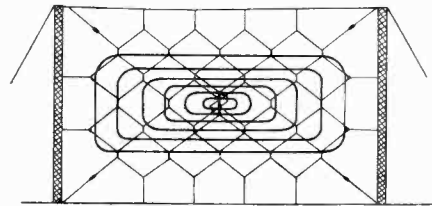

Fig. 8.

made principally by Dr. Meissner both for transmission and for reception (*), which tests show that at great distances it is preferable to transmit and receive energy in a practically horizontal direction.

(4) Due to its construction the system is well adapted also for aerials which are high and are well above the ground, thus raising the whole outfit and particularly the central feeding point. It is, in fact, observed that the mean value of the current in the different elements may be represented by Fig. 8, in which the degree of approach of the field lines gives a certain estimate of the density of the mean current. This density is at the maximum near the centre, and by raising the whole sheet of currents we remove from the ground the whole transmitter or receiver of power. The practical gain obtained in this manner is quite considerable, both for transmission and reception (†).

(5) The fact that when proceeding from the central feeding point the number of half-wave elements is not great, added to the consideration of the damping due to the

* Jahrbuch der drahtlosen Telegraphie und Telephonie, Zeitschrift für Hoch Frequenztechnik, Band 32, Heft 4, von A. Meissner und H. Rothe.

† Remark: The aerial might be constructed for the "day wave" in the form indicated, then using the free space beneath the aerial for a "beam" of reduced value, for the "night wave," as shown in Fig. 8(a). This is justified by the fact that the night wave is used for a shorter time than the day wave, and only in the no-load traffic hours. This arrangement has been adopted in practice for the receiving aerials.

radiation, renders this type of antenna hardly critical as regards the wavelength. In fact, we may allow a total range of 10 to 15 per cent.

For greater changes in the wavelength the apparatus can be readily dismantled and installed.

(6) From a mechanical point of view the plant can be readily constructed, and, on the other hand, since the number of feeding points is now reduced to two, the feeder system is much simplified, as well as the accessory outfit consisting of transforming or coupling boxes, as will be explained later on.

(7) The adjustment is very simple and rapid, since it is limited to the placing in phase of the two sections shown in Fig 6, and to the tuning of the screen. This consideration can well be of great importance, especially in plants in the

colonies where skilled or competent persons may be lacking.

Other Constructions.

Figs. 9 and 10 show another arrangement

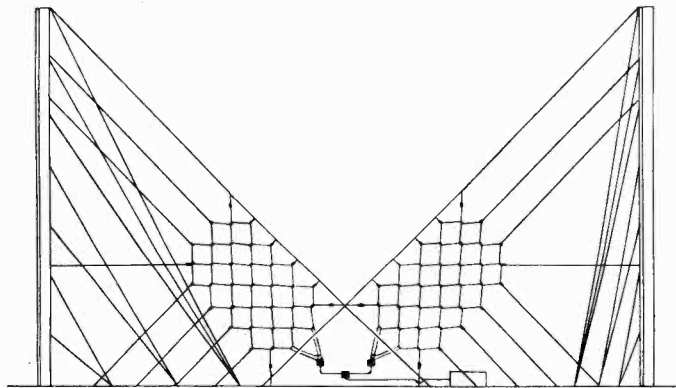

Fig. 9.

which is most advantageous in the case of projectors for short wavelengths to be erected in great centres of transmission

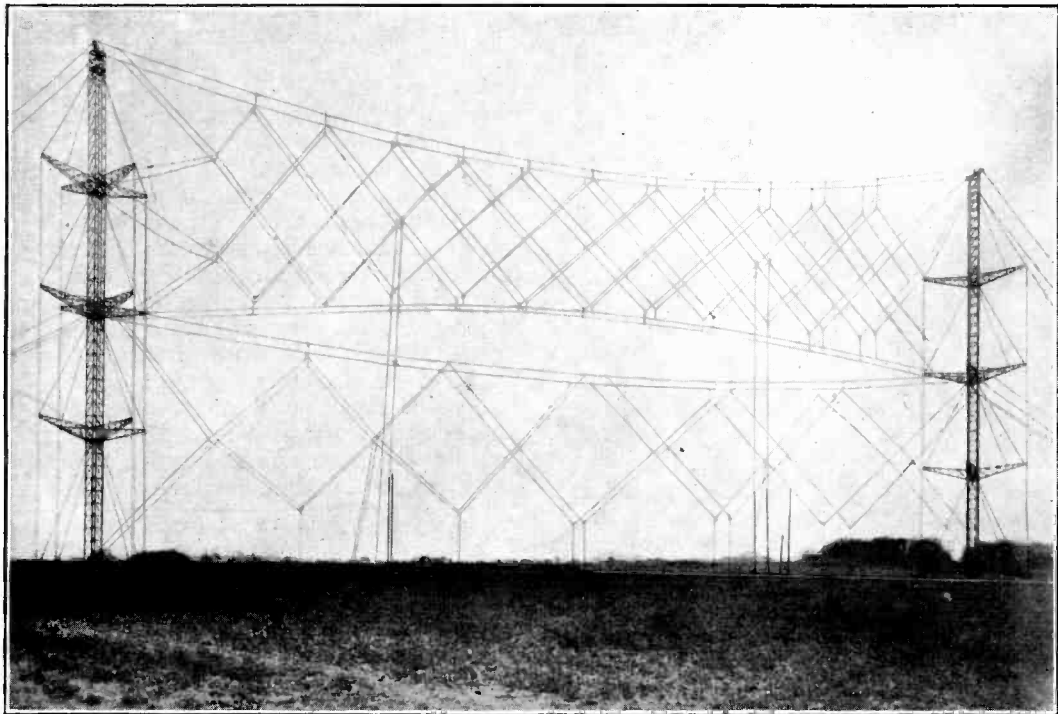

Fig. 8(a).

cular to the plane of the wires; that is, the maximum energy is radiated in a direction parallel to the ground.

The reflector, of identical construction, is placed at about $\frac{1}{4}$ -wave length in the rear of the aerial, and in normal conditions it is not supplied with current. The feeding lines of the reflector instead of being connected to the transmitter are simply short-circuited at a suitable spot, so as to obtain the "general tuning" of the reflector. This tuning consists in exciting in the reflector currents which are leading by $\pi/2$ in advance to the antenna currents. It is easy to verify this by observing that the *back field* is almost entirely absorbed, while it is doubled in front, for a given current in the aerial.

The normal projector constructed by the Société Française Radio-Électrique will practically concentrate all the energy in an angle of 8 deg. to 10 deg. on the horizontal plane.

Principal Advantages.

(1) Owing to their construction, either of the two sheets can serve as an aerial or as a screen, and hence the diagram can be

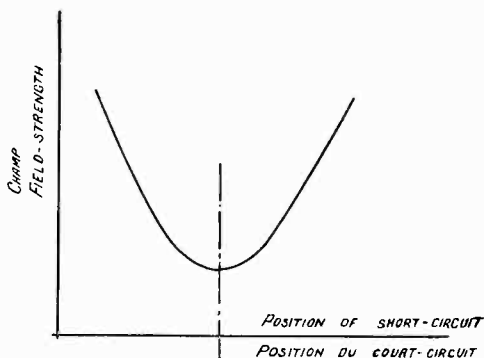

Fig. 7.

readily turned through 180 deg. by suitable switching.

(2) It is an easy matter to tune the screen to the exact wavelength (and to modify this tuning if the wavelength changes) by acting only upon the short-circuiting position of the wires of the screen. Fig. 7 shows the manner in which the back field is modified by the position of the short-circuit. We attain practically the figure 20 for the ratio between the front and back fields.

By slightly modifying this adjustment we may give the beam a slight vertical inclination, as above stated, as we thus change the relative phase of the currents in the aerial and in the reflector.

(3) Similarly, owing to this construction the diagram in the zenithal plane afforded by each sheet will give a maximum effect in the horizontal direction, and this is a very favourable condition, according to tests

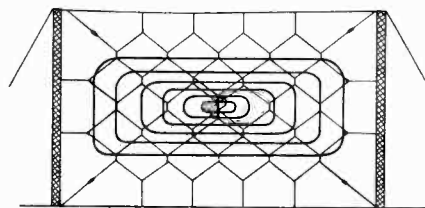

Fig. 8.

made principally by Dr. Meissner both for transmission and for reception (*), which tests show that at great distances it is preferable to transmit and receive energy in a practically horizontal direction.

(4) Due to its construction the system is well adapted also for aeriels which are high and are well above the ground, thus raising the whole outfit and particularly the central feeding point. It is, in fact, observed that the mean value of the current in the different elements may be represented by Fig. 8, in which the degree of approach of the full lines gives a certain estimate of the density of the mean current. This density is at the maximum near the centre, and by raising the whole sheet of currents we remove from the ground the whole transmitter or receiver of power. The practical gain obtained in this manner is quite considerable, both for transmission and reception (†).

(5) The fact that when proceeding from the central feeding point the number of half-wave elements is not great, added to the consideration of the damping due to the

* Jahrbuch der drahtlosen Telegraphie und Telephonie, Zeitschrift für Hoch Frequenztechnik, Band 32, Heft 4, von A. Meissner und H. Rothe.

† Remark: The aerial might be constructed for the "day wave" in the form indicated, then using the free space beneath the aerial for a "beam" of reduced value, for the "night wave," as shown in Fig. 8(a). This is justified by the fact that the night wave is used for a shorter time than the day wave, and only in the no-load traffic hours. This arrangement has been adopted in practice for the receiving aeriels.

radiation, renders this type of antenna hardly critical as regards the wavelength. In fact, we may allow a total range of 10 to 15 per cent.

For greater changes in the wavelength the apparatus can be readily dismantled and installed.

(6) From a mechanical point of view the plant can be readily constructed, and, on the other hand, since the number of feeding points is now reduced to two, the feeder system is much simplified, as well as the accessory outfit consisting of transforming or coupling boxes, as will be explained later on.

(7) The adjustment is very simple and rapid, since it is limited to the placing in phase of the two sections shown in Fig 6, and to the tuning of the screen. This consideration can well be of great importance, especially in plants in the

colonies where skilled or competent persons may be lacking.

Other Constructions.

Figs. 9 and 10 show another arrangement

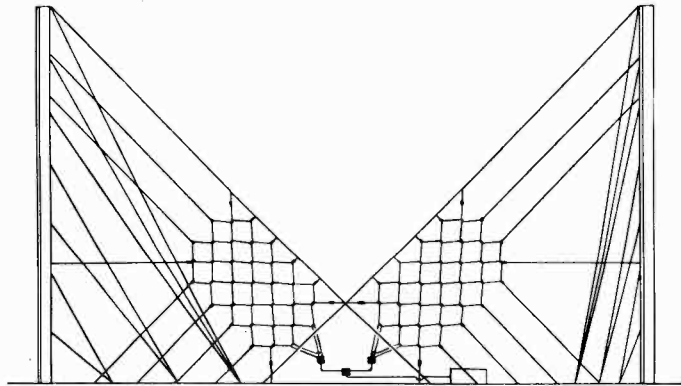

Fig. 9.

which is most advantageous in the case of projectors for short wavelengths to be erected in great centres of transmission

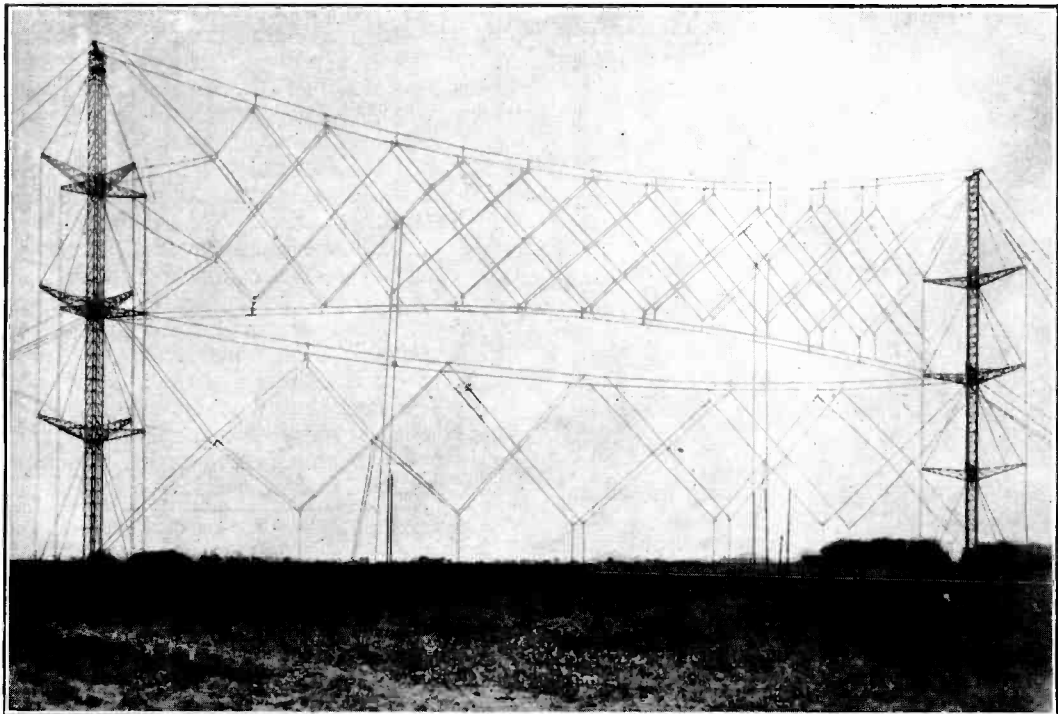

Fig. 8(a).

central feeding point. It is thus necessary to place between the output end of the tubular feeder and the input end of the aerial a junction box which serves, firstly, to produce at the input end towards the aerial potentials which are equal and symmetrical with reference to the ground, and, secondly, to extinguish the stationary waves in the tubular feeder. This double condition is realised by the Wheatstone bridge arrangement shown in Figs. 12 and 12(a), which comprises two equal self-inductions and two equal capacities. It can be readily

(a) The condition of resonance for the given wave, and (b) the additional condition $\frac{L}{C} = R\rho$; otherwise stated, the characteristic impedance of the circuit is made equal to the geometrical mean of the outward and inward impedances. In these conditions it can be easily verified that the stationary waves are extinguished on the upper side—*i.e.*, in the tubular feeder—by disposing in this tube, and opposite suitable sight holes, three ammeters equally spaced (at about $\frac{1}{4}$ - or $\frac{1}{3}$ -wave length) and by observing

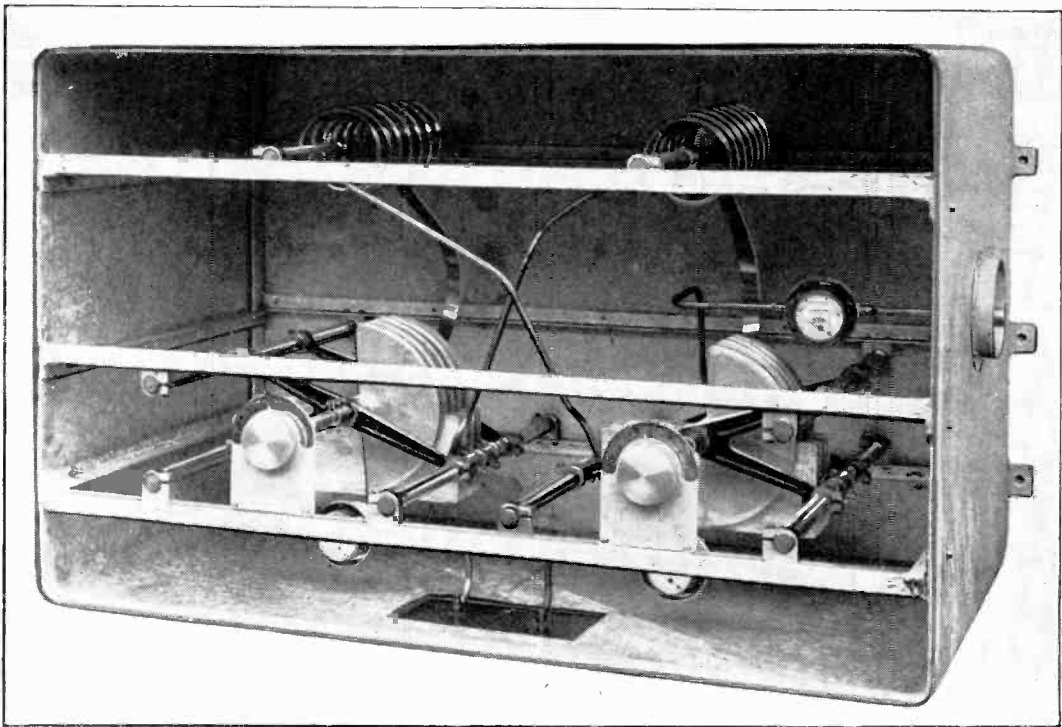

Fig. 12(a).

demonstrated that, if ρ (*) is the characteristic impedance of the tubular feeder and R that of the antenna to be connected, and if the box is placed at a point so that the antenna will represent at this point a pure resistance (that is, a node or an anti-node) it can comply with the two conditions in several ways, especially by realising:

* At the frequencies employed, the characteristic impedances become reduced to pure resistances.

the deflections which should then be the same for the three ammeters.

The general diagram of the distribution, starting from the transmitter, and for a two-section aerial, is as follows (Fig. 13).

The output takes place in a tubular feeder (1) as far as a branch box 2, at which the single feeder is divided into two tubular feeders 3 and 4. This box essentially comprises (a) a transformer consisting of the self-induction L and the capacity C , which

provided with large aerials with long waves. The towers already erected are used to support the aerials. As shown in Fig. 9, the disposition is practically the same, but the whole plant is rotated by 45 deg., thus rotating to the same degree the plane of polarisation of the electromagnetic field.

Figs. 9 and 10 correspond to an experimental construction for telephone connection between France and Indo-China, and it is observed in Fig. 10, which is a plan view, that the plant comprises two aerials situated in different planes, which was required by the nature of the ground but gave no additional complications, since it is always easy to adjust the relative phases in order to obtain the maximum effect in the desired direction. Fig. 11 shows the diagram of the corresponding field, which is particularly sharp.

Feeders and Transformation Boxes.

Owing to the disposition of the projecting aerials and to the fact that in a great transmitting centre it is necessary to use several aerials for the different receiving stations and the various wavelengths, the feeders must

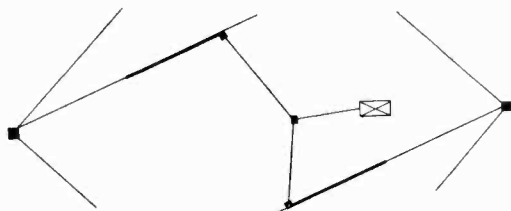

Fig. 10.

often measure several hundred metres in length, that is, a length corresponding to a considerable number of wavelengths. In this case care should be taken that firstly the feeders will not radiate any appreciable amount of energy, which would offer prejudice to the directive properties of the antenna, and, secondly, that there should be a minimum loss in the feeders. These conditions can be fulfilled by using tube feeders comprising two concentric tubes. The current flows forward through the inner tube, which is at a certain potential above earth, and it returns through the outer tube, which is at ground potential. In these conditions the outer tube forms a Faraday cage with reference to the inner field, thus preventing

all prejudicial radiation, and, on the other hand, the metal has a large enough surface to afford a low ohmic resistance in spite of

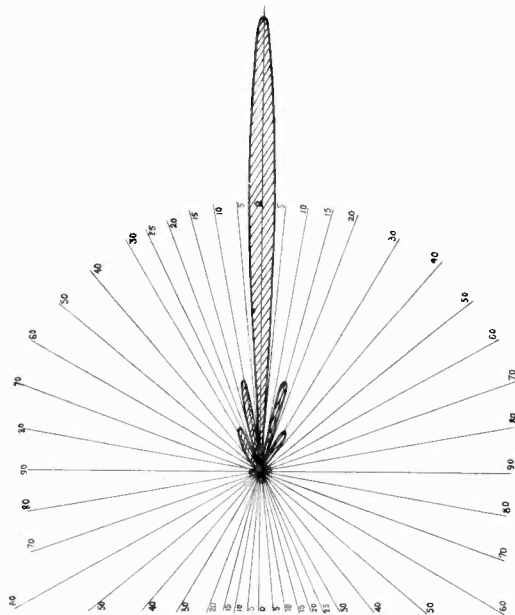

Fig. 11.

the great skin effect at the usual frequencies of projecting aerials.

Since the minimum loss takes place when the feeders carry currents free from stationary waves—that is, when the feeder supplies current at its characteristic impedance—we thus realise this condition. Referring to Fig. 5 or Fig. 6, which represents the arrangement of the wires leading to the central point, it is observed that the two supply wires should possess, in the parts oppositely

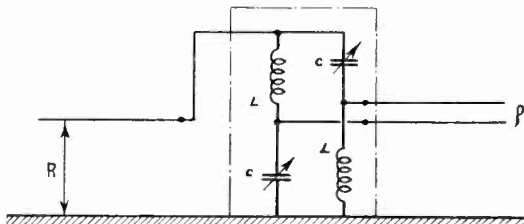

Fig. 12.

placed, potentials which are equal and opposite with reference to the ground. These supply wires also carry stationary waves, as there is no transformer at the

connects the feeder (1) to the parallel set of feeders (3), (4) of a different characteristic impedance;

(b) An element of "adjustable line 1" consisting of a copper worm tube. It is observed

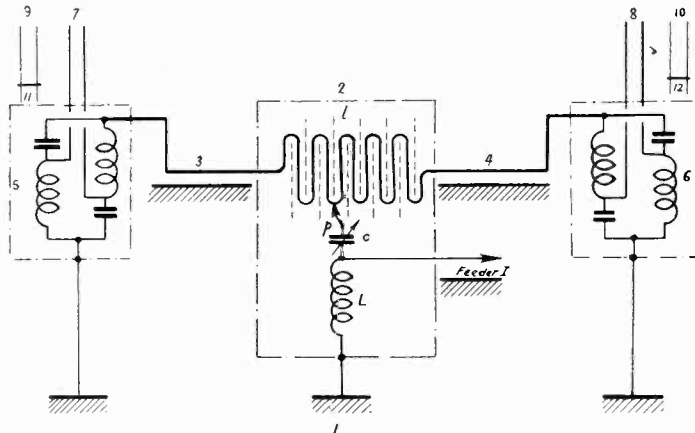

Fig. 13.

that by moving the point *p* to the right, for instance, we reduce the length of the line 4 and increase the length of the line 3, so that we can readily adjust the relative phase of the two sections, this effect being obviously reversed if the point *p* is moved to the left.

The feeders 3 and 4 end at the above-mentioned junction boxes 5 and 6, 7 and 8 are now the outputs towards the aerials, 9 and 10 are descents from the screen; 11 and 12 are the tuning short-circuits of the screen, as already mentioned.

The adjustments are readily made by placing a checking aerial in the direction in which it is wished to transmit, and at some distance to avoid errors due to parallax. If the connections are reversed at 8, the two fields will not be added but will be subtracted, thus producing a zero. It will then suffice to again establish the connections at 8 in their normal direction. We then proceed with the tuning of the reflector by reversing the aerial and reflector, so that the checking aerial will show only a negligible field.

If instead of adjusting the two sections so as to have equal phases we modify the relative phase, the shape of the diagram Fig. 14 can be somewhat changed so as to favour the radiation in a slightly different

direction. This may be advantageous for two receiving correspondents such as Rio and Buenos Ayres, which, when considered from Europe, have but a slight difference in direction, and it will suffice to act upon the point *p* so as to favour one correspondent or the other. This operation may be made instantaneously.

Practical Results Obtained.

The first aerial of this type which was put in use was operated at Sainte Assise in January, 1928, for corresponding with South America. At the start it comprised only a single section, mounted on two 39-metre towers, 75 metres apart. This plant could handle the rapid automatic traffic for most of the day, while before this time, the automatic traffic was practically impossible above 30 words per minute (Fig. 15). Although the plant was of a very reduced size, it showed practically the same results in the traffic as the other stations on the "beam" system. It was even possible during the month of March to maintain a permanent connection with Buenos

Ayres (which had no receiving beam nor very modern receivers) for the whole 24 hours, on a 15.45 metre wave, simply by changing several times during the night (15 metres is a day wave) the direction in which the waves were sent (reversal of the beam). These reversals, which were requested by Buenos Ayres, served to counteract the fading or the echo effect.

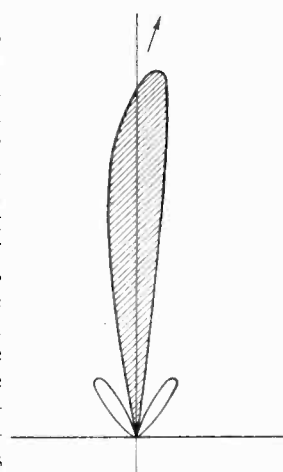

Fig. 14.

The same aerial, used somewhat later as a receiving aerial, afforded to the receiving end the same advantages as the other beam installations.

When the second section was added we were able to verify, according to theory, that the energy radiated in the selected direction for a given power, was now double; in other words, that the field at a distance was multiplied by $\sqrt{2}$.

During the summer of 1928, and to within a recent date, numerous telephony tests were made with Saigon on the aerials shown in Figs. 9 and 10, in the presence of various official personages.

It is interesting to note in this connection that a beam as narrow as the one shown in the diagram 11, obtained with the two aerials of Figs. 9 and 10, gave better results than the beam of twice the width corresponding to a single aerial in operation. The telephone reception in Indo-China and Siam with a transmitter not exceeding 10 kilowatts on antenna was greatly appreciated as being much stronger than that of the other stations,

and particularly the stations operating a telephone service with Java.

Since the beginning of this year public telephone conversations have been exchanged

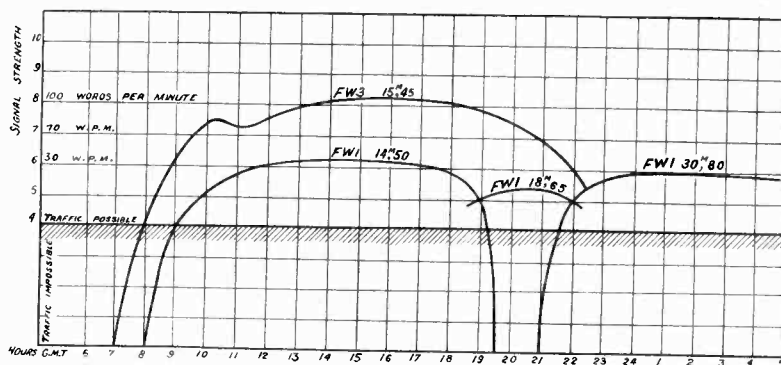

Fig. 15.

between Paris and Buenos Ayres. The transmitter and receiver on the French side are equipped with projecting aerials of the type described. The fact that it has been possible to open and regularly maintain a public telephone communication between such distant countries shows more than anything else the great technical progress realised during the last years by the use of projecting aerials.

Book Reviews.

AN INVESTIGATION OF THE INTERFERENCE CAUSED BY TRANSMISSIONS FROM RADIO STATIONS. Special report No. 8 on Radio Research issued by the Department of Scientific and Industrial Research. Pp. 40+vi. 10 Figs. Pubd. by H.M. Stationery Office. Price 1s.

In the Regulations of the Washington Draft Convention of 1920, it was proposed to classify radio transmitting stations under four headings—viz., A1, keyed C.V.; A2, Tonic Train; A3, Telephony; B, damped waves, and it was proposed to specify an allowable capacity for interference for each type. The method suggested was based on the assumption that the equivalent decrement of the transmission as determined from a resonance curve was a measure of its capacity for interference. Doubts soon arose as to the correctness of this assumption and in 1923 the matter was submitted to the Radio Research Board. The present report is the result of the investigations carried out for the Board; it consists of two parts: (1) The measurement of the equivalent decrement of various types of transmissions, by R. L. Smith-Rose and F. M. Colebrook; and (2) The study of the interfering properties of radio transmissions by the latter. The report shows firstly, that the equivalent decrement is not a criterion of the

interference and, secondly, that it appears impossible, with the present technique, to devise a method of measurement which would give a proper criterion. What is required is a complete spectrum analysis of the radiated wave over the whole range of frequencies. Unfortunately, the best of wavemeters responds to a relatively wide band of frequency and defeats one's attempts to take a "narrow sample." This is discussed very ably in the Report, both from a mathematical and experimental point of view, and a bibliography of the various works referred to is added, making the Report a very valuable one to all those interested in this important subject.

By way of criticism, we think that such sentences as "high-speed telegraphy by key controlled amplitude modulation of single frequency waves" and "in the case of a pure tone modulated carrier wave" would be improved by a judicious use of hyphens. The authors seem undecided between "detuning" and "distuning" a circuit, and try both within half-a-dozen lines. There is something wrong with the statement on page 18 that "at a nominal frequency of 15,000 cycles per second at, say, a speed corresponding to 55 words per second (i.e., about 250 complete oscillations to a dot.)" When sending at this speed the duration of a dot would only cover about 15 complete oscillations.

The Establishment of a General Formula for the Inductance of Single-turn Circuits of Any Shape.

By *V. I. Bashenoff, Mem. I.R.E., Member of the Russian Society of Radio Engineers.*

SUMMARY.—The article contains a brief description of the first part of the author's work in investigating the design and use of closed aerials—namely, on the calculation of the inductance of single-turn circuits of any shape, including curved ones.

The author has derived a general formula and shows that all the well-known formulæ are, practically speaking, special cases of this general law. From the general formula are derived the special formulæ in a new and simplified form.

Numerous tests of the accuracy of this general formula made by practical measurements on closed aerials and other figures, with a height at the point of support of from 2 m. to 65 m., with perimeter from 16 m. to 385 m., with area from 10 m.² to 6,200 m.², have fully confirmed the author's conclusions.

IN the May issue of this Journal (Vol. V, No. 56, pp. 259-263) there appeared an interesting article by Mr. Allen, in which the author obtained formulæ for the inductance of a circle, square, rectangle, equilateral triangle and hexagon. The technical editor of this Journal commented in the same number on my article on the subject printed in the December, 1927, issue, of the Proceedings of the Institute of Radio Engineers.

This encourages me to bring before the readers of this Journal a brief description of my recent work in establishing a single formula for the inductance of single-turn circuits of any shape.

This is the more timely since the question of using closed aerials is now regarded as most important (see "J.I.E.E.," VI, 1928, *E.W. & W.E.*, II, 1928, Proc. I.R.E., VII, 1928, etc.).

The investigation referred to below owed its inception to the necessity of finding a formula for the inductance of closed aerials of irregular shape; this forms the first part of the general problem "Calculation of closed aerial" successively solved by the author and his pupils in the State Electrical Research Institute, Moscow.

In 1915 the author made an experimental and theoretical comparison of different receiving factors when using on the one hand frame aerials (with a winding area up to 20 m²) and on the other closed aerials

carried from a mast 25 m. high. Similar experiments as regards transmitting factors were made by the author in 1918. He came to the conclusion that closed aerials with a large winding area and small number of turns show most decided advantages in both transmitting and receiving as compared with the ordinary frame aerial with a large number of turns and small winding area.

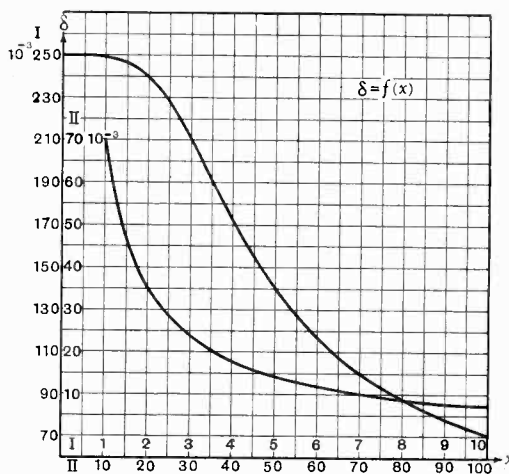

Fig. 1.

This basic principle was applied by the author when building all the wireless stations of his system (more than 40 in number).

Experience showed that owing to economic and other reasons closed aerials supported

from one mast were the most popular. In all the stations built by the author only one mast was used. For further details of the closed aerial system reference should be made

$$x = 0.2142 \times r \times \sqrt{f}$$

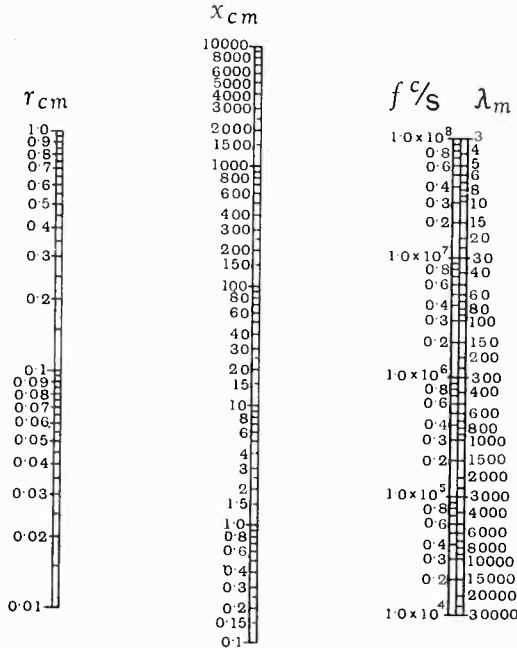

Fig. 2.

to the author's patents: D.R.P., No. 420450 and 430695, U.S.A. Patent No. 1652388 (of 13th December, 1927), Brit. Patent No. 223713, Patent in U.S.S.R., Nos. 353, 3251 and 5261, and other patent applications in other countries.

My formula mentioned by Prof. Howe is :

$$L = 2l \left(\log_e \frac{2l}{r} - a_k + \mu\delta \right) \quad \dots (1)$$

where l = the length of wire (the perimeter), r = its radius, μ = permeability and δ is a correction factor depending on the frequency f , which, of course, only modifies the flux within the material of the wire itself; $\delta = 0.25$ for D.C. and low frequencies and decreases as the frequency increases; in general δ is determined as a function of x (see Fig. 1)—which in turn is expressed by

$$x = 0.281 r \sqrt{\frac{\mu f}{\rho}} \quad \dots \quad (2)$$

In this formula: f = frequency, ρ = specific resistance of wire in microhms per cm. cube (for copper wire at 20 deg. C, $x = 0.2142 r \sqrt{f}$ and is found by means of the nomogram, Fig. 2).

As concerns the value of a_k in the formula (1) the author was of the opinion that it must be the same for all figures with equal l/\sqrt{s} , i.e., the parameter a_k is a function of this ratio only (s = the area of the circuit). In the above-mentioned work reference is made to the method of finding the value of $a_k = f(l/\sqrt{s})$, graphically shown in Fig. 3.

In the concluding part of the published work a correction was added to Formula 1; this correction Δ is a function of l/r and is expressed as a percentage addition to the value of L found by formula (1). The values of Δ are shown on Fig. 1. The final expression for L of any flat figure of round wire having no re-entrant angles was found in the form

$$L = 2l \left(1 + \frac{\Delta}{100} \right) \left(\log_e \frac{2l}{r} - a_k + \mu\delta \right) \quad \dots (3)$$

Particularly in the case of radiotechnical practice where $\Delta \cong 0$ and $\mu\delta = 0$ (with

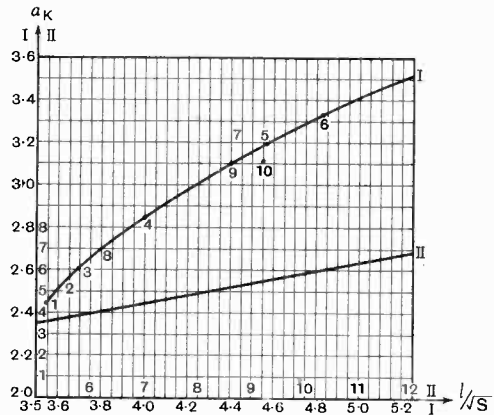

Fig. 3.

currents of radio frequency) the formula becomes

$$L = 2l \left(\log_e \frac{2l}{r} - a_k \right) \quad \dots \quad (4)$$

In using this it is convenient to use a simple nomogram (Fig. 5) for rough calculating purposes which gives an accuracy of 5 per cent. Knowing for the given figure l/\sqrt{s}

and l/r , noting the corresponding figures on the left and middle columns and producing the line connecting these points to cut the right-hand column, we find the value L_1 , *i.e.*, the inductance in centimetres per metre of length (perimeter) of the figure. This nomogram permits solving also other cases: for instance, knowing the perimeter and radius of the wire, one can determine what area the figure must have in order that the inductance will be equal to a certain value. Also the following problem can be solved: knowing the perimeter and area of the figure, to determine the radius of the wire with which the figure would possess the necessary value of inductance.

For the sake of verifying the application of formula (1) as regards curvilinear figures an elliptical former was built up with half axes 1.5 and 3.47 m. The former was wound with copper wire ($d = 0.8$ mm.). The inductance of the ellipse was measured by means of a Siemens and Halske bridge at low frequency.

The average of seven measurements made by three investigators was $L = 30800 (\pm 1$ per cent.).

The inductance of the lead-in wires was calculated to be 1,213 cm. Inductance of the ellipse calculated by means of formula (1) (a_k being taken from the curve on Fig. 3 for $l/\sqrt{s} = 4.02$) was found to be $L = 29,562$ cm.

Therefore the total calculated value $L = 30,775$ cm., which is within 0.1 per cent. of the measured value.

value of a_k from previously calculated formulæ for L of various regular figures having two variable parameters. We have three such formulæ, *viz.*: those for a

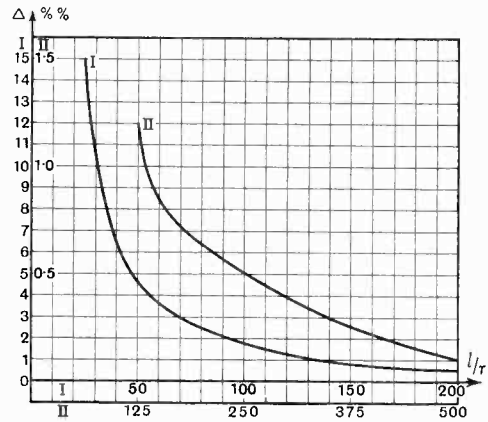

Fig. 4.

rectangle, an isosceles triangle and a rectangular triangle (see the author's papers in *Proc. I.R.E.*, Vol 15, No. 12).

The formula for a rectangle is

$$L = 4 \left\{ (a + b) \log_e \frac{2ab}{r} - a \log_e (a + d) - b \log_e (b + d) \right\} + 4 [\mu\delta (a + b) - 2(d + r) - 2(a + b)] \dots (5)$$

where a and b = the sides of the rectangle, d = its diagonal.

TABLE I.

a/b	1	2/3	0.427	1/4	1/9	1/15	1/20	1/30	1/50
l/\sqrt{s}	4	4.08	4.37	5	6.67	8.24	9.35	11.3	14.37
a_k	2.853	2.866	3.006	3.269	3.826	4.226	4.471	4.849	5.330
$\log_e l^2/s$	2.773	2.79	2.94	3.22	3.8	4.218	4.471	4.849	5.330
$\phi = a_k - \log_e l^2/s$	0.080	0.076	0.066	0.049	0.026	0.008	0	0	0

The author extended the analysis begun by Grover (*Proc. I.R.E.*, Vol. 15, No. 12) to determine the dependence of a_k on the magnitude of l/\sqrt{s} and especially (1) to determine if a depends only on l/\sqrt{s} and (2) to find a mathematical formula for a_k for large values of l/\sqrt{s} .

For this purpose the author found the

This can be written

$$L = 2l \left[\log_e \frac{2b}{r} - a_k + \mu\delta + 4 \frac{r}{l} \right] \dots (6)$$

where

$$a_k = - \log_e \frac{ab}{l^2} + \frac{2a}{l} \log_e \frac{a+d}{l} + \frac{2b}{l} \log_e \frac{b+d}{l} - \frac{4d}{l} + 2 \dots (7)$$

Calculating a_k for different values of a/b (i.e., for different values of l/\sqrt{s}) we get Table 1.

We see that the dominating rôle in the formula (7) is played by the first term,

$$-\log_e \frac{ab}{l^2} = +\log_e \frac{l^2}{s}$$

The value of this term is the greater the greater l/\sqrt{s} is. (See the last line in Table 1.)

Replacing a_k by the formula $\log_e \frac{l^2}{s} + \phi$ we get :

$$L = 2l \left\{ \log_e \frac{2s}{rl} - \phi + \mu\delta + 4 \frac{r}{l} \right\} \dots (8)$$

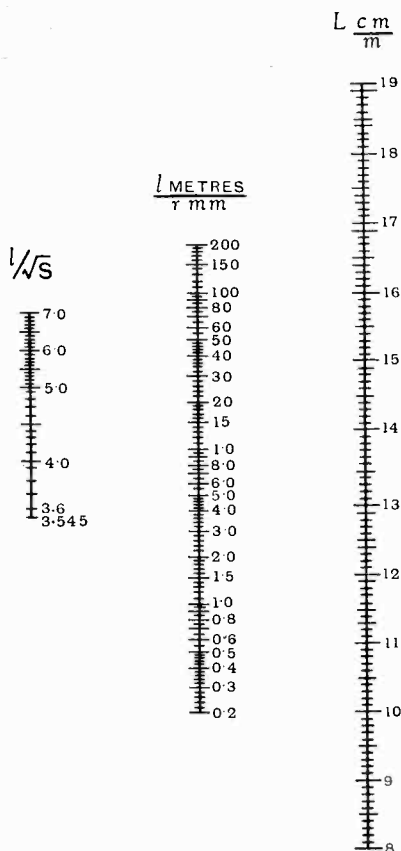

Fig. 5.

Neglecting as before for large values of l/\sqrt{s} , terms of the order r/l and ϕ we get :

$$L \approx 2l \left(\log_e \frac{2s}{rl} + \mu\delta \right) \dots (9)$$

wherefrom (as pointed out by Kliatskin) the known formula for L of long lines is found :

$$L \approx 2l \left(\log_e \frac{d}{r} + \mu\delta \right) \dots (10)$$

in which d = distance between the wires, l = the length of both wires.

More exactly

$$L = (4l_1 + 4d) \log_e \frac{dl_1}{l_1 r + dr} \dots (10a)$$

where l_1 = the length of each wire.

The author thinks that also for all the other forms of closed polygons and curves having no re-entrant angles a_k is near to $\log_e l^2/s$. To prove the correctness of this analytically is unfortunately possible only for the triangle, by means of formulae found by the author and Prof. Grover (*loc. cit.*). Only for rectangle and triangle have functions been found analytically expressing L for figures with two changeable parameters.

For a rectangular triangle (with sides a , b , and hypotenuse c), the formula is

$$L = 2 \left[a \log_e \frac{2a}{r} + b \log_e \frac{2b}{r} + c \log_e \frac{2c}{r} - (a + b + c) - (a + c) \operatorname{arc} \sinh \frac{a}{b} - (b + c) \operatorname{arc} \sinh \frac{b}{a} \right] \dots (11)$$

which can be written :

$$L = 2l \left[\log_e \frac{2s}{rl} + \mu\delta - \phi \right] \dots (12)$$

where

$$\phi = -\frac{a^2}{2lc} \log_e \frac{a(c-a)}{b(c+b)} - \frac{b^2}{2lc} \log_e \frac{b(c-b)}{a(c+a)} - \frac{c}{2l} \log_e \frac{c^2}{ab} + \frac{a+c}{l} \log_e (a+c) + \frac{b+c}{l} \log_e (b+c) - \log_e l + 1 - \log_e 2 \dots (13)$$

TABLE 2.

l/\sqrt{s}	4.828	5.84	7.01	8.99	10.2	12
ϕ	0.182	0.223	0.252	0.271	0.276	0.282

The calculated values of ϕ are given in Table 2.

The same calculation for a right triangle is as follows :

$$L = 2 \left[2a \log_e \frac{2a}{r} + c \log_e \frac{2c}{r} - (2a + c) - 2a \operatorname{arc} \sinh \frac{2a^2 - c^2}{c \sqrt{4a^2 - c^2}} - 2(a + c) \operatorname{arc} \sinh \frac{c}{\sqrt{4a^2 - c^2}} \right] \dots \text{(I4)}$$

which may be written

$$L = 2l \left(\log_e \frac{2s}{rl} - \phi + \mu\delta \right) \dots \text{(I5)}$$

where

$$\phi = 1 - \frac{2a}{l} \log_e \frac{2a}{h} - \frac{c}{l} \log_e \frac{8h}{l} \dots \text{(I6)}$$

(*h* = the height of the triangle). The values of ϕ are given in Table 3.

Evidently all the known expressions for *L* of fixed figures can be expressed in this form.

A summary is given in Table 4, where

TABLE 3.

l/\sqrt{s}	4.559	5.67	6.94	8.01	8.95	9.8	10.59	11.3	12	12.95
ϕ	0.164	0.225	0.26	0.276	0.285	0.29	0.293	0.296	0.298	0.299

a is the side of the polygon (or the radius of the circle).

We see that for all regular polygons we

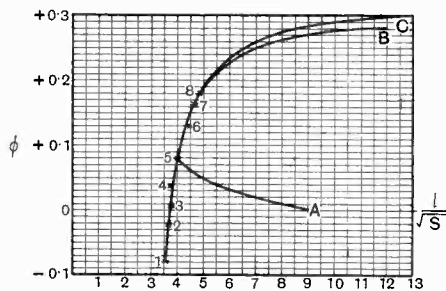

Fig. 6.

can write down a simple formula :

$$L = 2na \left\{ \log_e \frac{R_2 \cos \frac{\pi}{n}}{r} - \phi \right\} = 2na \left\{ \log_e \frac{K_n}{r} - \phi \right\} \dots \text{(I7)}$$

wherein *n* is the number of sides, *R*₂ = radius of the circumscribed circle, *K*_{*n*} = radius of the inscribed circle. We see that

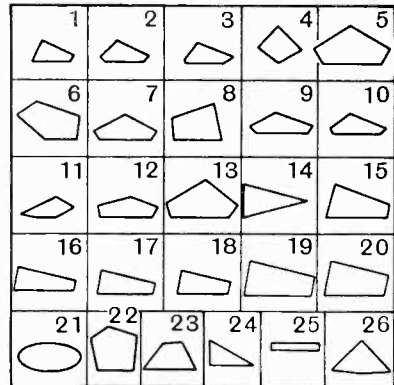

Fig. 7.

ϕ only varies between -0.08 for the circle and +0.164 for equilateral triangle.

Similar transformations can easily be carried out for other figures with a known

relation between *l* and *s*. As, for example, for any triangle the following formula holds

$$L = 2l \left\{ \log_e \frac{R_1}{r} - \phi \right\} \dots \text{(I8)}$$

where *R*₁ is the radius of the inscribed circle and ϕ is found from the curve (Fig. 6).

For the rhombus with the perimeter *l* with an acute angle α the formula is

$$L = 2l \left\{ \log_e \frac{l \sin \alpha}{8r} - \phi \right\} \dots \text{(I9)}$$

Prof. Grover has given the following exact expression for ϕ for the rhombus :

$$\phi = (2 - \log_e 4) + \log_e \sin \alpha - \cos \frac{\alpha}{2} - \sin \frac{\alpha}{2} + \cos^2 \frac{\alpha}{2} \left(\operatorname{arc} \sinh \cotan \alpha + \operatorname{arc} \sinh \tan \frac{\alpha}{2} \right) + \sin^2 \frac{\alpha}{2} \left(\operatorname{arc} \sinh \cotan \frac{\alpha}{2} - \operatorname{arc} \sinh \cotan \alpha \right) \dots \text{(I9a)}$$

On calculating ϕ for the various values of a , i.e., various values of l/\sqrt{s} , Prof. Grover found that the law $\phi = f(l/\sqrt{s})$ is very nearly the same as for the triangle (curves B, C of Fig. 6).

The curves showing ϕ as a function of l/\sqrt{s} from the Tables 1, 2, 3 and 4 are shown in Fig. 6. For the rectangle (curve A) ϕ falls to zero; for the right-angled triangle (curve B) and the isosceles triangle (curve C) ϕ increases. But the rate of increase of ϕ for $l/\sqrt{s} > 7$ to 8 is rapidly decreasing and already at $l/\sqrt{s} \approx 10$ and more ϕ for both forms is nearly constant. In general, for practical purposes for the triangular and rhomboidal forms with $l/\sqrt{s} > 12$ it is possible to assume that $\phi = 0.29$.

practical purposes to use the formula :

$$L \approx 2l \left\{ \log_e \frac{2s}{rl} - 0.15 \right\} \dots (20)$$

Calculations of L by formula (12) with the data of practical measurements for the different figures shown in Fig. 7 gave the results shown in Table 5.

Comparison of the calculated and measured values shows that the errors may be expressed approximately in relation to $\frac{2s}{r}$ as shown in Table 5.

Therefore our formula should be modified as follows :

$$L = 2l \left(1 + \frac{\Delta}{100} \right) \left(\log_e \frac{2s}{rl} - \phi + \mu\delta \right) \dots (22)$$

TABLE 4.

No.	Form of the Figure.	$\frac{l}{\sqrt{s}}$.	Former Formula (4).	New Formula (12) where $\mu\delta = 0$.	$\log_e \frac{l^2}{s}$	$\phi = a_k - \log_e \frac{l^2}{s}$.
1	Circle	3.541	$2l \left(\log_e \frac{2l}{r} - 2.451 \right)$	$4\pi a \left(\log_e \frac{a}{r} - \phi \right)$	2.53	-0.08
2	Regular octagon ...	3.641	$2l \left(\log_e \frac{2l}{r} - 2.561 \right)$	$2na \left(\log_e \frac{k_n}{r} - \phi \right)$	2.58	-0.0235
3	Regular hexagon ..	3.722	$2l \left(\log_e \frac{2l}{r} - 2.636 \right)$		2.63	+0.0065
4	Regular pentagon ..	3.812	$2l \left(\log_e \frac{2l}{r} - 2.712 \right)$		2.68	+0.0355
5	Square	4.000	$2l \left(\log_e \frac{2l}{r} - 2.853 \right)$		$8a \left(\log_e \frac{a}{2r} - \phi \right)$	2.77
6	As per Fig. 7	4.395	$2l \left(\log_e \frac{2l}{r} - 3.091 \right)$	$2l \left(\log_e \frac{0.1036l}{r} - \phi \right)$	2.96	+0.13
7	Equilateral triangle	4.559	$2l \left(\log_e \frac{2l}{r} - 3.197 \right)$	$6a \left(\log_e \frac{a}{2\sqrt{3}r} - \phi \right)$	3.03	+0.164
8	Isosceles right triangle (equal sides).	4.828	$2l \left(\log_e \frac{2l}{r} - 3.331 \right)$	$(2 + \sqrt{2}) \left[\log_e \frac{a}{(2 + \sqrt{2})r} - \phi \right]$	3.15	+0.182

In practice the value of ϕ can be taken from Fig. 6. If the figure has $l/\sqrt{s} > 4$ and has a contour differing considerably from the triangles (curves B and C) and the rectangle (curve A) the author thinks it possible for

This discrepancy (1) lies near the limits of the accuracy of measurement, (2) is natural because in almost all cases (except No. 21) the inductance of lead-in wires (to the measurement bridge) was neglected.

In conclusion I would like to express my heartiest thanks to Prof. Grover of Schenectady (U.S.A.) who in the course of two years showed the most lively interest in my work, gave me a great amount of most valuable

carrying out the experiment. For the most part the experiments were carried out at the Radio Department of the State Electrical Research Institute ; I am obliged especially to my pupils, El. Eng. M. E.

TABLE 5.

	Closed Aerials and Circuits.	Perimeter <i>l</i> .	Area <i>s</i> .	l/\sqrt{s} .	Radius of Wire.	<i>L</i>		ΔL per cent.	
						Measured $\times 10^3$.	Calculated [formula 12] $\times 10^3$.		
1	The closed aerials of Lübertzy's radio receiving station near Moscow (Types 1920-1924)	Warsaw	285	3,705	4.68	0.2	552	544	-1.44
2		Nauen	310	4,343	4.68	0.2	606	597	-1.51
3		San-Paolo	315	4,315	4.794	0.2	609	604	-0.80
4		Paris I	160	1,593	4.00	0.2	308	300	-2.49
5		South	275	4,525	4.08	0.2	565	512	-3.99
6		Tashkend I	304	4,816	4.38	0.2	598	594	-0.61
7		S.E.	335	5,736	4.42	0.2	685	660	-3.68
8		Carnarvon I	220	2,794	4.17	0.2	445	421	-5.34
9		Carnarvon II	375	5,868	4.89	0.2	753	729	-3.24
10		Paris II	370	5,038	5.2	0.2	740	707	-4.31
11		Tashkend II	350	5,005	4.95	0.2	695	677	-2.62
12		America	385	6,234	4.87	0.2	785	754	-3.95
13		West	330	4,352	5.00	0.2	666	629	-5.49
14	The isosceles triangle	45.2	85	4.9	0.1	81	75	-7.42	
15	The irregular quadrilateral	44.9	161	4.46	0.1	76.5	76	-1.44	
16	The irregular quadrilateral	61.4	158	4.88	0.1	104	106	+1.67	
17	The irregular quadrilateral	57.85	152	4.69	0.1	100	100	-0.81	
18	The irregular quadrilateral	54.3	141	4.57	0.1	95	94	-1.33	
19	The irregular quadrilateral	50.7	135	4.365	0.1	89	88	-1.01	
20	The irregular quadrilateral	47.2	122	4.275	0.1	83	82	-1.37	
21	The ellipse	see page 5	4.02	0.04	30.8	30.8	-0.1		
22	The irregular pentagon	52.12	185	3.81	0.1	98	95	-3.28	
23	The irregular quadrilateral	45.94	115	4.28	0.1	75	79	+4.82	
24	The right-angled triangle	15.92	9.86	5.07	0.04	25.5	26	+1.07	
25	The rectangle	70	150	5.71	0.1	121.5	120	-1.17	
26	The Marconi d.f. aerial	97.5	330	5.37	0.1	164	173	-5.39	

ΔL per cent. (mean value for 26 examples), - 2.13 per cent.

$\frac{2s}{nl}$ - of the order 10^6 $\Delta L = 1.1$ per cent. $\frac{2s}{nl}$ - of the order 10^3 $\Delta L = 2.2$ per cent.

$\frac{2s}{nl}$ - of the order 10^2 $\Delta L = 3.3$ per cent.

advice, and verified the results found by me. I also express my thanks to Prof. M. V. Schuleikin and B. A. Vvedensky, both of Moscow, for their interest and advice in

Starik and Eng. N. K. Swijtoff, who besides their work in the measurements afforded me very real help by making some of the calculations.

The Measurement of the Voltage Amplification Factor of Tetrodes.

By W. Jackson, M.Sc.

THE main advantage possessed by the screened grid valve or tetrode over the triode is its ability to provide

high values of the mutual conductance $\frac{\mu_0}{R_p}$ where μ_0 is the voltage amplification factor and R_p the alternating current plate-filament resistance, with high values of μ_0 at comparatively low plate voltages. The quantities μ_0 and R_p may be derived from the valve characteristics, obtained by a continuous variation of one of the battery voltages with the remainder constant, but an investigation of their variation with plate, screen and control grid voltage is by this method a long and tedious process. The use of a slightly modified form of Miller's alternating current bridge has enabled the values of μ_0 and R_p to be measured directly, simultaneously with the recording of the valve characteristic; so that their variation over the characteristic could be analysed at once. This is of importance in view of the variety of conditions of battery voltages under which these valves may be used in practice and especially when operated under conditions of gradually falling battery pressure, as occurs with dry high-tension batteries.

headphones of low resistance compared with the tube resistance.

With the switch S open, the ratio of r_2

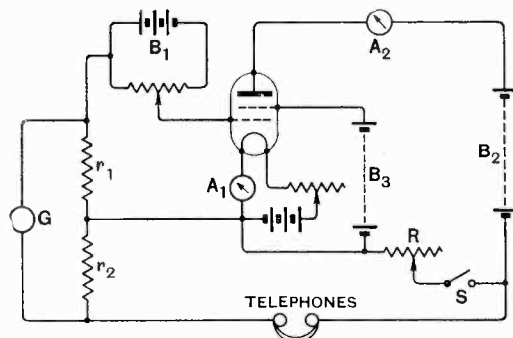

Fig. 2.—The modified arrangement for use with four-electrode valve.

to r_1 is varied until no sound is heard in the phones, when

$$\mu_0 i r_1 = i r_2$$

or

$$\mu_0 = \frac{r_2}{r_1} \dots \dots (1)$$

With the switch S closed, the ratio $\frac{r_1}{r_2}$ is fixed and R varied until no signal is audible in the headphones, then, with this adjustment

$$\frac{\mu_0 i r_1}{R + R_p} \cdot R = i r_2 \dots *$$

$$R_p = R \left(\mu_0 \frac{r_1}{r_2} - 1 \right) \dots (2)$$

The use of these two balance conditions enables the values of the voltage amplification factor and of the plate filament resistance to be measured for any battery voltages; the latter determining the steady plate current, from which the valve characteristic may be plotted, on which is superposed an alternating component of plate current caused by the variation of grid potential due to the audio input signal.

It is important in making the measurements to work with as small an alternating

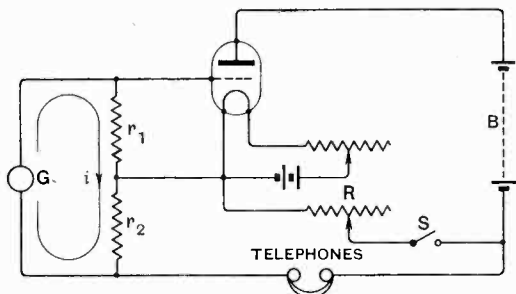

Fig. 1.—Bridge for triode measurements.

A diagrammatic sketch of the bridge arrangement for triode measurements is shown in Fig. 1, in which r_1 , r_2 and R are variable non-inductive resistances, G a coupling coil to a valve generator of audio frequency currents and Ph: a pair of

* Appendix.

input voltage as possible since the plate-filament resistance must vary throughout the cycle of grid potential and thus tend to render the production of complete silence at the balance point in the measurement of R_p impossible. For the same reason, it is advisable to keep r_1 and r_2 small throughout the measurements.

The modified circuit arrangement for use with a four-electrode valve is given in Fig. 2, a milliammeter is shown included in the plate circuit to enable the valve characteristic to be plotted, along with the measured values of μ_0 and R_p , against the variable battery voltage.

The curves of Fig. 3 show the variation with anode voltage of the plate current, voltage amplification factor μ_0 , alternating current plate filament resistance R_p , and mutual conductance $\frac{\mu_0}{R_p}$, for constant filament

current, control and screen grid voltages for an S625 tetrode. They serve to show that the flat portions of the valve characteristic at A, B and C are those of high voltage amplification while on the steep parts between A and B and

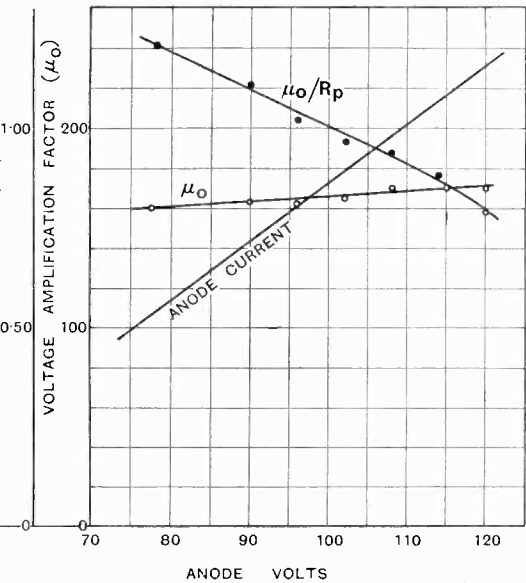

Fig. 4.—Filament current 0.25 amp.; control grid at zero potential.

between C and O, μ_0 becomes very small. It is interesting to note that a change in anode pressure from 100 to 80 volts leads to a change in μ_0 from 110 to 2.5, for a constant screen voltage of 80. While the voltage amplification obtainable at B is

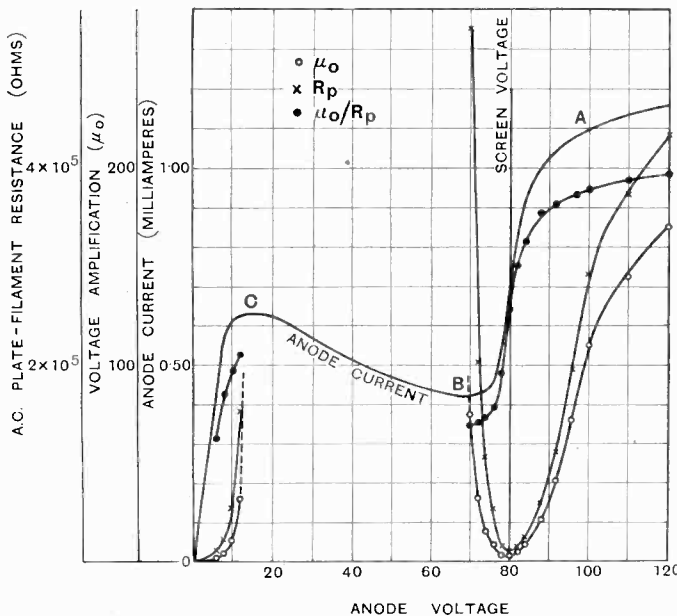

Fig. 3.—Filament current 0.25 amp.; control grid at zero potential.

high the low value of $\frac{\mu_0}{R_p}$ renders this portion of the curve of small utility compared with the flat portion of the curve at A. Over the portion BC of the characteristic the alternating current plate-filament resistance is negative and both R_p and μ_0 were indeterminate over this range.

It would appear that a variation in anode voltage may be attended by a serious drop in the voltage amplification obtainable from a stage of high frequency amplification employing a four-electrode valve. Since, however, the anode and screen voltages are in general taken from a common supply, the effect of a drop in battery pressure is not so serious, as will be seen from a consideration of the curves of Fig. 4. These curves

were obtained with varying anode pressure but with a constant ratio of anode to screen voltage such as might occur in the case of a set operated from dry high-tension batteries. The voltage amplification factor shows a slight decrease with decreasing anode and screen voltages, but at the same time the mutual conductance increases, indicating a probable increase in stage amplification together with a decrease in high-tension supply current required.

Essentially similar results to those recorded in Fig. 3 were obtained in a series of measurements on the P.M.12 four-electrode valve. A change in anode pressure from 120 to 80 volts with normal filament, control grid and screen grid voltages produced a change in μ_0 from 210 to 2.

Fig. 5 shows a series of curves obtained with constant plate and control grid voltages but with varying screen voltage. Both μ_0 and R_p increase with decreasing screen voltage producing a small decrease in the mutual conductance $\frac{\mu_0}{R_p}$.

The effect of variation of control grid voltage with normal conditions of plate and

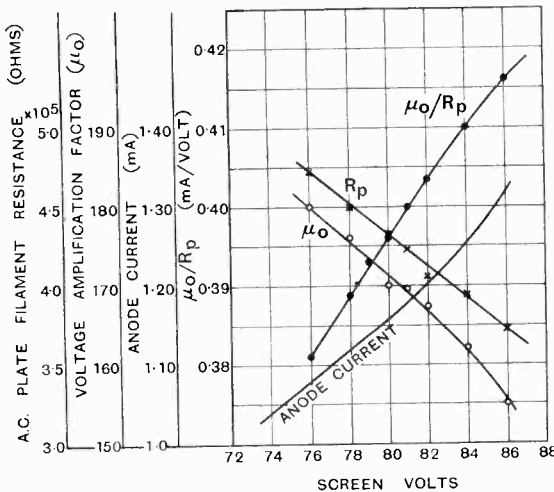

Fig. 5.—Anode volts 120, filament current 0.25 amp.; control grid at zero potential.

screen voltages is shown in Fig. 6. The anode current-grid voltage characteristic is straight for a grid swing of 1.5 volt, while little variation in μ_0 was noticeable with grid voltage.

The results indicate that tetrodes when operated from dry batteries providing a decreasing high-tension voltage with time operate satisfactorily so long as the anode

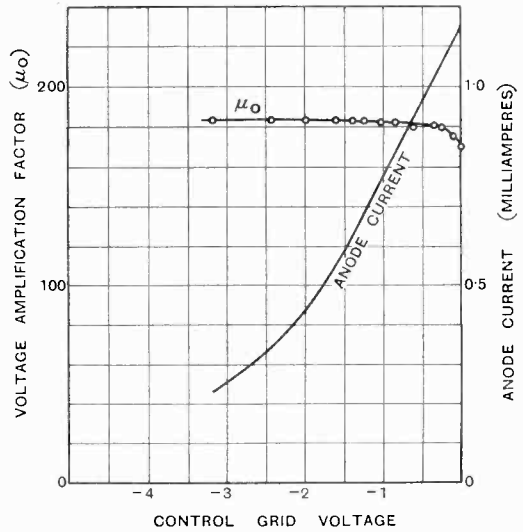

Fig. 6.—Effect of variation of control grid voltage.

and screen voltages vary from their normal values simultaneously and in doing so ensure continuous operation on the flat portion A (Fig. 1) of the anode current-anode volts characteristic.

Appendix.

An alternating voltage $i v_1$ impressed between grid and filament will produce an equivalent alternating voltage in the plate circuit equal to $\mu_0 i v_1$. This voltage will cause an alternating current $\frac{\mu_0 i v_1}{R + R_p}$ to flow in the plate circuit, superposed on the steady current produced by the steady plate and grid voltages. The voltage drop across R due to this alternating current equals

$\frac{\mu_0 i v_1}{R + R_p} \cdot R$, which, for no sound in the phones, must be balanced round the local circuit consisting of r_2 , R and the phones by the voltage $i v_2$ across r_2 , from which

$$\frac{\mu_0 i v_1}{R + R_p} \cdot R = i v_2.$$

An Investigation of Short Waves

(Paper by Mr. T. Eckersley, B.A., B.Sc., read before the Wireless Section, Institution of Electrical Engineers, on 10th April, 1929.)

ABSTRACT.

THIS is a very extensive paper on the subject of Short Waves. The discussion is grouped under the main heads: (1) Echoes and Scattering, (2) Direction-Finding Results, (3) Fading (including the effect of Magnetic Storms), (4) Theory.

(1) ECHOES AND SCATTERING.

The author suggests that perhaps the main interest in short-wave transmission lies in echo and scattering effects. He classes them together because in the long run the two effects merge into one. Signal distortion, due to echoes and scattering, imposes a severe limitation on high-speed working and on facsimile transmissions. The time lag of echoes and multiple signals may be anything from 0.001 sec. (observed in facsimile transmissions) up to the 25 secs. observed by Stormer and Van der Pol, but it is the short echoes up to 0.1 second or so which are associated with scattering.

In a previous paper,* the author suggested the existence of considerable scattering of short waves, and the two years' intensive study which has intervened confirms his ideas on this subject.

A two-aerial system is described, in which signals from any station not too nearly in line with the aerials can be balanced, provided the energy is travelling along any ray or set of rays in the vertical plane. From the results of observations with this it is assumed that close to the transmitting station the direct ray, with its definite direction of

existence of a main ray together with a scattered residue which remains when the main ray has faded out. Scattering in this sense merely implies the existence of energy travelling to the receiver along more than one path in the horizontal plane, and is, in its ultimate analysis, an irregular reflection.

The aerial system referred to led to the development of an Adcock direction finder, one limb of which is shown in Fig. 2.† The arrangement is stated by the author to be better as a means of investigating transmission than as a direction finder.

The results obtained were very diverse and varied. One very peculiar result has occurred on the bearings of British beam stations working to great distances. In the majority of cases, a more or less defined bearing is found which is close to the bearing of the distant station to which the British beam transmission is working. As an example, the Grimsby beam, working to Australia, gave bearings close to the bearings for Australia, and Bodmin, working to South Africa, gave bearings close to those of South Africa. The explanation offered by the author is that the direct rays from the beams are so weak as to be negligible and the rays received at Broomfield (near Chelmsford) are those scattered back from the regions where the main transmitted beam penetrates into the scattering regions of the Heaviside layer—like the case of a searchlight (itself invisible) playing on a reflecting cloud. From an analysis given, it is concluded that quite an appreciable amount of

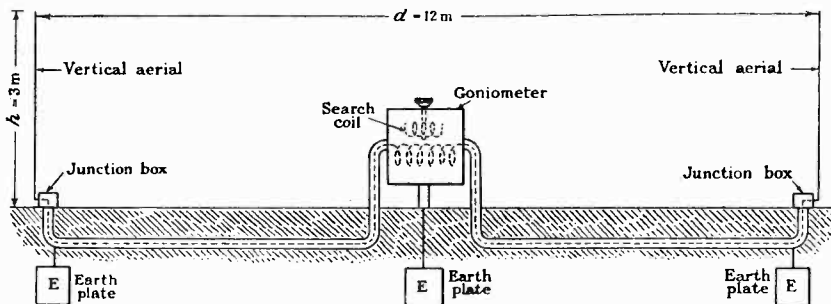

Fig. 2.

travel, is predominant. The direct ray is attenuated very quickly, and at distances of a few miles (depending on the wavelength, nature of the transmitting aerial, etc.) this direct ray is swamped by radiation scattered from the Heaviside layer. At great distances the evidence points to the

energy is scattered back from distances of about 2,000 km.

The author discusses mutilation of signals at some length and concludes that this may arise from the following causes:—

(1) *Long Echo*, due to signals arriving by the two

* Jour. I.E.E., 1927, Vol. 65, p. 600. Abstract in *E.W. & W.E.*, 1927, Vol. 4, p. 213.

† The Author's original figure numbers are adhered to throughout this abstract.

different great-circle paths round the world, or by one traversing an extra complete circumference of the world. These effects are easily recognisable, but taking due account of them there are, no doubt, other causes of signal mutilation.

(2) *Quick Echo*.—There are cases of quick echo with a lag of the order of 0.01 sec., which are probably due to long-distance scattering, such as mentioned above in connection with the beam stations.

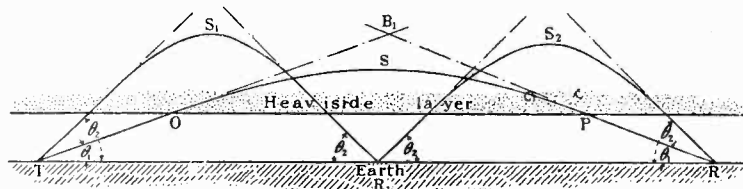

Fig. 11.

(3) *Blurring*, due to multiple scattering. This probably occurs mostly on local signals.

(4) *Double signals or multiple signals*, due to double or multiple paths. These produce double or multiple signals with a time interval between signals of the order of 0.01 sec. They have been brought to light by picture transmission results, but are not likely to mutilate Morse signals.

The last three effects are likely to contribute to mutilation in different proportions according to the actual conditions of transmission.

There may also be mutilation due to dispersion, as any signal changes shape when travelling through a dispersive medium such as the Heaviside layer. Reasons are given for supposing that this effect is negligible on the short-wave band, although there is evidence of dispersion effects on very long waves, e.g., musical Xs.

Scattering also introduces an additional attenuation, since the fact that energy is scattered out of the main path of a beam must reduce the useful energy received, broaden the beam, and produce an effective attenuation over and above that normally produced by the resistivity of the conducting layer.

The author states that scattering is observed on all wavelengths from 50 m. downwards, but does not appear to exist in the broadcast band. Recent experiments have also shown that there is very little scattering on the 75-100 m. band.

In considering the mechanism of scattering, the author postulates a layer in the form of a complicated structure of ionic clouds. The average distance between clouds must be large compared with the wavelengths under consideration (i.e., below 50 m.), but small compared with 300 m. Consideration of the ionic density suggests that the scattering layer is confined to regions below 115 km. and does not vary much from day to day.

(2) DIRECTION-FINDING RESULTS.

Bearings can be roughly divided into three classes:—

- (a) Correct or approximately correct.
- (b) Definitely wrong, but having some distinct characteristic, e.g., local beam station bearings (already mentioned) or bearings perpendicular to the true direction.
- (c) Nil bearings, when little or no sign of direction is given by the goniometer.

An extensive table of results is given of nine months' regular interception in 1928.

In the table, distant stations, normally outside the skip distance, show as a rule 100 per cent. true bearings, but there are occasional cases of right-angled bearings. These occur almost invariably when signals are weak and transmission conditions along the direct route are poor.

Observations on stations within the skip distance show almost complete absence of true bearings. Longer wave stations in general show some true bearings, but the percentage is small. True bearings generally imply that for some reason the station was, at the time, beyond the skip distance. It is generalised that within the skip distance scattering predominates, and that outside it the main ray predominates.

Right-Angled Bearings.—On occasions when the main ray from a station is obliterated, due to adverse conditions on the true great-circle route, signals may pass to one or the other side of the receiving station. The energy is then scattered from the nearest point of the energy flow to the receiver. An illustration of this effect is shown in Fig. 13. In the case of one station 22 per cent. of the bearings gave a mean direction 91.6 deg. from true bearing.

Sunset Effects.—There is some evidence of considerable variation of bearings during sunset periods. The effect has been very noticeable on Vienna and Cairo, and at times on Lisbon, Rio and other South American stations. An example is given in Fig. 14. The error is in general such as

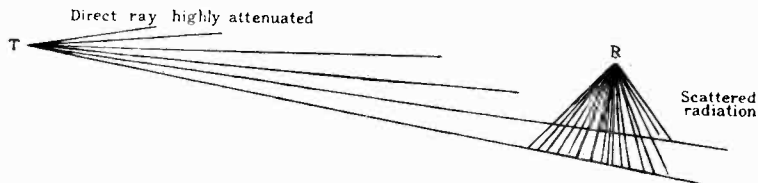

Fig. 13.

might be produced by horizontal refraction in the Heaviside layer.

Very short skip distance effects.—In some recent experiments reflection at practically normal incidence from the Heaviside layer has been observed on waves down to 30 m. At 11.27 km. distance, all waves from 60 to 30 m. showed marked vertical reflection, which appeared to be less on the longer

waves than on the shorter. These results are interesting in connection with the very long (Stormer) echoes.

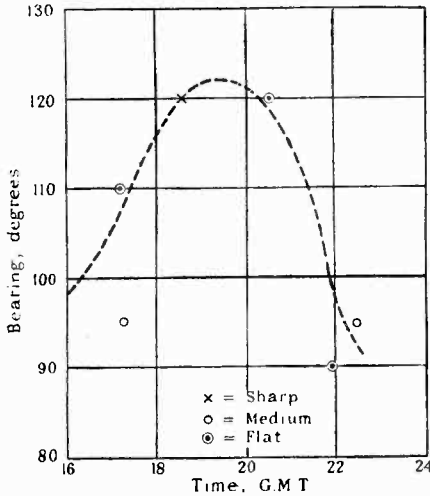

Fig. 14.—Vienna (OHK, 3995 m.).

(3) FADING.

The multiple signals, of which the total received signal is composed, will not all arrive in phase. Interference of the components will produce fading as the relative phases change. The character of the fading will depend on the number of signals arriving at any moment and the rapidity with which relative phases change. There is also another type of fading due to change on the plane of polarisation. In its ultimate analysis this is also a case of interference, for it is the interference between two circularly polarised rays, travelling with slightly different velocities, that produces the change in the plane of polarisation.

In connection with interference fading, illustrations are given implying two, three or four separate paths. The simplest explanation, consistent with the facts, is of two rays, one making a single jump and one making a double jump, as in Fig. 11. Multiple signals in this case imply multiple ricochets between the earth and the Heaviside layer.

This type of interference can be greatly reduced by adding the effects of two slightly different frequencies, for if the path difference *d* remains

constant it is possible to choose two wavelengths λ_1 and λ_2 so that the fading of the two is inverse. Thus, if *N* = number of $\frac{1}{2}$ wavelengths of λ_1 in *d*, i.e., $N\lambda_1 = d$, then for phase equality $N = 2n$, where *n* is an integer. For interference

$$(2n + 1)\lambda_2 = d$$

$$\text{or } \frac{\delta\lambda}{\lambda} = \frac{df}{f} = \frac{1}{4n}$$

where $\delta\lambda = \lambda_1 - \lambda_2$, in the particular case where $d = 300$ km., $\lambda = 20$ m. and $\delta f = 500$ cycles.

If a station sends a marking and a spacing wave of this order of frequency, fading on the two waves is quite different. The advantage of this method can be obtained by modulating the emitted waves with a 500-cycle note and heterodyning the received note. The rectified current will then consist of f_1 , $(f_1 + 500)$ and $(f_1 - 500)$, where f_1 is the beat frequency of the heterodyne and carrier wave. The mean square value of the total rectified current should then remain constant, unless complicated by multi-ray and polarisation fading. Recent tests seem to indicate that there is a big gain in using modulated waves instead of pure c.w., with a much higher speed of working.

The fading on two aerials spaced many wavelengths apart is also found to be very different, and an experiment on this subject is being carried out jointly by the Marconi Co. and the B.B.C. Statistical calculations suggest that the variability is reduced to about half for two rays. If limiting can be resorted to, it is only the occasions when signals are reduced to below a certain limiting

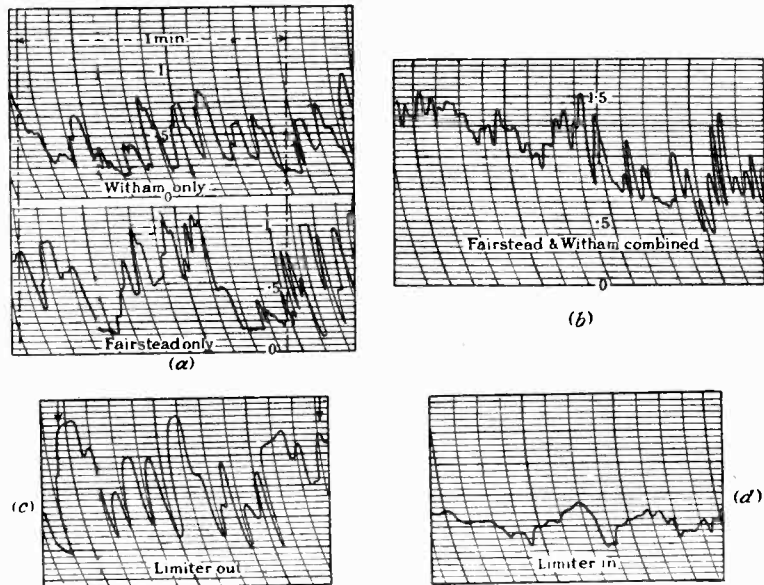

Fig. 20.

value that are likely to be troublesome. If the limiting value is about $\frac{1}{3}$ R.M.S. strength, a gain of 20 to 1 may be possible. Fig. 20 shows records

of combined signals compared with signals taken from each aerial separately.

Experiments are also described on the combination of signals from a horizontal and from a

(and incidentally less attenuated) of the two rays, circularly polarised by the earth's field, alone is received; at slightly greater distances both rays combine and produce marked inverse or "polarisation" fading, as it might be called; at great distances the horizontal ray diminishes in importance and the fading is mainly of the "interference" type.

Magnetic Storms.—The systematic observation of short-wave transmissions has provided an opportunity of testing the effect of magnetic storms. The general effect is to produce a "fade-out" on short-wave transmissions and to reduce attenuation on long-wave transmissions.

It is assumed that in a magnetic storm electrified particles are shot out from disturbed areas of the sun and in certain circumstances enter the upper layers of the atmosphere in regions surrounding the magnetic poles, producing mass movements of the electrons and ionised molecules. This sets up currents which disturb the earth's magnetic field.

Long-distance short-wave attenuation takes place in the lower regions of the Heaviside layer and is proportional to N/τ , where N

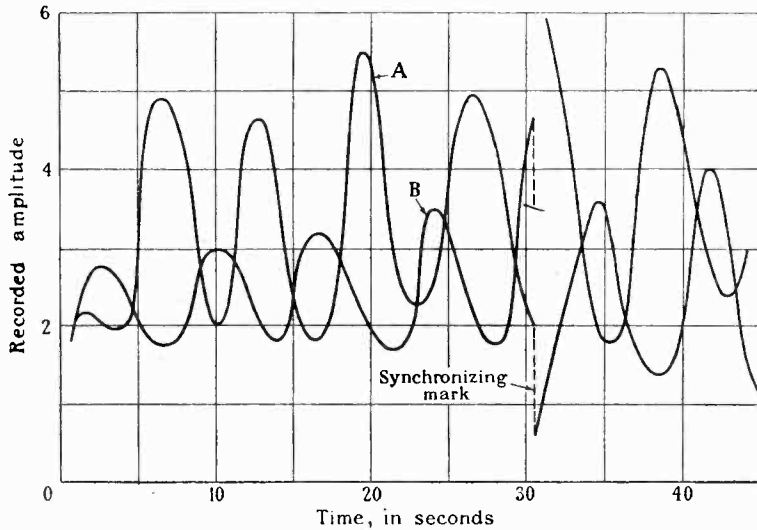

Fig. 24.—Signals from PQW (Lisbon, beam, 15.6 m.) sending high-speed dots.

vertical aerial. Results with the arrangement described showed that there were considerable differences in the fading, but it is difficult to give any numerical estimate of the gain likely to accrue from the addition of the rectified currents.

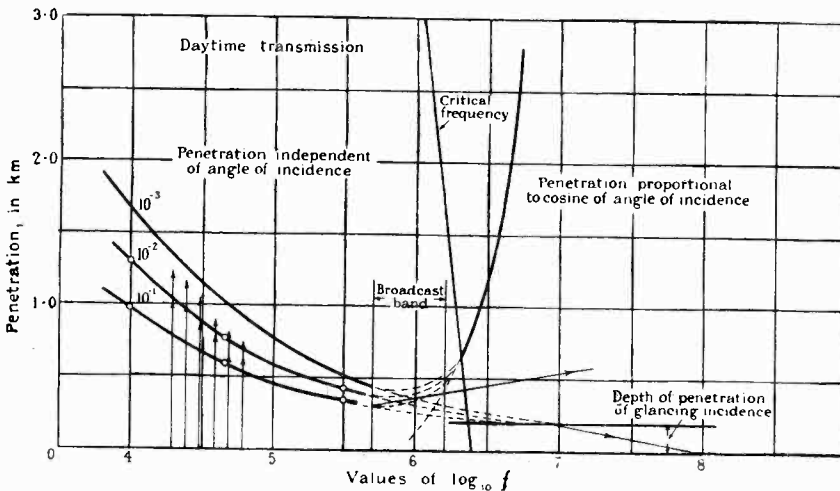

Fig. 29.

An example of simultaneous record from a horizontal and vertical aerial is given in Fig. 24.

In connection with fading effects, it is concluded that in the skip distance no direct ray is received; at the edge of the skip distance the more bent

is electronic density and τ the mean time between collisions. An increase of N due to a magnetic storm will drop the layer into a region of higher pressure where τ is less. Both effects will increase N/τ and increase short-

wave attenuation. The effect on long waves will depend on whether the change in N or in τ is the more potent factor. If the change in N is the predominating factor, magnetic disturbance will increase short-wave and decrease long-wave attenuation, as is usual.

As magnetic storm disturbances are more violent at the polar regions, signals passing these regions are likely to be more subject to fades from this cause. This is the case in practice, Canadian and American stations being more subject to magnetic-storm fades than Indian and South American stations.

The author also mentions a considerable increase of "whistlers" during magnetic storms. These are very long-wave atmospherics which can be heard giving a whistling sound, with telephones directly in the aerial, or with the aerial joined to an audio-frequency amplifier alone, without high-frequency tuning or rectification.

(4) THEORY.

The concluding section of the paper discusses theory, more particularly of the Heaviside layer and its rôle in transmission. The conception of the layer as a complex structure of scattering clouds necessitates revision of the usually accepted ray theory. If the scattering in the lower levels of the layer is particularly intense, the emergent ray may be very highly diffused and the emergent energy may entirely lose its ray formation.

Arising from the author's calculations, Fig. 29 shows the penetration into the layer on the various frequencies over the whole of the working wireless waveband, i.e., $f = 10^3$ to $f = 10^4$. The wavelength spectrum may conveniently be divided into three regions, those for which $f \gg 1/\tau$, those for which $f \ll 1/\tau$, and finally the intermediate range which corresponds very fairly to the broadcast band. For the first (short wave) group, the depth of penetration depends on f and the angle of incidence. For long waves the depth of penetration is independent of the angle of incidence, and there is no sharp line of demarcation.

The author also calculates the joint effect of frequency and angle of incidence, and gives his results in Fig. 30, which is a perspective view of a solid diagram representing the total ray attenuation as a function of each of these factors. In the absence of definite knowledge of the density at any given height, only relative values are given, but it is seen that the example exhibits also the observed characteristics of skip effects. For any

given wavelength, for instance, attenuation increases up to a maximum at some intermediate angle and then decreases up to normal incidence. At normal incidence the attenuation increases with increasing wavelength and at small incidence decreases with increasing wavelength. The dia-

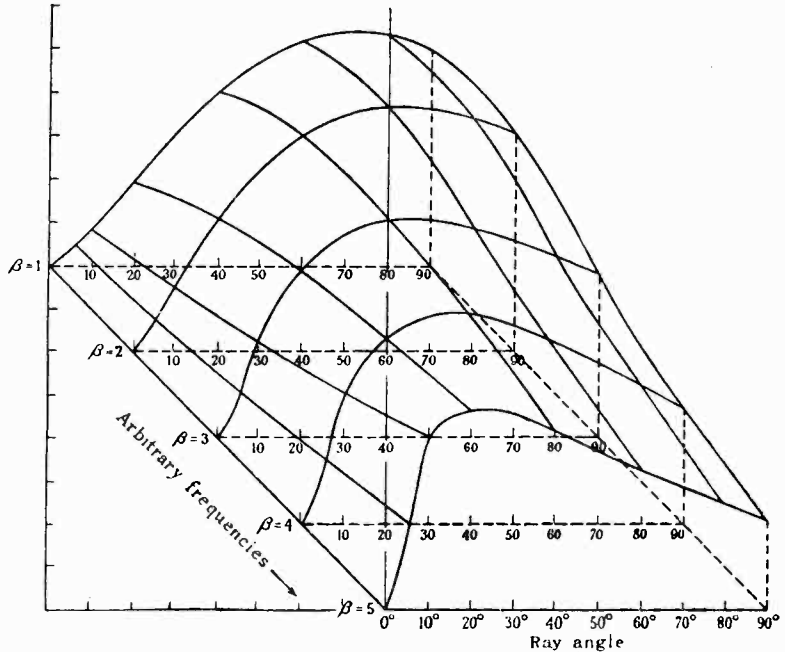

Fig. 30.—Attenuation diagram in skip distance.

gram is, of course, not correct at glancing incidence.

The work described by the author has been carried out in the Research Dept. of Marconi's Wireless Telegraph Co., at Chelmsford.

DISCUSSION.

The unusual length of the paper curtailed the time available for discussion, which was therefore much shorter than usual.

In opening the discussion DR. R. L. SMITH-ROSE referred to the enormous work which the paper represented. The fact that details of experimental methods were largely put in the background was made up for by the excellent analysis of the results obtained.

With reference to the Adcock aerial scheme (Fig. 2) he criticised the arrangement of buried cable shown. Such cable was not screened from horizontal electric forces. He also discussed the effect of the current in the horizontal portion (when signals were actually being received) upon the vertical aerial. The author's results upset previous ideas which Mr. Barfield and he had gathered from the Adcock system on broadcasting waves, viz.: that it was free from night error. He suggested that the dispersion effects discussed by the author might be used to explain Störmer (long-period) echoes within the atmosphere. One

of the alternative theories of these echoes, due to Prof. Appleton and Dr. van der Pol, already led to such an idea. The evidence of Fig. 24 was very interesting and afforded confirmation of the fact that fading could be due to change of polarisation.

MR. J. E. TAYLOR said he was much impressed by the beam D.F. results. These left no doubt about scattering from the fact that waves might travel round the globe several times, one would expect antipodean regions of concentration of waves. Had this been found? He would be glad of more information on the difference between short and long waves for the same power. Whistlers were very clear on telephone lines, and he had previously connected them with the entry into the atmosphere of meteoric matter.

MR. R. A. WATSON WATT suggested that the author's work could have been facilitated by the use of the cathode-ray system of direction finding, and thought that it would be better to get results

by converting the incoming signals to something that could be watched. The Adcock D.F. aerial and cathode ray indication would be excellent for studying scattering. Friis had shown that, in frequency changing from a common oscillator, relative phase of the high frequency was conserved in the audio frequency. With reference to magnetic storms he illustrated a record from long-wave atmospherics-recording apparatus, showing a marked increase of atmospherics intensity at a time (10th October, 1928) when the author had noted short-wave fade-out, although no magnetic storm was reported. On the subject of "whistlers" he suggested that the author already had an excellent method of observation of these in the facsimile transmission work mentioned in the paper.

MR. T. L. ECKERSLEY briefly replied to some of the points in the discussion, and on the motion of the chairman (Commander J. A. Slee, C.B.E.) the author was cordially thanked for his paper.

Correspondence.

Letters of interest to experimenters are always welcome. In publishing such communications the Editors do not necessarily endorse any technical or general statements which they may contain.

Effect of Anode-Grid Capacity in Anode-Bend Rectifiers.

To the Editor, E.W. & W.E.

SIR,—In the last paragraph of my article on the above subject in your March issue, the statement is made that with anode-bend detectors only a comparatively small increase of resistance is caused by feed-back through the anode-grid capacity. I regret I did not make it clear that in saying this I was referring only to anode-bend detectors working under the conditions of low amplification factor, of the order 0.1 to 0.2, contemplated by Mr. Medlam in his article on the same subject.* With normal values of amplification factor the increase of resistance may be very considerable, as is easily seen by inserting numerical values in formula (36).

E. A. BIEDERMANN.

Brighton.

March 11, 1929.

Frequency Modulation.

To the Editor, E.W. & W.E.

SIR,—In the March number of *E.W. & W.E.*, is described a recent patent: Signalling by frequency modulation; a system obviously based on the same principle is described in the November number last year.

In the first-mentioned description, it is said that "the width of the side-bands is stated to be reduced to a few hundred cycles only." This result seemed to me to be of such great importance in these days

of an overcrowded ether that I took a special interest in the matter. I tried to solve the problem mathematically, but came to a result quite different from that stated in the description. This may, of course, be due to an error in my conception of the system, but if so I would be glad to have it pointed out.

The modulated high-frequency current may be

$$i = A \sin(\omega t + k \sin mt) \quad \dots \quad (1)$$

written where A is the constant amplitude, ω the (cyclic) frequency of the carrier, m the modulating frequency, and k a modulation constant, the latter determining to what extent the carrier-frequency is varied.

The "instantaneous frequency" of the modulated current as written in (1) may be determined by differentiating the expression in the parentheses with regard to time:

$$n = \frac{d(\omega t + k \sin mt)}{dt} = \omega + km \cos mt \quad \dots \quad (2)$$

The "instantaneous frequency" thus oscillates between the limits $\omega + km$ and $\omega - km$.

For further investigation the equation (1) is written:

$$i = A \sin \omega t \cos(k \sin mt) + A \cos \omega t \sin(k \sin mt) \quad \dots \quad (3)$$

Now the terms $\cos(k \sin mt)$ and $\sin(k \sin mt)$ are periodic, with the period $\frac{2\pi}{m}$; hence they may be expanded in fourier-series; it is easily seen that these series can be written:

$$\begin{aligned} \cos(k \sin mt) &= a_0 + a_1 \cos mt + a_2 \cos 2mt + \dots \\ \sin(k \sin mt) &= b_1 \sin mt + b_2 \sin 2mt + \dots \end{aligned}$$

* "Effect of Anode-Grid Capacity in Detectors and L. F. Amplifiers," by W. B. Medlam, B.Sc., A.M.I.E.E., *E.W. & W.E.*, Oct., 1928.

Hence the expression (3) for i can be written :

$$\begin{aligned}
 &= a_0 A \sin \omega t + a_1 A \sin \omega t \cos mt \\
 &\quad + a_2 A \sin \omega t \cos 2mt + \dots \\
 &\quad b_1 A \cos \omega t \sin mt \\
 &\quad + b_2 A \cos \omega t \sin 2mt + \dots \\
 &= a_0 A \sin \omega t + \frac{A}{2} (a_1 + b_1) \sin (\omega + m)t \\
 &\quad + \frac{A}{2} (a_1 - b_1) \sin (\omega - m)t \\
 &\quad + \frac{A}{2} (a_2 + b_2) \sin (\omega + 2m)t \\
 &\quad + \frac{A}{2} (a_2 - b_2) \sin (\omega - 2m)t \\
 &\quad + \dots
 \end{aligned}$$

It is seen that the current contains not only the carrier and the usual side-bands $\omega + m$ and $\omega - m$, but also side-bands of the harmonics of the modulating frequency; and it does not at all—as could perhaps be expected—contain the side-bands $\omega + km$ and $\omega - km$.

When k is small compared with unity (e.g., $k = \frac{1}{10}$), in the expression (3) $\cos(k \sin mt)$ may be replaced by 1 and $\sin(k \sin mt)$ by $k \sin mt$. With this approximation we get :

$$\begin{aligned}
 i &= A \sin \omega t + A k \cos \omega t \sin mt \\
 &= A \sin \omega t + \frac{1}{2} A k \sin (\omega + m)t \\
 &\quad - \frac{1}{2} A k \sin (\omega - m)t.
 \end{aligned}$$

This is, in fact, the expression for an ordinary amplitude modulated wave. For small values of k the method is thus identical with the usual method of modulation (though not with regard to the phase of the sidebands); for greater values of k much broader sidebands are introduced.

N. E. HOLMBLAD.

The Transmitting Station actually sends out Waves of One Definite Frequency but of Varying Amplitude.

To the Editor, E.W. & W.E.

SIR,—May I enter the correspondence on the above subject.

The practical problem is to deduce in one's head the main characteristics of the output from a system, the input to which is a modulated carrier oscillation.

We have $\theta = \phi(I)$, meaning that the output θ is a function of, or the result of an operation ϕ on the input I . We may consider I as the sum of, say, three components X , Y and Z (carrier and two sidebands), but if we do this we must guard against saying that $\theta = \phi(X) + \phi(Y) + \phi(Z)$ in all cases. This is the mistake made at first by Mr. Aughtie, leading to his false conclusion. Messrs. A. B. Howe and Biedermann consider the case $\phi(I) \equiv AI + BI^2$, where A and B are constants. They point out that the output is $A(X + Y + Z) + B(X + Y + Z)^2$ and not $(AX + BX^2) + (AY + BY^2) + (AZ + BZ^2)$. In some cases, however, we do have $\theta = \phi(X) + \phi(Y) + \phi(Z)$, one of the most common being the case of the oscillatory circuit. The problem is to find θ from an

equation of the form $L \frac{d^2\theta}{dt^2} + R \frac{d\theta}{dt} + C\theta = I$. The

components X , Y and Z of I each give a particular integral in the solution; let these be $\phi_1(X)$, $\phi_2(Y)$, $\phi_3(Z)$, then the complete solution is $\theta = \phi_1(X) + \phi_2(Y) + \phi_3(Z) +$ (complementary function). The reason why in this case it is simpler to think of I as carrier and sidebands, is that $\phi(\)$ is itself a function of I and extremely complicated, whereas $\phi_1(\)$, $\phi_2(\)$, and $\phi_3(\)$ are well known and easily pictured from the resonance curve (it is assumed that the carrier is modulated by a single frequency for simplicity). Another case, namely, reflection from the Heaviside layer is mentioned by Mr. Ladner. Again it is simpler to consider I as the sum of its components, for the same reason that $\phi(\)$ is a function of I .

The argument given by Mr. Ladner in favour of the "reality" of the components is futile. It is exactly analogous to the old argument "proving" that white light consists of trains of waves of all frequencies. All it shows is that a resonant circuit can be adjusted to make, say, $\phi_2(Y)$ large compared with $\phi_1(X)$ and $\phi_3(Z)$, i.e., the result of the action of this circuit is to make a certain sideband so predominant that we may neglect the other components. We consider a current to be a real motion of electrons, hence the criterion whether a current is real or not should be whether the electrons move or not. Let i_1 and i_2 be any two steady currents, then $i_1 = (i_1 + i_2) + (-i_2)$; this is a mathematical identity exactly analogous to

$$\begin{aligned}
 I_0(I + m \cos \omega t) \sin pt &= \\
 I_0\{\sin pt + m/2 \sin (p + \omega)t + m/2 \sin (p - \omega)t\}.
 \end{aligned}$$

In particular, when $i_1 = 0$ we have $0 = (i_2) + (-i_2)$, the physical interpretation of which is that zero current is equivalent to two equal currents flowing in opposite directions. We do not infer that the two currents actually flow. The heat developed in a resistance R is $(i_2 + (-i_2))^2 R = 0$, but if the two components really existed, the heat developed would be $\{(i_2)^2 + (-i_2)^2\} R = 2i_2^2 R$, since the heat developed is merely the result of collisions which must accompany the flow. If we use the mathematical transformation $I_0(I + m \cos \omega t) \sin pt = I_0\{\sin pt + m/2 \sin (p + \omega)t + m/2 \sin (p - \omega)t\}$ we must stick to the rules of the game, and work the problem out by mathematics, and must not introduce physical arguments like the collisions of electrons when half-way through the mathematics.

To sum up, we may only consider the modulated carrier as carrier and sidebands, TREATING EACH COMPONENT SEPARATELY, and adding the results, when mathematical analysis has shown it to be permissible. We may always consider it as an oscillation of "one definite frequency" but of varying amplitude, but in a great many cases it is difficult to picture the operation performed by a circuit or system on such an input—e.g., reflection from the Heaviside layer. The operation performed by an oscillatory circuit is easily pictured, as Mr. A. B. Howe explained. Of course, we may always consider the modulated carrier as carrier and sidebands, if we operate on all the components as parts of the whole, but this usually entails working on paper and not in one's head.

W. B. LEWIS.

C

Abstracts and References.

Compiled by the Radio Research Board and reproduced by arrangement with the Department of Scientific and Industrial Research.

PROPAGATION OF WAVES.

ESSAI D'EXPLICATION DE L'ÉCHO STÖRMER-HALS (A Suggested Explanation of the Störmer-Hals Echoes).—H. S. Jelstrup. (*L'Onde Élec.*, December, 1928, pp. 538-540.)

As an alternative to Störmer's explanation, the writer suggested (*Norgebladet*, 29th and 31st October, and 3rd November, 1928), that the long-time echo was due to the waves having made a large number of "bounces," between Heaviside layer and earth (perhaps far from the transmitter) and on other atmospheric layers, then concentrating themselves—more or less in phase—on the receiving station. "They may perhaps undergo also reflections and refractions in other layers higher than the ordinary layer. . . . We know, from the theory of fading, how the Heaviside layer changes its shape under the influence of sunlight, electrical conditions, aurora borealis, etc. At certain moments this layer may take shapes—curvatures—at different points such that they act as a kind of spherical mirror. The different parts could at the same time reflect the waves directly towards the receiving station, producing a maximum if there is phase agreement, a minimum if there is opposition. These effects of reinforcement interferences—partially a result of the variation of curvature of the layer—must be remembered in considering the Störmer echo." Finally, the writer calculates that after enough reflections to produce a 10 seconds delay, the strength of the echo (from Howes' formula) would be great enough to be audible on a good amplifying receiver.

ÉTUDE EXPÉRIMENTALE DES ZONES DE SILENCE DANS LA PROPAGATION DES ONDES COURTES (Experimental Study of the Zones of Silence in the Propagation of Short Waves).—R. Bureau. (*Comptes Rendus*, 4th February, 1929, V. 188, pp. 455-457.)

A paper based on a long series of maps representing conditions of reception of short waves, of various lengths, noted during 1927 and 1928 by an increasing number of observers, ending with 35 in France, 15 in other parts of Europe, and 8 in Africa. The following results are deduced from the hundreds of maps (not shown):—the zones of silence practically never present a regular and symmetrical disposition round the transmitter: they can vary very greatly from one day to another: they do not always evolve in the same way along the scale of wavelengths: they prolong themselves into zones of weak audibility: they very often contain in their centre a zone of audition—sometimes variable, sometimes strong (but almost always homogeneous) of very varying extent—sometimes reaching hundreds of kilometres—and definitely *not* the zone of direct radiation. In some cases several successive rings (or crescents) of

silence are observed, separated by rings (or crescents) of audition. Anomalous results, both positive and negative, are frequent. Transitory but vigorous effects of accidental causes are observed, at times acting on the whole band of wavelengths, at others on a very limited band only. The tests were made on two powers—150 and 300 w. to the aerial. "If the zones of silence are due to insufficient refraction, or some kindred phenomenon, and if absorption only plays a secondary part, the influence of the power on the limits of the zones would be very slight. Experience, on the contrary, shows that the above doubling of the power has a very marked effect in reducing the zones." It is quite definite that on some days the zones as a whole are more extended than on others—as if the ionised layers had increased in height. On other occasions, the extension of the zones only takes place in certain directions, as if the layers had taken on a slope. The writer is led more and more to the belief in a multiplicity of ionised layers, if only to explain the anomalies between one wave and another and the existence of the audition zones within the zones of silence. Finally, meteorological action is far from negligible, as can be seen from a comparison of the propagation maps with certain meteorological charts (those showing fronts and masses of air): he sums up by the following hypothesis:—"The ionised layers of the upper atmosphere play the principal rôle; but—in certain critical conditions—a slight modification can decide between two possible and different paths along these layers. This modification may be the act of the phenomena of the troposphere, which would then become the arbiters of the propagation and would decide the fate of the wave."

THE ATTENUATION OF WIRELESS WAVES OVER TOWNS.—R. H. Barfield and G. H. Munro. (*Journ. I.E.E.*, February, 1929, V. 67, pp. 253-265, and Discussion to p. 270.)

Full version of the paper referred to in February Abstracts, p. 98. Interesting conclusions drawn from the tests are:—For transmissions confined to "town" areas only, consisting of offices, large buildings and residential districts without gardens, there is a very important increase of attenuation with frequency obeying approximately a fifth-power wavelength law, but there is no sign of any selective absorption due to receiving aerials. Over suburban areas only there is marked selective absorption, this effect being a maximum on a wavelength *just below* the wave to which the aerials are tuned. When the area traversed combines the two cases there are some indications that the steep attenuation/wavelength curve is combined with the selective absorption curve. These results are considered and theoretical grounds found for them.

BEMERKUNG ZU DEM AUFSATZ VON J. FUCHS: DAS VERHALTEN KURZER WELLEN IN UNMITTLBARER NÄHE DES SENDERS (A Note on Fuch's paper "The Behaviour of Short Waves in the Immediate Neighbourhood of the Transmitter").—P. O. Pedersen. (*Zeitschr. f. Hochf. Tech.*, February, 1929, V. 33, p. 66.)

Referring to the paper abstracted on p. 97, 1929, V. 6, the writer says: "The observed dependence of field-strength on lighting conditions, at small distances from the transmitter, is probably due either to partial reflection at surfaces of discontinuity, particularly in the higher, strongly ionised atmosphere, or to waves reflected by ground behind the skip zone." He refers to pp. 66, 136, 139, 213, 214 and 235 of his book "The Propagation of Radio Waves."

THE REFLECTION AND TRANSMISSION OF ELECTRIC WAVES AT THE INTERFACE BETWEEN TWO TRANSPARENT MEDIA.—H. M. Macdonald. (*Proc. Roy. Soc.*, 6th March, 1929, V. 123 A, pp. 1-27.)

The writer obtains approximate expressions for the electric and magnetic forces in the transmitted and in the reflected waves, where electric waves are incident on the interface between two media, the surface of separation being any surface.

FORTPFLANZUNG DES LICHTES DURCH FREMDE KRAFTFELDER (The Propagation of Light Through Extraneous Fields).—V. Wisniewski. (*Zeitschr. f. Phys.*, No. 9/10, 1928, V. 50 pp. 644-647.)

ÉTUDE SUR LA PROPAGATION DES ONDES COURTES (On the Propagation of Short Waves).—Guyot. (*L'Onde Élec.*, December, 1928, pp. 509-530.)

This paper is divided into two parts: in the first, the laws of propagation of short waves are considered, on the supposition that the Heaviside layer has its properties controlled simply by the position of the sun; the second deals with the alterations which must be made to those laws to allow for the rate of change of the ionisation at a point in the atmosphere: as a result of these modifications, what the writer calls "the Dynamic Theory of the Heaviside Layer" is reached. The lag between cause and effect in ionisation has the following results:—a lag in the appearance of signals at a given spot, behind the time calculated on the "classic" (static) theory—this lag varies with the distance and is of the order of several hours: a lag in the disappearance of the signals—this lag can be very considerable, and in certain cases (in the tropics) causes a disappearance of the silence zone: a decrease in the variations of the height of the layer as calculated on the static theory—this decrease is the more pronounced the stronger the sun's action. The paper includes graphs of observations on waves ranging from 33 to 82 m., some derived from Mesny's reports, others from tests in N. Africa. It ends by considering the limiting range (apart from reflection at the earth) for various wavelengths, as obtained

from the critical angle of incidence ($\cos^{-1}\theta = \frac{\lambda}{75}$) and the tangent to the earth from the layer. "At the equator it will be possible to have notable ranges with waves shorter than 10 m."—but only by day when the layer is low.

SOME POLARISATION PHENOMENA OF VERY SHORT RADIO WAVES.—E. A. Paulin. (*Phys. Review*, March, 1929, V. 33, pp. 432-443.)

A 5-7.5 m. wave transmitter, similar to that of Tykociner, is briefly described: also a "detector" (a complete portable receiving set, one triode and micro-ammeter) which "furnishes an excellent means for surveying a radiation field in the immediate vicinity of an oscillation generator, to establish its condition of polarisation. Furthermore, it may be used to measure the distribution of the field."

Tests resulted in the following conclusions:—"The loop of the oscillator, and the linear radiator coupled to it, imprint their character on the polarisation of the waves. That is, the wave is the resultant of components which have their source in the individual current-carrying elements in the radiating system. . . . Evidence of this is the modification of the field concomitant with the rotating of the loop and the directing of the linear oscillator." This seems to contradict the results obtained by Pickard, another of whose findings—that whatever the plane of the transmitter, reception was predominantly horizontal—is also contradicted here; for within the range considered (up to 100 metres) the type of polarisation showed no tendency whatever to change. This agrees with Austin and with Smith-Rose and Barfield.

Experiments with interference phenomena are described which illustrate the importance of secondary radiations from conductors, etc., near transmitter or receiver, which may affect materially the intensity or the polarisation of the total radiation received. The use of tuned rods for the formation of a beam is described, and illustrated by polar curves made with the apparatus.

RECEPTION EXPERIMENTS IN MOUNT ROYAL TUNNEL.—A. S. Eve, W. A. Steel, G. W. Olive, A. R. McEwan, and J. H. Thompson. (*Proc. Inst. Rad. Eng.*, February, 1929, V. 17, pp. 347-376.)

The tunnel is $3\frac{1}{2}$ miles long; the mountain is for the greater part composed of limestone, but the entire centre portion—where it is highest—is of Essexite. Tests were made on wavelengths round 50, 400, 1,400 and 17,000 m. The summarised conclusions are:—the penetration of any wave into the tunnel is some definite function of the wavelength: waves below 100 m. do not penetrate rock or soil to any appreciable extent: cables and rails do not conduct the short and broadcast waves to the same extent as they do the long waves—though their effect is appreciable on the broadcast band: wires and cables, when ungrounded, appear to act as wave antennæ—when grounded they act as loops: much more energy appears to enter *via* the tunnel mouth than was at first suspected, though the short waves do not

penetrate well or far into the tunnel even by this way of entry (cf. Ritz, tunnel results with very short waves, Abstracts 1929, V. 6, p. 150).

ABHÄNGIGKEIT DER REICHWEITE SEHR KURZER WELLEN VON DER HÖHE DES SENDERS ÜBER DER ERDE (Dependence of the Range of Very Short Waves on the Height of the Transmitter above the Earth).—H. Fassbender and G. Kurlbaum. (*Zeitschr. f. Hochf. Tech.*, February, 1929, V. 33, pp. 52-55.)

Authors' summary: "The range of an aeroplane transmitter [3.7 m. wave] was measured in its dependence on height above ground. Subsequent

The receiving circuit used is shown in the diagram—a super-regenerative receiver described by E. Busse (*Funkbasler*, p. 687, 1928) combined with L.F. amplifier, rectifier and measuring instrument—3 being an oscillating audion, 4 the super-regenerative valve; 1-2 is the dipole aerial. The height of the aeroplane varied from 50 to 2,700 m. The greatest range obtained (telegraphy) was about 125 km. All the ranges shown in the curves lie considerably below those calculated from the geometrical tangent; but in one test the receiver was raised 15 m. above the ground (to get rid of the effect of trees and buildings) and the range then agreed well with the calculated value. (Cf. Gerth and Scheppmann, April Abstracts.)

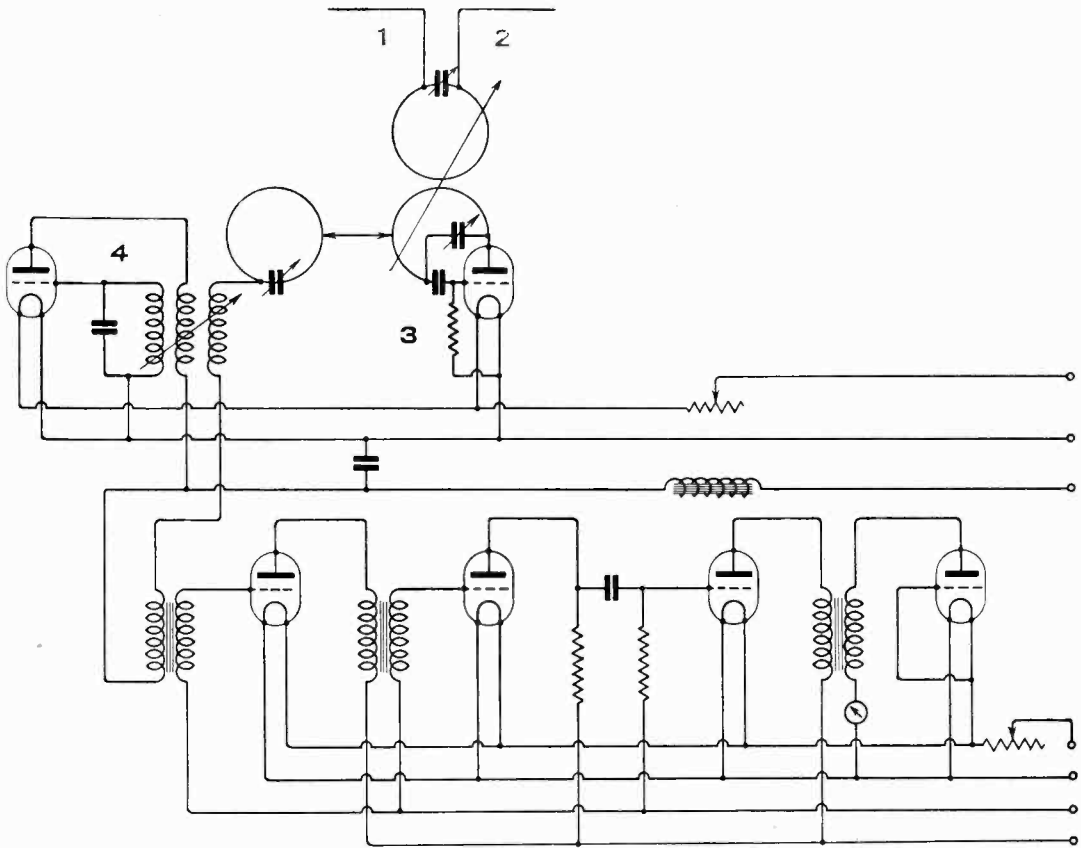

tests on longer waves failed to show such relation, but the 3.7 m. wave displayed a close dependence. The ranges obtained with 1 watt power were distinctly less (even at great heights) than those obtained with the 'short' waves in general use, under similar conditions. Taking into consideration the present state of the technique of ultra-short wave reception, the ordinary short waves have a considerable superiority for general communication purposes. Whether there are possible uses for the ultra-short waves, for special purposes such as short-range bearings, remains to be seen."

MESURE DE L'OZONE DE LA HAUTE ATMOSPHERE PENDANT L'ANNÉE 1928 (Measurements of the Ozone in the Upper Atmosphere during 1928).—H. Buisson. (*Comptes Rendus*, 25th February, 1929, V. 188, pp. 647-648.)

A continuation of the work at Marseilles carried out in 1927. As in that year, a main annual variation was found (a maximum of 375 in Spring and a minimum of 225 in Autumn), but less accentuated than in 1927. Irregular variations connected with movements of the atmosphere were

marked at the beginning and end of the year, but decreased in the Summer. The curve of annual variation is altogether similar in form to that at Arosa taken by a different technique. The amount of ozone has been slightly but definitely less in 1928 than in 1927.

EXPERIMENTELLE UNTERSUCHUNGEN ÜBER DIE DIFFUSION LANGSAMER ELEKTRONEN IN EDELGASEN (Experimental Investigation into the Diffusion of Slow Electrons in Inert Gases).—H. Pose. (*Zeitschr. f. Phys.*, 4th December, 1928, V. 52, No. 5/6, pp. 428-447.)

RECOMBINATION OF IONS IN ATMOSPHERIC AIR.—P. J. Nolan and C. O'Brolchain. (Short Summary in *Nature*, 2nd March, 1929, V. 123, p. 338.)

TWO ENERGY TYPES IN WAVE MOTION AND THEIR RELATION TO GROUP AND WAVE VELOCITY.—Lewi Tonks. (*Phys. Review*, February, 1929, V. 33, pp. 239-242.)

Author's abstract:—The energy of an element in a wave motion can be of two kinds: first, non-interactive like the energy of a set of independent pendulum bobs, and second, interactive like the potential energy of an element of a stretched string which is dependent only on the relative position of two neighbouring elements. In the former case the group velocity is zero, and in the latter it equals the wave velocity. The slowing down of energy transmission in intermediate cases is discussed qualitatively, and the ratio of group to wave velocity is calculated quantitatively in a number of cases on the assumption that the energy propagation is given not only by the product of energy density and group velocity, but also by the product of twice the interactive energy density and wave velocity. A general relation is suggested, without proof, for the connection between energy types and the ratio of group to wave velocity. The same ideas are applied to de Broglie's phase waves, the group velocity of which is the particle velocity.

LA PROPAGATION DE LA LUMIÈRE DANS L'ÉTHÉR (The Propagation of Light in the Ether).—H. Malet. (*Comptes Rendus*, 4th February, 1929, V. 188, pp. 443-445.)

Michelson's negative result leads to the statement "everything happens as though electromagnetic phenomena are exactly carried along with the earth's movement." The same applies to the phenomena due to the earth's gravitational field. If it is admitted that the electromagnetic and the gravitational fields both result from modifications of the same non-material medium (the ether) it is reasonable to see in the above-named agreement more than a coincidence, and to deduce from it a bond between the two groups of phenomena. The writer, therefore, postulates that "the velocity of light at a point of the ether is a (diminishing) function of the value of the gravitational potential at that point: in other words, the ether is—as regards the propagation of electromagnetic waves—an isotropic but not homogeneous medium." Besides defining the velocity at each point, it is

necessary to define the "isokinetic" reference-system in regard to which the propagation takes place with the same velocity in all directions. The absence of inertia in the ether makes it illegitimate to assume (as is done in the majority of theories) that this medium itself forms the system of reference. The writer formulates as a second postulate: "the isokinetic system at a point M is determined by the condition that the value of the velocity c is the same at all points infinitely near to M ; i.e., by the condition that $\text{grad } c = 0$." With these two simple hypotheses he accounts for the essential phenomena of the propagation of light: for an observer situated at the surface of the earth, the isokinetic system possesses an ascending vertical movement—hence Michelson's negative result, which would have been positive if his test had been made vertically (but only if the path employed had been very long)—cf. Corps, on Esclangon's results. Abstracts 1928, V. 5, p. 588. An approximate integration gives for the deviation of a light ray passing a star, at a distance R from its centre, the expression $2hm/c^2R$, which coincides with the Einstein formula when $h = 2$.

ATMOSPHERICS AND ATMOSPHERIC ELECTRICITY.

A THEORY OF AURORAS AND MAGNETIC STORMS.—H. B. Maris and E. O. Hulburt. (*Phys. Review*, March, 1929, V. 33, pp. 412-431.)

Another paper on the "ultraviolet blast, high-flying atom" theory (see February Abstracts, p. 101). Among many other points brought forward as examples of known phenomena supporting their theory, the writers say that the blast "would be expected to cause changes in comets, such as it does in our own atmosphere, and we find that this actually happens . . . for in nearly every instance the date on which a comet was observed to undergo an unusual change, such as breaking up of the nucleus, loss of tail, sudden increase in brightness, etc., was found to follow, within a few days, the date on which a strong magnetic storm occurred on earth—provided . . . the earth and the comet were approximately on the same side of the sun."

THE ANALYSIS OF IRREGULAR MOTIONS WITH APPLICATIONS TO THE ENERGY-FREQUENCY SPECTRUM OF STATIC AND OF TELEGRAPH SIGNALS.—G. W. Kenrick. (*Phil. Mag.*, January, 1929, V. 7, No. 41, pp. 176-196.)

In his work on the spectrum of static and the limitations to the advantages to be gained by the use of linear selective circuits for the elimination of interference, Carson considers a function $R(\omega)$ measuring the energy of interference on the frequency corresponding to ω ; this function he considers to be a continuous finite function converging to zero at unity, and everywhere positive, but he does not study in detail its form for various types of random disturbance. This paper indicates a method by which its form may in certain cases be computed. The method is of general application, but the specific examples chosen are suggested by the researches of Appleton and Watt: pulses disclosing an $R(\omega)$ varying over a wide range directly with the square of the wavelength. It

seems probable that such a relation applies to the types of disturbances important in static—except, of course, inductive interference from power lines, etc. The method here described introduces a formula due to Wiener, by means of which it is possible to obtain a function $\theta(\omega)$ such that

$$\theta(\omega) = \int_0^{\omega} R(\omega) d\omega.$$

The graph of $\theta(\omega)$ against ω , for a function having predominantly but not entirely random characteristics, is such that the rise between any two ω 's is proportional to the energy in the spectrum of $f(t)$ over that region; moreover, whenever there is a "line" in the $f(t)$ spectrum (or a truly periodic disturbance of finite energy) there is a sharp perpendicular rise in $\theta(\omega)$. Having shown how to analyse irregular motions defined over a finite interval by means of a graph or other set of data, the writer goes on to show how the same formulae can be employed to characterise irregular motion analytically defined by probability conditions over an indefinite time: using the Poisson exponential binomial limit and applying it to automatic telegraph signals of square wave-form and alternately of opposite sign, after justifying the treatment of these as random pulses rather than as the sequence of equally spaced dots assumed by other investigators. Then by making certain adjustments he applies his results to the frequency spectrum of static (square wave-form, or exponential: chance alone determining the signs); coming to the conclusion that the energy due to gross outline of such pulses, of the order of 10^{-3} sec. in duration, can produce appreciable fields (proportional to the square roots of the energies) on the longer wavelengths employed in practice; but that on the shorter wavelengths pulses or ripples of smaller energy content but shorter duration will be increasingly important. The methods employed are useful also in the harmonic analysis of many other types of irregular motions, such as voice waves or noise.

ON THE NATURE OF THE IONS IN AIR.—H. A. Erikson. (*Phys. Review*, March, 1929, V. 33, pp. 403-411.)

Results are given showing the production and ageing of the initial positive ion in dried air and dried nitrogen; also showing that when the final positive air ion of mobility 1.36 is passed into moist air the final ions disappear and a swifter 1.87 ion appears. Results are also given showing that these in turn change back into a 1.35 ion. The interpretation given of the above is that a neutral H_2O molecule gives up an electron to the final 1.36 two-molecule positive ion, thus giving a one-molecule positive ion which has a higher mobility. This H_2O^+ ion ages by attaching itself to another molecule forming a slower 1.36 ion. The article closes with a statement of the reasons for the author's view that the initial and final positive ions are respectively one and two molecules large. Cf. an earlier paper, March Abstracts, p. 147.

NUOVO REGISTRATORE DI ATMOSFERICI E PRIMI RISULTATI CON ESSO OTTENUTI (A New Atmospheric Recorder, and Its First Results).—I. Ranzi. (*Nuovo Cim.*, August/October, 1928, V. 5, pp. 326-330.)

The recorder, in which a very sensitive super-

heterodyne receiver controls a neon lamp, record^s continuously on a photographic film. Results of a 2,000 hours' run are said to confirm Bureau's conclusions as to the classification and origins of atmospherics. (Abstracts, 1928, V. 5, p. 684.)

ON THE VARIABILITY OF THE QUIET-DAY DIURNAL MAGNETIC VARIATION AT ESKDALEMUIR AND GREENWICH.—S. Chapman and J. M. Stagg. (*Proc. Roy. Soc.*, 6th March, 1929, V. 123 A, pp. 27-53.)

THE ENERGY OF LIGHTNING.—A. McAdie. (*Monthly Weath. Rev.*, June, 1928, V. 56, pp. 216-219.)

The results obtained by Peek, C. T. R. Wilson, Simpson and others are considered. Blue Hill Observatory results on the fusion of kite wires indicate voltages of the order of 1.3×10^7 v. and energies of the order of 11 kwh. The importance of a study of the side discharges or split-off flashes is stressed.

SUR L'ÉLECTRICITÉ ATMOSPHÉRIQUE AU COURS DES VENTS DE POUSSIÈRE DU NORD DE LA CHINE (Atmospheric Electricity during the Dust Winds of N. China).—H. Pollet. (*Comptes Rendus*, 28th January, 1929, V. 188, pp. 406-409.)

Wind velocity is about 10-15 m. per sec.; diameter of particles about 34μ ; number of particles per c.c. from 5-42. The particles are negatively charged, with a mean charge of about 4.4×10^{-8} e.s.u.—that is, about 100 times the charge of an ion. The height of the layer of air containing the particles is about 50 m. During the wind, the electric field is reversed and about 20 times stronger than it is normally. Before, during and after such a wind, atmospherics are very numerous; 17 per minute have been counted.

ACCUMULATION OF ELECTRIC CHARGE ON THUNDER-CLOUDS.—D. Nukiyama. (*Jap. Journ. Astron. & Geophys.*, No. 1, 1928, V. 6, pp. 63-69.)

A NOTE ON THE DIRECTIONAL OBSERVATIONS ON GRINDERS IN JAPAN.—E. Yokoyama and T. Nakai. (*Proc. Inst. Rad. Eng.*, February, 1929, V. 17, pp. 377-379.)

The U.R.S.I. paper dealt with in Abstracts, 1928, V. 5, p. 684.

RADIUM EMANATION CONTENT OF THE ATMOSPHERE AS DETERMINED BY AEROPLANE OBSERVATIONS.—A. Wigand and F. Wenk. (*Ann. der Physik.*, 28th July, 1928, V. 86, pp. 657-686.)

PROPERTIES OF CIRCUITS.

FILTERING ANTENNAS AND FILTER-VALVE CIRCUITS.—J. Plebanski. (*Proc. Inst. Rad. Eng.*, January, 1929, V. 17, pp. 161-173.)

Author's summary:—"Some methods of coupling together many circuits or antennas, giving them simultaneous excitation from the same source of energy, are described. The purpose of such arrangements is the construction of practical filter circuits (filtering antennas) giving square-topped resonance curves with good efficiency. Some interesting

phenomena with coupled antennæ are described." After referring to Vreeland's filter circuits with square-topped curves for the distortionless reception of modulated waves, the author describes his own methods, by which the time of the disappearance of the transitory condition is made shorter than in ordinary series band filters. Taking the case of two antennæ or loops coupled together, and plotting their power-absorbed/frequency curves, he shows that the mutual coupling of the two circuits reduces the resistance of the first

By diminishing the detunings, curve IV appears and the square-topped filter action is obtained, a band approximately 20,000 cycles wide being received with uniform intensity, while frequencies outside this band are strongly damped—curve IV going below curve V at each side. If the detunings are decreased still further, curve III—similar to a normal resonance curve—is obtained. "It is obvious that with five or more circuits still better results can be obtained." If the second and third frames have their resistances reduced to zero by reaction, an "inverted resonance curve" results. The author ends by describing the use of such coupled circuits for multiplex transmission, and by showing various ways of employing them as interval filters with flat-topped resonance curve or some other curve suitable for a particular purpose of transmission or reception.

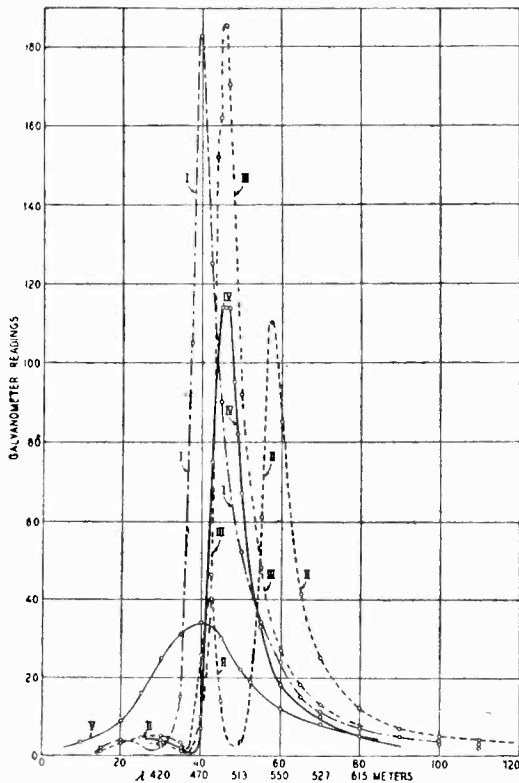

circuit, which receives energy not only from the incoming wave but also from the second circuit. The efficiency can be 90 per cent. or more, while the overall efficiency of a series filter is only about 50 per cent. Taking the case of a variable frequency of wave and constant tuning, for an arrangement of three frame aerials coupled according to his method, he describes the procedure of his tests. The second and third frames are removed and curve V (see diagram) is taken—the ordinary resonance curve.

The second frame is then coupled with the first and adjusted to give maximum current in the first frame for its own resonance wavelength. The third is then added and adjusted to give still more current; the curve for the current in the first frame is then taken—curve I. Then the second and third frames are slightly detuned by changing their capacities about ± 3 per cent. respectively. The resulting curve has two maxima—curve II.

THE VALVE AS AN ANODE BEND DETECTOR: OBTAINING MAXIMUM EFFICIENCY WITH LARGE INPUTS.—W. I. G. Page. (*Wireless World*, 13th and 27th March, 1929, V. 24, pp. 279-283 and 326-329.)

This method of detection has now attained a new importance owing to broadcasting and the need for selectivity and high-quality reproduction, and to the advent of new valves specially suitable for it. Among other points in the first instalment, the effect of percentage modulation at the transmitter is discussed; it is mentioned that at present the maximum peak modulations of 2LO, 5GB and 5XX are 80, 100 and about 85 per cent. respectively.

DYNAMIC RESISTANCE: THE TUNED CIRCUIT IN ITS RELATIONSHIP TO RECEIVER DESIGN.—A. L. M. Sowerby. (*Wireless World*, 13th March, 1929, V. 24, pp. 274-278.)

For the calculation of the H.F. amplification afforded by a receiver at different wavelengths, the high frequency resistance ("equivalent series resistance" r) of the tuned circuit is not used directly, its place being taken by the "dynamic" resistance ("equivalent parallel resistance" R). In this article the relationship of r and R is discussed non-mathematically, and the use of the

equation $R = \frac{L}{Cr}$ in the amplification calculations is shown.

NEUTRALISATION DES RESONANZ-VERSTÄRKERS (Neutralisation of the Resonance Amplifier).—K. Schlesinger. (*Zeitschr. f. Hochf. Tech.*, February, 1929, V. 33, pp. 63-66.)

If the anode of a valve is loaded with a circuit of L and C in parallel which is tuned to the frequency of a similar input grid circuit, oscillations are set up just as in the Huth-Kühn oscillator circuit; i.e., as a result of the coupling due to the grid-anode capacity. To suppress this self-excitation, a compensating current must be arranged to flow by a second path from the input circuit to the loading circuit, so as to produce at the neutralising points of the latter an A.C. potential equal in frequency and amplitude but displaced in phase by 180° . The

action of the well-known three-point neutralising circuit is readily understood by representing it as a bridge-circuit, but Hazeltine's classic Neutrodyne circuit cannot be explained on these lines. In the present paper the equivalent circuit of the Neutrodyne arrangement is considered, the Ohm-Kirchoff equations derived, and an expression found for the value of the neutralising capacity. The dependence of this on the frequency is shown; as a way of getting rid of this dependence, taps (for the neutralising path) on both circuit-inductances are indicated. Experimental verification of some of the calculations is given.

CIRCUIT ANALYSIS APPLIED TO THE SCREEN-GRID TUBE.—J. R. Nelson. (*Proc. Inst. Rad. Eng.*, February, 1929, V. 17, pp. 320-338.)

Author's summary: "General radio-frequency circuit theory is discussed in this paper. The theoretical work and discussion is divided into two parts, amplification and stability.

"General amplification equations for impedance and transformer coupling, using an untuned primary whose period is above the highest frequency considered, are derived and discussed for the case of a screen-grid tube such as Cunningham type CX-322.

"Feedback through the mutual capacity plate to grid capacity is also considered. A general expression for the limit of stable amplification per stage is inferred for n stages from the expressions found for one and two stages. This general expression $Av. < \sqrt{2gm/nwc_0}$ is in terms of the mutual conductance, total grid to plate capacity, frequency and number of stages."

NOTE SUR LES TRANSFORMATEURS INTERMÉDIAIRES DE BASSE FRÉQUENCE (Note on Inter-valve L.F. Transformers).—P. K. Turner. (*L'Onde Élec.*, December, 1928, pp. 541-542.)

Jouaust's article (January Abstracts, p. 41) says that to avoid the parallel resonance due to the action of the magnetising current, by shifting it to the high regions of the frequency spectrum, the inter-winding capacity should be reduced as much as possible by a suitable design of spool and winding. The writer points out that in England it was found impossible to reduce this capacity enough to put the first resonance above 2,000 p.p.s., but that by employing valves of low anode resistance this resonance was made imperceptible, while at the same time—by reducing the leakage flux—the second resonance only occurred in the highest frequencies. Jouaust replies (p. 542) that when he wrote his paper, only high resistance valves were readily available in France.

ON THE BEHAVIOUR OF NETWORKS WITH "NORMALISED" MESHES.—E. A. Guillemin and W. Glendinning. (*Proc. Inst. Rad. Eng.*, February, 1929, V. 17, pp. 380-393.)

Authors' summary: "The theory of normalising meshes in electrical networks, as outlined in a recent article appearing in this journal (Abstracts, 1928, V. 5, p. 33), is verified and illustrated by examples and figures relating to two- and three-mesh circuits. In the two-mesh circuit mesh No. 1 was normalised, thus confining the corresponding

frequency to that mesh both for the transient and steady states, as illustrated by Figs. 2 to 6 [graphs and oscillograms]. For the three-mesh circuit meshes Nos. 1 and 3 were normalised, and the results are illustrated in Figs. 6-16 inclusive. In each case the theory was checked in every detail." They conclude by pointing out that it is safe to assume that the theory holds in its general form and applies to any type of network however complex. "It seems reasonable that these properties of isolation and suppression of resonance effects should have some practical application in the design of circuits with special characteristics."

A NEW TRANSFORMATION IN ALTERNATING CURRENT THEORY, WITH AN APPLICATION TO THE THEORY OF AUDITION.—B. van der Pol. (*Phil. Mag.*, March, 1929, No. 43, V. 7, pp. 477-488.)

So long as positive resistances only were known, the real part of an impedance was always positive; but with the advent of negative resistances (e.g., arc, dynatron, or triode with reaction), the real part of an impedance—like the imaginary part—may have both signs. The transformations here considered (which may be called j -transformations) consist in multiplying all complex impedances of a network by j , j^2 , j^3 and j^4 respectively. Examples of well-known circuits, thus treated, are given; in particular a circuit is obtained with the valuable property that the amplitude of the current is unaffected by the value of R (the resistance), but its phase is affected, so that the phase can be changed over 180° without affecting the amplitude. This circuit is applied experimentally to verify Ohm's acoustic law that the human ear perceives, from a complicated sound, the amplitudes of the various components only—that it cannot recognise changes in phase of these components. This law was found to be valid for periodic sounds (such as vowels) and normal amplitudes; for aperiodic sounds (the spoken word) it holds good so long as the relative phase retardation between high and low components is not greater than 360° .

DIE MAGNETISCHE FELDSTÄRKE IN DER EBENE EINER STROMDURCHFLOSSENEN KREISFLÄCHE (The Magnetic Field Strength in the Plane of a Circular Surface Traversed by a Current).—L. Fleischmann. (*Arch. f. Elektrot.*, V. 21, 1928, p. 30.)

ON NEGATIVE RESISTANCE.—M. A. Bontch-Bruevitch. (*Teleg. i Telef. b. Prov.*, Nichny Novgorod, October, 1928, V. 10, pp. 572-586.)

TRANSMISSION.

DIE ERZEUGUNG KÜRZESTER ELEKTRISCHER WELLEN MIT ELEKTRONENRÖHREN (The Production of the Shortest Electric Waves by Valves).—H. E. Hollmann. (*Zeitschr. f. Hochf. Tech.*, February, 1929, V. 33, pp. 66-74.)

The first part of this survey was dealt with in April Abstracts. This second part deals with the production of oscillations by the control of the electron movements by brake-fields. (1) Whiddington's pioneer work: Electron oscillations of

Barkhausen-Kurz: the wavelength formula

$$\lambda = \frac{1000d_a}{\sqrt{E_g}} \cdot \frac{E_g - d_g E_a}{E_g - E_a}$$

d_g and d_a being diameters of grid and anode: working independently, with ordinary three-electrode valves, Zilitinkewitsch obtained similar oscillations and—also from the path-times of the electrons—arrived at a somewhat similar formula which agreed well with his results on 40 and 70 cm. waves: the dependence of electron oscillations on the gas pressure—Scheibe, Nettleton, Pierret, Grechowa, Kapzov: the influence of the space charge—Barkhausen-Kurz, van der Pol, Gill, Kapzov and Gwosdower: the influence of a coupled circuit—Gill and Morrell, Sahanek and others, the oscillator of Tank and Schiltknecht, Wechsung (with A.C. feed), Kohl. (2) The simultaneous appearance of B.-K. and G.-M. oscillations—Tank, Kapzov and Gwosdower, Hollmann. The work of most of the workers quoted above is illustrated by curves or other diagrams. The paper will be concluded by a third part.

VACUUM TUBES AS OSCILLATION GENERATORS.—D. C. Prince and F. B. Vogdes. (*Gen. Elec. Review*, December, 1928, V. 31, pp. 678-683.)

This seventh instalment of the series deals with methods of improving the efficiency of valves driving oscillating circuits. With sinusoidal waves under good operating conditions, the alternating voltage has a peak value slightly less than the direct voltage of the supply source, and if the plate current is drawn only at the time of minimum plate potential, power conversion occurs with high efficiency. In practice, however, such operation is not desirable since full use is not being made of the capabilities of the valve; accordingly, efficiency of conversion is relinquished to get more output from the same apparatus, by allowing the plate current to flow through a longer period of time. The additional power thus obtained is produced at a much lower efficiency than the first. The paper considers alternative plans to avoid this loss of efficiency: increasing the instantaneous value of current flow while the plate voltage is near its minimum: control of the plate-voltage wave by adding harmonics, to produce a flat or slightly cupped wave—with increase of output and decrease of loss (an "harmonic trap" circuit is described which effects this): a high efficiency circuit with square current wave. The causes and prevention of parasitic oscillations are discussed.

MESSUNGEN AN KURZWELLENRÖHREN (Measurements on Short Wave Valves).—H. Hornung. (*Ann. der Phys.*, 25th February, 1929, 5th Series, V. 1, No. 4, pp. 417-456.)

A quantitative investigation of the arrangements used by Kohl (see the next two abstracts) for the production of waves below 1 m. Among other results, the wavelengths are found to be dependent not only on the circuit constants but also on grid and anode potentials and on the emission current; the dependence on these, however, diminishing with diminishing wavelength. Results by no means

agree with the theory of Barkhausen-Kurz and Scheibe.

For a given circuit, increasing emission (with constant anode and grid voltages) causes λ to decrease almost linearly. Increasing grid voltage (with constant emission and anode voltage) causes λ again to decrease almost linearly. Increasing anode voltage (with constant emission and grid voltage) causes λ to increase almost linearly. The valves will oscillate with isolated anodes, wavelengths then being somewhat smaller: for a constant wavelength, very sudden and intense amplitude maxima (as the emission current was varied) were noted: these are not yet explained. The author mentions that preliminary efforts at arc-production of very short waves were unsuccessful.

ÜBER KURZE UNGEDÄMPFTE ELEKTRISCHE WELLEN (On Short Undamped Electric Waves).—K. Kohl. (*Zeitschr. f. tech. Phys.*, December, 1928, pp. 472-475.)

An earlier paper on the same subject was dealt with in Abstracts, 1928, V. 5, p. 464. The author's interpretation of his method of producing 30-90 cm. wavelengths is that the electron stream in the grid-anode gap excites the oscillatory circuit to oscillate at the latter's own frequency, whereby the electron stream in its turn is controlled by the oscillating voltage between grid and anode. The difficulty, that the frequency is nevertheless dependent on working conditions, is explained by the supposition that the electron-gas between grid and anode has a dielectric constant less than unity, the difference becoming greater the more dense the electrons. On this supposition he shows that all the observed results naturally follow. This explanation he applies also to the Barkhausen-Kurz oscillations, in opposition to the purely "electron-oscillation" idea of those workers.

NEUE ERFABRUNGEN BEI ELEKTRISCHEN KURZWELLEN (New Experiments with Short Waves).—K. Kohl. (*Verh. d. Dent. Phys. Ges.*, No. 2, 1928, V. 9, pp. 36-37.)

A theory of the dependence of wavelength on working conditions, in the generation of oscillations by grid-excitation of small circuits. The wavelength is linked to the dielectric constant of the electron-gas forming the dielectric in the grid-anode capacity. According to Einstein, this dielectric constant $\epsilon = 1 - \text{const. } n \cdot \lambda^2$, where n is the mean electron density in the grid-anode space. The theory fits in with experimental results.

EXPERIMENTELLE UNTERSUCHUNGEN ÜBER DIE BARKHAUSEN-KURTZSCHEN SCHWINGUNGEN IN MAGNETISCHEN FELDERN (Experimental Investigations of the B.-K. Oscillations in Magnetic Fields).—M. Forró. (*Ann. der Phys.*, 25th February, 1929, 5th Series, V. 1, No. 4, pp. 513-528.)

With different valves three different "classes" of oscillation, differently affected by magnetic field changes, were found. Full details are given.

ÜBER DIE INSTABILITÄT DER FREQUENZ VON RÖHRENGENERATOREN UND DEREN STABILISIERUNG (The Frequency-instability of Valve Generators, and their Stabilisation).—W. Lazaref. (*Zeitschr. f. Hochf. Tech.*, February, 1929, V. 33, pp. 55-63.)

Author's summary:—"The mechanism of the frequency changes of valve generators due to alterations in heating current, anode potential, and coupling, is here elucidated. The cause lies in the grid-current, whose A.C. component acts on the oscillating circuit and increases the damping factor; this increase produces a phase difference between the A.C. components of the anode current and of the anode potential, and this leads to a change of frequency.

"A stabilised generator has been constructed which keeps its frequency constant with a sufficient accuracy, namely:—the frequency variation is less than 0.003 per cent. for a change of heating current from its lowest (40 mA.) to its maximum (75 mA.): for a ten-fold change of anode voltage from 100 to 10 v., the frequency variation is less than 0.0001 per cent." In the particular circuit set up by the writer, frequencies can be chosen between 435 and 3×10^6 p.p.s. The method (patented in Russia in 1927) is shown in the diagram.

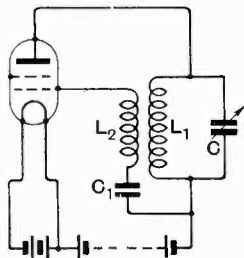

The control grid is left free. The condenser C_1 (in the space-charge grid circuit) can be varied between 0.01 and $2 \mu\text{F}$. The stabilisation is the more perfect the smaller the conductivity of this condenser. In the particular case considered, the ohmic resistance of C_1 and the resistance of the valve holder are each 100 megohms; even for a small current, the grid receives a negative charge. The grid-current, at the setting-in of oscillation, is about 10^{-6} A., and the grid obtains a considerable negative charge. Oscillation takes place only in the negative region of the characteristic; only a purely capacitive current flows in the grid (the capacity of the system grid-cathode may reach 10 cm.). Under these conditions the generator current is a pure or nearly pure sine wave: no harmonics can be detected. Loose coupling is essential: too tight a coupling produces irregularity. The whole generator, or at least the inductances, must be electrostatically screened; otherwise the external fields may induce such a negative charge on the grid that no oscillations can take place. The advantage of using a two-grid valve appears to be due to its small "durchgriff" ($1/\mu$); the second grid appears to play no part.

HAND GENERATOR (40-WATT) WITH AUTOMATIC SIGNALLING. (*Wireless World*, 27th February, 1929, V. 24, p. 226.)

In an article "Radio at the British Industries Fair," a generator shown by the M.L. Magneto Syndicate is described, the output of which is stated to be 40 w., the handle being turned by one hand. Incorporated in the casing is the Frost

automatic signalling device, on whose disc the studs can be arranged for any pre-arranged signal; so, for example, in use in outlying places, a call for a doctor would be sent out again and again so long as the handle continued to be turned.

INVESTIGATION OF THE STABILISATION OF A SHORT WAVE OSCILLATOR WITH NEGATIVE RESISTANCE BY MEANS OF A SPECIAL STABILISING ELECTROMOTIVE FORCE.—P. N. Ramlau. (*Teleg. i Telef. b. Prov.*, Nizhny Novgorod, October, 1928, V. 10, pp. 514-529.)

DEPENDENCE OF THE RANGE OF VERY SHORT WAVES ON THE HEIGHT OF THE TRANSMITTER ABOVE THE EARTH.—H. Fassbender and G. Kurlbaum. (See under "Propagation of Waves.")

RECEPTION.

AN AIRCRAFT RADIO RECEIVER FOR USE WITH RIGID ANTENNA.—F. H. Drake. (*Proc. Inst. Rad. Eng.*, February, 1929, V. 17, pp. 306-319.)

Author's summary: "An outline is given of the physical and electrical requirements of an aircraft radio receiver suitable for the reception on a rigid antenna of radio beacons and weather service. The design of a special unicontrol receiver calculated to fulfil these requirements is described. Quantitative performance data are presented, with particular attention to the problem of detector overloading when operating a visual indicator from a beacon of the Bureau of Standards type. The corroboration of these data by practical tests is briefly discussed. The paper is concluded with quantitative discussion of the problem of ignition shielding on a particular type of airplane motor."

Regarding the method of detection, the paper mentions that a detector capable of withstanding considerable overloading is provided by the use of anode rectification with automatic grid bias (Ballantine); this feature being particularly important in connection with the visual beacon indicator (see recent Abstracts). It also has other advantages:—though it is commonly supposed that grid rectification gives greater sensitivity than anode, the micro-volt sensitivity of the tetrode receiver described is twice as great with anode detection as with grid, although the small-signal detection factor for the latter is about three times as great as for the former. "Plate detection exceeds grid rectification in this case because it leaves unaffected the ratio gain of the preceding stage, whereas due to electronic conductance grid detection reduces this gain by a factor greater than 2 to 1. For the same reason the selectivity is considerably greater with plate rectification than with grid rectification. The higher output impedance resulting from plate detection does not impair the uniform transmission of low modulation frequencies essential for the visual beacon provided the coupling between detector and audio amplifier is properly designed."

The diagram reproduced gives the relation between the permissible receiver sensitivity (to render ignition interference just audible) and the degree of shielding, in an aeroplane equipped with a single Wright Whirlwind motor; the results must of

course be applied with caution to other installations, but the relative magnitudes of the various factors contributing to the total disturbance are of general interest.

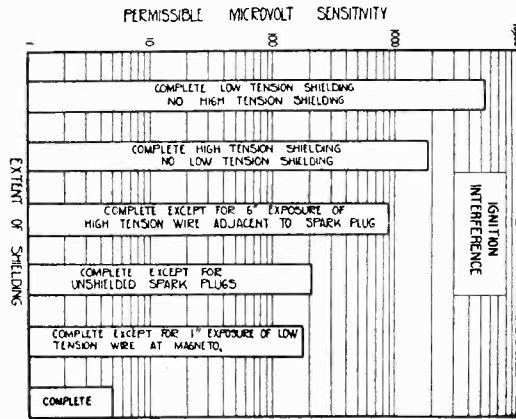

DAS PROBLEM DER ÖKONOMISCHTEN VIELFACH-TRANSPONIERUNG (The Problem of the Most Economic Multiple Frequency-Changing Reception).—F. Aigner. (*Zeitschr. f. Hochf. Tech.*, February, 1929, V. 33, pp. 47-52.)

This second and final part of the paper referred to in April Abstracts deals with apparatus with increased sharpness of selection:—(a) for unmodulated waves, with the help of a single fixed-frequency local generator and the use of frequency-

from the incoming signal by means of an input frequency transposer "of variable frequency": it passes through a frequency-doubler and becomes 150,000; subtracted from the fixed transposing frequency (250,000) it yields 100,000 which is then doubled by the same doubler to 200,000. This, transposed by the 250,000 frequency, gives 50,000. These particular frequency-changes are supersonic, but this is not essential. Unfortunately, the method is not applicable to modulated waves, but these are dealt with in (b):—the use of a single fixed local frequency with the help of special Helmholtz combination-frequencies. The diagram below shows the lay-out of such a multiple wave-change, frequency doubling circuit with reflex connection. T_1 is the variable input frequency-transposer, T_2 the fixed transposer of frequency ν . V represents an intermediate-frequency reflex amplifier for amplifying the frequencies n_1 , n_2 and n_3 (see later); R is the wave-change rectifying amplifier, and D is the output demodulator. The method depends on the utilisation of suitable members of the group of Helmholtz combination tones formed by the demodulation of a carrier wave of frequency H with its side-bands $H \pm N$. The choice lies between those possessing the form aH and $aH \pm N$ (a being a whole number) and a suitable value for a is 2 (giving a long wave); the method adopted is to use a rectifier-amplifier whose anode circuit is tuned to $2H$. The idea of increasing selectivity by the use of frequencies $2H$ and $2H \pm N$ was originally suggested by Grimes, for his "octamonic" receiver using frequency doubling; but even for the longest broadcast waves only one stage was possible. With the present method several stages are possible.

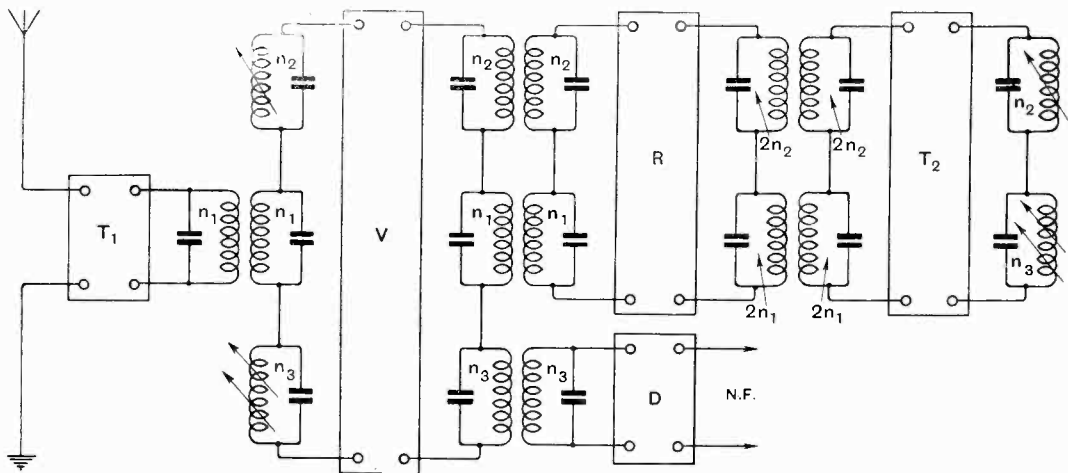

multiplication. The obtaining of freedom from interference by repeated frequency-doubling alone is limited by the speedy arrival at the short wave region and the need for impracticable decrements; it is therefore only applicable to telegraphy on very long waves. This difficulty is avoided by the alternate use of frequency-doubling and frequency-transposing by heterodyne. In an example given, a first difference-frequency of 75,000 is obtained

The first difference-frequency n_1 (obtained from the signal and the variable-frequency input heterodyne) is passed through the rectifying amplifier R which selects, out of the resulting complex Helmholtz combination tones, the frequency $2n_1$ by means of its tuned anode circuit. This then combines with the fixed frequency ν of the transposer T_2 , giving $n_2 (= \nu - 2n_1)$ which is returned to R , leading to the selection of $2n_2$ and finally to

the production of $n_3 (= \nu - 2n_2)$. The various values are selected with attention to the frequencies of the principal interfering stations. A later paper will deal with the practical design of these two types of receiver (for which patents are being taken out).

RECEIVING SETS FOR AIRCRAFT BEACON AND TELEPHONY.—H. Pratt and H. Diamond. (*Proc. Inst. Rad. Eng.*, February, 1929, V. 17, pp. 283-305.)

A reprint of the Bureau of Standards paper dealt with in April Abstracts.

THE PERFORMANCE OF VALVE DETECTORS.—W. B. Medlam and U. A. Oschwald. (*J. Inst. Wireless Tech.*, March-June, 1928, V. 1, pp. 147-223.)

A record of experiments carried out to determine the audio-frequency efficiency of, and the nature and magnitude of various forms of distortion which may be introduced in, a triode detector stage using a high external anode resistance. The effects on the performance of the following factors are considered: magnitude of external resistance, shunting capacity, amplification factor, method of rectification (grid or anode circuit), input voltage, and modulation depth. Experimental results are also given for the determination of optimum working conditions, and for the relation between D.C. change in anode current and audio-frequency output. Some account is also given of measurements made with a triode with neutralised space charge used as a diode. The paper contains a number of experimental results which should prove useful for correlation with analytical investigations. The most outstanding result is perhaps that a considerable degree of output-modulation frequency variation can arise with resistance loads in the anode circuit, if there is shunt capacity across the resistance.

THE RECEIVING SYSTEM FOR LONG-WAVE TRANS-ATLANTIC RADIO TELEGRAPHY: DISCUSSION.—(*Proc. Inst. Rad. Eng.*, January, 1929, V. 17, pp. 174-184.)

Discussions following the paper referred to in April Abstracts.

DIE UMÄNDERUNG VON BATTERIE-EMPFÄNGERN AUF HEIZUNG MIT WECHSELSTROM OHNE UMBAU DES EMPFANGSGERÄTS (Changing-over Battery-supplied Receivers to A.C. Filament Supply without Dismantling).—(*Rad. f. Alle*, January, 1929, pp. 11-13.)

A description of the use of Telefunken adapters—A.C. valve holders plugging into the ordinary sockets. The A.C. sockets lead out by terminals at the side, which are connected to additional bus-bar leads going to the heating-current transformer.

RECEPTION AND RETRANSMISSION ON THE SAME ANTENNA.—V. A. Pavlov. (*Teleg. i Telef. b. Prov.*, Nizhny Novgorod, October, 1928, V. 10, pp. 552-555.)

A METHOD OF DIMINISHING INTERFERENCE IN RADIO TELEGRAPHY.—G. A. Ostroumov. (*Teleg. i Telef. b. Prov.*, Nizhny Novgorod, October, 1928, V. 10, pp. 530-535.)

SUPER-REGENERATIVE RECEIVER FOR ULTRA-SHORT WAVES.—Fassbender and Kurlbaum. (*See under "Propagation of Waves."*)

AERIALS AND AERIAL SYSTEMS.

INVESTIGATIONS ON WIND PRESSURE ON POLES AND CABLES FOR OVERHEAD TRANSMISSION LINES.—(*Journ. I.E.E.*, February, 1929, V. 67, pp. 229-240.)

Technical Report of the British Electrical and Allied Industries Research Association.

OVERHEAD ELECTRIC LINES.—W. B. Woodhouse. (*Journ. I.E.E.*, February, 1929, V. 67, pp. 217-228, and Discussion, pp. 241-252.)

An account of the work of the British Electrical and Allied Industries Research Association.

ON THE CALCULATION OF THE RADIATION OF DIRECTIONAL ANTENNAE: AND ON THE RADIATION OF A SIMPLE ANTENNA IN THE PRESENCE OF A REFLECTING WIRE.—A. Pistolokors. (*Teleg. i Telef. b. Prov.*, Nizhny Novgorod, October, 1928, V. 10, pp. 540-551.)

VALVES AND THERMIONICS.

CONTROL OF CURRENT IN A DISCHARGE-TUBE BY MEANS OF A MAGNETIC FIELD.—R. F. Earhart and C. B. Green. (*Phil. Mag.*, January, 1929, V. 7, pp. 106-115.)

Plane parallel brass plates at ordinary temperatures were used as electrodes, in air (and hydrogen) at pressures ranging from 0.80 to about 9.0 mm. Hg. With d (mm. between plates) equal to 15 or more, a longitudinal field (1,000-1,800 gauss) produced an increase in current but only a small one, especially for a current of several ma. If d was reduced to the order of 1, and the pressure properly adjusted, variations in current produced by varying the field might be as much as several hundred per cent. The results obtained fit in with the presence of two effects of the longitudinal field—increase of current by increase of ionisation by collision owing to the helical motion of such ions as initially have a component perpendicular to the electric force, and limitation (or decrease) of current by the effect that the ions executing such motion may spiral out of the path between the electrodes and be dispersed to the sides of the tube (*cf. Hull, Phys. Rev.*, July, 1921). It was soon found that the variation of current by the field depended on at least 3 variables—(1) distance between electrodes, (2) pressure of gas, and (3) magnitude of the current under stress. It is suggested that a failure to realise (3) may be responsible for lack of agreement reported by different observers. Not only does the curve of the percentage current change/field slope up more steeply for the smaller currents, but the saturation point (where further increase of field adds little to the change) occurs only at much higher values of field. The unidirectional component in a point-

to-plane discharge was affected by the magnetic field "in much the same way as the sinusoidal current." Tests with a transverse field confirmed that the usual current diminution (as utilised in the magnetic blowout for arc discharges) took place for $d=50$ mm. about, or for pressures exceeding a few mm.; but for small gaps, with pressure properly adjusted (e.g. 1.8 mm.), fields of a few hundred gauss may considerably increase the current, while larger fields may reduce it. There is a critical region of pressure and distance where the form of the graphs alters: in some experiments with hydrogen, it was found that a magnetic control could be effected where small transverse fields would decrease the current quite uniformly to 50 or 60 per cent. of the original value, while larger fields restored and even increased the current by more than 100 per cent. Still further increase of field reduced the current to extinction. Such a critical region was given by $d=4.6$ mm., $P=1.15$ mm., $i=3$ ma.

OSCILLATIONS IN IONIZED GASES.—Lewi Tonks and I. Langmuir. (*Phys. Review*, February, 1929, V. 33, pp. 195-210.)

Authors' abstract: A simple theory of electronic and ionic oscillations in an ionized gas has been developed. The *electronic* oscillations are so rapid (ca. 10^9 cycles) that the heavier positive ions are unaffected. They have a natural frequency $\nu_e = (ne^2/\pi m)^{1/2}$ and, except for secondary factors, do not transmit energy. The *ionic* oscillations are so slow that the electron density has its equilibrium value at all times. They vary in type according to their wavelength. The oscillations of shorter wavelength are similar to the electron vibrations, approaching the natural frequency $\nu_p = \nu_e(m_e/m_p)^{1/2}$ as upper limit. The oscillations of longer wavelength are similar to sound waves, the velocity approaching the value $v = (kT_e/m_e)^{1/2}$. The transition occurs roughly (*i.e.* to 5 per cent. of limiting values) within a 10-fold wavelength range centering around $2(2)^{1/2}\pi\lambda_D$, λ_D being the "Debye distance." While the theory offers no explanation of the cause of the observed oscillations, the frequency range of the most rapid oscillations, namely from 300-1,000 megacycles, agrees with that predicted for the oscillations of the ultimate electrons. Another observed frequency of 50-60 megacycles may correspond to oscillations of the beam electrons.

Frequencies from 1.5 megacycles down can be attributed to positive ion oscillations. The correlation between theory and observed oscillations is to be considered tentative until simpler experimental conditions can be attained.

DETECTION CHARACTERISTICS OF THREE-ELEMENT VACUUM TUBES.—F. E. Terman and T. M. Googin. (*Proc. Inst. Rad. Eng.*, January, 1929, V. 17, pp. 149-160.)

Authors' summary: "The change of grid potential in a grid-leak grid-condenser detector can be determined by considering a fictitious 'rectified voltage' acting in series with the grid resistance. This equivalent voltage is inversely proportional to the tube 'voltage constant' v , which has the value $v = 2R \frac{dR_g}{dE_g}$, and can be readily measured by an A.C. resistance bridge.

"The rectifying action of different tubes can be compared on the basis of the respective voltage constants at grid resistances inversely proportional to the size of grid condenser. Tubes are then compared under conditions of equal detector distortion, and the change of grid potential is inversely proportional to the voltage constants.

"The voltage constant of ordinary vacuum tubes at first drops rapidly as the grid resistance is increased, but soon flattens out and becomes constant at grid resistances above 50,000 to 150,000 ohms.

"The highest audio-frequency that can be satisfactorily reproduced with the detector adjusted to full sensitivity is inversely proportional to the grid resistance at the lower end of the flat part of the $v-R_g$ characteristic.

"It was found that tubes of the same type had uniform detection characteristics, that age, use, plate voltages between 16 and 122, and filament voltage (above the minimum necessary to give electron saturation) had little or no effect on the rectifying ability of high vacuum tubes at a given grid resistance in the useful range of operation."

The authors end by saying that although the results in this paper do not answer the question "exactly what design and construction features give a sensitive detector valve?" the data do indicate that the most important elements are *not* the voltage-drop in filament, type of filament (oxide or thoriated), power rating of valve, or changes in μ . It is hoped that definite conclusions can be reported later.

DETECTION WITH THE FOUR-ELECTRODE TUBE: DISCUSSION.—(*Proc. Inst. Rad. Eng.*, January, 1929, V. 17, pp. 185-186.)

Discussion on Nelson's paper (Abstracts, 1928, V. 5, p. 521).

THORIUM- ODER ACID-RÖHREN? (Thorium or "Acid" Filaments for Valves?)—Telefunken Company. (*Rad. f. Alle*, January, 1929, pp. 16-17.)

Valves with the so-called "Acid" filaments have such increased emission and steepness (working as "dark-emitters") that in some ways it would be better to stop manufacturing thorium filaments altogether. Various reasons are given here, however, for the existence side by side of the two types.

OXIDE-COATED FILAMENTS AND SOME OF THEIR PROPERTIES.—A. M. Schemaew. (*Journ. Applied Phys.*, Moscow, No. 2, 1928, V. 5, pp. 35-49.)

In Russian, with German summary. A method is described by which a small platinum surface can be coated with a firm, smooth coating of oxide. Various phenomena are discussed—e.g., a filament carefully out-gassed by prolonged heating in vacuo yields a great deal more gas when giving its emission current. The filament is activated by passing a large emission current. The activation is increased by the presence of mercury vapour at considerable pressure. One over-heating causes a complete loss of emission at low temperature, but this can be restored by the activating process.

An activated filament left cold in the presence of mercury vapour loses its activity after a time. A tungsten wire stretched near a heated oxide-coated filament acquires a strong emissivity for low temperatures.

VERY LOW VAPOUR PRESSURE GREASES AND OILS; THEIR PRODUCTION BY VACUUM DISTILLATION AND THEIR USE FOR JOINTS IN HIGH VACUUM SYSTEMS (10^{-6} MM.), FOR CONDENSATION PUMPS AND FOR LIQUID AIR TRAPS. (See *Proc. Roy. Soc.*, 6th March, 1929, V. 123 A., pp. 271-284: "Some Experiments on Vacuum Distillation," C. R. Burch.)

PHOTO-ELECTRIC EMISSION AND THERMIONIC EMISSION ONCE MORE.—E. H. Hall. (*Proc. Nat. Acad. Sci.*, February, 1929, V. 15, pp. 126-127.)

The writer argues that Du Bridge's experimental results (*Abstracts*, 1928, V. 5, p. 226) do not really imply that the amount of work required to overcome resisting forces is the same for an electron taken from the "free" state within a metal to the free state outside it, as for an electron taken by photoelectric action out of the metal. As for the so-called "universal constant" A , a 1927 paper of his predicted that it would prove different in different metals.

THE TEMPERATURE DEPENDENCE OF ELECTRON EMISSION UNDER HIGH FIELDS.—W. V. Houston. (*Phys. Review*, March, 1929, V. 33, pp. 361-363.)

Author's abstract: An expression . . . is secured by combining the results of Fowler and Nordheim with the Fermi distribution of velocities used in the Sommerfeld electron theory of metals. The result is similar to that obtained previously by considering the diminution of the work function by the field. The temperature variation is small and decreases as the external field increases. It is of the right order of magnitude to agree with the most recent observations.

PAPERS ON THE EMISSION OF IONS FROM CERTAIN SALTS (Halogen Derivatives of Lead, etc.).—J. Kahra and O. Birkenberg. (*Ann. der Phys.*, 2nd January, 1929, 5th Series, V. 1, No. 1, pp. 135-156 and 157-168.)

ÜBER DIE IONISATION DURCH ELEKTRONEN IN EINEM HOMOGENEN ELEKTRISCHEN FELDE (Ionisation by Electrons in a Homogeneous Electric Field).—M. J. Druyvesteyn. (*Zeitschr. f. Phys.*, 22nd November, 1928, V. 52, No. 3/4, pp. 197-202.)

The probability of ionisation in an inert gas is worked out by a method different from that of Penning and considered more likely to be accurate.

ARCS WITH SMALL CATHODE CURRENT DENSITY.—J. Slepian and E. J. Haverstick. (*Phys. Review*, January, 1929, V. 33, pp. 52-54.)

To account for the electric arc with cold cathode, Langmuir has proposed that electrons are drawn

from the cathode by a very intense electrostatic field at the cathode surface, this field being set up by the positive space charge sheath which forms next the cathode. The writer shows that a consequence of this view would be that cold cathode arcs should not be able to exist with less than a minimum cathode current density of considerable magnitude; whereas he has found experimentally that at gas pressures of 10-50 mm., arcs with cathode current densities of less than 100 a. per cm.² can exist.

ON THE MECHANISM OF ELECTRON OSCILLATIONS IN A TRIODE.—H. E. Hollmann. (*Proc. Inst. Rad. Eng.*, February, 1929, V. 17, pp. 229-251.)

An abridged translation of the German paper referred to in *Abstracts*, 1928, V. 5, p. 582.

ON THE CHEMICAL INTERACTION OF IONS AND THE "CLEAN UP" OF GASES AT GLASS SURFACES UNDER THE INFLUENCE OF THE ELECTRICAL DISCHARGE.—J. Taylor. (*Proc. Roy. Soc.*, 6th March, 1929, V. 123 A, pp. 252-270.)

CALCULATIONS ON VACUUM TUBES AND THE DESIGN OF TRIODES.—Y. Kusunose. (*Researches of the Electrol. Lab.*, Tokio, No. 237, September, 1928, 163 pp.)

ÜBER DIE BEFREIUNG DES ELEKTRONS AUS DER METALLOBERFLÄCHE DURCH LANGSAME POSITIVE IONEN (The Setting Free of an Electron from the Surface of a Metal by Slow Positive Ions).—O. Klemperer. (*Zeitschr. f. Phys.*, 31st December, 1928, V. 52, No. 9/10, pp. 650-653.)

The probability of an electron being set free is worked out by two fundamentally different ways—from the known current-voltage measurements of the Townsend discharge and from the minimum spark potential and ionisation-expenditure of the electron in gas.

DIRECTIONAL WIRELESS.

FLUGZEUGSTEUERUNG BEI UNSICHTIGEM WETTER (The Piloting of Aircraft in Fog, etc.).—O. Scheller. (*E.T.Z.*, 7th February, 1929, pp. 191-192.)

The author patented, in 1907, the equi-signal beacon system recently re-developed for aircraft in the U.S.A. His system was tested (for ships) before the war, and for aeroplanes in 1917/1918.

ACOUSTICS AND AUDIO-FREQUENCIES.

THE EFFECT OF A FINITE BAFFLE ON THE EMISSION OF SOUND BY A DOUBLE SOURCE.—M. J. O. Strutt. (*Phil. Mag.*, March, 1929, No. 43, V. 7, pp. 537-548.)

From physical reasoning it may be expected that enlargement of the baffle beyond a certain critical point (the wavelength being given) will have only little effect; from phase considerations, this point may be expected to be about where the shortest air-path between front and back of the loudspeaker equals one half of the wavelength. In this paper,

the effect of a finite baffle on the sound emitted by an oscillating circular plate, of dimensions small with respect to the wavelength, is calculated by supposing two simple sources of equal amplitude and opposite phase to be placed at two diametral points of a sphere; the effect of increasing the diameter of this sphere on the circulation of air from one source to the other is taken to be essentially the same as the effect of increasing that of a flat baffle of finite dimensions.

The critical size of the baffle, predicted above, is confirmed by this investigation at the predicted value. Also, the effect of the baffle on the directive properties of the emitter is shown.

ÜBER STRAHLUNGS- UND RICHTWIRKUNGSEIGENSCHAFTEN VON SCHALLSTRAHLERN (Radiating and Directional Properties of Sound Emitters).—H. Backhaus. (*Zeitschr. f. tech. Phys.*, December, 1928, pp. 491-495.)

Theory of the energy-radiation from a spherical radiator; application to bowed instruments; method of determining the vibration-form of violins and similar instruments; directional effects with violins.

ON THE CONDENSER-TELEPHONE.—G. Green. (*Phil. Mag.*, January, 1929, V. 7, No. 41, pp. 115-125.)

A former paper (*ibid.*, September 1926) gave a preliminary discussion of the mathematical theory of a two-plate telephone, one fixed and the other free to move. The present paper deals with a condenser consisting of a pile of plates, of which only the undermost is regarded as fixed. It explains the fundamental dynamical theory and indicates clearly the nature of the response curve and the conditions which determine the shape of the curve in any actual case. But in neglecting all second-order terms the investigation has been restricted to the case where the e.m.f.'s impressed on the condenser are very small compared with the constant e.m.f. applied to its plates, whereas in some of the more important applications so far made of the condenser-telephone this condition is far from being fulfilled.

ACOUSTIC CONSIDERATIONS INVOLVED IN STEADY STATE LOUD SPEAKER MEASUREMENTS.—L. G. Bostwick. (*Bell Tech. Journ.*, January 1929, V. 8, pp. 135-158.)

Author's synopsis: Certain difficulties encountered in acoustic measurements of the performance of loud speakers are described. Because of the nature of these difficulties it has not yet been possible to specify a complete and simple set of measurements or conditions which will completely express the performance of a loud speaker. Data are given showing the performance of two representative types of loud speaker both when measured in outdoor space free from reflections and when measured under varying conditions in a specially treated acoustic laboratory. The differences serve to emphasise the importance of certain precautions in the making of indoor acoustic measurements.

DIE BISHER ÜBLICHEN ELEKTROMAGNETISCHEN LAUTSPRECHER-SYSTEME UND DAS NEUE SPANNUNGSFREIE SYSTEM (The Ordinary Electromagnetic Loud-speaker Systems, and the New Tension-free System).—F. Gabriel. (*Rad. f. Alle*, January, 1929, pp. 18-22.)

After describing how the older biased electromagnetic movements led to reproduction of bad quality, the writer illustrates an example of the more modern bias-free movement and shows how, in actual practice, it is impossible to adjust this so as to obtain real freedom from bias. He then

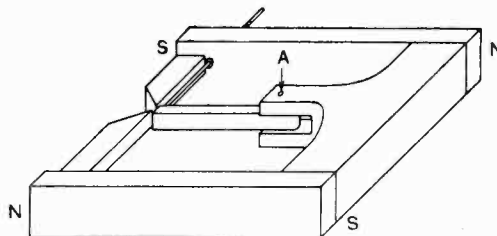

describes his own patent, which is not only free from bias, but also free from any spring tension—it is truly electromagnetically controlled. The illustration explains the construction; the pivot at *A* is jewelled; the rectilinear construction of the magnet system allows the highest quality of steel to be used. Tests are said to show great naturalness of reproduction.

A MICROPHONE WITH UNIFORM RESPONSE (Igranic).—(*Engineer*, 18th January, 1929, V. 147, pp. 68-69.)

In an article on the Physical and Optical Societies' Exhibition, a microphone is described which is said to respond uniformly to "sound waves of all audible frequencies," with complete freedom from background noises. Several compartments are interspaced between the electrodes, each containing carbon granules of a size different from those in the other compartments. The diaphragm is non-conducting and non-resonant, and the "sound waves impinge on the diaphragm at right angles to the direction of current flow."

APPARATUS FOR GENERATING AND MEASURING SOUND, FOR THE STUDY OF ARCHITECTURAL ACOUSTICS.—D. M. Crawford. (*Science*, 31st August, 1928, V. 68, pp. 209-211.)

The apparatus is said to give a constant pitch of tuning-fork accuracy over a wide range of intensities and for long periods of time, and can be made portable.

TRANSMISSION OF SONIC AND ULTRASONIC WAVES THROUGH PARTITIONS.—R. W. Boyle. (*Nature*, 14th January, 1928, V. 121, pp. 55-56), and PASSAGE OF ACOUSTIC WAVES THROUGH MATERIALS.—R. W. Boyle and J. F. Lehmann. (*Trans. Roy. Soc. Canada*, No. 1, 1927, V. 21, pp. 115-125.)

Ultrasonic tests showed that at (metal) plate

thicknesses of an odd number of quarter wavelengths, reflection was maximum and transmission minimum, while at thicknesses of a small integral number of half wavelengths the reverse was the case and nearly all the incident energy got through. Thus with a frequency of 300,000 p.p.s., a 2 mm. plate of type-metal could block off the beam completely, while a plate 2 or 4 or 6 times this thickness allowed the larger part of the energy to emerge through it. This agrees with Rayleigh's mathematical treatment of longitudinal waves, which led to the equation which may be expressed verbally in the words "when the mass of a wavelength in incident and reflecting media is the same, reflection is nil and transmission is perfect."

DU CHOIX D'UN CORNET ACOUSTIQUE (The Choice of an Ear Trumpet).—Marage. (*Comptes Rendus*, 4th February, 1929, V. 188, pp. 466-468.)

The writer gives four curves each representing the loss of acuteness of hearing for the five vowel sounds, and each corresponding to a definite type of deafness. The shape of the curves remains fixed though their position on the loss-of-hearing scale may vary; two curves belong to the class due to injury to the middle ear, the other two to defects in the internal ear and auditory centres. He shows that the aid to hearing should be designed to suit the curve of the particular subject.

DIE TONERZEUGUNG DURCH SPITZEN AN HOHEM WECHSELPOTENTIAL UND IHRE VERWENDUNG ALS MEMBRANLOSER LAUTSPRECHER (Sound Production by Points at High A.C. Potential, and their Use as Membraneless Loud Speakers).—L. Fleischmann. (*Naturwiss.*, No. 42, 1928, V. 16, pp. 795-796.)

The A.E.G. have patented a loud speaker in which the sound is produced by A.C. voltage fluctuations at a metallic point, a suitable D.C. polarising potential being superimposed. Purity of tone depends on the field strength and becomes bad when this is high enough to produce a glow discharge. The sound is due to the point action, and not to electrostatic forces.

THE ACOUSTIMETER.—R. F. Norris. (*Rad. Engineering*, February, 1929, V. 9, pp. 36-37.)

Description of a sound-intensity measuring apparatus, including a vacuum thermopile and millivoltmeter, used in the design of sound-proof partitions, investigation of auditorium acoustics, etc. "In each of these investigations, very slight differences of sound intensity were found to be the deciding factors in the direction of the research and in the final solution of the problems."

RADIO-GRAMOPHONES (Commercial Equipment reviewed): GRAMOPHONE PICK-UPS (19 Commercial Types discussed, with Table of Relative Outputs at different frequencies): FITTING A PICK-UP. (*Wireless World*, 6th March, 1929, V. 24.)

THE CONDENSER MICROPHONE DEVELOPED BY THE RADIO LABORATORY, NICHNY NOVGOROD.—S. I. Shaposhnikov. (*Teleg. i Telef. b. Prov.*, Nichny Novgorod, October, 1928, V. 10, pp. 536-539.)

EXPERIMENTS WITH HIGH FREQUENCY SOUND WAVES.—F. L. Hopwood. (*Journ. Scient. Instr.*, February, 1929, V. 6, pp. 34-40.)

A discourse given at the recent Exhibition of the Physical and Optical Societies. Various properties of the ultra-sonic waves are described and illustrated. Their application to the study of architectural acoustics is illustrated by a photograph showing how a beam of sound directed tangentially along the circular wall of a model "whispering gallery" tends to hug the wall, in accordance with Rayleigh's theory. Biological effects are described—the effect on the potency of the ultra-microscopic virus of Vaccinia, the arrest or retardation of beating of the embryonic heart of a chick, an increase in the agglutinating power of certain streptococci, the breaking up of the red blood corpuscle, the killing of tadpoles, etc., etc. Many of the results were also obtained independently by Wood and Loomis in America. Cf. Abstracts, 1928, V. 5, pp. 409 (Langevin) and 591 (Boyle).

THE MEASUREMENT OF SOUND ABSORPTION COEFFICIENTS.—P. E. Sabine. (*Journ. Franklin Inst.*, March, 1929, V. 207, pp. 341-368.)

A description of the methods used at the Riverbank laboratories. A table of coefficients is included, dealing with thirty-eight different materials or variations of the same material.

DYNAMIC SPEAKER HUM ELIMINATION.—P. G. Andres. (*Rad. Engineering*, February, 1929, V. 9, pp. 37-38.)

Copper spool head: "bucking" coil in series with moving coil: condensers across field winding—when used with dry-disc rectifier, shorten the life of this: electrical counteraction by adjustable resistance, the A.C. voltage drop across this being fed in opposite phase relation into the moving coil circuit—this has the advantage that it can often balance out, also, any hum introduced by the amplifier.

DER SELBSTTÖNENDE KRISTALL UND DAS MEMBRANLOSE (KRISTALL-) TELEPHON (The Singing Crystal and the Membraneless-Crystal—Telephone).—A. Ensbrenner. (*T.F.T.*, September, 1928, pp. 285-287.)

An account of Seidl's experiments with Lossev's crystal adaptation of the singing arc circuit discovered by Duddell. Methods of using the crystal as loud speaker, microphone and telephone are shown.

ÜBER DIE FREQUENZABHÄNGIGKEIT VON VERSTÄRKERTRANSFORMATOREN (The Frequency Dependence of Amplifier Transformers).—K. Matthies and G. Ganswindt. (*Arch. f. Elektrot.*, 15th February, 1929, V. 21, pp. 477-487.)

An experimental investigation, in the Telefunken

laboratories, of transformers for broadcast receivers. The test frequency range was from 50 to 15,000 p.p.s.

THE ANALYSIS OF IRREGULAR MOTIONS, WITH APPLICATIONS TO THE ENERGY-FREQUENCY SPECTRUM OF STATIC AND OF TELEGRAPH SIGNALS.—G. W. Kenrick. (See under "Atmospherics.")

VERIFICATION OF OHM'S ACOUSTIC LAW REGARDING NON-PERCEPTION OF PHASE CHANGES. (See van der Pol, under Properties of Circuits.)

PHOTOTELEGRAPHY AND TELEVISION.

TELEVISION AND THE PROBLEMS INVOLVED.—T. Thorne Baker. (*Photogr. Journ.*, June, 1928, V. 68, pp. 267-272.)

The difficulties in the way of the production of good quality images, by any of the present television processes, are considered.

ÜBER DIE ELEKTROLYTISCHE HERSTELLUNG VON PHOTOZELLEN UND DEREN VERWENDUNG (The Electrolytic Manufacture of Photoelectric Cells, and its Application).—L. Márton and E. Rostás. (*Zeitschr. f. tech. Phys.*, February, 1929, pp. 52-57.)

Sodium photoelectric cells can be turned out in quantity by the authors' simple process, using bulbs of lead-free soda-glass. No silvering process is needed, for after evacuation, sealing, and socketing, the layer of sodium is deposited on the inside surface by electrolysis of the glass, condensation into a continuous layer in the right position being ensured by air-cooling the right part of the bulb. A uniform matt coat is usually formed, but this is sometimes marred by well-defined mirror-like spots whose origin is still uncertain. The long wave limit of these cells is about 5,500 A.U.; for white light the average sensitivity is 3×10^{-10} A.U. per metre-candle. This is enough for photometric purposes, for which these cells should find a ready application; but it is far below the sensitivity of the carefully prepared potassium hydride cells used in phototelegraphy, etc.

Unfortunately, attempts to use potash glass and thus to make a corresponding potassium cell encountered unexpected difficulties which have not yet been overcome. The potash glass would apparently have to contain less than 0.1 per cent. of sodium—a condition technically difficult to satisfy.

The paper ends with a description of the application of these cells to photometric purposes, two amplifying arrangements being shown; one is electrically, the other photoelectrically, compensated against circuit variations.

TELEVISION.—(*Wireless World*, 13th March, 1929, V. 24, p. 273.)

A leading article based on a recent demonstration of the Baird system in London.

"Since the image is viewed through a magnifying lens and the internal mechanism was not disclosed to us, it is somewhat difficult to define the impression of the size of the image, but it would

perhaps be safe to say that the image of the head and shoulders of a subject appeared as slightly under the size of a passport photograph, and the image was clear enough for the face to be recognisable on meeting the subjects of the transmissions face to face after the demonstration, though, in a witness box, one would probably decline to give evidence of identification." The picture transmission was on 200 m., and 2LO (358 m.) was tuned in without interfering.

"There is no doubt that the demonstration was a marked improvement, as far as steadiness of the picture and consequent appearance of sharpness and greater detail, over the demonstration which we witnessed at Olympia during the Radio Show last autumn."

DER GEGENWÄRTIGE STAND DER BILDTELEGRAPHIE: DIE NEUESTE ENTWICKLUNGSSTUFE DES KORNSCHEN VERFAHRENS (The Present Position of Picture Telegraphy: the latest Development of the Korn System).—F. Noack. (*Rad. f. Alle*, February, 1929, pp. 88-91.)

Details, with schematic diagrams and photographs, of the latest form of the apparatus; together with two excellent black-and-white examples of the product.

ZUR THEORIE DER LICHELEKTRISCHEN WIRKUNG (On the Theory of the Photoelectric Effect).—H. Th. Wolff. (*Zeitschr. f. Phys.*, 22nd November, 1928, V. 52, No. 3/4, pp. 158-160.)

A hypothesis is put forward that in the photoelectric process, conduction electrons are emitted from the metal, energy being supplied to them (by collisions of the second kind) from optically excited atoms.

DAS LICHELEKTRISCHE VERHALTEN DES QUECKSILBERS BEIM ÜBERGANG VOM FLÜSSIGEN IN DEN FESTEN AGGREGATZUSTAND (The Photoelectric Behaviour of Mercury on its Change from Fluid to Solid Aggregate State).—M. Grützmann. (*Ann. der Phys.*, 2nd January, 1929, 5th Series, V. 1, No. 1, pp. 49-73.)

A contribution to the problem of the mechanism of photoelectric action. As a result, it is found that the total photoelectric emission remains constant through the melting point, in contrast to electrical behaviour in other ways. At the melting point there is an electric effect independent of light, probably to do with the formation of vapour.

MEASUREMENTS AND STANDARDS.

A VACUUM-TUBE CIRCUIT FOR MEASURING SMALL ALTERNATING CURRENTS.—R. E. Martin. (*Journ. Opt. Soc. Am.*, January, 1929, V. 18, pp. 58-61.)

An arrangement of four three-electrode valves and a D'Arsonval galvanometer, which will measure A.C. currents of the order of 10^{-9} A.—accurately at low frequencies, and with only small percentage

errors at high frequencies after the proper corrections are made, even though the calibration is carried out at low frequencies and for relatively high currents. The four valves, in two pairs, are so arranged that for each direction of the E.M.F. in the external circuit the current will pass through the galvanometer in the same direction.

During each half-cycle, one valve of each pair acts as a condenser and a resistance in parallel, while the other of each pair acts only as a condenser.

EINE KOMPENSATIONSMETHODE ZUR MESSUNG SCHWACHER STRÖME (A Compensation Method for the Measurement of Small Currents).—R. Jaeger. (*Zeitschr. f. Phys.*, 31st December, 1928, V. 52, No. 9/10, pp. 627-636.)

A "current standard," variable from zero to about 5×10^{-10} A., is here described which is useful for many types of small-current measurement (particularly by the constant deflection method). The principle involved is the use of the saturation current from a system of surfaces covered with uranium oxide, a screen with calibrated adjustment controlling the area of active surface. Examples of its use are described and illustrated.

KAPAZITÄTSVARIATOREN FÜR PRÄZISIONSMESSUNGEN (Variable Condensers for Precision Measurements). (*E.T.Z.*, 28th February, 1929, p. 319.)

Description of a German series of condensers specially designed for great accuracy. Quartz glass insulation is used. In one small-capacity condenser, the distance between plates can be adjusted by a micrometer spindle-adjustment—so that when so required the capacity change for one scale division can be reduced to $0.001 \mu\mu\text{F}$. In another, the patented construction leads to "an initial capacity which is truly zero."

ERMITTLUNG DER ENTLADKURVE VON KONDENSATOREN (Plotting the Discharge Curves of Condensers).—H. Rühlemann. (*E.T.Z.*, 14th February, 1929, pp. 230-231.)

The use of a glow-discharge tube enables the discharge characteristic of a condenser to be obtained with very simple apparatus. The method is described and examples given.

ÜBER KAPAZITÄTSMESSUNGEN MITTELS PIEZOELEKTRISCHER OZILLATOREN UND RESONATOREN (The Measurement of Capacity by the Use of Piezoelectric Oscillators and Resonators).—G. A. Kjandsky. (*Zeitschr. f. Phys.*, 31st December, 1928, V. 52, No. 9/10, pp. 743-745.)

After describing how a piezoelectrically stabilised oscillator can be used, by the zero beat-note method, to measure the capacity of an unknown condenser in a second circuit, the writer shows how the luminous quartz resonator of Giebe and Scheibe can be employed for such measurements: this method (the principle of which is obvious) is simpler than the former one and is very accurate. Its use

need not, of course, be limited to capacity measurements.

BEITRAG ZUR MESSUNG DER SPANNUNGSVERTEILUNG AUF ISOLATOROBERFLÄCHEN (Contribution to the Measurement of Voltage-distribution on the Surface of Insulators).—P. Pulides and A. L. Müller. (*E.T.Z.*, 8th November, 1928, pp. 1648-1650.)

An improved method, applicable to insulators of all shapes, is described; it employs an amplifier and loud speaker.

EIN BELLATI-DYNAMOMETER SEHR HOHER EMPFINDLICHKEIT (A Bellati Dynamometer of Very Great Sensitivity).—A. Pfeiffer. (*Résumé in E.T.Z.*, 25th October, 1928, p. 1582.)

The writer has increased the sensitivity of this instrument (which measures A.C. as well as D.C.) sixty-three times by various improvements, to a value of 1.8×10^{-8} A.

ON THE MEASUREMENT AT RADIO FREQUENCY OF THE CONDUCTIVITY OF LIQUIDS WITHOUT IMMERSED ELECTRODES.—W. F. Powers and M. F. Dull. (*Journ. Opt. Soc. Am.*, October, 1928, Part I, V. 17, pp. 323-325.)

Burton and Pitt measure conductivity by means of an oscillating valve circuit. The authors use a non-generating circuit for the sake of the simpler theoretical treatment, employing a circuit described by Gunn for the measurement of very small capacity changes (*Phil. Mag.*, July, 1924). The paper is only a preliminary report on the method, giving some idea of its sensitivity. Change of strength of a salt solution from 0.025 per cent. to 0.038 per cent. produced a change of galvanometer deflection of about 8 cm. on the scale.

THE MEASUREMENT OF CONDUCTIVITIES BY MEANS OF OSCILLATING CIRCUITS.—S. D. Gehman and B. B. Weatherby. (*Phil. Mag.*, March, 1929, No. 43, V. 7, pp. 567-569.)

The writers believe Burton and Pitt's results (see above) to depend not on the conductivities but on the dielectric constants of the liquids concerned, and quote experiments to prove their point: in one of these, liquids were chosen whose conductivities were in the reverse order of their dielectric constants, and the Burton-Pitt deflections were found to be in the order of the latter, not of the conductivities.

ÜBER DIE VERWENDBARKEIT DER RESONANZ-METHODE ZUR MESSUNG VON DIELEKTRIZITÄTSKONSTANTEN LEITENDER FLÜSSIGKEITEN (The Applicability of the Resonance Method to the Measurement of the Dielectric Constants of Conducting Fluids).—H. Kniepkamp. (*Zeitschr. f. Phys.*, No. 1/2, V. 51, 1928, pp. 95-107.)

Results, using a 530 m. wave, showed satisfactory agreement with the values found by other workers by other methods. Resonance was judged by a potential-measuring indicator; a current-measuring indicator gave direct values which were always too small.

A CONVENIENT METHOD FOR REFERRING SECONDARY FREQUENCY STANDARDS TO A STANDARD TIME INTERVAL.—L. M. Hull and J. K. Clapp. (*Proc. Inst. Rad. Eng.*, February, 1929, V. 17, pp. 252-271.)

A method is described for obtaining a convenient low frequency from a high frequency standard by means of "harmonic control of distorted wave oscillators," *i.e.*, by injecting into an Abraham multivibrator a frequency which is an integral multiple of the multivibrator fundamental, thus making the multivibrator into a step-down frequency transformer.

A 50 kc. piezo oscillator, temperature-controlled by a bi-metallic thermostat, feeds into a 10 kc. multivibrator through an isolating amplifier. (This multivibrator circuit has a coupling coil which is used to provide a series of harmonics on the 10 kc. fundamental, for calibrating purposes.) Next comes a second isolating amplifier and a 1 kc. multivibrator, followed by a 1 kc. amplifier and by a synchronous motor with clock train, designed to keep time when the frequency supplied is 1,000 cycles p.s.—so that the timing of the H.F. source is reduced to observations of small time errors indicated by the clock.

Assuming that the momentary deviations from the 24-hour mean are not greater than the maximum fluctuations observed in a long interval (10 days), the variations worked out at about 8 parts per million. This result was improved by the building of a "new temperature control box . . . though use was still made of the bi-metallic thermometer." The variation was thus reduced to about 2 per million. Lines of further development are (1) provision of temperature control within one or two hundredths of a degree; (2) replacement of present quartz-bar holder insulation by a vitreous material showing negligible distortion with age at constant temperature; and (3) improvements in the clock mechanism and in methods of checking against the time signals.

A large middle section of the paper deals with a systematic experimental investigation of the behaviour of the Abraham multivibrator when thus harmonically controlled, leading to the conclusion that the appropriate multivibrator harmonic bears a constant and permanent phase relation to the injected "control" oscillation; and that the frequency of this harmonic, and therefore of the fundamental, follows any drift or perturbation in the frequency of the control oscillation without appreciably altering the phase relation or dropping out of synchronism even for a single cycle. The use of a neon tube relaxation oscillator, as a substitute for the dissymmetrical valve oscillator, is therefore abandoned as inferior.

A 50/1 step-down is considered the suitable limit—hence two compounded multivibrators would have been used even if the 10 kc. stage had not been needed for harmonic calibration purposes.

The quartz oscillator circuit selected was one of the class in which sustained oscillations are impossible without the quartz bar: experience had indicated that the frequency is more precisely determined by the mechanical vibration of the quartz if no other periodic element is present which can support sustained oscillations independent of the mechanical vibrator.

LA MESURE DES TRÈS HAUTES FRÉQUENCES RADIOTÉLÉGRAPHIQUES AU MOYEN DES OSCILLATEURS À QUARTZ PIÉZO-ÉLECTRIQUE (The Measurement of Very High Frequencies by Means of Piezoelectric Quartz Oscillators).—B. Decaux. (*Comptes Rendus*, 11th February, 1929, V. 188, pp. 498-499.)

Oscillators in general use have fundamental frequencies of the order of 10^6 . Using a tuning fork with a fundamental of about 1,024, the writer obtains a series of frequencies differing by 1,024 up to 10^8 , by the following method:—the H.F. oscillator (frequency F) is coupled to one of the grid circuits of a two-grid valve whose plate circuit contains the oscillating circuit coupled to the indicating instruments. The second grid circuit receives a L.F. potential (frequency f) from the tuning-fork circuit. Currents of frequencies $F \pm f$, $F \pm 2f$, etc., appear in the plate circuit. By repeating the process with the various harmonics of F , a whole series is obtained. (*Cf.* the same writer, April Abstracts.)

A SYSTEM FOR FREQUENCY MEASUREMENTS BASED ON A SINGLE FREQUENCY.—E. L. Hall. (*Proc. Inst. Rad. Eng.*, February, 1929, V. 17, pp. 272-282.)

A method for calibrating piezo-oscillators or frequency meters, in terms of an accurately known fixed frequency standard—the result *not* depending (as in usual methods) on the calibration of a (H.F.) frequency meter as an intermediate step in the measurement. The method depends on the audio-frequency measurement of the beat note between the apparatus under test and a local generator oscillating at a harmonic of the fixed standard.

EIN GERÄT ZUR MESSUNG VON MAXIMALSPANNUNGEN IN FERNSPRECHÜBERTRAGUNGSSYSTEMEN (An Apparatus for the Measurement of Maximum Peak Voltages in Telephone Transmission Systems).—D. Thierbach. (*Zeitschr. f. tech. Phys.*, November, 1928, pp. 438-442.)

Describes a direct-indicating "impulse meter" designed to watch over the transmission so that over-control may be avoided. Previous apparatus only indicated whether the incoming voltages were greater or less than the grid bias of the indicator valve. The actual measurement of the maximum peaks is complicated by the short duration of some of these. The method adopted is the audion circuit with condenser in the grid circuit, the indication being given by a meter in the plate circuit. The charging-up time of the condenser is very small (the curve becoming almost horizontal after 1/50 sec.): it is periodically (once in 2-10 secs.) discharged either by hand or by a relay so as to be ready for a new measurement. *Cf.* Mayer, March Abstracts, p. 166. Full details are given, together with examples of the uses of the apparatus.

MESSUNGEN AN NIEDERFREQUENZVERSTÄRKERN (Measurements on L.F. Amplifiers).—R. Wigand. (*Rad. f. Alle*, February, 1929, pp. 64-70.)

The article includes diagrams of various methods (including the Telefunken and the author's own

method) of obtaining L.F. pure sine-wave oscillations.

DETERMINING THE DISTRIBUTION OF ELECTRIC AND MAGNETIC FIELDS.—B. Hague. (*Electrician*, 15th March, 1929, V. 102, pp. 315-317.)

Second and final part of the paper referred to in April Abstracts. The methods described include the thermal analogy method, the isotherms being indicated by lines of demarcation in a mixture of wax and elaidic acid; the electrochemical and hydrodynamical (Hele-Shaw) methods and (probably the most generally useful) the electric conduction method (especially in the modified form using an electrolyte tank—capable of attacking three-dimensional problems) and the soap-film method. A very extensive index to the literature is given.

ZUR BERECHNUNG VON EISENLOSEN DROSSELSPULEN UND DER ZWISCHEN KOAXIALEN SPULEN WIRKENDEN KRÄFTE (The Calculation of Air Core Chokes and the Forces between Co-axial Coils).—J. Hak. (*E.T.Z.*, 7th February, 1929, pp. 193-198.)

Includes graphs giving the inductance of air-core circular coils with rectangular winding-section; and others giving the ratio weight of copper/inductance for various proportions of coil, mutual induction between co-axial coils (near and distant), and forces between co-axial coils.

DAS RÖHRENVOLTMETER ALS ANZEIGEINSTRUMENT FÜR OBERWELLEN (The Thermionic Voltmeter as an Indicating Instrument for Harmonics).—W. Deutschmann. (*T.F.T.*, January, 1929, pp. 24-26.)

Since its readings depend on relative amplitude, harmonic order and phase displacement, the thermionic voltmeter is unsuitable for the measurement of harmonics.

SUBSIDIARY APPARATUS AND MATERIALS.

ÜBER DIE DURCH KATHODENSTRAHLEN BEWIRKTE ELEKTRISCHE AUFLADUNG DES GLASES UND DEREN PRAKTISCHE VERWENDUNG (The Charge on Glass produced by Cathode Rays, and its Practical Utilisation).—P. Selényi. (*Zeitschr. f. tech. Phys.*, November, 1928, pp. 451-454.)

An extension of a previous paper (Abstracts, 1928, V. 5, p. 467) on the formation of cathode ray oscillograph figures by scattering powder (sulphur and red-lead) on the outside of the glass wall. Various improvements have been made, and a number of specimen records are given (including one of 500 frequency A.C.). A recording speed of 4,000 cm./sec. is obtained with a ray intensity of about 2 μ A.; it is argued that with a ray intensity of 1 mA. the speed should be raised to 10 km./sec., so that a H.F. oscillograph, electrostatically recording, would appear to be within reach. Improvements still to be desired, and difficulties, are mentioned: e.g., the thickness of the glass wall causes a "fuzziness" in the record.

REGISTRIERENDES PRÄZISIONSGERÄT FÜR SEHR SCHWACHE STRÖME (Precision Recording Apparatus for Very Weak Currents).—C. Müller and R. Frisch. (*Zeitschr. f. tech. Phys.*, November, 1928, pp. 445-451.)

Designed primarily for recording values of light-intensities, ionisation processes, etc., the apparatus works with comparative rapidity and great freedom from interference—on currents of the order of 10^{-12} A., with a mean error of 1-2 in a thousand. It consists in a projecting thread-electrometer controlled by a photoelectric cell, the projection of the image of the thread on to a photographic drum being interrupted by a disc (carrying apertures arranged to suit the particular purpose) driven in intermittent rotation by clockwork. This clockwork also effects an intermittent earthing of the thread. Many records of performance are illustrated.

EINE NEUE SCHALTUNG ZUR ERZEUGUNG VON SCHWINGUNGEN MIT LINEAREM SPANNUNGSVERLAUF (A New Arrangement for the Production of Oscillations with Linear Voltage-Curve).—G. Frühauf. (*Arch. f. Elektrot.*, 15th February, 1929, V. 21, pp. 471-472.)

Oscillations of a triangular wave-form, useful for laboratory purposes (e.g., for use with a Braun

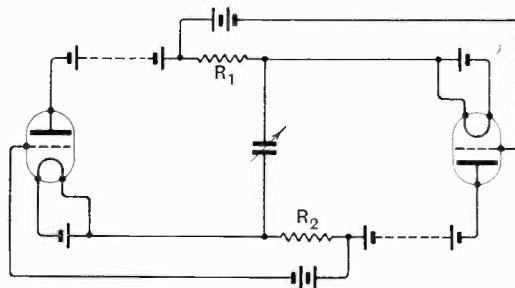

tube), can be produced by this circuit using a pair of matched valves.

BESEITIGUNG DER NEBENFREQUENZEN BEIM STATISCHEN FREQUENZWANDLER (Suppression of Secondary Frequencies in Static Frequency Multipliers).—H. Freese. (*Zeitschr. f. Hochf. Tech.*, January, 1929, V. 33, pp. 1-8.)

This, the first of two parts, deals with the determination (first theoretical, then experimental) of these frequencies. The second part will deal with their suppression (see below).

BESEITIGUNG DER NEBENFREQUENZEN BEIM STATISCHEN FREQUENZWANDLER (Suppression of Secondary Frequencies in Static Frequency Multipliers).—H. Freese. (*Zeitschr. f. Hochf. Tech.*, February, 1929, V. 33, pp. 41-46.)

This second and final part of the paper referred to above deals with the experimental investigation of two methods (due to Lorenz and Zenneck respectively) of suppressing the unwanted

oscillations without seriously weakening the working oscillation. The first consists in the use of two absorption circuits connected in parallel, each of which by itself is tuned to an harmonic next to the wanted frequency (e.g., for 15-fold multiplication, one is tuned to the 13th, the other to the 17th, harmonic—since it was shown in the first part that only the odd harmonics of the primary frequency are formed) while in parallel they are tuned to form a rejector circuit for the working frequency (15th harmonic). The second method uses two circuits each tuned to the working frequency but coupled together so that the resultant coupling-frequencies correspond to the two neighbouring unwanted frequencies. The two methods are shown to be very similar in their working. There is a critical value for the coupling between absorption system and main system; below this value the system is practically ineffective, while above it the system suppresses the two particular frequencies but increases other more distant harmonics. This holds good for secondary or tertiary circuit cleaning. When using the absorption system in the secondary circuit of a 15-fold multiplier, small detunings of the secondary circuit were found to have no special effect; but when using it in a tertiary circuit loosely coupled to the secondary, it was better to tune this tertiary circuit to a slightly lower frequency.

THE ELECTRICAL CONDUCTIVITY OF THIN OIL FILMS. PART I.—GENERAL NATURE OF THE PHENOMENON.—H. E. Watson and A. S. Menon. (*Proc. Roy. Soc.*, 6th March, 1929, V. 123 A., pp. 185-202.)

Vaseline and heavy paraffin oil are now widely used for application to plugs and sliding contacts on measuring instruments—an apparent anomaly in view of the fact that these substances are ordinarily regarded as excellent insulators. The paper describes a detailed examination of the region in which a transition from insulation to conduction appears to take place. Flooded films of paraffin oil will stand a high potential gradient (over 100,000 v./cm.) as long as their thickness is more than about 15μ . At 11μ there is a tendency to break down with a much smaller gradient, the breakdown thickness not varying greatly with the voltage. The film becomes conducting in two stages; in the second stage the resistance is very low. The paper includes a description of the methods for determining non-conducting film thicknesses by means of capacity measurements.

THE DIRECT CURRENT CONDUCTIVITY OF INSULATING OILS.—D. H. Black. (*Phil. Mag.*, No. 36, 1928, V. 6, pp. 369-384.)

The writer propounds a theory to explain the irreversible process of the gradual decrease, with time, of the current flowing between two electrodes in an insulating liquid when a constant P.D. is applied. The theory calls for a contact resistance, at one or both electrodes, produced by the passage of the current. Various results fit in with the theory.

TESTS ON VACUUM LIGHTNING ARRESTERS FOR COMMUNICATION LINES.—T. Nishi and M. Hoshiai. (*Journ. I.E.E., Japan*, October, 1928, pp. 1028-1064.)

DURCHSCHLAG VON FESTEN ISOLATOREN BEI HOCHFREQUENZ (The Breakdown of Solid Insulators by High Frequency).—L. Inge and A. Walther. (*Arch. f. Elektrot.*, 7th December, 1928, V. 21, pp. 209-227.)

Measurements on the dielectric strength of glass, mica, and porcelain, mostly at a frequency of 4.35×10^6 , in air, transformer oil and xylol. A glow discharge at the electrodes lowered the breakdown voltage considerably: xylol, which weakens this discharge the most, gave the highest breakdown values. With glass and porcelain there is a very marked dependence on frequency and temperature—the breakdown voltage is about proportional to the square root of the frequency (actual range of wavelengths used was about 250 m. to 1,140 m.). Mica behaves very differently, the breakdown voltage being independent of the frequency and only very slightly dependent on the temperature: the mechanism of breakdown seems to be quite different—probably an ionisation effect, as at low frequencies; whereas with glass and porcelain it is a heat effect.

ELECTRICAL INSULATING MATERIALS FROM A CHEMICAL STANDPOINT.—W. H. Nuttall. (*Chem. and Industry*, 28th December, 1928, V. 47, pp. 1359-1368.)

The main object of this paper is to answer the question "Considering the insulating compounds in general use, can we discover among them any common chemical characteristic, the possession of which bestows insulating properties?" At the end the writer says: "It is thus evident that most organic compounds employed as electrical insulators are employed in a high state of polymerisation or degree of association. We have here, so it seems, the exact converse of a dilute electrolytic solution which conducts by virtue of the electrolyte dissociating into positive and negative ions. An insulator can only become conducting after the material of which it is composed has become ionised or dissociated, and it is reasonable to suppose that a highly associated molecule is more difficult to ionise than an unassociated one. In any case, so far as I am aware, matter in a high degree of association is always a bad conductor of electricity. In conclusion, I would add that the more immediate improvements in electrical insulating media are most likely to be in the direction of the employment of purer materials. A trace of an unsuitable constituent in an insulator can easily render it quite unsuitable for its purpose. Thus, it has recently been shown that by removing the protein matter from rubber latex by means of caustic alkali, the breakdown voltage of ebonite prepared therefrom can be raised by 300-400 per cent."

A TRANSFORMER FOR THE FILAMENT CURRENT OF HIGH TENSION RECTIFYING VALVES.—E. P. Hudson and P. M. S. Blackett. (*Journ. Sci. Inst.*, December, 1928, V. 5, pp. 391-392.)

Specification and photograph of a transformer for supplying filament current (3A. at 6V.) to a valve working on 40,000 v. Primary (600 turns) is wound on a stallo ring 18 cm. diam.; secondary (20 turns bound together into a ring 21 cm. diam.)

interlaces primary at right angles and is nowhere nearer than 7 cm. from it.

FERROMAGNETIC FERRIC OXIDE.—E. F. Herroun and E. Wilson. (*Proc. Physical Soc.* 15th December, 1928, V. 41, Part 1, pp. 100-111.)

CARBOLLOY—A NEW TOOL MATERIAL.—S. L. Hoyt. (*Gen. Elec. Review*, November, 1928, V. 31, pp. 585-591.)

A tungsten carbide and cobalt combination which will scratch sapphire and will retain its hardness and cutting edge at a bright red heat. Tools made from it successfully turn grooves in glass: manganese steel becomes machinable.

DIE THEORIE DES TELEPHONRELAIS (The Theory of the Telephone Relay).—W.Th.Bähler. (*E.T.Z.*, 6th and 13th December, 1928, pp. 1780-1784 and 1810-1814.)

AN UNUSUAL WAY OF INSULATING A HEATING ELEMENT.—(*Engineer*, 4th January, 1929, V. 147, p. 13.)

The Westinghouse Company wrap the element round with metallic magnesium ribbon and insert the whole into a copper tube. Steam at 450 lbs. pressure converts the magnesium into its oxide: the result is a tube containing a heater element embedded in a hard, dense insulating material.

THE THEORY OF THE METAL RECTIFIER: SOME NOTES ON THE PROPERTIES AND METHOD OF USING THE DRY METAL RECTIFIERS.—Engineering Dept., Westinghouse Co. (*Wireless World*, 19th December, 1928, V. 23, pp. 824-826.)

THE DURIRON-DURALUMIN ELECTROLYTIC RECTIFIER.—N. E. Woldman. (*QST.*, October, 1928, V. 12, pp. 45, 80, 82, 84, 86 and 88.)

Anode is duralumin (copper-aluminium alloy specially heat-treated and aged) and cathode is duriron (non-machinable, brittle iron-silicon alloy which resists electrolytic corrosion): electrolyte contains diammonium hydrogen phosphate and (as depolariser) potassium dichromate and oxalic acid. Normal operating current is 40 mA., at an output voltage up to 180 v. Temperature never rises above 40 deg. C., giving long life: this cool working is largely due to the oxide film on the duralumin electrode being very thin.

L'ALIMENTATION DES RÉCEPTEURS RADIOTÉLÉPHONIQUES: ÉTAT ACTUEL, DERNIERS PROGRÈS (Power Supply for Radiotelephone Receivers: Present Position: Latest Progress).—L. G. Veyssière. (*T.S.F. Moderne*, September and October, 1928, V. 9, pp. 538-551 and 617-631.)

Anode and filament supply is dealt with. The conclusion is that at the moment one can supply a receiver completely from any mains supply, but that the apparatus required is fairly complicated and lacks flexibility.

THE EVERLITE LAMP: A BATTERY LAMP UNIT FOR WHICH EFFICIENCY AND ECONOMY ARE CLAIMED.—*Electrician*, 1st February, 1929, V. 102, p. 141.)

Schmid, the inventor of the Everlite battery, says that the fact that only from 5 to 10 per cent. of a dry cell is used up chemically led him to develop a battery which has a constant discharge curve and can be re-charged: the refills being made in non-hygroscopic capsules. Tests are described on a battery giving 3 A. for 6 hours at 1½ v.

WEITERE UNTERSUCHUNGEN AN DEN HOCHOHMWIDERSTÄNDEN (Further Investigations on High Resistances).—A. Gyemant. (*Wiss. Veröff. a.d. Siemens-Konz.*, No. 1, 1928, V. 7, pp. 134-143.)

Deals with high resistance liquid resistances. The negative temperature coefficients of certain liquids can be nullified by the admixture of other substances. Up to about 4 kv./cm. the resistance remains constant, but decreases gradually with higher field-strengths.

STATIONS, DESIGN AND OPERATION.

KALUNDBORG RADIO.—K. Christiansen. (*Elec. Communication*, July, 1928, V. 7, pp. 24-32.)

Description of the main Danish broadcasting station. The four-wire aerial, 145 m. long, is suspended from two 100 m. masts spaced 220 m. apart, so that there are considerable gaps between the down-leads and the masts. There is a down-lead at each end of the aerial, the one going to the transmitter, the other (through a tuning coil) to the earth system. When properly tuned, the currents in the two down-leads are equal; there is a current node at the mid-point of the aerial. More effective current distribution to the earth network, and consequently smaller earth losses, are claimed as advantages of this arrangement.

EIN KURZWELLENSENDER FÜR DIE TSCHESCHOSLOWAKEI (A Short-Wave Transmitting Station for Czecho-Slovakia).—(*Rad. f. Alle*, February, 1929, p. 87.)

A Telefunken short-wave station at Pödeprady, near Prague, is being constructed, to open "in the first half of 1929." It possesses two transmitters, each of 20 kw. valve-output, working on 15-30 m. wavelengths for communication with America.

DER KURZWELLENSENDER "AFK" IN DÖBERITZ (The Short Wave Station "AFK" at Döberitz).—(*E.T.Z.*, 21st February, 1929, p. 268.)

Summary of a paper in *T.F.T.*, V. 17, p. 305, by G. Kette, describing the Telefunken 15-100 m. transmitter installed for the German P.O. for research work, etc., in telegraphy, telephony and picture transmission.

DIE FUNKSTELLEN DER WELT; EIN NEUES VERZEICHNIS DER FUNKSTELLEN (The Wireless Stations of the World: a new List).—(*E.T.Z.*, 7th February, 1929, pp. 202-203.)

An article on the 12th edition of the international

list published by the Berne International Bureau in English, French and German.

THE NEW BROADCAST AMPLIFIER PLANT IN THE BERLIN STATION (ILLUSTRATED).—K. Müller. (*T.F.T.*, December, 1928, pp. 366-370.)

GENERAL PHYSICAL ARTICLES.

EINSTEIN'S FIELD-THEORY.—A. S. Eddington. (*Nature*, 23rd February, 1929, V. 123, pp. 280-281.)

The writer gives a modified and shortened version of Einstein's recently published "Unified Field-Theory," and compares it with his own affine field theory (*Proc. Roy. Soc.*, 1921, V. 99, p. 104) which, though resting on the same equation, presents very marked contrasts. While pointing out that to say that Einstein's or Weyl's or Eddington's illustrative geometry is the only right one would be like saying that a graph of a moving particle with time and space as co-ordinates is right but a graph with velocity and curvature as co-ordinates is wrong, he confesses that he cannot readily give up the affine picture, where gravitational and electrical quantities supplement one another as belonging respectively to the symmetrical and anti-symmetrical features of world measurement. One point in the new theory he criticises, as raising hopes that the field laws are about to appear as identities, whereas these hopes are not fulfilled: "Can any theory which requires field laws other than identities give real satisfaction? To introduce a field law limiting the geometrical possibilities is a confession that the initial geometry was too wide."

UNIFIED FIELD THEORY OF ELECTRICITY AND GRAVITATION.—N. Wiener and M. S. Vallarta. (*Nature*, 2nd March, 1929, V. 123, p. 317.)

The writers urge the application of Einstein's recent work on distant parallelism to the harmonisation of the general relativity theory with the quantum theory, particularly with Dirac's theory of the spinning electron—"a much more pressing need" than the development of a unified field theory of electricity and gravitation.

AN UPPER LIMIT TO ENERGY DENSITY.—S. Suzuki. (*Nature*, 23rd February, 1929, V. 123, p. 296.)

Summary of a paper in a Japanese physico-mathematical "proceedings." Just as on the theory of relativity there is a limit to the velocity a body can have, so there should be a limit to the energy which can be concentrated in a given volume, and (since the energy density in an enclosure is proportional to the fourth power of the absolute temperature of the enclosure) an upper limit to temperature. Planck's radiation formula would require an additional term becoming important for long waves and high temperatures. The frequency of a light quantum could not increase indefinitely, and the Compton increased frequency effect could not be produced when an extremely rapid electron struck a quantum of extremely high frequency. Cf. Pokrowski, April Abstracts.

ANFANGSSPANNUNG UND GASDICHTHE BEI VERSCHIEDENEN ELEKTRODENFORMEN (Sparking Voltage and Gas Density for Electrodes of various Shapes).—S. Franck. (*Arch. f. Elektrot.*, 17th December, 1928, V. 21, pp. 318-374.)

An exhaustive investigation which deals with the behaviour not only of a large number of different electrode shapes, of length of spark gap, of temperature and pressure, but also of moisture.

ELECTRIC FLASHES TRAVEL IN SPIRALS, AS SHOWN BY HIGH-SPEED CAMERA. (*Technique*, *Montreal*, November, 1928, V. 3, pp. 28-29.)

A Westinghouse engineer has designed a camera taking 2,600 photographs per second: with this he shows that the path pursued by an electric flash is a highly complex spiral.

A NEW HIGH POTENTIAL X-RAY TUBE.—C. C. Lauritsen and R. D. Bennett. (*Phys. Review*, December, 1928, V. 32, No. 6, pp. 850-857.)

Description of the attempt, at the California Institute of Technology, to generate and investigate X-rays in the region beyond 300 kv. The tube has been designed to work at 1,000,000 volts: so far 750 kv. have been successfully used without special out-gassing of the electrodes. Cold emission is utilised, the full potential being applied between suitably curved electrodes close together. Absorption measurements of the X-rays have been made with lead up to 2 cm. thick, and it is shown that secondary emission plays an important part in the photo-chemical action of these rays.

MEASUREMENTS ON THE ABSOLUTE INTENSITY OF X-RAYS.—T. E. Aurén. (Abstract in *Science Abstracts*, 25th December, 1928, V. 31, pp. 929-930.)

The method depended on the measurement of the heat excited in metals by absorption of the rays. One of the deductions is that the energy necessary to produce a pair of ions shows no increase with decreasing wavelength.

SECOND CONTRIBUTION TO THE STUDY OF THE LIGHT ETHER.—V. Posejpal. (*Bohemian Ac. Sc. and A.*, Class II, 19th October, 1928.)

Nature summarises thus:—"ultra-penetrating radiation, heat of the earth and sun, the source of Swanne's electrons keeping up the earth's negative charge, are accounted for by the hypothetical neutron constitution of the ether."

WEITERE MESSUNGEN DER DURCHDRINGENDEN HÖHENSTRAHLEN (Further Measurements of the Penetrating Radiation).—K. Wölcken. (*Vortragshandbuch*, 90 *Versamm. d. Ges. deut. Natur. forsch.*, Hamburg, September, 1928.)

The summary gives the statement that the only things we know for certain about these "Hess radiations" are:—that they exist, that their mass-absorption coefficient μ/ρ is of the order of $2.0 \times 10^{-3} \text{ cm}^{-1}$, that the source must be over 30 km. high, and that no such radiations are known on

earth. They are very probably ultra-short gamma rays. The measurements of Kollhörster, v. Salis and Buttner indicate a cosmic origin: the radiation shows a daily period, depending on stellar time. Those of Millikan, Hoffmann, Steinke and Clay contradict this. Further measurements by the writer (round Mont Blanc and Göttingen) confirm the daily period, but only by averaging over periods of at least one hour. A decrease of relative amplitude through screening by air, ice or lead was not established. Göttingen measurements indicated variations of shorter duration, which could not be explained by assuming the passage of the centre of radiation through the meridian.

COSMIC RADIATION AND RADIOACTIVE DISINTEGRATION.—L. R. Maxwell. (*Nature*, 29th December, 1928, V. 122, p. 997.)

The test of Perrin's theory (that the disintegration of radioactive elements may be due to their absorption of cosmic radiations) mentioned in Abstracts, 1928, V. 5, p. 469, has now been made, with a negative result: unless it is assumed that the radiation responsible for the disintegration is of such penetrating power that it remains practically unabsorbed in going about eleven hundred feet through the earth, and yet has the property of being appreciably absorbed by relatively small amounts of radioactive elements.

THE ELECTRICAL CONDUCTIVITY OF METALS.—R. Ruedy. (*Nature*, 8th December, 1928, V. 122, p. 882.)

"In the recent theories of metallic conduction the exchange of electrons between neighbouring atoms has perhaps not been sufficiently considered. . . . For distances of the order of those which separate the atoms in a crystal lattice, electrons go over from one atom to the other more than 10^{10} times per second." The frequency of interchange is a function of certain variables shown by Herzfeld to be decisive in making an element a metallic conductor. Certain values would result in super-conductivity. This sharing of electrons would account for the magnetic properties of single metal crystals of zinc and cadmium, recently investigated.

ON FREE AND BOUND ELECTRONS IN METALS.—R. Ruedy. (*Phys. Review*, December, 1928, V. 32, No. 6, pp. 974-978.)

Author's abstract: When the theory of dispersion in an absorbing medium is applied to the values published in recent years for the optical properties of different metals, it follows that bound electrons exist inside the metal comparable in number with that of the free electrons.

THE PHOSPHORESCENCE OF FUSED QUARTZ.—A. C. Bailey and J. W. Woodrow. (*Phil. Mag.*, December, 1928, V. 6, pp. 1104-1107.)

Many samples of fused quartz when excited by ultra-violet light will emit a visible phosphorescent light of considerable strength upon the application of heat: even without heating they will affect a photographic plate for at least 3 weeks after their irradiation. Natural quartz crystals do not possess

this property, but they can be brought into this condition by heating slowly in an electric furnace to a temperature of 1,600 deg. C.

A THERMAL PROPERTY OF MATTER.—O. Majorana. (*Nature*, 24th November, 1928, V. 122, p. 825.)

Summary of experiments described in the Proceedings of the Royal Academy, Bologna. "Certain substances, in particular lead and iron, are found to be capable of exhibiting, in relation to the surrounding medium, thermal super-elevations which depend on the previous treatment of the substance and are not in accord with the well-known laws of the progressive cooling of bodies." This phenomenon is regarded as due to a progressive emission of thermal energy by matter after being heated to any marked degree. Cf. Brush (tests on complex silicates, with reference to his "energy-shadow" theory of gravitation), Abstracts, 1928, p. 588.

AN ATTEMPT TO POLARISE ELECTRON WAVES BY REFLECTION.—C. J. Davison and L. H. Germer. (*Nature*, 24th November, 1928, V. 122, p. 809.)

Describes an experiment to test whether or not electron waves are polarised by reflection from the face of a crystal. The method was similar to the double mirror experiment by which the polarisation of light by reflection from glass is demonstrated, and was such that any polarisation occurring would be indicated by a periodic variation of current with angle. Within the limits of accuracy of the experiment, no such variation was found; so that it would appear that there is no polarisation by reflection.

IMPOSSIBILITY OF POLARISING ELECTRONIC WAVES.—A. F. Joffé, A. N. Arsenieva, J. Frenkel. (*Comptes Rendus*, 7th January, 1929, V. 188, pp. 152-155.)

The first two writers give experimental proof; the last shows that theoretically there is no effect, for electronic waves, corresponding to the polarisation of light.

VERSUCH ÜBER DIE POLARISATIONSFÄHIGKEIT EINES ELEKTRONSTRAHLS (Experiments on the Polarizability of an Electron Beam).—F. Wolf. (*Zeitschr. f. Phys.*, 4th December, 1928, V. 52, No. 5/6, pp. 314-317.)

If electrons are magnetic dipoles, a beam of them passing through a magnetic field should show some effect of polarisation. The experiment described shows no such effect.

APPARENT EVIDENCE OF POLARISATION IN A BEAM OF BETA-RAYS.—R. T. Cox, C. G. McIlwraith and B. Kurrelmeyer. (*Proc. Nat. Acad. Sci.*, July, 1928, V. 14, pp. 544-549.)

This preliminary report records an apparently definite asymmetry in double scattering, which can be qualitatively explained in terms of the properties of the spinning electron.

THE RAMAN EFFECT WITH LIQUID OXYGEN, NITROGEN, AND HYDROGEN.—J. C. McLennan and J. H. McLeod. (*Nature*, 2nd February, 1929, V. 123, p. 160.)

Results show: (1) that Raman effects can be obtained with homopolar molecules; (2) that part of the energy of light quanta can be taken up directly as rotational energy, the balances appearing as quanta degraded in frequency; (3) that two-quantum rotational transitions can be demonstrated in connection with light-scattering phenomena; (4) that Dennison is correct in his view that hydrogen at low temperatures must be regarded as a mixture of two effectively distinct sets of molecules, symmetrical and antisymmetrical.

WAVELENGTH SHIFTS IN SCATTERED LIGHT.—A. E. Ruark. (*Nature*, 1st September, 1928, V. 122, pp. 312-313.)

Although the writer believes that the Raman-Krishnan radiation is actually the scattered light of modified wavelength predicted by Kramers and Heisenberg, he points out that it has never yet been proved *not* to be a fluorescent emission following the absorption process after a finite interval. He suggests that the question could be settled by determining whether there is a time lag; the method of Abraham and Lemoine, using a Kerr cell as a very rapid electromagnetic shutter, has already been used to show a lag of 2×10^{-8} sec. for the phosphorescence of rhodamine.

LES RADIATIONS SECONDAIRES DANS LA LUMIÈRE DIFFUSÉ PAR LE QUARTZ (Secondary Radiations in the Light diffused by Quartz).—J. Cabannes. (*Comptes Rendus*, 14th January, 1929, V. 188, pp. 249-250.)

The writer has suggested, in his paper on the polarisation of the secondary radiations diffused by liquids, that the action of the light on a molecule depends on the orientation of the latter (*cf.* Abstracts, 1928, V. 5, p. 691).*

The present paper deals with experiments on crystals, in which the molecules are oriented in a small number of fixed directions.

ON THE MAGNETOSTRICTION OF A SINGLE CRYSTAL OF NICKEL.—Y. Masiyama. (*Sci. Report, Tôhoku Univ.*, August, 1928, V. 17, No. 5, pp. 945-961.)

"In all directions, the longitudinal effect is always contraction for all fields. . . . The transverse effect is just the reverse of the longitudinal one. . . . The magnetic contraction of ordinary nickel is . . . a mean value of contractions in different orientations of the microcrystals constituting the nickel." In English.

THE MAGNETO-RESISTANCE EFFECT IN SINGLE CRYSTALS OF NICKEL.—S. Kaya. (*Sci. Report, Tôhoku Univ.*, September, 1928, V. 17, No. 6, pp. 1027-1037.)

In English. The change in electrical resistance of single crystals of nickel when placed in a magnetic field parallel or perpendicular to the direction of the current was measured.

* An analogous hypothesis has already accounted for the polarisation of fluorescence. *cf.* F. Perrin, *Journ. de Phys.*, 1926.

RESISTANCE AND THERMO-ELECTRIC PHENOMENA IN METAL CRYSTALS.—P. W. Bridgman. (*Proc. Nat. Acad. Sci.*, December, 1928, V. 14, pp. 943-946.)

SUR LES DIRECTIONS D'ÉMISSION DES PHOTO-ÉLECTRONS (The Direction of Emission of Photoelectrons).—P. Auger. (*Comptes Rendus*, 10th December, 1928, V. 187, pp. 1141-1142.)

DÉTERMINATION DU RÔLE DE LA LUMIÈRE DANS LES RÉACTIONS CHIMIQUES THERMIQUES (Determination of the part played by Light in Thermal Chemical Reactions).—J. Perrin. (*Génie Civil*, 1st December, 1928, V. 93, p. 535.)

"The part taken by light in a purely thermal reaction is, for each reagent, equal to the amount of fluorescence yielded by that reagent under the conditions under which it finds itself."

ANGULAR DISTRIBUTION OF INTENSITY OF RESONANCE RADIATION.—R. W. Gurney. (*Proc. Nat. Acad. Sci.*, December, 1928, V. 14, pp. 946-951.)

ÜBER ELEKTRONENBEUGUNG IN EINEM GERITZTEN GITTER (Electron Diffraction at a Scratched Grid).—E. Rupp. (*Zeitschr. f. Phys.*, 16th November, 1928, V. 52, No. 1/2, pp. 8-15.)

Hitherto, electron diffraction has been with crystals as grids. These experiments show not only that mechanically made metallic grids give diffraction, but also that the de Broglie wavelength relation holds good (within the limits of error— ± 2 per cent.—of the test).

HOW MICHELSON SUPPORTS EINSTEIN. (*Sci. News-Letter*, 17th November, 1928, V. 14, pp. 303-304.)

Since Michelson's recent repetition of the Michelson-Morley experiment resulted in the detection of a fringe shift less than a 500th of that calculated for drift through the ether, and only a 10th of the small effect found at the first trial, he concludes that it is due to experimental errors, and that the positive result found by Miller was due to some other cause. Michelson, therefore—it is stated—has now joined the ranks of the relativists, though still maintaining his belief in the existence of the ether.

MISCELLANEOUS.

A NOISE TESTER.—(*The Engineer*, 18th January, 1929, V. 147, p. 71.)

Description of the Noise Tester made by the M.L. Magneto Company for giving a quantitative measure for noises such as those emitted by ball bearings, gear-boxes, exhaust noises, and the like. Three 3-electrode valves are used, the indicating being by a milliammeter.

THREE-ELECTRODE VALVES USED IN CHEMICAL TITRATING PROCESSES.—B. Kamienski. (*Bull. Acad. Polon. Sci. et Lettres*, January/February, 1928, pp. 33-60.)

In a titration method in which the solution is continually stirred and circulated through a curved

tube, containing a "sheltered" electrode near each end, the end-point is indicated by a pronounced rise in P.D. at the two electrodes which, through the mediation of a valve, is caused to give an audible signal.

AUTOMATIC TITRATION, USING PHOTOELECTRIC CELL AND VALVE AMPLIFIER.—General Electric Company. (*Journ. Scient. Instr.*, February, 1929, V. 6, pp. 74-75.)

Methyl orange is used as the indicator, and the photoelectric cell detects the change of tint and through amplifier and relay shuts off the burette.

SUR UNE NOUVELLE MÉTHODE DE LA MESURE DE LA VITESSE DES FLUIDS BASÉE SUR L'EMPLOI D'OSCILLATEURS À LAMPE (A New Method of Measuring the Velocity of Fluids, using Valve Oscillators).—P. Dupin. (*Comptes Rendus*, 18th February, 1929, V. 188, pp. 546-548.)

The flow exerts a pressure (counterbalanced by a spring) which varies a capacity or self-inductance in an oscillating circuit. By zero beat-note methods this variation is determined. Several advantages over other methods (Pitot tube, etc.) are mentioned—one being a linear calibration.

ENREGISTREMENT OSCILLOGRAPHIQUE DES VARIATIONS INSTANTANÉES DE LA PRESSION DANS LES CANALISATIONS D'EAU. MÉTHODE DU QUARTZ PIÉZOÉLECTRIQUE (Oscillographic Registration of Instantaneous Pressure Variations in Water Systems. Piezo-electric Quartz Method).—R. Hocart. (*Journ. de Phys. et le Rad.*, No. 6, 1928, V. 9.)

PHOTOELECTRIC CONTROL WITH MIRROR READING INSTRUMENTS.—K. Lark-Horovitz and G. W. Sherman. (*Phys. Review*, No. 2, V. 32 p. 328.)

A photoelectric cell is screened by a plate with three sections; the mid-section is half-opaque, the others respectively clear and opaque. The relay circuit is arranged to be at rest when the mirror of the galvanometer directs its ray on to the mid-section. An electric oven thus controlled, with a range of variation 80-600 degrees, keeps constant within 1 degree. A Röntgen apparatus can similarly be kept constant, using a H.T. mirror electrometer.

SOUND RECORDING WITH THE LIGHT VALVE.—D. MacKenzie. (*Bell Tech. Journ.*, January, 1929, V. 8, pp. 173-183.)

The sound-recording here described is of the variable density type, based on the use of the Bell Laboratory Light Valve. This consists essentially of a loop of duralumin tape formed into a slit at right angles to a magnetic field; currents flowing in the loop cause the slit to open and close and thus to let more or less light pass.

SYNCHRONISATION AND SPEED CONTROL OF SYNCHRONISED SOUND PICTURES.—H. M. Stoller. (*Bell Tech. Journ.*, January, 1929, V. 8, pp. 184-195.)

The important problem now (in systems where

the sound-reproducing mechanism is coupled mechanically to the picture projector) is to ensure that this synchronisation does not affect the pitch of the sound to a degree noticeable by a musical ear. A change, made abruptly, of one half of 1 per cent. can be noticed.

The paper describes valve frequency-bridge control circuits, and also the modified Michalke electric gear system for interlocked linking of sound-recorder and picture-recorder when these are at a distance.

SPEAKING TO EARTH FROM AN AEROPLANE.—(*Rad. Engineering*, February, 1929, V. 9, p. 48.)

Tests made by an American firm show that from an aeroplane equipped with a special loud speaker, flying at full throttle at 500 feet, the pilot's voice can be plainly heard and understood over an area of "about one-half mile square."

HEIGHT OF AEROPLANE ABOVE GROUND BY RADIO ECHO.—E. F. W. Alexanderson. (*Rad. Engineering*, February, 1929, V. 9, pp. 34-35.)

A fuller description of the methods referred to in March Abstracts, p. 168. Either one oscillator can be used, in which case the operator periodically changes the wavelength by—say—8 per cent. by pressing a key, and thus obtains two graphic curves which show the phase relation of the two waves, the amplitude of the echo indication having to be taken into account also, to avoid ambiguity; or two oscillators and two aerials can be used, in which case maxima of beat-frequency will be produced at certain heights.

BESEITIGUNG DER DURCH HOCHFREQUENZHEILGERÄTE HERVORGERUFENEN STÖRUNGEN DES RUNDFUNKEMPFANGES (Prevention of Interference with Broadcast Reception due to H.F. Medical Apparatus).—(*E.T.Z.*, 14th March, 1929, p. 394.)

PHYSICAL AND OPTICAL SOCIETIES' EXHIBITION: DESCRIPTION OF THE EXHIBITS.—(*Journ. Scient. Instr.*, February, 1929, V. 6, pp. 51-78.)

ÜBER HERZTÖNE UND HERZGERÄUSCHE (Heart Tones and Sounds).—K. Posener and F. Trendelenburg. (*Zeitschr. f. tech. Phys.*, December, 1928, pp. 495-499.)

Auscultation by condenser-microphone—illustrated by numerous oscillograms.

EXPLICATION DES EFFETS THÉRAPEUTIQUES DES CIRCUITS OSCILLANTS OUVERTS SUR L'ORGANISME DES ÊTRES VIVANTS (Explanation of the Therapeutic Effects of Open Oscillating Circuits on the Organism of Living Creatures).—G. Lakhovsky. (*Comptes Rendus*, 25th February, 1929, V. 188, pp. 657-658.)

The writer recalls his early work on the healing effects, on cancer in plants, of waves of the order of 2 m. Seidel has shown recently that milk, etc., can

be sterilised by waves of 1.5—3 m. Esau has just shown that mice inoculated with tuberculosis can be cured by 2 m. waves. The paper then deals with the writer's results with open insulated spirals surrounding diseased plants, unexcited by any oscillations other than those picked up from the atmosphere. His results in curing plant tumours have since been successfully repeated by other workers. These open circuits have been tested on human maladies, with results of marked improvement and sometimes complete cure in what were considered incurable cases. He attributes their effect to their being excited, to oscillate at their own natural frequencies (0.35—2 m.), by the numerous and varied electromagnetic oscillations present nowadays in the atmosphere—due to arcs, magnetos, dynamos and motors, rectifiers, lighting, wireless stations, and the "cosmic rays." The therapeutic effects may be similar to those produced by X-rays, ultra-violet light, radium, etc., but are less violent and more permanent owing to the constancy and feebleness of the radiations. The writer refers to the pioneer work in H.F. therapeutics of d'Arsonval, who on p. 659 recalls his first results.

QUELQUES STATISTIQUES SUR LA MORTALITÉ ET L'ÂGE D'ÉLECTION DES MEMBRES DE L'ACADÉMIE (Some Statistics on the Age at Death and Age at Election of the Members of the French Academy).—C. Richet. (*Comptes Rendus*, 25th February, 1929, V. 188, pp. 591-594.)

For the physicists, the statistics show that the average life is 70 years (Becquerel reached 90, while Malus died at 37); the average age at election—taken from members still alive—is 57, whereas for past members since 1800 it was 48. Gay Lussac was the youngest—at 28.

JOFFÉ'S UNTERSUCHUNGEN ÜBER DIE ELEKTRISCHE DURCHSCHLAGSFESTIGKEIT (Joffé's Investigations into Dielectric Strength).—A. Smekal. *Entgegnung* (Reply). A. Joffé. (*Naturwiss.*, No. 39, 1928, V. 16, pp. 743-745.)

An argument concerning Joffé's interpretation of his results on the high dielectric strength of very thin films. Smekal refuses to accept the "ionisation by collision" idea.

CONTACT EFFECTS BETWEEN ELECTRODES AND DIELECTRICS.—B. G. Churcher, C. Dannatt and J. W. Dagleish. (*Journ. I.E.E.*, February, 1929, V. 67, pp. 271-290.)

Among the results of this research are the following: Barlow's view, that "such materials as slate, red fibre, paxolin and celluloid can only be classed as dielectrics in virtue of their high contact resistance," is exaggerated; when testing dielectrics with mercury electrodes, contact effects of a certain order are to be anticipated, but these are only important in relation to that class of materials known as "semi-conductors," in which the volume resistivity is low. The importance of these effects in industrial tests upon commercial

dielectrics is shown to be small provided that specimens of adequate thickness are employed. An endeavour is made to assess the significance of the contact effect in relation to dielectric measurements of a fundamental nature. Contrary to the general idea that mercury electrodes are the ideal arrangement for testing dielectrics, two methods of obtaining better contact are found: the spraying of zinc by Schoop's "metallisation" process (February Abstracts, p. 112), and, better still, the use of a graphited surface backed with mercury. More finely divided graphite without mercury backing (only tested on D.C. at present) gives better contact than mercury alone.

SILVER SULFLUORIDE CRYSTALS AS RECTIFIERS (Silver-wire Contact).—A. Hettick. (*Z. anorg. Chem.*, 1927, V. 167, p. 67.)

PHOTOMETRY OF THERAPEUTIC LAMPS.—D. T. Harris. (*Journ. Scient. Instr.*, January, 1929, V. 6, pp. 2-7.)

A rapid method of measuring the ultraviolet emission from luminous sources is described, involving the use of a photoelectric cell, thermionic valve and a microammeter.

CORONAPHONE TESTING INSTRUMENT FOR DETECTION OF INCIPIENT TROUBLE IN A TRANSFORMER. (*Gen. Elec. Review*, January, 1928, V. 32, pp. 45-46.)

It is known that various types of insulation trouble have their characteristic noise. By the use of the coronaphone the normal hum is filtered and suppressed, while the remaining noise is amplified and is used either to listen to or to operate a relay.

USE OF THYRATRON FOR FURNACE TEMPERATURE CONTROL. (*Gen. Elec. Review*, January, 1929, V. 32, p. 37.)

The thyatron is stated to be the best means yet found for amplifying the feeble impulses from thermocouples or resistance thermometers, to control the large amounts of power used for furnace heating. The variations in plate current are enough to operate a contact-maker requiring two or three amperes. Very delicate mechanical devices have hitherto been used as relays.

RECORDING COLORIMETER.—(*Gen. Elec. Review*, January, 1929, V. 32, p. 38.)

This apparatus automatically, rapidly, and accurately measures and records the wavelengths of colours of any substance. The fundamental idea of the mechanism is that when the standard material and the specimen, one after the other, reflect different amounts of light of a particular wavelength, a ray of pulsating intensity is produced which (through the mediation of a photoelectric cell) runs a small motor whose motion works a shutter and automatically finds a position on the spectrum where—owing to equal reflection—the pulsations cease. A complete colour analysis takes less than a minute.

Some Recent Patents.

The following abstracts are prepared, with the permission of the Controller of H.M. Stationery Office, from Specifications obtainable at the Patent Office, 25, Southampton Buildings, London, W.C.2, price 1/- each.

PICTURE TRANSMISSION.

(Application date, 27th July, 1927. No. 300148.)

In order to facilitate amplification, the photo-electric cell used to scan the picture is subjected to an alternating current, so that its effective output is modulated periodically, independently of the light-and-shade effects. The resulting picture has a background of dots evenly and regularly spaced

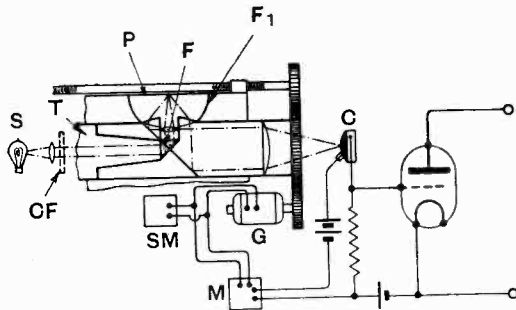

and grouped according to the frequency of modulation. Further, in order to ensure synchronism between transmitter and receiver, constant-frequency generators controlled by a tuning fork or piezo crystal are used for driving the scanning apparatus.

In the present invention the means for driving the scanning apparatus is so linked with the modulating source that a definite ratio is maintained between these two frequencies in operation. Light from a source S is focussed along a tube T and reflected at right angles by a prism F on to the picture P. The reflected light is collected by a mirror and prism F₁ and focussed on to a photoelectric cell C. The rotating and traversing mechanism for the picture-carrying tube is driven through gearing from a motor G, whilst the independent modulation frequency is applied to the cell C from a source M. Both M and G are driven in turn from a common constant-frequency source SM controlled by tuning fork or piezo crystal. The motor G is directly connected to the supply SM, whilst the modulator M comprises a frequency-changer which can be adjusted to give an output definitely related in frequency to the speed of the motor G.

Patent issued to G. M. Wright and S. B. Smith.

EXPONENTIAL HORNS.

(Application date, 9th August, 1927. No. 302199.)

In designing an acoustic horn it is desirable (a) that the proportion of available mechanical energy in the diaphragm converted into sound shall be a maximum, and (b) that this proportion shall be the same for all audible frequencies. The requirement under (a) depends upon the area of the initial

throat opening of the horn, whilst that under (b) depends upon the rate of expansion of the bore, and the overall length of the horn.

In the exponential type of horn, the area of the bore is made to increase by a constant percentage per unit length along the axis from throat to mouth. Theoretical considerations show, however, that the smaller this percentage is made, the more uniform is the loading on the diaphragm for the various frequencies in question. Also in order to minimise end-reflection from the mouth of the horn, the flare should be as large as possible. Obviously both these requirements involve a long horn.

According to the present invention, the same benefits are secured from a comparatively short horn, by making the percentage increase in bore area per unit length a gradually increasing quantity, from throat to mouth, instead of being a constant quantity as in the standard design.

Patent issued to R. E. Lloyd-Owen and T. Watson.

LOUD SPEAKERS.

(Application date, 10th September, 1927. No. 301960.)

The main structure consists of a disc S built up from several thicknesses of corrugated paper or strawboard, with the corrugations running in different directions. The magnetic movement M is mounted at the centre of the disc, but is cushioned or isolated from it by thick felt or rubber. A conical diaphragm D is vibrated by the magnet through a light stiff rod R.

The edge of the diaphragm D abuts closely against the surface of the disc S to prevent any air leakage, a sound insulating buffer or ring B being interposed as shown. Openings O are formed in the main disc inside the area covered by the diaphragm to allow free passage of air. The outer edges of the main discs are bound or clamped together between sheet-metal rings K. The whole structure is mounted on a heavy base-plate P, which also supports a spider frame F consisting of two splayed metal rods which serve to strengthen the structure from top to bottom.

Patent issued to Sterling Telephone Co., Ltd., N. Blades and J. R. Beard.

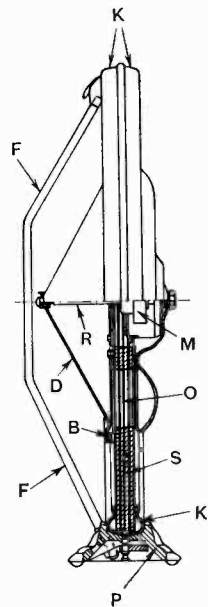

HIGH-POWERED H.F. GENERATORS.

(Application date, 27th August, 1927. No. 301355.)

The dielectric strain on the vitreous material of a short-wave transmitting-valve, consuming say 10 kilowatts and generating at a wavelength of 25 metres or less, frequently leads to excessive heating, electrolysis, and consequent destruction of the bulb. The inventors have discovered that the strain can be more equally distributed, and therefore reduced to safe dimensions by fitting a metal screen inside the bulb between the grid collar and the filament leads.

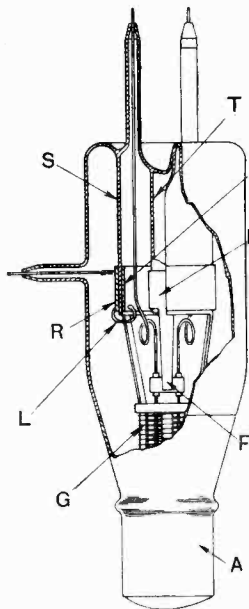

The Figure represents a power valve fitted with a fused-on metal anode *A*. The grid *G* is suspended from a metal ring *R* which grips the re-entrant stem *S* of the bulb. The support *F₁* for the filament is carried by a collar *M* fixed to a central stem *T*. The protective screen *P* consists of a ring of copper gauze or sheet nickel bent around and expanded into position

inside the bulb. It is metallically connected to the grid collar *R* by a short lead *L*. In this way the inside and outside of the glass are both maintained at the same potential level, and the risk of damage by fracture is minimised.

Patent issued to Standard Telephones and Cables, Ltd., and W. T. Gibson.

PICTURE-TRANSMISSION SYSTEMS.

(Convention date (U.S.A.), 25th July, 1927. No. 294546.)

At the transmitting end, a special synchronising signal is sent out at regular intervals corresponding

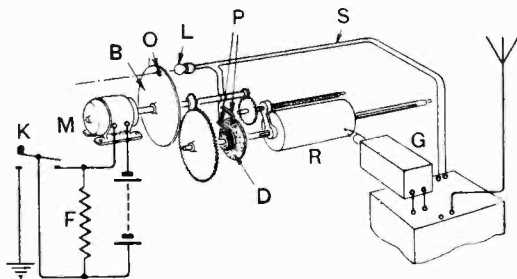

to each complete rotation of the picture-carrying drum. At the receiving end, this signal is separated out from the light-modulated signals, the latter being fed to the recording-drum *R* through an

oscillograph *G* in known manner. The synchronising signals will pass through leads *S* to energise a lamp *L* so long as the contacts *P* occupy a certain segment on the surface of a disc *D*. This disc is keyed to the shaft of the recording drum *R* and is driven by the motor *M*.

If the rotation of the drum *R* is exactly in step with that used at the transmitting station, the position of the flicker from the lamp *L*, as viewed through a hole *O* in the rotating disc *B*, will appear to remain stationary. If one motor is either leading or lagging the other, the direction of drift is indicated by the stroboscopic movement of the lamp-image, thus enabling the operator to accelerate or slow down the motor *M* as necessary. The local speed control consists of a field resistance *F* and a short-circuiting key *K* manipulated by the operator.

Patent issued to The British Thomson-Houston Co., Ltd.

GRAMOPHONE PICK-UPS.

(Application date, 24th February, 1928. No. 302838.)

Electrostatic and electromagnetic action is combined in the same pick-up, the resultant voltage fluctuations being applied to the grid of the amplifier in parallel, the object being to increase the fidelity

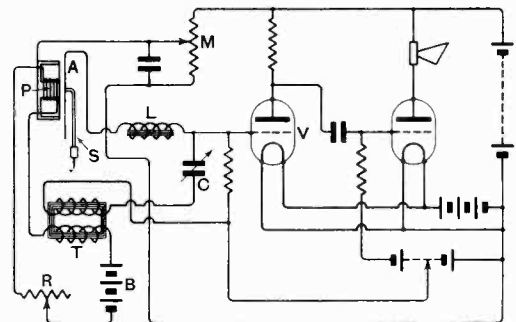

of response towards the upper and lower limits of audibility. The outer diaphragm *A* of the pick-up *P*, when vibrated by the stylus needle *S*, co-acts with a flat annular pole-piece (*a*) to alter the effective capacity of the condenser system, and (*b*) to vary the magnetic flux across the pole-pieces.

The electrostatic effect is applied directly to the grid of the amplifier *V* through a choke *L*, whilst the magnetic variation is applied across a step-up transformer *T*. The initial voltage on the condenser plates of the pick-up is derived from a tapping *M* on a potentiometer fed from the high-tension battery. The windings of the magnetic pick-up are energised from a battery *B* through a variable resistance *R*. The choke *L* prevents the shunting of high-frequency magnetic impulses away from the grid, whilst the condenser *C* serves a similar purpose in the case of low-frequency impulses due to the electrostatic action of the pick-up.

Patent issued to H. Andrewes and Dubilier Condenser Co. (1925), Ltd.

GAS-FILLED DISCHARGE TUBES.

(Application date, 29th August, 1927. No. 301763.)

The Figure shows a convenient switch arrangement for controlling a discharge tube of the type in which an incandescent filament is used to start the discharge. Once the discharge has been started, it is self-sustaining, the filament being switched out of circuit. When the switch is on contact 1, current from the mains is supplied through a portion of the common resistance R to heat the filament. The switch is next moved over to point 2 where the discharge is initiated by the biasing potential so applied to the control electrode. Once the discharge stream is established, the switch is moved over to the idle point 3.

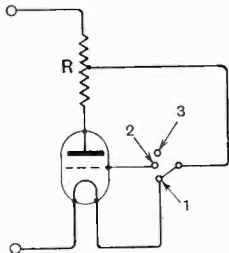

Patent issued to S. G. S. Dicker.

SCREENING AMPLIFIER CIRCUITS.

(Convention date (U.S.A.), 8th February, 1927. No. 285020.)

The use of a screened-grid valve whilst preventing capacity coupling across the internal electrodes does not eliminate reaction due to the proximity of external circuit components. For this additional screening-means are necessary. The Figure shows two H.F. valves enclosed in a metal casing subdivided into four compartments, so as to screen not only the input circuit I_1 of the valve V_1 from the output circuit O_1 , but also the corresponding circuits I_2, O_2 of the valve V_2 . The valve holders

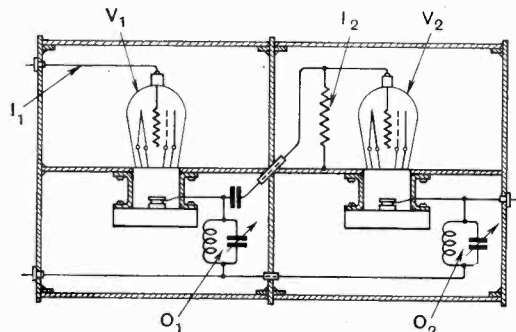

are suspended from the intermediate partition so that the valves can be easily removed without disturbing the circuit connections.

Patent issued to The British Thomson-Houston Co., Ltd.

MULTIPLE VALVES.

(Convention date (Germany), 19th July, 1926, No. 274514.)

In a valve of the type in which several complete amplifying stages are housed in the same glass bulb, special screening elements are fitted, more especially around the last stage, in order to prevent the humming or ringing noise due to free or uncon-

trolled electrons which periodically "load" the glass wall of the tube. In each case the screen consists of a metallic cylinder surrounding the ordinary electrode system but spaced away from the inner wall of the bulb, and connected to a point of fixed potential. Alternatively, the ordinary "getter" coating of magnesium on the inside wall of the bulb may be connected by a special fused-in lead to a point of fixed potential for the same purpose.

Patent issued to Dr. S. Loewe.

PREVENTING FADING.

(Application date, 19th September, 1927; No. 302634.)

Fading is attributed to the fluctuating effect of the Heaviside layer upon the polarisation of the transmitted wave. For instance, signals transmitted with a vertical polarisation often reach the earth, after reflection, with a predominant horizontal polarisation, in which case there is no

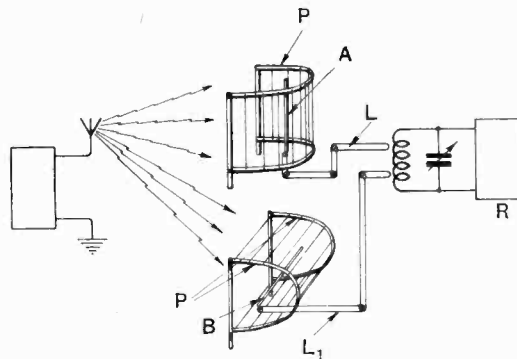

appreciable pick-up by an aerial designed to receive the former type of wave.

To compensate for this effect, two or more receiving aerials A, B are spaced apart, but are linked to a common receiver R . The aerial A is arranged with its axis vertical, whilst B is horizontal, both being associated with a suitable reflecting system P . Should fluctuations occur in the polarisation of the incoming wave, energy missed by one aerial will be received upon the other, and *vice versa*. The length of each of the combining lines L, L_1 is such that the received energy reaches the final collecting circuit in correct phase. For short-wave working, both receiving aerials A, B are preferably elevated several wavelengths above the ground.

Patent issued to Standard Telephones and Cables, Ltd.

TESTING ACCUMULATORS.

(Application date 16th November, 1927, No. 302784.)

Near the top of the accumulator casing is a small self-contained chamber which is perforated at the bottom to allow free passage of the electrolyte. The chamber contains one or more specific-gravity balls, so that it serves as a permanent hydrometer. The condition of the electrolyte can be estimated at any time from the level of the floating balls as seen through a small glass panel let into the main casing.

Patent issued to G. H. Trotter.