

EXPERIMENTAL WIRELESS & The WIRELESS ENGINEER

VOL. V.

AUGUST, 1928.

No. 59.

Editorial.

Quality *versus* Selectivity in Distant Broadcasting Reception.

IN the March number of the Proceedings of the Institute of Radio Engineers a paper is published which was read by Mr. F. K. Vreeland and discussed at a recent meeting of the Institute. It is entitled, "On the Distortionless Reception of a Modulated Wave and Its Relation to Selectivity." The problem is summarised in the following terms: "Selectivity requires that a certain group of radio frequencies, comprising a modulated signal wave, must be separated from all other radio waves. Fidelity requires that all the frequencies included in the transmitted wave must be received in their true relative proportions. These two conditions give rise to a peculiar and highly specialised problem of receiver design, namely, to construct a selective system that is equally responsive to all frequencies within a given range or band and unresponsive to frequencies outside this band. The condition of crowded air channels requires a very sharp cut-off at the edges of the band."

The transmitting station actually sends out waves of one definite frequency, but of varying amplitude and such a modulated wave has the same effect on the receiver as waves of constant amplitude but of different frequencies. the different frequencies cover-

ing a range on either side of the actual frequency of the wave. If we take 10,000 cycles per second as the highest audible frequency which we need consider, then for this case, the amplitude of the current in the transmitting aerial will vary in amplitude 10,000 times per second, which will have the same effect on the receiving apparatus as if three waves of unvarying amplitude were being received, one having the nominal frequency f of the transmitter, one a frequency $f + 10,000$, and the other $f - 10,000$. If all the audible frequencies are to be received in their true relative proportion the receiver must respond uniformly to all frequencies within a band of 20,000 cycles per second. The absence of frequencies above about 10,000 would perhaps be detected by a very critical listener in the distinctive timbre of high notes on the violin, oboe, piccolo, etc. This refers to steady oscillations; the absence of the higher frequencies may affect the transient phenomena associated with percussion instruments and certain speech consonants. Setting 10,000 as our limiting audible frequency, the requirement of selectivity, *i.e.*, of non-interference from any wave outside our band, would best be met by a rectangular response curve. By this we mean that if

our receiver is acted on by a wave of constant amplitude, the frequency of which is gradually changed, the receiver should give no response except over a band 20,000 cycles wide, and uniform response within this band. Now, an ordinary tuned circuit gives a response curve approximating more closely to a triangle than to a rectangle if it is made highly selective, with the result that the higher audible frequencies are not reproduced to the same extent as the lower ones. If to minimise this defect, the damping is increased, then the response curve broadens out into a wide hump and neighbouring wavelengths cause interference, to say nothing of the sacrifice of sensitiveness.

In the paper referred to, Vreeland discusses two methods of overcoming the difficulty, but unfortunately the treatment is very popular and little or no attempt is made to submit the proposals to vigorous mathematical or experimental examination. Both methods employ well-known devices to obtain an approximation to the rectangular response curve. A device which has such a characteristic is known as a band-pass filter. A band-pass filter consists of a cascade of tuned oscillatory circuits, each unit being coupled both to the preceding and following unit. Every wireless receiving set with more than one tuned high-frequency circuit may be regarded as a band-pass filter; even a single tuned circuit constitutes a primitive band-pass filter.

If one has two low-loss oscillatory circuits in cascade with loose coupling between them, the selectivity can be made very great by tuning them both to the same frequency, but the response will fall off very rapidly with increasing audio frequency. Now, there are several ways in which, by sacrificing selectivity—and sensitivity—the response can be made more uniform over the audible range. One method is to insert damping in each oscillatory circuit; two or three damped circuits in cascade give a much closer approximation to the desired rectangular response curve than a single low-loss circuit. There is, of course, a loss of sensitivity which has to be made up for by inserting amplifying valves between successive high-frequency stages. The use of

two or three stages of high-frequency amplification is not always a sign that the set is intended to receive very distant stations, but more often that it is designed to give selectivity and quality on moderately distant stations. The reverse phenomenon occurs when a set is made super-sensitive by the use of excessive reaction; the super-sensitiveness is confined mainly to the carrier wave with the result that the quality is poor.

There is another method by which the response of a cascade of two low-loss circuits can be made more uniform over the audible range—again with a sacrifice of selectivity and sensitivity—and that is by the simple expedient of detuning them, one above and the other below the carrier frequency. If there are three circuits, then one can be left in tune. This is one of the methods advocated by Vreeland, but we presume that everyone who has experimented with a set in which this detuning is possible has adopted it when the reception was strong enough to allow of it. Vreeland proposes, however, to put the circuits out of tune in a definite ratio by adding fixed inductances, and leaving the condensers gang controlled.

The alternative method suggested by Vreeland consists in keeping the two oscillatory circuits tuned, but coupling them so closely together that the well-known double hump just appears in the resonance curve. This method is really very similar to the previous one since when two similar oscillatory circuits are coupled, they cease to have their individual resonant frequency, but the combination exhibits two resonant frequencies differing by an amount depending on the tightness of coupling.

We suggest as an interesting problem the theoretical investigation of the relative merits of the three methods of achieving the desired result. It is interesting to note that, in each case, what is usually regarded as a defect is deliberately introduced; in the first case, damping is introduced into the tuned circuits; in the second, the gang-controlled circuits are deliberately detuned; in the third, the coupling is made so tight that the double hump appears.

G. W. O. H.

Inter-Electrode Capacities and Resistance Amplification.

By *L. Hartshorn, A.R.C.S., B.Sc., D.I.C.*

(The National Physical Laboratory.)

RECENT developments in resistance amplification have been towards the use of high voltage factor valves, and high anode resistances. A general discussion of this matter, particularly of the use of very high anode resistances, was given by F. M. Colebrook some time ago in this journal (*E.W. & W.E.*, April, 1927, p. 195). Mr. Colebrook showed that when moderate anode voltages are used (say 50 to 100 volts), the "working characteristic" of the valve-anode resistance combination will be a straight line provided that the anode resistance R is large compared with the internal resistance of the valve R_a , and therefore, in order to avoid distortion, this condition should be fulfilled. It was further pointed out that in multi-stage amplifiers, certain of the inter-electrode capacities of the valves act as shunts across the anode resistances, and the effect of this is to cause the impedance of the anode circuit to vary with the frequency, thereby causing distortion. This effect is larger, the larger the value of the anode resistance, and the choice of a suitable anode resistance is a matter of compromise. A high value is required in order to keep the "working characteristic" straight, and also to make the amplification per stage approximate to that of the voltage factor of the valve used, but the value must not be so high that the shunting effect of the electrode capacities causes considerable distortion.

In a subsequent letter (*E.W. & W.E.*, June, 1927) Mr. Colebrook emphasised the fact that his analysis of the coupling conditions in the resistance amplifier was valid only under the conditions stated, viz., that the shunting effect of the electrode capacities of the valves on the various resistances was small, whereas from measurements of the input impedance of valves made by the writer, it appears that the effective values of the capacities of valves may reach values as high as 100 $\mu\mu\text{F}$. in the case of an ordinary R valve, and that valves with a high voltage

factor may be expected to possess even higher effective values, under the conditions obtaining in a resistance amplifier. Further, Mr. Colebrook drew the attention of the writer to the importance of making measurements of the input capacities of valves of high voltage factor, and of investigating the bearing of the results on the limitations of resistance amplifiers. This article is the outcome of these suggestions.

Input Impedance, Admittance and Capacity.

Fig. 1 (taken from Mr. Colebrook's article previously referred to), represents a two-stage resistance amplifier of the usual type.

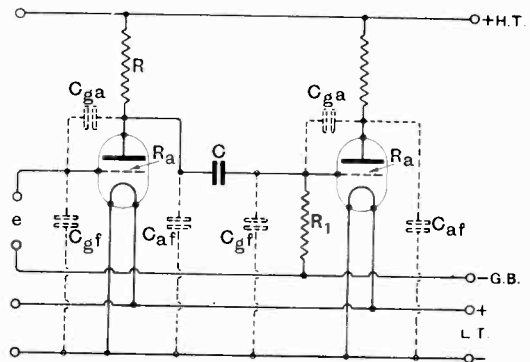

Fig. 1.—Two-stage resistance amplifier.

In order to prevent inter-electrode capacities from being overlooked, these are indicated by dotted lines and lettered C_{ga} , C_{gf} , etc. Here C_{gf} represents the electrostatic capacity between the grid and the filament of a valve. This is a quantity which can be measured fairly easily, and is known to be of the order 5 to 10 $\mu\mu\text{F}$. Thus on tracing out the network, one is tempted to believe that the grid leak R_1 is shunted merely by a capacity of this order. From one point of view, however, diagrams of this nature showing inter-electrode capacities are incomplete. We are apt to assume that these capacities are carrying currents which can be deter-

mined by a simple application of Ohm's Law (in the generalised form used in alternating current work $V = IZ$), that is, they can be regarded as ordinary electrostatic capacities, linking up the appropriate points of the network. This is only partially true. The diagram is defective (from the point of view

conductance negligibly small. Also it only represents the behaviour of the valve with respect to small alternations of applied voltage. Within these limitations a two-stage resistance amplifier may be completely represented by Fig. 3. It should be noticed that the grid leak R_1 is shunted, not merely by the capacity $G'F'$, but by the whole network lying to the right of $G'F'$, including the E.M.F. $\mu e'$. The resultant shunting effect is determined by the magnitude of the grid current i'_g , and this is determined by the input admittance $A'_g = i'_g/e'$, or by the input impedance $Z'_g = e'/i'_g$ of the second valve. It will now be shown that the input admittance of such a valve is much greater than that of the grid filament capacity $G'F'$, which is, of course, given by $jC'_{gf}\omega$, where j is the operator rotating through a right-angle, and $\omega = 2\pi \times$ frequency.

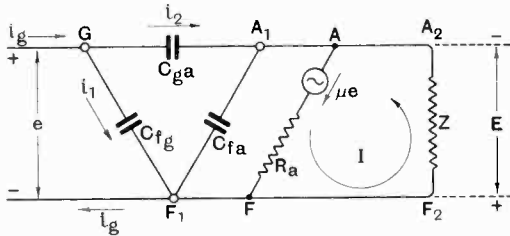

Fig. 2.—Equivalent network for single valve.

of analysing the behaviour of the circuit) inasmuch as there is nothing in it to represent the amplifying properties of the valves, and as the effective values of certain of these capacities may also be considered to be amplified, the point is one of importance. A diagram intended to represent completely the behaviour of a valve should take the form shown in Fig. 2. Here F , G and A are the filament, grid, and anode respectively. They are connected by the inter-electrode capacities. R_a represents the internal resistance of the valve, and Z is the external impedance added in the anode circuit, e being the alternating component of the P.D. between filament and grid. i_g is the alternating component of the grid current, i.e., the current entering the valve at G and leaving at F . This current, entering at G , may be considered as dividing into two components, i_1 passing through the capacity C_{gf} to F , and i_2 passing through the capacity C_{ga} to A , where it again divides, finally reaching F by the three paths C_{gf} , R_a and Z in parallel.

will cause an increase in anode current, i.e., it must drive current through the resistance R_a in the direction A to F , as in the diagram. (The anode current consists of negative electrons passing from F through R_a to A , and this is the equivalent of positive electricity passing from A to F .) It should be mentioned here that this diagram only applies to valves in which sufficient negative grid bias is used to make the grid-filament

Refer again to Fig. 2, which is the network equivalent to a single valve, of voltage factor μ , and internal resistance R_a , with an impedance Z in the anode circuit, e being the alternating component of the P.D. between filament and grid. i_g is the alternating component of the grid current, i.e., the current entering the valve at G and leaving at F . This current, entering at G , may be considered as dividing into two components, i_1 passing through the capacity C_{gf} to F , and i_2 passing through the capacity C_{ga} to A , where it again divides, finally reaching F by the three paths C_{gf} , R_a and Z in parallel.

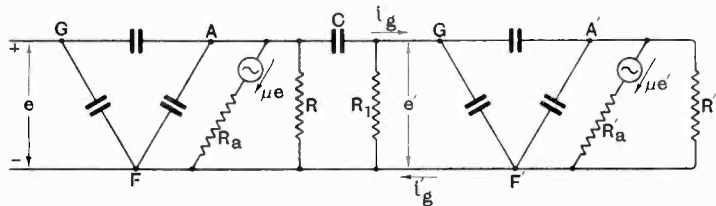

Fig. 3.—Equivalent network for two-stage resistance amplifier.

Evidently, $i_g = i_1 + i_2$, and if we can calculate the magnitude of the currents i_1 and i_2 , the grid current i_g will be known. Now the P.D. across the condenser C_{gf} is e , and therefore the current i_1 carried by this condenser must be

$$i_1 = j e \cdot C_{gf} \omega \quad \dots \quad (1)$$

Let E be the alternating P.D. produced by the valve across the impedance Z , so that

$k = E/e$ is the actual amplification of voltage produced by the valve. The current through Z , which gives rise to the potential difference E , is driven by the E.M.F. μe , and therefore flows in the direction A, F, F_2, A_2 . Thus the direction of E must be such as to make the anode A_2, A, A_1 negative with respect to the filament F_2, F, F_1 . Therefore the P.D. between G and A_1 is $e + E$, G being positive with respect to A_1 . The current i_2 through the condenser C_{ga} is therefore given by

$$i_2 = j(E + e) C_{ga}\omega \quad \dots (2)$$

and the total grid current is thus

$$i_g = i_1 + i_2 = j\omega [eC_{fg} + (E + e) C_{ga}] \\ = j\omega \left[C_{fg} + C_{ga} + \frac{E}{e} C_{ga} \right] \quad (3)$$

The input admittance of the valve is therefore given by

$$A_g = j\omega \left[C_{fg} + C_{ga} + \frac{E}{e} C_{ga} \right]$$

or $A_g = j\omega [C_{fg} + C_{ga} + kC_{ga}] \quad \dots (4)$

The actual amplification k produced by the valve must be regarded as a vector, since the two P.D.s e and E are not necessarily in phase. At low frequencies (the audio range, say), when the admittances of the valve capacities are small compared with that of the main anode circuit, A, F, F_2, A_2 , the currents through these capacities will be very small compared with the anode current I , and as a first approximation we may write

$$I = \mu e / (R_a + Z).$$

$\therefore k = E/e = IZ/e = \mu Z / (R_a + Z) \quad \dots (5)$

and $A_g = j\omega [C_{fg} + C_{ga} + \mu Z C_{ga} / (R_a + Z)] \quad \dots (6)$

When the load in the anode circuit is a pure resistance R , as in the resistance amplifier, this becomes

$$A_g = j\omega [C_{fg} + C_{ga} + \mu RC_{ga} / (R + R_a)] \quad \dots (7)$$

In this case the input admittance is purely capacitive, the effective value of the capacity being $C_{fg} + C_{ga} + \mu RC_{ga} / (R + R_a)$. When the impedance added in the anode circuit possesses a reactance component, the input admittance will be found to contain a conductance component, which is positive when the reactance is negative (capacitive) and negative when the reactance is positive (inductive). A more detailed mathematical

investigation of these points is given in my Physical Society* paper previously referred to, but the above is sufficient to show that the grid current of a valve is usually much greater than that passing through the grid-filament capacity, its actual value being greater, the greater the value of the actual voltage amplification obtained. This increase of grid current is due to the current carried by the grid-anode capacity, and can only be kept small by making this capacity as small as possible. On the input side, a valve with a resistance R in the anode circuit can be regarded as a condenser of capacity $C_{fg} + C_{ga} + kC_{ga}$, where k is the actual voltage amplification given by the valve. Thus, if a high voltage factor valve gives an actual amplification of 20 per stage, and the inter-electrode capacities are each $5 \mu\mu\text{F.}$, the effective grid capacity is $110 \mu\mu\text{F.}$, and if this is the second valve in Fig. 3, the grid leak R_1 must be regarded as shunted not merely by $5 \mu\mu\text{F.}$ but by $110 \mu\mu\text{F.}$

The above results have been deduced on the assumption that the network shown in Fig. 2 is exactly equivalent to a valve. Some workers have found difficulty in accepting this diagram. It must be regarded as being to some extent empirical. The justification for its use lies in the fact that if the general equations of the network are written down, and then compared with the most generalised form of the equations† for small changes in the currents and voltages in a three-electrode valve network, the two are found to be identical, if the following relations are satisfied:—

(1) The thermionic current I between filament and anode is a function of the single variable $(V + \mu v + c)$, where V is the anode-filament P.D., v the grid-filament P.D., μ the voltage factor of the valve, and c a constant (which may be zero) depending on the construction of the valve, *i.e.*,

$$I = F(V + \mu v + c).$$

Also $\frac{\delta I}{\delta V} = \frac{I}{R_a}$

(2) The thermionic current i between filament and grid is practically zero and is unaffected by small changes in anode

* Proc. Phys. Soc., Vol. 39, p. 108, 1927.

† Nichols, Phys. Rev., Vol. 13, p. 411, 1919.

potential or grid potential, *i.e.*,

$$\frac{\delta i}{\delta V} = 0 \text{ and } \frac{\delta i}{\delta v} = 0.$$

These relations can be verified experimentally for a valve, used under the conditions which exist in amplifiers, *i.e.*, with sufficient negative grid bias to keep the grid current zero.

The author has made direct measurements of input admittance, and since the results were found to satisfy equations (6) and (7), these measurements may also be regarded as establishing the validity of the network given.

The Direct Measurement of Input Admittance.

The circuit used for measuring input admittance is shown in Fig. 4. It will be

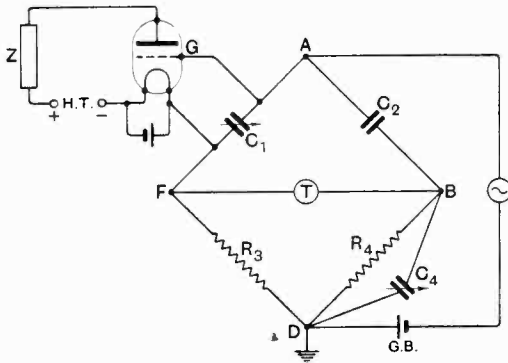

Fig. 4.—Bridge for input impedance measurement.

seen to consist essentially of a simple four-arm bridge for the measurement of capacity and conductance. The ratio arms R_3 and R_4 are equal non-inductive resistances of, say, 1,000 or 5,000 ohms each. C_1 is a standard variable air condenser reading up to $0.001 \mu\text{F}$. C_2 may be a fixed condenser of this amount, and C_4 is a variable air condenser of $0.001 \mu\text{F}$. Alternating current of telephonic frequency is applied between the points A and D . The balance detector T , connected to the points F and B , consists of a two-stage amplifier and telephone receiver. The grid circuit of the valve under test is connected in parallel with the condenser C_1 as shown. The grid bias battery GB is in series with the valve oscillator supplying the alternating current, and it is to be noted that this maintains the grid G

at any desired static potential with respect to the filament F .

The measurement is made as follows: The circuit being completed as shown, the condensers C_1 and C_4 are varied until the bridge is balanced, and the telephone detector is silent. The readings of C_1 and C_4 are noted. The grid of the valve is then disconnected from the bridge at the point G , and balance again obtained by adjusting the values of C_1 and C_4 . Let C_1' and C_4' be the new values, then we have

$$\text{Input capacity} = C_1' - C_1 \dots \dots (8)$$

$$\text{Input conductance} = \omega^2(C_4 - C_4')R_4^2C_2/R_3 \dots (9)$$

This may be proved as follows: When the bridge is balanced, there is no current in FB , and therefore the current through R_3 is equal to that flowing from F to A , *i.e.*, in the usual notation $i_g + jv_gC_1\omega$. The current through the arms DB and AB will similarly be equal. Denote it by i_2 . Then equating the potential differences in the arms DF and DB ,

$$(i_g + jv_gC_1\omega)R_3 = i_2 \left(\frac{1}{R_4} + j\omega C_4 \right)$$

Similarly, for the arms FA and BA

$$v_g = i_2/j\omega C_2$$

Dividing the first of these equations by the second, we have

$$\left(\frac{i_g}{v_g} + j\omega C_1 \right) R_3 = j\omega C_2 / (1/R_4 + j\omega C_4) \dots (10)$$

When the valve is disconnected from the bridge at G , the current i_g no longer flows from F to A , and C_1' being the new reading of the condenser C_1 , the equation of balance becomes

$$j\omega C_1'R_3 = j\omega C_2 / (1/R_4 + j\omega C_4') \dots (11)$$

Subtracting (10) and (11)

$$\left[\frac{i_g}{v_g} + j\omega(C_1 - C_1') \right] R_3 = j\omega C_2 \left[\frac{j\omega(C_4' - C_4)}{\left(\frac{1}{R_4} + j\omega C_4 \right) \left(\frac{1}{R_4} + j\omega C_4' \right)} \right]$$

In practice ωC_4 is small compared with $1/R_4$. We therefore obtain the working equation

$$\frac{i_g}{v_g} = j\omega(C_1' - C_1) + \omega^2 C_2(C_4 - C_4')R_4^2/R_3$$

which is equivalent to the equations (8) and (9) given above. In a bridge of this nature

the most probable sources of error are the earth capacities of the various batteries, but if the measurement is carried out exactly as described above, these are eliminated. The point *D* of the bridge being earth connected, the earth capacities of the H.T. and filament batteries may be regarded as a capacity shunt across the resistance R_3 . This is balanced by the condenser C_4 , and as the valve is disconnected at the point *G* only, these earth capacities are present when both balances are being obtained. They could be represented by constant terms added to equations (10) and (11), but on taking the difference they cancel out so that the working equation remains correct in spite of such capacities. The valve circuit was mounted on a board which was insulated by paraffin wax blocks, and batteries of small bulk were used, so that the earth capacities were as small as possible, but measurements can be successfully made even when these conditions are less satisfactory. The battery providing the grid bias lies entirely outside the bridge proper, and therefore has no undesirable effect on readings at the balance point.

The input P.D. used for the measurement was of the order of 0.1 volt.

Typical Values of Input Capacity and Conductance.

The values of the input capacities and conductances of a series of typical valves with various resistance loads in the anode

TABLE I.

VALUES OF INPUT CAPACITY FOR VARIOUS VALVES.

<i>R</i>	Input Capacity for Valve.			
	P.M.1 H.F.	S.P.18.	R.C.2.	P.M.5B.
Ohms.	$\mu\mu\text{F.}$	$\mu\mu\text{F.}$	$\mu\mu\text{F.}$	$\mu\mu\text{F.}$
0	12	9	8	13
10,000	54	58	—	69
20,000	81	83	—	103
50,000	124	118	67	171
100,000	165	139	82	231
200,000	—	—	164	1,257
570,000	202	179	298	2,450
1,000,000	—	—	330	2,570
4,300,000	220	173	303	2,730
6,000,000	218	171	358	—

circuit were determined by the method described above. The values of input capacity are given in Table I, and those of con-

ductance in Table II. In the case of valve R.C.2, the observations were made at a frequency of 2,000 cycles; in the other cases the frequency was 1,000 cycles. In the tables, *R* is the resistance added in the anode circuit of the valve. Throughout each series of measurements the H.T.

TABLE II.
VALUES OF INPUT CONDUCTANCE FOR VARIOUS VALVES.

<i>R</i>	Input Conductance for Valve.			
	P.M.1 H.F. at 1,000.	S.P.18 at 1,000.	R.C.2 at 2,000.	P.M.5B at 1,000.
Ohms.	μ mho.	μ mho.	μ mho.	μ mho.
0	0.004	0.002	0.006	0.004
10,000	0.015	0.026	—	0.020
20,000	0.027	0.041	—	0.037
50,000	0.045	0.061	0.11	0.079
100,000	0.060	0.065	0.13	0.137
200,000	—	—	0.33	1.06
570,000	0.12	0.098	0.67	2.21
1,000,000	—	—	0.89	2.71
4,300,000	0.23	0.14	1.7	4.92
6,000,000	0.26	0.16	1.9	—

ductance in Table II. In the case of valve R.C.2, the observations were made at a frequency of 2,000 cycles; in the other cases the frequency was 1,000 cycles. In the tables, *R* is the resistance added in the anode circuit of the valve. Throughout each series of measurements the H.T. battery voltage was kept constant the actual P.D. between filament and anode varied therefore when the resistance load in the anode circuit was changed. The actual values of the H.T. battery voltage, filament voltage, and grid bias, together with other data for the various valves are given in Table III.

Both the internal resistance R_a of the valve, and the voltage factor μ were actually measured under the conditions of use. In the cases of valves P.M.1 H.F. and S.P.18 the negative grid bias used might have been smaller with advantage, but in the other two cases the best value of the grid bias was found by trial, and this value was then used in making the measurements. The rated filament voltage of the valve P.M.5B was higher than 4 volts, but in practice the valve was found to be less effective when the filament voltage was increased.

The general trend of the results given in Tables I and II is such as may be expected from the theoretical discussion given above *i.e.*, as the resistance load in the anode circuit is increased, the input capacity becomes larger in accordance with equation (7). When the anode resistance is 1 megohm,

the input capacity is several hundreds of micro-microfarads, the higher values being associated with valves of high voltage factor. The input conductance increases in a similar manner. The agreement between measured values and theory is not, however, strictly quantitative. Thus when $R = 0$ the input capacity is by equation (7) equal to $C_{fg} + C_{ga}$, and when R is very large the input capacity gradually approximates to $C_{fg} + C_{ga} + \mu C_{ga}$. Thus the difference between the initial and final values should give the value of μC_{ga} , and knowing the value of μ , the value of C_{ga} should be calculable. The values of C_{ga} calculated from the results in Tables I and III are given in Table IV.

Comparing these results for C_{ga} with the values of the input capacity when $R = 0$, we notice that the calculated values are all larger than is to be expected. In the case of the valve P.M.5B the difference is very large. The values of input capacity for this valve reached the enormous value of $2,730 \mu\mu F$. The author cannot at present offer any complete explanation of this. It may be that this particular valve is not typical of its class, but no other sample was available at the time these measurements were made, so that this point could not be investigated. In any case, the fact that such very high values of input capacity can be met with is of obvious practical importance.

TABLE III.

FUNDAMENTAL CONSTANTS OF THE VALVES.

Valves.	Fila-ment Volt-age.	Anode Volt-age.	Grid Bias.	R_a .	μ .
P.M.1 H.F.	2.0	60	-2.0	57,500	12
S.P.18	2.0	60	-2.0	27,000	8.5
R.C.2	2.0	100	-1.0	338,000	45
P.M.5B	4.0	150	0	57,100	34

The values of the input conductance given in Table II corresponding to high values of anode resistance are also larger than is to be expected from formulæ derived from the equivalent circuit for a valve given in Fig. 2, assuming that the constants of this circuit are those measured by the usual methods. These deviations from the formulæ are, however, mainly of theoretical interest.

Generally speaking, the results can be expressed with all the accuracy required in practice, by the formulæ given. As for the

TABLE IV.
CALCULATED VALUES OF GRID-ANODE CAPACITIES.

Valve.	μC_{ga} .	μ .	C_{ga} .
	$\mu\mu F$.		$\mu\mu F$.
P.M.1 H.F.	207	12	17
S.P.18	163	8.5	19
R.C.2	350	45	7.8
P.M.5B	2,720	34	80

deviations, it is sufficient to remember that in using the formulæ, the input capacity and conductance are more likely to be underestimated than over-estimated.

The input conductance is apt to vary greatly with the frequency, but as it is usually of very little importance compared with the input capacity, this point will not be considered in detail. The input capacity was found to decrease as the frequency increased, but the change is not very great, e.g., the capacity decreased by 15 per cent. when the frequency increased from 1,000 ~ to 4,000 ~. This is almost certainly due to the fact that the inter-electrode capacities decrease by about this amount with increase of frequency. In studying the effect of input capacity in low frequency amplifiers, this change of capacity with frequency may be safely ignored, as being a second order effect.

Application to the Resistance-capacity Amplifier.

It has been shown that for the purposes of analysis two stages of a resistance amplifier should be represented by the diagram shown in Fig. 3. Let us now confine our attention to the amplification produced by any one stage, that is to say, we wish to find the relation between the P.D. (e) applied to the grid-filament of this stage, and the P.D. (E) transferred to the grid-filament of the next valve. E is evidently the P.D. across the grid leak R_1 (Fig. 3). Now we have just shown that the effect of the second valve on R_1 is merely to shunt it by its "input admittance" which is equivalent to a capacity C_g (of the order of several hundreds of micro-microfarads) in parallel with a

conductance, which is likely to be at least of the order 0.1 μ mho (equivalent to a shunt of 10 megohms) at 1,000 cycles, and larger at higher frequencies. Thus when considering only the amplification produced by the first stage, we may simplify the diagram to that shown in Fig. 5. Here the leaky condenser $G_g + jC_{ga}\omega$ represents the second valve. The filament-anode capacity of the first valve merely acts as a shunt across the anode resistance R_a , as may be seen from Fig. 3; it is therefore transferred to this resistance in Fig. 5, where Z denotes the impedance of this resistance with its capacity shunt. Let Z_y denote the input impedance of the second valve with its grid leak, i.e., Z_y is the resultant of the resistance R_1 in parallel with the admittance $G_g + jC_{ga}\omega$. Let also the various mesh currents be as

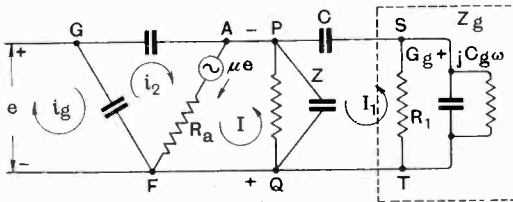

Fig. 5.—Simplified equivalent network for two-stage amplifier.

shown in Fig. 5. The equation for the mesh $APQF$ is

$$\mu e = I(R_a + Z) - I_1 Z + R_a i_2 \dots (12)$$

For the mesh $PSTQ$ we have

$$0 = I_1(Z + Z_c + Z_g) - IZ \dots (13)$$

where Z_c denotes the impedance of the condenser C .

Also $E = I_1 Z_g \dots (14)$

and, as was shown in a previous paragraph,

$$i_2 = j(E + e)C_{ga}\omega \dots (2)$$

Eliminating I and i_2 from equations (12), (13) and (2) we have

$$\begin{aligned} \mu e - j(E + e)C_{ga}\omega R_a \\ = I_1 \left[\frac{(Z + Z_c + Z_g)(R_a + Z)}{Z} \right] - Z \end{aligned} \dots (15)$$

Now eliminating I_1 from (14) and (15) and denoting the actual magnification of voltage E/e by k we find

$$\begin{aligned} k &= \frac{E}{e} \\ &= \frac{\mu - jR_a C_{ga}\omega}{\left\{ \frac{(Z + Z_c + Z_g)(R_a + Z)}{Z Z_g} - Z \right\} + jR_a C_{ga}\omega} \dots (16) \end{aligned}$$

This may be written in the form

$$k = \frac{\mu B D (1 - jA)}{(1 + jABD)} \dots (17)$$

where $A = R_a C_{ga}\omega$

$$B = Z / (Z + R_a)$$

$$D = Z_g / \left(Z_g + Z_c + \frac{Z R_a}{Z + R_a} \right)$$

Thus the expression for the actual voltage magnification (k) may be regarded as consisting of the voltage factor (μ) of the valve, multiplied by three modifying factors, viz., the anode impedance term B , the coupling term D , and the remaining term

$$(1 - jA/\mu) / (1 + jABD)$$

which represents the effect of the grid-anode capacity of the valve. Consider now the effect of these factors on the performance of the amplifier.

(a) The Grid-anode Capacity Effect.

It is evident that in a well-designed amplifier the coupling terms B and D will approximate to unity, being actually somewhat less than this. The magnitude of the quantity A was determined for a number of valves, the values for a typical audio-frequency being given in Table V.

TABLE V. VALUES OF THE REACTION FACTOR A .

Valve.	R_a .	C_{ga} .	ω .	$A = R_a C_{ga}\omega$
	Ohms.	$\mu\mu\text{F.}$		
P.M.1 H.F.	57,500	4.5	10,000	0.00256
S.P.18G...	27,000	2.9	10,000	0.00078
R.C.2 ...	338,000	2.2	10,000	0.0074
P.M.5B ...	57,100	5.3	10,000	0.0030

The values of grid-anode capacity given in this table were determined by a method previously described,* the valve being mounted in its holder (a commercial valve holder of low capacity), and the filament

* E.W. & W.E., Vol. 2, p. 263, Feb., 1925.

being cold. The values of input impedance previously given suggest that the effective value of the grid-anode capacity when the valve is operating under certain conditions, may be appreciably larger than this. The values given in Table V must, therefore, be regarded as minimum values. Values of A are given for a typical audio frequency ($\omega = 10,000$ or $1,600$ cycles). It will be seen that for all audio frequencies the value of A is always small compared with unity.

Now since the terms B and D approximate to unity, the grid-anode capacity term approximates to $(1 - j\frac{A}{\mu})/(1 + jA)$, and bearing in mind that A is small compared with unity at audio frequencies, it is easy to see that this expression has an amplitude which is given approximately by $1 - \frac{1}{2}A^2(1 - \frac{1}{\mu^2})$, or still more simply $1 - \frac{1}{2}A^2$. Thus the reaction effect of the grid-anode capacity causes a reduction of voltage amplitude, which expressed as a percentage has a maximum value of $A^2/200$. It is evident from Table V that this will be negligible in all practical cases of audio frequency amplification. This reduction of amplitude is associated with a change of phase, which, since A is small compared with unity, is given approximately by

$$\tan \phi = -\frac{\mu + 1}{\mu} A$$

where ϕ represents the rotation of the output voltage vector due to grid-anode capacity coupling. Thus both the change of phase and the reduction of amplitude are very small in all practical cases of L.F. amplification. The effect is larger the higher the anode circuit resistance of the valve. As an extreme case, consider a valve with an anode circuit resistance of 500,000 ohms, and let the grid-anode capacity be $4.5 \mu\mu\text{F}$. It will be found that the reduction of amplitude due to this cause is 1 per cent. at 10,000 cycles, and the change of phase is about 8 degrees. The change of phase is, of course, proportional to the frequency, and the reduction of amplitude to the square of the frequency.

(b) The Anode Impedance Term

$$Z/(Z + R_a).$$

This term allows for the reduction of

amplitude due to the internal resistance of the valve. In order that this reduction may be small, the added anode impedance Z should be large compared with the valve resistance R_a . If this condition is satisfied, there will also be no distortion due to this term, even when the impedance Z is not a pure resistance, since Z appears in both the numerator and denominator of the above term and thus, provided R_a is small compared with Z , any frequency changes in Z cancel out.

(c) The Coupling Term

$$Z_g/[Z_g + Z_c + ZR_a/(Z + R_a)].$$

This term represents the effect of the coupling condenser C and the grid leak, and input impedance of the next valve. Now since the impedance Z_c is inversely proportional to the frequency, this will cause distortion unless it is small compared with Z_g even at the lowest frequency. This condition is easily satisfied by making C large. Mr. Colebrook has discussed this point, and what he has said is entirely unaffected by the discussion in this paper. His value of $0.001 \mu\mu\text{F}$. or $0.002 \mu\text{F}$. may therefore be taken as a good practical case, and the term Z_c may be omitted from further consideration. The coupling term now reduces to $Z_g/[Z_g + ZR_a/(Z + R_a)]$. From this it is evident that, in order to get a large amplification, the resultant grid circuit impedance Z_g must be large compared with $ZR_a/(Z + R_a)$ which is the impedance of R_a and Z in parallel. Now we have seen that Z should be large compared with R_a , in which case $ZR_a/(Z + R_a)$ becomes simply R_a , and the coupling term reduces to $Z_g/(Z_g + R_a)$. The condition for maximum amplification is therefore that Z_g must be large compared with R_a . If this condition can be satisfied it does not matter what the phase angle of Z_g is, since it appears in both numerator and denominator, and thus frequency changes cancel out as long as R_a is small compared with Z_g .

In making a quantitative study of these effects it is convenient to work in terms of admittances and conductances, rather than impedances and resistances. Thus putting $G_a = 1/R_a$:

$$\begin{aligned} 1/Z &= A_x = G_x + jC_x\omega, \\ 1/Z_g &= A_g = 1/R_1 + G_g + jC_g\omega \text{ (see Fig. 5)} \\ &= G_1 + G_g + jC_g\omega. \end{aligned}$$

Then neglecting Z_c , the coupling term may be written

$$D = \frac{A_x + G_a}{A_x + G_a + A_g}$$

The anode impedance term becomes

$$B = \frac{G_a}{A_x + G_a}$$

Thus the product of these becomes

$$BD = \frac{G_a}{G_a + A_x + A_g}$$

whence, neglecting the grid-anode capacity effect,

$$k = \mu BD$$

$$= \frac{\mu G_a}{G_a + G_x + G_1 + G_g + j\omega C_x + j\omega C_g} \quad (18)$$

which expresses in a very simple manner the reduction of voltage amplitude due to the anode circuit added resistance ($1/G_x$), the grid leak ($1/G_1$), and the input conductance of the following valve (G_g); and also the reduction of amplitude and change of phase due to the capacity C_x associated with the load in the anode circuit (this includes the filament-anode capacity of the valve) and the input capacity C_g of the following valve. The design of a L.F. amplifier should be such that all these reductions in amplitude are kept small, and when this is the case the actual fractional reduction of amplitude is given by:

Fractional decrease in voltage amplitude

$$= \frac{G_x}{G_a} + \frac{G_1}{G_a} + \frac{G_g}{G_a} + \frac{1}{2} \left(\frac{C_x^2 \omega^2}{G_a^2} + \frac{C_g^2 \omega^2}{G_a^2} \right) \dots \quad (19)$$

and the change of phase is an angle ($-\theta$) given by

$$\begin{aligned} \tan \theta &= \frac{(C_g + C_x)\omega}{G_a + G_x + G_1 + G_g} \\ &\div \frac{C_g \omega}{G_a} = R_a C_g \omega \dots \dots \quad (20) \end{aligned}$$

These expressions show that the effects of the various components of the amplifier, on the voltage amplification produced by any one stage, are as follows:—

(1) The anode circuit resistance. This causes a reduction of voltage amplitude, which expressed as a fraction is given by R_a/R_x .

(2) The filament-anode capacity of the valve causes a fractional reduction of

voltage of $\frac{1}{2}R_a^2 C_{fa}^2 \omega^2$, and a change of phase of approximately $R_a C_{fa} \omega$ radians. If the load in the anode circuit possesses an appreciable reactance, this may be regarded as modifying the value of C_{fa} giving a resultant value C_x .

(3) The grid leak of the following valve causes a fractional reduction of voltage amplitude given by R_a/R_1 .

(4) The Input Conductance of the following valve causes a fractional reduction of voltage of G_g/G_a .

(5) The Input Capacity of the following valve causes a fractional reduction of voltage amplitude of $\frac{1}{2}R_a^2 C_g^2 \omega^2$, and a change of phase of approximately $R_a C_g \omega$ radians.

The change of phase is of no great consequence, but the reduction of voltage may be serious. The reduction of voltage due to the grid leak R_1 and the resistance added in the anode circuit R_x , is independent of the frequency, and therefore causes no distortion. The input conductance G_g of the following valve may vary greatly with the frequency, and unless it is small compared with $1/R_a$, there will be distortion in addition to a reduction of amplitude. For a valve of high voltage factor G_a may be no more than 4μ mhos and since G_g may be as large as 0.5μ mho (see Table II) this effect may be quite serious. Table II shows that the input conductance of a valve increases rapidly when the resistance in its anode circuit becomes very great. Thus the practice of using very high anode resistances in any stage of an amplifier may have this undesirable effect. The reduction of voltage amplification in that particular stage due to this resistance is certainly made small, but the input conductance of the valve is increased, and the voltage amplification produced by the preceding stage is thereby decreased, and a certain amount of distortion is introduced.

The effects of filament-anode capacity, reactance in the anode circuit load, and the input capacity of the following valve, are of exactly the same nature. Table I shows that the input capacity of any ordinary valve is likely to be between 100 and 200 $\mu\mu F$. The filament anode capacity may be neglected in comparison, or we may combine the two and consider the resultant capacity.

The fractional reduction of voltage amplitude due to this capacity is approximately given by $\frac{1}{2}R_a^2 C_g^2 \omega^2$. Take the case of a valve like the P.M.I H.F. for which $R_a = 57,000$ ohms. C_g will be at least $100 \mu\mu\text{F}$. and it will be found that the fractional reduction of voltage amplitude in such a case is about 4 per cent. at 8,000 cycles and 0.04 per cent. at 800 cycles. In the case of a high voltage

the following valve, the effect of this on the amplification is calculated for values of ω up to 50,000 (8,000 cycles per sec.). The value of $R_a C_g \omega$ gives $\tan \theta$, from which the change of phase θ , and the amplification factor $\cos \theta$, are immediately obtained. The last column gives the percentage reduction of voltage due to the input capacity of $100 \mu\mu\text{F}$. It will be seen from Table I that

TABLE VI.
EFFECT OF AN INPUT CAPACITY OF $100 \mu\mu\text{F}$. ON VOLTAGE AMPLIFICATION.

Valve.	ω .	$R_a C_g \omega$.	Change of Phase θ .	$\cos \theta$.	Reduction of Voltage — per cent.
P.M.I H.F.	5,000	0.0287	$1^\circ 39'$	0.9996	0.04
$R_a = 57,500$ ohms	10,000	0.0574	$3^\circ 17'$	0.9984	0.16
$G_a = 17.4 \mu$ mho	20,000	0.115	$6^\circ 34'$	0.9934	0.66
	40,000	0.230	$12^\circ 57'$	0.9746	2.54
	50,000	0.287	$16^\circ 1'$	0.9612	3.88
R.C.2	5,000	0.170	$9^\circ 39'$	0.9859	1.4
$R_a = 338,000$ ohms	10,000	0.338	$18^\circ 41'$	0.9473	5.3
$G_a = 2.95 \mu$ mho	20,000	0.676	$34^\circ 4'$	0.8284	17.2
	40,000	1.35	$53^\circ 28'$	0.595	40.5
	50,000	1.70	$59^\circ 32'$	0.507	49.3

factor valve, R_a is much greater and the loss of voltage amplitude becomes so great that the above approximate expression no longer holds. A more accurate expression which can be used in such cases is obtained from equation (18), from which it will be seen that the magnitude of the voltage amplification is

$$\frac{\mu}{\sqrt{\left(1 + \frac{G_x}{G_a} + \frac{G_g}{G_a}\right)^2 + R_a^2 C_g^2 \omega^2}}$$

$$= \frac{\mu}{\sqrt{\left(1 + \frac{R_a}{R_x} + G_g R_a\right)^2 + R_a^2 C_g^2 \omega^2}}$$

It is a convenience in calculation to denote $R_a C_g \omega$ by $\tan \theta$ (equation 20). Then the above expression is approximately

$$\mu \cos \theta \left(1 - \frac{R_a}{R_x} - R_a G_g\right)$$

since the terms R_a/R_x and $R_a G_g$ are small. Thus the effect of the input capacity C_g is given by the factor $\cos \theta$. Values of these effects for certain cases are given in Table VI. Two typical valves are taken, and assuming a value of $100 \mu\mu\text{F}$. for the input capacity of

the actual input capacity may be very considerably greater than this, and the effects may therefore be even larger than those given in Table VI. In the case of the valve with 300,000 ohms anode circuit resistance, the reduction of voltage is nearly 50 per cent. at 8,000 cycles, and 1.4 per cent. at 800 cycles. The 50,000 ohm valve shows a voltage reduction of only 3.9 per cent. at 8,000 cycles. It is evident that if a valve of high internal resistance is used in a resistance-capacity amplifier, considerable distortion must result, unless the effect of the input capacity of the following valve can be corrected in some way.

The Compensation of Input Capacity.

Probably the simplest way of making this correction is to use in the anode circuit of the valve, not a pure resistance load, but an inductive one.

Let L_x be the inductance of the anode circuit load and R_x be its resistance. The admittance A_x is given by $1/(R_x + jL_x\omega)$, and if $L_x\omega/R_x$ is so small that its square may be neglected in comparison with unity, this

becomes $\frac{1}{R_x} - j \frac{L_x\omega}{R_x^2}$. The factor BD now

becomes

$$BD = \frac{G_a}{G_a + 1/R_x + G_1 + G_g - j \frac{L_x}{R_x^2} \omega + j C_g \omega + j C_x \omega} \quad (21)$$

If now the inductance L_x is such as to satisfy the condition

$$C_g + C_x = L_x/R_x^2 \quad (22)$$

then it is evident that all the terms in involving frequency in the above expression for BD vanish, and therefore the inductance will compensate for both the change of phase and reduction of amplitude due to the capacities C_g and C_x . This compensation will hold for all frequencies for which $L_x^2 \omega^2 / R_x^2$ is negligibly small. Hence by (22) $R_x^2 (C_g + C_x)^2 \omega^2$ must be negligibly small, say = 0.01. Suppose the capacity to be compensated ($C_g + C_x$) is 100 $\mu\mu\text{F.}$, and that this is required to hold up to a frequency of 8,000 cycles ($\omega = 5 \times 10^4$). Then we must have $R_x \times 10^{-10} \times 5 \times 10^4 \geq 0.1$, i.e., $R_x \geq 20,000$ ohms. If the anode resistance is greater than this amount, the compensation will be less perfect at the upper frequencies, but in all cases there will be a definite reduction of distortion due to inter-electrode capacities if an inductive anode resistance is used.

In order to obtain some idea of the performance of typical anode resistances, a number of these were tested for self-

TABLE VII.

SELF-CAPACITY VALUES FOR WIRE-WOUND ANODE RESISTANCES.

Resistance.	Type.	Effective Self-capacity.
Ohms.		$\mu\mu\text{F.}$
20,000	Standard	- 30
50,000	"	0
80,000	"	+ 60
100,000	"	+ 50
200,000	Bi-duplex	+ 8
500,000	"	+ 200

inductance. Those of the type in which a metal film is contained in an evacuated glass tube were found to be very nearly pure resistances. Actually each one tested was found to have a self-capacity of about 0.2 $\mu\mu\text{F.}$, which is accounted for by the

capacity of the metal caps at the ends of the tube. This self-capacity was the same for all values of the resistance tested. Interesting results were obtained for the wire-wound anode resistances. The values, which were obtained at a frequency of 1,000 cycles, are shown in Table VII.

It seemed probable at first sight that resistances of this type would be inductive, but actually the capacity effect was found to predominate for all resistances greater than 50,000 ohms. The 20,000 ohm resistance alone was found to be inductive. In this case the inductance is expressed as an equivalent negative capacity (= $-L_x/R_x^2$). The inductance present would evidently compensate at audio frequencies an input capacity of this amount. It is to be noted that the resistances of higher values may have very considerable self-capacities. This is doubtless due to the fact that they are made of such small bulk. The "bi-duplex" type of winding evidently possesses advantages, but even this is not good for 500,000 ohms. It is important to realise that the reduction of amplitude due to input capacity may be doubled by the self-capacity of an anode resistance. If distortionless amplification is desired, it is evident that anode resistances must be kept low, which means that valves of high resistance are not desirable; also, if the anode resistances are not already inductive they should be made so by adding suitable copper wound inductance coils in series with them.

Conclusions.

From this discussion we see that if a low-frequency resistance amplifier is required to give distortionless amplification the components should satisfy the following conditions:—

- (1) The condenser coupling the anode circuit of one valve to the grid of the next should be of large capacity, say, 0.002 $\mu\text{F.}$ or greater. It must also have high insulation resistance.
- (2) The valves used should not have a high internal resistance, R_a , since:
 - (a) The loss of amplification at the higher frequencies due to inter-electrode capacities is proportional to the square of this quantity.

(b) High resistance valves require high anode resistances in order to avoid a large reduction of output voltage. The use of high anode resistances possesses the disadvantages enumerated below (3).

(3) The anode resistances should be considerably larger than the internal resistances of the valves, but should not be of higher resistance than is necessary, and they should preferably be inductively wound, so as to compensate to some extent the input capacity of the following valve. Many wire-wound anode resistances of high value have large self-capacities, and should be used with discrimination. The metallic film in vacuum type is generally superior (from the point of view of distortion due to capacity reactance) for values greater than 50,000 ohms. The use of high anode resistances has also the following undesirable effects.

(a) The input conductance of the valve is increased, and as this may vary considerably with frequency, distortion will result.

(b) The internal resistance of the valve is increased unless the H.T. battery voltage is also increased. The increase in R_a means increased distortion as mentioned above (2).

This effect of increase in the resistance of the valve with increasing values of anode resistance is shown by the following results of measurements made on two valves (Table VIII). It will be seen from this that a valve of nominal resistance 10,000 ohms may have an actual resistance of 100,000

ohms or more, if it is used with a very high anode resistance, and the usual H.T. battery voltage.

(4) The resistance of the grid leak R_1 should be large compared with that of the preceding valve. It should not be of a type having large self-capacity, otherwise the input capacity effect of the next valve will be increased. As in the case of the anode resistance, an inductive winding will tend to diminish distortion due to inter-electrode capacity effects.

The general conclusion is that, although very high amplification per stage may be

TABLE VIII.

THE INTERNAL RESISTANCES OF VALVES WITH VARIOUS ANODE RESISTANCES.

H.T. Battery voltage: 100 (maintained constant).
Grid Bias: - 2 volts.

Anode Resistance.	Internal Resistance of Valve.	
	D.E.R.	P.M. I L.F.
1,000 ohms	18,800 ohms	9,560 ohms
20,000 "	23,600 "	13,000 "
100,000 "	33,100 "	20,450 "
500,000 "	66,000 "	44,000 "
2 megohms	130,000 "	100,000 "

obtained by the use of valves of high voltage factor (and correspondingly high resistance) associated with high anode resistances, such amplification must be subject to considerable frequency distortion due to inter-electrode capacity effects. This distortion can only be avoided by using low resistance valves, in which case a lower amplification per stage will be obtained.

The Heaviside Operator and the Operational Calculus.

By *W. A. Barclay, M.A.*

"I never use a big, big D!"—H.M.S. PINAFORE.

MR. RATCLIFFE'S article on Symbolical Algebra (*E.W. & W.E.*, May, 1928) and Professor Howe's editorial on the same subject must doubtless have caused some heart searching among many wireless workers who are accustomed to use the symbol "*j*" without enquiring too closely into its meaning. The contributions in question, however, are contradictory, and cannot be said to approach that finality which we expect in scientific matters; they are statements of fundamentally opposite points of view regarding the meaning of *j*, whose use and functions appear to be as ill-defined as ever. Mr. Ratcliffe wishes it to mean $\sqrt{-1}$ on all occasions; Prof. Howe takes the more usual view that it has also an "operational" significance, and that there is a very great distinction between the two meanings. When honest men thus differ, a simple perversion of an old proverb would indicate that thieves are likely to come into their own. The writer accordingly makes no apology for taking advantage of this latest instance of the discord occasioned by the different interpretations of *j* to champion the cause of what is known as the "Heaviside Operator."

The *j* notation is, indeed, so universally established that there would be little point in attempting to supersede it in A.C. work were it not for the unfortunate cleavage of opinion in regard to its real meaning. Comparatively few people are acquainted with the Heaviside symbolism, which, as Prof. Howe has pointed out, involves merely a change of label without any change of fundamental ideas. In the following notes the writer will seek to prove his contention that of the two systems, the differential operator is the more fundamental, but in any case (and it is a big but) the Heaviside label has the advantage of admitting no possible misunderstanding. It should be remembered,

too, that the extremely simple symbolism here described is only a very small portion of a vastly more general Operational Calculus which was devised by the fertile genius of Heaviside for wider fields of electrical work.

Symbolic Systems.

It is elementary knowledge that the bulk of the currents and voltages dealt with in wireless work are simple harmonic functions of a time variable, *i.e.*, they may be represented mathematically by functions of $\sin t$ and $\cos t$, where *t* represents time reckoned from some fixed zero. These sinusoidal functions are what are known as "steady-state" functions, and represent a condition of affairs which sets in after the transient initial variations have disappeared and the apparatus has settled down to the production of a steady alternating current. We thus deal throughout with variations similar to the C.W. system of transmission, where amplitude and frequency remain constant. Given such conditions, it is possible to devise several systems of mathematical "shorthand" which will materially lessen the labour of dealing with these functions.

In devising such a system of shorthand, care must always be taken to maintain a proper perspective, in order that any new symbols introduced may never be allowed to outrun their legitimate functions. Such undue liberty, unfortunately, has been accorded to the symbol *j*, which was introduced originally to amplify a geometrical interpretation of the variables $\sin t$ and $\cos t$. The conception of *j* as a vector operator is legitimate enough, but to make it stand, as Mr. Ratcliffe would have it do, for $\sqrt{-1}$ is to strain the meaning too far. A geometrical diagram is undoubtedly convenient to represent the circular functions, and geometrical statements may be used to illustrate their relations. But when we are asked to put

these geometrical statements into algebraic form and reason about them "without any thought as to the geometrical meaning of the symbols," it will be realised that we have left our original electrical conceptions very far behind. To apply algebra to pure geometry is not at all the same thing as to apply it to the conceptions the geometry was originally intended to illustrate.

It is only natural, though from the point of view of logic a little unfortunate, that the sinusoidal variations of current and potential should lend themselves to such facile geometrical illustration as is afforded by the crank diagram. The use of circular functions leads immediately to talk of angles, phase difference as an angle, etc., conceptions which are highly convenient so long as recognised for what they are—polite fictions. The danger is that the crank diagram may become too geometrical a conception, and that algebra may be applied to this geometry *quâ* geometry.

The Heaviside Operator.

The Heaviside system completely ignores this extraneous and illustrative geometry. It confines itself strictly to the simplification of the algebra involved in the sine and cosine calculus which, as we have seen, is adequate to the steady state problems of A.C. work. The fundamental conception is the operation of time-differentiation, denoted by the symbol *D*, which thus stands for the operator

$\frac{d}{dt}$. At the outset, therefore, the operator

D is not to be treated as an algebraic quantity, but must be considered as operating on a function of the time. This operand may either be explicitly stated or implied. Thus, if

$$i = I \sin \omega t \quad \dots \quad (1)$$

represent the instantaneous value of a sinusoidal current at time *t*, its rate of increase at that instant will be written

$$Di = \frac{di}{dt} = \omega I \cos \omega t \quad \dots \quad (2)$$

If we again operate on equation (2) with the operator *D*, we have

$$D(Di) = \frac{d^2i}{dt^2} = -\omega^2 I \sin \omega t \quad \dots \quad (3)$$

and by a suitable convention we may rewrite this as

$$D^2i = -\omega^2 I \sin \omega t \quad \dots \quad (4)$$

being careful to remember that the index attached to the *D* does not stand for algebraic multiplication, but for a repetition of the operation. Whenever the symbol *D* is used to operate on a simple harmonic function of time, we automatically suspend the working of pure algebra in connection with it, and

translate the *D* into terms of $\frac{d}{dt}$ and hence of

differentiation. Thus no confusion should ever arise regarding the nature of *D*. It is always an operator, and is recognised for such whenever we meet it. This cannot be said of the symbol *j*.

Since $\frac{d}{dt} \left[\int i dt \right]$ is defined as *i*, i.e.,

$D \int i dt = i$, we may regard the operation of

time-integration as the inverse of time-differentiation, and write

$$\int i dt = \frac{i}{D} = D^{-1}i \text{ plus a constant.}$$

(When *i* is a sinusoidally varying current, this constant will be a non-oscillating or steady component which can be neglected in dealing with the reactions of a circuit to oscillatory currents.) If $i = I \sin \omega t$, we can thus write

$$D^{-1}i = \int i dt = -\frac{I}{\omega} \cos \omega t \quad \dots \quad (5)$$

The Operational Equation.

We have seen that,

$$D^2 \cdot I \sin \omega t = -\omega^2 I \sin \omega t \quad \dots \quad (6)$$

Also, by repeated differentiation it can be shown that

$$D^2 \cdot I \cos \omega t = -\omega^2 I \cos \omega t \quad \dots \quad (7)$$

Hence we see that, so long as the repeated operator *D*² is applied to a circular function of ωt , we may obtain the result of the operation by substituting $-\omega^2$ for *D*². We may express this fact by the operational pseudo-equation

$$D^2 = -\omega^2 \quad \dots \quad (8)$$

the nature of which we may pause to

consider. It is not an equation such as is commonly met with in algebra. The sign “ = ” does not here assert a numerical equality; the L.H.S. is purely an operator, the R.H.S. is an algebraic quantity. Equation (8) is really a disembodied equation, a sort of ghost. It is not, strictly speaking, an equation at all, and would be better left unwritten, since the meaning which we here give to the sign “ = ” must perforce differ from its usual connotation. What it implies is that we may always substitute $-\omega^2$ for D^2 whenever this occurs in an operator used in conjunction with a circular function of ωt . To establish fully the truth of this statement would take too long for our present purpose, but it is not difficult to show its truth in many simple instances. For example, if A be a numerical quantity, we may apply the operator

$A^2 + D^2$ to the function $\frac{1}{A^2 - \omega^2} \sin \omega t$. By

actual differentiation, the result will be seen to be $\sin \omega t$. Hence, applying the

inverse operator $\frac{1}{A^2 + D^2}$ to $\sin \omega t$, we obtain

$$\frac{1}{A^2 + D^2} \cdot \sin \omega t = \frac{1}{A^2 - \omega^2} \cdot \sin \omega t \text{ conformably to the above rule.}$$

To regard (8) as in any sort an equation is a delusion which must be rigidly guarded against. In particular, we must beware of the fallacy of any attempt to derive an expression for D in terms of ω by “taking the square root of both sides” of (8) as is sometimes thought possible. D is not “equal to” $\sqrt{-1} \cdot \omega$ any more than D^2 is “equal to” $-\omega^2$, and no such equality should be stated or even implied. D is defined as $\frac{d}{dt}$ and can

mean nothing else. D^2 is defined as $\frac{d^2}{dt^2}$, and it is only by virtue of the special properties of the circular functions that we may write equation (8) as the symbolic form of equations (6) and (7).

The present article does not pretend to furnish a systematic account of the development of the D -symbolism and its uses. Readers may like to show for themselves that D obeys some but not all of the laws of

algebra, in which respect it is analogous to the symbol j taken in its operational sense. The symbolism of the differential operator avoids all pictorial images, and by going directly to the root of the matter, gains much in simplicity and directness.

The Impedance Operator.

Let us now consider the circuit of Fig. 1 consisting of a resistance R , an inductance L , and a capacity C in series. If a current $i = I \sin \omega t$ flow through this, and e denote the instantaneous P.D. across the ends of the circuit at instant t , we have by Kirchoff's Law,

$$\begin{aligned} e &= R I \sin \omega t + L \cdot \frac{d}{dt} I \sin \omega t \\ &+ \frac{1}{C} \int I \sin \omega t \cdot dt \dots \quad (9) \\ &= \left(R + LD + \frac{1}{CD} \right) \cdot I \sin \omega t \\ &= \left(R + LD + \frac{1}{CD} \right) \cdot i \dots \dots \quad (10) \end{aligned}$$

To the symbols LD and $\frac{1}{CD}$ of equation (10)

Heaviside gives the name of “resistance operators” in that they act upon i analogously to the resist-

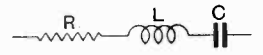

Fig. 1.

ances. Thus, the P.D. across the terminals of the inductance L (through which $i = I \sin \omega t$ is passing) is obtained by applying the operator LD to the current in analogy with multiplication by R in the case of a resistance. We have then for the P.D. across the inductance

$$LD (I \sin \omega t) = L\omega I \cos \omega t \dots \quad (11)$$

Compound expressions such as that in brackets in equation (10) are known as “impedance operators,” and may be written \bar{Z} , the bar denoting the operational character of the symbol. We may write, then,

$$e = \bar{Z} \cdot i \dots \dots \quad (12)$$

which is a generalised expression for Ohm's Law applied to alternating currents in which \bar{Z} is to be taken as an operator composed algebraically of ordinary circuital

symbols and functions of D . Considered by itself, this operator \bar{Z} may be treated algebraically, and reduced by algebraic rules to its simplest form. After this work is accomplished, it must be related to its operand,

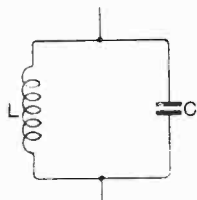

Fig. 2.

always a sinusoidal time function, so that the indicated differentiations may be performed. During the simplification of the operator \bar{Z} we can treat D algebraically, and in the process we may replace D^2 by $-\omega^2$ wherever it occurs. This

procedure is justified so long as the implicit operand is the sinusoidal time-function, and under these circumstances invariably leads to correct results.

An Example.

The above considerations will be made clearer by an example. Let us take an inductance L and capacity C in parallel (see Fig. 2). Let \bar{Z} denote the impedance operator for this combination. Then

$$\frac{1}{\bar{Z}} = \frac{1}{LD} + CD = \frac{1 + LCD^2}{LD}$$

Writing, as we may always do, $-\omega^2$ for D^2 , we have

$$\bar{Z} = \frac{LD}{1 - LC\omega^2} \dots \dots (13)$$

Then, if the line current flowing past the system is $i = I \sin \omega t$, the P.D. e across the combination is

$$\begin{aligned} e &= \bar{Z} \cdot i \\ &= \frac{LD \cdot I \sin \omega t}{1 - LC\omega^2} \\ &= \frac{L\omega I \cos \omega t}{1 - LC\omega^2} \dots \dots (14) \end{aligned}$$

If, however, the E.M.F. across the system were given as $e = E \cos \omega t$, we should have for the line current

$$\begin{aligned} i &= e/\bar{Z} \\ &= \frac{(1 - LC\omega^2) \cdot e}{LD} \end{aligned}$$

Rationalising the denominator,

$$\begin{aligned} i &= \frac{(1 - LC\omega^2)De}{LD^2} = \frac{(1 - LC\omega^2)D \cdot E \cos \omega t}{-L\omega^2} \\ &= \left(\frac{1}{L\omega} - C\omega\right) \cdot E \sin \omega t \dots \dots (15) \end{aligned}$$

Considerations of space forbid the detailed working out of the logical reasons on which this procedure is founded: those interested are recommended to study the treatment of the subject given by Dr. Eccles in his "Continuous Wave Telegraphy." An important feature, and one to which the writer has previously called attention, is the entire absence of any reference to the imaginary unit.

Equation (13) is to be regarded as "symbolic" of equations (14) and (15), which latter are merely expansions of it to suit particular operands. It will be noted that a D is present in the numerator. This indicates that if the operand is a sine function of time the result will be a cosine function—as in equation (14). If, however, the D had not been present the nature of the operand would remain unaffected, the process being merely algebraical multiplication. In working with impedance operators our aim should always be to reduce them to the simple form

$$\bar{Z} = A + BD \dots \dots (16)$$

the second term of which alone effects a functional change in the operand which is implicitly understood.

Another Example.

As a further example of the use of the symbolism, take the common wireless circuit illustrated in Fig. 3. If \bar{Z} be the operator impedance of the combination to line current,

$$\frac{1}{\bar{Z}} = \frac{1}{R + LD} + CD$$

Therefore

$$\begin{aligned} \bar{Z} &= \frac{R + LD}{1 + CD(R + LD)} \\ &= \frac{R + LD}{(1 - LC\omega^2) + CRD} \end{aligned}$$

This does not yet conform to the type of equation (16) as a D still occurs in the denominator. We must therefore multiply

above and below by $(1 - LC\omega^2) - CRD$, obtaining

$$\bar{Z} = \frac{R + \{L(1 - LC\omega^2) - CR^2\} \cdot D}{(1 - LC\omega^2)^2 + C^2R^2\omega^2}$$

Then, if the line current is given as $i = I \cos \omega t$, since $e = \bar{Z} \cdot i$, we can write down for the voltage e across the combination

$$e = \frac{R}{(1 - LC\omega^2)^2 + C^2R^2\omega^2} \cdot I \cos \omega t - \frac{\omega L(1 - LC\omega^2) - CR^2\omega}{(1 - LC\omega^2)^2 + C^2R^2\omega^2} \cdot I \sin \omega t \dots (18)$$

In this equation, the first term preserves unchanged the original cosine function, while the second, being the result of the operation of differentiation, has been changed.

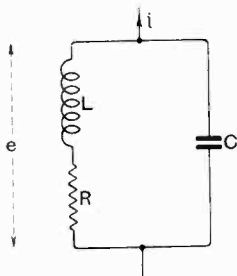

Fig. 3.

It will be evident that equation (16) is really the symbolic expression for an impedance in terms of its series resistive and reactive components. The ohmic value of the resistance is given by the term A ; the term BD is the reactance operator, and the corresponding

ohmic reactance is $B\omega$, obtained by simply replacing the D in the operator by ω . To prove this in the case of simple reactances, suppose we take first an inductance L . Here the operator is LD , which by the rule gives $L\omega$ for the ohmic reactance. Again, if we consider capacity, the operator is $\frac{1}{CD}$, which may be

brought to form (16) by writing $\frac{D}{CD^2}$ or $\frac{-D}{C\omega^2}$.

Replacing the D by ω , we have the correct capacitive reactance $-\frac{1}{C\omega}$.

Summary of Procedure.

We now briefly summarise the procedure connected with the Differential Operator as applied to A.C. problems.

First express the impedance of the circuit as an operator, using the resistance operators

R, LD and $\frac{1}{CD}$ as though they were ordinary resistances, and manipulate the expression algebraically until it assumes the form

$$\bar{Z} = A + BD.$$

The ohmic resistance is then A , the ohmic reactance is $B\omega$. Whence, as usual, $\phi = \tan^{-1} \frac{B\omega}{A}$, and the numerical value of the impedance is $|Z| = \sqrt{A^2 + B^2\omega^2}$.

Applying the operator \bar{Z} to its operand, a sinusoidal function of ωt , the D indicates a time-differentiation to be performed on that function. The symbolism is, therefore, applicable to R.M.S. and instantaneous values alike.

Criticism of the Differential Operator.

It will be admitted that the time rates of change of the currents and potentials met with in wireless work are not less important to the subject than are the varying values of the quantities themselves. Herein, it is claimed, lies the advantage of D over a vector operator which rotates an illustrative geometrical vector through 90° , and is liable to confusion with $\sqrt{-1}$! Indeed, the whole conception of a geometrical vector, indispensable though it undoubtedly is in electrical work, yet in strictness introduces additional complication into the subject, regarding the nature of which it is as well to be quite clear.

Two years ago in the correspondence columns of this journal, Prof. Howe called attention to a fact never in dispute, viz.: that D used in conjunction with its operand is not an algebraic quantity and cannot be treated as such. In his editorial of May, 1928, he returns to this charge, saying that I claimed an enormous simplification by using D/ω , but that he had shown the impossibility of using D/ω as an algebraic multiplier. Since, however, D/ω was never intended to be treated as an algebraic multiplier when used with a time operand, but can only operate on that operand, this cannot be regarded as a valid argument against D . When the operand is understood, i.e., when we are working symbolically, we can treat D algebraically even though it is

not an algebraic quantity; when, however, the operand is shown explicitly, we must remember that the function of D is to operate on it. The philosophy of the subject is abstruse, yet it may be defended on pragmatic grounds. It is, indeed, one of the leading recommendations of the Heaviside operator that we always know it for such whenever we meet it, and are on our guard against such unwarrantable algebraic treatment as Prof. Howe instances.

The Heaviside Operational Calculus.

The above necessarily brief sketch of the Heaviside operator in its application to alternating currents has taken no account of its wider employment in more recondite problems for the solution of which, indeed, it was first invented. The difficulties of the subject do not permit of even the slightest treatment here; nevertheless it is felt that in view of the gradually awakening interest in Heaviside and his methods by electrical engineers both in this country and abroad, some reference to the subject was desirable in *E.W. & W.E.*

As a mathematician Heaviside was mainly self-taught, and in consequence was accustomed to think out for himself new and unorthodox ways of tackling old problems. The chief operational method which he devised for the solution of the differential equations occurring in transmission-line and other problems depends upon the symbolic

expression of the equations in terms of D . The equation being expanded algebraically in ascending inverse powers of D , Heaviside gives rules for replacing the operators by specified functions of the time variable, thus giving a power series solution of the differential equation. Another very powerful method of symbolic solution, stated by the inventor without proof, is known as the Heaviside "Expansion Theorem," and depends on the algebraic solution of the symbolic equation. These rules, as given in somewhat haphazard fashion in the pages of his treatise "*Electromagnetic Theory*," are subject to notable exceptions, and were for long regarded with much suspicion by his fellow scientists who were disinclined to follow the prolixities of the inventor's rather tedious style. Of recent years, however, the great simplicity attending Heaviside's use and interpretation of fractional powers of his operator has resulted in more attention being paid, especially in America, to this important subject. As a consequence the Heaviside Operational Calculus—originally the outcome of an almost extraordinary intuition—may now be said to be established on a sound mathematical basis. To those who have the necessary mathematical equipment, J. R. Carson's "*Electric Circuit Theory and the Operational Calculus*" (McGraw-Hill) may be commended as an advanced but very adequate exposition of a fascinating subject.

The Resonance Curves of Coupled Circuits.

By Prof. E. Mallett, D.Sc., M.I.E.E.

INTRODUCTION.

IN a previous article* the resonance curves of single oscillatory circuits were obtained by vectorial methods, and it was shown how the simple resonance curves were modified by the inclusion of a valve in the circuit arrangement. It was found also that even if a second tuned circuit was coupled with the first the resonance curve obtained by varying the circuit condensers was still "simple," that is, it could be derived from a vector locus diagram consisting of straight lines and circles. It was, however, mentioned that the resonance curve in the case of coupled circuits obtained when the frequency is varied is no longer simple, but in one particular case is derived from a parabola. The purpose of this article is to follow up this treatment of the coupled circuit case with frequency varied, and to extend it to a chain of resonant circuits with three, four, or more links.

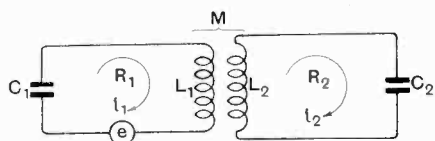

Fig. 1.

I. Two Tuned Circuits Coupled by Mutual Inductance.

Suppose that an electromotive force $e \cos \omega t$ is introduced into the first of two oscillatory circuits having inductance L_1 , capacity C_1 , and total resistance R_1 , coupled by a mutual inductance M (as indicated in Fig. 1) with a second oscillatory circuit with corresponding constants L_2, C_2, R_2 .

The steady currents i_1 and i_2 in the two circuits are connected by the two equations

$$e = \left\{ R_1 + j \left(\omega L_1 - \frac{1}{\omega C_1} \right) \right\} i_1 - j \omega M i_2$$

$$0 = \left\{ R_2 + j \left(\omega L_2 - \frac{1}{\omega C_2} \right) \right\} i_2 - j \omega M i_1 \quad \dots (i)$$

Writing $R_1 + j \left(\omega L_1 - \frac{1}{\omega C_1} \right) = Z_1$

and $R_2 + j \left(\omega L_2 - \frac{1}{\omega C_2} \right) = Z_2$

and eliminating i_1 gives

$$e = \left(\frac{Z_1 Z_2}{j \omega M} - j \omega M \right) i_2$$

which can be written

$$i_2 = \frac{e}{Z''} \quad \dots \quad (ii)$$

where Z'' is an impedance determining the secondary current for a given primary electromotive force.

$$Z'' = \frac{1}{j \omega M} (\omega^2 M^2 + Z_1 Z_2) \quad \dots \quad (iii)$$

It is desired to find the locus of Z'' when the frequency of the electromotive force $e \cos \omega t$ is varied, for then the secondary current locus will be obtained at once by inversion.

The simplest case is obtained when the two circuits are tuned, so that $L_1 C_1 = L_2 C_2 = 1/\omega_0^2$ say, and the first step in a graphical representation of equation (iii) is to find the locus of $Z_1 Z_2$.

$$Z_1 Z_2 = \left\{ R_1 + j \left(\omega L_1 - \frac{1}{\omega C_1} \right) \right\} \left\{ R_2 + j \left(\omega L_2 - \frac{1}{\omega C_2} \right) \right\}$$

$$= R_1 R_2 - \left(\omega L_1 - \frac{1}{\omega C_1} \right) \left(\omega L_2 - \frac{1}{\omega C_2} \right)$$

$$+ j \left\{ R_2 \left(\omega L_1 - \frac{1}{\omega C_1} \right) + R_1 \left(\omega L_2 - \frac{1}{\omega C_2} \right) \right\}$$

Expressing this vector equation in cartesian co-ordinates, the horizontal step x is the real part and the vertical step y is the imaginary, so that

$$x = R_1 R_2 - \left(\omega L_1 - \frac{1}{\omega C_1} \right) \left(\omega L_2 - \frac{1}{\omega C_2} \right)$$

$$y = R_2 \left(\omega L_1 - \frac{1}{\omega C_1} \right) + R_1 \left(\omega L_2 - \frac{1}{\omega C_2} \right)$$

* Simple Resonance Curves and their Modification by Valve Circuits, E.W. & W.E., February, 1927, and March, 1927.

Now
$$\left(\omega L_1 - \frac{I}{\omega C_1}\right) = L_1 \left(\omega - \frac{I}{\omega L_1 C_1}\right)$$

$$= L_1 \left(\omega - \frac{\omega_0^2}{\omega}\right)$$

and
$$\left(\omega L_2 - \frac{I}{\omega C_2}\right) = L_2 \left(\omega - \frac{\omega_0^2}{\omega}\right)$$

The equations become therefore

$$\left. \begin{aligned} x &= R_1 R_2 - L_1 L_2 \left(\omega - \frac{\omega_0^2}{\omega}\right)^2 \\ y &= (L_1 R_2 + L_2 R_1) \left(\omega - \frac{\omega_0^2}{\omega}\right) \end{aligned} \right\} \dots (iv)$$

and on eliminating $\left(\omega - \frac{\omega_0^2}{\omega}\right)$:

$$y^2 = \frac{(L_1 R_2 + L_2 R_1)^2}{L_1 L_2} (R_1 R_2 - x) \dots (v)$$

This is the equation to the parabola drawn in Fig. 2, which is the locus with pole O of $Z_1 Z_2$ when the circuits are tuned.

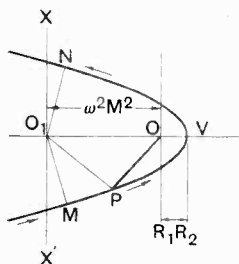

Fig. 2.

Any ray such as OP represents $Z_1 Z_2$ for a certain frequency.

When ω is very small, it is seen from equations (iv) that x has a large negative value and y a large negative value.

When ω is very large, x is negative and y positive. When $\omega = \omega_0$, $x = R_1 R_2$

and y is zero. Evidently therefore as ω increases from a very small value, the point P describes the parabola in a counter-clockwise direction, passing through the vertex V at resonance. The actual values of ω round the parabola can be put in from either of the equations (iv).

Returning to equation (iii), $\omega^2 M^2$ has next to be added to $Z_1 Z_2$. With the circuits in common use in wireless the damping is small and the whole resonance effects take place with only a very small alteration of ω . As an approximation therefore $\omega^2 M^2$ may be considered to be constant, and if a new pole O_1 is found by measuring OO_1 to the left along the axis of the parabola, $O_1 P$ will be equal to the vector sum of $\omega^2 M^2$ and $Z_1 Z_2$ for the particular frequency determining the location of P . Finally all rays $O_1 P$ are divided

by ωM , or the scale is altered (considering ωM to be constant), and to multiply by $-j$ the diagram is turned clockwise through 90 degrees or the reference vector is turned counter clockwise to the position $O_1 X$.

The magnitude of the secondary current is inversely proportional to the length of $O_1 P$. With ω very small P is situated far to the left on the

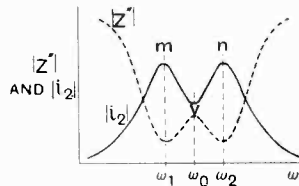

Fig. 3.

lower arm of the parabola and the current i_2 has a very small value. This is indicated in Fig. 3 in which $|i_2|$ and $|Z'|$ are plotted against ω . As ω increases P moves to the right and $O_1 P$ decreases (the current i_2 increases) until P reaches M , where $O_1 M$ is normal to the curve. Here the impedance $|Z'|$ is a minimum and the current i_2 a maximum. This is shown at ω_1 in the figure. From M , $O_1 P$ increases again until V is reached at ω_0 , and here the current is a minimum. From V $O_1 P$ decreases until N is reached at ω_2 , corresponding to a further current maximum, and finally $O_1 P$ increases without limit and the current i_2 decreases without limit. The well-known double hump resonance curve of two coupled circuits has been drawn.

The parabola diagram shows clearly how the frequencies of the current humps are further and further apart as the coupling between the two circuits is increased. For an increase in the mutual inductance means the lengthening of OO_1 and the pushing of the normal points M and N further to the left along the arms of the parabola. On the other hand if the coupling is very loose O_1 will be very close to O , and there will only be a single maximum value of the current, as the only normal to the curve will be that through the vertex.

Phase changes too are brought out quite clearly. $O_1 X$ is the reference vector, that is the vector representing the voltage in the primary circuit. With very small values of ω , Z'' is 270 degrees behind $O_1 X$ and the secondary current leads the primary voltage by 270 degrees. At $O_1 X$ i_2 and V_1 are in phase. At the resonance value ω_0 (at $O_1 V$) Z'' is 90 degrees behind $O_1 X$, and the

secondary current leads the primary voltage by 90 degrees.

Since OM and ON do not coincide with XO_1X^1 , it is seen that the current at the maximum values is not exactly in phase or exactly 180 degrees out of phase with the primary voltage, but that as the coupling is increased this relationship becomes more and more nearly true. The phase of the current at the minimum value in the trough is always exactly 90 degrees ahead of the primary voltage.

Fig. 4 shows the secondary current locus obtained by inverting the parabola of Fig. 2 with pole O_1 . With very loose coupling the locus of i_2 tends to become a cardioid, while with very tight coupling it approaches a pair of circles, as shown dotted in the figure. These extremes correspond in Fig. 2 to the pole O_1 approaching the focus of the parabola, and to the pole O_1 , being so far to the left along the axis that the locus of P is very nearly straight while the current changes are most marked.

II. Other Types of Coupling.

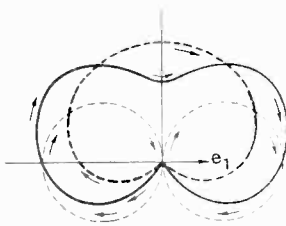

Fig. 4.

In the previous section the coupling of the two circuits was by mutual inductance. But quite similar results may be obtained with other methods of coupling.

(a) Take first the case of coupling by a common impedance Z_c which may be inductance, capacity or resistance or any combination provided that it is not in itself near resonance (see Fig. 5).

It is readily shown as in the first section that

$$Z'' = \frac{Z_1 Z_2 - Z_c^2}{Z_c} \dots \dots (vi)$$

where $Z_1 = R_1 + j \left(\omega L_1 - \frac{I}{\omega C_1} \right) + Z_c$

$$Z_2 = R_2 + j \left(\omega L_2 - \frac{I}{\omega C_2} \right) + Z_c$$

Z_c must be included in the series impedances Z_1 and Z_2 of the two circuits in drawing the $Z_1 Z_2$ parabola, but otherwise the proceeding is just the same.

If the common impedance has pure inductance

$$Z_c = j\omega l, Z_1 = R_1 + j \left\{ \omega(L_1 + l) - \frac{I}{\omega C_1} \right\}$$

and $Z_2 = R_2 + j \left\{ \omega(L_2 + l) - \frac{I}{\omega C_2} \right\}$

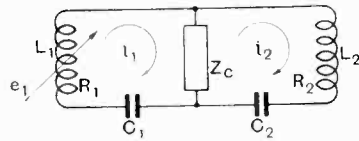

Fig. 5.

and l replaces M in equation (iii). The "coupling coefficient" $\tau = \frac{M}{\sqrt{L_1 L_2}}$ thus

becomes $\frac{l}{\sqrt{(L_1 + l)(L_2 + l)}}$.

Similarly, if $Z_c = -\frac{j}{\omega C_c}$, or the coupling is by a pure condenser, ωM in (iii) is replaced by $I/\omega C_c$ and the circuits must be retuned for any alteration of C_c , to make

$$\sqrt{\frac{C_1 + C_c}{L_1 C_1 C_c}} = \sqrt{\frac{C_2 + C_c}{L_2 C_2 C_c}} = \omega_0$$

If Z_c is a pure resistance R_c , $\overline{OO_1}$ is measured to the right of O , and a double hump cannot appear.

If the coupling impedance has resistance as well as inductance $Z_c = r + j\omega l$ say, Z_c^2 is also complex and the pole O_1 leaves the axis of the parabola. This is an interesting case. Although the circuits are retuned after the introduction of the coupling impedance, the current humps will have unequal maxima, as the lengths of the normals from O_1 to the curve must now be unequal, as is indicated in Fig. 6.

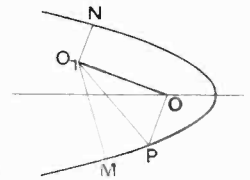

Fig. 6.

Here $OO_1 = Z_c^2$,
 so that $\overline{O_1 P} = O_1 O + OP$
 $= OP + O_1 O$
 $= OP - \overline{OO_1}$
 $= Z_1 Z_2 - Z_c^2$

as required by (vi) (the additions are, of course, vectorial).

(b) Coupling by an impedance Z_c not common to the two circuits (Fig. 7) demands a little more algebra. The most interesting case for the wireless engineer is when the coupling is by a condenser C_c . In this case it can be shown that the impedance Z'' is obtained from the same parabola as before, which by a shift of the y axis to the vertex becomes

$$y^2 = \frac{(L_1R_2 + L_2R_1)^2}{L_1L_2} (-x)$$

but that the distribution of the ω points round the parabola and the pole from which the Z'' rays are to be drawn to the parabola are different.

The ω distribution is determined very nearly by the expression

$$y = 2(R_1L_2 + R_2L_1)(\omega - \omega_0 + \omega_a)$$

where $\omega_a = \frac{1}{2}\omega C_c \left(\frac{1}{C_1} + \frac{1}{C_2} \right)$

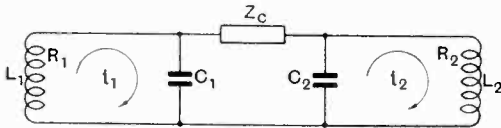

Fig. 7.

and the co-ordinates of the pole are

$$\left. \begin{aligned} -x_p &= R_1R_2 + \frac{1}{2}\omega^2 C_c^2 L_1L_2 \left(\frac{1}{C_1} + \frac{1}{C_2} \right)^2 \\ -y_p &= \omega C_c \left\{ \frac{1}{2}(L_1R_2 - L_2R_1) \left(\frac{1}{C_1} - \frac{1}{C_2} \right) \right\} \end{aligned} \right\}$$

The pole is thus only on the axis of the parabola when $C_1 = C_2$ (which since the circuits are tuned involves also $L_1 = L_2$), or

when $L_1R_2 = L_2R_1$, or $\frac{R_1}{2L_1} = \frac{R_2}{2L_2}$, i.e., when

the decay factors of the circuits are the same.

To find the frequencies for the capacity coupling we simply subtract ω_a from each of the values found for the Z_1Z_2 parabola. But since ω_a depends upon the coupling condenser, the ω distribution is not fixed as in the previous cases, but varies as the coupling is varied.

(c) A still more complicated case arises when the coils L_1 and L_2 of Fig. 7 are coupled by a mutual inductance M , Z_c being a condenser. This is a very common case in all wireless circuits where coupling by mutual inductance is intended, and capacity coupling cannot be avoided. Under these circumstances C_c is small compared

with C_1 and C_2 , and if C_1 is not very different from C_2 and/or the decay factors of the circuits are the same, the same remarks as to the parabola apply as in the capacity case (b) above, with

$$\begin{aligned} -x_p &= R_1R_2 + \{\omega M + C_c/\omega C_1C_2\}^2 \\ -y_p &= 0 \end{aligned}$$

and $\omega_a = \frac{1}{2}\omega C_c \left(\frac{1}{C_1} + \frac{1}{C_2} \right)$.

Since M may be either positive or negative, it is seen that the effective coupling may be either increased or decreased by the presence of the stray capacity coupling.

Full details of these cases will be found in the author's paper, "A Vector Loci Method of Treating Coupled Circuits," *Proceedings of the Royal Society, A*, Vol. 117, 1928, pp. 331-350.

III. Circuits a Little Distuned.

The result of distuning the two circuits a little is also in general to throw the pole off the axis of the parabola, but in this case it is the pole of Z_1Z_2 which is displaced.

Let ω_1 and ω_2 be the values of $1/\sqrt{L_1C_1}$ and $1/\sqrt{L_2C_2}$ respectively, and suppose the coupling is by mutual inductance and is not very tight, so that the resonance changes take place with only a small change of ω , so that ω_1/ω and ω_2/ω are not very different from unity.

Thus the reactances of the two circuits are very nearly $2L_1(\omega - \omega_1)$ and $2L_2(\omega - \omega_2)$ respectively, and it can readily be shown that the locus of Z_1Z_2 is given in cartesian co-ordinates by

$$\left. \begin{aligned} x &= R_1R_2 - 4L_1L_2(\omega - \omega_1)(\omega - \omega_2) \\ y &= 2L_1R_2(\omega - \omega_1) + 2L_2R_1(\omega - \omega_2) \end{aligned} \right\} \dots \text{(vii)}$$

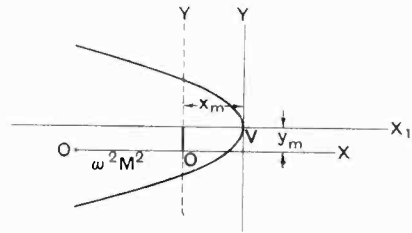

Fig. 8.

x has its largest positive value when $\omega = \frac{1}{2}(\omega_1 + \omega_2)$ and then the values of x and y are

$$\left. \begin{aligned} x_m &= R_1R_2 + L_1L_2(\omega_1 - \omega_2)^2 \\ y_m &= (L_2R_1 - L_1R_2)(\omega_1 - \omega_2) \end{aligned} \right\} \dots \text{(viii)}$$

Transferring to new axes $x^1 = x - x_m$, $y^1 = y - y_m$ (vii) becomes

$$x^1 = -L_1 L_2 \{(\omega_1 + \omega_2) - 2\omega\}^2$$

$$y^1 = (L_1 R_2 + L_2 R_1)(\omega_1 + \omega_2 - 2\omega)$$

and $y^{12} = \frac{(L_1 R_2 + L_2 R_1)^2}{L_1 L_2} (-x^1)$.

Hence the locus of $Z_1 Z_2$ when the circuits are a little out of tune is the same parabola as when they are in tune, but the pole is in a different position and the distribution of ω round the parabola is different. The former is fixed by equations (viii) and the latter by either of equations (vii).

Having found the locus of $Z_1 Z_2$ the rest of the construction proceeds as before.

In the mutual inductance case $\omega^2 M^2$ is measured horizontally to the left to give the new pole O_1 in accordance with equation (iii) and so on. (Fig. 8.)

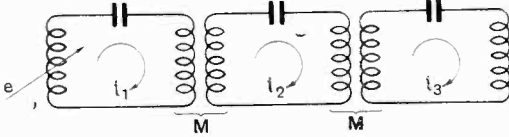

Fig. 9.

It is seen that generally O_1 is off the axis and the current humps will be of unequal height, but when y_m is zero, that is when the decay factors of the circuits are equal, the current humps are again equal.

IV. Extension to Three Coupled Circuits.

The graphical method can readily be extended to find the current in the last of the three coupled circuits shown in Fig. 9. The circuits are supposed to be identical and each coupled by a mutual inductance M . There is no coupling between the first and the third. With the currents i_1, i_2, i_3 taken as shown, and with each circuit consisting of coils and a condenser with combined inductance L and capacity C respectively and with total resistance R , so that the series impedance of each circuit is

$$Z = R + j(\omega L - \tau/\omega C),$$

the following equations hold:

$$\left. \begin{aligned} e &= Z i_1 + j\omega M i_2 & \dots & \dots & \text{(i)} \\ O &= j\omega M i_1 + Z i_2 + j\omega M i_3 & \dots & \dots & \text{(ii)} \\ O &= j\omega M i_2 + Z i_3 & \dots & \dots & \text{(iii)} \end{aligned} \right\} \dots \dots \dots 9$$

From (iii)

$$i_2 = -\frac{Z}{j\omega M} i_3 \dots \dots \dots 10$$

Putting this in (ii) gives

$$O = j\omega M i_1 + \left(-\frac{Z^2}{j\omega M} + j\omega M\right) i_3$$

or $i_1 = \left(-\frac{Z^2}{\omega^2 M^2} - 1\right) i_3 \dots \dots \dots 11$

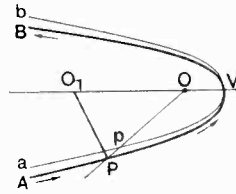

Fig. 10.

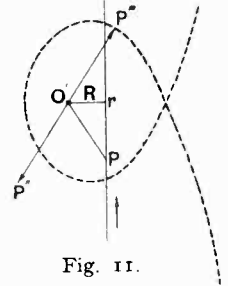

Fig. 11.

Putting 10 and 11 in (i) gives

$$\begin{aligned} e &= \left(-\frac{Z^3}{\omega^2 M^2} - Z - Z\right) i_3 \\ &= -Z \left(2 + \frac{Z^2}{\omega^2 M^2}\right) i_3 \\ &= Z_3'' i_3, \text{ say } \dots \dots \dots 12 \end{aligned}$$

where Z_3'' is the impedance from which the current in the last of three circuits is to be obtained from the electromotive force in the first. Z_3'' could be put into the form

$$-\frac{Z}{\omega^2 M^2} \{2\omega^2 M^2 + Z^2\} \dots \dots \dots 13$$

Starting with the parabola Z^2 we have to find a new pole distance $2\omega M^2$ to the left along the axis instead of $\omega^2 M^2$ as in the case of the two circuits. Finally, we have to

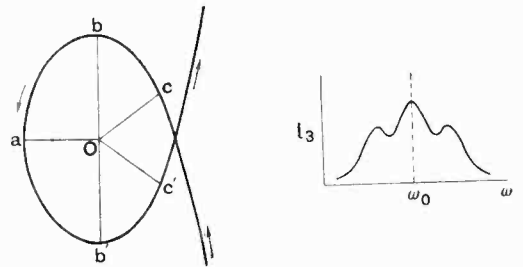

Fig. 12a and b.

multiply by $-Z/\omega^2 M^2$. It appears therefore that with a given coupling the resonance curve will extend over a greater ω range, and that the assumption that $\omega^2 M^2$ is constant will lead to greater errors, and this will be still further accentuated when the number of circuits is still further increased.

It is better, therefore, to make the construction quite accurate by starting with the expression

$$Z_3'' = -Z \left(2 + \frac{Z^2}{\omega^2 M^2} \right) \dots 14$$

and distorting the parabola $Z^2/\omega^2 M^2$ by multiplying each ray by the corresponding value of ω_0^2/ω^2 . Thus in Fig. 10, $apVb$ is the parabola $Z^2/\omega_0^2 M^2$, with pole O , and Op represents $Z^2/\omega_0^2 M^2$ for a certain value of ω . P is now found on Op or Op extended, so that $OP = \frac{\omega_0^2}{\omega^2} \times Op$, so that

OP is the ray representing $Z^2/\omega^2 M^2$ at the value of ω chosen. In this way the

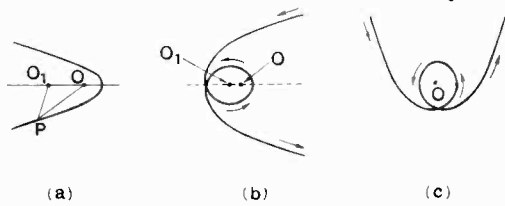

Fig. 13.

distorted parabola AVB with pole O is the true locus of $Z^2/\omega^2 M^2$. To add 2 to each ray we find a new pole O_1 distant 2 from the old one. It remains to multiply by $-Z$. The locus of Z is as shown in Fig. 11, and if the ω value at P in Fig. 11 is the same as that of P in Fig. 10, we have to multiply the vector O_1P , by the vector $O'P'$ and by -1 . The length of $O'P''$ is made equal to the product of the lengths of $O'P'$ and O_1P , and the angle $rO'P''$ is made equal to the sum of the angles $rO'P'$ and VO_1P . Finally, $P''O'$ continued to P''' , where $O'P''' = P''O'$ gives a point P''' on the required locus.

The complete locus takes the form shown in Fig. 12a, giving maximum impedances at b and b' and minimum at a , c and c' , thus leading to the three hump curve of Fig. 12b.

V. Four and More Circuits.

The process can quite readily be extended to four and more coupled circuits. With four circuits linked as in Fig. 9 the circuit equations are

$$\left. \begin{aligned} e &= Zi_1 + j\omega Mi_2 \\ O &= j\omega Mi_1 + Zi_2 + j\omega Mi_3 \\ O &= j\omega Mi_2 + Zi_3 + j\omega Mi_4 \\ O &= j\omega Mi_3 + Zi_4 \end{aligned} \right\}$$

and these solved for i_4 give

$$\begin{aligned} e &= \frac{j}{\omega^3 M^3} \left[(\omega M)^4 + Z^2 \{ 3(\omega M)^2 + Z^2 \} \right] i_4 \\ &= Z_4'' i_4 \end{aligned}$$

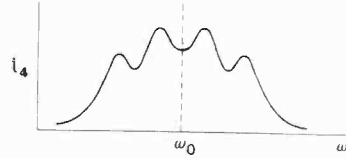

Fig. 14.

$$\text{or } Z_4'' = j\omega M \left[1 + \frac{Z^2}{\omega^2 M^2} \left\{ 3 + \frac{Z^2}{\omega^2 M^2} \right\} \right]$$

The successive steps in the graphical construction are indicated in Fig. 13. Starting with the distorted parabola $Z^2/\omega^2 M^2$, pole O , a new pole O_1 is found distance 3 to the left. The locus of

$$\frac{Z^2}{\omega^2 M^2} \left\{ 3 + \frac{Z^2}{\omega^2 M^2} \right\}$$

is found by multiplying vectors such as OP and O_1P . This gives the curve of Fig. 13b, pole O . Unity is added by finding a new pole O_1 , so that $O_1O = 1$, and finally each ray is multiplied by $j\omega M$ to give the final locus shown in Fig. 13c. This results in the four hump resonance curve of Fig. 14.

The process can be continued indefinitely. Figs. 15 and 16 indicate the forms of the

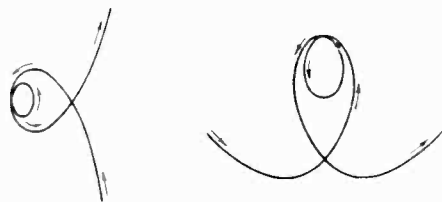

Fig. 15.

Fig. 16.

loci for five circuits and six circuits respectively drawn from the expressions

$$Z_5'' = Z \left[3 + \frac{Z^2}{\omega^2 M^2} \left\{ 4 + \frac{Z^2}{\omega^2 M^2} \right\} \right]$$

$$\text{and } Z_6'' = -j\omega M \left[1 + \frac{Z^2}{\omega^2 M^2} \left\{ 6 + \frac{Z^2}{\omega^2 M^2} \left(5 + \frac{Z^2}{\omega^2 M^2} \right) \right\} \right]$$

Microphone Amplifiers and Transformers.

By H. L. Kirke.

(Concluded from page 370 of July issue.)

Having dealt with the input and output transformer question, it is important to consider the components of the resistance or choke-capacity stages.

Inter-valve Condensers.

Distortion of the frequency characteristic may occur due to the use of too small inter-valve coupling condensers. Consider the circuit shown in Fig. 13. The reactance of the coupling condenser C will be negligible compared with R_2 at all except very low frequencies. Thus for medium and high frequencies the voltage variation produced at the anode of the first valve will be equal to

$$\frac{R_3}{R_0 + R_3} \mu v_g, \text{ where } R_3 = \frac{R_1 R_2}{R_1 + R_2}$$

μ is the magnification factor of the valve and v_g is the voltage applied to the grid. In general, R_1 is large compared with R_0 ,

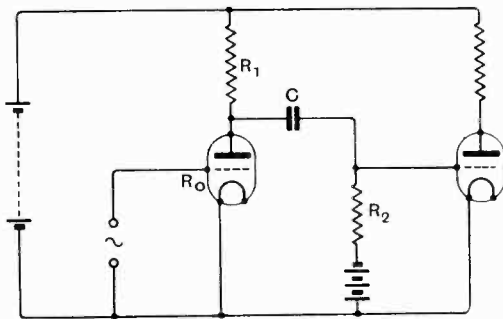

Fig. 13.

and R_2 is large compared with R_1 ; thus the external impedance R_3 , which determines the magnification for a given valve, is nearly equal to R_1 (if $R_2 = 5 R_1$, then $R_3 = 5/6 R_1$), and appreciable changes in R_2 produce only small changes in R_3 and consequently in the magnification. Now at some low frequency the reactance of C may be appreciable, say equal to $1/5 R_2$, and thus the external impedance R_3 is increased, but only very slightly. The increase in magnification due to this cause is so small that it can be neglected compared with the reduction of voltage across R_2 due to the reactance of C being in series with R_2 . The value of r

can thus be obtained approximately by assuming that the anode voltage variation is constant at all frequencies. The circuit can then be re-drawn as in Fig. 14, where e_a is the anode voltage variation.

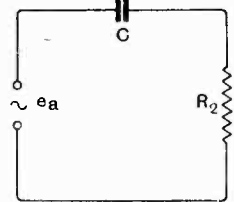

Fig. 14.

Now, at a medium frequency, where the reactance of C is negligible, the voltage across R_2 is equal to e_a .

At a low frequency, let the reactance of C be X_c .

Then the voltage across R_2 is

$$\frac{R_2}{\sqrt{R_2^2 + X_c^2}} e_a.$$

The reproduction factor is thus:

$$r = \frac{R_2}{\sqrt{R_2^2 + X_c^2}} \frac{e_a}{e_n} = \frac{R_2}{\sqrt{R_2^2 + X_c^2}}$$

As an example, if $R_2 = 1,000,000$, then for a value of r of 0.99 at a frequency of

$$50 \text{ p.p.s. } (\omega = 314) : 0.99 = \frac{10^6}{\sqrt{10^{12} + X_c^2}}$$

from which $X_c = 139,200$ ohms.

thus $C = 0.023$ mf.

For $R_2 = 100,000$, then, for r to be 0.99 at 50 p.p.s., C must be 0.23 mf.

In practice, however, it is usual to make the cut-down due to inter-valve condensers small, *i.e.*, the reproduction factor high, such as 0.995 at 50 p.p.s.

Feed-back Due to Inter-electrode Capacity.

The feed-back from anode to grid of an amplifying valve may cause distortion of the frequency characteristic. Referring to Fig. 15(a), if e_p be the actual voltage variation at the anode (assumed sinusoidal) and e_g the voltage fed back from the anode to the grid through the inter-electrode capacity

$$\text{of the valve, then } e_g = \frac{R_2}{R_2 + \frac{1}{j\omega C}} e_p,$$

where R_2 is the total effective resistance between grid and filament, including the

A.C. resistance and anode resistance associated with the preceding valve, if any.

The effective voltage on the grid necessary to produce e_p is $e_g = -\frac{e_p}{M}$ where

$$M = \frac{R_1}{R_1 + R_A}$$

Then if the total voltage to be applied to the grid is v_g , then $v_g + e_g = e_g^1$.

$$\therefore v_g + \frac{R_2}{R_2 + \frac{1}{j\omega C}} \cdot e_p = -\frac{e_p}{M}$$

$$\therefore v_g = -e_p \left[\frac{1}{M} + \frac{R_2}{R_2 + \frac{1}{j\omega C}} \right]$$

\therefore The effective amplification of the stage

$$M_1 = -\frac{e_p}{v_g} = \frac{1}{\frac{1}{M} + \frac{R_2}{R_2 + \frac{1}{j\omega C}}}$$

Put $\frac{R_2}{R_2 + \frac{1}{j\omega C}} = a$. $\therefore M_1 = \frac{1}{\frac{1}{M} + a} = \frac{M}{1 + Ma}$.

At low frequencies the reactance $\frac{1}{\omega C}$ will be so large that the feed-back is negligible and the amplification of the stage is M . At high frequencies the amplification of the stage is $M_1 = \frac{M}{1 + Ma}$.

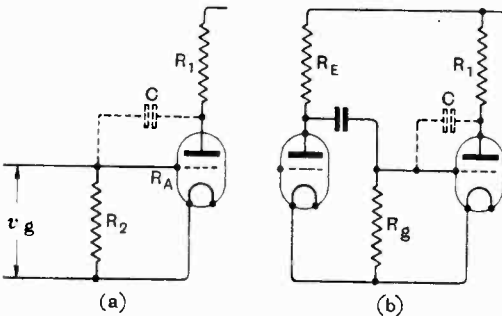

Fig. 15.

The reproduction factor r is thus:—

$$r = \frac{M_1}{M} = \frac{1}{1 + Ma}$$

where $a = \frac{R_2}{R_2 + \frac{1}{j\omega C}}$

from which

$$r = \frac{1}{\sqrt{1 + \frac{\omega^2 R_2^2 C^2}{1 + \omega^2 R_2^2 C^2} (2M + M^2)}}$$

numerically.

From this expression it will be seen that the reproduction factor is reduced as either of the quantities ωR_2 , C or M is increased. As ω is proportional to the frequency it is apparent that r is reduced as the frequency is increased, and so if the effect is appreciable it will result in a loss of high frequencies.

In practice it is found impossible to use valves having a magnification factor greater than 25 without an appreciable loss of high frequencies due to this cause.

When the stage is preceded by another resistance-coupled stage,

as in Fig. 15(b), the value of R_2 is made up of the grid leak R_g , the preceding anode resistance R_E , and the A.C. resistance of the previous valve R_A , all in parallel. Since, in general, R_g and R_E are several times greater than R_A , the value of R_2 is practically determined by R_A . Thus when using two or more high magnification valves

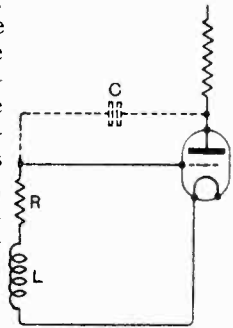

Fig. 16.

in cascade the value of R_2 is large due to the high impedance of these valves; consequently all the three factors R_2 , C and M are large, so increasing the amount of feed-back.

If the impedance between grid and filament is not a pure resistance, but has a positive phase angle, conditions may arise in which the feed-back produces reaction and not anti-reaction. Consider the case of Fig. 16. The anode voltage variation e_p is displaced 180 degrees from the effective grid voltage variation e_g^1 . The feed-back voltage e_g will be ahead of the anode voltage e_p , the phase angle approaching 90 degrees as $\frac{1}{C\omega}$ becomes large compared with R_2 .

The angle can never exceed 90 degrees. Now if R_2 be replaced by a resistance R and inductance L in series, then at frequencies

below $f = \frac{1}{2\pi\sqrt{LC}}$ the reactance $\frac{1}{C\omega}$ exceeds

the inductive reactance $L\omega$ and the current in the circuit is ahead of the voltage e_p . The voltage e_p , however, will be ahead of

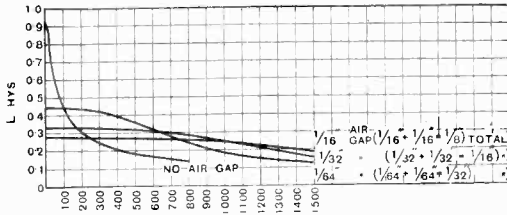

Fig. 17.—Curves of inductance of stalloy core coil for various air gaps and D.C. currents for 1,000-turn coil.

the current, since the grid filament impedance has a positive phase-angle and it is possible for e_g to lead e_p by more than 90 degrees, thus producing reaction and not anti-reaction.

Effect of D.C. on Transformers.*

While static curves for iron show that values of flux density up to 10,000 lines per sq. cm. do not saturate the iron, the effect on the dynamic characteristic is considerable. The effect of D.C. flux on iron is generally to reduce the permeability, unless the value of D.C. flux is small. This reduces the effective inductance; resulting in a considerable

increase in the leakage coefficient $\frac{L_3}{L_1}$, which in turn reduces proportionally the band of frequencies for which a transformer can be designed. The curves of Fig. 17 show the effect of D.C. flux on a stalloy core having a cross sectional area of 5.5 sq. cms. approximately a length of magnetic path (in iron) of 18 cms. and 1,000 turns, with various values of air-gap.

If a transformer or choke be made with a closed core having 1,000 turns, it will be seen that its inductance with no D.C. through the winding will be 0.92 henry. Now if a direct current of 50 milliamps flows through the winding the inductance will be reduced to 0.6 henry, and for a current of 100 milliamps the inductance will be only 0.44 henry. For a given core the D.C. flux depends upon the ampere-turns; so that for a transformer of 5,000 turns the percentage reduction of

inductance due to saturation for a current 10 milliamps is the same as that produced by 50 milliamps in 1,000 turns, *i.e.*, $\frac{0.6}{0.92} = 65$

per cent. Consider a circuit as shown in Fig. 18, which may represent the last stage of a microphone amplifier. Let the A.C. resistance of the valve be 6,000 ohms and the output transformer be designed for matched impedance so that the load R_L when referred to the primary of the transformer will have the value 6,000 ohms. Then if a cut-down to 0.95 at 50 p.p.s. is desired the value of primary inductance can be found from Fig. 5. R_4 is 3,000 ohms, and $\omega_1 L_1$ must be three times R_4 , *i.e.*, 9,000 ohms.

$$\therefore L_1 = \frac{9,000}{2\pi \times 50} = 28.6 \text{ henries.}$$

For 28.6 henries with no D.C., 5,670 turns will be required. Now if the valve normally operates with an anode current of 20 milliamps the ampere-turns will be 113.4, and the reduction of inductance will be to $\frac{.41}{.92} = 44.6$ per cent., the actual inductance being 12.7 henries. This will obviously produce a much worse value of cut-down at 50 p.p.s. than $r = 0.95$.

If the turns be increased in the ratio $\sqrt{\frac{28.6}{12.7}}$ so that the number of turns is 8,520, then with no D.C. the inductance is 64.5 henries, and with 20 milliamps D.C. the

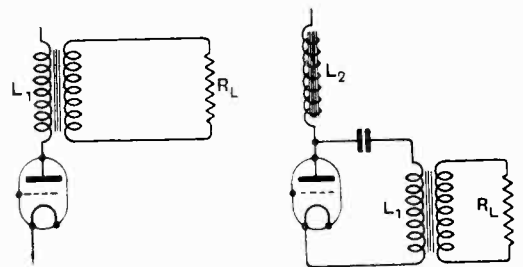

Fig. 18.

Fig. 19.

inductance is 21.2 henries. Thus, although the turns have been increased the inductance under working conditions is still not sufficient to give the performance $r = 0.95$ at 50 p.p.s. and if the turns be still further increased the loss of high frequencies due to leakage will be serious.

* See G. W. O. Howe, Design of Choke Coil and Transformers to carry Direct Current, *E.W. & W.E.*, Feb., 1928.

In order that no D.C. shall flow in the output transformer it may be choke-fed, as shown in Fig. 19. The choke L_2 is effectively in parallel with the transformer primary L_1 , and so its inductance must be kept high, as the total reactance of L_1 and L_2 in parallel must be three times R_4 if the reproduction factor r is to be 0.95 at 50 p.p.s. If the core of the choke is similar to that of the transformer, then there is double the winding space available and so the number of turns may be considerably increased, as leakage has no significance in a choke. If the turns be increased three times, the inductance is increased nine times for a closed core or 4.5 times for a core having a 1/32 in. air gap (the introduction of a 1/32 in. air gap approximately doubles the reluctance of the magnetic path). If then the choke be made with

that for a core with a total air gap of 1/32 in. the inductance of the core with 340.2 ampere-turns is $\frac{.4I}{.44}$ of its inductance with no D.C.

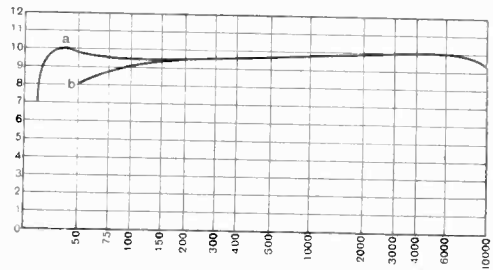
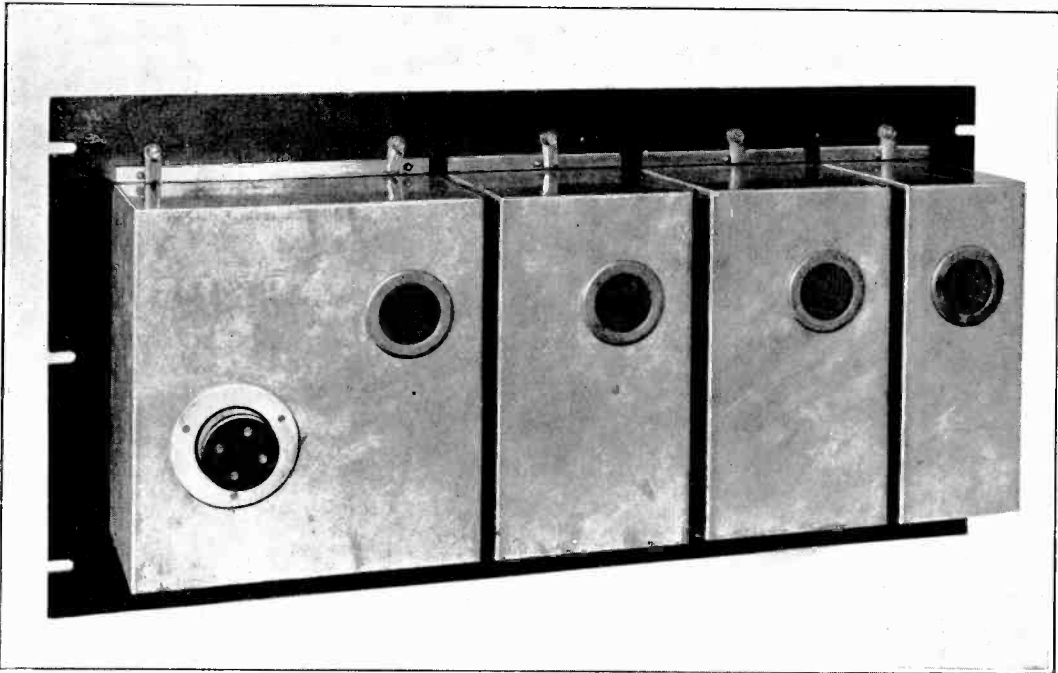

Fig. 20.

Hence the inductance of the choke will be $\frac{.4I}{.44} \times 129 = 120$ henries. Then since the



Studio Microphone Amplifier with screening covers.

$3 \times 5,670 = 17,010$ turns and with an air gap of 1/32 in., its inductance will be $4.5 \times 28.6 = 129$ henries. Then with an anode current of 20 milliamps the ampere-turns will be 340.2. Reference to Fig. 17 shows

combined inductance of L_1 and L_2 must be 28.6 henries, L_1 will be 37.6 henries and the turns required will be 6,500. In this case, therefore, the value $r = 0.95$ at 50 p.p.s. is actually obtained with 6,500 turns on the

transformer primary, whereas by passing the D.C. through the transformer it could not be obtained even with 8,520 turns. Conditions can be steadily improved by increasing the inductance of the choke until the point is reached when its D.C. resistance causes too large a voltage drop. In practice the choke can be made so that its inductive reactance at 50 p.p.s. is about 7 to 10 times the A.C. resistance of the valve.

This method of choke-feeding the output stage has the additional advantage that the load current does not pass through the choke and back through the H.T. supply; this reduces any tendency to reaction or cross-talk effects due to common resistance in the H.T. supply when a number of amplifiers have a common H.T. supply.

The value of the coupling condenser should be chosen so that its reactance at all frequencies is low in comparison with the resultant primary impedance, plus the valve resistance, as described under intervalve condensers.

The value of this condenser can be chosen so that it assists the output at low frequencies where the output is low due to lack of self-inductance in the primary winding. If the values are chosen carefully the frequency characteristic may be improved as shown in Fig. 20, where "a" is a curve with the condenser at the critical value and "b" is the curve for a condenser of negligible reactance. The effect is produced by the condenser reactance tending to reduce the resultant reactance component of the loaded transformer, so increasing the current and consequently the P.D. At low frequencies (near resonance) the values must be so chosen that the circuit is always effectively damped by the valve A.C. resistance and transformer load and/or losses.

The method has the disadvantage that the phase shift is considerable—this will be particularly bad if there are several such stages in the chain. It will be seen that the total impedance will be reduced at frequencies at which the effect occurs, and this again will tend to reduce the maximum output from the last stage due to the alteration of the dynamic characteristics of the valve. A further disadvantage is that the magnetising current will be increased, bringing distortion where values of flux density

are so great as to vary the permeability over the cycle. This point will be dealt with later.

Resistance and Choke-Capacity Coupling.

The magnification obtainable from a resistance-coupled stage is given by the well-known expression $M = \frac{R_3 \mu}{R_3 + R_A}$, where R_3 is the total resistance of R_1 and R_2 in parallel (Fig. 21), μ the magnification factor and R_A the A.C. resistance of the valve, C being so large that its reactance is negligible at all frequencies within the band. M approaches the value μ as R_3 is made large compared with R_A .

With choke coupling (Fig. 22), if the inductance of the choke be fairly high, then, at a medium frequency f_2 , $M = \frac{R_2}{R_2 + R_A}$, since $\omega_2 L_1$ is very large. The reproduction factor at a low frequency f_1 is obtained in

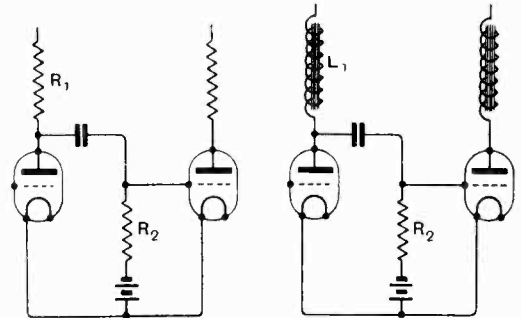

Fig. 21.

Fig. 22.

the same way as explained with reference to Figs. 3 and 4—i.e.—

$$r = \frac{1}{\sqrt{1 + \left(\frac{R_4}{\omega_1 L_1}\right)^2}} \text{ where } R_4 = \frac{R_2 R_A}{R_2 + R_A}$$

$$\text{or } \frac{\omega_1 L_1}{R_4} = \frac{r}{\sqrt{1 - r^2}}$$

If $R_A = 20,000$ ohms and $R_2 = 1,000,000$ ohms, then for

$r = .98$ at 50 p.p.s., $L = 308$ henries.

$r = .99$ at 50 p.p.s., $L = 440$ henries.

These figures indicate how difficult it is to make a choke suitable for a valve of as high an impedance as 20,000 ohms if several stages of such choke coupling are to be used.

The great advantage of choke coupling is that the drop of H.T. voltage is low and the H.T. at the anode therefore high, so that the maximum distortionless output is greater

bulk are used. As far as frequency performance is concerned choke coupling is a considerable improvement on transformer coupling, since for a given size of core there is double the winding space and consequently the possibility of getting at least four times the inductance. However, from the figures given it will be seen that if a very good performance is to be obtained in an amplifier having, say, five stages, then the chokes must be so large that they are not worth while. For a good overall curve from a multi-stage amplifier resistance coupling is the only solution, and this is the only form of inter-valve coupling that can be used in microphone amplifiers for broadcast purposes.

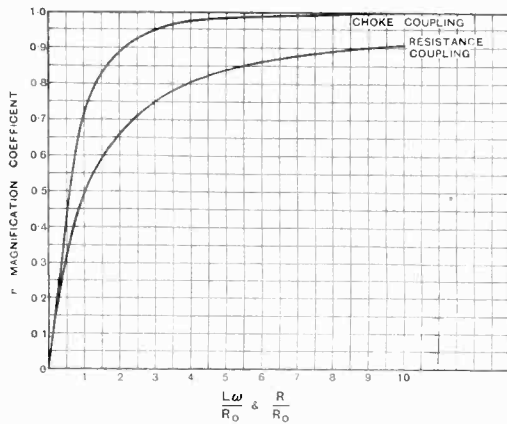

Fig. 23.

Distortion of the Amplitude-magnification Characteristic.

When an amplifier fails to amplify equally at all amplitudes, it may be said to be a non-linear amplifier. The effect of this is that currents non-existent in the input waveform will be produced in the output. These currents are odd or even multiples of the fundamental frequencies, dependent on the type of distortion. This form of distortion is far more unpleasant than distortion of the frequency characteristic of the same order of magnitude.

Distortion may be caused by valves, transformers and chokes. Valve distortion is of two classes: firstly, due to grid current; secondly, by non-linear anode current characteristics.

If grid current flows due to the grid being allowed to become positive relative to the filament for a portion of the cycle, then during that portion of the cycle the effective grid-filament impedance is low, whereas normally it is very high. If the previous stage is a resistance or choke-coupled stage, then this low grid-filament impedance, if it is comparable with the preceding anode impedance, will materially reduce the magnification of the preceding stage over that portion of the cycle, so that the wave-form is distorted. The same applies if the grid is fed from a transformer, the low grid-filament impedance damping the secondary to such an extent that the magnification is materially reduced. In resistance or choke-capacity coupling the grid current leaves an extra negative charge in the inter-valve condenser which will discharge at a rate

than with resistance coupling for a given valve. Alternatively, a valve having a higher resistance and magnification factor may be used with choke coupling to give the same value of distortionless output as a low-resistance low-magnification valve with resistance coupling. The magnification obtainable with a given valve—particularly a high impedance valve—is greater with choke coupling as the H.T. at the plate is higher and the choke can be made of higher impedance than the resistance. In any case, the choke has more effect than a resistance having the same impedance as the choke; this will be seen from Fig. 23, which shows the magnification coefficient "x" of a valve against ratio of external to internal impedance

$$x = \frac{I}{I + \frac{R_0}{Z}}$$

voltage between anode and filament.

Comparison of Resistance Coupling, Choke Coupling and Transformer Coupling.

The use of transformer coupling must be restricted to valves of fairly low impedance, say 8,000 ohms, if a good performance is to be obtained; and even so, if there are several such stages in cascade, the loss of low frequencies is bound to be serious unless transformers of very considerable weight and

depending on the time constant of the circuit. If the circuit is arranged so that R_2 is small compared with the grid-filament impedance when the grid is positive, then grid current will not cause distortion; but this is obviously a very inefficient arrangement, since it puts such a low effective resistance in the anode circuit of the preceding valve. In general it is good practice to avoid grid current in all low frequency stages.

The second type of valve distortion is that due to the non-linearity of the plate current characteristics of the valve. This can be avoided by:—

(a) Having a large factor of safety in each stage.

(b) Using relatively high impedance output circuits.

The non-linear characteristic gives the same effect as a generator with an internal

city stages this is both convenient and efficient, as a high value of anode resistance gives a high value of magnification.

Iron Distortion.

All circuits having iron-cored inductance of any kind are a potential source of distortion. This is because the permeability μ varies with flux density B and magnetising force H .

Referring to Fig. 24, the E.M.F. e_p applied to the choke L_1 will be equal and opposite to the back E.M.F. produced by the changing flux in the choke, neglecting the D.C. resistance of the choke. Taking one extreme case: if R_0 is small compared with the impedance of the choke, then $e_p = e_1$; so that if e_1 is a sine wave, e_p will be a sine wave. The back E.M.F. is proportional to the rate of change of flux in the core, so that if ϕ is

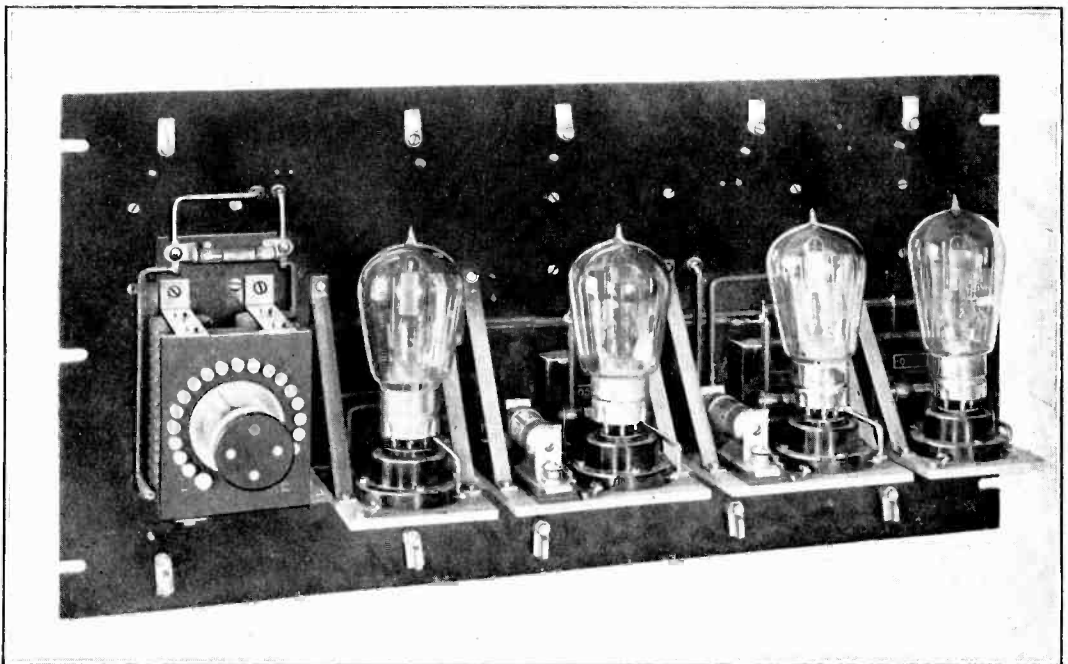

Studio Microphone Amplifier (three stages) without screening covers.

resistance varying with amplitude of load. The ratio of output volts to input volts will therefore vary with amplitude unless the output impedance is high compared with the internal resistance; in resistance-capacitance

the flux, $e_p \propto \frac{d\phi}{dt}$. Therefore $\frac{d\phi}{dt}$, and consequently ϕ , must be sinusoidal. If B/H for the iron is not constant over the cycle, then ϕ/i_1 will not be constant, and therefore i_1

will not be a sine wave. In the other extreme case, if R_0 is large compared with the choke impedance, $i_1 = \frac{e_1}{R_0}$, thus i_1 is sinusoidal, and ϕ and therefore the back E.M.F. and thus e_p will not be sinusoidal.

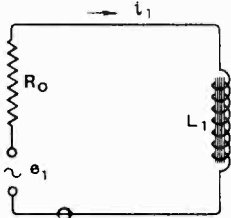

Fig. 24.

The practical case lies between these two extremes, so that, if R_0 is of the same order as the reactance of L_1 , both e_p and i_1 are distorted. In the case of a transformer R_0 is the total resistance of the source of E.M.F.

and the load across the transformer in parallel, as in the case of Figs. 3 and 4. The smaller R_0 the less the final distortion, since the output voltage across the secondary depends directly upon e_p and not upon i_1 , so that when e_p is sinusoidal the output voltage is sinusoidal, although i_1 may be distorted. If the reactance of L_1 at some low frequency is made three or four times R_0 a Stalloy core may be worked at that frequency up to 4,000 to 5,000 lines/sq. cm., nickel-iron up to 2,100 lines/sq. cm., and Mumetal up to 1,500 lines/sq. cm. If this frequency is the lowest it is desired to transmit, no distortion will be introduced at any higher frequency, since for constant voltage output the flux density will decrease as the frequency increases and also $\frac{\omega L_1}{R_0}$ will increase with increasing frequency.

Magnification required in Amplifiers.

Most amplifiers are designed to have their outputs connected to a line. If a number of amplifiers are used in cascade with a line connecting the output of one amplifier to the input of the other, see Fig. 25, it might appear that a lack of magnification on one amplifier could be made up by an increase in magnification on one of the others. This, however, is not strictly true, as line noise and other interference introduce certain desiderata. The ultimate factor governing the amount of extraneous disturbance heard is the ratio of signal to such disturbances. This ratio must naturally be made high, because in practice on commercial lines noise cannot be reduced below a certain amount. In order that the ratio signal

strength to noise shall be great, the signal strength or output from any amplifier should not be less than a certain amount. On the other hand, to prevent cross-talk on other lines the signal must not exceed 2.5 mA. This means that each and every amplifier must be capable of delivering a maximum R.M.S. current of 2.5 mA. to a line on any type of programme without distortion. This will determine the overall maximum magnification which must be obtainable between a microphone and a line, also the type of valve and H.T. voltage required for the output stage. It has been found that owing to low value of step-up of the input transformer, which is obtainable with a good frequency characteristic, the magnification has to be proportionately increased. For an amplifier having a good frequency characteristic for use with a Marconi-Reiss Microphone, sufficient amplification and adequate factor of safety as regards distortionless output power, four stages must be employed. The first two stages should be high magnification valves, the third a medium magnification valve and the last a low-resistance power valve; the high tension voltage may be 120 to 150 volts for short line work and 200 to 300 volts for

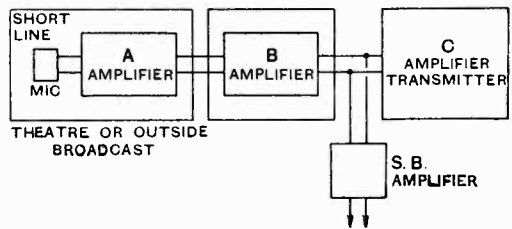

Fig. 25.—Arrangement of Amplifiers between Microphone and Broadcast Transmitter.

long line work. A diagram of connections of an "A" amplifier is shown in Fig. 26.

Intermediate amplifiers must have sufficient amplification to bring the power level up to normal before connecting to a line, i.e., must make up for losses in the line, local circuit, correction or equalising apparatus, with always an adequate factor of safety.

Factor of Safety.

It is almost impossible to overdo the factor of safety on an amplifier. By factor of safety is meant the ratio of maximum output obtainable without distortion to average

output; if the normal output is 2.5 mA. into a 500 ohm line, then the maximum peak value may be 20 mA. This at 500 ohms is 10 volts; if the transformation ratio is 5 : 1, the primary peak volts will be 50 and

volume control. Where this is required for artistic fading-in the adjustments should be fine, not greater than an increment of 1.2 : 1 per step (in voltage amplification). For volume control the increment should

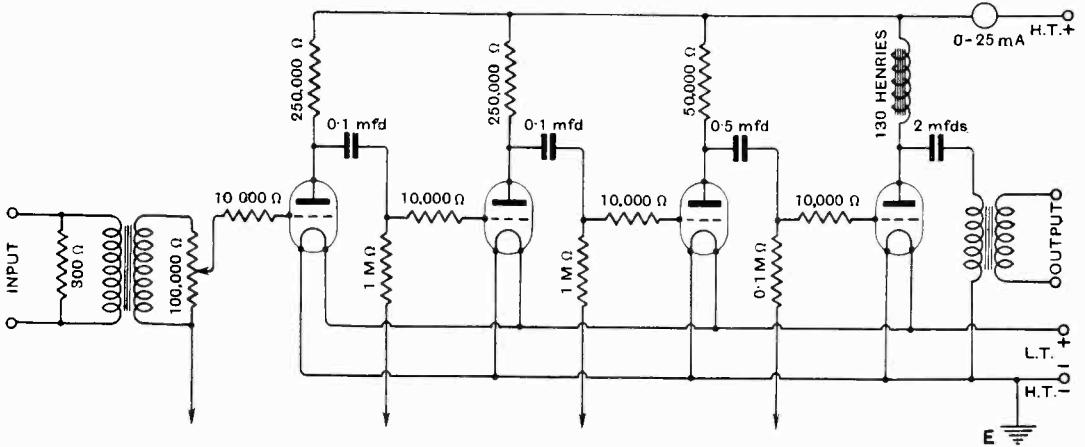

Fig. 26.—Diagram of connections of "A" Amplifier.

peak current 4 mA. Allowing a safety factor of 2 (at least) then the H.T. to the last valve would need to be 150 for a normal L.R. valve with an anode current of 10 mA. It is advisable, however, to exceed even this in special circumstances.

Mechanical Design.

In outside or theatre broadcast work it is necessary to make an amplifier comparatively portable and compact, but this need not be carried to excess, as, owing to weight of batteries, vehicular conveyance is usually required for transporting apparatus from one place to another.

It is of very great importance to choose valves for early stages which are non-microphonic and to arrange to have them suitably mounted; microphonic noises are of two kinds: those transmitted to the valve by mechanical vibration of the amplifier and those by air vibrations to the glass.

Other factors to be borne in mind are:—

- (1) Mechanical strength.
- (2) Accessibility for fault finding.
- (3) Convenience of external connections.
- (4) Screening.

Volume Control.

All amplifiers should be equipped with

not be greater than 1.4 : 1 per step. It has been found necessary to provide volume control over very wide ranges of amplitude to provide for extremes of programmes, and various circuit and line losses. Early amplifiers had a maximum variation of 100 : 1 for "B" amplifiers and about 10 : 1 for "A" amplifiers. It has been found that a variation of 10,000 : 1 is required with a complete fade-out for "B" amplifiers and a variation of 200 : 1 with a complete fade-out for outside broadcast "A" amplifiers.

The Future.

The present tendency is to eliminate all transformers, even input and output, unless transformers can be designed which are robust in every sense of the word and which are electrically good, *i.e.*, have good frequency characteristics. The difficulty with transformers will always be phase change of transients. It has been stated that this is unimportant, as the phases become changed due to acoustical reflections. A number of transformers may, however, change the phase very considerably, even more than 360 degrees, as the phase changes in each transformer are additive.

The Measurement of Small Variable Capacities at Radio-frequencies.

By *W. H. F. Griffiths, A.M.I.E.E., Mem.I.R.E.*

THE actual capacity of a small variable air condenser cannot be determined or stated with accuracy unless its leads and screening conditions to be employed subsequent to calibration are known and exactly set up at the time of calibration. That is to say, a small variable condenser cannot be calibrated precisely for capacity value unless the apparatus and circuit with which it is to be associated are known also.

Indeed, a statement of capacity for a small condenser (even if perfectly screened) is of little use if given at its terminals with no reference to the leads without which it cannot be used. Such a statement, moreover, cannot be made to include the distributed capacity and capacity to earth of any apparatus ultimately to be associated with the condenser.

The Difficulty of Calibrating Small Variable Condensers.

In Fig. 1, S_1 represents the metallic screening of the small variable condenser C to be calibrated; of its two terminals D and E the latter is joined electrically to this screen.

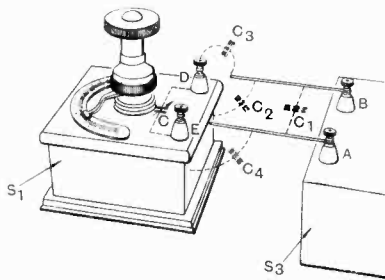

Fig. 1 (see also Fig. 2).

The earthy mass of the screening metal work of the measuring apparatus is indicated by S_3 and the two terminals A and B (the former earthy) are for the capacity to be tested.

Any method of test usually consists, in effect, of obtaining two values of capacity,

one (C') prior to connecting the capacity to be measured and the other (C'') with the latter in circuit—the difference between the two values being taken as the required calibration value.

If, as shown in Fig. 1, two stiff self-supporting wires are taken from the measuring apparatus close to the terminals of the condenser C to be calibrated so that a minimum of alteration is made in the positions of those wires upon joining them

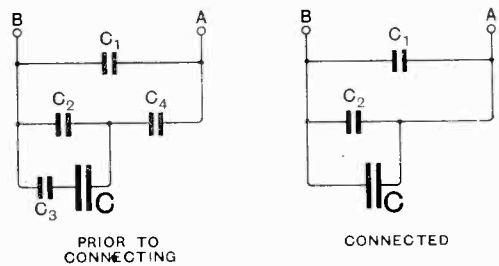

$$C' = c_1 + \frac{c_4(c_3 + c_2)}{c_2 + c_3 + c_4} \qquad C'' = c_1 + c_2 + C.$$

Fig. 2.

to the terminals, it is seen that

$$C' = c_1 + \left\{ \frac{c_4 \left(\frac{c_3 C}{c_3 + C} + c_2 \right)}{\frac{c_3 C}{c_3 + C} + c_2 + c_4} \right\} \text{ (see Fig. 2).}$$

If c_3 is small compared with C

$$C' = c_1 + \frac{c_4(c_3 + c_2)}{c_2 + c_3 + c_4}$$

Upon connecting up the condenser C to be measured, provided that c_2 is not appreciably increased by doing so,

$$C'' = c_1 + c_2 + C.$$

Therefore the capacity actually measured will be

$$C'' - C' = C + c_2 - \frac{c_4(c_3 + c_2)}{c_2 + c_3 + c_4}$$

Moreover, in addition to this uncertainty, the capacity c_4 is augmented prior to cali-

bration by that between the mass of the screen S_1 and the earthy screening metal work S_3 of the measuring apparatus, since these two systems are not at the same potential. This augmentation of c_4 may be larger than that capacity itself, is certainly variable with varying proximity to the test set and, together with c_1 , it is short-circuited upon joining up the condenser for calibration.

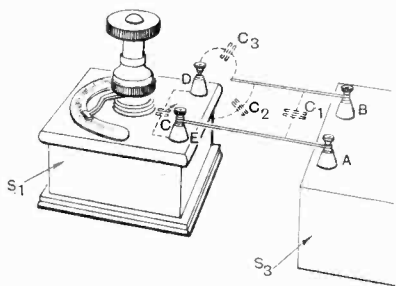

Fig. 3 (see also Fig. 4).

In order to eliminate this latter uncertainty a simplification may be effected by joining the low potential wire A direct to the earthy terminal E . The positions of the connecting wires prior to calibration (for the measurement of C') are now as indicated in Fig. 3 and it is seen that

$$C' = c_1 + c_2 + \frac{c_3 C}{c_3 + C} \text{ (see Fig. 4)}$$

or, if c_3 is small compared with C

$$C' = c_1 + c_2 + c_3$$

and upon joining the B wire to terminal D

$$C'' = c_1 + c_2 + C.$$

The capacity measured in this case is therefore $C - c_3$, i.e. it is low by the amount of c_3 .

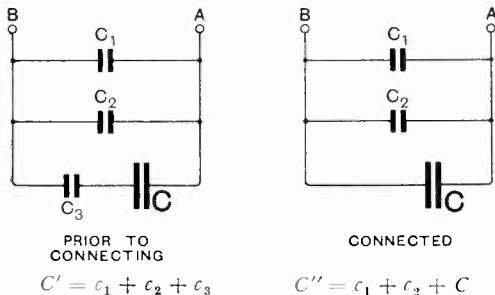

Fig. 4.

But if c_3 is made sensibly zero by withdrawing wire B to make the gap at D large, then c_1 and c_2 will not be constant—they will be increased when connecting the wire B to terminal D thus making the capacity measured high by the amount of this increase.

The capacity C can be more easily defined and measured if rigid self-supporting wires or strips AE and BD are fitted to the terminals of the condenser being measured as shown in Fig. 5, and their ends arranged permanently so that the points A and B will exactly coincide with corresponding points of the apparatus ultimately to be associated with the condenser, and to which points *thin* wires AG and JH can be taken from the testing set. Even in this case, however, although the points A and B are sufficiently far from the screen S_1 to make c_1 and c_2 constant prior to, during, and subsequent to calibration, and although the gap capacity

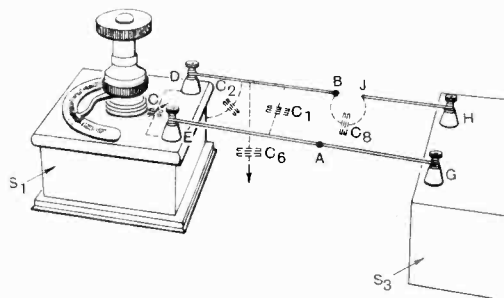

Fig. 5.

c_8 can be made small without greatly varying c_2 , there is still the danger of a varying capacity c_6 to earthy bodies from the un-screened high potential lead DB .

The obvious remedy for this is, of course, to let the low potential lead AE take the form of a tube concentric with DB and screening it to a point near to its end B . This would, however, too greatly augment the residual value of a variable air condenser of very low capacity.

The capacity c_6 to earth of the lead DB can, however, be made constant by placing below it a metal sheet S_2 which is joined electrically to the screen S_1 of the condenser and is, in effect, a continuation of it as shown in Fig. 6. Although the plate S_2 does not screen the high potential lead completely it is usually a great safeguard since it screens

it from unknown and sometimes unseen earthy objects which chance to be under the surface of the laboratory table. Moreover, the lead and the apparatus which it associates with the condenser are remote from the operator whose body and hand during operation are, of course, at the front *F* of the variable condenser which should,

not always necessary to know the *actual* capacity of the condenser. It should be quite sufficient to know the capacity "differences" throughout its range.

Moreover, this method of variable air condenser calibration can be made to ensure that the linear portion of the condenser scale only is used. In calibrating by this method a "false zero" of capacity is fixed arbitrarily near the minimum capacity end of the scale, but sufficiently far from it to be certain of avoiding the non-linear portion.

In this way the constant "*b*" is thus, in effect, eliminated from the condenser law $C = a\theta + b$ and added to the unknown self-capacity c_s of the coil and leads. This change of scale is indicated graphically in Fig. 8.

It will be seen later that a capacity difference or "slope" calibration from this arbitrary "zero" can be readily effected with precision although the actual capacity

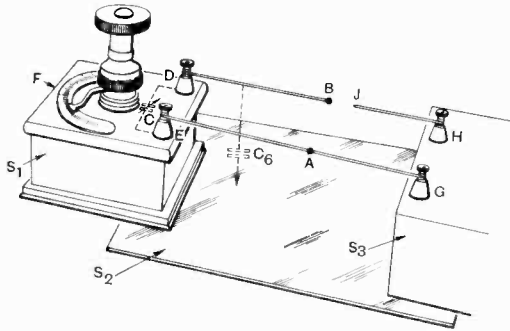

Fig. 6.

for this reason, be perfectly screened in this direction.

Even after these precautions have been taken in order to obtain as nearly as possible the actual capacity of the variable condenser up to the points *A* and *B* this value is augmented immediately upon the completion of the circuit as, for instance, in the case of the simple resonant wavemeter circuit of Fig. 7 which is, perhaps, to the

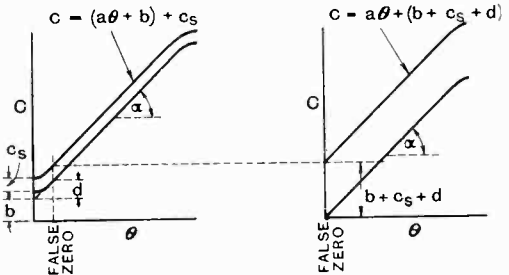

Fig. 8.

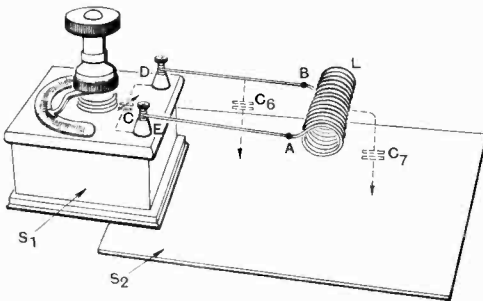

Fig. 7.

at any point of the condenser scale is difficult to determine to the same degree of accuracy. For the majority of work for which a precisely calibrated variable air condenser is required, a statement of differences or of degree of conformity to slope ($\tan a$ or $a\theta$) will suffice.

A difference calibration is certainly all that is needed if the condenser is to be used as a standard in a simple resonant circuit or in a symmetrical A.C. bridge of the Wien form. For in the latter case one can usually balance initially the "zero" of the standard condenser and in the former its "zero" value may be included in the distributed capacity (self-capacity and capacity to earth) of the coil associated with it and the whole determined directly by an accurate method.

radio engineer, the best-known example of the augmentation of the capacity of a calibrated condenser by the unknown capacity of apparatus associated with it.

Slope Calibration.

In this case, since capacity augmentation to an unknown extent always occurs, it is

Frequency the only Precise Measurement that can be Effected on a Simple Resonant Circuit.

It is interesting to note that in the case of the simple resonant circuit a similar trouble exists with the determination of the inductance of a small coil if the condenser with which its circuit is to be completed is unknown. In this case as with the calibration of a small condenser the only exact measurements that can be effected are those made by a frequency standard on the whole assemblage of apparatus, the effective inductance as well as the uncertain residual capacity being determined by using the known law connecting frequency and capacity.

A Precise Method of "Slope Capacity" Calibration.

A method of determining exact capacity differences which has been employed by the author and which may be original in detail will now be described.

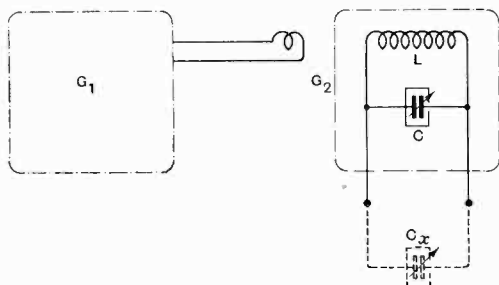

Fig. 9.

The method owes its high degree of accuracy not only to the fact that the capacity change is determined in terms of frequency change of a heterodyne beat note, but also to the fact that the capacity increments throughout the whole range of the condenser are determined in terms of one standard tuning fork only—a calibrated low-frequency oscillator not being required. Moreover, it will be seen later that only one standardised radio frequency is required even for the highest possible accuracy.

In Fig. 9, which is a simplified diagram of apparatus set up for such a calibration, G_1 is a radio-frequency triode generator (or heterodyne wavemeter) for which a frequency calibration exists and G_2 is one for which no

frequency calibration is necessary, but the variable condenser C of which is calibrated for capacity (a slope calibration is all that is needed).

C_x is the small screened variable air condenser to be calibrated and this is connected directly across C without any preliminary determinations having been made. C_x is first set at a low scale reading (preferably just on the linear portion of its scale) and this reading is noted or marked accurately as its "zero" from which the calibration is to commence.

Since C is calibrated in capacity throughout its scale it is possible to determine the self-capacity (and, incidentally, the effective inductance) of G_2 . This should be effected, in the manner to be described later, with C_x connected across C and set to its "zero" reading.

Having found a value C_s for this composite self-capacity it should, of course, be added to the calibration value of C in order to give the actual capacity of the whole circuit at any scale reading.

G_1 is now set oscillating at a frequency for which a frequency calibration exists—a frequency which is convenient also for the production of the desired heterodyne beat notes for the desired capacity changes. While still keeping C_x set to its "false zero" reading, C is adjusted until a heterodyne beat note of 500 cycles per second is obtained—the note being adjusted exactly to this frequency by the aid of the slow synchronisation beating between its first even harmonic and a tuning fork standardised at 1,000 cycles per second.

For this setting of G_1 , C and C_x the values of frequency, capacity and inductance are known.

The value of C_x is now increased until the heterodyne beat note is raised to 1,000 per second exactly by comparison with the same fork. The capacity change from C_x' to C_x'' can be calculated corresponding with an exact frequency change of 500 cycles per second at a known frequency.

Keeping C_x at its C_x'' setting the frequency of G_1 is now reduced until the beat note is again reduced to 500 exactly and then the capacity of C_x is again increased to a calculable third value C_x''' by again raising the pitch of the heterodyne beat note to 1,000 cycles per second exactly.

In this way the variable condenser can be calibrated throughout its range with a number of 500 cycle increments of frequency and as an example a few points of an actual calibration are given below in Table I.

G_1 first set to 100.2 kilocycles per second = G_1' .

The corresponding first setting of G_2 plus C_x gave the following :

$$f = 99.7 \text{ kc.}$$

$$C_T = C + c_s + C_x' = 255.5 \mu\mu\text{F.}$$

$$\therefore L = 9970 \mu\text{H. (effective).}$$

$$C = 2.54 \times 10^6 f^{-2} \mu\mu\text{F.}$$

$$\frac{dC}{df} = -5.08 \times 10^6 f^{-3} \mu\mu\text{F./kc.}$$

factors of the overall inaccuracy will probably predominate.

The inaccuracy introduced by imperfect adjustment of frequency differences can be made negligible by comparing the heterodyne beat notes with a valve maintained tuning fork standardised to an accuracy of 1 part in 10,000 or higher, such as most laboratories now possess. But here again this refinement is unnecessary and the overall accuracy of measurement will probably not be limited by the fork inaccuracy if the latter is quite an ordinary hand pattern of 0.1 per cent. accuracy.

Assuming that the frequency of G_1 remains sensibly constant (except when altered intentionally) throughout the period

TABLE I.

G_1		Heterodyne Beat Note kc.	G_2		$\frac{dC}{df}$ $\mu\mu\text{F./kc.}$	$\frac{\delta C}{\delta f}$ $= 0.5 \frac{dC}{df}$	C_x	
Setting.	kc.		Setting.	kc.			$\mu\mu\text{F.}$	Setting.
G_1'	100.2	0.5	G_2'	99.7	5.165	2.582	0*	C_x'
G_1''	100.2	1.0	G_2''	99.2			2.582	C_x''
G_1'''	99.7	0.5	G_2'''	99.2	5.244	2.622		
G_1''''	99.7	1.0	G_2''''	98.7			5.204	C_x''''
G_1'''''	99.2	0.5	G_2'''''	98.7	5.325	2.662		
G_1''''''	99.2	1.0	G_2''''''	98.2			7.866	C_x''''''

* Note.—The number of significant figures of the values in this column must not be taken as an indication of the accuracy claimed.

Possible Errors.

It will be seen that $\frac{dC}{df}$ and consequently C_x is proportional to f^{-3} , but the accuracy of this term depends (almost wholly) upon one wavelength setting of the oscillator G_1 . It will be obvious therefore that the same calibrated setting of G_1 should always be employed and, if this is done, a high degree of frequency accuracy is possible since frequent checks can then be made with facility even though the wavemeter is not of very good quality. A standardised quartz oscillator could, if necessary, be used for this single frequency, but is probably unnecessary as the percentage error of $\frac{dC}{df}$ is only three times that of f and other

of the test, the accuracy is limited by the accuracy with which the standard condenser C can be read and the accuracy with which the effective self-capacity C_s can be determined. For this reason therefore the value of C used should be as great as possible and an accurate method of self-capacity measurement employed.

Simplification of Method.

If one standardised frequency is used always for G_1 , the values of $\frac{dC}{df}$ need be computed once only and will remain constant. This is important for it means that the capacity increments may be directly standardised. All that has to be done is to fix on the scale of the small variable condenser

to be calibrated a false zero such that the correct 0.5 kilocycle heterodyne beat note is obtained with the single standardised frequency of G_1 . At each 0.5 kc. interval throughout the calibration the direct capacities are then immediately known without any computation whatever.

In calibrating *very* small variable condensers the capacity increments will need to be less than those given in the tabulation and the frequency of G_1 is, of course, adjusted to meet these altered conditions, using a harmonic check, if necessary, to transfer the accuracy from the one standardised frequency.

A Useful Approximation.

For an accuracy of the order 2 per cent. and for very low capacities up to, say, 10 to 15 $\mu\mu\text{F}$., the calibration increments of capacity may be, as an approximation, taken as constant and may even be fixed at, say, 1.0 $\mu\mu\text{F}$ intervals exactly by making a suitable corresponding adjustment of the initial frequency setting of G_1 , which, for

this accuracy, need not be a standardised point provided a wavemeter of reasonable quality is used. The fork also can be of quite ordinary quality.

As an example of this direct calibrating at 1.0 $\mu\mu\text{F}$. intervals, the following is given :

$$\begin{aligned} \text{Initial setting } G_1' &= 201.5 \text{ kc.} \\ \text{'' '' } G_2' &= 201.0 \text{ kc.} \\ L &= 3160 \mu\text{H. (effective)} \\ \text{Total capacity of } G_2 &= C + c_s + C_x' \\ &= 198 \mu\mu\text{F.} \end{aligned}$$

$$C = 8.0 \times 10^6 f^{-2} \mu\mu\text{F.}$$

$$\frac{dC}{df} = -1.6 \times 10^7 f^{-3} \mu\mu\text{F./kc.}$$

The results of this calibration are given in Table 2.

The test is very quickly performed as no computation is needed and there are no constants to be remembered. Two initial conditions only must be adhered to, G_1' must be 201.5 kilocycles per second and the total capacity of G_2 at its initial setting must

TABLE 2.

G_1		Heterodyne Beat Note. kc.	G_2		$\frac{dC}{df}$ $\mu\mu\text{F./kc.}$	δC $= 0.5 \frac{dC}{df}$	C_x		Error %
Setting.	kc.		Setting.	kc.			Setting.	$\mu\mu\text{F.}$	
G_1^i	201.5	0.5	G_2^i	201	1.975	0.9875	C_x^i	0	0
G_1^{ii}	201.5	1.0	G_2^{ii}	200.5	1.995	0.9975	C_x^{ii}	0.9875	+1.3%
G_1^{iii}	201	0.5	G_2^{iii}	200					
G_1^{iv}	200.5	1.0	G_2^{iv}	199.5	2.005	1.0025	C_x^{iv}	1.9850	+0.7%
G_1^{v}	200	0.5	G_2^{v}	199.5					
G_1^{vi}	200	1.0	G_2^{vi}	199	2.025	1.0125	C_x^{vi}	4.0	0
G_1^{vii}	199.5	0.5	G_2^{vii}	199					
G_1^{viii}	199.5	1.0	G_2^{viii}	198.5	2.040	1.020	C_x^{viii}	5.02	-0.4%
G_1^{ix}	199	0.5	G_2^{ix}	198.5					
G_1^{x}	199	1.0	G_2^{x}	198	2.055	1.0275	C_x^{x}	6.0475	-0.8%
G_1^{xi}	198.5	0.5	G_2^{xi}	198					
G_1^{xii}	198.5	1.0	G_2^{xii}	197.5	2.065	1.0325	C_x^{xii}	7.08	-1.1%
G_1^{xiii}	198	0.5	G_2^{xiii}	197.5					
G_1^{xiv}	198	1.0	G_2^{xiv}	197	2.082	1.041	C_x^{xiv}	8.12	-1.5%
G_1^{xv}	197.5	0.5	G_2^{xv}	197					
G_1^{xvi}	197.5	1.0	G_2^{xvi}	196.5	2.10	1.05	C_x^{xvi}	9.17	-1.9%

be 198 $\mu\mu\text{F}$. This latter condition is easily complied with, after adjusting C_x' (the false zero of the condenser being calibrated) during the first self-capacity measurement by adjusting L to give the required 0.5 kc. heterodyne beat note with the 201.5 kc. setting of G_1 .

Once adjusted L will remain unaltered for all tests and the self-capacity is not required to be measured again because C_x' can usually be adjusted to give the required beat note.

Measuring the False Zero C_x' .

If it is necessary to determine the value of the false zero C_x' , the same method cannot, of course, be employed. A calibrated audio-frequency triode oscillator will be required to determine the pitch of the heterodyne beat note before and after completing the high potential lead from C to C_x when connecting the two condensers as Figs. 5 or 6. After finding the value of C_x' , however, the calibration may be proceeded with by this constant frequency change method.

The Accurate Determination of Effective Self-capacity.

It has been seen in the foregoing notes that before the exact capacity increments corresponding with exact frequency increments can be computed, an accurate method of determining the effective self-capacity of the generator G_2 (as augmented by C_x') must be found.

The elementary method of plotting* the square of the wavelength against added capacity is, of course, not sufficiently accurate for the purpose unless very precise wavelength standards are available.

The first method of experimentally obtaining, more accurately, the self-capacity of an inductance was that due to G. W. O. Howe.* This method may be employed when several inductances are available whose values are such as to give wavelength ranges slightly overlapping with the same variable condenser. For a given wavelength two variable condenser readings may be obtained, one near the zero of the condenser scale, where a knowledge of the self-capacity of the coil is essential, and a corresponding reading, obtained with a smaller inductance, near the

maximum capacity end of the condenser scale, where the effect of the coil self-capacity is almost negligible. From two such readings the self-capacity in the first case (of the larger inductance) can be determined with fair accuracy as a large error in its assumed value when its effect is small causes only a small error in the calculated value when its effect is large.

Prof. Howe in his paper gives an example of the method using a simple resonant circuit wavemeter (with helium tube detector) loosely coupled to a "spark" source of oscillations—this was in the year 1912, it will be remembered.

In determining experimentally the self-capacity of a wavemeter the method should, if possible, as in that described above, be independent of wavelength in order to obtain accuracy. With the modern triode generator available, the best method of accomplishing this in the case of an oscillating triode wavemeter is one in which the necessary number of capacity readings are obtained by using harmonics of one constant source frequency only.

It will be remembered that the effective self-capacity C_s of the whole heterodyne wavemeter G_2 (Fig. 9) is required—a value as augmented by the "zero" value C_x' of the condenser being calibrated and by the leads by which the latter is connected to the calibrated variable condenser C . G_2 is therefore completely set up before commencing the test.

To commence the determination C is first set to a calibrated reading well towards the maximum capacity end of the scale and G_1 is adjusted nearly to resonance with G_2 , the heterodyne beat note being adjusted to 1,000 cycles per second. G_1 then remains untouched throughout the test and assumed to be of constant frequency during this period.

Let this first capacity setting of C be C_1 .

The wavemeter condenser is now adjusted to two other values C_2 and C_3 , such that the corresponding wavelengths heterodyne with the second ($2f$) and third ($3f$) harmonics of G_1 respectively. Care must be taken to see that heterodyne beat notes of 2,000 and 3,000 per second are obtained in these two adjustments and that they are obtained on the same side of resonance as in heterodyning the fundamentals.

* "The Calibration of Wavemeters . . ." *Proc. Physical Soc. of London*, Vol. XXIV, Part V, 15th Aug., 1912.

Although the actual value of the wavelength is perhaps unknown, since C_1 , C_2 and C_3 correspond with three wavelengths in the ratio λ , $\lambda/2$ and $\lambda/3$, the following expressions must hold :—

$$\frac{C_1 + C_s}{C_2 + C_s} = 4 \qquad \frac{C_1 + C_s}{C_3 + C_s} = 9$$

from which two values for self-capacity C_s can be found.

The Final Method of Determining C_s .

In good wavemeters, however, the total wavelength range covered at one sweep of the variable condenser rarely exceeds one octave, and this renders impossible the third harmonic adjustment or even, possibly, the second. In order to overcome this difficulty and in any case to obtain a larger number of values for C_s at all parts of the condenser scale the fundamental adjustment and even those of the lower harmonics may be omitted.

To do this the wavelength of G_1 is adjusted so that its fourth ($\lambda/4$) harmonic heterodynes with G_2 near the maximum end of the scale of the condenser C , the heterodyne beat note being adjusted to, say, 800 cycles per second. Let the capacity of C for this adjustment be C_4 .

second, the beat notes corresponding with C_5 , C_6 , C_7 and C_8 must be adjusted to 1,000, 1,200, 1,400 and 1,600 cycles per second respectively so as to be in the same ratio as the actual frequencies of G_2 . Care must, of course, be taken to make sure that all heterodyning takes place on the same side of resonance.

The following relations now hold :—

$$\frac{C_4 + C_s}{C_5 + C_s} = \left(\frac{5}{4}\right)^2$$

$$\frac{C_5 + C_s}{C_6 + C_s} = \left(\frac{6}{5}\right)^2$$

$$\frac{C_6 + C_s}{C_7 + C_s} = \left(\frac{7}{6}\right)^2$$

$$\frac{C_7 + C_s}{C_8 + C_s} = \left(\frac{8}{7}\right)^2$$

from which values for C_s can be computed for various parts of the scale of C .

As an example will be given the results of an experimental determination of the effective self-capacity of a heterodyne wavemeter (G_2) having a range of 3,500 to 8,000 metres with one sweep of its variable condenser.

G_1 was set to about 30,500 metres.

Although the range of G_2 was little over an octave, no fewer than five harmonic

TABLE 3.

Harmonic of G_1 .	Appropriate Beat Note. cycles/sec.	Capacity Notation Previously Employed.	Capacity of C only. $\mu\mu\text{F}$.	Self-capacity C_s $\mu\mu\text{F}$.
$\lambda/4$	800	C_4	1211	102.9
$\lambda/5$	1000	C_5	738	103.1
$\lambda/6$	1200	C_6	481	103.2
$\lambda/7$	1400	C_7	326	104.5
$\lambda/8$	1600	C_8	225	

The capacity of C is now reduced to other values C_5 , C_6 , C_7 and C_8 corresponding with the heterodyning of the fifth, sixth, seventh and eighth harmonics of the original unaltered wavelength of G_1 . Since at C_4 the heterodyne beat note between the fundamental of G_2 and the fourth harmonic of G_1 has been adjusted to 800 cycles per

readings could be obtained. Each of these together with its appropriate heterodyne beat note and corresponding capacity reading is given in Table 3.

For the most accurate capacity measurements C should, if possible, have a value over 400 $\mu\mu\text{F}$. in order to reduce the uncertainty in the value of $C + C_s$.

Abstracts and References.

Compiled by the Radio Research Board and reproduced by arrangement with the Department of Scientific and Industrial Research.

PROPAGATION OF WAVES.

OBSERVATIONS ET TRAVAUX RÉCENTS SUR LA PROPAGATION DES ONDES ÉLECTROMAGNÉTIQUES (Observations and recent work on the Propagation of electromagnetic waves).—R. Mesny. (*L'Onde Élec.*, April, 1928, V. 7, pp. 130-155.)

The author's summary states that he passes in review the work done during the past two years on the question of propagation: the importance of the question of absorption, discussion on the nature of effective ions and on the mechanism of their formation, laboratory results on their influence on the electrical constants of gases, the influence of solar activity and of temperature. He then groups together the observations which agree with the present theories and those which appear in opposition. The field of research enlarges, but at the same time the points on which attention should be concentrated define themselves more clearly. He goes on to say that the paper does not deal with any new main theory, since the ideas of Eccles, taken up by Larmor and completed by Appleton and by Nichols and Schelling, are still to be found at the bottom of the theories; but their consequences have undergone rather profound modifications and certain details have been discussed and clinched more closely by various authors, whose results throw a more complete light on the phenomena. Among the observations not in agreement with the theories are the following: according to the theories, the rays useful for transmission should be those which make a smaller angle with earth in proportion as the wavelength is shorter. Whether the rays lose themselves by insufficient refraction (as Taylor considers) or by absorption in the ionising medium (as maintained by Eckersley), the rays with small zenith distance should not return to earth or should only return in a very small proportion. The good results produced by horizontal aerials do not fit in with these provisions, since their radiation to great zenith distances is very feeble; and Meissner's results in short-wave transmission from Berlin to Buenos Ayres are still more clearly in disagreement; good communication was obtained with a beam of 11 m. wavelength, directed almost vertically. The author concludes by summing-up some of the lines now demanding exploration: paying less attention to the idea of free electrons in an inactive space, the factors of ionisation and the nature of the ions require elucidation; new phenomena must perhaps be considered such as those which Nagaoka introduces into calculation and which Gutton and Clément deduce from experiments on the ionisation of gases; the earth's magnetic field does not play such a simple rôle as had been supposed; the Meissner results require an entirely new explanation; the true nature of the zones of silence and the attenuation of waves around 200 m. are further definite objects of research.

The abstract cannot even approximately cover the whole article, which deals with the work of numerous workers in addition to those already mentioned: including Lassen, Wegener, Watson, Pedersen, Breit and Tuve, Heising, Barnett, Ratcliffe, Bureau, Quäck, Howe, Pannecoek, Chapman, Cabannes and Dufay, Pickard, Austin, Van der Pol, Huber and Herath. A bibliography of 45 references is given.

THE POLARISATION OF RADIO WAVES.—J. Hollingworth. (*Proc. Royal Soc.*, 1st June, 1928, V. 119, Series A, pp. 444-464.)

The work described (part of the programme of the Radio Research Board) is being carried out by the author and Mr. Naismith to study by experimental methods the propagation of long radio waves. The present paper deals with waves longer than 10,000 m. and with distances between 400 and 1,000 km. (though results below 400 km., suggesting entirely different conditions of propagation, are indicated briefly). Present results show that: (a) during the hours of darkness, long wave intensities are moderately steady but show considerable abnormal polarisation; (b) at a time before sunrise corresponding to the sun's position of 7 degrees below the horizon at a point on the earth's surface mid-way between transmitter and receiver, an abrupt change lasting about 12 minutes occurs, during which the polarisation becomes much less; (c) a similar effect but with increase of polarisation occurs at sunset, its period being sometimes rather less definite and slightly longer; (d) at sunrise the value of the reflection coefficient which has remained at about its night value throughout period (b) falls gradually to its day value, which in summer is usually about 30 per cent. of its night value (but appears to be zero occasionally), and during this period the remainder of the abnormal polarisation disappears; (e) the evidence points to a much smaller change in equivalent height of the layer than has been assumed up to the present; it also suggests that a considerable proportion of the loss of energy in the indirect ray may occur below the actively refracting part of the layer rather than in it. The author also inclines to the idea that no real mechanical rising of the layer occurs, but merely a change in its electrical and physical state. The abrupt changes in the rotation of the plane of polarisation are shown in curves: the actual amount of rotation occurring varies daily, and a discussion of it is reserved for another paper.

STUDIES OF HIGH-FREQUENCY RADIO WAVE PROPAGATION.—A. Hoyt Taylor and L. C. Young. (*Proc. Inst. Rad. Eng.*, May, 1928, V. 16, pp. 561-578.)

Six questions of theoretical and practical interest which the authors set themselves to answer wholly

or partially are given below, together with the summarised answer to each: (1) Why are signals usually received during the daylight hours in Washington from the Radio Corporation's group of stations at Rocky Point, operating on frequencies so high that Washington is well inside of the skip-distance zone? (2) Why do distant stations show what may be termed a normal time interval for round-the-world signals, whereas the Radio Corporation's group as measured in Washington invariably show time intervals notably shorter than the normal? These two questions are intimately related, and are therefore answered together as follows: It is shown that the signals in question do not violate the skip-distance law, nor are they signals formed by a scattering in the normal Heaviside layer, or by ground waves. They are signals thrown into the skip-distance area from a point or a number of points well outside that area, such that while the great circle distance between sender and receiver is only 420 kms., these signals travel from 2,900 km. to over 10,000 km. Tentative suggestions are made that these reflections occur at a heavily ionised region near the N. pole, or that they are scattered reflections thrown backwards from rough portions of the earth's surface in the first and second zones of reception following the skip-distance region—although it is admitted that this explanation when applied to the 10,000 km. results drives one to the Andes or Switzerland in order to get a suitable region.

Question (2) is automatically answered directly it is recognised that the first arriving signal is itself a form of echo signal of variable time-interval corresponding to the above-mentioned path-retardations.

The next question set is: (3) Can any further explanation be given of the fact that high-frequency signals usually show the worst fading at moderate distances and much less fading at the extreme limits of range? This is briefly answered by the suggestion that the "short-time" or nearby echo signals previously described may overlap and in continually shifting phase thus contribute to the fading at moderate distances. At much greater distances the nearby echoes would be much reduced in their effects.

Questions and Answers (4) and (5) deal with the influence of echo signals on various kinds of radio-communication, including facsimile telegraphy and television. The long-time echoes coming round the world can usually be taken care of by directive receiving systems, but this will probably not be the case for nearby echoes. Fortunately, we shall usually be mainly interested in telephony, facsimile transmission and television only over long distances, and it is suggested that this forms another argument for the reservation of such frequencies for long-distance work only. It is also suggested that the short-time echoes may be largely responsible for the widening of the angle of a beam to greater values than would be expected from an observation of its local performance.

Question (6) asks during what hours of the day and what seasons of the year different types of echo or "multiple" signals are to be expected, and this is answered (for round-the-world signals) by simple calculations based on the fact that such a

signal must make most of its night transit in the summer hemisphere, and that if the great circle between two stations is such that this is not possible, round-the-world echoes will not occur. There is entirely too little information at hand to predict in the matter of short-time echoes, and it is urgently requested that observations on a quantitative basis be carried out in various parts of the world to demonstrate whether this is a phenomenon more or less peculiar to the locality of the authors' tests, or more general in its occurrence.

OSCILLOGRAPHIC OBSERVATIONS ON THE DIRECTION OF PROPAGATION AND FADING OF SHORT WAVES.—H. T. Friis. (*Proc. Inst. Rad. Eng.*, May, 1928, V. 16, pp. 658-665.)

The short-wave transmission path is generally but not always located in the vertical plane through the transmitting and receiving points. Direction-finding depends upon determining the direction of the wave at the receiving point; it does not give accurate results when the twilight zone is in the way of the wave path.

The angle between the earth and the direction of short-wave propagation varies continuously, and the changes in this angle are much larger than the changes in angle of propagation in the horizontal plane. The observations are consistent with the view that the fading is mainly caused by wave interference.

The above "author's summary" may be amplified as follows: the signals generally used were from the British beam station, GBK, 16 m. The method depends on the use of two spaced receivers at a distance of one-third or half a wavelength, each with a vertical aerial; beats are produced in each by a common local oscillator situated in the direction of the great circle, the line joining the spaced receivers being at right-angles to this line where direction in the horizontal plane is being studied, and in line with it where the vertical plane is in question. The local signal does not vary or suffer from fading; therefore the beat note outputs of the two receivers can be combined to give cathode-ray oscillograph figures representing the phase difference and amplitude of the signal waves at the two receiving points. For complete results, the vertical and horizontal systems are in use simultaneously. The figures produced during fading have a rotating characteristic strikingly resembling that of figures based on the assumption of two waves of the same amplitude coming in at different angles.

ÜBER BEOBACHTUNGEN REGELMÄSSIGER SCHWUNDERSCHWANKUNGEN IN ZUSAMMENHANG MIT SCHWANKUNGEN DER SENDEFREQUENZ BEI KURZEN WELLEN (Observations of regular fading effects connected with variations in transmitter frequency in short-wave transmission).—Eppen, Scheibe and Weight. (*Zeitschr. f. Hochf. Tech.*, May, 1928, V. 31, pp. 151-152.)

Tests in Germany on a crystal controlled transmitter ($\lambda = 37.65$ m.) showed very marked periodic fading varying, from day to day, between $\frac{1}{2}$ and 2 periods per sec. The effects were very noticeable

at distances from 3 to 17 km., and less regularly at greater distances.

No variation of wavelength was noticeable by ear with heterodyne reception, and local measurements showed no variation in transmitter aerial-current comparable with the effects noted (which caused aural signals to vary from good to inaudible). It was therefore concluded that the fading was caused by interference between two rays (arriving by different paths) giving maxima at certain receiving points and minima at others: and that these maxima and minima were periodically shifted by periodic small changes in the transmitted wavelength. To verify this, the heterodyned continuous dash (at a distance of 17 km.) was recorded by an oscillograph and showed regular pulsations of amplitude of 4.1 sec. duration. A second oscillograph loop simultaneously recorded the heterodyned signals, with a buzzer frequency of 1,000 p.s. superimposed. Variations in wavelength caused a varying number of beats per second, and these changes of beat-frequency synchronise with the amplitude changes. It was afterwards discovered that the changes of amplitude coincided with fluctuations in the filament-current of the crystal controlled first-stage valve.

WOODS AND WIRELESS.—R. H. Barfield. (Letter to *Nature*, 9th June, 1928, V. 121, p. 908.)

The writer refers to Dr. Rolf's letter (*Nature*, 7th April, 1928; see Abstracts for June) and while agreeing that the capacity effect should be considered as well as the conductivity effect, doubts whether the simple adaptation of Sommerfeld's theory (suggested by Rolf) can be correct, the constants being for an isotropic medium and therefore applying only to the vertical axis of a tree. He points out that if we increase the conductivity of a tree we clearly increase the energy absorbed and hence the attenuation, whereas by Rolf's method the opposite is the case. He also doubts whether the effect of negative damping at Daventry was caused by trees, as this region is one of comparatively few trees, and the departure of the attenuation from its ideal value (assuming a bare surface) has been found to be small. The explanation, however, should not be abandoned without further investigation.

PROPAGATION DES ONDES COURTES AUTOUR DE LA TERRE (Propagation of Short Waves round the Earth).—J. Reyt. (*T.S.F. Moderne*, Jan., Feb. and March, 1928, V. 9, pp. 1-12, 73-86, 150-164.)

A review of the present knowledge and ideas. The writer particularly examines the variation of skip-distance with the wavelength and with the seasons, and finishes by showing how the present knowledge can be applied in choosing wavelengths, and other conditions, for a given radio service.

ATMOSPHERICS AND ATMOSPHERIC ELECTRICITY.

A NOTE ON CORONA AT HIGH HUMIDITY.—A. W. Simon. (*Proc. National Acad. Sciences, Washington*, March, 1928, V. 14, quoted in *Nature*, 2 June, 1928, p. 891.)

A description of an effect noticed on an arrange-

ment normally giving heavy visual corona. On very wet days no corona was visible, the current flowing was much reduced, and intermittent sparking occurred, possibly due to reduced mobility of the negative ions.

RELATIONS ENTRE LA PROPAGATION DES ONDES ÉLECTROMAGNÉTIQUES, L'ACTIVITÉ SOLAIRE ET L'ÉTAT ATMOSPHÉRIQUE (Relations between the propagation of electromagnetic waves, solar activity and the condition of the atmosphere).—A. Nodon. (*L'Onde Élec.*, April, 1928, pp. 156-161.)

Solar disturbances, at the periods of evolution of diametrically opposed conjugate foci, were particularly intense during the summer of 1927, and the author records in graphical form, and discusses, his observations in the W. Pyrenees from the end of May to the end of September. The diagram shows, one above the other and plotted on the same time scale, the various effects in question: transient foci, lasting foci, passage of these across the sun; electro-magnetic oscillations; propagation of waves ("good reception" above the zero line, "bad reception" below); general state of the atmosphere (deduced from information at distances by wireless and from the press); and local atmospheric conditions.

Good reception seems to occur as the lasting active foci pass to the edges of the sun's disc, but this effect is sometimes obscured by the appearance of transient foci. The curve for "general state of the atmosphere" corresponds very closely with that for "good and bad reception." Magnetometer and electrometer results (not represented graphically) showed continuous disturbances, day and night, throughout the long period of activity; two short intervals of rest coincided with two marked improvements on the curves, and quiescence entered abruptly when the two very active foci disappeared. General atmospheric disturbances disappeared at the same time, and radio reception became normal. The curves of "local atmospheric conditions" differ greatly from the others; the only agreements noticeable are at the dates of the most violent disturbances, which thus seem to dominate the local actions. The writer says: "The new observations seem to confirm this hypothesis" (the influence on radio propagation of ultra-radiations of origin extra-terrestrial and more particularly solar); "the effects of ionisation in the upper atmosphere and at the ground surface being probably attributable to the Compton Effect, giving birth to radiations of a much greater length than that of the ultra-radiations which provoke them."

HIGH VOLTAGES FROM THE ATMOSPHERE.—(*Elec. Review*, 8 June, 1928, V. 102, p. 1006.)

A paragraph referring to the experiments now in progress near Lugano.

During storms, spark discharges 15 feet long at the rate of about one per second have been obtained for half an hour on end. It is hoped finally to attain 30 million volts.

THE SUN'S OUTER ATMOSPHERE.—E. A. Milne. (*Nature*, 9 and 16 June, 1928, V. 121.)

OBSERVATIONS ON ATMOSPHERIC ELECTRICAL CONDUCTIVITY IN CONNECTION WITH THE SOLAR ECLIPSE OF JUNE 29, 1927.—Nolan and O'Brolchain. (*Proc. Roy. Irish Acad.*, Jan. 1928, pp. 1-17.)

AN AUTOMATIC RECORDER FOR MEASURING THE STRENGTH OF RADIO SIGNALS AND ATMOSPHERIC DISTURBANCES.—(See under "Subsidiary Apparatus.")

PROPERTIES OF CIRCUITS.

ON BANKS OF PARALLELED VALVES FEEDING RESISTIVE LOADS WITHOUT DISTORTING THE WAVE FORM.—W. Baggally. (*E.W. & W.E.*, June, 1928, V. 5, pp. 315-321.)

DAMPING DUE TO GRID CURRENT IN THE CASE OF A VALVE OSCILLATOR.—M. Reed. (*E.W. & W.E.*, June, 1928, V. 5, pp. 322-324.)

REACTANCE AND ADMITTANCE CURVES: APPLIED TO TUNED CIRCUITS WITH AND WITHOUT RESISTANCE.—L. T. Bird. (*E.W. & W.E.*, June, 1928, V. 5, pp. 327-334.)

TRANSMISSION.

"BEAM" WIRELESS TELEGRAPHY.—N. Wells. (*Elec. Review*, 25th May and 1st June, 1928, V. 102, pp. 898-902 and 940-943.)

A straightforward explanation of the theory underlying the Franklin aerial system used in the Marconi beam transmitters; illustrated by photographs, diagrams and curves. The June article is an appendix to the first, describing the graphical construction of polar curves.

LA THÉORIE DU RAYONNEMENT DE LA BEAM ANTENNE (The Theory of the Radiation from a Beam Aerial).—G. F. d'Ailly. (*Q.S.T. Français*, June, 1928, No. 51, pp. 14-19.)

The general theory of the beam aerial with its reflector is outlined, and the rest of the article neglects the reflector in order to work out simply the mathematics of the aerial itself. The next article will show how the reflector is introduced.

DIE RUNDFUNKSENDER DER WELT (The World's Broadcasting Stations).—(*Rad. f. Alle*, June, 1928, V. 7, pp. 251-252.)

A complete table arranged in increasing order of wavelengths. The corresponding "kilohertz" (kilocycles per sec.) and the power are also given in all but a few cases.

THE DISTRIBUTION OF CURRENT IN A TRANSMITTING ANTENNA.—R. M. Wilmotte. (*Journ. I.E.E.*, June, 1928, V. 66, pp. 617-627.)

It is well known that, owing to the proximity of the ground, the effective capacity per unit length at the lower end of an aerial will be greater than that at the upper end; moreover, there are end-effects which give the appearance of producing a

larger capacity near the ends than in the central portions. For the purpose of calculating polar radiation diagrams, radiation resistances and effective heights, it is very important to know whether the assumption of a sinusoidal distribution of current (neglecting the above effects) is sufficiently accurate, and what errors such an assumption is likely to produce. The writer describes experiments in which the current distribution of a straight vertical aerial (and later of variously shaped aerials) was found by placing ammeters at various points along the aerial and reading them by means of a telescope. Results showed remarkably good agreement with the sinusoidal assumption, over the whole range of wavelengths (15 m. to 800 m.). The highest frequency was nearly three times the nat. frequency of the aerial. The experiments were extended to test the effect of certain changes, and the results are given. The simple theory for the Current Distribution is given in an appendix, and the paper itself includes a theoretical investigation of the problem without the assumption of uniformly distributed constants. The investigation was carried out as part of the programme of the Radio Research Board.

RECENT DEVELOPMENTS IN LOW POWER AND BROADCASTING SETS.—I. F. Byrnes. (*Proc. Inst. Rad. Eng.*, May, 1928, V. 16, pp. 614-651.)

Various types of radio transmitting equipments are described and illustrated, ranging in output from 200 to 2,000 watts. The application of master-oscillator power-amplifier circuits for low and medium frequency transmitters is explained, and the uses of quartz crystal control for high frequency and broadcast transmitters are described. A full schematic circuit-diagram of a 1 kW. broadcast transmitter is shown. A brief explanation is also given of the equi-signal system of radio beacon transmission, which promises to become an important aid in the navigation of aircraft. This beacon transmitter uses as aerials two large loops at right angles, to which it is coupled by a modified goniometer whose rotating primary consists of two coils. These rotor-coils are alternately connected to the radio transmitter by an automatic relay, and by suitable adjustment of the angle between them, the patterns of the two loops are made to overlap. In this overlapping zone, what is known as an equi-signal area is maintained, and by rotating the whole rotor the course set by this equi-signal area can be altered. Interlocking signals are produced by the automatic relay, e.g., the letter *N* on one rotor-coil interlocking with the letter *A* on the other, so that the receiving operator flying in the equi-signal zone hears a series of uniform dashes; whereas if he deviates from the course set, he hears *N* or *A* predominating. The only example given of such a beacon-transmitter uses wavelengths of the order of 1,000 metres.

SHORT-WAVE AERIAL SYSTEMS: AN ELEMENTARY THEORY OF THE TRANSMISSION OF HIGH-FREQUENCY ENERGY ALONG THE FEEDERS.—E. Green. (*E.W. & W.E.*, June, 1928, V. 5, pp. 304-311.)

ÉTUDE D'UN GÉNÉRATEUR À ONDES COURTES (Study of a Short-wave Generator).—F. Flaud. (*L'Onde Élect.*, May, 1928, V. 7, pp. 196-205.)

The particular arrangement obtained by the author, which he considers to be so stable and free from difficulties that it should lend itself to the production of shorter waves than have hitherto been obtained by valve methods outside the laboratory, is a modification of the Hartley method. The wavelength used by the writer is of the order of 30 metres.

THE DESIGN OF VARIABLE CONDENSERS FOR HIGH VOLTAGE OPERATIONS.—B. E. Smith. (*Q.S.T.*, March, 1928, V. 15, pp. 49-51, 66 and 68.)

An article on the design of continuously variable condensers for valve-transmitters.

RECEPTION.

DREI EINRÖHREN - EXPERIMENTIER - EMPFÄNGER (Three One-Valve Experimental Receivers). Günther and Schreiber. (*Rad. f. Alle*, June, 1928, V. 7, pp. 257-272.)

Constructional details are given, and a great number of circuit-diagrams show how a very large variety of circuits, all using only one three-electrode valve, can be employed. These vary from simple circuits, such as those of the Audion with or without reaction, to those of Reinartz, Flewelling ("pendulum") and the Super-regenerative system.

DIE VERWENDUNG VON SIEBKREISEN (The Use of Filter Circuits).—W. Nestel. (*Rad. f. Alle*, June, 1928, V. 7, pp. 241-243.)

The particular circuit dealt with here is a wave-stopper or trap for cutting out the local station to get distant reception.

ÜBER DEN NETZANSCHLUSS VON WIDERSTAND-VERSTÄRKERN (Mains Supply for Resistance Amplifiers).—H. Kröncke. (*Rad. f. Alle*, June, 1928, V. 7, pp. 248-250.)

A.C. mains are here meant; the circuit is due to v. Ardenne and includes a triple receiving valve.

A.C. TUBES VERSUS SERIES FILAMENT OPERATION.—W. P. Lear. (*Rad. Engineering*, June, 1928, V. 8, pp. 45-49.)

The writer recommends the use of rectified A.C. through filaments in series, as superior to the recently popular use of A.C. valves. Reaction with the latter arrangement leads to trouble which is absent in the former.

THE THEORY OF "PUSH-PULL."—N. W. McLachlan. (*Wireless World*, 13th, June, 1928, V. 22, pp. 629-634.)

The author reviews the position of this method which is now coming into vogue (although invented 13 years ago) and indicates practical points essential for proper performance, e.g., the necessity for "matched" valves.

DISCUSSION ON THE DISTORTIONLESS RECEPTION OF A MODULATED WAVE AND ITS RELATION TO SELECTIVITY.—(*Proc. Inst. Rad. Eng.*, May, 1928, V. 16, pp. 671-673.)

A further contribution to the discussion on Dr. Vreeland's paper (see Abstracts for May and June.)

THE APPARENT DEMODULATION OF A WEAK STATION BY A STRONGER ONE.—R. T. Beatty. (*E.W. & W.E.*, June, 1928, V. 5, pp. 300-303.)

MODERN NAVAL RECEIVERS (Long-Range Sets with Screened Grid H.F. Amplifiers).—(*Wireless World*, 30th May, 1928, V. 22, pp. 566-569.)

An illustrated description of some receivers designed by the Marconi Company in collaboration with British naval experts. An interesting point is a new modification of "gang-control" which is here used for four separate variable condensers.

WIRELESS AT THE PARIS FAIR (Some Interesting Exhibits Described).—(*Wireless World*, 30th May, 1928, V. 22, pp. 581-583.)

An illustrated description of several French broadcast receivers, most of which are super-heterodynes and are distinguished by ingenious methods for calibrated adjustment.

AMERICAN SETS OF TO-DAY: PROGRESS IN RADIO RECEIVER DESIGN DURING THE LAST YEAR (ILLUSTRATED).—(*Wireless World*, 27th June, 1928, V. 22, pp. 685-688.)

TUNED RADIO-FREQUENCY AMPLIFIERS.—R. S. Glasgow. (*Journ. A.I.E.E.*, May, 1928, V. 47, pp. 327-331.)

A simplified method of calculating the performance of a tuned amplifier circuit is given and the effect of the various circuit constants on the characteristics is shown. The predicted results are found to check experimental observation quite closely. The factors affecting the stability are pointed out, and typical methods ("bridge-type" circuits) for suppressing undesired oscillations are given, together with the principles involved.

VALVES AND THERMIONICS.

ÉTUDE EXPÉRIMENTALE ET THÉORIQUE DES LAMPES À DEUX ÉLECTRODES (Experimental and theoretical study of two-electrode valves).—Y. Doucet. (*Q.S.T. Français*, June, 1928, No. 51, pp. 31-39.)

The phenomena of the two-electrode valve are examined in detail by experimental and mathematical methods: thus the laws of Richardson, Langmuir and Maxwell ("distribution of velocities") the Saturation Curve and the Influence of the gaseous medium are all considered.

SHORT UNDAMPED ELECTRIC WAVES.—K. Kohl. (*Ann. der Physik*, 18th January, 1928, pp. 1-62.)

Valve methods of producing waves of length

30-60 cms. A positive potential of the order of 600 volts was used for the shortest waves and in certain cases the oscillatory circuit was sealed inside the valve.

THE EFFECT OF INITIAL VELOCITY OF ELECTRONS UPON THE ANODE CURRENT OF A VACUUM TUBE.—N. Kato. (*Phys. Review*, May, 1928, V. 31, pp. 858-861.)

By eliminating the other causes of deviation, the author measured the degree of deviation of the current-voltage curve from the three-halves power law (derived from the space-charge equation). He finds the effective initial velocity of electrons to vary from about 0.5 v. at 2,250 degrees to 4 v. at 3,000 degrees. The velocity seems to be independent of the dimensions of the electrodes.

SUR LA RÉALISATION ET LE FONCTIONNEMENT D'UN NOUVEL OSCILLATEUR À ONDES TRÈS COURTES (The construction and method of working of a new oscillator for very short waves).—E. Pierret. (*Comptes Rendus*, 11th June, 1928, V. 186, pp. 1601-1603.)

Further reports on the production of stable oscillations (wavelength about 16 cms.) mentioned in July Abstracts; this time only one valve is used, as it was found that the two valves previously required had to be very carefully "paired." A mathematical explanation of the method is given.

USE OF AN OSCILLOGRAPH FOR RECORDING VACUUM-TUBE CHARACTERISTICS.—W. A. Schneider. (*Proc. Inst. Rad. Eng.*, May, 1928, V. 16, pp. 674-680.)

This paper describes the method involved and the results obtained. The main requirement is an alternating voltage of fairly pure wave-form with as few harmonics as possible. The "dynatron" action is shown very clearly when large alternating E.M.F.'s are applied to the grid. Static and dynamic characteristics can also be recorded quite easily. The author particularly used the method for the study of the behaviour of valves when large positive potentials are applied to the grid, *i.e.*, when the valve acts as a negative resistance.

EINIGE ÜBERLEGUNGEN ZUR PHYSIKALISCHEN BEDEUTUNG DER GLÜHELEKTRONENEMMISSION (Some considerations as to the physical meaning of thermionic emission).—v. Hippel. (*Zeitschr. f. Phys.*, No. 9/10, 1928, V.46, pp. 716-724.)

The author maintains that the cause of emission is temperature-ionisation by electron impact, and not volatilisation as is stated by Richardson and Dushman. He arrived at equations for the emission exactly similar to those of the workers named, except that his constants have different physical meanings.

DETECTION BY GRID RECTIFICATION WITH THE HIGH-VACUUM TRIODE.—S. Ballantine. (*Proc. Inst. Rad. Eng.*, May, 1928, V. 16, pp. 593-613.)

The theory of detection of small signals by grid

rectification with the high-vacuum triode of the 201A type is briefly discussed by means of the mathematical method of Carson. Special attention is given to the grid-leak, grid-condenser arrangement. The relations between the non-linear distortion and the degree of modulation, and between the frequency distortion and the grid impedances, are discussed. A convenient method is described for ascertaining experimentally the frequency distortion in detection, illustrated by means of results in a typical case; this distortion is compared with that due to resonance in the H.F. amplifier circuits. A method of securing efficient grid-rectification in the super-heterodyne system is described. The detection coefficients for the 200A valve are given in an appendix: this valve appears to contain alkali vapour derived from a capsule contained in a small hemi-spherical boss welded to the plate.

PLATINUM ALLOYS IN THERMIONIC VALVES.

(*Nature*, 2nd June, 1928, V. 121, p. 884, summarised from Bell Lab. Record for April.)

For thermionic valve repeaters, J. E. Harris describes the manufacture of platinum alloys which are used because there is no chemical action between them and the barium and strontium oxides with which they have to be coated. It is found that chemical reaction weakens the thermionic activity of the coating when metals such as tungsten are used.

SCREENED-GRID VALVES: INFORMAL DISCUSSION AT I.E.E. WIRELESS SECTION. (*E.W. & W.E.*, June, 1928, V. 5, pp. 335-338.)

L'INFLUENCE DES ÉMISSIONS SECONDAIRES DES MÉTAUX SUR LE FONCTIONNEMENT DES LAMPES À TROIS ÉLECTRODES (The influence of secondary emission from metals on the working of three-electrode valves).—H. Le Boiteux. (*Rev. Gén. de l'Élec.*, 2nd June, 1928, V. 23, pp. 939-946, and 9th June, pp. 984-992.)

The secondary emissions studied by Farnsworth and Langmuir are here used to explain certain valve phenomena which have obtruded themselves specially since valves have been employed to generate very short waves: such as abnormal heating of the glass, etc., parasitic waves (always shorter), impossibility of producing a clear heterodyne beat-note, and the production of unstable conditions with the liberation of energy quite out of proportion to the normal power of the valve. Mathematical development leads to a formula for the calculation of the efficiency of an oscillator-valve, and the author shows that this agrees admirably with experimental results both for small and large (20 kW.) valves. In the second part, the author deals with: (a) conditions for working without disturbance by secondary emission effects; (b) zone of period affected; (c) consequences of the emission; (d) form of secondary current during the oscillation; (e) possibility of electrons returning to cathode; etc., etc.

DIE STROMVERTEILUNG IN DREIELECTRODENRÖHREN . . . (Current distribution in three-electrode valves . . .).—H. Lange. (*Zeitschr. f. Hochf. Tech.*, May, 1928, V. 31, pp. 133-140.)

Continuation of the paper abstracted in July number. The present part is divided into the following: C, The electron paths: lines of constant potential: lines of constant action: influence of thickness of grid: experimental verification (curves taken with three valves with very different types of grid are shown, and the slight discrepancies in shape between observed and calculated curves are explained). Having thus laid down the theoretical foundations of Current Distribution, the author investigates how it is affected by higher filament-temperatures, by the appearance of Space Charges, and (following the removal of the rotating commutator used in the previous tests) by the voltage-drop in the filament. The present instalment deals with these points in Section D; the completion of the whole paper is to follow next month.

ÜBER DIE KOMPENSATION DER SCHÄDLICHEN KAPAZITÄTEN . . . (The Compensation for undesired capacities . . .).—Ardenne and Stoff. (*Zeitschr. f. Hochf. Tech.*, May, 1928, V. 31, pp. 152-157.)

Continuation of the paper abstracted in July issue: C2. Valve circuits with aperiodic couplings: compensation by interconnection of alternate valves (Leithäuser-Heegner): compensation by double-grid valves: compensation by amplifiers in opposition. Practical work: low-frequency opposition of amplifiers: high-frequency opposition of amplifiers.

DIRECTIONAL WIRELESS.

APPARENT NIGHT VARIATIONS WITH CROSSED-COIL RADIO BEACONS.—H. Pratt. (*Proc. Inst. Rad. Eng.*, May, 1928, V. 16, pp. 653-657.)

The equi-signal zone system of aircraft directing, by "Crossed-coil" Radio beacons, is described in an article abstracted elsewhere (see these Abstracts, "Recent Developments in Low Power and Broadcasting Sets," I. F. Byrnes, under "Transmission"). The present article again outlines the system and its advantages, but is chiefly devoted to unfortunate defects which became evident in the system when used for night-flying. These effects were a combination of apparent wave-direction shifts and fading, and resulted in the beacon being difficult to use between 25 and 50 miles, of questionable value at about 100 miles, and of no use at all at 125 miles. The shifting of the zone was gradual, so that at first one would be inclined to think it due to the movement of the aircraft itself. The topography of the country between beacon and aircraft exerted a considerable influence on the extent of the variation. Exceptional variations in shift over an arc as great as 100 degrees in Azimuth were noted, but in general the change was confined to within possibly 25 degrees. Beyond 15 miles the fading of the general level of signal received was very severe during flight over mountains. Observations on the ground, at a distance of 134 miles, gave less pro-

nounced shifting than in the air. Further ground tests, in mountainous country at distances of 18 to 53 miles, seemed to show that fading played only a minor part in the phenomenon, but a variation in the direction of the arriving field was observed as large as 30 degrees over a ten minute interval. On the other hand, on one particular night-flight signals from a second beacon, near which there were no marked mountain ranges, showed no shifting whatever. The wavelength employed throughout was about 1,000 m., modulated at 500 cycles. Further investigation is urgently needed.

DIRECTIONAL PROPERTIES OF TRANSMITTING AND RECEIVING ANTENNA.—Clapp and Chinn. (*Q.S.T.*, March, 1928, V. 15, pp. 17-30.)

Methods of obtaining a beam effect for private stations transmitting or receiving on short wavelengths (40 m. is mentioned as an upper limit above which mechanical difficulties become serious) are thoroughly gone into in this article.

THE EQUI-SIGNAL SYSTEM OF RADIO BEACON FOR AIRCRAFT TO SET COURSES BY PROJECTING EQUI-SIGNAL ZONES OF INTERLOCKED SIGNALS. (See Abstract under "Transmission," entitled "Recent Developments in Low Power and Broadcasting Sets.")

OSCILLOGRAPHIC OBSERVATIONS ON THE DIRECTION OF PROPAGATION AND FADING OF SHORT WAVES.—H. T. Friis. (See under "Propagation of Waves.")

MEASUREMENTS AND STANDARDS.

THE EQUIVALENT INDUCTANCE AND CAPACITY OF AN AERIAL.—(Editorial.) (*E.W. & W.E.*, June, 1928, V. 5, pp. 297-299.)

GRAPHICAL COMPUTATION.—M. H. Ashworth. (*E.W. & W.E.*, June, 1928, V. 5, pp. 311-314.)

SUBSTANDARD WAVEMETER DESIGN.—W. H. F. Griffiths. (*E.W. & W.E.*, June, 1928, V. 5, pp. 324-326.)

ELECTRICAL MEASURING INSTRUMENTS OTHER THAN INTEGRATING METERS.—C. V. Drysdale. (*Journ. I.E.E.*, June, 1928, V. 66, pp. 596-616.)

A comprehensive "review of progress" dealing first with Commercial Indicating and Recording Instruments, then with Laboratory Instruments, and finally with Sensitive Controlling Devices. The latest developments in all these fields are described. Among those of special interest for radio work are the "signal strength meter" (accurate to about 10 per cent.); the Moll thermo-converter (in which a long straight heating wire of about 16 ohms resistance is plaited through a series of 50 thermo-junctions; a current of 16 mA produces a full deflection of a millivoltmeter, but the heating wire can carry 300 mA without injury) and the Moll wattmeter for direct measurements of H.F. power down to a fraction of a watt; photo-electric cells; cathode ray oscillographs; the Dye standard multi-vibrator wavemeter; and many others.

A NEW AMMETER FOR MEASURING VERY HIGH FREQUENCY CURRENTS.—(*Electrician*, 25th May, 1928, V. 100, p. 576.)

A description of Mr. E. B. Moullin's new ammeter exhibited at the Royal Society Conversation. It is suitable for currents of very high frequency such as are used in "beam" systems, and avoids the various sources of error common to the usual thermal methods. It depends on the repulsive force between two long parallel cylinders traversed by the high frequency current to be measured, one cylinder being movable (parallel to itself) against an elastic constraint; the movement is observed by a microscope. The geometrical form of the components enables the frequency-correction to be calculated exactly, and there is nothing to "burn out." The particular instrument gives a scale deflection of a hundred divisions for a current of 1.2A, and the power absorbed is about 0.25 W.

LEISTUNGS- UND STRAHLUNGSMESSUNGEN AN FLUGZEUG- UND BODENSTATIONEN (Power and Radiation Measurements in Aeroplane and Land Stations).—Eisner, Fassbender and Kurlbaum. (*Zeitschr. f. Hochf. Tech.*, May, 1928, V. 31, pp. 141-151.)

The second and final part of this paper (see Abstracts for July) comprising II. Radiation measurements in Aerials: description of method (Anders' process): results of tests. The chief conclusions drawn are that: (a) the usual trailing aerial has not, as often supposed, a specially good radiation; (b) the international aircraft wavelength of 900 m. gives a comparatively poor efficiency; (c) the height of the aircraft, at short distances (*i.e.*, to the limit of the short-range zone), has very little effect on the strength of the field produced; (d) the polar curve of the trailing aerial is circular, not irregular as had been supposed; (e) the radiation varies by nearly straight line law with its length; (f) fixed aeroplane aerials of practical form have a radiation about 10 per cent. of that of a trailing aerial 70 m. long.

CONTINUOUS READING OF VARYING POTENTIALS BY MEANS OF THERMIONIC VALVES.—D. T. Harris. (*Journ. Sci. Instruments*, May, 1928, V. 5, pp. 161-166.)

An assembly of apparatus with steady zero-reading is described. Primarily designed for following changes in bio-electric potential differences, it is suitable for many other purposes, *e.g.*, for measuring photo-electric potentials. The drift in the zero is usually less than the equivalent of a rate of change of grid potential of one milli-volt per hour, and can be still further reduced.

LABORATORY MEASUREMENT OF CAPACITY, POWER FACTOR, DIELECTRIC CONSTANT, INDUCTANCE AND RESISTANCE, BY USE OF THE SERIES RESISTANCE BRIDGE.—C. L. Lyons. (*Journ. Sci. Instruments*, May, 1928, V. 5, pp. 155-160.)

The ordinary bridge is often hampered by the fact that stray capacities are frequently of the same order of magnitude as those under measurement. This paper (of which the present article is the first part) describes a more satisfactory form (modified from Wiens' Series Resistance Bridge)

incorporating the complete shielding of its elements: it is made by the General Radio Co. (America). Auxiliary equipment is surveyed, including items such as sources of A.C. suitable in wave-form and of fixed frequency (Vreeland Oscillator, Tuning-fork-controlled oscillator); auxiliary valve amplifier of tuned audio-frequency type; and the general operations, formulæ, etc., are given.

SUBSIDIARY APPARATUS AND MATERIALS.

AN AUTOMATIC RECORDER FOR MEASURING THE STRENGTH OF RADIO SIGNALS AND ATMOSPHERIC DISTURBANCES.—E. B. Judson. (*Proc. Inst. Rad. Eng.*, May, 1928, V. 16, pp. 666-670.)

The receiver, amplifiers, rectifier and recorder are switched on by relays controlled by a clock and arranged so that for different five-minute periods during the hour the strength of several stations may be recorded. Only audio-frequency amplification is used, for greater constancy of sensitivity. A Cambridge-Paul Thread Recorder is employed. Keeping filament-currents and plate-voltages constant, the system retains its calibration within 10 per cent. over periods of several months. Typical curves of the variations in signals and atmospheric disturbances are given.

THE KLYDONOGRAPH.—J. Fallow. (*Rev. Gén. de l'Elec.*, 2nd June, 1928, V. 23, pp. 958-961.)

This portion of a long article, dealing with the probable form of the extra high tensions induced in aerial lines by thunderstorms, etc., describes the instrument in question, which permanently records, classifies, and measures voltages even of ephemeral duration. The method of record is by the effect of the discharge on a photographic plate or film, producing figures resembling those of Lichtenberg.

MECHANICAL PRODUCTION OF SHORT FLASHES OF LIGHT.—J. W. Beams. (*Nature*, 2nd June, 1928, V. 121, p. 863.)

A method of obtaining a train of very rapid flashes of light, of duration 10^{-8} second or less, for stroboscopic study of phenomena which occur in a very short interval of time.

INSTRUCTION ON THE MAKING OF POTASSIUM HYDRIDE PHOTO-ELECTRIC CELLS.—W. B. Nottingham. (*Journ. Franklin Inst.*, May, 1928, V. 206, pp. 637-648.)

A full description of the process developed at the Franklin Institute for making cells of high sensitivity.

A PORTABLE CATHODE RAY OSCILLOGRAPH.—(*E.T.Z.*, 7th June, 1928, V. 49, p. 868.)

A new G.E.C. production, the whole equipment being distributed between two vans, one of which forms a dark room.

EINE NEUERUNG AM KATHODENOSZILLOGRAPHEN (A new form of Cathode-ray Oscillograph).—P. Selényi. (*Zeitschr. f. Physik*, V. 47, 1928, p. 895.)

The passage of the Cathode-ray is marked, in

this new method, by powder scattered on the flat glass wall and affected by the negative charge left by the ray. Positive ions (which would tend to neutralise this charge) are kept away by an auxiliary electrode.

FOLGESCHALTUNGEN FÜR KATHODENSTRAHL-OSZILLOGRAPHEN (Sequence-switching for Cathode-ray Oscillographs).—(E.T.Z., 24th May, 1928, V. 49, pp. 798-799.)

An article giving the collated methods of various workers, among whom are Dufour, Rogowski and Flegler, Harrington and Opsahl, and Gábor; the methods ranging from the quaint arrangements of ring-formed electrodes traversed by bullets, through the mechanical methods of contact-discs and commutators, to the purely electrical methods, two of these using spark-gaps, one (Rogowski) using a 3-electrode valve and a condenser charged through a resistance, while one (Gábor) uses two 3-electrode valves.

NOTES ON THE DESIGN OF IRON-CORE REACTANCES WHICH CARRY DIRECT CURRENT.—D. E. Replogle. (Q.S.T., April, 1928, V. 15, pp. 23-27.)

Curves and calculations for the design of filter chokes carrying a large amount of D.C. with a superimposed A.C. ripple.

AUTOMATIC VOLTAGE-STABILISER FOR APPARATUS FED FROM A.C. MAINS.—Soulié. (Comptes Rendus, 4th June, 1928, V. 186, pp. 1428-1530.)

A circuit consisting of a condenser and a solenoid with a laminated iron core which can displace itself along the vertical axis of the solenoid, its movement being damped by a disc in oil.

When the supply voltage varies from 90 to 112 volts, the voltage across the condenser (*i.e.*, the working voltage) varies only from 96.5 to 96 volts. With a better model of solenoid, even better results were obtained, and the filament of a Coolidge tube was kept practically constant in temperature although the supply voltage varied between 105 and 140 v. The A.C. frequency was 50 per sec.

SAFETY AND THE MAINS: PRECAUTIONS TO BE TAKEN WHEN USING BATTERY ELIMINATORS.—P. R. Coursey. (Wireless World, 20th June, 1928, V. 22, pp. 657-660.)

METAL RECTIFIERS.—(The Engineer, 22nd June, 1928, V. 145, p. 684.)

An illustrated article on the copper-disc rectifiers made, in various sizes and for various purposes, by the Westinghouse Company. (Cf. article by C. Chouquet, July Abstracts, under "Subsidiary Apparatus.")

THE SULPHIDE RECTIFIER: AN EXPLANATION OF ITS FUNCTIONING AND ITS APPLICATION TO RADIO AND INDUSTRIAL USES.—H. Shoemaker. (Rad. Engineering, June, 1928, V. 8, pp. 35-38.)

A full description of the "Elkon" metal-disc rectifier in which the copper disc has a sulphide

deposit on one side and the separating discs (which also act as cooling fins) are of aluminium. For battery-charging purposes, a life of 5,000 hours may be expected.

PAPER VERSUS MICA CONDENSERS IN RADIO FREQUENCY CIRCUITS.—J. G. Uzmann. (Rad. Engineering, June, 1928, V. 8, p. 53.)

A note on the comparative power-factors of paper and mica condensers, leading to the conclusion that the growing tendency to substitute small paper condensers for the more expensive mica ones is completely unsound, so far as resonant circuits are concerned.

LE PROBLÈME DU FILTRAGE (The Filter Problem).—P. Olinet. (Q.S.T. Français, June, 1928, No. 51, pp. 3-10.)

The continuation of a series of articles (see July Abstracts, "The Supply of Electricity to Radio-stations"). Former articles having dealt with rectifiers and wave-band filters, the present one concentrates on single-wave-stoppers as an adjunct to the other filters. As before, frequent diagrams and simple mathematics are used. The question of the Anode Feed both for transmission and reception having been satisfactorily settled, similar treatment of the filament supply is promised in the next article.

CONSTANT SPEED MECHANISM FOR AN ACCURACY OF 1 IN 10,000.* (See Miscellaneous, "Picture Reception.")

* This cross-reference appeared by error in the July Abstracts.

STATIONS, DESIGN AND OPERATION.

TRANSATLANTISCHE TELEPHONIE (Transatlantic Telephony).—F. Anton. (E.N.T., May, 1928, V. 5, pp. 221-227.)

A description of the England-America Telephone. The article includes details concerning the suppression of carrier wave and one side-band.

SOME INVESTIGATIONS OF SHORT WAVES AT NIJNI-NOVGOROD.—W. W. Grzybowski. (Q.S.T., April, 1928, V. 15, pp. 9-14.)

Powers of about 25 kW. were at first used; a wavelength of about 80 m. was successful in getting strong telegraphic signals to Newfoundland and Porto Rico; but for 24-hour communication with Turkestan this was reduced to one of 20-30 m., various types of directional aerials were used, and the power cut down very greatly. Present efforts are directed to communication with Siberia, Vladivostok and Central Asia.

UN SYSTÈME FRANÇAIS D'ÉMISSION À ONDES COURTES PROJÉTÉES (A French system of short-wave "beam" transmission).—M. Chireix. (L'Onde Elect., May, 1928, V. 7, pp. 169-195.)

A full and authoritative account of the Ste. Assise station for communication with Buenos Ayres, Rio de Janeiro and elsewhere.

LA TRANSMISSION RADIOTÉLÉPHONIQUE PAR ONDES COURTES DIRIGÉES ET LA STATION D'ESSAIS DE COMMUNICATION PARIS-ALGER (Radio-telephonic transmission by short wave "beam," and the trial station for the Paris-Algiers service).—R. Villem. (*Rev. Gén. de l'Élec.*, 16th June, 1928, V. 23, pp. 1035-1043.)

This contains much of the same material as the article by Noël dealt with in July Abstracts.

THE MAINS DANGER.—(*Wireless World*, 30th May, 1928, V. 22, p. 565), and

THE MAINS AND THE EARTH CONNECTION (Some Considerations when obtaining Power from D.C. Supplies).—(*Wireless World*, same issue, pp. 570-572.)

GENERAL PHYSICAL ARTICLES.

ELECTRICAL CONDUCTIVITY.—W. V. Houston. (*Nature*, 2nd June, 1928, V. 121, p. 884, summarised from *Zeitsch. f. Physik*, 7th May.)

The author applies the principles of wave-mechanics to the problem of electrical conductivity, extending Sommerfeld's revived electron theory of metals. After certain assumptions, mathematical development leads to a very satisfactory account of the temperature coefficient of resistance, except in the region of super-conductivity.

THE STUDY OF THE SPECIFIC RESISTANCE OF BISMUTH CRYSTALS AND ITS CHANGE IN STRONG MAGNETIC FIELDS, AND SOME ALLIED PROBLEMS.—P. Kapitza. (*Proc. Royal. Soc.*, 1st June, 1928, V. 119, Series A, pp. 358-443.)

Experiments are described which were carried out with the support of the Department of Scientific and Industrial Research, on the behaviour of bismuth crystals under the very powerful transitory magnetic fields (up to 300 kilogauss) obtained by the author's new method. Among the interesting conclusions arrived at may be mentioned the suggestion that the disturbance produced by the magnetic field in the atoms of the conductor will increase the efficiency of "small collisions" (which sum up to form the "complete" collision of Sommerfeld's theory), and that this will increase the resistance. Thus from a formal point of view, the effect of a magnetic field may be regarded as a decrease in the length of the free path of the electron.

DIRECT EVIDENCE OF ATOM BUILDING.—Millikan and Cameron. (*Science*, 13th April, 1928, abstracted in *Journ. Franklin Inst.*, June, 1928, V. 205, p. 766.)

Latest work on Cosmic Rays shows that they consist of wavelengths occurring in bands of definite frequency, not covering continuously long stretches of the spectrum. Four chief regions have been determined, which can be accounted for, according to Einstein's equation, as emitted upon the combination of positive electrons (that is, of hydrogen nuclei or protons) with negative electrons to form the atoms of light elements. The authors

suggest, with reserve, that this forms the first evidence of the constructive process of atom-building.

COSMIC RAYS.—(*World Power*, June, 1928, V. 9, p. 331.)

A short history of the observations, beginning in 1903, which have led to our present knowledge regarding these Rays.

ÉTUDE DES OSCILLATIONS ENTRETENUES (The Study of Sustained Oscillations).—A. Liénard. (*Rev. Gén. de l'Élec.*, 26th May, 1928, V. 23, pp. 901-912, and 2nd June, pp. 946-954.)

Continuing the work of the two Cartans, Van der Pol and others, the author gives a simple graphical solution of the equation governing several oscillating phenomena (e.g., singing arc, multi electrode valves etc.), namely:

$$\frac{d^2x}{dt^2} + \omega \cdot f(x) \frac{dx}{dt} + \omega^2 x = 0$$

He shows that for the general case there is one solution for the stable oscillatory condition and one only, and indicates processes for the evaluation of the amplitude of the oscillations, and a lower limit to the duration of the oscillating condition.

THE VELOCITY OF SOUND IN LIQUIDS AT HIGH FREQUENCIES BY THE SONIC INTERFEROMETER.—Hubbard and Loomis. (*Phil. Mag.*, June, 1928, V. 5, pp. 1177-1190.)

REPORT OF WORK OF BARTOL (RESEARCH) FOUNDATION.—W. F. G. Swann. (*Journ. Franklin Inst.*, June, 1928, V. 205, pp. 767-829.)

The problems dealt with are: (1) The emission of electrons from wires under the influence of intense electric fields. The use of different sized wires has enabled del Rosario to produce different surface fields for the same differences of potential, or different differences of potential for the same surface field, and to obtain apparently conclusive evidence that the total potential difference, and not the field at the surface, is the factor which determines primarily the magnitude of the current. This leads to the suggestion that the electrons are given off by thermionic emission, caused by the bombardment of positive ions (emitted from the surrounding cylindrical anode and travelling to the wire, gaining as they go energy proportional to the difference of potential) which raise the temperature of the wire in the extreme local regions where they hit. Experiments are being continued to determine whether the emission of X-rays from the cylinder as a result of the electron bombardment may play a part in maintaining the current. (2) The excitation of spectra in mercury vapour by electron impact (Maxwell). (3) A possible effect of the Cosmic Radiation in stimulating Radioactivity. Maxwell proposes to measure the activity of a radioactive preparation in a deep mine, to see if its radioactivity is appreciably diminished, as it would be if Perrin's suggestion is true that cosmic radiation produces radiation from radioactive materials in the same kind of way that the emission of electrons from

atoms can be brought about by X-rays. (4) The production by X-rays by positive ions (Barton). The protons, when obtained, must be led out of the compartment containing hydrogen sufficiently dense to allow an appreciable production of protons, into one where the pressure is low enough to allow the production of X-rays. So far, a beam of 10^{-4} ampère has been obtained and it is hoped to improve this to 10^{-3} . No results are yet announced as regards the production of X-rays. A cheap and simple device for measuring the high potentials used comprises a metal hydrometer floating in transformer oil and surrounded by a metal cylinder. The hydrometer has two light guides which keep it central and through which it is connected to earth. (5) The loss of energy by electrons in the production of characteristic X-radiation. Method described but no results announced. (6) An attempt to detect a magnetic field as a result of the rapid rotation of a copper sphere (Swann). The question arises in connection with endeavours to account for the earth's magnetic field. Method and precautions against spurious effects are described, and curves are given showing the production of a field rising in one case (with increased speed of rotation) from 0 to 2×10^{-4} Gauss. (7) The effect of an electric field on the production of double refraction in sodium vapour (Bramley). Results were in agreement with the old ideas embodied in Voigt's theory, so long as the temperature was above 230 degree C., but below this temperature they departed from the theory; thus confirming the modern atomic idea of the two intermittently-appearing virtual oscillators and providing information as to the differences in the action of the electric field on the two kinds of virtual oscillators.

Further problems will be dealt with in next month's Abstracts.

PIEZO-ELECTRIC QUARTZ RESONATORS: AN OPTICAL INTERFERENCE METHOD OF OBSERVING THEIR MODES OF VIBRATION.—(*Electrician*, May, 25, 1928, V. 100, p. 576.)

A short description of the demonstration at the Royal Society Conversazione of Dr. Dye's method, by which the nodes and antinodes on the polished surface of a quartz plate excited by an alternating electric field (of adjustable frequency) are made visible and can be photographed.

PIEZO-ELECTRIC EXCITATION OF LONGITUDINAL, TRANSVERSE AND TORSIONAL VIBRATIONS IN QUARTZ RODS.—Giebe and Scheibe. (*Zeitschr. f. Physik*, V. 46, 9-10, 1928, pp. 607-652.)

The electrical glow produced in a rarified gas is used to make visible the distribution of the piezo-electric charges. Photographs can also be taken.

MECHANICAL OSCILLATIONS OF QUARTZ CRYSTALS.—Wachsmath and Auer. (*Zeitschr. f. Physik* V. 47, 5-6, 1928, pp. 323-329.)

Optical methods were supplemented by a method using lycopodium powder.

Propagation velocity was found to vary from 2,250 at a frequency of 200 kc. to 2,700 at 400 kc.

THE INFLUENCE OF VARIOUS GASES UPON WIRE VIBRATION IN A CORONA DISCHARGE TUBE.—Snyder and Evans. (*Journ. Sci. Instruments*, May, 1928, V. 5, pp. 166-167.)

In corona-discharge tubes of the wire and coaxial cylinder type, the vibration of the wire under the influence of an A.C. discharge is well known. It is normally prevented by having the wire carefully centred and under tension. The writers found that such means were perfectly satisfactory for tubes containing air, ammonia, oxygen, hydrogen or hydrogen-nitrogen mixture, but failed with pure nitrogen, methane or carbon monoxide under the particular conditions of their experiment, where a 60-cycle frequency and 13,700 volts pressure were used.

DEMONSTRATIE VAN EEN NIEUW PHOTOELECTRISCH EFFECT (Demonstration of a new photoelectric effect).—F. M. Penning. (*Physica*, V. 8, No. 4, 1928, pp. 137-140.)

The sparking-potential of a discharge tube, containing Neon and a small percentage of Argon, is increased by 50 v. when the gas between the electrodes is exposed to intense radiation from another Neon tube. The effect may be demonstrated by using an intermittent glow discharge and a loud-speaker: the note is lowered when the light from the second Neon tube falls on the first. The effect is due to the Neon light partly destroying the metastable atoms, thus diminishing the number of ionised argon atoms present.

KATHODENZERSTÄUBUNG (Wearing-away of Cathodes by emission of particles).—(*E.T.Z.*, 17th May, 1928, p. 765.)

A paragraph summarising the work of Günther-schulze, published in *Zeit. Phys.*, V. 36 and 38, in which he investigates cathodes of 24 different elements in hydrogen. Some six of these behave in an anomalous way, both in the distribution of the deposit, and because they give a deposit even when disconnected from the cathode and simply placed in the path of the discharge, the presence of hydrogen ions being sufficient to produce what is, in their case, an electro-chemical process. The normal, electrical process is exemplified by silver in hydrogen, which behaves according to the law $Q = \frac{CV}{c\bar{p}}$ where Q is the quantity of the silver deposited per a.h., V is the cathode drop of potential, c is the distance between electrodes and \bar{p} is the gas-pressure. The constant C is for silver in hydrogen 0.868.

WHAT IS AN ATOM?—P. R. Heyle. (*Scientific American*, July, 1928, pp. 9-12.)

The newest idea of the atom is the "Schrödinger" atom, which has replaced the Bohr conception of a miniature solar system of electrons rotating about a central proton. The author, physicist in the Bureau of Standards, deals in a popular way with these and older ideas, and the reasons for abandoning each in turn.

LA THEORIE DE MAXWELL ET L'ÉLECTRICITÉ MODERNE (Maxwell's Theory and Modern Electricity).—L. La Porte. (*Q.S.T. Français*, June, 1928, No. 51, pp. 52-56.)

The objects of the writer is to show, without considering high frequency currents, and without using a single mathematical symbol, how matter and electricity are related, both proceeding from ether whose normal condition has been modified.

MISCELLANEOUS.

A GALVANOMETRIC RELAY WITHOUT CONTACTS.—*Bull. de la Soc. Franç. des Elec.*, April, 1928, V. 7, pp. 351-352.)

The galvanometer needle carries at its end a small differential thermo-couple. When this is swung under a small electric heater, the thermo-electric current produced works a polarised relay. The position of the heater is adjustable with regard to the galvanometer scale. The instrument is brought out by the Cambridge Scientific Instrument Company.

RADIO APPLIED TO PETROLEUM PROSPECTING.—G. R. Chinski. (*Q.S.T.*, March, 1928, V. 15, pp. 43-46.)

Wireless plays merely a subsidiary (though important) part in the "Seismic" method described, providing a means of synchronisation as well as of inter-communication.

METHODS FOR INVESTIGATION OF LOUD SPEAKERS.—*Bull. de la Soc. Franç. des Elec.*, April, 1928, V. 7, pp. 393-399.)

A discussion of various methods, including the use of a Rayleigh disc and of Gerlach's device using an alternating magnetic field to oppose the vibrations of a diaphragm.

VERSUCHE MIT PHOTOZELLEN FÜR BILDFUNKZWECKE (Experiments with Photo-cells for Picture-Wireless purposes).—W. Nestel. (*Rad. f. Alle*, June, 1928, V. 7, pp. 283-288.)

Investigations start with a determination of the Sensitivity (measured by the photo-electric current per metre-candle power of illumination) and the Inertialess property (measured by the number of impulses per second it can deal with), continue with light-telephony, in which the light from an arc-lamp is modulated by speech and concentrated into a ray which carries to the receiving photo-cell; and finally deal briefly with Picture- or Facsimile-Wireless.

LES STATIONS DE SIGNAUX HORAIRES (Time-Signal Stations).—L. de la Forge. (*Q.S.T. Français*, June, 1928, No. 51, pp. 45-51.)

A continuation of the article mentioned in the July Abstracts. The present instalment deals with Asia and Africa. Full tables are given.

LA RADIODIFFUSION BRITANNIQUE DÉCRITE PAR ELLE-MÊME (British Broadcasting described by itself).—L. de la Forge. (*Q.S.T. Français*, June, 1928, No. 51, pp. 20-26.)

Broadcasting in France will have to be organised properly and promptly. In order to profit by the

experiences of other countries, the author now brings to the public attention the recently published "B.B.C. Handbook" from which he quotes at length.

FERNABLESUNG VON ZEIGERSTELLUNGEN MITTELS HOCHFREQUENZ (Distant-reading of Meters, etc., by H. F. Method).—Hollmann and Schultes. (*E.N.T.*, May, 1928, V. 5, pp. 217-221.)

A method is described which reduces to a minimum the work (against friction, etc.) which has to be done by the moving-part of the meters, and thus permits its application to delicate instruments. The moving-part carries with it the rotor of a variable condenser, and thus changes the wavelength of oscillations which are carried (either by wireless or wired wireless) to the distant receiver.

GEOPHYSICAL METHODS OF LOCATING MINERALS.—(*Engineering*, 8, June, 1928, V. 125, pp. 696-697.)

A summary of papers read before the American I.M. and Met. Eng. Many of the writers deal with the use of the Eötvös Torsion Balance method (a "Gravity" method) but various electrical and magnetic methods are mentioned, as well as a Seismic method depending on the recording, by a series of seismographs along a profile line, of the vibrations set up by an explosion; the velocity of transmission varying with the character of the sub-strata.

MÉFIEZ-VOUS DES CHIFFRES INSCRITS SUR LES APPAREILS (Distrust the figures inscribed on Component Parts).—J. Granier. (*Q.S.T. Français*, June, 1928, No. 51, pp. 11-13.)

The value of an Inductance, the capacity of a condenser or of an accumulator, the power of a motor, are not constant quantities; they vary according to the conditions of use. Therefore the marked values of such pieces of apparatus can only certainly apply when they are used under conditions similar to those under which they were tested. The present article deals with condensers measured ballistically.

AMERICA'S SHORT WAVE DEVELOPMENT.—(*Electrician*, 8, June, 1928, V. 100, p. 648.)

A paragraph noting the additional short-wave facilities asked for from the Washington Government, for new telephone and telegraph channels. Three more channels to Europe are desired, as well as others to the Argentine, the Philippines, China, Japan, Australia, Dutch East Indies, Liberia, Cuba, Chili, Brazil, Egypt, the Republic of Georgia, and elsewhere.

SUR L'UTILISATION DE L'ÉNERGIE THERMIQUE DES MERS (The Utilisation of the thermal energy of seas).—Claude and Boucherot. (*Comptes Rendus*, 4, June, 1928, V. 186, pp. 1491-1496.)

An account of the preliminary trials, on 1st June, 1928, of the authors' plant for deriving power from the different temperatures (at surface and at great

depth) of the water of tropical seas. In this trial (in Belgium) the difference in temperature (about 10 degrees) was produced artificially, and the plant worked with perfect success. The turbine-driven dynamo gave an output of nearly 60 kW., of which about 70 per cent. was available for power. The next step will be on the coast of Cuba, where a complete plant is to be installed under actual working conditions.

MACHINES À COURANT CONTINU AVEC OU SANS COLLECTEUR (D.C. generators with or without commutators).—(*Bull. de la Soc. Franç. des Elec.*, April, 1928, V. 7, pp. 405-428.)

A long discussion on the much sought-after commutatorless generator (*c.f.* Abstracts for July, "Dynamo Unipolaire Poirson").

LA REMISE À L'HEURE AUTOMATIQUE DES PENDULES PAR T.S.F. (Clock-setting by Wireless).—(*Bull. de la Soc. Franç. des Elec.*, April, 1928, V. 7, pp. 399-404.)

Discussion of the paper mentioned in the July Abstracts.

PICTURE RECEPTION (Recent Important Developments in Home-reception Process).—(*Wireless World*, 23rd May, 1928, V. 22, pp. 542-546.)

Describes a new picture receiver suitable for use

with a broadcast receiving set; the difficulties of synchronising have, it is stated, been successfully overcome by the new mechanism which will run the cylinder continuously with an accuracy of not less than one part in ten thousand. Control by valve oscillator or pendulum is dispensed with.

THE MEASUREMENT OF SOUND-ABSORPTION IN A ROOM.—V. O. Knudsen. (*Phil. Mag.*, June 1928, V. 5, pp. 1240-1257.)

A RECTIFIER FOR HIGH TENSION ELECTRICITY.—(*Génie Civil*, 2nd June, 1928, V. 92, p. 531.)

In the course of a 5-page article on the precipitation of dust by electricity, a mechanical rectifier is described and illustrated which rectifies A.C. at 50,000 v. and 50 frequency.

LOUD SPEAKER LOCATION.—A. H. Davis. (*Wireless World*, 20th and 27th June, 1928, V. 22, pp. 651-655 and 678-682.)

The first article deals with "Tracing Sound Pulses by Photography in the Auditorium" (reverberation; work of the National Physical Laboratory; distortion due to draping of room; shadows cast by invisible gases; photographing sound pulses), the second with "How Resonances in Small Rooms may affect Loud Speaker Reproduction" (resonances in small rooms; loud speakers in large halls; directive action of loud speakers; difficulties when microphone and loud speaker are in the same hall).

Esperanto Section.

Abstracts of the Technical Articles in Our Last Issue.

Esperanto-Sekcio.

Resumoj de la Teknikaj Artikoloj en Nia Lasta Numero.

PROPRECOJ DE CIRKVIITOJ.

LA EKVALENTA INDUKTECO KAJ KAPACITO DE ANTENO KUN ENMETITA AGORDA BOBENO AŬ KONDENSATORO.

Redakcia noto (super la ĉefliteroj de Prof. Howe), kiel daŭrigo de tiu en la antaŭa numero kaj naskita de la letero de D-ro. Palmer (ĉi-supre). La pli-grandigo de ondolongo per enmeto de induktanco, kaj la malpli-grandigo de ondolongo per enmeto de kondensatoro, estas diskutitaj detale, kun kurvo montranta la efekton de ĉi tiuj ŝarĝoj ĉe la ekvivalenta indukto de la anteno. Oni atentigas, ke la traktado de D-ro. Palmer nerimarkas la ŝanĝon de la ekvivalenta indukto de l'anteno dum indukto aŭ kapacito estas enmetita laŭserie kun ĝi.

PRI LA EKVALENTA INDUKTECO KAJ KAPACITO DE ANTENO.

Letero (en fako de korespondado al la Redaktoro) de D-ro. L. S. Palmer, naskita de la Redakcia artikolo en la antaŭa numero. La Redakcia kritiko estas diskutita kaj kurvoj donitaj montrantaj rezultojn obtenitajn de (1) Teoria Formulo, (2) Formulo de Howe, (3) Formulo de Palmer.

REAKTANCAJ KAJ ADMITANCAJ KURVOJ APLIKITAJ AL AGORDITAJ CIRKVIITOJ KUN KAJ SEN REZISTECO.

Daŭrigita el antaŭa numero. La nuna parto studas la ĝeneralan ekzemplon de resonanca cirkvito, en kiu la rezisteco de la bobeno kaj la elfluobleco de la kondensatoro estas ambaŭ kun-konsideritaj. La seria resonanca cirkvito estas unue pritraktita, kaj partaj vektoraj diagramoj jam donitaj, estas kombinitaj por la tuta cirkvito kaj resonanca kurvo desegnita. La rezonado estas poste aplikita al la ekzemplo de paralela resonanco, kaj vektoraj diagramoj kaj resonancaj kurvoj estas desegnitaj por kelkaj malsamaj kondiĉoj de rezisteco kaj elfluobleco.

RICEVADO.

SISTEMO POR KONTRAŬBATALI LA EFEKTON DE STATIKO.—E. A. Tubbs.

La sistemo priskribita estas uzata en la ricevaj stacioj de la *Federal Telegraph Company* de San Francisko. La cirkvito estas tiu de la ekvilibrita modulatoro (ŝuldata al Carson), kiu estas jam uzata en portaj sistemoj kaj transatlantika tele-

fonio, la ricevita signalo estante aplikita al la kradoj en fazo kaj al la loka heterodino en kontraŭfazo. Oni montras ke, per alĝustigo de la loka oscilado, alĝustigo estas trovebla, kie ia ajn interfero enkondukita en la elmeton neniam estos plilaŭta ol la dezirita signalo.

Aldonaĵo pritraktas la teorion de la sistemo.

LA UZADO DE ALTERNKURENTO POR VARMIGI VALVAJN FILAMENTOJN.—C. W. Oatley.

Oni unue aludas al la fakto, ke kiam riceva valva filamento estas senpere varmigita per a.k.—aparte de l'ekzemplo de la sensepense varmigita katodo—la a.k. tono estas aŭdita en la kaptelefoniloj aŭ laŭtparolilo. Ĉi tio eble povas esti kaŭzita de variado de filamenta temperaturo kaj de ŝanĝiĝado de l'efektiva krada potencialo, laŭ ĉu ĝi estas momente konektita al la negativa aŭ pozitiva fino de l'filamento.

Ĉi tiuj ekzemploj estas ambaŭ konsideritaj detale, kaj oni konkludas, ke filamentoj senpere varmigitaj per a.k. ne taŭgas por la detektora ŝtupo, sed ke estas eble elimini la zumadon, kiam la valvo estas uzita kiel amplifikatoro.

HELPA APARATO.

MIKROFONAJ AMPLIFIKATOROJ KAJ TRANSFORMATOROJ.—H. L. Kirke.

Post enkonduka sekcio, la aŭtoro diskutas evoluigon de progresado, frekvenca amplekso de muzikaj instrumentoj, korektecon de reproduktado, distordadon de frekvenca karakterizo, k.t.p. Li poste turnas sin al longa diskutado pri la transformatoro, enmeta kaj elmeta, la intervalva transformatoro estante konsiderita kiel elmeta transformatoro, kvankam li indikas, ke la ŝoka kuplo estas preferinda.

La kondiĉoj por "detrancado" je diversaj frekvencoj estas konsideritaj, kaj oni montras, ke estas necese, ke la transformatoro havu altan primarian induktecon por bona frekvenca karakterizo. Magneta elflueto estas ankaŭ diskutita, kun ĝia efekto ĉe frekvenca karakterizo, kaj la funkcio de l'transformatoro funkcianta sub kondiĉoj de parigita impedanco. La enmeta transformatoro estas poste pritraktita. La diskutado estas laŭ vidpunkto de transformatoro tiel desegnita, ke ĝia primario havas impedancon, kiu egalas la mezajn impedancon de la enmeta cirkvito. Tipaj detaloj estas donitaj pri transformatoro por 500-oma enmeta impedanco, havanta "detrancado" de 0.95 je 50 kaj 9,000 periodoj ĉiusekunde. La kerna materialo estas ankaŭ diskutita kaj ĝia efekto je la funkciado de la transformatoro.

La artikolo estas finota en la venonta numero.

STACIOJ: DESEGNADO KAJ FUNKCIADO.

INTERESA NOVA 100-VATA APARATO.

Mallonga priskribo estas donita, kun fotografaĵoj, de nova 100-vata fiks-ondolonga telefonila aparato lastatempe produktita de la Marconi'a Kompanio.

La ondolongo povas esti fiksita inter la limoj de 150 kaj 400 metroj (fiksita je la tempo de instalado). La aparato estas aparte taŭga por uzado sur malgrandaj ŝipoj, lumturoj, k.t.p., kie sperta funkciisto ne deĵoras.

DIVERSAĴOJ.

RESUMOJ KAJ ALUDOJ.

Kompilita de la *Radio Research Board* (Radio-Esplorada Komitato), kaj publikigita laŭ arango kun la Brita Registara Fako de Scienca kaj Industria Esplorado.

DISTRIBUADO DE EŬROPAJ BRODKASTAJ ONDOLONGOJ—KELKAJ NOVAJ VIDPUNKTOJ.—S. Lemoine.

La aŭtoro estas ĉef-inĝeniero de la Sveda Telegrafa Administrado kaj membro de la Teknika Komitato de l'*Union Internationale de Radiophonie* (Internacia Unio de Radiofonio).

Post enkonduka diskutado pri la Geneva plano, la aŭtoro mallonge traktas pri la rezolucioj aprobitaj de la Washington'a Konferenco kaj ilia signifo. Li poste diskutas areon kaj loĝantaron kiel principojn regantajn la distribuadon de ondolongoj, urĝante, ke ĉiu lando devus havi nombron da frekvencoj, kiu estas funkcio de ĝia areo kaj loĝantaro, esprimita kiel procentaĵo, la unua rigardita kiel tuto kaj la ĉi-lastaj kiel duono. Tabeloj estas donitaj pri komparaj nombroj por ondolonga distribuado laŭ proporcioj de ĉi-tiuj faktoroj.

Li poste konsideras la principon de la komuna loĝigo de la ondolongoj kaj faras proponon por la enkonduko de "ondolonga ekvivalento," kiu ekkonas la servan valoron de la diversaj ondolongoj laŭ konataj leĝoj pri la variado de maldenseco laŭ frekvenco. Ĉi tiu ondolonga ekvivalento estas sugestita kiel la kubradiko de la proporcio inter la inversaj valoroj de frekvencoj. Tabelo de ondolongoj ekvivalentaj pro diversaj frekvencoj estas donita, kaj la aplikado de la principo estas montrita. Ekskluzivaj kaj partoprenaj ondolongoj estas poste diskutitaj, la aŭtoro sugestante la malpliigon de la ĉi-lastaj de 16 ĝis 12. Laste, grupa distribuado de ondolongoj estas sugestita, t.e., ke la ekskluzivaj frekvencoj asignitaj al iu ajn lando devus esti en apudaj frekvencaĵoj.

Resumo kaj finaj observadoj finas la artikolon.

AN AMALGAMATION.

Those of our readers who are photographers will be interested to learn that our sister journal, *The Amateur Photographer* and its contemporary *The New Photographer*, have been merged into one publication. The combined journal, which is known as *The Amateur Photographer, Incorporating The New Photographer*, will continue to be published from these offices every Wednesday, price 3d., and

obtainable from newsagents, bookstalls and leading photographic dealers. All the features of the two journals which have proved most attractive to readers in the past are embodied in the combined paper, and every effort will be made to make the one weekly journal more and more interesting and valuable to amateur photographers in the practice of their hobby.

Some Recent Patents.

The following abstracts are prepared with the permission of the Controller of H.M. Stationery Office, from Specifications obtainable at the Patent Office, 25, Southampton Buildings, London, W.C.2, price 1s. each.

PHOTO-ELECTRIC "PICK-UPS."

(Application date, 11th January, 1927. No. 288,711.)

A light-sensitive cell is used to convert the mechanical movements of a gramophone stylus into electric current-variations for subsequent reproduction in a loud-speaker. As shown, a selenium cell *C*, having a plane surface, is mounted on the top of the stylus *S*, which is vibrated by the sound record *R*. A lamp *L* and lens *M* direct a concentrated ray of light through a perforated screen *N* so that it impinges at an acute angle on the sensitive cell *C*.

The vibrations of the stylus alter the angle of the cell with respect to the incident ray, so that the intensity of illumination varies with each movement, the interposition of the perforated screen *N* serving to increase this effect. The cell *C* is connected in series with a battery in the input

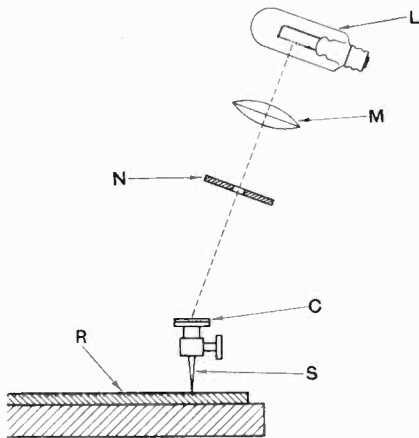

circuit of a thermionic valve, by which the resultant current fluctuations are suitably amplified.

Patent issued to The British Thomson-Houston Co., Ltd.

PREVENTING FADING EFFECTS.

(Convention date (Germany), 6th September, 1926. No. 277,939.)

It has been shown in connection with investigations into the behaviour of different combinations of vertical and horizontal receiving aerials, relatively to the angle of incidence of the incoming waves and their plane of polarisation, that a horizontal frame of correct dimensions will pick up an amount of energy equivalent to a vertical aerial, provided that in both cases the plane of polarisation is such that maximum energisation takes place. The resultant strength of reception is, however,

also dependent upon the relative phase relations of the respective aerial currents.

According to the present invention, in order to rule-out fading variations arising from fluctuations

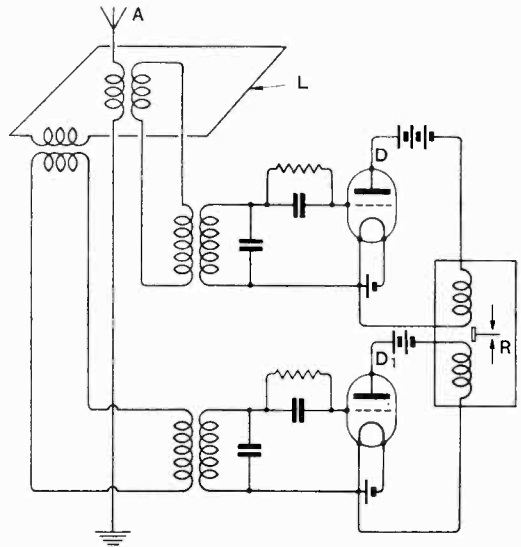

in the plane of polarisation, the currents from each aerial are fed to separate detectors. As the output from each valve varies as the square of the instantaneous aerial current, the final result is made independent of the instantaneous phase or vector relation existing in each aerial. As shown, a vertical aerial *A* and horizontal loop *L* are separately coupled to two detectors, the output currents from which are combined to operate a common recording device *R*.

Patent issued to the Telefunken Co.

A NEW BALANCED AMPLIFIER.

(Convention date (U.S.A.), 11th January, 1927. No. 283497.)

When using the ordinary methods for neutralising the effect of interelectrode capacity, difficulty is experienced in securing an absolutely true balance, particularly at high frequencies. In Fig. *a* the dotted-line condensers C_1, C_2, C_3 represent the effective valve capacities, including the external leads, when the valve is in actual operation, whilst *N* represents the usual balancing condenser inserted in series with the plate and the split input L, L_1 . So far the arrangement is ineffective at high frequencies because the capacity C_2 , in parallel with the input coil *L*, spoils the symmetry of the divided circuit.

According to the invention, the balance is restored by inserting a condenser N_1 in shunt across the coil L_1 and equal in value to the condenser C_2 as shown. Further the plate of the valve is so arranged that it becomes a common

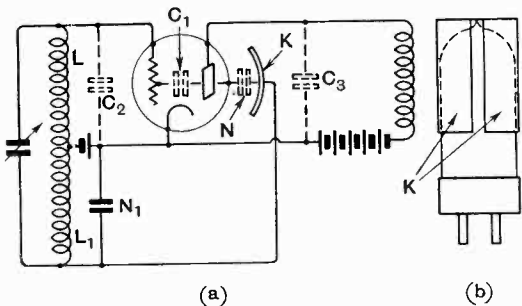

condenser plate between the capacities C_1 and N . This is effected by providing an external element K in the form of a split cylinder as shown in Fig. *b*. This encircles the glass bulb with a sliding fit so that the effective capacity value, represented by the condenser N , can be adjusted as desired.

Patent issued to The Marconi Co., Ltd.

TELEVISION APPARATUS.

(Application date, 15th October, 1926; 26th January and 10th March, 1927. No. 288,882.)

The apparatus is described as a means for providing a visible image of an object which is in darkness, an effect to which the term "Noctovision" has since been applied by the inventor. The arrangement is shown and is used when the object to be viewed is some distance away from the observer. A searchlight projector SL is closed by a relatively-thin diaphragm of ebonite, which cuts off all visible light but passes infra-red rays on to the object so as to form an invisible image I .

This is explored by the familiar Baird system of rotating obturator discs D, D_1 . The interrupted infra-red rays are then projected on to a bolometer B or similar device sensitive to such energy. The current from the bolometer is passed through an amplifier V to a glow-discharge lamp GL , which operates in conjunction with an exploring disc D_2 to produce a visible image of the original "dark" object on the viewing screen VS . The local and distant exploring devices D, D_1 and D_2

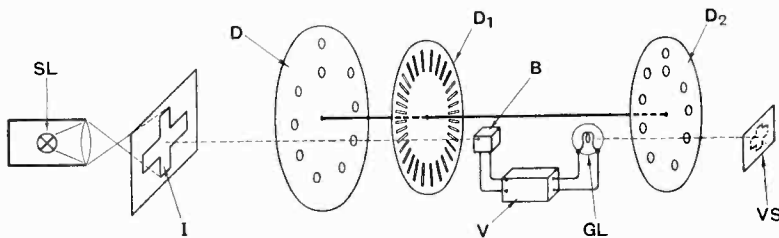

are mounted on the same rotating shaft so as to ensure synchronisation under all conditions.

Patent issued to Television Ltd., and J. L. Baird

INTERVALVE COUPLINGS.

(Application date, 10th March, 1927. No. 289,217.)

To avoid distortion due to the use of grid-leak rectification, and at the same time to provide a simplified system of intervalve coupling, where an extended source of high-tension voltage is available, the circuit arrangement shown is adopted. The plate of the first valve V_1 is connected directly to the grid of the next valve V_2 and to a point on the H.T. supply through an impedance K . The filament supply to the second valve is tapped off from the common supply at a point of higher potential than the plate voltage on the first valve, so that successive electrodes are maintained at effective operating potentials. A similar arrangement is adopted in connection with the filament supply to the valve V_3 .

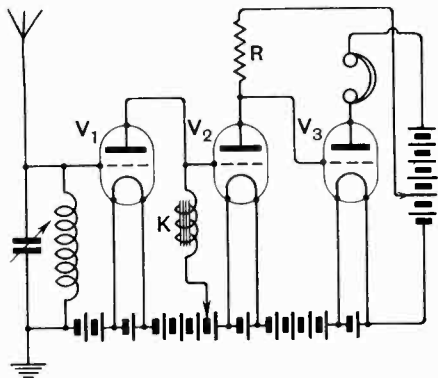

The grid-bias on the first valve is such as to secure anode-bend rectification, the subsequent low-frequency current variations being communicated from one valve to the next through the choke K and the resistance coupling R . The system is particularly adapted for use with mains supply units.

Patent issued to J. F. Johnston.

LOUD-SPEAKER DIAPHRAGMS.

(Application date, 4th January, 1927. No. 289910.)

In order to prevent distortion and to ensure a uniform sound response over a wide range of frequencies, the vibration of the diaphragm is

damped by a number of supporting points, distributed over both sides of its surface but separated therefrom by small air-gaps of adjustable width.

Fig. a shows a cross-sectional elevation of a square diaphragm *D* energised by a magnetic system *M* and having a number of inner supports *A*, *B*, *C*

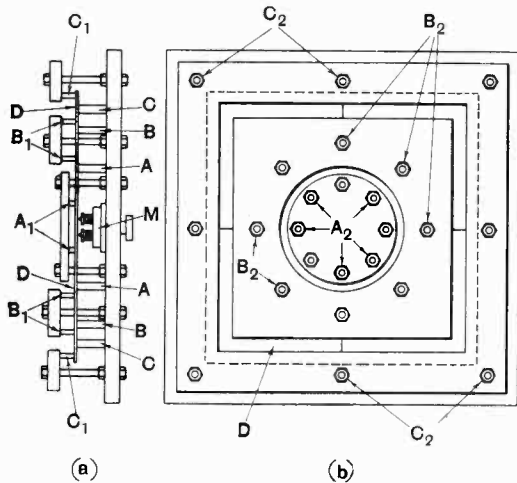

and outer supports *A*₁, *B*₁, *C*₁ arranged symmetrically at nodal points over the vibrating surface. Fig. b is a front elevation showing the distribution of the posts *A*₂, *B*₂, *C*₂, carrying the outer supports *A*₁, *B*₁, *C*₁.

In this way it is stated that the diaphragm vibrations, usually conceived in terms of appreciable mechanical movements, are restrained and limited to molecular vibrations, so that the whole of the audible energy is converted into molecular vibratory energy, which it is stated results in an accurate reproduction throughout a wide frequency-range without distortion or blasting.

Patent issued to F. and M. M. D. Clutsam.

MASS PRODUCTION SETS.

(Application date, 10th February, 1927. No. 290350.)

In the case of resistance-capacity coupled sets, the cost of the intervalve coupling units is relatively

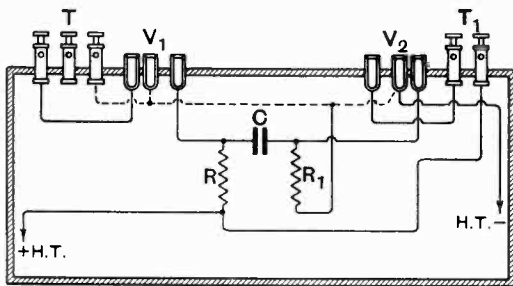

small in comparison with that of the high or low tension batteries or the actual valves. The inventors accordingly propose to incorporate suitable coupling-units with say the high-tension battery,

so that the latter practically comprises a wired receiver, to which only the valves need be added to enable it to function.

The Figure shows a high-tension dry battery fitted with suitable terminals, *T*, *T*₁, valve-sockets *V*₁, *V*₂, and the necessary high-resistances *R*, *R*₁ and fixed condenser *C* to form the coupling circuit. The latter are preferably embedded in the insulating material which is used to fill up the interstices in the assembled battery and to insulate the various connections. Alternatively the construction may be applied to low-tension dry-cell batteries. Or both batteries may be moulded together and designed so as to last for approximately an equal period, so that the whole receiver is contained in one compact unit.

Patent issued to The British Thomson-Houston Co., Ltd.

SHORT-WAVE SIGNALLING.

(Convention date (U.S.A.), 5th May, 1927. No. 289875.)

In short-wave signalling, such as the well-known Beam system, it is found that the most efficient working wave-length varies from 15 to 30 metres during the daytime, to from 30 to 60 metres at

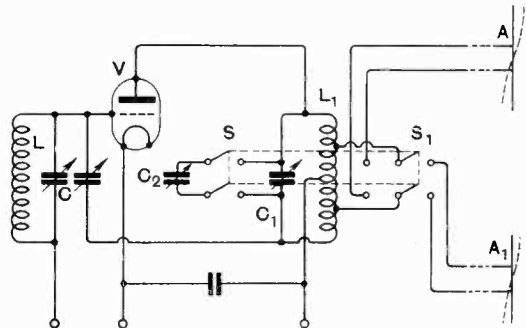

night. It follows that in order to maintain a 24 hours' service it is necessary to provide means for expeditiously changing the signal frequency from time to time. In certain cases, the terminal stations are equipped with two or more independent transmitters for this purpose. The present invention provides a method for making the necessary change-over when using only a single transmitter.

As shown in the Figure the amplifying stage *V* of the transmitter is adapted to be used either for straight amplification from an input circuit *LC* tuned say to a wavelength of 40 metres, or for frequency-multiplication to an harmonic say of 20 metres. With this object in view the output inductance *L*₁ is shunted by two condensers *C*₁, *C*₂ of such value that when the switch *S* is closed, the working frequency corresponds to a wavelength of 40 metres, whilst when it is opened the aerial supply is tuned to 20 metres. A second switch *S*₁ is provided to connect the H.F. supply to a 20-metre bank of aerials *A*₁ or to a 40-metre aerial system *A*.

Patent issued to The Marconi Co., Ltd.