

# EXPERIMENTAL WIRELESS & The WIRELESS ENGINEER

---

VOL. II.

JUNE, 1925.

No. 21.

---

## Editorial Views.

### Contributions.

IT will be remembered that a short time ago we suggested a series of articles showing how, from a small and reasonably cheap beginning, one could build up by degrees a collection of calibrated apparatus for test work. Our readers will be glad to know that arrangements have now been made for such a series, which will be written in collaboration by two valued contributors who have great experience of such work. Unfortunately, we are not in a position to start the series immediately: it is, of course, being specially written for E.W. & W.E., and, as such material needs especial care in preparation, it will be yet a month or two before it appears.

While we are on the subject of the contents of future issues of E.W. & W.E., we might point out that there are two ways in which readers may help us. First, we are always glad to have suggestions as to subjects which our readers want to see dealt with. Naturally we cannot always follow such suggestions; sometimes the subjects asked for would only interest a very limited circle of readers; sometimes the subject is one of which only a little is known. But, obviously, our one object is, as far as possible, to give what our readers ask for.

One point in particular arises in this connection. Would our readers like to see more of our space devoted to reports of tests on current commercial accessories and components? At present, as will have been

noted, we have confined such reports to new apparatus, and have made a very rigid selection; but it would be easy to extend this feature if it would be appreciated.

The second way in which readers can help us is by sending in contributions for consideration. In this regard, we suggest a previous careful perusal of previous issues, as a guide to the type of matter likely to be useful. It is by no means necessary that contributions be highly technical—in fact, at the moment we have almost an excess of this very valuable kind of material.

There are two other kinds of article which we are always prepared to consider favourably. On the one hand, there is the description of new home-made apparatus or experimental work. In connection with apparatus, however, it must be remembered that we do not as a rule give detail descriptions of more or less ordinary receivers. We only do so in cases either where the circuit embodies a really new principle, or where the arrangement has uncommon advantages. "New" experimental work, again, should be something more than a record of long-distance work. Transmission and reception on extra-short waves, records of fading, etc., comparison of various aerials and earthing arrangements, H.T. supply for transmitters, feeding receivers from the mains—these are just a few items that occur to us as we write, all of which offer scope for articles, in addition to the varied opportunities of pure laboratory work.

B

Also, there are openings for articles dealing with real working principles, even of comparatively elementary parts of our great subject. But here a word of warning is called for. As we have already stated in our columns, these articles are difficult to write: and the writer must be very, very thoroughly abreast of his subject. We have no use for the sketchy type of elementary article which is, unfortunately, too common, where the writer skates over the surface of his subject and dodges round the thin ice where his knowledge is defective. For E.W. & W.E., elementary articles are welcome, but they must go fairly deep and be very sound.

To those who may fear that their lack of practice in writing may be a handicap, we would say that if the *matter* is there, our own staff will assist in the *manner*, by appropriate editing and revision also; we can always prepare the finished drawings for illustrations—in fact, we prefer pencil sketches, in order that we can finish them in uniform style.

Lastly, a few practical hints. Type-writing is preferred, but not absolutely necessary: but *don't* try and type X's and Y's—hand-write any mathematical matter. Think out the article completely before starting to write it. Follow the universal practice of using one side only of the paper, and space the writing well to allow of revision and correction if necessary. Send a stamped envelope for the return of the MS. if it should prove unsuitable; do not be insulted if this

should unfortunately occur; and remember that there must, as a rule, be some months between the acceptance of an article and its appearance.

#### Aerial Tuner Design.

An interesting article which commences in this issue deals with the question of the best proportions of aerial tuning inductance and capacity when making due allowance for the constants of the aerial itself and the load introduced by the detector.

The authors give in their article the full analysis of the problem; but it may be useful to note here a few of their conclusions in simple language. In general, it may be stated that the presence of aerial tuning condensers, either in series or parallel, is a disadvantage, though there may be occasions when the reverse is the case. Where there is a load (such as a detector) on the circuit, there is a clearly-defined best value of the A.T.I., which increases with the resistance of the load. In many cases, especially with crystals, this "best" value of inductance is not enough to tune to the wave-length required with ordinary aeri-als. In this case the best step is to increase the aerial capacity as far as possible, and if this is not sufficient, to increase the inductance rather than use a parallel condenser. If this is done, it will be an advantage to tap off the crystal across part only of the inductance, as has been already suggested by other writers. Many other interesting points are brought out in the article, which we hope to complete in our next issue.

# Aerial Tuner Design.

## Part I.

[R141

By *W. B. Medlam, B.Sc., A.M.I.E.E., and U. A. Oschwald, B.A.*

**I**N this article the effect on the efficiency of the tuner of the constants of the aerial and those of its associated tuning circuits is discussed. It is shown that for most efficient reception on a given wavelength there is an optimum value of A.T.I. which depends on the nature of the receiving circuits. The circuits are analysed

due to the receiving circuit are taken into account. In Fig. 2,  $r$  represents the high frequency resistance of the A.T.I.,  $K_2$  the capacity of the aerial in series with the series tuning capacity  $K_1$ , and  $r_1$  represents the aerial resistance. The inductance of the aerial may be allowed for by subtracting the inductive reactance from the actual capacity reactance of the aerial, and calling the result the effective capacity reactance. In the following, the aerial capacity is taken to be that capacity which has this effective reactance. The receiving circuit will act as a capacity and resistance load on the A.T.I. The resistance component of the load is represented by a constant resistance  $R$ . Actually, the value of  $R$ , either in a crystal or valve circuit, varies continuously throughout the current or voltage cycle, but the results are consistent with the assumption of some constant effective value of  $R$ . The capacity component of the load, and the self-capacity of the A.T.I., are combined with the tuning capacity  $K$  (Fig. 1) with which they are in parallel. The sum of these capacities is represented by  $K_3$  in Fig. 2.

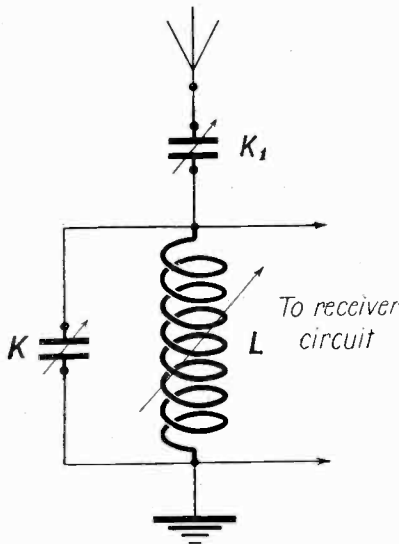

Fig. 1.

theoretically and confirmatory experimental results are given.

### The Single Circuit Tuner.

A single circuit tuner may be brought into resonance by varying the A.T.I., or by varying a capacity connected either in series or in parallel with the A.T.I. The general form of the circuit, incorporating all these tuning arrangements, is shown in Fig. 1. This circuit becomes equivalent to that shown in Fig 2 when the constants of the aerial, the resistance of the A.T.I., and the load

The electromagnetic waves from the transmitter set up alternating charges on the aerial capacity  $K_2$ . When the circuit resonates, the amplitude of the alternating

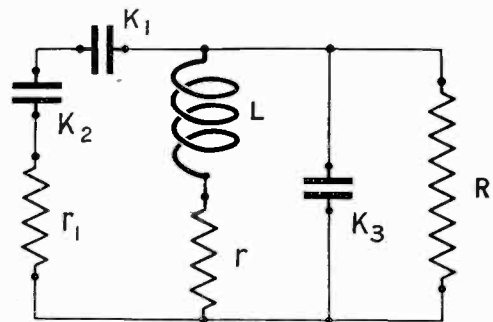

Fig. 2.

B2

voltage across this capacity will continue to rise until the energy loss per second in the resistances of the circuit just equals the amount of energy per second picked up from the ether. If the latter is constant the alternating voltage across any part of the circuit will then remain at a constant amplitude. We are concerned here only with this final steady state of the circuit. In view of some uncertainty as to whether the aerial E.M.F. remains constant for various loads, we have investigated this point. The results, shown in Appendix A, indicate that it is constant.

Analysis of the circuit shown in Fig. 2 is simplified a little by replacing the series capacities  $K_1$  and  $K_2$  by the equivalent capacity  $K_4$  (Fig. 3), so that

$$\frac{1}{K_4} = \frac{1}{K_1} + \frac{1}{K_2}$$

Also, it makes no difference to the result if we consider that energy is injected into the

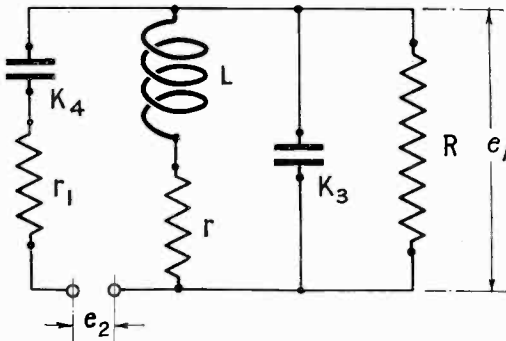

Fig. 3.

circuit by means of a generator  $e_2$  in series with  $K_4$  instead of by the actual means.

Let the voltage across the A.T.I. be represented by

$$e_1 = E_1 \sin \omega t \dots (1)$$

The total current,  $i$ , supplied to the circuit by the generator, is given by the expression

$$i = \frac{E_1 \sin \omega t}{R} + \omega K_3 E_1 \cos \omega t + \frac{E_1}{Z^2} (r \sin \omega t - \omega L \cos \omega t) \dots (2)$$

in which  $Z = \sqrt{r^2 + \omega^2 L^2}$

The supply voltage,

$$e_2 = E_2 \sin (\omega t + \psi)$$

$$= \left( \frac{r_1}{R} + \frac{r r_1}{Z^2} + \frac{K_3}{K_4} - \frac{L}{K_4 Z^2} + 1 \right) E_1 \sin \omega t + \left( -\frac{1}{\omega K_4 R} - \frac{r}{\omega K_4 Z^2} + \omega K_3 r_1 - \frac{\omega L r_1}{Z^2} \right) E_1 \cos \omega t \dots (3)$$

or,  
 $E_2 \sin (\omega t + \psi) = A E_1 \sin \omega t + B E_1 \cos \omega t$  (4)  
where

$$A = \frac{r_1}{R} + \frac{r r_1}{Z^2} + \frac{K_3}{K_4} - \frac{L}{K_4 Z^2} + 1 \dots (5)$$

and

$$B = -\frac{1}{\omega K_4 R} - \frac{r}{\omega K_4 Z^2} + \omega K_3 r_1 - \frac{\omega L r_1}{Z^2} (6)$$

We have

$$\psi = \arctan \frac{B}{A}$$

and

$$\frac{E_2}{E_1} = \sqrt{A^2 + B^2} \dots (7)$$

The condition for maximum voltage across the A.T.I. is that  $E_1$  shall be a maximum for a given value of  $E_2$ , i.e.,  $\sqrt{A^2 + B^2}$  shall be a minimum.

When  $1/\omega K_4$  has been eliminated by means of the resonance condition  $\omega^2 L (K_3 + K_4) = 1$ (1) from Equations (5) and (6) we have

$$A = \frac{r_1}{r} + \frac{r}{Z^2} \left( r_1 + \frac{r}{1 - \omega^2 K_3 L} \right) \dots (8)$$

and

$$B = -\frac{\omega L}{R(1 - \omega^2 K_3 L)} - \frac{\omega L}{Z^2} \left( r_1 + \frac{r}{1 - \omega^2 K_3 L} \right) + \omega K_3 r_1 \dots (9)$$

Writing  $p$  for  $r_1 + \frac{r}{1 - \omega^2 K_3 L}$ , and  $q$  for  $1 - \omega^2 K_3 L$  in Equations (8) and (9) gives

$$A = \frac{r_1}{R} + \frac{r p}{Z^2}$$

and

$$B = -\frac{\omega L}{R q} - \frac{\omega L p}{Z^2} + \omega K_3 r_1$$

From this we can easily show that, writing  $k^2$  for  $A^2 + B^2$ , and assuming  $\frac{\omega L}{Z}$  to be unity,

$$k^2 = \left( \frac{p}{Z} - \omega K_3 r_1 + \frac{\omega L}{R q} \right)^2 + \frac{r_1^2}{R^2} + \frac{2 p r r_1}{Z^2 R}$$

(1) More correctly, the resonance condition is  $\omega^2 L (K_3 + K_4) = 1 - \omega^2 K_3 K_4 r r_1$ .

The resistance term is negligible with normal values of the quantities involved.

Substituting the value of  $\hat{p}$ , the last term of the above expression becomes

$$\frac{2rr_1}{Z^2R} \left( r_1 + \frac{r}{1-\omega^2K_3L} \right)$$

Now, in general,  $1-\omega^2K_3L$  is greater than 0.5, so that the value of the whole expression will never exceed about

$$\frac{2rr_1}{Z^2R} (r_1+2r).$$

As  $r$  and  $r_1$  are small compared with  $Z$  and  $R$ , the expression represents the cube of a small quantity, and may be safely neglected.

Neglecting this term,

$$k^2 = \left( \frac{\hat{p}}{Z} - \omega K_3 r_1 + \frac{\omega L}{Rq} \right)^2 + \frac{r_1^2}{R^2} \quad (10)$$

or, replacing  $Z$  by  $\omega L$  and neglecting the term  $\frac{r_1^2}{R^2}$ , we have

$$k = \frac{\hat{p}}{\omega L} - \omega K_3 r_1 + \frac{\omega L}{Rq} \quad \dots (11)$$

As  $\hat{p} = r_1 + \frac{r}{q}$  the last equation may be written

$$k = \frac{r_1 q^2 + r + \frac{\omega^2 L^2}{R}}{\omega L q} \quad \dots (12)$$

Since both terms on the right hand side of Equation (10) are positive, the minimum value of  $k^2$  occurs when the first term is a minimum, *i.e.*, the minimum value of

$$\frac{E_2}{E_1} (= k)$$

occurs when

$$\frac{P}{Z} - \omega K_3 r_1 + \frac{\omega L}{Rq}$$

is a minimum.

Now, we have altogether three variables linked by the resonance condition

$$\omega^2 L (K_3 + K_4) = 1.$$

After using this condition for the elimination of  $K_4$  we are left with the two independent variables  $L$  and  $K_3$ . We can make the parallel capacity,  $K_3$ , the variable and determine the condition under which  $K_3$  shows an optimum value greater than zero, or we can make  $L$  the variable.

We will first make  $K_3$  the variable. Differentiating Equation (11) with respect to  $K_3$  and equating to zero for a maximum or minimum gives

$$\frac{dk}{dK_3} = \frac{1}{\omega L d} \frac{dp}{dK_3} - \omega r_1 - \frac{\omega L}{Rq^2} \frac{dq}{dK_3} = 0$$

in which

$$\frac{dq}{dK_3} = -\omega^2 L$$

and

$$\frac{dp}{dK_3} = \frac{r\omega^2 L}{(1-\omega^2 K_3 L)^2} = \frac{r\omega^2 L}{q^2}$$

Substituting for  $\frac{dq}{dK_3}$  and  $\frac{dp}{dK_3}$  and multiplying

through by  $\frac{q^2}{\omega}$  gives the optimum condition

$$r - q^2 r_1 + \frac{\omega^2 L^2}{R} = 0$$

Whence

$$q^2 = \frac{rR + \omega^2 L^2}{Rr_1}$$

and the optimum value of parallel capacity

$$K_3 = \frac{1}{\omega^2 L} \left( 1 - \sqrt{\frac{Rr + \omega^2 L^2}{Rr_1}} \right) \quad (13)$$

Thus, in certain circumstances, more fully discussed later, capacity in parallel with the A.T.I. may be beneficial.

Substituting the optimum value of  $K_3$  given by (13) in Equation (11) gives, after simplification,

$$\frac{E_{1(max)}}{E_2} = \frac{1}{k} = \frac{\omega L}{2} \sqrt{\frac{R}{r_1(Rr + \omega^2 L^2)}} \quad (14)$$

We will now make  $L$  the variable. Differentiating Equation (11) with respect to  $L$  and equating to zero, we have

$$\frac{dk}{dL} = \frac{1}{\omega L d} \frac{dp}{dL} - \frac{p}{\omega L^2} + \frac{\omega}{Rq} - \frac{\omega L}{Rq^2} \frac{dq}{dL} = 0$$

in which

$$\frac{dq}{dL} = -\omega^2 K_3$$

and

$$\frac{dp}{dL} = \frac{r\omega^2 K_3}{(1-\omega^2 K_3 L)^2} = \frac{r\omega^2 K_3}{q^2}$$

Substituting these values of  $\frac{dq}{dL}$  and  $\frac{dp}{dL}$  gives the optimum condition

$$\frac{r\omega K_3}{Lq^2} - \frac{1}{\omega L^2} \left( r_1 + \frac{r}{q} \right) + \frac{\omega}{Rq} + \frac{\omega^3 L K_3}{Rq^2} = 0$$

On substituting the value of  $q$ , and rearranging the terms the last equation reduces to

$$\left\{ \frac{1-\omega^2 K_3^2 R r_1}{R(r+r_1)} \right\} \omega^2 L^2 + 2\omega K_3 \cdot \omega L = 1 \quad (15)$$



The positive root of this quadratic equation gives the value of  $L$  which makes the voltage,  $E_1$ , across the A.T.I. a maximum. The magnitude of this voltage, or rather the ratio of  $E_1$  to  $E_2$ , is obtainable by substituting this optimum value of  $L$  in Equation (11). As the final expression so obtained is too complicated to be of much use, the results for three special cases will be considered, and our deductions will be drawn

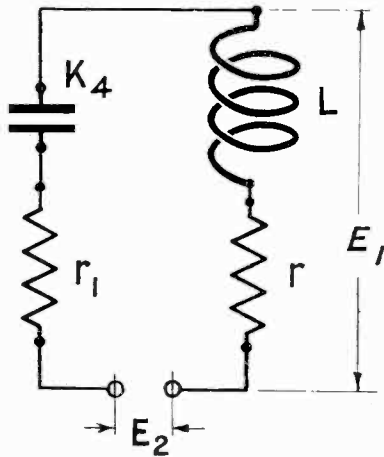

Fig. 4.

from these results. In the first case, of theoretical interest, it is assumed that the receiving circuit produces no loading whatever, and that the A.T.I. has no self-capacity and no parallel condenser. Such conditions are approached in retro-active valve sets. That is, it is assumed that  $K_3$  (Fig. 3) is zero, and that  $R$  is infinite. The circuit then reduces to that shown in Fig. 4.

In the second case, particularly applicable to receivers with series tuning only, it is assumed that the loading effect of  $K_3$  is very small in comparison with that of  $R$ , and the effect of  $R$  is investigated. The circuit for this case is shown in Fig. 5.

In the third case, it is assumed that the load resistance  $R$  is great compared with the parallel capacity reactance, and the effect of the latter is investigated. This circuit is shown in Fig. 6.

*Case I.—Aerial Circuit Unloaded.*

$K_3 = 0$  and  $R = \infty$ . (Fig. 4).

Although the results for this case may be deduced from equations (7), (8) and (9) they are more easily obtained directly.

Denoting the supply voltage by  $E_2$ , and the voltage across the A.T.I. by  $E_1$ , we have, when the circuit is resonant:

$$\text{current } (I) = \frac{E_2}{r + r_1}$$

and

$$E_1 = I \sqrt{r^2 + \omega^2 L^2} = \frac{E_2 \sqrt{r^2 + \omega^2 L^2}}{r + r_1}$$

So that

$$\frac{E_1}{E_2} = \frac{\sqrt{r^2 + \omega^2 L^2}}{r + r_1}$$

As  $r$  is small compared with  $\omega L$ , we have approximately

$$\frac{E_1}{E_2} = \frac{\omega L}{r + r_1} \dots \dots (16)$$

As the turns on the A.T.I. are increased,  $L$  increases approximately as the square of the turns, while  $r$  increases more or less in direct proportion to  $L$  if the type of coil is constant; so that for any given value of  $E_2$ , the value of  $E_1$  increases to the asymptotic value  $\frac{\omega L}{r}$  as the turns on the A.T.I. are increased.

*Case II.—Effect of Load Resistance.*

$K_3 = 0$ . (Fig. 5).

Neglecting terms involving  $K_3$ , Equation (15) reduces to

$$\omega^2 L^2 = R(r + r_1) \dots \dots (17)$$

and Equation (12) becomes

$$k = \frac{r + r_1}{\omega L} + \frac{\omega L}{R} \dots \dots (18)$$

since, in this case,  $q = 1$ .

Substituting in (18) the value of  $L$  given by (17) we have

$$k = 2 \sqrt{\frac{r + r_1}{R}}$$

or

$$\frac{E_{1(max)}}{E_2} = \frac{1}{2} \sqrt{\frac{R}{r + r_1}} \dots \dots (19)$$

*Case III.—Effect of Parallel Capacity.*

$R$  infinite. (Fig. 6).

Neglecting terms involving  $1/R$ , Equation (14) becomes

$$-\frac{\omega^2 K_3^2 r_1}{r + r_1} \cdot \omega^2 L^2 + 2\omega k_3 \cdot \omega L = 1_1$$

Whence the optimum value of inductance

$$L = \frac{I}{\omega^2 K_3} \cdot \frac{r+r_1}{r_1} \left( 1 - \sqrt{\frac{r}{r+r_1}} \right)^3 \quad (20)$$

Similarly, Equation (11) becomes

$$k = \frac{\phi}{\omega L} - \omega K_3 r_1 \dots \quad (21)$$

Substituting in (21) the optimum value of  $L$  from (20) gives, after simplification,

$$\frac{E_{1(max)}}{E_2} = \frac{I}{k} = \frac{(\sqrt{r+r_1} - \sqrt{r})^2}{r_1^2 \omega K_3} \quad (22)$$

Also, making  $\frac{I}{R}$  equal to zero in Equation (13) gives the optimum value of

$$K_3 = \frac{I - \sqrt{r/r_1}}{\omega^2 L} \dots \quad (23)$$

As  $\omega^2 K_3 L$  must be positive,  $r/r_1$  must not be greater than unity for this optimum value to be admissible.

Similarly, from Equation (14) we have

$$\frac{E_{1(max)}}{E_2} = \frac{\omega L}{2} \sqrt{\frac{I}{r r_1}} \dots \quad (24)$$

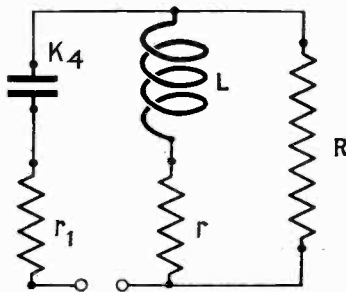

Fig. 5.

The last equation gives the voltage across the A.T.I. using the optimum value of  $K_3$ . The fact that this voltage is greater than that obtained when  $K_3$  is zero is easily seen from Equation (21).

Putting  $K_3 = 0$  in this equation gives

$$k = \frac{\phi}{\omega L}$$

As, in this case,  $\phi = r+r_1$ , we have

$$\frac{E_1}{E_2} = \frac{I}{k} = \frac{\omega L}{r+r_1} \dots \quad (25)$$

Since  $(\sqrt{r_1} - \sqrt{r})^2$  must be positive,  $r_1 + r - 2\sqrt{r r_1}$  is positive; that is,

$$r+r_1 > 2\sqrt{r r_1}, \text{ or } \frac{I}{r+r_1} < \frac{I}{2\sqrt{r r_1}}$$

<sup>3</sup> The solution having the positive sign before the square root sign is inadmissible as  $\omega^2 K_3 L$  must be less than unity.

Hence, the value of  $\frac{E_1}{E_2}$  given by Equation (24) is greater than that given by Equation (25). Thus, when  $r_1$  is greater than  $r$  there is a true optimum value of parallel capacity. If  $r$  is greater than  $r_1$  the voltage across the A.T.I. increases to the asymptotic value given by Equation (25) when  $K_3$  is indefinitely reduced.

Collecting together the essential formulæ developed above we have the following results:—

*Notation.*

$L$  = inductance of A.T.I. in henries.

$K_3$  = total capacity in parallel with the A.T.I. (including self-capacity of A.T.I. and capacity of receiving circuit) in farads.

$K_4$  = resultant of aerial and series tuning capacities, in farads.

$r$  = resistance of A.T.I., in ohms.

$r_1$  = total aerial resistance, in ohms.

$R$  = equivalent resistance of receiving circuit, in ohms.

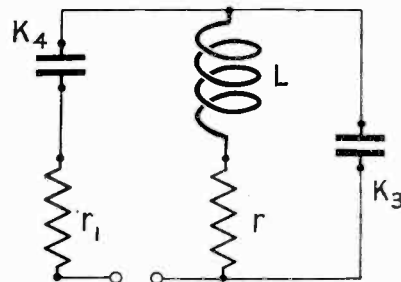

Fig. 6.

$E_1$  = voltage across A.T.I.

$E_2$  = a constant voltage supplied to the circuit.

$\omega = 2\pi \times \text{frequency}$ .

*General Case.*

$$\frac{E_1}{E_2} = \frac{\omega L q}{r_1 q^2 + r + \frac{R}{r}} \dots \quad (I)$$

in which  $q = I - \omega^2 K_3 L$

(a) There is an optimum value of parallel capacity

$$K_3 = \frac{I}{\omega^2 L} \left( 1 - \sqrt{\frac{Rr + \omega^2 L^2}{Rr_1}} \right) \quad (II)$$

For this value of  $K_3$

$$\frac{E_{1(max)}}{E_2} = \frac{\omega L}{2} \sqrt{\frac{R}{r_1(Rr + \omega^2 L^2)}} \quad (III)$$

(b) There is an optimum value of  $L$ , say  $L_0$ , given by the positive solution of the quadratic.

$$\left\{ \frac{1 - \omega^2 K_3^2 R r_1}{R(r + r_1)} \right\} \omega^2 L^2 + 2\omega K_3 \cdot \omega L - 1 = 0 \quad \text{(IV.)}$$

With this value of  $L$

$$\frac{E_{1(max)}}{E_2} = \frac{\omega L_0 q_0}{r_1 q_0^2 + r + \omega^2 L_0^2} \dots \text{(V.)}$$

in which  $q_0 = 1 - \omega^2 K_3 L_0$ .

Case I.— $K_3 = 0$ , and  $R = \infty$ . Aerial circuit unloaded.

In this case there is no optimum value of  $L$ , and

$$\frac{E_1}{E_2} = \frac{\omega L}{r + r_1} \dots \text{(VI.)}$$

Here  $E_1$  increases to the asymptotic value  $\frac{\omega L}{r}$  as  $L$  is increased, if we assume that  $r$  is proportional to  $L$  at constant frequency.

Case II.— $K_3 = 0$ . Effect of  $R$ .

$$\frac{E_1}{E_2} = \frac{\omega L R}{R(r + r_1) + \omega^2 L^2} \dots \text{(VII.)}$$

In this case there is an optimum value of  $L$  given by the equation

$$L = \frac{\sqrt{R(r + r_1)}}{\omega} \dots \text{(VIII.)}$$

For this value of  $L$

$$\frac{E_{1(max)}}{E_2} = \frac{1}{2} \sqrt{\frac{R}{r + r_1}} \dots \text{(IX.)}$$

Case III.— $R = \infty$ . Effect of parallel capacity.

$$\frac{E_1}{E_2} = \frac{\omega L (1 - \omega^2 K_3 L)}{r_1 (1 - \omega^2 K_3 L)^2 + r} \dots \text{(X.)}$$

(a)  $r > r_1$ .

In this case there is no optimum value of  $K_3$ , and the value of  $\frac{E_1}{E_2}$ , given in Equation (X.), increases as  $K_3$  is reduced. When  $K_3$  becomes zero, the right hand side of the equation reduces to that given above in Case I.

(b)  $r < r_1$ .

In this case there is the optimum value of parallel capacity

$$K_3 = \frac{1 - \sqrt{\frac{r}{r_1}}}{\omega^2 L} \dots \text{(XI.)}$$

With this value of  $K_3$ ,

$$\frac{E_{1(max)}}{E_2} = \frac{\omega L}{2\sqrt{r r_1}} \dots \text{(XII.)}$$

(c) For any values of  $r$  and  $r_1$ , there is the optimum value of aerial tuning inductance

$$L = \frac{1}{\omega^2 K_3} \cdot \frac{r + r_1}{r_1} \left( 1 - \sqrt{\frac{r}{r + r_1}} \right) \quad \text{(XIII.)}$$

With this value of  $L$

$$\frac{E_{1(max)}}{E_2} = \frac{(\sqrt{r + r_1} - \sqrt{r})^2}{r_1^2 \omega K_3} \dots \text{(XIV.)}$$

With regard to Case III. (b), Equation (XII.) shows that the voltage across the A.T.I. increases with  $L$ . But Equation (XI.) shows that if  $L$  is increased the optimum value of  $K_3$  decreases. Thus, the best results are obtainable when  $K_3$  is made as small as possible. We will illustrate this by numerical examples.

Assuming the following numerical values for the constants:—

$$\frac{r}{r_1} = .64, \text{ so that } \sqrt{\frac{r}{r_1}} = .8$$

$$L = 100 \text{ microhenries} = 10^{-4} \text{ henries.}$$

$$\omega = 5.2 \times 10^6 \text{ (for a wave-length of 360 metres).}$$

From Equation (XI.) the best value of parallel condenser

$$K_3 = \frac{(1 - .8) \cdot 10^6}{5.2 \times 5.2 \times 10^{12} \times 10^{-4}} = .00007 \mu\text{F}$$

and, for this value of  $K_3$ , we have from Equation (XII.)

$$\frac{E_{1(max)}}{E_2} = \frac{5.2 \times 10^6 \times 10^{-4}}{2 \times .8 r_1} = \frac{325}{r_1}$$

If we make  $K_3$  zero instead of .00007, we have from Equation (VI.)

$$\frac{E_1}{E_2} = \frac{5.2 \times 10^6 \times 10^{-4}}{1.64 r_1} = \frac{317}{r_1}$$

Thus, in this particular case the parallel condenser of capacity .00007  $\mu\text{F}$  increases the voltage across the A.T.I. in the ratio  $\frac{325}{317}$ —an increase of  $2\frac{1}{2}$  per cent.

If we increase  $L$  to 200 microhenries, retaining the previous values of  $\frac{r}{r_1}$  and  $\omega$ , the optimum value of  $K_3$  is now only .000035  $\mu\text{F}$ , and with this value of  $K_3$ ,

$$\frac{E_1}{E_2} = \frac{650}{r_1}$$

If  $K_3$  is zero,

$$\frac{E_1}{E_2} = \frac{634}{r_1}$$



showing that the parallel condenser again increases the voltage  $2\frac{1}{2}$  per cent.; but the voltages in the second case are double what they were before with the smaller value of  $L$ .

The above calculation is not quite an accurate comparison of the two cases, for we assumed that when  $L$  was doubled,  $\frac{r}{r_1}$  remained unchanged. If we assume that the larger coil has the same power-factor as the smaller, the resistance  $r$  of the A.T.I. will be approximately twice its original value. Thus  $\frac{r}{r_1}$  will be increased to  $2 \times .64 = 1.28$ , and  $\sqrt{\frac{r}{r_1}}$  will be 1.13.

Using these corrected figures there is no optimum value of  $K_3$ , as  $\frac{r}{r_1}$  has become greater than unity.

With zero value of  $K_3$ ,

$$\frac{E_1}{E_2} = \frac{546}{r_1}$$

Here the previous advantage of the parallel condenser disappears as  $\frac{r}{r_1}$  exceeds unity. The voltage across the A.T.I. is reduced from  $\frac{650}{r_1}$  to  $\frac{546}{r_1}$ —a reduction of 16 per cent. if  $r_1$  remains unchanged<sup>7</sup>—due to the increase in resistance of the A.T.I.

We have dealt with Case III. (b) at some length as this was the only case in which a parallel tuning condenser appeared to justify itself. But we have seen that it is only of use in cases where the inductance of the A.T.I. is too low for efficient working without the condenser. Better results are obtainable by increasing the inductance of the A.T.I. to the optimum as limited by the unavoidable parallel capacity and employing series tuning. The importance of keeping down the self-capacity of the A.T.I. and the capacity of the grid-filament circuit is that by reducing these capacities to a minimum we are able to force up the optimum value of  $L$ .

It may be as well, perhaps, to point out that if the value of  $L$  is increased beyond

<sup>7</sup> Actually  $r_1$  may not remain constant, as it includes the equivalent series resistance of the series condenser, and this resistance may increase rapidly as the capacity is reduced.

the optimum value the voltage across the A.T.I. is reduced. The circuit may be tunable with a series condenser when the inductance is a long way above its optimum value—as is shown by the experimental results given below.

We will now discuss the effect of the resistance loading of the receiving circuit. Reverting to Case II, we see that the voltage across the A.T.I. has its maximum value when the inductance has the particular value defined by Equation (VIII.), and that this voltage is directly proportional to the square root of the load resistance  $R$ , and inversely proportional to the square root of the total resistance in the aerial circuit. Thus, if we double the former resistance, or halve the latter,  $E_1/E_2$  will be increased 41 per cent. provided that the value of  $L$  is suitably readjusted. If  $R$  is doubled then  $L$  must be increased 41 per cent. (neglecting any change in  $r$  due to alteration of  $L$ ), but if  $r+r_1$  is halved  $L$  would have to be reduced in the ratio of 1 to  $\sqrt{2}$ .

In the case of a valve the value of  $R$  depends on the grid bias and signal strength, and also on the load in the anode circuit.<sup>8</sup> Its value is often not as high as is sometimes imagined, and a useful increase in voltage may be obtainable by putting negative bias on the grid, and thus increasing  $R$ . The effect of grid bias on the input grid-filament voltage in the case of an  $R$ -type valve is shown later. (See Figs. 12 and 13.)

High frequency valves are often stabilised by putting positive bias on the grids. Unfortunately, this also reduces the grid-filament voltage. It is much preferable to stabilise by damping the plate circuit, or, better still, by one of the neutrodyne or bridge methods. With the neutrodyne, nearly the maximum grid-filament signal volts and the maximum valve amplification may be maintained. With resistance damping of the tuned plate circuit, the valve amplification may be reduced somewhat, but the grid-filament volts are maintained, whereas with positive bias the valve amplification is maintained but the signal voltage on the grid is reduced. Assuming the loudness of the final results to be equal in the last two cases, the quality of telephony signals given by the former method must surely be the better.

<sup>8</sup> See Appendix B for values of  $R$  for valves.

In the case of crystal circuits, where  $R$  has a lower value, the equations in Case II. are applicable, but we have to regard these equations in rather a different way. The criterion of efficiency of a crystal circuit is not to get the greatest voltage across the A.T.I., but to get the greatest rectified current through the crystal, *i.e.*, to get the greatest current through a resistance  $R$  equivalent to that of the crystal circuit.<sup>9</sup>

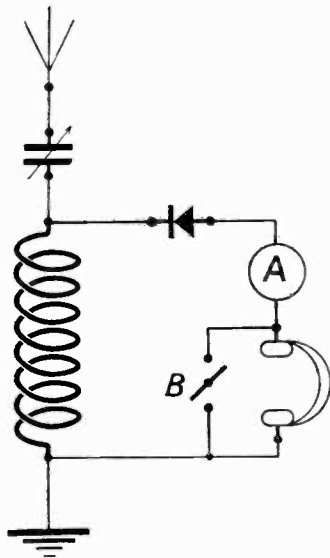

Fig. 7.

Denoting the crystal current obtained with the optimum value of  $L$  (as defined in Equation (VIII.)) by  $I_{(max)}$ , we have

$$I_{(max)} = \frac{E_{1(max)}}{R}$$

Substituting for  $E_{1(max)}$  from Equation (IX.) gives

$$I_{(max)} = \frac{E_2}{2\sqrt{R(r+r_1)}} \quad \therefore \text{(XV.)}$$

Equation (XV.) shows that the optimum crystal current is inversely proportional to the square root of the equivalent resistance of the crystal circuit. Thus, low resistance crystals, such as the galena type, must give better results than those of high resistance, such as the perikon type, assuming that the crystals have equally good rectifying powers, and that the optimum value of  $L$  is used in each case.

Equation (VIII.) shows that the value of

<sup>9</sup> See Appendix B for details as to the value of  $R$  for crystals.

$L$  should be lower for the galena crystal than for the perikon. In either case  $L$  will be very much lower than is required for a valve circuit.

The best value of  $L$  for a crystal circuit is a matter of considerable variation. It depends on the type of crystal and on its adjustment. It also varies with the signal strength, as the crystal resistance varies with the current. Also, the number of pairs of phones in use will affect the result. Quantitative data on these points are given below.

**Limitation Set by Aerial Capacity.**

We have shown above that capacity across the A.T.I. should be reduced to a minimum, and that the inductance should have a definite value for maximum efficiency on a given wave-length. Thus, in order to tune the circuit, it is necessary to use a series condenser to bring down the resultant aerial capacity to its correct value. This assumes, of course, that the aerial capacity is great enough to enable the series condenser to be used. On present broadcast wave-lengths, *with valve circuits*, indoor and small outdoor aerials may require two or more wires in parallel to bring up their capacity to the requisite value—which is about  $\cdot 0002\mu F$ . An outside single wire aerial of the full 100 ft. dimensions has sufficient capacity, and there is no advantage to be gained, on the 300 to 500 metre wave-band, by still further increasing the aerial capacity. But if it is desired to obtain the maximum efficiency on longer waves it is necessary to run additional wires in parallel, for the capacity required increases in proportion to the wave-length.

Arrangements may be made to disconnect, and earth, the extra parallel wires when it is required to tune down to short waves.<sup>10</sup>

In the case of crystal circuits the optimum inductance is only about one-third of that required for a valve, and hence an aerial capacity three times greater is required for the crystal. For maximum crystal results on 500 metres, an aerial capacity of about  $\cdot 002\mu F$  is required if the set is tuned with a variometer or tapped coil. With series condenser tuning, the aerial capacity should

<sup>10</sup> This arrangement is open to criticism, as it would appear that the effective height of the aerial is reduced. However, on our twin aerial we invariably get an increase in signal strength when one-half of the aerial is earthed. This result may be quite exceptional.

be made two or three times this amount so as to enable the resultant capacity to be brought down to  $\cdot 002\mu\text{F}$ .

The average aerial has a capacity certainly not greater than  $\cdot 00025\mu\text{F}$  and the best

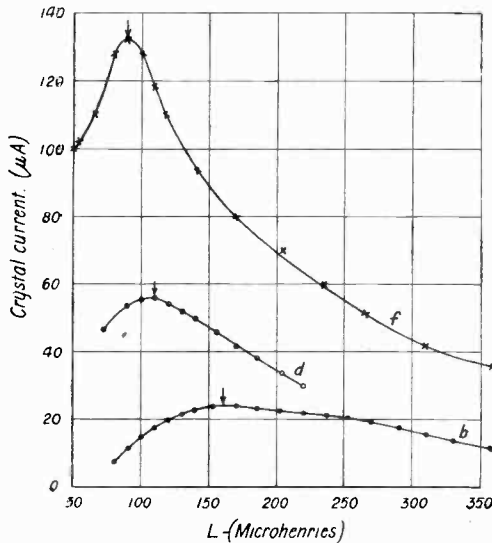

Fig. 8.

possible results with a crystal receiver are not obtainable on such an aerial on wavelengths above about 250 metres.

If, for some reason, it is impossible to increase the aerial capacity to the required value, the next best thing to do is to increase the inductance until it tunes with the full aerial capacity. This method gives greater efficiency than using a smaller inductance value and a parallel condenser. Under these conditions an improvement may be obtainable by tapping the crystal circuit off a portion of the inductance, as advocated by F. M. Colebrook; but while this method secures a better balance between the losses in the various parts of the circuit with a given aerial, in our experience it does not fully compensate for a deficiency of aerial  $K$ . Using approximately the best aerial  $K$ , the best crystal tap will be found at, or very near, the extreme end of the coil, giving practically plain coil connections. As the aerial  $K$  is reduced the A.T.I. must be increased, and the best crystal tap gets further from the end of the coil. At the same time the signal strength gradually decreases at the best crystal tapping.<sup>11</sup>

### Experimental Results.<sup>12</sup>

Experimental results confirming the above conclusions will now be given.

#### Case II.—Effect of load resistance of a crystal.

The connections for the first series of tests on crystal circuits, with series condenser tuning, are shown in Fig. 7. A microammeter  $A$  was connected in series with the crystal, and a switch  $B$  was arranged so that the crystal current could be read with the phones (4 000 ohms) short-circuited. Voltages across the A.T.I. were measured on a thermionic voltmeter. Basket coils were used for the A.T.I. These coils were wound initially with a sufficient number of turns to tune with a small value of series capacity. Turns were then removed, step by step, the circuit being kept tuned by means of the series condenser.

The variation of crystal current with the inductance, on 2LO's carrier, is shown by the graphs in Figs. 8 and 9. The curves in Fig. 8 were obtained with the phones short-circuited; those in Fig. 9 with one pair of 4 000 ohms phones in series with the crystal. The curves  $a$ ,  $b$ ,  $c$  and  $d$ , refer to high resistance zincite-copper pyrites crystal

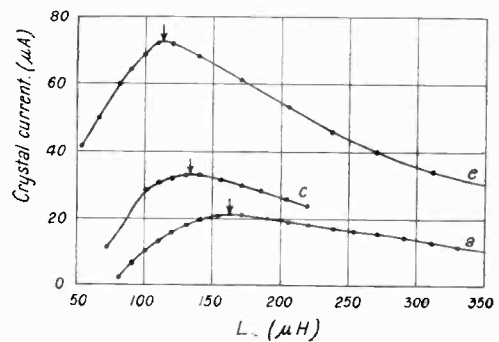

Fig. 9.

combinations. A large number of specimens of these crystals were tried. Curves  $c$  and  $d$  refer to the most sensitive, and  $a$  and  $b$  to the least sensitive of these specimens. Curves  $e$  and  $f$  are representative of the sensitised galena type of crystal with silver catwhisker.

<sup>11</sup> Author's paper on "Best Crystal Circuits," *Wireless World and Radio Review*, August 20 and 27, 1924.

<sup>12</sup> All the experiments described in this article were carried out at the Chelsea Polytechnic.

The graphs in Fig. 10 show how the voltage across the A.T.I. varies with its inductance with the same crystal loading as for the corresponding graphs (*i.e.*, graphs with the same lettering) in Figs. 8 and 9. The curve *g*, Fig. 10, shows the variation of volts with inductance when the A.T.I. is loaded only with the voltmeter.

Figs. 8 to 10 show very clearly the effect of the resistance of the receiving circuit on the optimum inductance. Taking the extreme cases shown by the curves *f* and *g* we find that with the light loading of the voltmeter the best results are obtained with

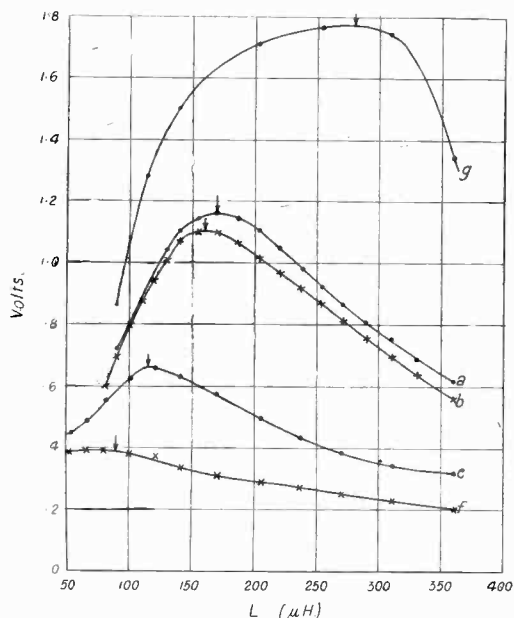

Fig. 10.

an inductance of about 280 microhenries whereas with the heavy loading of a low resistance galena crystal, without phones, the best results are given with an inductance of only 90 microhenries. If the A.T.I. is wound with an inductance of 280 microhenries for the latter circuit the crystal current is only 48 microamps against 132 microamps with 90 microhenries. Conversely, if an inductance of 90 microhenries—the best for the crystal—is used with the valve circuit the grid-filament volts are reduced to 0.86, against 1.77 volts with an inductance of 280 microhenries.

The effect of the number of pairs of phones on the optimum value of *L* is shown in Fig. 11. These curves show the variation of crystal current with inductance for one, two or three pairs of 4 000 ohm phones connected in series with the crystal. The number against each curve indicates the number of pairs of phones to which the curve refers. The curve (0) shows the variation of crystal current with *L* with all the phones short-circuited, leaving only the crystal and microammeter across the A.T.I. A "Talite" crystal was used in this case and its adjustment remained unaltered throughout the test.

The chief results are collected in Table I.

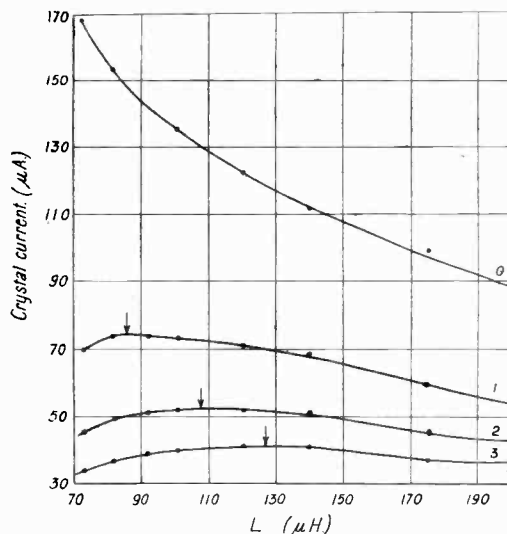

Fig. 11.

TABLE I.

Number of Pairs of Phones in Series.	Maximum Crystal Current.	Optimum Inductance in Microhenries.
0	> 168	< 73
1	75	86
2	52	108
3	42	127

The curve (0) could not be continued for values of *L* lower than 73 microhenries, as at this point the full aerial capacity—0.004 mF. was in use.



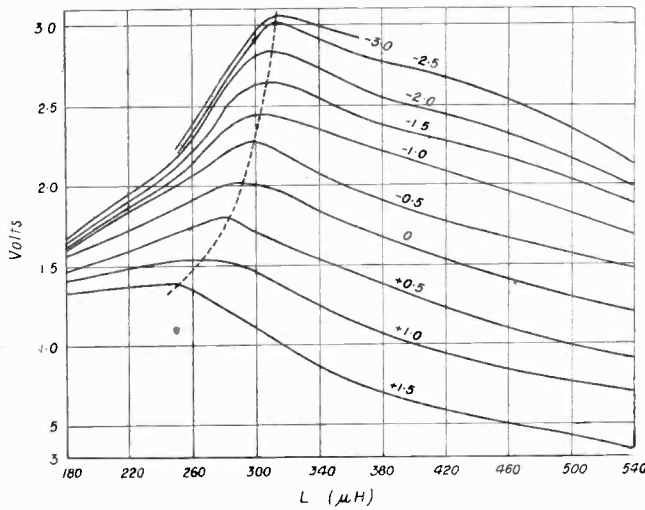

Fig. 12.

Comparing the curve (o), Fig. 11, with (f), Fig. 8, and also (r), Fig. 11, with (e), Fig. 9, which pairs of curves refer to similar conditions, it will be noted that (o) and (r) which have higher maximum currents also have lower values of optimum inductance respectively than (f) and (e). This is what would be expected on theoretical grounds, for in the test referred to in Fig. 11 a more efficient aerial was used and the signal strength was greater. As the crystal current was increased its resistance was reduced, and hence the optimum value of  $L$  was reduced.

It is surprising that the two sets of curves are in such close agreement, for the readings were taken on different aerials (one having a capacity of  $.0008\mu\text{F}$ , the other  $.0004\mu\text{F}$ , and different makes of crystals, phones, and tuning condensers were used. Also, ten months elapsed between the two sets of tests. This is a good testimony to the constancy of  $2LO$ 's transmission.

**Effect of Valve Detector.**

The families of curves in Fig. 12 and 13 show how the voltage across the A.T.I. varies with its inductance for a number of different values of grid bias in the case of an R-type valve. The H.T. was 4 volts only for the curves in Fig. 12 and 70 volts for those in Fig. 13. It was impracticable to obtain a complete range of curves in the latter case as the valve under these conditions became insensitive as a rectifier (no

grid-condenser and leak being usable) and accurate calibration of the readings was impossible.

The magnitude of the grid bias, in volts, is indicated by the figures against the curves. The dotted line in Fig. 12 is drawn through the highest points of the curves, and shows that the best value of inductance steadily increases as the grid is made more negative. They also prove that the voltage across the A.T.I. (i.e., the grid-filament voltage) increases as the optimum value of  $L$  is increased. For example, from Fig. 12 an inductance of 314 microhenries is the optimum for the particular value of grid-filament resistance  $R$  given by a grid bias of  $-3$  volts. The corresponding voltage

across the A.T.I. is 3.06 volts. With this same value of  $L$ , but with  $+1$  volts grid bias, the voltage across the A.T.I. is reduced to 1.40 volts. If the value of  $L$  is now reduced to 266 microhenries, which is the optimum value for  $+1$  volts grid bias, the voltage across the A.T.I. is increased to 1.55 volts.

The variation of the optimum value of  $L$  with grid bias is illustrated in Fig. 14, while Fig. 15 shows how the maximum voltage across the A.T.I., using optimum values of  $L$ , varies with the grid bias. It will be seen from Fig. 15 that the greatest possible grid-filament voltage is not attained for all values of H.T. until the negative bias reaches 3 volts. As the R.M.S. value of the signal voltage is 3.06, its peak value will be about 4.3 volts. Thus, with the grid biased to  $-3$  volts, the tops of the signal waves

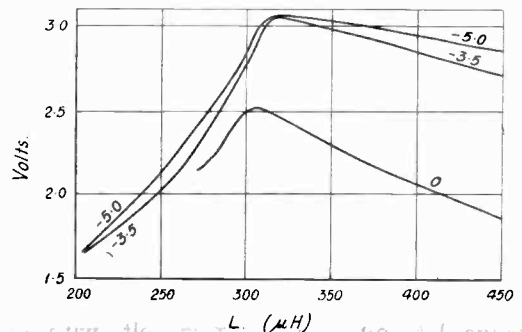

Fig. 13.

take the grid to a positive potential of 1.3 volts—and some grid current will still flow during parts of the cycle. With 4 volts H.T. the average value of grid current over

the peaks of the voltage waves will be flattened. To avoid entirely distortion due to

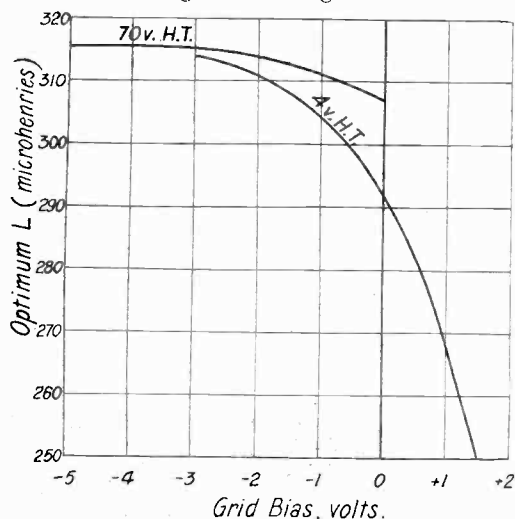

Fig. 14.

the whole cycle was 2 microamperes, and its instantaneous value at the peak of the wave was 20 microamperes. Although there is no appreciable loss of voltage when the grid current is reduced to these limits some distortion of the strong signals will result, as

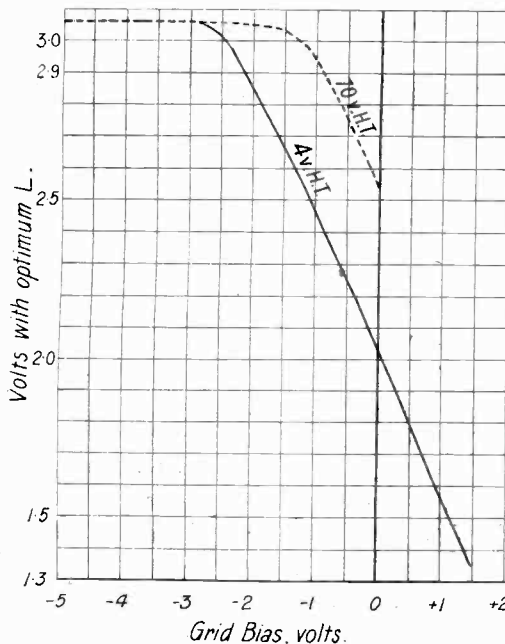

Fig. 15.

this cause it is necessary to bias the grid to -5 volts with signals of 3 volts R.M.S. value.  
(To be concluded)



A number of the delegates to the recent Conference in Paris at the home of Mr. G. Marcuse (2 NM) just after the Conference closed. Standing (left to right): Mr. Hight (U.S.A.), Major W. C. Borrett (Nova Scotia), Mr. Reid (Newfoundland), Mr. J. Morris (U.S.A.), and Mr. Nicholls (Gt. Britain). Seated (left to right): Mrs. Hiram P. Maxim (France), Mr. Hiram P. Maxim (Pres. A.R.R.L.), Mr. G. Marcuse, Mr. K. B. Warner (Sec. A.R.R.L.), and Mrs. G. Marcuse.



# A Further Note on Parasitic Losses in Inductance Coils.

By Raymond M. Wilmotte, B.A.

[R382·1

**I**N the article which appeared under this heading in last month's E.W. & W.E., through an unfortunate clerical error, the value of the D.C. resistance in the table on page 481 was given as 0.245 ohm instead of 0.405 ohm. I would also like to add a further note on this subject.

It was not my intention to create the belief that the dielectric losses in coils were usually the most important source of their effective resistance—the impression I unwittingly appear to have given a number of people. In fact, the results showing the effect of different materials for the insulation covering of the wires (given in the table on page 481) show that the difference is not very large.

The drastic treatment of plunging the coil into a bucket of water shows a considerable effect with cotton-covered wire, but it is to be supposed that inductance coils are not usually subjected to such treatment. The results were given to show the order of magnitude of the effect which the nature of the dielectric could produce; they also show that the effect is not excessive unless the dielectric is appallingly bad, as wet cotton certainly is.

with air as the only dielectric,  $L$  is the self inductance, and  $K$  and  $P$  are the "average" dielectric constant and power factor respectively of the insulation. It should be noticed that the products  $PK$  and  $I/C_0\omega$  have to be large to produce a really large effect for ordinary values of the impedance of the coil. The term may become appreciable, but will rarely be overwhelmingly so.

With further reference to this formula, it was pointed out to me that the meaning of the terms "average" power factor and "average" dielectric constant should be more definitely explained. By these terms I meant the power factor and dielectric constant of an imaginary substance in which the winding of the coil would be completely immersed, and which would produce the same effect as the various insulations which form the dielectric surrounding the coil; that is, it would produce the same self-capacity and the same dielectric loss as in the original coil.

Two cases are of special interest. The first is the case in which part of the electrostatic lines of force can be considered to pass from one turn to another wholly through the air and part wholly through the insulation,

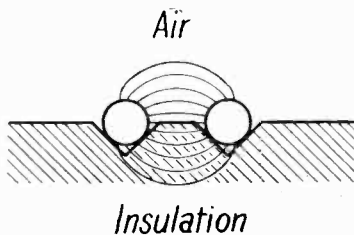

Fig. 1.

A method of estimating very roughly the possible effect of the dielectric in a coil of which the self inductance and self capacity are known was given in the article of last month and resulted in the formula

$$PKL^2C_0\omega^3 \dots \dots (1)$$

for the added effective resistance due to the dielectric loss, where  $C_0$  is the self capacity

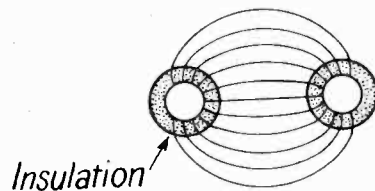

Fig. 2.

as in Fig. 1. This is very often the case for the supporting insulation. In the second case, the lines of electrostatic force pass from one turn to another with part of their path lying in the insulation and the other in the air as in Fig. 2. This is the usual case of the insulation covering the wire.

Let us consider the first case. Fig. 1 can evidently be replaced by two condensers in

parallel (Fig. 3), one having zero power factor, a dielectric constant equal to unity, and a capacity  $C_0$ ; the other having a power factor  $P_1$ , a dielectric constant  $K_1$  and a capacity  $K_1C_0'$ . As a first approximation, we can assume  $C_0$  and  $C_0'$  to be independent of  $K_1$ —that is of the nature of the dielectric. (This is not strictly true, for a change in the value of the dielectric constant of the insulation will affect the distribution of the electrostatic lines of force.)

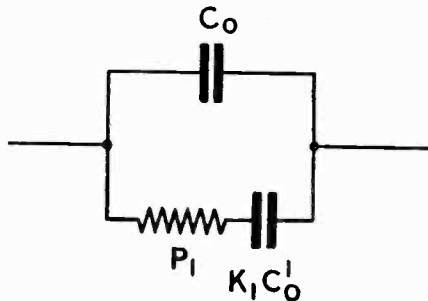

Fig. 3.

With the above assumption, the effective resistance of the combination of the two condensers is

$$\frac{P_1 K_1 C_0'}{(C + K_1 C_0')^2 \omega'}$$

and the effective capacity is  $(C_0 + K_1 C_0')$ , so long as the power factor  $P_1$  is not excessively large.

Hence the equivalent power factor of the combination is

$$\frac{P_1 K_1 C_0'}{(C_0 + K_1 C_0')} \dots \dots (2)$$

the equivalent dielectric constant is

$$\frac{C_0 + K_1 C_0'}{C_0 + C_0'} \dots \dots (3)$$

and the product of the dielectric constant and power factor becomes

$$\frac{P_1 K_1 C_0'}{C_0 + C_0'} \dots \dots (4)$$

If the whole coil could be represented in this way, expressions (2) and (3) would become approximately the "average" power factor and dielectric constant respectively of the insulation of the coil as used in expression (1).

It will be seen that the product of the power factor and dielectric constant is pro-

portional to  $P_1 K_1$ , which I took as the criterion by which to compare dielectrics. For this case, then, this product still gives the true value by which to compare dielectrics.

Turning now to the second case, it is seen that Fig. 2 can, to a first approximation, be replaced by two condensers in series (Fig. 4), one having zero power factor, a dielectric constant of unity and a capacity  $C_0$ , and the other having a power factor  $P_2$ , a dielectric constant  $K_2$  and a capacity  $K_2 C_0''$ , where, as before, it is assumed that  $C_0$  and  $C_0''$  are independent of the value of  $K_2$ .

The effective series resistance of this combination is

$$\frac{P_2}{K_2 C_0'' \omega'}$$

and the effective capacity is

$$\frac{K_2 C_0'' C_0}{K_2 C_0'' + C_0}$$

The "average" power factor therefore is

$$\frac{P_2 C_0}{K_1 C_0'' + C_0} \dots \dots (5)$$

the "average" dielectric constant is

$$\frac{K_2 (C_0 + C_0'')}{K_2 C_0'' + C_0} \dots \dots (6)$$

and the product of the dielectric constant and power factor becomes

$$\frac{P_2 K_2 C_0 (C_0 + C_0'')}{C_0 + K_2 C_0''} \dots \dots (7)$$

The whole coil can be represented approximately by a combination of cases similar to the two considered, which are represented by expressions (2) to (4) and (5) to (7). Other cases in which the lines of electrostatic force pass through a series of different dielectrics may occur, and they may be treated in the same way.

It will be noticed, however, that expression (7) is not proportional to  $P_2 K_2$ , which product has been taken for comparing dielectrics. The dielectric constant  $K_2$  also forms part of it, unless it happens that  $K_2 C_0''$  is small compared to  $C_0$ , which is only the case when the length of the air path of the lines of force is small compared to the length of their path through the insulation.

In many cases this will admittedly not be so. Since however expression (7) shows that a knowledge of both  $C_0$  and  $C_0''$  is necessary to compare dielectrics, and neither of

these quantities can at present be evaluated, the product  $PK$  can still be considered the best criterion for comparing dielectrics, but it must be remembered that for the second case considered it is at best only an approximate comparison value. Thus from expression (7) we see that for two dielectrics for which the product  $PK$  is the same the one having the smaller value of  $K$  will be inferior to the other. For the first case, however, we saw that the product  $PK$  remains a true comparison factor.

Since the article of last month was published, I have come across a paper which shows that, though my statement—that I had not seen the product of the power factor and the dielectric constant mentioned as the true value to compare dielectrics from the point of view of their losses—was at the time correct, that point actually had been emphasised previously.

In this paper, entitled "Power Losses in Insulating Materials," by E. T. Hoch, of the Research Laboratories of the American Telephone and Telegraph and Western Electric Companies, published in *The Bell System Technical Journal* (Vol. I., November, 1922), the product of the dielectric constant and the phase angle is mentioned. The paper says: "Thus it is seen that, while no single factor of the expression can be used to represent the losses, the product of the phase difference and the dielectric constant can be used in this way."

In this paper is given a table of the phase angle, dielectric constant and their product for a number of dielectrics at various radio frequencies and at a number of temperatures.

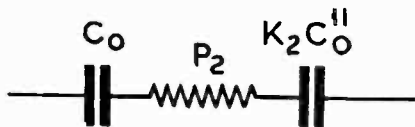

Fig. 4.

The materials are various forms of phenol fibre, oak, maple, birch, ebonite and various glasses (flint, plate, cobalt and pyrex). The frequency range was from about 300 to 1 000 kilocycles and the temperature from about 20°C. to 120°C.

The values for wood are particularly interesting, and I reproduce them in Table I.

Unfortunately the effect of temperature on wood is not given.

TABLE I.

Material.	Frequency (kilo-cycles).	Dielectric Constant $K$	Phase Difference $\psi$	$K \psi$
Oak ..	300	3.2	2.1	6.7
" ..	425	3.3	2.0	6.6
" ..	635	3.3	2.2	7.3
" ..	1 060	3.3	2.4	7.9
Maple ..	500	4.4	.9	8.4
Birch ..	500	5.2	3.7	19.2

The effect of temperature on ebonite is also interesting and the values are reproduced in Table II.

TABLE II.

Temperature °C.	Dielectric Constant $K$	Phase Difference $\psi$	$K \psi$
21	3.0	0.5	1.5
71	3.1	1.2	3.7
120	3.2	3.7	11.8

This table shows that the quality of ebonite, as far as its dielectric losses are concerned, does not change very much with variations of (ordinary air) temperatures. At higher temperatures, however, it becomes rapidly worse. Fortunately no one is likely to attempt to use ebonite at high temperatures!

I would like to add a remark to the editorial footnote which appeared at the bottom of page 481. The Editor remarked that the self-capacity could be reduced, and more of the dielectric consist of air, if the diameter of the wire were reduced without altering the pitch of the turns. This might in certain cases reduce the dielectric loss, particularly if the turns were wound very close together; but in general I would think that the increase of the potential gradient at the surface of the wire would more than counterbalance this. I wish to point out, however, that any reduction in the resistance of a coil, brought about by a decrease in the diameter of the wire used, would not necessarily be due to the effect explained in the editorial footnote.

From the theoretical formulæ of the copper losses of inductance coils, notably those of

S. Butterworth (*Phil. Trans.*, Vol. 222, pp. 57-100, 1921, and *Roy. Soc. Proc.*, Vol. 107, 1925), it is seen that the effect of decreasing the diameter of the wire, if the spacing is too close, may actually decrease the effective resistance of the coil, irrespective of any dielectric loss.

If a big improvement is obtained when the diameter of the wire is reduced, the cause can be put down safely to a reduction in the copper loss and not the dielectric, unless it happens that the dielectric used is ridiculously bad.

It is to be concluded, therefore, that for ordinary commercial coils, the effect of the dielectric loss is not of very great importance, so long as reasonable care is taken in the choice of the materials used; but this is not always the case.

It is only when very high-class inductance coils are designed that it is worth while paying very particular attention to the use and the choice of the insulating material. Dielectric loss exists, and may sometimes be quite appreciable, but with ordinary care it is generally far from being the most important cause of the effective resistance of inductance coils at ordinary radio frequencies. Unfortunately "ordinary care" does not appear to be taken in the design of many small receiving coils now on the market, and in these cases there is no doubt that considerable improvement could be obtained if dielectrics occupied a greater portion of the designers' thoughts. In transmitting coils the position is quite different. Owing to the large potentials used, the dielectric losses may often be very considerable even in good designs.

## The Paris Conference. [R545'06

IT will be remembered that in our last issue we gave a brief *résumé* of the conclusions reached at the International Conference of Amateurs held in Paris just after Easter. This month we are able to publish, almost *in extenso*, a translation of the official report of the discussions and findings of the several sub-committees. The first sub-committee dealt with the constitution of the International Amateur Radio Union. It will be given in full at a later date. In addition, a specially written Esperanto

report—not a translation—will be found on page 584.

### Report of the Second Sub-Committee on Standards and Methods of Working.

The following countries were represented:—  
Poland, U.S.A., Italy, Canada, Newfoundland, Great Britain, France, Holland.

The Committee was of the opinion that it is only possible at the present moment to give rather general suggestions on the subject of experiments to be made later on. It suggested that a representative should be nominated for each country whose duty should be to study its problems and to submit its point of view to the Headquarters of the Union.

In the meanwhile, however, the Committee made the following recommendations:—

(1) That standard methods should be adopted for dealing with time, traffic and the transmission of technical details. These points required immediate consideration and it recommended that Greenwich time should be adopted universally, and should be sent in the form of a group of four figures ranging from 0 000 to 2 359. It was suggested that in future the time 24 00 should not be given, as it creates considerable confusion. A system of letters or figures or the combination of the two should be universally adopted to indicate strength of signal and atmospheric conditions in all international tests.

(2) It was requested that there should be appointed for each country a representative of Headquarters to collect all useful details on the subject of tests and pass them to the central office, who will attend to their publication or transmission by broadcasting.

(3) That each country should establish a sufficient number of amateur stations who will undertake to broadcast information from Headquarters.

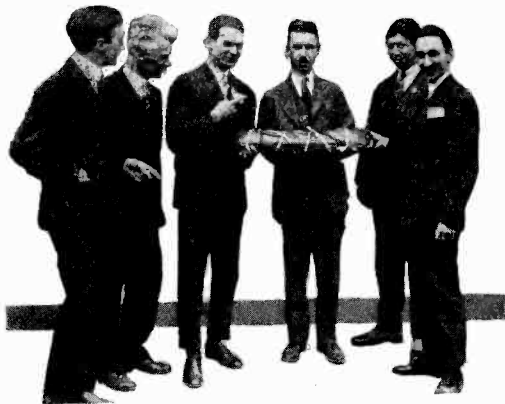

Following a discussion on the question of forming an international roll of wireless "hams," Mr. Warner, secretary of the A.R.R.L., was presented with the gigantic ham roll shown.



(4) In order that tests should be regulated as well as possible to allow the exchange of ideas, there should be established as soon as possible definite international communication at fixed hours between all the countries represented in the Union, which will make it possible to communicate at frequent intervals any messages that may be necessary.

- T .. Poland, Esthonia and Lithuania.
- U .. U.S.A.
- V .. (Tuning Letter).
- W .. Hungary.
- X .. Portable Stations and Ships.
- Y .. India.
- Z .. New Zealand.
- CS .. Czecho-Slovakia.
- é .. Egypt.
- ö .. Austria.



The representative of Sweden proposed that the letter S for Scandinavian countries should be followed by a different letter or number for each of the following: Sweden, Norway, Denmark, Finland. This proposition was accepted by the other delegates.

The Committee proposed that Central and South American countries, excepting Mexico and Cuba, should use the letter A followed by the first letter of the



Two photographs taken during the sitting of the International Congress in Paris.

Left: The presiding bench at which can be seen M. Leon Deloy, F8AB, (third from left), Mr. E. Belin, President of the Congress and Inventor of the Telautograph (fourth from left), and Mr. Hiram P. Maxim and Mr. R. B. Warner (seventh and eighth from left; Pres. I.A.R.U. and Sec. A.R.R.L., respectively.

Right: The general assembly, in which a number of prominent people can be recognised.

**Sub-Committee for Call Letters.**

The following countries were represented:— France, Great Britain, U.S.A., Holland, Belgium, Italy.

Nationality letters were first discussed, and the following list was approved unanimously:—

- A .. Australia.
- B .. Belgium.
- C .. Canada and Newfoundland.
- D .. —
- E .. Spain.
- F .. France.
- G .. Great Britain.
- H .. Switzerland.
- I .. Italy.
- J .. Japan.
- K .. Germany.
- L .. Luxembourg.
- N .. Holland.
- O .. South Africa.
- P .. Portugal.
- Q .. Cuba.
- R .. Russia.
- S .. Scandinavian Countries.

country, as, for example, AA — Argentine, AB—Brazil, etc., and it was suggested that the letter B should be used in the same way for the Balkan countries, as, for example, BA—Albania, BR—Roumania. For other countries that have at present no transmitting amateurs the Committee suggested that the Union itself should provide call letters.

With the exception of the Colonies of Great Britain, all Colonies should adopt the call letters of the nation to which they belong.

The Committee also discussed the nationality numbers for Europe, and accepted the following numbers, which are already recognised by Governments:—

- Italy .. .. . 1;
- Great Britain .. .. . 2, 5 and 6;
- Denmark .. .. . 7;
- France .. .. . 8;
- Switzerland .. .. . 9.

The Committee recommended national associations to propose to their respective Governments the following in addition:—

- Finland .. .. . 3;
- Germany .. .. . 4.

It was suggested that for Belgium and Holland the system actually employed should be continued, in which letters of the alphabet followed by a number are used for Belgium, and the same preceded by the letter P for Holland.

It was recommended that the Association of each country should ask their Government to adopt a single number for the country and to see that it should not be the same as that of neighbouring countries. It was unanimously decided to adopt the American system of calling, in which the call letters of the station wished for are followed by the national letter of the called station, then by the national letter of the calling station and the call sign of the calling station.

Where a CQ call is being sent the dividing letter will be only the national letter of the transmitter.

When it is desired to establish communication at long range, the following call shall be used :

CQ DX x ABC.

in which the small letter x will be replaced by the national letter of the calling station. In order to avoid confusion it is recommended that no national letter shall be used when calling stations which are licensed for receiving only.

An international call book should be published by the Union. The Committee suggested that any national Association of the type of the A.R.R.L. in America, or the A.D.R.S. in Italy, should publish monthly a list of changes of addresses and of new stations licensed ; this should be sent to the general Headquarters of the Union which should undertake to publish supplements whenever there are a certain number of changes.

After a further investigation in full session of the Congress the following propositions were added to those preceding :—

(1) That the approval of the list of national letters was confirmed.

(2) It was confirmed that it is not satisfactory to have the same call-number repeated in neighbouring States.

(3) That the general call-signal CQ should not be repeated more than six times, and the call signals of stations not more than three times.

(4) That as soon as possible the Union should undertake the service of providing call lists kept up to date each month. The service should be offered to those interested, and payment should be made by annual subscription in the same manner as is done for the annual list published at Berne.

**Sub-Committee for International Language.**

The following countries were represented :—

Germany, England, Argentine, Austria, Canada, Spain, U.S.A., France, Hungary, Italy, Ireland, Japan, Netherlands, Poland, Sweden, Switzerland, Czecho-Slovakia, Newfoundland, Uruguay.

After a long discussion the following resolutions were adopted :—

(a) The first International Congress of wireless amateurs, realising the difficulties caused by the diversity of language in International relationships, resolves to recommend the study and employment of Esperanto as an auxiliary language for International communication and radio-telephonic transmissions, as well as in abstracts for translation in the Press and for reports of congresses.

(b) The same resolution applies to radio-telegraphic communication when the correspondents cannot understand one another in a National language.

(c) According to the above resolutions, the Congress itself adopts Esperanto as its own auxiliary International language in addition to the national languages used.

After these three resolutions had been carried, Mr. Warner of the A.R.R.L. asked that a reservation should be made for any case where Governments should decide later on to adopt another language.

**Report of Sub-Committee on Wave-Lengths.**

The Wave-length Committee proposed the following bands for use between different countries :— metres.

Europe ..	.. 43 to 47; 70 to 75; 95 to 115.
Canada & Newfoundland }	.. 41.5 to 43; 115 to 120.
U.S.A. ..	.. 37.3 to 41.5; 65 to 95
The Rest of the World..	35 to 37.3; 85 to 95.

This distribution is designed so that on the one hand different tests can be arranged, and on the other hand there would be the minimum of interference between the transmissions of neighbouring countries. With regard to other wave-lengths, the Committee advises that these should be left free to be employed for experimental work generally, while those given above should be kept for International traffic.



*The British section of the Congress, among whom will be recognised a number of prominent amateurs.*



# More about Errors in Measurement.

By P. K. Turner.

[R800:519·8

(CONCLUSION.)

A simplified treatment of the Method of Least Squares, by which experimental results are treated to find the most accurate possible values.

Table I. reads as follows:—

TABLE I.—EXAMPLE I.

Observation.	$a'$	$m'$
1	1	7
2	2	8
3	3	10
	3) 6	3) 25
	$a_0 = 2$	$m_0 = 8\frac{1}{3}$

and from it we make out the first part of Table II.

As soon as the first three columns have been filled in, the first check is applied, and we find that  $\Sigma a = \Sigma m = 0$ ;  $\Sigma s = n$ , as should be the case. The other columns are then filled up, and we find:—

$$A + C = 5 = P; \quad B + C = 7\frac{2}{3} = Q,$$

thus fulfilling the second check.

We then have

$$x = \frac{C}{A} = 1\frac{1}{2}$$

$$y = m_0 - a_0 x = 8\frac{1}{3} - 2 \times 1\frac{1}{2} = 5\frac{1}{3}.$$

For the probable errors, we have

$$D = B - xC = 4\frac{2}{3} - 3 \times 1\frac{1}{2} = \frac{1}{6}.$$

$$R = Q - xP = 7\frac{2}{3} - 5 \times 1\frac{1}{2} = \frac{1}{6}.$$

The third check being  $D = \frac{1}{6} = R$ .

From the value of  $D$  we have

$$r_x = \sqrt{\frac{.455 \times \frac{1}{6}}{(3-2) \times 2}} = \sqrt{.038} = .195$$

$$r_y = a_0 r_x = 2 \times .195 = .38.$$

As a final check, we will fill up Table III.

TABLE III.

Observation.	$a'$	$a'x$	$a'x + y$	$v = a'x + y - m'$	$v^2$
1	1	$1\frac{1}{2}$	$6\frac{3}{6}$	$-\frac{1}{6}$	$\frac{1}{36}$
2	2	3	$8\frac{1}{3}$	$+\frac{1}{3}$	$\frac{1}{9}$
3	3	$4\frac{1}{2}$	$9\frac{5}{6}$	$-\frac{1}{6}$	$\frac{1}{36}$
				$-\frac{1}{6} + \frac{1}{3} - \frac{1}{6} = 0$	$D = \frac{1}{6} = R$

and we find  $\Sigma v = 0$  and  $\Sigma v^2 = D = R$ , as should be the case. We are therefore justified in saying

$$\left. \begin{aligned} x &= 1\frac{1}{2} \pm .2 \\ y &= 5\frac{1}{3} \pm .4 \end{aligned} \right\}$$

approximate values being inserted for the probable errors.

TABLE II.—EXAMPLE I.

	$a = a' - a_0$			$m = m' - m_0$		$s = a + m + 1$		
Observation.	$a$	$m$	$s$	$a^2$	$m^2$	$am$	$as$	$ms$
1	-1	$-1\frac{1}{3}$	$-1\frac{1}{3}$	1	$1\frac{1}{9}$	$1\frac{1}{3}$	$1\frac{1}{3}$	$1\frac{1}{9}$
2	0	-	+	0	0	0	0	-
3	+1	$+1\frac{1}{3}$	$+3\frac{1}{3}$	1	$2\frac{1}{9}$	$1\frac{1}{3}$	$3\frac{1}{3}$	$6\frac{1}{3}$
	0	0	$3 = n$	2	$4\frac{2}{3}$	3	5	$7\frac{1}{3}$
				A	B	C	P	Q

Unfortunately, practical experimental results do not as a rule fall into convenient whole numbers, so that the work is more laborious. As an example, we will give an actual case of finding inductance and self-capacity, and during the working some special points will be noted. It is perhaps hardly necessary to state that the readings taken were degrees of condenser and wave-meter setting. The corresponding capacities and wave-lengths were worked out from the calibration curves of the instruments, and for each wave-length  $\frac{\lambda^2}{3550}$  was found, 3550 being the constant for  $L$  in  $\mu\text{H}$  and  $C$  in  $m\mu\text{F}$ . The form of equation shown in (13) was selected, as we had reason to believe that  $C$  was probably more accurate than  $\lambda^2$ . Thus

$$C = m'$$

$$C_s = y$$

$$\frac{\lambda^2}{3550} = a'$$

$$\frac{1}{L} = x.$$

Five readings were taken.

TABLE I.—EXAMPLE 2.

Observation.	$a'$	$m'$
1	10.3	0.000
2	24.9	.091
3	65.1	.312
4	105.8	.543
5	145.5	.769
5 )	351.6	1.715
	$a_0 = 70.32$	$m_0 = .343$

Next, Table II. was set up. It was worked out on the basis of six-figure accuracy. It will appear later that this was hardly sufficient—seven-figure work would have been better. But it was not realised quite how close the experimental work had been—for it is obvious that the more accurate the test work the more accurate must be the calculation.

On completing the first three columns, we find that the first checks

$$\Sigma a = \Sigma m = 0$$

$$\Sigma s = n$$

TABLE II.—EXAMPLE 2.

	$a = a' - a_0$			$m = m' - m_0$			$s = a + m + 1$		
Observation.	$a$	$m$	$s$	$a^2$	$m^2$	$am$	$as$	$ms$	
1	- 60.02	- .343	- 59.363	3 602.40	.117 649	20.586 9	3 562.97	20.361 5	
2	- 45.42	- .252	- 44.672	2 062.98	.063 504	11.445 8	2 029.00	11.257 3	
3	- 5.22	- .031	- 4.251	27.26	.000 961	.161 8	22.19	.131 8	
4	+ 35.48	+ .200	+ 36.680	1 258.83	.040 000	7.096 0	1 301.41	7.336 0	
5	+ 75.18	+ .426	+ 76.606	5 652.03	.181 476	32.026 7	5 759.24	32.634 2	
	-110.66	- .626	-108.286	12 603.50	.403 590	71.317 2	12 674. 82	71.720 8	
	+110.66	+ .626	+113.286	$A$	$B$	$C$	$P$	$Q$	
	0	0	5 (=n)						

We can now make out Table I. from the notes of readings taken at the test. These figures are, of course, the basis of all the following work. To save space, the actual derivation of  $a'$  and  $m'$  ( $\frac{\lambda^2}{3550}$  and  $C$ ) from the experimental readings is not shown. The "Least Squares" work begins when it has been done.

are satisfactorily fulfilled. We therefore proceed to the rest of the table. In a future article it is hoped to give some practical hints on doing numerical work of this kind; but for the present we will assume seven-figure logs.

The table being completed, we find

$$A = 12\ 603.50 \quad B = .403\ 6$$

$$C = 71.32 \quad C = 71.317\ 2$$

$$\text{Sum} = 12\ 674.82 = P \quad \text{Sum} = 71.720\ 8 = Q$$

Our second check is accurate to the last figure, which is unexpected ; there is always, of course, the prospect of a discrepancy of one or two in the last figure, but any larger divergence should at once be investigated.

From the results in the table,

$$x = \frac{C}{A} = .005\ 658\ 53.$$

Now it will be seen by looking onward to equations (IX.), (X.), and (XI.), that we shall use  $x$  as a multiplier three times and subtract the results from other numbers. It is good practice to get all three jobs done together, so we set out :—

$$C = 71.3172 \quad P = 12674.8 \quad a_0 = 70.32$$

$$x \quad .005\ 658\ 53$$

$$xC = .403\ 551. \quad xP = 71.720\ 7. \quad A_0x = .397\ 908.$$

$$B = .403\ 590. \quad Q = 71.720\ 8. \quad M_0 = .343$$

$$D = .000\ 039. \quad R = .0001. \quad -y = .054\ 908.$$

On applying our third check, we find a discrepancy— $D$  does not equal  $R$ . But examination shows the reason. Working to six figures, we are likely to find an error of one unit or so in the sixth place. Hence  $R$  might very easily have come out anything between 0 and .000 2! As we have already hinted,  $D$  and  $R$  are very small. The practical work was more accurate than was anticipated, and seven or eight figures should have been used in calculation. This is the point that was raised in discussing equation (XII.) in the body of the article.

Instead of re-calculating Table II. with extended accuracy, we will adopt another device. For, be it noted, we have got  $x$  to six figures and  $y$  to five—ample accuracy ; the

inaccuracy in  $D$  or  $R$  is only going to affect the probable error, not the actual values of  $x$  and  $y$ . We will work out Table III., which gives

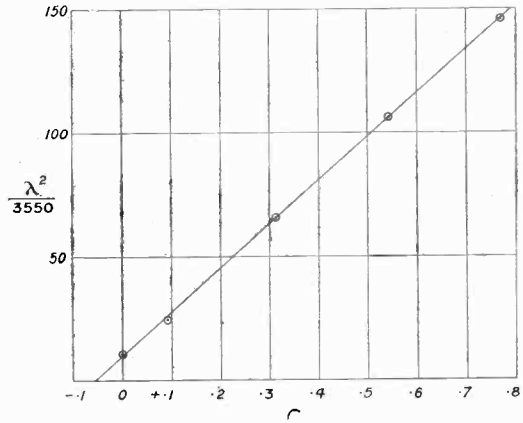

The five readings of Example 2 with the best straight line through them.

use a check figure for  $D$  and  $R$  with better accuracy than either of equations (X.) and (XI.) and also gives another check on the general accuracy of the work.

On completing the column for  $v$  in Table III., we find that its sum is zero within our limit of accuracy, having an error of two in the last figure. Also, the sum of the last column,  $\Sigma v^2$ , is .000 039 57, giving excellent agreement with  $D$ . We will, in fact, adopt the value  $D = .000\ 039\ 6$  for our final work, though, as will be seen, we shall not need high accuracy from now onward.

We have for the probable error of  $x$  (following equation XIII.) :—

$$r_x = \sqrt{\frac{.455 D}{(n-2) A}} = \sqrt{\frac{.455 \times .000\ 039\ 6}{3 \times 12\ 603.5}}$$

TABLE III.—EXAMPLE 2.

$$x = .005\ 658\ 53, y = -.054\ 908$$

Observation.	$a'$	$a'x$	$a'x+y$	$m'$	$v = a'x + y - m'$	$(1\ 000\ v)^2$
1	10.3	.058 283	.003 375	.0	+.003 375	11.39
2	24.9	.140 897	.085 989	.091	-.005 011	25.11
3	65.1	.368 370	.313 462	.312	+.001 462	2.14
4	105.8	.598 672	.543 764	.543	+.000 764	.58
5	145.5	.823 316	.768 408	.769	-.000 592	.35
Sums					+.005 601 -.005 603 = -.000 002	39.57

Since this figure is in any case only an *estimate* of the error; since, in fact, we mean by "probable error" that it is an even bet whether the error in  $x$  is greater or less than  $r_x$ , it is meaningless to push the calculation for  $r_x$  to high accuracy.

We have

$$\begin{aligned} r_x &= .001 \sqrt{\frac{.455 \times 39.6}{3 \times 12600}} \\ &= .00001 \sqrt{\frac{.455 \times 39.6}{3 \times 1.26}} \\ &= .00001 \sqrt{4.8} = .000022 \end{aligned}$$

and by equation XIV.

$$r_y = a_0 r_x = 70 \times .000022 = .00154$$

We have found  $x = .00565853$ ,

from which, since

$$\begin{aligned} L &= \frac{1}{x} \\ L &= 176.725. \end{aligned}$$

What, then, is  $r_L$ ? We can find it thus:

The *percentage* error in  $x$  is  $\frac{100r_x}{x}$ , or approximately .39 per cent. It is obvious, on a little thought, that the *percentage* error in  $L$  will be the same as that in  $x$ , and we therefore see that  $r_L$  must be .39 per cent. of  $L$ , or  $.69\mu\text{H}$ .

We have now found that the probable error in  $L$  is .69—say  $.7\mu\text{H}$ , and that in  $y$  ( $-C_s$ )  $.00154\mu\text{F}$ . It is therefore quite absurd to give the value of  $L$  as 176.725. The final "25" is meaningless, as there may be an error of .7. Similar considerations apply to  $C_s$ , so, expressing the latter in  $\mu\text{F}$ , as is more usual for such very small capacities, we have:—

$$\begin{aligned} L &= 176.7 \pm .7\mu\text{H} \\ C &= 55 \pm 1.5\mu\text{F} \end{aligned}$$

the percentage accuracies being 0.4 per cent. for  $L$  and about 3 per cent. for  $C_s$ .

For ordinary workshop or "drawing-room" conditions, as distinct from those of a first class laboratory, this accuracy is not bad.

But one important point must be noted. The errors above are those incurred *in the test*; they do not provide for errors in the standards by which we are testing. These errors have arisen because, for example, we read our condenser as  $140^\circ$  when it was

really  $139.9^\circ$ , and so got, say,  $.0008\mu\text{F}$  instead of  $.000799$ . But there is always the probability that the condenser itself has changed, so that even if we read it correctly at  $139.9^\circ$ , and made no mistake in reading  $.000799$  from the curve, the capacity might *really* be something different, say  $.000805$ .

In other words, no measurement can be more accurate than the standards it is made by—an obvious point, but one sometimes forgotten.

In this particular case, it is probable that the accuracy of our test is nearly, if not quite, as good as that of our standards. In such a case proper allowance should be made for the errors in the standard.

But two types of error must be distinguished. Suppose that the fixed inductance of our wavemeter had suffered a blow and been changed by 5 per cent. All readings would be affected proportionately, and our results would not show up the error at all. *The Method of Least Squares does not deal with constant or systematic errors.* But if it was the condenser of the wavemeter that had been damaged, so that it was upset irregularly at various points of its scale—now high, now low—this *would* show up as part of our error, and while the "probable error" would show as a larger figure, the values for  $L$  and  $C_s$  would still be the best obtainable.

As regards irregular errors, the question of errors in the standard condenser leads to a useful rule, so we will consider it. We have already found that our practical work had led to an estimate of  $55 \pm 1.5\mu\text{F}$  for  $C_s$ . Now suppose that  $C$  itself is subject to an uncertainty of  $1\mu\text{F}$ . Then since  $C$  and  $C_s$  enter the original equation as the sum  $C + C_s$ , this uncertainty must affect the value of  $C_s$  found from the equation. One might therefore be tempted to put the uncertainty of  $C_s$  at  $\pm 2.5$  ( $1 + 1.5$ ). But this is not so. There is quite a chance that in a series of measurements the error in  $C$  might cancel out the other errors.

Here again the mathematicians come to our help with a rule based on theory. We find the error in a sum just as we find the impedance in a circuit, by adding squares and taking the root. This rule leads to a value for  $r'_c$  (the error taking account of uncertainty in the standard) of

$$r'_c = \sqrt{(1)^2 + (1.5)^2} = \sqrt{3.25} = \pm 1.8.$$

Now  $r_c$  and  $r_L$  are proportionate, therefore

$$r'_L = r_L \times \frac{r'_c}{r_c} = .7 \times \frac{1.8}{1.5} = \pm .84$$

reducing our accuracy from 0.4 per cent. and 3 per cent. to 0.5 per cent. and 3.5 per cent. approximately.

We might go on to consider errors in the wavemeter, but this is too complicated for accurate calculation, for the percentage error of the wavemeter is a variable quantity, being greatest when the condenser is all in, as far as it is affected by the condenser, but varying with the substitution of coils in so far as it is caused by the coils.

If, however, we care to say that its accuracy is, on the whole, say, 0.5 per cent. at any wave-length, we can say that  $L$  will be affected by 1 per cent. (double the error

because  $\lambda$  comes in as  $\lambda^2$ ). The percentage error of  $L$  is then

$$\sqrt{(.4)^2 \times (1)^2} = \sqrt{1.16} = 1.08.$$

Thus the actual error of  $L$ , which we will call  $r''_L$ , allowing for error in the wavemeter, is

$$r''_L = \frac{176.7 + 1.08}{100} = 1.9\mu\mu\text{H},$$

from which, by the relation between  $r_L$  and  $r_{cs}$ ,

$$r''_{cs} = \frac{1.9 + 1.5}{7} = 4\mu\mu\text{F}.$$

It is feared that these notes on the effect of errors in standards are rather sketchy, but a serious exposition would be beyond our limits of space. After all, the main object of this article is to give a definite scheme for finding the errors of the observation experiment itself.

## The Perfect Set.

### Part IX: Reflex Circuits.

[R342·4

We now begin a discussion of this exceptionally efficient and useful class of set.

HAVING tried to elucidate some of the main principles of detection and H.F. and L.F. amplification, we propose to talk about Reflex Circuits.

But before getting down to detailed consideration, there are two matters which we desire to clear up. The first is as to the history of the reflex: for perhaps in this design more than any other there is a widespread misconception as to where the real credit should go.

The first official or public mention of a reflex circuit is as far back as 1913, in British Patent No. 8821 of that year. The invention was a German one, by Messrs. Shlömlich and von Bronk, and was afterwards acquired by Marconi's W.T. Co. It gives details of a typical reflex circuit, which has only had quite minor improvements right up to the present day. During and since the war, however, much has been done in detail, the main credit, in the writer's opinion, being due to Voigt in England, Latour in France, and Grimes in the U.S.A. The present writer has consistently used these circuits since 1915, and without claiming to have achieved anything notable, may, he thinks, justly state that he knows them fairly well.

Secondly, one sometimes hears reflex circuits classified among "freaks": "no use for DX," "no use for broadcast," "only fit for experimenters," etc. We should like strongly to emphasise our considered opinion that this is utter nonsense. Subject to certain limitations, which we will deal with in due course, "reflexing" (to coin a word) need have no adverse influence whatever, either on performance, stability or quality.

Let us now set up a typical reflex circuit, before proceeding to discuss it. It may be useful to show first the H.F. part only, to emphasise how small a difference (in some ways) there is. Fig. 1 shows a straight H.F. transformer-coupled amplifier, with a detector of unspecified type. The only point in which it differs from dozens of similar wiring diagrams is that, instead of placing condensers directly across the H.T. battery and grid battery or potentiometer, the condensers go straight from the low-potential side of the H.F. circuit to filament negative. This is good practice, as the H.F. currents are not then compelled to go along the (sometimes rather long) leads to the battery condenser.

In Fig. 2 this set is turned into a reflex in the simplest possible manner: each



battery lead is opened and has an L.F. component inserted, and the former "output" terminals are led back *via* a transformer to the first grid.

Now what are the changes produced by this (a) in the H.F. amplification, as compared with Fig. 1; (b) in the L.F. amplification as compared with a straight amplifier? Well (taking the H.F. side first) in Fig. 1 condenser *A* has across it only a 2- or 3-volt battery. It could almost be omitted, and the H.F. voltage between earth and filament is quite low. In Fig. 2, this condenser has a high impedance across it, and there may be an appreciable H.F. voltage: in other words the filament is not earthed. But this is got over by using the earth connection shown dotted in Fig. 2. This in turn

be completely got over by the insertion of a filter at *B* instead of a simple condenser, but it is only under exceptional conditions that we have found this necessary. It is useful for long-wave work at (say) 10 000 metres or over, because when we are confronted with the job of completely separating two components, it is naturally more difficult as they approach one another. To separate 1 000 000 from 5 000 cycles is easy; to separate 15 000 or 30 000 from 5 000 not quite so easy.

Lastly, we have the fact that the input to the valve is increased. But this affects both the H.F. and L.F. sides at once, and we will consider it later.

As regards the L.F. side (apart from the matter just raised above) the most important

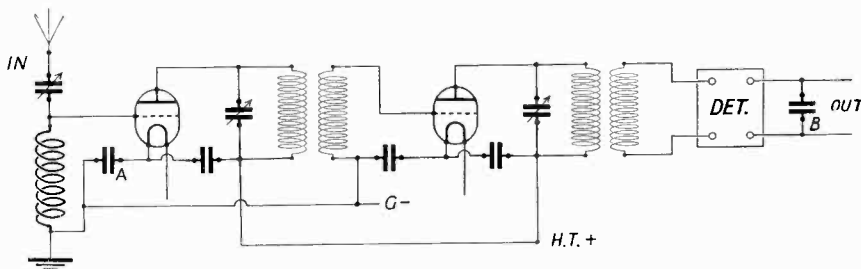

Fig. 1.

throws condenser *A* into the aerial circuit; but the only effect is to alter the tuning. There are other methods of arranging this input circuit, by which the point is avoided. But they have their own disadvantages, so we will defer consideration of them till later.

Next, we must remember that the detector output contains an H.F. component as well as an L.F. one. Although this component will mostly flow through condenser *B*, there will be an H.F. voltage on the primary of the first L.F. transformer; and owing to the capacity between windings, some sort of an H.F. voltage will appear on the secondary and hence be applied to the grid of the first valve. There is, in fact, some reaction due to reflexing, which will be positive or negative according to the connections of the H.F. transformers, but depending also on their exact tuning. This effect can be bothering in a badly-designed multi-stage reflex, but as a rule is quite unimportant, because reaction will probably be used in any case, and the presence of this extra coupling merely alters the best position of the ordinary reaction adjustment. It can

point is that each winding of each L.F. transformer is shunted by a condenser. These condensers must be large enough to offer a low impedance to H.F.; but if they are too large, they will lead to L.F. distortion by by-passing the highest frequencies and giving an unduly low tone. The question is, then: is there enough latitude between the minimum necessary for the H.F. duty and the maximum permissible for L.F. reasons? Luckily there is ample, although at really long wave-lengths (over 10 000 metres) it is a tight fit. For morse, of course, the matter is not important.

There is also the following point. If the aerial is picking up any L.F. disturbances (mains hum, tramline noise, etc.), the L.F. couplings may let it go right through the set. The writer has never, in actual fact, found any trouble from this, but he has heard of it. There are various ways of dealing with it, such as by the "inverse" circuit, to be described later, or by using the first valve as H.F. only.

The last sentence leads us down a side alley. One often sees, in the popular press,



headlines about a new "three-valve reflex" or "two-valve reflex," and on looking into the circuit finds that it is nothing of the kind.

A "three-valve reflex," to our mind, is a set with six stages of amplification, three H.F. and three L.F., all got with three valves (apart from the detector). One particular set we remember described as a "three-valve reflex," consisted of a detector, one H.F. and L.F.

dual valve, and one H.F. valve. It was a "one-valve reflex with detector and one H.F." A real "three-valve reflex" is a fairly lively set, but (like any set with three H.F. valves) not too easy to handle.

Coming back to the high road of our subject, there is yet to be discussed that most important point: the possibility of interaction within the valve between the H.F. and L.F. components. It will, we think, be at once appreciated that by applying both these input voltages to the valve we are increasing the total grid swing, and must use a valve with enough capacity to handle it. But there is rather more in it than this. For instance, examine Fig. 3. Here we are applying an input *HL*, whose two components are *L* and *H*, to a valve. (We assume, of course, that proper bias and H.T. voltages are applied.) The current *H* is meant to be a pure sine-wave, but for simplicity in drawing we are showing it as straight-sided.

The result, as actually got by plotting up and across, as shown at *AAA*, is the current *HLA*, and by subtracting in turn the D.C. component and the L.F. component *L'*, we are left with the H.F. component *H'*. On measuring, we find that *H'* and *L'* are both exact magnified reproductions of the corresponding input. But now look at Fig. 4. Here the valve is overloaded, and on analysing the output (which was obtained as shown by actual plotting across) we find,

not only L.F. distortion—a flat-topped curve—but a modulation of the H.F. current. Now remember that the H.F., in our actual

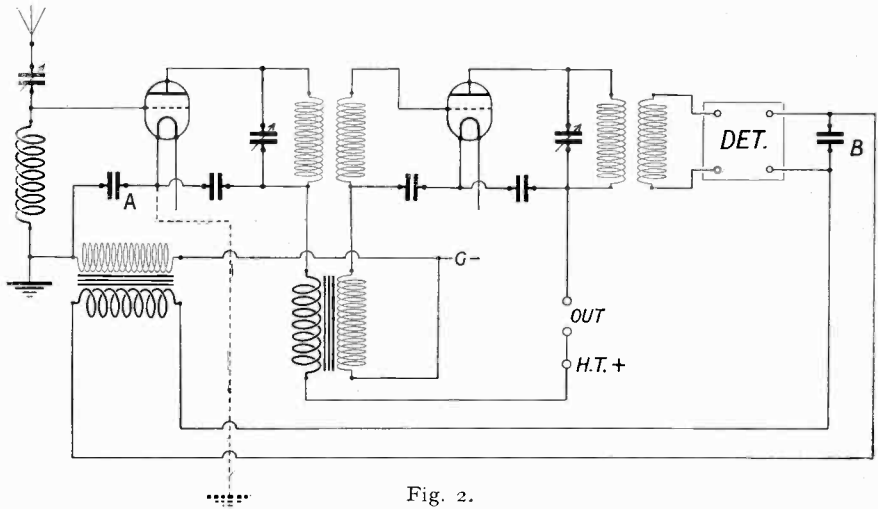

Fig. 2.

reflex, is itself modulated, and that the L.F. component is that same modulation as separated out by the detector, and we see that, according to conditions, we are either going to weaken the incoming modulation or unduly strengthen it. Moreover, it can easily be shown that the distortion thus produced is much more important than that due simply to the flattening of the curve of L.F. output. This means that a slight or moderate

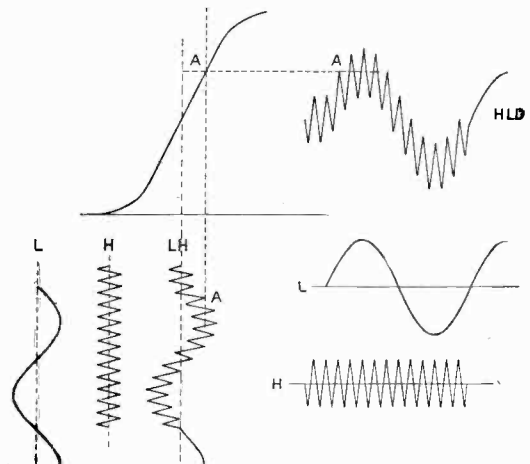

Fig. 3.

curvature of the valve characteristic, not enough to produce noticeable L.F. distortion by its primary effect, may yet upset a reflex due to this modulating action. So that one

must take care to use good valves, and well within their power. In actual practice we have no difficulty whatever in using .06 valves, provided we choose a good make with a nice straight characteristic.

The most important limitation of the reflex is due to a phenomenon somewhat akin to the foregoing. It is a limitation, however, which is in some ways a blessing: as a general rule, the reflex is not a suitable circuit for the self-heterodyne reception of C.W. If the reaction is increased to oscillation point the set usually howls aloud. As far as the writer knows, no careful explanation of this has yet been published: but he believes the reason to be the following: Suppose the set to be stable in a non-

turn depends on the inductance, resistance, and capacity of the transformer.

This limitation is a disadvantage for the DX worker who wants to receive C.W. without the trouble of a separate oscillator. But it is a blessing to the broadcast listener—or, rather, to his neighbours—for it means that he cannot accidentally oscillate without noticing it.

Hitherto we have said nothing as to the detector. It is, in the writer's own opinion, a great virtue of the reflex that it lends itself especially to crystal rectification. The reason is obvious. The reflexed valves are each producing a total amplification of at least 100 times—say 4.5 for H.F. and 20-25 for L.F. The detector, besides rectifying,

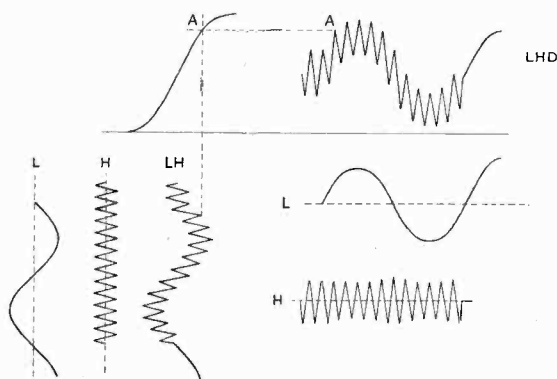

Fig. 4.

oscillating condition, and that the reaction is then increased so that it suddenly bursts into oscillation. There will immediately arise a considerable voltage on the crystal, and hence a large rectified voltage on the primary of the "throw-back" transformer. Owing to the high inductance of the latter, it will take some time—say, 1/1000 second, for the current through it to reach full value. In fact, if in Fig. 5 curve *a* shows the sudden oscillation, then *b* shows the voltage on the first L.F. transformer primary, and *c* the primary current. The result is a secondary voltage such as *d*. But in actual practice, this secondary voltage is applied to the grid of the oscillator, and immediately causes a decrease in the oscillation strength, causing a new change in *b*. There is thus a periodic change in the oscillation—a modulation in fact—which is duly detected and reproduced as a howl, the frequency depending on the rate of rise of *c*, which in

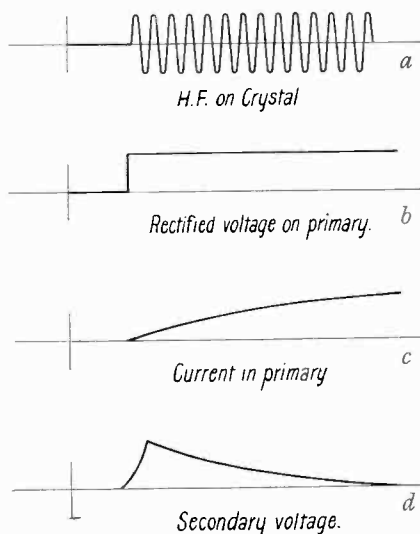

Fig 5.

may produce an effective amplification of 4 or 5. Obviously it is bad economy to use a valve for this purpose. Further, the crystal gives better results on telephony, for which the reflex is most suited, and, again, it has a useful effect in stabilising the H.F. amplifier. Lastly, the crystal in such a set works better than in any other way, for it has a comparatively large input, and is then both efficient and stable. It is quite unnecessary to adjust a galena oftener than once in two or three months, and a zincite pair will go on indefinitely.

In our next part we propose to follow these general notes with a detailed discussion of each part of the "standard" circuit of Fig. 2.

# Insulation Tests.

By C. H. Stephenson.

[R280·0122

**T**HE writer was desirous of making rough tests on the insulating properties of various materials used for wireless work, and it occurred to him that some interesting data might be obtained by means of a common gold leaf electroscope. One of these instruments was accordingly made up at a nominal cost, and the results obtained were certainly surprising. The electroscope, in the simple form used in these experiments, is not an accurate instrument, nevertheless it serves its purpose in differentiating between really good and only indifferent insulators.

For the benefit of those readers who are not familiar with the gold leaf electroscope, it may be explained that this simple device consists of two strips of gold leaf (say  $1\frac{1}{2}$  in. by  $\frac{1}{4}$  in.) which hang vertically downwards from the end of a well-insulated metal rod. The leaves are surrounded by a case, preferably of metal, so as to shield them from draughts. When the leaves are electrified, for example by touching the rod with a piece of ebonite which has been lightly rubbed on the sleeve, they diverge, forming an inverted V, and remain in this position until the charge leaks away through the insulator and, to a lesser extent, through the air. It will be clear that some indication of the insulating qualities of a material may be obtained if a piece of the substance is held in the fingers and the far end brought into contact with the rod to which the leaves are attached. If the material is a good conductor the leaves will collapse instantly; on the other hand a first-class insulator will produce practically no effect. We may say that the time taken for the leaves to collapse is a rough measure of the insulating qualities of the material under test. This was the scheme adopted in the following experiments, the results of which are distinctly interesting.

## Tests.

**Ebonite.**—Various pieces were selected at random from the scrap box, some with the polish removed, others highly polished. The leaves fell very slowly indeed, taking much more than 30 seconds in all cases. There seemed to be no appreciable difference

between the polished and unpolished specimens.

(Time measurements greatly exceeding 30 seconds were not recorded.)

It is interesting to note that these pieces of ebonite were not cleaned or prepared in any way. They were ordinary scrap pieces collected during several years.

**Valve-holders.**—Three types were tested. The grid leg was held in the fingers and the plate leg brought into contact with the electroscope.

(a) Home made, with the usual legs mounted on ebonite. Discharge was very slow indeed.

(b) Moulded flange type. Discharge was instantaneous both when cold and after warming.

(c) Moulded type without flange, composition different from (a). Discharge instantaneous.

Here again the excellence of ebonite shows up, as the home made holder had been in use, exposed to light and dust, for over a year, nor was it cleaned before being tested.

**Coil-holder.**—This was of the double type, the material being ebonite. Make unknown. The tests were made between the socket and plug of each half. Both parts discharged in 30 seconds.

This was quite a good result considering the dirty condition of the holder.

**Condensers.**—

(a) *Variable.*—Vernier type, with two moving plates and ebonite insulation. The test was made between the fixed and moving plates at minimum capacity. Discharged in 10 seconds.

(b) *Fixed.*—Standard pattern of well-known make. Capacity 0.005mF.

The first test was made between the fixing lugs, that is to say, the leakage was through the moulded case.

When cold, discharge occurred in 4 seconds; after warming, this increased to over 30 seconds. The next test was for leakage between the wax filling on the under side and one terminal. Discharge took place in 25 seconds when cold.

The same tests were made in a similar

pattern of condenser but of a different make. Capacity 0.000 3mF.

*Test 1.*—Discharged in 6 seconds.

*Test 2.*—No apparent leakage.

*Valves.*—Several types were tested, the method being to hold the grid leg in the hand and touch the electroscopie with the plate leg.

All the tests showed an instantaneous discharge, no matter whether warm or cold, with the exception of a 4-pin Mullard Weco-

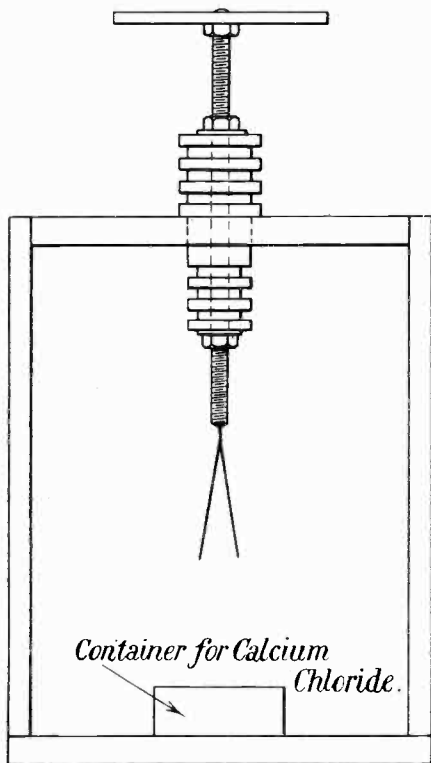

Fig. 1.

valve. This required 20 seconds for discharge when cold, but the leaves collapsed instantly after the valve had been warmed.

This unexpected result may have been due to some surplus flux spreading into contact with the grid and plate legs under the influence of the heat.\*

A very odd thing was noticed with one

\*It seems possible that this may be due simply to the capacity of the electrodes, the discharge of the electroscopie charging them up. A similar explanation might apply to the glass in the next paragraph.—Ed. E.W. & W.E.

valve, it being found that the leaves were instantly discharged when the valve was held by the glass and a leg brought into contact with the electroscopie. This persisted in spite of thorough cleaning and warming followed by rubbing with silk. The glass could not be electrified.

*Grid-Leak Tube.*—An old-type Mullard grid-leak and condenser was tested for insulation along the containing tube. The test points were  $2\frac{3}{4}$  in. apart, and the insulation was found to be as nearly perfect as one could wish.

*Effect of Moisture on Ebonite.*—A strip of ebonite, the insulation of which was very satisfactory, was gently breathed on. Discharge took place instantly. On testing again 10 seconds later the insulation was as good as originally.

*Effect of Oil.*—It was found that an oily piece of ebonite was just as good an insulator as a clean piece.

*Pipe-Stem.*—In order to test ebonite under very bad conditions an experiment was made with a pipe-stem. The pipe, at least eight years old, had been alight only a few minutes prior to the test, but the insulation was found to be excellent.

It seems fairly clear that either the material used for such parts as fixed condenser cases, valve insulators, valve-holders, etc., is not a sufficiently good insulator, or that there is really no need to use high grade ebonite for panels and other parts. It must be admitted that these tests do not give any idea of the actual resistance between the grid and plate legs of a valve, for example, but they do show that the insulation is far inferior to that obtained by the use of ordinary good quality ebonite.

### Construction of Electroscopie.

As perhaps some experimenters may wish to make up a simple electroscopie, the following constructional notes are added. Anyone who goes to the trouble of making up this instrument will find it of considerable interest. A sketch of the instrument is given in Fig. 1.

*Case.*—This is made from a light wooden box which had a sliding lid. It measures 4 in. high by 3 in. wide by 2 in. deep inside. The bottom, sides and back are lined inside with brass foil (tin foil will do just as well) and a photographic quarter plate slides in the lid grooves and forms a window. (Any other construction will do equally well.)



**Leaf System.**—This consists of about  $2\frac{1}{2}$  in. of 4 B.A. screwed brass rod having a thin brass strip  $\frac{1}{4}$  in. square soldered into a slot cut at one end.

The rod passes through an ebonite bush (see Fig. 2) and carries a brass plate  $1\frac{1}{4}$  in. in diameter at the top end, the rod being located and secured in the bush by means of brass nuts. The ebonite bush is made a push fit in a  $\frac{1}{2}$  in. hole drilled in the centre of the top of the box.

The gold leaves measure  $1\frac{1}{2}$  in. by  $\frac{1}{4}$  in., and the cutting and fixing of these is the only tricky part of the whole job.

The leaf is supplied in book form, each sheet of gold being between two sheets of non-sticky paper. It is essential to purchase the loose leaf, *i.e.*, the type used by picture frame gilders. Another type is made which is useless, the leaf being stuck to the paper sheets. The writer is not an expert in handling gold leaf, but has found the best method of cutting and manipulating is as follows: Take the new book of leaf and remove the *second* leaf of gold and scrap it. Place a glass sheet in the place the leaf occupied. Cut two strips of the required size from the first gold leaf, keeping it between the leaves of paper and using a razor guided against a wooden rule or straight edge. The leaf can be seen through the paper, so that measurement is easy. Separate the strips (still between the papers) from the rest of the book, and, using a couple of needles, lift the top paper off each strip, leaving the gold leaf exposed. Moisten *each* side of the  $\frac{1}{4}$  in. by  $\frac{1}{4}$  in. flat piece on the rod with some *thick* varnish or adhesive and gently bring one side of the flat on to one end of one of the strips of gold leaf. The leaf will adhere at once and it only remains to lift the leaf off the lower paper strip. This will require a little coaxing and some patience. When this is done attach the other strip of gold leaf to the other side of the flat in a similar manner.

The assembly is now ready to be passed through the hole in the top of the case, during which operation the leaves must not touch the wood.

The success of the whole operation depends on the paper and leaf being cut cleanly, on care in handling, and on an absolute absence of draughts. Shorter leaves may be used if desired, as they are easier to cut and handle.

**Drying.**—It is an advantage if the case

can be made reasonably air tight and a few small pieces of calcium chloride in a shallow watertight container in the case helps to keep the air dry and improve the insulation of the ebonite.

**Charging.**—The most convenient source of electricity is a piece of ebonite which has been lightly rubbed on the coat sleeve. The ebonite should be brought near the metal disc till the leaves diverge to the required extent. Keeping the ebonite in this position the disc is touched with the finger, which causes the leaves to collapse.

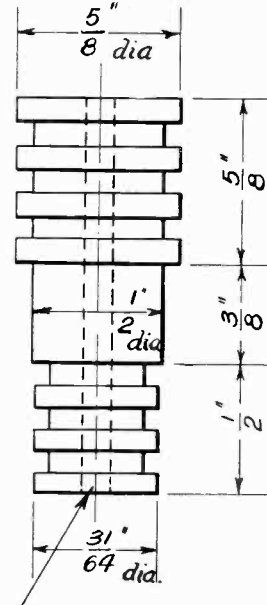

4 B.A. Clearance hole.

Fig. 2.

The finger is then removed and finally the ebonite is withdrawn, when the leaves will again diverge. The electrostatic may be charged by bringing the ebonite into contact with the disc. This is not a good method, as the leaves may diverge so violently as to be torn away. The other method is quite safe, as the maximum divergence is under complete control.

It will be found that on bringing any conductor, no matter how perfectly insulated, near the charged electrostatic, the leaves will partly collapse. This is merely due to the increased capacity of the system (the insulated conductor forming one plate of a condenser) which reduces the potential of the leaves and so their mutual repulsion.

# Radio 2FP.

# An Amateur Station.

By J. L. Pritchard.

[R612

**I**N 1913, when FxM—the forerunner of the present station—was started, it was a spark station of 50 watts. The installation was dismantled at the outbreak of the war and subsequently lost in the archives of the Post Office. With the advent of the valve, which was largely developed during the war, it was decided to instal a continuous wave transmitter when the cessation of hostilities permitted a renewal of amateur wireless activities. The necessary permission was, unfortunately, a long time in being given.

It was necessary to design the transmitting and receiving sets to occupy the smallest possible space, since, owing to the shortage of houses, the new station started its being in the confined limits of a flat.



Fig. 1. The complete transmitter and Receiver.

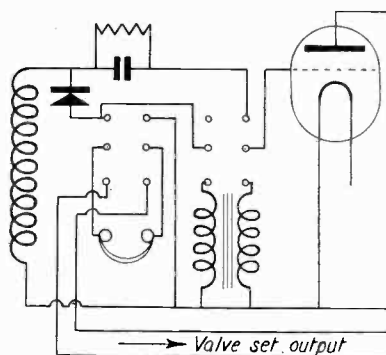

Fig. 2.

The present outfit is illustrated in Fig. 1. On the left side of the apparatus is the transmitter, which is of the Hartley type, but embodying certain modifications to suit the special requirements. The right half of the panel is devoted to the receiving part of the set. The instruments are secured on a Radion panel, sloping backwards in a wooden framework, which has a front that may be hinged over to cover the top half of the panel. This part of the installation is attached to a specially constructed table resembling a writing table, with a cupboard on either side, in which certain parts of the apparatus are housed.

Anode current is obtained from a Newton generator giving 1000 volts. The current is smoothed by chokes and condensers, and is supplied to the transmitter in shunt. The generator is housed in the left-hand cupboard referred to above (see Fig. 1). By the cupboard is the motor-starter panel



for controlling the generator. The tapping key is attached to the table towards the front, on which also stands a hand microphone and a pair of telephones.

The circuit diagram of the transmitter is given in Fig. 3, from which it will be seen that

be seen that the normal detecting valve is used as the first stage of L.F. amplification when the crystal is used for rectification. The telephones may also be used with the crystal detector alone if desired.

For local broadcasting, a crystal and two-stage amplifier is used, distant control from a separate room being obtained by means of a relay placed on the top of the installation and a push-pull switch. The latter is seen in the photograph on page 560, which shows the

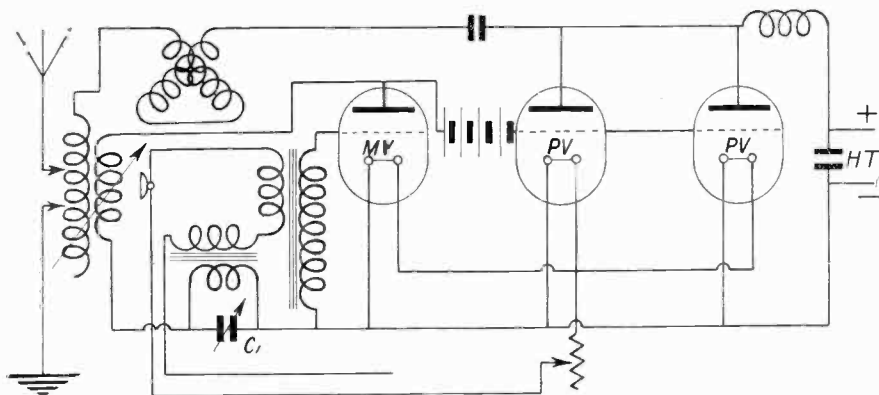

Fig. 3.

modulation takes place in two distinct places in the grid circuit, the two impressions being of different intensities. The major intensity takes place slightly after the impression at  $C_1$  owing to the time lag of the electronic flow between the modulator and power valves. If the impression at  $C_2$  is in the opposite direction to that at  $MV$ , the small impression or modulation at  $C_1$  will form a cushion, as it were, for the larger  $MV$  modulation output. This method of modulation control has been found to give excellent results, and many reports of good reception have been received.

The receiving circuit employs two stages of radio-frequency, transformer-coupled amplification and two stages of L.F. amplification. Rectification is obtained by either crystal or valve as desired, by the use of switches, which also enable any combination of valves to be used. Fig. 2 shows the necessary switching arrangements for the use of either crystal or valve, from which it will

loud-speaker, which is of home construction. The size of the loud-speaker can be estimated from the Amplion "Dragonfly" seen with the larger instrument.

The relay and the accumulator which operates it are seen in Fig. 4, which shows a back view of the installation. In the top right-hand corner is the choke coil for

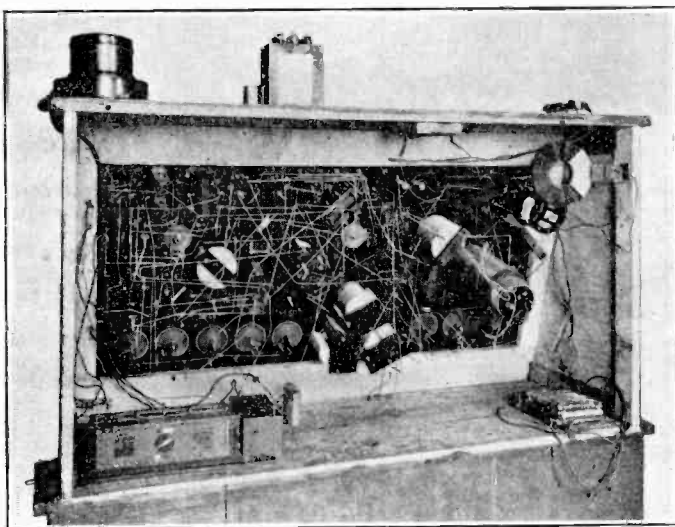

Fig. 4. Showing a back view of Fig. 1.

smoothing the H.T. current, and below it, on the base of the framework, are the smoothing condensers. High tension batteries are placed inside the case and are seen to the left of the illustration. Filament resistances for controlling the valves are arranged in line towards the bottom of the panel. Between the groups are three variable condensers for tuning the receiving set.

As far as possible all wiring is carried out

with bare tinned wire, which, in addition to improving the efficiency of the installation, adds considerably to its appearance. A feature worthy of note is the parallel arrangement of the grid connecting wires, which are seen towards the top of the panel and equi-distant from the sides. A neutralising effect is obtained by this arrangement, similar to the Neutrodyne principle, which tends to prevent self-oscillation and render the set more stable.

## Things we should like to know, or points of interest to all Transmitters.

The name of the amateur who can light a Neon lamp off his stair rods when his transmitter is running?

And what his input is?  
And why?

\* \* \*  
The amount of the electric light bill of a well-known DX man on the southern outskirts of London?

And why rumour has it he has to start up his high-tension generator in the afternoon?

And if the Electric Light Company make any special arrangements?

\* \* \*  
If Joe Fassett QSL's every QSO with England? And why?



The loud-speaker in use at 2FP. The small one is an Amphon "Dragonfly."

How 5BV manages to use raw A.C. on one wavelength at the same time as partially smoothed A.C. on another?

And whether it is another attempt at "Effective Transmission"?

\* \* \*  
If 2PC lent 8BV his bug?  
And why?

\* \* \*  
Why 5LF doesn't put a flywheel on his generator to steady her down on key load?

\* \* \*  
If 5RZ has dispensed with filament-heating batteries now that he uses a separate aerial for reception?

\* \* \*  
Why a BCL should be blanked out at 50 yards range by a 100-watt transmitter when there is a difference of 265 metres in wave-length?

And why does he complain?

\* \* \*  
Why some "hams" Morse out "yep" when "yes" would be quicker?

\* \* \*  
Why 2NM calls "ARRRL" ?  
And why some other stations call "RRLA" ?

\* \* \*  
How 5OX learnt Morse?  
And if he has sold his microphone?  
And why?

\* \* \*  
How 6QB was QSO the American 5th district on 3½ watts input?

\* \* \*  
Why 2TK's 100-metre harmonic is louder than his fundamental?  
And if he knows it?

\* \* \*  
Why some people like spacing waves . . . and some don't?  
What the Post Office thinks about it?

\* \* \*  
Why all British stations are always "QSA vy" in United States?  
Who started "es" ?  
And why?

\* \* \*  
Why was all this written?  
Why not?

ANOTHER TRANSMITTER.

# Communication on Wave-Lengths other than those in General Use. [R800:650

A paper read by Mr. G. G. BLAKE, M.I.E.E., A.Inst.P., before the Radio Society at the Institute of Electrical Engineers on 22nd April, 1925.

**A**N Ordinary General Meeting was held at the Institute of Electrical Engineers, London, on Wednesday, 22nd April, 1925. Lieut.-Col. Holden presiding.

The minutes of the previous meeting were taken as read. Mr. G. G. Blake then read his paper.

Mr G. G. BLAKE: When I accepted your invitation to give this lecture, I had intended to give you a short history of the numerous experiments which have been conducted in telegraphy and telephony on wave-lengths in the ether other than those discovered by Hertz and named after him; but in preparing the experiments for this lecture I came across so many interesting things that I now propose to touch only briefly upon the most practical systems, so that we may have sufficient time to make our demonstration as interesting as possible. In order

since been filled in. The portions with which we shall deal this evening are those occupied by the infra-red rays, visible light, and the ultra-violet rays. I have designed an apparatus<sup>1</sup> (Fig. 2), in order to demonstrate that an electric spark may be the source of ultra-violet radiations (illustrated by the fluorescence of Willemite), the whole visible spectrum (viewed through a spectro-scope), dark heat waves (measured by a thermometer), and Hertzian waves (which light a lamp at a distance). These various wave-lengths can be demonstrated singly or simultaneously. (A demonstration was then given.)

The condenser spark is rich in the short ultra-violet waves but deficient in long ultra-violet radiations.

A carbon arc is rich in long but deficient in short radiations.



Fig. 1. Showing the complete range of the spectrum, with its divisions.

to justify the delivery of this lecture to a Radio Society I will first show a few experiments to prove that the wave-lengths I am employing this evening are really a part of the same ether spectrum as those ordinarily employed for wireless purposes.

There are at present known to Science 53 octaves in the ether spectrum and of these our eyes are only able to perceive one octave—we are blind to all the rest. Supposing a great artist, like Turner, had been able to see all the beauty of colour present, when he surveyed some beautiful view, even his vision was so limited that he would only have been able to perceive one 53rd of the colours which may have been there.

The illustration on this page (Fig. 1) indicates the range of the spectrum. Practically all the spaces marked unknown have, I believe,

A tungsten arc, as used for artificial sunlight treatment, is rich in all wave-lengths; so rich that an exposure to the skin of two minutes at 18 inches from an 8 ampere tungsten arc will produce an erythema or sunburn.

A quartz mercury vapour lamp is similarly very rich in ultra-violet radiations.

The presence of ultra-violet rays in light from a carbon arc was then shown by the interposition of a "Chance" glass filter, and the fluorescence of Willemite (the ore in which zincite is found).

Zinc sulphide, Barium platino-cyanide, uranium glass, a candle, liveteeth, butter, etc., were demonstrated.

<sup>1</sup> This apparatus was demonstrated at the Royal Institution on 20th March, 1925.



A couple of years ago, using an enclosed tungsten arc so screened that no visible light was present in the room, but fitted with a window of "Chance" glass through

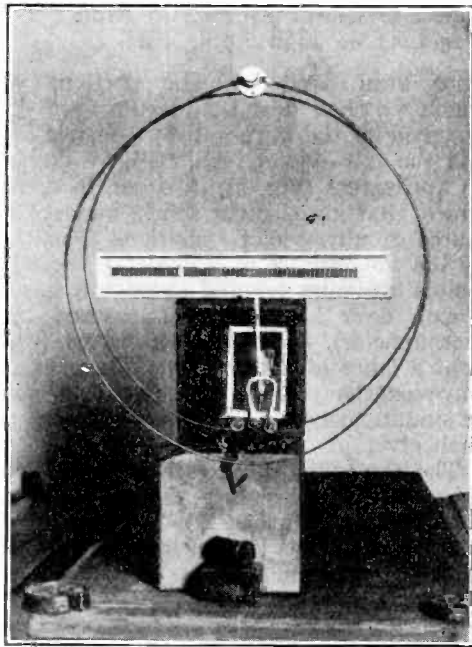

Fig. 2. The apparatus devised to show that an electric spark is the source of various radiations.

which invisible ultra-violet rays were projected, I succeeded in taking a photograph in a completely darkened room. As I have unfortunately broken the negative, I have for the purposes of this lecture taken another still-life group under similar conditions.

The group shown in Fig. 3 was taken by unfiltered light of a tungsten arc in ten seconds.

That in Fig. 4 was taken with room completely dark, the objects being irradiated by invisible ultra-violet rays only, all visible light being screened off by a filter of "Chance" glass (exposure five minutes).

Fig. 5 shows one taken by ultra-violet radiations only from a mercury vapour lamp with an exposure of five minutes.

A photograph taken under similar conditions, but with all fluorescent objects removed from the group, to exclude the possibility of fluorescence being in any way responsible for the results, is shown in Fig. 6.

Ultra-violet radiations were employed quite successfully during the war, both for

signalling and for keeping the ships of a convoy together in their relative positions. Professor Wood gave a most interesting account of their use by the Admiralty in a lecture before the Physical Society in March, 1919. A mercury arc, of the Cooper-Hewitt type, was employed as transmitter; this was encased in a tube of "Chance" glass, which screened off its visible light and transmitted only the ultra-violet, so that at a very short distance the arc was invisible to the eye. The rays received from this arc were focused by a lens upon a screen of barium platino-cyanide, the fluorescence of which, caused by the action of the received ultra-violet radiations, could be seen when four miles away. In America, Lewis Bell and Marshall carried out very similar experiments a few months prior to the entry of America into the war, and the U.S. Army in France employed an ultra-violet signalling lamp with a fluorescent screen. Professor Wood in his lecture also described a small signalling lamp of unique design. This consisted of a 6-volt electric lamp, hidden in the interior of a telescope and so arranged that it only transmitted an exceedingly narrow beam of light, visible only to observers on whom the telescope was focused. In daylight a red filter was placed in front of the lamp so that only red was transmitted. This could not be seen at a distance, unless a similar red screen was employed to cut out the daylight; but, under these conditions, signals could be received at a distance of six miles. By night



Fig. 3. Photo taken in the visible light from a tungsten arc.

a filter of "Chance" or similar glass was used to cut out all but the invisible ultra-violet rays, and the receiving telescope was fitted with a small fluorescent screen in the focus of the received rays. This also had a 6-mile range.

In France, Dussaud carried out experiments with a photophonically controlled beam of ultra-violet light. At the receiving end he focused the ray upon a fluorescent screen placed in proximity to a selenium cell connected in series with a battery and telephone. Variations in the fluorescence of the former caused corresponding variations in the electrical resistance of the selenium and the transmitted sounds were reproduced in the phones.

#### Signalling by Visible Light.

White light consists of 7 colours: Violet indigo, blue, green, yellow, orange

Heliography, or the method of signalling by the sun's rays, was in use in Algeria in the 11th century. In an article published in the *Athenæum* in January, 1882, it is stated that at that early date (11th century) many cities in Algeria communicated one with the other, in clear weather, by the sun's rays reflected from mirrors erected on the tops of high towers. In 1877 Mance devised a heliograph which was employed extensively for military purposes. Since then many others have contributed to the perfection of this form of signalling. In Algeria, French engineers have by this means (in ideal weather) succeeded in signal-

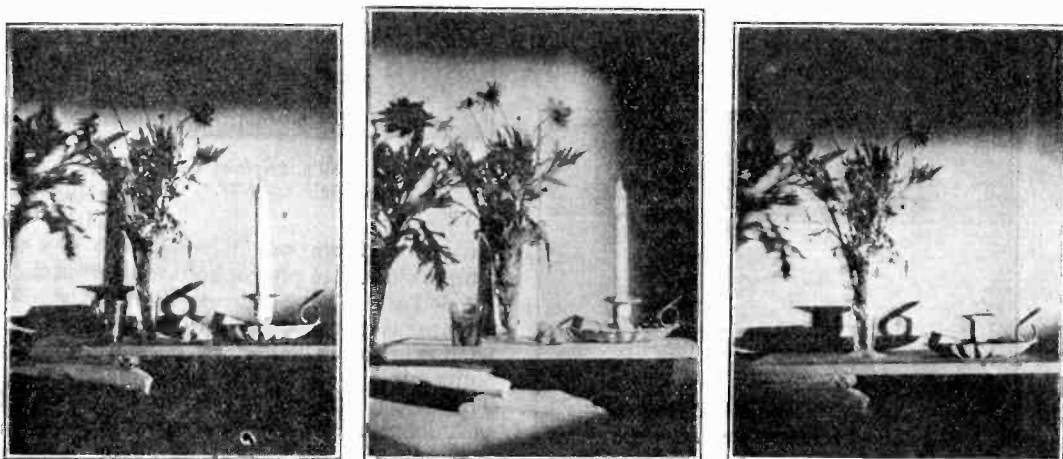

Figs. 4, 5, and 6. Three more photographs taken of objects illuminated by radiations from various parts of the spectrum.

and red. Each of these represents a different wave-length in the ether. When all these waves reach our eyes simultaneously, we receive the sensation of white light.

When we say that an object has a certain colour, we mean that it is absorbing all the other waves which make up the light by which it is illuminated, and it is rejecting or reflecting the colour which we see.

Here a beam of white light was passed through a prism, and its spectrum demonstrated. A barium platino-cyanide screen was held in the dark portion below the last visible violet light, and it was seen to fluoresce thus demonstrating the presence of ultra-violet rays.

#### White Light.

We may now consider what use has been made of white light for signalling purposes.

ling over a distance of 170 miles. A record distance of 190 miles has been bridged in California. During the Boer War, General Buller heliographed to Ladysmith while it was besieged.

#### Selenium.

In 1817 Berzelius, a Swedish scientist, discovered Selenium, a by-product of the manufacture of sulphuric acid from iron pyrites. Shortly after this Willoughby-Smith's assistant, May, showed that selenium would conduct electricity better when brightly illuminated than when screened from the light. Several other substances have been shown to be light-sensitive, and many types of photo-electric cells have been devised. In 1907 F. M. Jalger showed that natural antimony sulphide responded to light in a different part of the spectrum. A. H. Pfund has shown that copper oxide



is light-sensitive. In my own experiments I have only tried selenium and a photo-electric cell kindly lent me by Mr. C. C. Paterson of the G.E.C. Research Laboratories. When using the latter, I found that too much amplification was required, the former being simpler in use, as it required less amplification. Fig. 7 illustrates the photo-electric cell.

Much work has been carried out in the construction of photo-electric cells, which can be made to respond to various wavelengths of the spectrum, including ultra-violet and infra-red.

One of the most sensitive of these cells is that known commercially as the Thalofide photo-electric cell, invented by Case. It is claimed for this cell that its electrical resistance is reduced 50 per cent. on exposure to

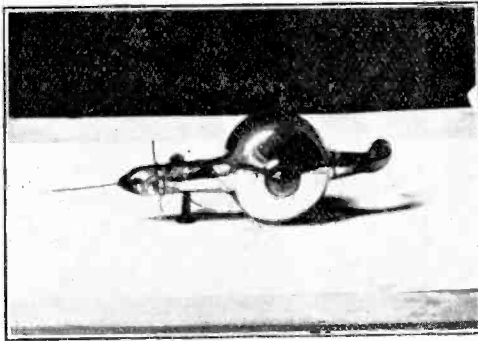

Fig. 7. The photo-electric cell.

light of 0.06 of a foot candle, and that its response is extremely rapid.

#### The Photophone.

In 1878, Graham Bell and Summer Tainter showed that a beam of light could be modulated by the sound-waves from the human voice and reproduced in a telephone, connected in circuit with a battery and a selenium cell, the latter being placed in the focus of the beam. Their researches were very comprehensive, for they actually showed no less than 50 ways in which a beam of light could be controlled by the voice. Figs. 8 and 9 show Bell's original apparatus and were made from an old illustration in "Science for All," published by Messrs. Cassell, Petter, Galpin & Co.

Fig. 10 illustrates several methods proposed by Bell for modulating the beam photophonically. (B) is a diagram of the method employed for the instrument shown

in Fig. 8. (A) illustrates one of Bell's earliest methods in which the beam of light has to pass through two gratings *G* and *G*<sub>r</sub>, the former fixed and the latter movable

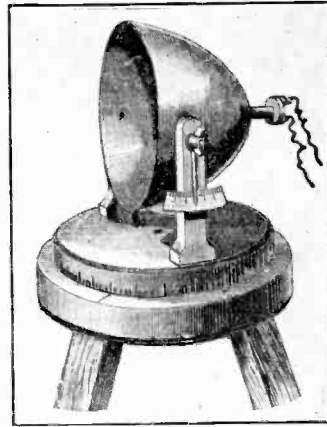

Fig. 8. Bell's original "Photophone" receiver.

and attached to a diaphragm *D*, so that it would vibrate in response to the voice. The modulation was said to be very poor by this method. In 1916 W. H. Bragg and A. O. Rankine patented a very perfect type of grating control which was demonstrated at the meeting of the British Association at Liverpool in 1923.

(C) is a very simple method of photophonic reception shown by Bell at the 1893 Chicago Exhibition. The apparatus consists simply of a glass tube with a thin-walled glass bulb at one end, containing a fragment of charred cork. The latter expands and contracts with the very least heat changes when a photophonic beam is focused upon it, and produces corresponding movements in the column of air in the tube. These movements are heard as sound. I repeated this experiment in 1908 using a speaking arc as transmitter and found that it worked quite well over a distance of 50 yards.

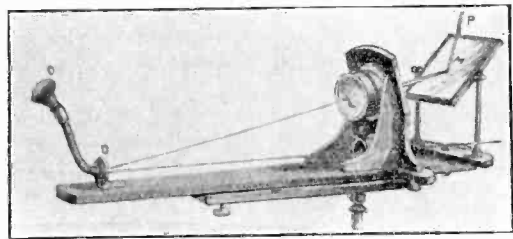

Fig. 9. The "Photophone" transmitter.

Mecadier successfully employed a sheet of mica covered with lampblack in place of cork, and Bell and Tainter showed that many, other substances—chips of wood, solids,

liquids and gases—acted in a similar manner. Even the smoke from a cigar, it was stated, would in this way reproduce sounds. Diaphragms of various substances placed at the opening of a tube leading to the ears will reproduce sounds when placed in the beam of a photophone. Thermopiles, connected to a telephone, have also been employed successfully. (D) is another interesting type of receiver in which variations in the strength of the magnetic field of a small magnet NS, under the action of heat from the photophonic beam upon a thin-walled iron bulb J, induces currents in a winding connected to a phone T. In 1881 Andrew Jamieson of Glasgow employed a manometric flame as transmitter. In 1897 Bell and Hayes in America employed a speaking D.C. arc as a photophonic transmitter which they patented on 7th June of that year. And at the same time in Germany, H. T. Simon

in my next experiment and will describe later.

From 1902 and during the two or three succeeding years Ruhmer, Schuckert, and several others carried out many practical experiments in photophony.

Fig. 11 shows several other methods of modulating an arc, including Simond's microphonic arc, in which the currents in an arc circuit are modulated by sound waves impinging upon the arc itself.

Fig 12 shows four methods which I have devised for modulating an arc, when coupled directly to a wireless receiving set. They all work quite well, but on the whole I have obtained the best results with that shown in the centre diagram. We will show you this arrangement working presently.

**Demonstration. (A) Indirect Method.**

In the case of the indirect method the sound waves from a loud-speaker

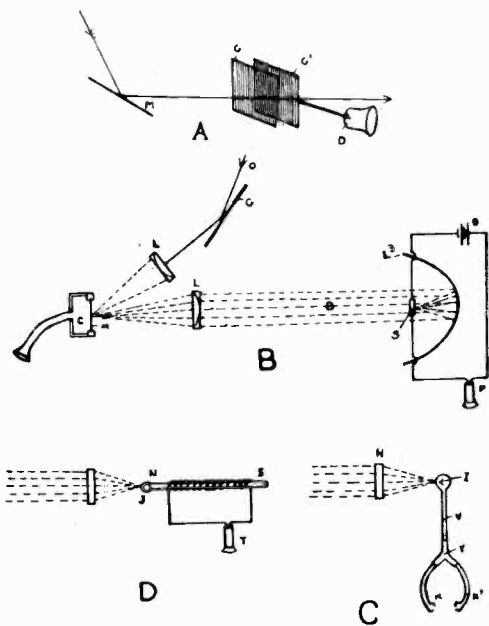

Fig. 10. Illustrating methods of modulating a photophonic beam.

was making quite independent experiments on similar lines which he described in a paper in November, 1897, to the Erlanger Physical Society, covering almost identical ground.

In 1900 Duddell showed another method of arc modulation which I am employing

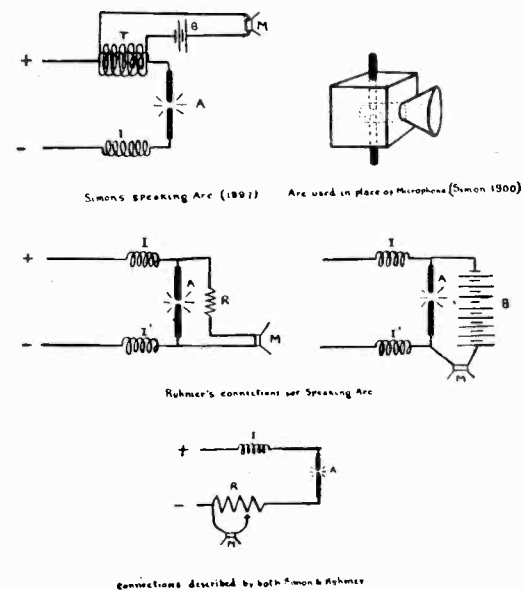

Fig. 11. Methods of modulating an arc.

were employed to operate a microphone connected in series with the primary of a 1 to 1 transformer and an 8-volt battery, the secondary of which was connected by the Duddell method in series with a condenser across the arc.

[At this point the photophone was shown

in action, and speech and music from 2LO were transmitted across the Lecture Hall on a beam of light. The arc was controlled in two ways: (A) by an indirect, (B) by a direct method.]

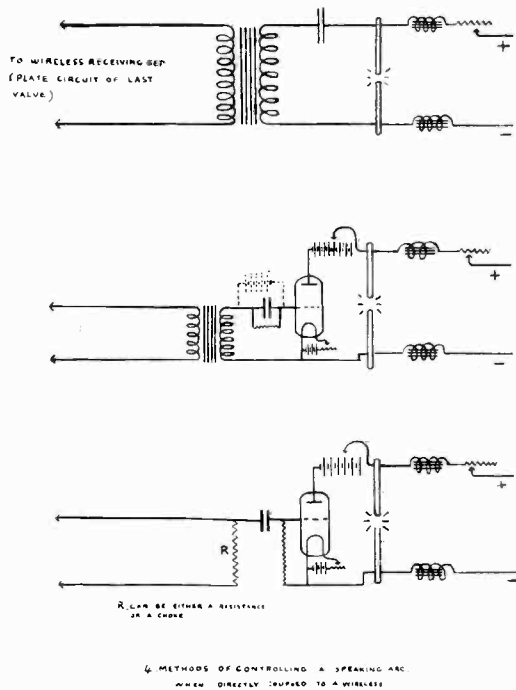

Fig. 12. Three of the methods devised by the author for modulating an arc.

In Fig. 13 the upper diagram A shows the connections employed. B, C, and D in the same figure show three other indirect methods which, I suggest, might be used for photophonic arc modulation, but which I have not had time to try.

(B) represents what I will call the arc blow flame method. The arc is driven outwards by a permanent magnet, as shown, and variations in the magnetism of *M* by microphone currents passing through a winding round it should modulate the arc currents.

(C) The principles of Simons' arc microphone might be employed, *i.e.*, the arc might be modulated directly by sound waves directed through a speaking tube, straight against the arc. In this case a piece of loofah should be placed in the mouthpiece. This prevents any wind from blowing on to the arc, while it allows the sound waves themselves to pass quite

freely. (The use of loofah for this purpose was, I believe, suggested by Major Tucker.)

(D) is a variation of method C, in which two arcs would be coupled in series, "A" being used as a "Simons" microphone, and *A* employed as the source of the photophonic beam. The General Electric Co. have, I believe, made use of Ruhmer's Photographophone for the modulation of powerful searchlight beams. The speech-modulated light of a small photophone is recorded on a photographic film, producing variations of density on the film, which is afterwards passed across the path of a powerful searchlight beam and made to modulate the latter.

Fig. 14 represents four different methods of beam modulation which I suggest but have not had time to try. (A) A powerful light, from any source, is focused upon one

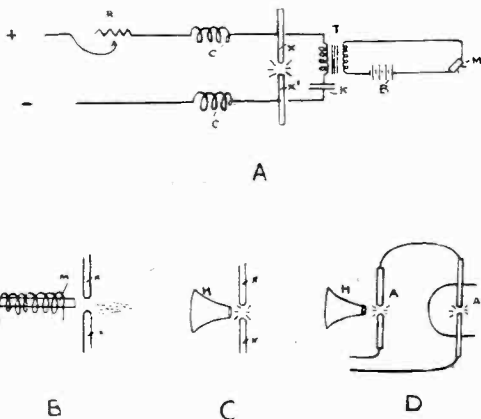

Fig. 13. The author's fourth method of arc modulation and three others suggested, but not tried.

end of a glass, silica, or other light conducting rod, and re-transmitted from its further end onto a parabolic mirror *M*, whence it is transmitted as a parallel beam. For signalling purposes, code signals could be transmitted by a hand-controlled shutter *K* and a musical note given to the beam either by the interposition of a revolving disc studded with holes, as used by Dr. Fournier d'Albe in his television experiments, or a little vibrator, as shown in the diagram, similar to the hammer of an electric bell, could be employed.

(B) The light might be brought to focus by means of a concave mirror and made to move more or less on or off the end of a silica rod *G*, in response to the movements

of a diaphragm *D*, under the action of sound waves.

(C) The light might be focused upon a small sheet of glass *S*, resting against a globule of mercury at the end of a tube, the column of mercury in the latter being moved by alterations of gas pressure in the space below the diaphragm *D*. *G* is a rod transmitting the light to a parabolic reflector as before.

(D) This is another method which I think should answer quite well. The light is focused upon the end of a short length of glass tube *G* and so led to one side of a chamber *B* filled with carbon bisulphide having the same refractive index as glass, thence it is conveyed by a second glass tube *G'* to a parabolic mirror for projection.

The chamber should be very narrow, so that the globule of mercury at the end of a tube leading to a space below a diaphragm *L* is flattened fanwise and acts as a shutter, which will move up and down, and so more or less obstruct the light when sound waves impinge upon the diaphragm *D*.

Any of the four direct methods shown in Fig. 12 answer quite well, the method I showed you this evening was that illustrated in the central diagram. The currents from the plate circuit of the last valve of a receiving set were passed through a transformer and made to control a triode valve connected across the arc. The circuit (which is my own), includes a grid-condenser and leak to ensure that the valve may function at the correct point on its charac-

teristic curve; also in addition to the H.T. supply derived from the mains there is an

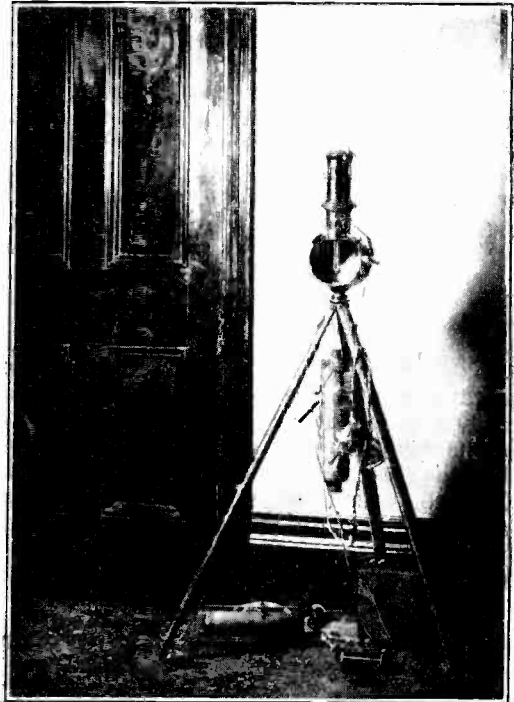

Fig. 15. The author's speaking arc transmitter.

extra H.T. battery in the plate circuit of the valve

Fig. 15 is a photograph of the transmitter. The speaking arc is fitted in a "Lucas" signalling lamp supported on a tripod.

Figs. 16 and 17 show my photonic receiver. The soniferous beam is received by the reflector of a second "Lucas" lamp and focused upon one end of a silica rod with optically polished ends. This rod conveys the light to a selenium cell.

I have used rods of glass and silica and tubes containing carbon-bisulphide (having the same refractive index as glass).<sup>1</sup>

The optical instrument makers tell me that not more than 7 per cent. of the light is lost in

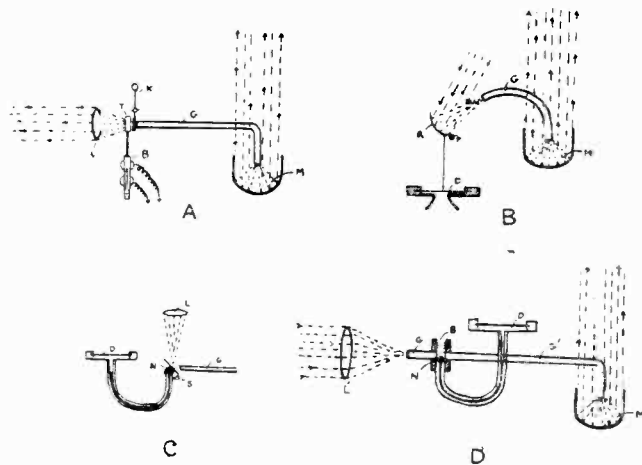

Fig. 14. Four suggested methods for beam modulation.

<sup>1</sup> Patents applied for: Nos. 6691/25 and 5801/25.



transmission along the rods. Quite as much would be lost if the selenium cell was placed in the centre of the signalling lamp in the path of the beam, and it would, in the latter position, rapidly lose its sensitivity to light by over-heating in the focal point of the rays. The silica or glass rods do not transmit sufficient heat to affect it at all. A silica rod carries both ultra-violet and visible radiations and I suggest that when signalling with the ultra-violet rays, such a rod might be used to convey the latter to a fluorescent screen, the visible light from which would act on a selenium cell or the cell itself might have a thin layer of fluorescent material over the selenium.

I experienced considerable difficulty in obtaining amplification of the photophonically controlled current; but after trying numerous experiments I solved the problem by the use of the circuit illustrated in Fig. 18, which shows the first method of amplification that I employed, in which transformer coupling was used. *Se* is a selenium cell included in the primary circuit



Fig. 16. A photograph of the author's photophonic receiver.

of a step-up transformer which controls the grid of a B.T.H. B4 valve. With this type of valve a grid bias of 16 volts gave the best results.

The H.T. battery gave a voltage across the selenium cell of 225 volts, and 75 volts to the plate circuit. *T* represents a pair of high resistance phones. When further amplification is required to operate a loud-speaker a transformer *F* is employed in place of the phones to connect the circuit to further stages of note-magnification. (Obviously a separate H.T. battery could if desired be employed to energise the selenium and plate circuits.) At the suggestion of Mr. Maurice Child I tried resistance-capacity coupling, which proved simpler and gave very excellent results. The circuit as I have finally fitted it up is shown in Fig. 19.

A high resistance is connected across the grid-condenser *C*; by the movement of a slider across this resistance a balance of adjustment can be obtained. The part of resistance on the right-hand side of the slider acts as a grid-leak and keeps the grid from building up too negative a charge, while that portion on the right of the slider gives the necessary voltage drop in the selenium circuit. To ensure that the grid side of the selenium cell is more positive than the negative terminal of the high-tension battery, a milliammeter which I employ in the plate circuit is not shown in the diagram. I have not conducted any long distance tests with the photophone but I have transmitted part of the 2LO programme on a beam of light from my house to that of a neighbour on the other side of the street, a distance of about a hundred yards or so, and obtained very good reception at loud-speaker strength. The circuits I have just described and demonstrated in operation require hundreds of volts of high-tension supply.

I will now show you a circuit I have devised<sup>1</sup> in which a selenium cell controls the grid of an oscillating valve. This arrangement requires only the use of a 60 or 75 volts H.T. battery. (I have had it working on 15 volts H.T.)

It can be employed by itself when the coupling between the grid and plate circuits is tight, and it is oscillating at audible

<sup>1</sup> Patent applied for: No. 9305/25.



frequency, or it can be oscillated at radio-frequency and used to heterodyne with any

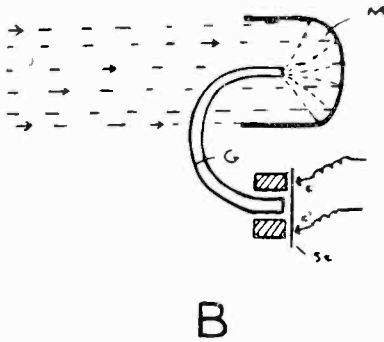

Fig. 17. The principle of the receiver.

ordinary receiving set using reaction. In the latter case an enormous increase in sensitivity is obtained in addition to any required degree of amplification. This arrangement is so sensitive that the light from a distant hall lamp from a house 50 yards or more away is ample, when allowed to fall upon the selenium cell, to give an appreciable change in the beat note.

Fig. 20 shows the selenium cell in the grid circuit of the valve; but I find it can be placed across the inductance or across the reaction coil or between the grid and reaction circuits, in almost any position. The cell can be placed between the grid and the leg of the filament in place of an ordinary grid-leak; but I find that owing to its exceedingly high resistance it is best to connect it to a more positive point on the H.T. battery and so adjust the valve to function at the most suitable point on its characteristic curve.

[Here a demonstration was given and the sensitiveness of the circuit was shown in the following ways:—

- (1) Heterodyned with a receiving set.
- (2) By itself when oscillating at an audible frequency.]

The circuit, it seems to me, is capable of a good many applications, including the following:—

(a) For cable telegraphy it might be operated by very minute movements of light from a mirror galvanometer and the

beat note could cause a suitably tuned reed, placed at the orifice of a resonant tube or cylinder, to respond and operate a relay. Considerable selectivity could be thus obtained and by use of a plurality of such cells, etc., a number of messages might be transmitted, each on a different note-frequency. All the notes could be produced simultaneously in a loud-speaker and each one separately recorded by its own suitably tuned reed relay and recording instruments.

Alternatively the relay might be arranged directly in the plate circuit of the receiving valves.

(b) To indicate the transit of a star across the field of view of a telescope. In this case the selenium or other light sensitive cell would be arranged at the eyepiece of the telescope. Dr. Fournier d'Albe has already used selenium cells in another way for this purpose; he is here this evening and I hope, Mr. Chairman, you will be able to prevail upon him to describe his experiments to us in this direction.

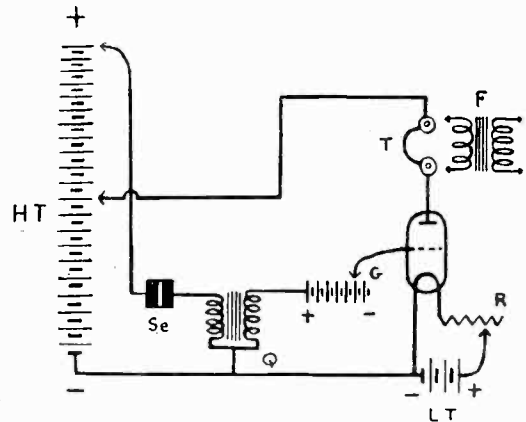

Fig. 18. The circuit diagram of the first method of amplifying the photophonic current.

(c) On board ships in the vicinity of a lighthouse, such an arrangement would give a loud signal or change of note, when the beam of light from the latter passed across the field of view of the cell.

(d) For photometric purposes, standardisation of candle-power, etc. In this case a self-luminous screen coated with radium paint might be employed as a standard.

(e) The comparison and measurement of quantities or radiations of radium or other radio-active substances by measurement of the fluorescence of the fluorescent screen exposed to the radiations therefrom, and their effect on a selenium cell.

(f) The transparency of an object to light or other radiations could be compared.

(g) The density of various patients' bodies to X-rays could be measured with a view to ascertaining correct exposures in radiography.

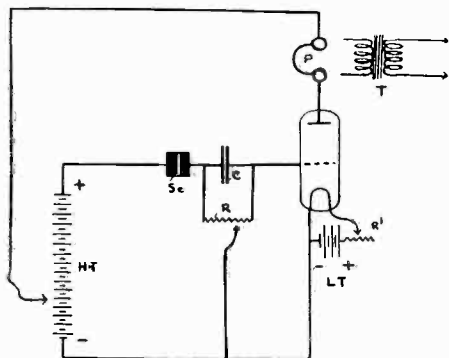

Fig. 19. Showing the finally adopted circuit.

(h) For naval, military and police purposes such a circuit, suitably disguised, could be placed in proximity to a light at a distance from a camp, building or ship. The circuit being employed as a transmitter would be picked up and caused to heterodyne a wireless set at the camp. This arrangement would then act as an invisible sentry. If anyone came between the light-sensitive cell and the light or tampered with either, his presence would be indicated by a change of note.

(i) This method might also be applicable in methods of distant control of airships, torpedoes, etc.

(j) Another possible application would be on the road at dangerous corners to give a loud howl when a motor passes and so give warning to motorists of dangerous corners.

(k) It might also find application in systems of television.

(l) For heliographic and other forms of light signalling.

(m) In methods used for assisting the blind to realise the presence of light, etc.

In cases c, h, and j, the interfering effect

of a rising moon or other unwanted light could be balanced out by the employment of two selenium cells in different arms of a Wheatstone Bridge, the light acting equally and oppositely upon them both and thus balancing out its effect; the control beam would, of course, only be directed on to one of the cells.

### Infra-red Rays.

We now come to waves longer than visible light in the region of the spectrum between visible light and Hertzian waves.

L. A. Charbonneau applied for a British patent in 1920. His idea was to make use of the fact that infra-red radiations rapidly quench fluorescence. A small screen of green zinc sulphide, wrapped round a cylinder or drum, was kept in a state of mild fluorescence by slow rotation in front of a small light, itself hidden from the observer behind the drum. The infra-red rays used for signalling were allowed to fall upon the screen, and each signal would cause a dark patch to appear where it destroyed fluorescence. The signals could be read by eye or photographically recorded. At the transmitter the visible light from an incandescent filament lamp was cut off by a filter of specially prepared black glass.

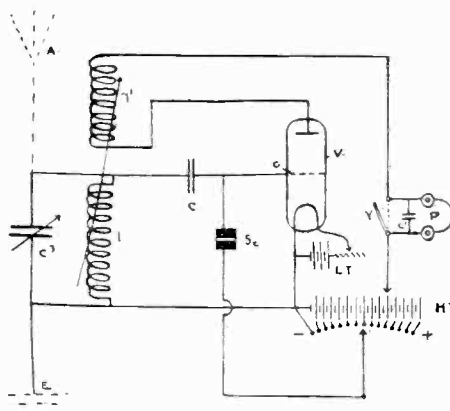

Fig. 20. Illustrating how the selenium cell is incorporated in the grid circuit.

Several other workers have developed methods of signalling employing infra-red radiations but time will not permit us to go further into the subject this evening.

## The Discussion.

Dr. E. E. FOURNIER D'ALBE: I have been exceedingly interested in Mr. Blake's prolific and fruitful discourse on many methods of signalling on wave-lengths in the ether other than those ordinarily used and I congratulate him upon it, and upon giving us a very interesting contribution to our Proceedings. He made one slight slip when he said that Berzelius discovered selenium in 1871; it should be 1817, but it is remarkable to think that between 1817 and 1871 the remarkable properties of selenium remained undiscovered, and when they were discovered they were regarded as a bit of a nuisance because high resistance was wanted in the cable stations and selenium was found to be useless for the purpose because it changed its resistance during sunlight. Mr. Blake showed us a new method of producing a change of note. I did not quite hear how this change of note is affected by slowness or rapidity of intermittence, but I should judge that when the emissions are slow, the change of note is rather greater than when the emissions are more rapid. That is a thing I am particularly interested in because theoretically the amount of difference between the lower and the higher note should be in exact proportion to the length of exposure. Thus, we might get an interval of a semitone when experimenting at second intervals and, say, one-third of a semitone if the rate is accelerated three times. In this experiment very minute quantities of light are involved, but I think it is quite sound to believe that, used judiciously, selenium is a great deal more sensitive to light than the human eye, and that is saying a great deal because the human eye is sensitive to an extraordinarily small amount of energy, I believe about 30 quanta per second, so that if this new heterodyne circuit is used we might find that with light of very low intensity we might get an intermittent effect due to the fact that we had got down to single quanta. That seems to offer a very interesting contribution to the theory of the general constitution of light. The controversy about the quantum theory is still raging, and it may be that we are at last in touch with the real crucial experiment to decide whether light has a structure or not, whether it comes in lumps or a steady stream. As regards the stars, there are methods of making stars audible without amplification. It was done in the case of Aldebaran about ten years ago and I was interested to hear that Mr. Blake now has this quick and ready method of using this change in note. As a rule, when you rely on the steady effect of selenium you have to wait some time before it comes into full force. I am entirely with Mr. Blake in saying that so far as we know at present only intense light can be made really useful. This is due to the fact that we cannot use dim light with any real effectiveness on account of the very small energy which we can obtain in that way. If this new method could be used with rapid emissions it would have the advantage that you would get an instantaneous effect when you use rapidly intermittent light. As regards the use of this method for giving warnings, I can quite understand that it would be useful for burglar alarms and motor car purposes. Especially can I see a very valuable field for it for burglar alarms in America, where it should find a most

remunerative field of application, because in New York and one or two other places burglars are very rife just now. Generally speaking, I have been extremely interested, because Mr. Blake has thrown out quite a number of new methods and I think probably they are very promising, at any rate all with the exception of the one with mercury, because I think that tube of mercury would have too much inertia to follow the rapid fluctuations of speech. Nevertheless, they all ought to be tried and I think it is very kind of Mr. Blake to give these suggestions to the world because any one of them might be very valuable to himself. I am sure we must thank Mr. Blake for his lecture.

Admiral Sir HENRY JACKSON: I should like to add my congratulations to Mr. Blake for his interesting paper and the valuable suggestions contained in it. There are a great many points of ingenuity in it to which we are indebted to him. I think bending the ray round the corner is rather a good idea and altogether the paper has given us plenty to think about. Mr. Blake has also shown us that wireless waves are not the only means of communication through the ether.

Mr. F. H. HAYNES: I have no observations to make on the extremely interesting subject to which Mr. Blake has devoted his attention. He has shown what can be done with very short ether waves; we are getting down now to waves as short as 20 metres, but we have no idea as to what may eventually be achieved with ultra-violet and infra-red waves at the hands of the wireless amateur.

Mr. Blake has outlined several microphonic methods and has shown us their application in wireless communication by means of the selenium cell. His work is full of suggestions and in the application of the selenium cell with reasonably low resistance to wireless circuits we have a new field to work in, particularly in regard to telephony. We certainly must thank Mr. Blake for having opened up what is an entirely new field.

Mr. BLAKE: Before I reply to the questions that have been raised I would like to thank those who have helped me this evening. I have had a great deal of help from Mr. Child, who took the trouble to bring all his receiving apparatus here and undertook to receive 2LO and relieve me of all the trouble of getting the signals from Selfridge's. I also wish particularly to thank Dr. Fournier d'Albe for lending me an unlimited supply of selenium cells. He told me that I could have any cells that I wanted and he has been most kind in helping me in that way. Mr. Patterson also very kindly lent me a photo-electric cell which I used in my experiments. I also must thank my assistant, Mr. Pickering, for assisting me to prepare these experiments and I think I also ought to thank the lanternist for working the slides. Dr. Fournier d'Albe pointed out the slip I made with regard to the date of the discovery of selenium. Of course 1817 is the date. Then he raised the point with regard to the change of note not corresponding quite to the rapidity of the light change. I am afraid I am not sufficiently musical; in fact I am not at all musical and am not able to appreciate these half tones and fine differences. I wish somebody else who is musical would speak on this point after what they have heard this evening, because I am afraid



I am not able to appreciate it. Then he spoke of the controversy between the quanta theory and that of the undulatory theory of light and suggested that my experiments might prove very valuable. I am very glad he raised that point and I hope somebody will take it up and carry it forward as a serious investigation. With regard to burglar alarms, I am afraid I am not altogether with Dr. Fournier d'Albe, because I can foresee that in place of the loss that we might get through burglaries, our money would go to the makers of high tension batteries, etc. I am afraid also that I am not quite so unselfish as Dr. Fournier d'Albe represented, because I have taken the precaution to patent several of the circuits that I have shown this evening. I do not think there is anything to reply to in the remarks of Admiral Sir Henry Jackson nor those of Mr. Haynes.

Captain L. F. PRÜGGE: I should like to propose a hearty vote of thanks to Mr. Blake for his most interesting lecture. It is certainly a most important thing to know that there are vibrations in the ether which we can make use of in the manner he has suggested which are quite different from the

wireless waves that we have been working with for so long.

Mr. GREENWOOD WATKINS: I have pleasure in seconding the proposition. I have listened with very great pleasure indeed to Mr. Blake's lecture and I am sure we have all benefitted from what he has told us about the various circuits and the use of radiation in such an unusual way.

The vote of thanks was carried with acclamation.

Mr. CHILD (who was in the Chair, Lieut.-Col. Holden having left): Before I close the meeting I should like to mention that we have had with us to-night some representatives from the States who have come over recently to attend the Conference in Paris. I should like to say to them on behalf of the Radio Society of Great Britain how very much we welcome them and hope they will go away with a better understanding of matters radio, as they occur in this country. On behalf of the Radio Society of Great Britain we welcome our friends from the States and are very pleased to see them.

The meeting then closed.

## R.S.G.B. Transmitter and Relay Section Dinner. [R545'06

**A** VERY successful dinner, which served the dual purpose of honouring distinguished foreign guests who had attended the recent Paris Conference and laying the foundation of the International Amateur Radio Union in Britain, was held at the Waldorf Hotel on 24th April. Mr. H. Bavin-Swift, Chairman of the Transmitter and Relay Section, presided, and the guest of honour was Mr. Hiram Maxim, President of the American Radio League. Mr. Maxim, replying to the toast of the I.A.R.U., proposed by Mr. Marcuse, emphasised the serious work of amateurs at the Conference at which, he said, twenty-three nations were represented. He pleaded for a spirit of wide tolerance on the part of amateurs who were perhaps sometimes as intolerant as the early Puritans. "Remember," he said, "that we amateurs who are interested in the scientific side of two-way communication must be tolerant and reasonable. Given unanimity, nothing can hold us back, but unanimity can only be attained through a spirit of tolerance.

Mr. Kenneth Warner, Secretary of the A.R.R.L., returning thanks for the cordial reception he had met with in England, said that for a long time past Americans had taken a keen interest in English developments and now looked forward to regular talks. "It is," he said, "a very great pleasure to meet in the flesh the friends made through the medium of the ether." America was looking forward eagerly to the day when every citizen with his own home-made set would be able to communicate with friends in any part of the world. This would be a great step towards the promotion of international understanding.

Canada, France, Newfoundland and other countries were represented among the fifty-two members and visitors present and even Mesopotamia had its ambassador in Captain Durrant, who, in a delightfully humorous speech, explained how, with no gear and only junk available, he had constructed a short wave station in the desert and had established communication over a distance of 3 000 miles.

After dinner, Mr. Marcuse invited those interested in the formation of a British Section of the I.A.R.U. to confer and give in names. It has since been stated that 40 members have joined and that 50 per cent. of this number were recruited at the dinner. Mr. Simmonds (2OD) has been elected the first President of the British Section of the Union and, for the time being, Headquarters will be in Connecticut and the organisation of the A.R.R.L. and the Journal *Q.S.T.* will be at their disposal.

Our photograph shows Mr. Maxim standing on the right of the Chairman.

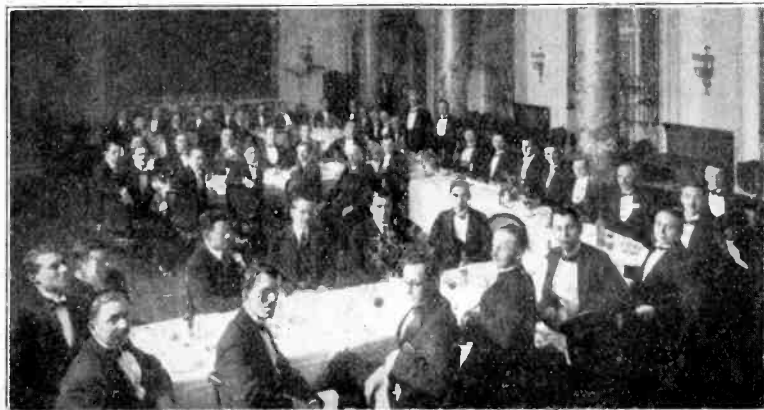

*A Photograph taken during the Waldorf Hotel Dinner.* 

# Testing Accumulators.

[R800 : 621·354.]

IT is perhaps not very widely known among the general public that in recent years a rather important advance has been made in the methods of testing the state of accumulators.

We think that it is fairly widely realised by now that the voltmeter, as usually applied, is quite useless as an indication of whether a battery is charged or not, and the use of the hydrometer is

negative and positive plates of the battery. After various investigations as to the most satisfactory material for the third plate, it has been found that cadmium metal is the most satisfactory: the surface of the cadmium is allowed to become slightly sulphated, which is achieved by keeping it when not in use in a pot of acid. The cadmium "plate" is in the form of a small rod covered by a perforated ebonite tube to prevent it from actually touching the positive or

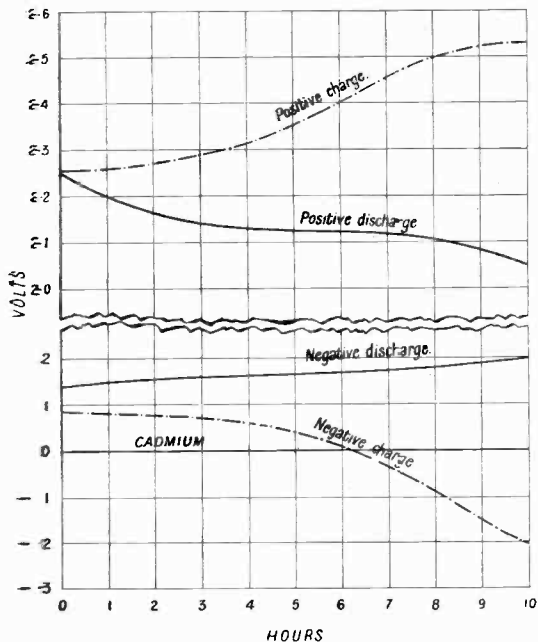

Fig. 1.

increasing. While, however, the hydrometer gives a particularly good estimate of the state of charge of the battery, it gives comparatively little information as to the condition of the plates. In order to get information on this heading, the usual requirements hitherto have been not only a hydrometer, but also a voltmeter and lastly considerable experience.

The new method, however of which we speak, simplifies matters considerably for it enables one to get definite information as to the state of the positive plates and the negative plates separately. This is achieved by placing in the electrolyte a third temporary "plate" of a definite unchanging material, and measuring the voltages between this third plate and the existing

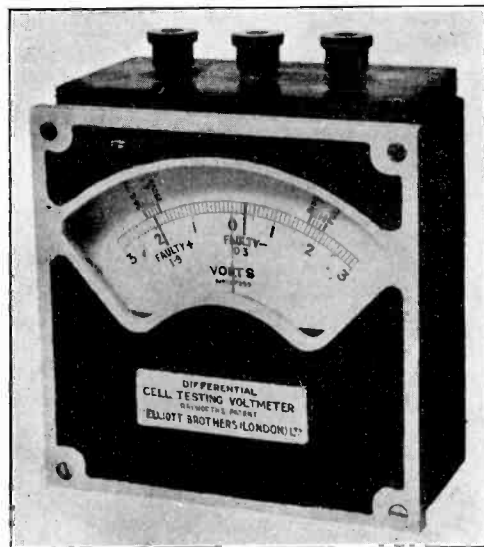

Fig. 3.

negative plates, and is attached to a flexible lead. This is shown in Fig. 2.

It is not necessary that it should be completely immersed in the electrolyte, and in the case of ordinary small wireless batteries it is simply inserted through the vent plug of the cell, making sure that at least the tip is below the top of the acid.

Fig. 1 shows the voltages that may be expected between the cadmium electrode and the accumulator plates in various states of the battery (it should be noted that the readings are to be taken while the current is actually flowing). In this diagram the voltage of the cadmium electrode itself has been taken as zero, and it will be seen that during discharge the negative plate becomes more positive

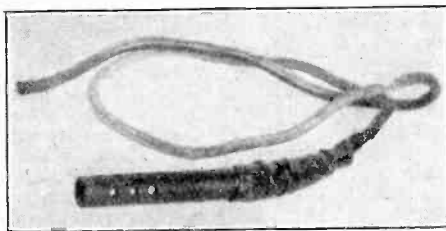

Fig. 2.



with regard to the cadmium, the voltage between them rising from 0.14 to 0.2. During charge the reverse takes place, and towards the end of the charge the negative plate falls below the cadmium electrode in voltage, the difference being rather more than 0.2. The voltage between the positive plate and the cadmium electrode moves in the opposite direction, falling from 2.25 to 2.05 during discharge, and rising from 2.25 to near 2.5 on charge.

It is obvious that the difference between these two voltages, *i.e.*, between positive to cadmium and negative to cadmium, represents the actual

voltage of the cell itself. Therefore it is obvious that if the total voltage of the cell is irregular, an examination of the two separate voltages from the plates to the cadmium will show which of the accumulator plates is at fault, and thereby gives definite information which can be obtained in no other manner.

It is, of course, possible to use a cadmium electrode of this type on an ordinary voltmeter, but it should be noted that a first-class meter must be used, *i.e.*, one of high resistance and with an even open scale. Messrs. Elliott Bros. (London), Ltd.,

Century Works, Lewis-ham, S.E.13, have now produced a special voltmeter for the purpose, the scale of which is marked over the range of positive plate voltages with special indications showing the state of discharge of the battery. Special marks are also placed on the scale showing the danger voltages, below which a positive plate is in bad order or above which the negative plates need attention. Fig. 3 shows this voltmeter as now being produced, while Fig. 4 shows detailed curves of all three voltages in a particular case, these latter having been supplied by Messrs. Elliott Bros. It should be noted that the voltmeter itself is covered by patents and is known as the "Rayworth" differential cell testing voltmeter.

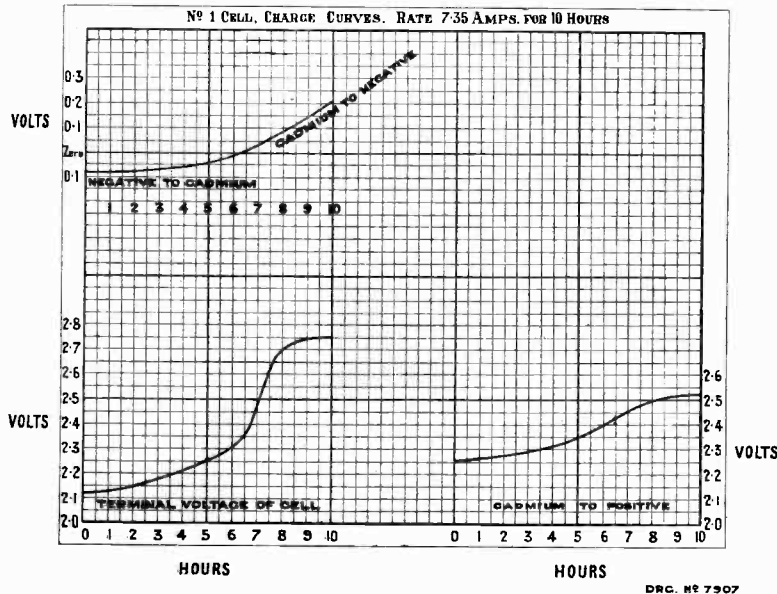

Fig. 4

### THE AIRMAX COIL.

In our last issue, when referring to the Airmax Coil, it was mentioned as being manufactured by Messrs. Airmax, Ltd., of Sheffield. It has been brought to our notice, however, that J. Dyson, 5 & 7, Godwin Street, Bradford, is the sole concessionaire for this piece of apparatus.

### SHORT WAVES FROM BERLIN.

Interesting experiments on the transmission of short wave-length signals were carried on during May by the Telegraphentechnische Reichsamt in Berlin. Transmission was made in morse three times a day all through the month on a wave-length of 54 metres. The signals were broadcast for twenty minute periods from 2 until 2.20 p.m., from 6 until 6.20 and from 10 until 10.20 p.m. The signals were composed of groups of six morse letters and intervals of eight seconds alternately. The first of these experiments took place on 1st May, at 2 p.m.

### A COURSE OF VALVE LECTURES.

"The Thermionic Valve and its Uses in Wireless Circuits" is the subject of an interesting series of six lectures being given by Captain W. H. Date, B.Sc., at the Regent Street Polytechnic Institution. The first and introductory lecture was delivered on Tuesday, 19th May, at 6.30 p.m. All the lectures will be given on Tuesdays (with the exception of 2nd June) at the same hour. The syllabus indicates that a wide field is being covered, from a brief outline of the electron theory to the use of the valve in transmitting and receiving circuits. Such a course should be of interest to all amateurs, and in some cases might serve to clear away haziness on certain points of the work valves are capable of doing. The modest fee of 7s. 6d. for the course, brings it within easy reach of all. The apparatus and equipment of the wireless laboratory of the Polytechnic will be available for the demonstrations and experiments given in the course of the lectures.

# Directional Properties of Receiving Aerials.

By *R. L. Smith-Rose, Ph.D., M.Sc., A.M.I.E.E., and*  
*R. H. Barfield, M.Sc., A.C.G.I.*

[R115]

Describing some experiments from which were obtained definite equations for determining the relations between the orientation of the receiving aerial and the resulting signal strength.

**E**ARLY in the development of wireless telegraphy it was discovered that certain types of receiving antenna possessed directional characteristics, *i.e.*, that the amount of energy picked up partly depended on the orientation of the various parts of the aerial with regard to the transmitting station.

The simplest form of directional aerial is the inverted "L" aerial, which consists of a horizontal length of wire with a vertical down lead at one end. It was found by Marconi and others that an aerial of this type was most efficient when erected so that its horizontal length was in the line joining transmitter and receiver, with its free end pointing *away* from the transmitter; while it was least efficient with its horizontal length in the same direction but with its free end pointing *towards* the transmitter. (See Fig. 1.)

The existence of this property has been definitely proved by a number of experiments, the most important of which are probably those of Prof. Fleming,<sup>1</sup> carried out in 1906 who drew a number of characteristic polar curves for various aerials, and showed that the effect was of considerable importance with the particular wave-length and aerial dimension with which he was working. At a much more recent date the directional effect is seen in its most extreme form in the Beverage Antenna,<sup>2</sup> in which everything is done to enhance its value.

The practical question now arises: to what extent is the directional effect of importance in the common types of aerial in use at the present day, such, for instance, as a simple broadcasting receiving aerial?

As far as the authors are aware, this

question has not hitherto been satisfactorily answered in any published work, with the result that at the present time there exists a considerable difference of opinion as to whether or not it is worth while to make the most of the directional properties of a receiving aerial. Thus from the experimental work on the subject already referred to it is not possible to draw any general conclusion valid for the most common forms of aerial and wave-lengths at present in use; nor is there any simple theoretical formula existing which can be employed for the determination of the directional characteristics of aerials.

It is therefore the object of the investigation described in this article to provide the answer to this question; that is, to determine, both experimentally and theoretically, the directional properties of aerials under as widely varying conditions of dimension and wave-length as possible.

## I.—Theoretical Considerations.

We shall first attack the problem from a theoretical point of view. When a wave

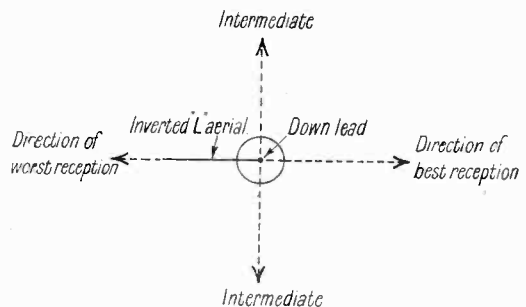

Fig. 1.

travels over the surface of the earth its front is not perfectly vertical, but, owing to a sort of dragging action of the imperfectly conducting earth on the feet of the waves,

<sup>1</sup> "On the Electric Radiation from Bert Antennæ." J. A. Fleming, *Phil. Mag.*, 1906, page 588.

<sup>2</sup> "The Wave Antenna." H. Beverage, C. Rice and E. Kellogg, *Jour. Amer. Inst. Elect. Eng.*, 1923, pages 258, 372, 510, 636, 728.

the front is inclined to the vertical at a small angle. (See Fig. 2.) Zenneck has pointed out that this phenomenon provides a simple explanation of the directional characteristic of aerials; for, in such a wave, the electric force has a horizontal component in the direction of transmission which will act on any horizontal conductor placed in that direction, such as the horizontal top of an inverted "L" aerial.

If, then, the aerial is directed with its free end towards the transmitter, the horizontal and vertical components oppose; if in the opposite direction, they assist. This is shown clearly in Fig. 3. Thus the aerial should be a better receiver in the latter position than in the former, which, as already indicated, is what is actually found by experiment to be the case.

Accepting the above explanation as the correct one, we will attempt to use it as a basis for the quantitative determination of the degree of directivity of an aerial.

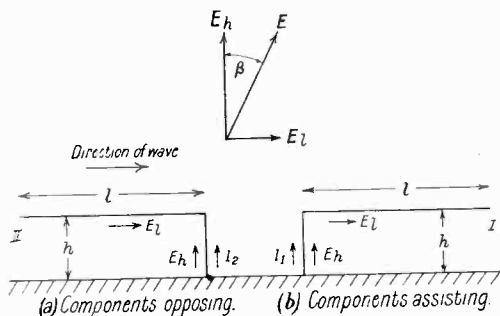

Fig. 3.

First of all it is necessary to have some definition of the quantity we are trying to determine. The strength of signals obtained from a given aerial depends on what is known as the aerial current, that is, the current in the aerial at a point near the earth; we may therefore conveniently define the directive effect of an aerial as the difference in the aerial current obtained by rotating a given aerial from its least favourable to its most favourable position, this quantity being expressed in terms of the average value of the two currents. Thus, if  $I_2$  be the aerial current when the aerial is pointing towards the transmitter (Fig. 3), and  $I_1$  the current when it is pointing in the opposite direction, and we call the directive effect  $D$ , we have:—

$$D = \frac{2(I_1 - I_2)}{I_1 + I_2} \dots \dots (1)$$

- Let  $l$  = horizontal length of aerial ;
- $h$  = vertical height of aerial ;
- $E$  = field strength at receiver ;
- $\beta$  = angle of inclination of wave front to vertical.

Then for the E.M.F. in the horizontal portion we have:  $E_l = El \sin \beta$ , and for the E.M.F. in the vertical portion  $E_h = E_h \cos \beta$ . Each of these E.M.F.s will produce at the foot of the aerial a certain current proportional to that E.M.F., so that the total aerial current will be the resultant of two currents given by

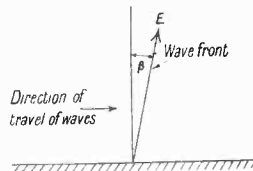

Fig. 2.

$$I_h \text{ (due to } E_h) = K_h E$$

$$I_l \text{ (due to } E_l) = K_l E,$$

where  $K_h$  will not be equal to  $K_l$ , since the aerial current is not the same at all points of the aerial, but falls off along its length. Hence, for the total aerial current at aerial foot in the two respective aerial positions (most favourable and least favourable):—

$$I_1 = I_h + I_l \text{ (E.M.F.s assist, Fig. 3b)}$$

$$I_2 = I_h - I_l \text{ (E.M.F.s oppose, Fig. 3a),}$$

or, substituting values of  $I_h$ ;  $I_l$ ;  $E_h$ ;  $E_l$ ,

$$I_1 = E (K_h h \cos \beta + K_l l \sin \beta)$$

$$I_2 = E (K_h h \cos \beta - K_l l \sin \beta)$$

and  $I_1 - I_2 = 2EK_l l \sin \beta$   
 $I_1 + I_2 = 2EK_h h \cos \beta$

Hence

$$D = \frac{2(I_1 - I_2)}{I_1 + I_2} = 2 \frac{K_l}{K_h} \cdot \frac{l}{h} \tan \beta \dots (2)$$

We will take the various factors in the right hand side of this expression in turn:—

(A)  $l/h$  — the ratio of the horizontal length to the vertical height is obtainable by direct measurement.

(B) In practice the determination of  $\tan \beta$  is complicated by the fact that the angle of inclination of the wave-front ( $\beta$ ) actually suffers a periodic variation during each cycle of the advancing wave; in other words, the electric field is elliptically polarised in the vertical plane through its direction of travel. Fortunately, however, this effect is sufficiently small in most practical cases to be ignored when considering the directional properties of aerials, and we can obtain a very good approximation by assuming the field to be

linear and inclined at a fixed angle  $\beta$ , as depicted in Fig. 2, unless we are dealing with very short waves or with ground of abnormally high resistance.

This angle ( $\beta$ ) can be measured by direct experiment by means of a rotating rod aerial, or it can be calculated if the value of the conductivity of the earth at the receiver is known. Thus it can be shown from simple electro-magnetic theory that the relation is—

$$\tan \beta = \frac{I}{2} \sqrt{\frac{n}{\sigma}} \quad \dots (3)$$

where  $\sigma$  = conductivity of earth in E.S.U. and  $n$  = frequency of received waves, holds good as a close approximation as long as  $\beta$  remains small.

In some recent experiments conducted by the authors, the conductivity of most typical kinds of soil to be found in England was determined. It was found that the value of the conductivity for each locality did not differ greatly from  $10^8$  E.S.U. and was not appreciably affected by the degree of humidity near the surface. It may thus be fairly safely concluded that this can be taken as a representative value for the majority of localities in England; although in an exceptional place, where the ground was quite dry to a great depth, it would undoubtedly be much smaller. We therefore see that  $\tan \beta$  is a determinable factor.

(c) The remaining factor is the ratio  $K_1/K_2$ .  $K_1$ , as we have seen gives the relation between the E.M.F. induced in the horizontal portion of the aerial and the current produced by that E.M.F. at the foot of the aerial; and  $K_2$  is a similar constant for the vertical portion of the aerial. These constants are unfortunately very difficult to calculate, as a complete knowledge of the current distribution in the whole aerial system is involved. The attempt to determine the directivity of a given aerial from simple theoretical considerations alone therefore breaks down unless we are prepared to plunge into an elaborate mathematical analysis of aerial current distribution.

## II.—Experimental Determination of Directivity.

It was therefore decided to attempt to determine "D" by experiment. The basis of the method was to measure by means of a

"radiogoniometer," as used in the Bellini-Tosi system of direction-finding, the ratio of the currents induced in two aeriels of identical dimensions but of which one was pointing directly towards the transmitting station and the other directly away from it. The arrangement is shown in Fig. 4.

The radiogoniometer consists of two field coils  $F_1$  and  $F_2$  with axes at right angles to each other, with a coupling or "search" coil "S" which can rotate within the space enclosed by the two field coils, thus varying the coupling between each of the field coils and the search coil in such a way that when the coupling attains a maximum value for one of them, it is zero for the other. The search coil is provided with a pointer and scale graduated in degrees. One of the field coils is connected in the earth lead of each of the aeriels, which are left untuned.

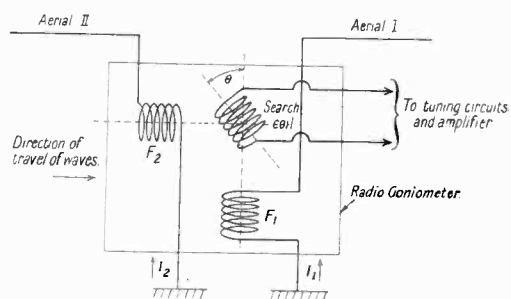

Fig. 4.

The search coil was connected to the tuning circuit and amplifier of the receiver.

The method of operation (having adjusted the receiver so that the required transmitting station can be heard) is to rotate the search coil until a position is found when the signals vanish or pass through a minimum. If, then, the search coil makes an angle  $\theta$  with this field coil  $F_1$  in this minimum position, and  $I_1$  be the current through this coil while  $I_2$  is the current through  $F_2$ , it can very simply be shown that:—

$$I_1/I_2 = \tan \theta.$$

The apparatus thus provides a very convenient method for comparing the currents in the two aeriels. If the aeriels were non-directional we should, of course, find that  $\theta = 45^\circ$ ; because  $I_1 = I_2$ , so that  $\tan \theta = 1$ . If they are directional and aerial I is oriented most favourably,  $I_1$  is greater than  $I_2$ , so that we should expect to find  $\theta > 45^\circ$ . In



practice this was always found to be the case, giving an experimental proof that an aerial pointing away from a transmitter is more efficient than an aerial pointing towards the transmitter. But we require more definite information than this. We have defined the directivity  $D$  of an aerial by means of the relationship.

$$\begin{aligned}
 D &= \frac{\text{Current Difference}}{\text{Current Average}} \\
 &= 2 \frac{I_1 - I_2}{I_1 + I_2} \\
 &= 2 \frac{I_1/I_2 - 1}{I_1/I_2 + 1} \\
 \therefore D &= 2 \frac{\tan \theta - 1}{\tan \theta + 1} \dots \dots (4)
 \end{aligned}$$

so that from a measurement of the angle  $\theta$  we are at once able to obtain  $D$  from Equation (4).

A great part of the success of the method depended on the ability to erect two aerials identical as to their electrical properties. For this great care had to be taken in ensuring equality of the aerials' dimensions and symmetry of the leading-in arrangements. In order to become satisfied that it was possible to fulfil this condition, the two aerials in the earlier experiments were first erected at right angles to the transmitting station, in which position their horizontal portions would be ineffective. Hence the two aerial currents should be equal and it should be found that  $\theta = 45^\circ$ . By means of this check it was proved that the desired equality of the two aerials could be established to a sufficient degree of approximation for the experiments to be successful.

Another very necessary precaution which had to be taken was to ensure that there was no "direct pick up" by any part of the receiving system except the aerials. It was therefore found necessary thoroughly to screen the amplifier and its associated circuits, even including the telephone leads.

Taking the above precautions, a number of different sized aerials were tested by the method, and the value of  $D$  obtained in each case. These values are recorded in the table below for three different sizes of aerials on various wave-lengths between 365 and 7 000 metres.

TABLE SHOWING DIRECTIVITY OF VARIOUS AERIALS AS DETERMINED EXPERIMENTALLY.

Metres.	SIZE OF AERIAL.			$D$ = $\frac{\text{current diff.}}{\text{current average}}$
	Length ( $l$ )	Height ( $h$ )	$\frac{l}{h}$	
7 000	200 ft.	10 ft.	20	0.24
2 500	"	"	"	0.30
750	"	"	"	0.60
750	100 ft.	"	10	0.36
365	80 ft.	20 ft.	4	0.23

On the longer wave-lengths very long low aerials were employed, as will be seen from the table. This was necessary in order to obtain large enough directive effects to be measured. Even with the ratio of length to height as large as twenty, the directive effect on a 7 000 metre wave is quite small—the difference in current between the worst and best positions of the aerial being only 24 per cent. For the same aerial on 750 metres the difference, however, is as high as 60 per cent.

On the shortest wave-lengths such long aerials could not be used with this method, as their natural wave-length became of the same order as that of the waves, thus making the balancing of the aerials too difficult a task. For such waves, therefore, a smaller value of  $l/h$  had to be employed. Thus it was not possible on a given aerial to obtain a value of  $D$  for all wave-lengths.

The directivity of the "four to one" aerial on 365 metres is of particular interest, since it is a typical broadcasting aerial of standard 100 feet length, measured for a wave-length in the middle of the present British broadcasting band. Its directional properties are seen to be comparatively small, but hardly small enough to be completely ignored where it is a question of obtaining the utmost from a given aerial.

### III.—Discussion of the above Results.

These experimental results, besides being in themselves of value as giving definite information with regard to certain aerials on certain wave-lengths, can fortunately be used to obtain more general information, if we now return to the theoretical considerations which were laid aside earlier.



We can now insert the experimentally obtained value of  $D$  in Equation (1), and thus obtain a value for the ratio  $K_l/K_h$ , since this is the only unknown factor now remaining in this equation. If we do this, we find that for every experimental observation recorded in the table, the value of  $K_l/K_h$  lies between 0.44 and 0.64 ( $\tan \beta$  being obtained on the assumption  $\sigma = 10^8$  E.S.U. from Equation (3)).

Suppose then we take  $K_l/K_h = 0.5$  as the approximate value of this ratio for all aerials and wave-lengths within the limits of the experiments, we shall then be able to calculate  $D$  for any desired case. The approximation is admittedly a rough one—the maximum possible error cannot be safely put at less than 30 per cent.—but the majority of the values will be much closer to truth than this; whereas, even assuming the maximum error, the information obtained will be sufficiently accurate for most purposes and will give a considerably better idea of the directive properties of aerials than exists at present.

Thus, taking  $K_l/K_h = 0.5$ , we get from Equation (2) the simple relation—

$$D = l/h \tan \beta \quad \dots \quad (5)$$

In Fig. 5 the values of  $D$  obtained from Equation (5) are shown plotted against the ratio  $l/h$  for a number of different wave-lengths. The graphs are, of course, straight lines passing through the origin; their slope becoming steeper and steeper as the wave-length decreases.

Outside the limits of wave-lengths 365 to 7 000 metres and below the value  $l/h = 4$ , we are extrapolating in assuming  $K_l/K_h = 0.5$ ; the values must, therefore, be accepted in these regions with reserve. The graphs are accordingly here distinguished from the more certain cases by employing dotted lines. From the simplest considerations, however, there does not seem much reason for supposing that this constant should differ greatly from the assumed value in the particular cases covered by the graphs; except, possibly, where  $l/h$  is very small. Since  $D$  is then also obviously negligibly small, however, the case is not worth considering.

The results obtained from these curves cannot be applied to cases where  $l$  becomes comparable with the wave-length, for in such cases the phase differences in the wave at different parts along the aerial become of

importance and may greatly enhance the directive effect, as in the Beverage or wave antenna.

If we then take these graphs as valid approximations we have all the information we require on the question of aerial directivity. Consider first of all the wave-lengths 400 and 300 metres, which are of particular interest since they may be considered as representing the broadcasting band. We see at once that unless the aerial is exceptionally long compared to its height, say  $l/h = 10$ —a very unlikely value with the present legal limitation of the aerial to 100 feet—its directional properties are small,  $D$  being less than half. On the most typical kind of broadcasting aerial (e.g.,  $l/h = 2$  or 3) the directivity does not exceed 0.16, so that allowing for all possible errors we are safe in asserting that for such an aerial the difference in current between its worst and best

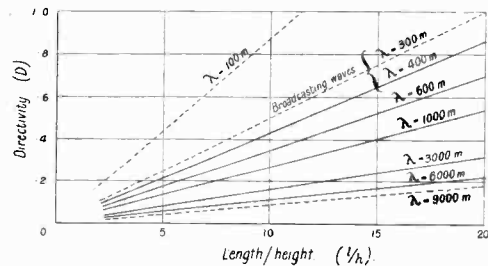

Fig. 5.

positions is less than 20 per cent.—Such a difference, it is true, may be worth while taking into account in the same way that other minor points are attended to in the construction of an efficient set, but it is definitely of secondary importance.

When we come to consider a standard 100-foot aerial being used for waves of length greater than 1 000 metres, say, on the broadcasting wave of 1 700 metres of the high power station, the directive effect is only about 5 per cent., and in such cases it may be neglected altogether in comparison with other considerations.

Some idea of the weight which should be attached to the directional properties of an aerial can be got from the fact shown by simple calculation, that if the erection of a broadcasting aerial in its least favourable direction is unavoidable, the adverse effect can be more than compensated for under the worst conditions by increasing the height

of the aerial by three feet; while, again, if we take a vertical aerial and bend over the top of it into the most favourable direction the advantage gained by the directional effect is outweighed by the disadvantage due to the decrease in the vertical height.

#### IV.—Conclusions.

The investigation described has verified the possession by inverted "L" aeri-als of directional characteristics and shown that in accordance with Zenneck's theory the directional effect is greater for short waves than for long, and increases with the ratio length/height of the aerial.

From the results of the direct measurements of the directivity of various aeri-als and from an application of Zenneck's theory to the problem we conclude that, within the present commercial range of wave-lengths and with normal aeri-als the directive effect is of secondary importance only, becoming entirely negligible on long waves received on short aeri-als, but of just sufficient importance

on broadcasting waves (300-600 metres) to be taken into account with the other secondary factors.

It must, however, be borne in mind that these conclusions are only valid for aeri-als erected in localities where the conductivity of the earth is approximately the same as that assumed in the calculations.

There is strong evidence that this value is but little departed from by all normal localities in England, but for places where the ground is very dry—too dry, say, for any vegetation—it is probable that the conductivity may have a much lower value, giving rise to enhanced directional effects.

In such places the directivity could, however, be easily determined from the formula given above, when once the conductivity had been determined.

On sea, on the other hand, where the conductivity is some hundred times greater than that assumed above, the directional effects will be about 1/10 of their land value, and consequently entirely negligible.

## Precision Measuring Instruments. [R384·009

THE importance of accurate measurement in all research work is so great that it is gratifying to note that instrument makers are turning their attention to the design of precision instruments particularly adapted to the needs of the wireless experimenter. We have recently had the opportunity of testing three well-designed instruments that form part of a series now being put on the market by Messrs. F. C. Heayheard &

Co., 8-9, Talbot Court, E.C.3, and in planning the calibration it is evident that the object aimed at was to provide a maximum number of the most generally useful ranges and to make both volts and ammeters capable of universal application so far as D.C. work is concerned.

Fig. 4 illustrates a very convenient form of combined portable moving coil, milliamp-volt-ammeter, contained in a well-made wooden box of suitable size for the pocket. When the lid is slid off and reversed the box, as will be seen in the photograph, forms a robust support for the instrument. Although the scale is only 2½ ins. in diameter, the divisions are clear and open and the fine point of the diamond-shaped end of the pointer enables a fraction of a division to be read with ease and accuracy. The voltmeter ranges are 0-6 and 0-120 and are therefore exactly suited to the testing of either L.T. or H.T. batteries and, since the resistance of the 120-volt range is 40 000 ohms, it can be used for testing the latter without fear of damage to the battery—a rather important matter that is too frequently overlooked by designers of pocket instruments. Equal forethought has been shown in the milliamp and ampere ranges. The shunt box, seen below the instrument, is constructed of highly finished brass and the four terminals enable the following useful ranges to be obtained: 0-3, 0-12, 0-120 milliamps and c-6 amps. This renders the instrument available for any current measurement from the plate current of a single valve up to the charging current of a reasonably large accumulator. The price of the instrument alone is 37s. 6d. The shunt box costs 17s. 6d. and the wooden case 10s. 6d.



Fig. 1. *The Universal Testing Meter.*

Fig. 1 illustrates an instrument that justifies the maker's description of it as a "Radio Universal Testing Meter." It is mounted in a finely finished

of the long slide wire in the one case and the plug in resistance arm in the other. The various ratios, the values of which are clearly shown, are



Fig. 2. The Wheatstone Bridge.

brass case which is set on a base-board that also forms the lid of a stout carrying case. An ingenious form of hinge permits the lid to be detached instantly from the case. The scale is 6 ins. in diameter and an anti-parallax mirror is fitted which, in conjunction with a knife-edge pointer, makes it an easy matter to read to 2 of a division. The following table gives the ranges of the instrument and the respective resistances:—

Volt Ranges.	Milliamp Ranges.	Resistance.
0—5	0— .5	800 ohms.
0—100	0— 10	123 "
Resistance.	0— 100	12.72 "
500 ohms.	0—1 000	1.287 "
10 000 "		

In addition, 5 and 10 ampere shunts can be supplied and also external series resistances giving a top scale reading up to 3 000 volts.

The damping of the instrument is so proportioned that it is very "comfortable" to use, being nicely dead-beat, but at the same time so free that the observer need have no fear of pivot friction. A further refinement is also supplied in the form of a magnetic calibration shunt. The price of the instrument, complete in case, is £5 6s. and the external shunts for the 5 and 10 amp ranges 15s. each. Prices of the high voltage series resistances can be obtained on specifying the desired range.

A very convenient form of Wheatstone Bridge is illustrated in Fig. 2 and Fig. 3 shows the internal connections. This compact instrument combines the facility of operation associated with the metre bridge with the requirements of the P.O. type and, as its dimensions are only 9½ by 5½ by 3½ inches, it is more portable than either.

Fig. 4 shows that the spiral P.Q. takes the place

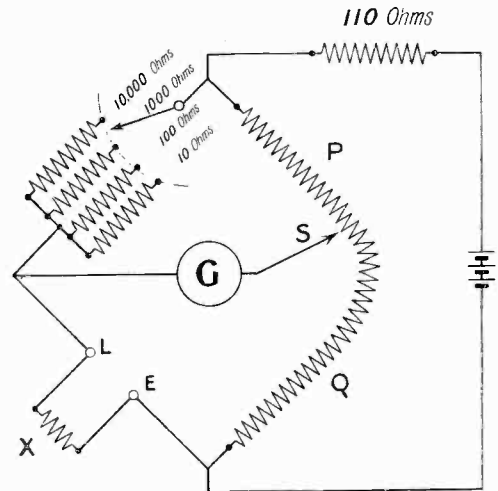

Fig. 3. Schematic Diagram of the Bridge.

introduced as desired by a switch of special design. The moving-coil instrument is built into the panel and is fitted with a powerful magnifying lens with the zero point in its exact focus. To the left of this, in the photograph, can be seen the two press buttons for the battery and galvanometer circuits. Readings are made, after balance has been obtained, on a silvered scale which carries a slider (S) fitted with a fine pointer.

Measurements ranging from .1 ohm to 1 megohm can be made easily and swiftly on the instrument, which is priced at £7 7s. Larger instruments, covering other ranges up to 200 megohms, can be supplied at proportionately increased prices, and another pattern has a range of .01 to 20 megohms. Price £9 12s. 6d. The instrument described, however, provides a very useful bridge for all ordinary purposes at a very modest price. The finish is excellent in every way: accuracy about in 1 1000.

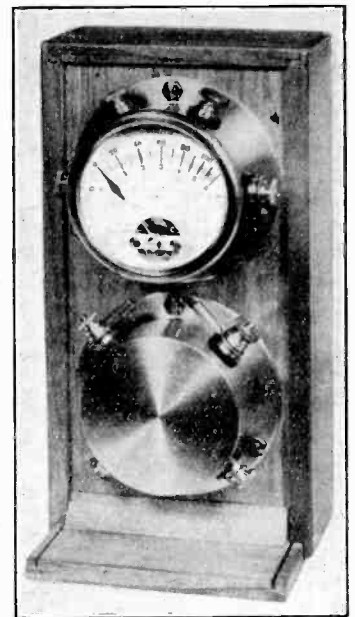

Fig. 4. The Portable Testing Set.



## Long-Distance Work.

By *Hugh N. Ryan (5BV)*.

[R545·009·2.

**R**ATHER less work than usual has been done this month. This is partly due to rather unfavourable weather conditions and partly to the Paris Convention taking many of us from our stations for a week.

However, a number of the Paris delegates have done their best to make up for lost time, and many other stations have kept the work going, so there is some interesting work to report.

The 20-metre work, which I mentioned last month, has been proceeding regularly, though nothing of any great interest has occurred in its continuance so far as transatlantic work is concerned. A very great step in our work has, however, been achieved on this wave-length in working with Australia. The contact established can hardly be termed "daylight communication" in the same sense as our daylight working with America, but it was accomplished when it was daylight at both ends, which is as near to daylight working as we can get when dealing with the Antipodes. The question of "which way round?" arises again, but as far as our present knowledge goes, the answer is probably "the daylight way."

Australian 20-metre signals were first heard in this country by 2KF and 6UV, and communication was first established by 2OD. The Australian station was 2CM. The most important feature of the 2OD—2CM communication was, I think, not the fact of contact being established (as we all knew it soon would be), but the fact that the work was done to a pre-arranged schedule.

Famous amateur pioneer achievements in the past have usually been of a somewhat "fluky" nature in the first case, and though always followed up by work which has established their usefulness, their apparent "flukiness" has been the subject of some adverse criticism on amateur achievement. 2OD has supplied the final answer to all such criticism, by making the first daylight contact across the world "to schedule." F.B., O.M.!

Another event, which promised to be of great interest, was 5LF's Atlantic voyage

for the purpose of experimenting on the short waves. He was to spend about a week crossing to the United States, a week in the States, and a week returning, carrying on the boat transmitters and receivers for 20, 40 and 90 metres. The object was, of course, to work American and European amateurs during the voyages, and obtain records of the variation of his and our signal strengths at different points. At the time of writing the outward voyage is over, but the return voyage not yet commenced. He will be back in England by the time this article appears.

The results obtained on the outward journey were, from our end, disappointing, although he probably has some interesting records of our signals. His own signals were often heard, and of good strength, but rendered extremely difficult to read by violent swinging. This is a matter of great surprise, as the signals from 5LF's home station are notable for their steadiness. However, he has been informed of the trouble, and will probably have remedied it for the return voyage, when we hope to have some interesting tests with him. His call sign on the boat is 6YM, and he will welcome reports from all who have heard his signals from the boat, which reports should be sent to 5LF's home address.

The month has brought, as we feared, a considerable crop of atmospheric, but we have had quite a number of clear nights. American signals on 90 metres are disappearing rather more rapidly than I anticipated, and two-way work on this wave has now almost ceased, although the Americans may still be heard fairly often.

Two-way work across the Atlantic is, however, going strong on 45 metres now that many of us have our 23 and 45-metre licences. I doubt if even 45 metres will cross the "Pond" right through the summer, but it is certainly giving better results than 90 metres; 20 metres is still somewhat difficult to handle for prolonged communication, and has not yet taken its place in this work, although much fruitful experimenting is going on, as already reported.



Some months ago I commented upon the paucity of our work with Canada, as compared with that with America. I discussed this at Paris with Major Borrett (C1DD), and he said that this fact is noticed and greatly deplored in Canada. He ascribes it to the fact that we do not listen sufficiently on the 125-metre wave, on which so many Canadians call us. They are extremely keen on working with us, as one would expect, and are very disappointed at their calls to us, on 125 metres, and their replies to our tests, eliciting no response other than further calls from us to the Americans. The remedy is clearly indicated, and is in our hands.

Now that Newfoundland is "on the air," it is hoped in the near future to run an "all British" relay right round the world, going through Canada, Newfoundland, Australia and New Zealand and back through South Africa. The Canadians are the moving spirits in this effort, and it is up to us to back it up.

SAR is the first transmitting amateur in Newfoundland, and hopes soon to be QSO Great Britain, as does 1AC, a similarly-placed amateur in Brazil. We had the pleasure of meeting both of them in Paris, and vowed to "get QSO" next autumn.

After the Convention, Brazil 1AC, accompanied by Swedish SMYY, travelled across the Pyrenees into Spain, taking a small portable transmitter, with which they were able to work G2FU from Andorra, in the Pyrenees.

In London very little work has been done. 2KF has not been on very much, and 5LF is away, though before his departure he worked America regularly on 23 and 45 metres. 6NF has nearly ceased working, being in need of a rest after a strenuous winter. 2OD's work has already been mentioned. 6QB has been exploring the forgotten region of 200 metres, and reports that things still happen there, while QRM is not what it used to be. Which reminds me that an American has worked a New Zealander on 200 metres. Well, many of us are licensed for 440 metres, and quite a few have not forgotten our old 1000 metre licences! Perhaps our flight down the scale may one day reverse its direction.

6QB intends running a small generator by weights hung out of the window, and wound up at intervals, so he says. 6UV is regularly on 45 and 23 metres and having

great success on both waves. He and 2KF receive A2CM well on 20 metres, but have not, at the time of writing, established contact.

2AYL, a fairly recent Chatham station, has received many Americans on a single valve Flewelling, without any aerial or earth, chiefly on the lower waves. 5QV has worked Florida, and received confirmed signals from 7ADQ (Seattle). 2FO has just obtained a licence for very high power on short waves, and will soon be using it.

5IG, of Havant, is licensed for a particularly large assortment of waves between 15 and 200 metres, but works mostly on 87 and 95, on which he has worked all over Europe. He would welcome reports of his signals on any wave-length.

6RY, of Bath, has practically given up 90-metre DX, and devotes himself almost entirely to 20 metres, where he transmits and receives with great success. 2GY, of Bristol, is working all over Europe, and should soon reach farther.

5SI, of Shrewsbury, is apparently bent on breaking all the world's low-power records. In February he worked America with 2.2 watts; in March, Finland with .8 watt; in April, Sweden with .36 watt.

6JV (Norwich) has accomplished similar, but not quite so startling, low-power results on the 40-metre band. 2AWP, of Yorkshire, has now a full licence with his call changed to 6YR, and would appreciate reports.

2GZ, an old friend of the pre-broadcasting days, is now in operation again after two years' inactivity, and his signals have reached America already. 2KK has been working chiefly on the receiving side, and has received signals from a large number of countries.

Mr. Gordon Ritchie, of Glasgow, has also been doing some interesting reception work, which confirms entirely the figures for distribution of 20-metre signals which I gave last month, except that in one instance he heard two Americans, evidently about 200 miles apart, working together. This interesting case is the first exception to my last month's figures that I have yet met. Apparently the 25-400 mile "shadow" is not quite inevitable.

Next month's report will probably deal almost entirely with 23 and 45-metre work. Please let me have reports by 10th June, mentioning especially the extent to which 90-metre work is still practicable.

## For the Esperantists.

[R800

## La Internacia Amatora Radio-Konferenco.

Originala Raporto de nia Speciala Korespondanto.

**L**A unua Internacia Konferenco de Radio-Amatoroj okazis en Parizo de la 14a ĝis 18a Aprilo, sub la prezido de S-ro. Edouard Belin, Prezidanto de la Radio-Klubo de Francujo kaj Honora Prezidanto de la Internacia Radio-Asocio. La kunvenoj okazis en la Fakultato de Sciencoj.

Subtenante S-ron. Belin dum la solena malferma ceremonio je mardo, estis la Generalo Ferrié, Estro de la Telegrafa Fako de la Franca Armeo, kaj S-ro. Hiram P. Maxim, Prezidanto de la Amerika Radio-Relaja Ligo.

La ĉefa celo de la kongreso estis la fondo de Internacia Unio de Radio-Amatoroj, kiu unuigos la radio-amatorojn en ĉiu parto de la mondo. Inter la gravaj temoj diskutotaj estis la alĝustigo de ondolongoj inter amatoroj, la organizo de transatlantikaj provoj, la rearanĝo de voksignaloj, kaj fine, la elekto de internacia helpa lingvo.

Dum la unua kunveno, la ĉambrego estis plenplena, kun pli ol 250 delegitoj kaj kongresanoj el dudek-du landoj. La Prezidanto bonvenis la delegitojn franclingve; ankaŭ faris mallongajn paroladojn Gen. Ferrié, S-ro. Maxim, kaj aliaj naciaj reprezentantoj.

Poste oni longe diskutis la tagordon de la kongreso. Ĉiun regulon oni diskutis kaj voĉdonis aparte. Oni uzis du lingvojn, la franca kaj la angla. Kiam ajn delegito parolis angle, lia parolado estis tradukita francen, kaj kontraŭe. S-ro. Leon Deloy, la fama franca amato, estis la ĉef-interpretisto, kaj li estis helpita de angla delegito; dum unu okazo tri oficialaj interpretistoj samtempe deĵoris.

Estis mem-evidente, eĉ je la komenco, ke lingva malfacilo kaŭzus multe da ĝeno, kvankam oni uzis nur du lingvojn. Oni malŝparis multege da tempo pro la ofta tradukado kaj pro la deziro havigi ĝustajn tradukojn de paroladoj faritaj en unu aŭ alia de la du lingvoj. Kelkafoje, la originalaj reguloj en franca lingvo ne estis klare komprenitaj eĉ de la francoj mem, kaj pro tio, kompreneble, estis neeble fari ĝustan

tradukon. Kiel ekzemplon, mi povas citi la regulon kiu, laŭ la franca originalo, pritraktis la "kvorumon" necesan por efektiviĝi la voĉdonojn de kunvenoj. Dum pli ol duon-horo oni argumentadis pri la supozita signifo de tiu regulo, sen sukceso, kaj eĉ dum la sama vespero, kiam okazis akcepto ĉe la Hotelo Lutetia, kelkaj personoj kunvenis neformale (inter ili S-roj. Belin, Maxim, Warner, Corret, Mesny, Turner kaj Epton) por trovi la ĝustan signifon de la regulo. Oni fine interkonsentis, post konsulto kun la aŭtoro de la originalo, ke anstataŭ la vorto "kvorumo" oni devus uzi la vorton "plimulto"!

Dum la posttagmezo, por rapidigi la laborojn, oni decidis elekti komisionon por ĉiu temo; ĉiu komisiono kunvenu aparte kaj samtempe por diskuti detalojn kaj poste prezenti raporton al la plena kunsido. Ĉiu nacio tenis kunvenon de siaj reprezentantoj, kaj selektis membron por ĉiu komisiono pri kiu ĝi interesis sin. Tia membro havas la rajton voĉdoni por sia lando en tiu komisiono, por kiu oni lin selektis. Oni ankaŭ konsentis, ke ĉiu lando havos nur unu voĉdonon en ĉiu komisiono.

Kiam komisiono finos sian laboron, ĝi prezentos raporton al la plena kunsido, kaj oni permesos diskutadon de la aliaj kongresanoj. Se la raporto renkontos ĝeneralan aprobon, oni permesos voĉdonon, sed nur tiuj landoj, kiuj havas reprezentantojn sur la komisiono koncernita, rajtus voĉdoni ĉe la plena kunsido. Jen unika metodo por voĉdono, sed ĝi funkciis tre bone.

Dum la dua tago, merkredo, oni faris malmulton ĉe la plena kunsido. Oni finis diskutadon pri la tagordo, korektis kelkajn erarojn faritajn hieraŭ. Poste la diversaj komisionoj kunvenis.

Ĉi-sube estas presita raporto pri la kunsidoj de la Komisiono pri Internacia Lingvo.

Je la tria tago, ĵaŭdo, la Komisiono pri Ondolongoj prezentis sian raporton. Ĝi rekomendis, ke amatoraj stacioj uzu ondolongojn inter 115 kaj 95 metroj, inter

75 kaj 70 metroj, kaj inter 47 kaj 43 metroj, sed kvankam la Kongreso aprobis la raporton, estis komprenite, ke tiuj rekomendoj estas nur deziresprimoj kaj ke sole la registaroj rajtas decidi pri ili.

Poste, la diversaj komisionoj daŭrigis siajn diskutojn, kaj ĉiu, kun escepto de la Komisiono pri la proponita Unio, finis sian laboron la saman posttagmezon. La tasko de la Komisiono pri la Unio estis tiel peza, ke ĝi devis ree kunveni dum la noktomezo por konsideri la multajn regulojn de la konstitucio. Unu el la membroj de tiu komisiono estis tiel laborema, ke dum 24 horoj li ne manĝis, sed la venontan matenon oni donacis al li longegan francan panon, ĉirkaŭ kiuestis volvita belega silka rubando!

Ce la plena kunsido dum la kvara tago, vendredo, la Komisionoj pri Transatlantikaj Provoj kaj Voksignaloj prezentis siajn raportojn. La rekomendoj, ke por ĉiuj provoj oni ĉiam uzu la Tempon de Greenwich, kaj pri normigo de ĉiuj mallongigoj pri fortoco de signaloj, stato de vetero, k.t.p., estis unuanime aprobitaj.

Ĉe la sama kunsido la Komisiono pri fondo de la proponita Unio prezentis sian raporton, kaj post iom da diskutado, oni ĝin unuanime aprobis inter granda entuziasmo. Tiel naskiĝis la INTERNACIA AMATORA RADIO-UNIO, kiu markas la komencon de nova epoko en la historio de amatora radio.

Kelkaj el la pli gravaj punktoj pri la aprobita konstitucio eble interesos niajn legantojn.

La originala intenco de la Amerika Ligo

estis, ke la Unio konsistu el naciaj radio-societoj, kiuj plejparte interesas sin pri du-voja telegrafa interkomunikado, sed post kontraŭstaro de aliaj landoj, oni decidis, ke la Unio konsistu el individuoj. Kvankam la ĉefa celo de la Unio estos antaŭenigi la interkomunikadon telegrafan, ĉiu persono, kiu montras seriozan intereson pri la progreso de la radio-arto, rajtos membriĝi. Tiel, ne nur telegrafemuloj, sed ankaŭ eksperimentistoj povos aliĝi.

La ĉiujara kotizaĵo estos unu dolaro, kaj kiam en iu lando estos almenaŭ 25 membroj, oni povos fondi nacian sektion, kiu rajtos al unu voĉdono pri aferoj de la Unio. Oni tenos kongreson ĉiudujare, kaj la oficistoj deĵoros du jarojn.

Por la komenco, la sidejo de la oficejo de la Unio estos en Usono, kaj preskaŭ ĉiuj oficistoj estos usonanoj, kaj la oficiala organo de la Amerika Ligo, nome "Q.S.T.," estos la oficiala organo de la Unio. Tamen, tio estos nur provizora.

Sabato estis la lasta tago de la Kongreso; la ferma kunsido okazis dum la posttagmezo.

La raporto de la Komisiono pri Internacia Lingvo estis prezentita ĉe ĉi tiu kunveno, kaj post iom da diskuto la tri rekomendoj de la komisiono estis aprobitaj. Mallonge, la Kongreso decidis adopti Esperanton kiel sian oficialan lingvon kaj rekomendi ĝian studadon kaj uzadon inter radio-amatoroj. Plena raporto sekvas ĉi-sube.

Oni esprimis multan ĝojon pri la rezultoj atingitaj ĉe la kongreso, kaj oni esprimis tutkoran dankon al diversaj oficistoj, kiuj organizis la kongreson.

## Raporto de la Komisiono pri INTERNACIA HELPA LINGVO.

Landoj, kies reprezentantoj ĉeestis:—

Granda Britujo, Germanujo, Argentino, Aŭstrio, Kanado, Usono, Francujo, Hungarujo, Italujo, Irlando, Japanujo, Nederlando, Polujo, Svedujo, Svislando, Ĉeĥo-Slovakujo, Novlando, Urugvajo, kaj Hispanujo.

### UNUA KUNSIDO.

La unua kunsido okazis je merkredo, 15a Aprilo. Oni elektis la jenajn oficistojn de la komisiono:

*Prezidanto*: D-ro. E. Privat (Svislando);

*Vic-Prezidantoj*: S-roj. P. K. Turner (Britujo) kaj Nordin (Svedujo);

*Sekretario*: S-ro. Epton (Irlando).

Dek-unu delegitoj ĉeestis la kunvenon.

Post mallonga diskutado pri tagordo, oni unuanime decidis dividi la laboron en du partojn: telefonio kaj telegrafio. Oni do malfermis la diskutadon rilate al la telefona flanko.

Troviĝis antaŭ la komisiono kvar definitivaj proponoj pri lingvo elektota: angla, Esperanto, Ido kaj Interlingua. Oni unue diskutadis, ĉu oni preferu nacian lingvon, ekz., angla, aŭ artefaritan lingvon. Krom unu sindeteno, oni unuanime decidis favori artefaritan lingvon.

La Sveda delegito tiam proponis, ke la elekto de artefarita lingvo estu lasata al komitato de spertuloj, kiu povus konsideri la aferon kaj raportoj al la plej proksima kongreso post du jaroj. Kelkaj membroj kontraŭstaris tiun proponon, konstatantaj ĝian gravecon kaj urĝecon. Ili ankaŭ opiniis, ke eĉ post du jaroj, la spertula komitato plej certe ne povus decidiĝi pri plej taŭga lingvo. Per 13 voĉdonoj por, neniun kontraŭ, kaj unu sindeteno, la komisiono malakceptis la proponon pri prokrasto.

La komisiono tiam ekzamenis la pretenojn de Interlingua, Ido kaj Esperanto. Kelkaj personoj parolis angle aŭ france, aliaj esperante aŭ ide. La Prezidanto tradukis ĉiun paroladon rapide kaj ĝuste en la francan kaj anglan lingvojn.

Post longa debato, la komisiono decidis, per 13 voĉdonoj kontraŭ 1, kaj unu sindeteno, rekomendi al la Kongreso la adopton de ESPERANTO pro ĝia granda disvastiĝo, kaj pro tio, ke ĝi estas lingvo jam uzata praktike. Jen teksto de la rezolucio akceptita:—

**“La Unua Internacia Kongreso de Radio-Amatoroj, bone scianta la malfacilaĵojn kaŭzitaĵajn de internacia interrilato pro la diverseco de lingvoj, rekomendas la studon kaj uzon de Esperanto kiel la helpa lingvo de radio-telefona komunikado kaj sendado, kaj de resumoj aŭ tradukoj en gazetoj kaj kongresoj.”**

Pro tio, ke la horo malfruiĝis, la komisiono decidis denove kunsidi la venontan tagon por diskuti proponon de D-ro. Corret (Francujo), ke oni aldonu rekomendon rilate al radio-telegrafio en okazoj kiam la korespondantoj havas neniun lingvon komunan.

Oni elektis kiel raportontojn al la Plena Kunsido, D-rojn. Corret kaj Privat.

## DUA KUNSIDO.

La komisiono kunvenis posttagmeze, je ĵaŭdo, 16a Aprilo.

Krom la landoj reprezentitaj je la unua kunsido, la jenaj pluaj landoj sendis delegitojn al la dua kunsido: Argentino, Germanujo, Japanujo, kaj Hispanujo.

La delegitoj el Polujo kaj Hungarujo forestis. La Franca delegito reprezentis ankaŭ Ĉeĥio-Slovakujon kaj Italujon.

Sciĝite pri la rezulto de la unua kunsido, la argentina, japana kaj germana delegitoj subtenis la rekomendon jam faritan.

La komisiono tiam diskutis la proponon de D-ro. Corret rilate al radio-telegrafio. Post longa debato, per 12 voĉdonoj kontraŭ 2, kaj unu sindeteno, oni akceptis la jenan aldonan rekomendon:—

**“La sama rekomendo rilate al radicelegrafaj komunikoj kiam la korespondantoj ne povas komprenigi sin per iu nacia lingvo.”**

S-ro. Turner (Granda Britujo) tiam proponis, ke la Kongreso tuj efektivigu la decidon (se akceptota) per adopto de Esperanto kiel sia propra helpa lingvo, flanke de la naciaj lingvoj uzitaj, kaj per publikigo de la rezultoj de siaj diskutadoj en tiu lingvo.

Post mallonga diskuto, oni decidis, per 8 voĉdonoj kontraŭ 5, kun unu sindeteno, aldoni la jenan rekomendon al la du antaŭaj rezolucioj:—

**“Sekve de tiu ĉi decido, la Kongreso adoptas Esperanton kiel sian propran helpan lingvon flanke de la naciaj lingvoj uzataj.”**

La tasko de la komisiono tiam finiĝis, kaj la delegitoj el Svedujo, Francujo, Granda Britujo, kaj Urugvajo, proponis koran dankesprimon al la Prezidanto pro lia pacienco kaj senpartieco dum la diskutado. Oni entuziasme aplaudis tiun dankesprimon.

Dankante la komisionon, la Prezidanto anoncis, ke la sindetenoj de Svislando (kies reprezentanto li estas) estis pro tio, ke li devis resti neŭtrala kiel prezidanto de la komisiono.

La kunsido tiam fermiĝis.

## PLENA KONGRESA KUNSIDO

Ĉe la lasta kunsido de la Kongreso, je sabato, la 18a de Aprilo, D-ro. Privat legis la raporton de la Komisiono pri Internacia Lingvo en franca kaj angla lingvoj.

La Prezidanto de la Kongreso, S-ro. Belin, tiam malfermis la temon por diskutado. S-ro. Nordin (Svedujo) ripetis angle paroladon, kiun li antaŭe faris ĉe kunsido de la komisiono, en kiu li kritikis Esperanton kaj fanfaronis la virtojn de Ido, kaj li denove proponis, ke oni sendu la demandon al komitato de spertuloj.



Respondis D-ro. Corret (Francujo), kiu citis eliraĵojn el la decido lastjara de la Amerika Radio-Relaja Ligo, kiu tiam decidis subteni Esperanton. Li multe amuzis la aŭskultantojn per cito de ĉirkaŭ dudek artefaritaj lingvoj, kiuj pretendas, ke ili estas plibonaj ol Esperanto aŭ Ido.

Alia Sveda delegito tiam parolis favore de la angla lingvo kiel la internacia lingvo. kaj konstatis, ke en lia lande preskaŭ ĉiu amatoro konas anglan, kaj ili tial reĵetis Esperanton *kaj Idon*. Tiu deklaro nuligis la fikton de la parolado de la alia sveda delegito.

S-ro. Warner (Usono) diris ke, pro la deklaro de la A.R.R.L., ili intencis voĉdoni por la unuaj du rezolucioj, kun la rezervo, jam anoncita, ke se iam en la estonteco iu gravega internacia aŭtoritata komisiono, kies kompetenteco estos akceptita, decidus favore de iu alia lingvo aŭ de ia modifo de Esperanto, ili estus liberaj sekvi ĝian rekomendon.

S-ro. Isbrucker (Nederlando), kiu parolis esperante, konstatis, ke la aŭtoro de Esperanto mem antaŭ multaj jaroj, deklaris sin preta akcepti la decidon de iu aŭtoritata komisiono, simila al tiu aludita de S-ro. Warner. Lian paroladon tradukis en anglan kaj francan D-ro Privat.

Post paroladoj de S-ro. Ryan (Britujo), kiu favoris anglan, kaj S-ro. Grenkamp (Polujo) pro Esperanto, kaj de S-ro. Usami (Japanujo), kiu faris bonegan paroladon en Esperanto, konstatanta ke, en sia lando, la eŭropaj lingvoj, kiel ekzemple la angla, estas tre malfacilaj, dum Esperanto estas tre populara pro sia simpleco, la Prezidanto fermis la diskutadon kaj petis voĉdonon pri la rekomendoj de la komisiono.

*La unua rekomendo rilate al telefonio estis aĵrobota per 12 voĉdonoj kontraŭ 2; la dua per 14 kontraŭ 2; kaj la tria per 12 kontraŭ 5.*

La Prezidanto tiam anoncis, ke ĉiuj rekomendoj de la komisiono estis akceptitaj, kaj la rezulto estis multe aplaŭdita.

### Diversaĵoj.

Dum la mateno de merkredo, granda partio, veturanta en benĉaroj, vojaĝis al Malmaison, la laborejo de S-ro. Belin, la Prezidanto de la Kongreso. S-ro. Belin mem kondukis la vizitatojn tra siaj laborejoj, klarigante detalojn pri sia mirinda aparato por telegrafado fadene aŭ senfadene de veraj mesaĝoj aŭ bildoj. Oni vidis multajn fotografaĵojn senditajn per la aparato.

S-ro. Epton, Sekretario de la *Internacia Radio, Asocio* (kies Prezidanto estas S-ro. Belin), parolis mallonge en Esperanto, dankante S-ron. Belin pro lia malavaro, kaj en la nomo de la Esperantistoj, kiuj ĉeestas, deziris al li sukceson. La parolado, verŝajne komprenebla al ĉiu ĉeestanto, estis multe aplaŭdita.

Dum sama vespero, ĉe la fama *Trocadero*, oni aranĝis senpagan kinematografan programon, montrante filmon nomitan "La Mistera Voĉo de la Ondoj." Ankaŭ faris franclingve paroladon D-ro. Pierre Corret, pri Radio. Granda amaso ĉeestis.

Je jaŭdo matene, oni faris oficialan viziton al la senda stacio ĉe Eiffel'a Turo. La ĉef-inĝeniero kondukis la partion tra la diversajn cambrojn.

Tre frue vendredon matene, kelkaj kongresanoj vojaĝis aŭtomobile al la fama senda stacio ĉe Sainte-Assise, la plej granda stacio en la mondo.

La lasta okazintaĵo de la Kongreso estis festeno ĉe la Hotel Lutetia, kaj preskaŭ ĉiu kongresano ĉeestis.

Tiel finiĝis semajno, kiu certe estos gravega en la historio de amatora radio, kaj ni esperas, ke la lingvaj malfacilaĵoj tiel rimarkeblaj ĉe la kongreso, estos forigitaj per la saĝa decido adopti kiel helpan lingvon, la lingvon Esperanto!

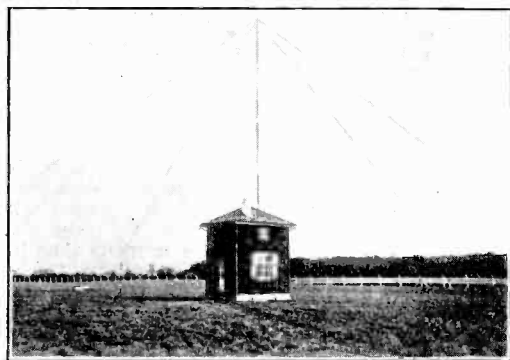

*As a sequel to the involuntary flight of the R 33, the above photograph is interesting. It shows the receiving aerial of the wireless station at Basle, one of the latest aerodromes to be equipped with receiving and transmitting apparatus. The transmitting aerial is shown on a later page.*



*Letters of interest to experimenters are always welcome. In publishing such communications the Editors do not necessarily endorse any technical or general statements which they may contain.*

### Corrugated Diaphragms.

*The Editor, E.W. & W.E.*

SIR.—In the April No., Vol. II., No. 19, page 454, particulars appear regarding the use of corrugated diaphragms. It would be interesting to know if priority or Master Patent rights are claimed for this particular form of construction.

It is curious that there is not a single loud-speaker on the market employing this system of diaphragms (I am open to correction).

Personally I think it is the only correct method, for the original Edison, and also the Edison Bell phonographs, used this on their reproducers fifteen years ago, and no other form of phonograph or gramophone music has equalled that obtained when the diaphragm has been made of thin corrugated copper.

There is an opening here for some brainy person.

J. P. J. CHAPMAN.

Glen Lee,  
Alumdale Road,  
Westbourne, Bournemouth.

[We believe, as a matter of fact, the well-known Western Electric loud-speaker uses a corrugated diaphragm of fibre.—Ed., E.W. & W.E.]

### Parasitic Losses in Coils.

*The Editor, E.W. & W.E.*

SIR.—In the article by Mr. R. M. Wilmotte in your current issue, statements which appear to be incorrect are made regarding parasitic losses. On p. 477, column 2, the assertion is made that "at all frequencies and for all sizes of objects, the loss will be greater the lower the specific resistance of the material." For high frequencies, however, the opposite is the truth. As Mr. Wilmotte shows, the loss is proportional to

$$\frac{R\omega^2}{R^2 + L^2\omega^2}$$

Now it is only at low frequencies that the square of the reactance ( $L^2\omega^2$ ) is small compared with  $R^2$ . At radio frequencies, the value of the current (for such conductors as copper, brass, aluminium,

etc.) is practically determined by the reactance only and is the same with either metal, other conditions remaining constant. The loss therefore increases with the specific resistance of the metal.

As an example, consider a small closed ring of wire an inch or two in diameter. If we calculate the square of its reactance at half a million cycles per sec. (600 metres) we find that it is several hundred times the resistance. The current induced in such a ring when placed in a magnetic field will therefore be the same whether the ring be of copper or brass. The power dissipated in the ring however will be greater for the brass.

A simple experiment shows that the induced current is independent of the resistance. A coil of a dozen turns was wound on a 4 in. former. It was tuned by a condenser and loosely coupled to a heterodyne wavemeter. Three similar discs of copper, brass and aluminium  $3\frac{1}{2}$  in. diameter and of equal thicknesses were prepared. The inductance of the coil was measured (1) alone, (2) with each of the discs placed inside the coil at the centre. The effect of each disc was to reduce the coil inductance to 47 per cent. of its full value, but there was no measurable difference between the effects of the three materials, the figures agreeing to one-half per cent. This shows that the currents in the three discs were closely equal.

The case is similar to that of the commercial current transformer in which the secondary current is, over a wide range, independent of the resistance of the secondary circuit. The secondary winding is purposely made with high inductance to ensure this result.

R. C. CLINKER.

Engineering Laboratory,  
The British Thomson-Houston Co., Ltd.,  
Rugby.

*The Editor, E.W. & W.E.*

SIR.—With reference to Mr. R. C. Clinker's letter pointing out an apparent error in my article in the May issue, I wish to point out that the metallic objects I had in mind were small, very much smaller than 1 in., such as the usual size of screws that are used in coils for receiving sets.

With this limitation, which I certainly ought to have inserted, and which I thank Mr. Clinker for pointing out, I think my statement is correct.

For large objects, and for very high frequencies, my statement does not hold, but Mr. Clinker's argument is far from conclusive, nor do his experiments prove that the distribution of current is the same for the three discs used. I fear that in a letter I cannot deal with this fully, but I can state that for large objects at high frequencies, the loss due to eddy currents is proportional to the square root of the specific resistance of the material. This is not difficult to prove, but I shall not take up your space unless some of your readers are particularly interested.

RAYMOND M WILMOTTE.

4, Priory Mansions,  
Drayton Gardens,  
S.W.10.

**Wire Gauges.**

*The Editor, E.W. & W.E.*

SIR,—Most amateur transmitters who really make their own components probably base their work on Ballantine's *Radio Telephony for Amateurs*, there being no equivalent published in England, and they probably find that they are unable to get their windings in the space given. This is not necessarily because of bad workmanship, but because they are using s.w.g. wire while copper wire in the U.S.A. is measured by Brown & Sharpe's gauge, which in some cases is much smaller.

A. WM. BOWMAN.

23, Lister Street,  
Rotherham.

Following is a list of Brown & Sharpe wire gauges, together with the corresponding diameter in inches, and the nearest British Standard gauge.

B. & S.	Diameter in inches.	S.W.G.
8	.. .128 5	.. 10
10	.. .101 9	.. 12
12	.. .080 8	.. 14
16	.. .050 8	.. 18
20	.. .032 1	.. 21
24	.. .020 1	.. 25
28	.. .012 6	.. 30
32	.. .008 0	.. 35
36	.. .005 0	.. 40
40	.. .003 1	.. 44

**Celluloid as an Insulator.**

*The Editor, E.W. & W.E.*

SIR,—With reference to Mr. Simeon's article on "The Aerial-Earth System," p. 507, second column, I notice that he suggests the use of celluloid for insulation in low loss coils.

Apparently he has not yet tried this or he would not be so anxious to recommend it to others. The dielectric losses in celluloid are very much higher than those in wax, and more than compensate for the gain in reduction of capacity.

D. DINKLER.

17, Lockharton Crescent,  
Edinburgh.

**Fine Wire Coils.**

*The Editor, E.W. & W.E.*

SIR,—In your April issue, Mr. Reeves points out that he experienced an increase in amplification of the higher side bands of telephony by using fine wire coils (probably resistance wire) and pushing reaction almost to the point of oscillation. An explanation of this may be found in the fact that the resonance curve of a tightly coupled circuit has two humps, these humps approaching one another as coupling is decreased, the spreading of the humps being governed by the resistance of the coils.

Now it will be apparent from the above facts that if we are receiving a modulated wave, and tune in between these two humps, all the high harmonic of the modulation will come under the influence of the humps, which spread out more and more as the reaction is increased. Increase of reaction necessitates the increase of coupling of the plate and grid coils, or the windings of the H.F. transformer.

In reducing coupling the two humps meet when  $2\pi fm = \sqrt{R_1' R_2'}$ ,  $R_1'$  and  $R_2'$  being the resistance of primary and secondary windings, and  $M$  the mutual inductance.

The effect may be far more pronounced in long wave reception, as the necessary coils increase in resistance.

S. WILSON BROWNING.

43, Clarnda Park, East,  
Kingstown, Co. Dublin.

**More Short Wave Work.**

*The Editor, E.W. & W.E.*

SIR,—Further to my letter to you dated 31st March, I have pleasure in informing you that on Monday, 6th April, at 04.00 GMT, R CB8 and myself were successful in establishing two-way working.

Communication was carried on easily for nearly one hour and we signed off voluntarily, it being daylight here. My wave-length was 95 metres while CB8 worked on 63 metres. His signals are very QSA here, and he reports mine as "QSA and steady."

As I am now in touch with R CB8 it will not be necessary for me to carry out the schedule given in mine of 31st March, and I shall now be working as follows for the whole of May and June:—

Wednesdays : 04.00 to 05.00  
Thursdays : 20.45 to 21.30  
Saturdays : 17.15 to 17.45—(calling Z 4AG)  
Saturdays : 20.00 to 21.00

All times are GMT and the wave-length 95 metres.

J. S. STREETER  
(O A4Z).

Myrtle Grove,  
Irwell Street, Observatory,  
Cape Town.

**Call Signs.***The Editor, E.W. & W.E.*

SIR,—I should esteem it a favour if you would publish in your next issue the address of amateur station 5IS (power 10 watts, 150/200 metres, C.W. and telephony) as below.

All DX reports welcomed and cards answered.

Thanking you in anticipation, and with congratulations on your excellent journal.

P. JOHNSON.

49, Carson Road,  
Dulwich, London, S.E.21.

*The Editor, E.W. & W.E.*

SIR,—Will you please note that the call sign 2ZB, previously owned by an amateur at Clacton-on-Sea, has been re-allotted to me. Reports on reception of my signals will be welcomed.

L. F. ALDOUS  
(2ZB).

St. Hilda,  
43, Harpenden Road,  
West Norwood, S.E.27.

*The Editor, E.W. & W.E.*

SIR,—The call sign 2SW which formerly belonged to the Marconi Wireless Telegraph Co., Ltd., Strand, London, has now been allocated to me; and as I believe that reports are still being addressed to London, I should be very much obliged if you will give the correct address in a future issue of your paper.

A. H. FIELDING.

Pomona,  
32, Stanley Avenue,  
Birkdale, Lancashire.

*The Editor, E.W. & W.E.*

SIR,—Reports have reached me twice within the current month that 5QK, the call sign of this Society, has been received at Sutton, Surrey, strength R5, wave-length 93 metres. Our transmitter has been temporarily dismantled and is not in use.

I should therefore much appreciate any evidence which would help me in locating the offender who is using our call, and should feel much obliged if you could insert a notice to this effect in your next issue of E.W. & W.E. My informant states that there is no room for doubt that the call used is G5QK, otherwise I would not worry you with the matter.

FRED WALLER,

*Hon. Sec.*, Southend & Dis. Radio Society.

Eastwood House,  
Rochford, Essex.

*The Editor, E.W. & W.E.*

SIR,—I should be very much obliged if you would draw attention to the following: The name and address of 6HC (Six Harry Charlie) are: H. Cooper, "Morning Dawn," Burnt Ash Lane, Bromley, Kent.

Apparently my address is unknown to many amateurs, and I understand that several have reports for me, but do not know where to send them.

H. COOPER.

Bromley.

*The Editor, E.W. & W.E.*

SIR,—Would you mind making it known that 2OZ (two oh zed) has been held by me for some time, and not by the owner of the name and address shown in most lists? I understand several have tried to establish contact, and have probably been unable to write, or have written to the address in the directories.

JOHN W. NORTON.

"Konrad," Salisbury Road,  
Exmouth, Devon.

*The Editor, E.W. & W.E.*

SIR,—Station 2QB, located at this address, is now active on 190 metres. Any reports on transmissions will be welcomed and all cards answered.

R. W. BAILEY.

Broadeaves,  
Fairfield Road,  
Widnes, Lancs.

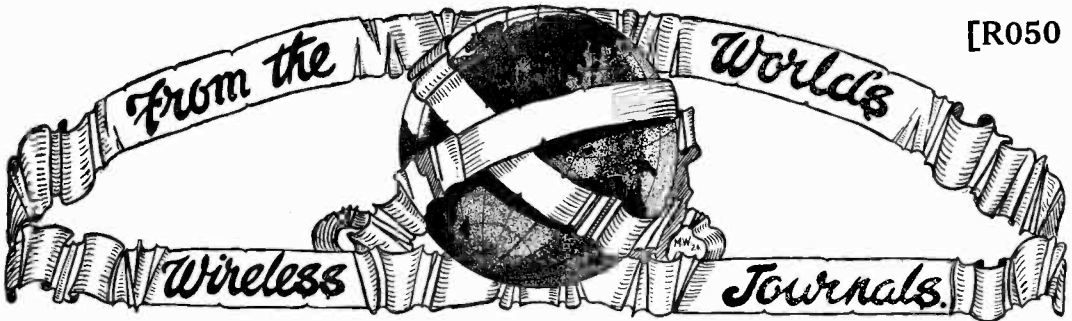

[R050

**R100.—GENERAL PRINCIPLES AND THEORY.**

R149.—THE RECTIFYING DETECTOR.—F. M. Colebrook, B.Sc. (*Exp. W.*, May, 1925).

The third and concluding portion of a paper dealing exhaustively with the problem of rectification with special reference to wireless detectors.

**R200.—MEASUREMENTS AND STANDARDS.**

R201.060.—THE TESTING AND MEASUREMENT OF WIRELESS COMPONENTS.—P. K. Turner (*Exp. W.*, May, 1925).

A paper read before the Radio Society of Great Britain on 25th March, 1925. The measurement of valve characteristics, high-frequency resistance, losses in inductance coils, power factor of circuits, measurement of capacity, calibration of condensers, and determination of the characteristics of crystal detectors are described.

R213.—IMPROVED CATHODE-RAY TUBE METHOD FOR THE HARMONIC COMPARISON OF FREQUENCIES.—D. W. Dye, B.Sc. (*Proc. Phys. Soc. Lond.*, April, 1925).

A method is described in which a circular or elliptical time base is provided, the oscillations under investigation being made to produce a radial displacement. The circular time-trace is obtained by splitting the output of an audio-frequency oscillator into two components differing in phase by ninety degrees and applying these two components to the two pairs of control plates in a cathode-ray oscillograph. By making the time-trace an elongated ellipse instead of a circle a considerable portion of the displacements under observation may be observed against a nearly linear time base. By means of the method the wave-forms of the currents and voltages in the grid and anode circuits of valve oscillators may be investigated for harmonics.

R213.—A METHOD OF MEASURING RADIO FREQUENCY BY MEANS OF A HARMONIC GENERATOR.—A. Hund (*Proc. I.R.E.*, April, 1925).

An improved method has been developed for standardising a wavemeter by means of the harmonics produced by a simple type of harmonic

generator the fundamental frequency of which is an audio-frequency alternating current. The fundamental may be checked against a standard frequency tuning fork and the harmonics may be utilised up to the 100th and higher. Very sharp settings are rendered possible by the use of a visual resonance indicator.

R240.—AN ELECTROMETER METHOD FOR THE MEASUREMENT OF RADIO-FREQUENCY RESISTANCE.—P. O. Pedersen (*Proc. I.R.E.*, April, 1925).

The author criticises the existing methods for the measurement of radio-frequency resistance and describes a new electrometer method, where a quadrant electrometer is put across the inductance of an oscillatory circuit. The condenser of this circuit is charged to the voltage  $V_0$  and discharged through the inductance by means of a special key. The throw of the electrometer will then be proportional to  $V_0^2 - \frac{L}{2R}$ . The theory of the method

is given and it is shown how to eliminate the different possible sources of error. With this method the radio-frequency resistance of even a very feebly damped circuit may be determined with an error well within one part in a thousand, and this determination may be made in a few seconds.

R270.—SOME TRANS-PACIFIC RADIO FIELD INTENSITY MEASUREMENTS.—L. W. Austin (*Proc. I.R.E.*, April, 1925).

Description of measurements on the daylight radio field intensity produced in San Diego, California, by the arc stations at Cavite, Philippine Islands, 11,800 km., and Malabar, Java, 14,700 km. distant. This distance is nearly twice as great as any previously studied except for a few scattered measurements. The average observed intensities were, from Cavite 2.04 microvolts per metre, and from Malabar 4.02 microvolts per metre, while those calculated from the Austin-Cohen formula are respectively 0.69 and 1.83 microvolts per metre. These ratios of observed to calculated values indicate an increase in the divergence from the formula with increasing distance, but not so great as was indicated by earlier scattered observations.

**R300.—APPARATUS AND EQUIPMENT.**

R329.—TOP-LOADING ANTENNAS AND LOOPS.—  
W. H. Murphy (*Q.S.T.*, May, 1925).

Some experiments were made by the writer to ascertain whether there is any advantage in inserting loading inductances high up in the aerial system between the down-lead and the horizontal top portion. The conclusion reached is that top-loading might have distinct advantages under certain conditions such as in cases where height and span are limited.

R336.—THE MAGNETRON AMPLIFIER AND POWER OSCILLATOR.—Frank R. Elder (*Proc. I.R.E.*, April, 1925).

The magnetron is essentially a two-electrode thermionic discharge tube in which the electron current is controlled by an electromagnetic field and not by an electrostatic control grid. The paper opens with a discussion of details of tube design together with a partial list of the sizes studied. A résumé of the general theory of magnetic control is given. The first part of the paper deals with the magnetron as an amplifier on 8 000 metres. The circuit is described and the results of tests on tube impedance, design of control coils, and the variation of amplification with anode voltage, design of polarising field coils, and description of a four-stage amplifier are given.

The second part is concerned with the use of the magnetron as a generator. The circuit and necessary apparatus are described in considerable detail. The conditions necessary for efficient operation are then discussed. Based on observed wave shapes of anode voltage and anode current, formulæ for suitable circuit design are developed, and the complete calculation of a typical circuit is given. The results of tests at various voltages are then compared with calculated performance and representative oscillograms shown. In conclusion a few factors which may cause departure from theoretical results are briefly discussed.

R337.—QUELQUES APPLICATIONS SCIENTIFIQUES DES LAMPES À 3 ET 4 ÉLECTRODES ASSOCIÉES À DES CELLULES PHOTOÉLECTRIQUES.—Général Ferrière.

A description of some methods of employing the potassium photoelectric cell to record optical phenomena. The potassium cell consists essentially of a vacuum tube containing an anode and a potassium cathode. When light falls on the potassium the latter emits electrons and a space-current may be established if a suitable potential is applied. The chief difficulty is the minute magnitude of this space-current; it rarely exceeds a microampere under the most intense illumination. A number of methods are given of employing three- and four-electrode valves to magnify the effect of the photoelectric currents so that they may actuate some recording instrument.

R337.—A STUDY OF THE PRODUCTION OF "FLASHING" IN AIR ELECTRIC DISCHARGE TUBES.—J. Taylor, B.Sc. and J. Clarkson, B.Sc. (*Proc. Phys. Soc., Lond.*, April, 1925).

This paper deals with an extension of the study of flashing in discharge tubes containing air instead of neon and helium. Only very slow periods of flashing, of the order of a second, are dealt with.

R340.—NOVEL CURRENT SUPPLY SYSTEM FOR AUDIIONS.—C. V. Logwood (*Proc. I.R.E.*, April, 1925).

A number of substitutes doing away with H.T. and L.T. batteries for receiving sets are discussed. Amongst the devices which have been tried with varying degrees of success are rectified and filtered alternating current supplies, thermo-electric devices, radio-frequency current generators, electrolytic rectifiers, and motor generators. The author makes some interesting suggestions about the construction of thermo-couple generators for supplying filament current and describes one which he constructed to operate off a bunsen burner and deliver 1 ampere at 8 volts.

R342.6.—IMPROVING THE R.F. AMPLIFIER.—E. E. Burns (*Q.S.T.*, May, 1925).

A method is described of overcoming the effect of grid-plate capacity in high-frequency amplifiers by making this capacity one arm of an all-condenser Wheatstone Bridge.

R342.7.—TESTING FOR DISTORTION.—A. P. Castelain, B.Sc. (*W. World*, 6th May, 1925).

Some experiments carried out with the aid of a simple home-made oscillograph to investigate the distortion in an audio-frequency amplifier working with different conditions of grid bias, loading, etc.

R376.—NOTE ON TELEPHONE RECEIVER IMPEDANCE.—E. Z. Stowell (*Proc. I.R.E.*, April, 1925).

Measurements were made on about 50 pairs of telephones, representing 14 makes. It was found in most cases that the resonant frequency lies between 9 000 and 15 000 cycles per second and that the resistance at this frequency is of the order of 100 000 to 200 000 ohms. At frequencies above 50,000 the telephones may be considered as a condenser of .0001 mf.

R376.3.—LOUD SPEAKER HORNS.—Dr. J. P. Minton (*W. Age*, May, 1925).

The characteristics of sound radiation and reflection in different sizes and shapes are discussed. A number of experimentally-determined curves are given which show the relation between the dimensions of a conical horn and the response at different frequencies. Horn resonance, as distinct from diaphragm resonance, depends upon reflection at the open end and by suitable design this resonance at one particular frequency may be eliminated. In order to obtain a maximum intensity of sound from a conical horn of given length its solid angle has a certain optimum value; the longer the horn the smaller is the magnitude of this optimum solid angle. Horns are investigated whose variations of diameter with length conform to the following mathematical functions: Exponential, logarithmic, parabolic, hypocycloid, hyperbolic, cissoid, cubic and cone.

R382.1.—PARASITIC LOSSES IN INDUCTANCE COILS AT RADIO FREQUENCIES.—R. M. Wilmette, B.A. (*Exp. W.*, May, 1925).

The most important sources of loss in inductance coils are discussed. The losses due to eddy currents in neighbouring metallic objects are first dealt with. The concluding part of the article deals with dielectric losses and some practical data are given on the effect on coil resistance of the insulating material used for the wire and its state of dryness.

R385.52.—LE MICROPHONE À RUBAN.—M. Henard (*Onde Elec.*, March, 1925).

A description of the Siemens-Halske microphone. This belongs to the magnetophone order. A corrugated band of aluminium alloy is suspended by its ends between the poles of a powerful magnet. Impinging sound waves cause the band to vibrate; this causes the flux cut by the band to vary and therefore potentials are set up across the ends of the bands. In principle this microphone is really the converse of the Einthoven string galvanometer.

**R400.—SYSTEMS OF WORKING.**

R401.24.—PIONEER SHORT-WAVE WORK.—F. C. Jones (6XM) (*Q.S.T.*, May, 1925).

Some experimental work on wave-lengths between 1 and 20 metres is described, special attention being devoted to the wave-length of 3 metres. For the latter wave-length a parabolic reflector was used at the transmitter, the receiver being portable and used in conjunction with a single-wire aerial operating on a harmonic. A number of polar radiation curves were plotted, and are reproduced, showing the effect of varying the number and length of wires in the reflector. With a reflector consisting of only three wires the gain in received power was about 10/1 compared with a single transmitting aerial without reflector. The transmitter valve circuits were coupled to the aerial at the focus of the reflector by means of a radio transmission line. Signals on 3 metres were received up to a distance of 14 miles on quite low power. The screening effect of hills was found to be very pronounced. With a 50-watt set working on 13 metres a distance of 1500 miles was covered easily. The various circuits used are given and the question of wavemeters is dealt with briefly.

R423.0124.—A TRANSMITTING CIRCUIT FOR SHORT WAVE-LENGTHS.—E. H. Robinson (*Exp. W.*, May, 1925).

A novel method of tuning an aerial below its fundamental for short-wave transmission.

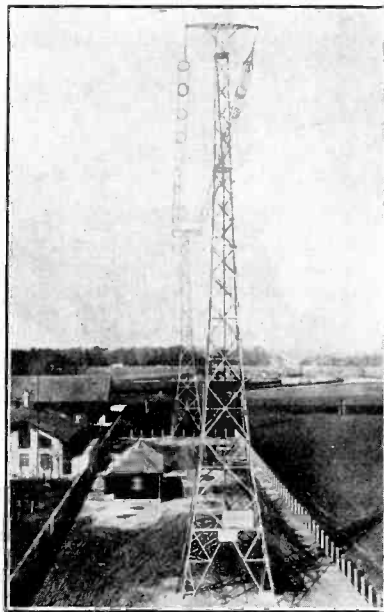

The Transmitting Station and Aerial at Basle Aerodrome (see page 587).

*Although levity is not usually a feature of our pages, the following amused us sufficiently to make us believe that it would also be appreciated by our readers.*

**Neutrodyne's Melody in CW.**

**[R084**

This was the yell of a B.C.L.  
In the land of the U.S. afar:  
"The code I'll cram like a regular ham  
Till I master the dah-du-dah."  
And he built him a set, with which to get  
The hams with their dash and dot;  
He chuckled with glee as he tuned in a "3,"  
But this was all he got.

(Chorus.)

O.K., O.M., O.K. U.R.,  
F.B. ES. Q.S.A.  
Ill tri mi fone—pse QRK  
Pse QRK mi fone.

A "7" came thru with a long CQ,  
Which tickled our friend to death.  
All limp and slack, he settled back  
For a chance to catch his breath.  
"Aha!" said the ham, "he's raised his man.  
To copy this bird is pie;  
His fist is great, he's raised an "8,"  
But this was the 8's reply:—

"H—!" quoth he, "that's no good to me;  
I was taught to talk by mother.  
So with an expert twist of his nimble wrist,  
He then tuned in another.  
With a high-pitched whine, a powerful "9"  
Was pounding "CQ" for fair.  
But this was the trash that was tearing a gash  
In the poor, inoffensive air.

(Chorus—as before.)

His heart was strong and he strung along  
Till he covered the country o'er.  
He sure was game, but when morning came,  
He was feeling mighty sore.  
For the love of Mike, are they all alike  
From Atlantic to 'Frisco Eay?  
From Bangor, Maine to the Andes chain,  
I've heard a thousand say:—

(Chorus—as before.)

K. S.





# Some Recent Patents

(The following notes are based on information supplied by Mr. Eric Potter, Patent Agent, Lonsdale Chambers, 27, Chancery Lane, W.C.2.)

[R008

## SHORT WAVE AERIALS.

(Application dates, June 21st, 1923 and September 6th, 1923. No. 226,246.)

A very interesting short wave aerial is described in British Patent No. 226,246 by C. S. Franklin. The form of the aerial is shown in the upper half of the illustration, while the manner in which it is energised is shown in the bottom portion. The aerial is constructed of a number of vertical wires or rods *W*, which are spaced a fraction of a wave-length apart in a plane which is at right angles to the desired direction of working. The wires or rods are connected together at the top and bottom, and each rod, together with the wires connecting it to the top and bottom of the next rod, is in tune with the waves to be used when in its position in the aerial. An aerial system of this nature can be extended indefinitely, and by making the system several times as long as the length of the wave to be employed, very sharp transmission or reception in a horizontal plane is obtained, the directional effect being a function of the length in relation to the wave-length. Thus, in the accompanying illustration, the vertical wires or rods *W* are fixed between the horizontal rods *A*, *B*, *C*, and *D*. The two systems *AB* and *CD* are coupled together electrostatically through condensers *K*. Oscillations produced in any one of these systems will cause corresponding oscillations to be produced in the system above or below it. The lengths of the vertical members and the coupling capacities should be so adjusted that the currents are in the same phase in each system. It is essential that no oscillations in a horizontal direction occur in the

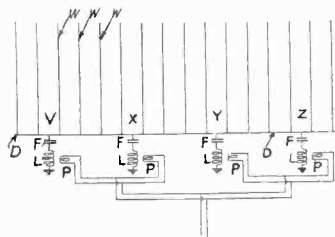
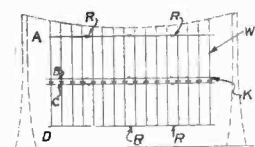

aerial system, as this would represent a source of considerable loss, and accordingly it is found desirable to include resistances *R* in the horizontal members, *A*, *B*, *C* and *D*, which tend to suppress any

oscillations. The lower portion of the illustration indicates one method of feeding the system. *D* represents the bottom horizontal wire of the aerial system, and four equi-distant points *V X Y Z* are chosen along this. These are connected through condensers *F* and inductances *L* (which constitute the secondaries of a transformer), either to earth or a balancing capacity. The primaries *P* of the transformer are connected by separate cables of equal length. It is necessary for efficient working that no reflection of the oscillations transmitted through the cable by the generator should take place at the feeding points. This can be accomplished by making the ratio of the transformer such that the effective resistance of each portion of the aerial fed by the transformer as applied to the cable is equal to the critical resistance required at the cable terminals to prevent reflection. Under these conditions no stationary surface will be produced. A convenient form of cable consists of parallel tubes or rods arranged in a Lecher wire system, which are enclosed in metal conduits for screening purposes.

## CONSTANT RECEPTION.

(Convention date (United States), 28th December, 1922. No. 209,037.)

A rather interesting system of reception is described in British Patent No. 209,037 by Marconi's Wireless Telegraph Company, Limited and R. H. Ranger. Many schemes have been devised for eliminating interference effects caused by atmospheric disturbances. Some of the most successful have consisted in receiving the given signal at two or more points, and conveying the received currents to a central station where they are combined. A modification of this system is described in the above patent, and consists essentially in providing two receiving systems, one of which is normally inoperative, and is only rendered operative by the signal being received in the other system. It is somewhat difficult to describe the exact functioning of the system in so limited a space, but the reader should be able to grasp the idea by reference to the accompanying illustration. Thus *X* and *Y* represent two receiving systems. The aerial circuits are connected to two detectors *A* and *A1*. The detectors are followed by two amplifiers *B* and *B1*. The amplifier *B1* is coupled to another three-electrode valve *C*, the output of which is connected through land lines to the central station. The amplifier *B*, however, is coupled to a two-electrode



valve *D*. Connected in the anode circuit of the two-electrode valve *D* there is a resistance *R*, across which there is an artificial line *L*, consisting of the usual capacity and inductance network provided with a selector switch *S* for adjusting it. The positive terminal of the resistance *R* is connected to the filament of a three-electrode valve *E*. The grid of this valve is connected to the selector-switch *S*. The anodes of the valves *E* and *C* are connected together as shown, and derive their potential from a battery *F*, through a large inductance *G*, which has considerable resistance. The output circuit of the valve *C* contains a coupling coil *H*, the primary of which is in shunt with a coupled trap circuit *I*. The secondary of the coupler *H* is connected to the input of a valve *J* which contains the telephone receivers *T*, the latter also being coupled to a further amplifier operating a commercial recorder. Let us consider the effect

*F* to approximately half its value. The voltage drop through the inductance *G* will then decrease from about 40 to 20 volts, which accordingly raises the potential of the anode of the valve *C* to approximately 200 volts. Under these conditions the valve *C* will be operative, and the received signal will be amplified and passed on to the telephone receivers *T*. Thus it will be seen that the telephones or other indicating device are only rendered operative so long as signals are received simultaneously on both systems. Most of the interference caused by static is due to local discharges, and it is not so likely that similar static discharges will be received simultaneously by both systems. According to this arrangement therefore, it will be obvious that the interference from static is considerably minimised, and it appears to us to be a very sound scheme.

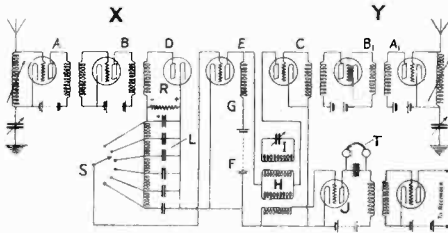

of receiving a signal on the system *X*. The amplified signal will eventually be impressed upon the plate-filament circuit of the two-electrode valve *D*. As the current through the rectifier only flows in one direction, one end of the resistance will always be positive with respect to the other. As soon as the voltage is impressed upon the plate the current will vary and one end of the resistance will become more negative. To this resistance is connected the grid of the valve *E*, which will accordingly be given a negative bias. The valve *E* is normally operated so that when there is no negative bias on the grid it draws a large current from the battery *F*. When a signal is received upon the system *X*, the bias on the grid will give it sufficient potential practically to stop the flow of the current. Let us now consider the effect of simultaneously receiving the signal on the system *Y*. Oscillations will eventually be impressed upon the grid circuit of the valve *C*. Since the battery *F* supplies the anodes of both these valves it will be seen that when no bias is on the grid of the valve *E* approximately twice the current which flows when the grid is biased as described will flow through the battery *F* and the inductance *G*. It is stated that 220 volts have been used for the battery *F*, a drop of 40 volts being obtained across the inductance *G*. The valve *E* is operated at such a point that with an anode potential of 180 volts (220-40) the impressed voltage on the grid is insufficient to control the output. This is the condition which obtains when no signal is received from the system *X*. However, when a signal is received from *X*, the grid of the valve *E* will receive a negative bias sufficient to stop the anode current, and will therefore decrease the current through the battery

**THE HOLWECK DEMOUNTABLE VALVE.**

(Convention date (France), 27th October, 1922. No. 206,155.)

The construction of the Holweck demountable valve is described by F. Holweck in British Patent No. 206,155, and is illustrated by the accompanying diagram. The construction will not be dealt with in great detail, as those desirous of studying the valve to such an extent can find all the information in the specification; only a brief outline of the general construction will therefore be given. Briefly the invention consists in making a thermionic valve which can be taken to pieces and put together again. The container of the valve consists of a metal anode *A* which is provided with a cooling chamber *C*. Inside the valve are mounted the usual grid and filament *G* and *F* respectively. The filament leads are brought out at one end, while the grid lead is brought out at the other end. In order to maintain an air-tight joint two stuffing boxes *S* are provided at each end of the tube through which the filament leads pass. The other end of the container of the valve is connected to a member *T* of the shape shown, which is also secured in position by stuffing boxes. This tubular member *T* is connected to the well-known Holweck molecular pump. The valve is of considerable interest owing to the fact that it is really pumped each

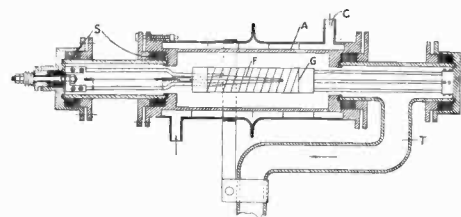

time it is in use. Should the filament fail, for example, the filament support member has merely to be unscrewed, removed, the new filament fixed and reinserted, the valve then being exhausted once more.

**HETERODYNE RECEPTION.**

(Application date, 11th August, 1923. No. 225,907.)

A SYSTEM of heterodyne reception is described by T. H. Kinman in British Patent No. 225,907. The accompanying illustration shows one form of the invention, and one great advantage of the method lies in the fact that radiation from the aerial due to the local oscillation is practically non-existent. The idea consists essentially in providing two sources of

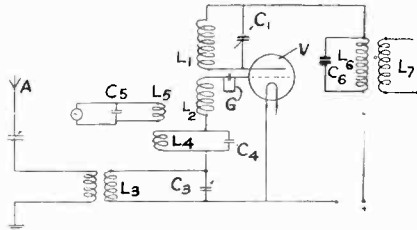

local oscillation which beat together, this beat frequency being combined with the frequency of the incoming signals. The resultant beat can be at an audible or inaudible frequency, and can be further amplified or rectified as desired. Thus, in the accompanying illustration, the valve *V* produces continuous oscillations by virtue of the coupling between *L1 C1* and *L2*. The incoming signals are received by an aerial *A* and are transferred to a tuned circuit *L3 C3*, which is included in the grid circuit of the valve *V*. A third tuned circuit *L4 C4* is also included in the grid circuit, and this is coupled to a tuned circuit *L5 C5*, which is associated with another source of local oscillations. The anode circuit of the valve also includes the circuit *L6 C6*, which is tuned to the resultant beat note. Thus, the oscillations produced in the circuit *L5 C5* beat with those produced by the valve *V*, and combine with the incoming oscillations, which are also introduced into the grid circuit, and are rectified by the valve by virtue of the grid-leak and condenser *G*. In the particular circuit shown the resultant beat note is intended to be further amplified, and the circuit *L6 C6* is therefore coupled to another inductance *L7*. We imagine that this system of reception should prove of value to experimenters working on the lower wavelengths, which are very crowded.

**HIGH FREQUENCY CORES.**

(Convention date (Germany), 25th July, 1923. No. 219,703.)

The Telefunken Gesellschaft für Drahtlose Telegraphie M.B.H. describe in British Patent No. 219,703 an interesting method of constructing an iron core for use in high frequency circuits. Essentially the invention consists in making a core of colloidal metal, which is preferably enclosed in a porcelain tube of some description. When a closed core is required some form of tubular vessel closed upon itself is used. The colloidal metal may be obtained in any suitable manner, formation by an electrical arc under water being mentioned. A claim is made for the use of ferro-magnetic metal

in colloidal form for a core for use in high frequency circuits. We should imagine that this would be quite efficient.

**A REAL A.C. VALVE.**

(Convention date (United States), 3rd October, 1922. No. 205,058.)

Many readers will no doubt remember hearing of a special type of alternating current valve which was described by Hull a year or two ago. Details of the valve and the circuit are disclosed in British Patent No. 205,058, which is granted to The British Thomson-Houston Company, Limited and A. W. Hull. The object of the invention is to provide a valve which derives its electrical emission from an electrode which is heated by an alternating current, but at the same time rectifies a fairly high voltage alternating current for the purpose of obtaining its anode supply. One form of circuit is shown in the upper half of the illustration, while a diagrammatic representation of the valve itself is shown in the lower portion. The valve contains a filament *F* which is heated by alternating current. Surrounding this filament there is a metallic cylinder *C* which is coated externally with some compound which has a good emission at low temperature. Around this cylinder there is a grid *G*, and surrounding the grid there is the usual anode *A*. The operation of the device is exceedingly ingenious. Considering first of all the filament *F* and the inside of the cylinder *C*, this, it will be seen, is comparable with an ordinary two-electrode rectifier valve. Referring to the circuit it will be seen that a transformer *T* is connected between the filament and the cylinder *C* through a filter *R*. The filament, it will be noticed, is also heated from this transformer, a tapping being taken to provide a suitable voltage. Here, then, we have an ordinary two-electrode valve, the filament, of

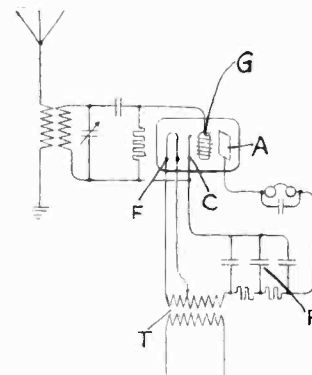

course, becoming positive with respect to the cylinder. Owing to the heat from the filament the cylinder becomes sufficiently hot to emit electrons from its external surface. Hence the cylinder can be regarded as an ordinary equi-potential cathode, and the other electrodes cause the device to operate as an ordinary three-electrode valve, which obtains its anode supply from the current which is rectified between the filament and the cathode. The circuit shown, of course, is an ordinary single valve non-regenerative detector, working with grid condenser rectification. We should imagine that this scheme is one of the most satisfactory solutions of the problem of using alternating current with receiver valves.

**A SYSTEM OF MODULATION.**

(Convention date (Germany), 16th September, 1922. No. 204,064.)

(Application date (United Kingdom), 17th September, 1923.)

A system of modulation is described by Dr. E. F. Huth and Dr. L. Kuhn in British Patent No. 204,064. This is rather novel, in that the actual modulation is carried out in the supply to the anode, before being rectified. One method of carrying the invention into effect is shown in the accompanying illustration. A valve *V* is used as the generator of high frequency current, a tuned grid oscillator being shown coupled to a condenser *C*. It will be noticed that the anode supply is obtained from a step-up transformer *T*, which is connected to a rectifier *R*, consisting of a double anode two-electrode valve. The transformer is supplied with alternating current of a fairly high frequency, the frequency after rectification, of course, being doubled. If an alternator working at a frequency of a few thousand cycles

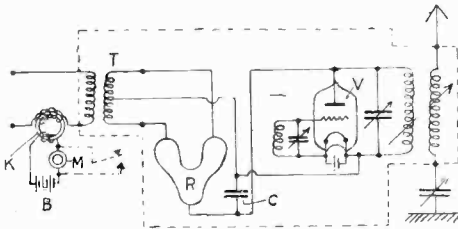

be connected to the transformer, and if the modulating means be inserted in the primary winding of this transformer, then assuming that rectification takes place according to a linear function, the voltage of the rectified current will at any particular instant be proportional to the primary current and consequently proportional to the modulating current. Owing to the high frequency of the supply current the condenser across the rectified output can be exceedingly small. If this condenser were made too large many of the speech frequencies would be lost, as its impedance would be substantially zero. It will be seen that by using a fairly high frequency supply current it is possible to include the modulating means directly in the circuit. Thus, referring again to the illustration, we find that the microphone *M*, which is energised by a battery *B* is connected with the primary circuit of the transformer *T* by means of a closed core modulation transformer *K*.

**AN INTERESTING VALVE SEAL.**

(Convention date (United States) 2nd May, 1923. No. 215,317.)

A rather interesting valve seal is described in British Patent No. 215,317 by the Western Electric Company Limited and V. L. Roncl. The object of the invention is to provide an effective gas-tight seal for a leading-in conductor capable of carrying a fairly heavy current. This object is attained by means of a metal disc sealed into a

glass tube, through the centre of which the leading-in conductor passes, to which it is fixed by solder. The wire and disc are joined together by a solder containing no volatilisable material. A solder suitable for this purpose is an alloy containing the metal of which the leading-in wire and the disc are composed. An interesting point is that the proportions of the constituents are such that the addition to the alloy of more of the metal of which the disc and the leading-in wire are composed increases the melting point. This ensures that no leak will occur during the fusing of the disc to the glass tube. The specification states that a copper-silver alloy containing 80 per cent. of copper and 20 per cent. of silver is found to be very suitable, and incidentally has approximately the same melting point as that of pure silver. The accompanying illustration indicates how the invention is carried into effect. It will be seen that the usual glass foot *F* is provided with two cylindrical tubes *S*, the ends of which are closed by discs *D* fused on in the usual manner, the leading-in conductor *C* passing through the centre of the discs and being soldered at *X*.

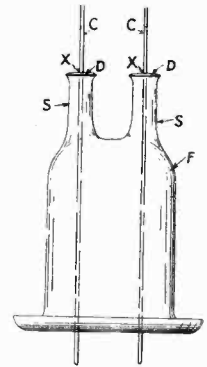

**A HIGH-FREQUENCY AMPLIFIER.**

(Convention date (France), 24th August, 1922. No. 210,440.)

L. Levy describes in the above British Patent a form of amplifier which is illustrated by the accompanying diagram. Referring to the illustration it will be seen that the valves *A* and *B* act as high frequency amplifiers, valve *C* as the rectifier, and valve *D* as a low frequency amplifier. An ordinary input tuned circuit is shown at *T*. The patent relates to the method of coupling the high frequency valves, which consists in employing a reactance wound with fine wire, and provided with a movable core of fine iron wire shown at *L* and *F* respectively. The specification states that the coupling devices may be made by winding fine wire into a number of grooves in a fibre or similar tube which

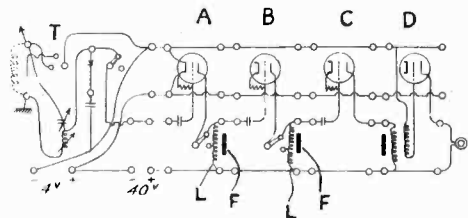

is provided with a movable iron wire core. We should imagine that while being rather stable the amplification would not be very great unless the cores were exceedingly carefully constructed.



**ELECTRODE SUPPORTS.**

(Application date, 12th December, 1923. No. 229,429.)

The Edison Swan Electric Company, Limited and T. W. Price describe in the above British Patent a method of supporting electrodes in power valves. Referring to the accompanying illustration it will be seen that the usual stem *S* of glass or silica is provided with a ring *R* of similar material, which is arranged concentrically with the stem, and is fused to it at several points such as *X*. The supports *L* for the electrodes are passed through the annular space which exists between the ring and the stem. Welded or otherwise fixed to the end of the support *L* is a length of wire *W*, which can also be passed through the annular space, the ends of which are twisted together, and secure the support firmly in position.

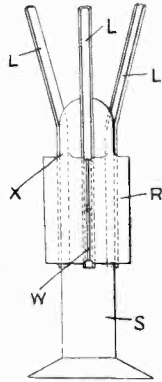

**A SAFETY DEVICE FOR CONDENSERS.**

(Application date, 16th November, 1923. No. 229,010.)

C. Seymour, D.S.O., and W. Ure describe in British Patent No. 229,010 the construction of a condenser suitable for high voltage, high frequency current working. The object of the invention is to produce a condenser such that a more uniform distribution of electric flux exists, thus minimising the possibility of local over-voltage stress in the insulator and consequent failure of the condenser. Referring to the illustration it will be seen that the condenser is built up as usual with metal foil which may be rectangular in shape with rounded corners. This, of course, is the usual practice. One element of the condenser is earthed at *E*, while the other element is connected by a lead *L* to a guard *G* of the shape shown, to which a high voltage terminal is also attached.

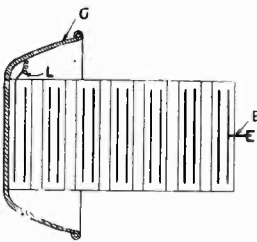

**AN EXTERNALLY HEATED VALVE.**

(Application date, 22nd November, 1923. No. 229,019.)

A. I. B. Ghyssaert describes in British Patent No. 229,019 the construction of an externally heated valve which is represented diagrammatically by the accompanying illustration. The object of the invention is to obviate the necessity of using a heated filament as a cathode, and accordingly the inventor proposes to make the cathode in the form of a metallic cylinder closed at each end, inside which the anode and grid are supported. According to this construction it is stated that the cathode can be placed in the fire or heated by a gas flame. Thus in the accompanying illustration the cathode takes the form

of a cylinder *C* which may be coated with some barium, thorium, or similar compound. The grid is shown at *G* and the anode at *A*. The cathode

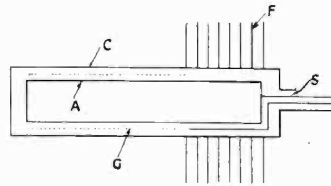

is also provided with a number of radial fins *F* for the purpose of cooling it at one end in the neighbourhood of the seal *S*, through which the anode and grid leads pass. It would appear at first sight that the idea would be quite practicable but we should imagine that certain difficulties would arise in practice. In the first place, the inter-electrode capacities would probably be high, and also if used for very high frequencies trouble would no doubt arise owing to eddy currents and other undesirable effects. Another drawback is the fact that if the temperature of the cathode was in the neighbourhood of a dull red heat or even black heat osmosis would occur, and it seems probable that after running for a little while the vacuum would be destroyed.

**A FOUR-ELECTRODE VALVE CIRCUIT.**

(Application date, 27th June, 1924. No. 227,364.)

A rather peculiar arrangement of two four-electrode valves is described by Rodo Patents, Limited and F. A. L. Slood in British Patent No. 227,364. Apparently the object of the invention is simply to provide a means for amplifying signals at radio frequency by two very peculiarly arranged four-electrode valves, which incidentally necessitate the use of two filament batteries. The circuit is shown in the accompanying diagram, and it will be seen that both four-electrode valves are operated at very low anode voltages, which are obtained by direct connection to the positive side of the filament battery, the inner grids also being connected to the positive terminal in order to neutralise the effect of the space charge. It will be seen that there are two tuned circuits *L1 C1*, *L2 C2*, both of which are tuned to the incoming frequencies. The circuit *L2 C2* is connected

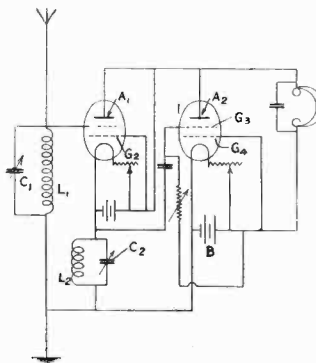

between earth and the filament of the first valve, while the aerial circuit is connected between the outer grid and the earth. The anode *A1*, inner grid *G2*, and anode *A2* of the second valve, are all connected together. The circuit *L2 C2* is connected by a grid condenser and leak across the outer grid *G3* and the filament battery *B* of the second valve. From the information given in the specification we cannot see how the scheme is intended to work, and we do not see the advantage of using two four-electrode valves and two filament batteries.