

**Making sense  
of it all**

The contents of this booklet have been reprinted from the *Electronics Service Manual*. The material is part of Section B4 which, in the Base Manual, goes on to describe Linear Integrated Circuits, Operational Amplifiers and Digital Integrated Circuits.

Part B of the Base Manual (of which B4 is a small section) is titled "Underpinning Knowledge" and covers:

Understanding electricity, Understanding electronics, Understanding passive components, Understanding active components, Using manufacturers' data, Understanding circuit diagrams, Fault diagnosis, Interpreting circuit measurements, Understanding radio, Understanding microcomputers, Understanding valves.

*Further details on the Electronics Service Manual are given inside.*



**Wimborne Publishing Ltd**

**FREE**  
with  
**Everyday Practical  
Electronics**

## **Understanding Active Components**

*Active components (such as transistors, diodes and f.e.t.s) are found in almost every electronic circuit. This booklet introduces a variety of common types of active component and shows you how to:*

- **Identify component types**
- **Recognize component symbols and connections**
- **Ascertain current, voltage and power ratings**
- **Observe precautions for handling and use**
- **Understand the limitations of certain types of component**
- **Select suitable replacement or substitute components**

**Covers:** Signal and Rectifier Diodes, Zener Diodes, Variable Capacitance Diodes, Thyristors, Triacs, Light Emitting Diodes, Bipolar Transistors, Field Effect Transistors

*Reprinted from Electronics Service Manual*

# ESM/MEM PRIORITY ORDER FORM

Full name: .....

(BLOCK CAPITALS PLEASE)

Address: .....

Post code: .....

Telephone Number: .....

Please supply  Electronic Service Manual  Modern Electronics Manual  
**NOTE Special Offer price: take £15 off the total price if you order both together**

I enclose cheque/PO payable to WIMBORNE PUBLISHING LTD  
 Please charge my Mastercard/Visa card. Card Ex. date.....

Card No: .....  
(Please advise cardholder's address if different from above)

Please send me each new quarterly Supplement when it is published. I understand that these are billed separately and that they can be returned within 10 days or discontinued at any time. Supplements cost £23.50 each plus postage.

I understand that should I decide not to keep the Manual I can return it to you within 30 days for a FULL REFUND (overseas customers must pay the postage).

Signature: .....

Please send this form (or a copy) to: **Wimborne Publishing Ltd, Dept. X4, Allen House, East Borough, Wimborne, Dorset BH21 1PF**

## PLEASE SEND ME URGENTLY

Item	Cost	Postage Total	
ESM/MEM Manual	£39.95ea	£.....	£.....
One Supplement free with Manual	FREE	FREE	£0.00
Payment in £ Sterling only		Total	£.....

## POSTAGE CHARGES (per manual)

Postal Region	ESM Manual	
	Surface	Air
Mainland UK	£5.50	N/A
Scottish Highlands, UK Islands and Eire	£11	N/A
Europe (EEC)	N/A	£20
Europe (Non-EEC)	£20	£26
USA & Canada	£25	£32
Far East & Australia	£31	£35
Rest of World	£25	£45

NOTE: Surface mail can take over 10 weeks to some parts of the world. Each Manual weighs about 4kg when packed.

# Understanding Active Components

by Mike Tooley B.A.

Reprinted from *Electronics Service Manual*  
(Sections B4.1 to B4.8 - Section B parts 1 to 15  
cover "Underpinning Knowledge")



Wimborne Publishing Ltd

Allen House  
East Borough  
Wimborne

Dorset BH21 1PF

Tel: 01202 881749

Fax: 01202 841692

E-mail: [editorial@epemag.wimborne.co.uk](mailto:editorial@epemag.wimborne.co.uk)  
Web Site: <http://www.epemag.wimborne.co.uk>

© Wimborne Publishing Ltd 1996

Typeset by The Typesetting Bureau, Wimborne  
Printed by Benham & Co. Ltd. Colchester

# ESM

## ELECTRONICS SERVICE MANUAL

# The Modern Electronics Manual

ESM, the *Electronics Service Manual*, is a unique publication which aims to provide clear and concise instructions on how to test and diagnose faults on a wide range of electronic equipment, providing users with the level of knowledge and confidence required to tackle even the most complex faults. A principal editorial objective is that of ensuring that ESM is comprehensive, informative and up-to-date. It is a living publication and ideal for use by technicians, engineers, students and hobbyists.

Quarterly Supplements provide the on-going means of keeping ESM current. Major new developments are featured as and when they occur. Unlike conventional textbooks, ESM offers you the ability to keep fully abreast with new technology without having to invest in a whole new library of textbooks every time there is a new development.

### BASE MANUAL

The base Manual (from which the content of this booklet has been reprinted) consists of about 850 A4 pages which are supplied in a red robust ring-binder. The quarterly Supplements each consist of about 160 A4 pages which can be readily inserted into the binder. Additional binders are available. **A recent Supplement is sent FREE with each Manual.**

### ESM PRICES

The ESM Base Manual itself costs **£39.95 plus P&P**. The quarterly Supplements are **£23.50 each plus P&P**.

To obtain the ESM manual, payment for it must be sent with your order. On receipt of the Manual you are welcome to browse through it to ensure that it meets your needs. If you decide not to keep it, **FOR WHATEVER REASON**, you are welcome to **return it within 30 days of receipt and your money will be refunded**. Overseas customers do have to pay the postage, though.

Having purchased the ESM manual, you are then sent on approval each quarterly Supplement when it is published, together with an invoice for **£23.50 plus P&P**. There is **NO OBLIGATION** to keep any Supplement – it may be returned within 10 days of receipt and the invoice can be ignored as no payment is then necessary. If, however, you decide to keep the Supplement, payment for it becomes due as shown on the invoice. Should you eventually decide that you no longer wish to receive the Supplements, just let us know.

**AN ORDER FORM IS PRINTED ON PAGE 48**

In a nut-shell, the *Modern Electronics Manual*, MEM, is one of the world's finest introductions to the art of electronics. It contains wisdom distilled from a number of experts in the electronics and computing fields. It is written clearly, illustrated effectively and organised logically.

Containing nearly 1000 pages, the Basework of MEM aims to teach you the basic elements of electronics, to guide you in the creation of electronic projects, and to thoroughly inspire your interest in electronics technology.

The base Manual covers: Safety; Basic Principles in ten varied sections, from Graphical Symbols through Passive and Active Components to Power Supplies and Measuring Instruments; Circuits To Build; basic information on Repairs and Maintenance; Tables of Data in seven sections; Vocabulary and Suppliers.

Whilst the MEM Basework is complete in its own right, you will undoubtedly wish to benefit too from the additional information which is published quarterly through the MEM Supplements.

By means of these Supplements, each of around 160 pages, your knowledge and understanding of electronics is encouraged to grow, not only through the expansion of selected subjects contained within the Basework, but also through the introduction and in-depth explanation of other aspects of modern electronics. **A recent Supplement is sent FREE with each Manual.**

### MEM PRICES

The MEM Manual costs **£39.95 plus P&P**. The quarterly Supplements are **£23.50 each plus P&P**.

To obtain the MEM manual, payment for it must be sent with your order. On receipt of the Manual you are welcome to browse through it to ensure that it meets your needs. If you decide not to keep it, **FOR WHATEVER REASON**, you are welcome to **return it within 30 days of receipt and your money will be refunded**. Overseas customers do have to pay the postage, though.

Having purchased the MEM manual, you are then sent on approval each quarterly Supplement when it is published, together with an invoice for **£23.50 plus P&P**. There is **NO OBLIGATION** to keep any Supplement – it may be returned within 10 days of receipt and the invoice can be ignored as no payment is then necessary. If, however, you decide to keep the Supplement, payment for it becomes due as shown on the invoice. Should you eventually decide that you no longer wish to receive the Supplements, just let us know.

**AN ORDER FORM IS PRINTED OVERLEAF**

The maximum permissible value for  $R_{DS}$  is thus  $0.52\Omega$ . To ensure reliable operation and to avoid the risk of over-dissipation, we should obtain a device which has an 'on' resistance somewhat less than this value (e.g.,  $0.2\Omega$ , or less). An IRF530 would be eminently suitable.



*Power MOSFETs should be de-rated at high operating temperatures (particularly when heat sinking arrangements do not meet the manufacturer's recommendations). The normal requirement is to de-rate power dissipation linearly to zero at  $100^{\circ}\text{C}$  whenever the junction temperature exceeds  $40^{\circ}\text{C}$ .*

### FET packages

As with their bipolar counterparts, a wide variety of packaging styles are used for field effect transistors. Small-signal FETs normally use plastic packages (e.g., TO92), however, devices may also be supplied in miniature metal cases (e.g., TO18). Power FETs often make use of plastic cases with integral metal heat-sinking tabs (e.g., TO126, TO218 or TO220) although some devices are supplied in metal cases (e.g., TO3).



*Care should be taken when handling and soldering MOSFET devices as they can be easily damaged by stray static charges. JFET devices are more robust in this respect and are thus less easily damaged by careless handling. In extreme cases, a shorting ring can be placed around the connecting leads of a MOSFET and then removed (using a pair of long nosed pliers) when the device has been safely soldered into place.*

## CONTENTS

<b>Signal and rectifier diodes</b>	<b>4</b>
<b>Zener diodes</b>	<b>11</b>
<b>Variable capacitance diodes</b>	<b>16</b>
<b>Thyristors</b>	<b>18</b>
<b>Triacs</b>	<b>21</b>
<b>Light emitting diodes</b>	<b>24</b>
<b>Bipolar transistors</b>	<b>28</b>
<b>Field effect transistors</b>	<b>40</b>

All reasonable precautions are taken to ensure that the advice and data given to readers is reliable. We cannot, however, guarantee it and we cannot accept legal responsibility for it.

# Signal and rectifier diodes

Semiconductor diodes generally comprise a single p-n junction of either silicon (Si) or germanium (Ge) material. In order to obtain conduction, the p-type material must be made positive with respect to the n-type material (the p-type connection constitutes the anode whilst the n-type connection constitutes the cathode). The direction of current flow is from anode to cathode when the diode is conducting, as shown in Fig. 1. Very little current (negligible in the case of most silicon devices) flows in the reverse direction (Fig. 2).

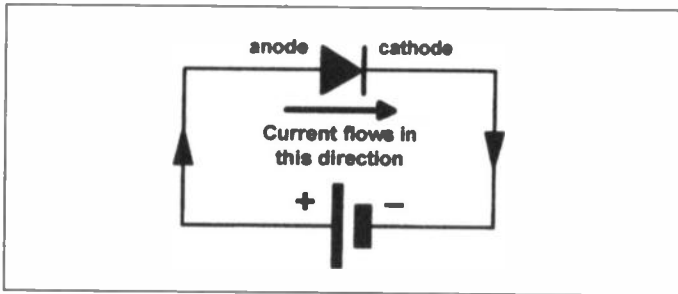

Fig.1. Forward biased diode

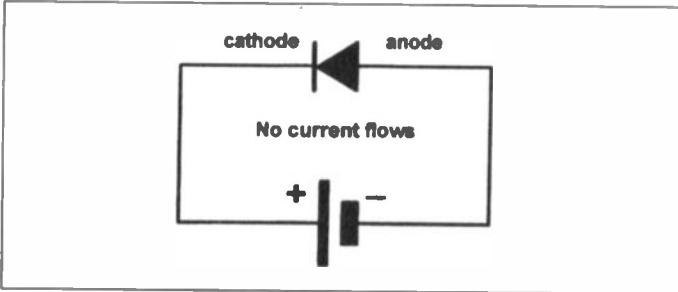

Fig.2. Reverse biased diode

gate-source bias of  $-1\text{V}$ . If the device has a  $g_{fs}$  of  $0.25\text{S}$ , determine the change in drain current if the bias voltage increases to  $-1.1\text{V}$ .

The change in gate-source voltage ( $V_{gs}$ ) is  $-0.1\text{V}$  and the resulting change in drain current can be determined from:

$$I_d = g_{fs} \times V_{gs} = 0.25\text{S} \times -0.1\text{V} \\ = -0.025\text{A} = -25\text{mA}$$

The new value of drain current will thus be  $(100\text{mA} - 25\text{mA})$  or  $75\text{mA}$ .

## Example

A MOSFET is to be used in a static switching application in which a maximum current of  $12\text{A}$  is to be controlled. If the device is rated at  $75\text{W}$ , determine the maximum permissible value of  $R_{DS(on)}$ .

The maximum dissipation can be determined from:

$$P_{D\max} = I_L^2 \times R_{DS}$$

Thus the maximum value of  $R_{DS}$  will be given by:

$$R_{DS} = \frac{P_{D\max}}{I_L^2} = \frac{75\text{W}}{(12\text{A})^2} = \frac{75}{144} = 0.52\Omega$$

Table 1

Device	Type	Construct	$I_D$ max.	$V_{DS}$ max.	$P_{D\max}$	$g_{fs}$ min.	Application
2SK135	MOSFET	N-chan.	7A	160V	100W	0.7S	AF power
2N4351	JFET	N-chan.		30V	300mW		Switching
2N5457	JFET	N-chan.	10mA	25V	310mW	1mS	General purpose
BF244A	JFET	N-chan	100mA	30V	360mW	3mS	RF amplifier
VN66AF	MOSFET	N-chan.	1.8A	60V	15W	0.2S	LF/RF power

necessitate the application of bias. The method of applying bias will differ according to the mode of operation (depletion or enhancement) but, in either case, it will involve the application of a gate-source bias voltage and a standing (quiescent) value of drain current will result (see Fig. 5). Typical values of gate-source bias voltage vary between  $-2V$  and  $+2V$ , according to mode of operation.

### Field effect transistor data

The data in Table 1 refers to popular field effect transistors.

### Example

A FET operates with a drain current of 100mA and a

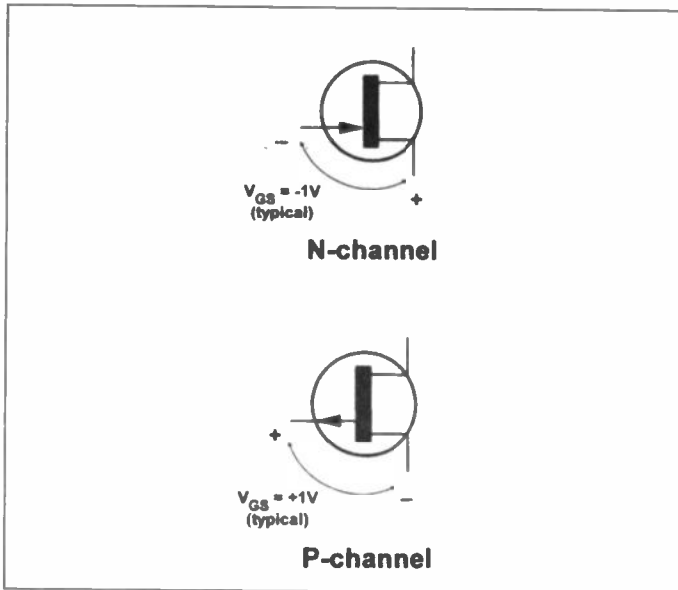

Fig.5 Bias voltages for a JFET transistor

Diodes exhibit a low resistance to current flow in one direction and a high resistance to current flow in the other. The direction in which current flows is referred to as the forward direction whilst that in which negligible current flows is known as the reverse direction. When a diode is conducting, a diode is said to be forward biased and a small voltage (ideally zero) is dropped across it. This voltage is known as the forward voltage drop. The maximum reverse voltage that a diode can tolerate is usually specified in terms of its reverse repetitive maximum voltage ( $V_{RRM}$ ) or peak inverse voltage (PIV).

Typical values of forward current and forward voltage for commonly available silicon and germanium diodes are given in Table 1 below:

Table 1

Forward current	Forward voltage drop		
	Silicon (1N4148)	Silicon (1N5401)	Germanium (OA91)
$10\mu A$	0.43V	—	0.12V
$100\mu A$	0.58V	0.55V	0.26V
1mA	0.65V	0.60V	0.32V
10mA	0.75V	0.65V	0.43V
100mA	—	0.72V	—
1A	—	0.85V	—

Germanium diodes conduct at lower forward voltages than their silicon counterparts (typically 100mV as compared with 600mV) but they tend to exhibit considerably more reverse leakage current ( $1\mu A$  as compared with 10nA for an applied reverse voltage of 50V). Furthermore, the forward resistance of a conducting silicon diode is much lower than that of a comparable germanium type. Hence germanium diodes are used primarily for signal detection purposes whereas silicon devices are used for rectification and for general purpose applications. Typical

forward and reverse characteristics for comparable germanium and silicon diodes are shown in Fig. 3.

Diodes are often divided into signal and rectifier types according to their principal field of application. Signal diodes require consistent forward characteristics with low forward voltage drop. Rectifier diodes need to be able to cope with high values of reverse voltage and large values of forward current, consistency of characteristics is of secondary importance in such applications. Various diode packages are illustrated in Fig. 4.

### Diode coding

The European system for classifying semiconductor diodes involves an alphanumeric code which employs

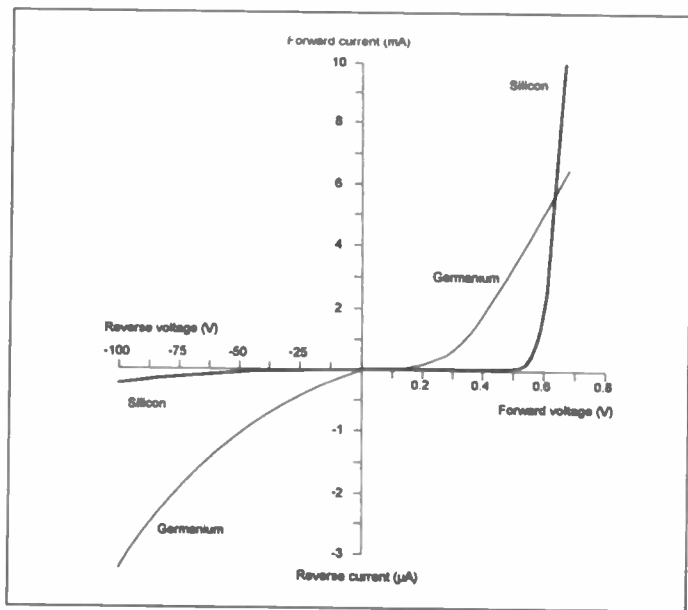

Fig.3. Typical diode characteristics

The common source forward transfer conductance is given by:

$$g_{fs} = I_d/V_{gs}$$

where  $I_d$  is the change in drain current resulting from a corresponding change in gate-source voltage ( $V_{gs}$ ). The units of forward transfer conductance are Siemens (S).



*Forward transfer conductance ( $g_{fs}$ ) varies with drain current. For most small-signal devices,  $g_{fs}$  is quoted for values of drain current between 1mA and 10mA. It is also worth noting that most FET parameters (particularly forward transfer conductance) are liable to wide variation from one device to the next. Circuits are, therefore, designed on the basis of minimum  $g_{fs}$  values in order to ensure successful operation with a variety of different devices.*

Other important FET parameters quoted by manufacturers and suppliers are:

- $I_{D \max}$ . – the maximum drain current.
- $V_{DS \max}$ . – the maximum drain-source voltage.
- $V_{GS \max}$ . – the maximum gate-source voltage.
- $P_{D \max}$ . – the maximum drain power dissipation.
- $t_r \text{ typ.}$  – the typical output rise-time in response to a perfect rectangular pulse input.
- $t_f \text{ typ.}$  – the typical output fall-time in response to a perfect rectangular pulse input.
- $R_{DS(on) \max}$ . – the maximum value of resistance between drain and source when the transistor is in the conducting (on) state.

### Bias for field effect transistors

As with bipolar devices, linear FET applications

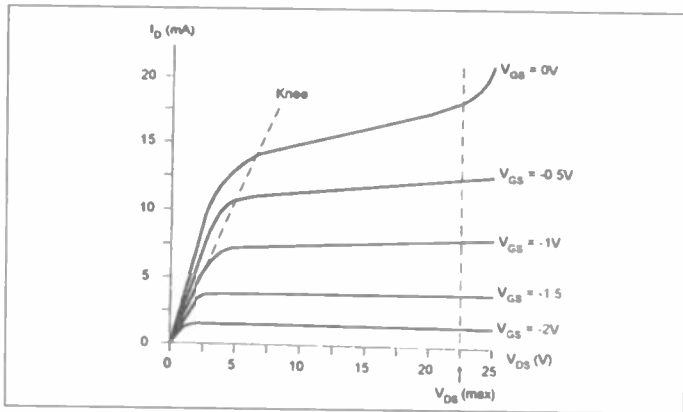

Fig.4 Typical in-channel JFET characteristics

devices generally offer improved switching characteristics as they combine low drain-source resistance in the on-state with very high drain-source resistance in the off-state.

IGFETs may be designed for either depletion mode or enhancement mode operation. In the former case, conduction occurs within the channel even when the gate-source voltage ( $V_{GS}$ ) is zero. In the latter case, a gate-source bias voltage must be applied in order to obtain conduction within the channel. Symbols and connections for various types of JFET and IGFET are depicted in Fig. 3.

A typical set of characteristics for a general purpose n-channel JFET are shown in Fig. 4.

### FET parameters

The gain offered by a field effect transistor is normally expressed in terms of its forward transfer conductance ( $g_{fs}$  or  $Y_{fs}$ ) in common source mode. In this mode, the input voltage is applied to the gate and the output current appears in the drain (the source is effectively common to both the input and output circuits).

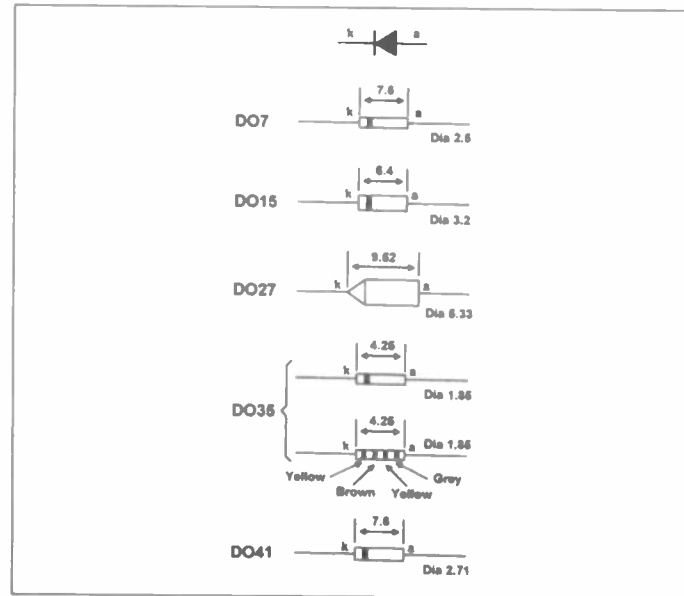

Fig.4 Common diode encapsulations

either two letters and three figures (general purpose diodes) or three letters and two figures (special purpose diodes). The first two letters have the following significance:

- **First letter** – semiconductor material:
  - A Germanium
  - B Silicon
  - C Gallium arsenide etc
  - D Photodiodes etc
- **Second letter** – application:
  - A General purpose diode
  - B Tuning (varicap) diode
  - E Tunnel diode
  - P Photovoltaic diode
  - Q Light emitting diode



- T Controlled rectifier
- X Varactor diode
- Y Power rectifier
- Z Zener diode

In the case of diodes for specialised applications, the third letter does not generally have any particular significance. Zener diodes have an additional letter (which appears after the numbers) which denotes the tolerance of the Zener voltage. The following letters are used:

- A  $\pm 1\%$
- B  $\pm 2\%$
- C  $\pm 5\%$
- D  $\pm 10\%$

Zener diodes also have additional characters which indicate the Zener voltage (e.g., 9V1 denotes 9.1V).

### Example

Identify each of the following diodes:

- i) AA113
- ii) BB105
- iii) BZY88C4V7

Diode i) is a general purpose germanium diode.

Diode ii) is a silicon diode for tuning applications (sometimes referred to as a varicap).

Diode iii) is a silicon Zener diode having  $\pm 5\%$  tolerance and 4.7V Zener voltage.

Prior to the introduction of the European coding system, several manufacturers used the prefix 'OA' to denote a diode followed by a serial number.

capacitively coupled to the channel. IGFETs use either metal on silicon (MOS) or silicon on sapphire (SOS) technology. Fig. 1 and Fig. 2 show the basic construction of N-channel JFET and IGFET devices.

JFET devices are less noisy and more stable than comparable IGFET devices. JFET devices offer source input impedances of around 100M $\Omega$  compared with 10,000M $\Omega$  for comparable IGFETs. Note, however, that FET devices offer very much higher input impedances (at the gate) than bipolar transistors (at the base). IGFET

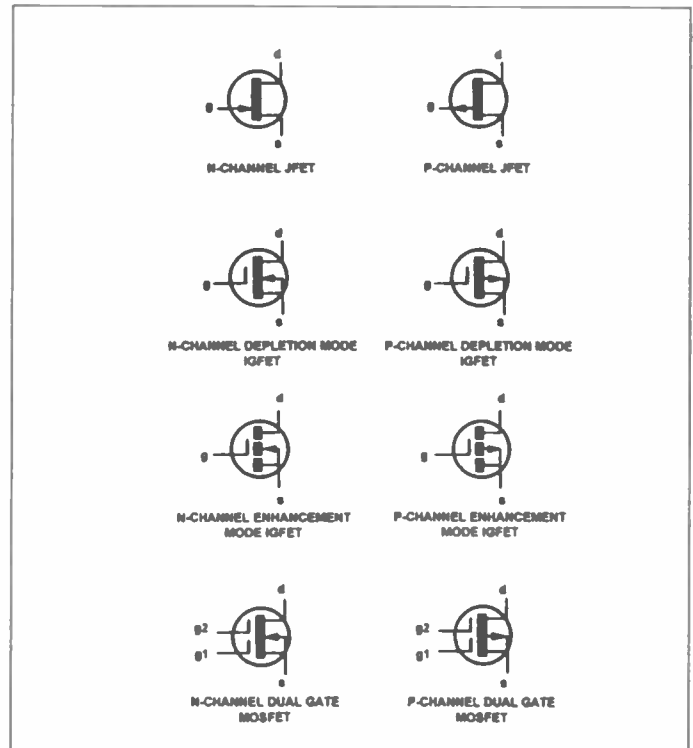

Fig.3 Symbols and connections for various types of JFET and IGFET

# Field effect transistors

Field effect transistors (FET) comprise a channel of P- or N-type material surrounded by material of the opposite polarity. The ends of the channel (in which conduction takes place) form electrodes known as the source and drain. The effective width of the channel (in which conduction takes place) is controlled by a charge placed on the third (gate) electrode. The effective resistance between the source and drain is thus determined by the voltage present at the gate.

Field effect transistors are available in two basic forms; junction gate and insulated gate. The gate-source junction of a junction gate field effect transistor (JFET) is effectively a reverse-biased P-N junction. The gate connection of an insulated gate field effect transistor (IGFET), on the other hand, is insulated from the channel and charge is

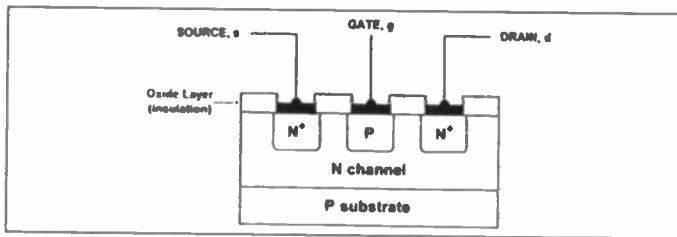

Fig.1 N-channel JFET construction

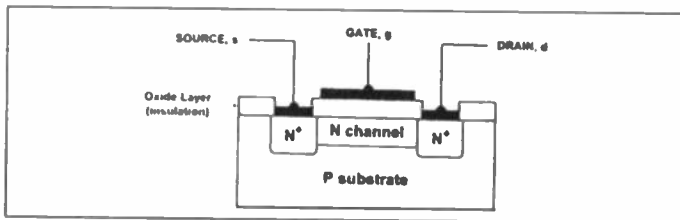

Fig.2 N-channel IGFET construction

The American numbering system used for semiconductors involves a code that begins with '1N' for diodes. The 1N prefix is then followed by a serial number. Section G1 contains a comprehensive listing of diodes, specifications and case styles.

## Diode data

The table below summarises the characteristics of some of the more popular semiconductor diodes.



*When carrying out in-circuit measurements on diodes that are in the forward biased (conducting) state it is important to remember that the diode will not behave like a perfect switch. Instead, there will be a small voltage drop (typically in the range 0.6V to 0.8V for silicon diodes) which will increase as the forward current increases.*

Table 2

### General purpose, signal and RF diodes

Device	Material	PIV	$I_f$	$I_{rmax.}$	Application
1N4148	Si	100V	75mA	25nA	General purpose
1N914	Si	100V	75mA	25nA	General purpose
AA113	Ge	60V	10mA	200 $\mu$ A	RF detector
AA119	Ge	45V	35mA	350 $\mu$ A	Signal detector
OA200	Si	50V	80mA	100nA	General purpose
OA47	Ge	25V	110mA	100 $\mu$ A	Signal detector
OA90	Ge	30V	10mA	1.1mA	General purpose
OA91	Ge	115V	50mA	275 $\mu$ A	General purpose
1N4001	Si	50V	1A	10 $\mu$ A	Low voltage rectifier
1N4004	Si	400V	1A	10 $\mu$ A	High voltage rectifier
1N5400	Si	50V	3A	10 $\mu$ A	Low voltage rectifier
1N5404	Si	400V	3A	10 $\mu$ A	High voltage rectifier
BY126	Si	650V	1A	10 $\mu$ A	Low voltage rectifier
BY127	Si	1250V	1A	10 $\mu$ A	High voltage rectifier

In the reverse biased (non-conducting) state, on the other hand, a high voltage may be present. At the same time, a small reverse leakage current may flow. This current increases markedly as the junction temperature increases.



*Operating a diode at, or beyond, the stated limits for  $V_{RRM}$  or  $PIV$  will result in a high risk of breakdown. Since rectifier failure can have disastrous consequences, it is always advisable to operate diodes well within the stated limits (to ensure safety, a 100% margin should be allowed).*

### Schottky diodes

Schottky diodes exhibit a forward voltage drop which is approximately half that of conventional silicon diodes coupled with very fast reverse recovery. Schottky diodes are thus preferred in switching applications (e.g., switched mode power supplies) where very low forward voltage drop and fast switching is a prime consideration.

transistors are supplied in metal cases (either TO66 or TO3). Some popular transistor case styles are shown in Fig. 9.

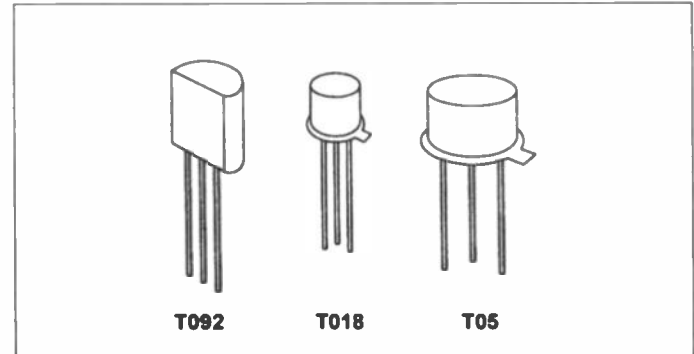

Fig.9 Some common transistor packages

Current gain ( $h_{fe}$ ) varies with collector current. For most small-signal transistors,  $h_{fe}$  is a maximum at a collector current in the range 1mA to 10mA. Current gain  $h_{fe}$  falls to very low values for power transistors (other than Darlington devices) when operating at very high values of collector current.

Most transistor parameters (particularly common-emitter current gain,  $h_{fe}$ ) are liable to wide variation from one device to the next. It is, therefore, important to design circuits on the basis of the minimum value for  $h_{fe}$  in order to ensure successful operation with a variety of different devices.

Transistors will usually operate reliably as amplifiers using conventional circuits in common-emitter mode at frequencies which are not in excess of one tenth of the quoted value for  $f_t$ . Special techniques (including neutralisation or the use of common-base mode) are required when it is necessary to operate at frequencies in excess of this value.

Power transistors should be de-rated at high operating temperatures (particularly when heat sinking arrangements do not meet the manufacturer's recommendations). The normal requirement is to de-rate power dissipation linearly to zero at 100°C whenever the junction temperature exceeds 40°C.

### Transistor packages

A wide variety of packaging styles are used for bipolar transistors. Small-signal transistors tend to have either plastic packages (e.g., TO92) or miniature metal cases (e.g., TO5 or TO18). Medium and high-power devices may also be supplied in plastic cases but these are normally fitted with integral metal heat-sinking tabs (e.g., TO126, TO218 or TO220) in order to conduct heat away from the junction. Some older power

## Zener diodes

Zener diodes are silicon diodes which are specially designed to exhibit consistent reverse breakdown characteristics. Zener diodes are available in various families (according to their general characteristics, encapsulation and power ratings) with reverse breakdown (Zener) voltages in the E12 and E24 series (ranging from 2.4V to 91V). A typical characteristic for a 5.1V Zener diode is

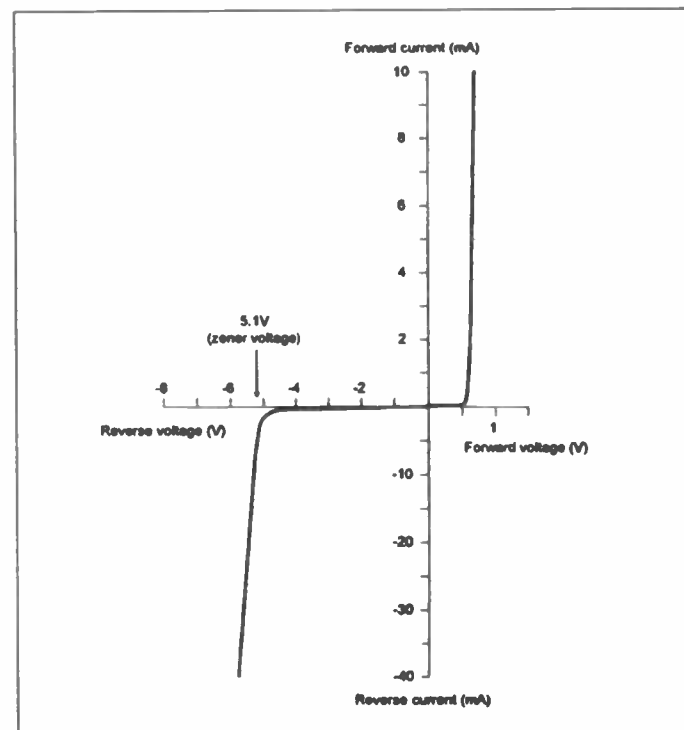

Fig.1 Typical Zener diode characteristic

shown in Fig. 1. The following series of Zener diodes are used in a wide range of electronic equipment:

- BZX55 series – low-power diodes rated at 500mW and offering Zener voltages in the range 2.4V to 91V.
- BZX61 series – encapsulated alloy junction rated at 1.3W (25°C ambient). Zener voltages range from 7.5V to 72V.
- BZX85 series – medium-power glass-encapsulated diodes rated at 1.3W and offering Zener voltages in the range 5.1V to 62V.
- BZY88 series – miniature glass encapsulated diodes rated at 500mW (at 25°C). Zener voltages range from 2.7V to 15V (voltages are quoted for 5mA reverse current at 25°C).
- BZY93 series – high power diodes in stud mounting encapsulation. Rated at 20W for ambient temperatures up to 75°C. Zener voltages range from 9.1V to 75V.
- BZY97 series – medium power wire-ended diodes rated at 1.5W and offering Zener voltages in the range 9.1V to 37V.
- 1N5333 series – plastic encapsulated diodes rated at 5W. Zener voltages range from 3.3V to 24V.

Zener diodes use plastic or glass packages just like conventional silicon diodes. As in the case of conventional silicon diodes, the cathode connection is marked with a stripe (see Fig. 2).

### Slope resistance and temperature coefficient

The slope resistance of a Zener diode is the rate of change of reverse voltage (Zener voltage) with diode current. Slope resistance is measured in the breakdown region and expressed in  $\Omega$ . An ideal Zener diode would

and an emitter current of 98mA. Determine the value of base current and common-emitter current gain.

Since  $I_E = I_B + I_C$ , the base current will be given by:

$$I_B = I_E - I_C = 98\text{mA} - 97\text{mA} = 1\text{mA}$$

The common-emitter current gain will be given by:

$$h_{FE} = I_C / I_B = 97\text{mA} / 1\text{mA} = 97$$

### Example

A transistor is to be used in a regulator circuit in which a collector current of 1.5A is to be controlled by a base current of 30mA. What value of  $h_{FE}$  will be required?

The required current gain can be found from:

$$\begin{aligned} h_{FE} &= I_C / I_B = 1.5\text{A} / 30\text{mA} \\ &= 1500\text{mA} / 30\text{mA} = 50 \end{aligned}$$

### Example

A transistor is used in a linear amplifier arrangement. The transistor has large and small signal current gains of 200 and 175 respectively and bias is arranged so that the static value of collector current is 10mA. Determine the value of base bias current and the change of output (collector) current that would result from a  $10\mu\text{A}$  change in input (base) current.

The value of base bias current can be determined from:

$$I_B = I_C / h_{FE} = 10\text{mA} / 200 = 50\mu\text{A}.$$

The change of collector current resulting from a  $10\mu\text{A}$  change in input current will be given by:

$$I_c = h_{fe} \times I_b = 175 \times 10\mu\text{A} = 1.75\text{mA}$$

The voltage developed across a forward biased base-emitter junction of a silicon transistor will be about 0.6V (0.1V for a germanium device). In the case of an NPN device, the base and collector will be positive with respect to the emitter whilst for a PNP device the base and collector will be negative with respect to the emitter (see Fig. 8).

### Bipolar transistor data

The data in Table 1 refers to some of the most popular types of transistor.

### Example

A transistor operates with a collector current of 97mA

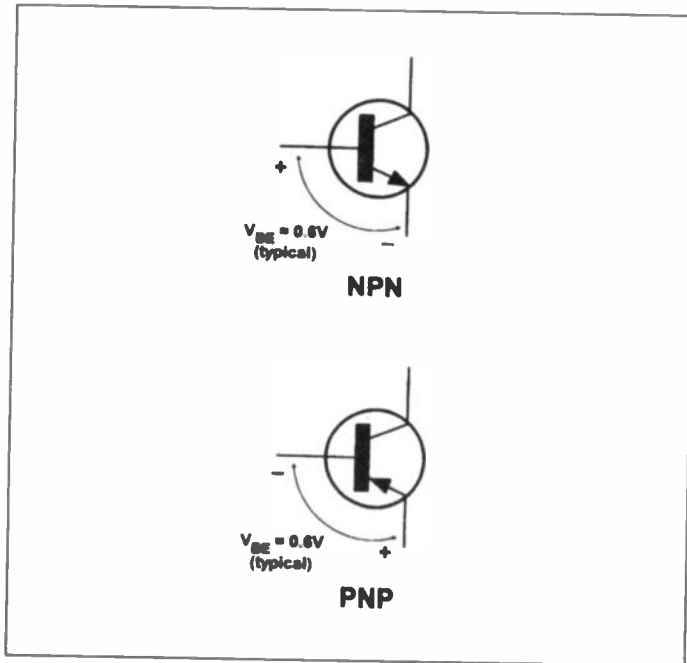

Fig.8 Base-emitter voltages for NPN and PNP transistors

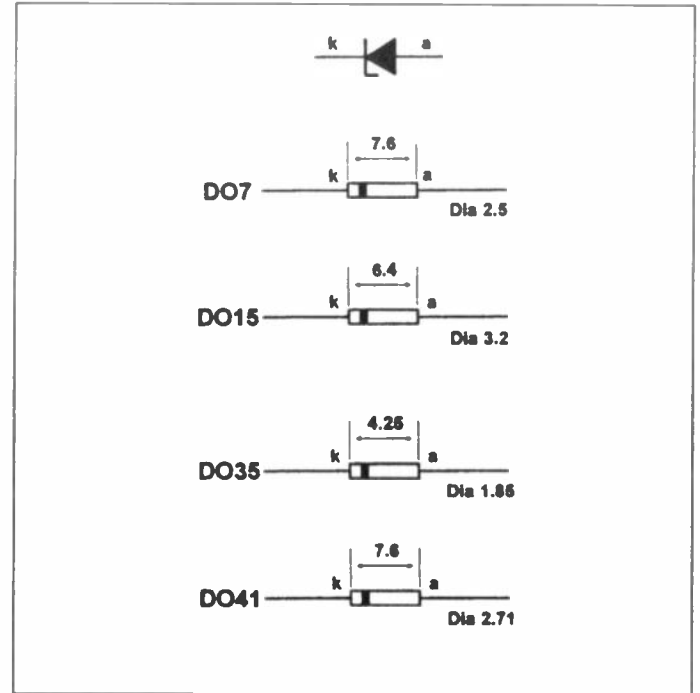

Fig.2 Zener diode encapsulation

have zero slope resistance (i.e., the diode would conduct perfectly at its rated Zener voltage). In practice, values of  $20\Omega$ , or less, can be achieved.

The temperature coefficient of Zener voltage is the change of Zener voltage (from its rated value) which results from a temperature change of  $1^\circ C$ . Temperature coefficient (which should ideally be zero) is expressed in  $mV/^\circ C$ . In many voltage reference applications, it is essential for the reference diode to exhibit a Zener voltage which does not vary with temperature. The data shown in Table 1 (for the BZX55 series) is typical of most low-power Zener diodes.

## Example

A Zener diode is to be used as a voltage reference. The diode has the following specifications:

Zener voltage (at 20°C): 9.1V

Temperature coefficient: +4mV/°C

If the equipment is designed to operate over the range -10°C to +40°C, determine the extreme values of reference voltage and the percentage change in reference voltage over the working range.

The temperature coefficient is positive and thus the Zener voltage will increase with temperature. At 40°C the Zener voltage will be given by:

$$\begin{aligned} V_Z &= 9.1\text{V} + ((40 - 20) \times 4\text{mV}) \\ &= 9.1\text{V} + 80\text{mV} = 9.18\text{V} \end{aligned}$$

At -10°C the Zener voltage will be given by:

$$\begin{aligned} V_Z &= 9.1\text{V} - ((20 - -10) \times 4\text{mV}) \\ &= 9.1\text{V} - 120\text{mV} = 8.98\text{V} \end{aligned}$$

Table 1

Zener voltage (V)	Slope resistance (Ω)	Temperature coefficient (mV/°C)
2.7	100	-3.5
5.1	60	-2.7
5.6	40	-2.0
6.2	10	+0.4
6.8	12	+1.2
7.5	14	+2.5
8.2	16	+3.2
9.1	18	+3.8

Table 1

Device	Type	$I_c$ max.	$V_{ce0}$ max.	$V_{cbo}$ max.	$P_T$ max.	$h_{fe}$	at $I_c$	$f_t$	Application typ.
2N2926	NPN	100mA	18V	18V	200mW	200	2mA	200MHz	General purpose
2N3053	NPN	700mA	40V	60V	800mW	150	50mA	100MHz	Driver
2N3055	NPN	15A	60V	100V	115W	50	500mA	1MHz	RF power
2N3866	NPN	400mA	30V	30V	3W	105	50mA	700MHz	RF power
2N3903	NPN	200mA	40V	60V	350mW	100	50mA	250MHz	Switching
2N3904	NPN	200mA	40V	60V	310mW	150	50mA	300MHz	Switching
2N4427	NPN	500mA	20V	20V	2.5W	100	100mA	500MHz	RF power
BC107	NPN	100mA	45V	50V	360mW	200	20mA	250MHz	Driver
BC108	NPN	100mA	20V	30V	300mW	125	2mA	250MHz	General purpose
BC109	NPN	100mA	20V	30V	360mW	250	2mA	250MHz	Low noise amp.
BC478	PNP	50mA	40V	40V	360mW	175	2mA	150MHz	General purpose
BCY70	PNP	200mA	40V	50V	360mW	150	2mA	200MHz	General purpose
BD131	NPN	3A	45V	70V	15W	50	250mA	60MHz	AF power
BD132	PNP	3A	45V	45V	15W	50	250mA	60MHz	AF power
BF180	NPN	20mA	20V	20V	150mW	100	10mA	650MHz	RF amplifier
MJ2501	PNP	10A	80V	80V	150W	1000	1A	1MHz	Power Darlington
MJ3001	NPN	10A	80V	80V	150W	1000	1A	1MHz	Power Darlington

operation), a static bias current must be applied to the transistor in order to obtain satisfactory operation. This bias is usually applied in the form of a small current to the base terminal (see Fig. 7). This current sets up a standing (quiescent) current of larger magnitude in the collector circuit. The signal current is added to the bias current, effectively increasing and decreasing the standing current above and below its quiescent (no signal) value.

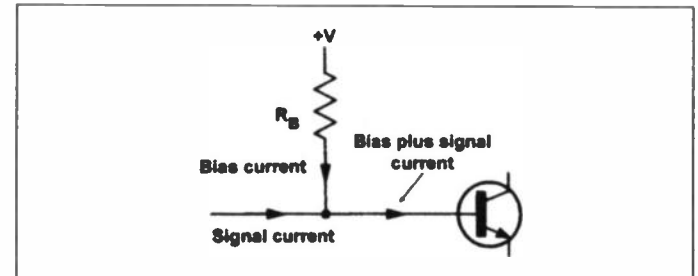

Fig.7 Bias current for an NPN transistor

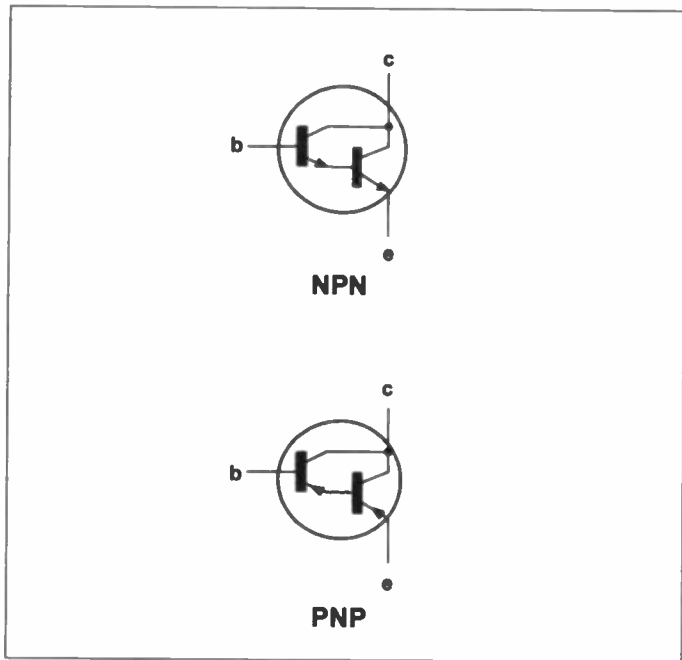

Fig.6 Darlington transistor

- $h_{fe}$  the small-signal common-emitter current gain.
- $h_{femax}$  – the maximum value of small-signal common-emitter current gain.
- $h_{fe\ min}$  – the minimum value of small-signal common-emitter current gain.
- $f_{t\ typ}$  – the transition frequency (i.e., the frequency at which the small signal common-emitter current gain falls to unity).

### Bias for bipolar transistors

In most circuits (particularly those designed for linear

The total change in temperature will be 50°C and the corresponding change in Zener voltage will be  $50 \times 4\text{mV}$  or 200mV. The percentage change will thus be given by:

$$\% \text{ change} = \frac{200\text{mV} \times 100}{9.1\text{V}} = 2.2\%$$

Zener diodes may be connected in series to obtain higher voltages. As an example, a 15.9V reference can be produced by connecting a 6.8V Zener diode in series with a 9.1V Zener diode.



*Zener diodes generally perform best when rated at voltages of between 5V and 6V. Hence, in order to obtain optimum performance (in terms of both slope resistance and temperature coefficient) reference voltage sources based upon Zener diodes often utilise components which have Zener voltages between 5.1V and 6.2V.*



*It is worth noting that a Zener diode requires a minimum forward current in order to provide satisfactory voltage regulation. If this current is not available, the voltage developed across the Zener will not reach the Zener voltage.*



# Variable capacitance diodes

The capacitance of a reverse-biased diode junction will depend on the width of the depletion layer which, in turn, varies with the reverse voltage applied to the diode. This allows a diode to be used as a voltage controlled capacitor. Diodes that are specially manufactured to make use of this effect (and which produce comparatively large changes in capacitance for a small change in reverse voltage) are known as variable capacitance diodes (or 'varicaps'). Such diodes are used (often in pairs) to provide tuning in radio and TV receivers. A typical characteristic for a variable capacitance diode is shown in Fig. 1.

## Variable capacitance diode data

The following table summarises the characteristics of a variety of common varicap diodes:

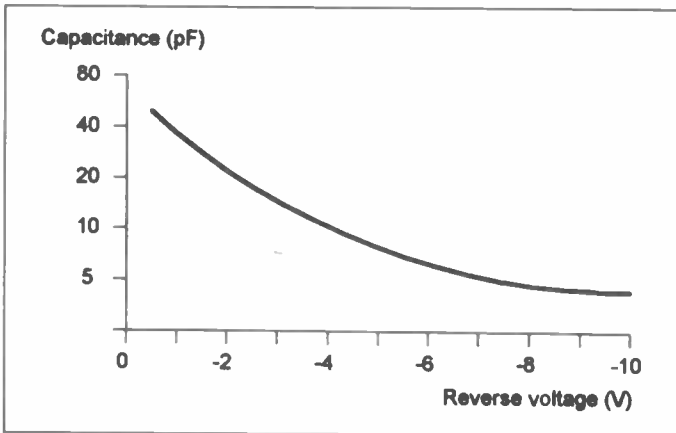

Fig.1 Typical characteristics for a variable capacitance diode

commonly quoted parameter is that which relates to common emitter mode. In this mode, the input current is applied to the base and the output current appears in the collector (the emitter is effectively common to both the input and output circuits).

The common emitter current gain is given by:

$$h_{FE} = I_C / I_B$$

where  $h_{FE}$  is the hybrid parameter which represents large signal (DC) forward current gain,  $I_C$  is the collector current, and  $I_B$  is the base current. When small (rather than large) signal operation is considered, the values of  $I_C$  and  $I_B$  are incremental (i.e., small changes rather than static values). The current gain is then given by:

$$h_{fe} = I_c / I_b$$

where  $h_{fe}$  is the hybrid parameter which represents small signal (AC) forward current gain,  $I_c$  is the change in collector current which results from a corresponding change in base current,  $I_b$ .

Darlington transistors (see Fig. 6) are a special form of compound bipolar transistor in which a very high value of forward current gain can be achieved (typically several thousand).

Other important parameters to note are:

- $I_{C \max}$  – the maximum value of collector current.
- $V_{CE0 \max}$  – the maximum value of collector-emitter voltage with the base terminal left open-circuit.
- $V_{CBO \max}$  – the maximum value of collector-base voltage with the base terminal left open-circuit.
- $P_{t \max}$  – the maximum total power dissipation.

flows in the base. The current flowing in the emitter circuit is typically 100 times greater than that flowing in the base. The direction of current flow is from emitter to collector in the case of a PNP transistor, and collector to emitter in the case of an NPN device.

The equation which relates current flow in the collector, base, and emitter currents (see Fig. 4) is:

$$I_E = I_B + I_C$$

where  $I_E$  is the emitter current,  $I_B$  is the base current, and  $I_C$  is the collector current (all expressed in the same units).

A typical set of transistor characteristics for a small-signal general purpose NPN transistor is shown in Fig. 5.

### Bipolar transistor parameters

The current gain offered by a transistor is a measure of its effectiveness as an amplifying device. The most

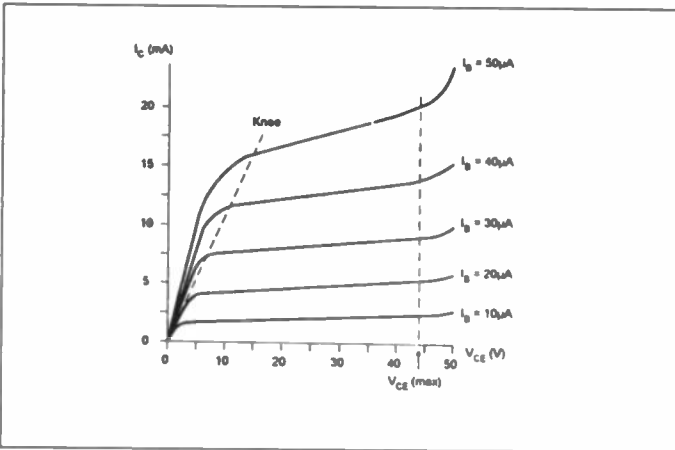

Fig.5 Typical NPN transistor characteristics

Table 1

Type	Capacitance	Capacitance ratio	Q-factor
1N5450	33pF at 4V	2.6 for 4V to 60V	350
MV1404	50pF at 4V	> 10 for 2V to 10V change	200
MV2103	10pF at 4V	2 for 4V to 60V	400
MV2110	39pF at 4V	2.5 for 4V to 60V	150
MV2115	100pF at 4V	2.6 for 4V to 60V	100

# Thyristors

Thyristors (or silicon controlled rectifiers) are three-terminal devices which can be used for switching and AC power control.

Thyristors can switch very rapidly from a conducting to a non-conducting state. In the off state, the thyristor exhibits negligible leakage current whilst, in the on state the device exhibits very low resistance. This results in very little power loss within the thyristor even when appreciable power levels are being controlled. Once switched into the conducting state, the thyristor will remain conducting (i.e., it is latched in the on state) until the forward current is removed from the device. In DC applications this necessitates the interruption (or disconnection) of the supply before the device can be reset into its non-conducting state. Where the device is used with an alternating supply, the device will automatically become reset whenever the main supply reverses. The device can then be triggered on the next half-cycle having correct polarity to permit conduction.

Like their conventional silicon diode counterparts, thyristors have anode and cathode connections; control is

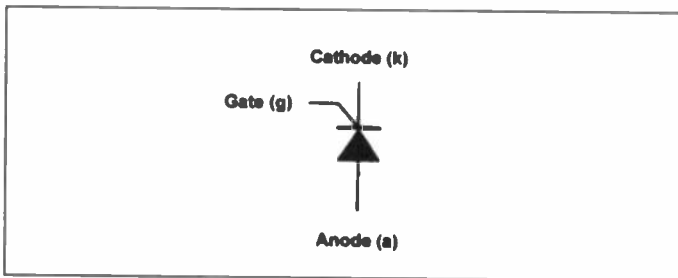

Fig.1 Thyristor connections

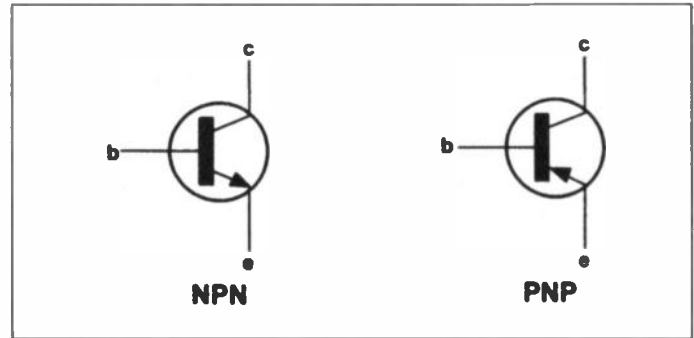

Fig.3 NPN and PNP transistor symbols



*Silicon transistors offer vastly superior performance when compared with their germanium counterparts in almost all applications. Germanium devices are particularly prone to temperature induced 'thermal runaway' and they are thus not used in modern equipment.*

## Current flow in a transistor

Each junction within the transistor, whether it be collector-base or base-emitter, constitutes a P-N junction diode. The base region is, however, made very narrow so that carriers are swept across and a relatively small current

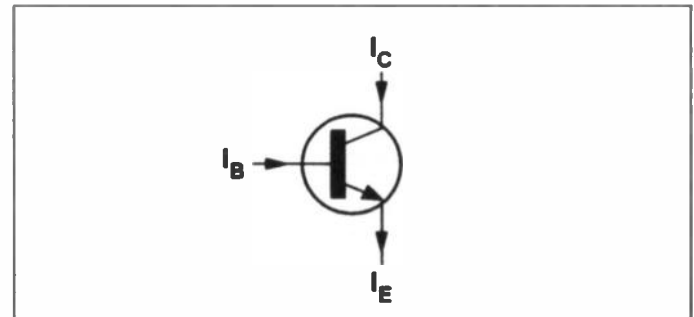

Fig.4 Current flow in an NPN transistor

Transistor iii) is a general purpose high-power, low-frequency silicon transistor.

Transistor iv) is a special purpose low-power, high-frequency silicon transistor.

### Transistor operation

Bipolar transistors generally comprise PNP or NPN junctions of either silicon (Si) or germanium (Ge) material. Fig. 1 and Fig. 2 respectively show the construction of NPN and PNP transistors, both of which are based on a small slice of silicon. In either case the terminals are labelled collector (c), base (b), and emitter (e), as shown in Fig. 3.

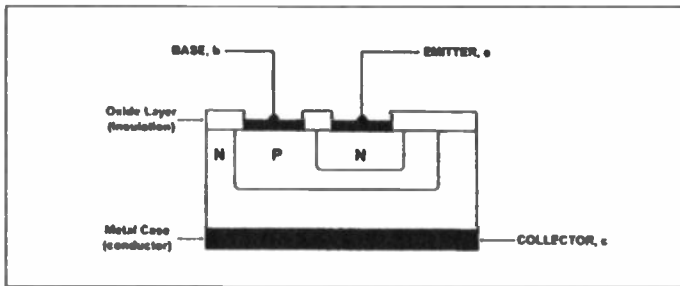

Fig.1 NPN transistor construction

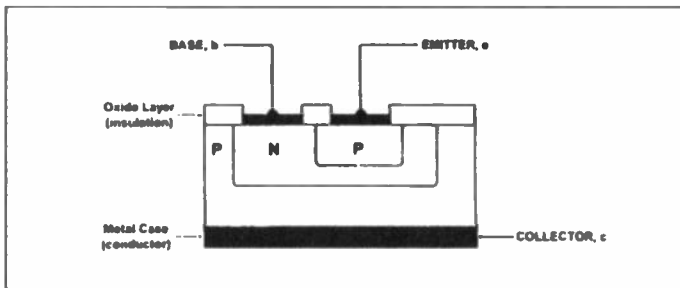

Fig.2 PNP transistor construction

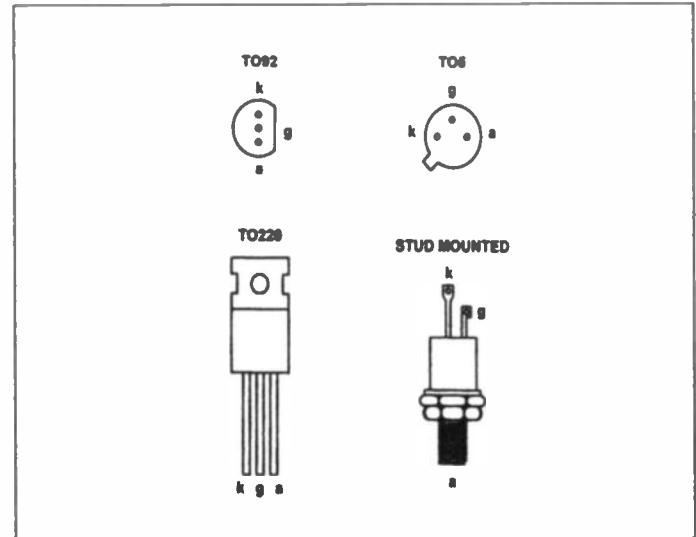

Fig.2 Common thyristor packages and pin connections

applied by means of a gate terminal (see Fig. 1). The device is triggered into the conducting (on state) by means of the application of a current pulse to this terminal.

### Thyristor data

The following table summarises the characteristics of a variety of popular thyristors:

Table 1

Type	$I_F(AV)$	$V_{RRM}$	$V_{GT}$	$I_{GT}$
2N4444	5.1A	600V	1.5V	30mA
BT106	1A	700V	3.5V	50mA
BT152	13A	600V	1V	32mA
BTY79-400R	6.4A	400V	3V	30mA
TIC106D	3.2A	400V	1.2V	200 $\mu$ A
TIC116D	5A	400V	2.5V	20mA
TIC126D	7.5A	400V	2.5V	20mA



*The effective triggering of a thyristor requires a gate trigger pulse having a fast rise time derived from a low-impedance source. Triggering can become erratic when insufficient gate current is available or when the gate current changes slowly.*

Common thyristor packages and pin connections are shown in Fig. 2. Readers are advised to consult Section G4 of the *Electronics Service Manual* for specifications, packages and pin connections for individual thyristor types.

- Driver – transistors that operate at medium power and voltage levels and which are often used to precede a final (power) stage which operates at an appreciable power level.

### Transistor coding

The European system for classifying transistors involves an alphanumeric code which employs either two letters and three figures (general purpose transistors) or three letters and two figures (special purpose transistors). The first two letters have the following significance:

- First letter – semiconductor material:
  - A Germanium
  - B Silicon
- Second letter – application:
  - C Low-power, low-frequency
  - D High-power, low-frequency
  - F Low-power, high-frequency
  - L High-power, high-frequency

In the case of transistors for specialised applications, the third letter does not generally have any particular significance.

### Example

Identify each of the following transistors:

- i) AF115
- ii) BC108
- iii) BD135
- iv) BFY50

Transistor i) is a general purpose low-power, high-frequency germanium transistor.

Transistor ii) is a general purpose low-power, low-frequency silicon transistor.

# Bipolar transistors

Transistor is short for *transfer resistor*, a term which provides something of a clue as to how the device operates; the current flowing in the output circuit is determined by the current flowing in the input circuit. Since transistors are three-terminal devices, one electrode must remain common to both the input and the output.

Transistors fall into two main categories (bipolar and field-effect) and are also classified according to the semiconductor material employed (silicon or germanium) and to their field of application (e.g., general purpose, switching, high-frequency, etc.). The following terminology is often used:

- Low-frequency – transistor designed specifically for AF applications (below 100kHz)
- High-frequency – transistors designed specifically for RF applications (100kHz and above)
- Power – transistors that operate at significant power levels (such devices are often sub-divided into audio frequency and radio frequency power types)
- Switching – transistors designed for switching applications
- Low-noise – transistors that have low-noise characteristics and which are intended primarily for the amplification of low-amplitude signals
- High-voltage – transistors designed specifically to handle high voltages

# Triacs

Triacs are a refinement of the thyristor which, when triggered, conduct on both positive and negative half-cycles of the applied voltage. Triacs have three terminals known as main-terminal one (MT1), main terminal two (MT2) and gate (G), as shown in Fig. 1. Triacs can be triggered by both positive and negative voltages applied between G and MT1 with positive and negative voltages present at MT2 respectively. Triacs thus provide full-wave control and offer superior performance in AC power control applications when compared with thyristors which only provide half-wave control.

In order to simplify the design of triggering circuits, triacs are often used in conjunction with diacs (equivalent to a bi-directional Zener diode). A typical diac conducts heavily when the applied voltage exceeds approximately 32V in either direction. Once in the conducting state, the resistance of the diac falls to a very low value and thus a relatively large value of current will flow. The characteristics of a typical diac are shown in Fig. 2.

## Triac data

Table 1 overleaf summarises the characteristics of a variety of popular triacs.

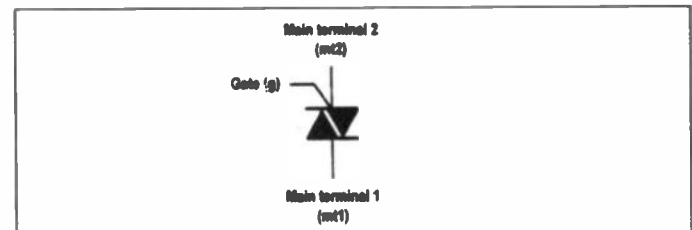

Fig.1 Triac connections

**Table 1**

Type	$I_T(\text{RMS})$	$V_{\text{RRM}}$	$V_{\text{GT}}$	$I_{\text{GT}}(\text{TYP})$
BT139	15A	600V	1.5V	5mA
TIC206M	4A	600V	2V	5mA
TIC216M	6A	600V	3V	5mA
TIC226M	8A	600V	2V	50mA

Common triac packages and pin connections are shown in Fig. 3.

Readers are advised to consult Section G5 for specifications, packages and pin connections for individual triac types.

### Power-line filters

Thyristors and triacs switch on and off very rapidly. In AC power control applications, this rapid switching can result in transients which may be conveyed some distance

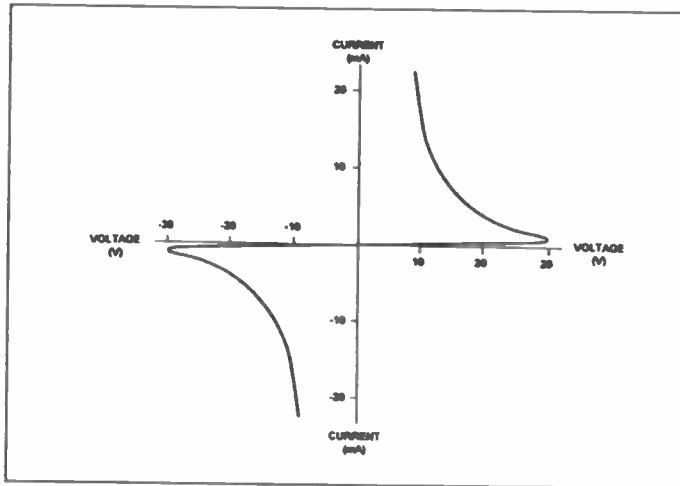

Fig.2 Diac characteristics



*Yellow and green LEDs generally give less light output (for a given forward current) than their standard red counterparts. To maintain an equal light output when several LEDs of different colours are used together, different values of series resistor may be employed. As a rule of thumb, series resistors for yellow and green LEDs are chosen so that they are 10% to 15% lower in value than those used with red LEDs (care should, however, be taken to ensure that operating currents are still within the manufacturer's specified maximum upper limit).*

**Example**

An LED is to be used to indicate the presence of a 21V DC supply rail. If the LED has a nominal forward voltage of 2.2V, and is rated at a current of 15mA, determine the value of series resistor required.

Here we can use the formula:

$$R = \frac{V - V_F}{I} = \frac{21V - 2.2V}{15mA} = \frac{18.8V}{15mA} = 1.25k\Omega$$

The nearest preferred value is 1.2kΩ. The power dissipated in the resistor will be given by:

$$P = I \times V = 15mA \times 18.8V = 280mW$$

Hence the resistor should be rated at 0.33W, or greater.

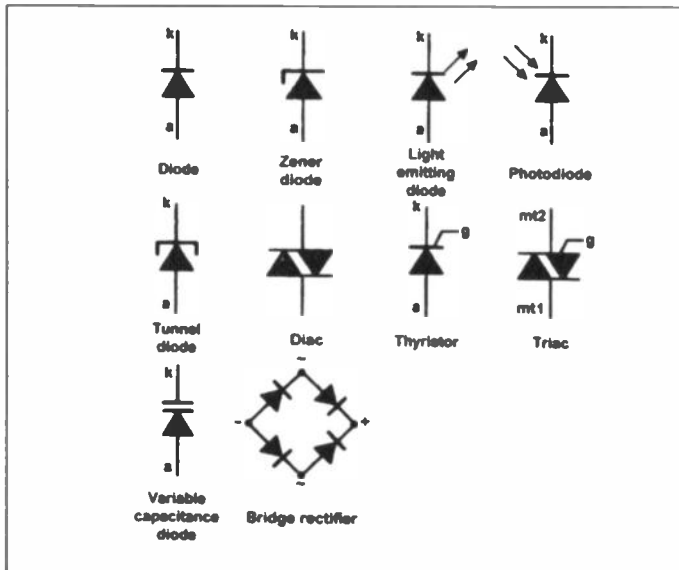

Fig.3 Diode symbols

via the AC mains wiring. To minimise such effects and prevent radiation of noise, L-C filters are usually fitted in close proximity to the power control device, as shown in Fig. 4.

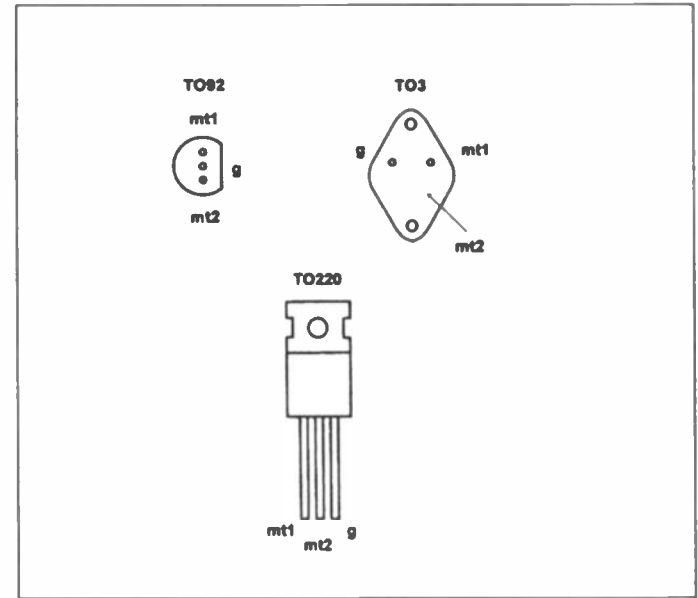

Fig.3 Common triac packages and pin connections

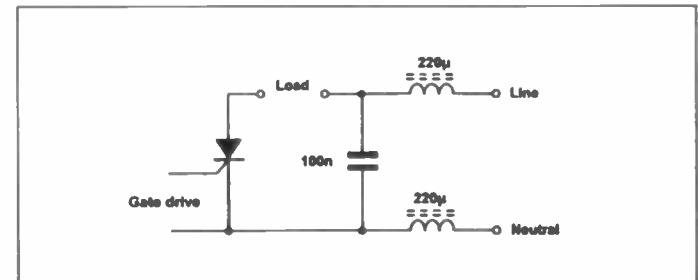

Fig.4 L-C filters used to remove noise produced by a thyristor or triac



# Light emitting diodes

Light emitting diodes (LEDs) can be used as general purpose indicators and, compared with conventional filament lamps, operate from significantly smaller voltages and currents. LEDs are also very much more reliable than filament lamps. Most LEDs will provide a reasonable level of light output when a forward current of between 5mA and 20mA is applied.

Light emitting diodes are available in various formats with the round types being most popular. Round LEDs are commonly available in the 3mm and 5mm (0.2 inch) diameter plastic packages (see Fig. 1) and also in 5mm x 2mm rectangular format. The viewing angle for round LEDs tends to be in the region of 20° to 40° whereas, for rectangular types this is increased to around 100°. Typical characteristics for commonly available red LEDs are given below:

**Table 1**

Parameter	standard	Type of LEDs		
		standard	high efficiency	high intensity
Diameter (mm)	3	5	5	5
Max. forward current (mA)	40	30	30	30
Typical forward current (mA)	12	10	7	10
Typical forward voltage drop (V)	2.1	2.0	1.8	2.2
Max. reverse voltage (V)	5	3	5	5
Max. power dissipation (mW)	150	100	27	135
Peak wavelength (nm)	690	635	635	635

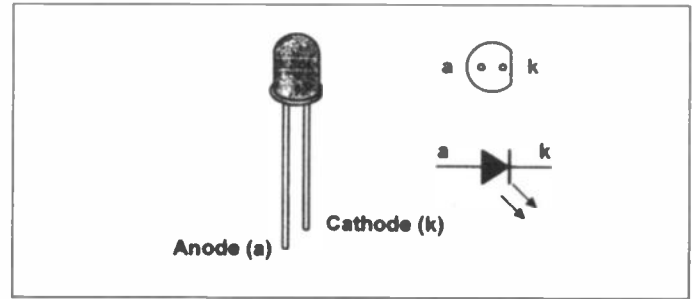

Fig.1 LED encapsulation

## Current limiting

In order to limit the forward current to an appropriate value, it is usually necessary to include a fixed resistor in series with an LED indicator, as shown in Fig. 2. The value of the resistor may be calculated from:

$$R = \frac{V - V_F}{I}$$

where  $V_F$  is the forward voltage drop produced by the LED and  $V$  is the applied voltage. Note that it is usually safe to assume that  $V_F$  will be 2V and choose the nearest preferred value for  $R$ .

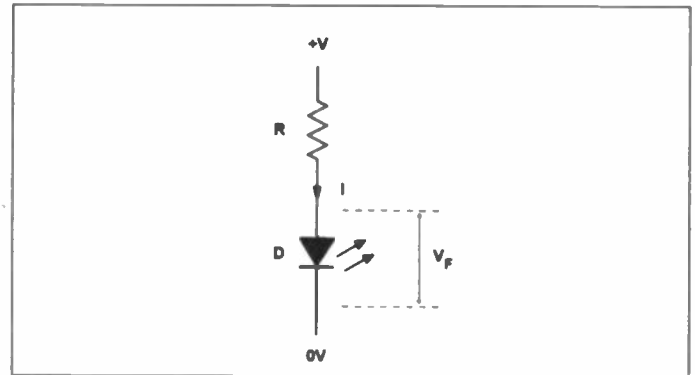

Fig.2 LED current limiting resistor