

EVERYDAY

3 Rev 2000

OCTOBER 1996

PRACTICAL

ELECTRONICS

<http://www.epemag.wimborne.co.uk>

£2.45

10MHz FUNCTION GENERATOR

Sine, square and triangular
waves from 10Hz to 10MHz

UNDERSTANDING
ACTIVE
COMPONENTS

NO FREE BOOK?
*Please ask your
newsagent*

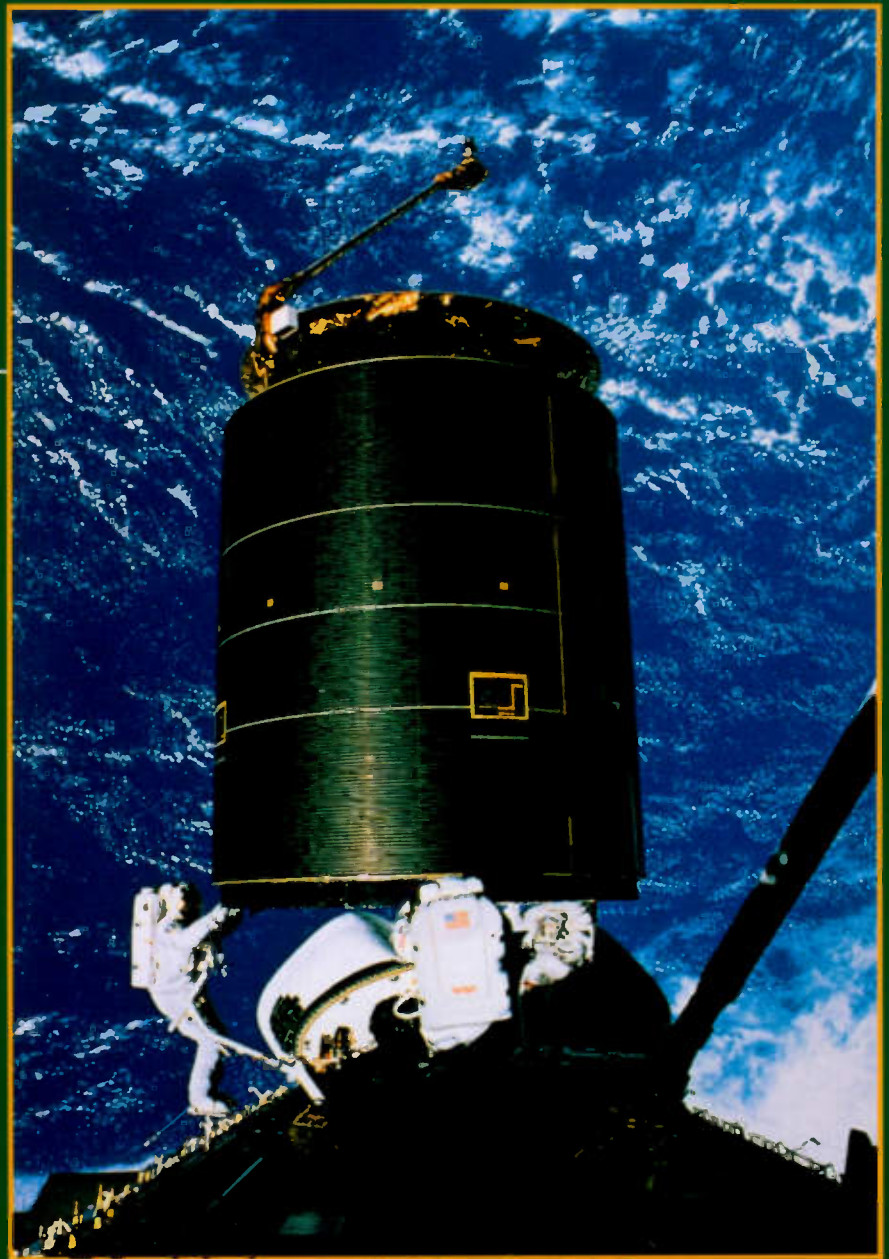

Special Feature
**INTRODUCTION
TO SATELLITE
TELEVISION**



MOONSHINE BIBLE 270 page book covering the production of alcohol from potatoes, rice, grains etc Drawings of simple home made stills right through to commercial systems. £15 ref MS1
NEW HIGH POWER MINI BUG With a range of 800 metres or more and up to 100 hours use from a PP3 this will be popular! Bug measures less than 1" square! £28 Ref LOT102.

SINCLAIR C5 MOTORS We have a new ones available without gearboxes at £50 ref LOT25

BUILD YOUR OWN WINDFARM FROM SCRAP New publication gives step by step guide to building wind generators. Armed with this publication and a good local scrap yard could make you self sufficient in electricity! £12 ref LOT81

PC KEYBOARDS PS2 connector, top quality suitable for all 286/386/486 etc £10 ref PCKB. 10 for £65.

TRACKING TRANSMITTER range 1.5-5 miles, 5,000 hours on AA batteries, also transmits info on car direction and motion! Works with any FM radio. 1.5" square. £65 ref LOT101

ELECTRIC DOOR LOCKS Complete lock with both Yale lock and 12v operated deadlock (keys included) £10 ref LOT99

GALLIUM ARSENIDE FISHEYE PHOTO DIODES Complete with suggested circuits for long range communications/switching £12 complete.

SURVEILLANCE TELESCOPE Superb Russian zoom telescope adjustable from 15x to 60x! complete with metal tripod (impossible to use without this on the higher settings) 66mm lens, leather carrying case £149 ref BAR69

WIRELESS VIDEO BUG KIT Transmits video and audio signals from a miniature CCTV camera (included) to any standard television! All the components including a PP3 battery will fit into a cigarette packet with the lens requiring a hole about 3mm diameter. Supplied with telescopic aerial but a piece of wire about 4" long will still give a range of up to 100 metres. A single PP3 will probably give less than 1 hours use. £99 REF EP79. (probably not licensable!)

CCTV CAMERA MODULES 46X70X29mm, 30 grams, 12v 100mA, auto electronic shutter, 3.6mm F2 lens. CCIR, 512x492 pixels, video output is 1v p-p (75 ohm). Works directly into a scart or video input on a tv or video. IR sensitive. £79.95 ref EF137.

IR LAMP KIT Suitable for the above camera enables the camera to be used in total darkness! £5.99 ref EF138.

REMOTE CONTROL DATA TD1400 MODEM/VIEWDATA Complete system comprising 1200/75 modem, auto dialler, infra red remote keyboard, (could be adapted for PC use?) psu, UHF and RGB output, phone lead, RS232 output, composite output. Absolute bargain for parts alone! £9.95 ref BAR33

9 WATT CHEFTAN TANK LASERS

Double beam units designed to fit in the gun barrel of a tank, each unit has two semi conductor lasers and motor drive units for alignment. 7 mile range, full circuit diagrams, new price £50,000? us? £349. Each unit has two gallium Arsenide injection lasers, 1 x 9 watt, 1 x 3 watt, 900nm wavelength, 28vdc, 600hz pulse frequency. The units also contain an electronic receiver to detect reflected signals from targets. five or more units £299 ea. £349 for one. Ref LOT4

TWO WAY MIRROR KIT Includes special adhesive film to make two way mirror(s) up to 60"x20" (glass not included) Includes full instructions. £12 ref TW1.

NEW LOW PRICED COMPUTER/WORKSHOP/HI-FIRCB UNITS Complete protection from faulty equipment for everybody! In line unit fits in standard IEC lead (extends to 750mm), fitted in less than 10 seconds, reset/test button, 10A rating. £6.95 each ref LOTS. Or a pack of 10 at £49.90 ref LOT6. If you want a box of 100 you can have one for £250!

RADIO CONTROLLED CARS FROM £6 EACH!!!! All returns from famous manufacturer, 3 types available, single channel (left, right, forwards, backwards) £6 ref LOT1. Two channel with more features £12 ref LOT2.

THOUSANDS AVAILABLE RING/FAX FOR DETAILS! MAGNETIC CARD READERS (Swipes) £9.95 Cased with flyleads, designed to read standard credit cards! they have 3 wires coming out of the head so they may write as well! complete with control electronics PCB. just £9.95 ref BAR31

WANT TO MAKE SOME MONEY? STUCK FOR AN IDEA? We have collated 140 business manuals that give you information on setting up different businesses, you peruse these at your leisure using the text editor on your PC. Also included is the certificate enabling you to reproduce (and sell) the manuals as much as you like! £14 ref EP74

PANORAMIC CAMERA OFFER Takes double width photographs using standard 35mm film. Use in horizontal or vertical mode. Complete with strap £7.99 ref BAR1

COIN OPERATED TIMER KIT Complete with coin slot mechanism, adjustable time delay, relay output, put a coin slot on anything you like! TV's, videos, fridges, drinks cupboards, HiFi, takes 50p's and £1 coins. DC operated, price just £7.99 ref BAR27.

ZENITH 900 X MAGNIFICATION MICROSCOPE Zoom, metal construction, built in light, shrimp farm, group viewing screen, lots of accessories. £29 ref ANAYLT.

AA NICAD PACK Pack of 4 tagged AA nicads £2.99 ref BAR34
PLASMA SCREENS 222x310mm, no data hence £4.99 ref BAR67

NIGHTSIGHTS Model TZS4 with infra red illuminator, views up to 75 metres in full darkness in infrared mode. 150m range, 45mm lens, 13 deg angle of view, focussing range 1.5m to infinity. 2 AA batteries required. 950g weight. £199 ref BAR61. 1 years warranty

LIQUID CRYSTAL DISPLAYS Bargain prices, 16 character 2 line, 99x24mm £2.99 ref SM1623A
 20 character 2 line, 83x19mm £3.99 ref SM2020A
 16 character 4 line, 62x25mm £5.99 ref SMC1640A

TAL-1 110MM NEWTONIAN REFLECTOR TELESCOPE Russian. Superb astronomical scope, everything you need for some

serious star gazing! up to 160x magnification. Send or fax for further

WOLVERHAMPTON BRANCH NOW OPEN AT WORCESTER ST W/HAMPTON TEL 01902 27030

details £249 ref TAL-1

CENTRAL POINT PC TOOLS Award winning software, 1,300 virus checker, memory optimiser, disc optimiser, file compression, low level formatting, backup scheduler, disk defragmenter, undelete, 4 calculators, Dbase, disc editor, over 40 viewers, remote computing, password protection, encryption, comprehensive manual supplied etc £25 ref lot 97 3.5" disks.

GOT AN EXPENSIVE BIKE? You need one of our bottle alarms, they look like a standard water bottle, but open the top, insert a key to activate a motion sensor alarm built inside. Fits all standard bottle carriers, supplied with two keys. SALE PRICE £7.99 REF SA32

GOT AN EXPENSIVE ANYTHING? You need one of our cased vibration alarms, keyswitch operated, fully cased just fit it to anything from videos to caravans, provides a years protection from 1 PP3 battery, UK made. SALE PRICE £4.99 REF SA33.

DAMAGED ANSWER PHONES These are probably beyond repair so just £4.99 each. BT response 200 machines. REF SA30.

COMPUTER DISC CLEAROUT We are left with a lot of software packs that need clearing so we are selling at disc value only! 50 discs for £4, (that's just 8p each!) (our choice of discs) £4 ref EP66

IBM PS2 MODEL 160Z CASE AND POWER SUPPLY Complete with fan etc and 200 watt power supply. £9.95 ref EP67
DELL PC POWER SUPPLIES 145 watt, +5, -5, +12, -12, 150x150x85mm complete with switch, flyleads and IEC socket. SALE PRICE £9.99 ref EP55

1.44 DISC DRIVES Standard PC 3.5" drives but returns so they will need attention. SALE PRICE £4.99 ref EP68

1.2 DISC DRIVES Standard 5.25" drives but returns so they will need attention. SALE PRICE NOW ONLY £3.50 ref EP69

PP3 NICADS Unused but some storage marks. £4.99 ref EP52

DELL PC POWER SUPPLIES (Customer returns) Standard PC psu's complete with flyleads, case and fan. +12v, -12v, +5v, -5v. SALE PRICE £1.99 EACH worth 10 for the bits alone! ref DL1. TRADE PACK OF 20 £29.95 Ref DL2.

GAS HOBS AND OVENS Brand new gas appliances, perfect for small flats etc. Basic 3 burner hob. SALE PRICE £24.99 ref EP72. Basic small built in oven. SALE PRICE £79 ref EP73

RED EYE SECURITY PROTECTOR 1,000 watt outdoor PIR switch. SALE PRICE £6.99 ref EP57

ENERGY BANK KIT 100 6"x6" 6v 100mA panels, 100 diodes, connection details etc. £69.95 ref EF112

PASTEL ACCOUNTS SOFTWARE, does everything for all sizes of businesses. Includes word processor, report writer, windowing, networkable up to 10 stations, multiple cash books etc. 200 page comprehensive manual. 90 days free technical support (01342-326009 try before you buy!) Current retail price is £128, SALE PRICE £9.95 ref SA12. SAVE £120!!!

COMPLETE PC 200 WATT UPS SYSTEM Top of the range UPS system providing protection for your computer system and valuable software against mains power fluctuations and cuts. New and boxed, UK made. Provides up to 5 mins running time in the event of complete power failure to allow you to run your system down correctly. LAST FEW TO CLEAR AT £49 SAVE £30 ref LOT61

BIG BROTHER PSU Cased PSU, 6v 2A output, 2m o/p lead, 1.5m input lead, UK made, 220v. SALE PRICE £4.99 REF EP7



Check out our
WEB SITE

<http://www.pavillon.co.uk/bull-electrical>

RACAL MODEM BONANZA! 1 Racal MPS1223 1200/75 modem, telephone lead, mains lead, manual and comms software, the cheapest way onto the net! all this for just £13 ref DEC13.

4.5mw LASER POINTER. BRAND NEW MODEL NOW IN STOCK! supplied in fully built form (looks like a nice pen) complete with handy pocket clip (which also acts as the on/off switch.) About 60 metres range! Runs on 2 AAA batteries. Produces thin red beam ideal for levels, gun sights, experiments etc. Just £39.95 ref DEC49 TRADE PRICE £28 MIN 10 PIECES

BULL TENS UNIT Fully built and tested TENS (Transcutaneous Electrical Nerve Stimulation) unit, complete with electrodes and full instructions. TENS is used for the relief of pain etc in up to 70% of sufferers. Drug free pain relief, safe and easy to use, can be used in conjunction with analgesics etc. £49 Ref TEN1

PC PAL VGA TO TV CONVERTER Converts a colour TV into a basic VGA screen. Complete with built in psu, lead and sware. Ideal for laptops or a cheap upgrade. Supplied in kit form for home assembly. SALE PRICE £25 REF SA34

EMERGENCY LIGHTING UNIT Complete unit with 2 double

*SOME OF OUR PRODUCTS MAY BE UNLICENSABLE IN THE UK

BULL ELECTRICAL

250 PORTLAND ROAD, HOVE, SUSSEX.
 BN3 5QT. (ESTABLISHED 50 YEARS).

MAIL ORDER TERMS: CASH, PO OR CHEQUE
 WITH ORDER PLUS £3 P&P PLUS VAT.

PLEASE ALLOW 7-10 DAYS FOR DELIVERYPHONE ORDERS
 WELCOME (ACCESS,VISA, SWITCH, AMERICAN EXPRESS)

TEL: 01273 203500
 FAX 01273 323077

E-mail bull@pavillon.co.uk

bulb floodlights, built in charger and auto switch. Fully cased. 6v 8AH lead acid req'd. (secondhand) £4 ref MAG4P11

YUASHA SEALED LEAD ACID BATTERIES Two sizes currently available this month. 12v 15AH at £18 ref LOT8 and 6v 10AH (suitable for emergency lights above) at just £6 ref LOT7.

ELECTRIC CAR WINDOW DE-ICERS Complete with cable, plug etc. SALE PRICE JUST £4.99 REF SA28

AUTO SUNCHARGER 155x300mm solar panel with diode and 3 metre lead fitted with a cigar plug, 12v 2watt. £8.99 REF SA25.

MICRODRIVE STRIPPERS Small cased tape drives ideal for stripping, lots of useful goodies including a smart case, and lots of components. SALE PRICE JUST £4.99 FOR FIVE REF SA26

SOLAR POWER LAB SPECIAL You get TWO 6"x6" 6v 130mA solar cells, 4 LEDs, wire, buzzer, switch plus 1 relay or motor. Superb value kit. SALE PRICE JUST £4.99 REF SA27

RGB/CGA/EGA/TTL COLOUR MONITORS 12" in good condition. Back anodised metal case. SALE PRICE £49 REF SA16B

PLUG IN ACORN PSU 19v AC 14w. £2.99 REF MAG3P10

13.8V 1.9A PSU cased with leads. Just £9.99 REF MAG10P3

UNIVERSAL SPEED CONTROLLER KIT Designed by us for the C5 motor but ok for any 12v motor up to 30A. Complete with PCB etc. A heat sink may be required. £17.00 REF: MAG17

PHONE CABLE AND COMPUTER COMMUNICATIONS PACK Kit contains 100m of 6 core cable, 100 cable clips, 2 line drivers with RS232 interfaces and all connectors etc. Ideal low cost method of communicating between PCs over a long distance utilizing the serial ports. Complete kit £8.99. Ref comp1.

VIEWDATA SYSTEMS made by Phillips, complete with internal 1200/75 modem, keyboard, psu etc RGB and composite outputs, menu driven, autodialler etc. SALE PRICE £12.99 REF SA18

AIR RIFLES. 22 As used by the Chinese army for training purposes, so there is a lot about! £39.95 Ref EF78. 500 pellets £4.50 ref EF80.

PLUG IN POWER SUPPLY SALE FROM £1.50 Plugs in to 13A socket with output lead. Three types available, 9vdc 150mA £1.50 ref SA19, 9vdc 200mA £2.00 ref SA20, 6.5vdc 500mA £2 ref SA21.

VIDEO SENDER UNIT. Transmits both audio and video signals from either a video camera, video recorder, TV or Computer etc to any standard TV set in a 100' range! (tune TV to a spare channel) 12v DC op. Price is £25 REF: MAG15 12v psu is £5 extra REF: MAG5P2

***MINIATURE RADIO TRANSCEVERS** A pair of walkie talkies with a range up to 2km in open country. Units measure 22x52x155mm. Including cases and ear pieces. 2xPP3 req'd. £30.00 pr. REF: MAG30

***FM TRANSMITTER KIT** housed in a standard working 13A adapter! the bug runs directly off the mains so lasts forever why pay £700? or price is £15 REF: EF62 (kit) Transmits to any FM radio.

***FM BUG BUILT AND TESTED** superior design to kit. Supplied to detective agencies. 9v battery req'd. £14 REF: MAG14

TALKING COINBOX STRIPPER COMPLETE WITH COIN SLOT MECHANISMS originally made to retail at £79 each, these units are designed to convert an ordinary phone into a payphone. The units have the locks missing and sometimes broken hinges. However they can be adapted for their original use or used for something else?? SALE PRICE JUST £2.50 REF SA23

GAT AIR PISTOL PACK Complete with pistol, darts and pellets £12.95 Ref EF82B extra pellets (500) £4.50 ref EF80.

6"X12" AMORPHOUS SOLAR PANEL 12v 155x310mm 130mA. SALE PRICE £4.99 REF SA24

FIBRE OPTIC CABLE BUMPER PACK 10 metres for £4.99 ref MAG5P13 ideal for experimenters! 30 m for £12.99 ref MAG13P1

MIXED GOODIES BOX OF
 MIXED COMPONENTS WEIGHING 2 KILOS
 YOURS FOR JUST £6.99

4X28 TELESCOPIC SIGHTS Suitable for all air rifles, ground lenses, good light gathering properties. £19.95 ref R77.

GYROSCOPES Remember these? well we have found a company that still manufactures these popular scientific toys, perfect gift or for educational use etc. £6 ref EP70

HYPOTHERMIA SPACE BLANKET 215x150cm aluminised foil blanket, reflects more than 90% of body heat. Also suitable for the construction of two way mirrors! £3.99 each ref OL041.

LENSTATIC RANGER COMPASS Oil filled capsule, strong metal case, large luminous points. Sight line with magnifying viewer. 50mm dia. 86gm. £10.99 ref OK604.

RECHARGE ORDINARY BATTERIES UP TO 10 TIMES! With the Battery Wizard! Uses the latest pulse wave charge system to charge all popular brands of ordinary batteries AAA, AA, C, D, four at a time! Led system shows when batteries are recharged, automatically rejects unsuitable cells, complete with mains adaptor. BS approved. Price is £21.95 ref EP31.

TALKING WATCH Yes, it actually tells you the time at the press of a button. Also features a voice alarm that wakes you up and tells you what the time is! Lithium cell included. £7.99 ref EP26.

PHOTOGRAPHIC RADAR TRAPS CAN COST YOU YOUR LICENCE! The new multiband 2000 radar detector can prevent even the most responsible of drivers from losing their licence!

Adjustable audible alarm with 8 flashing LEDs gives instant warning of radar zones. Detects X, K, and Ka bands, 3 mile range, 'over the hill' 'around bends' and 'rear trap' facilities. Micro size just 4.25"x2.5"x.75". Can pay for itself in just one day! £79.95 ref EP3.

3" DISCS As used on older Amstrad machines, Spectrum plus3's etc £3 each ref BAR400.

STEREO MICROSCOPES BACK IN STOCK Russian, 200x complete with lenses, lights, filters etc etc very comprehensive microscope that would normally be around the £700 mark, our price is just £299 (full money back guarantee) full details in catalogue.

WE BUY SURPLUS STOCK FOR CASH

BUYERS DIRECT LINE 0802 660377

FREE CATALOGUE

100 PAGE CATALOGUE NOW
 AVAILABLE, 50P STAMP OR FREE
 ON REQUEST WITH ORDER.

ISSN 0262 3617
PROJECTS ... THEORY ... NEWS ...
COMMENT ... POPULAR FEATURES ...

VOL. 25 No. 10 OCTOBER 1996

EVERYDAY

PRACTICAL

ELECTRONICS

The No. 1 Independent Magazine for
Electronics, Technology and Computer Projects

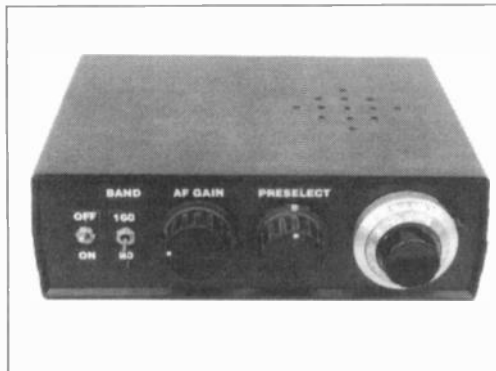
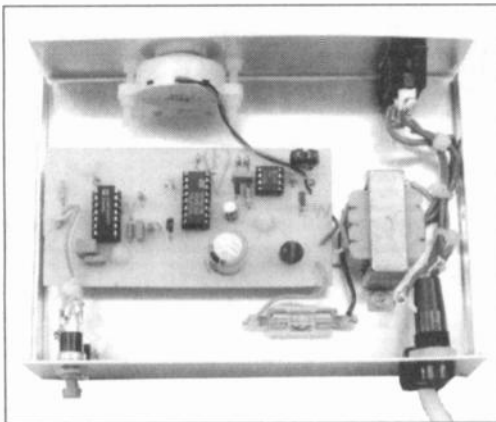
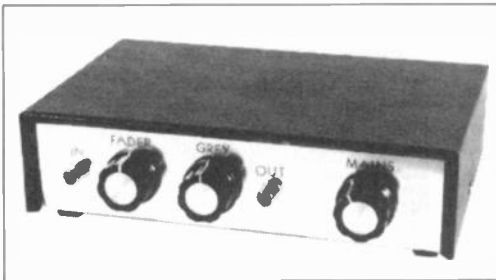

Projects and Circuits

- VIDEO FADE-TO-WHITE** by Robert Penfold **748**
How to simply extend your creative home video options
- 10MHz FUNCTION GENERATOR** by Andy Flind **757**
Precision waveform shaping to 10MHz is now practical using this MAX038-based sophisticated workshop instrument
- INTERFACE** by Robert Penfold **768**
Digital capacitance meter interface for PC parallel ports
- VEHICLE ALERT** by Terry de Vaux-Balbirnie **778**
Protect yourself and your family - be soundly warned when vehicles enter the driveway
- DIRECT CONVERSION TOPBAND AND 80m RECEIVER** **789**
by Adrian Knott G6KSN
Tuning into the world amateur bands couldn't be easier!
- INGENUITY UNLIMITED** hosted by Alan Winstanley **801**
Drink Aid for the Blind; Chart Recorder Input Attenuator; Heads or Tails Indicator

Series and Features

- NEW TECHNOLOGY UPDATE** by Ian Poole **754**
Li-ion hearted batteries are stalking the portable power market
- INTRODUCTION TO SATELLITE TELEVISION** by Mike Rutherford **770**
Half a century on since Arthur C. Clarke predicted satellite comms, the practical technology has matured, yet still evolves
- CIRCUIT SURGERY** by Alan Winstanley **784**
PIC files now webbed; shining example; flashing l.e.d.s; retriggerable timers
- NET WORK - THE INTERNET PAGE** surfed by Alan Winstanley **804**
Snaffle more Stuff with FTP; Drag Net; Net Survival!; Surf Boarding

Regulars and Services

- EDITORIAL** **747**
- SHOPTALK** with David Barrington **764**
Component buying for *EPE* projects
- INNOVATIONS** **766**
Everyday news from the world of electronics
- BACK ISSUES** Did you miss these? **776**
- FAX ON DEMAND** **777**
Need a recent *EPE* article now? Dial our "instant" response Service!
- FOX REPORT** by Barry Fox **786**
Yet again the misery of new phone codes looms, this time thanks to Ofel
- ELECTRONICS VIDEOS** **796**
Our range of educational videos
- DIRECT BOOK SERVICE** **798**
A wide range of technical books available by mail order
- OHM SWEET OHM** by Max Fidling **802**
Golfing gadgets send Fidling off his trolley, but nothing sends Piddles off his food!
- PRINTED CIRCUIT BOARD SERVICE** **803**
PCBs for *EPE* projects. Plus *EPE* software
- ADVERTISERS INDEX** **808**

© Wimborne Publishing Ltd 1996. Copyright in all drawings, photographs and articles published in **EVERYDAY PRACTICAL ELECTRONICS** is fully protected, and reproduction or imitations in whole or in part are expressly forbidden.

Our November '96 issue will be published on Friday, 4 October 1996. See page 777 for details.

Everyday Practical Electronics, October 1996

Readers Services • Editorial and Advertisement Departments **747**
Cover photograph - see page 767

Surplus always wanted for cash!

THE ORIGINAL SURPLUS WONDERLAND!

THIS MONTH'S SELECTION FROM OUR VAST EVER CHANGING STOCKS

Surplus always wanted for cash!

LOW COST PC's -

SPECIAL BUY 'AT 286'

40Mb HD + 3Mb Ram



LIMITED QUANTITY only of these 12MHz HI GRADE 286 systems Made in the USA to an industrial specification, the system was designed for total reliability. The compact case houses the motherboard, PSU and EGA video card with single 5 1/4" 1.2 Mb floppy disk drive & integral 40Mb hard disk drive to the front. Real time clock with battery backup is provided as standard. Supplied in good used condition complete with enhanced keyboard, 640k + 2Mb RAM, DOS 4.01 and 90 DAY Full Guarantee. Ready to Run!

Order as HIGRADE 286 **ONLY £129.00 (E)**

Optional fitted extra: VGA graphics card	£29.90
1.4Mb 3 1/2" floppy disk drive (instead of 1.2 Mb)	£19.95
Wordperfect 6.0 for Dos - when 3 1/2" FDD option ordered	£22.50
NE2000 Ethernet (thick, thin or twisted) network card	£29.00

LOW COST 486DX-33 SYSTEM

Limited quantity of this 2nd user, superb small size desktop unit. Fully featured with standard simm connectors 30 & 72 pin. Supplied with keyboard, 4 Mb of RAM, SVGA monitor output, 256k cache and integral 120 Mb IDE drive with single 1.44 Mb 3.5" floppy disk drive. Fully tested and guaranteed. Fully expandable.

Many other options available - call for details. **£399.00 (E)**

FLOPPY DISK DRIVES 3 1/2" - 8"

5 1/4" or 3 1/2" from only £18.95!

Massive purchases of standard 5 1/4" and 3 1/2" drives enables us to present prime product at industry beating low prices! All units (unless stated) are BRAND NEW or removed from often brand new equipment and are fully tested, aligned and shipped to you with a 90 day guarantee and operate from standard voltages and are of standard size. All are IBM-PC compatible (if 3 1/2" supported on your PC).

3 1/2" Panasonic JU363/4 720k or equivalent RFE	£24.95 (B)
3 1/2" Mitsubishi MF355C-L 1.4 Meg. Laptops only	£25.95 (B)
3 1/2" Mitsubishi MF355C-D 1.4 Meg. Non laptop	£18.95 (B)
5 1/4" Teac FD-55FR 1.2 Meg (for IBM pc's) RFE	£18.95 (B)
5 1/4" Teac FD-55F-03-U 720k 40/90 (for BBC's etc) RFE	£29.95 (B)
5 1/4" BRAND NEW Mitsubishi MF501B 360k	£22.95 (B)
Table top case with integral PSU for HH 5 1/4" Floppy or HD	£29.95 (B)
8" Shugart 800/801 8" SS refurbished & tested	£195.00 (E)
8" Shugart 810 8" SS HH Brand New	£195.00 (E)
8" Shugart 851 8" double sided refurbished & tested	£250.00 (E)
Mitsubishi M2894-63 8" double sided NEW	£275.00 (E)
Mitsubishi M2896-63-02U 8" DS slimline NEW	£285.00 (E)
Dual 8" cased drives with integral power supply 2 Drives	£499.00 (E)

HARD DISK DRIVES

End of line purchase scoop! Brand new NEC D2246 8" 85 Mbyte drive with industry standard SMD interface, replaces Fujitsu equivalent model. Full manual. Only £299.00 or 2 for £525.00 (E)

3 1/2" FUJI FK-309-28 20mb MFM I/F RFE	£59.95 (C)
3 1/2" CONNER CP302 20 mb IDE I/F (or equiv) RFE	£59.95 (C)
3 1/2" CONNER CP3044 40mb IDE I/F (or equiv) RFE	£69.00 (C)
3 1/2" RODIME RC03057S 45mb SCSI I/F (Mac & Acorn)	£69.00 (C)
3 1/2" WESTERN DIGITAL 850mb IDE I/F Brand New	£185.00 (C)
5 1/4" MINISCRIBE 3425 20mb MFM I/F (or equiv.) RFE	£49.95 (C)
5 1/4" SDCAG ST-238R 30 mb RLL I/F Refurb	£69.95 (C)
5 1/4" CDC 94205-51 40mb HH MFM I/F RFE tested	£69.95 (C)
5 1/4" HP 9754B 85c Mb SCSI RFE tested	£89.00 (C)
5 1/4" HP C3010 2 Gbyte SCSI differential RFE tested	£195.00 (C)
8" FUJITSU M2322K 160Mb SMD I/F RFE tested	£195.00 (E)

Hard disc controllers for MFM, IDE, SCSI, RLL etc. from £16.95

THE AMAZING TELEBOX

Converts your colour monitor into a QUALITY COLOUR TV!



TV SOUND & VIDEO TUNER
CABLE COMPATIBLE

The TELEBOX is an attractive fully cased mains powered unit, containing all electronics ready to plug into a host of video monitors made by makers such as MICROVITEC, ATARI, SANYO, SONY, COMMODORE, PHILIPS, TATUNG, AMSTRAD etc. The composite video output will also plug directly into most video recorders, allowing reception of TV channels not normally receivable on most television receivers (TELEBOX MB). Push button controls on the front panel allow reception of 8 fully tuneable 'off air' UHF colour television channels. TELEBOX MB covers virtually all television frequencies VHF and UHF including the HYPERBAND as used by most cable TV operators. A composite video output is located on the rear panel for direct connection to most makes of monitor or desktop computer video systems. For complete compatibility - even for monitors without sound - an integral 4 watt audio amplifier and low level Hi Fi audio output are provided as standard.

TELEBOX ST for composite video input type monitors	£36.95
TELEBOX STL as ST but fitted with integral speaker	£39.50
TELEBOX MB Multiband VHF/UHF/Cable/Hyperband tuner	£69.95

For overseas PAL versions state 5.5 or 6 mHz sound specification. *For cable / hyperband reception Telebox MB should be connected to a cable type service. Shipping code on all Teleboxes is (B)

DC POWER SUPPLIES

Virtually every type of power supply you can imagine. Over 10,000 Power Supplies Ex Stock Call for info / list.

IC's - TRANSISTORS - DIODES

OBSELETE - SHORT SUPPLY - BULK

6,000,000 Items EX STOCK

For MAJOR SAVINGS - CALL FOR SEMICONDUCTOR HOTLIST

VIDEO MONITOR SPECIALS

One of the highest specification monitors you will ever see - At this price - Don't miss it!

Mitsubishi FA3415ETKL 14" SVGA Multisync colour monitor with fine 0.28 dot pitch tube and resolution of 1024 x 768. A variety of inputs allows connection to a host of computers including IBM PCs in CGA, EGA, VGA & SVGA modes, BBC, COMMODORE (including Amiga 1200), ARCHIMEDES and APPLE. Many features: Etched faceplate, test switching and LOW RADIATION MFR specification. Fully guaranteed, supplied in EXCELLENT

LENT little used condition. TR & Swivel Base £4.75

Only £119 (E) Order as MITS-SVA

VGA cable for IBM PC included. External cables for other types of computers CALL.

As New - Used on film set for 1 week only!! 15" 0.28 SVGA 1024 x 768 res. colour monitors. Swivel & tilt etc. Full 90 day guarantee. £145.00 (E)

Just In - Microvitec 20" VGA (600 x 600 res.) colour monitors. Good SH condition - from £299 - CALL for info

PHILIPS HCS335 (same style as CM8833) attractively styled 14" colour monitor with both RGB and standard composite 15.625 KHz video inputs via SCART socket and separate phono jacks. Integral audio power amp and speaker for all audio visual uses. Will connect direct to Amiga and Atari BBC computers. Ideal for all video monitoring / security applications with direct connection to most colour cameras. High quality with many features such as front concealed flip controls, VCR correction button etc. Good used condition - fully tested - guaranteed Dimensions: W14" x H12 1/4" x 15 1/4" D.

Only £95 (E)

PHILIPS HCS31 Ultra compact 9" colour video monitor with standard composite 15.625 KHz video input via SCART socket. Ideal for all monitoring / security applications. High quality, ex-equipment fully tested & guaranteed (possible minor screen blem). In attractive square black plastic case measuring W10" x H10" x 13 1/2" D. 240 V AC mains powered.

Only £79.00 (D)

KME 10" 15M10009 high definition colour monitors with 0.28" dot pitch. Superb clarity and modern styling. Operates from any 15.625 khz sync RGB video source, with RGB analog and composite sync such as Atari, Commodore Amiga, Acorn, Archimedes & BBC. Measures only 13 1/2" x 12" x 11". Good used condition.

Only £125 (E)

20" 22" and 26" AV SPECIALS

Superbly made UK manufacture. PIL all solid state colour monitors, complete with composite video & optional sound input. Attractive teak style case. Perfect for Schools, Shops, Disco, Clubs, etc. in EXCELLENT little used condition with full 90 day guarantee.

20"....£135 22"....£155 26"....£185 (F)

SPECIAL INTEREST ITEMS

MITS. FA3445ETKL 14" Industrial spec SVGA monitors 2Kw to 400 kW - 400 Hz 3 phase power source - ex stock	£245
EPOA	£950
IBM 8230 Type 1, Token ring base unit driver	£750
IBM 53F5501 Token Ring ICS 20 port lobe modules	£95
IBM MAU Token ring distribution panel 8228-23-5050N	£550
AIM 501 Low distortion Oscillator 9Hz to 330KHz, IEEE	£550
Trend DSA 274 Data Analyser with G703(2M) 64 Vo	£650
Marconi 6310 Programmable 2 to 22 GHz sweep generator	£3750
HP1850B Logic Analyser	£1800
HP3781A Pattern generator & HP3782A Error Detector	£175
HP APOLLO RK700 system units	£675
HP8821A Dual Programmable GPIB PSU 0-7 V 160 watts	£1850
HP3081A Industria workstation Cw Barcode swipe reader	£650
HP54124 Rack mount variable 0-20V @ 20A metered PSU	£1850
HP54124 DC to 22 GHz four channel test set	£650
HP7580A A1 8 pin HPGL high speed drum plotter	£650
EG-G Brookdale 95035C Precision lock in amp	EPOA
View Eng. Mod 1200 computerised inspection system	EPOA
Ling Dynamics 2Kw programmable vibration test system	EPOA
Computer controlled 1056 x 560 mm XY table & controller	£1425
Keithley 590 CV capacitor / voltage analyser	EPOA
Recal ICR40 dual 40 channel voice recorder system	£3750
Flukers 45KV4 3 ph On Line UPS - New bats Dec.1995	£9500
ICI RS030UV34 Cleanline ultrasonic cleaning system	EPOA
Mann Tally MT645 High speed line printer	£2200
Intel SBC 486/133SE Multibus 486 system. 8Mb Ram	£1200
Zeta 3220-05 A0 4 pen HPGL fast drum plotters	£1150
Nikon HFX-11 (Ephiphot) exposure control unit	£1450
Motorole VME Bus Boards & Components List. SAE / CALL	EPOA
Trio 0-18 dc linear, metered 30 amp bench PSU. New	£550
Fujitsu M3041R 600 LPM band printer	£1950
Fujitsu M3041D 600 LPM printer with network interface	£1250
Perkin Elmer 2998 Infrared spectrophotometer	EPOA
VG Electronics 1695 TELETEXT Decoding Margin Meter	£3750
Andrews LARGE 3.1 m Satellite Dish + mount (For Voyager)	£950
Sekonic SD 150H 18 channel digital Hybrid chart recorder	£1995
TAYLOR HOBSON Tallysurfer amplifier / recorder	£750
System Video 1152 PAL waveform monitor	£485
Test Lab - 2 mtr square qualified acoustic test cabinets	£300
Kenwood 9601 PAL Vectorscope - NEW	£650

Please call for further details on the above items

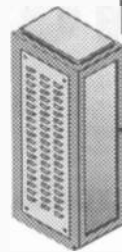

19" RACK CABINETS

Superb quality 6 foot 40U Virtually New, Ultra Smart Less than Half Price!

Top quality 19" rack cabinets made in UK by Optima Enclosures Ltd. Units feature designer, smoked acrylic lockable front door, full height lockable half louvered back door and louvered removable side panels. Fully adjustable internal fixing struts, ready punched for any configuration of equipment mounting plus ready mounted integral 12 way 13 amp socket switched mains distribution strip make these racks some of the most versatile we have ever sold. Racks may be stacked side by side and therefore require only two side panels to stand singly or in multiple bays.

Overall dimensions are: 77 1/2" H x 32 1/2" D x 22" W. Order as: OPT Rack 1 Complete with removable side panels. £335.00 (G) OPT Rack 2 Rack, Less side panels £225.00 (G)

32U - High Quality - All steel RakCab

Made by Eurocraft Enclosures Ltd to the highest possible spec, rack features all steel construction with removable side, front and back doors. Front and back doors are hinged for easy access and all are lockable with five secure 5 lever barrel locks. The front door is constructed of double walled steel with a 'designer style' smoked acrylic front panel to enable status indicators to be seen through the panel, yet remain unobtrusive. Internally the rack features fully slotted reinforced vertical fixing members to take the heaviest of 19" rack equipment. The two movable vertical fixing struts (extra available) are pre punched for standard 'cage nuts'. A mains distribution panel internally mounted to the bottom rear, provides 8 x IEC 3 pin Euro sockets and 1 x 13 amp 3 pin switched utility socket. Overall ventilation is provided by fully louvered back door and double skinned top section with top and side louvers. The top panel may be removed for fitting of integral fans to the sub plate etc. Other features include: fitted castors and floor levers, prepunched utility panel at lower rear for cable / connector access etc. Supplied in excellent, slightly used condition with keys. Colour Royal blue. External dimensions mm=1825H x 635D x 603 W. (64" H x 25" D x 23 3/4" W)

Sold at LESS than a third of makers price!!

A superb buy at only £195.00 (G)

Over 1000 racks - 19" 22" & 24" wide 3 to 44 U high. Available from stock!! Call with your requirements.

TOUCH SCREEN SYSTEM

The ultimate in 'Touch Screen Technology' made by the experts - MicroTouch - but sold at a price below cost!! System consists of a flat translucent glass laminated panel measuring 29.5 x 23.5 cm connected to an electronic controller PCB. The controller produces a standard serial RS232 or TTL output which continuously gives simple serial data containing positional X & Y co-ordinates as to where a finger is touching the panel - as the finger moves, the data instantly changes. The X & Y information is given at an incredible matrix resolution of 1024 x 1024 positions over the entire screen size!! A host of available translation software enables direct connection to a PC for a myriad of applications including: control panels, pointing devices, POS systems, controllers for the disabled or computer un-trained etc. Imagine using your finger with 'Windows' instead of a mouse!! (driver is included available!!) The applications for this amazing product are only limited by your imagination!! Complete system including Controller, Power Supply and Data supplied at an incredible price of only: £145.00 (B)

Full MICROTOUCH software support pack and manuals for IBM compatible PC's £28.95 RFE - Tested

LOW COST RAM & CPU'S

INTEL 'ABOVE' Memory Expansion Board. Full length PC-XT and PC-AT compatible card with 2 Mbytes of memory on board. Card is fully selectable for Expanded or Extended (286 processor and above) memory. Full data and driver disks supplied. RFE. Fully tested and guaranteed. Windows compatible. £59.95 (A1)

Half length 8 bit memory upgrade cards for PC AT XT expands memory either 256k or 512k in 64k steps. May also be used to fill in RAM above 640k DOS limit. Complete with data. Order as: XT RAM UG. 256k. £34.95 or 512k £39.95 (A1)

SIMM SPECIALS

1 MB x 9 SIMM 9 chip 120ns	Only £16.50 (A1)
1 MB x 9 SIMM 3 chip 80 ns £19.50 or 70ns	£22.95 (A1)
1 MB x 9 SIMM 9 chip 80 ns £21.50 or 70ns	£23.75 (A1)
4 MB 70 ns 72 pin SIMM - with parity	Only £95.00 (A1)

INTEL 486-DX33 CPU £55.00 INTEL 486-DX66 CPU £69.00 (A1)
FULL RANGE OF CO-PROCESSOR'S EX STOCK - CALL FOR LIST

FANS & BLOWERS

EPSON D0A12 40x40x20 mm 12v DC	£7.95 10 / £85
PAPST TYPE 612 80x80x25 mm 12v DC	£8.95 10 / £75
MITSUBISHI MMF-D6D12DL 60x50x25 mm 12v DC	£4.95 10 / £42
MITSUBISHI MMF-08C12DM 80x80x25 mm 12v DC	£5.25 10 / £49
MITSUBISHI MMF-09B12DH 82x82x25 mm 12v DC	£5.95 10 / £53
PANCAKE 12-3.5 92x92x18 mm 12v DC	£7.95 10 / £59
EX-EQUIP AC fans. ALL TESTED 120 x 120 x 38 mm specify 110 or 240 v £6.95. 80 x 80 x 38 mm - specify 110 or 240 v £5.95	
MMHOF B26 1900 rmt mkt 3U x 19" Blower 110/240V NEW	£79.95

Shipping on all fans (A). Blowers (B). 50,000 Fans Ex Stock CALL

Issue 13 of Display News now available - send large SAE - PACKED with bargains!

Display
-ELECTRONICS-

ALL MAIL & OFFICES
Open Mon-Fri 9.00-5.30
Dept PE. 32 Biggin Way
Upper Norwood
LONDON SE19 3XF

LONDON SHOP
Open Mon - Sat 9.00 - 5.30
215 Whitehorse Lane
South Norwood
On 68A Bus Route
N. Thornton Heath &
Selhurst Park SR Rail Stations

NEW DISTEL©
The Original
FREE On line Database
Info on 20,000+ stock items!
RETURNING SOON!

ALL ENQUIRIES
0181 679 4414
FAX 0181 679 1927

All prices for UK Mainland. UK customers add 17.5% VAT to TOTAL order amount. Minimum order £10. Bona Fide account orders accepted from Government, Schools, Universities and Local Authorities - minimum account order £50. Cheques over £100 are subject to 10 working days clearance. Carriage charges (A)=£3.00, (A1)=£4.00, (B)=£5.50, (C)=£8.50, (D)=£12.00, (E)=£15.00, (F)=£18.00, (G)=CALL. Allow approx 6 days for shipping - faster CALL. Scotland surcharge CALL. All goods supplied to our Standard Conditions of Sale and unless stated guaranteed for 90 days. All guarantees on a return to base basis. All rights reserved to change prices / specifications without prior notice. Orders subject to stock. Discounts for volume. TOP CASH prices paid for surplus goods. All trademarks etc acknowledged. © Display Electronics 1996. E & O.E. 06/6



Transform your PC

into a digital oscilloscope, spectrum analyser, frequency meter, voltmeter, data logger . . for as little as £49.00

Pico's Virtual Instrumentation enable you to use your computer as a variety of useful test and measurement instruments or as an advanced data logger.

Hardware and software are supplied together as a package - no more worries about incompatibility and no programming required.

Pico Technology specialises only in the development of PC based data acquisition instrumentation. We have the product range and experience to help solve your test and measurement problem.

Call for your guide on 'Virtual Instrumentation'. We are here to help you.



The ADC-10 supplied with PicoScope gives your computer a single channel of analog input.

ADC-10 £49
with PicoLog **£59**

Data Logging

Pico's range of PC based data logging products enable you to easily measure, display and record temperature, pressure and voltage signals.

TC-08 Thermocouple to PC Converter

- Supplied with PicoLog data logging software for advanced temperature processing, min/max detection and alarm.
- 8 Thermocouple inputs
- No power supply required.

TC-08 £199 TC-08 £224 with cal. Cert. complete with serial cable & adaptor. Thermocouple probes available.

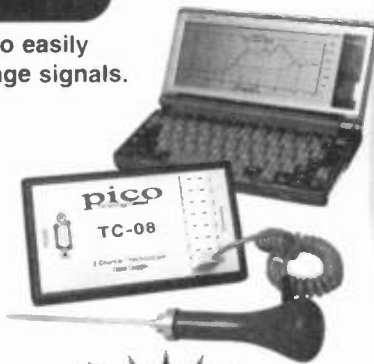

Virtual Instrumentation

Pico's PC based oscilloscopes simply plug into the parallel port turning your PC into a fully featured oscilloscope, spectrum analyser and meter. Windows and DOS software supplied.

ADC-100 Dual Channel 12 bit resolution

The ADC-100 offers both a high sampling rate 100kHz and a high resolution. Flexible input ranges ($\pm 50\text{mV}$ to $\pm 20\text{V}$) make the unit ideal for audio, automotive and education use.

ADC-100 £199 ADC-100 with PicoLog £219

ADC-200 Digital Storage Oscilloscope

- 50 MSPS Dual Channel Digital Storage Scope
- 25 MHz Spectrum Analyser
- Windows or DOS environment
- $\pm 50\text{mV}$ to $\pm 20\text{V}$
- Multimeter
- 20 MSPS also available

ADC 200-20 £359.00
ADC 200-50 £499.00

Both units are supplied with cables, power supply and manuals.

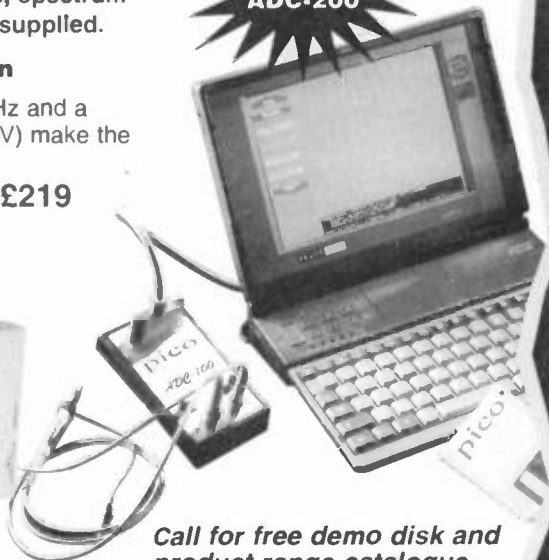

Call for free demo disk and product range catalogue

Post & Packing UK £3.50, Export customers add £9 for carriage & insurance.

Pico Technology Ltd. Broadway House, 149-151 St Neots Rd, Hardwick, Cambridge. CB3 7QJ UK Tel: + 44 (0)1954 211716 Fax: + 44 (0)1954 211880
E-mail: post@picotech.co.uk Web site: <http://www.picotech.co.uk/>

Phone or FAX for sales, ordering information, data sheets, technical support. All prices exclusive of VAT

releasing PC potential

releasing PC potential

PICO
Technology Limited



"extremely good value for money..."

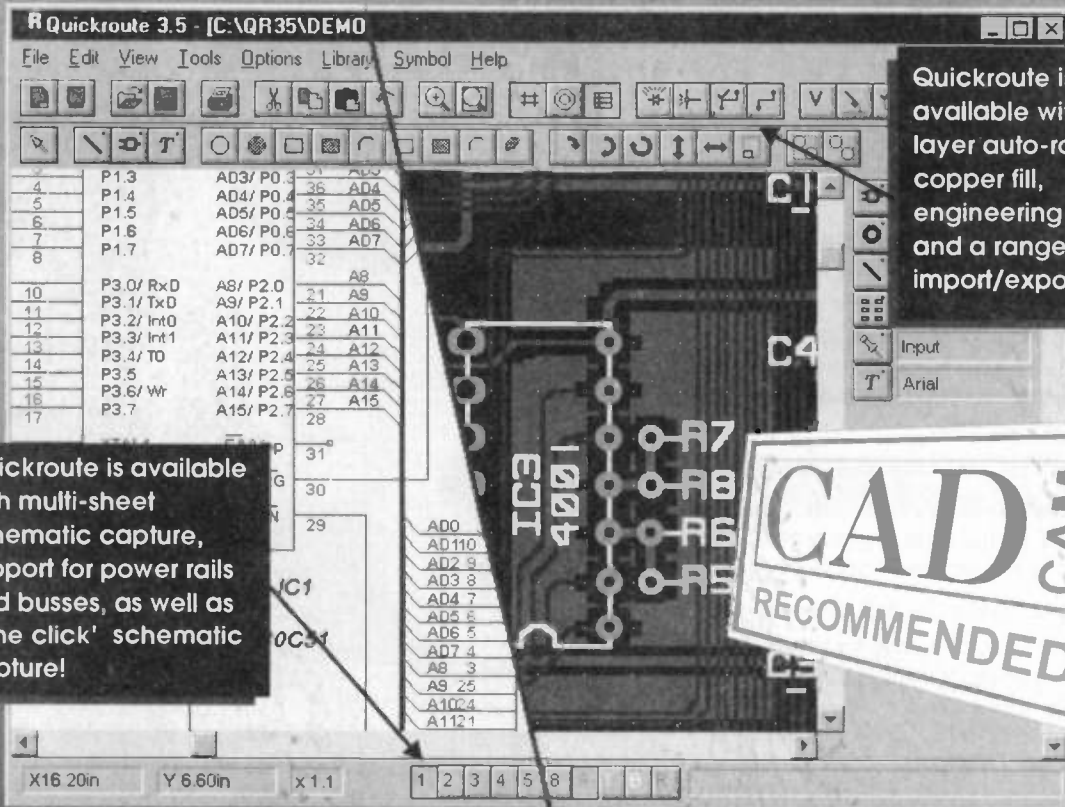

Quickroute is available with 1-8 layer auto-routing, copper fill, engineering change, and a range of import/export features.

Quickroute is available with multi-sheet schematic capture, support for power rails and busses, as well as 'one click' schematic capture!



..for such a comprehensive package"

Practical Wireless July 96

Quickroute 3.5 is a powerful, affordable and easy to use integrated schematic & PCB design system for windows. With its multiple button bars, 'tool tips' and parts-bin you will find that Quickroute helps you to work quickly and efficiently.

Whichever version of Quickroute you choose, you can be sure of getting value for money! Quickroute is available with multi-sheet schematic capture, 1-8 layer auto-routing, copper fill, engineering change, and a range of popular file import/export features allowing connection to simulators and other software packages (details on request). See the table for a selection of features.

Prices range from £68 to £399. Post and packing is £5 (UK), £8 (Europe), £12 (worldwide). VAT must be added to the total price.

**CAD/CAM Recommended March 96

	Personal	Designer	PRO	PRO+
PCB & Schematic Design	*	*	*	*
Schematic Capture	*	*	*	*
Design Rule Checking	*	*	*	*
Connectivity Checking		1	1	2
RouteASSIST (assisted routing)	*	*	*	*
Auto router		*	*	*
Export WMF & Tango		*	*	*
Export Gerber/NC-Drill		*	*	*
Extended Libraries		*	*	*
Tango & Gerber Import			*	*
Update PCB from schematic			*	*
DXF & SPICE Export			*	*
Copper Fill			*	*

1 Simple pass/fail 2 Advanced Check

NEW Now with RouteASSIST™



Tel/Fax 0161 449 7101



WWW: www.quickroute.co.uk EMail: info@quicksys.demon.co.uk

Quickroute Systems Ltd., 14 Ley Lane, Marple Bridge, Stockport, SK6 5DD, U.K.

DENMARK 45 33 25 0017 GERMANY 49 711 62 7740 NORWAY 22 16 7045 PORTUGAL 351 813 1975 8146230 SWEDEN 46 8 740 5500

Prices and specifications subject to change without notice. All trade marks are acknowledged & respected.

Phone Now For More Information

BTEC
Certificated



TUTOR
Supported

NATIONAL
COLLEGE OF
TECHNOLOGY

DISTANCE LEARNING COURSES

The National College of Technology offer a range of packaged learning short courses for study at home or in an industrial training environment which carry modular BTEC awards leading to a higher BTEC certificate. Study can commence at any time and at any level enabling you to create a study routine to fit around existing commitments. Courses on offer include:

- Analogue Electronics
- Digital Electronics
- Fibre/Optoelectronics
- Mechanics & Mechanisms
- Programmable Logic Controllers
- Electronic Testing & Fault Diagnosis

Tutor support and BTEC certification are available as options with no travelling or college attendance required. These very popular courses which are ideal for vocational training contain workbooks, audio cassette lectures, PCB's, instruments, tools, components and leads as necessary to support the theoretical and practical training. Whether you are a newcomer to electronics or have some experience and simply need an update or certification, there is probably a distance learning course ready for you. Write or telephone for details to:

National College of Technology
NCT Ltd., PO Box 11
Wendover, Bucks
Tel: (01296) 624270

VARIABLE VOLTAGE TRANSFORMERS

INPUT 220V/240V AC 50/60	OUTPUT 0V-260V	Price	P&P
PANEL MOUNTING			
0-5KVA 2.5 amp max		£33.00	£6.00
		(£45.83 inc VAT)	£7.00
1KVA 5 amp max		£45.25	£6.00
		(£61.39 inc VAT)	£7.00
SHROUDED			
0-5KVA 2.5 amp max		£34.00	£6.00
		(£47.00 inc VAT)	£7.00
1KVA 5 amp max		£46.25	£6.00
		(£62.57 inc VAT)	£7.00
2KVA 10 amp max		£65.00	£8.50
		(£86.36 inc VAT)	£9.50
3KVA 15 amp max		£86.50	£8.50
		(£111.63 inc VAT)	£9.50
5KVA 25 amp max		£150.00	(+ Carriage & VAT)
10KVA 45 amp max		£300.00	(+ Carriage & VAT)
6KVA 3 PHASE Star		£205.00	(+ Carriage & VAT)

Buy direct from the Importers. Keenest prices in the country.

COMPREHENSIVE RANGE OF TRANSFORMERS—LT-ISOLATION & AUTO

110V-240V Auto transfer either cased with American socket and mains lead or open frame type. Available for immediate delivery

WIDE RANGE OF XENON FLASHTUBES

Write/Phone your enquiries

ULTRA VIOLET BLACK LIGHT BLUE FLUORESCENT TUBES

4ft 40 watt £14.00 (callers only)	(£16.45 inc VAT)
2ft 20 watt £9.00 (callers only)	(£10.58 inc VAT)
12in 8 watt £4.80 + 50p p&p	(£5.52 inc VAT)
9in 6 watt £3.96 + 50p p&p	(£5.24 inc VAT)
6in 4 watt £3.96 + 50p p&p	(£5.24 inc VAT)

230V AC BALLAST KIT

For either 6in, 9in or 12in tubes £6.05 + £1.40 p&p (£8.75 inc VAT)

The above Tubes are 3500/4000 angst (350-400nm) ideal for detecting security markings, effects lighting & Chemical applications
Other Wavelengths of UV TUBE available for Germicidal & Photo Sensitive applications. Please telephone your enquiries.

400 WATT BLACK LIGHT BLUE UV LAMP

GES Mercury Vapour lamp suitable for use with a 400W P.F. Ballast.
Only £38.00 + £4.00 p&p (£49.35 inc VAT)

12V D.C. BILGE PUMPS

500 GPH 15ft head 3 amp £19.99
1750 GPH 15ft head 9 amp £34.55
Also now available:
24V D.C. 1750 GPH 15ft head 5 amp £35.55
All designed to be used submerged.
PRICES INCLUDE P&P & VAT.

SUPER HY-LIGHT STROBE KIT

Designed for Disco, Theatrical use etc.
Approx 16 pulses. Adjustable speed £50.00 + £3.00 p&p (£62.28 inc VAT)
Case and reflector £24.00 + £3.00 p&p (£31.73 inc VAT).
SAE for further details including Hy-Light and Industrial Strobe Kits.

5 KVA ISOLATION TRANSFORMER

As New Ex-Equipment. Fully shrouded. Line Noise Suppression. Ultra isolation Transformer with terminal covers and knock-out cable entries. Primary 120V/240V. Secondary 120V/240V, 50/60Hz, 0.005pF Capacitance. Size, L 37cm x W 19cm x H 16cm. Weight 42 kilos. Price £120 + VAT. Ex-warehouse. Carriage on request.

24V DC SIEMENS CONTACTOR

Type 3TH8022-0B 2 x NO and 2 x NC 230V AC 10A. Contacts Screw or Din Rail fixing. Size H 120 x W 45 x D 75mm. Brand New Price £7.63 incl. P&P and VAT.

240V AC WESTOOL SOLENOIDS

TT2 Mod. 1 Rat. 1 Max. stroke 1/4in. Base mounting 1/4in. stroke 5lbs pull approx. TT6 Mod. 1 Rat. 1 Max. stroke 1 in. Base mounting 1/4in. stroke 15lbs pull approx. SERIES 400 Mod. 1 Rat. 2 Max. stroke 1/4in. Front mounting 1/4in. stroke 15lbs pull approx. Price incl. p&p & VAT. TT5 £5.88. TT6 £8.81. SERIES 400 £7.64.

AXIAL COOLING FAN

230V AC 120mm square x 38mm 3 blade 10 watt Low Noise fan. Price £7.29 incl. P&P and VAT.

INSTRUMENT CASE

Brand new. Manufactured by imhof. L 31 x H 18 x 19cm Deep. Removable front and rear panel for easy assembly of your components. Grey textured finish, complete with case feet. Price £16.45 incl. P&P and VAT. 2 off £28.20 inclusive.

SEWING MACHINE MOTOR

Brand new 220V/240V ACDC SEWTRIC 2 lead Brush Motor. Size L 100mm x H 70mm x W 55mm Spindle 1/4 in. dia. x 1 in. long. Price £14.10 inc p&p & VAT.

GEARED MOTORS

71 RPM 20lb-inch torque reversible 115V AC input including capacitor and transformer for 240V AC operation. Price inc VAT and p&p £27.73.

SOLID STATE EHT UNIT

Input 230V/240V AC. Output approx 15KV. Producing 10mm spark. Built-in 10 sec timer. Easily modified for 20 sec, 30 sec to continuous. Designed for boiler ignition. Dozens of uses in the field of physics and electronics, e.g. supplying neon or argon tubes etc. Price less case £8.50 + £2.40 p&p (£12.81 inc VAT) NMS.

EPROM ERASURE KIT

Build your own EPROM ERASURE for a fraction of the price of a made-up unit. Kit of parts less case includes 12in 8 watt 2537 Angstrom Tube Ballast unit, pair of bi-pin leads, neon indicator, on/off switch, safety microswitch and circuit £15.00 + £2.00 p&p (£19.98 inc VAT)

WASHING MACHINE WATER PUMP

Brand new 240V AC fan cooled. Can be used for a variety of purposes. Inlet 1 1/2 in. outlet 1 in. dia. Price includes p&p & VAT. £11.20 each or 2 for £20.50 inclusive.

SUMMER '96 CATALOGUE



The new Summer '96 edition has 280 pages packed with over 4000 products.

- ▶ Even further additions to the Computer section extending our range of PC components and accessories at unbeatable prices.
- ▶ **WIN!** £250 Voucher to spend on any Cirket product of your choice in our easy to enter competition.
- ▶ 100's of new products including; Books, Connectors, Inductors, Switches, Test Equipment and Tools.
- ▶ New Multimedia CD ROM Titles.
- ▶ New Radio Amateur Equipment.
- ▶ £25 worth discount vouchers.
- ▶ 280 Pages, 25 Sections and Over 4000 Products from some of the Worlds Finest Manufactures.
- ▶ Available at WH Smith, John Menzies and most large newsagents, from 25th April, or directly from Cirket.
- ▶ **Get your copy today!**

£1.95
+ 30p p&p



Cirket Distribution Ltd
Park Lane · Broxbourne · Hertfordshire · EN10 7NQ
Telephone: 01992 448899 · Fax: 01992 471314

SERVICE TRADING CO
57 BRIDGMAN ROAD, CHISWICK, LONDON W4 5BB
TEL: 0181-995 1560 FAX: 0181-995 0549
ACCOUNT CUSTOMERS MIN. ORDER £10

Open Monday-Friday
VISA
Ample Parking Space

ELECTRONICS PRINCIPLES 3.0

For Windows 3.1, '95 or NT.

If you are looking for a means of improving your knowledge of electronics then this is the software for you.

Electronics Principles 3.0 now contains an extended range of fully interactive analogue and digital electronics topics, including the GCSE Electronics software in one package.

Formulae.

$Z_{in} = (150 + 1) \cdot R_e$

Current gain = 150
 Emitter Resistor = 1k
 Input Impedance = 151k

The software is completely self-contained, explanatory text and calculations are laid out in additional Windows, enabling you to see the effect of changing component values, one-at-a-time within the formulae. Graphics, text and calculations can be 'pasted', in colour into text documents for a hard copy reference.

$I = 2.3mA$

Loaded $V_{out} = 7.268V$
 Load = 10k
 $R2 \parallel Load = 3k19$

$V_{out} = V_{in} \cdot \frac{R2}{R1 + R2}$

Effect of connecting a load across R2.

$V_{out} = V_{in} \cdot \frac{R2 \parallel Load}{R1 + (R2 \parallel Load)}$

|| means in parallel

Analogue topics, range from simple dc current flow through a conductor to complex number ac arithmetic, including bi-polar, FET transistors and Op-Amps. Digital investigation, from simple logic gates to binary arithmetic and number conversion using counters and shift registers.

Two additional EPE publications are recommended to accompany the software, on which the GCSE topics are based. Thereby providing the most effective method of study, practical investigation, supported by additional reading.

REVIEWED IN AUGUST ISSUE of EPE!

Teach-In No. 6, 'Design your own circuits.' by Mike Tooley £3.45 and Teach-In No. 7, 'A complete electronics course.' by Alan Winstanley and Keith Dye. £3.95. + £1.50 each book for UK postage.

$V = 50V$
 $R = 100R$
 $L = 500mH$
 $C = 100\mu F$
 $f = 50Hz$
 $X_L = 157R1$
 $X_C = 31R02$
 $I_R = 500mA$
 $I_L = 318.3mA$
 $I_C = 1.571A$
 $I = 1.6486A$
 Phase $\theta = 68.4502^\circ$
 $Z = 37R06$

$I_R = \frac{V}{R}$
 $I_C = \frac{V}{X_C}$
 $I_L = \frac{V}{X_L}$

$\theta = \tan^{-1} \frac{I_C - I_L}{I_R}$

$Z = \frac{R \cdot X_L \cdot X_C}{\sqrt{X_L^2 \cdot X_C^2 + R^2 \cdot (X_L \cdot X_C)^2}}$

Teaching Electronics? Our electronics and mathematics software is currently used in hundreds of UK and overseas schools & colleges to support GCSE, A level, BTEC, City & Guilds, Degree level foundation courses and a range of NVQ's and GNVQ's where students are required to have an understanding of electronics theory. 'Copy to Clipboard' feature enables preparation of lecture overheads in colour, modify or expand the text to produce your own handouts or study notes.

Output Control
 '1'
 '0'
 Enable

1 of 8 Latches

$R1 = 1k$
 $R2 = 470R$

$+5V$
 $-0V$

'X' means don't care.
 'Z' means high impedance state.

Complete package still only £49.95

ELECTRONICS TOOLBOX 3.0

A Windows version of the popular Toolbox Software. Presents over a hundred commonly used formulae in a way that makes calculations easier, thus encouraging experimentation in circuit design. Just select the formula, 'pop' in your values and find the result. **Only £19.95.**

MATHEMATICS PRINCIPLES 3.0

An easy to use Windows package including GCSE topics, enabling you to study or revise in what we believe is an interesting and enjoyable way. There are over one hundred and fifty mathematics topics with interactive, full colour graphics, enabling a "learning through doing" approach to encourage experimentation. As used in many schools throughout the UK. **Only £49.95.**

EPT Educational Software, Pump House, Lockram Lane, Witham, Essex. UK. CM8 2BJ. Tel/Fax: 01376 514008.

E-Mail Address. Sales@eptsoft.demon.co.uk Web pages <http://www.octacon.co.uk/ext/ept/software.htm>

For software only add £2 per order for UK post and packing. Make cheques payable to EPT Educational Software.

Switch, Visa and Mastercard orders accepted - please give card number and expiry date.

OVERSEAS ORDERS: Add £2.50 postage for countries in the EEC. Outside EEC add £3.50 for airmail postage.



HART AUDIO KITS – YOUR VALUE FOR MONEY ROUTE TO ULTIMATE HI-FI

HART KITS give you the opportunity to build the very best engineered hifi equipment there is, designed by the leaders in their field, using the best components that are available.

Every HART KIT is not just a new equipment acquisition but a valuable investment in knowledge, giving you guided hands-on experience of modern electronic techniques.

In short HART is your 'friend in the trade' giving you, as a knowledgeable constructor, access to better equipment at lower prices than the man in the street.

You can buy the reprints and construction manual for any kit to see how easy it is to build your own equipment the HART way. The FULL cost can be credited against your subsequent kit purchase. Our list will give you full details of all our Audio Kits, components and special offers.

INTRODUCING The Hart "Chiara"

Single-Ended Class "A" Headphone Amplifier
Most modern high fidelity amplifiers either do not have a headphone output facility, or this may not be up to the highest standard.

The new Hart "Chiara" has been introduced as an add-on unit to remedy this situation, and will provide two ultra high quality headphone outlets. This is the first unit in our 2000 Range of modules to be introduced through the year. Housed in the neat, black finished, Hart Minibox it features the wide frequency response, low-distortion and "musicality" that one associates with designs from the renowned John Linsley Hood.

Both outputs will drive any standard high quality headphones with an impedance greater than 30 ohms and the unit is ideal for use with the Sennheiser range. A signal link-through makes it easy to incorporate into your system and two extra outputs, one at output level and one adjusted by the Volume control are available on the back panel. The high level output also makes a very useful long-line driver where remote mounted power amplifiers are used. Power requirements are very simple and can be provided by either of our new "Andante" power supplies. Use the K3565 to drive the "Chiara" on its own, K3550 if driving other modules as well. Volume and Balance controls are provided and as befits any unit with serious aspirations to quality these are the ultra high quality Alps "Blue Velvet" components.

Very easily built, even by beginners, since all components fit directly on the single printed circuit board and there is no conventional wiring whatsoever. The kit has very detailed instructions, and even comes with a roll of Hart audiograde silver solder. It can also be supplied factory assembled and tested.

Selling for less than the total cost of all the components, if they were bought separately, this unit represents incredible value for money and makes an attractive and harmonious addition to any hifi system.

K2100 The total cost of a complete set of all components to build this unit is £126.37. Our special discount price for all parts bought together as a kit is.....

£109.50
K2100SA Series Audiophile, with extra selected components..... £112.46

HART TC1D Triple Purpose TEST CASSETTE

Now available again and even better than before! Our famous triple purpose test cassette will help you set up your recorder for peak performance after fitting a new record/play head. This quality precision Test Cassette is digitally mastered in real time to give you an accurate standard to set the head azimuth, Dolby/NU level and tape speed, all easily done without test equipment.

TC1D Triple Purpose Test Cassette..... £9.99

Send or phone for your copy of our FREE List of these and many other Kits & Components. Enquiries from Overseas customers are equally welcome, but PLEASE send 2 IRCs if you want a list sent surface post, or 5 for Airmail.

Ordering is easy. Just write or telephone your requirements to sample the friendly and efficient HART service. Payment by cheque, cash or credit card. A telephoned order with your credit card number will get your order on its way to you THAT DAY.

Please add part cost of carriage and insurance as follows:--INLAND Orders up to £20 - £1.50, Orders over £20 - £3.50. Express Courier, next working day £10.

OVERSEAS - Please see the ordering information with our lists.

NEW BOOK

"Audio Electronics"

And now, hot off the press, yet another classic from the pen of John Linsley Hood. Following the ongoing enormous success of his "Art of Linear Electronics" the latest offering is the all-new edition of "Audio Electronics", now entirely re-written by the master himself.

Underlying audio techniques and equipment is a world of electronics that determines the quality of sound. For anyone involved in designing, adapting or using digital or analogue audio equipment understanding electronics leads to far greater control over the reproduced sound.

The subjects covered include tape recording, tuners, power output stages, digital audio, test instruments and loudspeaker crossover systems. John's lifetime of experience and personal innovation in this field allow him to apply his gift of being so familiar with his subject that he can write clearly about it and make it both interesting and comprehensible to the reader.

Containing 240 pages and over 250 line illustrations this new book represents great value for money at only £18.99 plus £2.50 postage. Send or telephone for your personal copy now.

ALPS "Blue Velvet" Precision Audio Controls

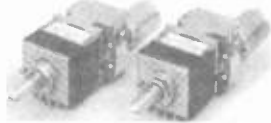

To fulfil the need for ultra high quality controls we import a special range of precision audio pots in values to cover most quality amplifier applications. All in 2-gang stereo format, with 20mm long 6mm diam. steel shafts, except for the 50K Log which is 25mm x 6mm. Overall size of the manual pot is 27W x 24H x 27Deep, motorised versions are 72.4mm Deep from the mounting face. Mounting bush for both types is 8mm diameter.

Now you can throw out those noisy ill-matched carbon pots and replace with the real hi-fi components only used selectively in the very top flight of World class amplifiers. The improvement in track accuracy and matching really is incredible giving better tonal balance between channels and rock solid image stability.

The motorised versions use a 5V DC motor coupled to the normal control shaft with a friction clutch so that the control can be operated manually or electrically. The idea of having electrically operated pots may seem odd, archaic even, but it is in fact the only way that remote control can be applied to any serious Hi-Fi system without loss of quality. The values chosen are the most suitable available for a low loss passive volume and balance control system, allowing armchair control of these two functions.

Our prices represent such super value for pots of this quality due to large purchases for our own kits.

MANUAL POTENTIOMETERS
2-Gang 100K Lin..... £15.67
2-Gang 10K, 50K or 100K Log..... £16.40
2-Gang 10K Special Balance, zero crosstalk and zero centre loss..... £17.48
MOTORISED POTENTIOMETERS
2-Gang 20K Log Volume Control..... £26.20
2-Gang 10K RD Special Balance, zero crosstalk and less than 10% loss in centre position..... £26.98

REEL TO REEL HEADS

999R 2/4 R/P 100mH..... £16.84
We have a few erase heads to suit which can only be supplied when 2 R/P heads are purchased..... £36.80

TAPE RECORDER CARE PRODUCTS

DEM1 Mains Powered Tape Head Demagnetizer, prevents noise on playback due to residual head magnetisation..... £4.08
DEM115 Electronic, Cassette Type, demagnetizer..... £8.61

LINSLEY HOOD 'SHUNT FEEDBACK' RIAA MOVING COIL & MOVING MAGNET PICKUP PREAMPLIFIERS



The HART K1450 Magnetic pickup preamplifier kit features a totally discrete component implementation with a specially designed low input impedance front end and the superior sound of the Shunt Feedback circuitry. High quality components fitting to an advanced double-sided printed circuit board make this a product at the leading edge of technology that you will be proud to own. Nevertheless with our step by step instructions it is very easy and satisfying to assemble. The higher current consumption of this unit means that it is best powered by our new **Andante** Audio Power Supply, itself an advanced piece of technology in a matching case. This supplies the superbly smoothed and stabilised supply lines needed by any sensitive preamplifier and features a fully potted Hi-grade toroidal transformer along with a special limited shift earth system for hum free operation. The K1450 is suitable for all moving coil and moving magnet transducers this unit is especially recommended for, and will extract the very best from the modern generation of low output high quality moving coil transducers.

K1450 Kit, complete with all parts ready to assemble inside the fully finished 228mm x 134mm x 63mm case. Kit includes full, easy to follow, assembly instructions as well as the Hart Guide to PCB Construction, we even throw in enough Hart Audiograde Silver Solder to construct your kit!

..... £111.58
K1450SA Series Audiophile version with selected components..... £133.94

HIGH QUALITY REPLACEMENT CASSETTE HEADS



Do your tapes lack treble? A worn head could be the problem. For top performance cassette recorder heads should be replaced every 1,500 hours. Fitting one of our high quality replacement heads could restore performance to better than new! Standard inductances and mountings make fitting easy on nearly all machines (Sony are special dimensions, we do not stock) and our TC1 Test Cassette helps you set the azimuth spot on. As we are the actual importers you get prime parts at lower prices, compare our prices with other suppliers and see! All our heads are suitable for use with any Dolby system and are normally available ex-stock. We also stock a wide range of special heads for home construction and industrial users.

HC80 NEW RANGE High Beta Permalloy Stereo head. Modern space saver design for easy fitting and lower cost. Suitable for chrome, metal and ferric tapes, truly a universal replacement head for everything from hi-fi decks to car players and at an incredible price too!..... £11.70
HRP373 Downstream monitor combi head..... £62.59
HQ551A 4-Track R/P..... £8.75
HQ551S Sony Mount 4-Tr. R/P..... £14.90
HQR560 Rotary Base 12.5mm R/P/E..... £21.90
HQR570 Rotary Base 15mm R/P/E..... £22.59
HQR580 Rotary Base 12.5mm R/P..... £14.29

HART Classical CD's.

Top quality, Full Digital (DDD), over 100 titles from only £1.99! Ring or send for your list!

TECHNICAL BOOKSHELF

We stock a good range of books of interest to the electronics and audio enthusiast, including many reprinted classics from the valve era. Some were in last months advertisement, but see our list for the full range.

New this month is the GEC Valve designs book at £18.95, and the VTL Book, a modern look at valve designs, £17.95.



QUALITY
AUDIO KITS

24 hr. SALES LINE
(01691) 652894

ALL PRICES
INCLUDE
UK/EC VAT



HART ELECTRONIC KITS LTD
8 PENYLAN MILL
OSWESTRY, SHROPSHIRE
SY10 8AF



MAIL ORDER ONLY ● CALLERS BY APPOINTMENT

EPE MICROCONTROLLER P.I. TREASURE HUNTER

The latest MAGENTA DESIGN - highly stable & sensitive - with MC control of all timing functions and advanced pulse separation techniques.

- New circuit design 1994
- High stability drift cancelling
- Easy to build & use
- No ground effect, works in seawater

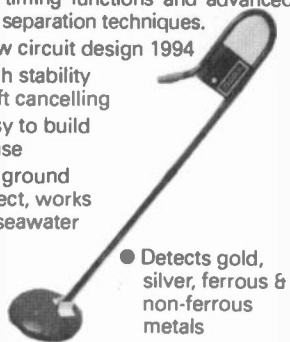

- Detects gold, silver, ferrous & non-ferrous metals

- Efficient quartz controlled microcontroller pulse generation.
- Full kit with headphones & all hardware

KIT 847.....£63.95

DIGITAL LCD THERMOSTAT

A versatile thermostat using a thermistor probe and having an l.c.d. display. MIN/MAX memories, -10 to 110 degrees celsius, or can be set to read in Fahrenheit. Individually settable upper and lower switching temperatures allow close control, or alternatively allow a wide 'dead band' to be set which can result in substantial energy savings when used with domestic hot water systems. Ideal for greenhouse ventilation or heating control, aquaria, home brewing, etc. Mains powered, 10A SPCO relay output. Punched and printed case.

KIT 841.....£29.95

PORTABLE ULTRASONIC PESt SCARER

A powerful 23kHz ultrasound generator in a compact hand-held case. MOSFET output drives a special sealed transducer with intense pulses via a special tuned transformer. Sweeping frequency output is designed to give maximum output without any special setting up.

KIT 842.....£22.56

DIGITAL CAPACITANCE METER

A really professional looking project. Kit is supplied with a punched and printed front panel, case, p.c.b. and all components. Quartz controlled accuracy of 1%. Large clear 5 digit display and high speed operation. Ideal for beginners - as the µF, nF and pF ranges give clear unambiguous read out of marked and unmarked capacitors from a few pF up to thousands of µF.

KIT 493.....£39.95

ACOUSTIC PROBE

A very popular project which picks up vibrations by means of a contact probe and passes them on to a pair of headphones or an amplifier. Sounds from engines, watches, and speech travelling through walls can be amplified and heard clearly. Useful for mechanics, instrument engineers, and nosey parkers!

KIT 740.....£19.98

WINDICATOR

A novel wind speed indicator with LED read-out. Kit comes complete with sensor cups, and weatherproof sensing head. Mainspower unit £5.99 extra.

KIT 856.....£28.00

BUCCANEER I.B. METAL DETECTOR

An Induction Balance (I.B.) detector with audible output. Providing good sensitivity and easy construction.

COMPLETE KIT - INCLUDES ALL HARDWARE, HANDLE, SEARCH HEAD, PCB etc. CIRCUIT REJECTS IRON WHILST PICKING UP GOLD, SILVER, COPPER etc. A SOLID RELIABLE DESIGN.

KIT 719.....£54.99

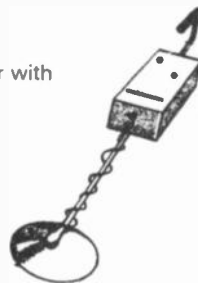

1000V & 500V INSULATION TESTER

Superb new design. Regulated output, efficient circuit. Dual-scale meter, compact case. Reads up to 200 Megohms. Kit includes wound coil, cut-out case, meter scale, PCB & ALL components.

KIT 848.....£32.95



MOSFET MKII VARIABLE BENCH POWER SUPPLY 0-25V 2.5A.

Based on our MkI design and preserving all the features, but now with switching pre-regulator for much higher efficiency. Panel meters indicate Volts and Amps. Fully variable down to zero. Toroidal mains transformer. Kit includes punched and printed case and all parts. As featured in April 1994 EPE. An essential piece of equipment.

KIT 845.....£64.95

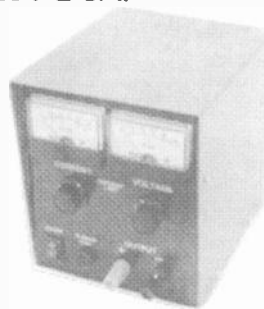

ULTRASONIC PESt SCARER

Keep pets/pests away from newly sown areas, fruit, vegetable and flower beds, children's play areas, patios etc. This project produces intense pulses of ultrasound which deter visiting animals.

- KIT INCLUDES ALL COMPONENTS, PCB & CASE
- EFFICIENT 100V TRANSDUCER OUTPUT
- COMPLETELY INAUDIBLE TO HUMANS

- UP TO 4 METRES RANGE
- LOW CURRENT DRAIN

KIT 812.....£14.81



SPACEWRITER

An innovative and exciting project. Wave the wand through the air and your message appears. Programmable to hold any message up to 16 digits long. Comes pre-loaded with "MERRY XMAS". Kit includes PCB, all components & tube + instructions for message loading.

KIT 849.....£16.99

12V EPROM ERASER

A safe low cost eraser for up to 4 EPROMS at a time in less than 20 minutes. Operates from a 12V supply (400mA). Used extensively for mobile work - updating equipment in the field etc. Also in educational situations where mains supplies are not allowed. Safety interlock prevents contact with UV.

KIT 790.....£28.51

MOSFET 25V 2.5A POWER SUPPLY

High performance design has made this one of our classic kits. Two panel meters indicate Volts and Amps. Variable from 0-25 Volts and current limit control from 0-2.5A. Rugged power MOSFET output stage. Toroidal mains transformer.

KIT 769.....£56.82

INSULATION TESTER

A reliable and neat electronic tester which checks insulation resistance of wiring and appliances etc., at 500 Volts. The unit is battery powered, simple and safe to operate. Leakage resistance of up to 100 Megohms can be read easily. A very popular college project.

KIT 444.....£22.37

DIGITAL COMBINATION LOCK

Digital lock with 12 key keypad. Entering a four digit code operates a 250V 16A relay. A special anti-tamper circuit permits the relay board to be mounted remotely. Ideal car immobiliser, operates from 12V. Drilled case, brushed aluminium keypad.

KIT 840.....£19.86

E.E. TREASURE HUNTER P.I. METAL DETECTOR MKI

Magenta's highly developed & acclaimed design. Quartz crystal controlled circuit MOSFET coil drive. D.C. coupled amplification. Full kit includes PCB, handle, case & search coil.

- KIT INC. HEADPHONES
- EFFICIENT CMOS DESIGN
- POWERFUL COIL DRIVE

- DETECTS FERROUS AND NON-FERROUS METAL - GOLD, SILVER, COPPER ETC.

- 190mm SEARCH COIL
- NO 'GROUND EFFECT'

KIT 815.....£45.95



DOLBY PRO-LOGIC DECODER

Experience the delight of SURROUND SOUND in your own home. This project brings full Genuine PRO-LOGIC surround sound to you at a fantastic price. The circuit meets all 'Dolby' specifications, with 'Stereo', '3-Stereo' and 'Surround Sound' selections. Exactly as described in this booklet.

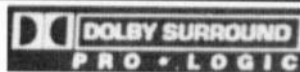

For minimum cost the "Short Form Kit" is ideal. This is complete except for the case and power transformer. It includes the switches, sockets, and pots, and is ideal for building into a custom set-up with pre-amp and power-amp modules, where power is available.

The alternative "Full Kit" gives the best value option. With a printed front panel, punched rear panel, power transformer and mains lead and black brushed aluminium knobs. This kit produces a complete stand-alone decoder that can be used with any audio.



Short Form Kit, Kit Ref: 858 £99.00
Kit with case and transformer, Kit Ref: 869 £124.99

*DOLBY and the double D symbol are trademarks.

DC Motor/Gearboxes

Our Popular and Versatile DC motor/Gearbox sets. Ideal for Models, Robots, Buggies etc. 1.5 to 4.5V Multi ratio gearbox gives wide range of speeds.

LARGE TYPE - MGL £6.95
SMALL - MGS - £4.77



Stepping Motors

MD38...Mini 48 step...£8.65
MD35...Std 48 step...£12.98
MD200...200 step...£16.80
MD24...Large 200 step...£22.95



SIMPLE PIC PROGRAMMER

INCREDIBLE LOW
PRICE!

Kit 857 **£12.99**

INCLUDES 1-PIC16C84 CHIP
SOFTWARE DISK, LEAD
CONNECTOR, PROFESSIONAL
PC BOARD & INSTRUCTIONS

Power Supply £3.99

EXTRA CHIPS:
PIC 16C84 £7.36

Based on the design in February '96 EPE Article
Magenta have made a proper PCB and kit for this
project. PCB has 'reset' switch, Program switch, 5V
regulator and test L.E.D.s. There are also extra
connection points for access to all A and B port pins.

PIC16C84 LCD DISPLAY DRIVER

INCLUDES 1-PIC16C84
WITH DEMO PROGRAM
SOFTWARE DISK, PCB,
INSTRUCTIONS AND
16 CHARACTER 2 LINE
LCD DISPLAY

Kit 860 **£17.99**

Power Supply £3.99

FULL PROGRAM SOURCE
CODE SUPPLIED - DEVELOP
YOUR OWN APPLICATION!

Another super PIC project from Magenta. Supplied
with PCB, industry standard 2 LINE x 16 character
display, data, all components, and software to include
in your own programs. Ideal development base for
meters, terminals, calculators, counters, timers - Just
waiting for your application!

★ Chip is pre-programmed with demo display ★

SUPER PIC PROGRAMMER

- READS, PROGRAMS, AND VERIFIES
- WINDOWS™ SOFTWARE
- PIC16CXX 17CXX AND 16C84
- USES ANY PC PARALLEL PORT
- USES STANDARD MICROCHIP • HEX FILES
- OPTIONAL DISASSEMBLER SOFTWARE (EXTRA)
- PCB, LEAD, ALL COMPONENTS, TURNED PIN
SOCKETS FOR 18, 28, AND 40 PIN ICs.

NEW!

- SEND FOR DETAILED
INFORMATION - A
SUPERB PRODUCT AT AN
UNBEATABLE LOW PRICE.

Kit 862 **£29.99**

Power Supply £3.99

PIC STEPPING MOTOR DRIVER

INCLUDES: PCB,
PIC16C84 WITH
DEMO PROGRAM,
SOFTWARE DISK,
INSTRUCTIONS
AND MOTOR.

Kit 863 **£18.99**

FULL SOURCE CODE SUPPLIED.
ALSO USE FOR DRIVING OTHER
POWER DEVICES e.g. SOLENOIDS.

NEW!

Another NEW Magenta PIC project. Drives any 4 phase unipolar
motor - up to 24V and 1 amp. Kit includes all components and 48
step motor. Chip is pre-programmed with demo software, then write
your own, and re-program the same chip! Circuit accepts inputs
from switches etc and drives motor in response. Also runs standard
demo sequence from memory.

PIC16C5x

- IN-CIRCUIT SIMULATOR
- POWERFUL ON-LINE MONITOR
- SINGLE STEP, DISPLAY REGISTERS,
MEMORY, AND I/O, READ & PROGRAM
- SUPPORTS PIC16C54, 55, 56, & 57.
- FULL SOFTWARE & DATA SUPPLIED
- THE IDEAL SYSTEM FOR
EDUCATIONAL USERS

DEVELOPMENT AND TRAINING SYSTEM

The easiest way to
get started with PIC
Microchips. This system
allows you to test programs
one line at a time and see
what happens to the I/O pins,
the internal registers and
memory. From these simple
steps you gain experience and
soon will be writing and running
longer and longer programs.

✳ WITH OPERATING
PROGRAMMING, AND
CROSS ASSEMBLER
SOFTWARE.

RUNS WITH
ANY PC

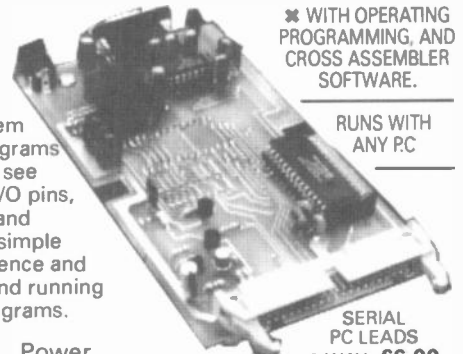

SERIAL
PC LEADS
9-WAY **£6.00**
25-WAY **£7.00**

Kit 853 **£99.00**

Power
Supply £8.99

68000 DEVELOPMENT AND KIT TRAINING SYSTEM

Never before at this price! Our own
68000 board kit. Used all over the
world in schools and universities.
Double Eurocard PCB with RAM, ROM,
and I/O. Full featured MONITOR and LINE
BY LINE ASSEMBLER ON BOARD. Just needs
power, and a serial link to your PC. Supplied
with full data and applications course. Use
to learn, or as a stand-alone computer board.

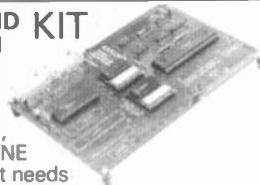

INCLUDES SOFTWARE

£55.00!

POWER SUPPLY +5V, +12V, -12V: £12.99 Kit Ref 601

NEW!

SUPER BAT DETECTOR

- 1 WATT OUTPUT
- BUILT IN SPEAKER
- COMPACT CASE
- 20-140kHz
- NEW DESIGN WITH
NEW 40kHz MICROPHONE

A new circuit
using a 'full bridge'
audio amplifier i.c.,
internal speaker, and
headphone/tape socket.
The latest sensitive transducer,
and 'double balanced mixer'
give a stable, high performance
superheterodyne design.



KIT 861... **£24.99**

Mini-Lab & Micro Lab Electronics Teach-In 7

As featured in EPE and now published as Teach-In 7. All parts
are supplied by Magenta. Teach-In 7 is £3.95 from us or EPE
Full Mini Lab Kit - £119.95 - Power supply extra - £22.55
Full Micro Lab Kit - £155.95 Built Micro Lab - £189.95

MAGENTA

Tel: 01283 565435 Fax: 01283 546932

All prices include VAT.
Add £3.00 p&p.

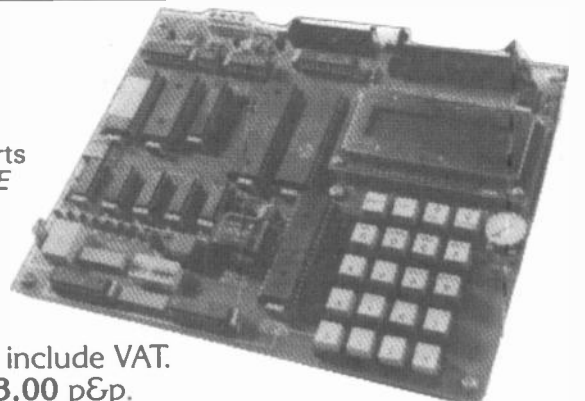

EVERYDAY
PRACTICAL
ELECTRONICS

VOL. 25 No. 10 OCTOBER '96

Editorial Offices:
 EVERYDAY PRACTICAL ELECTRONICS EDITORIAL
 ALLEN HOUSE, EAST BOROUGH, WIMBORNE
 DORSET BH21 1PF
 Phone: Wimborne (01202) 881749
 Fax: (01202) 841692. **Due to the cost we cannot reply to orders or queries by Fax.**
 E-mail: editorial@epemag.wimborne.co.uk
 Web Site: http://www.epemag.wimborne.co.uk
 See notes on Readers' Enquiries below - we regret lengthy technical enquiries cannot be answered over the telephone.
Advertisement Offices:
 EVERYDAY PRACTICAL ELECTRONICS
 ADVERTISEMENTS
 HOLLAND WOOD HOUSE, CHURCH LANE
 GREAT HOLLAND, ESSEX CO13 0JS
 Phone/Fax: (01255) 850596

CHEAP . . .

The theme of my piece this month is "cheap". Sounds awful doesn't it? What has triggered off this tacky thought? It all comes down to one thing - promotions. I don't mean the sort of promotion you get at work - or maybe you don't! - I mean the type of promotion we undertake to sell more copies of *EPE*.

We promote the magazine on a regular basis - it's a chain operation. Basically if we can stick something on the front cover that your friendly newsagent believes will help to sell more copies then he will take extra, we will hopefully get better availability and you, the interested shelf-browser, will buy more. If you like what you get you might even go on buying the magazine. If you don't like what you get please let us know.

The problem is that we have to pay for the free gift, and pay to bag it, and pay to stick it on the cover, and pay for the increased weight on postage and transport etc. And, unlike some magazines, we don't believe in putting up the cover price to give you a "free" gift! So we have to come up with something that is cheap, but it must also be valuable to all our readers - we don't want to give you something that you *think* is cheap and of no use!

For our last promotion we gave all our UK readers a free set of headphones, since we only paid 25p per pair for them they were cheap, but they were good quality and we reckoned that anyone would find them useful - don't ask how we came to buy 25,000 sets of headphones at that price because I won't tell you, well I might if you make it worthwhile (but I'm not cheap you understand!).

. . . BUT UNIQUE

Anyway this month we have presented you with a free *Understanding Active Components* 48-page booklet, we believe it will interest most readers and be worth keeping on file. If it had been produced to sell in its own right it would probably carry a £1.95 price tag. However, we have produced 30,000 of these so the print and paper costs are very low and, because the material has been reprinted from our *Electronics Service Manual* the text, typesetting, drawings, etc. have already been paid for.

The author Mike Tooley won't thank me for saying the item is cheap, but I'm sure, like you, he will understand what I mean. Because the material has been taken from the *Electronics Service Manual* this little booklet is *not available on its own* - so your free gift is also unique.

By the way, the rest of the Manual (and our *Modern Electronics Manual*) can be bought cheaply at present - you will find them advertised on pages 756 and 797 of this issue - there is a £10 off discount available on these until 1 December. That's a cheap plug!



SUBSCRIPTIONS

Annual subscriptions for delivery direct to any address in the UK: £24. Overseas: £30 standard air service (£47.50 express airmail). Cheques or bank drafts (in £ sterling only) payable to *Everyday Practical Electronics* and sent to *EPE Subscriptions Dept.*, Allen House,



East Borough, Wimborne, Dorset BH21 1PF. Tel: 01202 881749. Subscriptions start with the next available issue. We accept MasterCard or Visa. (For past issues see the *Back Issues* page).

BINDERS

Binders to hold one volume (12 issues) are available from the above address. These are finished in blue p.v.c., printed with the magazine logo in gold on the spine. Price £5.95 plus £3.50 post and packing (for overseas readers the postage is £6.00 to everywhere except Australia and Papua New Guinea which cost £10.50). *Normally sent within seven days but please allow 28 days for delivery - more for overseas orders.*

Payment in £ sterling only please. Visa and MasterCard accepted, minimum credit card order £5. Send or phone your card number and card expiry date with your name, address etc.

Editor: MIKE KENWARD

Secretary: PAM BROWN

Deputy Editor: DAVID BARRINGTON

Technical Editor: JOHN BECKER

Business Manager: DAVID J. LEAVER

Subscriptions: MARILYN GOLDBERG

Editorial: Wimborne (01202) 881749

Advertisement Manager:

PETER J. MEW, Frinton (01255) 850596

Advertisement Copy Controller:

DEREK NEW, Wimborne (01202) 882299

READERS' ENQUIRIES

We are unable to offer any advice on the use, purchase, repair or modification of commercial equipment or the incorporation or modification of designs published in the magazine. We regret that we cannot provide data or answer queries on articles or projects that are more than five years old. Letters requiring a personal reply *must* be accompanied by a **stamped self-addressed envelope or a self-addressed envelope and international reply coupons. Due to the cost we cannot reply to queries by Fax.**

All reasonable precautions are taken to ensure that the advice and data given to readers is reliable. We cannot, however, guarantee it and we cannot accept legal responsibility for it.

COMPONENT SUPPLIES

We do not supply electronic components or kits for building the projects featured, these can be supplied by advertisers.

We advise readers to check that all parts are still available before commencing any project in a back-dated issue.

We regret that we cannot provide data, or answer queries, on projects that are more than five years old.

ADVERTISEMENTS

Although the proprietors and staff of EVERYDAY PRACTICAL ELECTRONICS take reasonable precautions to protect the interests of readers by ensuring as far as practicable that advertisements are *bona fide*, the magazine and its Publishers cannot give any undertakings in respect of statements or claims made by advertisers, whether these advertisements are printed as part of the magazine, or in inserts.

The Publishers regret that under no circumstances will the magazine accept liability for non-receipt of goods ordered, or for late delivery, or for faults in manufacture. Legal remedies are available in respect of some of these circumstances, and readers who have complaints should first address them to the advertiser.

TRANSMITTERS/BUGS/TELEPHONE EQUIPMENT

We advise readers that certain items of radio transmitting and telephone equipment which may be advertised in our pages cannot be legally used in the UK. Readers should check the law before buying any transmitting or telephone equipment as a fine, confiscation of equipment and/or imprisonment can result from illegal use or ownership. The laws vary from country to country; overseas readers should check local laws.

VIDEO FADE-TO-WHITE

ROBERT PENFOLD

Extend your creative options when shooting home video movies with this "grey-to-white" fader.

VIDEO FADER projects have appeared in *Everyday Practical Electronics* in the past, and these have all provided a conventional fade out to a black screen. This video fader is slightly different in that it provides a fade out to a white screen, or to a preset grey level if preferred. This gives the home video producer a few more creative possibilities from a circuit that is only marginally more complex than an equivalent fade-to-black circuit.

Prospective constructors should note that this fader is intended for use with a standard composite video signal. In normal use it is connected between the video output of a camcorder or VCR, and the video input of a VCR or television/monitor. It cannot be used with a u.h.f. television signal, or with any form of RGB signal.

SYSTEM OPERATION

The block diagram of Fig. 1 helps to explain the way in which this video fader functions. The example waveforms of Fig. 2 show what the unit has to achieve, and also help to explain how it is achieved.

The top waveform (a) represents the composite input signal, but only for two and a bit lines. A short negative line synchronisation pulse is present at the beginning of each line, and this is followed by the colour burst signal.

Next comes the main part of the signal, which is the picture modulation. The UK PAL system utilizes positive modulation, which means that the more positive the modulation voltage, the brighter the line at that point.

Simply fading out the entire video signal will not give the desired result. The picture modulation will be faded out, but the burst and synchronisation signals will gradually disappear as well.

As the signal was faded out, the synchronisation pulses would be attenuated, and proper synchronisation would be lost well before the signal was fully faded out. The picture modulation must be attenuated, but the rest of the signal must be left unaltered.

SPLIT-UP

In order to do this it is necessary to separate the picture modulation and synchronisation signals, feed the picture signal through the variable attenuator, and then recombine the two parts of the signal again. The splitting of the signal is accomplished using two electronic analogue switches that are operated in anti-phase. Therefore, at any one time only one or other of the switches will connect its input signal through to the output.

One switch is fed directly with the input signal, and this switch is activated during



the initial part of each line scan, when the synchronisation and burst signals are present. The other switch is fed via the fader circuit, and this switch is active for the rest of the time. This is when the picture modulation is present.

The anti-phase control signals for the electronic switches are generated by a side chain, which starts with a synchronisation separator circuit. This clips the input signal in such a way that the picture and colour burst signals are stripped off, leaving somewhat amplified synchronisation pulses.

These pulses are fed to a monostable which is triggered on the leading edge of each synchronisation pulse. Its pulse duration is slightly longer than the time from the beginning of each synchronisation pulse to the end of the colour burst signal.

The output of the monostable is a positive pulse which activates the upper electronic switch (Fig. 1), which is fed with the unprocessed input signal. This switches the synchronisation pulses and burst signals straight through to the output in the required fashion. This signal is represented by the waveform of Fig. 2(b).

The other electronic switch is fed from the input via the fader circuit, and it is controlled by an inverted version of the signal from the monostable. It therefore passes the picture modulation through to the output, but blocks the synchronisation and burst signals.

This signal in its non-faded form is represented by Fig. 2(c), while Fig. 2(d) represents the picture signal when faded by 50 per cent. A buffer stage at the output ensures that the unit has a suitably low output impedance.

POSITIVE FADE-OUT

As described so far the unit provides what is just an ordinary fade-out to a black screen. In order to obtain a fade-out to a white screen it is necessary to introduce a positive bias to the picture signal as it is faded out.

An output signal with 50 per cent fade is represented by waveform Fig. 2(e). The picture modulation has been reduced to half its normal amplitude, but the positive bias keeps the overall brightness of the screen quite high.

The signal output waveform, with a fully faded picture, is shown in Fig. 2(f). The picture modulation has been faded out to zero, but a strong positive d.c. level during

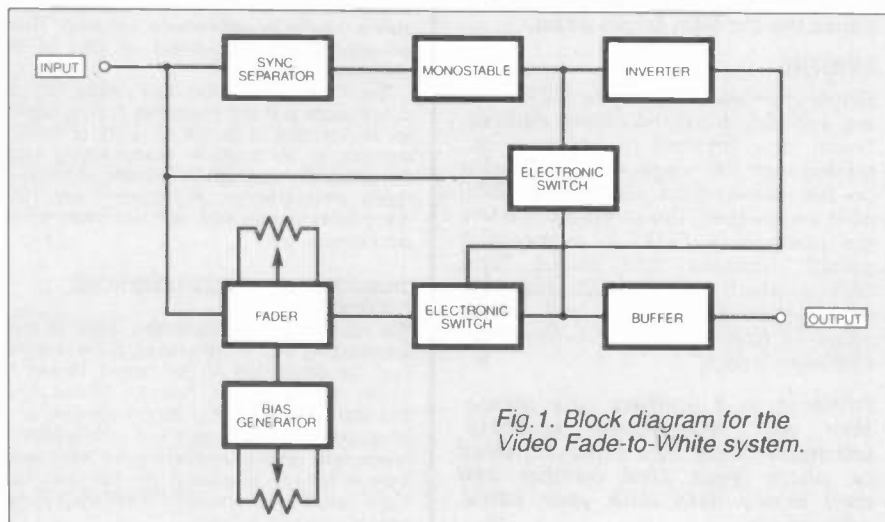

Fig. 1. Block diagram for the Video Fade-to-White system.

the picture modulation period gives a white level during each line scan.

The positive bias circuit is provided by a potentiometer which is ganged with the fader potentiometer, but is connected to operate out-of-phase with the fader control. Thus, as the signal is faded out, the bias level is steadily increased, ultimately giving a plain white screen.

The maximum bias level can be backed-off if required, so that the screen fades to a preset shade of grey rather than to white. To my eyes at any rate, a mid-grey background gives the best general purpose fade-out characteristic, but this is clearly a matter of personal choice. It is also a matter of using whichever background level is felt to be most appropriate to the subject matter.

CIRCUIT DESCRIPTION

The main circuit diagram for the Video Fade-to-White unit is shown in Fig. 3. The circuit diagram for the 12V mains power supply unit is shown separately in Fig. 4.

The synchronisation separator is based on transistors TR1 and TR2 which are both used as common emitter amplifiers. The biasing of these two stages (or lack of it in the case of TR2) provides the required clipping of the signal with the picture and colour burst signals being effectively stripped away.

The monostable uses IC1 in a conventional 555 monostable configuration. IC1 is triggered by a high to low transition on pin 2, which gives the required triggering at the beginning of each negative synchronisation pulse. Resistor R8 and capacitor C6 are the timing components for IC1, and these set the theoretical pulse duration at 11 microseconds. A low power 555 is used for IC1 as this avoids problems with

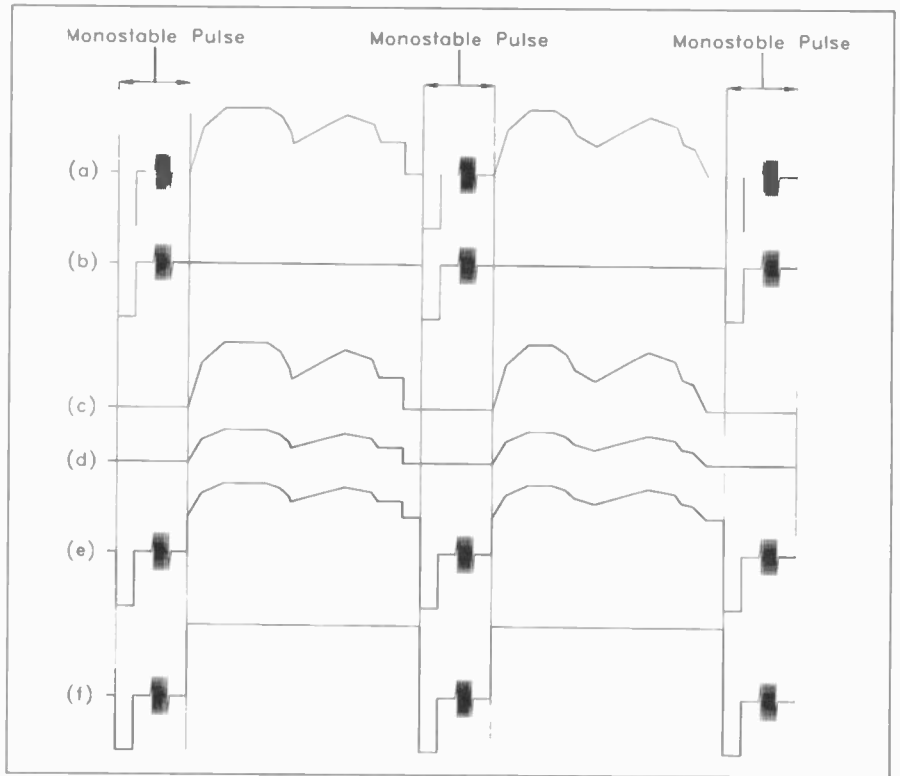

Fig.2. Example waveforms which help to explain the way the Fader functions.

“crowbaring” of the power supply, and low power versions such as the TS555CN have the advantage of being somewhat faster than the standard 555.

One section of a CMOS 4001BE quad 2-input NOR gate is used for IC2. In this circuit the two inputs of IC2 are wired together so that it operates as a simple inverter, and it is used to generate the complement of the monostable's output

signal. The other three gates of IC2 are not used, but their inputs are connected to the positive supply to prevent spurious operations of these gates.

ANALOGUE SWITCHING

The electronic switches are provided by IC3, which is a CMOS 4016BE quad analogue switch. Only two of the switches

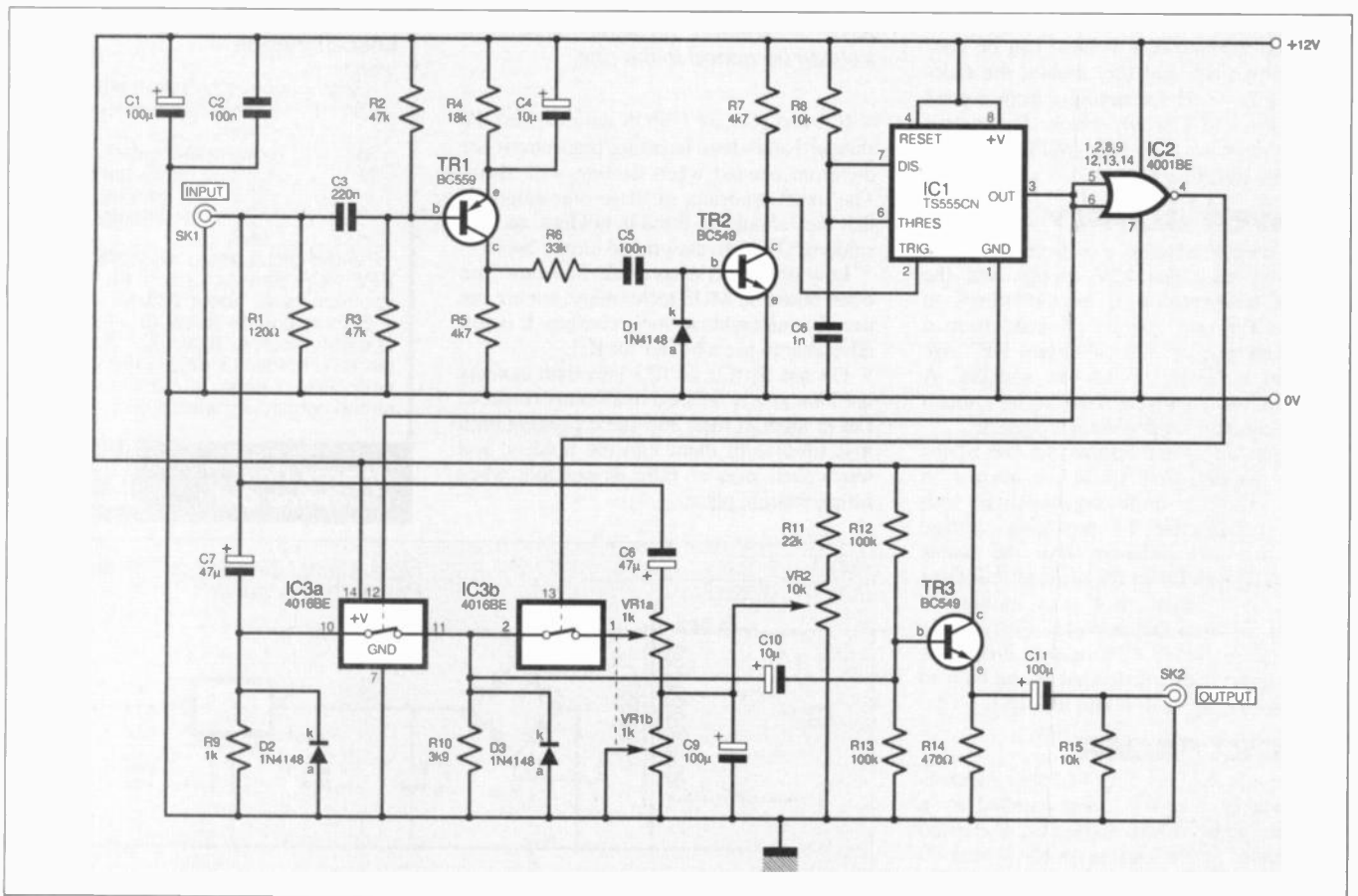
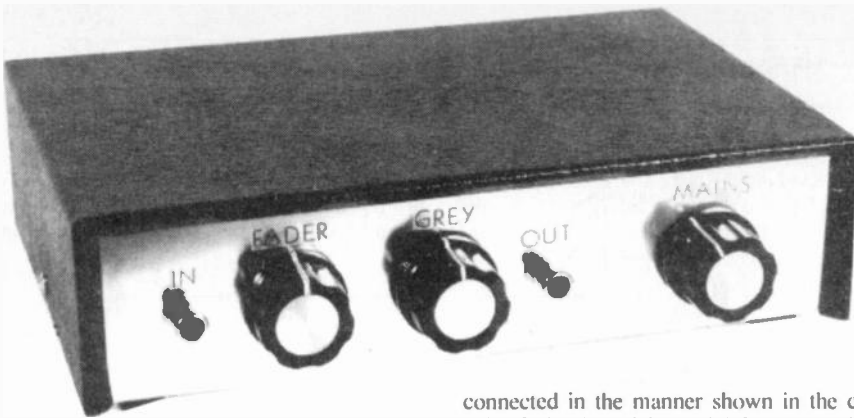

Fig.3. Main circuit diagram for the Video Fade-to-White project.



COMPONENTS

Resistors

R1	120Ω
R2, R3	47k (2 off)
R4	18k
R5, R7	4k7 (2 off)
R6	33k
R8, R15	10k (2 off)
R9	1k
R10	3k9
R11	22k
R12, R13	100k (2 off)
R14	470Ω

See

TALK
Page

All 0.25W 5% carbon film

Potentiometers

VR1	1k dual-gang rotary carbon, lin.
VR2	10k rotary carbon, lin.

Capacitors

C1, C9,	
C11	100μ radial elect 16V (3 off)
C2, C13,	
C14	100n disc ceramic (3 off)
C3	220n polyester
C4, C10	10μ radial elect. 25V (2 off)
C5	100n polyester
C6	1n polyester
C7, C8	47μ radial elect. 16V(2 off)
C12	1000μ radial elect. 25V

Semiconductors

D1, D2,	
D3	1N4148 signal diode (3 off)
D4 to D7	1N4002 100V 1A rectifier (4 off)
TR1	BC559 <i>npn</i> silicon transistor
TR2, TR3	BC549 <i>npn</i> silicon transistor (2 off)
IC1	TS555CN low power 555 timer
IC2	4001BE CMOS quad 2-input NOR gate
IC3	4016BE or 4066BE CMOS quad analogue switch
IC4	μA78L12 12V 100mA positive regulator

Miscellaneous

SK1,	
SK2	phono socket (2 off)
FS1	100mA 20mm quick-blow fuse
S1	rotary mains switch
T1	standard mains transformer; 230V a.c. primary, 12V 100mA secondary (see text)

Printed circuit board available from the *EPE PCB Service*, code 114; metal instrument case, about 203mm x 127mm x 51mm; control knob (3 off); pair of 20mm fuse-clips; 8-pin d.i.l. holder; 14-pin d.i.l. holder (2 off); mains lead and plug; 6BA fixings or stand-offs; multi-strand connecting wire; solder, etc.

Approx Cost
Guidance Only

£31

are needed in this application, and no connections are made to the other two.

The 4066BE is an improved version of the 4016BE, having faster operation and a lower "on" resistance. Both devices work well in this circuit, with no obvious difference in performance between the two components.

The unprocessed input signal is fed to IC3a, and it is controlled by the output signal from IC1 pin 3. The positive pulse from IC1 switches on IC3a during the initial part of each line scan, allowing the synchronisation and colour burst signals to pass through to the output.

Analogue switch IC3b is fed with the input signal via Fader potentiometer VR1a. This switch is controlled by the inverted signal from IC2, and it is therefore switched on while the picture modulation is present.

Varying positive bias is generated by a potential divider circuit which consists of resistor R11 and potentiometers VR2 and VR1b. As VR1a is adjusted to fade out the picture signal, VR1b provides an increasing resistance which provides a higher bias voltage. This takes the lower track terminal of VR1a steadily higher in voltage.

The maximum bias voltage can be controlled by VR2, and this enables the fade-out tone to be set for anything from a good white level to virtually black. The output buffer stage is a simple emitter follower amplifier based on TR3.

POWER SUPPLY

The circuit requires a reasonably stable and well smoothed 12V supply, and the current consumption is around 15mA to 17mA. The unit can be powered from a 12V battery if desired, and eight HP7 size cells in a plastic holder are suitable. A mains power supply is likely to be a much more economic choice in the long term.

A suitable circuit diagram for the Mains Power Supply Unit (p.s.u.) is shown in Fig. 4. This is quite conventional with mains transformer T1 providing voltage step-down and isolation from the mains supply. Diodes D4 to D7 provide full-wave bridge rectification. IC4 is a monolithic voltage regulator that provides a very stable and well smoothed 12V output. Protection against overloads is provided by the built-in current limiting of IC4, and fuse FS1.

AUDIO FADER

The unit has no built-in audio fader as this side of things is often handled by a separate audio mixer. However, if desired an Audio Fader can be incorporated in the Video Fader, and it is just a matter of adding input and output sockets plus a 10k logarithmic potentiometer. These are

connected in the manner shown in the circuit of Fig. 5, which has VR3 connected in conventional volume control fashion.

Ideally VR3 would be ganged with VR1, but as VR1 is a dual-gang type already, having a combined video and audio fader control is probably not a practical proposition. A three-gang potentiometer would be required, with one gang having a different value and law to the other two.

CONSTRUCTION

The Video Fade-to-White is built on a single-sided printed circuit board (p.c.b.), which is available from the *EPE PCB Service*, code 114. The topside component layout, full size underside copper track master and interwiring between off-board components are detailed in Fig. 6.

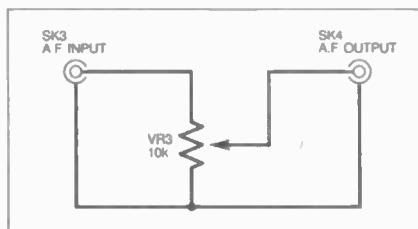

Fig.5. If required, an audio fader control can be added to the unit.

IC2 and IC3 are CMOS devices, and the standard anti-static handling precautions are therefore needed when dealing with them. The most important of these precautions is that they should be fitted in holders, and not soldered direct to the printed circuit board.

Low power versions of the 555 timer are often based on MOS technology, but are not usually vulnerable to static charges. It is still advisable to use a holder for IC1.

Do not fit IC2 or IC3 into their holders until the unit is finished in all other respects. Leave them in their anti-static packing until it is time to fit them into the holders, and touch their pins as little as possible when fitting them in place.

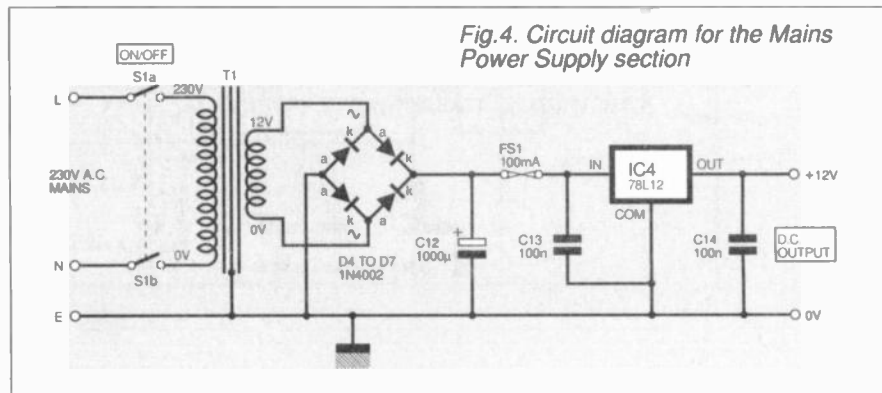

Fig.4. Circuit diagram for the Mains Power Supply section

It is not important to fit the other components in any particular order, but it is good practice to start with the resistors and capacitors and then fit the semiconductors. Fuse FS1 is fitted onto the board via a pair of printed circuit mounting fuse clips. Use plenty of solder when fitting these clips, so that they are securely anchored to the board.

CASE

The unit is housed in a metal instrument case which needs to be about 200mm wide in order to comfortably accommodate the printed circuit board and mains transformer. The circuit board is mounted well towards the left hand side of the case so as to leave

a generous amount of space for the mains transformer at the opposite end.

The p.c.b. must be mounted on plastic stand-offs that keep the underside of the board well clear of the metal case. Alternatively, 6BA or metric M3 screws can be used, but spacers at least six millimetres long should be used between the case and

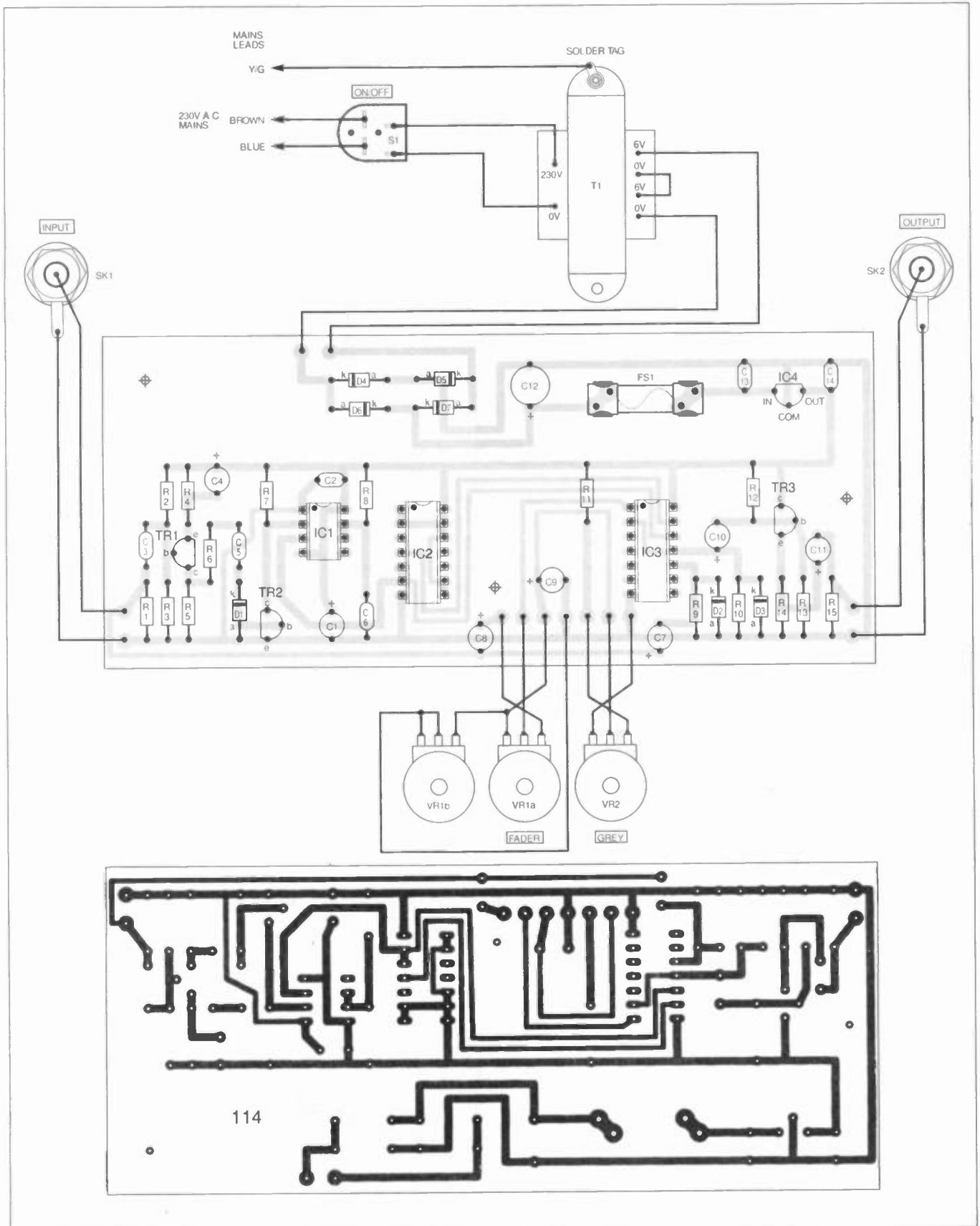
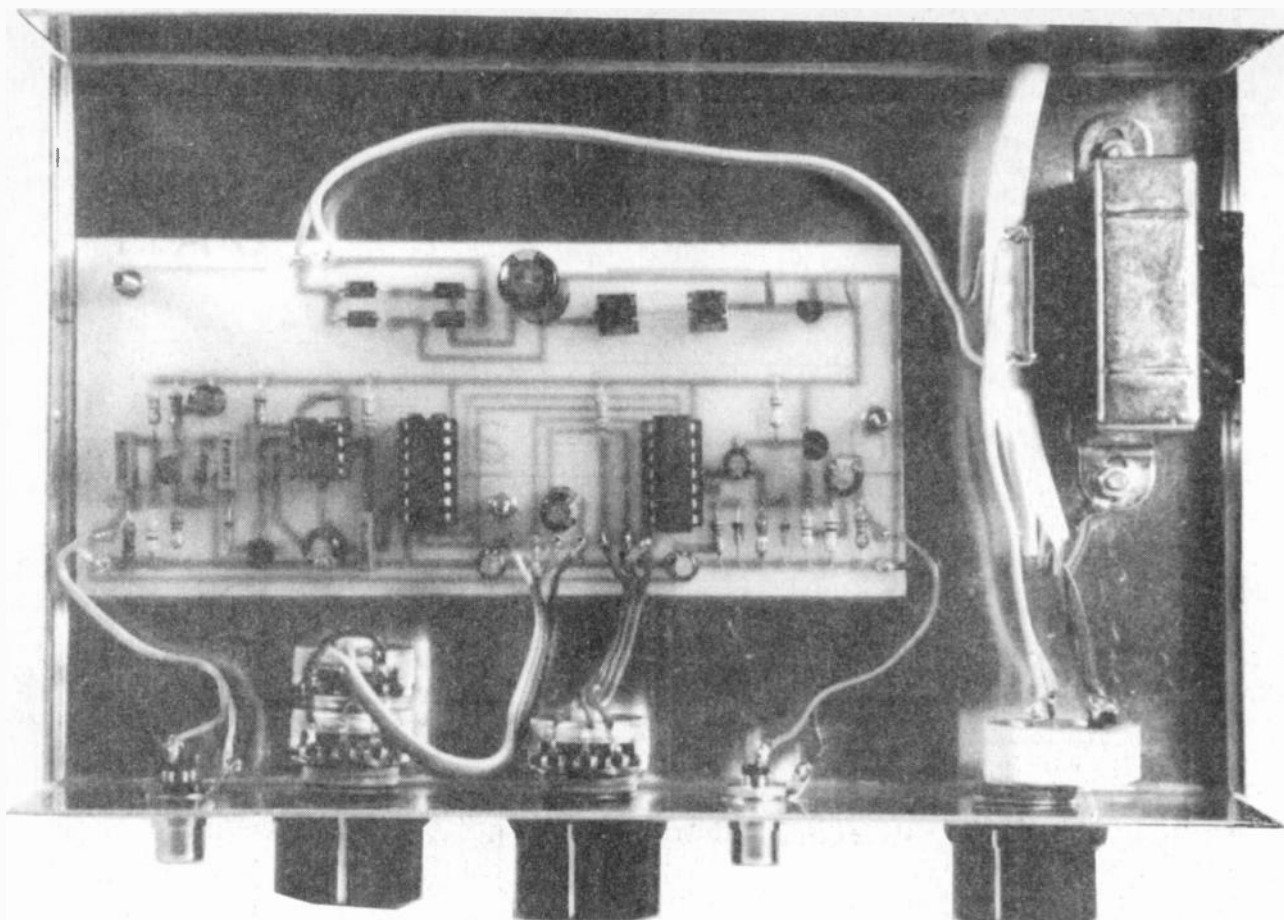

Fig.6. Video Fade-to-White printed circuit board component layout, full size copper foil master and interwiring to off-board components.



Layout and wiring of components inside the metal case. Note the use of a dual potentiometer for the Fade control and the positioning of the p.c.b. and transformer at the far ends of the case.

the board. A solder tag is fitted on one of transformer T1's mounting bolts, and this acts as a chassis "earth" connection point.

On/off switch S1 should be mounted well towards the extreme right hand end of the front panel, close to the mains transformer. In other respects the front panel layout is not critical, but it is a good idea to choose one that avoids a lot of long wires criss-crossing the case.

Sockets SK1 and SK2 are fitted on the front panel of the prototype, but they can be mounted on the rear panel if you prefer to keep the connecting leads tucked away out of sight at the rear of the unit. Both sockets are phono types, which is the standard connector for amateur video equipment.

FINAL ASSEMBLY

Details of the interwiring between off-board components and the p.c.b. are also provided in Fig. 6. This wiring is reasonably simple, but as the mains supply is involved it is essential to proceed with extra care, double-checking everything.

Projects which involve connections to the mains supply are potentially very dangerous, and are not really suitable for beginners unless carefully supervised.

Make quite sure that the mains Earth lead is reliably connected to the solder tag fitted on one of T1's mounting bolts.

Transformer T1 must provide a 12V winding having a current rating of 100mA or more. Modern mains transformers invariably seem to have centre-tapped windings or twin secondaries. A 6V-0V-6V type is suitable, and it is just a matter of ignoring the 0V centre-tap and connecting the other two tags to the printed circuit board.

A transformer having twin 6V secondary windings is also suitable, and it is just a matter of connecting the secondaries in series as shown.

On the prototype VR1 and VR2 are ordinary rotary potentiometers, but some constructors might prefer to use slider types. Unfortunately, the range of slider potentiometers available these days is strictly limited. It is unlikely that a suitable slider potentiometer for VR1 could be obtained, or anything even vaguely similar. Rotary potentiometers are probably the only option in this case.

IN USE

When initially testing the unit it is best to connect it between the video output of a VCR or Camcorder and the video input of a television set or monitor. This enables the effect of the unit to be seen immediately. Ordinary screened phono leads are used to provide the interconnections.

With the Grey control VR2 set in a fully

anti-clockwise direction, adjusting VR1 should enable you to obtain anything from a normal picture to a white screen with the signal fully faded.

Adjustment of VR2 should provide a wide range of grey levels with the picture faded. The faded picture should be very dark with VR2 fully backed-off, but it might not quite be possible to obtain a true black level. This is simply due to stray resistances and inductances in the circuit, and is not of any great significance.

It might be possible to obtain a "whiter white" by making resistor R11 a little lower in value, but overdoing things slightly could result in the system malfunctioning when fed with a fully faded signal. The monitor or VCR may well shut down if fed with even a slightly excessive white level.

The pulse duration from the monostable is slightly too long if there is a narrow strip down the left hand side of the screen which is not affected by VR1. This is unlikely to occur, but if necessary it can be corrected by reducing the value of R8 to 9.1 kilohms.

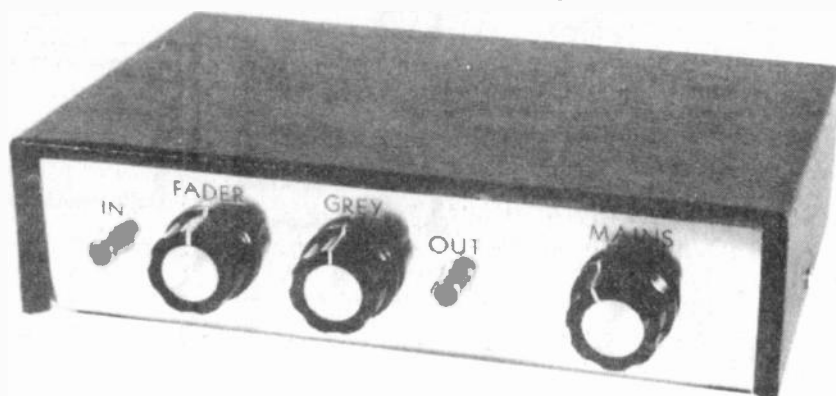

Is your PCB design package not quite as "professional" as you thought? Substantial trade-in discounts still available.

Board Capture

Schematic Capture Design Tool

- Direct netlist link to BoardMaker2
- Forward annotation with part values
- Full undo/redo facility (50 operations)
- Single-sheet, multi-paged and hierarchical designs
- Smooth scrolling
- Intelligent wires (automatic junctions)
- Dynamic connectivity information
- Automatic on-line annotation
- Integrated on-the-fly library editor
- Context sensitive editing
- Extensive component-based power control
- Back annotation from BoardMaker2

£395

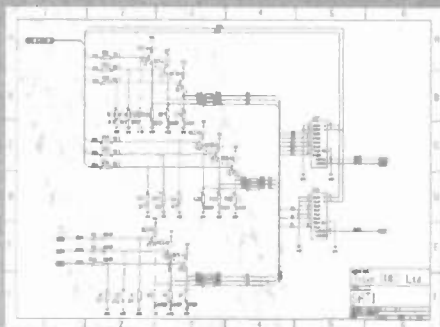

BoardMaker

BoardMaker1 - Entry level

- PCB and schematic drafting
- Easy and intuitive to use
- Surface mount and metric support
- 90, 45 and curved track corners
- Ground plane fill
- Copper highlight and clearance checking

£95

BoardMaker2 - Advanced level

- All the features of BoardMaker1
- Full netlist support- BoardCapture, OrCad, Schema, Tango, CadStar
- Full Design Rule Checking both mechanical and electrical
- Top down modification from the schematic
- Component renumber with back annotation
- Report generator- Database ASCII, BOM
- Thermal power plane support with full DRC

£395

BoardRouter

Gridless re-entrant autorouter

- Simultaneous multi-layer routing
- SMD and analogue support
- Full interrupt, resume, pan and zoom while routing

£200

Output drivers - Included as standard

- Printers - 9 & 24 pin Dot matrix, HPLaserjet and PostScript
- Penplotters - HP, Graphtec & Houston
- Photoplotters - All Gerber 3X00 and 4X00
- Excellon NC Drill and Annotated drill drawings (BM2)

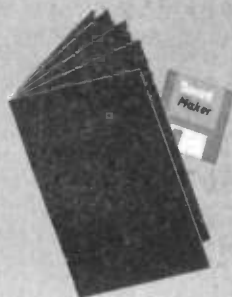
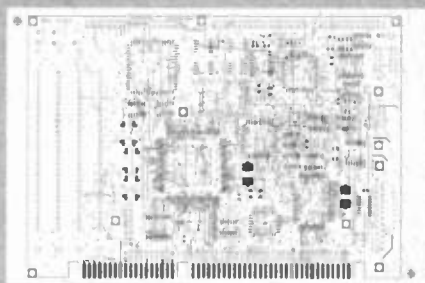

For further information contact

Tsien (UK) Limited

Aylesby House

Wenny Road, Chatteris

Cambridge, PE16 6UT

Tel 01354 695959

Fax 01354 695957

E-mail Sales@tsien.demon.co.uk



tsien

New Technology Update

Small portable equipment is demanding continued improvement in the types of battery available, and is being rewarded – Ian Poole reports.

NOT only is the demand for the number of batteries increasing, but people's expectations are also rising. Anyone who has used a portable computer will realise that battery life is relatively short between charges. Also portable phones need to be charged regularly.

To make batteries more convenient to use they need to be lighter, carry more charge and be smaller in size. To meet these requirements a number of new technologies are emerging. Much of the work is being directed towards the development of secondary or rechargeable batteries.

Green Issues

Apart from the operational requirements, other issues are important. At the moment the most popular form of battery used for electronic equipment is the nickel cadmium or NiCad battery. Unfortunately this technology is not ideal from an environmental standpoint. The cadmium present in the chemistry of the cell can be hazardous if it is disposed of in an unsuitable manner. As a result some countries have banned their sale and other technologies must be used. In other countries where their sale and use is permitted they have to be disposed of in a suitable manner.

The first real contender to the NiCad is the nickel metal hydride or NiMH cell. This is very similar to the NiCad, having a positive plate made from nickel, and an electrolyte which consists mainly of potassium hydroxide. The difference is in the negative plate. This consists of a complex metal-hydrogen storage material. This acts in a very complicated way storing or giving up hydrogen during different parts of the cycle.

The performance of this type of cell is very similar to that of the NiCad, having almost exactly the same output voltage. It does hold a greater amount of charge. Typically a small NiCad cell may hold 800mA hours whereas an equivalent NiMH cell may hold around 1200mA hours. This increase gives it a distinct edge over the older NiCad. In addition to this the removal of the cadmium make the cell environmentally acceptable. As a result many companies are switching over to these newer cells.

Unfortunately there are a few disadvantages to the NiMH cell. Great care must be taken when charging them. They do not tolerate over charging or reverse charging. In view of this the cells are normally only sold as complete battery packs for computers or cell phones. Although having said this some single cells are now appearing on the market.

Another problem follows on from the exact charging requirements. Today many systems use intelligent chargers. These note certain characteristics of the cell and can determine when to cease charging. For NiCad cells there is a small but pronounced increase in voltage as shown in Fig. 1. For NiMH cells this is very much smaller and can be difficult to detect. As a result it is necessary to detect both the terminal voltage and the cell temperature as this also rises when the cell is fully charged.

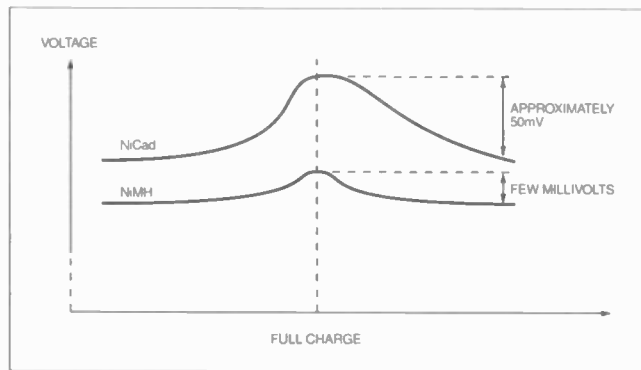

Fig. 1. Full charge characteristic of NiCad and NiMH cells.

Li-ion Batteries

Another new technology is beginning to enter the market. Termed the lithium ion or Li-ion battery this has an even greater charge density than the NiMH cell, although it has not been developed as far. The cells are made from a carbon anode which is doped with lithium ions and an electrolyte of ethylene carbonate.

The characteristics of the lithium ion cell are very different to those of the NiCad and NiMH cells. The output voltage is in the region of three or four volts dependent upon the exact cell chemistry and the state of charge. It is also found that the battery voltage falls during discharge (see Fig. 2). Again this differs from the NiCad and NiMH ones where the output voltage remains almost constant until most of the charge is exhausted.

Charging these batteries is very critical. If they are overcharged then the lithium separates within the cell and this can be very dangerous in view of the flammable nature of lithium. Cells which have been overcharged have been known to burst into flame. Manufacture also has to be undertaken with care as one factory has already burned down! Nevertheless if the proper precautions are taken they should be quite safe.

Intelligent Batteries

Battery technology does not stop with the chemistry in the cells. A variety of

integrated circuits are available to control the charge and monitor the discharge of the batteries. To monitor the state of the battery, fuel gauge chips are used. These monitor the amount of current entering or leaving the cell and as a result they know how much charge is left. They also know the state of the battery in terms of its ageing, monitoring its capacity from one charge to the next. Often these chips are very complicated, sometimes containing a small microprocessor.

These chips are becoming increasingly important. Computers are a very good example. Both NiCad and NiMH cells have a rapid fall in voltage once most of the charge has been used. This means it is important to have sufficient warning to save any files before all the charge has gone and the computer ceases operation.

Many of the new portable computers have a small indication on the screen showing the amount of charge remaining, and this allows the user to tailor any operation to the amount of time left in the battery.

Charging is equally important. To ensure that the equipment operates for as long as possible between charges it is necessary to ensure that it is fully charged. However, it is also necessary not to let the battery become over charged otherwise the amount of charge which the battery can hold will be reduced and its life shortened.

This function is normally performed by a special charger chip which monitors the battery and looks for signs that full charge has been reached.

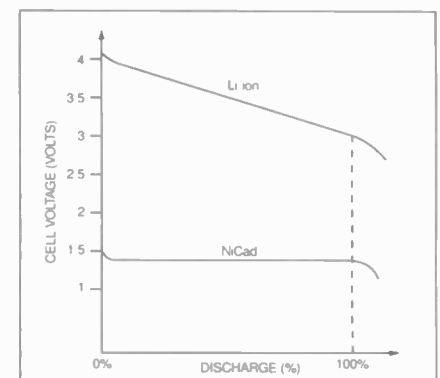
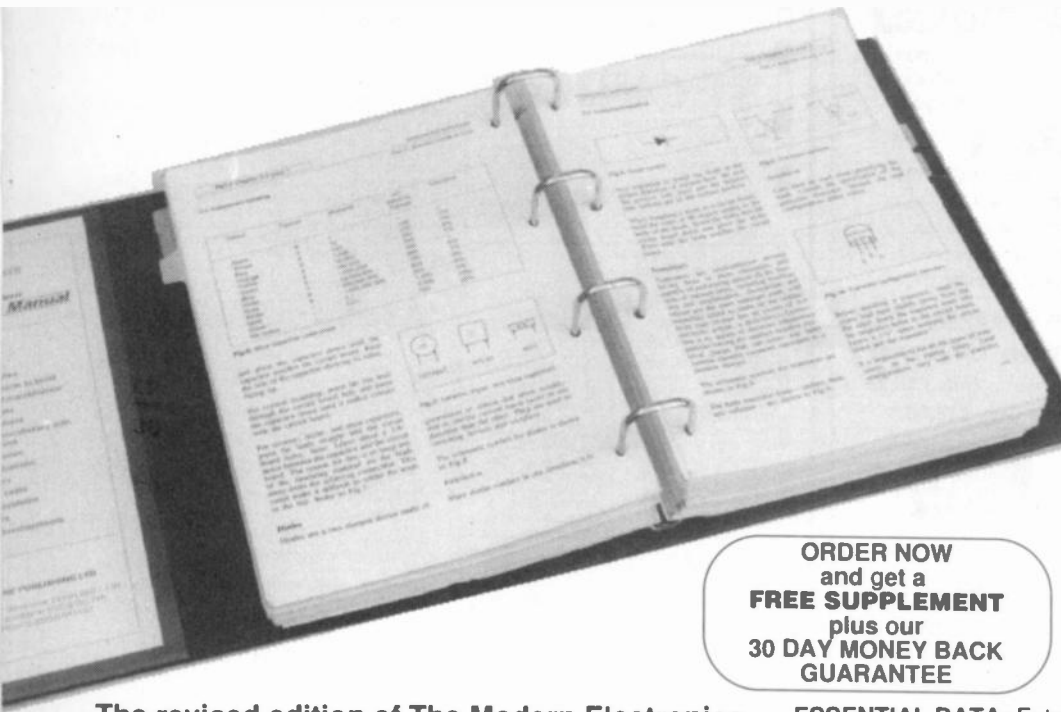

Fig. 2. Discharge curve of a Li-ion cell.

LEARN ALL ABOUT ELECTRONICS



The essential reference work

- Easy-to-use format
- Clear and simple layout
- Comprehensive subject range
- Regular Supplements
- Sturdy ring-binder
- Projects to build
- Components checklists
- Extensive data tables
- Detailed supply information
- Ready-to-transfer PCBs
- Detailed assembly instructions
- Professionally written

ORDER NOW
and get a
FREE SUPPLEMENT
plus our
**30 DAY MONEY BACK
GUARANTEE**

The revised edition of **The Modern Electronics Base Manual** contains practical, easy-to-follow information on the following subjects:

BASIC PRINCIPLES: Symbols, components and their characteristics, active and passive component circuits, power supplies, acoustics and electroacoustics, the workshop, principles of metrology, measuring instruments, digital electronics, analogue electronics, physics for electronics.

CIRCUITS TO BUILD: From basic principles to circuit-building, The Modern Electronics Manual and its Supplements describe how to assemble radios, loudspeakers, amplifiers, car projects, computer interfaces, measuring instruments, workshop equipment, security systems, etc.

Guarantee

Our 30 day money back guarantee gives you complete peace of mind. If you are not entirely happy with the Manual, for whatever reason, simply return it to us in good condition within 30 days and we will make a full refund of your payment – no small print and no questions asked.
(Overseas buyers do have to pay the postage charge)

ESSENTIAL DATA: Extensive tables on diodes, transistors, thyristors and triacs, digital and linear i.c.s, microprocessors. The Manual also has an extensive Glossary, and covers **Safety, Specialist Vocabulary with Abbreviations and Suppliers.** The most comprehensive reference work ever produced at a price you can afford, the revised edition of **THE MODERN ELECTRONICS MANUAL** provides you with all the essential information you need.

OVER 1,000 A4 loose leaf pages in a sturdy ring binder all for just £39.95 plus £5.50 post and packing. Regular Supplements continuously extend the Manual with new material, each Supplement contains approximately 160 pages of information. These are sent about five times a year and cost £23.50 plus £2.50 p&p. You can of course return any Supplement (within 10 days) or cancel the Supplements at any time.

Wimborne Publishing Ltd., Dept. Y10
Allen House, East Borough,
Wimborne,
Dorset BH21 1PF
Tel: 01202 881749 Fax: 01202 841692

PLEASE send me **THE MODERN ELECTRONICS MANUAL** plus a **FREE SUPPLEMENT.**

I enclose payment of **£45.45**. I shall also receive the appropriate supplements several times a year. These are billed separately and can be discontinued at any time. Should I decide not to keep the Manual I will return it to you within 30 days for a full refund.

FULL NAME
(PLEASE PRINT)

ADDRESS.....

..... **POSTCODE**

SIGNATURE.....

I enclose cheque/PO payable to Wimborne Publishing Ltd.

Please charge my Visa/Mastercard/Access

Card No. **Card Ex. Date**

ORDER FORM

Simply complete and return the order form with your payment to the following address:

**Wimborne Publishing Ltd, Dept. Y10
Allen House, East Borough, Wimborne,
Dorset BH21 1PF**

OVERSEAS ORDERS: All overseas orders must be prepaid and are supplied under a money-back guarantee of satisfaction. If you are not entirely happy with the Manual return it within a month for a refund of the purchase price (you do have to pay the overseas postage). **SEND £39.95 PLUS THE POSTAGE SHOWN BELOW:**

EIRE, SCOTTISH HIGHLANDS and UK ISLANDS	£11
EUROPE (E.E.C. Countries)	AIR MAIL ONLY £20
EUROPE (non E.E.C.)	SURFACE MAIL £20, AIR MAIL £26
U.S.A. & CANADA	SURFACE MAIL £25, AIR MAIL £32
FAR EAST & AUSTRALIA	SURFACE MAIL £31, AIR MAIL £33
REST OF WORLD	SURFACE MAIL £25, AIR MAIL £44

Note surface mail can take over 10 weeks to some parts of the world. Each manual weighs about 4kg including the free supplement when packed.

All payments must be made in £'s Sterling payable to Wimborne Publishing Ltd. We accept Mastercard (Access) and Visa credit cards.

Constructional Project

10MHz FUNCTION GENERATOR

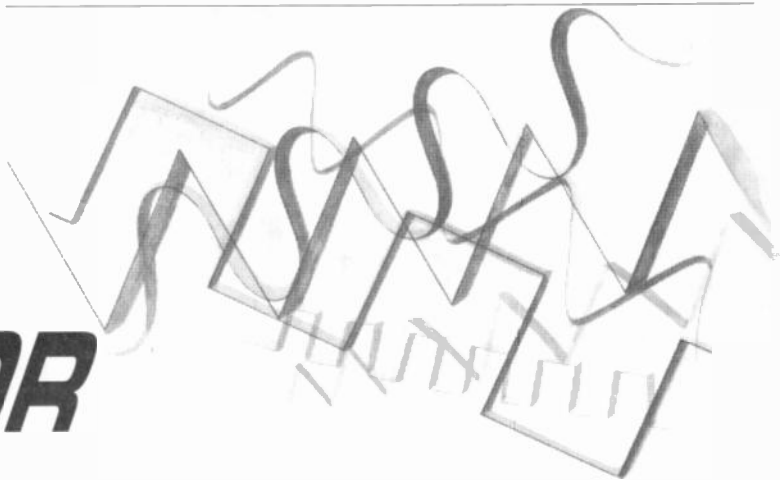

ANDY FLIND

The new MAX038 function generator chip can enhance the test gear facilities in your workshop.

TOGETHER with the multimeter and the oscilloscope, a function generator is one of the most useful pieces of equipment an electronics enthusiast can possess. It generates signals over a wide range of frequencies, and gets its name from the fact that it can also provide various output waveforms. Usually these are triangular waves and square waves in addition to the basic sinewaves, and users soon discover the value of these for testing different types of circuit.

Square waves, for example, are useful when checking for overshoot and ringing, whilst a triangular waveform is handy when looking for amplifier cross-over distortion. Sinewaves are useful when checking for harmonic distortion. Often the output can have a variable d.c. offset voltage added to the a.c. signal, shifting its relative level higher or lower to suit different circumstances.

BASIC DESIGNS

There are two basic approaches to function generator design. One is to construct from scratch using discrete components and i.c.s. The circuit usually works by supplying a capacitor with a constant current, using comparators to switch between charging and discharging at pre-determined voltages.

A square wave signal is then available from the comparators and a triangular wave from the capacitor, whilst the sinewave is created by processing the triangular wave with a "shaping" network.

Most commercial instruments are designed in this way and usually have maximum output frequencies of about 2MHz. Their circuits are generally very complex with many preset internal adjustments, the setting up of which requires sophisticated test equipment not normally possessed by home constructors. This explains why designs for such instruments rarely appear in the electronics hobby press.

The other way to build one of these instruments is to use a special waveform generator i.c. with the current sources, threshold switching and sinewave shaping circuits all built-in. Until recently, the only readily available i.c. of this nature was the type 8038, made by various manufacturers and having different prefix letters, such as ICL8038, AMZ8038, XR8038, Z8038, for example.

The claimed maximum frequency can vary, depending on the manufacturer, from 300kHz right up to 1MHz, but in practice the 8038 is usually struggling at 200kHz. If reasonably "clean" square and triangular waveforms are desired, it is wise to regard 100kHz as the upper limit. Most home constructors, therefore, have been limited to building function generators

working only to these maximum frequencies, which restricts their usefulness.

MAX038 DEVICE

This situation has now changed. The new MAX038 i.c. from Maxim offers all three waveforms, is much easier to use than the 8038, and the claimed maximum frequency is in excess of 20MHz! A review of the MAX038 was published in *EPE* September '96.

At 10MHz the output waveforms are excellent, so at long last it is possible for the amateur enthusiast to build instruments capable of this frequency at reasonable cost. The i.c. is capable of much more than basic waveform generation. The output duty-cycle can be varied, it may be frequency-modulated, and it is even possible to phase-lock it to an external signal.

However, the intention with the present design is to provide a comparatively low-cost and simple instrument having just the three basic waveforms and a d.c. offset facility. A minimum of equipment is needed for setting up as there is only one internal preset adjustment to be made.

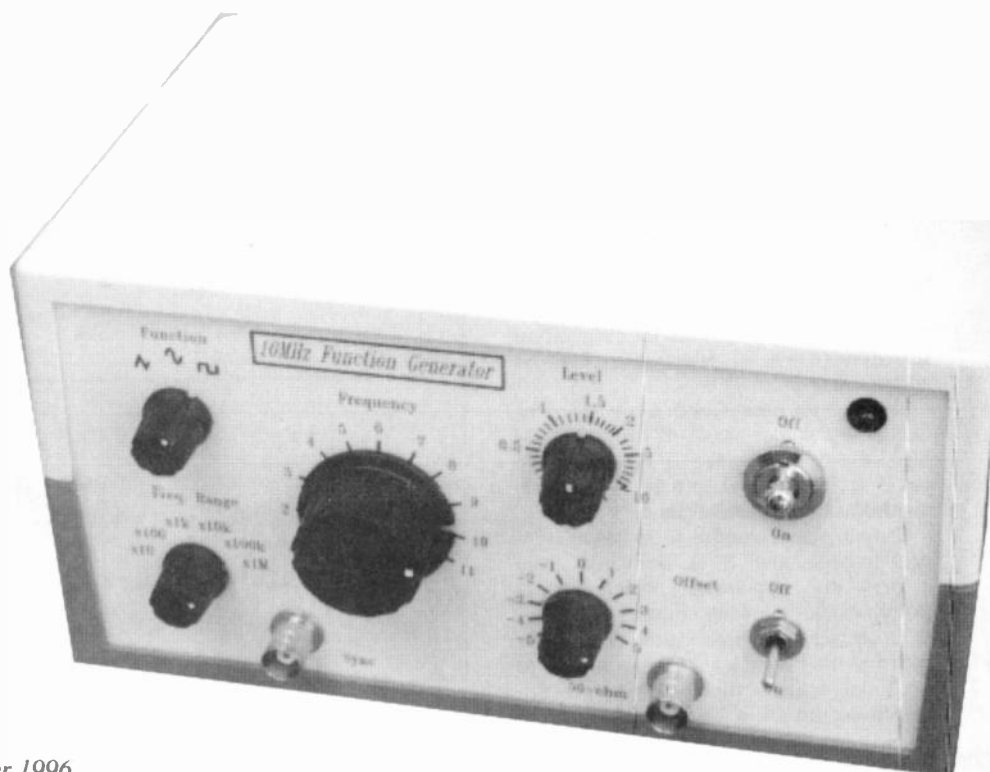

A PRACTICAL DESIGN

The project consists of two parts, the function generator itself and a separate regulated power supply. The circuit diagram for the 10MHz Function Generator is shown in Fig. 1, where the heart of the design is the MAX038 chip IC1. This is supplied in a 20-pin d.i.l. (dual-in-line) package but many of the control inputs are not used in this design and, therefore, are simply grounded.

Output frequency is variable over each of six ranges by controlling the current flowing into pin 10. This is supplied from Frequency potentiometer VR1 through resistor R2, with the minimum value set by resistor R1 to give a sweep range ratio of slightly more than 10:1.

The six frequency ranges are set by the values of external capacitors (C1 to C10) which are selected by the Range switch S1 for connection to pin 5. The lowest range is 10Hz to 100Hz and requires a capacitor value of 4.7 microfarads. This is not readily available as a single component with a reasonable tolerance factor, so four 1µF polyester layer capacitors are connected in parallel together with one of 680nF to make up the value.

Theoretically, the error is less than 0.5 per cent so, as these are five per cent tolerance capacitors, this is acceptable. The remaining ranges are set with decade multiples of 4.7, with the exception of the highest range of 1MHz to 10MHz, where a small trimmer capacitor (VC1) is used in parallel with a 22pF fixed capacitor to allow compensation to be made for stray capacitance, probably of several picofarads.

Decade multiples of 4.7 are used in preference to the more common value of 2.2 as this helps to reduce the effects of stray capacitance. A higher control current is required as a result, but it remains well within the i.c. specifications.

WAVEFORMS

Readers with experience of the type 8038 device will recall that all three waveforms (square, triangle and sine) were available simultaneously but at different amplitude levels. Furthermore, the square wave was supplied from an open-collector output requiring a pull-up resistor which led to the inevitable trade-off between speed and power dissipation.

A completely different approach is used in the MAX038. It has only one output, from pin 19, the waveform being selected internally by the logic levels applied to two control inputs, pins 3 and 4. In this circuit these are provided with pull-down resistors R3 and R4 and the Waveform selection switch S2 takes them high as appropriate.

When both pins 3 and 4 are low, the output is a square wave. If only pin 4 is high, the triangle wave is output. When pin 3 is high, the output is a sine wave, regardless of the state of pin 4.

Output signal amplitude is always 2V peak-to-peak and it is delivered from a very low impedance, which greatly simplifies the following circuitry.

A separate synchronisation (sync) output of normal logic level (nominally 0V to +5V, but actually slightly lower) is available from pin 14, and in this design it is

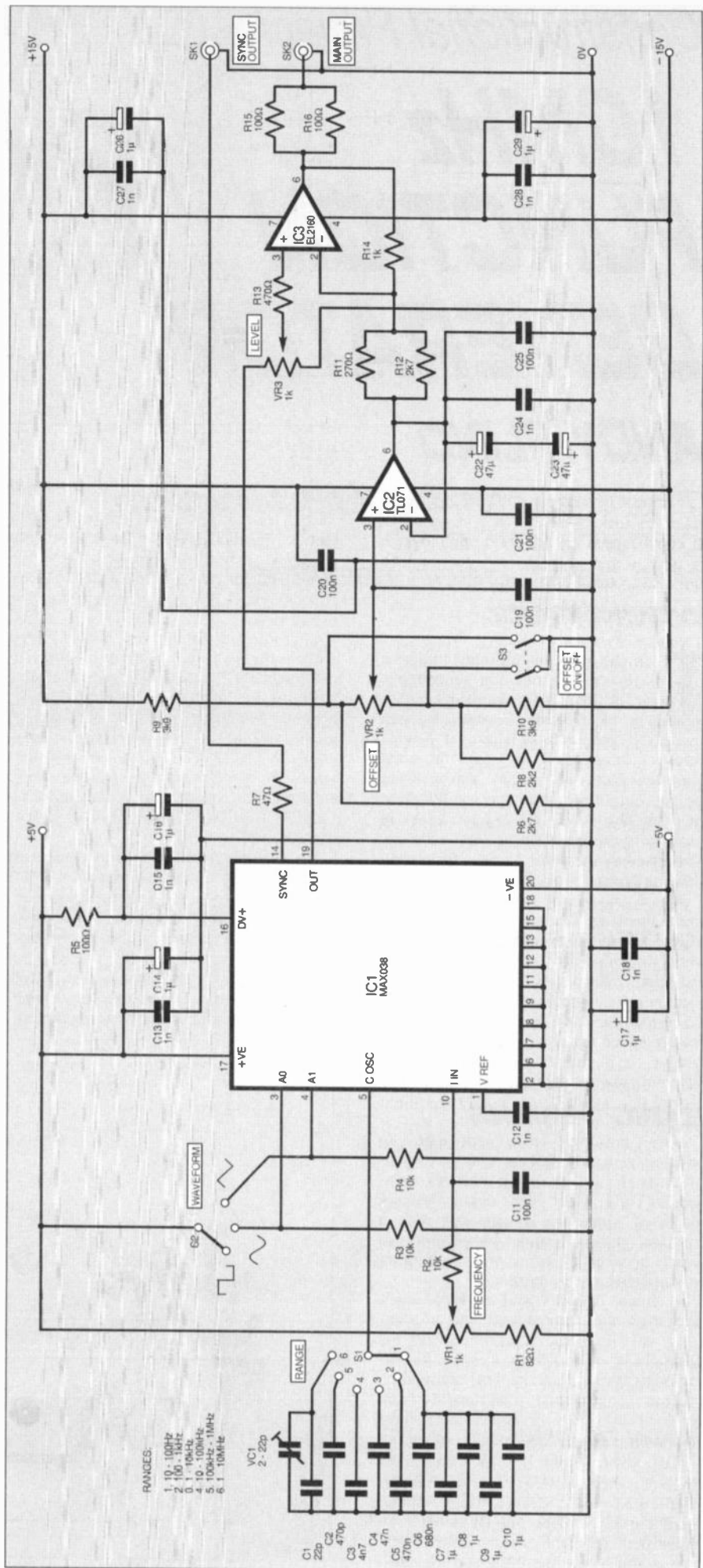

Fig. 1. Main circuit diagram for the 10MHz Function Generator.

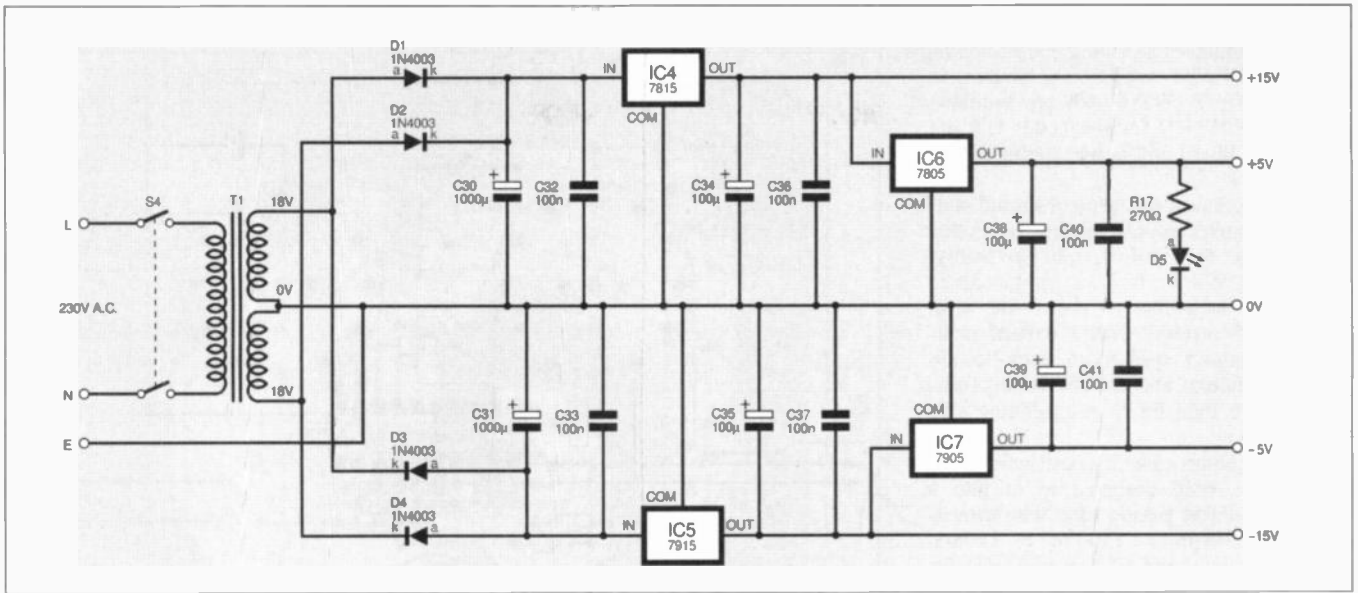

Fig. 2. Circuit diagram for the power supply.

taken to socket SK1 through resistor R7. It can be used to drive external logic, a frequency meter, or for any other suitable purpose chosen by the user.

POWER NEEDS

Power for the circuit around IC1 is $\pm 5V$, which is supplied to pins 17 and 20 respectively. There is a separate positive supply connection to pin 16 for the internal comparator that drives the sync output. This is supplied through resistor R5.

All the supply connections have local decoupling consisting of $1\mu F$ tantalum bead capacitors in parallel with $1nF$ ceramics, in accordance with the manufacturer's data sheet. Maxim's suggested alternative is to use $1\mu F$ ceramic capacitors, but these are too large and expensive for this design.

OUTPUT STAGE

The maximum output voltage is boosted from 2V to 10V peak-to-peak by IC3. This is an EL2160 op.amp, a current feedback type having a unity gain bandwidth of 180MHz. The signal level is controlled by potentiometer VR3, which is a logarithmic type, chosen to give greater control over the lower part of the output amplitude range.

IC3 is used in the non-inverting configuration, and a d.c. offset is added to the output by adjusting the voltage of the point to which the resistors R11 and R12 are connected. This point must have a low impedance so it is supplied from the output of IC2, which is a unity gain follower for the Offset control potentiometer VR2, with comprehensive decoupling added by capacitors C22 to C25. Switch S3 is used to disable the offset feature when it is not required.

The circuit around IC2 and IC3 requires a power supply of $\pm 15V$.

POWER SUPPLY UNIT

Full power supply details are shown in Fig. 2, where it will be seen that it is a straightforward design using standard regulator i.c.s. To simplify layout and construction of the main printed circuit board, the power supply is constructed on a separate board.

Power is taken from the 18V-0-18V

centre-tapped output of transformer T1 and rectified by diodes D1 to D4 to give both positive and negative supplies. These are then regulated to $+15V$ and $-15V$ by IC4 and IC5 respectively, and decoupled by capacitors C34 to C37. The $\pm 15V$ voltages are further reduced to $+5V$ and $-5V$ by IC6 and IC7, with decoupling by capacitors C38 to C41.

The current drawn by the MAX038 is around 50mA from each 5V supply. Whilst this is within the capabilities of the 100mA type of regulator, it would be difficult to cope with the heat dissipation from their packages so 1A types are used instead. These have mounting lugs to which heatsinks can easily be fitted.

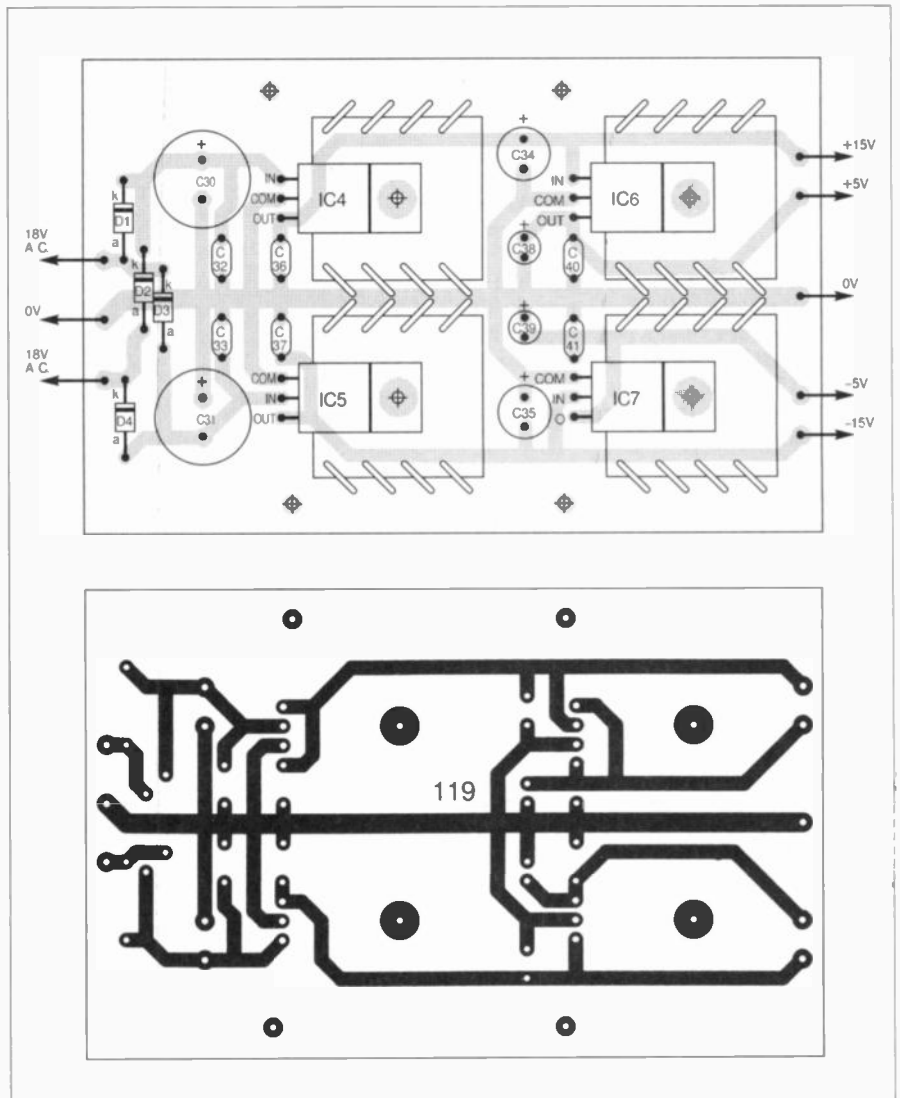

Fig. 3. Details of the component layout and full-size underside copper foil master track pattern for the power supply printed circuit board.

CONSTRUCTION

Details of the two printed circuit boards (p.c.b.s) for this project are shown in Fig. 3 to Fig. 5. The boards are available from the *EPE PCB Service*, codes 118 and 119, Main Board and power supply (PSU) respectively.

Construction of this project should start with the power supply as this is needed for testing the main p.c.b. assembly. Regulators IC4 to IC7 are first secured with their heatsinks to the board with short M3.5 screws, with a dab of heat-sink compound applied to each to aid heat dissipation, and the remaining components are then fitted in ascending size order.

For maximum ease of construction, this project has been designed to fit into a readily available plastic case with dimensions of 205mm x 140mm x 110mm which has two sets of internal slots for holding p.c.b.s or chassis plates.

The transformer and power supply board are mounted on an aluminium plate cut to fit into a pair of these slots, as shown in the final photograph. This plate is cut to the same size as the front and rear panels supplied with the case, but the internal slots need extending slightly at top and bottom to accommodate it. A few moments with a sharp knife will suffice.

The transformer and p.c.b. are fitted to the front-facing side, with short plastic spacers keeping the board clear of the plate. Note that the mounting tabs of the regulator i.c.s, and hence their heatsinks, are internally connected to their outputs so they should not touch any surrounding metalwork. The board is mounted in a vertical position with capacitors C30 and C31 at the bottom to assist with thermal dissipation.

A terminal block on the other side of the plate allows easy connection to the mains power lead and a hole fitted with a grommet allows wiring to pass through safely. The plate is earthed via a tag secured by one of the transformer mounting screws.

TRANSFORMER NOTE

A note about transformers is appropriate here. Ideally, the input voltage to the 15V regulators IC4 and IC5 with a normal load should be about 20V to minimise heat dissipation. The voltage obtained from a rectified transformer output is usually closer to the peak value of the output than the stated value, which is given as an r.m.s. (root-mean-square) value, and on load it usually drops a bit.

Transformer outputs often deviate quite a bit from their stated values too. With this project a 20V-0-20V 6VA transformer gave around 29V on load which was a little high but tolerable. Based on this, a 15V-0-15V transformer should have been about right, but a 250mA type actually gave only 18V.

An 18V-0-18V 6VA transformer was then tried; this produced about 30V without load, but when loaded this fell to about 27V. This was an improvement on the 20V-0-20V unit so it was selected for the project. It has two separate output windings, connected together to make a centre tap as shown in Fig. 2, and Fig. 7.

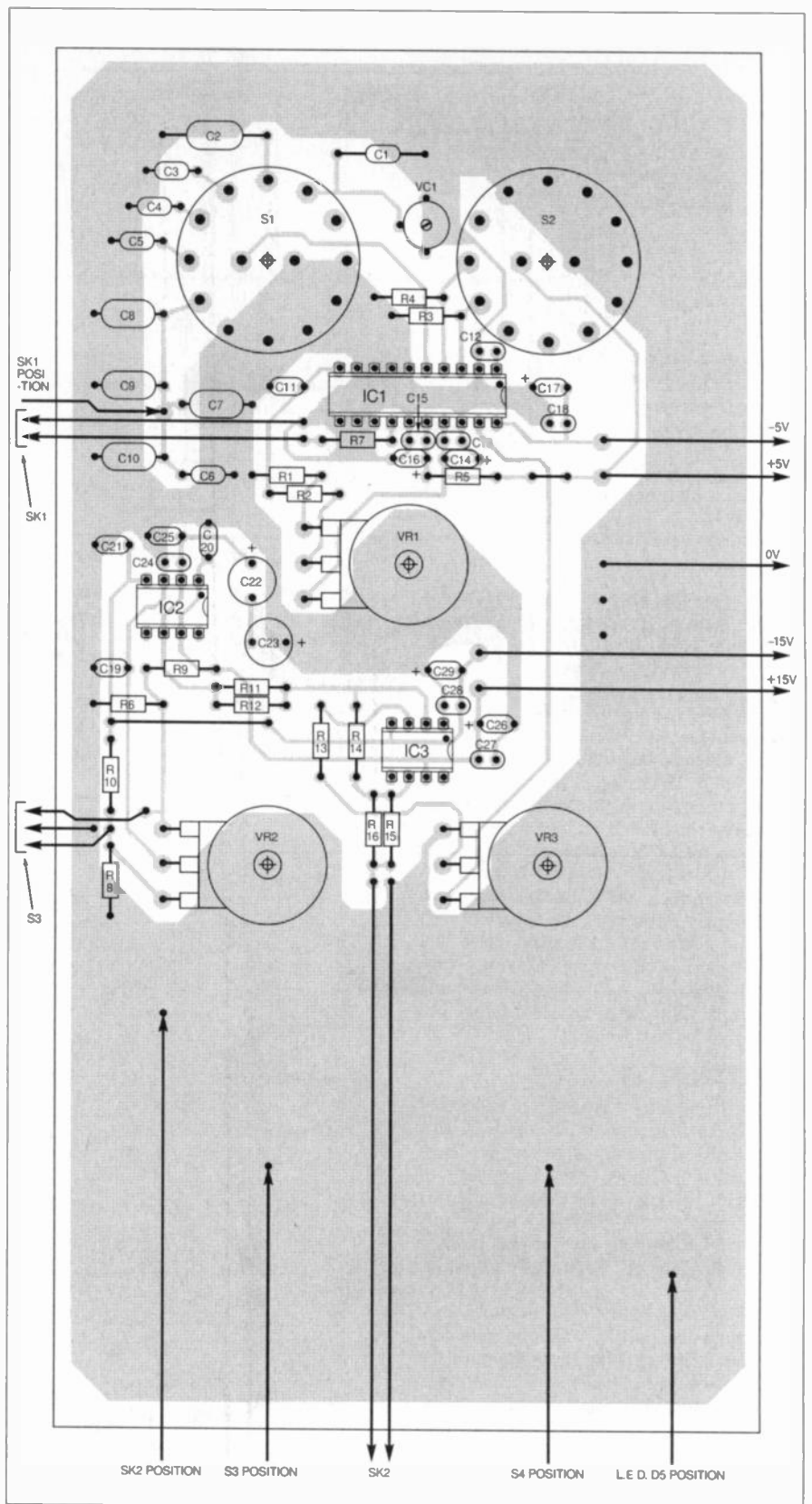

Fig. 4. Details of the component layout for the main printed circuit board.

Testing of the power supply simply involves powering up the transformer and checking that the four output voltages are present and correct.

MAIN P.C.B. PREPARATION

With the power supply complete, construction of the main p.c.b. can be commenced, positioning the components as

shown in Fig. 4. For simplicity and also to minimise stray capacitance around high-frequency parts of the circuit, some of the controls are fitted directly to the p.c.b. with their shafts projecting through holes drilled in the front panel.

To ensure alignment of the holes and shafts, the p.c.b. can be used as a template for marking their positions. It should be placed behind the front panel, with the

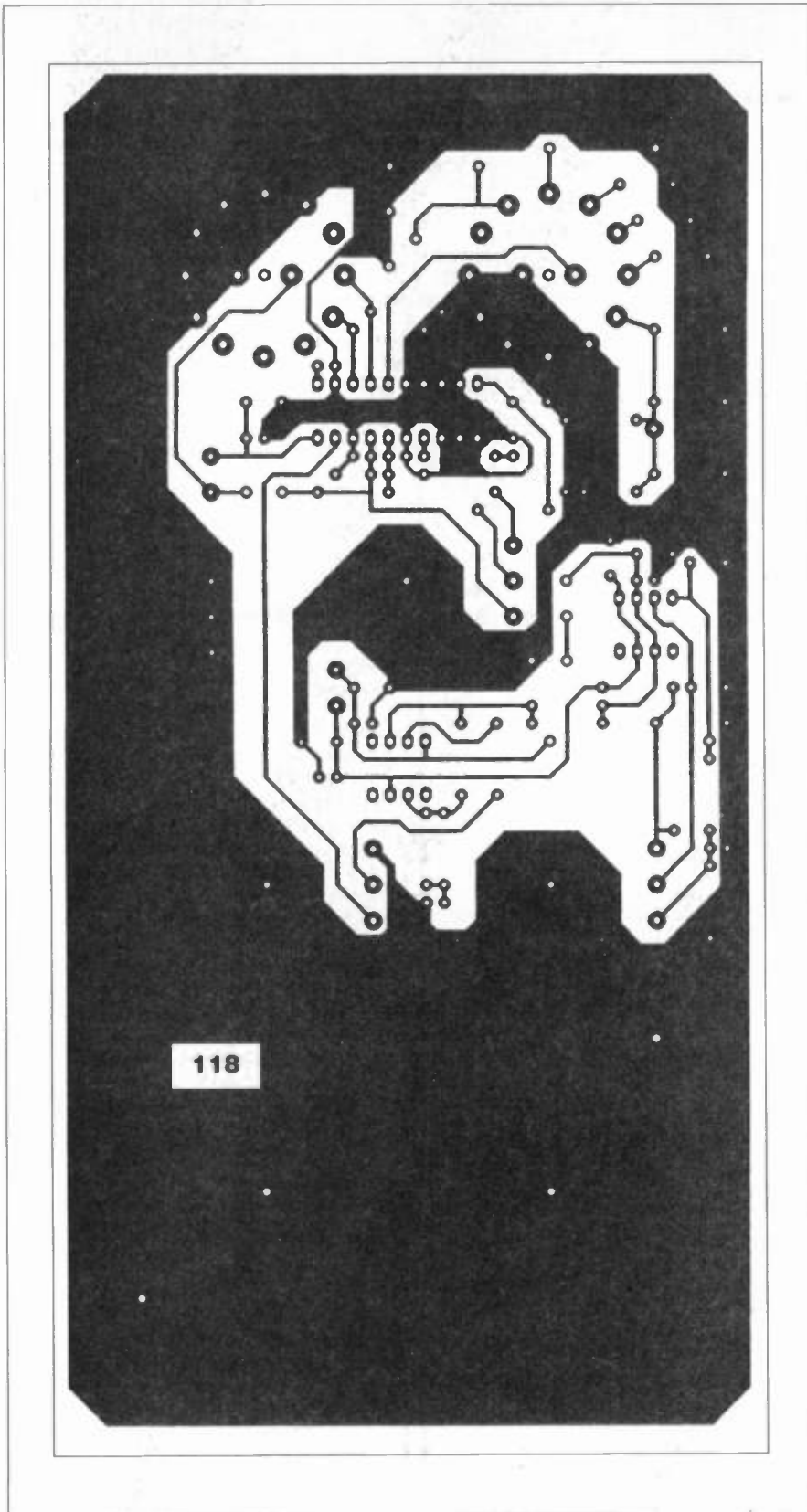

Fig. 5. Full-size underside copper foil master track pattern for the main printed circuit board.

copper side facing away from it and the switch S1 and S2 positions on the left. The bottom edges of the p.c.b. and panel should be aligned and secured with adhesive tape whilst the centres for panel drilling are marked out through the p.c.b.

On the p.c.b. the small pads at the centres of the S1 and S2 positions mark their centres, whilst the slightly oversize pad between capacitors C7 and C9 marks the centre for socket SK1. Small holes in the ground plane also indicate the

positions of SK2, S3, S4 and D5. One of these holes can be enlarged later and fitted with a grommet to take the wiring to the front panel mounted components. The use of a small pilot drill is recommended to maintain accuracy when drilling the holes.

Following this operation, the p.c.b. can be assembled and tested. Assuming that you are using a p.c.b. assembly frame, the two link wires and the resistors and capacitors should be fitted first, in order of size. Care should be taken with the tantalum bead

capacitors as the polarity markings on these are sometimes difficult to read.

To ensure good performance the author chose not to use sockets for the i.c.s, however, readers might wish to use them to protect the i.c.s from heat damage which might otherwise occur during soldering. If you use sockets make sure they are high quality ones since low cost ones may impair performance at high frequency.

Potentiometers and switches should be fitted next. The switches will probably have small "eyes" at the ends of their solder tags which should be cut off so that the tags can be pushed into the board from the component side and soldered.

Behind the nut and washer of each switch there should be a lugged washer for setting the number of positions available. On switch S1 this should be set to "6", on S2 to "3".

The potentiometers are fitted with their bodies on the copper (track) side, so it is best to solder three short lengths of bare wire to their connection points on the board first. When they are secured in place, they can be wrapped around the potentiometer tags and soldered. Some makes of potentiometer may not have shafts long enough to project through the front panel as intended, so where the recommended case is to be used this should be checked first!

TESTING

The i.c.s should be fitted and tested in sequence, starting with IC1, for which only the 0V, +5V and -5V supplies need be connected. The output from pin 19 can be checked with an oscilloscope. The amplitude should be 2V peak-to-peak, and the three waveforms should be selectable with switch S2.

The frequency ranges should all operate correctly when selected by switch S1. If a frequency meter is available, set switch S1 to the "1kHz to 10kHz" range, and then adjust potentiometer VR1 to set the output frequency to 10kHz. Leaving VR1 at this setting, now check how well the corresponding points in the other ranges match up.

In the unlikely event of there being any serious discrepancies, these can then be investigated and rectified, perhaps by substituting other capacitors. This probably will not be necessary, though, as despite the use of five per cent components, the ranges matched up very well in the prototype.

Still with VR1 at the same setting, trimmer VC1 should be used to adjust the output in the top range to 10MHz. If a frequency meter is not available, VC1 should be set to the mid-point, which will probably be close enough.

It is likely that IC1 will be found to run slightly warm to the touch; this is quite normal.

IC2 should be fitted next, and will require the +15V and -15V supplies to be connected for testing. Offset control VR2 should cause the output at IC2 pin 6 to vary by about 1.4V to either side of zero. If this seems satisfactory, IC3 can be fitted and its output checked with the oscilloscope.

The Offset On-Off switch S3 is not connected at this stage so VR2 should provide a variable d.c. offset range of just

COMPONENTS

Resistors

R1	82Ω
R2, R3, R4	10k (3 off)
R5, R15, R16	100Ω (3 off)
R6, R12	2k7 (2 off)
R7	47Ω
R8	2k2
R9, R10	3k9 (2 off)
R11, R17	270Ω (2 off)
R13	470Ω
R14	1k

All 0.6W 1% metal film.

Potentiometers

VR1, VR2	1k rotary carbon lin. (2 off)
VR3	1k rotary carbon log.

Capacitors

C1	22p polystyrene, 5%
C2	470p polystyrene, 5%
C3	4n7 polyester layer, 5%
C4	47n polyester layer, 5%
C5	470n polyester layer, 5%
C6	680n polyester layer, 5%
C7 to C10	1μ polyester layer, 5% (4 off)
C11, C19, C20, C21, C25, C32,	
C33, C36, C37, C40, C41	100n ceramic disc (11 off)
C12, C13, C15, C18, C24, C27, C28	1n ceramic disc (7 off)
C14, C16, C17, C26, C29	1μ tantalum bead, 35V (5 off)
C22, C23	47μ tantalum bead, 16V (2 off)
C30, C31	1000μ elect. radial, 35V (2 off)
C34, C35	100μ elect. radial, 35V (2 off)
C38, C39	100μ elect. radial, 10V (2 off)
VC1	2p to 22p trimmer, sub-min

Semiconductors

D1 to D4	1N4003 1A rectifier diode (4 off)
D5	red l.e.d. and mounting clip
IC1	MAX038CPP high-frequency waveform generator
IC2	TL071CN f.e.t. op.amp
IC3	EL2160CN current feedback op-amp
IC4	7815 15V 1A regulator
IC5	7915 -15V 1A regulator
IC6	7805 5V 1A regulator
IC7	7905 -5V 1A regulator

Miscellaneous

S1, S2	2-pole 6-way rotary switch (2 off)
S3	d.p.d.t. min. toggle switch
S4	d.p.d.t. mains toggle switch
SK1, SK2	50-ohm BNC chassis socket (2 off)
T1	18V-0-18V 6VA transformer (see text)

Printed circuit board (2 off), available from the *EPE PCB Service*, codes 118 and 119; plastic case, 205mm x 140mm x 110mm; knob (5 off); heatsink, vanned, 19°C/W, for plastic packaged i.c.s (5 off) (see text); cable grommet (2 off); aluminium sheet (see text); 3-way terminal block, mains voltage rated; cable; connecting wire, solder, etc.

See
TALK
Page

Table 1. Output Attenuation Details

Ratio	R1	R2	% error	Full Scale
1:2	100 + 100 parallel	100	0	5V
1:3	100	150 + 150 parallel	0	3.3V
1:5	100 + 100 series	68 + 820 parallel	0.37	2V
1:10	330 + 120 series	56 + 6k8 parallel	0.02	1V
1:20	390 + 560 series	56 + 820 parallel	0.38	500mV
1:30	1k5 + 47k parallel	56 + 680 parallel	0.2	333mV
1:50	2k7 + 27k parallel	3 + 18 series	0.22	200mV
1:100	6k8 + 18k parallel	47 + 3.3 series	0.11	100mV

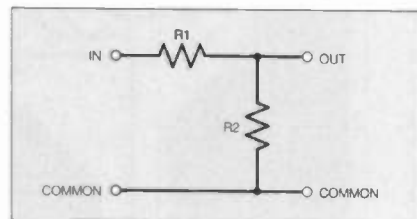

Fig. 6. Output attenuator circuit diagram.

over $\pm 5V$. Sharp-eyed readers may have noticed an apparent discrepancy in the values of R6 and R8 from those that calculations might suggest for a symmetrical $\pm 5V$ shift. This difference is needed to compensate for input current drawn by IC3 through R11 and R12. Any errors in the d.c. offset range obtained can be corrected by adjusting the value of these two resistors.

Potentiometer VR3 should control the a.c. signal level output from IC3 pin 6 between 0V and 10V peak-to-peak.

The optional attenuator shown in Fig. 6 and Table 1 are discussed later.

OUTPUT LINEARITY

The output of the prototype was checked with a 40MHz oscilloscope. The sinewave maintained an excellent waveform to beyond 10MHz with hardly any perceptible drop in amplitude with rising frequency. The triangle wave gave similar performance, with slight rounding of the points observed as the maximum was approached.

Some ringing was noted with the square wave above 1MHz, though a surprisingly good waveform was maintained to beyond 5MHz, which is going some for a square wave! Above this frequency, rise and fall slopes were a bit more visible, with small "dips" in the flat portions as maximum was reached.

It is likely that most of the imperfections seen were due mainly to the leads, probes and other limitations of the scope used, rather than to distortion *actually* present in the output.

OUTPUT LOADING

IC3 dissipates heat when driving an output load. Consequently, to avoid damage, it should be fitted with a small heatsink. With the prototype, a piece cut from a heatsink similar to those used for the voltage regulators was glued to IC3 with a dab of resin adhesive, as seen in the photograph of this board.

Approx Cost
Guidance Only

£75

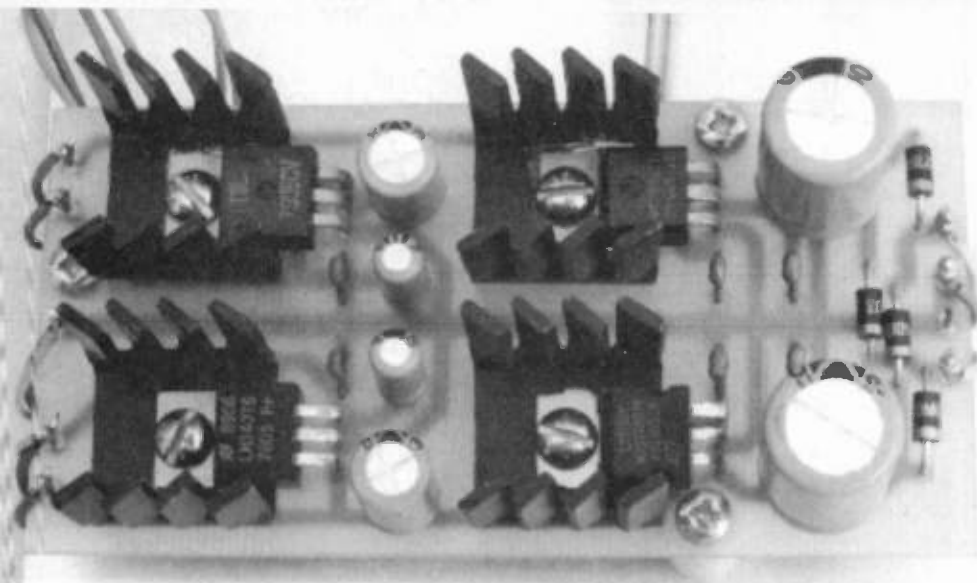

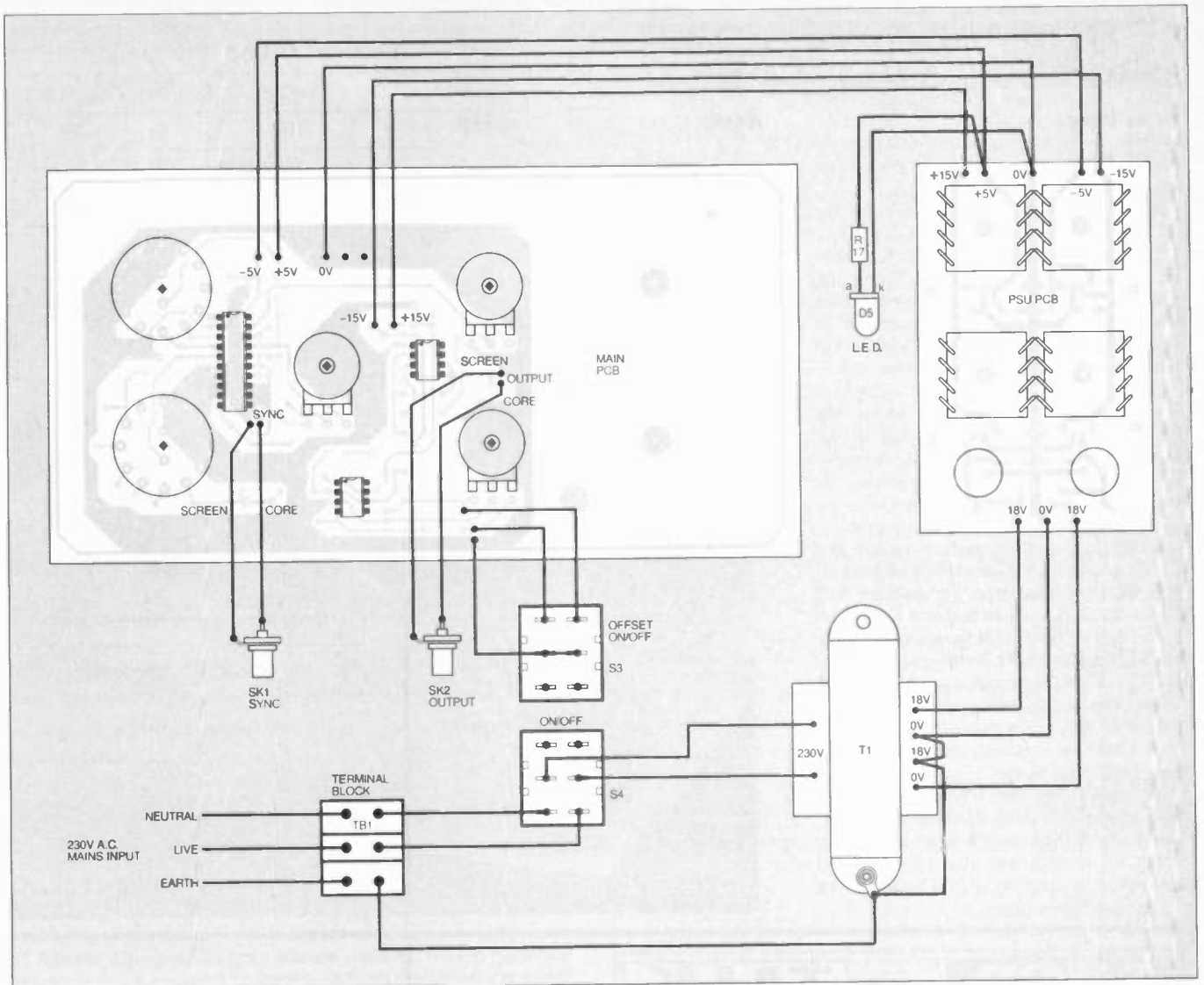

Fig. 7. Interconnecting details for the printed circuit boards.

Output loading should be kept in mind when using the instrument. The output of IC3 is internally limited to about 80mA, so the worst case would be a short-circuited output with a 5V offset applied. In this condition heat dissipation within the i.c. could be just under one watt. Obviously an 8-pin d.i.l. package will not stand this for long. Even though the output impedance is further limited to 50 ohms by the parallel resistors R15 and R16, the first rule is to avoid this condition!

However, an instrument such as this will not normally be used for driving heavy loads with large voltages, so it should not be a problem. A more typical case might be driving a 50 ohm load with a 3V peak-to-peak signal, where the dissipation is only about 160mW. With the heatsink it can sustain this indefinitely.

COMPLETION

Final assembly consists of fitting sockets SK1 and SK2, switches S3 and S4, and the l.e.d. D5 plus its resistor R17 to the panel and connecting them as shown in Fig. 7. This resistor should have its leads insulated with some heat-shrink film or insulating tape. Screened leads should be used for the sockets, keeping them as short as possible.

The front panel and p.c.b. have to be slotted into position together, so it is preferable to first make the connections between them, fit leads for the remaining connections, and then place them in the case.

CALIBRATION

Calibration of the Frequency control VRI is best carried out with the help of a frequency meter, the author's *Analogue Frequency Meter* project in *EPE* February '96 being well suited to this task.

One of the middle ranges, perhaps the 1kHz to 10kHz range, can be used, the

control positions being marked "1" to "10". All the ranges on the prototype actually reached the "11" point, so this was also marked. The Offset control can be calibrated with a d.c. voltmeter. The output Level control can be calibrated with an oscilloscope, or a DVM (digital voltmeter) set to an a.c. range can be used

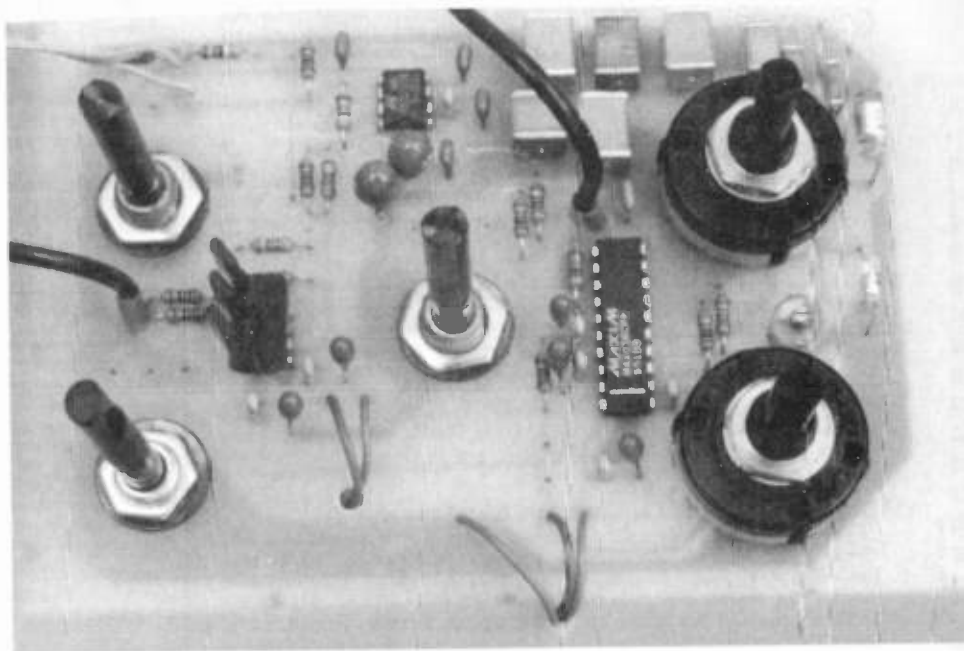

if a low frequency sinewave is selected; about 70Hz would be suitable.

Note that a DVM will show the level in volts r.m.s. whereas a function generator output is usually calibrated in volts peak-to-peak, so the reading on the meter should be 0.354 times the value to be marked on the control.

For instance, to calibrate the point for "2", the level should be adjusted for a DVM reading of 0.708V. The logarithmic potentiometer used for VR3 in the prototype gives 1.5V at just over centre scale, 2V at about 2.0 o'clock and 5V at about 3.0 o'clock, giving some idea of the low-end range expansion to be expected.

There will undoubtedly be occasions when a lower range of output levels will be needed. This is not provided in the instrument itself as it might cause degradation of the signal at high frequencies. In many cases a simple external resistive attenuator as shown in Fig. 6 can be used.

Table 1 shows component values and arrangements for various levels of attenuation, using resistors from the ordinary E12 range. These have been selected for use on the assumption that this design has an output impedance of 50 ohms, and that they will be driving an input impedance of 50 ohms. This means that stages can be connected in series, e.g. two 1:10 stages will give 1:100 for a 100mV range, three will give 10mV and so on.

Be aware that the 1:2 and 1:5 stages may cause excessive dissipation in IC3, especially if used with a large output d.c. offset so, as this will also be attenuated anyway, it is better to keep it switched out when using attenuation. □

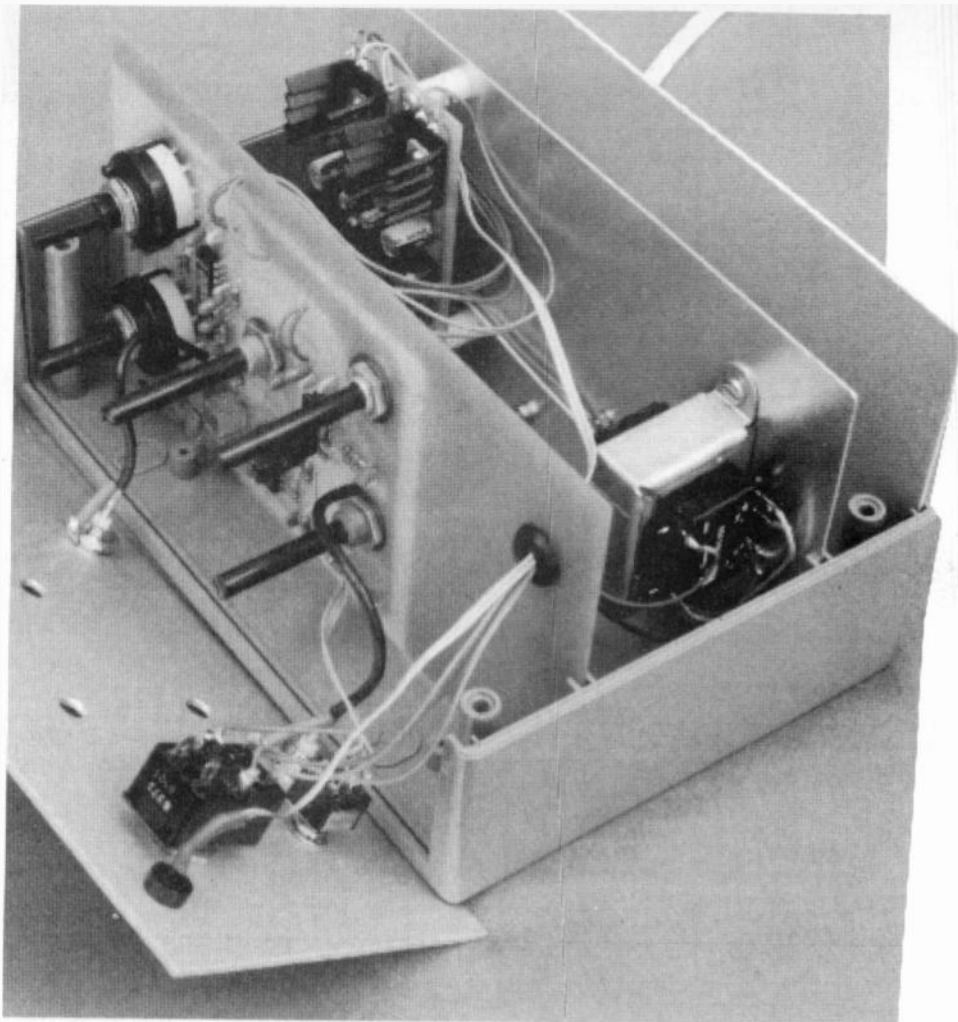

SHOP TALK

with David Barrington

10MHz Function Generator

The Maxim MAX038CCP waveform generator chip which forms the heart of the 10MHz Function Generator project can be obtained from **Electromail** (#01536 204555) code 810-396, or **Maplin** (#01702 554161) code DT25. We understand, Maxim will also supply direct against credit card orders (#Tel: 01734 303388).

To date, the only source we have found for the current feedback op.amp type EL2160CN (Elantek) has been **Electromail**, see above. Quote code 177-5424 (the four digit bit is correct!).

The 6VA twin 18V secondary mains transformer used in the final model also came from the above company, code 804-919. The 20V version mentioned in the article is a **Maplin** WB16S. This can be used, but costs about twice as much and will warm-up the p.s.u. chips a bit more! The case was purchased from **Maplin**, Verobox 203, code LL07H. Don't forget, if you elect to use i.c. sockets they *must* be high quality low-profile types.

Vehicle Alert

Two most important points to remember when building the *Vehicle Alert* are: the unit has been designed for continuous operation from the mains supply – so take extreme care; and the use of a "fully isolated" jack socket for connecting the remote sensor to the main unit. Obviously, the main unit must therefore be situated in a *dry indoor location* close to a mains supply socket. Use double-insulated cable for all external interconnections.

A 3.5mm plastic-bodied chassis mounting jack socket should be widely available, but if difficulties do arise order the CX93B socket and HF80B plug from **Maplin**. They also supplied the mains transformer, code WB01B.

The special "air" pressure switch can be purchased from **Electromail** (#01536 204555), code 407-209. Finally, use nylon nuts and bolts for securing the pressure switch, circuit board and buzzer in position.

Direct Conversion Topband and 80m Receiver

Several items called-up for the *Direct Conversion Topband and 80m Receiver* are "special" components and may not be available from your favourite component advertiser. The 10-turn "tuning" potentiometer, used in the model, is of Spectrol (534 series) manufacture and, for the value specified by the author, appears to be only listed by **Farnell** (#0113 263 6311), code 351-829. They are also the only supplier of the larger size

"counting" drive mechanism, all-be-it a 15-turn type, code 146-835. The 10-turn pot. will govern the drive "count".

The varicap diodes and Toko inductors were all purchased from **Cirkit** (01992 448899). For the inductors type KANK3333R quote stock code 35-33330 and 35-33340 for KANK3334R(L3). For the KV1235 "triple" varicap diode quote 12-12355.

Video Fade-to-White

All components required to put together the *Video Fade-to-White* project should be readily available from most of our component advertisers. A low power version of the 555 timer, such as the TS555CN, is recommended for the Fader to avoid any possible power supply problems and also has a faster response.

For details of all this month's p.c.b.s, see page 803.

TAKE NOTE

Component Analyser

Page 590, Fig. 1 and "Comp. List". Resistor R2 should ideally be 100k *not* 47k. Fig. 2, Blue probe lead should connect to IC7c pin 9 instead of 3. The p.c.b. is correct.

Simple Exposure Timer

To ensure safety, there should be *NO* touchable *metal* parts on the *outside* of the case. Also you must use double-insulated cable for *all* external leads.

August 1996

September 1996

HIGH QUALITY LOW COST
C.C.T.V. CAMERA
VERY LOW LIGHT LEVEL.
AUTO ELECTRONIC SHUTTER.
COMPOSITE VIDEO OUT VIA
BNC PLUG.
SMALL DISCRETE SIZE.
CAN BE USED WITH PC DIGITISER.

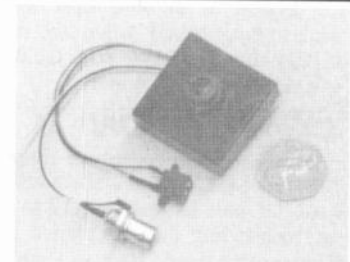

This super quality CCD camera can be connected into your existing TV or video using the AV channel and can be used for discrete surveillance or observing your property externally using a suitable weatherproof housing. Can accommodate lighting levels ranging from daylight to street lighting using its built in electronic shutter. Excellent when using with an infra red source. Built in wide angle fixed focus lens the camera has a resolution of 380 TVL. Can be housed inside an empty floodlight case. (extra).

Special offer price of only: £79.95 Plus VAT (P&P £3.50)

For full range of CCTV products send SAE to:
Direct CCTV Ltd., Dept. PE27., Direct House, Florence Street, Middlesbrough TS2 1DR.

YOUTH SCORES AGAIN IN DURACELL AWARDS

From Laser Plumb Bob to Vibration Data Logger, Sailcraft Speedo and Super-safety Domestic Irons, they're winners! – Hazel Cavendish

IF WE had any need to be reminded that Britain's young are leading from the front in innovative technology, this year's prizewinners in the fourth annual Duracell Science and Technology Schools Competition – run in conjunction with the Association for Science Education – proves it beyond any doubt.

Entries came from schools all over England, Scotland, Wales and Northern Ireland. It is interesting that neither a London school nor any of the major public schools produced a finalist, with the state sector and small private schools in the provinces emerging strongly in science education.

Quite apart from the 16-year old overall winner's original and marketable invention (for which a patent has already been lodged) the competition is notable for introducing one of the youngest inventors in the country, an 11-year old Polish boy who is a finalist for the second year running.

Although only one girl is amongst the finalists this year, a North country science teacher remarks that her sex are featuring outstandingly in science classes, particularly when the subject is introduced in the nine to ten years age group in middle school.

Mike Amos, Duracell's Vice President of Human Resources for Europe, says "This year's entries continue to demonstrate the wealth of enthusiasm and creativity being fostered in our schools". Competition Judge Maggie Hannon, who is Senior Inspector, Science, for the Liverpool Education Authority, has commented on the improvement in quality this year of both the students' written work and the finish of the devices.

The Duracell competition is designed for 15 to 17 year olds, but is open to younger students, although they are judged by the same criteria as the older ones. Five first prize winners are selected – six this year because one invention was developed by a two-boy team – and as well as winning prizes for themselves and their schools, student's devices are in contention for the overall prize of an all expenses paid trip to the USA, awarded for outstanding creativity and innovation.

Bob Plumbs It!

This year Robert Jordan, aged 16, a pupil at Woodlands High School in Gillingham, Kent, was the overall winner,



Robert Jordan (16) and his award winning Laser Plumb Bob.

receiving his prize from the Royal Society in London and winning £1,000 for his school technology department and £250 for himself with his battery-powered "Laser Plumb Bob". His trip to Massachusetts will include a visit to the famous Institute of Technology there – a thrill for anyone with a bent for technology.

Robert was working with his stepfather at a building site where workmen were erecting partition walls when he got the idea which inspired his award-winning device. He watched the workmen using a plumb bob and line to ensure that ceiling fixings were fitted directly above and perpendicular to predetermined markings on the floor of the building. He noticed that they were finding this a precarious, tedious and labour-intensive task, and went away to think of a way technology could be used to help.

A year later he had designed and made his Laser Plumb Bob at the school's Young Engineers' Club, with advice from his science teacher. His plumb bob sits on a tripod, using gravity to ensure it is precisely vertical. A gimbal, made from a large ball bearing with a pendulum holding the battery, is set on smaller roller bearings which compensate for any unevenness on the floor or surface. A laser diode with a low divergence beam points upwards from inside the ball bearing. When switched on, it shoots the laser at the ceiling, leaving a mark indicating the required position of the wall.

The Laser Plumb Bob will also have other uses, such as detecting the movement of a bridge. It will cost about £100 to manufacture.

Vibration Logger

Eleven-year-old Martin Rosinski, the son of a Polish scientist now working at Newcastle University, emerges as a finalist for the second time, having beaten children more than three years older than himself. He has produced the prototype of a "Shipment Vibration Data Logger" which can establish exactly when valuable equipment is damaged during transit.

His device monitors acceleration levels by using a microcontroller linked to an analogue-to-digital converter, which systematically records the output of a miniature accelerometer. The data on the shock or vibration levels that a package of fragile instruments receives during shipment is stored in the form of a histogram. An intelligent liquid crystal display provides a simple way of displaying the required information.

"Martin is a highly gifted boy, and ideal scientist material," said David Elliott, his science teacher at Coates Endowed Middle School at Ponteland near Newcastle. "He is away ahead of his contemporaries, and very probing with his questions, with a mind always looking

ahead. He is well beyond GCSE standard with this latest project. In fact, after winning this prize he is already working on ways to reduce the size of his device with an output to a computer."



With his Vibration Logger, Martin Rosinski (11) beat children more than three years older than himself.

Sailboard Speedo

A two-boy team from Monmouth School has won equal first prize for an interesting "Sailcraft Speedometer" which measures and displays the speed of a dinghy or – appropriately for our times – a sailboard. This should prove useful for competition use as sailboards have become a hot number among the young.

Now skippers and sailboarders can improve their technique by getting the optimum performance from their craft. Air speed has proved not to be an accurate or entirely useful measurement when sailing, and using land speed for a water-based object is complicated and relatively expensive.

Matt Chandler and Will Johnson have based their device on measuring the water speed as it flows past the craft. An impeller is used to rotate a slotted disk through a photoelectric gate. This generates pulses which are counted and numerically output to a display.

Modern Iron Age

The two other finalists have based their inventions on the domestic iron, showing the intelligent interest young scientists can bring to solving everyday household problems.

Simon Lee Todd of Bolton School was so upset when his mother burnt a hole while ironing his favourite pair of trousers that he set out to perfect an "Iron Safety Device". Countless housewives will have cause to thank him if it reaches the market.

Simple as so many of the best inventions are, his electric iron has a circuit which triggers an alarm when the iron is horizontal and *does not* move for more than five seconds.

When the iron is placed in a horizontal position a mercury tilt switch is closed, which activates a timing device.

The time is constantly reset by a vibration detector which pulses open and shut when the iron is in motion. If the iron stops moving and the mercury switch is still closed, the five-second countdown will end and the alarm will be triggered. The iron is easily reset by merely placing it in the vertical position.

Lucy Ann Eyles of Matravers School, Westbury, demonstrated a pragmatic concern for the problem of inadvertently putting away a dangerously hot iron at the conclusion of ironing, or touching it when it is still hot and sustaining a painful burn.

Her solution is an iron stand made from heat-proof material which not only covers the whole of the metal plate and stops the ironer from

burning his or her hands, but also utilises a sensor in the form of a bimetallic strip which switches on a light emitting diode when the temperature hits 40°C, and thus warns the operator not to touch the iron until the light goes out.

It is so simple and yet basic that one wonders why no manufacturer has thought of it before – perhaps because manufacturing design has been dominated by men up to now?

HIGHER-TECH X-RAY SYSTEM

The first London hospital implements revolutionary archiving X-ray techniques – by Hazel Cavendish

LOCKHEED Martin, the US giant most commonly associated with Defence developments of awe-inspiring complexity, would appear to be beating their swords into ploughshares – in a manner of speaking. One of the most exciting developments in hospital efficiency this century has been introduced at a cost of £8 million to the Hammersmith Hospital in West London, where the entire conventional X-ray set-up has been replaced by the American firm's electronic X-ray archiving and communication system.

The new picture archive with its high quality monitors cuts out the need for hundreds of thousands of X-ray films which the hospital produced, filed and handled each year, replacing them with 160 workstations in every department of the hospital, from wards and operating theatres to outpatient and casualty units.

Hammersmith is only the second hospital in Europe to adopt this electronic system; the other is the Danube Hospital in Vienna.

The Lockheed Martin Western Development Laboratories, which have long specialised in integrating complex information systems, have given the world the Vantage Picture Archiving and Communication system (PACS) as a digital and image management system for diagnostic examinations and powerful, high-speed communication network.

The core of Vantage PACS is the Information Storage Unit, an integrated central host computer and image storage system. In its smallest configuration it processes 150 requests for image transfers per minute, and at its most powerful, 600 per minute.

Described as a "breath-taking development" by Dr Nicola Strickland, consultant radiologist responsible for implementing the system, it will not only make doctors' work immeasurably quicker and simpler, but will increase efficiency throughout any hospital adopting it, and greatly benefit the patient – particularly those in intensive care.

OUR COVER PHOTO

THE dramatic photograph on our front cover shows the capture of the *Intelsat VI* (F3) communications satellite by three crew members of the Space Shuttle *Endeavour* on mission STS-49. The astronauts from left to right are: Richard J. Hieb, Thomas D. Akers and Pierre J. Thuot.

Intelsat VI was launched on 14 March 1990 by a Titan rocket but due to a malfunction it was not raised to a geosynchronous orbit. The main goal of the mission was to capture the satellite and bring

it into the cargo bay where a new perigee kick-motor was installed.

For the first time in the Shuttle's history, three members participated in an Extravehicular Activity (EVA). Mission STS-49 (7-16 May 1992) was *Endeavour's* first flight.

Whilst *Intelsat* is not a television satellite, the photograph does set the scene for our *Introduction to Satellite Television* feature this month. Photo has been used by courtesy of NASA/Science Photo Library.

Upgraded PIC16C84

MICROCHIP have introduced the PIC16C84A EEPROM-based microcontroller, an upgrade on the popular PIC16C84 used recently in several *EPE* projects. The new device features a greater endurance performance than the standard version – 10 million erase/write cycles compared to one million. The other parameters remain unchanged.

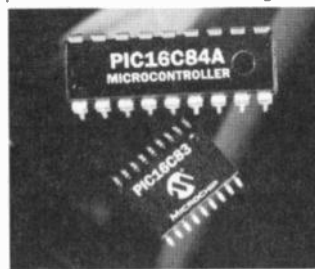

Simultaneously introduced is the PIC16C83, which is also an EEPROM-based microcontroller, but which has a reduced memory capacity of 512 x 14 bits, whereas the '84 has 1024 x 14 bits. Also coming up from Microchip are the PIC16CR84 and PIC16CR83 EEPROM data/read-only memory versions for users with stable program codes.

For more information, contact: Arizona Microchip Technology Ltd., Dept. EPE, Unit 6, The Courtyard, Meadowbank, Furlong Road, Bourne End, Bucks SL8 5AJ. Tel: 01628 851077.

New SMPSU Chips

NATIONAL Semiconductor have expanded their Simple Switcher-power converter family with the introduction of two new 3A flyback power converters. Called the LM2585 and LM2586, the i.c.s are DC/DC converters which deliver high power in a small form factor and are designed for ease of use.

The new devices feature an increased operating frequency of 100kHz, allowing designers to specify smaller external magnetic components and capacitors, shrinking the overall p.c.b. area. Other advantages include: synchronisation of multiple devices; external turn-off; flyback, forward and step-up modes; availability in 3.3V, 5V and 12V versions.

They are also supported by "Switchers Made Simple" design software which provides complete design solutions, including schematics, component lists and vendor information.

For more information contact: National Semiconductor European Customer Support Centre on (X) 49 180 5327 832. National's World Wide Web site can be found at: <http://www.national.com>

Connect

National Consumer Electronics Show
A VISION OF TOMORROW AT CONNECT

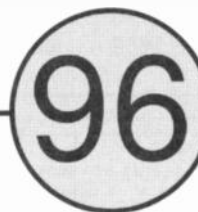

THERE are 20 pairs of tickets to be given away *Free* to *EPE* readers for *Connect 96* at the National Consumer Electronics Show taking place at Birmingham's NEC from 18-27 October 1996.

Connect is proudly proclaimed by its organisers to be "an entertainment experience transporting you into tomorrow's electronic world". It will feature a custom-built TV studio, giving a unique insight into the world of television and a sneak preview into Central's new £15 million HQ in Birmingham.

The Connect Sound Stage will be a state of the art "UFO" structure and will be the focal point for the impressive entertainment line-up planned for the show, which includes top chart bands, DJs, light shows and special effects displays.

There will be interactive displays, a Hi-Fi and Home

Cinema Theatre, New Media Village, and the latest in home entertainment products which can be purchased at the exhibition in the Retail Village.

Connect, the Home PC Show, Autumn Ideal Home Show and the International Motor Show are all taking place simultaneously. Connect tickets cost £7 for adults and £5 for children and senior citizens, and include entry into the Autumn Ideal Home Show and Home PC Show. *BUT*, the first 20 callers to phone 0121 767 4114 will each get a pair of tickets *free* – as long as they also quote "Everyday Practical Electronics, reference C09". (*Don't phone us direct at EPE for these tickets – we haven't got them!*)

This offer has been made available through the Home Interest Division, dmg Exhibition Group Ltd.

INTERFACE

Robert Penfold

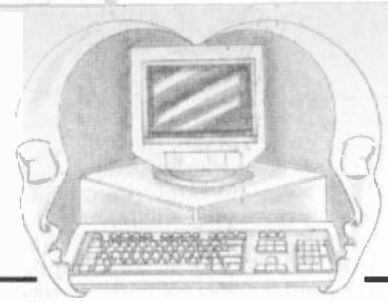

DIGITAL CAPACITANCE METER INTERFACE

A PC-based Transistor Tester was described in last month's *Interface* article, and this month we continue in a similar vein with a PC-based Digital Capacitance Meter.

The unit has four measuring ranges of zero to 2550pF, 25.5nF, 255nF, and 2.55 μ F. It is based on six inexpensive integrated circuits, and it interfaces to the host PC via one of its printer ports.

Counting On It

The block diagram of Fig.1 helps to explain the basic way in which the Digital Capacitance Meter Interface functions. It operates using a simple gate and counter system. A clock oscillator feeds into a nine-bit binary counter via a gate. The latter is controlled by a monostable. The duration is controlled by a monostable.

The duration of the output pulse from the monostable is governed by the value of a resistor and a capacitor. The capacitor is the component "under test", and the pulse duration is proportional to the value of the test component.

Suppose that the clock frequency is one kilohertz (1kHz), and that the monostable produces an output pulse of one millisecond per nanofarad (ms/nF) of test capacitance. At the end of the pulse, the value stored in the counter would be equal to the value of the test component in nanofarads. For example, a 150n component would produce a pulse duration of 150ms (0.15 seconds), and with 1000 clock pulses per second this would result in 150 pulses being fed to the counter.

In practice, the monostable actually provides a pulse duration of under 100 nanoseconds per nanofarad. However, the clock frequency is made proportionately higher so that the correct relationship between capacitance and final counter value is still obtained.

The clock frequency is made adjustable so that it can be trimmed to compensate for any variations from one monostable to another, and the unit can be accurately calibrated against a close

tolerance capacitor. The monostable has four switched timing resistors, and these give the unit its four measuring ranges.

On Display

The computer provides the display and most of the control logic. Each control cycle starts with a handshake output of the computer pulsing high to reset the counter to zero.

Interface Circuit

The main circuit diagram for the Digital Capacitance Meter Interface is shown in Fig.2. The circuit for the eight-bit input port and connections to the printer port are provided in Fig.3.

Taking Fig.2 first, the clock oscillator is a standard 555 astable (IC1). Its output frequency can be trimmed using pre-

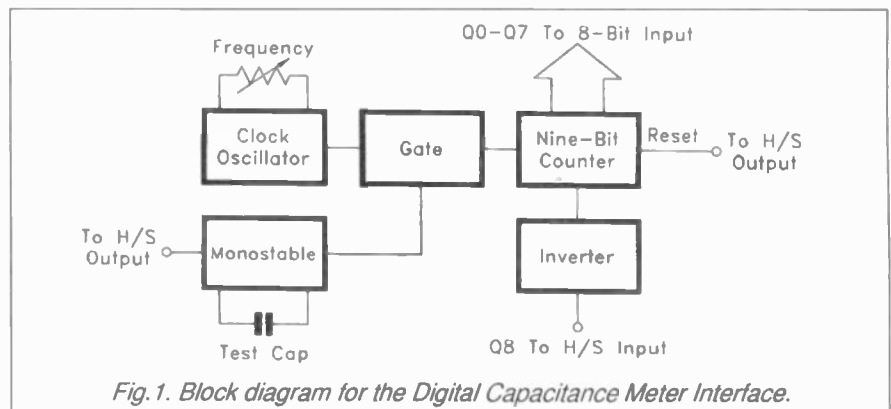

Fig.1. Block diagram for the Digital Capacitance Meter Interface.

Next, another handshake output pulses high in order to trigger the monostable. The computer then waits long enough for the pulse to end, and reads the contents of the counter via an eight-bit input port.

There is a slight snag in that the printer port does not actually have eight inputs. Four handshake inputs and a handshake output, plus some simple logic circuitry, are used to read the counter a nibble (four bits) at a time.

The counter is a nine-bit type, but the system only has eight-bit resolution. The ninth bit of the counter is used to provide an overflow warning if the test capacitance is too high for the range in use. If the maximum count of 255 is exceeded, bit nine goes high, and this is detected by a software routine via a handshake input of the printer port.

set potentiometer VR1, and it is typically about 16kHz to 17kHz. IC2a and IC2b act as the signal gate, and they enable the clock signal to pass through to the counter (IC3, IC4) when the input signal to IC2a is "high".

The other two NOR gates in IC2 are used in a simple CMOS monostable. S1 is the range switch, and resistors R6 to R9 are the Range resistors. In order to obtain good accuracy on all ranges R6 to R9 should have a tolerance of one per cent.

The full scale value is 2.55n with R6 in circuit, running through to 2.55 μ with R9 switched into circuit. The test component can be an electrolytic or other polarised type, but it *must* be connected with the polarity indicated in Fig.2.

It was possible to obtain a fifth range on the prototype interface using a timing resistance of about 1.2 kilohms (1k2). This

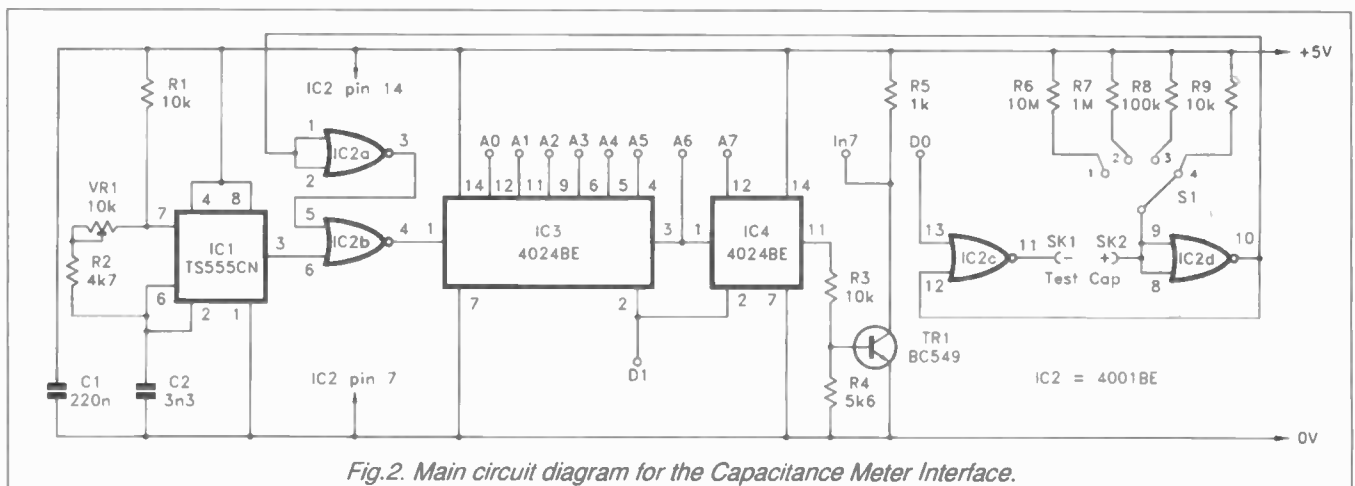

Fig.2. Main circuit diagram for the Capacitance Meter Interface.

gives a full scale value of 25.5 μ , but it cannot be guaranteed to work well on all units built to this design. The extra timing resistor *must be a preset* type so that it can be adjusted to give accurate results.

The counter circuit is comprised of two 4024BE seven-bit counters wired in series (IC3 and IC4). Only the first nine outputs are used, and the final five outputs of IC4 are left unconnected.

The eight least significant outputs drive the eight-bit input port, and the ninth bit drives a handshake input via an inverter based on transistor TR1. The inversion provided by TR1 is not actually of any significance, and its real purpose is to ensure that the CMOS output of IC4 can drive the TTL compatible input of the printer port.

Input Port

The 8-bit Input Port (Fig.3) is basically the same as the one described in the *Interface* feature published in Feb '95 issue of *EPE*. The main difference is that IC5 has been changed from a 74LS244 to a 74HC244 octal buffer. This gives sufficient drive to operate the TTL compatible inputs of the printer port, but also gives CMOS compatible inputs that will interface to the counter circuit correctly.

The only other change is that a CMOS inverter (IC6) has been used in place of the 74LS TTL type of the original design. For a detailed explanation of how this port functions refer to the Feb '95 issue (see Back Issues page).

Five handshake inputs are available on the printer port, and bits three to six of the handshake address are used to provide the eight-bit input port. This leaves bit seven free to read the overflow output of the counter. One handshake output is used to control the eight-bit input port, leaving three unused, plus the eight data outputs of the port.

The suggested method of connection uses data output D0 to trigger the monostable, and D1 to reset the counter. Using two data outputs rather than handshake outputs avoids the possibility of inadvertently upsetting the operation of the input port when controlling the interface (or vice versa).

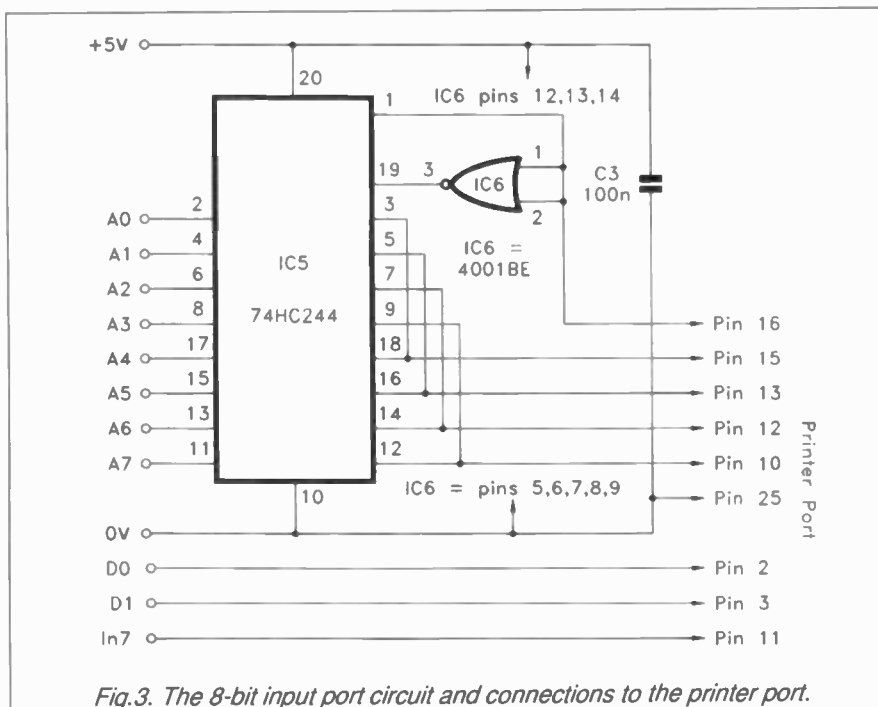

Fig.3. The 8-bit input port circuit and connections to the printer port.

Listing 1: Digital Capacitance Meter Interface Program.

```

10 REM capacitance meter program
20 CLS
30 LOCATE 7,30
40 PRINT "RANGE 3"
50 B$ = "n"
60 R = 1
70 OUT &H378,0
80 OUT &H378,2
90 OUT &H378,0
100 OUT &H378,1
110 OUT &H378,0
120 A$ = INKEY$
130 IF A$ = "1" THEN GOSUB 380
140 IF A$ = "2" THEN GOSUB 430
150 IF A$ = "3" THEN GOSUB 480
160 IF A$ = "4" THEN GOSUB 530
170 IF A$ = "s" THEN END
180 FOR D = 1 TO 1000
190 OVER = INP(&H379) AND 128
200 IF OVER = 128 THEN GOSUB 350
210 NEXT D
220 OUT &H37A,0
230 X = INP(&H379) AND 120
240 X = X/8
250 OUT &H37A,4
260 Y = INP(&H379) AND 120
270 Y = Y * 2
280 Z = X + Y
290 Z = Z * R
300 LOCATE 5,30
310 PRINT " "
320 LOCATE 10,30
330 PRINT Z B$
340 GOTO 70
350 LOCATE 5,30
360 PRINT "OVERLOAD"
370 RETURN
380 R = 10
390 B$ = "p"
400 LOCATE 7,30
410 PRINT "RANGE 1"
420 RETURN
430 R = .1
440 B$ = "n"
450 LOCATE 7,30
460 PRINT "RANGE 2"
470 RETURN
480 R = 1
490 B$ = "n"
500 LOCATE 7,30
510 PRINT "RANGE 3"
520 RETURN
530 R = .01
540 B$ = "u"
550 LOCATE 7,30
560 PRINT "RANGE 4"
570 RETURN

```

Software

The program, Listing 1, is set to the appropriate range using keys "1" to "4" on the keyboard. To stop the program either press the "S" key or use the normal CONTROL-BREAK combination.

The program prints to the screen the range in use, and the capacitance value in the appropriate units (e.g. "1.57u" rather than simply "157"). Where appropriate, it also prints an "OVERLOAD" warning on the screen.

The first few lines of the program simply set up the initial operating conditions, and start the program on Range 3. Variable "R" is the value by which read values are multiplied in order to give a reading in the appropriate units. String variable "B\$" is the letter displayed after the value, and is either "p", "n", or "u".

Lines 130 to 160 detect if keys "1" to "4" have been pressed and, when appropriate, branch the program to one

of four sub-routines. These make the necessary changes to the two variables, and change the range number displayed on the screen. Line 170 detects whether or not the "S" key has been pressed, and ends the program if it has.

The Reset and Trigger pulses are generated at lines 70 to 110. Line 180 and 210 simply provide a short delay which prevents the port being read before the count has been completed. With fast PCs it might be necessary to use a higher value at line 180 in order to obtain a long enough delay.

Lines 190 and 200 read bit nine of the counter, and branch the program to a subroutine if it is set high. The subroutine simply prints an overload warning on the screen.

A simple routine at lines 220 to 280 reads the port. The returned value is then multiplied by variable "R" and printed to the screen followed by B\$. Line 340 loops the program indefinitely so that a continuous stream of readings are taken and displayed.

Note that the addresses found in this listing are correct for printer port 1. If you use printer port 2, addresses &H378, &H379, and &H37A should be changed to &H278, &H279, and &H27A respectively.

To calibrate the system, switch it to Range 2 and connect a close tolerance 22nF capacitor across sockets SK1 and SK2. Then simply adjust preset VR1 to produce the correct reading of "22.0n" on the screen.

Improvements

There are six unused data outputs on the printer port, and this should permit the unit to be fully controlled from the computer. Four of the unused outputs could be used to control four small relays which could be used in place of Range switch S1.

The software would then be modified to select the correct range resistor when one of the range keys was operated. It should be possible to implement a system of auto-ranging, and there is certainly plenty of scope for experimentation here.

INTRODUCTION TO SATELLITE TELEVISION

Mike Rutherford

The basic operation of current and proposed systems.

WELCOME to the world of satellite television. It has definitely come to stay! In a few years it has become firmly established across the world as a simple and reliable means of receiving television and radio broadcasts. It's simplicity, to the layman, is brought about by the incredibly sophisticated transmission and reception techniques to which have been applied mass-production techniques. The result is a well-priced product, but to reason that it is cheap because it is simple would be extreme folly.

It has all been made possible by the invention of the microchip which allows a lot of electronics to be crammed into a small space and is repeatable in vast quantities.

Satellite broadcasting has very few disadvantages but it does not herald the end of terrestrial transmissions. The latter have the advantage that, because of the need for several transmission sites to enable coverage of the entire country, regional programmes can be put out easily. Also, in the event of a war, the enemy cannot disable a network of terrestrial stations as easily as he can knock out one satellite by jamming it or by actually destroying it.

But, for the aspiring broadcaster with his sights on a National or Pan-European service, the satellite is the answer!

GEOSTATIONARY

The suggestion that a satellite could be stationed in an orbit around the Earth above the equator that would be synchronous with the Earth's rotation (geostationary) was first made by Arthur C. Clarke in the article *Extraterrestrial Relays* in *Wireless World*, October 1945.

Once a satellite has flown clear of the drag imposed by the Earth's atmosphere, it attains a linear speed of about 6900 m.p.h.. If the satellite remains close to the earth it will complete one orbit in less time than it takes the Earth to make one rotation. The surface speed of the Earth is about 1,000 m.p.h., the circumference at the equator is 24,000 miles and it takes 24 hours to rotate once. The Earth's angular velocity is 15 degrees per hour.

The satellite must achieve an angular velocity also of 15 degrees per hour to appear stationary from Earth. As the approximate speed of the satellite is 6,900 m.p.h., the circumference of its orbit must be $6,900 \times 24 = 165,600$ miles. Expressed as a radius this becomes 26,356. Subtract the radius of the Earth (4,000 miles) and you get 22,356 which is about 56 miles out, but the figures are all very approximate. In fact the Clarke Orbit is 22,300 miles above the Earth's surface and lays directly over the equator, see Fig. 1. The mathematics are fairly simple to understand, anyway!

We do not live on the equator! If we did we would perspire and our satellite dishes in some instances would face almost directly upwards. In our temperate climate at 53 degrees north we would get a view of the Clarke Orbit similar to the one shown in Fig. 2.

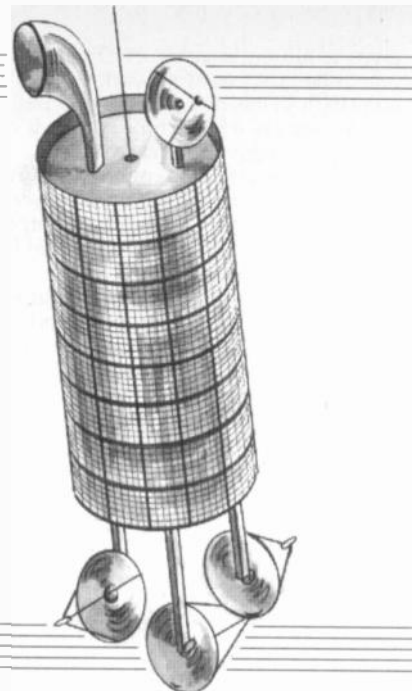

Facing true south we would get an elevation of nearly 40 degrees, and this would curve downwards off to the east and west. The total orbit sweep it is practical to use from 53 degrees North is about 120 degrees of arc (Fig. 2). At the extremities reception is curtailed by trees and buildings - not on the horizon but those close-by. Satellite reception demands a clear view of the satellite by the dish.

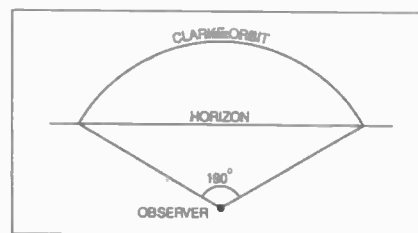

Fig.2. View of Clarke Orbit from Earth - approximate UK position.

UPLINK

Satellite TV programmes are sent up to the satellite from an earth station on a band of frequencies slightly above those used for the downward transmission into our homes. The uplink frequencies are in the 14GHz band. A powerful transmitter is used on the ground to ensure a clean signal is received by the satellite, 22,300 miles away (Fig. 3). One dish can send about eight channels or more to the satellite, though in theory a great many more could be accommodated. In practice, the number is kept down for other technical reasons associated with the combining of the outputs of several transmitters into one feedhorn on the dish.

The uplink signals are converted to the downlink frequencies by the equipment on board the satellite and each piece of equipment is known as a transponder. A transponder receives the incoming signal, converts its frequency to that used for the downlink and transmits it via the dish or horn antennas pointed back at Earth. The power output stage of the transponder is a travelling wave tube (TWT), a valve in fact, designed for producing power at microwave frequencies. TWTs have been

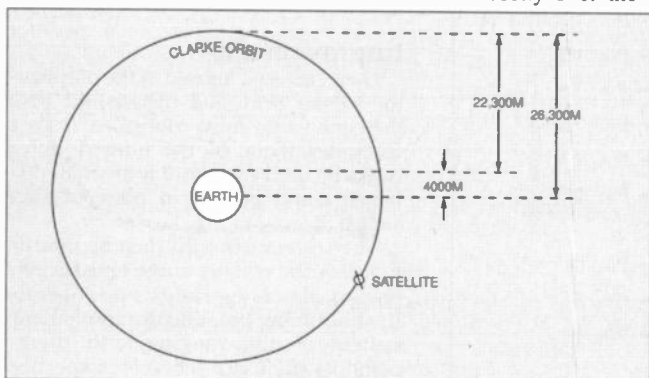

Fig.1. The Clarke Orbit.

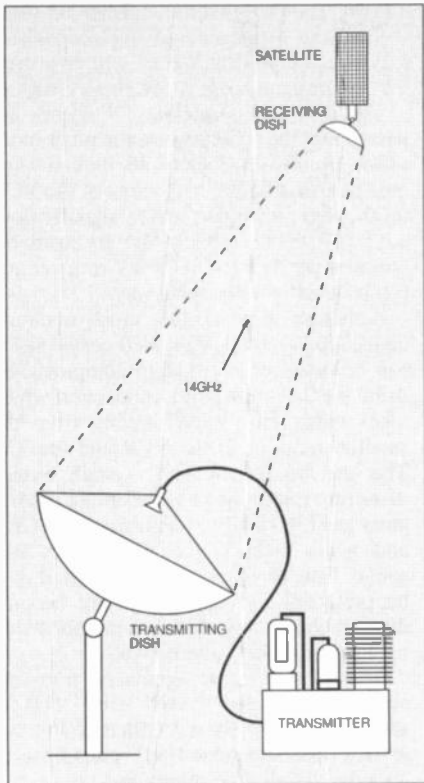

Fig.3. Arrangement of the uplink.

around since the Second World War. Because they are thermionic devices they have a limited life.

The dish or horn antennae used for transmitting the signals on the downlink back to Earth are shaped to give coverage of predetermined areas of the Earth's surface so that the strongest signals can be sent to where the "customers" are situated.

THE SATELLITE

Satellites are usually cylindrical (Fig. 4), though rectangular or spherical ones have been used and are in no way inferior. Power is derived from solar-cell panels which extend from the craft on stalks, and the outer shell of the satellite itself is sometimes completely covered by solar cells also. The cells generate current from the sun's radiation to provide operating supplies for the equipment on board, and to maintain the batteries in a fully-charged state.

Along with the batteries are containers of compressed gas. The gas can be directed to jets on the satellite's exterior to control the attitude of the craft in orbit, i.e. to keep the antennas pointing earthwards. This is necessary because the satellite's position drifts slightly, and has to be maintained in one spot accurately. (Otherwise we would have to keep moving our dishes down here on Earth!)

Obviously the quantity of gas available for attitude correction is finite, and is designed to last the life of the satellite – said to be about ten years. The maintenance of all of the satellite's systems on board is monitored by a telemetry channel accessed through a separate antenna on the craft. The travelling wave tube bays contain the power output stages of the transponders, sixteen in all on the *Astra* satellites.

At certain times of the day the satellite will move briefly into the shadow of the Earth, and the solar power will "drop out". This will occur during the night in the UK, possibly at peak viewing times, but the batteries take over the supply and re-charge again when the satellite leaves the Earth's shadow.

DOWNLINK

Satellite direct-to-home broadcasting is banned in Iran and some Middle-Eastern states. It is tolerated elsewhere but is

given Ku-band. This is also called the Water-Absorption Band because the signals in the frequency range 10.7GHz to 12GHz are attenuated by moisture. This means that satellite reception suffers when it rains or snows, and even thick cloud cover can reduce the signal strength to produce "sparklies" on your pictures.

In many countries the first choice of the available spectrum space for communication is given to defence, then to governmental and diplomatic agencies, and then to commercial users, and lastly to entertainment. Possibly this is how we got Ku-band!

However, Ku-band is not all that bad now that higher transponder powers are available and, on the receiving side, improved-performance LNBs (Low Noise Blocks) are available. The dish acts as a "magnifying-glass". A concave mirror magnifies as well as reflects, you can use a concave mirror as a burning-glass as it will concentrate the sun's rays by focussing them into one spot. The action of the microwave dish is similar, but works on radio frequencies instead of light-waves, focussing the radio waves from the satellite into the throat of the feed-horn on the LNB, see Fig. 5.

The LNB, is the small box fastened to the end of the pole that protrudes from the dish and has a funnel-shaped device which faces the dish. The LNB contains several separate items for the reception of satellite signals. It is sited at the focus of the dish to collect the magnified satellite signals from space. Microwave signals can be polarised vertically or horizontally.

POLARISATION

TV aerials are fitted vertically or horizontally, depending on the signal polarisation, a similar arrangement exists with satellite signals and it means that two transmitters can share the same frequency if they have different polarity. The selection of vertically or horizontally polarised transmissions is done by the LNB right at the input.

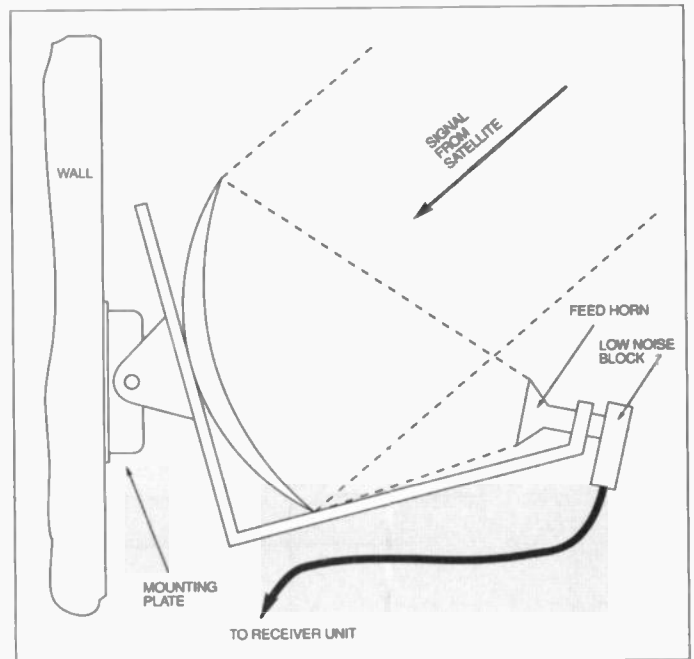
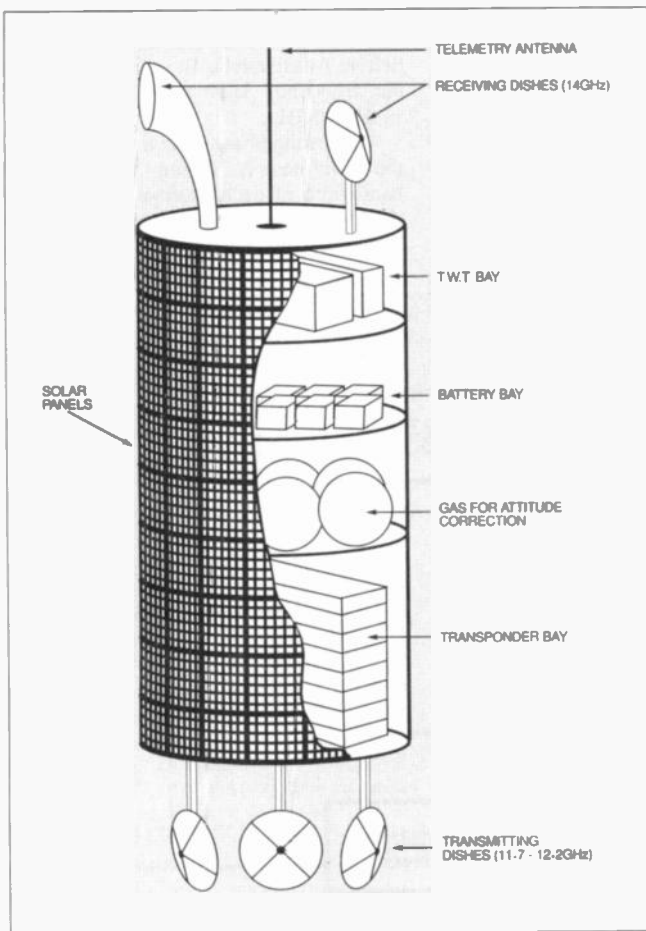

Fig.5 (above). Receiving dish and offset LNB.

Fig.4 (left). Arrangement of a typical television satellite.

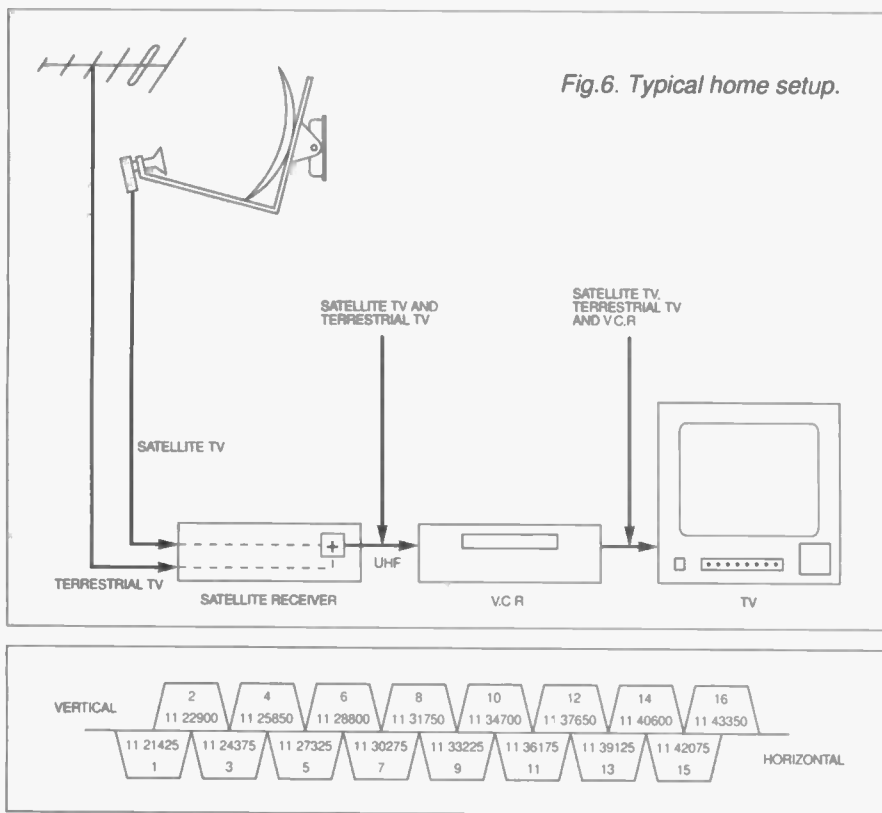

Fig. 7. Satellite downlink channel arrangement (frequencies in GHz).

The very weak signals from the satellite are then passed through amplifiers which are designed to contribute very little noise themselves, which would spoil reception with snowy pictures. Finally, the clean signals are then converted down en-bloc to a lower band of frequencies for piping to the receiver unit via co-axial cable. Very high quality co-axial cable should be used for this link to ensure the maximum possible signal transfer from the dish to the receiver unit.

The receiver enables the viewer to select the desired satellite TV channel, descramble it if necessary, and pass it to the VCR and TV, either in a standard form similar to terrestrial u.h.f. TV signals or as separate video and audio signals directly into the display section of the TV or the

video and audio recording circuits of the VCR.

HOME SET-UP

The commonest arrangement used in the average home which also sports a video cassette recorder will be the one shown in Fig. 6. The satellite receiver has a socket for the viewer's u.h.f. terrestrial TV aerial as well as the socket for the cable coming from the satellite dish. Within the satellite receiver are the tuner and descrambling circuits and a modulator, which is a small and rudimentary TV transmitter.

The u.h.f. terrestrial TV signals are passed through the satellite receiver and the selected satellite TV channel is added to them before they pass out of the "r.f." socket for onward feeding to the VCR or

TV set. The modulator is tuneable to allow the satellite TV channel to be placed where it does not cause interference to terrestrial TV. A similar system is used on VCRs.

U.H.F. TV plus satellite TV signals are passed into the VCR and here another modulator, usually on Channel 36, though some now use Ch. 60, adds the output of the VCR to the five incoming u.h.f. signals (four u.h.f. TV plus satellite). The six available channels are then fed to the TV receiver and can be tuned in the normal way.

Although this is the most common connection method, improved performance can be obtained on modern equipment by using the 21-pin SCART connection which takes video plus audio directly from the satellite receiver to the VCR and the TV. The use of the SCART system avoids distortion introduced by the simple modulators used in satellite receivers and VCRs, and gives cleaner, clearer pictures and sound. This direct connection method is to be preferred and eventually will become the first choice of connection methods with r.f. linking as the "alternative".

SCART-connected signals are normally accessed via the "AUX" or "EXT" selection button. Some VCRs and TVs call it "LI" etc, and some "S1" etc. On some TVs the "0" button selects it.

CHANNELS

Each transponder aboard the satellite is allocated a frequency and polarity. The standard frequency spacing employed is 29.5MHz between channels of similar polarity (Fig. 7). The standard spacing between adjacent channels of different polarity is a half channel-width, or 14.75MHz. The half-channel spacing virtually removes the possibility of crosstalk from adjacent channels of opposite polarities. There are four active satellites in the *Astra* group which can deliver 64 channels, 16 per satellite, within the frequency span of 10.71425GHz to 11.68550GHz.

The arrangement of channels for one of the satellites is shown in Fig. 7. The bandwidth of each channel is 27MHz and within that space is provision for one vision carrier and four stereo pairs (or

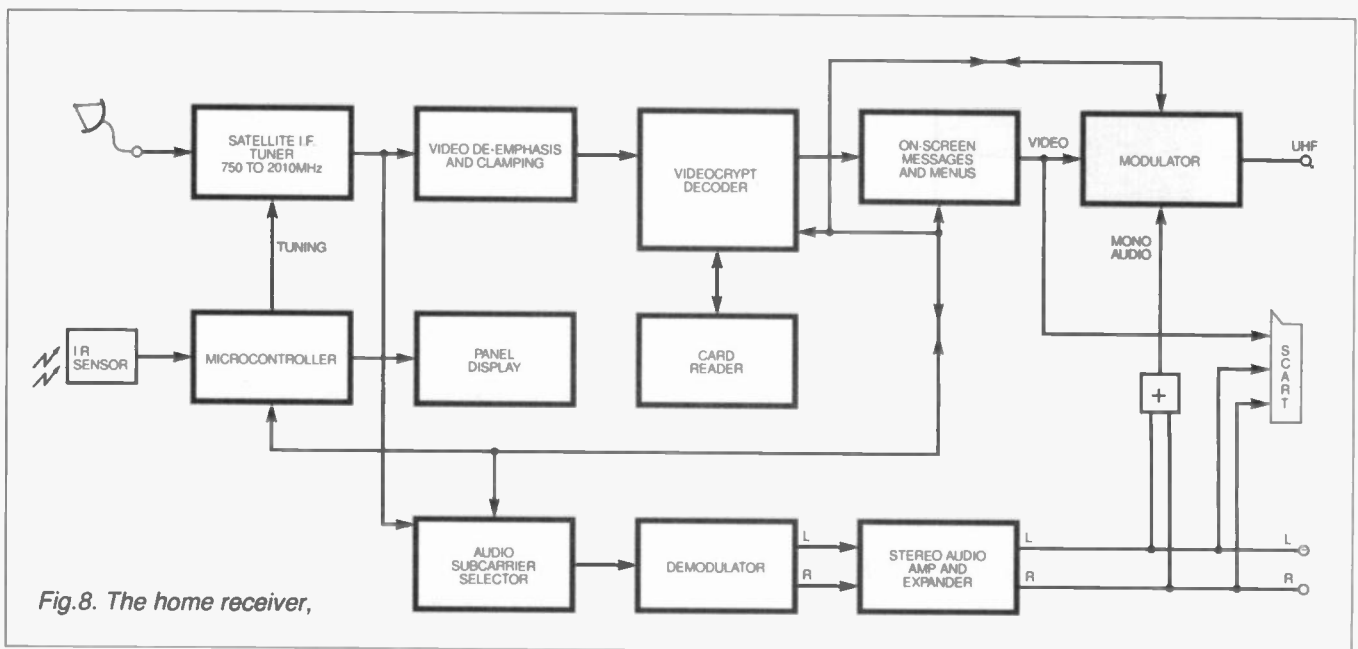

eight mono programmes) on subcarriers. In practice only three stereo pairs are used. The subcarriers are spaced at 7.02, 7.20, 7.38, 7.56, 7.74MHz and 7.92MHz from the vision carrier centre frequency. Sound and vision are frequency modulated. On some channels there still exists a single monophonic subcarrier at 6.5MHz, but this is being phased out rapidly to make way for digital radio. The frequencies quoted are for the unmodulated carriers.

RECEIVER

A block diagram of a typical satellite receiver is shown in Fig. 8. This consists of a tuner for selection of the desired programme, a descrambling circuit, normally for Videocrypt-encoded video, a section which puts up the on-screen messages like "Your card has expired" or the set-up menus, sound, and the output modulator circuit.

Sound is handled by a comprehensive set of circuits which will probably include the Wegener Panda Stereo expander circuits as well as the subcarrier selection circuits which enable the viewer to have speech in another language, for instance. There is a modulator provided also for viewers without SCART connections on their TVs or VCRs.

All functions within the receiver are under the control of the main microprocessor. This chip masterminds tuning, descrambling, on-screen messages, sound and the modulator output channel, amongst many other things. It also handles the infra-red remote control system, translating its commands into actions.

The receiver is powered from an electronic high-efficiency power supply, also under the control of the microprocessor, and enabling the receiver to be set to its standby mode when not required for viewing. In the standby mode some of the internal circuits of the receiver and the LNB on the dish are kept powered-up. This avoids tuning drift problems which may occur if the entire installation is powered-up from cold. It also allows the timer clock to function and enliven the receiver for a timed recording of a satellite TV programme.

MODULATION

Satellite TV uses frequency modulation (f.m.) at present. Terrestrial TV uses amplitude modulation (a.m.) at present, see Fig. 9. In amplitude modulation the strength of the carrier wave is varied by the video signal whilst the frequency of the signal is maintained constant. In frequency modulation the frequency of the carrier wave is varied by the video and audio subcarrier signals whilst the strength is held constant. This allows the transmitter to always operate at full power, improving the reception of such signals. It also ignores, to a large extent, any impulsive interference and is remarkably resilient under adverse reception conditions.

On the other hand, f.m. requires considerably more bandwidth, i.e. an f.m. signal would occupy about three times the spectrum space required by an equivalent a.m. service. In satellite TV there is, fortunately, plenty of space in the spectrum, at least, at present.

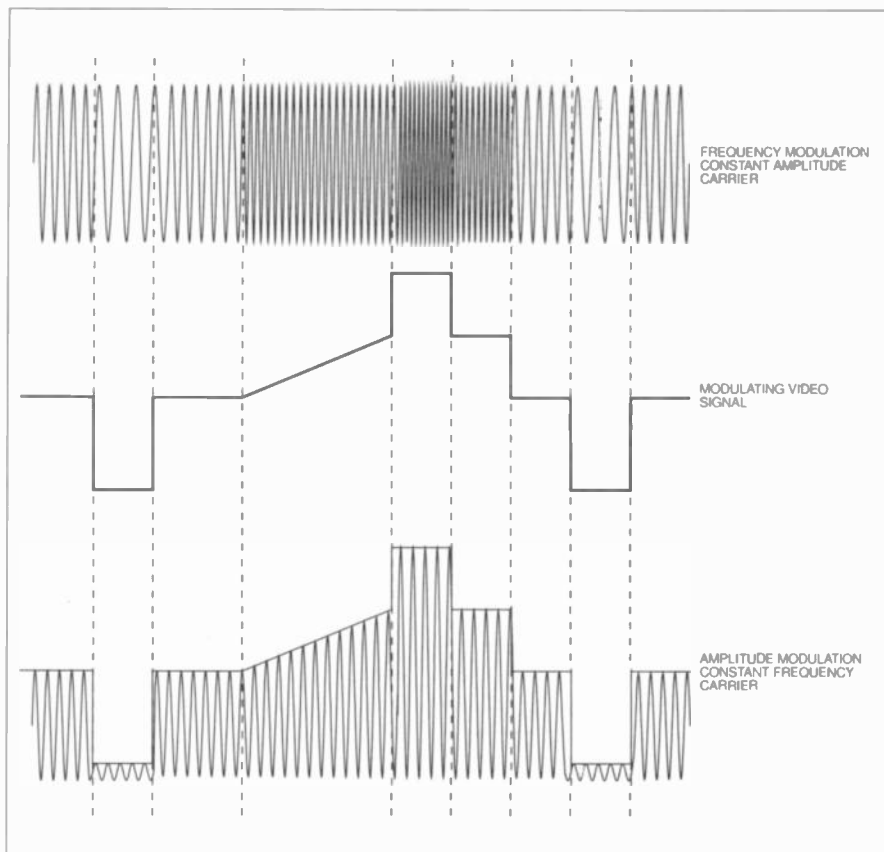

Fig. 9. Frequency and amplitude modulation.

CHANNEL SPECTRUM

The channel bandwidth is 27MHz and includes the audio subcarriers. The video bandwidth is standard for a 625-line signal, allowing a 5.5MHz bandwidth. For PAL colour signals the colour subcarrier is placed at the standard 4.4MHz. When demodulated and processed, the video signal is fully compatible with all 625-line TV receivers. Fig. 10 shows the channel spectrum.

Along with the picture signal (video), there are accompanying audio channels. Four stereo pairs are also available for use as follows:

- A: 7.02MHz and 7.20MHz
- B: 7.38MHz and 7.56MHz
- C: 7.74MHz and 7.92MHz
- D: 8.10MHz and 8.28MHz (not in use at present)

Some receivers allow selection of individual carriers of a stereo pair to permit multi-lingual monophonic operation. This means that up to eight separate mono audio channels can be accessed.

RADIO

On most of the TV channels there are spare audio subcarriers, and as most radio is in stereo at the present time, some television and radio stations broadcasting on the satellite as well as on terrestrial transmitters considered it useful to put their radio programmes on them. Currently there are 29 stations using *Astra* with more on *Eutelsat*.

Some of the stations are only in mono on terrestrial transmissions because they are using long or medium waves. BBC Radio 5 is an example, as is Virgin.

Not all of the transmissions are available all of the time, and many come and go. A notable bonus of satellite radio is the ability to receive BBC World Service, pushed off 464 metres some years ago and relatively inaudible on its other frequencies since then.

Obviously it is not necessary to use a television receiver to hear satellite radio if a small audio amplifier and a pair of loudspeakers is available close to the satellite receiver. Since the advent of radio on

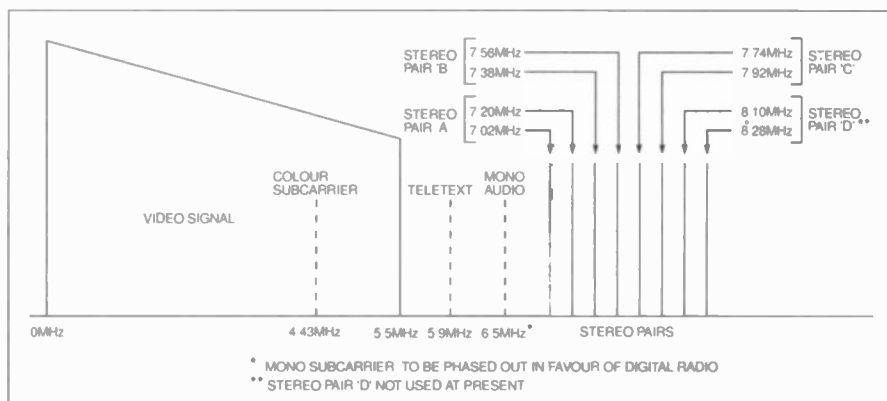

Fig. 10. Channel spectrum.

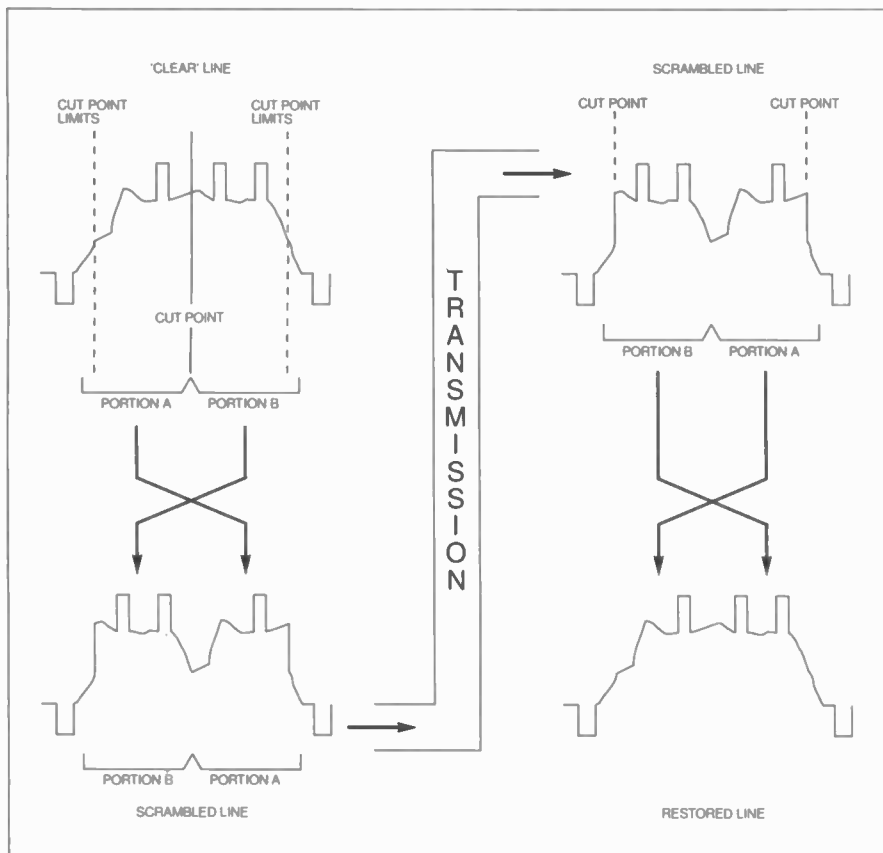

Fig.11. Videocrypt scrambling.

Astra many viewers/listeners have incorporated better audio facilities in their "TV corner", and all satellite receivers include audio output sockets.

SCRAMBLING

A television picture is made up of lines, in our case 625 of them, though only about 575 are used. The total duration of each line is 64 microseconds, though the active portion of the line is only 52 microseconds.

Videocrypt scrambling is achieved by taking the active portion of each television line and slicing it into two within the cutting limits in an apparently random manner (Fig. 11). The two portions are stored in memory, and the latter portion is read out of memory first, the former portion being joined onto it to give a line which makes no sense.

The apparently random manner (called pseudo-random) is actually a sequence of 65,000 numbers corresponding to the cutting-point of a line. It is generated by a computer and the pseudo-random byte sequence can be identified by a code called its "seed". Half of the seed is held in the viewing card, the other half is transmitted.

This is called the "cut and rotate" method and is the basis of most European scrambling systems. Others are Luxcrypt and Syster, and use a pseudo-random number sequence to delay the start of each line by a small amount. Videocrypt can now be "pirated", but its design is such that it can easily be changed without affecting the basic system, defeating the pirates at no extra cost to the legitimate viewer.

DESCRAMBLING

Obviously the reverse of scrambling is principally the method used for

descrambling, but the decoder has to know what the random number sequence is. The seed is the key to the coding, with half of the seed carried in the "smart card", and the other half on the transmission. The two halves are united in the descrambler circuitry and verified over the air. If verification is a success the seed is then used to identify the pseudo-random number sequence and the decoder synchronises with the encoder, resulting in viewable video once more.

The cut-point is determined by the decoder and the incoming scrambled lines are cut again at the correct place, stored in memory and read-out is again from memory 1, containing the "A" portion of the line, then memory 2 containing the "B" portion. The decoding is not performed on an analogue video signal, the incoming video is digitised at 14MHz before being descrambled. This results in a seamless join.

DIGITAL TV

Current TV transmissions are in analogue form, that is to say that the signal transmitted bears a direct resemblance to the picture being scanned and the sound picked up by the microphones. Analogue transmissions allow fairly rudimentary circuitry to be employed for reception, and the analogue method has been used since the start of television experimentation by Baird and others in the 1920s.

Terrestrial analogue transmission suffers from a number of defects which impair the enjoyment of television for anyone less than the electronics enthusiast. Signals pick up reflections causing ghosting, aircraft can cause fluttering of the picture in some areas and electrical interference from many sources impairs the quality of reception.

A satellite transmission does not suffer from these impairments, but each service occupies a channel over three times the bandwidth of a terrestrial one. The benefits of a digital service are, therefore, slightly different for satellite and terrestrial transmissions.

In a digital service the picture to be transmitted is scanned in the normal way, but the signal voltage from the camera is not used directly. Instead it is "sampled" by a much faster train of pulses, the voltage of the video waveform being taken on every pulse and turned into a binary number corresponding to it. We are left with a stream of data which can be processed and transmitted. Because some form of memory is used in the receiver, the digital data can be sectioned into "packets" for vision, sound, teletext, etc., and one single carrier wave replaces the four or more which are currently in use.

Furthermore, standard error correction techniques can be applied to the signal which will enable the receiver to ignore anything that is not true data, such as reflected signals and interference. In fact, a digital service can be tailored to occupy a smaller bandwidth than current analogue ones, and provide more services to the end-user at the same time.

Cable TV will benefit also from digital services, allowing it greater programme capacity within existing arrangements, and full "interactive" services can be offered – if we can be persuaded that we really need them.

PROCESSING

The real attraction of digitally encoded TV is the amount of processing one can employ to remove redundant information. Watch a television picture and you will realise that, from frame to frame – and there are 25 frames every second – there is much that does not alter.

In digital TV one can, by storing in memory a previous frame, get a comparison between one frame and the next. Only the changes in the picture need be transmitted. At the receiver the memory is refreshed only where changes have taken place.

Complete scene changes are accommodated by circuitry which re-writes a complete picture in four or five frames, the picture on the screen changing only when the complete picture has been built-up. Techniques such as these reduce the bit rate to a maximum of 15Mbit/s, and is often as low as 2Mbit/s.

Four stereo or eight mono sound channels and a serial data channel are included in the data stream. One could watch the progress of a computer game on TV and download the program for it into your PC at the same time!

A final note – the first digital TV transmissions for public consumption in the UK will be from Astra (probably in 1998 when receiver prices should have fallen).

Several manufacturers have developed receivers with a 500-channel capability. The initial cost of these receivers is high and the domestic electronics trade will have to learn a whole new TV engineering philosophy if they are to provide installation and repairs. Whatever happens, the future should be very interesting!

CADPAK for Windows

CADPAK is especially suited to educational, hobby and small scale schematic and PCB design. CADPAK includes both schematic drawing and 32-bit PCB drafting tools but as an entry level product, there is no netlist link between them.

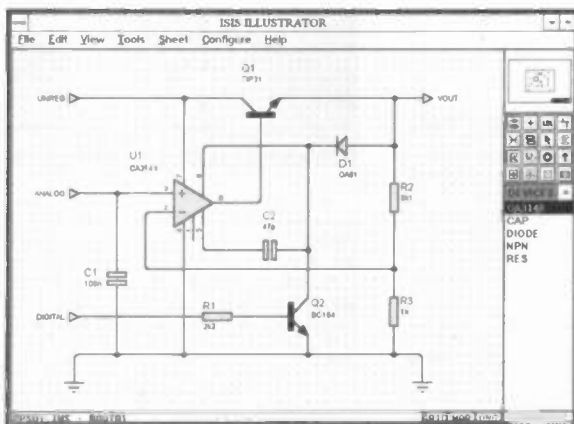

The schematic drawing module of CADPAK, ISIS ILLUSTRATOR, enables you to create circuit diagrams like the ones in the magazines.

- Runs under Windows 3.1 making full use of Windows features such as on-line help.
- Full control of appearance including line widths, fill styles, fonts, colours.
- Automatic wire routing & dot placement.
- Fully automatic annotator.
- Complete with device and comprehensive package libraries for both through hole and SMT parts.
- Advanced route editing allows deletion or modification of any section of track.
- Gerber, Excellon and DXF outputs as well as output via Windows drivers. Also includes Gerber viewer.
- Exports diagrams to other applications via the clipboard.
- CADPAK is also available for DOS.

CADPAK FOR WINDOWS £ 149
CADPAK FOR DOS £ 79

PROPAK for Windows

PROPAK has all of the features in CADPAK plus netlist based integration, automatic power plane generation and a powerful auto-router. PROPAK includes enough schematic capture and PCB design functionality for all but the most demanding applications.

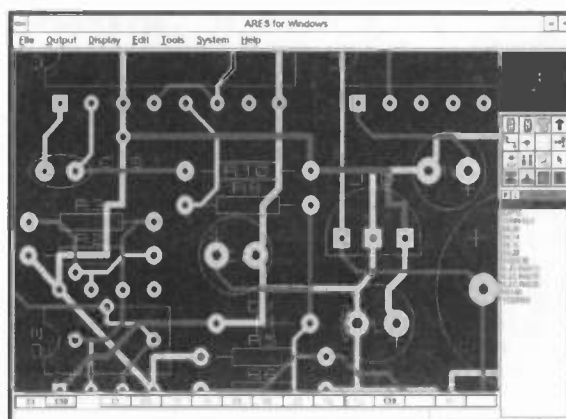

PROPAK's schematic drawing editor ISIS ILLUSTRATOR+ includes even more features than ISIS ILLUSTRATOR. PROPAK's 32-bit PCB design tool, ARES for Windows, is our most powerful and easy to use yet.

- Multi-sheet and hierarchical designs.
- Netlist link between modules guarantees consistency between schematic and PCB.
- Netlists are also compatible with SPICE-AGE and most other electronics CAD packages.
- Generates a full bill of materials.
- ASCII data import facility.
- Electrical rules and connectivity checkers.
- Ratsnest display with automatic update during placement and routing.
- Multi-strategy autorouter gives high completion rates.
- Power plane generator creates ground planes with ease.
- PROPAK is also available for DOS.

PROPAK FOR WINDOWS £ 495
PROPAK FOR DOS £ 395

Call or fax us today for a demo pack. Please state whether you would like a DOS or Windows pack.

Prices exclude postage (£5 for UK) and VAT. ISIS ILLUSTRATOR and ARES for Windows are also available separately. All manufacturers trademarks acknowledged.

labcenter

E l e c t r o n i c s

53-55 Main St. Grassington, N. Yorks. BD23 5AA
 Tel: 01756 753440 Fax: 01756 752857

EVERYDAY

PRACTICAL

ELECTRONICS

BACK ISSUES

We can supply back issues of *EPE* by post, many issues from the past five years are available. An index for each year is also available - see order form. Alternatively, indexes are published in the December issue for that year. Where we are unable to provide a back issue a photostat of any *one article* (or *one part* of a series) can be purchased for the same price.

DID YOU MISS THESE?

APRIL '95

PROJECTS ● National Lottery Predictor ● Auto-Battery Charger ● Light-Activated Switch ● Switch On/Off Timer ● Continuity Tester ● Name of the Game-2 Counterspin.
FEATURES ● Electronics from the Ground Up, Part 7 ● Circuit Surgery ● The Hard Cell (Mobile Telephones).

MAY '95 Photostats Only (see below)

PROJECTS ● PIC-DATS-1 (PIC Development and Training System) ● R.F. Signal Generator - 1 ● MIDI Pedal ● Club Vote Totaliser ● Name of the Game-3, On Your Marks and Games Timer.
FEATURES ● Electronics from the Ground Up, Part 8 ● Las Vegas Show Report.

JUNE '95 Photostats Only (see below)

PROJECTS ● PIC-DATS-2 (PIC controlled 4-Channel Light Chaser) ● EPE HiFi Valve Amplifier - 1 ● R.F. Signal Generator - 2 ● AA to PP3 Converter ● Name of the Game - 4, Star-Struck!, Six-Shot Light Zapper, Wander Wands.
FEATURES ● Electronics from the Ground Up, Part 9 ● Smart Cards.

JULY '95

PROJECTS ● Windicator ● Curtain Winder ● Ramp Generator - 1 ● High Voltage Capacitor Reformer ● EPE HiFi Valve Amplifier - 2
FEATURES ● Bridge Rectification Enhanced ● Ingenuity Unlimited.



AUG '95

PROJECTS ● Solar Seeker ● Personal Practice Amplifier ● Infra-Red Remote Control Unit ● Versatile Microcontrolled 3-Digit Timer ● Ramp Generator - 2.
FEATURES ● Static ● Circuit Surgery.

SEPT '95 Photostats Only (see below)

PROJECTS ● Simple Theremin ● Low Range Ohmmeter Adaptor ● Comprehensive Security System ● Vandata ● Hum-Free Battery Eliminator.
FEATURES ● Cave Radio ● Ingenuity Unlimited.

OCT '95

PROJECTS ● Ginormous VU Meter ● Sound Switch ● Audio Sinewave Generator ● Treble Booster ● Infra-Red Controller/Alarm ● Capacitor Check ● Experimenter's Bargraph Test Board.
FEATURES ● Circuit Surgery ● Security Tagging ● Using Bargraph Displays.
FREE ● Multi-Project PCB with this issue.

NOV '95 Photostats Only (see below)

PROJECTS ● Digital Delay Line ● Video Enhancer ● 50Hz Field Meter ● Temperature Warning Alarm ● Current Tracer ● Distortion Effects Unit.
FEATURES ● Teach-In '96 Part 1 ● Developments in Radio Broadcasting Technology ● Turnpike for Windows Review ● Ingenuity Unlimited.

DEC '95 Photostats Only (see below)

PROJECTS ● Light Operated Switch ● Stereo "Cordless" Headphones ● EPE Met Office - 1 ● Modular Alarm System ● Audio Meter and Amplifier.
FEATURES ● Teach-In '96 Part 2 ● Circuit Surgery ● Index for Volume 24.

JAN '96

PROJECTS ● Printer Sharer ● Mains Signalling Unit ● Automatic Camera Panning System ● Audio Signal Generator ● EPE Met Office - 2.
FEATURES ● Teach-In '96 Part 3 ● Ingenuity Unlimited ● European Consumer Electronics Show ● Techniques - Actually Doing It ● Maths Plus Review ● Decibels and dBm Scale.

FEB '96 Photostats Only (see below)

PROJECTS ● Simple PIC16C84 Programmer ● Mains Signalling Unit - 2 ● PIC Electric Meter - 1 ● Vari-Speed Dice ● Analogue Frequency Meter.
FEATURES ● Teach-In '96 Part 4 ● Circuit Surgery ● Making Your Own P.C.B.s ● Techniques - Actually Doing It.



MARCH '96

PROJECTS ● Mind Machine Mk III Part 1 ● High Current Stabilized Power Supply ● Multi-Purpose Mini Amplifier ● Infra-Zapper ● PIC-Electric Meter - 2.
FEATURES ● Teach-In '96 Part 5 ● Ingenuity Unlimited ● Flight PAL Trainer Review.
FREE ● Headphones (UK copies only).

APRIL '96

PROJECTS ● Dolby Pro-Logic Decoder (Free Booklet) ● Bat-Band Converter ● Event Counter ● Mind Machine Mk III Part 2 - Programmer ● Hearing Tester.
FEATURES ● Teach-In '96 Part 6 ● Circuit Surgery ● Thermionic Valves Part 1.

URGENT?
NEED AN ARTICLE TODAY? TRY OUR FAX ON DEMAND SERVICE
- see opposite for details

MAY '96

PROJECTS ● Midi Analyser ● Mind Machine Mk III Part 3 - Tape Controller ● Versatile PIR Detector Alarm ● Countdown Timer ● Bat Band Converter B.F.O.
FEATURES ● Teach-In '96 Part 7 ● Ingenuity Unlimited ● Thermionic Valves Part 2 - The C.R.T.

JUNE '96

PROJECTS ● Sarah's Light ● Ultra-Fast Frequency Generator and Counter Part 1 ● VU Display and Alarm ● Pulstar ● Home Telephone Link.
FEATURES ● Teach-In '96 Part 8 ● More Scope for Good Measurements Part 1 ● Circuit Surgery ● Microscope Review.

JULY '96

PROJECTS ● Advanced NiCad Chargers ● Single-Station Radio 4 Tuner ● Games Compendium ● Twin-Beam Infra-Red Alarm ● Ultra-Fast Frequency Generator and Counter - 2.
FEATURES ● Teach-In '96 Part 9 ● More Scope for Good Measurements Part 2 ● Circuit Surgery ● The Internet ● Ingenuity Unlimited.

AUG '96

PROJECTS ● Component Analyser ● Garden Mole-Ester ● Mono "Cordless" Headphones ● Bike-Speedo ● Mobile Miser.
FEATURES ● Teach-In '96 Part 10 ● Circuit Surgery ● Ingenuity Unlimited ● Spies, Lies and Electronics ● EPT 3.0 Review.

SEPT '96

PROJECTS ● Analogue Delay and Flanger ● Simple Exposure Timer ● PIC-Tock Pendulum Clock ● Draught Detector ● Power Check.
FEATURES ● Circuit Surgery ● Ingenuity Unlimited ● Net Work - The Internet ● MAX038 Waveform Generator.

BACK ISSUES ONLY £2.50 each inc. UK p&p.

Overseas prices £3.10 each surface mail, £4.10 each airmail.

We can also supply issues from earlier years: 1990 (except March), 1991 (except May, June, Aug., Sept. and Nov.), 1992 (except April and Dec.), 1993 (except Jan., Feb., March, April and May), 1994 (except April, May, June and Nov.), 1995 (except Jan., May, June, Sept., Nov. and Dec.). Please note we are not able to supply copies (or 'stats of articles) of *Practical Electronics* prior to the merger of the two magazines in November 1992. Where we do not have an issue a photostat of any *one article* or *one part* of a series can be provided at the same price.

ORDER FORM - BACK ISSUES - PHOTOSTATS - INDEXES

Send back issues dated

Send photostats of (article title and issue date)

Send copies of last five years indexes (£2.50 for five inc. p&p - Overseas £3.10 surface, £4.10 airmail)

Name

Address

I enclose cheque/P.O./bank draft to the value of £.....

Please charge my Visa/Mastercard £.....

Card No. Card Expiry Date

Note: Minimum order for credit cards £5. Please supply name and address of cardholder if different from that shown above.

SEND TO: **Everyday Practical Electronics, Allen House, East Borough, Wimborne, Dorset BH21 1PF.**
Tel: 01202 881749. Fax: 01202 841692. (Due to the high cost we cannot reply to queries or orders by Fax.)
E-mail: editorial@epemag.wimborne.co.uk

Payments must be in £ sterling - cheque or bank draft drawn on a UK bank. Normally supplied within seven days of receipt of order.
Send a copy of this form, or order by letter if you do not wish to cut your issue.

M10/96

FAX ON DEMAND EVERYDAY PRACTICAL ELECTRONICS ON FAX

WHY WAIT?

We Give You The Fax!
Projects and Series
From Past Issues of *EPE*
AVAILABLE INSTANTLY!
24 HOURS A DAY!

HAVE you ever wanted to get hold of a past project or part of a Teach-In series fast? *EPE ON FAX* is a service aimed at providing you with the article you need, on-demand, seven days a week, 365 days a year, 24 hours a day.

All the projects and major series from the the April '95 issue onwards have been stored on computer and linked to a sophisticated selection system that uses the latest voice and Fax technology. You can select the article you require from a menu and have it downloaded to any UK Fax machine on demand.

The service will be constantly updated with new material as each issue is published, thus providing a live, instantly available, resource.

HOW TO USE *EPE ON FAX*

- From your tone telephone or Fax machine call 0897 124 125, making sure that your handset is switched to "tone". You will then hear a series of messages, which will help to guide you through the system.
- For one of the available indexes, which contain the document numbers and the number of pages of each article, press "1" when prompted.
- To obtain a particular document, press "2" when prompted and, when requested, enter the document number you want from the keypad on your phone or Fax machine. The system will then confirm your selection.
- When you have selected the document that you require, you will then be prompted to enter the phone number of the Fax machine you want the article sent to, including the dialing code, finishing with the # key; the system will then confirm the phone number. Ring off when prompted and the Fax will automatically be sent to the given number.

HOW MUCH WILL IT COST?

EPE ON FAX service is a higher rate premium line phone service. Calls cost £1.50 a minute. First time use should cost no more than £3 per index or article. Subsequent use should only be £1.50 per article.

NOTE. Articles over six pages long are split in two, requiring two calls.

FURTHER INFORMATION

If you would like further information about how this project was put together, ring Starcomm Limited on (0113) 294 0600.

TRY IT NOW!
CALL 0897 124 125

Everyday Practical Electronics, October 1996

WORLD FIRST! MIDI THEREMIN

As far as we can tell, this is the first ever design for a Theremin with MIDI Interface.

Next month we start with details of a full specification professional design Theremin which will be described together with full constructional details over two months, we then follow up with a MIDI Theremin Interface in the January and February issues.

The full specification Theremin provides wide free space control movement, employs standard components with a minimum inductor count and uses varicap tuning of both pitch and volume aerials. It provides a continuous output for pitch monitoring and has both loudspeaker and headphone outputs.

Don't miss this unique project.

ORDER YOUR COPIES NOW!

CENTRAL HEATING CONTROLLER

A microcontroller based Central Heating Controller similar in performance to typical commercial units. It can provide independent switching of heating and hot water with once or twice per day switching cycles. The unit uses an integral or external temperature sensor and has a two line 14 character l.c.d. display, giving user messages and prompts in plain English and providing a continuous display of time and temperature.

BUILD YOUR OWN PROJECTS

A new fully-illustrated series describing modern methods for constructing your electronic projects. This first part offers some initial tips for beginners and discusses essential tools and equipment needed to make a start.

*Future parts will look at circuit board assembly, case and enclosure preparation, workshop tips and tricks - in fact, everything you need to know to get satisfying results when building your latest *EPE* project. Go for it!*

EVERYDAY

PRACTICAL

ELECTRONICS

**NOVEMBER ISSUE ON SALE
FRIDAY, OCTOBER 4**

NEXT MONTH

VEHICLE ALERT

TERRY de VAUX-BALBIRNIE



Protect yourself and your family – be soundly warned when vehicles enter the driveway.

THIS circuit is useful for signalling the movement of cars along a driveway and for similar purposes. It works by sensing the increased air pressure inside a flexible tube over which the vehicle passes. Tubing up to a length of about three metres (10 feet approx.) has been tested successfully with the prototype unit and this will be sufficient to monitor practically any driveway.

Remember, it only takes about a metre (three feet) of tubing to "cover" a driveway for a car of average width since the wheels on one side will trigger the unit.

There are two parts to the system – a pressure sensor plus tubing placed at ground level close to the position being monitored, and a mains-operated power supply. These sections may be situated any reasonable distance apart.

The circuit has been designed for continuous operation and has negligible power consumption. Note that although the sensor and tubing will probably be placed outdoors, the main unit *must* be situated in a dry indoor location close to a mains supply socket.

GOOD IMMUNITY

Most readers will use the Vehicle Alert circuit for detecting four-wheel vehicles, or motorbikes or bicycles – that is, two pulses being provided by the pressure sensor. It would be a simple matter to arrange for any other number of pulses, up to nine, to trigger the unit. This may be useful for certain applications – for example, three pulses to respond to a car towing a trailer or caravan.

The system is reasonably immune from people triggering it since they are likely to give only one pulse within a five-second period. However, it will respond to cars and bicycles which provide two pulses within this time (that is, due to the front and rear wheels passing over the tubing).

When car tyres pass over the tubing, it will be squashed, causing an increase in

pressure inside it. There could also be an increase in pressure due to any rise in temperature of the air inside, although such a change is likely to be small and no problems were experienced with the prototype unit.

The audible signal is given by a buzzer situated inside the main unit. Alternatively, the buzzer may be placed remotely. The operating time is adjustable between about 0.5 and 20 seconds. Note that the circuit cannot distinguish between an approaching vehicle and one which is retreating, so a signal will be given in whichever direction it moves.

(variable period) monostable will be triggered which, in turn, operates the sounder.

Referring to the circuit diagram Fig. 2, switch S1 is the Pressure Sensor connected to the circuit through the plug and socket pair PL1/SK1. The pressure sensor has a diaphragm which moves when air pressure is applied to one side of it through an inlet port. This causes the contacts to "make".

Note that some devices do not give a true on-off switching action but provide a varying voltage output proportional to the pressure applied. Some of these are described as piezo devices and are *unsuitable* in this application.

IC1 is a dual timer integrated circuit (that is, it contains two identical units) and IC3 contains a single timer of the same type. All three timers are configured as monostables which operate when a low-going pulse is applied to the appropriate trigger input. Once triggered, the corresponding output will go high (close to the positive supply voltage) for a certain time then revert to low.

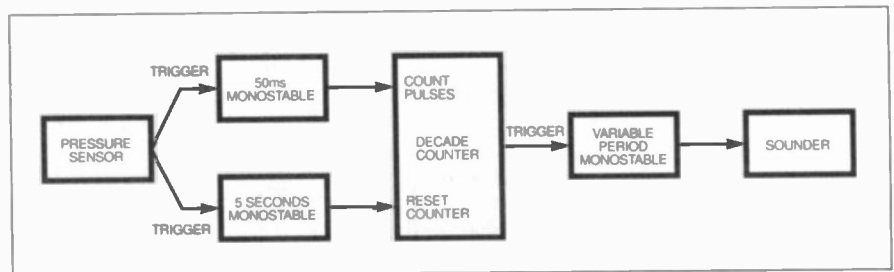

Fig. 1. Block diagram for the Vehicle Alert system.

CIRCUIT DESCRIPTION

The system is illustrated by the block diagram in Fig. 1, while the Vehicle Alert circuit diagram, excluding the power supply, is shown in Fig. 2.

Referring to Fig. 1 first, an increase of air pressure inside the tube operates the contacts of a pressure sensor switch which simultaneously triggers two monostables having timed periods of 50 milliseconds and five seconds, respectively.

Pulses from the 50ms monostable are registered by the decade counter. If the required number of pulses do not arrive within the longer monostable period, the counter will be reset and the circuit revert to its original state. If the correct number of pulses (or more) do arrive, the third

Consider IC1 first. A trigger pulse derived from pressure sensor switch S1 (or pushbutton Test switch S2 connected in parallel with it) provides a low-going pulse which is transferred via capacitor C1 to the trigger inputs of both timers (IC1 pins 6 and 8). The outputs of both timers will therefore go high simultaneously.

After the timers have been triggered by this pulse, capacitor C1 rapidly discharges through resistors R1 and R2 ready for another pulse to be received. A further purpose of resistor R2 is to maintain the trigger inputs in a normally high condition, which prevents false operation.

CLEAN SWITCHING

The timed periods of the monostables are set by the values of two pairs of external components. These are resistor R3 and

capacitor C2 connected to IC1 pins 1 and 2 for the first (5s) timer, and resistor R4 and capacitor C3 connected to pins 12 and 13 for the second (50ms) timer.

The purpose of the second monostable is to eliminate the effect of contact bounce in switch S1 or S2. This would cause multiple triggering and false operation. Only the first "make" of the switch contacts will trigger the monostables and "clean" output pulses will be provided by

R7. The wire link as shown configures the circuit to operate with two pulses.

The collector of TR2 provides a low pulse to the third monostable (IC3) at its trigger input pin 2 via capacitor C4. Resistor R9 maintains the trigger input in a normally high condition which prevents false operation.

The timed period of IC3 is related to the values of capacitor C5, fixed resistor R10 and preset potentiometer VR1. With the

values specified, this can be varied between about half a second (with VR1 at minimum resistance) and 20 seconds (VR1 at maximum). It could be increased by raising the value of resistor R10 or capacitor C5.

With IC3 output pin 3 high, transistor TR3 is turned on by the base current entering through resistor R11. This operates the sounder, WD1, connected in its collector circuit.

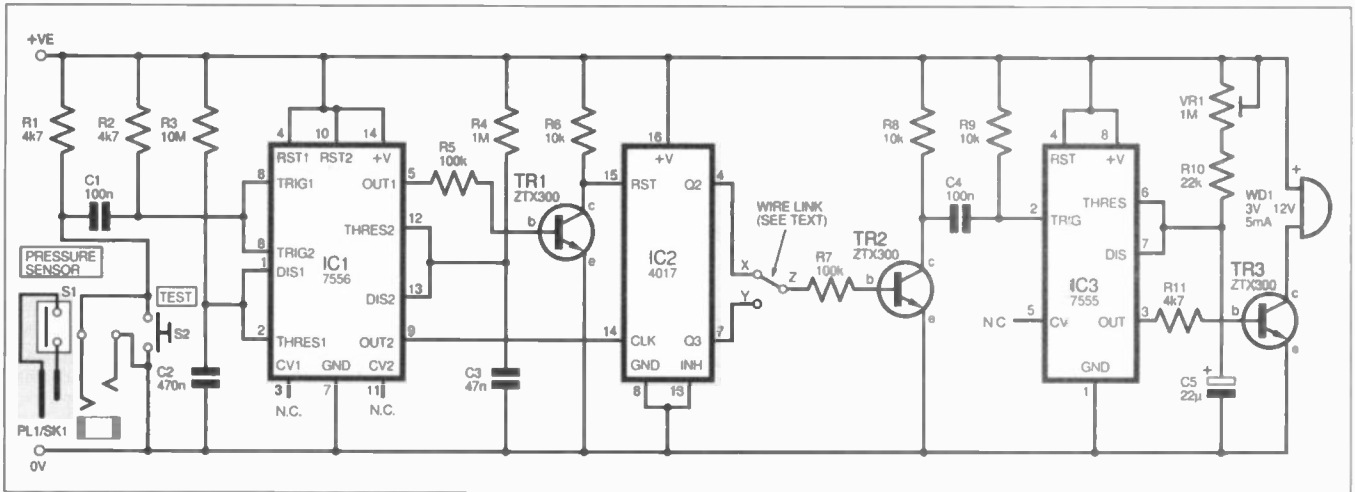

Fig. 2. Complete circuit diagram, excluding power supply, for the Vehicle Alert.

the shorter one suitable for counting by decade counter IC2.

Further trigger pulses arriving within the 50ms period will have no effect. After this time, all contact bouncing will have ceased and the shorter monostable will be ready to respond again.

ABLE TO COUNT

The output of the shorter-period monostable IC1, pin 9, is applied to IC2's clock input pin 14. Providing the reset input, pin 15, is low (assume for the moment that this is so) any pulses provided by switches S1 or S2 will be registered and successive IC2 outputs will go "high" in turn.

The standby state - that is, with no pulses having been received - is output Q0 (pin 3) high. On receipt of the first pulse, output Q1 (pin 2) will go high followed by outputs Q2 to Q9 in turn (pins 4, 7, 10, 1, 5, 6, 9 and 11, respectively). Note that only connections to outputs Q2 and Q3 (pins 4 and 7) are shown in Fig. 2.

While high, the output from the five-second monostable, pin 5, turns on transistor TR1 due to base (b) current entering via resistor R5. The transistor provides a low state at its collector (c) which is applied to IC2 pin 15 (reset input). This "enables" the chip.

After the five seconds time-out of the monostable, transistor TR1 turns off and its collector goes high. This resets the counter and maintains it in this state.

The five-second timing is regarded as the maximum that it would take for both axles of a slow moving vehicle to pass over the tubing. It could be altered if necessary by raising or lowering the value of resistor R3 in proportion, a larger value providing a longer timing period.

With either IC2 output pin 4 (which turns on after two pulses) or output pin 7 (after three), transistor TR2 is turned on due to base current entering via resistor

COMPONENTS

Resistors

- R1, R2, R11 4k7 (3 off)
 - R3 10M
 - R4 1M
 - R5, R7 100k (2 off)
 - R6, R8, R9 10k (3 off)
 - R10 22k
- All 0.25W 5% carbon film

Potentiometer

- VR1 1M sub-min. preset, vert.

Capacitors

- C1, C4 100n polyester (2 off)
 - C2 470n polyester
 - C3 47n polyester
 - C5 22µ radial elect., 16V
 - C6 1000µ radial elect., 16V
- Polyester capacitors should have 5mm lead spacing

Semiconductors

- TR1 to TR3 ZTX300 npn transistor (3 off)
- IC1 7555 CMOS dual timer
- IC2 4017 CMOS decade counter
- IC3 7555 CMOS timer
- REC1 W005 50V 1A bridge rectifier

Miscellaneous

- FS1 250mA 20mm fuse, with chassis mounting holder
- FS2 1A 20mm, with panel mounting holder
- S1 pressure-operated switch
- S2 min. pushbutton switch, press-to-make
- S3 mains rated rocker switch, with neon indicator (see text)
- SK1/PL1 3.5mm mono. chassis mounting, jack socket and plug - fully insulated, see text
- T1 sub-min. 100mA mains transformer, with single 9V or 9V-0V-9V secondary
- WD1 buzzer, solid-state, 5mA 3V to 12V operation

Printed circuit board, available from the EPE PCB Service, code 117; aluminium case, 152mm x 114mm x 44mm; plastic case, 50mm x 37mm x 24mm; 8-pin d.i.l. socket; 14-pin d.i.l. socket; 16-pin d.i.l. socket; p.c.b. supports (3 off); solder tag; plastic feet, self-adhesive (4 off); cable gland; grommet; connecting wire, mains-rated cable, plastic tubing and adaptor (see text); solder, etc.

Approx Cost
Guidance Only

£37

excluding tubing
and cable

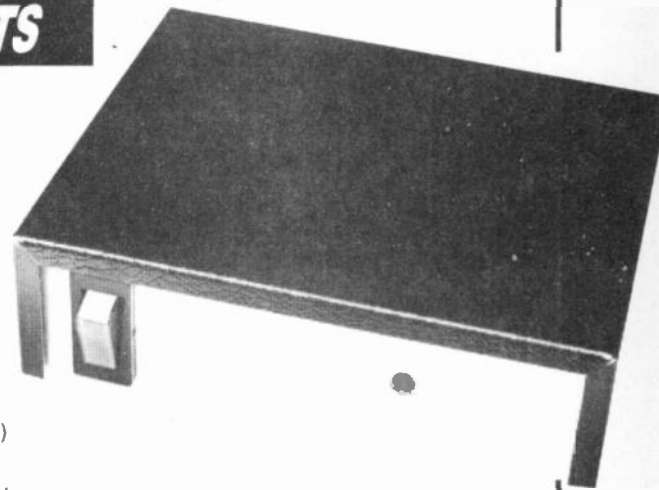

See

TALK
Page

POWER SUPPLY

As shown in Fig. 3, power is supplied by the conventional arrangement of mains transformer T1, bridge rectifier REC1 and smoothing capacitor C6. Fuses FS1 and FS2 protect the secondary and primary windings, respectively, and S3 is the mains On-Off switch.

The specified mains transformer limits the sounder current to 100mA maximum but, in practice, this is sufficient for all small sounders of the specified type.

IMPORTANT SAFETY NOTE

Since constructing this circuit involves making mains connections, the reader must be satisfied with his or her ability to make a safe job. If there is any doubt whatsoever, the services of a qualified electrician must be sought.

All safety measures referred to in the text must be followed. In particular, the circuit must be constructed using an Earthed metal box and be correctly switched and fused. An insulating cover must be provided for all internal mains connections.

CONSTRUCTION

Most of the components for the Vehicle Alert are mounted on a single-sided printed circuit board (p.c.b.). The component layout and full-size foil master track pattern are shown in Fig. 4. This board is available from the *EPE PCB Service*, code 117.

Begin construction by drilling the three mounting holes and soldering the i.c. sockets into position. Do not unpack the i.c.s themselves yet, however. Follow with the resistors, including preset VR1, noting that some are mounted flat against the board while others are fitted vertically.

Add the capacitors, taking care over the polarity of electrolytic capacitors C5 and C6. Solder the three transistors into position observing their correct orientation (the "flats" all face the right-hand edge of the circuit panel). Add the bridge rectifier, again taking care over the orientation, as marked on the board.

The p.c.b. as shown will provide for triggering on either two or three pulses from the pressure switch S1. The mode is selected by linking resistor R7 to pin 4 or pin 7 of IC2. If two-pulse triggering is required, link points Z and X on the p.c.b. If three-pulse triggering is needed, link points Z and Y.

If any other number of pulses up to nine is required, then point Z should be wired directly to the appropriate pin on the socket for IC2. This should be done using a piece of light-duty insulated wire on the copper track side of the board. For four to nine pulses, the pin numbers to use are 10, 1, 5, 6, 9 and 11 respectively.

CASE PREPARATION

Prepare the suggested case for internal components by marking out and drilling three mounting holes in the base to correspond with those already made in the p.c.b. Also drill holes for the transformer and chassis fuseholder, FS1. Drill holes in the rear panel for the strain relief bush to be used on the mains lead, panel fuseholder

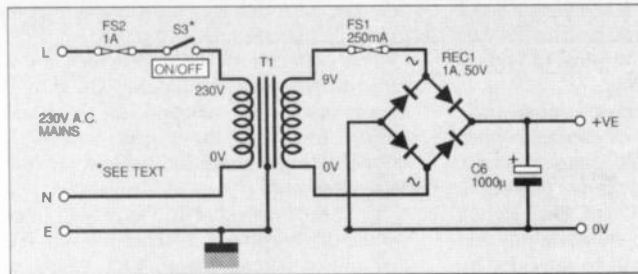

Fig. 3. Circuit diagram for the mains derived power supply for the Vehicle Alert.

FS2, pushbutton Test switch S2 and jack socket SK1 to which the sensor connections will be made.

Finally, drill the front panel for the mains on-off switch S3 and sounder WD1 - if mounted internally. (The finished appearance of the unit will be enhanced if the sounder is mounted internally rather than on the outside.)

CONNECTIONS

Mount the p.c.b. on plastic supports so

that the soldered joints stand at least 5mm above the base of the box. Mount all components for which holes have been drilled. When attaching the transformer, include a solder tag on one of its fixings. This will be used to "Earth" the case later and is an essential safety requirement.

Refer to Fig. 5 and complete the internal wiring apart from that for the mains input. Note that the wire connecting fuse FS2 to switch S3 must be made with mains-type wire of 3A rating minimum.

Observe the correct polarity for the leads of the sounder WD1 or it will not work.

When wiring up the jack socket SK1, note that many types have one terminal (the sleeve) connected to the metalwork.

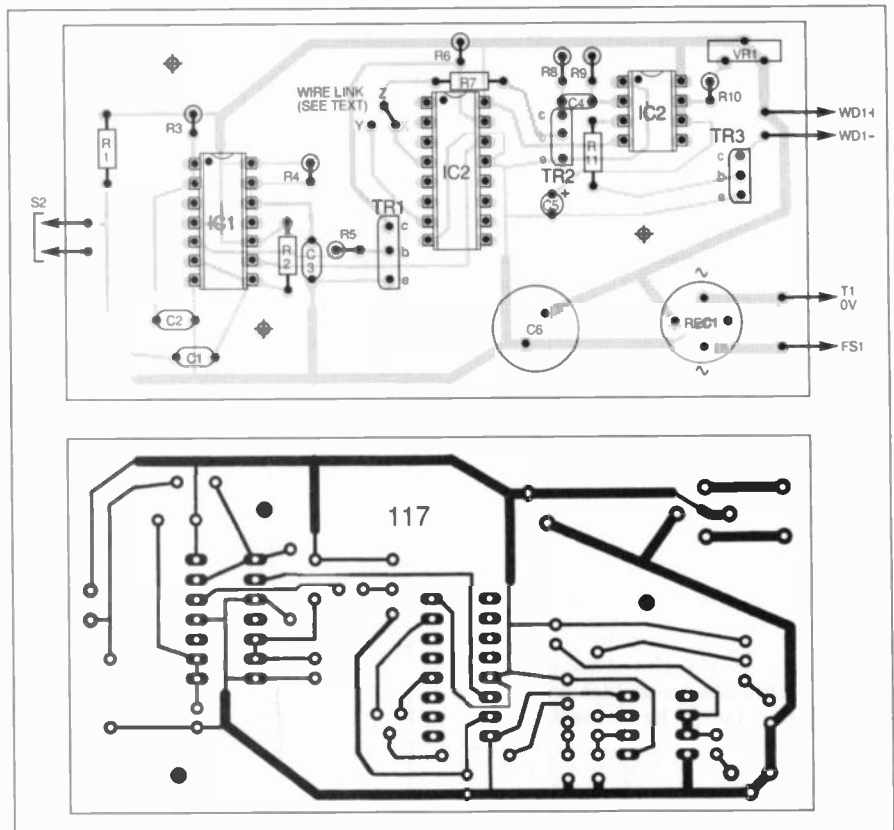
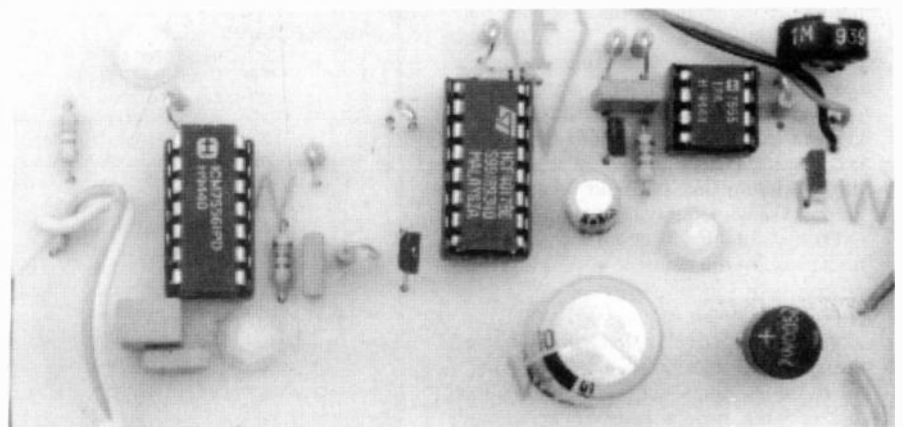

Fig. 4. Printed circuit board component layout and full size underside copper foil master for the Vehicle Alert. The completed p.c.b. (below) is mounted well clear of the case base on nylon bolts with "locking" nuts.



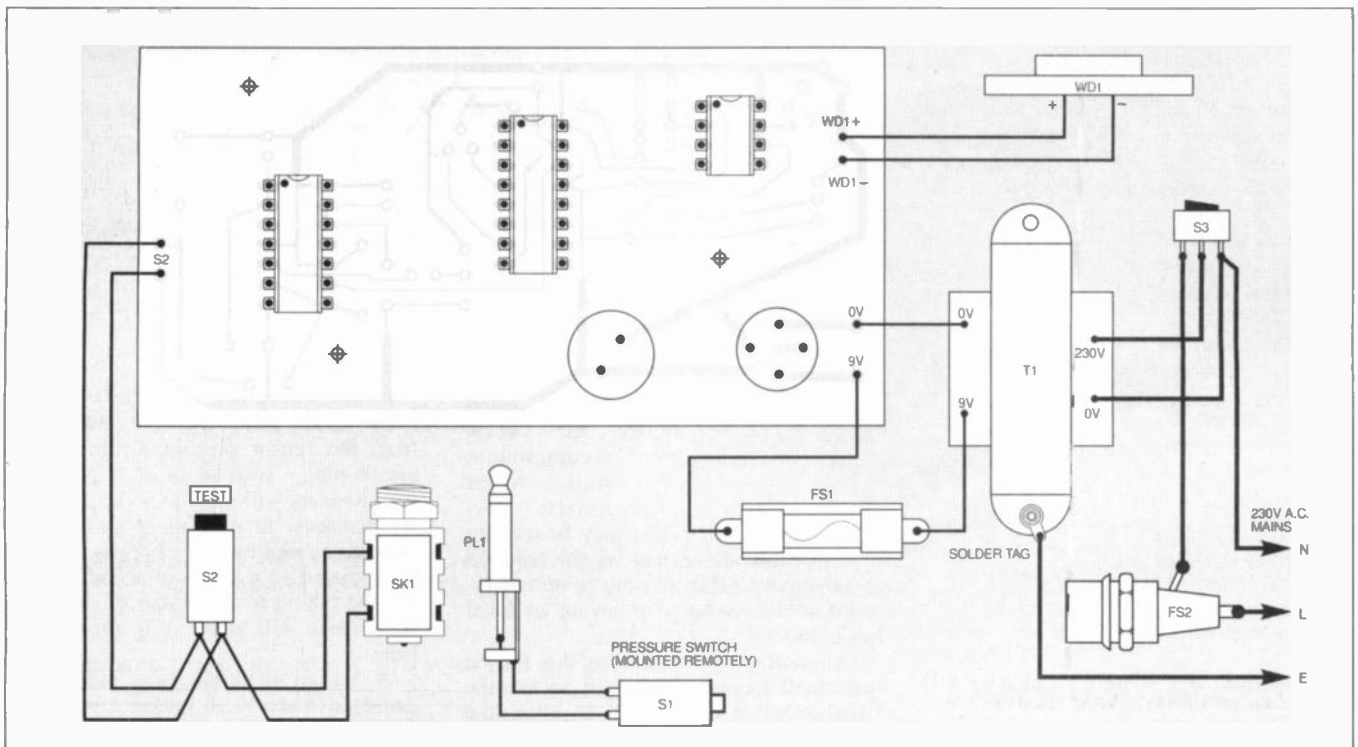

Fig. 5. Interwiring between off-board components and p.c.b. Note wiring between fuse FS2 and switch S3 must be made with 3A minimum mains-type wire. Also, socket SK1 must be an insulated (plastic bodied) type.

However, a fully insulated (plastic bodied) type socket *MUST* be used here – i.e. neither terminal makes metallic contact with the case. Make the ‘‘tip’’ connection to the upper ‘‘S2’’ pad as shown in Fig. 5.

MAINS LEAD

Make up the mains supply input lead by cutting off a piece of mains-rated cable having a capacity of 3A minimum. Remove 8cm of the outer sheath from one end, pass the wire through the hole made for the purpose and secure it using a strain relief bush. It is essential to use a proper strain relief here – do *not* tie a knot in the wire or secure it using a piece of string!

Refer to Fig. 5 again and connect the cable as shown. The specified mains switch contains a neon indicator which is convenient because it requires both a Live and a Neutral connection. It thus acts as an anchorage point for the Neutral feed wire. If a switch without a built-in neon indicator is used, the Neutral wire should be connected directly to the transformer primary lead using a single piece of 2A screw terminal block.

Solder the Earth wire securely to the solder tag leaving some slack inside the case. Attach a mains plug to the other end of the lead and insert a 2A or 3A fuse. Fit a 250mA glass fuse in the chassis fuseholder (FS1) and a 1A ceramic mains-type in the panel fuseholder (FS2).

Make an insulating cover for the entire left-hand side of the box. This will provide protection to all the mains connections (this cover has been removed in the photograph to show the internal details).

Finally, attach self-adhesive plastic feet to the base of the box.

TESTING

All the i.c.s are CMOS components and there is a possibility of them being damaged by static charge which might exist on the body. To avoid this, touch

something which is earthed (such as a water tap) before unpacking them and touching the pins. Insert them into their sockets observing the correct orientation.

Note that all testing and operation must be carried out with the lid of the case in position. When making adjustments, the mains plug must be removed from the socket.

Adjust preset VR1 fully clockwise (as viewed from the edge of the circuit panel) for minimum sounder time.

The circuit should be checked for correct operation *before* the pressure sensor is connected. Plug the unit in to the mains

and switch on – the sounder may give a bleep and this is of no consequence. If the circuit has been set for two pulses, press switch S2 twice. The buzzer should bleep.

Wait for ten seconds (so that the circuit is definitely reset) and repeat the test a few times. Next, press S2 once, wait for ten seconds and press it again. The buzzer should remain silent. If the unit has been set for three pulses, work accordingly.

Remember, when making tests you will need to wait for up to ten seconds each time to allow the counter to reset. The bleep time may be adjusted by anti-clockwise rotation of preset VR1.

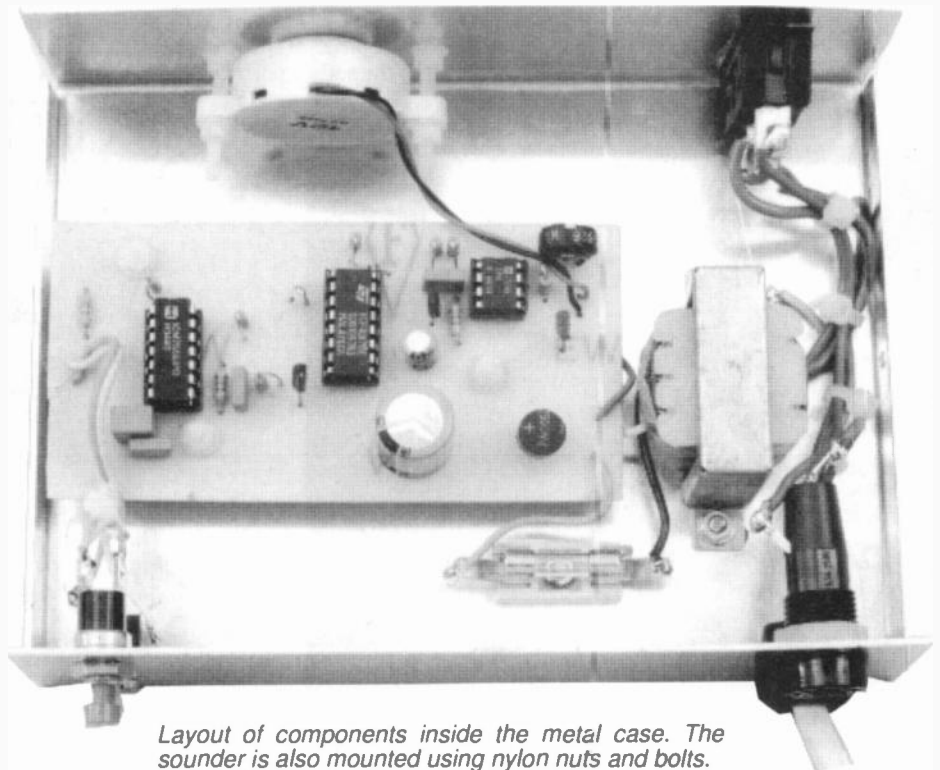

Layout of components inside the metal case. The sounder is also mounted using nylon nuts and bolts.

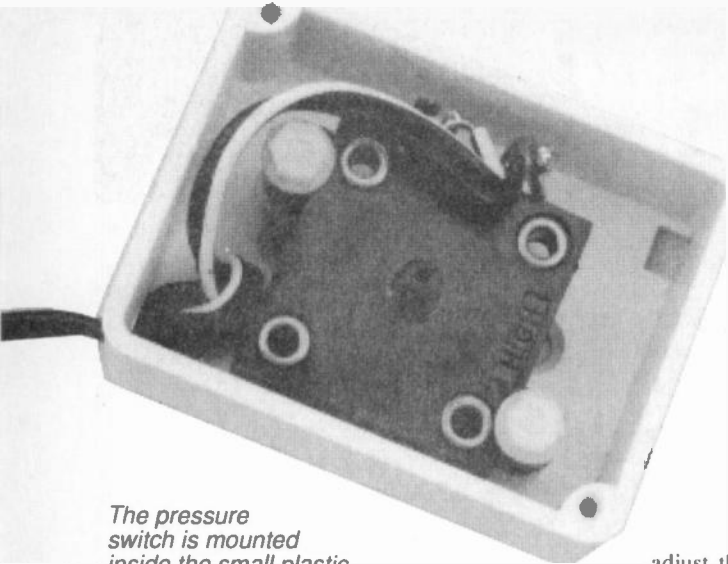

The pressure switch is mounted inside the small plastic box with nylon nuts and bolts. A hole must be drilled in the lid to align with the "high" port.

EXTERNAL SAFETY

When finally installing the pressure switch unit outside, it is imperative to bear in mind the safety aspects of the cabling. The remote location of the sensing box would extend the mains earth (via 0V rail of 12V supply) outside the building if the preferred "insulated" jack socket were not used. Under exceptional mains fault conditions, it could be "live" up to 240V a.c. relative to any nearby surfaces at ground potential (e.g. metal railings, metal greenhouse frames) and may present a shock risk.

Readers should ensure that the cable to the remote sensing box is double insulated and that there is no possibility of external contact being made with the electrical connections within the box. Ordinary twin-cored mains cable is suitable (each core separately insulated with both jointly wrapped by an external insulating sheath). Also observe the precaution of using a fully insulated jack socket as specified. Twin flex, e.g. bell wire or similar, is not suitably insulated. If in any doubt, consult a qualified electrician.

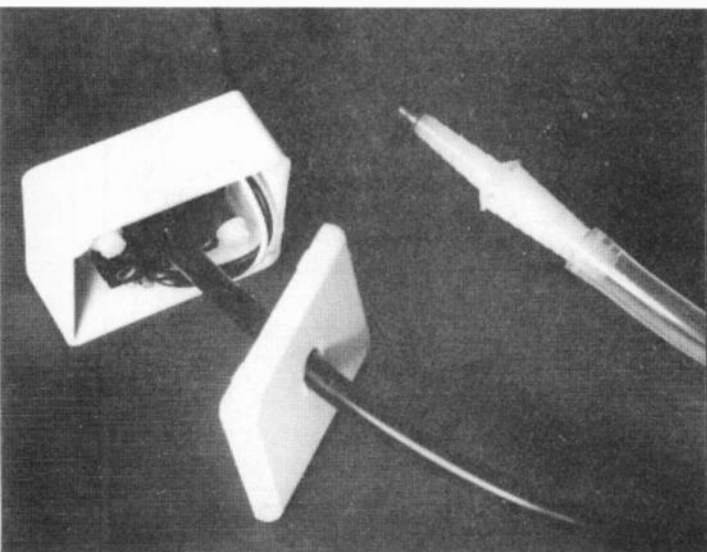

The smaller diameter "pressure" tubing connected to the pressure switch and, via a plastic adaptor, to the larger diameter "driveway" tubing.

UNDER PRESSURE

To mount the pressure switch S1 inside the specified small plastic box it will be necessary to gently bend the tags so that it will fit. The plastic (unused) port labelled "low" should also be cut off short.

On the same side as this port a recess will be seen to accommodate a small Allen (hexagonal) key.

This may be used to adjust the switch for the required sensitivity. (This may not be necessary, so do not be too hasty in buying an Allen key to fit.)

Drill holes in the rear of the box for the two small fixings which will secure the switch. Drill a further hole to allow the Allen key to be inserted, if necessary.

Attach the switch temporarily. The position of the port labelled "high" should now be carefully measured and a hole drilled in the lid of the box to correspond with this.

It should be large enough to allow narrow bore (3mm diameter) tubing to be attached (see photographs). Remove and re-attach the switch with spacers on the nylon bolt shanks so that the inlet port protrudes slightly through the hole in the lid.

Measure the length of double-insulated cable to be used between the pressure switch and main unit, the cable should be soldered to the pressure switch S1 at one end (polarity unimportant), and to plug PL1 at the other end.

ADAPTING WELL

Decide on the length of tubing to be used and the route it is to follow. Begin with a piece of 3mm diameter and attach it to the sensor port. Using a plastic adap-

tor, connect the main section consisting of a piece of wider diameter tubing (see photograph).

Good results were obtained using plastic tubing having an inside diameter of 5mm or 6mm. Tubing sold for wine-making was found to be suitable. It must be of a type which springs back into shape quickly. Adaptors may sometimes be made from old pen parts. Alternatively, a local school may help with the ordering of tubing and adaptors since they are standard chemistry materials.

Fit the tubing into position taking care not to cause kinks. Seal the end furthest from the sensor position using a small plastic plug – such as the end of a plastic pen. Readers will need to make their own arrangements to prevent people tripping over the tubing by, for example, fitting it in a groove in a piece of wood. Do not run the tubing over a rough or stony surface which will puncture it after a short time.

A rise in air temperature outside will cause an increase in pressure inside the tubing but this was not sufficient to cause problems in the prototype unit. Even so, it would be best to avoid direct sunlight shining on it. Making a very small vent hole in the end cap should minimise any problem. It will allow expanded air to escape yet will not be large enough to have an effect on rapid changes, such as when car wheels pass over the tubing.

It may be found that the sensitivity of the pressure switch is satisfactory as supplied. However, it may be adjusted using an Allen key (size 1.27mm) through the hole drilled for the purpose. To make the adjustment, clip the probes of a multimeter, set to a resistance or buzz-test range, to the terminals of the switch.

Turn the Allen key very slowly anti-clockwise until the switch operates continuously (near-zero resistance). Now rotate it slightly clockwise until the contacts open (infinite resistance). Further adjustment may be needed over a trial period. Do not adjust the switch too critically or operation will be unreliable. []

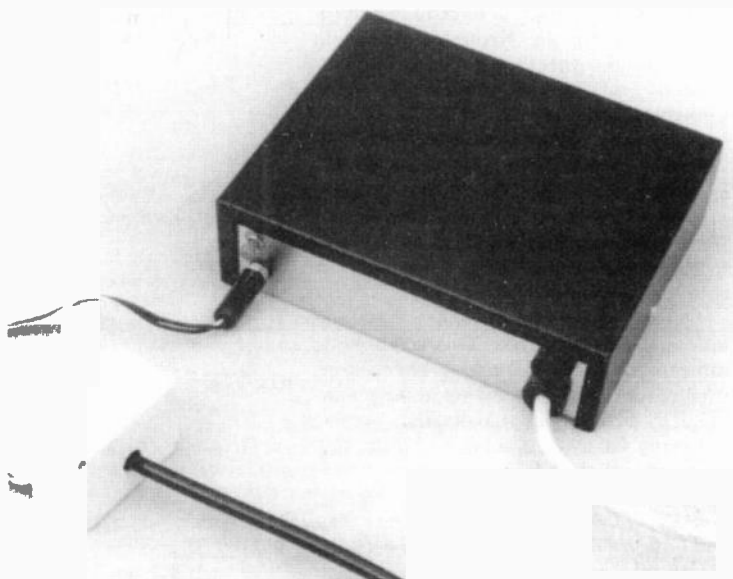

The completed remote pressure switch unit, with pressure tube, linked to the main Vehicle Alert circuit box.

EASY-PC Professional XM Schematic and PCB CAD

From Super Schematics

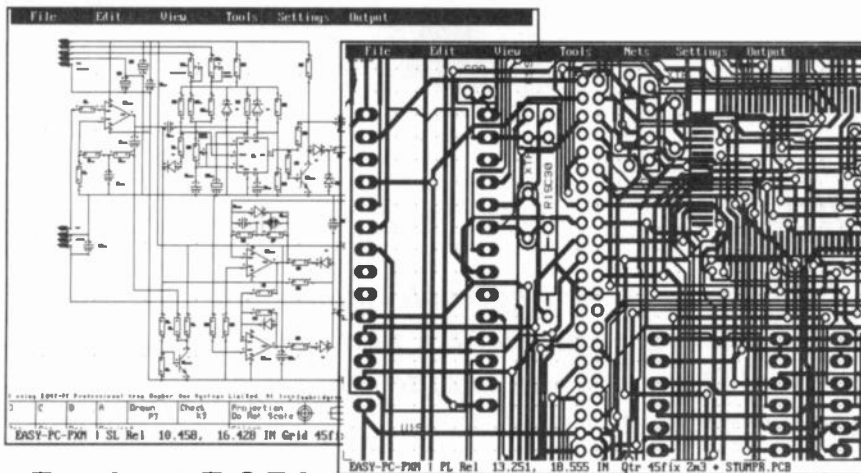

- Runs on:- PC/ 386/ 486 with VGA display
- Links to PULSAR (logic), ANALYSER III (analogue) & LAYAN (electromagnetic) simulators.
- Design:- Single sided, Double sided and Multi-layer boards.
- Provides full Surface Mount support.
- Standard output includes Dot Matrix / Laser / Ink-jet Printer, Pen Plotter, Photo-plotter and N.C. Drill.
- Optional, powerful, 32 bit, Multi-pass, Shape based, Shove Aside, Rip-up and Re-tray Autorouter.

To Perfect PCB's

Prices From £75/\$135

Number One Systems

Please contact us for a demonstration disc and full information

UK/EEC: Ref: EVD, Harding Way, St.Ives, Cambridgeshire, ENGLAND, PE17 4WR. Email: sales@numberone.com

Telephone UK: 01480 461778 (7 lines) Fax: 01480 494042

International +44 1480 461778

USA: Ref: EVD, 126 Smith Creek Drive, Los Gatos, CA 95030

Telephone/Fax: (408) 395-0249



adhipro1

PIC EEZE

This is the easiest way to start using PIC microcontrollers. PIC EEZE is a powerful and versatile development system that allows you to start at the level you like and upgrade if needed whenever your ready. All systems have ZIF sockets, high quality PCBs (unlike similar priced systems). Fully featured Assembler/Simulator & Programming environment, designed to be software upgraded (All software upgrades are FREE).

Programs/ Features	PIC EEZE 1	PIC EEZE 2	PIC EEZE 3
16C54/55/56/57/58	-	YES	YES
16C61/62/63/64/65	YES	YES	YES
16C71/73/74	YES	YES	YES
16C84	YES	YES	YES
16C620/621/622	YES	YES	YES
Serial Eeproms	YES	YES	YES
In Circuit Emulation	-	-	YES
Lpak (learning package)	YES	YES	YES
Expansion Port	YES	YES	YES
BASIC compiler	-	-	YES
Price (built and tested)	£44.95	£52.95	£72.95

Upgrading is simple, just order the required system firmware and pay the difference

IN CIRCUIT EMULATION Target probe can be taken from the expansion port to application circuit. Your program can then be stepped/run etc. with results on screen and at probe.

BASIC COMPILER Allows you to make your own BASIC PICs and evaluate your program with Real Time Emulation through target probe. (Please write/call for details/availability).

LPAK plugs into the expansion port and has coloured LEDs, 7 segs, buttons and switches and minicore emulator to show PIC programming methods (includes examples). £28.00.

DPAK stand alone demo boards (2). One is like LPAK and the other will accept 18/28 pin PIC, has oscillator and power sections ready built. Can be used with breadboards or you own circuit etc. £28.00.

SUPPORT We will give continuing support to our users and products. Future expansion planned - 17CXX Programmer - smart card reader/writer and more.

Please write or telephone for further information if required.



Please add £2.00 P&P and make cheques payable to LENNARD RESEARCH

29 Lavender Gardens, Jesmond, Newcastle upon Tyne, NE2 3DD.
Telephone (0191) 281 8050.

FREE CATALOGUE

THINK COMPONENTS - THINK CRICKLEWOOD

- TELEVISION & VIDEO SPARES • RESISTORS & CAPACITORS • HI-FI GADGETS & SPEAKERS
- TRANSISTORS & I.C.'s • AUDIOPHILE CAPACITORS
- IN CAR AUDIO • COMPUTER BOARDS • TOOLS & TEST EQUIPMENT • PLUGS SOCKETS & LEADS

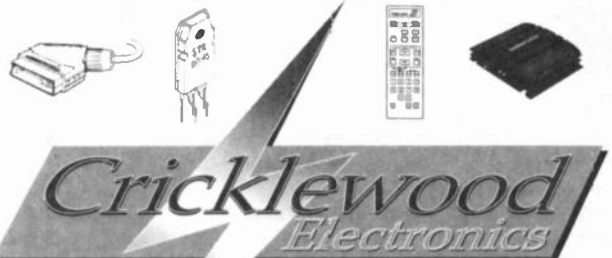

PLEASE SEND ME A COPY OF THE CRICKLEWOOD CATALOGUE.

Name

Address

..... EPE

PRICES HELD INTO 1996

Cricklewood Electronics Ltd, 4C-42 Cricklewood Broadway,
London NW2 3ET. Tel: 0181-450 0995 Fax: 0181-208 1441

CIRCUIT SURGERY

ALAN WINSTANLEY

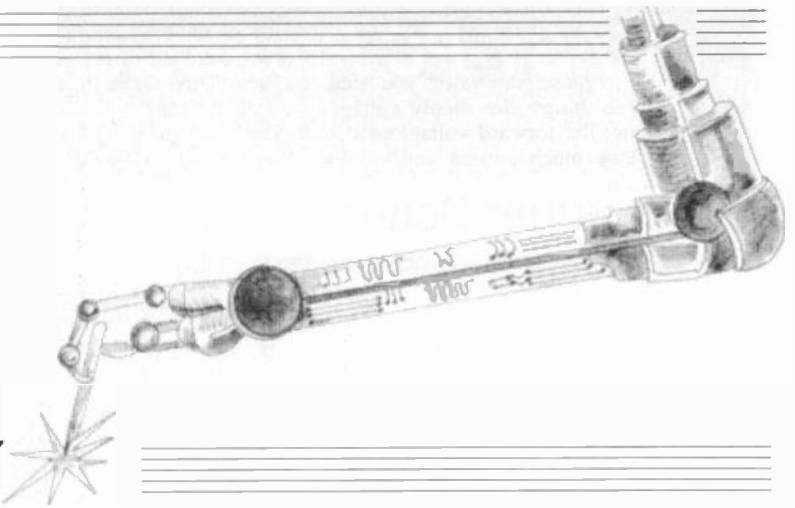

Our monthly Help Desk looks at retriggerable monostable timers, making those plastic project boxes sparkle like new, and a new way our overseas readers (and UK ones!) can snaffle those codes for our PIC-based microcontroller projects.

PICs away Chaps

DIPPING into this month's post-bag (and sifting through our "electronic" mailbox, too), by E-mail came the following topical comments from Dr. Pieter le Roux in South Africa:

Referring to your comments on PIC programming (Take Your Pic, Circuit Surgery, July 96), I have a lot of sympathy with gifted programmers who wish to keep their code copyrighted - I certainly would!

However, out here in South Africa it is extremely difficult to obtain even the released codes using the methods you provide (floppy disk by post) because of the poor exchange rates which makes foreign purchases prohibitively expensive. The delays using (affordable) surface mail make one lose interest in favour of the subsequent two months projects which you publish!

Parts can be very difficult to source, making PICs about the only project that readers out here can safely attempt, since they seldom need a lot of specialised peripheral devices. So my questions are:

When will the WWW site to which you allude, be available? Is there some other means of obtaining the source codes when new PIC projects are released?

We recognise all of these problems, hopefully the Maplin outlet in Somerset West will help to reduce the component supply problems in South Africa. You will be pleased to hear that all available project PIC files are now available by free "anonymous FTP" from our server. Overseas readers with an Internet connection will find this tremendously useful, we hope.

The files for the PIC-Tock Pendulum Clock project (Sept. '96 issue), for example, were immediately available from the date of publication of that issue. The URL is <ftp://ftp.epemag.wimborne.co.uk/pub/PICS/pictock>. Note that certain PIC project source codes are not available as they remain the property of their respective designers.

Our World Wide Web site is also open.

growing slowly and surely - we hope you have spotted the URL and E-mail address on our cover and Editorial page! Also, check our Net Work column for current information.

Shining Example

My thanks to Mark McGuinness of Clondalkin, Dublin, whom I know is a regular Surgery reader and Ingenuity Unlimited contributor. Mark suggests:

I've found that some plastic boxes which arrive by mail order come complete with unwanted scratches visible on one or more sides of the box. These can spoil a project's appearance.

I have found that using an aerosol spray paint, the scratches can be hidden and you can give the box a more attractive colour, too! It is a good idea to drill the holes etc., first, before spray painting the box, to preserve the paint finish.

These days, plastic boxes can form a major part of the cost of project building, and I shop around the same as everybody else, so I object if it arrives bashed in the post. It is not widely known that one of the best ways of polishing scratches (minor ones, anyway) out of plastic is to use traditional metal polish.

Something like "Brasso" or chrome polish paste (try a cycle shop) is excellent - all you need is some elbow grease! Paste-type metal polishes are based on a micro-abrasive (e.g. very fine grade aluminium oxide powder in an oily base) and at surface level these smooth off the plastic and eventually leave a mirror finish.

Spray-painting a plastic box can be trickier than you'd think. The older cellulose-based paints have a characteristically pungent smell and they can actually melt many plastics, doing irreparable damage to the surface which you will never clean up. More than once, I have damaged my carefully-applied rub-down lacquer, which dissolved the lettering and the plastic with it!

Nowadays, it is usual to use acrylic-based formulations instead and these can

leave a superb mirror finish on plastic surfaces. (Car touch-up paint is based on these same modern acrylics.) It is still wise to test the plastic first (e.g. spray a small area inside the lid, and you are right, Mark, always do the drilling and fabricating beforehand! Professionals actually use a RAL colour-matched aerosol paint to touch up those boring but bashed, grey boxes.

You might be interested in my new feature series *Build Your Own Projects* which commences very soon here in EPE, once I have got more film loaded in my camera! You'll find lots of interesting information to help you get the best results for your money!

Flashing L.E.D.s

A topic which to old hands is "done to death", but still important to many people, especially our younger readers, is how to use light-emitting diodes (l.e.d.s) correctly! It crops up very frequently on Internet newsgroups.

They have a very low operating or "forward voltage" (typically, 1.8V to 2.2V) which needs to be taken into account when using them at a higher voltage than this. You need a series-limiting resistor which is used as shown in Fig. 1. The resistor

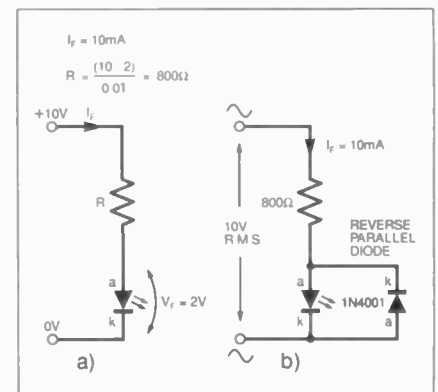

Fig.1(a) Series resistor calculation, (b) using an l.e.d. on an a.c. supply.

(R) causes two things to happen: first, it creates a voltage drop; and second, it limits the current.

To calculate the resistor value, you need to know *three* things: the supply voltage you are using; the forward voltage of the l.e.d. and, how much current you would like to flow through the device.

The more current flowing, the brighter it will be, but there is usually nothing to be gained by exceeding more than 10mA to 20mA or so. In normal operation, the forward voltage appears "automagically" across the l.e.d. so you have to "lose" the excess voltage somewhere - across the resistor.

It is pretty easy once you get the hang of it. In the example of Fig. 1a, the supply voltage is +10V, and the supplier's catalogue says that the l.e.d. forward voltage is 2V.

So, first we have got to lose 8V across the series resistor. Second, let's decide that we want 10mA to flow. The series resistor is then easily calculated with Ohms Law:

$$R = V/I$$

so $R = 8V/10mA (0.01A) = 800 \text{ ohms}$. The nearest preferred value is 820 ohms, which would be fine.

What would happen if you had only a 560 ohm resistor available, for example? Well, the l.e.d. will still try to maintain 2V, so the current will be $8V/560 \text{ ohms} = 15mA$. This is still well within a typical l.e.d.'s specification. If you want to use them on an a.c. supply, a reverse-parallel diode is needed as shown in Fig. 1b.

If you want to save some work but spend more money, you can buy l.e.d.s with resistors already built in. Ready-made flashing light-emitting diodes (f.l.e.d.s) are a neat way of adding one of these blinking beacons to your project (see February and April '96 issues).

The main factor to watch for is really just the supply voltage, since this varies depending on the type of f.l.e.d. you've bought. Check the specs. carefully at the time of purchase. Some types are safe to use from, say, 3-5V to 13V absolute maximum, other varieties have a 5V maximum.

There is a potential trap using the f.l.e.d. types! If you want to use them with a higher voltage, then when the flasher l.e.d. is ON, forward current flows as usual, so you'd think you could use a series resistor as before. But when the f.l.e.d. turns OFF, there is hardly any current flowing, so there is no voltage drop across the resistor, and all the supply voltage appears across the f.l.e.d. instead!

Therefore, if the supply rail is higher than the f.l.e.d.'s maximum voltage rating,

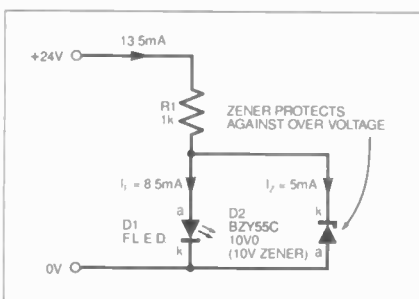

Fig.2. Using flashing l.e.d.s at higher voltages.

it is wise to take extra precautions by using, for example, a Zener diode across the f.l.e.d. to protect it against over-voltages. This means that the series resistor should allow for a nominal Zener current (say, 5mA) too. The supply rail is +24V and the f.l.e.d. in Fig.2 is rated at 8.5mA and runs safely at 10V in this example, thanks to the Zener.

Retriggerable Timers

A question arose on a particular type of timer called a "retriggerable" monostable. Mr. J. M. Bloodworth of Maidenhead asks for guidance:

"Could you explain a little about retriggerable monostables. I have spent years waiting to see some examples of how this can be done."

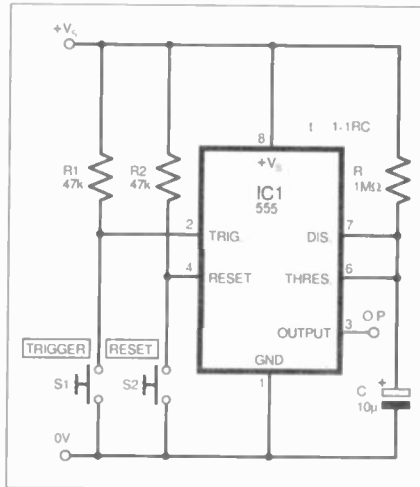

Fig.3. Classic 555 monostable.

The familiar 555 monostable is shown in Fig. 3. This has a period of roughly 10 seconds ($1.1 RC$). My experience has highlighted one or two hidden snags which you might need to take into account when using this as the basis for an appliance timer circuit or whatever.

Closing switch S1 starts the time period, and switch S2 resets it. Providing you open S1 again before the chip times out, you're OK.

Furthermore, sending more trigger signals makes no difference once the 555 has started timing. But if the trigger signal is present just as the ten seconds are up, then the 555 output remains high, and it will only go low when the trigger signal is finally removed! Then, the timing period is the same length as the trigger signal.

The monostable's operation is well known - the capacitor C is discharged by an internal transistor within the 555 at pin 7 when the timing period has elapsed. The retriggerable monostable you're interested in will re-start the timing period if a fresh trigger signal is sent.

You cannot do this directly with the 555 and it is therefore necessary to discharge the capacitor by some

other means. This is accomplished by adding an external *pnp* transistor in parallel with the 555's internal discharge (pin 7) transistor and also hooking the base (b) lead to the trigger pin (2), as shown in Fig. 4.

When a (negative-going) trigger signal is received, pin 2 of IC1 and TR1 base (b) are grounded. Therefore the 555 triggers internally so its output toggles high, but the transistor also turns hard on which keeps the timing capacitor (C) discharged.

The output remains latched high, but the monostable period cannot actually start until the triggering signal is then removed; then TR1 turns off, capacitor C charges up as normal and the monostable will time out. It is not technically a true retriggerable monostable because the output latches when a "trigger" is received, but the actual timing period does not commence until the trigger is removed.

Nonetheless, the period will recommence again if the trigger is briefly applied once more, when the capacitor will recharge from near zero, having been discharged by TR1. Maybe you can adapt it for your needs.

The capacitor may have a small residual voltage across it (40mV as measured), depending on how hard the transistor saturates, which may affect accuracy but it may be good enough for many purposes. Another option would be to use a small MOSFET transistor which might shunt the capacitor down to a lower voltage. There is room for experimentation.

There are indeed other true retriggerable chips available, notably TTL timers including the 74122 (single) or 74123 (dual) monostable retriggerable timers, but they are really only good for fractions of a second in high speed logic circuits. The 74121 is also a non-retriggerable chip but is more complex to use. Whilst not being inherently retriggerable, the 555 is better for general use.

At your service

Circuit Surgery is your page. If you have any questions to ask or comments to make, please write to Alan Winstanley, Circuit Surgery, Wimborne Publishing Ltd., Allen House, East Bournemouth, Wimborne, Dorset, BH21 1PF. E-mail alan@epemag.wimborne.co.uk

We cannot guarantee an individual reply nor undertake to answer questions on commercial equipment but we do try to help wherever possible.

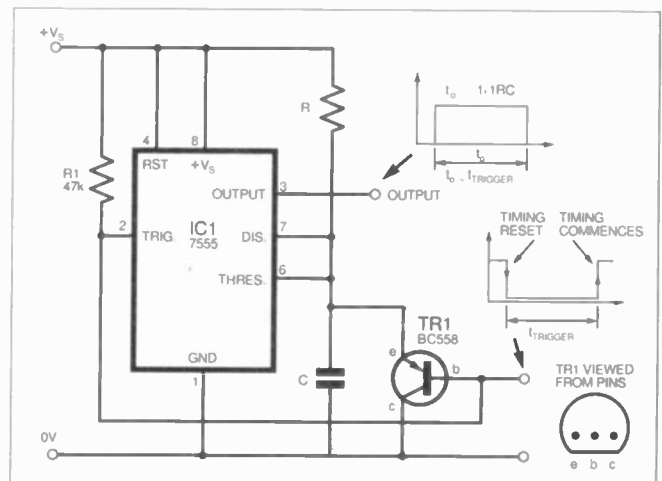

Fig.4. Retriggerable 555 monostable.

FOX REPORT

by Barry Fox



Your Number's Up

If there was a best time for telecommunications watchdog Oftele to announce that the UK was again running out of telephone numbers, it was when they did. August, with many people away on holiday, including MPs. But there was still outrage.

There was also a lot of nonsense talked and written. For example, people still see BT and Oftele as one and the same organisation, or partners in conspiracy, when in fact lawyers for Oftele and BT get rich on the running battles between the two quite separate organisations. It does not help that other telecoms operators, such as Mercury, seldom bother to contribute to the open debate.

There are two reasons why Britain is short of telephone numbers.

Gone are the days when you phoned a company's switchboard and asked them to try and connect you to Mr Jones. You now dial Mr Jones on his *direct* dial extension, or send a fax to his personal machine. The explosion in cellphones, answering and paging services adds to the fax explosion and direct dialling.

Also, the UK uses telephone numbers inefficiently, because we try to tie subscribers' numbers to their locations. When you phone long distance to Wigan you know it's Wigan because of the code, and cannot be fooled into thinking it is a local call.

Oftele clings to this tradition, while allowing a proliferation of premium phone lines and answering services which leave users paying long distance rates for local calls and being charged literally pounds per minute for special services.

Passing the Buck

Put all this together, add some good old British muddle, and you get the current mess. Add another ingredient, "passing the buck", and no-one feels the need even to say sorry for the mess.

The one over-riding impression I got from the press conference called by Oftele to announce the number shortage was the overwhelming confidence of Director General Don Cruickshank that none of it was anything to do with him. Not once did I see even a flicker of sympathy for the small businesses who will now have to pay yet again to reprint their stationery, change their signs, re-program memory diallers and security devices and warn clients round the world of the new numbers.

After reassuring that the next number change will cost less than the last change, *Phoneday* in April 1995, Cruickshank dismissed all questions on the actual cost.

"I don't know how much *Phoneday* cost. How should I know? Why should I? It cost nothing because of the net benefit"

The bare facts are that London's telephone subscribers face their *third* number change in ten years. Four more cities face their *second*. The only other option is for businesses to start using a completely new range of numbers from domestic subscribers.

The details are to be found in a Consultative document, *The National Numbering Service, Options for the Future - 2* which is available *free* of charge from Oftele. You have until 18 October to comment. Oftele then decides in December what to do before five cities including London run out of numbers by the year 2000.

"This leaves plenty of time for planning" says Cruickshank. He works on the principle that people are happy to reprint stationery and re-write signs every couple of years.

Sorry - Wrong Number!

Until 1990 BT was responsible for telephone numbering. In April that year, with BT's monopoly slipping away, Oftele started to take over responsibility, initially relying on TNAB, a Telephone Number Advisory Board, for guidance. In June 1994, Oftele took over complete responsibility.

In May 1990 Oftele implemented BT's plan to split London's numbering from 01 to 071 and 081. Oftele then planned a national code change for Easter 1994, with every number in the UK growing an extra "1" at the front, to make London's numbers 0171 and 0181. The codes for Leeds, Sheffield, Nottingham, Leicester and Bristol changed completely at the same time.

Industry was so slow to react that Oftele had to delay the national *Phoneday* upheaval until April 1995. Don Cruickshank appeared on the *Newsnight* TV programme to pledge that "Once we have put the '1' in front of all the present numbers, no-one who has such a number will have to change again during their lifetime".

But even before *Phoneday* dawned, rapid business expansion in Reading, Belfast, Southampton and Portsmouth had made it inadequate. Last year Oftele gave Reading a completely new code, which came into operation in April 1996.

In last year's Consultation document, Oftele proposed an idea, called "Overlay", from the US to save other cities. In New York City new subscribers get 917 codes while existing subscribers keep their 212 and 718 numbers. So as a British zone runs out of 01 numbers, new subscribers would get 02 numbers.

Oftele says it abandoned the overlay scheme because consumer groups objected that people living next door to each other would have different codes and so need to dial long strings of numbers to talk to a next door neighbour. When reminded of his now-broken pledge, Cruickshank simply says that all bets were off when he had to abandon the 02 overlay idea.

Equal Misery

Having ploughed through Oftele's obscure documents I would say it is a safe bet that most people never realised Oftele was offering them a straight choice - either accept that new subscribers in crowded cities like London will get quite different numbers, or be prepared for everyone in those cities to have to change all their numbers.

Oftele's new fix is to change all the numbers in the five most starved cities (London, Cardiff, Belfast, Southampton and Portsmouth). Old and new subscribers alike will all get 02 numbers.

So, London's 0171 and 0181 codes will become 020 or 022. Because the area code is now one digit shorter, the local number can be extended by one digit (to increase the number pool tenfold) without making the total number string too long for existing equipment, in the UK and abroad, to handle.

Remember, that foreign countries have to dial extra digits to get into the UK. The current international limit is 12 digits, and although it will soon rise to 15 this will not help old switchboards in Russia etc.

Don Cruickshank rejects the suggestion that his new policy inflicts "equal misery" on everyone, to ensure that no-one can complain of unequal treatment. He prefers to describe it as policy of "equal opportunity". Remember that when you are paying for new notepaper and signs.

Personal Number

There is one alternative option. This is to leave domestic numbers untouched and persuade businesses to migrate onto a new set of numbers which all begin 05.

Another new idea is to use the 07 code for "Find me anywhere" or "portable" numbers. Subscribers keep the same number for life, regardless of which phone service they are using, and who they are paying to provide it, e.g. BT, Mercury, Cellnet, Vodafone, Orange, or One-2-One. But this will be slow to catch on. The service operators want to stop subscribers "churning" onto a rival service, and what better way to achieve this than make them reprint all stationery as a punishment!

£1 BARGAIN PACKS - List 1

1,000 items appear in our Bargain Packs List - request one of these when you next order.

- 1 x 12V Stepper Motor. 7.5 degree. Order Ref: 910.
- 1 x 10 pack Screwdrivers. Order Ref: 909.
- 2 x 5 amp Pull Cord Ceiling Switches. Brown. Order Ref: 921.
- 5 x reels Insulation Tape. Order Ref: 911.
- 2 x 14mm Bull-races. Order Ref: 912.
- 2 x Cord-Grip Switch Lamp Holders. Order Ref: 913.
- 1 x D.C. Voltage Reducer 12V to 6V. Order Ref: 916.
- 1 x 10 amp 40V Bridge Rectifier. Order Ref: 889.
- Lightweight Stereo Headphones. Moving coil so superior sound. Order Ref: 896.
- 2 x 25W Crossovers. For 4ohm loudspeakers. Order Ref: 22.
- 2 x NiCad Constant Current Chargers. Easily adaptable to charge almost any NiCad battery. Order Ref: 30.
- 18V-0V-18V 10VA mains transformer. Order Ref: 813.
- 2 x White Plastic Boxes. With lids, approx. 3" cube. Lid has square hole through the centre so these are ideal for light-operated switch. Order Ref: 132.
- 2 x Reed Relay Kits. You get 8 reed switches and 2 coil sets. Order Ref: 148.
- 12V-0V-12V 6VA mains transformer, p.c.b. mounting. Order Ref: 938.
- 1 x Big Pull Solenoid. Mains operated. Has 1/2" pull. Order Ref: 871.
- 1 x Big Push Solenoid. Mains operated. Has 1/2" push. Order Ref: 872.
- 1 x Mini Mono Amp. 3W into 4 ohm speaker or 1W into 8 ohm. Order Ref: 495.
- 1 x Mini Stereo 1W Amp. Order Ref: 870.
- 15V D.C. 500mA p.s.u., nicely cased. Order Ref: 942.
- 1 x In-Flight Stereo Unit is a stereo amp. Has two most useful mini moving coil speakers. Made for BOAC passengers. Order Ref: 29.
- 1 x 0-1mA Panel Meter. Full vision face 70mm square. Scaled 0-100. Order Ref: 756.
- 2 x Lithium Batteries. 2.5V penlight size. Order Ref: 874.
- 2 x 3m Telephone Leads. With BT flat plug. Ideal for phone extensions, fax, etc. Order Ref: 552.
- 1 x 12V Solenoid. Has good 1/2" pull or could push if modified. Order Ref: 232.
- 4 x In-Flex Switches. With neon on/off lights, saves leaving things switched on. Order Ref: 7.
- 2 x 6V 1A Mains Transformers. Upright mounting with fixing clamps. Order Ref: 9.
- 2 x Humidity Switches. As the air becomes damper the membrane stretches and operates a microswitch. Order Ref: 32.
- 5 x 13A Rocker Switch. Three tags so on/off, or changeover with centre off. Order Ref: 42.
- Mini Cassette Motor, 9V. Order Ref: 944.
- 1 x Suck or Blow-Operated Pressure Switch. Or it can be operated by any low pressure variation such as water level in tanks. Order Ref: 67.
- 1 x 6V 750mA Power Supply. Nicely cased with mains input and 6V output lead. Order Ref: 103A.
- 2 x Stripper Boards. Each contains a 400V 2A bridge rectifier and 14 other diodes and rectifiers as well as dozens of capacitors, etc. Order Ref: 120.
- 12 Very Fine Drills. For PCB boards etc. Normal cost about 80p each. Order Ref: 128.
- 5 x Motors for Model Aeroplanes. Spin to start so needs no switch. Order Ref: 134.
- 6 x Microphone Inserts. Magnetic 400 ohm, also act as speakers. Order Ref: 139.
- 6 x Neon Indicators. In panel mounting holders with lens. Order Ref: 180.
- 1 x In-Flex Solderstat. Keeps your soldering iron etc always at the ready. Order Ref: 196.
- 1 x Electric Clock. Mains operated. Put this in a box and you need never be late. Order Ref: 211.
- 4 x 12V Alarms. Makes a noise about as loud as a car horn. All brand new. Order Ref: 221.
- 2 x (6" x 4") Speakers. 16 ohm 5 watts, so can be joined in parallel to make a high wattage column. Order Ref: 243.
- 1 x Panostat. Controls output of boiling ring from simmer up to boil. Order Ref: 252.
- 2 x Oblong Push Switches. For bell or chimes, these can switch mains up to 5A so could be footswitch if fitted in pattern. Order Ref: 263.
- 50 x Mixed Silicon Diodes. Order Ref: 293.
- 1 x 6 Digit Mains Operated Counter. Standard size but counts in even numbers. Order Ref: 28.
- 2 x 6V Operated Reed Relays. One normally on, other normally closed. Order Ref: 48.
- 1 x Cabinet Lock. With two keys. Order Ref: 55.
- 6 1/2 Ohm 5 Watt Speaker. Order Ref: 824.
- 1 x Shaded Pole Mains Motor. 3/4" stack, so quite powerful. Order Ref: 85.
- 2 x 5 Aluminium Fan Blades. Could be fitted to the above motor. Order Ref: 86.
- 1 x Case, 3 1/2" x 2 1/4" x 1 3/4" with 13A socket pins. Order Ref: 845.
- 4 x Luminous Rocker Switches. 10A mains, Order Ref: 793.
- 4 x Different Standard V3 Microswitches. Order Ref: 340.
- 4 x Different Sub-Mln. Microswitches. Order Ref: 313.

12V 10A SWITCH MODE POWER SUPPLY. For only £9.50 and a little bit of work because you have to convert our 135W PSU. Modifications are relatively simple - we supply instructions. Simply order PSU Ref 9.5P2 and request modification details, price still £9.50.

LAMP DIMMER. Suitable for up to 250W, on standard plate so fits directly in place of existing switch. Coloured red, blue, yellow or green but will take emulsion paint, £2 each, Order Ref: 2P380.

PHILIPS 9" HIGH RESOLUTION MONITOR. Black and white in metal frame for easy mounting. Brand new, still in maker's packing, offered at less than price of tube alone, only £15, Order Ref: 15P1.

MAINS KLAXON TYPE ALARM. Very loud output but adjustable. Completely

encased, shelf or wall mounting, £5, Order Ref: 5P226.

FIGURE-8-FLEX. Figure-8 flat white pvc lead, flexible with 4 sq.mm cores. Ideal for speaker extensions and bell circuits. Also adequately insulated for mains lighting. 50m coil, £2, Order Ref: 2P345. 12m coil, £1, Order Ref: 1014.

HIGH CURRENT AC MAINS RELAY. This has a 230V coil and changeover switch rated at 15A with PCB mounting with clear plastic cover, £1, Order Ref: 965.

AMSTRAD 8" 15W SPEAKER with matching tweeter, 8 ohm, Order Ref: 4P57.

VERY POWERFUL MAINS MOTOR. With extra long (2 1/2") shafts extending out each side. Makes it ideal for a reversing arrangement for, as you know, shaded-pole motors are not reversible, £3, Order Ref: 3P157.

SMART HIGH QUALITY ELECTRONIC KITS

All kits are complete with PCB and other components in a blister pack. We feel that most readers will know these kits, but if you want more information about them, then we have copies of the illustrated Smart catalogue, this gives full details and circuit diagrams of each kit, price is £1, deductable if you order kits to the value of £20.

CAT. No.	DESCRIPTION	PRICE £	CAT. No.	DESCRIPTION	PRICE £
1002	VU Meter, with l.e.d. display	4.60	1062	5V 0-5A Stabilized Supply for TTL	2.30
1003	5W Electronic Siren	2.53	1063	12V 2A Power Supply	2.30
1004	Light Switch	3.22	1064	+ 12V 0-5A Stabilized Supply	3.22
1005	Touch Switch	2.87	1067	Stereo VU Meter, with l.e.d.s	9.20
1007	Stabilized Power Supply: 3V to 30V at 2-5A	6.90	1068	18V 0-5A Stabilized Power Supply	2.53
1008	SF Function Generator	6.90	1069	Fluorescent Tube Unit from 12V d.c.	2.99
1010	5-input Stereo Mixer, with monitor output	19.31	1070	HiFi Pre-amplifier	7.47
1011	Motorbike Alarm	3.20	1071	4-input Selector	6.90
1012	Reverberation Unit	5.52	1074	Drill Speed Controller	2.76
1016	Loudspeaker Protection Unit	3.22	1077	100W HiFi Amplifier	12.50
1023	Dynamic head preamp	2.50	1080	Liquid Level Sensor - Rain Alarm	2.30
1024	Microphone preamp	2.20	1082	Car Voltmeter, with l.e.d.s	7.36
1025	7W HiFi Power Amplifier	2.53	1083	Video Signal Amplifier	2.76
1026	Running Lights	4.60	1084	TV Line Amplifier	1.84
1027	NiCad Battery Charger	3.91	1085	DC Converter, 12V to 6V or 7-5V or 9V	2.53
1029	4 sound electronic siren	3.00	1086	Music to light for your car	4.60
1030	Light Dimmer	2.53	1087	Thyristor/Triac Tester	2.76
1032	Stereo Tone Control	4.14	1088	Kit Scanner	10.12
1033	60W HiFi Power Amplifier	7.82	1089	LED Flasher/555 Tester	1.61
1034	Car Battery Checker	1.61	1090	Stress Meter	3.22
1035	Space Sound Effects	2.30	1093	Windscreen Wiper Controller	3.68
1038	AM/FM Aerial Amplifier	1.61	1094	Home Alarm System	12.42
1039	Stereo VU Meter	4.60	1096	2V-30V 5A Stabilized Variable PSU	11.04
1040	10W HiFi Power Amplifier	2.76	1098	Digital Thermometer, with l.c.d. display	11.50
1041	25W HiFi Power Amplifier	4.60	1100	2 x 18W Integrated Amplifier	18.39
1042	AF Generator, 250Hz-16kHz	1.70	1103	LED Power Meter	1.84
1043	Loudness Stereo Unit	3.22	1106	Thermometer with l.e.d.s	6.90
1047	Sound Switch	5.29	1107	Electronics to help win the pools	3.68
1048	Electronic Thermostat	3.68	1109	40W HiFi Amplifier	7.36
1050	3-input HiFi Stereo Pre-amplifier	12.42	1112	Loudspeaker protection, with delay	4.60
1051	Touch Dimmer, with memory	4.60	1113	2 x 18W Power Amplifier	5.98
1052	3-input Mono Mixer	6.21	1115	Courtesy Light Delay	2.07
1053	Electronic Metronome	3.22	1118	Time Switch with triac 0-10mins	4.14
1054	4-input Instrument Mixer	2.76	1123	Morse Code Generator	1.84
1056	8V-20V 8A Stabilized Power Supply	12.42	1124	Electronic Bell	2.76
1057	Cassette Head Pre-amplifier	3.22	1125	Telephone Lock	3.68
1058	Electronic Car Ignition	7.82	1126	Microphone Pre-amplifier	4.60
1059	Telephone Amplifier	4.60	1127	Microphone Tone Control	4.60
1060	+40V 8A Power Supply	8.28	1128a	Power Flasher 12V d.c.	2.53
			1130	Telephone Bug Detector	3.20
			1133	Stereo Sound-to-Light	5.26

YOU SAVE £40



THE JAP MADE 12V 15AH SEALED LEAD ACID BATTERY from regular suppliers costs £50, you can have one from us for only £10 including VAT if you collect or £12.50 if we have to send. Being sealed it can be used in any position and is maintenance free. All in tip top condition and fully guaranteed, Order Ref: 12.5P2. Or if you want a smaller one we have 12V 2.3AH, regular price £14, yours for only £5, Order Ref: 5P258.

Prices include VAT and carriage if order over £25 otherwise add £3. Send cash, uncrossed postal orders, cheque or quote credit card number.

J & N FACTORS
Pilgrim Works (Dept. E.E.)
Stairbridge Lane, Bolney,
Sussex RH17 5PA
Telephone: 01444 881965
(Also fax but phone first)

TRANSMITTERS

NEW Fully comprehensive guide to building and using short/medium range radio transmitters and receivers. Includes detailed and practical information on all aspects of construction, from simple FM room transmitters to more sophisticated and powerful audio and data transceivers.



Manual includes:

- ▶ **AM, FM and UHF** Transmitters from micro power up to 3 Watts. Covers simple 'bugs' as well as circuits operating on 27MHz and 418MHz etc.
- ▶ **TRACKING AND SIGNALLING.** How to build micro circuits for finding animals, cars etc.
- ▶ **CRYSTAL CONTROLLED TRANSMITTERS.** High stability circuits.
- ▶ **RADIO PAGER AND RADIO CONTROL.** How to build coded radio keys, multi-channel remote controls, radio alarms etc.
- ▶ **RECEIVER CIRCUITS.** Wide range of receiver projects for building high security audio links and transceivers.
- ▶ **EXTENSIVE** assembly information. Includes sections on construction, testing, mics, aerials, coils and miniaturisation.

£8.95
Inc. p&p

Over **100** detailed PCB, strip-board and point to point designs. Manual comes with **FREE** micro transmitter PCB.

(Some of the circuits included in the manual may not be used legally in the UK).



Make cheques/POs payable to
JCG ELECTRONICS
P.O. Box HP79, Woodhouse Street, Leeds, LS6 3XN.
Wide range of Audio/Radio kits available.
Send stamp for list. Mail order only.

WE HAVE THE WIDEST CHOICE OF USED OSCILLOSCOPES IN THE COUNTRY

PHILIPS PM2675 Dual Trace 35MHz Dual Channel	£2000
HP 34200A Systems Oscilloscope 50MHz	£1000
TEKTRONIX 7A605 Dual Trace 100MHz Dual Channel	£1100
TEKTRONIX 2445 4 Channel 100MHz Dual Channel	£1500
TEKTRONIX 465 Dual Trace 100MHz Single Channel	£400
TEKTRONIX 5334 Dual Trace 60MHz 17MB	£400
TEKTRONIX 2245 Dual Trace 60MHz Single Channel	£400
TEKTRONIX 2245 Dual Trace 60MHz	£350
HAMEG 705 Dual Trace 10MHz Single Channel	£375
HAMEG 8155 2 + 1 Ch. 50MHz Dual Trace	£500
TEKTRONIX 455 Dual Trace 50MHz	£375
TEKTRONIX 455 Dual Trace 50MHz Single Channel	£400
HITACHI 150 Dual Trace 50MHz Single Channel	£400
AVANT 5500A Dual Trace 35MHz	£220
COLSON DS 11051 Dual Trace 30MHz	£200
COLSON DS 11051 Dual Trace 30MHz	£200
COLSON DS 11051 Dual Trace 30MHz	£200
PHILIPS PM27 Dual Trace 50MHz SCHEMATA Dig. Storage	£800
35M Storage	£300
LANEY LE240E DUAL TRACE 20MHz Single Channel LED	£300
TEKTRONIX 4600A Dual Trace 100MHz Dual Channel Storage	£750
HITACHI VC6217 Dual Trace 60MHz Dig. Storage	£650
HP 7741A Dual Trace 100MHz Analog Storage	£400
TEKTRONIX 454 Dual Trace 25MHz SCHEMATA Dig. Storage	£250

THIS IS JUST A SAMPLE - MANY OTHERS AVAILABLE

HP 8593A Spectrum Analyser with 100MHz	£2000
HP 8593A Spectrum Analyser with 100MHz	£1750
MINITON 2022 AM/FM Sig. Gen. 100kHz-1MHz	£1600
MINITON 2019 Synthesised AM/FM Sig. Gen. 100kHz-10MHz	£1900
HP 8640A Power Loss Sys. Sig. Gen. 50kHz-50MHz	£800
HP 8640A AM/FM Sig. Gen. 50kHz-100MHz	£750
HP 8640A Sweep Generator Mod. System only	£200
FRANKLIN SEC 5310 AM/FM Sig. Gen. 10kHz-500kHz	£400
FRANKLIN SEC 5310 AM/FM Sig. Gen. 10kHz-500kHz	£400
MINITON 74181A Sig. Gen. Mod. 20kHz-20MHz 0.05% un-warm	£225
MINITON 74181A Sig. Gen. Mod. 20kHz-20MHz 0.05% un-warm	£225
MINITON 74181A Sig. Gen. Mod. 20kHz-20MHz 0.05% un-warm	£100
HP 8460A Frequency Counter 10-100MHz	£75
MINITON 2310 Multimeter Meter	£2250
HP 5100A Noise Meter 100Hz-20kHz with HP8262 10kHz-10MHz	£1500
MINITON 66104 Programmable Source Gen. 10kHz-20kHz	£1500
HP Spectrum analyser Model 82411 with P511	£1000
POA	POA

BRUEL & KJOER EQUIPMENT AVAILABLE - PLEASE ENQUIRE

SPECTRUM ANALYSERS

HP 8593A	£2000
HP 8593A	£1750
MINITON 2022 AM/FM Sig. Gen. 100kHz-1MHz	£1600
MINITON 2019 Synthesised AM/FM Sig. Gen. 100kHz-10MHz	£1900
HP 8640A Power Loss Sys. Sig. Gen. 50kHz-50MHz	£800
HP 8640A AM/FM Sig. Gen. 50kHz-100MHz	£750
HP 8640A Sweep Generator Mod. System only	£200
FRANKLIN SEC 5310 AM/FM Sig. Gen. 10kHz-500kHz	£400
FRANKLIN SEC 5310 AM/FM Sig. Gen. 10kHz-500kHz	£400
MINITON 74181A Sig. Gen. Mod. 20kHz-20MHz 0.05% un-warm	£225
MINITON 74181A Sig. Gen. Mod. 20kHz-20MHz 0.05% un-warm	£225
MINITON 74181A Sig. Gen. Mod. 20kHz-20MHz 0.05% un-warm	£100
HP 8460A Frequency Counter 10-100MHz	£75
MINITON 2310 Multimeter Meter	£2250
HP 5100A Noise Meter 100Hz-20kHz with HP8262 10kHz-10MHz	£1500
MINITON 66104 Programmable Source Gen. 10kHz-20kHz	£1500
HP Spectrum analyser Model 82411 with P511	£1000

MANY OTHER POWER SUPPLIES AVAILABLE

NEW EQUIPMENT

HAMEG OSCILLOSCOPE PERIODS Scope 100MHz	£847
Scope Transmitter	£655
HAMEG 705 Dual Trace 10MHz Single Channel	£422
HAMEG 8155 2 + 1 Ch. 50MHz Dual Trace	£655
HP 8593A Spectrum Analyser with 100MHz	£2000
HP 8593A Spectrum Analyser with 100MHz	£1750
MINITON 2022 AM/FM Sig. Gen. 100kHz-1MHz	£1600
MINITON 2019 Synthesised AM/FM Sig. Gen. 100kHz-10MHz	£1900
HP 8640A Power Loss Sys. Sig. Gen. 50kHz-50MHz	£800
HP 8640A AM/FM Sig. Gen. 50kHz-100MHz	£750
HP 8640A Sweep Generator Mod. System only	£200
FRANKLIN SEC 5310 AM/FM Sig. Gen. 10kHz-500kHz	£400
FRANKLIN SEC 5310 AM/FM Sig. Gen. 10kHz-500kHz	£400
MINITON 74181A Sig. Gen. Mod. 20kHz-20MHz 0.05% un-warm	£225
MINITON 74181A Sig. Gen. Mod. 20kHz-20MHz 0.05% un-warm	£225
MINITON 74181A Sig. Gen. Mod. 20kHz-20MHz 0.05% un-warm	£100
HP 8460A Frequency Counter 10-100MHz	£75
MINITON 2310 Multimeter Meter	£2250
HP 5100A Noise Meter 100Hz-20kHz with HP8262 10kHz-10MHz	£1500
MINITON 66104 Programmable Source Gen. 10kHz-20kHz	£1500
HP Spectrum analyser Model 82411 with P511	£1000

Used Equipment - Guaranteed. Manuals supplied if possible.
This is a VERY SMALL SAMPLE OF STOCK. SAE or telephone for lists. Please check availability before ordering. CARRIAGE all units £16. VAT to be added to Total of Goods and Carriage.

STEWART OF READING
110 WYKHAM ROAD, READING, BERKS RG6 1PL
Tel: 01734 268041 Fax: 01734 351696
Callers welcome 9am to 5.30pm MON-FRI

PCB Designer



Runs on any PC running Windows 3.1, Windows 95 or Windows NT with a minimum 2MB RAM
Will work with any Windows supported printer and monitor

For Windows 3.1, '95 or NT



Internet

Visit our WWW site at www.niche.co.uk for more information and a working demo. The demo is also available via anonymous FTP from <ftp:demon.co.uk> in the dir /pub/ibmpc/win3/apps/pcbdemo/ as pcbdemo.zip. Internet e-mail pcb@niche.demon.co.uk.

Looking for the price?
It's just **£49.00** all inclusive!
...no VAT...no postage...
...no additional charges for overseas orders.
Dealers and distributors wanted.

- ✓ Produce Single or Double sided PCBs.
- ✓ Print out to **any** Windows supported printer.
- ✓ **Toolbar** for rapid access to commonly used components.
- ✓ Helpful prompts on screen as you work.
- ✓ Pad, track & IC sizes fully customisable.
- ✓ No charges for technical support.
- ✓ Snap-to grid sizes 0.1", 0.05" 0.025" and unrestricted.
- ✓ SMT pads and other pad shapes.
- ✓ Prints at the resolution of your printer, much higher than the screen shot shown here.

Niche Software (UK)
12 Short Hedges Close, Northleach, Cheltenham, GL54 3PD Phone (01451) 860 737

Available in South Africa from JANCA Enterprises, PO Box 32131, 9317 Fichardt Park at R299,00

DIRECT CONVERSION TOPBAND and 80m RECEIVER



ADRIAN KNOTT G6KSN

Tuning into the world amateur bands couldn't be easier with this receiver!

AS AN introduction to short wave listening on the amateur bands, probably the easiest type of receiver to construct is of the direct conversion variety. This type of receiver is at its best when resolving single sideband (SSB) and Morse code (CW) signals. This is perfect for the H.F. amateur bands since most stations use these modes of transmission nowadays.

The demise of the Sunday morning "A.M. nets" on topband sadly occurred in the 1970s in the Midlands area. SSB is, of course, a more effective communications medium for weak signal work and also theoretically uses only half the bandwidth of an equivalent a.m. transmission.

The consequence of using SSB on topband does mean that the casual listener tuning around the "high end" of medium wave will never resolve any amateur transmissions on a domestic set. This is a great shame because many people (me included) got bitten by the bug listening to such signals.

TOPBAND

Until recently, topband or 160 Metres was the lowest frequency range available to radio amateurs and novices. It extends from 1.8MHz to 2.0MHz, this is just above the upper limit of the medium waveband.

A new allocation at 73kHz means that topband is no longer the lowest frequency range available. However, 73kHz does have a lot of restrictions imposed on it at present and is only available to those who have applied for a special notice of variation to the basic amateur licence.

Topband behaves in a similar manner to medium wave with local ground wave stations coming in loud and clear during the day. After dusk the band opens up to Europe and beyond with skywave being the predominant mode of propagation.

The reason for this is one of the layers of the ionosphere called the *D-layer*.

During the day, solar radiation causes the D-layer to become heavily ionised. This layer absorbs radio energy at low frequencies and so prevents long distance reception.

At night in the absence of solar radiation, the D-layer disappears to some degree and allows radio waves to pass through to the upper layers of the ionosphere. These reflect the radio signals back down to earth, usually at some considerable distance.

Expect to hear stations up to about 50km during the daytime on top band. In the evening (particularly during the winter) it is possible to hear stations as far away as America or even further.

The 80 Metre band behaves slightly differently. Its frequency range extends from 3.5MHz to 3.8MHz. Also, because of its higher frequency range, groundwave range is reduced and the D-layer has slightly less influence.

Weakish signals up to around 200km can be received during the day although these tend to be unstable and very prone to fading. Reception from just about anywhere on the globe is possible at night.

The communications range of both the amateur

bands is affected by many factors such as the time of day, month of the year, the sunspot cycle, solar flares etc etc. With so many different variables it becomes difficult to predict whether a path to a certain country will be viable or not – All this adds to the fascination of tuning the amateur bands.

CALLING CARD

Each radio amateur has a unique callsign allocated to him (or her) by the Radiocommunications Agency. There are around 60,000 licensed amateur radio stations in Great Britain and many hundreds of thousand worldwide. Stations in Great Britain are prefixed by the letter "G" (or 2E0 for a novice station) for example. (All G callsigns have now been issued and so the latest series of newcomers have the prefix "M".)

If you obtain a copy of the amateur radio callbook (available from good book shops) then it is possible to find out where the station you are listening to is located. Amateurs are always keen to receive reception reports from shortwave listeners and will often send out a QSL card to confirm the report.

Radio amateurs are not just restricted to voice and Morse code communications on these bands either. Radio teletype, Slow-scan television, Facsimile and Data transmissions (Packet radio) are also used. These modes can all be resolved

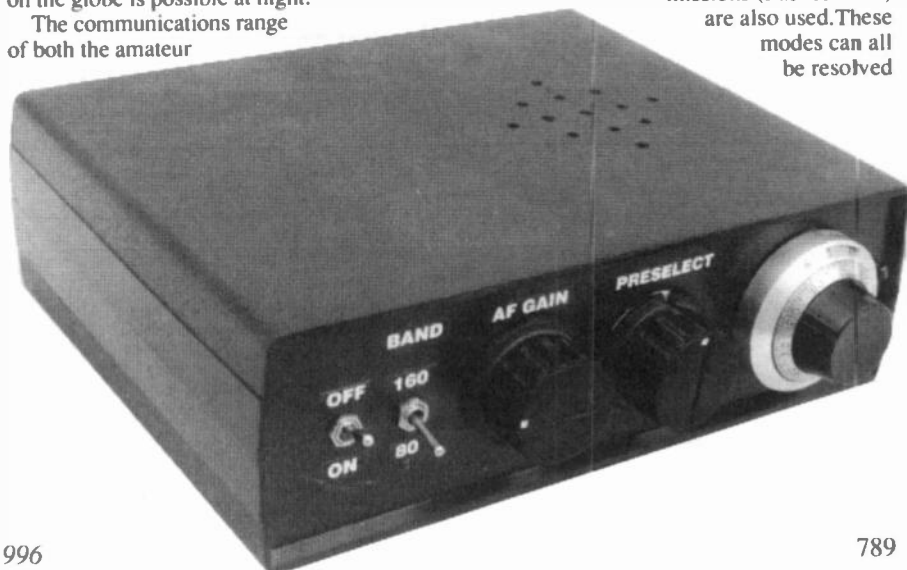



Front panel layout and lettering.

with this receiver connected to a suitable decoder.

DIRECT CONVERSION

The direct conversion principle relies on a local oscillator operating on the same frequency as the suppressed carrier of the transmitter and a product detector. The wanted output from the product detector lies in the audio frequency spectrum and is indeed the resolved audio from the SSB transmitter.

For CW the local oscillator is tuned a few hundred hertz away so that the result is an audible beat note. Since there is no intermediate frequency, the majority of the systems gain lies within the audio spectrum.

With this type of receiver the chances of r.f. instability occurring due to layout are much reduced. The design featured here

has good sensitivity since an r.f. amplifier is included ahead of the mixer, good selectivity due to the active filtering used and a wide dynamic range as a result of the digital balanced mixer.

CIRCUIT DESCRIPTION

The full circuit diagram, except for power supply, for the Direct Conversion Topband and 80 Metre Receiver is shown in Fig. 1. Suggested Power Supply/Charger circuit details being given in Fig. 2.

Incoming r.f. from the antenna is fed to the primary side of coil L1. This transformer/coil is bought to resonance at the required frequency by a pair of back-to-back varicap diodes VD1 and VD2.

From here, r.f. at the "hot" end of the secondary of L1 is then fed to the gate (g)

of the field effect transistor (f.e.t.) TR1, an r.f. amplifier in common source configuration. The drain (d) of TR1 is d.c. coupled to the base (b) of transistor TR2, an emitter follower. The output of TR2 feeds the primary coil of L2, the secondary being resonated at signal frequency by varicaps VD3 and VD4. The inclusion of capacitor C4 was found to be unnecessary in the final model.

LOCAL OSCILLATOR

The variable frequency oscillator (v.f.o.) comprises a tuned circuit consisting of transformer L3 which is bought to resonance by the variable trimmer capacitor VC1 and varicap diode VD5. Variable bias to VD5 is provided by Tuning control VR2 and is fed via resistor R29 and C23. C24 is a d.c. blocking capacitor.

Transistor TR4 maintains oscillations at the desired frequency and TR5 is an emitter follower. Its base (b) being connected to the hot end of coil L3 via capacitor C28.

Transistor TR5 acts as a buffer and prevents subsequent circuitry loading the oscillator stage. The output of TR5 is sufficient to drive the CMOS divider chain formed by IC4.

The v.f.o. (variable frequency oscillator) covers the frequency range 6-9MHz to 8-1MHz, this being divided by IC4 to give 3450kHz, to 4050kHz for 80 metres and 1725kHz to 2025kHz for 160 metres. The tuning rate of VR2 is 60kHz/rev on 80 metres and 30kHz/rev on 160 metres which is more than adequate for SSB/CW resolution.

Since the v.f.o. runs at a different frequency to the received frequency,

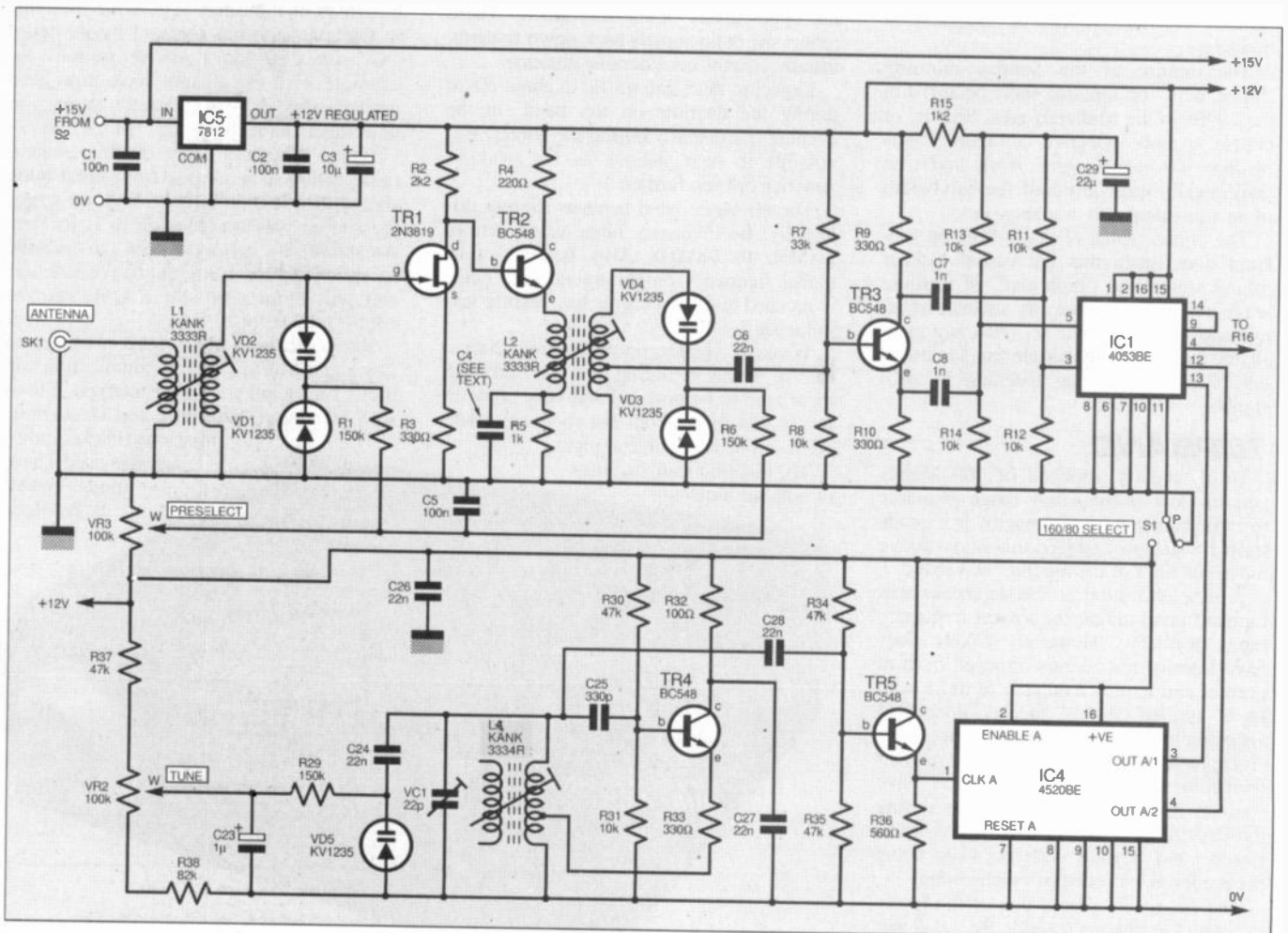

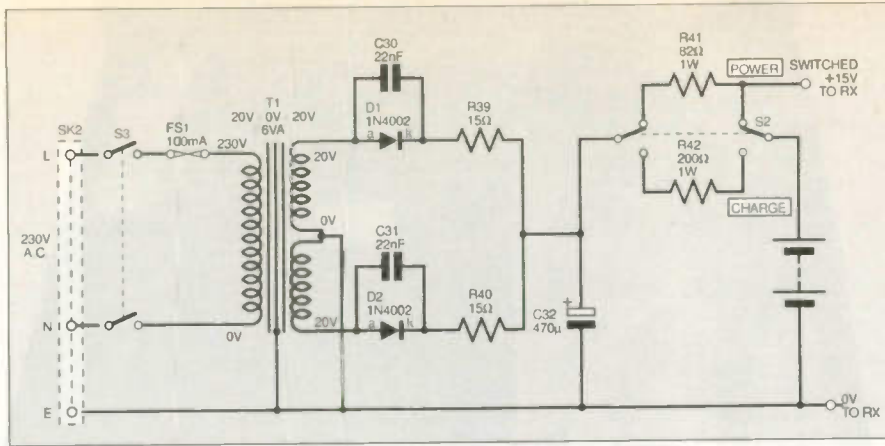
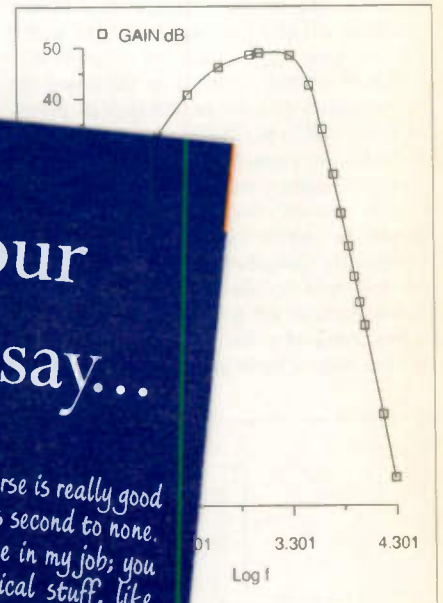

Fig 2. Circuit diagram for the combined PSU/Charger.

CONSTRUCTION

All components for the Direct Conversion Topband and 80 Metre Receiver, with the exception of the aerial socket, tuning controls, switches, loudspeaker and power supply, are mounted on a single printed circuit board. This board is available from the *EPE PCB Service*, code 116. The power supply components are wired directly around the mains transformer and the NiCad pack positioned in the base of the metal case next to the p.c.b.

If you are not familiar with the use of a soldering iron then it is suggested that a little practice is done on a piece of strip-board before attempting construction of



amplifier and filter response graph.

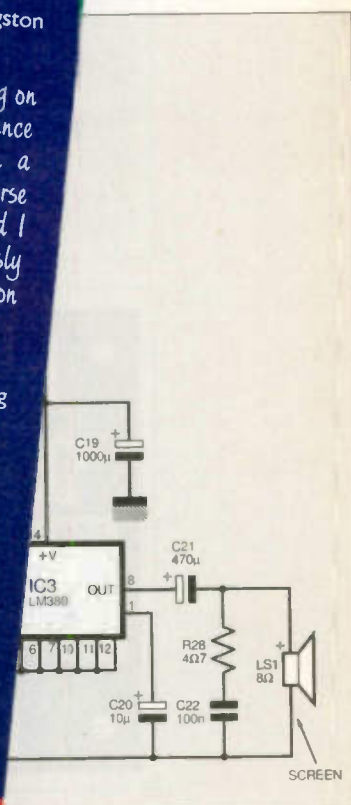

Topband and 80m Receiver.

POST NOW!
Don't lose
time -
do it today!

OR CALL US FREE
ON 0500 888 006

ICS

Learning for Life

Fold

INTERNATIONAL CORRESPONDENCE
SCHOOLS
Freepost 002
8 ELLIOT PLACE
CLYDEWAY SKYPARK
GLASGOW
G3 8BR

What our
students say...



"The PC Repair course is really good - the course work is second to none. It's really helped me in my job; you get loads of practical stuff, like testers, circuit boards and software - I'm even building my own computer now!"

John Cunningham Uddingston



"Within a few weeks of enrolling on the ICS Motorcycle Maintenance course, I had an interview in a motorcycle shop. I took my course work along to the interview, and I think it clinched it for me as it showed them how seriously interested I am in motorbikes. Now I'm Senior Salesperson and really enjoy my job."

Lisa Appleby Woking



"I try to do some study every day, but you can work for half an hour here and half an hour there, as it suits you. It's not like going back to college, because you can keep working while you're studying. Once I've got the qualification under my belt, it'll give me more choices in what I want to do."

Craig Yuley Dundee

Over 100 subjects in all these areas

- ▶ Arts, Design & Creative Writing
- ▶ Business Management
- ▶ Computer Studies
- ▶ GCSE / A' Levels
- ▶ Languages
- ▶ Leisure and General Interest
- ▶ Marketing
- ▶ Office Skills
- ▶ Technical Studies

this receiver. A 15W soldering iron with a fine tip is recommended.

Two of the i.c.s (IC1 and IC4) are static sensitive and should be mounted in sockets. In fact, it is a good idea to use d.i.l. sockets for all the i.c.s. Do not mount any i.c.s in their sockets at this stage but wait until board construction has been completed.

CIRCUIT BOARD

Printed circuit board (p.c.b.) component layout and underside full size copper track master are shown in Fig. 4.

Start construction by positioning and soldering the 12 solder pins around the periphery of the board. Following this, the resistors can be positioned and soldered, cropping off any excess lead length with a pair of wire snips. Note that resistors R37 and R38 are not mounted on the board but are soldered directly on the tags of potentiometer VR2 (see Fig.5).

Next, the capacitors can be soldered in position taking care to observe the polarity of the electrolytics, failure to do so can result in some quite spectacular (and potentially dangerous) results! This should be followed by the inductors, be careful not to damage the leads, there are very fine wires attached to the pins on these and it is all too easy to damage them.

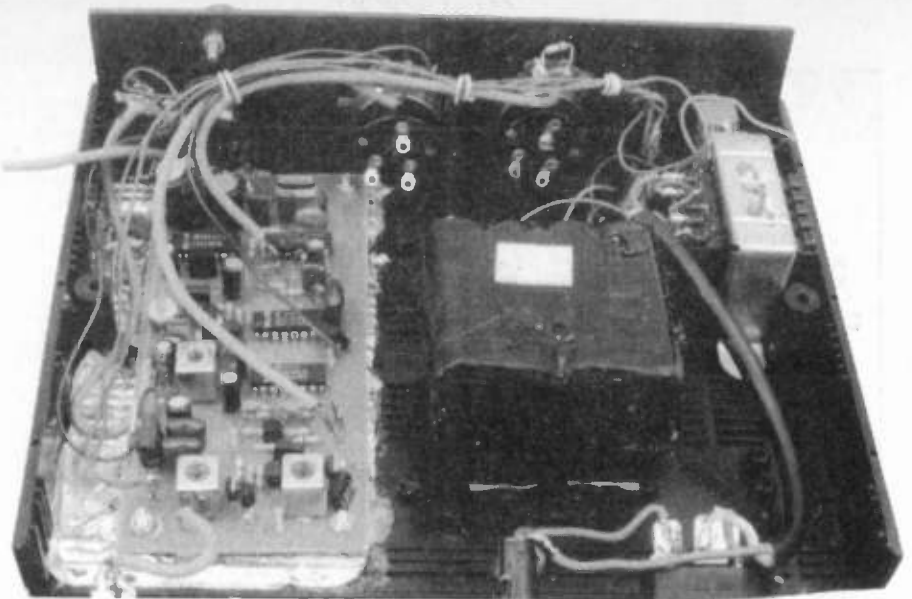

The completed p.c.b. is sited above a piece of aluminium foil to give additional circuit screening.

The transistors and varicap diodes are next in line to be soldered into position. Start with the five transistors taking care to insert them into the board the correct way round.

The five varicaps are also polarity conscious so do take care. Also, these devices

are supplied as three varicaps all encapsulated in *one* package (you need two of these). It is necessary to separate them into individual devices. Use a junior hacksaw. One or two light strokes with the saw in the grooves should enable them to be snapped apart.

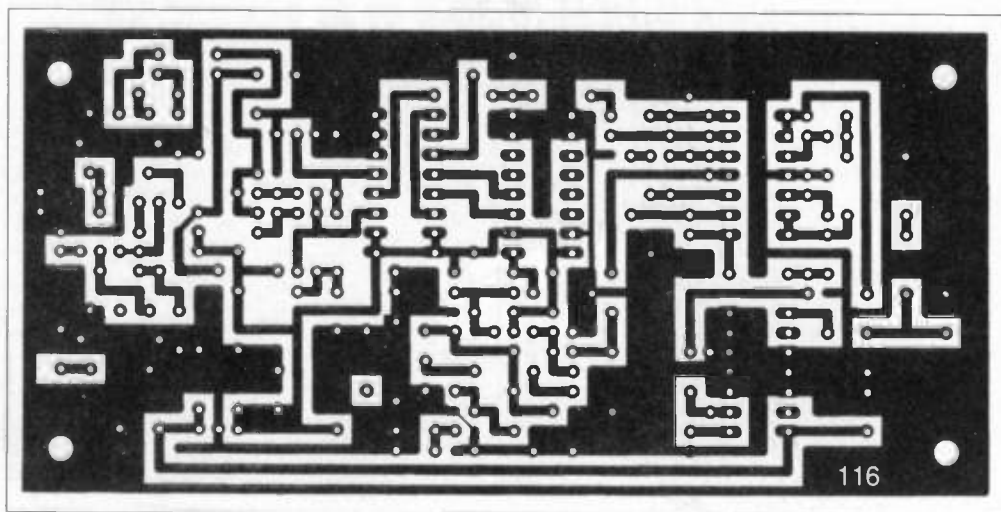
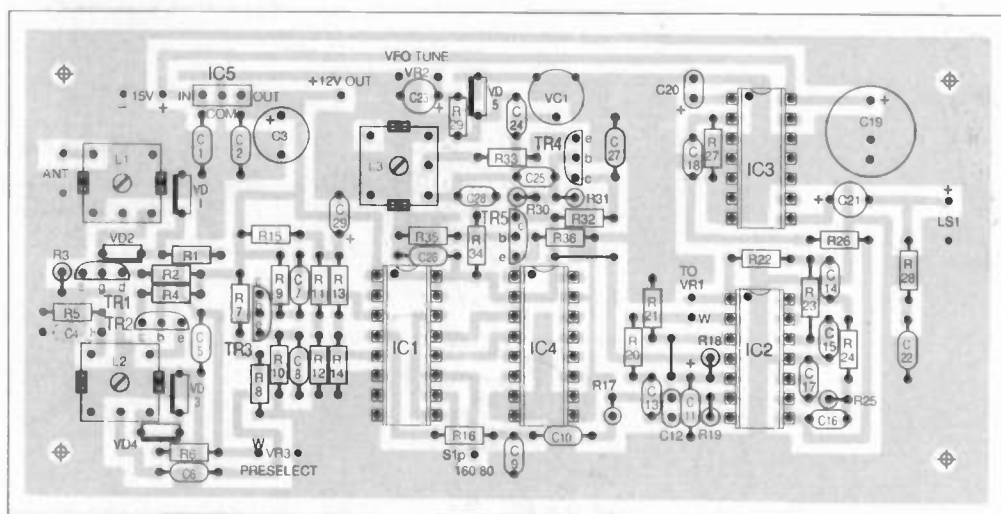

Fig.4. Printed circuit board component layout and full size copper track master.

COMPONENTS

PSU/CHARGER

Resistors

R39, R40 15 Ω 0.6W 1% metal film (2 off)
R41 82 Ω 1W
R42 200 Ω 1W

See

Capacitors

C30, C31 22n ceramic disc (2 off)
C32 470 μ radial elect. 35V

TALK
Page

Semiconductors

D1, D2 1N4002 1A 100V rect. diode (2 off)

Miscellaneous

T1 230V mains transformer, with 6VA 20V-0V-20V secondaries
FS1 100mA 20mm fuse, with panel mounting fuseholder
S2 d.p.d.t. switch
S3 d.p.d.t. mains toggle switch
IEC chassis mounting male socket; (SK2); AA 600mAh NiCad (12 off), with holder; 3-core mains cable, fitted with IEC female plug; mounting bolts; solder etc.

Approx Cost
Guidance Only

£12 excluding
NiCads

Table 1: Typical Voltages

Here is a list of voltage readings, with respect to ground (0V), taken on the prototype receiver around the semiconductors. All voltages were taken with a digital voltmeter set to the 20V d.c. range with an input impedance of 10 megohms.

IC1 Pins 1, 2, 15, 16	12V	IC5 Input	15V
IC1 Pins 3 to 5	5.2V	IC5 Common	0V
IC1 Pins 6 to 8, 10	0V	IC5 Output	12V
IC1 Pins 9, 12 to 14	6V	TR1 Drain	7.8V
IC1 Pin 11 either 0V or 12V depending on S1		TR1 Gate	0V
		TR1 Source	0.7V
IC2 Pins 1 to 3, 5 to 10, 12 to 14	6V	TR2 Collector	10.7V
IC2 Pin 4	12V	TR2 Base	7.8V
IC2 Pin 11	0V	TR2 Emitter	7.1V
IC3 Pin 1, 8	7.6V	TR3 Collector	10.1V
IC3 Pin 2 to 7, 10 to 12	0V	TR3 Base	2.8V
IC3 Pin 9, 13	0.2V	TR3 Emitter	2.2V
IC3 Pin 14	16V	TR4 Collector	11.7V
IC4 Pin 1	8.3V	TR4 Base	2.1V
IC4 Pin 2, 16	12V	TR4 Emitter	2.4V
IC4 Pin 3 to 6	6V	TR5 Collector	12V
IC4 Pin 7 to 15	0V	TR5 Base	5V
		TR5 Emitter	7.7V

Finally, the integrated circuits (i.c.s) can be plugged into place. Again, be particularly careful to get them the right way round.

PRELIMINARY CHECKS

Check the printed circuit board thoroughly for dry joints and shorts. Also check once more that all components are inserted in the right place and if polarity conscious the right way round. A few minutes checking these things now could well save hours of fault finding at a later stage.

Next, measure the resistance between the *output* side of the voltage regulator IC5 and ground (0V). This should be around 1000 ohms. If it is dramatically higher or lower than this value then you have a problem, so re-check everything on the board.

If all is well apply 15V d.c. (observe polarity) to the circuit. Place an ammeter in line, around 60mA should be being drawn, gross deviations from this indicate a fault condition, you cannot proceed until this figure is correct.

Temporarily connect up loudspeaker LS1 and a.f. gain potentiometer VR1. Re-apply power to the board and if all is well a fair amount of "hiss" should be evident from the loudspeaker with VR1 set to maximum resistance.

If a frequency counter or oscilloscope is available then examine pin 4 of IC4 with a "times ten" (X10) probe. A frequency of around 2MHz (squarewave approx. 12V pk/pk) should be available and should be adjustable by turning the core of coil L3.

Try applying 0V and 12V to the junction of R29 and C23 and the frequency should jump by around 600kHz. If all is well so far and there are no significant differences between the voltages given in Table 1 then all is probably correct.

FINAL ASSEMBLY

Before anything is attempted, holes for the three potentiometers, two (three) switches, the BNC socket, the power inlet socket, the four mounting holes for the

main p.c.b. and the loudspeaker grille must be drilled.

If the case you are using is a plastic one then it is a good idea to glue a piece of aluminium foil just slightly larger than the size of the board directly below where the p.c.b. is to be mounted. This prevents hand capacitance from causing the v.f.o. to change frequency and also helps prevent unwanted r.f. getting at the audio stages.

The foil must be "earthed" and this can be accomplished through the mounting posts for the board.

If you want to label the control panel with Letraset, or similar, then now is the time. Once the controls and sockets are installed the task becomes infinitely more difficult. Don't forget to lacquer the front and rear of the box to prevent the Letraset from getting rubbed off.

COMPONENTS

Approx Cost
Guidance Only **£50** excluding
case

RECEIVER

Resistors

R1, R6, R29 150k (3 off)
R2, R16 2k2 (2 off)
R3, R9
R10, R33 330 Ω (4 off)
R4 220 Ω
R5 1k
R7, R27 33k (2 off)
R8, R11 to R14, R17, R18, R20 to R26, R31 10k (15 off)
R15 1k2
R19 560k
R28 4 Ω 7
R30, R34, R35, R37 47k (5 off)
R32 100 Ω
R36 560 Ω
R38 82k
All 0.6W 1% metal film

Potentiometers

VR1, VR3 100k rotary carbon, lin. (2 off)
VR2 100k 10-turn rotary, lin.

Capacitors

C1, C2, C5, C22 100n polyester (5 off)
C3, C11, C20 10 μ F radial elect. 16V (3 off)
C4 Not fitted (see text)
C6 to C9, C18, C26, C27 22n ceramic disc (7 off)
C10 100n ceramic disc
C12 100p ceramic plate
C13 47n ceramic disc

See

TALK
Page

C14, C16 10n polyester (2 off)
C15, C17 3n3 polyester (2 off)
C19 1000 μ radial elect, 25V
C21 470 μ radial elect., 16V
C23 1 μ radial elect., 16V
C24, C28 22n polyester (2 off)
C25 330p ceramic plate
C29 22 μ radial elect., 16V
VC1 22p miniature film trimmer

Semiconductors

VD1 to VD5 KV1235 triple a.m. tuning varicap diode (2 off - see text)
TR1 2N3819 n-channel f.e.t.
TR2 to TR5 BC548 npn transistor (4 off)
IC1 4053BE triple 2-channel analogue multiplexer
IC2 TL074 quad low-noise f.e.t. op.amp
IC3 LM380 power op.amp
IC4 4520BE dual binary counter
IC5 7812 12V 1A regulator

Miscellaneous

L1, L2, Toko KANK3333R inductor (2 off)
L3 Toko KANK3334R
S1 s.p.d.t. toggle switch
Printed circuit board available from the EPE PCB Service, code 116; loudspeaker, 8 Ω 76mm dia.; case to suit; BNC chassis mounting socket (SK1); knob (3 off); counting drive for VR2; multistrand connecting wire; solder pins; solder etc.

Once this has been completed, the loudspeaker LS1 can be glued into position behind the speaker grille and the p.c.b. bolted into position and interwiring commenced, following Fig. 5. Connect up controls VR1, VR2 and VR3, loudspeaker LS1, the switches and the BNC socket SK1 (the latter should ideally be connected with 50 ohm coaxial cable but audio screened lead will suffice). It is also desirable but not absolutely essential that the two varicap tuning feeds are via screened cable also, thin audio type cable is ideal.

ALIGNMENT

Don't worry, there are only four items to adjust and no test equipment is required. If a counter is available then that's fine but not essential.

Similarly an r.f. signal generator and oscilloscope would be useful. If you have these then connect as follows: Oscilloscope across the loudspeaker; Counter to pin 4 IC4, via a X10 probe, and R.F. Generator to the aerial input socket SK1.

The v.f.o. needs to be aligned first. Set preset capacitor VC1 midway. Tuning pot. VR2 to its "earthy (0V)" end and adjust the core of coil L2 until the counter reads 1725kHz.

If a counter is not available then attach a small length of wire to pin 5 of IC4 and tune a Medium Wave radio (preferably one with a digital readout) to 864kHz (343 metres). Adjust the core of L2 until a carrier is received.

Now adjust VR2 to its "hot" end (fully clockwise) and adjust VC1 until the counter reads 2025kHz. Alternatively,

using the Medium Wave receiver tune to 1008kHz (298 metres) and adjust VC1 until a carrier is heard.

These two previous adjustments will interact and so should be repeated until the two band edges are correctly defined. The actual coverage will be 1725kHz to 2025kHz on the lower range and 3450kHz to 4050kHz on the upper range.

Of course, it is possible to change the frequency coverage to suit personal needs. Lowering the values of resistors R37 and R38 will increase the tuning range at the expense of resolution. The two frequency ranges covered will always be harmonically related and the upper frequency limit will be around 6MHz.

Now the front end can be aligned. Set the v.f.o. to 3450kHz, i.e. high range and VR2 at its earthy end. Set Preselect control

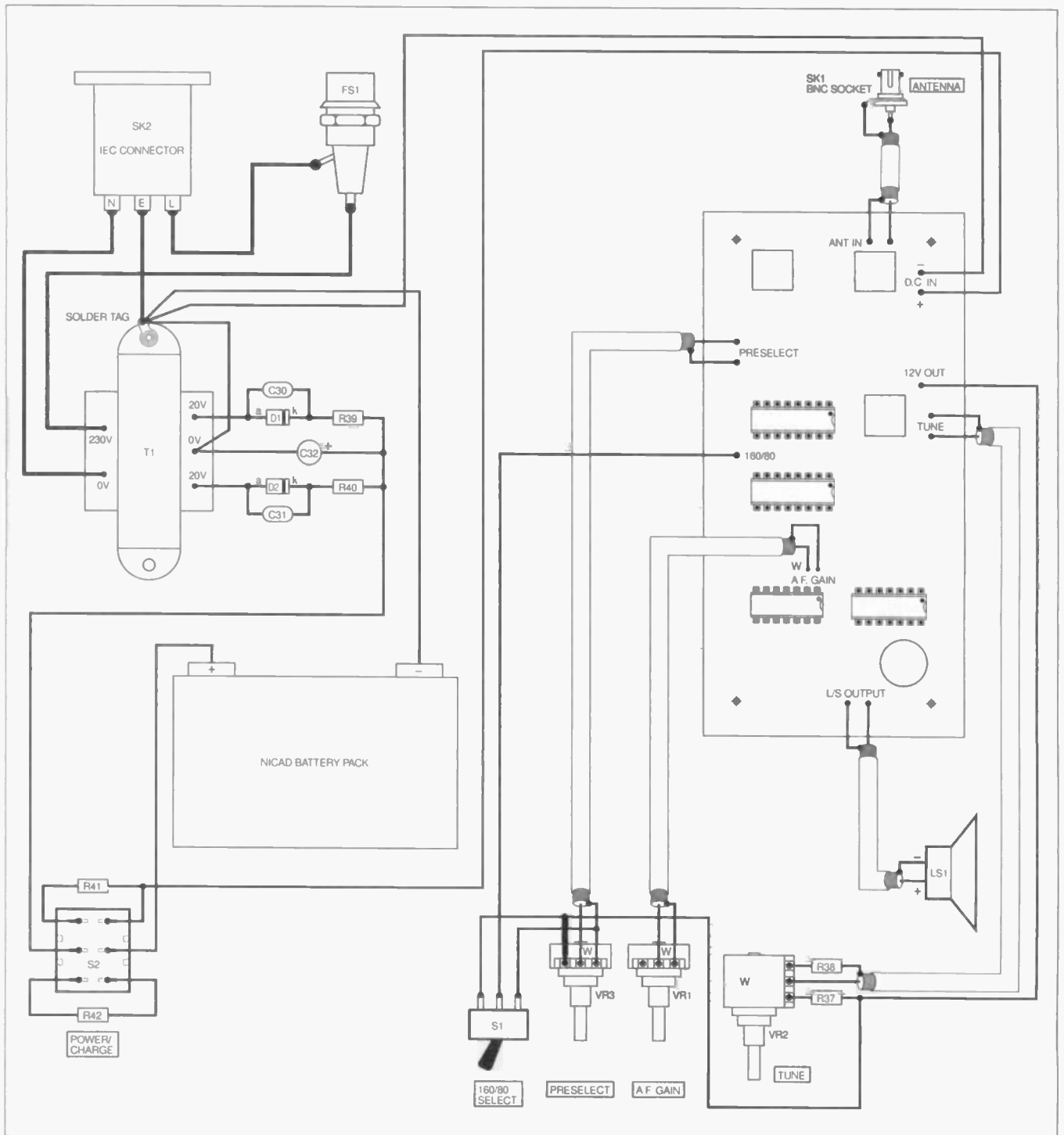
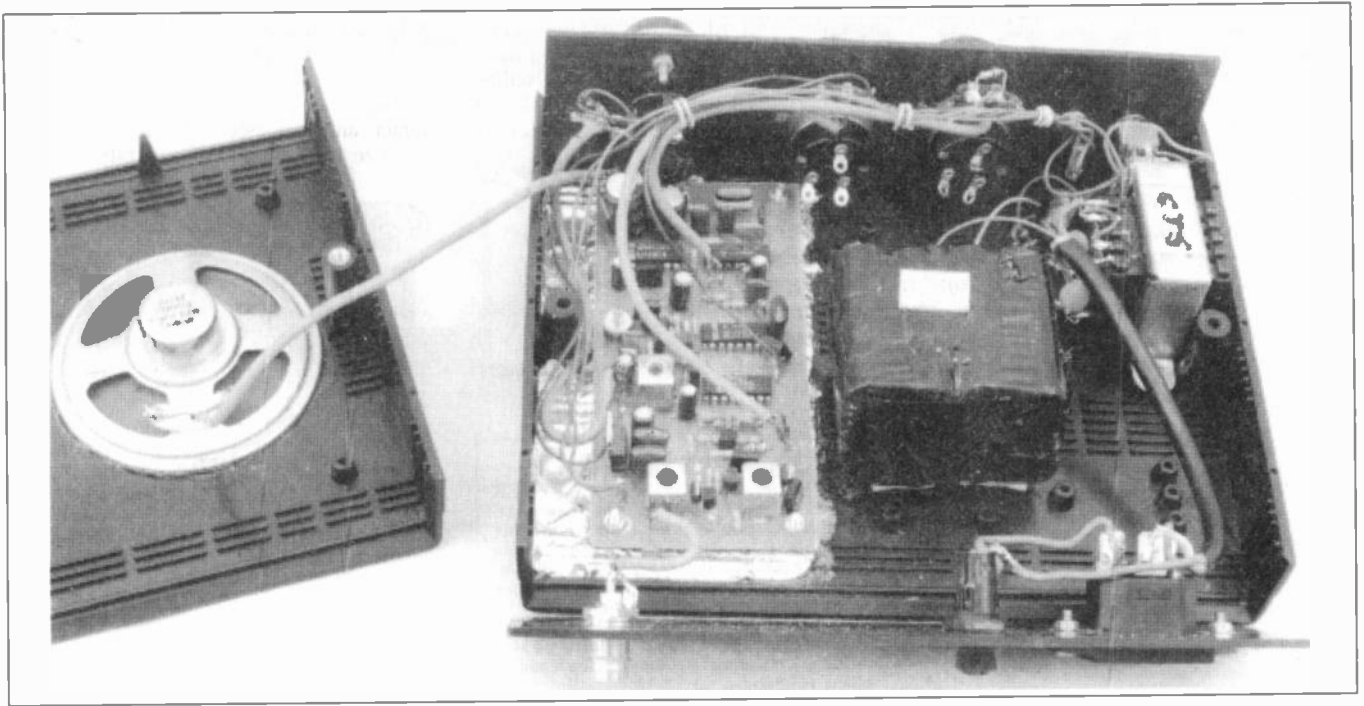

Fig.5. Interwiring details for the power supply and between off-board components and printed circuit board.



Layout of components inside the completed prototype receiver.

VR3 so that there is 5V on its wiper (w) and either connect an antenna or apply a signal from an r.f. generator, 100 microvolts, unmodulated and 3451kHz.

A 1kHz tone or noise should be heard from the loudspeaker depending on the signal source. Adjust the ferrite cores in coils L1 and L2 for maximum as observed on the oscilloscope (or ears), reducing the signal strength as appropriate to prevent overloading.

The sensitivity can be measured if the generator is calibrated and should be better than one microvolt for 12dB SINAD. This has not been checked and is of little consequence on l.f. bands due to the high natural noise level.

SINAD (signal-to-interference, noise and distortion ratio) is a measure of readability, the term is similar to signal-to-noise ratio as used to evaluate hifi equipment. A SINAD of 12dB basically means that the signal is 12dB or about 16 times more powerful than all interference, noise and distortion put together.

POWER SUPPLIES

Choice of power supply is very much up to the individual. The supply can be from dry cells, NiCads or from the mains via a suitable step-down unit.

The regulation of the latter must be good in order to ensure that the LM380 doesn't get too much voltage when the volume is turned down low. Either use a regulated supply or at least use a good quality transformer

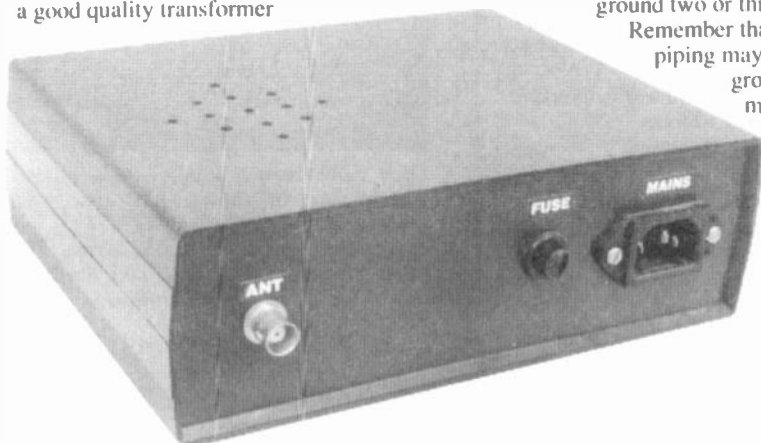

with say 10 per cent regulation or better. Make sure that the unloaded voltage is less than 18V.

The prototype is run from 12 AA type NiCads which have a 600mAH capacity and so will run the set for about eight hours continuous. Also included is a charging circuit which can be active whilst the receiver is in use, see Fig. 2.

The charge rates are about 10mA when switched on (70mA diverted to power the set) and 50mA to 60mA when switched off and in charge mode (recommended charge rate for AA cells). A completely discharged set of NiCads will take about 15 hours to fully recover.

ANTENNAS

The Receiver requires a good antenna/aerial in order to function properly. This should ideally be resonant although a half-wave dipole for topband would be 75 metres long, supported at each end via an insulator and centre fed with coaxial cable.

This is obviously not going to be possible in a lot of cases! A good compromise is a random length long wire antenna running the length of the garden.

Do note that indoor antennas are not recommended. These tend to pick up far too much interference from domestic appliances. A foot (30.5cm.) of wire outdoors is better than 10ft (305cm.) in the loft!

A good "earth" will also help enormously. A metal rod driven into the ground two or three feet is fine.

Remember that water or gas piping may not be a good ground due to the modern practice

of using plastic pipes.

When using an aerial and earth setup such as this an aerial tuning unit (ATU) will

improve reception enormously. The ATU matches the impedance of the antenna to the impedance of the receiver's input terminals (50 ohm unbalanced).

One possibility for people with limited space is an active antenna. These consist of a small loop or "whip" and an amplifier.

Results can be very good, mainly because the unit can be positioned away from sources of interference. The disadvantage is the need to remotely power the device and also the need to waterproof the amplifier unit.

IN USE

The Receiver is very easy to use, expect a little warm up drift of the order of a couple of kilohertz. Simply adjust the Preselector (VR3) for maximum loudness and tune in stations with VR2, the Tune control.

If you have never tuned in an SSB station before then a little patience and practice soon leads to reliable results. In order to obtain natural sounding speech you have to hit on the right frequency to within about 50 Hertz or so or you will end up with people sounding like "Donald Duck".

When there are a group of amateurs on a "Net" then they will seldom all be on exactly the same frequency so don't worry, the name of the game is communication certainly do not expect "hifi".

Do not use VR3 as a volume control, use VR1 the A.F. Gain control, failure to observe this protocol will result in reduced performance. One thing that has been noticed is that local stations are LOUD, this is due to the lack of any a.g.c. (automatic gain control).

In conclusion, I hope you have many hours of fun both building and operating the Direct Conversion Receiver. I have a number of receivers in the shack that cover 160/80 metres but for its simplicity, this little box of tricks rivals the best of them in terms of selectivity, sensitivity and audio quality.

VIDEOS ON ELECTRONICS

A range of videos designed to provide instruction on electronics theory. Each video gives a sound introduction and grounding in a specialised area of the subject. The tapes make learning both easier and more enjoyable than pure textbook or magazine study. They have proved particularly useful in schools, colleges, training departments and electronics clubs as well as to general hobbyists and those following distance learning courses etc.



BASICS

VT201 to VT206 is a basic electronics course and is designed to be used as a complete series, if required.

VT201 54 minutes. Part One; D.C. Circuits. This video is an absolute must for the beginner. Series circuits, parallel circuits, Ohms law, how to use the digital multimeter and much more.

Order Code VT201

VT202 62 minutes. Part Two; A.C. Circuits. This is your next step in understanding the basics of electronics. You will learn about how coils, transformers, capacitors, etc. are used in common circuits.

Order Code VT202

VT203 57 minutes. Part Three; Semiconductors. Gives you an exciting look into the world of semiconductors. With basic semiconductor theory. Plus 15 different semiconductor devices explained.

Order Code VT203

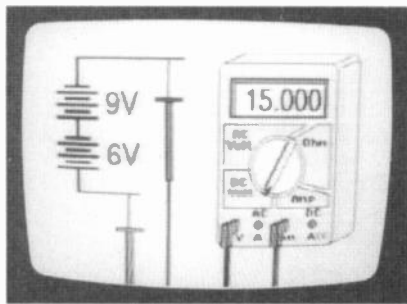

VT204 56 minutes. Part Four; Power Supplies. Guides you step-by-step through different sections of a power supply.

Order Code VT204

VT205 57 minutes. Part Five; Amplifiers. Shows you how amplifiers work as you have never seen them before. Class A, class B, class C, op.amps. etc.

Order Code VT205

VT206 54 minutes. Part Six; Oscillators. Oscillators are found in both linear and digital circuits. Gives a good basic background in oscillator circuits.

Order Code VT206

£34.95 each
inc. VAT & postage

Order 8 or more get one extra FREE
Order 16 get two extra FREE

VCR MAINTENANCE

VT102 84 minutes: Introduction to VCR Repair. Warning, not for the beginner. Through the use of block diagrams this video will take you through the various circuits found in the NTSC VHS system. You will follow the signal from the input to the audio/video heads then from the heads back to the output.

Order Code VT102

VT103 35 minutes: A step-by-step easy to follow procedure for professionally cleaning the tape path and replacing many of the belts in most VHS VCR's. The viewer will also become familiar with the various parts found in the tape path.

Order Code VT103

DIGITAL

Now for the digital series of six videos. This series is designed to provide a good grounding in digital and computer technology.

VT301 54 minutes. Digital One; Gates begins with the basics as you learn about seven of the most common gates which are used in almost every digital circuit, plus Binary notation.

Order Code VT301

VT302 55 minutes. Digital Two; Flip Flops will further enhance your knowledge of digital basics. You will learn about Octal and Hexadecimal notation groups, flip-flops, counters, etc.

Order Code VT302

VT303 54 minutes. Digital Three; Registers and Displays is your next step in obtaining a solid understanding of the basic circuits found in today's digital designs. Gets into multiplexers, registers, display devices, etc.

Order Code VT303

VT304 59 minutes. Digital Four; DAC and ADC shows you how the computer is able to communicate with the real world. You will learn about digital-to-analogue and analogue-to-digital converter circuits.

Order Code VT304

VT305 56 minutes. Digital Five; Memory Devices introduces you to the technology used in many of today's memory devices. You will learn all about ROM devices and then proceed into PROM, EPROM, EEPROM, SRAM, DRAM, and MBM devices.

Order Code VT305

VT306 56 minutes. Digital Six; The CPU gives you a thorough understanding in the basics of the central processing unit and the input/output circuits used to make the system work.

Order Code VT306

RADIO

VT401 61 minutes. A.M. Radio Theory. The most complete video ever produced on a.m. radio. Begins with the basics of a.m. transmission and proceeds to the five major stages of a.m. reception. Learn how the signal is detected, converted and reproduced. Also covers the Motorola C-QUAM a.m. stereo system.

Order Code VT401

VT402 58 minutes. F.M. Radio Part 1. F.M. basics including the functional blocks of a receiver. Plus r.f. amplifier, mixer oscillator, i.f. amplifier, limiter and f.m. decoder stages of a typical f.m. receiver.

Order Code VT402

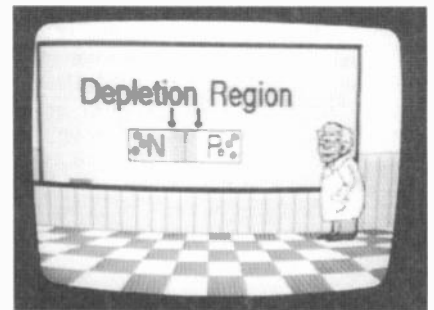

VT403 58 minutes. F.M. Radio Part 2. A continuation of f.m. technology from Part 1. Begins with the detector stage output, proceeds to the 19kHz amplifier, frequency doubler, stereo demultiplexer and audio amplifier stages. Also covers RDS digital data encoding and decoding.

Order Code VT403

MISCELLANEOUS

VT501 58 minutes. Fibre Optics. From the fundamentals of fibre optic technology through cable manufacture to connectors, transmitters and receivers.

Order Code VT501

VT502 57 minutes. Laser Technology A basic introduction covering some of the common uses of laser devices, plus the operation of the Ruby Rod laser, HeNe laser, CO₂ gas laser and semiconductor laser devices. Also covers the basics of CD and bar code scanning.

Order Code VT502

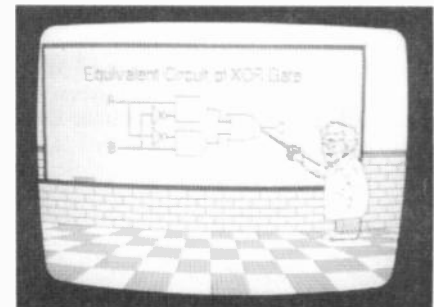

Each video uses a mixture of animated current flow in circuits plus text, plus cartoon instruction etc., and a very full commentary to get the points across. The tapes are imported by us and originate from VCR Educational Products Co, an American supplier. (All videos are to the UK PAL standard on VHS tapes)

ORDERING: Price includes postage to anywhere in the world.

OVERSEAS ORDERS: We use the VAT portion of the price to pay for airmail postage and packing, wherever you live in the world. Just send £34.95 per tape. All payments in £ sterling only (send cheque or money order drawn on a UK bank).

Visa and Mastercard orders accepted - please give card number, card expiry date and cardholder's address if different from the delivery address.

Orders are normally sent within seven days but please allow a maximum of 28 days - longer for overseas orders.

Send your order to: Direct Book Service, 33 Gravel Hill, Merley, Wimborne, Dorset BH21 1RW (Mail Order Only)

Direct Book Service is a division of Wimborne Publishing Ltd.,

Tel: 01202 881749. Fax: 01202 841692

E-mail: editorial@epemag.wimborne.co.uk

THE ELECTRONICS SERVICE MANUAL

ESM IS ABOUT ELECTRONICS AND ELECTRONIC EQUIPMENT, EXPLAINING:

- What it is • How it works • How to test it • How to take it apart
- How to find faults • How to fix it

OFFERING:

- Down to earth advice • Vital data • Facts to feast on
- Knowledge at your finger-tips

TOPICS COVERED:

- TV • Audio • Video • Computers • Disk drives • Techniques
- Test gear • Workshops • Addresses • Pinouts • Symbols • Safety
- Logos • Tools • Data • etc

WHO IT'S FOR:

- Across the board appeal!
- Ideal for: Technicians • Engineers • Students • Hobbyists

LITERARY MERIT:

- Authoritatively written • Clearly presented • Highly readable
- A living library in words, drawings and photographs

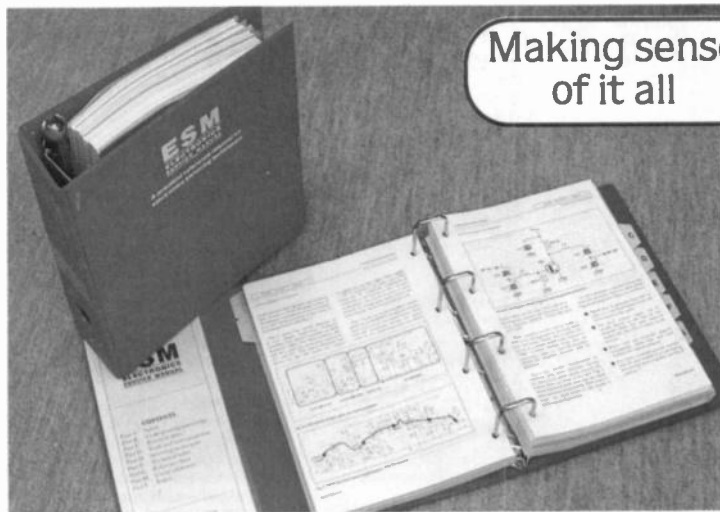

Making sense of it all

SUPPLEMENTS
Detailed technical servicing notes on various types of equipment are covered in the quarterly Supplements, plus additional valuable information for other sections of the Manual

FREE
We will send you the latest Supplement FREE with your Manual

PRICES
Manual only £39.95 plus P&P
Over 850 A4 pages edited by Mike Tooley. Supplied in robust ring binder. Latest Supplement included FREE. 24-hour despatch
Supplements £23.50 plus P&P
Approximately 160 pages of facts and data in each Supplement

GUARANTEE
Our NO-QUIBBLE MONEY-BACK GUARANTEE gives you *complete peace of mind*. If you are not entirely happy with the Manual or its Supplements, for whatever reason, simply return to us in good condition (within 30 days for the Manual, 10 days for Supplements) and we will make a FULL REFUND of your payment. (Overseas buyers do have to pay the postage charge.)

HOW TO OBTAIN ESM
Order now! - just fill in the order form.
Or, to find out more about ESM, ring, fax or write to:
Wimborne Publishing Ltd, Dept Y10
Allen House, East Borough, Wimborne
Dorset BH21 1PF
Tel: 01202 881749 Fax: 01202 841692

ELECTRONICS SERVICE MANUAL COVERAGE AND CONTENTS	
SAFETY Safety practices, life-saving techniques, legal requirements	A
UNDERPINNING KNOWLEDGE Electronics theory, component theory & functions, circuit techniques, fault diagnosis, detailed equipment principles	B
PRACTICAL SKILLS Component identification, avoiding static, soldering & component replacement techniques	C
TOOLS AND EQUIPMENT Choosing tools & test gear, workshop practice, optimising test equipment	D
SERVICING TECHNIQUES The Supplements include detailed guidelines on how to service specific types of electronic equipment	E
TECHNICAL NOTES Detailed examination of how specific types of electronic equipment work	F
REFERENCE DATA Detailed tables of specifications for semiconductors, including pinouts	G
USEFUL ADDRESSES Manufacturers' & suppliers' addresses, including logos	H
INDEX Itemised key subjects in the Manual and individual Supplements	I

PRIORITY ORDER FORM

Full name:
(BLOCK CAPITALS PLEASE)

Address:

Post code:

Telephone Number:

I enclose cheque/PO payable to WIMBORNE PUBLISHING LTD
 Please charge my Access (Mastercard)/Visa card. Expiry date:

Card No:
(Please advise cardholder's address if different from above)

Please send me each new quarterly Supplement when it is published. I understand that these are billed separately and that they can be returned within 10 days or discontinued at any time.

I understand that should I decide not to keep the Manual I can return it to you within 30 days for a FULL REFUND (overseas customers must pay the postage).

Signature:

Please send this form (or a copy) to: **Wimborne Publishing Ltd, Dept. Y10, Allen House, East Borough, Wimborne, Dorset BH21 1PF**

PLEASE URGENTLY SEND ME

Item	Cost	Postage	Total
ESM Manual	£39.95	£	£
One Supplement free with Manual	FREE	FREE	£0.00
Payment in £ Sterling only		Total	£

POSTAGE CHARGES

Postal Region	Manual	
	Surface	Air
UK	£5.50	-
Eire	-	£11
Europe (EEC)	-	£20
Europe (Non-EEC)	£20	£26
USA & Canada	£25	£32
Far East & Australia	£31	£33
Rest of World	£25	£44

NOTE: Surface mail can take over 10 weeks to some parts of the world.
Each Manual weighs about 4kg when packed.

Everyday Practical Electronics Books



ELECTRONIC PROJECTS - BOOK 1

Published by *Everyday Practical Electronics* in association with *Magenta Electronics*.

Contains twenty of the best projects from previous issues of *EE* each backed with a kit of components. The projects are: Seashell Sea Synthesiser, *EE* Treasure Hunter, Mini Strobe, Digital Capacitance Meter, Three Channel Sound to Light, BBC 16K Sideways Ram, Simple Short Wave Radio, Insulation Tester, Stepper Motor Interface, Eprom Eraser, 200MHz Digital Frequency Meter, Infra Red Alarm, *EE* Equaliser Ioniser, Bat Detector, Acoustic Probe, Mains Tester and Fuse Finder, Light Rider - (Lapel Badge, Disco Lights, Chaser Light), Musical Doorbell, Function Generator, Tilt Alarm, 10W Audio Amplifier, *EE* Buccaneer Induction Balance Metal Detector, BBC Midi Interface, Variable Bench Power Supply, Pet Scarer, Audio Signal Generator.

128 pages (A4 size) **Order code EP1** £2.45

ELECTRONICS TEACH-IN 88/89 - INTRODUCING MICROPROCESSORS

Mike Tooley BA (published by *Everyday Practical Electronics*)

A complete course that can lead successful readers to the award of a City and Guilds Certificate in Introductory Microprocessors (726/303). The book contains everything you need to know including full details on registering for assessment, etc. Starting with basic terminology, integrated circuits, logic families and numbering systems the text builds in stages, with revision and assessments built in, up to programming, languages, flow charts, etc. The course is ideal for the newcomer to the subject.

80 pages (A4 size) **Order code TI-88/89** £2.45

ELECTRONICS TEACH-IN No. 6 DESIGN YOUR OWN CIRCUITS

(Published by *Everyday Practical Electronics*)

Mike Tooley BA

This book is designed for the beginner and

experienced reader alike, and aims to dispel some of the mystique associated with the design of electronic circuits. It shows how even the relative newcomer to electronics can, with the right approach, design and realise quite complex circuits.

Fourteen individual p.c.b. modules are described which, with various detailed modifications, should allow anyone to design and construct a very wide range of different projects. Nine "hands-on" complete DIY projects have also been included so readers can follow the thinking behind design, assembly, construction, testing and evaluation, together with suggested "mods" to meet individual needs. The practical projects have each been designed to stand on their own as complete items of equipment. P.C.B.s for all the modules and projects are available by mail order.

The subjects covered in each chapter of the book are: Introduction and Power Supplies; Small Signal Amplifiers; Power Amplifiers; Oscillators; Logic Circuits; Timers; Radio; Power Control; Optoelectronics.

The nine complete constructional projects are: Versatile Bench Power Supply; Simple Intercom; Bench Amplifier/Signal Tracer; Waveform Generator; Electronic Die; Pulse Generator; Radio Receiver; Disco Lights Controller; Optical Communications Link.

136 pages (A4 size) **Order code T16** £3.45

TEACH-IN No. 7 plus FREE Software ANALOGUE AND DIGITAL ELECTRONIC COURSE

(Published by *Everyday Practical Electronics*)

Alan Winstanley and Keith Dye

B.Eng(Tech)AMIEE

The highly acclaimed *Teach-In* series, which included the construction and use of the *Mini Lab* and *Micro Lab* test and development units, has been put together in book form. Additionally EPT Educational Software have developed a GCSE Electronics software program to complement the course and a FREE DISC covering the first two parts of the course is included with the book.

DIRECT BOOK SERVICE

The books listed have been selected by *Everyday Practical Electronics* editorial staff as being of special interest to everyone involved in electronics and computing. They are supplied by mail order direct to your door. Full ordering details are given on the last book page. For another selection of books see next month's issue.

An interesting and thorough tutorial series aimed specifically at the novice or complete beginner in electronics. The series is designed to support those undertaking either GCSE Electronics or GCE Advanced Levels, and starts with fundamental principles.

If you are taking electronics or technology at school or college, this book is for you. If you just want to learn the basics of electronics then this is for you. If you are teaching electronics or technology you must make sure you see it. *Teach-In No. 7* will be invaluable if you are considering a career in electronics or even if you are already training in one. The *Mini Lab* and software enable the construction and testing of both demonstration and development circuits. These learning aids bring electronics to life in an enjoyable and interesting way: you will both see and hear the electron in action! The *Micro Lab* microprocessor add-on system will appeal to higher level students and those developing microprocessor projects.

152 pages (A4 size) **Order code T17** £3.95

Computers and Computing

HOW TO CHOOSE A SMALL BUSINESS COMPUTER SYSTEM

D. Weale

This book is for anyone intending to buy an IBM compatible computer system, whether it is their first system or a replacement. There are sections on hardware, application and systems programs and how to actually make your choice as well as sections on the law, ergonomics and a glossary of common terms.

The text contains many useful tips and some warnings (which could save much effort and expense).

114 pages **Order code BP323** £4.95

MAKING MS-DOS WORK FOR YOU (covers version 6.2)

N. Kantaris & P. R. M. Oliver

This book was written with the busy person in mind and, as such, it has an underlying structure based on "what you need to know first, appears first". Nonetheless, the book has also been designed to be circular, which means that you don't have to start at the beginning and go to the end.

The book explains: How to write customised batch files which allow you to display what you want on your screen, and in the form and order you want it, instead of being forced to use the DOS prompt on a blank screen. How to design and set up a fast interactive and professional looking menu system, so that you or anyone else can run utility applications or commercial software packages easily. How the ANSI.SYS display and keyboard commands can be used to position the cursor on any part of the screen, change the intensity of the displayed characters or change their colour. How the Edit screen editor or the Edlin line editor can be used to enter ESCape (ANSI.SYS) commands into simple ASCII files to allow control of both your screen display and your printer. How to control the operation of the two main types of printers in use today, Epson compatible dot matrix and HP compatible laser printers. How to use several routines, such as moving and finding files, protecting

files from accidental erasure, a simplified backup process, a screen saver, and a disc cataloguing system.

The Debug program and how it can be used to create, see and change the contents of any file, including those of programs written in assembler code. This includes how to find your way around the names and tasks of the CPU registers and the meeting of some simple assembler mnemonics.

182 pages **Order code BP319** £4.95

MULTIMEDIA ON THE PC

Ian R. Sinclair

In this book, you'll find out what a CD ROM is, how it works, and why it is such a perfect add-on for a PC, allowing you to buy programmes, text, graphics and sound on a CD. It also describes the installation of a CD ROM drive and a sound card, pointing out the common problems that arise, and then shows how to use them to create a complete multimedia presentation that contains text, photos, a soundtrack with your own voice recorded as a commentary, even animation and edited video footage.

184 pages **Order code PC112** £11.95

A CONCISE INTRODUCTION TO MS-DOS

N. Kantaris

(Revised Edition Covers Version 6.2)

This guide is written with the non-expert, busy person in mind and, as such, it has an underlying structure based on "what you need to know first, appears first". Nevertheless, the guide is also designed to be circular, which means that you don't have to start at the beginning and go to the end. The more experienced user can start from any section.

176 pages **Order code BP232** £3.95

UNDERSTANDING PC SPECIFICATIONS

R. A. Penfold (Revised Edition)

If you require a microcomputer for business applications, or a high quality home computer, an IBM PC or compatible is often the obvious choice. They are competitively priced, and are backed up by an enormous range of applications programs, hardware add-ons, etc. The main difficulty for the uninitiated is deciding on the specification that will best suit his or her needs. PCs range from simple systems of limited capabilities up to complex systems that can happily run applications that would have been considered beyond the abilities of a microcomputer not so long ago. It would be very easy to choose a PC system that is inadequate to run your applications efficiently, or one which goes beyond your needs and consequently represents poor value for money.

This book explains PC specifications in detail, and the subjects covered include the following: Differences between types of PC (XT, AT, 80386, etc); Maths co-processors; Input devices (keyboards, mice, and digitisers); Memory, including both expanded (EMS) and extended RAM; RAM disks and disk caches; Floppy disk drive formats and compatibility; Hard disk drives (including interleave factors and access times); Display adaptors, including all standard PC types (CGA, Hercules, Super VGA, etc); Contains everything you need to know if you can't tell your EMS from your EGA!

128 pages **Order code BP282** £4.95

AN INTRODUCTION TO 6800 ASSEMBLY LANGUAGE

R. A. & J. W. Penfold

Obtain a vast increase in running speed by writing programs for 6800 based micros such as the Commodore, Amiga, Atari ST range or Apple Macintosh range etc., in assembly language. It is not as difficult as one might think and this book covers the fundamentals.

112 pages **Order code BP184** £2.95

Circuits and Design

PRACTICAL ELECTRONIC FILTERS

Owen Bishop

This book deals with the subject in a non-mathematical way. It reviews the main types of filter, explaining in simple terms how each type works and how it is used.

The book also presents a dozen filter-based projects with applications in and around the home or in the constructor's workshop. These include a number of audio projects such as a rhythm sequencer and a multi-voiced electronic organ.

Concluding the book is a practical step-by-step guide to designing simple filters for a wide range of purposes, with circuit diagrams and worked examples.

88 pages **Order code BP299** £4.95

ELECTRONIC ALARM CIRCUITS MANUAL

R. M. Marston

One hundred and forty useful alarm circuits, of a variety of types, are shown in this volume. The operating principle of each one is explained in concise but comprehensive terms, and brief construction notes are given where necessary.

Aimed at the practical design engineer, technician and experimenter, as well as the electronics student and amateur.

124 pages **Order code NE11** £13.95

DIGITAL GATES AND FLIP-FLOPS

Ian R. Sinclair

This book, intended for enthusiasts, students and technicians, seeks to establish a firm foundation in digital electronics by treating the topics of gates and flip-flops thoroughly and from the beginning.

Topics such as Boolean algebra and Karnaugh mapping are explained, demonstrated and used extensively, and more attention is paid to the subject of synchronous counters than to the simple but less important ripple counters.

No background other than a basic knowledge of electronics is assumed, and the more theoretical topics are explained from the beginning, as also are many working practices. The book concludes with an explanation of microprocessor techniques as applied to digital logic.

200 pages **Order code PC106** £8.95

ELECTRONIC CIRCUITS FOR THE COMPUTER

CONTROL OF ROBOTS

Robert Penfold

Robots and robotics offer one of the most interesting areas for the electronics hobbyist to experiment in. Today the mechanical side of robots is not too difficult, as there are robotics kit and a wide range of mechanical components available. The microcontroller is not too much of a problem either, since the software need not be terribly complex and many inexpensive home computers are well suited to the task.

The main stumbling block for most would-be robot builders is the electronics to interface the computer to the motors, and the sensors which provide feedback from the robot to the computer. The purpose of this book is to explain and provide some relatively simple electronic circuits which bridge this gap.

92 pages **Order code BP179** £2.95



50 SIMPLE LED CIRCUITS

R. N. Soar

Contains 50 interesting and useful circuits and applications, covering many different branches of electronics, using one of the most inexpensive and freely available components - the light-emitting diode (LED). Also includes circuits for the 707 common anode display.

64 pages **Order code BP42** £1.95

BOOK 2 50 more I.e.d. circuits.

50 pages

Order code BP87 £1.95

CIRCUIT SOURCE BOOK 1

A. Penfold

Written to help you create and experiment with your own electronic designs by combining and using the various standard "building block" circuits provided. Where applicable, advice on how to alter the circuit parameters is given.

The circuits covered in this book are mainly concerned with analogue signal processing and include: Audio amplifiers (op.amp and bipolar transistors); audio power amplifiers; d.c. amplifiers; highpass, lowpass, bandpass and notch filters; tone controls; voltage controlled amplifiers and filters; triggers and voltage comparators; gates and electronic switching; bargraphs; mixers; phase shifters, current mirrors, hold circuits, etc.

Over 150 circuits are provided, which it is hoped will be useful to all those involved in circuit design and application, be they professionals, students or hobbyists.

182 pages **Order code BP321** £4.95

A BEGINNER'S GUIDE TO TTL DIGITAL ICs

R. A. Penfold

This book first covers the basics of simple logic circuits

in general, and then progresses to specific TTL logic integrated circuits. The devices covered include gates, oscillators, timers, flip/flops, dividers, and decoder circuits. Some practical circuits are used to illustrate the use of TTL devices in the "real world"

142 pages **Order code BP332** £4.95

CIRCUIT SOURCE BOOK 2

R. A. Penfold

This book will help you to create and experiment with your own electronic designs by combining and using the various standard "building blocks" circuits provided. Where applicable, advice on how to alter the circuit parameters is provided.

The circuits covered are mainly concerned with signal generation, power supplies, and digital electronics.

The topics covered in this book include: 555 oscillators; sinewave oscillators; function generators; CMOS oscillators; voltage controlled oscillators; radio frequency

oscillators; 555 monostables; CMOS monostables; TTL monostables; precision long timers; power supply and regulator circuits; negative supply generators and voltage boosters; digital dividers; decoders, etc.; counters and display drivers; D/A and A/D converters; opto-isolators, flip/flops, noise generators, tone decoders, etc.

Over 170 circuits are provided, which it is hoped will be useful to all those involved in circuit design and application, be they professionals, students or hobbyists.

192 pages **Order code BP322** £4.95

HOW TO USE OPAMPs

E. A. Parr

This book has been written as a designer's guide covering many operational amplifiers, serving both as a source book of circuits and a reference book for design calculations. The approach has been made as non-mathematical as possible.

160 pages **Order code BP88** £2.95

Project Building

ELECTRONIC PROJECTS FOR EXPERIMENTERS

R. A. Penfold

Many electronic hobbyists who have been pursuing their hobby for a number of years seem to suffer from the dreaded "seen it all before" syndrome. This book is fairly and squarely aimed at sufferers of this complaint, plus any other electronics enthusiasts who yearn to try something a bit different. No doubt many of the projects featured here have practical applications, but they are all worth a try for their interest value alone.

The subjects covered include:- Magnetic field detector, Basic Hall effect compass, Hall effect audio isolator, Voice scrambler/descrambler, Bat detector, Bat style echo location, Noise cancelling, LED stroboscope, Infra-red "torch", Electronic breeze detector, Class D power amplifier, Strain gauge amplifier, Super hearing aid.

136 pages **Order code BP371** £4.95

PRACTICAL FIBRE-OPTIC PROJECTS

R. A. Penfold

While fibre-optic cables may have potential advantages over ordinary electric cables, for the electronics enthusiast it is probably their novelty value that makes them worthy of exploration. Fibre-optic cables provide an innovative interesting alternative to electric cables, but in most cases they also represent a practical approach to the problem. This book provides a number of tried and tested circuits for projects that utilize fibre-optic cables.

The projects include:- Simple audio links, FM audio link, P.W.M. audio links, Simple d.c. links, P.W.M. d.c. link, P.W.M. motor speed control, RS232C data links, MIDI link, Loop alarms, R.P.M. meter.

All the components used in these designs are readily available, none of them require the constructor to take out a second mortgage.

132 pages **Order code BP374** £4.95

ELECTRONIC PROJECT BUILDING FOR BEGINNERS

R. A. Penfold

This book is for complete beginners to electronic project building. It provides a complete introduction to the practical side of this fascinating hobby, including the following topics:

Component identification, and buying the right parts; resistor colour codes, capacitor value markings, etc.; advice on buying the right tools for the job; soldering; making easy work of the hard wiring; construction methods, including stripboard, custom printed circuit boards, plain matrix boards, surface mount boards and wire-wrapping; finishing off, and adding panel labels; getting "problem" projects to work, including simple methods of fault-finding.

In fact everything you need to know in order to get started in this absorbing and creative hobby.

135 pages **Order code BP392** £4.95

45 SIMPLE ELECTRONIC TERMINAL BLOCK PROJECTS

R. Bobbington

Contains 45 easy-to-build electronic projects that can be constructed, by an absolute beginner, on terminal blocks using only a screwdriver and other simple hand tools. No soldering is needed.

Most of the projects can be simply screwed together, by following the layout diagrams, in a matter of minutes and readily unscrewed if desired to make new circuits. A theoretical circuit diagram is also included with each project to help broaden the constructor's experience and knowledge.

The projects included in this book cover a wide range of interests under the chapter headings: Connections and Components, Sound and Music, Entertainment, Security Devices, Communication, Test and Measuring.

163 pages **Order code BP378** £4.95

HOW TO DESIGN AND MAKE YOUR OWN P.C.B.s

R. A. Penfold

Deals with the simple methods of copying printed circuit board designs from magazines and books and covers all aspects of simple p.c.b. construction including photographic methods and designing your own p.c.b.s.

80 pages **Order code BP121** £2.50

A BEGINNER'S GUIDE TO MODERN ELECTRONIC COMPONENTS

R. A. Penfold

The purpose of this book is to provide practical information to help the reader sort out the bewildering array of components currently on offer. An advanced knowledge of the theory of electronics is not needed, and this book is not intended to be a course in electronic theory. The main aim is to explain the differences between components of the same basic type (e.g. carbon, carbon film, metal film, and wire-wound resistors) so that the right component for a given application can be selected. A wide range of components are included, with the emphasis firmly on those components that are used a great deal in projects for the home constructor.

166 pages **Order code BP285** £3.95

ELECTRONICS SIMPLIFIED - CRYSTAL SET CONSTRUCTION

F. A. Wilson, C.G.I.A., C.Eng., F.I.E.E., F.I.E.R.E., F.B.I.M.

Especially written for those who wish to participate in the intricacies of electronics more through practical construction than by theoretical study. It is designed for all ages upwards from the day one can read intelligently and handle simple tools.

80 pages **Order code BP92** £1.75

DIRECT BOOK SERVICE ORDERING DETAILS

Please state the title and order code clearly, print your name and address and add the required postage to the total order.

Add £1.50 to your total order for postage and packing (overseas readers add £3 for countries in the EEC, or add £6 for all countries outside the EEC, surface mail postage) and send a PO, cheque, international money order (£ sterling only) made payable to Direct Book Service or credit card details (including card expiry date), Visa or Mastercard (Access) - minimum credit card order is £5 - quoting your name and address, the order code and quantities required to DIRECT BOOK SERVICE, 33 GRAVEL HILL, MERLEY, WIMBORNE, DORSET BH21 1RW (mail order only).

Although books are normally sent within seven days of receipt of your order, please allow a maximum of 28 days for delivery. Overseas readers allow extra time for surface mail post.

Please check price and availability (see latest issue of Everyday Practical Electronics) before ordering from old lists.

For a further selection of books see next month's issue.

DIRECT BOOK SERVICE IS A DIVISION OF WIMBORNE PUBLISHING LTD.

SURVEILLANCE

PROFESSIONAL QUALITY KITS

No. 1 for Kits

Whether your requirement for surveillance equipment is amateur, professional or you are just fascinated by this unique area of electronics SUMA DESIGNS has a kit to fit the bill. We have been designing electronic surveillance equipment for over 12 years and you can be sure that all our kits are very well tried, tested and proven and come complete with full instructions, circuit diagrams, assembly details and all high quality components including fibreglass PCB. Unless otherwise stated all transmitters are tuneable and can be received on an ordinary VHF FM radio.

Genuine SUMA kits available only direct from Suma Designs. Beware inferior imitations!

UTX Ultra-miniature Room Transmitter

Smallest room transmitter kit in the world! Incredible size of 10mm x 20mm including mic. 3V-12V operation. 500m range..... £16.45

MTX Micro-miniature Room Transmitter

Best-selling micro-miniature Room Transmitter. Just 17mm x 17mm including mic. 3V-12V operation. 1000m range..... £13.45

STX High-performance Room Transmitter

High performance transmitter with a buffered output stage for greater stability and range. Measures 22mm x 22mm, including mic. 6V-12V operation, 1500m range. £15.45

VT500 High-power Room Transmitter

Powerful 250mW output providing excellent range and performance. Size 20mm x 40mm. 9V-12V operation. 3000m range..... £16.45

VXT Voice-Activated Transmitter

Triggers only when sounds are detected. Very low standby current. Variable sensitivity and delay with LED indicator. Size 20mm x 67mm. 9V operation. 1000m range. £19.45

HVX400 Mains Powered Room Transmitter

Connects directly to 240V A.C. supply for long-term monitoring. Size 30mm x 35mm. 500m range..... £19.45

SCRX Subcarrier Scrambled Room Transmitter

Scrambled output from this transmitter cannot be monitored without the SCDM decoder connected to the receiver. Size 20mm x 67mm. 9V operation. 1000m range..... £22.95

SCLX Subcarrier Telephone Transmitter

Connects to telephone line anywhere, requires no batteries. Output scrambled so requires SCDM connected to receiver. Size 32mm x 37mm. 1000m range..... £23.95

SCDM Subcarrier Decoder Unit for SCRX

Connects to receiver earphone socket and provides decoded audio output to headphones. Size 32mm x 70mm. 9V-12V operation..... £22.95

ATR2 Micro-Size Telephone Recording Interface

Connects between telephone line (anywhere) and cassette recorder. Switches tape automatically as phone is used. All conversations recorded. Size 16mm x 32mm. Powered from line..... £13.45

UTLX Ultra-miniature Telephone Transmitter

Smallest telephone transmitter kit available. Incredible size of 10mm x 20mm! Connects to line (anywhere) and switches on and off with phone use. All conversation transmitted. Powered from line. 500m range..... £15.95

TLX 700 Micro-miniature Telephone Transmitter

Best-selling telephone transmitter. Being 20mm x 20mm it is easier to assemble than UTLX. Connects to line (anywhere) and switches on and off with phone use. All conversations transmitted. Powered from line. 1000m range..... £13.45

STLX High-performance Telephone Transmitter

High performance transmitter with buffered output stage providing excellent stability and performance. Connects to line (anywhere) and switches on and off with phone use. All conversations transmitted. Powered from line. Size 22mm x 22mm. 1500m range..... £16.45

TKX900 Signalling/Tracking Transmitter

Transmits a continuous stream of audio pulses with variable tone and rate. Ideal for signalling or tracking purposes. High power output giving range up to 3000m. Size 25mm x 63mm. 9V operation..... £22.95

CD400 Pocket Bug Detector/Locator

LED and piezo bleeper pulse slowly, rate of pulse and pitch of tone increase as you approach signal. Gain control allows pinpointing of source. Size 45mm x 54mm. 9V operation..... £30.95

CD600 Professional Bug Detector/Locator

Multicolour readout of signal strength with variable rate bleeper and variable sensitivity used to detect and locate hidden transmitters. Switch to AUDIO CONFORM mode to distinguish between localised bug transmission and normal legitimate signals such as pagers, cellular, taxis etc. Size 70mm x 100mm. 9V operation..... £50.95

QTX180 Crystal Controlled Room Transmitter

Narrow band FM transmitter for the ultimate in privacy. Operates on 180MHz and requires the use of a scanner receiver or our QRX180 kit (see catalogue). Size 20mm x 67mm. 9V operation. 1000m range..... £40.95

QLX180 Crystal Controlled Telephone Transmitter

As per QTX180 but connects to telephone line to monitor both sides of conversations. 20mm x 67mm. 9V operation. 1000m range..... £40.95

QSX180 Line Powered Crystal Controlled Phone Transmitter

As per QLX180 but draws power requirements from line. No batteries required. Size 32mm x 37mm. Range 500m..... £35.95

QRX 180 Crystal Controlled FM Receiver

For monitoring any of the 'Q' range transmitters. High sensitivity unit. All RF section supplied as pre-built and aligned module ready to connect on board so no difficulty setting up. Output to headphones. 60mm x 75mm. 9V operation..... £60.95

A build-up service is available on all our kits if required.

UK customers please send cheques, POs or registered cash. Please add £1.50 per order for P&P. Goods despatched ASAP allowing for cheque clearance. Overseas customers send Sterling Bank Draft and add £5.00 per order for shipment. Credit card orders welcomed on 01827 714476.

OUR LATEST CATALOGUE CONTAINING MANY MORE NEW SURVEILLANCE KITS NOW AVAILABLE. SEND TWO FIRST CLASS STAMPS OR OVERSEAS SEND TWO IRCS.

★★★ Specials ★★★

DLTX/DLRX Radio Control Switch

Remote control anything around your home or garden, outside lights, alarms, paging system etc. System consists of a small VHF transmitter with digital encoder and receiver unit with decoder and relay output, momentary or alternate, 8-way d.I.I. switches on both boards set your own unique security code. TX size 45mm x 45mm. RX size 35mm x 90mm. Both 9V operation. Range up to 200m.

Complete System (2 kits)..... £50.95

Individual Transmitter DLTX..... £19.95

Individual Receiver DLRX..... £37.95

MRX-1 Hi-Fi Micro Broadcaster

Not technically a surveillance device but a great idea! Connects to the headphone output of your Hi-Fi, tape or CD and transmits Hi-Fi quality to a nearby radio. Listen to your favourite music anywhere around the house, garden, in the bath or in the garage and you don't have to put up with the DJ's choice and boring waffle.

Size 27mm x 60mm. 9V operation. 250m range..... £20.95

**SUMA
DESIGNS**

DEPT. EE
THE WORKSHOPS, 95 MAIN ROAD,
BAXTERLEY, NEAR ATHERSTONE,
WARWICKSHIRE CV9 2LE
VISITORS STRICTLY BY APPOINTMENT ONLY



**Tel/Fax:
01827 714476**

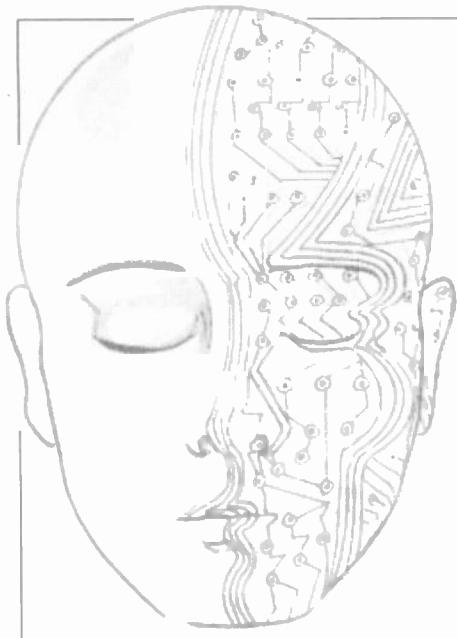

Our regular round-up of readers' own circuits. We pay between £10 and £50 for all material published, depending on length and technical merit. We're looking for novel applications and circuit tips, not simply mechanical or electrical ideas. Ideas *must be the reader's own work* and **not have been submitted for publication elsewhere**. The circuits shown have NOT been proven by us. *Ingenuity Unlimited* is open to ALL abilities, but items for consideration in this column should preferably be typed or word-processed, with a brief circuit description showing all relevant component values. Please draw all circuit schematics as clearly as possible.

Send your circuit ideas to: Alan Winstanley, *Ingenuity Unlimited*, Wimborne Publishing Ltd., Allen House, East Borough, Wimborne, Dorset BH21 1PF. They could earn you some real cash!

Drink Aid for the Blind

AN ELDERLY member of my congregation having gone blind, had great difficulty in making a cup of tea. She couldn't tell whether she had poured enough milk or enough hot water.

The simple solution to this problem is shown in Fig. 1. It is an audio oscillator based around IC1, a 555 astable which drives a piezo disc directly.

Transistor TR1 acts as a switch which will enable the audio oscillator when the two probes detect liquid. By using two sets of probes formed at different lengths (see inset diagram), the audio alarm will activate when enough milk and then water, has been added.

The circuit is powered by a small 12V battery (e.g. MN21 type) which should give many years continuous service as the quiescent current is virtually nil.

The device was housed in a small circular plastic box, approximately 4cm in diameter. The probes were formed from sheathed, thick solid-core copper wires protruding from either side, so that the container could clip onto the side of the cup.

Rev. Thomas Scarborough, Fresnaye, South Africa.

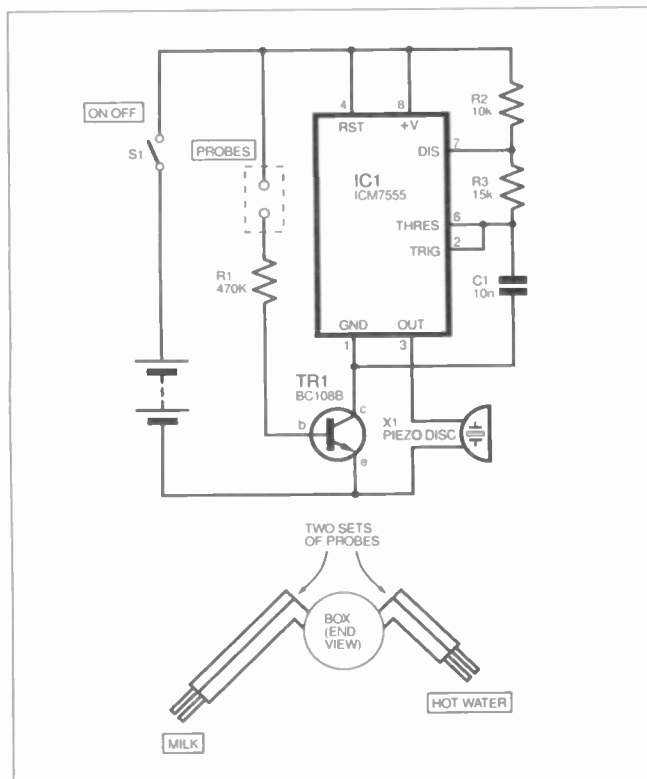

Fig. 1. Circuit diagram and possible probe arrangement for the Drinks Aid for the Blind. Note, the longest probe is for the milk level.

Chart Recorder Input Attenuator

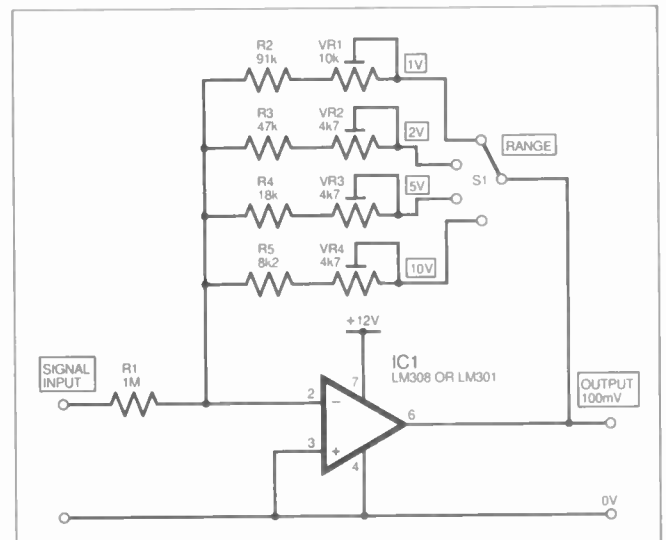

Fig. 2. Chart Recorder Range Extender circuit.

THE CIRCUIT diagram shown in Fig. 2 was designed to adapt a laboratory chart recorder with 100mV input for full-scale deflection, to accept input voltages of 1V, 2V, 5V or 10V at the flick of a switch.

The op.amp IC1 is configured as an inverting amplifier, whose feedback resistance is much less than the input resistance (R1), therefore the output voltage will be a fraction of the input signal. Range switch S1 selects four different feedback resistors which consist of fixed metal film resistors and a 20-turn cermet trimmer, which is adjusted to give 100mV output at the selected input voltage range.

For example, on the 2V range, if R_{IN} is R1 (1M) and R_f is the feedback resistor value, then $V_{OUT} = -R_f/R_{IN} \times V_{IN}$. By setting the input value at 2V and the output at 100mV,

$$V_{OUT} = \frac{(R3 + VR2)}{R1} \times V_{IN}$$

$$\text{so } (R3 + VR2) = \frac{(10^{-2} \times 10^6)}{2}$$

$$\text{and } (R3 + VR2) = 50,000$$

If R3 is set at 47 kilohms (47k) then VR2 is trimmed to 3k. In practice VR2 should be adjusted to give 100mV output at 2V input. The other ranges are set up in the same manner.

Frank Sweeney, Glasgow

Heads or Tails Indicator

DESIGNED to simulate by electronic means the tossing of a coin, the simple circuit of Fig. 3 is based upon a 4049 HEX inverter i.c., of which two inverters are used. IC1a and IC1b are wired as an astable oscillator which causes two l.e.d.s (light-emitting diodes) D1 and D2 to alternate rapidly, at a frequency too high to be distinguished by the naked eye. Both l.e.d.s. therefore appear to be constantly illuminated.

When the "Spin" switch S2 is closed, this has the effect of freezing the display, and the l.e.d. which was illuminated at the instant the switch was closed will now be continuously alight. Opening the switch enables the oscillator once more.

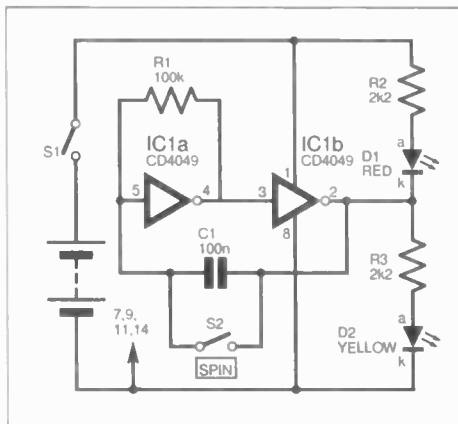

Fig.3. Circuit diagram for the Heads or Tails Indicator.

I found that there was an equal chance of either l.e.d. lighting, and the circuit can be used in board games, for example, to choose which player will move first.

Mark McGuinness,
Clondalkin,
Dublin, Ireland.

Please Take Note

Mini Roulette – August 1996

Page 643, Fig.2. IC1 pins 2 and 6 should be connected to capacitor C1 negative.

Ohm Sweet Ohm

Max Fidling

Fore!

Golf, to me, is a pretty futile kind of sport. I can't see the point of hitting a golf ball with one of those golf sticks and taking all day to do it. Why not just carry it over and drop it in by hand? Much simpler!

Which brings me to the subject of trolleys, as in electrically powered golf ones. It appears that you have not arrived in the golfing fraternity until you've bought an electric trolley to hold your golf "bats" and paraphernalia. I always thought that the idea of this sport was to get some exercise, so having a motorised caddy thing was defeating the object, if you ask me.

So anyway, Terry, an acquaintance of mine, was an avid golf player and he would be found on the greens most Saturdays. After a few rounds he and his opponents would venture to the bar for "a few more rounds of the other sort" (his standard joke), and it was at the Club watering hole that the subject of electric trolleys cropped up.

One of his fellow players owned such a beast which had an annoying intermittent fault. What was needed, they concluded, was someone who could check it out (preferably for no charge) and fix it accordingly. Guess who? *Correct!* Fidling's name was volunteered!

My friend's car drew up outside the house and the electric trolley was thus delivered. Trundling it up the garden path to the shack, I manoeuvred this thing into the shed, complete with its recharger, and I set about it with the "talking voltmeter" and multi-coloured screwdriver set.

The cat was busily scoffing his lunch, the shack taking on a heady fragrance of rabbit and salmon cat food. This mingled well with the smell of freshly-mown grass, because I'd put the lawnmower in there as well.

So with hardly any room to spare in the shack, one foot rested on the mower

and I contorted myself around this gadget awkwardly, occasionally getting a whiff of cat food. Piddles munched on blithely.

Bunkered

The trolley had a likely-looking electrical cover which came away with a few twiddles of the screwdriver. Clicking a few switches and generally fiddling around pulling at things (because I hadn't the faintest idea how it worked), had no effect, but the talking multimeter confirmed that there was life in the old thing yet. "Six Point Three Volts!" it declared triumphantly, as I poked it across a small lead-acid battery.

The moggy mooched over, having decided to leave the rest of his grub (typical), and sniffed one of the tyres of the trolley. By now I was hanging precariously over the mower, more like a circus contortionist than a member of the electronics elite, and I shooed the cat out of the way with my spare foot as I fidgeted and tugged the electrical innards of the trolley a little more, balancing agilely on the lawnmower and bending over to rummage.

Piddles, sensing an opportunity to bug me, ambled in the way again, his tail tickling my nose as I tried to finish screwing the trolley's electrical box together once again! As usual, I had a few too many screws remaining over, but they'll never know, I told the cat, as I tipped them into a jam-jar I kept for the purpose. Funny how screws never seem to go back the same way.

On A Charge

Stuffing the trolley up against the mower to make more room, I turned my attention to the recharger thingy which was moulded into a large mains plug. This plugged into the trolley and I took it apart in a jiffy.

Reaching out to the shelf near the bench, I grabbed my favourite tin of



ElectroLube and started to squirt this inside the recharger liberally, followed by a good blast of air duster to round things off impressively, as I disappeared temporarily in a cloud of aerosol spray. (Useful thing, air duster: it's good for splatting flies on the window of the shed and rendering them senseless.) Everything looked ship-shape and I screwed the recharger unit back together.

I teetered over the trolley once more, standing with one foot on the mower, having given up hope of finding a fault. Before calling it a day I gave the on-off switch one last tug by grabbing the handle and squeezing the switch. The trolley immediately burst into life like a mad Hoover possessed!

With a motorised whirr it careered aimlessly out of control, hitting the cat's half-empty food bowl, and scattering the morsels of Rabbit and Salmon everywhere! Letting go of the switch, the demonic golf trolley stopped and stood to attention, as though controlled by an unforeseen hand.

Yikes! What a mess! Piddles, fearless as ever, started lapping up the surplus grub. Meantime, I'd had enough - and I'm not sure to this day if the owner fathomed out why his trolley was returned smelling distinctly of rabbit and salmon!

SURFING THE INTERNET

NET WORK

ALAN WINSTANLEY



OUR World Wide Web site (<http://www.epemag.wimborne.co.uk>) is up and running and we hope you'll drop in at regular intervals. It is constantly being updated, and you can also link to the *Dept. of Electrical Engineering, University of Hull* to see the latest developments on their "Mouse Organ" student assignment. Also, our FTP site is located at <ftp://ftp.epemag.wimborne.co.uk> where we are uploading various PIC and support files.

Snaffle more Stuff with FTP

File Transfer Protocol (FTP) is the means by which you can copy files residing on the Internet, onto your own computer. You might want to download anything from simple text files to software applications, bug fixes or perhaps the latest drivers for your hardware. You'll frequently hear references to "anonymous FTP". *Anonymous* implies that *anybody* can connect to a remote "FTP Server" to copy (download) files onto their own "local" computer. You can FTP using basic terminal-type software from a DOS prompt equivalent, but your life will be made much happier with graphical programs running in, say, Windows. A slight handicap for DOS users is that most FTP servers run the *Unix* operating system as standard.

We've uploaded all available computer-based files (e.g. for our PIC projects) to our own FTP server in the `/pub/PICS` directory and these are freely available to you as "anonymous FTP users". Proceed as follows if you've not done this before. I have to assume for now that you're using Windows-based software.

Open an FTP session and you'll be prompted for the location or address of the FTP server. Enter just [ftp.epemag.wimborne.co.uk](ftp://ftp.epemag.wimborne.co.uk) – when it asks you for a password, you would normally type in your full E-mail address, since most transfers are logged. This will be sufficient to enter and then navigate your way around.

You can't damage FTP servers – they won't let you delete or rename any files. Remembering that you'll be on a Unix machine: these have a directory and file structure pretty similar to those in DOS or Windows, but there are some differences.

Unix uses the forward slash (/) in file pathnames. You may be confronted with `/pub/docs/epe_info.txt` as a file pathname. Unix files and directories can also have longer names, for example `pub/PICS/games/compedium`

With graphical-based software, all you need do is double click on "folder" symbols to open out that directory on-screen: it's exactly like using Windows File Manager or Explorer. It's easy! Navigate your way through the directories on the remote computer until you find what you're looking for. You're compelled to start with our "public" (`/pub`) directory. Expect some greetings messages to pop up on screen.

Next question: is the file a binary type or an ASCII (text file)? Somewhere on your software, you'll now need to set the file type. Plain text files mostly finish with a `*.txt` extension (ours do, anyway.) Software files, graphics, "ZIP" files etc. are binary and you must select this or you will download "garbage". In my experience, ASCII text files generally seem to download OK whichever you select. Now, you're ready to snaffle the stuff!

Drag Net

Windows-based software (e.g. Turnpike, or Procomm for Windows) should support "Drag and Drop" file transfer. You can navigate around your own local machine using File Manager-type windows. Beforehand, perhaps create a special directory called *incoming* on your machine for receiving FTP downloads. Click on the filename you desire and "drag" it onto your chosen directory.

Release the mouse and after confirmation, the transfer will commence. It could take seconds to many minutes depending on file size and conditions; there may be a progress indicator. You

should then use your software's "Disconnect" command (or quit) after the transfer is complete, or instead open another address. With Turnpike, I find I have to both *Disconnect* and *Stop*, to close some sessions.

You can practice on the file `epe_info.txt` which I've placed in the `/pub/docs` directory on our server. Try entering the FTP address in your Web browser, too, and see what happens!

Those using command-line systems (e.g. KA9Q) start with an `ftp>` prompt where you can type in the following commands; italics represent typical commands displayed. Type the bold text as follows, remembering you're entering *Unix* commands now.

```
open ftp.epemag.wimborne.co.uk
[enter username] anonymous
[enter password] type your full E-mail address here
cwd pub/docs [Change Working Directory – cd may work too]
ascii [sets ASCII transfer mode]
hash [optional: displays a # to indicate transfer progress]
get epe_info.txt [fetches the file epe_info.txt]
quit [disconnects]
```

Survival Chart

Also try the massive FTP Server maintained by Demon Internet Services, on <ftp://ftp.demon.co.uk> where you'll find tons of Amiga, Mac and PC files all available by anonymous FTP. *Niche Software*, for example, have a (binary!) *PCB Designer* demo file called `pcbdemo.zip` available from [ftp.demon.co.uk](ftp://ftp.demon.co.uk) in the `/pub/ibmpc/win3/apps/pcbdemo` directory. You'll often fetch zipped (compressed) files and you *must* become familiar with file compression tools such as PKZIP/UNZIP. They are simple but essential.

One text book for novices is *The Complete Idiot's Guide to the Internet* by Peter Kent (2nd edition, Alpha Books, ISBN 1-56761-535-X £18.95). Although Americanised, I recommend it because I like the style very much; it's fun, not patronising and will answer many FTP related questions, and it shows all those essential Unix commands I can't list here, on a fluorescent *Internet Survival Cheat Sheet!* It's good for getting to grips with Internet jargon, too.

Surf Boarding

It's time to apply the sunblock and strut your surfboard! The on-line version of *Net Work* will be found on our web site, where we've "made" the URL links shown here, to save you having to type them in manually. A worthwhile directory of passive and active components, CPUs, EMC, PCBs and more, is maintained in Belgium by Vincent Himpe on <http://www.ping.be/~ping0751>

Thanks to Steve Walton for the pointer to <http://www.parallaxinc.com> for PIC development tools, BASIC Stamps with more links leading off. Steve also mentions <http://www.albany.net/allinone/> as a useful (Top 5% Site) source of Internet search engines. It looks good – I'll be looking at search engines in a future column.

Follow the `alt.comp.hardware.homebuilt` newsgroup? The FAQ and lots more will be found on Dave Baldwin's FTP site <ftp://ftp.netcom.com/pub/di/dibald>, says Tom Boyd. I saw Amstrad PCW and Notepad files there too. A fundamental Teach-In style package of self-study material on digital electronics is posted in Hong Kong from <http://www.hkstar.com/~hkiedsci> which is intended for high-school students.

You can see the latest version of the Digital Storage Scope FAQ maintained by John Seney on <http://www.mv.com/ipusers/wdlv> (that's `wd-one-v`). There are many links for robotics fans, radio hams and Macintosh users too. Theremin enthusiasts will be intrigued by <http://www.Nashville.Net/~theremin/EPEArticle.html>.

See you next month. My E-mail address is: alan@epemag.demon.co.uk.

DC TO DC CONVERTERS

DRM58 input 10-40vdc output 5v 8A £15
DRM128 input 17-40vdc output 12v 8A £50
DRM158 input 20-40vdc output 15v 8A £50
DRM248 input 29-40vdc output 24v 8A £40
DRS123 input 17-40vdc output 12v 3A £20
DRS153 input 20-40vdc output 15v 3A £20
DRS243 input 29-40vdc output 24v 3A £15

SOLID STATE RELAYS

CMP-DC-200P 3-32vdc operation, 0-200vdc 1A £2.50
SMT20000/3 3-24vdc operation, 28-280vac 3A £4.50
SMT20000/4 3-24vdc operation, 28-280vac 4A £5.00
ZRA6025F 28-280vdc operation, 28-280vac 25A £7.00

200 WATT INVERTERS Nicely cased units 12v input 240v output 150watt continuous, 200 max £49 ref LOT62.

6.8MW HELIUM NEON LASERS New units, £65 ref LOT33

COIN SLOT TOKENS You may have a use for these? mixed bag of 100 tokens £10 ref LOT20.

PORTABLE X RAY MACHINE PLANS Easy to construct plans on a simple and cheap way to build a home X-ray machine! Effective device, X-ray sealed assemblies, can be used for experimental purposes. Not a toy or for minors! £65/set Ref F/XP1.

TELEKINETIC ENHANCER PLANS Mystify and amaze your friends by creating motion with no known apparent means or cause. Uses no electrical or mechanical connections, no special gimmicks yet produces positive motion and effect. Excellent for science projects, magic shows, party demonstrations or serious research & development of this strange and amazing psychic phenomenon. £45/set Ref FTKE1.

ELECTRONIC HYPNOSIS PLANS & DATA This data shows several ways to put subjects under your control. Included is a full volume reference text and several construction plans that when assembled can produce highly effective stimuli. This material must be used cautiously. It is for use as entertainment at parties etc only, by those experienced in its use. £15/set Ref F/EH2.

GRAVITY GENERATOR PLANS This unique plan demonstrates a simple electrical phenomena that produces an anti-gravity effect. You can actually build a small mock spaceship out of simple materials and without any visible means - cause it to levitate. £10/set Ref FIGRA1.

WORLDS SMALLEST TESLA COIL/LIGHTENING DISPLAY GLOBE PLANS Produces up to 750,000 volts of discharge, experiment with extraordinary HV effects, "Plasma in a jar", St Elmo's fire, Corona, excellent science project or conversation piece. £5/set Ref F/BTC1/LG5.

COPPER VAPOUR LASER PLANS Produces 100mw of visible green light. High coherency and spectral quality similar to Argon laser but easier and less costly to build yet far more efficient. This particular design was developed at the Atomic Energy Commission of NEGEV in Israel. £10/set Ref F/CVL1.

VOICE SCRAMBLER PLANS Miniature solid state system turns speech sound into indecipherable noise that cannot be understood without a second matching unit. Use on telephone to prevent third party listening and bugging. £65/set Ref F/V59.

PULSED TV JOKER PLANS Little hand held device utilises pulse techniques that will completely disrupt TV picture and sound works on FM too! DISCRETION ADVISED. £85/set Ref F/TJ5.

BODYHEAT TELESCOPE PLANS Highly directional long range device uses recent technology to detect the presence of living bodies, warm and hot spots, heat leaks etc. Intended for security, law enforcement, research and development. Excellent security device or very interesting science project. £85/set Ref F/BHT1.

BURNING, CUTTING CO2 LASER PLANS Projects an invisible beam of heat capable of burning and melting materials over a considerable distance. This laser is one of the most efficient, converting 10% input power into useful output. Not only is this device a workhorse in welding, cutting and heat processing materials but it is also a likely candidate as an effective directed energy beam weapon against missiles, aircraft, ground-to-ground, etc. Particle beams may very well utilize a laser of this type to blast a channel in the atmosphere for a high energy stream of neutrons or other particles. The device is easily applicable to burning and etching wood, cutting, plastics, textiles etc £125/set Ref F/LC7.

MYSTERY ANTI GRAVITY DEVICES PLANS Uses simple concept. Objects float in air and move to the touch. Defies gravity, amazing gift, conversation piece, magic trick or science project. £65/set Ref F/ANT1K.

ULTRASONIC BLASTER PLANS Laboratory source of sonic shock waves. Blow holes in metal, produce 'cold' steam, atomize liquids. Many cleaning uses for PC boards, jewellery, coins, small parts etc. £65/set Ref F/ULB1.

ULTRAHIGH GAIN AMP/STETHOSCOPIC MIKE/SOUND AND VIBRATION DETECTOR PLANS Ultrasensitive device enables one to hear a whole new world of sounds. Listen through walls, windows, floors etc. Many applications shown, from law enforcement, nature listening, medical heartbeat, to mechanical devices. £65/set Ref F/HGA7.

ANTI DOG FORCE FIELD PLANS Highly effective circuit produces time variable pulses of acoustical energy that dogs cannot tolerate. £65/set Ref F/D0G2.

LASER BOUNCE LISTENER SYSTEM PLANS Allows you to hear sounds from a premises without gaining access. £125/set Ref F/LLIST1.

LASER LIGHT SHOW PLANS Do it yourself plans show three methods. £6 Ref F/LLS1.

PHASOR BLAST WAVE PISTOL SERIES PLANS Handheld, has large transducer and battery capacity with external controls. £65/set Ref F/PSP4.

INFINITY TRANSMITTER PLANS Telephone line grabber/room monitor. The ultimate in home/office security and safety! simple to use! Call your home or office phone, push a secret tone on your telephone to access either: A) On premises sound and voices or B) Existing conversation with break-in capability for emergency messages. £7 Ref F/TELEGRAB.

BUG DETECTOR PLANS Is that someone getting the goods on you? Easy to construct device locates any hidden source of radio energy! Sniffs out and finds bugs and other sources of bothersome

WOLVERHAMPTON BRANCH NOW OPEN AT WORCESTER ST W'HAMPTON TEL 01902 22039

Interference. Detects low, high and UHF frequencies. £55/set Ref F/BD1.

ELECTROMAGNETIC GUN PLANS Projects a metal object a considerable distance requires adult supervision £5 ref F/EML2.

ELECTRIC MAN PLANS, SHOCK PEOPLE WITH THE TOUCH OF YOUR HAND! £55/set Ref F/EM1.

PARABOLIC DISH MICROPHONE PLANS Listen to distant sounds and voices, open windows, sound sources in 'hard to get' or hostile premises. Uses satellite technology to gather distant sounds and focus them to our ultra sensitive electronics. Plans also show an optional wireless link system. £85/set Ref F/PM5.

2 FOR 1 MULTIFUNCTIONAL HIGH FREQUENCY AND HIGH DC VOLTAGE, SOLID STATE TESLA COIL AND VARIABLE 100,000 VDC OUTPUT GENERATOR PLANS Operates on 9-12vdc, many possible experiments. £10 Ref F/HVM7/TC14.

INFINITY TRANSMITTERS The ultimate 'bug' fits to any phone or line, undetectable, listen to the conversations in the room from anywhere in the world 24 hours a day 7 days a week! Just call the number and press a button on the mini controller (supplied) and you can hear everything! Monitor conversations for as long as you choose £249 each, complete with leads and mini controller! Ref LOT9. Undetectable with normal RF detectors, fitted in seconds, no batteries required, lasts forever!

SWITCHED MODE PSU'S 244 watt, +5 32A, +12 6A, -5 0.2A, -12 0.2A. There is also an optional 3.3v 25A rail available. 120/240v I/P. Cased, 175x90x145mm. IEC inlet Suitable for PC use (6 d/drive connectors 1 mboard). £10 ref PSU1.

VIDEO PROCESSOR UNITS/76V 10AH BATT/12V 8A TX Not too sure what the function of these units is but they certainly make good strippers! Measures 390X320X120mm, on the front are controls for scan speed, scan delay, scan mode, loads of connections on the rear. Inside 2x 6V 10AH sealed lead acid batts, pcb's and a 8A/12v toroidal transformer (mains in). Condition not known, may have one or two broken knobs due to poor storage. £17.50 ref VP2.

RETRO NIGHT SIGHT Recognition of a standing man at 300m in 1/4 moonlight, hematically sealed, runs on 2 AA batteries, 80mm F1.5 lens, 20mw infrared laser included. £325 ref RETRON.

MINI FM TRANSMITTER KIT Very high gain preamp, supplied complete with FET electret microphone. Designed to cover 88-108 Mhz but easily changed to cover 63-130 Mhz. Works with a common 9v (PP3) battery. 0.2W RF. £7 Ref 1001.

3-30V POWER SUPPLY KIT Variable, stabilized power supply for lab use. Short circuit protected, suitable for professional or amateur use 24v 3A transformer is needed to complete the kit. £14 Ref 1007.

1 WATT FM TRANSMITTER KIT Supplied with piezo electric mic. 8-30vdc. At 25-30v you will get nearly 2 watts! £12 ref 1009.

FM/AM SCANNER KIT Well not quite, you have to turn the knob your self but you will hear things on this radio that you would not hear on an ordinary radio (even TV). Covers 50-160mhz on both AM and FM. Built in 5 watt amplifier, inc speaker. £15 ref 1013.

3 CHANNEL SOUND TO LIGHT KIT Wireless system, mains operated, separate sensitivity adjustment for each channel, 1,200 w power handling, microphone included. £14 Ref 1014.

4 WATT FM TRANSMITTER KIT Small but powerful FM transmitter, 3 RF stages, microphone and audio preamp included. £20 Ref 1028.

STROBE LIGHT KIT Adjustable from 1-60 hz (a lot faster than conventional strobes). Mains operated. £16 Ref 1037.

COMBINATION LOCK KIT 9key, programmable, complete with keypad, will switch 2A mains. 9v dc operation. £10 ref 1114.

PHONE BUG DETECTOR KIT This device will warn you if somebody is eavesdropping on your line. £6 ref 1130.

ROBOT VOICE KIT Interesting circuit that distorts your voice! adjustable, answer the phone with a different voice! 12vdc £9 ref 1131.

TELEPHONE BUG KIT Small bug powered by the 'phone line, starts transmitting as soon as the phone is picked up! £8 Ref 1135.

3 CHANNEL LIGHT CHASER KIT 800 watts per channel, speed and direction controls supplied with 12 LEDs (you can fit tracs instead to make kit mains, not supplied) 9-12vdc £17 ref 1026.

12V FLOURESCENT LAMP DRIVER KIT Light up 4 foot tubes from your car battery! 9v 2a transformer also required. £8 ref 1069.

VOX SWITCH KIT Sound activated switch ideal for making bugging tape recorders etc, adjustable sensitivity. £8 ref 1073.

*SOME OF OUR PRODUCTS MAY BE UNLICENSEABLE IN THE UK

BULL ELECTRICAL

250 PORTLAND ROAD, HOVE, SUSSEX.
BN3 5QT. (ESTABLISHED 50 YEARS).

MAIL ORDER TERMS: CASH, PO OR CHEQUE
WITH ORDER PLUS £3 P&P PLUS VAT.

PLEASE ALLOW 7-10 DAYS FOR DELIVERY PHONE ORDERS
WELCOME (ACCESS, VISA, SWITCH, AMERICAN EXPRESS)

TEL: 01273 203500
FAX 01273 232077
E-mail bull@pavilion.co.uk

SOUND EFFECTS GENERATOR KIT Produces sounds ranging from bird chips to sirens. Complete with speaker, add sound effects to your projects for just £9 ref 1045.

16 WATT FM TRANSMITTER (BUILT) 4 stage high power, preamp required 12-18vdc, can use ground plane, yagi or opea dipole. £69 ref 1021.

HUMIDITY METER KIT Builds into a precision LCD humidity meter, 9ic design, pcb, lcd display and all components included. £29

PC TIMER KIT Four channel output controlled by your PC, will switch high current mains with relays (supplied). Software supplied so you can program the channels to do what you want whenever you want. Minimum system configuration is 286, VGA, 4.1, 640K, serial port, hard drive with min 100k free. £24.99

FM CORDLESS MICROPHONE KIT This unit is an FM broadcasting station in miniature, 3 transistor transmitter with electret condenser mic-fet amp design results in maximum sensitivity and broad frequency response. 90-105mhz, 50-1500hz, 500 foot range in open country! PP3 battery required. £15.00 ref 15P42A.

MAGNETIC MARBLES They have been around for a number of years but still give rise to curiosity and amazement. A pack of 12 is just £3.99 ref GI/R20.

NICKEL PLATING KIT Professional electroplating kit that will transform rusting parts into showpieces in 3 hours! Will plate onto steel, iron, bronze, gunmetal, copper, welded, silver soldered or brazed joints. Kit includes enough to plate 1,000 sq inches. You will also need a 12v supply, a container and 2 12v light bulbs. £39.99 ref NIK39.

Miniature adjustable timers, 4 pole c/o output 3A 240v, HY1230S, 12vDC adjustable from 0-30 secs. £4.99

HY1260M, 12vDC adjustable from 0-60 mins. £4.99

HY2405S, 240v adjustable from 0-5 secs. £4.99

HY24060M, 240v adjustable from 0-60 mins. £6.99

BUGGING TAPE RECORDER Small voice activated recorder, uses micro cassette tape complete with headphones. £28.99 ref MAR29F1.

POWER SUPPLY fully cased with mains and dp leads 17v DC 900mA output. Bargain price £5.99 ref MAG6P9.

9v DC POWER SUPPLY Standard plug in type 150ma 9v DC with lead and DC power plug, price for two is £2.99 ref AUG3P4.

COMPOSITE VIDEO KIT Converts composite video into separate H sync, V sync, and video. 12v DC. £8.00 REF: MAG8P2.

FUTURE PC POWER SUPPLIES These are 295x135x60mm, 4 drive connectors 1 mother board connector. 150watt, 12v fan, sec inlet and on/off switch. £12 Ref F66.

VENUS FLYTRAP KIT Grow your own carnivorous plant with this simple kit £3 ref F234.

6"X12" AMORPHOUS SOLAR PANEL 12v 155x310mm 130mA Bargain price just £5.99 ea REF MAG6P12.

FIBRE OPTIC CABLE BUMPER PACK 10 metres for £4.99 ref MAG5P13 ideal for experimenters! 30m for £12.99 ref MAG4P1.

ROCK LIGHTS Unusual things these, two pieces of rock that glow when rubbed together believed to cause rain! £3 a pair REF F29.

3' by 1' AMORPHOUS SOLAR PANELS 14.5v, 700mA 10 watts, aluminium frame, screw terminals. £44.95 ref MAG45.

ELECTRONIC ACCUPUNCTURE KIT Builds into an electronic version instead of needles good to experiment with. £7 ref 7P30.

SHOCKING COIL KIT Build this little battery operated device into all sorts of things, also gets worms out of the ground! £7 ref 7P26.

FLYING PARROTS Easily assembled kit that builds a parrot that actually flaps its wings and flies! 50 m range £6 ref EF2.

HIGH POWER CATAPULTS Hinged arm brace for stability, tempered steel yoke, super strength latex power bands, departure speed of ammunition is in excess of 200 miles per hour! Range of over 200 metres! £7.99 ref R9.

BALLOON MANUFACTURING KIT British made, small blob blows into a large, longlasting balloon, hours of fun! £3.99 ref GUE99R.

9-0-9V 4A TRANSFORMERS, chassis mount £7 ref LOT19A.

2.5 KILOWATT INVERTERS, Packed with batteries etc but as they weigh about 100kg CALLERS ONLY! £120.

MEGA LED DISPLAYS Build your self a clock or something with these mega 7 seg displays 55mm high, 38mm wide. 5 on a pcb for just £4.99 ref LOT16 or a bumper pack of 50 displays for just £29 ref LOT17.

CLEARANCE SECTION, MINIMUM ORDER £15, NO TECHNICAL DETAILS AVAILABLE, NO RETURNS, TRADE WELCOME.

2000 RESISTORS ON A REEL (SAME VALUE) 99P REF BAR340

AT LEAST 200 CAPACITORS (SAME VALUE) 99P REF BAR342

INFRA RED REMOTE CONTROLS JUST 99P REF BAR333

CIRCUIT BREAKERS, OUR CHOICE TO CLEAR 99P REF BAR335

MICROWAVE CONTROL PANELS TO CLEAR £2 REF BAR 329

2 TUBES OF CHIPS (2 TYPES OUR CHOICE) 90P REF BAR305

LOTTERY PREDICTOR MACHINE! JUST £1.50 REF BAR313

HELLA/ROVER ELECTRIC H/LAMP VELLER £2 REF BAR311

SINCLAIR G5 16" TYRES TO CLEAR AT JUST 75P REF BAR318

LARGE MAINS MOTORS (NEW) TO CLEAR AT 75P REF BAR310

MODEMS ETC FOR STRIPPING £2.50 EACH REF BAR324

110V LARGE MOTORS (NEW) TO CLEAR AT 50P REF BAR332

MODULATOR UNITS UNKNOWN SPEC JUST 50P REF BAR323

GX4000 GAMES COSESLS JUST £4 REF BAR320

SMART CASED MEMORY STORAGE DEVICE, LOADS OF BITS INSIDE, PCB, MOTOR, CASE ETC. BUMPER PACK OF 5 COMPLETE UNITS TO CLEAR AT £2.50 (FOR 5) REF BAR 330.

2 CORE MAINS CABLE 2M LENGTHS PACK OF 4 £1 REF BAR337

PC USER/BASIC MANUALS, LOADS OF INFO. £1 REF BAR304

PCB STRIPPERS TO CLEAR AT 2 FOR 99P REF BAR341

3 M 3CORE MAINS CABLE AND 13A PLUG. 60P REF BAR325

WE BUY SURPLUS STOCK

FOR CASH

BUYERS DIRECT LINE 0802 660377

FREE CATALOGUE

100 PAGE CATALOGUE NOW AVAILABLE, 45P STAMPS.

EVERYDAY

CLASSIFIED

PRACTICAL

ELECTRONICS

Everyday Practical Electronics reaches nearly twice as many UK readers as any other independent monthly hobby electronics magazine, our audited sales figures prove it. We have been the leading independent monthly magazine in this market for the last eleven years.

If you want your advertisements to be seen by the largest readership at the most economical price our classified and semi-display pages offer the best value. The prepaid rate for semi-display space is £8 (+VAT) per single column centimetre (minimum 2.5cm). The prepaid rate for classified adverts is 30p (+VAT) per word (minimum 12 words).

All cheques, postal orders, etc., to be made payable to Everyday Practical Electronics. VAT must be added. Advertisements, together with remittance, should be sent to Everyday Practical Electronics Advertisements, Holland Wood House, Church Lane, Great Holland, Essex CO13 0JS. Phone/Fax (01255) 850596.

For rates and information on display and classified advertising please contact our Advertisement Manager, Peter Mew as above.

RCS VARIABLE VOLTAGE D.C. BENCH POWER SUPPLY
Up to 38 volts d.c. at 6 amps continuous, 10 amps peak, fully variable from 1 to 38 volts. Twin Voltage and Current meters for easy read-out. 240 volt a.c. input. Fully smoothed, size 14½ x 11 x 4½ inches.



£96 inc. VAT
carriage £6

RADIO COMPONENT SPECIALISTS
337 WHITEHORSE ROAD, CROYDON SURREY, CR0 2HS. Tel: 0181-684 1665

Lots of transformers, high volt caps, valves, speakers, in stock. Phone or send your wants list for quote.

BTEC ELECTRONICS TECHNICIAN TRAINING

GNVQ ADVANCED ENGINEERING (ELECTRONIC) - PART-TIME
HND ELECTRONICS - FULL-TIME
B.Eng FOUNDATION - FULL-TIME

Next course commences
Monday 16th September 1996
FULL PROSPECTUS FROM

LONDON ELECTRONICS COLLEGE
(Dept EPE) 20 PENYWERN ROAD
EARLS COURT, LONDON SW5 9SU
TEL: 0171-373 8721

THE BRITISH AMATEUR ELECTRONICS CLUB

exists to help electronics enthusiasts by personal contact and through a quarterly Newsletter.

For membership details, write to the Secretary:

Mr. J. F. Davies, 70 Ash Road, Cuddington, Northwich, Cheshire CW8 2PB.

Space donated by Everyday Practical Electronics

THE ELECTRONICS BOOK AND COMPONENT LISTING

A regular listing of hundreds of secondhand electronics books and magazines from 1940-1995 for the hobbyist, student and engineer. Includes numerous electronics reference books and surplus electronic components and hardware at bargain prices. Send six first class stamps for listing.

Dept E, Chevett Supplies Ltd., 157 Dickson Rd., Blackpool FY1 2EU
Tel: 01253 751858 Fax: 01253 302979

HARD TO FIND SPECIALISED & UNUSUAL PC SOFTWARE

We have the largest range of specialised technical & scientific & rare programs for DOS & Windows in Europe, on CD Rom or Floppy disk.

1000s of programs in 250+ categories including Electronics, Radio, Audio, Math, Chemistry, Music, Education, Engineering, etc. Send Stamped SAE for Free printed catalogue of 4000+ items.

PDSL Dept PE, Winscombe House, Beacon Rd, Crowborough Sussex TN6 1UL Tel 01892 663296 Fax 01892 667473

Veronica FM TRANSMITTERS

Full range of transmitter Kits from under £10. Wide range Mono, Stereo and Surveillance. Also professional FM broadcasting transmitters.

18 Victoria St., Queensbury, BRADFORD, BD13 1AR
Tel 01274 816200 Email veronica@legend.co.uk

PROTOTYPE PRINTED CIRCUIT BOARDS one offs and quantities, for details send s.a.e. to B. M. Ansbro, 38 Poynings Drive, Hove, Sussex BN3 8GR, or phone Brighton 883871.

G.C.S.E. ELECTRONICS KITS, at pocket money prices. S.A.E. for FREE catalogue. SIR-KIT Electronics, 70 Oxford Road, Clacton, CO15 3TE.

VALVE ENTHUSIASTS: Capacitors and other parts in stock. For free advice/lists please ring Geoff Davies (Radio), Tel: 01788 574774.

PRINTED CIRCUIT BOARDS - QUICK SERVICE. Prototype and Production. Artwork raised from magazines or draft designs at low cost. PCBs also designed from schematics. Production assembly also undertaken. For details send to P. Agar, 36 Woodcot Avenue, Belfast, BT5 5JA or phone 01232 473533 (7 days).

PCB SCHEMATIC AND ARTWORK LAYOUT, customised product design, surface-mount component sourcing and much more. Prices from £15.00. Contact ULTRA-TECH. Tel/Fax: 0181 472 8213. Mobile: 0850 973555.

RETIRING ENGINEER seeks to purchase old double-bass (violin) in any condition (including good). Write 23 Innis Road, CV5 6AX.

AMPLIFIER MODULES . . . Free list!! K.I.A.. 1 Regent Road, Ilkley, LS29 9EA. Look . . . 30+30W - T+B+V controls+7 push-button selector+3 heatsinks+leads, directions, £9.95.

PIC 16C84 BLANK CHIPS (4MHz) £5.00 each, add £1.50 P+P. PIC's programmed with your code etc. Send cheque or requirements (S.A.E.). To: Engineering Services, Unit 16, Brampton Business Centre, Brampton, Rotherham S63 6BB.

PCBs FROM SKETCHES. Vero and bread-board layouts. Low cost. SAE to: Williams, 29 Albert Rd., Mexborough, S. Yorks. S64 9BZ.

MOSFET AMPLIFIERS, 100W-1kW. Built and guaranteed. £75 upwards. Also kits. Details: SAE, 415 Blackmoorfoot Rd., Huddersfield.

STAG PP39 PROGRAMMER with EEPROM Module 39M100. WAVETEK 4MHz Function Generator, Model 182A. Sensible offers please. Telephone 01933 316189 (evenings).

Miscellaneous

SAVE OVER £5 - SUBSCRIBE NOW!

EVERYDAY

PRACTICAL

ELECTRONICS

SUBSCRIPTION ORDER FORM

Annual subscription rates
(1996/7): UK £24.00.

Overseas £30.00 standard air service,
£47.50 express airmail.

To:
Everyday Practical Electronics,
Allen House, East Borough,
Wimborne,

Dorset BH21 1PF
Tel: 01202 881749
Fax: 01202 841692



E-mail: editorial@epemag.wimborne.co.uk

Name

Address

I enclose payment of £.....

(cheque/PO in £ sterling only, payable to Everyday Practical Electronics).
Alternatively send Mastercard or Visa number and card expiry date.

Signature

Please supply name and address of cardholder if different from the subscription address shown above. Subscriptions can only start with the next available issue. For back numbers see the Back Issues page.

M10/96

N. R. BARDWELL LTD (EPE)

200	Signal diodes 1N4148	£1.00	25	5mm red l.e.d.s.	£1.00
75	Rectifier Diodes 1N4001	£1.00	25	3mm red l.e.d.s.	£1.00
50	Rectifier Diodes 1N4007	£1.00	25	Assid. high brightness l.e.d.s.	£1.00
10	W04 Bridge Rectifiers	£1.00	50	Axial l.e.d.s (Diode package)	£1.00
5	NE555 Timer I.C.s.	£1.00	12	Assid. 7-segment displays	£1.00
50	Assid. Zener Diodes	£1.00	2	ORP12 light dependant resistors	£1.00
20	BC182L Transistors	£1.00	30	Assid. IF transformers	£1.00
30	BC212L Transistors	£1.00	48	Assid. coil formers	£1.00
30	BC213L Transistors	£1.00	50	Assid. RF chokes (inductors)	£1.00
30	BC214C Transistors	£1.00	30	Assid. connectors edge d.i.l. sil etc	£1.00
30	BC237 Transistors	£1.00	30	Assid. d.i.l. sockets up to 40 pin	£1.00
20	BC327 Transistors	£1.00	200	Assid. disc ceramic capacitors	£1.00
20	BC328 Transistors	£1.00	80	Assid. capacitors 1nF to 1µF	£1.00
20	BC337 Transistors	£1.00	80	Assid. electrolytic capacitors	£1.00
30	BC478 Transistors	£1.00	10	4P3W MBB min. rotary switches	£1.00
30	BC546 Transistors	£1.00	20	Min. SP/CO slide switches	£1.00
30	BC547 Transistors	£1.00	20	1" glass reed switches	£1.00
30	BC548 Transistors	£1.00	200	4N7 min axial capacitors	£1.00
30	BC549 Transistors	£1.00	24	24-pin d.i.l. wire wrap i.c. skts	£1.00
25	BC557 Transistors	£1.00	1	12V motorised volume control 50K	£1.00
30	BC558 Transistors	£1.00	50	Grommets 6-3mm id, 9-5mm od	£1.00
30	BC559 Transistors	£1.00	100	ct ¼W 5% resistors any one value, E24, range 1R to 10M	£0.45
25	BC640 Transistors	£1.00			
20	MPSA42 Transistors	£1.00			
20	MPSA92 Transistors	£1.00			
20	2N3904 Transistors	£1.00			
5	78L12 12V 100mA Pos Regulators	£1.00			
10	79M08 8V 500mA Neg Regulators	£1.00			

Prices include VAT, postage £1.25, 30p stamp for Lists
288 Abbeydale Road, Sheffield S7 1FL
Phone (0114) 2552886 Fax (0114) 2500689

SERVICE MANUALS & Technical Books

Available for most equipment, any make, age or model.
Technical Book and Manual Compilations now on CD-ROM
Return the coupon for your FREE catalogue



MAURITRON TECHNICAL SERVICE (EPE)

8 Cherry Tree Road, Chinnor, Oxon, OX9 4QY.

Tel: 01844-351694 Fax: 01844 352554



Please forward your latest catalogue for which I enclose 2 x 1st Class Stamps or £4.11 for the complete 'Service Manuals Index on PC Disc' plus catalogue.

NAME _____

ADDRESS _____

POSTCODE _____

Photocopy this coupon if you do not wish to cut the magazine

Cooke International

SUPPLIER OF QUALITY USED TEST INSTRUMENTS

ANALYSERS, BRIDGES, CALIBRATORS, VOLTMETERS, GENERATORS,
OSCILLOSCOPES, POWER METERS, ETC. ALWAYS AVAILABLE

ORIGINAL SERVICE MANUALS FOR SALE
COPY SERVICE ALSO AVAILABLE

EXPORT, TRADE AND U.K. ENQUIRIES WELCOME
SEND FOR LISTS OF EQUIPMENT & MANUALS
ALL PRICES EXCLUDE VAT AND CARRIAGE
DISCOUNT FOR BULK ORDERS SHIPPING ARRANGED

OPEN MONDAY TO FRIDAY 9AM-5PM
Unit Four, Fordingbridge Site, Main Road, Barnham, Bognor Regis,
West Sussex, PO22 0EB. U.K.
Tel (+ 44) 01243 545111/2 Fax (+ 44) 01243 542457
EQUIPMENT & ACCESSORIES PURCHASED

3lb mixed component pack	£4.95	6V d.c. motor, 1,200 r.p.m. 600mA	£1 each, 10 for £8
Jumbo component pack	£10	9V d.c. motor, 13,000 r.p.m. 460mA	£1 each, 10 for £8
250 off mixed capacitors	£4.95	10.5V d.c. motor, 9,000 r.p.m., 220mA	£1 each, 10 for £8
250 off i.c. sockets	£3.95	S.M. P.S.U., mains input, +5.2V 6A, +24V 0.5A, +24V 5.5A outputs	£6 each
1000 off mixed ceramic caps	£7.50		
20 off mixed crystals/filters	£4.95		
25 off mixed relays	£3.50		
100 off phono plugs	£2.95		
10 off mixed displays	£3.75*		
50 off d.i.l. switches	£3.75*		
30 off mixed heatsinks	£3.75*		
30 off mixed switches	£3.75*		
Brand new 360k 5¼" floppy drive	£4.50		
5¼" to 3½" floppy drive converter leads	£1.50*		
1-2MB 5¼" floppy drive	£10		
200MB 3½" E.S.D.I. hard drive	£28		
12V d.c. 200 r.p.m. geared motor	£1.50 each, 10 for £12		
220V 1500 r.p.m. geared motor	£6 each, 10 for £50		
7V-12V d.c. motor, 4/6000 r.p.m. 700mA-1450mA	£4 each, 10 for £30		
12V d.c. motor, 13,000 r.p.m. 180mA	£1 each, 10 for £8		

QUANTITY DISCOUNTS AVAILABLE PLEASE RING.
We also buy all forms of electronic components, p.s.u.s, disk drives etc. Lists to below address.

ALL PRICES INCLUDE V.A.T. PLEASE ADD £2.00 p&p EXCEPT ITEMS MARKED * WHICH ARE 50P. SAE FOR BULK BUYING LIST PAYMENT WITH ORDER TO:
Dept EE, COMPELEC,
14 Constable Road,
St. Ives, Huntingdon,
Cambs PE17 6EQ
Tel/Fax: 01480 300819

TECHNICAL INFORMATION SERVICES

76 Church St, Larkhall, Lanarks, ML9 1HE
Tel: 01698 883334/884585 Fax: 01698 884825

PHONE NOW FOR YOUR FREE QUOTE

We have the World's Largest Collection of SERVICE MANUALS

Why not join Europe's fastest growing "Information Library Service"

Buy ANY Service Manual for £10.00 and return any manual no longer needed for a £5.00 credit
CALL/WRITE NOW FOR FURTHER DETAILS
Initial joining fee of £70 : Thereafter £20 Yearly
Join Now: Get your first Manual FREE!

Millions of quality components at lowest ever prices!

Plus anything from bankruptcy - theft recovery - frustrated orders - over production etc.

NO VAT to add on.

Send 45p stamped self addressed label or envelope for clearance lists.

Brian J Reed
6 Queensmead Avenue, East Ewell
Epsom, Surrey KT17 3EQ
Tel: 0181-393 9055 Mail order UK only.

Lists are updated and only 40 are sent out every 2 weeks. This normally ensures that orders can be fulfilled where only a few thousand of an item is available. (Payment is returned if sold out. I do not deal in credit notes). This will sometimes entail a delay of up to eight weeks - but the prices will be worth the wait!

THE CR SUPPLY CO

RESISTORS

½ Watt Mixed metal/carbon film resistors
5% E12 series 10 ohms to 1 Megohm.....2p
¼ Watt Carbon film resistors 5% E24 series
1 ohm to 10 Megohm.....1p
100 off per value - 85p even hundreds
per value totalling 1000.....£7.50

¼ Watt Metal film resistors 5% E12 series
10 ohm to 1 Meg - 1½p, 1% E24 series.....2p
½ Watt Mixed metal/carbon film resistors
5% E24 series 1 ohm to 10 Megohm.....2½p
1 Watt Mixed metal/carbon film 5%
E12 series 4R7 to 10 Megohms.....5p

NEW Resistor development kits, ¼ Watt C/Film
5x78 different values from 1 ohm to 10 Megohm, comes in storage drawer with printed colour code on outside, ideal for laboratories, education, service depts., repairers and hobbyists, etc.....£6.95

CAPACITORS

Radial Aluminium Electrolytics (mfd/Volts).
1/63, 2/263, 4/7100, 10/25, 10/63 - 6p,
100/16, 100/25 - 8p; 100/63 - 13p; 22/16,
22/25, 22/50, 33/16, 47/16, 47/35, 47/50 - 7p,
220/16 - 9p; 220/25, 220/50 - 11p; 470/16,
470/25 - 13p; 1000/25 - 23p; 2200/25 - 42p;
4700/25 - 74p.

Miniature Polyester, 250V working vertical mounting (mfd). 01, 015, 022, 047, 068 - 5p; 0.1 - 6p; 0.12, 0.15, 0.22 - 7p; 0.47 - 9p; 0.68 - 10p; 1.0 - 13p.

Mylar (polyester) 100V working E12 series vertical mounting (pf). 1000 to 8200 - 4p; 0.01 to 0.068 - 5p; 0.1 - 6p; 0.12, 0.15, 0.22 - 7p; 0.47/50V - 9p.

Submin Ceramic Plate, 100V working E12 series vertical mountings (pf). 2% 1.8 to 47 - 4p; 2% 56 to 330 - 5p; 10% 390p-4700p - 6p

Polystyrene, 63V working E12 series, long axial wires (pf). 10 to 820 - 5p; 1000 to 10,000 - 6p; 12,000 - 8p.

Subminiature, Tantalum Bead electrolytics (mfd/Volts). 0.1, 0.22, 0.47, 1.0, 2.2, 3.3 (0.35V, 4.7/16, 10/8, 8/35 - 13p; 4.7/25, 6.8/16, 10/16 - 15p; 15/16, 22/6, 33/10 - 21p; 10/25 - 22p; 10/35, 22/16 - 28p; 47/10 - 29p; 47/16 - 65p; 47/20 - 72p; 47/35 - 76p; 100/3 - 78p; 100/6, 220/6 - 81p.

TRANSISTORS

BC107/8/9 - 18p; BC547/8/9 - 7p; BC557/8/9 - 8p; BC182, 182L, BC183, 183L, BC184, 184L, BC212, 212L - 10p; BC327, 337, 337L - 8p; BC727, 737 - 12p; BD135/6/7/8/9 - 27p; BCY70 - 28p; BFY50/51/52 - 32p; BFY88 - 38p; 2N3055 - 55p; TIP31, 32 - 40p; TIP41, 42 - 40p; BU208A - £1.50; BF195, 197 - 12p.

20mm fuses
100mA to 5A, O/blank - 8p, A/urge - 14p.
Holders, chassis, mounting - 8p

CMOS
4001B - 23p; 4011B - 25p; 4017B - 45p; 4069UB unbuffered - 25p.

D.I.L. HOLDERS
8-pin - 9p; 14, 16, 18-pin - 15p; 24-pin - 19p; 28-pin - 22p; 40-pin - 31p.

VOLTAGE REGULATORS
1A +ve or -ve 5V, 8V, 12V, 15V, 18V & 24V - 61p; 100mA +ve 5V, 8V, 12V, 15V - 38p.

DIODES (PIV/amps)
75/150mA 1N4148 - 2p; 800/1A 1N4006 - 5p; 400/3A 1N5404 - 14p; 115/50mA OA91 - 18p; 100/1A 1N4002 - 4p; 1000/1A 1N4007 - 5p; 60/1.5A S1M1 - 7p; 100/1A bridge - 28p; 400/1A 1N4004 - 4p; 1250/1A BY 127 - 14p; 30/150mA OA47 gold bonded - 24p.

Zener diodes E24 series 3V3 to 33V 400mW - 6p; 1 watt - 12p.

L.E.D.'s
3mm, and 5mm, Red, Green, Yellow - 14p; Grommets to suit 3mm - 2p, 5mm - 3p; 5mm Tincolor & Bicolor - 22p; Red flashing L.E.D.'s require 9V-12V supply only, 5mm - 70p.

BATTERIES
AA/HP7 NiCad rechargeable cells - £1.78 each. With PCB mounting pins 600mAh, £2.28p. AA/HP7 zinc/carbon batteries in packs of 4 - £1.10 per pack. Watch batteries, diam x thickness in mm 7.9x3.6, 11.6x3, 11.6x4.2, 11.6 x 5.4 - 55p each.
Battery snaps for PP3 - 8p; for PP9 - 16p.

ELECTRIC MOTORS
1.5V to 3V with bracket, 18x25mm shaft diam 2mm - £1.24p; high torque 30x23mm - £1.45p; 3V to 6V, 25x21mm diam - £1.20.

MISCELLANEOUS
Mains indicator neons with 220k resistor.....14p
High speed PCB drill bits 0.8, 1.0, 1.3, 1.5, 2.0mm - 47p; 12V mini drill, 3 jaw chuck - £14.75
Helping-hands & ball joints and 2 croc clips to hold awkward jobs, cast-iron base.....£4.50
Glass reed switches with single-pole make contacts - 11p; Magnets - 28p.
0.1" Stripboard 2½" x 1" 9 rows 25 holes - 26p.
3" x 2½" 24 rows 37 holes - 80p.
Jack plugs 2.5 & 3.5m - 16p; Sockets Panel Mgt. 2.5 & 3.5m - 11p.
Earplugs 2.5 & 3.5m, dynamic - 29p;
3.5m crystal - £1.60
Multi-cored solder, 22SWG - 11p/yard,
18SWG - 21p/yard
Air Purifier and Ioniser complete with mains adaptor and car lead made by Smiths Industries. £12.50
21-pin Scart to 21-pin Scart lead, 1.2m all pins connected - £3.95p; PCB Scart sockets - 92p.
Satellite cable 75 ohm semi air spaced 6.5mm, CD black or white - 36p/yard.
741 Op Amp - 24p; 555 Timer - 25p; 555L Low Power - 30p; 555 Dual Timer - 40p; 556L Low Power - 24p; 358 Dual Op. Amp - 22p.

44 Chapelfield Way, Rotherham, South Yorkshire S61 2TL.
Tel/Fax: 0114 2468049

OMNI ELECTRONICS

174 Dalkeith Road, Edinburgh EH16 5DX ★ 0131 667 2611

The supplier to use if you're looking for:-

★ A WIDE RANGE OF COMPONENTS AIMED AT THE HOBBYIST

★ COMPETITIVE VAT INCLUSIVE PRICES ★

★ MAIL ORDER - generally by RETURN OF POST ★

★ FRIENDLY SERVICE ★

1995/6 CATALOGUE NOW IN STOCK!
 COST: £2.00. Includes vouchers to offset against future purchases.

OPEN: Monday-Thursday 9.15 - 6.00.

Friday 9.15-5.00

Saturday 9.30-5.00



SHERWOOD ELECTRONICS

FREE COMPONENTS

Buy 10 x £1 Special Packs and choose another one FREE

SP1	15 x 5mm Red Leds	SP118	2 x Cmos 4047
SP2	12 x 5mm Green Leds	SP119	4 x Cmos 4072
SP3	12 x 5mm Yellow Leds	SP124	20 x Assorted ceramic disc caps.
SP6	15 x 3mm Red Leds	SP125	10 x 1000/16V radial elect caps.
SP7	12 x 3mm Green Leds	SP130	100 x Mixed 0.5W C.F. resistors
SP8	10 x 3mm Yellow Leds	SP131	2 x TL071 Op.amps
SP10	100 x 1N4148 diodes	SP135	6 x Min. slide switches
SP11	30 x 1N4001 diodes	SP137	4 x W005 1.5A rectifiers
SP12	30 x 1N4002 diodes	SP138	20 x 2.2/50V rad. elect. caps.
SP13	20 x Assorted radial elect. caps.	SP142	2 x Cmos 4017
SP18	20 x BC182 transistors	SP144	3 x TIP31A transistors
SP19	20 x BC183 transistors	SP145	6 x ZTX300 transistors
SP20	20 x BC184 transistors	SP147	5 x Stripboard 9 strips/25 holes
SP21	20 x BC212 transistors	SP151	4 x 8mm Red Leds
SP22	20 x BC214 transistors	SP152	4 x 8mm Green Leds
SP23	20 x BC549 transistors	SP153	4 x 8mm Yellow Leds
SP24	4 x Cmos 4001	SP156	3 x Stripboard, 14 strips/27 holes
SP25	4 x 555 timers	SP160	10 x 2N3904 transistors
SP26	4 x 741 Op.amps	SP161	10 x 2N3906 transistors
SP28	4 x Cmos 4011	SP162	10 x 100K hor. trimpots
SP29	4 x Cmos 4013	SP165	2 x LF351 Op.amps
SP33	4 x Cmos 4081	SP167	6 x BC107 transistors
SP35	26 x 10/25V radial elect caps	SP168	6 x BC108 transistors
SP37	15 x 100/35V radial elect caps	SP173	10 x 220/25V rad. elect. caps
SP39	10 x 470/16V radial elect caps	SP175	20 x 1/63V radial elect caps
SP41	20 x Mixed transistors	SP182	20 x 4.7/50V radial elect caps
SP42	200 x Mixed 0.25W C.F. resistors	SP183	20 x BC547 transistors
SP47	5 x Min. pushbutton switches	SP187	15 x BC239 transistors
SP48	12 x Assorted axial elect. caps.	SP192	3 x Cmos 4066
SP102	20 x 8-pin DIL sockets	SP193	20 x BC213 transistors
SP103	15 x 14-pin DIL sockets	SP194	10 x OA90 diodes
SP104	15 x 16-pin DIL sockets	SP195	3 x 10mm Yellow Leds
SP105	5 x 74LS00		
SP106	5 x 74LS02		
SP112	4 x Cmos 4093		
SP115	3 x 10mm Red Leds		
SP116	3 x 10mm Green Leds		
SP117	15 x BC556 transistors		

RESISTOR PACKS - C.Film

RP3	5 each value - total 365 0.25W	£2.40
RP7	10 each value - total 730 0.25W	£3.75
RP10	1000 popular values 0.25W	£6.00
RP4	10 5 each value-total 365 0.5W	£3.40
RP8	10 each value-total 730 0.5W	£6.00

Catalogue £1 inc. P&P or FREE with first order.

P&P £1.25 per order. NO VAT.

Orders to:
Sherwood Electronics,
 7 Williamson St., Mansfield,
 Notts. NG19 6TD.

NEW MINI CAMERA and SPECIAL OFFERS

NEW - Mini Waterproof TV Camera, 40 x 40 x 15mm, requires 10V to 16V at 120mA with composite video output (to feed into a Video or a TV with a SCART plug). It has a high resolution of 450 TV lines vertical and 380 TV lines horizontal, electronic auto iris for nearly dark (1 LUX) to bright sunlight operation and a pinhole lens with a 92 degree field of view; it focuses down to a few cm. It is fitted with a 3-wire lead (12V in, gnd and video out). £93.57 + VAT = £109.95 or 10+ £89.32 + VAT = £104.95.

High quality Stepping Motor Kits (all including stepping motors) Complete independent control of two stepping motors by PC (via the Parallel Port) with two motors and software.....Kit £67.00. Built £99.00

Software support and 4 digital inputs kit.....£27.00

Power Interface: 4A kit £36.00. 8A kit, £46.00.

Stepper kit 4 (manual control) includes 200 step stepping motor and control circuit.....£23.00

Hand Held Transistor Analyser. It tells you which lead is the base, the collector and emitter and if it is NPN or PNP or faulty. £33.45. Spare 6V battery £1.20.

LEDs 3mm or 5mm Red or Green 7p each. Yellow 11p each. Cable Ties 1p each. £5.95 per 1000. £49.50 per 10,000.

RECHARGEABLE BATTERIES

AA (HP7) 500MAH.....£0.99

AA 700MAH.....£1.75

C 2AH with solder tags.....£3.60

D 4AH with solder tags.....£4.95

1/2AA with solder tags.....£1.55

AAA (HP16) 180MAH.....£1.75

AA 500MAH with solder tags.....£1.55

C (HP11) 1.2AH.....£2.20

D (HP2) 1.2AH.....£2.60

PP3 8-4V 110MAH.....£4.95

Sub C with solder tags.....£2.50

1/3 AA with tags (Philips CTV).....£1.95

Standard Charger, charges 4 AA cells in 5 hours or 4 Cs or Ds in 12 to 14 hours, plus 1xPP3 (1, 2, 3 or 4 cells may be charged at a time).....£5.95

High Power Charger, as above but charges the Cs and Ds in 5 hours; AAs, Cs and Ds must be charged in twos or fours.....£10.95

Nickel Metal Hydride AA cells, high capacity with no memory. If charged at 100mA and discharged at 250mA or less 1100mAh capacity (lower capacity for high discharge rates).....£3.75

SPECIAL OFFERS

PLEASE CHECK FOR AVAILABILITY

Stick of 4, 42mm x 16mm NiCad batteries 171mm x 16mm dia. with red and black leads. 4.8V.....£5.95

Five button cell, 6V 280MAH battery with wires (Varia 5 x 250DK).....£2.45

Shaded-pole motor, 240V a.c. 5mm x 20mm shaft. 30mm x 88mm x 55mm, excluding the shaft.....£4.95

115V a.c. 80V d.c. motor, 4mm x 22mm shaft. 50mm dia. x 60mm long body (excluding the shaft) it has a replaceable thermal fuse and brushes.....£4.94 each. £3.95 100+

7-Segment common anode. Led display, 12mm.....45p

LM337K, TO3 case. Variable regulator. £1.95, 100+ £1.44

Gas's F.E.T. low leakage current SB873.....£12.95 each. £9.95 10+., £7.95 100+

BS250 p-channel MOSFET.....45p

BC559 transistor.....£3.95 per 100

BC547A transistor.....20 for £1.00

74LS05 Hex inverter.....£10.00 per 100

Used 8748 Microcontroller.....£3.50

SL952 UHF Limiting amplifier, LC 16 surface mounting package with data sheet.....£1.95

DC-DC Converter, Reliability model V12P5, 12V in, 5V 200mA out, 300V input-to-output isolation, with data.....£4.95 each or pack of 10 £39.50

Hour Counter used 7 digit 240V a.c. 50Hz.....£1.45

OWERTY keyboard, 58-key, good quality.....£6.00

Airfax AB2903-C large stepping motor 14V 7.5" step, 27 ohm, 68mm dia. body, 6.3mm shaft.....£8.95 or £200 for a box of 30

Polyester capacitors, box type, 22.5mm lead pitch 0.5µF 250V d.c. 18p each. 14p 100+. 9p 1000+ 1µF 250V d.c. 20p each. 15p 100+. 10p 1000+ 1µF 50V bipolar electrolytic axial leads. 15p each. 7.5p 1000+.

0.22µF 250V polyester axial leads. 15p each. 100+ 7.5p each

Polypropylene 1µF 400V d.c. (Wima MKP10) 27.5mm pitch. 30mm x 29mm x 17mm case. 7.5p each. 60p 100+

Philips 123 series solid aluminum axial leads. 33µF 10V and 2.2µF 40V 40p each. 25p 100+

Philips 108 series, long life.....30p each. 15p 1000+

72µF 63V axial.....30p each. 15p 1000+

Multilayer AVX ceramic capacitors all 5mm pitch. 100V 100µF. 150µF. 220µF. 10,000µF (10n) 10p each. 5p 100+. 3.5p 1000+

500µF compression trimmer capacitor.....60p

40µF 370V a.c. motor start capacitor (falalectrol type containing no PCB's).....£5.95 or £49.50 for 10

Solid carbon resistors, very low inductance, ideal for I.T. circuits. 27 ohm 2W, 68 ohm 2W 25p each, 15p each 100+

We have a range of 0.25W, 0.5W, 1W and 2W solid carbon resistors - please send SAE for list

P.C. 400W PSU (Intel part 201035-001) with standard motherboard and five disk drive connectors. fan and mains input/output connectors on back and switch on the side (top for lower case) dims. 212mm x 149mm x 149mm excluding switch. £26.00 each. £138.00 for 6

MX180 Digital Multimeter 17 ranges. 1000V d.c. 750V a.c. 2Megohm 200mA transistor Hfe 9V and 1.5V battery test.....£9.95

AMD 27256-3 EPROMs: £2.00 each. £1.25 100+ and DIP switch 3PCO 12-pin (ERG SDG-3-023).....60p each. 40p 100+

Disk Drive Box for a 5.25 disk drive, with room for a power supply, light-grey plastic 67mm x 268mm x 247mm £7.95 or £49.50 for 10

Handheld Ultrasonic Remote Control.....£3.95

CV2486 Gas Relay 30mm x 10mm dia. with 3-wire terminals, will also work as a neon light.....20p each, or £7.50 per 100

Varblimit R300NH Streamer tape commonly used on nc machines and printing presses etc. It looks like a normal cassette with a slot cut out of the top.....£4.95 each. £3.75 100+

Heatsink Compound Tube.....95p

HV3-2405-ES 5V 24V 50mA Regulator (c. 18V-264V a.c. input. 8-pin DIL package.....£3.49 each. 100+ £2.25

LM555 timer Lc., 16p; 8-pin DIL socket, 6p

All products advertised are new and unused unless otherwise stated.

Wide range of CMOS TTL 74HC74F Linear, Transistors kits, rechargeable batteries, capacitors, tools etc. always in stock. Please add £1.95 towards P&P. VAT included in all prices

ADVERTISERS INDEX

N. R. BARDWELL.....	807
B. K. ELECTRONICS.....	Cover (iii)
BRIAN J. REED.....	807
BULL ELECTRICAL.....	Cover (ii)/805
CIRKIT DISTRIBUTION.....	741
COMPELEC.....	807
COOKE INTERNATIONAL.....	807
CRICKLEWOOD ELECTRONICS.....	783
CR SUPPLY CO.....	807
DIRECT CCTV.....	764
DISPLAY ELECTRONICS.....	738
ELECTRONICS SERVICE MANUAL.....	797
ELECTROVALUE.....	765
EPT EDUCATIONAL SOFTWARE.....	742
ESR ELECTRONIC COMPONENTS.....	746
HART ELECTRONIC KITS.....	743
JCG ELECTRONICS.....	788
J&N FACTORS.....	787
JPG ELECTRONICS.....	808
LABCENTER ELECTRONICS.....	775
LENNARD RESEARCH.....	783
MAGENTA ELECTRONICS.....	744/745
MAPLIN ELECTRONICS.....	Cover (iv)
MAURITRON.....	807
MODERN ELECTRONICS MANUAL.....	756
NATIONAL COLLEGE OF TECHNOLOGY.....	741
NICHE SOFTWARE.....	788
NUMBER ONE SYSTEMS.....	783
OMNI ELECTRONICS.....	808
PICO TECHNOLOGY.....	739
QUASAR ELECTRONICS.....	755
QUICKROUTE SYSTEMS.....	740
RADIO-TECH.....	755
SERVICE TRADING.....	741
SHERWOOD ELECTRONICS.....	808
STEWART OF READING.....	788
SUMA DESIGNS.....	800
TECHNICAL INFORMATION SERVICES.....	807
TSIEN (UK).....	753

ADVERTISEMENT MANAGER: PETER J. MEW

ADVERTISEMENT OFFICES:

EVERYDAY PRACTICAL ELECTRONICS,

ADVERTISEMENTS,

HOLLAND WOOD HOUSE, CHURCH LANE,

GREAT HOLLAND, ESSEX CO13 0JS.

Phone/Fax: (01255) 850596

For Editorial address and phone numbers see page 747.

OMP MOS-FET POWER AMPLIFIERS
HIGH POWER, TWO CHANNEL 19 INCH RACK

THOUSANDS PURCHASED BY PROFESSIONAL USERS



THE RENOWNED MXF SERIES OF POWER AMPLIFIERS
FOUR MODELS:- MXF200 (100W + 100W) MXF400 (200W + 200W)
MXF600 (300W + 300W) MXF900 (450W + 450W)
ALL POWER RATINGS R.M.S. INTO 4 OHMS, BOTH CHANNELS DRIVEN

FEATURES: ★Independent power supplies with two toroidal transformers ★ Twin L.E.D. Vu meters ★ Level controls ★ Illuminated on/off switch ★ XLR connectors ★ Standard 775mV inputs ★ Open and short circuit proof ★ Latest Mos-Fets for stress free power delivery into virtually any load ★ High slew rate ★ Very low distortion ★ Aluminium cases ★ MXF600 & MXF900 fan cooled with D.C. loudspeaker and thermal protection.

USED THE WORLD OVER IN CLUBS, PUBS, CINEMAS, DISCOS ETC.

SIZES:- MXF200 W19"xH3" (2U)xD11"
MXF400 W19"xH5" (3U)xD12"
MXF600 W19"xH5" (3U)xD13"
MXF900 W19"xH5" (3U)xD14"

PRICES:- MXF200 £175.00 MXF400 £233.85
MXF600 £329.00 MXF900 £449.15
SPECIALIST CARRIER DEL. £12.50 EACH



OMP X03 STEREO 3-WAY ACTIVE CROSS-OVER

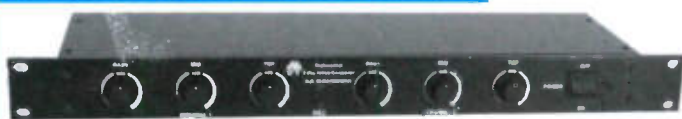

Advanced 3-Way Stereo Active Cross-Over, housed in a 19" x 1U case. Each channel has three level controls: bass, mid & top. The removable front fascia allows access to the programmable DIL switches to adjust the cross-over frequency: Bass-Mid 250/500/800Hz, Mid-Top 1.8/3/5KHz, all at 24dB per octave. Bass invert switches on each bass channel. Nominal 775mV input/output. Fully compatible with OMP rack amplifier and modules.

Price £117.44 + £5.00 P&P

STEREO DISCO MIXER SDJ3400SE ★ ECHO & SOUND EFFECTS★

STEREO DISCO MIXER with 2 x 7 band L & R graphic equalisers with bar graph LED Vu meters. MANY OUTSTANDING **FEATURES:-** including Echo with repeat & speed control, DJ Mic with talk-over switch, 6 Channels with individual faders plus cross fade, Cue Headphone Monitor, B Sound Effects. Useful combination of the following inputs:- 3 turntables (mag), 3 mics, 5 Line for CD, Tape, Video etc.



Price £144.99 + £5.00 P&P

SIZE: 482 x 240 x 120mm

PIEZO ELECTRIC TWEETERS - MOTOROLA

Join the Piezo revolution! The low dynamic mass (no voice coil) of a Piezo tweeter produces an improved transient response with a lower distortion level than ordinary dynamic tweeters. As a crossover is not required these units can be added to existing speaker systems of up to 100 watts (more if two are put in series). **FREE EXPLANATORY LEAFLETS ARE SUPPLIED WITH EACH TWEETER.**

TYPE 'A' (KSN1036A) 3" round with protective wire mesh. Ideal for bookshelf and medium sized Hi-Fi speakers. Price £4.90 + 50p P&P.
TYPE 'B' (KSN1005A) 3 1/2" super horn for general purpose speakers, disco and P.A. systems etc. Price £5.99 + 50p P&P.
TYPE 'C' (KSN1016A) 2" x 5" wide dispersion horn for quality Hi-Fi systems and quality discos etc. Price £6.99 + 50p P&P.
TYPE 'D' (KSN1025A) 2" x 6" wide dispersion horn. Upper frequency response retained extending down to mid-range (2KHz). Suitable for high quality Hi-Fi systems and quality discos. Price £9.99 + 50p P&P.
TYPE 'E' (KSN1038A) 3 1/2" horn tweeter with attractive silver finish trim. Suitable for Hi-Fi monitor systems etc. Price £5.99 + 50p P&P.
LEVEL CONTROL Combines, on a recessed mounting plate, level control and cabinet input jack socket. 85x85mm. Price £4.10 + 50p P&P.

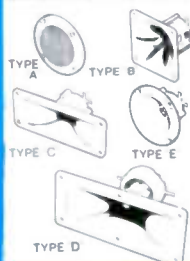

OMP MOS-FET POWER AMPLIFIER MODULES

SUPPLIED READY BUILT AND TESTED.

These modules now enjoy a world-wide reputation for quality, reliability and performance at a realistic price. Four models are available to suit the needs of the professional and hobby market i.e. Industry, Leisure, instrumental and Hi-Fi etc. When comparing prices, NOTE that all models include toroidal power supply, integral heat sink, glass fibre P.C.B. and drive circuits to power a compatible Vu meter. All models are open and short circuit proof.

THOUSANDS OF MODULES PURCHASED BY PROFESSIONAL USERS



OMP/MF 100 Mos-Fet Output power 110 watts
R.M.S. into 4 ohms, frequency response 1Hz - 100KHz
-3dB, Damping Factor > 300, Slew Rate 45V/uS,
T.H.D. typical 0.002%, Input Sensitivity 500mV, S.N.R.
-110 dB. Size 300 x 123 x 60mm.
PRICE £40.85 + £3.50 P&P



OMP/MF 200 Mos-Fet Output power 200 watts
R.M.S. into 4 ohms, frequency response 1Hz - 100KHz
-3dB, Damping Factor > 300, Slew Rate 50V/uS,
T.H.D. typical 0.001%, Input Sensitivity 500mV, S.N.R.
-110 dB. Size 300 x 155 x 100mm.
PRICE £64.35 + £4.00 P&P



OMP/MF 300 Mos-Fet Output power 300 watts
R.M.S. into 4 ohms, frequency response 1Hz - 100KHz
-3dB, Damping Factor > 300, Slew Rate 60V/uS,
T.H.D. typical 0.001%, Input Sensitivity 500mV, S.N.R.
-110 dB. Size 330 x 175 x 100mm.
PRICE £81.75 + £5.00 P&P



OMP/MF 450 Mos-Fet Output power 450 watts
R.M.S. into 4 ohms, frequency response 1Hz - 100KHz
-3dB, Damping Factor > 300, Slew Rate 75V/uS,
T.H.D. typical 0.001%, Input Sensitivity 500mV, S.N.R.
-110 dB, Fan Cooled, D.C. Loudspeaker Protection, 2
Second Anti-Thump Delay. Size 385 x 210 x 105mm.
PRICE £132.85 + £5.00 P&P



OMP/MF 1000 Mos-Fet Output power 1000 watts
R.M.S. into 2 ohms, 725 watts R.M.S. into 4 ohms,
frequency response 1Hz - 100KHz -3dB, Damping
Factor > 300, Slew Rate 75V/uS, T.H.D. typical
0.002%, Input Sensitivity 500mV, S.N.R. -110 dB, Fan
Cooled, D.C. Loudspeaker Protection, 2 Second
Anti-Thump Delay. Size 422 x 300 x 125mm.
PRICE £259.00 + £12.00 P&P

NOTE: MOS-FET MODULES ARE AVAILABLE IN TWO VERSIONS:
STANDARD - INPUT SENS 500mV, BAND WIDTH 100KHz.
PEC (PROFESSIONAL EQUIPMENT COMPATIBLE) - INPUT SENS
775mV, BAND WIDTH 50KHz. ORDER STANDARD OR PEC.

LOUDSPEAKERS

LARGE SELECTION OF SPECIALIST LOUDSPEAKERS AVAILABLE, INCLUDING CABINET FITTINGS, SPEAKER GRILLES, CROSS-OVERS AND HIGH POWER, HIGH FREQUENCY BULLETS AND HORNS, LARGE (A4) S.A.E. (60p STAMPED) FOR COMPLETE LIST.



McKenzie and Fane Loudspeakers are also available.

EMINENCE:- INSTRUMENTS, P.A., DISCO, ETC

ALL EMINENCE UNITS 8 OHMS IMPEDANCE
8" 100 WATT R.M.S. ME8-100 GEN. PURPOSE. LEAD GUITAR, EXCELLENT MID, DISCO. PRICE £32.71 + £2.00 P&P
RES. FREQ. 72Hz, FREQ. RESP. TO 4KHz, SENS 97dB.
10" 100 WATT R.M.S. ME10-100 GUITAR, VOCAL, KEYBOARD, DISCO, EXCELLENT MID. PRICE £33.74 + £2.50 P&P
RES. FREQ. 71Hz, FREQ. RESP. TO 7KHz, SENS 97dB.
10" 200 WATT R.M.S. ME10-200 GUITAR, KEYB/D, DISCO, VOCAL, EXCELLENT HIGH POWER MID. PRICE £43.47 + £2.50 P&P
RES. FREQ. 65Hz, FREQ. RESP. TO 3.5KHz, SENS 99dB.
12" 100 WATT R.M.S. ME12-100LE GEN. PURPOSE, LEAD GUITAR, DISCO, STAGE MONITOR. PRICE £35.64 + £3.50 P&P
RES. FREQ. 49Hz, FREQ. RESP. TO 6KHz, SENS 100dB.
12" 100 WATT R.M.S. ME12-100LT (TWIN CONE) WIDE RESPONSE, P.A., VOCAL, STAGE MONITOR. RES. FREQ. 42Hz, FREQ. RESP. TO 10KHz, SENS 98dB. PRICE £38.67 + £3.50 P&P
12" 200 WATT R.M.S. ME12-200 GEN. PURPOSE, GUITAR, DISCO, VOCAL, EXCELLENT MID. RES. FREQ. 58Hz, FREQ. RESP. TO 6KHz, SENS 98dB. PRICE £46.71 + £3.50 P&P
12" 300 WATT R.M.S. ME12-300GP HIGH POWER BASS, LEAD GUITAR, KEYBOARD, DISCO ETC. RES. FREQ. 47Hz, FREQ. RESP. TO 5KHz, SENS 103dB. PRICE £70.19 + £3.50 P&P
15" 200 WATT R.M.S. ME15-200 GEN. PURPOSE BASS, INCLUDING BASS GUITAR. RES. FREQ. 46Hz, FREQ. RESP. TO 5KHz, SENS 99dB. PRICE £50.72 + £4.00 P&P
15" 300 WATT R.M.S. ME15-300 HIGH POWER BASS, INCLUDING BASS GUITAR. RES. FREQ. 39Hz, FREQ. RESP. TO 3KHz, SENS 103dB. PRICE £73.34 + £4.00 P&P

EARBENDERS:- HI-FI, STUDIO, IN-CAR, ETC

ALL EARBENDER UNITS 8 OHMS (Except EB8-50 & EB10-50 which are dual impedance tapped @ 4 & 8 ohm)
BASS, SINGLE CONE, HIGH COMPLIANCE, ROLLED SURROUND
8" 50watt EB8-50 DUAL IMPEDANCE, TAPPED 4/8 OHM BASS, HI-FI, IN-CAR. PRICE £8.90 + £2.00 P&P
RES. FREQ. 40Hz, FREQ. RESP. TO 7KHz, SENS 97dB.
10" 50WATT EB10-50 DUAL IMPEDANCE, TAPPED 4/8 OHM BASS, HI-FI, IN-CAR. PRICE £13.65 + £2.50 P&P
RES. FREQ. 40Hz, FREQ. RESP. TO 5KHz, SENS 99dB.
10" 100WATT EB10-100 BASS, HI-FI, STUDIO. PRICE £30.39 + £3.50 P&P
RES. FREQ. 35Hz, FREQ. RESP. TO 3KHz, SENS 96dB.
12" 100WATT EB12-100 BASS, STUDIO, HI-FI, EXCELLENT DISCO. PRICE £42.12 + £3.50 P&P
RES. FREQ. 26Hz, FREQ. RESP. TO 3KHz, SENS 93dB.
FULL RANGE TWIN CONE, HIGH COMPLIANCE, ROLLED SURROUND
5 1/2" 60WATT EB5-60TC (TWIN CONE) HI-FI, MULTI-ARRAY DISCO ETC. PRICE £9.99 + £1.50 P&P
RES. FREQ. 63Hz, FREQ. RESP. TO 20KHz, SENS 92dB.
6 1/2" 60WATT EB6-60TC (TWIN CONE) HI-FI, MULTI-ARRAY DISCO ETC. PRICE £10.99 + 1.50 P&P
RES. FREQ. 38Hz, FREQ. RESP. TO 20KHz, SENS 94dB.
8" 60WATT EB8-60TC (TWIN CONE) HI-FI, MULTI-ARRAY DISCO ETC. PRICE £12.99 + £1.50 P&P
RES. FREQ. 40Hz, FREQ. RESP. TO 18KHz, SENS 89dB.
10" 60WATT EB10-60TC (TWIN CONE) HI-FI, MULTI-ARRAY DISCO ETC. PRICE £16.49 + £2.00 P&P
RES. FREQ. 35Hz, FREQ. RESP. TO 12KHz, SENS 98dB.

IBI FLIGHT CASED LOUDSPEAKERS

A new range of quality loudspeakers, designed to take advantage of the latest speaker technology and enclosure designs. Both models utilize studio quality 12" cast aluminium loudspeakers with factory fitted grilles, wide dispersion constant directivity horns, extruded aluminium corner protection and steel ball corners, complimented with heavy duty black covering. The enclosures are fitted as standard with top hats for optional loudspeaker stands.



POWER RATINGS QUOTED IN WATTS RMS FOR EACH CABINET
FREQUENCY RESPONSE FULL RANGE 45Hz - 20KHz

ibi FC 12-100WATTS (100dB) PRICE £159.00 PER PAIR
ibi FC 12-200WATTS (100dB) PRICE £175.00 PER PAIR

SPECIALIST CARRIER DEL. £12.50 PER PAIR

OPTIONAL STANDS PRICE PER PAIR £49.00
Delivery £6.00 per pair

IN-CAR STEREO BOOSTER AMPS

THREE SUPERB HIGH POWER CAR STEREO BOOSTER AMPLIFIERS
150 WATTS (75 + 75) Stereo, 150W Bridged Mono
250 WATTS (125 + 125) Stereo, 250W Bridged Mono
400 WATTS (200 + 200) Stereo, 400W Bridged Mono
ALL POWERS INTO 4 OHMS

Features:
★ Stereo, bridgable mono ★ Choice of high & low level inputs ★ L & R level controls ★ Remote on-off ★ Speaker & thermal protection.



PRICES: 150W £49.99 250W £99.99
400W £109.95 P&P £2.00 EACH

TRANSMITTER HOBBY KITS

PROVEN TRANSMITTER DESIGNS INCLUDING GLASS FIBRE PRINTED CIRCUIT BOARD AND HIGH QUALITY COMPONENTS COMPLETE WITH CIRCUIT AND INSTRUCTIONS

3W TRANSMITTER 80-108MHz, VARICAP CONTROLLED PROFESSIONAL PERFORMANCE. RANGE UP TO 3 MILES. SIZE 38 x 123mm. SUPPLY 12V @ 0.5AMP. PRICE £14.85 + £1.00 P&P

FM MICRO TRANSMITTER 100-108MHz, VARICAP TUNED, COMPLETE WITH VERY SENS FET MIC, RANGE 100-300m. SIZE 56 x 46mm. SUPPLY 9V BATTERY. PRICE £8.80 + £1.00 P&P



PHOTO: 3W FM TRANSMITTER



POSTAL CHARGES PER ORDER £1.00 MINIMUM. OFFICIAL ORDERS FROM SCHOOLS, COLLEGES, GOVT. BODIES, PLC. ETC. PRICES INCLUSIVE OF V.A.T. SALES COUNTER, VISA AND ACCESS ACCEPTED BY POST, PHONE OR FAX.



B.K. ELECTRONICS

UNITS 1 & 5 COMET WAY, SOUTHERNO-ON-SEA, ESSEX. SS2 6TR.

Tel.: 0702 - 527572 Fax.: 0702 - 420243

NEW!

The **MAPLIN** **MPS**
MAPLIN PROFESSIONAL

Catalogue is now available

**Over 17,000
technical products
for industry,
education and
the enthusiast**

**New! Free delivery
on all orders***

MAPLIN **MPS**

MAPLIN PROFESSIONAL

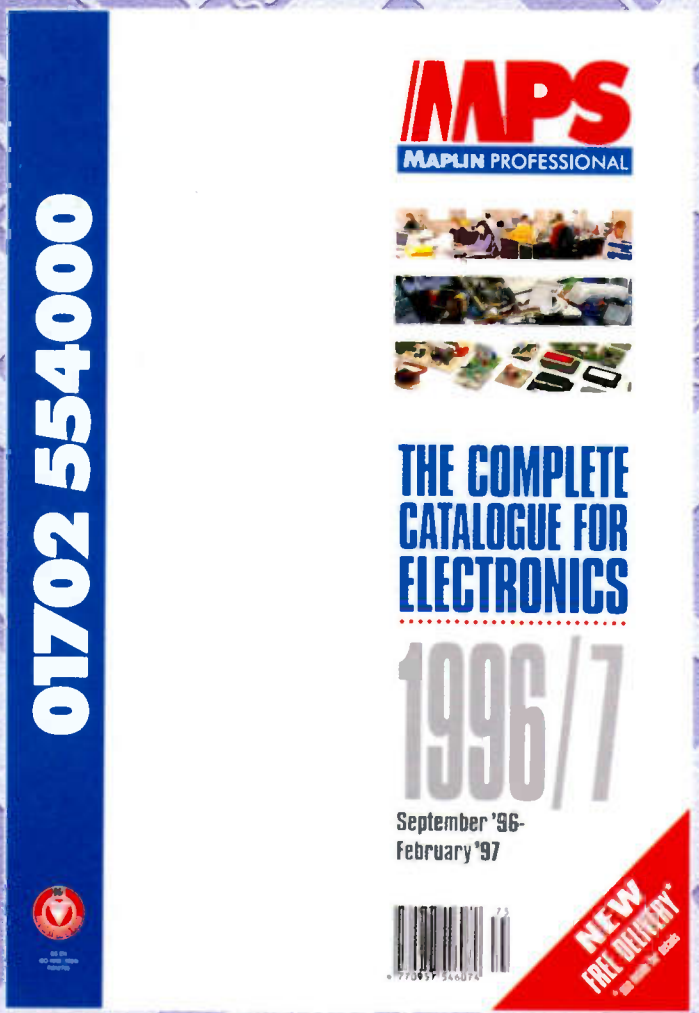

01702 554000

BRITAIN'S BEST-SELLING ELECTRONICS CATALOGUE

**Call in for your copy at WH SMITH, John Menzies and
Maplin stores nationwide, or order direct by mail-order
on 01702 554000 - Only £3.45 (plus 50p packaging).**

If you live outside the U.K. send £8.45 or 21 IRCs for Airmail in Europe or Surface mail outside Europe;
£16.00 or 37 IRCs for Airmail outside Europe to Maplin MPS, P.O. Box 777, Rayleigh, Essex, England SS6 8LU,

* on orders over £30.00 (Inclusive of VAT). Free delivery on ALL orders for Business Account customers.

See us on the Web at <http://www.maplin.co.uk>