

**EVERYDAY**

OCTOBER 1993

**WITH PRACTICAL**

# **ELECTRONICS**

INCORPORATING ELECTRONICS MONTHLY

FULLY S.O.R. £1.95

## MULTI-PURPOSE AUDIO SYSTEM - 1 SIX CHANNEL STEREO MIXER

**RIAA PRE-AMP,  
MIC PRE-AMP,  
CONTROL UNIT,  
AMPLIFIERS**



## KETTLE ALERT

## BECOMING A RADIO AMATEUR





**MICROWAVE CONTROL PANEL.** Mains operated, with touch switches. Complete with 4 digit display, digital clock, and 2 relay outputs one for power and one for pulsed power (programmable). Ideal for all sorts of precision timer applications etc. **Now only £4.00** ref 4P151. Good experimenters board.

**FIBRE OPTIC CABLE.** Stranded optical fibres sheathed in black PVC. Five metre length £7.00 ref 7P29R or £2 a metre.

**12V SOLAR CELL.** 200mA output ideal for trickle charging etc. 300 mm square. Our price £15.00 ref 15P42R. Gives up to 15v.

**PASSIVE INFRA-RED MOTION SENSOR.** Complete with daylight sensor, adjustable lights on timer (8 secs - 15 mins), 50' range with a 90 deg coverage. Manual override facility. Complete with wall brackets, bulb holders etc. Brand new and guaranteed. **Now only £19.00** ref 19P29

Pack of two PAR38 bulbs for above unit £12.00 ref 12P43R

**VIDEO SENDER UNIT.** Transmit both audio and video signals from either a video camera, video recorder or computer to any standard TV set within a 100' range (tune TV to a spare channel), 12V DC op. £15.00 ref 15P39R Suitable mains adaptor £5.00 ref 5P191R. Turn your camcorder into a cordless camera!

**FM TRANSMITTER** Housed in a standard working 13A adapter (bug in mains driven). £26.00 ref 26P2R. Good range.

**MINIATURE RADIO TRANSCIEVERS.** A pair of walkie talkies with a range of up to 2 kilometres. Units measure 22x52x155mm. Complete with cases and earpieces. £30.00 ref 30P12R

**FM CORDLESS MICROPHONE.** Small hand held unit with a 500' range! 2 transmit power levels. Reqs PP3 battery. Tuneable to any FM receiver. Our price £15 ref 15P42AR.

**12 BAND COMMUNICATIONS RECEIVER.** 9 shortbands, FM, AM and LW DX/local switch, tuning 'eye' mains or battery. Complete with shoulder strap and mains lead. £19 ref 19P14R. Ideal for listening all over the world.

**CAR STEREO AND FM RADIO.** Low cost stereo system giving 5 watts per channel. Signal to noise ratio better than 45db, wow and flutter less than .35%. Neg earth. £19.00 ref 19P30

**LOW COST WALKIE TALKIES.** Pair of battery operated units with a range of about 200'. Our price £8.00 a pair ref 8P50R. Ideal for garden use or as an educational toy.

**7 CHANNEL GRAPHIC EQUALIZER** plus a 60 watt power amp! 20-21KHZ 4-8R 12-14V DC negative earth. Cased. £25 ref 25P14R.

**NICAD BATTERIES.** Brand new top quality. 4 x AA's £4.00 ref 4P44R. 2 x C's £4.00 ref 4P73R. 4 x D's £9.00 ref 9P12R. 1 x PP3 £6.00 ref 6P35R Pack of 10 AA's £4.00 ref 4P92R.

**TOWERS INTERNATIONAL TRANSISTOR SELECTOR GUIDE.** The ultimate equivalents book. New ed. £20.00 ref 20P32R.

**GEIGER COUNTER KIT.** Complete with tube, PCB and all components to build a battery operated geiger counter. £39.00 ref 39P1R

**FM BUG KIT.** New design with PCB embedded coil. Transmits to any FM radio. 9v battery req'd. £5.00 ref 5P158R. 35mm square.

**FM BUG** Built and tested superior 9v operation £14.00 ref 14P3R

**COMPOSITE VIDEO KITS.** These convert composite video into separate H sync, V sync and video. 12V DC. £8.00 ref 8P39R.

**SINCLAIR C5 MOTORS.** 12v 29A (full load) 3300 rpm 6"x4" 1/4" O/P shaft. New. £22.00 ref 20P22R. Limited stocks.

**ELECTRONIC SPEED CONTROL KIT** for C5 motor, PCB and all components to build a speed controller (0-95% of speed). Uses pulse width modulation. £17.00 ref 17P3R. Potentiometer control.

**SOLAR POWERED NICAD CHARGER.** Charges 4 AA nicads in 8 hours. Brand new and cased £6.00 ref 6P3R. 2x C cell model £6.00.

**ACORN DATA RECORDER ALF503.** Made for BBC computer but suitable for others. Includes mains adapter, leads and book. £15.00 ref 15P43R

**VIDEO TAPES.** Three hour superior quality tapes made under licence from the famous JVC company. Pack of 10 tapes **Now low price £15.00** ref J15P4

**PHILIPS LASER 2MW HELIUM NEON LASER TUBE.** BRAND NEW FULL SPEC £40.00 REF 40P10R. MAINS POWER SUPPLY KIT £22.00 REF 22P33R READY BUILT AND TESTED LASER IN ONE CASE £75.00 REF 75P4R.

**12 TO 220V INVERTER KIT.** As supplied it will handle up to about 15w at 220v but with a larger transformer it will handle 80watts. Basic kit £12.00 ref 12P17R. Larger transformer £12.00 ref 12P41R.

**WIND UP SOLAR POWERED RADIO!** FM/AM Radio takes rechargeable batteries. Complete with hand charger and solar panel. £14.00 REF 14P200RA.

**BARGAIN NICADS AAA SIZE 200MAH 1.2V PACK OF 10** £4.00 REF 4P92R, PACK OF 100 £30.00 REF 30P16R

**FRESNEL MAGNIFYING LENS.** 83 x 52mm £1.00 ref BD827R.

**12V 19A TRANSFORMER** Ex equipment £20 but OK.

**POWER SUPPLIES** Made for the Spectrum plus 2 give +5 @ 2A, +12 @ 700mA & -12 @ 50mA. £8 ref Q8P3

**UNIVERSAL BATTERY CHARGER.** Takes AA's, C's, D's and PP3 nicads. Holds up to 5 batteries at once. New and cased, mains operated. £6.00 ref 6P36R.

**IN CAR POWER SUPPLY.** Plugs into cigar socket and gives 3.4, 5.6, 7.5, 9, and 12v outputs at 800mA. Complete with universal spider plug. £5.00 ref 5P167R.

**QUICK CUPPA?** 12v immersion heater with lead and cigar lighter plug £3.00 ref 3P92R. Ideal for tea on the move!

**LED PACK.** 50 red, 50 green, 50 yellow all 5mm £8.00 ref 8P52

**360K 5.25" DISK DRIVE.** Industry standard, ideal replacement or second drive for most computers. £9.00 EACH ref. X9P1.

**PPC PSU** 13.8V 1.9A (not plug in). £10.00 EACH. REF: X10P1.

**MINIMUM GOODS ORDER £5.00. TRADE ORDERS FROM GOVERNMENT, SCHOOLS, UNIVERSITIES & LOCAL AUTHORITIES WELCOME. ALL GOODS SUPPLIED SUBJECT TO OUR CONDITIONS OF SALE AND UNLESS OTHERWISE STATED GUARANTEED FOR 30 DAYS.**

**RIGHTS RESERVED TO CHANGE PRICES & SPECIFICATIONS WITHOUT PRIOR NOTICE. ORDERS SUBJECT TO STOCK. QUOTATIONS WILLINGLY GIVEN FOR QUANTITIES HIGHER THAN THOSE STATED.**

## THIS MONTHS SPECIAL OFFERS

### SOLAR CELLS

#### 10 WATT SOLAR CELL (3" x 1") 14.5v/700mA

Now available by mail order

Coated with exceptionally efficient amorphous silicon

these glass solar cells have

an almost timeless lifespan

and will not suffer with

discolouration. There are

possibly hundreds of uses

for these cells, a few of

which could be: for **Car**

**Battery Charging,** for use

on **Boats** or on **Caravans,**

in fact anywhere a portable

**12V** supply is required.

Several of our overseas

Mediterranean customers

with homes in remote hilly

sites, use these solar cells

as a daytime power source

to backup generators. The

solar cells can be

connected in series or

parallel to give higher

voltages or larger current

capacity. **REF: EV34P1**

**PRICED at only**

**£33.95. PLUS** an additional

**£2.00 special packaging charge on this**

**item in addition to £3.00 PP charge.**

#### OTHER SOLAR PANELS:

12V 200mA GLASS SOLAR PANEL.

12" x 12" in dimension £15.00 EACH. ref: 15P42.

.45V 700mA SOLAR CELL.

silicon plastic encapsulated. 95 x 65 x 7.5mm in dims.

£3.00 EACH. ref: 3P42.

.45V 400mA SOLAR CELL.

silicon plastic encapsulated. 75 x 45 x 7.5mm in dims.

£2.00 EACH. ref: 2P199.

.45V 100mA SOLAR CELL.

silicon plastic encapsulated. 45 x 26 x 7.5mm in dims.

£1.00 EACH. ref: BD631.

SOME OF OUR PRODUCTS MAY BE UNLICENSABLE IN THE UK

## BULL ELECTRICAL

250 PORTLAND ROAD HOVE SUSSEX

BN3 5QT

MAIL ORDER TERMS: CASH PO OR CHEQUE WITH ORDER PLUS £3.00 POST PLUS VAT.

PLEASE ALLOW 7 - 10 DAYS FOR DELIVERY

TELEPHONE ORDERS WELCOME

TEL: 0273 203500

FAX: 0273 323077

#### INDUCTIVE AMPS £5.00

Made for amplifying a telephone handset for the hard of hearing. However if you hold one against a piece of wire carrying a telephone conversation you can hear both sides of the conversation! It can also be used for tracing live wires in a wall or detecting cables carrying mains etc. Fully cased complete with battery and fixing strap. Approx 2.5" diameter 1" thick.

**Our Price :£5.00 Our Ref :EV5P11**

#### CTM644 COLOUR MONITOR £79.00

Refurbished monitor suitable for many home computers standard RGB input.

**Our Price :£79.00 Our Ref :EV79P11**

#### ARCHEMEDIES A3000 PSU £10.00

A compact switch mode PSU with on/off switch, selectable voltage input 110/240. NEW O/P via fly leads. GOOD STOCKS AVAILABLE.

**Our Price :£10.00 Our Ref :EV10P11**

#### ANSWERPHONES from only £18.00

Yes its true BT approved push button dialling. These are customer returned units and have two faults. We will supply you with a chip to cure one fault then you have to sort out the other problem! NON RETURNABLE.

Prices:

**£18.00 each. REF: EV18P21**

**£60.00 PKT 4. REF: EV60P21**

#### PORTABLE ALARM SYSTEM £17.00

'PAL' Portable Multi Beam Scanning System. Lockable Stand-alone PIR unit with removable keys (3 supplied). This unit uses a PP3 battery and when activated emits a piercing SHRILL! The unit scans the room and memorises the layout. Should this change, the alarm is triggered. There is a 60 second exit delay.

**Our Price :£17.00 Our Ref :EV17P11**

#### PIR MOVEMENT DETECTOR £15.00

Once again we have acquired stocks of this popular line and are able to offer you a very high quality and professional detector at only \*\*£15\*\*. Range: 20m with a 90° arc. Day and Night Mode Dims: 15cm x 9cm x 11cm. New and boxed, complete with installation guide.

**Our Price :£15.00 Our Ref :EV15P21**

#### MANY MORE SPECIAL OFFERS IN OUR REGULAR NEWSLETTERS

#### WE HAVE HUNDREDS AND HUNDREDS MOST STOCK LINES - TOO MANY TO LIST IN ONE ADVERT ! CHOOSE FROM

AERIAL AMPLIFIERS	FANS
AEROSOLS	FUSES
ALARMS	GLUE GUN AND GLUE
AMPLIFIED SPEAKERS	HEADPHONES
ANALOGUE MULTIMETERS	HEATSHRINK SLEEVING
APPLIANCE LEADS	HIFI SPEAKERS
BATTERIES AND HOLDERS	IONISERS
BATTERY CHARGERS	LED's
BOOKS	LASERS AND LASER PSU's
BOXES AND CASES	LOGIC PROBES
CAMCORDER BITS	LOUD AND MARINE SPKRS
CAPACITORS	MICROPHONES
CAR AMPS, RADIOS & SPKRS	PIR LIGHTS AND DETECTORS
CB SPEAKERS AND PSU's	POWERS SUPPLIES
COMPUTER BITS	POWER AMPLIFIERS
CONNECTORS	RADIOS
DESOLDER PUMP	SERVICE AIDS
DIGITAL MULTIMETERS	SOLDERING EQUIPMENT
DISCO LIGHTING	STEAM ENGINES
DISPLAYS	TRANSISTERS
DUBBING KIT	TRANSFORMERS
DRILLS	WIRELESS MICROPHONES

#### IN SUSSEX?

CALL IN AND SEE US!!

TURN YOUR SURPLUS STOCK INTO CASH. IMMEDIATE SETTLEMENT. WE WILL ALSO QUOTE FOR COMPLETE FACTORY CLEARANCE.

MUCH MUCH MORE IN OUR 1993 CATALOGUE. PLEASE SEND 41P, A4 SIZED SAE FOR YOUR FREE COPY.



# EVERYDAY WITH PRACTICAL ELECTRONICS

INCORPORATING ELECTRONICS MONTHLY

VOL. 22 No. 10 OCTOBER 1993

The No. 1 Independent Magazine for Electronics,  
Technology and Computer Projects

ISSN 0262 3617

PROJECTS ... THEORY ... NEWS ...  
COMMENT ... POPULAR FEATURES ...

## Projects

- MULTI-PURPOSE AUDIO SYSTEM** by Max Horsey **728**  
System overview plus Six-Channel Stereo Mixer design
- MAGIC SOCKET** by T. R. de Vaux-Balbirnie **740**  
Master socket controls four further sockets
- LINEAR POWER SUPPLY** by Jason Sharpe **764**  
Designed for computer applications, in particular the Amstad PCW 8-Channel ADC (Aug/Sept '93)
- FAKE CAR ALARM** by Mungo Henning **778**  
Probably the most basic electronic theft deterrent possible
- KETTLE ALERT** by Bart Trepak **780**  
An electronic version of the "steam whistle" for automatic kettles
- L.E.D SANDGLASS** by Mark Daniels **784**  
A modern approximation of an ancient timepiece

## Series

- INTERFACE** by Robert Penfold **744**  
The page for computer enthusiasts
- AUDIO AMPLIFIER DESIGN - ENGINEERING OR ALCHEMY** by John Linsley Hood **748**  
Part Three: The influence of different semiconductors
- TEACH-IN '93 - 12** **752**  
by Alan Winstanley, Keith Dye and Geoff MacDonald  
Our intrepid team bring the series to a close with more on the *Micro Lab*
- CIRCUIT SURGERY** by Mike Tooley **770**  
Mike solves your problems and provides circuit ideas
- TECHNIQUES - ACTUALLY DOING-IT** by Robert Penfold **776**  
Building your own project enclosures
- AMATEUR RADIO** by Tony Smith G4FAI **789**  
ISWL Awards; RF Radiation Hazards; Exclusions; French No-Code Referendum; Free Morse Programs

## Features

- EDITORIAL** **727**
- INNOVATIONS** **738**  
Everyday news from the world of electronics
- NEW TECHNOLOGY UPDATE** by Ian Poole **739**  
Display developments and reducing on-chip component sizes
- SHOPTALK** with David Barrington **743**  
Component buying for EPE projects
- FOX REPORT** by Barry Fox **750**  
Pirate Space; Prizes; Digital Audio
- BECOMING A RADIO AMATEUR** by Ian Poole **772**  
If you are interested in becoming a radio HAM, or just listening in, then this is for you
- HOME BASE** by Terry Pinnell **788**  
Jottings of an electronics hobbyist
- DIRECT BOOK SERVICE** **791**  
A wide range of technical books available by mail order
- PRINTED CIRCUIT BOARD SERVICE** **794**  
PCBs for EPE projects - some at sale prices
- ELECTRONICS VIDEOS** **796**  
Our range of educational videos to compliment your studies
- FREE WITH THIS ISSUE - MARCO '94 CATALOGUE** Banded to the magazine
- ADVERTISER'S INDEX** **800**

Readers Services • Editorial and Advertisement Departments 727

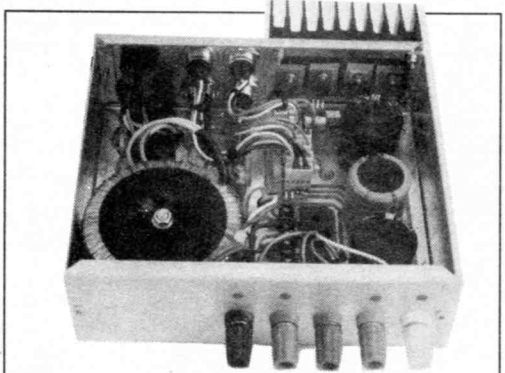
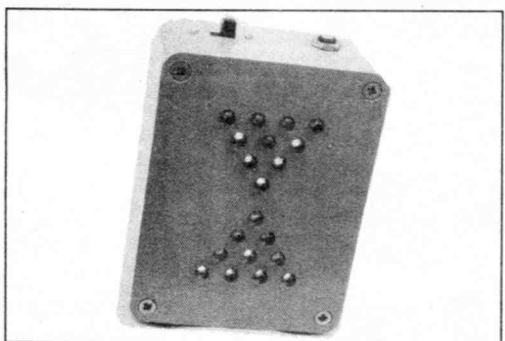
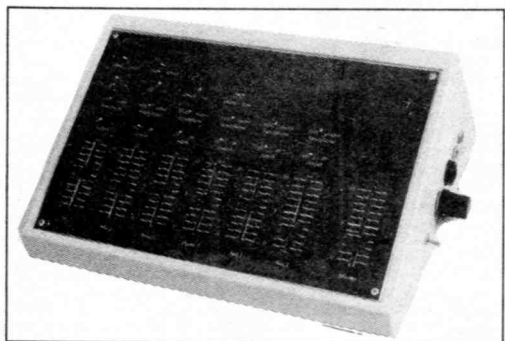
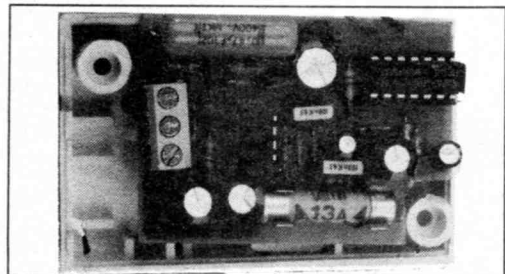

© Wimborne Publishing Ltd 1993. Copyright in all drawings, photographs and articles published in EVERYDAY with PRACTICAL ELECTRONICS is fully protected, and reproduction or imitations in whole or in part are expressly forbidden.

Our November '93 Issue will be published on Friday, 1 October 1993. See page 715 for details.



# FREE

## COVER MOUNTED TRACKTRONICS COPPER CIRCUIT TRACK

Together with three circuit cards and full details of using the track to build three different projects



## SPECIAL SUPPLEMENT

### **ELECTRONICS PRINCIPLES**

Describes a new software package that EPE is marketing. Full details are given together with information on how to obtain a special minimal cost demonstration disc. If you are interested in teaching or learning about electronics don't miss this important innovation.

### **MINIGUARD**

**A portable PIR alarm – take it wherever you go!**

This passive infra-red intruder alarm is a miniature version of the larger system now often found in homes and commercial premises. However, Miniguard differs from its larger counterpart in being totally self-contained with integral batteries and sounder. It is therefore entirely safe in operation and may be carried from place to place as the need arises. Arming and disarming is carried out by means of a key-operated switch on the unit and there are built-in time delays which allow this to be carried out without the user setting it off.

Miniguard operates a siren when a person walks into the protected zone. The detection range is at least eight metres (26ft approximately) which should be sufficient for most purposes.

### **20 METRE RECEIVER**

An article describing a direct conversion receiver for the 80 metre amateur band appeared in the June 1990 issue of *Everyday Electronics*. The project to be featured next month is firmly based on that design, but it has been modified for operation on the 20 metre amateur band.

Reception on the 20 metre band is in many ways the opposite of 80 metre reception. During daylight hours the radio waves are reflected from the upper atmosphere, and long distance reception is possible. The signals are reflected from a very high layer of the atmosphere, enabling very long distances to be covered on each bounce. The groundwave tends to be absorbed by the earth, giving little reception of signals via the direct route. Distances of several thousand miles can usually be covered, and even with quite simple receiving equipment it is often possible to pick up stations on the other side of the world.

# EVERYDAY WITH PRACTICAL ELECTRONICS

NOVEMBER ISSUE ON SALE FRIDAY, OCTOBER 1ST

# NEXT MONTH



# SURVEILLANCE PROFESSIONAL QUALITY KITS

## No. 1 for Kits

Whether your requirement for surveillance equipment is amateur, professional or you are just fascinated by this unique area of electronics SUMA DESIGNS has a kit to fit the bill. We have been designing electronic surveillance equipment for over 12 years and you can be sure that all of our kits are very well tried, tested and proven and come complete with full instructions, circuit diagrams, assembly details and all high quality components including fibreglass PCB. Unless otherwise stated all transmitters are tuneable and can be received on an ordinary VHF FM radio.

### UTX Ultra-miniature Room Transmitter

Smallest room transmitter kit in the world! Incredible 10mm x 20mm including: mic. 3-12V operation. 500m range.....£16.45

### MTX Micro-miniature Room Transmitter

Best-selling micro-miniature Room Transmitter  
Just 17mm x 17mm including mic. 3-12V operation. 1000m range.....£13.45

### STX High-performance Room Transmitter

Hi performance transmitter with a buffered output stage for greater stability and range. Measures 22mm x 22mm including mic. 6-12V operation, 1500m range.....£15.45

### VT500 High-power Room Transmitter

Powerful 250mW output providing excellent range and performance. Size 20mm x 40mm. 9-12V operation. 3000m range.....£16.45

### VXT Voice Activated Transmitter

Triggers only when sounds are detected. Very low standby current. Variable sensitivity and delay with LED indicator. Size 20mm x 67mm. 9V operation. 1000m range...£19.45

### HVX400 Mains Powered Room Transmitter

Connects directly to 240V AC supply for long-term monitoring. Size 30mm x 35mm. 500m range.....£19.45

### SCRX Subcarrier Scrambled Room Transmitter

Scrambled output from this transmitter cannot be monitored without the SCDM decoder connected to the receiver. Size 20mm x 67mm. 9V operation. 1000m range.....£22.95

### SCXL Subcarrier Telephone Transmitter

Connects to telephone line anywhere, requires no batteries. Output scrambled so requires SCDM connected to receiver. Size 32mm x 37mm. 1000m range.....£23.95

### SCDM Subcarrier Decoder Unit for SCRX

Connects to receiver earphone socket and provides decoded audio output to headphones. Size 32mm x 70mm. 9-12V operation.....£22.95

### ATR2 Micro Size Telephone Recording Interface

Connects between telephone line (anywhere) and cassette recorder. Switches tape automatically as phone is used. All conversations recorded. Size 16mm x 32mm. Powered from line.....£13.45

### UTLX Ultra-miniature Telephone Transmitter

Smallest telephone transmitter kit available. Incredible size of 10mm x 20mm!  
Connects to line (anywhere) and switches on and off with phone use.  
All conversation transmitted. Powered from line. 500m range.....£15.95

### TLX700 Micro-miniature Telephone Transmitter

Best-selling telephone transmitter. Being 20mm x 20mm it is easier to assemble than UTLX. Connects to line (anywhere) and switches on and off with phone use. All conversations transmitted. Powered from line. 1000m range.....£13.45

### STLX High-performance Telephone Transmitter

High performance transmitter with buffered output stage providing excellent stability and performance. Connects to line (anywhere) and switches on and off with phone use. All conversations transmitted. Powered from line. Size 22mm x 22mm. 1500m range.....£16.45

### TKX900 Signalling/Tracking Transmitter

Transmits a continuous stream of audio pulses with variable tone and rate. Ideal for signalling or tracking purposes. High power output giving range up to 3000m. Size 25mm x 63mm. 9V operation.....£22.95

### CD400 Pocket Bug Detector/Locator

LED and piezo bleeper pulse slowly, rate of pulse and pitch of tone increase as you approach signal. Gain control allows pinpointing of source. Size 45mm x 54mm. 9V operation.....£30.95

### CD600 Professional Bug Detector/Locator

Multicolour readout of signal strength with variable rate bleeper and variable sensitivity used to detect and locate hidden transmitters. Switch to AUDIO CONFORM mode to distinguish between localised bug transmission and normal legitimate signals such as pagers, cellular, taxis etc. Size 70mm x 100mm. 9V operation.....£50.95

### QTX180 Crystal Controlled Room Transmitter

Narrow band FM transmitter for the ultimate in privacy. Operates on 180 MHz and requires the use of a scanner receiver or our QRX180 kit (see catalogue). Size 20mm x 67mm. 9V operation. 1000m range.....£40.95

### QLX180 Crystal Controlled Telephone Transmitter

As per QTX180 but connects to telephone line to monitor both sides of conversations. 20mm x 67mm. 9V operation. 1000m range.....£40.95

### QSX180 Line Powered Crystal Controlled Phone Transmitter

As per QLX180 but draws power requirements from line. No batteries required. Size 32mm x 37mm. Range 500m.....£35.95

### QRX180 Crystal Controlled FM Receiver

For monitoring any of the 'Q' range transmitters. High sensitivity unit. All RF section supplied as a pre-built and aligned module ready to connect on board so no difficulty setting up. Output to headphones. 60mm x 75mm. 9V operation.....£60.95

### A build-up service is available on all our kits if required.

UK customers please send cheques, POs or registered cash. Please add £1.50 per order for P&P. Goods despatched ASAP allowing for cheque clearance. Overseas customers send sterling bank draft and add £5.00 per order for shipment. Credit card orders welcomed on 0827 714476.

**OUR LATEST CATALOGUE CONTAINING MANY MORE NEW SURVEILLANCE KITS NOW AVAILABLE. SEND TWO FIRST CLASS STAMPS OR OVERSEAS SEND TWO IRCS.**

## ★★★ Specials ★★★

### DLTX/DLRX Radio Control Switch

Remote control anything around your home or garden, outside lights, alarms, paging system etc. System consists of a small VHF transmitter with digital encoder and receiver unit with decoder and relay output, momentary or alternate, 8-way diode switches on both boards set your own unique security code. TX size 45mm x 45mm. RX size 35mm x 90mm. Both 9V operation. Range up to 200m.

Complete System (2 kits).....£50.95

Individual Transmitter DLTX.....£19.95

Individual Receiver DLRX.....£37.95

### MBX-1 Hi-Fi Micro Broadcaster

Not technically a surveillance device but a great idea! Connects to the headphone output of your Hi-Fi, tape or CD and transmits Hi-Fi quality to a nearby radio. Listen to your favourite music anywhere around the house, garden, in the bath or in the garage and you don't have to put up with the DJ's choice and boring waffle. Size 27mm x 60mm. 9V operation. 250m range.....£20.95

**SUMA  
DESIGNS**

DEPT. EE  
THE WORKSHOPS, 95 MAIN ROAD,  
BAXTERLEY, NEAR AATHERSTONE,  
WARWICKSHIRE CV9 2LE  
VISITORS STRICTLY BY APPOINTMENT ONLY



Tel/Fax:  
**0827 714476**



LAST CHANCE  
TO ORDER  
GOODS IN OUR

# SALE

**MUST END  
SEPT 30TH**

If you missed July's issue and the FREE 48 page SALE SUPPLEMENT, send a large (A4) 28p SAE for your revised copy NOW, before all the Bargains go!

**NEW! FaxOnDemand SERVICE - SEE ADDRESS PANEL FOR DETAILS**

## Teach-In 93

Microlab kits All parts as specified by the authors, including PC board, EPROM, PAL and booklet

# £149.95

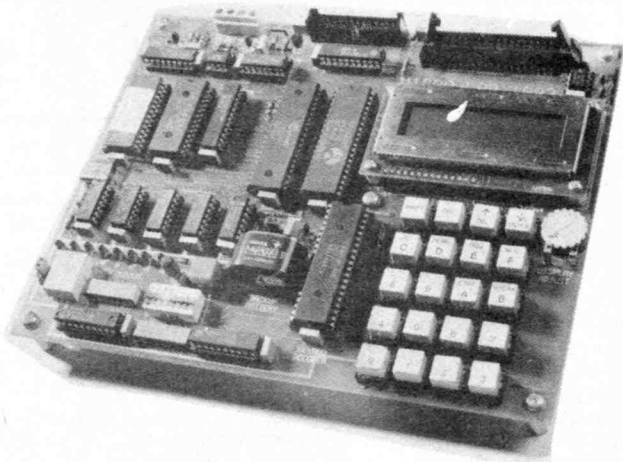

**SCANNERS**

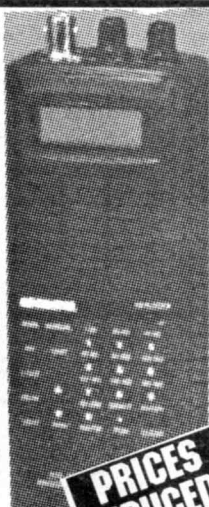

**PRICES  
REDUCED!**

### COM203

The COM203 programmable scanner lets you in on all the action, giving you direct access to over 35,000 frequencies which can be stored in its 200 channels. Its custom-designed tiny microprocessor gives the scanner these special features:

- ★ Nine radio bands ranging from 68 - 980MHz
- ★ Superscan enables you to carry out frequency scanning up to 50 steps per second
- ★ Liquid crystal display
- ★ Memory back-up
- ★ Built-in charging circuit for rechargeable batteries

Frequency coverage .....	68-88MHz
.....	108-136.975MHz
.....	137-144MHz
.....	144-148MHz
.....	148-174MHz
.....	380-450MHz
.....	450-470MHz
.....	470-512MHz
.....	806-960MHz
Antenna impedance .....	50Ω
Audio power .....	200mW
Power requirements .....	9Vdc (6 x AA batteries)
.....	or suitable mains adaptor
Dims .....	145 x 58 x 42mm
Weight .....	250g (less batteries)

**Price £230**

### COM204

The COM204 programmable scanner gives you direct access to more than 48000 frequencies. It incorporates a custom designed microprocessor giving you these special features:

- ★ AM/FM Selectable
- ★ 200-channel direct entry scanning
- ★ Triple conversion superheterodyne receiver
- ★ High speed scanning at 50 steps per second
- ★ Liquid crystal display indicating all active functions
- ★ Manual and auto scan for rapid selection of broadcasts
- ★ Lockout function allowing you to skip specified channels

Frequency coverage .....	68-88MHz (in 5kHz steps)
.....	118-136.975MHz
.....	137-174MHz
.....	220-225MHz
.....	225.0125-400MHz
.....	400.0125-512MHz
.....	806-999.9875MHz
Sensitivity .....	1µV (FM) 2µV (AM)
Antenna impedance .....	50Ω
Audio power .....	250mW
Power requirements .....	9Vdc (6 x AA batteries)
.....	or suitable mains adaptor
Dims (H x W x D) .....	145 x 58 x 42mm
Weight .....	250g without antenna and batteries

**Price £272**

### COM102

A compact hand held programmable scanner covering wide VHF/UHF ranges of more than 22000 frequencies, enabling you to scan through up to ten channels. The liquid crystal display indicates channel, frequency and all other key modes.

- ★ Front panel keypad
- ★ Liquid crystal display with back up light
- ★ 2-second scan delay
- ★ Memory back up
- ★ Lockout function
- ★ Built-in charging circuit for rechargeable batteries

Frequency coverage .....	30-50MHz
.....	50-54MHz
.....	138-144MHz
.....	144-148MHz
.....	148-174MHz
.....	380-450MHz
.....	470-512MHz
Sensitivity .....	1µV
Antenna impedance .....	50Ω
Audio power .....	250mW
Power requirements .....	9Vdc (6 x AA batteries)
.....	or suitable mains adaptor
Dims (H x W x D) .....	160 x 70 x 40mm
Weight .....	300g without antenna and batteries

**Price £109**

All scanners are supplied with FREE Ni-cads and charger!

## IMPORTANT NOTICE END OF SALE



At the end of September, we'll be clearing all remaining stocks of most SALE goods at unbelievably low prices! - but the only way to know about these further massive reductions will be to become a Subscriber\* - only this privileged group of important customers will be mailed with the

## END OF SALE PRICE LIST

\*£6 a year for the next 12 issues of The Greenwell Guardian and latest Bargain List

## POWER SUPPLY BARGAIN

One of the best power supplies we've seen for the money - this 397 watt switch mode beauty is of the highest quality, made by Delta Electronics Inc. Removed from equipment, but in excellent condition (less than a year old!) the unit is totally enclosed in a steel case 340x152x152mm. It has an IEC mains inlet with suppressor fitted and on/off mains rocker switch, and all outputs are on leads with power connectors.

Now for the Spec:

Inputs: 100-120V @ 10A or 200-240V @ 6A, switchable on front panel.

Outputs: +5V @ 40A  
+12V @ 15A  
-5V @ 1A  
-12V @ 1A

A 12V DC 120x120mm fan is fitted at the rear of the case. Current distributor price of a unit of this ilk would be around £400!

**OUR PRICE £29.95**

SAVE 92%! Order Code Z 9157



All 1 off and pack prices include VAT, qty prices do not. P&P £2.75 per order (£9.50 next day) Min Credit Card £12. Official orders from Education welcome; min invoice charge £15. Payment is accepted by cheque, PO, cash (inc foreign currency banknotes), book tokens, Access, Visa, Connect. Our stores have enormous stocks - we are open from 9-5.30 Mon-Sat. Come and see us!



Due to a massive increase in business, we've now installed some extra facilities on new numbers:

**SALES & GENERAL ENQUIRIES: 0703 236363**  
**TECHNICAL QUERIES: 0703 325999; ACCOUNTS: 0703 231003; FAX (ALL DEPTS) 0703 236307**

**FaxOnDemand** - A new service from Greenwell to replace our BBS. Masses of information, details of latest offers, all faxed to you automatically. By using the touch tone keys on your fax machine, you will be guided through a menu and be able to select the information you want - or you can leave a voice message. The number for this service is **0703 236315**

**27D PARK ROAD, SOUTHAMPTON, SO1 3TB**



# SUMMER 1993 CATALOGUE



## The new enlarged Cirkit Catalogue is out now!

- 32 more pages
- New range of Kenwood 'scopes
- The latest scanning receivers and accessories
- New section of low cost security products
- Extended range of Velleman kits including: 250W 12Vdc to 220Vac inverter, in-car amplifier power supply, 200 and 400W amplifiers, suppressed lamp dimmer, halogen lamp dimmer, day/night thermostat and telephone remote control unit
- New test equipment, includes: 2.3GHz bench frequency counter, EPROM emulator/programmer, portable 'scopes and bench function generators
- Host of new components, including: compression trimmers, variable capacitors, connectors, fuses, and fuseholders, potentiometers, IC's, soldering irons and lead free solder
- Published 27th May 1993
- Available from most large newsagents or directly from Cirkit
- **Send for your copy today!**

**£1.90**  
+ 30p p&p

# Cirkit



## CIRKIT DISTRIBUTION LTD

Park Lane · Broxbourne · Hertfordshire · EN10 7NQ  
Telephone (0992) 444111 · Fax (0992) 464457

**OLP**  
TRANSFORMERS from

# JAYTEE

## UK Distributor for Standard Toroidal Transformers

- 107 types available from stock
- Sizes from 15VA to 625VA
- Dual 120v primaries allowing 110/120v or 220/240v operation

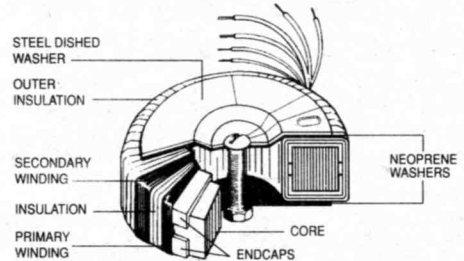

TYPE	SERIES NO.	SEC VOLTS	RMS CURRENT	TYPE	SERIES NO.	SEC VOLTS	RMS CURRENT		
15VA £10.68	03010	6+6	1.25	225VA £21.04	63012	12+12	9.38		
	03011	9+9	0.83		63013	15+15	7.50		
	03012	12+12	0.63		63014	18+18	6.25		
	03013	15+15	0.50		63015	22+22	5.11		
	03014	18+18	0.42		63016	25+25	4.50		
	03015	22+22	0.34		63017	30+30	3.75		
	03016	25+25	0.30		63018	35+35	3.21		
	03017	30+30	0.25		63026	40+40	2.81		
30VA £12.21	13010	6+6	2.50	63025	45+45	2.50			
	13011	9+9	1.66	63033	50+50	2.25			
	13012	12+12	1.25	63028	110	2.04			
	13013	15+15	1.00	63029	220	1.02			
	13014	18+18	0.83	63030	240	0.93			
	13015	22+22	0.68	300VA £22.94	73013	15+15	10.00		
	13016	25+25	0.60		73014	18+18	8.33		
	13017	30+30	0.50		73015	22+22	6.82		
50VA £13.84	23010	6+6	4.16		73016	25+25	6.00		
	23011	9+9	2.77		73017	30+30	5.00		
	23012	12+12	2.08		73018	35+35	4.28		
	23013	15+15	1.66		73026	40+40	3.75		
	23014	18+18	1.38		73025	45+45	3.33		
	23015	22+22	1.13	73033	50+50	3.00			
	23016	25+25	1.00	73028	110	2.72			
	23017	30+30	0.83	73029	220	1.36			
23028	110	0.45	73030	240	1.25				
23029	220	0.22	500VA £29.57	83016	25+25	10.00			
23030	240	0.20		83017	30+30	8.33			
80VA £15.43	33010	6+6		6.66	83018	35+35	7.14		
	33011	9+9		4.44	83026	40+40	6.25		
	33012	12+12		3.33	83025	45+45	5.55		
	33013	15+15		2.66	83033	50+50	5.00		
	33014	18+18		2.22	83042	55+55	4.54		
	33015	22+22		1.81	83028	110	4.54		
	33016	25+25	1.60	83029	220	2.27			
	33017	30+30	1.33	83030	240	2.08			
33028	110	0.72	625VA £32.64	93017	30+30	10.41			
33029	220	0.36		93018	35+35	8.92			
33030	240	0.33		93026	40+40	7.81			
120VA £16.45	43010	6+6		10.00	93025	45+45	6.94		
	43011	9+9		6.66	93033	50+50	6.25		
	43012	12+12		5.00	93042	55+55	5.68		
	43013	15+15		4.00	93028	110	5.68		
	43014	18+18		3.33	93029	220	2.84		
	43015	22+22	2.72	93030	240	2.60			
	43016	25+25	2.40	160VA £19.21	13.8V DC POWER SUPPLY TRANSFORMERS	8C267	500VA	18+18V	£32.64
	43017	30+30	2.00			9T845	675VA	16.1V	£38.06
43018	35+35	1.71							
43027	20+20	3.00	Prices include VAT and carriage						
43028	110	1.09	Quantity prices available on request						
43029	220	0.54							
43030	240	0.50							
53011	9+9	8.89							
53012	12+12	6.66							
53013	15+15	5.33							
53014	18+18	4.44							
53015	22+22	3.63							
53016	25+25	3.20							
53017	30+30	2.66							
53018	35+35	2.28							
53026	40+40	2.00							
53028	110	1.45							
53029	220	0.72							
53030	240	0.66							

Write, phone or fax for free Data Pack

## Jaytee Electronic Services

143 Reculver Road, Herne Bay, Kent CT6 6PL  
Telephone: (0227) 375254 Fax: 0227 365104



# EASY-PC, SCHEMATIC and PCB CAD

Over 17,000 Installations  
in 70 Countries World-wide!

**Still  
Only  
£98.00!**  
Plus P&P+VAT

**BRITISH  
DESIGN  
AWARD  
1989**

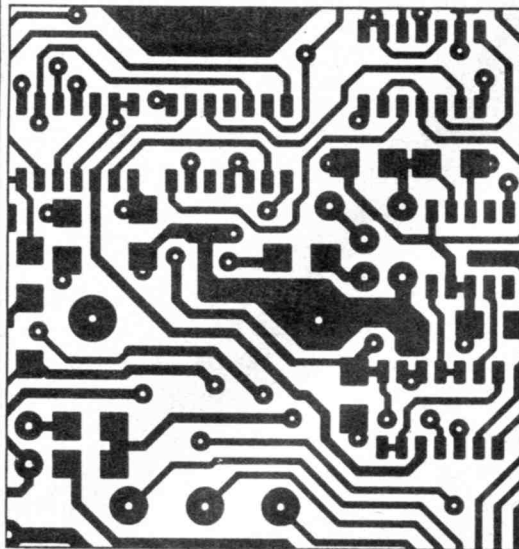

- Runs on:- PC/XT/AT/ 286/ 386/ 486 with Hercules, CGA, EGA or VGA display and many DOS emulations.
- Design:- Single sided, Double sided and Multi-layer (8) boards.
- Provides full Surface Mount support.
- Standard output includes Dot Matrix / Laser / Ink-jet Printer, Pen Plotter, Photo-plotter and N.C. Drill.
- Tech Support - free.
- Superbly easy to use.

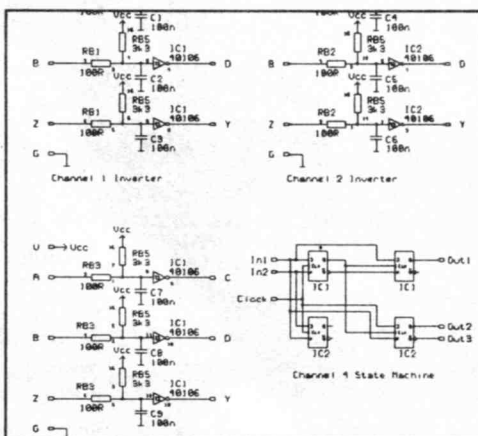

Options:-500 piece Surface Mount Symbol Library £48,  
1000 piece Symbol Library £38, Gerber Import facility £98.

## Electronic Designs Right First Time?

Ask for our fully functional Integrated Demo

### Integrated Electronics CAD

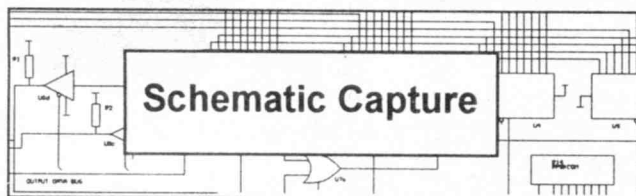

Analogue  
& Digital  
Simulation

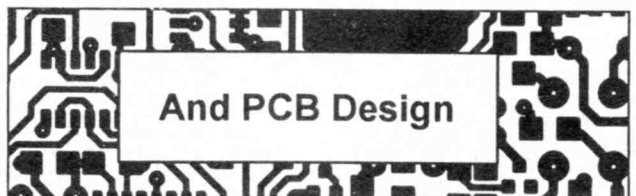

For Less than £400/\$775!

### Affordable Electronics CAD

EASY-PC: Low cost, entry level PCB and Schematic CAD.	\$195.00	£98.00
EASY-PC Professional: Schematic Capture and PCB CAD. Links directly to ANALYSER III and PULSAR.	\$375.00	£195.00
PULSAR: Low cost Digital Circuit Simulator ~ 1500 gate capacity.	\$195.00	£98.00
PULSAR Professional: Digital Circuit Simulator ~ 50,000 gate capacity.	\$375.00	£195.00
ANALYSER III: Low cost Linear Analogue Circuit Simulator ~ 130 node capability	\$195.00	£98.00
ANALYSER III Professional: Linear Analogue Circuit Simulator ~ 750 node capability.	\$375.00	£195.00
Z-MATCH II: Smith Chart program for RF Engineers - direct import from ANALYSER III.	\$375.00	£195.00
<i>We operate a no penalty upgrade policy. You can upgrade at any time to the professional version of a program just for the difference in price.</i>	<i>US\$ prices include Post and Packing.</i>	<i>Sterling £ prices exclude P&amp;P and VAT</i>

For full information, Write, Phone or Fax:-

### Number One Systems Ltd.

REF: EVD, HARDING WAY, ST.IVES, HUNTINGDON, CAMBS, ENGLAND, PE17 4WR.

Telephone: 0480 461778 (7 lines) Fax: 0480 494042

International: +44 -480-461778, Fax:+44-480-494042



- TECHNICAL SUPPORT FREE FOR LIFE!
- PROGRAMS NOT COPY PROTECTED.
- SPECIAL PRICES FOR EDUCATION.

ACCESS, AMEX, MASTERCARD, VISA Welcome.



## NEW TO PC COMPUTING

ONLY £14.95 £1.50 P&P

A complete set of programs (P.D. & S/Ware) on 6 disks, that takes a novice step by step from the very basics of PC computing to an advanced and competent PC user, should be of use to anyone who wishes to improve their knowledge of PCs and compatibles, or DOS. The programs are menu driven and include the following tutorials for the PC computer. PC & MS DOS to advanced level, typing tutor, file management and much more, also included are a word processor, database & spreadsheet. (PLEASE STATE DISK SIZE).

## 100 GAMES

ONLY £10.95 PLUS £2.00 P&P

OVER 100 OF THE BEST PD/SHAREWARE GAMES PROGRAMS FOR IBM AND COMPATIBLES COMPRESSED ON TO TEN DISKS

Driving & flying simulations, war & business strategy games, arcade games, adventure games, casino & gambling games, pinball, trivia, word games, board games.

Plus 3 CGA emulators that will enable owners mon/herc monitors to run most of these and many commercial games/programs.

NO EXTRA CHARGE FOR 3.5" DISKS.

## YOUR OWN PD/SHAREWARE LIBRARY

ONLY £19.95 £2.00 P&P

OVER 750 OF THE BEST PD/SHAREWARE PROGRAMS/FILES FOR IBM PC'S AND COMPATIBLES

Using the very latest archiving techniques, together with easy to use extraction facilities, we have compressed what would normally be supplied on 40 or 45 disks on to a 12 disk set.

## JOLLY ROGER TREASURE CHEST

£12.95 + £1.50 P&P

A collection of over 200 PD programs and text files that will remove or circumvent the copy protection on hundreds of programs. This will enable the owner to make backups, transfer to hard disk or different size disk, to name just a few. Lotus 123, DBase Flight Simulator, Leisure Suit Larry, Visicalc etc.

**Warning** These programs must not be used for software piracy.

Supplied on six 5.25 360K disks or four 3.5 720K disks.



P.C.L. (Software) Ltd, Silvery Grove, Spondon, Derby DE21 7GH.

Tel: 0332 678713



## SERVICE MANUALS TEST EQUIPMENT MAINTENANCE SPARE PARTS

Did you know that we provide repair and calibration services, supply technical manuals, and spare parts for test equipment-manufactured by over 100 different companies?

POWER SUPPLIES, SIGNAL GENERATORS, SPECTRUM ANALYSERS, AMPLIFIERS, FREQUENCY COUNTERS, MULTIMETERS (ANALOGUE & DIGITAL), OSCILLOSCOPES, POWER METERS ETC. ETC.

FULL TECHNICAL SUPPORT INCLUDING PROFESSIONAL DESIGN, DEVELOPMENT, COMMISSIONING, CONTRACT MAINTENANCE AND SYSTEM INTEGRATION.

## Hesing Technology HT

NEW & SECONDHAND TEST EQUIPMENT

Cromwell Chambers, 8 St. Johns Street, Huntingdon, Cambs. PE18 6DD  
Tel: (0480) 433156  
Fax: (0480) 413357

REPAIR AND CALIBRATION (TRACEABLE IF REQUIRED)

Tone dialling keypad, use services that require DTMF tone signals for a rotary dial pulse phone, size 90mm x 55mm x 12mm



£6.95 + 70p p&p

Filofax Personal Organiser Radio/Calculator. This neat little unit simply fits inside your filofax so you can listen to AM Radio with earphone or use it as a solar powered 8-digit calculator. Punched with six holes to fit all personal organisers. UK Made under 1/2 price.



£7.20 + £1 p&p

AM, FM, LW Ross Pushbutton Radio. With this neat unit you can easily tune in to five pre-set stations of your choice without fiddling or fuss, runs off six C-cell batteries or 240V mains. Output 400mW, volume and tone control. Size 230mm x 150mm x 65mm



£9.95 each + £3.70 p&p

## 11 BAND COMPONENT GRAPHIC EQUALIZER FOR CARS



This neat unit connects between the line output of your car stereo and your power amplifiers so you are able to adjust the sound as in a studio compensating for soft furnishing and sound reflections from glass, also it has a sub-woofer output to drive a separate amplifier for that extra deep bass sound. FEATURES: 2 channel inputs 4 channel outputs via phono sockets. CD input via 3.5mm jack 11 band graphic. SPECIFICATION RANGE 20Hz-60KHz THD 0.05%, S/N RATIO 85dB, EQ FREQUENCIES 60Hz, 120Hz, 250Hz, 380Hz, 500Hz, 750Hz, 1KHz, 2KHz, 4KHz, 8KHz, 16KHz (Boost cut of ±12 dB) Size 178mm x 25mm x 140mm. £40.00 + £3.75 p&p.

### Model: AVA - 450

320 Watt Bridgeable Power Amplifier  Power Output Per Channel: 75 Watts RMS  Two Channel Bridgeable Amplifier  Heavy Duty Aluminium Alloy Heatsink

Chassis  Class A-B Operation  Built-in Electronic Crossover Network Adjustable from 40Hz-500Hz  Continuously Variable Input Gain Adjustment  Tri-level Input Configuration  Gold Plated RCA, Low Level High Impedance Input  8-PIN DIN Connection, Low Level High Impedance Input compatible with Alpine and Kenwood

Wire Harness, High Level Low Impedance Input  Remote Turn-on/Turn-off Circuit  MOSFET Pulse Width Modulated Power Supply

2 Ohm Stable Operation with Output Power Increase  Soft Turn-on Circuit  Thermal Overheat Protection  Speaker Short Circuit Protection  Input Overload Protection  Speaker Short Condition Indicator  Automotive Style Protection Fuses  Upright Easy Access Speaker and Power/Ground/Remote Connection Terminals  Power On LED Indicator  Dimensions: 9"8"(W)x2"6"(H)x8"3"(L). £155.55 + £5 p&p

### AUDAX JBL 40-100 watt CAR TWEETERS

These state of the art advanced technology, high performance 10mm dome tweeters are Ferrofluid coded and are active horn-loaded for high dispersion of sound with very low distortions. Ideal for turning up your dull sounding in-car system.

SPECIFICATION IMP4Q 40 watts at 5KHz, 100 watt at 10KHz, MAGENT, SIZE 5mm x 30mm, VOICE COIL SIZE 10.5mm EFFICIENCY 92.8 dB, 5k. SIZE 51mm x 51mm x 16.5mm. RECOMMENDED. 1st ORDER CROSSOVER, VALUE 1.5uf-2.2uf supplied. £7.50 pair plus 90p post.



## PA400 POWER AMPLIFIER

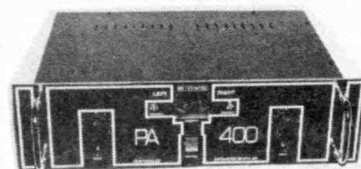

A high power stereo amplifier with independent volume controls, stereo output meter and fan cooled for extra reliability.

### FEATURES

Thermal, fuse, short circuit protection. Stereo VU meters. Fan cooled. 19" rack mount (size 3 units). 125W x 2 into 4Ω RMS Max.

Input sensitivity 450MV@22K

Price £149.99 inc. VAT p&p £7.50p



400W 15mm Bass Tube fitted with a brand new improved response eminence subwoofer. The enclosure is of a sealed type to give a linear bass response down to 17Hz. The tube is 94 dB efficient and is constructed from 15mill fibreboard. Finished in black vinyl. Supplied with straps + 6UH coil.

ONLY £128.95 inc. VAT. p&p £12.

## RTVC

376 EDGWARE ROAD LONDON W2 1EB

MAIL ORDER TERMS, POSTAL ORDERS and/or CHEQUES with orders. Access & Visa accepted.

Nett monthly accounts to Schools, Colleges and P.L.C. only. Overseas readers write for quote on delivery.

Please cross all cheques and postal orders "Account Payee Only" and make payable to RTVC Ltd.

Phone 071 723 3462  
Fax 071 723 3467



# MAILTECH

## ELECTRONIC COMPONENTS

**PROJECT BOXES** A range of high quality boxes moulded in black high impact ABS, easily drilled or punched to produce a professional looking end product

TYPE	W	L	H	PRICE
T2	75	56	25	£0.77
T4	111	57	22	£0.92
MB1	79	61	40	£1.35
MB2	100	76	41	£1.47
MB3	118	98	45	£1.71
MB4	216	130	85	£5.19
MB5	150	100	60	£2.35
MB6	220	150	64	£3.95
MB7	177	120	83	£3.42
MB8	150	80	50	£2.22

All sizes are in millimetres

**MICRO SWITCH** roller arm operation spdt 40p each

TYPE	PRICE	TYPE	PRICE
spdt	60p each	spdt 3 position c/off	70p each
dpdt	70p each	dpdt 3 position c/off	80p each
spdt biased	60p each	spdt 3 position c/off biased both ways	70p each
		dpdt 3 position c/off biased one way	80p each

**MINIATURE PUSH TO MAKE SWITCH**

TYPE	PRICE
DIL RELAYS 5 volt dp/changeover	60p 10 for £5.00
12 volt dp/changeover	80p 10 for £6.00

**RELAY** 10 amp contacts sp/changeover 12 volt coil  
**CAR HORN RELAY** in metal can with fixing lug, s/pole on 10 amp contacts £1.00 each 6 for £5.00  
**20 AMP RELAY** dp on 12 volt coil £1.50 each 4 for £5.00

**REED RELAY** 12 volt 50p each 10 for £4.00  
**240 VOLT AC RELAY**, 3-pole c/o 10 amp contacts £1.50 each 4 for £5.00

**SEMICONDUCTORS - TRANSISTORS - ICs - DIODES - REGULATORS - ETC**

**VOLTAGE REGS**  
 7812/7805/7912/7905 all 35p each, any 4 for £1.20  
 AD592An Temperature Sensor i.c. mounted on 1.5m screened lead complete with data and application notes £1.50 each  
 LM3914/LM3915 Bargraph ics £2.95 each  
 78512 12V +VE 2amp regulator 50p each  
 78505 5V +VE 2amp regulator 50p each  
**MICRO IC'S** - Z80A CPU £1.20; Z80A PIO £1.50; Z80B SIO-1 £4.00

**OPTO DEVICES - LEDS - ETC**

5mm rnd red/yellow/green/amber 10p each 12 for £1.00 any mix  
 5mm rnd high brightness red/green 20p each 6 for £1.00 any mix  
 5mm rnd flashing red 60p each, yellow/green 70p each  
 5mm rnd bi-colour 35p each, tri-colour 45p each  
 LED mounted in chrome bezel red, yellow or green 30p each, 4 for £1  
 LED mounted in a black bezel red only 25p each, 5 for £1.00  
 PLASTIC BEZEL for 5mm rnd leds 10 for 40p  
 High brightness bi-colour i.e.d., rectangular, red/green, two leads 40p each

**RESET TIMER PCB**

Gives a timed relay closure following a momentary input. Requires 12V d.c. supply SP c/o relay output LED indication. 19 different time intervals from 25sec to 35min 20sec. £5.98 each.

**UNIVERSAL BELL TIMER**

10 or 20 minute bell cut off +ve or -ve trigger\* timed relay contacts. £4.96

**ALARM CONTROL UNIT**

Single zone alarm control unit built into a domestic light switch box. Ideal for home, caravan, boat, garage, shed etc.  
 Facilities: - Normally closed loop for pir sensors, door/window contacts etc. Normally open loop for pressure mats. 24-hour loop for personal attack button Visual indication that the system is operational.  
 Automatic entry/exit delay.  
 Automatic system reset.  
 Alarm output cmos logic level.

**SIREN**  
 12 volt dc for external use 115db £8.95

**PRICE COMPLETE WITH FULL INSTRUCTIONS**  
**SUB-MINIATURE PASSIVE INFRA-RED SENSOR ONLY £5.95**

Brand new passive infra-red sensor, measures only 33mW x 24mmH x 29mmD. Logic level output. Full data and application notes supplied.

**EX INSTALLATION SENSORS** tested working.

Type 1. Measures 180 x 112 x 70mm with walk test led, relay output and tamper protection. 12 volt dc supply required £8.50 each  
 Type 2. As above but a smaller unit 123 x 62 x 50mm £11.75 each  
 Type 3. Ceiling mounting passive, infra red sensor 360° detection, 12V d.c. supply relay output, tamper circuit and pulse count option. Data supplied. £15.70 each

**DOOR/WINDOW CONTACTS**  
 Surface or flush mounting, white £1.10 each  
**JUNCTION BOX**  
 white 6 way 60p

Please note: There may be variations in the size of the above passive infra red sensors depending on stock at the time of ordering. But the unit will certainly be within the stated sizes.

**DUAL TECH SENSOR** Microwave and passive infra-red combined. Separate led indication for each function. Measures 120 x 75 x 50mm. 12 volt d.c. supply. Relay output. Tamper protection. £29.95 each

**ALARM CONTROL PANEL ST3000**

"Wire free alarm control panel, detectors communicate with the panel by means of radio transmitters". Speech synthesis for programming and general operating guidance". Built in user programmable telephone dialler". Up to 32 transmitters can be used". Programmable exit/entry and bell timers". Programmable user codes". Full installation data supplied, the only thing that has to be handwired is the output to the siren/bell unit (not supplied)". These control panels cost over £300.00. Yours for only £59.95. Suitable **PASSIVE INFRA SENSOR/TX £25.85**

Battery operated, available in 8m range, 10m range or 25m range.

**UNIVERSAL TX**

For connection of normally open or closed contacts e.g. door/window switches, pressure mats etc. £17.63

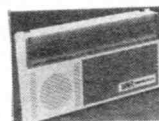

**BREADBOARDS - CAPACITORS - SOLAR CELLS - HEATSHRINK - ETC**

**SOLAR CELL** 2 volt 150mA max, size 60 x 100mm £1.35 each 5 for £6  
**BNC SOCKETS** 50 ohm single hole fixing 50p each 10 for £4.00

**MERCURY TILT SWITCH**  
 Standard on/off £1.00 each  
 4 Contact (Directional) £1.50 each  
**PIEZO VIBRATION SENSOR**  
 with data sheet £1.00 each

**BREADBOARD**  
 173 X 65mm 840TP £5.25 each  
**TEXT TOOL ZIF SOCKET**  
 28 pin zero insertion socket £5.95 each

**6 VOLT NI-CAD PACK** 5AA NI-CADS, fast charge type £3.95  
**CAPACITOR** 10,000 mfd 25 volt with fixing clip 60p each  
**EPROMS 27C256 - 30 27C512 - 25.** Once programmed but never used eprom. Mounted on a plastic carrier, can easily be removed from the carrier or used with a low insertion force socket.  
**27C256** £1.00 each 6 for £5.00 **27C512** £1.20 each 5 for £5.00  
 Suitable low insertion force socket 28 pin 40p each 3 for £1.00  
**MULTITURN PRESETS** 20mm RECT, 500R, 1K, 5K, 10K, 20K, 50K, 100K 1MO. 40p each, 3 for £1.00

**CAR CIGAR LIGHTER ADAPTER (DUAL SIZE)**  
 mounted on two metres of cable £2.00 each

**100db PIEZO SOUNDER**  
 2KHz note, 3-12V d.c. 40Ma, 45mm dia. x 26mm £1.76 each

**VIBRATION SENSITIVE ALARM BOARD WITH PIEZO SOUNDER**  
 Originally a bike alarm. There is a short delay after activation then the piezo sounder operates for a preset period. £3.76 each

or the above alarm board with custom designed case, fixing clip and keyswitch £9.95  
**INFRA-RED BREAK BEAM** Transmitter and receiver p.c.b. with 2 lens assemblies. 12V d.c. supply. These are ex-installation units and are not guaranteed to be working. £4.96 pair

**RECHARGEABLE BATTERIES**  
 AA (HP7) 600 mA £1.02 each C (HP11) 1200 mA £2.29 each  
 D (HP2) 1200 mA £2.40 each PP3 8.4V 100 mA £4.77 each

**FLOURESCENT LIGHT INVERTOR.** Drives an 8 watt tube directly from 6V d.c. Data supplied £4.50 each

## £1.00 BARGAIN PACKS

**SUB-MINIATURE TOGGLE SWITCHES**

P.C.B. Mounting

- BO1 S.P. on 4 for £1.00
- BO2 D.P. on 3 for £1.00
- BO3 3 x D.P. 3 pos, centre off
- BO04 DIL SWITCHES 4-way S.P. on 3 for £1.00
- BO05 DIL SWITCHES 8-way S.P. on 2 for £1.00
- BO06 DIL SWITCHES 12-way 90° sp on 2 for £1.00
- BO07 12 x PP3 BATTERY SNAPS
- BO08 1 x CAPACITOR 1 FARAD 5.5 VOLT 20mm dia. x 7mm high
- BO09 INSTRUMENT KNOBS (0.25" SHAFT) High quality grey plastic knob, collet fixing 15mm dia, 5 for £1.00
- BO10 as above but 29mm dia, 3 for £1.00
- BO11 4 x MAGNETIC EARPIECE 8 ohm with 3.5mm plug
- BO12 4 x 28-WAY TURNED PIN DIL SOCKET
- BO13 15 x 12 VOLT WIRE-ENDED LAMPS
- BO14 8 x 2 PIN DIN PLUGS screw terminal connection
- BO15 2 x LIGHT DEPENDENT RESISTOR Less than 200 ohms in daylight, greater than 10 megohms in darkness
- BO16 1 x KEYPAD 20-key in 5 x 4 matrix bubble type switch contacts
- BO17 2 x PIEZO BUZZERS approx 3 to 20 volt d.c.
- BO18 5 x 78M12 VOLTAGE REGULATORS positive 12V 500mA
- BO19 4 x TL082CP bi-fet op-amps
- BO20 20 x ASSORTED LEDS full spec. various shapes and sizes
- BO21 3 x INFRA-RED DIODE TX/RX PAIRS made by Honeywell (no info)
- BO22 4 x CONSTANT CURRENT LED 5mm round, red 2-18V d.c. or a.c. nominal 14mA
- BO23 50 x IN4148 diode
- BO24 2 x INFRA-RED TRANSISTOR FPT5133
- BO25 5 x DIACS
- BO26 3 BDX33C 10 amp 100V npn transistor
- BO27 12 x 2N3702 Transistor
- BO28 12 x 2N3904 Transistor
- BO29 12 x BC337 Transistor
- BO30 4 x LM317T Variable regulator mounted on a small heatsink
- BO31 2 x MAN6610 2 digit 0.6" 7 segment display Com anode, amber
- BO32 3 x PHONO TO PHONO LEAD 63cm long
- BO33 15 x RECTANGULAR RED LEDS 6 x 6 x 2mm stackable
- BO34 1 x PHOTO SENSITIVE SCR mounted on a PCB, data sheet supplied
- BO35 4 x IEC Panel Mounting Mains Plug Snap fix
- BO36 5 x ASSORTED PIEZO TRANSDUCERS
- BO37 5 LENGTHS OF HEATSHRINK SLEEVING 8mm dia. 400mm long
- BO38 25 x CERAMIC DISC CAPACITORS 0.1 mfd 63V
- BO39 15 x MONOLITHIC CERAMIC CAPACITORS 0.1 mfd 63V, in a dil package
- BO40 25 x ASSORTED ELECTROLYTIC CAPACITORS PCB mounting useful values
- BO41 25 ASSORTED PRE-SET RESISTORS
- BO42 6 x 3-5mm LINE JACK SOCKETS (mono)
- BO43 6 x 3-5mm JACK PLUG (mono)
- BO44 8 x 3-5mm CHASSIS SOCKET (mono)
- BO45 2 x TRIACS 800 volt 8 amp
- BO46 12 x BC213L Transistor
- BO47 12 x MIN SLIDE SWITCH dpdt
- BO48 15 x MIN CERMET TRIMMER POTS (good range of values)
- BO49 1 x PCB WITH TWO LARGE LEDS 15mm square, one red and one green
- BO50 1 x 12V DC RELAY 4-pole c/o with plug in base
- BO51 4 x LM324 quad op-amps
- BO52 4 x 555 Timer
- BO53 5 x 741 op-amp
- BO54 25 x IN4001 diode
- BO55 20 x IN4007 diode
- BO56 1 x SLOTTED OPTO
- BO57 1 x DAC08 Digital to analogue converter with data
- BO58 4 x OPTO ISOLATOR
- BO60 3 x CT106D Thyristor

Please use order code when ordering the bargain packs.

Please make cheques and postal orders payable to Mailtech.

All prices include VAT.

Please add 75p postage to all orders.

At the moment it is not possible to have a full telephone answering service. But we will have the phone definitely manned on Tuesdays, Wednesdays and Thursdays between 10am and 4pm.

**Dept EE, Mailtech**  
**PO Box 16 Ludlow**  
**Shropshire SY8 4NA**  
**Tel: 058 474475**



## ELECTRONIC DESIGNERS TOOLKITS SHAREWARE FROM ONLY £4.95

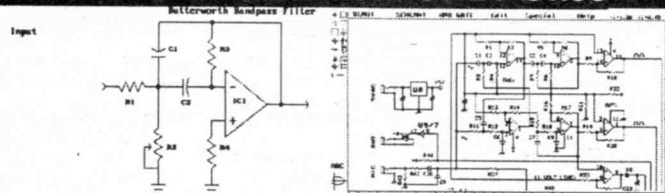

Filter20, CCI Analysis, DCCAD PCB Design, and Utils

Previously sold at over £100.00, now you can try these professional aids for only £19.95. These fully featured packages offer easy to use facilities for beginner and expert alike. Design Butterworth, Chebyshev, Elliptical, Bessel filters at the touch of a key. CCICAP analyses circuits with R,C,I, and FETs, BJTs, op-amps. DCCAD designs schematics and PCB layouts for double sided boards. Utils minimise logic circuits and provide electronic calculators. E1:- 8 360k discs all the above for £19.95. E2:- Filters and Circuit analysis 4 360k discs £9.95. E3 Electrical and Electronic calculators and Utils only £4.95. Please state size when ordering. Charges relate solely to admin. See our FREE CATALOGUE for registration details.



S&N Enterprises Tel: 0252 510486  
Mail Order:- 5 Polden Close, Farnborough, Hants GU14 9HN



## CONTROL PORT for PCs

This I/O Port follows the general approach of the 'INTERFACING to PCs' series in this mag, with the Port safely inside the PC, BUT allows user's prototype control circuitry to be set up and run OUTSIDE the PC. The double sided pcb fits into an I/O slot, and a ribbon cable terminating in a D-25 plug allows the control of projects with little risk to the PC. On board facilities include: 8-bit A-D, 8-bit D-A, 8 inputs, 8 latched outputs, 3 strobes and 1 IRQ.

Available as:

- (a) Etched double sided board only, with full instructions for drilling/assembly/testing using BASIC.....£12.50
- (b) Complete I/O card with ribbon cable and BASIC test programs. (Built and tested).....£29.00

Also available: Test pod with D-25 socket providing analogue and digital test signals/outputs for the I/O card, with BASIC test plus oscilloscope and data logger programs on disc.....£17.00

Please add £1 P&P in UK, Europe £1.50, others £2.00.

(Please send A4 S.A.E. or 2 IRCs for more details of the Port and the range of circuits enabling a full Measurement and Control System)

Mail Order only from:-

R. BARTLETT

17 LIME TREE AVENUE, TILE HILL, COVENTRY CV4 9EY  
(0203) 473 851

# Call us now! We have the widest range of components available - At competitive prices!

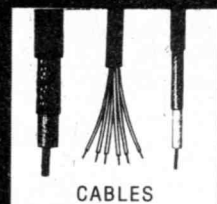

CABLES

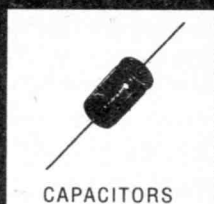

CAPACITORS



VIDEO HEADS

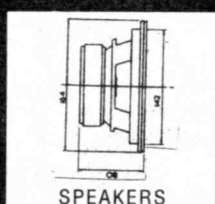

SPEAKERS

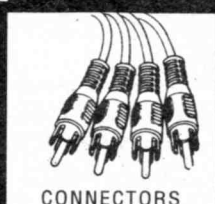

CONNECTORS

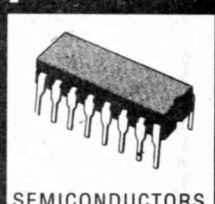

SEMICONDUCTORS

# CRICKLEWOOD ELECTRONICS

Cricklewood Electronics Ltd. 40 Cricklewood Broadway, London NW2 3ET.  
Telephone: 081 452 0161 Faxsimile: 081 208 1441

All Major Credit Cards Accepted



## LOW COST RANGER1 PCB DESIGN FROM SEETRAX

- Circuit Schematic
  - Circuit Capture
  - PCB Design
  - Host Of Outputs
- All-In-One Design System**

**£100**

**Fully Integrated Auto Router**

**£50**

**Ask Us About Trade-In Deals**

**Call Now For Demo Disk on 0705 591037**

Seetrax CAE • Hinton Daubnay House  
Broadway Lane • Lovedean • Hants • PO8 0SG

Tel: 0705 591037 • Fax: 0705 599036

**REDUCED  
PRICE!**

### What The Press Said About RANGER1

For most small users, Seetrax Ranger1 provides a sophisticated system at an affordable price. It is better than EasyPC or Tsien's Boardmaker since it provides a lot more automation and takes the design all the way from schematic to PCB - other packages separate designs for both, that is, no schematic capture. It is more expensive but the ability to draw in the circuit diagram and quickly turn it into a board design easily makes up for this.

**Source JUNE 1991  
Practical Electronics**

Pay by Visa or Access





# Low cost data acquisition for IBM PCs & compatibles...

A unique range of low cost data acquisition products for IBM PCs and compatibles. Installed in seconds they simply plug directly into either the serial or parallel port. They are completely self contained, require no external power supply and take up no expansion slots.

Each device comes with an easy to use software package (PicoScope, PicoLog or both). C, Pascal, and Basic drivers are supplied for those who want to develop their own software, as is a manual giving full details of the hardware and software. All software supplied on 3.5" disk.

# PICO TECHNOLOGY

**ADC-10** Up to 24kHz sampling rate from a 386/33MHz machine  
0-5V Input range  
BNC input connector allows use of standard scope probes  
30V overload protection  
Parallel port connection  
Includes PicoScope software

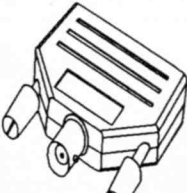

Single Channel 8 bit ADC **£49**

**ADC-16** Software selectable single ended or differential inputs  
Resolution programmable between 8 and 16 bits + sign  
 $\pm 2.5V$  input range  
5V reference output  
Connects to serial port  
Includes PicoLog software

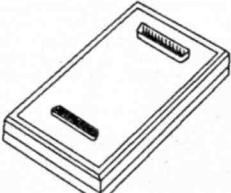

8 Channel 16 bit + sign ADC **£99**

**ADC-11** 15K samples per second  
0-2.5V Input range  
Digital output  
D25 input connector  
30V overload protection  
Parallel port connection  
Includes both PicoScope and PicoLog software

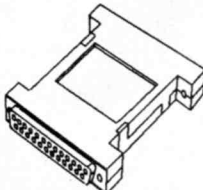

11 Channel 10 bit ADC **£75**

**PicoScope** 'Virtual instrument' software package for the ADC-10, ADC-11 and ADC-12.

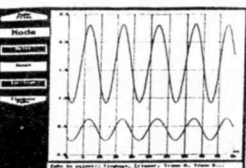

Scope, voltmeter, spectrum analyser

Storage oscilloscope with trigger and timebase. Traces can be printed and saved. Multiple meters on screen. Real time spectrum analysis.

**ADC-12** Up to 18kHz sampling rate  
0-5V Input range  
BNC input connector allows use of standard scope probes  
30V overload protection  
Parallel port connection  
Includes both PicoScope and PicoLog software



Single Channel 12 bit ADC **£85**

**PicoLog** Collect samples from 1 per ms to one per day. Scale samples linearly, by equation or by table look-up. Graphical (against time or XY) and text reports can be displayed, printed or exported.

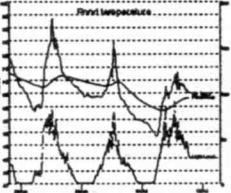

Advanced data logging software

Picolog is also available for the ADC-10: call for details.

Typical application	ADC-10	ADC-11	ADC-12	ADC-16
Oscilloscope	●	●	●	
Voltmeter	●	●	●	●
Spectrum analyser	●	●	●	
Audio sampling	●		●	
Chart recorder emulation		●		●
Temperature measurement	●	●	●	●
Pressure measurement	●	●	●	●
Chromatography				●
Automotive monitoring		●		●
Medical research		●	●	●
Education	●	●	●	●

## PICO BENEFITS

- 30 day no quibble money back policy
- Full 1 year guarantee
- 1 year's free software upgrades
- Free technical support
- Free user newsletter
- Same day dispatch

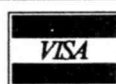

Pico Technology Ltd. Broadway House, 149-151 St Neots Road, Hardwick, Cambridge. CB3 7QJ.

**TEL: 0954-211716 FAX: 0954-211880**



Phone or FAX for sales, ordering information, data sheets, technical support. All prices exclusive of VAT.



**SHOP OPEN 9-5 MON-FRI. CLOSED SAT --- OFFICIAL ORDERS WELCOME**

## E.E. TREASURE HUNTER P.I. METAL DETECTOR

Magenta's highly developed & acclaimed design. Quartz crystal controlled circuit MOSFET coil drive. D.C. coupled amplification. Detects 10p coin at 20 cm. Full kit includes PCB, handle, case & search coil.



- KIT INC. HEADPHONES
- EFFICIENT CMOS DESIGN
- POWERFUL COIL DRIVE

- DETECTS FERROUS AND NON-FERROUS METAL - GOLD, SILVER, COPPER ETC.
- 190mm SEARCH COIL
- NO 'GROUND EFFECT'

KIT 815.....£45.95

## DIGITAL LCD THERMOSTAT

A versatile thermostat using a thermistor probe and having an I.c.d. display. MIN/MAX memories, -10 to 110 degrees celsius, or can be set to read in Fahrenheit. Individually settable upper and lower switching temperatures allow close control, or alternatively allow a wide 'dead band' to be set which can result in substantial energy savings when used with domestic hot water systems. Ideal for greenhouse ventilation or heating control, aquaria, home brewing, etc. Mains powered, 10A SPCO relay output. Punched and printed case.

KIT 841.....£29.95

## 4 CHANNEL LIGHT CHASER

A 1000W per channel chaser with Zero Volt Switching, Hard Drive, and full inductive load capability. Built-in mic. and sophisticated 'Beat Seeker' circuit - chase steps to music, or auto when silent. Variable speed and mic. sensitivity control, i.e.d. mimic on front panel. Switchable for 3 or 4 channels. P552 output socket. Suits Rope Lights, Pin Spots, Disco, and Display lighting.

KIT 833.....£32.13

## SUPERHET LW MW RADIO

At last an easy to build SUPERHET AM radio kit. Covers Long and Medium waves. Built in loudspeaker with 1 Watt output. Excellent sensitivity and selectivity provided by ceramic IF filter. Simple alignment and tuning without special equipment. Supplied with pre-drilled transparent front panel and dial, for interesting see-through appearance.

KIT 835.....£17.16

## ACOUSTIC PROBE

A very popular project which picks up vibrations by means of a contact probe and passes them on to a pair of headphones or an amplifier. Sounds from engines, watches, and speech travelling through walls can be amplified and heard clearly. Useful for mechanics, instrument engineers, and nosy parkers!

KIT 740.....£19.98

## KIT HIGHLIGHT

### DIGITAL CAPACITANCE METER KIT 493

This has been one of Megenta's best ever kits. It provides clear readings of capacitance values from a few pF up to thousands of µF. It is ideal for beginners as there is no confusion over the placing of the decimal point, and it allows obscurely marked components to be identified quickly and easily. Quartz controlled accuracy of 1%, large clear 5 digit display and high speed operation make it a very useful instrument for production and testing departments. The kit is now supplied with a punched and printed front panel as well as the case, all components and top quality printed circuit board. When assembled it looks a really professional job. For a limited time this kit is offered at a new low price.



PRICE  
£39.95

### MOSFET VARIABLE BENCH POWER SUPPLY 25V 2.5A

Our own high performance design. Variable output Voltage from 0 to 25V and Current limit from 0 to 2.5A. Capable of powering almost anything. Two panel meters indicate Voltage and Current. Fully protected against short-circuits. The variable Current limit control makes this supply ideal for constant current charging of NICAD cells and batteries. A Power MOSFET handles the output for exceptional ruggedness and reliability. Uses a toroidal mains transformer.

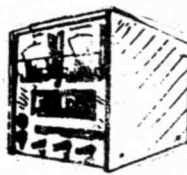

KIT 769.....£56.82

## ULTRASONIC PEST SCARER

Keep pets/pests away from newly sown areas, fruit, vegetable and flower beds, children's play areas, patios etc. This project produces intense pulses of ultrasound which deter visiting animals.



- KIT INCLUDES ALL COMPONENTS, PCB & CASE
- EFFICIENT 100V TRANSDUCER OUTPUT
- LOW CURRENT DRAIN

- COMPLETELY INAUDIBLE TO HUMANS
- UP TO 4 METRES RANGE

KIT Ref. 812.....£14.81

MAINS ADAPTOR.....£2.50

## IONISER

A highly efficient mains powered Negative Ion Generator that clears the air by neutralising excess positive ions. Many claimed health benefits due to the ioniser removing dust and pollen from the air and clearing smoke particles. Costs virtually nothing to run and is completely safe in operation. Uses five point emitters.

KIT 707.....£17.75

## BAT DETECTOR

An excellent circuit which reduces ultrasound frequencies between 20 and 100 kHz to the normal (human) audible range. Operating rather like a radio receiver the circuit allows the listener to tune-in to the ultrasonic frequencies of interest. Listening to Bats is fascinating, and it is possible to identify various different types using this project. Other uses have been found in industry for vibration monitoring etc.

KIT 814.....£21.44

## 12V EPROM ERASER

A safe low cost eraser for up to 4 EPROMS at a time in less than 20 minutes. Operates from a 12V supply (400mA). Used extensively for mobile work - updating equipment in the field etc. Also in educational situations where mains supplies are not allowed. Safety interlock prevents contact with UV.

KIT 790.....£28.51

## EE TREASURE HUNTER

Our own widely acclaimed design. This sensitive Pulse Induction metal detector picks up coins and rings etc up to 20cm deep. Negligible 'ground effect' means that the detector can even be used with the head immersed in sea water. Easy to use, circuit requires only a minimum of setting up as a Quartz crystal provides all of the critical timing. Kit includes search-head, handle, case, PCB and all components.

KIT 815.....£45.95

## INSULATION TESTER

A reliable and neat electronic tester which checks insulation resistance of wiring and appliances etc., at 500 Volts. The unit is battery powered, simple and safe to operate. Leakage resistance of up to 100 Megohms can be read easily. A very popular college project.

KIT 444.....£22.37

## 3 BAND SHORT WAVE RADIO

Covers 1.6 to 30MHz in three bands using modern miniature plug-in coils. Audio output is via a built-in loudspeaker. Advanced stable design gives excellent stability, sensitivity and selectivity. Simple to build battery powered circuit. Receives a vast number of stations at all times of the day.

KIT 718.....£30.30

## DIGITAL COMBINATION LOCK

Digital lock with 12 key keypad. Entering a four digit code operates a 250V 16A relay. A special anti-tamper circuit permits the relay board to be mounted remotely. Ideal car immobiliser, operates from 12V. Drilled case, brushed aluminium keypad.

KIT 840.....£19.86

## PORTABLE ULTRASONIC PEST SCARER

A powerful 23kHz ultrasound generator in a compact hand-held case. MOSFET output drives a special sealed transducer with intense pulses via a special tuned transformer. Sweeping frequency output is designed to give maximum output without any special setting up.

KIT 842.....£22.56

## LIGHT RIDER DISCO LIGHTS

A six channel light driver that scans from left to right and back continuously. Variable speed control. Up to 500 watts per channel. Housed in a plastic box for complete safety. Built on a single printed circuit board.

KIT 560.....£22.41

## LIGHT RIDER 9-12V CHASER LIGHTS

A low voltage DC powered end-to-end type chaser that can be set for any number of lights between 3 and 16. The kit is supplied with 16 I.e.d.s but by adding power transistors it is possible to drive filament bulbs for a larger brighter display. Very popular with car customisers and modellers. I.e.d.s can be randomly positioned and paired to give twinkling effects.

KIT 559.....£15.58

**SEE OUR FULL RANGE OF KITS, BOOKS, TOOLS, AND COMPONENTS IN OUR CATALOGUE**

## HAMEG HM203-7 20 MHz DUAL TRACE OSCILLOSCOPE & COMPONENT TESTER

Western Europe's best selling oscilloscope - It is RELIABLE, HIGH PERFORMANCE, & EASY TO USE. Sharp bright display on 8 x 10cm screen with internal graticule. A special extra feature is the built-in component tester which allows capacitors, resistors, transistors, diodes and many other components to be checked. The quality of this instrument is outstanding, and is supported by a two year parts and labour warranty. If you are buying an oscilloscope - this is the one. - It costs a fraction more than some other 20 MHz scopes but it is far superior. Supplied with test probes, mains lead, and manual.

£338.00 + £59.15 VAT Includes FREE Next-day delivery

## EDUCATIONAL BOOKS & PACKS

### ADVENTURES WITH ELECTRONICS

The classic book by Tom Duncan used throughout schools. Very well illustrated, ideal first book for age 10 on. No soldering. Uses an S.DEC breadboard.

Book & Components £28.95, Book only £6.25

### FUN WITH ELECTRONICS

An Osborne book, wonderfully illustrated in colour. Component pack allows 6 projects to be built and kept. Soldering is necessary. Age 12 on, or younger with adult help.

Book & Components £20.88, Book only £2.95

### 30 SOLDERLESS BREADBOARD PROJECTS

A more advanced book to follow the others. No soldering. Circuits cover a wide range of interests.

Book & Components £30.69, Book only £2.95

## DC MOTOR/GEARBOXES

Ideal for robots, buggies, and many other mechanical projects. Min. plastic gearbox with 1.5-4.5V DC motor. 6 ratios can be set up.

Small type MGS.....£4.77  
Large type MGL.....£5.58

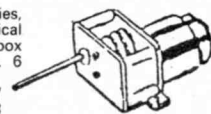

## STEPPING MOTORS

For computer control via standard 4 pole unipolar drivers.

MD38 - miniature 48 steps per rev.....£9.15  
MD35 1/4 - standard 48 steps per rev.....£12.99  
MD200 - miniature 200 steps per rev.....£17.10



# Teach-In '93

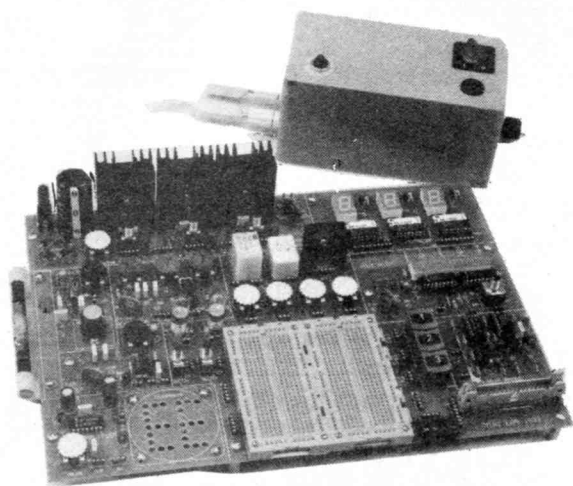

## MINI LAB KITS

ALL COMPONENTS TO ASSEMBLE THE EPE MINI LAB ARE AVAILABLE FROM MAGENTA.

The easy way to buy the correct parts to follow this exciting new educational series.

Components are supplied in packs to keep ordering simple.

A full MINI LAB consists of ML1, ML3, ML5, ML6. These are available at a special combined price of.....**£114.99**  
or less the p.c.b.

ML2, ML3, ML5, ML6 at.....**£104.99**

The transformer unit ML4 is also needed....**£21.45**

- |         |   |               |
|---------|---|---------------|
| KIT ML1 | MINI-LAB P.C.B. + all components inclusive of breadboard for Part 1 (Nov. '92)..... | <b>£49.95</b> |
| KIT ML2 | All Components for Part 1 less p.c.b.....   | <b>£39.95</b> |
| KIT ML3 | Power Supply components.....  | <b>£19.95</b> |
| KIT ML4 | Transformer unit.....   | <b>£21.45</b> |
| KIT ML5 | L.E.D. Voltmeter, signal generator, audio amplifier and 555 timer.....              | <b>£33.95</b> |
| KIT ML6 | Logic probe, display, radio tuner.....  | <b>£17.95</b> |

(Note: batteries not included)

All prices include V.A.T. Add **£2.00** p&p.

Tel: 0283 65435 Fax: 0283 46932

# Teach-In '93

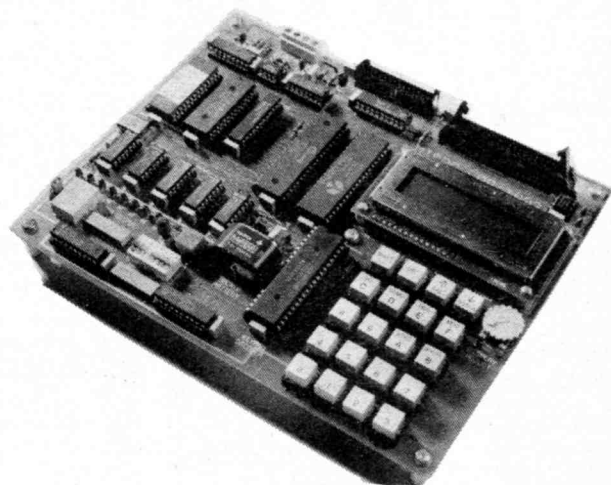

## MICRO LAB KITS

ALL COMPONENTS TO ASSEMBLE THE EPE MICRO LAB ARE AVAILABLE FROM MAGENTA.

Be sure that you have all the correct parts for the MICRO LAB.

Repair/fault-finding help assured when you buy your kit from us.

Full MICRO LAB kit including PC Board, EPROM, PAL, & Booklet

MIC 1 .....**£149.95**

(Also available less PCB etc. if required).

## BUILT & TESTED

Full MICRO LAB AS MIC1 (above) MIC1B.....**£179.95**

Professionally assembled, inspected, cleaned and tested. Full back-up service, spares, etc available.

All prices include V.A.T. Add **£2.00** p&p.

Tel: 0283 65435 Fax: 0283 46932



ESR ELECTRONIC COMPONENTS

Station Road, Cullercoats, Tyne & Wear NE30 4PQ

Tel. 091 251 4363

Fax. 091 252 2296

74LS-Series

Table with 2 columns: Part Number, Price. Lists various 74LS series components like 74LS00, 74LS01, etc.

4000 Series

Table with 2 columns: Part Number, Price. Lists various 4000 series components like 4000, 4001, etc.

TRANSISTORS

Table with 4 columns: Part Number, Price, Part Number, Price. Lists various transistor models like 2N1613, BC107, etc.

DIODES

Table with 4 columns: Part Number, Price, Part Number, Price. Lists various diode models like 1N4148, 1N914, etc.

LINEAR ICs

Table with 4 columns: Part Number, Price, Part Number, Price. Lists various linear IC models like CA311E, LM741, etc.

SOLDERING IRONS

Table with 2 columns: Item, Price. Lists soldering irons like Antex Soldering Irons, M12 Watt, etc.

RF CONNECTORS

Table with 2 columns: Item, Price. Lists RF connectors like BNC Solder Plug 50R, etc.

PCB EQUIPMENT

Table with 2 columns: Item, Price. Lists PCB equipment like UV EXPOSURE UNIT, PLASTIC DEVELOPING TRAY, etc.

BREADBOARD

Table with 2 columns: Item, Price. Lists breadboard models like 64mm x 25mm, 64mm x 95mm, etc.

COPPER BOARD

Table with 2 columns: Item, Price. Lists copper board models like 100mm x 160mm, 110mm x 220mm, etc.

ENAMELLED COPPER WIRE

Table with 2 columns: Gauge, Price. Lists wire gauges like All 2oz Reels, 14 SWG, etc.

OPTO DEVICES

Table with 2 columns: Item, Price. Lists opto devices like 5mm Red LED, 5mm Yellow LED, etc.

TRIACS

Table with 2 columns: Part Number, Price. Lists triac models like Z0105DA, TIC206D, etc.

THYRISTORS

Table with 2 columns: Part Number, Price. Lists thyristor models like P1020AA, TIC206D, etc.

HARDWARE

Table with 2 columns: Item, Price. Lists hardware items like T2 Box 75 x 56 x 25mm, T3 Box 75 x 51 x 25mm, etc.

ELECTROLYTIC RADIAL CAPACITORS

Table with 4 columns: Voltage, Price, Voltage, Price. Lists electrolytic capacitor values like 0.47, 1.0, 2.2, etc.

ELECTROLYTIC AXIAL CAPACITORS

Table with 4 columns: Voltage, Price, Voltage, Price. Lists electrolytic capacitor values like 0.47, 1.0, 2.2, etc.

COMPUTER ACCESSORIES

Table with 2 columns: Item, Price. Lists computer accessories like Parallel Printer Lead 2m, RS232 Lead, etc.

DIODES

Table with 2 columns: Item, Price. Lists diode models like Zener Diodes 2V7-33V, BZY88400M, etc.

ORDERING INFORMATION

All prices exclude VAT. Please add £1.25 carriage to all orders and VAT (1.75%). No minimum order charge. Please send payment with your order.

CALL IN - OPEN: MON-FRI 8.30-5.00 SAT 10.00-5.00



# EVERYDAY WITH PRACTICAL ELECTRONICS

INCORPORATING ELECTRONICS MONTHLY

**Editorial Offices:**  
EVERYDAY with PRACTICAL ELECTRONICS EDITORIAL,  
6 CHURCH STREET, WIMBORNE,  
DORSET BH21 1JH  
Phone: Wimborne (0202) 881749  
Fax: (0202) 841692. DX: Wimborne 45314.  
See notes on **Readers' Enquiries** below – we regret that lengthy technical enquiries cannot be answered over the telephone.

**Advertisement Offices:**  
EVERYDAY with PRACTICAL ELECTRONICS  
ADVERTISEMENTS,  
HOLLAND WOOD HOUSE, CHURCH LANE,  
GREAT HOLLAND, ESSEX CO13 0JS.  
Phone/Fax: (0255) 850596

**VOL. 22 No. 10                      OCTOBER '93**

## FREE

This issue sees the start of our annual autumn promotion period. This year there will be a number of free catalogues plus a free cover-mounted gift which we are working on now. Regular readers will know that we are often able to include catalogues with the issue and these are always well received. They often represent excellent reference material and even if you don't need anything immediately they are well worth hanging on to for future reference.

We expect to give away three catalogues over the next few months so make sure you don't miss out. – Place an order with your *Newsagent Now!*

## SOFTWARE

Next month also marks a new step for EPE, we will be marketing some software designed to help teach *Electronics Principles*. The software has been written and developed by E.P.T. Educational Software and Mike Tooley has produced a Special Supplement on the product which will also be included in next month's issue.

A special demonstration disc will be available at minimal cost to readers so that everyone can sample the package for themselves. When Mike reviewed the software for us he made the following comments:

"Having reviewed a dozen, or more, educational software packages designed to 'teach' electronics, I was more than a little sceptical when I first heard about *Electronics Principles*; there seemed to be little that could be done that has not been done elsewhere.

"When I started to use the package my views changed. Indeed, I was so impressed with it that I quickly came to the conclusion that *Everyday with Practical Electronics* readers should have an opportunity to try the package for themselves."

The full package has over 200 menu driven screens with interactive graphics, enabling a "learning by doing" approach. We believe it will be enthusiastically received by everyone involved in teaching and learning electronics. The addition of this software is an important enhancement to the range of books and videos available through our *Direct Book Service*.

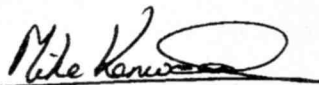

## SUBSCRIPTIONS

Annual subscriptions for delivery direct to any address in the UK: £22. Overseas: £28 (£45.50 airmail). Cheques or bank drafts (in £ sterling only) payable to Everyday with Practical Electronics and sent to EPE Subscriptions Dept., 6 Church Street, Wimborne, Dorset BH21 1JH. Tel: 0202 881749. **Subscriptions start with the next available issue.** We accept Access (MasterCard) or Visa payments, minimum credit card order £5.

## BACK ISSUES

Certain back issues of EVERYDAY ELECTRONICS, PRACTICAL ELECTRONICS and EVERYDAY with PRACTICAL ELECTRONICS (from Nov '92 onwards) are available price £2.00 (£2.50 overseas surface mail) inclusive of postage and packing per copy – **£ sterling only please.** Visa and Access (MasterCard) accepted, minimum credit card order £5. Enquiries with remittance, made payable to Everyday with Practical Electronics, should be sent to Post Sales Department, Everyday with Practical Electronics, 6 Church Street, Wimborne, Dorset BH21 1JH Tel: 0202 881749. In the event of non-availability one article can be photostatted for the same price. *Normally sent within seven days but please allow 28 days for delivery.* **We have sold out of Jan, Feb, Mar, Apr, May, June, Oct, & Dec 88, Mar, May & Nov 89, Mar 90, April, Aug & Sept 91** Everyday Electronics, and can only supply back issues from Jan 92 to Sept 92 (excluding Mar 92) of Practical Electronics. Dec 92, Jan 93 and Feb 93 Everyday with Practical Electronics are also unavailable.

## BINDERS

New style binders to hold one volume (12 issues) are now available from the above address for £4.95 plus £3.50 post and packing (for overseas readers the postage is £6.00 to everywhere except Australia and Papua New Guinea which cost £10.50). *Normally sent within seven days but please allow 28 days for delivery.*

**Payment in £ sterling only please.** Visa and Access (MasterCard) accepted, minimum credit card order £5. Send card number and card expiry date with your name and address etc.

**Editor:** MIKE KENWARD

**Secretary:** PAM BROWN

**Deputy Editor:** DAVID BARRINGTON

**Business Manager:** DAVID J. LEAVER

**Subscriptions:** MARILYN GOLDBERG

**Editorial:** Wimborne (0202) 881749

**Advertisement Manager:**  
PETER J. MEW, Frinton (0255) 850596

**Advertisement Copy Controller:**  
DEREK NEW, Wimborne (0202) 882299

## READERS' ENQUIRIES

We are unable to offer any advice on the use, purchase, repair or modification of commercial equipment or the incorporation or modification of designs published in the magazine. We regret that we cannot provide data or answer queries on articles or projects that are more than five years old. Letters requiring a personal reply must be accompanied by a **stamped self-addressed envelope** or a **self addressed envelope and international reply coupons.**

All reasonable precautions are taken to ensure that the advice and data given to readers is reliable. We cannot however guarantee it and we cannot accept legal responsibility for it.

## COMPONENT SUPPLIES

**We do not supply electronic components or kits** for building the projects featured, these can be supplied by advertisers.

We advise readers to check that all parts are still available before commencing any project in a back-dated issue.

**We regret that we cannot provide data or answer queries on projects that are more than five years old.**

## ADVERTISEMENTS

Although the proprietors and staff of EVERYDAY with PRACTICAL ELECTRONICS take reasonable precautions to protect the interests of readers by ensuring as far as practicable that advertisements are *bona fide*, the magazine and its Publishers cannot give any undertakings in respect of statements or claims made by advertisers, whether these advertisements are printed as part of the magazine, or are in the form of inserts.

The Publishers regret that under no circumstances will the magazine accept liability for non-receipt of goods ordered, or for late delivery, or for faults in manufacture. Legal remedies are available in respect of some of these circumstances, and readers who have complaints should first address them to the advertiser.

## TRANSMITTERS/BUGS/TELEPHONE EQUIPMENT

We would like to advise readers that certain items of radio transmitting and telephone equipment which may be advertised in our pages cannot be legally used in the UK. Readers should check the law before using any transmitting or telephone equipment as a fine, confiscation of equipment and/or imprisonment can result from illegal use. The laws vary from country to country; overseas readers should check local laws.

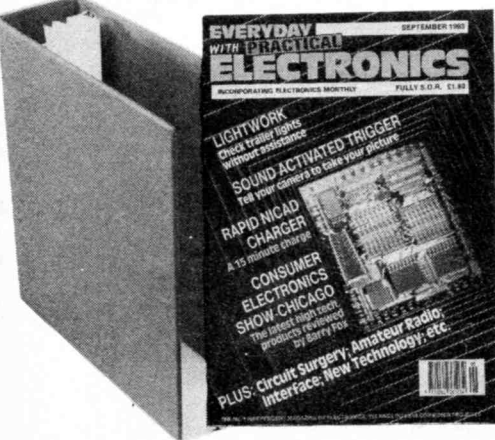

# MULTI-PURPOSE AUDIO SYSTEM

## Part 1 - SIX-CHANNEL, LOW NOISE STEREO MIXER



**MAX HORSEY** P.C.B. Design **PHILIP CLAYTON**

*If you want to set up a home recording system, mix sound videos, run a disco or a small band then these modules are for you! All modules will operate alone, but are compatible with each other.*

**T**HIS short series features a number of audio modules which will enable the constructor to produce a tailor made system. All the modules will operate alone, but are compatible with each other, and are designed to run on 12V d.c.

The system block diagram is shown in Fig. 1 and includes the following modules:

- Module 1: 6-Channel, Low Noise Stereo Mixer
- Module 2: RIAA Stereo Pre-Amp (for Record Decks)
- Module 3: Microphone Pre-Amp
- Module 4: Bass/Treble/Volume/Balance Control Unit
- Module 5: One watt Stereo Amplifier
- Module 6: 10 + 10 Watt Amplifier and P.S.U.

Note: The main mixer p.c.b. includes two Module 2's and two Module 3's. Separate p.c.b. layouts are also included for Modules 2 and 3 (next month).

Having now settled on our preferred line-up, we shall start by describing the 6-Channel Stereo Mixer module, followed

by Modules 4 and 5 and finally the 10 + 10 Amplifier - Module 6. Being the "brain" of the system - accepting incoming signals, analysing, mixing and generally directing them to their designated "location" - the introduction and description is naturally fairly lengthy (and will be spread over two issues).

### OVERVIEW

A stereo six channel mixer - i.e. 12 channels in all - provides many possibilities and the proposed system, as shown in Fig. 2, comprises.

- Channel 1:- AUX or MICrophone 1
- Channel 2:- AUX or MICrophone 2
- Channel 3:- AUX or PHONO 1
- Channel 4:- AUX or PHONO 2
- Channel 5:- AUXiliary 1
- Channel 6:- AUXiliary 2

### CHOICES

The size of the final printed circuit board (p.c.b.) is determined by the layout of the slider potentiometers. It seemed wise

therefore to include the microphone pre-amplifiers and the RIAA pre-amplifiers on the same board.

If these are not required a simple wire link can be inserted to bypass that section of the p.c.b. Also, separate microphone and RIAA pre-amp p.c.b. layouts are provided in case the constructor wishes to include six microphone inputs or six phono inputs or any other combination.

### MICROPHONE INPUTS

Since all inputs are stereo, the microphone inputs can be "joined" by means of switch S1 (and S2) to connect the left and right inputs together, see Fig. 2, enabling an ordinary microphone to mix into both left and right channels at the same time. If a stereo pair of microphones is required they could be connected to the right and left inputs of say Channel 1. Note that the left and right channels are controlled by a single slider; if independent control is required the left microphone could be connected to Channel 1 and the right microphone to Channel 2.

If full independent control of four microphones is required a variable resistor (potentiometer) could be fitted to one or both channels of each microphone pre-amp. This is described in the relevant section.

The microphone inputs, Fig. 2, are amplified before being fed to slider control VR1 (and VR2). Switches S3 and S4 may be used to bypass the microphone pre-amps if devices such as CD players or tape recorders are used with Channel 1 and/or Channel 2.

### PHONO INPUTS

"Phono" is a term used to imply that the input is suitable for use with a magnetic cartridge - as fitted to most good quality record decks. The term should not be confused with the type of connector known as a "phono" plug or socket.

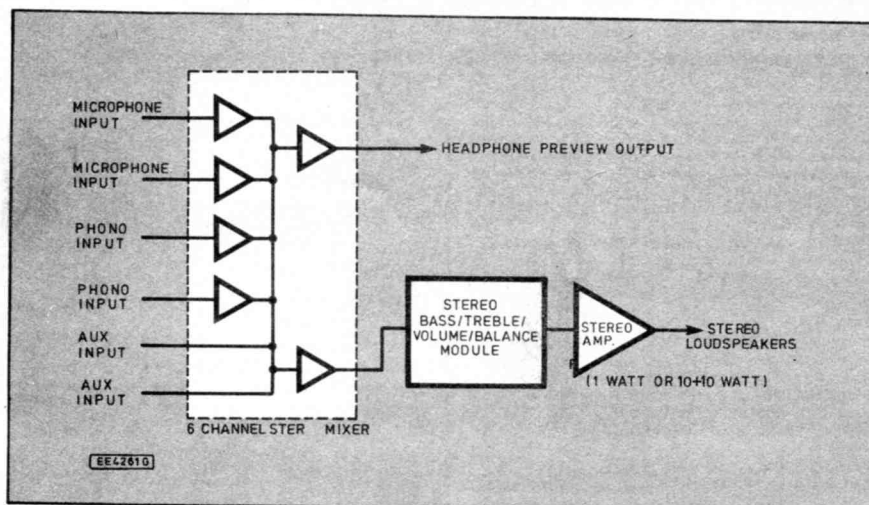

Fig. 1. Block diagram of the Multi-Purpose Audio System.



The phono or gramophone input requires amplification and frequency correction. The type of correction required is known as *RIAA* equalisation, and is described fully later.

Like the microphone pre-amps, the *RIAA* pre-amps can be bypassed by means of switches S5 and S6 to enable Channel 3 and/or Channel 4 to be connected to devices other than record decks.

## AUX(AUXILIARY) INPUTS

Channel 5 and Channel 6, the *AUX* inputs, can only be used with equipment which does not require a pre-amp or frequency correction. Such equipment includes CD players, tape decks, tuners and video recorders.

There is no reason why external microphone pre-amps or *RIAA* pre-amps could not be connected to Channel 5 and/or Channel 6. It is also a fairly simple matter to convert a *RIAA* pre-amp to a microphone pre-amp, and this is described in the *RIAA* pre-amp section.

## SLIDER/SWITCH CONTROLS

Potentiometers VR1 to VR6 are stereo "slide"/"fader" controls which enable the various sound inputs to be mixed at suitable levels. Switches S8, S10, S12, S14, S16 and S18 enable the inputs to be connected to the main mixer.

The odd number switches S7 to S17 allow the inputs to be monitored and/or previewed on headphones, via the headphone mixer. These switches are two way "centre off" types which allow monitoring at full volume or via the faders.

## MAIN MIXER

The main mixer circuit and the headphone preview mixer are identical although for convenience in the p.c.b. design, different pins of the i.c. are used for the left and right channels. The circuit diagrams for audio mixer and headphone preview mixer are shown in Fig. 5 and Fig. 6 respectively.

The main mixer is based on an i.c. type

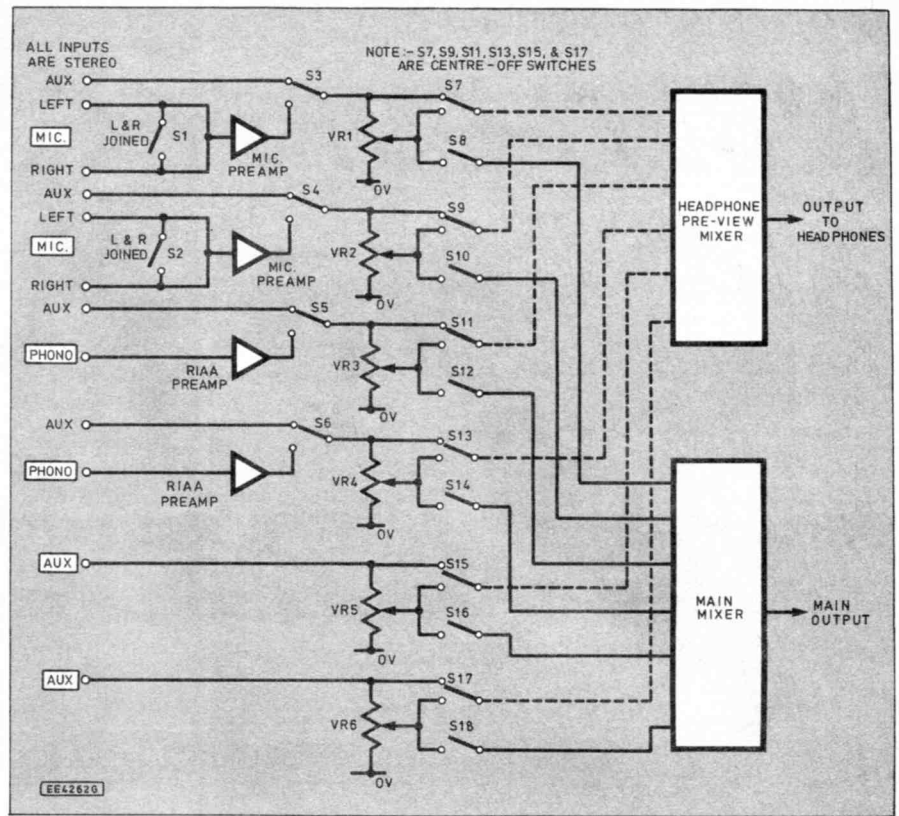

Fig. 2. Block diagram for the 6-Channel Stereo Mixer. Note: All lines, switches etc are stereo pairs.

NE5532. This chip includes two ultra low noise op-amps, which allow a simple yet effective high quality sound mixer to be realised. The mixer circuit is designed for a single rail supply (i.e. a normal 9V or 12V battery or power unit), and provides a gain of unity (i.e. the output is equal in magnitude to the input).

The printed circuit board allows up to six stereo channels (i.e. 12 channels in all). The constructor need only build the channels required - most of the cost of each channel being the slider potentiometer and switches.

## INPUT CONTROLS

The sound input level controls (VR1 to VR6), Fig. 2, are the most obvious part of any mixer unit, and sliders were chosen since they provide the more professional finish, and visual comparisons between sound levels are more obvious than with rotary controls. However, sliders are more expensive and more difficult to mount in a case. The complexity of wiring up stereo sliders, and the availability of miniature types pointed toward their inclusion on the p.c.b. design.

The System - Six Channel Stereo Mixer (left), Tone Control/1W Amp (centre) and 10+10 Amplifier Modules. Separate Microphone and Phono p.c.b.s are shown in the foreground.

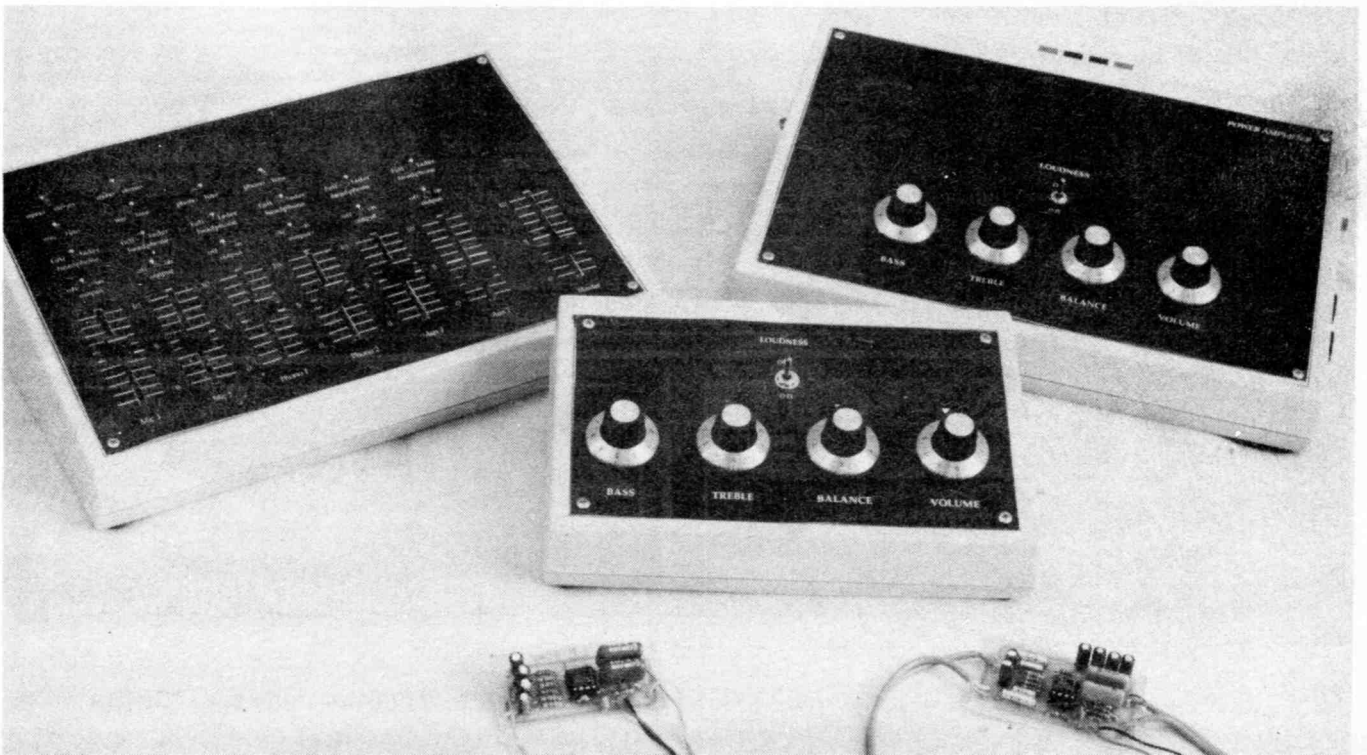

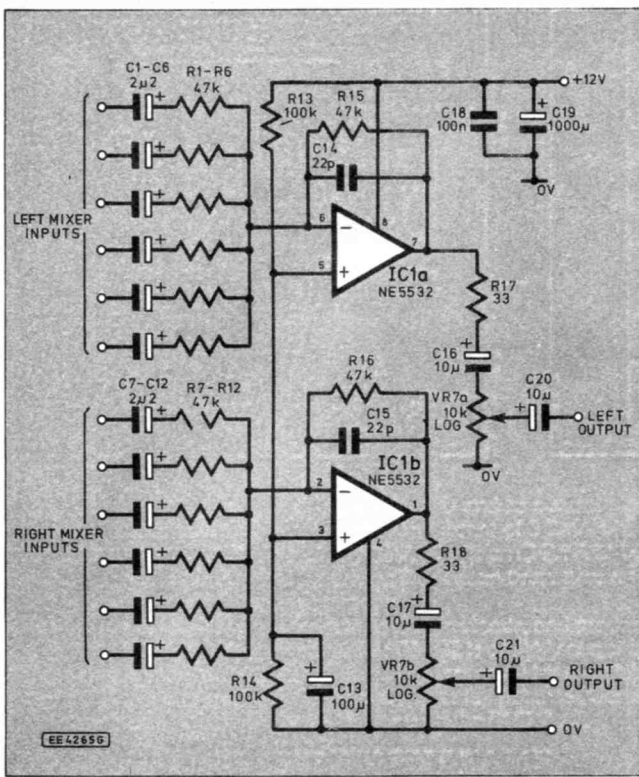

Fig. 5. Circuit diagram for the Main Mixer.

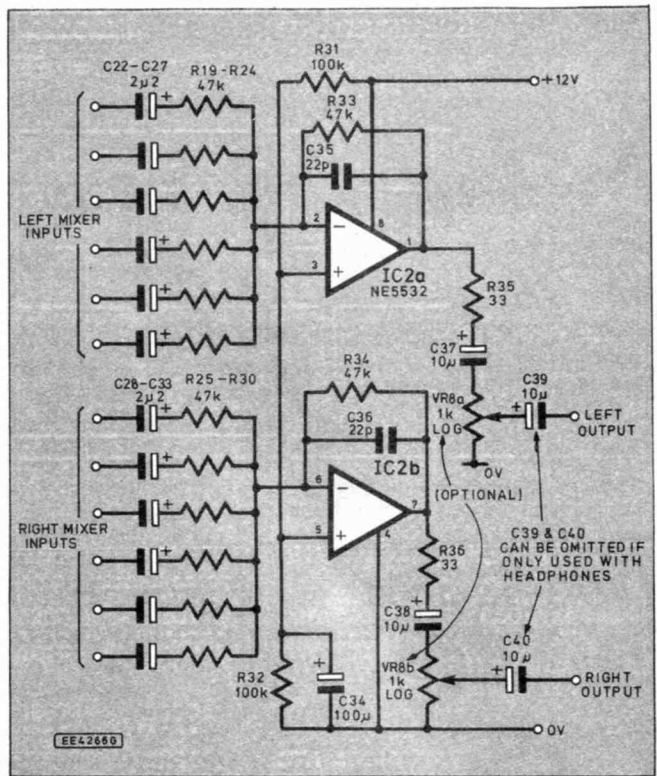

Fig. 6. Headphone Preview Mixer circuit diagram.

Pin 8 and pin 4 are the power supply pins, and capacitor C19 decouples the supply, providing a smooth d.c. supply for all the modules in the project. Capacitor C18 removes any voltage spikes on the supply in the vicinity of IC1. Since the two stereo halves IC1a and IC1b are identical, only the left channel will be described.

The non-inverting input (pin 5) is held at half the supply voltage (i.e. 6V) by the potential divider formed by resistors R13 and R14. Output pin 7 will also assume 6V since it is connected to inverting input pin 6 via R15. Pin 6 is also held at 6V, since any change in the d.c. level at the output will feed back to the inverting input and be self cancelling.

## INPUT IMPEDANCE

The a.c. audio signal is applied to inverting input pin 6 via capacitor C1 (or C2 etc.) and resistor R1 (or R2 etc). The input capacitors are required to prevent the flow of d.c. away from pin 6 (which remember is at 6V) to ground via the input potentiometer VR1 (Fig. 2).

The inverting input pin 6 acts as "ground" as far as audio a.c. signals are concerned, and therefore the effective input impedance at this stage is the value of resistor R1. Since pin 6 acts as an a.c. ground, no a.c. signals can flow back through any of the other input resistors (i.e. R2-R6). This ensures that the various input sources (CD player, tape deck etc) are truly independent.

## GAIN

The gain of the circuit for Left Channel 1 is given by  $R15/R1$ , i.e. unity. Note that the output will be out of phase with the input. Capacitor C14 is required to remove any very high frequencies which may cause unwanted oscillations.

## OUTPUT

The output from pin 7 is fed via a 33ohm resistor (R17), which protects the output if it is accidentally shorted to ground. Capacitor C16 prevents the flow of d.c. from the output of the i.c. to 0V, but allows the a.c. audio signal through to the Master fader (VR7a) control.

The master fader is a dual (i.e. stereo) slider potentiometer identical to the other slider potentiometer. No balance control is provided since this is included within the tone control module (a separate article).

## HEADPHONE PREVIEW MIXER

The circuit diagram for the Stereo Headphone Preview Mixer stages is shown in Fig. 6. Note that for the left hand channel, pins 1, 2, and 3 of the i.c. are used instead of pins 5, 6 and 7. This aided the p.c.b. design. Otherwise the headphone mixer is identical to the main mixer except that the output capacitors C39 and C40 (in the main mixer) are not required in the headphone mixer.

The headphone Volume control VR8 (if required) is a one kilohm "log". dual rotary potentiometer. Note that C39, C40 and VR8 are not included on the p.c.b. since the capacitors are unlikely to be required, and VR8 may be mounted at the side of the case.

Rear view of the mixer console showing the layout of the input and output sockets.





## STEREO MICROPHONE PRE-AMP

The Stereo Microphone Pre-Amplifier is based on the NE5532 i.c. as used in the mixer. The basic principal of operation is shown in Fig. 7 and the circuit diagram in Fig. 8. The component references in brackets in Fig. 8 refer to the second microphone preamplifier (MIC 2).

This time the op.amp is used in its non-inverting mode, where the input is connected to the non-inverting input (see Fig. 7), and the output is in phase with the input. The reason for this arrangement is that the gain can be quite high, without reducing the input impedance of the circuit. The input impedance and gain are described below; note how (unlike the previous inverting circuit) the two are not related.

### CIRCUIT DESCRIPTION

One half of the circuit (Fig. 8) will be described, the other stereo half being identical. As with the mixer, this circuit is designed to operate on a single 12V supply, and it is necessary to hold the input and output at half the supply voltage (i.e. 6V) in order to accommodate the a.c. audio signal.

The non-inverting input pin 3 is held at 6V by the potential divider formed by resistors R37 and R38. The output pin 1 also remains at 6V since it is connected to inverting input pin 2, via resistor R41. Any change of d.c. level at the output will tend to self cancel.

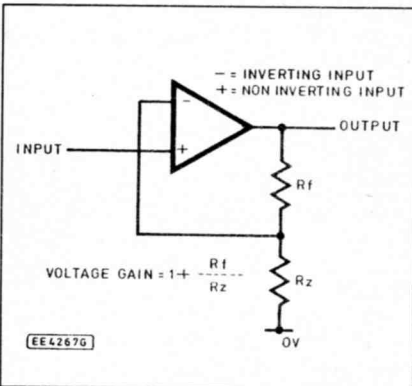

Fig. 7. Op.amp in non-inverting mode.

### INPUT IMPEDANCE

Having set the d.c. levels, the a.c. audio signal input is supplied via d.c. blocking capacitor C41 to pin 3. The effective input impedance of the circuit is determined by the resistance to a.c. between the input and ground.

As far as audio frequencies are concerned, the two supply rails both act as grounds and the input impedance is therefore given by resistors

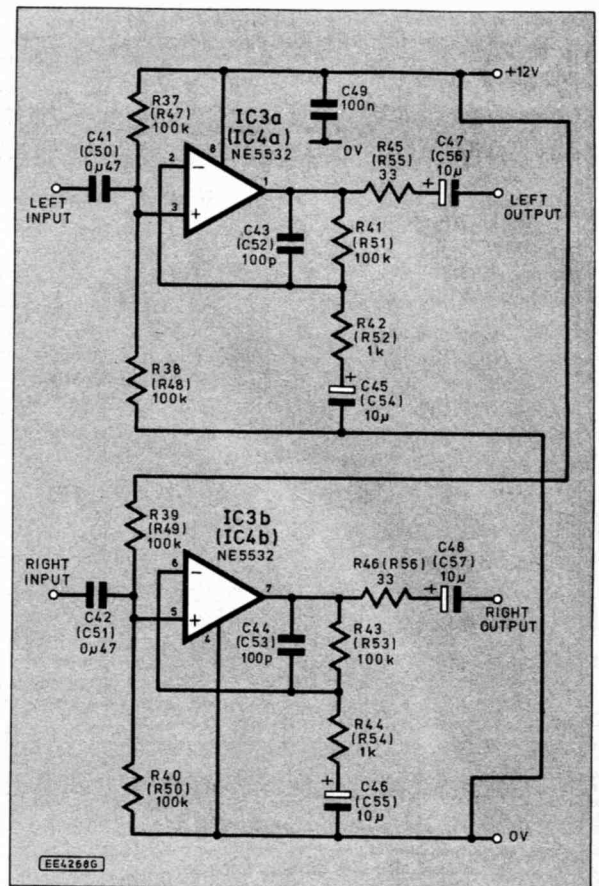

Fig. 8. Stereo Mic Pre-Amp circuit.

R37 and R38 as if in parallel, i.e. 50 kilohm. This may seem high considering that microphones are generally rated at a few hundred ohms, but a good microphone pre-amp should not drain much current from the microphone and a high input impedance is therefore wise, if not essential.

### GAIN

The gain of the pre-amp (see Fig. 7) is given by:  $1 + R41/R42$ , i.e.  $1 + 100k/1k = 101$ . Capacitor C45 plays no part in this equation since all audio frequencies will pass through C45 as if resistor R42 was connected directly to ground. However, C45 blocks the flow of d.c. ensuring that pin 2 is effectively tied to pin 1 as far as d.c. is concerned, thus maintaining the average d.c. level of 6V. Capacitor C43 provides a low impedance path for very high frequencies, thus eliminating unwanted interference.

Individual constructors may wish to change the gain to suit their particular microphones. The gain may be increased by increasing the value of resistor R41 (and R43), or reduced by reducing the value of these resistors the result being based on the formula above. Alternatively, variable gain controls may be provided by means of potentiometers of say 100 kilohm or 250 kilohm in place of R41 (and R43), but keep the wires short (or screened), and remember that the gain cannot be reduced to zero; in other words the "pots" will not act like normal volume controls.

### OUTPUT

Resistor R45 prevents any damage which might occur if the output was shorted to ground, and capacitor C47 blocks the flow of d.c. into the next stage of the project – in this case the potentiometer which controls the mixed input level. Capacitor C49 removes any short spikes on the supply in the vicinity of the i.c.

## CUTTING CORNERS APPLIES TO ALL SECTIONS OF THE MIXER

IT MAY have occurred to some readers that some circuitry could be saved by mixing the inputs before the microphone pre-amp or RIAA stages. For example, if a six (stereo) channel microphone mixer was required, the saving in circuitry could be considerable.

However, be warned! Mixing is best done with "line level" signals, not the tiny signals from microphones or magnetic cartridges. Potentiometers tend to produce noise (i.e. random voltages) and this will seriously reduce the quality of sound from the mixer. If the cost of the electronic components is compared with the cost of the case and slider controls, the savings made in this way are not worth the loss in quality which would result.

### BEFORE BUYING THE PARTS

It is important to have a clear idea of exactly what is required from the mixer before buying the parts. A second glance at the "System Options" panel will help clarify the system required. Remember that the p.c.b. provides six stereo channels (although less could be built if preferred), and two channels are designed for Microphone or "Aux." inputs, and two channels are designed for Phono or "Aux." inputs.

If you require six "auxiliary" inputs, none of the pre-amps need be built, and switches S3 to S6 could be replaced by pairs of wire links inserted to bridge each centre switch pad to each left-hand switch pad viewed from the component side. The "line input" pads will then be permanently connected to the slider control.

If you require three or four stereo microphone inputs, and no phono inputs, the RIAA pre-amps can be converted to microphone pre-amps by replacing resistors R66 and R68 by wire links, fitting 100pF capacitors for C64 and C66, and omitting C65 and C67. Resistors R65 and R67 could be substituted by 100 kilohm types to match the gain of the other microphone pre-amp circuits.

The switches represent a significant part of the cost of the project, but switches S7 to S18 are necessary if you wish to preview sounds before including them in the final mix. If such previewing is not required, all these switches and the headphone preview mixer can be omitted. In this case, the even numbered switches S8 to S18 must each be replaced by a pair of wire links inserted sideways to link the pads not already joined together by copper tracks.

If all the switches are required it is worth shopping around for low cost versions. Threaded types tend to be more expensive, but have long levers. However, non-threaded types allow the front panel of the case to be seated a little lower, and fairly low cost plastic body versions are available. P.C.B. pads are provided for 2-way switches. Cheaper on/off switches may be used in many cases, as described in "System Options".

## 6-CHANNEL STEREO MIXER SYSTEM

### MAIN MIXER

#### Resistors

R1 to R12, R15, R16  
R13, R14  
R17, R18  
All 0.25W 5% carbon film

47k (14 off)  
100k (2 off)  
33 (2 off)

#### Potentiometers

VR1 to VR7

10k min. dual (stereo) slider carbon, log. (7 off)  
(p.c.b. mounting type, with metal body)

#### Capacitors

C1 to C12  
C13  
C14, C15  
C16, C17, C20, C21  
C18  
C19

2 $\mu$ 2 radial elect. (12 off)  
100 $\mu$  radial elect.  
22p ceramic (2 off)  
10 $\mu$  radial elect. (4 off)  
0 $\mu$ 1 disc ceramic  
1000 $\mu$  axial elect.

#### Semiconductors

IC1

NE5532 dual low noise op.amp

#### Miscellaneous

S1, S2  
S3 to S6  
S8, S10, S12, S14, S16, S18  
S19

S.P.D.T. p.c.b. mounting toggle switch (2 off)  
D.P.D.T. p.c.b. mounting toggle switch (4 off)  
D.P.D.T. p.c.b. mounting toggle switch (6 off)  
On/Off supply toggle switch

### HEADPHONE MIXER

#### Resistors

R19 to R30, R33, R34  
R31, R32  
R35, R36

47k (14 off)  
100k (2 off)  
33 (2 off)

#### Potentiometers

VR8

1k dual (stereo) rotary carbon, log. (optional)

#### Capacitors

C22 to C23  
C34  
C35, C36  
C37, C38, C39, C40

2 $\mu$ 2 radial elect. (12 off)  
100 $\mu$  radial elect.  
22p ceramic (2 off)  
10 $\mu$  radial elect. (4 off)  
(C39, C40 not required for headphone application)

#### Semiconductors

IC2

NE5532 dual low noise op.amp

#### Miscellaneous

S7, S9, S11, S13, S15, S17

D.P.D.T. centre off p.c.b. mounting toggle switch (6 off)

*The items below are required only for the Main Mixer, apart from where indicated.*

Printed circuit board available from the *EPE PCB Service*, code 845. 8-pin d.i.l. socket (also required for Headphone Mixer); knobs for slider "pots" (6 off); 1/4in. mono chassis jack sockets (4 off); phono chassis sockets (18 off); 1/4in. stereo chassis jack socket (Headphone Mixer only); chassis power input socket (2 off); console case (see *Shoptalk*); M3 nuts, bolts and spacers; connecting cable; solder, etc.

## STEREO MICROPHONE PRE-AMP

### MIC 1

#### Resistors

R37 to R41, R43  
R42, R44  
R45, R46  
All 0.25W 5% carbon film

100k (6 off)  
1k (2 off)  
33 (2 off)

#### Capacitors

C41, C42 0 $\mu$ 47 polyester film, 100V  
(2 off)  
C43, C44 100p ceramic (2 off)  
C45, C46,  
C47, C48 0 $\mu$ F radial elect. (4 off)  
C49 0 $\mu$ 1 disc ceramic

#### Semiconductors

IC3

NE5532 dual low  
noise op.amp

### MIC 2

#### Resistors

R47 to R51, R53  
R52, R54  
R55, R56

100k (6 off)  
1k (2 off)  
33 (2 off)

#### Capacitors

C50, C51  
C52, C53  
C54, C55, C56, C57

0 $\mu$ 47 polyester film, 100V (2 off)  
100p ceramic (2 off)  
10 $\mu$ F radial elect. (4 off)

#### Semiconductors

IC4

NE5532 dual low noise op.amp

#### Miscellaneous

8-pin d.i.l. socket; unless you are building all the circuits on the main mixer p.c.b., you will also need a p.c.b. for each pre-amp. (Separate small p.c.b.s available from *EPE PCB Service*, code 846). Note that 100V capacitors are specified for C41, C42, C50, C51 due to space problems on the p.c.b. if physically larger types are used.

## STEREO RIAA PRE-AMP

### PHONO 1

#### Resistors

R57, R58 47k (2 off)  
R59, R62 100k (2 off)  
R60, R63 820k (2 off)  
R65, R67 56k (2 off)  
R66, R68 680k (2 off)  
R69, R70 1k (2 off)  
R71, R72 33 (2 off)  
All 0.25W 5% carbon film

#### Capacitors

C58, C59 0 $\mu$ 47 polyester film,  
100V (2 off)  
C60 to C63,  
C68, C69 10 $\mu$  radial elect. (6 off)  
C64, C66 1n8 close tolerance  
polystyrene (2 off)  
C65, C67 5n6 close tolerance  
polystyrene (2 off)  
C70 0 $\mu$ 1 disc ceramic

#### Semiconductors

IC5 NE5532 dual low noise  
op.amp

### PHONO 2

#### Resistors

R73, R74 47k (2 off)  
R75, R78 100k (2 off)  
R76, R79 820k (2 off)  
R81, R83 56k (2 off)  
R82, R84 680k (2 off)  
R85, R86 1k (2 off)  
R87, R88 33 (2 off)

#### Capacitors

C71, C74 0 $\mu$ 47 polyester film,  
100V (2 off)  
C73 to C76,  
C81, C82 10 $\mu$  radial elect. (6 off)  
C77, C79 1n8 polystyrene, 1%  
(2 off)  
C78, C80 5n6 polystyrene, 1%  
(2 off)

#### Miscellaneous

8-pin d.i.l. socket; unless you are building all the circuits on the main mixer p.c.b., you will also need a p.c.b. for each RIAA pre-amp. (Separate small p.c.b.s available from *EPE PCB Service*, code 847).

Note that 100V capacitors are specified for C58, C59, C71, C74 due to space problems on the p.c.b. if physically larger types are used.

**NOTE:** All electrolytic capacitors can be 16V, 25V or 35V types.

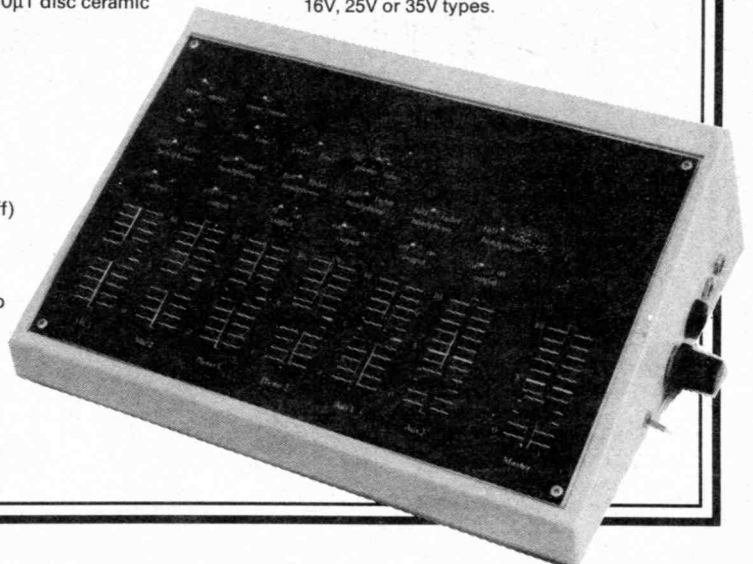



## STEREO RIAA PRE-AMP FOR RECORD DECKS (PHONO)

The RIAA Pre-Amp is necessary because if a magnetic record deck cartridge was connected directly to the mixer there would be two problems:

1. The input signal level from the cartridge would be much too low.
2. There would be a severe lack of bass.

A pre-amp (like the microphone pre-amp) would boost the audio signal, but the bass problem would remain. A pre-amp is required which both *amplifies* the audio signal and *corrects* the frequency response of the record.

### RIAA FILTER

When a record is cut, a filter circuit is used to increase the amplitude of the high frequencies and reduce the amplitude of the low frequencies. This is necessary to prevent the bass frequencies from occupying too much space on the record surface.

When replayed, a similar but opposite filter must be used to re-balance the frequency spectrum to its original level. The circuit required is known as a *RIAA filter*.

### HOW IT WORKS

The circuit diagram for the RIAA Stereo Pre-Amp, for magnetic cartridge input (Phono), is shown in Fig. 9. The figures in brackets on the circuit diagram refer to the second channel or Phono 2. The RIAA filter pre-amp is again based on the NE5532 i.c., used in its non-inverting mode.

The non-inverting input (pin 5) of IC5a is held at about half the supply voltage by resistors R59, R60 and R61. The signal from the record deck is applied to pin 5 via d.c. blocking capacitor C58.

The amplified output from pin 7 is fed back to inverting input pin 6 via a resistor/capacitor filter which allows the necessary bass boost and treble cut. The overall gain of the circuit can be changed by changing the value of resistor R69. For example, increasing the value of R69 will reduce the gain.

The corrected and amplified signal is fed via R71 and C68 to the mixer. Resistor R71 prevents any damage should the output be accidentally connected to ground, and capacitor C68 blocks the flow of d.c. from the output, but conducts the a.c. audio signal.

The right hand signal is treated in exactly the same way via IC5b. Capacitor C70 removes any spikes from the supply rails in the vicinity of the i.c.

### CONSTRUCTION

The Six-Channel, Low Noise Stereo Mixer module is built on a large (to take the slider controls) single-sided printed circuit board (p.c.b.). Separate p.c.b.s have also been designed for the Microphone and RIAA (Phono) Pre-Amp stages – see later. These board are available from the EPE PCB Service, codes 845 (6-Channel Stereo Mixer), 846 (Microphone Pre-amp) and 847 (RIAA Pre-amp).

The topside component layout on the large mixer board and

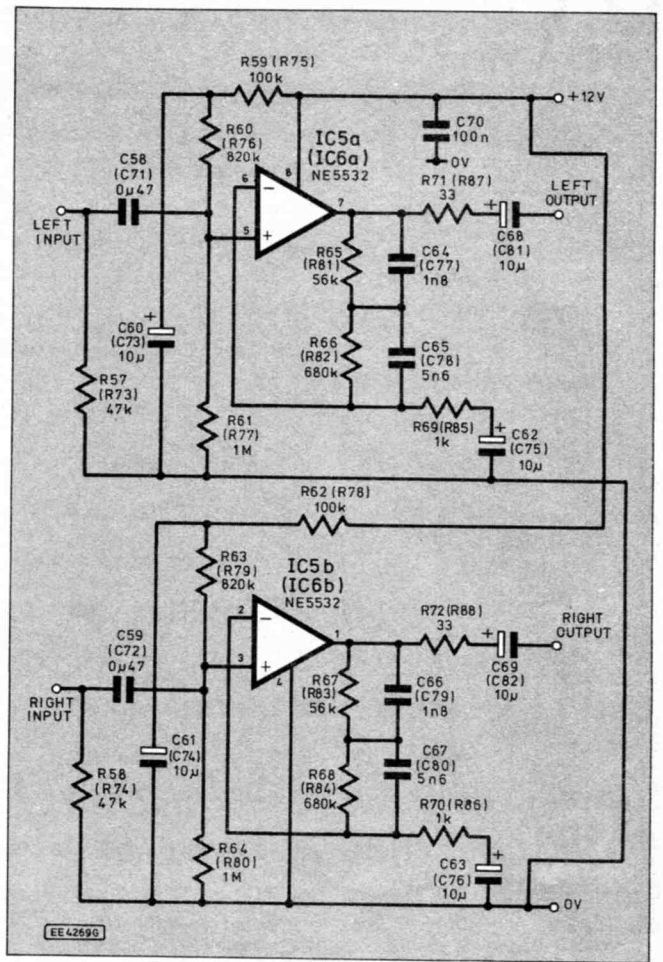
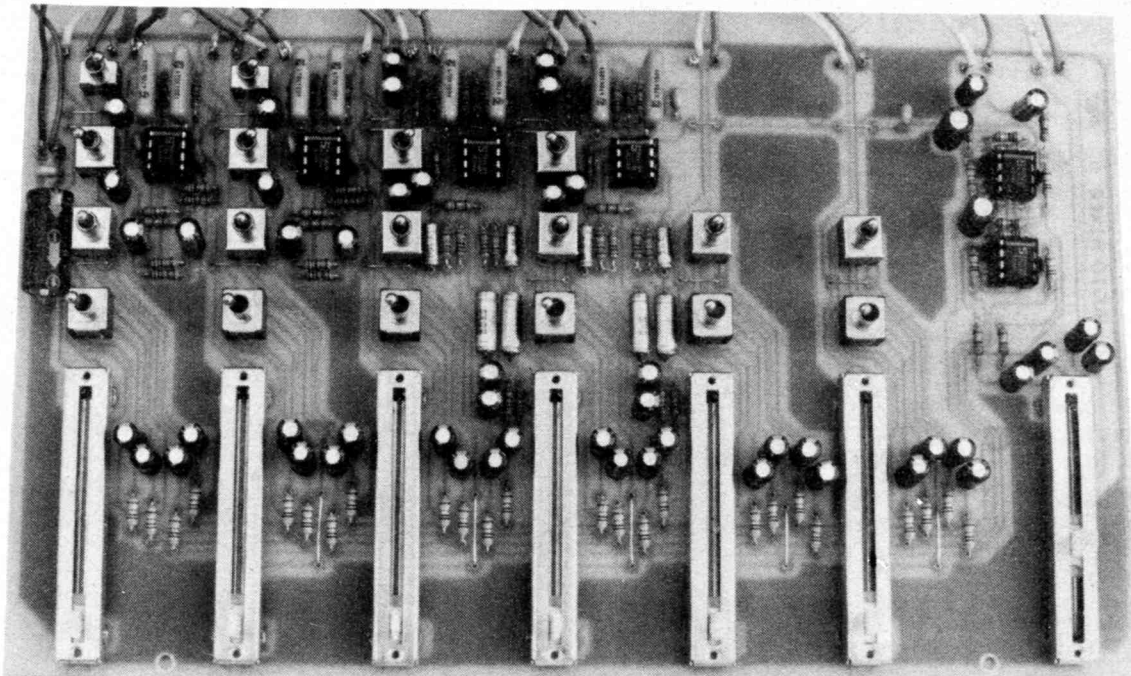

Fig. 9. Stereo RIAA Pre-Amp circuit diagram.

underside copper foil master pattern is shown in Fig. 10. Begin construction by checking that the holes will accommodate the most awkward items such as the switches and slider "pots". Small holes can be enlarged by a miniature reamer if necessary.

Having established that the pots and switches will fit, begin by inserting the smallest components first, and the i.c. sockets. Check the polarity of the electrolytic capacitors; the negative side is usually marked (-), and the longer wire is on the positive side. Solder very carefully using a soldering iron with a miniature bit since some of the pads are quite closer to other pads or tracks.

Fit the stereo slider potentiometers, noting that the log scale only works correctly when the pot. is fitted the correct way up, as shown



# 6-CHANNEL STEREO MIXER BOARD

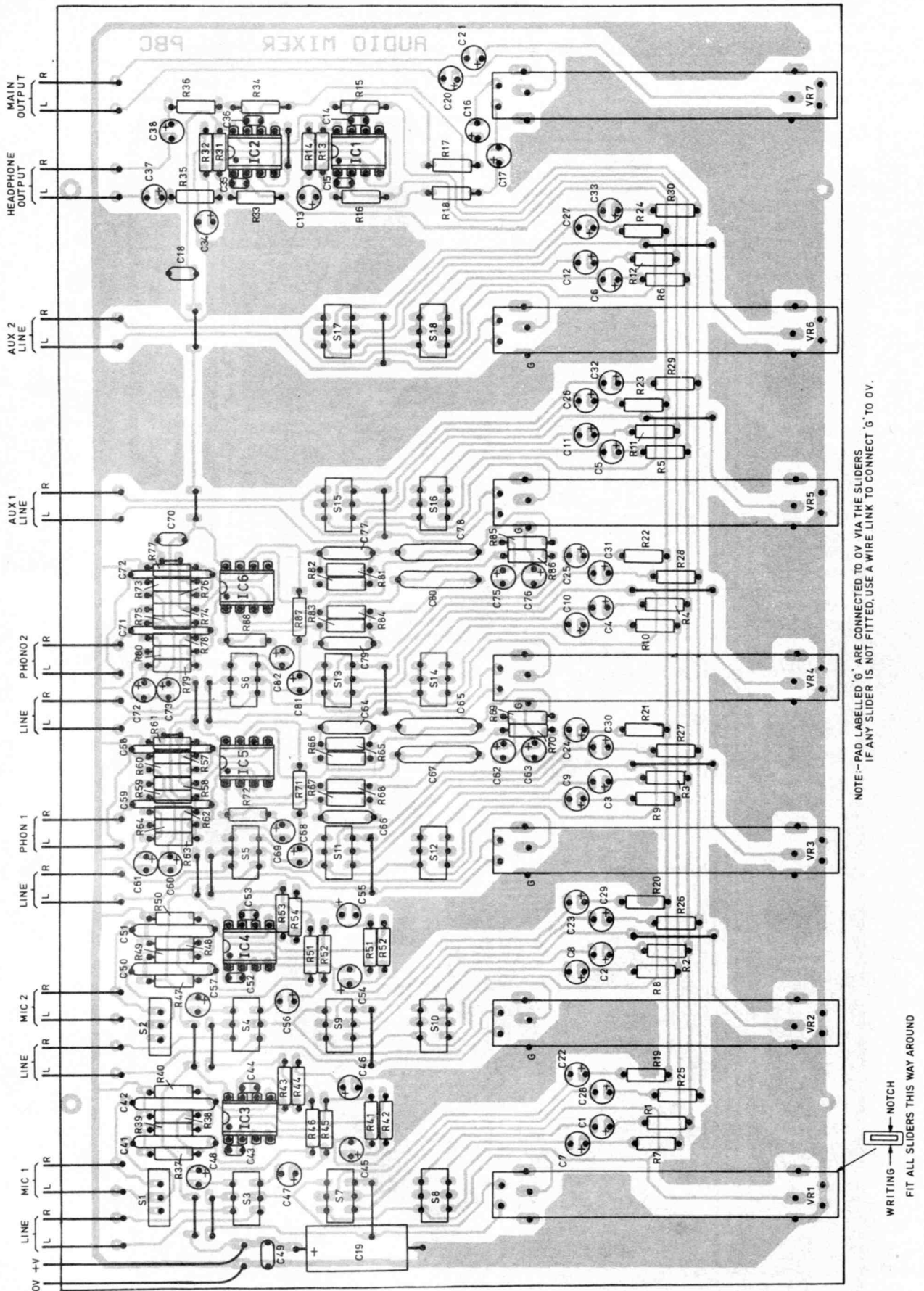

Fig. 10. Six-Channel, Low Noise, Stereo Mixer printed circuit board topside component layout. The completed board is shown opposite (left) and the copper foil master pattern appears on the next page.



in Fig. 10. If the drilling is accurate, it will be very difficult to fit the pots in the wrong way round. Next fit the switches, ensuring a firm fit against the board since some strain will be placed on the p.c.b. tracks when the switches are operated.

It is important to note that the metal case of most of the slider potentiometers is used to link each left-hand adjacent circuit to 0V.

If any sliders are omitted, it is essential to use wire links to join the unused pads labelled "G" to 0V

Connect the leads, using screened wire for the sensitive microphone and RIAA Pre-amp inputs and screened or ordinary wires for the line inputs. Note that the outer core of the screened cable is *not* connected to the p.c.b. since the "ground"

connection is looped through all the input sockets from 0V on the power input socket. Ensure that all the leads are long enough, so that when connected to their sockets in the case, the p.c.b. can still be removed.

Finally, insert the i.c.s into their sockets ensuring they are aligned correctly.

Next month: Mixer final wiring, assembly and testing. Also separate pre-amp boards.

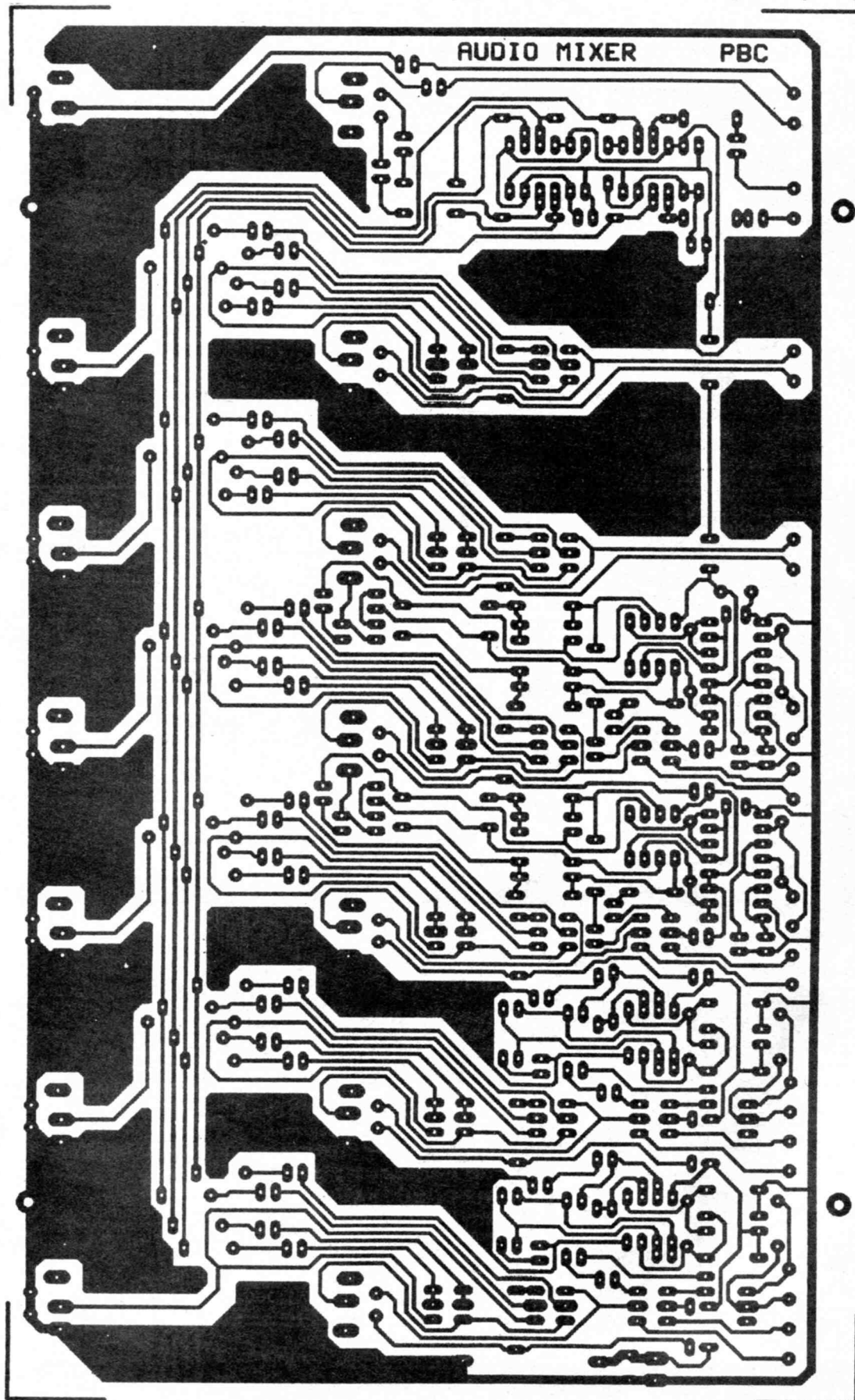

Full size printed circuit board (p.c.b.) copper foil master pattern for the Six-Channel Stereo Mixer (12-channels in all). This board is available from the EPE PCB Service, code 845. Details of separate Microphone and RIAA Pre-Amp p.c.b. modules will be given next month.

# ORCHARD COMPUTERS

251-257 Burnt Oak Broadway, Edgware, Middlesex HA8 5ED

Tel: 081-905 6445 Fax: 081-905 7137

**BUILDING OR UPGRADING A P.C. – LOOK NO FURTHER!**

## MOTHERBOARDS

	CACHE	ISA	EISA	VESA-LB	EISA-LB
386SX 33MHz	OK	£73.00	-	-	-
386DX 40MHz	128K	£119.00	-	-	-
486SX 25MHz	128K	£160.00	-	£185.00	-
486DX 33MHz	256K	£310.00	£431.00	£320.00	£448.00
486DX2 50MHz	256K	£372.00	£493.00	£386.00	£520.00
486DX 50MHz	256K	£401.00	£536.00	£414.00	£533.00
486DX2 66MHz	256K	£455.00	£568.00	£480.00	£568.00

## VGA CARDS

Trident VGA card 256K .....	<b>£25.00</b>
Trident 8900C 32-BIT VGA card 1MB .....	<b>£45.00</b>
Tseng Labs ET4000 1MB .....	<b>£58.00</b>
Tseng Labs ET4000 16.7M colours .....	<b>£79.00</b>
Tseng Labs ET4000 Local Bus .....	<b>£80.00</b>
Acumos AVGA3 16.7M colours .....	<b>£55.00</b>
Paradise WD90C31 64K 1MB .....	<b>£75.00</b>
S3 1MB Windows accelerator card .....	<b>£145.00</b>
Cirrus Logic 5426 Local Bus .....	<b>£80.00</b>
Diamond Stealth S3 1MB VGA Card .....	<b>£145.00</b>
Diamond Stealth S3 1MB LB VGA Card .....	<b>£155.00</b>
Orchard Prodesigner IIs 1MB VGA Card 1024 x 768 VESA Bus .....	<b>£110.00</b>
Orchid Fahrenheit 1280VA VLBus Windows Accelerator .....	<b>£183.00</b>
Orchid P9000 Fahrenheit .....	<b>£350.00</b>

## MONITORS

14" Samsung SVGA monitor .28 pitch Low Radiation .....	<b>£195.00</b>
Panasonic 17" .26 pitch .....	<b>£665.00</b>
AOC 14" 1024 x 768 non interlaced .....	<b>£225.00</b>
Panasonic 20" FST .26 pitch .....	<b>£ CALL</b>

**CALL FOR OTHER MONITOR SIZES  
AND MANUFACTURES**

## DISKETTES & HARD DRIVES

IDE	
Conner 120MB CP30104H 64K Cache .....	<b>£130.00</b>
Conner 170MB CP30174E 64K Cache .....	<b>£155.00</b>
Western Digital AC2200 212MB 12MS .....	<b>£188.00</b>
Western Digital AC2250 340MB 12MS .....	<b>£270.00</b>
Western Digital AC2424 420MB 12MS .....	<b>£350.00</b>
Seagate ST351AX 40MB .....	<b>£85.00</b>
Seagate ST3120A 107MB .....	<b>£149.00</b>
Seagate ST3144A 130MB .....	<b>£135.00</b>
Seagate ST3243A 214MB .....	<b>£199.00</b>
Seagate ST3283A 341MB .....	<b>£265.00</b>
FLOPPY	
1.2MB Mitsubishi/TEAC 5.25" .....	<b>£40.00</b>
1.44MB Mitsubishi/TEAC 3.5" .....	<b>£32.00</b>
TEAC dual floppy 1.2 x 1.44 .....	<b>£95.00</b>
Frame for HD or floppy .....	<b>£7.00</b>

CALL FOR ALL OTHER HARD DISK SIZES. WE SUPPLY: CONNER, SEAGATE, WESTERN DIGITAL, MAXTOR, FUJITSU HARD DISKS.

**ALL PRICES SUBJECT TO CURRENT EXCHANGE RATE**

## OTHER ITEMS

1MB 70NS Simms .....	<b>£ CALL</b>
4MB 70NS Simms .....	<b>£ CALL</b>
CO Processor .....	<b>£ CALL</b>
BTC 102 Standard keyboard .....	<b>£20.00</b>
BTC 102 Quality keyboard .....	<b>£25.00</b>
PS2 Adaptor for any standard keyboard .....	<b>£10.00</b>
MS DOS 6 & Win 3.1 .....	<b>£90.00</b>
MS DOS 6 .....	<b>£55.00</b>
ZNIX Mouse .....	<b>£15.00</b>
Summit SE120 120MB tape unit internal .....	<b>£120.00</b>
Summit SE250 250MB tape unit internal .....	<b>£175.00</b>
Summit SE305 305MB tape unit internal .....	<b>£225.00</b>

## ADD ON CARDS

IDE 2S, 1P, 1G, 2HD, 2FDD .....	<b>£16.00</b>
Twin Serial .....	<b>£20.00</b>
Twin Parallel .....	<b>£20.00</b>
IDE 2S, 1P, 1G, 2HD, 4FDD .....	<b>£35.00</b>
EISA SCSI Cache controller 0K .....	<b>£245.00</b>
Promise ISA DC2032 Cache controller to 16MB ..	<b>£125.00</b>
Promise VESA DC2040 Cache controller to 16MB	<b>£150.00</b>
IDE 2S, 1P, 1G, 2HD, 2FDD Local Bus .....	<b>£50.00</b>
NE2000 compatible card .....	<b>£65.00</b>

PRICES EXCLUDE VAT AND DELIVERY.



## Multimedia Centre

A VOLNET (Vocational Open Learning Network) Centre has been set up in Central London to provide educators and trainers with practical knowledge of multimedia systems.

The centre is equipped with state of the art hardware and software including Multimedia 486 PCs with Video Capture and Compression, Video for Windows and Apple Centris Multimedia System. There is also laser disc interactive Video and CDI.

The Centre offers initial training in Multimedia Free to professional trainers and educators. Workshops are held weekly. There will also be a number of special conferences during Autumn 1993.

### Learning Network

The Vocational Open Learning Network - VOLNET - is jointly managed by the British Association for Open Learning and the National Council for Educational Technology.

"All trainers and further education lecturers are invited to make an appointment and come in - free of charge. We would particularly like to see those who do not already have computer skills," said Michael Furminger, NCET director.

For further details contact: VOLNET UK, Dept EPE, 3 Devonshire Street, London W1N 2BA. Tel: 071 636 4186.

## Electronic Fingerprinting

AN encapsulated 96-bit microprocessor, about the size of a grain of rice, is claimed to provide "electronic fingerprinting". Tiny enough to be hidden in a small circuit board or within any component or equipment, the IntaTag gives that item permanent identification which is virtually impossible to erase.

Each chip is programmed with its own recognition code as unique as an individual's fingerprint, the code being registered on a secure database. The 12-digit alpha numeric code is read by a hand-held scanner which excites the chip and reads back the code for identification purposes.

For further details contact DH Associates, Dept EPE, 7 The Lawn, St Leonards-on-Sea, East Sussex TN38 0HH. Tel: 0424 426187/720616. Fax: 0424 717971.

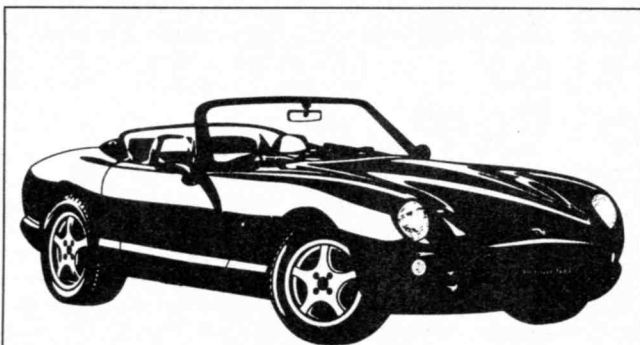

## Safety First

A UNIQUE microprocessor based security system for a new car has been designed and manufacture by UK Electronics in conjunction with TVR Engineering.

The TVR Chimaera sports car, has a double dead locking system which, apart from giving special door locking facilities, also activates the electronic immobiliser to reduce further the chance of loss.

Normal external central locking is enhanced by having an internal locking control for use by an occupant. If an intruder breaks a window the doors will remain locked, denying easy access.

The locking/immobilising system supplied by UK Electronics of Oldham for fitting to the TVR cars has all the electronics fitted to one compact double-sided plated through hole printed circuit board.

## Showing Initiative

KINGTON in Herefordshire has been selected for a unique initiative as the "high tech" rural community of the future. The project named Connected Community is the most innovative of its kind to be run in Europe and is supported by Apple Computer UK, BT, the Department of Trade and Industry and the Rural Development Commission.

The project, to be hosted by Kington, will study the potential benefits that state-of-the-art technology can provide for the economic and social fabric of small towns and villages.

The effects of Kington's use of computer and communications equipment will be monitored over a 12 month period by The Henley Centre, Britain's leading social and economic research company.

Apple Computer, BT and secondary partners will provide over £1/4 million of computer and communications equipment and support for Kington's winning bid specification.

## NEW RANGE OF HIGH QUALITY KITS

GREENWELD have been appointed the sole importer in the UK for the range of excellent kits from DIY Electronics, currently selling extremely well in Australia. All kits are supplied with a full set of components, including sockets for all i.c.s; screen printed, solder masked, tinned fibreglass p.c.b.s and comprehensive instructions with chip data where relevant. Attractively packaged in Hong Kong using top grade components, they represent outstanding value for money.

There are 41 kits in the range at present covering all abilities and interests. They are especially recommended for the educational market, giving a detailed insight into the theory of electronics through practical experience. The projects range from a simple siren through to digital panel meters, logic probe, amplifiers, converters and a laser kit.

Prices start at under £5 including VAT, and a full list is available from Greenweld, 27D Park Road, Southampton SO1 3TB. Tel: 0703 236363, Fax: 0703 236307 - or use their FaxOn-Demand service - just dial 0703 236315 from any fax machine for instant information. Trade terms on all kits are available to bona fide dealers.

## MILLENNIUM POWER SYSTEM

MILLENNIUM, one of the largest manufacturers of rechargeable power products in the world, has launched a new comprehensive range of Power Cells, Rapid Chargers and Power Packs in the UK.

These rechargeable products are said to offer a cost-effective, convenient and environmentally friendly alternative to throwaway batteries. They are ideal for products which use a lot of power, such as pocket TV's and electronic keyboards.

The cells come with a lifetime replacement guarantee and are all colour coded for easy identification.

Available in five sizes - AA, AAA, C, D and 9V - they range in price from £4.95 for an AA cell 2-pack to £7.99 for a D cell 2-pack.

The charger pictured is priced at £16.99 and is claimed to be the fastest charger available in the UK - it can recharge four AA cells in just one hour. It is now available from electrical retailers.

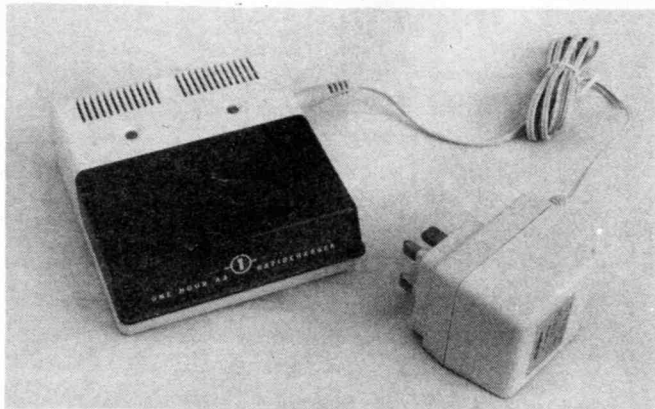

# New Technology Update

Ian Poole investigates display developments and new ideas for reducing on-chip component sizes.

**L**IQUID crystal display technology is heralded as the way forwards for future display technology. Many companies are looking to it for the next generation of displays for everything from computers to televisions. Although the l.c.d. is well established in the computer industry where it is widely used for portables, it has not yet been able to successfully enter the television market. The reason for this is twofold. In the first case it is more expensive than the traditional cathode ray tube. This is a very important feature in what is a very cost sensitive market. The other problem is that it is too slow to respond.

Currently large amounts of development work are being invested in overcoming these problems. Although some success is being experienced, estimates indicate that the earliest time that l.c.d.s could be available for widespread use in televisions is likely to be at the beginning of the next century.

However another new type of display which is being developed may be more suitable. Although the basic idea has been known for many years it has now been developed to a point where it can show many of its advantages. The display is known as an orientated colloidal particle flat panel display and it has been developed by a company in New York called Research Frontiers.

## How It Works

The new display bears many similarities to an l.c.d. in its construction, but it works on a totally different principle. A simplified diagram is shown in Fig. 1.

A solution containing particles in a colloidal suspension is held between two glass plates. On the inside of the two plates patterned electrodes are deposited. However to prevent any current flowing between them through the colloidal solution a transparent insulating layer is placed over the electrodes as shown.

The key to the display is found in the particles in the solution. The long particles are normally orientated in a random fashion

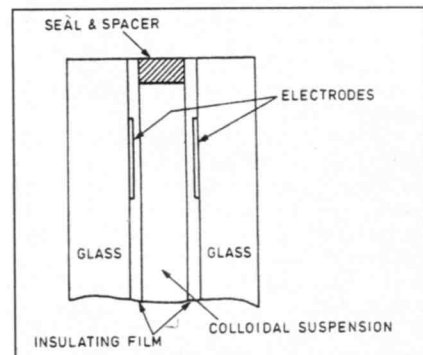

Fig. 1. Cross section through the display.

preventing light passing through as shown in Fig. 2a. However when a voltage is applied across the electrodes the particles align so light can pass across the display (Fig.2b).

## Voltage

Unfortunately if a d.c. voltage is applied to the electrodes it is found that all the particles migrate to the same area giving depletion zones and destroying the display. To overcome this an a.c. voltage has to be used.

A large amount of work was undertaken to develop the correct solution. A number of different suspensions have been found to operate with varying degrees of success. The suspension which is used now is based upon Pyrazine compounds. This gives much better performance than any of the other solutions which have been tried in terms of life and operating temperature.

Current indications of the display are very encouraging. Not only is it expected to give an exceedingly good contrast ratio vastly better than that of an l.c.d., but it also gives a wide viewing angle in excess of 90 degrees. In addition to this it can operate down to temperatures of less than -30 degrees C. As a comparison l.c.d.s only work down to about 0 degrees C. Finally it has a reasonably fast response, slightly better than 100mS. This makes it just usable for video applications.

As the displays are likely to be cheaper than l.c.d.s this means that the next generation of displays for use in televisions may not be based around l.c.d. technology, but rather orientable colloidal particle displays.

## New Ideas for Photolithography

Turning to a different topic, one subject which has cropped up a number of times in this column is the miniaturisation of components within integrated circuits. The smaller the individual components can be made, the greater functionality which can be placed on each chip.

Many ideas for reducing components sizes

have been devised, some of which involve totally new processes. However there is still plenty of research being undertaken to improve existing techniques. Whilst this may not appear to be quite as exciting as some of the revolutionary new ideas it is every bit as important.

A wide variety of different technologies are used in the production of integrated circuits. One of these is called photolithography. This process is used to transfer the necessary patterns onto the silicon wafers so that operations like diffusion, epitaxial growth, and etching can be undertaken on the correct areas of the silicon.

## Limiting Factor

Whilst the technique works very successfully, it is now becoming a limiting factor in the further reduction of i.c. component sizes. Currently the feature sizes are limited to about 0.6µm. However it is expected that a 16 megabit SRAM will be produced in the reasonably near future. It is calculated that if these chips are to become a reality then feature sizes of a little less than 0.4µm will be needed.

One method of achieving this is to use X-ray lithography. Unfortunately this is more expensive than normal photolithography and requires expensive re-tooling. If normal photolithography techniques can be used then the cost of these i.c.s could be kept to a minimum.

To achieve the required sizes two methods are being investigated. The first is called phase shifting. This entails depositing some optical material onto the mask. This phase shifts the light so that it is collimated onto the wafer.

Normally the mask is placed over the wafer and collimated light is passed through it to expose the photo-resist on the silicon. However the light will normally diverge slightly reducing the definition which can be obtained.

The second technique is the use of vertical cell capacitor structures. These are required so that sufficient cell capacitance is maintained to give reliable operation of the memory as cell sizes are reduced.

Progress on these developments has been very fast to date. The first trials of the techniques have already been undertaken. With them complete, minor modifications are being made before the trial production of a 4 megabit SRAM is made. This is expected to be completed by the end of 1993. If this is successful and it appears that it will be, then the project will be well on course for making a major contribution to the 16 megabit SRAM development. Apart from this it is likely that it will have a significant impact on other i.c. development programmes where size and cost are of great importance.

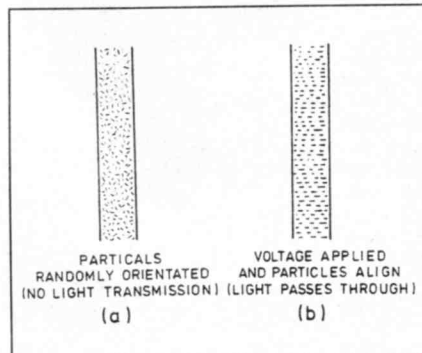

Fig. 2. Operation of the display.



# MAGIC SOCKET

T. R. de VAUX-BALBIRNIE



## Automatic switching of mains socket outlets.

**T**HIS circuit is a convenient way of operating up to four 240V a.c. mains appliances at once without having to use individual switches. One possible use is for items of audio equipment where the amplifier, tuner, cassette and CD players or other possible devices such as a graphic equalizer need to be switched on together. The Magic Socket may also be found useful for switching on pieces of computing equipment such as the computer itself, disc drive, printer, monitor, modem, etc.

It is, of course, possible to provide a master switch to perform this function. However, if this is on view it is likely to look amateurish or out of place and, if situated out of sight, may be inconvenient to use. The Magic Socket therefore provides a neat solution.

### MASTER AND SLAVES

The Magic Socket project appears as a standard four-socket trailing mains outlet (distribution board) with an additional box, which houses the electronic control circuit, mounted on the side. This box has a standard single mains socket - the master

or *magic* socket - mounted on top (see photograph).

To use the device, a mains lamp is plugged into the "magic socket". When the light is switched on using its own on-off switch, the other four *slave* sockets will be activated automatically. The slave sockets may be used with any loads up to a total of 1000W on 240V mains (4A approximately).

It is important that the lamp, which is plugged into the master socket, be fitted with a standard tungsten-filament bulb with a rating of 60W. Apart from that, any type will do such as an Anglepoise lamp, a decorative reading lamp or a strip light.

Whatever type of lamp is used it must, of course, be provided with its own on-off switch. Once set up with the appliances plugged into it, the whole device is placed out of sight and may be forgotten.

Note that there are some items which are not advised for use with the Magic Socket. These are appliances where a mains supply needs to be maintained to the circuit (even when apparently switched off) for memory-retention purposes (for storing a selection of radio station frequencies, for example).

Some pieces of audio and TV equipment come into this category. Cutting off the mains supply completely to such devices may, over a period of hours, result in the loss of memory contents. It will be necessary to check this point in the instruction manual before using such appliances with the Magic Socket. Also, due to the inherent unreliability of filament lamps, the device should not be used where it is *essential* to maintain a supply since failure of the bulb will cause the slave sockets to switch off.

**Constructing this circuit involves making mains connections. Any reader who is not certain of being able to make a safe job must therefore seek professional advice.** Particular care must be taken over the quality of the soldered joints, to Earthing the case and to the values and type of fuses used. These latter points will be explained presently.

### CIRCUIT DESCRIPTION

The complete circuit diagram for the Magic Socket project is shown in Fig. 1. Note mains lamp, LP1, plugged in to the master - or *magic* - socket, SK1. When this is switched(S) on, current flows from the live supply wire, through fuse FS1, bulb LP1 filament and resistor, R1. From here it completes the circuit back to mains Neutral. With current flowing through R1, 9V approximately will be developed across its ends.

An explanation of how this figure comes about is given later but it is not essential to understand it to construct the circuit or to have a basic idea of how it works. The important point is that this low-voltage a.c. "supply" operates the rest of the circuit. *Note that although low voltage, it is still connected directly to the mains - it must therefore be regarded as potentially dangerous and treated with the same respect as the mains.*

The supply developed at R1 flows through fuse FS2, is half-wave rectified by diode, D1, and smoothed by electrolytic capacitor C1. The final result is a steady output of approximately 5V applied to the coil of relay RLA.

The specified relay having a nominal 6V coil is designed to operate at 4.5V approximately so this output voltage is sufficient to energize it. The normally-open contacts, RLA1, "make" and complete the circuit from the live wire (L) of the mains feed to the four slave sockets, SK2 to SK5 in the trailing socket. When LP1 is switched off, the supply is interrupted, the relay contacts part and operation of the slave sockets is cancelled.

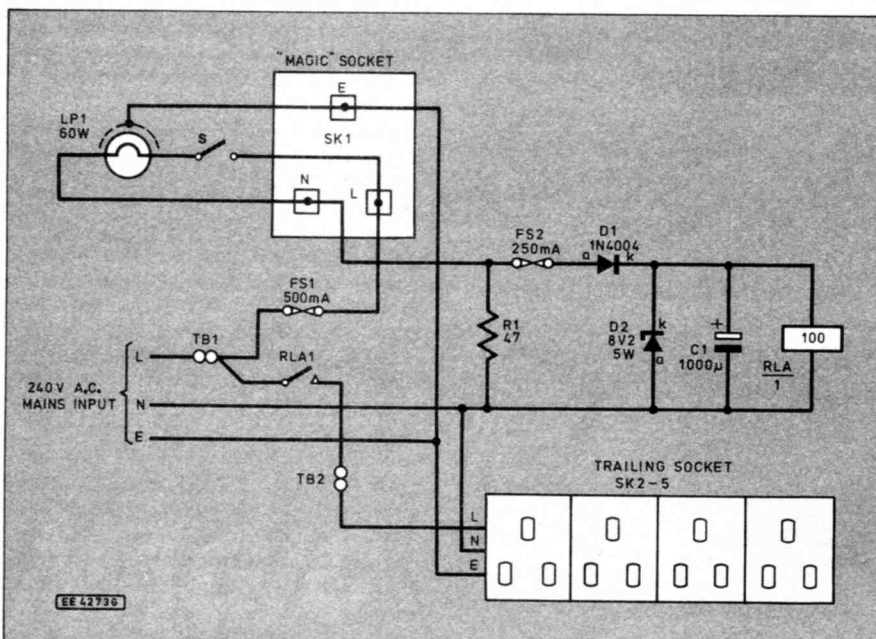

Fig. 1. Complete circuit diagram for the Magic Socket. Switch (s) is the lamp switch.

The voltage developed across RLA coil is derived from a fairly complex interaction of circuit components which involves the resistance of the lamp filament and that of the relay coil. It is unnecessary to enter into details but the final outcome is that this voltage is less than that appearing across resistor R1.

Note that when the lamp is operating, the voltage across it will be some 9V less than the mains – that is, by the voltage “lost” across R1. The effect on its brightness is slight and, in fact, will extend its life significantly.

Zener diode D2 is connected in parallel with capacitor C1 and the relay coil as shown. Since in the absence of a fault there will be 5V approximately across its ends, it will have no effect. However, if the voltage were to rise for whatever reason, D2 would immediately conduct and the voltage “lock” at the Zener breakdown value of 8.2V. This happens briefly when the lamp is switched on.

### COLD START

When the filament is cold (room temperature) its resistance (70 ohms approximately) is much less than when it is at full operating temperature (960 ohms). This has the effect of allowing a much higher current than normal to flow through resistor R1 (2A approximately) with a consequent high voltage appearing across it.

Although R1 is not designed to carry such a high current, it only happens briefly and it does not heat up appreciably in this time. Moreover, D2 locks the voltage across C1 and the relay coil to 8.2V for long enough to allow the filament to heat

up and prevent damage. In a test on the prototype where the lamp was switched on and off repeatedly, all circuit components survived indefinitely.

It is important for fuses FS1 and FS2 to be of the correct type and have the correct rating as specified in the components list so that any rise in the operating current over a longer period of time than that due to a cold lamp filament will cut-off the supply as rapidly as possible. If this were not done, D2 would be destroyed and the high voltage developed across electrolytic capacitor, C1 would damage it. This would probably show its displeasure by exploding violently. It could also mean that diode D1 and the relay would be destroyed.

### LARGE CURRENT

Should the relay coil itself fail and become open-circuit, the total current requirement for the lamp would flow through resistor R1. This would cause a higher voltage than normal to be developed across it – 12V approximately. The power dissipated by the resistor would therefore rise and it would become very hot but still remain within its power rating. With this type of fault, the slave sockets would, of course, fail to work.

Should the output circuit be overloaded – that is, if more than 4.5A were drawn so putting the contacts RLA/1 under strain, the plug fuse for the unit would blow or the fuse in the trailing outlet itself if it has one. Note, however, that this could still damage the relay contacts so overloading must be avoided in practice.

The prototype unit was tested under fault conditions of the type described and this confirmed that the circuit behaves safely as theory suggests.

### CONSTRUCTION

**Note that the circuit MUST be built in an Earthed metal box. A plastic box will not be strong enough for the purpose.**

In view of the small component count, it is convenient to construct most of the Magic Socket circuit on a piece of tagboard and the relay on a subsidiary piece of 0.1in. matrix stripboard mounted on this. The tagboard component layout and positioning of the “relay board” is shown in Fig. 2.

Begin construction by cutting the tagboard to size (two rows of seventeen tags). Make the inter-tag links – sleeve the link wire between tags 28 and 33 to make certain it cannot touch any other tag.

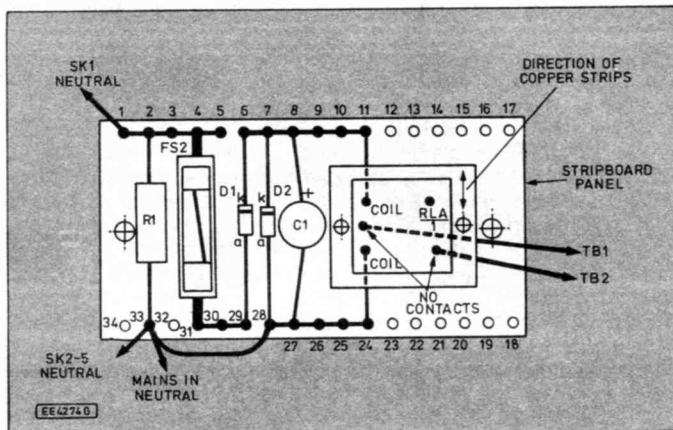

Fig. 2. Tagboard component layout, positioning of relay board and wiring (using 6A mains rated wire) to relay contacts directly.

## COMPONENTS

#### Resistor

R1 47 3W

#### Capacitor

C1 1000µ radial elect. 16V

#### Semiconductors

D1 1N4004 400V 1A rectifier diode  
D2 8.2V 5W Zener diode

#### Miscellaneous

FS1 20mm panel fuse holder with 500mA high breaking capacity ceramic quick-blow fuse.  
FS2 20mm chassis fuse holder with 250mA high breaking capacity ceramic quick-blow fuse  
RLA Miniature relay with 6V 100 ohm coil, and 240V “make” or changeover contacts rated at 5A.

Tag board, 2 rows of 17 tags required; 0.1in. matrix stripboard, size 8 strips x 13 holes; 4-socket trailing outlet; single mains socket; 5A screw terminal block - 2 sections required; aluminium box, size 133mm x 102mm x 38mm approx; strain relief grommets (2 off); solder tag; 5A mains fuse for trailing socket (if required); 5A fuse for mains input plug; 1A (or 2A) plug fuse for lamp. 6A mains rated wire; stranded connecting wire; M3.5 nuts (2 off) (see text); small fixings; stand-off insulators (4 off); solder, etc.

Approx cost guidance only

**£11**

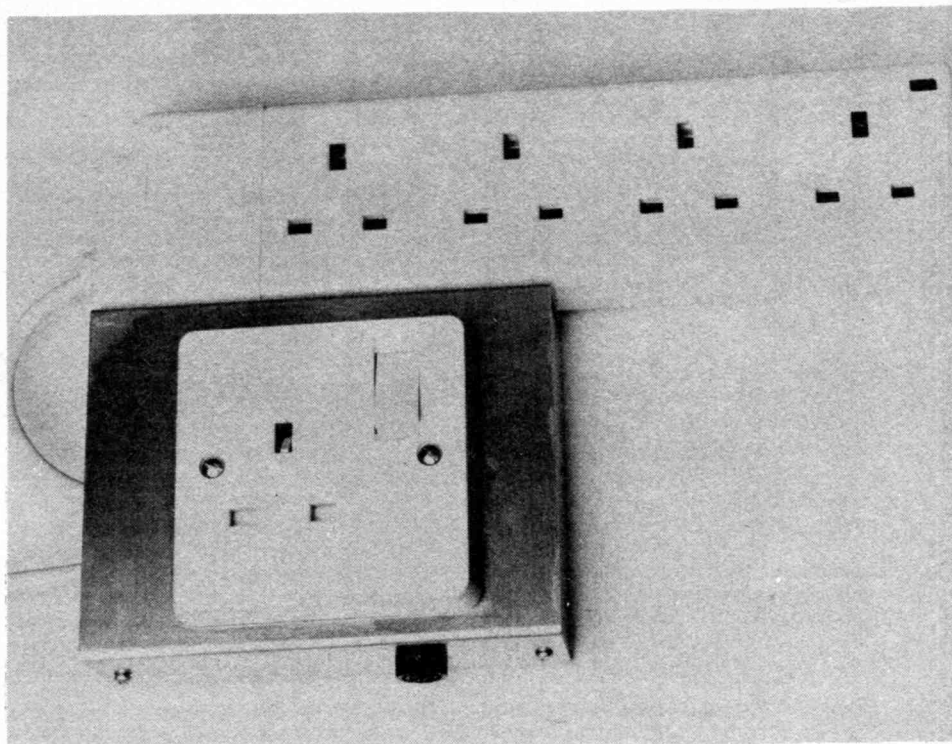



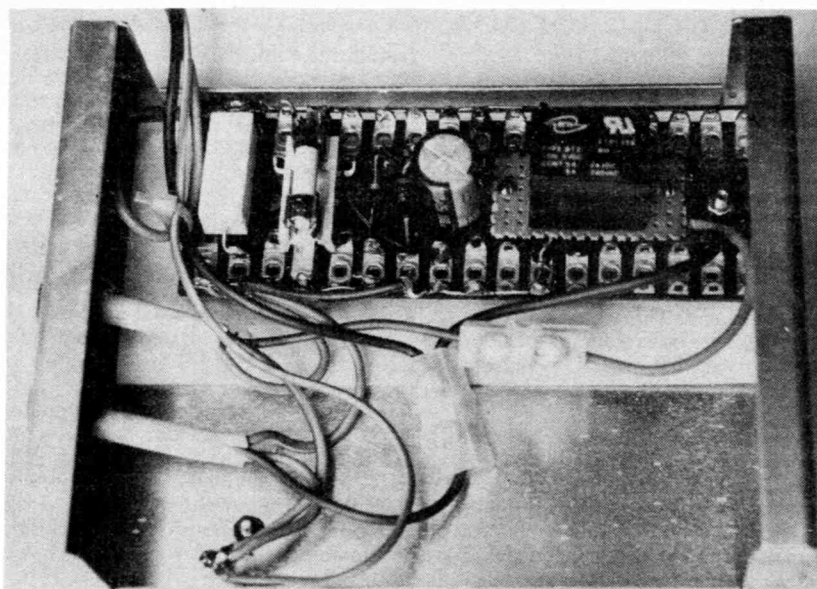

Layout of components inside the METAL box. The relay board is mounted above the mains board using plastic spacers. Note the use of two screw-terminal strips.

Follow by soldering the on-board components into position. It may be necessary to flatten some of the tags for resistor R1 and fuse FS2 to fit properly. R1 should stand about 3mm clear of the panel to allow a free flow of air around it – this is because it becomes warm in operation and can become hot under fault conditions. Some ventilation is therefore necessary.

Make certain that all soldered joints, particularly those at R1, are sound and cannot dislodge in service. Take care to observe the polarity of capacitor C1. This is because it is an electrolytic and may rupture if connected the wrong way round. Take care also to connect correctly the other polarity-sensitive components, diodes D1 and D2.

## RELAY BOARD

Referring to Fig. 3, cut a piece of 0.1in. matrix stripboard to size 8 strips x 13 holes. Drill the two mounting holes in the posi-

tions shown and, referring to Fig. 2, make holes in the tagboard panel to correspond with these.

Solder the relay on the stripboard as indicated. Note that the pins on the specified relay do not match the 0.1in matrix perfectly. However, by bending the pins slightly and using a little gentle persuasion it can be made to fit. If necessary, drill the holes in the stripboard to a slightly larger diameter.

Solder 10cm pieces of mains-rated wire of 6A rating minimum direct to the "make" contacts – i.e. not via the copper strips. Make certain these connections are secure and cannot break free in use. Connect short pieces of light-duty wire to the relay coil tags.

Attach the stripboard to the tagboard panel using two small fixings through the holes drilled for the purpose (see photograph). Place 3mm plastic stand-off insulators on the bolt shanks to allow suffi-

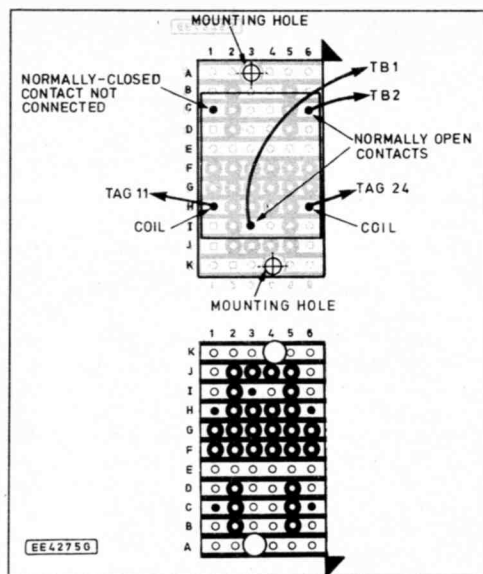

Fig. 3. Using a piece of stripboard to mount the relay. The breaks in the copper must be made as shown.

cient clearance for the relay wiring to pass between the stripboard and tagboard panel. Solder the coil connections to tags 11 and 24 as shown (see Fig. 2).

## BOXING CLEVER

Hold the completed circuit panel assembly in position on the base of the box and mark the positions of the fixing holes. Drill holes in the box to correspond with these.

Make the large hole in the top section of the box to accommodate the single mains socket, SK1. To do this, first make a paper template of the shape of the rear of the socket. Hold this in position and draw round the outline in pencil. Drill a series of closely-spaced holes around this then cut out the shape using a small hacksaw blade. Finish by filing the edges smooth, drilling the two mounting holes and attaching the socket.

The size of the fixing bolts provided with the socket are size M3.5 so if using these you will need a pair of matching nuts. Since these are not available from all suppliers, it may be easier to use more readily-obtainable nuts and bolts perhaps of a slightly different diameter.

Drill holes for fuseholder FS1 mounting, for entry of the mains input lead and for the wire passing through to the trailing socket – make these latter holes large enough to accommodate the strain relief grommets which will be used to secure them later. Drill a small hole in the base section of the box for the "Earthing" solder tag and attach all remaining components.

When mounting the circuit panel, include short stand-off insulators on the bolt shanks to keep it 3mm minimum clear of the base of the case. Use a piece of thick cardboard wider than the tag board underneath to provide insulation as an additional precaution.

## RELIEVE THE STRAIN

Remove the top of the trailing multi-socket and check where holes may be drilled in the side to attach the new section. The site of these will depend on the exact type of trailing socket used.

Mark the positions in both sections

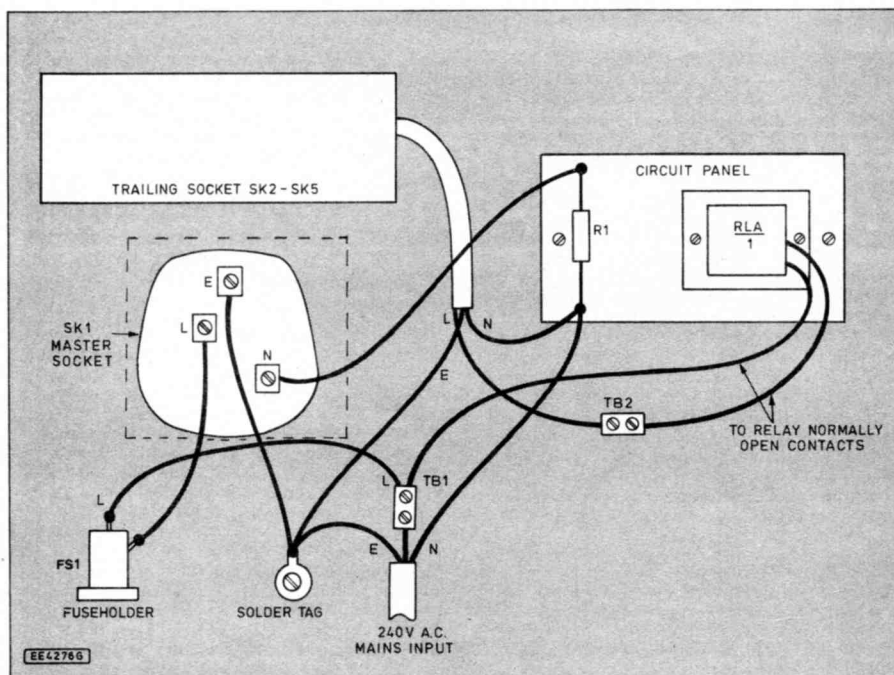

Fig. 4. Interwiring from the circuit board to the master socket, fuseholder, "earth" tag, mains input cable and trailing 4-socket outlet strip. All wiring must be rated at 6A minimum.

and drill the holes. Secure the two sections together using small fixings. Note that the fixing bolts must remain clear of any obstructions and must under no circumstances cause short-circuits inside the trailing socket housing.

Cut off a piece of 3-core mains wire of 6A rating minimum about 20cm long and connect this to the trailing socket. Feed it through the hole in the box and secure it with a strain relief bush. Re-assemble the trailing socket.

Cut off another piece of similar mains wire to use as the input lead. Strip 5cm of the outer sheath from the end, feed it through the hole made in the box and fit a strain relief bush to hold it securely. Refer to Fig. 4 and complete the internal wiring shortening any wires as necessary. Note that all wiring must be made with mains-type wire of 6A rating minimum.

Note also the method of using the pieces of screw terminal block, TB1 and TB2 – do not use taped joints or other makeshift methods. Check that the Earth (E) wiring to the solder tag is secure and cannot break free. Fit a plug to the free end of the input wire and insert a 5A fuse.

While thinking about fuses, fit the reading lamp plug with a 1A fuse (if this is unavailable use a 2A fuse) and the fuseholder on the trailing socket (if one exists) with a 5A fuse. Insert fuses FS1 (500mA) and FS2 (250mA) – note that these must be 20mm types described as mains fuses and having high breaking capacity ceramic construction. Not all

suppliers stock these – see *Shop Talk*. Glass fuses are unsuitable here since, under certain fault conditions, they could blow very violently and shatter. For the correct degree of protection, it is essential for all fuses to have the values specified (see components list).

Replace the lid of the box and secure it with the self-tapping screws provided. It may be necessary to drill new fixing holes in the side to which the trailing socket is attached. Note that the case must be assembled before the unit is plugged in to the mains.

As the two sections of the case are brought together, check carefully for possible trapped wires and obstructions. Check also that resistor R1 does not touch anything since it becomes hot in operation.

## TESTING

It is convenient to test the Magic Socket project by using two reading lamps – one for the magic socket and the other plugged into one of the trailing socket outlets. Remember, the one in the master socket must have a 60W bulb fitted.

Plug the unit into the mains and switch on. Switch on the lamp plugged into the master socket – the other lamp should operate. Switch the magic socket lamp off and the slave sockets should switch off too.

If all is well, the Magic Socket may be put into permanent service. If the unit is to be placed on a surface where scratching must be avoided, it will be necessary to fit self-adhesive plastic feet to the base. Note

that it is normal for the unit to become warm after a prolonged period of use.

If the lid of the box needs to be removed for any reason, it is essential first to unplug the unit from the mains. This is because of the danger of possible touching of the exposed mains connections inside.

## NINE VOLTS

Some readers will wish to know why 9V exists across resistor R1 while the circuit is operating. The current for the lamp flows partly through R1 and partly through the relay coil RLA, via diode D1. The current through the lamp filament is nominally 250mA because it is a 60W bulb and the current is given by the Power Formula:

$$I = P/V = 60/240 = 0.25A \text{ or } 250mA$$

In fact, the current is slightly less than this because R1 reduces it. The current through the relay coil is found by using Ohm's Law. Since the resistance of the coil is 100 ohm for the specified relay and there is 5V approximately across it:

$$I = V/R = 5/100 = 50mA$$

The current through R1 is therefore the total current minus the current through the relay coil – i.e. 200mA approximately. Since the value of R1 is 47 ohm, Ohm's Law may be used to find the voltage across it:

$$V = I \times R = 0.2 \times 47 = 9.4V$$

Whatever the application, let the Magic Socket take control! □

# SHOP-TALK

with David Barrington

## Teach-In '93

Most parts used in this month's *Teach-In* are similar to those used for the *Mini Lab* series. The thermistor could be any small bead or disk type with a resistance of 4.7 kilohm at 25°C, i.e. Maplin FX21X. The Darlington transistor type TIP112 is also available from the same source.

The logic level f.e.t. is a little more difficult to find. We understand that Farnell Electronic Components have a good selection – the cheapest is the STP17N05L. If you have some suitable *n*-channel MOSFETs (< 1A at 50V) give them a try, but some types will not be fully turned on by the logic level output voltages from the VIA.

The stepper motor could be any small device – perhaps from a printer or plotter. Magenta Electronics (☎ 0283 65435) supplies both 6V and 24V units that move in 7½ degree steps. The 24V device has an impedance of 50 ohms and will operate from 5V to 12V without consuming large amounts of current, and still produces adequate torque for the demonstrations. Many other advertisers have small steppers available, but avoid types that have a low impedance as the *Mini Lab* will not be able to supply enough current.

## Linear Power Supply

The components and double-sided p.c.b. for the *Linear Power Supply* were chosen and designed to fit into a steel (it must be metal) instrument case. The one depicted in the article is the Maplin XJ27E. Most of our advertisers will be able to offer something similar, but it must be metal so that it can be safely "earthed".

The toroid mains transformer was custom-made and available from Lyon Forge (☎ 0702 610607). Formerly Lord Transformers, the device carries the code 30/LT/14-10. The transient suppressor should be the 250V a.c. type.

The multi-way audio locking connectors/sockets may prove difficult to find locally, the ones on the model were obtained from Maplin. Similar connectors are stocked by audio specialists Henry's Audio Electronics

(☎ 071 723 1008). The heatsink is the Maplin "high power type 2E" (code HQ70M). This is claimed to be rated as having a temperature rise, at the centre of the sink, of 2.4°C/W.

The double-sided printed circuit board is available from the EPE PCB Service, code 844.

## Magic Socket

Mains-rated wire of 6A minimum must be used in the *Magic Socket* project to make connections directly to the relay "make" contacts. Likewise, similar rated wire must be used for all interwiring connections.

Extreme care must be taken at all times when constructing this project as mains voltages are present on the circuit board. It is important that the correct type and rating fuses are used so that the supply will cut-off rapidly in the event of any fault condition.

It is most important that all fuses, including the 1A/2A "reading lamp" fuse, have the values specified. The circuit fuses FS1 and FS2 should be the 20mm ceramic types and should be stocked by most of our component advertisers. If not, then a visit to the local electrical shop should provide the correct types.

The 6V miniature relay used in the prototype model was purchased from Maplin (code JM17T) and has contacts rated 5A at 240V a.c. The pins of the relay will have to be bent slightly to fit it on the board. Other relays can, of course, be used provided the coil rating is the same, the contacts can handle the load and it will work down to 4.5V.

Remember that the lamp, plugged into the "master socket" must be fitted with a 60W tungsten filament bulb.

## L.E.D. Sandglass

Looking through the requirements for the *L.E.D. Sandglass* project, all devices seem to be readily available items and should be stocked by most of our component advertisers. The header plug and socket are now standard lines with most suppliers.

In some instances, you may have to settle for a "metal film" resistor when ordering the 5.6 megohm resistor. Not all advertisers stock the

complete range of "carbon film" types, but the difference in price is very small.

Regarding the l.e.d.s, it might be worthwhile approaching one of our advertisers, such as Greenweld, to see if they are prepared to give a small discount on a "10-plus" basis. The "bargain lists", issued at this time of year, usually carry some opto-devices at reduced prices.

The two printed circuit boards for the *Sandglass* are available as a pair from the EPE PCB Service, codes 841/842 (see page 795).

## Multi-Purpose Audio System 1-Six Channel Stereo Mixer

The only items that need careful consideration when buying parts for the *Six-Channel Stereo Mixer* are the case, centre-off switches and slider potentiometers.

The dual 9stereo) slider "pots" for which the large p.c.b. is designed were purchased from Maplin (code JM87U) and must have metal bodies and be p.c.b. mounting types. Most advertisers only seem to stock "mono" types. The centre-off switches came from the same source and are type F from their sub-Min range.

Suitable plastic console cases, with sloping aluminium front panels, are stocked by advertisers, but prices do vary quite considerably and it might be worth "shopping" around. The large p.c.b. and "optional" pre-amp boards are obtainable from the EPE PCB Service, see list on page 795.

## Kettle Alert

Before looking at component buying for the *Kettle Alert*, we must endorse the warning that, "as this unit carries up to 12A at 240V a.c. it should not be constructed by anyone without experience of working on mains voltages."

The polyester capacitor rated at 400V d.c./250V a.c. may be difficult to locate locally. However, metalised polypropylene types specially manufactured for continuous connections across the mains, are fairly common and should be readily available – you must specify the rating above when ordering.

We have been searching far and wide for a plug box with a metal earth pin. Nearly all advertisers stock these boxes but they have a plastic earth pin. The only source we have found is from Harrogate Electronic Services (☎ 0423 564353). Supplies are limited and are on a "first come first served" basis.

The printed circuit board is available from the EPE PCB Service, code 843.



# INTERFACE

## Robert Penfold



ANYONE who has followed developments in the world of computers could not have failed to notice that software prices have come down quite dramatically over the past few years. In "real terms", something like a top word processor program is much less than half the cost of its equivalent program five years ago.

The modern equivalent is certain to be far more advanced than its predecessor. With competitive upgrades and other special offers, some popular "mega" software can be had at such low prices that it is tending to squeeze budget software out of the market.

### Freebies

This is probably one reason that so much "free" software of good quality is currently available. Most of the major new offerings from shareware libraries seem to be ex-commercial software which has simply been placed into the public domain, or is being sold at very low cost as shareware.

There is also quite a lot of "free" software which is either old versions of well known programs, or basic versions of normal commercial software. This software has been given the name "freeware". In most cases anyone can use the software without having to pay any registration charges. This might seem to be unduly generous, but the software companies are clearly hoping that a reasonable percentage of users will like the programs, and will buy the full-priced "real thing".

Specialist software for use in electronics is now starting to get the freeware treatment. Several examples have been mentioned in previous *Interface* articles. The latest example is a freeware printed circuit design program called "Easytrax". This is actually the most basic of the programs in the range sold by Protel Technology Ltd.

This is not a "crippled" version of the program, and it is supplied with a useful range of screen, printer, and plotter drivers. A large library of component outlines is provided, and the program seems to be able to handle very large and complex boards.

Although it is freeware, there are "strings attached". The main one is that only "non-commercial" use is permitted. Professional users who wish to continue using the program after a trial period are expected to purchase the commercial version. However, private and educational users can use this software for as long as they like, free of charge.

### Making Tracks

Although this is the most basic of Protel's printed circuit design programs, it is still a fairly advanced piece of software. It can be

run on a basic PC having twin floppy drives, but it is much better using a machine that has a hard disk, VGA or super VGA display, and a 80286 (or better) microprocessor. The optional mouse should be regarded as essential. Installation is reasonably straightforward as an installation program is included.

The program has a modern user interface. Status information, etc. is provided at the bottom of the screen via two lines of text. The rest of the screen is normally given over to the drawing area. Pressing the left hand mouse button brings up the main menu in the top left hand corner of the screen. Selecting a menu option brings up a sub-menu, which might in turn give access to a further sub-menu or a dialogue box.

The menu structure is very logical and I found it quite easy to control the program. There are keyboard shortcuts to some functions, such as preset zooming and changing layers.

The basic method of using the program is to first place the various components. The connections are then added, one by one, working from a list of interconnections (a netlist). Double-sided tracking can be accommodated, as can multi-layer tracking with up to four mid-layers. There is a simple but reasonably effective auto-router which operates on a one track at a time basis. Like most simple auto-routers, it cannot handle single-sided boards.

The program can then generate a netlist from the interconnections in the drawing, and this list is checked against the original netlist. If preferred, you can ignore netlists and simply work direct from a circuit diagram. This is a less reliable method because it is more difficult to locate any errors or missing tracks, but it has the advantage of being very quick and simple. It is the method that is most appropriate to relatively simple boards, but it is often a bit awkward to use this system with the more sophisticated printed circuit design programs.

### Output Drivers

Completed designs are printed or plotted via a separate program. This has drivers for

a range of dot-matrix printers, laser printers, pen plotters, and photo plotters. It provides full control over X and Y scaling, layers to be plotted, plot quality, etc. Provided the output device is up to the task, the hard copy is of a high standard (see Fig.1).

Although the program is relatively simple, it has quite a good range of features, including excellent pan and zoom facilities, an undelete function, independent snap and visual grid settings, connection highlighting, etc. The graphics are superb, and the screen redraws at a very impressive rate.

Many of the more simple printed circuit design programs are let down by poor editing facilities, but Easytrax has a full range of editing commands. Moving tracks and components, for example, is very straightforward. The program showed no signs of instability, and it seems to be free from traps which make it hard to get out of an option chosen by mistake.

### Documentation

There is about 60k of on-disk documentation. This consists mainly of installation notes, a tutorial dealing with the basics of drawing up a board, and a further tutorial on plotting a board. The final section provides a brief description of every command.

The documentation does not provide a detailed description of every facility, but unlike much software of this type, everything seems to work in a logical and sensible manner. Once a few basics have been mastered there is little difficulty in finding and using the more advanced facilities.

The manual claims that this program is so easy to use that you could be using it to design your own printed circuit boards within an hour of installation. While this is probably a slight exaggeration, it is no more than that. I found this program to be much easier to use than most of the other printed circuit software I have tried. It is simple enough to be easy to learn and use, but is sophisticated enough to comfortably handle complex boards.

Easytrax is well suited to the needs of electronic hobbyists. Occasional users should not find themselves having to continually relearn how to use the program. Of the various shareware, freeware, and public domain programs of this type, Easytrax is not the most sophisticated, but for electronics hobbyists it is probably a good choice. It is one of the best thought out programs I have encountered, and is certainly a piece of software I can wholeheartedly recommend.

Easytrax 2.06 is available on a single high density disk from The PDSL, Winscombe House, Beacon Road, Crowborough, Sussex, TN6 1UL (Tel. 0892 663298, Fax 0892 667473). It is on disk H251. It might be

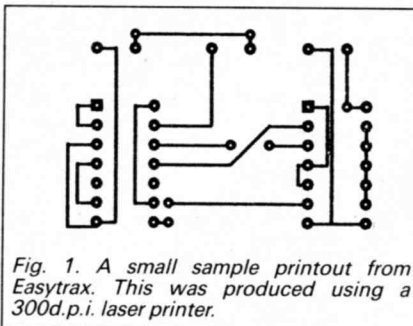

Fig. 1. A small sample printout from Easytrax. This was produced using a 300d.p.i. laser printer.

available from other shareware sources, but it will be under a different catalogue number.

## Memory Loss

Erasable programmable read only memories (EPROMs) are extremely useful devices, which are not restricted to ROM software applications. They are to be found in many pieces of equipment, some of which are not even microprocessor based.

As an example, some time ago I experimented with a MIDI pedal unit which sent various MIDI messages to a synthesiser when the pedal was operated. This was easily achieved using a UART, an EPROM, and some simple logic hardware. The EPROM was programmed with the bytes of data that had to be transmitted.

The alternative would have been to have numerous octal tri-state buffers with their inputs hard wired with the appropriate binary patterns. This would not be very practical, and would make it difficult to implement changes to the transmitted data. By contrast, an EPROM is easily erased and reprogrammed with totally different data.

The obvious problem with EPROMs is that they are only a practical proposition if you have some means of programming and erasing them. Erasing is achieved using what is basically just a box containing an ultra-violet tube. The latter emits short wavelength ultra-violet radiation.

EPROMs have a window in the top of the encapsulation which permits the ultra-violet to reach the silicon chip. Here the ultra-violet causes electrical charges to be leaked away, and after about 20 minutes or so the EPROM has total amnesia.

Note that an ultra-violet light box of the type used for producing printed circuit boards is unsuitable for erasing EPROMs. These light boxes produce light at the long wavelength end of the ultra-violet spectrum. This has no significant effect on EPROMs.

EPROM erasers are not exactly cheap, but they are not that expensive either. The same is not true of EPROM programmers. Stand-alone units mostly cost several hundred pounds, and even the lower cost add-on units for computers now seem to cost well over £100. Simple home constructed add-on programmers can be produced for very much less than this.

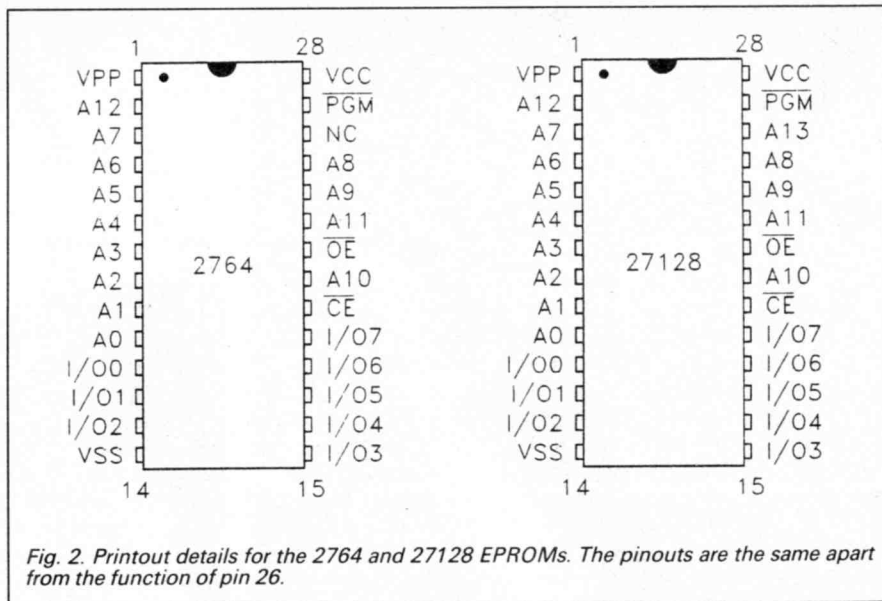



# Roline Systems Ltd

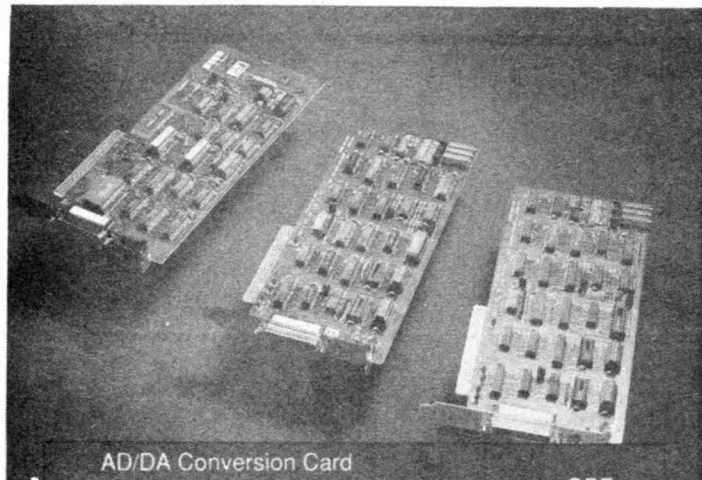

AD/DA Conversion Card  
12 Bit Res. 16 Channels I/P  
From £55

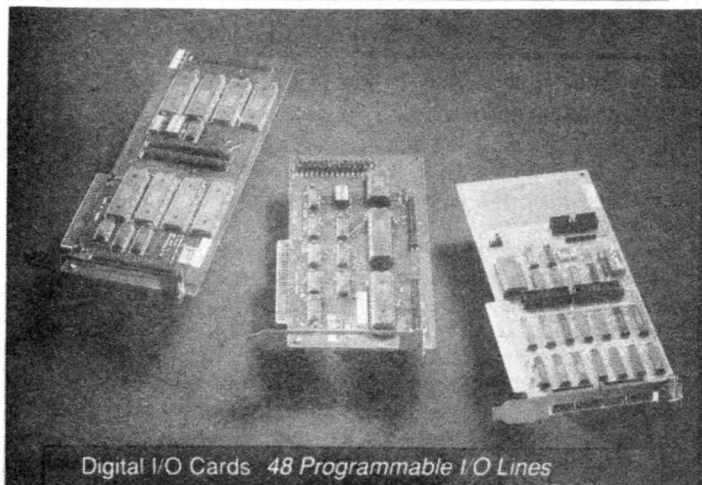

Digital I/O Cards 48 Programmable I/O Lines  
(3 Independent 16 Bit Counters)  
From £35



Voice Communications Card  
Intelligent Telephone Card  
From £175

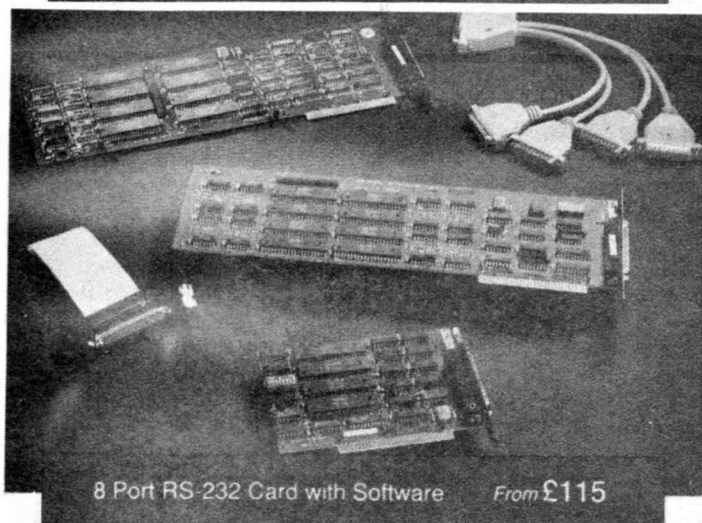

8 Port RS-232 Card with Software  
From £115

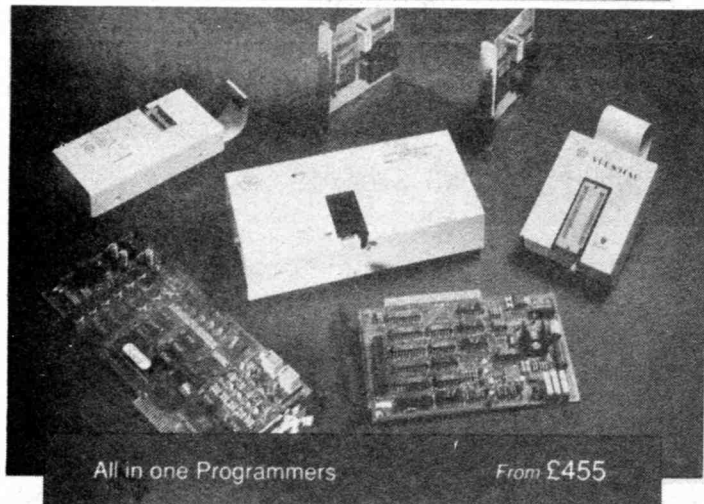

All in one Programmers  
From £455

## PC Based Industrial and Lab, Data Acquisition, Control and Measurement, Instrument Cards

### AD/DA Cards

Plus Accessories & Software

### C.P.U. Boards

### Device Programmers

### Digital I/O Cards

### IEEE 488 Cards

### Industrial Chassis

### Industrial Control Cards

### Interface Convertors

### Relay Output Cards

### RS 232 Cards

Single, 2, 4, 8, 16, Port

### RS 422 Cards

Single, 2, 4, 8, Port

### PC ROM Disk Cards

### Slot Extender Cards

For further information,

Product/Price List

Call Us On :

**Tel: 0902 20267**

Roline Systems Ltd  
Imex House  
Imex Business Park  
Upper Villiers Street  
Wolverhampton  
West Midlands  
WV2 4NU

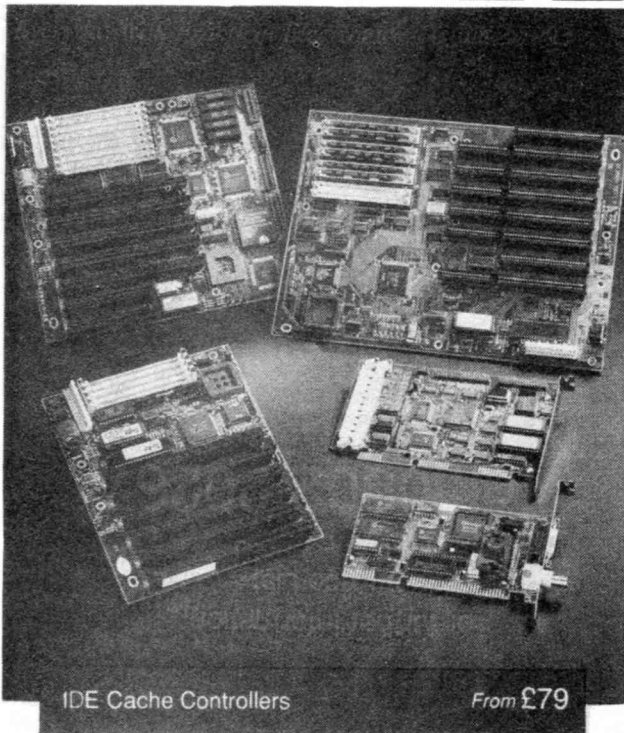

IDE Cache Controllers

From £79

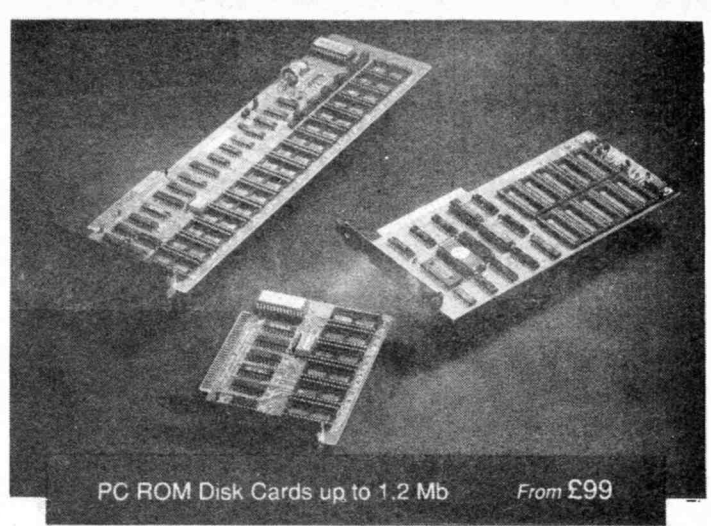

PC ROM Disk Cards up to 1.2 Mb

From £99

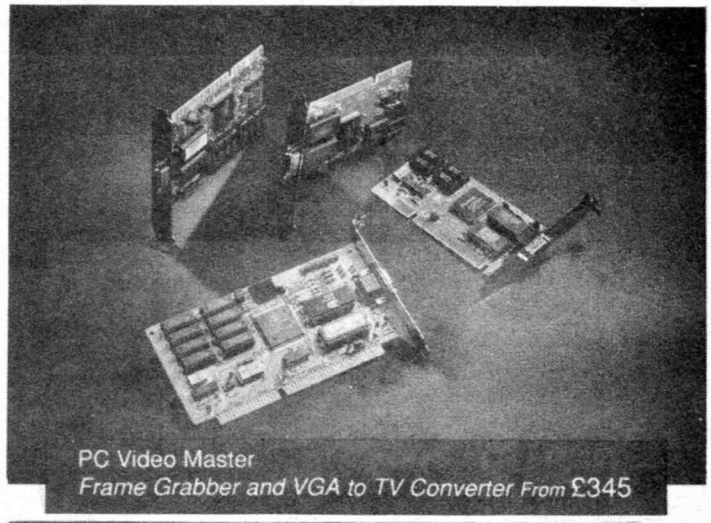

PC Video Master

Frame Grabber and VGA to TV Converter From £345

## Specialist PC & Multimedia Add-on Cards

PC - Telephone Voice  
Communication Cards  
Fax Modem Cards  
Voice Recognition Cards  
Voice Digitiser Cards  
TV/Video - PC Adaptor  
Video Grabber Cards  
Video/TV - PC - Video/TV Cards  
Sound Cards

## Components

Cases  
Floppy Disk Drives  
Hard Disk Drives  
From 40MB to 2.1GB  
Keyboards  
Monitors  
Mother Boards  
Cache Controller Cards  
Network Cards  
Tape Back Up Units

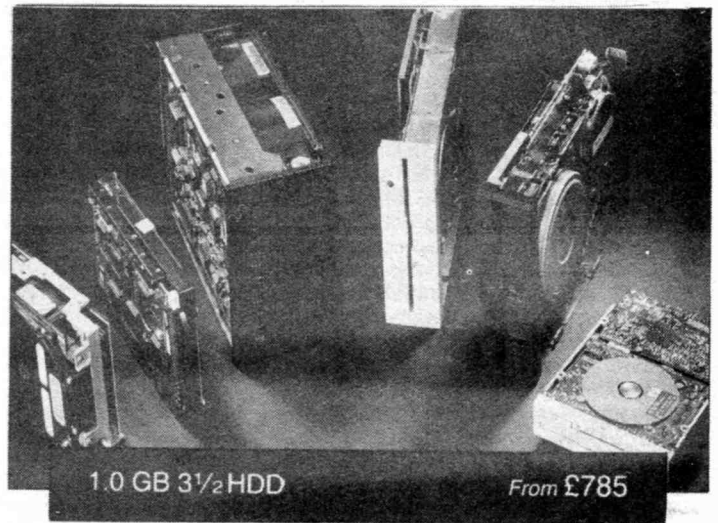

1.0 GB 3 1/2 HDD

From £785



**Fax: 0902 28439**



# Audio Amplifier Design, Engineering or Alchemy?

JOHN LINSLEY HOOD **PART 3**

*The effects of transistor types on sound quality.*

IN THE previous part of this short series, I took a brief look at the differences between bipolar and MOSFET transistors as power amplifier output devices, and concluded that MOSFETs were to be preferred in this position because they didn't suffer from "hole storage" and "minority carrier" effects. This could, among other things, lead to a sluggish "switch off" response if the transistor was driven hard on – a phenomenon which had exactly the same effect, in producing a signal blanking paralysis of the amplifier, under turn-off conditions, as Transient Intermodulation Distortion, (TID), has under turn-on conditions, and is just as audibly unpleasant.

## BIPOLARS vs MOSFETS

However, the fact that MOSFETs are much faster in action – have a much higher  $f_T$  – also means that the "h.f. compensation", the "slugging" of the h.f. gain characteristics of the system normally required to achieve loop stability in an amplifier using negative feedback, need not come into operation at as low a frequency, or to such a great extent. This usually allows the negative feedback loop to remain effective, both in reducing noise and distortion, and in cleaning up the transient response of the amplifier, up to much higher frequencies.

The effect of this is usually to give a MOSFET based audio amplifier a somewhat "cleaner" sound quality in the upper mid and high end of the audio frequency range. MOSFETs are also known to have a much more "linear" relationship between their input voltage and output current than any bipolar junction transistors, and this makes it easier to design a low distortion amplifier with MOSFETs than with bipolars, and reduces the amount of negative feedback (NFB) needed for a given performance. This generally helps the designer achieve good stability under awkward loudspeaker load conditions.

While most of the differences proclaimed by the "subjective sound" fraternity are, in reality, pretty tiny I am convinced that there are generally some small but noticeable differences in tonal quality between MOSFET and junction transistor based power amplifiers and that designs based on MOSFETs usually sound better. (I say "usually" because there are some grotty MOSFET designs around, so their use gives no automatic guarantee of excellence).

## INFLUENCE OF CIRCUIT DESIGN

There are three main tasks which the would-be audio amp. circuit designer must accomplish, apart from the need to achieve some target level of harmonic and intermodulation distortion and output power over the required frequency range and into some specified load, usually a high power eight ohm resistor. These are: the need to ensure that the circuit will still deliver the required output signal into a real-life output load, such as a loudspeaker, which isn't just a pure resistor; that it will do so without sporadic instability; and that it will also amplify transient signals, having steep rise or fall rates, without significant waveform deformation.

It is the effectiveness of the design in avoiding these three snags, ones that I think of as the "Cinderella" problems – because they are so often neglected – which is, I believe, the main source of the differences, usually fairly subtle, in sound quality between one design and another. Yes, I will accept the engineers point that a design which exhibits these problems is not "competently engineered" – but, since these faults are always present to some extent, the question is then "how much is too much?". There is certainly no agreed specification on these things.

## OPTIONS

In achieving these objectives, the skilled engineer will have a number of design options at his disposal. Each of these has advantages and drawbacks. For example, at the input of an amplifier, one could use a single transistor in what is called a "single-ended" layout, shown in Fig. 1a. Where the signal input is connected to its base(b), its emitter(e) is taken to some reference voltage line, and the output is taken from its collector(c), and negative feedback, (NFB), if any, is also taken to its emitter.

The advantage of this layout is that it is simple, but there will always be a large amount of distortion in this stage, except on very small input signals. This layout is awkward to use in "Direct Coupled" amplifiers where the output d.c. level is required to be the same as that of the input.

A simple improvement on the single-ended layout is shown in Fig. 1b, where two transistors are used, connected as a "long tailed pair". This gives much less distortion than the single-ended arrangement, for the same input signal level, but has only half the

stage gain, and the "tail" resistor, R3, which is connected, in this case, to the positive supply line, offers a route for the intrusion of unwanted, and probably distorted signals from this line.

From the point of view of the purist, there is also the snag that if the distortion reducing negative feedback signal is taken to the base of TR2, it doesn't do anything to correct for any errors in the path between the input (TR1 base) and TR2 base. Some "ultra-Fi" designs therefore take their NFB line directly to TR1 base, as I have shown in Fig. 1c, though this leads to an awkwardly low input impedance. Using a very high impedance "constant current source", (CC1), as the tail load, both helps to keep out supply line rubbish,

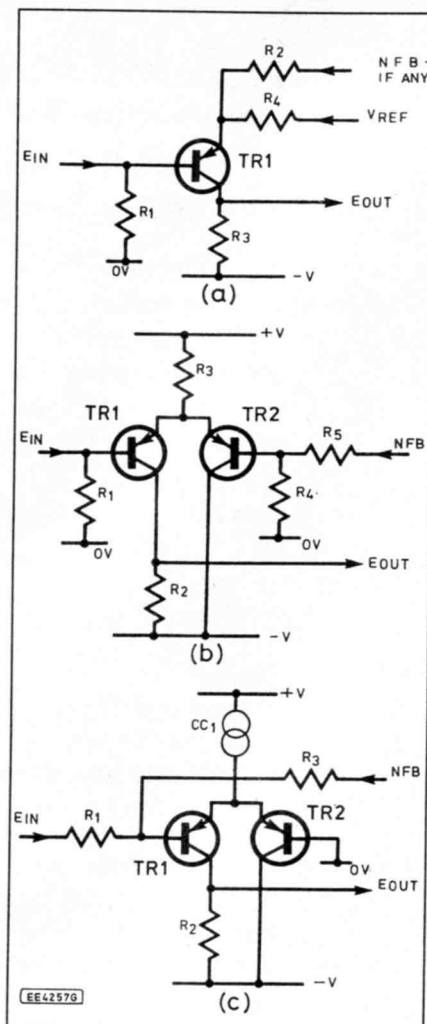

Fig. 1. Transistor amplifier input stage arrangements.

and also improve the TR1 to TR2 coupling.

I have shown *pnp* transistors in the circuit diagrams of Fig. 1, because they have a somewhat lower input noise level, but, in most applications, there is no significant difference. Now, do these circuit configurations sound the same?

I have never made a direct comparison between all three circuits. However, for the sake of simplicity, I used the input layout of Fig. 1a, in a "Simple 10W Class A Amplifier", back in 1968. I later tried out an "improved" version, using an input long-tailed pair, as in Fig. 1b.

This had a lower measured harmonic distortion figure, but I still preferred the sound of the original circuit. To be fair, there were several reasons why this could have been, possibly including the observation that simpler systems often sound better – regardless of their measured performance.

## FEEDBACK ON DISTORTION

Negative feedback (NFB) is widely used as a means of improving the performance of amplifier designs. It is good practice to try to make the circuit as distortion free as possible before applying NFB, and then to use the correct amount. (Too little may actually worsen the performance, by introducing higher order, and more dissonant, harmonic components not originally present. Too much may simply worsen the stability of the amplifier). The use of an input long-tailed pair circuit shown in Fig. 1b and Fig. 1c is helpful, as is the "cascode" layout shown in Fig. 2.

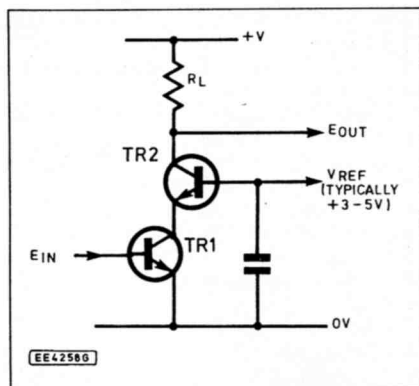

Fig. 2. The "cascode" type of layout.

The advantage of this last arrangement, Fig. 2, is that the input transistor, TR1, operates under a nearly constant collector voltage, to convert an input (base) current, into a larger collector current – a process which is normally quite linear. The "cascode" transistor, TR2, simply takes the output current from TR1, and delivers it to the output load,  $R_L$ , as from a very high impedance source. This usually gives a somewhat greater stage gain than the simple layout of Fig. 1a, as well as a much flatter frequency response, and a lower phase shift and distortion factor.

These benefits greatly appeal to circuit designers, and in some published layouts every gain stage is cascode connected. I have done no comparative tests on the sound quality of simple vs. cascode stages, but I would be surprised if there are no differences.

Another commonly used technique in circuit design is to make the circuitry as nearly fully symmetrical as possible. One approach is that in which the standard long-tailed pair layout of Fig. 1b is elaborated into the

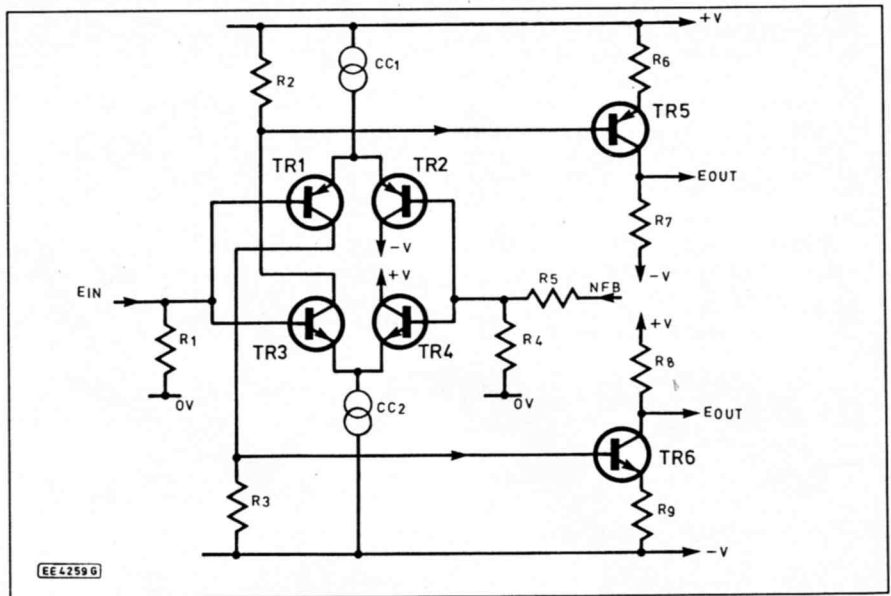

Fig. 3. Elaboration of input long-tailed pair into fully symmetrical layout.

circuit of Fig. 3, and so on throughout the amplifier. The idea of this approach is that positive going signal voltage excursions will be handled identically to negative going ones.

In my experience, there is an audible difference between symmetrical and non-symmetrical designs, with the symmetrical design sounding somewhat "brighter", in spite of an apparently identical frequency response within the audio pass-band. I do not know why this should be, but one can theorise. Certainly there are user preferences in this area.

Two other major sources of sound quality differences in commercial amplifier systems lie in the variations in the circuitry of, and the frequency response inaccuracies resulting from, the preamplifier "RIAA" gramophone input circuitry, and the nature of the power amplifier loop stability h.f. compensation techniques used. In this case, layouts which give the amplifier the kind of "open loop", i.e. prior to the application of negative feedback, frequency response shown in Fig. 4a, are preferable to me to those which give the kind of frequency response shown in Fig. 4b, though both may be arranged to give a similar stability margin.

## OXYGEN-FREE HYPE

Hi-Fi product promotion, these days, seems to consist of an ounce of reality,

flattened under a ton of advertisers "hype". A convenient recent example is the widely claimed "oxygen-free single crystal copper".

Frankly, I regard this as a myth, along with the hippogryphs and sea-monsters that old-time map makers used to fill in blank bits on their charts. Certainly, copper can, and will, be made oxygen-free – for a time – though it rapidly re-absorbs oxygen if it is heated above about 180°C: and remember that a typical soldering iron bit, in use, will sit at some 220°C to 250°C.

Care is necessary when making and refining copper, and the best electrical grade material is electrolytically formed, with the electrolytic slabs being melted into bars in an oxygen free environment. The practical reason for this is that copper is annealed, after rolling into sheets or drawing into wires, in an atmosphere of hydrogen, at 250°C to 325°C, and the hydrogen, which diffuses into the copper, will react with any dissolved oxygen to release steam, which disrupts the structure, and impairs its electrical conductivity. This is called "embrittlement" in the trade.

"Single crystal"? That's another matter. Most things which can be melted, and which can exist in crystalline form, can be made into single crystals by the "Czochralski" technique, in which a small seed crystal is very slowly withdrawn, during a day or two, from the surface of the melt.

This is hardly a practical large scale

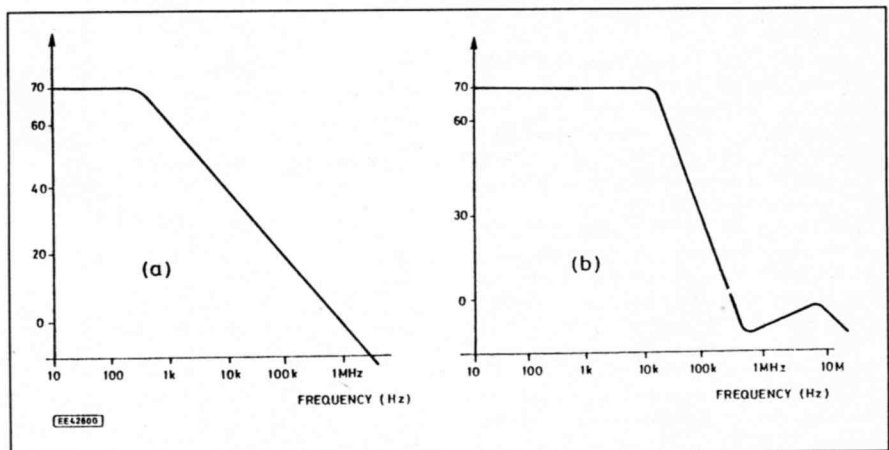

Fig. 4. Alternative h.f. "closed loop" compensation characteristics.



production process. Moreover, even if it was mono-crystalline in the first place, any subsequent extrusion, rolling or drawing will cause it to recrystallise, as would heating above about 180°C to 190°C, due, perhaps, to soldering.

The reason for the "hype"? Because someone observed that the conductivity of copper could be worsened, by one or two percent, by the presence of crystal interfaces, known to the metallurgist as "grain boundaries", because these serve to con-

centrate the inevitable impurities which then scatter the moving electrons which comprise the current flow.

## CONCLUSIONS

I do believe that there are small differences between the results given by different circuit designs and component constructions, and that even quite small defects in operation can often be heard. They can usually also be measured, if one looks in the right place; an exercise which

is often more difficult than I would wish. However, when the engineering is done well, different approaches can lead to remarkably similar results – or otherwise there would be a vast difference in sound quality between say a *Quad 405*, and a *Pioneer M-90*, and there isn't.

Much of what is claimed by the "golden eared" fraternity, does exist – but is much, much smaller than they think – and when it exists, and it sometimes doesn't, there are good reasons why. □

# FOX REPORT by Barry Fox



## PIRATE SPACE

The launch of Virgin's rock radio station, 1215 AM, has sparked a lot of interest in why there are so many new radio stations and how many more there can be. Much of what is happening can best be summed up by the old adage, where there is a will, there is a way.

Just as the pirate radio ships of the 60s forced the British government into starting Radio One, so the pirate stations of the 80s made it impossible for the government to keep on saying that there were no spare frequencies. People could hear for themselves that the pirates were operating in spare frequencies. But they were also causing interference, largely because they were using cheap equipment.

They used cheap kit because they knew it was at risk of confiscation by the DTI's inspectors. Also the pirates were using as much power as they could muster.

Nature is cruel. Although it needs a strong radio signal to provide clear hiss free stereo, it takes only a very weak interference signal to spoil reception of a stereo station with fluttering sounds, "birdy" chirping noises and occasional snatches of distorted music or speech. Licensing stations, on carefully defined frequencies at restricted power, was an obvious way out. The government also stood to earn some money from the licences, too.

Essentially, the Government did a deal with the BBC. It could retain its four national f.m. networks, but had to end the wasteful luxury of simulcasting the same programme on two different wavebands. The BBC had to agree to give up the two m.w. frequencies this released.

Also, although a large number of public and emergency services used to operate in the v.h.f. "entertainment" band, for everyone to hear, they have been moving out to get some privacy.

The Radio Authority is granting three licences for national commercial networks. Two have already been given, one to Classic FM, the national v.h.f. station, and the other to Virgin's m.w. rock station. Virgin is using the m.w. fre-

quency which Radio 3 gave up in February 1992. Radio One quits the m.w. at the end of next year, and its slot goes to INR3, the third national network.

## PRIZES

The real prizes are the v.h.f. frequencies because f.m. provides hifi stereo and better resistance to interference. Hence Richard Branson's current game plan. Having applied for and won m.w. 1215 for Virgin's music station, he is now lobbying for something quite different, on the v.h.f. band. This is greedy and cheeky, like satellite broadcaster BSB's whine that it was saddled with the MAC TV system, when that was the franchise it had applied for.

The v.h.f. band is neatly bundled into packages, all spoken for by the BBC and Radio Authority. There is nothing for Branson.

The BBC has 88-90.2MHz for Radio 2, 90.2-92.4 for Radio 3 and 92.4-94.6 for Radio 4. Radio 2 and Radio 3 currently have around 170 transmitters. Radio 4 has around 130, which accounts for the complaints of patchy coverage. But Radio 4 coverage should eventually match Radio 2 and 3. Unlike the commercial stations, the BBC is obliged to go on investing in the many new transmitters needed to reach the last few percent of listeners, even though it is not cost-effective.

Local BBC stations use 94.6-96.1 and local commercial stations use the band 96.1-97.6. Radio One has 97.6-99.8 and the national commercial radio stations, such as Classic FM, have 99.8-102. Independent local radio stations also has 102-103.5 and BBC local has 103.5-105.

The top slot in the f.m. band, 105-108 MHz, is still used in Britain by public utilities such as the gas, electricity and water authorities. The police, ambulance and fire brigade emergency services have already moved out of the lower slots in the bands which they occupied. The 105-108MHz slot should be clear by 1995, a year earlier than planned.

The Radio Authority will license this band, probably for use by low power local radio stations because there is a real risk of high power stations at these frequencies

interfering with the radio location beacons used by aircraft in the band just above. These beacons put out overlapping fan beams and the aircraft lines up to fly down a null path in the middle, where the beams cross. Any interference will make the null line wobble.

This, incidentally, is why airports now ban cars from parking on roads in the flight path. Their electronics, and radios, can leak enough signal to wobble the null. (The glide path transmitters which give the aircraft height information are in the u.h.f. band).

Most of Radio 4 is currently duplicated on f.m. and l.w., but the BBC has long been planning a split, putting a news and current affairs station on l.w. and theatre speech output on f.m.. This has angered those who find difficulty in receiving Radio 4 on f.m. either because they live in areas of poor reception or abroad.

Robbing the BBC of its Radio 4 f.m. frequency would kill the plan for a news and current affairs station and mean that people who currently enjoy good reception of Radio 4 on f.m. would in future have to make do with narrow bandwidth mono on the long wave. Many hifi receivers will not tune to the long wave. So this argument will run and run.

## DIGITAL AUDIO

There will be even more contention in the mid-90s, if the DTI and broadcasters are successful in their plan to start a completely new digital audio broadcasting service on a slice of frequencies in the v.h.f. band once used by the old 405 line TV system. This DAB service would provide digital quality reception all over the UK without the fluttering interference on f.m. caused by multi path reception, especially in cars. There would be room for around twenty new programmes.

But who will run these programmes, and pay for them? Should they be split evenly between the BBC and independent commercial broadcasters? These are the questions which will very soon start burning and it is where Branson should be concentrating his energies.

# HART

## HART AUDIO KITS – YOUR VALUE FOR MONEY ROUTE TO ULTIMATE HI-FI

HART KITS give you the opportunity to build the very best engineered hifi equipment there is, designed by the leaders in their field, using the best components that are available.

Every HART KIT is not just a new equipment acquisition but a valuable investment in knowledge, giving you guided hands-on experience of modern electronic techniques.

In short HART is your 'friend in the trade' giving you, as a knowledgeable constructor, access to better equipment at lower prices than the man in the street.

You can buy the reprints and construction manual for any kit to see how easy it is to build your own equipment the HART way. The FULL cost can be credited against your subsequent kit purchase.

Our list will give you fuller details of all our Audio Kits, components and special offers.

### AUDIO DESIGN 80 WATT POWER AMPLIFIER.

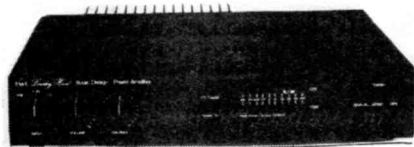

This fantastic John Linsley Hood designed amplifier is the flagship of our range, and the ideal powerhouse for your ultimate hifi system. This kit is your way to get £K performance for a few tenths of the cost! Featured on the front cover of 'Electronics Today International' this complete stereo power amplifier offers World Class performance allied to the famous HART quality and ease of construction. John Linsley Hood's comments on seeing a complete unit were enthusiastic: "The external view is that of a thoroughly professional piece of audio gear, neat elegant and functional. This impression is greatly reinforced by the internal appearance, which is redolent of quality, both in components and in layout." Options include a stereo LED power meter and a versatile passive front end giving switched inputs using ALPS precision, low-noise volume and balance controls. A new relay switched front end option also gives a tape input and output facility so that for use with tuners, tape and CD players, or indeed any other 'flat' inputs the power amplifier may be used on its own, without the need for any external signal handling stages. 'Slave' and 'monobloc' versions without the passive input stage and power meter are also available. All versions fit within our standard 420 x 260 x 75mm case to match our 400 Series Tuner range. ALL six power supply rails are fully stabilised, and the complete power supply, using a toroidal transformer, is contained within a heavy gauge aluminium chassis/heatsink fitted with IEC mains input and output sockets. All the circuitry is on professional grade printed circuit boards with roller tinned finish and green solder resist on the component ident side, the power amplifiers feature an advanced double sided layout for maximum performance. All wiring in this kit is pre-terminated, ready for instant use!

RLH11 Reprints of latest articles.....£1.80  
K1100CM HART Construction Manual.....£5.50

### LINSLEY HOOD 1400 SERIES ULTRA HIGH-QUALITY PREAMP

Joining our magnificent 80 Watt power amplifier now is the most advanced preamplifier ever offered on the kit, or indeed made-up marketplace. Facilities include separate tape signal selection to enable you to listen to one programme while recording another, up to 7 inputs, cross recording facilities, class A headphone amplifier, cancellable 3-level tone controls and many other useful functions, all selected by high quality reprints. For full details see our list.

Send or phone for your copy of our List (50p) of these and many other Kits & Components. Enquiries from Overseas customers are equally welcome, but PLEASE send 2 IRCs if you want a list sent surface post, or 5 for Airmail.

Ordering is easy. Just write or telephone your requirements to sample the friendly and efficient HART service. Payment by cheque, cash or credit card. A telephoned order with your credit card number will get your order on its way to you THAT DAY.

Please add part cost of carriage and insurance as follows:—INLAND Orders up to £20 - £1.50,  
Orders over £20 - £3.50. Express Courier, next working day £10.

OVERSEAS - Please see the ordering information with our lists.

### LINSLEY HOOD 'SHUNT FEEDBACK' R.I.A.A. MOVING COIL & MOVING MAGNET PICKUP PREAMPLIFIERS



Modern, ultimate sound systems are evolving towards built-in preamplifiers within or near the turntable unit. This keeps noise pickup and treble loss to a minimum. We now offer two units, both having the sonically preferred shunt feedback configuration to give an accurate and musical sound, and both having the ability to use both moving magnet and moving coil cartridges.

Kit K1500 uses modern integrated circuits to achieve outstanding sound quality at minimal cost. The very low power requirements enable this unit to be operated from dry batteries and the kit comes with very detailed instructions making it ideal for the beginner. K1500 Complete kit with all components, printed circuit board, full instructions and fully finished case.....£67.99  
Instructions only.....£2.80  
Kit K1450 is a fully discrete component implementation of the shunt feedback concept and used with the right cartridge offers the discerning user the ultimate in sound quality from vinyl disks. Can be fitted inside our 1400 Preamp, used externally or as a standalone unit. It has a higher power requirement and needs to be powered from our 1400 Series preamplifier or its own dedicated power supply. K1450 Complete Discrete Component RIAA Phono Preamp.....£109.58  
Factory Assembled and Tested.....£159.58  
K1565 Matching Audio Grade Power Supply with potted-toroidal transformer and limited shift earthing system.....£79.42  
Factory Assembled and Tested.....£118.42  
U1115 Power Interconnect Cable.....£7.29

### ALPS PRECISION LOW-NOISE STEREO POTS

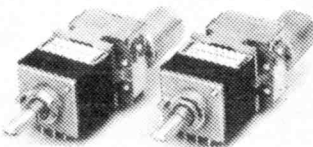

Super Savings with our "3 for the price of 2" Offer. Now back in stock our range of the fabulous ALPS range of High Grade Audio Pots fulfill the need for no compromise quality controls as used in HART Kits and other World Class Amplifiers. This exciting range covers the values needed for most quality amplifier applications.

Now you can throw out those noisy ill-matched carbon pots and replace with the real hi-fi components. The improvement in track accuracy and matching really is incredible giving better tonal balance between channels and rock solid image stability.

All pots are 2-gang stereo format, with 20mm long 6mm diam. steel shafts. Overall size of the manual pot is 27mm wide x 24mm high x 27mm deep, motorised versions are 72.4mm deep from the mounting face. Mounting bush for both types is 8mm diameter. Motorised versions have 5V d.c. drive motor.

MANUAL POTENTIOMETERS  
2-Gang 100K Lin.....£15.67  
2-Gang 10K, 50K or 100K Log.....£16.40  
2-Gang 10K Special Balance, zero crosstalk and zero centre loss.....£17.48  
MOTORISED POTENTIOMETERS  
2-Gang 20K Log Volume Control.....£26.20

2-Gang 10K RD Special Balance, zero crosstalk and less than 10% loss in centre position.....£26.98  
OUR SPECIAL OFFER ON ALPS POTS: Buy any two and get the third FREE. (The third must be the same or a cheaper type).

### STUART REEL-TO-REEL TAPE RECORDER CIRCUITS

Complete stereo record, replay and bias circuit system for reel-to-reel recorders. These circuits will give studio quality with a good tape deck. Separate sections for record and replay give optimum performance and allows a third head monitoring system to be used where the deck has this fitted. Standard 250mV input and output levels. Ideal for bringing that old valve tape recorder back to life. Suitable stereo heads are in our head list. This basic kit is suitable for advanced constructors only. K900W Stereo Kit with Wound Coils and Twin Meter Drive.....£123.99  
RJS1 Reprints of Original Descriptive Articles.....£3.60

### HIGH QUALITY REPLACEMENT CASSETTE HEADS



Do your tapes lack treble? A worn head could be the problem. For top performance cassette recorder heads should be replaced every 1,500 hours. Fitting one of our high quality replacement heads could restore performance to better than new! Standard inductances and mountings make fitting easy on nearly all machines (Sony are special dimensions, we do not stock) and our TC1 Special Cassette helps you set the azimuth spot on. As we are the actual importers you get prime parts at lower prices, compare our prices with other suppliers and see! All our heads are suitable for use with any Dolby system and are normally available ex stock. We also stock a wide range of special heads for home construction and industrial users.

HC80 NEW RANGE High Beta Permalloy Stereo head. Modern space saver design for easy fitting and lower cost. Suitable for chrome metal and ferric tapes, truly a universal replacement head for everything from hi-fi decks to car players and at an incredible price too!.....£8.30  
HRP373 Downstream Monitor Stereo Combination Head.....£53.90  
HQ551A 4-Track Record/Play Head.....£8.75  
HM120 Standard Mono R/P Head.....£3.44  
H524 Standard Erase Head.....£1.90  
H561 Hi Field Erase Head for METAL Tapes.....£3.49  
SM150 2/2 (Double Mono) DC Erase Head.....£5.20  
HQ751E 4/4 True 4-Track Erase Head.....£57.06

### REEL TO REEL HEADS

999R 2/4 Record/Play 110mH. Suits Stuart Tape Circuits.....£13.34  
998E 2/4 Erase Head 1mH. Universal Mount. Suits Stuart.....£11.96

**"Full spec., treble D Quality Classical and Opera Compact Disks at incredible prices. Send for full list of titles."**

### HART TC1D Triple Purpose TEST CASSETTE

Now available again and even better than before! Our famous triple purpose test cassette will help you set up your recorder for peak performance after fitting a new record/play head. This quality precision Test Cassette is digitally mastered in real time to give you an accurate standard to set the head azimuth, Dolby/VU level and tape speed, all easily done without test equipment.  
TC1D Triple Purpose Test Cassette.....£14.99

### TAPE RECORDER CARE PRODUCTS

DEM1 Mains Powered Tape Head Demagnetizer, prevents noise on playback due to residual head magnetisation.....£4.08  
DEM115 Electronic, Cassette Type, demagnetizer.....£8.61



QUALITY AUDIO KITS

24 hr. SALES LINE (0691) 652894

ALL PRICES INCLUDE UK/EC VAT

**HART**  
HART ELECTRONIC KITS LTD  
6 PENYLAN MILL  
OSWESTRY, SHROPSHIRE  
SY10 9AF



# Teach-In '93

with Alan Winstanley  
Keith Dye B.Eng(Tech)AMIEE and  
Geoff MacDonald B.Sc(Hons) AMIEE

Part 12

*Teach-In '93 continues a tradition of offering an interesting and thorough tutorial series aimed specifically at the novice or complete beginner in electronics. The series is designed to support those undertaking either GCSE Electronics or GCE Advanced Levels.*

**W**ELCOME to the last part of *Teach-In*. In this part we will look at further ways of interfacing peripherals to computers using the *Micro Lab*, and give examples of software to control the devices. The final batch of experiments that have been built into the *Micro Lab* are revealed to allow closed loop control of external loads, voltage to frequency conversion, and playing tunes from internal lookup tables. We conclude with a look at a reaction timer that will allow you to test both yourself and your new software skills.

## CONTROLLING EXTERNAL PERIPHERALS

Controlling external devices with the *Micro Lab* is achieved through the 65C22 *Versatile Interface Adapter* (VIA). The circuit diagram for the 65C22 and 34-way output connector are shown in

Fig. 12.1. The VIA may be used to simply turn devices on and off or to automatically perform more complex tasks such as counting input pulses and serial to parallel and parallel to serial conversion.

When interfacing a computer to external devices, you should always use a suitable interface circuit. This is because most computer outputs cannot supply enough current to power devices like lamps, i.e.d.s, relays and motors so you will need to use a transistor of some sort to do the actual switching of the device. Also, if anything goes wrong with the device, then an interface circuit will (hopefully!) protect the more expensive computer circuitry from damage.

The data sheet for the 65C22 shows that port A (pins 2 to 9) and port B (pins 10 to 17) outputs have different drive capabilities. Port A and its two associated control lines CA1 and CA2 can drive two standard TTL loads and present two TTL loads to an input source. In current terms these pins can typically source 1.5mA (minimum

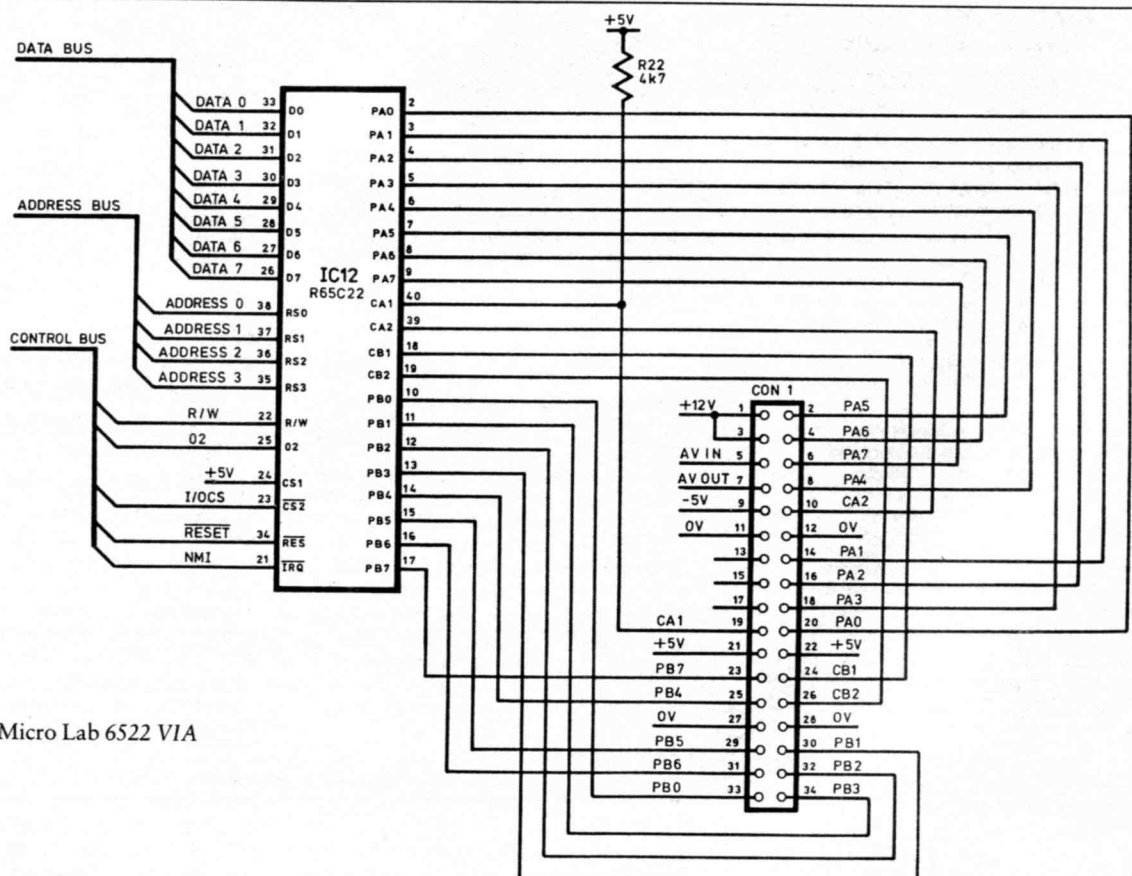

Fig. 12.1. Micro Lab 6522 VIA

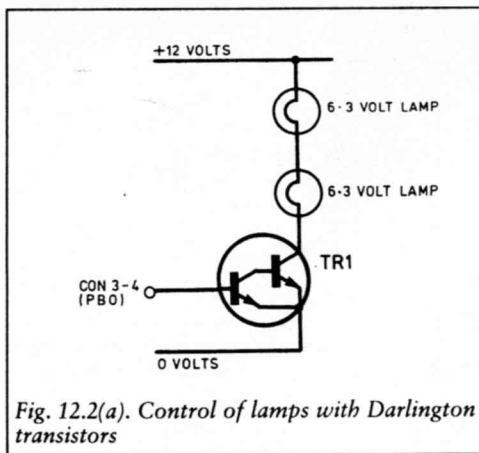

Fig. 12.2(a). Control of lamps with Darlington transistors

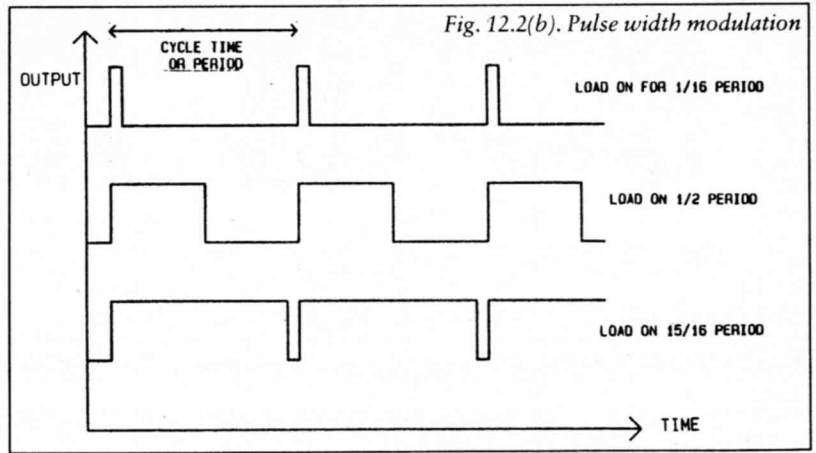

Fig. 12.2(b). Pulse width modulation

0.2mA), and sink a minimum of 3.2mA. Port B and its control pins CB1 and CB2 can sink the same minimum current of 3.2mA while being able to source (or drive) typically 6mA (minimum 3.2mA at 1.5 volts). This makes port B ideal for driving Darlington transistors and other loads requiring higher drive currents.

We will use the 65C22 ports for driving external loads, and producing variable frequency square waves. The 65C22 is a highly complex i.c. capable of many other functions and readers are advised to obtain a full data sheet on the device to use it to its full potential. Some details are included in the separate box item on the 65C22.

### CONTROLLING A FILAMENT LAMP

A circuit which may be used to control a filament lamp is shown in Fig. 12.2(a), although you could replace the lamp by any device which requires no more than the maximum rated current of the Darlington transistor (2A for the TIP112) or the current available from the power supply (up to 1 amp on the *Mini Lab*). To control the lamp, we must first turn the port connected to the base of the Darlington transistor into an output:

```
0200 A9 01 LDA #01 ;Set PBO to output
0202 8D 42 80 STA $8042
```

Now, we can turn on the lamp by writing a "1" to the output register of the 65C22 corresponding to pin PBO (i.e. bit 0 of ORB/IRB):

```
0205 A9 01 LDA #01 ;Turn lamp on
0207 8D 40 80 STA $8040
```

To turn the lamp off, we would write a "0" to ORB/IRB. Before we do this, we will make the program pause for one second:

```
020A A9 64 LDA #64 ;Delay for one second
020C 20 18 00 JSR $0018
020F A9 00 LDA #00 ;Turn lamp off
0211 8D 40 80 STA $8040
0214 00 BRK ;End program
```

When you run this program, the lamp will turn on for one second then turn off (you may find that the lamp turns on when the *Micro Lab* is reset, so you will need to run the program twice to see it work correctly).

We can change the program to flash the lamp by adding the following code:

```
0214 A9 64 LDA #64 ;Delay for one second
0216 20 18 00 JSR $0018
0219 4C 05 02 JMP $0205 ;Repeat
```

We can make the lamp flash faster by reducing the values at addresses 020B and 0215 - this shortens the delay time. If we make the delays short enough, the lamp will become continuously on because it takes time for the filament to heat up and cool down, however it will appear to be dimmed because it is unable to reach full brightness before being turned off again.

The brightness of the lamp depends on the average power being delivered to it. So, if the value at address 020B is greater than the value at address 0215, the lamp will be powered longer than it is turned off and, so, will glow brighter. The cycle time is constant due to the software program looping round, and the brightness (or average power) is proportional to the *mark to space ratio* of the on/off times.

The following program uses this fact to vary the brightness of the lamp under control of the user. It works by having a byte in memory (at 90h) which sets the lamp brightness. The lamp is first turned on then the program counts down to zero from this value. Next, the

lamp is turned off and the program counts down to zero from 127 - "lamp brightness". Finally, the program checks to see if the user has pressed either the "0" or the "1" key and subtracts or adds 4 to the lamp brightness as required.

```
0200 A901 LDA #01 ;Set PBO as an output
0202 8D4280 STA $8042
0205 A900 LDA #00 ;Set the initial
;brightness of the lamp

0207 8590 STA $90
0209 A901 LDA #01 ;Switch the lamp on
020B 8D4080 STA $8040
020E A690 LDX $90 ;Count up to the
;"lamp brightness"

0210 CA DEX
0211 10FD BPL $0210
0213 A97F LDA #$7F ;Calculate 127 -
;"lamp brightness"

0215 38 SEC
0216 E590 SBC $90
0218 AA TAX
0219 A900 LDA #00 ;Switch the lamp off
021B 8D4080 STA $8040
021E CA DEX ;Count to 127-"lamp
;brightness"

021F 10FD BPL $021E
0221 201E00 JSR $001E ;Key pressed?
0224 AA TAX ;Store key value in IX
0225 A590 LDA $90 ;Store "lamp
rightness" in Acc
;Key = "0"?

0227 E030 CPX #30
0229 D006 BNE $0231
022B 38 SEC ;Yes - Subtract 4 from
;brightness

022C E904 SBC #04
022E 4C3802 JMP $0238
0231 E031 CPX #31 ;Key = "1"?
0233 D003 BNE $0238
0235 18 CLC ;Yes - Add 4 to lamp
;brightness

0236 6904 ADC #04
0238 297F AND #7F ;Make brightness
;between 0 and 127

023A 8590 STA $90
023C 4C0902 JMP $0209 ;Start again ...
```

This type of power control is called *Pulse Width Modulation* or *PWM*. Fig. 12.2(b) shows three output waveforms for 1/16, 1/2, and 15/16 lamp brightness. Note that the cycle time remains constant whilst the on/off times are varied as a proportion of the cycle. A common use of PWM is to control d.c. motor speeds, particularly in models. Switching the load on and off to control the average power is a very efficient method of using transistors. By only operating in one of two states - either hard on (e.g. saturation) or hard off, they never operate in their linear region. This means that the internal resistance of the transistor is either very low (on) or very high (off), and the transistor can switch high currents without dissipating great amounts of heat.

### SOUND OUTPUT

The 65C22 contains two sixteen bit timer/counters which may be used for many operations. To generate sound output, we can make Timer 1 continuously count down from a specified value and invert the PB7 output when it goes below zero. This generates a square wave with a controllable period on this pin. When connected to an



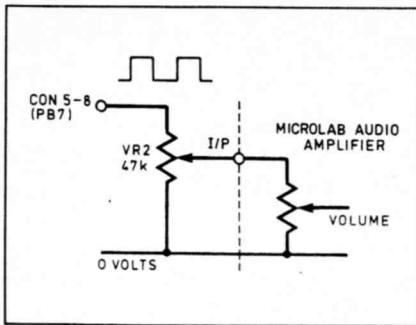
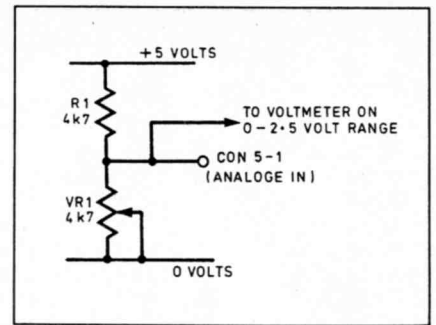

Fig. 12.3 (left). Frequency output to amplifier.

Fig. 12.5 (right). Varying the input voltage for Demonstration Program 6.

Fig. 12.4 (below). Demonstration Program 6.



```

81F8 ;*****
81F8 ;***
81F8 ;*** Everyday Electronics Micro-Lab
81F8 ;***
81F8 ;*** Name: Demonstration 6
81F8 ;*** Version: 1.0
81F8 ;*** Author: Geoff MacDonald
81F8 ;*** Date: 13/01/1993
81F8 ;*** Last Update:
81F8 ;***
81F8 ;*****
81F8 ;Read the analogue input and use the result to set the
81F8 ;frequency of pulses output by the 65C22.
81F8
81F8 A901 D_DEMO6: LDA #1 ;Initialise the 65C22 for sound
81FA 201500 JSR SOUND
81FD 8DFFFF DEMO6A: STA $FFFF ;Initiate A/D conversion
8200 A00A LDY #10 ;Delay
8202 88 DEMO6B: DEY
8203 D0FD BNE DEMO6B
8205 AD2080 LDA AIN ;Read analogue input
8208 A8 TAY ;Set sound output frequency
8209 A201 LDX #1
820B A900 LDA #0
820D 201500 JSR SOUND
8210 A90A LDA #10
8212 201800 JSR DELAY
8215 A55D LDA KBSIZE ;Key pressed?
8217 F0E4 BEQ DEMO6A ;No - repeat
8219 202100 JSR KBCLR ;Clear keyboard buffer
821C A900 LDA #0 ;Sound off
821E AA TAX
821F A8 TAY
8220 201500 JSR SOUND
8223 00 BRK ;Terminate

```

amplifier (such as the one on the *Mini Lab*) a sound is produced. Fig. 12.3 shows a method of connecting port PB7 to the amplifier. The variable resistor VR2 is used to attenuate the typically four volt signal before the amplifier input volume control.

To set the frequency of the sound, we load the Timer 1 latches with the desired count. This value is automatically loaded into the timer whenever it goes below zero. The timer decrements at the system clock rate. So, the sound output frequency is given by:

$$f_s = \frac{f_c}{2t}$$

Where:  $f_c$  = system clock frequency,  
 $f_s$  = sound output frequency,  
 $t$  = Timer 1 latch value (T1L)

To initialise this mode of operation, we write a C0h to the Auxiliary Control Register (ACR) of the 65C22. This sets Timer 1 into continuous run mode with output on PB7. To set the output frequency, we firstly write the high byte of T1L into T1L-H, then write the low byte into T1L-L then we write the high byte into T1C-H. This last operation sets the counter running. There is a subroutine within the *Micro Lab* monitor program which does all of this for you. Calling the routine with  $Acc = 1$  will initialise the 65C22 to output sound. Calling it with  $Acc = 0$ ,  $IX = High\ byte$  and  $IY = Low\ byte$  will output a sound. If  $IX = 0$  and  $IY = 0$  then sound output is disabled.

## SIGNAL CONVERSION

As we have seen before, it is often necessary to convert one type of signal into another (the modern telephone is a good example of this - sound signals are converted into analogue voltages by the microphone in the telephone, this is then converted into a

digital data stream at the exchange which is then converted into pulses of light and sent down fibre optic cable to the next exchange. At the final destination exchange the signals are converted back to analogue signals for transmission to the receiving telephone). This type of conversion may be performed using the *Micro Lab*. Demonstration Program 6 (see Fig. 12.4) converts an analogue voltage into variable frequency pulses by continuously reading the analogue input port then calling the SOUND routine with the value read. The circuit in Fig. 12.5 allows you to vary the input voltage using a potentiometer. The frequency output from PB7 is coupled to the amplifier using the circuit shown in Fig. 12.3. Thus allowing you to hear the output frequency through the *Micro Lab* speaker.

We found that we could also leave the analogue input to the *Micro Lab* open. The floating input to the A/D converter can be controlled by placing your finger across the analogue in and analogue out terminals on the *Micro Lab*. Weird "music" can be created this way!

## DIGITAL MUSIC

Last month, we looked at sound sampling. One of the drawbacks of sound sampling is the large amount of memory required to store the samples. It is possible to get a computer to play music without the need to have massive amounts of memory using the method described above. For the musically minded, each note in the scale is at a particular frequency, and as you go up an octave, the frequency doubles. So, a note A is at a frequency of 440Hz, the note A an octave higher is at a frequency of 880Hz and the A an octave lower is at a frequency of 220Hz. If we number the notes Rest=0, C=1, C#=2, D=3, Eb=4, E=5, etc. and have a table in memory which converts a note number into a value which can be loaded into the Timer 1 latches, we can play simple tunes.

Fig. 12.6. Demonstration Program 7.

```

8224 ;*****
8224 ;***
8224 ;*** Everyday Electronics Micro-Lab
8224 ;***
8224 ;*** Name: Demonstration 7
8224 ;*** Version: 1.0
8224 ;*** Author: Geoff MacDonald
8224 ;*** Date: 18/01/1993
8224 ;*** Last Update:
8224 ;***
8224 ;*****
8224 ;
8224 ;Reads data from memory and uses it to play a
8224 ;tune using the 65C22 VIA. The data is of the
8224 ;form:
8224 ; NOTE, LENGTH, NOTE, LENGTH, NOTE, LENGTH...
8224 ;Where NOTE =(0;Rest | 1:A1 | 2:Bb1 | 3:B1 | 4:C2..)
8224 ;And LENGTH =(1:0.16S | 2:0.32S | ... | 7:1.12S)
8224 ;A NOTE of value $FF terminates the tune.
8224 ;The start address of the tune data should be stored
8224 ;in locations $90 (low) and $91 (high)
8224
8224 FFFF070606+ FREQTABH: DFB $FF,$07,$06,$06,$06,$05,$05,$05,$04
822D 04040403+ DFB $04,$04,$04,$03,$03,$03,$03,$03
8235 02020202+ DFB $02,$02,$02,$02,$02,$02,$02,$01,$01
823E FFFF6DFFFAFF89+FREQTABL: DFB $FF,$6D,$FA,$89,$3B,$E3,$88,$31,$E4
8247 FFAD6929FFEC+ DFB $AD,$69,$29,$EC,$B1,$7A,$4C,$1B
824F FFF5FFC3FF997B+ DFB $F5,$C3,$99,$7B,$53,$33,$14,$F3,$DB
8258
8258 A590 D_DEMO7: LDA $90 ;Save tune start on stack
825A 48 PHA
825B A591 LDA $91
825D 48 PHA
825E A901 LDA #$01 ;Initialise 65C22 for sound
8260 201500 JSR SOUND
8263 A000 DEMO7A: LDY #$00
8265 B190 LDA ($90),Y ;Get note value
8267 C9FF CMP #$FF ;End of tune?
8269 F036 BEQ DEMO7B
826B AA TAX
826C BD3E82 LDA FREQTABL,X ;Convert to 65C22 count value
826F A8 TAY
8270 BD2482 LDA FREQTABH,X
8273 AA TAX
8274 A900 LDA #$00
8276 201500 JSR SOUND ;Play sound
8279 A001 LDY #$01 ;Get note length
827B B190 LDA ($90),Y
827D 0A ASL A ;Convert to delay time
827E 0A ASL A
827F 0A ASL A
8280 201800 JSR DELAY ;Delay
8283 A2FF LDX #$FF ;Staccato pause
8285 A0FF LDY #$FF
8287 A900 LDA #$00
8289 201500 JSR SOUND
828C A901 LDA #$1
828E 201800 JSR DELAY
8291 18 CLC ;Point to next note
8292 A590 LDA $90
8294 6902 ADC #$02
8296 8590 STA $90
8298 A591 LDA $91
829A 6900 ADC #$00
829C 8591 STA $91
829E 4C6382 JMP DEMO7A
82A1 A200 DEMO7B: LDX #$00 ;Turn sound off
82A3 A000 LDY #$00
82A5 A900 LDA #$00
82A7 201500 JSR SOUND
82AA 68 PLA ;Restore tune start address
82AB 8591 STA $91
82AD 68 PLA
82AE 8590 STA $90
82B0 00 BRK

```



Scale of C	Twinkle Twinkle Little Star
\$01, \$04 ;C	\$01, \$04 \$08, \$04
\$03, \$04 ;D	\$01, \$04 \$06, \$04
\$05, \$04 ;E	\$08, \$04 \$06, \$04
\$06, \$04 ;F	\$08, \$04 \$05, \$04
\$08, \$04 ;G	\$0A, \$04 \$05, \$04
\$0A, \$04 ;A	\$0A, \$04 \$03, \$08
\$0C, \$04 ;B	\$08, \$08 \$01, \$04
\$0D, \$04 ;C	\$06, \$04 \$01, \$04
\$0D, \$04 ;C	\$06, \$04 \$08, \$04
\$0C, \$04 ;B	\$05, \$04 \$08, \$04
\$0A, \$04 ;A	\$05, \$04 \$0A, \$04
\$08, \$04 ;G	\$03, \$04 \$0A, \$04
\$06, \$04 ;F	\$03, \$04 \$08, \$08
\$05, \$04 ;E	\$01, \$08 \$06, \$04
\$03, \$04 ;D	\$08, \$04 \$06, \$04
\$01, \$04 ;C	\$08, \$04 \$05, \$04
\$FF, \$FF ;End	\$06, \$04 \$05, \$04
	\$06, \$04 \$03, \$04
	\$05, \$04 \$03, \$04
	\$05, \$04 \$01, \$08
	\$03, \$08 \$FF, \$FF
	\$08, \$04

Fig. 12.7. Micro Lab stored tunes

Demonstration 7 (see Fig. 12.6) uses such a table to play tunes stored in memory. A tune is stored in memory in the following way:

**Note, Length, Note, Length, Note, Length . . .**

To tell the program to stop, we put a note value of FFh. So, to play a scale of C, the table would be:

0200	01 04	;C
0202	03 04	;D
0204	05 04	;E
0206	06 04	;F
0208	08 04	;G
020A	0A 04	;A
020C	0C 04	;B
020E	FF FF	;End of tune

Next, you need to tell the program where in memory the tune table is stored. The low byte of the start address is stored at 90h and the high byte of the start address is stored at 91h:

0090 00 02 ;Tune start address

If you now run Demonstration 7, you should hear a scale of C.

There are two tunes stored in the *Micro Lab* EPROM. The first, a scale of C which goes up then down, is stored at B000h. The second is *Twinkle, Twinkle Little Star* and is stored at address B100h. To play these, simply store the start address of the tune you want to listen to in 90h and 91h as:

0090 00 B0 ;Tune start address -  
Scale of C

then run Demonstration Program 7. The data for these tunes is shown in Fig. 12.7.

## FEEDBACK CONTROL

When a computer system is used to control a device or process, it will often need to know the state of the thing which it is controlling. For example, an active suspension system on a car will be continuously monitoring the forces on each wheel in order to set the suspension hardness. The computer will estimate and set the required hardness and will continue to monitor the wheel forces in order to refine and correct the setting. This type of control is called *Feedback Control*, as the output from the system is fed back into the input.

The simplest form of feedback control is to simply switch a device on or off depending on the input value. Demonstration Program 4, see Fig. 12.8, is a simple temperature control system using this technique. The program reads an input voltage level on the analogue I/P and compares it to a stored value. An output is switched on if the input is below the stored value, and off if the output is above. For our experiment we will use the same Darlington driver circuit used in Fig. 12.2(a). The lamps become the measured heat source, and we will control the average temperature of one of the lamps.

Connect up the circuit in Fig. 12.9, placing the thermistor R1 against one of the lamps. Hold it in place with some insulating tape to enable it to measure the heat emitted from the lamp glass. The output from the circuit is connected to the *Mini Lab* voltmeter on the 0 to 2.5 volt scale, and to the *Micro Lab* input via CON5.1. Adjust VR1 to set the thermistor output using the voltmeter to see the analogue output range. Remember that the analogue input of the *Micro Lab* is exactly the same as the voltmeter on 0 to 2.5 volt range. This makes it easy to "see" the voltage being applied to the *Micro Lab* analogue input. The lamp drive circuit from the *Micro Lab* is the same circuit we used in Fig. 12.2.

Run the Demonstration Program 4. The bottom line of the l.c.d. shows a bar which represents the temperature, and the top line shows the desired temperature. This may be changed using the "0" and "1" keys. When the input temperature is below this point, the lamp is turned on, when it is above the line, the lamp is turned off. The end result is that when the temperature is approximately correct, the lamp will flash on and off, attempting to keep the temperature constant.

This type of on/off control is how a central heating system normally works - although the on/off times are measured in minutes and not microseconds as in this last experiment. Figure 12.10 shows the temperature of a room in which a typical mechanical thermostat switches on when the temperature falls below the set point, and off when above. These mechanical thermostats have some hysteresis in their operating points of about two degrees C.

## Serial Input/Output

There are two common ways in which computers communicate with complex external peripherals (such as disk drives, printers, other computers, etc.). One is *parallel I/O*, which sends data bits in parallel down several wires at once (similar to the way devices communicate on the computer data bus). The other way is to use *serial I/O*, which sends the data one bit at a time using a pair of wires - normally one for a reference voltage the other for the actual signal. Bi-directional communication may be achieved by adding a third wire. Using this method is obviously slower than sending the data in parallel, but it is often used for long distance connections as the wiring is cheaper.

To send data serially, a *shift register* is used. This comprises a series of latches, each with two inputs. One input is connected to the output of the previous latch and the other input connected to the computer data bus to allow the computer to load the register with a value to send:

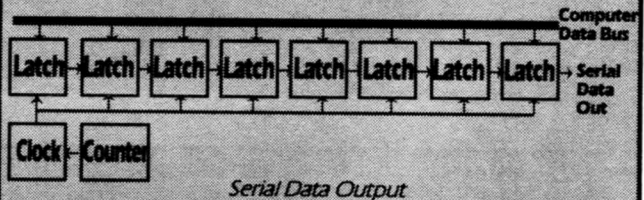

The clock generates a square wave which makes the data shift into the next latch. The counter ensures that the clock stops when all of the data has been shifted out. A similar circuit is used to read serial data in.

Before sending a byte of data, it is normal to send a *start bit*. This is a single bit which informs the receiving shift register that data is to follow, so it should reset its counter and start its clock running. The receiver usually samples the incoming data roughly at the mid-point of each bit to improve reliability. As long as both clocks are running at approximately the same speed the data will be received correctly, as they are re-synchronised each time a start bit is received. The 65C22 VIA contains serial to parallel and parallel to serial circuits.

A standard for serial communications called RS232 evolved many years ago. This standard uses +12V for a "0" and -12V for a "1". This relatively large voltage difference makes it possible to transmit data over quite large distances. Additionally, a *parity bit* is transmitted at the end of each byte of data. This bit is used to check that the data has been received correctly. It is either set or cleared to make the total number of 1's in the byte either even or odd (depending on the protocol used - this must be agreed upon by the sending and receiving equipment). If the receiver is expecting, say, an even number of bits and it receives an odd number, then it knows that the data is incorrect.

Fig. 12.8. Demonstration Program 4.

```

8129 ;*****
8129 ;***
8129 ;*** Everyday Electronics Micro-Lab
8129 ;***
8129 ;*** Name: Demonstration 4
8129 ;*** Version: 1.0
8129 ;*** Author: Geoff MacDonald
8129 ;*** Date: 13/01/1993
8129 ;*** Last Update:
8129 ;***
8129 ;*****
8129 ;Read a temperature via the analogue input and switch on
8129 ;a lamp if the temperature falls below an adjustable level.
8129
8129 200C00 D_DEMO4: JSR CLEAR ;Clear display
812C A990 LDA #90 ;Set initial required temp. set-point
812E 8590 STA $90
8130 A9FF LDA #FF ;Initialise 65C22
8132 8D4280 STA VIA+2
8135 A590 DEMO4A: LDA $90 ;Show required temp. set-point
8137 4A LSR A
8138 4A LSR A
8139 4A LSR A
813A 4A LSR A
813B AA TAX
813C A000 LDY #0
813E A97C LDA #$7C
8140 201200 JSR POSCHAR
8143 A200 LDX #0 ;Write set point in Hex.
8145 A000 LDY #0
8147 A900 LDA #0
8149 200900 JSR CURSOR
814C A590 LDA $90
814E 202400 JSR HEXOUT
8151 A200 DEMO4I: LDX #0 ;Position cursor at left side
8153 A001 LDY #1 ;of bottom row of screen
8155 A900 LDA #0 ;with cursor switched off
8157 200900 JSR CURSOR
815A 8DFFFF STA $FFFF ;Initiate A/D conversion
815D A00A LDY #10
815F 88 DEMO4B: DEY
8160 D0FD BNE DEMO4B
8162 AD2080 LDA AIN ;Display current temp. as a bargraph...
8165 48 PHA ;Save temperature
8166 4A LSR A ;Get bargraph length...
8167 4A LSR A
8168 4A LSR A
8169 4A LSR A
816A AA TAX ;...in IX
816B A010 LDY #$10 ;Get display line length in IY
816D A9FF DEMO4C: LDA #FF ;Display a solid block...
816F 200600 JSR OPCHAR
8172 88 DEY
8173 CA DEX
8174 10F7 BPL DEMO4C ;...the required number of times
8176 A920 DEMO4H: LDA #$20 ;Clear the rest of the line
8178 200600 JSR OPCHAR ; by writing space characters
817B 88 DEY
817C D0F8 BNE DEMO4H
817E 68 PLA ;Restore temperature reading
817F C590 CMP $90 ;Compare it with the set-point
8181 9004 BCC DEMO4D
8183 A200 LDX #00 ;Too hot - turn lamp off
8185 F002 BEQ DEMO4E
8187 A201 DEMO4D: LDX #01 ;Too cold - turn lamp on
8189 8E4080 DEMO4E: STX VIA
818C A55D LDA KBSIZE ;Key in buffer?
818E F0C1 BEQ DEMO4 ;No - get next temp. reading
8190 A590 LDA $90 ;Clear temperature set-point char.
8192 4A LSR A
8193 4A LSR A
8194 4A LSR A
8195 4A LSR A
8196 AA TAX
8197 A000 LDY #0
8199 A920 LDA #$20
819B 201200 JSR POSCHAR
819E 201E00 JSR KBLAST ;Get ASCII value of key
81A1 C930 CMP #30 ;Key = "0"?
81A3 D009 BNE DEMO4F
81A5 A690 LDX $90 ;Yes - set-point > 0?
81A7 F011 BEQ DEMO4J ;Yes - decrement set-point
81A9 C690 DEC $90
81AB 4CBA81 JMP DEMO4J
81AE C931 DEMO4F: CMP #31 ;Key = "1"?
81B0 D00B BNE DEMO4G
81B2 A690 LDX $90 ;Yes - setpoint < 255?
81B4 E0FF CPX #FF
81B6 F002 BEQ DEMO4J ;Yes - increment set-point
81B8 E690 INC $90
81BA 4C3581 DEMO4J: JMP DEMO4A
81BD C91B DEMO4G: CMP #1B ;Key = "ESC"?
81BF D0F9 BNE DEMO4J
81C1 00 BRK ;Yes - terminate

```

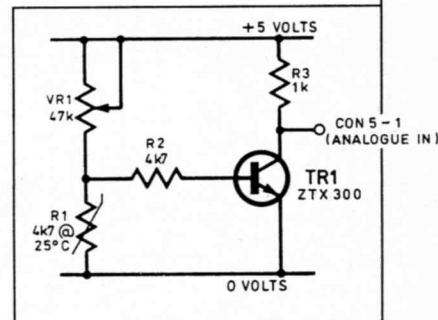
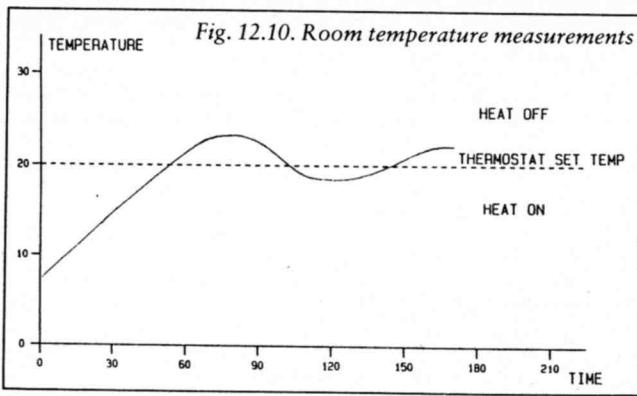

Fig. 12.9. Temperature measuring circuit.





Because most systems use hot water in radiators the room carries on heating after the system has been turned off. Similarly, as the boiler has to heat the water when the system turns back on there is a delay in putting more heat back into the room. This allows the room temperature to fall further before once again rising and overshooting the desired setpoint. Greater accuracy could be obtained if the mechanical controller was replaced by a computer that measured the temperature and controlled the heat source more intelligently.

### PROPORTIONAL FEEDBACK

A slightly more complex type of control would determine the *difference* between the actual temperature and the desired temperature and set the lamp brightness to a multiple of this difference. This is called *proportional* feedback control, because the control signal

is proportional to the difference between the actual and desired signals. Using this type of control would result in less oscillation of the temperature. In fact, if the multiplier is small enough, the system is unlikely to oscillate at all, but will respond very slowly to changes in temperature.

More complex systems would determine the *rate* at which the temperature varies and sets the control signal accordingly. This allows the system to predict what is going to happen and reduce oscillation even further whilst still maintaining a fast response to changes in temperature. This is called *derivative* control – the control signal is determined by differentiating (calculus) the input signal with respect to time.

The most complex systems use an accurate computerised *model* of the system being controlled, allowing the computer to predict the effect a change will have. The model will be modified by the program to allow for changes in the system over a period of time. This is the way in which car *engine management systems* work. They allow the characteristics of the car to be changed as required – one minute you could be using the economy setting which uses one gallon of petrol every 50 miles and the next you could be accelerating to 70 m.p.h. in a few seconds with the sports setting!

The more complex control systems measure the combustion efficiency of the exhaust gases. The computer will continuously use this information to change the model of the car as the car itself changes with use, automatically compensating for wear and tear.

### STEPPER MOTORS

Stepper motors are used in many control devices such as printers and plotters, robots, computer disk drives, etc. This is because they allow the computer to accurately position the motor without the need for complicated and expensive feedback mechanisms such as

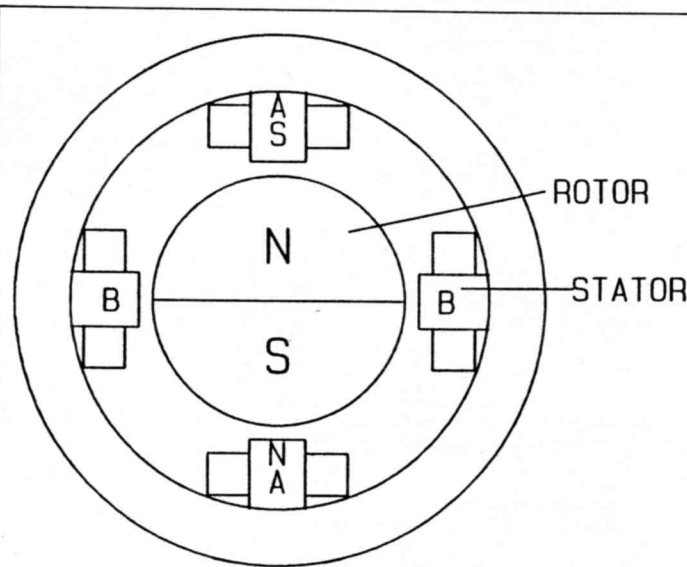
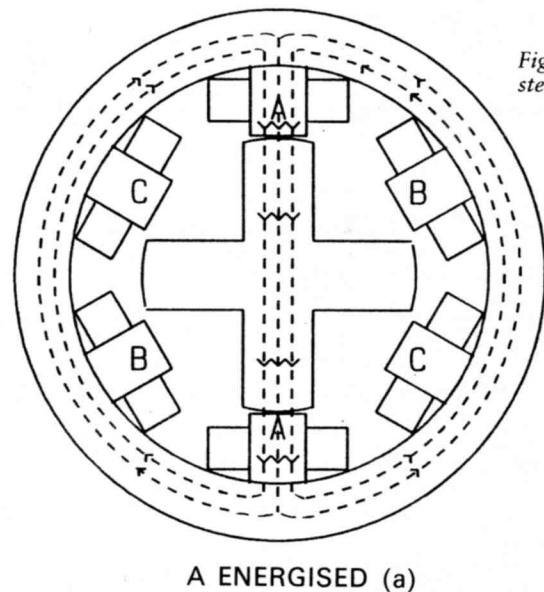
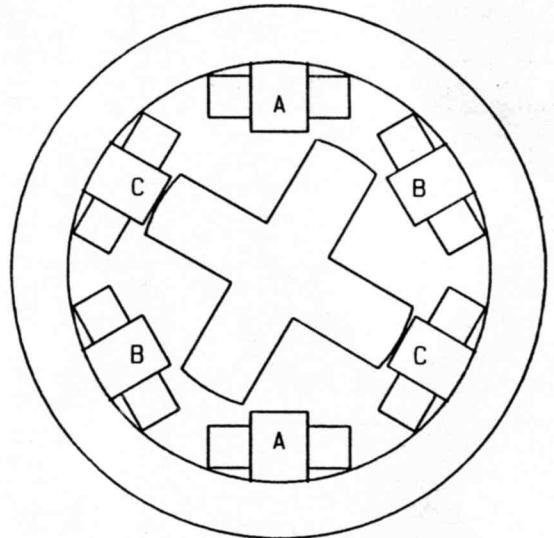

Fig. 12.11. Permanent magnet stepper motor.



A ENERGISED (a)



A and B ENERGISED (b)

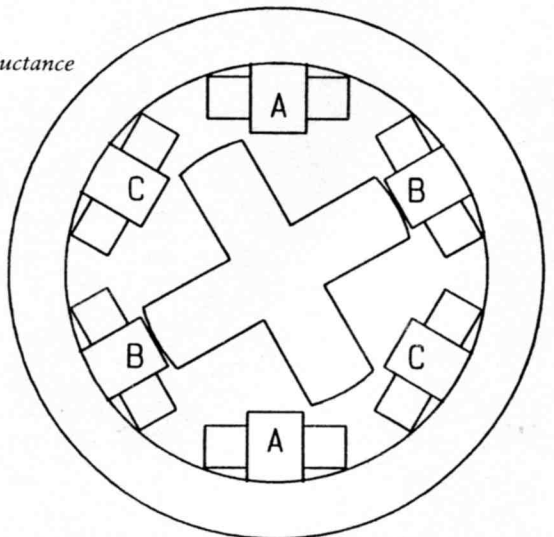

B ENERGISED (c)

Fig. 12.12. Variable reluctance stepper motor

rotary shaft encoders. The shaft encoder is a device that gives an output proportional to its rotational position. The output is used by the controlling computer to ensure that the motor has turned the shaft to the desired angle.

When using a stepper motor, once the program knows the start position of the motor – which can be determined using a simple switch – it can keep count of the number of steps which have been sent to it, adding one for a step in one direction and subtracting one for a step in the other direction. It therefore knows the exact angle of the motor shaft at all times. The only problem occurs if the load on the motor is sufficient to stop it from rotating. To allow for this, programs occasionally return the motor to the start position to verify that all is well.

A simple permanent magnet stepper motor is shown in Fig. 12.11. Coils A are wound such that when a d.c. voltage is applied the top pole generates a south pole, and the bottom pole generates a north pole. The rotor is a permanent magnet with half polarised as a north and half a south pole. The rotor will turn to allow the magnetic poles to align with their equal and opposite electromagnetic poles. When coil A is turned off and coil B energised the rotor will turn 90 degrees to align with the new electromagnetic poles.

The direction of rotation can be controlled by the direction of current flow in the coils. When this type of motor is de-energised the permanent magnet will still hold the rotor in alignment with the stator poles. This is a useful feature as it would allow a control system to remain in its current state in the event of a power failure.

Another type of stepper motor is the variable reluctance type shown in Fig. 12.12(a). The winding pairs produce large magnetic fields when energised by a d.c. current. This flux will flow through the rotor teeth. The rotor will turn to allow a pair (or set) of teeth to align with the poles of the energised electro magnets and present a minimum reluctance to the main flux path.

When A is turned off and B energised the rotor will turn to align with the pole faces. In this motor this would be a 60 degree step. Turning off B and turning on C would produce a further 60 degree step. If the energising sequence ABC is repeated the motor will rotate in these 60 degree steps. Fig. 12.12(b) shows a variation of this sequence where coils A and B are energised at the same time. This will produce a half step as the rotor attempts to align itself halfway between the two poles.

Now a sequence A, AB, B, BC, C, CA, A, will rotate the motor in 30 degree steps.

The variable reluctance motor has no torque when the power is removed from the coils, and can easily be turned. Most small stepper motors are of a hybrid construction where the variable reluctance rotor contains some magnetic properties. These motors have a small torque when the power is removed that can stop them from moving.

## MOTOR DEMONSTRATION

Stepper motors are readily available, and we can demonstrate their operation with the *Micro Lab*. The stepper motor we used for our experiments was designed for use in a printer mechanism and is an example of the hybrid type. Turning the motor by hand the magnetic indentations can be felt as the internal teeth align. To avoid consuming too much current from the *Mini Lab* the 24 volt stepper motor was run from 12 volts. (It will even run from 5 volts with reduced torque!). This motor has four coils or phases. The motor is more complex than our simple diagram as the motor has split each coil into smaller sections, and the rotor has more teeth to provide a smaller step size of 7½ degrees, or 48 steps per revolution.

A circuit for connecting the stepper motor to the *Micro Lab* is shown in Fig. 12.13. The four Darlington transistors are TIP112 with a minimum  $h_{fe}$  of 1,000. This will allow the port B drive to fully turn on the devices. The diodes D1 to D4 are needed to suppress back e.m.f. induced in the coils when the Darlington transistors are turned off. This is similar to the protection diode placed across the relay coil in the *Mini Lab*. The colour code will only apply to the type of stepper motor that we used for our experiments.

Check your own motors to ascertain the coil sequence. If you do not have any data use a resistance meter to establish the coil connections. Apply voltage to each coil and observe the step direction. When you have the right sequence the motor will increment a step each time power is applied to a coil.

An alternative driving circuit is shown in Fig. 12.14. This uses a special class of f.e.t. designed to interface with logic level voltages. The f.e.t.s are particularly efficient, and have a very low on resistance. This allows quite small devices to handle 10s of amps without overheating. The input impedance of the gates is high and can easily be driven

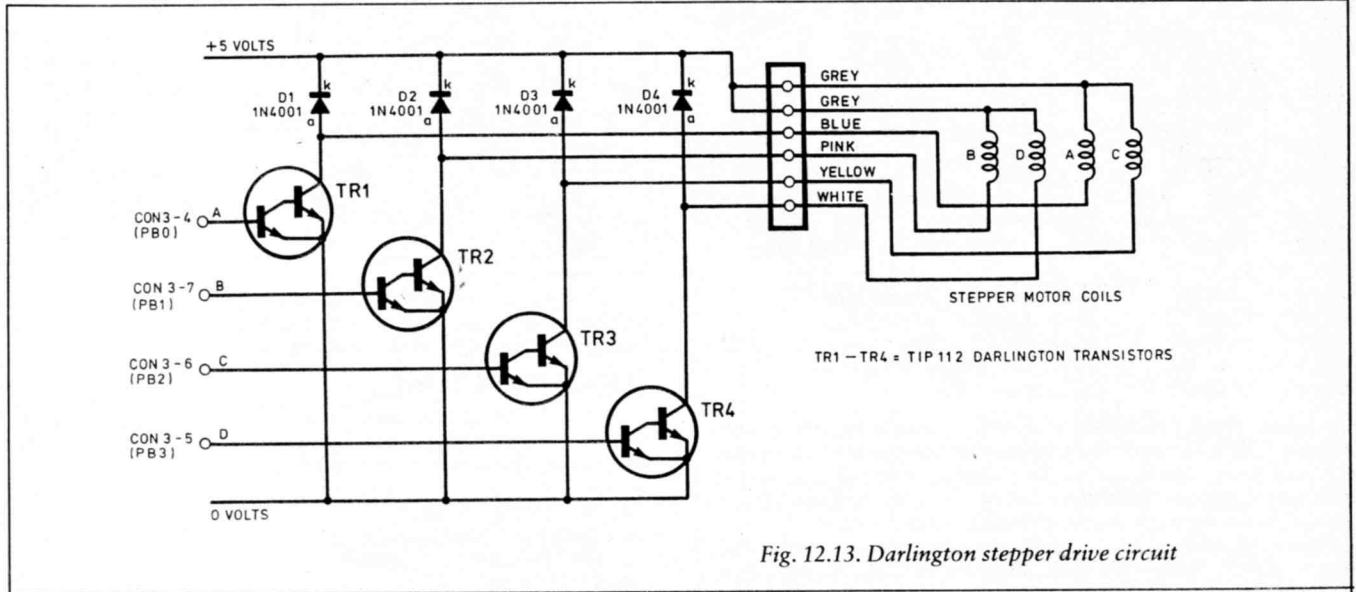

Fig. 12.13. Darlington stepper drive circuit

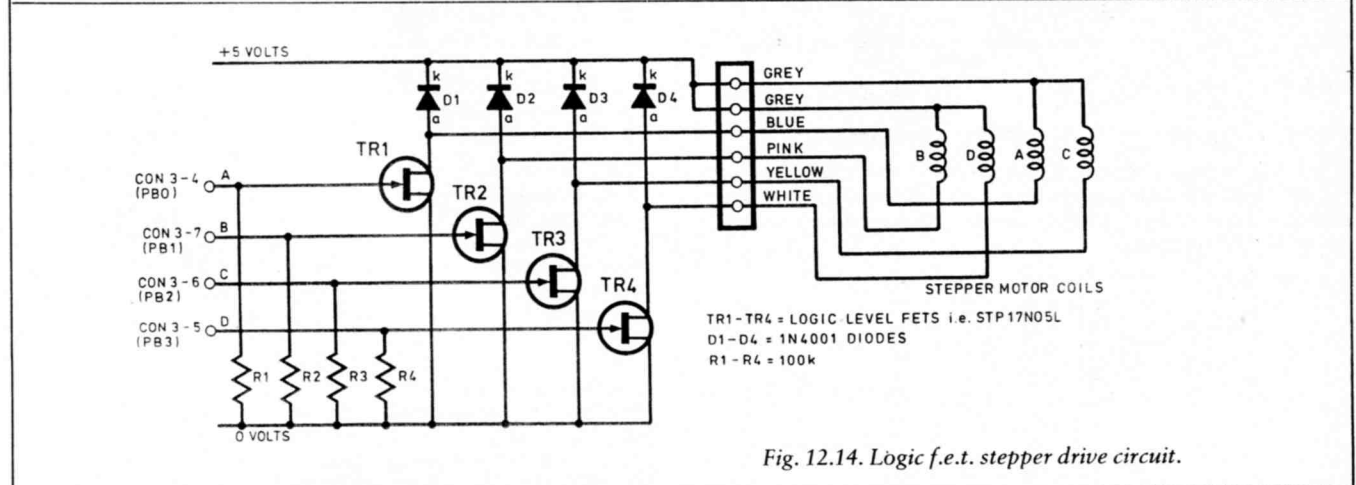

Fig. 12.14. Logic f.e.t. stepper drive circuit.



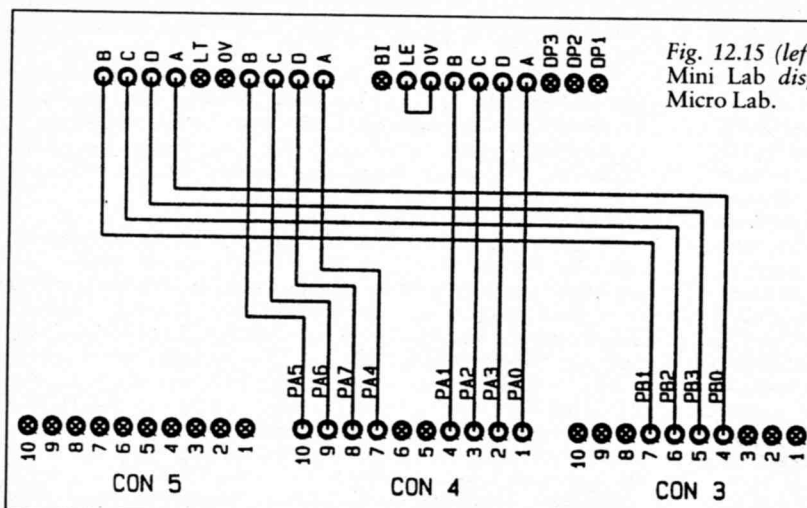

Fig. 12.15 (left). Driving the Mini Lab display from the Micro Lab.

from port A of the 65C22 VIA. The high impedance can lead to false triggering by radiated electrical noise into the gate connections as they act as aerials. To avoid this resistors R1 to R4, each 100 kilohms, are placed between the gate and ground.

### MOTOR CONTROL PROGRAM

A simple stepper motor control program is given below. This program uses a look up table to read the value which is to be sent to the port connected to the stepper. Fig. 12.13 or 12.14 can be used to drive the stepper motor. The look up table drives each coil in turn:

Step Number	Coil: D	C	B	A
1	0	0	0	1
2	0	0	1	0
3	0	1	0	0
4	1	0	0	0

```

0200  A9 FF    LDA  #FF      ;Set port B to all
                                outputs
0202  8D 43 80 STA  $8042     ;Initialise the table
0205  A2 00    LDX  #000     pointer
0207  BD 19 02 LDA  $0219,X ;Get value to send to
                                stepper
020A  8D 41 80 STA  $8040     ;Send it to stepper
020D  A9 08    LDA  #08      ;Delay for 0.08
                                seconds
020F  20 1E 00 JSR  $001E     ;Point to next table
0212  E8      INX              entry
0213  E0 04    CPX  #04      ;End of table?
0215  D0 F0    BNE  $0207     ;No - start again
0217  F0 EC    BEQ  $0205     ;Yes - reload IX with 0
0219  01 02    DFB  $01, $02 ;Data table
021B  04 08    DFB  $04, $08

```

You can change the speed of the motor by altering the value at address 020Eh. However, the faster the motor is turning the weaker it is. Also, if you attempt to turn the motor too fast, the shaft will not have time to align itself with the next coil before the next step occurs. This will make the shaft oscillate rather than rotate.

Making the shaft rotate in the opposite direction can be performed in two ways: 1. Change the data table to read 08h, 04h, 02h, 01h. 2. Change the following lines of code:

```

0205  A2 03    LDX  #03      ;Initialise the table
                                pointer
0212  E8      DEX              ;Point to next table
                                entry
0213  E0 04    CPX  #FF      ;End of table?

```

This type of stepper control is called *wave drive*. On our motor this produced 48 steps per revolution. You can use the following table to generate *half-steps*. This increases the step resolution but halves the rotation speed.

Step Number	Coil: D	C	B	A
1	0	0	0	1
2	0	0	1	1
3	0	0	1	0
4	0	1	1	0
5	0	1	0	0
6	1	1	0	0
7	1	0	0	0
8	1	0	0	1

Fig. 12.16 (right). seven segment multiplex display.

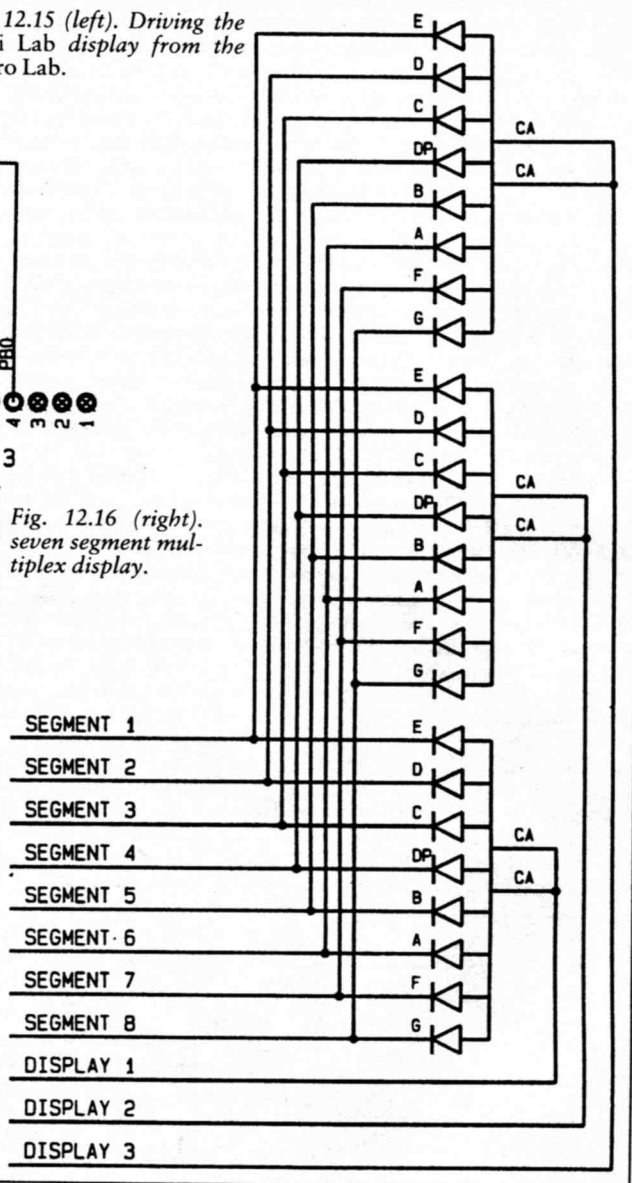

Modify the above program to use this table. You will need to convert the binary values into hexadecimal in order to enter it and also modify the program to allow for a larger table.

### REACTION TIMER

To round things off, we will build a reaction timer game, similar to one of the *Mini Lab* projects, using several different input/output peripherals. The game operates in the following way:

1. User starts the game
2. Switch off "start" light
3. Wait for a random period of time
4. Light "start" light
5. Set a counter to 999
6. Display count value
7. Subtract one from count value
8. If count = 000, then go to step 10
9. If "stop" key not pressed, go to step 6
10. Stop program

Now, we should decide what we are going to use for input and output devices. The eight i.e.d.s on the *Micro Lab* are suitable for the "start" light, and the keypad is suitable for the "stop" key, but the i.c.d. is a bit small for the counter - 7-segment i.e.d.s would be much more effective, but there is only one on board the *Micro Lab*. So, before we write the program, we should connect up three 7-segment displays on the *Mini Lab* as shown in Fig. 12.15. The circuit uses three i.c.s which convert a four bit binary number into a display code (similar to the exercise given in *Teach-In* part 7).

Without these BCD to 7-segment display i.c.s, we would either need to use seven (or eight if we needed the decimal point) output pins for each display or we would need to *multiplex* the displays. Multiplexing is used to reduce the number of pins and i.c.s required when driving several displays. Each similar segment on all

of the displays is connected together (all of the top segments would be connected together, etc.). The eight lines are then connected to eight output ports via suitable drive transistors and resistors. Next, the common pin on each digit is connected to an output port via a suitable drive transistor, see Fig. 12.16.

We can now switch each display on one at a time by switching the common pin and set up the digit to be displayed on the eight segment-lines. If this is performed quickly enough, there will be no flicker. However, each digit is only on for a fraction of the time, and with longer displays this on time is reduced. This will make the dis-

play appear dim in the same way as the lamp was made to dim in the PWM experiment.

Right, back to the reaction timer. We now have suitable input and output devices set up, so we can get on with the program. The first part is easy, it should turn off the "start" indicator:

```
0200 A9FF LDA #5FF ;Switch LEDs off
0202 8D0080 STA $8000
```

Next, we need to delay for a random period of time. To make sure that the period is not too short, we should put in a fixed delay of a

## The 65C22 VIA

The 65C22 Versatile Interface Adapter (VIA) is a flexible input/output (I/O) control device. It contains 16 bi-directional (either input or output) ports, four handshaking lines used for controlling the data into and out from the ports, two 16 bit counter/timers, a serial to parallel/parallel to serial shift register and it can latch data on the input ports. Because of the large number of facilities offered by the 65C22, a complete description of its operation and use is beyond the scope of this article, however a description of some of the more common aspects of the device is given here. The diagram below shows the internal logic blocks in the 65C22.

Operation of the 65C22 is controlled by sixteen registers. In the *Micro Lab*, these are at addresses 8040h to 804Fh. The registers are described below.

Address	Designation	Description
8040h	ORB/IRB	Input/Output Register (port) B.
8041h	ORA/IRA	Input/Output Register (port) A.
8042h	DDRB	Data Direction Register B.
8043h	DDRA	Data Direction Register A.
8044h	T1C-L	Timer 1: Latches/Counter-Low byte.
8045h	T1C-H	Timer 1: Counter - High byte.
8046h	T1L-L	Timer 1: Latches - Low byte.
8047h	T1L-H	Timer 1: Counter - High byte.
8048h	T2C-L	Timer 2: Latches/Counter-Low byte.
8049h	T2C-H	Timer 2: Counter - High byte.
804Ah	SR	Shift Register.
804Bh	ACR	Auxiliary Control Register.
804Ch	PCR	Peripheral Control Register.
804Dh	IFR	Interrupt Flag Register.
804Eh	IER	Interrupt Enable Register.
804Fh	ORA/IRA	Input/Output Register A (as 8041h).

Operation of the 16 I/O ports is controlled by the four registers ORA/IRA, DDRA, ORB/IRB and DDRB. The DDR registers are used to set whether individual pins are inputs or outputs. A "0" in a bit of the DDR causes the corresponding pin to be an input, a "1" causes it to be an output. So, to set bits 0, 1, 6 and 7 of port A as outputs and bits 2, 3, 4 and 5 of port A as inputs, you would use a program like this:

```
0200 A9 C3 LDA #5C3 ;Set up DDRA
0202 8D 43 80 STA $8043
0205 00 BRK
```

To set all eight bits of the port as outputs, you would load the accumulator with FFh, and to set the whole port as input you would use 00h. Reading from ORA/IRA (8041h) or ORB/IRB (8040h) will return the logic level at the port (bit 0 if 8041h returns the level at PA0, etc.) in much the same way as the switch inputs on the *Micro Lab*. When a pin is programmed as an output, the voltage on a pin is controlled by the corresponding bit of ORA/IRA or ORB/IRB. A "1" causes the output to go high (<2.4V), a "0" causes the output to go low (>0.8V). Data may be written to bits corresponding to inputs, but the output signal is unaffected. This is similar to writing to the I.e.d.s on the *Micro Lab*.

As example, to set all eight bits of port B to outputs and have PB0, PB2, PB4 and PB6 at >2.4V and PB1, PB3, PB5 and PB7 at <0.8V, we would use:

```
0200 A9 FF LDA #5FF ;Port B all outputs
0202 8D 42 80 STA $8042
0205 A9 55 LDA #55 ;Bits 0, 2, 4 & 6 = 5V
0207 8D 40 80 STA $8040 ;Bits 1, 3, 5 & 7 = 0V
020A 00 BRK
```

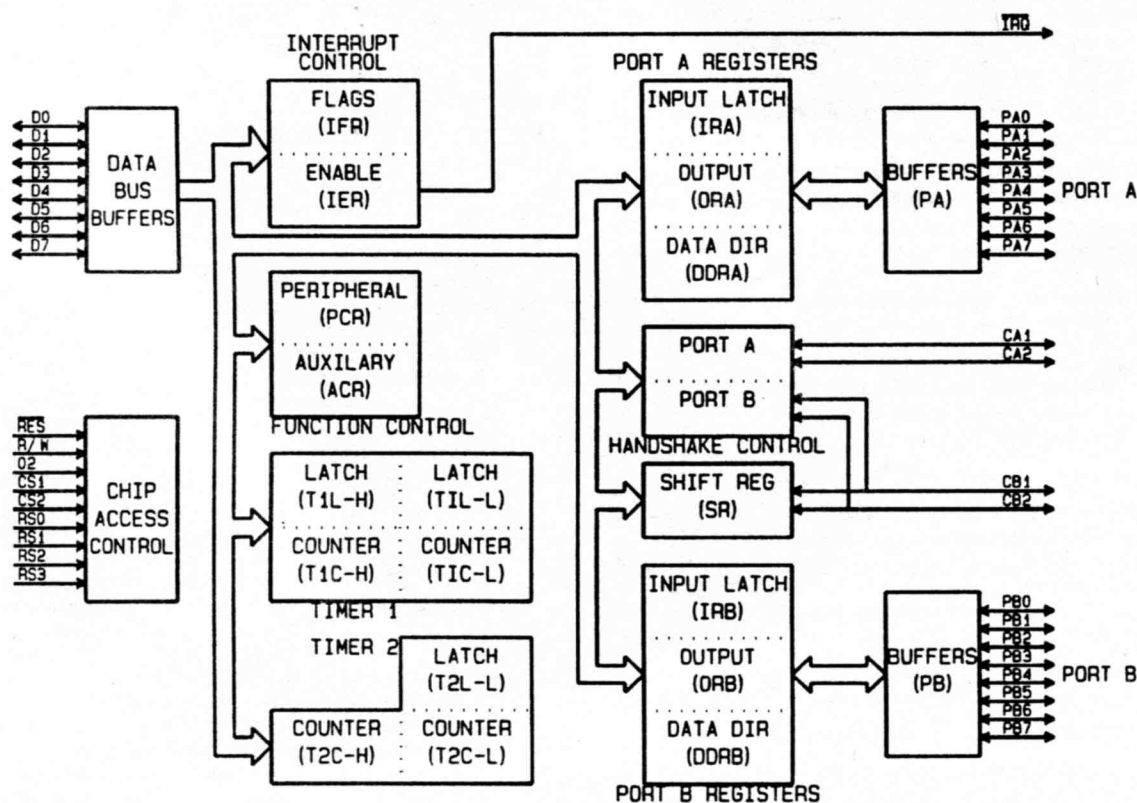



couple of seconds before doing the random delay. This delay is actually for 2.55 seconds, as we are not changing the accumulator value after switching off the l.e.d.s. The random delay is performed by reading the value of TICL (the low byte of timer 1 counter) which continually counts down when the 65C22 has been reset. This value is loaded into the accumulator before calling the DELAY subroutine. We do this twice to increase the total possible time.

```
0205    201800    JSR    $0018    ;Delay for 2.55 Sec
0208    A002      LDY    #$02      ;Random delay from
                                0 to 6.1 Sec

020A    AD4480    LDA    $8044
020D    201800    JSR    $0018
0210    88        DEY
0211    D0F7      BNE    $020A
```

Now, we need to switch on the "start" indicator (l.e.d.s), set the start value of the counter to "999", initialise the 65C22 so that we can use the three 7 segment displays to display the count on and, finally, empty the keyboard buffer so that no one can cheat!

```
0213    A900      LDA    #$00      ;Switch on LEDs
0215    8D0080    STA    $8000
0218    A909      LDA    #$09      ;Set counter to 999
021A    8590      STA    $90
021C    A999      LDA    #$99
021E    8591      STA    $91
0220    A9FF      LDA    #$FF      ;Set ports A&B to
                                output

0222    8D4280    STA    $8042
0225    8D4380    STA    $8043
0228    202100    JSR    $0021    ;Empty keyboard
                                buffer
```

OK, the system is now initialised, so we can display the count on the 7 segment displays.

```
022B    A590      LDA    $90      ;Display count
022D    8D4080    STA    $8040
0230    A591      LDA    $91
0232    8D4180    STA    $8041
```

Now, we can subtract one from the counter. As we are counting in decimal, the easiest way to do this is to use the 6502's decimal mode (by setting the decimal flag in the PSW), then subtract 1 using the SBC instruction:

```
0235    F8        SED          ;Set decimal mode
0236    A591      LDA    $91      ;Subtract 1 from low
                                byte of counter

0238    38        SEC
0239    E901      SBC    #$01
023B    8591      STA    $91
023D    A590      LDA    $90      ;Subtract borrow from
                                high byte

023F    E900      SBC    #$00
0241    8590      STA    $90
0243    D8        CLD          ;Set normal binary
                                mode
```

If the counter has gone below zero, then the high byte will equal 99. We can check for this to see if the player was too slow.

```
0244    C999      CMP    #$99      ;Counter
                                under flow?
0246    F00D      BEQ    $0255      ;Yes - stop
                                program
```

We should now have a short delay, otherwise only another computer would be able to play! The delay routine in the monitor is a bit long for this application, so we will use our own.

```
0248    A040      LDY    #$40      ;Short delay
024A    88        DEY
024B    D0FD      BNE    $024A
```

Finally, we should check to see if the "stop" button has been pressed. If it has not, then the program should jump back. If it has, then the program should stop.

```
024D    201E00    JSR    $001E      ;Key pressed?
0250    D003      BNE    $0255      ;Yes - Stop
0252    4C2B02    JMP    $022B      ;No - jump back
0255    00        BRK
```

Once you have entered the program, run it with the GO command. You can adjust the value in the delay (at address 0249h) to either speed it up or slow it down, as necessary.

Feel free to modify the program. Some suggestions are:

- Add some sound effects - a ticking "clock" noise before the "start" lamp comes on, or "well done" and "hard luck" noises.
- The "start" l.e.d.s could be made to display a pattern before they all come on.
- Rating messages could be displayed on the l.c.d. depending upon the final count value.
- A high score could be kept and displayed on the l.c.d.

## CONCLUSION

We have come to the end of the *Teach In* series. We hope that readers who joined up in the first episodes have managed to survive the course. Congratulations to you. We have tried to include most topics covered by the GCSE and A level syllabuses, but inevitably space has seen the exclusion of some topics. Check the syllabus with your tutors to see where additional study is needed.

## ON GOING

The *Micro Lab* does not end here and will become the basis for a number of new projects. The first will be the addition of the printer port to allow hard copy of your developed programs. A relay board will be designed to allow interfacing to larger loads, and a *Micro Lab* power supply will allow the unit to survive on its own without the *Mini Lab*. Following on from these will be a robot buggy called *RoboSpot*. This will allow *Micro Lab* to grow up and move under its own intelligence!

After that it's up to you. Write and let us know your ideas for any useful applications utilising the power of the *Micro Lab* at the heart of a command and control centre. We will investigate any worthwhile suggestions with a view to sharing them with other *Micro Lab* users. Meanwhile *RoboSpot* is wagging its tail expectantly in the workshop waiting to be let out to play! □

*Mini Lab* and *Micro Lab* p.c.b. designs are copyright Dytronics 1992/1993.

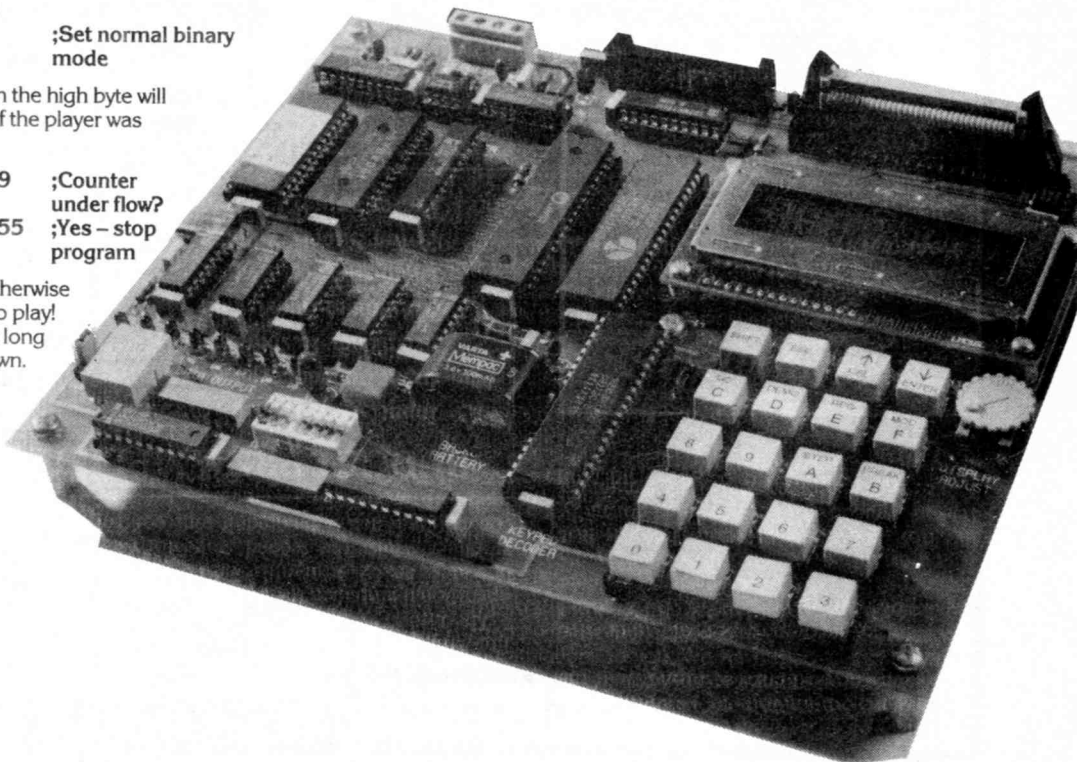

NEW VERSION 2  
NOW SHIPPING

# SCHEMATIC DRAWING FOR WINDOWS

NEW  
LOW PRICES

ISIS ILLUSTRATOR combines the high functionality of our DOS based ISIS products with the graphics capabilities of Windows 3. The result is the ability to create presentation quality schematics like you see in the magazines. ILLUSTRATOR gives you full control of line widths, fill styles, fonts, colours and much more. When the drawing is complete, transferring it your WP or DTP program is simply a matter of cutting and pasting through the Windows Clipboard.

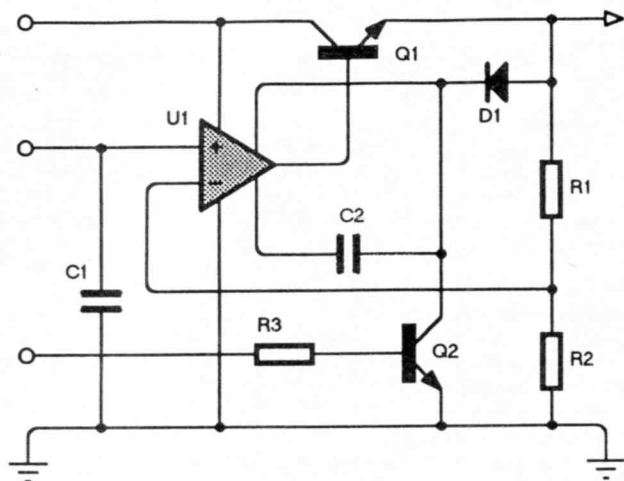

## Features

- Full control of drawing appearance including line widths, fill styles, fonts, colours and more.
- Curved or angular wire corners.
- Automatic wire routing and dot placement.
- Fully automatic annotator
- Comes complete with component libraries.
- Full set of 2D drawing primitives + symbol library for logos etc.
- Output to Windows printer devices including POSTSCRIPT and colour printers.
- ILLUSTRATOR+ adds netlist generation, bill of materials etc. and is compatible with most popular CAD software for DOS & Windows.

From  
**£99**

## CADPAK - Two Programs for the Price of One.

### ISIS SUPERSKETCH

A superb schematic drawing program for DOS offering Wire Autorouting, Auto Dot Placement, full component libraries, export to DTP and much more.

Only  
**£79**

Exceptionally easy and quick to use. For example, you can place a wire with just two mouse clicks - the wire autorouter does the rest.

### PCB II

High performance manual PCB layout package for DOS. Many advanced features including curved tracks, auto track necking, DXF export, Gerber and NC file generation, Gerber viewing and more.

Graphical User Interface with intuitive "point and do" operation gives unparalleled ease of use.

## ISIS and ARES for DOS - The Professional's Choice

### ISIS

from **£275**

ISIS DESIGNER+ forms the ideal front end of your CAD system, providing schematic capture, netlisting, bill of materials and electrical rules checks. Advanced features include automatic annotation, hierarchical design and an ASCII data import facility. Put simply, DESIGNER+ is one of the easiest to learn and most powerful schematics packages available for the PC.

### ARES

from **£275**

The ARES range of advanced PCB design products links with ISIS (DOS or Windows) and other schematics programs. Working from a netlist, ARES helps you get it right first time with each connection automatically verified against the schematic.

ARES AUTOROUTE adds multi-strategy autorouting, whilst for the ultimate in performance, ARES 386 goes up to 400% faster with unlimited design capacity.

**Labcenter**  
Electronics



Call us today on 0274 542868 or  
fax 0274 481078 for a demo pack.  
Combination, multi-copy and  
educational discounts available.

14 Mariner's Drive, Bradford, BD9 4JT



# LINEAR POWER SUPPLY

## AMSTRAD PCW 8-CHANNEL A/D CONVERTER

JASON SHARPE

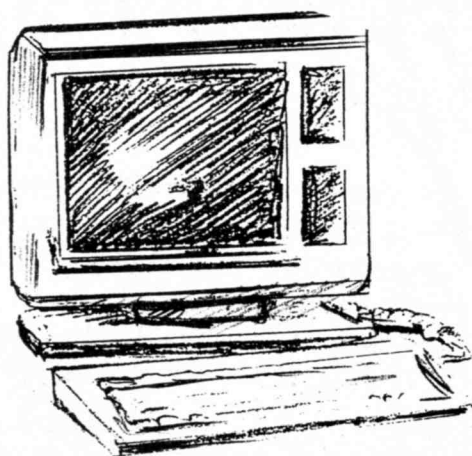

## PART THREE

A "stand-alone", high quality p.s.u. for the serious experimenter. Outputs:

+5V(1.5A); +12V(1A); -12V(0.5A) -5V(0.5A)

ALTHOUGH designed specifically for the Amstrad PCW A/D Converter, and written for the ADC project, the range of voltages covered by this unit make it an ideal general purpose power supply for the workbench. It will find a particular niche for those experimenters working on i.c. based circuits or where a "split" (plus and minus) supply is needed.

Back to the ADC, for the unity gain buffers to give an output voltage swing of 0V to 5V they require a supply voltage of at least  $\pm 1V$  either side of this. The PCW has a 12V output, a voltage inverter could have been used to give -12V. This approach, however, was not used as the resulting voltage would have been rather noisy.

Completed Linear Power Supply with the Amstrad A/D converter (August '93).

Instead, it was decided to run the whole ADC unit from an external supply. The Linear Power Supply Unit was designed for general purpose use, to give most of the voltages normally associated with computers. It can also be used to power a second (external) disc drive.

### TRANSFORMER

A custom wound toriod transformer (see *Shoptalk*) was used for this circuit. A custom transformer was chosen, rather than an "off the shelf" type for several reasons.

For the range of output voltages / currents required it would have been necessary to use two transformers, this would have meant more wiring, and also a larger case.

With the custom transformer the voltages have been chosen to be quite close to the output voltage (plus voltage drops), so that regulators only have to dissipate small amounts of power. Toriodal transformers also have the advantages of being compact, efficient and have low external magnetic fields.

Although the custom transformer is slightly more expensive than using two standard transformers the extra cost is recuperated because a smaller case can be used.

### CIRCUIT DESCRIPTION

The full circuit diagram for the Linear Power Supply is shown in Fig. 1. The circuit is quite simple and just consists of standard regulator i.c.s.

The outputs of the secondary windings of transformer T1 are rectified by REC1 and REC2. The d.c. output from REC1 is smoothed by capacitor C1. IC1 is a variable regulator which is used to regulate the voltage to  $\approx 5V$  (see Testing).

Capacitor C4 improves the circuits ripple rejection and diode D2 provides a discharge path. D1, D3 to D6 are included to protect the regulators.

The mains input is switched and fused with a 500mA anti-surge fuse as toriod transformers draw a large current at switch-on. Also included is a transient suppressor which absorbs any high voltage spikes that may appear on the mains supply.

### POWER SUPPLY FORMULAE

When designing this power supply it was discovered that there was very little in-

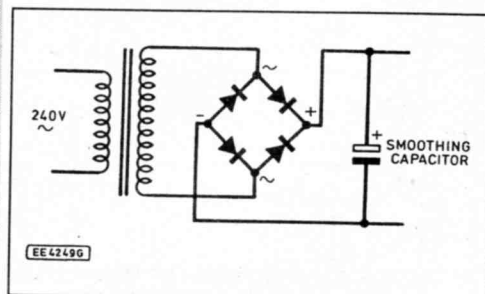
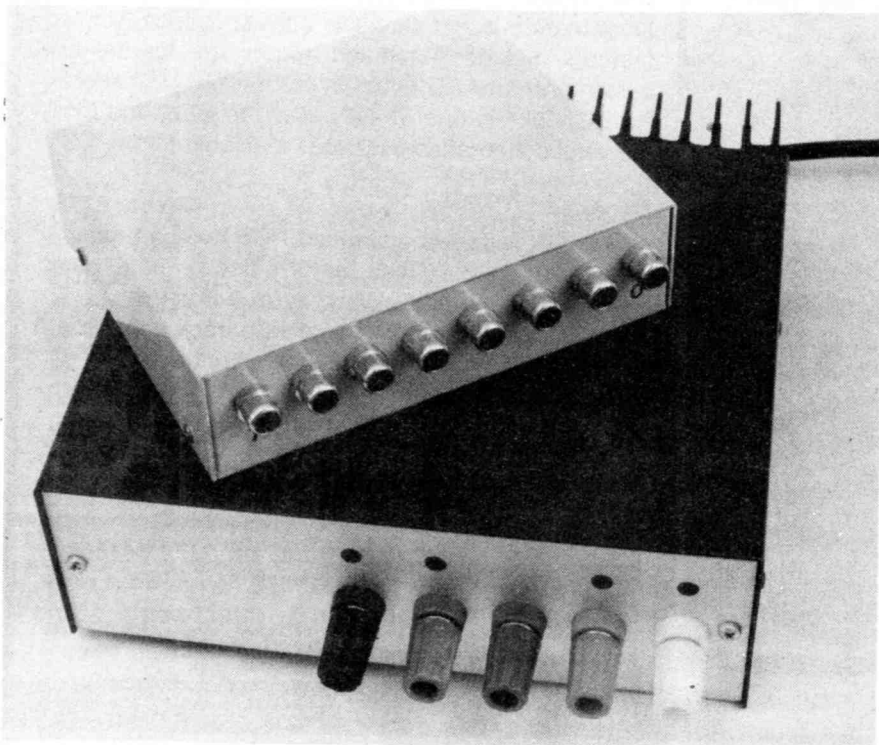

Fig. 2. Full-wave bridge rectifier circuit, with smoothing.

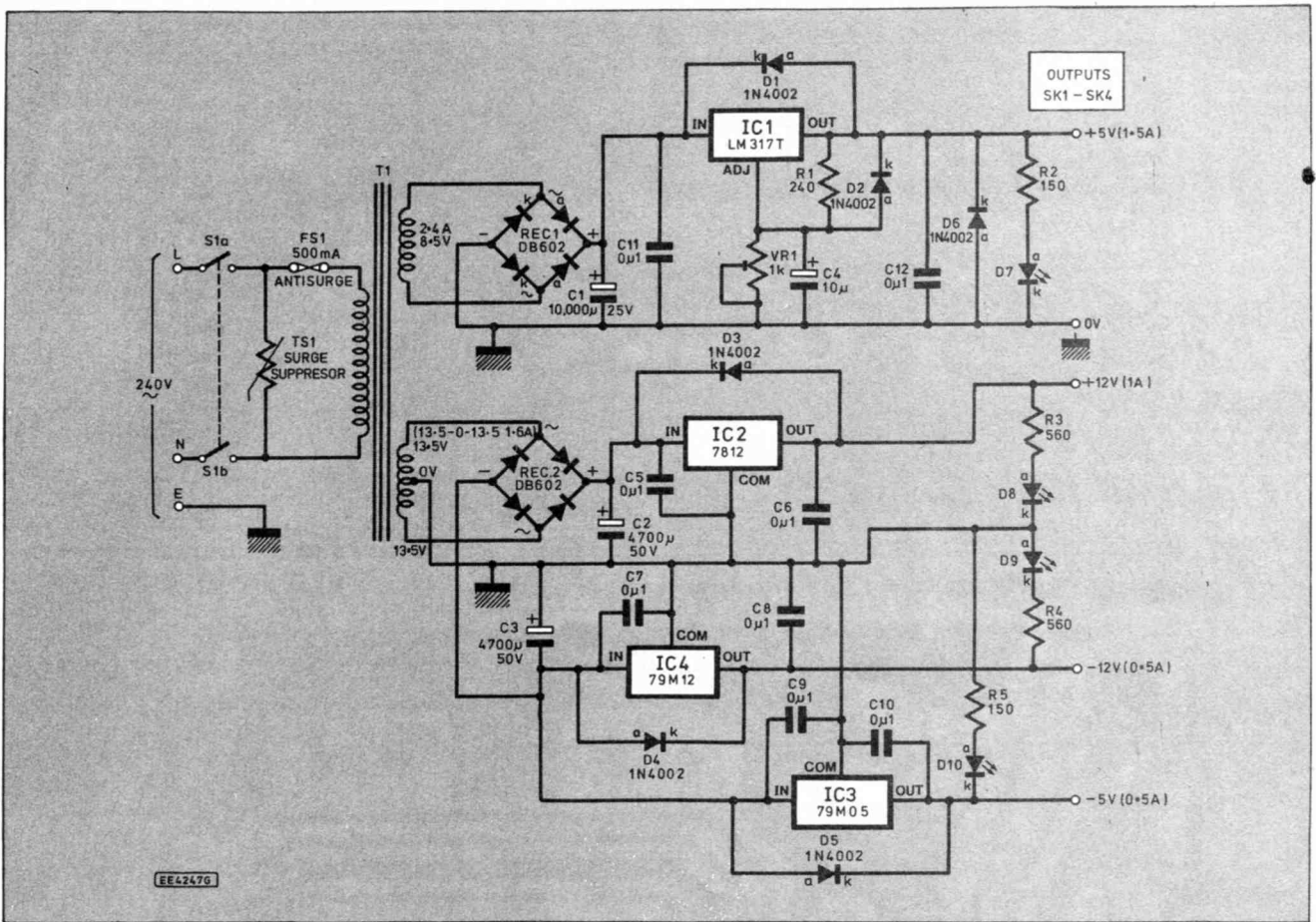

Fig. 1. Complete circuit diagram for the Linear Power Supply.

formation about power supply design in my reference material. Below is some useful information for choosing power supply components.

The information is basically all you need to build power supplies using the 78/79 series regulators, with output currents of a couple of amperes. With larger currents other items need to be taken into consideration.

#### Transformer Rating

For full-wave "bridge" rectification refer to Fig. 2. The output voltage of a transformer *decreases* as the load *increases*. The output voltage normally quoted for transformers is the *Full Load* voltage.

The output voltage with no load will be:

$$\approx (1 + (\text{Regulation}\% \div 100)) \times (\text{Full load Voltage})$$

Transformer current should be:

$$\approx 1.6 \times [\text{Max. d.c. current required}]$$

Transformer Voltage

$$\approx 0.707 \times [\text{Rectified (d.c.) voltage}]$$

#### Smoothing Capacitor

The voltage rating of the smoothing

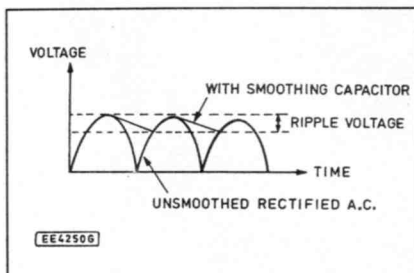

Fig. 3. Showing the effect that the smoothing capacitor has on the waveform.

capacitor should be at least 5V higher than the transformers [NO LOAD voltage]  $\times 1.5$ .

The value of capacitor required depends on the amount of ripple that is acceptable (see Fig. 3), normally the full load voltage ripple is kept below two volts.

$$[\text{Full load Ripple (V)}] \approx \frac{0.01 \times [\text{Full load d.c. current}]}{[\text{Capacitor size (Farads)}]}$$

**Note 1:** Large electrolytics typically have tolerances of  $\pm 20$  per cent, this means a capacitor marked 10,000µF may in the worst case only have a capacitance of 8000µF so this should be taken into account, especially if you intend to make more than one power supply.

**Note 2:** You should avoid using excessively large capacitors as this will increase transformer heating, and ultimately stress the rectifiers.

#### Rectifiers

A general rule of thumb is to use rectifiers with a current rating twice the maximum d.c. current required.

### UNREGULATED D.C. VOLTAGE

To work out the *minimum* required transformer output voltage, all voltage drops (worst case) should be taken into account. How to work out the minimum required transformer voltage for the 78 series regulators is shown below:

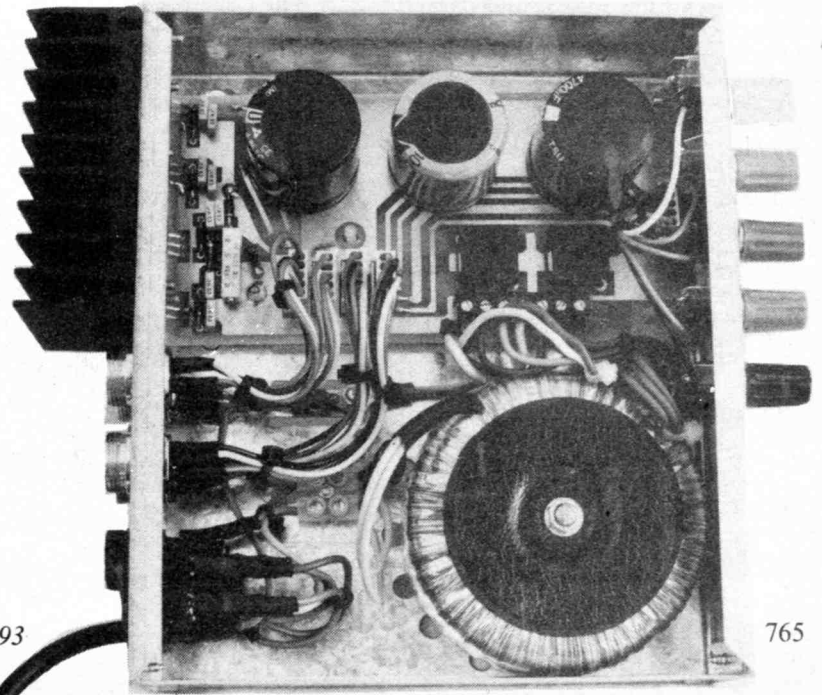



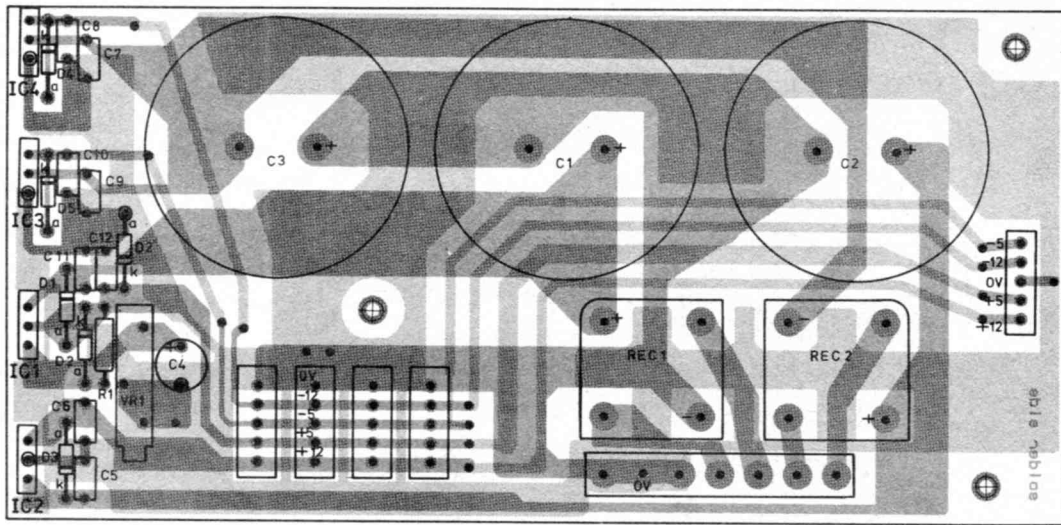

EE42480

● Solder to top (ground plane) and bottom tracks

● Track solder pin

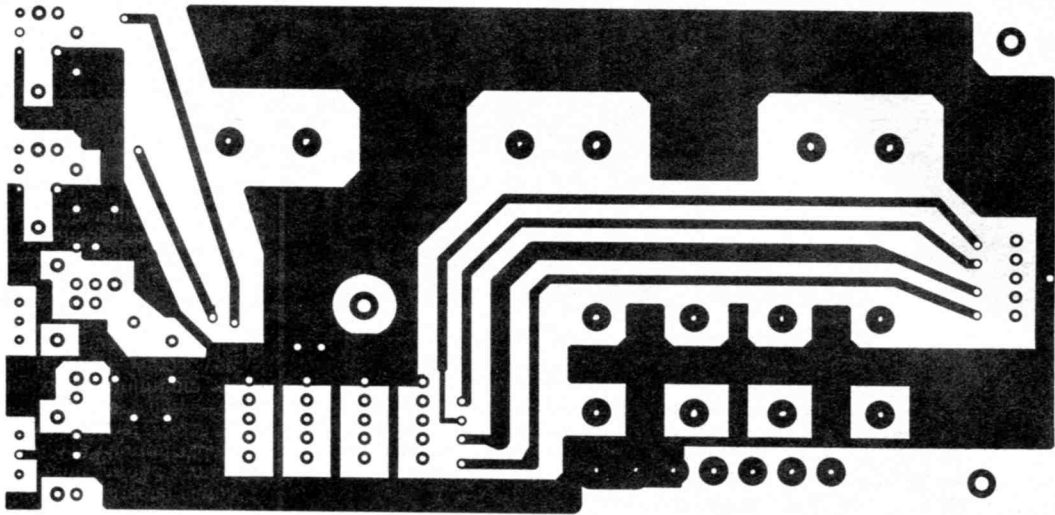

[Transformer Full load voltage]  $\times$  1.41  
 $\approx$  Vreg (regulator output voltage)  
 + 2.5V (Regulator voltage drop)  
 + Vrip (Full Load ripple voltage)  
 + 1.2V (Diode voltage drop)

## CONSTRUCTION

The Linear Power Supply is built on a double-sided printed circuit board (p.c.b.), which is housed in a *Metal* instrument case. The circuit board topside component layout and details of the copper foil master patterns are shown in Fig. 4. This p.c.b. is available from the *EPE PCB Service*, code 844.

When assembling the p.c.b., first insert the track-pins into the VIAs (VIAs are used to connect tracks on one side of the p.c.b. to tracks on the other side, marked ● on the component overlay). Push them in from the top side of the board and solder the track-pins on both sides of the p.c.b. and check the connections with a multimeter (set to Ohms or "tone").

You will probably find it easiest to solder in the components in ascending size e.g. resistors, diodes, p.c.b. plugs, up to the regulators, do not insert the three large electrolytics yet. The regulators should be mounted approximately 9mm above the p.c.b. (Fig. 5a). Finally, check the p.c.b. for shorts caused by solder splashes etc.

The leads marked with a ● on the component overlay should be soldered to the top layer of the p.c.b. as well as the bottom. The

interwiring details from the p.c.b. to the off-board components is shown in Fig. 8.

## CASE

The power supply components and p.c.b. were designed to fit into a metal (steel) instrument case measuring 175mm  $\times$  155mm  $\times$  58mm (see *Shoptalk*). All drilling and mounting details below and in Fig. 5 refer to this size case.

Drill the rear panel and heatsink as shown in Fig. 5b and remove all burrs especially on the heatsink. Also drill the base of the case. File the heads off four small bolts so they will fit into the slots at the ends of the heatsink and then mount it on the rear panel.

Fix the partially completed p.c.b. into the case and then attach the rear panel.

Mark the location of the mounting holes required for the regulators. Then disassemble the unit, drill the heatsink and solder the remaining components into the p.c.b.

When fixing the heatsink to the rear panel for the last time smear some heatsink compound around the edges of the heatsink which touch the metal box. Fix the completed p.c.b. into the case.

The regulators should now be bolted to the heatsink (on the assembled rear panel) using bushes and silicon rubber washers, these require no heatsink paste. When this is completed use a multimeter to check that none of the regulator metal tabs are *electrically* connected to the case or heatsink.

The wiring and assembly of the front and rear panels, is shown in Fig. 8. Fig. 6 shows

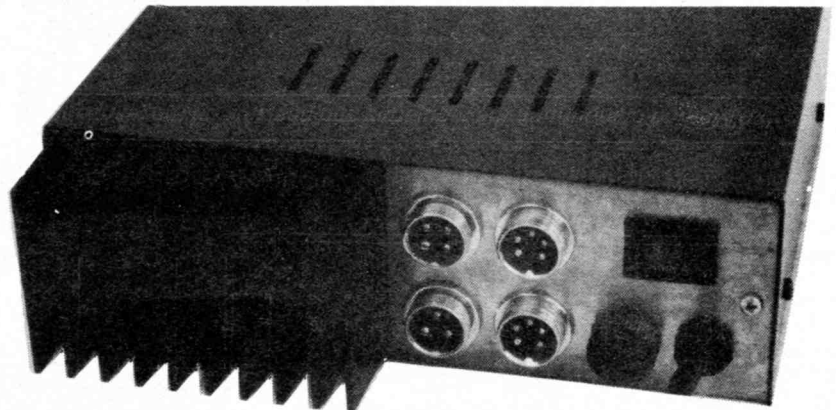

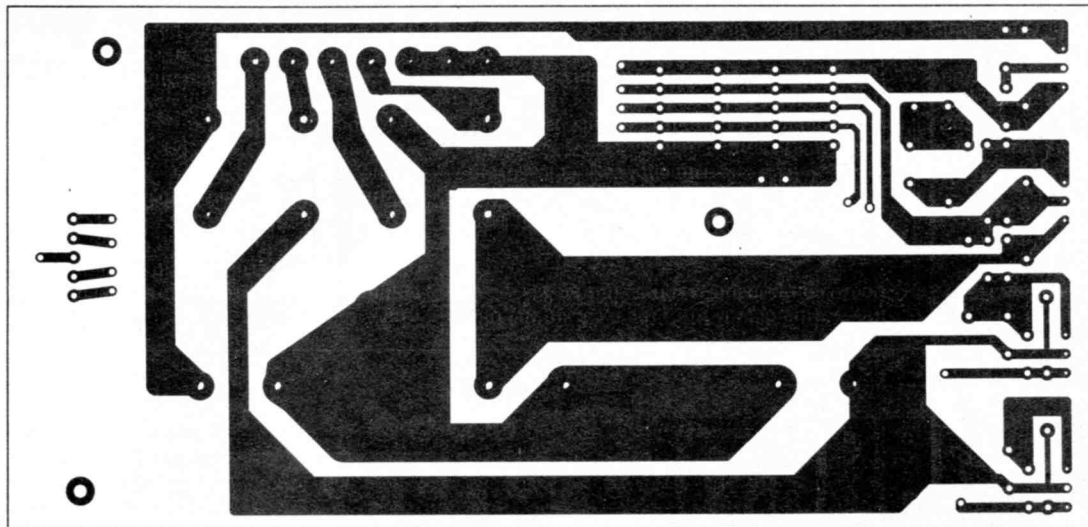

Fig. 4 (opposite page). Printed circuit board component layout and topside copper foil master pattern. The underside foil master is shown left.

See  
**SHOP  
TALK**  
Page

## COMPONENTS

### Resistors

R1	240
R2, R5	150 (2 off)
R3, R4	560 (2 off)

All 0.25W 5% carbon film

### Potentiometer

VR1	1k multi-turn cermet preset
-----	-----------------------------

### Capacitors

C1	10,000 radial elect. 25V
C2, C3	4700 $\mu$ radial elect. 50V (2 off)
C4	10 $\mu$ tantalum bead 25V
C5 to C12	0 $\mu$ 1 polyester 63V (8 off)

### Semiconductors

REC1,	
REC2	DB602 6A 200V bridge rectifier (2 off)
D1 to D6	1N4002 1A 100V rec. diode (6 off)
D7 to D10	Green cylindrical i.e.d. (4 off)
IC1	LM317T adjustable voltage regulator (+1.2V to 37V) 1.5A
IC2	7812 +12V 1A voltage regulator
IC3	79M12 -12V 0.5A voltage regulator
IC4	79M05 -5V 0.5A voltage regulator

### Miscellaneous

T1	Toroid mains transformer; 240V primary; 13.5V-0V-13.5V at 1.6; and 8.5V at 2.4A secondaries (30/LT/14-10)
S1	D.P.S.T. illuminated rocker switch
FS1	500mA anti-surge fuse and chassis mounting fuseholder
TS1	Mains (250V a.c.) transient suppressor
SK1	4-pin chassis plug/line socket (audio locking connectors)
SK2	3-pin chassis plug/line socket (audio locking connectors)
SK3,	
SK4	5-pin chassis plug/line socket (audio locking connectors)

Metal (steel) case, size 175mm x 155mm x 58mm; printed circuit board, available from EPE PCB Service, code 844; screw terminal post, one black, blue, green, red and yellow; 7-way p.c.b. mounting screw terminal block; 2-way screw terminal block; 5-way Minicon connectors (5 off); heat-sink (2.4°C/W); insulated crimp eyelet terminals; heatshrink sleeving; multi-coloured stranded connecting wire; plastic cable ties; insulating mounting kit for voltage regulator (4 off); heatsink compound; solder etc.

Approx cost  
guidance only

**£64**

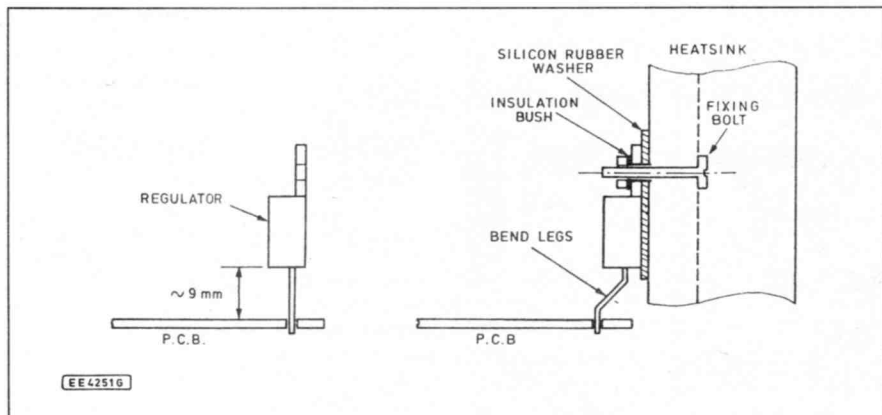

Fig. 5a. Method of mounting the regulators and heatsink on the rear panel.

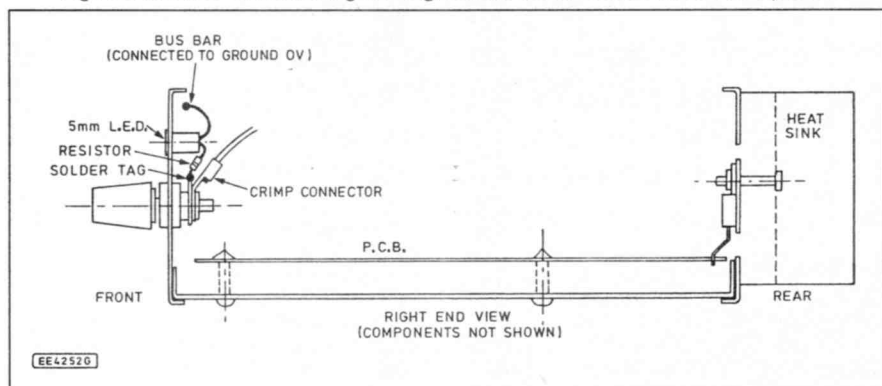
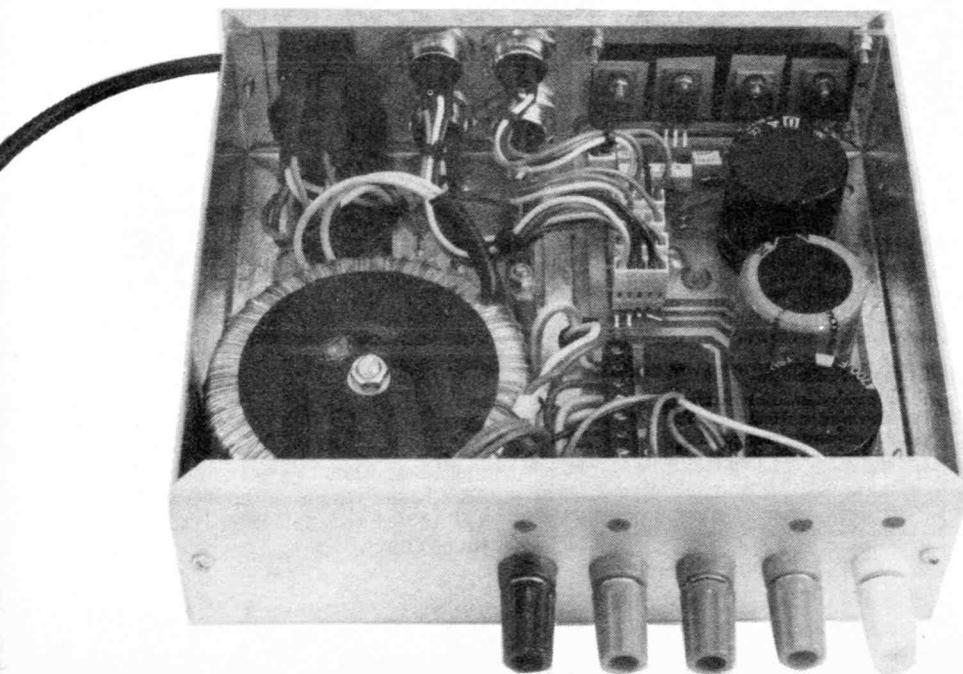

Fig. 5b. Output terminal mounting (and wiring). See Fig. 8. for bus bar wiring.





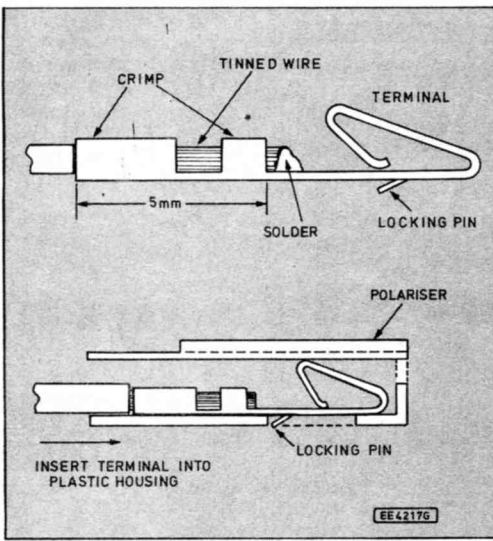
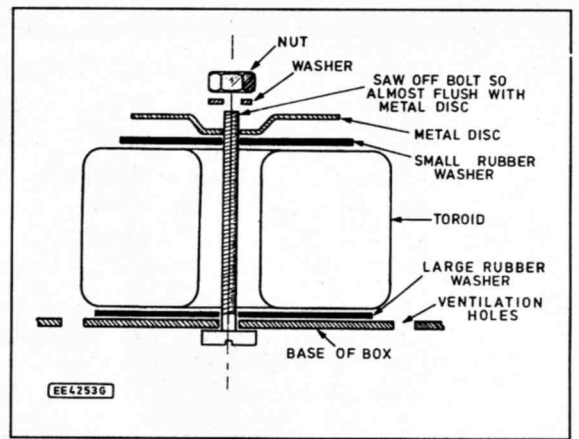

Fig. 6 (left) Assembly of the "Minicon" connector.

Fig. 7. (right). Method of mounting the toroidal transformer on the base of the metal case.

Fig. 8 (below left). Interwiring from the front and rear panels to the circuit board and transformer.



how to assemble the Minicon connectors. The use of the p.c.b. connectors is recommended as this makes assembly and disassembly far easier than it would be if the wires were soldered directly to pins.

All the solder connections on the rear panel should be insulated (heatshrink sleeving was used on the prototype). When wiring up the fuseholder, connect the incoming "live" wire to the *BACK* of the holder.

## TRANSFORMER MOUNTING

The method of mounting the toroidal transformer on the base of the case is shown in Fig. 7. Once the position of the mounting bolt hole has been established and drilled, and before the transformer is fixed to the case base, a series of ventilation holes need to be drilled in the base around the transformer. You can use the large rubber washer as a "rough" guide for marking out the holes, but leave plenty of room for the coils which overhang the washer.

**Important note:** Make sure that both ends of the toroid fixing bolt does not simultaneously come into contact with the case, as this will create a "shorted turn" and cause damage to the transformer winding.

## TESTING

Before connecting the power check the connections at the plug with a multimeter. make sure the earth (E) is connected to the case and live (L) and neutral (N) are not!

Commence testing by connecting the unit to the mains and testing the output voltages. All of the indicator lights should light up.

Measure the voltage between pins 3 and 5 of the PCW expansion connector (the voltage should be around 5V). Then adjust the output voltage of the power supply with preset VR1 to the same voltage, within 0.1V, as that on the expansion connector. Also check that the other outputs are at the required voltage.

## IN USE

In normal use the power supply runs well, producing very little heat. It will run with full current load on all channels, but if you intend to do this for *long* periods of time you are recommended to fit heatsinks to the rectifiers. Also the LM317 regulator becomes very hot if left in this state, so additional heat sinking may be required.

In full load condition the regulator (and hence the heatsink) can become very warm to the touch, so you should be careful of this, and ensure adequate ventilation. The unit should not "overheat" as the regulators shut down when they get too hot (at about 120°C), but the life of the semiconductors will be reduced if they are run in high temperatures. □

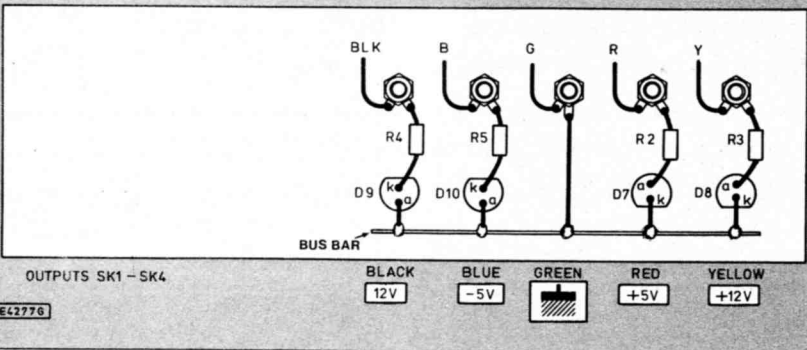
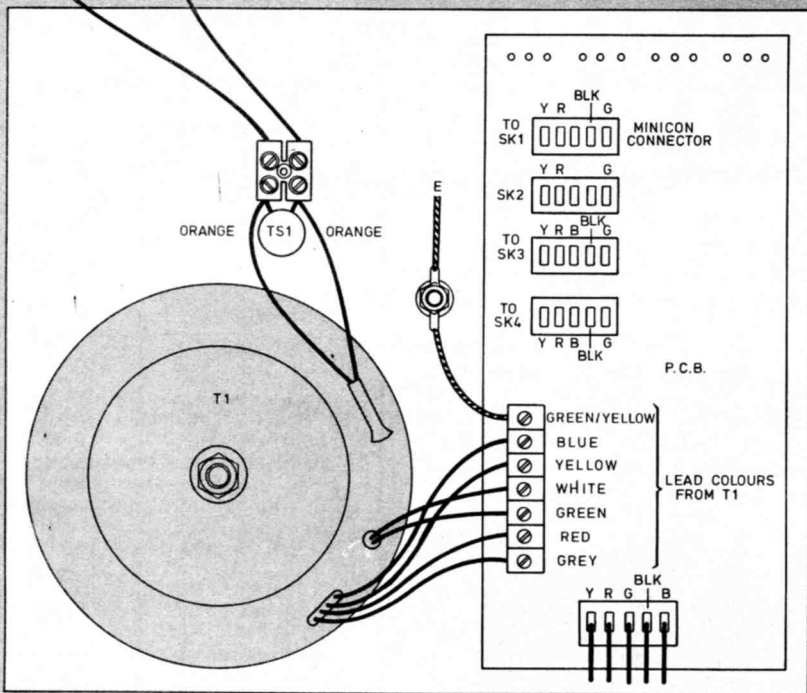
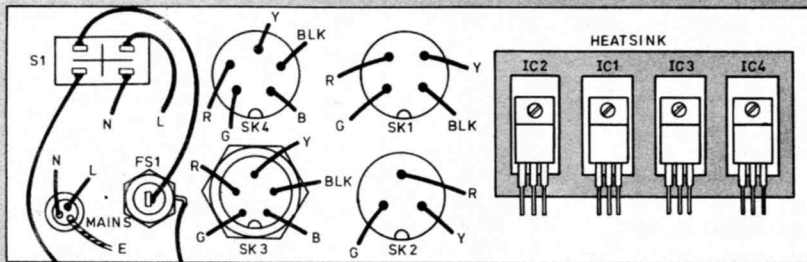

## SYSTEM 200 DEVICE PROGRAMMER

- SYSTEM:** Programs 24, 28, 32 pin EPROMS, EE-PROMS, FLASH and Emulators as standard, quickly, reliably and at low cost. Expandable to cover virtually any programmable part including serial E<sup>2</sup>, PALS, GALS, EPLD's and microcontrollers from all manufacturers.
- DESIGN:** Not a plug in card but connects to the PC serial or parallel port; it comes complete with powerful yet easy to control software, cable and manual.
- SUPPORT:** UK design, manufacture and support. Same day dispatch, 12 month warranty. 10 day money back guarantee.

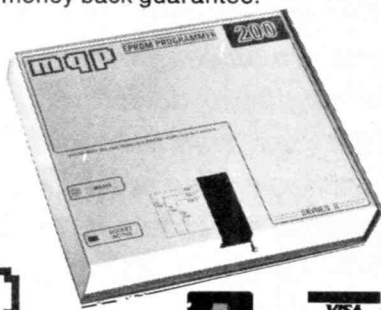

ASK FOR FREE  
INFORMATION  
PACK



MQP ELECTRONICS Ltd.  
Unit 2, Park Road Centre,  
Malmesbury, Wiltshire, SN16 0BX UK  
TEL. 0666 825146 FAX. 0666 825141

GERMANY 089/4602071  
NORWAY 071-17890  
ITALY 02 92 10 3554  
FRANCE (1)69.41.28.01  
Also from VEROSPEED UK

# OUT NOW!!

## HENRY'S NEW 1994 COLOUR CATALOGUE

TRADE • EDUCATION  
RETAIL • MAIL ORDER  
EXPORT



Open 6  
days a  
week -  
CALLERS  
WELCOME

### HENRY'S

404 Edgware Road,  
London W2 1ED

Components  
Telephone: 071-723 1008

Security - Communications  
Telephone: 071-724 0323

Audio and Test Instruments  
Telephone: 071-724 3564

Trade/Quantity  
Telephone: 071-258 1831  
Fax: 071 724 0322

#### RETAIL - MAIL ORDER VERSION

With price lists, special offers and purchase vouchers. Send PO/Cheque £4.00 (UK) £6.00 (EC) £10.00 (Non EC) Callers £2.00.

#### Education, trade, quantity purchasers

Post or fax letterhead for **FREE** copy with trade/quantity price list (UK). Overseas prices as above.

"... there is no doubt that running under *Windows* puts it ahead of the field and makes it a visually attractive package." *Electronics World + Wireless World July 1993*

*High Quality PCB and Schematic Design for Windows 3/3.1 and DOS*

- Supports over 150 printers/plotters including 9 or 24 pin dot-matrix, DeskJet, LaserJet, Postscript, and HPGL. Professional Edition imports GERBER files, and exports GERBER and NC-DRILL files.
- Up to 200,000 pads/track nodes depending on memory. Simple auto-router and schematic capture tools with SPICE compatible net-list output.
- Low cost DOS version (reduced features) also available. Ring for full details!

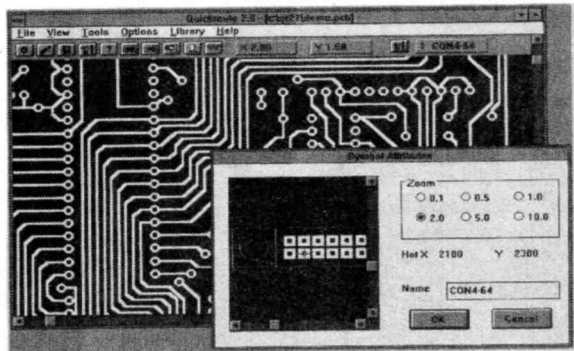

"Quickroute provides a comprehensive and effective introduction to PCB design which is a pleasure to use" *Radio Communication May 1993.*

# Quickroute



POWERware  
Software • Design

POWERware, Dept EE, 14 Ley Lane, Marple Bridge, Stockport, SK6 5DD, UK.  
Ring us on 061 449 7101 or write, for a full information pack.

Quickroute is available for Windows 3/3.1 in Professional (£99.00) and Standard (£59.00) editions, and for DOS with reduced features (£39.00). All prices inclusive. Add £5 P+P outside UK.

from  
**£39**



# CIRCUIT SURGERY

MIKE TOOLEY B.A.

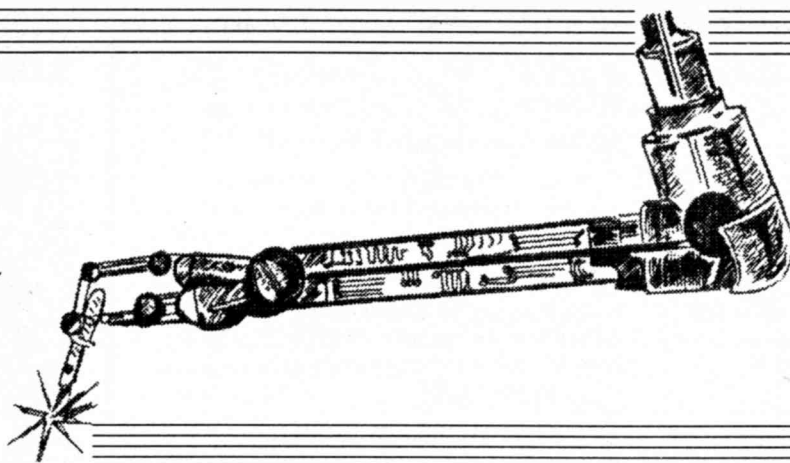

Welcome once again to Circuit Surgery, our regular clinic devoted to readers' problems. This month we provide information on component substitution together with a list of "preferred" semiconductor devices. This will be particularly useful for those of you who may from time to time have experienced difficulty obtaining the parts specified in EPE articles. We also describe a "Budget Pre-Amplifier" which can be used with the Power Amplifier described last month:

## Optical fibre

Anton Sutton writes from Cyprus with two questions:

"I wonder if you could show a simple design of an alarm system using possibly the CD4001 CMOS i.e., with exit and entry delay. Could you also tell me how much fibre optic costs in England because I can't buy it in Cyprus."

Well Anton, I will be describing a simple "Room Alarm" in next month's *Surgery*. In the meantime, you can obtain optical fibre from Maplin Electronic Components (Maplin order code: XR56L).

The fibre is 0.1 inch in diameter and is sold in multiples of one metre up to a maximum length of 100m in one single length. The fibre costs 98p per metre (postage and packing is extra), but you should note that the cable is supplied "rough cut" and you will have to very carefully trim each end cleanly with a razor blade (or a very sharp knife) before use.

Maplin can also supply you with some low-cost fibre optic couplers (MFOE71 and MFOE76 emitters and FD12N detectors). Details for using these are found in their latest catalogue. If you haven't

got one of these it is available at very reasonable cost and is well worth sending for!

## Component Substitution

I am often asked to suggest component substitutes for the designs that appear in *EPE*. Sometimes readers are attempting to build circuits that appeared many years ago (in which case some components may have become "obsolete" and therefore unavailable from the usual suppliers). In other cases the devices in question may no longer appear in suppliers' catalogues.

In difficult cases it is, however, nearly always possible to substitute an alternative component. However, before you attempt to replace that high-voltage diode or giant power transistor you *must* ensure that the replacement component is up to the job!

The considerations will vary with the type of component but the following should provide you with a basic guide:

## Capacitors

When dealing with capacitors, make sure that the substitute component has an equal or higher working voltage than the component you are replacing. A 25V electrolytic makes a suitable replacement for a 16V device but not for a capacitor rated at 35V.

It is generally unwise to replace a non-electrolytic component with a polarised (electrolytic) one. There are usually good reasons for *not* using electrolytics!

It is also worth noting that capacitors vary greatly in size and performance depending upon the type of dielectric and construction. In general, you can use a component having a similar or better quality dielectric than the unit you are replacing *provided* the working voltage is greater than that of the original component.

Finally, it is worth mentioning that electrolytic (and some other types of capacitor) exhibit a rather wide tolerance. If the exact value is important (as in the case of timing and oscillator circuits) it is wise to check the value of the component before

**Table 1: Recommended "industry standard" transistors which will replace the majority of other devices in the same class**

Small signal general purpose:	BC108, BC548 ( <i>nnp</i> ) BC178, BC558 ( <i>pnp</i> )
Low noise audio amplifier:	BC109, BC549 ( <i>nnp</i> ) BC179, BC559 ( <i>pnp</i> )
Low power switching:	BSX20, 2N706, 2N2369 ( <i>nnp</i> )
High voltage switching:	BU326A, 2N6545 ( <i>nnp</i> )
VHF RF amplifier stages:	BF173, BF180 ( <i>nnp</i> )
MF/HF RF amplifier stages:	BF115, BF494 ( <i>nnp</i> )
Low power audio output:	BD131 ( <i>nnp</i> ) BD132 ( <i>pnp</i> )
Medium power audio output:	TIP41A ( <i>nnp</i> ) TIP42A ( <i>pnp</i> )
High power audio output:	TIP3055, 2N3055 ( <i>nnp</i> ) TIP2955, MJ2955 ( <i>pnp</i> )
Medium power Darlington:	TIP121 ( <i>nnp</i> ) TIP122 ( <i>pnp</i> )
High power Darlington:	MJ3001 ( <i>nnp</i> ) MJ2501 ( <i>pnp</i> )

- Notes:**
1. Check pinouts before fitting replacements.
  2. Check tab/case connections of power transistors fitted on heatsinks (in some cases insulating washers and bushes may be required)
  3. If possible, check data sheets for absolute maximum ratings.

use. In many cases (e.g., in coupling and decoupling applications) this will not be necessary.

## Resistors

Make sure that the substitute resistor has an equal or higher power rating than the component you are replacing. A 0.5W resistor makes a suitable replacement for one rated at 0.25W but not for a component rated at 1W.

It is also worth checking that the replacement component is of similar type and construction to the one you are replacing. For various reasons, carbon resistors do not usually make sensible replacements for wirewound components, and vice versa.

As with capacitors, it is wise not to deviate too far from specified resistor values in the case of oscillator and timing circuits. Most designers will, however, allow for some variation in tolerance. Note, however, that if the author has specified a close tolerance (e.g., plus or minus one per cent) component, there is usually a very good reason!

## Diodes

When considering diodes, the replacement component must have an equal or higher working voltage (expressed either in terms of "peak inverse voltage" or "reverse maximum voltage") and an equal or greater forward current rating than the original.

Note that certain types of diode are unsuitable for operation in high speed switching applications, or where leakage is important, or when the forward voltage drop may be important. For the last reason, silicon diodes do not normally make sensible replacements for germanium components, and vice versa.

## Transistors

For transistors, the maximum working voltage (collector-emitter and collector-base) is important as is maximum collector current. The maximum reverse collector-base and emitter-base voltages can also be critical when the stage is used in large-signal or switching applications. It is also wise to consider maximum power dissipation, upper frequency limit, noise figure, etc, depending upon the application.

As with diodes, silicon transistors should not normally be used to replace germanium components, and vice versa. Finally, it should go without saying that you should only replace an *npn* transistor with another *npn* component, and similarly for *pn*p devices!

Table 1 shows a list of "industry standard" transistors which will cope with the vast majority of replacement and substitution problems. Note that you *must* carefully check the pinouts in relation to the device that is being replaced - failure to do this can result in the instant destruction of the transistor and possibly some of the other components too!

## Budget Pre-Amplifier

Lastly this month I have included the circuit details of a simple pre-amplifier to complement our Budget Power Amplifier. The complete circuit diagram of the Budget Pre-Amplifier is shown in Fig. 1.

The circuit is based on a low-cost dual operational amplifier, the first stage of which operates as a straightforward inverting amplifier whilst the second stage forms a conventional active Baxandall tone control

stage with individual Treble and Bass controls. This approach is cost effective and uses the minimum of components.

The circuit provides 12dB of boost and cut at about 100Hz (bass) and 10kHz (treble). A single Volume control is provided but you can easily add "mixer" controls for each of the inputs (simply connect each input to the top end of a 47k log. carbon potentiometer and take each slider to its respective positive connection on capacitors C1, C2 or C3).

Note that Input 1 is designed for a five kilohm source (such as a microphone or guitar pick-up); Input 2 is available for general purpose ("auxiliary") use (50 kilohm) whilst Input 3 is ideal for use with a radio tuner (500 kilohm). When used with the Budget Power Amplifier, full output can be obtained for signals of less than 10mV at the "auxiliary" input.

Construction is not at all critical but it is essential to use screened input and output leads to avoid unwanted hum and feedback. If desired, the components associated with the tone controls (VR1 and VR2) may be wired directly to the two potentiometers.

**Next month:** We describe a simple "Room Alarm" with exit and entry delay. In the meantime, if you have any comments or suggestions for inclusion in *Circuit Surgery*, please drop me a line at: Faculty of Technology, Brooklands College, Heath Road, Weybridge, Surrey, KT13 8TT. Please note that I *cannot* undertake to reply to individual queries from readers however I will do my best to answer all questions from readers through the medium of this column.

# COMPONENTS

## Budget Pre-Amplifier

### Resistors

R1, R4	4k7 (2 off)
R2	47k
R3, R5	470k (2 off)
R6, R7	10k (2 off)
R8, R9	22k (2 off)
All 0.25W 5% carbon film	

### Potentiometers

VR1, VR2	100k rotary carbon, lin (2 off)
VR3	47k rotary carbon, log

### Capacitors

C1, C2, C3	1 $\mu$ axial elect. 35V (3 off)
C4	10 $\mu$ axial elect. 25V
C5, C6, C7, C8	10n ceramic (4 off)
C9, C10	47 $\mu$ radial elect. 25V 2 off

### Semiconductor

IC1	TL082 Dual J-f.e.t. op. amp
-----	-----------------------------

### Miscellaneous

Matrix board (approx. 60mm x 100mm); terminal pins (9 off); 8-pin low-profile d.i.l. socket; knobs (3 off); screened lead; connecting wire; case, to choice; solder etc.

Approx cost guidance only

**£8.50**

## BUDGET PRE-AMPLIFIER SPECIFICATIONS

<b>Input Signal</b> (for full output):	less than 10mV pk-pk at 1kHz
<b>Input Impedance:</b>	5k, 50k and 500k (nominal)
<b>Frequency Response:</b>	10Hz to 30kHz at -3dB (flat)
<b>Maximum Boost/Cut:</b>	$\pm$ 12dB (typical)
<b>Distortion:</b>	less than 0.005% at 1V output
<b>Power Supply Voltage:</b>	+15V and -15V d.c. (max.)
<b>Power Supply Current:</b>	less than 15mA

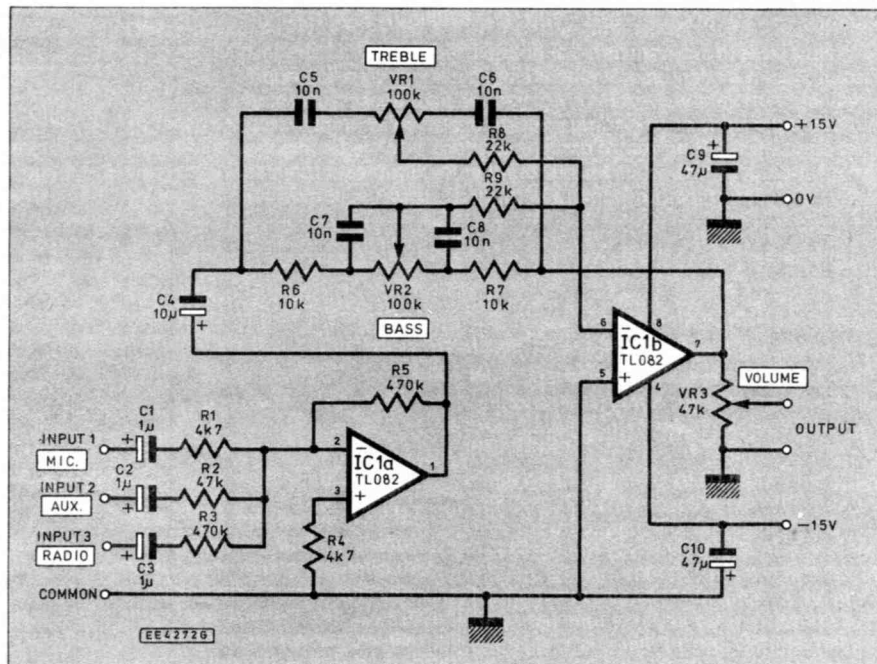

Fig. 1. Complete circuit diagram for the Budget Pre-Amplifier.



# BECOMING A RADIO AMATEUR

IAN POOLE

*Becoming a licenced amateur is quite easy. Virtually anyone can get "on the air" with a little effort.*

**A**MATEUR RADIO is a hobby which has captivated the interest of many millions of people since the very dawn of the wireless era. It can be a relaxing, interesting, creative or in fact whatever you want it to be.

Some people enjoy chatting to friends on the other side of town, or possibly the other side of the world. Other people enjoy constructional projects or experimenting with new techniques and finding out how they work. Some enjoy the challenge of contacting stations from as many different countries around the world as possible. In fact it is surprising how many countries there are, and where amateur radio operation has taken place.

## PIONEERS

The hobby does not only benefit its members. Down the years radio amateurs have made large contributions to science. If it was not for the pioneering spirit of many of the early amateurs the short wave bands would not have been opened up as quickly as they were.

In the early 1920s radio amateurs were relegated to the short waves because they were thought to be of little use for long distance communications. Not deterred by this amateurs continued to experiment. As a result they made the first transatlantic contact in November 1923, and then almost a year later a contact was made with the other side of the globe.

Today amateurs still display this pioneering spirit. They are still playing a vital role in pushing back the frontiers of technology. The large number of active stations means that propagation studies can be carried out relatively easily. Not only this, but new systems like packet radio have been tried out to a large degree by amateurs pursuing their hobby.

Apart from helping in new discoveries the hobby can benefit others when amateurs use their equipment to help the emergency services. This can be of particular use when large scale disasters occur. Fortunately these occasions do not happen very often but when they do amateur radio has a vast fund of equipment and expertise which can be volunteered.

With such a wide variety of aspects to the hobby, amateur radio can be tailored to suit the needs of every individual. Some will like operating whilst other like constructing and experimenting. There will be those who like to have a mixture of both. In fact whatever one's interest there is plenty in the hobby. Even if one's interests change there are still plenty of new aspects to investigate.

## FIRST STEPS

Anybody can listen to the amateur bands, see Table 1, without a licence. It can be very interesting and quite instructive as well. In fact it is probably one of the best ways of starting in the hobby. Many people start with one of the "World Band" types of radio to get a flavour of the bands. A number of them are available. The large manufacturers like Sony, Panasonic and Grundig make a very good selection, and prices start at around £130.

However when it comes to more serious listening, especially on the h.f. bands a proper communications receiver is needed. The various dealers offer a wide selection of receivers with prices from about £300 upwards. Unfortunately these receivers are not cheap but the cost can be brought within more reasonable limits if second hand equipment can be considered. There can be a bit more risk in buying a receiver this way, but if it is bought from a reputable

dealer the risk can be minimised. Alternatively an experienced amateur could look at the receiver and give a second opinion.

## BUILD IT YOURSELF

Apart from listening, it can be very useful to try a bit of construction. There are plenty of designs in the amateur radio literature for useful pieces of equipment. (A 20 Metre Receiver design will be published in *EPE* next month - Ed.) Another idea which is probably more appropriate for anyone building up something for the first time is to use a kit. This approach makes it a lot easier to build a circuit because a lot of the difficult p.c.b.s and metalwork will be completed. It also gives a much more professional appearance as it is often possible to buy a ready made case for the item.

Once most people have listened on the bands for a while they will want to transmit. However before this can be done it is necessary to have a licence. Fortunately they are not difficult to obtain, although a degree of commitment is needed.

## TYPES OF LICENCE

In the UK there are now four types of licence to cater for the needs of a wide variety of people. There are two standard licences: the class A and the class B licences and in addition to this there are class A and B Novice licences. However before any of them can be obtained some tests or courses have to be completed.

The standard class A licence gives access to all modes and to all of the amateur bands. However to be issued with one of these

Table 1: UK Amateur Bands

Frequency Limits (MHz)	Approximate Wavelength	
1-8.1	2-00	160 metres (Top Band)
3-5.0	3-80	80 metres
7-0.0	7-10	40 metres
10-10	10-15	30 metres
14-0.0	14-35	20 metres
18-0.68	18-168	17 metres
21-0.0	21-45	15 metres
24-8.9	24-99	12 metres
28-0.0	29-70	10 metres
50-0.0	52-00	6 metres
70-0.0	70-50	4 metres
144-0.0	146-00	2 metres
430-0.0	440-00	70 cms
1240-0.0	1325-00	23 cms
2310-0.0	2450-00	13 cms
3400-0.0	3475-00	9 cms
5650-0.0	5680-00	} 6 cms
5755-0.0	5765-00	
5820-0.0	5850-00	
10000	10500	3 cms
24000	24250	
47000	47200	
75500	76000	
142000	144000	
248000	250000	



**Table 2: UK Novice Licence Bands**

Frequency Band (MHz)	Types of Transmission Permitted
1-950	2-000 Morse, Telephony, RTTY, Data
3-565	3-585 Morse
10-130	10-140 Morse
21-100	21-149 Morse
28-100	28-190 Morse, RTTY, Data
28-300	28-500 Morse, Telephony
50-620	50-760 Data
51-250	51-750 Morse, Telephony, Data
433-000	435-000 Morse, Telephony, Data
1240-000	1325-000 Morse, Telephony, RTTY, Data Facsimile, SSTV, FSTV
10000-000	10500-000 Morse, Telephony, RTTY, Data Facsimile, SSTV, FSTV

**Maximum power 3 watts r.f. output or 5 watts d.c. input.**

RTTY – Radioteletype  
SSTV – Slow-scan television  
FSTV – Fast-scan television

licences it is necessary to have passed a theory examination called the Radio Amateurs Examination (RAE) as well as a Morse test.

For people who do not want to learn Morse the class B licence giving access to the bands above 30MHz may be the answer. This only requires a pass in the RAE and it gives sufficient facilities for many people.

Novice licences have been introduced quite recently. They are intended to give a route to help newcomers into the hobby, particularly those who are younger, although anyone can apply to hold a novice licence. As a result the tests required for these licences are less stringent than the standard ones.

As might be expected the novice licences do not give the same facilities as the standard ones. The bands are summarised in Table 2. From this it can be seen that access is allowed to a wide variety of bands and modes of transmission. This is ideal because it gives a good introduction to all aspects of amateur radio from the more recognised forms of communication like speech and Morse to the new data modes which are fast gaining popularity all around the world.

## NOVICE POWER

It will be noticed that the power limits for the novice licence are fairly low. However, it is still quite sufficient to make some very good contacts. On the h.f. bands, broadly speaking those below 30MHz, it is possible to make contacts over many thousands of miles even with a comparatively modest aerial. The use of a better aerial will obviously bring better results and make long haul contacts easier.

On the v.h.f. and u.h.f. bands the power restrictions will probably be less noticeable. Indeed many people with even the standard licence use powers below the maximum permitted by the novice licence. They must obtain satisfactory results otherwise they would change to higher power equipment.

In order to obtain a novice licence you have to attend a specially designed course. It gives a basic understanding about radio and there is a large element of practical work. In fact the emphasis is on learning by doing. There are a number of these courses around the country which are run under the auspices of the RSGB (Radio Society of Great Britain) who will be able to supply details.

Having successfully completed the course it is necessary to sit an examination based on the work covered in the course. This Novice Radio Amateurs Examination is fairly straightforward and is conducted by the City and Guilds. The actual examinations are held in a number of centres around the country. The City and Guilds Institute are able to supply details of the examination centres, although the course tutor will no doubt know where the nearest one is.

With both the course and the examination successfully completed it is possible to apply for a class B novice licence. This gives access to all the novice frequencies above 30MHz. To have access to the novice frequencies below 30MHz it is necessary to pass a Morse test at five words per minute. This test is conducted by the RSGB.

## FULL LICENCES

The novice licences have been very successful since they were first introduced in 1991. Through them a large number of people have entered the hobby. However many people will find that they want to progress to either the class A or class B licences. Alternatively some may want to apply for this licence straight away.

Holders of these licences have access to far more frequencies as shown by Table 1. Those holding the class B licence have access only to the bands above 30MHz whilst class A licensees can use any of the bands. Power levels are much higher than for the novice licence. On many bands powers up to 400 watts can be used. This means that far greater distances can be reached with ease.

To be able to apply for these licences different examinations have to be passed. For the class B licence the Radio Amateurs Examination has to be taken. Then in addition to this a Morse test is required for the class A licence.

## THE RAE

The RAE examination is more advanced than the examination for the novice licence but even so there is no reason why most people should not be able to pass it.

Like the novice licence examination the RAE is set by the City and Guilds. It is held twice a year: in May and December, and it consists of two multiple choice papers. The first lasts for 75 minutes and covers the licensing conditions, transmitter interference, and EMC (Electromagnetic Compatibility). The second paper lasts for only 30 minutes but it covers operating procedures, simple electrical theory, solid state devices, receivers, transmitters, propagation, aerials and measurements.

As the RAE may seem like a very large hurdle there are a number of steps which can be taken to make it easier. The first one is to try to find a local evening course. There are a number of them which are run around the country at schools and also radio clubs. To find out where they are being held a visit to the local radio club (the RSGB will tell you where the nearest one is) could help. Alternatively contact the local education authority or the RSGB.

If it is not possible to find a course all is not lost. Many people have studied by themselves and have successfully passed the exam - including myself. It must be admitted that it is a little harder to do it this way, but if one is determined to pass the exam this can easily make up for missing out on a course.

There are a number of good books to help prepare for the examination. The first is called the *RAE Manual* and it is published by the RSGB. Another book from the RSGB is called *How to Pass The RAE* and this is also very useful. In addition some general background reading about the hobby always helps. Magazines like *Everyday With Practical Electronics* are ideal because they give a lot of general information about electronics and radio.

Finally it can be a great help to listen on the bands. This gives first hand experience of the operating procedures which are used. It can also be quite instructive as many people talk about their equipment, how it works and the problems they have encountered.

## THE MORSE TEST

With the RAE under your belt the next step is the Morse. Many people will not need to take it because the class B licence will offer all they need, but for anyone wanting to transmit on the h.f. bands it is necessary to take it.

Unfortunately, a number of people find the thought of learning Morse quite daunting and as a result there are a lot of stories around about the difficulties involved and how people have struggled with it. Whilst this is true in some instances by no means everybody has problems with it and you should not be put off by it. Be determined, settle down to learning it with real determination and that is the major battle overcome.

There are many ways of learning the code. Often one person will find one way better than another so it is as well to remember to be



An amateur radio station does not need to take up much space.

flexible and if the first method does not work try another. Keep plugging away at it and you will succeed.

Often radio clubs will run classes for their members. If there is a club locally then it is worth investigating to see whether it runs anything. Even if there are not any formal classes it is still possible to obtain a lot of encouragement and assistance from people who have been through the same learning process themselves.

In addition to courses and clubs there are a number of other approaches which can be adopted. One is to buy a pre-recorded tape, or alternatively a local ham could be enlisted to help make one. All it may need is some characters recorded.

Another approach is to use a Morse "tutor". These items are electronic units which generate random sets of characters. The speed can be adjusted to suit and as such they make an ideal aid to learning. In fact a specialized tutor does not necessarily have to be bought because there is plenty of software around to do this sort of thing on a wide variety of different computers.

It is often helpful to learn Morse with a friend. In this way the impetus can be kept up more easily. On your own it can be very easy to let things slip and not practice as regularly. With a friend there can be a bit more pressure to keep things going.

## FIRST STEPS

When starting out the different characters must be learnt first of all. The best way to do this is to listen to each character several times, possibly on a pre-recorded tape. By doing this the actual rhythm of each character is learnt and this is all important. It is no good learning each character by looking at its dots and dashes.

Once the basic characters have been learnt practice in reading Morse is needed. This can be achieved with tutors, tapes, and even listening on the air. The bottom ends of the eighty and forty metre bands have a fair amount of reasonably slow Morse, especially at the weekends. Look between frequencies of 3-500 to 3-600MHz and also 7-00MHz to 7-04MHz. There is even some activity on two metres around 144-050MHz, although not nearly as much.

Sending Morse should be left until it is possible to read at least 10 words a minute. If you start to send too soon then bad sending habits can be created which are difficult to "unlearn" later.

Eventually it will be possible to read at the required speed. Before applying it is best to be able to read a little faster than the basic speed because exam nerves will undoubtedly slow you down. However when you are in the test remember that the examiner is there to enable you to pass and he will help you as much as he can.

## ON THE AIR

The day will eventually come when the licence arrives. The rig can be "fired up" and the first contacts made. To most people there is a mixture of excitement and nervousness. Because of this it is best to try for a few easy contacts with local stations. Don't try to contact some fantastically rare station which has a great pile up on top of his signal.

It is also worth bearing in mind for those that have taken the trouble to learn the Morse code that it can be very useful on the air. It is a great pity if all the effort put into learning it is wasted and it is not used at all. Many people find that they can make contacts using Morse when they would have no chance any other way. It can also be a very enjoyable mode to use anyway.

The main thing to bear in mind is to enjoy the hobby. Investigate new areas and try new bands or modes. All of this keeps a lively interest in amateur radio and adds to the enjoyment of the hobby.

**Addresses:** Radio Society of Great Britain (RSGB),  
Lambda House, Cranborne Road, Potters Bar,  
Herts EN6 3JE. Tel 0707 695015

### Further Reading:

*An Introduction To Amateur Radio* I D Poole  
ISBN 0 85934 202 6 **Order code BP257 Price £3.50**  
Pub Bernard Babani (Publishing) Ltd

*An Introduction To VHF/UHF For Radio Amateurs* I D Poole  
ISBN 0 85934 226 3 **Order code BP281 Price £3.50**  
Pub Bernard Babani (Publishing) Ltd

*Setting Up An Amateur Radio Station* I D Poole  
ISBN 0 85934 245 X **Order code BP300 Price £3.95**  
Pub Bernard Babani (Publishing) Ltd

All the above, and a further selection of amateur radio books, are available from the *EPE Direct Book Service* - see the book pages towards the end of this issue for information and ordering details.

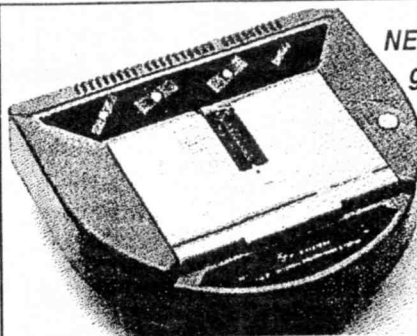

## NEW - Universal Programmer & Tester ALL07.

Operating on mains supply with parallel printer port operation. This highly professional unit has built in capability for future 256 pin driver needs. This new unit incorporates all the advantages of the ALL03A together with a

greater component range for its universal socket thus reducing the need to purchase special adaptors for special components. UK price £490 excl VAT

## Universal Programmer and Tester ALL03A by HILO.

Complete programming and testing system with a vast range of components including Eproms, Eeproms, Bproms, MPUs, PLDs et TTLs (74 et 75), SRAM & DRAM. This system, the result of six years of development, approved by makers such as TI, NS & Atmel, has been adopted in France by companies such as Dassault, Aérospatiale, SNCF, France Telecom. A simple high-speed PC interface ensures complete DOS accessibility of the system. Phone Steve Watt to obtain a complete specification by fax or by mail. £379 excl VAT.

## E/EPROM programmers by Hilo.

8 bit series 16k to 2M	16 bit series 16k to 8M		
EPP01A for 1 EPROM	SEP81 1 EPROM + original	£107	£143
EPP04A for 4 EPROM	SEP84 4 EPROM + original	£139	£183
EPP08A for 8 EPROM	SEP88 8 EPROM + original	£244	£301

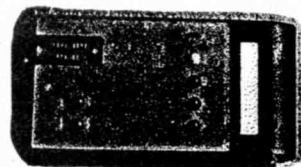
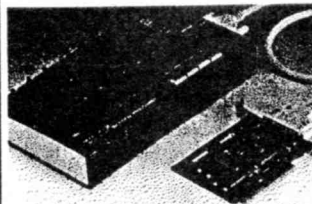

## Handy Tester by Hilo

Test of TTLs 74 series, CMOS series 40, 45 & RAMs 4164, 256, 44256 & 411000. Uses 9v battery. Automatic TTL identification, LCD display 16 characters. Automatic battery off when unused. Price £72.

## Professional EPROM erasers.

Equipped with security drawer and timer switch 240v. Standard model (Ref AT-201a (10 Eproms 27256) £60. Large model (Ref AT601/A) (60 Eproms) £91.

## HILO Eprom Emulator

Can be used as two 8 bit EPROM emulators or as one 16 bit emulator

- DOS shell enabling access during tests
- 120ns access time
- Emulations ROM: 2764, 27128, 27256, 27512 (also in CMOS), RAM: 6264, 62256
- Full page editor HEX & ASCII
- Supplied with 8 bit PC interface, connecting cable and tulip EPROM connectors, conversion programmes for Intel, Motorola, Tektronix, TI, Digital Research formats, file splitter and shuffler. Price £157

Optional disassemblers for :

8748, 8751, 68HC11, 68H09, 8085 et Z80 £20 per unit

**All prices exclusive of VAT at 18.6%. Invoiced exclusive of VAT to companies supplying order form with European VAT number. Other buyers please add 18.6% VAT.**

Delivery by registered post - full VAT invoice and 1 year guarantee included. Please add £4 post and packing per order. Payment by cheque or by Visa. Purchase orders from major corporations accepted.

For full information and documentation by fax or by post ask for Steve Watt.

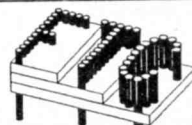

## FTC

4 Bd Chasteney de Géry - 94800 Villejuif, France

Tél: (010 33 1) 47 26 35 30 / 46 78 63 13

Fax: (010 33 1) 47 26 36 27

Monday to Friday 8h30 - 12h00 / 13h00-17h00

# MAURITRON TECHNICAL PUBLICATIONS

*A selection from our range of Technical Books and Guides for the TV & Video Trade*

<b>TELEVISION EQUIVALENTS.</b> <i>New Book lists Exact Equivalent for Many different Makes.</i>	Order MP-150. £5.95
<b>TELEVISION CHASSIS GUIDE.</b> <i>Identify your TV chassis from the model number.</i>	Order MP-18. £5.95
<b>VIDEO RECORDER &amp; CAMCORDER EQUIVALENTS.</b>	Makes A-J. Order MP-217. £5.95
<i>Lists all known models and their Equivalents. New 2 Volume Set.</i>	Makes K-Z. Order MP-218. £5.95
<b>VIDEO RECORDER FAULTS.</b> <i>Repair Guide for Beginners. Know where to start looking!</i>	Order MP-5. £3.00
<b>VHS VIDEO RECORDER PRINCIPLES.</b> <i>Essential Theory on the Principles of Operation of VHS.</i>	Order MP-58. £3.00
<b>CMOS DATABOOK.</b> <i>Detailed Specification on the 4000 Series with circuits.</i>	Order MP-10. £5.00
<b>TTL DATABOOK.</b> <i>Detailed Specification on the 7400 Series with circuits.</i>	Order MP-34. £5.00
<b>TRANSISTOR EQUIVALENTS AND TESTING MANUAL.</b> <i>Includes Testing Procedure.</i>	Order MP-24. £3.00
<b>POWER SUPPLIES, STABILISERS &amp; VOLTAGE REGULATORS.</b> <i>Includes Circuits.</i>	Order MP-9. £3.00
<b>REMOTE CONTROL CIRCUITS – TV.</b> <i>Dozens of Remote Control Circuits for Colour TV's.</i>	Order MP-167. £10.00
<b>MANUFACTURERS EQUIVALENTS.</b> <i>Know which Makers Trade Names are the Same.</i>	Order MP-220. £3.00
<b>VIDEO HEAD CLEANING KIT.</b> <i>Unique Kit with Comprehensive Instructions on how to do it right.</i>	Order VHCK. £4.00
<b>VIDEO TEST JIG.</b> <i>Run the machine and gain access to the mechanics as well.</i>	Order VTJ. £15.00
<b>SCART EUROCONNECTOR SYSTEM.</b> <i>Detailed Pinout Specifications of this interface.</i>	Order MP-21. £3.00
<b>SWITCH MODE PSU IC TYPE TDA-4600.</b> <i>Comprehensive Details of this popular TV PSU IC.</i>	Order MP-37. £6.00
<b>TELETEXT REPAIR MANUAL.</b> <i>Covers the SAA range as used in many sets.</i>	Order MP-38. £6.00
<b>P.C. HARD DISC DRIVE REFERENCE MANUAL.</b> <i>Specifications of Hundreds of Hard Discs.</i>	Order MP-84. £5.00
<b>CITIZENS BAND RADIO CIRCUITS MANUAL.</b> <i>Covers Dozens of popular models.</i>	Order MP-40. £10.00
<b>RECORD PLAYER SPEED DISC.</b> <i>Lets you accurately align any turntable speed.</i>	Order MP-8. £1.00
<b>CITIZENS BAND RADIO DATA REFERENCE BOOK.</b> <i>Technical Specifications of C.B. IC's.</i>	Order MP-165. £5.00
<b>TELEPHONE CODE LOCATION GUIDE.</b> <i>Find the Town from the Phone Code.</i>	Order MP-19. £5.00
<b>VALVE AMPLIFIERS CONSTRUCTION MANUAL.</b> <i>Full Building Details for Vintage Buffs.</i>	Order MP-173. £5.00
<b>VINTAGE WIRELESS SERVICING.</b> <i>2 Volume set covers Vintage Servicing in detail.</i>	Order MP-22 + 35. £6.00
<b>OFFICE EQUIPMENT EQUIVALENTS.</b> <i>Complete Cross Reference for all Photocopier or Fax.</i>	Order MP-200. £6.00
<b>REEL TO REEL TAPE RECORDER SERVICING.</b> <i>Details on Reel Servicing for Collectors.</i>	Order MP-201. £5.00

## SERVICE MANUALS

**WE HAVE THE MOST COMPREHENSIVE LIBRARY OF SERVICE MANUALS AVAILABLE ANYWHERE.**  
From the Earliest Valve Wireless to the Latest Video Recorder. Originals or Photostats as available.  
Colour Televisions, Video Recorders, Test Gear, Audio, Computers, in fact practically anything.  
If you need a Service Manual, Give us a call.

**MAURITRON PUBLICATIONS (EPE)**

8 Cherry Tree Road,  
Chinnor,  
Oxfordshire, OX9 4QY

Tel:- (0844) 351694

Phone your Credit Card Order  
for Immediate Despatch



All orders plus Post &  
Packing. U.K. £2.35  
Overseas £5.00 Surface  
or £15.00 Airmail.



Fax:- (0844) 352554

*Many new Titles coming soon – Write or Phone for your FREE catalogue.*



# Techniques

## ACTUALLY DOING IT!

by Robert Penfold

**S**OME time ago I commented on the fact that do-it-yourself project cases were much less popular now than they were about 20 years ago. In fact I suggested that do-it-yourself case construction was probably of little interest to anyone these days. Inevitably perhaps, this brought in some readers letters asking for more information in the magazine about this aspect of project building. Therefore, by popular demand, this month's *Techniques* is devoted to the subject of home constructing simple project cases.

### BEG, BORROW, OR BUY

It is only fair to point out that unless you are careful, it is quite possible to spend more money producing a home constructed case than if you simply went out and bought a ready-made equivalent. In days gone-by there were plenty of small do-it-yourself shops which had lots of off-cuts of plywood, chipboard, aluminium, and other materials at very low prices. Although these were offcuts, in many cases they were actually quite large. The aluminium offcuts in particular, were often larger than the sheets sold by most of the component retailers.

If you are lucky you might still be able to find a local source of cheap materials. If there are no do-it-yourself outlets that sell cheap offcuts, there may be a local manufacturing company which is willing to supply some suitable materials. Larger do-it-yourself stores sometimes sell off damaged or substandard goods at low prices. These will often be perfectly adequate for case building.

If you are going to produce your own cases, you must learn to be a hoarder who throws nothing away. I have used a lot of chipboard and hardboard in home made cases, and much of this material came from the packaging around self-assembly furniture.

### FULL PRICE

If all else fails, materials have to be purchased at full price from component retailers, do-it-yourself superstores, or whatever. It is well worthwhile shopping around though, as prices seem to differ significantly from one supplier to another.

I would strongly advise potential case builders to work out the costs involved before starting to buy the materials. Twenty years ago there were relatively few ready-made cases available, and those that were on offer had very high price-tags by today's standards. You are unlikely to obtain the same financial advantage in project case construction these days, and could end up paying more by doing it yourself.

I would not take the view that it is definitely not worthwhile building a case if it will cost about the same as a ready-made unit, or even if it costs slightly more.

If you enjoy case building, any marginally higher costs are not of any real importance. If you do not particularly enjoy this aspect of project building, and are only interested in making cost savings, it is something that may no longer be worthwhile.

In general, the larger the case, the greater your chances of being able to undercut the ready-made variety. This is simply because large ready-made cases seem to cost disproportionately more than the smaller types.

A point worth making is that building your own case means that you can produce a case of precisely the right size and style for any given project. When using ready-made cases it is normally necessary to compromise to some degree. There are dozens of small cases to choose from, and it is usually possible to find something that will accurately match your requirements. There are relatively few medium and large cases available though, and with large cases in particular, quite a high degree of compromise is often called for.

### DRESSING UP

Before considering the construction of cases from scratch, it would be a good idea to take a look at a few simple methods of turning a very basic chassis or case into a much more presentable case. An ordinary aluminium chassis actually makes quite a good instrument case if it is used up-side down, so that the removable base panel becomes the lid. With a few minor additions a chassis can be turned into quite a good cabinet for hi-fi projects, or other projects that must look reasonably good in order to blend into the decor.

The easiest way of doing this is to produce a "book-ends" type case. These

seem to be less fashionable than they once were, but a case of this type can still look very smart, and it is very easy to convert a chassis into one of these. Basically, it is just a matter of drilling a couple of holes in each side panel of the case so that a wooden end cheek can be mounted at each end of the case.

Each end cheek should be about 10mm bigger than the case on each of its larger dimensions. This gives the end cheeks an all-round overhang of about 5mm

The thickness of the end cheeks is not too important, and anything from about 10mm to 25mm should give attractive results. Ideally the end pieces would be made from pieces of good quality timber (mahogany, teak, etc.), varnished to give a good natural finish.

The more usual alternative is to use a low-grade timber or scraps of particle board. In either case, covering the ends with a wood grain effect self-adhesive plastic will give a very acceptable finish. This material is available from Woolworths, etc., in a range of patterns. There is usually at least one wood grain finish material which is suitable for our present purposes. A teak effect material is probably the best choice.

The pieces of wood or particle board must be clean and dust-free if the plastic veneer is to adhere properly. In order to obtain neat results the material needs to be stretched quite tightly around corners. It is easily trimmed to a neat finish using either a sharp modelling knife or a good pair of small scissors.

Sometimes this material can be a bit reluctant to stick down properly at the edges. This is easily cured by augmenting the existing adhesive with a minute amount of any general purpose adhesive.

### QUALITY

Although in the past these self-adhesive materials had a deserved reputation for being rather short-lived, modern soft plastics seem to be much longer lasting. I have some cases which were covered with self-adhesive plastic veneers over ten years ago, and they show no signs of the hardening and cracking which often plague these materials in the past.

The photograph below shows a 202mm by 153mm by 65mm chassis which has been given the book-ends treatment. It has also been fitted with four cabinet feet, and some left-over brushed aluminium effect veneer has been added to the front

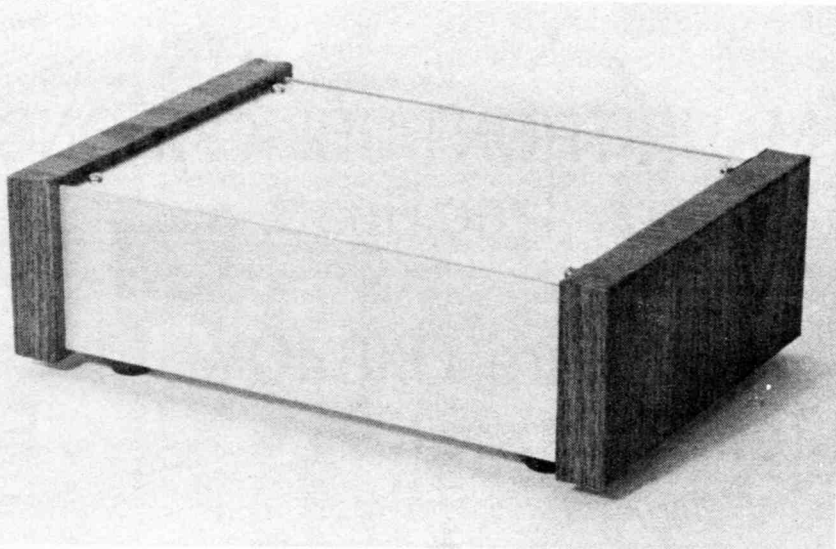

A standard chassis turned into a bookend style cabinet.

panel. This veneer seems to be genuine plastic, but it gives quite a convincing finish. It is very much thicker than normal self-adhesive plastic veneers, and is semi-rigid. The plastic is tough, but it can be cut to size using a modelling knife fitted with a new blade. It is available from Maplin Electronics in two sizes.

With a bit of ingenuity it is possible to make practically any aluminium chassis or simple folded aluminium case look quite elegant. This method almost certainly represents the cheapest way of producing smart looking cases.

## FROM SCRATCH

It is possible to build some very simple but effective cases using a combination of aluminium sheet and either wood or particle board. Fig.1 shows a case that is about the most simple form of do-it-yourself case that is reasonably neat and practical. This type of case has the advantage of not requiring any metal bending, which is something that can be difficult to carry out successfully unless you have access to the correct equipment.

This case is based on two pieces of timber or particle board, and four sheets of aluminium. The wooden end pieces are about 20 mm to 25 mm thick. If particle

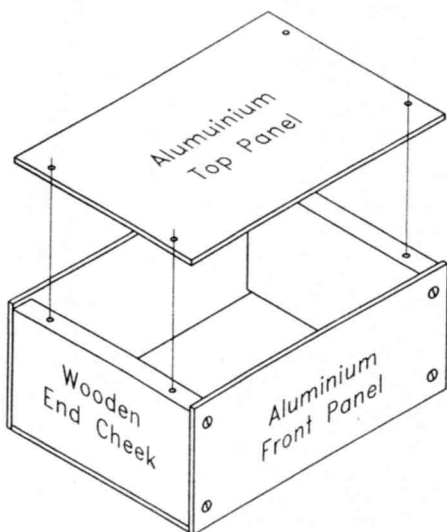

Fig. 1. Simple case construction.

board is used, it should obviously be covered with a self adhesive plastic veneer to give a neat finish. Again, a teak effect wood grain finish is probably the most appropriate.

The four aluminium panels are made from 16 or 18 s.w.g. material. These seem to be the only gauges of aluminium that are readily available these days. 16 s.w.g. aluminium is the thicker gauge, and as such it is significantly more expensive than the 18 s.w.g. variety.

For very large cases it might be worthwhile using 16 s.w.g. material, but 18 s.w.g. aluminium is usually more than adequate for home constructed cases. In fact 20 s.w.g. aluminium is adequate for most small and medium size cases, but it seems to be difficult to obtain at present.

## CUTTING

In order to produce neat results it is essential that the aluminium panels are accurately cut to the right sizes, with good straight cuts. A hacksaw will cut through aluminium quite well, but making long cuts with a hacksaw is awkward. It is also very difficult to make long straight cuts using this tool.

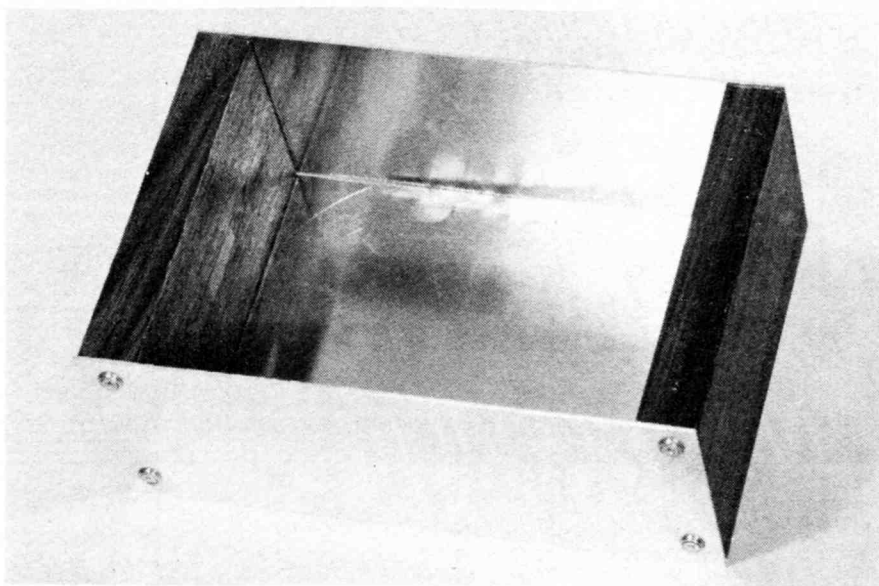

Simple case with wooden end panels.

I find that the best way to cut aluminium is to make a deep score line using a sharp modelling knife. A steel rule (or a plastic one having a metal insert) is used to guide the blade along the correct line.

If the aluminium is then repeatedly bent backwards and forwards along this line, it will soon fatigue and break along the score line. Unless the aluminium is very deeply scored, it is advisable to clamp it between two pieces of wood so that the score line is just slightly clear of the wood pieces. Otherwise there is a tendency for the aluminium to become curved close to the cut. If this is allowed happen, it will be very difficult to flatten the two pieces of aluminium out again.

This method should produce a reasonably clean cut with no significant wastage. The cut edge will probably be slightly rough, but it can be quickly and easily smoothed off using a small flat file.

## PRIZE SIZE

Remember that the front and rear panels are slightly taller than the end pieces, so that the top and rear panels will fit flush with them. The extra height is obviously equal to double the thickness of the aluminium, but in practice it is probably better to play safe and allow fractionally more than this. The front and rear panels should therefore be about four millimetres higher than the end pieces when using 18 s.w.g. aluminium panels. An extra five to six millimetres is about right when using 16 s.w.g. panels.

The top, bottom, front, and rear panels are all fixed to the end pieces using woodscrews. For most cases four woodscrews per panel will suffice, but for larger cases it might be necessary to use six screws per panel. The panels themselves can be used as templates when marking the positions of the screw-holes. A bradawl is then used to make start-holes for the screws.

Decorative cup washers can be used over the screws to give a better appearance, and I would certainly recommend the use of these on the screws which hold the front panel in place. If the end pieces are covered with a veneer, the case will probably look smarter if the top panel is covered with the same material. To complete the case four cabinet feet are added.

## VARIATIONS

Numerous variations on this basic type of case are possible. For instance, smaller end pieces can be added inside the main end cheeks. The four aluminium panels are then fixed to these smaller end pieces, so that a book-ends style case is produced. With a little ingenuity it is possible to modify the basic design to produce a case that will suit practically any project.

Next month we will continue on the subject of home-made cases, but will consider some designs that involve metal bending.

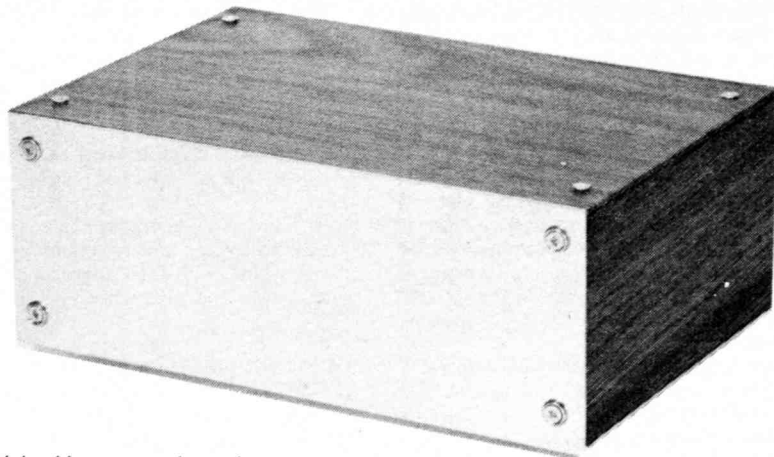

The finished home-made project case.

# FAKE CAR ALARM

MUNGO HENNING

*No false triggering, just three components will, it is hoped, persuade any would-be intruder to "drive-on".*

TAKE a moment to consider your car. What's the insurance premium like? Got an excess on the policy? Assuming that you do not already have a car alarm, consider the penalties that you will pay for an attempted break-in, never mind a full break-in, or even the car being stolen altogether.

Just such an incident happened to the author last year. Parked beside lots of other cars, someone ripped off the horizontal weather-seal strip between the driver's window and the driver's door, then proceeded to bow-out the thin metal at the middle-top of the door to gain access to the lock mechanism.

Probably more by luck than anything else we assume that the culprits were disturbed, because nothing was stolen from the car. After involving the police, the next day I had all the hassle of telephoning my insurance company and arranging for a claim form to be sent out.

This was followed by a visit to my local car repair firm (the state of the car meant that it would be trivial for anyone else to gain entry, what with the lock mechanics in full view), to assess damage and repair cost. Luckily the repair was swift and cheap, but it made me anxious to avoid a repetition now that I know how vulnerable the car is.

To digress, it is most important to always inform the police about any such incidents. A police relative recalls going to an incident only to be told by the complainant that "this was the sixth time it had happened".

When asked about the other five occurrences the complainant said that they had not informed the police. Fair dues: if the police are not informed of incidents how can they take any action?

## FALSE ALARM

The obvious first thought I had about the attempted break-in was to fit a car alarm. I always get annoyed when I hear car alarms falsely going off (usually accompanied by the quizzical looks from the culprit/owner as they embarrassingly fumble for the suitable off switch), which seems to be a growing occurrence.

Since car alarms can also be expensive, I decided against this course of action. The next best thing would be a fake car alarm, in the form of a flashing l.e.d.

Appropriately mounted, it could act as a

warning to any would-be intruder. Many real car alarms have such flashing l.e.d.s fitted, to warn the user as well as the owner that the alarm is operating.

I am also quite lazy about things, so a FIFI design (Fit It and Forget It) would be ideal. The tiny circuit diagram shown in Fig. 1 meets these requirements. There is not much to the circuit, but the lack of components should not detract from its effectiveness.

The l.e.d. is of the special "flashing" variety in that a flash unit is integral to the l.e.d. itself. The one used did not require a limiting resistor if fed from five volts. Since a car battery is nominally 12V it seemed prudent to add such a resistor.

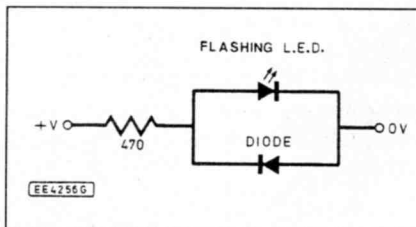

Fig. 1. Circuit diagram for the Fake Car Alarm. The cathode (k) connection of the flashing l.e.d. is indicated by a chamfer on its body and the shorter lead. The lead nearest to a "band" on the body of a diode indicates the cathode (k). A typical value for the resistor would be 470 ohms.

The third component is a simple diode wired across the l.e.d. but with its anode (a) connected to the l.e.d.'s cathode (k). This is to protect the l.e.d. should a large negative voltage appear across its anode to cathode terminals.

The current consumption of the unit is minimal, so there would be no problem with powering it all the time from the battery. However, the unit is meant to attract people's attention and this could include the driver whilst driving, so it would be nice to only power the unit when the ignition is OFF.

The solution chosen here is to power the unit across the ignition switch (that which is operated by the ignition key). This may seem daft at first, but in this way, the unit is truly FIFI since the driver need do nothing to switch it off.



This of course relies on a tiny bleed current path available when the ignition is off, but in my experience such a path is available.

## CONSTRUCTION

**IMPORTANT:** The vehicle battery MUST be disconnected when carrying out any wiring and/or soldering to the car electrics. An in-line fuse is recommended for this unit.

Not being a top-of-the-range model, my car had an unused switch socket covered by a plastic blanking plate. This proved ideal as the location for the l.e.d. and the components are simply soldered directly onto the l.e.d. leads once the appropriate hole is drilled and the l.e.d. fitted to the blanking plate (a dab of superglue works wonders).

Connect two leads to power the unit using thin wire of length to reach through the steering column cover and up to the ignition switch. Access to the ignition switch will be different for each model of car, but in mine all it took was removing a couple of awkwardly-placed screws and the switch points were exposed.

Without re-soldering the whole ignition switch it was quite straight-forward to briefly melt the top layer of the solder at the connection and "weld-on" the new wire. A bit of experimentation is probably in order to determine which points you should connect to!

## TAKE NOTE

A couple of final points. Should you decide to fit an in-line fuse to the unit, fit it near to the ignition switch and if possible make sure that this is concealed. Either way, use thin connecting wire to power the unit. Note that a short across these power wires is the equivalent of by-passing the ignition-key switch, perhaps termed "hot-wiring" the ignition.

Of course, the aim of this circuit is to deter potential criminal activity involving your car (when the car next to it has no such signs of an alarm). However, this deterrent is a bluff and gives no real protection. Determined criminals will go to great lengths if a particular car (or its contents) are desired, so you probably won't stop them, even with a real alarm system.

But for a few quid (or a rummage through your component box), and an hour or so of your time the FIFI benefits are, in my opinion, well worth it.

You can always boast to your neighbours that your car has a true "silent alarm" (groan). □



# AITKEN BROS & Co

## HM102 ANALOGUE MULTIMETER

19 ranges Inc leads & batts  
AC volts.....0-10-50-250-1KV  
DC volts.....0-2.5-10-50-250-1KV  
DC current.....0-5m-50m-500m-10A  
Resistance.....0-10K-100K-10M  
Dims.....135x89x40mm

SEPTEMBER PRICE £13.50  
NP £13.99



## BREADBOARD

840 tie points, in 2 sets of 64 rows of 5, + 4 power rails.

Complete with baseboard & mounting plate for switches & pots etc. NP £10.16  
SEPTEMBER PRICE £8.99

## 4-WAY 13A. EXTENSION with 3 yds 13A cable

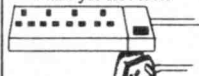

NP £9.99  
SEPTEMBER PRICE £6.99

## ALT26 DIGITAL MULTIMETER

7 ranges inc 10A DC Inc leads & batts  
3.5 digit 12mm LCD display  
AC volts.....0-500v  
DC volts.....0-20-200v  
DC current.....0-10A  
Resistance.....0-2K-2M  
Dims.....148x73x32mm

SEPTEMBER PRICE £14.99  
NP £20.99



## SOLDERING EQUIPMENT



ANTEX  
18W SOLDERING IRON  
SEPTEMBER PRICE £8.50  
NP £9.99



DE-SOLDER  
PUMP  
SEPTEMBER PRICE £2.99  
NP £3.99



PORTASOL  
GAS IRON  
SEPTEMBER PRICE £11.99  
NP £14.99

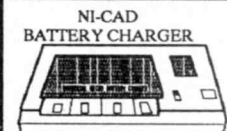

NI-CAD  
BATTERY CHARGER  
SEPTEMBER PRICE £5.99  
NP £6.99



4x NIKAD  
AA BATTERIES  
SEPTEMBER PRICE £3.80  
NP £4.00 per 4

Order the  
BATTERY CHARGER  
+  
4x AA NI-CAD'S  
TOGETHER  
SEPTEMBER PRICE £8.99  
NP £10.99

PLEASE ADD £1.00 POSTAGE TO ORDER

CATALOGUE AVAILABLE £1.50

(refundable with order)

35 HIGH BRIDGE, NEWCASTLE UPON TYNE

NE1 1EW Tel. 091 2329877 Fax 091 2619664

SCHOOL & COLLEGE ORDERS WELCOME (automatic account facility)

*Don't let the digital world  
pass you by!*

TEACH YOURSELF DIGITAL ELECTRONICS  
THE EASY WAY, USING OUR ALL-IN-ONE  
PROFESSIONAL TRAINER.

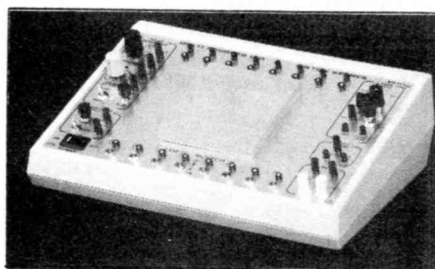

The model MS101 is a self contained mini lab which can be used without additional external equipment. The special features will enable you to move up the learning curve in digital electronics.

To get you started we provide a comprehensive range of digital ICs with instruction package.

**FREE!**

Introductory offer includes 50, yes 50 digital integrated circuits with each digital trainer. These include Gates, Buffers, Flip Flops, Decoders, Multivibrators, Counters, Shift Registers, Comparators, Arithmetic Logic, Parity Generators & Interconnecting Wires.

Take advantage - order now.

Yours for only  
**£149.00** (VAT)  
P&P extra  
Including 50  
Digital ICs

## FEATURES.

- Pulse & Delay Generator
- Power Supplies
- Built in Logic Probe
- De-bounced Switches
- Generous Breadboarding Area
- 1mm & BNC Connectors
- LED Indicators
- Manual Clock

Learn digital techniques, through step by step exercises.

For further information-  
Phone: (0908) 265311  
Fax: (0908) 263035  
Post: Multi Sources Ltd.  
Unit 5, Potters Lane  
Kiln Farm Ind Estate  
Milton Keynes  
MK11 3HE  
We accept Access & Visa  
credit cards

revised  
edition

# TRANSMITTERS

**AT LAST.** A fully comprehensive, easy to follow guide to building short range micro transmitters. Packed with useful information and circuits.

- ★ How to build micro surveillance devices.
- ★ Radio mics.
- ★ Tracking and signaling transmitters.
- ★ Only **£3.95** inc p&p.

(Some of the circuits included can not be used legally in the UK)

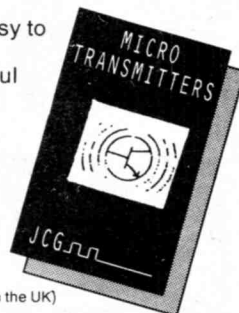

# AUDIO KITS

JCG have put together a superb range of audio kits that mean you can build your own high quality amplifiers and auxiliary equipment for a fraction of the cost of ready made units. Not only that, but you'll have the option of tailoring designs to your exact needs whether you're simply upgrading the power amp in your Hi-Fi, or building a sound system from scratch. All our power and preamps are interchangeable making them ideal building blocks for a whole range of audio projects. Kits come complete with pre drilled fibre glass PCBs, Hi spec components and full instructions.

## POWER AMPS

**3 WATT.** A versatile low cost amp for intercoms, radios etc. Onboard vol. makes for easy mounting on control panels. Easy build. **£4.95**

**15 WATT.** High quality power amp. Good specs., ideal bench amp or upgrade for stereos etc. **£9.95**

**40 WATT.** The best value power amp kit available. It'll deliver 40 Watts into an 4Ω load with total harmonic distortion lower than 0.0032%. The circuit incorporates switch on mute along with thermal and short protection. Unbeatable performance, perfect for compact disc and other demanding applications. **£18.50**

**150 WATT.** A real monster of a power amp. High reliability MOSFET design coupled with excellent response and rugged power. Great for PA's, guitar and sound systems. **£22.95**

## PREAMPS

Studio quality at home build prices.

**LOW NOISE PREAMP.** Designed as input stage for studio mixers - variable gain, high output. Exceptional performance. **£4.50**

**ACTIVE TONE BOARD.** Complete preamp and active bass/treble. Perfect for driving our 150 watt power amp in guitar/PA applications or as basic EQ for mixers etc. **£8.95**

**7 BAND EQ.** High quality active unit for graphic EQ or advanced tone control systems. **£10.95**

**NOISE GATE.** Complete dynamic noise reduction system, outperforms many commercial units. Input gain and cut off controls. Can handle inputs from tape decks etc. or effects units. Wide range of applications. **£15.95**

## MUSIC KITS

Full range of on board units for guitars etc. - active tone controls/ boosters, wah wah and other effects kits - send for list.

## TRANSMITTERS

**MICRO FM TRANSMITTER.** Easy to build, 1 mile range, very small including mic. Pick up on any FM radio. **£6.95**

**TRACKING FM.** Transmits a constant pulse tone that can be used for direction finding, tracking cars or animals etc. **£8.50**

**CRYSTAL RADIO.** Simple introduction to radio and electronics. Includes easy instructions, ferrite rod, tuner etc. **£5.75**

**AM RADIO.** Tuner and power amp that make a tiny AM radio. Will drive a small pair of headphones. Simple to make and fun to use. **£8.50**

**INFRA RED AUDIO LINK.** Short range low cost audio link. Wide frequency response. Kit includes transmitter and receiver. **£8.95**

**INFRA RED REMOTE CONTROL.** Simple but effective remote control of relay switch up to 10 metres. Ideal for car alarms, light switches etc. Includes 240V relay. **£10.05**

Prices include P&P. SAE for full list of kits and projects. Make cheques and postal orders payable to:

JCG

3 Bainbrigge Road, Headingley, Leeds LS6 3AD.

# KETTLE ALERT

**BART S. TREPAK**



*A bleeping reminder that the kettle has boiled - can be used with all automatic electric kettles.*

**T**HE OLD adage that a watched kettle never boils is obviously not true unless of course there is something wrong with it. The fact remains that they do appear to take a long time to boil with the result that when you want a cup of tea, you put the kettle on and go off to do something else.

After what seems like an appropriate time you return to find that the kettle has indeed boiled and switched off but you are then left wondering how long ago this was and if the water has since cooled down. Just to make sure, you switch the kettle on again to bring it to the boil and stand over it to watch which can sometimes take another 20 or 30 seconds, which can seem like an hour.

We are, of course, bad at estimating the passage of time even when we are not engrossed in some other task. In the past this was not a problem as the kettle itself would inform the user when it had boiled by utilising the steam produced to blow a whistle.

With the advent of electric kettles, manufacturers seem to have concerned themselves more with experimenting with different shapes and materials and making sure that the kettle switches itself off when

it has boiled, but seem to have forgotten to add a buzzer to alert the user that it has done so. Often it only produces a "click" which can be missed when you are in the kitchen and is certainly inaudible when you are elsewhere. The idea for this project was born when we took out our old (non electric) whistling kettle for a camping holiday and realised what we had been missing.

## SELF-SERVICE

The initial concept was to mimic the action of the conventional kettle, by using a thermistor to sense the production of steam and activate a sounder of some description, but further thought revealed some problems. The thermistor, for instance, would of course need to be mounted on or near the spout which was quite difficult in itself. This would tend to interfere with the normal use of the kettle and would probably need to be removed to pour out the water.

From a safety point of view, the device would also have to be battery powered so a box would be needed to house the battery and electronics and the whole lot mounted on the kettle, adding the further requirement that the box would also have to be

at least splash-proof and preferably waterproof. This would not be too difficult at the manufacturing stage as the kettle itself could be designed to accommodate the extra circuit, but to fit a box to an existing kettle without it looking like a box stuck on a kettle would be virtually impossible.

Then a better solution presented itself. The kettle itself must already have a sensor which operates when the water has boiled as this is used to switch off - so why fit another? All we then need to do is to switch on a sounder when the kettle switches off. This can, of course, be done anywhere, such as at the plug and neatly side steps the problem of mounting a box on the kettle.

The other requirements are also relaxed as the unit no longer needs to be particularly waterproof and the mains supply can be used to power the unit saving the inconvenience of housing the batteries and changing them at regular intervals once the unit is in use. On the debit side, the unit will only work with a kettle which switches itself off when it has boiled, but these tend to be the most common types nowadays so this should not really present a problem.

*This unit carries up to 12A at 240V a.c. and it should not be constructed by anyone without some experience of project building and of working with mains voltages.*

## VOLTAGE DROP

The obvious way to determine when the kettle has switched off would be to monitor the voltage across the element. Unfor-

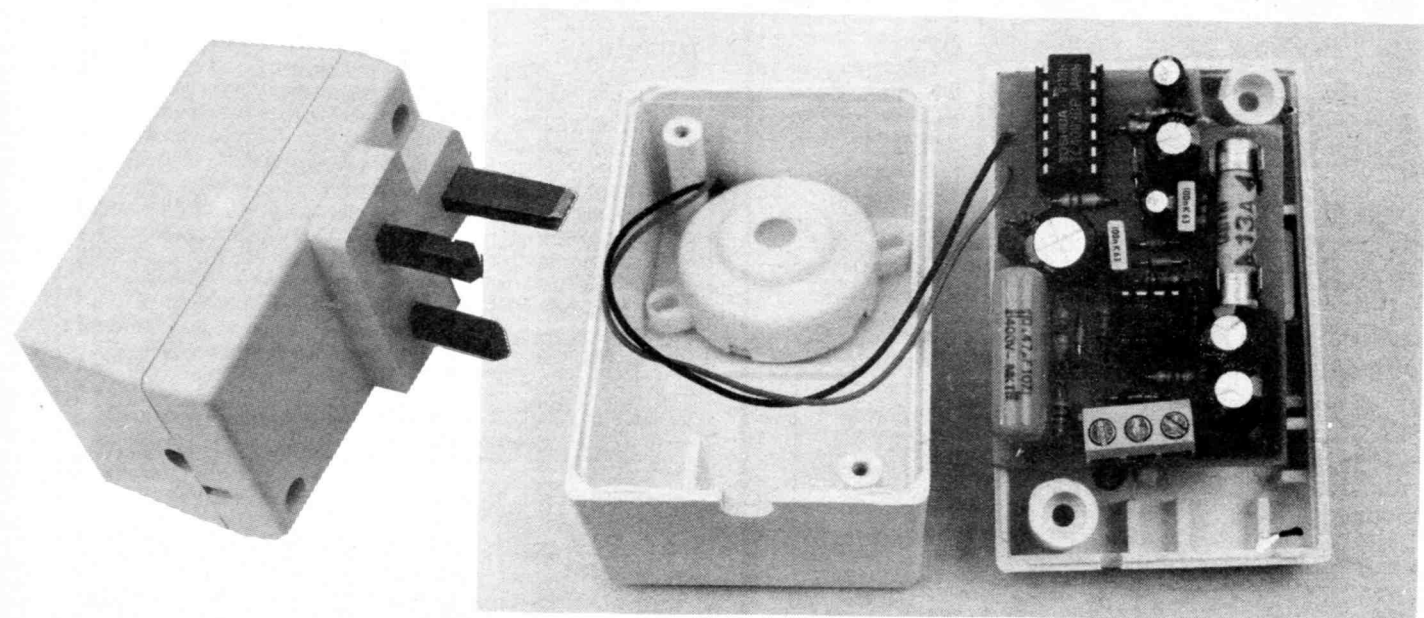

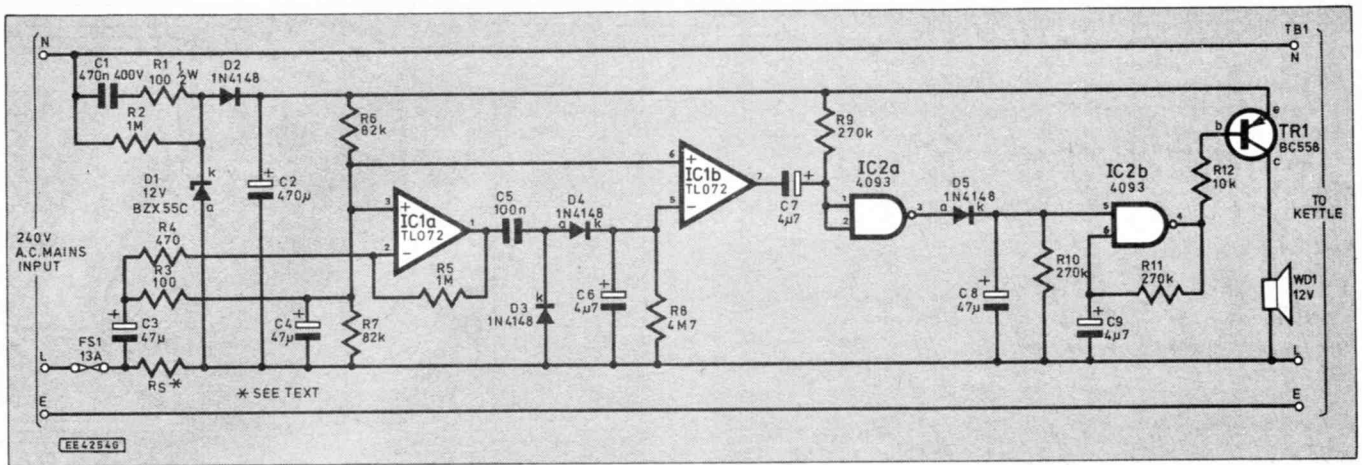

Fig. 1. Complete circuit diagram of the Kettle Alert.

unately, the element is in series with the switch inside the kettle and its connections are not available externally so this method cannot be used.

This leaves only the current drawn by the kettle which will range from a few amperes when the kettle is on to zero when it has switched off. This current can be passed through a resistor and the resulting voltage drop monitored.

Most kettles seem to have a power rating of between 1.5W and 3kW which at 240V represents a current of between 6A and 12A and to obtain a usable voltage drop of say 1V, a resistor of about 0.2 ohm would be required. With a 1.5kW kettle the power dissipation in this resistor would be 7.2W ( $I^2R$ ) rising to 28.8W for a 3kW kettle. This is obviously too high a dissipation to accommodate in a small box so a smaller value resistor must be used and the resulting voltage amplified to a suitable level.

A glance through a few component catalogues revealed that wirewound resistors appear to be available with a minimum resistance value of either 0.1 ohm or 0.5 ohm which, as we have said, is too high if the dissipation is to be kept to reasonable proportions, so it was decided to make one. Resistance wire was considered but this is difficult to solder to, so a piece of p.c.b. track was tried.

Using 2oz copper clad board with a piece of track 3mm wide (which should be capable of carrying up to 18A) and 24mm long, it was found that a voltage drop of about 1.7mV was obtained from a 100W light bulb (which is a current of about 400mA). A 6A to 12A current would produce a voltage drop of 25mV to 50mV which, with only a modest amount of amplification, would produce a usable signal.

## CIRCUIT DETAILS

The complete circuit diagram for the Kettle Alert is shown in Fig. 1. This consists of resistor Rs (etched on the printed circuit board) and an amplifier based on IC1 together with the alarm circuit based on IC2.

The a.c. voltage across Rs is amplified by the op.amp IC1a which has a gain set by resistors R4/R5 with capacitors C3 and C4 coupling the signals to the input. The amplified voltage is rectified by diodes D3 and D4 producing a voltage across capacitor C6. IC1b compares this voltage to that appearing across resistor R7 and its output goes high when the kettle is switched on, and falls when the kettle switches off as the charge on capacitor C6 leaks away, via resistor R8.

The negative transition is passed to IC2a by capacitor C7, causing a positive pulse at its output (pin 3) which charges capacitor C8 via diode D5. IC2b forms a gated oscillator which now oscillates at a frequency determined by capacitor C9 and resistor R11 (about 1Hz with the component values specified), causing transistor TR1 to turn on and off pulsing the buzzer WD1. If required, the value of C9 could be changed to produce an audio frequency and the buzzer replaced by a piezo element to provide a continuous tone, however a pulsed tone is much better in attracting attention.

Capacitor C8 now discharges via resistor R10 causing the buzzer to switch off after about 10 seconds. Again the time for which the buzzer sounds can be varied to suit individual requirements by changing the values of either C8 or R10.

The power for the circuit is supplied by a low loss voltage dropper capacitor C1 (*this*

capacitor must be rated for use at 240V a.c.), and clamped by the Zener diode D1. This is then rectified and smoothed by diode D2 and capacitor C2 to give a 12V d.c. supply.

## CONSTRUCTION

Because of the way that the resistor Rs is implemented, it is advisable to build the circuit on a printed circuit board (p.c.b.). It may be possible to use stripboard but this has not been tried, especially as the current carrying capacity of many types of board is not specified.

## COMPONENTS

### Resistors

R1	100 ½W
R2	1M
R3	100
R4	470
R5	1M
R6, R7	82k (2 off)
R8	4M7
R9 to R11	270k (3 off)
R12	10k
Rs	see text

All 0.25W 5% carbon film, except R1 and Rs

### Capacitors

C1	470n polyester, 400V d.c./250V a.c.
C2	470µ radial elect. 16V
C3, C4, C8	47µ min. radial elect. 50V (3 off)
C5	100n
C6, C7, C9	4µ7 min. radial elect. 63V (3 off)

### Semiconductors

D1	BZX55C 12V Zener diode
D2 to D5	1N4148 silicon diode (4 off)
TR1	BC558 pnp transistor
IC1	TL072 op.amp
IC2	4093 CMOS quad 2-input NAND Schmitt trigger

### Miscellaneous

FS1	13A mains fuse
WD1	12V buzzer
Printed circuit board available from the EPE PCB Service, code 843; plug box with metal Earth pin; 3-way p.c.b. mounted terminal block; 8-pin i.c. socket; 14-pin i.c. socket; two p.c.b. fuse clips; connecting wire; double-sided adhesive tape; solder etc.	

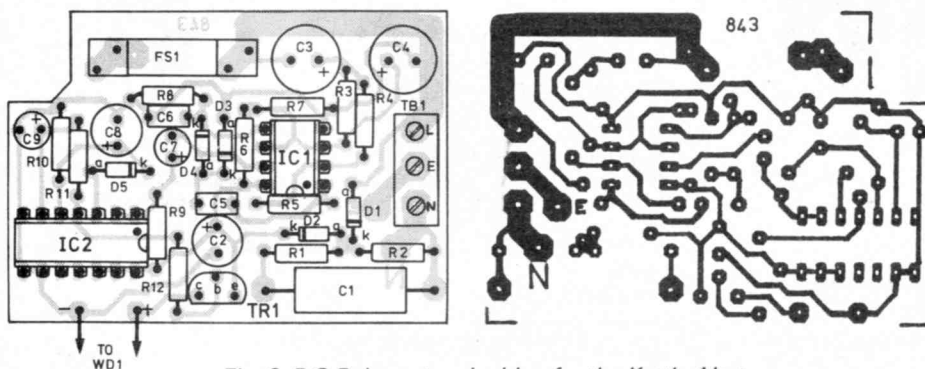
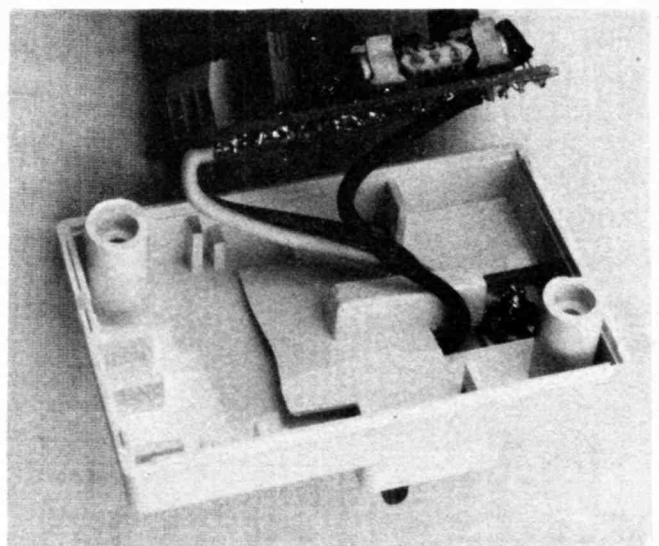
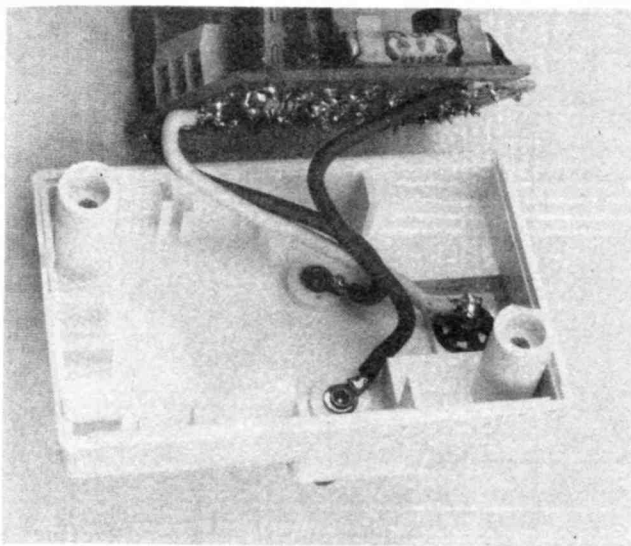

Fig. 2. P.C.B. layout and wiring for the Kettle Alert.

Approx cost guidance only

**£13**





The connections to the mains pins . . . must be protected with an off-cut of plastic

The printed circuit board topside component layout and underside copper foil master is shown in Fig. 2. This p.c.b. is available from the *EPE PCB Service*, code 843.

Construction of the circuit is fairly straight-forward and should not pose any problems as long as care is taken to ensure that diodes, electrolytic capacitors and i.c.s are soldered into the circuit the right way around. Sockets are recommended for the i.c.s, especially IC2 which is a CMOS device and static sensitive and should therefore be handled carefully.

The circuit is quite tolerant of component changes and many may be varied to tailor the circuit to individual requirements. Make sure however that capacitor C1 has a rating of at least 250V a.c. or 400V d.c. and is suitable for use at mains voltages, as failure of this component could cause severe damage to the rest of the circuit.

When assembly has been completed, double-check the wiring again to make sure that there are no bridged tracks. In a circuit of this type, an incorrect connection or a bridged track could easily result in the full 240V a.c. mains voltage being applied to a component rated at only 20V or 30V d.c. and it doesn't take much imagination to visualise the result!

**Do not attempt to test the unit without mounting it in a fully enclosed plastic case. Mains voltages are present on the p.c.b. and**

**the finished unit should be carefully checked before plugging it in.**

### PLUGGED-IN

The circuit has been designed to fit into a plug box of the type used for small d.c. mains adaptors and since it is designed to replace the plug itself, provision for fitting a mains fuse has also been made. These boxes are readily available but most do not have a metal Earth pin. In this application it is *essential* that a box with a *metal earth pin* is purchased as even in a plastic kettle, the element itself must be "earthed".

The three pins in the box should be connected to the appropriate points on the printed circuit board with suitably rated wire. Remember that the current flowing in these wires could be as high as 12A depending on your kettle. Note that the earth (E) and neutral (N) wires go straight to the output terminal block TBI.

Finally, connect the buzzer to the printed circuit board at the points shown, making sure that it is connected the right way around (red lead to the hole nearest to the transistor). The buzzer may be secured to the lid of the box with a piece of double-sided adhesive tape.

In practice, it was found that the sound from the buzzer was quite adequate from within the box. However, if you are in the habit of putting the kettle on and then going to the potting shed at the bottom

of the garden, then the buzzer may be mounted behind a hole drilled in the lid of the box to enable a louder sound to be generated.

Remember to make a hole for the kettle lead. As there is no provision on the box for anchoring the cable, another method of doing so must be found such as a cable strain relief bush or grommet to prevent direct stress on the p.c.b. and terminal block if the cable should be pulled.

### FULL STEAM AHEAD

The unit is now ready to test. Connect a kettle lead to the terminals with the brown wire (L) to the right hand terminal, the blue wire (N) to the left hand terminal and the green/yellow or earth wire (E) to the centre. Insert an off-cut of plastic over the back of the pin connections – see photos above – to make sure that nothing can short with them, then close up the box and switch on.

After a few seconds, switch the kettle off manually whereupon a series of "beeps" should be produced and after some 10 to 15 seconds these should stop. You may find that sometimes the circuit produces its series of beeps when it is first powered up but this is of no consequence.

If all is well, fill the kettle with water and switch on. When you hear the "beeps" you will know that its time to relax with a well earned cup of tea.

# EVERYDAY WITH PRACTICAL ELECTRONICS

## SUBSCRIPTION ORDER FORM

Annual subscription rates (1993/4): UK £22.00  
Overseas £28 (surface mail) £45.50 (airmail)

To: Everyday with Practical Electronics  
6 Church Street, Wimborne, Dorset BH21 1JH  
Tel: 0202 881749 Fax 0202 841692

Name.....

Address.....

.....

.....

I enclose payment of £..... (cheque/PO in £ sterling only, payable to Everyday with Practical Electronics) Access or Visa No.



--	--	--	--	--	--	--	--	--	--	--	--	--	--	--	--	--	--	--	--

Signature..... Card Ex. Date .....

Please supply name and address of card-holder if different from the subscription address shown above. Subscriptions can only start with the next available issue. For back numbers see the Editorial page.

**M10/93**

# COMPLETE SECURITY SYSTEM ONLY £63.95 + VAT

**DIRECT FROM THE MANUFACTURER**

INCLUDES THE LATEST MICRO CONTROL UNIT, PASSIVE INFRA-RED SENSOR, SIREN & BELL BOX, CONTACTS, CABLE, ETC.

**EASY TO INSTALL - SIMPLE TO USE**

+ complete range of systems & accessories stocked

**CALL FOR FULL DETAILS TO-DAY!!**

**AUTONA LTD** 51 POPPY RD., PRINCES RISBOROUGH  
BUCKS HP27 9DB. **TEL: 0844 346326**

## N. R. BARDWELL LTD (EPE)

200	Signal diodes 1N4148.....	£1.00	200	Printed circuit board 20mm fuse clips.....	£1.00
75	Rectifier Diodes 1N4001.....	£1.00	200	Asstd. disc ceramic capacitors.....	£1.00
50	Rectifier Diodes 1N4007.....	£1.00	80	Asstd. capacitors 1nf to 1uf.....	£1.00
56	Rectifier Diodes 1N5401.....	£1.00	80	Asstd electrolytic capacitors.....	£1.00
100	Asstd. Zeners.....	£1.00	80	1Uf 16V Radial electrolytics.....	£1.00
10	NE555 Timer ICs.....	£1.00	80	4.7Uf 16V Radial electrolytics.....	£1.00
30	BC478 Transistors.....	£1.00	75	4.7Uf 63V Radial electrolytics.....	£1.00
8	BFY51 Transistors.....	£1.00	80	10Uf 16V Radial electrolytics.....	£1.00
20	2N3904 Transistors.....	£1.00	50	100Uf 50V Radial electrolytics.....	£1.00
30	MPSA42 Transistors.....	£1.00	80	22Uf 25V Radial electrolytics.....	£1.00
30	5mm red l.e.d.s.....	£1.00	60	33Uf 16V Radial electrolytics.....	£1.00
25	Asstd. high brightness l.e.d.s.....	£1.00	80	100Uf 10V Radial electrolytics.....	£1.00
24	Miniature red l.e.d.s 3mm dia.....	£1.00	50	220Uf 16V Radial electrolytics.....	£1.00
50	Axial l.e.d.s (Diode package) wide angle l.e.d.s.....	£1.00	60	470Uf 10V Radial electrolytics.....	£1.00
12	Asstd. seven segment displays.....	£1.00	40	1000Uf 10V Axial electrolytics.....	£1.00
30	Asstd. IF transformers.....	£1.00	12	1000Uf 25V Axial electrolytics.....	£1.00
48	Asstd. coil formers.....	£1.00	1	1 Farad 5.5V memory back up capacitor.....	£1.00
100	Asstd. RF chokes (inductors).....	£1.00	100	4N7 Mini Axial capacitors.....	60p
30	Asstd. connectors edge-dil-sil etc.....	£1.00	1	10 watt Stereo amplifier, 4 controls plus data.....	£2.95
10	4P 3W MBB min. rotary switches.....	£1.00			
20	1 inch Glass reed switches.....	£1.00			
20	Magnetic ear pips plus lead & plug.....	£1.00			
20	Min SP/CO slide switches.....	£1.00			
30	Asstd. d.i.l. sockets up to 40 pin.....	£1.00			
20	24-way turned pin IC sockets.....	£1.00			
16	40 pin d.i.l. wire wrap IC sockets.....	£1.00			
2	ORP12 light dependant resistors.....	£1.00			

Prices include VAT, postage £1.25. Stamp for Lists  
288 Abbeydale Road, Sheffield S7 1FL  
Phone (0742) 552886 Fax (0742) 500689

## PCB Designer

For Windows 3.0 & 3.1

Runs on any PC running

Windows in standard or

enhanced mode

with 2MB

RAM

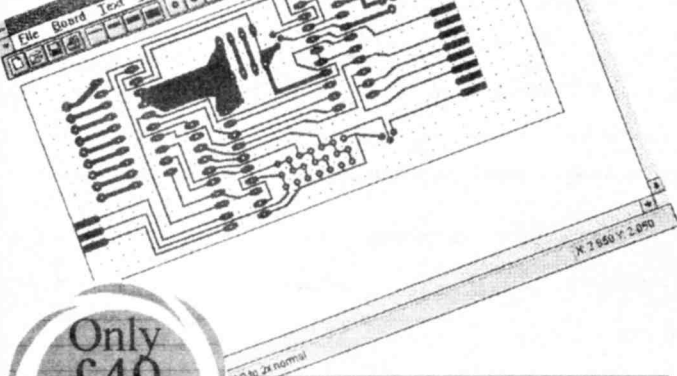

**Only £49**  
All Inclusive

PCB Designer allows you to produce single and double sided printed circuit boards. It is easy to use and makes use of the best features from Windows. Features such as Button bars and Hint text are all present. Note that the price is all inclusive, no VAT, no Postage. What You See Is What You Pay (WYSIWYP).

## Niche Software

The Bannut Tree, Kerrys Gate, Hereford, HR2 OAG

Please Note: Since PCB designer is so easy to use, and to keep costs down, PCB Designer has an On-Line manual, in Windows Help format. A tutorial is also supplied online. No paper manual is supplied.

Everyday with Practical Electronics, October, 1993

# READY NOW

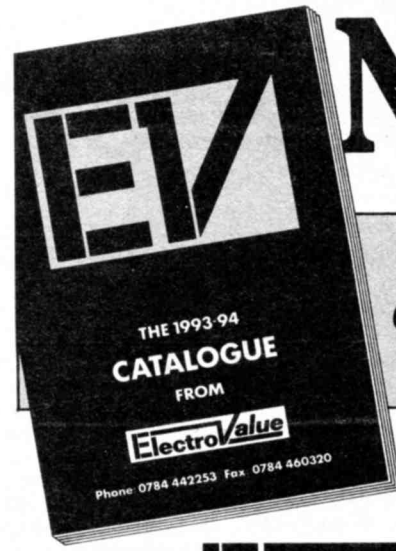

**Every keen constructor needs it**

**THE 1993-94**

## ElectroValue CATALOGUE

Profusely illustrated, this 140+ page A4 size catalogue packs a wealth of information on items from the highly sophisticated to modest but essential screws, washers and wire, etc. With 28 years in personal mail order service we know how much you rely on quality of goods above everything plus back-up service from the supplier *i.e.* Electrovalue. We've got the catalogue you want **and we deliver the goods!**

### To get your Catalogue

Send cheque or postal order for £1.50 to address on coupon or phone your Credit Card No. & its expiry date.

Catalogue comes with two £1 vouchers, each for spending with orders value £10 or more.

### \*Shops at

**Egham, Surrey**  
28 St. Jude's Road, Englefield Green.  
Tel: 0784 434757.

**Burnage, Manchester**  
680 Burnage Lane  
Tel. 061 4324945.

\*PERSONAL SHOPPERS, NOT MAIL ORDER

DISTRIBUTORS FOR

**SIEMENS**

**PROFESSIONAL ELECTRONIC PRODUCTS**

SEMICONDUCTORS  
OPTO-ELECTRONICS  
FERRITES  
CONNECTORS  
SWITCHES  
CAPACITORS  
INDUCTORS  
etc.

**ELECTROVALUE LTD., UNIT 3, CENTRAL TRADING ESTATE, STAINES, MIDDX TW18 4UX**

Tel: 0784 442253 Fax: 0784 460320

Your 1993/94 Catalogue please, to

Name .....

Address .....

.....

.....

Block letters please, and POST CODE

I enclose cheque/postal order for £

Ep.1

If not using coupon please quote this journal when writing.

# L.E.D. SANDGLASS

MARK DANIELS

An l.e.d. novelty that mimics the "sands of time".

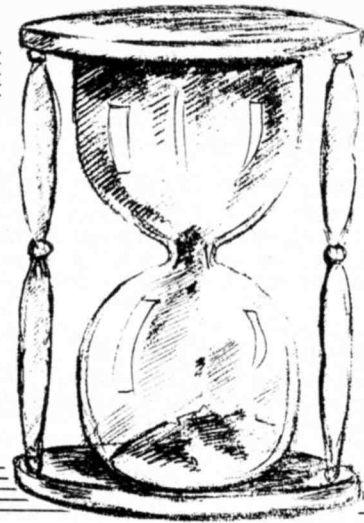

**T**HE boiling of an egg has for centuries, been timed using a sandglass. There have been many recent attempts to update the egg-timer using modern electronics, many of which have enjoyed a reasonable degree of success.

However, most, if not all of these attempts have deviated quite considerably from the original concept of sand in glass, usually opting for some form of visual or audible indication that the timing period has ended. This often removes the need for continual monitoring of the timer, which can be an advantage.

The egg-timer described here is intended only to mimic the sand in glass device it replaces without providing (sometimes annoying?) audible evidence of its presence. It merely attempts to bring the traditional egg-timer up to date without greatly altering the original concept. The display medium in this timer is an array of twenty light emitting diodes (l.e.d.s), rather than the slightly more traditional sand.

## DISPLAY

The display consists of twenty 5mm diameter l.e.d.s arranged as two isosceles triangles placed point to point, thus forming

ing the figure 8 shape of a sandglass as in Fig. 1.

The illustration also shows the order in which the l.e.d.s "fall". As the sand falls the red l.e.d.s of the upper inverted triangle turn off and their corresponding partners in the lower triangle illuminate green to represent the sand which has fallen. The operation continues until all of the red l.e.d.s have switched off, and all of the green ones are glowing, at which point the timing ceases and, with luck, if the timer is set correctly the egg should be done to perfection!

## CIRCUIT DESCRIPTION

The complete circuit diagram for the L.E.D. Sandglass is shown in Fig. 2. Power for the circuit is drawn from a PP3 9V battery, B1 via switch, S2, the on/off switch, a miniature slide type.

The 555 timer, IC1 is employed in its astable mode to generate a low frequency rectilinear waveform of unequal mark-space ratio, which is determined by resistors R1 and R2. These two resistors, along with capacitor C2 also set the basic timing intervals of the astable oscillator.

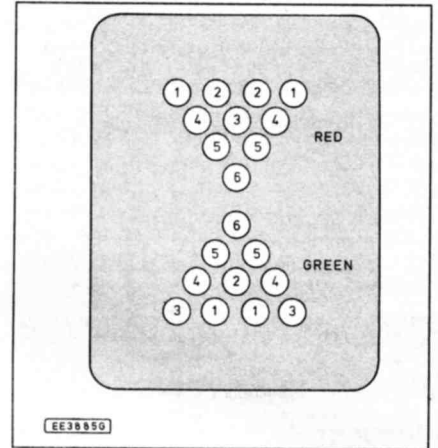
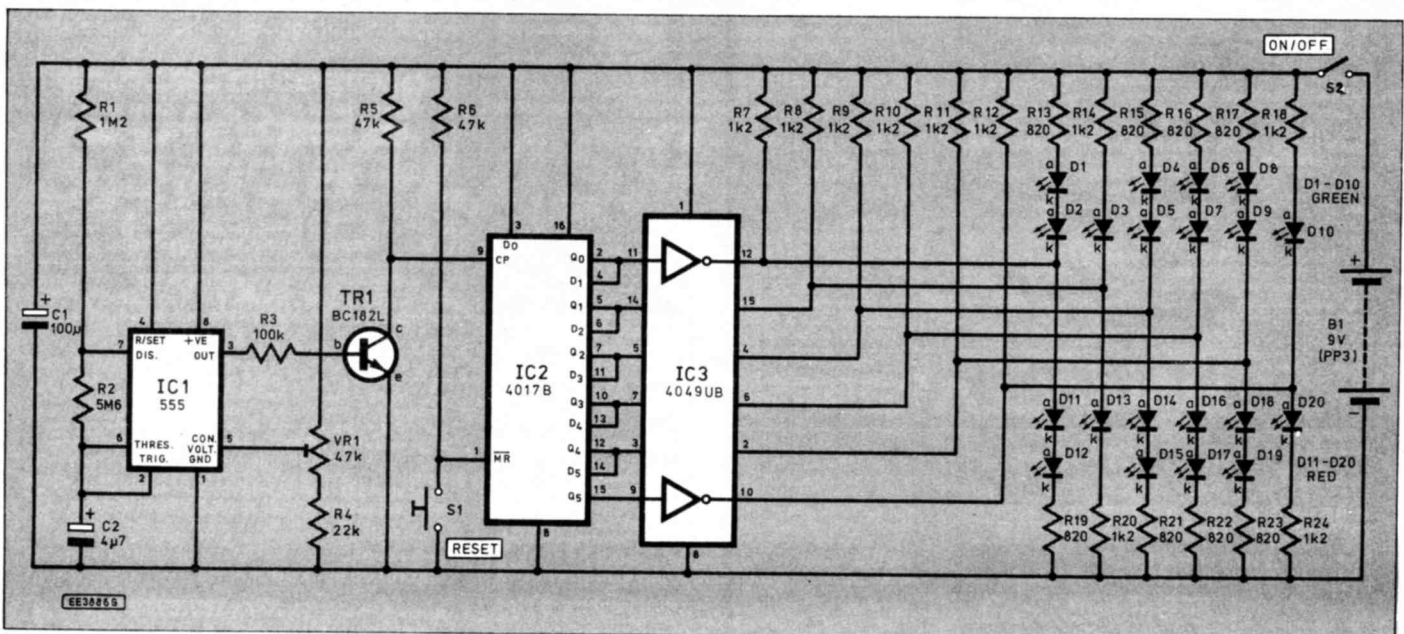

Fig. 1. Display layout and operating sequence.

A control voltage applied to pin 5 of IC1 allows adjustment of the operating frequency without altering the mark-space ratio of the timer. The necessary control voltage is derived from the 9 volt supply using a potential divider network, consisting of a preset potentiometer, VR1 and fixed resistor, R4, the control voltage appearing at pin 5 of IC1.

The output of IC1 at pin 3 is applied to the base of transistor TR1, via current limiting resistor R3. The transistor is configured as a common emitter amplifier and,

Fig. 2. Complete circuit diagram for the L.E.D. Sandglass.





as such, the waveform at its collector is inverted compared to the output of IC1. Resistor, R5 is included to pull the input pin of IC2 high when TR1 is turned off, since CMOS inputs must not be left floating.

The inversion performed by TR1 and R5 is necessary since the clock input of IC2 (pin 9) is positive edge triggered and would be clocked immediately at switch on or after reset, as the first half cycle of IC1 is positive.

The CMOS integrated circuit, IC2 is a Hex D-type flip-flop. Each of the six flip-flops contained in the device have a single input and output. All are internally linked to the clock input.

In this circuit the input terminal of the first gate, pin 3, is connected to the positive supply rail and when a clock pulse arrives on pin 9 the data on pin 3 is transferred to its output, pin 2 which goes high.

The input of the next flip-flop in the chain (pin 4) is connected to the output of the first (pin 2) and on the second clock pulse its output also goes high. The first, and all the remaining flip-flops in the chain are unaffected by this change, since their inputs and outputs were both low before the clock pulse. The third flip-flop now has a high on its input, but its output cannot change state until the next clock pulse arrives.

The data is thus transferred through the divider chain one bit at a time, until all outputs are high. When the last output goes high the process does not stop, although it appears to do so, as all the data moving down the chain is now identical and all the outputs thus remain high until a reset pulse is applied to pin one of IC2 by depressing switch, S1 momentarily.

## DISPLAY DRIVER

The outputs of IC2 are only standard low current CMOS outputs which are not capable of supplying the current required to drive the l.e.d.s and a buffer stage is necessary. A 4049UB Hex inverting buffer, IC3, which has high current outputs, was used in the prototype to drive the display.

A 4050UB could be used equally well in this application, being pin compatible with the 4049UB with the exception that its outputs are not inverted. This causes no electrical problems here, as the display can simply be inverted to compensate for the inverted display which results from the use of this alternative component.

The outputs of IC3 are connected to the positive supply rail via pull-up resistors, R7 to R12. This provides the buffers with balanced current driving capabilities, since the i.c. is capable of sinking considerably larger currents than it can source. Without the resistors the buffers would not be able drive sufficient current through the l.e.d.s, D11 to D20 which may, as a result, only glow dimly, or worse IC3 may be damaged by the excess current.

Diodes D1 to D10 are the green l.e.d.s and have their current limited by resistors R13 to R18. Where the l.e.d.s light up in pairs they are series connected to keep the current through IC3 to a minimum, whilst maintaining brightness. The remaining l.e.d.s D11 to D20, with their respective current limiting resistors, form the red half of the display.

The electrolytic capacitor C1, included for the purposes of supply decoupling, absorbs the spikes produced by IC1 as it "crowbars" the supply once per cycle. Without this decoupling IC2 may be triggered falsely by the spikes, thus producing inaccurate timing.

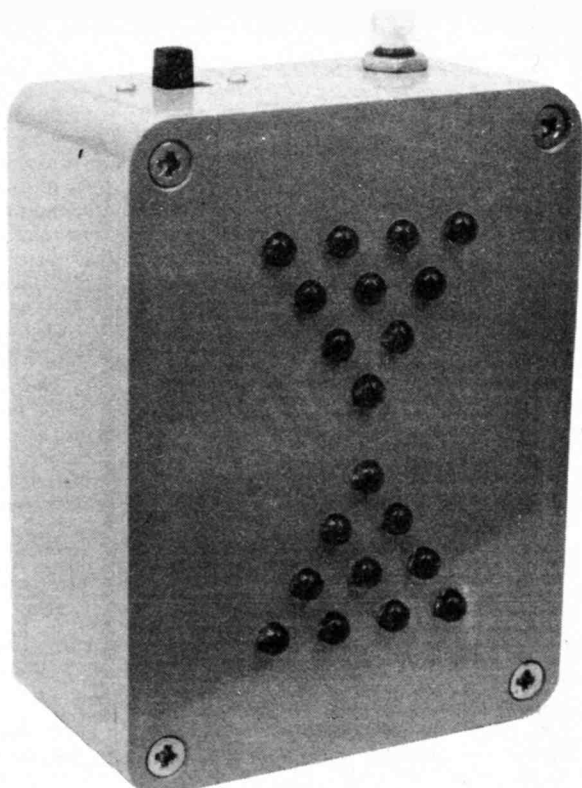

The completed unit showing the two circuit boards mounted on the lid of the case.

## COMPONENTS

### Resistors

R1	1M2
R2	5M6
R3	100k
R4	22k
R5, R6	47k (2 off)
R7 to R12, R14, R18, R20, R24	1k2 (10 off)
R13, R15 to R17, R19, R21 to R23	820 (8 off)

All 0.25W 5% carbon film

### Potentiometer

VR1	47k sub-min. horizontal preset, lin.
-----	--------------------------------------

### Capacitors

C1	100µ radial elect., 25V
C2	4µ7 tantalum

### Semiconductors

D1 to D10	5mm green l.e.d.s (10 off)
D11 to D20	5mm red l.e.d.s (10 off)
TR1	BC182L npn silicon transistor
IC1	555 timer
IC2	40174B or 74C174 Hex D-type flip-flop
IC3	4049B Hex buffer inverter

### Miscellaneous

B1	PP3 9V battery, with connector
S1	Push-to-make switch
S2	d.p.d.t. miniature slide switch

Plastics case, size 100mm x 76mm x 41mm; 8-pin d.i.l. socket; 16-pin d.i.l. socket (2 off); 8-way p.c.b. header plug and socket; connecting wire, self-adhesive rubber feet (4 off); solder etc.

Printed circuit boards available from the EPE PCB Service, codes 841 and 842.

See  
**SHOP  
TALK**  
Page

Approx cost  
guidance only

**£14**

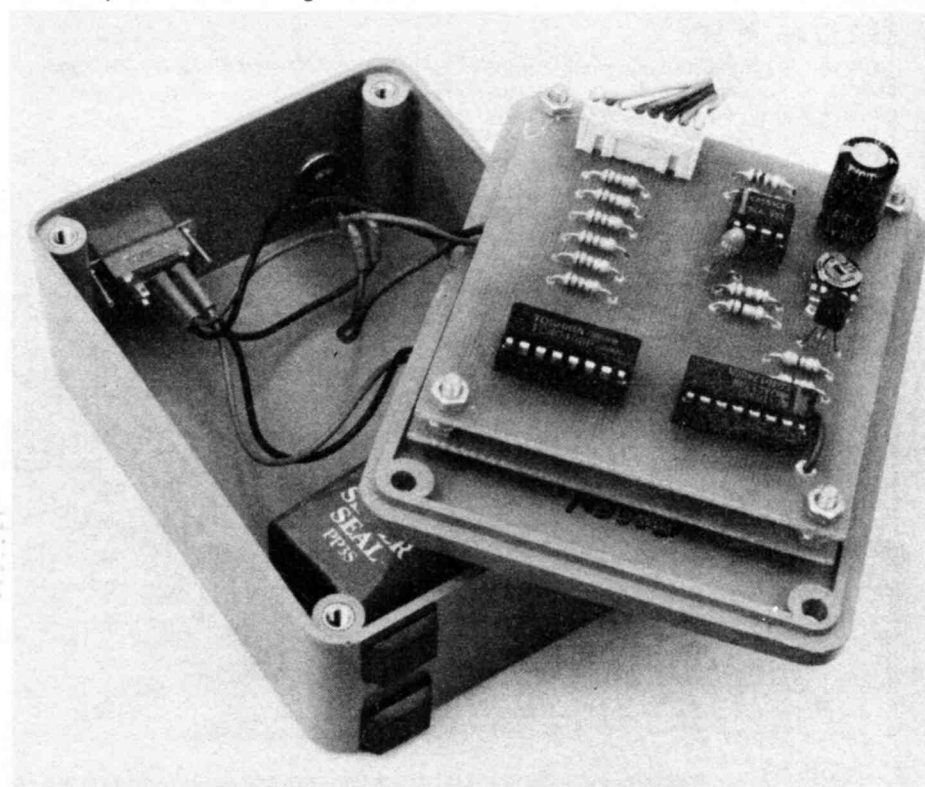

## CONSTRUCTION -MAIN BOARD

The three i.c.s and their support components are mounted on a single-sided glass-fibre printed circuit board, the full size copper foil pattern and component layout for which are shown in Fig. 3. This board is obtainable from the *EPE PCB Service*, code 841.

The order of assembly of this board is relatively unimportant if sockets are used for the three i.c.s. Transistor TR1 should be the last component to be soldered into place.

An 8 way p.c.b. header set, comprising a 0.1in. pitch plug, which is soldered to the board and a socket which is fitted to flying leads is recommended for the main external connections to this board. The header socket uses crimp terminals, which are fitted to the wires by crimping with a special tool and then inserting them into the plastic plug body.

It is not envisaged that a great many readers will have access to the correct tool for the crimping the terminals and the following method may be adopted. Bare approximately 3mm of conductor and insert it into the crimp, close the crimp over the conductor using narrow nosed pliers and carefully solder the wire to the terminal.

Finally close the insulation crimp over the insulation of the wire. The terminal may then be inserted into the header socket, when it should engage with a positive click.

The final connection to this board is made by threading a lead through the hole in the p.c.b. adjacent to its pad, from the underside and then inserting it into its correct hole from the top before soldering it into place.

The three i.c.s may now be inserted into their respective sockets, observing normal handling precautions for the CMOS devices, IC2 and IC3.

## DISPLAY BOARD

All twenty l.e.d.s and their current limiting resistors are mounted on a separate printed circuit board. The foil pattern and respective component overlay are shown in Fig. 4. This board (842) is also available from the *EPE PCB Service* and forms a pair with the main board.

It is recommended that the resistors are assembled on the board first as the l.e.d.s are sensitive to excess heat. All of the l.e.d.s of each colour should ideally come from the same manufacturing batch to ensure accurate colour and intensity matching, although in practice the differences in separate batches of the same l.e.d.s are normally minimal.

If there is any uncertainty a simple comparison test using a 9 volt battery and an 820 ohm resistor in series with each l.e.d. in turn should avoid any problems at a later stage of construction.

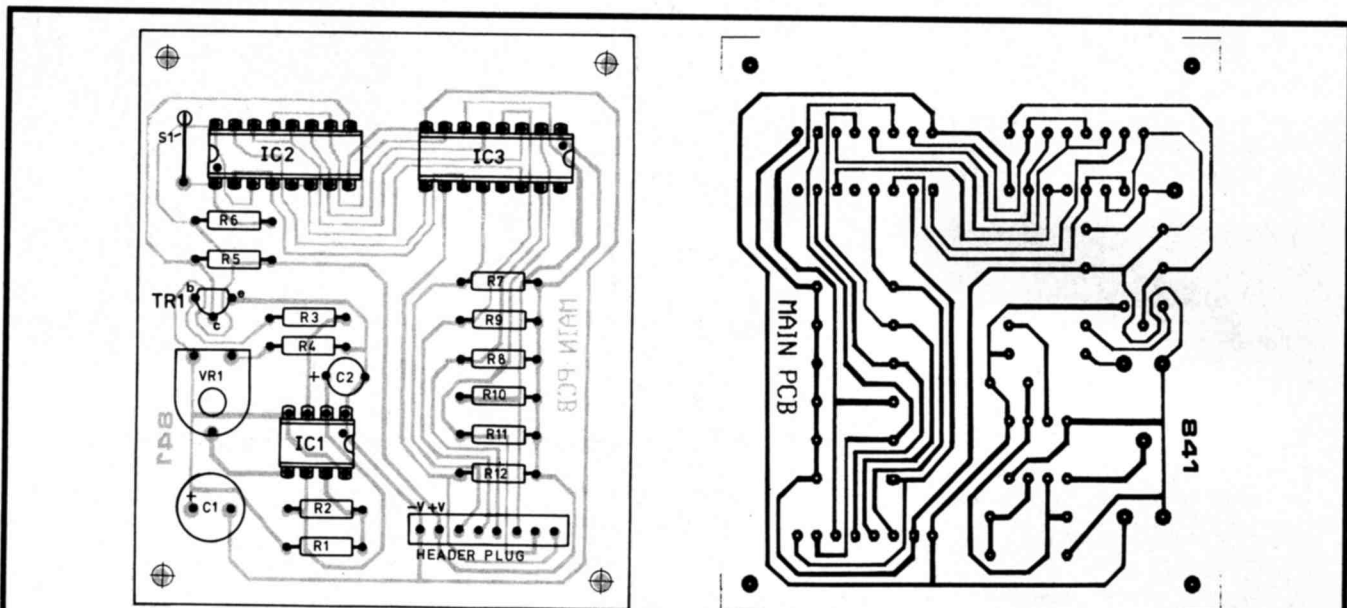

EE38870

Fig. 3. Printed circuit board topside component layout and full size copper foil master pattern for the Main board.

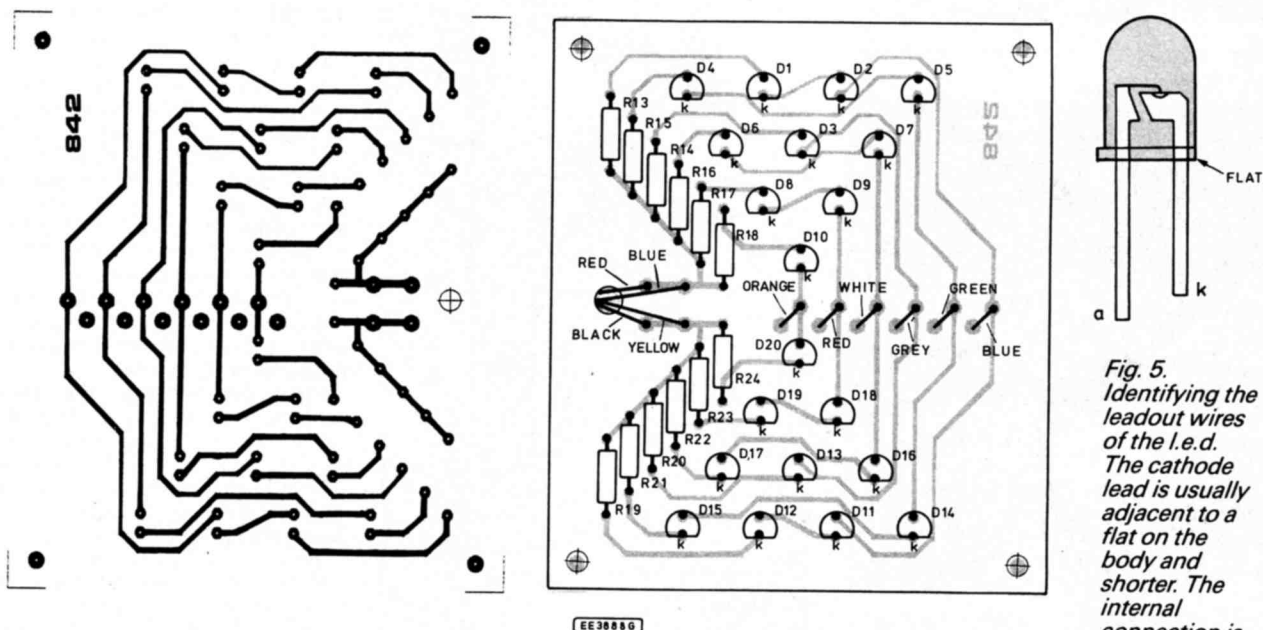

EE38850

Fig. 4. Display board full size copper foil master pattern and topside component layout.

Fig. 5. Identifying the leadout wires of the l.e.d. The cathode lead is usually adjacent to a flat on the body and shorter. The internal connection is the larger of the two.

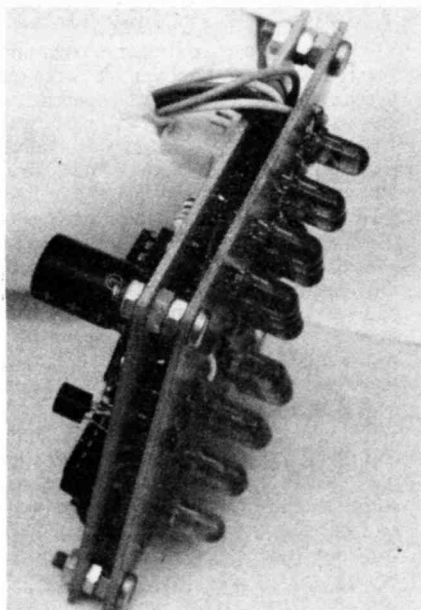

Using nuts as spacers to form a "sandwich" of the two boards.

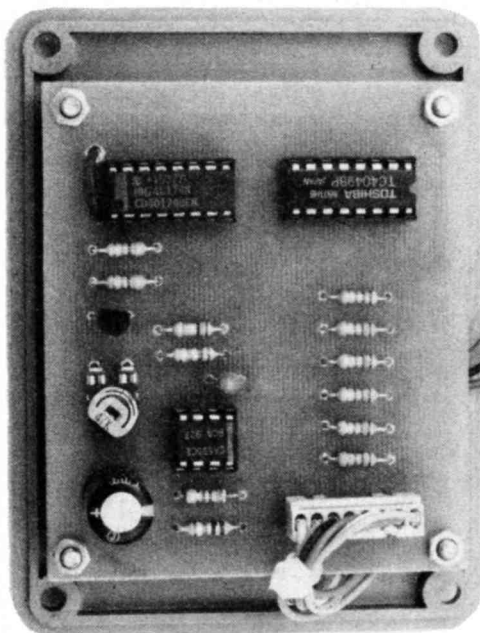

The completed timer board mounted on the case lid.

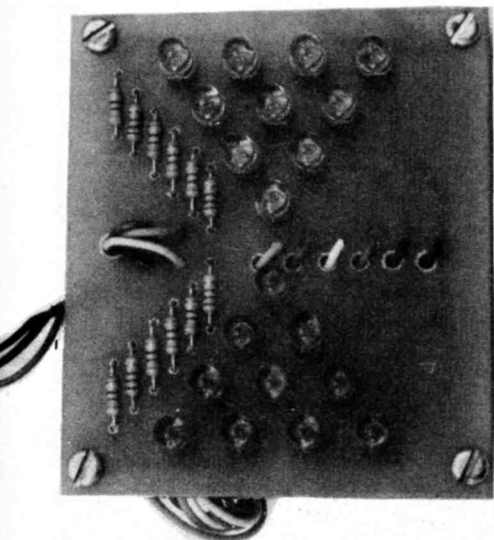

The finished display board is mounted face-down below the main board, the l.e.d.s protruding through the case lid.

Assembling the l.e.d.s on the board requires a little care, since they must all end up at the same height above the p.c.b. Stops are provided on the pins of most l.e.d.s and when they are inserted into 0.8mm holes they set them above the surface of the board by a fixed amount, thus setting them all at the correct height.

Ensure that when they are fitted the l.e.d.s stand square to the board and in line with the others in the same row. It is also important to ensure that all l.e.d.s are inserted the correct way round as they are polarity conscious - see Fig. 5.

## INTERWIRING AND CASE

All interconnecting details between the two boards and the external components are shown in Fig. 6. Ensure that the leads used between the header plug/socket and the display board are sufficiently long to enable the boards to be mounted back to back when assembled.

The main board and display board have been designed so that when mounted in the manner described the connections between the two are in line and in the correct order without crossing any leads over. The wires are threaded through the holes next to their respective pads, as shown and are then inserted into the holes in the pads before being soldered in the normal manner.

If the recommended size of box is used the positions of the holes for the two switches will be as shown in Fig. 7. The switches should be mounted close to the back of the case, in order to clear the main p.c.b. when it is fitted.

Allow sufficient length of connecting lead to permit the box lid to be laid flat on the bench next to the main box, when removed. Both battery connections are made to switch, S2, a double-pole change-over slide switch, which in this application is only used as a double pole on/off switch.

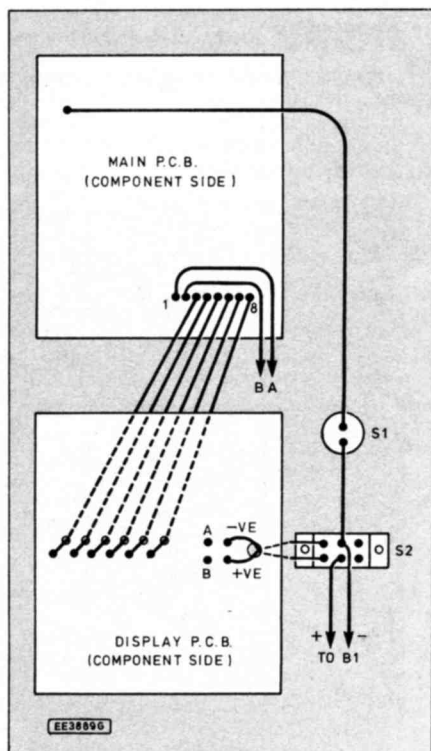

Fig. 6. Interwiring between the two p.c.b.s and switches.

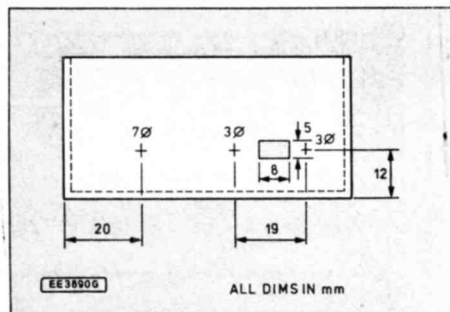
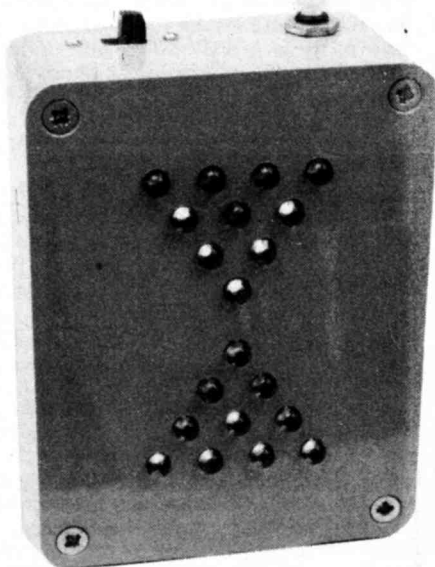

Fig. 7. Drilling and dimensions for mounting the switches in the case. The display l.e.d. layout can be seen below.



## SETTING UP AND TESTING

Connect a 9V battery to the battery connector and switch on. Ten l.e.d.s should be illuminated. Pressing the Reset button, S1 should reset the display to all red l.e.d.s lit and all green ones off. If the display already shows this then a reset operation will do nothing.

If the above can be obtained leave the unit running and check the display for correct operation against Fig. 1. Any discrepancies may be corrected by checking and altering the wiring between the two boards, although mistakes here are unlikely.

If one or two of the l.e.d.s do not illuminate at any time it is most likely due to incorrect connections being made to them, and simple de-soldering and re-insertion the correct way round will cure this. The polarity of an l.e.d. may be ascertained by comparing it with Fig. 5 where it will be seen that the internal cathode (k) connection is the larger of the two. This applies in the vast majority of cases, but one notable exception is Ultra and Hyper-bright types where the opposite normally applies.

Preset potentiometer, VR1 should be adjusted once the unit is functioning correctly, to give the desired time for your eggs. If it is not possible to obtain the required time further adjustment may be made by changing the value of resistor, R2 or capacitor C2. Making either of these larger in value lengthens the delay.

Resistor R2 should ideally be kept in the range 1M to 10M, while C2 may be varied between 1μF and 22μF. Values outside of this range may be used but will give times vastly different from those required for the aforementioned purposes. □



# Home Base

*Jottings of an electronics hobbyist—Terry Pinnell*

## Deaf Alarm

Chatting to a friend in the office, we got onto the topic of early rising, and he mentioned that he had to wake his deaf teenage daughter each morning. She had to leave very early for work but because of her handicap could not use normal alarms like a clock or radio. I could feel my problem-solving muscles flexing as he spoke, and the following weekend found me engrossed in exploring the electronic possibilities.

There were really two distinct design decisions to be made: what device should do the actual waking, and how to trigger it at the chosen time. Ruling out sound, the options I considered for the waking device were:

## Light

How pleasant it would be to make a virtue out of a necessity and wake her by simulating the sun beaming down onto her face. A bright spotlamp perhaps, or an infra-red lamp of the sort sometimes fitted in expensive bathrooms. The latter was quickly dismissed as I didn't know enough about IR to be sure of its complete safety in the case of prolonged exposure.

However I did try a few experiments with a normal domestic 100W spotlamp, but came rapidly to the conclusion that even flashing a couple of feet away it couldn't be reliably expected to wake someone up, even if they happened to be facing directly towards it.

## Breeze

So how about a pleasant stream of refreshing air from a bedside fan? The only type I could immediately put my hands on was a little novelty affair with self-extending vanes about 50mm across, driven by a 1.5V battery. Predictably, that proved virtually useless.

When holding it even as close as a couple of inches from one ear, I could just about convince myself that it might wake me up, rather than just prompt me to pull the duvet around my head. But it was clearly impossible to devise a reliable way of ensuring the fan *stayed* in position relative to the sleeper — short of strapping it to her head!

This minuscule device was clearly not doing justice to the basic idea though, so I next rigged up a much larger fan, using a mains driven motor and a set of blades I dug out of my junk box. Finding a way to mount it was not easy. With the fan inside a large aluminium coffee tin for example, I could only just detect the breeze a couple of feet away. The impracticality of this idea was by then becoming glaringly obvious, so I abandoned it.

## Electric Shock.

I have to confess that I did fleetingly toy with the idea of a (battery operated!) wrist

strap of some sort. The contacts would deliver a modest voltage of 40V or 50V. But it really was fleeting!

## Good Vibrations

I suppose you would not be surprised if I told you that I went on to consider water dripped over the unfortunate sleeper, or perhaps a rope around her ankle connected to a heavy-duty winch . . . but even I have my limits. No, the idea finally implemented was very simple, but proved extremely effective.

The method selected was to improvise something which would vibrate sufficiently if placed under the pillow. After experimentation I eventually chose a small d.c. motor with a lead weight (courtesy of my fishing tackle box) secured off-centre to its spindle. This was all enclosed snugly in a sturdy plastic pill container.

I tried various d.c. voltages using my home-built bench supply and experimented with several different motors. The one I finally settled on was a powerful specimen, which produced a strong vibration when using 3V to 4.5V. It had a hungry peak current consumption of about 1 to 2 amps though, so I was certainly going to need HP2 (D-type) batteries.

I suppose if I'd been making it for use within my own family then I would probably have considered NiCads, as they could have been smaller and still delivered the high current and I would have been able to recharge them easily.

## Trigger

Having selected the "output" medium, the other main design decision was how to trigger it at the set time. I dismissed the absurdly expensive (although potentially reliable) method of extracting a signal from

a clock/radio. Also discarded were ideas dependent on a long duration timer circuit. Conventional analogue versions using a large capacitor and resistor would be inexact and would be quite impractical in use.

Digital types would either be too expensive, or, if made out of the simple TTL or CMOS i.c.s which I had to hand, they would probably require starting the device at precisely 2-to-the-power-N seconds before wake up. For anyone other than full time members of the Masochists' Society that was not exactly what you'd call a user friendly arrangement, nor a welcome chore before falling into bed after a late night party, even if she had a Ph.D in Maths, which she didn't.

No, my choice was right at the other end of the technology scale: an old, cheap mechanical alarm clock — which I just happened to have in my loft. Almost as far removed from a digital alarm as an abacus is from an Intel 486 chip. The astonishing thought occurs that there may conceivably be young EPE readers who have never encountered one of these archaic items of bedroom equipment. If so, they will no doubt want to study the photograph with appropriate awe.

But how could this old alarm clock trigger power to the motor-vibrator? Unfortunately I jumped to what I now realise was the silly conclusion that some form of sound detector was the answer. I spent several days cheerfully experimenting with a plethora of such designs. My loose-leaf circuits binder is six pages thicker as a result of this digression. If it's sound-detection you want, I'm your man.

## Waste of Time?

But for reasons which I won't attempt to fathom, sometimes the further back I can push the finishing point of a project, and the more options I can explore en-route, the more satisfaction I get out of it. So what might sound a real waste of time was actually fun. Who can confidently define "a waste of time" anyway?

Sanity eventually prevailed and I abandoned the sound detecting approach as gross over-kill. The finally chosen method will be revealed when I conclude the saga next month; hope the suspense doesn't keep you awake nights.

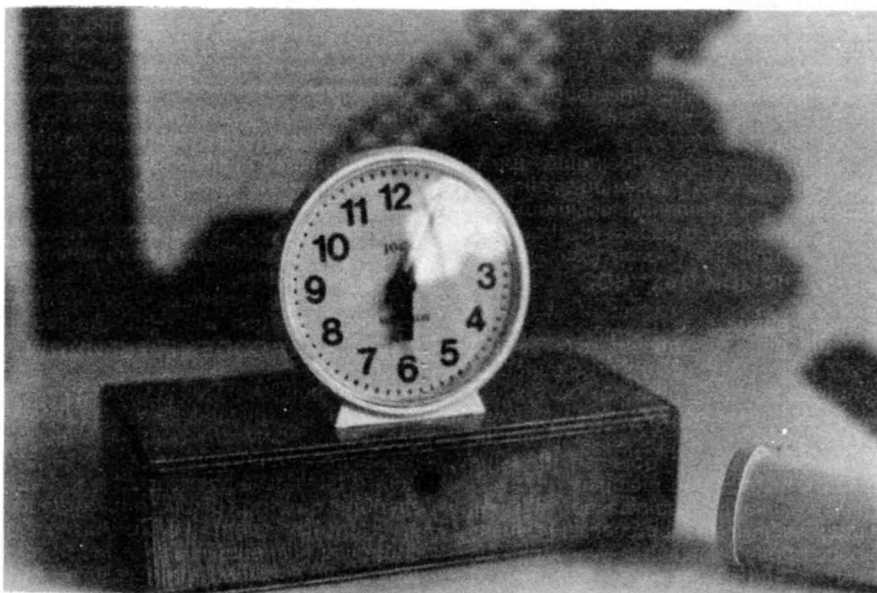

*The final alarm using a mechanical clock.*

# REPORTING

# AMATEUR RADIO

**Tony Smith G4FAI**

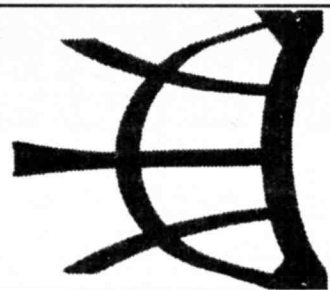

## ISWL AWARDS

As the winter nights draw in radio hobbyists spend more time tuning round the bands, often working for operating awards which record their achievements and decorate their shack walls at the same time! Apart from providing a demonstrable record, working for an award adds a pleasurable extra dimension and purpose to both amateur radio operating and shortwave listening.

Chris Carrington, Publicity Officer of the *International Short Wave League*, has drawn my attention to the fact that the ISWL has nine awards available to both members and non-members of the League. Eight are open to both licensed amateurs and SWLs; several are open to broadcast band listeners as well, while the ninth is exclusively for broadcast listeners. They are free to members and a small charge is made to non-members.

Full details can be obtained from the ISWL Awards and Contests Manager, *Herbert Yeldham G6XOU, Deal Hall Farm, Burnham Marshes, Burnham-on-Crouch, Essex CM0 8NQ*. There's no mention of postage, but I'm sure an s.a.e. or IRC would be appreciated.

## R.F. RADIATION HAZARDS

In the USA, the Federal Communications Commission proposes to update its guidelines for evaluating environmental radio frequency (r.f.) radiation from FCC regulated transmitters, including those used by amateur radio operators.

The existing (1982) guidelines use a term called "specific absorption rate" (SAR). This is basically the time frame in which r.f. is absorbed into the human body.

The formulae are complex, but the guidelines generally indicate that low power transmitters with seven watts or less r.f. input power are safe. They recommend frequency-dependent exposure limits as studies have shown that the human body absorbs r.f. energy at some frequencies better than others, with the most restrictive limits being in the 30MHz to 300MHz range.

The even more stringent 1992 standards proposed, and already adopted by the American National Standards Institute and the Institute of Electrical and Electronic Engineers, are based on recent data on biological effects, and look at r.f. exposure under both "controlled" and "uncontrolled" conditions.

A controlled environment is one "... under the control of an aware user." Again complex formulae apply when determining safe levels for both environments. There are also new restrictions on r.f. fields induced in the human body at frequencies below 100MHz.

## EXCLUSIONS

In certain situations, however, there are exclusions from the formula. For example,

in a controlled environment, low power transmitters radiating seven watts or less are deemed safe at 450MHz or below when the antenna is more than 2.5cm from the body (but note that a "rubber duck" antenna on a handheld transceiver is frequently closer to the head than that).

The safe level is reduced as the frequency rises. For example, 2.5 watts is the maximum safe level for low power devices at 1240MHz in a controlled environment.

While transmitter users are considered to be in a controlled environment, others in the immediate vicinity are deemed to be in an uncontrolled environment, where the guidelines are stricter.

The safe level of a low power transmitter operating below 450MHz in an uncontrolled environment is 1.4 watts, and at 1240MHz about half a watt. Field strengths drop off sharply as the distance from a radiator increases, and a 2-metre transmitter running 500 watts e.r.p. (effective radiated power) would meet the required limits if the antenna was 11 metres above ground level. (*W5YI Report*).

## FRENCH NO-CODE REFERENDUM

Anticipating that the IARU Region 1 Conference in Belgium, in September, would be discussing the question of a Morse-free licence, the French national radio society, REF, conducted a referendum last April.

Members were asked: "Do you want radio amateurs to have access to 28 MHz (observing the IARU bandplan) without having to pass a Morse code examination? 'Yes' or 'No'?"

The result of this referendum was a majority of 71 per cent saying "Yes", and I understand that REF then decided to submit a proposal to the IARU Conference based on that result, suggesting code-free operation for amateurs in the 10-metre band.

The conference, is one of three regional conferences under the aegis of the *International Amateur Radio Union*, and does not, itself, have the power to change the international regulations. The rules are formulated by the *International Telecommunications Union*, and it may be some years yet before formal proposals for change, supported by all three IARU regions are placed before the ITU; especially as the influential American Radio Relay League (ARRL) decided earlier this year to continue to support the retention of the code as an examination requirement for amateur operation below 30MHz.

## FREE MORSE PROGRAMS

In the meantime, anyone wishing to be a radio amateur operating on the h.f. bands will still need to pass a Morse test. Learning the code is not all that difficult once you are committed to the idea and a popular way to do it nowadays is by computer.

In this connection, *Morsum Magnificat*

(the Morse magazine) is offering free copies of a number of Morse learning programs developed by Dr. Gary Bold ZL1AN, who writes the "Morseman" column in *Break-In*, the journal of New Zealand's national radio society. These provide a complete learning package ranging from the needs of complete beginners to those wishing to achieve high operating speeds.

TEACH, is a "start from scratch" code teacher which teaches all Morse characters from their sound. New symbols are introduced one at a time, with the longest, most uncommon, symbols first. This program is adaptive inasmuch as it uses feedback from the student's performance to modify the teaching process, deciding which characters need to be sent most often and when new characters should be introduced.

RNDM generates random code groups at any speed, at any audio frequency, from any subset of characters, printing each group on the screen after it has been sent.

FSEND sends any ASCII file as Morse.

KBD is a Morse keyboard simulator with anything typed on the keyboard sent as audio Morse.

RWD is a random word sender. It reads any ASCII file, pulls out individual words and sends them in random order. This provides practice in reading "real words" without the possibility of anticipating what follows.

MREAD reads Morse after connecting a key across two pins of the RS232 port. It decodes what is sent and prints it on the screen. This can be of great assistance in learning to send readable Morse or improving existing keying ability.

All sent codes in these programs use Farnsworth (ie, extended) spacing up to 14wpm but any other Farnsworth speed can be set while programs are running if this is desired.

The original (IBM compatible) programs require GWBASIC or QBASIC to run them. However, compiled versions are also included in the UK distribution for those preferring to run them without BASIC. A long README ASCII text file explains everything, and detailed instructions are provided in TXT files for each program.

Some of the advice given is based on the New Zealand plain language amateur Morse test but learners aiming for the UK test, which involves sending and receiving amateur abbreviations, etc., can still master the code using TEACH. They can then generate suitable material in ASCII text files, which can be used with FSEND or RWD, to help them prepare for the UK test.

The complete set of programs, is available free of charge by sending a formatted 3.5 inch disk (DD or HD), together with a *stamped addressed envelope* for its return, to me at 1 Tash Place, New Southgate, London N11 1PA.



## £1 BARGAIN PACKS

In fact, cheaper than £1 because if you buy 10 you can choose one other and receive it free!

- 1 X 12V STEPPER MOTOR 7.5 degree. Order Ref. 910.
- 1 X 10 PACK SCREW DRIVERS. Order Ref. 909.
- 2 X SAMP PULL CORD CEILING SWITCHES, brown. Order Ref. 921.
- 5 X REELS INSULATION TAPE. Order Ref. 911.
- 4 X 14MM BULL-RACES. Order Ref. 912.
- 2 X CORD GRIP SWITCH LAMP HOLDERS. Order Ref. 913.
- 1 X DC VOLTAGE REDUCER 12V-6V. Order Ref. 916.
- 1 X 10AMP 40V BRIDGE RECTIFIER. Order Ref. 889.
- LIGHTWEIGHT STEREO HEADPHONES moving coil so superior sound. Order Ref. 896.
- 2 X 25W CROSSOVERS for 4ohm loudspeakers. Order Ref. 22.
- 2 X NICAD CONSTANT CURRENT CHARGERS easily adaptable to charge almost any NICAD battery. Order Ref. 30.
- 10m TWIN SCREENED FLEX white p.v.c. cover. Order Ref. 122.
- 2 X WHITE PLASTIC BOXES with lids, approx. 3" cube. Lid has square hole through the centre so these are ideal for light operated switch. Order Ref. 132.
- 2 X REED RELAY KITS you get 8 reed switches and 2 coil sets with notes on making relays and other gadgets. Order Ref. 148.
- 1 X BIG PULL SOLENOID mains operated. Has ½" pull. Order Ref. 871.
- 1 X BIG PUSH SOLENOID mains operated. Has ½" push. Order Ref. 872.
- 1 X MINI MONO AMP 3W into 4 ohm speaker or 1W into 8ohm. Order Ref. 268.
- 1 X MINI STEREO 1W AMP. Order Ref. 870.
- 1 X IN-FLIGHT STEREO UNIT is a stereo amp. Has two most useful mini moving coil speakers. Made for BOAC passengers. Order Ref. 29.
- 1 X 0-1mA PANEL METER full vision face 70mm square. Scaled 0-100. Order Ref. 756.
- 2 X LIQUID BATTERIES 2.5V penlight size. Order Ref. 874.
- 2 X 3M TELEPHONE LEADS with BT flat plug. Ideal for 'phone extensions, fax, etc. Order Ref. 552.
- 1 X 12V SOLENOID has good ½" pull or could push if modified. Order Ref. 232.
- 4 X IN-FLEX SWITCHES with neon on/off lights, saves leaving things switched on. Order Ref. 7.
- 2 X 6V 1A MAINS TRANSFORMERS upright mounting with fixing clamps. Order Ref. 9.
- 2 X HUMIDITY SWITCHES, as the air becomes damper the membrane stretches and operates a microswitch. Order Ref. 32.
- 5 X 13A ROCKER SWITCH three tags so on/off, or change-over with centre off. Order Ref. 42.
- 2 X FLAT SOLENOIDS you could make your multi tester read AC amps with this. Order Ref. 79.
- 1 X SUCK OR BLOW OPERATED PRESSURE SWITCH or it can be operated by any low pressure variation such as water level in tanks. Order Ref. 67.
- 1 X 6V 750mA POWER SUPPLY nicely cased with mains input and 6V output leads. Order Ref. 103A.
- 2 X STRIPPER BOARDS each contains a 400V 2A bridge rectifier and 14 other diodes and rectifiers as well as dozens of condensers, etc. Order Ref. 120.
- 12 VERY FINE DRILLS for p.c.b. boards etc. Normal cost about 80p each. Order Ref. 128.
- 5 X MOTORS FOR MODEL AEROPLANES spin to start so needs no switch. Order Ref. 134.
- 6 X MICROPHONE INSERTS magnetic 400 ohm also act as speakers. Order Ref. 139.
- 6 X NEON INDICATORS in panel mounting holders with lens. Order Ref. 180.
- 1 X IN-FLEX SIMMERSTAT keeps your soldering iron etc. always at the ready. Order Ref. 196.
- 1 X MAINS SOLENOID very powerful, has ½" pull or could push if modified. Order Ref. 199.
- 1 X ELECTRIC CLOCK mains operated, put this in a box and you need never be late. Order Ref. 211.
- 4 X 12V ALARMS makes a noise about as loud as a car horn. All brand new. Order Ref. 221.
- 2 X (6" X 4") SPEAKERS 16 ohm 5W so can be joined in parallel to make a high wattage column. Order Ref. 243.
- 1 X PANOSTAT controls output of boiling ring from simmer up to boil. Order Ref. 252.
- 2 X OBLONG PUSH SWITCHES for bell or chimes, these can switch mains up to 5A so could be foot switch if fitted in pattrass. Order Ref. 263.
- 50 X MIXED SILICON DIODES. Order Ref. 293.
- 1 X 6 DIGIT MAINS OPERATED COUNTER standard size but counts in even numbers. Order Ref. 28.
- 2 X 6V OPERATED REED RELAYS one normally on, other normally closed. Order Ref. 48.
- 1 X CABINET LOCK with 2 keys. Order Ref. 55.
- 1 X MAGNETIC BRAKE for stopping a motor or rotating tool. Order Ref. 66.
- 1 X SHADED POLE MAINS MOTOR ¼" stack so quite powerful. Order Ref. 85.
- 2 X 5 ALUMINIUM FAN BLADES could be fitted to the above motor. Order Ref. 86.
- 1 X CASE 3 ½" X 2 ¼" X 1 ¼" with 13A socket pins. Order Ref. 845.
- 2 X CASES 2 ½" X 2 ¼" X 1 ¼" with 13A pins. Order Ref. 565.
- 4 X LUMINOUS ROCKER SWITCHES 10A mains. Order Ref. 793.
- 4 X DIFFERENT STANDARD V3 MICROSWITCHES. Order Ref. 340.
- 4 X DIFFERENT SUB-MIN MICROSWITCHES. Order Ref. 313.

## SOME POPULAR BARGAINS

### BARGAINS - GALORE

- MEDICINE CUPBOARD ALARM or it could be used to warn when any cupboard door is opened. The light shining on the unit makes the bell ring. Completely built and neatly cased, requires only a battery. £3, Order Ref. 3P155.
- DO NOT LET IT OVERFLOW be it bath, sink, cellar, sump or any other thing that could flood. This device will tell you when the water has risen to the pre-set level. Adjustable over quite a useful range. Neatly cased for wall mounting, ready to work when battery fitted. £3, Order Ref. 3P156.
- VERY POWERFUL MAINS MOTOR with extra long (2 ½") shafts extending out each side. Makes it ideal for a reversing arrangement for, as you know, shaded pole motors are not reversible. £3, Order Ref. 3P157.
- SOLAR PANEL BARGAIN gives 3V at 200mA. £2, Order Ref. 2P324.
- A 63MM AXIAL FAN FOR £1 sounds incredible doesn't it? But that is what we can now offer. It's really beautifully made by a West German company. Uses a brushless motor and is operated by a simple transistor 12V circuit, details of which we supply. It thus would make a good equipment cooling fan. Also, with a simple handle it could be used for cooling in the car. It's nine-bladed so a very good air mover. We have a large quantity of these, the price is £1, Order Ref. 919. Quantity price, if you buy 100, 75p each plus VAT or 1,000 65p each plus VAT.
- LCD 3 ½" DIGIT PANEL METER this is a multi range voltmeter/ammeter using the A-D converter chip 7106 to provide 5 ranges each of volts and amps. Supplied with full data sheet. Special snip price of £12. Order Ref. 12P19.
- PC OPERATING SYSTEMS fully user documented and including software. MS-DOS 3.20, with 5" disk, £5, Order Ref. 5P2076; MS-DOS 3.3 with 3 ½" disk, £5, Order Ref. 5P208; MS-DOS 4.01, with 3 ½" disk, £10, Order Ref. 10P99.
- 45A DOUBLE POLE MAINS SWITCH mounted on a 6" X 3 ½" aluminium plate, beautifully finished in gold, with pilot light. Top quality, made by MEM. £2, Order Ref. 2P316.
- AMSTRAD 3" DISK DRIVE brand new and standard replacement for many Amstrad and other machines. £20, Order Ref. 20P28.
- HIGH QUALITY KEY SWITCH this is a single-pole, 2 position switch, changeover or on/off. Ideal for mounting through a front panel when it would be secured by a hexagonal nut. It's a Yale type switch and comes complete with two keys. Good British make, normally retails at £3, our price £1.50, Order Ref. 1.5P12.
- 12V DC BRUSHLESS AXIAL FAN Japanese made, battery operated. 93mm square, optimum is 12V but it performs equally well at only 6V and its current then is only 100mA so it could be made into a hand-held dry battery-operated cooler. Or, on your desk operated by a PSU or in the car using the lighter socket. Snip price only £4, Order Ref. 4P65. Mains power unit to operate this at variable speeds, £2, Order Ref. 2P3.
- MOVEMENT ALARM goes off, with the slightest touch. Ideal to protect car, cycle, doorway, window, stairway, etc. Complete with Piezo shrieker, ready use. Only £2, (PP3 battery not supplied) Order Ref. 2P282.
- PROJECT BOX a first-class, Japanese two-part moulding size 95mm x 66mm x 23mm. Held together by two screws, this will hold a PP3 battery and a PCB and is ideal for many projects. To name just a few, the Washer Bottle Monitor described in September '92 issue of E.E. This is nicely finished and very substantial. You get 2 for £1, Order Ref. 876.
- AM/FM RADIO CHASSIS with separate LCD module to display date and time. This is complete with loudspeaker, £3.50, Order Ref. 3.5P5.
- £1 SUPER BARGAIN
- 12V axial fan for only £1, ideal for equipment cooling, brand new, made by West German company. Brushless so virtually everlasting. Needs simple transistor drive circuit, we include diagram. Only £1, Order Ref. 919. When we supply this we will include a list of approximately 800 of our other £1 bargains.
- 2, 3 AND 4 WAY TERMINAL BLOCKS the usual grub screw types. Parcel containing a mixture of the three types, giving you 100 ways for £1, Order Ref. 875.
- 12/24 DC SOLENOID. The construction of this is such that it will push or pull as the plunger is a combined rod and piston. With 24V this is terrifically powerful but is still quite good at 12V and, of course, it can be operated by any intermediate voltage. Price £1, Order Ref. 877.
- 2M 3-CORE LEAD terminating with flat pin instrument socket, £1, Order Ref. 879. Ditto but with plug on the other end so that you could use this to extend an instrument lead, £1.50, Order Ref. 1.5P10.
- 20W 5" 4 OHM SPEAKER mounted on baffle with front grille, £3, Order Ref. 3P145. Matching 4 ohm 20W tweeter on separate baffle, £1.50, Order Ref. 1.5P9.
- SOLAR ENERGY EDUCATIONAL KIT it shows how to make solar circuits and electrical circuits, how to increase to voltage or current, to work a radio, calculator, cassette player and to charge NICAD batteries. The kit comprises 8 solar cells, one solar motor, fan blades to fit motor and metal frame to hold it to complete a free-standing electric fan. A really well written instruction manual. Price £8.00, Order Ref. 8P42B.
- HIGH POWER SWITCH MODE PSU normal mains input, 3 outputs: - +12V at 4A, +5V at 16A and -12V at ½A. Completely enclosed in plated steel case. Brand new. Our special offer price of £9.50, Order Ref. 9.5P1.
- MULTI-CORE CABLES all with 8A 230V cores so suitable for disco and other special lighting effects. With earthable woven screen and thick p.v.c. outer, 3 core, 30p per metre, 16 core, 50p per metre, 18 core, 80p per metre, 25 core, £1 metre and 36 core, £1.50 per metre.
- ULTRA THIN DRILLS actually 0.3mm. To buy these regular costs a fortune. However, these are packed in half dozens and the price to you is £1 per pack, Order Ref. 797B.
- YOU CAN STAND ON IT! Made to house GPO telephone equipment, this box is extremely tough and would be ideal for keeping your small tools, internal size approx. 10 ½" X 4 ½" X 6" high. Complete with carrying strap, price £2, Order Ref. 2P283B.
- SAFETY LEADS curly coil so they contract but don't hang down. Could easily save a child from being scalded. 2 core, 5A, extends to 3M, £1, Order Ref. 846. 3 core, 13A, extends to 3M, £2 each, Order Ref. 2P290.

- POWER SUPPLY WITH EXTRAS mains input is fused and filtered and the 12V DC output is voltage regulated. Intended for high class equipment, this is mounted on a PCB and, also mounted on the board but easily removed, are two 12V relays and a Piezo sander. £3, Order Ref. 3P80B.
- ULTRA SONIC TRANSDUCERS two metal cased units, one transmits, one receives. Built to operate around 40kHz. Price £1.50 the pair. Order Ref. 1.5P4.
- 100W MAINS TRANSFORMERS normal primaries 20V-0V-20V at 2.5A, or 30V at 3.5A. £4, Order Ref. 4P24. 40V at 2.5A, £4, Order Ref. 4P59. 50V at 2A, £4, Order Ref. 4P60.
- PHILIPS 9" HIGH RESOLUTION MONITOR black & white in metal frame for easy mounting, brand new still in maker's packing, offered at less than price of tube alone, only £15, Order Ref. 15P1.
- 16 CHARACTER 2-LINE DISPLAY screen size 85mm x 36mm, Alphanumeric LCD dot matrix module with integral micro processor made by Epson, their Ref. 16027AR, £8, Order Ref. 8P48.
- INSULATION TESTER WITH MULTIMETER internally generates voltages which enable you to read insulation directly in megohms. The multimeter has four ranges, AC/DC volts, 3 ranges DC milliamps, 3 ranges resistance and 5 amp range. These instruments are ex-British Telecom but in very good condition, tested and guaranteed OK, probably cost at least £50 each, yours for only £7.50 with leads, carrying case £2 extra. Order Ref. 7.5P4.
- MAINS 230V FAN best make "PAPST" 4 ½" square, metal blades, £8, Order Ref. 8P8.
- 2MW LASER helium neon by Philips, full spec. £30, Order Ref. 30P1. Power supply for this in kit form with case is £15, Order Ref. 15P16, or in larger case to house tube as well £18, Order Ref. 18P2. The larger unit, made up, tested and ready to use, complete with laser tube £69, Order Ref. 69P1.
- 1/3 HP 12V MOTOR - THE FAMOUS SINCLAIR CS brand new, £15, Order Ref. 15P8.
- SOLAR CHARGER holds four AA NICADS and recharges these in 8 hours, in very neat plastic case, £6, Order Ref. 6P3.
- FERRITE AERIAL ROD 8" Long x ¼" diameter, made by Pilot Ltd. Complete with two coils, 2 for £1, Order Ref. 832B.
- AIR SPACED TRIMMER CAPS 2-20pF ideal for precision tuning UHF circuits, 4 for £1, Order Ref. 818B.
- MAINS ISOLATION TRANSFORMER stops you getting "to earth" shocks. 230V in and 230V out. 150 watt, £7.50, Order Ref. 7.5P/5 and a 250W version is £10, Order Ref. 10P97.
- 5RPM MAINS DRIVEN. This is a shaded-pole motor, £5, Order Ref. 5P54.
- AMSTRAD POWER UNIT 13.5V at 1.9A or 12V at 2A enclosed and with leads and output plug, normal mains input £6, Order Ref. 6P23.
- ATARI 65XE at 65K this is quite powerful, so suitable for home or business, unused and in perfect order but less PSU, only £19.50, Order Ref. 19.5P/5B.
- 80W MAINS TRANSFORMER two available, good quality, both with normal primaries and upright mounting, one is 20V 4A, Order Ref. 3P106, the other 40V 2A, Order Ref. 2P3.
- PROJECT BOX size approx. 8" X 4" X 4 ½" metal, sprayed grey, louvered ends for ventilation otherwise undrilled. Made for GPO so best quality, only £3 each, Order Ref. 3P74.
- WATER VALVE 230V operated with hose connections, ideal for auto plant spray or would control air or gas into tanks etc. £1 each, Order Ref. 370.
- BT POWER SUPPLY UNIT output 9.5V AC at 600mA, in black plastic case with 13A plugs to go straight into socket, and approximately 3 metres of twin output lead. Price £1.50, Order Ref. 1.5P7.
- 500V BRIDGE MEGGER developed for GPO technicians the Ohmmeter 18B is the modern equivalent of the bridge megger. 9V battery operated, it incorporates a 500V generator for insulation testing and a null balance bridge for very accurate resistance measurement. Ex BT £45, Order Ref. 45P2.
- EXPERIMENTING WITH VALVES don't spend a fortune on a mains transformer, we can supply one with standard mains input and secs. of 250V-0V-250V at 75mA and 6.3V at 3A, £5, Order Ref. 5P167.
- 15W 8 OHM 8" SPEAKER & 3" TWEETER made for a distinguished high quality music centre, gives real hi-fi, and only £4 per pair, Order Ref. 4P57.
- WATER PUMP very powerful, mains operated. £10, Order Ref. 10P74.
- 0-1MA FULL VISION PANEL METER 2 ¼" square, scaled 0-100 but scale easily removed for re-wiring, £1 each, Order Ref. 756.
- VU METER illuminate this from behind becomes on/off indicator as well, 1 ½" square, 75p each, Order Ref. 366.
- EDGE-WISE PANEL METER ideal when short of panel space only 40mm x 14mm, also have built-in i.e.d., 500µA f.s.d., scaled 0-5, £1 each, Order Ref. 131.

Prices include VAT. Send cheque/postal order or ring and quote credit card number.  
Add £3 post and packing.  
Orders over £25 post free.

## M & B ELECTRICAL SUPPLIES LTD

Pilgrim Works (Dept. E.E.)  
Stairbridge Lane,  
Bolney,  
Sussex RH17 5PA  
Telephone: 0444 881965  
(Phone for Fax)

Callers to:  
12 Boundary Road, Hove, Sussex.



# DIRECT BOOK SERVICE

The books listed have been selected by Everyday with Practical Electronics editorial staff as being of special interest to everyone involved in electronics and computing. They are supplied by mail order direct to your door. Full ordering details are given on the last book page. For another selection of books see next month's issue.

## EVERYDAY ELECTRONICS DATA BOOK

**Mike Tooley BA**  
(published by EE in association with PC Publishing)  
This book is an invaluable source of information of everyday relevance in the world of electronics. It contains not only sections which deal with the essential theory of electronic circuits, but also deals with a wide range of practical electronic applications.

It is ideal for the hobbyist, student, technician and engineer. The information is presented in the form of a basic electronic recipe book with numerous examples showing how theory can be put into practice using a range of commonly available "industry standard" components and devices.

A must for everyone involved in electronics!  
256 pages **Order code DATA** £8.95

## ELECTRONICS TEACH-IN No. 3 - EXPLORING ELECTRONICS

(published by Everyday Electronics)  
**Owen Bishop**  
Another EE value for money publication aimed at students of electronics. The course is designed to explain the workings of electronic components and circuits by involving the reader in experimenting with them. The book does not contain masses of theory or formulae but straightforward explanations and circuits to build and experiment with.

Exploring Electronics contains more than 25 useful projects, assumes no previous knowledge of electronics and is split into 28 easily digestible sections.  
88 pages (A4 size) **Order code T13** £2.45

## HOW TO CHOOSE A SMALL BUSINESS COMPUTER SYSTEM

**D. Weale**  
This book is for anyone intending to buy an IBM compatible computer system, whether it is their first system or a replacement. There are sections on hardware, application and systems programs and how to actually make your choice as well as sections on the law, ergonomics and a glossary of common terms.

The text contains many useful tips and some warnings (which could save much effort and expense).  
114 pages **Order code BP323** £4.95

## UNDERSTANDING PC SPECIFICATIONS

**R. A. Penfold**  
If you require a microcomputer for business applications, or a high quality home computer, an IBM PC or compatible is often the obvious choice. They are competitively priced, and are backed up by an enormous range of applications programs, hardware add-ons, etc. The main difficulty for the uninitiated is deciding on the specification that will best suit his or her needs. PCs range from simple systems of limited capabilities up to complex systems that can happily run applications that would have been considered beyond the abilities of a microcomputer not so long ago. It would be very easy to choose a PC system that is inadequate to run your applications efficiently, or one which goes beyond your needs and consequently represents poor value for money.

This book explains PC specifications in detail, and the subjects covered include the following: Differences between types of PC (XT, AT, 80386, etc); Maths co-processors; Input devices (keyboards, mice, and digitisers); Memory, including both expanded (EMS) and extended RAM; RAM disks and disk caches; Floppy disk drive formats and compatibility; Hard disk drives (including interleave factors and access times); Display adaptors, including all standard PC types (CGA, Hercules, Super VGA, etc); Contains everything you need to know if you can't tell your EMS from your EGA!

104 pages **Order code BP282** £3.95

# Special Everyday Electronics Books

## ELECTRONICS TEACH-IN No. 4 INTRODUCING DIGITAL ELECTRONICS

(published by Everyday Electronics)  
**Michael J. Cockcroft**  
Although this book is primarily a City & Guilds Introductory level course (726/301), approximately 80% of the information forms a very basic introduction to electronics in general, it therefore provides an excellent introductory text for beginners and a course and reference book for GCSE students.

Full details on registering for C&G assessment, details of assessment centres, components required and information on the course in general are given.

The City & Guilds introduction to module 726/301 reads: "A candidate who satisfactorily completes this module will have a competence to identify basic components and digital integrated circuits and connect them together to form simple working circuits and logic units." This provides an excellent introduction to the book.

112 pages (A4 size) **Order code T14** £2.95

## ELECTRONIC PROJECTS - BOOK 1

(Published by Everyday Electronics in association with Magenta Electronics).

Contains twenty of the best projects from previous issues of EE each backed with a kit of components. The projects are: Seashell Sea Synthesiser, EE Treasure Hunter, Mini Strobe, Digital Capacitance Meter, Three Channel Sound to Light, BBC 16K Sideways Ram, Simple Short Wave Radio, Insulation Tester, Stepper Motor interface, Eprom Eraser, 200MHz Digital Frequency Meter, Infra Red Alarm, EE Equaliser Ioniser, Bat Detector, Acoustic Probe, Mains Tester and Fuse Finder, Light Rider - (Lapel Badge, Disco Lights, Chaser Light), Musical Doorbell, Function Generator, Tilt Alarm, 10W Audio Amplifier, EE Buccaneer Induction Balance Metal Detector, BBC Midi Interface, Variable Bench Power Supply, Pet Scarer, Audio Signal Generator.

128 pages (A4 size) **Order code EPT** £2.45

## ELECTRONICS TEACH-IN No. 5 GUIDE TO BUILDING ELECTRONIC PROJECTS

(Published by EVERYDAY ELECTRONICS)  
Due to the demand from students, teachers and hobbyists we have put together a range of articles from past issues of Everyday Electronics that will assist those involved with the construction of electronic projects.

The book contains the complete Project Development for GCSE series.

**Contents: Features** - First Steps in Project Building; Building with Vero; Project Development for GCSE; Getting your Project Working; Guide to Printed Circuit Boards; Choosing and Using Test Equipment - The Multimeter, The Oscilloscope, P.S.U.s, Logic Probes, Digital Frequency Meters, Signal Generators, etc; **Data** - Circuit Symbols; Component Codes; Resistors; Identifying Components; Capacitors; Actually Doing It - Understanding the Circuit Diagram, Component Codes, Mounting circuit boards and controls, Understanding Capacitors; **Projects** - Lie Detector; Personal Stereo Amplifier; Digital Experiments Unit; Quizmaster; Siren Effects Unit; UV Exposure Unit; Low-cost Capacitance Meter; Personal Radio.

88 pages (A4 size) **Order code T15** £2.95

## ELECTRONICS TEACH-IN 88/89 - INTRODUCING MICROPROCESSORS

**Mike Tooley BA** (published by Everyday Electronics)

A complete course that can lead successful readers to the award of a City and Guilds Certificate in Introductory Microprocessors (726/303). The book contains everything you need to know including full details on registering for assessment, etc. Starting with basic terminology, integrated circuits, logic families and numbering systems the text builds in stages, with revision and assessments built in, up to programming, languages, flow charts, etc. The course is ideal for the newcomer to the subject.

80 pages (A4 size) **Order code T1-88-89** £2.45



# Computers and Computing

## AN INTRODUCTION TO 68000 ASSEMBLY LANGUAGE

**R. A. & J. W. Penfold**  
Obtain a vast increase in running speed by writing programs for 6800 based micros such as the Commodore Amiga, Atari ST range or Apple Macintosh range etc., in assembly language. It is not as difficult as one might think and this book covers the fundamentals.

112 pages **Order code BP184** £2.95

## THE ART OF PROGRAMMING THE ZX SPECTRUM

**M. James, B.Sc., M.B.C.S.**  
It is one thing to have learnt how to use all the Spectrum's commands and functions, but a very different one to be able to combine them into programs that do exactly what you want them to. This is just what this book is all about - teaching you the art of effective programming with your Spectrum.

144 pages **Order code BP119** £2.50

## A CONCISE INTRODUCTION TO MS-DOS

**N. Kantaris**  
This guide is written with the non-expert, busy person in mind and, as such, it has an underlying structure based on "what you need to know first, appears first". Nonetheless, the guide is also designed to be circular, which means that you don't have to start at the beginning and go to the end. The more experienced user can start from any section.

The guide covers versions 3.0, 3.1 and 3.2 of both PC-DOS and MS-DOS as implemented by IBM and other manufacturers of "compatible" microcomputers, including the AMSTRAD PCs. It covers both floppy disc-based systems and hard disc-based systems.

64 pages **Order code BP232** £2.95

## MAKING MS-DOS WORK FOR YOU

**N. Kantaris & P. R. M. Oliver**  
This book was written with the busy person in mind and, as such, it has an underlying structure based on "what you need to know first, appears first". Nonetheless, the

book has also been designed to be circular, which means that you don't have to start at the beginning and go to the end.

The book explains: How to write customised batch files which allow you to display what you want on your screen, and in the form and order you want it, instead of being forced to use the DOS prompt on a blank screen. How to design and set up a fast interactive and professional looking menu system, so that you or anyone else can run utility applications or commercial software packages easily. How the ANSI.SYS display and keyboard commands can be used to position the cursor on any part of the screen, change the intensity of the displayed characters or change their colour. How the Edit screen editor or the Edlin line editor can be used to enter ESCAPE (ANSI.SYS) commands into simple ASCII files to allow control of both your screen display and your printer. How to control the operation of the two main types of printers in use today, Epson compatible dot matrix and HP compatible laser printers. How to use several useful routines, such as moving and finding files, protecting files from accidental erasure, a simplified backup process, a screen saver, and a disc cataloguing system.

The Debug program and how it can be used to create, see and change the contents of any file, including those of programs written in assembler code. This includes how to find your way around the names and tasks of the CPU registers and the meaning of some simple assembler mnemonics.

182 pages **Order code BP319** £4.95

## AN INTRODUCTION TO CP/M

**R. A. Penfold**  
In order to run and use programs operating under CP/M it is not essential to have an understanding of the system, but a reasonable knowledge of the subject can certainly be of immense help when minor problems occur, and also in fully exploiting the possible potential of the system. This book tells the story!

84 pages **Order code BP183** £2.95

# Audio and Music

## ACOUSTIC FEEDBACK - HOW TO AVOID IT

Feedback is the bane of all public address systems. While feedback cannot be completely eliminated, many things can be done to reduce it to a level at which it is no longer a problem.

Much of the trouble is often the hall itself, not the equipment, but there is a simple and practical way of greatly improving acoustics. Some microphones are prone to feedback while others are not. Certain loudspeaker systems are much better than others, and the way the units are positioned can produce or reduce feedback. All these matters are fully explored as well as electronic aids such as equalizers, frequency-shifters and notch filters.

The special requirements of live group concerts are considered, and also the related problem of instability that is sometimes encountered with large set-ups. We even take a look at some unsuccessful attempts to cure feedback so as to save readers wasted time and effort duplicating them.

Also included is the circuit and layout of an inexpensive but highly successful twin-notch filter, and how to operate it.  
92 pages **Order code BP310** £3.95

## PRACTICAL MIDI HANDBOOK

R. A. Penfold

The Musical Instrument Digital Interface (MIDI) is surrounded by a great deal of misunderstanding, and many of the user manuals that accompany MIDI equipment are quite incomprehensible to the reader.

The Practical MIDI Handbook is aimed primarily at musicians, enthusiasts and technicians who want to exploit the vast capabilities of MIDI, but who have no previous knowledge of electronics or computing. The majority of the book is devoted to an explanation of what MIDI can do and how to exploit it to the full, with practical advice on connecting up a MIDI system and getting it to work, as well as deciphering the technical information in those manuals.  
128 pages **Order code PC101** £6.95

## PREAMPLIFIER AND FILTER CIRCUITS

R. A. Penfold

This book provides circuits and background information for a range of preamplifiers, plus tone controls, filters, mixers, etc. The use of modern low noise operational amplifiers and a specialist high performance audio preamplifier i.c. results in circuits that have excellent performance, but which are still quite simple. All the circuits featured can be built at quite low cost (just a few pounds in most cases).

The preamplifier circuits featured include:- Microphone preamplifiers (low impedance, high impedance, and crystal). Magnetic cartridge pick-up preamplifiers with R.I.A. equalisation. Crystal/ceramic pick-up preamplifier. Guitar pick-up preamplifier. Tape head preamplifier (for use with compact cassette systems).

Other circuits include:- Audio limiter to prevent overloading of power amplifiers. Passive tone controls. Active tone controls. PA filters (highpass and lowpass). Scratch and rumble filters. Loudness filter. Audio mixers. Volume and balance controls.  
92 pages **Order code BP309** £3.95

## AN INTRODUCTION TO LOUSPEAKERS AND ENCLOSURE DESIGN

V. Capel

This book explores the various features, good points and snags of speaker designs. It examines the whys and wherefores so that the reader can understand the principles involved and so make an informed choice of design, or even design loudspeaker enclosures for him or herself. Crossover units are also explained, the various types, how they work, the distortions they produce and how to avoid them. Finally there is a step-by-step description of the construction of the *Kapellmeister* loudspeaker enclosure.  
148 pages **Temporarily out of print**

## COMPUTERS AND MUSIC - AN INTRODUCTION

R. A. Penfold

Computers are playing an increasingly important part in the world of music, and the days when computerised music was strictly for the fanatical few are long gone.

If you are more used to the black and white keys of a synth keyboard than the QWERTY keyboard of a computer, you may be understandably confused by the jargon and terminology bandied about by computer buffs. But fear not, setting up and using a computer-based music making system is not as difficult as you might think.

This book will help you learn the basics of computing, running applications programs, wiring up a MIDI system and using the system to good effect, in fact just about everything you need to know about hardware and the programs, with no previous knowledge of computing needed or assumed. This book will help you to choose the right components for a system to suit your personal needs, and equip you to exploit that system fully.  
174 pages **Order code PC107** £8.95

## ELECTRONIC PROJECTS FOR GUITAR

R. A. Penfold

This book contains a collection of guitar effects and some general purpose effects units, many of which are suitable for beginners to project building. An introductory chapter gives guidance on construction.

Each project has an introduction, an explanation of how it works, a circuit diagram, complete instructions on strip-board layout and assembly, as well as notes on setting up and using the units. Contents include: Guitar tuner; Guitar preamplifier; Guitar headphone amplifier; Soft distortion unit; Compressor; Envelope waa waa; Phaser; Dual tracking effects unit; Noise gate/expander; Treble booster; Dynamic treble booster; Envelope modifier; Tremolo unit; DI box.  
110 pages **Order code PC110** £8.95

## HIGH POWER AUDIO AMPLIFIER CONSTRUCTION

R. A. Penfold

Practical constructional details of how to build a number of audio power amplifiers ranging from about 50 to 300/400 watts r.m.s. Includes MOSFET and bipolar transistor designs.  
96 pages **Order code BP277** £3.95

# Project Building

## HOW TO GET YOUR ELECTRONIC PROJECTS WORKING

R. A. Penfold

We have all built projects only to find that they did not work correctly, or at all, when first switched on. The aim of this book is to help the reader overcome just these problems by indicating how and where to start looking for many of the common faults that can occur when building up projects.  
96 pages **Order code BP110** £2.95

## HOW TO DESIGN AND MAKE YOUR OWN P.C.B.s

R. A. Penfold

Deals with the simple methods of copying printed circuit board designs from magazines and books and covers all aspects of simple p.c.b. construction including photographic methods and designing your own p.c.b.s.  
80 pages **Order code BP121** £2.50



## A BEGINNERS GUIDE TO MODERN ELECTRONIC COMPONENTS

R. A. Penfold

The purpose of this book is to provide practical information to help the reader sort out the bewildering array of components currently on offer. An advanced knowledge of the theory of electronics is not needed, and this book is not intended to be a course in electronic theory. The main aim is to explain the differences between components of the same basic type (e.g. carbon, carbon film, metal film, and wire-wound resistors) so that the right component for a given application can be selected. A wide range of components are included, with the emphasis firmly on those components that are used a great deal in projects for the home constructor.  
166 pages **Order code BP285** £3.95

## BEGINNER'S GUIDE TO BUILDING ELECTRONIC PROJECTS

R. A. Penfold

Shows the complete beginner how to tackle the practical side of electronics, so that he or she can confidently build the electronic projects that are regularly featured in magazines and books. Also include examples in the form of simple projects.  
112 pages **Order code 227** £1.95

## ELECTRONICS SIMPLIFIED - CRYSTAL SET CONSTRUCTION

F. A. Wilson, C.G.I.A., C.Eng., F.I.E.E., F.I.E.R.E., F.B.I.M.

Especially written for those who wish to participate in the intricacies of electronics more through practical construction than by theoretical study. It is designed for all ages upwards from the day one can read intelligently and handle simple tools.  
80 pages **Order code BP92** £1.75

## GUIDE TO BUILDING ELECTRONIC PROJECTS

Published by *Everyday Electronics*

See the first page of books - ELECTRONICS TEACH-IN No.5 - for full details.

## ELECTRONICS PROJECT BOOK

Published by *Everyday Electronics* in association with *Magenta Electronics*.

See the first page of books for full details.

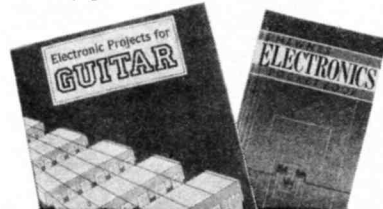

# Testing and Test Gear

## HOW TO USE OSCILLOSCOPES AND OTHER TEST EQUIPMENT

R. A. Penfold

This book explains the basic function of an oscilloscope, gives a detailed explanation of all the standard controls, and provides advice on buying. A separate chapter deals with using an oscilloscope for fault finding on linear and logic circuits, plenty of example waveforms help to illustrate the control functions and the effects of various fault conditions. The function and use of various other pieces of test equipment are also covered, including signal generators, logic probes, logic pulsers, and crystal calibrators.  
104 pages **Order code BP267** £3.50

# Theory and Reference

## ELECTRONIC HOBBYISTS HANDBOOK

R. A. Penfold

Provides an inexpensive single source of easily located information that the amateur electronics enthusiast is likely to need for the day-to-day pursuance of this fascinating hobby. Covers common component colour codes. Details the characteristics and pinouts of many popular semiconductor devices, including various types of logic ICs, operational amplifiers, transistors, FETs, unijunctions, diodes, rectifiers, SCRs, diacs, triacs, regulators and SMDs, etc. Illustrates many useful types of circuits, such as timers and oscillators, audio amplifiers and filters, as well as including a separate section on power supplies. Also contains a multitude of other useful data.  
88 pages **Order code BP233** £4.95

## FROM ATOMS TO AMPERES

F. A. Wilson

Explains in crystal clear terms the absolute fundamentals behind electricity and electronics. Really helps you to discover and understand the subject, perhaps for the first time ever.

Have you ever: Wondered about the true link between electricity and magnetism? Felt you could never understand the work of Einstein, Newton, Boltzmann, Planck and other early scientists? Just accepted that an electron is like a little black ball? Got mixed up with e.m.f. and p.d.? Thought the idea of holes in semiconductors is a bit much?

Then help is at hand with this inexpensive book, in as simple a way as possible and without too much complex mathematics and formulae.  
244 pages **Order code BP254** £3.50

## ELECTRONICS - A "MADE SIMPLE" BOOK

G. H. Olsen

This book provides excellent background reading for our *Introducing Digital Electronics Teach-In Book* and will be of interest to everyone studying electronics. The subject is simply explained and well illustrated and the book assumes only a very basic knowledge of electricity.  
330 pages **Order code NE10** £5.95

## A REFERENCE GUIDE TO PRACTICAL ELECTRONICS TERMS

F. A. Wilson

Electronic devices surround us on all sides and their numbers are increasing without mercy. Ours is the problem therefore in keeping up with this relentless expansion. Unfortunately we cannot know it all and most

of us do not wish to afford the cost of large reference books which explain many concepts in fair detail. Here is an answer, an inexpensive reference guide which explains briefly (but we hope, well) many of the underlying electronics features of practical devices, most of which, to a certain extent, control our lives.

This book is in effect more than just a dictionary of practical electronics terms, it goes a stage further in also getting down to fundamentals. Accordingly the number of terms may be limited but the explanations of the many which are included are designed to leave the reader more competent and satisfied - and this is without the use of complicated mathematics which often on first reading can even be confusing.

For those who also wish to get right down to the root of the matter, there is a second volume entitled *A Reference Guide to Basic Electronics Terms* (BP286), each of the books referring to its companion as necessary.

A reference guide for practically everybody concerned with electronics.  
432 pages **Order code BP287** £5.95

## NEWNES ELECTRONICS POCKET BOOK

E. A. Parr

Newnes Electronics Pocket Book has been in print for over twenty years and has covered the development of electronics from valve to semiconductor technology and from transistors to LSI integrated circuits and microprocessors. To keep up to date with the rapidly changing world of electronics, continuous revision has been necessary. This new Fifth Edition takes account of recent changes and includes material suggested by readers of previous editions. New descriptions of op.amp. applications and the design of digital circuits have been added, along with a totally new chapter on computing, plus other revisions throughout.  
315 pages (hard cover) **Order code NE02** £10.95

## ELECTRONIC MODULES AND SYSTEMS FOR BEGINNERS

Owen Bishop

This book describes over 60 modular electronic circuits - how they work, how to build them, and how to use them. The modules may be wired together to make hundreds of different electronic systems, both analogue and digital. To show the reader how to begin building systems from modules, a selection of over 25 electronic systems are described in detail, covering such widely differing applications as timing, home security, measurement, audio (including a simple radio receiver), games and remote control.  
200 pages **Order code BP266** £3.95



# Circuits and Design

## PRACTICAL ELECTRONIC BUILDING BLOCKS - BOOK 2

**R. A. Penfold**  
This book is designed to aid electronic enthusiasts who like to experiment with circuits and produce their own projects, rather than simply following published project designs.

Contains: Amplifiers - low level discrete and op-amp circuits, voltage and buffer amplifiers including d.c. types. Also low-noise audio and voltage controller amplifiers. Filters - high-pass, low-pass, 6, 12, and 24dB per octave types. Miscellaneous - i.c. power amplifiers, mixers, voltage and current regulators, etc.

112 pages **Order code BP118** £1.95

## PRACTICAL ELECTRONIC FILTERS

**Owen Bishop**  
This book deals with the subject in a non-mathematical way. It reviews the main types of filter, explaining in simple terms how each type works and how it is used.

The book also presents a dozen filter-based projects with applications in and around the home or in the constructor's workshop. These include a number of audio projects such as a rhythm sequencer and a multi-voiced electronic organ.

Concluding the book is a practical step-by-step guide to designing simple filters for a wide range of purposes, with circuit diagrams and worked examples.

192 pages **Order code BP299** £4.95

## ELECTRONIC ALARM CIRCUITS MANUAL

**R. M. Marston**  
One hundred and forty useful alarm circuits, of a variety of types, are shown in this volume. The operating principle of each one is explained in concise but comprehensive terms, and brief construction notes are given where necessary.

Aimed at the practical design engineer, technician and experimenter, as well as the electronics student and amateur.

124 pages **Order code NE11** £13.95

## ELECTRONIC CIRCUITS FOR THE COMPUTER

**CONTROL OF MODEL RAILWAYS**  
**R. A. Penfold**  
The projects consist of various types of interface and controllers, including a high quality pulse type, as well as circuits for train position sensing, signal and electric points control etc.

The use of computers does not have to be restricted to massive layouts. Something as simple as an oval track with

a single siding can be given a new dimension by adding computer control and much fun can be had from these relatively simple set ups.

88 pages **Order code BP180** £2.95

## DIGITAL LOGIC GATES AND FLIP-FLOPS

**Ian R. Sinclair**  
This book, intended for enthusiasts, students and technicians, seeks to establish a firm foundation in digital electronics by treating the topics of gates and flip-flops thoroughly and from the beginning.

Topics such as Boolean algebra and Karnaugh mapping are explained, demonstrated and used extensively, and more attention is paid to the subject of synchronous counters than to the simple but less important ripple counters.

No background other than a basic knowledge of electronics is assumed, and the more theoretical topics are explained from the beginning, as also are many working practices. The book concludes with an explanation of microprocessor techniques as applied to digital logic.

200 pages **Order code PC106** £8.95

## ELECTRONIC CIRCUITS FOR THE COMPUTER

**CONTROL OF ROBOTS**  
**Robert Penfold**  
Robots and robotics offer one of the most interesting areas for the electronics hobbyist to experiment in. Today the mechanical side of robots is not too difficult, as there are robotics kit and a wide range of mechanical components available. The micro controller is not too much of a problem either, since the software need not be terribly complex and many inexpensive home computers are well suited to the task.

The main stumbling block for most would-be robot builders is the electronics to interface the computer to the motors, and the sensors which provide feedback from the robot to the computer. The purpose of this book is to explain and provide some relatively simple electronic circuits which bridge this gap.

92 pages **Temporarily out of print**

## ELECTRONIC POWER SUPPLY HANDBOOK

**Ian R. Sinclair**  
This book covers the often neglected topic of electronic power supplies. All types of supplies that are used for electronics purposes are covered in detail, starting with cells and batteries and extending by way of rectified supplies and linear stabilisers to modern switch-mode systems, IC switch-mode regulators, DC-DC converters and inverters.

The devices, their operating principles and typical cir-

cuits are all dealt with in detail. The action of rectifiers and the reservoir capacitor is emphasised, and the subject of stabilisation is covered. The book includes some useful formulae for assessing the likely hum level of a conventional rectifier reservoir supply.

136 pages **Order code PC108** £7.95

## HOW TO USE OP-AMPS

**E. A. Parr**  
This book has been written as a designer's guide covering many operational amplifiers, serving both as a source book of circuits and a reference book for design calculations. The approach has been made as non-mathematical as possible.

160 pages **Order code BP88** £2.95

## MICRO INTERFACING CIRCUITS - BOOK 1

**MICRO INTERFACING CIRCUITS - BOOK 2**  
**R. A. Penfold**  
Both books include practical circuits together with details of the circuit operation and useful background information. Any special constructional points are covered but p.c.b. layouts and other detailed constructional information are not included.

Book 1 is mainly concerned with getting signals in and out of the computer; Book 2 deals primarily with circuits for practical applications.

**BOOK 1** 112 pages **Order code BP130** £2.75

**BOOK 2** 112 pages **Order code BP131** £2.75

## 50 SIMPLE LED CIRCUITS

**R. N. Soar**  
Contains 50 interesting and useful circuits and applications, covering many different branches of electronics, using one of the most inexpensive and freely available components - the light-emitting diode (LED). Also includes circuits for the 707 common audio display.

64 pages **Order code BP42** £1.95

**BOOK 2** 50 more l.e.d. circuits **Order code BP87** £1.95

## CIRCUIT SOURCE BOOK 1

**R. A. Penfold**  
Written to help you create and experiment with your own electronic designs by combining and using the various standard "building block" circuits provided. Where applicable, advice on how to alter the circuit parameters is given.

The circuits covered in this book are mainly concerned with analogue signal processing and include: Audio amplifiers (op amp and bipolar transistors); audio power amplifiers; d.c. amplifiers; highpass, lowpass, bandpass and notch filters; tone controls; voltage controlled amplifiers and filters; triggers and voltage comparators; gates and electronic switching; bargraphs; mixers; phase shifters, current mirrors, hold circuits, etc.

Over 150 circuits are provided, which it is hoped will be useful to all those involved in circuit design and application, be they professionals, students or hobbyists.

182 pages **Order code BP321** £4.95

# Radio, TV, Satellite

## PROJECTS FOR RADIO AMATEURS

**AND S.W.L.S.**  
**R. A. Penfold**  
This book describes a number of electronic circuits, most of which are quite simple, which can be used to enhance the performance of most short wave radio systems.

The circuits covered include:- An aerial tuning unit; A simple active aerial; An add-on b.f.o. for portable sets; A wavetrapp for combat signals on spurious responses; An audio notch filter; A parametric equaliser; C.W. and S.S.B. audio filters; Simple noise limiters; A speech processor; A volume expander.

Other useful circuits include a crystal oscillator, and RTTY/C.W. tone decoder, and a RTTY serial to parallel converter. A full range of interesting and useful circuits for short wave enthusiasts.

92 pages **Order code BP304** £3.95

## AN INTRODUCTION TO AMATEUR RADIO

**I. D. Poole**  
Amateur radio is a unique and fascinating hobby which has attracted thousands of people since it began at the turn of the century.

This book gives the newcomer a comprehensive and easy to understand guide through the subject so that the reader can gain the most from the hobby. It then remains an essential reference volume to be used time and again. Topics covered include the basic aspects of the hobby, such as operating procedures, jargon and setting up a station. Technical topics covered include propagation, receivers, transmitters and aerials etc.

150 pages **Order code BP257** £3.50

## SIMPLE SHORT WAVE RECEIVER CONSTRUCTION

**R. A. Penfold**  
Short wave radio is a fascinating hobby, but one that seems to be regarded by many as an expensive pastime these days. In fact it is possible to pursue this hobby for a minimal monetary outlay if you are prepared to undertake a bit of d.i.y., and the receivers described in this book can all be built at low cost. All the sets are easy to construct, full wiring diagrams etc. are provided, and they are suitable for complete beginners. The receivers only require simple aerials, and do not need any complex alignment or other difficult setting up procedures.

The topics covered in this book include: The broadcast bands and their characteristics; The amateur bands and their characteristics; The propagation of radio signals; Simple aerials; Making an earth connection; Short wave crystal set; Simple t.r.f. receivers; Single sideband reception; Direct conversion receiver.

Contains everything you need to know in order to get started in this absorbing hobby.

88 pages **Order code BP275** £3.95

## AN INTRODUCTION TO SATELLITE TELEVISION

**F. A. Wilson**  
As a definitive introduction to the subject this book is presented on two levels. For the absolute beginner or anyone thinking about purchasing or hiring a satellite TV system, the story is told as simply as such a complex one can be in the main text.

For the professional engineer, electronics enthusiast, student or others with technical backgrounds, there are numerous appendices backing up the main text with additional technical and scientific detail formulae, calculations, tables etc. There is also plenty for the DIY enthusiast with practical advice on choosing and installing the most problematic part of the system - the dish antenna.

104 pages **Temporarily out of print**

## AN INTRODUCTION TO AMATEUR COMMUNICATIONS SATELLITES

**A. Pickford**  
Communications and broadcast satellites are normally inaccessible to individuals unless they are actively involved in their technicalities by working for organisations such as British Telecom, the various space agencies or military bodies, even those who possess a satellite television receiver system do not participate in the technical aspects of these highly technological systems.

There are a large number of amateur communications satellites in orbit around the world, traversing the globe continuously and they can be tracked and their signals received with relatively inexpensive equipment. This equipment can be connected to a home computer such as the BBC Micro or IBM compatible PCs, for the decoding of received signals.

This book describes several currently available systems, their connection to an appropriate computer and how they can be operated with suitable software.

102 pages **Order code BP290** £3.95

## AERIAL PROJECTS

**R. A. Penfold**  
The subject of aerials is vast but in this book the author has considered practical aerial designs, including active, loop and ferrite aerials which give good performances and are relatively simple and inexpensive to build. The complex theory and mathematics of aerial design have been avoided.

Also included are constructional details of a number of aerial accessories including a pre-selector, attenuator, filters and tuning unit.

96 pages **Order code BP105** £2.50

## INTERNATIONAL RADIO STATIONS GUIDE

**P. Shore**  
Provides the casual listener, amateur radio DXer and the professional radio monitor with an essential reference work designed to guide him or her around the ever more complex radio bands. This new edition has been completely revised and rewritten and incorporates much more information which is divided into the following sections:

Listening to Short Wave Radio; Choosing a Short Wave Radio Receiver; How to Use the IRSG; Abbreviations; Country Codes; Worldwide Short Wave Radio Stations; European, Middle Eastern and African Long Wave Radio Stations; European, Near and Middle Eastern and African Medium Wave Radio Stations; Canadian Medium Wave Radio Stations; USA Medium Wave Radio Stations; Broadcasts in English; Programmes for DXers and Short Wave Listeners; UK FM Radio Stations; Time Differences From GMT; Wavelength/Frequency Conversion.

226 pages **Order code BP255** £5.95

# DIRECT BOOK SERVICE

## ORDERING DETAILS

Please state the title and order code clearly, print your name and address and add the required postage to the total order.

**Add £1 to your total order for postage and packing (overseas readers add £2 for countries in Europe, or add £5 for all countries outside Europe, surface mail postage) and send a PO, cheque, international money order, (£ sterling only) made payable to Direct Book Service or credit card details (including the card expiry date), Visa or Mastercard (Access) - minimum credit card order is £5 - quoting your name and address, the order code and quantities required to DIRECT BOOK SERVICE, 33 GRAVEL HILL, WIMBORNE, DORSET BH21 1RW (mail order only).**

Although books are normally sent within seven days of receipt of your order, please allow a maximum of 28 days for delivery. Overseas readers allow extra time for surface mail post.

Please check price and availability (see latest issue of *Everyday with Practical Electronics*) before ordering from old lists.

**Note - our postage charge is the same for one book or one hundred books!**

## MORE BOOKS NEXT MONTH

*Direct Book Service is a division of Wimborne Publishing Ltd*



# BABANI BOOKS

We now supply *all* the books published by Bernard Babani (Publishing) Ltd. We have always supplied a selected list of Babani books and you will find many of them described on the previous pages or in next months issue of *Everyday with Practical Electronics* (the books with a BP prefix to the order code are Babani books).

Many readers have asked us to also supply various other Babani books, which have a reputation for value for money. Our customers tell us they appreciate our speedy service and low postage charge and they

would like to be able to purchase all the books from us and thus keep the postage charge to an absolute minimum (£1 for UK p&p no matter how many books you buy). We are pleased to be able to respond; with the aid of Michael Babani (M.D.) we are now able to meet all your requirements for their books. *If it's Babani and in print we can supply it.* Babani presently list over 180 different technical titles those *not* described in detail on the previous *Direct Book Service* pages or in next months issue are listed below:

Code	Title	Price	Code	Title	Price	Code	Title	Price
BP28	Resistor Selection Handbook	£0.60	BP190	More Advanced Electronic Security Projects	£2.95	BP280	Getting the Most From Your PC's Hard Disc	£3.95
BP37	50 Projects using Relays, SCRs and TRIACs	£2.95	BP192	More Advanced Power Supply Projects	£2.95	BP283	A Concise Introduction to SmartWare II	£4.95
BP39	50 (FET) Field Effect Transistor Projects	£2.95	BP193	LOGO for Beginners	£2.95	BP284	Programming in QuickBASIC	£4.95
BP44	IC 555 Projects	£2.95	BP196	BASIC & LOGO in Parallel	£2.95	BP287	A Reference Guide to Practical Electronics Terms	£5.95
BP48	Electronic Projects for Beginners	£1.95	BP197	An Introduction to the Amstrad PC's	£5.95	BP288	A Concise Introduction to Windows 3.0	£3.95
BP49	Popular Electronic Projects	£2.50	BP198	An Introduction to Antenna Theory	£2.95	BP291	A Concise Introduction to Ventura	£3.95
BP56	Electronic Security Devices	£2.50	BP230	A Concise Introduction to GEM	£2.95	BP292	Public Address Loudspeaker Systems	£3.95
BP58	50 Circuits Using 7400 Series IC's	O.O.P.	BP243	BBC BASIC86 on the Amstrad PC's and IBM Compatibles - Book 1: Language	£3.95	BP293	An Introduction to Radio Wave Propagation	£3.95
BP74	Electronic Music Projects	£2.95	BP244	BBC BASIC86 on the Amstrad PC's and IBM Compatibles - Book 2: Graphics and Disk Files	£3.95	BP294	A Concise Introduction to Microsoft Works	O.O.P.
BP76	Power Supply Projects	£2.50	BP245	Digital Audio Projects	£2.95	BP298	A Concise Introduction to the Mac System & Finder	£3.95
BP78	Practical Computer Experiments	£1.75	BP246	Musical Applications of the Atari ST's	£5.95	BP302	A Concise Users Guide to Lotus 1-2-3 Release 3.1	£3.95
BP84	Digital IC Projects	£1.95	BP247	More Advanced MIDI Projects	£2.95	BP303	Understanding PC Software	£4.95
BP90	Audio Projects	£2.50	BP249	More Advanced Test Equipment Construction	£3.50	BP306	A Concise Introduction to AmiPro 3	£4.95
BP94	Electronic Projects for Cars and Boats	£1.95	BP250	Programming in FORTRAN 77	£4.95	BP307	A Concise Introduction to QuarkXPress	£4.95
BP95	Model Railway Projects	£2.95	BP251	Computer Hobbyists Handbook	£5.95	BP311	An Introduction to Scanners and Scanning	£4.95
BP97	IC Projects for Beginners	£1.95	BP258	Learning to Program in C	£4.95	BP312	An Introduction to Microwaves	£3.95
BP99	Mini-matrix Board Projects	£2.50	BP259	A Concise Introduction to UNIX	£2.95	BP313	A Concise Introduction to Sage	£3.95
BP122	Audio Amplifier Construction	£2.95	BP260	A Concise Introduction to OS/2	£2.95	BP314	A Concise Introduction to Quattro Pro	£4.95
BP125	25 Simple Amateur Band Aerials	£1.95	BP261	A Concise Introduction to Lotus 1-2-3 (Revised Edition)	£3.95	BP315	An Introduction to the Electromagnetic Wave	£4.95
BP126	BASIC & PASCAL in Parallel	£1.50	BP262	A Concise Introduction to Wordperfect (Revised Edition)	£3.95	BP322	Circuits Source Book 2	£4.95
BP132	25 Simple SW Broadcast Band Aerials	£1.95	BP263	A Concise Introduction to dBASE	O.O.P.	BP324	The Art of Soldering	£3.95
BP136	25 Simple Indoor and Window Aerials	£1.75	BP264	A Concise Advanced User's Guide to MS-DOS (Revised Edition)	£3.95	BP329	Sage Explained	£5.95
BP137	BASIC & FORTRAN in Parallel	£1.95	BP269	An Introduction to Desktop Publishing	O.O.P.	BP329	Electronic Music Learning Project	£5.95
BP138	BASIC & FORTH in Parallel	£1.95	BP270	A Concise Introduction to Symphony	£3.95	BP330	A Concise user's Guide to Lotus 1-2-3 Release 2.4	£4.95
BP144	Further Practical Electronics Calculations & Formulae	O.O.P.	BP272	Interfacing PC's & Compatibles	£3.95	BP331	A Beginners Guide to MIDI	£4.95
BP145	25 Simple Tropical and MW Band Aerials	£1.75	BP273	Practical Electronic Sensors	£4.95	BP334	Magic Electronics Projects	£4.95
BP148	Computer Terminology Explained	£1.95	BP274	A Concise Introduction to SuperCal5	£3.95	BP336	A Concise Users Guide to Lotus 1-2-3 Release 3.4	£5.95
BP171	Easy Add-on Projects for Amstrad CPC 464, 664, 6128 and MSX Computers	£2.95	BP276	Short Wave Superhet Receiver Construction	£2.95	BP339	A Concise Introduction to WordPerfect 5.2 for Windows	£5.95
BP182	MIDI Projects	£2.95	BP279	A Concise Introduction to Excel	£3.95			
BP187	A Practical Reference Guide to Word Processing on the Amstrad PCW8256 and PCW8512	£5.95						

IF NO PRICE IS SHOWN THE BOOK IS OUT OF PRINT (O.O.P.)  
SEE PREVIOUS PAGE FOR FULL ORDERING DETAILS

## PCB SERVICE

Printed circuit boards for certain EPE constructional projects are available from the PCB Service, see list. These are fabricated in glass fibre, and are fully drilled and roller tinned. All prices include VAT and postage and packing. Add £1 per board for airmail outside of Europe. Remittances should be sent to **The PCB Service, Everyday with Practical Electronics, 6 Church Street, Wimborne, Dorset BH21 1JH.** Cheques should be crossed and made payable to *Everyday with Practical Electronics* (Payment in £ sterling only).

**NOTE:** While 95% of our boards are now held in stock and are dispatched within seven days of receipt of order, please allow a maximum of 28 days for delivery - overseas readers allow extra if ordered by surface mail.

**Please check price and availability in the latest issue.**

Boards can only be supplied on a payment with order basis.

**SALE!** All p.c.b.s on this page reduced to **1/2 PRICE**

(Just send half the price shown, while stocks last.)  
PCBS ON OPPOSITE PAGE PRICES AS SHOWN

PROJECT TITLE	Order Code	Cost
Video Guard Alarm	556	£3.80
Fridge Alarm	565	£3.00
Multi-Chan Remote Light Dim Relay/Decoder	601	£4.86
Power Supply	603	£3.00
Tea Tune Thermostat	609	£3.00
Time Switch	614	£4.84
Suntan Timer	610	£3.07
Car Alarm	615	£3.12
Eprom Eraser	620	£4.07
Doorbell Delay	616	£3.56
Sound-to-Light Interface	637	£6.24
Midi Pedal	639	£7.00
Midi Merge	640	£3.00
Audio Lead Tester	641	£5.77
Light Sentinel: Main Board	632	£9.20
4-Channel Auto-Fader Interface	642	£6.80

PROJECT TITLE	Order Code	Cost
Electron A/D Interface	645	£4.84
Programmable Pocket Timer	648	£3.82
Electronic Spirit Level	649	£3.85
Distance Recorder	651	£5.23
Power Supplies: Fixed Voltage	654	£4.08
Music on Hold	646	£3.85
Power Supplies - 25V 700mA	656	£4.35
EE Seismograph - Control board only	658	£4.08
Wash Pro	643	£3.83
Logo/lego & Sepctrum Interface	664	£5.60
Biofeedback Signal Generator	666	£4.08
Quick Cap Tester	668	£3.92
Superhet Receiver/Tuner/Amp	679/680	£4.22
Stereo Noise Generator	681	£4.24
Digital Experimenter's Unit - Pulse Generator	682	£4.46
Power Supply	683	£3.66
Amstrad Speech Synthesiser	689	£4.68
80 Metre Direct Conversion Radio	691	£4.95
The Tester	696	£4.15
Mains Appliance Remote Control	697	£4.55
Mains ON/OFF Decoder	697	£4.55
Hand Tally: Main Bd and Display Bd	699, 700	£10.95
Alarm Bell Time-Out	701	£4.10
Mains Appliance Remote Control	702	£5.20
Temperature Controller (p.c.b. only)	702	£5.20
Ghost Waker	703	£4.32
Frequency Meter	704	£5.25
Freq. Meter/Tachometer	705	£3.98
EE Musketeer (TV/Video/Audio)	706	£5.78
Microcontroller Light Sequencer	708/709	£10.90
Teach-In '91, Part 1 - L200 Module	711	£3.93
LM723 Module	713	£4.21
Spatial Power Display	714	£5.33
Amstrad PCW Sound Generator	715	£5.03
Teach-In '91, Part 2 - G.P. Transistor Amp	717	£3.77
Dual Op.Amp Module	718	£3.83
Intercom (Teach-In '91 Project 2)	719	£4.41
Analogic Test Probe	720	£3.24
MARC Phone-In	721	£6.87
Teach-In '91 Part 3 - TBA820M Amplifier	723	£4.05
High Quality Power Amp	724	£4.93
Bench Amplifier (Teach-In '91 Project 3)	725	£4.45

PROJECT TITLE	Order Code	Cost
Gingnurt 80m Receiver R.F. section (726), Voltage Regulator (727) Audio Amplifier (728)	FEB '91 726/7/8 all 3 together	£3.06 per board £8.16
Pocket Tone Dialler	MAR '91 729	£4.36
Simple Basic Alarm	731	£4.50
Car Code Lock (pair)	732a/b	£4.69
Teach-In '91 Part 4 - Sinusoidal Oscillator	733	£4.39
8038 Oscillator	734	£4.15
Waveform Generator (Teach-In '91 Project 4)	735	£4.72
Humidity Tester	APR '91 716	£4.97
Model Train Controller (double-sided)	736	£9.75
Electronic Die (Teach-In '91 Project 5)	737	£4.93
Teach-In '91 Part 5 - Digital Counter Module	738	£4.35
Modular Disco Lighting System	MAY '91	
Switched Power Output Module	739	£5.91
Digital LCD Thermostat-Control Board	740	£4.05
-Power/Relay Board	741	£3.76
Pulse Generator (Teach-In '91 Project 6)	742	£4.97
Teach-In '91 Part 6- Timer Module	743	£4.62
Digilogue Car Tachometer	JUN '91 744	£5.63
Modular Disco Lights - Simple Chaser	745	£5.00
Sweeper Module	746	£5.17
Automatic Light Control - PSU Board	747	£4.88
Logic Board	748	£5.17
Radio Receiver (Teach-In '91 Project 7)	749	£4.57
Teach-In '91 Part 7 - R.F. Amplifier Module	750	£4.23
Modular Disco Lights - Masterlink	JULY '91 752	£6.36
Ultrasonic Proximity Meter		
Display Unit (753) & Sensor Unit (754)	753/754	£7.06
Disco Lights (Teach-In '91 Project 8)		
PSU and Pre-amplifier	755	£4.54
Low, Mid, High Filter/Triac (set of 3 boards)	756	£11.00
Teach-In '91 Part 8 - Solid State Switch Module	757	£4.24
Mod. Disco Lights - Pattern Gen	AUG '91 760	£6.79
Teach-In '91 Part 8-Light Sensitive Switch	761	£4.74
Opto-Link (Teach-In '91 Project 9) - Transmitter	762	£4.85
Receiver	763	£4.88
Portable PESt Scarer	764	£3.77
Capacitance Meter	SEP '91 751	£5.17
Modular Disco Lights - Dimmer Interface	765	£8.17
Mod. Disco Lights	OCT '91	
VU Sound Module (Double-sided)	767	£8.68
UV Exposure Unit	768	£4.63
PC-Scope Interface - Main Board	769	£6.95
Expansion Plug (Double-sided)	770	£5.96
Mod. Disco Lights	NOV '91	
Superchaser (Double-sided)	771	£6.91
Supersweep (Double-sided)	772	£8.26
Bicycle Alarm	773	£5.01
Darts Scorer	774	£7.90
Knockerbox	DEC '91 775	£5.35
Signal Generator - Main Board	776	£7.46
PSU	777	£4.73
Mind Machine - Main Board	778	£7.00
Auto Nightlight	779	£5.03
Mind Machine - Programmer Board	JAN '92 780	£7.39
Transistor Checker	781	£4.63
Stepping Motor Driver/Interface	782	£10.39
Micro-Sense Alarm	783	£5.42
Telesound	FEB '92 784	£4.66
Programmable Timer	785	£4.63
Auto Garage Light	MAR '92 786	£6.10
Versatile BBC Computer Interface	787	£11.59
Economy Seven Timer	788	£5.20
Sonic Continuity Tester	APR '92 789	£4.79
Telephone Ringer	790	£5.46
Experimental Weighing Scale	MAY '92 792	£5.17
12V Drill Charger/PSU (both boards)	793	£5.31
Digital Servo Interface	JUNE '92 791	£4.73
Tie Pulser	794	£5.19
CCD Reverb Unit	795	£6.39
Switch-Mode Power Supply	796	£7.01
UV Exposure Timer	JULY '92 797	£5.33
Cricket Game	798	£6.77
Quick Prom	799	£5.61
Gas Alarm	AUG '92 800	£5.47
Dual Metronome	801	£6.74

PROJECT TITLE	Order Code	Cost
Ultrasonic Tape Measure	SEP '92 802	£6.06
Quicktest	803	£4.82
Extended Range Capacitance Meter	OCT '92 804	£5.63
Traffic Lights System	806	£5.04
Mini Lab	NOV '92 MINI LAB	£14.95
EPE Altimeter (Altimeter)	807	£6.30
Personal Stereo Amplifier	808	£6.47
Universal Infra-Red Remote Control	DEC '92 811T/811R	£6.56
Combination Switch	812	£5.68
Christmas Lights Colour Spectrum	813	£5.97
TV/UHF Aerial Amp (double-sided)	JAN '93 814	£7.23
Continuously Variable Balanced Power Supply	815	£5.65
Emergency Lighting Unit	816	£6.77
Biomet Pulse Monitor	FEB '93	
Sensor	817	£6.30
Display	818	£6.30
Biomet Pulse Monitor	MAR '93	
- ADC Interface (double-sided)	819	£7.11
Car Electric Window Enhancer	821	£5.00
Simplify Atari STFM Interface	822	£5.55
Personal Stereo Amp. Add-On	823	£3.90
Electronic Fire	APR '93 820	£4.84
Mind Machine MkII - Signal Generator	824	£5.57
Ventilation Fan Timer	825	£4.70
Universal Data Logger	826	£5.88
Mind Machine MkII - Magic Lights	MAY '93 827	£6.58
Superhet Radio Control Receiver	828	£5.93
Guitar Preamp and Distortion Unit	829	£5.46
Linear Clock - Timing Board	830	£8.00
Display Board	831	£7.00
Universal Alarm Module	9070	£3.00
Electronic Snooker Scoreboard	JUNE '93 832	£9.17
Mind Machine MkII	JULY '93	
- Computer Interface	833	£6.39
Xenon Strobe	834	£5.84
Electronic Gong	835	£7.50
Micro Lab - p.c.b., EPROM, PAL and booklet	MICRO	£35.00
Bike Odometer (pair of boards)	AUG '93 836/7	£7.00
Amstrad PCW A to D Converter (double sided)	838	£9.85
Experimental Electronic Pipe Descaler	839	£5.50
Sound Activated Camera Trigger	SEP '91 840	£5.34
L.E.D. Sandglass	OCT '93	
Main and Display boards	841/2	£7.30
Kettle Alert	843	£5.19
Linear Power Supply (double-sided)	844	£9.77
Six Channel Stereo Mixer	845	£11.98
Microphone Pre-Amp module	846	£4.88
RIAA Pre-Amp module	847	£5.11

## EPE PRINTED CIRCUIT BOARD SERVICE



Order Code    Project    Quantity    Price

Name.....

Address.....

.....

I enclose payment of £ ..... (cheque/PO  
in £ sterling only to  
Everyday with Practical Electronics)  
Access (MasterCard) or Visa No.  
Minimum order for credit cards £5

Signature..... Card Ex. Date.....

Please supply name and address of card-holder if different from the address shown

BLOCK CAPITALS PLEASE

# VIDEOS ON ELECTRONICS

Everyday with Practical Electronics is pleased to announce the availability of a range of videos designed to provide instruction on electronics theory. Each video gives a sound introduction and grounding in a specialised area of the subject. The tapes make learning both easier and more enjoyable than pure textbook or magazine study. They should prove particularly useful in schools, colleges, training departments and electronics clubs as well as to general hobbyists and those following distance learning courses etc.

**VT201 to VT206 is a basic electronics course and is designed to be used as a complete series, if required.**

**VT201** 54 minutes. Part one; D.C. Circuits. This video is an absolute must for the beginner. Series circuits, parallel circuits, Ohms law, how to use the digital multimeter and much more. **Order Code VT201**

**VT202** 62 minutes. Part two; A.C. Circuits. This is your next step in understanding the basics of electronics. You will learn about how coils, transformers, capacitors, etc are used in common circuits. **Order Code VT202**

**VT203** 57 minutes. Part three; Semiconductors. Gives you an exciting look into the world of semiconductors. With basic semiconductor theory. Plus 15 different semiconductor devices explained. **Order Code VT203**

**VT204** 56 minutes. Part four; Power Supplies. Guides you step by step through different sections of a power supply. **Order Code VT204**

**VT205** 57 minutes. Part five; Amplifiers. Shows you how amplifiers work as you have never seen them before. Class A, class B, class C, op.amps. etc. **Order Code VT205**

**VT206** 56 minutes. Part six; Oscillators. Oscillators are found in both linear and digital circuits. Gives a good basic background in oscillator circuits. **Order Code VT206**

By the time you have completed VT206 you have completed the basic electronics course and should have a good understanding of the operation of basic circuit elements.

**Now for the digital series of six videos. This series is designed to provide a good grounding in computer technology.**

**VT301** 56 minutes. Digital One begins with the basics as you learn about seven of the most common gates which are used in almost every digital circuit, plus Binary notation. **Order Code VT301**

**VT302** 55 minutes. Digital Two will further enhance your knowledge of digital basics. You will learn about Octal and Hexadecimal notation groups, flip-flops, counters, etc. **Order Code VT302**

**VT303** 56 minutes. Digital Three is your next step in obtaining a solid understanding of the basic circuits found in todays digital design. Gets into multiplexers, registers, display devices, etc. **Order Code VT303**

**VT304** 57 minutes. Digital Four shows you how the computer is able to communicate with the real world. You will learn about digital to analogue and analogue to digital converter circuits. **Order Code VT304**

**VT305** 56 minutes. Digital Five introduces you to the technology used in many of todays memory devices. You will learn all about ROM devices and then proceed into PROM, EPROM, EEPROM, SRAM, DRAM, and MBM devices. **Order Code VT305**

**VT306** 56 minutes. Digital Six gives you a thorough understanding in the basics of the central processing unit and the input/output circuits used to make the system work. **Order Code VT306**

By now you should have a good understanding of computer technology and what makes computers work. This series is also invaluable to the computer technician to understand the basics and thus aid troubleshooting.

## NEW NEW NEW

**VT102** 84 minutes: Introduction to VCR Repair. Warning, not for the beginner. Through the use of block diagrams this video will take you through the various circuits found in the VHS system. You will follow the signal from the input to the audio/video heads then from the heads back to the output. **Order Code VT102**

**VT103** 35 minutes: A step-by-step easy to follow procedure for professionally cleaning the tape path and replacing many of the belts in most VHS VCR's. The viewer will also become familiar with the various parts found in the tape path. **Order Code VT103**

Each video uses a mixture of animated current flow in circuits plus text, plus cartoon instruction etc., and a very full commentary to get the points across. The tapes are imported by us and originate from VCR Educational Products Co, an American supplier.

(All videos are to the UK PAL standard on VHS tapes)

## ORDERING

To order see our *Direct Book Service* "Ordering Details" - the postage for tapes is the same as for our range of books and you can order tapes and books at the same time and pay only one lot of postage. Each video costs £29.95 inc. VAT. If ordering eight or more together we will give you an extra video FREE, just indicate on your order which extra one you would like.

**£29.95**  
each inc. VAT





Metal detector boards with Data has tuner, mode, discriminate, headphone jack, on/off volume & push button facilities.....£7.95 ea\*

35mm Camera returns with auto flash, wind on etc.....£6 ea or 2 for £10

Dictaphone cassette, mech/record erase playback heads, 6V solenoid, motor, hall effect switch.....£2.00 ea\*

Dot matrix LCD 10x2 lines.....£3.75 ea

40 characters x 1 line dot matrix LCD with data.....£6.95\*

2 digit 16 segment VF display with data.....£2.95 ea\*

17 segment V.F. display with driver board and data.....£2.99 ea\*

8 digit liquid crystal display.....£1.75 ea\*

4 digit LCD with 7211 driver chip.....£3.50 ea\*

Digital clock display.....£2.50

19" 3U sub rack enclosures.....£8.95

12V stepper motor, 48 steps per rev, 7.3° step angle.....£3.95 ea\*

Stepper motor board with 2 slotted opto + 2 mercury tilt switches.....£3.95 ea\*

1000 mixed ¼ watt 1% resistors.....£4.95 ea

250 electrolytic axial + radial caps.....£4.95 ea

200 off mixed polyester caps.....£7.95\*

100 Mixed trimmer caps popular values.....£4.95\*

100 off Phono plugs (red/black/grey).....£3.50\*

50 Mixed terminal blocks.....£2.95

25 off asst. buzzers & sounders.....£4.95\*

Cable box UHF modulator/video preamp/transformer/R's + C's/leads.....£6.95

1000 off mixed Multilayer Ceramic Caps.....£7.95

SM P.S.U. 115-240V input + 5V 5.5A + 12V 1.5A - 12V 0.3A - 5V 0.3A with IEC inlet and outlet, fully cased.....£6.95 ea

UM1233 Video Modulators.....£3.50 ea

Universal bell timer, both 10 min. delay and 20 min. cut off functions.....£4.95

Spectrum 128k + 2 PSU's.....£6.95

STC P.S.U. 240V input 5V 6A output (converts to 12V 3A details available).....£5.95 ea

3 to 16V Piezoelectric sounders.....50p\*

DIL switches PCB MT 3/4/6 way.....35p\*

5V SPCO SIL reed relay.....40p\*

5V 2PCO DIL miniature relay.....60p\*

12V 2PCO or 4PCO continental relay.....60p\*

12V 10A PCB MT (to make contact) relay.....95p\*

3 to 12V electro magnetic acoustic transducer with data.....75p\*

2.4576/8.8329/21.10 MHz crystals.....50p ea\*

31b Mixed components pack.....£4.95

25 off mixed relays.....£5.95\*

40 off mixed toggle switches.....£9.95\*

50 off mixed switches, toggle, rocker, slide, micro.....£9.95

250 off 16/22/24/40 way IC Sks.....£4.95\*

Crystal Oscillators 10/24/48 MHz.....£1 ea\*

**TOOLS**

40 pce socket set.....£7.95

16 pce socket set.....£3.50

Hand Rivet Gun.....£6.95

Crimping tool.....£2.95

Safety goggles.....£1.50\*

Baby bench vice.....£4.95

3m retractable tape.....£2.50

5 pce wood carving set.....£2.50

6 utility knife.....£1.95\*

25 pce allen key set.....£3.95

7 pce powerbit set.....£2.50

Conerclamps.....£2.50

4" adj wrench.....£1.50

6" adj wrench.....£1.50

8" adj wrench.....£2.50

21 pce mini precision wrench/crosspoint/hex screwdriver set.....£5.95\*

Universal test lead kit.....£3.95\*

10 crocodile clip leads.....£3.50\*

10 AA rechargeable ni-cads.....£7.50\*

Glue gun glue sticks.....36/£4.50

**QUANTITY DISCOUNTS AVAILABLE PLEASE RING**

We also buy all forms of electronic components, p.s.u.'s, disk drives etc. Lists to below address.

**ALL PRICES INCLUDE V.A.T. PLEASE ADD £2.00 p&p EXCEPT ITEMS MARKED \* WHICH ARE 50P SAE FOR BULK BUYING LIST PAYMENT WITH ORDER TO:**

**Dept EE, COMPELEC, 14 Constable Road, St. Ives, Huntingdon, Cambs PE17 6EQ Tel/Fax: 0480 300819**



**NATIONAL COLLEGE OF TECHNOLOGY**

**DISTANCE LEARNING COURSES**

The National College of Technology offer a range of packaged learning short courses for study at home or in an industrial training environment which carry national BTEC awards. Study can commence at any time and at any level enabling you to create a study routine to fit around existing commitments. Courses on offer include:

- Analogue Electronics
- Digital Electronics
- Fibre/Optoelectronics
- Programmable Logic Controllers
- Electronic Testing & Fault Diagnosis

Tutor support and BTEC certification are available as options with no travelling or college attendance required. These very popular courses which are ideal for vocational training contain workbooks, audio cassette lectures, PCB's, instruments, tools, components and leads as necessary to support the theoretical and practical training. Whether you are a newcomer to electronics or have some experience and simply need an update or certification, there is probably a distance learning course ready for you. Write or telephone for details to:

**National College of Technology  
NCT Ltd., PO Box 11  
Wendover, Bucks  
Tel: (0296) 624270**

**CAMBRIDGE COMPUTER SCIENCE LIMITED**

Borland C++ 2.0 for DOS & Windows complete with mouse £45.00

LCD modules.....16 char by 1: £4.00, 20 char by 2: £6.00, 40 char by 1: £6.00

3.5" 720K Diskette Drives.....£25.00 each

Used hard disk drives, 112MByte £110, 70MByte £75, 40MByte £45, 20MByte £29, 10MByte £14, Limited quantities, phone before ordering

Used PC memory/IO card AST six pack with 384k RAM.....£15.00 each

Used IBM PC hard disk controller, 8 bit MFM.....£5.00 each

Used Tseng labs, multi I/O + mono video card for PCs.....£10.00 each

Used Compaq Enhanced Colour Graphics Card.....£5.00 each

Lucky Dip PC cards, untested, no warranty, various types.....£1.00 each

5.25" Disk Drives, 1.2MByte Slimline PC.....£19.00 each

5.25" Disk Drives, 80 Tk, DSD.....£19.00 each

5.25" Disk Drives, 80 Tk, DSD Used, No Wty.....£7.00 each

(The £7.00 drives are sold on a strictly "as is" basis)

5.25" Disks, DSD, 48tpi, boxes of 10.....£2.00/box

Digital multimeter, 14 ranges, inc. leads & manual.....£9.00 each

Apricot Disk drive PSU 5V @ 2.5A, 12V @ 2A.....£10.00 each

5V @ 6A PSU.....£4.00 each

5V @ 10A PSU.....£5.00 each

Disk Drive Data lead BBC Micro to Disk Drives.....Single 2.00 Dual £4.00 each

Disk Drive Power lead BBC Micro to Disk Drives.....Single 2.00 Dual £4.00 each

68000 CPUs 8MHz.....£2.50 each

8086 CPU chips.....£2.00 each

Z80A CPU, CTC, PIO.....£1.20 each; DMA £2.00; £4.50 all 4

74LS TTL, pick and mix, buy 10 or more for £0.12 each

Types available: 00 02 04 08 10 11 12 13 14 15 20 21 26 27 30 32 33 37 38 42 74 83 85 86 96 107 109 122 125 132 136 138 139 145 151 153 157 158 160 162 163 164 165 174 191 193 240 253 257 260 298 353

27128 EPROMS (Ex equipment).....£1.20 each OF £5.00/5

27128 EPROMS.....£2.50 each

27C256 EPROMS (Ex Equipment).....£1.40 each

27256 EPROMS.....£2.60 each

27C256-25 EPROMS.....£3.50 each

27C512 EPROMS (Ex Equipment).....£1.40 each

256K DRAM (Ex Equipment).....£0.40 each

1MBit-10 DRAM (Ex Equipment).....£1.40 each

6116 2K Byte SRAM.....£1.10 each

6264-12 8K Byte SRAM.....£3.80 each

62256-10 32K Byte SRAM.....£5.00 each

65256 32K Byte RAMs.....£4.00 each

8K Byte NV ram chips.....£3.00 each OF £10.00 four

16, 18 & 20 pin dil low profile IC sockets 0.3" wide.....£0.40/10; £3.00/100

22 & 24 pin dil low profile IC sockets 0.4" wide.....£0.40/10; £3.00/100

24, 28, 32, 40 & 48 pin dil low profile IC sockets 0.6" wide.....£0.40/10; £3.00/100

Circuit tester, finds faults in TTL & CMOS logic circuits, inc leads.....£4.00 each

Metal project boxes drilled & painted but unused 28 x 32.5 x 5cm.....£4.00 each

Eurocard Racks.....£10.00 each

Smoke detectors.....£4.00 each

Used computer cards many useful components (large ones socketed)

Wini controller (WD HDC chip).....£1.00 each

CPU card (8088, Z80 & EPROMS).....£3.00 each

Keyboards, Full Qwerty, number pad and LCD.....£8.00 each

Desktop computer case with 200W mains PSU (used).....£19.00 each

Used IBM PC Cases with PSU.....£30.00 each

Prices include postage. Add £1 (plus VAT) to orders below £5.00. All items new unless stated. Add 17.5% VAT to all prices. Send an SAE for our latest list or for more info.

**Dept EE, 374 Milton Road, Cambridge CB4 1SU**  
Tel: 0223 424602, 0831 430496 or 0831 430552 (Mail order only)

**VARIABLE VOLTAGE TRANSFORMERS**

INPUT 220/240V AC 50/60	OUTPUT 0-260V	Price	P&P
0.5KVA 2.5 amp max		£29.00	£4.65 (£39.54 inc VAT)
1KVA 5 amp max		£37.40	£6.25 (£51.29 inc VAT)
2KVA 10 amp max		£54.00	£7.80 (£72.62 inc VAT)
3KVA 15 amp max		£71.50	£7.80 (£93.18 inc VAT)
5KVA 25 amp max		£126.50	(Plus Carriage)

Buy direct from the Importers. Keenest prices in the country

**COMPREHENSIVE RANGE OF TRANSFORMERS-LT-ISOLATION & AUTO**

110-240V Auto transfer either cased with American socket and mains lead or open frame type. Available for immediate delivery.

**WIDE RANGE OF XENON FLASH TUBES**

Write/Phone your enquiries

**ULTRA VIOLET BLACK LIGHT FLOURESCENT TUBES**

4ft 40 watt £12.00 (callers only) (£14.10 inc VAT)

2ft 20 watt £7.44 + £1.25 p&p (£10.21 inc VAT)

12in 8 watt £4.80 + 75p p&p (£6.52 inc VAT)

9in 6 watt £3.96 + 50p p&p (£5.24 inc VAT)

6in 4 watt £3.96 + 50p p&p (£5.24 inc VAT)

**230V AC BALLAST KIT**

For either 6in, 9in or 12in tubes £6.05 + £1.40 p&p (£8.75 inc VAT)

**400 WATT UV LAMP**

Only £38.00 + £4.00 p&p (£49.35 inc VAT)

**160 WATT SELF BALLASTED BLACK LIGHT MERCURY BULB**

Available with B.C. or E.S. fitting. Price inc VAT & p&p £25.55

**12V D.C. BILGE PUMPS**

500 GPH 15ft head 3 amp £19.98

1750 GPH 15ft head 9 amp £34.55

Also now available:

24V D.C. 1750 GPH 15ft head 5 amp £36.55

All designed to be used submerged. PRICES INCLUDE P&P & VAT

**EPROM ERASURE KIT**

Build your own EPROM ERASURE for a fraction of the price of a made-up unit kit of parts less case includes 12in 8 watt 2537 Angst Tube Ballast unit, pair of bi-pin leads, neon indicator, on/off switch, safety microswitch and circuit £14.00 + £2.00 p&p (£18.80 inc VAT)

**SUPER HY-LIGHT STROBE KIT**

Designed for Disco, Theatrical use etc. Approx 16 joules. Adjustable speed £50.00 + £3.00 p&p (£62.28 inc VAT)

Case and reflector £24.00 + £3.00 p&p (£31.73 inc VAT)

SAE for further details including Hy-Light and industrial Strobe Kits.

**"BOFFINS SPECIAL" - UNIQUE OFFER**

Surplus Precision Medical Unit, internally in excellent condition. Designed primarily to eject a precise controllable amount of fluid from a medical syringe (letter not supplied). Contains the following removable components: Dual Micro Processor Boards and EPROMS. Escap Precision 12V DC Motor with 300:1 Gear Box and optical encoder coupled to a precision threaded drive mechanism. Mains supply with 6 x 1.5V Ni-Cad A.A. cells back-up. L.C.D. Digital read-out 17mm high with legends. Audible warning.

These are sold for the dismantling of the exceptional quality components. Regret no Circuits available. Ridiculously low price: £16.00 + £4.00 p&p (£23.50 incl VAT).

**12V D.C. GEARED MOTOR**

12V D.C. Reversible precision-built Motor Output speeds no load approx. 12V-26 rpm; 9V-20 rpm; 6V-12 rpm. Will work at lower voltages and still retain a reasonable torque. Ideal for robotics etc. Size: L 40mm, W 29mm, H 39mm. Shaft: 3mm dia x 10mm long. Price: £8.00 + 50p p&p (£10.00 inc VAT)

**TORIN CENTRIFUGAL BLOWER**

230V AC, 2.800 RPM, 0.9 amp, 130mm diameter, impeller outlet 63 x 37mm, overall size 195 x 160 x 150mm. long. Price £17.50 + £2.50 p&p (£23.50 inc VAT)

**SOLID STATE RELAY**

7 amp @ 240V A.C. when mounted on suitable Heat-sink. Can be driven from T.T.L. or Computer output between 3-10V D.C. Size: 24mm x 17mm x 15mm high. Fixing centres 30mm (TO-3). Price: £3.00 + 40p p&p (£4.00 inc VAT)

**GEARED MOTORS**

71 RPM 20lb inch torque reversible 115V AC input including capacitor and transformer for 240V AC operation. Price inc VAT & p&p £27.73.

**SOLID STATE EHT UNIT**

Input 230/240V AC. Output approx 15KV. Producing 10mm spark. Built-in 10 sec timer. Easily modified for 20, 30 sec to continuous. Designed for boiler ignition. Dozens of uses in the field of physics and electronics, eg supplying neon or argon tubes etc. Price less case £8.50 + £2.40 p&p (£12.81 inc VAT) NMS

**SAVE POUNDS!!!**

Build your own forged bank note detector. Can detect counterfeits amongst a quantity of notes. Complete kit of parts less case, 240V a.c., including 6" µV black light tube, starter and holder, a pair, b1-pin tube holders. Total price including p&p & VAT only £13.99.

**MICROSWITCH**

Pye 15 amp changeover lever microswitch, type S171. Brand new, price 5 for £7.05 inc VAT & p&p

**WASHING MACHINE WATER PUMP**

Brand new 240V AC fan cooled. Can be used for a variety of purposes. Inlet 1 1/2in, outlet 1in. dia. Price includes p&p & VAT. £11.20 each or 2 for £20.50 inclusive.

**SERVICE TRADING CO**  
57 BRIDGMAN ROAD, CHISWICK, LONDON W4 5BB  
TEL: 081-995 1560 FAX: 081-995 0549  
ACCOUNT CUSTOMERS MIN. ORDER £10

# EVERYDAY WITH PRACTICAL ELECTRONICS

CLASSIFIED

Everyday with Practical Electronics reaches twice as many UK readers as any other independent monthly hobby electronics magazine, our audited sales figures prove it. We have been the leading independent monthly magazine in this market for the last eight years

If you want your advertisements to be seen by the largest readership at the most economical price our classified and semi-display pages offer the best value. The prepaid rate for semi-display space is £8 (+VAT) per single column centimetre (minimum 2.5cm). The prepaid rate for classified adverts is 30p (+VAT) per word (minimum 12 words).

All cheques, postal orders, etc., to be made payable to Everyday with Practical Electronics. **VAT must be added.** Advertisements, together with remittance, should be sent to Advertisements, Everyday with Practical Electronics, Holland Wood House, Church Lane, Great Holland, Essex CO13 0JS. Phone/Fax (0255) 850596.

For rates and information on display and classified advertising please contact our Advertisement Manager, Peter Mew as above.

**PC TECHNICAL SHAREWARE**  
 Would you like to see the best range of low cost technical and scientific public domain & shareware for IBM PC in the UK? HUGE RANGE includes:—PACKET, FAX, RX, TX control, PCB design, Circuit and ANTENNA analysis, QSO logging, CAD ELECTRONIC & MECH engineering, SCIENTIFIC, MATHS & STATS, MEDICAL, PROGRAMMING, SOURCE CODE, DATA, EDUCATIONAL, WINDOWS, BUSINESS and lots more. Write, phone or fax today for your free 124 page printed catalogue

The Public Domain Software Library  
 Winscombe House, Beacon Road  
 Crowborough, Sussex TN6 1UL  
 Tel 0892 663298, Fax 0892 667473

ASP Approved Vendor

**RCS VARIABLE VOLTAGE D.C. BENCH POWER SUPPLY**  
 1 to 24 volts up to 1/2 amp. 1 to 20 volts up to 1 amp. 1 to 16 volts up to 1 1/2 amps d.c. Fully stabilised. Twin panel meters for instant voltage and current readings. Overload protection.  
 Fully variable.  
 Operates from 240V a.c.  
 Compact unit.  
 Size 9 x 5 1/2 x 3 in.  
**NEW MODEL.** Up to 38volts d.c. at 6 amps. 10 amps peak. Fully variable. Twin panel meters. Size 14 1/2 x 11 x 4 1/2 in. £96 inc VAT. Carr £6.

**£45 inc. VAT**  
 + Post and insurance £4

**RADIO COMPONENT SPECIALISTS**  
 337 WHITEHORSE ROAD, CROYDON  
 SURREY, U.K. Tel: 081-684 1665

List. Large SAE. Delivery 7 days. Callers welcome. Closed Wednesday

This 3cm space in  
 Everyday with  
 Practical Electronics  
 Will ONLY cost you  
**£24 + VAT**

**BTEC ELECTRONICS  
 TECHNICIAN  
 FULL-TIME TRAINING**

THOSE ELIGIBLE CAN APPLY FOR E.T. GRANT SUPPORT AN EQUAL OPPORTUNITIES PROGRAMME

O.N.C., O.N.D. and H.N.C.

Next course commences  
**Monday 20th September 1993**  
 FULL PROSPECTUS FROM

**LONDON ELECTRONICS COLLEGE**  
 (Dept EPE) 20 PENYWERN ROAD  
 EARLS COURT, LONDON SW5 9SU  
 TEL: 071-373 8721

Voltage Regs	100+	1000+
BC182	-13	-10
CD 4053	-026	-02
IN4001G	-19	-15
Dual 7 Segment Disp	-028	-015
Fuses 20mm 2 Amp	-60	-40
"D" PCB 15 pin Skt	-05	-03
	-15	-11
Elect Caps 2-2µF 50V Ax 20.00/1000		

Amstrutt, Unit 10, Pixon Trading Centre  
 Pixon Lane, Tavistock, Devon PL19 8AQ  
 Tel 0822 610127

**SOLAR PANELS**  
 Special offer 12V nom (20V o/c) 80mA. 12"x6" pre-wired Amorphous Silicon panel £4.50 (5 for £18) plus £1.50 p&p per order. Many other sizes, wind generators and other products. Orders to (Catalogue 2 x 1st class stamps)

Keysolar Systems, 4 Glanmor Crescent  
 Newport, Gwent NP9 8AX

**Typefit**  
 The Typesetting programme for all your Typesetting needs.

If you need typesetting for your Adverts, Brochures, etc. Typefit can help you.

Please telephone 0202 882299

**AMSTRAD 1640/1512 pc**

Search through an EE project index by pressing a few keys on your pc. First you must enter the data you want. Then you can access it in order of year and month or month and year. You can add to the data in any order. For single or double 5 1/4 in drives. Send a PO or cheque for £3.00 inc p&p to: **K. Shepherd, 10 Browning Road, Foxhill, Sheffield, Yorks S61DA**

**SURVEILLANCE KITS**  
 MICRO TRANSMITTER, tuneable 70-115MHz, 500M range, 40mm x 20mm including microphone, 3-12V. Kit £5.95, Assembled £9.95. Order Code KT1.  
 TELEPHONE TRANSMITTER, 30mm x 10mm, powered from line, transmits both sides of conversation, 500M range, 88-130MHz. Kit £7.95, Assembled £12.95. Order Code KT3.  
 3 WATT TRANSMITTER, 80-110MHz, 12-15V, adjustable input sensitivity, varicap controlled, several miles range. Kit £15.95, Assembled £25.95. Order Code KT4.  
 All prices include p&p.  
 Credit card orders telephone 021 486 3092.  
 Send 2x1st class stamps for Catalogue. Cheques/P.O.s payable to:

**QUANTEC ELECTRONICS**  
 Kits Dept. (EPE), 3 Houldrey Road, West Heath, Birmingham B31 3HL

**THE BRITISH AMATEUR ELECTRONICS CLUB**  
 exists to help electronics enthusiasts by personal contact and through a quarterly Newsletter. For membership details, write to the Secretary

**Mr J. S. Hind, 7 Carlyle Road**  
 West Bridgford, Nottingham NG2 7NS  
 Space donated by Everyday with Practical Electronics

**EVERYDAY WITH PRACTICAL ELECTRONICS**

**SUBSCRIPTION ORDER FORM**

Name .....

Address .....

I enclose payment of £..... (cheque/PO in £ sterling only, payable to Everyday with Practical Electronics). Alternatively send Access or Visa number and card expiry date.

Signature .....

Please supply name and address of card-holder if different from the subscription address shown above. Subscriptions can only start with the next available issue. For back numbers see the Editorial page.

M10/93

**Miscellaneous**

**G.C.S.E. ELECTRONICS KITS** at pocket money prices. S.A.E. for FREE catalogue. **SIR-KIT ELECTRONICS**, 70 Oxford Road, Clacton CO15 3TE.

**PROTOTYPE PRINTED CIRCUIT BOARDS** one offs and quantities, for details send s.a.e. to **B. M. Ansbro**, 38 Poyning Drive, Sussex BN3 8GR, or phone Brighton 883871.

**THE HOMEBUILT DYNAMO** (Plans). Reviewed 1989 in PE January and Model Engineer December 15th. Price £42 post paid airmail from Alfred Forbes, PO Box 3919, Auckland, New Zealand. Tel (09) 818-8967.

**PLDs and EPROMS** copied or programmed. 25p each + set up and postage. We supply logic devices/convert discrete logic to PLDs. Also PCBs designed. Send for details to PO Box 1561 Bath, or phone 0225-444467 (evenings).

**SOLAR PANELS** 48W £265, 52W £285, many more sizes, with lights, fans, pumps, fridges, portable rechargeable lamps, various solar gifts and a wide range of DIY components. Send £5 for catalogue (£10 overseas), £3 refund with order and quarterly newsletter. Solar Products (Ref EPE), 4 The Mount, Guildford GU2 5HN.

**TURN YOUR PC** into a 4-Channel Digital Data Logger. Up to 25KHz Sampling, ± Triggering, one shot or real time modes, variable timebase. Very cost effective instructions on building your own interface unit to connect into the printer port. £10.00. Telephone 0453 835692 24 hours.

**TRANSMITTER** circuit diagrams - f.m., medium, shortwave, CB. - Full instructions. Seventeen circuits. Cheques/P.O.s £4.25 to - D. Davies, 33 Gwaloddygarth, Merthyr Tydfil, CF47 8YU, U.K.

**TRANSFORMER**. Approx 100,000 volts output. Oil cooled, h/duty, £120. Auto transformers 4 surplus to requirements, new, 1/2 KVA £15, 1KVA £25, 2KVA £35 (1/2 price). Tel 0986 781542. (Suffolk).

**ARE YOU** interested in making extra money? Full details from: Mr J. Sen, 44 Sitwell Way, Port Talbot, West Glamorgan SA12 6BL.

**DO YOU** want to generate your own power? Over 25 DIY plans available for wind, water, solar and petrol generators. Plus books and guides. Send SAE for full descriptive price list. Jemmett Engineering, 8 Hallam Gardens, Pinner, Middlesex HA5 4PR.

Annual subscription rates (1993/4):  
 UK £22.00.  
 Overseas £28 (surface mail).  
 £45.50 (airmail)

To: Everyday with Practical Electronics  
 6 Church Street, Wimborne  
 Dorset BH21 1JH



# MAKE YOUR INTERESTS PAY!

Over the past 100 years more than 10 million students throughout the world have found it worth their while! An ICS home-study course can help you get a better job, make more money and have more fun out of life! ICS has over 100 years experience in home-study courses and is the largest correspondence school in the world. You learn at your own pace, when and where you want under the guidance of expert personal tutors. Find out how we can help YOU. Post or phone today for **FREE INFORMATION** on the course of your choice. (Tick one box only)

- |  |                          |                                  |                          |
|--|--------------------------|----------------------------------|--------------------------|
| Electronics                                  | <input type="checkbox"/> | TV, Video & Hi-Fi Servicing      | <input type="checkbox"/> |
| Basic Electronic Engineering (City & Guilds) | <input type="checkbox"/> | Refrigeration & Air Conditioning | <input type="checkbox"/> |
| Electrical Engineering                       | <input type="checkbox"/> | Car Mechanics                    | <input type="checkbox"/> |
| Electrical Contracting/Installation          | <input type="checkbox"/> | Computer Programming             | <input type="checkbox"/> |
- GCSE/CCE/SCE over 40 examination subjects to choose from

Name \_\_\_\_\_ Address \_\_\_\_\_

**ICS** International Correspondence Schools Dept ECS A3  
312/314 High Street, Sutton, Surrey SM1 1PR or 041-221 7373 (24 hours).



# Cooke International

**SUPPLIER OF QUALITY USED TEST INSTRUMENTS**

ANALYSERS, BRIDGES, CALIBRATORS, VOLTMETERS, GENERATORS, OSCILLOSCOPES, POWER METERS, ETC ALWAYS AVAILABLE

ORIGINAL SERVICE MANUALS FOR SALE  
COPY SERVICE ALSO AVAILABLE

EXPORT, TRADE AND U.K. ENQUIRIES WELCOME  
SEND S.A.E. FOR LISTS OF EQUIPMENT AND MANUALS  
ALL PRICES EXCLUDE VAT AND CARRIAGE  
DISCOUNT FOR BULK ORDERS SHIPPING ARRANGED

OPEN MONDAY TO FRIDAY 9AM-5PM  
Unit Four, Fordingbridge Site, Main Road, Barnham, Bognor Regis, West Sussex, PO22 0EB  
Tel (+ 44) 0243 545111/2 Fax (+ 44) 0243 542457

# SHERWOOD ELECTRONICS

**9 Lower Birchwood, Somercotes, Derbyshire DE55 4NG**

£1 Special Packs - select 2 packs **FREE** for every 10 purchased

SP1 15 x 5mm Red Leads	SP42 200 x Mixed 0.25W C.Film resistors
SP2 15 x 5mm Green Leads	SP47 5 x Min. push button switches
SP6 15 x 3mm Red Leads	SP48 15 x Axial elect. sockets
SP7 12 x 3mm Green Leads	SP102 20 x 8 pin DIL sockets
SP10 100 x 1N4148 diodes	SP103 15 x 14 pin DIL sockets
SP11 30 x 1N4001 diodes	SP104 15 x 16 pin DIL sockets
SP12 30 x 1N4002 diodes	SP105 6 x 74LS00
SP18 20 x BC162 transistors	SP112 6 x Cmos 4093
SP22 20 x BC164 transistors	SP125 10 x 1000uF/16V rad. elect caps
SP23 20 x BC214 transistors	SP130 100 x Mixed 0.5W C.Film resistors
SP25 5 x 555 timers	SP133 20 x 1N4004 diodes
SP26 5 x 741 Op-amps	SP134 15 x 1N4007 diodes
SP28 6 x Cmos 4011	SP135 6 x Min. slide switches
SP36 25 x 100uF/25V radial elect caps	SP138 20 x 2.2uF/50V radial elect caps
SP37 20 x 100uF/40V radial elect caps	SP139 12 x 1000uF/10V radial elect caps

RESISTOR PACKS - 0.25W C.Film  
RP3 5 each value - total 365 £2.50  
RP7 10 each value - total 730 £3.95  
RP10 1000 popular values £5.30

Catalogue available £1 or **FREE** with first order over £5

Cheques or P.O. to **NO VAT** Please add £1 P&P to all orders  
**SHERWOOD ELECTRONICS**

# COMPONENTS For TV Video Audio Computer

WE CAN SUPPLY A VAST RANGE OF SPARES for many makes of TV, Video, Computer & Audio Equipment. WRITE (Encl. s.a.e. please) or PHONE FOR A 'PRICE & AVAILABILITY' on your requirements. **0452 526883**

**VIDEO BELL KITS**  
AMSTRAD VCR4600/4700/5200.....£3.19  
FISHER FVH905/906/908.....£3.03  
JVC HR3300/3330/3680.....£3.30  
Large range of Pinch Rollers, Idlers, Heads, etc., from stock.

**SERVICE MANUALS**  
PHILIPS CST427.....£4.50  
TOSHIBA STU2L Tuner.....£6.99  
Many other Manuals available.

**SEMICONDUCTORS**  
BU508A.....£1.50 TDA4601.....£3.25  
BUV48A.....£4.99 UC3884.....£8.95  
LM7303N.....£2.43 UM6522.....£6.99  
MA88049H.....£5.17 UPC1378H.....£2.82  
P8255A.....£2.85 UPC1397C.....£4.34  
STK4141H.....£8.79 2SK301R.....£1.85  
TA7280P.....£6.88 27C256-200.....£2.98  
This is just a very small sample of our stock.

Send £1.25 for our Selected Spares CATALOGUE. Includes voucher spendable on future orders.

**COMPUTER SPARES**

**PHILIPS MONITORS**  
BM7513 Serv. Manual.....£3.49  
CM8833 Serv. Manual.....£4.71  
CM8833 Line O/P Tx.....£2.94  
R9C973 O/O Switch.....£8.63  
CM11342 Line O/P Tx.....£28.51

**AMSTRAD/SINCLAIR**  
CP464 User Manual.....£10.95  
PC1640 Serv. Manual.....£19.32  
PCW 9512 Serv. Manual.....£14.99  
AY38912.....£7.06  
SE99420CAC.....£14.93  
STK7356.....£13.81  
ULA6001E.....£18.49  
Spec./QL Modulator.....£7.36

**ATARI**  
CO25913 DMA (ST).....£33.24  
PC900V/H11L3 (ST).....£2.88  
THERMISTOR (ST-PSU).....£1.37  
PCT13V (ST-PSU).....£2.84  
2SC2331 (ST-PSU).....£1.59

**SPECIAL OFFER Spectrum/QL CHIPS**  
40054 ROM (+2).....£11.69  
TMS4632N1.4 DRAM.....£0.99  
Z80302 ULA (QL).....£6.49  
ZX8401 ULA.....£5.44  
Further savings for (+) quantities. Please phone or send S.A.E.

**COMMODORE**  
906114-01 PLA.....£9.24  
251641-02 PLA.....£5.95  
MB81416-12 DRAM (C16) £4.99  
6869 V/C.....£19.95  
8865 V/C.....£23.96  
906114-01 PLA.....£9.24  
251641-02 PLA.....£5.95  
MB81416-12 DRAM (C16) £4.99

Many other parts from STOCK - Please enquire!

Order by Post or Phone. VISA, ACCESS, DELTA & SWITCH accepted with pleasure. Minimum P&P charge is £1.25 - Please then add extra 50p if ordering a Manual or LOPTX. All items subject to availability. Prices can change without notice.

**MARAPET (EEK)**  
1 HORNBEAM MEWS  
GLOUCESTER GL2 0UE

# WE HAVE THE WIDEST CHOICE OF USED OSCILLOSCOPES IN THE COUNTRY

- TEKTRONIX 7000 SERIES OSCILLOSCOPES**  
Dual Trace Plug-in with TB from £200. Many Plug-in options available. 4 Traces. Differential etc. **PLUG-INS SOLD SEPARATELY.**
- TEKTRONIX 2445 4-Channel 150MHz Delay Sweep  
Cursors/Graphics £1200
- NIKUSU C05E100M3 3-Channel - Ch4 Ch5 Trng View 100MHz Delay Sweep £600
- TEKTRONIX 475 Dual Trace 200MHz Delay Sweep £350
- H.P. 17154 Dual Trace 200MHz Delay Sweep £500
- TEKTRONIX 465 Dual Trace 100MHz Delay Sweep £450
- H.P. 1740A Dual Trace 100MHz Delay Sweep £400
- PHILIPS PM3217 Dual Trace 50MHz Delay Sweep £400
- HITACHI V650F Dual Trace 60MHz Delay Sweep £200
- TELEQUINT DB3 Dual Trace 50MHz Delay Sweep £200
- COULD OS5000A Dual Trace 40MHz Delay Sweep £180
- NIKUSU S530 Dual Trace 30MHz £160
- COULD OS1100 Dual Trace 30MHz £160
- COULD OS900 Dual Trace 20MHz £125
- COULD OS250B Dual Trace 15MHz £125
- THIS IS JUST A SAMPLE - MANY OTHERS AVAILABLE**
- PHILIPS PMS193 Programmable Synthesizer/Function Generator 0.1MHz-50MHz. IEEE-488.** As new £1500
- H.P. B656A Synthesized AM/FM Sig Gen 0.1-990MHz £1750
- MARCONI 2022 AM/FM Sig Gen 10MHz-1GHz £1200
- MARCONI 2019 Synthesized AM/FM Sig Gen 80kHz-1040MHz £2000
- MARCONI 2018 Synthesized AM/FM Sig Gen 80kHz-520MHz £950
- EP 545 Microwave Frequency Counter 10Hz-18GHz £400
- EP/DANA 351D Microwave Frequency Counter 20Hz-18GHz £950
- RACAL 9921 Frequency Counter 3GHz £300
- H.P. 339A Distortion Measuring Set 10Hz-110kHz £1500
- RACAL/DANA 1991 Nanosecond Universal Counter £800
- RACAL 9302 RF Millivoltmeter True RMS 10kHz-1.5GHz £450
- RACAL 9301A RF Millivoltmeter True RMS 10kHz-1.5GHz £300
- RACAL 9009 Automatic Mod Meter 10MHz-1.5GHz Wide Deviation £250
- H.P. Pulse Generator type 214B £780
- LYONS PGT3N Pulse Gen. PRF 1Hz-20MHz £190
- MARCONI 2610 True RMS Voltmeter £800
- KEITHLEY 224 Programmable Current Source £1000
- FARNELL P50520H Syn AM/FM Sig Gen 100kHz-520MHz £900
- LEADER LSG216 AM/FM Sig Gen 0.1-30MHz & 75-115MHz £400
- SPECTRUM ANALYSERS**
- H.P. 141T B555A & IF Plug-in 10MHz-180GHz £1800
- H.P. 141T with B554B & B552B 500kHz-1750MHz £1300
- H.P. 140T with B554L & B552A 500kHz-1750MHz £1000
- H.P. 141T with B556A & B552B 10kHz-300kHz £1000
- H.P. 140T with B555L & B552A 160Hz-110MHz £800
- MARCONI TF2370 1kHz-110MHz £1500
- H.P. 182C with B558B 100kHz-1500MHz £1500
- H.P. 3582A 0.02Hz-25.5kHz £2000
- DATRON 1061A Multimeter 6 digit with True RMS AC Current £1250
- DATRON 1065 Multimeter 5 digit AC/DC/Ohms IEEE £600
- HEWLETT PACKARD 3490A Bench Multimeter 5 digit AC/DC/Ohms £200
- PHILIPS PM2354 Multi Function DMM 6 digit GPIB IEEE £450
- MARCONI Digital Frequency Meter 2450A 10Hz-80MHz £125
- MARCONI Digital Frequency Meter 2451A 10Hz-200MHz £160
- MARCONI Universal Counter Timer 2457 DC-100MHz £175
- MARCONI Universal Counter Timer 2458 DC-520MHz £225
- BLACK STAR Jupiter 500 Sine/SqTrn 0.1Hz-500kHz £70
- FEEDBACK FG600 Sine/SqTrn 0.1Hz-100kHz £60
- MULTI TRAC Handheld MZ255 32 ranges AC/DC 10 Amps Diode Transistor Tester: Freq Counter £32.50
- FARNELL ELECTRONIC LOAD R8100-35**  
1KW 30amp 35 volt £600
- H.P. B608B Sweep Osc with B6974 Plug-in 26.5-400Hz £300
- RACAL/DANA RF Power Meter 9104 £600
- RACAL/DANA 9341 Data Bridge Automatic LCR & Q £350
- WAYNE KERR B905 Automatic Precision Bridge 0.05% £300
- WAYNE KERR B605 Automatic Component Bridge 0.1% £300
- FARNELL PSU TV570M2C 70V 5A 30V 10A £400
- FARNELL PSU H60/25 0-60V 0-25A Metered £400
- FARNELL B30/20 0-30V 0-5A Metered £80
- FARNELL B20/10 0-30V 10A £200
- TELEQUINT CT71 Curve Tracer £250
- MARCONI TF2700 Universal LCR Bridge Battery from £150
- AVO Valve Characteristic Meter VCM163 £300
- FARNELL H520 RF Power Amp 1.5-520MHz 300mW £175
- RACAL 9100 Absorption Wattmeter 1MHz-1GHz 3W £200
- TRO Wav & Fluter Meter R180 £100
- H.P. 3311A Function Gen 0.1Hz-5MHz Sine/SqTrn £125
- KINUSUR AV4123 AC Voltmeter Dual 10Hz-500MHz £100
- FARNELL ISOLATING TRANSFORMERS**  
GUSO. 240V 500VA Un-used £50
- NEW EQUIPMENT**
- HAMEG OSCILLOSCOPE HM1005 Triple Trace 100MHz Delay Timebase £847
- HAMEG OSCILLOSCOPE HM604 Dual Trace 60MHz Delay Sweep £653
- HAMEG OSCILLOSCOPE HM2003-7 Dual Trace 20MHz Component Tester £362
- HAMEG OSCILLOSCOPE HM2005-3 Dual Trace 20MHz Digital Storage £653
- All other models available - all oscilloscopes supplied with 2 probes
- BLACK STAR EQUIPMENT (P&P all units £5)**  
APOLLO 100 100MHz Counter Timer Ratio/Period/Time interval etc £222
- APOLLO 100 100MHz (as above with more functions) £325
- METEOR 100 FREQUENCY COUNTER 100MHz £109
- METEOR 1000 FREQUENCY COUNTER 600MHz £135
- METEOR 1000 FREQUENCY COUNTER 1GHz £200
- JUPITOR 500 FUNCTION GEN 0.1Hz-500kHz Sine/SqTrn £110
- ORON COLOUR BAR GENERATOR Pal/TV/Video £220
- All other Black Star equipment available £11
- OSCILLOSCOPE PROBES Switched X1 10 (P&P £3)

Used Equipment - guaranteed. Manuals supplied if possible.  
This is a VERY SMALL SAMPLE OF STOCK. SAE or telephone for lists. Please check availability before ordering. CARRIAGE all units £16. VAT to be added to total of goods and carriage.

**STEWART OF READING**  
110 WYKEHAM ROAD, READING, BERKS RG6 1PL  
Tel: 0734 268041 Fax: 0734 351696  
Callers welcome 9am to 5.30pm MON-FRI (UNTIL 8pm THURS)



# OMNI ELECTRONICS

174 Dalkeith Road, Edinburgh EH16 5DX ★ 031 667 2611

The supplier to use if you're looking for:-

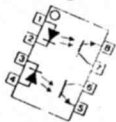
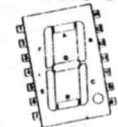

**A WIDE RANGE OF  
★ COMPONENTS AIMED AT THE ★  
HOBBYIST**

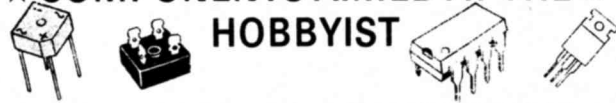

**★ COMPETITIVE VAT INCLUSIVE ★  
PRICES**



**★ MAIL ORDER – generally by ★  
RETURN OF POST**



**★ FRIENDLY SERVICE ★**

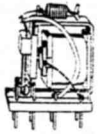

OPEN:  
Monday-Thursday 9.15 - 6.00  
Friday 9.15-5.00  
Saturday 9.30-5.00

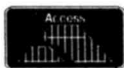

Carbon Film resistors 1/4W 5% E24 series 0.51 R to 10MΩ	1p
100 off per value - 75p. even hundreds per value totalling 1000	£6.00p
Metal Film resistors 1/4W 10R to 1 MΩ 5% E12 series - 2p. 1% E24 series	3p
Mixed metal/carbon film resistors 1/2W E24 series 1R to 10MΩ	1 1/2p
1 watt mixed metal/Carbon Film 5% E12 series 4R7 to 10 Megohms	5p
Linear Carbon pre-sets 100mW and 1/4W 100R to 4M7 E6 series	7p
<b>Miniature polyester capacitors 250V working for vertical mounting</b>	
015, 022, 033, 047, 068 4p. 0.1 - 5p. 0.12, 0.15, 0.22 - 6p. 0.47 - 8p. 0.68 - 8p. 1.0 - 12p	
<b>Mylar (polyester) capacitors 100V working E12 series vertical mounting</b>	
1000p to 8200p - 3p. 0.1 to 0.68 - 4p. 0.1 - 5p. 0.12, 0.15, 0.22 - 6p. 0.47/50V - 8p	
<b>Submin ceramic plate capacitors 100V wkg vertical mountings. E12 series</b>	
2% 1.8pf to 47pf - 3p. 2% 56pf to 330pf - 4p. 10% 390p - 4700p	4p
Disc/plate ceramics 50V E12 series 1P0 to 1000P, E6 Series 1500P to 47000P	2p
<b>Polystyrene capacitors 63V working E12 series long axial wires</b>	
10pf to 820pf - 5p. 1000pf to 10,000pf - 6p. 12,000pf	7p
741 Op Amp - 20p. 555 Timer - 20p. LM3900	80p
cmos 4001 - 20p. 4011 - 22p. 4017 - 40p. 4069UB unbuffered	20p
<b>ALUMINIUM ELECTROLYTICS (Mfds/Volts)</b>	
1/50, 2.2/50, 4.7/50, 10/25, 10/50	5p
22/16, 22/25, 22/50, 33/16, 47/16, 47/25, 47/50	6p
100/16, 100/25 7p, 100/50	12p
220/16 8p, 220/25, 220/50 10p, 470/16, 470/25	11p
1000/25 25p, 1000/35, 2200/25 35p, 4700/25	70p
<b>Submin. tantalum bead electrolytics (Mfds/Volts)</b>	
0.1/35, 0.22/35, 0.47/35, 1.0/35, 3.3/16, 4.7/16	14p
2.2/35, 4.7/25, 4.7/35, 6.8/16 15p, 10/16, 22/6	20p
33/10, 47/6, 22/16 30p, 47/10 35p, 47/16 60p, 47/35	80p
<b>VOLTAGE REGULATORS</b>	
1A + or - 5V, 8V, 12V, 15V, 18V & 24V - 55p. 100mA. 5.8, 12, 15, V +	30p
<b>DIODES (piv/amps)</b>	
75/25mA 1N4148 2p. 800/1A 1N4006 4 1/2p. 400/3A 1N5404 14p. 115/15mA OA91	8p
100/1A 1N4002 3 1/2p. 1000/1A 1N4007 5p. 60/1.5A S1M1 5p. 100/1A bridge	25p
400/1A 1N4004 4p. 1250/1A BY 127 10p. 30/150mA OA47 gold bonded	18p
Zener diodes E24 series 3V3 to 33V 400mW - 8p. 1 watt	12p
Battery snaps for PP3 - 6p for PP9	12p
L.E.D.'s 3mm, & 5mm. Red, Green, Yellow - 10p. Grommets 3mm - 2p. 5mm	2p
Red flashing L.E.D.'s require 9-12V supply only	50p
Mains indicator neons with 220k resistor	10p
20mm fuses 100mA to 5A. O. blow 6p.A/surge 10p. Holders, chassis, mounting	6p
High speed pc drill 0.8, 1.0, 1.3, 1.5, 2.0mm - 40p. Machines 12V dc	£15.00
HELPING HANDS 6 ball joints and 2 croc clips to hold awkward jobs	£3.50
AA/HP7 Nicad rechargeable cells 90p each. Universal charger unit	£6.50
AA/HP7 zinc/carbon batteries in packs of 4	£1.10 per pack
Glass reed switches with single pole make contacts - 8p. Magnets	15p
0.1" Stripboard 2 1/2" x 1" 9 rows 25 holes - 25p. 3 1/2" x 2 1/2" 24 rows 37 holes	70p
Jack plugs 2.5 & 3.5mm - 14p. Sockets Panel Mtg. 2.5 & 3.5mm	10p
Ear pieces 2.5 & 3.5mm, dynamic - 20p. 3.5mm crystal	£1.50
<b>Multi cored solder. 22G - 8p yard, 18G - 14p yard.</b>	
<b>TRANSISTORS</b>	
BC107/8/9 - 12p. BC547/8/9 - 8p. BC557/8/9 - 8p. BC182, 182L, BC183, 183L, BC184, 184L, BC212, 212L - 10p.	
BC327, 337, 337L - 12p. BC727, 737 - 12p. BD135/6/7/8/9 - 25p. BCY70 - 18p. BFY50/51/52 - 20p.	
BFX88 - 15p. 2N3055 - 55p. TIP31, 32 - 30p. TIP41, 42 - 40p. BU208A - £1.50, BF195, 197 - 12p	
Ionisers with seven year guarantee, list price £16.95	£12.50
All prices are inclusive of VAT. Postage 30p (free over £5). Stamp for list.	
<b>THE CR SUPPLY CO</b>	
127 Chesterfield Rd., Sheffield S8 0RN	
Tel: 0742 557771 Return posting	

# ADVERTISERS INDEX

AITKEN BROS. & CO	779
AUTONA	783
N. R. BARDWELL	783
R. BARTLETT	722
B.K. ELECTRONICS	Cover (iii)
BRIAN J. REED	800
BULL ELECTRICAL	Cover (ii)
CAMBRIDGE COMP. SCIENCE	797
CIRKIT DISTRIBUTION	718
CHATWIN GUITARS (JCG)	779
COMPELEC	797
COOKE INTERNATIONAL	799
CRICKLEWOOD ELECTRONICS	722
CR SUPPLY COMPANY	800
DISPLAY ELECTRONICS	714
ELECTROVALUE	783
ESR ELECTRONIC COMPONENTS	726
FTC	774
GREENWELD ELECTRONICS	717
HART ELECTRONIC KITS	751
HENRYS AUDIO ELECTRONICS	769
HESING TECHNOLOGY	720
ICS	799
JAYTEE ELECTRONIC SERVICES	718
JPG ELECTRONICS	799
LABCENTER	763
MAGENTA ELECTRONICS	724/725
MAILTECH	721
MAPLIN ELECTRONICS	Cover (iv)
MARAPET	799
MAURITRON PUBLICATIONS (TV)	775
M&B ELECTRICAL SUPPLIES	790
MOP ELECTRONICS	769
MULTI SOURCES	779
NATIONAL COLLEGE OF TECHNOLOGY	797
NICHE SOFTWARE	783
NUMBER ONE SYSTEMS	719
OMNI ELECTRONICS	800
ORCHARD COMPUTERS	737
PICO TECHNOLOGY	723
POWERWARE	769
PCL SOFTWARE	720
RADIO & TV COMPONENTS	720
ROLINE SYSTEMS	746/747
SEETRAX CAE	722
SERVICE TRADING CO	797
S&N ENTERPRISES	722
SHERWOOD ELECTRONICS	799
SUMA DESIGNS	716
STEWART OF READING	799

**ADVERTISEMET MANAGER:**  
PETER J. MEW

**ADVERTISEMENT OFFICES:**  
EVERYDAY with PRACTICAL ELECTRONICS  
ADVERTISEMENTS,  
HOLLAND WOOD HOUSE, CHURCH LANE, GREAT  
HOLLAND, ESSEX CO13 0JS.  
Phone/Fax: (0255) 850596

*For Editorial address and phone numbers see page 727.*

**Millions of quality components  
at lowest ever prices!**

Plus Tools, Watches, Fancy Goods, Toys.  
Mail order UK only.

All inclusive prices -  
**NO VAT to add on.**

Send 41p stamped self addressed label or  
envelope for catalogue/clearance list.

At least 2,100 offers to amaze you.

**Brian J Reed**  
**6 Queensmead Avenue, East Ewell**  
**Epsom, Surrey KT17 3EQ**  
**Tel: 081-393 9055**

Published on approximately the first Friday of each month by Wimborne Publishing Ltd., 6 Church Street, Wimborne, Dorset BH21 1JH. Printed in England by Benham & Co. Ltd, Colchester, Essex. Distributed by Seymour, Windsor House, 1270 London Road, Norbury, London SW16 4DH. Sole Agents for Australia and New Zealand-Gordon & Gotch (Asia) Ltd., South Africa-Central News Agency Ltd. Subscriptions INLAND £22 and OVERSEAS £28 (£45.50 airmail) payable to "Everyday with Practical Electronics" Subs Dept, 6 Church Street, Wimborne, Dorset BH21 1JH. EVERYDAY with PRACTICAL ELECTRONICS is sold subject to the following conditions, namely that it shall not, without the written consent of the Publishers first having been given, be lent, resold, hired out or otherwise disposed of by way of Trade at more than the recommended selling price shown on the cover, and that it shall not be lent, resold, hired out or otherwise disposed of in a mutilated condition or in any unauthorised cover by way of Trade or affixed to or as part of any publication or advertising, literary or pictorial matter whatsoever.



**OMP MOS-FET POWER AMPLIFIERS**  
HIGH POWER, TWO CHANNEL 19 INCH RACK

**THOUSANDS PURCHASED BY PROFESSIONAL USERS**



**THE RENOWNED MXF SERIES OF POWER AMPLIFIERS**

**FOUR MODELS:- MXF200 (100W + 100W) MXF400 (200W + 200W) MXF600 (300W + 300W) MXF900 (450W + 450W)**  
ALL POWER RATINGS R.M.S. INTO 4 OHMS, BOTH CHANNELS DRIVEN

**FEATURES:** ★ Independent power supplies with two toroidal transformers ★ Twin L.E.D. Vu meters ★ Level controls ★ Illuminated on/off switch ★ XLR connectors ★ Standard 775mV inputs ★ Open and short circuit proof ★ Latest Mos-Fets for stress free power delivery into virtually any load ★ High slew rate ★ Very low distortion ★ Aluminium cases ★ MXF600 & MXF900 fan cooled with D.C. loudspeaker and thermal protection.

**USED THE WORLD OVER IN CLUBS, PUBS, CINEMAS, DISCOS ETC.**

**SIZES:-** MXF200 W19" x H3 1/2" (2U) x D11"  
MXF400 W19" x H5 1/4" (3U) x D12"  
MXF600 W19" x H5 1/4" (3U) x D13"  
MXF900 W19" x H5 1/4" (3U) x D14 3/4"

**PRICES:-** MXF200 £175.00 MXF400 £233.85  
MXF600 £329.00 MXF900 £449.15  
SPECIALIST CARRIER DEL. £12.50 EACH



**OMP X03 STEREO 3-WAY ACTIVE CROSS-OVER**



Advanced 3-Way Stereo Active Cross-Over, housed in a 19" x 1U case. Each channel has three level controls: bass, mid & top. The removable front fascia allows access to the programmable DIL switches to adjust the cross-over frequency: Bass-Mid 250/500/800Hz, Mid-Top 1.8/3/5KHz, all at 24dB per octave. Bass invert switches on each bass channel. Nominal 775mV input/output. Fully compatible with OMP rack amplifier and modules.

**Price £117.44 + £5.00 P&P**

**STEREO DISCO MIXER SDJ3400SE**

**\* ECHO & SOUND EFFECTS \***

**STEREO DISCO MIXER** with 2 x 7 band L & R graphic equalisers with bar graph LED Vu meters. **MANY OUTSTANDING FEATURES:-** including Echo with repeat & speed control, DJ Mic with talk-over switch, 6 Channels with individual faders plus cross fade, Cue Headphone Monitor, 8 Sound Effects. Useful combination of the following inputs:- 3 turntables (mag), 3 mics, 5 Line for CD, Tape, Video etc.

**Price £144.99 + £5.00 P&P**



**SIZE: 482 x 240 x 120mm**

**PIEZO ELECTRIC TWEETERS - MOTOROLA**

Join the Piezo revolution! The low dynamic mass (no voice coil) of a Piezo tweeter produces an improved transient response with a lower distortion level than ordinary dynamic tweeters. As a crossover is not required these units can be added to existing speaker systems of up to 100 watts (more if two are put in series. **FREE EXPLANATORY LEAFLETS ARE SUPPLIED WITH EACH TWEETER.**

**TYPE 'A' (KSN1036A)** 3" round with protective wire mesh. Ideal for bookshelf and medium sized Hi-Fi speakers. **Price £4.90 + 50p P&P.**  
**TYPE 'B' (KSN1005A)** 3 1/2" super horn for general purpose speakers, disco and P.A. systems etc. **Price £5.99 + 50p P&P.**  
**TYPE 'C' (KSN1016A)** 2" x 5" wide dispersion horn for quality Hi-Fi systems and quality discos etc. **Price £6.99 + 50p P&P.**  
**TYPE 'D' (KSN1025A)** 2" x 6" wide dispersion horn. Upper frequency response retained extending down to mid-range (2KHz). Suitable for high quality Hi-Fi systems and quality discos. **Price £9.99 + 50p P&P.**  
**TYPE 'E' (KSN1038A)** 3 3/4" horn tweeter with attractive silver finish trim. Suitable for Hi-Fi monitor systems etc. **Price £5.99 + 50p P&P.**  
**LEVEL CONTROL** Combines, on a recessed mounting plate, level control and cabinet input jack socket. 85x85mm. **Price £4.10 + 50p P&P.**

**IBI FLIGHT CASED LOUDSPEAKERS**

A new range of quality loudspeakers, designed to take advantage of the latest speaker technology and enclosure designs. Both models utilize studio quality 12" cast aluminium loudspeakers with factory fitted grilles, wide dispersion constant directivity horns, extruded aluminium corner protection and steel ball corners, complimented with heavy duty black covering. The enclosures are fitted as standard with top hats for optional loudspeaker stands.

**POWER RATINGS QUOTED IN WATTS RMS FOR EACH CABINET**  
**FREQUENCY RESPONSE FULL RANGE 45Hz - 20KHz**

**ibi FC 12-100WATTS (100dB) PRICE £159.00 PER PAIR**

**ibi FC 12-200WATTS (100dB) PRICE £175.00 PER PAIR**

SPECIALIST CARRIER DEL. £12.50 PER PAIR

**OPTIONAL STANDS PRICE PER PAIR £49.00**

Delivery £6.00 per pair



**IN-CAR STEREO BOOSTER AMPS**



**PRICES: 150W £49.99 250W £99.99**  
**400W £109.95 P&P £2.00 EACH**

**THREE SUPERB HIGH POWER CAR STEREO BOOSTER AMPLIFIERS**  
150 WATTS (75 + 75) Stereo, 150W Bridged Mono  
250 WATTS (125 + 125) Stereo, 250W Bridged Mono  
400 WATTS (200 + 200) Stereo, 400W Bridged Mono  
**ALL POWERS INTO 4 OHMS**

**Features:**  
★ Stereo, bridgable mono ★ Choice of high & low level inputs ★ L & R level controls ★ Remote on-off ★ Speaker & thermal protection.

**OMP MOS-FET POWER AMPLIFIER MODULES**

**SUPPLIED READY BUILT AND TESTED.**

These modules now enjoy a world-wide reputation for quality, reliability and performance at a realistic price. Four models are available to suit the needs of the professional and hobby market i.e. Industry, Leisure, Instrumental and Hi-Fi etc. When comparing prices, NOTE that all models include toroidal power supply, integral heat sink, glass fibre P.C.B. and drive circuits to power a compatible Vu meter. All models are open and short circuit proof.

**THOUSANDS OF MODULES PURCHASED BY PROFESSIONAL USERS**



**OMP/MF 100 Mos-Fet** Output power 110 watts R.M.S. into 4 ohms, frequency response 1Hz - 100KHz -3dB, Damping Factor >300, Slew Rate 45V/uS, T.H.D. typical 0.002%, Input Sensitivity 500mV, S.N.R. -110 dB. Size 300 x 123 x 60mm.  
**PRICE £40.85 + £3.50 P&P**



**OMP/MF 200 Mos-Fet** Output power 200 watts R.M.S. into 4 ohms, frequency response 1Hz - 100KHz -3dB, Damping Factor >300, Slew Rate 50V/uS, T.H.D. typical 0.001%, Input Sensitivity 500mV, S.N.R. -110 dB. Size 300 x 155 x 100mm.  
**PRICE £64.35 + £4.00 P&P**



**OMP/MF 300 Mos-Fet** Output power 300 watts R.M.S. into 4 ohms, frequency response 1Hz - 100KHz -3dB, Damping Factor >300, Slew Rate 60V/uS, T.H.D. typical 0.001%, Input Sensitivity 500mV, S.N.R. -110 dB. Size 300 x 175 x 100mm.  
**PRICE £81.75 + £5.00 P&P**



**OMP/MF 450 Mos-Fet** Output power 450 watts R.M.S. into 4 ohms, frequency response 1Hz - 100KHz -3dB, Damping Factor >300, Slew Rate 75V/uS, T.H.D. typical 0.001%, Input Sensitivity 500mV, S.N.R. -110 dB, Fan Cooled, D.C. Loudspeaker Protection, 2 Second Anti-Thump Delay. Size 385 x 210 x 105mm.  
**PRICE £132.85 + £5.00 P&P**



**OMP/MF 1000 Mos-Fet** Output power 1000 watts R.M.S. into 2 ohms, 725 watts R.M.S. into 4 ohms, frequency response 1Hz - 100KHz -3dB, Damping Factor >300, Slew Rate 75V/uS, T.H.D. typical 0.002%, Input Sensitivity 500mV, S.N.R. -110 dB, Fan Cooled, D.C. Loudspeaker Protection, 2 Second Anti-Thump Delay. Size 422 x 300 x 125mm.  
**PRICE £259.00 + £12.00 P&P**

**NOTE: MOS-FET MODULES ARE AVAILABLE IN TWO VERSIONS: STANDARD - INPUT SENS 500mV, BAND WIDTH 100KHz. PEC (PROFESSIONAL EQUIPMENT COMPATIBLE) - INPUT SENS 775mV, BAND WIDTH 50KHz. ORDER STANDARD OR PEC.**

**LOUDSPEAKERS**

**LARGE SELECTION OF SPECIALIST LOUDSPEAKERS AVAILABLE, INCLUDING CABINET FITTINGS, SPEAKER GRILLES, CROSS-OVERS AND HIGH POWER, HIGH FREQUENCY BULLETS AND HORNS, LARGE (A4) S.A.E. (60p STAMPED) FOR COMPLETE LIST.**

McKenzie and Fane Loudspeakers are also available.



**EMINENCE:- INSTRUMENTS, P.A., DISCO, ETC**

**ALL EMINENCE UNITS 8 OHMS IMPEDANCE**

**8" 100 WATT R.M.S. ME8-100 GEN. PURPOSE, LEAD GUITAR, EXCELLENT MID, DISCO.** RES. FREQ. 72Hz, FREQ. RESP. TO 4KHz, SENS 97dB. **PRICE £32.71 + £2.00 P&P**  
**10" 100 WATT R.M.S. ME10-100 GUITAR, VOCAL, KEYBOARD, DISCO, EXCELLENT MID.** RES. FREQ. 71Hz, FREQ. RESP. TO 7KHz, SENS 97dB. **PRICE £33.74 + £2.50 P&P**  
**10" 200 WATT R.M.S. ME10-200 GUITAR, KEYB'D, DISCO, VOCAL, EXCELLENT HIGH POWER MID.** RES. FREQ. 65Hz, FREQ. RESP. TO 3.5KHz, SENS 99dB. **PRICE £43.47 + £2.50 P&P**  
**12" 100 WATT R.M.S. ME12-100LE GEN. PURPOSE, LEAD GUITAR, DISCO, STAGE MONITOR.** RES. FREQ. 49Hz, FREQ. RESP. TO 6KHz, SENS 100dB. **PRICE £35.64 + £3.50 P&P**  
**12" 100 WATT R.M.S. ME12-100LT (TWIN CONE) WIDE RESPONSE, P.A., VOCAL, STAGE MONITOR.** RES. FREQ. 42Hz, FREQ. RESP. TO 10KHz, SENS 98dB. **PRICE £36.67 + £3.50 P&P**  
**12" 200 WATT R.M.S. ME12-200 GEN. PURPOSE, GUITAR, DISCO, VOCAL, EXCELLENT MID.** RES. FREQ. 58Hz, FREQ. RESP. TO 6KHz, SENS 98dB. **PRICE £46.71 + £3.50 P&P**  
**12" 300 WATT R.M.S. ME12-300GP HIGH POWER BASS, LEAD GUITAR, KEYBOARD, DISCO ETC.** RES. FREQ. 47Hz, FREQ. RESP. TO 5KHz, SENS 103dB. **PRICE £70.19 + £3.50 P&P**  
**15" 200 WATT R.M.S. ME15-200 GEN. PURPOSE BASS, INCLUDING BASS GUITAR.** RES. FREQ. 46Hz, FREQ. RESP. TO 5KHz, SENS 99dB. **PRICE £50.72 + £4.00 P&P**  
**15" 300 WATT R.M.S. ME15-300 HIGH POWER BASS, INCLUDING BASS GUITAR.** RES. FREQ. 39Hz, FREQ. RESP. TO 3KHz, SENS 103dB. **PRICE £73.34 + £4.00 P&P**

**EARBENDERS:- HI-FI, STUDIO, IN-CAR, ETC**

**ALL EARBENDER UNITS 8 OHMS** (Except EB8-50 & EB10-50 which are dual impedance tapped @ 4 & 8 ohm)

**BASS, SINGLE CONE, HIGH COMPLIANCE, ROLLED SURROUND**  
**8" 50watt EB8-50 DUAL IMPEDANCE, TAPPED 4/8 OHM BASS, HI-FI, IN-CAR.** RES. FREQ. 40Hz, FREQ. RESP. TO 7KHz SENS 97dB. **PRICE £8.90 + £2.00 P&P**  
**10" 50watt EB10-50 DUAL IMPEDANCE, TAPPED 4/8 OHM BASS, HI-FI, IN-CAR.** RES. FREQ. 40Hz, FREQ. RESP. TO 5KHz, SENS 99dB. **PRICE £13.65 + £2.50 P&P**  
**10" 100watt EB10-100 BASS, HI-FI, STUDIO.** RES. FREQ. 35Hz, FREQ. RESP. TO 3KHz, SENS 96dB. **PRICE £30.39 + £3.50 P&P**  
**12" 100watt EB12-100 BASS, STUDIO, HI-FI, EXCELLENT DISCO.** RES. FREQ. 26Hz, FREQ. RESP. TO 3 KHz, SENS 93dB. **PRICE £42.12 + £3.50 P&P**  
**FULL RANGE TWIN CONE, HIGH COMPLIANCE, ROLLED SURROUND**  
**5 1/4" 60WATT EB5-60TC (TWIN CONE) HI-FI, MULTI-ARRAY DISCO ETC.** RES. FREQ. 63Hz, FREQ. RESP. TO 20KHz, SENS 92dB. **PRICE £9.99 + £1.50 P&P**  
**6 1/2" 60WATT EB6-60TC (TWIN CONE) HI-FI, MULTI-ARRAY DISCO ETC.** RES. FREQ. 38Hz, FREQ. RESP. TO 20KHz, SENS 94dB. **PRICE £10.99 + 1.50 P&P**  
**8" 60WATT EB8-60TC (TWIN CONE) HI-FI, MULTI-ARRAY DISCO ETC.** RES. FREQ. 40Hz, FREQ. RESP. TO 18KHz, SENS 89dB. **PRICE £12.99 + £1.50 P&P**  
**10" 60WATT EB10-60TC (TWIN CONE) HI-FI, MULTI ARRAY DISCO ETC.** RES. FREQ. 35Hz, FREQ. RESP. TO 12KHz, SENS 98dB. **PRICE £16.49 + £2.00 P&P**

**TRANSMITTER HOBBY KITS**

**PROVEN TRANSMITTER DESIGNS INCLUDING GLASS FIBRE PRINTED CIRCUIT BOARD AND HIGH QUALITY COMPONENTS COMPLETE WITH CIRCUIT AND INSTRUCTIONS**

**3W TRANSMITTER** 80-108MHz, VARICAP CONTROLLED PROFESSIONAL PERFORMANCE, RANGE UP TO 3 MILES, SIZE 38 x 123mm, SUPPLY 12V @ 0.5AMP. **PRICE £14.85 + £1.00 P&P**

**FM MICRO TRANSMITTER** 100-108MHz, VARICAP TUNED, COMPLETE WITH VERY SENS FET MIC, RANGE 100-300m, SIZE 56 x 46mm, SUPPLY 9V BATTERY. **PRICE £8.80 + £1.00 P&P**



PHOTO: 3W FM TRANSMITTER

**B.K. ELECTRONICS**

**UNITS 1 & 5 COMET WAY, SOUTHEAST-ON-SEA, ESSEX. SS2 6TR.**

**Tel.: 0702-527572 Fax.: 0702-420243**



**NEW**

**FULL COLOUR GUIDE TO ELECTRONIC PRODUCTS**

# Maplin



BS 5750  
Part 2 1987  
Level B:  
Quality Assurance  
RS12750

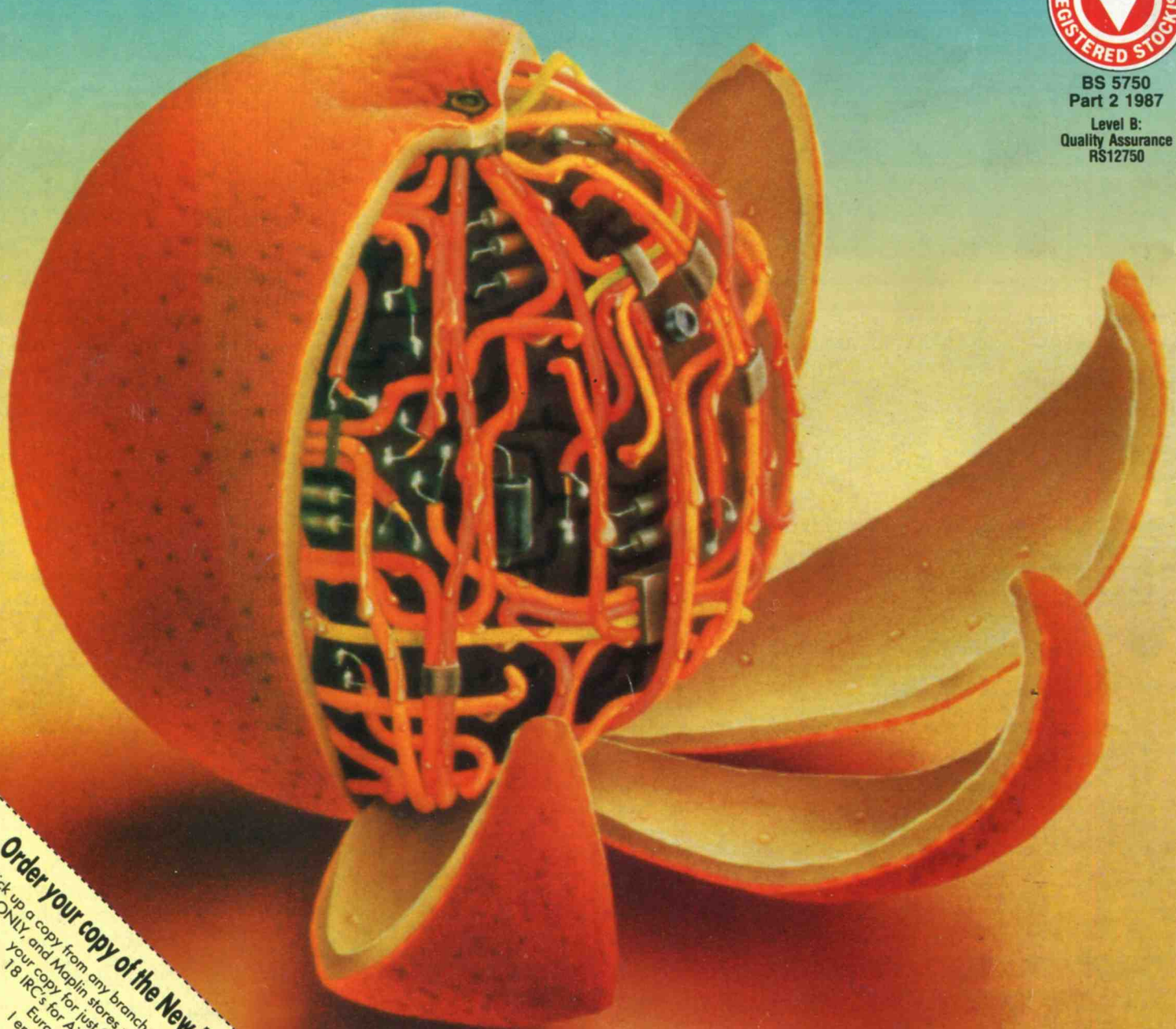

**Order your copy of the New MAPLIN Catalogue on sale NOW!**  
Pick up a copy from any branch of WHSMITH, selected branches of RSM<sup>COLL</sup> in Scotland ONLY, and Maplin stores nationwide for just £2.95 or post this coupon now to receive your copy for just £3.45 inc. p&p. If you live outside the U.K. send £6.80 or 18 IRC's for Airmail in Europe/£5.20 or 13 IRC's for surface mail outside Europe; or £11.50 or 30 IRC's for Airmail outside Europe. (delete as applicable).  
I enclose £3.45/£6.80/£5.20/£11.50 (delete as applicable).

Name.....  
Address.....  
Post Code.....  
Send to Maplin Electronics,  
P.O. Box 3, Rayleigh,  
Essex, England  
SS6 8LR.  
EE94

Over 700 colour packed pages with hundreds of brand New Products at Super Low Prices, on sale now, **only £2.95.**

Available from all branches of WHSMITH, selected branches of RSM<sup>COLL</sup> in Scotland ONLY, and Maplin stores nationwide. The Maplin Electronics 1994 Catalogue - **UNIQUELY DIFFERENT!**

