

# EVERYDAY *Gardner* ELECTRONICS and computer PROJECTS

APRIL 1984

90p

## A WIDE SPECTRUM



**QUASI STEREO  
QUIZ MASTER II • FUSE / DIODE CHECKER  
MULTIPURPOSE INTERFACE FOR COMPUTERS  
plus  
DATA ACQUISITION & CONTROL SYSTEM FOR  
BBC MICRO, PET, VIC-20 & COMMODORE 64**

electronize

# AUTO-ELECTRONIC PRODUCTS

KITS OR READY BUILT

## TOTAL ENERGY DISCHARGE ELECTRONIC IGNITION

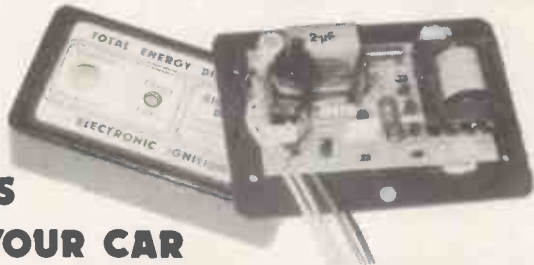

### IS YOUR CAR AS GOOD AS IT COULD BE ?

- ★ Is it **EASY TO START** in the cold and the damp? Total Energy Discharge will give the most powerful spark and maintain full output even with a near flat battery.
  - ★ Is it **ECONOMICAL** or does it "go off" between services as the ignition performance deteriorates? Total Energy Discharge gives much more output and maintains it from service to service.
  - ★ Has it **PEAK PERFORMANCE** or is it flat at high and low revs. where the ignition output is marginal? Total Energy Discharge gives a more powerful spark from idle to the engines maximum (even with 8 cylinders).
  - ★ Is the **PERFORMANCE SMOOTH**. The more powerful spark of Total Energy Discharge eliminates the "near misfires" whilst an electronic filter smoothes out the effects of contact bounce etc.
  - ★ Do the **PLUGS and POINTS** always need changing to bring the engine back to its best? Total Energy Discharge eliminates contact arcing and erosion by removing the heavy electrical load. The timing stays "spot on" and the contact condition doesn't affect the performance either. Larger plug gaps can be used even wet or badly fouled plugs can be fired with this system.
  - ★ **TOTAL ENERGY DISCHARGE** is a unique system and the most powerful on the market - 3½ times the power of inductive systems - 3½ times the energy and 3 times the duration of ordinary capacitive systems. These are the facts:  
Performance at only 6 volts (max. supply 16 volts)  
SPARK POWER — 140W, SPARK ENERGY — 36mJ  
SPARK DURATION — 500µS, STORED ENERGY — 35mJ  
LOADED OUTPUT VOLTAGE  
50pF load — 38kV, 60pF + 500K — 26kV
- We challenge any manufacturer to publish better performance figures. Before you buy any other make, ask for the facts, its probably only an inductive system. But if an inductive system is what you really want, we'll still give you a good deal.
- ★ **All ELECTRONIZE electronic Ignitions feature:**  
**EASY FITTING, STANDARD/ELECTRONIC CHANGEVER SWITCH, STATIC TIMING LIGHT and DESIGNED IN RELIABILITY** (14 years experience and a 3 year guarantee).
  - ★ **IN KIT FORM** it provides a top performance system at less than half the price of comparable ready built units. The kit includes: pre-drilled fibreglass PCB, pre-wound and varnished ferrite transformer, high quality 2uF discharge capacitor, case, easy to follow instructions, solder and everything needed to build and fit to your car. All you need is a soldering iron and a few basic tools.

Most NEW CARS already have electronic ignition. Update YOUR CAR

## ELECTRONIZE ELECTRONIC CAR ALARM



### HOW SAFE IS YOUR CAR ?

More and more cars are stolen each week and even a steering lock seems little help. But a car thief will avoid a car that will cause him trouble and attract attention. If your car has a good alarm system - well there are plenty of other cars to choose from.

#### LOOK AT THE PROTECTION AN ELECTRONIZE ALARM CAN GIVE :

- ★ **MINIATURE KEY PLUG** A miniature jack plug attaches to your key ring and is coded to your particular alarm.
- ★ **2025 INDIVIDUAL COMBINATIONS** The key plug contains two 1% tolerance resistors, both must be the correct value and together give 2025 different combinations.
- ★ **ATTRACTS MAXIMUM ATTENTION** This alarm system not only intermittently sounds the horn, but also flashes the headlight and prevents the engine being started.
- ★ **60 SECOND ALARM PERIOD** Once triggered the alarm will sound for 60 seconds, unless cancelled by the key plug, before resetting ready to be triggered again.
- ★ **30 SECOND EXIT DELAY** The system is armed by pressing a small button on a dashboard mounted control panel. This starts a 30 second delay period during which the owner can open and close doors without triggering the alarm.
- ★ **10 SECOND ENTRY DELAY** When a door is opened a 10 second delay operates to allow the owner to disarm the system with the coded key plug. Latching circuits are used and once triggered the alarm can only be cancelled by the key plug.
- ★ **LED. FUNCTION INDICATOR** An LED is included in the dashboard unit and indicates the systems operating state. The LED lights continuously to show the system is armed and in the exit delay condition. A flashing LED indicates that the alarm has been triggered and is in the entry delay condition.
- ★ **ACCESSORY LOOP - BONNET/BOOT SWITCH - IGNITION TRIGGER** These operate three separate circuits and will trigger the alarm immediately, regardless of entry and exit delays.
- ★ **SAFETY INTERLOCK** The system cannot be armed by accident when the engine is running and the car is in motion.
- ★ **LOW SUPPLY CURRENT** CMOS IC's and low power operational amplifiers achieve a normal operating current of only 2.5 mA.
- ★ **IN KIT FORM** It provides a high level of protection at a really low cost. The kit includes everything needed, the case, fibreglass PCB, random selection resistors to set the code and full set of components etc. In fact everything down to the last washer plus easy to follow instructions.

fill in the coupon and send to:

**ELECTRONIZE DESIGN** Dept C · Magnus Rd · Wilnecote · Tamworth · B77 5BY · tel 0827 281000

Please Supply:  Send More Information

**TOTAL ENERGY DISCHARGE** (6 or 12 volt negative earth)

D.I.Y. parts kit £15.90 £14.95

Assembled ready to fit £26.70 £19.95

(positive earth unit) £22.95

**TWIN OUTPUT** for cars and motor cycles with dual ignition

Twin, D.I.Y. parts kit £24.55 £22.95

Twin, Assembled ready to fit £36.45 £29.95

**CAR ALARM** (12 volt negative earth)

D.I.Y. parts kit £24.95 £19.95

Assembled ready to fit £37.95 £29.95

**SPECIAL OFFER.** Buy one electronic ignition kit plus one alarm kit for £30.85 or assembled units for £44.65. Goods must be purchased at the same time.

I enclose cheque/postal order OR debit my Access/Visa card

VISA

Name \_\_\_\_\_

Address \_\_\_\_\_

Code \_\_\_\_\_

Please Add £1.00 P&P(UK) Per Unit Prices Include VAT

# EVERYDAY ELECTRONICS and computer PROJECTS

VOL. 13 NO. 4 APRIL 1984

PROJECTS . . . THEORY . . . NEWS . . .  
COMMENT . . . POPULAR FEATURES . . .

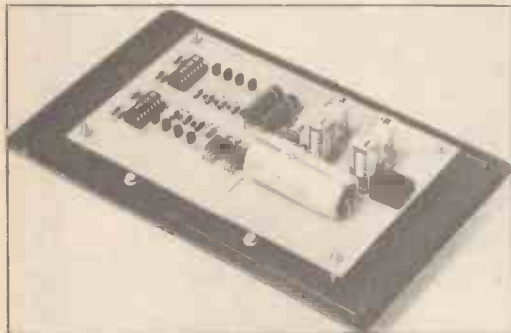
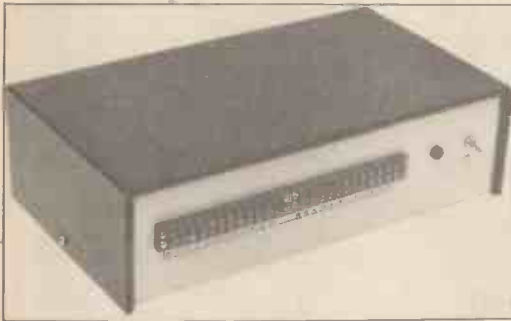

## EE MOVES

With effect from April 1, the EE Editorial offices will be located at:  
Westover House, West Quay Road, Poole, Dorset.  
See page 257 for further details.

© IPC Magazines Limited 1984. Copyright in all drawings, photographs and articles published in EVERYDAY ELECTRONICS is fully protected, and reproduction or imitations in whole or in part are expressly forbidden.

Our May 1984 issue will be published on Thursday, April 19. See page 259 for details.

## PROJECTS

- AUDIO SINEWAVE SWEEP GENERATOR**  
by R. E. Liddiard 226  
For amplifier performance checks
- FUSE/DIODE CHECKER** by L. A. Privett 232  
Black Box Project—Rapid continuity and polarity indication
- DATA ACQUISITION SYSTEM**  
by J. Adams and G. M. Feather 244  
**QUIZ-MASTER II** by S. Lyons 250  
Determines who "hit" the button first in panel games
- MULTIPURPOSE INTERFACE FOR COMPUTERS**  
by M. P. Horsey 260  
Eight channel control from the Micro User Port
- QUASI-STEREO ADAPTOR** by R. A. Penfold 270  
Adds stereo effect to TV sound
- TIMER MODULE FOR CENTRAL HEATING SYSTEMS**  
by S. Ibbs 274  
Accurate interval timer for fuel economy

## SERIES

- TEACH-IN 84** by George Hylton 234  
Part 7: Waveforms and Distortion
- MICROCOMPUTER INTERFACING TECHNIQUES**  
by J. Adams and G. M. Feather 240  
Part 10: Data monitoring, acquisition and control processes
- WHY NARROW BAND F.M.?** by E. A. Rule 266  
Modulation systems compared

## FEATURES

- EDITORIAL** Home Entertainment: A Wider View 225
- SHOPTALK** by Dave Barrington 231  
Product news and component buying
- READERS' LETTERS** 237  
Your news and views
- SOFTWARE SERVICE** 239
- COUNTER INTELLIGENCE** by Paul Young 239  
A retailer comments
- FOR YOUR ENTERTAINMENT** by Barry Fox 249  
Mole Proof: Cashless Society
- EVERYDAY NEWS** 256  
What's happening in the world of electronics
- RADIO WORLD** by Pat Hawker G3VA 258  
Reliability; Radio Callsigns; CB Changes
- PLEASE TAKE NOTE** 268  
Games Scoreboard; Oric Port Board
- CIRCUIT EXCHANGE** 276, 277  
A forum for readers' ideas
- NEW PRODUCTS** 278  
Facts and photos of instruments, equipments and tools
- SQUARE ONE** 279  
Beginners' Page: Capacitors
- PRINTED CIRCUIT BOARD SERVICE** 280

Readers' Services • Editorial and Advertisement Departments 225

# MASTER ELECTRONICS NOW! The PRACTICAL way!

YOUR CAREER..YOUR FUTURE..YOUR OWN BUSINESS..YOUR HOBBY  
THIS IS THE AGE — OF ELECTRONICS!  
the world's fastest growth industry...

There is a world wide demand for designers/engineers and for men to service and maintain all the electronic equipment on the market today — industrial — commercial and domestic. No unemployment in this walk of life!

Also — the most exciting of all hobbies — especially if you know the basic essentials of the subject. . . .

A few hours a week for less than a year — and the knowledge will be yours. . . .

We have had over 40 years of experience in training men and women successfully in this subject.

Our new style course will enable anyone to have a real understanding of electronics by a modern, practical and visual method. No previous knowledge is required, no maths, and an absolute minimum of theory.

You learn by the practical way in easy steps, mastering all the essentials of your hobby or to start, or further, a career in electronics or as a self-employed servicing engineer.

All the training can be carried out in the comfort of your own home and at your own pace. A tutor is available to whom you can write personally at any time, for advice or help during your work. A Certificate is given at the end of every course.

You will do the following:

- Build a modern oscilloscope
- Recognise and handle current electronic components
- Read, draw and understand circuit diagrams
- Carry out 40 experiments on basic electronic circuits used in modern equipment using the oscilloscope
- Build and use digital electronic circuits and current solid state 'chips'
- Learn how to test and service every type of electronic device used in industry and commerce today. Servicing of radio, T.V., Hi-Fi, VCR and microprocessor/computer equipment.

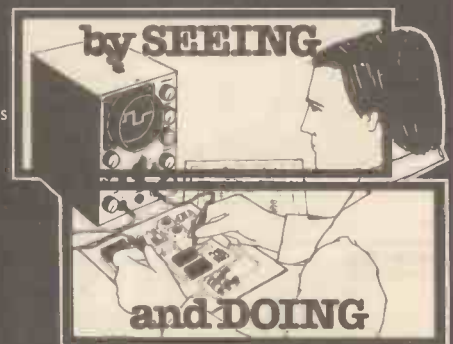

**British National Radio & Electronics School Reading, Berks. RG1 1BR**

**FREE!**

COLOUR BROCHURE



POST NOW TO

Please send your brochure without any obligation to

NAME \_\_\_\_\_

ADDRESS \_\_\_\_\_

\_\_\_\_\_

BLOCK CAPS PLEASE  
EE/4/841

I am interested in:

- COURSE IN ELECTRONICS as described above
- RADIO AMATEUR LICENCE
- MICROPROCESSORS
- OTHER SUBJECTS please state below

OR TELEPHONE US  
0734 51515 OR  
TELEX 22758  
(24 HR SERVICE)



**British National Radio & Electronics School Reading, Berks. RG1 1BR**



# Heathkit - IT'S A PLEASURE TO BUILD

Bring the enjoyment back into your hobby with a kit from Heathkit. The beautifully illustrated documentation and step-by-step instructions make building a Heathkit a relaxing, absorbing pleasure! Every kit includes a constructors' guide covering soldering and component identification which makes construction straightforward even for a beginner.

The Heathkit range contains many kits ideal for beginners as well as amateur radio kits, computerised weather stations, a highly sophisticated robot, a 16-bit computer kit and a range of home (or classroom) learning courses that have easy-to-understand texts and illustrations, in sections so that you can progress at your own pace, whilst the hands-on experiments ensure long-term retention of the material covered.

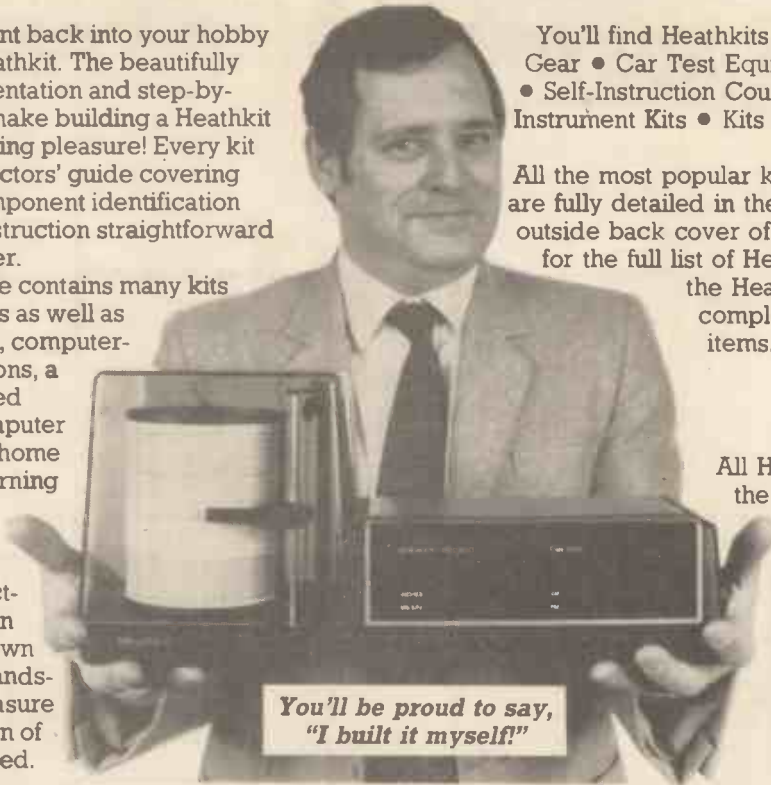

You'll find Heathkits available for Amateur Radio Gear • Car Test Equipment • Kits For The Home • Self-Instruction Courses • Computer Kits • Test Instrument Kits • Kits For Weather Measurements.

All the most popular kits and educational products are fully detailed in the 1984 Maplin catalogue (see outside back cover of this magazine for details) or for the full list of Heathkit products send 50p for the Heathkit International Catalogue complete with a UK price list of all items.

All Heathkit products available in the UK from:

**Maplin Electronic Supplies Ltd.**  
P.O. Box 3, Rayleigh,  
Essex, SS6 8LR.  
Tel: (0702) 552911.

(For shop addresses see back cover.)

## PRACTICAL DESIGN GUIDES

### A Guide to Printed Circuit Board Design

Charles Hamilton

Printed circuit boards can look, and sometimes are, extremely complicated. The high density of components on modern boards combined with the mass tracking can deter the would-be designer. This new book strips away the aura of mystique surrounding PCB design. A practical book covering design methods and practice currently employed in the modern drawing office, it describes a logical step by step approach to PCB design. Fully illustrated throughout, the book is an invaluable guide and practical aid to the young or inexperienced designer in the drawing office.

Softcover 104 pages 216 x 138 mm Illustrated 0 408 01398 2 £7.50 March 1984

### The Art of Micro Design

A A Berk

*The Art of Micro Design* has been written for engineers, technicians and students looking for a practical guide to the design of microprocessor-based systems. It presents down-to-earth information to allow the reader to begin immediate design of anything using microprocessors, from control systems to large computers. Throughout the book the emphasis is on hardware, and the practical 'cookbook' style of presenting information reflects the author's many years of micro systems design.

Softcover 320 pages 216 x 138 mm Illustrated 0 408 01403 2 £13.95 1984

Available from your nearest bookseller



**Butterworths** Borough Green, Sevenoaks, Kent TN15 8PH





# Multicore makes solder

## The Five Core Advantage

Only Multicore wire solders have a 5-core, or 4-core flux construction. The 5-cores identify non corrosive fluxes; the 4-core, water soluble fluxes.

If you were to slice through a section of Multicore cored solder you would see separate round cores of flux symmetrically arranged around its perimeter. Only a thin wall of solder separates the flux cores from the surface.

What are the advantages of the Multicore construction?

1. Because the flux is peripherally arranged it will react and flow faster.
2. Flux voids are eliminated with Multicore. That's why you can depend on continuity of the flux stream for complete wetting every time.
3. Because wetting is faster, complete and uniform, you use less solder and transmit less heat to the joint area. With Multicore Solders, you get the highest purity metals, vigorous fluxing action and a wire solder that meets all applicable International standards.



## Ersin Multicore

Contains 5 cores of non-corrosive flux.  
Uses: For all electrical joints.  
Handy Pack: Size 19A 60/40 tin/lead 1.22mm dia  
**£1.50 RRP**  
Tool Box Reel: Size 3 60/40 tin/lead 1.6mm dia  
**£4.37**



## Ersin Multicore

Contains 5 cores of non-corrosive flux.  
Uses: Small transistors, components and fine wire.  
Handy Pack: Size PC115 60/40 tin/lead 0.7mm dia  
**£1.61 RRP**  
Tool Box Reel: Size 10 60/40 tin/lead 0.7mm dia **£4.37**



## Multicore Savbit

Increases the life of your soldering bit by 10 times.  
Uses: For all electrical work.  
Reduces copper erosion.  
Handy Pack: Size 5 1.2mm dia **£1.38 RRP**  
Tool Box Reel: Size 12 1.2mm dia **£4.37**



## XK113 MW RADIO KIT

Based on ZN414 IC, kit includes PCB, wound aerial and crystal earpiece and all components to make a sensitive miniature radio. Size: 5.5 x 2.7 x 2cms. Requires PP3 9V battery. IDEAL FOR BEGINNERS. **£5.50**

## HOME LIGHTING KITS

These kits contain all necessary components and full instructions & are designed to replace a standard wall switch and control up to 300w of lighting.

- TDR300K Remote Control Dimmer **£14.95**  
MK6 Transmitter for above **£4.50**
- TD300K Touchdimmer **£7.75**
- TS300K Touchswitch **£7.75**
- TDE4K Extension kit for 2-way switching for TD300K **£2.50**
- LD300K Rotary Controlled Dimmer **£3.95**



## DVM/ULTRA SENSITIVE THERMOMETER KIT

This new design is based on the ICL7126 (a lower power version of the ICL7106 chip) and a 3 1/2 digit liquid crystal display. This kit will form the basis of a digital multimeter (only a few additional resistors and switches are required—details supplied), or a sensitive digital thermometer (-50°C to +150°C) reading to 0.1°C. The basic kit has a sensitivity of 200mV for a full scale reading, automatic polarity indication and an ultra low power requirement—giving a 2 year typical battery life from a standard 9V PP3 when used 8 hours a day, 7 days a week.

Price **£15.50**



NOW OPEN

# COMPUTER SHOWROOM

Hours: Mon-Fri 9am-5pm  
SAT 10am-4pm



We also stock peripherals and accessories - disc drives, printers, joy sticks etc. together with a wide range of books and the latest software for all the above computers including ZX81.

SEND S.A.E. FOR LIST TODAY!

## COMPONENT PACKS

- PACK 1 650 Resistors 47 ohm to 10 Mohm - 10 per value **£4.00**
- PACK 2 40 x 16V Electrolytic Capacitors 10µF to 1000µF - 5 per value **£3.25**
- PACK 3 60 Polyester Capacitors D 01 to 1µF/250V - 5 per value **£5.95**
- PACK 4 45 Sub-miniature Presets 100 ohm to 1 Mohm - 5 per value **£2.90**
- PACK 5 30 Low Profile IC Sockets 8, 14 and 16 pin - 10 of each **£2.40**
- PACK 6 25 Red LEDs 15mm dia **£1.50**

## 3-NOTE DOOR CHIME

Based on the SAB0600 IC the kit is supplied with all components, including loudspeaker, printed circuit board, a pre-drilled box (95 x 71 x 35mm) and full instructions. Requires only a PP3 9V battery and push-switch to complete. AN IDEAL PROJECT FOR BEGINNERS. Order as XK 102. **£5.50**

## FREE YELLOW CATALOGUE yet?

NO! Send S.A.E. 6" x 9" TODAY!  
It's packed with details of all our KITS plus large range of SEMICONDUCTORS including CMOS, LS TTL, linear, microprocessors and memories, full range of LEDs, capacitors, resistors, hardware, relays, switches etc. We also stock VERO and Arlex products as well as books from Texas Instruments, Barban and Elktor.

ALL AT VERY COMPETITIVE PRICES  
ORDERING IS EVEN EASIER JUST RING  
"THE NUMBER YOU CAN'T FORGET FOR THE PRICES YOU CAN'T RESIST."

5-6-7 8-9-10

and give us your Address or Barefaced No. or write enclosing cheque or postal order. Official orders accepted from schools etc.  
Answering service evngs and wnds

## TEACH-IN 84 Complete kit of top quality components as specified by EE including two EBBO starter packs.

**£15.80**



## LCD 3 1/2 DIGIT MULTIMETER

16 ranges including DC voltage (200 mv-1000 v) and AC voltage, DC current (200 mA-10 A) and resistance (0.2 M) + NPN & PNP transistor gain and diode check. Input impedance 10M. Size 155x88x31 mm. Requires PP3 9v battery. Test leads included. **ONLY £29.00**

## ELECTRONIC LOCK KIT XK101

This KIT contains a purpose designed lock IC, 10-way keyboard, PCBs and all components to construct a Digital Lock, requiring a 4-key sequence to open and providing over 5000 different combinations. The open sequence may be easily changed by means of a pre-wired plug. Size: 7 x 6 x 3 cms. Supply: 5V to 15V d.c. at 40mA. Output: 750mA max. Hundreds of uses for doors and garages, car anti-theft device, electronic equipment, etc. Will drive most relays direct. Full instructions supplied. **ONLY £11.50**

Electric lock mechanisms for use with latch locks and above kit **£14.95**

DL 1000K  
This value-for-money kit features a bi-directional sequence, speed of sequence and frequency of direction change, being variable by means of potentiometers and incorporates a master dimming control. **£15.95**

DL2100K  
A lower cost version of the above, featuring unidirectional channel sequence with speed variable by means of a pre-set pot. Outputs switched only at mains zero crossing points to reduce radio interference to a minimum. **£8.95**

Optional opto input DL1  
Allowing audio ("beat") light response. **60p**

DL3000K  
This 3 channel sound to light kit features zero voltage switching, automatic level control & built in mic. No connections to speaker or amp required. No knobs to adjust - simply connect to mains supply & lamps. **£12.95**

FAST SERVICE - TOP QUALITY - LOW LOW PRICES

No circuit is complete without a call to

# TK

## ELECTRONICS

11-13 Boston Road  
London W7 3SJ

Add 65p postage & packing - 15% VAT to total Overseas Customers.  
Add £2.50 (Europe), £6.00 (elsewhere) for o.p.  
Send S.A.E. for further STOCK DETAILS  
Goods by return subject to availability.  
9am to 5pm (Mon to Fri)  
10am to 4pm (Sat)

OPEN

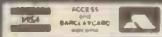

TEL: 01-567 8910 ORDERS  
01-579 9794 ENQUIRIES  
01-579 2842 TECHNICAL AFTER 3PM

ALL PRICES EXCLUDE VAT



# g easy, fast and reliable

**Multicore Solder Cream**  
Mixture of powdered 60/40 (tin/lead metal alloy and rosin flux).  
Uses: Micro electronics and printed circuits.  
Handy Tube: Size BCR 10  
£1.73



**Bib Wire Strippers and Cutters**  
With precision ground and hardened steel jaws. Adjustable to most wire sizes. With handle locking-catch and easy-grip plastic covered handles.  
Wire Strippers: Size 9  
£2.88



**Multicore Alu-Sol**  
Contains 4 cores of flux.  
Uses: Suitable for aluminium and aluminium alloys. (non-electrical).  
Handy Dispenser: Size HP27  
1.6mm dia £0.99 RRP  
Tool Box Reel: Size 4  
1.6mm dia £7.82



**Multicore Solder Wick**  
Absorbs solder instantly from tags and printed circuits with the use of a 40 to 50 watt soldering iron. Quick and easy to use, desolders in seconds.  
Handy Pack: Size AB10  
£1.43



**Multicore All Purpose Handyman Solder Pak**  
Contains three types of solder for electrical, metal and aluminium repairs, all in handy easy to use dispensers.  
Handy Pak: Size 8  
£2.99

All prices include VAT



Bib Audio/Video Products Limited,  
(Solder Division),  
Kelsey House, Wood Land End,  
Hemel Hempstead, Hertfordshire, HP2 4RQ  
Telephone: (0442) 61291 Telex: 82363

If you have difficulty in obtaining any of these products send direct adding 50p for postage and packing. For free colour brochure and Hints on soldering booklet send S.A.E.

## ELECTROVALUE

Your **SPECIALIST SUPPLIERS** for **SWITCHES**



Out of a very wide range of types, we show some of the more popularly demanded ones. The full range currently stocked will be found in our latest free 36 page A-Z products price list. Please mention this journal when contacting Electrovalue.



**MINIATURE TOGGLES, 7000**  
Series. 250 V/2 A. 120 V/5 A. Single, double, three and four pole configurations inc. Centre Off/On and biased

**CK WAVECHANGE** with adjustable stops. 1 P/12 way, 2 P/6 W, 3 P/4 W, 4 P/3 W, 6 P/2 W.

**Switch Kits**  
RA Shalt Assemblies up to 6 wafers.  
DP Mains switch, Screens, Spacers.



**PUSH BUTTON**  
Miniature  
Single and Double Pole Changeover  
Standard  
Latching and momentary  
**SLIDERS**  
Miniature & Standard. SP and DP in one, 2 or 3 positions.  
Many other types such as for timing and other special applications.

**BRITAINS LEADING QUALITY COMPONENT SUPPLIERS - SEND FOR FREE 36 PAGE A-Z LIST**  
ATTRACTIVE DISCOUNTS - FREE POSTAGE - GOOD SERVICE & DELIVERY

**ELECTROVALUE LTD**

Tel. (0784) 33606, Telex 264475  
North-680 Burnage Lane, Manchester (061-432 4945).  
EV Computing Shop, 700 Burnage Lane, Manchester (061-431 4866).

28 St. Jude's Road,  
Englefield Green,  
Egham, Surrey  
TW20 0HB.

ACCESS AND  
BARCLAYCARD  
Phoned Orders  
Welcome

2

## FREE CAREER BOOKLET

**Train for success, for a better job, better pay**

Enjoy all the advantages of an ICS Diploma Course, training you ready for a new, higher paid, more exciting career.

Learn in your own home, in your own time, at your own pace, through ICS home study, used by over 8 million already!

Look at the wide range of opportunities awaiting you. Whatever your interest or skill, there's an ICS Diploma Course there for you to use.

Send for your **FREE CAREER BOOKLET** today—at no cost or obligation at all.

TICK THE FREE BOOKLET YOU WANT AND POST TODAY

<b>ELECTRONICS ENGINEERING</b> <input type="checkbox"/>	<b>TV &amp; AUDIO SERVICING</b> <input type="checkbox"/>
<b>ELECTRICAL ENGINEERING</b> <input type="checkbox"/>	<b>RUNNING YOUR OWN BUSINESS</b> <input type="checkbox"/>

Name .....

Address .....

**ICS**  
Division of National Education Corporation

ICS  
Dept EC144  
160 Stewarts Road,  
London SW8 4UJ



01-622 9911  
(all hours)



# EVERYDAY ELECTRONICS and computer PROJECTS

VOL. 13 No. 4 APRIL 1984

**Editor**

F. E. BENNETT

**Assistant Editor**

B. W. TERRELL B.Sc.

**Production and News Editor**

D. G. BARRINGTON

**Projects Editor**

G. P. HODGSON

**Technical Sub-Editor**

R. A. HOOPER

**Art Editor**

R. F. PALMER

**Assistant Art Editor**

P. A. LOATES

**Technical Illustrator**

D. J. GOODING Tech. (CEI)

**Secretary**

JACQUELINE DOIDGE

**Editorial Offices**

KING'S REACH TOWER  
STAMFORD STREET  
LONDON SE1 9LS  
Phone: 01-261 6873

**Advertisement Manager**

D. W. B. TILLEARD  
Phone: 01-261 6676

**Secretary**

CHRISTINE POCKNELL

**Sales Executive**

A. TONGE  
Phone: 01-261 6819

**Representative**

R. WILLETT  
Phone: 01-261 6865

**Classified Supervisor**

B. BLAKE  
Phone: 01-261 5897

**Make-Up and Copy Department**

Phone: 01-261 6615

**Advertisement Offices**

KING'S REACH TOWER  
STAMFORD STREET  
LONDON SE1 9LS

**Readers' Enquiries**

We cannot undertake to answer readers' letters requesting modifications, designs or information on commercial equipment or subjects not published by us. All letters requiring a personal reply should be accompanied by a stamped self-addressed envelope.

We cannot undertake to engage in discussions on the telephone.

**Component Supplies**

Readers should note that we do not supply electronic components for building the projects featured in EVERYDAY ELECTRONICS, but these requirements can be met by our advertisers.

All reasonable precautions are taken to ensure that the advice and data given to readers are reliable. We cannot, however, guarantee it and we cannot accept legal responsibility for it. Prices quoted are those current as we go to press.

## HOME ENTERTAINMENT: A WIDER VIEW

SOME changes or new developments seem patently obvious after the event and make one wonder why they were not thought of before. The home entertainment scene currently provides a couple of such cases.

For a first example, consider the time it has taken for the combined TV and audio system to appear. Except for rare and expensive up-market versions, the television set has maintained a separate and independent existence; its makers apparently confident that limitations imposed by miniscule speakers were more than adequately compensated for by the alluring colour pictures it could display.

Another example is the coolness shown by set makers towards any wider use of the TV as a monitor or display unit for other forms of signal input.

But things have been changing. First video games, then microcomputers and video recorders, and now just around the corner is cable TV and the direct broadcast satellite. Set manufacturers are at last showing signs of appreciating this changing situation and are introducing facilities for auxiliary inputs to their latest models. And now finally the bringing together of visual and sound systems within a single rack or cabinet assembly has been realised—and by a British company, we are pleased to note. Fidelity launched their AVS1600 hi fi rack system with 16in colour TV last month and are to be congratulated on being the first in this field.

This development serves also to bring attention to the progress made in electronic engineering and manufacture in the consumer products' area, which is no less impressive than in the professional and defence electronics areas. Quite remarkable is the close packing of high technology that is commonly achieved today in electronic products. Moreover, hand in hand with miniaturisation of components goes a high standard of reliability.

To be honest, these two important aspects of contemporary electronics go unheeded by the vast majority of consumers who use and depend upon these products. But to the technically minded, and especially those brought up on valves or familiar at least with the early transistor days, the transformation is remarkable. Sudden breakdowns are no longer commonplace. Even with the most complex products, such as TV receivers, calls upon the service engineer are rare and when they do occur the service engineer's task is relatively simple and speedily performed, usually involving the substitution of a module or circuit board. (Component reliability is in fact discussed by Pat Hawker in this month's *Radio World*.)

The home constructor cannot expect to match the degree of close-packing now routine in factory produced equipments. But he does enjoy the benefits of greater reliability that is inherent in modern components, and this must make his hobby all the more satisfying and worthwhile. And, however comprehensive the electronic conglomerations that appear on the domestic market may become, it is fair to assume there will always remain needs and opportunities for extending further their usefulness by peripheral and auxiliary units designed and built at home.

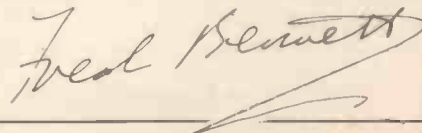

**Back Issues**

Certain back issues of EVERYDAY ELECTRONICS are available worldwide price £1.00 inclusive of postage and packing per copy. Enquiries with remittance should be sent to Post Sales Department, IPC Magazines Ltd., Lavington House, 25 Lavington Street, London SE1 0PF. In the event of non-availability remittances will be returned.

**Binders**

Binders to hold one volume (12 issues) are available from the above address for £4.60 inclusive of postage and packing worldwide. Please state which Volume.

**Subscriptions**

Annual subscription for delivery direct to any address in the UK: £12.00. Overseas: £13.00. Cheques should be made payable to IPC Magazines Ltd., and sent to Room 2613, King's Reach Tower, Stamford Street, London SE1 9LS.

# AUDIO SINEWAVE SWEEP GENERATOR



BY R. E. LIDDIARD

THE requirement for low distortion sine waves for use in audio equipment is well-known. Testing the performance of an amplifier, for example, demands that the signals used be of particularly good quality. In some applications sweep generators are required—audio frequency spectrum analysers being one example, and freedom from harmonics is often very important. Designing low distortion sine-wave sweep generators using conventional components is both cumbersome and expensive, frequently involving several voltage controlled filter stages.

This article introduces a new device—an opto-coupled resistor—and describes an inexpensive, but excellent performance, audio frequency sinewave sweep generator/oscillator.

## WIEN BRIDGE OSCILLATORS

A basic Wien Bridge Oscillator is shown in Fig. 1. Oscillations are produced in this circuit when the gain in the amplifier exactly compensates for the losses in the RC feedback circuit and the input is in-phase with the output. (Phase is the amount that a.c. current and a.c. voltage are "out of step" with each other.) In Fig. 1 this occurs when the phase change from C2 R2 is the same as the phase change from C1 R1. If C2 = C1 and R2 = R1 these phase changes are only equal when the frequency

$$f = \frac{1}{2\pi RC}$$

and the gain of the amplifier is exactly 3.

If the gain is greater than 3, the output will increase until it reaches the supply voltage, when "clipping" will occur. If the gain is less than 3, the output will simply die away, so we use a thermistor circuit to control the gain automatically. If the output from the amplifier rises, the average current through the thermistor RTH rises and so does its temperature. This reduces its resistance and lowers the gain of the amplifier again, giving just the control we need.

## LOW DISTORTION CIRCUIT

Distortion in this type of circuit is about 0.02 per cent and this is mostly due to non-linearities in the amplifier as the voltage on both its inputs swing up and down over a range one-third of the output. By using two amplifier stages, with one input on each stage connected to earth, this "common-mode" non-linearity can be eliminated and distortion reduced to around 0.001 per cent. Such a circuit is shown in Fig. 2.

In this case, sinusoidal oscillations are maintained when the output of op-amp A1 is just greater or equal to twice the output of op-amp A2, and the outputs are exactly out-of-phase. Automatic gain control is still achieved by means of a thermistor circuit, though its operation has been reversed.

Frequency can be altered either by changing the values of R or by changing the values of C. Traditionally double-ganged potentiometers have been used to change R.

## DESIGNING A SWEEP GENERATOR

Modifying the circuit of Fig. 2 to produce a sweep generator presents two problems:

Firstly, whatever components are used to replace the resistances R, they must respond equally and simultaneously to external control. Any tracking error between the two resistive elements will result in "bounce"—fluctuations in output amplitude as the frequency is changed.

Secondly, the resistances of the devices must be strictly linear, that means the same both forward and reverse biased,

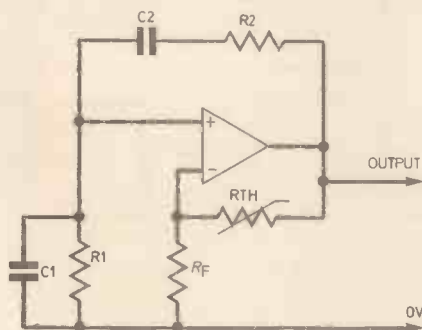

Fig. 1. Basic Wien Bridge Oscillator.

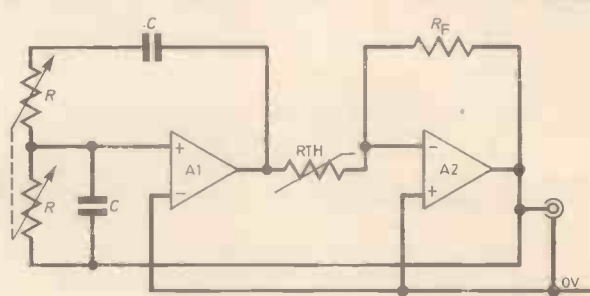

Fig. 2. Low distortion a.f. sinewave oscillator.

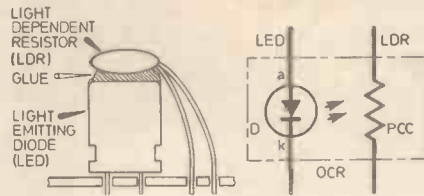
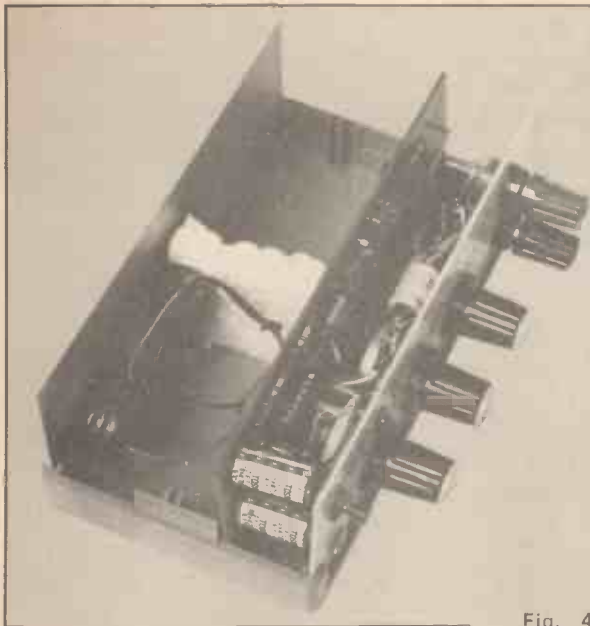

Fig. 3. Opto-coupled resistor (OCR): (a) physical arrangement of light dependent resistor (l.d.r.) and light emitting diode (l.e.d.); (b) circuit symbol.

otherwise distortion will occur. This latter problem tends to eliminate all directional components such as diodes and transistors, but leaves one device which has good resistive properties at suitable signal levels—the light dependent resistor (l.d.r.).

### OPTO-COUPLED RESISTORS

By physically connecting a light dependent resistor (l.d.r.) to a light emitting diode (l.e.d.), as in Fig. 3, a truly bi-directional "opto-coupled resistor" is formed, whose resistance is inversely proportional to control current (or conversely, whose conductance is proportional to control current) as shown in Fig. 4.

Different combinations of l.e.d. and l.d.r. will produce different "slopes" because of physical differences in construction and variations in internal performance, but the characteristics remain essentially linear. These can be matched by means of external components as illustrated in Fig. 5.

$R_x$  is a high value resistance applied across the output of one of the l.d.r.s to compensate for differences in resistance at low control currents.  $V_{Ry}$  is used to overcome the variation of light outputs of different l.e.d.s and different transfer characteristics of l.e.d./l.d.r. combinations. Good matching can be achieved in this way over a 1000:1 range of resistance. In the Sweep Generator described below,  $R_x$  was found to be unnecessary.

Such opto-coupled resistors are suitable for use in any application where an external control of resistance is required, provided the current through the l.d.r. is not too small, when noise levels may become prohibitive. Multiple devices can be constructed and matched by "cascading" opto-coupled resistors as shown in Fig. 6. Note that the control circuit is completely isolated from the resistance circuits, which are also isolated from each other.

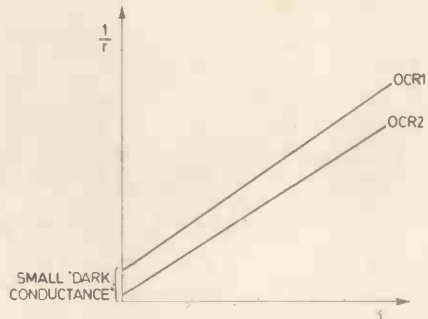

Fig. 4. Opto-coupled resistor characteristics.

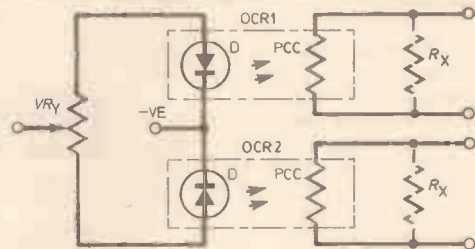

Fig. 5. Matching circuit for two opto-coupled resistors.

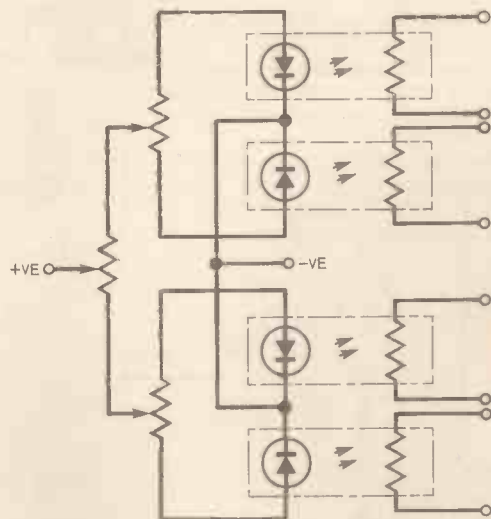

Fig. 6. Multiple opto-coupled resistors in cascade.

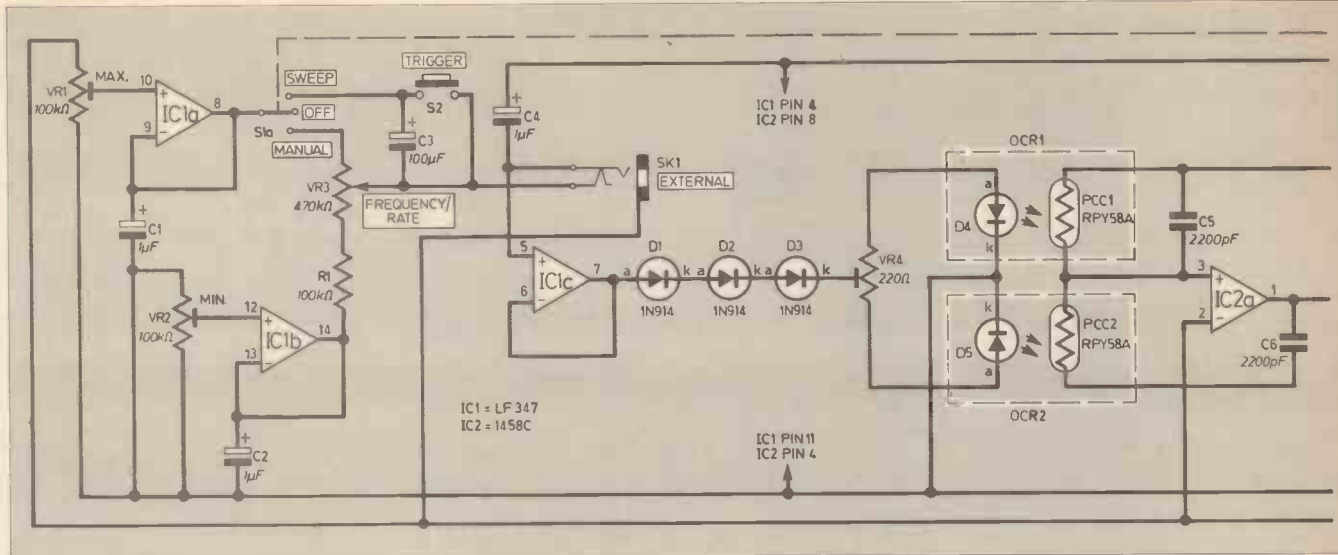

Fig. 7. The full circuit diagram for the Audio Sinewave Sweep Generator.

## AUDIO SINEWAVE SWEEP GENERATOR CIRCUIT

The full circuit for the Audio Sinewave Sweep Generator is shown in Fig. 7. The Wien Bridge oscillator as described above, is formed by IC2, OCR1, OCR2, VR4, C5, C6, R2 and RTH1.

IC1a and IC1b set the maximum and minimum voltages applied to the buffer IC1c which supplies the OCRs through D1 to D3 and VR4, so effectively VR1 and VR2 set the maximum and minimum frequencies respectively.

The FREQUENCY/RATE control, VR3, permits the selection of any frequency between these limits in MANUAL mode and determines the sweep rate in SWEEP mode—the sweep rate being set by the rate at which C3 is charged. C3 can be increased or decreased if slower or faster ranges of sweep rate are required, and for this reason C3 has been mounted on the back of the fascia panel, not the printed circuit board.

The circuit is designed to sweep from high frequency to low (the delay at the start of a sweep as RTH1 takes effect is much reduced at higher frequency) but by re-adjusting VR1 and VR2 and reversing the polarity of C3, a sweep from low to high frequency can be produced.

S1 provides MANUAL/SWEEP selection and S2 is the sweep TRIGGER. A socket is provided at the input of IC1c for EXTERNAL frequency control and lends itself to phase-locked loop techniques if required.

At the output of the oscillator a buffer is provided in IC1d with VR5 as a LEVEL control, but loads less than 1kΩ should be avoided.

A 9V plus 9V power supply is provided by two PP9 batteries, B1, B2.

## SPECIFICATION

- Operating Modes: Manual or Sweep
- Distortion: <0.002% at 1kHz
- Frequency Range: 20Hz to 20kHz (but see text)
- Output Amplitude: 0V to 5V r.m.s. (0V to 14V peak-to-peak)
- Buffered Output Stage. Suits loads of greater than 1kΩ impedance
- External Frequency Control is also provided

## COMPONENTS

### Resistors

- R1 100kΩ
- R2 1kΩ
- R3 100kΩ
- R4 1MΩ
- R5 2.2kΩ
- All 1/4W carbon ±5%

### Potentiometers

- VR1,2 100kΩ miniature horizontal skeleton preset (2 off)
- VR3 470kΩ linear, standard spindle
- VR4 220Ω miniature horizontal skeleton preset
- VR5 10kΩ linear, standard spindle

### Capacitors

- C1 1μF 100V elect.
- C2 1μF 100V elect.
- C3 100μF 25V elect.
- C4 1μF 100V elect.
- C5 2200pF polystyrene
- C6 2200pF polystyrene
- C7 470μF 16V elect.
- C8 470μF 16V elect.

### Semiconductors

- D1,2,3 1N914 diode (3 off)
- D4,5 light emitting diode, square (overall 6.4mm x 3.8mm), yellow (2 off)

### D6

light emitting diode 5mm dia., red, with clip

### IC1

LF347 quad op-amp, 14-pin d.i.l.

### IC2

1458C dual op-amp, 8-pin d.i.l.

### Switches

- S1 4-pole, 3-way rotary
- S2 single-pole, on/off push button

### Sockets

- SK1 jack socket 3.5mm,
- SK2 terminal post, red, with 4mm top socket
- SK3 terminal post, black, with 4mm top socket

### Miscellaneous

- B1,2 9V battery, PP9 (2 off)
- PCC1,2 light dependent resistor, RPY58A (2 off)
- RTH1 thermistor, R53

Battery clips for PP9 (2); collet knob black, 15mm collet cap grey, 15mm collet nut cover; d.i.l. socket, 8-pin; d.i.l. socket 14-pin; p.c.b.; Veropins 1mm; Verobox 212 or similar plastics case, size 153mm wide, 84mm deep, 59mm high.

# CONSTRUCTION

## PRINTED CIRCUIT BOARD

A diagram of the printed circuit board is shown in Fig. 8. The layout has been designed to accommodate the close proximity of S1 when using a Verobox type 212.

**COMPONENTS**  
**approximate**  
**cost £25**

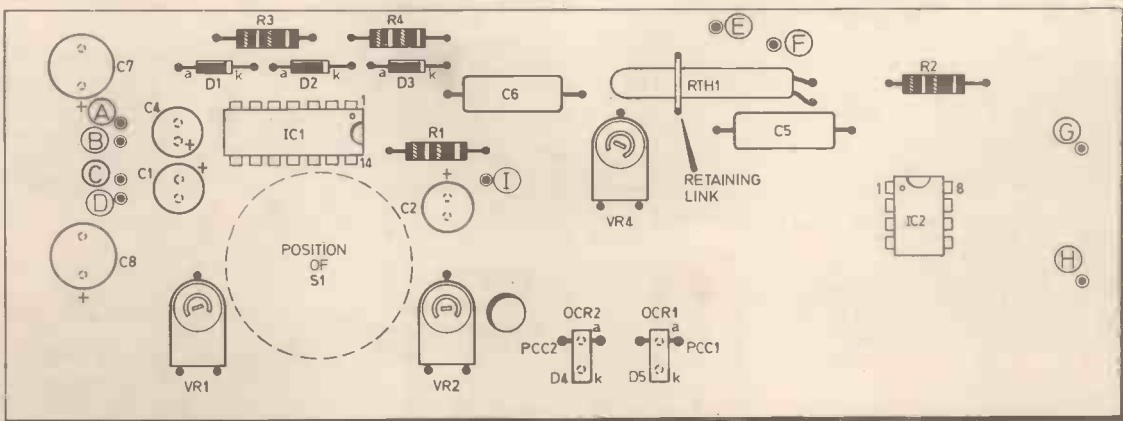
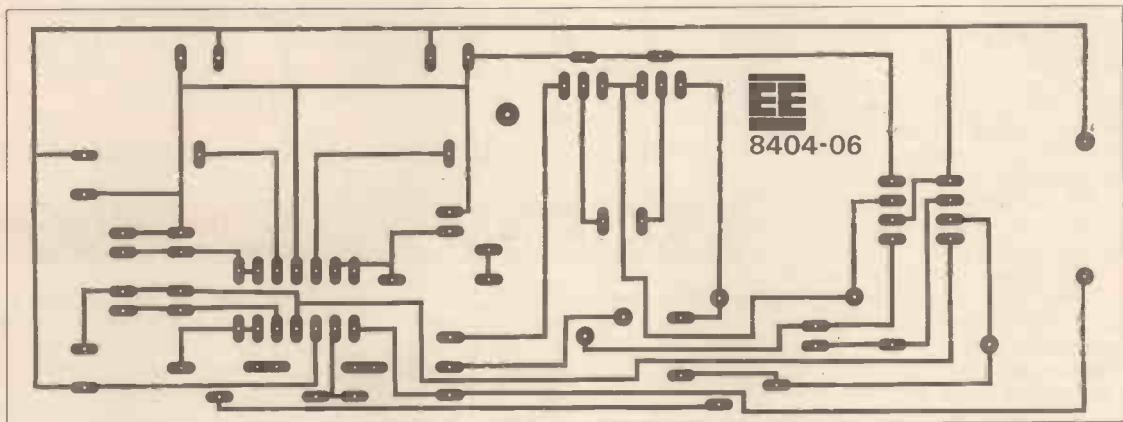

⊙ = VEROPINS (A) - (H)

Fig. 8. Printed circuit board for the Audio Sinewave Sweep Generator.

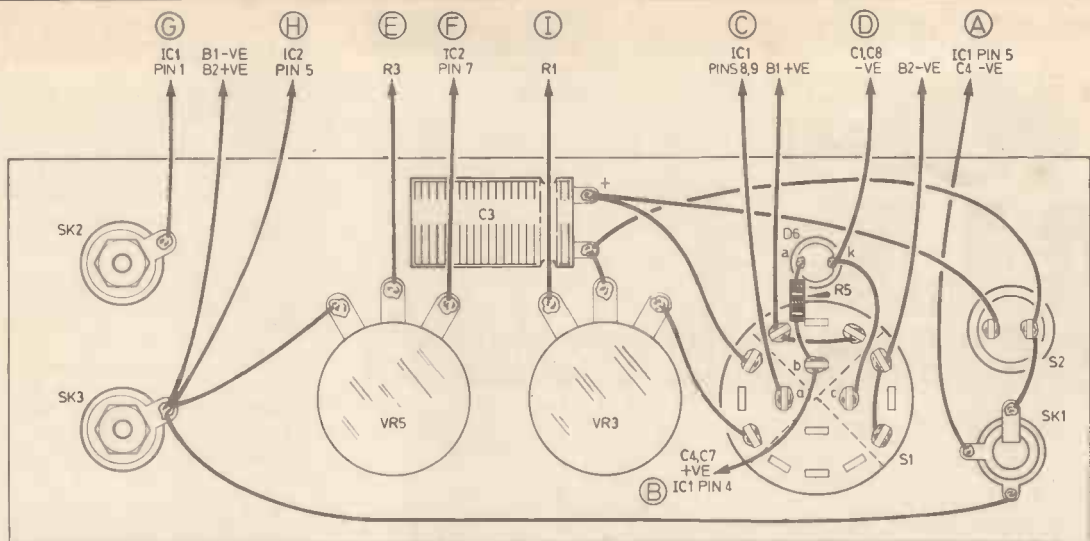

Fig. 9. Facia panel (rear view) showing panel mounted components and wiring to p.c.b.

Drill a  $\frac{1}{16}$ in hole in the p.c.b., as shown, to accommodate leads from the battery to S1 and the earth terminal SK3. Fit Veropins—where indicated. These will facilitate the interwiring to the off-board components.

Solder the l.e.d.s in position first, taking care to ensure the correct polarity.

Glue the l.d.r.s to the l.e.d.s using a clear adhesive and solder the l.d.r. leads in position. When the glue has set, paint the l.e.d./l.d.r. combinations with several coats of black paint. It is vital that all external light is excluded from these devices.

Solder the remaining components as shown and solder the retaining link in position over the thermistor using insulated wire. NOTE: this link also forms part of the circuit. Finally check that the p.c.b. is free from short circuits between the tracks, and insert the i.c.s.

Mount components onto the facia panel and wire up in accordance with Fig. 9.

## SETTING UP

Starting with all presets and potentiometers in the mid-position, and S1 set to MANUAL, adjust VR1 and VR2 until oscillations are produced. If the oscillations are fluctuating, adjust VR4 until a constant amplitude sine wave is heard. With VR3 set alternately to maximum and minimum, adjust VR1 and VR2 respectively to set the desired range of frequencies.

At this stage it is useful to check that the output is not affected by the presence of a bright light. If any change is detected, apply another coat of paint to the opto-coupled resistors and repeat the setting-up procedure.

## OPERATION

In MANUAL mode, the Audio Sinewave Sweep Generator provides low distortion sine waves between 20Hz and 20kHz. In SWEEP mode the entire audio spectrum can be swept in 20 seconds with no detectable "bounce". Faster sweep rates

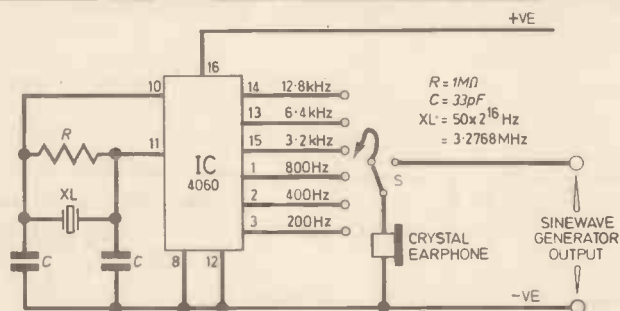

Fig. 10. Circuit of a crystal oscillator and frequency divider suitable for calibration purposes.

can be readily achieved by reducing the value of C3.

Amplitudes up to 16V peak-to-peak are produced without clipping.

## CALIBRATION

A simple, yet accurate method of calibrating the sine-wave generator can be performed using the circuit in Fig. 10. This consists of a crystal oscillator and frequency divider using a single chip—a CMOS 4060. A range of accurate fre-

quencies are provided as shown in the diagram. Any supply voltage between 5V and 15V can be used.

To calibrate the sine-wave generator switch S1 to MANUAL and adjust the FREQUENCY/RATE until the same tone is heard when compared with the crystal oscillator. Although the crystal oscillator produces square waves, it is quite easy to match the tones using this circuit.

If required, a calibration scale can be added to the FREQUENCY/RATE control. □

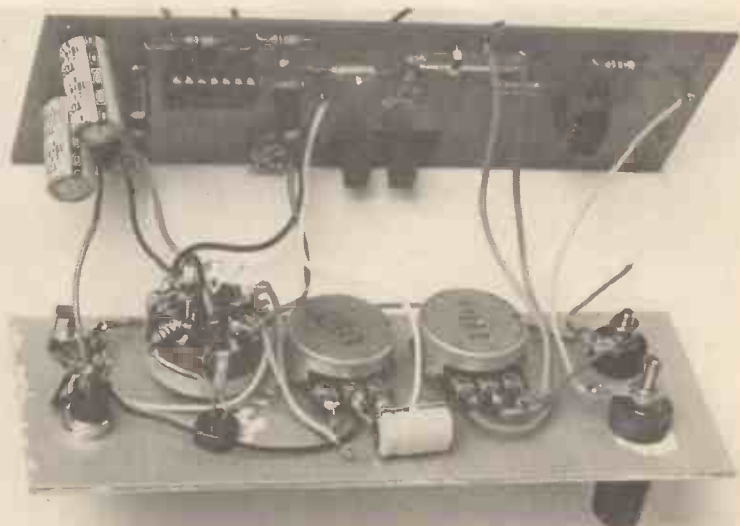



# SHOP TALK



BY DAVE BARRINGTON

## Catalogue Received

The latest edition of the excellent **Greenweld 1984/5 Components Catalogue** has been increased to 84 pages and includes many new lines.

The biggest increase appears to be in the "Connector" section, where the increasing demands of the computer interfacing requirements has resulted in a new family of special edge connectors and multi-cable "artery" leads. These include RS232 and Centronics connectors.

Other additions include an expanded range of audio modules and semiconductors.

All prices are quoted on the page and include VAT. Also, there are five 20p "Big G" discount vouchers on the inside back cover. These are redeemable with purchases on the basis of: one voucher accepted with any order over £4; thereafter one voucher for every £3 worth of goods ordered up to a maximum of five vouchers.

Copies of the Greenweld 1984/5 Components Catalogue cost £1 (70p plus postage), or 70p to callers to their shop. Mail orders for copies should be sent to **Greenweld Electronics Ltd., Dept. EE, 443 Millbrook Road, Southampton, SO1 0HX.**

## Mothercard

Talking of the increasing demands from readers for "inter-active" modules

to make the home computer more versatile and practical, **Velleman (UK)** have developed a range of plug-in boards for the Sinclair ZX machines.

Resulting from customers' enquiries wanting to expand the features of their systems, they have introduced an interface system consisting of a specific motherboard for each type of computer, and interface cards that can be plugged onto the motherboards.

It is possible, using the various cards, to add to each system the following features: Eight open collector outputs (25V/50mA); code K2609. Analogue-to-Digital conversion, 8-bit precision, 5-1V full-scale; code K2610. Eight opto coupler inputs; code K2611. A Centronics parallel printer interface; code K2614. Digital-to-Analogue conversion, 8-bit precision, 1-02V full-scale.

The motherboards for the ZX81 and the ZX Spectrum are available now, offering space for four interface cards. They are provided with a 23-pole edge connector at the back, giving the facility to connect the ZX printer or to stack more motherboards one after the other.

Power is taken from the computer's 9V d.c. supply or from an external unregulated 9V to 12V d.c. power source, depending on the consumption and the number of interface cards used.

For details and prices write to: **Velleman (UK) Ltd., Dept. EE, PO Box 30, St. Leonards-on-Sea, East Sussex TN37 7NL.**



ZX Expansion boards from Velleman

## CONSTRUCTIONAL PROJECTS

### Multipurpose Interface for Computers

The mains transformer used in the *Multipurpose Interface for Computers* project was purchased from RS Components. This is from their 20VA range and carries the stock number: 207-582.

The two 9V 1.1A secondary windings are wired in parallel to give the required 9V 2.2A rating.

The 2A circuit breaker CB1 is also listed by RS Components under the "sub-miniature" range and should be ordered as stock number: 335-996.

If this project is to be built on the EE p.c.b., the relay used should be of the type specified: RS 349-658. This is to agree with the allocation of mounting holes and solder pads on the board. If other relays are used then suitable leads can be taken from the board to the relay mounting tags.

It must be pointed out that RS Components will not supply to the general public and the above components will have to be ordered through your local recognised component supplier.

The 16-pin quad opto-isolator is stocked by Bi-Pak and is designated ILQ74 and should be ordered as: Code 1517. It is also available from Rapid and TK Electronics.

### Microcomputer Interfacing Techniques

The ADC 0817 40-pin 16-channel 8-bit analogue-to-digital i.c. used in the *Data Acquisition and Control Data Board* appears to be only available from Cricklewood Electronics Ltd.

### Timer Module for Central Heating Systems

The choice of relay for the *Timer Module for Central Heating Systems* is not critical and is dependent on the power requirements of the appliance being controlled. A relay with a coil resistance of between 180 to 500 ohms, with mains rated contacts should be suitable.

For a wider choice of relay, it is possible to wire two sets of contacts on a double-pole changeover type in parallel to enable it to handle higher currents. The relay can be mounted to the side of the board and leads taken from the board to the relay contact tags.

### Audio Sinewave Sweep Generator

The bead thermistor type RA53 used in the *Audio Sinewave Sweep Generator* is stocked (No. 151-114) by RS Components. It is also listed by Greenweld and Maplin as type R53. This thermistor is rated 5kΩ at 20°C and has a minimum resistance of 80Ω.

The "square" i.e.d.s are now stocked by most advertisers. However, the light dependent resistor, type RPY58A, is currently only listed by Maplin (code: HB09K (LDR RPY58A)) and Cricklewood Electronics.

### Quasi-Stereo

The dual operational amplifier i.c., type 1458C, used in the *Quasi-Stereo* project appears to be only listed by Enfield Electronics, Greenweld and Maplin.

An alternative device, with identical technical specification, is the  $\mu$ A747C. However, this is a 14-pin device and would necessitate changing the printed circuit board layout to cater for the different pinning of this i.c.

We cannot foresee any component buying problems for the *Quizmaster II* and the *Fuse and Diode Checker*—the second in our "Black Box" projects.

# A Black Box Project

# FUSE / DIODE CHECKER

THIS simple circuit is for quick testing of fuses that are not visibly checkable such as those found in 13A plugtops. Because of its oscillating action, it will also test diodes and give an indication as to which end is the cathode.

## CIRCUIT DESCRIPTION

The circuit diagram of the Diode/Fuse Checker is shown in Fig. 1. The design is based around the CMOS 4011 input NAND gate. Two NAND gates (IC1a and IC1b) are used to form a bistable multivibrator (as in last month's Black Box circuit) using R1, R2 and C1. This in turn feeds two more NAND gates, one of which inverts the signal of the other.

The output of IC1c goes to a touch plate, the output of the other gate (IC1d) goes to the two l.e.d.s connected inversely back to back and then on to the other touch plate. Because of the oscillating function of the circuit, the polarity across the two plates alternate, so that if a short connects the two plates together (such as a fuse), then current will first flow as shown in Fig. 2a illuminating D1, current will then flow in the opposite direction as in Fig. 2b, illuminating D2.

This will continue while there is a connection across the plates. If the fuse has blown, then no current can flow either way and neither l.e.d. will light.

## DIODE CHECKER

If a diode is connected across the plates, then current will flow only in one direction, illuminating the appropriate l.e.d. (as in Fig. 2c) and if the l.e.d. is positioned accordingly, it will show the cathode end (k) of the diode under test, if that diode is functioning.

If the diode has gone short circuit, both l.e.d.s will light (as for the fuse) and if it is open circuit, neither will come on.

## CONSTRUCTION

The circuit is built on a piece of stripboard 24 holes by 10 strips and the layout is shown in Fig. 3. The case is the same black plastic case, 80 × 61 × 41mm, as used in all Black Box projects.

Mount the i.c. socket first, followed by the links, resistors and capacitors. A small piece of copper was used as the two touch plates (see photo), as it was easy to solder to the back of them. Alternatively, brass could be used or even another piece of stripboard.

Drill the four holes in the lid of the box, solder the wires to the plate and glue the plates to the lid after passing the cables through the appropriate holes, using epoxy resin or something similar. While this is setting, prepare the cutout for the switch and then fix this in the box.

Connect up all the cables to the board and switch, and also to the l.e.d.s and touch plates. Fit the i.c. into the holder, taking usual precautions for CMOS. The board was held in the box with double-sided tape, and foam was used to stop the battery shaking about.

## TESTING

Switch the unit on, short out the two touch plates with a piece of wire and both l.e.d.s should light up (you should just be able to see them oscillating). Place a known, good diode across the plates (such as a 1N4001) after taking away the piece of wire and one l.e.d. will light up corresponding to the cathode end (k) of



the diode. If the other end is illuminated then swap the connections to each l.e.d. around. If, however both l.e.d.s light up or not at all, then the diode is either short circuited or open circuited.

Please note: due to the simplicity of this circuit, diodes with an average forward current of less than 10mA (such as AA144) or diodes with less than a peak reverse voltage of 7V (such as a BA104 or BA117) should not be used with the Diode/Fuse Checker, as damage to the diode may result. □

Fig. 1. Circuit diagram of the Fuse/Diode Checker.

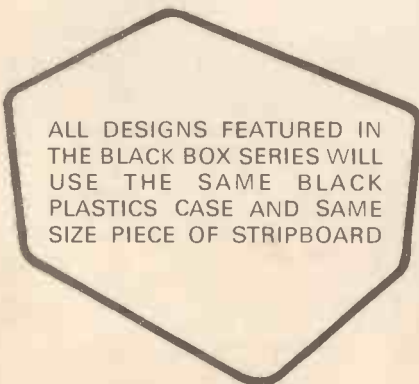
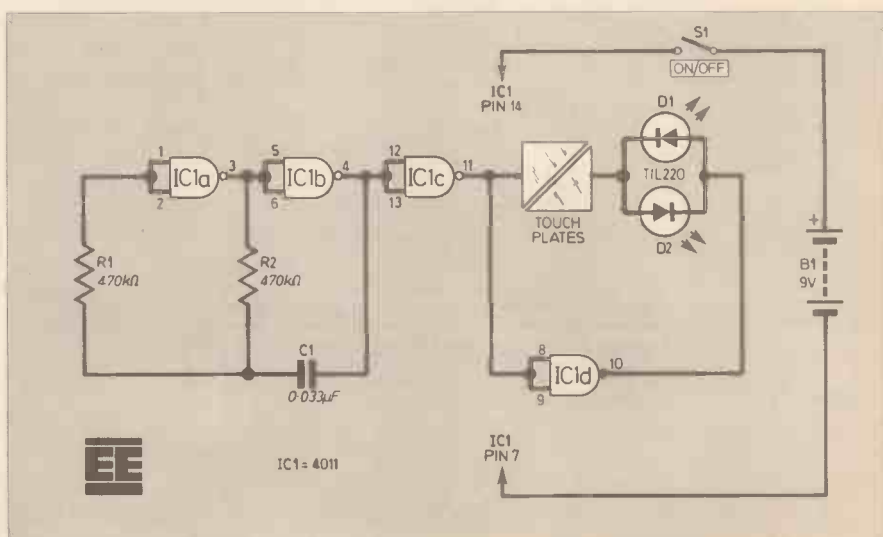

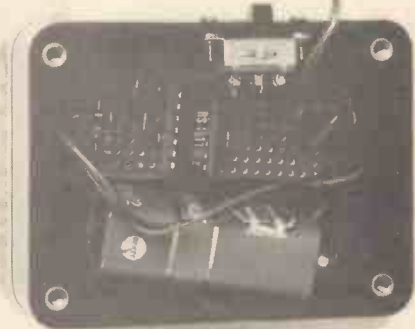
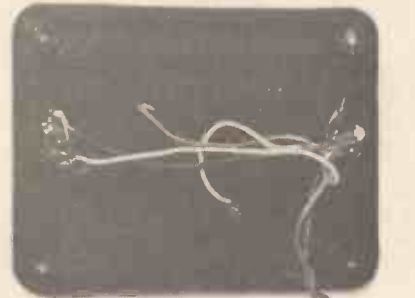

View inside the finished model. A piece of foam holds the board and battery in place when closed.

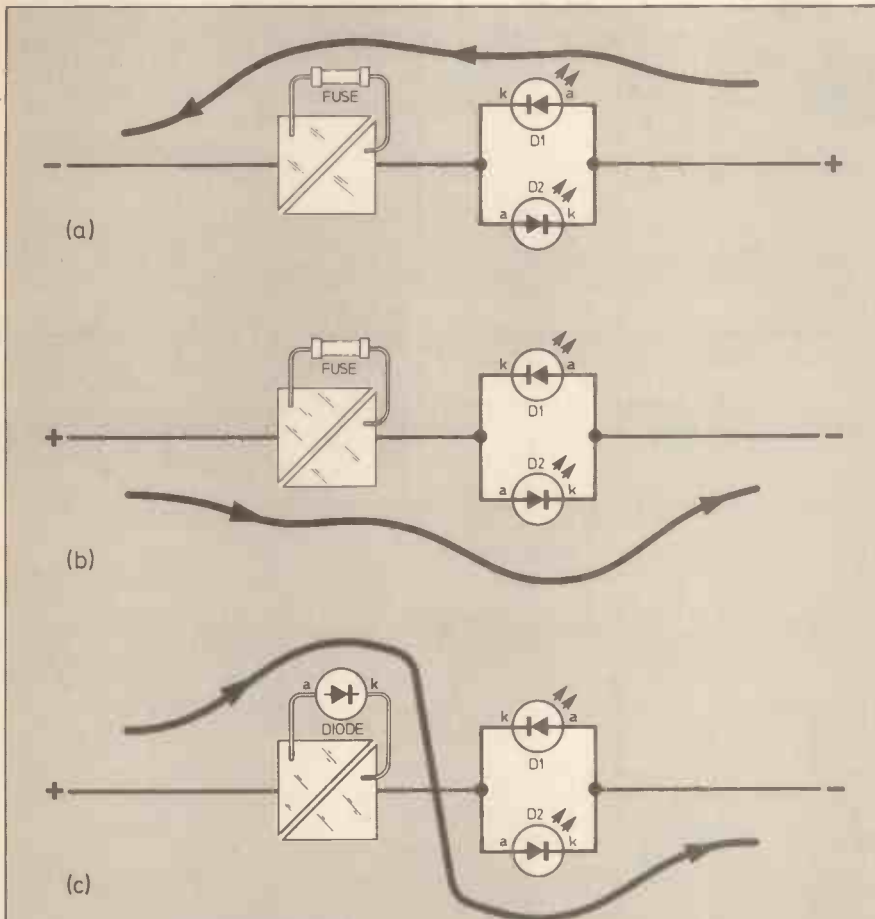
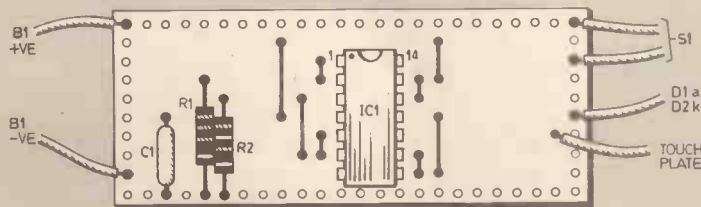

Fig. 2. (a) and (b) show the current path when testing a good fuse. Note that both l.e.d.s light alternately. (c) shows the current flow when a good diode is placed across the touch plates lighting only one l.e.d.



**COMPONENTS**  
approximate  
cost £2.00

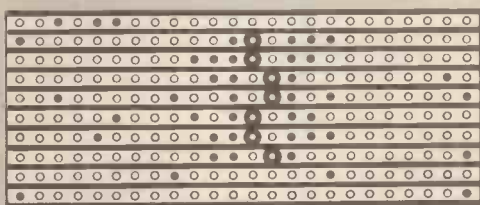

Fig. 3. The stripboard layout of the Fuse/Diode Checker. To complete the wiring, the other touch plate is connected to D1k/D2a.

## COMPONENTS

### Resistors

R1,2 470kΩ (2 off)

### Capacitor

C1 0.033μF polyester

### Semiconductors

D1,2 TIL220 5mm red l.e.d. (2 off)

IC1 4011 CMOS quad 2-input NAND gate

### Miscellaneous

S1 d.p.d.t. miniature slide switch  
B1 9V PP3 battery  
Black plastic case, 80 x 61 x 41mm; 0.1in matrix stripboard, 10 strips by 24 holes; battery clip; 14-pin i.c. socket; wire; piece of copper sheet, 40 x 40mm (for touch plates); double-sided tape; small piece of foam rubber.



A TWELVE-PART HOME STUDY COURSE IN THE PRINCIPLES AND PRACTICE OF ELECTRONIC CIRCUITS. ESSENTIALLY PRACTICAL, EACH PART INCLUDES EXPERIMENTS TO DEMONSTRATE AND PROVE THE THEORY. USE OF A PROPRIETARY BREADBOARD ELIMINATES NEED FOR SOLDERING AND MAKES ASSEMBLY OF CIRCUITS SIMPLE. THE IDEAL INTRODUCTION TO THE SUBJECT FOR NEWCOMERS. ALSO A USEFUL RÉFRESHER COURSE FOR OTHERS.

By GEORGE HYLTON

# WAVEFORMS & DISTORTION

THE oscillators we've made so far have been of a type that generates something approximating to square waves (Fig. 7.1). Any repeating waveform which is not a sine wave contains harmonics (multiples of the basic frequency). These affect the tonal quality of the sound heard when the wave is used to energise a loudspeaker or earphone. Square waves have a timbre reminiscent of organs or reed instruments.

## EXPERIMENT 7.1

### PHASE SHIFT OSCILLATOR

A pure sine wave makes a rather smooth-sounding note. To demonstrate this, build the oscillator shown in Fig. 7.2. This is a phase-shift oscillator. You'll remember that when talking about op-amps I explained how what is meant to be negative feedback can become positive and cause oscillation. The phase-shift oscillator exploits this.

Normally, if the collector output of a single-stage transistor amplifier is fed back to the base, feedback is negative and the circuit is stable. (This is the basis of the auto-bias technique.) In a phase-shift oscillator, CR "time constant" components are inserted in the negative feedback path to provide enough time delay to provoke oscillation at one particular frequency.

With the values of R and C shown, oscillation is at an audio frequency. At low settings of VR1, oscillation stops, because the fed-back signals are too attenuated.

Set VR1 so that the circuit just oscillates. You'll find that the sound has the pure quality I mentioned.

If you set VR1 very carefully to a point where the circuit just fails to oscillate you'll find that any sudden upset, like disconnecting then re-connecting the battery, produces a bell-like "ting".

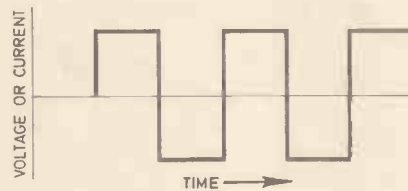

Fig. 7.1. Square wave.

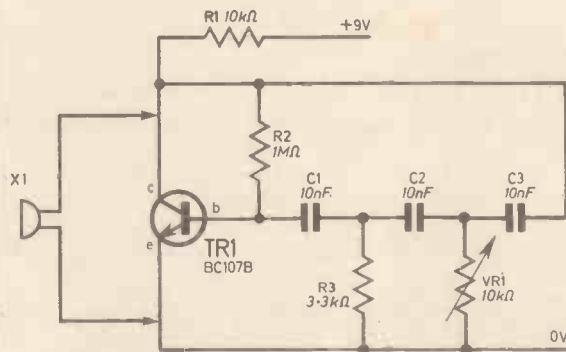

Fig. 7.2 (left). Phase shift oscillator circuit.

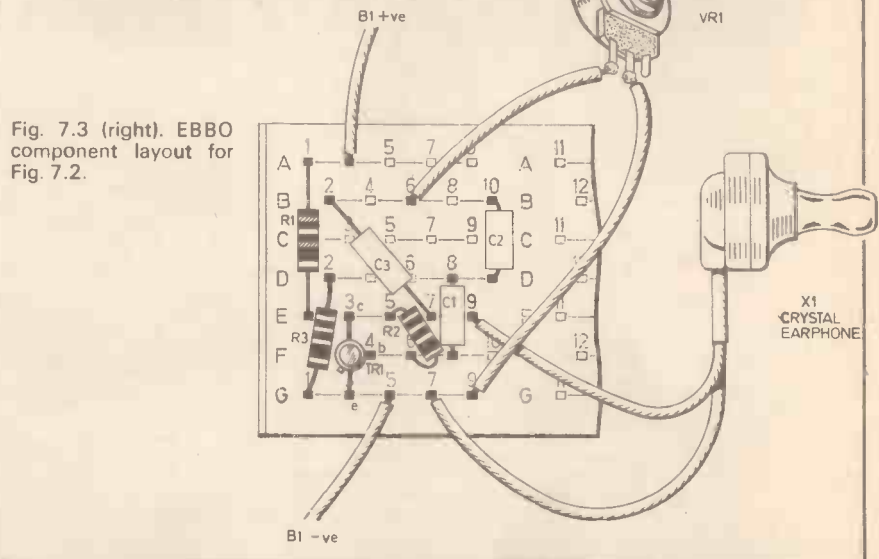

Fig. 7.3 (right). EBBO component layout for Fig. 7.2.

The explanation is that the sharp change of voltage caused by suddenly connecting the battery generates frequencies, some of which are close to the oscillation frequency. The circuit tries to keep these circulating. It can't, but they die away slowly, turning what would normally be a click into a "ting". This process, called ringing, can occur in badly-designed negative feedback amplifiers and in filters with sharp cut-offs.

At high settings of VR1 the tone sounds harsher. Some other noise seems to creep in. The pure sine wave of the just-oscillating circuit is now distorted.

## OVERLOAD

What causes the distortion? Well, there is a limit to the size of sine wave which your circuit can generate. Suppose TR1 collector voltage ( $V_{CE}$ ) is 4V. If the oscillation makes the collector current increase, this voltage falls (because R1 drops more volts).

At some low collector voltage TR1 ceases to function as an amplifier. Let's say this is 0.1V. Then driving the base harder has no effect: the collector voltage just stays at 0.1V. The result is that, at the collector, what should have been a sine wave gets its negative voltage peaks flattened (Fig. 7.4).

When the collector current is driven too far the other way, a similar overloading effect happens. A negative drive to the base reduces  $I_C$ . But  $I_C$  can't be reduced below zero. Once the zero point ( $I_C = 0$ ) is reached, further negative base drive has no effect. The collector current is cut off and that's that. Under these conditions there is no voltage drop in R1 and  $V_{CE}$  is the same as  $V_{CC}$ .

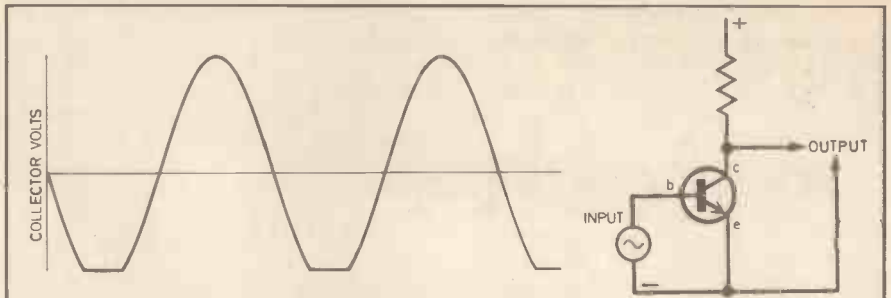

Fig. 7.4. Peak clipping: collector voltage waveform when the positive peaks of the input signal are too large.

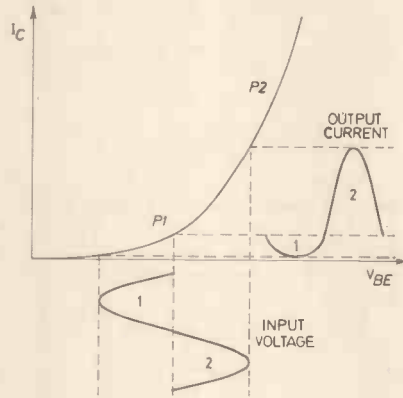

Fig. 7.5. How the non-linear characteristic of a transistor produces distortion.

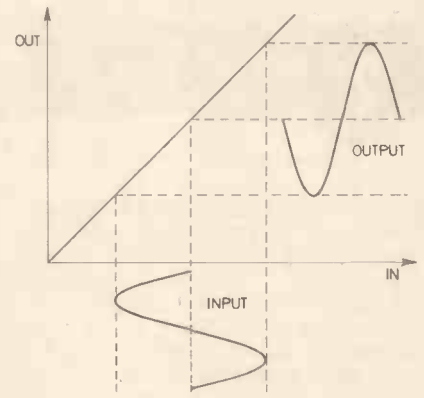

Fig. 7.6. A linear transfer characteristic gives distortionless amplification.

## NON-LINEAR TRANSFER

This form of peak clipping or limiting is a common sort of distortion. It is easily cured by reducing the signal level. There

is another common kind of distortion which is harder to deal with. It occurs when a transistor is voltage-driven.

Changing the base voltage ( $V_{BE}$ ) of a bipolar transistor makes the collector current vary as shown in Fig. 7.5. The important point about this graph is that it is curved. (In the case of field-effect transistors, the shape of the curve is rather different but it is still a curve rather than a straight line.)

This is unfortunate. In audio amplifiers we want the output waveform to be a faithful enlargement of the input. With a curved input-versus-output graph (often called a transfer characteristic) this kind of fidelity is impossible. If we bias the transistor to a working point such as P1 and apply a sine-wave input voltage as shown, the output current wave is distorted. The negative-going parts of the input wave have less effect on  $I_C$  than the positive-going parts.

What can be done about it? One possibility is to operate at point P2 where the characteristic is less bent. This means biasing the transistor to a greater d.c. collector current.

## CURRENT DRIVE

What is needed is a straight-line transfer characteristic, like Fig. 7.6. Such a linear characteristic gives zero distortion. It so happens that the relationship between base current and collector

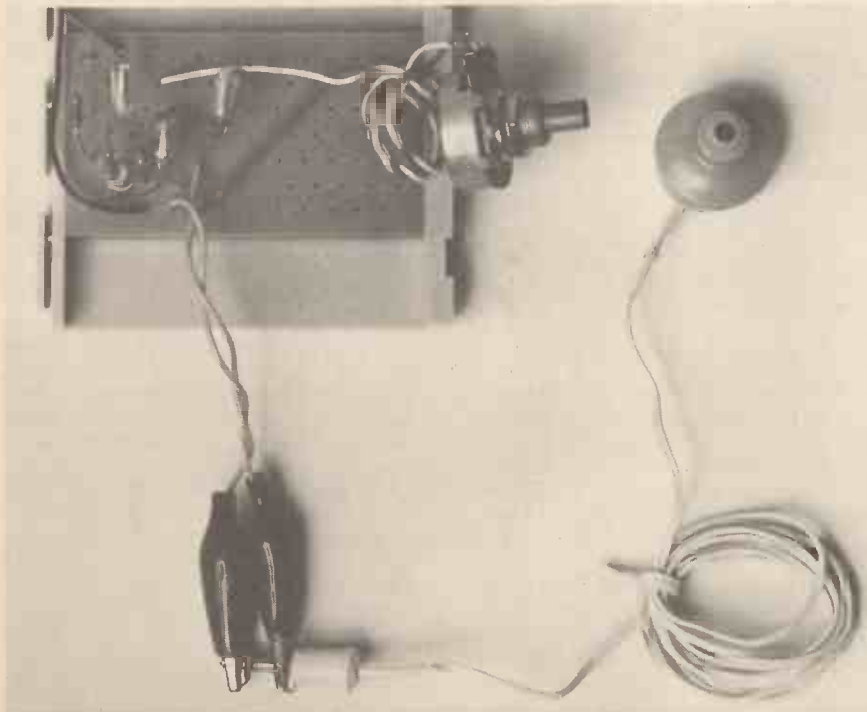

current is linear. So if a bipolar transistor can be current-driven rather than voltage-driven, distortion is minimised.

Current drive means that the signal must come from a source whose impedance is very much greater than the input impedance of the transistor. Unfortunately, the input stage of an amplifier usually can't be current-driven because, for lowest noise, a bipolar transistor has to be voltage-driven. The only useful distortion-reducing trick left is negative feedback. Distortion is reduced as the feedback reduces the gain.

## EXPERIMENT 7.2

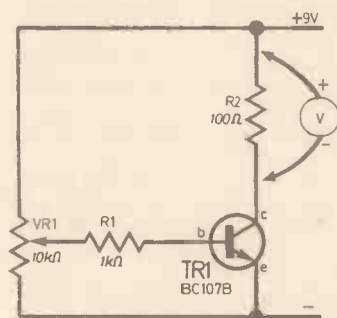

Fig. 7.7. Experiment to show heat effects.

### TEMPERATURE EFFECTS

Set up the circuit of Fig. 7.7. (Work out your own EBBO layout.) R2 drops 1V for every 10mA of collector current. Set the collector current to 30mA (3V). Switch off the battery for five minutes. Switch on again and observe the voltage reading. It increases slowly, indicating an increase in collector current.

This is the result of the transistor warming up internally. Let's confirm that transistors are affected by heat by warming this one externally. Switch off. Leave for five minutes to cool. Remove R2 but leave the meter in place.

Switch on. Set VR1 to give any convenient meter reading. Squeeze the case of TR1 between finger and thumb, taking care not to touch the leadout wires. After squeezing for a while the meter reading increases, as your body heat travels to the active semiconductor material inside the case.

### ENERGY CONVERSION

Where did the heat come from in the first experiment, when we weren't holding the transistor? It was generated inside the transistor. When current flows through a resistor, the resistor warms up. The electrical energy is turned into thermal energy.

A transistor is not a resistor, but to the battery it looks rather like one. When 9V

drives 1mA through any circuit, to the 9V source the circuit looks like 9kΩ. If the circuit is a transistor then the warming effect is just the same.

In our first experiment (R2 in place) the current was set high to increase the heating effect. The amount of heat released in a resistor depends on the current, naturally. But the current depends on the voltage. Take 1Ω and apply 1V: 1A flows. Apply 2V and 2A flows. The amount of heat released depends on both voltage and current.

To be precise, it depends on voltage times current. So if 1V and 1A gives one unit of heating, 2V and 2A give, not two but four units. The units are in fact watts, and watts (W) are the measure of the rate at which energy is being expended. So  $2V \times 2A = 4W$ .

### THERMAL RUNAWAY

Internal heating can be dangerous. Make a transistor too hot and it dies.

The danger is great in "power amplifiers", that is, amplifiers which have to deliver considerable power (to loudspeakers, for example).

Your finger-and-thumb experiment shows that a warm bipolar transistor passes more current. It therefore consumes more power. But this in turn raises the internal temperature, and this makes the transistor pass more current . . . and consume more power . . . and get hotter . . . and hotter . . . and hotter. The circuit "runs away".

So why haven't all our transistors destroyed themselves by thermal runaway? Two reasons. First, there has always been enough resistance in the way to limit the current to something safe. Take Fig. 7.7. Here there is 100Ω. Even if the full 9V were applied to 100Ω the current would only be 90mA. In fact, the transistor can't get hot enough to pass 90mA, because the more volts lost in R2 the less volts across the transistor. At 90mA, the voltage across TR1 would be zero; so, no heating. The most heating occurs when the current is 45mA and the voltage across TR1 and R2 is the same (4.5V).

The power being expended in each of them is then  $4.5V \times 45mA$ . Volts times milliamps gives the power in milliwatts (mW);  $1000mW = 1W$ .

### COOLING

The other reason why our transistors haven't destroyed themselves is that they are cooled by the air around them and by radiating heat. These cooling processes get more efficient as the transistor gets hotter. For once, nature is on our side.

But only up to a point. There is a limit to the rate at which heat can be removed. The only practicable way of increasing the cooling rate is to clamp the transistor to a metal plate. The plate provides a larger escape area for the heat.

Small transistors can't be helped much by such a heatsink because the internal

heat has to get to the outside case of the device from the hidden semiconductor material inside. It can't do this instantaneously; the heat has to cross the thermal barrier between semiconductor and case.

But our transistors are designed only for low-power operation. High-power transistors are mounted on metal plates or studs which can be bolted to heatsinks.

Heatsinks are often made of aluminium, with fins to increase the surface area, as on a radiator, and blackened. A heatsink is described in terms of the amount by which its temperature rises when 1W is being dissipated. Thus a heatsink may be described as "3°C/W". In this case, if it were clamped to a transistor dissipating 3W its temperature would rise by 9°C.

### POWER IN A.C. CIRCUITS

Power is volts times current. The meaning of voltage and current in a d.c. circuit is quite clear. But in a.c. circuits voltage and current are constantly changing. How do you measure power in this case?

The principle is to measure the a.c. quantities in a way that makes them directly comparable with d.c. An a.c. meter "reads" an a.c. current whose heating effect, when it flows through a resistor, is the same as d.c. of equal strength.

To make a.c. and d.c. equivalent in this way, the quantities have to be what are called r.m.s. currents and voltages. R.m.s. ("root mean square") refers to the mathematical basis for the equivalence.

Multimeters with a.c. scales are marked in r.m.s. voltage or current. Unfortunately, meters are liars. They really measure another kind of a.c., average-value a.c., which is much easier to measure than r.m.s. So your meter measures average-value a.c. but its scales are marked in r.m.s.

The meter reads correctly only if the a.c. currents and voltages have waveforms which are sine waves. With other wave shapes the meter reading is wrong. True r.m.s. meters do exist, but they are expensive.

### AUDIO POWER

Fortunately, the errors are usually not too enormous. All the same, they exist. To make life easier when talking about audio power, equipment makers usually quote values for sine-wave signals. (Real speech and music are not of sine wave form.)

Amplifier specifications often don't quote r.m.s. power but peak power, which is greater and makes the figures look good. Peak power is also more relevant to distortion. As we've seen, an "overload" type of distortion happens when an amplifier can't handle the peak signal. So an amplifier's peak power rating says how much it can deliver round about the point where peak clipping begins. See page 238

## CHECK YOUR PROGRESS

Questions on *Teach-In 84 Part 7*  
Answers next month

- Q7.1 A transistor has a collector load resistor of  $100\Omega$ . The supply voltage ( $V_{cc}$ ) is 10V.
- What is the maximum current that can flow in the load?
  - What is then the load power dissipation?
  - What is the transistor power dissipation? (i.e., collector volts times collector current).
  - What are the conditions in this type of circuit for maximum power dissipation in the transistor?
  - What are then the collector voltage ( $V_{ce}$ ) and current?
  - If the transistor has  $h_{FE} = 100$  what base current is required in condition (e)?
- Q7.2 In transistor data, the temperature rise due to internal heating is described in terms of a "thermal resistance" RTH between the collector-base junction and the case or mounting stud of the tran-

sistor; for example, if  $R_{TH}$  (junction to case) =  $10^\circ\text{C}/\text{W}$  and the transistor is dissipating 2W, the junction temperature is  $20^\circ\text{C}$  higher than the case temperature.

- If the maximum safe junction temperature is  $150^\circ\text{C}$  and the transistor is on a heatsink which holds its case at  $50^\circ\text{C}$ , what is the maximum power which can safely be dissipated in the transistor?
  - If the ambient temperature around the heatsink is  $25^\circ\text{C}$ , what must be the thermal resistance between heatsink and air?
- Q7.3 In audio power stages like Fig. 7.10, the peak load current is half  $V_{cc}$  divided by  $R_L$ . (This occurs when one transistor is "cut off" and the other is "hard on" with its  $V_{ce} = 0$ .) The peak load power is then  $(V_{cc}/2)$  times the load current, which in turn is  $(V_{cc}/2)/R_L$ .
- If  $V_{cc} = 20\text{V}$  and  $R_L = 4\Omega$  what is the peak power?
  - What is the peak power if  $V_{cc}$  is raised to 40V?

(c) If the r.m.s. (sine wave) power is half the peak power, how can it be calculated in terms of  $V_{cc}$  and  $R_L$ ?

## ANSWERS TO PART 6

- Q6.1 (a) pnp.  
(b) The circuit is similar to Fig. 6.9 except that TR1 is pnp. The input voltage is fixed at 4.5V by R1 and R2. The meter is replaced by R3. Negative feedback forces  $V_x$  to be equal to  $V_y$ . This makes the voltage across R3 be 4.5V, so the emitter current is 4.5mA.  
(c) 4.5mA approx., since  $I_c$  is nearly the same as  $I_e$ .  
(d) If R4 were  $1k\Omega$  it would drop 4.5V. But there is a drop of 4.5V in R3. Together these would use up all the supply voltage, leaving nothing to operate TR1.  
(e) None.  $V_y$  is still  $V_{cc}/2$ .  
(f) 3mA. ( $V_y$  and  $V_x$  become 3V.)

# LETTERS

## Teach-In Buzz

Sir—I have a problem; in your *Experiment 4.4* (see *Teach In '84*—January issue) I constructed the circuit according to the schematic (Fig. 4.10) using Veroboard and it didn't work. No buzz. I then noticed that the EBBO layout was different, so I rewired accordingly. Still no buzz.

By experimenting I found that if I left the VR1 as shown on the EBBO layout, but connected the earpiece to the TR1 input instead of to earth, I did get a buzz, which varied (in volume) with the setting of the VR1, but there was no change in frequency. The system worked equally well if either the (a) or (b) connections of the potentiometer (VR1) were totally disconnected. And in all cases the system worked better (louder) if the  $10k\Omega$  was replaced by  $100k\Omega$  potentiometer.

Evidently I am doing something wrong, and as I am conscientiously (!) working through all the experiments and progress checks, I would be very glad if you would please tell me where I am going wrong.

R. W. Seymour-Lee  
Newbury,  
Berks.

Sorry about the error in Fig. 4.11. The end of VR1 marked "a" should be connected to C2 and the earphone X1, as shown in the corrected version of Fig. 4.11 given here.

However, this is not the only problem in your case. I deduce from the symptoms which you describe that your output coupling capacitor C2 is faulty. It has gone "open". The result is that no a.c. can get through it, hence no oscillation.

The reason why your last circuit did oscillate is that the earpiece itself is (electrically) a capacitance; in your circuit it couples the output of the amplifier back to the input. Your  $100k\Omega$  potentiometer acts as a

"volume control" by bypassing some of the output current to "earth." As the slider approaches "a" the volume then falls (and eventually oscillation ceases).

Thank you for drawing the problem of the drawings to my attention.—George Hylton.

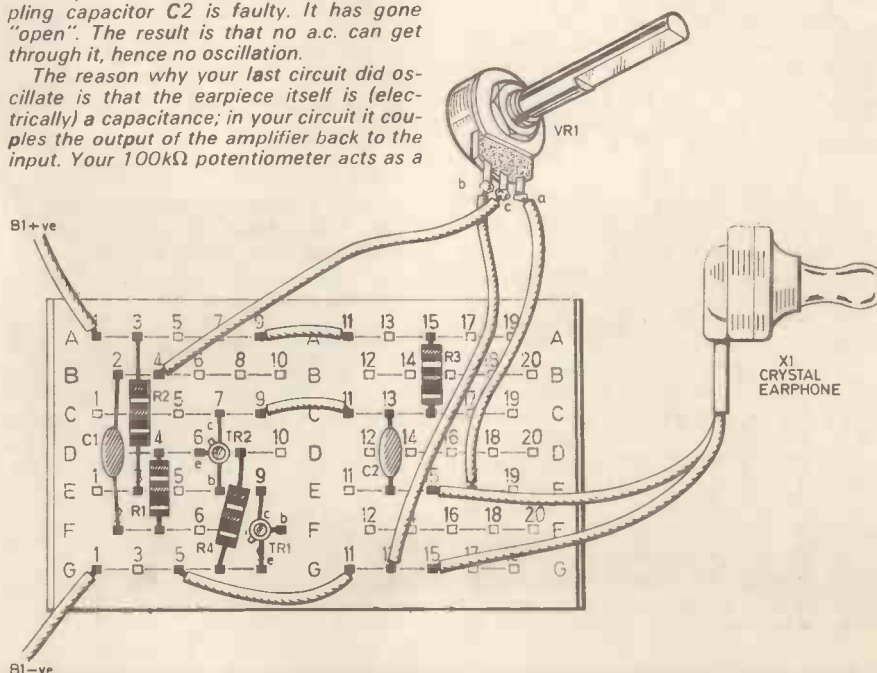

## DISTORTION VERSUS DISSIPATION

We've seen (Fig. 7.5) that for low distortion a transistor should operate with a fairly large standing collector current. That's fine for a pre-amplifier or the low-signal-level parts of a power amplifier. But for the output stage, where signal voltages and currents are highest, high standing current is bad from the power dissipation point of view.

Suppose, for example, that the transistor in Fig. 7.8 has to deliver maximum power to a  $10\Omega$  load. The condition for this is that  $V_{CC}$  is shared equally between load and transistor. In this example, the  $10\Omega$  load drops 10V so the current is 1A. The transistor also runs at 10V, 1A so its "collector dissipation" is 10W. The transistor dissipates 10W whether or not there is any signal present.

This is a warm and wasteful mode of operation. For economy, it would be preferable if the transistor were switched off when there is no signal. Then, when a signal arrives, it should be switched on just enough to handle this particular strength of signal without overloading.

## PUSH-PULL

Such an amplifier can be built. It is called a "sliding bias" amplifier. But you are unlikely to come across one. There is another way of achieving the same objective which works better. It's called push-pull working.

The principle is illustrated in Fig. 7.9. Here  $R_L$  is the load to which power must be delivered. There are two batteries.  $V_1$  is twice the voltage of  $V_2$ .

Suppose  $VR_1$  is a linear-law "pot". With the slider at the half-way point, half of  $V_1$  is tapped off: 10V. No current flows in  $R_L$  because the "tapped off" 10V is opposed and cancelled by  $V_2$ .

If the slider is now moved up, towards (a), more of  $V_1$  is tapped off. This overcomes  $V_2$  and current flows downwards through  $R_L$ . When the slider reaches (a), the net voltage applied to  $R_L$  is  $V_1 - V_2$ . This is 10V in our case ( $20V - 10V$ ) so 1A flows in  $R_L$  and the power is 10W.

Now move the slider back to the midpoint of  $VR_1$ , then on downwards. Below the midpoint, the tapped-off portion of  $V_1$  is less than 10V. So  $V_2$  overcomes it. Current flows from  $V_2$  into the slider and upwards through  $R_L$ . With the slider at (b), the full 10V of  $V_2$  is applied to  $R_L$ . Current is now 1A and power 10W.

By moving the slider up and down past the midpoint, current can be made to flow first one way then the other through  $R_L$ . In other words, the arrangement generates a.c. If  $R_L$  were a loudspeaker, and the slider were wagged up and down at an audio frequency, sound would be emitted. The peak power would be 10W.

This mode of operation is called push-pull working. To make it practical, we first replace  $V_2$  with a capacitance  $C_1$  (Fig. 7.9b). With the slider at the mid-

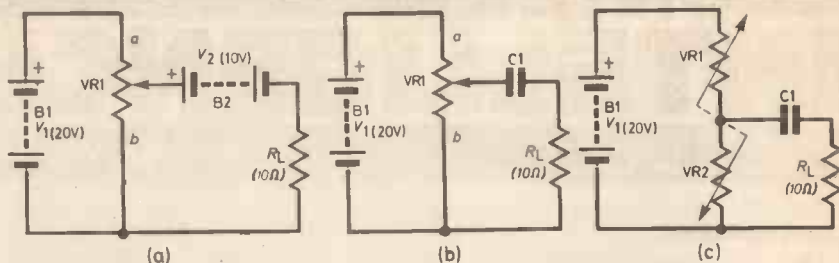

Fig. 7.9. "Thought experiments" to illustrate push-pull operation. (a) Two-battery circuit. (b) How a capacitor can replace one battery. (c) Two-resistance version of (b) which is easier to transistorise.

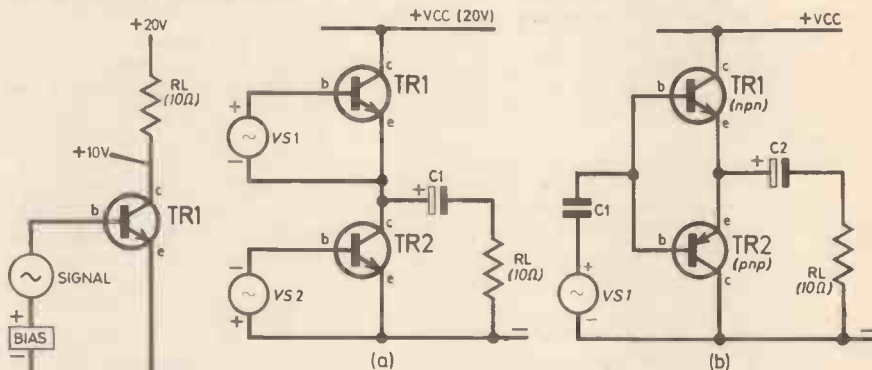

Fig. 7.8. Rudimentary power amplifier.

Fig. 7.10. Two versions of a push-pull power stage. (a) Single polarity transistors with two signals in anti-phase. (b) Complementary transistors with single signal.

point  $C_1$  charges to 10V. Move it up, and more current flows into  $C_1$ . Move it down towards (b) and  $C_1$  discharges, current flowing out.  $R_L$  receives to-and-fro currents as before.

The next step is taken purely because a potentiometer like  $VR_1$  can't be imitated directly by transistors. But an equivalent can (Fig. 7.9c). Here  $VR_1$  increases as  $VR_2$  decreases and vice-versa. The voltage at their junction moves up and down exactly as before.

By substituting transistors for  $VR_1$  and  $VR_2$ , and controlling their effective resistances by applying signals to their bases, the circuit becomes an audio power amplifier. Peak power to  $R_L$  is 10W.

## TRANSISTOR PUSH-PULL

One possible scheme is shown in Fig. 7.10a. Here, the signal voltage is duplicated. One copy,  $V_{s1}$ , drives  $TR_1$ . The other copy,  $V_{s2}$ , drives  $TR_2$ , but with the reverse polarity.

When the voltages are as shown,  $TR_1$  is turned on. Current flows from  $V_{CC}+$  via  $TR_1$  into  $C_1$ , so  $R_L$  gets a downward current. The actual amount depends on how hard  $TR_1$  is turned on, and this depends on the signal amplitude. Meanwhile,  $TR_2$  is held off. No collector current can flow as base is negative.

When the next audio half-cycle occurs, the signal polarity reverses.  $TR_1$  is now held off but  $TR_2$  turned on.  $C_1$  discharges through  $TR_2$ , giving an upward current through  $R_L$ . If there is no signal,  $TR_1$  and  $TR_2$  are both off.

## BIAS

The arrangement has one drawback. Since a transistor passes no collector current until  $V_{BE}$  reaches around 0.6V, audio signals less than 0.6V are ignored. The result is bad distortion.

To avoid this,  $TR_1$  and  $TR_2$  must be given enough bias to turn them on slightly in the absence of a signal. Even a small positive signal can then turn a transistor on further.

## COMPLEMENTARY OUTPUT STAGE

The Fig. 7.10a arrangement is often used in high-power amplifiers. But for low and medium power circuit (b), Fig. 7.10b, is commoner. Its advantage is that only one signal ( $V_{s1}$ ) is needed. The arrangement makes use of the fact that a positive signal turns an *npn* transistor on, but a *pnp* transistor off.

When  $V_{s1}$  polarity is as shown,  $TR_1$  is turned on and delivers a current to  $C_2$  and  $R_L$ . When the polarity reverses, the negative signal turns  $TR_1$  off but  $TR_2$  on, and  $R_L$  gets a reverse current as before.

In the no-signal condition, both transistors are off. But in practical circuits they are given enough bias to turn them on slightly in the absence of a signal.

With both circuits, when the signal is large,  $TR_1$  handles the positive half cycles and  $TR_2$  the negative ones. For small signals the standing bias makes both transistors operative.

Next month: Power In General



# COUNTER INTELLIGENCE

BY PAUL YOUNG

## Unsurpassed

The introduction of the home micro-computer has produced a curious dichotomy and in the short term view, the electronics hobby has suffered. Those who started constructing them, soon found they were more fascinating to play with, worse still, many teenagers who were almost certain candidates for the electronics hobby were being wooed on to the home computer by advertising and television coverage.

The other day, I happened to visit a large stationer's in London and the first thing that met my eyes was several shelves full of home computers. I think they might have had more success, assuming they were trying to attract the casual buyer, if they had avoided such arcane language. The large notice saying "128 Kilobytes of RAM" would be meaningless to the tyro, whereas, "Produces 130,000 characters or 20,000 words" might give him some idea what it was all about.

Well, they are here to stay and I suppose

I shall be told, "If you can't beat 'em, join 'em", though it goes against the grain for some of us more mature chaps. It was therefore, with great interest, that I read what the Right Honorable Tony Benn had to say on the subject, in one of the "nationals".

"This technology represents as great an advance in the communications arts as did the printing press, the television, radio—or telephone and tape recorders". He goes on to say, "It is for typing—simple typing—that the machine has proved itself to be unsurpassed, offering to my shaky two-fingered typing an undreamed of capacity to produce perfect copy without, as before, consuming more bottles of Tippex than mugs of tea."

## Positive Charge

I was interested to see in the February issue of EVERYDAY ELECTRONICS a constructional article on a *Negative Ion Generator*. I have been exchanging letters on the subject

of the benefit of negative ions with a knowledgeable reader.

We were discussing when the air was more likely to be charged with an excess of positive ions. During thunderstorms, of course, but he said there was also a theory that people living under high voltage electric pylons suffer in this way although no satisfactory conclusion has been arrived at.

It made me wonder if the average colour television produces positive ions. As a corollary, has anyone produced a meter that would show the amount of positive or negative ions in a room.

I suppose an Electro-scope might be the answer. Readers' views on this would be most welcome.

Finally, here is a way of testing your ioniser that I can personally vouch for. View the end of the pin in total darkness and a tiny blue corona will be visible round the tip. It is very small, and a magnifying glass would be helpful.

I don't know whether it will work with five pins and it might be better to make the test after the first pin is placed in position.

# EVERYDAY ELECTRONICS SOFTWARE SERVICE

The EE Software Service provides an easy and reliable means of program entry for our computer-based projects. All programs have been tested by us and consist of two good quality copies of the working program on cassette tape. Certain program listings are also available.

All prices include VAT, postage and packing. Remittances should be sent to Everyday Electronics Software Service, Editorial Offices, Westover House, West Quay Road, Poole, Dorset BH15 1JG. Cheques should be crossed and made payable to IPC Magazines Ltd.

PROJECT TITLE	CASSETTE CODE	CASSETTE COST	LISTING CODE	LISTING COST
ZX81 SPEED COMPUTING SYSTEM (Feb 83)	T001	£2.95	L001	£2.95
REAL-TIME CLOCK ( <i>Apple II</i> ) (May 83)	T002	£2.95	L002	£2.95
REAL-TIME CLOCK ( <i>BBC Micro</i> ) (May 83)	T003	£2.95	L003	£2.95
EPROM PROGRAMMER ( <i>TRS-80 &amp; GENIE</i> ) (June 83)*	T004	£3.95	N/A	—
STORAGE SCOPE INTERFACE ( <i>BBC Micro</i> ) (Aug 83)	T005	£2.95	—	—
ELECTRO-CARDIOGRAPH ( <i>BBC Micro</i> ) (Jan 84)	T006	£2.95	—	—
EPROM PROGRAMMER/ROM CARD ( <i>ZX81</i> )** (Feb 84)	T007	£3.95	—	—

\*Includes Command List with examples.

\*\*Includes Keyboard Overlay.



# MICROCOMPUTER INTERFACING TECHNIQUES

INCLUDING MANY USEFUL CONSTRUCTIONAL PROJECTS

PART TEN: DATA ACQUISITION AND CONTROL

BY J. ADAMS B.Sc., M.Sc. & G.M. FEATHER B.Sc.

In the previous articles the techniques of I/O control and the monitoring of analogue quantities from the real world have been treated separately.

In many actual applications it is necessary to take corrective action on the basis of comparisons made between readings of physical parameters and their prescribed values. For example, analogue voltages developed from separate temperature probes, could be converted into digital values monitored by the microcomputer and compared with pre-determined values allotted for the particular application.

If this comparison shows that correction is desirable then appropriate signals could be sent to individual output devices controlled by the microcomputer so that the necessary correction could be achieved.

Such a system allows the repetitious monitoring of analogue quantities over long periods of time and this allied with a precise control in response to these measurements will obviate human error.

In addition, if transient events are monitored using the system, the speed of the microcomputer allows an almost instantaneous response. It should be apparent that the considerable flexibility and undoubted accuracy of such systems offer many advantages over manual systems.

## CLOSED-LOOP SYSTEM

This month's project in the series is a closed-loop feedback control system. Information obtained from a 16-channel analogue-to-digital converter is fed back to the microcomputer so that it can control seven separate output devices to compensate for the effect of external changes.

This method is, of course, more crude than a closed-loop system including full proportional control (employing perhaps a DAC) but it is cheaper and easier to implement.

In practice a degree of pseudo-proportional control can often be achieved by the subsequent on-and-off switching of appropriate devices and this can be further improved by anticipatory on-off control. In such control systems the devices are actuated before the measured physical parameters reach their threshold values. This approach reduces

oscillations of the monitored quantities of "hunting" as it is generally termed.

It is a relatively straightforward matter to write the requisite software with appropriate anticipation values included to prevent this occurring.

## APPLICATIONS

There are many applications for such regulatory control systems. Two obvious

and useful applications—in the house and in the greenhouse—are outlined below.

## HOUSE ENERGY MANAGEMENT SYSTEM

The main shortcoming of conventional central heating control systems is the inherent lack of flexibility. This is exemplified by the continuous reprogramming

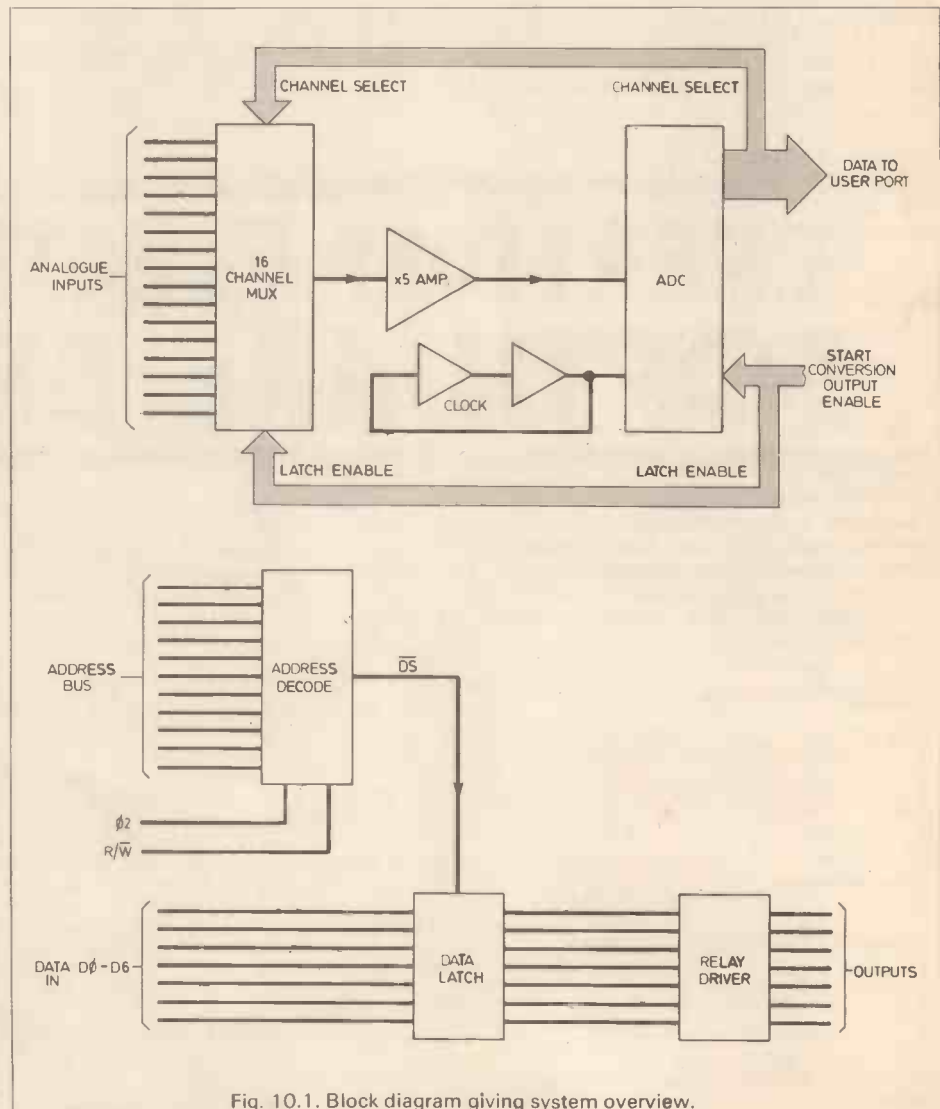

Fig. 10.1. Block diagram giving system overview.

of the clock needed, for example, every weekend. If measurements of individual room temperatures are collated periodically together with the temperature of the water and perhaps the external air temperature, then the appropriate output responses can be triggered to provide a closed-loop feedback control system.

## GREENHOUSE MANAGEMENT SYSTEM

A similar closed-loop procedure may be adopted in a greenhouse management system. "Dry" temperature probes can be used to send information to the microcomputer so that air and soil temperatures can be monitored efficiently.

If "wet" temperature probes are also used, then the relative humidity can also be computed. The ambient light conditions may also be measured and assessed.

Suitable software controlled responses to complete the feedback loop include using output signals to switch a heater on or off, controlling a ventilator fan or perhaps opening or closing blinds.

## SYSTEM OVERVIEW

The reader should by now be fully versant with the techniques of analogue data acquisition using an ADC and the control of external devices, as these have been fully dealt with earlier in this series.

Fig. 10.1 shows the individual input and output sections of a closed-loop microcomputer control system.

## INPUT SECTION

The input section can handle simultaneously up to sixteen channels of analogue data from appropriate transducers. All channels have a full range sensitivity of 1V and are unipolar. The input impedance of each is approximately 10k $\Omega$ .

Digital data from this section is transferred to the microcomputer via its user port, the ADC and channel multiplexing operation being also fashioned from this port. Simple transducers, for temperature and light intensity, are described briefly at the end of the article.

## OUTPUT SECTION

Seven individually controllable outputs are provided which can operate a 5V relay situated at the device to be controlled. The output board is driven from the extension bus, suitable address bus decoding and data bus latching circuitry being included.

## POWER SUPPLY

The power supply included is quite conventional circuitry to develop the  $\pm 7.5V$  supplies for the analogue signal amplifier on the input board and +5V for all the TTL supplies and the output relay drivers.

# COMPONENTS

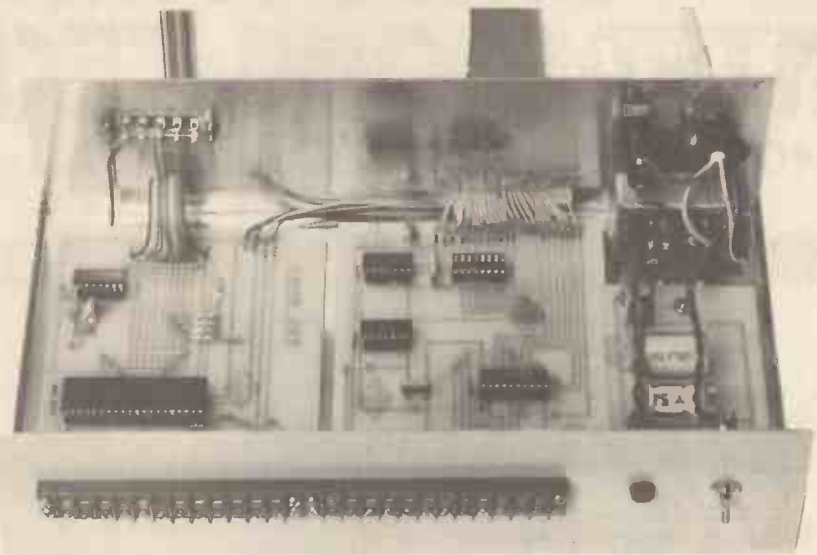

### Resistors

R1-8	} 10k $\Omega$ x 8 commoned s.i.l. (2 off)
R9-16	
R17	30k $\Omega$
R18	7.5k $\Omega$
R19-26	100k $\Omega$ (8 off)
R27	1k $\Omega$
R28,29	220 $\Omega$ (2 off)

All  $\frac{1}{4}W$  carbon  $\pm 5\%$  unless specified otherwise

### Capacitors

C1	1000pF ceramic plate
C2,3	0.1 $\mu F$ polyester type C280
C4,5	1000 $\mu F$ 25V elect. axial (2 off)
C6	0.1 $\mu F$ polyester type C280

### Semiconductors

D1	BZX61 5-6V Zener 1-3W
D2-5	WO05 1A 50V bridge rectifier
D6,7	BZX61C7V5 7.5V 1-3W Zener (2 off)
IC1	741 op-amp
IC2	ADC 0B17 16-channel multiplexed A-to-D converter i.c.
IC3	74LS04 low power Schottky TTL hex inverter
IC4	74LS133 low power Schottky TTL 13-input NAND
IC5	74LS27 low power Schottky TTL triple 3-input NOR
IC6	74LS04 low power Schottky TTL hex inverter
IC7	74LS273 low power Schottky TTL octal latch
IC8	ULN2001 7-stage Darlington driver i.c.
IC9	7805 +5V 1A voltage regulator

### Miscellaneous

S1	miniature on-off toggle
FS1	1.25A anti-surge 20mm fuse
LP1	panel mounting mains neon
T1	mains primary/two 0-9V 330mA secondaries
TB1,2	12-way barrier strips (2 off)
TB3	5-way barrier strips
VR1	10k $\Omega$ miniature horizontal carbon skeleton preset

**Printed circuit boards:** Input board, single-sided size 135 x 100mm, *EE PCB Service*, Order code 8404-02; Output board, single-sided size 135 x 100mm, *EE PCB Service*, Order code 8404-03; Power supply board, single-sided size 100 x 57mm, *EE PCB Service*, Order code 8404-04; 20mm panel mounting fuse holder; aluminium case, vinyl covered top size 275 x 153 x 75mm approx.; 6BA fixings, soldertag and board spacers; p.v.c. covered stranded connecting wire; 11-way ribbon cable; 23-way ribbon cable; single-sided Veropins (73 off); 22 s.w.g. tinned copper wire; d.i.l. i.c. sockets: 40-pin (1 off), 20-pin (1 off), 16-pin (2 off), 14-pin (3 off), 8-pin (1 off); 3-core mains cable; cable clamp and grommet for mains cable.

**COMPONENTS**  
approximate  
cost **£50**

See  
**Shop  
Talk**  
page 231

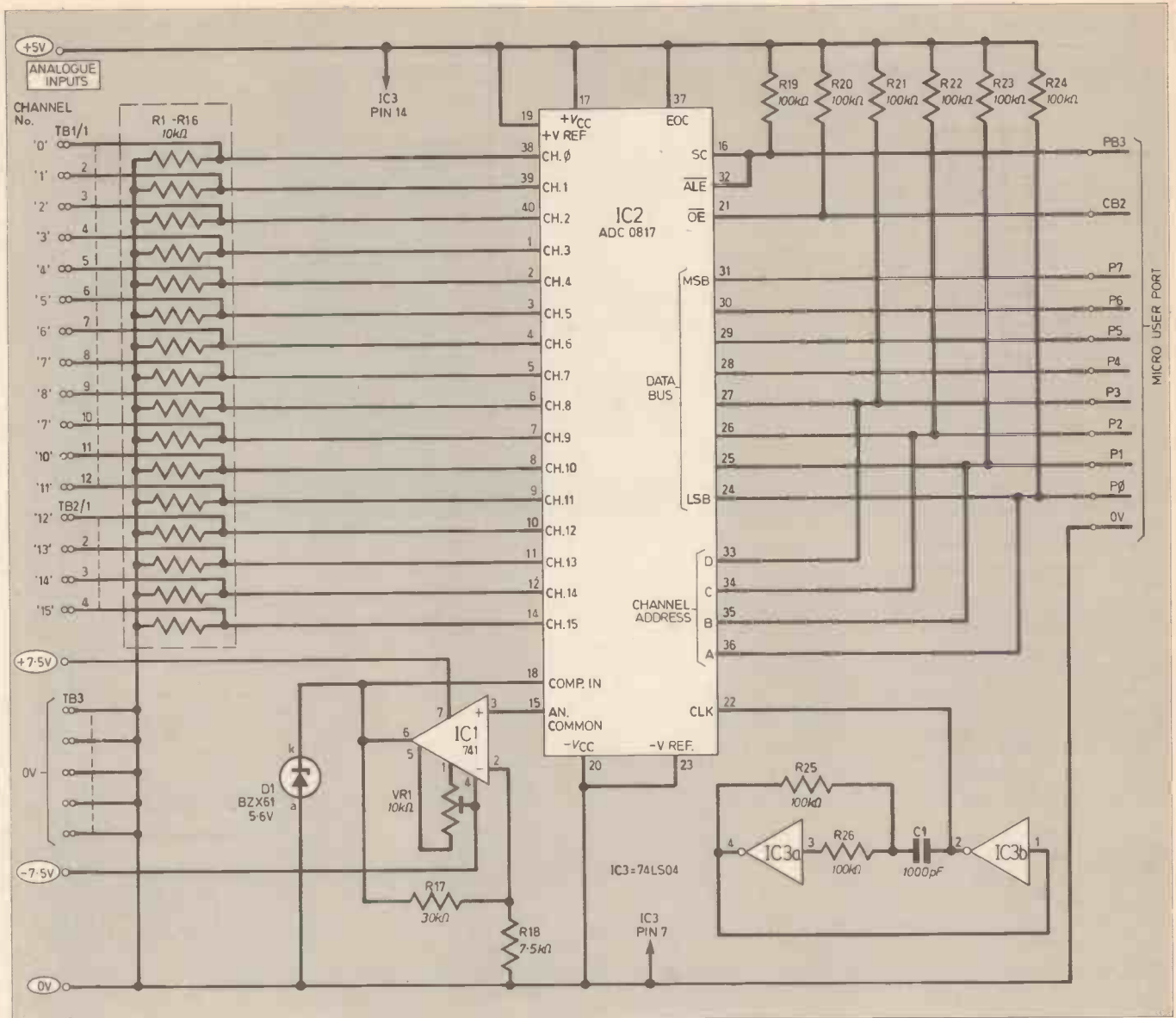

Fig. 10.2. Circuit diagram of the input section of the Data Acquisition System (DAS).

## THE INPUT SECTION CIRCUITRY

Fig. 10.2 shows the complete circuit of the input board section of the system.

The ADC 0817 (IC2) is a 16-channel 8-bit successive approximation type analogue-to-digital (ADC) and is provided with tri-state output lines. The maximum input range for each analogue channel is dependent upon the reference voltage used and is, in this case, +5V.

This is rather higher than the usual range of transducer output circuitry and an operational amplifier, IC1, is included between the output of the multiplexer (channel selector) and the input to the ADC section of the device.

No on-chip clock is provided with the ADC 0817. The necessary clock signals are generated by IC3 which is wired as a simple astable circuit.

The maximum clock frequency for the ADC 0817 is quoted by the manufacturers as being 640kHz, but in this

application a much lower clock is permissible and a frequency of approximately 30kHz is employed.

The 16-channel multiplexer section of the ADC 0817 requires a 4-bit address code and this is routed from the user port via the four least significant lines of the 8-bit port configured for output. This operation precedes the start conversion signal and the address is latched into the multiplexer hence holding the selected channel whilst conversion takes place. This procedure is explained in more detail in the software section.

## THE OUTPUT SECTION CIRCUITRY

As previously mentioned, the output section of the circuitry interfaces directly with the extension bus. Readers of last month's article will realise that address bus decoding is necessary to provide the device select signal for the data bus latch.

Fig. 10.3 shows the complete circuit of the output section circuitry. IC4, IC5 and IC6 provide decoding for up to twelve address bus lines along with the  $\phi 2$  clock signal, I/O and R/W lines. The number of lines actually used depends upon the microcomputer as detailed last month. Note that any unused inputs to the 74LS133 thirteen input NAND gate should be pulled up to logic 1 by direct connection to +5V.

The arrangement of this decoding circuitry and the number of lines used depends upon the microcomputer used and is identical to that featured in the output port design feature detailed in last month's article. In order to avoid unnecessary repetition, readers are referred to that article for further details.

When a valid address is detected by the circuit and the I/O and R/W control bus lines are low, data present on D0 to D6 is latched into IC7, the 74LS273 octal latch.

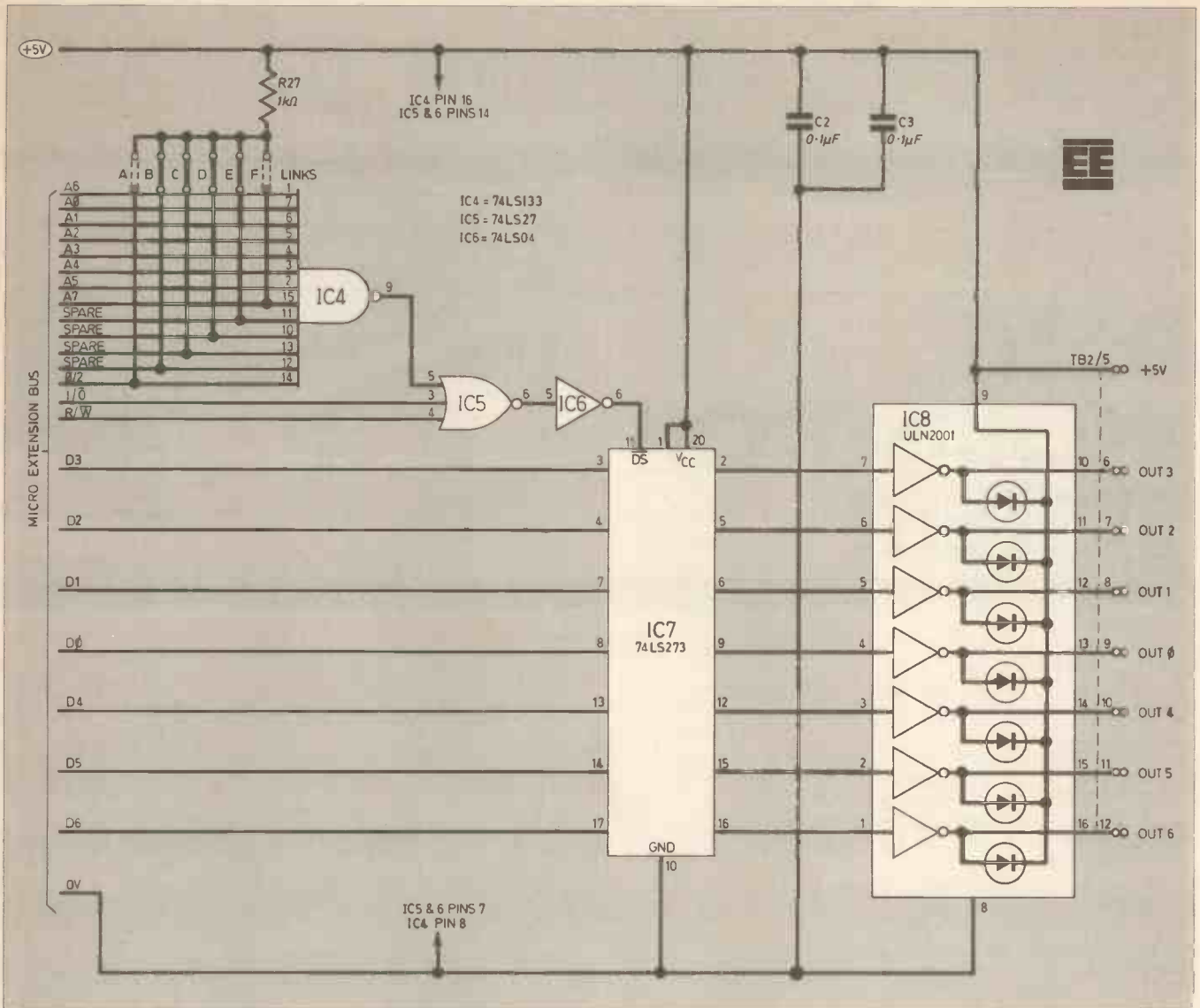

Fig. 10.3. Circuit diagram of the output section of the DAS.

The Q outputs of this drive the seven stage Darlington transistor array, IC8. Each output of this is capable of switching up to 500mA and can be used to actuate a switch located at the particular device to be controlled.

It should be noted, however, that the use of relays can induce spurious signals on the buses. One practical solution to this problem is to use optically isolated zero-crossing solid-state switches. These allow the switching of perhaps a heater when the mains voltage is at the zero-point of its cycle.

### POWER SUPPLY CIRCUITRY

The power supply for the system is relatively conventional and Fig. 10.4 should be consulted.

The 240V a.c. mains is placed across the primary of T1 via S1 the on-off switch. Power on is indicated by mains neon, LP1.

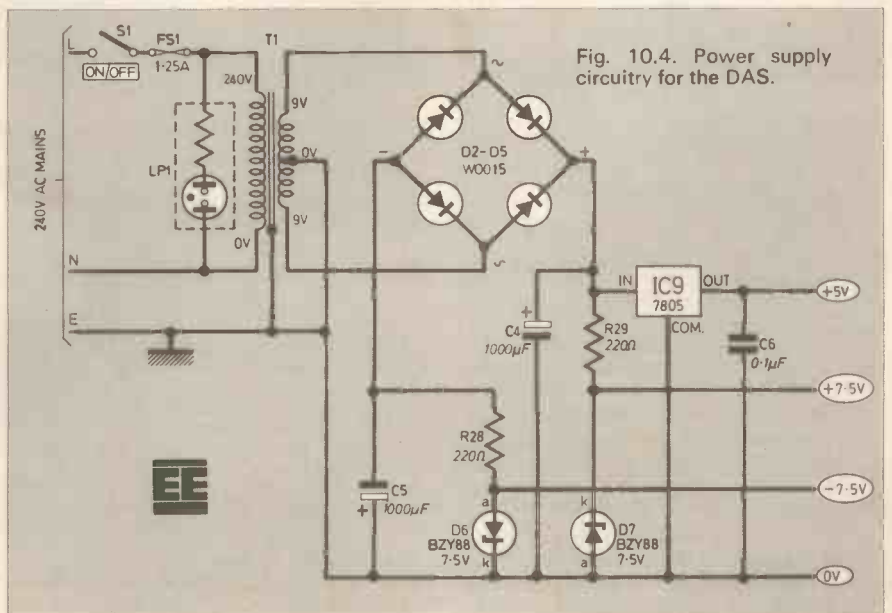

Fig. 10.4. Power supply circuitry for the DAS.

18V appears across the centre tapped secondary of T1. The bridge rectifier (D1 to D4) provides full-wave rectification to give pulsating d.c. of peak value, about  $\pm 13V$ . C3 smooths the +ve peaks to feed

IC9. Negative peaks are smoothed by C4.

The ADC and other digital sections of the circuitry require the usual +5V supply, which is provided for by the 7805 voltage regulator, IC9. The 741 operational am-

plifier is operated at  $\pm 7.5V$ . The current requirement is very small and these supplies are derived from the Zener diodes, D6 and D7, and associated dropper resistors R28 and R29.

# DATA ACQUISITION SYSTEM

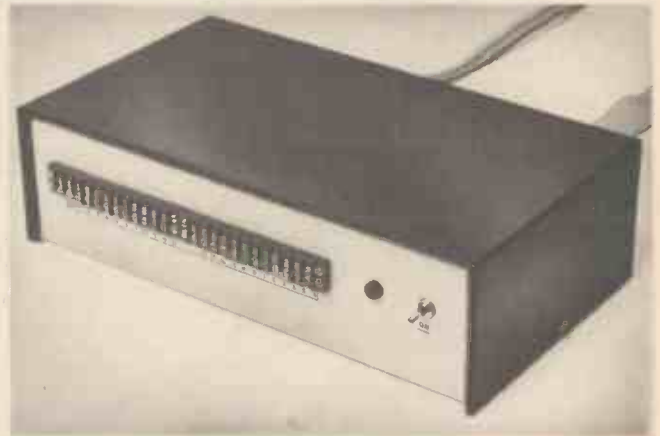

## INPUT BOARD

The three sections of the system are each constructed on separate printed circuit boards.

The actual-size master p.c.b. pattern for the ADC input board is shown in Fig. 10.5. This board is available from the *EE PCB Service*, Order code 8404-02. The layout of the components on the board topside is given in Fig. 10.6.

Assemble the components as shown paying attention to the polarity of D1. Resistors R11 to R27 are a little unusual in appearance to those normally found in EE. These are s.i.l. packaged (single-in-line) and contain eight equal value resistors all "commoned" at one end. This gives nine s.i.l. pins. These packages must be assembled the correct way round. There is a small white dot above the "common" pin.

In the prototype the leads to the board were soldered directly to the board. It may be better to use Veropins for each of these connections, as then the boards may be positioned in the case, and interwired, and to the case mounted components in situ.

Sockets were used to hold all i.c.s (except IC9), and we recommend that constructors do likewise. Do not reset the i.c.s in their sockets until the system has been fully wired up.

## OUTPUT BOARD

The printed circuit board master pattern actual-size, for the Output board is shown in Fig. 10.7, with the component layout on the p.c.b. topside given in Fig. 10.8.

The p.c.b. is available from the *EE PCB Service*, Order code 8404-03. Assemble the board as indicated. Use Veropins for all cable connection points.

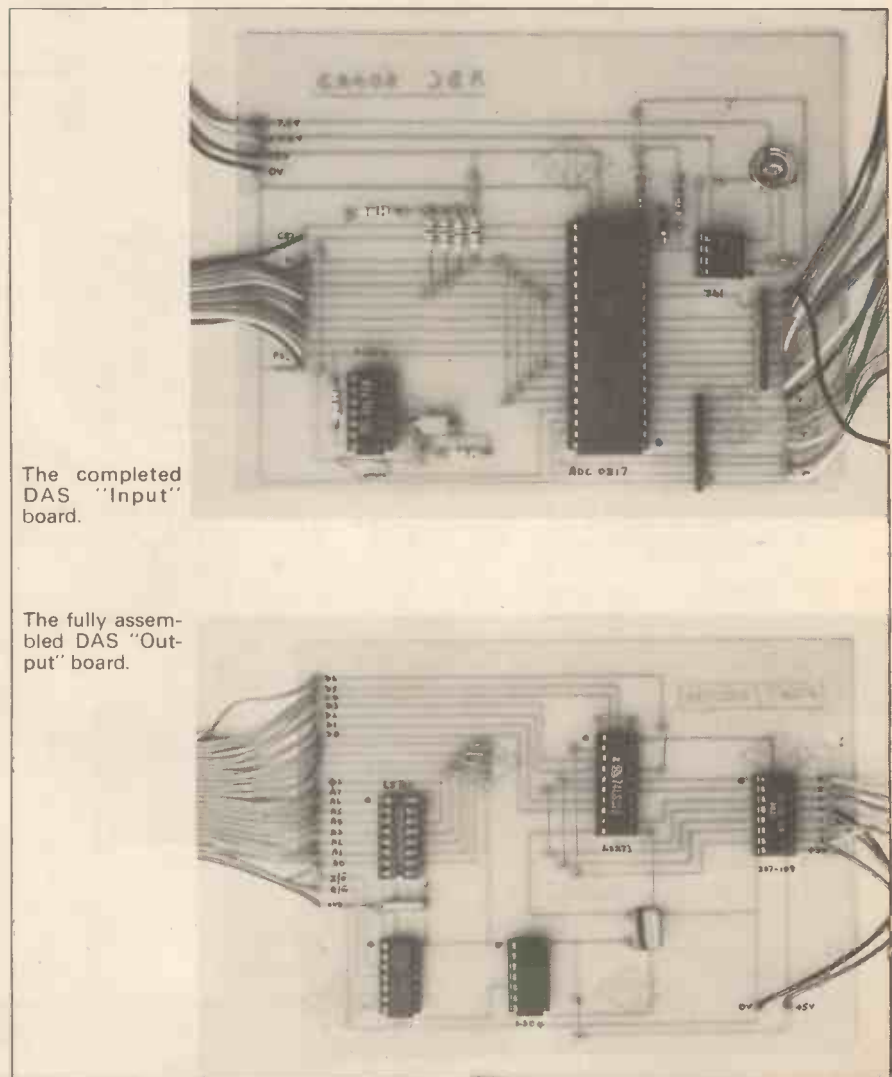

The completed DAS "Input" board.

The fully assembled DAS "Output" board.

# INPUT BOARD

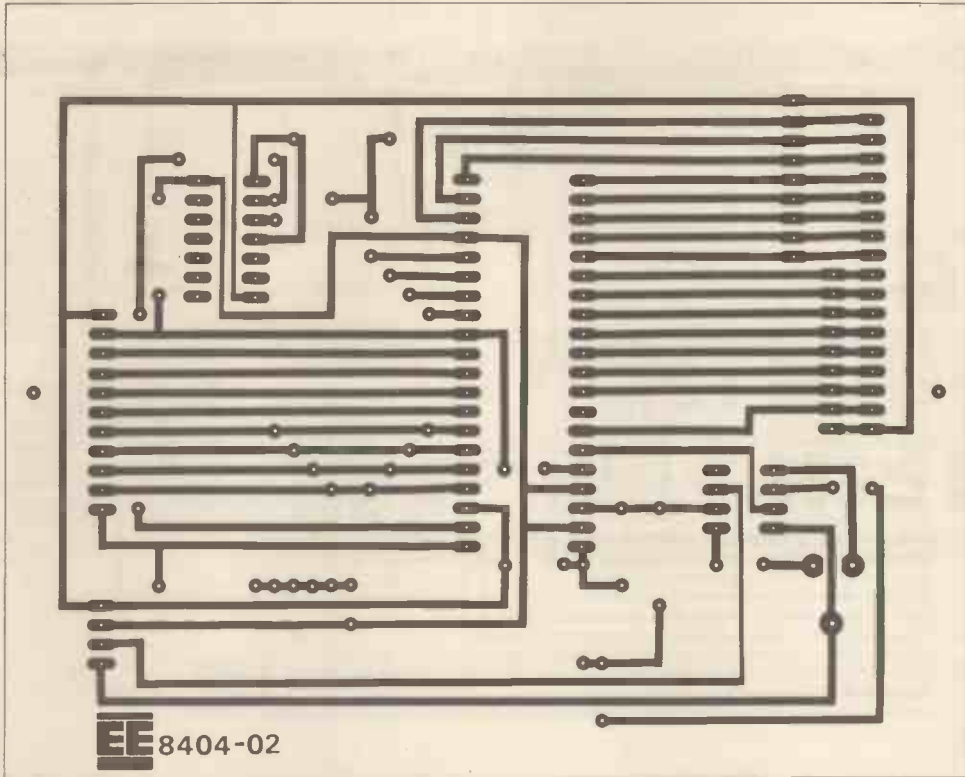

Fig. 10.5. Actual-size master pattern for the DAS input section. This board is available from the *EE PCB Service*, Order code 8404-02.

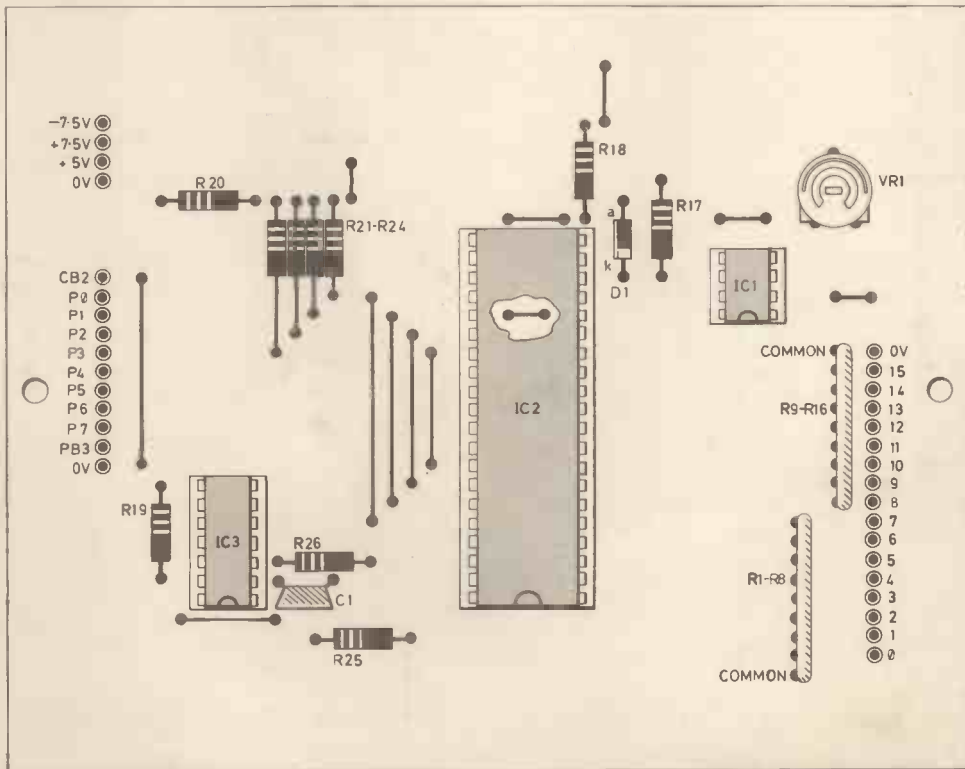

Fig. 10.6. Layout of the components on the topside of the "Input" board.

# OUTPUT BOARD

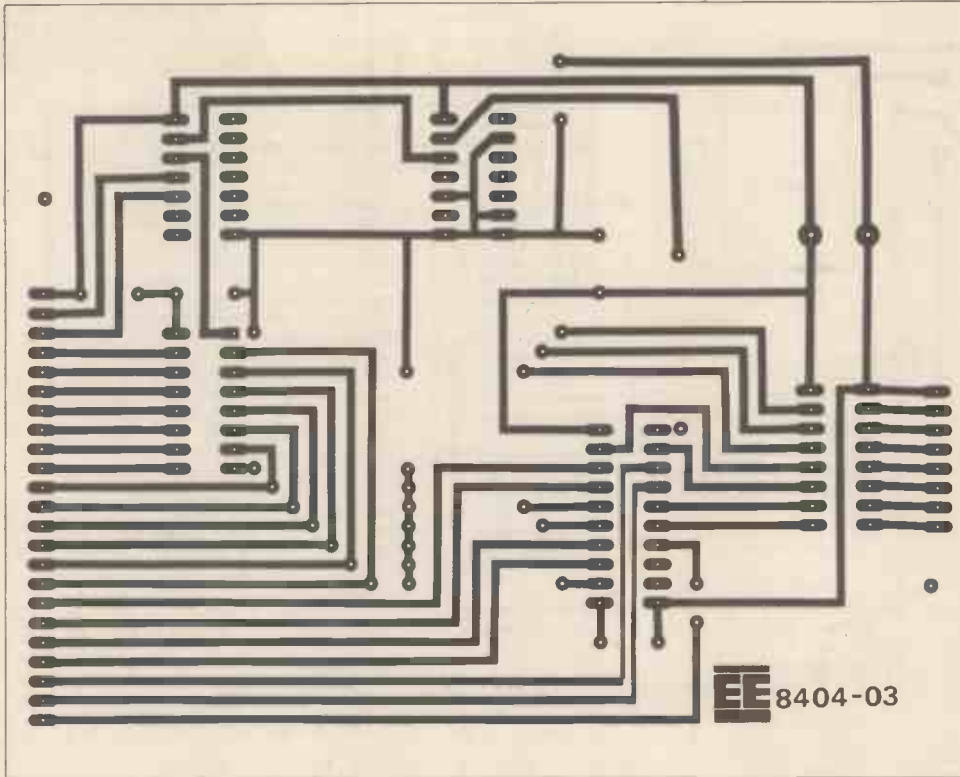

Fig. 10.7. Actual-size master pattern for the DAS "Output". This board is available from the *EE PCB Service*, Order code 8404-03.

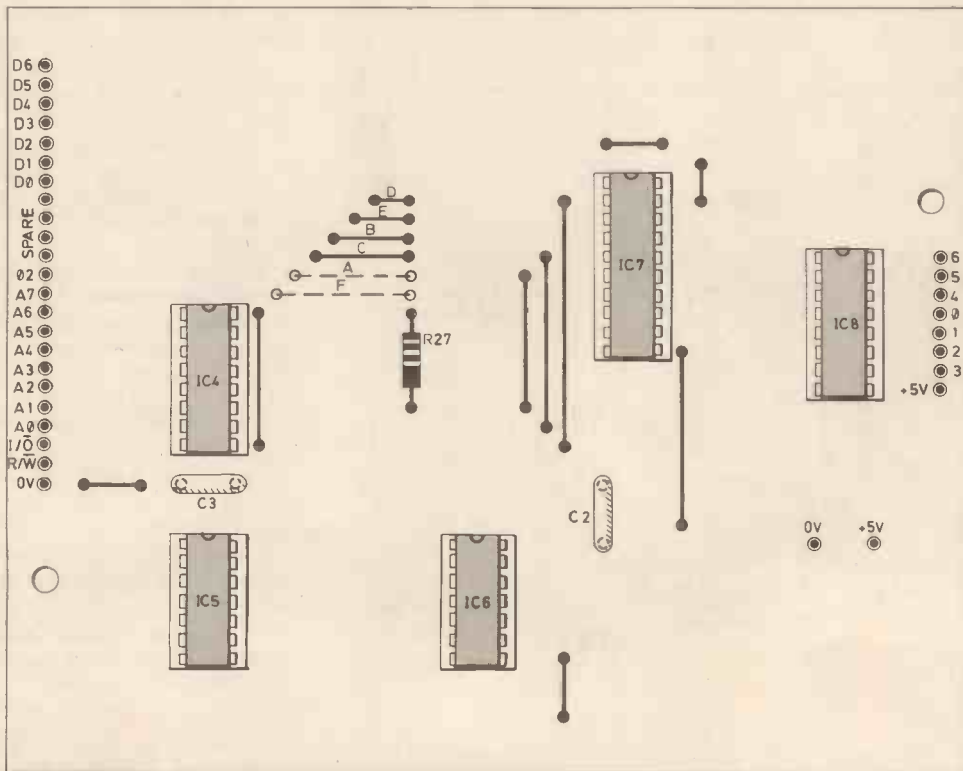

Fig. 10.8. Layout of the components on the topside of the "Output" board.



# POWER SUPPLY

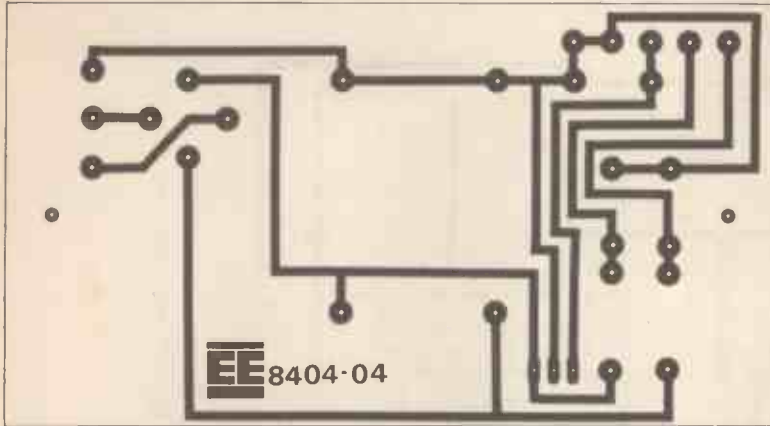

Fig. 10.9. The actual-size master p.c.b. pattern for the power supply board for the DAS. This board is available from the *EE PCB Service*, Order code 8404-04.

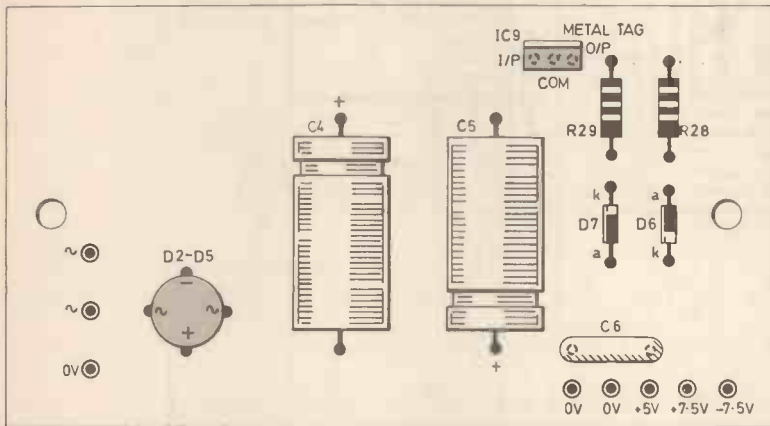
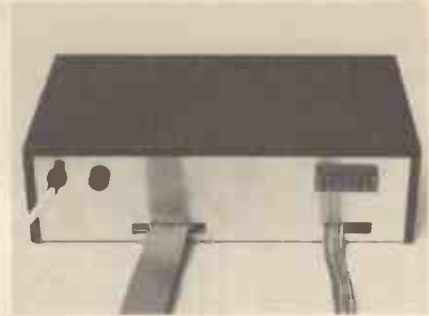

Fig. 10.10. The layout of the components on the topside of the DAS power supply board.



Rear panel of the prototype DAS.

## SOFTWARE

The techniques involved for the software Microcomputer Data Acquisition and Control System have been covered in earlier articles. A possible sequence of operations is outlined below:

1. Disable tri-state by taking the appropriate output line from the microcomputer (to pin 21 of the ADC) to logic zero.
2. Disable address-latch by taking the appropriate output signal line from the microcomputer (to pin 32 of the ADC) to logic zero.
3. Configure the user port for output by setting all bits in the appropriate data direction register for the port.
4. Select ADC channel required (0-15).
5. Route channel selected (to pins 36, 35, 34, 33 of the ADC) using the four least significant lines of user port previously configured for output.
6. Enable address-latch by sending logic one output signal to pin 32 of the ADC.
7. Initiate conversion by sending the address-latch line to logic zero thus allowing a negative going pulse to reach the start conversion pin (16) of the ADC.
8. Wait for the conversion to be completed (not necessary if using BASIC).
9. Configure user port for input by clearing all bits in the appropriate data direction register.
10. Enable the tri-state by taking the appropriate output signal line to logic one.
11. Read the value presented to the user port via lines 31 to 24 from the ADC.
12. Disable the tri-state by taking the appropriate output signal line to logic zero.
13. Configure the user port again for output by setting the requisite bits in the data direction register.
14. Compare digital result obtained from ADC with allotted value.
15. Turn on or off appropriate output control device on extension bus.
16. GOTO step 4.

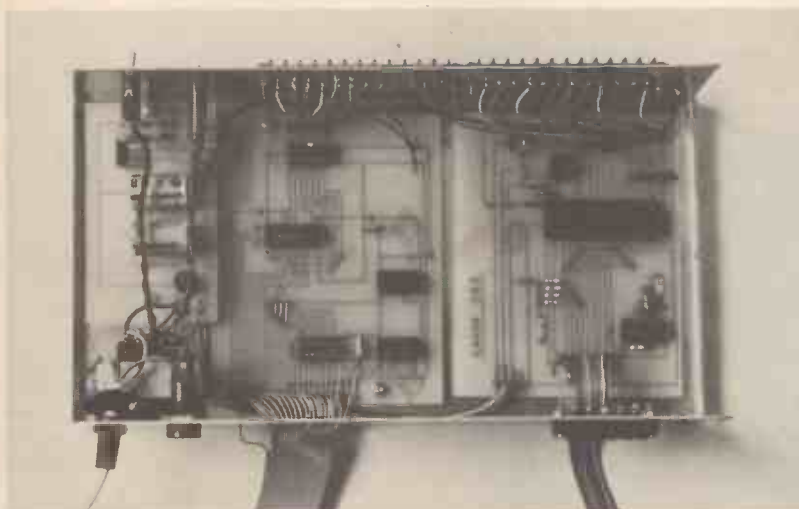

Plan view of the prototype DAS with lid removed from case.

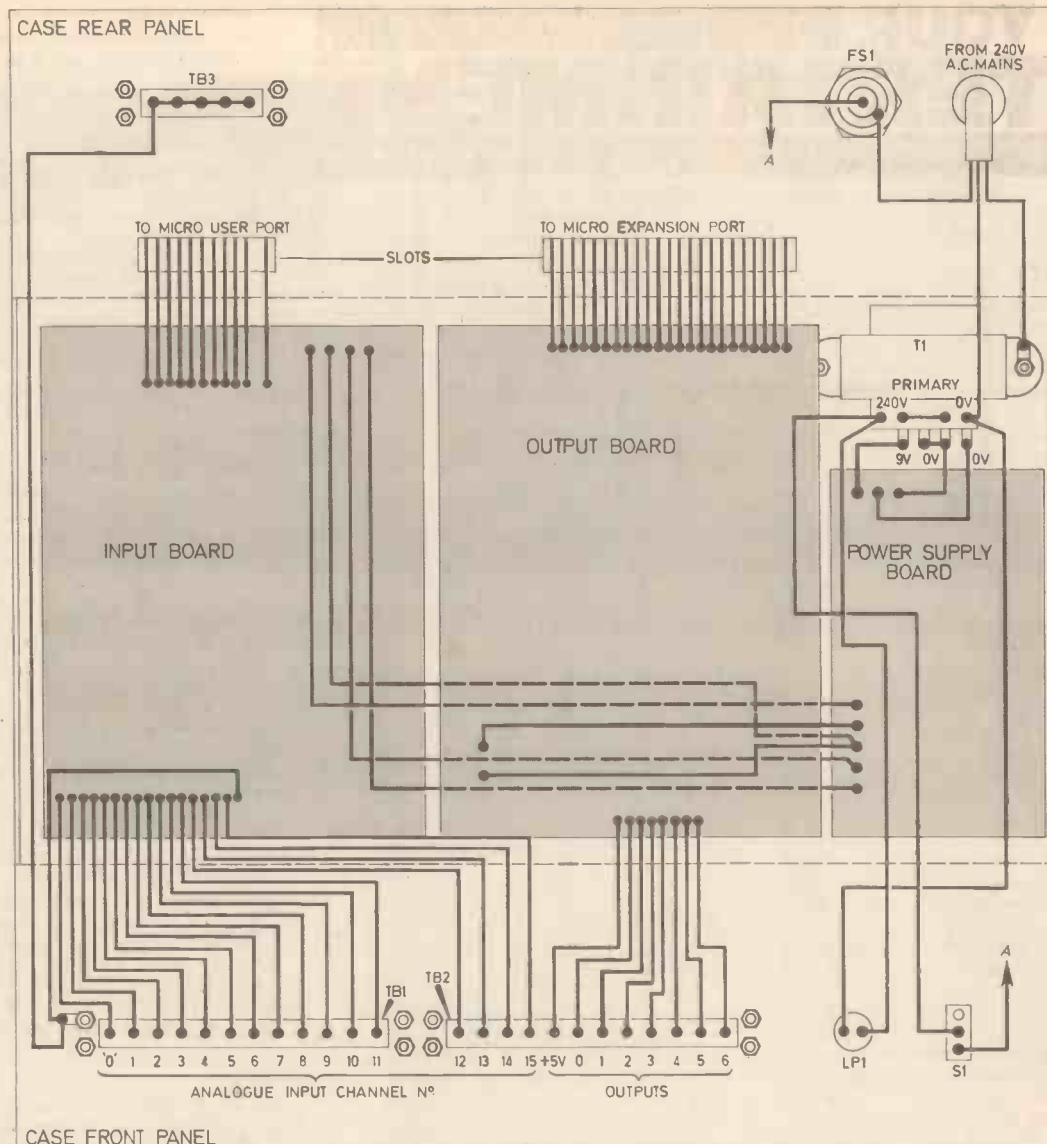
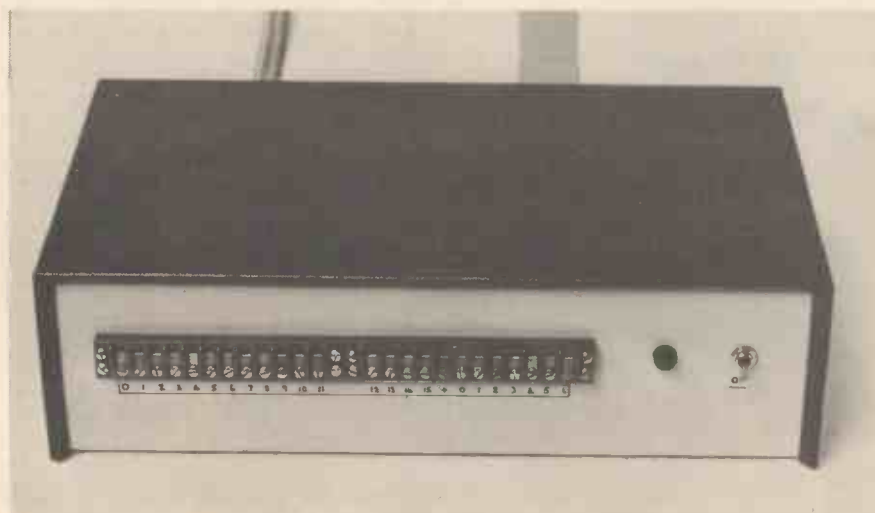

Fig. 10.11. Position of components and circuit boards for the complete DAS with full interwiring details.



Shows the front panel of the prototype DAS.

## POWER SUPPLY

Most of the power supply components are mounted on a p.c.b. The actual-size master p.c.b. pattern is given in Fig. 10.9. This board is available from the *EE PCB Service*, Order code 8404-04.

Assemble the components on the top-side of the board according to Fig. 10.10 paying attention to the orientation of the diodes, electrolytic capacitors and IC9.

## INTERWIRING

Prepare the case and fit all the components. Mount the three p.c.b.s on suitable height spacers above the base of the case and interwire and connect to the case mounted components as shown in Fig. 10.11.

The ends of the ribbon cables should be suitably terminated to mate with the micro in use. Insert all i.c.s paying attention to polarity. Label the case as shown in the photographs.

### Next month:

Vehicle Control with the Micro

# FOR YOUR ENTERTAINMENT

BY BARRY FOX

## Mole Proof

Earlier this year there was considerable cuffle about the leakage of secret Government documents. Leaking of course, has been much, much easier since the ready availability of Xerox copy machines in the 60s.

Before the advent of copying machines it was very hard to copy a document quickly and unobtrusively. Although spy films still show the hero or villain snapping away with a miniature camera, this is stretching credibility.

As anyone who has ever tried to take close-up shots with a camera will know, there are any number of pitfalls. Focussing is critical, especially if the light level is low and the camera aperture wide open. You need a very steady hand, or a tripod, to avoid camera shake. It is all too easy to get highlights, with the light source reflected from the surface of the paper.

"Wet" photo copy machines made things easier. But they were slow to use and there was the added problem of how to get rid of the throw away wet negative sheet that came out of the machine along with the positive copy. It's no joke, if you are a mole copying a hundred-page document, to try to get rid of a hundred sheets of paper sodden with chemical developer!

Although the original Xerography invention, made by Chester Carlson, dates back to before the war, it was not until the 60s that Rank Xerox made plain paper copying a part of office routine. It wasn't long before people with secret documents, started worrying about unauthorised copying. So Rank-Xerox invented and patented, a system of making documents uncopyable.

There is a high intensity light in a Xerocopy machine and if the paper being copied contains a coloured fluorescent material this light is absorbed at one wavelength and re-emitted at another. This dazzles the copier by swamping the image contrast.

## Secret Message

On early Xerox copying machines, the 813 and 3600, it was possible to make a message secure simply by writing it on paper with red or orange fluorescent colouring. The original message is perfectly legible, but completely uncopyable.

The Xerox anti-copy patent specified the best type of dyes to use in aerosol sprays. But in the 70s, Rank-Xerox came out with a new generation of machine, for instance, the 4000, which could produce superbly clear copies of dye-masked messages that baffled the older machines.

All modern Xerox machines contain dazzle proof optics. So they can make clear copies of virtually any messages that can be read by the human eye. Paradoxically, if Government departments were to use older machines, they would be able to make a document secure by dye masking.

Some of the early machines are in fact available, for outright purchase. They are reconditioned models taken out of rental service. So if anyone wants to make their office mole proof, they need only buy an old machine and some sprays of fluorescent dye.

## Radio Mole

The hunt for Government moles reminded me of something that happened when I was in the Air Force, during the last few months of National Service. We were learning to service high power radio transmitters. The only way to check the transmitter was to tune it to the transmission frequency and run the valves up to full power. But the output stages would blow up if there was no aerial.

Obviously stray radio transmissions from a workshop on an RAF base could have interfered with important communications. So the workshop transmitter could be either connected to a real aerial, or a string of light bulbs that served as a dummy aerial.

One day, one conscript unplugged the dummy aerial and plugged in the real one. He then broadcast a "Mayday" emergency signal. All across England air-sea rescue was mobilised and they soon pin-pointed the Wiltshire air base.

The military police on the airbase swiftly pin-pointed the workshop most likely to house the guilty man. All but two people denied knowledge of the incident. The remaining two pleaded innocence but blamed each other. The military police, fearing questions in Parliament about unfair collective punishment, couldn't lock up both airmen. The police tried for days to extract an admission of guilt. But they failed and both suspects walked free.

We never did know which one of the two had done the deed.

## Cashless Society

The cashless society is coming. Some cash and credit cards carry a magnetically coded identity strip. The next generation of cards are quite literally miniature computers.

It is not generally known that the Cardphone public telephone boxes, which are being installed by British Telecom around Britain, use a holographic technique. You buy a card, that looks like a credit card, which lets you make a limited number of "free" phone-calls when you push it into a slot in the telephone box. As you make the calls, an f.c.d. shows how the units are being used up.

It would be possible to base the phone-card system on magnetic technology, erasing areas of magnetism, one at a time, a holographic card is much more secure. However, the phonecard system, which comes from the Swiss company Landis and Gyr, relies on the optical phenomenon

whereby light shone on an ultra-fine pattern will create interference effects, like fringing round a grating or colours from oil on water.

## Phonecard

The Phonecard, which is made of plastic and looks like a credit card, has a track in the surface which contains a series of individual holograms.

Each one produces a characteristic pattern of light and shade when illuminated by a strong lamp.

This light and shade pattern is sensed by photo cells which switch the telephone on. As each unit of telephone time is used up, the holograms are destroyed, one by one, by a sharply focussed heat beam. If you look carefully at a Phonecard you can see the track along the top surface, with tiny bumps where units have been burned out.

On the continent, especially France, they are experimenting with an even more exotic kind of card, appropriately christened the "Smart Card". Again, this looks like a plastic credit card, but it contains an astonishing array of electronics.

Buried inside the plastic there is a micro-processor, and several levels of memory. Some levels are readily accessible to give a readout of the card serial number. Some are accessible only when the micro-processor is interrogated by another computer.

For instance, the card can be used instead of cheques, with each cash withdrawal or payment subtracted from a credit balance programmed into the card's memory. The Smart Card is in effect an electronic wallet.

Current cards have a memory of 8K bits, which is sufficient capacity for 200 separate banking transactions. Several French cities, including Lyon, have shops and telephones equipped with computer units which can interrogate Smart Cards so that they function instead of cash.

## Paper Security

In theory the cashless society makes life safer and easier for everyone. But in practice this isn't necessarily so.

A friend of mine has been trying for over a month to subscribe to one of the new video systems that lets you do banking and shopping by a telephone line hooked up to a home computer. The delays have all been caused by office bureaucrats fumbling the paper work.

Exotic cash cards can only be secure if they rely on the user keying in a secret password or code number. But all too many people write their secret word or number on their card, or on a piece of paper which they keep in the same wallet as the card. So security is gone!

Thanks to the cashless society, it's possible to order goods, services and theatre tickets by telephone or video screen, using the number of your credit card. But often people who use credit cards throw away the copy receipt which they are given when they have used the card in a shop or restaurant. These receipts give the card number, the owner's name and signature. So once again security is jeopardised.

Your cash will never be 100 per cent safe, even in a cashless society. We shall always need paper, if only to keep a record of electronic transactions. And, of course, pen and paper is the only system that works when there's a power cut!

EXECUTED?

WHEN DID CABLE BROADCASTING

FRANCE?

WHAT IS THE NAME OF

WHO WAS THE FIRST MAN ON THE MOON?

E MICROCHIP?

# QUIZ MASTER II

IT TAKES THREE MF

TELEVISION?

BY S. LYONS

WHAT YEAR WA

DISCOVERED NEW ZEALAND?

WHY DO BIRDS MIGR

**D**ETERMINE who is first on the button in panel games with the Quiz-Master II. For up to eight players, each with a hand-held response control, the unit gives both audible and visual indication of the fastest to press, upon which, all other response units are disabled.

The design has provision for up to eight response units to be used, each connected to the main control unit by 5-pin DIN plugs on leads to 5-pin DIN sockets.

The circuit of the Quiz-Master II is in two parts, the response units, and the main control unit. It is the function of the latter to determine who pressed first, and isolate all other response units. The response unit consists of a switch, resistor, and an l.e.d.

## RESPONSE UNIT CIRCUIT

The response unit circuit is shown in Fig. 1. L.e.d. D1 is not physically connected to switch S1 (except by the zero volts line) and is driven by the main control unit, and will only light up if its switch closure has been accepted as a valid response (that is, if it was pushed first).

Switch S1 is a non-latching push-to-make type, and is used to generate a TTL logic 1 when open and logic 0 when closed. The required voltage level is set by resistor R1.

All this is housed in a small, plastic box. To link it to the main control unit, individual twin screened cable is used, terminated with a 5-pin DIN plug.

## MAIN CONTROL UNIT

Fig. 3 shows the circuit diagram of the main control unit. The heart of the circuit is IC1, a 74LS373 octal transparent latch. The inputs of this device are fed from the switches of the response units, and the outputs are fed to three logic gates. Two of these gates are used to produce the signals for the indicators, the other is an 8-input NAND gate.

This gate produces the necessary latch signal for IC1, and also the signal to control the piezo-electric buzzer. Note that there is an inverter gate immediately after the NAND gate output; this is to produce the correct logic level for IC6.

The RESET signal is produced by S2 and R2. S2 is a non-latching push-to-break switch. The logic levels generated by these components are logic 1 when the switch is pressed, and logic 0 when not pressed. The signal is ored with the inverted output of IC5 to produce the latch enable signal fed to pin 11, IC1.

When a response unit has been pressed, it sends a logic 0 to an input of

IC1. If no other unit has been pressed before it, the output associated with this input will also be at logic 0, all other outputs at logic 1. This will cause the output of IC5 to go to logic 1.

Inverter IC4e inverts this to logic 0 to drive the buzzer, and to change the output of IC6 from logic 1 to logic 0. This will latch the outputs of IC1, in effect, freezing the state of it, preventing any other response unit operating. To reset the unit, a logic 1 is required on the other input of IC6, produced by S2.

## RESPONSE DISPLAY

A visual indication of which response unit initiated the above effect is displayed on both the master control unit's front panel, and on the appropriate response unit. The signal to drive the l.e.d.s comes from the outputs of IC1, via an inverter. The inverter is used as an inverting buffer, one for each l.e.d., two per output line. The l.e.d. is extinguished when the unit is reset.

## POWER SUPPLY

The power supply unit is quite simple (see Fig. 2), using a standard 5V monolithic voltage regulator integrated

Fig. 1. Response unit circuit diagram.

Fig. 2. Circuit diagram of the power supply section.

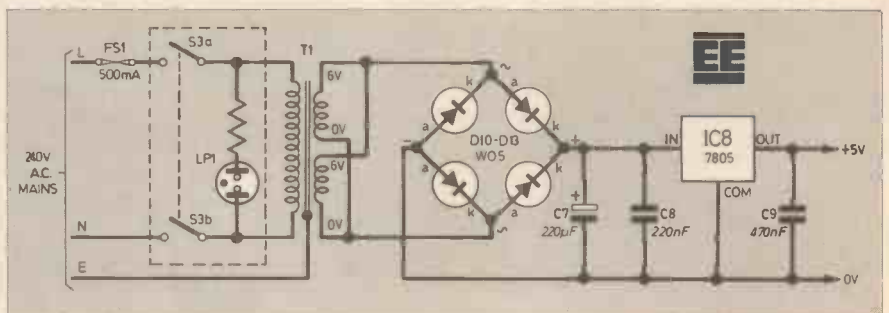
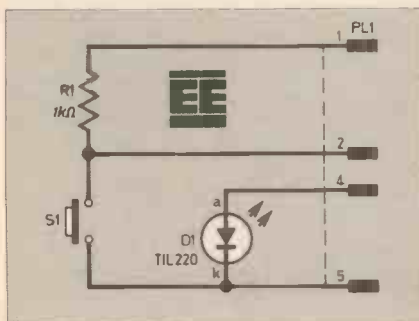

circuit (IC7). This is the only device which requires heatsinking, bolting it to the case with a mica washer between it and the case should be fine. A few holes or slots to allow air to circulate inside the case would be helpful.

The rest of the circuit is straightforward, the illuminated mains switch S3 on both "live" and "neutral" lines of mains, with a 500mA fuse FS1 in the live line placed before the switch. The transformer T1 has two secondary windings of 0V to 6V each at 250mA, wired in parallel. The bridge rectifier is a standard readily available 50V, 1A type.

## CONSTRUCTION

### MAIN CIRCUIT BOARD

With the exception of the l.e.d.s and the buzzer, all the components are mounted on the circuit board. The circuit takes



Fig. 3. Complete circuit diagram of the Quiz-Master II main control unit.

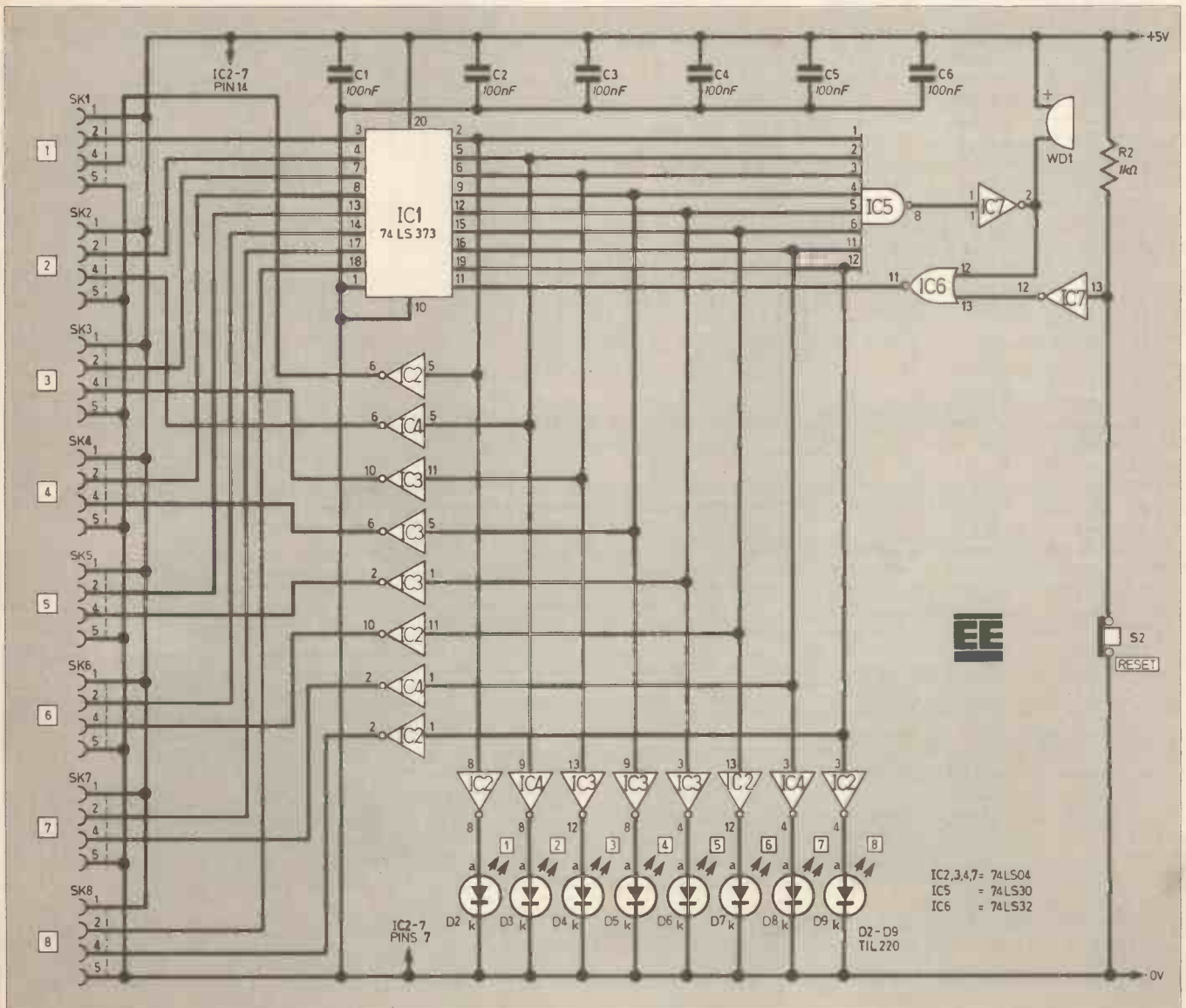

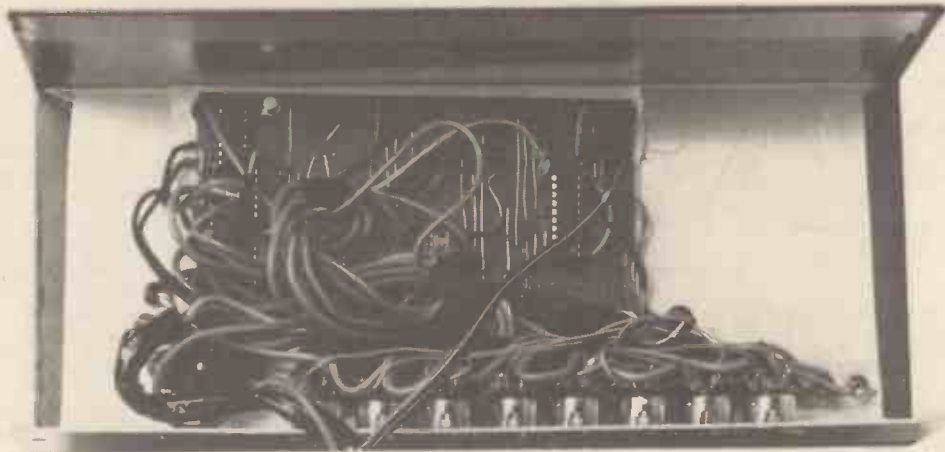

TABLE 1

- A—+12V
- B—SK8/2
- C—SK7/2
- D—SK6/2
- E—SK5/2
- F—SK1/2
- G—SK2/2
- H—SK3/2
- J—SK4/2
- K—D5a
- L—D8a
- M—SK2/4
- N—D3a
- O—WD1
- P—SK7/4
- Q—SK8/4
- R—D9a
- S—SK1/4
- T—D7a
- U—SK6/4
- V—D2a
- W—SK5/4
- X—D6a
- Y—SK4/4
- Z—D4a
- AA—SK3/4
- BB—0V
- CC—WD1

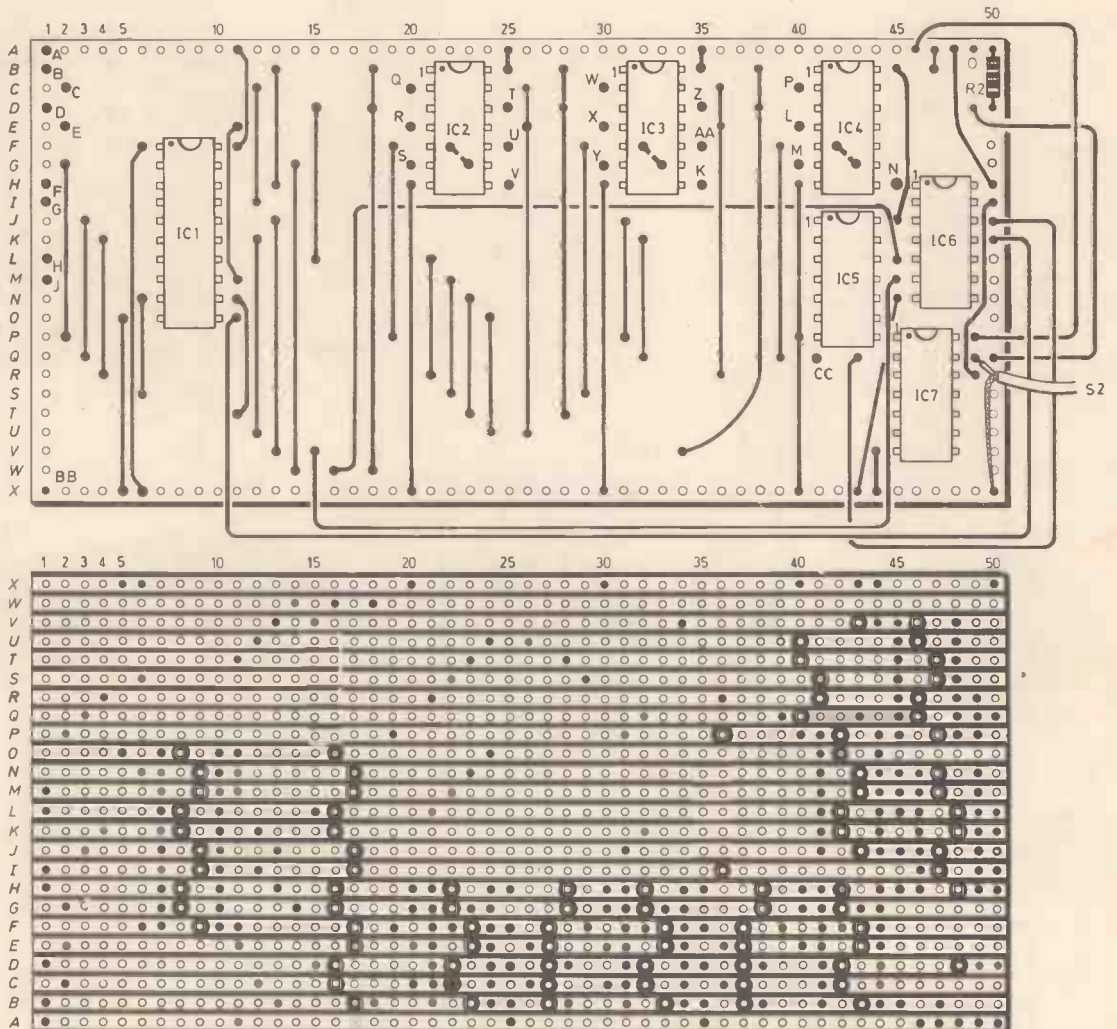

Fig. 4. The component layout and trackside view of the main control unit stripboard assembly. Note that the wires to case-mounted components are lettered (A, B, C and so on) and the destinations of these wires are given in Table 1 (above left). For clarity, the decoupling capacitors, C1 to C6, have been omitted from this view, but should be soldered across the power supply pins of the i.c.s (on the trackside, if necessary). Note also the links under IC2,3 and 4 and that some links use the same holes in the board.

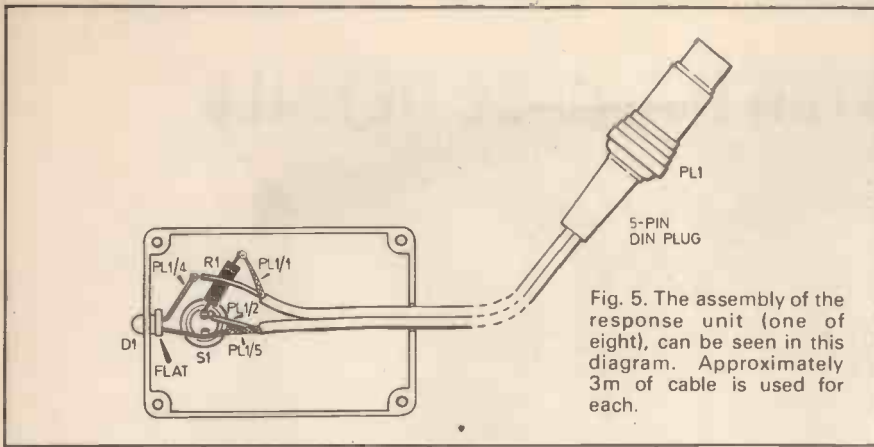

Fig. 5. The assembly of the response unit (one of eight), can be seen in this diagram. Approximately 3m of cable is used for each.

the form of a stripboard. The component layout and trackside view are shown in Fig. 4.

Although TTL i.c.s are used, sockets are used in the construction to allow easy replacement of faulty chips. As TTL is used, decoupling capacitors are required to be mounted close to the i.c.s. It is advised that the sockets are soldered in first, followed by the capacitors, so as not to forget them. The rest of the components are then fitted in as normal.

The connectors for the response units can be fitted into the aluminium case, along with the other case-mounted items, such as mains switch, reset switch, fuse holder and l.e.d.s. Once fitted, they can be wired up to the circuit board.

## COMPONENTS

### RESPONSE UNIT (8 off)

#### Resistors

R1 1k $\Omega$  (8 off)

#### Semiconductors

D1 TIL220 5mm red l.e.d. (8 off)

#### Miscellaneous

S1 non-latching push-to-make switch (8 off)  
 PL1 5-pin 240° DIN plug (8 off)  
 Twin screened cable (approximately 24m); plastic case, 70 x 50 x 25mm (8 off)

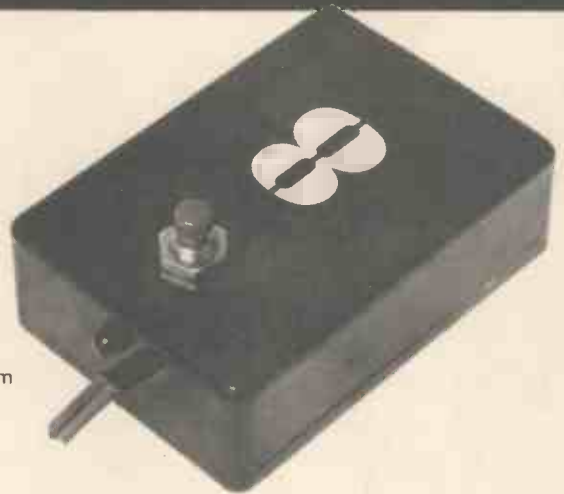

### MAIN CONTROL UNIT

#### Resistor

R2 1k $\Omega$

#### Capacitors

C1-6 0.1 $\mu$ F ceramic (6 off)  
 C7 220 $\mu$ F 16V elect.  
 C8 220nF polyester C280  
 C9 470nF polyester C280

#### Semiconductors

IC1 74LS373 TTL octal latch  
 IC2-4,7 74LS04 TTL hex inverter (4 off)  
 IC5 74LS30 TTL 8-input NAND gate  
 IC6 74LS32 TTL quad 2-input OR gate  
 IC8 7805 5V, 1A regulator  
 D2-9 TIL220 5mm red l.e.d. (8 off)  
 D10-13 W005, 1A, 50V bridge rectifier

#### Miscellaneous

S2 non-latching push-to-make switch  
 S3/LP1 mains switch with integral neon indicator  
 SK1-8 5-pin 240° DIN socket (8 off)  
 WD1 piezo-electric buzzer  
 FS1 500mA 20mm quick blow fuse  
 T1 0V-6V, 0V-6V 250mA mains transformer  
 Aluminium case, 250 x 110 x 80mm; 20-pin d.i.l. holder; 14-pin d.i.l. holder (6 off); wire; mica insulating mounting kit (for IC8); chassis fuse holder for 20mm fuse; 0.1in matrix stripboard, 24 strips by 50 holes.



**COMPONENTS**  
 approximate  
 cost **£34**

# QUIZ-MASTER II—CASE DETAILS

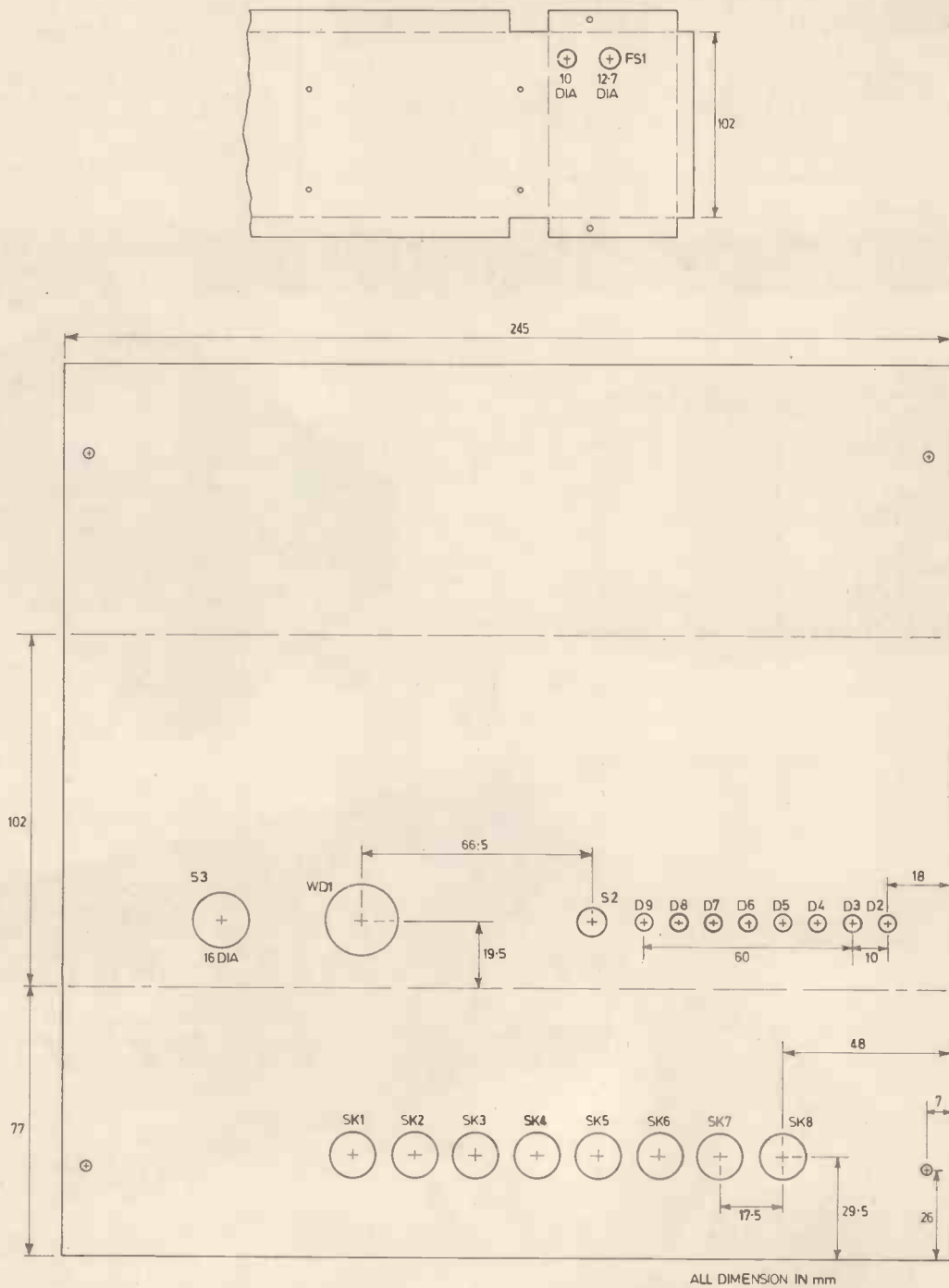
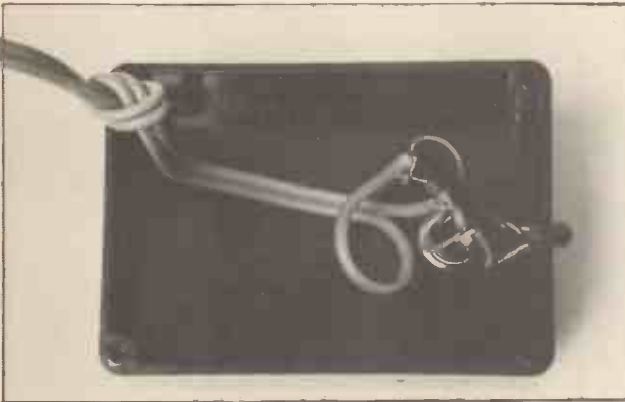

Fig. 6. Drilling details and case-mounted component positions for the Quiz-Master II case. This case is a two-part chassis type and can either be fabricated or a box of similar dimensions can be purchased. The top diagram shows the end panel of the bottom half with holes for the mains cable and fuse holder. Note all hole sizes must be checked with components to be used.





(Above). The rear view of the Quiz-Master II showing the DIN sockets with one response unit plugged in.



(Left). The internal wiring of one of the response units.

(Below). The two halves of the chassis separated to show the internal wiring of the main control unit. Note the prototype unit uses a proprietary power supply unit rather than the unit described in the text.

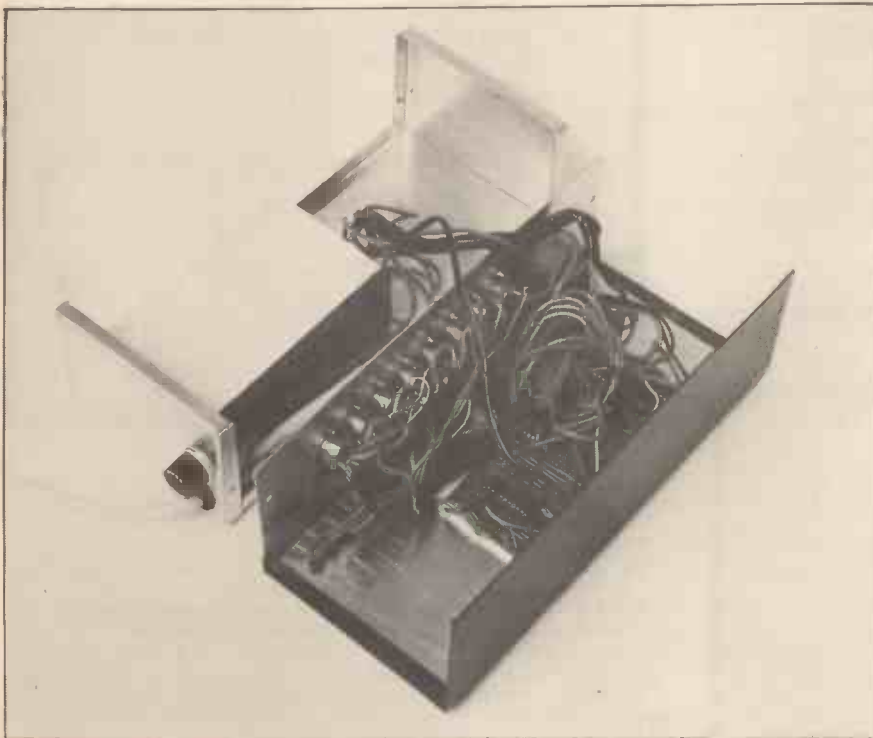

The power supply is constructed on a separate board, and is straightforward to build. The only thing to remember is to make sure the voltage regulator is facing the right way, to allow it to be bolted to the case. Two wires for both the 5V rail and 0V rail emerge from the p.s.u. This is to provide five volts to both the circuit, and the response units via SK1 to SK8.

As the prototype unit uses a proprietary power supply module, no construction drawing has been given. However, it can be seen from the circuit diagram (Fig. 2) that it is a fairly simple assembly made on a piece of stripboard.

The transformer and IC8 (via a mica washer and insulating bush) should be screwed to the case and the bridge rectifier and capacitors soldered to the small piece of board. Wires are then taken to the main board, sockets and l.e.d.s.

The response units are easy to construct, as no circuit board is needed. All components are mounted on the switch. Three holes are required in the box housing the components, one for the switch, one for the l.e.d., and the other for the cable to leave the box. See Fig. 5.

## TESTING

Before any i.c.s are inserted on the main board, it is advisable to check that the power supply is in order. Although TTL are quite hardy little bugs, they do not like their power rails swapped over. This can be done with a multimeter on the 10V range. The correct voltage should be 5V.

Next, the inputs to IC1 should be checked. The voltage on these inputs should be 5V when the switch is open, dropping to 0V on pressing the switch. With no i.c.s installed, no l.e.d.s should light. If any light, there is a solder bridge somewhere on the board.

Once all i.c. sockets have been checked for power, switch the unit off and insert the i.c.s, making sure they are the correct way round. Now switch on. If the buzzer sounds, press RESET. Assuming that no i.c. is faulty, and no solder bridges remain undetected, the buzzer should stop, and no l.e.d. will light. Press a response unit's button. The buzzer should sound, and two l.e.d.s will light up; one on the response unit pressed, and the other on the main control board. Now press another response unit. It should have no effect.

## OPERATION

To operate the unit in a quiz, each contestant should be given a response unit, plugged into the back of the main control unit. Any number of units up to eight may be plugged in, unused response units need not be plugged in. Switch on, and press RESET. This may not be necessary, but is a good habit. Now proceed with the questions. After a response unit has been activated, it can be reset, whilst the answer is given ready for the next question. At the end of a session, switch off and remove the response units. □

## HOME and AWAY WINS for UK

### UNDERSEA LINKS

A £7.25 million contract for the world's first international optical fibre undersea cable was signed recently by Sir George Jefferson, Chairman of British Telecom.

It was for a 122km cable, linking the UK and Belgium, to be made in Britain by the submarine systems division of Standard Telephones and Cables. Sir Kenneth Corfield, STC's Chairman, signed the contract for the company.

The contract award means that, in two year's time, phone calls, computer data and messages will travel between Britain and continental Europe as pulses of laser light along tiny strands of ultra pure glass as thin as a human hair.

The investment is shared between four countries. Half will be held by British Telecom International, and the balance by three European telecommunications administrations—the Deutsche Bundespost of West Germany, the Belgian RTT and the Netherlands PTT.

The cable, capable of carrying nearly 12,000 phone calls simultaneously, will be laid by British Telecom's cables ship *HMS Alert* in the spring of 1985. It will be buried to protect it against damage by shipping, in particular by trawling activities.

The new optical fibre cable will operate in digital form, at speeds of up to 280 million bits (binary digits) a second (Mbit/s). Digital operation uses on-off impulses to carry a variety of information technology services, as well as speech, along the same path more efficiently than present-day analogue transmission.

It offers considerable savings in transmission costs by using the advanced form of optical fibre operation known as singlemode transmission. This enables a single ray of laser light to travel great distances along the fibre before regeneration at a repeater.

#### Technical Note

The new UK-Belgium cable, the fifth system between the two countries, will contain three pairs of fibres. Each pair will work at 280Mbit/s—a

capacity of 3,840 64kbit/s circuits, giving a total cable capacity of 11,520 circuits.

The system will use long-wavelength (1,300nm) singlemode transmission. It will contain three submerged repeaters, each containing three both-way optical regenerators. They will be installed at approximately 30km intervals, to give a total system length between terminal stations of 122km.

*British Telecom notched up another major world first in optical fibre communications.*

*In this latest achievement, they successfully brought into service the world's first 140Mbit/s commercial optical fibre link, using singlemode transmission, between Luton and Milton Keynes.*

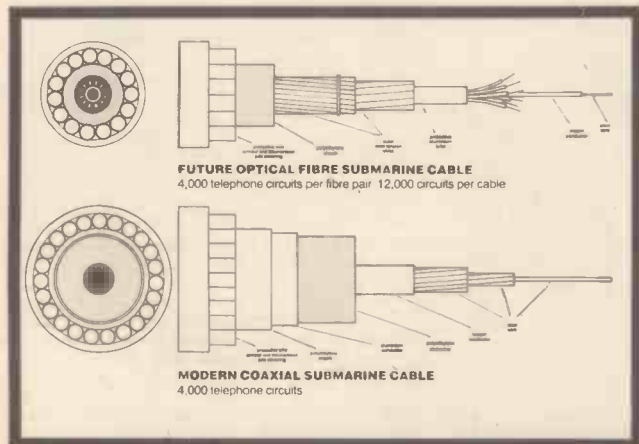

### ROYAL PET

The microcomputer manufacturer, Commodore Business Machines (UK) Ltd, has become the first manufacturing company to be granted the Royal Warrant of Appointment by Her Majesty The Queen for computer business systems.

General Manager of Commodore UK, Mr Howard Stanworth, said: "As a high technology company with a growing manufacturing and ancillary supplier base in the UK, we are delighted and honoured to receive the Royal Warrant of Appointment to Her Majesty The Queen."

## ALL-ROUND HOME ENTERTAINMENT CENTRE — FIDELITY SCORES A FIRST

**V**ISUAL and audio home entertainment from one integrated system. It had to happen of course, and to London-based Fidelity go the honours for being first in this field.

The Audio Visual System 1600 announced in February incorporates a 16-in colour TV, a 3-waveband tuner, a belt driven record player, a stereo cassette deck, a 24 watt amplifier (12 watt per channel) and comes with matching loudspeakers and a remote control.

The television has an optional spatial sound which electronically separates the sound to create a stereo effect through the floor standing speakers. The television can function as a video monitor for use with home computers and video equipment. Either can be plugged directly into the 21-pin Euro connector monitor socket at the rear of the system to give crisper computer graphics and sharper reproductions on video recordings. Fidelity is looking ahead, for this monitor socket will additionally suit cable and satellite systems of the future.

The expected inclusive retail price is around £400.

Stereo (from tape, record or radio) and TV can be operated at the same time, with video sound being available via headphones. Thus all



the family needs seem to be catered for by this stylish rack equipment with hinged glass door. The floor standing speakers are finished in a dark rosewood effect.

Whether as a second set for the larger household, a natural for the teenager's room or a perfectly adequate main entertainment centre for the smaller home — the AVS1600 seems sure of a warm welcome by the British public.

## EE MOVES



The London-based editorial team. (Left to right) Derek Gooding, Brian Terrell, Dick Hooper, Fred Bennett, Jackie Doidge, Peter Loates, Roy Palmer, Graham Hodgson and Dave Barrington.

From the dizzy heights of the 21st floor, King's Reach Tower, with panoramic views of Westminster and the meandering Thames in old London Town, Everyday Electronics moves to the 2nd Floor offices by the quayside at Poole Harbour in Dorset, with an elevation a mere masthead above sea level.

As from next month Everyday Electronics editorial department will be based at Poole, Dorset. The editorial team currently producing our companion magazine Practical Electronics in Poole, will then be responsible also for Everyday Electronics.

Mike Kenward, Editor of Practical Electronics will be editor of both magazines. As many readers will know, Mike was assistant editor of Everyday Electronics from its launch in 1971 until 1977. He took over as editor of Practical Electronics from Fred Bennett when PE moved from London.

The existing PE editorial team will be augmented to meet this new situation. Dave Barrington will move from London to take up the post of Assistant Editor/Production. Fred Bennett, present editor of Everyday Electronics, will be Consultant Editor and will remain based in London.

All other members of the present EE team are seeking pastures new.

### ADVERTISEMENT DEPARTMENT

Earlier this year Advertisement Manager Roy Smith handed over to David Tilleard who now has overall responsibility for both titles. He is assisted by Richard Willett who continues as Advertisement Representative for Everyday Electronics.

### EDITORIAL TEAM

Of the present EE editorial team Brian Terrell and Peter Loates are "founder members", working on this publication continuously since issue number one. In 1977 the following transferred to EE: David Barrington and Derek Gooding (ex-Practical Electronics); and Roy Palmer (ex-Practical Householder). More recent recruits are: Jackie Doidge, Graham Hodgson and Richard Hooper.

The disbanding of this team has been a considerable wrench to all concerned and particularly so for the longer serving members. The old team now bid farewell to their readers and hand over to their colleagues at Poole confident that readers' needs and interests will be in safe hands.

# RADIO WORLD

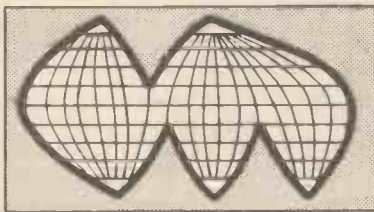

BY PAT HAWKER G3VA

## Reliability

Over the years we have come to expect a great improvement in the reliability of consumer electronics of all types. Perhaps the most dramatic has been in colour television receivers; with an improvement of from an average of about four faults per year, with the early dual-standard sets, to an average of only about one fault in three years in current models.

Murphy's Law unfortunately seems to mean that there are still a few "rogue" models that keep service engineers busy. A recent *Which?* report, however, suggests that the differences between brands are unlikely to be big enough to worry about—regardless of whether manufactured in Europe, or Japan the country that a decade ago did so much to improve the reliability of mass-produced equipment.

Today, relatively few faults are due to basic electronic circuit design, while semiconductor devices do not have the inherent failure mechanism of the diminishing cathode emission of thermionic devices. Though it should not be forgotten that for such specialised applications as submerged cable repeaters, the Post Office at their research centre at Dollis Hill in the 1960s developed valves designed to provide continuous operation for at least 20 years.

Although semiconductor devices do not wear out, this does not mean they are immortal. Their working lives can be brought to a sudden end by over-voltage transients, although good circuit design can provide protection against these events. Protection circuits may not themselves always prove satisfactory and for some professional equipment it may be necessary to ask "do we need a protection circuit for the protection circuit?"

Dust-free manufacture of materials is one of the major reasons for improved reliability. But semiconductors can still fail or change characteristics from such mechanisms as electro-migration; that is, the movement of aluminium atoms along a conductor caused by collisions with the conducting electrons to the extent where eventually this results in an open-circuit.

Also there is dielectric breakdown; for example, due to defects in the very thin gate insulator regions of metal oxide semiconductors, and that old enemy corrosion, due to absorbed moisture on the chip surfaces. Contamination of materials during manufacture; for example, oil contamination from machines may not show up for months or years.

## Q-Fax

For over a decade electronic device manufacturers have aimed at what they call "zero defects" and published life-test data,

though these figures may be averaged over different factories in different parts of the world, and have to be viewed with caution.

The UK's largest manufacturer of electronic components, Mullard Ltd., has recently introduced in its factories a Q-Fax ("quality facts") system to keep the workforce informed on results, defects and targets. A 380-page teletext-type Q-Fax system has been installed at Simonstone, Lancashire where component parts for colour picture tubes are made. A rotating sequence of six-pages is displayed automatically, but staff are encouraged to call-up any of the pages.

After three months' operation, Mullard claim the system, by improving communication between management and the shopfloor, is resulting in a steady decrease in component defects. The idea raises the age-old question, does this type of information technology have lasting effects once the novelty has worn off?

I recall one major Japanese manufacturer has another approach. Workers are encouraged regularly to beat-up with sticks dummies representing the management!

In the end it all comes down to finding ways in which people can be encouraged to exercise continuous care and skill over long periods—and to ensure that dust-free really means dust free.

## Radio Callsigns

It is now some 50 years since every radio broadcasting station on the medium- or long-wave bands had its own callsign. For instance, 2MT for the Writtle experimental station; 2LO for London; 6ZY for Manchester and 5XX for the Daventry long-wave station.

This practice was dropped in Europe in the early 1930s, but continues, even today, in the USA, with many thousands of three- or four-letter callsigns (each beginning W or K) and with suffixes AM for amplitude-

## CB Changes

The new conditions attached to British CB licences since 1 February seem unlikely to have any major effect on this service, particularly since there does not seem to be much effort devoted to enforcing the regulations or to checking on whether only the 280,000 licence holders are using 27MHz transmitters, though there have been a lot of prosecutions.

No new licences will be issued to anyone under 14 years, but there is no restriction on younger people using transmitters under supervision. It will be possible to use home-constructed aerials with loading coils in the more effective position two-thirds of the way up the element.

modulated medium-wave stations; FM for the VHF frequency-modulated stations; and TV for television stations.

With so many stations on the air it is not surprising that the owners value greatly callsigns that are easy to remember. Particularly those that identify with city or network such as WNBC and WNYC.

Callsigns are issued by the Federal Communications Commission (FCC) though the call-letters are often suggested by the applicants. As part of the current "deregulation" process FCC has made it clear that it no longer expects to be involved in the call-letter disputes that arise.

The FCC will no longer officially insist that all call-letters should be in "good taste", although FCC's Mass Media Bureau staff have warned the commissioners that it would not be proper for an agency of the federal government to issue "clearly obscene or indecent" callsigns. The commissioners however believe that if a community objects to a callsign it can "make its displeasure known to the station or the advertiser".

In the days when the Post Office used to issue amateur radio callsigns there were a number of three-letter combinations listed as "not to be issued". Even so, I can think of one or two people who were saddled with embarrassingly explicit callsigns!

## Legal Transceivers

The Department of Trade and Industry have recently confirmed to the R.S.G.B. that the installation and use by short-wave listeners of two-way transceivers is not in contravention of the existing Wireless Telegraphy Acts. This is provided, of course, that the equipment is used only to receive sound radio broadcasts from authorised broadcasting stations or to receive transmissions from licensed amateur radio stations.

This ruling shows how difficult it is to bring prosecutions for "pirate" operation of unlicensed transmitting equipment under the existing law since it is necessary always to prove use of the equipment. Whether this will remain true when the current Telecommunications Bill (including the Part VI amendments to the Wireless Telegraphy Acts), is enacted, is an interesting question since this would seem to make possible prosecution of persons in control of or in possession of specified equipment.

There is also, of course, the point that many people buy equipment while they are h.f. listeners with the genuine intention of using the transmitting facilities only when they obtain a licence. But for some the temptation proves too great!

The ban on the playing of music and re-broadcasting radio programmes has always existed but is now made more explicit. The licence now highlights the recommendation that *Channel 9* should be used only for calls requesting assistance and other emergencies.

What may produce greater changes not only in "pirate" CB but also "pirate" broadcasting and pirating on h.f. and on amateur bands is the Telecommunications Bill when (or if) it finally reaches the Statute Book, following the delay caused by the General Election and the political controversy about privatisation of British Telecom.

# MAY FEATURES...

## EXPERIMENTERS PSU...

All serious constructors require a reliable power supply. This unit fits the bill admirably with a switchable output ranging from 2-12V in steps of 1V. A novel feature is the use of a power op/amp which provides the output current up to a maximum of 325mA. The output is short-circuit protected and is accurate to within 0.1V.



## VARICAP AM RADIO

In this a.m. receiver the principle of the variable capacitance diode is employed as the tuning medium. The full medium-wave band is covered, the output is designed for a crystal earphone.

## SIMPLE LOOP/ BURGLAR ALARM

This battery operated alarm system has been designed around the wire loop principle often seen in shops to protect easily stolen articles such as radios. The design does, however, have many other uses since the alarm sounds for a preset period once the loop is broken.



EVERYDAY  
**ELECTRONICS**  
and computer PROJECTS

MAY 1984 ISSUE ON SALE FRIDAY, APRIL 19

# MULTIPURPOSE INTERFACE FOR COMPUTERS

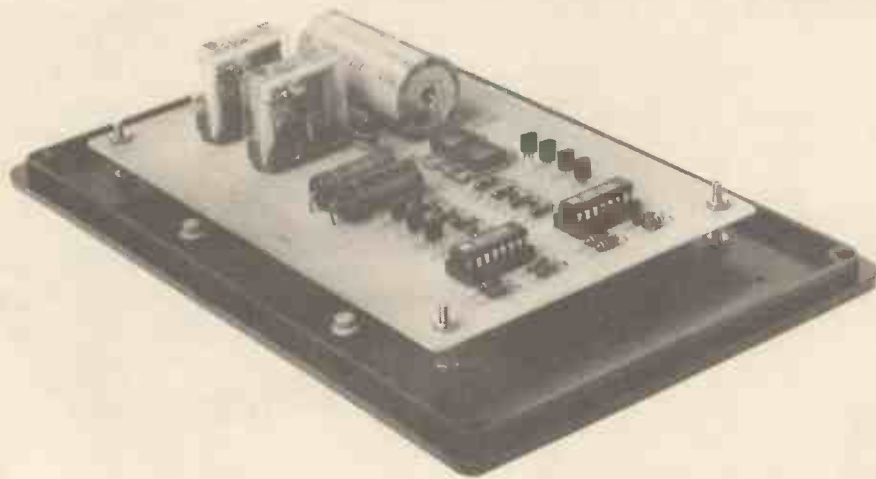

M. P. HORSEY

## SOFTWARE APPLICATIONS FOR MODEL RAILWAY CONTROL USING THE RM380Z AND VIC-20

THE unit described here is designed to interface to the user port or parallel printer port of a micro. Details of its use with the Research Machines 380Z computer—popular in schools—and the VIC-20 are given. The circuit is expected to work with most other machines, since it uses the standard data outputs as required by a parallel interface printer.

The unit has eight separate channels to control eight devices. It was built with a model railway in mind, and channels one to four will sink 100mA—suitable for l.e.d.s, or small beepers, and so on.

Channels five and six will sink 500mA to 1A, depending on the heatsink used on the power transistors. These outputs will drive small motors in train-sets, robots, and the like. Channels seven and eight have relay outputs, and provide a variety of uses, including controlling the polarity of the motor outputs, to enable the motor to reverse.

The unit will therefore power two trains, forward and reverse, and provide four more low current outputs for signals and other accessories.

Considerable economies may be made if fewer outputs are required. For exam-

ple, for just one train, only the components associated with channels five and seven will be needed. The simple programs included, will enable the speed and direction of a train to be computer controlled, via channels five and seven.

### OPTICAL ISOLATION

The interface power supply is totally isolated from the computer data and power outputs by means of an optical isolator chip. This ensures that should a

disaster occur to the interface, the computer cannot be damaged. Each l.e.d. in the interface chip requires a sink current into the computer of about 7mA. Thus with all computer data outputs low, a maximum current of 56mA is required from the 5-volt supply from the computer.

### COMPUTER DATA OUTPUTS

The eight data outputs are normally numbered 0 to 7. This may cause some confusion since channel 1 will be driven from data 0, channel 2 from data 1, and so on to channel 8 from data 7.

Each computer data output is normally low (that is, nearly 0V). When a suitable number is POKEd to the appropriate address, the required data output will go high (nearly 5V), and this in turn switches on the chosen output from the interface.

### SOFTWARE CONTROL

The combination of data outputs required, is controlled by POKeing a suitable number, determined in the following way:

The number POKEd must be converted into an 8-bit binary number. If the right-hand bit is a zero, then D0 will be low. If the right-hand bit is a one, then D0 will be high. If the next bit is a zero, then D1 will be low. The examples in Table 1 should clarify the situation.

In a computer program, the command POKe A,B is used to POKe the number B (as described above), into address A. Different computers will require different addresses for A, and some computers may employ an alternative to the command POKe (for example, the BBC computer).

### CIRCUIT DIAGRAM

The complete circuit diagram is given in Fig. 1.

Each of the eight channels work in a similar way. Consider channel 1. When D0 is low (nearly 0V), current from the computer 5-volt supply will flow via current limiting resistor R1, through the internal l.e.d. in the quad opto isolator chip IC1, and into D0. Channel 1 internal photo-transistor will turn on, and the voltage at the base of transistor TR1 will

Table 1. POKeing data into the port.

POKEd number (decimal)	Equivalent binary number	Data outputs							
		D7	D6	D5	D4	D3	D2	D1	D0
0	00000000	low	low	low	low	low	low	low	low
1	00000001	low	low	low	low	low	low	low	hi
2	00000010	low	low	low	low	low	low	hi	low
3	00000011	low	low	low	low	low	low	hi	hi
16	00010000	low	low	low	hi	low	low	low	low
64	01000000	low	hi	low	low	low	low	low	low
80	01010000	low	hi	low	hi	low	low	low	low

be near zero. Thus TR1 will be turned off and no current will flow into its collector.

If the decimal number 1 (binary 00000001) is POKed to the computer port, then D0 will go high (nearly 5V), and no current will flow through the l.e.d. The internal photo-transistor will turn off, and the voltage at the base of TR1 will rise—due to the current flowing through resistor R9. Transistor TR1 will therefore turn on, and current will flow from the 12-volt supply, through the load connected to OUTPUT 1.

Channels 1 to 4 work in an identical way. Channels 5 and 6 are similar, except that the emitter of the BC184L transistor is connected to the base of the power transistor type TIP41A. Thus a much larger current can be controlled.

Channels 7 and 8 drive relays, which can in turn control a variety of options—even mains circuits if suitable precautions are taken.

Diodes D1 to D8 protect their respective transistors against any back-e.m.f. voltage spikes caused by inductive loads such as motors and relays.

### SHORT CIRCUITS

It should be noted that a 2-amp thermal circuit breaker, CB1, is included in the design. This is rather large for model railways, and in this application, a lower current circuit breaker may be considered desirable. Alternatively, the circuit could be powered from a train-set controller, in which case the cut-out switch on the controller will provide the necessary protection.

### POWER SUPPLY

A fairly conventional power supply circuit is included, and a transformer can be selected to suit the current requirements

Fig. 1. Complete circuit diagram of the Microcomputer-Interface.

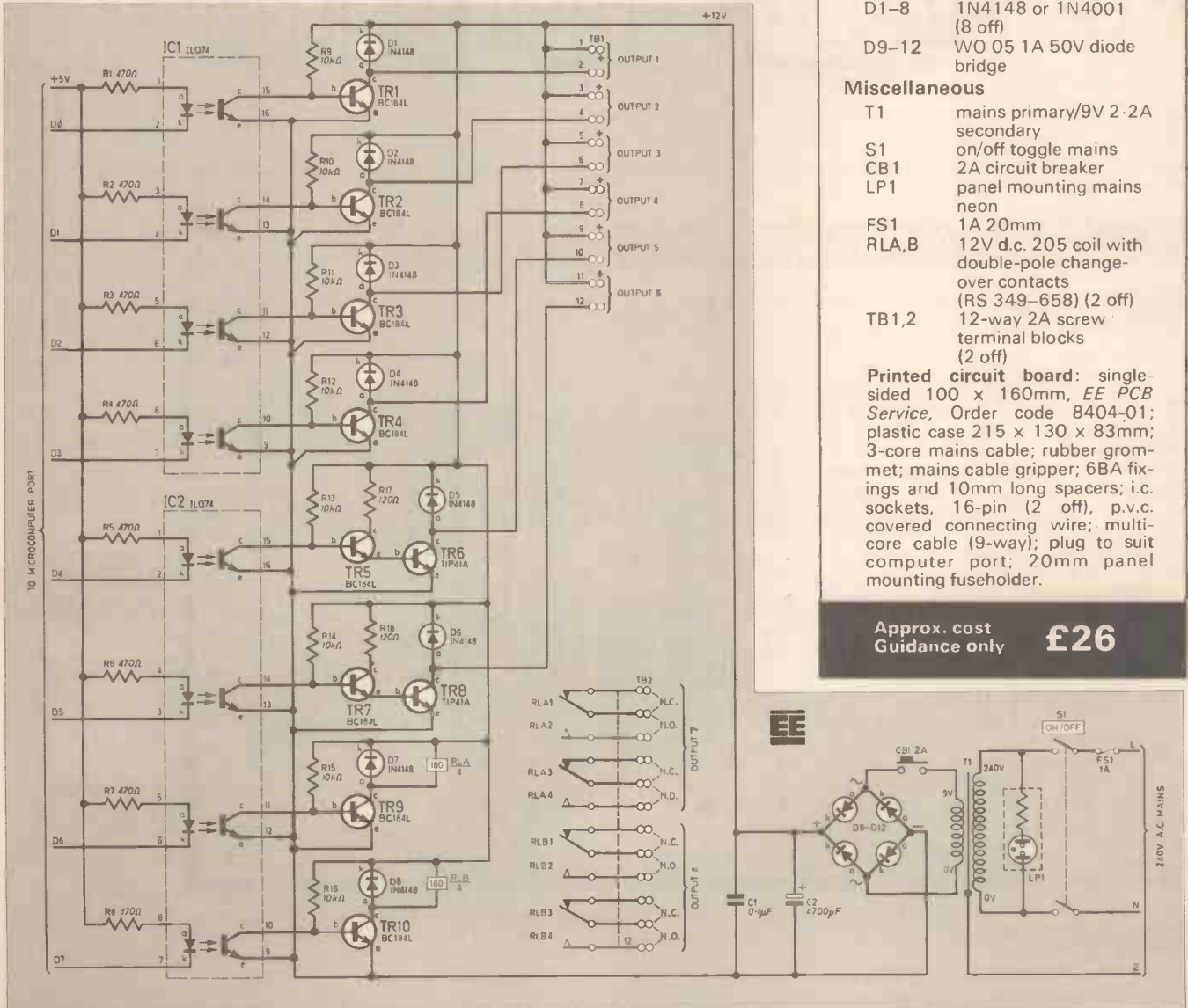

## COMPONENTS

### Resistors

- R1-8 470Ω (8 off)
- R9-16 10kΩ (8 off)
- R17,18 120Ω 2W (2 off)
- All ¼W carbon ±5% except where stated otherwise

### Capacitors

- C1 0.1µF polyester type
- C2 4700µF 25V elect. axial

See  
**Shop  
Talk**

page 231

### Semiconductors

- IC1,2 14074 quad opto-isolator (16-pin d.i.l.) (2 off)
- TR1-5,7,9,10 BC184L npn silicon (8 off)
- TR6,8 TIP41A npn silicon (2 off)
- D1-8 1N4148 or 1N4001 (8 off)
- D9-12 WO 05 1A 50V diode bridge

### Miscellaneous

- T1 mains primary/9V 2.2A secondary
- S1 on/off toggle mains
- CB1 2A circuit breaker
- LP1 panel mounting mains neon
- FS1 1A 20mm
- RLA,B 12V d.c. 205 coil with double-pole change-over contacts (RS 349-658) (2 off)
- TB1,2 12-way 2A screw terminal blocks (2 off)

**Printed circuit board:** single-sided 100 x 160mm, EE PCB Service, Order code 8404-01; plastic case 215 x 130 x 83mm; 3-core mains cable; rubber grommet; mains cable gripper; 6BA fixings and 10mm long spacers; i.c. sockets, 16-pin (2 off), p.v.c. covered connecting wire; multi-core cable (9-way); plug to suit computer port; 20mm panel mounting fuseholder.

Approx. cost  
Guidance only

**£26**

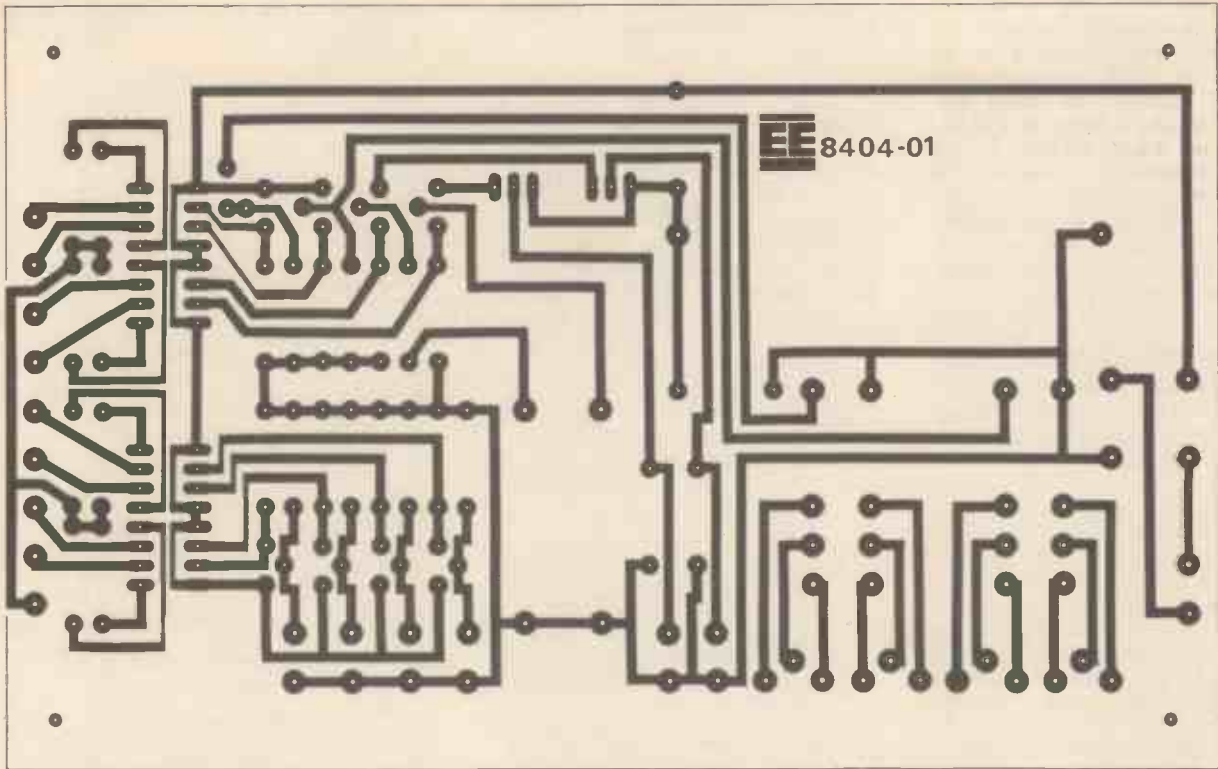

Fig. 2. The actual-size master pattern for the Multipurpose Interface p.c.b. This board is available from the *EE PCB Service*, Order code 8404-01.

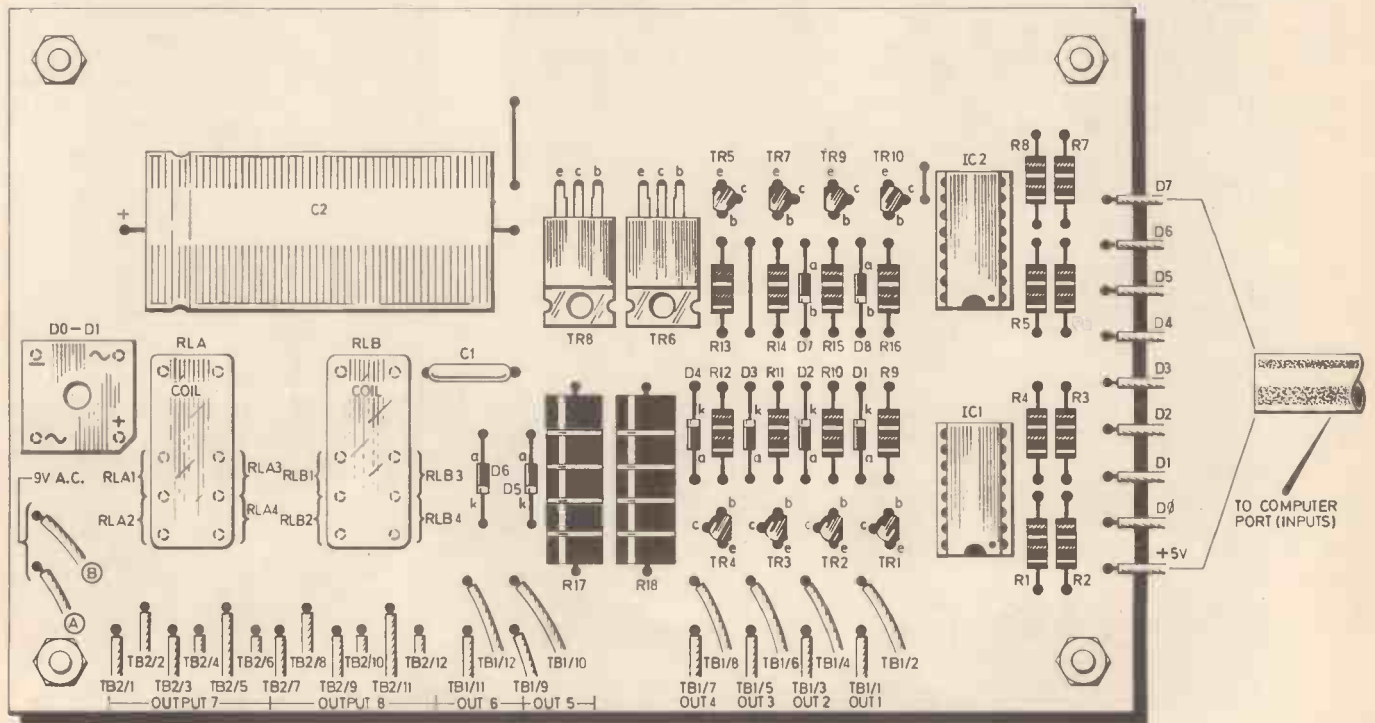

Fig. 3. The layout of the components on the topside of the p.c.b. with full interwiring details to case mounted components and computer output port.



envisaged. Note that the 9-volts a.c. transformer output is raised to nearly 13-volts d.c. when connected to a bridge rectifier (D9 to D12) and smoothing capacitor C2, but the maximum a.c. current is reduced by a factor of  $\times 0.62$ . Thus if the two 9-volt windings of the transformer listed are connected in parallel the maximum a.c. current is 2.2A. This is reduced to a maximum of 2A using the thermal cut-out switch indicated, but the maximum d.c. current available is  $2A \times 0.62 = 1.24A$ .

## CONSTRUCTION

### CONSTRUCTION

The prototype was constructed using a printed circuit board measuring  $160 \times 100\text{mm}$ . The actual-size master p.c.b. pattern is shown in Fig. 2. Provision has been made for all eight channels. If less are required omit the relevant components. This board is available from the *EE PCB Service*, Order code 8404-01. Begin by drilling the holes required to anchor the p.c.b. to the case.

Next, assemble the p.c.b. according to Fig. 3.

Solder in the i.c. holders, wire links and resistors, noting that resistors R17 and R18 are 2 watt types.

The diodes must be fitted with the correct polarity (that is, the right way round), and care must be taken with the BC184L transistors, to ensure that the leads are correctly orientated. If BC184 (without the L) transistors are used, note that the leads will be in a different order.

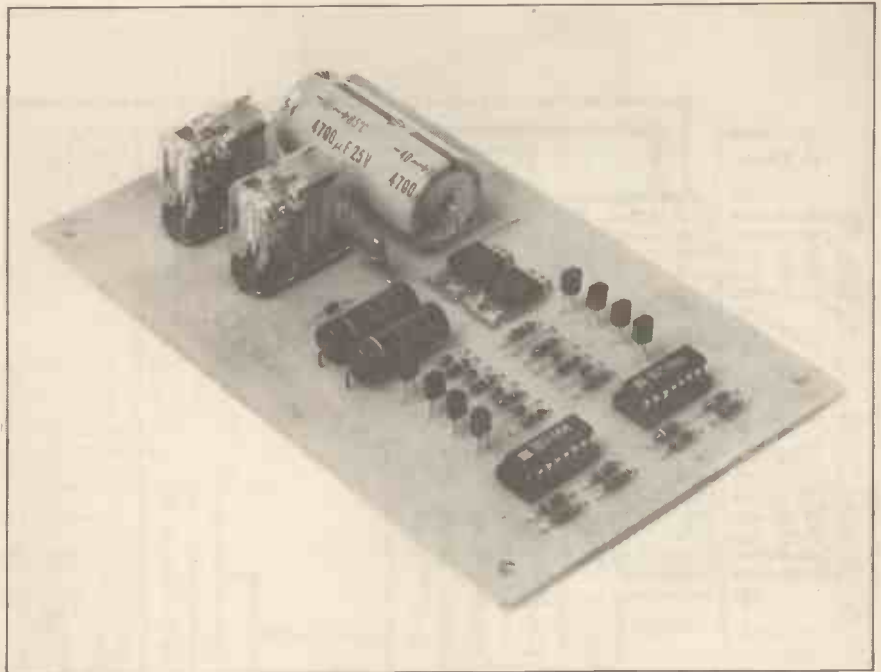

The fully assembled p.c.b. ready for wiring up.

The power transistors may be fitted to the circuit board as shown, and no heat-sink is necessary if small model railway motors are driven. For larger currents, heatsinks should be secured to the metal plates of the transistors.

Alternatively, the power transistors may be fastened to a sheet of metal (or the case—if made of metal), and flexible wires used to connect them to the p.c.b. If both transistors share one heatsink, use mica washers and insulating bushes.

The relays specified will fit directly to

the p.c.b. Other relays may be used with different pin-outs. These would be mounted off-board and connected to the board using flexible wires.

### CASE

A sturdy plastic box measuring  $215 \times 130 \times 83\text{mm}$  was used to house the interface and power supply. Drill the necessary holes for the mains lead, fuse, mains switch, cut-out switch, neon and transformer. Drill holes in the lid of the case for mounting the stripboard, and

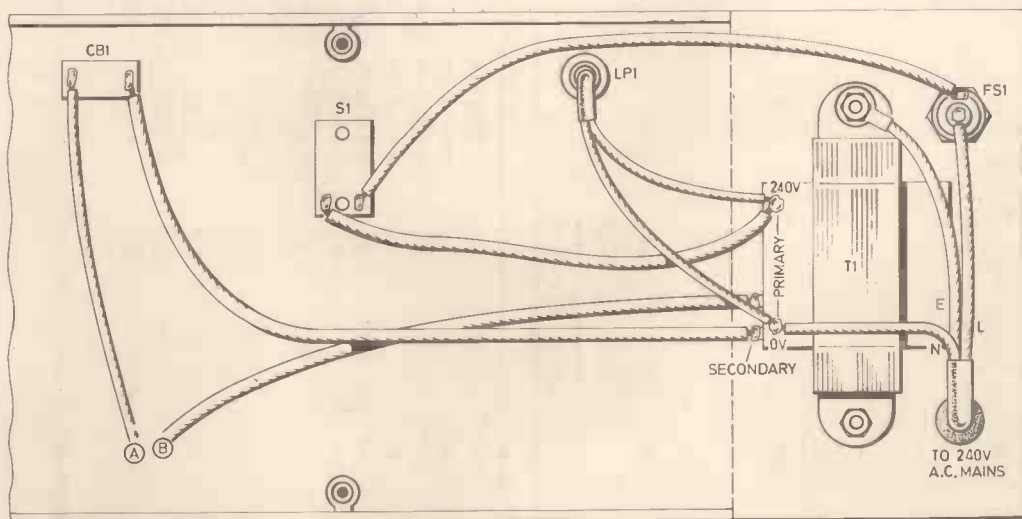
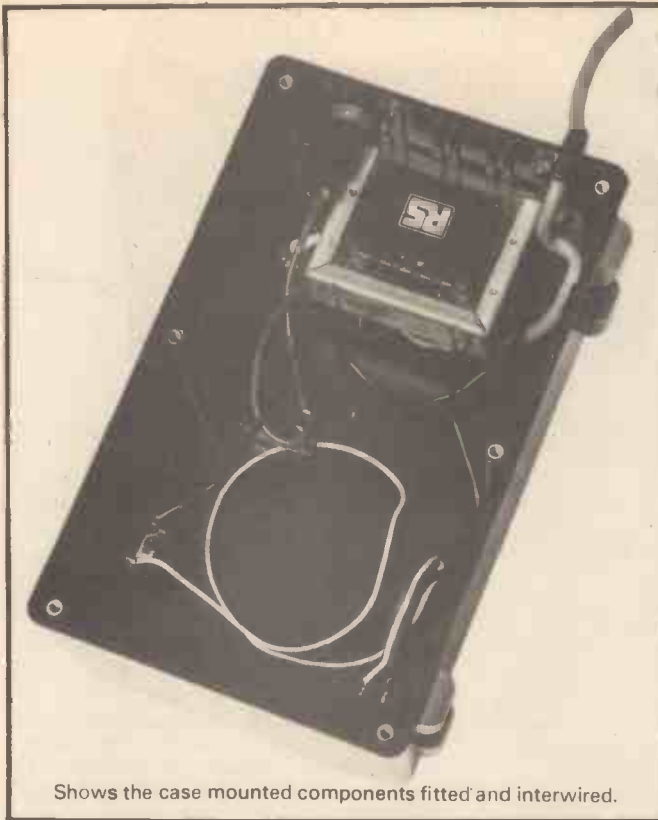

Fig. 4. Interwiring of the case mounted components fitted in position.



Shows the case mounted components fitted and interwired.

### MODEL RAILWAY CONTROL SOFTWARE FOR RM380Z

```

10 REM" TRAINS"RML380Z
20 LET P=&FBFF:Q=0
30 PUT12:GRAPH
40 PLOT 30,55,"T R A I N"
50 PLOT 30,52,"*****"
60 PLOT 0,40,"You may select the following:"
70 PLOT 10,34,"F:forward R:reverse S:stop"
80 PLOT 22,28,"Speed: type 1 to 9"
90 PLOT 0,22,"-----"
100 PLOT 0,16,"Present Conditions:"
110 PLOT 5,10,"Direction:"
120 PLOT 50,10,"Speed:"
130 PLOT 0,2,"-----"
140 IF B$="" THEN LET B$="STOPPED"
150 IF Q=0 THEN A=0
160 LET C$=STR$(A)
170 PLOT 27,10,B$
180 PLOT 62,10,C$
190 REM TRAIN RUNNING LOOP
200 LET A$=GET$(0)
210 IF A$<>"" THEN GOTO 310
220 IF A$>8 THEN 270
230 FOR X=1 TO 10-A
240 IF B$="REVERSE" THEN POKE P,64 ELSE POKE P,0
250 NEXT X
260 IF A<1 THEN 200
270 FOR X=1 TO A
280 POKE P,Q
290 NEXT X
300 GOTO 200
310 REM SELECT DIRECTION & SPEED
320 IF A$="F" OR A$="f" THEN B$="FORWARD":LET Q=16:V=0
330 IF A$="R" OR A$="r" THEN B$="REVERSE":LET Q=80
340 IF A$="S" OR A$="s" THEN B$="STOPPED":LET Q=0:V=0
350 LET A=VAL(A$)
360 GOTO 150

```

Table 2. User port pin assignments

#### RM 380Z

Pin no.	Function
5	DO0
6	DO2
7	DO4
8	DO6
9	+5V
18	DO1
19	DO3
20	DO5
21	DO7

#### VIC-20

Pin no.	Function
2	+5V
C	D0
D	D1
E	D2
F	D3
H	D4
J	D5
K	D6
L	D7

### MODEL RAILWAY CONTROL SOFTWARE FOR VIC-20

```

0 REM *****
1 REM *** **
2 REM *** ADAPTED ***
3 REM *** **
4 REM *** FOR THE ***
5 REM *** **
6 REM *** VIC20 ***
7 REM ** **
8 REM ** BY J.HALL **
9 REM ** **
10 REM*****
15 POKE37138,255
20 LETP=37136:Q=0
30 PRINT"□":POKE36879,157
40 PRINT"□□ TRAIN"
50 PRINT"□□ *****"
60 PRINT"□□ YOU MAY SELECT THE FOLLOWING.□"
70 PRINT"□□□ F = FORWARD"
72 PRINT"□□□ R = REVERSE"
75 PRINT"□□□ S = STOPPED"
80 PRINT"□□□ SPEED = 1-9"
85 FORV=0TO8000:NEXT
90 FORT=38TO160:POKE36881,T:NEXT
95 POKE36879,29
100 PRINT"□□□□ PRESENT CONDITIONS "
105 PRINT"□□□□□□□□□□ *****"
110 PRINT"□□□□ DIRECTION:"
120 PRINT"□□□□ SPEED:"
130 FORT=160TO38STEP-1:POKE36881,T:NEXT
140 IFB$="" THENLETB$="STOPPED"
150 IFQ=0 THENA=0
160 LETC$=STR$(A)
170 PRINT"□□□□□□□□□□□□□□□□":B$
180 PRINT"□□□□□□□□□□□□□□□□":C$
190 REM **TRAIN LOOP**
200 GETA$
210 IFA$<>"" THENGOTO310
220 IFA$>8 THEN270
230 FORX=1TO10-A
240 POKEP,V
250 NEXT
260 IFA<1 THEN200
270 FORX=1TOA
280 POKEP,Q
290 NEXTX
300 GOTO200
310 REM **SELECT**
320 IFA$="F" THENB$="FORWARD":Q=16:V=0
330 IFA$="R" THENB$="REVERSE":Q=80:V=64
340 IFA$="S" THENB$="STOPPED":LETQ=0:V=0
350 LETA=VAL(A$)
360 GOTO150

```

READY.

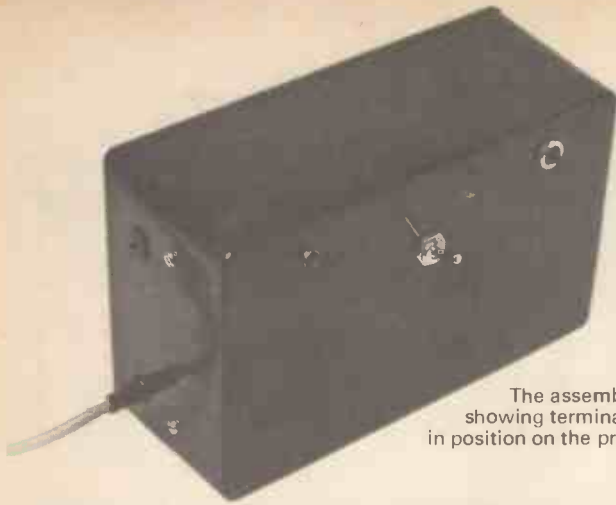

The assembled unit showing terminal blocks in position on the prototype.

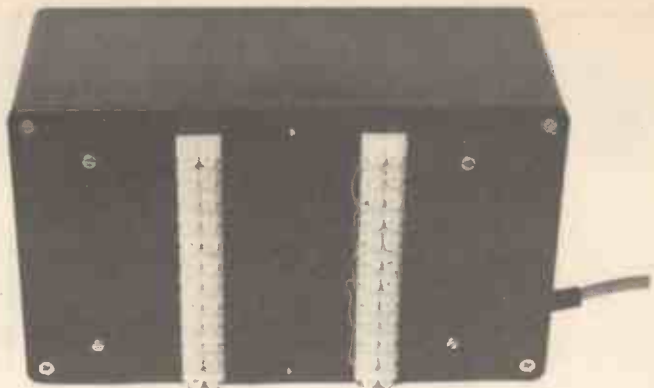

terminal blocks, and holes for the computer lead, and output connections. Connect the data input cable to a suitable connector to mate with the socket on the computer. Fig. 5 in conjunction with Table 2 gives details.

Care must be taken with the clearance between the p.c.b. components and the transformer. For added safety, the transformer was mounted with its mains connections the opposite side from the p.c.b.

### OUTPUT TERMINAL BLOCKS

Take care to use wire capable of carrying the required current to the output terminal blocks. The connections to channel 7 (relay 1) are shown to permit forward/reverse motion of a motor driven from channel 5. This enables the interface to be used with the programs listed below.

### MOTOR CONTROL

The speed of the motor may be controlled by rapid switching on and off of the appropriate power transistor, and providing the program loop which controls this is quite short, the results achieved can be very good. The direction is controlled by a relay, such that if the relay is switched off, the motor direction is forward, but if the relay is turned on, the motor direction is reversed.

### COMPUTER PROGRAM FOR MODEL RAILWAY

The variable P is used to select the appropriate output address, and Q is the number to be POKEd to that address.

The program plots some instructions on the TV monitor, and indicates the present conditions (that is, what the train should be doing).

Care has been taken to keep the speed control loop short, to ensure smooth running.

Another precaution is, that if the direction is changed from FORWARD to REVERSE (or vice versa) the speed drops to zero and has to be typed again. This ensures that the motor is not unduly strained.

### SETTING UP AND TESTING

Double check construction and interwiring. Do not connect the interface to the computer at this stage.

To test the interface, begin by switching on the power supply. Connect a voltmeter to the +12V line (+ve terminal of C2), and connect its negative lead to output 1. The voltmeter should read about 12 volts. Repeat this procedure for outputs 2 to 6. Observe the relays; they should be on, that is, the n.o. contacts should be closed.

If further testing is desired—before connecting to the computer, a 5 or 6 volt supply may be connected to the +5V supply line, and the negative of the supply connected in turn to each data input. A voltmeter connected as before should indicate a zero reading when the appropriate data input is negative.

Finally, switch off the interface unit, and connect it to the computer. Switch on the computer and interface. The initial data output will be zero (binary 00000000). Thus each output should be

“off”. This may be checked with a voltmeter connected as before.

With the Research Machines 380Z computer, typing the BASIC command: POKE&FBFF,1 should produce the binary number 00000001 to be output, and hence D0 will go high, causing the voltmeter on output 1 to read 12 volts. POKE&FBFF,2 will cause the next output to switch on, POKE&FBFF,4 the next, then 8,16,32,64,128 will cause outputs 3 to 8 to switch on respectively.

Finally, try out the program listed with a small motor or model train. Designing more complex programs to use with the interface is where the fun really begins.

### CONNECTING TO THE VIC-20

Like the Research Machines 380Z, the VIC-20 computer also provides the required data outputs, but at address 37136. The VIC-20 also requires the number 255 to be POKEd at address 37138, in order to set the lines as outputs.

Bearing this in mind, the VIC-20 may be connected to the interface unit using a 2 x 12-way 0.156in p.c. edge connector, the connector should be wired to suit the socket shown in Fig. 5 and Table 2.

Converting the train program for use with the VIC-20, required numerous modifications, as this computer has no PLOT or PRINT@ command. The large display characters also required program modification to display the required information.

The finished program does perform exactly the same task as the one designed for the Research Machines 380Z computer. □

Fig. 5. Location and pin numbering of suitable outlet sockets on the RM380Z and VIC-20 micros.

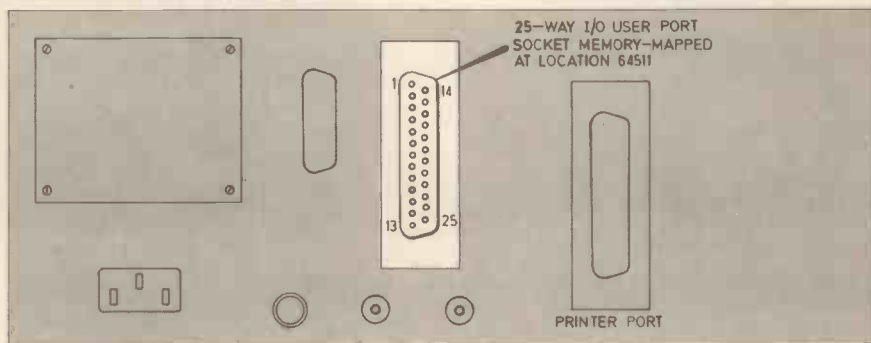
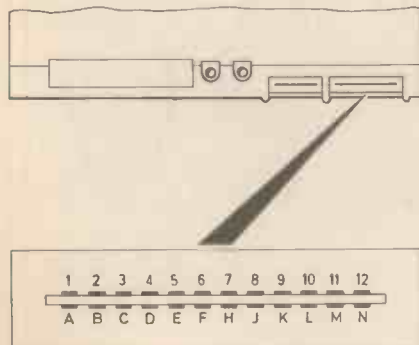

# WHY NARROW BAND F.M. ?

## Part 1

BY E.A. RULE

**D**URING the past few years prior to the establishment of a Citizen's Band radio service in the UK, there was much debate concerning the best modulation system for such a service. Many arguments were put forward either in favour or against single sideband (s.s.b.), frequency modulation (f.m.), or amplitude modulation (a.m.), depending on personal viewpoints. The system that was finally chosen for CB radio was narrow band frequency modulation (n.b.f.m.).

In this article we shall now take a closer look at this mode of transmission and compare it with a.m. in the context of amateur radio, CB radio and point-to-point communications. Broadcasting has certain special requirements and features, and does not come into the present discussion.

First we must consider the major difference between the two systems and that is in regard to the actual method of modulation of the carrier wave. Fig. 1 shows an a.m. signal which consists of the modulating audio signal and r.f. carrier being added together in a way that causes the *amplitude* of the carrier to change. As the audio and carrier frequencies are different there will be phase differences between them and when the two signals are in-phase their amplitudes will add, and when they are out-of-phase their amplitudes will subtract, thus producing the amplitude modulated carrier wave in Fig. 1(c). Note that the actual *frequency* of the carrier wave is constant.

With the f.m. system, the modulating audio is added to the carrier in such a way that its *frequency* varies but its amplitude remains constant. Fig. 2 shows how this occurs. This change in frequency is called the deviation of the carrier and is the equal to the modulation of the a.m. carrier wave.

### OVER MODULATION

Now with the a.m. system it is possible to over-modulate the carrier, Fig. 3 shows what happens. If the amplitude of the audio modulating signal is greater than the amplitude of the carrier it will still increase the overall amplitude when they are in-phase but as it cannot reduce the carrier to less than zero when they are out-of-phase the carrier is "cut off" for the duration of the time that the audio is trying to take the carrier below zero. This results in severe distortion of the carrier and "splatter" into nearby channels adjacent to the transmitter frequency.

In theory it is not possible to over-modulate an f.m. carrier as when the audio modulating signal is increased in amplitude it simply causes a larger shift in the frequency of the carrier. This would at first seem to be the answer to many problems, but, in practice there are other factors which set the limit to how much deviation can be applied.

First the actual tuned circuits of the transmitter will limit the amount of deviation. These have to have a response that

is even, over the total amount of frequency shift, otherwise as the signal shifts towards the edge of the selectivity of the tuned circuits there will be a reduction in the output, Fig. 4. This would mean that amplitude modulation was being introduced. Therefore the total deviation must be kept to within the capabilities of the transmitter tuned circuits (and aerial) bandwidths.

### RECEIVER BANDWIDTH

Also there is the question of receiver bandwidth. If the deviation of the transmitter is greater than the receiver bandwidth then the signal would pass outside the receiver passband and be lost, or at the very least again have amplitude variations added to it (Fig. 4). For normal amateur and CB equipment this maximum deviation is limited to around 5kHz and this is equal to the 100 per cent modulation of the a.m. system. Without going into the technical reasons, this also means that a similar number of stations can be spaced into a given frequency band. A wider deviation would reduce the number of f.m. stations in a given band.

### DETECTION SYSTEMS

The next major difference between the two signals is in the detection system used in the receivers. The a.m. detector has to respond to amplitude changes in the incoming signal and this means that it will

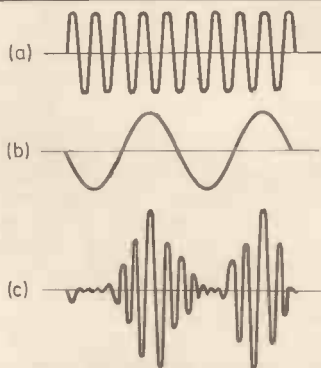

Fig. 1. Amplitude modulation, showing how the two signals are added in- or out-of-phase to produce the final modulated carrier.

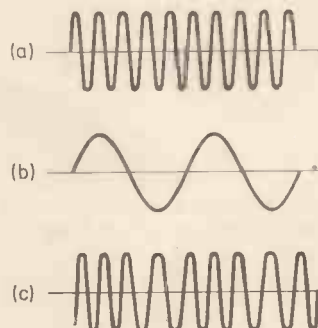

Fig. 2. Frequency modulation. Note that the final carrier is constant in AMPLITUDE.

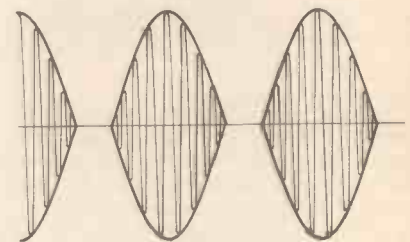
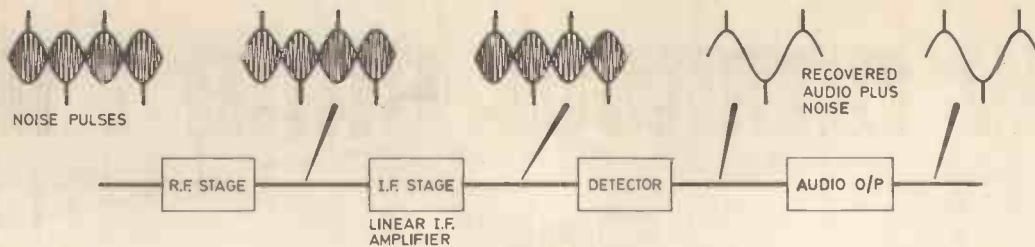
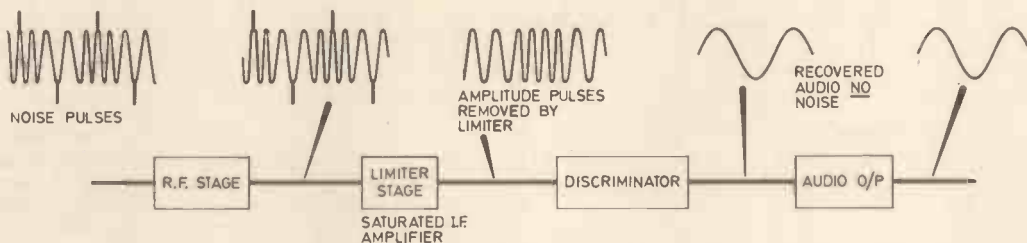

Fig. 3. Over-modulated carrier wave. Note the gaps in the carrier where the modulating signal has tried to reduce the amplitude below zero.



(a)



(b)

Fig. 5 (above). Showing how noise pulses are removed by the f.m. limiter stage and prevented from being passed on to the output. On a.m. the detector responds to noise pulses as if it were a normal amplitude modulated signal and passes them on to the output.

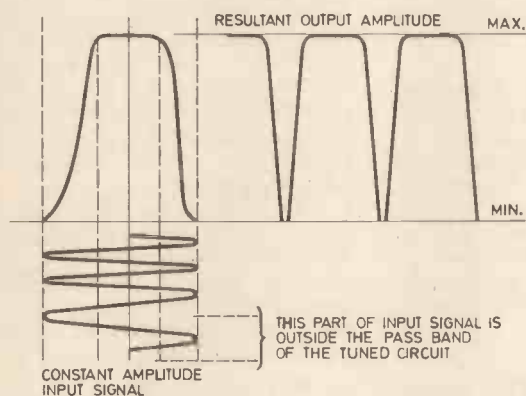

Fig. 4 (left). Showing how a signal of constant amplitude, but frequency shifted due to modulation, can be moved outside the tuned circuit's passband and cause resulting amplitude modulation of the signal.

also respond to amplitude interference such as, car ignition systems, switching, motor commutators, and so on.

The f.m. detector is designed to respond to changes in frequency of the incoming carrier and can be made insensitive to amplitude changes. Therefore it is far less likely to respond to amplitude sources of interference like car ignition. This at once makes it a better system for use in mobile installations, as it is automatically immune to impulse noises, and is many hundreds of times better than the a.m. system.

Fig. 5 shows a carrier with impulse noise on it and how it passes through the two types of receiver.

## SIGNAL AMPLIFICATION

The next main difference between the two types of receiver is the way the stages amplify the signal. With the a.m. system, the changes in amplitude must be preserved and this means that any amplifying stage must not distort the signal. In order for this to happen arrangements must be made to reduce the amplification on strong signals so that the stages are not overloaded. This automatic gain control (a.g.c.) is an important design feature of all a.m. receivers.

On f.m. we are not concerned with amplitude variations but only the changes in frequency, and in fact the stages can be allowed to saturate and this will prevent amplitude changes from reaching the f.m. detector, further improving the immunity to impulse noises and the like. It also simplifies the design of the amplifying stages. A further advantage is that once saturation (limiting) has been reached the audio output from the receiver is constant.

On a.m., if you are listening to a weak station with the volume control turned up and a strong local comes on, you will get deafened! On f.m. both signals would be the same volume—although in practice only the stronger one would be heard, due to the *capture effect* (more about this later).

Fig. 6 shows a typical input output curve of an f.m. receiver. Note the rapid reduction in noise as the signal strength increases. Compare with the a.m. curve Fig. 7.

A good f.m. receiver will be designed so that even very weak signals fully saturate (limit) the i.f. amplifier stages, which in practice means that all signals will be at the same output volume irrespective of their actual strength. This is why changing the transmitter power

has no effect whatever on the received signal once it is strong enough to reach the limiting level, unlike a.m. where increasing the transmitter power will produce a change in output at the receiver.

## CAPTURE EFFECT

With a f.m. receiver the detector or, to give it its proper name, the discriminator will "capture" a signal which is on the same frequency but stronger. The better the receiver, the less difference there will be between the two signals in strength before the receiver captures the stronger.

For example, if you are listening to say a fixed station of a given strength and a mobile station is on the same frequency, at first you will only hear the fixed station. Then quite suddenly as the mobile station comes into range its signal will become slightly stronger than the fixed stations and the receiver will "capture it". The result is a sudden switch from one station to the other. The better the receiver the more abrupt the change-over will be. There is no warning, it just happens. This is unlike a.m. where you can hear the weaker signal building up underneath the stronger until it is strong

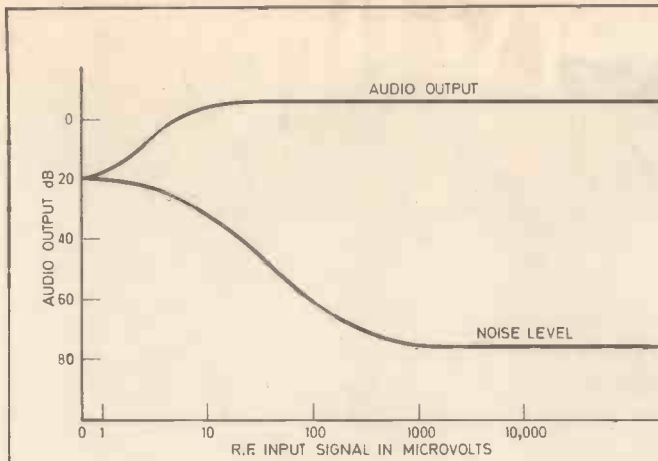

Fig. 6. Typical f.m. receiver input/output response.

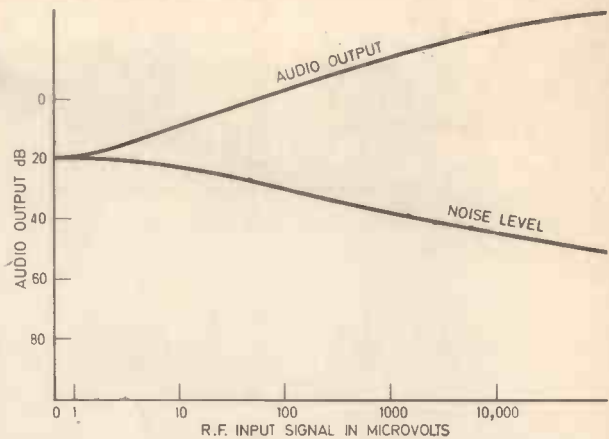

Fig. 7. Typical a.m. receiver output/input response. Responses will vary from design to design with the better receivers having a more constant output and quicker reduction in noise. However, on a.m. there is *not* an equivalent effect to the "capture" effect of f.m.

enough to cause severe interference before taking over.

This is one of the reasons why it is possible to "break in" on an a.m. contact but not an f.m. one. If you tried to break in on an f.m. contact you would just not be heard unless your signal was strong enough to be captured by the receiver.

#### RESIDUAL NOISE

Now this capture effect also applies to noise. When the signal you are trying to receive drops below the residual noise level the receiver will capture the noise in the same way as it would a stronger signal. The result is that f.m. signals which are getting weaker will suddenly disappear into the noise, whereas on a.m. you can often "copy" them right down into and sometimes even below the residual noise level. At this threshold point an increase in f.m. transmitter

power can make an improvement in reception which is quite dramatic due to the receiver again capturing the stronger signal.

On the a.m. system an increase in signal of 3dB (double power) will not make much practical difference to the received signal although of course it will improve it to some extent. On f.m. the same change in power at the capture point can make all the difference between a signal being 100 per cent copy and not being heard at all, assuming of course that the receiver has a good capture ratio.

#### CAPTURE RATIO

This is normally quoted in dBs and the smaller the figure the better. The figure quoted is the difference in power required between two signals on the same frequency before the receiver will capture the stronger.

For example, if the receiver is quoted as having a 3dB capture ratio then one signal would have to be twice the power of the other. If the receiver was quoted as 0.5dB (modern hi-fi stereo receivers achieve this) then the power change is only 1.12 times. Note here that we are referring to *received* power and not transmitter power.

The effect of this "capturing" of the stronger signal is why it is possible for f.m. stations that are in different localities to have "nets" on the same frequency without mutual interference. On a.m. there would be a heterodyne whistle in the background all the time.

Next month we shall consider some of the actual circuits used and their differences, as between the f.m. and a.m. systems.

## PRACTICAL ELECTRONICS

MAY 1984

FREE:  
LOGIC DESIGN CARD

PROJECTS  
SIMPLE POWER SUPPLY UNIT  
LOGIC SIGNAL GENERATOR  
SUSTAIN UNIT  
EPROM DUPLICATOR

PLUS  
SPECIAL TEST GEAR BUYERS' GUIDE  
MULTIMETERS

MAY ISSUE ON SALE  
FRIDAY, APRIL 6

## PLEASE TAKE NOTE

### Games Scoreboard (January 1984)

The first paragraph on page 44 should read:

"If for example, S4 was set to position '2' and S3 set to position '5', on the 25th pulse from the low frequency oscillator, the inputs . . ."

The original text had inadvertently transposed the references to switches S3 and S4.

The last sentence in the first paragraph of page 45 states incorrectly that 4066 quad bilateral switches (IC9 to IC12) are *opened* by taking the control pins to logic high when in fact the opposite is true, that is, a logic high on the control pin *closes* the switch.

### Teach-In 84 (January 1984)

Experiment 4.4, diagram Fig. 4.11. The end of potentiometer VR1 marked "a" should be connected to capacitor C2 and the earphone X1 at point E17. See page 237.

### Microcomputer Interfacing Techniques Part 8 (February 1984)

Oric Port Board. There is an error in the circuit diagram, Fig. 8.6, and the component layout Fig. 8.9. In both diagrams the signal line labelled "I/O pin 5" should be labelled "I/O Control Pin 6".

# You win every time!

When you get this NEW & FREE project from GSC

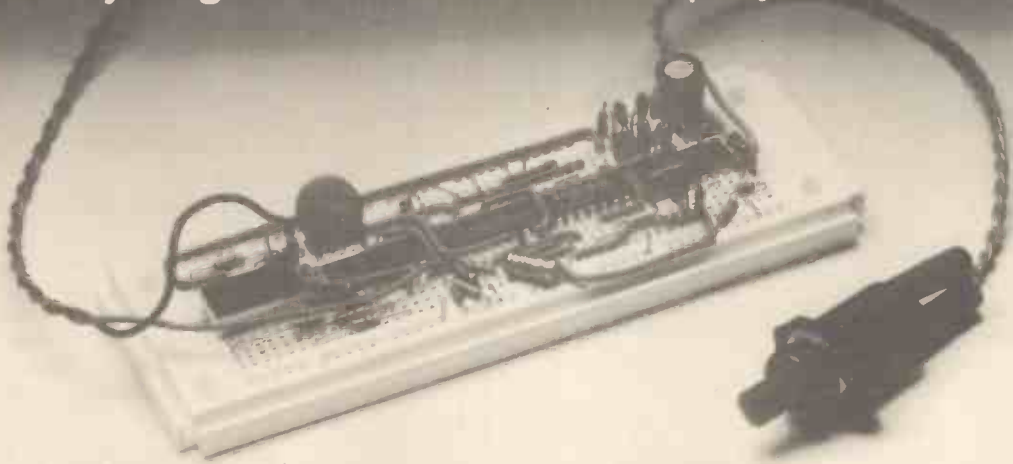

**NEW:** an exciting range of projects to build on the **EXP300** breadboards.  
**NOW** anybody can build electronics projects; it's as easy as **A.B.C.** with **G.S.C.!**

## EXPERIMENTOR BREADBOARDS

The largest range of breadboards from GSC. Each hole is identified by a letter/number system. EACH NICKEL SILVER CONTACT CARRIES A LIFE TIME GUARANTEE. Any Experimentor breadboard can be 'snap-locked' with others to build a breadboard of any size.

1. **EXP 325** £2.25 The ideal breadboard for 1 chip circuits. Accepts 8, 14, 16 and up to 22 pin ICs. Has 130 contact points including two 10 point bus-bars.
2. **EXP 350** £3.80 Specially designed for working with up to 40 pin ICs perfect for 3 & 14 pin ICs. Has 270 contact points including two 20 point bus-bars.
3. **EXP 300** £6.50 The most widely bought breadboard in the UK. With 550 contact points, two 40 point bus-bars, the EXP 300 will accept any size IC and up to 6 x 14 pin DIPS. Use this breadboard with Adventures in Microelectronics.
4. **EXP 600** £7.95 Most MICROPROCESSOR projects in magazines and educational books are built on the EXP 600.
5. **EXP 650** £4.75 Has 6" centre spacing so is perfect for MICROPROCESSOR applications.
6. **EXP 4B** £2.75 Four more bus-bars in "snap-on" unit.

## PROTO-BOARDS

The ultimate in breadboards for the minimum of cost. Two easily assembled kits.

7. **PROTO-BOARD 6 KIT** £12.00 630 contacts, four 5-way binding posts accepts up to six 14-pin Dips.
8. **PROTO-BOARD 100 KIT** Complete with 760 contacts accepts up to ten 14-pin Dips, with two binding posts and sturdy base. Large capacity with kit economy. **£14.25**

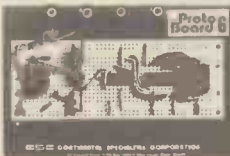

## FREE project:

### AUTO-DICE

Live up your board games with this sophisticated electronic dice circuit! When the 'throw' switch is pressed, a numerical display flashes up rapidly changing numbers. After a few seconds, the 'rolling' stops, and the final result is displayed; any number, randomly selected, from 1 to 6. A few seconds later the display turns off to conserve your battery, letting the games go on uninterrupted for weeks!

### HOW DO YOU MAKE IT?

Our **FREE** project sheet gives you a large, clear diagram of the components layed out on an **EXP 300** breadboard. Each component is labelled, and the values are given in a component listing. Even the 'row and column' lettering of our **EXP 300** is shown to make the location of the correct holes, in which to push the components, easy to find. There's no soldering involved; it couldn't be easier! As an extra bonus, there's a full circuit description, and the details of a regulated power supply on the other side of the sheet.

"Clip the coupon" and get your **FREE** project sheet with each **EXP 300** bought. **AND** a free catalogue! Just ask about our other free projects too.



GOODS DESPATCHED WITHIN 24 HRS FROM RECEIPT OF ORDER

For further details of our **FULL PROTO-BOARD RANGE**, please send for our free catalogue.

## GLOBAL SPECIALTIES CORPORATION



**G.S.C. (UK) Ltd.** Dept. 5B  
 Unit 1, Shire Hill Industrial Estate,  
 Saffron Walden, Essex CB11 3AQ  
 Telephone: Saffron Walden (0799) 21682

G.S.C. (UK) Limited Dept. 4B, Unit 1, Shire Hill Industrial Estate, Saffron Estate, Walden, Essex CB11 3AQ  
 Prices include P & P and 15% VAT

1	QTY.	2	QTY.	3	QTY.	4	QTY.	5	QTY.	6	QTY.	7	QTY.	8	QTY.
	£3.95		£5.23		£8.63		£10.29		£6.33		£4.03		£14.95		£20.07

Name \_\_\_\_\_ Address \_\_\_\_\_

I enclose Cheque/P.O. for £ \_\_\_\_\_ or debit my Barclaycard/Access/  
 American Express card no. \_\_\_\_\_ expiry date \_\_\_\_\_

FOR IMMEDIATE ACTION - The G.S.C. 24 hour, 5 day a week service  
 Telephone (0799) 21682 and give us your Barclaycard, Access, American  
 Express number and your order will be in the post immediately

For **FREE**  
 Catalogue  
 tick box

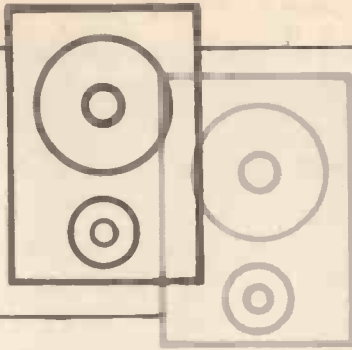

# QUASI-STEREO ADAPTOR

BY R.A. PENFOLD

TELEVISION sound is often criticised as being of a rather poor technical quality, but this is not strictly true as the f.m. sound channel used in the UK television system is capable of providing quite a high level of fidelity with good bandwidth, signal-to-noise ratio, and low distortion.

Television sets generally have a comparatively poor sound quality due to the rather simple output stages and small loudspeakers which do not equal those of even low cost hi-fi systems.

These days many television sets have an earphone or tape socket which can be coupled to a hi-fi amplifier and speakers to give a considerable improvement in the audio quality. However, the television sound channel provides only a monophonic signal (with no immediate prospect of stereo being introduced), and this can lead to disappointing results.

## QUASI-STEREO EFFECT

With a monophonic signal coupled to both channels of a stereo system the sound produced seems to emanate from mid-way between the two loudspeakers and a stereo image is obviously not obtained. This can sound rather as if the sound is being fed to the listener along a tunnel and results may actually be preferable if only one stereo channel is fed with the input signal.

There is no way of producing a true stereo signal from a mono one, but there

are various ways of producing a *quasi-stereo effect*. Rather than producing a proper stereo image processors of this type, spread out the sound between the two loudspeakers so that more spacious and realistic results are obtained.

## FILTERING SYSTEM

The most common method of synthesising a pseudo-stereo signal from a mono input is to use a simple system of filtering, where the lower middle and bass frequencies are fed into one channel with the upper middle and treble frequencies being fed into the other channel.

The two filters used to split the signal are designed to give no overall change in the frequency response of the system. High frequency sounds are on one side of the sound stage, low frequency sounds are on the opposite side and middle frequencies are in the central image area.

This system can sometimes work well, but a major drawback is the imbalance in the signal-to-noise ratio of the two channels that is produced. One channel is fed with the high frequency sounds and therefore has most of the background "hiss" and a poor signal-to-noise ratio, while the other channel has most of this hiss filtered out and therefore has a very good signal-to-noise ratio.

This problem can be overcome using more complex filtering with two complementary filters having several peaks and troughs in their frequency response

being used, but quite complex circuits are needed to completely eliminate the problem using this method.

## PHASE CHANGES

A less well-known method of producing a quasi-stereo signal is to use phase changes to spread out the pseudo-stereo image. As this method does not alter the frequency response of either channel there is no problem at all with an imbalance of the signal-to-noise ratios of the two channels and quite a good quasi-stereo effect can be obtained using this method.

In order to produce a good stereo image it is essential for the signals fed to the loudspeakers to be in-phase, like the two signals in the oscillograph shown in Fig. 1a. In other words the two signals must rise and fall in amplitude together, and must be of the same polarity. Furthermore, the two loudspeakers must be connected with the same phase so that a signal in both channels causes the speaker diaphragms to move backwards and forwards together, and not one diaphragm to move forwards while the other travels backwards.

Signals in both stereo channels then produce a central image, or one slightly offset from the centre of the sound stage, depending on the relative strength of the signal in each channel.

The most simple method of producing a quasi-stereo effect using a phasing

Fig. 1a. In-phase signals.

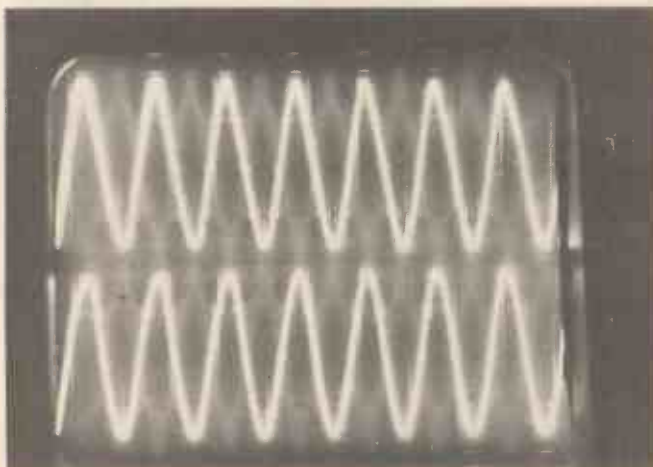
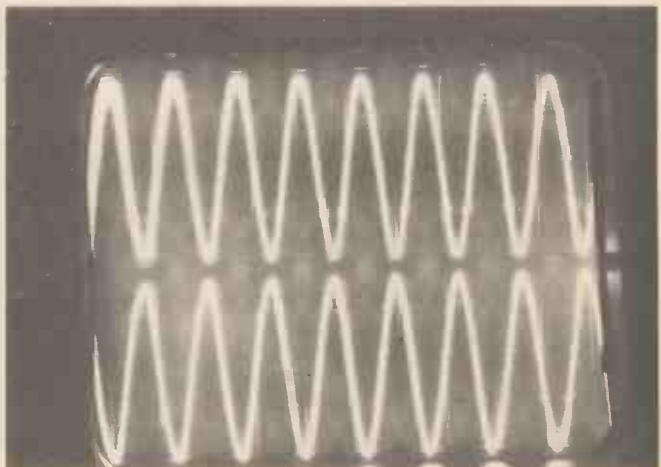

Fig. 1b. Out-of-phase signals.





technique is to simply reverse the connections to one loudspeaker so that the in-phase relationship of the two channels (and thus the central image as well) are destroyed. The sounds then seem to come, as they actually do, from the two loudspeakers. An obvious limitation of this system is that no central image at all is obtained and a less obvious one is that bass frequencies tend to be phased-out and there is consequently a noticeable loss of bass performance.

Much better results are obtained using a phase shift circuit in one channel so that the two channels are in-phase at some frequencies, out-of-phase at certain frequencies (as in Fig. 1b) and somewhere between these two extremes at other frequencies (as in Fig 1c). This produces a central image at frequencies where an in-phase relationship is produced and the sides of the quasi-stereo image at frequencies where the phase difference between the two channels is substantial.

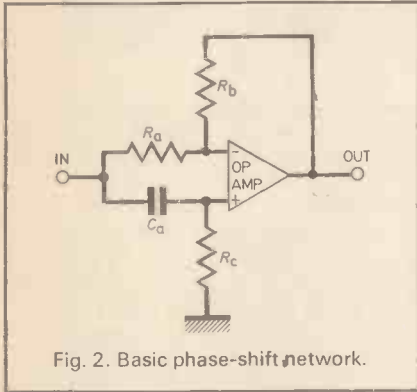

Fig. 2. Basic phase-shift network.

## PHASE SHIFTER

Phase shifting without introducing any changes in frequency response can be obtained using a simple circuit based on an operational amplifier and Fig. 2 shows the standard configuration.

At low frequencies  $C_a$  has a very high impedance in relation to the resistance of  $R_c$ , and  $C_a$  therefore has no significant

effect on the circuit. The operational amplifier then acts as a simple inverting amplifier with  $R_c$  biasing the non-inverting input to the central 0V supply rail, and  $R_a$  plus  $R_b$ , normally having the same value, so that unity voltage gain is obtained.

At high frequencies  $C_a$  has a low impedance and effectively couples the input signal direct to the non-inverting input of the operational amplifier. Although at first sight it might seem that the coupling to the non-inverting input would cancel out the basic unity gain inverting amplifier function of the circuit and produce no output, this is not the case.  $R_a$  and  $R_b$  set the voltage gain from the non-inverting input to the output at two times, but this is reduced to unity by the coupling of the inverting input.

Thus the circuit acts as an inverter at low frequencies, gives no phase change at high frequencies and produces intermediate degrees of phase change between these two extremes. Unity voltage gain is obtained at all frequencies.

## CIRCUIT DESCRIPTION

The full circuit diagram of the Quasi-Stereo Adaptor is shown in Fig. 3. IC1 is used as a simple buffer amplifier and this ensures that the first phase-shift circuit is fed from a suitably low source impedance. R1, R2 and C1 are used to produce a centre-tapping on the supply which is used to bias the non-inverting input of IC1 (and the other operational amplifiers used in the circuit).

One output is taken from the output of the buffer amplifier, and this signal undergoes no phase change.

The output of the buffer amplifier is also fed to a series of four phase-shift circuits of the type described above. At low frequencies there is no overall phase shift through these four circuits since the inversion through the first phase shifter is cancelled out by the inversion through the second stage and the inversions through stages three and four also cancel out each other.

Fig. 1c. Randomly-phased signals.

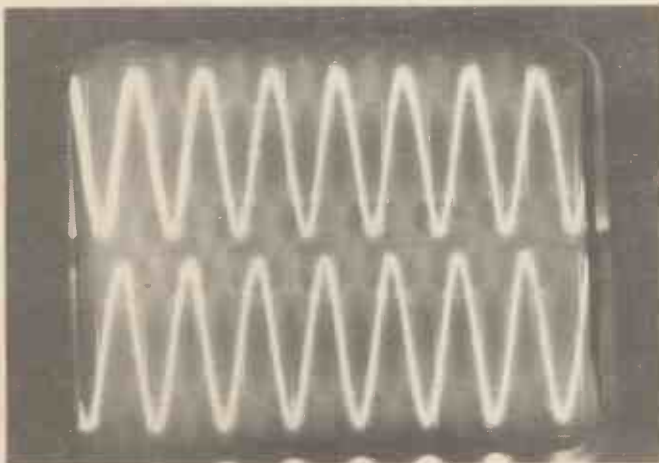

## COMPONENTS

### Resistors

R1,2	4.7k $\Omega$ (2 off)
R3	56k $\Omega$
R4,5,7,8,	
10,11,	
13,14	18k $\Omega$ (8 off)
R6,9,12,	
15	100k $\Omega$ (4 off)
All	$\frac{1}{4}$ W carbon $\pm 5\%$

### Capacitors

C1	4.7 $\mu$ F 63V axial elect.
C2	1 $\mu$ F 63V radial elect.
C3,8	10 $\mu$ F 16V radial elect. (2 off)
C4-7	1nF polycarbonate (4 off)
C9	100 $\mu$ F 10V radial elect.
C10	100nF polyester

### Semiconductors

IC1	741C op-amp
IC2,3	1458C dual op-amp (2 off)

See  
**Shop  
Talk**

page 231

### Miscellaneous

S1	rotary on/off switch
B1	9V PP6 battery
SK1,2,3	phono sockets (3 off)

**Printed circuit board:** single-sided, size 105 x 48mm, *EE PCB Service*, Order code 8404-01; case, 133 x 102 x 38mm (AB10); Veropins; battery connector; connecting wire.

Approx. cost  
Guidance only

£8

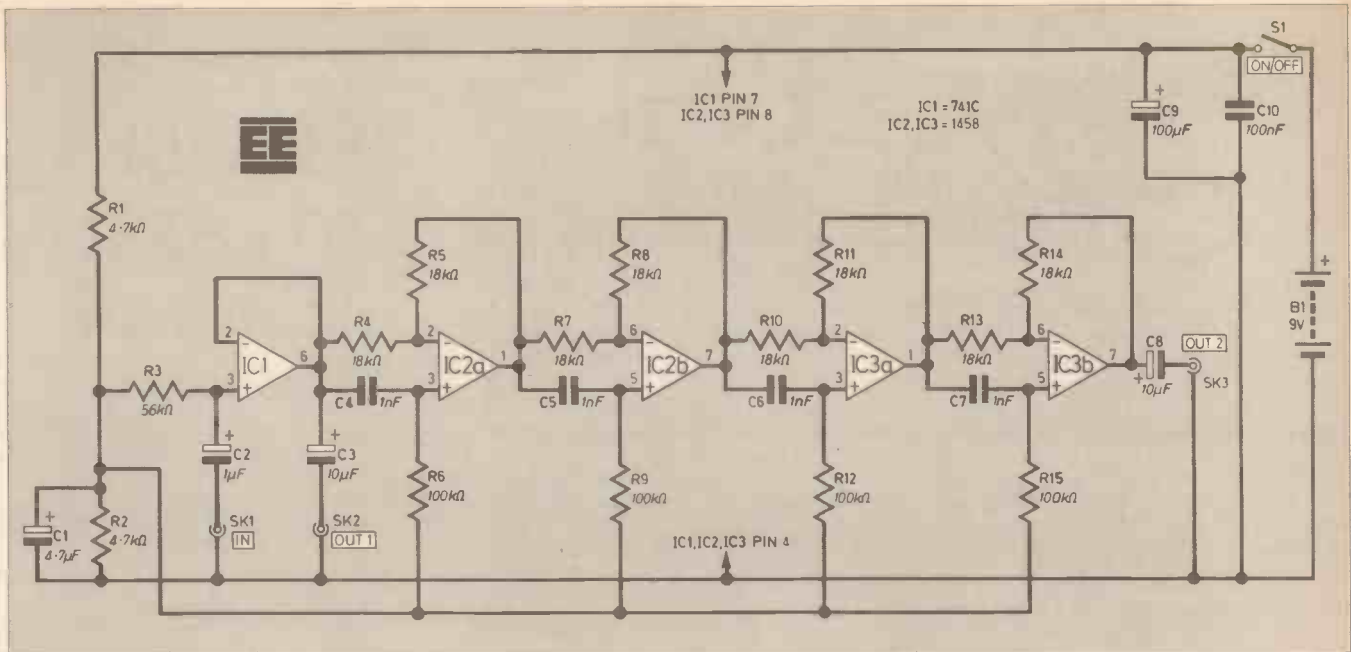

Fig. 3. Complete circuit diagram for the Quasi-Stereo Adaptor.

This is an important factor as it gives in-phase signals at bass frequencies and avoids the cancelling effect mentioned earlier and its attendant loss of bass response.

## FREQUENCY INCREASE

As the input frequency is gradually increased the degree of phase shift through the circuit increases as well, until the signals become out-of-phase at frequencies around 700Hz. Increasing the input frequency further gives a greater phase shift so that the signals gradually move back into phase again, and then back into antiphase at about 4kHz.

At still higher frequencies the signals move back into phase again, but at this point the maximum phase shift of the circuit is achieved and a further increase in frequency does not produce a further change in phase shift.

The circuit, thus, gives outputs that are in-phase at high frequencies, low frequencies and a narrow band of frequencies, at a little over 1kHz, with antiphase outputs being produced at frequencies at around 700Hz and 4kHz. In practice this seems to give good results without either the sides or centre of the sound stage being excessively strong and dominant and certainly seems to give a much more spacious sound than straightforward monophonic reproduction.

## POWER SUPPLY

A 9-volt supply at a current drain of only about 4mA is required, and this is obtained from a PP6 size battery. The unit only has one control, and this is merely on/off switch S1. The maximum input level that can be handled without clipping and severe distortion occurring is around 2V r.m.s. which is more than adequate. Although the processed signal

passes through five operational amplifiers, these are all used with only unity voltages gain and the noise and distortion levels of the unit are therefore negligible.

# CONSTRUCTION

## CASE

An aluminium box measuring about 133 x 102 x 38mm makes a neat housing for this project, but there are a number of cases of a similar size that are readily available and any of these should suffice. A metal case is a better choice than a plastic one for this application though, since a metal case will provide screening and should eliminate any slight pick-up of mains hum or similar interference.

The overall layout of the unit is quite simple and straightforward. Phono sockets are used for SK1 to SK3 on the prototype, but these can be changed for any type of audio connector that will be more convenient in use.

The copper track pattern and component layout of the printed circuit board (105 x 48mm) are reproduced actual-size in Fig. 4. Construction of the board should be perfectly straightforward provided the appropriate types of capacitor specified in the components list (or a physically similar alternative) are used. Veropins are used on the board at points where connections to B1, S1, or the sockets will be made.

The finished printed circuit board is mounted on the base panel of the case using 12.5mm 6BA bolts, and 6.35mm spacers to keep the underside of the board clear of the metal case. The final wiring is then completed and it is not essential to use screened cable to make the connections from the component panel to the sockets.

Note, the printed circuit board is available from the *EE PCB Service*, Order code 8404-01.

## IN USE

An important point to note is that the unit should only be used with a television set that has an output socket of some kind, which should come from the audio stages of the set via an isolation circuit so that there is no risk of obtaining an electric shock. Simply taking an audio output from across the loudspeaker of a television receiver is not satisfactory since one of the output leads would almost certainly connect direct to one side of the mains and this would be extremely dangerous indeed.

The input signal is coupled to SK1 and the outputs from SK2 and SK3 are coupled to the inputs of the amplifier. The prototype is used with the phase-shift circuits in the left-hand channel, but it does not really matter which channel is the ordinary mono signal and which is the phase shifted one. The effect is much the same either way.

It is possible to use the unit with sources other than a television receiver and it can be used with a video cassette recorder, for example, or if f.m. stereo reception is very noisy it may be advantageous to switch to mono in order to obtain a much lower noise level and then use the adaptor to give a quasi-stereo effect.

The effect of the adaptor is most noticeable when a signal having a large number of frequency components spread across the whole audio spectrum is processed, such as a piece of orchestral music or applause from a large audience. The sound stage should then clearly extend from one loudspeaker to the other with a reasonably strong central image and not just the sound seeming to emanate from the two loudspeakers. □

# QUASI-STEREO ADAPTOR

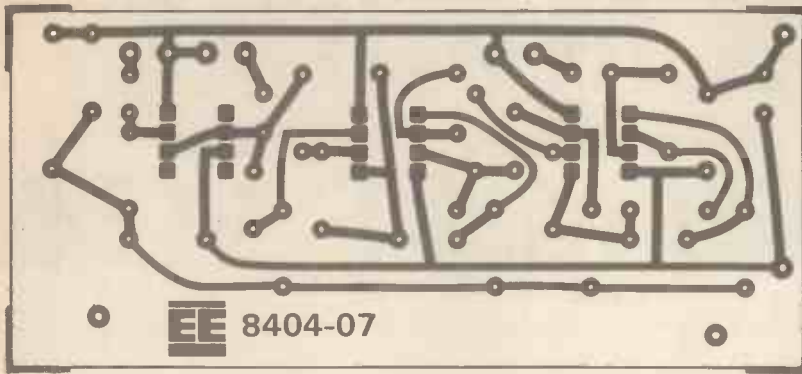

Fig. 4. The master p.c.b. (full-size) for the Quasi-Stereo Adaptor.

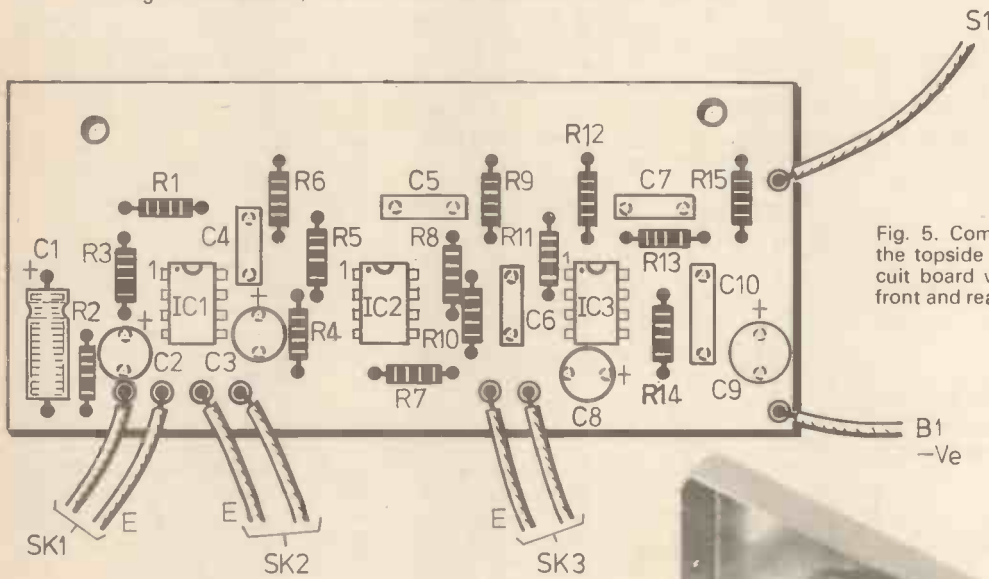
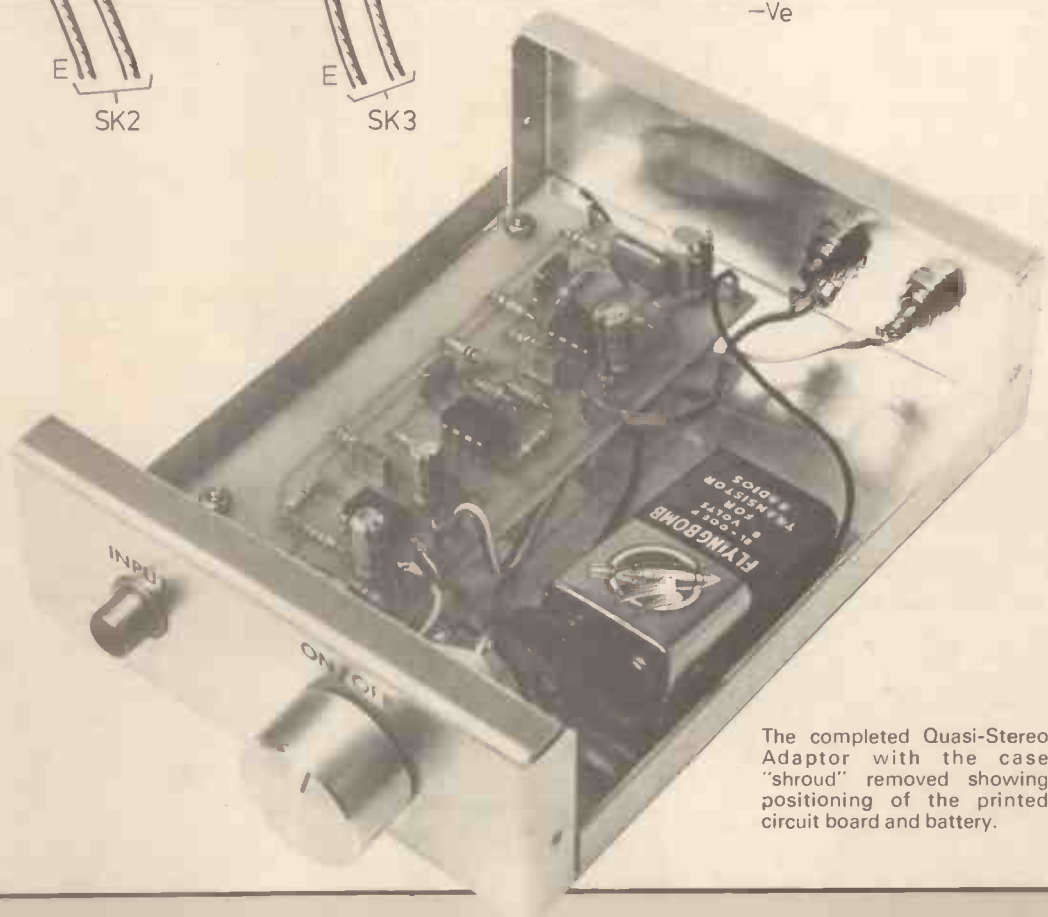

Fig. 5. Component layout on the topside of the printed circuit board with wiring to the front and rear panels.



The completed Quasi-Stereo Adaptor with the case "shroud" removed showing positioning of the printed circuit board and battery.

# TIMER MODULE FOR CENTRAL HEATING SYSTEMS

BY S.IBBS

There are many occasions when an accurate interval-timer is extremely useful in the home and elsewhere. This simple-to-build module was originally designed to control a central-heating system, but details are given to show how its use can be extended far beyond this.

Most central heating systems have a manual/auto switch, the normal arrangement being a switch in the live line to either bypass or go via the clock mechanism (see Fig. 1). It is all too easy to switch it to manual, for example, to heat up the water, and then forget to turn it back, so that money is wasted with the system being on too long.

Thus an easy way of providing control would be to insert a timing module between points A and B in the diagram,

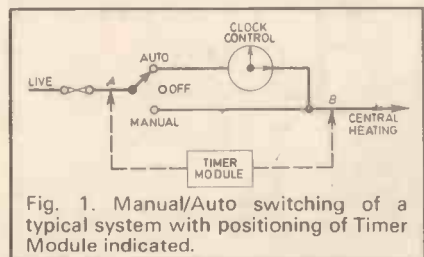

Fig. 1. Manual/Auto switching of a typical system with positioning of Timer Module indicated.

which would automatically bypass the switch and clock for a predetermined length of time. Such a circuit would not affect the normal Auto/Manual operation of the heating. The project described here has a push to start button, and a push-button to abort the timing sequence at any time. It also contains a range switch, the prototype being set to 40 minutes (low) and 80 minutes (high), to cater for hot water or radiators, respectively.

## CIRCUIT DESCRIPTION

The first design used a 555 in a simple monostable circuit, but experiments showed that the large electrolytic capacitors needed for long timing periods could not be depended upon to give the required repeatable accuracy. The solution was to use an oscillator clocking a binary ripple counter, the 4020, the frequency of the oscillator being adjustable.

The oscillator is formed around two gates of a CMOS 4011 quad 2-input NAND gate, and the output is fed into the input pin 10 of the 4020. See circuit diagram,

Fig. 2. At switch-on, a brief reset pulse is fed by C2 and R2 to the 4020 reset (pin 11) to ensure that all the outputs are low. This is achieved because at the instant of switch-on, C2 acts like a short circuit, but very quickly charges up, and then R2 pulls the pin down to 0V to enable counting to commence.

The low output at either pin 1 or 2 (selected via S1) is inverted by another gate of the 4011 (IC1c) to provide a high level at the base of the transistor TR1, which turns on and energises the relay placed as a collector load. One set of contacts short out the push-to-make switch, so that the supply line is established and retained when the start button is released,

whilst the other set of contacts is connected between points A and B (Fig. 1) to provide the live line to the central heating.

The pins of the 4020 go high and low in a very specific sequence after a predetermined number of input pulses; pin 1 after 4096 pulses and pin 2 after 8192, and so on until eventually the selected pin goes high, causing the base of the transistor to go low, turning off the relay. This opens both sets of contacts, thus disconnecting the supply to the circuit and the live to the central heating. S2 is included so that the timing sequence can be cancelled at any time. It is a push-to-break, and disconnects the relay coil from the supply line, turning the whole unit off.

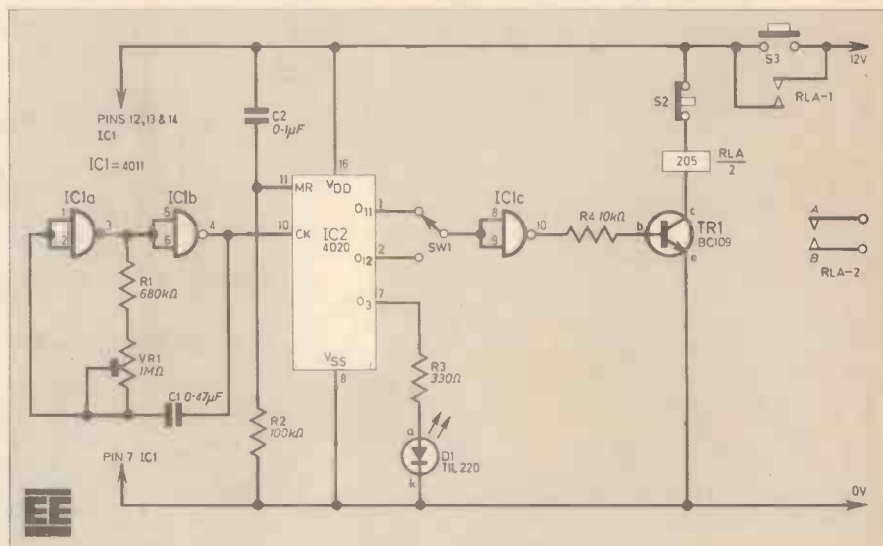
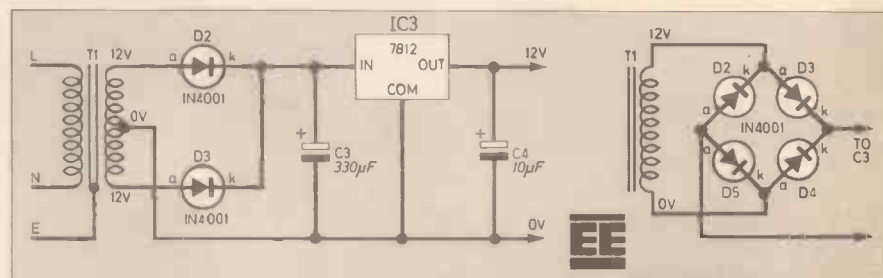

Fig. 2 (above). The oscillator circuit diagram and (below) suggested power supply circuits for the Timer Module. S3 is the start button and S2 aborts the timing cycle.



## SUPPLY

The power lead is taken from the supply to the central heating, after the fuse for safety reasons, and is transformed by T1, rectified by the diodes and smoothed by C3 before being regulated by the 7812 (IC3). An l.e.d. and a current limiting resistor is connected to another of the 4020 outputs to provide a flashing indication that the circuit is operating, but this is purely optional and may be omitted if desired.

## CONSTRUCTION

### CIRCUIT BOARD

There should be no problems associated with construction; however, readers are reminded that parts of the circuit are at mains potential, so great care is obviously essential. It is advisable to

use a p.c.b. and a suggested design for one is given in Fig. 3. Mount the components, taking care to observe the polarity of the diodes and capacitor, and the orientation of the i.c.s, transistor and regulator. See Fig. 4.

The transformer can be either a 12V-0-12V centre-tapped type, in which case the diodes D2 and D5 are omitted, and the centre tapping is connected to 0V, or a 0-12V transformer, which will need all four diodes as a bridge rectifier.

The relay was soldered to the board as shown, and small lengths of wire used to make the necessary connections. Ensure that the relay contacts are capable of carrying the required current, if necessary by connecting more than one set of contacts in parallel.

S3 has a pair of normally open (N/O) contacts wired across it, and the other set of N/O contacts will eventually be connected between points A and B, but it is best to calibrate the unit first. Monitor pin 4 of IC2 and adjust VR1. The time taken for pin 2 to go high will be time taken for

pin 4 of IC1 to change from one state to the other, times 128. For example, if it changes state every 37.5 seconds, pin 2 will go high after 80 minutes (pin 1 after 40 minutes). The other contacts can now be wired in.

The module can be mounted in any convenient sized box (earthed if metal is used), with two leads running from it via grommets or strain relief bushes. One lead provides the mains supply to the module, the other runs from the relay to A and B. The transformer is bolted inside the case, with the mains earth lead connected to a soldertag.

### CONCLUSION

Spare pads have been provided on the p.c.b., and looking at the waveform diagram it can be seen that if, for example, pin 2 of IC2 goes high after 60 minutes, pin 3 does not change state until two hours have passed, whilst pin 15 changes state every 15 minutes. For those constructors who would like to, S1 can be

## COMPONENTS

### Resistors

R1	680k $\Omega$
R2	100k $\Omega$
R3	330 $\Omega$
R4	10k $\Omega$

See  
**Shop  
Talk**  
page 231

### Capacitors

C1	0.47 $\mu$ F polyester
C2	0.1 $\mu$ F polyester
C3	330 $\mu$ F 25V elect.
C4	10 $\mu$ F 16V single elect.

### Semiconductors

D1-4	1N4001 (4 off—see text)
D5	TIL220 5mm red l.e.d.
TR1	BC109 npn silicon
IC1	4011 CMOS quad 2-input NAND gate
IC2	4020 CMOS 14-stage binary ripple counter
IC3	7812 12V, 1A regulator

### Miscellaneous

VR1	1M $\Omega$ miniature horizontal preset
T†	12V (or 12V-0-12V see text) 100mA mains transformer
RLA-2	miniature 12V relay, 205 $\Omega$ coil with d.p.d.t. mains rated contacts
S1	s.p.d.t. miniature toggle momentary action
S2	push-to-break momentary action
S3	push-to-make momentary action

**Printed circuit board:** single-sided size 90 x 65mm, EE PCB Service, Order code 8404-05; case to suit; mains lead; soldertag; equipment wire; mounting hardware.

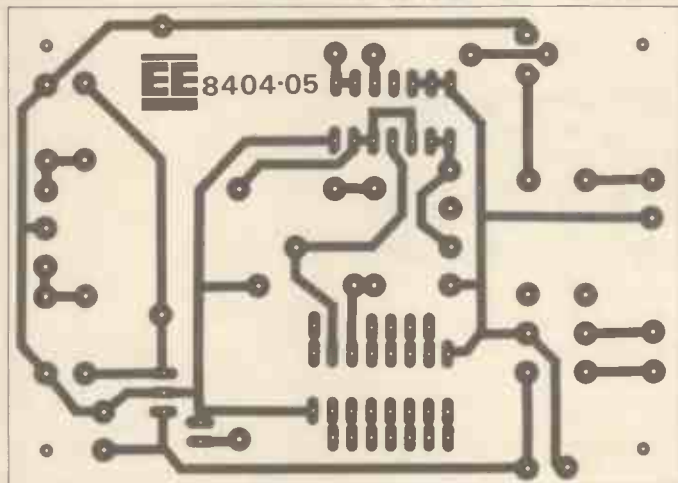

Fig. 3. Full-size printed circuit master pattern for the Timer Module.

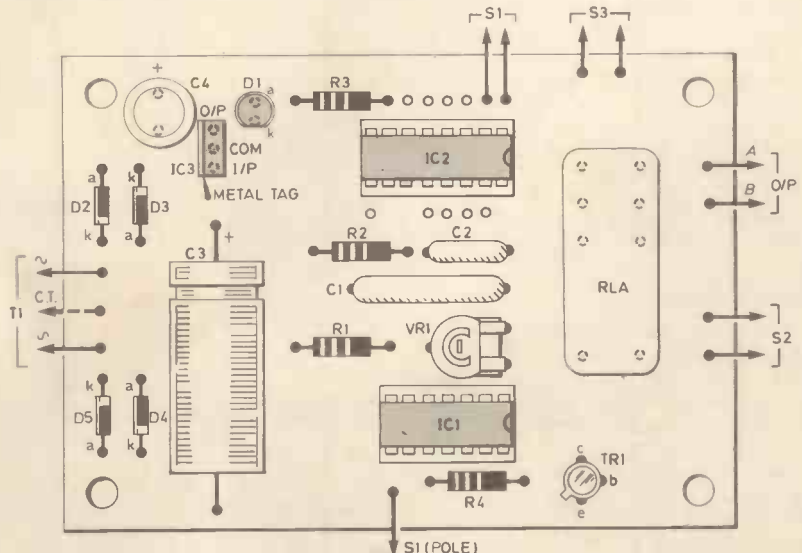

Fig. 4. Layout of components on the topside of the p.c.b. If the 12V-0-12V transformer is used, D2 and D5 are omitted and the C.T. terminal is used.

Approx. cost  
Guidance only **£14**

Table 1

pin no.	pulses needed to switch output on
9	$2^1$ (2)
7	$2^4$ (16)
5	$2^5$ (32)
4	$2^6$ (64)
6	$2^7$ (128)
13	$2^8$ (256)
12	$2^9$ (512)
14	$2^{10}$ (1024)
15	$2^{11}$ (2048)
1	$2^{12}$ (4096)
2	$2^{13}$ (8192)
3	$2^{14}$ (16384)

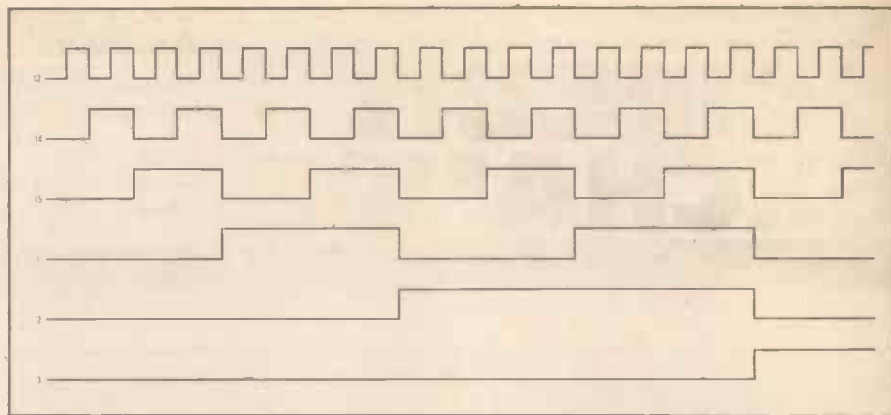

Fig. 5. Waveform diagram for some of the pins of the 4020 binary counter i.c.

changed for a 4-way rotary switch to select any of these outputs, and indeed if R1 were removed and two leads run to a two megohm linear pot, a four range variable timer (very useful in the kitchen) would be provided, with VR1 acting as a minimum time adjustment control.

The table shown gives the sequence of pins on IC2, each one going high after twice the period of its predecessor, pin 3

taking the longest time, so if two pins, for example, 12 and 14 were chosen, again with a pot replacing the fixed resistor R1, a two range darkroom timer could be constructed.

With a little imagination, the module can form the basis of several very useful

projects, and it is hoped that the above suggestions have provided food for thought. If used for the central heating, there is no reason why the pushbuttons should not be mounted remotely in the kitchen, making the unit even more convenient to use. □

# CIRCUIT EXCHANGE

## HEADS AND TAILS

THIS project is ideal for school laboratories as a probability demonstrator or study aid.

The simple circuit diagram shown uses a TTL i.c. and four low-cost transistors. The visual readout of the second flip-flop indicates heads or tails. Rather than using

an astable, or some other potentially unsymmetrical "odds determinator", heads and tails counts the power line frequency so that both the length of time the push button is held down and the phase of the power at the instant the push button is depressed combine to provide a truly random 50-50 long term result.

In the first J.K. flip-flop only the direct inputs (CLEAR and PRESET) are used so that the circuit squares up and follows the power line frequency as long as S1 is closed. Transistors R1 and R2 alternately set and reset the flip-flop immediately after each sequential power line zero crossing. The Q output of the first J.K. is a noise-free squarewave when S1 is

closed, and either a logic 1 or 0 when the switch is open.

The output of the first J.K. flip-flop is used to cycle the second J.K. which is connected as a binary divider. One of its outputs drives the HEADS indicator and the other drives the TAILS lamp. Transistors TR3 and TR4 provide sufficient power for the flip-flop outputs to drive the lamps. When S1 is closed both lamps cycle on and off 30 times a second, a speed much faster than the eye can follow to discourage cheating.

Hamid Reza Nameri,  
Tehran,  
Iran.

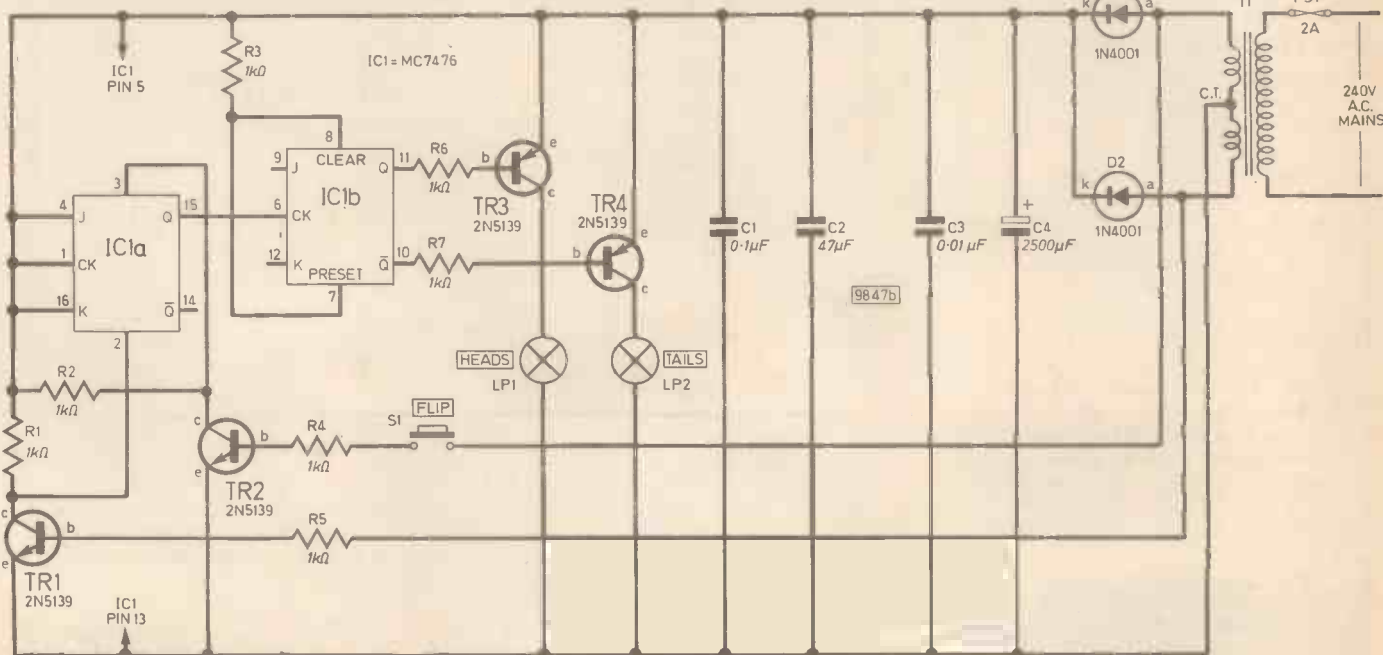

# CIRCUIT EXCHANGE

This is the spot where readers pass on to fellow enthusiasts useful and interesting circuits they have themselves devised. Payment is made for all circuits published in this feature. Contributions should be accompanied by a letter stating that the circuit idea offered is wholly or in significant part the original work of the sender and that it has not been offered for publication elsewhere.

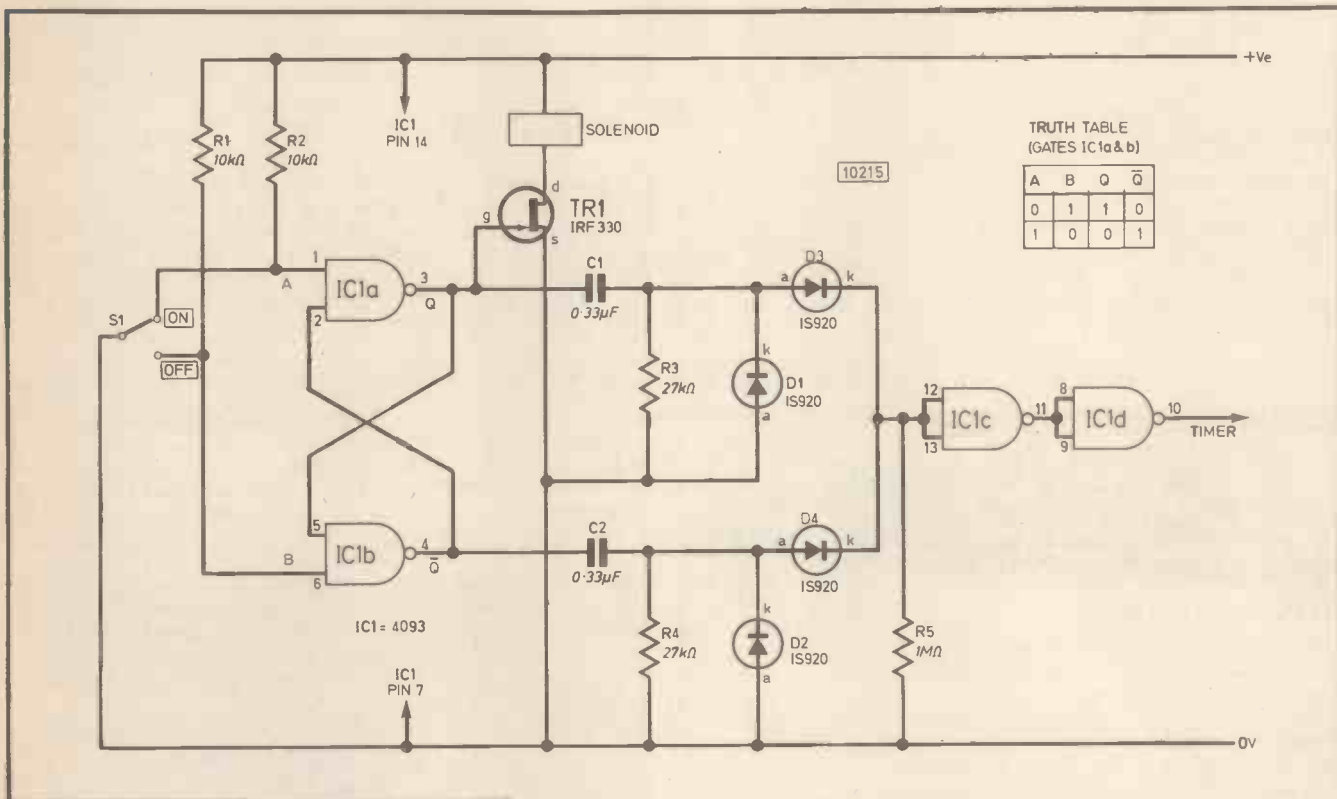

## PULSE GENERATOR

THE purpose of this circuit is to measure the time period for which the solenoid is energised. This is done by generating a positive pulse for every operation of the on/off switch. These pulses are fed to a timer counter set to single line count. With the on pulse the timer starts to count and on the off pulse the timer stops and displays the period.

When the on/off switch is switched to the on position the output from gate 1 becomes positive, the f.e.t. TR1 is gated and the solenoid becomes energised. Capacitor C1 and resistor R3 differentiate this voltage and produce a pulse whose length is  $C1 \times R3 = \text{time}$ . Diode D3 conducts this pulse to gate 4 via gate 3 which gives a double inversion so that the pulse maintains the same polarity but is buffered from the circuit. This pulse is used to gate (start) the timer.

As the output from gate 1 becomes positive the output from gate 2 decays in a negative direction. This negative pulse is fed to the common rail via C2 and D2.

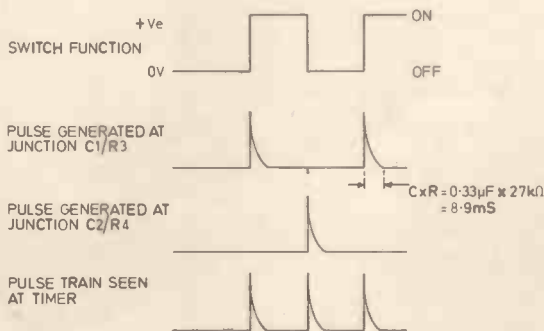

When the on/off switch is switched to the off position the output states of gates 1 and 2 will reverse (R1, R2 and gates 1, 2 are a simple debounce circuit). Gate 2 will generate a positive-going pulse whose duration is  $C2 \times R4$  which will be fed to the timer via D4 and gates 3 and 4 which will stop the counter.

The negative pulse generated at gate 1 will be fed to the common rail via C1 and D1. The time displayed on the timer will be the duration for which the solenoid has been energised.

D. R. Fownes,  
Wolverhampton.

# NEW · NEW · NEW · NEW PRODUCTS NEW · NEW · NEW · NEW

## TRANSISTOR TESTER

THE latest addition to the Osborne Electronics 4000 series of hand-held test units is the model 4500 Transistor Tester.

Completely self-contained, the unit is claimed to simplify and speed the task of checking the pn junctions of discrete semiconductors whether in or out of circuit.

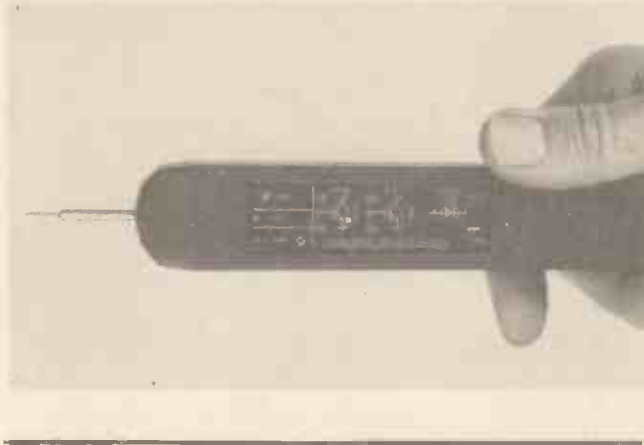

The checking of *pn* or *npn* transistors, diodes and open or short circuit junctions are instantly identified by a series of l.e.d.s which indicate the junction status. This is carried out by connecting two test probes across the junction to be checked.

Further information is available direct from:

Osborne Electronics,  
Dept EE, Binstead Road,  
Ryde, Isle of Wight.

## CLEAN SWEEP

THE introduction of their new VHS VCR head cleaner, which may be used wet or dry, is announced by Bib Audio/Video Products. Bib claim that this cleaner is the safest and easiest to use cleaner yet devised.

Developed in the Bib Laboratories, they claim many special features for the cleaner. The most significant being the type of non-abrasive cleaning tape, which is a special spun bonded polyester made to their own specification.

Another feature is the automatic way in which the correct amount of fluid is applied to the cleaning tape. The fluid is released by pressing a button for one second on the side of the cassette housing, which feeds the fluid into a chamber through which the cleaning tape passes, eliminating the chance of applying too much or too little.

This ensures that the whole tape travel path, including tape heads, drum, guides, audio heads

and capstan are cleaned in one simple operation. The cleaning time takes only 10 seconds.

It is recommended that the cleaning tape is never re-wound as each cleaning operation presents a new portion of cleaning tape to the heads and avoids the "re-playing" of accumulated contaminants. The cleaner will last for 35 cleanings, or four years' average use.

Bib recommend "Preventive Video Maintenance" as the key to good quality pictures. VCR heads should be cleaned regularly after 40 to 50 hours' playing time, as oxide particles and dust accumulate. These all stick to tape heads, drum and guides and other parts causing "snow" in the picture, poor tape handling and even tape damage.

Attractively packed in a descriptive carton, this new cleaner has a recommended retail price of £9.98 including VAT.

Bib Audio/Video Products Ltd,  
Dept EE, Kelsey House,  
Wood Lane End,  
Hemel Hempstead HP2 4RQ.



## SUPER SAVER

How often do you turn on the immersion heater for a quick boost, then forget to turn it off again? To prevent this wastage, and to help older people who may not feel comfortable using a programmable timer, Superswitch have introduced a simple run-back timer control.

Operating on the same principle as many kitchen timers, but designed so that it is capable of switching the immersion heater load, Superswitch's 1512 controller is claimed to be easy to use and understand.

With the two-position switch at "timed", the dial is set to the time required; anything from a few minutes to two hours. The controller then counts down to zero. At any time, you are able to see how much time is left to run, or turn the dial forward or back, to adjust the length of time the immersion heater will remain on.

The Superswitch 1512 Immersion Heater Controller is expected to sell for around £20. Further information and local stockists addresses may be obtained from:

Superswitch Electric Appliances  
Ltd., Dept EE,  
7 Station Trading Estate,  
Camberley, Surrey GU17 9AH.





# SQUARE ONE FOR BEGINNERS

**C**APACITORS come in a bewildering range of types and sizes mainly because, unlike resistors, it is impossible to devise a single method of construction that will yield a sufficiently wide range of values and working voltages.

A capacitor consists of two plates of conductive material separated by an insulator or dielectric. It is the combination of materials for these two elements that causes the confusion. Besides its value, a capacitor also has a working voltage and tolerance. If either of these are important, they are specified in the components list.

Another major division is polarised and non-polarised capacitors. Generally the polarised types are large in value and must be connected up correctly. Within the above parameters, a capacitor is often chosen because of its size and stability.

This being the case, it means that virtually any capacitor with the same value and the same, or higher, voltage rating will work in a given circuit and this should be borne in mind when experimenting with spare or surplus components.

## NON-POLARISED CAPACITORS

Polyester capacitors are widely used and cover the middle range of capacitances and the typical range is from 0.01 $\mu$ F to 2.0 $\mu$ F. Polyester capacitors are available in tubular, tablet and block forms and have a tolerance of 10 and 20 per cent. The normal working voltage is up to 400V d.c.

A miniature dipped case type often referred to as a C280 is shown in Table 1. This type of capacitor is wax treated and covered with a hard lacquer. The various coloured bands represent the value of the capacitor, using a similar code to the resistor one. The two top bands give the first two digits and the third the multiplier. A fourth band gives tolerance and the fifth the working voltage.

The smallest capacitors are the ceramic type and range from 1.8pF to 0.1 $\mu$ F (see Fig. 1). These capacitors have close tolerance, low loss and high stability.

A wide range of polystyrene capacitors are available in the range 10pF to 0.1 $\mu$ F. Thus they cover very nearly the same

## CAPACITOR COLOUR CODE

Band (ring) Colour	TANTALUM microfarads ( $\mu$ F)				SERIES C280 picofarads (pF)				
	1st band	2nd band	Spot (Multiplier)	3rd band	1st band	2nd band	3rd band (Multiplier)	4th band	5th band
BLACK	-	0	1	10V	-	0	1	20%	-
BROWN	1	1	10	-	1	1	10	-	100V
RED	2	2	100	-	2	2	100	-	250V
ORANGE	3	3	-	-	3	3	1000	-	-
YELLOW	4	4	-	6.3V	4	4	10000	-	400V
GREEN	5	5	-	16V	5	5	100000	5%	-
BLUE	6	6	-	20V	6	6	1000000	-	-
VIOLET	7	7	-	-	7	7	0.01	-	-
GREY	8	8	0.01	25V	8	8	0.001	-	-
WHITE	9	9	0.001	3V	9	9	-	10%	-
PINK	-	-	-	35V	-	-	-	-	-

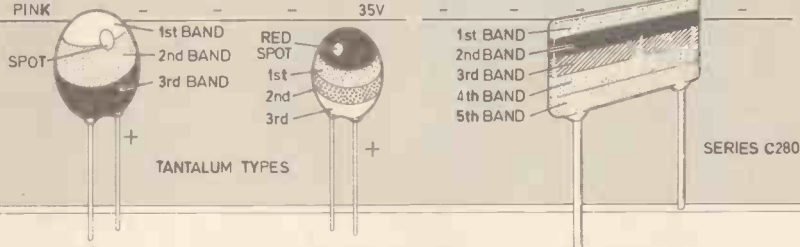

Table 1: The capacitor colour coding for tantalum and series C280 capacitors.

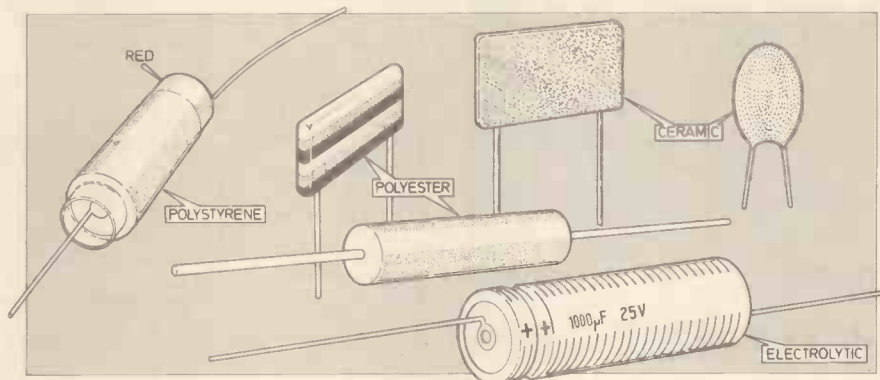

Fig. 1. A diagram showing the various shapes of commonly used capacitors.

range as ceramics. They have a better electrical performance than the ceramics and are available with close tolerances such as 5, 2 $\frac{1}{2}$  and 1 per cent.

However, polystyrene capacitors are rather more expensive and are only used where there special characteristics are essential. Polystyrene capacitors are tubular in shape and rather more bulky than ceramics. They can be used as a general purpose low value type where tolerance is not so important.

## ELECTROLYTICS

Electrolytic or polarised capacitors are a special case. They provide quite a large value of capacitance, but must be connected the right way round in the circuit. They are made with specific working voltages, which must not be exceeded in practice.

It is however, permissible to use them at a lower voltage than the stated working

voltage. Electrolytics are available as "double-ended" types with the connecting leads emerging from either end; also as "single-ended" types with both leads at the same end of the component. Double-ended types, as shown in Fig. 1, are recommended for general purpose use.

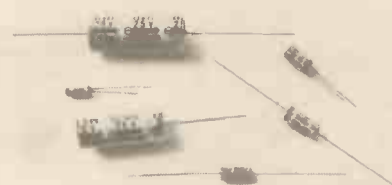

Aluminium electrolytic capacitors.

# EVERYDAY ELECTRONICS PRINTED CIRCUIT BOARD SERVICE

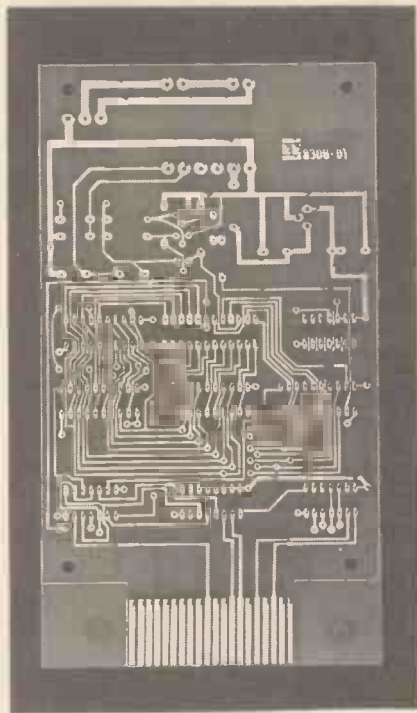

Printed circuit boards for certain EE constructional projects are now available from the EE PCB Service, see list. These are fabricated in glass-fibre, and are fully drilled and roller tinned. All prices include VAT and postage and packing. Remittances should be sent to: EE PCB Service, Everyday Electronics Editorial Offices, Westover House, West Quay Road, Poole, Dorset BH15 1JG. Cheques should be crossed and made payable to IPC Magazines Ltd.

We regret that the ordering codes for the August projects have been incorrectly quoted in the Sept-Oct issues. Correct codes are given here.

Please note that when ordering it is important to give project title as well as order code. Please print name and address in Block Caps.

Readers ordering both p.c.b.s and software cassettes may send a single cheque/PO for the combined amounts listed.

Readers are advised to check with prices appearing in current issue before ordering.

PROJECT TITLE	Order Code	Cost
Eprom Programmer, TRS-80 (June 83)	8306-01	£9.31
Eprom Programmer, Genie (June 83)	8306-02	£9.31
Eprom Programmer, TRS-80 & Genie (June 83)	8306-03	£1.98
User Port Input/Output <i>M.I.T. Part 1</i> (July 83)	8307-01	£4.82
User Port Control <i>M.I.T. Part 1</i> (July 83)	8307-02	£5.17
Storage Scope Interface, BBC Micro (Aug 83)	8308-01	£3.20
Car Intruder Alarm (Aug 83)	8308-02	£5.15
High Power Interface <i>M.I.T. Part 2</i> (Aug 83)	8308-03	£5.08
Pedestrian Crossing Simulation <i>M.I.T. Part 2</i> (Aug 83)	8308-04	£3.56
Electronic Die (Aug 83)	8308-05	£4.56
High Speed A-to-D Converter <i>M.I.T. Part 3</i> (Sept 83)	8309-01	£4.53
Signal Conditioning Amplifier <i>M.I.T. Part 3</i> (Sept 83)	8309-02	£4.48
Stylus Organ (Sept 83)	8309-03	£6.84
Distress Beacon (Sept 83)	*8309-04	£5.36
Distress Beacon Pocket Version (Sept 83)	8309-05	£3.98
D-to-A Converter <i>M.I.T. Part 4</i> (Oct 83)	8310-01	£5.77
High Power DAC Driver <i>M.I.T. Part 4</i> (Oct 83)	8310-02	£5.13
Electronic Pendulum (Oct 83)	8310-03	£5.43
TTL/Power Interface for Stepper Motor <i>M.I.T. Part 5</i> (Nov 83)	8311-01	£5.46
Stepper Motor Manual Controller <i>M.I.T. Part 5</i> (Nov 83)	8311-02	£5.70
Digital Gauss Meter (Nov 83)	8311-03	£4.45
Speech Synthesiser for BBC Micro (Nov 83)	8311-04	£3.93
Car On/Off Touch Switch (Nov 83)	8311-05	£3.11
4-Channel High Speed ADC (Analogue) <i>M.I.T. Part 6</i> (Dec 83)	8312-01	£5.72
4-Channel High Speed ADC (Digital) <i>M.I.T. Part 6</i> (Dec 83)	8312-02	£5.29
TRS-80 Twin Cassette Interface (Dec 83)	8312-03/09	£7.43
Environmental Data Recorder (Dec 83)	8312-04	£7.24
Touch Operated Die (Dot matrix) (Dec 83)	8312-05/06	£4.34
Touch Operated Die (7-segment) (Dec 83)	8312-05/07	£4.34
Continuity Tester (Dec 83)	8312-08	£3.41
Central Heating Pump Delay (Jan 84)	8401-01	£3.33
Biological Amplifier <i>M.I.T. Part 7</i> (Jan 84)	8401-02	£6.27
Temp. Measurement and Control System for ZX Computers (Jan 84)		
Analogue Thermometer Unit	8401-03	£2.35
Analogue-to-Digital Unit	8401-04	£2.56
Games Scoreboard (Jan 84)	8401-06/07	£9.60
Eprom Programmer/ROM Card for ZX81 (Feb 84)	**8402-01	£7.84
Oric Port Board <i>M.I.T. Part 8</i> (Feb 84)	8402-02	£9.56
Negative Ion Generator (Feb 84)	*8402-03	£8.95
Temp. Measurement and Control System for ZX Computers (Feb 84)		
Relay Driver Unit	8402-04	£3.52
Latched Output Port <i>M.I.T. Part 9</i> (Mar 84)	8403-01	£5.30
Buffered Input Port <i>M.I.T. Part 9</i> (Mar 84)	8403-02	£4.80
VIC-20 Extension Port Connector <i>M.I.T. Part 9</i> (Mar 84)	8403-03	£4.42
Commodore 64 Extension Port Connector <i>M.I.T. Part 9</i> (Mar 84)	8403-04	£4.71
Digital Multimeter Add-On for BBC Micro (Mar 84)	8403-05	£4.63
Multipurpose Interface for Computers		
Data Acquisition "Input" <i>M.I.T. Part 10</i> (Apr 84)	8404-01	£5.72
Data Acquisition "Output" <i>M.I.T. Part 10</i> (Apr 84)	8404-02	£5.20
Data Acquisition "PSU" <i>M.I.T. Part 10</i> (Apr 84)	8404-03	£5.20
Timer Module (Apr 84)	8404-04	£3.09
A.F. Sweep Generator (Apr 84)	8404-05	£3.58
Quasi Stereo Adaptor (Apr 84)	8404-06	£3.55
	8404-07	£3.56

\*Set of four boards. \*\*Calibrated with C1, VR1 and IC3 fitted.  
*M.I.T.*—Microcomputer Interfacing Techniques, 12-Part Series.



# Put the thrill-power back into your programs with **BIG K!**

KEVIN WAS ONCE AN OBSESSIVE, INTROVERTED MIDNIGHT HACKER...

DURN BUG'S GOT TO BE IN HERE SOMEWHERE - YAWN!!



...UNTIL ONE DAY HE DISCOVERED **BIG K!**

GOSH! THIS IS A-MAZE-ING!



NOW BUGS ARE A THING OF THE PAST...



...THANKS TO **BIG K!**

**BIG K** is the nation's most colourful, fact-filled, stylish, unusual, obnoxious and irritatingly well-informed computer games magazine.

**BIG K gives you -**

Great games listings for the top micros. Reviews to drive you insane with excitement. Technical know-how to make your fingers itch. Facts to help you expand your micro and your brain.

**FREE C15 COMPUTER CASSETTE** WITH EVERY COPY

**BIG K** - On sale 15th March

85p





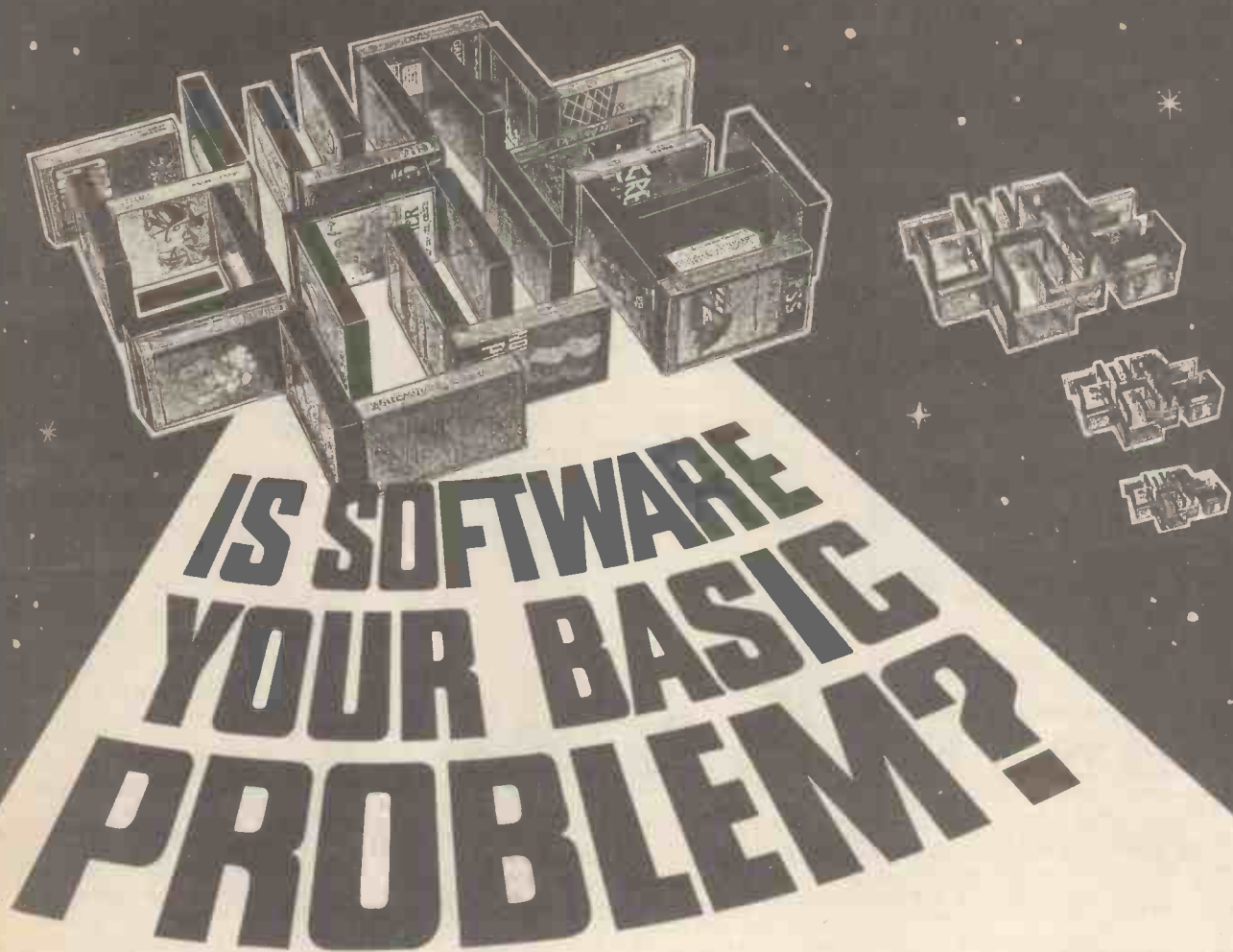

# IS SOFTWARE YOUR BASIC PROBLEM?

Are you bewildered by the choice of Software Programs on the market? Not sure what Program you really need, what it does or where to get it?

## **SOFTWARE INDEX** Is your answer.

The most comprehensive magazine listing of Software programs for the eight leading Microcomputers.

● BBC ● COMMODORE 64 ● DRAGON ● VIC 20  
● ORIC ● ATARI 400/800 ● SPECTRUM ● ZX81

Software Index takes the headache out of choosing the programs suited to your Micro.

For people involved in electronics and specialist programs, Software Index will provide the information you need and be a valuable time-saving guide.

Games, education, business and personal management are also covered.

**DON'T LET SOFTWARE GIVE YOU  
A HARD TIME, GET THE USER  
GUIDE TO MICROCOMPUTER  
SOFTWARE—**

**OVER  
2,500  
PROGRAMS  
LISTED**

**IN YOUR  
NEWSAGENT'S  
NOW**

User Guide to Microcomputer Software  
**SOFTWARE  
INDEX** 1984 No.2 £1.50

## Miscellaneous

### COPPERFOIL TAPE

A NEW CONCEPT FOR LOW VOLTAGE PROJECTS

Thin self-adhesive pure Copperfoil tape. A new concept for low voltage projects (up to 24 volts AC/DC) with a current carrying capacity of over 5 amps.

Ideal for bus bar supplies, prototype boards, burglar alarms etc, etc. The possibilities are endless.

5/32" wide x 36 yard rolls @ £2.95 per roll plus 40p post and packing per order or send SAE for Data Sheet and sample.

**COPPERFOIL ENTERPRISES,**  
Dept. EE, 141 Lyndhurst Drive,  
Hornchurch, Essex RM11 1JP.

### LEARN ELECTRONICS WITHOUT SOLDER

Build electronic circuits without solder on a Roden S-Dec. This has built-in contacts and holes into which you plug your components. Suitable for all ages. Can be used time after time. Ideal gift for students or experimenters. Full Instructions and 2 circuit diagrams with each S-Dec.

Send cheque or P.O. to:  
Roden Products, Dep EE  
High March, Daventry,  
Northants, NN11 4QE

**£4.99**

including p & p

**ORIC-1 EPROM PROGRAMMER.** Full hardware and software plans of a low-cost unit which programs, stimulates and duplicates Eproms on your 48K Oric. Price £2.50 from **HOWELL & COLLINS**, 43 Crossways, Crawley, Sussex RH10 1QT.

### For Sale

**VARIABLE VOLTAGE POWER SUPPLY 0-15v 1.5A.** 14 in working order with built in voltmeter and overload protection £13.50 + £3.00 p&p. S.A.E. lists. S.H.E. 5, St. Josephs Park, Ballycruttie, Downpatrick BT30 7EN.

### Security

**BURGLAR ALARM EQUIPMENT.** Free catalogue. C.W.A.S. Ltd., 0274-308920. Showrooms open 9-5, Mon-Sat.

### ORDER FORM PLEASE WRITE IN BLOCK CAPITALS

Please insert the advertisement below in the next available issue of **Everyday Electronics** for ..... Insertions. I enclose Cheque/P.O. for £ .....  
(Cheques and Postal Orders should be crossed Lloyds Bank Ltd. and made payable to Everyday Electronics)

NAME .....  
ADDRESS .....

**EVERYDAY ELECTRONICS**  
Classified Advertisement Dept., Room 2612,  
King's Reach Tower, Stamford Street, London SE1 9LS  
Telephone 01-261 5942

Rate:  
33p per word, minimum 12 words. Box No. 60p extra.

Company registered in England. Registered No. 53626. Registered Office: King's Reach Tower, Stamford Street, London SE1 9LS.

# EVERYDAY ELECTRONIC and computer PROJECT

Reach effectively and economically to-days enthusiasts anxious to know of your products and services through our semi-display and classified pages. Semi-display spaces may be booked at £7.80 per single column centimetre (minimum 2.5cm). The prepaid rate for classified advertisements is 33 pence per word (minimum 12 words), box number 60p extra. All cheques, postal orders, etc., to be made payable to

## SECURITY Alarm Systems

FREE COMPREHENSIVE CATALOGUE!

- LOWEST DISCOUNT PRICES
- HIGHEST QUALITY EQUIPMENT
- FREE DIY DESIGN GUIDE
- FULLY ILLUSTRATED
- MICROCHIP CIRCUITRY
- QUICK DESPATCH SERVICE
- FULL INSTRUCTIONS

SEND SAE OR PHONE

C-TEC SECURITY, Dept EE,  
60 Market St, Wigan WN1 1HX.  
Telephone (0942) 42444



### Receivers & Components

**ELECTRONIC COMPONENTS MERSEYSIDE,**  
Myca Electronics, 2 Victoria Place, Seacombe Ferry,  
Wallasey L44 6NR. 051-638 8647.

### AERIAL BOOSTERS

Next to the set fitting

**B45H/G-UHF TV,** gain about 20dbs, Tunable over the complete UHF TV band. PRICE £8.70.

**BII-VHF/FM RADIO,** gain about 14dbs, when on the off position connects the aerial direct to the radio. £7.70.

All Boosters we make work off a PP3/006p/6F22 type battery or 8v to 18v DC. P&P 30p PER ORDER.

**ELECTRONIC MAILORDER, 62 Bridge St, Ramsbottom,**  
Lancs BL0 9AG. Tel (070682) 3036

Access/Visa Cards Welcome SAE Leaflets

**COMPONENTS & EQUIPMENT - 1984 Catalogue**  
70p + 20p P&P. Callers: 18 Victoria Road,  
TAMWORTH. 369 Alumrock Road, BIRMINGHAM.  
103 Coventry Street, KIDDERMINSTER.  
Express Mail Order Service. **LIGHTNING ELECTRONICS, PO Box 8, Tamworth, Staffs.**

### BUMPER BOX OF BITS

WOW!!! We've got so many components in stock, we can't possibly list them all!!! - So buy a box, in it you'll find resistors, capacitors, displays, switches, panels with transistors, diodes, IC's etc, coils, pots ... and so on. All modern parts - guaranteed at least 1000 items, minimum weight 10lbs. ONLY £8.50.

### PSU PANEL

Stabilized 5v, variable  $\pm 0.5v$ . Regulation 1% Max. current 2A. Will take AC I/P up to 15V, or DC I/P up to 24V. Panel 140x35mm contains all components except series reg. transistor which is mounted separately. PCB stand-offs, included ONLY £3.95. Heatsink 75p; transformer £5.00.

### RESISTOR PACK

All sorts - everything from 1 $\Omega$  to 10W. Carbon, Film, W/W, Oxide, PCB, etc. 2000 resistors - yes, 2000!!! For only £4.95.

### SWITCH PACK

Slide (up to 9 way), push button banks, push types - a total of 50 switches for only £3.95.

All prices include VAT and Post/Packing.

Send SAE for latest lists.

### ELECTRONICS WORLD

1d Dews Road, Salisbury, Wilts, SP2 7SN

**S.A.E. ELECTRO,** mechanical catalogue of kits and bits. 200 quality components £2.25 inclusive. E.M.S. 15 Windmill Gardens, Whixall, Whitchurch, Shropshire.

**500 SMALL COMPONENTS** including TTL transistors £2.50, 7lbs or 10lbs assorted components £5.00/£6.50. Fifty 74 series ICs on panel £2.20. Post Paid. J. W. BLANSHARD, 2 Barnfield Crescent, Sale Cheshire, M33 1NL.

**TURN YOUR SURPLUS** capacitors, transistors etc., into cash. Contact Coles Harding & Co., 103 South Brink Wisbech, Cambs. 0945-584188. Immediate settlement.

### Courses

**CONQUER THE CHIP** - master modern electronics the practical way by seeing and doing in your own home. Write for your free colour brochure now to **BRITISH NATIONAL RADIO & ELECTRONICS SCHOOL,** Dept C3, Reading, Berks RG1 1BR.

### Service Sheets

**FULL SIZE SERVICE SHEETS** £2 + 1sae; CTV/MusC £3 + 1sae. Repair/circs almost any named TV/VCR £9.50. 1sae free quotations for manuals, sheets - free mag inc. service sheet. T.I.S.E.E. 76 Church Street, Larkhall, Lanarks - Phone 0698 883334.

**BELL'S TELEVISION SERVICE** for service sheets on Radio, TV etc. £1.50 plus S.A.E. Service Manuals on Colour TV and Video Recorders, prices on request. S.A.E. with enquiries to: **BTS, 190 King's Road, Harrogate, N. Yorkshire.** Tel: 0423 55885.



# AT YOUR SERVICE

Everyday Electronics and Computer Projects and crossed "Lloyds Bank Ltd." Treasury notes should always be sent registered post. Advertisements, together with remittance, should be sent to the Classified Advertisement Department, Everyday Electronics and Computer Projects, Room 2612, IPC Magazines Limited, King's Reach Tower, Stamford St, London SE1 9LS. (Telephone 01-261 5942).

### Bimconsoles - Metal Brown base, Beige top

Part No.	A	B	C	D	E	Price
BIM 2601	178	51	210	38.5	70	10.96
BIM 2602	280	51	210	38.5	70	12.19
BIM 2603	381	51	210	38.5	70	14.10
BIM 2604	483	51	210	38.5	70	16.01
BIM 2605	480	51	251	38.5	70	17.85
BIM 2701	178	76	210	38.5	70	11.52
BIM 2702	280	102	210	38.5	70	13.40
BIM 2703	381	102	210	38.5	70	14.86
BIM 2704	483	102	210	38.5	70	16.97

### Bimconsoles - ABS Black or Grey base with Grey Aluminium top

Part No.	A	B	C	D	E	Price
BIM 6005	106	55.5	143	31.5	37.5	2.25
BIM 6006	170	55.5	143	31.5	37.5	2.80
BIM 6007	170	81.8	21.8	31.5	57.8	3.85

### BIMBOARDS

Prototype with plug-in breadboards. Component support brackets supplied with all except Eurobreadboard

Type	Number of Contact Points	Price
Eurobreadboard	500	6.25
Eurobreadboard PCB	500	0.75
Bimboard 1	550	6.55
Bimbusstrip	80	2.50
Bimboard PCB	630	1.44
Bimboard Layout Pad		0.46
MP Urobreadboard	1422	17.25
Bimboard Designer		77.00

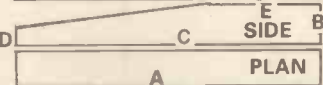

All prices inc VAT. Add 60p per order on Bimboards, £2.30 per order on Bimconsoles for p&p. SAE for full list. Mail Order only.



### BIMSALES

Dept EE4, 48a Station Road, Cheadle Hulme, Cheshire, SK8 7AB. Tel: 061 485 6667.

### ★ BAKER ★

#### GROUP P.A. DISCO AMPLIFIERS post £2

150 watt Output, 4 input Mixer pre-amp. Illustrated	£99
150 watt Output, Slave 500 mv. Input 3 Speaker Outputs	£80
150+150w Stereo, 300w Mono Slave 500 mv. Inputs	£125
150w P.A. Vocal, 8 inputs, High/Low Mixer Echo Socket	£139
100 watt Valve Model, 4 inputs, 5 Outputs, Heavy duty	£125
60 watt Valve Model, 4 inputs, Low imp and 100v line output	£69
60 watt Mobile 240v AC and 12v DC. 4-8-16 ohm+100v line	£89

#### BAKER LOUDSPEAKERS

Type	Model	Size	Watts	Ohms	Price
Hi-Fi	Major	12in	30	4/8/16	£16.00
Hi-Fi	Superb	12in	30	8/16	£26.00
Disco/P.A.	Group 45	12in	45	4/8/16	£16.00
Hi-Fi	Woolfer	12in	80	8	£19
Hi-Fi	Auditorium	12in	45	8/16	£24.00
Hi-Fi	Auditorium	15in	60	8/16	£37.00
Disco/P.A.	DG75	12in	75	4/8/16	£20.00
Disco/P.A.	DG100	12in	100	8/16	£26.00
P.A.	Group 100	15in	100	8/16	£35.00
P.A.	Disco 100	15in	100	8/16	£35.00

#### BAKER DISCO SYSTEMS

150 Watts twin turntables, twin speakers, headphones, microphone, slide controls. Complete £330 or Console only £185.

#### RCS SOUND TO LIGHT CONTROLLER KIT

Printed circuit. Cabinet. 3 channels. 1,000 watts each. Will operate from home Hi-Fi or Disco. £19. Post £1 or Ready Built £27. Coloured Disco Bulbs 100w ES or BC £2.20 pp £1.50 for 6.

#### LOW VOLTAGE MAINS TRANSFORMERS £5.50 post paid

9 volt 3 amp, 12 volt 3 amp, 16 volt 2 amp, 20 volt 1 amp, 30 volt 1 1/2 amp, 30 volt 5 amp + 174-177 volt 2 amp, 35 volt 2 amp, 20-40-60 volt 1 amp, 12-0-12 volt 2 amp, 20-0-20 volt 1 amp, 25-0-25 volt 2 amp.

#### ALUMINIUM CHASSIS 18 s.w.g. Undrilled, 4 sides, riveted corners:

6 x 4 x 2 1/2in. £1.75; 8 x 6 x 2 1/2in. £2.20; 10 x 7 x 2 1/2in. £2.75; 14 x 9 x 2 1/2in. £3.60; 16 x 6 x 2 1/2in. £3; 12 x 3 x 2 1/2in. £1.80; 12 x 8 x 2 1/2in. £3.20; 16 x 10 x 2 1/2in. £3.80.

ALI ANGLE BRACKET 6 x 1 x 1/2in. 30p. ALUMINIUM PANELS 18 s.w.g. 12 x 12in. £1.80; 14 x 9in. £1.75; 6 x 4in. 55p; 12 x 8in. £1.30; 10 x 7in. 90p; 8 x 6in. 90p; 14 x 3in. 72p; 12 x 5in. 90p; 16 x 10in. £2.10; 16 x 6in. £1.30.

ALUMINIUM BOXES. MANY OTHER SIZES IN STOCK. 4 x 2 1/2 x 2in. £1.00; 3 x 2 x 1in. 80p; 6 x 4 x 2in. £1.60; 8 x 6 x 3 in. £2.50; 12 x 5 x 3in. £2.75; 6 x 4 x 3in. £1.80; 10 x 7 x 3in. £3.

#### HIGH VOLTAGE ELECTROLYTICS 32+32/350V

20/500V	75p	8+8/500V	£1	32+32/500V	£2
32/350V	45p	8+16/450V	75p	125/500V	£2
32/500V	95p	16+16/350V	75p	16+32+32/500V	£2

#### SINGLE PLAY DECKS. Post £2.

Make	Model	Cartridge	Price
BSR	P170	Ceramic	£20
GARRARD	6200	Ceramic	£22
BSR	P182	Ceramic	£26
BSR	P232	Magnetic	£28
AUTOCHANGER	BSR	Ceramic	£20



#### RADIO COMPONENT SPECIALISTS

Dept 4, 337, WHITEHORSE ROAD, CROYDON SURREY, U.K. TEL: 01-684 1665

ACCESS

Post 55p Minimum Callers Welcome Lists 32p. Same day despatch. Closed Wed.

VISA

# MOTORIST

BRITAIN'S No. 1. PRACTICAL MOTORING MAGAZINE

APRIL ISSUE

## FREE GIFT

LITTLE CHEF MAP

# Practical Householder

FOR D.I.Y. HOME IMPROVEMENTS

APRIL ISSUE

## FREE GIFT

20 FISCHER WALLPLUGS

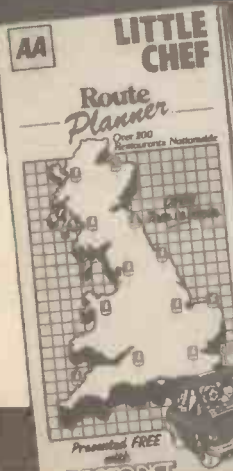

# home plus

EXTRA, EXTRA, Home Plus This colour magazine extra is free with P. Motorist and P. Householder. SPECIAL FEATURES: GADGETS FOR THE HOME. RAISING THE READIES, WINTER RAVAGES REPAIRED.

Don't miss out on these BUMPER ISSUES ON SALE NOW!

# T.V. SOUND TUNER

**SERIES II BUILT AND TESTED** Complete with case. £26.50 + £2.00 p&p.

In the cut-throat world of consumer electronics, one of the questions designers apparently ponder over is "Will anyone notice if we save money by chopping this out?" In the domestic TV set, one of the first casualties seems to be the sound quality. Small speakers and no tone controls are common and all this is really quite sad, as the TV companies do their best to transmit the highest quality sound. Given this background a compact and independent TV tuner that connects direct to your Hi-Fi is a must for quality reproduction. The unit is mains-operated.

This TV SOUND TUNER offers full UHF coverage with 5 pre-selected tuning controls. It can also be used in conjunction with your video recorder. Dimensions: 10½" x 7½" x 2½". E.T.I. kit version of above without chassis, case and hardware. £16.20 plus £1.50 p&p.



Also available with built-in headphone amp. ONLY £32.50 + £2.00 p&p.

## PRACTICAL ELECTRONICS STEREO CASSETTE RECORDER KIT COMPLETE WITH CASE

ONLY £34.50 plus £2.75 p&p.

• NOISE REDUCTION SYSTEM. • AUTO STOP. • TAPE COUNTER. • SWITCHABLE E.Q. • INDEPENDENT LEVEL CONTROLS. • TWIN V.U. METER. • WOW & FLUTTER 0.1%. • RECORD/PLAYBACK I.C. WITH ELECTRONIC SWITCHING. • FULLY VARIABLE RECORDING BIAS FOR ACCURATE MATCHING OF ALL TYPES.

Kit includes tape transport mechanism, ready punched and back printed circuit board and all electronic parts, i.e. semiconductors, resistors, capacitors, hardware, top cover, printed scale and mains transformer. You only supply solder & hook-up wire. Featured in April P.E. reprint 50p. Free with kit.



## BSR RECORD DECKS

Auto-Changer model - takes up to 6 records with manual override. Supplied with stereo ceramic cartridge.

£12.95 plus £1.75 p&p.



3 speed, auto, set-down; with auto return. Fitted with viscous damped cue, tubular aluminium counter-weighted arm, fitted with ceramic head. Ideally suited for home or disco use.

£17.50 plus £1.75 p&p.



Manual single play record deck with auto return and cueing lever. Fitted with stereo ceramic cartridge 2 speeds with 45 rpm spindle adaptor ideally suited for home or disco.

13" x 11" approx.

£14.95 plus £1.75 p&p.



**SPECIAL OFFER!** Replacement st. cassette tape heads. £1.80 ea. Add 50p p&p to order. Philips st. mag. cartridge. £3.95 + 60p p&p.

**PLINTH** to suit BSR Record Player Deck (with cover). Size 16½" x 14½" x 2½". Cover size: £14½" x 13½" x 3½". Due to fragile nature, Buyer collect only. Price: £8.95.

## STEREO TUNER KIT

**SPECIAL OFFER!**

£13.95 + £2.50 p&p.



This easy to build 3 band stereo AM/FM tuner kit is designed in conjunction with P.E. (July '81). For ease of construction and alignment it incorporates three Mullard modules and an I.C. IF System. Front scale size 10½" x 2½" approx. Complete with diagram and instructions.

## 125W HIGH POWER AMP MODULES

The power amp kit is a module for high power applications - disco units, guitar amplifiers, public address systems and even high power domestic systems. The unit is protected against short circuiting of the load and is safe in an open circuit condition. A large safety margin exists by use of generously rated components, result, a high powered rugged unit. The PC board is back printed, etched and ready to drill for ease of construction and the aluminium chassis is preformed and ready to use. Supplied with all parts, circuit diagrams and instructions.

Accessories: Stereo mains power supply kit with trans. £10.50 + £2 p&p. Mono: £7.50 + £2 p&p.



**SPECIFICATIONS:**

Max. output power (RMS): 125 W. Operating voltage (DC): 50 - 80 max. Loads: 4 - 16 ohm. Frequency response measured @ 100 watts: 25Hz - 20KHz. Sensitivity for 100w: 400mV @ 47K. Typical T.H.D. @ 50 watts, 4 ohms: 0.1%. Dimensions: 205x90 and 190x36mm.

KIT £10.50 + £1.15 p&p.

BUILT £14.25 + £1.15 p&p.

## HI-FI SPEAKER BARGAINS

AUDAX 8" SPEAKER £5.95 + £2.20 p&p.

High quality 40 watts RMS bass/mid. Ideal for either Hi-Fi or Disco use this speaker features an aluminium voice coil and a heavy 70mm dia. magnet. Freq. Res.: 20Hz to 7kHz. Imp.: 8 ohms.



AUDAX 40W FERRO-FLUID HI-FI TWEETER Freq. res.: 5KHz - 22KHz. Imp.: 8 ohms. 60mm sq. £5.50 + 60p p&p.

GOODMANS TWEETERS 8 ohm soft-dome radiator tweeter (3¾"sq) for use in systems up to 40W. £3.95 ea + £1 p&p. £6.95 pr + £1.50.



## MONO MIXER AMP

Ideal for halls and clubs.

£45.00 + £2 p&p.



50 Watt, six individually mixed inputs for 2 pickups (Cer. or mag), 2 moving coil microphones and 2 auxiliary for tape tuner, organs etc. Eight slider controls - 6 for level and 2 for master bass and treble. 4 extra treble controls for mic, and aux. inputs. Size: 13½" x 6½" x 3¾" app. Power output 50 W RMS (cont.) for use with 4 to 8 ohm speakers. Attractive black vinyl case with matching fascia and knobs. Ready to use.

All mail to: 21A HIGH ST, ACTON W3 6NG. Callers: Mon - Sat 9.30 - 5.30. Half day Wed. Access phone orders on 01-992 8430.

Note: Goods despatched to U.K. postal addresses only. All items subject to availability. Prices correct at 30/11/83 and subject to change without notice. Please allow 14 working days from receipt of order for despatch. RTVC Limited reserves the right to update their products without notice. All enquiries send S.A.E. Telephone or mail orders by ACCESS welcome.

CALLERS TO: 323 EDGWARE ROAD, LONDON W2. Telephone: 01-723 8432. (5 minutes walk from Edgware Road Tube Station) Now open 6 days a week 9 - 5.30. Prices include VAT.



# INDEX TO ADVERTISERS

Bib Audio .....	222, 223
Big K .....	282
Bimsales .....	287
Bi-Pak .....	221
BK Electronics .....	Cover III
B.N.R.E.S. ....	218
Butterworths .....	220
Bull J. ....	284
Copperfoil Ltd .....	286
C-Tec Security .....	286
Electronics Mail Order .....	286
Electronics World .....	286
Electronize Design .....	Cover II
Electrovalue .....	223
Enfield Electronics .....	224
Global Specialties Corporation .....	269
Greenweld Electronics .....	281
Homeplus .....	287
ICS Intertext .....	223
Magenta Electronics .....	283
Maplin Electronics .....	Cover IV, 220
Radio Component Specialists .....	287
R & TVC .....	288
Rapid Electronics .....	219
Riscomp Ltd .....	281
Roden Products .....	286
Software Index .....	285
T.K. Electronics .....	222



### MULLARD SPEAKER KITS

Purposefully designed 40 watt R.M.S. and 30 watt R.M.S. 8 ohm speaker systems recently developed by MULLARD'S specialist team in Belgium. Kits comprise Mullard woofer (8" or 5") with foam surround and aluminium voice coil. Mullard 3" high power domed tweeter. B.K.E. built and tested crossover based on Mullard circuit, combining low loss components, glass fibre board and recessed loudspeaker terminals. SUPERB SOUNDS AT LOW COST. Kits supplied in polystyrene packs complete with instructions. 8" 40W system - recommended cabinet size 240 x 216 x 445mm  
 Price £14.90 each + £2.00 P & P.  
 5" 30W system - recommended cabinet size 160 x 175 x 295mm  
 Price £13.90 each + £1.50 P & P.

Designer approved flat-pack cabinet kits, including grill fabric. Can be finished with iron on veneer or self adhesive vinyl etc.  
 8" system cabinet kit £8.00 each + £2.50 P & P.  
 5" system cabinet kit £7.00 each + £2.00 P & P.

### STEREO CASSETTE TAPE DECK MODULE

Comprising of a top panel and tape mechanism coupled to a record/play back printed board assembly. Supplied as one complete unit for horizontal installation into cabinet or console of own choice. These units are brand new, ready built and tested.

Features: Three digit tape counter. Autostop. Six piano type keys: record, rewind, fast forward, play, stop and eject. Automatic record level control. Main inputs plus secondary inputs for stereo microphones. Input Sensitivity: 100mV to 2V. Input Impedance: 68K. Output level: 400mV to both left and right hand channels. Output Impedance: 10K. Signal to noise ratio: 45dB. Wow and flutter: 0.1%. Power Supply requirements: 18V DC at 300mA. Connections: The left and right hand stereo inputs and outputs are via individual screened leads, all terminated with phono plugs (phono sockets provided). Dimensions: Top panel 5 1/2 in x 11 in. Clearance required under top panel 2 1/2 in. Supplied complete with circuit diagram and connecting diagram. Attractive black and silver finish.  
 Price £26.70 + £2.50 postage and packing.  
 Supplementary parts for 18V D.C. power supply (transformer, bridge rectifier and smoothing capacitor) £3.50.

### LOUDSPEAKERS POWER RANGE

THREE QUALITY POWER LOUD-SPEAKERS (15", 12" and 8" See Photo). Ideal for both Hi-Fi and Disco applications. All units have attractive cast aluminium (ground finish) fixing escutcheons. Specification and Prices.

15" 100 watt R.M.S. Impedance 8 ohms. 50 oz. magnet. 2" aluminium voice coil. Res. Freq. 20 Hz. Freq. Resp. to 2.5KHz. Sens. 97dB. Price: £34.00 each + £3.00 P&P  
 12" 100 watt R.M.S. Impedance 8 ohms. 50 oz. magnet. 2" aluminium voice coil. Res. Freq. 25Hz. Freq. Resp. to 4 KHz. Sens. 95dB. Price £26.00 each + £3.00 P&P.  
 8" 50 watt R.M.S. Impedance 8 ohms. 20 oz. magnet. 1 1/2" aluminium voice coil. Res. Freq. 40Hz. Freq. Resp. to 6 KHz. Sens. 92dB. Black Cone. Price: £9.50 each. Also available with black protective grille Price: £9.99 each. P&P £1.50.

12" 85 watt R.M.S. McKENZIE C1285GP (LEAD GUITAR, KEYBOARD, DISCO) 2" aluminium voice coil. aluminium centre dome. 8 ohm imp., Res. Freq. 45Hz., Freq. Resp. to 6.5KHz., Sens. 98dB. Price £24.00 + £3 carriage.

12" 85 watt R.M.S. McKENZIE C1285TC (P.A., DISCO) 2" aluminium voice coil. Twin cone. 8 ohm imp., Res. Freq. 45Hz., Freq. Resp. to 14KHz. Price £24.00 + £3 carriage.

15" 150 watt R.M.S. McKENZIE C15 (BASS GUITAR, P.A.) 3" aluminium voice coil. Die cast chassis. 8 ohm imp., Res. Freq. 40Hz., Freq. Resp. to 4KHz. Price £49 + £4 carriage. Cabinets fixings in stock S.A.E.

### PIEZO ELECTRIC TWEETERS MOTOROLA

Join the Piezo revolution. The low dynamic mass (no voice coil) of a Piezo tweeter produces an improved transient response with a lower distortion level than ordinary dynamic tweeters. As a crossover is not required these units can be added to existing speaker systems of up to 100 watts (more if 2 put in series). FREE EXPLANATORY LEAFLETS SUPPLIED WITH EACH TWEETER.

TYPE 'A' (KSN2036A) 3" round with protective wire mesh, ideal for bookshelf and medium sized Hi-Fi speakers. Price £4.29 each.

TYPE 'B' (KSN1005A) 2 1/2" super horn. For general purpose speakers, disco and P.A. systems etc. Price £4.99 each.

TYPE 'C' (KSN6016A) 2" x 5" wide dispersion horn. For quality Hi-Fi systems and quality discos etc. Price £5.99 each.

TYPE 'D' (KSN1025A) 2" x 6" wide dispersion horn. Upper frequency response retained extending down to mid range (2KHz). Suitable for high quality Hi-Fi systems and quality discos. Price £7.99 each.

TYPE 'E' (KSN1038A) 3 1/2" horn tweeter with attractive silver finish trim. Suitable for Hi-Fi monitor systems etc. Price £4.99 each.

TYPE 'F' (KSN1057A) Cased version of type 'E'. Free standing satellite tweeter. Perfect add on tweeter for conventional loudspeaker systems. Price £10.75 each  
 P&P 30p ea. (or SAE for Piezo leaflets).

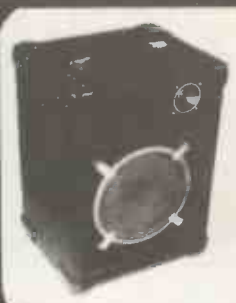
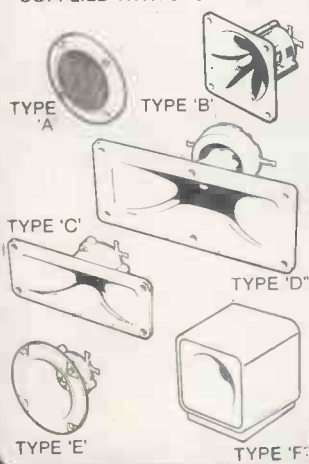

### OMP 12 LOUDSPEAKER

The very best in quality and value.

Ported tuned cabinet in hard-wearing black vinyl with protective corners and carry handle. Built and tested, employing 12in British driver and Piezo tweeter. Spec 100 watts RMS; 8 ohms; 45Hz-20KHz; Size: 20in x 15in x 12in; Weight: 30 pounds.

Price: £3.00 each  
 £120 per pair  
 Carriage: £5 each £7 per pair

### BK ELECTRONICS

Prompt Deliveries  
 VAT inclusive  
 prices  
 Audio Equipment  
 Test Equipment  
 by  
 Thandar  
 and  
 Leader

### PANTEC

HOBBY KITS. Proven designs including glass fibre printed circuit board and high quality components complete with instructions.

FM MICROTRANSMITTER (BUG) 90/105MHz with very sensitive microphone. Range 100/300 metres. 57 x 46 x 14mm (9 volt)  
 Price: £7.99p

DIGITAL THERMOMETER -9.9 C to +99.9 C. LED display. Complete with sensor. 70 x 70 mm (9 volt) Price: £27.60p

3 WATT FM TRANSMITTER 3 WATT 85/115MHz varicap controlled. professional performance. Range up to 3 miles 35 x 84 x 12 mm (12 volt) Price: £12.49p

SINGLE CHANNEL RADIO CONTROLLED TRANSMITTER/RECEIVER 27MHZ Range up to 500 metres. Double coded modulation. Receiver output operates relay with 2amp/240 volt contacts. Ideal for many applications. Receiver 90 x 70 x 22 mm. 9/12 volt) Price: £16.49 Transmitter 80 x 50 x 15 mm (9/12 volt) Price £10.29 P&P All Kits + 75p each. S.A.E. for complete list.



3 watt FM Transmitter

### BSR P256 TURNTABLE

P256 turntable chassis. S shaped tone arm.  
 • Belt driven • Aluminium platter • Precision calibrated counter balance • Anti-skate (bias device) • Damped cueing lever • 240 volt AC operation (Hz) • Cut-out template supplied • Completely manual arm. This deck has a completely manual arm and is designed primarily for disco and studio use where all the advantages of a manual arm are required.

Price £32.35 each. £2.50 P&P.



### OMP POWER AMPLIFIER MODULE READY BUILT

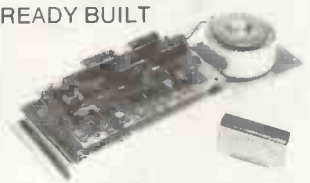

New model.  
 Improved specification

NEW OMP100 Mk.II POWER AMPLIFIER MODULE Power Amplifier Module complete with integral heat sink toroidal transformer power supply and glass fibre p.c.b. assembly. Incorporates drive circuit to power a compatible LED Vu meter. New improved specification makes this amplifier ideal for P.A., Instrumental and Hi-Fi applications.

SPECIFICATION  
 Output Power: - 110 watts R.M.S.  
 Loads: - Open and short circuit proof 4/16 ohms.  
 Frequency Response: - 15Hz - 30KHz -3dB.  
 T.H.D.: - 0.01%.  
 S.N.R. (Unweighted): - -118dB ±3.5dB.  
 Sensitivity for Max Output: - 500mV @ 10K.  
 Size: - 360 x 115 x 72 mm Price: - £31.99 + £2.50 P&P. Vu Meter Price: - £8.50 + 50p P&P.

MOSFET versions available up to 300W. R.M.S.

### HOME PROTECTION SYSTEM

Better to be 'Alarmed' than terrified. Thandar's famous 'Minder' Burglar Alarm System. Superior microwave principle. Supplied as three units, complete with interconnection cable. FULLY GUARANTEED.

Control Unit - Houses microwave radar unit, range up to 15 metres adjustable by sensitivity control. Three position, key operated fascia switch - off - test - armed. 30 second exit and entry delay.

Indoor alarm - Electronic swept freq. siren. 104dB output.

Outdoor Alarm - Electronic swept freq. siren. 98dB output. Housed in a tamper-proof heavy duty metal case.

Both the control unit and outdoor alarm contain rechargeable batteries which provide full protection during mains failure. Power requirement 200/260 Volt AC 50/60Hz. Expandable with door sensors, panic buttons etc. Complete with instructions

SAVE £128 Usual price £228.85

BKE's PRICE £99.p&p£4

SAE for colour brochure



READY BUILT

### STEREO DISCO MIXER

STEREO DISCO MIXER with 7 band graphic equaliser and 10 segment L.E.D. Vu Meters. Many outstanding features.

5 Inputs with individual fader controls: - 2 Mag. turntable, 2 Aux. plus Mic. with talk-over switch. Headphone monitor. Master output control with Hi-Low outputs. Compatible with our OMP Power Amplifiers.

Size: 360 x 200 x 120 mm. Supply 240V/50Hz AC.

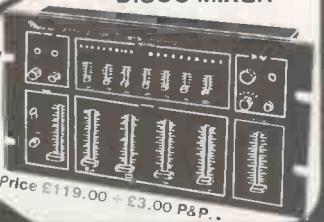

Price £119.00 + £3.00 P&P.

# B.K. ELECTRONICS

UNIT 5, COMET WAY, SOUTHEND-ON-SEA, ESSEX, SS2 6TR



★ SAE for current lists. ★ Official orders welcome. ★ All prices include VAT. ★ Sales Counter. ★ All items packed where applicable in special energy absorbing PU foam. ★ Please phone 0702 527572 ★

Full-travel, full size

# KEYBOARD

Simply plugs into expansion port on your

# SPECTRUM

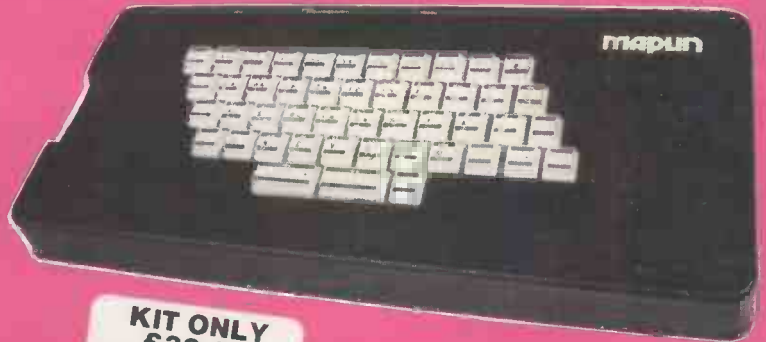

**KIT ONLY**  
**£39.95**  
**READY-BUILT**  
**£44.95**

Case included in both prices

- ★ Single-key selection of all major multi-key functions.
- ★ Plugs directly into Spectrum expansion port and extends port for other peripherals.
- ★ Can accept Atari-type joysticks (optional extra).
- ★ Absolutely no soldering or dismantling of Spectrum.
- ★ Available in kit-form or ready-built.

The kit is sold in three parts — the Keyboard Main Kit which allows you to make your own arrangements for connection to the Spectrum — the Adaptor Kit which contains the extension board and socket for the expansion port and the cable between the

extension board and the keyboard — and the Case Kit which includes all the necessary mounting hardware.

Order As	LK29G (Keyboard Main Kit)	Price £28.50
	LK30H (Adaptor Kit)	Price £6.50
	XG35Q (Case)	Price £4.95

Full construction details in Projects Book 9.

Also available ready-built for direct connection and including case.

Order As	XG36P (Spectrum Keyboard)	Price £44.95
----------	---------------------------	--------------

## Maplin's Fantastic Projects

Full details in our project books. Price 70p each.

In Book 1 (XA01B) 120W rms MOSFET Combo-Amplifier • Universal Timer with 18 program times and 4 outputs • Temperature Gauge • Six Vero Projects.

In Book 2 (XA02C) Home Security System • Train Controller for 14 trains on one circuit • Stopwatch with multiple modes • Miles-per-Gallon Meter.

In Book 3 (XA03D) ZX81 Keyboard with electronics • Stereo 25W MOSFET Amplifier • Doppler Radar Intruder Detector • Remote Control for Train Controller.

In Book 4 (XA04E) Telephone Exchange for 16 extensions • Frequency Counter 10Hz to 600 MHz • Ultrasonic Intruder Detector • I/O Port for ZX81 • Car Burglar Alarm • Remote Control for 25W Stereo Amp.

In Book 5 (XA05F) Modem to European standard • 100W 240V AC

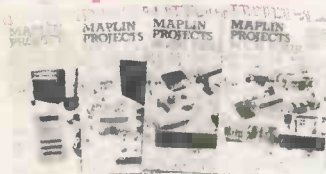

Inverter • Sounds Generator for ZX81 • Central Heating Controller • Panic Button for Home Security System • Model Train Projects • Timer for External Sounder.

In Book 6 (XA06G) Speech Synthesiser for ZX81 & VIC20 • Module to Bridge two of our MOSFET amps to make a 350W Amp • ZX81 Sound on your TV • Scratch Filter • Damp Meter • Four Simple Projects.

In Book 7 (XA07H) Modem (RS232) Interface for ZX81/VIC20 • Digital Enlarger Timer/Controller • DXers Audio Processor • Sweep Oscillator • CMOS Crystal Calibrator.

In Book 8 (XA08J) Modem (RS232) Interface for Dragon and Spectrum • Synchime • I/O Ports for Dragon • Electronic Lock • Minilab Power Supply • Logic Probe • Doorbell for the Deaf.

In Book 9 (XA09K) Keyboard with electronics for ZX Spectrum • Infra-Red Intruder Detector • Multimeter to Frequency Meter Converter • FM

Radio with no alignment • Hi-Res Graphics for ZX81 • Speech Synthesiser for Oric • VIC Extendiboard • ZX81 ExtendIRAM • Dynamic Noise Limiter for Personal Cassette Players • TTL Levels to Modem/RS232 Converter • Logic Pulser • Psuedo-Stereo AM Radio • NI-Cad Charger Timer • Adder-Subtractor • Syndrums' Interface • Microphone Pre-Amp Limiifer.

## THE MAPLIN MODEM KIT

Exchange programs with friends, leave or read messages from the various Billboard services, talk to computer bureaux, or place orders and check stock levels on Maplin's CashTel



service. A Maplin Modem will bring a whole new world to your computer and vastly increase its potential.

Now you can exchange data with any other computer using a 300 baud European standard (CCITT) modem and because the Maplin Modem uses this standard, you could talk to any one of tens of thousands of existing users.

Some computers need an interface and we have kits for the ZX81, VIC20/Commodore 64, Dragon and Spectrum and shortly Atari, whilst the BBC needs only a short program which is listed in Projects Book 8.

A Maplin Modem will add a new dimension to your hobby.

Order As	LW99H (Modem Kit) excluding case.	Price £39.95.
	YK62S (Modem Case)	Price £9.95.

Full construction details in Projects Book 5.

## 1984 CATALOGUE

A massive 480 big pages of description, pictures and data and now with prices on the page. The new Maplin catalogue is the one book no constructor should be without. Now includes new Heathkit section. On sale in all branches of W.H. Smith. Price £1.35 — It's incredible value for money. Or send £1.65 (including p & p) to our mail-order address.

## Great Projects From E&MM

Our book "Best of E&MM Projects Vol. 1" brings together 21 fascinating and novel projects from E&MM's first Year.

Projects include Harmony Generator, Guitar Tuner, Hexadrum, Syntom, Auto Swell, Partylite, Car Aerial Booster, MOS-FET Amp and other musical, hi-fi and car projects. Order As XH61R. Price £1.

Post this coupon now for your copy of the 1984 catalogue. Price £1.35 + 30p post and packaging. If you live outside the U.K. send £2.20 or 11 International Reply Coupons. I enclose £1.65

Name.....

Address.....

EE/4/84



## MAPLIN ELECTRONIC SUPPLIES LTD

Mail Order. P.O. Box 3, Rayleigh, Essex SS6 8LR. Tel: Southend (0702) 552911 • Shops at: 159-161 King Street, Hammersmith, London W6. Tel: 01-748-0926. • 8 Oxford Road, Manchester. Tel: 061-236-0281. • Lynton Square, Perry Barr, Birmingham. Tel: 021-356-7292. • 282-284 London Road, Westcliff-on-Sea, Essex. Tel: 0702 554000. • 46-48 Bevois Valley Road, Southampton. Tel: 0703 25831. All shops closed all day Monday. All prices include VAT and carriage. Please add 50p handling charge to orders under £5 total value (except catalogue).