

Easy to build projects for everyone

**Everyday**

SEPT. 80  
50p

**ELECTRONICS** 198

TTL POWER SUPPLY UNIT  
LOGIC PROBE • DUD-DECI TIMER





# MAGENTA ELECTRONICS LTD.

## E.E. PROJECT KITS

Make us YOUR No. 1 SUPPLIER OF KITS and COMPONENTS for E.E. Projects. We supply carefully selected sets of parts to enable you to construct E.E. projects. Project kits include ALL THE ELECTRONICS AND HARDWARE NEEDED—we have even included appropriate screws, nuts and I.C. sockets. Each project kit comes complete with its own FREE COMPONENT IDENTIFICATION SHEET. We supply—you construct. PRICES INCLUDE CASES UNLESS OTHERWISE STATED. BATTERIES NOT INCLUDED. IF YOU DO NOT HAVE THE ISSUE OF E.E. WHICH CONTAINS THE PROJECT—YOU WILL NEED TO ORDER THE INSTRUCTIONS/REPRINT AS AN EXTRA—45p. each.

4 STATION RADIO. May 80. £13-94 less case.  
 AUTOFADE. May 80. £9-96.  
 LIGHTS WARNING SYSTEM. May 80. £3-83.  
 BATTERY VOLTAGE MONITOR. May 80. £4-03.  
 AUDIO TONE GENERATOR. May 80. £3-35.  
 DUAL LINE GAME. May 80. £27-70 less case.  
 GAS SENTINEL. April 80. £28-32.  
 SPRING LINE REVERB. UNIT. Jan. 80. £21-95.  
 MICROCHIME DOORBELL. Feb. 79. £13-48.  
 AUTO LEVEL CONTROL. April '80 £7-69.  
 CABLE & PIPE LOCATOR. Mar. 80. £3-48 less coil former.  
 KITCHEN TIMER. Mar. 80. £12-46.  
 STEREO HEADPHONE AMPLIFIER. Mar. 80. £14-94.  
 5 RANGE CURRENT LIMITER. Mar. 80. £4-24.  
 MICRO MUSIC BOX. Feb. 80 £13-82. Grey Case £3-63 extra.  
 SIMPLE SHORT WAVE RECEIVER. Feb. 80. £28-47, headphones £3-28.  
 SLIDETAPE SYNCHRONISER. Feb. 80. £19-48.  
 MORSE PRACTICE OSCILLATOR. Feb. 80. £3-75.  
 UNIBOARD BURGLAR ALARM. Dec. 79. £4-95.  
 BABY ALARM. Nov. 79 £8-20  
 OPTO ALARM. Nov. 79 £5-77 inc. optional parts.  
 MW/LW RADIO TUNER. Nov. 79 £15-50 less dial.  
 3 FUNCTION GENERATOR. Nov. 79 £18-44 less pointer, case extra £7-18.  
 ONE ARMED BANDIT. Oct. 79. £18-39, case extra £3-98.  
 HIGH IMPEDANCE VOLTMETER. Oct. 79. £15-87.  
 LIGHTS ON REMINDER. Oct. 79. £4-85.  
 CHASER LIGHTS. Sept. 79. £18-95.  
 VARICAP M.W. RADIO. Sept. 79. £8-98.  
 SIMPLE TRANSISTOR TESTER. Sept. 79. £6-28.  
 ELECTRONIC TUNING FORK Aug. 79 £9-15. Suitable microphone & plug £1-59 extra.  
 WARBLING TIMER. Aug. 79. £8-25  
 9V POWER SUPPLY Aug. 79. £9-94 inc. pcb.  
 SWANEE WHISTLER Aug. 79 £3-19  
 DARKROOM TIMER. July 79. £2-47.  
 WATER LEVEL INDICATOR. July 79. £4-80.  
 TREMOLO UNIT. June 79. £11-28.  
 ELECTRONIC CANARY. June 79. £4-99.  
 LOW COST METAL LOCATOR. June 79. £5-44.  
 Handle & coil former parts extra £5-55.  
 METER AMPLIFIER. June 79. £4-32.  
 QUAD SIMULATOR. June 79. £8-25.  
 INTRUDER ALARM. May 1979. £16-71. Less Ext. Buzzer & Lamp and Loop Components.

LATEST KITS: S.A.E. OR 'PHONE FOR PRICES

LOW COST E.E. June 78

### METAL LOCATOR

COMPLETE KIT with HANDLE, COIL FORMER, SCREWS etc., ELECTRONIC COMPONENTS and Case £10-99. or separately ELECTRONICS & CASE £5-44, HARDWARE £5-55.

MAGENTA gives you FAST DELIVERY BY FIRST CLASS POST OF QUALITY COMPONENTS & KITS. All products are stock lines and are new & full specification. We give personal service & quality products to all our customers—HAVE YOU TRIED US?

## MAGENTA ELECTRONICS LTD.

EW20, 98 CALAIS ROAD, BURTON-ON-TRENT, STAFFS., DE13 0UL. 0283-65435. 9-12, 2-5 MON.-FRI. MAIL ORDER ONLY

ADD 35p. P.&P. TO ALL ORDERS. ALL PRICES INCLUDE 15% V.A.T. OFFICIAL ORDERS FROM SCHOOLS ETC. WELCOME. ENQUIRIES MUST INCLUDE S.A.E. OVERSEAS: SEND ORDER WITH 3 INTERNATIONAL POSTAL COUPONS WE WILL QUOTE EXACT PRICE BY AIR MAIL.

SHORT WAVE CONVERTER. May 79. £15-38 inc. case.  
 THERMOSTAT. 'PHOTO' SOLUTIONS. May 79. £16-02. Less socket, tube and grease.  
 TRANSISTOR TESTER. April 79. £3-87.  
 TOUCH SLEEPER. April 79. £3-34.  
 ONE TRANSISTOR RADIO. Mar. 79. with Amplifier & Headset. Less case. £6-93.  
 VERSATILE POWER SUPPLY. Mar. 79. £8-99.  
 AUDIO MODULATOR. Feb. 79. £1-56 less case and pins.  
 LW CONVERTER. Feb. 79. £8-46.  
 THYRISTOR TESTER. Feb. 79. £3-83.  
 ADJUSTABLE PSU. Feb. 79. £24-80. Case (horizontal layout) £3-21 extra.  
 FUZZ BOX. Dec. 78. £5-53.  
 VEHICLE IMMOBILISER. inc. PCB. Dec. 78. £5-74.  
 "HOT LINE" GAME. Nov. 78. £4-65 less case & rod.  
 AUDIO EFFECTS OSCILLATOR. Nov. 78. £3-81 inc. board.  
 FUSE CHECKER. Oct. 78. £1-97.  
 C.MOS RADIO. Oct. 78. £9-39.  
 TREASURE HUNTER. Oct. 78. £17-88 less handle & coil former.  
 GUITAR TONE BOOSTER. Sept. 78. £4-99 inc. p.c.b.  
 SOUND TO LIGHT. Sept. 78. £8-98.  
 FILTER. £1-86  
 SLAVE FLASH. Aug. 78. £3-20 less SK1.  
 LOGIC PROBE. July 78. £2-53.  
 IN SITU TRANSISTOR TESTER. June 78. £5-79.  
 VISUAL CONTINUITY CHECKER. June 78. £3-72 inc. probes.  
 FLASHMETER. May 78. £12-84 less calc and diffuser.  
 POCKET TIMER. April 78. £2-98.  
 WEIRD SOUND EFFECTS GENERATOR. Mar. 78. £4-81.  
 CHASER LIGHT DISPLAY. Feb. 78. £23-59 inc. p.c.b. case extra £5-21.  
 AUDIO VISUAL METRONOME. Jan. 78. £4-93.  
 RAPID DIODE CHECK. Jan. 78. £2-34.  
 AUTOMATIC PHASE BOX. Dec. 77. £9-55 inc. p.c.b.  
 VHF RADIO. Nov. 77. £14-38.  
 ULTRASONIC REMOTE CONTROL. Nov./Dec. 77. £16-09.  
 TREASURE LOCATOR. Oct. 77. £16-81 case extra. £3-53. Less handle, etc.  
 ELECTRONIC DICE. March 77. £4-83.  
 SOIL MOISTURE INDICATOR. June 77. £4-07 inc. probe.  
 PHONE/DOORBELL REPEATER. July 77. £8-38.  
 CAR BATTERY STATE INDICATOR. Sept. 78. £1-79 less case inc. PCB.  
 R.F. SIGNAL GENERATOR. Sept. 78. £18-17 less case.  
 ADD-ON CAPACITANCE UNIT. Sept. 77. £5-99.  
 HEADPHONE ENHANCER. Jan. 79. £2-80.  
 PASSIVE MIXER. Oct. 78. £3-72.  
 MIC AMP. Dec. 78. £2-80.  
 AUDIBLE FLASHER. Dec. 78. £1-21.

### 3 BAND S.W. RADIO

Simple T.R.F. Design. Covering most Amateur Bands and Short Wave Broadcast Bands. Five controls:—Bandset, Bandspread, Reaction, Wavechange and Attenuator. Coil selection is by Wavechange Switch. Use with Headphones or a Crystal Earpiece. Kit contains all the components required, including the P.C. Board & Case. Instructions are included with this kit. KIT: £18-97. Headphones extra £3-28.

## 1980 ELECTRONICS CATALOGUE

Magenta's Catalogue has been carefully designed for E.E. Readers. Product Data and Illustrations make the Magenta Catalogue an indispensable guide for the constructor. Catalogue includes: Electronic Components, Hardware, Cases, Tools, Test Equipment, details of advertised Items and Circuit Ideas for you to build.

No minimum order—all products are stock lines. First class delivery of first class

EUROBREAD BOARD. £6-20.  
 LOW COST LONG NOSE PLIERS. £1-97.  
 LOW COST CUTTERS. £1-98.  
 SWING STORAGE DRAWERS £5-98.  
 MULTIMETER TYPE 3100,000 o.p.v. with translator tester ranges £39-95.  
 WIRELESS INTERCOM 2 STATION £42-95.  
 SIREN. 12V £5-95.  
 P.C.B. ASSEMBLY JIG. £11-98.  
 P.C.B. ETCHING KIT. £4-98.  
 A.M.-F.M. AIRCRAFT BAND PORTABLE RADIO £18-95.  
 WIRE STRIPPERS & CUTTERS £2-48.  
 ULTRASONIC TRANSDUCERS. £5-50 pair.

P.A. MICROPHONE coiled lead & switch £4-68.  
 STEREO MICROPHONE PAIR £10-95.  
 MULTIMETER TYPE 1, 1,000 o.p.v. with probes. 2" x 3/4" x 1". £8-66.  
 MULTIMETER TYPE 2, 20,000 o.p.v. with probes. 5" x 3/4" x 1". £11-52.  
 F.M. INDOOR AERIAL. 57p.  
 TELESCOPIC AERIAL 120 c.m. £2-38.  
 TELEPHONE PICK-UP COIL. 72p.  
 CRYSTAL MICROPHONE INSERT. 58p.  
 SPEAKERS MINIATURE. 8 ohm 87p. 84 ohm 98p. 80 ohm £1-28.  
 PILLOW SPEAKER. 8 ohm 98p.  
 6" ROUND SPEAKER. 8 ohm, 5W, £2-28.  
 CABINET SPEAKER. 8 ohm, 5W, 5" speaker, Cabinet 10" x 7" x 4". £9-79.  
 RE-ENTRANT HORN SPEAKER. 8 ohm S.W. Horn dia. 3 1/2". £5-27.  
 EARPIECES. Crystal 48p. Magnetic 18p.  
 STETHOSCOPE ATTACHMENT. Fits our earpieces 89p.  
 BUZZER. 6V 82p. 12V 85p.  
 MONO HEADPHONES. 2K Padded. Superior. Sensitive. £3-28.  
 STEREO HEADPHONES. 8 ohm. Padded. £4-35.

components. Send for your copy and see how easy it is to use the Magenta Catalogue! Write today enclosing 6 x 10p stamps.

\*\*\*\*\*

### June 80 KITS!!

AUTOPHASE June 80 £21-41 Rectangular Case.  
 COURTESY LIGHT DELAY June 80 £5-91.  
 A.F. SIGNAL GENERATOR June 80 £22-54  
 AUTOWAA June 80 £21-33 Rectangular Case.  
 VOLTAGE CONVERTER June 80 £5-38  
 G.P. AMPLIFIER June 80 £6-89  
 SIGNAL TRACER June 80 £5-59  
 ZENER DIODE TESTER June 80 £5-67

\*\*\*\*\*

CAPACITANCE SUBSTITUTION BOX. Nine values, 100pF—0.22uF. £2-98. QUICKTEST. Mains connector. £7-38.  
 PLUG IN POWER SUPPLY. 6, 7, 8-9V d.c. 300mA. £4-95.  
 SPRINGS—SMALL. 100 Ass'd. £1-08.  
 CROC CLIP TEST LEAD SET. 10 leads with 20 clips. £1-15.  
 DIMMER SWITCH. 240V. 800W. £4-48.  
 TRADITIONAL STYLE BELL. 3-8V. 70mm chrome gong. £1-60.  
 UNDERMERE BELL. 4-10V. Smart. Dia. 70mm. £2-48.  
 F.M. TUNER CHASSIS. 88-108MHz. 9V d.c. £9-48.  
 MORSE KEY. High speed. £4-28.  
 PANEL METERS. 80 x 45mm. Modern style. 50uA, 100uA, 1mA, 1A, 25V d.c. £5-88.  
 NIGHT LIGHT. Plug type. £1-08.  
 CONNECTING WIRE PACK. 5 x 5yd. coils. 55p.  
 VERO SPOT FACE CUTTER. £1-21.  
 VERO PIN INSERTION TOOL. 0-1" £1-68. 0-15" £1-87.  
 RESISTOR COLOUR CODE CALCULATOR. 21p.

## ADVENTURES WITH ELECTRONICS by Tom Duncan

An easy to follow book suitable for all ages, ideal for beginners. No Soldering. Uses an 'S Dec' breadboard. Gives clear instructions with lots of pictures, 16 projects—including 3 radios, siren, metronome, organ, intercom, timer, etc. Helps you learn about electronic components and how circuits work. Component pack includes an S Dec and the components for the projects.

Adventures With Electronics £1-75.  
 Component Pack £16-72 less battery.

ALSO AVAILABLE  
 ADVENTURES WITH  
 MICROELECTRONICS  
 BOOK £2-35  
 COMPONENTS £30-59

# TEACH IN 80

E.E. SERIES—ALL COMPONENTS IN STOCK NOW FOR FAST DELIVERY. All top quality components as specified by Everyday Electronics. Our kit comes complete with FREE COMPONENT IDENTIFICATION SHEET. Follow this educational series and learn about electronics—Start today LIST A & B components £22-95 also available LIST C (parts 7-12) £2-45. All orders sent by FIRST CLASS POST. Our kit contains all these parts:—LIST A & B: METER, BREADBOARD, TRANSFORMER, LEDS, POTENTIOMETERS, SWITCHES, SPEAKER, PLUGS, SOCKETS, BATTERY CLIPS, WIRE, CABLE, FUSES, FUSE-HOLDERS, KNOBS, RESISTORS, PHOTOCELL, DIODES, CAPACITORS. REPRINTS OF PREVIOUS PARTS — 45p EACH.

CASE WOODWORK KIT £5-98 extra. Complete kit for tutor deck woodwork, contains all the softwood, hardboard, lamin. panel pins, adhesive, screws, feet, strap-handle, and fixings. Cut to size and ready to assemble.

### IDEAL SOLDERING EQUIPMENT FOR THE TEACH IN AND ELECTRONICS

ANTEX X25 SOLDERING IRON 25W £4-98  
 SOLDERING IRON STAND £2-03  
 SPARE BITS. Small. Standard, Large. 65p each.  
 SOLDER. Handy size 98p.  
 DESOLDER BRAID 60p  
 HOW TO SOLDER BOOKLET 12p  
 HEAT SINK TWEEZERS 15p.  
 SOLDER BOBBIN 30p  
 DESOLDER PUMP £5-98

# ELECTRONI-KIT

## DENSHI KITS— SPECIAL OFFER



"... fun and entertainment  
as well as education"—  
(EVERYDAY ELECTRONICS mag.)

The SR-3A kit (over 100 circuits) and the SR-3A de luxe kit (over 105 circuits) are available again, at little more than their 1977 prices

Circuits are constructed by plugging the encapsulated components into the boards provided, following the instruction manual. Technical details are also given concerning each project. The components are used over and over again and you can design your own circuits too, or use the kit as a useful testing board.

No previous experience of electronics is required but you learn as you build—and have a lot of fun too. The kits are safe for anyone.

### SR-3A KIT £29.95

(16½ × 10 × 2½")

Build over 100 projects including 3-TR reflex radio receiver, 3-TR radio receiver with RF amplifier, 2-TR reflex radio receiver, 3-TR amplifier for crystal mike, 3-TR amplifier for speaker/mike, 3-TR signal tracer, Morse Code trainer, 2-TR electronic organ, electronic metronome, electronic bird, electronic cat, electronic siren, electronic gun, 2-TR sleeping aid, high voltage generator, discontinuity warning device, water supply warning device, photoelectric alarming device, 3-TR burglar alarm, 3-TR water supply warning device, 3-TR water level warning device, 3-TR photoelectric alarming device, Morse Code trainer with sound & light, discontinuity warning device with sound & light, water level warning device with sound & light, electronic metronome with sound & light, buzzer with sound & light, wireless mike, wireless telegraph set, wireless discontinuity warning device, wireless water level warning device, wireless water supply warning device, wireless photoelectric warning device etc. etc.

### SR-3A de luxe KIT £39.95

(illustrated 16 × 14 × 3½")

Similar to SR-3A, more components including solar cell and additional Speaker unit plus sophisticated control panel.

All kits are guaranteed and supplied complete with extensive construction manuals PLUS Hamlyn's "All colour" 160 page book "Electronics" (free of charge whilst stocks last).

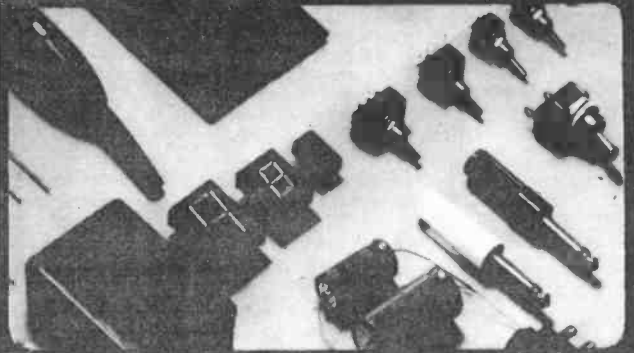
Prices include batteries, educational manuals, free book, VAT, p&p (In the UK), free introduction to the British Amateur Electronics Club.

Cheque/P.O./Access/Barclaycard (or 20p. for illustrated literature) to DEPT. EE.

**ELECTRONI-KIT LTD.**  
**RECTORY COURT, CHALVINGTON,**  
**E.SUSSEX, BN27 3TD (032 183 579)**

# ELECTROVALUE

SUPPLIERS OF COMPONENTS THAT COUNT



<b>SIEMENS</b> SEMI-CONDUCTOR CAPACITORS FERRITES	<b>NASCOM</b> MICRO COMPUTERS AND ANCILLARIES	<b>VERO</b> BOARDS CASES & KITS
<b>ISKRA</b> RESISTORS	RADIOHM POTENTIOMETERS	BREADBOARDS
	OP TO-ELECTRONICS	SOLDER TOOLS
	SWITCHES	CATALOGUE 10

GOOD DISCOUNTS AND FREE POSTAGE ON SUBSTANTIAL  
C.W.O. U.K. ORDERS

COMPUTER-CONTROLLED SERVICE AIDS PROMPT DELIVERY  
128-PAGE CATALOGUE No. 10 FREE FOR THE ASKING

**ELECTROVALUE LTD.**, 28 (EE7), St. Jude's Road, Englefield Green,  
Egham, Surrey TW20 0HB.

Phone: 33603 (London 87) STD 0784.

Telex 264475.

**NORTHERN BRANCH (Personal Shoppers Only):** 680 Burnage Lane,  
Burnage, Manchester M19 1NA. Phone (061) 432 4945.

## PROFESSIONAL TOOLS

At Discount Prices

Examples:



S.R.B. 18 watt Soldering Iron £4-97

Bench Stand with Sponge £5-14



STEADFAST Sheffield Steel

Side Cutters £4-47

Snipe Nose Pliers £4-04



TELPRO Desolder Pump £6-47

SPIRIG Desolder Braid £0-98

TELPRO Wire Cutter &

Stripper £1-71



ALL PRICES INCLUDE  
POSTAGE & V. A. T.

Send for FREE Catalogue & Price List.

*TRI-tronic Marketing Ltd.*

75 ALBERT STREET, RUGBY, WARCS. CV21 2SN.  
Telephone (0788) 73328



# All these advantages...

- Instant all-weather starting
- Smoother running
- Continual peak performance
- Longer battery & plug life
- Improved fuel consumption
- Improved acceleration/top speed
- Extended energy storage

## ..in kit form

SPARKRITE X5 is a high performance, top quality inductive discharge electronic ignition system designed for the electronics D.I.Y. world. It has been tried, tested and proven to be utterly reliable. Assembly only takes 1-2 hours and installation even less due to the patented 'clip on' easy fitting.

The superb technical design of the Sparkrite circuit eliminates problems of the contact breaker. There is no misfire due to contact breaker bounce which is eliminated electronically by a pulse suppression circuit which prevents the unit firing if the points bounce open at high R.P.M. Contact breaker burn is eliminated by reducing the current by 95% of the norm.

There is also a unique extended dwell circuit which allows the coil a longer period of time to store its energy before discharging to the plugs. The unit includes built in static timing light, systems function light, and security changeover switch. Will work all rev counters.

**Fits all 12v negative-earth vehicles with coil/distributor ignition up to 8 cylinders.**

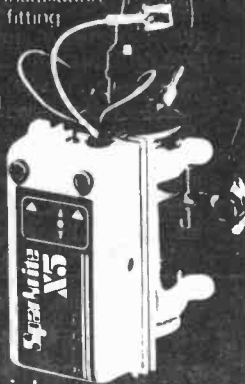
THE KIT COMPRISES EVERYTHING NEEDED. Die pressed case, Ready drilled, aluminium extruded base and heat sink, coil mounting clips and accessories. All kit components are guaranteed for a period of 2 years from date of purchase. Fully illustrated assembly and installation instructions are included.

Roger Clark the world famous rally driver says "Sparkrite electronic ignition systems are the best you can buy."



# Sparkrite

HIGH PERFORMANCE  
ELECTRONIC IGNITION  
Electronics Design Assoc.  
82 Bath Street, Walsall WS1 3DE



## Summertime Special Offers

A further



All our normal discount prices



A further



All our normal discount prices for  
**ALARM CHRONOGRAPHS and  
CALCULATOR WATCHES**

**OFFER CLOSES SEPTEMBER 12th, 1980  
SUBJECT TO AVAILABILITY**

*Send 25p for our illustrated catalogue*

Our normal service is **By Return Of Post**. However in anticipation of heavy demand, please allow up to 14 days for delivery.

# TEMPUS

Tempus (Dept. EE)  
FREEPOST, 164-167 East Road  
Cambridge CB1 1BR. Tel. 0223 312866

Electronics Design Associates, Dept. EE 980  
82 Bath Street, Walsall, WS1 3DE. Phone: (0922) 614791

Name \_\_\_\_\_  
Address \_\_\_\_\_

Phone your order with Access or Barclaycard

Inc. V.A.T. and P.P.

QUANTITY REQ'D.

I enclose cheque/PO's for

**X5 KIT £16.95**

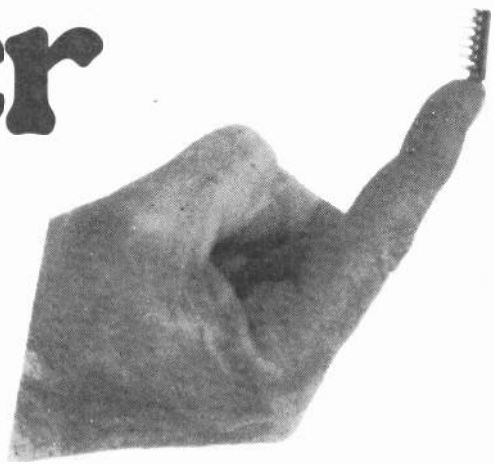
£

Cheque No. \_\_\_\_\_

ACCESS OR BARCLAY CARD No. \_\_\_\_\_

Send SAE if brochure only required.

# Conquer the chip.

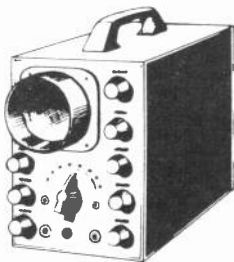


Be it career, hobby or interest, like it or not the Silicon Chip will revolutionise every human activity over the next ten years.

Knowledge of its operation and its use is vital. Knowledge you can attain, through us, in simple, easy to understand stages.

Learn the technology of the future today in your own home.

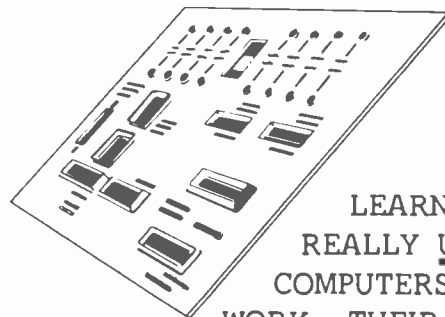
## MASTER ELECTRONICS



LEARN THE  
PRACTICAL WAY BY  
SEEING AND DOING

- Building an oscilloscope.
- Recognition of components.
- Understanding circuit diagrams.
- Handling all types Solid State 'Chips'.
- Carry out over 40 experiments on basic circuits and on digital electronics.
- Testing and servicing of Radio, T.V., Hi-Fi and all types of modern computerised equipment.

## MASTER COMPUTERS



LEARN HOW TO  
REALLY UNDERSTAND  
COMPUTERS, HOW THEY  
WORK - THEIR 'LANGUAGE'  
AND HOW TO DO PROGRAMS.

- Complete Home Study library.
- Special educational Mini-Computer supplied ready for use.
- Self Test program exercise.
- Services of skilled tutor available.

## MASTER THE REST

- Radio Amateurs Licence.
- Logic/Digital techniques.
- Examination courses (City & Guilds etc.) in electronics.
- Semi-conductor technology.
- Kits for Signal Generators - Digital Meters etc.

**FREE**

Please send your **FREE** brochure without obligation to:-

Name .....

Address .....

.....

.....

BLOCK CAPS PLEASE

I am interested in :-

EE9/8/811

PRACTICAL ELECTRONICS .....

COMPUTER TECHNOLOGY .....

OTHER SUBJECTS .....

(please state your interest)

.....

.....

**BRITISH NATIONAL RADIO & ELECTRONICS SCHOOL**

4 CLEVELAND ROAD, JERSEY, CHANNEL ISLANDS.

ALL PRICES IN PENCE EACH UNLESS OTHERWISE STATED

C-MOS (BUFFERED)			LINEAR			SEMICONDUCTORS					
HEF4006	22	HEF4044	105	HEF4512	136	CA3046	84	IN914	5	BC182L	12
HEF4001	22	HEF4046	133	HEF4516	127	CA3080E	77	IN4001	5	BC194	11
HEF4002	22	HEF4047	109	HEF4517	478	CA3130E	99	IN4002	5	BC184L	12
HEF4006	119	HEF4049	57	HEF4518	118	CA3140E	48	IN4004	7	BC212	11
HEF4007	22	HEF4050	57	HEF4519	69	CA3189E	293	IN4007	9	BC212L	12
HEF4008	100	HEF4051	87	HEF4520	111	LM301AN	34	LM148	4	BC214	11
HEF4011	22	HEF4052	90	HEF4521	235	LM339N	78	IN5402	15	BC214L	12
HEF4012	22	HEF4053	90	HEF4528	124	LM380N	104	2N2369	21	BC547	13
HEF4013	57	HEF4066	62	HEF4532	150	LM381AN	198	2N2646	46	BC548	11
HEF4014	105	HEF4067	475	HEF4534	638	LM390N	75	2N2926G	13	BC549	12
HEF4015	100	HEF4068	22	HEF4539	138	MC3403P	156	2N3053	18	DC557	15
HEF4016	57	HEF4069	22	HEF4585	122	NE531	131	2N3054	55	BC558	15
HEF4017	100	HEF4070	22	HEF4724	214	NE536T	259	2N3055	55	BCY70	15
HEF4018	100	HEF4071	23	HEF4009?	77	NE555N	28	2N3702	9	BCY71	15
HEF4019	58	HEF4072	23	HEF4009E	92	NE555M	56	2N3704	9	BD131	39
HEF4020	111	HEF4073	23	HEF40106	78	NE566N	171	2N3705	10	BD132	39
HEF4021	107	HEF4075	23	HEF40160	149	NE570N	465	2N3773	297	BD139	39
HEF4022	103	HEF4076	130	HEF40192	149	NE571N	505	2N3819	22	BD140	39
HEF4023	22	HEF4077	22			RCA136	146	2N3820	39	BFR90	333
HEF4024	26	HEF4078	23			TDA1205	98	2N3904	9	BF485	28
HEF4025	22	HEF4081	23			TDA1022	713	2N5457	39	BFV50	17
HEF4026	24	HEF4082	23			TDA1034B	239	2N5459	35	BFV51	17
HEF4027	57	HEF4085	80			LM309DAIKI	119	40673	88	BRV39	50
HEF4028	89	HEF4086	80			UA723CN	42	TLO84CN	156	BSK20	21
HEF4029	113	HEF4093	63			UA7805CU	78	UA741CN	20	CL8960	2850
HEF4030	58	HEF4094	219			UA7812CU	78	UA741CT	47	BC108C	18
HEF4031	250	HEF4104	204			UA7815CU	78	BC109	14	TIP32	54
HEF4035	138	HEF4502	114			UA7912CU	97	BC109B	19	TIP41C	76
HEF4040	107	HEF4505	714			UA7915CU	97	BC109C	20	TIP42C	76
HEF4041	94	HEF4508	230			BC109CS	38	BC148	10	TIP295	75
HEF4042	83	HEF4510	135			400mW CV7-C33		Zener Diodes		BC158	10
HEF4043	100	HEF4511	157			UA78L12CS	38	BZY88/BZK79		BC177	17
						UA78L15CS	38	+ Voltage		BC177	17

**GMT SELL P.A. EQPT.** PLEASE SEND AN SAE FOR D-TAILS

CAPACITORS			Polyester Radial Leads			Electrolytic Radial Leads		
Electrolytic Axial -10% to +50% Tol. Cap 0715 + μF			Dipped Type, C280/352 Style			-10% to +50% Tol. Cap 034 + μF		
μF	V	16 25 40 63	μF	362 360	352 360	μF	V	10 16 25 35 40 50 63
1.0	9		1001	7	15	47	9	7
1.5	9		0015	7	15	68	10	7
2.2	9		0022	6	7	10	15	7
3.3	9		0033	6	7	11	11	7
4.7	9		0047	6	7	14	11	7
6.8	8	9 10	0068	6	7	17	11	7
10	8	9 11	01	6	8	21	7	8
15	8	9 11	015	6	8	22	7	8
22	8	9 11	022	6	8	25	7	8
33	8	9 11	033	6	8	30	7	8
47	8	9 11	047	6	8	33	8	9
68	8	9 11	068	6	8	39	8	9
100	9	10 13	068	6	8	47	8	9
150	9	10 13				68	9	11
220	13	26 36				100	9	11
330		30 40				150	11	
470	23	32 47						
880	21	30 39 54						
1000	26	30 59						
1500	35	39						
2200	42							

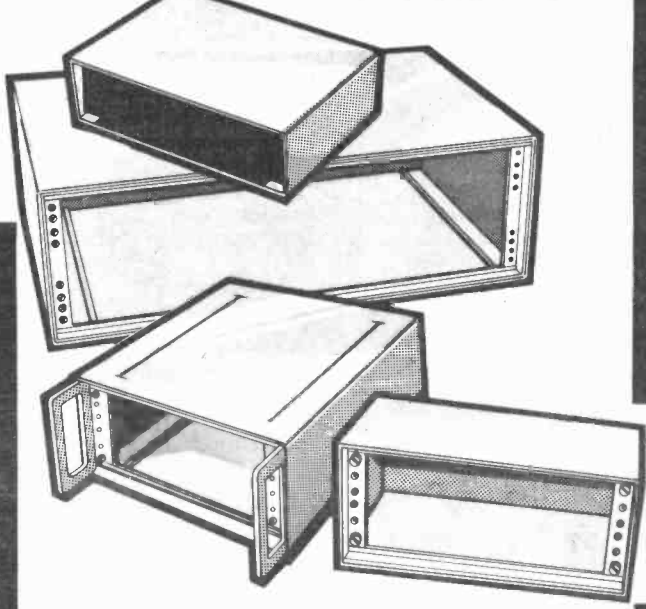
**SEND A LARGE SAE FOR OUR 'FLOG LIST' & OTHER INFO.**

MAINS TRANSFORMERS			Plastic Boxes - Box Industrial Mouldings		
Sec. windings may be connected in series or parallel to give wide voltage range			Moulded Box and Close Fitting Flanged Lid		
Primaries 0.220, 240V			ABS Box, CW Brass Bushes, and Lid in Orange		
6VA - Clamp Type Construction	235 each	Trans 6VA	L112 W62 D31	99	Case BIM2003 DR
Approx. 18% Regulation F.C. 54, H36, W35			L150 W80 D50	131	Case BIM2005 DR
0.4 5V, 0.4 5V Secondaries			L190 W110 D60	223	Case BIM2006 DR
0.5V, 0.6V					
0.12V, 0.12V			Plastic Boxes with Metal Lids		
0.15V, 0.15V			Recessed Top Box		
0.20V, 0.20V			ABS Box, CW Brass Bushes, In-Drum		
			1mm Aluminium Top Panel, Finished Grey		
20VA - Clamp Type Construction	360 each	Trans 20VA	L85 W56 D29	112	Case BIM4003 DR
Approx. 16% Regulation F.C. 70, H48, W46			L111 W71 D42	150	Case BIM4004 DR
0.4 5V, 0.4 5V Secondaries			L161 W96 D53	208	Case BIM4005 DR
0.6V, 0.6V					
0.12V, 0.12V			Diecast Boxes		
0.15V, 0.15V			Diecast Box and Flanged Lid		
0.175V, 0.175V			Aluminium Box and Lid in Natural Finish		
0.20V, 0.20V			L113 W63 D31	124	Case BIM5003 NA
			L152 W82 D50	215	Case BIM5005 NA
			L192 W113 D61	334	Case BIM5006 NA

VERO ELECTRONICS PRODUCTS			SWITCHES		
2.5" x 5" 1" pitch Veroboard	71	200-21069J	Miniature Toggle - Honeywell		
3.75" x 5" 1" pitch Veroboard	79	200-21072D	SPDT	C/O/H	67
2.5" x 1" 1" pitch Veroboard (5)	85/Pack	200-21076C	SPDT	Double Bus To Centre	90
3.75" x 5" 1" pitch Plain Board	68	200-21078H	DPDT		99
0.82" x 2.8" 1" pitch V-DIP Board	135	200-21084E	DPDT	C/O/H	111
Spot Face Cutter	107	200-21013A	Miniature Push - C & K		
Pin Insertion Tool For 040 type pin	147	203-21015F	SP	Push To Make, Momentary	62
DS Pin (040 1100)	44/Pack	200-21087G	SP	Push To Break, Momentary	62
SS Pin (040 1100)	44/Pack	200-21017H			
Verovene Kit (11-pin, 2-wire, 25-comb)	454/Kit	200-21341D			
Verovene Combs (25)	109/Pack	200-21339F			
Verovene Wire (2)	109/Pack	200-21340G			



**Metal Cases**



Our catalogue contains small metal enclosures for every application including the attractive new G range cases, with unique integrated chassis and sloping visor front and the inexpensive kit-form Veropak. We've also got circuit boards, accessories, module frames and plastic boxes - all to the highest standard to give your equipment the quality you demand. Send 40p to cover post and packing and the catalogue's yours.

**VERO ELECTRONICS LTD RETAIL DEPT.**  
**Industrial Estate, Chandler's Ford,**  
**Hampshire SO5 3ZR**  
**Tel: (04215) 62829**



**1**  
GENTS QUARTZ LCD, 5-function. Hours, minutes, secs, month, date, backlight.  
**ONLY £4.95**

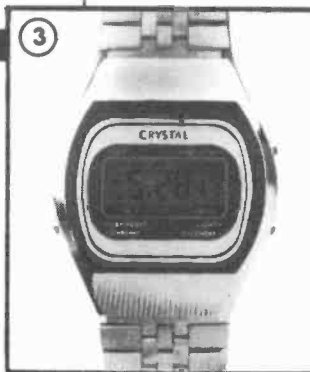
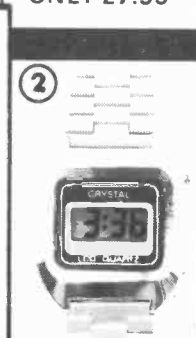
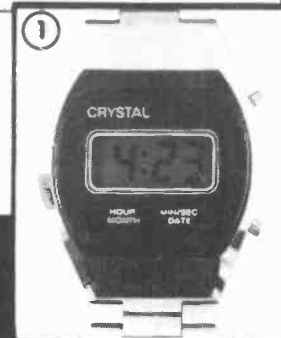
**2**  
GENTS QUARTZ LCD. SAME AS 1 - Alternative style.  
**ONLY £4.95**

**3**  
QUARTZ LCD Slim Chronograph. 11-function. Hours, mins, secs, 6 digit-month, date, day of week, 1/100 sec stopwatch, split and lap modes, backlight.  
**ONLY £7.95**

**4**  
QUARTZ LCD ALARM. 6 digit, hours, mins, secs, day, date. 24-hour alarm with on/off indicator.  
**ONLY £8.95**

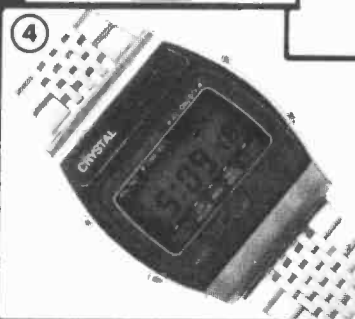
**5**  
QUARTZ LCD Alarm/Chronograph. 22 functions. Hours, mins, secs, day, date, month, 1/10 sec stopwatch, split and lap modes, 12 and 24 hour alarm.  
**ONLY £12.95**

We don't believe you can find better value combined with quality, than these - our special introductory prices. Compare the savings we offer and order now.



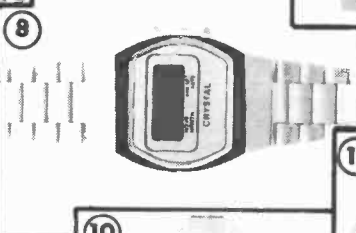
**6**  
QUARTZ LCD Musical Multi-Alarm/Chronograph. 6-digit. Hours, mins, secs, day, date, 1/100 second stopwatch, split and lap modes, 24 hour alarm, dual time zone.  
**ONLY £13.45**

**14** CREDIT CARD CALCULATOR. Very slim with standard 4 functions plus memory, percentage and square root. Complete with a mock leather wallet with credit card pocket.  
**ONLY £6.95**



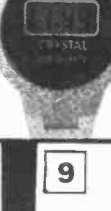
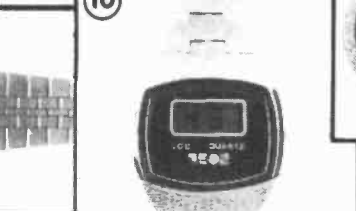
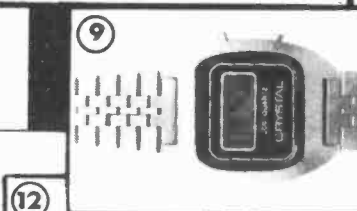
**7** SINCLAIR PROGRAMMABLE SCIENTIFIC CALCULATOR  
Genuine programmable model using micro processor technology, this amazing device is more like a computer than a calculator. Complete with programme library book containing approx. 370 programmes for ELECTRONICS, MATHS, PHYSICS, ENGINEERING ETC. Limited quantity available.  
**ONLY £7.95**  
+ 75p carriage.

**13** BELTIME 29F. Alarm/Chrono. Advanced and accurate, this watch has 8 time functions, 4 alarm functions and 17 chronograph functions. Complete with backlight and stainless steel bracelet.  
**ONLY £19.95**



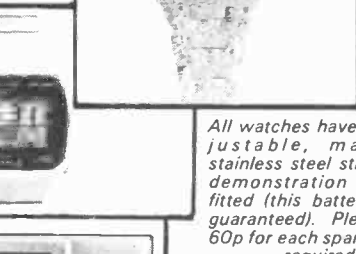
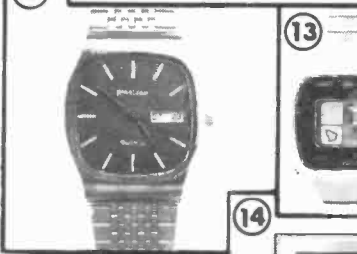
**8** LADIES QUARTZ LCD. 5-function as Gents No. 1. Available with black or white face.  
**ONLY £5.95**

**12** GENTS ANALOGUE QUARTZ. Conventional display, accuracy normally associated with digital watches. Automatic calendar, elegant and robust.  
**ONLY £19.95**



**9** LADIES QUARTZ LCD. SAME FUNCTIONS AS 8. - Alternative style. Available with black or white face.  
**ONLY £5.95**

**11** LADIES QUARTZ LCD SAME AS 10. Alternative "Round" shape. Available in gold or silver colour.  
**ONLY £8.95**



**10** LADIES QUARTZ LCD. 5 functions. Dress Style. Functions same as 1. Available in gold or silver colour.  
**ONLY £8.95**



All watches have fully adjustable, matching stainless steel straps, and demonstration battery fitted (this battery is not guaranteed). Please add 60p for each spare battery required.

All products carry a Full 7-Day Money-Back Reassurance, plus 12-Month Guarantee. Prices include VAT.

Send stamped addressed envelope for Colour Brochure of 120 other bargains.

**KEELMOOR LTD**

78 CASTLE STREET,  
MELBOURNE, DERBY,  
DE7 1DY

Please send me items..... (list numbers)

I enclose cheques/P.O.s for £.....

NAME.....

ADDRESS.....

Please add 35p P/P per item

EE 4



## RUN YOUR HOME BY REMOTE CONTROL

How many times have you considered building a remote control project for the home but were put off by the dozens of ICs, special coils, lenses and other hard to get components, not to mention the need for a well equipped lab. to set the unit up. T. K. ELECTRONICS have changed all that. Three ICs can build a sophisticated system that requires only a capacitor and resistor to set the clock frequency (which can drift by up to 20% without affecting performance). Control radios, hi-fi (including bass, treble and volume), lighting, toys, garage doors, etc. Still not convinced?

Then look at the prices!

LD271	IR Emitting Diode	36p
SFH205	Photodiode Detector	95p
SL460	IC Pulse Amplifier	£1.70
SL490	Keyboard Controlled Encoder/Transmitter	£2.40
ML922	10-channel Receiver & 3 Analogue Outputs	£4.20
ML926	16-channel Receiver (4 Momentary binary outputs)	£1.40
ML928	16-channel Receiver (4 latched binary outputs)	£1.40

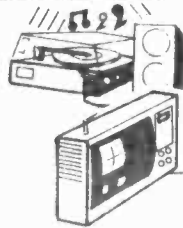
Data sheets (per device) £1.50

These ICs can also be used with ultrasonic and radio links, depending on range, cost and speed of operation. For more details, why not give us a ring—or send sae. We will be pleased to advise you.

### NEW KIT ★★ ★ NEW KIT ★★ ★ NEW KIT

If you do not require a sophisticated multi-channel remote control, we have developed a simple single-channel ON/OFF infra red transmitter and receiver. The transmitter unit comes complete with a hand held box and requires a PP3 (9V) battery. The receiver includes a triac capable of switching up to 500W at 240V a.c. and comprises a reamplifier bistable latch and a mains power supply, making the unit completely self-contained. The small size of the receiver enables the unit to be "built into" all kinds of equipment from lamps to tape recorders. The minimum range is 20 feet. A suitable box for the receiver is available if required.

ONLY £12.00



### DISPLAY LIGHTING KITS

Each unit has 4 channels (rated at 1KW at 240V per channel) which switch lamps to provide sequencing effects, controlled manually or by an optional opto-isolated audio input.

#### DL1000K

This kit features a bi-directional sequence, speed of sequence and frequency of direction change being variable by means of potentiometers. Incorporates master dimming control. £14.60

#### DL21000K

A lower cost version of the above, featuring unidirectional channel sequence with speed variable by means of a preset pot. Outputs switched only at mains zero crossing points to reduce radio interference to minimum. £8.00  
Optional Opto Input DLA1 60p

### TRIACS



400V Plastic Case (Texas)			
3A	49p	16A	90p
8A	58p	20A	165p
12A	70p	25A	190p
6A with trigger	80p		
8A isolated tab	82p		
Diac	18p		

### MINI KITS

These KITS form useful subsystems which may be incorporated into larger designs or used alone. Kits include PCB short instructions and all components.

#### TEMPERATURE CONTROLLER/THERMOSTAT

Uses LM3911 IC to sense temperature (80°C max.) and triac to switch heater. PCB (4 cm. sq.) potentiometer, plus all other components included with instructions. £2.60  
500W £3.20 1KW £3.50.

#### SOLID STATE RELAY

Ideal for switching motors, lights, heaters etc. from logic. Opto isolated with zero voltage switching. Supplied without triac. Select the required triac from our range. £2.60

#### BAR/DOT DISPLAY

Displays an analogue voltage on a linear 10-element LED display as a bar or single dot. Ideal for thermometers, level indicators etc. May be stacked to obtain 20 to 100 element displays. Requires 5-20V supply. £4.75

#### BURST FIRE/PROPORTIONAL TEMPERATURE CONTROLLER

Based on the TDA 1024 Zero Voltage Switch this kit contains all the components required to make a "burst fire" power controller or a "proportional temperature" controller enabling the temperature of an enclosure to be maintained to within 0.5°C.  
1.5KW £5.25 3KW £5.55

### INTEGRATED CIRCUITS

555 Timer	21p
741 Op. Amp	19p
AY-5-1224 Clock	£2.60
AY-5-1230/2 Clock/Timer	£4.20
AY-3-1270 Thermometer	£8.20
ICL7106 DVM (LCD drive)	£1.40
LM377 Dual 2W Amp	£1.45
LM379S Dual 6W Amp	£3.50
LM380 2W Audio Amp	80p
LM382 Dual low noise preamp	£1.00
LM386 250mW low voltage amp	75p
LM1830 Fluid Level Detector	£1.50
LM2907 LV Converter	£1.40
LM3909 LED Flasher/Oscillator	55p
LM3914 Thermometer	£1.20
LM3914 Dot/Bar Driver	£2.10
MM57160 (sac) Timer	£5.90
MM74C911 4-digit display controller	£6.50
MM74C915 7-segment-BCD converter	96p
MM74C925 4-digit counter with 7-seg outputs	£4.50
S566B Touchdimmer	£2.50
S9263 Touchswitch 16-way	£4.35
TBA800 5W Audio Amp	58p
TBA810AS 7W Audio Amp	85p
TDA1024 Zero Voltage Switch	£1.90
TDA2020 20W Audio Amp	£2.85
ZN1034E Timer	£1.80

All ICs supplied with data & circuits. Data sheets only 5p.

### LIGHTING CONTROL KITS

Directly replace conventional light switch and control up to 300W of lighting. No mains rewiring. Insulated touchplates. Easy to follow instructions.

TD300K TOUCHDIMMER. Single touchplate with alternate action. Brief touch switches lamp on and off, longer touch dims or brightens lamps. Neon lamp helps find the switch in the dark. £6.50  
TDE/K Extension kit for TD300K for 2-way switching etc. £1.50  
TSD300K — TOUCHSWITCH & DIMMER. Single touchplate, small knob controls brightness. £6.50  
TSA300K — AUTOMATIC. Single touchplate. Time delay variable 2 secs. to 3 mins. £4.30  
LD300K — LIGHTDIMMER KIT. £2.90

### 24hr CLOCK/APP. TIMER KIT

Switches any appliance up to 1KW on and off at preset times once per day. Kit contains: AY-5-1230 IC, 0.5" LED display, mains supply, display drivers, switches, LEDs, trinc, PCBs & full instructions. £14.90

CT1000K Basic Kit	£14.90
CT1000KB with white box (56/131 x 71mm)	£17.40
Ready Built	£22.50

### MINI TRANSFORMERS



Standard mains primaries 240V a.c.  
100mA secondaries

6-0-6V	80p
0-0-9V	85p
12-0-12V	90p

### D.I.L. I.C. SOCKETS

8 pin	8p	18 pin	71p
14 pin	12p	28 pin	24p
16 pin	14p	40 pin	35p

### TK'S SPECIAL OFFERS OF THE MONTH

Orders must be received by 30/9/80.

5X TIC 106D 5A/400V SCR	£1.75
5X TIC 206D 3A/400V TRIAC	£2.00
5X TIC 226D 8A/400V TRIAC	£2.50
10X Rectangular Green LED	£1.75
10X Rectangular Yellow LED	£1.75
5X 78 LIS 12V 100mA regulator	£1.10
5X 7805 5V 1A regulator	£2.25

All components brand new and to specification. Add V.A.T. AT CURRENT RATE TO ABOVE PRICES PLUS 35p P. & P. Mail Order. Callers welcome by appointment.

BARCLAYCARD

VISA

T.K. ELECTRONICS (PE) 106 Studley Grange Road, London W7 2LX Tel. 01 579 5794

## KITS FOR SOUND EFFECTS AND OTHER PROJECTS

# PHONOSONICS

DEPT EE88, 22 HIGH STREET, SIDCUP, KENT DA14 6EH

MAIL ORDER SUPPLIERS OF QUALITY PRINTED CIRCUIT BOARDS, KITS AND COMPONENTS TO A WORLD-WIDE MARKET.

#### P.E. AUTO-WAH UNIT

Automatic Wah or Swell sounds with each note played. Basic comps, PCB & chart KIT 58-1 £9.68  
Text photocopy 58

#### ELEKTOR CHOROSYNTH

A 2½-Octave Chorus synthesiser with an amazing variety of sounds ranging from violin to cello and flute to clarinet, amongst many others. Experienced constructors can readily extend the octave coverage. Basic comps, PCBs & charts KIT 100-8 £44.39  
Text photocopy 70

#### ELEKTOR FUNNY TALKER

Incorporates a ring modulator, chopper and frequency modulator to produce fascinating sounds when used with speech and music signals. Basic comps, PCB (as publ.) KIT 99-1 £9.60  
Text photocopy 40

#### ELEKTOR FREQUENCY DOUBLER

For use with guitars and other electronic instruments to produce an output 1 octave higher than the input. Inputs and outputs may be mixed to give greater depth. Basic comps, PCB (as publ.) KIT 98-1 £5.48  
Text photocopy 20

#### P.E. SPLIT-PHASE TREMOLO

Simple but effective substitute for a rotary cabinet. An internal generator is phase-split and modulated by the music input signal and fed to 1 or 2 amplifiers. Suitable for electronic guitars and other instruments. Basic comps, PCB & chart KIT 102-3 £17.58  
Text photocopy 65

#### P.E. PHASER

An automatic 6-stage phasing unit with integral oscillator. Set of basic comps, PCB & chart KIT 88-1 £10.69  
Text photocopy 68

#### ELEKTOR PHASING & VIBRATO UNIT

Includes manual and automatic control over the rate of phasing & vibrato, and has been slightly modified to also include a 2-input mixer stage. Set of basic comps, PCB & layout chart KIT 70-2 £21.87  
Text photocopy 67

#### P.E. PHASING UNIT

A simple but effective manually controlled phasing unit. Set of basic comps PCB & chart KIT 25-1 £4.06  
Text photocopy 28

#### P.E. SWITCHED TONE TREBLE BOOST

Provides switched selection of 4 preset tonal responses. Set of basic components, PCB & chart KIT 89-1 £4.34  
Text photocopy 78

#### P.E. SMOOTH FUZZ

Set of basic components, PCB & chart KIT 91-1 £6.40  
Text photocopy 55

#### P.E. TUNING FORK

Produces 84 switch-selected frequency-accurate tones with an LED monitor clearly displaying beat-note adjustments. Set of basic comps, PCB & chart KIT 46-3 £23.32  
Text photocopy 87

#### P.E. CONSTANT DISPLAY FREQUENCY COUNTER

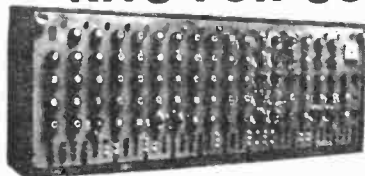
An improved version of the project published in P.E. Readout does not count visibly or flicker due to blanking. Set of basic components & PCB KIT 79-4 £31.35  
Text photocopy 78

#### DYNAMIC NOISE LIMITER

Effectively reduces tape-recording hiss. Stereo Unit. Set of basic components, PCB & chart KIT 97-1 £8.07  
Text photocopy 75

#### MANY MORE KITS

for synthesisers, Rhythm Generators, Electronic Pianos and other projects, big, small, simple or complex, are available, plus a range of keyboards, separate components and accessories. Details in our lists.



#### P.E. MINISONIC MK2 SYNTHESISER

A portable mains operated miniature sound synthesiser with keyboard circuits. Although having slightly fewer facilities than the large Formant and P.E. synthesisers the functions offered by this design give it great scope and versatility. Set of basic component kits (excl. KBD R's & tuning pots—see list for options available) and PCBs (Incl. layout charts) KIT 38-25 £80.12  
£1.00

#### "Sound Deslgn" booklet

#### P.E. 128-NOTE SEQUENCER

Enables a voltage controlled synthesiser to automatically play pre-programmed tunes of up to 32 pitches and 128 notes long. Programs are keyboard initiated and note length and rhythmic pattern are externally variable. Basic comps, PCBs & charts KIT 76-7 £35.56  
Set of text photocopies £1.36

#### P.E. GUITAR EFFECTS PEDAL

Modulates the attack, decay and filter characteristics of a signal from most audio sources, producing 8 different switchable effects that can be further modified by manual controls. Basic parts, PCB & chart KIT 42-3 £10.37  
Text photocopy 28

#### P.E. GUITAR OVERDRIVE

Sophisticated versatile fuzz unit including variable controls affecting the fuzz quality whilst retaining the attack and decay, and also providing filtering. Can be used with other electronic instruments. Basic parts, PCB & chart KIT 56-3 £11.82  
Text photocopy 68

#### P.E. GUITAR SUSTAIN

Maintains the natural attack whilst extending note duration. Basic comps, PCB & chart KIT 75-1 £6.73  
Text photocopy 38

#### P.E. WAH-WAH UNIT

Can be controlled manually or by integral automatic control. Set of basic components, PCB & chart KIT 51-1 £4.93

**COMPONENT SETS** Incl all necessary res, caps, s/cs, pots, t/formers. Hardware such as cases, skts, knobs, kbds, etc, are not incl, but most can be bought separately. Fuller details in lists.

#### ADD 15% VAT

(or current rate if changed). Must be added to full total of goods, post & handling on all U.K. orders. Does not apply to exports, or to photocopies.

50p for cover up to £50, £1 for £100 cover, etc., pro-rata, must be added to credit card orders. N.B. Eire, C.L., B.F.P.O. and other countries are subject to higher rates.

ADD 15% VAT (or current rate if changed). Must be added to full total of goods, post & handling on all U.K. orders. Does not apply to exports, or to photocopies.

**LIST:** Send stamped addressed envelope with all U.K. requests for free list giving fuller details of our goods. Europe send 35p, other countries send 75p, or equivalent in international reply coupons

**TERMS: C.W.O., MAIL ORDER OR COLLECTION BY APPOINTMENT (TEL: 01-302 6184)**



### SIX DIGIT COUNTERS

One pulse moves one digit—Type 1 for 230V AC not resettable. Price 80p—Type 2 for 48V DC or 115V AC and resettable £1.35.



### PUNCHED TAPE EQUIPMENT

for controlling machine tools etc. motorised 8 bit punch with matching tape reader. Ex-computers, believed in good working order, any not so would be exchanged, £15 the pair. Carriage £3.

### SIREN OR BLEEPER

American Delta mechanical type, works on 6 to 12v to DC or 12 to 24v AC. Price 75p or £80 per 100. Electronic Bleeper TH3S emits high pitched wailing note of varying pitch. In red plastic case with fixing bracket. £5.00.



### CASSETTE PLAYER/RECORDERS

With record and playback heads, all electronics, switches and speaker. Price £9.95 (surely this must be the bargain of the year). Music centre replacement stereo with heads but not electronics. £14.95.

### FRUIT MACHINE HEART

4 wheels with all fruits, motorised and with solenoids for stopping the wheels, with a little ingenuity you can defy your friends getting the "jackpot". £9.95 + £4 carriage.

### DESOLDERING PUMP

Ideal for removing components from computer boards as well as for service work generally. Price £6.35.



### 4 CORE FLEX CABLE

White pvc for telephone extensions, disco lights etc. 10 metres £2, 100 metres £15. Other multicore cable in stock.

### HEADPHONE AMPLIFIER (STEREO)

With volume, tone and balance control 9v operation. All made up ready to go. Price £4.50.



### MUGGER DETERRENT

A high note bleeper, push latching switch, plastic case and battery connector. Will scare away any villain and bring help. £2.50 complete kit.

### RELAYS

Open type with 2, 10 amp c/o contacts—single screw fixing £1.25 each, please state the coil voltage you require.

### HUMIDITY SWITCH

American made by Honeywell. The action of this device depends upon the dampness causing a membrane to stretch and trigger a sensitive micro-switch, very sensitive—breathing on it for instance will switch it on. Micro 3 amp. at 250V a.c. Only £1.15.



### SAFE BLOCK

Mains quick connector will save you valuable time. Features include quick spring connectors, heavy plastic case and auto on and off switch. Complete kit £1.95.

### VERSA DRILL

A 12 volt battery operated power drill, not just suitable for printed circuit boards but will do all the jobs and is powerful enough to perform all the functions and operations normally expected of Black & Decker and other mains drills. Its chuck accepts up to 1/2" drills. Size approx. 150mm x 50mm. Price £16.75.



### TWIST DRILLS

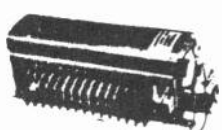
Precision Swiss made—normal price 50p each 10 diff. sizes covering 1/8" to 1/2". £1.99 the lot—don't miss this super bargain.

### V3 MICROSWITCHES

Over 50,000 in stock all 250 AC working, with 3 silver contacts for c/o circuits—10 amp 25p each or £20 per 100, 15 amp 35p each or £30 per 100.

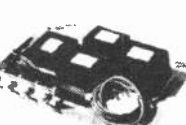
### MOTORISED DISCO SWITCH

With 10 amp changeover switches. Multi adjustable switches are rated at 10 amps. This would provide a magnificent display. For mains operating, 8 switch model £6.25, 10 switch model £6.75, 12 switch model £7.25.



### MULLARD UNILEX

A mains operated 4+4 stereo system. Rated one of the finest performers in the stereo field this would make a wonderful gift for almost anyone. In easy-to-assemble modular form this should sell at about £30—but due to a special bulk buy and as an incentive for you to buy this month we offer the system complete at only £16 including VAT and postage. FREE GIFT—Buy this month and you will receive a pair of Goodman's elliptical 8" x 5" speakers to match this amplifier.



### NEW KITS

**5 WAVE BAND SHORT WAVE KIT** Bandspeed covering 13.5 to 52 metres. Complete kit includes case, materials, six transistors and diodes, condensers, resistors, inductors, switches etc. Nothing else to buy. If you have an amplifier to connect it to or a pair of high resistance headphones. Special price is £11.95 inc.

**SUB-MIN MICROPHONE** Size only 1 1/2" x 1 1/2" x 3/16" so small enough for a bugging device, ex-hearing aids but guaranteed. Price £1.50.

**TRANSMITTER SURVEILLANCE** Tiny, easily hidden but which will enable conversation to be picked up with FM radio. Can be made in a matchbox—all electronic parts and circuit. £2.00.

**RADIO MIKE** Ideal for discos and garden parties, allows complete freedom of movement. Play through FM radio or tuner amp. £6.50.



### DRILL CONTROLLER

Electrically changes speed from approximately 10 revs to maximum. Full power at all speeds by finger-tip control. Kit includes all parts, case, everything and full instructions. £3.45 Made up model £11.00 extra

**VENNER TIME SWITCH** mains operated with 20 amp switch, one on and one off per 24 hrs. repeats daily automatically correcting for lengthening or shortening day. An expensive time switch but you can have it for only £2.95. These are new but without case, but we can supply plastic cases (base and cover) £1.75 or metal case with window £2.95. Also available is adaptor kit to convert this into a normal 24 hr. time switch but with the added advantage of up to 12 on/off's per 24 hrs. This makes an ideal controller for the immersion heater. Price of adaptor kit is £2.30.



### THIS MONTH'S SNP MULLARD STEREO DECODER MODULE

Mullard Reference No. LP 1401. This ready made-up and tested unit is suitable for almost any tuner or radio, feeding a stereo amplifier. £2.00 + 30p (complete with connection diagram. Beacon lamp indicator can be supplied at an extra 50p.

### SOUND AND LIGHT UNITS

**3 CHANNEL SOUND TO LIGHT KIT** Complete kit of parts for a three channel sound to light unit controlling over 2000 watts of lighting. Use this at home if you wish but it is plenty rugged enough for Disco work. The unit is housed in an attractive two-tone metal case and has controls for each channel, and a master on/off. The audio input and output are by 1/2" sockets and three panel mounting fuse holders provide thyristor protection. A four pin plug and socket facilitate ease of connecting lamps. Special snip price is £13.50 in kit form or £16.50 assembled and tested.

**REMOTE CONTROL** for Sound to Light (ours or any other circuit) saves connecting to speaker or amp—kit consists of 1 watt amplifier, crystal mike, case, sundries and diagram. Price £3.95.

**LIGHT EXPANDER AND LATCH** for Sound to Light, enables 3000 watts of lighting to be controlled by single channel or each channel and enables lights to be latched on. Kit consists of latching relay, control switch, case, sundries and diagram. Price £4.25.

**SINGLE CHANNEL KIT** still available. Price £5.18

### DELAY SWITCH

Mains operated—delay can be accurately set with pointers knob for periods of up to 2 1/2 hrs. 2 contacts suitable to switch 10 amps—second contact opens a few minutes after 1st contact. £1.50.



### MINI-MULTI TESTER

Deluxe pocket size precision moving coil instrument, jewelled bearings—2000 o.p.v. mirrored scale.

11 instant ranges measure:—DC volts 10, 50, 250, 1000. AC volts 10, 50, 250, 1000. DC amps 0-100 mA. Continuity and resistance 0-1 meg ohms in two ranges. Complete with Test Prods and instruction book showing how to measure capacity and inductance as well. Unbelievable value only £6.75 + 50p post and insurance.

**FREE Amps ranges** kit to enable you to read DC current from 0-10 amps, directly on the 0-10 scale. It's free if you purchase quickly but if you already own a mini tester and would like one, send £2.50.

**TERMS:** Cash with order—but orders under £10 must add 50p to offset packing, etc. **BULK ENQUIRIES INVITED. PHONE: 01-688 1833. ACCESS & BARCLAYCARD ACCEPTED.**

## J. Bull [ELECTRICAL] Ltd.

(DEPT. (EE7))

34-36 AMERICA LANE,  
NEW ENGLAND ROAD,  
HAYWARDS HEATH SUSSEX.  
RH16 3QU

### BURGLAR ALARM CONTROL PANEL

Contains labelled connection block, latching relay, test switch and removable key control switch. Simplifies the whole installation—clear dials have to do is to take wires to pressure pads and to alarm bell. Price £6.00 + 90p. With complete diagram.

### PRECISION MAINS OPERATED CLOCK

For only £1.50 + 22p. Sounds unbelievable but that's what you can have if you send your order right away. The clocks which have the clear dials were made by the famous Smiths Company for use with their domestic cooker switch and are brand new and guaranteed.

### 15-0-15V @ 2 AMP MAINS TRANSFORMER

Mains transformer, upright mounting primary and secondary wound on separate bobbins with fixing lugs. Price £3 + 45p. Post 60p.

### 25-0-25V @ 750 mA MAINS TRANSFORMER

Mains transformer C core construction, heavily varnished for dead quiet operation. Upright mounting with fixing lugs. Price £2.75 + 41p. Post 50p.

### 25 WATT MID-RANGE SPEAKER 3 1/2"

Made by Goodmans so there's none better. 4 ohm coil. Price £3.50 + 45p. Post £1.00.

### 8 OHM TWEETER

Made by Goodmans. 3 1/2" square, 4" across fixings. Price £1.50 + 22p. Post 30p.

### ROTARY SOLENOID

As most customers know we have solenoids of the normal types for pulling and pushing through a magnetic assembly. We have now acquired some which have a rotating action, D.C. operated. A shaft which comes out of the centre, rather like a motor spindle, travels approx. 90°. Price £5 + 75p.

### WATERPROOF HEATING WIRE

As used for electric blankets, etc. This has dozens of other applications—in gloves or socks for people with poor circulation are obvious uses. One unusual use suggested by a customer is a 'grow' bag heater. The wire which consists of an element wound on glass fibre then PVC covered has a resistance of 60 ohms per yard. The price is 20p + 3p per yard.

**TELEPHONE PICK-UP** coil attaches by suction to phone body, enabling conversation to be recorded, put through amp or headphones. Price £1 + 15p.

### TRANSDUCERS

As used remote control T.V. receivers. Price £1.50 + 22p.

### LIGHT CHASER

Gives a brilliant display—a psychedelic light show for discos, parties and pop groups. These have three modes of flashing, two chase-patterns and some which have a rotating action, 750 watts per channel. Complete kit. Price £14 + £2.10. Ready made up for £4 extra.

### PRINTED CIRCUIT KIT

4 copper plated boards and the chemical for etching the printed circuits, also 50 interesting designs of all sorts of electronic gadgets which can be made on these boards. Price £1.70 + 30p.

**MAINS TRANSISTOR POWER PACK** to operate transistor radio, cassettes, amplifiers, etc. take the place of any of the following batteries, PP1, PP3, PP4, PP6, PP9 and others. You can make voltage output anything from 3v to 16v at up to 300 mA. Complete kit but no case £1.75 + 26p. Case 75p + 13p.

### TELESCOPIC AERIAL

5 sections, 21" when extended. Nickel plated superior make, one nut fixing, folds over for FM. Price 95p + 15p.

**FISH BITE INDICATOR** enables anglers to set up several lines then sit down and read a book. As soon as one has a bite the loudspeaker emits a shrill note. Kit. Price £4.50 + 65p.

### 6 WAVEBAND SHORT WAVE RADIO KIT

Brandspeed covering 13.5 to 52 metres. Based on circuit which appeared in a recent issue of Radio Constructor. Complete kit—includes case materials, six transistors and diodes, condensers, resistors, inductors, switches, etc. Nothing else to buy, if you have an amplifier to connect it to or a pair of high resistance headphones. Special price to get this kit off the ground. is £11.95 inc VAT and postage.

### 3" EDGEWISE PANEL METER

0-25 mA moving coil made for the G.P.O. A very useful instrument especially when panel space is limited. £2.50 + 30p.

### U.V. LAMPS

Can add a touch of novelty to a party or disco. We have in stock the Atlas 175 watt U.V. Lamps. These plug straight into a lampholder and need no control or starter gear. This is a black lamp about the size of the old-fashioned 200 watt lamp. Price £9.00 + £1.35p.

### PANEL METER 0-1mA

Japanese made full vision perspex front, flush mounting. Price £3 + 45p.

### 12v SUBMERSIBLE PUMP

Our drill pump is useful, but this new one is even more so. Just join it to your car battery, drop it into the liquid to be moved and up it comes, no messing about, no priming, etc. and you get a very good head. Suitable for water, paraffin and any non-explosive, non-corrosive liquid. One use if you are a camper, make yourself a shower. Price £8 + 90p. A free gift, first 100 purchasers will get tap with built in switch and length of plastic tubing.

**E.H.T. MAINS TRANSFORMER** with inductance control, normal primary, secondary output by our equipment, 3.5 kv 3 mA. E.H.T. voltage can be varied by applying a DC voltage to the lower normally unused bobbin. We are not sure how much the voltage may be increased or decreased but using a 9 volt battery we seem to get a rise or fall of about 30 volts. Ex unused P.S.U.'s. Price £2 + 30p. Post 40p.

### SHORT WAVE CRYSTAL RADIO

All the parts to make up the beginners model. Price £2 + 30p. Crystal earpiece 57p + 8p. High resistance headphones (give best results) £3.25 + 50p. Kit includes chassis and front but not case.

### RADIO STETHOSCOPE

Easy way to fault find—start at the aerial and work towards the speaker—when signal stops you have found the fault. Complete kit £4.25 + 65p.

### INTERRUPTED BEAM KIT

This kit enables you to make a switch that will trigger when a steady beam of infra-red or ordinary light is broken. Main components—relay, photo transistor, resistors and caps, etc. Circuit diagram but no case. Price £2 + 30p.

**EDITOR**

F. E. BENNETT

**ASSISTANT EDITOR**

B. W. TERRELL B.Sc.

**PRODUCTION EDITOR**

D. G. BARRINGTON

**TECHNICAL SUB-EDITOR**

S. E. DOLLIN B.Sc.

**ART EDITOR**

R. F. PALMER

**ASSISTANT ART EDITOR**

P. A. LOATES

**TECHNICAL ILLUSTRATOR**

D. J. GOODING

**EDITORIAL OFFICES**

Kings Reach Tower,  
Stamford Street,  
London SE1 9LS  
Phone: 01-261 6873

**ADVERTISEMENT MANAGER**

R. SMITH  
Phone: 01-261 6871

**REPRESENTATIVE**

N. BELLWOOD  
Phone: 01-261 6865

**CLASSIFIED MANAGER**

C. R. BROWN  
Phone: 01-261 5782

**MAKE-UP AND COPY DEPARTMENT**

Phone 01-261 6615

**ADVERTISEMENT OFFICES**

Kings Reach Tower  
Stamford Street,  
London SE1 9LS

# Projects... Theory ... and Popular Features ...

This month TTL logic provides a link between three different projects. These projects moreover illustrate how self-supporting, and even self-sufficient, our hobby can be. So let's consider each in turn.

First there is the *Duo-Deci Timer*. A useful item of equipment and a typical "end-product" of a building session. This instrument will find many applications around the home, perhaps in the kitchen or maybe in the photographer's darkroom, but there are numerous other uses of course.

Whilst building this timer it would be helpful or, at least instructive, to check out the operation of the logic circuitry. But the constructor does not have to go and buy an expensive instrument, he simply sets to and makes one. For the second project in our TTL linked trio happens to be a *TTL Logic Probe*.

This handy little instrument will prove indispensable to all who build and experiment with TTL logic circuits. It enables one to ascertain the state of the logic ("high" or "low") at any point, under working conditions. Worthy also of a mention is the homely touch introduced by the adaptation of a Multicore solder dispenser as the probe case. (How's that for conservation as well as self-sufficiency!)

Now the *Duo-Deci Timer*, like many other projects, is designed to operate

from a battery. But if one prefers, a mains power supply unit can be used instead. That is just one possible use for the remaining item of our trio, the *TTL Power Supply Unit*.

Designed to provide the maximum voltage needed for TTL devices, this compact unit will be an asset on the workbench, especially when running dynamic tests on TTL circuit hook-ups, or on completed projects. Or it may be employed as a permanent source of power in place of a battery.

Test equipment and power supplies are essential ancillaries in the hobbyist's workshop. They play their part during the creation of other—perhaps more imposing and more splendid—projects, destined in all probability for use away from the workshop and by "non-electronics" persons.

The fact that they are home-made gives added cause for pride of possession, and substantiates the claim that electronics is to a considerable degree self-supporting.

Sorry to finish on this note, but the price of EE will regrettably be increased to 60p as from the next issue (October). This is necessary because of increasing costs affecting the publishing business in general.



Our October issue will be published on Friday, September 19. See page 569 for details.

**Readers' Enquiries**

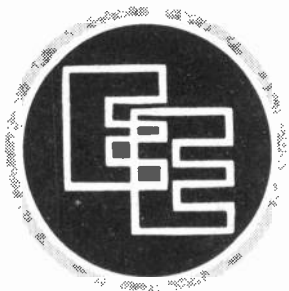
We cannot undertake to answer readers' letters requesting modifications, designs or information on commercial equipment or subjects not published by us. All letters requiring a personal reply should be accompanied by a stamped self-addressed envelope.

We cannot undertake to engage in discussions on the telephone.

**Component Supplies**

Readers should note that we do not supply electronic components for building the projects featured in **EVERYDAY ELECTRONICS**, but these requirements can be met by our advertisers.

All reasonable precautions are taken to ensure that the advice and data given to readers are reliable. We cannot however guarantee it, and we cannot accept legal responsibility for it. Prices quoted are those current as we go to press.



# ELECTRONICS

VOL. 9 NO. 8

SEPTEMBER 1980

## CONSTRUCTIONAL PROJECTS

<b>BEDSIDE RADIO</b> Medium wave radio with up to 17 minutes "snooze" facility by R. A. Penfold	548
<b>DUO-DECI TIMER</b> Two range timer, 0 to 99 minutes by F. G. Rayer	554
<b>TTL LOGIC PROBE</b> Detects high and low logic levels and pulses by A. Wheen	566
<b>WEATHER CENTRE</b> Part 2: Mechanical construction, interwiring and setting-up by F. C. Judd	570
<b>LIGHTS FAILURE MONITOR</b> Instantly alerts driver of car light bulb failure by C. K. Birrell	580
<b>PRECISION PARKING PAD</b> For accurate parking in the garage by T. R. de Vaux-Balbirnie	586
<b>TTL POWER SUPPLY UNIT</b> Regulated 5 volts at 1A maximum by F. G. Rayer	598

## GENERAL FEATURES

### EDITORIAL

<b>COUNTER INTELLIGENCE</b> A retailer comments by Paul Young	546
<b>SHOP TALK</b> Product news and component buying by Dave Barrington	552
<b>TEACH-IN 80</b> Part 11: Experiments	553
Part 12: This concluding article introduces the field effect transistor by S. R. Lewis B.Sc	558
<b>JACK PLUG AND FAMILY</b> Cartoon by Doug Baker	560
<b>BRIGHT IDEAS</b> Readers' hints and tips	565
<b>EVERYDAY NEWS</b> What's happening in the world of electronics	568
<b>RADIO WORLD</b> A commentary by Pat Hawker	576
<b>IN MY CLASS</b> Sir explains by T. R. de Vaux-Balbirnie	578
<b>WORKSHOP MATTERS</b> R.F. signal sources by Harry T. Kitchen	583
<b>SQUARE ONE</b> Beginners Page: Stocking-up with diodes and transistors	585
<b>FOR YOUR ENTERTAINMENT</b> Calculators; before their time; university consultants by Adrian Hope	590
<b>DOWN TO EARTH</b> Frequency modulation by George Hylton	593
	597

### Back Issues

Certain back issues\* of EVERYDAY ELECTRONICS are available worldwide price 70p inclusive of postage and packing per copy. Enquiries with remittance should be sent to Post Sales Department, IPC Magazines Ltd., Lavington House, 25 Lavington Street, London SE1 0PF. In the event of non-availability remittances will be returned.

\* Not available: October 1978 to May 1979.

### Binders

Binders to hold one volume (12 issues) are available from the above address for £4.40 (home and overseas) inclusive of postage and packing. Please state which Volume.

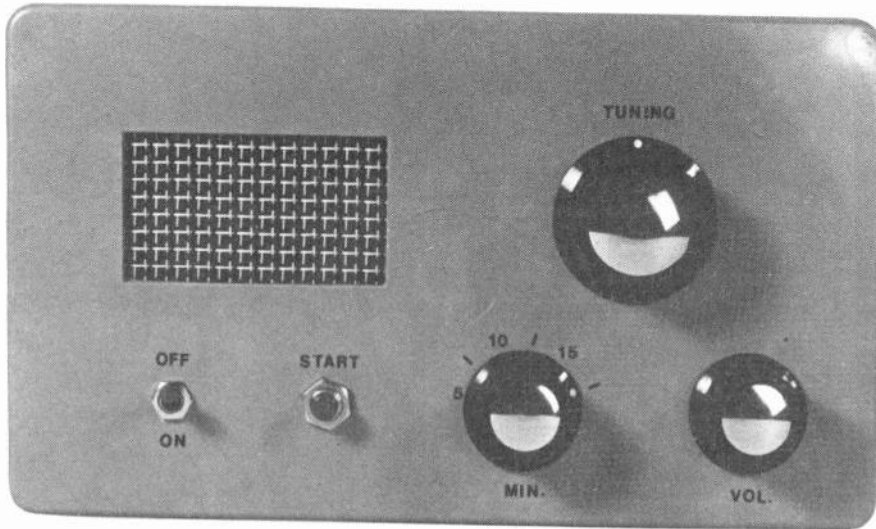
### Subscriptions

Annual subscription for delivery direct to any address in the UK: £9.00, overseas: £10.00. Cheques should be made payable to IPC Magazines Ltd., and sent to Room 2613 Kings Reach Tower, Stamford Street, London SE1 9LS.

© IPC Magazines Limited 1980. Copyright in all drawings, photographs and articles published in EVERYDAY ELECTRONICS is fully protected, and reproductions or imitations in whole or in part are expressly forbidden.

**I.C. SPECIAL**  
next month is a must  
~ see page 569

By R. A. PENFOLD



# BEDSIDE RADIO

**T**HIS two i.c. medium wave radio is primarily intended for use as a bedside set, although it can provide sufficient volume for normal domestic use.

There is an optional one i.c./one transistor timer circuit which can be used to automatically switch off the receiver after a switch-selected delay of 5, 7½, 10, 12½, 15, or 17½ minutes. This gives a simple "snooze" facility of the type fitted to many clock radios and other receivers these days.

## THE CIRCUIT

Fig. 1 shows the complete circuit diagram of the receiver including the timer circuitry. The range circuitry is shown in the inset of Fig. 1.

The r.f. and detector stages use a ZN414 i.c. (IC1) in a standard configuration. A tuned circuit is formed by L1 and C3. One end of this is coupled to earth by C2 and the other end couples into the input of IC1.

The low impedance coupling winding on the ferrite aerial is not needed because the ZN414 device has a buffer stage at the input which produces a high input impedance, and gives good results with direct connection to the ferrite aerial. The buffer stage is followed by three stages of amplification which provide a considerable amount of gain.

These are in turn followed by a transistor detector stage which has R2 as its load resistor and C4 to provide the necessary r.f. filtering. R1 is a

bias resistor. The ZN414 has a simple a.g.c. (automatic gain control) action which reduces the gain on strong signals so as to reduce the possibility of overloading and to provide a more consistent audio output level.

A nominal supply potential of 1.3V is required for the r.f. and detector circuitry. This is derived from the main 9 volt supply using a simple shunt stabiliser incorporating R3, D1, and D2, the two silicon diodes being forward biased to produce a voltage drop of 0.65V across each. The supply is decoupled by C1 and C6.

## AUDIO STAGE

A TBA820 i.c. (IC2) is used in the audio amplifier section of the receiver, and this is a type which can have its input direct coupled to the volume control. In this case the input is coupled to volume control VR1 via R4, this resistor forming an r.f. filter in conjunction with C7.

There was found to be a small amount of r.f. breakthrough and consequent instability without this additional r.f. filtering. Capacitors C9, C10, C12, plus R6 are also needed in order to ensure good stability. The audio output from IC1 to the volume control is coupled by C5 and this also provides d.c. blocking.

The output signal is coupled to the loudspeaker by way of d.c. blocking capacitor C11 and the break contact of phone socket SK1. This break con-

tact automatically switches out the loudspeaker when an earphone is in use. Both crystal and magnetic earphones are suitable.

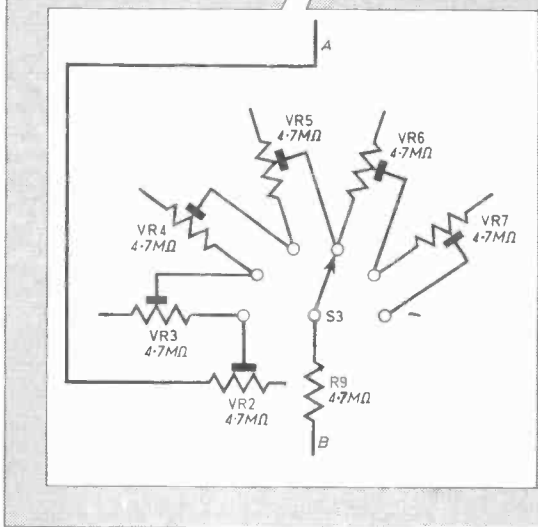
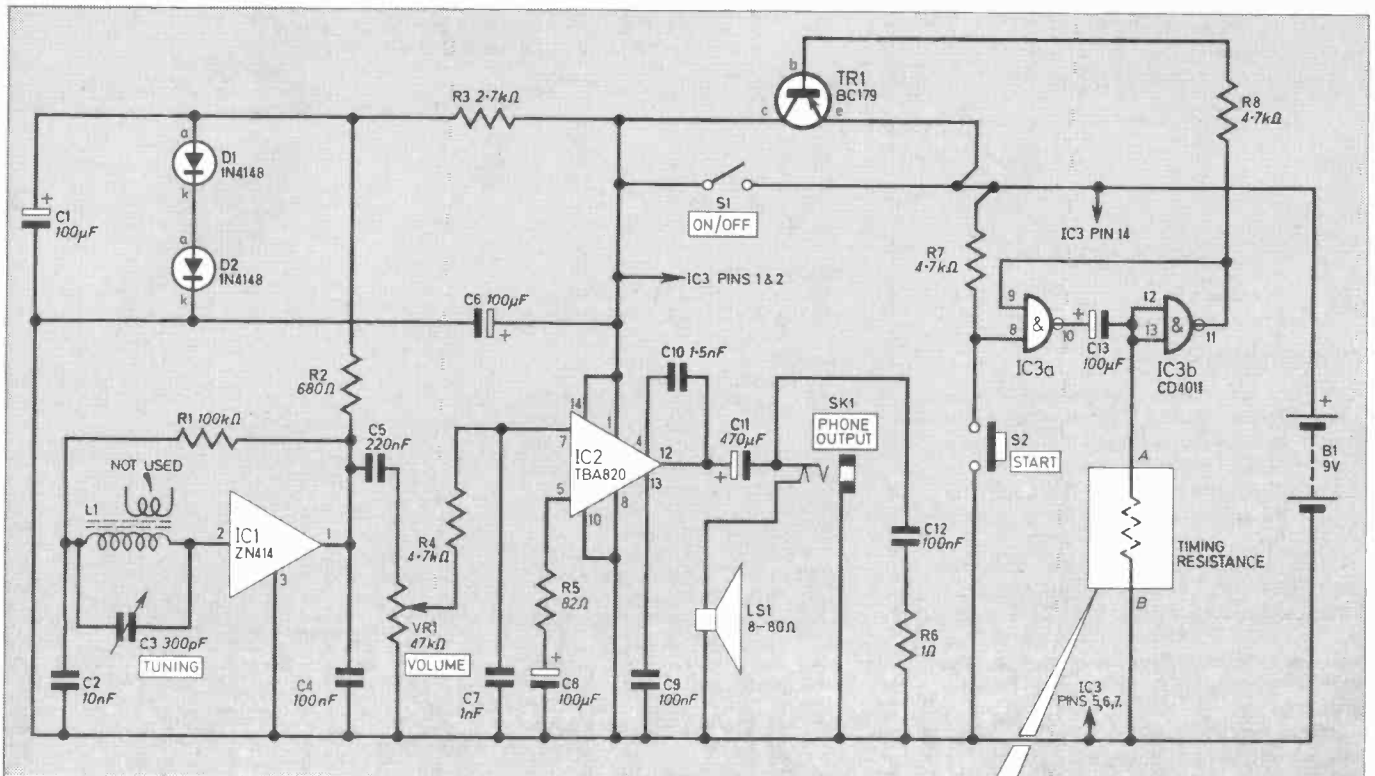
The voltage gain of the amplifier is controlled by R5, and the specified value actually gives a gain of approximately 73 times. This is sufficient to fully drive the amplifier from the signal level of about 30mV r.m.s. produced at the output of IC1.

The maximum output power is about 200mW r.m.s. or so, although it is somewhat less than this when using speakers of more than about 35 ohms impedance. The circuit will work well with any normal speaker having an impedance in the range 8 to 80 ohms.

## TIMER

It is important for the timer circuit to have a very low quiescent current consumption since it is permanently connected to the battery supply, and unlike the rest of the receiver is unaffected by on/off switch S1.

A CMOS i.c. has therefore been used as the basis of the timer as it has a stand-by current consumption of only a fraction of a microamp, and will not significantly affect battery life. Two of the four gates in a 4011 two-input NAND gate package are used in a conventional CMOS monostable circuit. The inputs of the unused gates are connected to one of the supply lines to prevent them from being spuriously operated by stray pick-up, but these gates are otherwise ignored.



### OPERATING PRINCIPLE

The two inputs of gate 2 are connected in parallel so that it works as an inverter, and its output is high since the input is taken low by the timing resistance. Transistor TR1 is fed from the output of the monostable, and is cut off when the output is in the high state.

The output of gate 1 is low because one input is taken high by R7, and the other is taken high by the output of the monostable. If either or both its inputs are taken low, however, gate 1 output will go high.

Momentarily operating S2 will indeed take one input of gate 1 low, causing its output to go high. This signal is coupled to the input of gate 2 by C13, causing its output to go low and switch on TR1 with the base current it supplies via R8. TR1 then effectively connects the positive battery terminal to the radio circuitry, and the set becomes operational.

The voltage at the negative terminal of C13 now gradually falls as this component charges up through the timing resistance. Eventually the voltage here will fall below the transition voltage of gate 2, resulting in the output reverting to the high state and the radio being switched off.

Both inputs of gate 1 are then back at the high state once again, and its output therefore returns to the low state. The circuit is now back in its original state and is ready to be started on another timing run by briefly operating S2 once again.

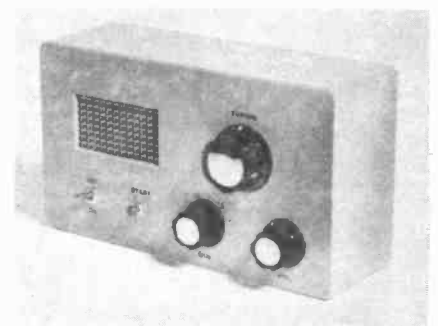
Fig. 1. Complete circuit diagram of the Bedside Radio. The resistive network which controls the time period for the automatic switch off is contained in the inset and is connected into the main circuit at the points A and B. It can also be seen that the small coupling winding on the tuning coil is not used in this design. The unused pins of IC3 are tied to the power lines to prevent spurious triggering.

### TIMING RESISTANCE

It is possible to control the time for which the set is switched on by means of the timing resistance, with the switch on time being roughly proportional to the value of this resistance.

Switch S3 provides six different resistance values, and presets are used so that these resistances can be trimmed to give the six nominal times specified at the beginning of this article.

Of course, on/off switch S1 must be in the "off" position when using the timer or S1 will keep the set switched on regardless of the timer circuit.



Front view of the Bedside Radio.

# CONSTRUCTION starts here

## COMPONENT PANEL

Most of the components are assembled on a 0.1 inch matrix strip-board having dimensions of 37 holes by 24 strips (3 $\frac{3}{4}$  x 2 $\frac{1}{2}$  inches). This is a standard size in which the board is sold. The component layout is shown in Fig. 2.

Drill the 3.3mm diameter mounting holes for the panel and the ferrite aerial, and make the 22 breaks in the copper strips before inserting and connecting the components. Be careful not to omit any of the 10 link wires.

The CMOS chip IC3 is the last component that is connected, and it should be left in its protective packaging until it is time to fit it onto the board. It should either be soldered into place using an iron having an earthed bit or it should be fitted into an i.c. socket. Handle the device as little as possible.

The Ambit ferrite aerial used in the prototype has plastic mounting clips which enable it to be easily mounted on the component panel using a couple of short M3 or 6BA bolts and fixing nuts.

A Denco MW5FR aerial also works well in this circuit, and can be mounted on the panel using a couple of 9.5mm "P" type cable clips.

## CASE

A plastics box measuring about 190 x 110 x 60mm is used as the case for the prototype. The case cannot be much smaller than this if it is to comfortably accommodate all the components, and a metal type is not suitable as it would screen the ferrite aerial and virtually eliminate any signal pick-up.

The component panel is mounted on the removable rear section of the case using a couple of M3 or 6BA fixings, but it is not finally bolted into place until it has been wired up to the rest of the receiver.

The layout of the front panel can be seen from the photographs. The rectangular cutout for the speaker can be cut using a fretsaw or a miniature file. Alternatively a grill of small holes can be drilled. A piece of speaker cloth or fret is glued over the rear of the cutout and the speaker is carefully glued onto this taking

## COMPONENTS

### Resistors

R1	100k $\Omega$	R6	1 $\Omega$
R2	680 $\Omega$	R7	4.7k $\Omega$
R3	2.7k $\Omega$	R8	4.7k $\Omega$
R4	4.7k $\Omega$	R9	4.7M $\Omega$
R5	82 $\Omega$		
All $\frac{1}{4}$ W carbon $\pm$ 5%			

### Potentiometers

VR1	47k $\Omega$ carbon log.
VR2-VR7	4.7M $\Omega$ vertical preset (6 off)

### Capacitors

C1	100 $\mu$ F 10V elect.
C2	10nF polyester type C280
C3	300pF solid dielectric variable (Jackson Dielecon or similar)
C4	100nF polyester type C280
C5	220nF polyester type C280
C6	100 $\mu$ F 10V elect.
C7	1nF ceramic plate
C8	100 $\mu$ F 10V elect.
C9	100nF polyester type C280
C10	1.5nF ceramic plate
C11	470 $\mu$ F 6.3V elect.
C12	100nF polyester type C280
C13	100 $\mu$ F 10V elect.

### Semiconductors

IC1	ZN414 tuned radio frequency i.c.
IC2	TBA820 a.f. amplifier i.c.
IC3	CD4011 CMOS quad 2-input NAND gate
TR1	BC179 <i>npn</i> silicon
D1, 2	1N4148 small-signal silicon diode (2 off)

### Switches

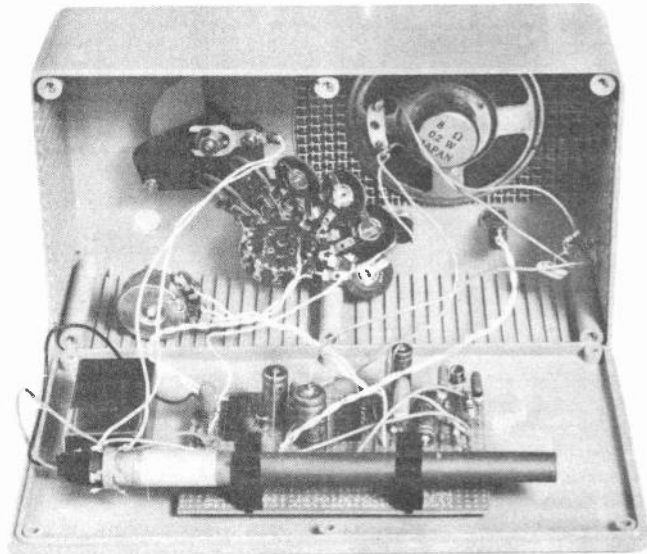
S1	s.p.s.t. miniature toggle
S2	push-to-make, release-to-break
S3	2-pole, 6-way rotary type

### Miscellaneous

B1	9V type PP3
LS1	miniature moving coil loudspeaker, 8 to 80 $\Omega$ impedance
SK1	3.5mm jack socket with single break contact
L1	Aerial coil, Ambit type MCW2 or Denco type MW5FR, or any other m.w. ferrite aerial coil wound on 9.5mm diameter ferrite rod with fixing clips
Case, dimensions 190 x 110 x 60mm plastic or wood; 0.1 inch matrix stripboard 37 holes x 24 strips; battery connectors; speaker fret; connecting wire.	

See  
**Shop  
Talk**  
page 553

COMPONENTS  
approximate  
cost **£12**



View inside the completed unit. Timing selection switch S3 can be clearly seen with its complement of variable resistors, VR2 to VR7.



# BEDSIDE RADIO

Inset left shows a close-up view of the timing selection switch S3. Only VR7 has been drawn out in full but all the presets should be soldered directly to the switch tags in a similar way. Reference to the photograph opposite will make this clearer. One tag of VR2 has been soldered to the first tag of the switch to make a solid anchoring point for connection to R9 on the circuit board.

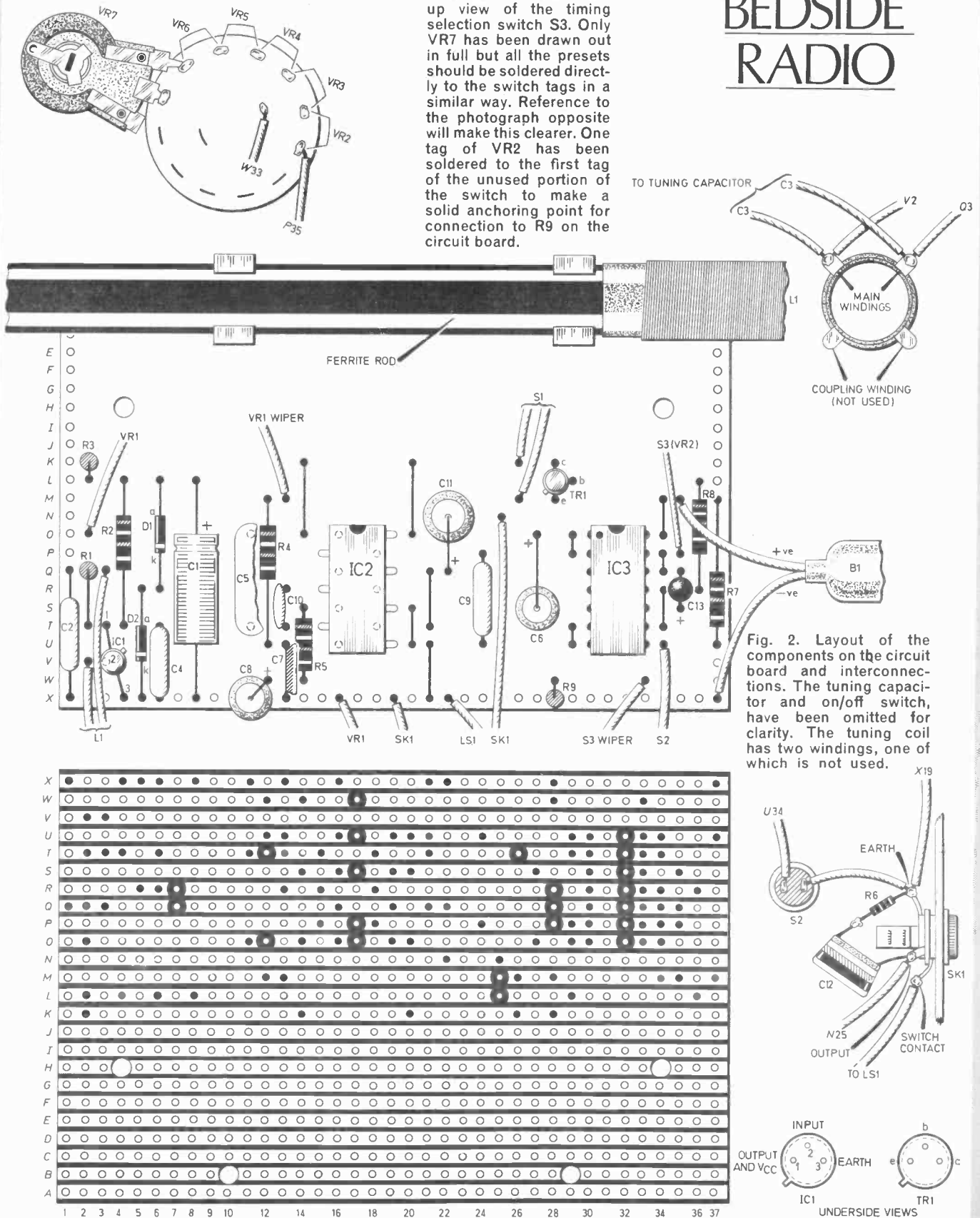
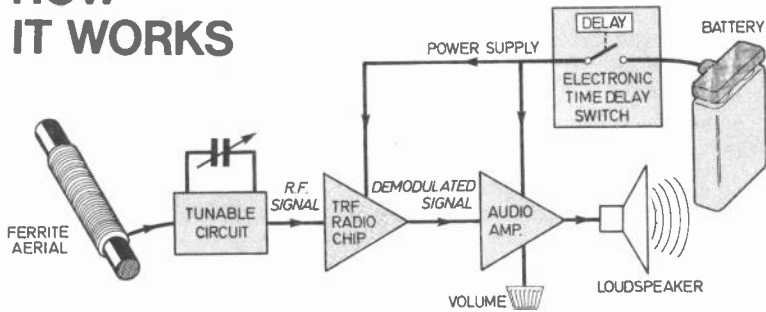


Fig. 2. Layout of the components on the circuit board and interconnections. The tuning capacitor and on/off switch, have been omitted for clarity. The tuning coil has two windings, one of which is not used.

## HOW IT WORKS



Radio signals from the transmitter induce electrical signals in the ferrite aerial. A certain portion of these are selected by the tuned circuit and passed onto the t.r.f. radio chip where they are processed into a low frequency or audio signal. This is then passed into the audio amplifier i.e. the output of which is used to drive a loudspeaker.

Power to the unit passes through an electronic time delay switch. This consists of a monostable circuit which keeps the radio switched on for a preset period after the main switch has been turned off, thus allowing the listener to dose off to sleep without needing to turn off the set manually.

care not to smear any adhesive onto the diaphragm. Use a good quality adhesive such as an epoxy type.

When the other components have been fitted onto the front panel and the earphone socket has been mounted on the left hand side panel of the case, the remaining wiring can be completed. This is illustrated in Fig. 2.

### ADJUSTMENT

Thoroughly check all the wiring for mistakes, and when confident that there are no errors, connect a battery and switch on. In most locations it should be possible to receive a number of stations at good volume even during daylight hours, and it should be possible to pick up more after dark.

The frequency coverage of the set depends to some extent on the position of the aerial coil on the ferrite rod. If the set cannot tune down to stations at the low frequency end of the band (the vanes of VC1 fully meshed), this can be corrected by moving the coil further onto the ferrite rod.

A lack of coverage at the other end of the band can be corrected by moving the coil towards the end of the rod.

When a suitable position for the coil has been found it should be glued or taped in place to prevent it from slipping out of adjustment.

### PRE-SET RESISTORS

The six preset resistors are adjusted by empirical means to give the correct time delays with a reasonable degree of accuracy, starting with VR2 which sets the 5 minute switch off delay. Resistors VR3 to VR7 are then adjusted in sequence to set the 7<sup>1</sup>/<sub>2</sub>, 10, 12<sup>1</sup>/<sub>2</sub>, 15, and 17<sup>1</sup>/<sub>2</sub> minute delay times respectively.

The presets must be adjusted in this order. This is a rather time consuming task and unfortunately there is no short cut, but at least in this application a high degree of accuracy is not necessary, and it is only necessary to get the actual times within a few seconds of the specified ones. ☐



### Mail Order and Books

This is a time with shortening days when the old hands will be deciding on their next project, and equally important, many new recruits will be joining their ranks. In one or two issues about this time, I usually devote some space to giving guidance on component buying and this year will be no exception.

I will commence as I usually do with pointing out that considerable use has to be made of firms who offer Mail Order facilities, and the first step is the acquisition of at least four good catalogues. It is best to accept the fact, straight away, that the number of electronic components is now so vast, that you are unlikely to be able to get all your requirements from one supplier.

Also, I think a few extra reference books would not come amiss. First of all I would suggest *Basic Electronics* prepared by Malcolm Plant for the Schools Council. It is in five parts which can be purchased

separately and is modestly priced. Eventually I would suggest that *Foundations of Wireless and Electronics* by Mr. G. Scroggie is a "must".

Another book I would strongly recommend is the *Dictionary of Electronics* published by Penguin. Lastly I would suggest the *Towers International Transistor Selector*.

### Blue Fingers

I am certain that many of our readers are married men and will confirm what I am about to say.

You find that within a few months of being spliced, you are being compared, always unfavourably, to Betty or Daisy's husband, Len or Bill. Compared to them you are a lazy good for nothing!

It turns out that Len or Bill, regularly clean all the windows, paint the house inside and out, and needless to say do all the gardening.

When you visit them, you are certain to have a conducted tour of the garden

which is like a miniaturised but greatly improved version of Kew.

Apparently Len or Bill have what are called "Green Fingers". On the way home this will be contrasted by the little woman with her own garden which looks like an inferior version of the Matto Grosso.

However, there is another side to the coin. When a fuse blows, the toaster, or vacuum breaks down, then we electronic types come into our own, someone ought to say that we have "Blue Fingers".

Only a short while ago my wife switched on our electric cooker, there was an almighty flash and a bang and the company fuse had blown. This would have had the Lens and the Bills yelling for help and dialling 999, but did old "Blue Fingers" turn a hair? Not a bit of it! In a trice he had the back off the cooker and quickly sized up the situation.

The main supply is connected to terminals with insulators big enough to carry the National Grid. The positive terminals had been arcing across to the earthed metalwork until the heat had split the insulation into about three pieces. The negative insulator was perfectly good, so I swapped them over. I reasoned that the potential difference between the negative line and earth was minimal although this is not always the case.

An interesting sidelight on this, is the fact that the cooker is fed through a 30 amp fuse and a 60 amp before the company fuse which is rated at 120 amps. Only the 120 amp fuse had blown. This looks like a practical example of Froud's Law "A transistor protected by a fast acting fuse will protect the fuse by blowing first"!



By Dave Barrington

### Vowel Power

Most of our readers will no doubt have heard of the Texas Speak and Spell education aid which lets children have fun while learning to spell. Now comes news that it has been given a bigger vocabulary.

The standard machine has a 240-word vocabulary and now by the addition of a plug-in word module a further 140 words has been added. The new plug-in word memory, called "Vowel Power", works in exactly the same way as the built-in processor but concentrates on words with difficult vowel sounds.

The new words relate to vowel sounds in four categories: short vowel sounds such as neck and much; long vowel sounds like wheel and toast; two letter or blended vowel sounds like cloud and clown; and words where the letter "r" changes the vowel sound—such as germ and church.

An improved voice synthesis is another feature of the Speak and Spell which retails for about £50. The plug-in word memory, which is the first of a series, retails for about £15.

### Remote ICs

A couple of exciting new integrated circuits for the experimenter take the spotlight this month.

Currently not on general supply, but available from Celdis Ltd, is a two-chip remote control system comprising the Plessey SL940 pulse-transmitting remote controller and ML920 receiver.

The SL940 is a bipolar, pulse transmitting circuit. Single-pole switches are used to select the required command which is transmitted as one of 32 5-bit code words. These words can be modulated as PPM onto a single carrier frequency or transmitted as baseband pulses.

The ML920 receiver is a 24-pin PMOS/LSI integrated circuit which, after demodulation of the incoming signal, first verifies and compares two consecutive code words. The signal is then decoded to give 20 channels, three analogue controls plus six other control functions.

Features of the receiver i.c. include all timing from an on-chip oscillator and automatic error detection. Only  $6\mu\text{A}$  of current is taken from the 9V supply by the transmitter on standby.

Typical applications would be the remote control of toys and models and domestic remote controls such as garage door operation, TV and hi-fi control. The transmitter and receiver can be combined to give a flexible system using as the control link a cable, sound, ultrasonics, visible light, infrared or radio frequency.

Further details, price and stockists can be obtained from Celdis Ltd., Active Components Division, Dept EE, 37 Lovelock Road, Reading, Berks, RG3 1ED.

### Remote Control

Talking of radio frequency, the Toko i.c.s. KB4446 and KB4445, available from Ambit International, provide the designer with the opportunity to build a 4-channel f.m. radio control receiver and transmitter on the 27MHz band.

All necessary data is contained in a comprehensive data sheet which comes with the i.c.s. Also contained in the data sheet are two circuits, one for the transmitter and one for the receiver. The system is based on the standard 27MHz band, i.e. 9.6V operation for the transmitter and 4.8V for the receiver, 1.2ms pulse width.

The transmitter i.c. (KB4445) only requires the channel and r.f. timing components together with an r.f. power transistor around it to give a practical working circuit. In the case of the receiver (KB4446) there are two input tuned coils together with a mixing coil, an i.f. ceramic filter and a detector coil, which with a sprinkling of R's and C's is all that is required. With the addition of a transistor in the r.f. input stage the sensitivity can be increased from  $40\mu\text{V}$  to  $2\mu\text{V}$ .

To sum up, these i.c.s. are a good buy for the home constructor wishing to develop his own radio control system.

Available from Ambit International, Dept EE, 200 North Service Road, Brentwood, Essex, CM14 4SG, the current price of the KB4445 is £2.30 and the KB4446 £2.65 including VAT. If purchased as a pair the combined cost will be £4.75. A charge of 35p post and packaging is levied.

### Hooked

The versatility of the miniature EZ test hooks have often proved invaluable in the workshop when checking out experimental "lash-ups". The only criticism has been that the interconnecting wires tended to get in the way and often been more an hindrance than help.

To allow greater flexibility of movement, when making test connections, EZ Hooks have recently been introduced joined by a p.v.c. coil cord which expand from a closed position of 180mm to 915mm. The leads are available in ten colour-coded colours.

Further information on the complete range of EZ Hooks is available from the British Central Electrical Co. Ltd., Dept EE, Unit 10 Carvers Industrial Estate, Southampton Road, Ringwood, Hants, BH24 1JS.

## CONSTRUCTIONAL PROJECTS

### Weather Centre

This month's concluding article for the *Weather Centre* project deals with the hardware. It is difficult to generalise on any supply problems as this will obviously vary from area to area and any good DIY or Hardware shop should be able to supply most items.

The TV aerial claw clamp for securing the boom to mounting pole was purchased through a Tandy store.

The only electronic items of note in this part of the *Weather Centre* are the infra red emitter (TIL32) and the infra red detector (TIL78). These are available from several suppliers and should not be difficult to find.

### Lights Failure Monitor

No purchasing problems should be experienced with components for the *Lights Failure Monitor*.

In view of the large number of semiconductor devices required some advertisers may even be willing to quote a special price for a "semiconductor pack" for this project.

### Bedside Radio

Most components for the *Bedside Radio* are generally available and should not cause concern.

However, should any readers have difficulty in obtaining the Dielecon 300pF tuning capacitor this is available from Home Radio. Also, suitable aerials are the MCW2 from Ambit International and the MW5FR from Denco Ltd., Dept EE, 355 Old Road, Clacton-on-Sea, Essex, CO15 3RN.

### Precision Parking Pad

Choosing and locating a magnet for the reed switch operation could prove quite a problem for the *Precision Parking Pad*. Probably one of the Eclipse range from James Neill (Sheffield) Ltd., would prove most suitable. The Minor 801 magnet or the 811 Power Magnet would seem to be ideal. These should be stocked by any good hardware shop.

No troubles should be encountered with the rest of the components for this project as they are generally available from most advertisers.

### Duo-Deci Timer

Checking through the list of components for the *Duo-Deci Timer* we cannot foresee any supply snags. People like Maplin, Watford, and Marshalls seem to stock most items.

### TTL Logic Probe

No buying problems should be experienced with parts for the *TTL Logic Probe*. Most of our advertisers who specialise in semiconductors should be able to meet any orders.

### TTL Power Supply

Standard parts are used throughout the *TTL Power Supply* and there should be no problems in obtaining components. The transformer should have an output of at least 6V and a rating of not less than 2A. The Universal Chassis member is available from Home Radio, catalogue number CU56A and the voltage regulator, type LM309K, can be found in most suppliers' catalogues.

# two-digit

## TIMER

BY F. G. RAYER

**T**his article describes an easy to build two-digit timer with optional decimal point.

To time an egg, develop a film or do some other process taking up to a maximum of 9.9 minutes, the "fast" range is used.

For fixing and washing film or prints, barbecuing sausages or parking time watching, the "slow" range is selected.

Operation is from a 4.5 volt battery or from a mains operated battery eliminator if the timer is used extensively.

### CIRCUIT OPERATION

Fig. 1 shows the complete circuit and its operation is straight forward and easily followed. Power is applied to the circuit via S3 and no more than 5 volts should be used because of the TTL devices in the unit.

The "fast" or "slow" range is selected by means of S1. With S1 in the "0.1" position, capacitor C1 charges through VR1 and R1. When the emitter of the unijunction transistor TR1 reaches sufficient potential due to C1 charging, TR1 conducts and discharges C1.

The process is repeated over and over again, and VR1 is adjusted so that this takes place at 0.1 minute or 6 second intervals. When S1 is in the "1" position, C1 charges through VR2 and R2 so that pulses are produced at the rate of one per minute instead of one every tenth of a minute.

The decimal point on X1 is illuminated when S1b is in the 0.1 position. It will be seen that the device will read down to 0.1 minutes on the "fast" range and 1 minute on the "slow" range and it is felt that this is easily close enough for the sort of activities the author has in mind. The two-range, two-figure indication also allows considerable simplification.

Timing is not initiated until S2 is closed. When this happens S2a applies voltage to TR1 and associated components whilst S2b previously held open to keep the display at 00 closes to allow the pulses to be counted.

### COUNTER

The counter i.c. IC4 is driven by the pulses from TR1 via TR2. These pulses are delivered at either 0.1 or 1 minute intervals, according to the setting of S1. The 7490 chip, IC4, is a binary coded decimal decade counter. It receives pulses at pin 14 and translates these into a binary output at pins 11, 8, 9 and 12. These binary outputs pass to pins 6, 2, 1 and 7 of the 7447 decoder-driver i.c. IC3.

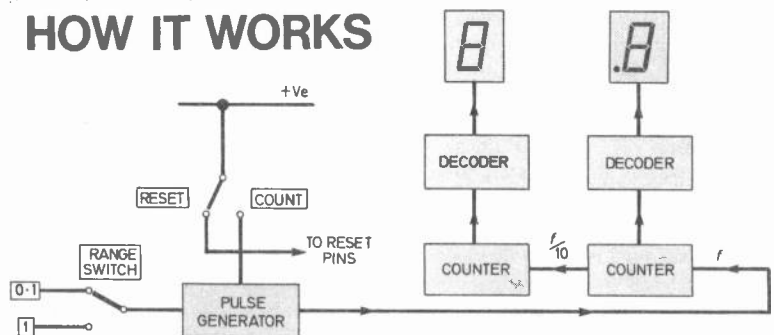
This integrated circuit decodes the binary inputs into a form that will drive the displays X1 and X2 and this appears at pins 9 to 15. Decoding is so arranged that the correct sectors of the seven-segment display are illuminated to display the numbers.

The components IC1, IC2 and X2 thus count from 0 to 9 as pulses arrive at pin 14 of IC4.

### TENS AND UNITS

At the next pulse, IC4 provides an input to IC3 which is decoded to return the numeral to 0 and a pulse passes from pin 11 of IC4 to pin 14 of IC2. This then provides a binary output for the number one which is decoded by IC1 and thus the "tens" numeral is advanced.

## HOW IT WORKS



An oscillator provides pulses at the rate of one every second or tenth of a second according to the setting of the range switch.

These pulses are passed on to the first counter which causes a seven-segment display to count up by one every time a pulse is received.

Every tenth pulse causes the display to return to zero and pass a single pulse on to the next stage where it is counted in the same way.

When 99 pulses have been received, the displays both return to zero and the process starts all over again.

To reset, the power is removed from the oscillator and fed to the reset inputs of the counters.

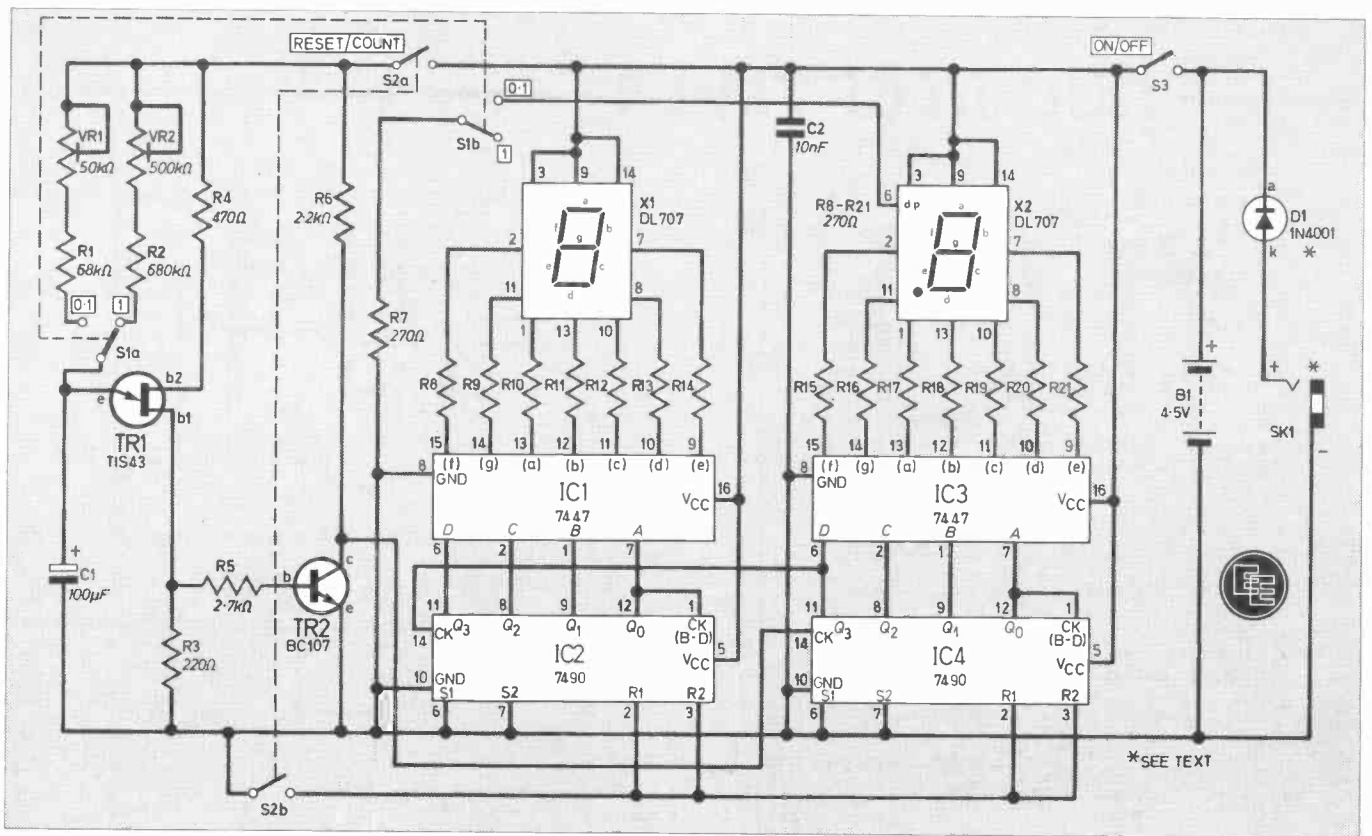


Fig. 1. Full circuit diagram of the Duo-Deci Timer.

This continues until 99 is reached. For the "fast" range, the decimal point is switched on and lies to the right of the units digit, that is between the two numbers. In fact this forms part of X2 and is illuminated when pin 6 is earthed.

If a battery eliminator is used, it should be plugged into SK1. It must be at a voltage of less than 6 volts.

Diode D1 is used to provide protection against the battery eliminator being connected the wrong way round and also drops the voltage down by about 0.6 volt thus allowing the more common kind of eliminator or even a large 6 volt battery to be used.

Outside view of completed unit.



## THE CASE

The timer is designed to fit into a case measuring 100×70×40mm, and is therefore very compact in construction.

Cut the 0.1 inch s.r.b.p. matrix board down to 76×52mm and place it against the top of the case. This will enable you to position the holes for the three 8BA mounting bolts which can be drilled through the board and the case. Once the holes have been drilled, the three 8BA bolts can be fastened in position and spacers added so that the board stands about 8mm clear of the front of the case.

Apertures are made to match the positions of the displays X1 and X2. This can be done accurately by drilling a few small holes so that a small flat file can be introduced. The holes are then filed to shape, checking as necessary that they will agree with the actual positions of the displays on the circuit board.

Afterwards, with the board removed, make three slots for the switches. Again a few small holes are drilled and the holes filed to shape. Of course you will also need to drill holes for the securing screws as well as these slots. The switches should be left off for the time being.

The battery used in this project is a three-cell flat battery type 1289 and it lies horizontally on top of the circuit board. Card or similar material is placed between the board and the battery.

## THE I.C.S

The i.c.s fit into 14- and 16-pin d.i.l. holders. Although not absolutely essential, they save a great deal of time and trouble when securing the i.c.s and there's no worry about thermal damage. This also applies to the displays X1 and X2.

Make sure you insert the i.c.s correctly when all the construction is completed. Pin one is always identified by a spot or indentation on the body.

## CIRCUIT BOARD

Assembly again is fairly compact and a few points should be noted. Fig. 2 shows the top or display side and also the underside. Pre-sets VR1 and VR2 are mounted on the underside so that they can be adjusted.

# DUO-DECI TIMER

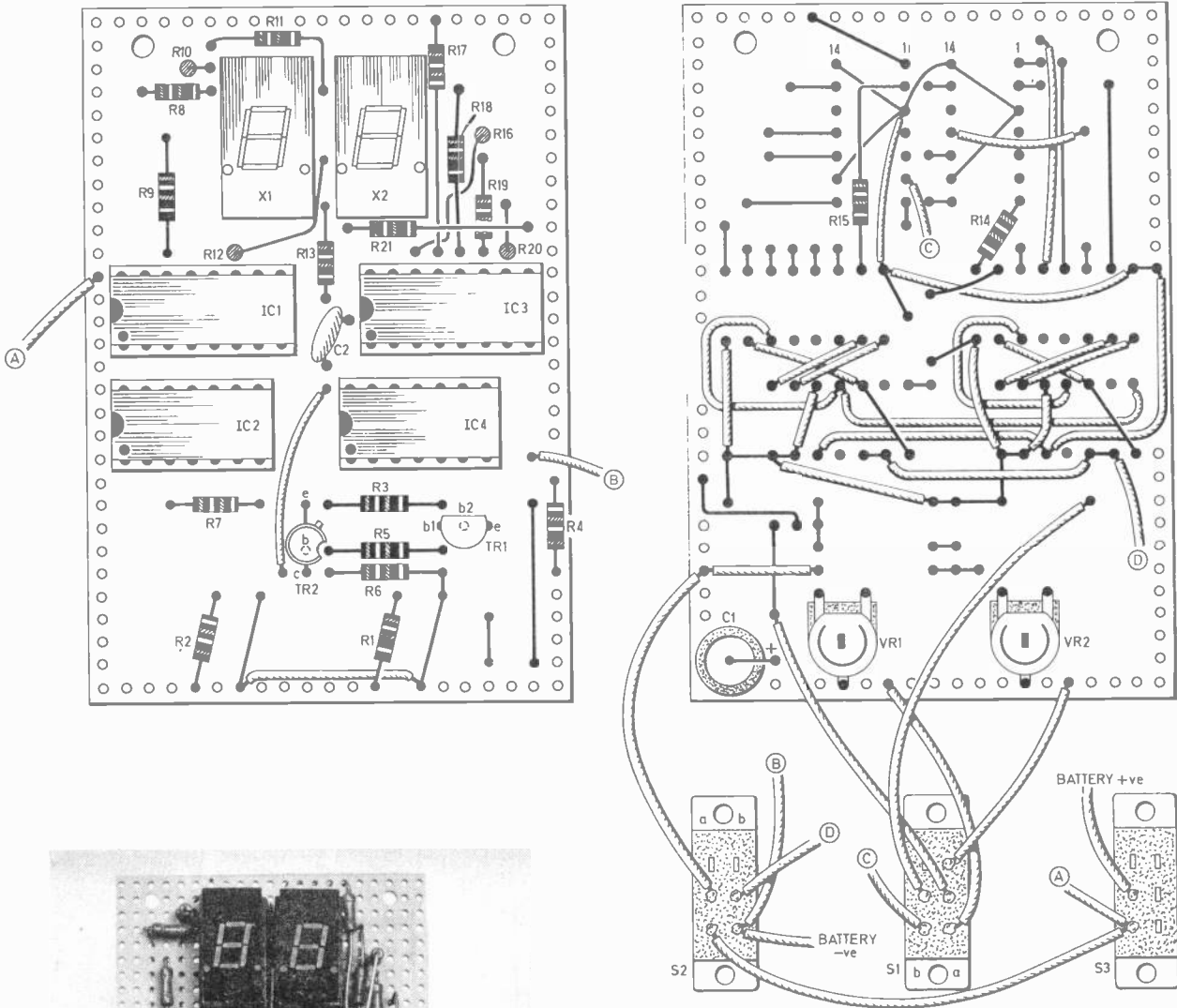
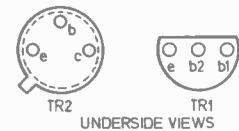


Fig. 2 (above) Wiring and layout details of the circuit board. Care must be taken that crossing wires are adequately insulated. Photograph left shows the circuit board from the prototype unit.



**COMPONENTS**  
 approximate  
 cost **£10**

When fitting the components make sure that all components are mounted lower than the top of the display chips. The transistors will therefore be very close to the board. Care must be taken to heatsink the transistors when soldering.

The resistors R7 to R21 which are in series with various segments of the displays should be as small as possible in size and  $\frac{1}{8}$  watt types will be adequate.

The first job when assembling the board is to wire the power lines to the i.c.s; positive to pins 3, 9, and 14 on X1 and X2, pins 16 on IC2/4 and pins 5 on IC1/3; negative to pins 6, 7 and 10 on IC2/4, and pins 8 on IC1/3. Other connections can then be put in as shown in Fig. 2.

Positive and negative circuits are wired with thin flex or 22 s.w.g. wire, although 30 s.w.g. is strong enough elsewhere and is much more easily handled. Sleeving is added as and when required.

With R16, R20 and R21, the leads should be shaped so that no short circuits can arise, these components being near R17, R18 and R19.

It is helpful to use colour coding for some of this wiring, especially things such as red for positive, black for negative and orange for re-set line.

## COMPONENTS

### Resistors

R1	68k $\Omega$
R2	680k $\Omega$
R3	220 $\Omega$
R4	470 $\Omega$
R5	2.7k $\Omega$
R6	2.2k $\Omega$
R7-R21	270 $\Omega$ $\frac{1}{8}$ W miniature (15 off)
All $\frac{1}{8}$ W carbon $\pm 5\%$ unless otherwise specified	

### Potentiometers

VR1	50k $\Omega$ miniature horizontal preset
VR2	500k $\Omega$ miniature horizontal preset

### Capacitors

C1	100 $\mu$ F 6V elect.
C2	10nF disc ceramic

### Semiconductors

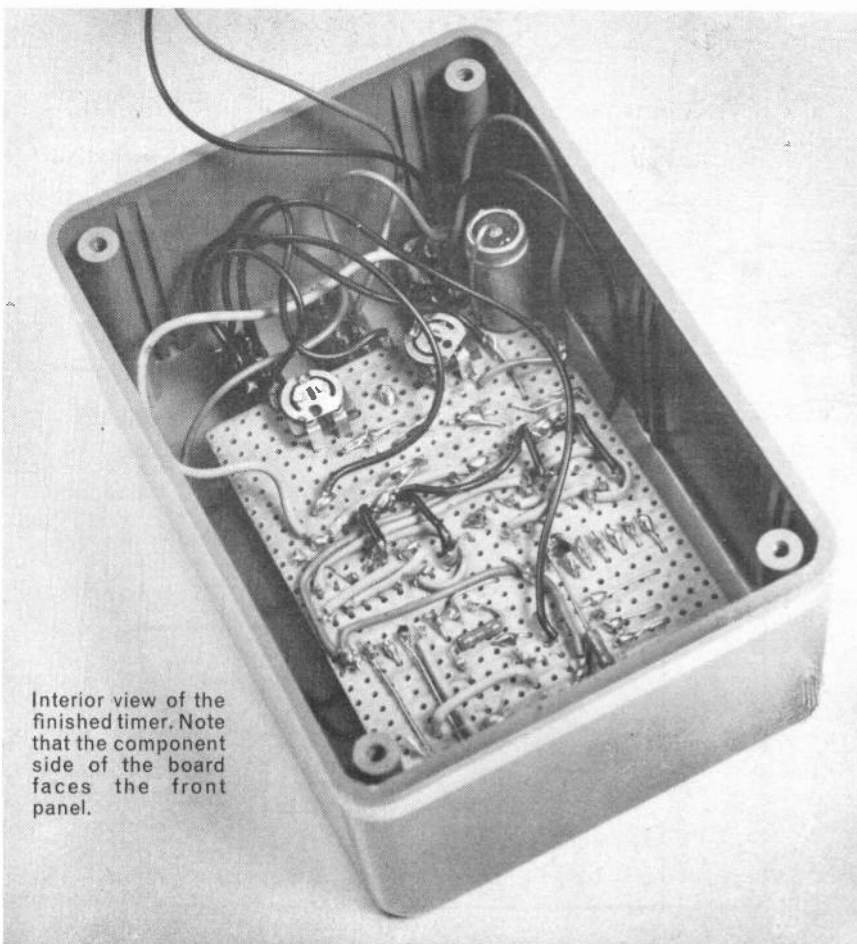
TR1	TIS43 <i>n</i> -channel unijunction
TR2	BC107 <i>n</i> p <i>n</i> silicon
IC1, IC3	7447 b.c.d. to seven segment decoder/driver (2 off)
IC2, IC4	7490 b.c.d. decade counter (2 off)
D1	1N4001 1A 50V silicon diode
X1, 2	DL707 8mm common anode seven segment display (2 off)

### Miscellaneous

S1, 2, 3	d.p.d.t. slider switch (3 off)
SK1	3.5mm jack or other socket to suit battery eliminator
B1	4.5V flat pack battery type 1289
Plastics box, size 100 $\times$ 70 $\times$ 40mm; 0.1 inch perforated s.r.b.p. board, size 52 $\times$ 76mm; 14 pin d.i.l. i.c. sockets (4 off); 16 pin d.i.l. i.c. sockets (2 off); 8BA nuts, bolts and spacers; inter-connecting wire; stiff wire for battery connectors.	

See  
**Shop  
Talk**

page 553



Interior view of the finished timer. Note that the component side of the board faces the front panel.

## OFF-BOARD CONNECTIONS

The switches and battery are wired to the board using thin stranded wire. Situate the switches approximately on the front panel according to Fig. 2 and wire them to the various points on the board, leaving an inch or so of extra wire. Note that S2 and S3 are joined. Battery negative also runs from S2.

Flat clips for the battery can be made from thin metal or paper clips and soldered to the leads, so that they can be fastened to the battery. Make sure that you connect up with the correct polarity.

## TESTING

This is most readily done before fitting the board or switches in the case. Initially set VR1 and VR2 at about middle position. Closing S3 should illuminate the displays and setting S1 at the 0.1 position should light up the decimal point.

With S2 closed, a count should begin to appear and run to 9.9. Meanwhile, VR1 can be adjusted so that the units change at exactly six-second intervals, or ten per minute.

Afterwards adjust VR2 for one-minute intervals. Opening S2 returns the displays to zero.

The switches can then be bolted to the case and the board located on its three bolts and fixed with nuts. The back of the case can then be screwed in position.  $\square$

# TEACH-IN 80

## Part 11

### EXPERIMENT 11.1:

#### WEIN BRIDGE OSCILLATOR

**Components needed:** 100kΩ ½W resistor, 10kΩ ½W resistors (2 off), 330Ω ½W resistor, 0.1μF capacitors (2 off), CA3140 op-amp, BC108 transistor, BC478 transistor.

A sine wave oscillator circuit which drives a loudspeaker is shown in Fig. 11.11a with the layout of the components on the Tutor Deck in Fig. 11.11b.

Because the op-amp itself cannot supply enough current to drive a loudspeaker directly, a buffer has been added in the form of the complementary pair transistors TR1 and TR2, with the resistor R3 used to limit the output current of the op-amp.

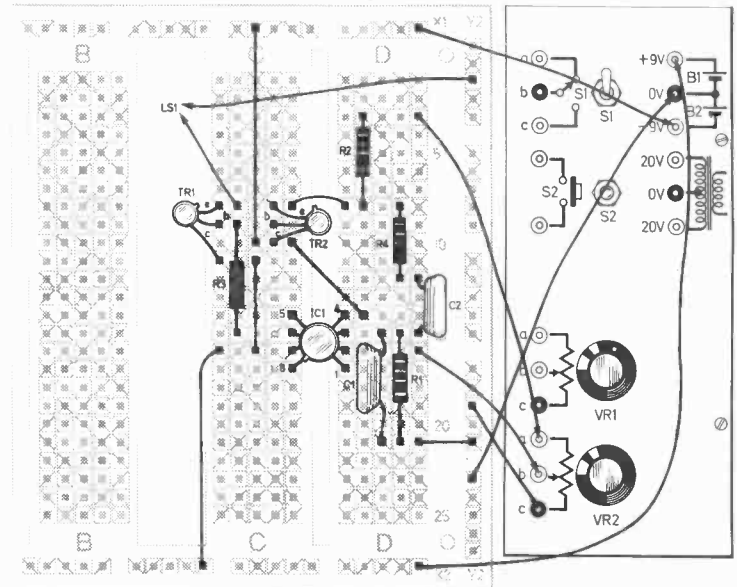
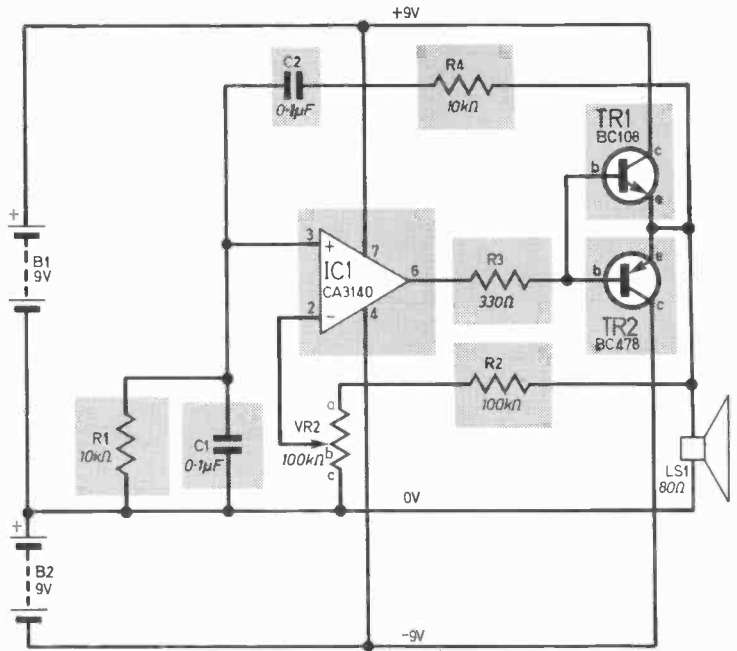
Feedback has been taken from the point where the buffer joins the speaker and a conventional Wien Bridge circuit has been used.

The gain has been made variable by using a potentiometer VR2 to vary the voltage fed back to the inverting input.

When the circuit has been connected up note how altering the setting of the potentiometer VR2 alters the output. For part of the track there is no output: the loop gain is less than one. As the pot is turned up the oscillation begins but as it is increased the sound becomes much harsher because the output is being distorted as the voltage hits the power rail. At a smaller range of settings the sound is quite clean because a pure (or nearly pure) sine wave is being produced.

Fig. 11.11(a) (top right) The circuit of Experiment 11.1.

Fig. 11.11(b) The layout of Experiment 11.1 on the Tutor Deck.

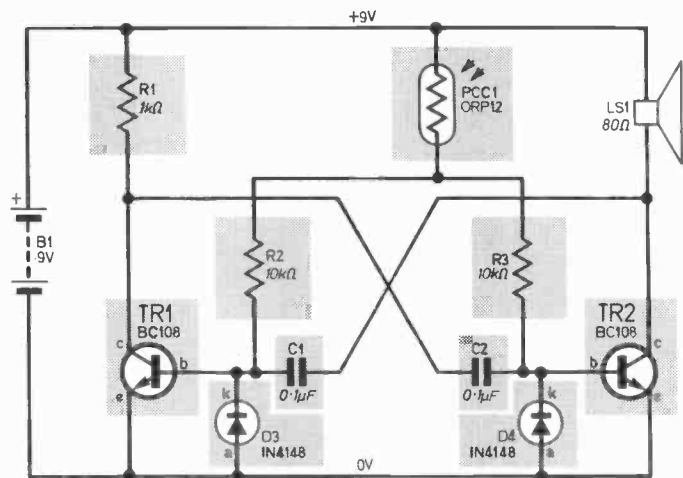


### EXPERIMENT 11.2:

#### TRANSISTOR MULTIVIBRATOR

**Components needed:** 1kΩ ½W resistor, 10kΩ ½W resistors (2 off), ORP12 light dependent resistor, 0.1μF capacitors (2 off), BC108 transistors (2 off), IN4148 diodes (2 off).

The circuit of Fig. 11.12a shows a simple multivibrator whose frequency is set by the amount of light falling on a light dependent transistor.





## EXPERIMENT 11.3: OP-AMP MULTIVIBRATOR

**Components needed:** 10kΩ ¼W resistors (2 off), 330Ω ¼W resistor, ORP12 light dependent resistor, CA3140 op-amp, BC108 transistor, BC478 transistor.

An op-amp version of the multivibrator is shown in Fig. 11.13a with the layout on the Tutor Deck in Fig. 11.13b. Again the output buffer circuit has been used to enable the op-amp to drive a speaker.

When the output (at the speaker) is at its most positive the capacitor charges at a rate determined by the resistance of the l.d.r. The voltage at pin 3 of the op-amp

will be approximately +7V.

When the voltage on C1 reaches this voltage the inverting input will be higher than the non-inverting so that the output will now swing to near the negative supply rail. The voltage at pin 3 is now -7V and C1 discharges through the l.d.r. until it reaches this voltage. The output then swings positive and the cycle starts again.

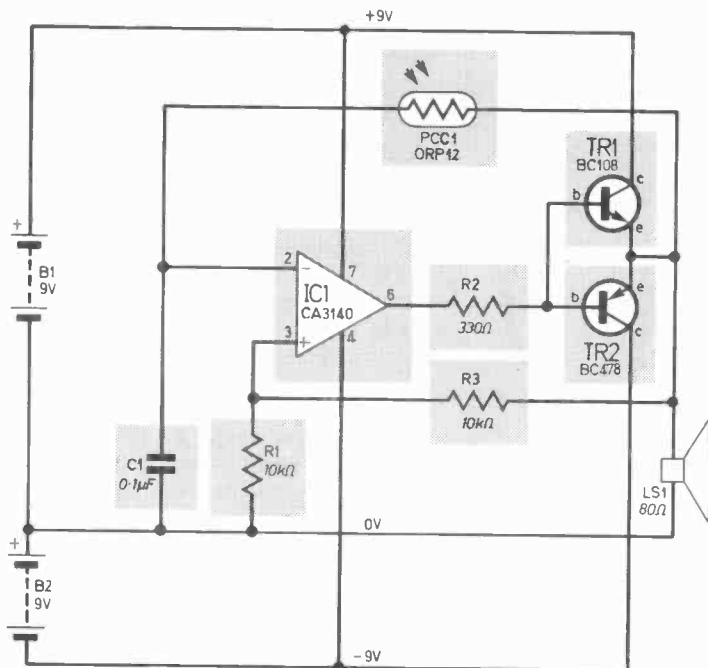


Fig. 11.13(a) The circuit of Experiment 11.3.

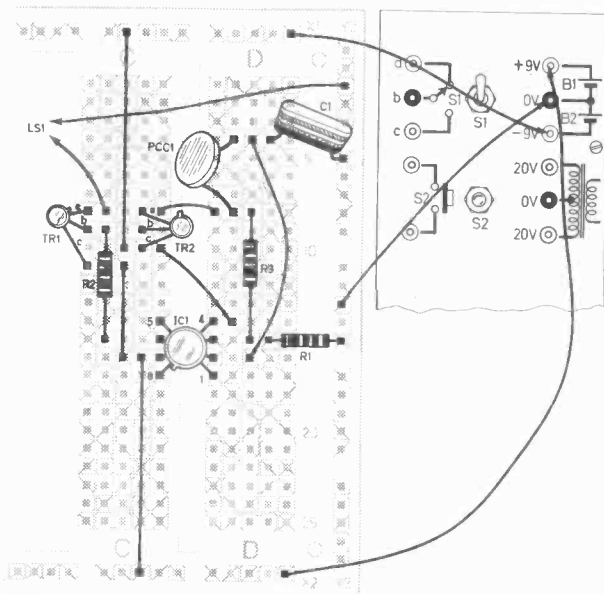
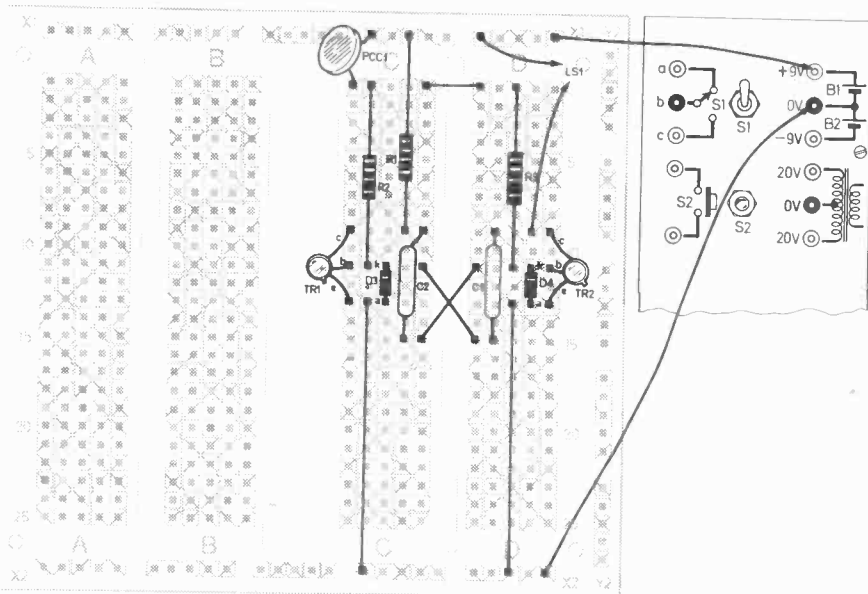


Fig. 11.13(b) The layout of Experiment 11.3 on the Tutor Deck.



The on and off times are the same for both TR1 and TR2 since the circuit is symmetrical. The load of one of the transistors is the speaker itself which saves using a separate amplifier stage.

Moving the hand across the l.d.r. will change the note from a high pitch to a very low pitch.

Note the diodes which are placed across the base to emitter junctions of both transistors. These are required to prevent the voltage on the base being pulled to -8.3V when the collector voltage on the opposite transistor goes from 9V to 0V. If the base is pulled more than 5V negative with respect to the emitter, there is the possibility that the transistor will be damaged.

Fig. 11.12(a) (far left) The circuit of Experiment 11.2.

Fig. 11.12(b) The layout of Experiment 11.2 on the Tutor Deck.

# Part 12

By S. R. Lewis,  
B.Sc.



# TEACH-IN 80

**N**EXT to the common bipolar transistor the most important semi-conductor device must be the field effect transistor or f.e.t.

Discrete f.e.t.s are similar to ordinary transistors in that they have three terminals, one of which controls the current flow from one of the other terminals to the third. However the principles upon which f.e.t.s are based are quite different from the bipolar transistor and hence it has unique properties which enable it to be used in applications where bipolar transistors need a great deal of external components to do the same job.

The other reason why f.e.t.s. are so important is that they are by far the most widely used type of transistor in logic integrated circuits (i.c.s).

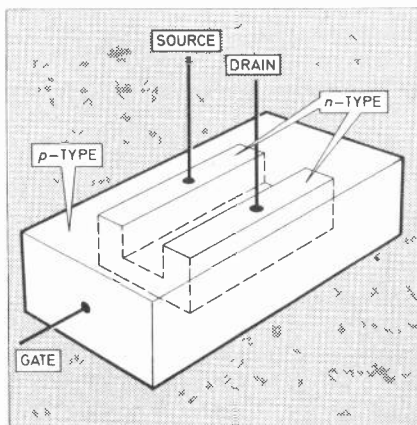
F.e.t.s can be made very small and therefore an extremely large number of logic elements can be packed together on a single chip of silicon. This has enabled the development of **microprocessors** with tens of thousands of components on a single chip at a price that is well within the grasp of amateur constructors.

## THE FIELD EFFECT

The field effect principle was developed in the early fifties, just when mass manufacture of bipolar transistors was starting.

The basic idea behind field effect is superficially much easier to understand than the principles behind the bipolar transistor.

A diagram of the geometry of a junction field effect transistor is shown in Fig. 12.1. Essentially the f.e.t. consists of a chip of silicon,



part of which is doped so as to be *n*-type and part of which is *p*-type. The *n*-type region forms a **channel** through the *p*-type region and terminals are placed at either end of this region, these being given the names **source** and **drain**.

A third terminal makes contact with the *p*-type area of the chip under which the channel passes. This terminal is the control input and is termed the **gate**.

The diagram shows the channel made of *n*-type material but a **complementary** type of f.e.t. can be made with the channel made from *p*-type material and the rest of the chip *n*-type.

The description of the action of the field effect transistor which follows assumes *n*-type channel, but the operation of a *p*-channel device is similar except that all the voltage polarities are reversed.

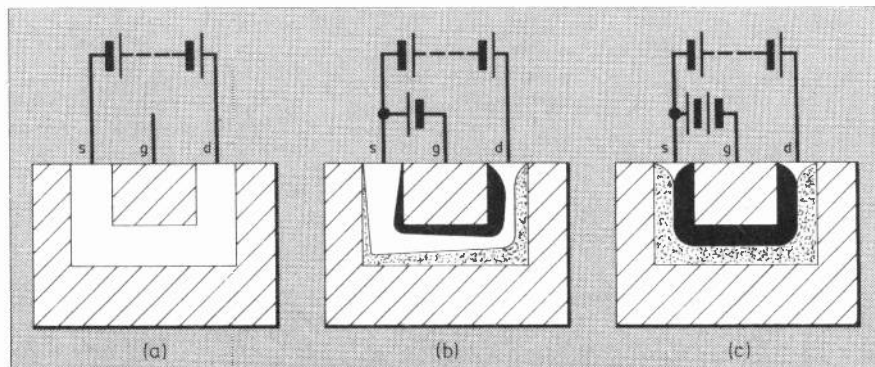
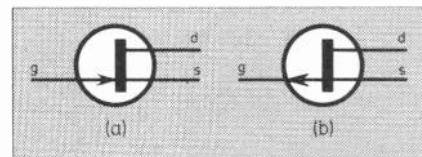
Fig. 12.2 shows the symbols for both *p*-type and *n*-type channel devices. As with the bipolar transistor, an arrow in the symbol distinguishes between the two types.

The channel through the f.e.t. normally has quite low resistance so that if a voltage is applied across the source and drain then a

Fig. 12.1 (*left*) Diagram of the construction of an *n*-channel type junction f.e.t. The source and drain make contact with a channel which is completely surrounded by the gate region.

Fig. 12.2 (*below*) (a) the symbol for an *n*-channel junction f.e.t. and (b) the symbol of a *p*-channel junction f.e.t.

Fig. 12.3 (*below*) The reduction of the effective conductivity of the channel is shown as the gate is made progressively more negative with respect to the source. At (a) the gate is unconnected so there is no field. At (b) the gate is slightly negative thus reducing the effective cross-section of the channel and at (c) the gate is so negative that no current can flow through the channel.



current will flow. If now the gate is taken negative with respect to the source then the  $p$ - $n$  junction will be reverse biased and a field will be set up within the channel.

The effect of this field is to reduce the number of current carriers in part of the channel. This effectively reduces the cross-sectional area of the channel thereby increasing its resistance. This effect is increased as the gate voltage is made more negative until a point is reached where the effective cross section of the channel has been reduced to zero making current flow from source to drain very difficult. Fig. 12.3 shows this process in diagrammatic form.

The essential point to note is that the f.e.t. is operated with its  $p$ - $n$  junction reverse biased so that only a tiny leakage current flows through the gate terminal. They can therefore be described as **voltage operated devices** rather than current operated devices as bipolar transistors are.

It is the fact that the gate terminal of f.e.t.s has extremely high impedance that gives them their unique properties. The main application area is in the amplification of signals from high impedance sources, that is sources which cannot stand low impedances placed across them. A crystal for instance as used in high stability oscillators cannot supply current and so the high impedance of the f.e.t. is very useful.

## F.E.T. CHARACTERISTICS

Table 12.1 shows the characteristics for a 2N3819  $n$ -channel f.e.t. Because the device operation is different from the bipolar transistor, the parameters quoted are different.

Like the transistor we need to know the maximum current which can be passed through the f.e.t. without damaging it. This is given the name  $I_{dss(max)}$ . The maximum power dissipation is quoted as  $P_{tot(max)}$ .

The maximum drain to source voltage is  $V_{ds(max)}$ , and the maximum drain to gate and gate to source voltage are  $V_{dg(max)}$  and  $V_{gs(max)}$  respectively.

The leakage current through the gate terminal is an important parameter in f.e.t.s since the lower this is, the higher the input impedance can be. This parameter is given the name  $I_{gsn(max)}$ .

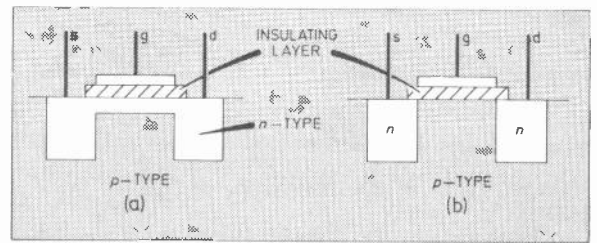
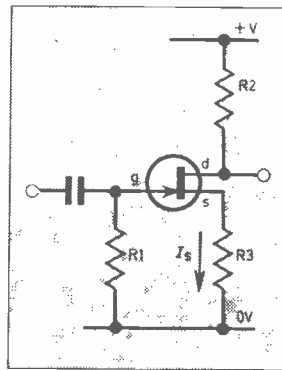


Fig. 12.4 (left) This circuit shows a simple way of biasing a junction f.e.t. so that the gate is negative with respect to the source. The voltage drop across R3 determines the negative bias since R1 holds the gate at 0V.

Fig. 12.5 (a) shows the construction of an  $n$ -channel depletion type m.o.s.f.e.t. and (b) an enhancement type m.o.s.f.e.t. The gate is separated from the silicon by an oxide insulating layer.

TABLE 12.1:  
2N3819 characteristics

Type	$P_{tot(max)}$	$I_{dss(max)}$	$I_{gsn(max)}$	$V_{ds(max)}$	$V_{gs(max)}$	$V_{dg(max)}$	$Y_{fs}$
2N3819	200mW	20mA	2nA	25V	25V	25V	4000 $\mu$ mho

The "gain" of an f.e.t. cannot be expressed in the same way as in a transistor since what is important is the change in current from source to drain with the change in voltage on the gate with respect to the source.

Now current divided by voltage is the inverse of resistance and is given the name **conductance**. The change in current produced by a change in voltage is therefore given the name **transconductance** and given the symbol  $Y_{fs}$ . Its units are **mhos** or **micromhos**, one mho being a change of one amp for a change of one volt.

## F.E.T. BIASING

The circuitry around f.e.t.s is different from that around bipolar transistors because of the fact that virtually no current flows in the gate terminal.

In order to use an  $n$ -channel f.e.t. as a linear amplifier the gate must be biased negative with respect to the source. If there is only a single supply rail then a simple way of achieving this is as shown in Fig. 12.4.

Current flowing through the source resistor R3 will produce a voltage drop across this resistor which can be calculated using Ohm's Law. A resistor R1 connects the gate to the 0V line and since virtually no current flows through this resistor, the gate will be at 0V. Because of the voltage drop across R3, the gate will therefore be negative with respect to the source which is what we are trying to achieve.

The resistor connected to the gate can be made large so that the input impedance of the circuit is kept high. Values of a few megohms and upwards are common. The signal which is to be amplified can be applied using a.c. coupling to the gate and the output can be taken from the drain.

As well as the f.e.t.s which we have looked at so far which go under the name of **junction f.e.t.s** there has grown up a number of other types of f.e.t. and we will now take a look at some of the more important types.

## M.O.S.F.E.T.S.

Undoubtedly the most important type of f.e.t. to the semiconductor integrated circuit manufacturer is the **metal oxide silicon** (or semiconductor) f.e.t., usually abbreviated to **m.o.s.f.e.t.**

The underlying principle of the m.o.s.f.e.t. is the same as the junction f.e.t. in that an electric field is used to control the conductivity of a channel, but the construction and detailed operation are different.

Instead of the gate terminal being a connection to a part of the silicon, an insulating layer is formed over the channel, the gate being an area of metal on top of this insulating layer which completely covers the channel.

Two types of m.o.s.f.e.t. can be produced: in one the field produced by the gate to source voltage can decrease the conductivity of the channel, as in the junction f.e.t., or increase it, this being known as a

## EXPERIMENT 12.1 TOUCH SWITCH

**Components needed:** 10kΩ ½W resistor (4 off), 2.2kΩ ½W resistor, 1MΩ ½W resistor, 2N3819 f.e.t., BC478 transistor, 5.1V 400mW Zener diode.

The circuit of Fig. 12.10a shows a simple touch switch that can be built using an *n*-channel junction f.e.t. type 2N3819. The f.e.t. is biased into conduction using the self-biasing arrangement as described in the text. In this state there should be only about 2V across R2 the drain resistor.

A finger has a skin resistance of around a few hundred kilohms so when it is placed across the two contacts the biasing of the f.e.t. is substantially changed causing a much greater drain current to flow and hence a greater drain voltage to be developed across R2.

The voltage change across R2 is detected by TR2. A 5.1V Zener diode is

placed in series with the emitters so the base must be at least 5.8V (Zener voltage + V<sub>be</sub>) below the positive rail before

it will conduct. The load for TR2 is formed by the l.e.d. and its current limiting resistor R6.

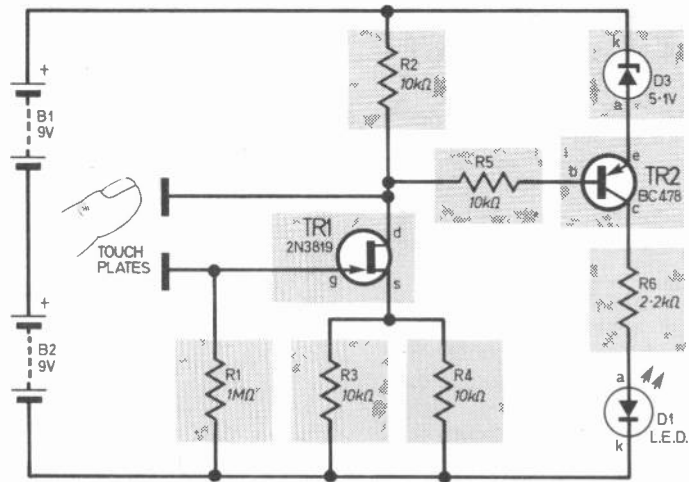


Fig. 12.10(a) (top right) The circuit of Experiment 12.1. Fig. 12.10(b) (below) The layout of Experiment 12.1 on the Tutor Deck.

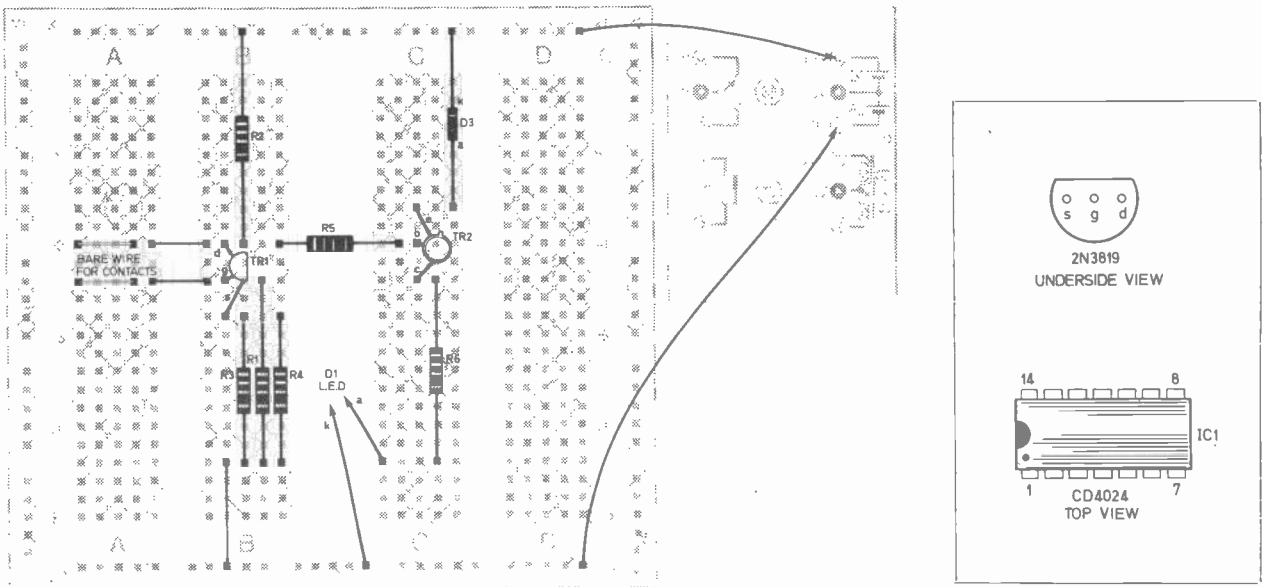
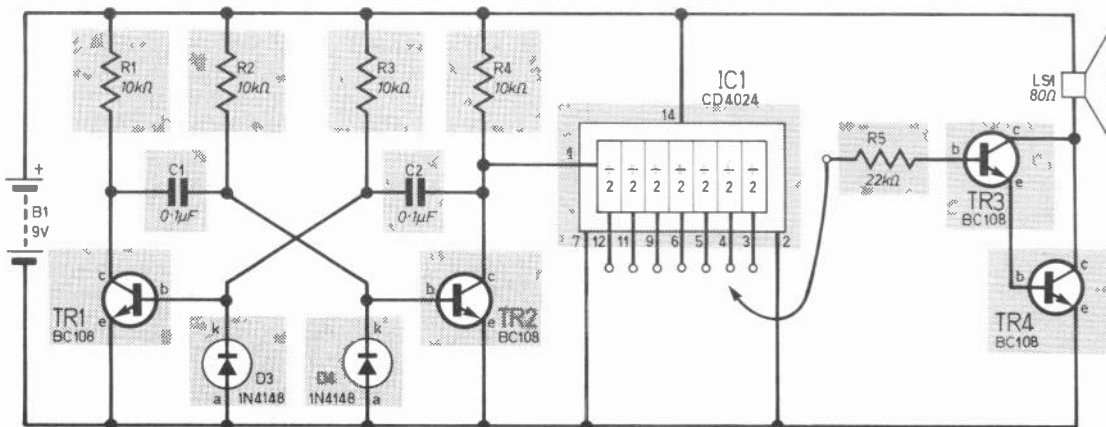


Fig. 12.12(a) The circuit of Experiment 12.3. Fig. 12.12(b) (right) The layout of Experiment 12.3 on the Tutor Deck.



## EXPERIMENT 12.2: TIME DELAY USING A F.E.T.

**Components needed:** 1MΩ ½W resistor (2 off), 10kΩ ½W resistor (2 off), 2.2kΩ ½W resistor, 10μF 16V tantalum capacitor, 2N3819 f.e.t., BC478 transistor, 5.1V Zener diode.

The circuit of Fig. 12.11a shows a timer circuit using the same f.e.t. as Experiment 12.1. There is no source resistor in this circuit as we want to keep the voltage across the two 1MΩ resistors R1 and R2 as low as possible.

When the pushbutton is pressed C1 charges up to about 16V. The gate of TR1 is at a voltage of about 1.5V so about 1.5V divided by 2MΩ (0.75μA) flows through R1 and R2.

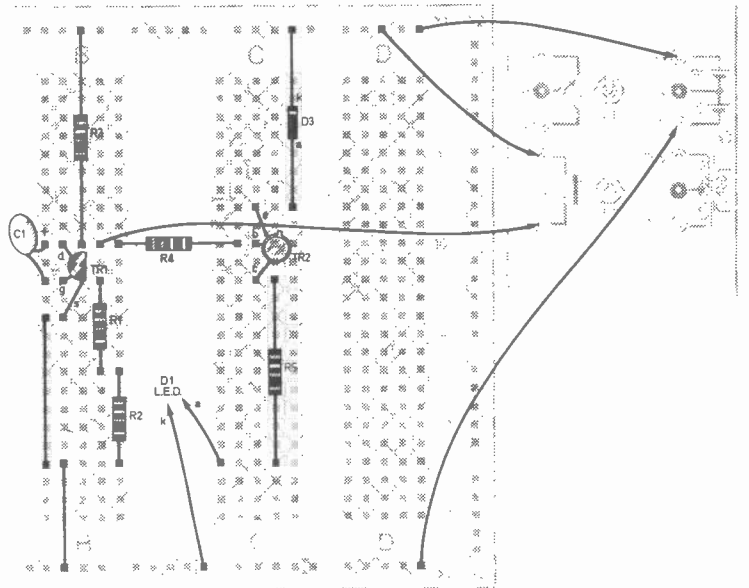
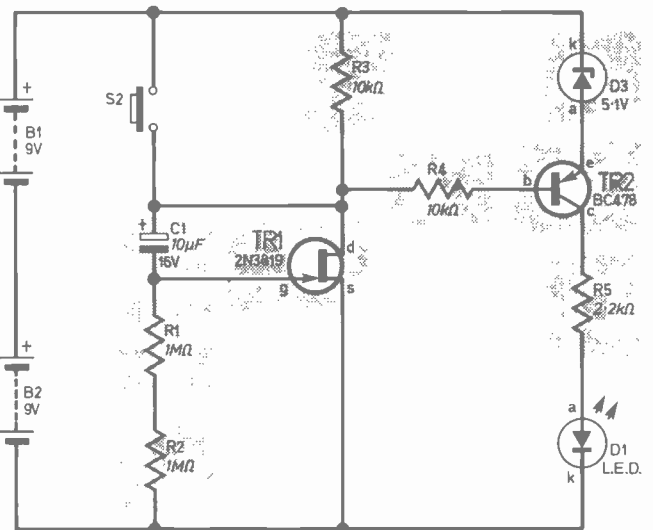
When the pushbutton is released, C1 will start to discharge. Because of the very high impedance of TR1 gate, all the discharge current flows through R1 and R2. The drain voltage will thus fall steadily until the voltage across R3 is large enough to cause TR2 to conduct when the i.e.d. will light.

The changeover from i.e.d. off to i.e.d. on is not particularly rapid and a Schmitt trigger in place of TR2 would be advantageous.

To start the timing cycle again, press the pushbutton.

Fig. 12.11(a) (right)  
The circuit of Experiment 12.2.

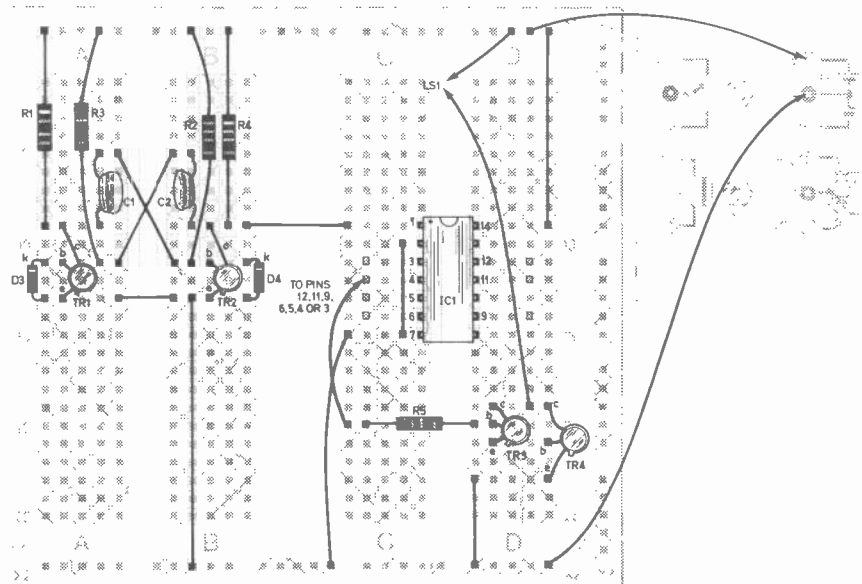
Fig. 12.11(b) (below)  
The layout of Experiment 12.2 on the Tutor Deck.



## EXPERIMENT 12-3: VARIABLE PITCH OSCILLATOR

**Components needed:** 10kΩ ½W resistors (4 off), 22kΩ ½W resistor, 0.1μF capacitors (2 off), CD4024 7-stage CMOS divider, BC108 (4 off), 1N4148 diodes (2 off).

This circuit (Fig. 12.12a) makes use of a CMOS integrated circuit type CD4024. This circuit contains seven dividers connected in series each of which will divide their input frequency by two.



TR1 and TR2 are connected to form a multivibrator as has been described in detail in a previous issue. The voltage at the collector of TR2 is a square wave of frequency about 700Hz. This is applied to the start of the divider chain.

TR3 and TR4 are connected in the Darlington pair configuration. This is so that the relatively small output current which the CMOS circuit can supply can be used to drive the loudspeaker.

The loudspeaker driver can be connected to any of the output pins of the divider. Working along the pins in sequence as shown in the circuit, the output tone will have a gradually lower pitch. In fact each step lower will be an octave below the previous note.

This circuit illustrates how integrated circuits can be used to perform complex functions which would take many discrete transistors to build. It also shows how easy it is to drive CMOS circuits since we do not have to use a precise power supply nor one of high current capability. Nearly all the current drawn from the batteries goes into the speaker.

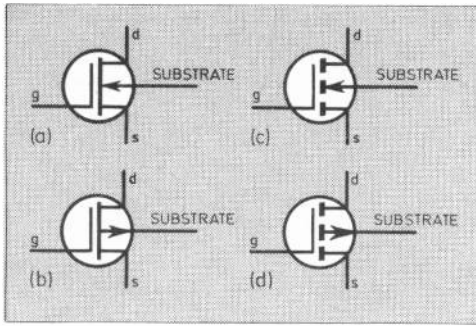
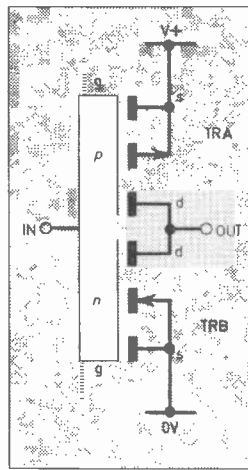


Fig. 12.6. The symbols for the various types of m.o.s.f.e.t. (a) and (b) are depletion types whilst (c) and (d) are enhancement types. (a) and (c) are *n*-channel and (b) and (d) *p*-channel.

Fig. 12.7 (right) A CMOS inverter formed from a complementary pair of enhancement type m.o.s.f.e.t.s.



depletion type m.o.s.f.e.t.; in the other there is no channel between the drain and source until a gate voltage of a given magnitude is applied, this being known as an enhancement type m.o.s.f.e.t.

Fig. 12.5 shows the geometry of the two types, which, like the junction f.e.t. can either be made with a *p*-channel or an *n*-channel.

The symbols distinguish between the depletion and enhancement types by using a dotted line between the drain and source to indicate that the enhancement type needs a gate voltage to complete the path (Fig. 12.6).

The *n*-channel m.o.s.f.e.t. is an important member of the family since it can be used with a single positive power supply. The gate does not need to be biased negative with respect to the source since a positive voltage on the gate is needed to produce current flow in the drain-source circuit.

### LOGIC INTEGRATED CIRCUITS AND F.E.T.S.

High density logic integrated circuits use field effect transistors almost exclusively although the technologies used vary widely.

The attraction of f.e.t.s in integration is that the actual f.e.t.s can be made very small in comparison with the area needed by bipolar types. They are also relatively simple to fabricate and consume only minimal power.

Logic circuits have been produced with an all *p*-channel m.o.s.f.e.t.s, all *n*-channel m.o.s.f.e.t.s and with both types on the same chip. This latter type of circuit goes under the name of complementary m.o.s. logic which is usually abbreviated to CMOS. It is outstanding for its extremely low power consumption and warrants a more detailed look.

### CMOS LOGIC

Complementary m.o.s. logic circuits use both *n*-channel and *p*-channel enhancement type m.o.s.f.e.t.s on a single piece of silicon. A single CMOS switch is shown in Fig. 12.7.

Transistor A requires its gate to be negative with respect to its source in order for it to conduct. Transistor B requires its gate to be positive with respect to the source for it to conduct.

Since the two drains are connected and the two gates are connected it will be seen that when one transistor is on the other is off and vice versa.

In the off state the transistors have very high impedance so while one transistor is off and the other is on (it does not matter which) hardly any current will flow from one power supply rail to the other. It is possible for both transistors to conduct but this only happens when the gate voltage is exactly halfway between the power supply rails. If the switching voltage is rapid then this current will only flow for a very short time.

When either of the transistors is in the on state, its impedance is very low so the voltage at the common drain terminal will swing almost from one power supply rail to the other as the gate voltage is swung from low to high.

Another important feature of CMOS circuits is that they will work over a very large range of power supply voltages. Typical commercial CMOS circuits will operate with power supplies of anything from 3 to 15V. This contrasts dramatically with TTL logic circuits which will only operate with a voltage of  $5V \pm 0.5V$ .

## PART 12 QUESTIONS

12.1. How many *p-n* junctions are there in a junction f.e.t.:

- a) 1
- b) 2
- c) 3
- d) 4

12.2. Large scale integrated circuits are usually made with which type of transistor:

- a) bipolar
- b) junction f.e.t.
- c) m.o.s.f.e.t.

12.3. CMOS logic uses what type of m.o.s.f.e.t.:

- a) *n*-channel depletion
- b) *n*- and *p*-channel depletion
- c) *p*-channel enhancement
- d) *n*- and *p*-channel enhancement

12.4. A m.o.s.f.e.t. when suitably biased produces a change of 1.5mA drain current for a

change of 0.5V in the gate voltage. What is its transconductance:

- a)  $3000 \mu\text{mho}$
- b)  $300 \mu\text{mho}$
- c) 3mho
- d) 0.3mho

12.5. A 2N3819 f.e.t. with a transconductance of  $4000 \mu\text{mho}$  is biased so as to act as a linear amplifier. What change in drain current would be produced for a 1V change in gate voltage:

- a)  $4 \mu\text{A}$
- b) 4mA
- c)  $40 \mu\text{A}$
- d) 2.5mA

## PART 11 ANSWERS

11.1 b). 11.2 c). 11.3 a). 11.4 b). 11.5 a).

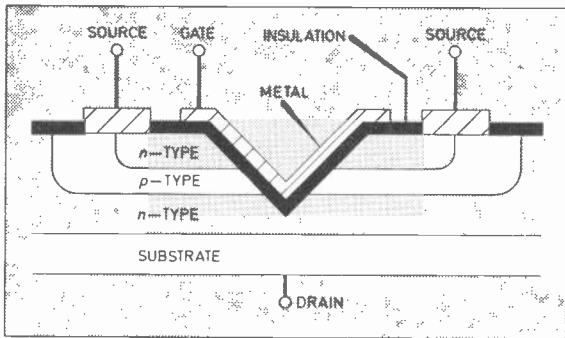


Fig. 12.8. The construction of a VMOS transistor. This differs from ordinary m.o.s.f.e.t.s in that it has a v-channel cut into the silicon.

The wide operating power supply range means that the power rail does not necessarily have to be pure d.c. but a large a.c. component can also be tolerated. Thus the power supply for a CMOS circuit does not have to be well-smoothed as it does for TTL and so can be relatively uncomplicated and thus cheap.

One problem with CMOS circuits is that they can be damaged by the static voltage which is often present on the body. This is because the tiny capacitance on the gate has a very low leakage and so any charge tends to produce very large voltages which exceed the breakdown voltage of the junctions.

Try to avoid touching the leads of the i.c.s until they are in the circuit, leaving them in the conductive foam in which they are supplied.

### F.E.T.S. IN LINEAR I.C.S.

In the last few years integrated circuit manufacturers have managed to combine f.e.t. and bipolar

transistors on a single chip thus producing operational amplifiers with extremely high input impedances but good drive capability and speed. Usually just the input stage is f.e.t. but some op-amps are made entirely from m.o.s.f.e.t.s.

The CA3140 op-amp which has been used in past articles is a combination of m.o.s. and bipolar technologies and the figures quoted earlier testify to its extremely high input impedance.

### POWER F.E.T.S.

Until the last couple of years f.e.t.s have not been produced which are capable of operating at high currents or powers. This gap has now been filled by a new breed of discrete f.e.t. known as v-channel m.o.s.f.e.t.s or vmos for short.

Conventional geometry of m.o.s.f.e.t.s meant that high currents could not be achieved with-

out huge chip area so a radically different geometry was needed. Fig. 12.8 shows a typical vmos transistor and it will be seen that instead of simply building up layers on the surface of the silicon, a v-shaped groove has been cut which is used for the gate.

VMOS transistors can handle currents of 10A but even higher current types are now appearing. They tend to be of the n-channel enhancement type since this allows a single power supply to be used. The real attraction of these vmos transistors is that currents of 10A can be switched by low power logic like CMOS making interfacing between logic and things like lamps or relays very simple indeed. Fig. 12.9 shows a typical circuit.

At the moment the price for these devices is very high but no doubt as the demand increases the price will fall and we will be seeing them used in EE projects. ☒

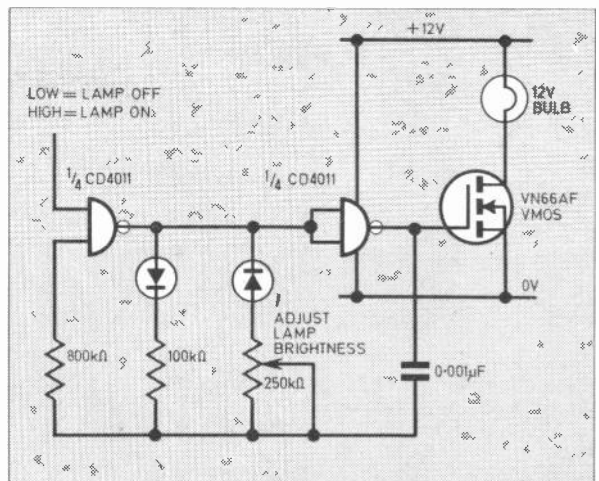
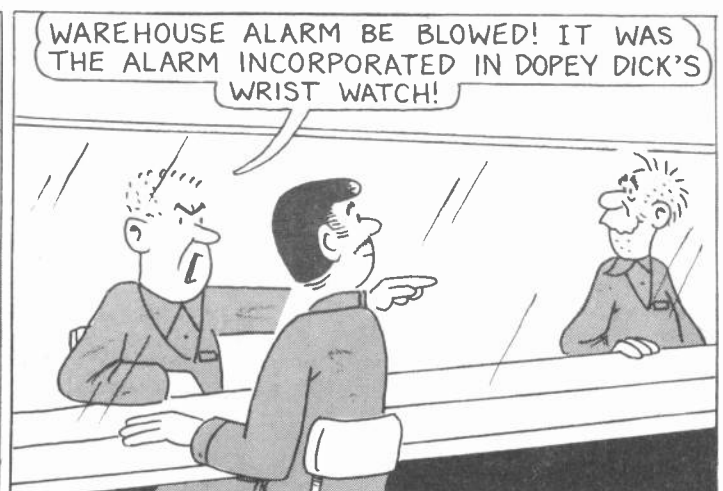


Fig. 12.9. This circuit illustrates how easy it is to interface low power logic in the form of CMOS to a high current output in the form of a lamp.

## JACK PLUG & FAMILY...

BY DOUG BAKER



# Logic

TTL

PROBE

BY A. WHEEN

ONE of the most useful pieces of test equipment for troubleshooting digital circuits is a logic probe. The probe to be described, which is for use on TTL devices, uses three l.e.d.s to indicate the state of the logic under test; these l.e.d.s are labelled HIGH, LOW and PULSE.

The HIGH and LOW l.e.d.s indicate logic 1 and logic 0 respectively, and when the point under test is oscillating between logic 1 and logic 0 the relative brightness of these two l.e.d.s gives some idea of the mark-space ratio of the waveform.

The l.e.d. labelled PULSE flashes on for one second every time the logic level at the probe input changes state. This can be used for detecting very short duration positive or negative-going spikes, which are much too fast to be visible on the HIGH and LOW l.e.d.s.

## CIRCUIT DESCRIPTION

IC1 is a quad Schmitt NAND circuit, with gates IC1a and IC1b being used as inverters and buffers. When the probe input is high (logic 1), D1 will light; similarly, when the probe input is low (logic 0), D2 will light. Since TTL regards an open-circuited input as being at logic 1, the output of gate IC1a will go low whenever the input is an open circuit.

To prevent the probe from indicating logic 1 for an open circuit input, TR1 was included in the circuit. Although a BC183 was used in the original design, any small npn transistor should operate satisfactorily in this circuit.

Integrated circuit IC2 is a quad 2-input exclusive-or device, and is wired so as to produce a short negative-going pulse whenever the probe input changes state. Since gates IC2a, b and c are all acting as inverters, the two inputs to gate IC2d are at opposite logic levels, and so the output of gate IC2d is high. However,

when the output of IC1a changes state, this change will not be reflected in the output of gate IC2 until about 45 nanoseconds later because of the propagation delays in gates IC2a, b and c. Thus, for about 45 nanoseconds, the inputs to gate IC2d are at the same level, causing a 45 nanosecond negative-going pulse to be produced.

This pulse sets the flip-flop formed by IC1c and d, and D3 lights to indicate that a change of state at the probe input has been detected. The flip-flop resets itself about one second later when the voltage across C1 has dropped to 0.9 volt; C1 is then charged up again via R4.



## CIRCUIT BOARD

The circuit is built on a piece of 0.1in matrix stripboard, size 9 strips by 29 holes. The i.c.s can be soldered directly to the board or mounted in Soldercon pins. If you wish to use i.c. sockets, note that some types mount the i.c. so high off the board that they will not fit in the case. Similarly, if you wish to use resistors rated at more than 1/4 watt, check that they can be fitted into the spaces allocated.

The case used in the prototype was an exhausted container for Multicore solder with three holes drilled in the side and spaced so that the three l.e.d.s on the circuit board can be seen through them.

The layout of the components on the topside of the board and the breaks to be made on the underside

are shown in Fig. 2. Note that there are some link wires to be connected beneath the i.c.s, and also on the underside of the board.

Begin by cutting the board to size and then filing it so that it is a little smaller than the internal diameter of the case.

Next make the cut-outs and solder in position all the link wires (above and below the board) followed by the components. Note the orientation of the l.e.d.s. These should be inserted so that the height to their tips above the board is a little more than the radius of the case. In this way, when the board is fixed in position the l.e.d.s will protrude a little allowing them to be seen more easily.

Drill three suitably sized holes in the case to align with the l.e.d.s on the board when the latter is in its final position.

Connect flying leads to the board, about 80mm to reach the probe point and about 1m for the supply lines. Red and black leads to represent "+" and "-" respectively are advised.

## PROBE POINT

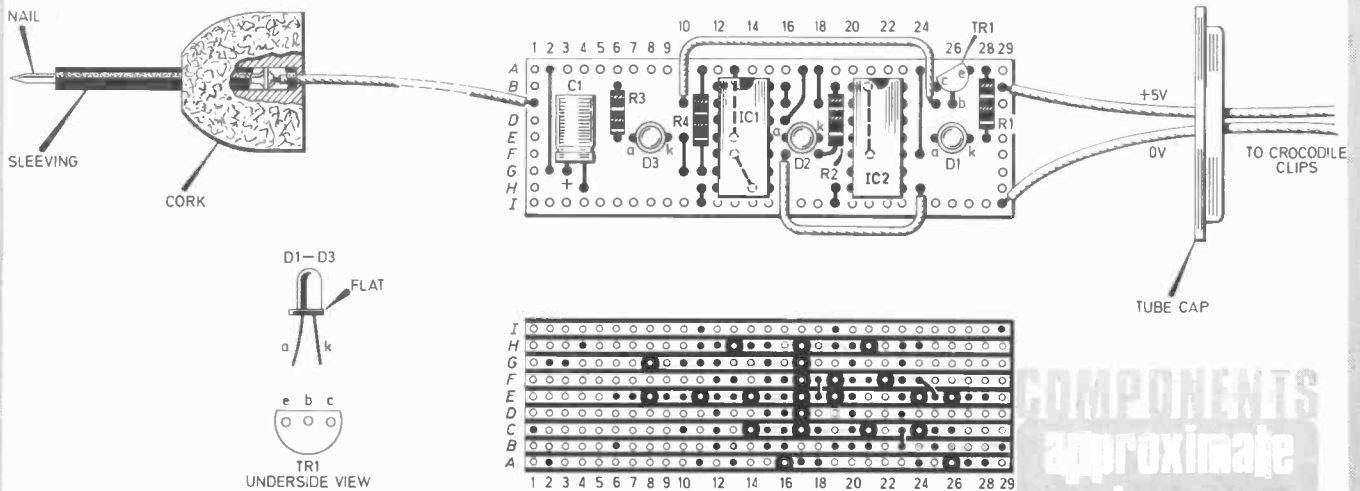
For the tip of the probe a small nail was used. The nail was driven through the centre of a cork shaped to fit the conical end of the tube and the section of the nail protruding from the cork was covered with rubber sleeving. It was necessary to enlarge the hole at the end of the tube so that the nail with its sleeving cover would fit tightly in it.

Solder the probe lead from the board to the head of the nail and cover the joint with some insulating tape.

Push the cork into the tube so that the nail protrudes through the hole in the tube. The cork can be glued in place, but in the prototype this was found to be unnecessary.



# LOGIC PROBE



COMPONENTS  
approximate  
cost £2.20

Fig. 2. Circuit board layout and construction. Note that there are three wire links on the underside of the board.

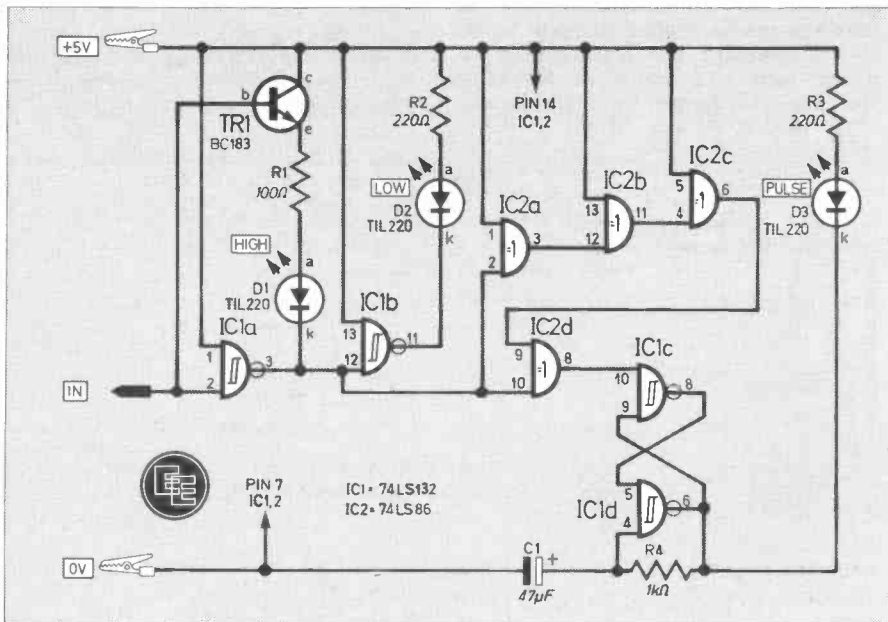
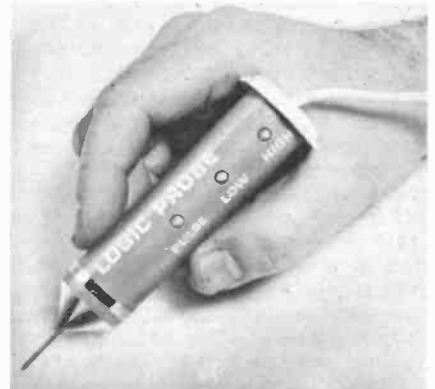
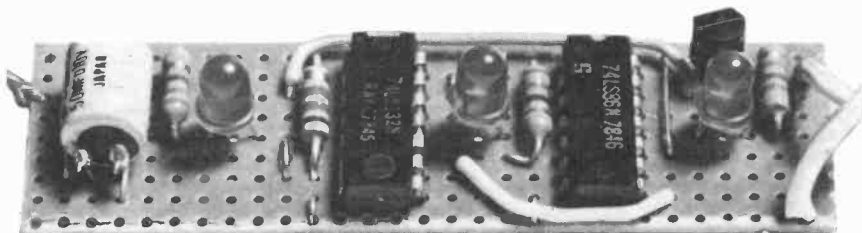


Fig. 1. Full circuit diagram of the Logic Probe.

The photograph below shows a close up view of the circuit board. The logic probe can be seen in its case in the right hand photograph.



## COMPONENTS

### Resistors

- R1 100Ω
- R2 220Ω
- R3 220Ω
- R4 1kΩ
- All ¼W carbon ± 5%

See  
**Shop  
Talk**  
page 553

### Capacitor

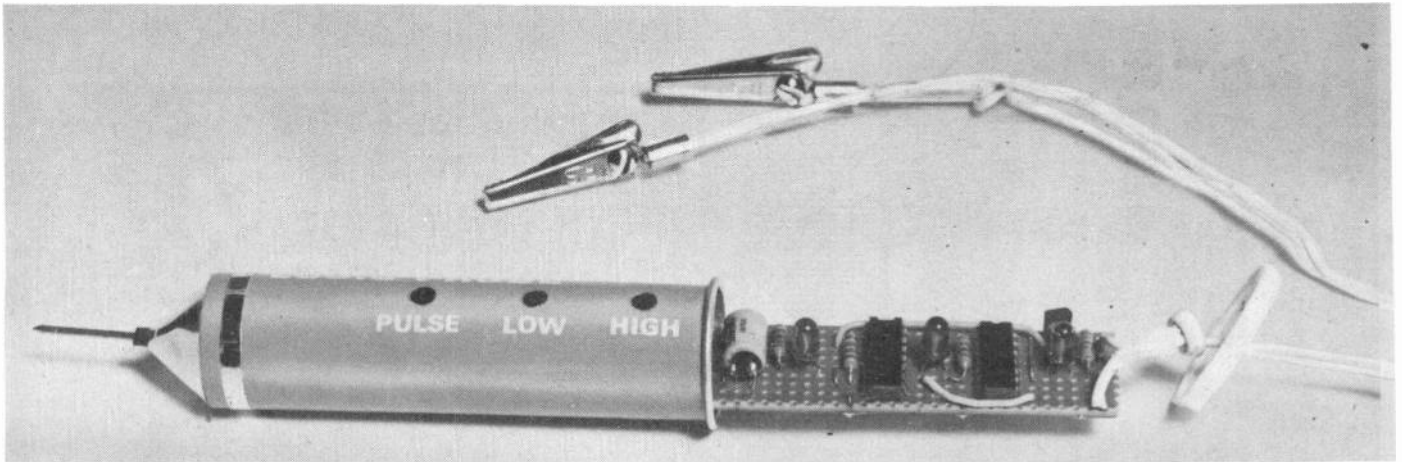
- C1 47µF 10V elect.

### Semiconductors

- IC1 74LS132 TTL quad 2-input Schmitt NAND gates
- IC2 74LS86 TTL quad 2-input exclusive-OR gates
- TR1 BC183 silicon *n**p**n*

### Miscellaneous

0.1 inch matrix stripboard, size 9 strips × 29 holes; Multicore solder dispenser (case); crocodile clips (2 off); stranded p.v.c. covered wire about 1 meter each red and black; cork and nail (probe tip assembly).



Exploded view of the unit showing the board ready for insertion in its case.

Next, drill a small hole in the white plastic cap which fits on the ends of the tube. Feed the supply wires through this hole and knot it inside the cap, allowing about 25mm of slack between the circuit board and the knot. The circuit board can now be fitted into the tube.

Ensure that l.e.d.s are lined up with their holes and then push the board upwards so that the l.e.d.s protrude through the holes. Secure in this position with a piece of polystyrene or foam sponge. Fit the cap

on the tube and crocodile clips on the two supply wires emerging from the cap.

### TESTING

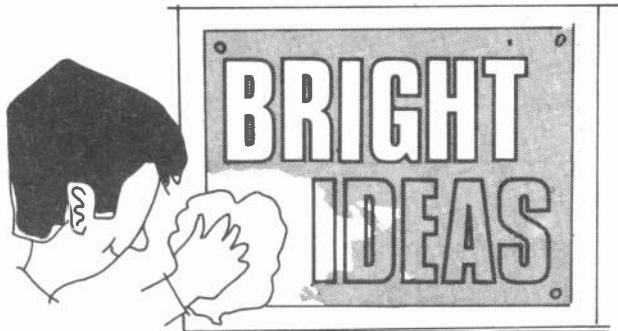
Carefully connect the supply leads to the power rails on a TTL circuit, or a p.s.u. set to +5 volt. Touch the probe on to the positive supply rail and the probe should indicate HIGH, D1 lit. Similarly, the probe should indicate LOW (D2 lit) when touching the negative supply rail, and should

not indicate anything when the probe is not touching anything.

Check that the PULSE l.e.d., D3, flashes when the probe is touched on to the negative supply rail, and once again when it is removed from the supply rail.

Note that this l.e.d. will not flash when the probe touches the positive supply.

If all is well the case may be painted and the three l.e.d.s labelled with their function as shown in the photographs. □



Readers' Bright Ideas; any idea that is published will be awarded payment according to its merit. The ideas have not been proved by us.

### BIT REMOVAL

When one wishes to renew the copper bit of a soldering iron, one almost always finds that it is almost impossible to remove the old bit, since the surface between the bit and the bit holder has become badly corroded.

It may be possible to remove the old bit by drilling it out, but one normally adopts the easier task of replacing both the bit and the bit holder.

This problem can be avoided if a copious layer of silicone grease is placed on each new bit before it is placed in the bit holder. The grease should be kept well away from the tip of the bit which will be used for soldering, but the regions which will come into contact with the bit holder should be well covered.

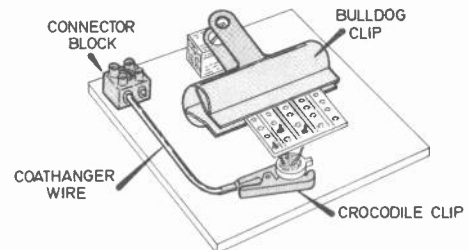
When the soldering iron is used, the silicone grease is converted into a white coating which seems to prevent appreciable

oxidation of the copper surface. The bit can be removed quite easily after the split pin has been taken out, since the white coating crumbles away.

J. B. Dance,  
Alcester,  
Warks.

### MINI-BENCH

I have devised a simple, inexpensive circuit board holder for when you are soldering, as seen below.



To hold the circuit board I used a bulldog clip. The metal clasps could also act as heatsinks, but where delicate boards were used I stuck draught excluder tape along them. To hold the component in place coathanger wire is used with a crocodile clip attached to the end. This is held in place by a screw terminal block fitted to the base.

R. Harrison,  
Witham,  
Essex.

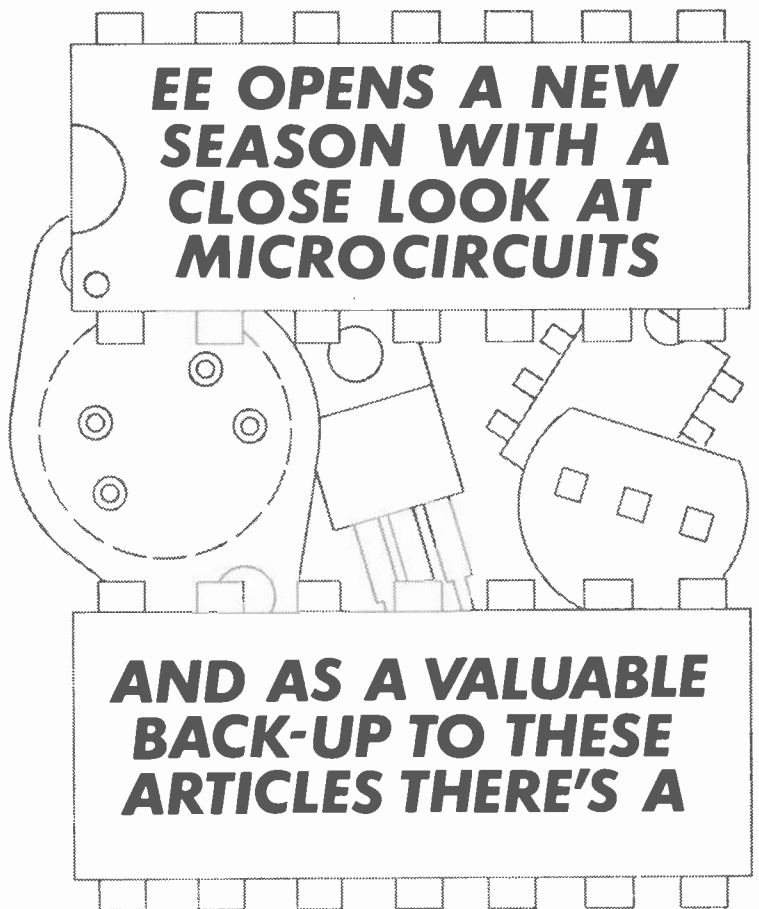
# NEXT MONTH

## INTRODUCING MICROCIRCUITS

This special feature puts the layman in the picture concerning the silicon chip or integrated circuit. It provides a good lead-in to our NEW SERIES, commencing in the same issue.

## I.C.s EXPLAINED

This series will discuss specific types of i.c.s. and illustrate typical circuit applications. The first four parts deal with LINEAR I.C.'s.



**free**

# WALLCHART

GUIDE TO POPULAR LINEAR I.C.s  
with every copy of the October issue

## CONSTRUCTIONAL PROJECTS INCLUDE

AUDIO EFFECTS UNIT

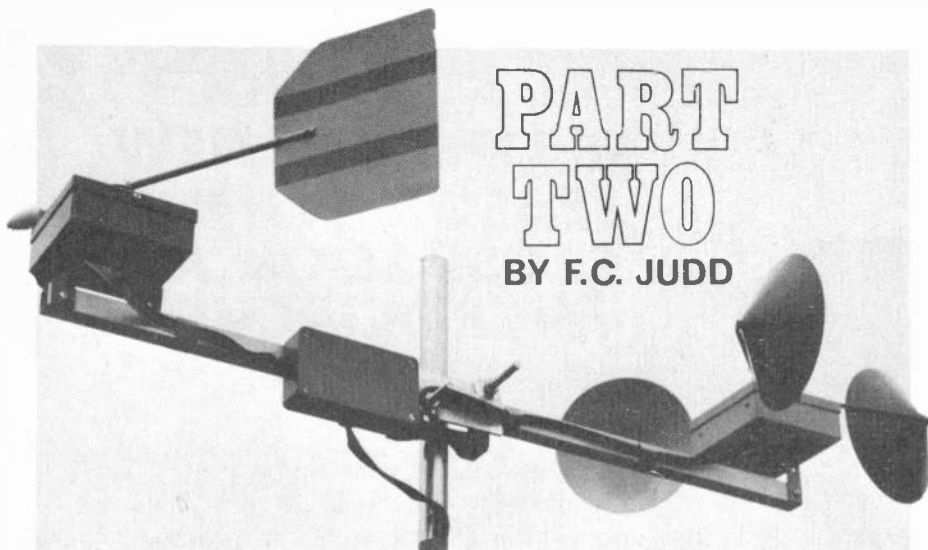
DARKROOM CONTROLLER

PHONE CALL CHARGE JOGGER

BICYCLE ALARM

# Everyday ELECTRONICS

OCTOBER 1980  
ISSUE ON SALE  
FRIDAY, SEPTEMBER 19



## PART TWO BY F.C. JUDD

# WEATHER CENTRE

**T**HIS second part of the Weather Centre deals with the construction of the sensors and final adjustment and setting up.

The main outdoor items are the anemometer and wind direction units both of which are mounted on a boom that can be attached to a short mast on a chimney stack or similar position clear of the roof top of the home.

### ANEMOMETER

The anemometer or wind speed unit is housed in an aluminium box as in the illustrations. Some mechanical work is involved in making the wind cups, chopper disc, etc, and it would be a good idea to study all the drawings and photographs before making a start.

The wind cups are first carefully cut out of aluminium sheet and folded into the required cone shape. The joins can be riveted or secured with small screws and nuts after which each cup is mounted on its arm with a 4BA screw and nut (see Figs. 13 and 14).

The three arms and cups should next be attached to the circular mounting plate (see Fig. 17). This consists of a 40mm diameter brass disc onto which a collar has been soldered. The disc is drilled through the centre with a 6mm clearance hole.

### CHOPPER

The next stage is to make the circular Perspex infra-red chopper disc as in Fig. 17. Cut the material as near round as possible and slightly oversize then drill a 6mm hole through the centre.

Fit the nearly formed disc to an arbor and mount it in an electric drill which has been clamped to the bench. Using a file (for example a "Surform" type), to cut the disc edges, continue to turn the disc until it is perfectly circular and of the correct diameter.

The same method is used to turn the brass discs and also the rain protection discs, one of which is shown on Fig. 17.

The chopper disc is finished off by drilling 18 equally spaced 6mm diameter holes according to the diagram. The bushes used for the shaft are standard  $\frac{3}{8}$  inch brass types and the collars for the brass discs can be cut from standard  $\frac{1}{4}$  inch brass spindle couplers.

The disc should be given a couple of coats of paint to make it completely opaque before it is installed in the final unit.

The next step is to build the circuit board according to Fig. 11. The infra-red i.e.d. D14 and the photo-transistor TR3, should be arranged so that they stand off the board and are bent at right angles facing each

other making sure that they are directly in line.

The completed board should then be mounted in position inside the aluminium box. The shaft which will take the chopper disc should be placed carefully in the bush through the bottom of the box and the chopper disc inserted between D14 and TR3. The shaft can then be pushed through the disc from beneath and tightened in position.

The top is then placed on the enclosure and the rotating assembly screwed in position. Note that there is a 6mm perspex disc between the cup assembly and the bush in the top of the case.

### CABLES

The cables from the circuit board need only be about 600mm long and consist of one single screened wire and a single insulated wire. These are eventually connected to a junction box on the boom.

When assembly is complete the wind cups should rotate freely with a slight breeze on them. The cups should rotate quite easily and smoothly in a wind down to 2 m.p.h.

### WIND DIRECTION UNIT

A 16-point compass wind direction indication is obtained from eight i.e.d.s on the readout display, these being activated by a series of reed relays operated by a magnet attached to a disc which is in turn fastened to the shaft of the wind vane (see Fig. 14).

As can be seen from Fig. 15, the reed relays are assembled in a circle on circuit boards and enclosed in a protective aluminium box. These circuit boards can either be printed circuit boards or plain s.r.b.p. board with Veropins at the appropriate locations.

However, whichever method is used, the reed relays are all connected together on the top board as a common return and have separate connections on the bottom board. The lead outs here are by means of 10-way ribbon cable.

The diagram in Fig. 15 shows how the unit is put together. The metal work is almost identical to that of the wind speed unit, the only difference being that the rotating chopper disc is replaced by a brass disc to which a magnet has been glued with epoxy resin.

### MAGNET AND ROTOR

In assembly of the direction unit, the one point that should be noted is that the rotor assembly and bottom board must be placed in position before the top board is soldered in. If this is not adhered to, it becomes

impossible to place the rotor disc with the magnet in position.

The unit is then finished off according to the illustrations and photographs.

## MAIN CABLE

The main cable from the direction indicator is a 10-way flat ribbon type available in 10 or 25 metre lengths. Connections to the wind speed unit are made via a single screened cable plus one of the wires of the 10-way cable. The nine other colour coded wires to the direction indicator unit are connected as in Fig. 16.

Connections of all cables from the wind speed and direction units are terminated at a 12-way terminal block housed in a small plastic box. This is mounted on the metal boom to which the wind speed and direction units are fixed (see Fig. 16). The boom itself can be fixed to a stub mast quite easily with a standard TV aerial claw clamp.

The whole assembly must, however, be mounted reasonably clear of the house roof top and any obstruction likely to impede the flow of air or cause fluctuation in wind direction, for example, a chimney stack in the path of the wind from any direction around the units.

# HARDWARE

20 or 22s.w.g. aluminium sheet for wind cups;  $\frac{1}{4}$  inch (6mm) aluminium rod or thick wall tube;  $\frac{3}{4}$  inch square-section aluminium tube for boom; Perspex and brass for chopper and discs as per diagrams;  $\frac{3}{8}$  inch ( $\frac{1}{2}$  inch bore) brass bushes (4 off); standard  $\frac{1}{4}$  inch bore brass spindle couplers for making collars (4 off); aluminium boxes  $4 \times 4 \times 1\frac{1}{2}$  inch, Bi-Pak type BA2 or similar (2 off); mild steel or aluminium angle for unit supports as per diagrams; small circular or square plastic boxes for temperature sensors; zinc plated self tapping screws; TV aerial claw clamp for securing boom to mounting pole.

Connections down to the readout display are made via the junction box, and use the 10-way ribbon cable plus one run of single core screened cable.

## PRELIMINARY CHECKS

When the wind speed and direction units are fully assembled on the boom the short cables from these to the junction box can be connected.

Take the whole assembly outside, preferably when there is a light wind blowing. When held horizontal at

head height, the anemometer cups should rotate freely and the direction vane move to a position 180 degrees to the wind direction, that is the small arrow should point into the wind.

Further notes on setting up will be given later, but a check could be made at this stage to confirm that all the reed relays are operating by connecting an ohm-meter between the common lead and each reed relay connection.

The meter should show continuity at each main compass point, with the

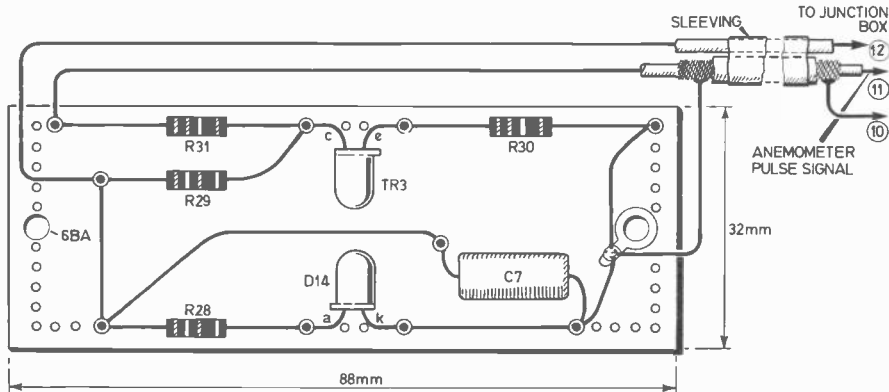
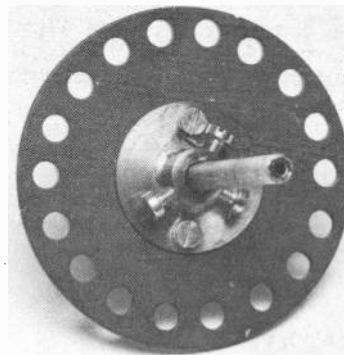
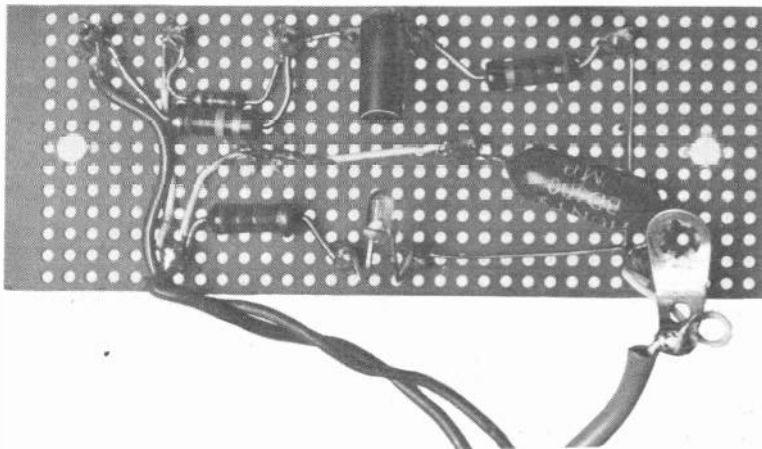
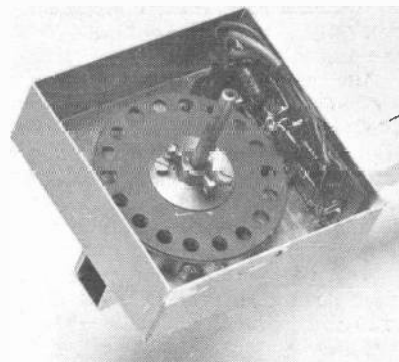


Fig. 11. Circuit board layout for the wind speed sensor unit. The photograph below shows the top view of the prototype board.

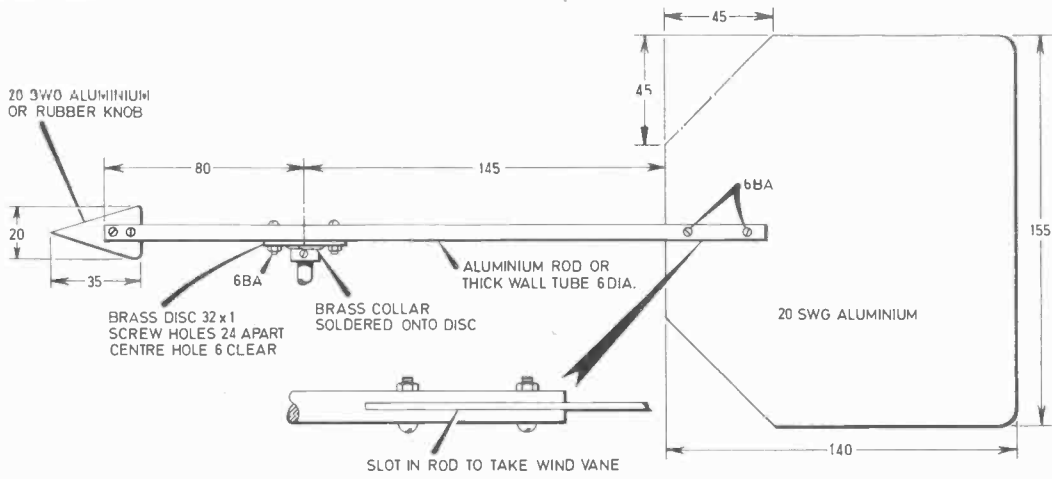


Close up view of the chopper disc.

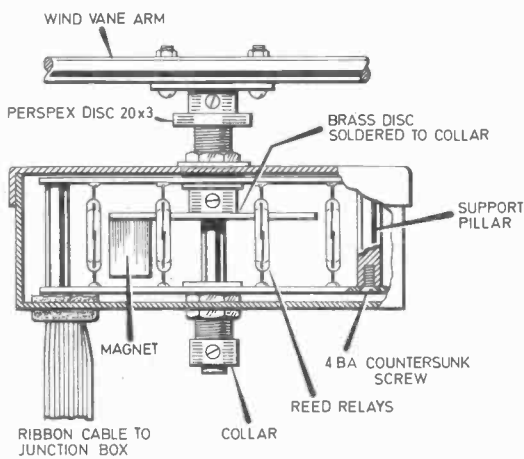
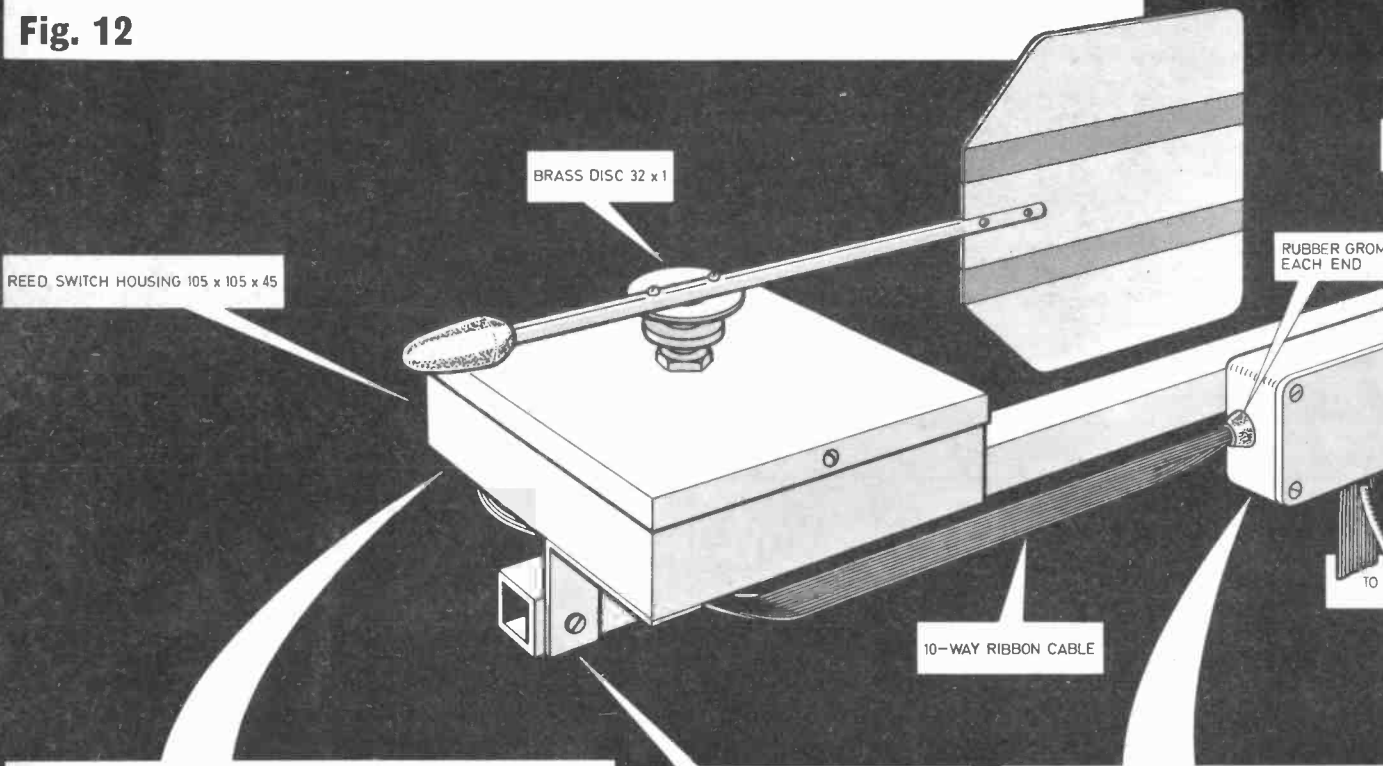


Interior view of completed wind speed detector unit.

# WIND VANE

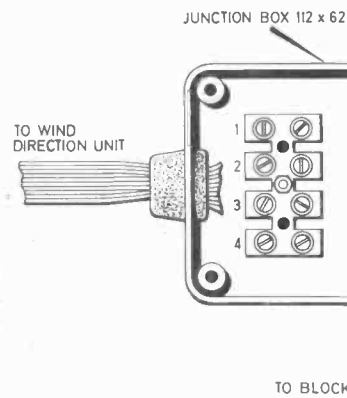


**Fig. 12**



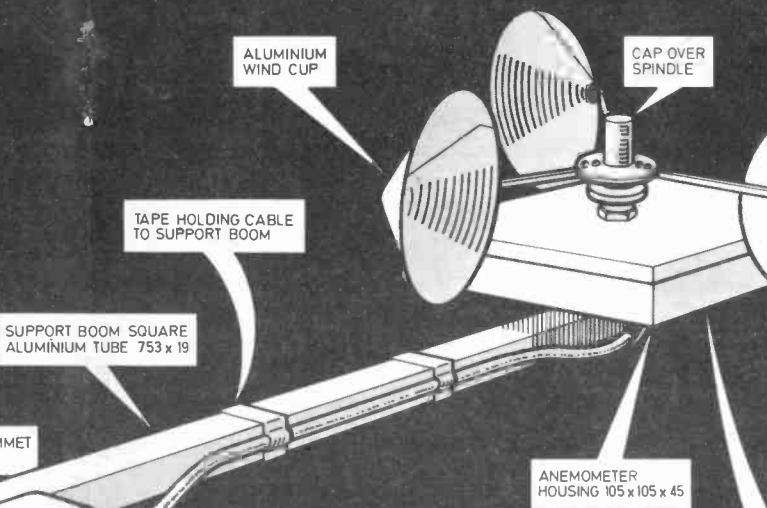
MILD STEEL FIXING BRACKET (4 OFF)  
35 x 35 x 15 HELD WITH SELF TAP  
SCREWS

**Fig. 15 REED SWITCH HOUSING**



**TERMINAL BLOCK HOUSING**

# WEATHER CENTRE



## WIND CUP

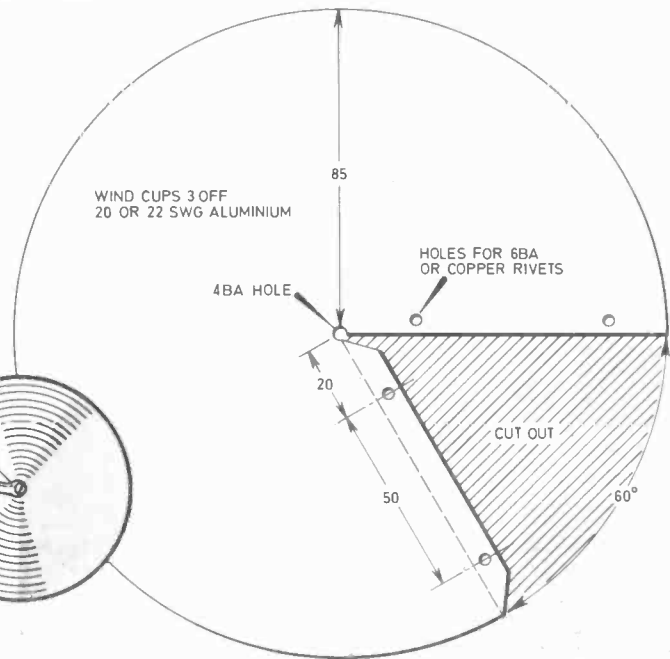


Fig. 13

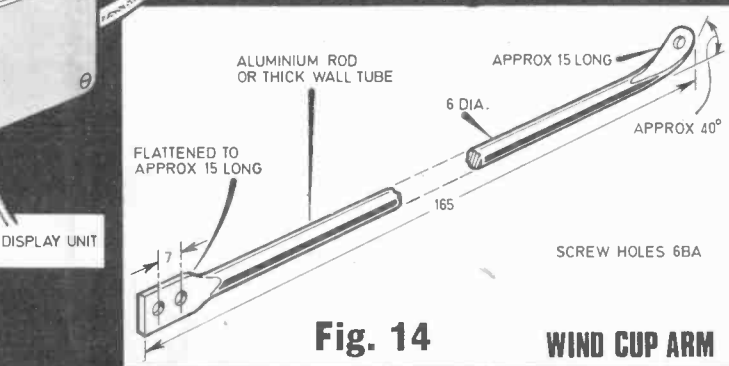


Fig. 14

## WIND CUP ARM

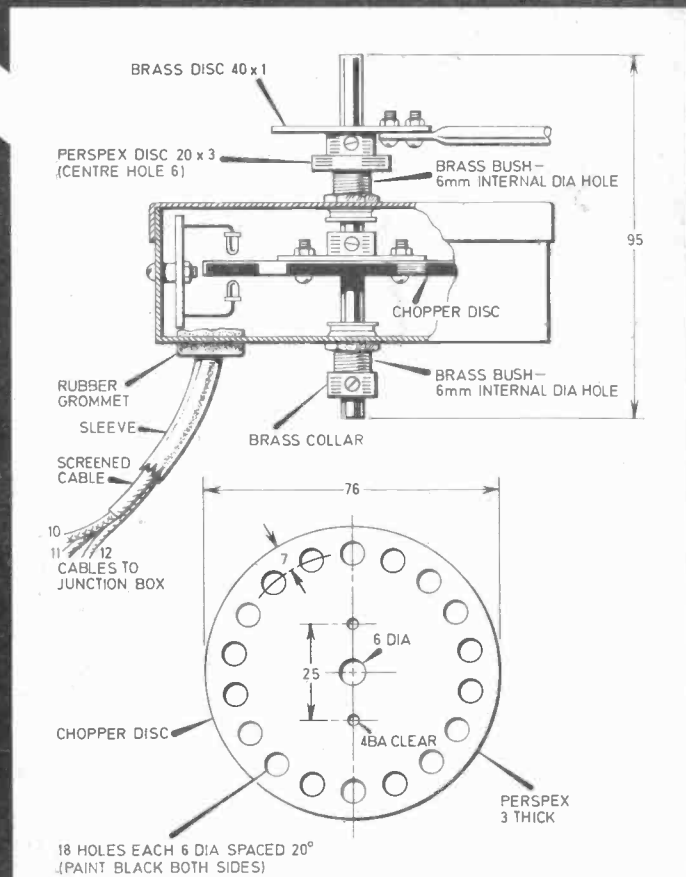


Fig. 17

## ANEMOMETER HOUSING

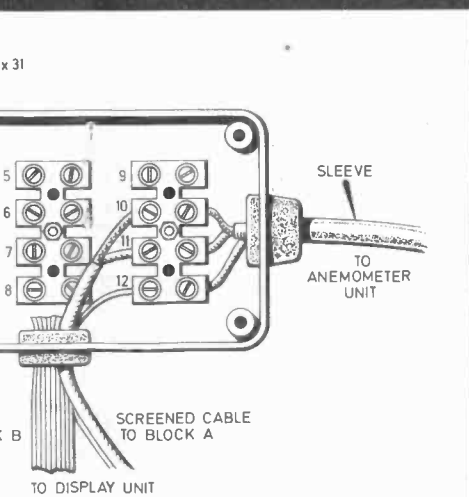


Fig. 16

ALL DIMENSIONS IN mm

appropriate switch closed, as the vane is moved slowly round by hand from N through to N.

If an oscilloscope is available, a preliminary check could also be made on the anemometer unit. Connect up a 12V battery with positive going to connection 12 on the terminal block, negative to connection 10. The output from connection 11 can then be fed to the oscilloscope.

Spinning the cups should produce a nearly uniform square wave as shown in Fig. 3 from Part One, last month.

## TEMPERATURE DIODES

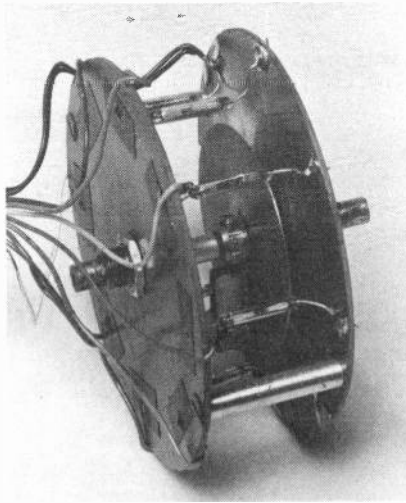
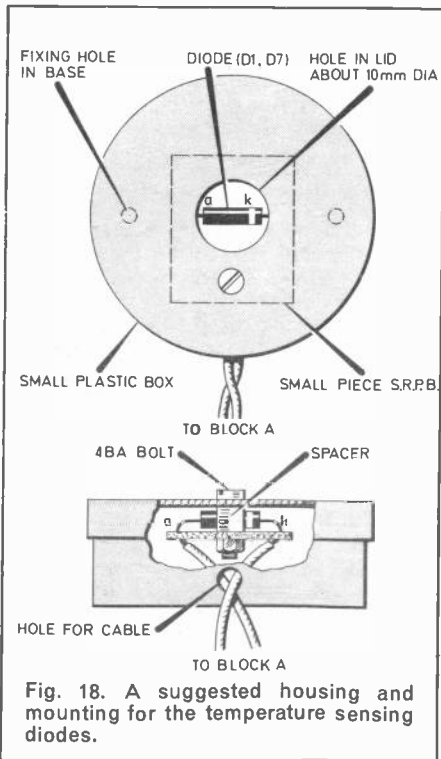
The final items in this project are the temperature sensing diodes D1 and D7 which are mounted in small plastic boxes, such as those used for typewriter ribbons, for protection.

Before this is done, however, the equipment needs calibrating for each diode.

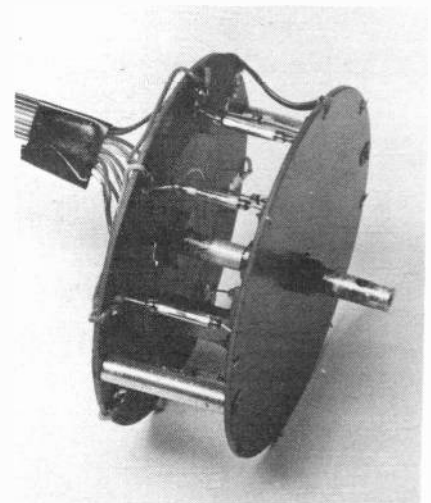
The specified meter has a scale of 0 to 100 in major units of 20, subdivided into divisions of 10 and 2 and therefore a total of 50 divisions. Each of these represent two degrees of temperature or 2 m.p.h. of wind speed.

## TEMPERATURE CALIBRATION

No two diodes, even of the same type, have exactly the same current/resistance characteristics, so the equipment must be calibrated separately for each sensing diode. For this purpose two wires are temporarily soldered to the ends of the diodes.



View of the reed switch assembly showing lower circuit board and common connection of the switches.



View of the reed switch assembly showing the upper circuit board and individual switch connections leading to the ribbon cable.

## OUTSIDE TEMPERATURE

Take one diode and connect it up to the outside temperature terminals on the back of the main display unit. Make sure that the cathode of the diode is connected to the common or earthed input terminal.

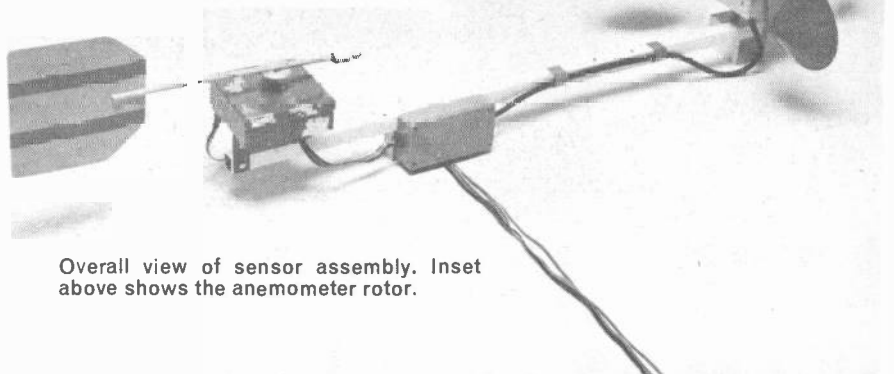
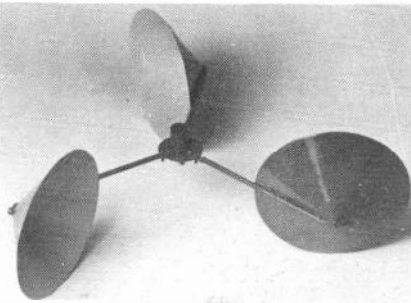
Set the wind speed select switch S3 to "wind speed cal" and the temperature select switch S1 to "0 degrees cal". The l.e.d. D8 should be flashing slowly. Adjust VR3 until the meter reads 0 degrees which is 40 on the normal meter scale.

For the next stage a small dish or glass of freezing mixture is needed. This should ideally consist of ice and water at zero degrees Celsius and the easiest way to obtain this is to put

the water into the dish or glass and place it in a freezer until ice is just beginning to form. Set the temperature select switch S1 to "outside temperature" and the wind speed select switch S3 to "temperature" and place the diode in contact with the mixture. Set VR5 about half way and adjust VR4 until the meter reads approximately 0 degrees.

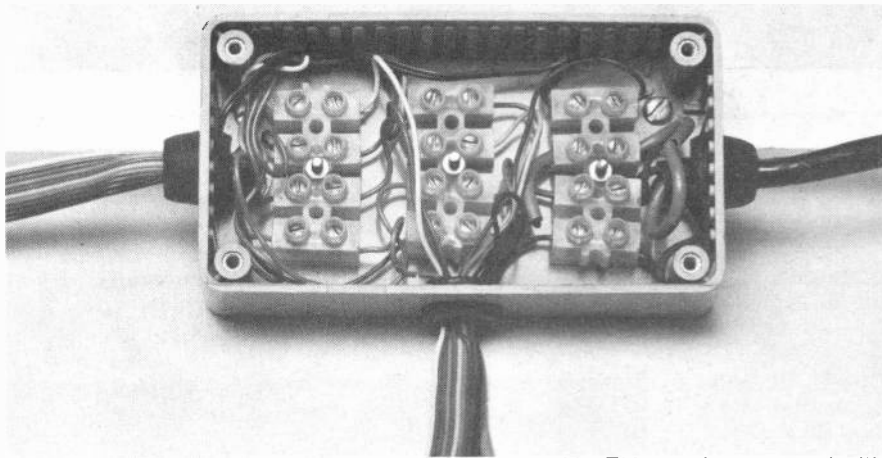
Remove the diode from the ice/water mixture and wait for a few minutes for the meter to increase its reading and then remain stationary. This will be at room temperature. Next adjust VR5 until the meter is reading the correct temperature. This can be verified with a normal mercury in glass thermometer.

Now return the diode to the ice/water mixture and readjust VR4 so that the meter reads 0 degrees and keep on moving the diode from ice to room temperature in turn and adjusting the relevant presets until



Overall view of sensor assembly. Inset above shows the anemometer rotor.





Interior view of the terminal block on the sensor assembly. This can be compared with Fig. 16.

correct reading appears every time.

The circuitry for the outside temperature of the unit is now calibrated for this particular diode. This diode must be kept only for outside temperature measurement.

### INSIDE TEMPERATURE

The procedure for setting up the inside temperature circuit is exactly the same but using the diode sensor chosen for this connected up to the appropriate input terminals. In this case the presets VR1 (zero degrees) and VR2 (room temperature) are used. This diode must be kept only for inside temperature measurement.

### DIODE MOUNTING

Each diode can now be mounted in a small plastic box and provided with a pair of connecting leads long

enough to reach the final positions from the readout display unit.

Likewise, the wind speed and direction unit can now be permanently mounted in position, although it would be a good idea to connect it up to the display unit and quickly check the wind speed and direction functions before finally installing the wind speed/direction sensor unit in its permanent location.

### WIND SPEED

Calibration is completed by setting up the display unit for correct wind speed. Set the wind speed select switch S3 to "wind speed cal". The l.e.d. D8 should be flashing slowly. Adjust VR6 until the meter reads 19, that is about half a division below 20. Calibration for wind speed is now complete for 0 to 100 m.p.h. but can always be checked again by repeating the above procedure.

At this point the meter can be labelled. First, remove the meter cover and very carefully release the scale itself by undoing the securing screws. Then slide the scale outward underneath the pointer. Calibration figures for temperature and wind speed can be put on with Letraset or drawing ink as shown in the photographs. Equally carefully, replace the scale and meter cover.

The Weather Centre is now ready for use.

### SENSOR LOCATION

The sensor for outside temperature should be mounted about 1.5m above ground on a North-facing wall or location shaded from direct sunlight. Make sure that water cannot enter the enclosure by sealing the lid all the way round with tape or epoxy resin. The sensor for inside temperature can of course be used anywhere in the house, the most likely place being the main living room. Alternatively, it can be used in a greenhouse.

The wind speed/direction sensors should be mounted well clear of any obstructions such as chimney stacks that might cause a disturbance in the air flow. The boom should also be lined up so that the reed relay S4 corresponding to the N l.e.d. D15 is in fact pointing North. Wind speed is measured in miles per hour or knots, either of which can be converted to the Beaufort scale. A printed scale is provided (see Fig. 10) for the constructor to fasten onto the front of the display unit for reference.

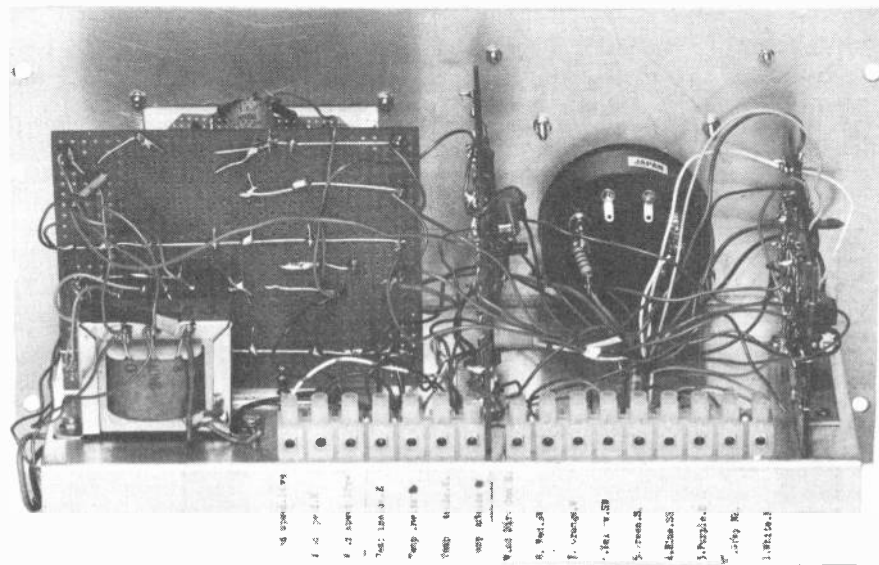
However, it must be remembered that even when the wind is blowing steadily, there are still fluctuations in wind speed known as gusts and lulls. For example, when the general wind speed is averaging 20 m.p.h. the speed over a period of a few minutes may fluctuate between 10 and 30 m.p.h.

Wind direction never remains absolutely steady either and even with normal wind the vane may move rapidly between two or three main compass points. For example, with a generally West wind the l.e.d. indicators may show SW and NW frequently together with W. If the dominant indication is West, then this will be the main direction.

### FURTHER INFORMATION

Bona fide applicants, such as school teachers, students engaged in weather studies, colleges, etc can usually obtain all kinds of information on weather and weather forecasting, quite free from the Independent TV companies' weather departments and you might also like to try your local Meteorological Office weather station, whose address is usually in the telephone directory. ☐

Rear view of display unit showing sensor connection points and terminal blocks.



# Everyday News

## CHALLENGE OF THE CHIP

The chips are down at the Science Museum and they're there for all to see! Over 200 microprocessors are on show, some working, in an exhibition on the first floor of the Science Museum, London

Aimed at showing the present and future possibilities of the chip in everyday life, this is an exhibition that tells the story from the beginning through to displays of applications of the very near future. It deals with the invention, development, and applications of the transistor, integrated circuit and the methods by which they are made on a minute scale.

Electronic games and toys take up a large section of the exhibition. This is because most people come into contact with microchip technology through these and therefore they come to terms with them more easily than just looking at a piece of technical equipment.

A large number of manufacturers and suppliers have contributed objects and equipment for display. The aim is to attract as many people as possible to this free exhibition. To this end special evening openings are being held to enable staff of industrial and commercial organisations to attend at their leisure.

### Super Market

One exhibit, that of a supermarket checkout point, is manned and the continuous demonstration shows just one application of the chip together with laser technology.

Each item "purchased" is passed over a window instead of the assistant lifting the item up to read the price. A laser beam scans the window until it reads a barcode (thick and thin black lines printed onto the packing of the item purchased), the information is fed to a microcomputer in the cash register automatically.

The printed bill gives details of the item: the price, an abbreviated "title" for each purchase i.e. B.FAST CEREAL for Corn Flakes (a breakfast cereal). The bill is totalled after the assistant touches the total button or touchplate. They then enter the amount of money tendered, the printout gives the amount of change due, the till drawer opens, when it closes the date and time of purchase prints out and a receipt number and message appear "THANK YOU, CALL AGAIN".



Another very interesting exhibit, contributed by Marconi Avionics, is a large model of an advanced fighter plane of the future, demonstrating the role of the microprocessor in "tomorrow's" military and civilian aircraft.

This is an exhibition that is a must for everyone. The whole family will find something of interest and fun in its presentation. Due to run until "at least the end of the year" it will be interesting to see how many items stand the pace of continuous use.

### Audio Agreement

A step forward to industry standardisation in digital audio discs has been made by a new agreement between Sony and Philips who are already in agreement on compatible video discs.

The audio discs will use 16-bit encoding on a 12cm disc and will be single-sided with a playing time of one hour. The discs play through an optical laser system with no wear on the disc.

### TX9 Exported

The new and highly successful Thorn TX9 TV chassis has attracted world-wide attention. An agreement recently signed allows the TX9 design to be assembled from kits of parts in Hong Kong and China. Similar agreements have also been made with electronics companies in Italy and Scandinavia.

**VDU's  
Cleared**

Anxiety about health hazards from visual display units has been largely dispelled in a report from the VDU Eye Test Advisory Group.

The report claims that there is no significant radiation hazard and that complaints of strain arise from method of use of the equipment and not the equipment itself. The report, however, urges the need for regular checks of the eyesight of continuous users.

### NEWSPAPER by Satellite

The New York Times is sending facsimile pages by high speed satellite data link to Chicago for local printing. Two pages are transmitted every 2½ minutes through unattended earth terminals at each end using 10 metre diameter dishes.

Computer manufacturer LogAbax has estimated that computers are being installed in the UK at a rate of 400 a week, mostly to small or medium business users.



## ANALYSIS

### TWO WORLDS

The electronic hobbyist soon acquires a good knowledge of what's happening and what's new in consumer electronics. He or she gets full exposure to component and kit availability through electronics constructor magazines such as *EVERYDAY ELECTRONICS*. The latest in ready-mades can be seen in every shopping centre. Whether we buy or build our equipment it ends up in our homes and, in the jargon of the economist, we are all members of the consumer electronics market.

Less well known to the hobbyist is the other world, that of electronic capital equipment also sometimes called "professional" electronics. This world is largely hidden from the public although we benefit daily from it.

The world of electronic capital equipment embraces the radio and TV transmitters and studio equipment, the radars and other navigational equipment that speed us on our holiday flights, the computers that remind us of our bank overdraft, the police radio network which helps preserve law and order, the industrial automation keeping industry going, and defence electronics which helps maintain peace.

Electronic capital equipment design and manufacture is a success story that is overlooked by the media who much prefer to report the failures of steel or shipbuilding, or industrial unrest. This industry is producing £1,500 million worth of equipment and systems a year and selling it profitably. About one third of the total is exported and after deducting imports in the same categories there is a surplus of £140 million in overseas trade balance.

The workforce of some 100,000 people is increasing yearly despite the fact that i.c.s have reduced labour content in the finished product. Another big plus factor is the level of enthusiasm in the industry and consequent lack of disputes. After all, everybody knows they are backing a winner and don't want to see it nobbled when order books are at their best ever levels.

There is only one snag. The sky would be the limit but for the fact of a chronic shortage of engineers and technicians. This is where the hobbyist can help while, at the same time, promoting his or her own interests. Anyone who understands the fundamentals of electronics can carve a career in an industry in which there is virtually no limit to growth. The jobs are there waiting to be filled and providing you are keen (which most hobbyists are) and know your basics the firm will help train you.

It's worth thinking about.

Brian G. Peck

### USA Buys British

Multi-million pound orders have been received by Redifon Simulator Ltd for flight simulators for the new generation Boeing 757 and 767 jet aircraft for the United States.

Britain's aerospace industry, which has a large electronics content, is having a record year with exports targeted at £1,500 million. Over 50,000 trade visitors from 100 countries will attend the Farnborough Air Show in September.

### Teletext in Print

The Department of Industry has just published a leaflet on "Teletext" as part of a campaign to make the public more aware of the TV information service in which the UK leads the world—who said the printed word was on the way out?

Copies of the Teletext leaflet are available free from MAP Information Centre, Freepost, Dept of Industry, Room 114, Dean Bradley House, 52 Horseferry Road, London SW1 2BR.

### WORRIED UNION

The Post Office Engineering Union is reported as "being worried" over the implementation by the BPO of the new System X digital telephone network, the first exchanges of which will enter service this year. Reason for Union concern is System X reliability of a measured call failure rate of one in 10,000, needing a staffing of only one technician per 10,000 lines, far fewer than at present.

In Union eyes System X is far too good. Subscribers, however, will welcome the improved reliability.

### SOLAR TELEPHONES

British company Lucas Energy Systems has won a £1.2 million contract for solar panels to power a rural telecommunications network in Colombia. Sun power will be converted to 100kW of electrical energy through

2,550 solar panels distributed throughout the network.

This is believed to be the largest single order ever taken in this area of solar panels and was won against fierce competition from the USA, Japan and France.

Japan's JVC and Britain's Thorn EMI are joining forces in the video disc business. The new tie-up will challenge RCA and Philips for dominance in the market place.

All three manufacturers have different proposed systems with none so far recognised as an industry standard.

### GOLD STANDARD

One of the measures of health in the electronics industry is gold consumption, used in high quality components and assemblies. The UK industry doubled its gold intake during the past year to a value of £60 million, fourth highest of the electronics producing nations with only the USA, Japan, and Germany ahead in the gold usage league table.

### Electronic Translation

The EEC Commission is reported to be investigating schemes for electronic translation between the six official languages used daily by the 7,000 civil servants in Brussels.

Automatic translation from one language to another would ease the task of, if not dispense with, the present force of highly paid translators.

The prospect of a flat "hang-on-the-wall" TV receiver is still a dream of the future according to speakers at a recent IEE colloquium on the topic. Except, that is, for tiny screens. For the foreseeable future the conventional c.r.t. will remain on top.

### Underwater Colour

An underwater colour TV camera for deep sea (up to 2,000ft) inspection of structures has been developed by Marconi Avionics. Special signal processing brings out colours which otherwise are obscured by sea water and can reveal information vital to safe maintenance.

The camera is housed in an anodised aluminium housing similar in specification to that used on naval torpedoes. It can be hand-held by a diver or operated by remote control.

# RADIO WORLD

By Pat Hawker, G3VA

## Electronics and reliability

Over many years, industry has been striving to overcome the feeling of many of the public that complex electronics equipment, although capable of doing many wonderful things, can still prove to be rather unreliable, particularly when it is used in hostile environments.

Semiconductors rather than glass valves have done much to improve matters, although, it could be argued, better packaging and materials research have done even more. It was said, for example, that over 90 per cent of the early radar cathode-ray tubes arrived overseas during wartime in a damaged or broken condition due to bad packaging.

The need to put equipment into packages capable of being launched into space and working unattended for from five to seven years has led to intensive work on discovering and overcoming failure mechanisms, and this has had a valuable spin-off throughout the industry. In the past decade, the number of service calls to the domestic colour TV set has dropped, on average, from over four per year to less than one.

But the 1980 *Observer* single-handed Atlantic yacht race cannot have done this image any good. Much was expected of the French *Argos* automatic position-reporting-via-satellite equipment that had performed well during some earlier events. But this time, using new deck-mounted equipment, more than 30 of the units failed within a matter of days.

According to preliminary reports this seems to have been due more to the redesigned plastics casing than due to the electronics. Instead of flexing, the plastics apparently stiffened and cracked in the presence of salt water, letting the highly conductive sea water reach batteries and electronic circuitry; so it now seems a case of "back to the drawing board".

This again emphasises a very old rule: mechanical engineering remains a vital part of good electronic engineering.

The UK domestic environment is much kinder to electronic equipment than is the case in many parts of the world—and very much kinder than any form of mobile service. One still hears complaints that "tropicalisation" is less effective than it might be when up against the combined onslaught of heat, humidity, dust and insects; semiconductors, on the other hand, have a particular dislike for low temperatures.

Printed circuit boards still give trouble, including those elusive hairline cracks and the peeling off of the copper; carbon 'pots' dislike moisture; rubber, springs, push-button switches etc can deteriorate rapidly in the tropics. The thin wires found in many receivers are vulnerable to hard use, while connectors, plugs and sockets and the like are all too easily damaged when used under field conditions.

Another problem is that while, for example, modern large-scale integrated circuits can form effective multi-channel synthesisers for hand-held equipment, the power they consume is considerable, particularly where dry batteries are stored at unsuitable temperatures.

## CB at the crossroads

As someone entirely sympathetic towards the concept of an "Open Channel", it is possible to understand why the frustrated CBers feel that only by keeping up constant pressure on Parliament, the Home Office and the media are they likely to live long enough to receive more than promises. But it has to be said that much of their "propaganda" is undoubtedly over-pitched and by no means easy to justify.

This could rebound on the movement in future as a similar (successful) campaign did in Australia a few years ago. Neville Williams, editor of *Electronics Australia* makes this clear in a trenchant editorial "CB radio is at the crossroads" in a recent issue of that magazine. It seems well worth quoting, if only as a warning:

"In 1977, with much fuss and fanfare, citizens band radio in Australia was legalised. On the one hand, the move was seen as a victory for human rights and free speech; on the other an opportunity for numerous companies to make a fast buck. For a while, CB was very much the "in" thing.

"But within 12 months, the scene had changed. For many, the fast buck dream had turned into a nightmare. And the platitudes about human rights and free speech had been buried under an avalanche of everything from jargon to obscenity. From being a "cause", CB became the target for widespread ridicule.

"Massive desertions from the ranks of licensed CBers followed, including at least two groups which the CB movement could ill afford to lose. One such involved many of the original human rights, free speech campaigners who had seen in CB a potential means of exchanging informed opinion on many subjects; they hadn't counted on the high level of adolescent ambient!

"The other group included people with an evolving interest in the technology of communication. Many such have moved into the ranks of amateur radio and have adopted the accepted manner and mores of the amateur fraternity.

"A large proportion of those who remain are not really CBers at all; they have no licence, no inhibitions about equipment, power, channels, or the way they use those channels. Ultimately, the Government will have to crack down on them and a recent prosecution in Sydney may provide an advance sample: a \$A1,000 fine, plus costs, plus confiscation of all equipment."

## Letters of Authority

So while the long-drawn-out controversy over CB rumbles on, with ever wilder estimates of the number of "illegals" or pirates using 27MHz CB equipment in the UK (between 150,000 and 200,000 according to some sources though about 15,000 to 25,000 seems a much more likely figure for regular users), less is heard about the "legal" use of 27MHz in the UK for radio-paging and model control.

I gather there are some 5,000 licences or "Letters of Authority" for radio-paging systems, plus as many again for inductive-loop systems. Since each system represents an average of about 20 pocket receivers or "bleepers", total users of both types of system must now amount to over 200,000. There are some 23,000 subscribers to the Post Office radio paging systems which opened in 1973 in the Thames Valley area and in 1976 in the London area, with plans to extend this nationwide.

Many of these systems operate on v.h.f. or u.h.f. and on 27MHz the systems are for "bleeping" only, on other bands systems may include talkback, "talk through" (ability to speak to another pocket set user via the control unit) etc, although the regulations are currently being changed so that systems providing speech facilities will be known in future as "local communications networks" as an intermediary category between "paging" and "private mobile radio".

Government-funded organisations are not "licensed" but operate under a "Letter of Authority" issued by the Home Office.

Licences for 27MHz radio control of models have long been available in the UK although for some reason or other the authorities have not been prepared to issue licences covering the garage-door opening systems long popular in the United States.

## Radio Control

A consumer boom in radio control of models is expected in the United States following the introduction of new special-purpose integrated-circuit devices by National Semiconductor Corporation. These, it is claimed, will make it possible to build complete, multi-channel, proportional-control systems with an operating range of about 100 metres for a small fraction of the cost of current designs.

## Tail-pieces

An American study suggests that watching television now occupies more waking hours than any other activity except work (43 hours per week for the typical household) based on a survey of 309 urban and suburban homes.

The recent revival by a Russian newspaper of the charge that the BBC external services are used to broadcast messages to secret agents makes one hope that, if this is so, which seems extremely doubtful, then it is conducted more effectively than the famous "personal messages" to the wartime French Resistance, when the vital "D-Day is coming" messages were known in advance to the Germans and could have led to a disaster had not the Germans mishandled the information they obtained from the messages!

## Complete Audio/Tuner Kits



### Mk III FM Tuner series

Carriage for Mk III tuner £3 inc

The Mark III series FM tuner has been updated, and now includes a centre zero tuning meter as standard. The instruction manual has been meticulously revised, enabling easy assembly by constructors of various levels of experience - a preview copy may be purchased for £1.00.

Mark III A series 'Reference series' tuner modules .....£171.35 inc.  
Mark III B series 'Hyperfi' modules, with switched IF BW, pilot cancel decoder .....£198.95 inc.

A matching synthesiser unit will be made available later this year, and can be retrofitted to either version. All versions include digital frequency readout/clock, VU deviation meters, 6 preset stations, 10 turn pot manual tuning, toroidal PSU, output level adjustment, 110/240v AC input. Full alignment service available.

### Power Amplifier

Style and performance - with a real 'belt and braces' PSU design.

After a couple of preview comments, it seems that many of you are waiting to hear about the matching HMOSFET power amplifier for the Mk III tuner. Well, it's out at last - complete with twin toroidal PSUs for comfortable 80W RMS per channel, over 100W peak, but limited by thermal shutdown of the HMOS. 10W-100W log LED output peak indicator, DC offset protection and switch-on pause relay. AC or DC input coupling, direct or relay protected output terminals. The works. Only one version of this item: Complete kit .....£178.25 inc. Carr. £5.

### Preamplifier

More features and facilities, thanks to DC switching and control design

Previewing the most comprehensive audio preamplifier yet..... DC switching of 7 inputs, plus two tape in/outs. 2 low pass, 2 high pass active filters, genuine volume related loudness, 1dB channel matching, with DC volume, balance, bass and treble controls. Suitable for bus/meter control, tape dubbing, switched monitor etc. 80dB S/N+, THD <math>^{-75}</math>dB or better. Pluggable PU equalization boards, tone control override. Price for complete unit about £149 ex VAT.

## Semiconductors

### Radio/Communications ICs

FOR COMPLETE LISTINGS - SEE OUR NEW PRICELIST

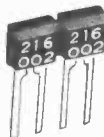
CA3089E	2.11	HA1197	1.61	SD6000	4.31
CA3189E	2.53	CA3123E	1.61	TD4420	2.59
HA1137W	1.95	TDA1072	3.09	MC1330P	1.38
HA11225	2.47	TBA651	2.53	MC1350P	1.38
HA1212	2.81	TDA1090	3.51	KB4412	2.24
KB4420	1.95	TDA1220	1.61	KB4413	2.24
TBA120S	1.15	TDA1083	2.24	KB4417	2.53
KB4406	0.80	TDA1062	2.24	MC3357P	3.16
SL1610	1.84	SL1626	2.80		
SL1611	1.84	SL1630	1.86		
SL1612	1.84	SL1640	2.17		
SL1613	2.17	SL1641	2.17		
SL1620	2.50	SL6600	4.31		
SL1623	2.80	SL6640	3.16		
SL1624	3.77	SL6690	3.68		
SL1625	2.50	MC1496	1.44		



### VARICAP DIODES.....

A section from our PL:

BA102	0.35	16:1 ratio AM tuning	
BB204	0.41	KV1215 9v triple	2.93
BB105	0.41	KV1211 9v dual	2.01
BB109	0.31	KV1225 25v triple	3.16
MVAM2	1.93	BB212 9v dual	2.25



### POWER MOSFETS

100W PA's made simple

Since pioneering the 100W complementary MOSFET technique - Hitachi have developed a range of output devices and drivers that ought to revolutionise opinions and attitudes towards the design of all LF amplification systems. We have a new 48 page application note (£1.50 incl) and complete sets of parts, modules and now the new complete PA system (see above).  
2SK133 120v N-ch 100W MOSFET £6.33 2SJ48 Pch complement £6.33  
2SK135 160v N-ch 100W MOSFET £7.29 2SJ50 Pch complement £7.39  
PA101B Kit for 100W MOSFET PA less Heatsink £16.10. (£23 inc heatsink/bkt)

### ULTRA LOW NOISE PU PREAMPLIFIER

The HA12017 is the last word in PU preamps, and general low noise audio design. It is an SIL IC, with 86dB S/N in RIAA configuration, 10v RMS output capability, 0.002% typ THD at 10v RMS output (imagine the overload margin !!). It comfortably supercedes discrete circuit designs in terms of price/performance, and takes the art beyond the TDA1042's capabilities. (Replaces HA1457) £1.80 each - or an RIAA applications PCB with two ICs for £5.75. Complete with Rs&Cs £9.95.

### Radio Control ICs

We have various RC ICs, including NE544 NE5044, and two new ones from OKI

KB4445 - 4 channel dig.prop. FM TX IC. 30mW out (amplifiable) -£2.30 inc  
KB4446 - 4/5 ch. dig. prop FM RX IC. Suits KB4445 or RCME syst. £2.65.  
KB4445/6 pair: £4.75. New 8 page data sheet 35p + SAE. More RC ICs in list

### CMOS, LPSNTTL, TTL, MPU:

Most CMOS is available in low volume - also LPSN. Standard linears and TTL OK.

Things like ICM7216B, ICL8038, 8080A, 6800P, 2708, NE555, NE556, etc

### Coming Soon.....

Contain yourselves, RF fans! Not yet ready for a full launch until autumn, but previewed here:-

### SSB transceiver system : 10kHz to 1000MHz !!

A modular VLF to UHF SSB TX/RX system at last. With the correct first mixer, the basic PCB covers 10kHz to 1000MHz - using LO fed from ext. source (Our 2 IC Mullard synth for instance) and RF PA for TX. OP. 0.2uV basic sensitivity in HF. Typ cost for HF synth SSB RX will be less than £200. Add an RF PA for full TRX for another £50. See one in our foyer, and marvel.

CALLERS WELCOME - all those for £1.00 PREVIEW COPY HERE IN OUR V.A.T. REGISTERED DISPLAY NEW YORK

Please send an SAE with all enquiries. Phone orders by ACCESS - but minimum £5 Callers welcome

**ambit**  
INTERNATIONAL

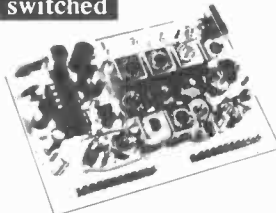
200 North Service Road, Brentwood, Essex

TELEPHONE (STD 0277) 230909 TELEX 995194 AMBIT G POSTCODE CM14 4SG

## Radio/Audio/Communications Modules

### LW-MW-SW-SW DC tuned and switched

91072- All switching of bands by a single pin to gnd. Varicap tuned, with LO output for synth. MW/LW version or MW/LW plus 1 or 2 SW bands MW/LW: £15.58 +1SW £16.73



### VHF Tunerheads

Europe's largest stock range for broadcast and communications. Probably also the world's - details in the catalogues and PL. Specials are also supplied in the region 30-220MHz.

### Pilot Cancel PLL Stereo decoders

Again, Europe's widest range of stereo decoders including pilot cancel PLL types. The pic shows the 944378 - pilot cancel including post decoder 26/38kHz filtering and muting preamp output

944378-2  
£26.45



### Switched bandwidth FM IF strips

Broadcast FM IF strips for all occasions, including the new 911225 - with diode switched narrow filter option, ultra linear phase ceramic filters, 84dB S/N, and 0.04% THD (40kHz deviation). Plus usual things like AGC, AFC, dev. mute, level meter drive. £23.95 (supplied in screen can with 0.1 edge connection system) Also the 7230 hyperfi series - as the 911225, but with slope controlled AFC that operates in conjunction with signal level - and an extra IF amp stage for DXing.

### Various digital frequency displays

The World's largest range of receiver DFM's is now joined by the DFM7 (shown) - and L shaped version of the DFM3 with remote display mount connector possibility. 1kHz SW resolution with 455kHz or 10.7MHz offsets, 100Hz res up to 3.9999MHz, and VHF to 299.99 MHz in 10kHz steps : £41.75



## Components

### Crystal Filters

Most popular types are available ex-stock, and in quantity.

10.7MHz	25kHz Channel spacing	8pole	£16.67
	12kHz		£17.82
	2.4kHz SSB		£19.78
	Monolithic dual roofing filter		£2.30
34.5MHz	1.3dB loss, 80dB stopband HF		
	first filter in synth. RX		£36.80
RC XTALS	FM pairs (no splits)		£3.74
	AM pairs		£3.57
USB/LSB	Xtals for 10.7SSB filter		£2.88 ea



### Piezo Sounders

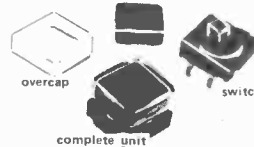
The most efficient warning sounders yet

The latest thing in electro-acoustic efficiency. 1mA of drive from CMOS will give an SPL of 83dB - 10v RMS drive from CMOS uses 3mA for 100dB SPL at 4.8kHz (88dB at 1.65kHz) The data sheets shows various drive circuits, and give full specifications with regard to broadband responses and power consumption etc. 1 off 44p inc. 100 off 28.75p (25p ex vat)



### Keyboard switches and caps

From the world's most widely used switch manufacturers - ALPS - come the biggest and best range of keyswitches, and data entry keyboard switches. The SCM81101 is shown here, with the KT5 2-part cap (with clear top, to enable easy fitting of your chosen legend. Other types are available with built in LED, 90° mounting etc. SCM81101 : 17p, KT5 : 16p - or 29p/pair



### LCD CLOCKS

Clocks use 7.5v at 15uA only - DVM 9v/1mA

### LCD DVM

CM161: 7mm LCD 12/24hr, alarms etc £11.44 each  
CM172: 13mm, 12hr, alarms, timer etc £14.32 each  
CM174: 13mm, 12hr, min/sec stopwatch £14.32 ea  
DVM 176: ICM7106 based LCD 3 1/2 digit £22.36 each



## WHAT'S NEW at AMBIT

### NEW PRICELIST/SHORTFORM:-

28 pages, FOC with A5 SAE pse

Bigger print than our recent one page list - and vastly extended

### POWER MOSFET APPLICATIONS HANDBOOK by HITACHI :

Everything you should know about HMOSFET devices theory and applications.

£1.50 each - or free with pairs of HMOS and the PA101B.

Parts 1-3 AMBIT catalogues 60p ea, or £1.60 the lot.

PLEASE Commercial MA terms on application Goods are offered subject to availability, prices subject to change - so please phone and check if in doubt.

ONE of the more insidious equipment breakdowns that plague the motorist is that of bulb failure. Often he will not notice until he either makes a special check (which should after all be carried out weekly) or he is stopped by the police, and we need hardly quote the old adage that ignorance of the law is no defence.

The device described here gives continuous monitoring of all external lighting equipment apart from the direction indicators and will give an instant warning should one of the bulbs go open circuit in use.

When failure of a monitored light bulb occurs, a corresponding l.e.d. illuminates at the same instant on a display unit installed inside the car.

## CIRCUIT

Although the circuit may look a little daunting at first, closer inspection reveals that it consists of ten individual identical sections plus a test facility.

Fig. 2 shows the complete circuit and it should be noted that each of the boxes A to J contain the same circuit network which is shown in Fig. 1.

At this point we should point out that the components are numbered in a slightly novel way in that all components associated with each box have the letter of that box after their reference number.

For example the transistor in box C is referred to as TR1C or the l.e.d. in box H is referred to as D2H, and so on.

Let us take circuit A for the moment. This is monitoring the off-side front side-light. The monitoring circuit is so arranged that there is a diode D5A in circuit between the bulb and its switch.

Consider Fig. 1. Suppose the light bulb is operational. When the switch is closed, a current will flow through

the silicon diode D5A and the light bulb.

A voltage of 0.7 volts is dropped across the diode. This voltage is large enough to provide the germanium transistor TR1 with sufficient base bias to switch it on.

In this mode TR1 acts as a short circuit across the l.e.d. D2 thus preventing it from lighting up.

## OPEN CIRCUIT

Let us take another case, this time with the bulb open circuit. When the switch is closed, current will not be able to flow through the diode. Hence the voltage across the diode will fall

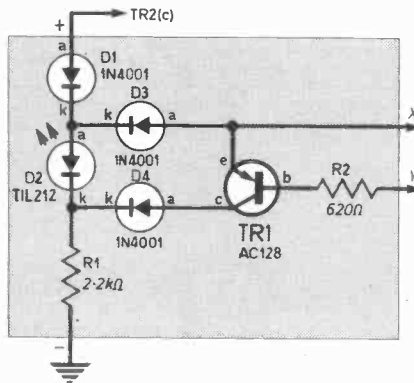


Fig. 1. Circuit diagram of one of the sensor modules of the Lights Failure Monitor.

**COMPONENTS**  
approximate  
cost **£9.00**

to zero and the transistor will switch off.

Of course there will no longer be a short circuit across the l.e.d. so it will light up indicating that the bulb has failed.

A further point should be made that when the light switches are off, then no current will flow into the sensing network at all so the unit is in effect switched off.

## TEST FACILITY

No monitoring unit is completely free from failure in itself so a test facility is provided to make sure that all the l.e.d.s are functional.

Essentially we have a line that feeds every l.e.d. via diode D1. When we wish to test the system, the base of TR2 is grounded via R3. This switches on TR2 which allows current to flow through every l.e.d. in the system and light them all up.

It is then very easy to spot a faulty indicator. Diodes D1 are necessary to prevent current flowing back down the test line when it is not being used.

## NEGATIVE EARTH

As can be seen from the circuit diagrams in Fig. 1 and Fig. 2, this unit has been designed for a negative earth system.

Fortunately nearly all new cars are built this way. However modifying this circuit for the older positive earth system poses several problems mainly because of the fact that the current flowing through the bulbs is going in the opposite direction.

In fact modification would involve changing the design of each boxed module, not to mention redesigning Fig. 2 so the author has decided to restrict himself to a negative only version.



By C. R. BIRRELL

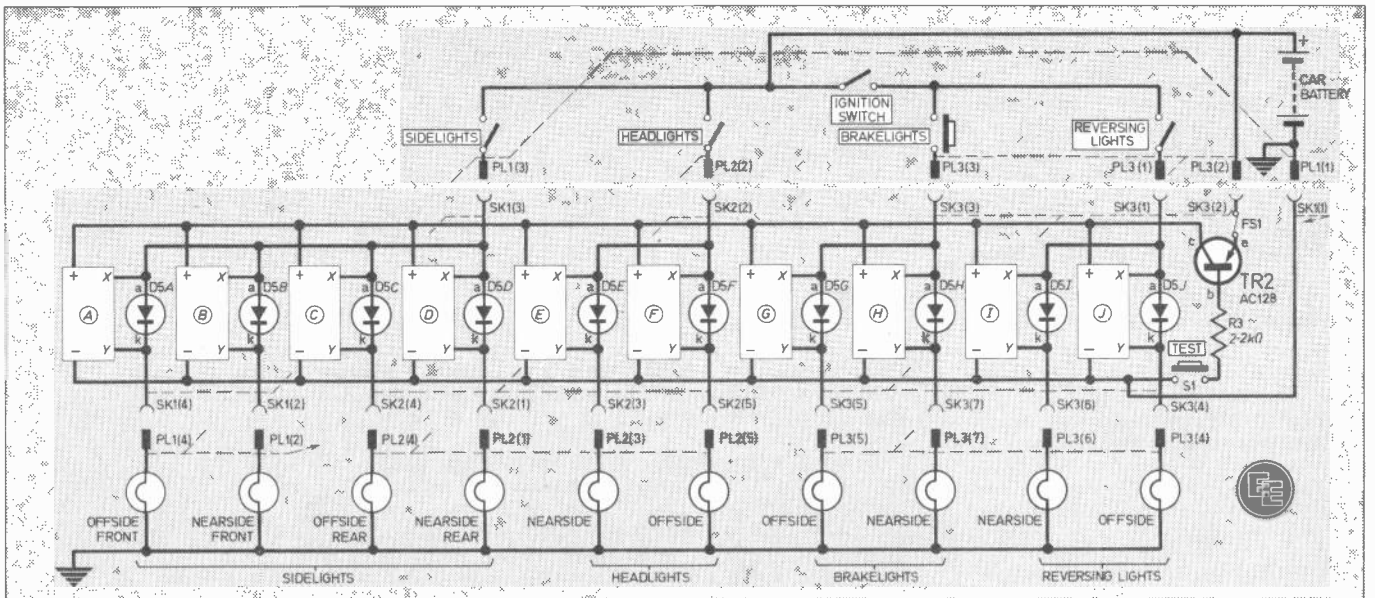


Fig. 2. Complete circuit diagram of the Lights Failure Monitor. Note that each lettered box contains the circuit elements from Fig. 1.



## CIRCUIT BOARD

The main part of the Monitor is built on a piece of 0.1 inch stripboard, 37 strips by 14 holes and the component layout is shown in Fig. 3.

Straight away it can be seen that the spacing between components is very close so some care will be needed in construction.

The board should first be prepared by making all the breaks in the copper strips. This can be done using a spot face cutter or small twist drill.

When this is completed solder the resistors and diodes in place. It is necessary to do this first because the wire links must fit around these components and in fact these can be put in next.

## FINISHING OFF

The board is finished off by soldering in the transistors, fuse clips and lead-off wires.

Readers will notice that the l.e.d.s are wired straight onto the board. Make sure that you leave long enough leads so that they will fit into their holders in the case.

In the prototype this meant bending the leads through ninety degrees so that they would slot into their holders in the side of the case.

## CASE

The circuit board is mounted in a plastics box 112 x 62 x 30mm. This should first be drilled and cut to accept the three switches, test switch and the ten l.e.d.s.

This involves marking up the side of the box with the correct drilling dimensions and making the holes, preferably with a hand drill. Larger holes can be made by making a small hole and opening it out with a file.

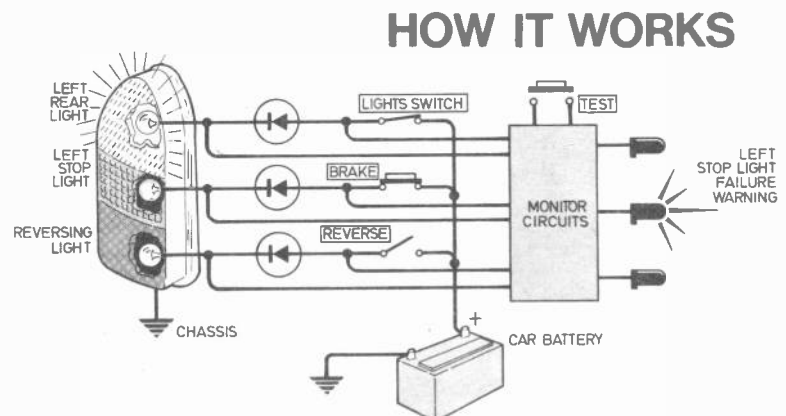
The sockets and switch are then fastened in position and the clips for the l.e.d.s pushed through their respective holes.

## INSTALLATION

Before attempting to install the Monitor, study the diagram in Fig. 4 very carefully.

The main task is to insert the diodes D5A to D5J in series with the power cables from the light switch to the bulbs. This involves finding the correct wire that feeds each bulb to be monitored and reference to your car manual may be necessary in order to work out the colour code of the individual wires within the vehicle's wiring harness.

The most convenient way to install the diodes is to insert them between



A diode is connected in series with each light bulb to be monitored and the voltage drop across each diode is also monitored.

If the light bulb is working, a current will flow through the diode which will keep the l.e.d. in the display unit turned off.

If the light bulb is open circuit then no current will flow and the l.e.d. will turn on indicating where the fault lies.

# LIGHTS FAILURE MONITOR

Fig. 3. Circuit board layout for the display unit. The cathodes on the i.e.d.s may be identified by a flat on the casing next to the cathode lead. It can also be seen that only one channel has been fully labelled. Each channel is identical and their layouts are exactly the same.

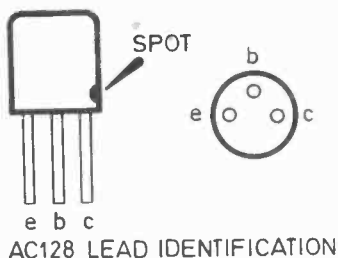
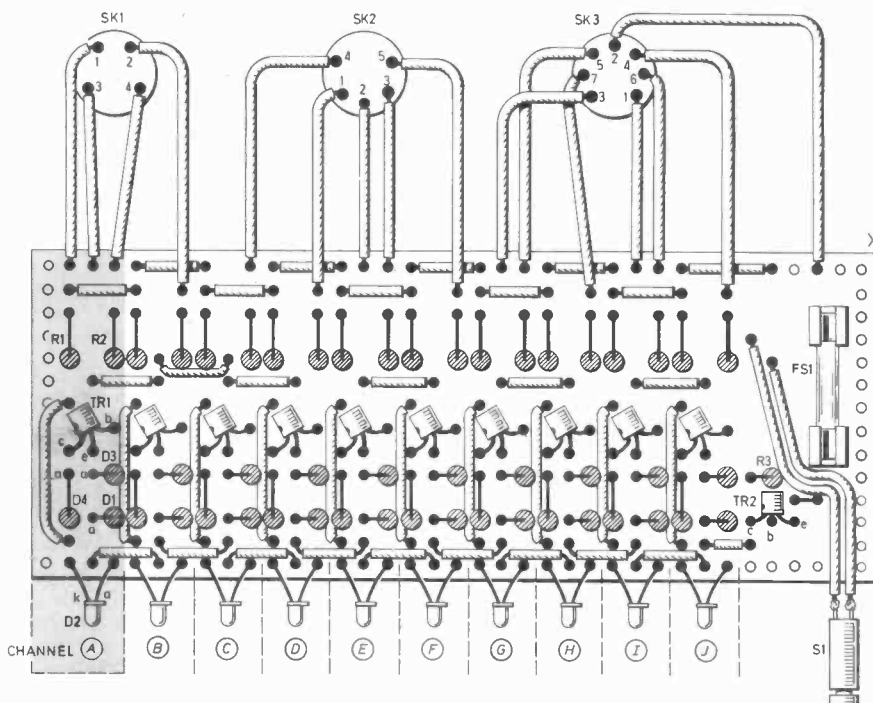
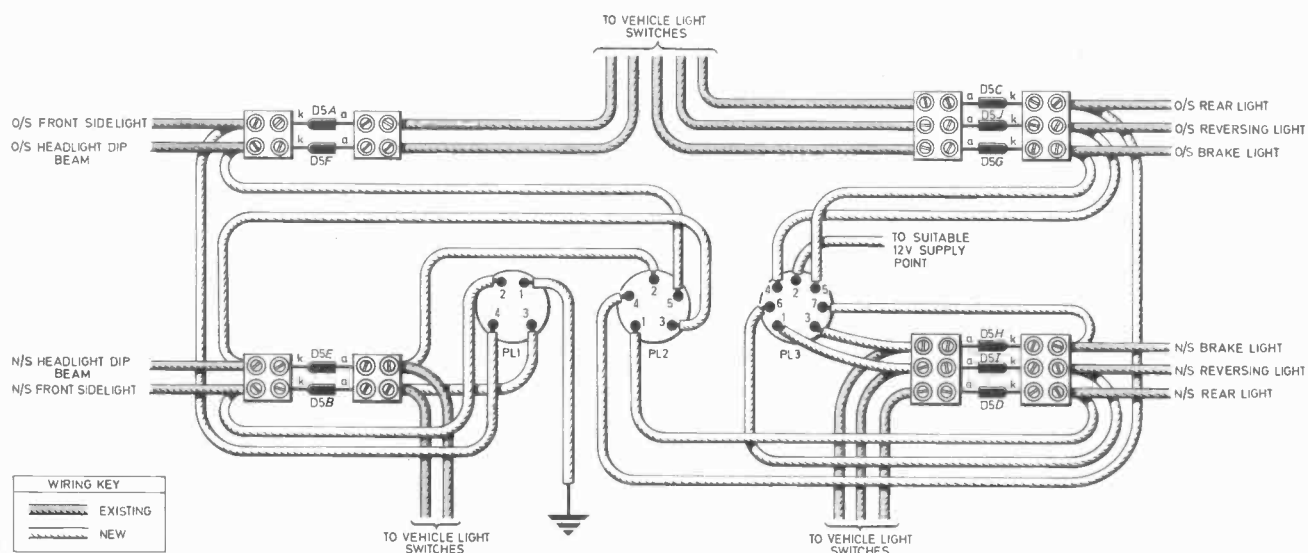


Fig. 4. Wiring diagram for installing the unit in the vehicle. The new and existing wiring can be seen clearly. Note that the contact numbering on the three plugs corresponds with the pin numbering on the sockets in Fig. 3. Care must also be taken to ensure that the correct diodes are used for D5E and D5F.





# COMPONENTS

## Resistors

- R1A-J 2·2kΩ (10 off)
- R2A-J 620Ω (10 off)
- R3 2·2kΩ
- All ¼W carbon ± 5%

## Semiconductors

- TR1A-J AC128 *pnp* germanium (10 off)
- TR2 AC128 *pnp* germanium
- D1A-J 1N4001 small signal silicon diode (10 off)
- D2A-J T1L212 yellow l.e.d. including clips (10 off)
- D3A-J 1N4001 small signal silicon diode (10 off)
- D4A-J 1N4001 small signal silicon diode (10 off)
- D5A-D 1N5400 3A silicon diode (4 off)
- D5E-F BYZ13 6A silicon diode (2 off)
- D5G-J 1N5400 3A silicon diode (4 off)

## Miscellaneous

- S1 push-to-make momentary action switch
  - PL1 4-pin DIN plug
  - PL2 5-pin 240 degree DIN plug
  - PL3 7-pin DIN plug
  - SK1 4-way DIN socket
  - SK2 5-way 240 degree DIN socket
  - SK3 7-way DIN socket
  - FS1 500mA 20mm cartridge fuse
- Plastics case, 112 × 62 × 30mm; 0·1 inch stripboard 37 strips × 14 holes; two-way screw terminal block (2 off); three-way screw terminal block (2 off); connecting wire.

See  
**Shop  
Talk**

page 553

two terminal blocks and use the terminals at the opposite end of the blocks to connect up the severed ends of the wire. Fig. 4 will make this clear.

As each different vehicle has a different wiring harness, it is impos-

sible to give precise details as to where you should cut the lighting cables and insert the diodes. However you should try to do this as close to the proposed site of the display unit as possible, and far away from any possible sources of damp.

Once all the diodes have been installed the wires that lead to the display unit can be attached as in Fig. 4. These should be terminated with the appropriate DIN plugs. An earth and positive supply should also be installed.

## SYSTEM TESTING

At this stage the system can be tested. Plug the three DIN plugs into their appropriate sockets on the back of the display unit. When the test button is pressed all the l.e.d.s should light up.

Each individual circuit should be checked next. To do this, loosen or remove each monitored bulb in turn. When the relevant switch is activated in the car, the corresponding l.e.d. should light up indicating that the circuit is faulty (in fact we have simulated an open circuit bulb).

As soon as you are satisfied that everything is working properly, the terminal blocks should be insulated, for example by binding with p.v.c. tape, and then fixed securely in the car.

The display unit can be finished off by labelling the indicator l.e.d.s using Letraset or other self adhesive transfers and then the display unit can be firmly attached to the dashboard or other suitable location inside the vehicle. ✧



ANDREW was gazing into the large compartmented drawers which we had adapted to carry our stock of resistors. The thing which struck him was the apparent "silly values" to be found—390, 470, 560 ohms and so on. He asked why the values did not run—350, 400, 450, 500 and simplify the whole business. He argued that calculations would be much easier that way and I agreed.

I told him that these were called "preferred values" and that I would talk to the whole class about them.

I told them that we were talking about ordinary carbon

resistors with 10 per cent tolerance—they are allowed to be up to 10 per cent higher or lower than their nominal value. These are cheap components and good enough for most purposes. A 100 ohm resistor could, for example, have an actual value of anything between 90 and 110 ohms.

I showed, with the aid of a diagram, that when the tolerance is taken into account, the preferred values just about cover all values. Naturally, the family of 5 per cent resistors will have its own set of preferred values.

There would be little point, I told them, in making a 200 ohm resistor if this value was covered (just about) by the upper limit of a 180 ohm (198 ohm) or the lower limit of a 220 ohm (198 ohm) resistor.

I went on to tell the class that when the actual value of a new carbon resistor is measured it is often surprisingly close to the nominal value—perhaps within 2 per cent—but it will not always stay that way. In service, its value "drifts" and if it is subject to mis-use it may easily go outside its 10 per cent limit. Hot running was one particular cause to be avoided.

# Bind it

It's so easy and tidy with the Easibind to file your copies away. Each binder is designed to hold approximately 12 issues and is bound and blocked with the Everyday Electronics logo. Gold leterset supplied for self blocking of volume numbers and years.

Price £4·40 including postage, packing and V.A.T., Why not place your order now and send the completed coupon below with remittance to: IPC Magazines Ltd, Post Sales Dept, Lavington House, 25 Lavington St, London SE1 0PF

it's easy with **EASIBIND**

## Order Form

**Everyday  
ELECTRONICS**

I enclose p.o./cheque value ..... for ..... binders. Years required .....

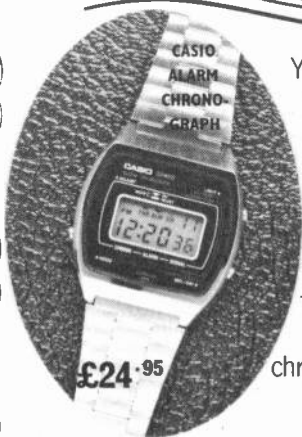
(BLOCK LETTERS PLEASE)

Name .....

Address .....

Date .....

We promise to pay the bearer on demand the sum of  
**£3**



£24.95

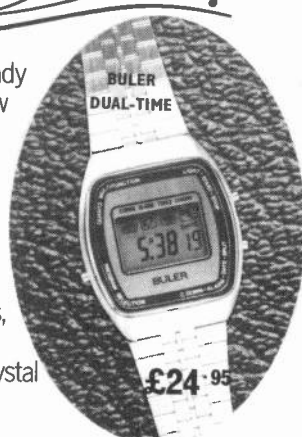
Yes, this really is worth money to you. Our prices are already as low as you are likely to find anywhere but we are now giving you another £3 off these sensational watches.

The Buler dual-time, multi-function, alarm chronograph with countdown—Time 1 and Time 2 both with alarms;

1/100 second chronograph; countdown timer; 100% stainless steel case; hard mineral crystal lens; water-resistant to 33ft.

The Casio 830s 41B alarm chronograph—hours, minutes, seconds, day, date; automatic calendar, 1/10 second chrono; hourly chimes; stainless steel case; hard mineral crystal lens; water-resistant to 99ft.

METAC ELECTRONICS. 47 HIGH STREET, DAVENTRY, NORTHANTS.



£24.95

**SEND OR TAKE THIS VOUCHER TO:**

London: 327 Edgware Road, W2  
 Daventry: 47 High Street  
 Northampton: 11 St. Giles Square

**SEND THIS VOUCHER TO: Metac Electronics, 24-hour Despatch Centre, 47 High Street, Daventry Northampton.**

Please send me Buler/Casio watches at a cost of £24.95 less my £3 voucher. I enclose cheque/P.O. made payable to Metac Electronics.

Name \_\_\_\_\_

Address \_\_\_\_\_

EE9

**TRAIN AT HOME**

# Be an ELECTRONIC ENGINEER

Do something PRACTICAL about your future.

Firms all over Britain are crying out for qualified people. With the right training, you could take your pick of these jobs.

Now, the British Institute of Engineering Technology will train you in your spare time to be an Electrical Engineer.

You risk nothing! We promise to get you through your chosen course—or refund your fee!

So, join the thousands who have built a new future through home study Engineering courses.

Courses in  
 C & G Elect. Technicians  
 C & G Elect. Installations  
 Telecomms. Technicians Exams  
 Television Servicing  
 Radio Maint. & Repairs (BIET)  
 Pract. Radio & Electronics  
 Plus over 60 other home study courses.

**POST COUPON FOR FREE 44 PAGE GUIDE**

## BRITISH INSTITUTE OF ENGINEERING TECHNOLOGY

Aldermaston Court, Dept. TEE 54 Reading RG7 4PF.

NAME (Block capitals please) \_\_\_\_\_

ADDRESS \_\_\_\_\_

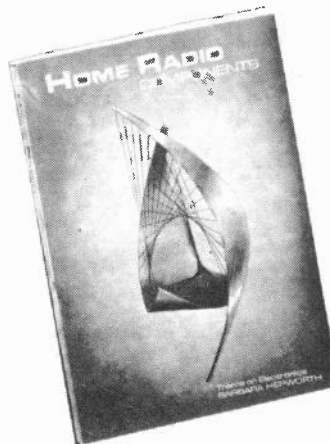
POSTCODE \_\_\_\_\_

Other Subjects \_\_\_\_\_ AGE \_\_\_\_\_

Accredited by CACC

Member of ABCC

**TOP PRIORITY** for every constructor...



### HOME RADIO CATALOGUE

- About 2,000 items clearly listed.
- Profusely illustrated throughout.
- Large catalogue A-4 size pages.
- Bargain List, Order Form and Pre-paid Envelope included. Also 2 coupons each worth 25p if used as directed.
- Catalogue £1, plus 50p for post, packing and insurance.

**HOME RADIO (Components) LTD.,**  
 Dept. EE., P.O. Box 92, 215 London Road, Mitcham, Surrey.  
 Phone 01- 543 5659

**POST THIS COUPON**  
 with cheque or P.O. for £1.50

Please write your Name and Address in block capitals

NAME \_\_\_\_\_

ADDRESS \_\_\_\_\_

**HOME RADIO (Components) LTD.** Dept. EE  
 P.O. Box 92, 215 London Road, Mitcham, Surrey

(Regn. No  
 London 912966)



# WORKSHOP MATTERS

By Harry T. Kitchen

## R.F. Sources

A few months ago (May) we looked at audio frequency signal sources, and this month I want to extend the frequency range to cover radio frequencies.

Such sources are invaluable whilst trouble-shooting or designing equipment, and again we have a very wide specification/price spectrum. The latter figure can range from a few tens of pounds for the very basic sorts of oscillator, to  $\times$  £100 and even more for the precision signal generator. Your ambition must therefore be tempered by your pocket!

## Oscillators

The term "oscillator" is used to describe a signal source where neither frequency or output voltage is closely controlled, (though advertising literature would often have you think otherwise). Such instruments comprise, essentially, (in the older type) two-separate valve oscillators, one for the radio frequency, the other for an audio frequency with which the former is modulated.

In the modern version oscillator, we usually have two transistors which fulfill precisely the same functions.

Modulation, incidentally, is the process of causing the *amplitude* of the radio frequency to vary at the same frequency as the audio frequency. Demodulation, at the receiver, consists of removing the radio frequency, leaving us with the audio frequency.

The process of modulation in such a simple oscillator consists of varying the voltage supplied to the r.f. oscillator at the required a.f. frequency. Thus, when the voltage is at its maximum, the r.f. oscillator oscillates more vigorously than when the supply is at its lowest level.

There is very little control over the "depth" of modulation, and the output voltage is extracted from the oscillator stage, possibly via a secondary winding on the oscillator coil.

The output control is a glorified volume control used for potting down the output voltage. As it is closely coupled to the oscillator varying loads will affect the frequency as well as the actual output voltage. Such an oscillator cannot be seriously considered for precision work, but within its limitations it is a useful tool.

## Signal Generators

We come now to the precision brigade, instruments that are entitled to the description signal generators, and our pockets must not only be very deep but also very well filled.

Signal generators should be capable of providing an accurate and stable frequency; accurate and stable output voltage; a means of setting the output voltage to a pre-determined point on an output

meter so that the precise output voltage from the attenuators can be determined, should be capable of being set, and reset to any pre-determined frequency and voltage; should have variable modulation depth; zero leakage; zero f.m. on an a.m. signal. A formidable list, justifying the high cost. Let us look at some of these items in greater detail.

The stability of frequency and output voltage will be clear, as will the requirements of setting, and resetting, accuracy. What of variable modulation depth, zero leakage, and zero f.m. on a.m.?

## Modulation Depth

Earlier we saw that the r.f. signal is modulated by the a.f. signal and thus varied in amplitude at the frequency of the a.f. signal. Theoretically it is possible to achieve 100 per cent. modulation where the r.f. signal varies from zero, when the a.f. signal is zero, to a maximum when the a.f. signal is at its peak.

In practice this is difficult to achieve since the modulating device, valve or transistor, cannot be completely saturated to achieve zero output, nor completely cut-off to achieve maximum output.

The normal, everyday, modulation depth is 30 per cent, and the modulating frequency is typically 400Hz or 1kHz, with provision for an external modulation frequency of variable depth. A variable modulation depth is essential for checking for detector distortion in receivers, and for this reason purity of the modulation signal is important.

## Zero Leakage

Zero leakage is impossible to achieve, but certainly the leakage of the oscillator frequency should be extremely low. If we are, as is sometimes necessary, measuring receiver sensitivity at the microvolt level, then even a very low leakage via the mains lead, which after all can act as a transmitting aerial, can invalidate our measurements.

The signal generator must be a box within a box; the oscillator contained in a leak-proof box, within the main cabinet. Mains input must be meticulously filtered to prevent the egress of the oscillator frequency.

For precise attenuation the various stages must be isolated from one another so that there is no possibility of the oscillator frequency getting out other than by the designed method.

## Zero F.M. on A.M.

So far it has been accepted, albeit tacitly, that we are discussing a.m. oscillators and generators only. The presence of an f.m. signal on what should be a purely a.m. signal can be embarrassing when measuring receiver selectivity.

Let us suppose that we are working at 1MHz, and that the generator has a (unwanted) deviation of 25kHz, so that our nominal 1MHz signal is actually sweeping from 975kHz to 1.025MHz. This means that our receiver can be up to 5 per cent inaccurate without us knowing about it, possibly an error of some magnitude, equally possible an error of considerable magnitude.

## Fundamental Tuning

Some of the cheaper sorts of oscillator are equipped with an additional scale enabling tuning to be effected on harmonics, whereas proper tuning is effected on fundamental frequencies only.

Fundamental tuning, if used as intended, restricts the user to the highest frequency provided. That means if the maximum frequency is 100MHz, then that is as high as you can go—officially. Unofficially you can go higher; using the second harmonic you can go up to 200MHz, the third harmonic enables you to go up to 300MHz, and so on.

This, in my opinion, is an undesirable practice, as it is all too easy to pick up the wrong harmonic, particularly if the frequency calibration is at all inaccurate. The only safe and accurate way is to use a fundamental frequency, though in an emergency it is possible to use the second harmonic and tune to twice the required frequency, that is 88MHz if 176MHz is required.

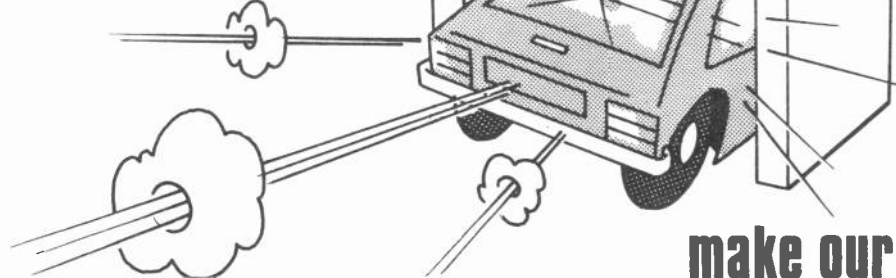
On harmonics the output signal is reduced, and this can also affect accuracy particularly if an insensitive receiver is involved.

Contributory factors to accurate measurement are the use of cables of the correct impedance to terminate the output from sig-gen's (as signal generators are invariably termed by those "who know") and the use of a dummy aerial. The reasons involve e.m.f. and p.d., and we will look at these in some detail in the next article.



# STOP

don't let this happen to you



# PRECISION PARKING PAD

By T. R. de Vaux-BALBIRNIE



THE PAD referred to in the title is a block of plastic foam which activates a warning light when compressed by pressure from a car bumper. With this pad suitably placed on the garage end wall and a separate unit housing the warning light, the device will ensure that the car will be parked close to the end wall without the possibility of damage and without assistance. Parking like this is sometimes necessary when the garage is only just big enough for the car or when two vehicles have to be squeezed in.

One feature of the circuit is that it requires no setting for day-to-day use. Nothing need be remembered on approaching the pad—the lamp will always be ready to signal attention. When the time for battery replacement approaches it will be seen that the warning light becomes dim long before the circuit fails to operate altogether.

The most difficult part of the project is not the electronics, which are very simple, but the construction of the pad unit itself. Experimental pads which reduced their electrical resistance when they were squashed were tried but they proved unreliable. A far better solution was found using a reed switch operated by a magnet. As the foam is compressed the magnet approaches the reed switch to the point where it switches on.

## CIRCUIT DESCRIPTION

The circuit diagram of the Precision Parking Pad is shown in Fig. 1. When the magnet approaches the reed switch, S2 closes (switches on) and connects the battery to C1. This voltage step is transmitted to the gate of CSR1 triggering it into conduction and C1 continues to charge up through the gate circuit. Once the thyristor has been fired in this way it will continue to conduct even when C1 is fully charged and the gate voltage and current drops to zero.

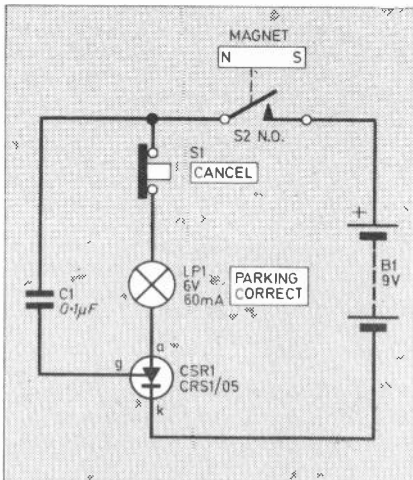


Fig. 1. The complete circuit diagram for the Precision Parking Pad.

When CSR1 conducts the warning light LP1 is illuminated. The operator may cancel the light by breaking the current to the lamp with S1, a miniature push-to-break switch. As C1 is left fully charged it can give no further gate current so the lamp will remain off when S1 is released.

When the car is driven away from the pad, the magnet moves away from S2 and the reed switch opens so cutting off the battery supply to the circuit. C1 will now discharge by leakage within a few seconds and will be ready to operate again as described above. When the reed switch is closed and the warning light cancelled, the only current flowing is leakage through C1 and CSR1. This leakage is so small as to be negligible. The life of the battery should be solely determined by the length of time the warning light is left glowing.

## PAD AND SWITCH

The foam pad itself was a 100mm cube cutout. Perhaps an old cushion could provide a suitable piece of foam or even a cheap car sponge. The magnet was bought from a local hardware shop. Although several types were offered, the kind shown in the illustration proved most effective. Good results will only be obtained with a powerful magnet made from modern materials.

The reed switch is of the normal open type—i.e. it switches on when the magnet is moved near. Two types of reed switch were tried.

The first was about 25mm long and the other about 38mm. Both worked very well but the longer switch proved slightly more sensitive and was finally chosen for the prototype. For testing purposes, a simple battery and bulb test-circuit should be made up with the reed switch placed in

# PRECISION PARKING PAD



The completed prototype warning light unit fitted to the garage wall. For convenience, a position close to the drivers side window is suggested. The battery is to be situated between this unit and the pad for easy replacement.

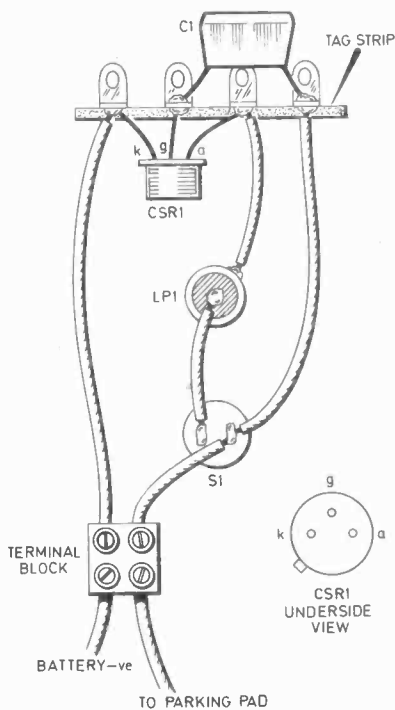


Fig. 4. Circuit construction details. The tag-strip, LP1 and S1 are mounted on the rear face of the blank socket box cover. Care should be exercised when drilling this cover as it is very brittle and likely to chip and crack.

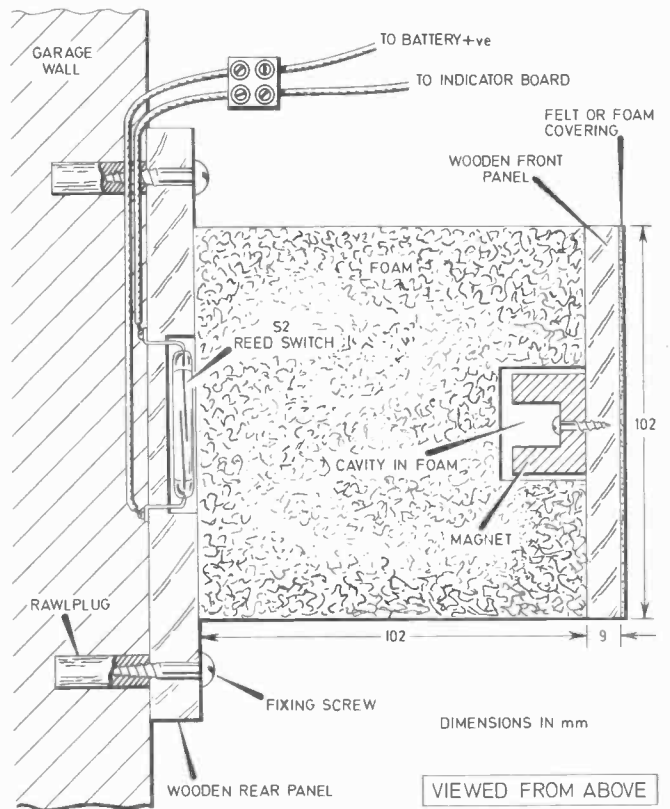
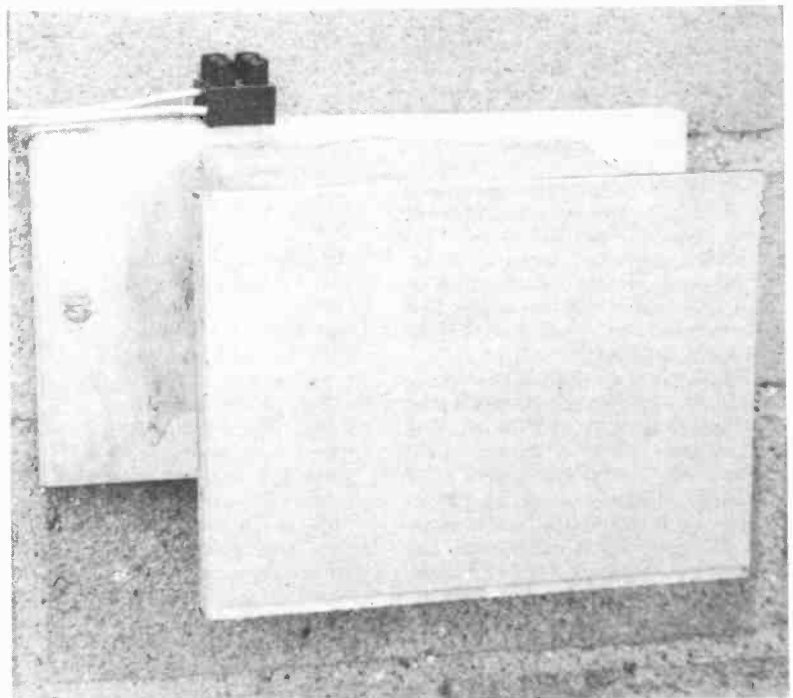


Fig. 3. Cut-away view of the pad assembly showing magnet and reed switch fixing. Note that the horizontal dimension of the foam cube will vary according to the magnet and reed switch used, and will depend on the findings with the test circuit (Fig. 2).



The completed pad assembly securely screwed to the garage end wall at bumper height.

series as shown in Fig. 2. The bulb should light when the magnet is moved to within about 70mm from the reed switch. Careful note of the best relative positions for these two components should be made so that they may be adhered to in the final construction.

The rear panel of the pad assembly was made from 12mm-thick plywood and has a cavity chiselled into it to accommodate the reed switch, see Fig. 3. This protection is necessary as reed switches are very fragile components and could easily be damaged if the pad was carelessly used.

Checks should be made to ensure that even with the foam fully compressed, the magnet cannot touch the reed switch.

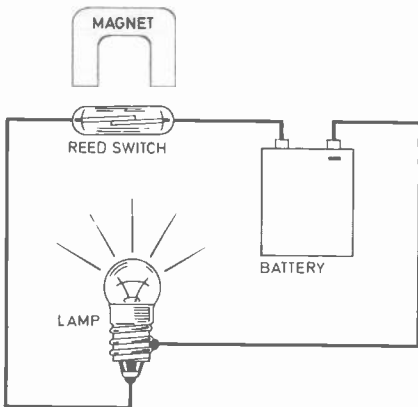


Fig. 2. A test circuit for determining the operating distance of the magnet from the reed switch.

In the prototype, the reed switch was secured by gently bending the end connectors at right angles and passing them through two holes drilled for the purpose. They protruded a short distance through the panel and were then bent over. Soldered connections were then made to them.

The wires leading from the reed switch must be run in grooves cut into the rear of the panel so that they will be protected from abrasion when the unit is finally attached to the wall. The wires lead to a piece of miniature terminal block mounted in a convenient position.

The front panel of the pad assembly was made of 10mm-thick plywood and has the magnet attached to it. The magnet chosen had a handy hole drilled in it so a wood screw was used to attach it. A cavity must be cut in the foam to accommodate the magnet. In the prototype, this was cut using a razor blade. It does not need to be particularly neat as it will be covered up.

The foam is sandwiched between the top and bottom panels using a suitable adhesive. This adhesive must be chosen with care as some have a devastating effect on foam. It is essential to try it out on a scrap piece first.

## COMPONENTS

C1	0.1 $\mu$ F plastic or ceramic
CSR1	CRS1/05 or similar 1A 50V thyristor
S1	miniature push-to-break, release-to-make button switch
S2	reed switch with normally open contact
LP1	6V 60mA m.e.s. bulb
B1	9V type PP9 or other, see text
Tagstrip, 4-way; magnet (811); 13A plastic surface mounting mains socket box with plain plastic cover; battery clips to suit; materials for pad assembly; bell-wire; 2-way terminal block (2 off).	

Approx. cost  
Guidance only  
(see page 553)

**£2.50**  
excluding  
battery

When the pad assembly is complete it may be checked by squashing the foam by hand and listening carefully. It is likely that a click will be heard somewhere along the travel as the reed switch operates. When relaxed it should click open again. If the clicks cannot be heard then an electrical test should be made using the battery and bulb test-circuit again (Fig. 2).

## COMPONENT ASSEMBLY

When the pad assembly has been checked, the circuit proper may be built. This was constructed on a piece of 4-way tag strip as shown in Fig. 4.

To house the prototype warning light assembly, a standard 13 amp surface mounting plastic box was obtained of the type used for mains sockets. At the same time a plain plastic cover was bought. These items are readily available from electrical dealers. The circuit was mounted on the cover using two small nuts and bolts to hold the tagstrip in place. Holes were drilled for the indicator light and the push-to-break switch. Great care must be taken.

For the indicator light, the prototype used a 6 volt bulb with the connections soldered direct to it. This is the cheapest way and gives maximum brightness. If a neater appearance is required then a proper panel indicator light may be used. Fix the panel-mounted components in place and wire up as shown in Fig. 4.

## BATTERY AND SETTING UP

In the prototype, a PP3 battery was mounted inside the box. These little batteries, however, tend to have a rather short life so it is advised that a larger battery be placed outside the case. It should be noted that it is quite in order to use a 9 volt battery to operate a 6 volt bulb in circuits such as this. There is a voltage drop of about 1 volt across the thyristor and there is an additional voltage drop across the internal resistance of the battery.

When the whole project has been constructed a suitable place for the pad assembly must be chosen. Tests should be made to find the best position so that the foam will be squeezed fairly and squarely by the car bumper. When the best position has been found, the unit should be mounted on the wall with two wood screws plugged in the usual way.

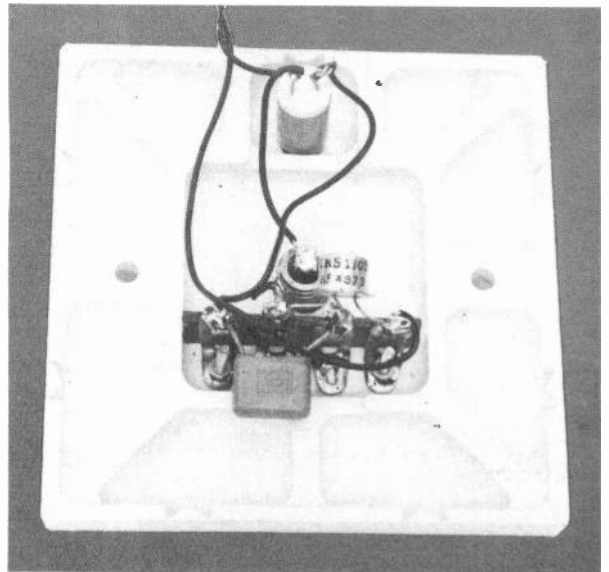
The indicator unit is wired to the pad assembly and battery by means of light-duty twin wire such as bell wire via the terminal blocks. It is best to mount this unit on the wall in such a way that the light can readily be seen from the driving position. If it is placed at window level then the unit may be cancelled before getting out of the car so conserving battery power.

When using the parking pad, the car is driven up very slowly to the pad and stopped as soon as the indicator lamp lights. The cancel button is then pressed.

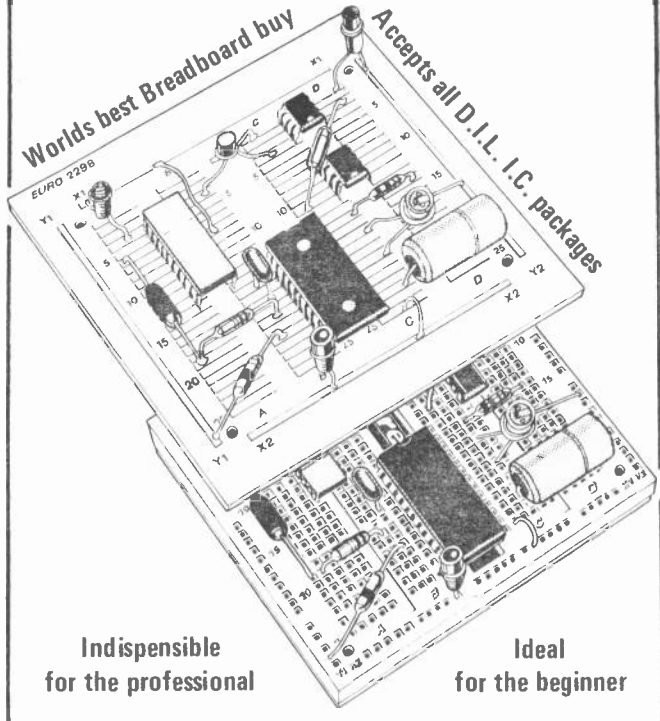
One final refinement is a felt covering for the wooden front panel. This prevents any chance of scratching the bumper.

In terms of broken light clusters and bent bumpers, this unit should recover its cost in no time! ☺

Completed circuitry on the rear face of the socket cover.



# First the EuroBreadBoard Now the EuroSolderBoard



Design on a EuroBreadBoard — Instal on a EuroSolderBoard

## First the EuroBreadBoard

Will accept 0.3" and 0.6" pitch DIL IC's, Capacitors, Resistors, LED's, Transistors and components with up to .85mm dia leads. 500 individual connections PLUS 4 integral Power Bus Strips along all edges for minimum inter-connection lengths. All rows and columns numbered or lettered for exact location indexing (ideal for educational projects) Long life, low resistance (<10m ohms) nickel silver contacts £6.20 each or £11.70 for 2

## Now the EuroSolderBoard

New 100mm square, 1.6mm thick printed circuit board with pre-tinned tracks identically laid out, numbered and lettered to EuroBreadBoard pattern. Four 2.5mm dia fixing holes. £2.00 for set of three ESB's

## And don't forget the EuroSolderSucker

Ideal for tidying up messy solder joints or freeing multi-pin IC's, this 195mm long, all metal, high suction desoldering tool has replaceable Teflon tip and enables removal of molten solder from all sizes of pcb pads and track. Primed and released by thumb, it costs only £7.25 including VAT & PP



Snip out and post to David George Sales, Unit 7, Higgs Industrial Estate, 2 Herne Hill Road, London SE24 0AU

David George Sales, Unit 7, Higgs Ind. Est., 2 Herne Hill Rd., London SE24 0AU. EE 9

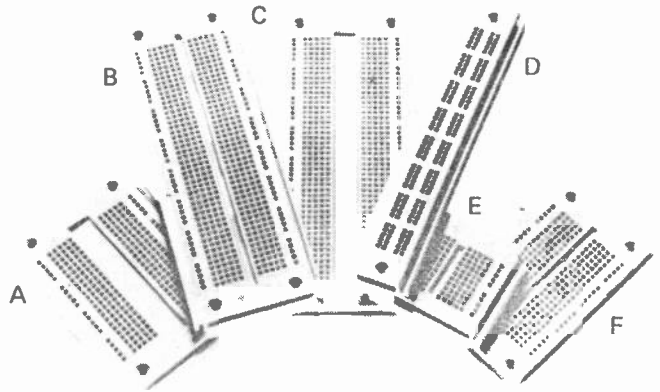
Please send me:—

- 1 EuroBreadBoard @ £ 6.20   
 or 2 EuroBreadBoards @ £11.70  Please  
 or 3 EuroSolderBoards @ £ 2.00  Tick  
 or 1 EuroSolderSucker @ £ 7.25

All prices are applicable from Jan. 1st 1980 and include VAT and PP but add 15% for overseas orders.

Name .....  
 Company .....  
 Address .....  
 Tel. No .....  
 Please make cheques/P.O. payable to David George Sales and allow 10 days for cheque clearance and order processing

# IT'S AS EASY AS A,B,C...



- A EXP 650 For microprocessor chips. £3.60
- B EXP 300 The most widely sold breadboard in the UK; for the serious hobbyist. £5.75
- C EXP 600.6" centre channel makes this the Microprocessor Breadboard. £6.30
- D EXP 4B An extra 4 bus-bars in one unit. £2.30
- E EXP 325 Built in bus-bars accepts 8, 14, 16 and up to 22 pin ICs. £1.60
- F EXP 350 270 contact points, ideal for working with up to 3 x 14 pin DIPs. £3.15
- G PB6 Professional breadboard in easily assembled kit form. £9.20 (Not illustrated.)
- H PB 100 Kit form breadboard recommended for students and educational uses. £11.80 (Not illustrated.)

## & IT'S AS EASY AS 1,2,3 with THE EXPERIMENTOR SYSTEM

SCRATCHBOARD  
 -BREADBOARD  
 -MATCHBOARD

1. EXP 300PC which includes one item. A matchboard pre-drilled PCB — £1.32
2. EXP 302 which includes three items. Three 50 sheet scratchboard workpads — £1.68
3. EXP 303 which includes three items. Two matchboards and an EXP 300 solderless breadboard — £8.60.
4. EXP 304 which includes four items. Two matchboards and EXP 300 breadboard and a scratchboard workpad — £9.30

The above prices do not include P&P and 15% VAT

# TOMORROW'S TOOLS TODAY

CONTINENTAL SPECIALTIES CORPORATION



C.S.C. (UK) Limited, Dept. 4H  
 Unit 1, Shire Hill Industrial Estate,  
 Saffron Walden, Essex CB11 3AQ.  
 Tel: Saffron Walden (0799) 21682  
 Telex: 817477

NAME .....  
 ADDRESS .....

I enclose cheque/PO for £ .....  
 or debit my Barclaycard, Access, American Express card  
 No. .... Exp. date .....  
 or Tel: (0799) 21682 with your card number and your order will be in the post immediately.

A EXP 650 £5.00	Qty. Reqd.	B EXP 300 £7.76	Qty. Reqd.
C EXP 600 £8.39	Qty. Reqd.	D EXP 4B £3.50	Qty. Reqd.
E EXP 325 £2.70	Qty. Reqd.	F EXP 350 £4.48	Qty. Reqd.
G PB6 £11.73	Qty. Reqd.	H PB 100 £14.72	Qty. Reqd.

### Experimenter System

1 EXP 300 PC £2.38	Qty. Reqd.	2 EXP 302 £2.79	Qty. Reqd.
3 EXP 303 £11.04	Qty. Reqd.	4 EXP 304 £11.85	Qty. Reqd.

Boxed prices include P & P and 15% VAT  
 If no dealer in your area contact CSC direct. FREE catalogue tick box

Continental Specialties Corporation, (U.K.) Limited, Dept. 4H  
 Unit 1, Shire Hill Industrial Estate, Saffron Walden, Essex. Tel: (0799) 21682



# FOR BEGINNERS

## STOCKING UP— SEMICONDUCTORS

Two previous articles have been devoted to resistors and capacitors. This month we discuss certain semiconductor devices that should be acquired by the beginner to start a stock of useful components.

### DIODES

Diodes are one-way devices—they will pass current only if connected in circuit right way round, that means anode connected to the positive side of the circuit and cathode to the negative side.

Diodes are broadly divisible into four classes: (1) small-signal diodes, as used for detection in radio receivers, and also in logic circuits; (2) power diodes, used for rectifying alternating current; (3) Zener voltage reference diodes; (4) photodiodes and light-emitting diodes (l.e.d.s).

A small quantity of class (1) should be held in stock since they are frequently needed. They are small components and inexpensive. Suggested types and quantities to be held as stock are given in Tables 1—3.

The larger "power" type diodes (or rectifiers) are more expensive and in comparison bulky in size. They are available also as bridge rectifiers—four rectifiers integrated within a package. Power diodes are made in a variety of voltage and current ratings, and are best purchased as required, for some specific purpose.

If a diode is connected in reverse, that is anode to negative side of circuit, the diode will not conduct. Should, however, the applied voltage be sufficiently high, the diode will "breakdown" and conduct. If the voltage subsequently falls below the breakdown value, the device will become a barrier to current flow once again.

This property is exploited in devices known as Zener voltage reference diodes. These are used for maintaining the voltage level or to provide a reference voltage at some point in a circuit.

Zener diodes are made with various "breakdown" voltages; from 2.7 volts upwards. A few Zeners should be held in stock. Those suggested in Table 4 should cover many normal needs.

Light emitting diodes are becoming increasingly commonplace, replacing filament lamps for signal and indicating purposes in many electronic projects, and it is worthwhile holding a small stock of selected types—see Table 5. The most practical colour is red, but these devices are available in green and yellow also.

Photodiodes are but rarely used and can be disregarded for the present.

### TRANSISTORS

Despite the large number of different transistor types, the constructor can cover many of his needs from a very small selection of small-signal, audio frequency transistors.

BC108 is an essential general purpose transistor for the constructor. Closely related types are the BC107 and the BC109, the latter being a low-noise version of the BC108. These three types are available in TO-18 cans.

Another popular general purpose transistor is the ZTX300. This is made in a plastic package, the leads being arranged in what is known as "E line" configuration.

These transistors and a few others are listed in Table 6, which includes in the final ("Qty") column recommended quantities that the new constructor should obtain and hold as initial working stock.

Other types of transistors, including special types such as field effect transistors (f.e.t.s) and unijunction

**TABLE 1**  
GERMANIUM SIGNAL DIODES

Type	Max p.i.v.	Current	Qty
OA91	100V	20mA	4

**TABLE 2**  
MINIATURE 1A PLASTIC  
ENCAPSULATED DIODES

Type	Max p.i.v.	Qty
1N4001	50V	4
1N4004	400V	4

**TABLE 4**  
ZENER VOLTAGE REFERENCE DIODES

Type	Voltage	Qty
BZY88	5.1V	2
BZY88	5.6V	2
BZY88	10V	2

**TABLE 5**  
LIGHT EMITTING DIODES

Type	Colour	Dia.	Qty
TIL220	Red	5mm	4

**TABLE 7**  
INTEGRATED CIRCUITS

Type	Function	Qty
741	Operational Amplifier	3
555	Timer	3

transistors, will be required from time to time, but these are best purchased as the need arises.

### INTEGRATED CIRCUITS

Integrated circuits (i.c.s) are now so commonly used that it makes sense for the beginner to purchase a few of the more popular types. We suggest just two types to commence with: the 741 operational amplifier and the 555 timer. See Table 7.

Both of these i.c.s are available in 8-pin dual-in-line packages.

**TABLE 3: HIGH SPEED SILICON SWITCHING DIODES**

Type	Max Voltage	Max Current	Qty
1N4148	75V	75mA	4

**TABLE 6: TRANSISTORS**

Type	Material	Outline	Application	Qty
BC107	npn S	TO-18	Audio driver stages	5
BC108	npn S	TO-18	General purpose	5
BC109	npn S	TO-18	Low noise audio	2
BFY51	npn S	TO-39/TO-5	General purpose	2
ZTX300	npn S	E-line	General purpose	2
2N3704	npn S	TO-92	Audio amplifier	2
2N3702	pnP S	TO-92	Audio amplifier	2



# ELECTRONIC GAMES

## ATARI



SPECIAL PRICE  
**£86 + VAT**

## SPACE INVADERS



HAND HELDS + CARTRIDGES  
ATARI - ACETRONIC  
PRINZTRONIC  
RADDFIN - DATABASE etc.  
We keep a full range!  
Send for cartridge lists stating which machine you own.

## INTELLIVISION MATTEL



£173.87 + VAT

Available August 1980  
This is the most advanced TV game in the world.  
Expandable next year into a full microcomputer.  
COLOUR CATALOGUE AVAILABLE WITH DETAILS ON ALL THE CARTRIDGES

## CHESS



Send for further details.

COMPUTERS  
NEW RANGE AVAILABLE AUGUST 1980  
We specialise in computer chess machines & stock over 13 different models from £20 to £300

## BRIDGE

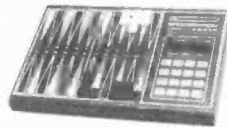
COMPUTER



- ★ Plays 1/2/3 or 4 Hands
- ★ Problem Mode
- ★ Audio Feedback
- ★ Instant Response
- ★ Auto scorekeeping

## BACKGAMMON

COMPUTERS

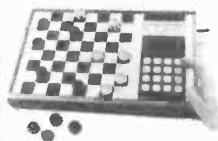


OMAR 1  
OMAR 2  
CHALLENGER  
GAMMONMASTER

From £38 to £108. Send for further details.

## DRAUGHTS

COMPUTER



- ★ Solves Problems
- ★ Rejects illegal moves
- 2 level machine £43 + VAT
- 4 level machine £77.78 + VAT

## LEISURE

- ★ CHEAP TV GAMES
- ★ TELEPHONE ANSWERING MACHINES
- ★ AUTO DIALLERS
- ★ CALCULATORS
- ★ DIGITAL WATCHES
- ★ PRESTEL
- ★ HAND HELD GAMES

## TELETEXT



RADFIN  
TELETEXT  
Add on Adaptor  
**£199 + VAT**

## 27 TUNE DOOR BELL

£17.13 + VAT



## FREE CATALOGUE

For a free copy of our 32 page catalogue, send a 12p stamp to Silica Shop Ltd or Telephone 01-301 1111

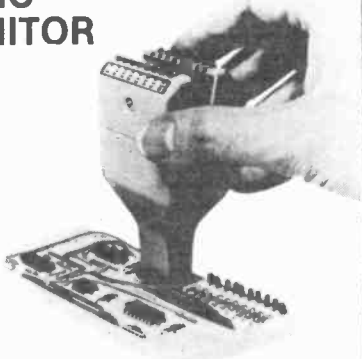
MAIL ORDER SERVICE - Free postage & Packing  
TELEPHONE & MAIL ORDERS - accepted on:  
Access ★ Barclaycard ★ American Express ★ Diners Club  
CALLERS WELCOME - at our shop in Welling - Demonstrations daily  
Open from 9am-5pm Mon-Sat (9am-1pm Wed)  
GUARANTEE - Full 12 months + After Sales Support!  
We have comprehensive brochures on all products. Please let us know what you are interested in and we will send you detailed brochures AND our own 32 page catalogue covering most games on the market.

## SILICA SHOP

SILICA SHOP LTD., Dept. EE 9  
102 Bellegrave Road  
Welling, Kent DA16 3QF  
Tel: 01-301 1111

# Faster than a scope safer than a voltmeter

## LOGIC MONITOR LM-1



## Instant - simultaneous monitoring of the logic state of all IC nodes

Just clip it over your IC

LM-1 Instantly and accurately shows both static and dynamic logic states on a bright 16 LED display.

LM-1 finds its own power.

LM-1 cuts out guesswork, saves time, and eliminates the risk of short circuits.

LM-1 is suitable for all dual-in-line logic ICs LED on = logic state 1 (high), LED off = logic state 0 (low), and each LED is clearly numbered 1 to 16 in the conventional IC pattern.

**ONLY £28.70** (Excluding P&P and VAT)

Total £34.44 including box and instruction manual.

CONTINENTAL SPECIALTIES CORPORATION



C.S.C. (UK) Limited  
Dept. 4S, Unit 1, Shire Hill Industrial Estate,  
Saffron Walden, Essex CB11 3AQ  
Tel: Saffron Walden (0799) 21682  
Telex: 817477

C.S.C. (UK) Limited, Dept. 4S, Unit 1, Shire Hill Industrial Estate, Saffron Walden, Essex CB11 3AQ  
LM-1 £34.44 (incl. P&P and 15% VAT) Qty. Reqd.  For FREE Catalogue tick box

Name ..... Address .....

I enclose PO/cheque for £..... or debit my  
Barclaycard, Access, American Express No. ....  
exp. date .....

FOR IMMEDIATE ACTION - The C.S.C. 24 hour, 5 day a week service, Telephone: (0799) 21682, and give us your Barclaycard, Access, American Express number and your order will be in the post immediately.

# How do you put over 2,000 different tools and toolkits into one envelope?



The New Toolrange Catalogue is still the only comprehensive single source of electronic tools and production aids.

Products from over 100 top manufacturers are available from stock.

For your free copy of the new catalogue contact Toolrange today.

# toolrange

Upton Road, Reading, Berks. RG3 4JA  
Telephone: Reading (0734) 22245 Telex: 847917



## Wilmslow Audio

*THE firm for speakers!*

SEND 50p FOR THE WORLD'S BEST CATALOGUE OF SPEAKERS, DRIVE UNITS, KITS, CROSSOVERS ETC. AND DISCOUNT PRICE LIST

AUDAX ● AUDIOMASTER ● BAKER  
BOWERS & WILKINS ● CASTLE  
CELESTION ● CHARTWELL ● COLES  
DALESFORD ● DECCA ● EAGLE ● ELAC  
EMI ● FANE ● GAUSS ● GOODMAN  
HARBETH ● ISOPHON ● I.M.F. ● JORDAN  
JORDAN WATTS ● KEF ● LOWTHER  
MCKENZIE ● MISSION ● MONITOR AUDIO  
MOTOROLA ● PEERLESS ● RADFORD  
RAM ● ROGERS ● RICHARD ALLAN  
SEAS ● SHACKMAN ● TANNOY  
VIDEOTONE ● WHARFEDALE

### WILMSLOW AUDIO (Dept. EE)

SWAN WORKS, BANK SQUARE, WILMSLOW,  
CHESHIRE SK9 1HF

Tel: 0625-529599 FOR MAIL ORDER & EXPORT OF DRIVE UNITS, KITS ETC.

Tel: 0625-526213 (SWIFT OF WILMSLOW) FOR HI-FI & COMPLETE SPEAKERS

## INTERESTED IN ELECTRONICS?

TRY A ZEDPACK!

COMPONENTS AT A PRICE  
EVERYONE CAN AFFORD

Z1 300 mixed  $\frac{1}{2}$  and  $\frac{1}{4}$  watt resistors £1.50  
Z2 150 mixed 1 and 2 watt resistors £1.50  
Z3 300 mixed capacitors, most types £3.30  
Z4 100 mixed electrolytics £2.20  
Z5 100 mixed polystyrene caps £2.20  
Z6 300 mixed printed circuit components £1.50  
Z7 300 mixed printed circuit resistors £1.20  
Z8 100 mixed high wattage resistors, wire-wound etc. £2.20  
Z9 100 mixed miniature ceramic and plate caps £1.20  
Z10 25 assorted pots. £1.50  
Z11 25 assorted presets, skeleton etc. £1.20  
Z12 20 assorted vdr's and thermistors £1.20  
Z13 400 mixed FILM RESISTORS only £2.50  
Z14 100 mixed, new and marked, full spec. transistors. Pack includes:— BC148, BF154, BF274, BC212L, BC238, BC184L, MEO412 and, or lots of similar types £4.95  
Z15 100 mixed diodes including:—zener, power, bridge, signal, germanium, silicon etc. All full spec. £4.95  
Z16 20 1N4148 £1  
Z17 20 1N4003/10D2 £1  
Z18 20 assorted zeners, 1 watt and 400mw £1.50  
Z20 6 BR100 diac. £1  
20mm ant surges fuses, 630ma 800ma, 1a, 1.25a, 1.6a, 2a, 2.5a, 3.15a, 12 of one type £1.100 of £7.  
ULTRASONIC TRANSDUCERS, trans-mitter and receiver. 40KHz. 14mm diam. £3.95 pair  
TBA 800 Audio I.C. £1 ea. 3 for £2.50  
Deluxe FIBREGLASS printed circuit etching kits, includes 100 sq ins. of copperclad F/G board, 1lb ferric chloride, (made for U.S. army to MIL SPEC), 1 dalo etch resist pen, abrasive cleaner, etch resist dish and instructions. OUR PRICE £4.95  
200µA Miniature level/batt. meters, as fitted to many cassette recorders. 90p

11b of FeCl. £1-25. 5lb. £5.  
150 sq. ins. single sided board. £2-20  
150 sq. ins. double sided board. £3-30  
Dalo pen. £1

UHF, Transistors T.V. TUNER with slow motion drive, AE.skt. and leads £1-95  
100 Miniature reed switches. £3-30

### P/B SWITCH BANKS

These cost a fortune! Were made for various music centres. Includes independent and interdependent latching types multi pole c/o etc. Can be modified. Can't be repeated. 3 Banks for £1.  
KNOBS for Switch Banks 10 for £1. Chrome or spun aluminium finish.

### MINIATURE MAINS TRANSFORMERS

Top quality. Split bobbin construction will give 4.5V-0-4.5V at 250MA,  $\frac{1}{2}$ " x  $\frac{1}{2}$ " x  $\frac{1}{2}$ ", all sorts of uses. ONLY 90p

1000 µf, 100V, Radial,  $\frac{1}{2}$ " x 2". ONLY 70p. 3 for £1.50, 2,200µf 40v. 60p, 3 for £1.50, 4,700µf 40v. 80p, 3 for £2.

Don't Let Your Environment Dehydrate You!

Buy our Honeywell Humidity Controller. Membrane actuated, very sensitive,  $\frac{1}{2}$ " shaft, 250V, 3-75A Contacts. Ideal for greenhouses, centrally heated homes, offices etc. Build your own humidifiers or alarms. Fraction of original cost 90p ea. 3 for £2.

### TRANSISTOR PUSHBUTTON TUNERS

For UHF Television (Decca Bradford or Rigonda chassis) 5 P/B Type (one for tuning). Only £2.50.

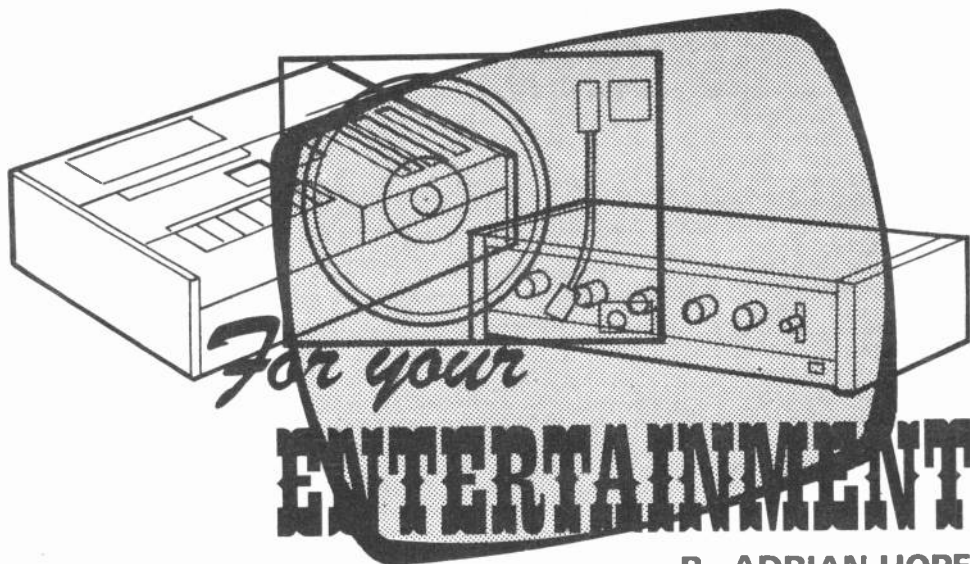
### ALTERNATOR RECTIFIERS

Make lovely 60 amp bridges. Ideal for High Power Battery Chargers. Type 4AFI. Set of 4 (2 neg. case + 2 pos. case) £2.

Special Purchase enables us to offer Mullard C200 Polyester Capacitors (Liquorice Allsorts) at the unbeatable price of £2 for 100 mixed. £15 for 1000. These consist of factory clearance lots i.e. spillages, floor sweepings, cosmetic rejects etc. Also Mullard miniature electrolytics 100 mixed £1.50, 1000 for £10. Pack of each £3. 1000 of each £30.

To: "GEMINI ELECTRONIC COMPONENTS"  
"THE WAREHOUSE" SPEEDWELL ST. LONDON S.E.8.

Please Quote ZED Code, Where shown. Send Cheque\* or Postal Order. Plus 40p P&P.  
\*Schools etc. SEND OFFICIAL ORDER



By ADRIAN HOPE

## Before Their Time

I'll bet that few people working today in electronics will even recognise the name John Sargrove. I certainly didn't until the Institution of Electronic and Radio Engineers organised an evening meeting to remind a few interested people of Sargrove's work.

In a nutshell he was another of those unfortunate inventors, like Alec Reeves, Charles Babbage and Alan Blumlein, who were way ahead of their time. It was Reeves who invented PCM in the 1930's, long before transistors were available to make the system work.

Working a few years earlier than Reeves, Blumlein invented stereo and film recording long before the industry was ready for it. And it was in the early 19th Century that Babbage first laid plans for a computer which was the mechanical equivalent of today's electronic calculator.

Although it is not widely recognised, John Sargrove, who died in 1974, worked soon after World War II on a system of total automation for radio and TV receiver production. Although the scheme, christened ECME (Electronic Circuit Making Equipment) won Sargrove the first ever Clerk Maxwell premium in 1946, the idea was too far ahead of its time to become a commercial success.

## Automated Radio

His dream was to build a factory which would build radios almost untouched by human hand. Those who remember him recall that "he wanted every Indian to have a radio".

Of course, in the 40's all radios had to rely on valves and all automation equipment for building them had to rely on mechanical relays. Transistors and solid state switching were still a pie in the sky.

Nothing to be daunted, Sargrove designed a radio that was based on large integrated circuits with sockets for valves. But the circuits weren't i.c.s as we know them. Each was a large board with 15 solder joints, 15 capacitors, two variable condensers (capacitors) and several valve sockets. But everything was laid out by robot hands. The resistors were deposited as layers and only the glass valves were plugged in by hand. The Sargrove production line was actually used by Cossor in 1947 to produce radios. Unfortunately the scheme was short lived.

He originally saw ECME as "the answer to the vexed problem of post war labour problems". But very soon fears of job shortages replaced concern over labour shortage. The Daily Mirror ran a centre spread on the risks to employment presented by automation. Sargrove himself argued that automation didn't create unemployment. What it created was the need to redeploy a labour force from tedious repetitive jobs into more rewarding and constructive work.

Energetically he went out round the country and lectured on his ideas. His faith in the viability of automated factory production of electronic equipment sprang from experience of the valve and light bulb industry. If these precision products can be made in millions by total automation why not circuit boards and whole radios?

## A Cautionary Tale

Beware the creeping calculator disease. Can you still do any mental arithmetic Here's a true cautionary tale.

Recently a sixth former left school with an impressive string of 'A' levels and an assured place at university to study engineering. To fill in the few months between school and college he took a temporary job as a milkman. Or more accurately, he tried to take a job as a milkman.

The dairy in question has a policy of giving every new milkman a half hour arithmetic test.

"I'm afraid I haven't brought my calculator" explained the would-be engineer. "No matter" said the dairy foreman "We wouldn't let you use it in the test anyway".

The student never did work as a milkman. Stripped of his calculator, he was arithmetically helpless and failed the test miserably.

## Innumerate Society

Are we becoming an "innumerate" society? I raised the subject with the head of the maths department of a large London comprehensive school along with some of the school governors.

"We are educating children for a technological age" was the reply. It seems that as far as schools are concerned, calculators became acceptable as an everyday tool and an exam aid, when their cost fell below £10. The maths master argued that skills like long division and long multiplication are no longer of much importance.

What does matter, he believes, is the ability to "estimate" an answer to check that a calculator answer isn't totally haywire, for instance through mis-keying a decimal point. But isn't this based on the wholly false premise that everyone now carries a calculator around with them at all times? What about holiday trips to the beach or to restaurants where you may need to split a bill accurately several ways. And what happens if your calculator batteries run down when you want to check the price of 13 litres of petrol at an odd number of francs per litre?

The teacher's argument is that where accuracy matters, for instance in business, there will now always be a calculator to hand. There will also be an electronic cash register in most shops so all you need is a rough estimation to check the decimal point.

Exactly the same arguments against "progress" were raised, argued the teacher, when schoolchildren were no longer required to work out square roots the hard way. But, as that student who tried-but-failed-to become a milkman found out to his cost, long multiplication and division are far closer to real life than square roots. It's part of the everyday routine of a milkman to work out the cost of several dozen bottles of milk at an awkward cost per pint.

The parent governors had a ready but unconvincing answer to the cautionary milkman tale. "Educate the dairy into allowing the use of calculators". Furthermore I never thought I'd hear a mathematics teacher say "call it £100" when explaining how he would divide a restaurant bill of £98.55 between a large party of diners caught without their calculators. But he did.

## Wristwatch Calculators

In the future calculators will become even more accessible than they are now. There is one coming soon from Japan that you wear on the wrist like a wrist watch; and of course it doubles as a watch, alarm and stop watch as well. But should we always take the easy way out?

Language translators with synthesised speech are already available and will become cheaper and cheaper. Should we bother to learn languages in the future? There is already a prototype portable electronic "typewriter" that stores long messages in a solid state memory. Is it worth learning to write?

Have you noticed how on television, especially in programmes imported from the USA, every important written message or caption is read out aloud? Need we now bother to learn to read? It's easy to lose sight of the sociological questions which are being posed by electronic answers.

It's unclear why exactly ECME failed. But in part it was due to the problems of automating such a complicated multi-stage process with mechanical relays. There was always some moving part somewhere ready to go wrong. What's more political pressure to kill off the idea mounted.

The idea surfaced again in the 50's when an attempt was made to produce an automated TV production plant. But that too failed for the same reasons.

Sargrove then concentrated his energies on automation processes that, although ingenious, were slightly less ambitious and considerably less touchy. For instance he built machinery to match the colour of rosary beads, sort good from bad coffee beans and check the weight of balls of bakers' dough prior to baking into bread.

These are all more difficult than they may sound but didn't bother the politicians. He also produced the tiniest condenser mic of the time, no larger than a farthing.

### Wisdom of Automation

The real irony of the Sargrove saga is that foreign factories, especially those in Japan and Italy, have long since seen the wisdom of automation. Although it is an expensive investment to automate, once the lines are running the mass-produced output is cheap and reliability is high. Workers displaced from routine jobs can often be redeployed in to more stimulating posts.

Printing works and car factories in Italy and almost every industrial factory in Japan now borrow from Sargrove's pioneering ideas of over 30 years ago. Many are heavily automated and very successful.

In the UK we are still debating the wisdom, cost and morality of automation, rather like the captain of a sinking ship worrying about the menu for that night's dinner.

### University Industrial Units

During the last decade over 30 British Universities have opened "industrial units" offering companies the benefit of their scientific experience on a consultancy basis. These are intended to be self-supporting departments, set up by the parent University and staffed by university scientists, but operating on a commercial basis.

For example UMIST in Manchester has a Corrosion Unit which worried companies will-approach when their pipe lines or swimming pools spring a leak or their foundations show unaccountable signs of rusting or rotting. At the Department of Cybernetics of Reading University, a Research Unit in Instrument Physics was established in 1969 and has been self-supporting since 1972.

Just some of this excellent pioneering development work undertaken by Universities was highlighted by a recent visit to Reading University.

### Ambisonics

One project which will probably already be familiar to some readers is the Ambisonics surround sound system. This is best described as "second generation quadraphonics" and already the BBC, IBA and many European radio stations

are appraising the system. A cross-licensing deal has been struck with the Japanese company Nippon-Columbia and the project is being financed by the NRDC.

Essentially Ambisonics differs from the old, and now obsolete, quadraphonic systems because there is no attempt at conveying four separate channels of sound for feeding to four loudspeakers. The original sound information is mixed or coded into two, three or four channels in dependence on the number of recording or transmission channels available e.g. two on a stereo record, four on a four track tape and so on.

This information is decoded in accordance with the type of reproduction system available. Surround sound in the azimuth or horizontal plane is conveyed by two or three channels, or even by two-and-a-half channels (a "half channel" has limited frequency bandwidth and limited amplitude level). Surround sound with height, or "periphery", is conveyed by four channels.

A demonstration of periphery at the Audio Engineering Society Convention in London, earlier this year used a four channel system and eight loudspeakers, above, around and below the listener. It certainly gave an appetite-whetting foretaste of the future of domestic audio.

Unfortunately no major record company has yet adopted the Ambisonic system. They are doubtless all too scared by the memory of the quadraphonic fiasco of non-standardisation.

### Driverless vehicles

One of the first Reading commissions was to produce a driverless tractor, intended for the Third World countries. It proved a pointless exercise because in the Third World there is no shortage of labour, but a considerable shortage of cash to spend on high technology!

This situation wasn't realised until Reading scientists had built a driverless tractor which ploughed a field, without human aid, by sensing signals transmitted from wire aerials laid down each side of the field. The Road Research Laboratory heard of this system and in 1973 commissioned work on a driverless bus using a similar system based on wires buried underneath the road.

Experimental cars, vans and even a coach were duly produced. But at the last minute plans to run test projects in British cities were abandoned as a result of local spending cuts.

Nothing daunted, Reading suddenly realised that they had unwittingly produced an automatic control system for a vehicle which could readily be converted into a manual control operable from a single joystick, like a model aircraft control. Such a system would obviously be a boon for handicapped drivers and they soon succeeded in putting a 50 seater coach under the control of a single joystick that could be moved by one finger.

Now the Thalidomide Trust is financing the development of add-on joystick control units for use in cars for the disabled. Around 20 vehicles are currently being modified at the cost of around £2,000 each and should be on the road by 1981.

### Speech Therapy

Doctors and speech therapists are faced with an especially difficult problem

when trying to teach speech to patients born without a roof to their mouth. This is because human speech relies on an exceedingly complex pattern of contact between the tongue and roof of the mouth.

Reading has now built an imitation roof palate which contains a matrix of tiny electrical contacts. These are connected by super-fine wires to a microprocessor which is coupled to a cathode ray tube screen. This screen displays the pattern of tongue movement over the imitation palate and so helps the patient to follow the example of a tutor.

Speech therapists in British hospitals should soon be using some of these electronic aids.

### Moisture Meter

In quite a different technology it is remarkably difficult to measure the amount of water in a solid, such as a house wall. But it can be very necessary to do so. The Reading answer, developed for the Building Research Establishment, is a circuit which registers the capacitive effect of the water rather than the conductive effect as normally sensed by a probe.

A hole is cut in the wall and then plugged with a central metal rod and silver sleeve. This plug creates a capacitor of which the dielectric constant depends on the amount of water in the wall.

A very high frequency current, of around 60MHz, is fed into the plug and its capacitance value read out alongside a scale of moisture content. In practice water has such a high dielectric constant that there is an 80-fold difference between a dry and wet wall.

Unfortunately there is a snag. Because any impurity such as salt in the water makes it conductive, the measurement readout will normally be a very confusing mixture of conductance and capacitance.

The answer is simple once you've thought of it. Conductance and capacitance are 90 degrees out of phase, so the readout is made phase sensitive to offer one value for conductance and another, displaced by 90 degrees, for capacitance. The conductance readout gives a measure of the salt content of the wall and the capacitance readout gives a measure of the amount of water present.

A similar electronic system is used to measure the "lushness" of pasture. Normally pasture has to be collected, burned and analysed to establish its water content or lushness.

Reading use a capacitance meter and a grid of condenser plates interleaved with the pasture. An accurate moisture content readout of the pasture between the plates can thus be obtained.

The system is so sensitive that it is sent haywire by the presence of a human body within 10 metres range. So the readouts have to be transmitted as a 3MHz signal.

The signal is mixed in a receiver with a signal from a tunable local oscillator. The result is a variable beat tone from the receiver, like that which issues from a metal detector.

The beat tone is zeroed by adjustment of the local oscillator by the operator. This gives a direct readout of the signal frequency coming from the condenser plates in the pasture. This in turn gives a direct tell-tale of the amount of water in the pasture which is serving as a dielectric between the plates.

# NEW CONSTRUCTORS PACK 7

## ALL THE PARTS TO BUILD THE PRACTICAL ELECTRONICS TRAVELLER CAR RADIO

- \* EASY TO BUILD \* 5 PUSH BUTTON TUNING \* MODERN STYLING DESIGN \* ALL NEW UNUSUAL COMPONENTS
- \* 6 WATT OUTPUT \* READY ETCHED & PUNCHED P.C.B.
- \* INCORPORATES SUPPRESSION CIRCUITS



The pack contains all the electronic components to build the radio, you supply only the wire and solder as featured in the Practical Electronics March issue.

The P.E. Traveller features pre-set tuning with five push button options, black illuminated tuning scale, with matching rotary control knobs, one, combining on/off volume and tone-control, the other for manual tuning, each set on wood simulated fascia.

The P.E. Traveller has a 6 watts output, negative ground and incorporates an integrated circuit output stage, a Mullard IF module LP1181 ceramic filter type, pre-aligned and assembled and a Bird pre-aligned push button tuning unit.

The P.E. Traveller fits easily in or under dashboards. Complete with instructions.

**£10.50** p&p £1.75

**CONSTRUCTORS PACK 7A**  
 Suitable stainless steel fully retractable locking aerial and speaker (approx 6" x 4") is available as a kit complete.  
**£1.95** Per Pack, p & p £1.00.  
 Pack 7A may only be purchased at the same time as Pack 7.  
**NOTE:** Constructor's pack 7A sold complete with radio kit **£15.20** including p&p.

**A FEATURED PROJECT IN PRACTICAL ELECTRONICS**



323 EDGWARE ROAD, LONDON W2. For Personal Shoppers Only. 21A HIGH STREET, ACTON W3 6NG. Mail Order Only. No Callers. Mon-Sat 9.30am-5.30pm Closed Thursday

**NEW 12+12 AMPLIFIER KIT**

An opportunity to build your own 12 watts per channel stereo amplifier with up-to-the-minute features. To complete you just supply screws, connecting wire and solder. Features include din input sockets for ceramic cartridge, microphone, tape or tuner. Outputs—tape, speakers and headphones. By the press of a button it transforms into a 24 watt mono disc amplifier with twin deck mixing. The kit incorporates a Mullard LP1183 pre-amp module, plus 2 power amplifier assembly kits. Also featured 4 slider level controls, rotary bass and treble controls and 6 push button switches. Silver finish fascia panel with matching knobs. Easy to assemble teak simulate cabinet and ready made metal work. For further information instructions are available price 50p. Free with kit. Size 9 3/4" x 8 3/4" x 4" approx. **£13.95** p&p £2.55

**TWO WAY SPEAKER KIT** To suit above amp. Comprising 2, 8" approx Philips base unit, and 2, 3 1/2" approx tweeters with 2 crossover capacitors **£4.95** p&p £1.65.

Available only to first time purchasers of the 12 + 12 kit.

**50WATT MONO DISCO AMP**

**£30.60** p&p £3.20

Size approx 13 3/4" x 5 1/4" x 6 3/4"

50 watts rms. 100 watts peak output. Big features include two disc inputs, both for ceramic cartridges, tape input and microphone input. Level mixing controls fitted with infegral push-pull switches. Independent bass and treble controls and master volume.

**NOW AVAILABLE**

**30 + 30 WATT STEREO AMPLIFIER**

Viscount IV unit in teak simulate cabinet. Silver finish rotary controls and pushbuttons with matching fascia, red mains indicator and stereo jack socket. Functions switch for mic magnetic and crystal pickups, tape tuner and auxiliary. Rear panel features fuse holder, DIN speaker and input socket 30 + 30 watts RMS 60 + 80 watts peak for use with 4 to 8 ohm speakers. Size 14 1/4" x 3 1/2" x 10 1/2" approx. **£32.90** p&p £3.30

**BUILT AND READY TO PLAY** p&p £3.30

**Mullard AUDIO MODULES IN BARGAIN PACKS**

ACCESSORIES ARE ONLY AVAILABLE TO THOSE CUSTOMERS WHO BUYING OUR BARGAIN PACKS

**CURRENT CATALOGUE PRICE AT OVER £25 PER PACK SEE OUR PRICES**

**1** PACK 1 2 x LP1173 10w RMS output power audio amp modules, + 1 LP1182/2 Stereo pre amp for ceramic and auxiliary input. **OUR PRICE £5.00** p&p £1.10

**2** PACK 2 2 x LP1173 10w RMS output power audio amp modules + 1 LP1184/2 Stereo pre amp for magnetic, ceramic and auxiliary inputs. **illus. OUR PRICE £7.65** p&p £1.15

**ACCESSORIES** Suitable mains power supply parts, consisting of mains transformer, bridge rectifier, smoothing capacitor and set of rotary stereo controls for treble, bass, volume and balance. **£3.00** plus p&p £1.60

**Two Way Speaker Kit** Comprising of two 8" x 5" approx. 4 ohm bass and two 3 1/2" 15 ohm mid-range tweeter with two cross-over capacitors. Per stereo pair plus p&p **£4.05**

**£76.00** p&p £4.00

**100 WATT MONO DISCO AMP** Bushed aluminium fascia and rotary controls. Size approx. 14" x 4" x 10 1/4"

Five vertical slide controls, master volume, tape level, mic level, deck level. PLUS INTER DECK FADER for perfect graduated change from record deck No. 1 to No. 2, or vice versa. Pre fade level control (PFL) lets YOU hear next disc before fading it in. VU meter monitors output level. Output 100 watts RMS 200 watts peak.

**EMI SPEAKER BARGAIN**

Stereo pair 350 kit. System consists of 13" x 8" approx. woofer with rolled surround. 3 1/2" Goodman tweeter crossover components and circuit diagram. Frequency response 20 Hz to 20 KHz. Power handling 15 watts RMS 20 watts max. 8 ohm impedance. **£18.25** Per stereo pair p&p £4.20

**BSR P200** **£25.50**

Belt drive chassis turntable unit semi-automatic, cueing device. p&p £3.00

Shure M75 6 Magnetic Cartridge to suit **£7.95**

**BSR** Manual single play record deck with auto return and cueing lever. Lined with stereo ceramic cartridge 2 speeds with 45 r.p.m. spindle adaptor ideally suited for home or disco use. **OUR PRICE £12.25** p&p £2.75

**PHILLIPS RECORD PLAYER DECK GC037**

HiFi record player deck, belt drive complete with GP401 magnetic cartridge—LIMITED STOCK. **£27.50** complete. UNBEATABLE OFFER AT BUYER COLLECT ONLY.

**BARGAIN OFFER**

Ariston pick-up arm manufactured in Japan. Complete with headshell. **OUR £11.95** LISTED PRICE OVER £30.00. **PRICE p&p £2.50**



323 EDGWARE ROAD, LONDON W2 21A HIGH STREET, ACTON W3 6NG

ACTON: Mail Order only. No callers. ALL PRICES INCLUDE VAT AT 15%. All items subject to availability. Price correct at and subject to change without notice. All enquires Stamped Addressed Envelope.

**NOTE:** Persons under 16 years not served without parent's authorisation.

Personal Shoppers EDGWARE ROAD LONDON W2 Tel: 01-723 8432. 9.30am-5.30pm. Closed all day Thursday ACTON: Mail Order only. No callers. GOODS DESPATCHED TO MAINLAND AND N. IRELAND ONLY

# NEW!

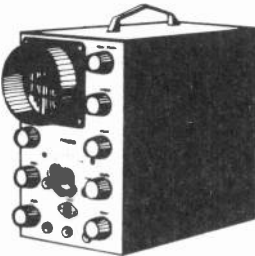
# LERNA-KITS!

● HIGH QUALITY EDUCATIONAL KITS

- LATEST SOLID STATE TECHNOLOGY – DESIGNED & MADE IN THE U.K.
- DETAILED STAGE BY STAGE BUILDING INSTRUCTIONS
- FREE ADVISORY SERVICE THROUGHOUT THE BUILDING

## LK1 OSCILLOSCOPE

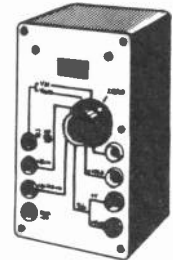
Solid state circuitry; D.C. coupled; 7 cm. dia. tube; Y input 0.3 v/cm. to 50 v/cm.; X input 1 volt/cm.; 1v. and 10v. cal. signals; response to 1MHz; Time base ranges to 8 $\mu$ S per cm.; Size 230 x 130 x 190mm. Wt. 2 Kg. Operates from 110 volt or 220/240-volt A.C. High quality kit complete with carrying case.



£130.00

## LK2 DIGITAL MULTIMETER

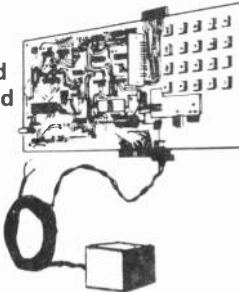
Solid state circuitry with large digital display. Ranges are up to 1000v. D.C. and A.C. and current D.C. to 100mA. Resistance ranges 100K ohms. Battery operated. Size 185 x 110 x 60mm. Digital display : 37 x 16mm



£40.00

## LK3 HOME COMPUTER

Ideal simple computer for beginners. Microprocessor has 8 bit data bus and 12 bit address bus. Ready programmed ROM has 4K bits. RAM of 0.5 x 8k bits fully addressable. 8 digit LED display. Hexadecimal read out. Hexadecimal keyboard. Re-set switch and single shot facility. Power supply kit included. Provision for cassette and V.D.U. operation.

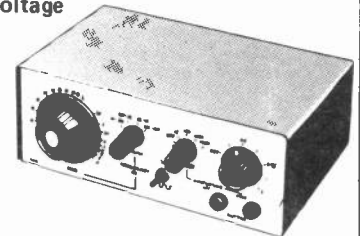


£190.00

## LK4 AUDIO GENERATOR

Covers 10Hz to 100kHz in four switched stages. Variable voltage output.

Distortion below 0.02%. Sine and square wave output. Ideal for HI-FI work and as signal tracer.

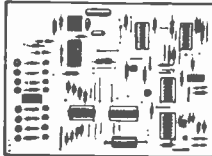


£40.00

## LK5 DIGITAL ELECTRONIC TECHNIQUES

Experiments carried out on a P.C. board, size 190 x 150mm covering operational amplifiers; integrators; basic logic circuits; NAND, NOR gates; Flip-Flops; Multi-vibrators; clock generator; 4 bit comparator feed back; analogue switching; building simple digital meter circuits; Timer.

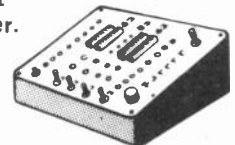
Note:— for full benefit with this kit a C.R.O. is desirable although circuits can be built without one.



£35.00

## LK6 LOGIC DEMONSTRATION PANEL

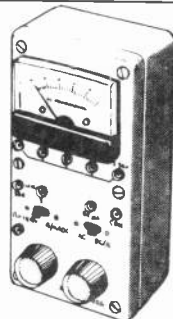
Basic introduction to computer technology; AND and OR gates; NOR and NAND; Data line selector; Truth tables; AND and INVERT gate; Half and Full Adder; Latches; Flip-Flops; Shift register; Binary coded decimal counter. Over 16 experiments are performed with panel. Battery operated.



£70.00

## LK7 ANALOGUE TEST METER

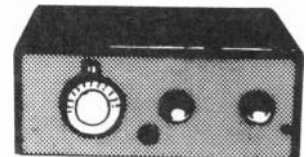
Basic multi range test meter kit with 20,000 ohm/volt sensitivity. Ranges: D.C. and A.C. volts 0-5, 0-25, 0-100, 0-500; 2.5kV. D.C. 0-5mA, 0-500mA, 0-50 $\mu$ A Resistance 0-50K; 0-5M. Size 150 x 75 x 50mm.



£17.00

## LK8 SHORT WAVE RECEIVER

A simple 3 stage short wave only radio receiver for the amateur. Very good selectivity and sensitivity and will give hours of enjoyment. Simple to construct by people of any age.



£25.00

To:— LERNAKITS, 4 Cleveland Road, Jersey, Channel Islands. (Est. 40 years)

Please supply ..... Kit at £ .....

add £2 postage U.K. only.  
£10 postage overseas Air Mail.

Catalogue available  
on receipt 12p stamp.

BLOCK CAPS PLEASE

EE/9/819

NAME .....

ALL CREDIT CARDS ACCEPTED

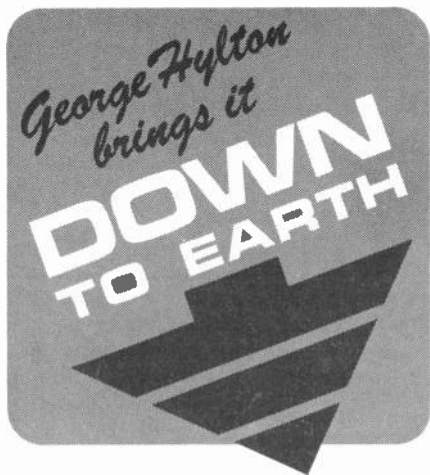
ADDRESS .....

Name of Card .....

(Dispatch is normally within 1 week of receipt of order)

No.

Signature .....



A READER has asked; "In articles about the reception of frequency-modulated radio transmissions I frequently come across the term, quadrature detector. Please explain what this means."

An f.m. signal, when it leaves the transmitter, has a constant amplitude. That is, the peak and trough sizes of the waves do not change. Only the frequency changes.

At the receiver, noise picked up along with the signal or generated by the components in the receiver itself can cause the amplitude to vary. But any variations are eliminated by a limiter which in effect slices the tops and bottoms off the incoming waves so that they end up all cut down to the same size. By limiting the signal in this way the effects of noise are greatly reduced. This accounts for the much lower "background hiss" of an f.m. receiver compared with an a.m. receiver.

### Limiting

Let's consider an f.m. transmitter which is not at the moment carrying any programme material. It sends out a steady frequency at a steady amplitude; nothing changes. At the receiver, after limiting, this signal is transformed into a steady square wave, Fig. 1a.

When the programme is transmitted this square wave will change in frequency, higher or lower, according to the variations in the voltage generated by the microphone in the studio. But for the time being there is no programme. It follows that the square wave of Fig. 1a must produce no output.

When its frequency varies, however, it means that a programme is being transmitted and it must then produce an audio output which for low distortion must be exactly proportional to its frequency.

### Sampling

In a quadrature detector the no-programme wave is sampled at regular

intervals. But the sampling periods are so timed that the samples consist of equal parts of positive and negative bits of the wave. These average out to zero because the positive bits just cancel the negative bits. You can think of the sampling process as switching. The wave is applied to a high speed switch which when on lets it pass but when off stops it.

If the "ons" and "offs" are timed as shown in Figs. 1a and b, then the positive samples are equal in size to the negative samples. If you think of the positive samples as charging a capacitor then it is clear that the negative samples will discharge it by the same amount. The result is that there is no net charge.

### Modulation

If the transmitter is now modulated by a programme the frequency varies. For negative going points in the audio modulation the frequency may go low. For positive points it may go high. The sampling periods must be adjusted so that the output goes positive or negative in sympathy.

Suppose the wave form of Fig. 1c is the limiter output for a strong negative interval of the audio wave. If we sample at the times shown then the whole of each negative half cycle is passed by the sampling switch and none of the positive half cycles. So the output is now as negative as it can be (Fig. 1d). For positive-going modulation the frequency goes high and for maximum positive output samples must accept the whole of each positive half cycle, Figs. 1e and f.

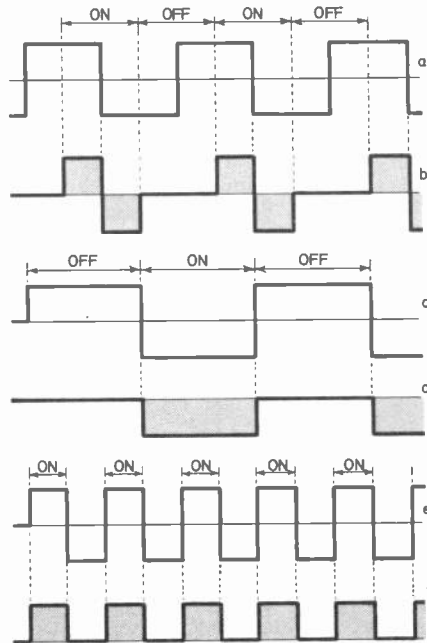


Fig. 1. Waveforms illustrating the operation of the quadrature detector.

When the audio is less intense the samples must include some positive bits and some negative bits but not equally positive and negative. In this way the cancellation will be incomplete and a certain amount of output will be produced. This can be positive or negative depending on whether the positive or negative bits are larger. By adjusting the timing of the samples any amount of net output can be obtained, from "full positive" to "full negative".

This is the principle of the quadrature f.m. detector (also called a quadrature demodulator and a quadrature discriminator). All that remains is to say how it can be made to work.

### How It Works

This requires some automatic method of adjusting the sampling times so that the correct outputs are obtained. This is a lot easier than it sounds. The standard method is to use the limited signal itself to time the sampling. The limited signal is applied to two parts of the detector at the same time. One is just to the sampling switch, which lets it pass or not. The other is to the timing mechanism which turns the switch on or off.

It so happens that all the clever work of adjusting the timing to suit the frequency can be done by one quite ordinary LC circuit tuned to approximately the frequency of the wave shown in Fig. 1a. This produces just enough phase shift to make the switch turn on and off as at (a).

If the frequency now goes low the phase shift changes and moves the timing towards Fig. 1c. If the frequency increases the sampling times are moved towards (e). The amount by which the times are moved is in proportion to the frequency and so the net output is also in proportion to the frequency which is what is required. As the frequency swings up and down in sympathy with the audio at the studio so the output swings positive or negative in the right way to reproduce the original audio wave.

### Quadrature

It is a curious feature of quadrature demodulators that they can be converted from f.m. detectors to a.m. detectors just by changing the phasing of the sampling timer. To be precise, when the detector is used for a.m. it is no longer a quadrature detector.

Quadrature just means that the sampling times are a quarter of a cycle out of phase with the input signal, as they are in (a). For a.m. detection the signal is not limited and the detector samples the positive peaks.

In this case the samples must be in phase with the signal.

# TTL POWER SUPPLY UNIT

BY F.G. RAYER

THE TTL integrated circuits in the 7400 series are normally operated at between 4.75V and 5.25V and the TTL Power Supply Unit described here is intended particularly for these. The output is approximately 5V and this is regulated so that there is negligible change in voltage from no load conditions up to a maximum available load current of 1A. Short circuit protection built in.

## CIRCUIT DESCRIPTION

The full circuit diagram of the unit is shown in Fig. 1. Transformer T1 steps down the a.c. mains from 240V to 6.3V and isolates the low voltage circuit. Single-pole switch S1 is the on-off switch and the neon indicator LP1 shows when the power is on.

The silicon bridge rectifier D1-D4 has four leads. Two are for the a.c. input from the transformer secondary, the two others are the positive and negative d.c. outputs. Direct current from these leads charges the smoothing or reservoir capacitor C1. About 9V will be present across C1. Instead of a bridge rectifier, four individual 1A silicon diodes could be used.

The LM309K integrated circuit is packaged in a TO-3 can and incorporates the voltage regulation and short circuit protection devices.

With the components shown, maximum current is about 1A and short-circuit current a little over 1.5A.

When the voltage at pin 1 of IC1 falls below about 7V, regulation is lost. A short circuit in the output circuit would naturally be corrected as soon as noticed but with T1 and the bridge rectifier rated at 2A, these items are not damaged.

## CASE

The metal case is made from a single piece of flanged aluminium 100mm x 200mm (e.g. a single Universal Chassis member.) A 90 degree section is cut from each flange 63mm from each end and after all the holes have been drilled, the piece is bent to form an open box as shown in Fig. 3.

After assembly a piece of perforated metal is bent to form a cover, and is fixed with short self-tapping screws run into the flanges.

## ASSEMBLY

The component layout is shown in Fig. 2. Before components are mounted all burrs and irregularities should be removed from the case. The front panel components are then fixed in position.

Pins 1 and 2 of IC1 should not touch the metal case and the integrated circuit should rest flat on the side of the case. A tag screwed to the integrated circuit can provide connections to the metal chassis and pin 3. After the transformer is in position it can be wired up. Finally

the tagstrips and remainder of components are fixed in position and interwired. Note that the neon indicator should be the type with a series resistor incorporated.

The mains cable enters the case through a grommet and is connected up as shown. Current is drawn from a 3-pin plug fitted with a 2 or 3 amp fuse. Internal wiring can be of insulated flex, or 20 s.w.g. covered.

## APPLICATIONS

The supply is very suitable for any TTL project incorporating 74 series i.c.s requiring 5V. Take care to connect the supply with the correct polarity. The output voltage has been found to change by only about 0.05V for loads from zero to 500mA. This power supply unit will run quite large and complex projects as well as simpler devices which may have been operated from a 4.5V battery supply.

## COMPONENTS

### Capacitors

- C1 4700 $\mu$ F 12V elect.
- C2 470 $\mu$ F 12V elect.
- C3 10nF ceramic or plastic

### Semiconductors

- D1-D4 50V 2A bridge rectifier
- IC1 LM309K voltage regulator i.c.

### Miscellaneous

- T1 mains primary/6.3V 2A secondary transformer
- S1 s.p.s.t. mains toggle
- SK1, 2 3mm sockets (one red, one black)

Tagstrips: 4-way with one earthed mounting tag (1 off), 2-way with one earthed mounting tag (1 off); solder tags (2 off); three-core mains cable; rubber grommet; p.v.c. covered wire; 100mm x 200mm piece of flanged aluminium (e.g. Universal Chassis member No. CU56A from Home Radio); 226mm x 74mm piece of perforated metal for cover; nuts, bolts, washers for securing transformer, i.c. and tagstrips.

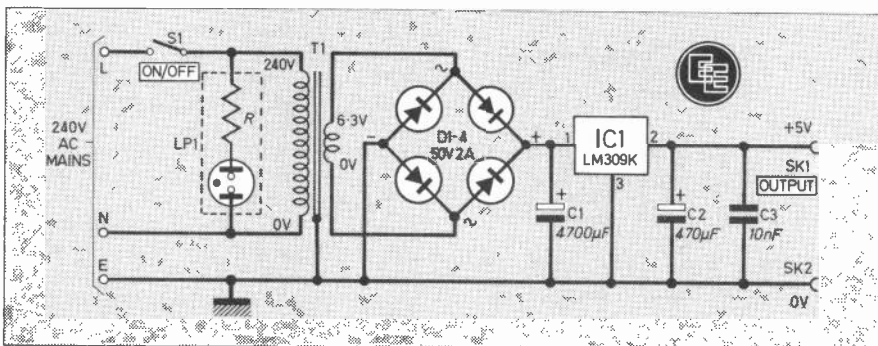


Fig. 1. Circuit diagram of the 5V Power Supply Unit.



# 5V power SUPPLY UNIT

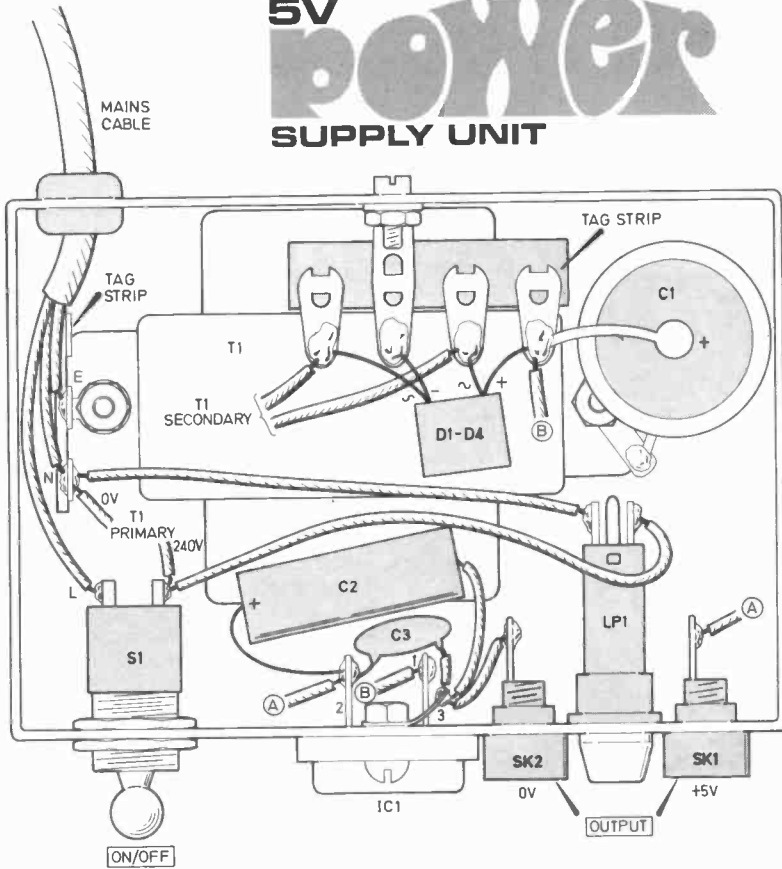
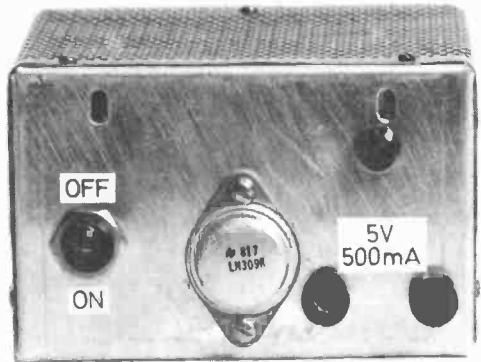
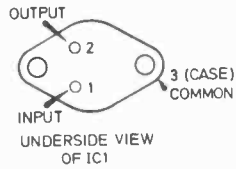
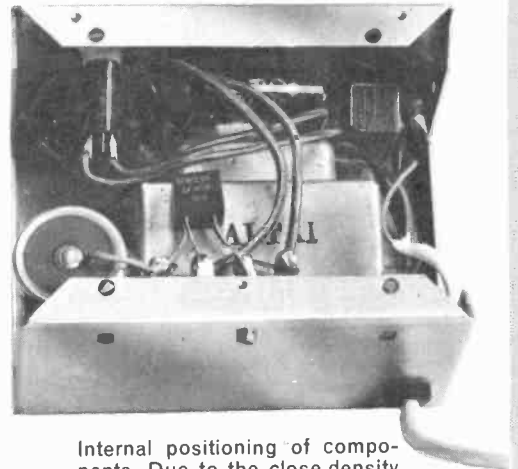


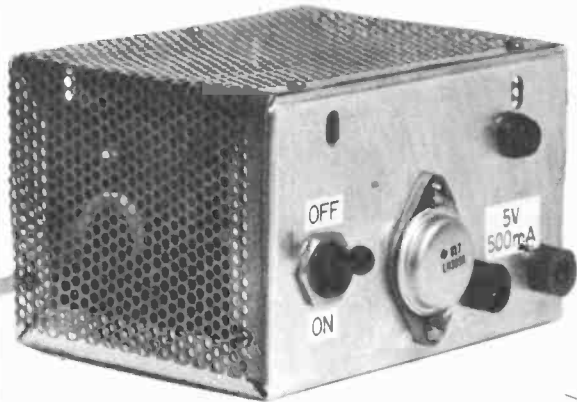
Fig. 2. Component layout and wiring. Make sure that pins 1 and 2 of the voltage regulator (IC1) do NOT touch the metal case.



Components mounted on the front panel.

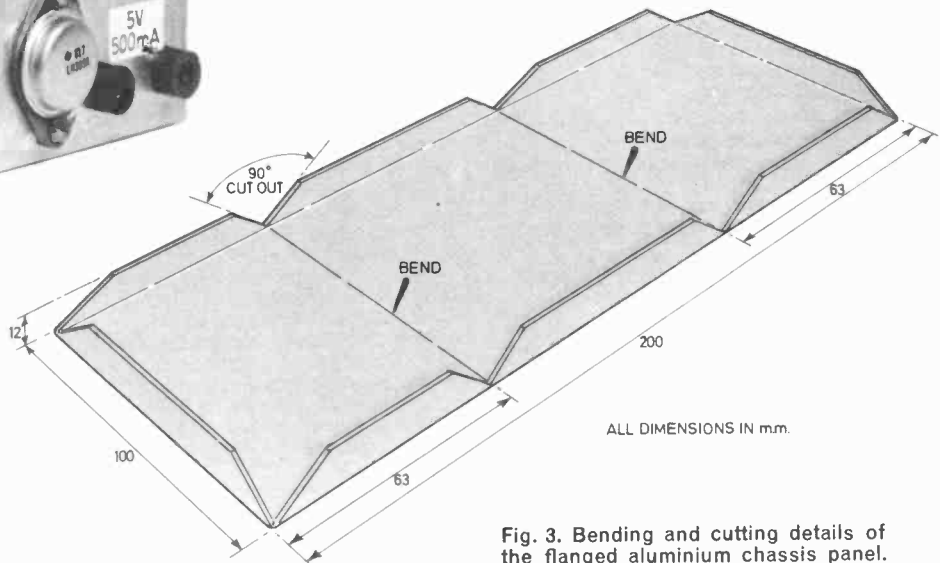


Internal positioning of components. Due to the close density care must be taken to ensure that components do not short on the transformer, particularly S1, IC1 and LP1.



The completed power supply with a suitable protective U-shaped cover fixed in position with self-tapping screws.

**COMPONENTS**  
approximate  
cost **£7**



ALL DIMENSIONS IN mm.

Fig. 3. Bending and cutting details of the flanged aluminium chassis panel.

# Britain's first com puter kit.

## The Sinclair ZX80.

# £79.95

Price breakdown  
ZX80 and manual: £69.52  
VAT: £10.43  
Post and packing FREE

Please note: many kit makers quote VAT-exclusive prices.

You've seen the reviews... you've heard the excitement... now make the kit!

This is the ZX80. 'Personal Computer World' gave it 5 stars for 'excellent value.' Benchmark tests say it's faster than all previous personal computers. And the response from kit enthusiasts has been tremendous.

To help you appreciate its value, the price is shown above with and without VAT. This is so you can compare the ZX80 with competitive kits that don't appear with inclusive prices.

### 'Excellent value' indeed!

For just £79.95 (including VAT and p&p) you get everything you need to build a personal computer at home... PCB, with IC sockets for all ICs; case; leads for direct connection to a cassette recorder and television (black and white or colour); everything!

Yet the ZX80 really is a complete, powerful, full-facility computer, matching or surpassing other personal computers at several times the price.

The ZX80 is programmed in BASIC, and you can use it to do quite literally anything from playing chess to managing a business.

The ZX80 is pleasantly straightforward to assemble, using a fine-tipped soldering iron. It immediately proves what a good job you've done; connect it to your TV... link it to an appropriate power source\*... and you're ready to go.

### Your ZX80 kit contains...

- Printed circuit board, with IC sockets for all ICs.
- Complete components set, including all ICs—all manufactured by selected world-leading suppliers.
- New rugged Sinclair keyboard, touch-sensitive, wipe-clean.
- Ready-moulded case.
- Leads and plugs for connection to domestic TV and cassette recorder. (Programs can be SAVEd and LOAded on to a portable cassette recorder.)
- FREE course in BASIC programming and user manual.

### Optional extras

- Mains adaptor of 600 mA at 9 V DC nominal unregulated (available separately—see coupon).
- Additional memory expansion boards allowing up to 16K bytes RAM. (Extra RAM chips also available—see coupon).

\*Use a 600 mA at 9 V DC nominal unregulated mains adaptor. Available from Sinclair if desired (see coupon).

### The unique and valuable components of the Sinclair ZX80.

The Sinclair ZX80 is not just another personal computer. Quite apart from its exceptionally low price, the ZX80 has two uniquely advanced components: the Sinclair BASIC interpreter; and the Sinclair teach-yourself BASIC manual.

The unique Sinclair BASIC interpreter offers remarkable programming advantages:

- **Unique 'one-touch' key word entry: the ZX80 eliminates a great deal of tiresome typing. Key words (RUN, PRINT, LIST, etc.) have their own single-key entry.**
- Unique syntax check. Only lines with correct syntax are accepted into programs. A cursor identifies errors immediately. This prevents entry of long and complicated programs with faults only discovered when you try to run them.
- Excellent string-handling capability—takes up to 26 string variables of any length. All strings can undergo all relational tests (e.g. comparison). The ZX80 also has string input to request a line of text when necessary. Strings do not need to be dimensioned.
- Up to 26 single dimension arrays.
- FOR/NEXT loops nested up to 26
- Variable names of any length.
- BASIC language also handles full Boolean arithmetic, conditional expressions, etc.
- Exceptionally powerful edit facilities, allows modification of existing program lines.
- Randomise function, useful for games and secret codes, as well as more serious applications.
- Timer under program control.
- PEEK and POKE enable entry of machine code instructions. USR causes jump to a user's machine language sub-routine.
- High-resolution graphics with 22 standard graphic symbols.
- All characters printable in reverse under program control.
- Lines of unlimited length.

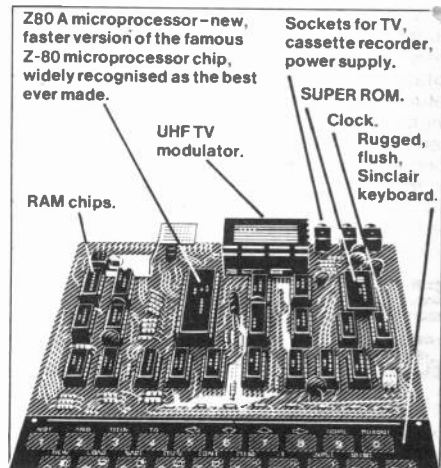


### Fewer chips, compact design, volume production—more power per pound!

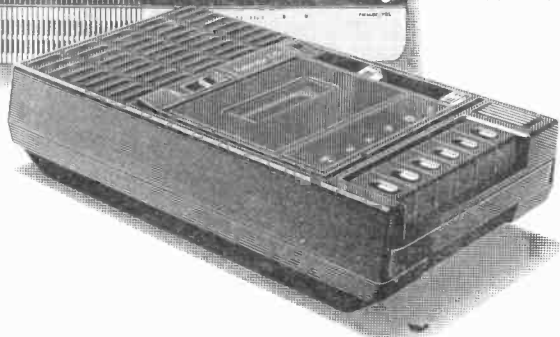
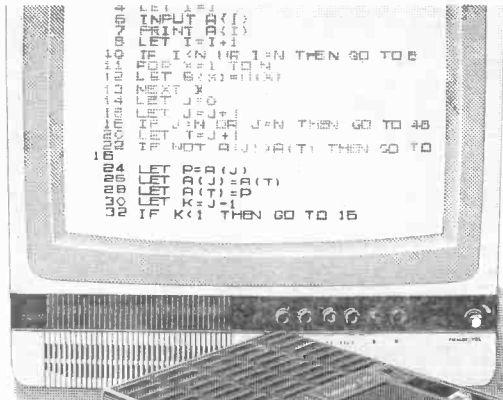
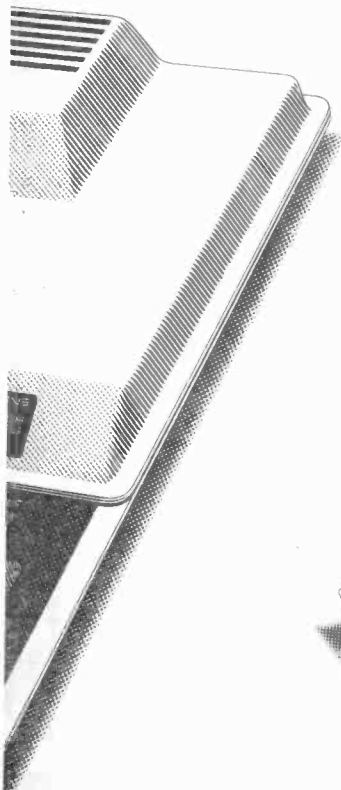
The ZX80 owes its remarkable low price to its remarkable design: the whole system is packed on to fewer, newer, more powerful and advanced LSI chips. A single SUPER ROM, for instance, contains the BASIC interpreter, the character set, operating system, and monitor. And the ZX80's 1K byte RAM is roughly equivalent to 4K bytes in a conventional computer—typically storing 100 lines of BASIC. (Key words occupy only a single byte.)

The display shows 32 characters by 24 lines. And Benchmark tests show that the ZX80 is faster than all other personal computers.

No other personal computer offers this unique combination of high capability and low price.



# plete



## ZX80 software – now available!

See advertisements in Personal Computer World, Electronics Today International, and other journals.

New dedicated software – developed independently of Science of Cambridge – reflects the enormous interest in the ZX80. More software available soon – from leading consultancies and software houses.

### The Sinclair teach-yourself BASIC manual.

If the specifications of the Sinclair ZX80 mean little to you – don't worry. They're all explained in the specially-written 128-page book free with every kit! The book makes learning easy, exciting and enjoyable, and represents a complete course in BASIC programming – from first principles to complex programs. (Available separately – purchase price refunded if you buy a ZX80 later.) A hardware manual is also included with every kit.

### The Sinclair ZX80. Kit: £79.95. Assembled: £99.95. Complete!

The ZX80 kit costs a mere £79.95. Can't wait to have a ZX80 up and running? No problem! It's also available, ready assembled and complete with mains adaptor, for only £99.95.

Demand for the ZX80 is very high: use the coupon to order today for the earliest possible delivery. All orders will be despatched in strict rotation. We'll acknowledge each order by return, and tell you exactly when your ZX80 will be delivered. If you choose not to wait, you can cancel your order immediately, and your money will be refunded at once. Again, of course, you may return your ZX80 as received within 14 days for a full refund. We want you to be satisfied beyond all doubt – and we have no doubt that you will be.

**sinclair**  
**ZX80**  
Science of Cambridge Ltd  
6 Kings Parade, Cambridge, Cambs., CB2 1SN.  
Tel: 0223 311488.

### ORDER FORM

To: Science of Cambridge Ltd, 6 Kings Parade, Cambridge, Cambs., CB2 1SN. Remember: all prices shown include VAT, postage and packing. No hidden extras. Please send me:

Quantity	Item	Item price £	Total £
	Sinclair ZX80 Personal Computer kit(s). Price includes ZX80 BASIC manual, excludes mains adaptor.	£79.95	
	Ready-assembled Sinclair ZX80 Personal Computer(s). Price includes ZX80 BASIC manual and mains adaptor.	£99.95	
	Mains Adaptor(s) (600 mA at 9 V DC nominal unregulated).	8.95	
	Memory Expansion Board(s) (each one takes up to 3K bytes)	12.00	
	RAM Memory chips – standard 1K bytes capacity	16.00	
	Sinclair ZX80 Manual(s) (manual free with every ZX80 kit or ready-made computer)	5.00	
		<b>TOTAL</b>	<b>£</b>

NB. Your Sinclair ZX80 may qualify as a business expense.

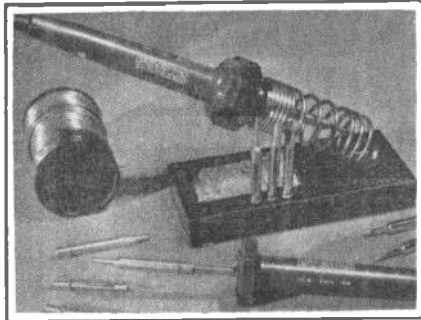
I enclose a cheque/postal order payable to Science of Cambridge Ltd for £ \_\_\_\_\_  
Please print  
Name: Mr/Mrs/Miss \_\_\_\_\_  
Address \_\_\_\_\_



# JOIN UP WITH LITESOLD.

New 'L' series irons, designed to latest safety standards. Outstanding performance, lightweight and easy maintenance. New non-roll GRP safety handles. Ceramic and mica insulated elements enclosed in stainless steel shafts.

Fully earthed with screw connected 3-core leads. Interchangeable, non-seize copper bits.



## MODEL LC18 18 watts

Lightweight, high-performance iron for all soldering from calculators to T.V. sets. Fitted with 3.2 mm copper bit and complete with

spare bits 1.6, 2.4 and 4.7 mm. £6.31 including p&p and VAT. 240 volts standard but also available 12 and 14 volts. Iron only £4.66 including P&P and VAT.

## MODEL LA12 12 watts

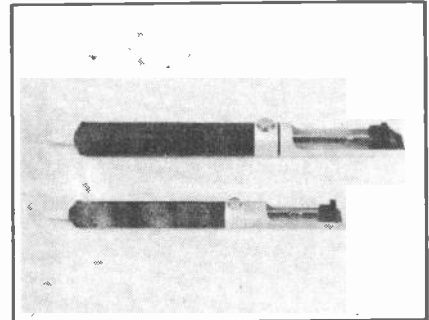
Similar to LC18 but with extra slim shaft and bits for fine work. Fitted with 2.4mm copper bit and complete with spare bits 1.2 mm and 3.2mm. £5.58 including p&p and VAT. 240 volts standard also available 6, 12 and 24 volts. Iron only £4.61 including P&P and VAT.

## No. 3 SAFETY SPRING STAND for LC18 & LA12

Complete with sponge and location for spare bits £4.41 including P&P and VAT.

## LOLA DE-SOLDERING PUMPS

Removes solder from pcb joints quickly, with no fuss. Simple one-handed operation leaves other hand free to hold soldering iron heat source. Needs no external power. Has replaceable PTFE nozzle. Thousands in daily use in major manufacturing companies. Two sizes to choose from.



**Lola A** 215 mm long x 20 mm dia. £6.89 (including VAT, P&P)

**Lola D** 165 mm long x 14 mm dia. £5.03 (including VAT, P&P)

# LITESOLD

LIGHT SOLDERING DEVELOPMENTS LTD

97/99 Gloucester Rd. Croydon Surrey CR0 2DN Tel. 01-689 0574 Telex 8811945

## ELECTRONIC MUSIC

INTERESTED IN ACCURATE, STABLE, EASILY BUILT AND CALIBRATED SYNTHESISER MODULES; POLYPHONIC SYNTHESISERS; COMPUTER MUSIC; OR SOUND PROCESSING? IF SO, FOLLOW THE EXAMPLE OF MANY PROFESSIONAL EQUIPMENT MANUFACTURERS AND USE INTEGRATED CIRCUITS WHICH HAVE BEEN SPECIALLY DEVELOPED TO MEET THESE NEEDS.

VOLTAGE CONTROLLED OSCILLATORS; VOLTAGE CONTROLLED FILTERS; VOLTAGE CONTROLLED AMPLIFIERS; AND VOLTAGE CONTROLLED TRANSIENT GENERATORS (ENVELOPE SHAPERS). ALL IN STANDARD DIL PACKAGES.

PRODUCTS PRODUCED BY CURTIS ELECTROMUSIC SPECIALTIES AND BY SOLID STATE MICROTECHNOLOGY FOR MUSIC ARE AVAILABLE EXCLUSIVELY FROM DIGISOUND LIMITED.

Application notes and specifications for the two sets of devices currently available may be obtained for 50p per set (state which set required) inclusive of postage, or 30p per set when included with an order. No VAT. Stamps accepted in payment.

WIDE RANGE OF SYNTHESISER KITS AVAILABLE. PRICE LIST 15p OR FREE WITH DATA SHEETS OR ORDER

WE CAN SUPPLY THE SSM2040 FILTER I.C. USED IN TWO SOUND EFFECT PROJECTS FEATURED IN THIS ISSUE.



**DIGISOUND LIMITED,**  
13 THE BROOKLANDS, WREA GREEN,  
PRESTON, LANCs. PR4 2NQ  
Tel.: 0772 683138 (MAIL ORDER ONLY)

## TECHNICAL TRAINING IN ELECTRONICS AND TELECOMMUNICATIONS

ICS can provide the technical knowledge that is so essential to your success; knowledge that will enable you to take advantage of the many opportunities open to you. Study in your own home, in your own time and at your own pace and if you are studying for an examination ICS guarantee coaching until you are successful.

**City and Guilds Certificates:**  
Telecommunications Technicians  
Radio, TV, Electronics Technicians  
Technical Communications  
Radio Servicing Theory  
Radio Amateurs  
Electrical Installation Work  
MPT Radio Communications Certificate

**Diploma Courses:**  
Colour TV Servicing  
Electronic Engineering and Maintenance  
Computer Engineering and Programming  
Radio, TV, Audio Engineering and Servicing  
Electrical Engineering, Installation  
and Contracting

POST OR PHONE TODAY FOR FREE BOOKLET

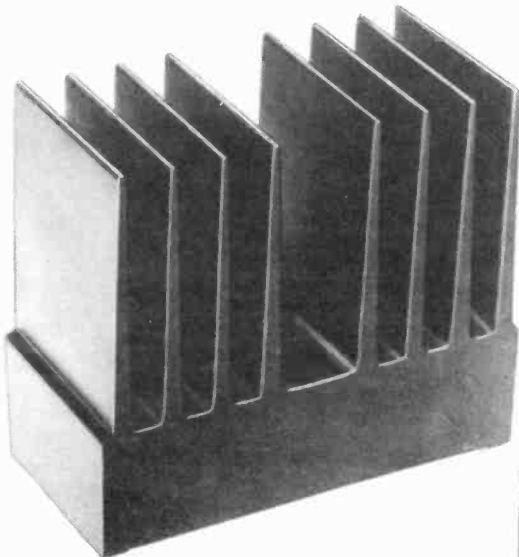
**ICS** To: International Correspondence  
Schools

Dept 268Y Intertext House, London  
SW8 4UJ or telephone 622 9911

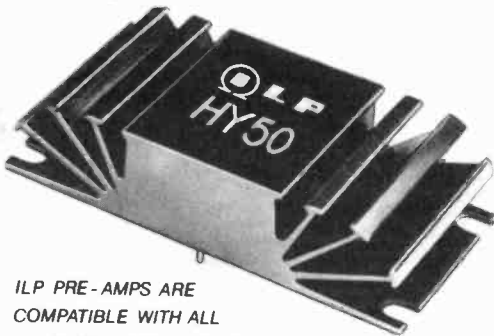
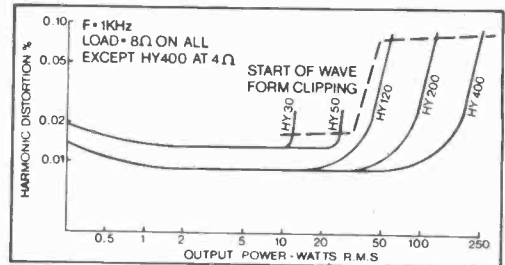
Subject of Interest .....  
Name .....  
Address .....  
Tel: ..... Age: .....

# Simply ahead...

## POWER AMPLIFIERS



ILP Power Amplifiers are encapsulated within heatsinks designed to meet total heat dissipation needs. They are rugged and made to last a lifetime. Advanced circuitry ensures their suitability for use with the finest loudspeakers, pickups, tuners, etc. using digital or analogue sound sources.



ILP PRE-AMPS ARE  
COMPATIBLE WITH ALL  
ILP POWER AMPS AND PSUs

Model	Output Power R.M.S.	Distortion Typical at 1KHz	Minimum Signal/Noise Ratio	Power Supply Voltage	Size in mm	Weight in gms	Price + V.A.T.
HY30	15 W into 8 Ω	0.02%	100 dB	-20 · 0 · +20	105x50x25	155	£6.34 + 95p
HY50	30 W into 8 Ω	0.02%	100 dB	-25 · 0 · +25	105x50x25	155	£7.24 + £1.09
HY120	60 W into 8 Ω	0.01%	100 dB	-35 · 0 · +35	114x50x85	575	£15.20 + £2.28
HY200	120 W into 8 Ω	0.01%	100 dB	-45 · 0 · +45	114x50x85	575	£18.44 + £2.77
HY400	240 W into 4 Ω	0.01%	100 dB	-45 · 0 · +45	114x100x85	1 15Kg	£27.68 + £4.15

Load impedance - all models 4 Ω - ∞  
Input sensitivity - all models 500 mV  
Input impedance - all models 100K Ω  
Frequency response - all models 10Hz - 45 KHz - 3dB

## POWER SUPPLY UNITS



ILP Power Supply Units with transformers made in our own factory are designed specifically for use with ILP power amplifiers and are in two basic forms - one with circuit panel mounted on conventionally styled laminated transformer, for smaller PSU's - in the other, for larger PSU's, ILP toroidal transformers are used which are half the size and weight of laminated equivalents, are more efficient and have greatly reduced radiation.

PSU 30 ± 15V at 100mA to drive up to 12 x HY6 or 6 x HY66} £4.50 + £0.68 VAT

THE FOLLOWING WILL ALSO DRIVE ILP PRE-AMPS

PSU 36 for 1 or 2 HY30's £8.10 + £1.22 VAT

PSU 50 for 1 or 2 HY50's £8.10 + £1.22 VAT

PSU 60 with toroidal transformer for 1 HY 120 £9.75 + £1.46 VAT

PSU 70 with toroidal transformer for 1 or 2 HY120's £13.61 + £2.04 VAT

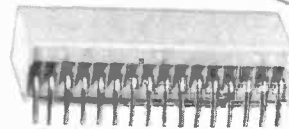
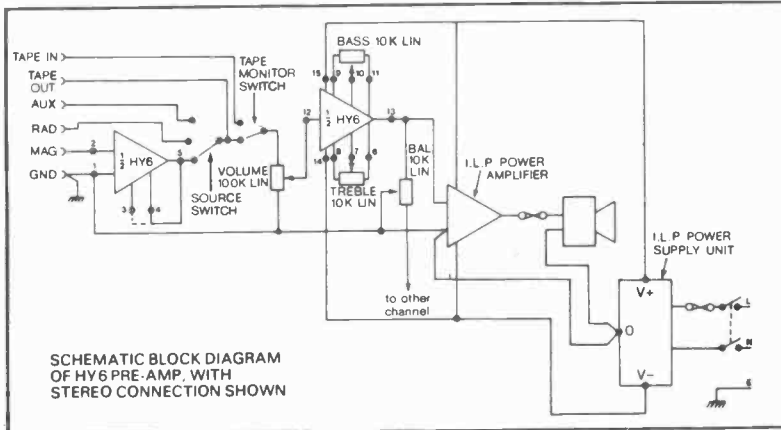
PSU 90 with toroidal transformer for 1 HY200 £13.61 + £2.04 VAT

PSU 180 with toroidal transformer for 1 HY400 or 2 x HY200 £23.02 + £3.45 VAT



AVAILABLE ALSO FROM WATFORD ELECTRONICS, MARSHALLS AND CERTAIN OTHER SELECTED STOCKISTS.

# this time with two new pre - amps



## HY6 mono HY66 stereo

When ILP add a new design to their audio-module range, there have to be very special reasons for doing so. You expect even better results. We have achieved this with two new pre-amplifiers – HY6 for mono operation, HY66 for stereo. We have simplified connections, and improved performance figures all round. Our new pre-amps are short-circuit and polarity protected; mounting boards are available to simplify construction.

Sizes – HY6 – 45 x 20 x 40 mm HY66 | 90 x 20 x 40 mm Active Tone Control circuits provide  $\pm 12$ dB cut and boost. Inputs Sensitivity – Mag. PU – 3mV. Mic – selectable 1.12mV. All others 100mV. Tape O/P – 100mV. Main O/P – 500mV. Frequency response – D.C. to 100KHz – 3dB.

**HY6** mono  
£5.60

+ VAT 84p

**HY66** stereo  
£10.60

+ VAT £1.59

Connectors included

B6 Mounting Board  
78p + 12p VAT

B66 Mounting Board  
99p + 15p VAT

- LOW DISTORTION - Typically 0.005%
- S/N RATIO - Typically 90 dB (Mag. P.U. – 68 dB).
- HIGH OVERLOAD FACTOR – 38 dB on Mag. P.U.
- LATEST DESIGN HIGH QUALITY CONNECTORS.
- REQUIRE ONLY POTS, SWITCHES, PLUGS AND SOCKETS.
- COMPATIBLE WITH ALL ILP POWER AMPS AND PSUs.
- NEEDS ONLY UNREGULATED POWER SUPPLY  $\pm 15$  V to  $\pm 50$  V.

NO QUIBBLE  
5 YEAR GUARANTEE  
7-DAY DESPATCH ON ALL ORDERS  
BRITISH DESIGN AND MANUFACTURE  
FREEPOST SERVICE  
– see below

★ ALL U.K. ORDERS DESPATCHED POST PAID  
HOW TO ORDER, USING FREEPOST SYSTEM

Simply fill in order coupon with payment or credit card instructions. Post to address as below but do not stamp envelope – we pay postage on all letters sent to us by readers of this journal.



FREEPOST Graham Bell House, Roper Close,  
Canterbury, Kent CT2 7EP.  
Telephone (0227) 54778 Telex 965780

Please supply .....  
..... Total purchase price £.....  
I enclose Cheque  Postal Orders  International Money Order   
Please debit my Access/Barclaycard Account No. ....  
NAME .....  
ADDRESS .....  
Signature .....



# CLASSIFIED

The prepaid rate for classified advertisements is 24 pence per word (minimum 12 words), box number 60p extra. Semi-display setting £6.16 per single column centimetre (minimum 2.5cm). All cheques, postal orders, etc., to be made payable to Everyday Electronics and crossed "Lloyds Bank Ltd." Treasury

notes should always be sent registered post. Advertisements, together with remittance, should be sent to the Classified Advertisement Manager, Everyday Electronics, Room 2337, IPC Magazines Limited, King's Reach Tower, Stamford St., London SE1 9LS. (Telephone 01-261 5942).

## Receivers and Components

**DISCOVER ELECTRONICS.** Build forty easy projects including: Metal Detector; Breathalyser; Radios; Stethoscope; Lie Detector; Touch time-switches; Burglar Alarms, etc. Circuits, plans all for £1.50 including FREE circuit board. Mail only. **RIDLEY PHOTO/ELECTRONICS**, Box 62, 111 Rockspark Road, Uckfield, Sussex.

P.C.B.s Paxolin 10½" x 4½" 4-£1.30 11½" x 8" 80p. 16" x 11½" £1.40 D.S. 10" x 8½" 85p. Fibreglass 12" x 8" £1.70 8" x 5" 75p. D.S. 10½" x 7" £1.35 8" x 7" £1.15 Panel with 40 assorted 74 series I.C.s £1.60. 20 Wire ended neons £1.00. Small 3 transistor Audio Amps 3-£1.20. 300 Small Components, Trans, Diodes £1.60. 7lbs Assorted Components £3.75 List 15p. refundable post 40p. Insurance add 20p.

### J. W. B. RADIO

2, Barnfield Crescent, Sale, Cheshire. M33 1NL.

100 DIODES 85p. 50 transistors 95p. 10 switches 90p. 10 Leds £1.15. All mixed. Lists 15p. Sole Electronics, E/E, 37 Stanley Street, Ormskirk, Lancs L39 2DH.

## NO LICENCE EXAMS NEEDED

To operate this miniature, solid-state Transmitter-Receiver Kit. Only £12.95 plus 35p P. & P.

'Brain-Freeze' 'em with a MINI-STROBE Electronics Kit, pocket-sized 'lightning flashes', vari-speed, for discos and parties. A mere £5.95 plus 35p P. & P. Experiment with a psychedelic DREAM LAB, or pick up faint speech/sounds with the BIG EAR sound-catcher; ready-made multi-function modules. £6.85 each plus 35p P. & P.

LOTS MORE! Send 30p for lists. Prices include VAT.

### BOFFIN PROJECTS

4 CUNLIFFE ROAD, STONELEIGH  
EWELL, SURREY. (E.E.)

**TURN YOUR SURPLUS** capacitors, transistors, etc. into cash. Contact **COLES-HARDING & CO.**, 103 South Brink, Wisbech, Cambs. 0945-4188. Immediate settlement.

**DIGITAL WATCH BATTERIES**, any sort 75p each. Send SAE or 15p with number or old battery to Disclec, 511 Fulbridge Road, Werrington, Peterborough PE4 6SB.

## Wanted

**WANTED: ELECTRONIC COMPONENTS**, Redundant Stock, Test Equipment, Tools, Machines, Hardware; Factories cleared. Immediate cash decision. Contact: Mr. Quirk, "Q" Services Electronic (Camberley) Ltd, 29 Lawford Crescent, Yateley 871048, Camberley, Surrey.

**ENTHUSIAST** seeks schematic diagram for Hallicrafters receiver SX 28. O. Fontana, PO Box 309, Manzini, Swaziland.

## For Sale

**NEW BACK ISSUES** of "EVERYDAY ELECTRONICS". Available 75p each Post Free, open PO/Cheque returned if not in stock. **BELL'S TELEVISION SERVICES** 190 Kings Road, Harrogate, Yorkshire. Tel: (0423) 55885.

## Books and Publications

"**ELECTRONIC AND MICROPROCESSOR BOOKS**". Send SAE for descriptive list of micro, electronic IC project books and solderless breadboard. Educational Data and Technical Services, 59 Station Road, Cogenhoe, Northampton NN7 1LU.

## WHY NOT START YOUR OWN BUSINESS REWINDING ELECTRIC MOTORS

A genuine opportunity to success. **LARGE PROFITS.** You can't help but make money if you follow the easy, step by step, instructions in our fully illustrated Manual showing how to rewind Electric Motors, Armatures and Field coils as used in Vacuum Cleaners, Electric Drills and Power Tools. **NO PREVIOUS KNOWLEDGE IS REQUIRED**, as the Manual covers in 13 Chapters, where to obtain all the work you need, materials required, all instructions rewind charts and how to take data, etc. A goldmine of information. How to set up your home workshop and how to cost each job to your customer. **£4.50** inclusive of P. & P. U.K. CWO to:

### INDUSTRIAL SUPPLIES

102 Parrwood Road, Withington,  
Manchester 20, Dept. EE

## Service Sheets

**BELL'S TELEVISION SERVICE** for service sheets on Radio, TV etc. £1 plus SAE. Colour TV Service Manuals on request. SAE with enquiries to **BTS**, 190 King's Rd, Harrogate, N. Yorkshire. Tel: 0423 55885.

**SERVICE SHEETS** from 50p and SAE. Catalogue 25p and SAE. **Hamilton Radio**, 47 Bohemia Road, St. Leonards, Sussex.

## Educational

**COURSES—RADIO AMATEURS EXAMINATION.** City and Guilds. Pass this important examination and obtain your G8 Licence, with an RRC home study course. For details of this and other courses (GCE, professional examinations, etc), write or phone: **THE RAPID RESULTS COLLEGE**, Dept JRI, Tuition House, London SW19 4DS. Tel: 01-947 7272 (Careers Advisory Service).

## ORDER FORM PLEASE WRITE IN BLOCK CAPITALS

Please insert the advertisement below in the next available issue of Everyday Electronics for .....  
insertions. I enclose Cheque/P.O. for £.....

(Cheques and Postal Orders should be crossed Lloyds Bank Ltd. and made payable to Everyday Electronics)


NAME .....

ADDRESS .....

Company registered in England. Registered No. 53626. Registered Office: King's Reach Tower, Stamford Street, London SE1 9LS.

Send to: Classified Advertisement Manager  
**EVERYDAY ELECTRONICS**  
GMG, Classified Advertisements Dept., Room 2337,  
King's Reach Tower, Stamford Street, London SE1 9LS.  
Telephone 01-261 5942  
Rate:  
24p per word, minimum 12 words. Box No. 60p extra.



## Miscellaneous

**PRINTED CIRCUITS.** Make your own simply, cheaply and quickly! Golden Fotoka Light Sensitive Lacquer—now greatly improved and very much faster. Aerosol cans with full instructions. £2.25. Developer 35p. Ferric Chloride 55p. Clear Acetate sheet for master 14p. Copper-clad Fibre-glass Board approx. 1mm thick £1.70 sq.ft. Post/packing 60p. **WHITE HOUSE ELECTRONICS**, PO Box 19, Castle Drive, Penzance, Cornwall.

## THE SCIENTIFIC WIRE COMPANY

PO Box 30, London E.4.  
Reg. Office, 22 Coningsby Gardens.

### ENAMELLED COPPER WIRE

SWG	1 lb	8 oz	4 oz	2 oz
10 to 29	3-10	1-86	1-10	-80
30 to 34	3-50	2-00	1-15	-80
35 to 39	3-95	2-36	1-34	-98
40 to 42	5-10	2-97	2-28	1-42
44 to 46	8-00	3-80	2-90	1-91
47	8-37	5-32	3-19	2-80
48 to 49	15-96	9-58	6-38	3-99

### SILVER PLATED COPPER WIRE.

14 to 22	6-30	3-03	1-85	1-20
24 to 30	6-50	3-75	2-20	1-40

Prices include P&P and VAT. Orders under £2 please add 20p SAE for list. Dealer enquiries welcome. Reg office 22 Coningsby Gardens.

**MK14 CORNER.** Interface Board, includes flag driven mains relays, Led Indicators for all Serial I/O, D/A and single step chips, and prototype area; also suitable for other Microcomputers; PCB and circuit £3.95. Replace calculator display with 1/2 in FND 500's; PCB, filter, instructions £1.95. Ready Built replacement Keyboard £11. Useful notes on MK14 75p. Rayner, 'Kismet', High Street, Colnbrook, Bucks.

**TUNBRIDGE WELLS COMPONENTS, BALLARD'S**, 108 Camden Road, Tunbridge Wells. Phone 31803. No lists, enquiries S.A.E.

## DIGITAL WATCH BATTERY REPLACEMENT KIT



These watches all require battery (power cell) replacement at regular intervals. This kit provides the means. We supply eyeglass, non-magnetic tweezers, watch screwdriver, case knife and screwback case opener. Also one doz. assort. push-pieces, full instructions and battery identification chart. We then supply replacement batteries—you fit them. Begin now. Send £9 for complete kit and get into a fast growing business. Prompt despatch.

**BOLSTER INSTRUMENT CO. (EE18)**  
11 Percy Avenue, Ashford, Middx., TW15 2PB

**LEARN ELECTRONICS THE EASY WAY.** Build—amplifiers, oscillators, detectors, testers, flashers, metronomes, etc., more than 25 projects, with our multi-kits, complete instructions manual supplied. Send £15.00 to—**MAJOR OAK SERVICES**, 33 Lillian Avenue, London W3.

## LEARN ELECTRONICS WITHOUT SOLDER

Build electronic circuits without solder on a Roden S-Dec. This has built-in contacts and holes into which you plug your components. Suitable for all ages. Can be used time after time. Ideal gift for students or experimenters. Full instructions and 2 circuit diagrams with each S-Dec.

Send cheque or P.O. to:  
**Roden Products**, Dep EE  
High March, Daventry,  
Northants, NN11 4QE

**£3.85**

plus 40p p.&p. each



## Situations Vacant

**INDUSTRIAL ELECTRONICS:** Are you an electronic wireman/tester or prototype wireman? Have you had an apprenticeship followed by at least 5 years practical experience? If so we can offer you employment as an instructor with good promotion opportunities and pensionable security at Bristol and Swindon Skillcentres. Starting salary £6,000 p.a. rising by two increments to £7,110 p.a. For more information contact Miss A. Curran MSC TSD, 11 Park Place, Clifton, Bristol. Telephone Bristol 20661.

**INDUSTRIAL ELECTRONICS:** Are you an electronic test technician or service mechanic? Have you had an apprenticeship followed by at least 5 years recent practical experience with a manufacturing or servicing organisation? If so we can offer you employment as an INSTRUCTOR, with good promotion opportunities and pensionable security, at Gloucester, Bristol and Swindon Skillcentres. Starting salary £6,000 p.a. rising by two increments to £7,110 p.a. For more information contact Miss A. Curran MSC TSD, 11 Park Place, Clifton, Bristol. Telephone Bristol 20661.

PLEASE MENTION  
EVERYDAY  
ELECTRONICS  
WHEN REPLYING  
TO  
ADVERTISEMENTS

## MAIL ORDER ADVERTISING

### British Code of Advertising Practice

Advertisements in this publication are required to conform to the British Code of Advertising Practice. In respect of mail order advertisements where money is paid in advance, the code requires advertisers to fulfil orders within 28 days, unless a longer delivery period is stated. Where goods are returned undamaged within seven days, the purchaser's money must be refunded. Please retain proof of postage/despatch, as this may be needed.

### Mail order Protection Scheme

If you order goods from Mail Order advertisements in this magazine and pay by post in advance of delivery, EVERYDAY ELECTRONICS will consider you for compensation if the Advertiser should become insolvent or bankrupt, provided:

- (1) You have not received the goods or had your money returned; and
- (2) You write to the Publisher of EVERYDAY ELECTRONICS summarising the situation not earlier than 28 days from the date you sent your order and not later than two months from that day.

Please do not wait until the last moment to inform us. When you write, we will tell you how to make your claims and what evidence of payment is required. We guarantee to meet claims from readers made in accordance with the above procedure as soon as possible after the Advertiser has been declared bankrupt or insolvent.

This guarantee covers only advance payment sent in direct response to an advertisement in this magazine not, for example, payment made in response to catalogues etc. received as a result of answering such advertisements. Classified advertisements are excluded.

**OHIO SCIENTIFIC Superboard 2.** Assembled 50Hz model £159.95 + 15% vat post free. Colourboard 2 (the new colour version of Superboard 2) £205 + 15% vat.

- ★ ★ ★ ★ ★ Special offer—if bought with super board or colourboard these items ★ ★ ★ are at the reduced price shown first.
- ★ Also sold separately at the ★ bracketed prices. Add 15% vat.
- ★ Modulator and power supply kit ★ £7.95 (£11), 4K extra ram £20 (£24).
- ★ Case £23 (£26), Cassette recorder ★ £13 (£15), Colour conversion ★ board £45 (£45).

★ ★ ★ ★ ★ **SINCLAIR PRODUCTS** New 10MHz scope £145, pfm200 £51.95, case £2.07, adaptor £4.20, connector kit £13.95. Microvision tv £89, adaptor £6.88, pdm35 £34.23, adaptor £4.20, case £2.07, dm350 £78.70, dm450 £102.17, dm235 £35.35, rechargeable batts £8, adaptor £4.20, case £9, enterprise prog calculator + accessories £19.95, TG105 £87, Bench frequency counter £160.

★ ★ ★ ★ ★ **COMPUTER GAMES** chess champion 6 £49.95, chess challenger 7 £75, New Sensory chess challenger 8 £109, Atari video-computer £129, cartridges £14.95.

**BATTERY ELIMINATOR KITS** 100ma radio types with press-studs 4½v £1.49, 6v £1.49, 9v £1.49, 4½ + 4½v £1.92, 6+6v £1.92, 9+9v £1.92, stabilized 8-way types 3/4½/6/7½/9/12/15/18v 100ma £2.80, 1Amp £6.50, stabilized power kits 2-18v 100ma £2.80, 1-30v 1A £6.75, 1-30v 2A £12.10, 12v car converter 6/7½/9v 1A £1.35.

**T-DEC AND CSC BREADBOARDS** s-dec £3.79, t-dec £4.59, exp4B £2.64, exp300 £6.61, exp350 £3.62, exp325 £1.84. **TV GAMES** AY-3-8550 + kit £7.26, AY-3-8600 + kit £12.98, slant cycle chip + kit £14.09, Colour generator kit £9.95. **IC AUDIO AMPS** with pcb, JC12 6W £2.98, JC20 10W £3.54.

**BATTERY ELIMINATORS** 3-way type 6/7½/9v 300ma £3.14, 100ma radio type with press-studs 9v £3.77, 9+9v £4.99, car converter 12v input, output 4½/6/7½/9v 800ma £2.76.

**SWANLEY ELECTRONICS**  
Dept. EE, 32 Goldsl Rd., Swanley, Kent. Post 35p extra. Prices include VAT unless stated. Official and overseas orders welcome. Lists 27p post free. Mail order only.

## MAINS INTERCOM



NO BATTERIES  
NO WIRES  
ONLY  
**£36.99**  
PER PAIR  
+ VAT £5.55

The modern way of instant 2-way communications. Just plug into power socket. Ready to use. Crystal clear communications from room to room. Range 1/4 mile on the same mains phase. On/off switch. Volume control, with 'buzzer' call and light indicator. Useful as inter-office intercom, between office and warehouse, in surgery and in homes. P. & P. £1.75. F.M. 2 channel 'touch' model £49.95 + VAT £7.50 + P&P £1.85.

## NEW AMERICAN TYPE CRADLE TELEPHONE AMPLIFIER



**£18.95**  
+ VAT £2.85  
+ P & P £1.15

Latest transistorised Telephone Amplifier, with detached plug-in speaker. Placing the receiver on to the cradle activates a switch for immediate two-way conversation without holding the handset. Many people can listen at a time. Increase efficiency in office, shop, workshop. Perfect for "conference" calls; leaves the user's hands free to make notes, consult files. No long waiting, saves time with long-distance calls. On/off switch, volume control, conversation recording, model at £20.95 + VAT £3.15. P&P £1.15.

## DOOR ENTRY SYSTEM

No house/business/surgery should be without a DOOR ENTRY SYSTEM in this day and age. The modern way to answer the door in safety to unwanted callers. Talk to the caller and admit him only if satisfied by pressing a remote control button which will open the door electronically. A boon for the invalid, the aged, and busy housewife. Supplied complete d.i.y. kit with one internal Telephone, outside Speaker panel, electric door lock release (for Yale type surface latch lock); mains power unit, cable (8-way) to 50 and wiring diagram. Price £49.95 + VAT £7.50 + P&P £1.85. Kit with two Telephone £59.95 + VAT £9.00 + P&P £1.95.

10-day price refund guarantee on all items  
**WEST LONDON DIRECT SUPPLIES (EE9)**  
169 KENSINGTON HIGH STREET,  
LONDON, W8

**"SPECIAL PRICES" POST £1-50  
BAKER LOUDSPEAKERS**

Model	Ohms	Size Inch	Power Watts	Type	Our Price
Major	4, 8, 16	12	30	Hi-Fi	£12
Deluxe Mk II	4, 8, 16	12	15	Hi-Fi	£14
Superb	8, 16	12	30	Hi-Fi	£20
Auditorium	8, 16	12	45	Hi-Fi	£20
Auditorium	8, 16	15	60	Hi-Fi	£29
Group 35	8, 16	12	40	PA	£12
Group 45	4, 8, 16	12	45	PA	£15
Group 50	4, 8, 16	12	60	PA	£20
Group 75	4, 8, 16	12	75	PA	£22
Group 100	8, 16	12	100	PA	£26
Group 100	8, 16	15	100	PA	£29
Disco 100	8, 16	12	100	Disco	£26
Disco 100	8, 16	15	100	Disco	£29

**4 CHANNEL MIXERS £8-00**

Add musical highlights and sound effects to recordings. Will mix Microphone, records, tape and tuner with separate controls into single output. 9 volt battery operated with switch for four channel mono or two channel stereo working.

**MINI MODULE BAFFLE KIT 10-95**

EMI 15 x 8 in. 3-way Loudspeaker System, 5in. Bass, 5in. Middle, 3in. Tweeter; 3-way Crossover & Ready Cut Baffle. Full assembly instructions supplied. Response 60 to 20,000 c.p.s. 12 watt RMS 8 ohms £10-95 per kit. Two kits £20. Sullable Bookshelf Cabinet £9-50 each. Post £1-50



**SINGLE RECORD PLAYER**

Fitted with auto stop, stereo cartridge. Baseplate. Size 11 x 8 in. Turntable size 7in. diameter. a.c. mains 240V 3 speeds plays all size records. £9-95  
Two for £18. Post £1 on each.

**NEW BSR SINGLE PLAYER £26-00**

Model P182 3-speeds flared aluminium turntable. "S" shaped arm, cueing device, stereo ceramic cartridge.

**B.S.R. DE-LUXE AUTOCHANGER £20**

with stereo cartridge, plays all size records. Post £2

**WOOD PLINTHS CUT FOR B.S.R. £4**

Size: 16 x 14 1/2 x 3 1/2 in. Teak Veneered. Post £2

**METAL PLINTH CUT FOR B.S.R. OR GARRARD**

Size: 16 x 14 x 3 in. £4.50 Silver or Black finish. Post £2.

**TINTED PLASTIC COVERS ALL POST £2**

Sizes: 14 1/2 x 12 1/2 x 3 in. £3-50, 16 x 14 x 3 1/2 in. £6. 15 1/2 x 13 1/2 x 4 in. £4. 17 1/2 x 9 1/2 x 3 1/2 in. £3. 18 x 13 1/2 x 3 in. £6. 18 x 12 1/2 x 3 in. £6. 18 x 13 1/2 x 3 1/2 in. with stand-up hinges £7.

**R.C.S. LOW VOLTAGE STABILISED POWER PACK KITS £2-95 Post 45p**

All parts and instructions with Zener diode printed circuit, rectifiers and double wound mains transformer input 200-240V a.c. Output voltages available 6 or 7, 5 or 9 or 12V d.c. up to 100mA or less. Size 3 x 2 1/2 x 1 1/2 in. Please state voltage required.

**PP BATTERY ELIMINATOR**

Mains stabilised power-pack 9 volt 400mA max. with overload cut out. Size 5 x 3 1/2 x 2 1/2 in. £4-50. Post 50p.

**MAINS TRANSFORMERS POST 99p**

250-0-250V 80mA 6-3V, 2A	£3-45
250-0-250V 80mA 6-3V, 3-5A, 6-3V 1A	£4-60
350-0-350V 250mA 6-3V 5 amp, 5V 2A	£12-50
300-0-300V 120mA 2 x 6-3V 2A C.T., 6-3V 2A	£8-50
330-0-330V 200mA 6-3V 3A 6-3V 2A 6-3V 2A	£12-00
220V 45mA, 6-3V 2A	£2-50

**GENERAL PURPOSE LOW VOLTAGE**

2A, 3, 4, 5, 6, 8, 9, 10, 12, 15, 18, 24 and 30V	£6-00
1A, 6, 8, 10, 12, 16, 18, 20, 24, 30, 36, 40, 43, 60	£6-00
2A, 6, 8, 10, 12, 16, 18, 20, 24, 30, 36, 40, 48, 60	£9-50
3A, 6, 8, 10, 12, 16, 18, 20, 24, 30, 36, 40, 48, 60	£12-50
5A, 6, 8, 10, 12, 16, 18, 20, 24, 30, 36, 40, 48, 60	£18-00
5, 8, 10, 15V 1/2 A £2-50 12V 100mA £1-30 12V 300mA £1-50 12V 750mA £2-25 40V 2A tapped 10V or 30V £3-50 10-0-10V 2A £2-6V 500mA £2-00 30V 5A + 34V 2A CT £4. 2 x 18V 6A £11. 12-0-12V 2 amp £3-50. 25-0-25V 2A £4-50. 20-0-20V 1A £3-50. 30V 1 1/2 A £3-30. 20V 1A £3. 9V 3 amp £3-50. 60V, 40V, 20V 1A £4. 15/0/15V 2A £3-75. 32-0-32V 6 1/2 A £11. 9V 250mA £1-50. 30V 2A £3-50.	

**AUTO TRANSFORMERS 115V to 240V 500W £10-00**

CHARGER TRANSFORMERS	CHARGER RECTIFIERS
6-12V-3A £4-00	6-12V-2A £1-00
6-12V-4A £6-50	6-12V-4A £2-00

**BLANK ALUMINIUM CHASSIS**, 18 s.w.p. 2 1/2 in slides. 6 x 4 in 95p; 8 x 6 in £1-40; 10 x 7 in. £1-55; 14 x 9 in. £1-90; 16 x 6 in. £1-85; 12 x 3 in. £1-20; 16 x 10 in. £2-20; 12 x 8 in. £1-70.

**ALUMINIUM PANELS**, 18 s.w.p. 6 x 4 in. 24p; 8 x 6 in. 38p; 10 x 7 in. 54p; 12 x 5 in. 50p; 12 x 8 in. 70p; 16 x 6 in. 70p; 14 x 9 in. 94p; 12 x 12 in. £1; 16 x 10 in. £1-16.

**ALUMINIUM ANGLE BRACKET**, 6 x 1/2 x 2 in. 25p.

**ALUMINIUM BOXES, MANY OTHER SIZES IN STOCK** 4 x 2 x 2 in. £1-00; 3 x 2 x 1 in. 80p; 6 x 4 x 2 in. £1-30; 8 x 6 x 3 in. £2-10; 9 x 4 x 4 in. £2-30; 10 x 7 x 3 in. £2-50; 12 x 8 x 3 in. £3-00.

**HIGH VOLTAGE ELECTROLYTICS**

8/350V 35p	8+8/450V 75p	50+50/300V 50p
16/350V 45p	8+16/450V 75p	32+32/450V 95p
32/300V 75p	16+16/450V 75p	100+100/275V 65p
50/500V £1-20	32+32/350V 75p	150+200/275V 70p
8/800V £1-20	16/500V 65p	220/450V 95p

Rapid Mail Order Service. Callers Welcome. Access-Barclay-Visa. Lists 20p. Closed Wed.

**Radio Components Specialists**

337 WHITEHORSE ROAD  
CROYDON, SURREY, U.K. Tel. 01-684 1665

**INDEX TO  
ADVERTISERS**

A.J.D. Direct Supplies (Silicon Shop) .. .. . 591  
Ambit .. .. . 579

B.I.E.T. .. .. . 584  
Birkett, J. .. .. . 602  
B.N.R.E.S. .. .. . 541, 596  
Bull J. .. .. . 545

Continental Specialties Corporation .. .. . 589, 591

Digisound .. .. . 603

EDA .. .. . 540  
Electroni-Kit .. .. . 538  
Electrovalue .. .. . 538

Gemini .. .. . 592  
George Sales, David .. .. . 589  
GMT .. .. . 542

Home Radio .. .. . 584

I.L.P. Electronics .. .. . 604, 605  
Intertext (ICS) .. .. . 603

Keelmor .. .. . 543

Litesold .. .. . 603

Magenta Electronics .. .. . 537  
Maplin Electronic Supplies Ltd. .. .. . Cov iv  
Marshalls .. .. . 602  
Metac .. .. . 584  
Micro-Circuits .. .. . Cov ii

Phonosonics .. .. . 544  
PIL .. .. . Cov iii  
Powell T. .. .. . 602

Radio Components Specialists .. .. . 608  
Radio TV Components .. .. . 595

Science of Cambridge .. .. . 600, 601  
Swanley Electronics .. .. . 607

Tempus .. .. . 540  
T.K. Electronics .. .. . 544  
Toolrange .. .. . 592  
Tri-tronic .. .. . 538

Vero Electronics .. .. . 542

Watford Electronics .. .. . 539  
West London Direct Supplies .. .. . 607  
Wilmslow Audio .. .. . 592

# THE NEW PIL SHOWROOM



More to see...  
more room to see it in.

Pil are pleased to announce the official opening of their new 1500 sq. ft. showroom to the public.

Offering a range of some 350 electrical measuring instruments manufactured by around 60 manufacturers, both British and international.

Pil can cater for practically every electrical measurement problem for any user on an ex-stock/short delivery basis.

The showroom facilities and its technical back-up are available to everyone from export

Factory/Repairs 01-639 0155  
North London Showroom 01-965 2352

houses and overseas users, buyers engineers, to do-it-yourself enthusiasts and hobbyists.

Instruments Electrical the service and calibration division can provide full guarantee facilities as well as offering their normal repair and calibration service.

For an immediate solution to your instrument problems, contact the Instrument Group at Instrument House.

Showroom/Sales/Export 01-639 4461  
Open Mon. to Fri. (ring for Sat. opening times)

## PIL

AN IEC GROUP  
COMPANY

**INSTRUMENT HOUSE, 727 OLD KENT ROAD, LONDON SE15**  
**TELEPHONE: 01-639 4461 TELEX: 8811854 (INSTEL)**

# STEP INTO A NEW WORLD WHEN YOU DISCOVER **MAPLIN**

For beginners or professionals, the Maplin catalogue will help you find just about everything you need for your project.

Over 5,000 of the most useful components — from resistors to microprocessors — clearly described and illustrated.

Send the coupon for your copy  
and **STEP UP TO  
MAPLIN SERVICE  
NOW**



Post this coupon now for your copy of our 1979-80 catalogue price 70p.

Please send me a copy of your 280 page catalogue. I enclose 70p (plus 46p p&p). If I am not completely satisfied I may return the catalogue to you and have my money refunded. If you live outside the U.K. send £1.35 or ten International Reply Coupons. I enclose £1.16.

NAME \_\_\_\_\_

ADDRESS \_\_\_\_\_  
\_\_\_\_\_  
\_\_\_\_\_



E/E/9/80

# MAPLIN

**ELECTRONIC SUPPLIES LTD**

All mail to:-

P.O. Box 3, Rayleigh, Essex SS6 8LR.

Telephone: Southend (0702) 554155.

Shop: 284 London Road, Westcliff-on-Sea, Essex. (Closed on Monday).

Telephone: Southend (0702) 554000.

**Catalogue now available in all branches of WHSMITH Price £1.00**