

An exciting hobby.... for everyone

# everyday electronics

DEC.76  
35 p



*Party time  
Projects...*

- **SCRABBLE TIMER**
- **MINI ORGAN**

PART ONE

**Let's figure it out!**

... TAKE THE STING OUT OF MATHS

*Plus*

**INDEX**

TO VOLUME 5

# Stirling Sound

## QV\* MODULES FOR COST-CONSCIOUS CONSTRUCTORS

**STIRLING SOUND** policy is to ensure customer satisfaction by designing and making their products in their own factory in Essex and selling direct. Production control-checked throughout. All QV Modules are compatible within the range and with much other equipment.

**SS.100** Active tone control, stereo.  $\pm 15$ dB on bass and on treble **£1.60**

**SS.101** Pre-amp for ceramic cartridges, radio, tape. Stereo. Passive tone control circuit shown in data supplied **£1.60**

**SS.102** Stereo pre-amp for low output magnetic P.U.s. R.I.A.A. corrected. Linear feedback facility. **£2.65**

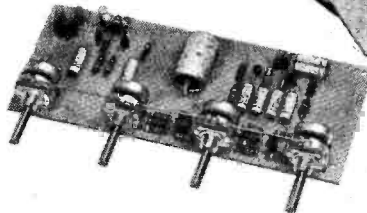

### PRE-AMP/TONE CONTROL MODULES

Combined pre-amp with active tone-control circuits.  $\pm 15$ dB at 10Khz treble and 30 Hz bass. Stereo. Vol./balance/treble/bass. 200mV out for 50mV in. Takes 10-16V. **£7.80**

### POWER AMPLIFIERS

**SS.103** 3 watt r.m.s. mono I.C. with built-in current, short, and thermal protection **£1.75**

**SS.103-3** Stereo version of above **£3.75**

**SS.105** 5 watts r.m.s. into 4 ohms, using 12V **£2.25**

**SS.110** 10 watts r.m.s. using 24V and 4 ohm load **£2.75**

**SS.120** 20 watts r.m.s. into 4 ohms, using 34V **£3.25**

*The above all measure 89 x 50 x 19mm (3 1/2 x 2 x 3/8 ins) Suitable power supplies will be found in the accompanying range.*

### FM TUNING MODULES

**SS.201** Front end tuner, slow geared drive, two gang. A.F.C. facility. Tunes 88-108 MHz **£5.00**

**SS.202** I.F. amplifier. Metering and A.F.C. facilities **£2.65**

**SS.203** Stereo Decoder for use with the above or other FM mono tuners. A LED may be fitted **£3.85**

**SS.110**

**SS.102**

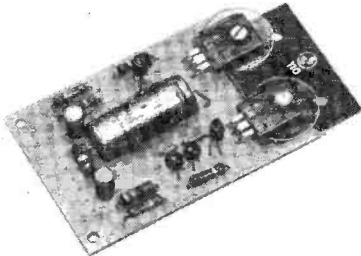

### ★ THE BUILT-IN QV FACTOR

means Stirling Sound's guarantee of QUALITY AND VALUE to give you to-day's best value all round.

# Stirling Sound

A member of the BI-PRE-PAK group of companies

220-224 WEST ROAD, WESTCLIFF-ON-SEA, ESSEX SS0 9DF

Telephone: Southend (0702) 46344

PERSONAL CALLERS WELCOME

616



**SS.140**

40 Watt r.m.s. into 4 ohms using 45V supply such as SS345. Ideal for small discos and P.A. 101 x 76 x 19mm (4" x 3" x 3/4")

**£3.95**

## TODAY'S BEST VALUE IN POWER SUPPLY UNITS

With 13-15v take-off points

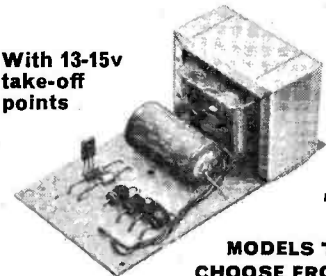

**7**

MODELS TO CHOOSE FROM

Complete with mains transformers and low volt take-off points. (except SS.300) All at 8% V.A.T. rate. Add 50p for p/p any model.

**SS.312** 12V/1A **£3.75\***

**SS.318** 18V/1A **£4.15\***

**SS.324** 24V/1A **£4.60\***

**SS.334** 34V/2A **£5.20\***

**SS.345** 45V/2A **£6.25\***

**SS.350** 50V/2A **£6.75\***

**SS.300** Power stabilising unit 10-50V adjustable for adding to unstabilised supplies. Built-in protection against short circuit (p/p 35p) **£3.25**



**SS.310/50** Stabilised power supply with variable output from 10 to 50V/2A. Built-in protection against short circuit. **£11.95\***

**SS.300**

### WHEN ORDERING

add 35p for p/p unless stated otherwise. V.A.T. add 12 1/2% to total value of order unless price is shown \* when the rate is 8%. Make cheques, etc. payable to BI-Pre-Pak Ltd. Every effort is made to ensure correctness of information at time of going to press. Prices subject to alteration without notice



# NEW! For home constructor FREE BLOB BOARD!

Worth 30p

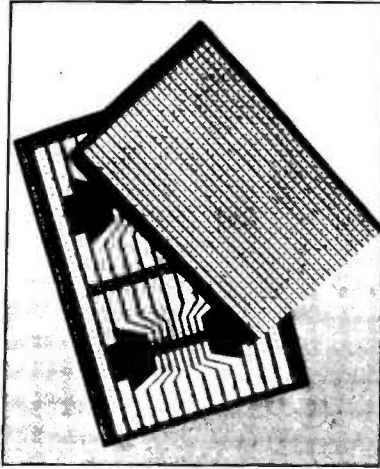

## BLOB BOARDS

Circuit diagram to circuit board in minutes. Layout circuit plan on .1" graph paper. Select Blob Board, lay components out with leads on copper strip. Blob of solder onto lead and your circuit is complete. Blob Boards normally half price of competitive boards. Roller tinned to ease of soldering, most require no cutting or breaking of contact rails. HALF PRICE AND RE-USABLE. That is NEW!

Blob Boards are circuit boards designed exclusively for the home constructor and prototype engineer and are normally half the price of competitive boards. Blob Boards are roller tinned for ease of soldering, most require no cutting or breaking of contact rails. HALF PRICE AND RE-USABLE. That is NEW!

Blob Board .1" or .15"	1 off	3 off	Dip Blob Boards	1 off	3 off
All approx. inch sizes					
ZB1V 2.5 x 5	£0.30	£0.75	ZB11C 4.5 x 3	£0.36	£0.90
ZB2V 2.5 x 3.75	£0.23	£0.57	ZB21C 4.8 x 3.2	£0.40	£0.96
ZB3V 3.75 x 5	£0.46	£1.14	ZB41C 4.75 x 7.5	£0.85	£2.13
ZB4V 10 x 6	£1.51	£3.78	ZB81C 9.5 x 7.5	£1.70	£4.26
Discrete Blob Board	1 off	3 off	Sample pack: 1 off ZB1V + 1 off ZB8D + 1 off ZB21C normally £2.32 only £2.00 + free Blob Board.		
ZB5D 3.6 x 2.4	£0.20	£0.51	Many other sizes and patterns available add 30p post + 8% VAT to all orders.		
ZB6D 2.4 x 7.3	£0.42	£1.05			
ZB7D 4.9 x 7.3	£0.69	£1.75			
ZB8D 9 x 7.5	£1.62	£4.05			



## S-DeC

Take an S-DeC, take a small stock of components. Plug components into S-DeC, no soldering, make a radio receiver, light operated switch, 3 stage amplifier. When circuit is made unplug components and use them again to make a Morse practice oscillator, LC oscillator, binary counter and any other discrete circuitry. See Practical Wireless for new series of S-DeC projects. S-DeC + step by step instructions to build above projects and 3 more + which components to use + free control panel for mounting switches, lamps etc. + free Blob Board. S-DeC only £1.98 + 37p (VAT + post) send only £2.35.

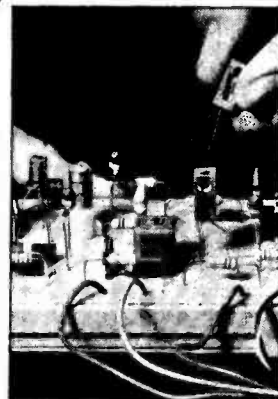

## T-DeC

If you are using IC's to build circuits use T-DeC for 1 chip circuits and U-DeC A for 2 chip circuits. Draw circuit on graph paper, plug IC into Adaptor and plug into DeC. No soldering, no bent leads, no wasted IC chip. Lines on DeC show contact rails, plug discrete components in. Cross overs, connections are made using different coloured leads. Circuit completed and working unplug components and use for next circuit. No soldering, no damage to components. Use your DeC and small stock of components over and over again. T-DeC send £4.30. U-DeC "A" send £4.60. Adaptor send £2.30.



## DRILL-SAW GRIND-BURR BRUSH-POLISH

PB announce a precision British built drill for the home constructor. Works better than most bigger drills and can be used for fine detailed work. Drills through any circuit board, need to break copper strip simply grind it off.  
9000 RPM Drill + 20 Assorted tools £11.20 (+VAT + post)  
Send £13.00.  
9000 RPM Drill only £5.22 + post + VAT send £6.00.  
Multi-purpose Drill stand £10.60 + Post + VAT send £12.00.

## POT LUCK

Off cuts of fibre glass circuit board	5 sq. ft.	£1.50.
Double sided fibre glass p.c.b.	5 sq. ft.	£2.00.
Ferric chloride	5 litre mix	£2.00.
Negative developer	1 litre	£1.50.

Add £0.75p. to all above for Post + VAT.

Mr. Trader please exchange for 1 Blob Board ZV1V worth 30p.  
Trade enquiries please contact Banbridge, London.  
Mr. John Evans Tel: 01-228 9227

30p

PB Electronics Scotland Ltd.  
57 High Street, Saffron Walden, Essex. CB10 1AA.  
For leaflets and further information please send stamped addressed envelope.



# B. BAMBER ELECTRONICS

Dept EE, 5 STATION ROAD, LITTLEPORT, CAMBS., CB6 1QE  
Telephone: ELY (0353) 860185 (2 lines) Tuesday to Saturday

PLEASE ADD 8% VAT UNLESS OTHERWISE STATED

## A Merry Xmas to all our Customers

**VARIABLE STABILISED POWER SUPPLY.** mains input, 0-24V output, stabilised and current limiting at 500mA + 32V at 50mA. Brand new by British manufacturer. Size approx. 7½" x 2½" x 4in. complete with external 5A/2.5-turn pot for voltage control. Connection data supplied. £7.

**50uA (25-0-25uA) EDGEWISE METERS,** modern type by Sangamo Western, display area 1" x 1½in with 2 mounting lugs. (Can be zeroed left or right hand.) £1.50 each while stocks last.

**MAINS ISOLATION TRANSFORMERS.** Tapped mains input 240V at 3A + 12V at 500mA output. New boxed made by Gardners, £12.

**HEATER STRIP,** 240V a.c. 150W, approx. 1 metre long (mounted with fibreglass) with mains connector block. Many many uses. 80p each

**Good Quality Pressure Gages,** 2½in dia. flange mounting, 3 models avail. 0-60 lba/inq, 0-100 lba/inq, 0-200 lba/inq. in. state which £1.25 each.

**2N3055 type Transistors,** O.K., but unmarked. 5 for £1.

**100V NEONS, SCREW-IN-TYPE,** 4 for 50p.

**SLOW MOTION MOTORS** (suitable for programmers, displays, etc.) 230-240V a.c. input, rotation 1 rev. every two to three minutes. £1.25 each.

**MINIATURE PLIERS** high quality "Crescent" made in USA. £4.35 + VAT (35p).

**SIDE CUTTERS,** high quality. £3.70 + VAT in pairs 30p.

**MIXED COMPONENT PACKS,** containing resistors, capacitors, switches, pots, etc. All new (random sample bag revealed approx. 700 items). £2 per pack, while stocks last.

**TUNED COILS,** 2 section coils, around 1MHz, with a black smart tuning knob, which moves an internal core to vary the inductance, many uses, easily rewound. 3 for 50p.

**HIGH QUALITY SPEAKERS,** 8½in x 5in elliptical, only 2½in deep, inverse magnet, 4 ohms, rated up to 10W. £1.50 each, or 2 for £2.75 (qty. discount available - 12½% VAT).

**PROGRAMMERS** (magnetic devices). Contain 9 microswitches (suitable for mains operation) with 9 rotating cams, all individually adjustable (ideal for switching disco lights, displays, etc. or industrial machine programming). (Need slow motion motor to drive cams, not supplied) 9 switch version £1.50.

**HEAVY DUTY HEATSINK BLOCKS,** undrilled, base area 2½in x 2½in, with 6 fins, total height 2½in 50p each.

**SPERRY 7-SEGMENT P.G.D. DISPLAYS,** digit height 0.3in red with decimal points, 150V to 200V (nominal 180V) operation. These are high-volt industrial type and therefore brighter than normal displays. All brand new. AT THE BARGAIN PRICE OF 50p PER DIGIT. TYPE 332 (two digits in one mount) £1 each, TYPE 333 (three digits in one mount) £1.50. (Sorry, no single digit available.) Data Supplied.

**BSX20 (VHF Osc/Multi),** 3 for 50p.  
**BC108 (metal can),** 4 for 50p.  
**PBC 108 (plastic BC108),** 3 for 50p.  
**BFY51 Transistors,** 4 for 80p.  
**BCY72 Transistors,** 4 for 50p.  
**PNP audio type TOS Transistors,** 12 for 25p.  
**BF152 (UHF amp/mixer),** 3 for 50p.  
**2N3819 Fet,** 3 for 80p.  
**BA121 Varicap Diodes,** 4 for 50p.  
**1N914 diodes,** 10 for 25p.

**SMALL MAINS SUPPRESSORS** (small chokes, ideal for radio, Hi-Fi inputs, etc.) approx. ½in x 1½in, 3 for 50p.

**PERFEX TUNER PANELS** (for FM Band 2 tuners) marked 88-108 MHz and Channels 0-70, clear numbers, neat blacked out, smart modern appearance, size approx. 8½in x 1½in, 2 for 35p. Lead suppressors (10kohm) for mobile plug leads, 4 for 50p.

**HEAVY DUTY RELAYS,** 24V d.c. operated (will work on 18V) 3 heavy duty make contacts (around 10A rating) + 4 change over contacts + 1 break contact. New, complete with mounting bracket (ideal for switching HT on Lines). Many uses for this high quality unit. £1.50 each.

TO3 transistor insulator sets 10 for 50p.

**ALL-SOL ALUMINIUM SOLDER** (made by Muller-corr). Solders aluminium to itself or copper, brass, steel, nickel or tinplate 16 s.w.g. with multicore flux, with instructions. Approx 1 metre coil 30p pack. Large reel £2.75.

1½in polythene chassis mounting fuseholders, 6 for 30p.

I.C.s: some coded, 14 DIL type, untested, mixed, 20 for 25p.

Mobile Converters, 24V DC input 13.8V at approx 3-4A DC output, fully stabilised £3.50 each (ideal for running 12V car radio from 24V lorry battery).

We now stock Spiralux Tools for the electronic enthusiast. Screwdrivers, Nut Spanners, BA and Metric sizes, pop rivet guns, etc. S.A.E. for list.

Miniature earphones with min. jack plug, 2 for 50p + 12½% VAT.

I.F. Cans, 1½in square, suitable for rewind, 8 for 30p + 12½% VAT.

TWIN I.F. CANS, approx. 1½in x ½in x 1½in high, around 3-5.5MHz, 2 separate transformers in 1 can, internally screened, 5 for 50p + 12½% VAT.

Dubilier Electrolytics, 50uF 450V, 2 for 50p.  
Dubilier Electrolytics, 100uF 275V, 2 for 50p.  
Plessey Electrolytics, 470uF 53V, 3 for 50p.  
TCC Electrolytics, 1000uF 30V, 3 for 50p.  
Plessey Electrolytics, 1000uF 180V, 40p each (3 for £1).

Dubilier Electrolytics, 5000uF 35V 50p each  
Dubilier Electrolytics, 5000uF 50V 80p each  
ITT Electrolytics, 6800uF 25V high grade, screw terminals, with mounting clips, 50p each.  
Plessey Electrolytics, 10,000uF at 53V 75p each  
Plessey Cathodray Capacitors, 0-0.4uF at 12-5kV DC. Screw terminals £1.50 each.  
**PLEASE ADD 12½% VAT TO ALL CAPACITORS**

**A LARGE RANGE OF CAPACITORS AVAILABLE AT BARGAIN PRICES, S.A.E. FOR LIST.**

PLEASE ADD 8% VAT UNLESS OTHERWISE STATED

**TV PLUGS AND SOCKETS**  
TV Plugs (metal type), 5 for 50p.  
TV Sockets (metal type), 4 for 50p.  
TV Line Connectors (back-to-back sockets), 4 for 50p. Please add 12½% VAT.

**PLUGS AND SOCKETS**  
N-Type Plugs 50 ohm, 80p each, 3 for £1.80.  
N-Type Sockets (4-hole chassis mounting), 50 ohms (a small coax lead type), 80p each.  
PL250 Plugs (PTFE), brand new, packed with reducers, 50p or 5 for £2.50.

SO239 Sockets (PTFE), brand new (4-hole fixing type), 80p each or 5 for £2.25.  
25-way ISEP Plugs and Sockets, 40p set (1 plug + 1 socket).

Plugs and sockets sold separately at 25p each. Builtin Round Face Sockets 3 pin, for mains input on test equipment, etc., 25p each.

**WELLER SOLDERING IRONS**  
EXPERT. Built-in spotlight illuminates work. Pistol grip with fingertip trigger. High efficiency copper soldering tip.

**EXPERT SOLDER GUN,** £5.95 + VAT (84p)  
**EXPERT SOLDER GUN KIT** (separate bits case, etc.), £2.95 + VAT (70p)

**SPARE BITS, PAIR,** 30p + VAT (8p)  
**MARKSMAN SOLDERING IRONS**

SP150 15W £3 + VAT (84p)  
SP250 25W £3 + VAT (84p)  
SP250K 25W + bits, etc. kit £3.85 + VAT (81p)  
SP400 40W £3.44 + VAT (80p)  
**BENCH STAND** with spring for Marksmen Irons, £2.22 + VAT (55p)

**SPARE BITS**  
MT8 for 15W, 80p + VAT (4p).  
MT4 for 25W, 30p + VAT (5p).  
MT10 for 40W, 63p + VAT (8p)

**TCPI TEMPERATURE CONTROLLED IRON,** Temperature controlled iron & PSU, £20 + VAT (£1.80)

**SPARE TIPS**  
Type CC single flat, Type K double flat fine tip. Type P, very fine tip, £1 each + VAT (8p).  
**MOST SPARES AVAILABLE**

**MULTICORE SOLDER**  
Size 5 Savbit 16 s.w.g. in alloy dispenser, 22p + VAT (5p).  
Size C15AV18 Savbit 16 s.w.g., 80p + VAT (4p).  
Size 12 SAVBIT 16 s.w.g. on plastic reel £1.80 + VAT (15p)

Terms of Business: CASH WITH ORDER. MINIMUM ORDER £1. ALL PRICES INCLUDE POST & PACKING (UK ONLY). SAE with ALL ENQUIRIES Please. PLEASE ADD VAT AS SHOWN. ALL GOODS IN STOCK DESPATCHED BY RETURN. CALLERS SATURDAYS ONLY 9.30-12.00, 1.30-5.00.

**QUALITY STEREO SOUND.**

ALMOST **½ PRICE OFFER!** SOLENT AUDIO SYSTEM

**£5.00 down**

MADE TO SELL AT DOUBLE THE PRICE IN CABINET FORM

OUR PRICE **£69.95**

Solent Mark II Stereo Tuner Amplifier chassis with AM/FM radio covering long medium short and Stereo FM wavebands. Separate Bass and Treble controls. 30 watts total power output (frequency response 25-20,000 Hz) AFC Switching Tape record and playback facilities. Dimensions 18½" x 9" x 3½". The very latest BSR automatic record deck with cue and pause control. Two matching elliptical speaker units.

Order early limited stocks available cash price £69.95. Credit Sale £5.00 deposit 9 monthly payments of £8.70 (Total Credit price £83.30). P. & P. £4.00. Send £9.00 today.

Tuner/Amplifier only available for cash at £49.00 + p. & p. £3.00.

Full 12 months Guarantee.

CALLERS WELCOME.

Access and Barclaycard Orders Accepted by Telephone

FREE! Stereo headphones supplied with every complete order

**LEWIS radio** EE/12/76 100 CHASE SIDE SOUTHGATE LONDON N14 5PL Telephone: 01-882-1644

**Become a radio amateur.**

Learn how to become a radio-amateur in contact with the whole world. We give skilled preparation for the G.P.O. licence.

WAA

Free! Brochure, without obligation to: **BRITISH NATIONAL RADIO & ELECTRONICS SCHOOL,** EEK126

P.O.Box 156, Jersey, Channel Islands.

NAME \_\_\_\_\_

ADDRESS \_\_\_\_\_

(Block caps please)

# NEWS FROM JOSTY KIT

## JOSTYKIT

### AF 300 3 WATT AUDIO AMPLIFIER

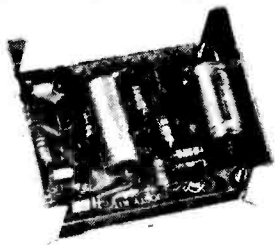

This is a 3 W complementary output stage, general purpose amplifier. Use it to boost the output from your record player, cassette recorder, transistor radio or drive it from one of the HF range of JOSTYKIT receivers. Try it with the HF 310 FM receiver in your car or boat. **£6.10**

## JOSTYKIT

### HF 61 DIODE MEDIUMWAVE RECEIVER

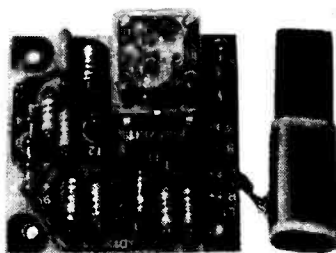

HF 61 is an extended diode receiver for mediumwave-reception. By means of a very simple technique a reasonable reception even from foreign medium stations is attained.

HF 61 is built on a small circuit board of the same size as the general purpose amplifier AF 380. The two assemblies should be connected to produce power for a loudspeaker. HF 61 is especially useful for beginners, who have not tried to assemble electronic kits before. **£4.30**

## JOSTYKIT

### HF 385 VHF/UHF AERIAL AMPLIFIER

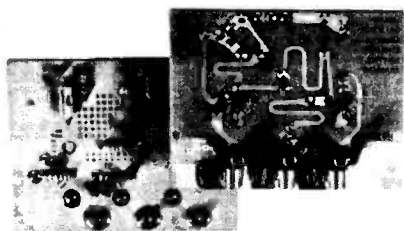

A quality, printed circuit, no trimming, aerial amplifier. Fantastic frequency range due to use of printed coils, 21 dB amplification at 400 MHz. Two separate inputs for UHF and VHF. No loss of signal or intercommunication problems. **£5.80**

## JOSTYKIT

### HF 305 VHF RADIO-CONVERTER

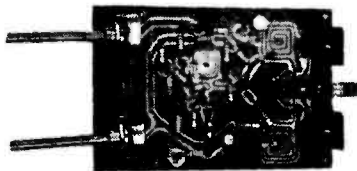

Extend the range of your transistor radio. Listen to Amateurs (2 metre band), Aircraft, Trawlers, etc. Two transistor circuit with printed circuit coils, varactor diodes and superior circuit design. Converts radio signals in the 100-200 MHz range to output signal at 100 MHz. Pipe this into your VHF receiver and you're in a new dimension. **£6.70**

## JOSTYKIT

### AT 365 3-CHANNEL DISCO LIGHT

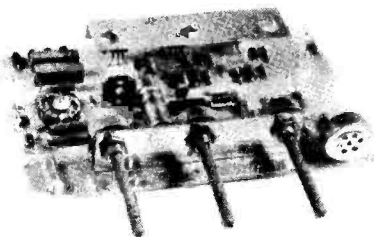

A new concept in psychedelic lighting. Uses built-in microphone. Avoids awkward connections to amplifiers. Position light-show to best advantage without long trailing leads—just plug in to the nearest power point. Circuit combines latest integrated circuit techniques with solid-state power control. Quad op. amp. makes selection of bass, midrange and treble frequencies easy. Three thyristors (SCRs) control three separate lampbanks. Kit includes fused dc power supply and FET zero light adjustment. **WARNING.** Only experienced persons should attempt the interconnection of mains equipment. **£17.00**

## JOSTYKIT

### AT 347 ELECTRONIC ROULETTE

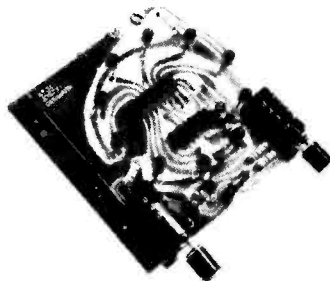

A set of exciting games for family and friends. In the home or in the pub they'll envy your electronics wizardry. Two integrated circuits provide a random number system. A 7490 counts the pulses and a 7442 decodes. The decoded outputs turn on a sequentially rotating L.E.D. light display. Your chance to try your hand with TTL digital electronics. Supplied with six colourful game indicators. **£8.75**

# JOSTYKIT (U.K.) LTD

MAIL ORDER DIVISION

P.O. BOX 68, Middlesbrough, Cleveland, TS1 5DQ, England

All prices include VAT. Please add 25p Post and Packing.



## "I MADE IT MYSELF"

Imagine the thrill you'll feel! Imagine how impressed people will be when they're hearing a programme on a modern radio you made yourself.

# Now! Learn the secrets of radio and electronics by building your own modern transistor radio!

Practical lessons teach you sooner than you would dream possible.

What a wonderful way to learn—and pave the way to a new, better-paid career! No dreary ploughing through page after page of dull facts and figures. With this fascinating Technatron Course, you learn by building!

You build a modern Transistor Radio... a Burglar Alarm. You learn Radio and Electronics by doing actual projects you enjoy—making things with your own hands that you'll be proud to own! No wonder it's so fast and easy to learn this way. Because learning becomes a hobby! And what a profitable hobby. Because opportunities in the field of Radio and Electronics are growing faster than they can find people to fill the jobs!

**No soldering - yet you learn faster than you ever dreamed possible.**

Yes! Faster than you can imagine, you pick up the technical know-how you need. Specially prepared step-by-step lessons show you how to read circuits—assemble components—build things—experiment—You enjoy every minute of it! You get everything you need. Tools. Components. Even a versatile Multimeter that we teach you how to use. All included in the course. **AT NO EXTRA CHARGE!** And this is a course anyone can afford. (You can even pay for it by easy instalments).

**So fast, so easy, this personalised course will teach you even if you don't know a thing today!**

No matter how little you know now, no matter what your background or education, we'll teach you. Step by step, in simple easy-to-understand language, you pick up the secrets of radio and electronics.

You become somebody who makes things, not just another of the millions, who don't understand. And you could pave the way to a great new career, to add to the thrill and pride you receive when you look at what you have achieved. Within weeks you could hold in your hand your own transistor radio. And after the course you can go on to acquire high-powered technical qualifications, because our famous courses go right up to City & Guilds levels.

**Send now for FREE 44 page book - see how easy it is - read what others say!**

Find out more now! This is the gateway to a thrilling new career, or a wonderful hobby you'll enjoy for years. Send the coupon now. There's no obligation.

**POST TODAY FOR FREE BOOK**

To: **ALDERMASTON COLLEGE DEPT. CEE 22 READING RG7 4PF**

Also at our London Advisory Office, 4 Fore Street Avenue, Moorgate, London EC2Y 5EJ. Tel: 01-628 2721. Yes, I'd like to know more about your course. Please send me free details—plus your big, 44 page book that tells about all your courses.

NAME .....

ADDRESS .....

POSTCODE .....



HOME OF BRITISH INSTITUTE OF ENGINEERING TECHNOLOGY

## CRESCENT RADIO Ltd.

164-166 HIGH ROAD LONDON N22 6EJ  
(also) 13 SOUTH MALL, Edmonton, N.9  
MAIL ORDER DEPT. 1 St Michaels Terrace Wood Green  
London N22 4SJ Phone 888 3206 & MAIL ORDER 888-4474

**POWER PACKS**  
FP1 Switched 3, 4, 6, 7, 9 and 12 volt @ 500 mA, with on/off switch and pilot light.  
Size - 130 mm x 65 mm x 75 mm  
**ONLY - \$4.50 + 8%**

**CASSETTE MICROPHONE**  
On/Off switch for Remote Control. Split Lead with 2.5mm and 3.5mm plugs, Standard Cassette Mics to suit all types. Complete with Desk Rest.  
Please state which Impedance required 200ohm/50K.ohm.  
**PRICE \$1.60 + 12% VAT.**

**P.O. ETCHING KIT**  
This kit contains all that the constructor will need to etch the circuits of his own design.  
Contents—Plastic etching dish. Sample copper clad board. Laminate Cutter. 1 lb Ferric Chloride. Large Plastic Spoon. Etch Resist Pen. Full Etching Instructions.  
Complete and Big Kit Value at **\$3.75p + 8% VAT.**

**FERRIC CHLORIDE**  
Anhydrous ferric chloride in double sealed one pound Poly packs.  
**OUR PRICE - 65p + PF + 8% per lb.**

### 2in. PANEL METERS

Size 59mm x 46mm

0-50µA —ME6	0-100mA—ME13
0-100µA—ME7	0-500mA—ME14
0-500µA—ME8	0-1A —ME15
0-1mA —ME9	0-50V —ME16
0-5mA —ME10	0-300V a.c.—ME17
0-10mA—ME11	8 meter —ME18
0-50mA—ME12	V.U. meter—ME19

**£3.50 + 8%**

### MINI LOUDSPEAKERS

2 1/2" 80 ohm 60p  
2 1/2" 40 ohm 60p  
2 1/2" 8 ohm 60p  
+ 12%

**GOODMANS CROSSOVER**  
3 way 8 ohm Crossover manufactured by Goodmans.  
Bargain at \$1 + 12%.

U.K. CARR. All prices are excluding VAT. Please 50p unless otherwise add to each item the VAT rate indicated to all orders stated

## VALVE BARGAINS

Any 5-54p, 10-£1-00, 50-£4-50.  
Your choice from the list below.

ECC82, EF80, EF183, EF184, EH90, PCF80, PCF802, PCL82, PCL84, PCL85, PCL86, PCL805, PL504, PY81/800, PY88, 30PL14, 6F28.

Colour Valves—PL508, PL509, PL519, PY500/A. All tested.  
**30p each.**

Television Aerial Splitters  
2-way, inside type. **£1.50**

Press Button UHF Tuners—4 Button Transistor—British made—**£2.50 each.**

## AERIAL BOOSTERS

Aerial boosters can produce remarkable improvements on the picture and sound, in fringe or difficult areas.  
**B11**—For TH stereo and standard VHF/FM radio.  
**B12**—For the older VHF television—Please state channel numbers.  
**B45**—For Mono or colour this covers the complete UHF Television band.

All boosters are complete with battery with Co-ax plugs & sockets. Next to the set fitting.  
**£3.80**

## 50p BARGAIN PACKS

All Packs Un-used Parts—PK1-40-C280 (Mullard) Axial Lead Capacitor mixed values from .01µF to .47µF (250V/W). PK2-30-C281 (Mullard) Radial Lead Capacitors mixed values from .015µF to 1.5µF (250V/W). PK3-6 Co-ax. plugs. PK4-6 Co-ax connectors. PK5-8.5m/m formers with slugs. PK6-25-AC128 Transistors. PK7-3 BF200 (VHF) Transistors. PK8-2 BF182 (UHF) Transistors. PK9 Any 6 Transistors—BC108, BC113, BC135, BC153, BC171B, CF172, BF 194, BF 195, BF 196, BE 197. PK10 8-1 amp 400 volts rectifiers. PK11 4-5 pin din plugs (180°). PK12-5 PP3 Battery Connectors.

All prices include VAT. P&P 20p per order. Please send uncrossed P.O. or Cheques for returning if we are out of stock of Bargain Packs or older types of new valves.

## ELECTRONIC MAILORDER LTD.

62 BRIDGE STREET, RAMSBOTTOM, BURY, LANCs.  
Tel. Rams. (070 482) 3036

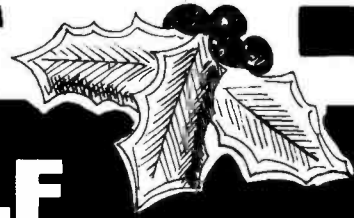

# TREAT YOURSELF THIS CHRISTMAS TO...

## a handy POCKET BOOK

**INTEGRATED CIRCUIT POCKET BOOK**  
R. G. Hibberd  
1972 282 pages 0 408 00767 7 £3.90

**TRANSISTOR POCKET BOOK – Revised**  
Impression – R. G. Hibberd  
1976 312 pages 0 408 00254 9 £3.90

**ELECTRONICS POCKET BOOK—3rd Edition**  
P. J. McGoldrick  
1976 358 pages 0 408 00209 3 £3.75

**NEWNES RADIO ENGINEER'S POCKET BOOK—14th Edition—H. W. Moorshead**  
1972 188 pages 0 408 00074 0 £1.90

**RADIO SERVICING POCKET BOOK—3rd Edition – Vivian Capel**  
1975 238 pages 0 408 00144 5 £2.50

**TELEVISION ENGINEERS' POCKET BOOK**  
6th Edition – P. J. McGoldrick  
1973 380 pages 0 408 00102 X £3.50

## or a CONSTRUCTORS GUIDE

**ELECTRONIC DIAGRAMS**  
M. A. Colwell  
1976 112 pages 0 408 00201 8 £1.80

**PRINTED CIRCUIT ASSEMBLY**  
M. J. Hughes and M. A. Colwell  
1976 96 pages 0 408 00203 4 £1.80

**ELECTRONIC COMPONENTS**  
M. A. Colwell  
1976 112 pages 0 408 00202 6 £1.80

**PROJECT PLANNING AND BUILDING**  
M. A. Colwell  
1976 112 pages 0 408 00229 8 £1.99

**SIMPLE CIRCUIT BUILDING**  
P. C. Graham  
1976 112 pages 0 408 00230 1 £1.99

**PRACTICAL ELECTRONIC PROJECT BUILDING – A. Ainslie and M. A. Colwell**  
1976 112 pages 0 408 00231 X £1.99

## or a PROJECT BOOK

**110 COSMOS DIGITAL IC PROJECTS FOR THE HOME CONSTRUCTOR—R.M. Marston**  
1976 115 pages 0 408 00216 6 £2.75

**110 OPERATIONAL AMPLIFIER PROJECTS FOR THE HOME CONSTRUCTOR**  
R. M. Marston  
1975 125 pages 0 408 00153 4 £2.50 limp  
0 408 00149 6 £3.95 STD

**110 ELECTRONIC ALARM PROJECTS FOR THE HOME CONSTRUCTOR—R.M. Marston**  
1976 120 pages 0 408 00269 7 £2.95

**110 THYRISTOR PROJECTS USING SCRs AND TRIACS**  
R. M. Marston  
1972 146 pages 0 592 00074 5 £2.50 limp  
Reprinted 1975 0 592 00073 7 £3.95 STD



Order now direct from your bookseller or from:

**NEWNES-BUTTERWORTHS, Borough, Green, Sevenoaks, Kent TN15 8PH**

# 1. Understand electronics.

Step by step, we take you through all the fundamentals of electronics and show you how easily the subject can be mastered using our unique Learn-Kit course.

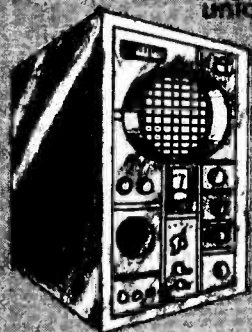

- (1) Build an oscilloscope.
- (2) Read, draw and understand circuit diagrams.
- (3) Carry out over 40 experiments on basic electronic circuits and see how they work.

# 2. Become a radio amateur.

Learn how to become a radio amateur in contact with the whole world. We give skilled preparation for the G.P.O. licence.

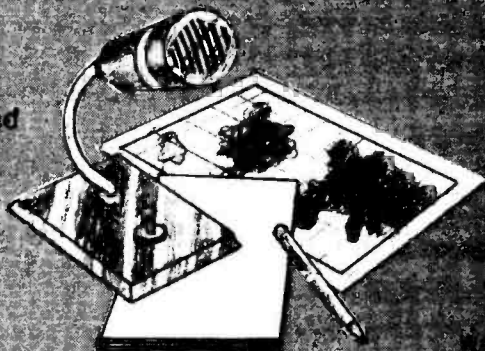

**Free!**

Brochure, without obligation to:  
**BRITISH NATIONAL RADIO & ELECTRONICS SCHOOL,**  
 P.O. Box 156, Jersey, Channel Islands.

EEC 126

NAME \_\_\_\_\_

ADDRESS \_\_\_\_\_ Block caps please

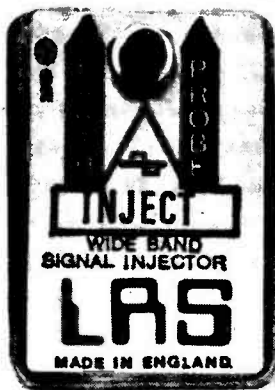

**£1.65★**  
**BUYS THIS**

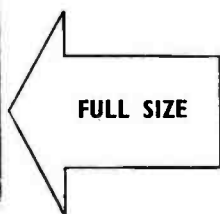

OUR HANDY LITTLE POCKET SIGNAL INJECTOR, RADIATES OVER MOST OF THE AUDIO/RADIO SPECTRUM WITH A 'RICH IN HARMONIC' SIGNAL. LOOK AT THE SPEC.

- \* I.C. Design with LED 'on' Indicator
- \* Complete with Probe, Earth Lead and Instructions.
- \* Also Batteries and 1 Year Guarantee.
- \* 10-Day Money-back Offer.





★ All for only £1.65 + p&p at 15p to:

**LRS Electronics**

3, CLIVESWAY, HINCKLEY, LEICESTERSHIRE  
 Mail order only — Trade enquiries welcome.

## SPANMAIN LTD

NORTH BLACK VIEN ESTATE,  
 CROSSKEYS, GWENT.

- |   |   |   |
|---|---|---|
|  | SYNCHRONOUS 230V 50Hz MOTOR AND GEARBOX UNIT. SPEED 15/20/30 R.P.M.<br>STATE WHICH SPEED REQUIRED | -90p  |
|  | MOUNTING PLATE FOR ABOVE WITH V3 MICRO-SWITCH HOLES   | -30p  |
|  | RELAYS - 230V 50Hz COIL - CONTACTS RATED AT 6A.   | 3 pole c/o -45p<br>1 pole c/o -32p            |
|  | NEW HIGH GRADE ELECTROLYTICS -  | 220µf - 16 v.w. -27p<br>3300µf - 18 v.w. -47p |
|  | ULTRA LOW TORQUE MICROSWITCH RATED AT 5A - 230V A.C.  | V3 M.S. with roller -32p<br>-15p              |

all above items ex-equip unless otherwise stated.

TERMS C.W.O. - cheques/p.o.'s make payable to Spanmain Ltd. S.A.E. for lists.

ALL PRICES INCLUDE POST, PACKING AND V.A.T.





**DRILL CONTROLLER**  
Electronically changes speed from approximately 10 revs to maximum. Full power at all speeds by finger-tip control. Kit includes all parts, case, everything and full instructions 45-45 including post & VAT. Made up model £1-00 extra.

**MAINS TRANSISTOR PACK**  
Designed to operate transistor sets and amplifiers. Adjustable output 0v, 9v, 12 volts for up to 500mA (class B working). Takes the place of any of the following batteries: 2P1, 2P3, 2P4, 2P6, 2P7, 2P9 and others. Kit comprises: main transformer, rectifier, smoothing and load resistor capacitors and instructions. Real snip at only £1-60 VAT & Postage 80p.

**RADIO STETHOSCOPE**  
Easiest way to fault find, traces signal from aerial to speaker, when signal stops you've found the fault. Use it on Radio, TV, amplifier, anything. Complete kit comprises two special transistors and all parts including probe tube and crystal case, £2-95, twin stetho-sec instead of ear-piece. £1-00 VAT and postage incl.

**MICRO SWITCH BARGAINS**  
Rated at 5 amps 250 volts, ideal to make a switch panel for a calculator and for dozens of other applications. Parcel of 10 for £1-00, VAT and post paid.

**MOTORISED DISCO SWITCHES**  
With six 10 amp changeover switches. Multi adjustable switches are rated at 10 amp each so a total of 3000w's can be controlled and this would provide a magnificent display. For mains operating £4-95 post & VAT Paid. Ditto 9 switch £4-95 Post & VAT Paid. DITTO BUT 18 SWITCH £4-75 POST & VAT PAID.

**AMMETERS**  
Ideal for chargers etc. 2" sq. full vision 0-8 amp 50p, 1 1/2" round 0-2 amp 45p, 0-3 amp 65p, 0-4 amp 75p. Post & VAT 25p each.

**MAINS OPERATED SOLENOIDS**  
Model 778—small but powerful 1in. pull—approx. size 1 1/2 x 1 1/2 in. £1-00  
Model 4001—1in. pull. Size 2 1/2 x 2 1/2 in. £1-50  
Model 771—1 1/2in. pull. Size 3 x 2 1/2 x 2in. £2-50  
Prices include VAT & postage.

**SOUND TO LIGHT UNIT**  
Add colour and white light to your amplifier. Will operate 1, 2 or 3 lamps (maximum 40W). Unit in box all ready to work. £7-95 plus 85p VAT & Postage.

**RELAY BARGAIN**  
Type 600 relay with twin 500 ohm coils which may be joined in series or parallel thus relay will operate off voltages between 5 and 30 volts DC. Price 44p each, 10 for 44 post and VAT paid.

**BATTERY CONDITION TESTER**  
Made by Mallory but suitable for all batteries made by Ever Ready and others, most of which are zinc carbon types but also mercury manganese—lead acid and alkaline batteries may be tested. The tester puts a dummy load on the battery and the meter scale indicates the maximum depending upon which section the pointer rests. The section reads "replace", "weak" or "good". The tester is complete in its case, size 8 1/2" x 6 1/2" x 2" with leads and prod. £4-50 post & VAT paid.

**BATTERY CHARGER**  
Famous Atlas in metal case with meter, output lead terminated by crocodile clip. For 6 or 12V charging—switched by changing plug on front panel. Ready built new and still £2-95 plus 41 Post & VAT

**HONEYWELL PUSH BUTTON PANEL MOUNTING MICRO SWITCH**  
1-3 Bank, each Bank consisting of the changeover micro switch rated at 10 amps 250 volts. Through panel fixing by 2 lock nuts complete with black 1" diameter knob. Prices—1 bank 40p—2 bank 65p—3 bank 75p.

**MULLARD UNILEX**  
A mains operated 4 + 4 stereo system. Rated one of the finest performers in the stereo field this would make a wonderful gift for almost any one in easy-to-assemble modular form and complete with a pair of Celestion speakers normally £8. This should sell at about £30—but due to a special bulk buy and as an incentive for you to buy this month we offer the system complete at only £16-50 including VAT and postage.



**TANGENTIAL HEATER UNIT**  
This heater unit is most efficient, and quiet running. Is as fitted in Hoover and blower heaters costing £16 and more. Comprises motor, impeller, 2kW element and 1kW element allowing switching 1, 2 and 3kW and with thermal safety cut-out. Can be fitted into any metal line case or cabinet. Only needs control switch. £5-83 plus VAT & post £1. 2kW Model as above except 2kW £4-25 plus VAT & post 75p. Don't miss this. Control Switch 44p. P. & A. 40p.

**ISA ELECTRICAL PROGRAMMER**  
Learn in your sleep! Have radio playing and kettle boiling as you wake—switch on lights to ward off intruders—have a warm house to come home to. All these and many other things you can do if you invest in an electrical programmer. Clock by famous maker with 15 amp. on/off switch. Switch-on time can be set anywhere to stay on up to 6 hours. Independent 60 minute memory jogger. A beautiful unit. Price £2-95, VAT & Postage 80p, or with glass front, chrome bezel, £1-50 extra.

**ROOM THERMOSTAT**  
Famous Ratchwell, elegant design, intended for wall mounting. Will switch up to 20 amps at mains voltage, covers the range 0-30°C. Special snip this month £2-50, post and VAT paid.

**MINI ORGAN SCRABBLE TIMER**  
To receive parts for the projects featured this month, send the estimated price + 40p post. Any cash adjustment can be made later.

**CENTRIFUGAL BLOWER**  
Miniature mains driven blower centrifugal type blower unit by Woods. Powerful but specially built for quick running—driven by cushioned induction motor with specially built low noise bearings. Overall size 4 1/2" x 4 1/2" x 4". When mounted by flange, air is blown into the equipment but to suck air out, mount from centre using clamp. Ideal for cooling electrical equipment or fitting into a cooker hood, film drying cabinet or for removing flux smoke when soldering etc. etc. A real bargain at £3-80, 60p post & VAT.

**THIS MONTH'S SNIP**  
**MAINS RELAYS**  
With triple 10 amp changeover contacts—operating coil wound for 230 volts AC, chassis mounting, one screw fixing, ex unused equipment 60p each, 10 for £5 post and VAT paid.

**HORSTMANN 24-HOUR TIME SWITCH**  
With 6 position programmer. When fitted to hot water systems this could programme as follows:

Programme	Hot Water	Central Heating
0	OR	OR
1	Twice Daily	OR
2	All Day	OR
3	Twice Daily	Twice Daily
4	All Day	All Day
5	Continuously	Continuously

Suitable, of course, to programme other than heating and hot water, for instance, programme upstairs and downstairs electric heating or heating and cooling or taped music and radio. In fact, there is no limit to the versatility of this Programmer. Mains operated. Size 3in x 3in x 2in deep. Price £5-50, 80p Post and VAT, as illustrated but less case.

**SHORTWAVE CRYSTAL SET**  
Although this uses no battery it gives really amazing results. You will receive an amazing assortment of stations over the 19, 25, 31, 29 metre bands. Kit contains chassis, front panel and all the parts £1-90—crystal ear-phone 55p including VAT and postage.

**PAPST MOTOR**  
West German make, these fine motors are noted for their performance and reliability. Special features are the rotating heavy outer which acts as a flywheel to eliminate wot and flutter and switchable reversing.  
We have four types in stock, all 1350 revs., including starting capacitor.  
(1) Reference No. KLZ 20.50-4, 230 volts 50HZ, price £5-50  
(2) Reference No. KLZ 32.50-4, 230 volts 50HZ, price £6-50  
(3) Reference same as above, 115 volts 60HZ, price £2-50  
(4) Reference same as above, 110 volts 60HZ, price £2-50  
Post and VAT 80p each extra.

**PANEL METER SNIP**  
Japan made 2" x 1 1/2" full vision flush mounting, 100uA f.a.d.—scale engraved DE easily changeable as pointer cover simply clips on. A real snip £1-75 post and VAT paid, or 10 for £15 post and VAT paid.

**TERMS:** Where order is under £5 please add 40p surcharge to offset packing expenses  
**J. BULL (ELECTRICAL) LTD.**  
(Dept. E.E.), 103 TAMWORTH ROAD, CROYDON CR9 1SG.

**ITS FREE!**  
Our monthly Advance Advertising Bargains List gives details of bargains arriving or just arrived—often bargains which sell out before our advertisement can appear—its an interesting list and its free—just send S.A.E. Below are a few of the Bargains still available from previous lists.

**Spit motor with Carter gear box.** Probably one of the best spit motors made. Originally intended to be used in very high priced cookers however, this can be put to plenty of other uses, for instance your garden barbecue or to drive a colour disc for a dance or display or to drive a tumbler for stone polishing; in fact, there is no end to its uses. Normal mains operation. Special price during May and June £2-50 + 20p, post 30p + 2p.

**Pulse transformer** with circuit for sound to light unit. It is a very simple circuit and all parts are readily obtainable from us or you may already have them in your junk box. Price of the transformer with circuit 75p, post and VAT paid.

**ORP 12 light cell.** This device has been going for some years now but it has not been bettered and new applications keep being found for it. We have good stocks, price 65p + 5p.

**Throat mikes.** These are an ex WD item as used by air crew on their intercom, but being electromagnetic they also serve as pick-ups on musical instruments, talking to passengers on motor bike and no doubt many other use. Price 60p a pair + 15p.

**12A watt speaker bargain.** 8" round mid-range, made for high price hi-fi outfit, a really super speaker, £3 + 37p, post 60p + 15p.

**O.G.P. photo transistor** by Mullard, very popular for circuits such as Infra-red burglar alarms, smoke detectors, etc. A big buy enables us to offer at the very favourable price of 25p each—2p, or 5 for £1 + 8p.

**Component boards,** mainly ex computer, these contain many useful parts and represent fantastic value at 5 for £1 + 8p. We guarantee the 5 would be different. You will also receive ICs etc., variable controls with long leads and so are easy to remove and re-use. Post 50p + 4p.

**Microswitch bargain,** made by Pye, Honeywell, Burgess and Shillier first class makers originally for the Post Office, in fact they have been fitted to Post Office Equipment which was never put into use. They are a changeover microswitch with 10 amp contacts offered at the very low price of 20 for £1 + 8p. Post 40p + 3p.

**Ferrite core (Vinko)** made by Mullard, maker's ref. No. LA 14107402K, circular, size approx. 1 1/2" x 1/2", size which in the same as the one specified for the Scorpio car ignition system. Price only 60p + 4p per pair. Post 15p + 1p.

**12V DC motor** made by Smiths, powerful, ideal for car blower; motor size 4 1/2" long x 3" diameter, 1" spindle, 1 1/2" long. £2 + 16p. Post 40p + 3p.

**Thermostat with capillary** with sensor joined by approx. 1 metre capillary covering the temperature range 0-170°C suitable of switching 16 amps at 250V. Made by the famous Ranco Company with screwed thread and spindle rather like a volume control—has dozens of applications. Offered at only 75p + 6p. Post 12p + 1p.

**Aerials.** For medium and long wave, wound and fitted on ferrite rod, 6" long by 1" diameter. Price 60p + 15p Post 10p + 5p.

**Dial thermometer** by Rototherm, indicates from 50F to 250F, dial size 3 1/2", chrome and glass front. 75p + 8p. Post 10p + 1p.

**Instrument Mains Transformer,** 6-3v at 1/2 amp and 115v at 100mA. This is an upright mounting open construction, small size (2 1/2" x 2 1/2" x 2 1/2"). £1-40 + postage and VAT 60p. DITTO, 6-3v at 1 amp and 150v at 200mA. This is a fully shrouded upright mounting transformer, size approx. 2 1/2" x 3" x 3". Price £1-95 + post and VAT 80p.

**Instrument power supply** mounted on a chassis size 9 1/2" x 2 1/2" x 4 1/2". This is suitable for instruments which use valves and the AC output of 6-3v at 1 amp and a fully smoothed DC outputs of 150v and 200v. Price £2-50 + post and VAT 74p.

**FM Band amplifier.** This is a 4 valve amplifier tunable to cover FM and nearby frequencies. Tuning is by lecherlines in fully screened compartments and the whole is mounted on a heavy metal chassis size 9" x 2 1/2" x 2 1/2". This requires a separate power supply of 150v DC at 100 mA and 6-3v at 1 amp. Price £3-75 + post and VAT £1-55.

**Instrument case,** grey steel finish size 9 1/2" x 3 1/2" x 2 1/2". These cases are not secondhand but come from partly assembled equipment, so the front panel has a few holes already punched through. However, these are very suitable for toggle switches, etc. There are no really big holes, 50p each + post and VAT 35p.

**Clock switch** for Tricity cooker, made by Smiths and probably a replacement in many other cookers. This has clock in the centre and the two control switches on the right-hand side. The top control switch sets the on-off times and is infinitely adjustable over the 12 hours; the lower switch selects manual or automatic. No glass front, but you could take this off your existing clock. Price £1-75 each + post & V.A.T. 35p.

**SMITHS 24-HR TIMER HEART** really the "Autoset" without its plastic case. This is a 24 hr twice on, twice off, clock switch which will repeat until re-programmed. Switches rated at 15 amp supply.  
PRICE £4-45 INCL. POST & VAT.



# SEMI-CONDUCTORS

## Linear IC's

Type	Quantities	Type	Quantities	Type	Quantities
	1 25 100+		1 25 100+		1 25 100+
72702	0.46 0.44 0.42	SL701C	0.46 0.42 0.37	76003	£1.39 £1.34 £1.30
72709	0.23 0.21 0.19	SL702C	0.46 0.42 0.37	76023	£1.39 £1.34 £1.30
72709P	0.19 0.18 0.17	TAA253	0.74 0.65 0.56	76660	0.95 0.88 0.83
72710	0.32 0.31 0.28	TAA293	0.93 0.88 0.83	LM380	0.83 0.80 0.80
72741	0.28 0.27 0.26	TAA350	£1.71 £1.67 £1.57	*NE555	0.45 0.43 0.40
72741C	0.28 0.25 0.24	µA703C	0.26 0.24 0.22	*NE556	0.84 0.86 0.83
72741P	0.28 0.27 0.26	µA709C	0.19 0.18 0.17	TBA800	£1.39 £1.34 £1.30
72747	0.79 0.74 0.61	µA711C	0.32 0.31 0.28		
72748P	0.35 0.33 0.31	µA712C	0.32 0.31 0.28		
SL201C	0.48 0.42 0.37	µA723C	0.45 0.43 0.40		

## ★ 74 Series TTL IC's

BI-PAK STILL LOWEST IN PRICE. FULL SPECIFICATION GUARANTEED. ALL FAMOUS MANUFACTURERS

Type	1	25	100+	Type	1	25	100+	Type	1	25	100+
7400	0.09	0.09	0.08	7448	0.80	0.78	0.76	74122	0.50	0.48	0.46
7401	0.16	0.16	0.15	7450	0.12	0.11	0.10	74123	0.58	0.58	0.54
7402	0.11	0.10	0.09	7451	0.12	0.11	0.10	74141	0.60	0.58	0.56
7403	0.11	0.10	0.09	7453	0.12	0.11	0.10	74145	0.96	0.94	0.92
7404	0.13	0.12	0.11	7454	0.12	0.11	0.10	74150	£1.30 £1.26 £1.20		
7405	0.13	0.12	0.11	7460	0.12	0.11	0.10	74151	0.76	0.74	0.72
7406	0.25	0.24	0.23	7470	0.26	0.24	0.23	74153	0.96	0.93	0.91
7407	0.25	0.24	0.23	7472	0.22	0.21	0.20	74154	£1.58 £1.48 £1.40		
7408	0.15	0.14	0.13	7473	0.26	0.24	0.23	74155	0.80	0.78	0.76
7409	0.15	0.14	0.13	7474	0.27	0.25	0.23	74156	0.60	0.78	0.76
7410	0.09	0.09	0.08	7475	0.48	0.46	0.44	74157	0.96	0.93	0.91
7411	0.23	0.22	0.21	7476	0.25	0.24	0.23	74160	£1.00	0.98	0.96
7412	0.25	0.25	0.24	7480	0.50	0.48	0.46	74161	£1.00	0.96	0.96
7413	0.28	0.25	0.25	7481	£1.02	£1.00	0.98	74162	£1.00	0.98	0.96
7414	0.28	0.27	0.26	7482	0.27	0.21	0.19	74154	£1.58 £1.48 £1.40		
7417	0.28	0.27	0.26	7483	0.98	0.98	0.94	74164	£1.25 £1.20 £1.15		
7420	0.12	0.11	0.10	7484	0.90	0.88	0.86	74165	£1.25 £1.20 £1.15		
7422	0.28	0.27	0.26	7485	£1.25 £1.20 £1.15						
7423	0.30	0.28	0.26	7486	0.32	0.30	0.29	74176	£1.00	0.95	0.90
7425	0.30	0.28	0.26	7489	£2.98 £2.80 £2.70						
7426	0.30	0.28	0.26	7490	0.37	0.35	0.33	74177	0.96	0.93	0.91
7427	0.30	0.28	0.26	7491	0.60	0.58	0.56	74178	£1.18 £1.11 £1.06		
7428	0.42	0.38	0.36	7492	0.43	0.42	0.41	74180	£1.10 £1.11 £1.06		
7430	0.12	0.11	0.10	7493	0.43	0.42	0.41	74181	£2.00 £1.90 £1.80		
7432	0.30	0.28	0.26	7494	0.43	0.42	0.41	74182	0.90	0.88	0.86
7433	0.30	0.37	0.35	7495	0.68	0.66	0.64	74184	£1.67 £1.62 £1.58		
7437	0.30	0.28	0.26	7496	0.68	0.66	0.64	74190	£1.50 £1.45 £1.40		
7438	0.30	0.28	0.26	74100	£1.00	0.98	0.96	74191	£1.18 £1.11 £1.06		
7440	0.12	0.11	0.10	74104	0.40	0.38	0.36	74192	£1.15 £1.10 £1.05		
7441	0.64	0.62	0.60	74105	0.40	0.38	0.36	74193	£1.15 £1.10 £1.05		
7442	0.65	0.63	0.61	74107	0.36	0.34	0.32	74194	£1.15 £1.10 £1.05		
7443	£1.10 £1.05 £1.00		74110	0.56	0.54	0.52	74195	0.80	0.78	0.76	
7444	£1.10 £1.05 £1.00		74111	0.83	0.81	0.79	74196	£1.00	0.98	0.96	
7445	0.85	0.80	0.85	74118	0.90	0.88	0.86	74197	£1.00	0.98	0.96
7446	£1.10 £1.05 £1.00		74119	£1.25 £1.20 £1.15							
7447	0.67	0.65	0.63	74121	0.26	0.26	0.25	74198	£2.10 £2.00 £1.90		
								74199	£1.95 £1.90 £1.85		

Devices may be mixed to qualify for quantity price. (TTL 74 series only). Data is available for the above series of I.C.'s in booklet form. PRICE 35p.

## ★ DTL 930 Series

Type	Quantities	Type	Quantities	Type	Quantities
	1 25 100+		1 25 100+		1 25 100+
BP930	0.20 0.19 0.19	BP944	0.21 0.20 0.19	BP962	0.20 0.19 0.18
BP932	0.21 0.20 0.19	BP945	0.34 0.32 0.29	BP963	0.48 0.46 0.44
BP933	0.21 0.20 0.19	BP946	0.20 0.19 0.18	BP9094	0.48 0.46 0.44
BP935	0.21 0.20 0.19	BP948	0.34 0.32 0.29	BP9097	0.48 0.46 0.44
BP936	0.21 0.20 0.19	BP951	0.71 0.66 0.62	BP9099	0.48 0.46 0.44

## ★ DIL Sockets

Type	1	25	100+
BPS8 8 pin type (low cost)	0.14	0.12	0.10
BPS14 14 pin type (low cost)	0.15	0.13	0.11
BPS16 16 pin type (low cost)	0.16	0.14	0.12
BPS24 24 pin type (low cost)	0.35	0.33	0.30

## ★ Voltage Regulators

TO-3 Plastic Encapsulation  
 µA.7805/L129 5V  
 (equiv. to MVR5V) £1.25  
 µA.7812/L130 12V  
 (equiv. to MVR12V) £1.25  
 µA.7815/L131 15V  
 (equiv. to MVR15V) £1.25  
 µA.7818 18V  
 (equiv. to MVR18V) £1.25



R.C.A. 2N5295 NPN to 3 Plastic Power  
 VCE 50v.  
 VCB 60v.  
 P 36w. Ic 4A  
 hFE 30-120  
 ONY  
 £1.50\*  
 for 10

## Untested LIN Paks

Manufacturers "Fall Outs" which include Functional and part Functional Units. These are classified as 'Out-of-spec' from the makers, very rigid specifications, but are ideal for learning about I.C.'s and experimental work.

**Untested Audio Paks**  
 Comprising 5, I.C.'s:—  
 76003/76023 series  
**ONLY £1 per Pak**  
 Complete with data  
**ULIC710 = 7 x 710 0.00**  
**ULIC741 = 7 x 741 0.00** FM Stereo Decoder  
**ULIC747 = 5 x 747 0.00** Pak  
**ULIC748 = 7 x 748 0.00**  
 Comprising 5, I.C.'s:—  
 like MC1307 and SN 76110  
**ONLY £1.50 per Pak**  
 Complete with data

## Mammoth IC Pak

APPROX. 200 PIECES  
 Assorted fall-out integrated circuits, including: Logic 74 series, Linear, Audio and D.T.L. Many coded devices but some unmarked—you to identify.  
**OUR SPECIAL PRICE £1.20\***



Postage and Packing add 25p unless otherwise shown. Add extra for airmail. Minimum order £1.

## ★ Indicators

3015F Minltron 7 Segment Indicator £1.11  
**L.E.D. DISPLAYS**  
 DL707 Common anode 0.3" 85p. DL747 Jumbo common anode 0.6" £1.76. DL727 Double digit display, common anode 0.5" £2.00  
**L.E.D.'s**  
 Available in 0.125" and 0.2" dia lenses  
 RED 10p. GREEN 17p. YELLOW 17p.  
 Mounting clips 2p. each  
**NIXI TUBE ITT 5870S.**  
 Character height 13.46mm.  
**SPECIAL OFFER 5 for £2**

## ★ Untested TTL Paks

Manufacturers "Fall Outs" which include Functional and part-Functional Units. These are classed as 'out-of-spec' from the maker's very rigid specifications, but are ideal for learning about I.C.'s and experimental work.

**74G**  
 100 Gates assorted 7400-01-04-10 50-60 etc.  
**\*£1.20**

**U74 SERIES IC PAKS**  
**74F 50 Flip-Flops** assorted  
 7470-72-73-74-76-104-109 Etc.  
**\*£1.20**

**U74 SERIES IC PAKS**  
**74M 30 MSI.** Assorted Types.  
 7441-47-90-154 etc.  
**\*£1.20**

# BI-PAK

P.O. BOX 6, WARE · HERTS

**VAT**  
 PLEASE ADD 8%  
 TO ITEMS  
 MARKED ★  
 REMAINDER  
 ADD 12½%

# everyday electronics

PROJECTS  
THEORY..

## A HIGHLY SUCCESSFUL RUN

After a 15-month highly successful run, this month we say a fond farewell to *Teach-In 76*. A loss will be felt by those who have been diligently following this series, that we know from the many expressions of appreciation received by us during its run. Another edition of *Teach-In* will appear in due course naturally, for it is part of our established tradition.

But with regard to the present, all who have studied these 15 articles and carried out the experiments and exercises will now be well initiated into the mysteries of electronics. Mysteries that are in fact more apparent than real, as *Teach-In* and, for that matter, all other articles we publish set out to demonstrate.

This fact should give added encouragement to anyone approaching electronics for the first time. Beginners are especially welcomed to our pages at anytime. And it is always the right time to start. Apart from the longer series like *Teach-In* and *Doing It Digitally* (now just entering upon its third part) a wide variety of short series or individual articles and features having some immediate appeal and usefulness to the beginner are presented regularly in EVERYDAY ELECTRONICS.

## GOING SHOPPING

Building electronic projects is of course the main attraction. Many of our constructional projects should present no problem to the aver-

**Our January issue will be published on Friday, December 17**  
See page 655 for details.

age person, provided the articles are read carefully and the details in the diagrams studied closely.

Good practical advice is given every month in *Shop Talk* on particular points relating to components and materials that might present some difficulties.

Advice to acquire a selection of catalogues from the established component stockists is frequently given in *Shop Talk* and elsewhere. It is not amiss to repeat it here. A collection of catalogues is a valuable and indispensable reference library for any constructor. Their pages provide a good shop window for the reader, wherever he or she may be, to gaze into at will.

## AN ANNUAL PROBLEM

It's always a puzzle deciding what to give at Christmas time. What to give young Elsie or Harry, to say nothing of those parlour game fanatics Aunt Mary and Uncle Brian. The *Mini Organ* and the *Scrabble Timer*, at any rate, should provide the solution for a couple of presents.

The value of such gifts is greatly increased by the knowledge that you the donor have made them yourself.



EDITOR F. E. Bennett • ASSISTANT EDITOR M. Kerward • TECHNICAL EDITOR B. W. Terrell B.Sc.  
ART EDITOR J. D. Pountney • P. A. Loates • K. A. Woodruff  
ADVERTISEMENT MANAGER D. W. B. Hilleard • P. Mew

© IPC Magazines Limited 1976. Copyright in all drawings, photographs, and articles published in EVERYDAY ELECTRONICS is fully protected, and reproduction or imitations in whole or part are expressly forbidden.

All reasonable precautions are taken by EVERYDAY ELECTRONICS to ensure that the advice and data given to readers are reliable. We cannot, however, guarantee it, and we cannot accept legal responsibility for it. Prices quoted are those current as we go to press.

Editorial Department: Everyday Electronics, Fleetway House, Farringdon Street, London EC4 4AD. Phone 01-634 4432.

Advertisement Departments: Everyday Electronics Advertisements, Fleetway House, Farringdon Street, London EC4 4AD. Phone 01-634 4504. Everyday Electronics Classified Advertisements, Kings Reach Tower, Stamford St., London SE1 9LS.

**EASY TO CONSTRUCT  
SIMPLY EXPLAINED**



VOL. 5 NO. 12

DECEMBER 1976

## CONSTRUCTIONAL PROJECTS

- SCRABBLE TIMER** Provides added interest to the game by S. R. Lewis 628  
**TRY THESE FOR STARTERS** 5 Cassette Power Supply—6 Amplifier & R. F. Probe 634  
**MINI ORGAN** A stylus organ with added facilities by R. A. Penfold 650  
**LIGHT FLASHER** Display unit for the home or disco by James Rawson 656

## GENERAL FEATURES

- EDITORIAL** 626  
**SHOP TALK** New products and component buying by Mike Kenward 636  
**FOR YOUR ENTERTAINMENT** Audience protection and Calculator counting by Adrian Hope 637  
**TEACH-IN 76** Part 15 Oscillators by A. P. Stephenson 638  
**JACK PLUG AND FAMILY** Cartoon 640  
**YOUR CAREER IN ELECTRONICS** Phillips Industries by Peter Verwig 641  
**COUNTER INTELLIGENCE** A retailer's comments by Paul Young 644  
**NOISE REDUCTION SYSTEMS** Part 3 by Adrian Hope 645  
**PHYSICS IS FUN** Your favourite experiments 659  
**LET'S FIGURE IT OUT** Part 1 by Phil Alcock 660  
**BRIGHT IDEAS** Readers' constructional hints 661  
**DOING IT DIGITALLY** Part 3 Bistable, NAND gates and I.C. Clock by O. N. Bishop 662  
**PROFESSOR ERNEST EVERSURE** The Extraordinary Experiments of: by Anthony J. Bassett 668  
**DOWN TO EARTH** Smoothing by George Hylton 670  
**INDEX FOR VOLUME 5** 672

## BACK NUMBERS, LETTERS AND BINDERS

We are unable to supply back copies of *Everyday Electronics* or reprints of articles and cannot undertake to answer readers' letters requesting modifications, designs or information on commercial equipment or subjects not published by us. An s.a.e. should be enclosed for a personal reply. Letters concerning published articles should be addressed to: The Editor, those concerning advertisements to: The Advertisement Manager, at the address shown opposite.

Binders for volumes 1 to 5 (state which) are available for £2.16, including postage, from Post Sales Department, Lavington House, 25 Lavington St., London SE1 0PF

**Next Month  
SPECIAL OFFER  
SOLDERING  
KIT**

**SEE  
PAGE 655**





# Scrabble Timer

By S. R. LEWIS B.S.

## *A Party time Project*

Adds to the excitement of the game.

**A**DDING a time limit to each move in Scrabble can liven up the game considerably—it prevents those situations where one player spends minutes pondering over a move, while the other players mutter their frustration. The timer to be described has a continuously variable nominal range of 5 to 70 seconds.

Such a timing system is often used in chess but in Scrabble there are often more than two players and to increase the excitement a random time factor can be introduced whereby a player does not know how long he has to make his move. If he makes his move quickly then the next player must use the remaining time and so on until the "time up" signal indicates that the player whose move it is at the time must lose some points. An apt name for this type of game is "panic" Scrabble.

### ELECTRONIC TIMER

A simple electronic timer which could be used for the "normal" game is shown in block form in Fig. 1.

An audio oscillator generates a frequency which, when amplified and fed to a speaker, produces a tone indicating time up. The output of the oscillator is fed to an electronic "gate" which has another input to which is connected a capacitor to ground and a variable resistor to the positive supply.

This "gate" will only allow the signal from the oscillator to pass through to its output when the voltage at input B is above a certain threshold.

To start a timing period, switch  $S_A$  is pressed which completely discharges  $C_A$ . The voltage across  $C_A$  will be 0V which closes the gate.

When  $S_A$  is released,  $C_A$  starts to charge up to the supply voltage via  $VR_A$ . Eventually the voltage on  $C_A$  and hence at input B will exceed the threshold and the gate will open, allowing the oscillator signal to be amplified.

The timing period is propor-

**FOR  
GUIDANCE  
ONLY**



**ESTIMATED COST  
OF COMPONENTS \***  
excluding V.A.T.

**£4.00**  
excluding case

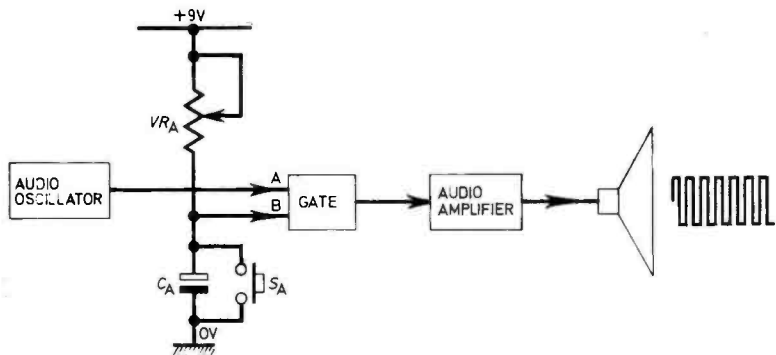

Fig. 1. Block diagram of the Scrabble Timer for the "normal" game.

tional to the value of the capacitor and the resistor ( $C_A$  and  $VR_A$ )—increasing either will increase the timing period.

If the threshold voltage of the gate is half the supply voltage, then the time taken for the capacitor to charge to this voltage from zero will be  $0.7C_A VR_A$  seconds where  $C_A$  is in microfarads and  $VR_A$  in megohms.

### RANDOM TIMING

The simple timing system described above is incorporated in the complete Scrabble Timer whose block diagram is shown in Fig. 2.

The two position switch  $S_B$  is used to select normal timing, with the period set by  $VR_A$ , or "panic" timing where the period is random (or nearly so).

In order to achieve "random" timing some way must be found of altering the capacitor, the resistor or the threshold voltage of the gate in a random manner. The method used here is to vary the timing resistor.

It will be seen that in Fig. 2,

Fig. 2. Block diagram of the complete Scrabble Timer incorporating the "panic" game.

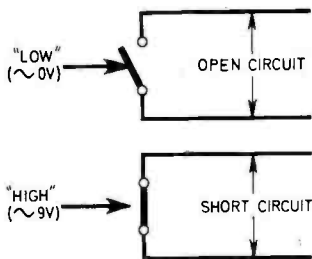
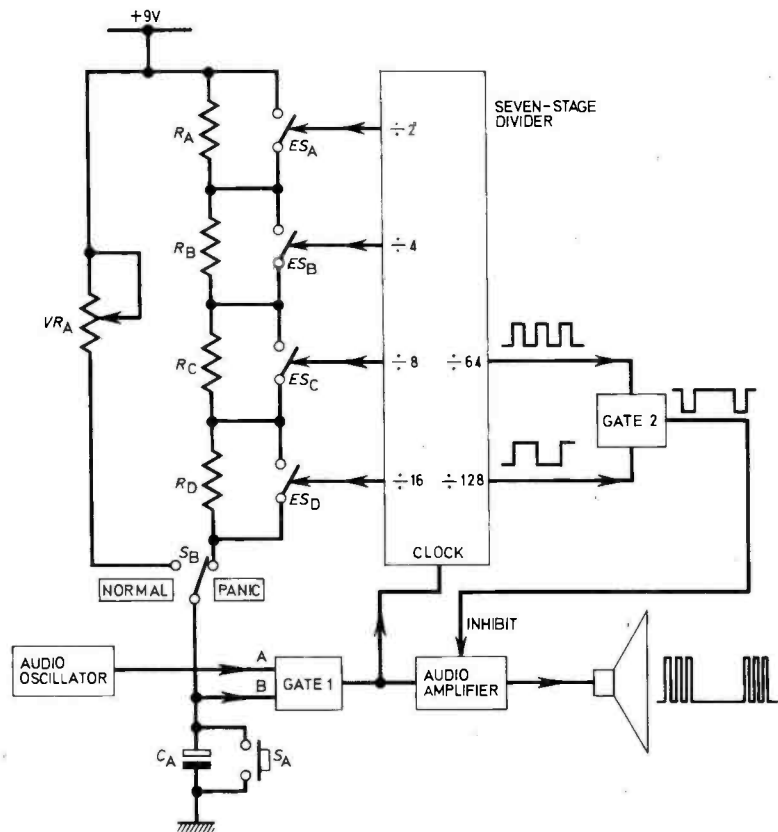

Fig. 3. Basic idea of the electronic switch in the CD4016.

with the switch on "panic" instead of  $VR_A$  a chain of four resistors  $R_A$  and  $R_D$  is placed in series with the capacitor. Across each of the resistors is a switch but not an ordinary switch, an electronic one!

### ELECTRONIC SWITCHES

Unlike an ordinary switch, the electronic switch does not need a finger to operate it—just an electrical signal.

Applying a low voltage to the control input causes the switch to be open circuit and a high voltage

### THE VERY IDEA

The idea for a Scrabble Timer was proposed by B. M. Phillips of Whitehaven, Cumbria who receives our special award.



causes it to be a short circuit. The two states are indicated in Fig. 3.

So much for theory, what about the switch in reality? Well, electronic switches are obtainable, four to a package in an integrated circuit designated CD4016.

The CD4016 is one of the family of CMOS, or Complementary Metal Oxide Semiconductor, integrated circuits which are cheap, highly efficient logic circuits. They work on a wide range of supply voltages and consume only minute currents.

In Fig. 3, the switches have been shown as either open or short circuits. The electronic switches in the CD4016 are not ideal having a resistance of about 300 ohms in one state and about  $10^{12}$  ohms in the other. Also, the switches need to be supplied with power, not being "powerless" as Fig. 3 would suggest.

## COUNTER

Well, we have found a way of varying the timing resistor electronically but where do the control voltages come from?

The answer is: the seven stage divider of Fig. 2. This is another CMOS i.c. designated CD4024. What it does is to take the frequency at its input and successively divide it by two seven times. Thus if the input frequency is  $f$ , the outputs are:  $f/2$ ,  $f/4$ ,  $f/8$ ,  $f/16$ ,  $f/32$ ,  $f/64$ ,  $f/128$ .

If we look at the outputs of the first four stages we see that the sequence shown in Table 1 keeps repeating. (A "1" indicates a 9V output and a "0" a 0V output.)

As soon as button  $S_A$  is pressed and the timing period started, the divider will "freeze" in one of the states in the table. Which particular one is impossible to predict.

The four outputs of the first four stages of the divider are connected to the electronic switches so that the combination of resistors in series with  $C_A$  depends on the state of the divider. For example if the divider stopped with its outputs at 1, 0, 0, 1, then  $ES_A$  and  $ES_D$  would be closed and  $ES_B$  and  $ES_C$  open so that  $C_A$  would charge through  $R_B$  and  $R_C$  in series.

Fig. 4. Shows how the bleeping tone is produced using the  $f/64$  and  $f/128$  outputs.

## Components

### Resistors

- R1 120k $\Omega$
- R2 150k $\Omega$
- R3 470k $\Omega$
- R4 120k $\Omega$
- R5 1M $\Omega$
- R6 220k $\Omega$
- R7 10k $\Omega$
- R8 47 $\Omega$
- All  $\pm 5\%$   $\frac{1}{4}$ W carbon

### Capacitors

- C1 0.01 $\mu$ F disc ceramic
- C2 50 $\mu$ F 10V electrolytic

### Semiconductors

- D1 OA91 germanium diode
- TR1 ZTX500 silicon npn
- IC1 CD4011 (or MCI4011) quad two-input NAND gate
- IC2 CD4016 (or MCI4016) quad bilateral switch
- IC3 CD4024 (or MCI4024) seven stage divider

### Miscellaneous

- VR1 2M $\Omega$  linear potentiometer
- S1 d.p.d.t. toggle switch
- S2 s.p.d.t. toggle switch
- S3 Momentary contact pushbutton
- LS1 40 $\Omega$  (or 35 $\Omega$ ) 57mm speaker
- B1 9V PP3 battery and connector
- 0.1in matrix stripboard 95 x 63mm, case 135 x 75 x 40mm, control knob, 6BA fixings, connecting wire, etc.

Table 1: Divider outputs

$f \div 2$ (pin 12)	$f \div 4$ (pin 11)	$f \div 8$ (pin 9)	$f \div 16$ (pin 6)
0	0	0	0
1	0	0	0
0	1	0	0
1	1	1	0
0	0	1	0
1	0	1	0
0	1	1	0
1	1	1	0
0	0	0	1
1	0	0	1
0	1	0	1
1	1	0	1
0	0	1	1
1	0	1	1
0	1	1	1
1	1	1	1

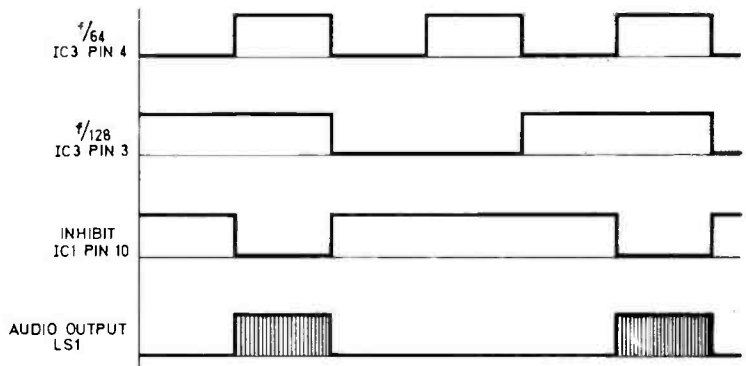

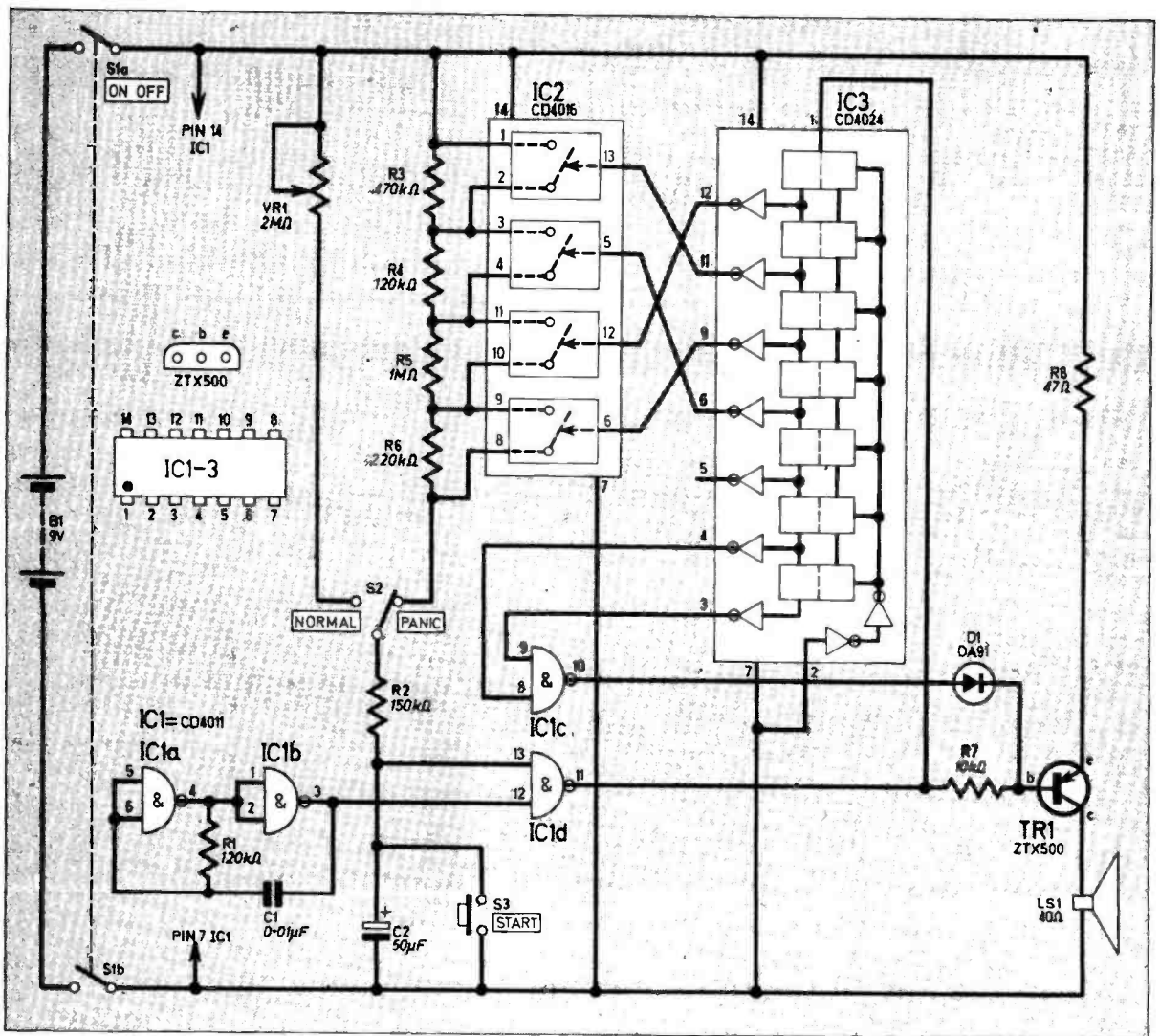

Fig. 5. The complete circuit diagram of the Scrabble Timer.

The resistors  $R_A$  to  $R_D$  are chosen to be roughly in the ratio 1:2:4:8, so that sixteen different values (and hence timing periods) are possible.

### INHIBIT

The counter has only been partly used, the  $f/32$ ,  $f/64$  and  $f/128$  outputs being unused so far. Now, if the input frequency is about 250Hz (round about middle C on the piano) then the  $f/128$  output will be at about 2Hz. If we could somehow arrange for this signal to switch the amplifier on and off then we would get a beeping output rather than a boring continuous tone. We can go further than this: by gating together the  $f/128$

and the  $f/64$  outputs we will produce short blips at the output rather than equal on and off time bleeps.

The outputs of the counter and the gate which generates this inhibit signal are shown in Fig. 4.

### CIRCUIT DIAGRAM

The complete circuit of the Scrabble Timer is shown in Fig. 5. It is easy to associate the components with the block diagram.

Another CMOS integrated circuit type CD4011 is used for the two gates and for the oscillator (gates IC1a and IC1b). All the gates are NAND gates which means they only produce a low (about 0V) output when both inputs are simultaneously high

(about 9V).

The timing components are connected to IC1d. The threshold voltage of this type of gate is about half the supply voltage (4.5V in this case) but it can vary by  $\pm 33$  per cent.

Resistor R2 sets the minimum timing period and also prevents S3 from shorting the battery.

The amplifier consists of TR1, R7 and R8; TR1 will only conduct (i.e. allow current to flow into LS1) when the output of IC1d is 0V and at the same time the output of gate IC1c is 0V.

The diode D1 is there to prevent IC1c switching on the transistor when its output goes low. Note that a germanium type must be used as the forward voltage drop across a silicon diode can

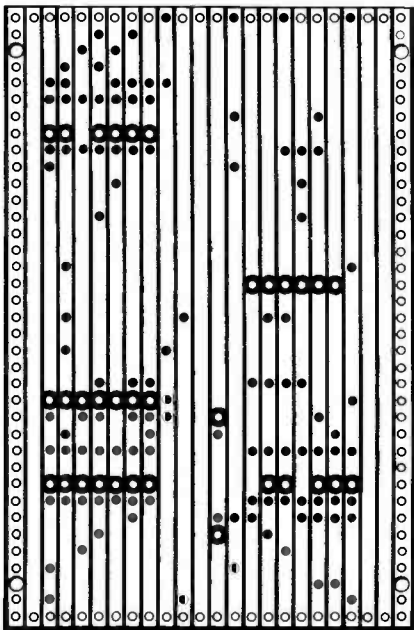
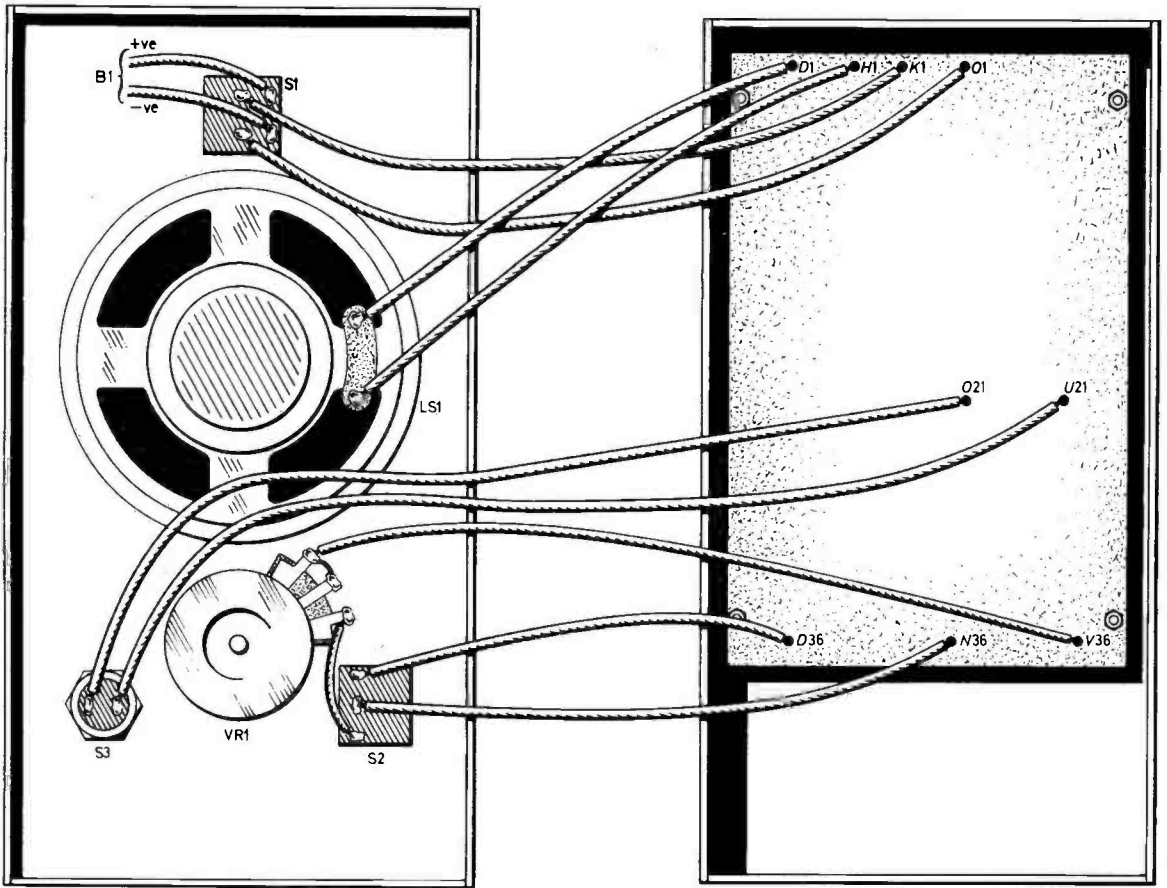

  
 c b e  
 TR1 FROM  
 UNDERSIDE

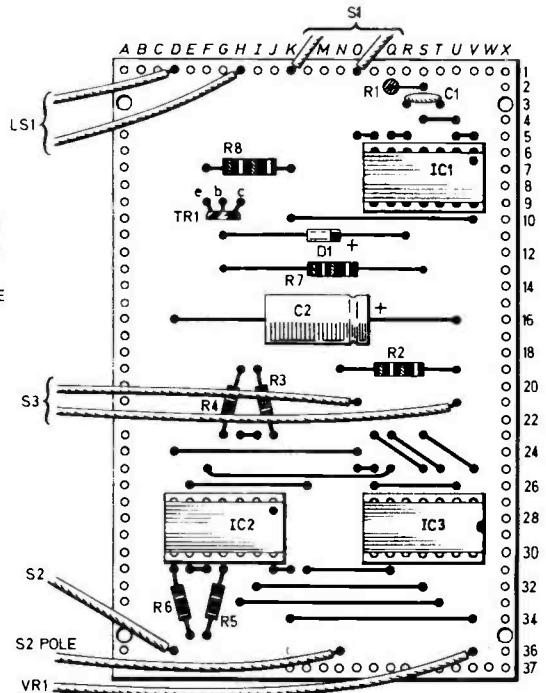

Fig. 6 (above). Position of the components and board within the case and (below) the layout of the components on the stripboard and the breaks to be made on the underside.



cause TR1 not to switch off properly when IC1c output is high.

Resistor R8 limits the current through the transistor to a maximum of about 100mA.

There is a reset input to IC3 which, when taken high sets all the outputs low. This facility is not needed so this input is connected to 0V.

With the timing components shown, the timing period can be varied (using VR1) from nominally about five seconds to about 70 seconds. The exact period can vary greatly since the value of C2 can be -50 to +100 per cent of its nominal value and also the threshold voltage of the i.c. can vary by  $\pm 33$  per cent. In the prototype the timing period at maximum setting of VR1 was 98 seconds.

## CONSTRUCTION

All components except the controls are mounted on a standard size piece of stripboard, cuts in the copper tracks being as shown in Fig. 6. In the prototype sockets were used for the i.c.s but these are not essential.

Note that different manufacturers use different prefixes for CMOS i.c.s. The two companies are RCA who use CD4XXX and Motorola who use MC14XXX. Sometimes advertisers just refer to them as the 4000 series.

The orientation of the i.c.s is important, the dot or indentation indicating pin 1.

The best order to proceed in building up the board is first to make the breaks in the copper

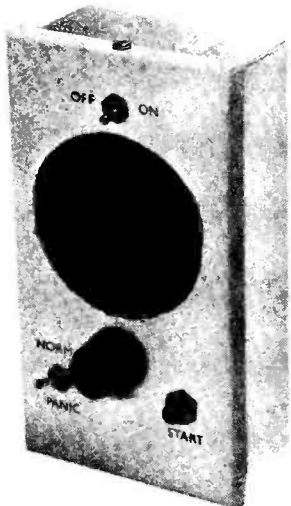

The completed prototype.

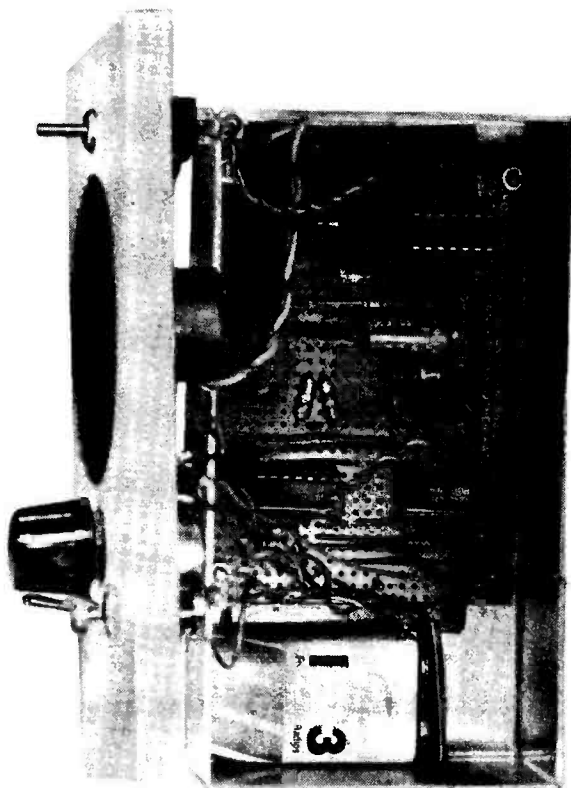

Photograph showing the prototype with lid removed.

tracks then insert the i.c. sockets (if used). Next connect all the wire links and terminal pins as shown in Fig. 6. Insert all resistors, then the two capacitors followed by the diode then transistor.

Finally insert the i.c.s. No special precautions are needed when handling these CMOS i.c.s but try to avoid handling the pins too much.

The controls are fitted to the lid of the aluminium box. Connect them to the appropriate pins on the component board leaving the wires about 6cm long. The board is bolted into the bottom of the box. There is a space for the battery if the specified box is used and this can be held in place with a piece of double-sided sticky tape.

To improve the appearance, the lid was covered with self-adhesive vinyl and the controls labelled with rub down lettering.

The holes over the speaker were covered with a small piece of speaker fret.

If it is thought that miniature toggle switches are too expensive then miniature slide switches can be used although this does mean cutting rectangular holes—not an easy matter.

## IN USE

To use the unit, first decide whether to play normal or panic Scrabble. For normal Scrabble set the speed knob to the required setting—the higher the setting, the faster the game. The first player then presses the START button and the second player begins his go. If the timer sounds "time up" then he loses a fixed number of points or misses his turn. If he moves before this then he presses the button and play moves to the next player.

For "panic" Scrabble the switch is set to PANIC and Player A begins his go. When he has finished Player B has to make his move in the time remaining and so on until the "time up" signal sounds when the player whose go it is loses the points or his turn. He then presses the START button and play proceeds round the table.

There are numerous other games where this timer could be used. One game which immediately springs to mind is Musical Chairs, where, instead of stopping the music, the bleep of the timer would indicate when to grab a chair, thus eliminating any bias. □

# Try these for

## 5 CASSETTE POWER SUPPLY

**T**HIS simple unit will find an immediate use in the car or connected to a simple 12V power supply to reduce the voltage for transistor radios, cassette recorders etc. It was designed for use in a car to supply a cassette recorder which it does very well.

The output voltage can be set from zero to about 10V on a 12V supply or up to 12V on a 14V (nominal car) supply.

The circuit is shown in Fig. 1. A voltage is taken from the wiper of the potentiometer to the base of TR1. Voltage at TR1 emitter will always be about 0.7V less than that at its base and will hence depend on the setting of VR1. Transistor TR1 then feeds a larger current into the base of TR2 and TR2 operates in the same way as TR1. Thus the output voltage at TR2 base is always about 1.4V less than that set at VR1 wiper.

Transistor types are not important providing TR1 has a reasonable gain and TR2 has high enough dissipation to supply the unit being operated. The BFY50 used in the prototype can only pass about 70mA at 3V, rising to 200mA at 10V output. If greater

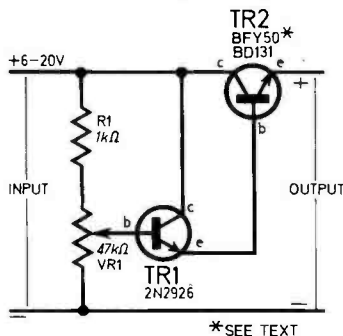

\*SEE TEXT

Fig. 1. Circuit diagram of the Cassette Power Supply.

### Components

#### Resistor

R1 1kΩ ¼W ± 5% carbon

#### Semiconductors

TR1 2N2926 silicon npn  
TR2 BFY50, BD131 (see text) silicon npn

#### Miscellaneous

VR1 47kΩ horizontal carbon pre-set  
Stripboard 0.1 inch matrix 11 holes by 10 strips; connecting wire; solder.

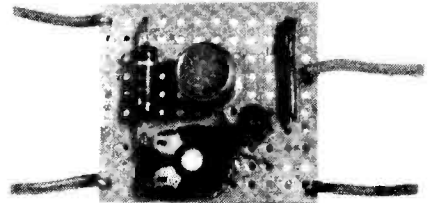

Voltage variation in the car will cause the output voltage to vary but this was not found to be a problem, provided the output voltage is set when the engine is running (not just ticking over) i.e. voltage is high. This can easily be done on most cassette recorders using the battery voltage indicator and gradually turning up VR1 until the needle is slightly into the green section. Alternatively a voltmeter can be used across the output. □

### ESTIMATED COST OF COMPONENTS

excluding V.A.T.  
**£0.50**

current is required the BD131 can be used—this can pass about 1A at 3V and 2A at 9V and above. Construction with the BFY50 fitted is shown in Fig. 2.

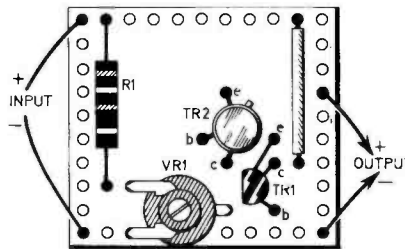

Fig. 2. The layout of the components on the stripboard. There are no breaks on underside. Strips run from left to right.

## 6 AMPLIFIER & R.F. PROBE

**T**HIS project, a two stage audio amplifier with volume control, is a "big brother" to the one stage audio amplifier for crystal sets described last month. It is suitable for a wider range of applications, as we shall see.

One use for this amplifier is that of tracing signals in audio circuits, the input of the amplifier being connected across signal points in the circuit being examined. This enables the user to determine the presence, or otherwise, of signals at any given point.

For example let us assume that it is desired to locate a fault in an audio amplifier. The input of the test audio amplifier can be connected to the input of the first stage of the equipment being tested, where a signal should be heard if all is in order. This

# Starters...

## 6 AMPLIFIER & R.F. PROBE

being so, the signal tracer can then be connected to the input of the second stage, and so on towards the loudspeaker until the signal cannot be heard. When this has been determined we know that the fault lies between that point and the last testing place where the signal was heard. A thorough examination of the circuit between these two points should reveal the faulty component or connection.

It is also possible to trace distortion in audio equipment using this approach, the signal tracer indicating at which point in the circuit the distortion is occurring.

When the amplifier is to be used in this application an isolating capacitor of about  $0.1\mu\text{F}$ , 400V, should be connected in series with the active input terminal in Fig. 1 (top of the 10 kilohm pot). Additional isolation can be provided by adding a resistor in series with the capacitor, say 10 kilohm or as much higher as can be tolerated without serious loss of gain.

### Components

#### Resistors

- R1 10k $\Omega$
- R2 1k $\Omega$
- R3 100k $\Omega$
- R4 1.2k $\Omega$
- All  $\frac{1}{4}$ W carbon  $\pm 5\%$

#### Capacitors

- C1  $5\mu\text{F}$  10V elect.
- C2  $33\mu\text{F}$  10V elect.
- C3 1nF plastic or ceramic

#### Semiconductors

- TR1 BC108 silicon npn
- TR2 BC108 silicon npn
- D1 OA91 or similar germanium diode

#### Miscellaneous

- T1 Miniature transistor output transformer with primary impedance greater than  $1\text{k}\Omega$  (LT700)
- LS1 Miniature loudspeaker, coil impedance 3 to  $15\Omega$
- Stripboard 0.1 inch matrix size 11 holes x 10 strips; crocodile clip; screened lead; connecting wire; exhausted ball point pen (for probe).

The sensitivity of this amplifier is such that it may be connected directly to tape heads, microphones and pickups to check their outputs. However, there are no equalisation circuits in this amplifier and, where equalisation is necessary due to the recording characteristics of either tape or disc, or where mismatch between pickup or microphone and the amplifier input suppresses the base response, the overall balance may sound "thin" or "tinny".

As it stands, this circuit can

### ESTIMATED COST OF COMPONENTS

excluding V.A.T.  
**£1.75**

Fig. 1. The circuit diagram of the Amplifier and R.F. probe.

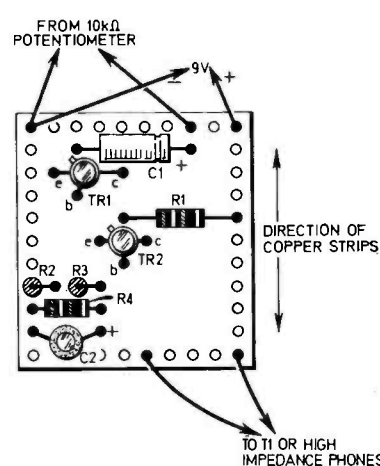
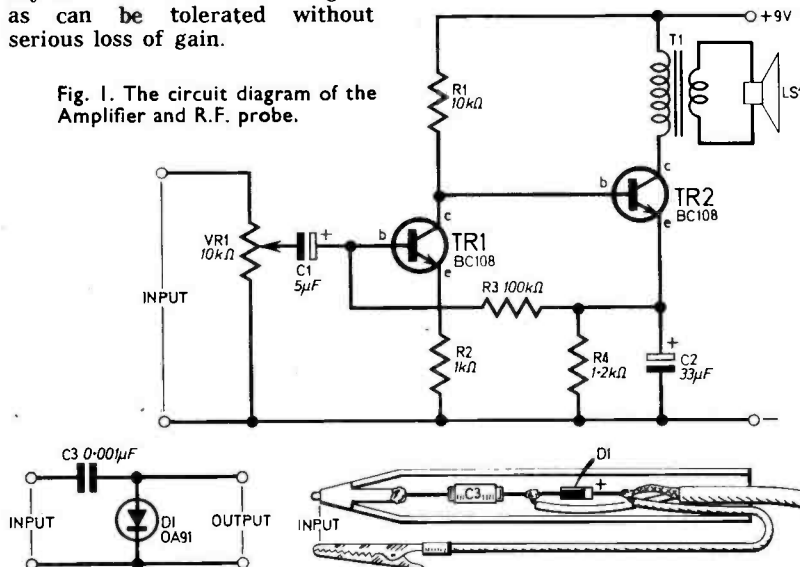

Fig. 2. The layout of the components on the stripboard (no breaks) and left details of the probe.

# Try these for Starters

only be used for tracing audio signals. In order to trace modulated r.f. signals it is necessary to precede the amplifier with a detector or demodulator. Such a device is simplicity itself, and consists of only two components, as shown in Fig. 2.

The r.f. signal is applied across the OA91 or similar germanium diode via a 0.001 $\mu$ F capacitor, and, with the circuit connected to the amplifier, the 10 kilohm input potentiometer acts as the diode load. Such a piece of equipment is called an r.f. probe.

As the circuit contains only two components. It is possible to construct it in a number of ways as a small and handy item. Probably the most convenient method is to house the capacitor and diode in a hollow pen-like holder, such as the plastic case of a ball-point pen. Suitably cleaned, and with the components soldered to it, the metal part housing the actual ball-point becomes the probe tip with which to pick up signals whilst a flying lead may be taken away and connected to chassis, thus giving a compact and easy to handle unit. Veroboard layout and wiring for the amplifier is shown in Fig. 2.

The combination of r.f. probe and amplifier allows r.f. signals in radio receivers to be traced by merely connecting the probe between any desired point in the circuit, and chassis. In most cases it should be possible to trace the r.f. signal path for any discontinuity between the detector and the output of the receiver.

As can be seen from the photograph, the components comprising the amplifier are easily accommodated on a small piece of Veroboard. The drawings illustrate the layout used, and the soldered connections necessary to form the circuit in conjunction with the copper strips and components.  $\square$

ONCE again this month we have more items than there is really room for. Now that the winter is coming—it will probably be here by the time you read this—the number of new products is increasing and, as always, we have more items to get into the magazine than we have pages for. We must be brief.

The best way to overcome the problem is to give each item a mention and leave you to follow them up if you are interested—please remember to tell the suppliers where you read about the products, it does help us to keep you informed in the long run.

## New Products

Might as well start with the one item very few of our readers will probably be able to afford—a 'scope. The 4D10A costs about £170 is made by Scopex, now well known for low price 'scopes, and has been designed to offer good performance with ease of use and low cost. The bandwidth is d.c. to 10MHz, sensitivity 10mV/cm to 50V/cm  $\pm$ 3 per cent.

This dual trace 'scope employs stabilised power supplies to prevent "drift" with mains variation, has been developed from the 4D10 and incorporates some features of the more expensive 4D25.

The 4D10A should be available from Maplin by the time you read this—see back of this issue for their address.

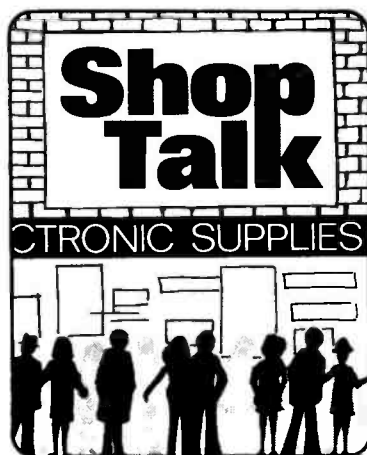

By Mike Kenward

*New products and component buying for constructional projects.*

## Constructional Projects

Once again, and fortunately because of the space available, most of the components we have used in the constructional projects this month are easily obtainable from the various component suppliers throughout the country.

The *Mini Organ* employs a fair number of miniature potentiometers so make sure the price is right before buying. The only other items needing a mention is the relay used in the *Flasher Light*, this is an R.S. type and is available from Doram Electronics Ltd. at P.O. TR8 Wellington Road, Industrial Estate, Wellington Bridge, Leeds, LS12 2UF. The cost is £1.42 including VAT and postage, etc. The transformer for the Amplifier and R.F. Probe is available from Henries, price 75p inclusive of postage. but other versions may be available locally.

Next down in price is a 150 watt mixer amplifier from Baker Loudspeaker Company. Obviously designed for the "pop" field it has four inputs each with its own level control and outputs for 4, 8 or 16 ohm loads.

The specification quotes 150 watts into 8 ohms r.m.s. music power. We do not know what that means but suspect that it will only deliver 150 watts for short duration sounds. It is *definitely not the same* as quoting 150 watts continuous r.m.s.

The amplifier weighs approximately 14lbs, carries a 12 month guarantee, is solid state and costs £75 plus V.A.T. etc. from Baker Loudspeaker Company, Bensham Manor Road Passage, Thornton Heath, Surrey.

We presume we are still following the reducing price order although RMS Audio did not supply a price for their Scan-ic Tuner. This tuner is for f.m. medium and longwave, and has been designed as an economically priced quality tuner having a high technical specification. At present the tuner is only available through RMS Audio Limited, The Old Maltings, Cavendish, Sudbury, Suffolk CO10 8AZ.

## Bits and Pieces

That concludes the equipment and now we come to the remaining bits and some literature. BASF, the German tape firm have launched a new range of audio accessories all under the Check-point banner. They stress that these items are put together in Britain although the actual parts come from all over the world. There are 24 items in the range costing from 40p for 2 cassette boxes, 2 index cards and 4 labels up to £10.28 for a complete reel-to-reel tape care kit (prices exclude V.A.T.), not cheap but BASF have a name for quality.

One item of particular note is the test cassette, although this costs £3.52 it is very good and has been recorded on BASF LH Super Cassette which BASF claim is the best tape for all machines. Only one point with which we are not happy—we feel that the enthusiasts guide should be free with any item, instead it costs 40p.

Glue—it's been well advertised on T.V. and we tried it; for some jobs it cannot be beaten, but not for all. Super Glue 3 bonds in seconds even your fingers or eyelids if you are not careful enough! The cost is 99p including VAT and it should last a long time even though the tube is small. Available from most hardware shops.

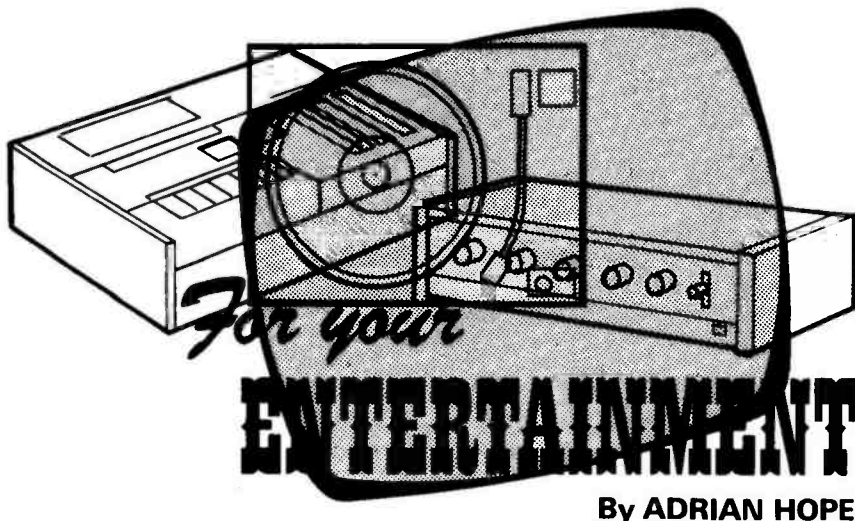

Luckily, most people using lasers in the theatre realise the problems and use diffraction gratings in front of the beam to split it into hundreds or thousands of tiny sub-beams. Some laser tubes will not switch on unless a grating is present. Also, the GLC now has a list of 15 stringent conditions which must be met before they will allow a laser to be used in any place of public entertainment.

### Over Protective?

One laser manufacturer with whom I spoke acknowledged that most of these restrictions were reasonable and necessary to protect audiences against incompetent, careless or stoned operators. But he also argued that the laser light levels regarded by the GLC as safe were over-protective and ten years behind research findings.

I don't doubt he's right, but in this case tend to feel happier about being over-protected. Whereas most of the risk from an excessively loud and clumsily handled sound system is in the long term, the risk from an irresponsible operator with a high power laser is very much in the short term.

### Counting

Calculators continue to capture the imagination. In the USA there is now a book out by Edwin Schlossberg and John Brockman called *The Pocket Calculator Game Book*. It is published in the USA by William Morrow & Co. at \$6.95 but should soon (if not already) be available in the UK. The book gives the rules for fifty games you can play with an electronic calculator. The intriguing titles include *Lovers' Maze*, *Commander-in-Chief*, and *Mind Control*. Perhaps some of our readers have already devised their own games?

A friend recently pointed out not a game but a useful trick that enables you to use a calculator easily to count objects one by one—such as paying customers through a door or sheep while you try to get to sleep. If the machine has "constant" facility on the "addition" function, the procedure is pretty obvious—you simply press the "1" key over and over again, to raise the readout figure from 1 to 2 to 3 to 4 and so on *ad infinitum*.

But only a few machines have a constant facility on the "addition" function; more likely they have it only on "multiply" and "divide". In this case the procedure is less obvious but just as simple. Punch in 1.0000001 and multiply it by 1.1 repeatedly on the constant function. The last digit of the readout will then increase by 1 on each subsequent multiplication.

The only possible source of confusion is that the display may shift momentarily every tenth entry to suppress end zeros but in practice this doesn't matter—try it and you will see what I mean.

THERE is an old saying to the effect that if it is nice, it must be either illegal, immoral or make you fat. But there are a few things in the world of pop that, although fitting none of these categories, have some decidedly unpleasant side effects. It can no longer come as news to anyone that excessively long exposure to excessively loud music can be as dangerous to the ear (in terms of causing long term deafness) as handling an unmuffled pneumatic drill. Although the GLC risks being over-protective in the safeguards it still plans to bring in, (the mooted peak limit of 102dBA would outlaw most pop concerts in London) the Council is at least showing itself aware of a very real problem.

Far more realistic an approach however, and much easier to adopt, would be to ensure that at no concert is there ever any loudspeaker which can fire direct into the ears of even the tallest teenager crowding up close to the stage.

### Strobe Lights

Odd things also happen with stroboscopic lights. It was in the late sixties "flower power" era that pop groups started using high power strobes on stage, and I can speak from bitter experience of how ill prolonged exposure to a powerful strobe light can make one feel. Some people are physically sick, others faint, and a few throw epileptic fits. If the strobe is particularly bright, you cannot even escape it by closing your eyes—the flashing radiation still gets through the eyelids.

### Frequencies

One theory proposed is that the trouble starts when the strobe frequency coincides with a natural bio-

rhythm of the brain.

A few years ago the GLC employed some neuro-ophthalmic consultants who came up with two interesting facts. First, even people who are not normally prone to epilepsy can be induced to throw a fit at some strobe frequencies. Secondly, the most dangerous area is in the range 11–28Hz, and things are worse if the strobe rate is varied while it is switched on.

As a result the GLC now insists that strobe lights in public places must be run only at a fixed frequency between 1 and 8 Hz.

### Lasers

The GLC has also looked closely at the potential risk of lasers used as a high power decorative light source in theatres and at pop concerts. As most people also by now know, a laser light beam is immensely powerful and can cause blindness if it is fired either direct into the eye or if it bounces into the eye from a good, plane reflective surface.

Although the actual power of a laser beam is only a few watts, all that power is concentrated into a pencil of coherent (in-phase) monochromatic (single colour) light. What is more, the light pencil is parallel rather than divergent or convergent, and so in theory can go on for ever. In practice it is gradually absorbed over a long journey by any foreign particles in the atmosphere. But in a confined space, such as a pop concert, a raw laser beam could do a considerable amount of damage to rear and front row spectators alike.

I recently saw one such beam, with a power of less than 2 watts concentrated into its 1.5mm width, draw smoke from a lump of plywood in its path. It is not hard to see why the retina of any unprotected eye even briefly catching that beam full on would be instantly and irrevocably fried.



# TEACH-IN '76

By A.P. STEPHENSON

## Part Fifteen

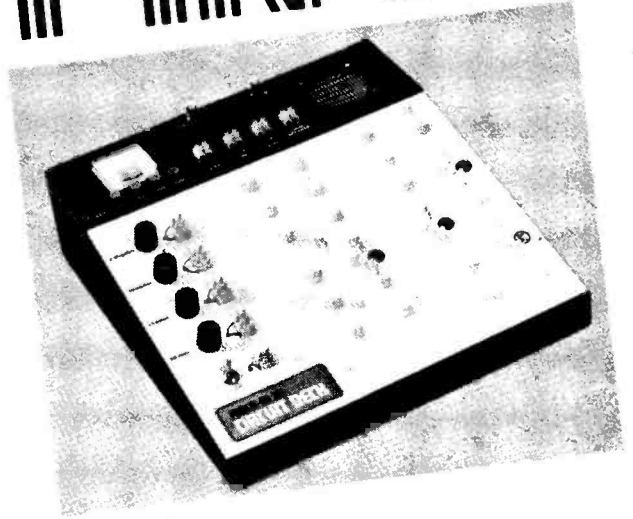

### 15.1 UNIJUNCTION OSCILLATOR

A special kind of transistor called the **unijunction transistor** (u.j.t.) (circuit symbol shown in Fig. 15.1a) can produce a simple **sawtooth** waveform and in addition, a narrow pulse waveform; Fig. 15.1b shows that a bar of *n*-material called the **channel** has two wires brought out, the bottom one called **base 1** and the top **base 2**. A piece of *p*-material is embedded about halfway up (in fact the actual fraction of the way up is called the **intrinsic stand-off ratio** ( $\eta$ ) and varies with different species) and a wire called the **emitter** is brought out; Fig. 15.1c is the equivalent circuit—the channel is shown as two resistors tapped by a diode representing the *p* to *n* junction.

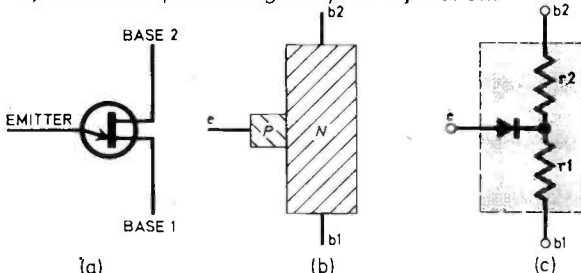

Fig. 15.1 (a) Unijunction symbol (b) unijunction schematic and (c) equivalent circuit.

To use the u.j.t. as an oscillator the circuit of Fig. 15.1d is the most popular and operates as follows:

Assume  $C1$  is initially uncharged but is slowly rising towards  $+V_s$  on a time constant  $C1 \times R_e$ . At some point on the upward climb the diode will start to conduct. This point will be about 0.6 volts more positive than  $\eta \times V_s$ .

As soon as the emitter conducts, more charges

are released into the bottom half of the channel, i.e.  $r_1$  becomes a lower resistance so the voltage across it drops, which makes the diode conduct harder still, which releases more charges.

This is another one of those avalanches which causes the bottom half of the channel to behave as a short circuit. The onset of avalanche results in a rapid discharge of  $C1$  to the point where the diode ceases conduction.

The waveform at the emitter is thus a climb, then a rapid fall, then a climb again, and so on. The shape is thus a rough kind of sawtooth and as a by-product a narrow pulse wave at  $b1$  due to the avalanche actions in the channel.

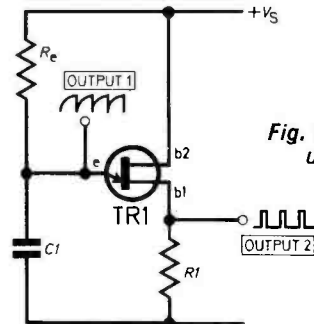

Fig. 15.1d. Details for wiring up a u.j.t. as a relaxation oscillator.

### 15.2 MONOSTABLE

The **monostable** may be aptly described as a "pulse-stretcher"; Fig. 15.2a shows the black box and 15.2b shows a possible circuit which, you may

notice, bears a striking resemblance to the Schmitt trigger. In fact the only difference is the capacitive instead of resistive coupling between stages.

**Fig. 15.2a.** Black box representation of a monostable multivibrator.

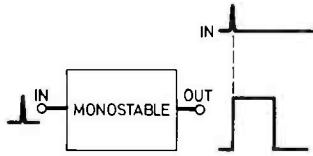

Like the Schmitt trigger, TR1 is normally off and TR2 is on. A narrow positive pulse at the input will upset this state and turn on TR1. Instantly its collector falls and because of  $C1$  the base of TR2 falls and cuts off the collector current. Then follows the relaxation period (determined by the time constant  $C1 \times R_B$  which ends when the capacitor voltage rises again to a point where TR2 re-conducts. A reverse avalanche then restores the circuit to its normal resting state.

The action can be summarised as (a) prior to trigger pulse—TR1 off, TR2 on so output is low. (b) trigger arrives—TR1 on, TR2 off so output switches to high and remains high until end of relaxation period.

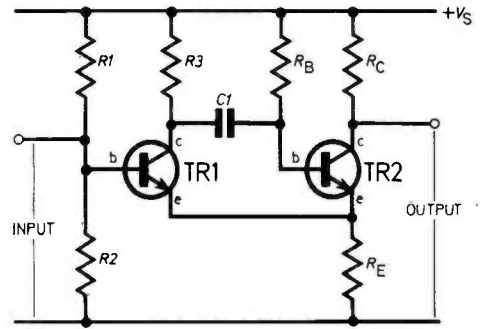

**Fig. 15.2b.** Circuit diagram of a basic monostable multivibrator.

By suitable choice of  $C1$  and  $R_B$ , the output pulse widths of anything from microseconds to minutes may be obtained.

## 15.3 DIFFERENTIATION

A wide pulse can be converted to positive and negative spikes by passage through a short time constant  $CR$  network, see Fig. 15.3a.

The term "short" normally means ten times shorter than the pulse width of the input. The explanation should be clear from what has been said previously about capacitor behaviour. The title **differentiation** is because output is proportional to rate of change of input.

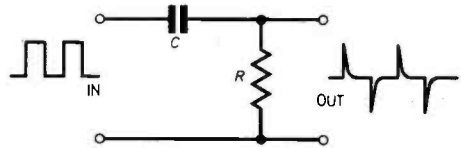

**Fig. 15.3a.** A simple differentiator circuit showing action on a square wave input.

## TEACH-IN '76 EXPERIMENTS

### EXPERIMENT 15A

To demonstrate monostable trigger action.

#### PROCEDURE

Assemble the components on the Circuit Deck according to Fig. 15A.1, leaving the flexible wire probe anchored safely. The lamp should be on because TR1 is conducting.

1. Measure the voltage across  $R_E$ —it should be around 4 volts due to the lamp current passing through. Measure point A to ground which by voltage

division should be  $(4.7/14.7) 9 \text{ volts} = 2.88 \text{ volts}$ . Thus TR1 is off, due to the base being less positive than the emitter.

2. Momentarily touch A with the probe. The result is the virtually instantaneous flash-over of the circuit causing TR2 to cease conducting and TR1 to come on. Since TR1 only draws a small current, the voltage across  $R_E$  is held low—which is why TR1 can remain on. This state of affairs lasts until the negative plate of  $C1$  returns to the cut-on point of TR2 when the circuit instantly flashes back again to its original state with the lamp on.

The time the lamp is off depends on the resistance in the base circuit of TR2 and  $C1$ .

For example, if VR1 is set to maximum resistance, the total resistance is 35 kilohms so the "relaxation time" (during which the lamp is off), is about  $0.7CR = 2.45$  seconds.

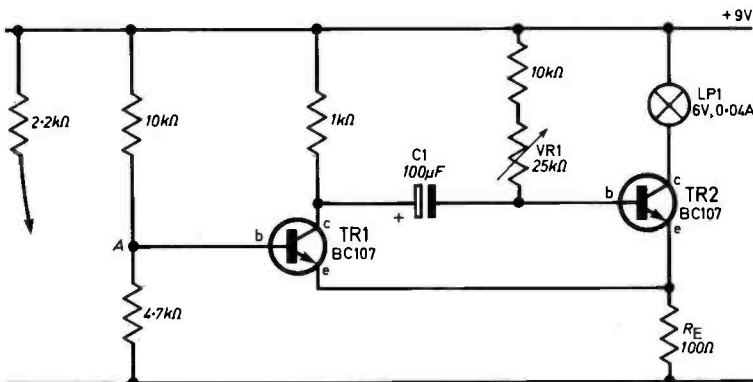

**Fig. 15A.1.** The circuit diagram for experiment 15A.

- Repeat the experiments with different settings of VR1 and also with a 1000 microfarad capacitor in place of the present 100 microfarad type.
- Exchange the 1 kilohm resistor in the collector of TR1 for another 6 volt, 0.04A lamp. The circuit no longer works. Why?

### EXPERIMENT 15B

To demonstrate the unijunction sawtooth oscillator.

#### PROCEDURE

Assemble the circuit as shown in Fig. 15B.1 but leave out the wire (shown dotted) across BC.

- Connect the voltmeter across A and ground. The needle should be flicking rhythmically, slowly up to about 4 volts and sharply down. Varying VR1 will be found to alter the frequency of the oscillator.
- Change the 100 microfarad capacitor C1 to 0.01 microfarad and connect a wire across BC. This will cause the sawtooth wave at point A to enter the emitter follower via C2 and an audible tone should

Fig. 15B.1. Circuit diagram for experiment 15B.

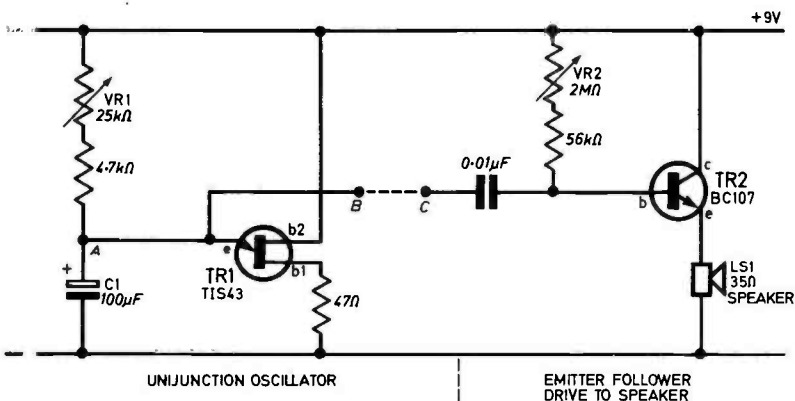

be heard from the speaker. The potentiometer VR2 should be varied to suit the bias requirements and optimise the audible output.

The frequency (with VR1 at maximum resistance) should be between 3 kilohertz and 4 kilohertz but will increase to a frequency above the capabilities of the speaker as VR1 is reduced. □

*This concludes the Teach-In 76 series, students who have completed the course will find other interesting series and articles to follow in this and future issues (e.g. Doing It Digitally). Next month we will be publishing constructional details of a Multi-Tester which has been designed by the author of the series to employ many of the parts originally specified. This Tester should prove very useful for future construction and fault finding work. A second project using more of the components will also be published shortly.*



## JACK PLUG & FAMILY...

HOW DID YOU EXPECT FATHER CHRISTMAS TO GET IN LAST NIGHT WHEN YOU HAD YOUR BURGLAR ALARM FIXED UP, UNCLE JACK? IT'S A GOOD THING I PUT IT...





ing plants in 50 countries and sales organisations in many more, Philips is still very much a family concern.

## HEADQUARTERS

The headquarters are still in Eindhoven, a bustling town which grew with Philips as the dominant local employer to the extent that Eindhoven was virtually Philipsville, the housing estates round the factories being occupied almost entirely by Philips workers and their families. Although the introduction of other large industries in recent years has diminished Philips dominance, if you go to Eindhoven today you are still very much aware of Philips influence and the historical role of the Philips family in developing not only the wealth of the town but also its social and cultural activities.

The Philips family had virtues which, today, might be considered old-fashioned and even, by some unthinking people, the subject of derision. The fact remains that the family built up a great concern, providing employment over succeeding generations to millions of people throughout the world and serving the needs of many more millions. The regime was paternalistic, but benevolently so, with the wider family of employees enjoying protection in the way of pensions, medical services, housing and recreational facilities as well as earned income as the concern flourished.

## U.K.

Philips came to the United Kingdom in 1925 and through a series of acquisitions and internal growth has developed a very strong position in the electrical and electronic industries. Although the manufacturing plants and other operations in the UK operate more or less autonomously with their own local British managers and even with company names other than Philips, the family atmosphere still prevails and young people entering the company today who can perform well in their jobs can expect a high level of security.

The changing conditions of world trade have, from time to

Heading photo shows an alphanumeric display with MOS random access memory under development at Central Applications Laboratory, Mitcham.

# Your Career in Electronics

by Peter Verwig

## PHILIPS INDUSTRIES

IN the May 1976 issue of EE, when I wrote on a career in radio and television servicing, I chose as my company example Combined Electronic Services Ltd., which provides service facilities for Philips and Pye consumer products. Combined Electronic Services is just one part of a giant organisation operating in the United Kingdom under the corporate banner of Philips Electronic and Associated Industries Ltd which, in turn, is part of a world-wide federation of Philips companies.

To the outsider, the organisation of Philips is confusing and even insiders, those actually in the organisation, often joke that they have difficulty in keeping abreast of events in what, by any standards, is a dynamic industrial and commercial operation subject to change in response to market demands and to advancing technology. This doesn't mean that Philips is plagued by instability. What it means is that Philips is a responsible and progressive company continually adapting itself to meet changing circumstances and

that very flexibility is, itself, a good index of competent management.

## STRUCTURE

A continuing theme in our "careers" series is to inform the reader on the structure of the electronics industry as well as to highlight particular career opportunities. A person applying for a post in electronics will make a far better showing at an interview if he or she understands the nature of a company and its background and where it fits in to the industry in general. Philips employs some 50,000 people in the UK and it is inevitable that a fair proportion of new intake into electronics will find themselves becoming involved somewhere in the Philips group.

Philips is among the oldest companies in electronics with its early origins in electric lamp manufacturing. The company was founded in 1891 by the Philips family in Eindhoven, Holland, the parent company still bearing the name Philips Gloeilampenfabrieken, and even today when the company employs nearly half a million people with manufactur-



Electronics in washing machines. A young operator assembles control modules at the Blackburn plant.



Electrolytic capacitor testing at Blackburn.

time, created redundancies and will continue to do so. Perfect job security can never exist but, within the bounds of the possible, Philips offers excellent long-term prospects and growth opportunity.

Philips is one of the world's great multinational companies but likes to be known not as a multinational but as the Worldwide Philips Federation. The Federation's international and official language is English although it is not unusual at meetings in Eindhoven for a mix of languages to be spoken. Because of the international ramifications of Philips a large number of executives are multilingual but all are expected to speak English.

To the man-in-the-street, Philips means consumer electrical and electronic goods. Washing machines, refrigerators, freezers, toasters, food blenders, lighting and heating, cleaning appliances, shavers and electronic home entertainment in the shape of radio, TV, tape recorders, hi-fi. Indeed, this is a very large part of the business but by no means all.

Philips is also great in the professional and industrial sectors of electronics, including defence electronics, and thus offers far more scope for technician and graduate engineers than might at first be realised. At last September's Farnborough Air Show, for example, no less than 13 Philips companies from seven countries (Holland, West Germany, UK, Canada, USA, France and Sweden) showed joint capabilities in aerospace from airfield lighting, through air traffic control and air communications, to missile tracking and fire control radars.

It is important to realise, however, that the design and production of consumer goods for the mass market is no less demanding than designing and producing for the so-called high technology markets such as aerospace. In some ways the former is more demanding.

To design and produce a really good colour TV for domestic use to sell in the £200-£300 price bracket is in many ways a greater achievement than an exotic CRT display for defence costing, say, £10,000. Although they may be similar in appearance they are two quite different animals, each demanding a special type of skill. Philips, with a huge spread of activities, offers scope for engineering talent right across the whole spectrum of electronics from components to large systems.

## TWO GROUPS

In the UK, Philips Electronic and Associated Industries Ltd is the parent company responsible for the whole of Philips operations throughout the country. For convenience it is generally known as Philips Industries. The organisation then splits into two broad streams, one being the original Philips Group in the UK founded over 50 years ago but since considerably developed, the other being the Pye of Cambridge Group as a comparatively recent acquisition. For simplicity let them be called Philips and Pye.

The main Philips companies include Philips Electrical and Philips Domestic Appliances making and selling all sorts of consumer products, many of them through the company's own retail outlets which include Loyds Retailers Ltd. with 300 shops, Eclipse cash-and-carry stores, and with TV rental through Loyds Surevision with 160 showrooms. Then there are Mullard, Britain's largest electronic component manufacturer, M.E.L. Equipment Co. Ltd. which designs and manufactures professional electronic systems, Philips Medical Systems involved in X-ray machines and other medical electronics, Philips

An experimental automatic drill for use with PCBs, developed at Mullard Research Laboratories. It uses TV techniques and a minicomputer to control the drilling routine.





Electrologica in business machines and Philips Electric Arc Welding. The whole of Philips manufacturing is spread over 17 locations in the UK.

## PYE

If we now look at Pye we find over 40 subsidiary companies with a geographical spread in another 12 locations. As well as companies with easily identifiable names such as Pye TMC, Pye Unicam, Pye TVT, there are subsidiaries like Magnetic Devices Ltd. (relay manufacture), Newmarket Transistors Ltd., Ekco Plastics Ltd. and Cathodeon Crystals Ltd.

From being a company almost entirely in domestic radio and TV, Pye has in the last two decades or so moved strongly forward in the professional market. It dominates the civil mobile radio business, has made (through Pye TMC) a strong impact in telecommunications and has a booming trade (through Pye TVT) in TV studio and transmitting equipment. Pye Unicam is a leading supplier of scientific and industrial instrumentation and is the UK marketing outlet for all instruments of Philips origin.

There is a great deal of local product development at factory level but long-range R and D is concentrated at Mullard Research Laboratories near Redhill, Surrey. This is one of five large Philips

research establishments in Europe which operate closely with Philips companies and with Government research establishments in their own countries, and with the great Natuurkundig Laboratorium research complex in Eindhoven.

Mullard has a long history of co-operation with educational authorities in the UK and with the world of science and, in passing, we should note that Mullard, through endowments, has assisted what are now known as the Mullard Radio Astronomy Observatory, Cambridge; the Mullard Cryomagnetic Laboratory, Oxford; and the Mullard Space Science Laboratory, London. The Mullard Gold Medal is also awarded annually by The Royal Society for technological achievement.

## OCCUPATIONS

It can be seen that, overall, Philips in the UK is an extremely powerful technology-based organisation in its own right and this power is further re-inforced by federation with sister organisations in Europe, North America and elsewhere in the free world. Thus, a career with Philips, has all the "plus" ingredients for a long term future limited only by personal ability.

The broad activities of the company provide a larger than normal spread of occupations and specialities and, once you are established and respected for

your abilities, there is the opportunity of climbing not only the local management ladder but also of gaining promotion by transfer within the operating groups and companies, generally at home, although there are opportunities for transfer overseas. Senior grade people inevitably find themselves involved in international liaison and there is a daily shuttle service by Philips own private aircraft between Gatwick and Eindhoven.

Technician or would-be technician engineers should apply to their local factories for information on student apprenticeship schemes as these tend to vary according to local conditions. As a generalisation, training normally lasts five years with day or block release for courses leading to ONC and HNC. All fees are paid by the company and full pay is given for time spent studying. Age limits for admission under these schemes are 16-19 years.

Younger applicants with four "O" levels, including English, Mathematics and Physics, get preference. Those nearer the top end of the entry age are expected to have two "A" levels, preferably in Mathematics and Physics. Write in before the end of February for interviews and selection tests in May or June to start training in August or September. But check on dates with the local establishment; there are variations.

Domestic TV studies at Central Applications Laboratory, Mitcham.

Flowcoating the screen of colour TV tube face plates at Mullard, Durham.

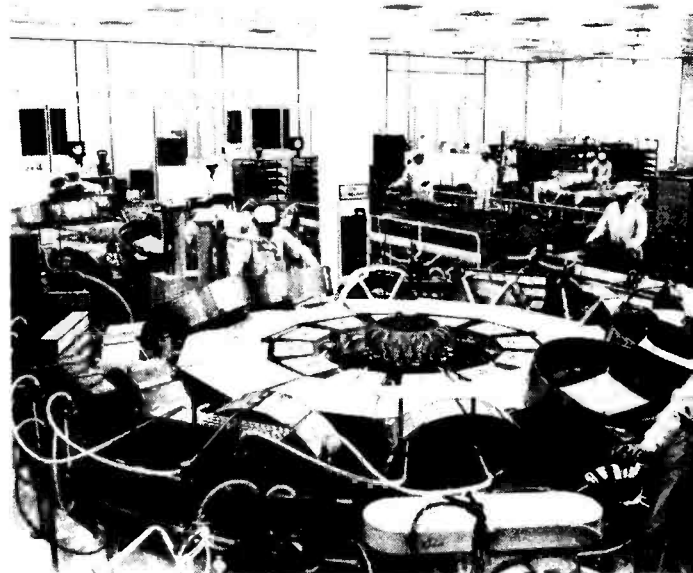
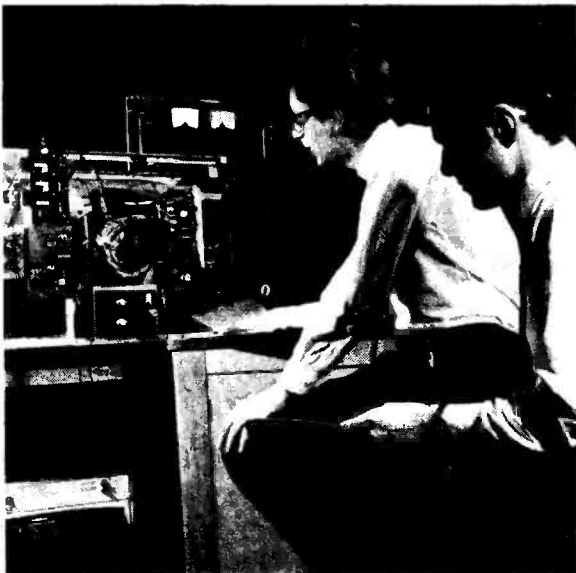

As your interests are in electronics your best chances are at Mullard, Stockport; Mullard, Blackburn; Mullard, Southport; Mullard, Mitcham; Mullard, Simonstone; M.E.L., Crawley; Philips Medical, London, S.W.12; Philips, Croydon; or practically any of the Pye establishments.

## GRADUATES

Graduates should apply to the Graduate Appointments Officer, Philips Industries, City House, 420-430, London Road, Croydon, CR9 3QR. Ask initially for a copy of "Graduate to Philips" which has a useful chart of 16 mainstream commercial and engineering occupations within Philips set against 14 educational disciplines, showing where you might fit in to the organisation.

The greatest demand is for electrical and electronic engineering graduates but, like all great organisations, there is also a demand for those with degrees in economics, the arts, social sciences and psychology. Most vacancies are

for direct appointment to specific jobs for which training will be given and Philips prides itself on the level of encouragement given to further develop your own ability and experience. This may be by change of job within an establishment, transfer to another establishment or, in some cases, by attending Philips own or external courses of instruction.

## SELECTIVE

In conclusion I would like to stress the hard fact of life that nobody owes you a living. Neither Philips, nor anyone else. An employer of the calibre of Philips can afford to be selective and, indeed, must be in its choice of employees if it is to be efficient and prosperous. It is just as important at any interview to show yourself as being keen and enthusiastic and willing to learn and adapt yourself as to show academic ability.

Don't start off asking what the company can give you. Try to put yourself in the employer's posi-

tion. Look at yourself in a mirror and ask, what can this young person offer me if I employ him? What contribution can he or she make? What qualities does he or she have that could make a real contribution to the success of a company?

If you can remember that there are two sides to a bargain and that you should demonstrate your willingness to honour your side, then any employer with vacancies suited to your actual or potential talents will favour your application.

A managing director of a large electronics company was telling me in September that he took on every school leaver who had recently applied directly for a job. Still needing more, he approached the local employment office. The job applicants from there had been waiting for the State to find them a job. He told me that not only were they unsuited to his vacancies but, in his opinion, were virtually unemployable in any occupation. ☐



ONE of the few remaining delights of being a shopkeeper (and there are not many left today, either shopkeepers or delights) is the anticipation of the unexpected happening. I am going back to the time before the Post Office Giro system was heard of, and our shop was still half radio and television and half components. One day a rather swarthy looking gentleman entered wearing a heavy overcoat with a turned up collar, and a black homburg hat, and asked for the manager. After we had reached my office, he leant across my desk and in a low voice said, "We want to include you in a film, are you willing to cooperate?"

Well, I had felt for years Hollywood had neglected me, so I positively beamed at him "Yes of course I will." To which the stranger replied coldly, "No not, you, although you may appear in it, I mean your shop".

And so was born "Watt and Ohm

Ltd", that was our name for the purpose of the film. What we were not prepared for, were the subsequent events. The day arrived and having warned the staff, we all stood by expectantly.

A line of about four lorries arrived filled with gear and a dozen technicians. Our shop was not all that large, but without batting an eyelid, they wheeled in these enormous spotlights, camera platforms, cameras, miles of heavy cable, booms, dollies, microphones, and mixers. It overflowed into the street, and a crowd, that always appears like magic at the sight of the unusual, started to gather round the doorway. The lights were tested the cameras run, the sound checked and the camera crews sat back and waited for the arrival of the director.

The great man arrived and he was the genuine article, right out of a Hollywood movie. Temperamental, arm waving, wearing a black beret, which

in moments of agitation he would hurl to the ground and jump on. After that the chief cameraman arrived, an excitable Hungarian with an unruly mass of white hair who quarrelled unceasingly with the director, followed by the assistant cameraman.

I had to pay the cashier and walk to the door. The director's final instructions were, "When you get to the door, shake hands with Stanley, smile and freeze it". Unfortunately just at the crucial moment, some passers by would walk by and the whole sequence had to be repeated. When you have "smiled" and "frozen it" eight times in a row, something happens to your facial muscles, which accounts for my present appearance. However with dry runs and re-runs these film characters were there the whole day.

After this, we sat back and waited for our contracts to arrive. We thought, it's bound to be on television and then our names will be household words. People will nudge each other in the street and say "Look there are the Giro men". Children will queue for our autographs.

We scanned the box nightly, but to no avail. In the end in desperation I wrote to the director to ask if we might see the film. It was a very amusing film. It lasted half an hour and it put over Giro very well, what is more we were all in it, but I am not too certain that the film moguls will be sending for me, you see the total time that we were on the screen was ninety seconds!

## Part Three

# Noise Reduction Systems

By Adrian Hope

WE continue this month with basic descriptions before moving on to the situation in practice.

### 110 SERIES

The other *dbx* consumer unit is the 110 series (units 117-119) but these are not strictly noise reduction units, and thus cannot be used to decode professionally made discs or tapes or indeed even domestic tapes made using a 120 unit. Whereas all the professional and consumer *dbx* units so far mentioned encode by compressing on "record" and expanding on "playback" together with equalisation and frequency weighting, the 110 series simply compress and expand, and have no frequency weighting.

Thus an amateur recording made using a 110 unit is encoded simply by compressing the material and decoded on playback simply by expanding it again to the same degree with consequent noise reduction. It follows from the absence of any frequency weighting curve, that the 110 series is incompatible with every other *dbx* series but can be used not only "double-ended" to encode on "record" and decode on "playback" but also "single-ended" to compress or expand any existing programme material.

Thus 110 series models are fre-

quently used in background music systems and discotheques, to compress the material into a smaller-than-natural dynamic range, so that no passages of music fall below a given level and no passages rise above a given level. In this way, background music never becomes inaudible through ambient noise such as conversation and never drowns out conversation by peaking too high.

As previously noted much of the output of BBC Radio One is already compressed in similar fashion, to the irritation of audio enthusiasts but to the satisfaction of pop pickers listening to noisy

reception on transistor radio sets. Just as the 110 series can be used to compress existing programme material passively, so it can also be used passively to expand existing material.

Any signal fed through a 110 series *dbx* unit can have its recorded dynamic range expanded to make soft sounds softer and the loud sounds louder. Up to a point, this can be an invigorating experience, because most commercial tape and disc recordings (and of course broadcasts such as Radio One) have an unnaturally limited dynamic range. On the other hand it can sound decidedly

The *dbx* model 119 compander



unnatural to have any programme source expanded to an exaggerated extent.

## JVC—ANRS

It is anybody's guess why the Japanese firm, JVC, should have gone to the lengths of developing a noise reduction system of its own (ANRS) and marketing it on a domestic level, when other systems (notably Dolby) were already available and commercially successful.

However, JVC developed its own automatic noise reduction system to cope with the particular difficulties which the company was encountering in producing CD-4 quadraphonic discs. Having produced a noise reduction system for this professional purpose, JVC took matters a stage further by adapting it for domestic use, i.e. in a manner parallel to that in which Dolby first developed the A system (for professional tape recording, land lines and even video) and then developed the modified B system for the domestic market.

The JVC ANRS system provides up to 10dB of noise reduction (mostly in the higher frequencies where hiss predominates), and in this respect exactly parallels Dolby. It achieves this by a compression-expansion system, which could best be described as a hybrid cross system, on the one hand, the *dbx* system (where all signals are compressed and expanded in substantially the same way) and, on the other hand, the Dolby system (where the extent to which the signals are compressed and expanded depends on their level and frequency). Thus the JVC ANRS domestic system applies neither compression nor expansion to high level (loud) high frequency signals and to low frequency signals of any level, but compresses and expands wanted low level (quiet) high frequency signals.

In other words bass notes pass through the system unaffected, regardless of how loud they are; high notes, as for instance from violins, are also passed through unaffected if they are loud; but quiet, high frequency signals, as for instance from violins played softly, will be boosted on "record" and de-boosted on "playback". Thus, irrespective of whether or not any bass notes

are present, tape noise will on playback be de-boosted and reduced as necessary. Hence there is no audible "breathing" due to modulation.

Because the ANRS system treats some signals in direct dependence upon their amplitude or level, it must, like the Dolby system, be set up with accurate calibration to ensure that the internal circuitry always has a working point of reference from which to determine what is a loud and what is a soft signal.

Both the Dolby B and ANRS systems are now available as fully integrated circuits or chips, and can thus be incorporated in even the smallest cassette machine without loss of valuable internal space.

There has now been launched the Super-ANRS system, and cassette machines are to be marketed with a three-position switch, of which one position is ANRS and a second position Super-ANRS. Super-ANRS exactly resembles the standard ANRS system but has additional circuitry to compress the high level (i.e. loud) high frequency signals which the basic ANRS system leaves untouched.

This compression is matched by mirror-image expansion on playback and is intended to provide additional head room during cassette recording by reducing the risk of overloading the narrow tape tracks with excessive high level, high frequency signal. The system is claimed to come into its own when there is a requirement to record live music, which has an intrinsically high dynamic range. However few people have both the inclination and the opportunity to cassette-record live music for themselves without breaking the copyright laws and risking ejection from a concert.

## PHILIPS DNL

Finally we come to Philips DNL, which is a playback only system. And as indicated above, there is also a professional Burwen system which in some respects a highly sophisticated version of the DNL.

The fact that DNL is used only for the playback of existing programme material (such as a conventional tape or disc recording or radio transmission) rather than to decode an encoded tape, disc or transmission, suggests that it might be closely comparable with the *dbx* 110 series, which can also be used on conventional material. However, this is not the case.

The *dbx* 110 functions to expand the material with constant slope, and as a by-product produces noise reduction effects. DNL does not, however, produce linear expansion, and is instead designed as an active noise gate. All noise gate systems suffer from the inherent disadvantage that they cannot be expected to distinguish between sounds that are wanted (such as quiet high notes) and sounds that are not wanted (such as hiss). Also, they can almost always be heard "breathing" as they come into and out of operation.

In the case of a DNL, breathing noise is minimised because the circuit is able to distinguish between high and low frequencies at different levels. Moreover DNL philosophy, like that of Dolby, is based on the masking effect whereby the presence of high level sounds of a given frequency mask the presence of low level sounds of a similar frequency.

When a signal is fed through a DNL unit, the circuit automatically evaluates how much is present in the way of high frequency sound. The result of this

A cassette deck incorporating the ANRS system.



evaluation is then used to control a high frequency filter.

If the unit circuitry senses that a fairly reasonable level of high frequency sound is present (in other words, if the violins are playing fairly loud), it does absolutely nothing and the signal passes through the unit untouched. If, however, the circuitry senses that there is only a low level of high frequency content, in other words if there is mainly only tape hiss to be heard, it brings the high frequency filter progressively into action, to roll off the high frequencies.

The problems begin when the unit is confronted with desirable high frequency sounds at a level which is not much above that of undesirable hiss (e.g. our old friends again, the violins, playing softly). Automatically recognising that there are no high frequency sounds of sufficient level to mask the hiss, or mistakenly regarding the high frequency sounds as hiss, the unit simply rolls off everything that is remaining in the top end.

It thus eliminates not only hiss but musical content as well. However, the DNL in fact works far better in practice than this bare description suggests.

## COMPROMISE

By now the general principles of noise reduction should be clear, along with the specific manner in which the various commercial systems work. But it should also by now be clear that no one system is perfect and each is very much a compromise between, on the one hand, a large degree of noise reduction and, on the other hand, freedom from unwanted side effects.

Moreover the discussion so far has been predominantly theoretical and, as often happens, the situation in practice is somewhat different.

## HISTORY

When Philips Electrical invented the audio cassette a decade ago, it was intended only as a convenient aid to dictation. Subsequently, enthusiasm grew in the public sector for convenience in tape recording comparable to that made available to amateur film makers by the

Super-8 film cassette.

The main obstacle to the Philips cassette as a domestic hi-fi medium was that of tape hiss, the narrow tracks on the narrow tape and the low running speed of the tape making the sound of the individual magnetic particles as irritating on good audio equipment as the photographic grain of a home movie film projected on a full-sized cinema screen. However, Dolby Laboratories proposed the use of the Dolby B format to reduce tape noise by 10dB (which is equivalent to using tape of ten times the width or a transmitter of ten times the power) and most of the rest is well documented history.

But it is not so well documented how Philips, the inventors of the cassette, was one of the last companies to acknowledge publicly that the Dolby system did have something to offer. For several years, while Dolbyised Musicassettes and machines on which to play them and make encoded recordings were emerging on the market from more and more firms under licence from Dolby Laboratories, Philips continued without a licence.

During all this time, anyone enquiring of Philips as to when a Dolby licence was likely to be taken was told that the matter was under consideration but that Philips had faith in its own DNL system. This attitude, more than anything else, accounted for the quite unreasonably severe criticism which has been levelled at the DNL system.

## ADD-ON DNL

Initially available as an add-on unit as well as switched circuitry built into some of Philips own cassette machines, DNL provides a valuable function when used to replay cassettes already recorded without the Dolby system. The add-on unit also proved useful when used in conjunction with a reel-to-reel tape recorder, or f.m. stereo radio receiver, in that the DNL circuitry is remarkably effective at generally minimising unwanted background noise while only occasionally making its presence felt by undesirable intrusion. (Recordings of voice and piano are most likely to show up breathing effects and very quiet violin passages may suffer roll off.)

In offering DNL as an *alternative* to Dolby, rather than as an addition, Philips almost killed the system. Indeed, manufacture of the add-on DNL unit has long since ceased (a fact which many informed audio enthusiasts now regard as regrettable). Philips now has a Dolby licence and is producing machines with Dolby circuitry and some Philips cassette machines (along, incidentally, with others for instance from BASF) incorporate both Dolby and DNL circuitry.

The DNL circuitry is switched in for tapes recorded without the Dolby system, and the Dolby circuitry is switched in for Dolbyised tapes. In some cases it is an improvement to use both Dolby and DNL together.

The ANRS system integrated into a single i.c. chip.

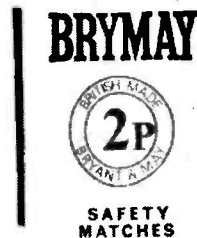
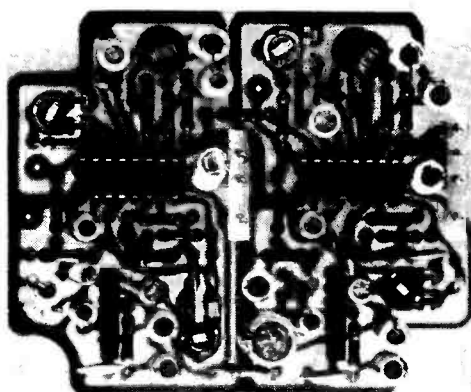



## DOLBY CALIBRATION

As explained, it is essential that Dolby circuitry be correctly calibrated. Briefly, the requirement is as follows. A professionally prerecorded test tape carrying a Dolby tone of carefully fixed and standard level is played on the machine and the internal circuitry adjusted until the machine meters register Dolby level (which will either be at zero dB, where the black markings change to red, or some other defined point in the scale).

Next, a blank tape is loaded into the machine, and a similar tone also of fixed level is produced by an internal local oscillator and recorded on to the tape. The tape is then played back, and the output level, as registered by the meters, is noted. If the registered level is above Dolby level, then the test is repeated, but with the internal pre-sets governing the record level of the machine pulled back slightly; if the registered level is below Dolby level, then the test is repeated with the pre-sets turned up slightly.

This trial-and-error procedure continues until the pre-sets in the machine are set so that it always records a standard level Dolby tone at standard Dolby level on tape.

As we have previously seen, the principle of the Dolby system demands that, for correct operation, the circuitry treats all signals of the same level in the same way. The described calibration technique provides the necessary level reference point for the

circuitry. When the machine is set up in this way, any tape recorded on a properly calibrated machine anywhere in the world will match any other correctly calibrated machine.

## VARIOUS TAPES

Fortunately for the domestic user, most good quality cassette machines now on the market contain built-in Dolby circuitry which has already been calibrated (both for "play" and "record") at the factory. Thus there is in theory no need, and often no facility, for the user to check or alter calibration. Indeed usually more harm than good is done by ill-informed knob twiddling. The only snag with this otherwise ideal approach is that different

tape types record fixed level signals at different strengths!

Tests which I have carried out show that the difference in coating as applied to tape types of two or three years ago and on similar tape types of today, may account for a difference in recorded level of up to 6dB. In other words, a fixed Dolby level fed from an oscillator to a tape two or three years old may produce 6dB less signal on playback than an exactly similar tone fed to a more modern type of tape, used in exactly the same way on the same machine.

There may even be a marked difference (3dB) between the performance of a C-60 and a C-120 of *exactly* the same, modern tape type. What this means is that a factory-calibrated machine will

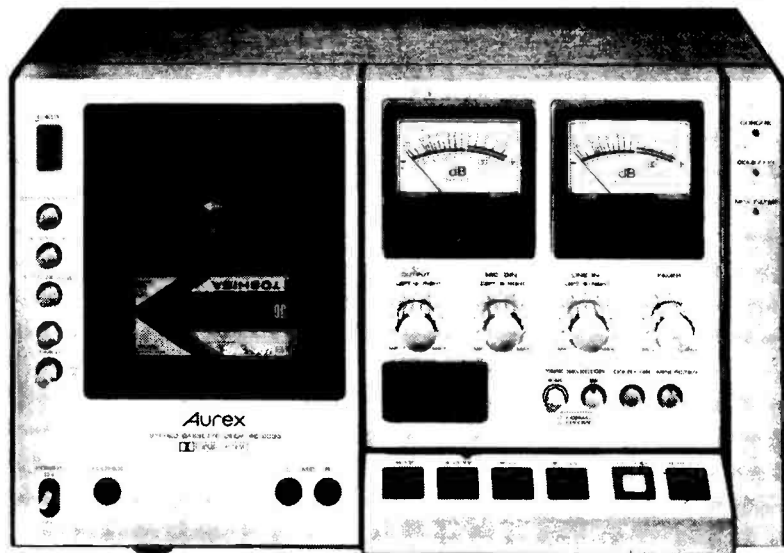

Two cassette decks which incorporate Dolby B noise reduction circuitry and have a switched calibration facility with front mounted pre-set adjustments (above) the Toshiba PC-6030 and (left) the Sony EL-7 Elcaset.



A Dolby A (professional) noise reduction unit.

only give correct Dolby results when used domestically with the tape type for which it was calibrated. Although the difference in output level performance between similar tape types may be insignificant and overshadowed by frequency response variations, the difference in output level performance between remote tape types may be sufficient to affect Dolby performance; in extreme cases miscalibration distorts the dynamic range.

It is thus essential that anyone using a Dolby cassette machine for anything other than casual purposes should establish the tape type for which that machine was factory-calibrated and then try always to use the same tape. In all too few cases the instruction book may help in this respect, but as a general guide in Europe, current calibration is centring round the use of a C-90 BASF Super LH cassette (and a C-90 BASF chrome cassette for the chrome setting) and in Japan calibration usually centres round the use of Maxell tape.

#### ADD-ON DOLBY

Although the Philips DNL add-on units are no longer available, Dolby add-on units (or "processors" or "adaptors") are still available. These are useful either to Dolbyise a non-Dolby, but otherwise treasured, cassette machine, or to Dolbyise one of the many reel-to-reel recorders which do not incorporate Dolby circuitry.

When Dolby adaptors first appeared on the market, several years ago, there was considerable confusion in the minds of the trade and public alike over the need to calibrate. Some adaptors were sold without calibration tapes; others were sold with calibration cassettes but not reel-to-reel tapes; and some were sold with blank tapes, even though the instruction books accompanying the machines clearly referred to the manner in

which a prerecorded calibration tape must be used! Some ill-informed or unscrupulous salesmen even made their own calibration tapes, which, in every case so far encountered, have proved to be useless.

Thus it is essential to establish from the outset that any calibration tape you use has a good pedigree, eg from Metrosound.

Apart from the matter of calibration the main snag in using an add-on unit is that it is awkward to use; not only the machine but also the add-on unit must always be switched from "record" to "playback" and *vice versa*. Also the user must remember to control levels during recording by operating the Dolby unit controls and maintain the tape machine controls at fixed level.

#### ANRS SYSTEM

As previously noted, the JVC ANRS system is in many respects similar to Dolby B. The two systems are not strictly compatible and on some programme material under some conditions a listener may be able to detect when an ANRS recording is re-

played with Dolby circuitry or *vice versa*. But I have used both systems side by side, with recordings made on one replayed on the other, and I have never been disturbed by the results.

However, the difference in transfer characteristics of the circuits shows that anomalies must inevitably occur on the reproduction of some material, and it seems pointless to mix systems if it can be avoided. Although JVC sell cassette decks which incorporate ANRS rather than Dolby circuitry, the company does have a Dolby licence, and has already brought out a model with Dolby circuitry. Also although the NR1020 ANRS add-on unit marketed by JVC is a well-engineered reasonably priced, and stylish piece of equipment, it seems superfluous on the market while there are Dolby add-on units available, for instance from Videosonic and Teac.

An important point worth noting is that because the ANRS system requires reference level calibration in exactly the same manner as the Dolby system, all the comments relating to calibration problems and tape type anomalies apply to ANRS as they do to Dolby. It is also worth noting that JVC have sensibly chosen the same calibration level standards for ANRS as are standard for Dolby; thus an ANRS calibration tape may be used to set up or check Dolby equipment, or *vice versa*.

Continued next month

The JVC CD-S200 cassette deck which incorporates the ANRS system.



# A Party time Project...

## Mini

# ORGAN

By R.A. PENFOLD

**M**ost miniature electronic organ designs for the home constructor, while providing a lot of fun for a modest outlay, leave a lot to be desired musically. The main reasons for this are that these designs cannot produce chords, but are limited to one note at a time. Also they are usually fitted with a miniature speaker which limits both the volume and tone of the instrument.

It is not really feasible to overcome the former in a very simple unit, but the latter is easily overcome by designing the instruments to feed into a hi-fi system or other speaker/amplifier combination. Suitable amplifiers are described in E.E. from time to time. Simple circuits to enhance the effect of the organ can then be included in place of the now unnecessary output stage and internal speaker. In this way a very versatile but simple organ can be produced at low cost.

It was with these points in mind that the organ described in this article was produced. It is of the stylus operated type for the sake of cheapness and simplicity, and has two circuits which help to give a more pleasant and interesting sound. The first effect is vibrato, and the second is an envelope shaper. The envelope shaper was originally included to enable the instrument to simulate a reed organ.

A reed organ has a sound which builds up to normal volume relatively slowly (although the actual time taken is only a fraction of a second), whereas the basic electronic organ builds up to normal volume instantaneously. The purpose of the envelope shaper is to delay this build up very slightly so as to give a smoother and more pleasing sound, not unlike a reed organ.

The time taken for the volume to swell up to maximum is adjustable, and it can be set to give a fairly long build up well in excess of one second. This produces a completely different and rather weird effect from the unit. Both the vibrato and envelope shaping circuits can be switched in and out of circuit as required.

### THE CIRCUIT

The unit comprises three separate stages, these being the tone generator, the envelope shaper, and the vibrato oscillator, as can be seen by referring to the circuit diagram of the instrument. This appears in Fig. 1.

A unijunction transistor in a relaxation oscillator circuit is used as the tone generator, and this part of the circuit is quite conventional. Two octaves are covered (C to C), these being the ones above and below middle C. The frequency of oscillation is

**FOR  
GUIDANCE  
ONLY**

**ESTIMATED COST  
OF COMPONENTS  
excluding V.A.T.**

**£5.00  
excluding case**

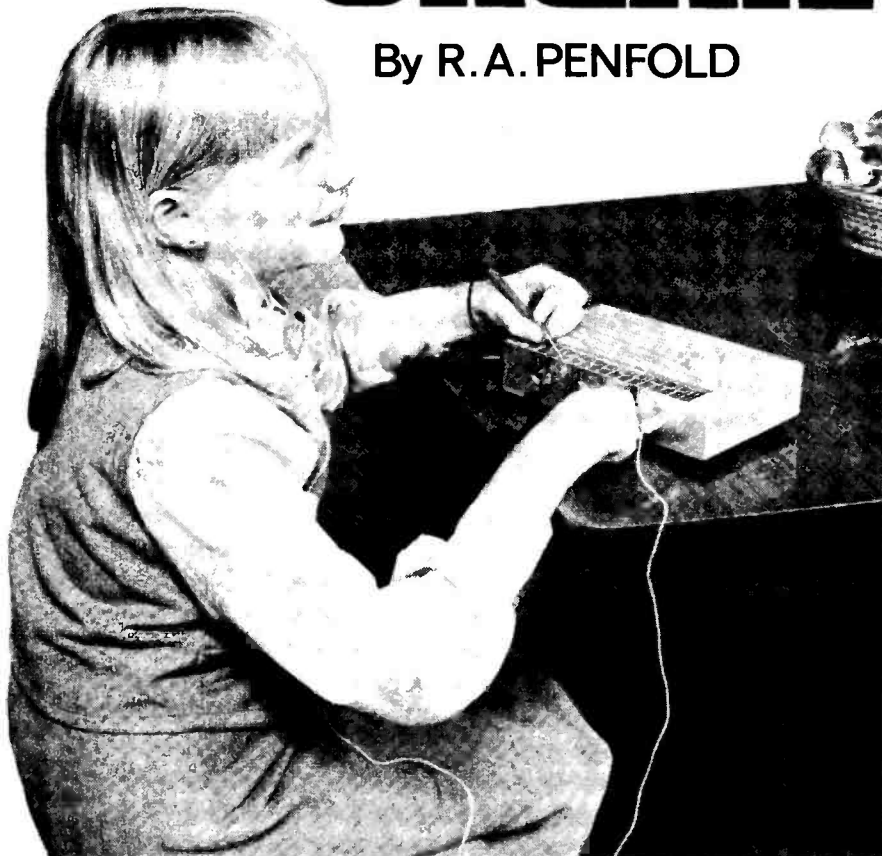

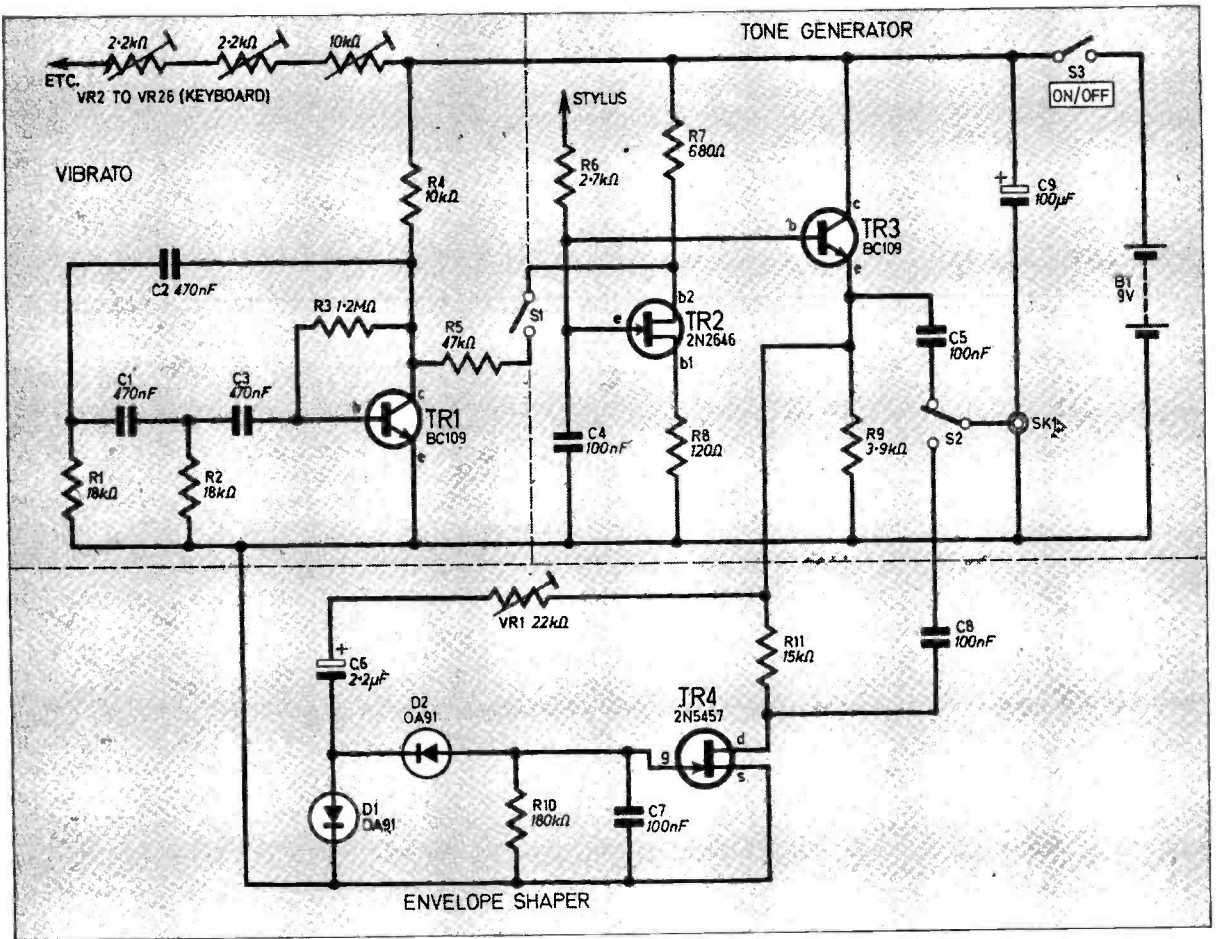

Fig. 1. The circuit diagram of the Mini Organ.

determined by the values given to the capacitor C4, and the resistance between TR2 emitter and the positive supply. Preset resistors connected in series provide 25 resistance values between the stylus and the positive supply rail, one preset being used to precisely tune each note. This type

of oscillator is quite stable, and variations in supply voltage due to battery ageing do not significantly detune the tone generator.

The output at the emitter of TR2 is a sawtooth waveform of quite high amplitude (about 1.8V peak to peak) but is at a fairly high impedance. An emitter

follower buffer stage using TR3 is interposed between TR2 and the output. TR3 provides only about unity voltage gain, but has a low impedance output which is capable of supplying enough current to drive the envelope shaper circuitry.

The envelope shaper is built

## HOW IT WORKS

An audio oscillator produces a range of two octaves (25 notes) and this can be fed either direct to an amplifier and speaker, or via an envelope shaper. The envelope shaper slightly delays the otherwise instantaneous build up of the output, to give a smoother more pleasant tone which is a simulation of the sound produced by a reed organ. It can also be adjusted to give a long build up which gives a weird effect.

A low frequency oscillator can also be switched into circuit to modulate the tone generator oscillator to provide a vibrato effect.

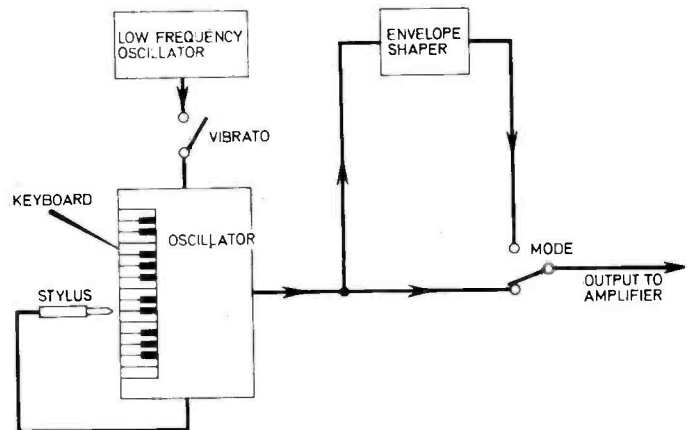

around TR4, which is a field effect transistor (f.e.t.). This has its gate and source connections tied together via R10, and under static conditions the d-s resistance of TR4 is only a few hundred ohms at most. The output from the attenuator formed by R11 and the d-s resistance of TR4 is therefore virtually zero. This attenuator is fed from the output of TR3.

When a signal is present at TR3 emitter, some of this signal is fed via VR1 and C6 to a voltage doubling rectifier circuit using D1 and D2. Capacitor C7 smoothes the output from these to a negative d.c. potential which reverse biases TR4. This increases the d-s resistance of TR4 to many meg-ohms, and increases the output level from TR4 drain to virtually that appearing at TR3 emitter.

It takes a short while for the bias on C7 to build up to maximum, and so it also takes a while for the signal at TR4 drain to swell to maximum as well. By adjusting VR1 it is possible to vary this time from little more than zero to a second or so. Although the stylus is only removed from the keyboard for a fraction of a second between notes, this is long enough for C7 to largely discharge through R10, so that the process starts off

afresh at the beginning of each note.

Capacitors C5 and C8 provide d.c. blocking at the output, and S2 selects the output either direct from the tone generator or via the envelope shaper.

### VIBRATO

A phase shift oscillator is used in the vibrato generator; TR1 is

biased as a high gain common emitter amplifier, and frequency selective positive feedback is provided between its collector and base via the three stage phase shift network using C2-R1, C1-R2, and C3-input impedance of TR1. This oscillator provides a sine-wave output at a very low frequency (about 5 Hertz). When S1 is closed this is fed to the b2 terminal of TR2 via R5. This has the effect of frequency modulating, and to a lesser extent amplitude modulating the tone generator oscillator. This gives a fuller, more satisfying tone on most types of music.

Switch S3 is the on/off switch and C9 is the sole supply decoupling component.

### CASE

It would probably be possible to fit the unit into any case of adequate dimensions, but a tailor made case will give the most compact and neat finish. The case design used by the author is probably easier from the constructional point of view than adapting a ready made case.

Two 118 x 40 x 19mm pieces of chipboard form the sides of the case and two 196 x 40mm pieces of 20 s.w.g. aluminium form the front and rear panels. The front panel is drilled to take the controls and SK1, and the general layout of this can be seen from the photographs. These case parts are then glued together using any good general purpose adhesive. Four 36 x 10mm square timber

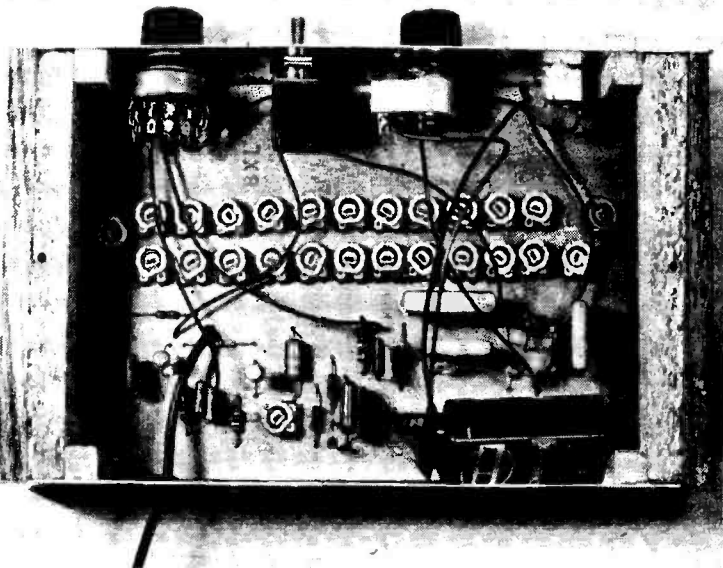

## Components

### Resistors

R1	18k $\Omega$	R7	680 $\Omega$
R2	18k $\Omega$	R8	120 $\Omega$
R3	1.2M $\Omega$	R9	3.9k $\Omega$
R4	10k $\Omega$	R10	180k $\Omega$
R5	47k $\Omega$	R11	15k $\Omega$
R6	2.7k $\Omega$		

All  $\frac{1}{4}$ W carbon  $\pm 10\%$

### Potentiometers

VR1	22k $\Omega$ horizontal miniature preset
VR2	10k $\Omega$ horizontal miniature preset
VR3 to VR26	2.2k $\Omega$ horizontal miniature preset (24 off)

### Capacitors

C1	470nF C280 type	C6	2.2 $\mu$ F 10V elect.
C2	470nF C280 type	C7	100nF C280 type
C3	470nF C280 type	C8	100nF C280 type
C4	100nF C280 type	C9	100 $\mu$ F 10V elect.
C5	100nF C280 type		

### Semiconductors

TR1	BC109 silicon npn
TR2	2N2646 unijunction
TR3	BC109 silicon npn
TR4	2N5457 n channel f.e.t.

### Miscellaneous

S1,3	s.p.s.t. toggle or rotary (2 off)
S2	s.p.d.t. toggle or rotary
B1	9V type PP3
SK1	3.5mm jack socket

Printed circuit board size 156 x 114mm plus etching materials; battery clip to suit; test prod or similar for stylus; control knobs (2 off); materials for case; suitably terminated screened lead for connecting unit to amplifier.

See  
**Shop  
Talk**

page 636



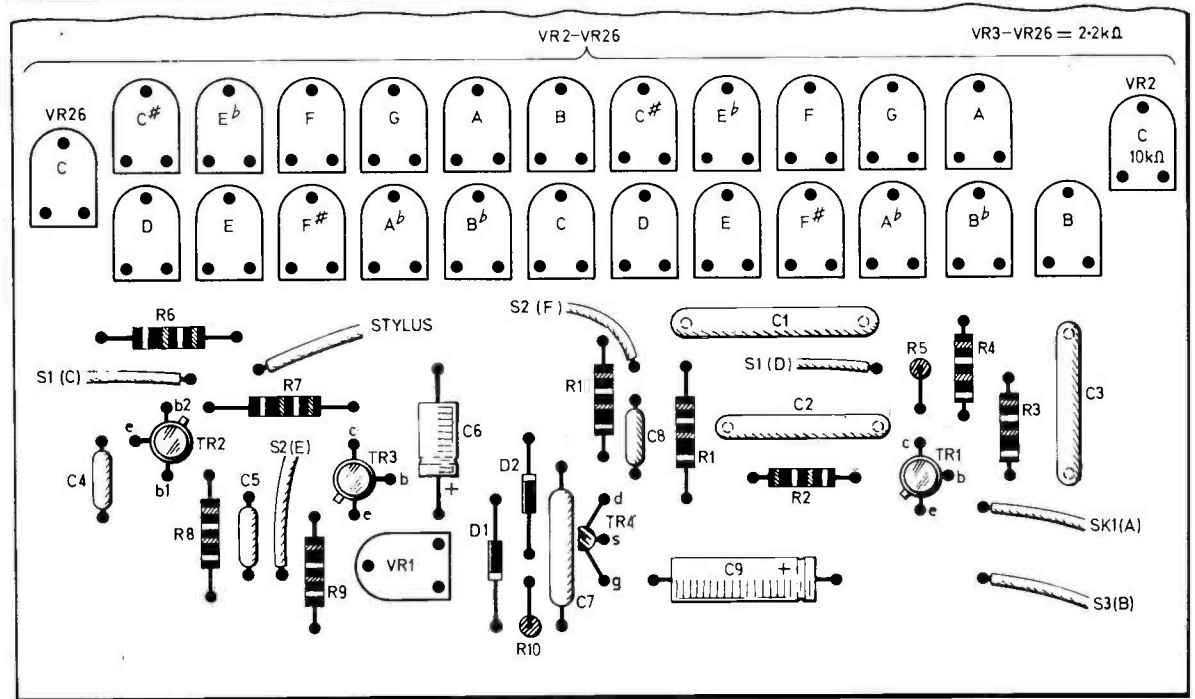
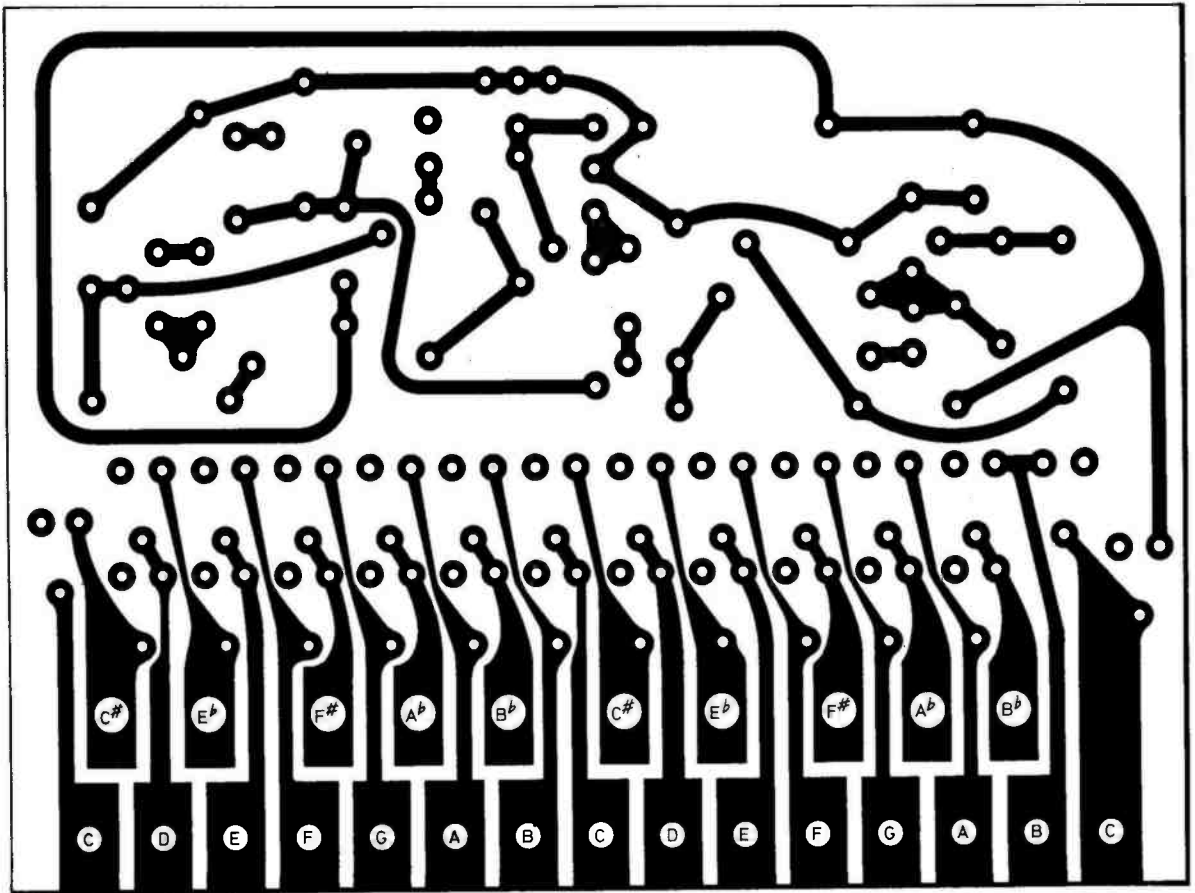

Fig. 2. Layout and wiring of the p.c.b. shown full size.

corner pieces are then glued into position, and the p.c.b. will eventually fit on top of these. They fit flush with the bottom of the case.

A 196 x 118mm piece of 20 s.w.g. aluminium forms the base-plate of the case, and 196 x 90mm panel of the same material is used as a lid. These are each held in place by two small wood-screws which screw into the chip-board sides. The base panel must be fitted with cabinet feet to prevent its mounting screws from scratching the surface on which the organ is placed.

Cover the lid completely with Fablon or a similar self adhesive plastic material. This acts as insulation as well as providing a neat finish. The ends of the case can also be finished with this material.

#### P.C.B.

All the small components are mounted on a printed circuit board, and this also contains the keyboard, as can be seen from Fig. 2. This shows both sides of the p.c.b. and is reproduced actual size so that the design can be easily copied.

Commence construction of the p.c.b. by cutting out a panel of the required size using a hack-saw, and then clean the board thoroughly (Brillo Pad or similar). Then mark out and drill the component mounting holes using a twist drill of about 1 to 1.5mm diameter.

Next draw the keyboard onto the board using a hard (4H) pencil. The dimensions of the keyboard can be obtained from Fig. 2. When it has been completed, the areas representing the keys are filled in with etch resist. This is most easily done using a resist pen and ruler, filling in the appropriate areas with a succession of overlapping lines working steadily down the board. In areas where one slips over the line, the dried resist can be removed with the point of a compass. The rest of the design can then be marked out.

After the board has been etched in ferric chloride solution it is cleaned again to remove the resist, and the components can then be mounted and soldered in. Leave the semiconductors until last, and be especially careful not to overheat the diodes while they are being soldered into circuit.

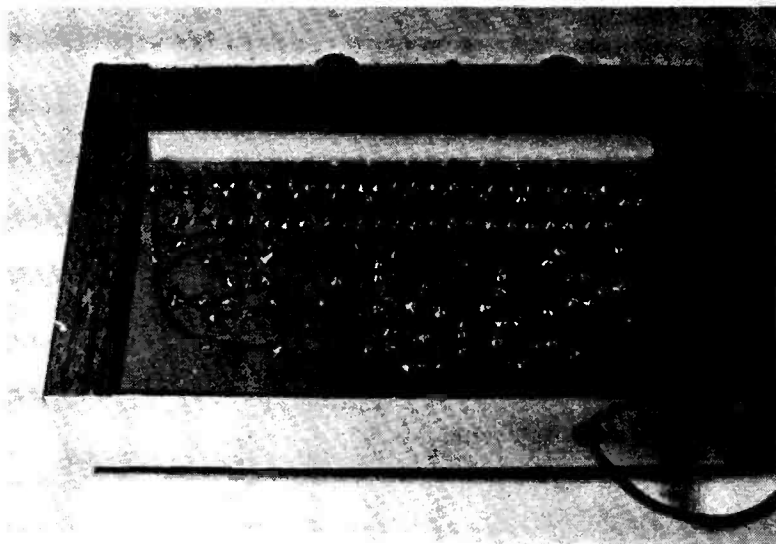

Underside view of the board showing key section and case mounting.

When all the components have been mounted, the top and base panels of the case are removed and the p.c.b. is placed in position. It is then an easy matter to complete the remaining wiring. This is shown in Fig. 3.

A strip of self adhesive foam rubber (sold as draught excluder) can be placed along the rear of the keyboard, and this will fill in the gap between the lid and the board and thus produce a neat finish. The lid is used to trap the p.c.b. in position, and it will be necessary to fix some foam rubber, Bostik Blue-Tak, or something of this nature to the underside of the lid to ensure that the board is firmly secured in place.

#### TUNING

The organ is tuned against a piano or pitch pipes starting with

the highest C, and working down chromatically to the lowest C. *It must be tuned in this sequence.* Fig. 2 shows which preset is used to tune which note.

Preset VR1 is merely adjusted to give the attack time which the user finds most acceptable, and a little experimentation is called for here.

The level of vibrato can be varied if desired by altering the value of R5. The lower the value of R5 the greater the amount of vibrato.

The output of the unit can be fed to any amplifier which has a high level, high impedance input, such as a crystal or ceramic cartridge input. A screened lead is used to connect the two pieces of equipment. It can also be used with a crystal earpiece for private listening and practising. □

# PLEASE TAKE NOTE

The answer to Exercise 13.5 Teach-In 76 October issue should be approx 715Hz.

In *Doing It Digitally* part 1 October issue the 1k $\Omega$  potentiometer called for in the components list should be lin. not log. We apologise for these errors.

# Next Month...

**GET OFF TO A GOOD START!**

## TUMBLE DRYER CONTROLLER

Not only does this controller ensure your clothes are dried just the right amount, but it also saves you money by switching off the machine when the preset level is reached.

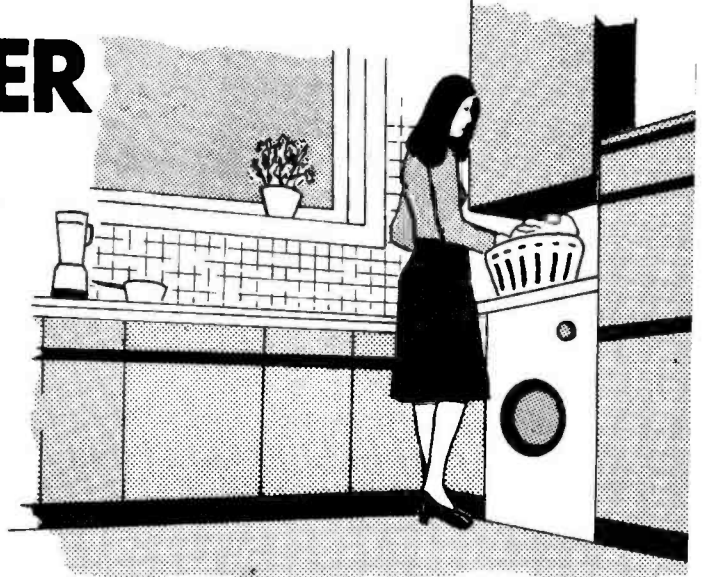
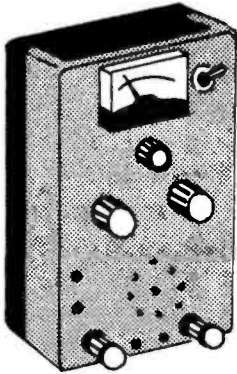

## MULTI-TESTER

A multi purpose test instrument designed specifically to incorporate many of the parts used in *Teach-In 76* but which will be attractive to all constructors.



**Plus...**

- Photocube Receiver
- Car Brake Warning Device
- Soldering in Easy Steps

# everyday electronics

JANUARY ISSUE  
ON SALE FRIDAY  
DECEMBER 17th

# A Simple Display Unit for the Home...

# LIGHT

# FLASHER

By JAMES RAWSON

**T**HIS simple mains powered Light Flasher will find many uses for entertainment around the home, such as an unusual light show at a party. It will also enhance the appearance of pop groups and discos alike. The prototype was constructed with two circuits in one unit to give a more interesting display but any number can be employed provided the power supply unit can handle the load. With the transformer specified, ten relays (as specified) can be operated simultaneously.

The total bulb wattage handled by each channel will depend on the rating of the relay contacts. With the type specified, up to 500 watts per pole can be achieved.

## CIRCUIT DESCRIPTION

The complete circuit diagram for one channel of the Light Flasher is shown in Fig. 1, and is

seen to be a simple astable multivibrator driving a "transistor switch" TR3 loaded with relay RLA.

Suppose that initially TR1 is off, and TR2 is on so that the relay contacts are open. The base of TR1 is at a low voltage. Capacitor C2 is charged up by the current flowing through VR2, and when the voltage at the base of TR1 becomes high enough, TR1 switches on which brings the collector of TR1 to low voltage. This immediately brings the other side of C2, and hence the base of TR2, to a low voltage, and TR2 switches off. This causes TR3 to switch on and close the relay contacts.

Capacitor C2 now charges up from the current flowing through VR1, until the base of TR2 is at a high enough voltage, and then TR2 switches on (TR3 then switches off and relay contacts open) causing the base of TR1 to

go to a low voltage once again. This process continues for as long as the supply is switched on.

Presets VR1 and VR2 control the rate that C1 and C2 charge up and therefore the time the relay is on and off respectively.

The power supply for the unit is mains derived. Mains voltage is stepped down by T1 and then full wave rectified by D2 and D3 and finally smoothed by capacitor C3 providing about 9 volts d.c.

## CONSTRUCTION

In the prototype having two channels, the circuit was constructed on two pieces of 0.15 inch matrix stripboard, one holding components for channel 1, power supply rectifiers and smoothing capacitor (board A) and the other for channel two components (board B) which is identical to board A up to hole 22.

Fig. 1. Shows the circuit diagram of the power supply and one channel of the Light Flasher.

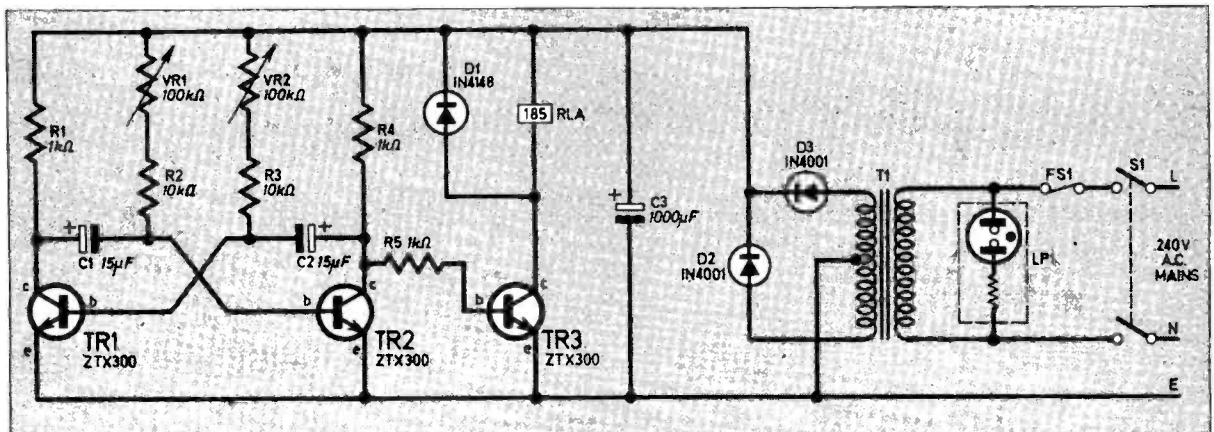

If only one channel is required, ignore board B. If more than two channels are required, board B should be repeated for as many times as required.

The layout of the components on the stripboard is shown in Fig. 2. Begin by making the breaks on the underside of the board as shown in Fig. 2 and then position and solder the link wires, resistors and capacitors in place followed by the semiconductors. Remember to use a heatshunt when soldering the latter in place to prevent possible thermal damage.

The size of the case to house the unit will depend on the number of channels required. The layout of the components is not critical and can be changed to suit individual requirements. A wiring diagram is shown in Fig. 3 for guidance but the exact location within the case may vary according to proposed use.

Begin by preparing the case to accommodate all the components and then secure these in position. The terminal blocks may be glued or bolted in place. The terminal blocks for connecting to the lamps may be substituted by two-pin sockets for ease of use and storage. Fixing brackets can be made from aluminium or tin plate to hold the relays in position.

If a metal box is employed, it is important that this is earthed. Make sure of this by checking that the solder tag fixed to the transformer fixing makes good contact. Also, the component board(s) should stand well clear of the base of the case. Spacers are recommended and it may be a good idea to lay a strip of insulating tape on the metal base immediately below the board position. The flying leads should be attached to the component boards and the boards fixed in position and the unit wired up as shown.

**FOR GUIDANCE ONLY**

**ESTIMATED COST OF COMPONENTS \* excluding V.A.T.**

**£7.00 for two channels excluding case**

## TESTING

When the wiring up has been thoroughly checked, the unit may be tested. If a testmeter is available, set to 100 volts d.c. and fix across capacitor C3. Do not connect any load to the relays (do

not connect the lamps) and then switch on. The mains neon should light up and the reading on the meter should be about 9 volts. You should hear the relays clicking in and out and the frequency of "clicking" should be variable by means of the potentiometers.

## Components

### Resistors

- R1 1k $\Omega$
- R2 10k $\Omega$
- R3 10k $\Omega$
- R4 1k $\Omega$
- R5 1k $\Omega$
- All  $\frac{1}{4}$ W/carbon  $\pm 10\%$

### Potentiometers

- VR1 100k $\Omega$  carbon lin.
- VR2 100k $\Omega$  carbon lin.

### Capacitors

- C1 15 $\mu$ F 12V elect.
- C2 15 $\mu$ F 12V elect.
- C3 1000 $\mu$ F 12V elect.

### Semiconductors

- D1 1N4148 or similar diode
- D2, 3 1N4001 or silicon rectifier diodes (2 off)
- TR1 ZTX300 silicon npn
- TR2 ZTX300 silicon npn
- TR3 ZTX300 silicon npn

### Miscellaneous

- T1 mains primary 6-0-6 280mA secondary type MT280
- LPI panel mounting mains neon with built-in resistor
- RLA type H/D 12V (Doram) 185 ohm coil mains/2A contacts
- FS1 500mA fuse with holder
- S1 d.p.d.t. mains toggle switch
- Veroboard: 0.15 inch matrix size 11 strips x 32 holes (board A), 11 strips x 22 holes (board B); mains cable; grommets; 2A terminal block; knobs; case; 4BA fixings and spacers.

See **Shop Talk**

page 636

Fig. 2. The layout of the components on the board and breaks to be made on the underside for the first channel. For further channels repeat up to hole 22.

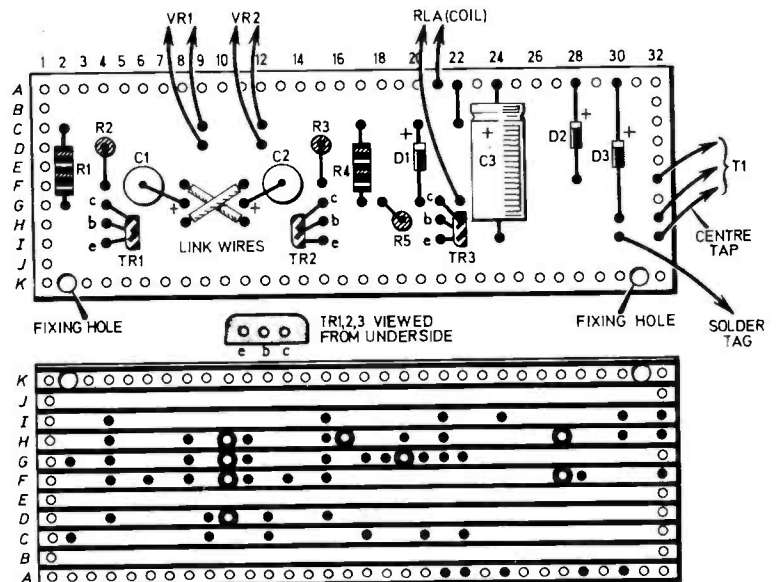



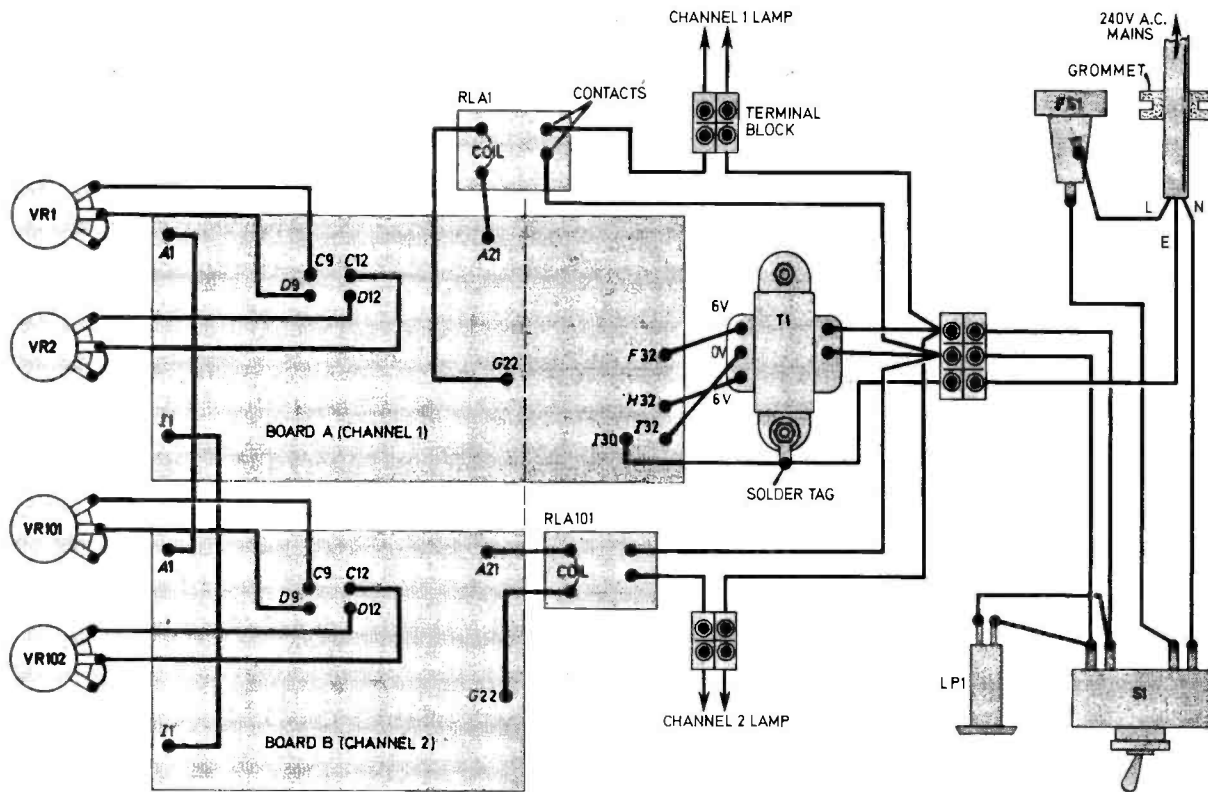

Fig. 3. Shows wiring up of a two channel system.

If all is well, switch off and set the meter to read 250 volts a.c. and connect to the lamp terminal blocks. Switch on. The meter needle will be reading alternately zero and 250V.

If all is well, switch off and replace the meter by a bulb. On switching on the bulb should flash on and off, the on and off times being controlled by the potentiometers VR1 and VR2.

Check the other channels in the same way.

A greater range of flash times can be obtained by using poten-

tiometers of greater value. If a different range of flash times is desired, then different capacitors must be used. For faster flash rates, smaller value capacitors and vice versa.

#### LAMPS

As stated earlier, the relays specified in the components list can handle up to 500 watts per contact pair. This can be made up in many ways e.g.  $2 \times 250W$ ,  $3 \times 150W$ ,  $5 \times 100W$  or combinations of these and other wattages

in same or different colours.

Cabinets to house the lamps are left to the designs of the constructor. The author suggests a few basic designs made from wood, and suitably ventilated (see Fig. 4).

Fig. 4. A few suggested layouts of the bulbs in various cabinet shapes.

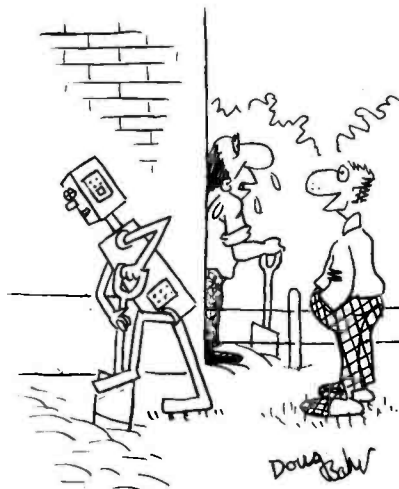
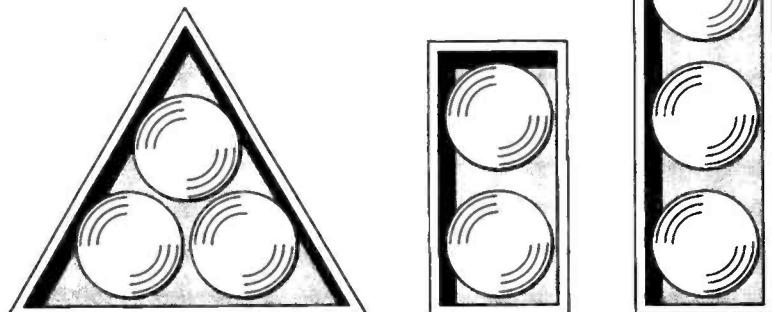

"Electronics? Why do you think I ought to start taking an interest in electronics?"

# Physics is FUN!

# THIS MONTH.... A selection of readers "Favourite Experiments!"

## The Impossible

Here's a simple experiment, which I have used many times for amusement.

Stick a needle vertically in a block of wood. Balance a spoon on the needle. Rub a candle on clothing and push or pull the spoon around on top of needle without touching the spoon, see Fig. 1.

The spoon can be made to spin quite fast. I always present it as, "you can make the spoon move without touching it".

Children like this one, and continue to do the "impossible", themselves.

E. Sharp,  
Leeds

*A good and simple trick demonstrating attraction and repulsion from static electricity. Fun to do.*

## Magic Box

I am enclosing details of a very simple gadget which I call the Magic Box. I made it up at the request of my grand daughter when she was invited to a teenage party, and wanted a little gadget to impress those present of her magical powers.

The little box, details in Fig. 2, is passed around the company present, with instructions to see if anyone has enough electricity in their hand, on picking up the box, to light the lamp.

It does not matter how they pick it up, they will always fail to light the lamp. But being returned to the operator, on being picked up, it never fails to light. Now how is this done?

The person passing around the box has a small circular magnet fixed to the palm of their right hand, this, when the hand is placed over the box, operates the reed switch.

The magnet can be securely fixed to the palm of the hand by a small narrow strip of sticking plaster. The box is cheap to construct, simple to operate (even a child can do so) and provides hours of entertainment at all sorts of parties.

Hoping this will be of interest to your readers.

F. G. Sadler, G3UZ  
Worthing.

*Thank you Mr. Sadler. An amusing toy that anyone can make.*

## Ring Levitator

I have tried this experiment (see Fig. 3) at school and reasonable results

occurred. It was found the larger the ring (heavier) the better it was lifted and if there was a break in the ring, levitation would not occur.

I am not too sure how it works but there is some connection between this experiment and the eddy current experiment in *Physics is Fun*, May, 1976.

Richard Baker,  
Newcastle-Upon-Tyne.

*There are links here with many basic facts about electricity and magnetism—some that have already been published in Physics is Fun! including the electromagnet and magnetic repulsion, and some that are due to be published that include induced magnetism and the transformer.*

Briefly, a magnetic field is formed round the coil by the passage of the current, and the iron rod is also magnetised. (Note that this experiment will only work with a.c.) The rod induces a current in the ring which causes a magnetic field which is repelled by the coil magnet. The rod therefore serves a

*dual purpose, the second of which is to keep the ring positioned above the coil. A nice one, Mr. Baker!*

## Moving Cotton!

I would like to submit this experiment which is very simple, and I think the explanation is in line with your explanation of the electroscope and light bulb experiment.

Take a simple 100 watt light bulb as shown in Fig. 4, and very gradually dangle a length of black cotton toward it with the cotton end about at the level of the centre of the bulb.

It will be found that the end of the cotton will jump or be pulled towards the surface of the bulb.

A. P. Pedrick,  
Selsey.

*I have tried duplicating this experiment, but I am not satisfied with the results that I get. I suppose that my study is too draughty! Perhaps readers will have better luck.*

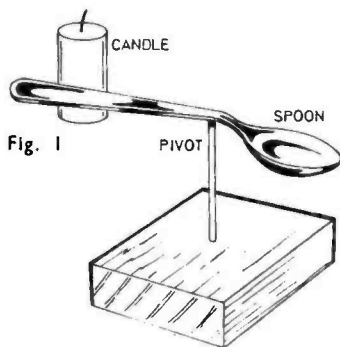

Fig. 1

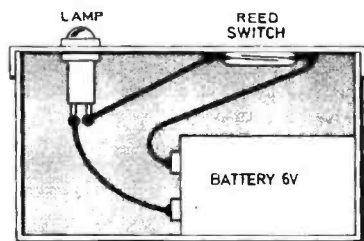

Fig. 2

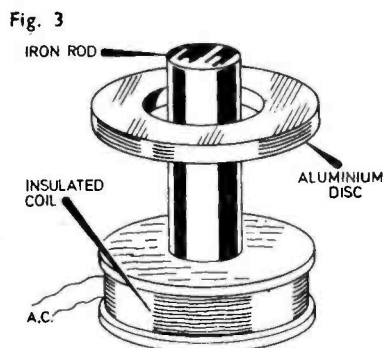

Fig. 3

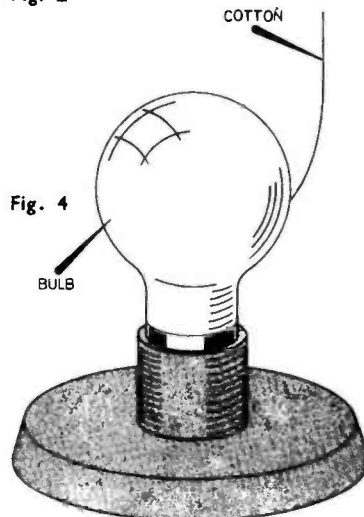

Fig. 4

# DO MATHS BOTHER YOU?...

# LET'S FIGURE IT OUT

Part 1 By PHIL ALCOCK



ONE of the aspects of electronics that sometimes troubles readers is the need to employ maths for some of the circuit calculations and descriptions. Fortunately we can learn quite a lot of electronics without using any difficult maths and this initial article is intended to help those readers who, in the past, have tended to shy away from equations and similar "unknowns" that crop up from time to time.

This article has been prompted by correspondence from readers of E.E., some of whom have followed the 'Teach-In series', but it is not necessary to have read these articles to follow the topics covered here.

## NAMES, SIZES AND UNITS

If we wish to measure some quantity such as current, voltage or resistance we need two things. The first requirement is an indication of the *unit* of measurement for the quantity considered. For example, a length of wire can be measured in centimetres, inches or yards.

Each of these names represents a particular choice of *unit of length* and, of course, they differ in magnitude. The yard unit is longer than the inch unit and similarly the inch unit is longer than the centimetre unit.

Some units are preferred because of the need to standardise but it is also necessary to be able to convert from one unit to another, since the information that we wish to use may be given in different units to those required.

As well as the unit of measure-

ment we need to say *how many* of these units represent the size of our particular article or quantity. Let us see how this works in practice. If we wish to measure the size of this page using the centimetre unit, we need a rule which is calibrated in terms of this standard length. We lay the rule on the paper with one edge at the "start" of the centimetre scale and read off the scale at the other edge of the page and we get an answer of 24.9 centimetres.

Since each of these centimetres contains 10 millimetres (which are simply smaller sub-divisions of the standard metre length) we could express the length as 249 millimetres. In the case of imperial units the answer would be approximately 9 $\frac{3}{4}$  inches.

Often it is convenient to abbreviate the unit name, to save space, and in addition we may use various letters to indicate sub-divisions or multiples of the basic unit. Some examples are ms (millisecond),  $\mu$ F (microfarad), mm (millimetre), M $\Omega$  (megohm).

Usually a small letter indicates a *subdivision* of the unit, as in ms for millisecond (one thousandth part of a second) whereas a capital letter indicates a multiple of the unit as in M $\Omega$  for a million ohms. One exception to this rule is the use of a small "k" (for kilo) in k $\Omega$  (kilohm). Most rules have exception!

## TOLERANCES

When dealing with the sizes of electronic components we may find that the manufacturer only provides his goods in certain specific sizes. In addition, because

of manufacturing difficulties or the economics of production the component values will have a spread or tolerance which simply means that the actual value is within a certain range. Tolerance is usually expressed by a percentage (%) and since the value may be high or low we find expressions like

$$R1 = 100k\Omega \pm 5\%$$

In this expression the value of a certain resistor, R1, is given as 100 kilohms (100,000 ohms) and the maximum possible deviation from this value during manufacture is plus 5% (higher than 100k $\Omega$ ) or minus 5% (lower than 100k $\Omega$ ). Since "one per cent" means "one hundredth part", which in this example corresponds to 1k $\Omega$ , the resistor R1 may have a value as high as

$$100k\Omega + 5k\Omega = 105k\Omega$$

or may be as low as

$$100k\Omega - 5k\Omega = 95k\Omega$$

The 100k $\Omega$  is sometimes called the *nominal* (or average) value.

Whenever we measure any quantity the result is only known to a certain accuracy, i.e. there is always some uncertainty in the answer. Accuracy here simply means closeness to the true value.

Electronic components can be tested in various ways to see if they are free from damage—they can also be tested to determine their electrical value.

Continued next month

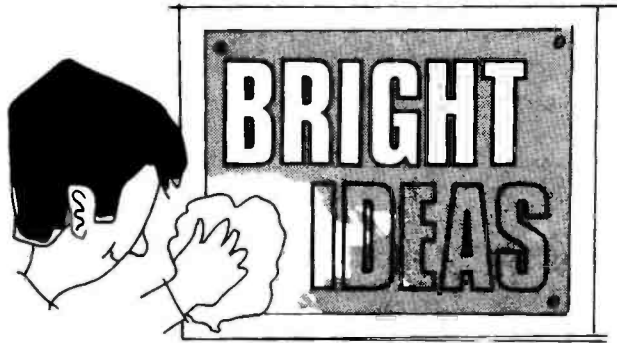

By using pieces of wire classed as scrap by an electrician, unlimited transistor holders can be made.

The solid-core plastic covered wire that will fit in the 0.15 inch and 0.1 inch matrix holes should be soldered in the holes required and then these "posts" cut to length as shown in Fig.1. Remove the plastic insulation pieces and place on the transistor leads, see Fig.2. and then push insulation piece over the post as shown in Fig.3.

E. R. Wall,  
Charlton, London.

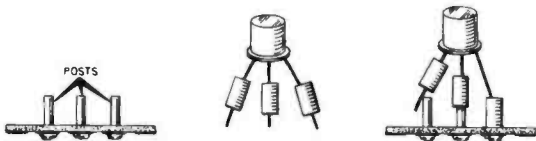

When testing many components on a meter to find their value, e.g., unmarked resistors, it is time-consuming to clip and unclip croc clips to each component in turn. A couple of aluminium foil plates, about 12 x 25 mm, separated from each other as in the diagram, and glued to the meter unit or elsewhere, can be used for quick testing.

The component is held onto the plates while the measurement is made, ensuring there is no contact with leads on the hand, and any size component can be fitted onto the plates. Large batches of unmarked parts can be quickly tested.

L. Robinson,  
Cheshire.

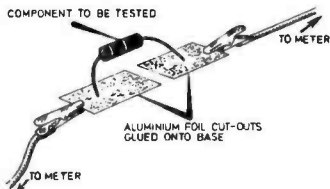

I have discovered a good way of brightening up a dull aluminium, plastic or diecast box or case.

The method involves a new material on the market for aero-modellers.

It is a cellophane type material which tightens up and adheres to smooth surfaces when it is touched with a warm iron.

This material comes in many different colours, transparent and opaque.

If applied according to the instructions given a finish superior to the best of paint works is achieved in under ten minutes. It is fool proof and hard wearing.

The material is available from aero-modeller shops under the name of "Solar film" and costs about £1 which should last for a long time.

This idea will prove invaluable to the constructor who wishes to put a professional touch to his/her project.

R. Gorden,  
East Lothian.

# SOUND DESIGN

A PRACTICAL ELECTRONICS PUBLICATION

## A SPECIAL SELECTION OF MUSICAL PROJECTS FROM PE

### THE MINISONIC MK2 SOUND SYNTHESISER

An up-dated version of the published Mk 1, the Mk 2 has an integral keyboard, two 250 mW monitoring channels and loudspeakers, and facilities for amplitude, frequency and harmonic modulation.

### THE JOANNA ELECTRONIC PIANO

has realistic piano effect with touch-sensitive keyboard and additional choice of harpsichord or honky-tonk voicing.

### THE ORION STEREO AMPLIFIER

A hi-fi amplifier with output of over 20 + 20 watts. Compact and complete in one unit, it measures only 14" x 6" x 2".

### PLUS

Some great sound effects units for guitars, keyboard instruments and general recording.

Available  
Now  
**£1.20**  
POST PAID

(Please allow at least 2 weeks for delivery)

If you do not wish to mutilate your copy of the magazine, please send your order on a separate sheet.

To: Practical Electronics  
IPC Magazines Ltd., Receiving Cashiers Dept.,  
King's Reach Tower, Stamford Street, London SE1 9LS

Please send me ..... copy(ies) of  
"Sound Design". I enclose a Postal Order/Cheque  
for £1.20 (post paid) or (state amount for  
more than one copy) ..... (£2.35 post paid  
for 2 copies)

PLEASE WRITE IN BLOCK LETTERS

Name .....

Address .....

.....

Post code .....

Remittances with overseas orders must be sufficient to cover despatch by sea or air mail as required. Payable by International Money Order only.

EE.1510

Company registered in England. Regd. No. 53626.  
A subsidiary of Reed International Limited.

# Doing it Digitally...

**New Series Part 3**

By O. N. Bishop

WHEN trying out the NOR circuits, was the circuit of Fig. 3.1 encountered?

Each gate receives its input from the output of the other gate. If this has not been tried already, wire it up and see what it does. To get the most information about it, wire up one lamp to each output (see Fig. 3.2). (If only one lamp is available, connect it to each output in turn.)

Connect both inputs to negative then make the battery connections. Which lamp lights?

Remove one of the inputs from negative (no need to touch it to positive as in effect the input has been taken high by leaving it open). What happens to the lamp?

Replace the input on negative. What happens? Take it away again. Replace it.

Remove input 2 from negative (keeping input 1 on negative) and so on.

Keep on removing one wire at a time from negative, sometimes 1 sometimes 2, sometimes 1 several times in succession, sometimes 2 several times in succession, sometimes 1 and 2 alternately.

Try to work out the behaviour of this circuit.

## THE BISTABLE

The circuit can be in either of two different states. In Fig. 3.3 the shaded wires show the high parts of the circuit and the unshaded the low parts.

If the inputs and outputs of each gate are checked against the NOR truth table it will be seen that all is correct. The circuit is stable in either state. This is called a **bistable circuit** for this reason.

To get from one state to the other we have to do what was

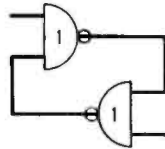
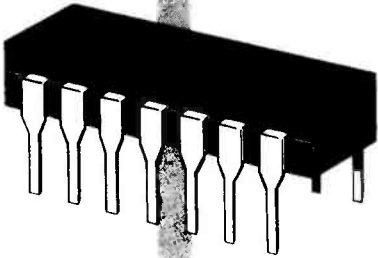

Fig. 3.1. The circuit of a bistable using two NOR gates.

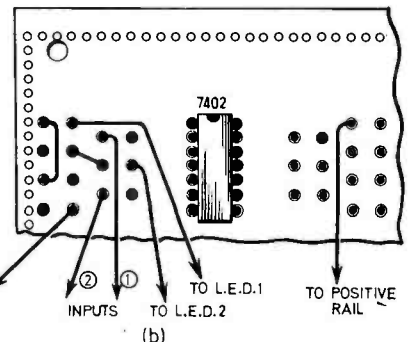
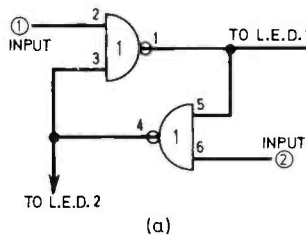

Fig. 3.2. Operation of a bistable can be investigated using the circuit shown in (a), the physical arrangement being shown at (b).

An introduction to or revision of, digit techniques.



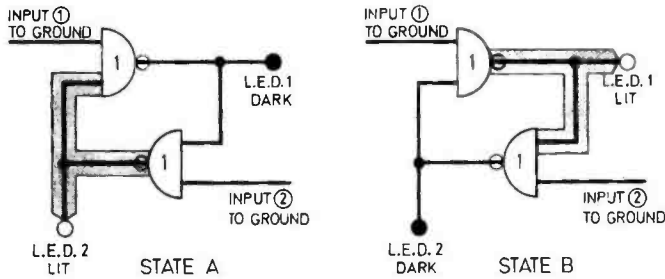

Fig. 3.3. The bistable has two stable states as shown above. The shaded wires indicate parts of the circuit which are high.

done in the experiment—let one input go high. Fig. 3.4 shows the sequence of events.

The bistables will not be affected if output 2 is removed from negative again. To change back to state A input 1 must be removed from negative then it will stay in state A until input 2 is taken high.

The circuit can “remember” which input was last removed from ground. If someone plays with the circuit while the reader is away then he could tell on coming back which input was the last to be removed from negative even though both inputs had been put back to negative.

This kind of circuit is used in some of the later gadgets and circuits.

The circuit works very quickly so that it will change state even if the input is removed from negative for less than a millionth of a second.

Having looked at the 7402 quad two-input NOR gate, we now go on to a new i.c., the 7400, described as a quadruple two-input NAND gate. We will also look at the construction of an i.c. “clock”.

## NAND GATES

The 7400, like the 7402 contains four identical gates each of which performs the NAND function. What does this gate do? The symbol for the NAND gate gives a clue (Fig. 3.5a), and the best way to work it out is to wire up a gate

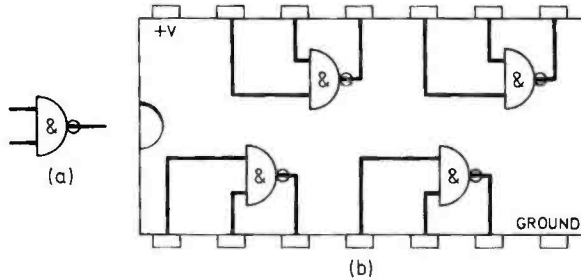

Fig. 3.5. The 7400 integrated circuit (a) shows the symbol for a NAND gate. (b) shows the pin connections for the i.c.

and make out the truth table.

When wiring up the i.c. on the breadboard constructed in Part 2, note that the gates in the 7400 are connected to different pins from the NOR gates in the 7402. Their outputs are on pins 3, 6, 8, and 11 (Fig. 3.5b). The voltage pins are the same as the 7402.

When the truth table for the 7400 gate has been worked out, check it against Fig. 3.6 and at the same time check the other gates in the i.c. to see that they are working properly.

If a NOR gate was made by putting an INVERTER after an OR gate, perhaps a NAND gate can be made by putting an INVERTER after an AND gate, but what is an AND gate?

It seems sense to think of this as a gate which gives a high output only when one input AND the other are high, otherwise its output is low. This is shown in Fig. 3.6, the fourth column showing

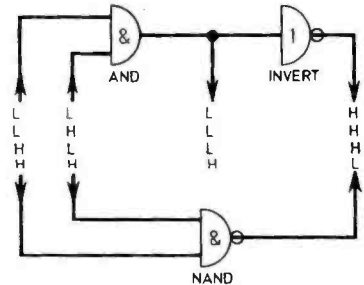

Fig. 3.6. Diagram and table indicating the equivalence between an AND gate followed by an inverter and a NAND gate.

the output inverted, to give NAND; NAND gates are used a lot in logic circuits and they will appear many times in this series.

Sometimes an AND gate i.c. is required and there is the 7408 which contains four of these. Usually contractors make up an AND gate by taking a NAND gate and wiring another gate after it.

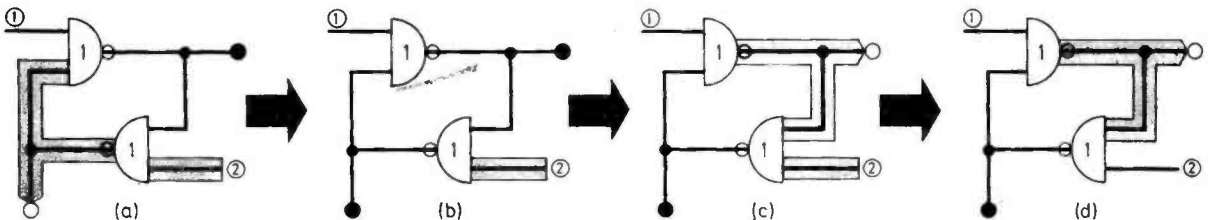

Fig. 3.4. To change from one state to another the sequence of events shown here takes place. Again shaded wires are high.

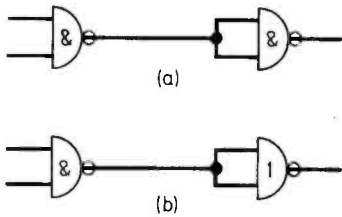

Fig. 3.7. Two ways of constructing an AND gate from a 7400 and a 7402 i.c. (a) uses two NAND gates, one acting as an inverter and (b) uses one gate from the 7402 as the inverter.

How can this be done? Work it out first and then construct the circuit on the breadboard to test the idea. Two possible solutions are shown in Fig. 3.7.

Now try other ways of wiring up NAND gates. Try joining them in the same patterns as the NOR gates in Part 2 but remember that the pin connections of the 7400 will not be the same.

Work out a circuit to solve this problem: "I will not go out today if the sun is NOT shining AND I have a cold. I do not have a cold and the sun is not shining—shall I go out?" When working this out use the following inputs and outputs.

Input 1: The sun is shining = high

Input 2: I have a cold = high

Output: I go out = high.

### A NAND BISTABLE

Wire up a bistable using NAND gates. The circuit is shown in Fig. 3.8. The connections are the same as for the NOR bistable though the pins of the i.c. are different. The NAND bistable behaves the same as the NOR bistable in some way but not in others. Find out what the differences are. It will be found that the bis-

table changes state when one of its inputs (normally high) is touched to ground.

There are lots of ways to wire up NAND gates so we will just look at the more interesting ones.

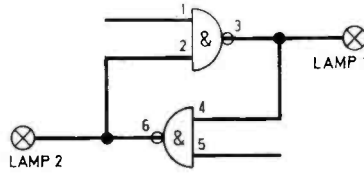

Fig. 3.8. A NAND gate bistable.

### SAME OR DIFFERENT?

The first combination of NAND gates that we will look at is very interesting in that it tells if its two inputs are the same (both high or both low) or if they are different (one high and one low).

Five gates are needed, two of which are INVERTERS. The circuit is shown in Fig. 3.9a. Two i.c.s are required, one of these being the three NAND gates and one INVERTER, and the other a 7402 to give the remaining INVERTER.

The wiring of the circuit is shown in full in Fig. 3.9b.

The truth table of the circuit, worked out in stages, is shown in Table 3.1. It will be seen that the lamp lights when the two inputs are the same.

The output of IC1a is obtained by NANDING the two inputs—it is high except when both inputs are high. Outputs of IC2a and IC1b are simply the inputs inverted. The output of IC1d is the outputs of IC2a and IC1b passed

through a NAND gate. Finally the output of IC1c is the outputs of IC1a and IC1d passed through a NAND gate.

Working like this across a table, it is not too hard to work out how any circuit will behave but it is still a good idea to build the circuit and test it, when any errors will be discovered.

### A NAND GATE LATCH

A latch holds something in position. The logic latch "freezes" the circuit output whenever it is necessary. To see how it operates, build the circuit of Fig. 3.10. Again, two i.c.s are required, the 7400 to give the four NAND gates and the 7402 to give the INVERTER.

Part of the circuit should be familiar. IC1c and IC1d are connected as a bistable only, it is drawn a little differently in the diagram. Also only one lamp is used though a second lamp can be connected to the output of IC1c if desired.

To operate the circuit, first disconnect both inputs (or connect them to the positive rail). Now, touch input 1 against ground, then take it away, then touch to ground again. What happens?

It will be found that the lamp is off when input 1 is grounded and on when it is open circuit or touched to positive. The truth table (Table 3.2) could not be simpler.

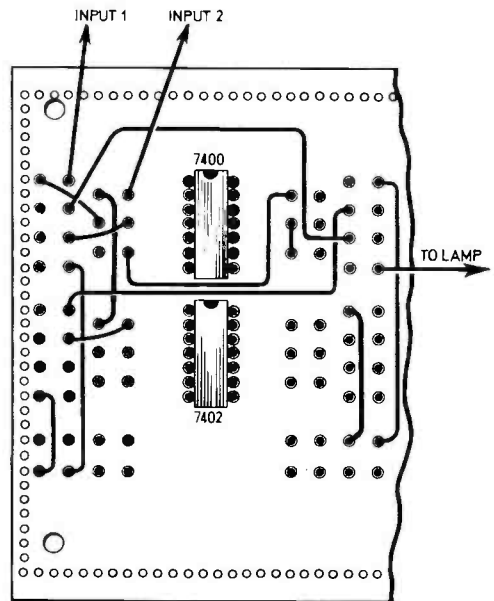
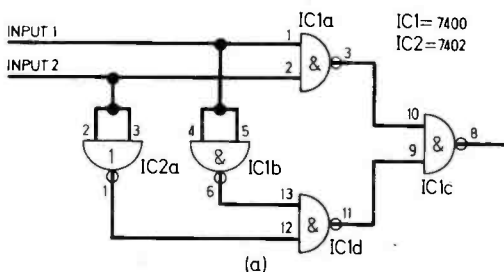

Fig. 3.9. An equivalence gate constructed from a 7400 and a 7402 i.e. (a) shows the circuit and (b) the practical layout.

Table 3.1: Truth Table for the circuit of Fig. 3.9

Inputs		IC1a	IC2a	Outputs		
1	2			IC1b	IC1d	IC1c
L	L	H	H	H	L	H
L	H	H	H	H	H	L
H	L	H	L	H	H	L
H	H	L	L	L	H	H

Now, if input 2 is grounded, the result depends on what state input 1 was at the time that input 2 was grounded.

When input 2 is grounded the output remains fixed (or "latched") at either high or low just as it was at that moment. When input 2 is made positive again the output once more follows input 1.

The explanation of this is that the output comes from the bistable (IC1c and IC1d) and this bistable can only change state if one or other of its inputs goes low. A low will only be obtained from IC1a and IC1b if both inputs to either one of these gates are high. So unless input 2 is high, outputs from IC1a and IC1b can never be high and the bistable can never change state—it remains latched in whatever state it was when input 2 went high.

Table 3.2: Truth Table of Fig. 3.9 with Input 2 high

Input	Output
L	L
H	H

### AN I.C. "CLOCK"

An i.c. pulse generator, or "clock" as computer designers call it, is a circuit which crops up in nearly all complex systems.

It does not look like a clock—

no hands or dials—but it can be made to tick and tell the time and has several other uses as well.

The clock is made from a single i.c., the 7400, as well as a few other components, namely two resistors and two capacitors. The exact value of the capacitors depends on how fast the clock is to run. In fact, it is best to have several pairs of capacitors so that the clock can be set to run at different speeds.

For a start, to get used to the circuit, it is best to use two capacitors of fairly large capacity, say 470µF, capable of storing a large charge. Capacitors of this value will almost certainly be "electrolytic" and the positively marked end must not be allowed to become negative with respect to the other end. With most other capacitors it does not matter which way round they are connected.

It is also interesting to have a pair of capacitors of medium capacity (1µF) and low capacity (0.1µF).

For this work in which the highest voltage encountered is 6V, there is usually no problem as to the working voltage of the capacitors as most are well over this rating.

### THE CIRCUIT IN ACTION

The clock circuit is shown in Fig. 3.11a and the practical layout on the breadboard in Fig. 3.11b.

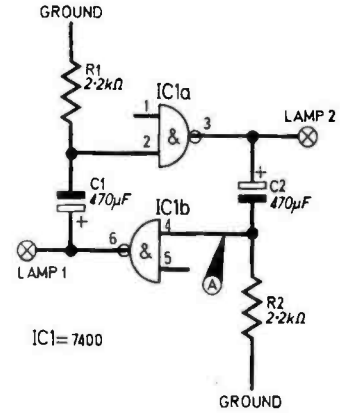

(a)

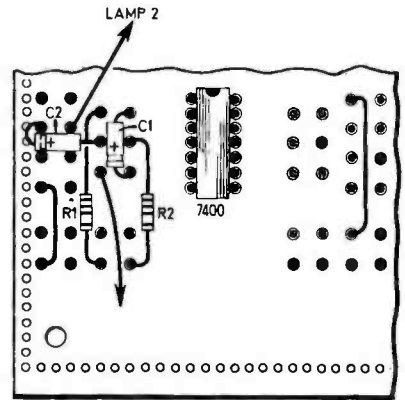

(b)

Fig. 3.11. An integrated circuit clock. (a) shows the circuit and (b) the layout. The frequency of oscillation may be changed by altering the value of the two capacitors C1 and C2.

When it is assembled switch on the supply and watch the lamps.

The lamps will be flashing on and off alternately, the rate of flashing being governed by the values of the two capacitors. With 470µF capacitors there will be about 30 flashes per minute.

Actually if the lamps are watched carefully, it will be noticed that when one lamp goes off the other comes on, each being on for the same time that it is off.

There is something about this regular sequence and also something about the circuit diagram that brings to mind the bistable circuit constructed earlier. This circuit too has two states but it is not stable in either of them—as soon as it changes to one state something happens that causes it to eventually revert to its former state.

The circuit is therefore unstable

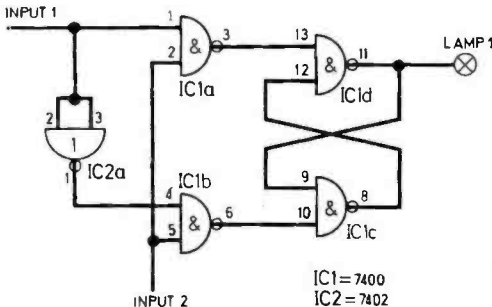

Fig. 3.10. A latch constructed from a 7400 and a 7402 i.c. This circuit "freezes" the state of the bistable when input 2 is taken low.

in either state and this is how it gets the name "astable".

The circuit of Fig. 3.11a uses only one input to each of the NAND gates, the other being left disconnected — effectively high. Try connecting one of them to the ground rail, then connect the other and try to explain what is observed.

## CIRCUIT OPERATION

The action of the circuit is best explained by looking at the state of the voltages just after one gate has switched from low to high.

Capacitor C2 cannot change its charge instantaneously, so as the voltage at the output of IC1a goes from about 0V to 6V, point A also rises from 0V to 6V, thus giving a high input to IC1b whose output goes low.

Now point A is connected to ground via R2 and capacitor C2 gradually charges up until eventually the voltage at point A falls to a voltage equivalent to a low input to IC1b whose output then switches to a high which, in turn, causes the input to IC1a to go high. The output of IC1a switches from 6V to 0V.

Capacitor C1 charges through R1 and capacitor C2 now discharges through R2. Eventually, the voltage at the input to IC1a falls to a low, the output of IC1a goes from low to high and the whole cycle begins again.

## FREQUENCY

Even if this description of how the circuit operates is too difficult to follow, it can be realised that it depends on the charging and discharging of capacitors. This takes time — the larger the capacitance the longer charging or discharging takes and the slower the clock runs.

Try using smaller capacitors, say  $1\mu\text{F}$ . The flashing effect will now probably be too fast to see, the lamps will just appear to glow at half their usual brightness.

To find out what is happening attach a high-impedance earphone to the circuit. Connect one lead of the earphone to one of the outputs and the other to ground. Now the clock can be heard as a tone. The outputs are changing state about two or three hundred times per second, the exact frequency or pitch depending on the values of the capacitors which, though

Table 3.3: Frequencies of notes on the piano (Hz)

C	D	E	F	G	A	B	C	D
256	288	320	341	384	427	480	512	576

marked as  $1\mu\text{F}$  can vary from this by about 20 per cent.

The author found the frequency with  $1\mu\text{F}$  capacitors was the same as the A below middle C on the piano — about 213.5 vibrations per second (213.5Hz).

With a pair of  $0.1\mu\text{F}$  capacitors the note was the same as C three octaves above middle C. Since an octave means a doubling of frequency and middle C is 256Hz, the note therefore had a frequency of about 2048Hz. Though this is a rough and ready way of measuring frequency it has shown that the frequency with  $0.1\mu\text{F}$  capacitors is approximately ten times that with  $1\mu\text{F}$  capacitors, which makes sense.

To measure other frequencies with the aid of a piano, the frequencies of other notes, starting from middle C are given in Table 3.3.

We now have a clock which can give slow pulses useful for timing and can also make "musical" sounds. This finds many uses in later parts of this series.

Before proceeding to the next section, put back the  $470\mu\text{F}$  capacitors and connect the earphone. The clock "ticks", making a sort of electronic metronome. It could be used as a darkroom timer but to be really useful in this application the ticks need to be louder.

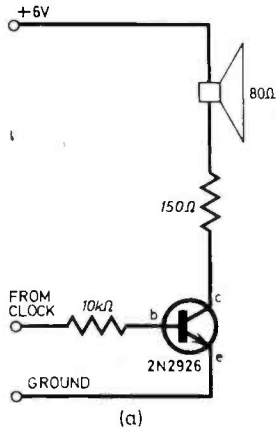

Fig. 3.12. Circuit for a loudspeaker unit.

## LOUDSPEAKER UNIT

The loudspeaker unit uses a transistor to switch current on and off through the speaker in time with the output of the clock. The speaker cannot be directly connected to the clock as it would take too much current.

The output of the clock is connected to the base of a transistor through a 10 kilohm resistor which limits the current. The circuit is shown in Fig. 3.12.

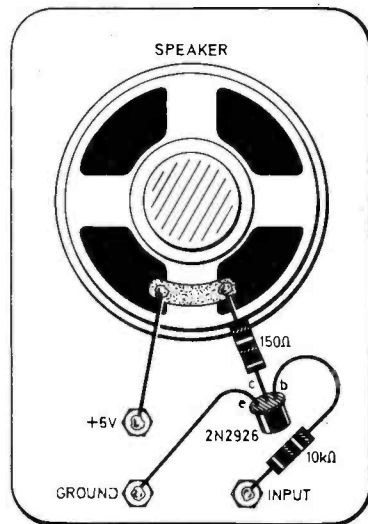

Fig. 3.13. The speaker unit may be constructed as a permanent unit.

When the clock output goes high, current flows into the base which switches the transistor on and a much greater current flows through the speaker and resistor (which simply limits the maximum current) through the collector and emitter to ground.

The circuit gives a really loud note — if it is too loud increase the value of the 150 ohm resistor to about one kilohm or a variable resistor of about one kilohm could be wired in series with the 150 ohm resistor.

For use later on in the series, the loudspeaker unit could be built into a box (Fig. 3.13) although this is by no means essential.

Continued next month

# Get a great deal from Marshall's

A. Marshall (London) Ltd Dept: EE

40-42 Cricklewood Broadway London NW23ET Tel: 01-4520161/2 Telex: 21492  
& 85 West Regent St Glasgow G2 2QD Tel: 041-332 4133  
& 1 Straits Parade Fishponds Bristol BS16 2LX Tel: 0272-854201/2  
& 27 Rue Danton Issy Les Moulineaux Paris 92

Call in and see us 9.5-30 Mon-Fri 9.5-10 Sat  
Trade and export enquiries welcome

160 page Catalogue price 40p  
(30p to callers)

Please enquire for types not listed

Our range covers over 7,000 items. The largest selection in Britain

## Top 200 IC's TTL, CMOS & Linear

CA3020A	£1.45	CD4050	56p	NE555	£1.30	SN7448	89p	SN74160	£1.20
CA3028A	85p	CD4510	£1.54	SN560	44.48	SN7450	21p	SN74161	£1.20
CA3035	47p	CD4511	£1.70	SN565	£1.30	SN7451	21p	SN74162	£1.20
CA3046	73p	CD4516	£1.54	SL414A	£2.35	SN7453	21p	SN74163	£1.20
CA3048	£2.15	CD4520	£1.38	SL610C	£2.35	SN7454	21p	SN74164	98p
CA3052	£1.62	CD4528	£1.38	SL611C	£2.35	SN7460	21p	SN74165	98p
CA3089C	£2.00	LM301AH	47p	SL612C	£2.35	SN7470	35p	SN74167	£4.20
CA3090Q	£4.25	LM308N	£1.17	SL620C	£3.90	SN7472	29p	SN74174	98p
CD4000	20p	LM309K	£1.80	SL621C	£3.50	SN7473	33p	SN74175	98p
CD4001	20p	LM380	98p	SL623C	£5.75	SN7474	33p	SN74176	98p
CD4002	20p	LM381AN	£2.07	SL640C	£4.00	SN7475	46p	SN74180	£2.96
CD4006	£1.16	LM702C	75p	SN7400	21p	SN7476	39p	SN74181	£2.85
CD4007	20p	LM709	57p	SN7401	21p	SN7480	55p	SN74190	£1.48
CD4008	97p	TO99	40p	SN7402	21p	SN7481	£1.25	SN74191	£1.27
CD4009	57p	8DIL	40p	SN7403	20p	SN7482	77p	SN74192	£1.27
CD4010	57p	14DIL	40p	SN7404	20p	SN7483	£1.04	SN74193	£1.27
CD4011	20p	LM704	15p	SN7405	26p	SN7484	£1.00	SN74196	£1.27
CD4012	20p	LM723C	60p	SN7406	59p	SN7485	£1.48	SN74197	90p
CD4013	99p	LM741C	SN7407	59p	SN7486	32p	SN74198	90p	
CD4014	£1.01	TO99	38p	SN7408	22p	SN7490	49p	SN74199	£2.28
CD4015	£1.01	8DIL	38p	SN7409	22p	SN7491	77p	SN76003N	
CD4016	56p	14DIL	40p	SN7410	21p	SN7492	49p		£2.28
CD4017	£1.40	LM740	78p	SN7412	21p	SN7493	49p	SN76013N	
CD4018	£1.01	LM784	SN7413	21p	SN7494	85p			£1.90
CD4019	£1.51	8DIL	44p	SN7416	46p	SN7495	61p	SN76023N	
CD4020	£1.56	14DIL	41p	SN7417	46p	SN7496	88p		£1.91
CD4021	£1.63	LM3900N	55p	SN7420	21p	SN74100	£1.23	SN76033N	
CD4022	£1.63	LM7805P	£1.39	SN7423	30p	SN74107	33p		£2.50
CD4023	20p	LM7812P	£1.39	SN7425	30p	SN74118	99p	TAA263	£1.25
CD4024	79p	LM7815P	£1.39	SN7427	30p	SN74119	£2.07	TAA300	£2.67
CD4025	79p	LM784P	£1.39	SN7430	21p	SN74121	39p	TAA350A	£2.48
CD4027	56p	MC1303L	£1.44	SN7432	20p	SN74122	54p	TAA550	40p
CD4028	91p	MC1310P	£1.91	SN7437	43p	SN74123	40p	TAA611C	£2.25
CD4029	£1.17	MC1330P	92p	SN7438	30p	SN74141	80p	TAA621	£2.15
CD4030	57p	MC1351P	97p	SN7440	21p	SN74145	83p	TAA661B	£1.32
CD4031	£2.28	MC14533	£4.30	SN7441	80p	SN74150	£1.66	TBA641B	£2.50
CD4037	97p	MC1466L	£4.59	SN7442	61p	SN74151	85p	TBA651	£1.80
CD4041	83p	MC1469R	£2.90	SN7444	96p	SN74153	85p	TBA800	£1.29
CD4049	56p	NE555V	48p	SN7477	89p	SN74154	£1.48	TBA810	£1.28
						SN74157	78p	TBA820	£1.00

DOING IT DIGITALLY KIT—AVAILABLE NOW—PRICE £11.75 INCLUDING POSTAGE, PACKING AND VAT—EXCL. BATTERIES

## POPULAR SEMICONDUCTORS

2N696	25p	2N3906	22p	AF139	69p	BD139	42p	MPSA56	20p
2N697	16p	2N4058	20p	AF239	74p	BF115	36p	OC28	£2.00
2N699	55p	2N4062	18p	AF279	80p	BF117	70p	OC42	50p
2N706	12p	2N4921	16p	AF280	85p	BF154	25p	TIP29A	50p
2N708	21p	2N4923	70p	AL102	£1.50	BF180	36p	TIP31A	62p
2N718	16p	2N524	20p	BC107	14p	BF181	36p	TIP32A	75p
2N918	34p	2N5294	35p	BC109	15p	BF184	35p	TIP34A	£1.20
2N1302	37p	2N5296	36p	BC147	10p	BF194	12p	TIP35A	£2.50
2N1306	45p	2N5458	26p	BC149	13p	BF196	13p	TIP36A	£3.35
2N1308	60p	2N5459	29p	BC157	12p	BF197	14p	TIP41A	70p
2N1711	27p	2N6027	48p	BC158	11p	BF198	15p	TIP42A	70p
2N2102	60p	3N128	80p	BC167	12p	BF244	35p	TIP295	£1.00
2N2148	£1.63	3N140	£1.00	BC168	12p	BF258	49p	TIP305S	50p
2N2218A	47p	3N141	85p	BC169	12p	BF259	49p	TIS43	30p
2N2219A	52p	3N200	£2.60	BC182	11p	BF598	27p	ZTX300	15p
2N2220	35p	40361	42p	BC182L	14p	BF739	24p	ZTX301	15p
2N2221	22p	40362	48p	BC183	11p	BF739	24p	ZTX501	15p
2N2222	25p	40406	48p	BC183L	14p	BF739	24p	ZTX502	15p
2N2369	25p	40407	30p	BC184	12p	BF739	24p	ZTX502	15p
2N2646	35p	40408	50p	BC184L	14p	BF739	24p	ZTX502	15p
2N2905	37p	40409	35p	BC122	14p	BF739	24p	ZTX502	15p
2N2906	28p	40410	35p	BC212L	14p	BF739	24p	ZTX502	15p
2N2907	21p	40411	£2.30	BC213L	16p	BF739	24p	ZTX502	15p
2N2926G	13p	40594	75p	BC214L	19p	BF739	24p	ZTX502	15p
2N3053	25p	40595	88p	BC237	14p	BF739	24p	ZTX502	15p
2N3054	30p	40636	£1.15	BC239	19p	BF739	24p	ZTX502	15p
2N3055	29p	40637	73p	BC259	18p	BF739	24p	ZTX502	15p
2N3059	29p	40638	47p	BC259	18p	BF739	24p	ZTX502	15p
2N3393	15p	AC127	44p	BC301	45p	BF739	24p	ZTX502	15p
2N3440	57p	AC128	37p	BC307	20p	BF739	24p	ZTX502	15p
2N3442	£1.20	AC152	50p	BC309	25p	BF739	24p	ZTX502	15p
2N3638	16p	AC153	40p	BC327	20p	BF739	24p	ZTX502	15p
2N3702	17p	AC176	40p	BC328	19p	BF739	24p	ZTX502	15p
2N3703	15p	AC187K	40p	BC328	19p	BF739	24p	ZTX502	15p
2N3706	14p	AC188K	45p	BC372	25p	BF739	24p	ZTX502	15p
2N3708	14p	AD161	75p	BD121	£2.00	BF739	24p	ZTX502	15p
2N3716	£2.60	AD162	75p	BD124	£2.00	BF739	24p	ZTX502	15p
2N3771	£1.60	AF106	45p	BD131	51p	BF739	24p	ZTX502	15p
2N3773	£2.65	AF109	45p	BD132	54p	BF739	24p	ZTX502	15p
2N3789	£2.60	AF115	65p	BD136	36p	BF739	24p	ZTX502	15p
2N3819	36p	AF116	65p	BD137	36p	BF739	24p	ZTX502	15p
2N3904	21p	AF118	65p	BD138	39p	BF739	24p	ZTX502	15p

PRICES CORRECT AT 22ND OCTOBER 1976, BUT PLEASE ADD VAT. P. & P. 30p

## MAGENTA electronics ltd. EE11, 61 Newton Leys, Burton on Trent, Staffs. DE15 0DW

for professional components and service

### COMPONENTS & HARDWARE

Applications. Inclusive prices. No minimum order. Speedy despatch by first class post.

SHEET METALS: CAPACITORS; ENAMELLED & TINNED COPPER WIRES; RESISTORS; CABLE; ICs; TOLDS; SWITCHES; SCREWS; CASES; DIODES; PCB SUPPLIES; TRANSISTORS; PLUGS & SOCKETS; LEDs; DRILLS; VEROBOARD ETC.

### FREE CATALOGUE

INCLUDES SAMPLES & TRANSISTOR TESTER DATA OFFER.

Please send 2 x 6p stamps to cover postage etc.

## CJL LTD. P.O. BOX 34, CANTERBURY, CT1 1YT ALL PRICES INCLUDE P&P AND V.A.T.

<b>AUDIO MODULES (BI-PAK)</b>	
AMPLIFIERS	SW RMS £3.15
10W RMS	£3.50
35W RMS	£7.70
125W RMS	£17.48
<b>PRE-AMPLIFIERS</b>	
Microphone	£2.75
Stereo for 5/10W	£7.50
Stereo for 25W PB Selector	£15.35
<b>STEREO FM TUNER</b>	
Decoder, PB Selector	£22.70
<b>POWER SUPPLY</b>	
10W £1.50, 25W £3.55	
<b>TRANSFORMERS</b>	
10W £2.95, 25W £3.35	
<b>EARPHONE/HEADPHONES</b>	
Crystal £0.65, Stethoscope £1.35	
2,000Ω £3.85, Stereo £4.15	
INTERCOMS 2 station	£8.75
MICROPHONES Dynamic	£2.15
SPEAKERS 75mm dia 8Ω	£1.90
TAPE HEAD	£2.00
DEMAGNETISERS	£3.65
TEST CASSETTES	£2.30

<b>SOLDERING IRONS (ANTEX)</b>	
15W "CCN" Miniature Irons	£3.20
15W "CCN" Low Leakage Irons	£3.45
18W "G" Miniature Irons	£3.25
25W "X25" Low Leakage Irons	£2.90
"SK1" Soldering Kits	£4.40
"MLX" 12V Kits	£4.10
Elements "C" £1.50, "CCN" £1.00	
Elements "G" £1.85, "X25" £1.60	
Bits 3/32in, 1/8in, 3/16in each	£0.50
(N.B. state type of iron)	
"ST3" Stands—for all models	£1.45
<b>SOLDER in handy dispenser</b>	
25W De-Soldering Irons	£0.50
18W De-Soldering Irons	£0.50
Foot Pump	£2.25
<b>WIRE STRIPPERS AND CUTTERS</b>	
£0.85	
<b>WELLER</b>	
Dual Heat Solder Gun Kits	
(Control grip with trigger control, Spotlight)	£10.55

# THE OPEN DOOR TO QUALITY

This 144 page catalogue—Electrovalue Catalogue No. 8 (Issue 2, up-dated) offers items from advanced opto-electronic components to humble (but essential) washers. Many options listed are very difficult to obtain elsewhere. The Company's own computer is programmed to expedite delivery and maintain customer satisfaction. Attractive discounts are allowed on many purchases; Access and Barclaycard orders are accepted. **FREE POSTAGE** on all C.W.O. mail orders in U.K. over £2.00 list value (excluding V.A.T.) if under add 15p handling charge.

EVERYDAY ELECTRONICS  
**TEACH-IN KIT** nett £15.75 inc. V.A.T.

**40p**  
inc. refund  
voucher worth  
40p

All communications to Dept. EE.10  
28 ST. JUDES RD., ENGLEFIELD GREEN, EGHAM, SURREY  
TW20 0EB. Phone Egham 3603. Telex 894478. Shop hours  
9-5.30. 1pm Bats.  
NORTHERN BRANCH: 680 Burnage Lane, Burnage, Manchester  
M19 1NA. Phone (061) 432 4945. Shop hours 9-5.30 p.m.;  
1 pm Bats.



# The Extraordinary Experiments of Professor Ernest Eversure

by Anthony John Bassett

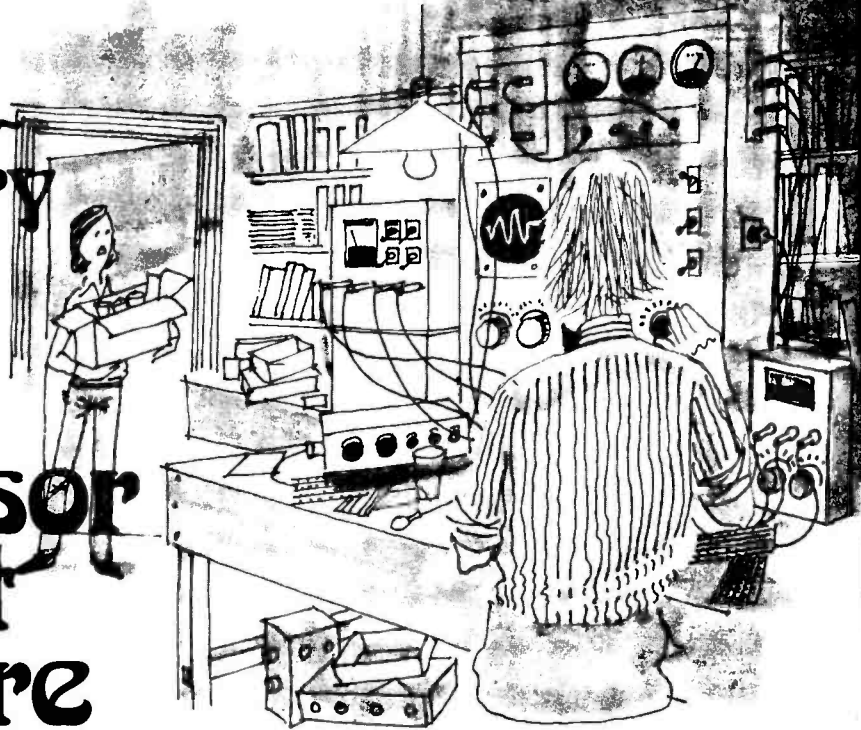

THE Professor continued his comments on Bob's idea for using an electronic impedance converter (Fig. 1) for the matching of an 8 ohm amplifier to a 4 ohm load consisting of two 8 ohm speakers connected in parallel.

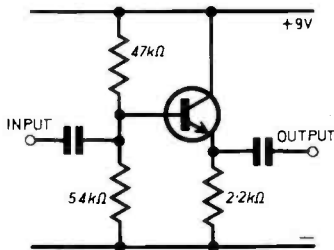

Fig. 1. Bob's circuit for an impedance converter.

"The special type of impedance-converter circuit which may be used really consists of two impedance-converters similar to the one you have drawn, one handling the positive half of the waveform and one the negative half. Special high-gain power-transistors are used, of a type known as 'Darlington transistors'. Each Darlington transistor really consists of two transistors in one case, and often the case also contains two resistors."

The Professor drew a few small sketches (Fig. 2) to show how a

'Darlington' transistor may consist of two transistors and two resistors in one case.

## THE CIRCUIT

He also drew another diagram (Fig. 3) showing the circuit of an experimental impedance converter suitable for use in matching extra loud-speakers to an audio amplifier.

"This circuit uses one Darlington *nnp* power transistor (TR1), and one Darlington *mpn* transistor (TR2). To avoid crossover distortion, each transistor must have a small amount of d.c. passing through it, even when no audio signal is present, and in order to adjust this two preset variable resistors (VR1, VR2) are used to control the bias, one on each

transistor".

"Can we build these impedance converters in time?" Tom wanted to know.

"Yes", the Prof. informed him, "I've got all the parts in stock, and if we all work on it we can build one today".

The Prof. gave some instructions to his experimental robot, and it began to deliver a series of components onto the workbench from the laboratory stores. A few minutes later it delivered a cardboard parcel onto a nearby workbench.

Meanwhile as Tom built a ventilated case for the impedance converter, and Bob assembled the Darlington transistor onto a large finned heatsink, using insulating washers to isolate each transistor from the heat sink, and silicon-

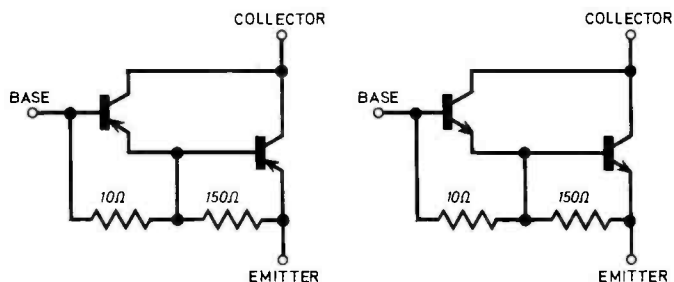

Fig. 2. Basic arrangement of a Darlington transistors.

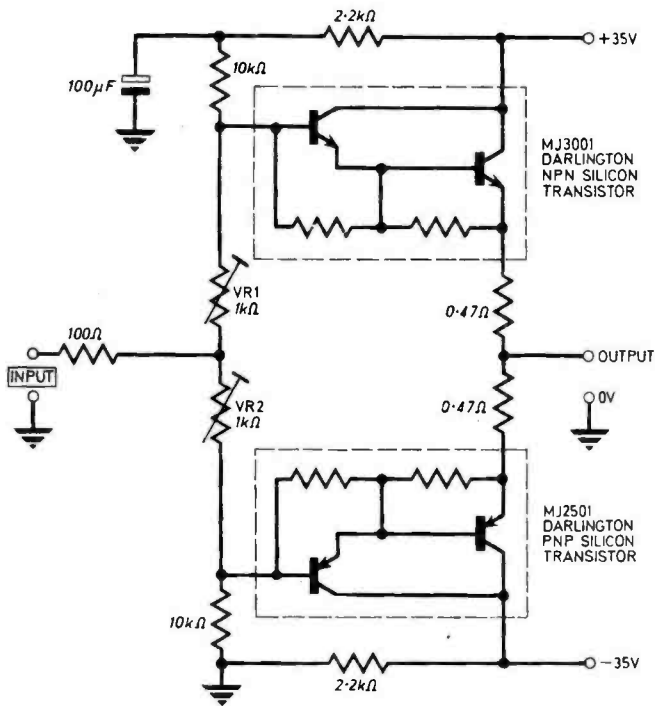

Fig. 3. Circuit diagram of the Prof's impedance converter.

grease to assist heat-transfer, the Professor gave Maurice instructions on how to build a suitable mains power-supply.

### POWER SUPPLY

"Although an electronically regulated power supply would be best", the Professor told Maurice, "for this purpose it is not necessary, and we can build a much simpler and less expensive power supply". He sketched a layout and connection diagram so that Maurice could assemble the

power-supply on a metal panel (Fig. 4).

### GROUP BOARD

Meanwhile Bob had assembled the remaining components onto a groupboard, (Fig. 5) which the Professor inspected very carefully.

"This impedance-converter is a 'Class AB' circuit, and like most other class AB circuits the construction and the bias are very important", the Professor informed Bob. "To begin with we will set the bias to zero".

The Prof. adjusted VR1 and VR2 to give lowest resistance. Soon Maurice brought along the power-supply which he had built, and after a brief inspection of this, the Prof. connected it to the mains and switched on. He measured the voltage across each of the capacitors in turn.

"35.0-35 volts. That is O.K." The Prof. informed Maurice. He disconnected the power-supply from the mains supply, and used a 100

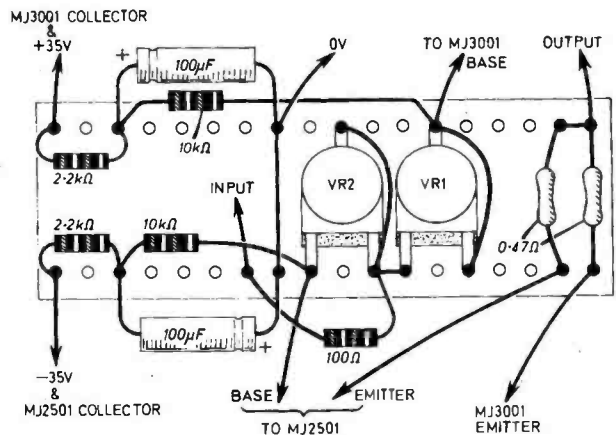

Fig. 5. Bob's layout and wiring of the impedance converter.

ohm wirewound resistor to discharge each capacitor, then connected the three output terminals of the power supply to the appropriate terminals of the impedance converter.

"Now we are ready to set the bias," the Prof. informed Bob and Maurice, "and with this circuit the bias can be set individually on each output transistor".

To be continued

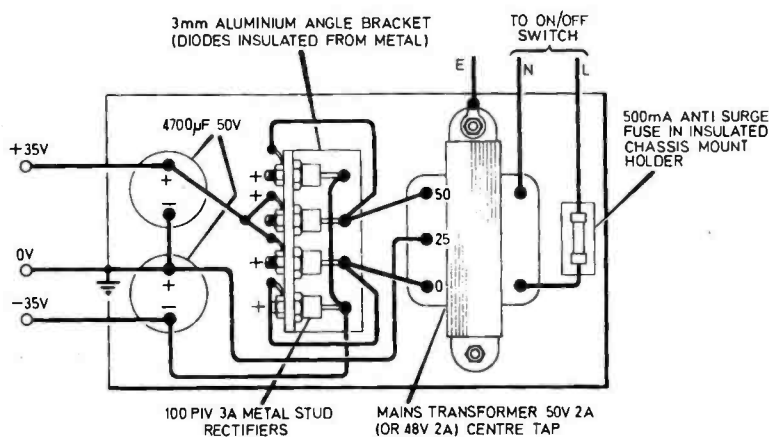

Fig. 4. Layout and wiring of a simple power supply for the converter.

# GEORGE HYLTON brings it down

SEVERAL readers have asked how to add smoothing filters to mains-operated d.c. supply units (also known as battery eliminators, a.c./d.c. converters, and, loosely, as power packs and power supply units or P.S.U.s). They think that adding a smoothing filter will reduce "mains hum" in the equipment.

Well, it may not, but that's a subject in itself. Assuming that you do have a "power pack" which gives out too much ripple, how do you remove the ripple without also removing the d.c.?

It often helps to have a circuit to think about, so try Fig. 1a. This is a common sort of "mains power pack." The high mains voltage (around 240V) is transformed to a low voltage (e.g. 6V) by step-down transformer T1. This low voltage is rectified by the four diodes. These form a bridge rectifier which allows current to flow into the reservoir capacitor C1, only in the direction which drives the upper plate of C1 positive and the lower plate negative. (D2 and D3 conduct for one half-cycle, D1 and D4 for the next, and so on.)

## LOAD EFFECT

If no current (d.c.) is taken from the unit, i.e., if it is "off load," C1 charges to a voltage close to the peak of the a.c. input voltage. The peak is about 1.4 times the nominal voltage; e.g. a voltage of 10V r.m.s. will give about 14V out.

When d.c. is drawn from the unit (by connecting a piece of apparatus) two things happen. First, the output voltage falls. Secondly, it is no longer completely steady, but rises and falls

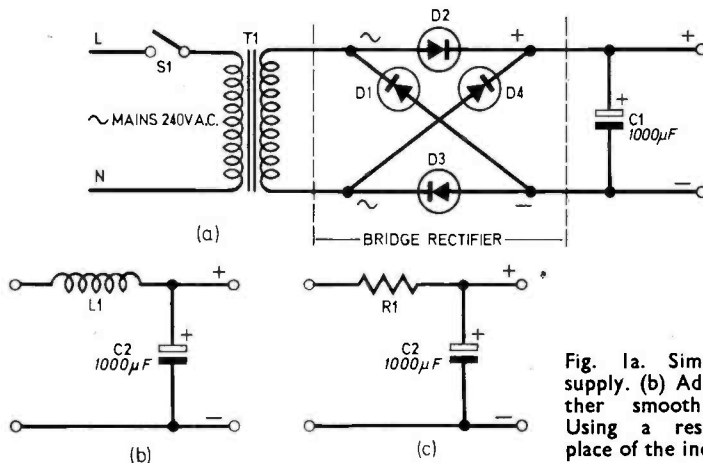

Fig. 1a. Simple d.c. supply. (b) Adding further smoothing. (c) Using a resistor in place of the inductor.

during each half-cycle of the mains frequency.

The reason for this is quite simple. The d.c. output drains part of the charge from C1 and causes the voltage to fall. The voltage is replenished from the transformer, via the rectifier. But the rectifier can only conduct when the a.c. voltage exceeds the d.c. voltage.

Since the a.c. voltage is constantly changing from zero to a peak value and back it follows that the rectifier can only conduct for part of the time; i.e. when the a.c. voltage approaches its peak. The rest of the time, the d.c. voltage stored on C1 exceeds the a.c. voltage and the diode cannot conduct.

This means, in practice, that the rectifier conducts in short sharp bursts. Each burst charges C1 quickly to something like the peak value. Thereafter, until the next burst arrives, the charge on C1 drains away. The resulting ripple on the d.c. output is a sawtooth wave at twice the mains frequency.

## REDUCING RIPPLE

The ripple voltage can cause mains hum in audio apparatus powered by the unit. One way of reducing the ripple is to increase C1. Doubling the capacitance halves the ripple, and so on. To get a tenfold reduction needs a tenfold increase in capacitance, which can mean a large capacitor!

A more effective method is to add a second capacitance, C2, the size of C1, or larger, connected via an inductance L1 (Fig. 1b). It is the property of an inductance that it resists any attempt to change the current it is passing.

Thus if the current tries to fall, the inductance tries to prevent it, and vice versa. Capacitor C2 therefore gets a more constant current, so the voltage across it is more constant (less ripple).

Unfortunately, suitable inductors are expensive. They must have a low resistance and an inductance high enough to be effective. A typical inductor for a power unit rated to supply 100mA would have an inductance of 0.1H (100mH) with 100mA d.c. flowing and a resistance of not more than 10 ohms. Used with a C2 of 1,000µF or more, a 10-fold reduction in ripple will be obtained. The ripple is attenuated by a factor of about  $4LC/10,000$  where L is in millihenries and C in microfarads, and full wave rectification of 50Hz is used.

If you can't get a suitable choke (and they are not easy to obtain) you have to use a resistor (Fig. 1c). The snag here is, that the output voltage is reduced. If  $R1=50$  ohms, and the power pack delivers 100mA, 5V is lost. Fortunately, useful extra smoothing of the d.c. output (i.e. ripple reduction) can often be obtained without losing too much voltage.

If  $C2=1,000\mu F$  its impedance at the ripple frequency (100Hz for 50Hz mains) is about 1.6 ohms. So long as R1 is substantially more than the impedance of C2 at the ripple frequency, a useful amount of ripple reduction is obtained. Whether it is enough is another matter—it depends on how strong the hum is to begin with. The factor by which the ripple is reduced for a 50Hz supply with fullwave rectification is approximately  $6CR/10,000$  where C is in microfarads and R in ohms. Eg.  $C=1,000\mu F$ ,  $R1=10\Omega$  gives a sixfold reduction.

# to earth

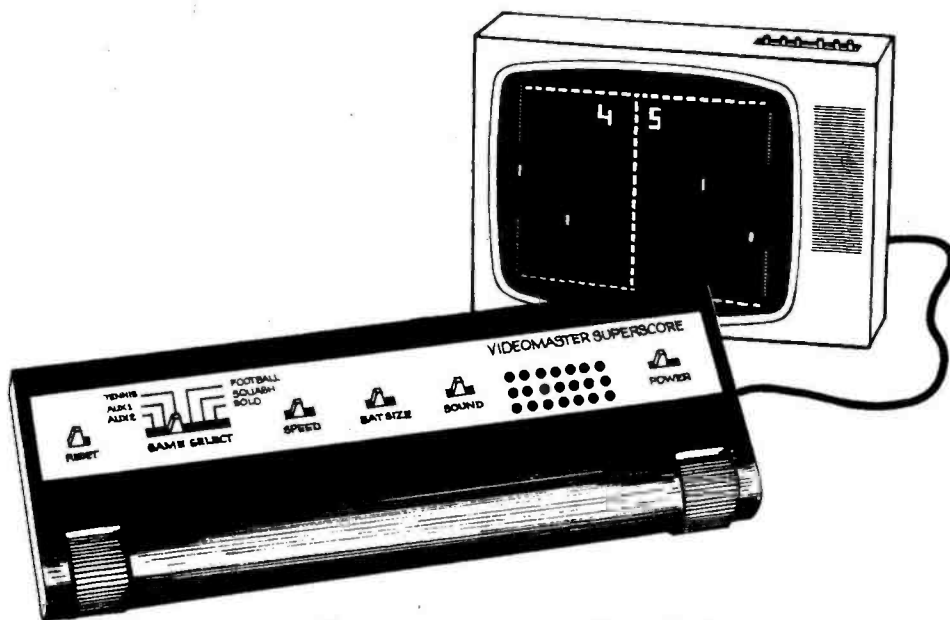

# Here's the remarkable new **VIDEOMASTER™** Superscore Home TV Game Get it together for only **£24.95**

Available to you in kit form at the same moment as its national launch, the brilliant new Videomaster Superscore contains the latest product of MOS technology: a TV game chip.

The logic contained in it had previously to be generated by 100 TTL devices. Now it is condensed into one 28-pin chip.

This all-new Videomaster plugs into your 625-line UHF TV set (for overseas customers having VHF sets we can supply the necessary VHF modulator) to give you four exciting games (including tennis and football) and two future game options. It features on-screen digital scoring, realistic hit sounds, two bat sizes, two

ball speeds, automatic serving and much more. It runs on six 1½ volt SP11 type batteries (not supplied).

The Videomaster Superscore kit costs only £24.95 including VAT (recommended retail price of the ready built model is over £40.00) and comes complete with ready-tuned UHF or VHF modulator, circuit board with printed legend, all resistors, transistors and diodes, built-in loudspeaker, socket for mains adaptor, and, of course, the TV game chip itself.

Easy to put together the Superscore has full assembly instructions, circuit diagram and circuit description. Don't miss this chance to own the newest electronic game at such low cost.

**POST TODAY TO:**

**Videomaster Ltd** 14/20 Headfort Place, London SW1X 7HN



Please send me (insert No. requ'd).....Videomaster Superscore Kits at £24.95 (inc. VAT & P&P in UK) or £23.10+£4.00 for P&P overseas)

I enclose my cheque/money order\* for £.....

VHF modulator required YES/NO\*

EE80

NAME \_\_\_\_\_

ADDRESS \_\_\_\_\_

ALLOW 21 DAYS FOR DELIVERY

\* delete as necessary

# everyday electronics

## VOLUME 5 INDEX

JANUARY 1976 TO DECEMBER 1976

Pages	Issue	Pages	Issue
1-64	January	353-400	July
65-128	February	401-448	August
129-184	March	449-496	September
185-240	April	497-552	October
241-296	May	553-616	November
297-352	June	617-680	December

We are unable to provide back numbers or copies of articles.

### CONSTRUCTIONAL PROJECTS

A.F. SIGNAL GENERATOR. R.F./	386	BEGINNERS SHORT WAVE RECEIVER by R. A. Penfold	424
ACCENTED METRONOME by R. A. Penfold	366	BELL REPEATER. 'PHONE	142, 278
ALARM. BOILING LIQUID	76	BITE INDICATOR. ANGLERS AID—	138
ALARM. GENERAL PURPOSE BURGLAR	534	BOILING LIQUID ALARM by P. J. Tyrrell	76
ALARM. TOUCH SENSITIVE DOOR	410	BRIDGE. RESISTANCE/CAPACITANCE	224
AMPLIFIER. 2 WATT	433	BURGLAR ALARM. GENERAL PURPOSE	534
ANGLER'S AID—BITE INDICATOR by Peter J. Homer	138	BUZZER. LIGHTNING CHESS	258
AQUAGUARD by Stephen Price	362		
AUDIO OSCILLATOR. TWO TONE	104	C-L RESONANCE TESTER by P. H. Alley	480, 605
AUTO COOL by C. E. Loney	384, 439	CAPACITANCE BRIDGE. RESONANCE/	224



CAR REV. COUNTER by C. J. Allen	506	OSCILLATOR. TWO TONE AUDIO	104
CARSAFE SYSTEM by C. J. Allen	274, 340	PEAK LEVEL INDICATOR by R. A. Shackelford	329
CINE TRIGGER. TIME LAPSE	46	PEDAL. WAA WAA	306
CLEAR SKY INDICATOR by A. J. Bassett	564	'PHONE BELL REPEATER by F. G. Rayer	142, 278
CLOCK. DIGITAL	10, 174	POWER CONTROLLER. MAINS	202
CLUNK-CLICK JOGGER by T. R. de Vaux Balbirnie	462, 518	POWER SUPPLY UNIT. STABILISED	46
CONTINUITY TESTER by R. A. Penfold	335	RF/AF SIGNAL GENERATOR by F. G. Rayer	386
CONTROL TRANSMITTER. RADIO	18	RADIO CONTROL TRANSMITTER by R. A. Penfold	18
CONTROLLER. MAINS POWER	202	RADIO. ONE TRANSISTOR	526
COUPLES by Alan Sproxton	415, 518	RECEIVER. BEGINNERS SHORT WAVE	424
DIGITAL CLOCK by P. J. Fischer	10, 174	REPEATER. 'PHONE BELL	142, 278
DOOR ALARM. TOUCH SENSITIVE	410	RESISTANCE/CAPACITANCE BRIDGE by F. G. Rayer	224
ELECTRONIC THERMOMETER by R. A. Penfold	476	RESONANCE TESTER. C-L	480, 605
ELECTRONIC WATCHDOG by O. Bishop	111	REV. COUNTER. CAR	506
ENLARGER EXPOSURE METER by S. R. Lewis	594	RUMBLE FILTER. SCRATCH AND	588
ENLARGER METER by A. P. Donleavy	311	SCRABBLE TIMER by S. R. Lewis	628
EXPOSURE METER. ENLARGER	594	SCRATCH AND RUMBLE FILTER by R. A. Penfold	588
FERMENTATION INDICATOR by S. R. Lewis	458, 518	SHORT WAVE RECEIVER. BEGINNERS	424
FIELD STRENGTH METER by R. A. Penfold	90	SIGNAL GENERATOR. RF/AF	386
FILTER. SCRATCH AND RUMBLE	588	SKY INDICATOR. CLEAR	564
FLASHER LIGHT by James Rawson	656	SNAP INDICATOR by L. Green	168
GENERAL PURPOSE BURGLAR ALARM		STABILISED POWER SUPPLY UNIT by C. F. Terrell	46
by D. H. Williams	534	STARTERS. TRY THESE FOR	510, 572
GENERATOR. RF/AF SIGNAL	386	SUPERHET. UNIT BUILD	218, 280
INDICATOR. ANGLERS AID—BITE	138	SUPPLY UNIT. STABILISED POWER	46
INDICATOR. CLEAR SKY	564	TACHOMETER by B. W. Terrell	156
INDICATOR. FERMENTATION	458, 518	TESTER. C-L RESONANCE	480, 605
INDICATOR. PEAK LEVEL	329	TESTER. CONTINUITY	335
INDICATOR. SNAP	168	THERMOMETER. ELECTRONIC	476
INTERCOM. TOUCH-TO-TALK	196, 340	TIME LAPSE CINE TRIGGER by P. H. Alley	46
JOGGER. CLUNK CLICK	462, 518	TIMER. SCRABBLE	628
LEVEL INDICATOR. PEAK	329	TOUCH SENSITIVE DOOR ALARM by J. H. Telford	410
LIGHTNING CHESSE BUZZER by L. Green	258	TOUCH-TO-TALK INTERCOM by R. A. Penfold	196, 340
LIGHT FLASHER by James Rawson	656	TRANSMITTER. RADIO CONTROL	18
MAGNETONE by Stephen Price	252	TRIGGER. TIME LAPSE CINE	46
MAINS POWER CONTROLLER by John S. Ryle	202	TRY THESE FOR STARTERS	
METER. ENLARGER	311	1 Microphone Preamp	510
METER. ENLARGER EXPOSURE	594	2 Multivibrator	511
METER. FIELD STRENGTH	90	3 Audio Oscillator	572
METRONOME. ACCENTED	366	4 Crystal Set Amplifier	573
MINI ORGAN by R. A. Penfold	650	5 Cassette Power Supply	634
ONE TRANSISTOR RADIO by R. A. Penfold	526	6 Amplifier and RF Probe	634
ORGAN, MINI	650	TWO-TONE AUDIO OSCILLATOR by G. C. Gooch	104
		UNIT BUILD SUPERHET by F. G. Rayer	218, 280
		WAA WAA PEDAL by B. W. Terrell	306
		WATCHDOG. ELECTRONIC	111
		2 WATT AMPLIFIER by R. A. Penfold	433

## GENERAL FEATURES

BOOK REVIEWS	108, 122, 150	READERS' LETTERS	50, 55, 110, 165, 223, 278, 379, 605
BRIGHT IDEAS	45, 174, 340, 578, 592, 661	SHOP TALK by Mike Kenward	17, 93, 141, 206, 284, 344, 383, 491, 512, 571, 636
COUNTER INTELLIGENCE by Paul Young	28, 107, 155, 205, 256, 332, 395, 432, 464, 599, 644	by Brian Terrell	427
EDITORIAL	8, 74, 136, 194, 250, 304, 360, 408, 456, 504, 562, 626	JACK PLUG AND FAMILY	36, 92, 212, 273, 379, 413, 474, 538, 609, 640
PLEASE TAKE NOTE	174, 278, 340, 439, 518, 605, 654	USING WIRING BOARDS	509
PROFESSOR ERNEST EVERSURE by Anthony J. Bassett	52, 118, 171, 228, 285, 338, 393, 440, 488, 537, 606, 668	YOUNG CIRCUIT IDEAS	483
		WIRE BENDING GAUGE	257

## SPECIAL FEATURES

ABOUT POWER SUPPLIES by J. H. Smith	79	GUIDE TO CIRCUIT BOARDS AND CONSTRUCTION	
CALCULATORS GALORE by Adrian Hope	38	METHODS by Mike Hughes	96
CHANNEL APPROACH AID by G. A. G. Brooke	539	I.C.s EXPLAINED by Brian Dance	270, 325, 380, 438, 484
EE KIT REPORT Sinclair Black Watch	162, 233	NOISE REDUCTION SYSTEMS by Adrian Hope	522, 582, 645



# Technical Training in Radio, Television and Electronics

ICS have helped thousands of ambitious people to move up into higher paid, more secure jobs in the field of electronics now it can be your turn. Whether you are a newcomer to the field or are already working in the industry, ICS can provide you with the specialised training so essential to success.

## Personal Tuition and Guaranteed Success

The expert and personal guidance by fully qualified tutors, backed by the ICS guarantee of tuition until successful is the key to our outstanding record in the technical training field. You study at the time and pace that suits you best and in your own home. In the words of one of our many successful students: "Since starting my course, my salary has trebled and I am expecting a further increase when my course is completed."

## City and Guilds Certificates

Excellent job prospects await those who hold one of these recognised certificates. ICS can coach you for: Telecommunications Technicians, Radio, TV Electronics Technicians, Technical Communications, Radio Servicing Theory, Radio Amateurs, Electrical Installation Work, Also MPT Radio Communications Certificate

## Diploma Courses

Colour TV Servicing, Electronic Engineering and Maintenance, Computer Engineering and Programming, Radio, TV and Audio, Engineering and Servicing, Electrical Engineering, Installations and Contracting

## Qualify for a New Career

Home study courses for leading professional examinations and diploma courses for business and technical subjects:—

G. C.E.	Engineering	Purchasing
60 subjects	Farming	Sales
at "O" &	Heating	Storekeeping
"A" levels	Industrial	Work Study
Accountancy	Management	
Air Conditioning	Mechanical	
Building		

**POST OR PHONE TODAY FOR FREE BOOKLET.**

## ICS To: International Correspondence Schools

SINCE 1890  
Dept 710A Intertext House, London  
SW8 4UJ or telephone 622 9911

Subject of Interest \_\_\_\_\_

Name \_\_\_\_\_

Address \_\_\_\_\_

Telephone Number \_\_\_\_\_

# Your free start to a rewarding new hobby.



Heathkit make the world's largest range of electronic kits.

Including hi-fi, amateur radio, test equipment and general interest kits.

Every one of which comes to you absolutely complete—right down to the last nut and bolt.

You'll also get a very easy to understand instruction manual that takes you step by step through the assembly.

So, besides making an attractive, useful piece of equipment, you'll also have the makings of a satisfying, rewarding hobby.

To find out more, post the coupon we'll send you our latest catalogue.

Heath (Gloucester) Ltd.,  
Dept. EE-126, Bristol Rd.,  
Gloucester, GL2 6EE.  
Tel: Glos (0452) 29451

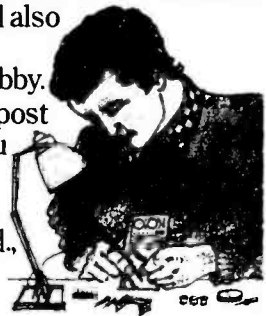

## HEATHKIT

**BETTER BUILT BECAUSE YOU BUILD IT YOURSELF**

**The new Heathkit catalogue. Out now FREE.**

To: Heath (Gloucester) Ltd., Dept. EE-126, Gloucester, GL2 6EE. Please send me my Heathkit catalogue. I enclose an 11p stamp for postage.

Name \_\_\_\_\_

Address \_\_\_\_\_

Postcode \_\_\_\_\_



**EASY TO USE AVAILABLE WITH HEATHKIT**

Showrooms at 233 Tottenham Court Road, London and Bristol Road, Gloucester.

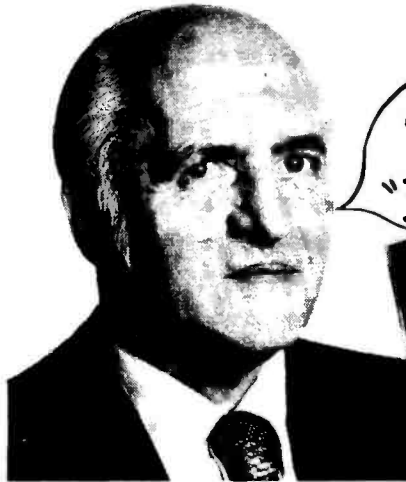

HOME RADIO  
have a  
"Double Feature"



Please write your Name and Address in block capitals

NAME .....

ADDRESS .....



POST  
THIS  
COUPON  
with cheque  
or p.o. for  
**£1.40**

By the way, the price of the catalogue is £1 plus 40p for postage and packing. Why hesitate? Send off your cheque or Postal Order for £1.40 today, together with the coupon on the left.

HOME RADIO (Components) LTD. Dept. PV  
234-240 London Road, Mitcham, Surrey CR4 3HD

(Regn. No.  
London 912966)

The price of £1.40 applies only to customers in the UK and the BFPO Addresses.

Perhaps you have to be of my vintage to know the phrase "a Double Feature", but up to a few years ago cinemas always ran a main film and a supplementary film. I was reminded of it because with their new catalogue Home Radio Components are now giving away a supplementary catalogue of bargain lines.

It sounds a very practical and sensible idea. After all, most electronic component firms accumulate surplus stocks of various items, and rather than dispose of them, why not offer them to customers at exceptionally low prices? I'm told that this bargain list will continue for several months and be updated from time to time.

No constructor should be without the Home Radio Components Catalogue (it contains 5,000 items clearly listed plus about 2,000 illustrations) but now you have a double incentive for buying one. In addition to getting one of the finest component catalogues available, you also receive a list of bargains at unbelievably low prices. For example, Gemini Mains Transformers: normal price £11.48, bargain list price £5, saving £6.48! This means that with a single purchase from the bargain list you can save the price of your catalogue several times over!

**HOME RADIO (Components) LTD. Dept EE, 234-240 London Road, Mitcham, CR4 3HD Phone 01-648 8422**

## 4-STATION INTERCOM



**£17.95**

+ V.A.T. £1.44

Solve your communication problems with this 4-Station Transistor Intercom system (1 master and 3 Subs), in robust plastic cabinets for desk or wall mounting. Call/talk/listen from Master to Subs and Subs to Master. Ideally suitable for Business, Surgery, Schools, Hospitals and Office. Operates on one 9V battery. On/off switch. Volume control. Complete with 3 connecting wires each 66ft. and other accessories. P. & P. 85p.

**MAINS INTERCOM NEW MODEL**  
No batteries—no wires. Just plug in the mains for instant two-way, loud and clear communication. On off switch and volume control. Price £21.49 per pair P. & P. 85p.

## NEW! AMERICAN TYPE CRADLE TELEPHONE AMPLIFIER



**£12.95**

+ V.A.T. £1.04

Latest transistorised Telephone Amplifier with detached hand in speaker. Placing the receiver on to the cradle activates a switch for immediate two-way conversation without holding the handset. Many people can listen at a time. Increase efficiency in office, shop, workshop. Perfect for "conference" calls: leaves the user's hands free to make notes, consult files. No long waiting, saves time with long-distance calls. On/Off switch, volume. Direct tap recording model at £14.95 + V.A.T. £1.20 P. & P. 75p, 10-day price refund guarantee.

WEST LONDON DIRECT SUPPLIES (E.E.12)  
189 KENSINGTON HIGH STREET, LONDON, W8

YES SIR 1st class post TONIGHT!

We specialise in high spec components with express service for phone customers



## HIGH SPEC components FAST!

Agents for VERO - ANTEX -

### BIB MULTICORE SOLDER

- OPEN 9am-5pm, 6 days—Phone orders 9am-4pm.
- S.A.E. for stock list including pots, presets, I.C.'s 7400 & CMOS.
- capacitors, plugs, sockets, switches, cable, etc.
- Post free envelope included for your next order.
- SUPER EXPRESS phone service—ask for details.
- Shop at keen prices 6 days per week. Late night—Fri. 7-10pm.

### TRANSISTORS - 200 OTHER TYPES IN STOCK

AC125 25p	BC109 11p	BC202A 13p	BFX29 26p	TIP41A 67p
126 25p	109B 12p	287 22p	84 22p	42A 80p
127 25p	109C 13p	300 27p	88 22p	TIS43 35p
128 25p	117 18p*	301 28p	BFY50 17p	ZTX300 13p*
151 35p	142 22p	303 36p	51 18p	302 18p*
153 35p	143 24p	338 16p*	52 18p	500 15p*
176 25p	147A 9p*	557 9p*	BY144 40p	502 18p*
187 25p	147B 10p*	BCV71 18p	ME0401 18p	1N914 5p
188 25p	148 9p*	72 14p	0411 18p*	1N4001 5p
AD149 68p	148B 10p*	BD123 30p	ME4001 18p*	4002 6p
161 42p	149 11p*	124 68p	4101 11p*	4005 9p
182 42p	149C 11p*	131 36p	MPF102 32p*	4006 10p
MCH/PR 154 18p*	132 38p	132 38p	OA47 8p	4146 5p
1.04	157B 12p*	139 54p*	90 20p	2N2219 20p
AF116 24p	177 17p	155 75p*	91 4p	2646 40p
117 24p	178B 18p	BF158 29p*	200 6p	2928O 13p*
124 30p	179B 19p	184 25p	OC28 90p	2928G 15p*
239 37p	184B 12p*	185 29p	29 58p	3053 18p
AU113 150p*	184L 11p*	184 11p*	35 80p	3065 60p
BC107 11p	187 20p	195 22p*	44 30p	3702 11p*
107A 12p	212A 13p*	197 12p*	71 25p	3703 16p*
108 10p	212L 15p*	199 15p*	ORP12 65p	3704 13p*
BC108 6p	213B 12p*	200 34p	TIP29A 47p*	3705 10p*
BC108B 11p	214 15p*	338 34p	30A 36p*	3707 12p*
108C 12p	214L 17p*	BFV11 65p	31A 57p	3819E 25p*

### DIODES

50V 3A 13p  
100V 3A 15p  
200V 3A 18p  
400V 3A 21p

### BRIDGES

100V 1A 24p  
200V 1A 25p  
400V 1A 28p

### RESISTORS 1/2w each

WATT E12 (5%)  
1 ohm - 10m ohm  
ZENERs(400mw) BZX83  
3V, 3V3, 5V1, 5V8, 7V5,  
9V1, 10V, 12V, 18V, 22V,  
30V. All at 12p each.

### LINEAR I.C.'s

LM380 SL00745 1.25  
LM3900N 60p  
NE555 90p  
SN76013ND 1.00  
SN76013N 1.75  
SN76023N 1.75  
TBA800 1.35  
TBA810S 1.48  
TBA820 1.28  
ZN414 1.35

### THYRISTORS

60V 1A 29p  
600V 1A 80p TAG 1 600  
700V 1A 1.28 BT106  
400V 4A 58p CT106D1  
500V 61A 1.25 BT109

### LED T11 200/0.125 0.2"

Red 29p  
Grn 29p  
Clips for above 1p.

Post & Packing 25p per order. V.A.T please add to total \* 12 1/2%, rest 8%

## ORCHARD ELECTRONICS

FLINT HOUSE, HIGH STREET, WALLINGFORD, OXON, OX18 8DE  
Telephone 0491 35529.

*Page 677 missing*





## RECEIVERS and COMPONENTS

IN4148 4p. Disc Ceramics .01, .02, .04, 3p. Polyester Caps - 1 250v 2p ea. 16p doz. Large Red L.E.D.s 20p, 6 for £1.00. Loudspeakers 8 ohm 2", 2 1/2", 80 ohm 2 1/2" 75p ea. 3 Digit Counters 15p. Mains Relays Treble Pole c/o £1-10. Small Mains Motor 250 rpm 45p. Siren 6v DC £1-28. Burglar Alarms Batt Op 75p. Reed Switch large/small 10p. Miniature Push to Test Switch 20p. Croc Clips red/black 7p. 90v Neons 8p. Veroboard 4" x 3" 35p. 8Ω Earphone & Plug 18p. Intercom Cases 35p. Enamelled Copper Wire 32, 34, 36, 38 SWG 1p ft. Tuning Capacitors 15pf 45p. Small Jap Radio Type 30p. Pops 10K, 25K, 1M LIN 16p. Solder 5p yd. Ferrite Rods 4 1/2" x 1/2" 18p. Slide Switch DPDT 16p. BC107/8/9 15p. BC147/8/9 15p. Cassette Mikes with 3.5mm & 2.5mm Plug £1-30. Asstd Transistor IFs 8 for 50p. Bank of 6 Reed Switches 38p. Resistors 1W 2p ea. Prices include VAT. Add 15p Post.

### GRIMSBY ELECTRONICS

64, TENNYSON ROAD, CLEETHORPE, HUMBERSIDE.

100's of Bargains at our Lambert Road Components shop (open Saturdays. 1976-77 List 9p.

### VALVES

Radio-TV Industrial Transmitting 2,200 Types, 1930 to 1975, many obsolete. List 20p S.a.e. for quotation. Postal export service. We wish to purchase all types of new and boxed valves. Wholesaler's, Dealer's, etc. stocks purchased.

COX RADIO (SUSSEX) LTD.,  
The Parade, East Wittering, Sussex.  
Tel: West Wittering 2823.

### NO LICENSE EXAMS NEEDED

To operate this miniature, solid-state Transmitter-Receiver Kit. Only £8-25 plus 20p P&P. 'Brain-Freeze' 'em with a MINI-STROBE Kit, pocket-sized 'lightning flashes', vari-speed, for discos and parties. A mere £3-80 plus 20p P&P. Experiment with a psychedelic DREAM LAB, or pick up faint speech/sounds with the BIG EAR sound-catcher; ready-made modules. £4-75 each plus 20p P&P. LOTS MORE! Send 20p for lists. Prices include VAT. (Mail order U.K. only).

### BOFFIN PROJECTS

4 Cunliffe Road, Stoneleigh Ewell, Surrey. (E.E.)

### WANTED

INFORMATION REQUESTED about Power Pack for infra-red monocular night viewing device. Prepared to purchase complete serviceable instrument. Broadhead, Low Burnham, Doncaster DN9 1DB. Elworth 872614.

# SMALL ADS

The prepaid rate for classified advertisements is 14 pence per word (minimum 12 words), box number 40p extra. Semi-display setting £9.00 per single column inch (2.5cm). All cheques, postal orders, etc., to be made payable to Everyday Electronics and crossed "Lloyds Bank Ltd." Treasury notes should always be sent registered post. Advertisements, together with remittance, should be sent to the Classified Advertisement Manager, Everyday Electronics, Room 2337, IPC Magazines Limited, King's Reach Tower, Stamford St., London, SE1 9LS. (Telephone 01-261 5918).

### CONDITIONS OF ACCEPTANCE OF CLASSIFIED ADVERTISEMENTS

1. Advertisements are accepted subject to the conditions appearing on our current advertisement rate card and on the express understanding that the Advertiser warrants that the advertisement does not contravene any Act of Parliament nor is it an infringement of the British Code of Advertising Practice.
2. The publishers reserve the right to refuse or withdraw any advertisement.
3. Although every care is taken, the Publishers shall not be liable for clerical or printers' errors or their consequences.

"GLENN MILLER" collector requires recordings taken from: BBC Broadcasts during 1944-5 of the American Band of the AEF under the headings: "AEF BAND" "SWING SHIFT" "UPTOWN HALL" "JOHNNY DESMOND SINGS", "STRINGS WITH WINGS" etc. condition not important, tape copies acceptable, good price paid or will exchange from my unique collection. A. Hibberd, 59 Waverley Road, Rugby, Warks. or phone: day 76473, evening 71066.

### BOOKS and PUBLICATIONS

#### Start your own business printing pound notes

Printing pound notes? Well not quite—but "Start your own business rewinding electric motors" could easily be your licence to make money in 1976.

Lavishly illustrated, this unique instruction manual shows step by step how to rewind motors, working part or full time, without experience. Everything you need to know easily explained. Including where to obtain materials, how to get all the work you need, etc., etc.

A goldmine of information and knowledge. Only £3-99 plus 26p P & P from:

MAGNUM PUBLICATIONS, Dept EE5, Brinkaway Trading Estate, Brinkaway, Stockport SK3 6EZ.

### SERVICE SHEETS

SERVICE SHEETS, Radio, TV, etc., 50p and SAE. Catalogue 20p and SAE. Hamilton Radio, 47 Bohemia Road, St. Leonards, Sussex.

BELL'S TELEVISION SERVICE for service sheets of Radio, TV etc. 75p plus SAE. Colour TV Service Manuals on request. SAE with enquiries to BTS, 190 King's Road, Harrogate, N. Yorkshire. Tel: 0423 55885.

### FOR SALE

40 ISSUES EVERYDAY ELECTRONICS April 1973 onwards in mint condition. Offers please Box No 7.

ELECTRONICS COURSE PLUS OSCILLOSCOPE. Hardly used. Cost £120, for £50. J. McCormick, 57 Arran Avenue, Port Glasgow, Renfrewshire.

FOR SALE—Back issues Everyday Electronics 1972-73. Offers. 041-884 4258.

### MISCELLANEOUS

STYL, CARTRIDGES & AUDIO LEADS ETC. For the best at keenest prices send SAE for free illustrated list to: FELSTEAD ELECTRONICS, (EE), Longley Lane, Gatley, Cheshire, Cheshire SK8 4EE.

### MINI ACCUMULATORS



2 volt MULTI-USE Sealed Lead Acid Rechargeable Cells.

Size L450—1.4" x 1.1" x 0.44". 3 for £2.65  
Size GA2—1.7" x 1.3" x 0.5". 3 for £2.95  
Add 25p P. & P. any qty"

Suits Fi-Cord

GARFIELDS, 295 Rye Lane, London SE15

RECHARGEABLE NICAD BATTERIES: 'AA' (HP7) £0-98. 'Sub C' £1-16. 'C' (HP11) £1-92. 'D' (HP2) £2-59. 'PP3' £4-48. Matching charges respectively, £4-48, £4-48, £4-98, £3-98. All prices include VAT. Please add 10% post and package. S.A.E. for full list plus 30p for information booklet if required. S AND W ELL PLANT LIMITED, 1 Denholm Road, Sutton Coldfield, West Midlands O21 354 9784.

### LOUDSPEAKERS



Speakers, kits and cabinets for D.I.Y., Hi Fi, P.A., Disco, etc. by EMI, Fane, Goodmans, Baker, Kef, Elac, Richard Allan, Wharfedale, etc. Send stamp for free booklet "Choosing a speaker"

### WILMSLOW AUDIO

Dept. EE, Swan Works, Bank Square, Wilmslow, Cheshire SK9 1HF  
Tel. Wilmslow 29599

BARGAIN BOX for BEGINNERS containing 2 Transistor/component panels, 1 Relay, 1 Rectifier, 1 earphone insert, 1 mike insert, 2 diodes, 1 buzzer, 3 core cord, 1 salvaged tool—an ideal collection for experiments. £1 20 inc. VAT & P.P. 5 digit counter, 40 digits/sec., 24-48v. non-reset, brand new GPO type 85p inc. Also 3, 4, 5, 6 & 9 core cords many other telephone spares at give away prices! Trade enquiries welcome. S.A.E. for lists or orders to:

### B. B. SUPPLIES

141, Shalmsford St., Near Canterbury, Kent. CT4 7QZ.

### ENAMELLED COPPER WIRE

SWG	1 lb	4oz	2oz
14-19	2-40	60	30
20-29	2-45	82	39
30-34	2-60	89	64
35-40	2-85	1-94	75

Inclusive of p&P and VAT.

SAE brings Catalogue of copper and resistance wires in all coverings.

THE SCIENTIFIC WIRE COMPANY  
PO Box 30, London E4 9BW

**NEW! From H.M. ELECTRONICS  
A BASIC D.I.Y. CASE**

- ★ One piece aluminium chassis.
- ★ Whitewood Ply end cheeks, that can be painted, stained, etc.
- ★ Simulated black leathergrain lid.

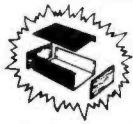

**REAL VALUE  
FOR MONEY**

GB1	14" x 6" x 2"	£2 65	Post and Packing
GB1a	9" x 6" x 2"	£2 05	90p
GB2	14" x 7" x 3"	£3 25	Plus
GB3	14" x 9" x 4"	£3 95	V.A.T.
Mini-Boc	7" x 5" x 3"	£1 75	V.A.T.

Other Types and Styles. Dry Transfer lettering.  
Send 15p for leaflets to:—  
275a Fulwood Road, Broomhill, Sheffield.  
S16 3BD

**AN L.C.D. FOR UNDER £22!**

**OUR INTRODUCTORY OFFER—**

**INSTAR 103P L.C.D.**  
Continuous readout of Hrs, Mins, and pulsating Secs. Gold plated case with S/S back and matching bracelet. Presentation box. Limited availability £21.50



**Special offer—new from U.S.A. FAIRCHILD TIMEBAND L.C.D.'s**  
These are beautiful watches.

5 + 4—Functions  
Constant readout Hrs, Mins, and pulsating Secs. Single command button—push once for Month/Date—auto return—twice for continuous Secs readout. Manual reset.  
+ PLUS + Auto 4—Yr calendar adjust/Backlight/ A.M.—P.M. setting Indicator



Optional cont. alt. Time—Date display.  
TC 411 Chrome finish £29 50  
TC 410 Gold plated £32 50  
With Leather strap and Presentation Box.  
Not illustrated  
TC 413 Chrome finish £34 50  
TC 412 Gold plated £37 50  
With matching bracelet and Presentation Box. Illustrated

**VERY SPECIAL L.E.D. OFFER**

**GALA 6 + 3 Functions**  
Hrs, Mins, Secs, Alpha Day, Date, and Month + PLUS + Auto 4—Yr calendar adjust/ A.M.—P.M. setting Indicator/ Auto hold and fade-out.  
Available in S/S or Gold-plated with S/S back and matching bracelet.  
Sold elsewhere at £22.95  
**OUR SPECIAL PRICE £18.95**



No quibble, 1 Year Guarantee. Prices include V.A.T. and P. & P. Free Battery/s. Compare our prices and specifications.

Send cheque/Money Order to:—  
**TEMPUS, Dept. E.E. 5-7 NORFOLK STREET CAMBRIDGE CB1 2LD Tel. 55094**

**DENCO (CLACTON) LIMITED**

Dept. E.E.

**357-8-9 OLD RD.,  
CLACTON-ON-SEA  
ESSEX CO15 3RH**



Our components are chosen by technical authors and constructors throughout the world for their performance and reliability, every coil being inspected twice plus a final test and near spot-on alignment.

General Catalogue showing full product range 32p. Overseas Customers 70p, Air-Mail Post Paid.

**U.K. & OVERSEAS MANUFACTURERS/STOCKISTS ENQUIRIES WELCOME**

Australian Readers Please Note—Our Complete Range of Coils are available from Hobipak, Box 224, South Carlton, 3053, Victoria, Australia and Watkin Wynne Pty. Ltd., 32, Falcon Street, CROWS NEST, 2065, AUSTRALIA. P.O. Box 392.

**TREASURE TRACER**

**MK III Metal Locator**



- Varicap tuning
- Britain's best selling metal locator kit; 4,000 sold
- Weighs only 22oz. Fitted with Faraday shield
- Speaker and earphone operation
- Knocks down to only 17in
- Prebuilt search coil assembly
- Thoroughly professional finish
- As seen on BBC1 and BBC2 TV
- You only need soldering iron, screwdriver, pliers and snips
- Five transistor circuit

Send stamped addressed envelope for leaflet

£14.75 Buy 3 send £19.75

**MINIKITS ELECTRONICS**  
5b CLEVELAND ROAD,  
LONDON, E15 2AN (Mail order only)

**PLEASE MENTION EVERYDAY**

**ELECTRONICS WHEN REPLYING**

**TO ADVERTISEMENTS**

OVER 2,000 ELECTRONIC COMPONENTS IN A

**BIG NEW FREE**

**100 PAGE CATALOGUE**

**YOURS BY POSTING TODAY**

Please send me the 100 page Tandy catalogue

Name \_\_\_\_\_

Address \_\_\_\_\_

Tandy Corporation (Branch UK), Bilston Road, Wednesbury, W. Midlands WS10 7JN.



**TANDY**  
Nationwide supermarket of sound!

Everyday Electronics, December 1976

**GREENWELD**

443 Millbrook Road Southampton  
SO1 0HX Tel: (0703) 772501

OPEN 6 DAYS A WEEK, 9 to 5. Callers Welcome.  
44 Page Illustrated Catalogue only  
VAT INCLUSIVE PRICES—NO EXTRAS TO PAY, JUST ADD 25p POST.

**VEROBOARD**  
100 sq ins asstd size offcuts (no tiny bits). All 0.1 or mixed £1.20. 17 x 31" x 0.1 sheets £1.80.

**CAPACITORS**  
Miniature ceramic plate. 50V 5%. 22pF to 1000pF 2p; 1500F to 0.47uF 4p. Polystyrene, 160V 2½%. 10pF to 1000pF 4p; 1200pF-10,000pF 6p; Polyester 250V Mullard C280 0.1 to 0.1uF 4p; 15, 225p; 336p; 478p; 6810p; 1uF 12p; 2.2uF 18p; 3.3uF 33p; 63V 24p. Electrolytic. 0.47, 1, 2.2, 4.7, 10, 22, 47uF 25V all 6p; 100uF 25V 7p; 100uF 63V 9p; 220uF 16V 7p; 220uF 25V 9p; 220uF 50V 11p; 470uF 16V 9p; 470uF 25V 11p; 470uF 63V 18p; 1000uF 16V 15p; 1000uF 25V 18p; 1000uF 50V 32p; 2200uF 16V 20p; 2200uF 25V 27p; 2200uF 40V 48p; 4700uF 16V 43p. All are wire ended horizontal mounting types.

**TRANSISTORS AND IC's**  
AC127 15p BD131 28p 2N2369 22p  
AC128 15p BD132 28p 2N2546 42p  
AC176 16p BD138 40p 2N2926G  
AC187 18p BD139 44p 12p  
AC188 18p BD140 48p 2N3053 18p  
AD161 40p BF181 28p 2N3054 49p  
AD162 40p BF194 14p 2N3055 35p  
BC107 19p BF109 22p 2N3440 54p  
BC109 19p BF184 28p 2N3442  
BC109 19p BF194 28p 2N3442  
BC109C 15p BF194 28p 2N3442  
BC182 12p BF194 28p 2N3702 19p  
BC183 12p BF194 28p 2N3703 19p  
BC184 12p BF194 28p 2N3705 19p  
BC212 14p TIP265 95p 2N3708 19p  
BC213 14p TIP265 95p 2N3819 22p  
BC214 14p TIP265 95p 2N3819 22p  
BCY70 15p 2N706 13p 2N4418 10p  
BCY71 15p 2N1613 26p 2N5294 39p  
BCY72 15p 2N2219 26p 40673 59p  
741 8 pin DIL 25p; 555 Timer 46p.  
8 pin sockets 12p.

**DIODES & LED's**  
1N4001 25p; 1N4003, 46p; 1N4005 7p; 1N4006 8p; 1N4007 8p; 1N4148 4p; OA81 5p; OA91 5p; BY127 12p; 100V3A 12p; 400V 3A 15p. Bridges: 50V 1A 22p; 800V 1A 48p; 250V 1A 48p; 250V 3A 70p; TIL209 Red LED 15p; 0.2" Red 22p, green or yellow 24p.

**RESISTORS**  
Miniature ½W Carbon Film Hi-stabs. All values from 1 ohm to 10 Megohm 5% (Over 1M 10%) 1½p each. 1W Metal film 5%. All values from 27 ohms to 10M. 2½p each.

**WIRE**  
Enamelled copper wire on 2oz reels. SWG/Price: 18/32p; 18/34p; 20/34p; 22/38p; 24/48p; 26/48p; 28/44p; 30/48p; 32/48p; 34/52p; 36/52p; 38/54p; 40/56p. Connecting wire, 40 x 2 metre lengths solid core asstd colours £1.5 x 5yd coils flex 23p.

**TRANSFORMERS**  
6-0-6V 100mA 90p; 9-0-9V 100mA 95p; 12-0-12V 100mA £1; 12-0-12V 50mA 90p; 12-0-12V 1A £2.95; 6-0-6V 1A £2.10; 6.3V 1A £1.75; 24V 1A £2.18; Ball transformer in white case, gives 4, 8, or 12V at 1A £1.80.

**DEVELOPMENT PACKS**  
Save £££'s by buying a full range of components at one go! All full spec marked devices, no rejects or old stock.  
50V Ceramic Plate Capacitors 5%. 10 of each value from 22pF to 1000pF. Total 210. £2.70. Save £1.50!

Carbon Film min. resistors, ½W 5%. 10 each value from 10 ohms to 1M, total 610. £5. Save £3.15!  
Electrolytics, 10 each value 1, 2.2, 4.7, 10, 22, 47 & 100uF. All 25V. Total 70 for £3.20. Save £1.10!



GIRO NO 331 7056. Access and Barclaycard accepted.  
C.W.O. only Terms of business as in our Catalogue.  
Export Order enquiries welcome (£5 min.)

Official Orders accepted from Educational and Government Departments.  
ALL PRICES include VAT & P & P  
E. & O.E. SHOP HOURS 9.12.30. 1.30-5.00 5 days.  
CLOSED WEDNESDAY.

### 1977 ISSUE

66 PAGES—3 000 ITEMS FULLY ILLUSTRATED  
200 CREDIT VOUCHERS  
\*ALL NEW STOCK  
\*SATISFACTION GUARANTEED  
\*DISCOUNTS

Electronic Components Catalogue 6  
C.W.O. Electronics Ltd

Boxes - Cases - PC Kits - Materials - Tools - Resistors - Test Meters - Capacitors - Hardware - Semiconductors - Books - Pots - Coils - Audio Accessories - Screws - Connectors - Audio Modules - Veroboard - Transformers - Knobs - Calculators - Audio Leads - Batteries - S. dec Storage Units - Heatsinks, etc., etc.

### SPECIAL CAPACITOR KITS

C280 Kit—PC Mounting polyester 250V 5 of each value: 0.01, 0.022, 0.047, 0.1, 0.22µF, 2 of 0.47, 1µF. £1.84 net.  
C286 Kit—Tubular polyester, 400V, 5 of each value 0.01, 0.022, 0.047, 0.1, 0.22µF, 2 of 0.47µF, £2.87 net.

### "DIGITAL MULTIMETER KIT" AS IN E.T.I. SAE FOR LIST

SPECIAL RESISTOR KITS (CARBON FILM 5%) (Prices include post & packing) 10E12—W or 1W KIT: 10 of each E12 value, 22 ohms—1M, a total of 570 £3.29 net. 25E12 1W or 1/2W KIT: 25 of each E12 value, 22ohms—1M, a total of 1425 £12.84 net.

### B. H. COMPONENT FACTORS LTD.

#### MULTIMETER U4323

22 Ranges plus AF/IF Oscillator 20,000Ω/Volt.  
Vdc—0.5—1000V in 7 ranges  
Vac—2.5—1000V in 6 ranges  
Idc—0.05—500mA in 5 ranges  
Resistance—5Ω—1MΩ in 4 ranges.  
Accuracy—5% of F.S.D.  
OSCILLATOR—1KHz and 465KHz (A.M.) at approx. 1 Volt.  
Size—180 x 97 x 40mm.  
Supplied complete with carrying case, test leads and battery.  
PRICE £10.95



U4323

### "DOING IT DIGITALLY"

DIGITAL TEACHING KIT TK1  
Complete Parts as specified in October E.E. (Including case).  
£11.35 Inc. V.A.T. & P.P.  
(Deduct £2.23 if case not required)

#### MULTIMETER U4313

33 ranges. Knife edge with mirror scale.  
20,000Ω/Volt, High accuracy, mVdc—75mV  
Vdc—1.5—600V in 9 ranges.  
Vac—1.5—600V in 9 ranges.  
Idc—60—120 microamps in 2.  
Idc—0.6—1500mA in 6 ranges.  
Iac—0.6—1500mA in 6 ranges.  
Resistance—1KΩ—1MΩ in 4 ranges.  
dB scale—10 to +12dB.  
Accuracy—±1%, ac—24%.  
Size—115 x 215 x 90mm.  
Complete with carrying case, test leads and battery.  
PRICE £17.99 net



U4313

### (E.E.), LEIGHTON ELECTRONICS CENTRE

99 North Street, Leighton Buzzard, LU7 7EG.  
Tel.: Leighton Buzzard 2316 (Std. Code 05253)

## ELECTRONIC KIT

### BUILD, DISMANTLE AND REBUILD OVER 100 DIFFERENT PROJECTS AND DESIGN NEW CIRCUITS TOO

Radio Receivers and Transmitters, Telephone Amplifiers, Time Buzzers, Battery Checkers, Computer Circuits, Amplifiers, Directional Transmitters, Metal Detectors, Continuity Testers, Electronics Birds, Guns, Metronomes, Sirens, Roulette, Etc., Etc. ALL IN ONE KIT

"... educational kits of exceptional quality" (AUDIO mag.)  
"... worthwhile... good value for money" (EVERYDAY ELECTRONICS mag.)

Educational manuals Included with each kit. No previous experience required. Suitable for beginners and experts too.

- 100 project kit £19.60
- 45 project kit £15.60
- 25 project kit £12.10 (Add-on kits available too)

Prices include Manuals; Batteries, VAT and p and p

Cheque/P.O. (or 11p for illustrated literature) to DEPT. EE

ELECTRONIC KIT LTD, 408 St. John's Street, London, EC1 0J1-278 4579

### An Audio Signal Generator for only £14.95!

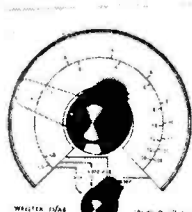

- STAR FEATURES:**
- 15Hz—150KHz
  - Sine/Square Wave Output Variable 0-3V PkPk
  - Very Low Current Consumption, 9V Bttry
  - One IC Plus 4 Transistor Circuit
  - Smart ABS Case, drilled and screen printed
  - KIT includes all Components, Drilled PCB, Controls, etc.
  - Unbeatable Value:

**KIT ONLY £14.95p (pp70p)**  
**READY BUILT £19.70 (pp 70p)**  
CWO To/

**WELLTEX MFG. CO.**  
9 SIRDAR STRAND,  
GRAVESEND DA12 4LP  
(C.O.D. orders accepted)

**PRINTED CIRCUIT KIT £4.25\***  
Make your own printed circuits. Contains etching dish, 100 sq ins of pc board, 1 lb ferric chloride, dazo pen, drill bit, laminate cutter.

#### JC12 AMPLIFIER

6W IC audio amp with free data and printed circuit £2.25\*



#### DELUXE KIT FOR JC12

Contains extra parts except JC12 needed to complete the amp including balance volume, bass and treble controls. Mono £2.33. Stereo £4.95.

#### JC12 POWER KIT

Supplies 25V 1 Amp £3.75.

#### JC12 PREAMP KITS

Type 1 for magnetic pickups, mics and tuners. Mono £1.50. Stereo £3.00. Type 2 for ceramic or crystal pickups. Mono 85p. Stereo £1.76.

#### SINCLAIR IC20

IC20 10W+10W stereo integrated circuit amplifier kit with free printed circuit + data £4.95.  
PZ20 Power supply kit for above £3.95.  
VP20 Volume, tone-control and preamp kit £7.95.

#### JC40 AMPLIFIER

New integrated circuit 20W amplifier kit complete with chip, printed circuit and data £4.45.

#### FERRANTI ZN414

IC radio chip £1.44. Extra parts and pcb for radio £3.85. Case £1. Send see for free data.

#### BATTERY ELIMINATOR BARGAINS

STABILIZED POWER UNITS  
Millivolt series. Switched 1 to 30V in 0.1V steps.  
1 Amp Kit £12.45. Kit + case £15.40. Built N/A.  
2 Amp Kit £14.95. Kit + case £17.90. Built N/A.

#### 4-WAY SPECIAL £5.20

Switched output of 3, 4, 6, 7, 9, 12V at 500mA



#### 3-WAY MODELS\*

With switched output and 4-way multi-jack connector. Type 1: 3/4/6V at 100mA £3.20.  
Type 2: 6/7/9V at 150mA £3.30.

#### RADIO MODELS

50mA with press-stud battery connectors. 9V £3.25. 6V £3.45. 9V+9V £3.45. 6V+6V £3.45. 41V+44V £3.45. Also 9V 300mA £3.95. 6V 400mA £3.95.

#### CASSETTE MAINS UNITS

74V with 5 pin din plug. 500mA £3.45. 300mA £3.95. CAR CONVERTERS £4.75.  
Input 12V DC. Output 6/7/9V DC 1Amp stabilized.

#### BATTERY ELIMINATOR KITS

Send see for free leaflet on range.  
100mA radio types with press-stud battery terminals. 41V £2.10. 6V £2.10. 9V £2.10. 41V+44V £2.80. 6V+6V £2.80. 9V+9V £2.80.  
100mA cassette type 74V with 5 pin din plug £2.10.  
Transistor stabilized 8-way type for low hum. 3/4/6/7/9/12/15/18V. 100mA £3.50. 1 Amp £6.50.  
Heavy duty 13-way types 41/67/81/113/141/171/215/283/442V. 1 Amp model £4.95. 2 Amp model £7.95.  
Car converter kit Input 12V DC. Output 6/7/9V DC 1A transistor stabilized £1.95.

#### MAINS TRANSFORMERS

0-6V 100mA £1. 9-0-9V 100mA £1. 18V 1A £1.95. 0/12/15/20/24/30V 1A £4.30. 12-0-12V 50mA £1. 0/12/15/20/24/30V 2A £3.95. 20V 2A £2.95. 0-6-0V 1A £2.85. 0-9-0V 1A £2.45. 12-0-12V 1A £2.95. 15-0-15V 1A £3.20. 30-0-30V 1A £4.10. 0-3V 11A £1.95. 0-24V twice 100mA N/A.

#### S-DECS AND T-DECS\*

S-DeC £2.24.  
T-DeC £4.95.  
µ-DeCA £4.45.  
µ-DeCB £7.95.  
IC carriers with sockets:—  
16 dit £2.95. 10T05 £1.95.

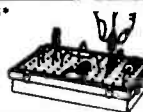

#### SINCLAIR CALCULATORS AND WATCHES\*

Cambridge Universal £8.00. Cambridge Scientific £8.95. Oxford 300 £13.30. Programmable Scientific with free mains unit £24.95. Mains adaptors for other models (state type) £3.20. Assembled Grey Watch with free stainless steel bracelet £16.45.

#### SINCLAIR PROJECT 80 AUDIO MODULES

PZ5 £4.95. PZ6 £8.70. Z40 £5.75. Project 805Q £18.95.

#### BI-PAK AUDIO MODULES

S450 tuner £18.95. AL20 £4.33. PA100 £13.45. MK30 audio kit £27.20. Teak 60 £16.95. Stereo 30 £13.95. TC30 £4.60. AL 250 £16.15. Send see for free data.

**SWANLEY ELECTRONICS**  
Dept E.E. PO BOX 68,  
SWANLEY, KENT BR88 8TQ.  
Send see for free leaflets on all kits. Post 30p on orders under £2.23, otherwise free. Prices include VAT. Overseas customers deduct 7% on items marked \*, otherwise 11%. Official orders welcome.

# Sparkrite mk2

Capacitive discharge  
electronic ignition kit

VOTED BEST OF 8 SYSTEMS TESTED BY 'POPULAR MOTORING' MAGAZINE



- \* Smoother running
- \* Instant all-weather starting
- \* Continual peak performance
- \* Longer coil/battery/plug life
- \* Improved acceleration/top speeds
- \* Up to 20% better fuel consumption

Sparkrite Mk. 2 is a high performance, high quality capacitive discharge, electronic ignition system in kit form. Tried, tested, proven, reliable and complete. It can be assembled in two or three hours and fitted in 15/30 mins.

Because of the superb design of the Sparkrite circuit it completely eliminates problems of the contact breaker. There is no misfire due to contact breaker bounce which is eliminated electronically by a pulse suppression circuit which prevents the unit firing if the points bounce open at high R.P.M. Contact breaker burn is eliminated by reducing the current to about 1/50th of the norm. It will perform equally well with new, old, or even badly pitted points and is not dependent upon the dwell time of the contact breakers for recharging the system. Sparkrite incorporates a short circuit protected inverter which eliminates the problems of SCR lock on and, therefore, eliminates the possibility of blowing the transistors or the SCR. (Most capacitive discharge ignitions are not completely foolproof in this respect). All kits fit vehicles with coil/distributor ignition and up to 8 cylinders.

### THE KIT COMPRISES EVERYTHING NEEDED

Ready drilled pressed steel case coated in matt black epoxy resin, ready drilled base and heat-sink, top quality 5 year guaranteed transformer and components, cables, coil connectors, printed circuit board, nuts, bolts, silicon grease, full instructions to make the kit negative or positive earth, and 10 page installation instructions.

### OPTIONAL EXTRAS

Electronic/conventional ignition switch. Gives instant changeover from "Sparkrite" ignition to conventional ignition for performance comparisons, static timing etc., and will also switch the ignition off completely as a security device. Includes switch connectors, mounting bracket and instructions. Cables excluded. Also available: RPM limiting control for dashboard mounting (fitted in case on ready built unit).

**CALLERS WELCOME.** For Crypton tuning and fitting service — phone (0922) 33008.

**PRICES INCLUDE VAT, POST AND PACKING.**

Improve performance & economy NOW

**POST TODAY!**

**Quick installation**  
No engine modification  
required

Electronics Design Associates, DEPT EE12  
82 Bath Street, Walsall, WS1 3DE. Phone: (0922) 33652

Name .....

Address .....

	QUANTITY REQD.	Price
Mk. 2 DIY Ass. Kit @ £11.80		
Mk. 2 Ready Built Negative Earth @ £14.97		
Mk. 2 Ready Built Positive Earth @ £14.97		
Ignition Changeover switches @ £4.30		
R.P.M. Limit systems in above units @ £2.42		

Enclose cheque/PO's for £  
Cheque No. \_\_\_\_\_  
Send SAE if brochure only required.

**BULK PURCHASE — EXCLUSIVE TO HENRY'S**  
ALLOWS US TO SELL AT SUCH FANTASTIC PRICES!

AS USED IN BRAUN DIGITAL CLOCKS

QUALITY ITEMS Compare performance and specification with units costing 3 times as much!

## DIGITAL 24 HOUR CLOCK

WITH BUILT IN ALARM

- SILENT RUNNING
- LARGE ILLUMINATED NUMERALS
- AC MAINS • SIZE 6 1/2 x 2 1/2 x 2 1/2

NORMALLY

£24 WITH CASE

Assemble, fit in an evening!

MECHANISM ONLY

MECHANISM inc. assembly AND CASE

Modern styling COMPLETE UNIT

**CALCULATOR DISPLAYS**

£6.00 + VAT 48p P&P 25p

£7.99 + VAT 64p P&P 25p

£8.99 + VAT 72p P&P 25p

THREE FOR £16.50 + VAT £1.32 POST FREE

THREE FOR £22.00 + VAT £1.76 POST FREE

THREE FOR £25.00 + VAT £2.00 POST FREE

1" digit height, bright red LED 7 segment displays for calculators, digital watches, miniature clocks, DVMS, timers etc.  
\* Fairchild FND-10, single digit common cathode £1.00 (+vat 8p) 6 for £5.00 (+vat 40p)  
\* HP 7414 4 digit, common cathode 12 pin d.i.l. pin out 89p (+vat 8p) 6 for £5.00 (+vat 40p)  
\* Gowmar 8 1/2 digit, common cathode with pc connector, and red bezel £1.85 (+vat 15p) 6 for £10 (+vat 80p)  
\* Texas 3 digit common cathode 12 pin d.i.l. pin out 85p (+vat 7p) 6 for £4.00 (+vat 32p)  
\* Texas 4-5 digit, common cathode 2x14 pin d.i.l. £1.85 pair (+vat 15p)  
\* 30 pin termination board for all types except FND-10 20p (+vat 2p)  
\* Texas calculator keyboards, 10 gold plated "snap" type key contacts on gold plated pcb. 75p (+vat 6p) p & p on all the above 25p.

30,000 ALREADY SOLD!

DESIGNED BY TEXAS



**TEXAN AMPLIFIER** featured by PRACTICAL WIRELESS still the best selling amp in the UK  
★ Can be built stage by stage. Ask for leaflet 21  
★ Everything necessary supplied. Full after sales service and guarantees.

Build the Texan stereo amplifier, and be doubly proud! You'll own a superb home entertainment unit. And the pleasure of doing it yourself. Look at the Texan specification! Fully integrated stereo preamp and power amp, 6 IC's, 10 transistors, 6 rectifiers and zener diodes. Plus stabilised, protected circuitry, glass fibre pcb; Gardeners low-field low-line mains transformer; all facilities and controls. Slim design, chassis 14 1/2" x 8" x 2" overall. 20 watts per channel RMS.

**TEXAN FM TUNER KIT** £20.95 + VAT £2. Built and tested £25.95 + VAT £3.24

Build the matching Texan stereo tuner Features advanced varicap tuning. Phase lock loop decoder. Professionally designed circuit. Everything you need is in the kit. From the glass fibre pcb to the cabinet itself. Excellent spec: 2.5 uV aerial sensitivity, 500 mV output (adjust). Tuning range 87-102 MHz. Mains powered.



**MULLARD TUNER MODULES**  
LP1171 - combined AM/FM IF strip - £4.28 (+vat 53p) \* LP1179 FM front end with AM tuning gang, used with LP1171 - £4.29 (+vat 53p) \* LP1171 & 79 pair - £8.00 (+vat £1.00) \* LP1157 complete AM strip - £2.85 (+vat 26p) \* Ferrite Aerial - 95p (+vat 7p) p & p all modules 25p each

**HENRY'S GREAT NEW CATALOGUE**  
★ OVER 5,000 ITEMS  
★ OVER 200 PAGES  
★ DISCOUNT VOUCHERS  
★ QUANTITY DISCOUNTS ON MOST ITEMS  
FREE - to educational establishments and manufacturers when ordered on official headed notepaper  
We will be pleased to quote for parts for circuits in this magazine. Send your list for quotation in S.A.E.

**HENELEC RADIO CONTROL SYSTEM**  
★ INCLUDING PROPORTIONALLY CONTROLLED SWITCH  
★ FEATURING COSMOS DIGITAL LOGIC to minimise power consumption and extend battery life.  
Specially designed to provide aircraft and boat modelmakers with a low-cost, easy-to-use radio control, the Henelec system gives you everything from single channel, up to sophisticated 7-channel Digital Proportional System! Buy the components you want. Ideal for any radio control application. \* Simple transmitter - £11.75 (+vat £1.47p) \* Single-ch. add-on for receiver - £2.95 (+vat 37p) \* PC board for above - 75p (+vat 6p) \* Case for transmitter - £1.25 (+vat 15p) \* Basic receiver - £8.95 (+vat 87p) Send now for leaflet No. 8 (35p) for full details. Post etc. 50p each. Ask for FREE leaflets and lists on our kits projects.

**Henry's Radio**  
LONDON W2:  
404/6 Edgware Road, London W2.  
Tel: 01-402 8381  
LONDON W1:  
231 Tottenham Ct Rd  
Tel: 01-636 6681

All mail to: Henry's Radio 303 Edgware Rd. London W2.  
LOWEST sales floor!



# The new Maplin Catalogue is no ordinary catalogue...

Hundreds of fascinating new lines.

Several major new projects to build.

**MAPLIN ELECTRONIC SUPPLIES**

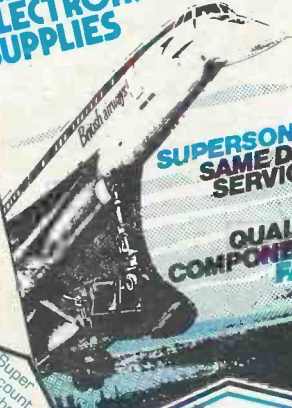

**SUPERSONIC SAME DAY SERVICE!**

**QUALITY COMPONENTS FAST!**



Test Gear Section includes superior quality single-beam and dual beam OSCILLOSCOPES at remarkably low prices. These superb SCOPEX scopes are undoubtedly the best value for money around.



Projects section includes complete construction details of a professional quality MULTI-CHANNEL MIXER with modular sections for complete flexibility. Extremely low noise and distortion AND low cost.

Super Discount Voucher - saves you pounds!

Hundreds of photographs and illustrations.

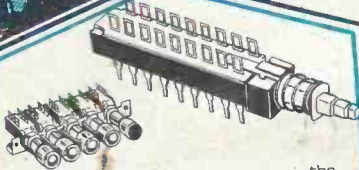

Just one of the hundreds of new lines in the component section. A new range of FULLY INTERLOCKING PUSH BUTTON SWITCHES - high quality - low price - large range.

Catalogue includes a very wide range of components: hundreds of different capacitors; resistors; transistors; I.C.'s; diodes; wires and cables; discotheque equipment; organ components; musical effects units; microphones; turntables; cartridges; styli; test equipment; boxes and instrument cases; knobs, plugs and sockets; audio leads; switches; loudspeakers; books; tools - AND MANY MANY MORE.



\* Our bi-monthly newsletter keeps you up to date with latest guaranteed prices - our latest special offers (they save you pounds) - details of new projects and new lines. Send 30p for the next six issues (5p discount voucher with each copy).

SEND THIS COUPON FOR YOUR COPY OF OUR CATALOGUE ON APPROVAL! Price 50p - SEND NO MONEY NOW. Please rush me a copy of your brand new 1977/78 catalogue the instant it is published. Only if I am completely satisfied that it is worth every penny, will I send 50p within 14 days of receipt. If I am not satisfied, I may return the catalogue to you within 14 days without obligation. I understand that I need not purchase anything from your catalogue should I choose to keep it.

NAME \_\_\_\_\_

ADDRESS \_\_\_\_\_

EE12

Maplin Electronic Supplies P.O. Box 3, Rayleigh, Essex, SS6 8LR

Owing to delay in completion of larger warehouse, catalogue will be delayed by up to four weeks - so there's still time to order before publication and get your pack of ten super special offer coupons, giving big discounts on ten different popular items. YOU COULD SAVE POUNDS! - SO DON'T DELAY - FILL IN AND POST COUPON NOW!

# MAPLIN

**ELECTRONIC SUPPLIES**  
P.O. BOX 3, RAYLEIGH, ESSEX SS6 8LR

Shop: 284, London Road, Westcliff-on-Sea, Essex  
(Closed on Monday) Telephone: Southend (0702) 44101