

An exciting hobby.... for everyone

APRIL 75
25p

everyday electronics



Easy to build



projects

TOUCH
SWITCH

CAR RALLY
INTERCOM SYSTEM

New Regular Feature...

CAREERS in ELECTRONICS



QUIZ
MASTER



PLUS

STARTING THIS MONTH
WORKSHOP PRACTICE

NEW EDU-KIT MAJOR

Completely Solderless Electronic Construction Kit
Build these projects without soldering iron or solder

- ★ 4 Transistor Earpiece Radio.
- ★ 5 Transistor Push Pull Amplifier.
- ★ Batteryless Crystal Radio.
- ★ Signal Tracer.
- ★ 7 Transistor Loudspeaker Radio MW/LW.
- ★ One Transistor Radio.
- ★ Signal Injector.
- ★ 5 Transistor Short Wave Radio.
- ★ 2 Transistor Regenerative Radio.
- ★ Transistor Tester NPN-PNP.
- ★ Electronic Metronome.
- ★ 3 Transistor Regenerative Radio.
- ★ 4 Transistor Push Pull Amplifier.
- ★ Electronic Noise Generator
- ★ Audible Continuity Tester.
- ★ Sensitive Pre-Amplifier.

Total Building Costs

£7-23

P P & Ins. 44p
(Overseas Seamail
P & P £2-35)

(+ 8% VAT 57p)

Components Include: 24 Resistors • 21 Capacitors • 10 Transistors • 3½" Loudspeaker • Earpiece • Mica Baseboard • 3 12-way connectors • 2 Volume controls • 2 Slider Switches • 1 Tuning Condenser • 3 Knobs • Ready Wound MW/LW/SW Coils • Ferrite Rod • 6½ yards of wire • 1 Yard of sleeving etc. • Parts Price List and Plans 35p free with parts.

NEW ROAMER NINE

WITH V.H.F. INCLUDING AIRCRAFT

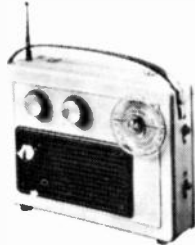

Nine Transistors, 9 Tunable wavebands as Roamer Ten. Built in ferrite rod aerial for MW/LW. Retractable chrome-plated telescopic aerial for VHF and SW. Push Pull output using 600 mW transistors. 9 Transistors and 3 diodes, tuning condenser with V.H.F. section, separate coil for aircraft, moving coil loudspeaker, volume ON/OFF and wavechange controls. Attractive all white case with red grille and carrying strap. Size 9½" x 7" x 2½" approx. Parts Price List and Plans free with parts.

Total Building Costs **£6-95**

P P & Ins. 44p
(Overseas Seamail P & P £2-35)

(+ 8% VAT 55p)

POCKET FIVE

NOW WITH 3" LOUD-SPEAKER

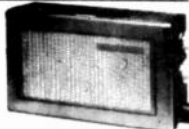

3 Tunable wavebands. M.W. L.W. and Trawler Band, 7 stages, 5 transistors and 2 diodes, supersensitive ferrite rod aerial, attractive black and gold case. Size 5½" x 1½" x 3½" approx. Plans and Parts Price List free with parts.

Total Building Costs **£2-50**

P P & Ins. 36p
(Overseas Seamail P & P £1-70)

(+8% VAT 20p)

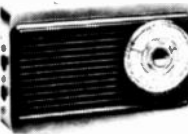

TRANSONA FIVE

NOW WITH 3" LOUD-SPEAKER

Wavebands, transistors and speaker as Pocket Five. Larger Case with Red Speaker Grille and Tuning Dial. Plans and Parts Price List free with parts.

Total Building Costs **£2-75**

P P & Ins. 38p
(+8% VAT 21p)

(Overseas Seamail P & P £1-70)

TRANS EIGHT

8 TRANSISTORS and 3 DIODES

6 Tunable Wavebands: MW, LW, SW1, SW2, SW3 and Trawler Band. Sensitive ferrite rod aerial for M.W. and L.W. Telescopic aerial for Short Wave. 3in. Speaker. 8 Improved type transistors plus 3 diodes. Attractive case in black with red grille, dial and black knobs with polished metal inserts. Size 9 x 5½ x 2½in. approx. Push pull output. Battery economiser switch for extended battery life. Ample power to drive a larger speaker. Parts price list and plans free with parts.

Total building costs **£4-48**

P P & Ins. 40p
(+ 8% VAT 36p)

(Overseas Seamail P & P £2 00)

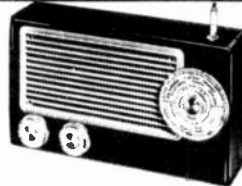

ROAMER SIX

CASE AND LOOKS AS TRANS-EIGHT

Trawler band plus an extra Medium waveband for easier tuning of Luxembourg, etc. Sensitive ferrite rod aerial and telescopic aerial for Short Waves. 3in. Speaker 8 stages—6 transistors and 2 diodes. Attractive black case with red grille, dial and black knobs with polished metal inserts. Size 9 x 5½ x 2½in. approx. Plans and parts price list free with parts.

Total building costs **£3-98**

P P & Ins. 40p
(Overseas Seamail P & P £2-00)

(+ 8% VAT 32p)

NEW Everyday Series

Build this exciting New series of designs



E.V.5. 5 Transistors and 2 diodes. MW/LW. Powered by 4½ volt Battery. Ferrite rod aerial, tuning condenser, volume control, and now with 3" loudspeaker. Attractive case with red speaker grille. Size 9" x 5½" x 2½" approx. Parts Price List and Plans free with parts.

Total Building Costs **£2-95**

(+ 8% VAT 23p)

E.V.6. Case and looks as above. 6 Transistors and 3 diodes. Powered by 9 volt battery. Ferrite rod aerial, 3" loudspeaker, etc. MW/LW coverage. Push Pull output. Parts Price List and Plans free with parts.

Total Building Costs **£3-60**

(+ 8% VAT 29p)

E.V.7. Case and looks as above. 7 Transistors and 3 diodes. Six wavebands. MW/LW, Trawler Band, SW1, SW2, SW3, powered by 9 volt battery. Push Pull output. Telescopic aerial for short waves. 3" Loudspeaker. Parts Price List and Easy Build Plans free with parts.

Total Building Costs **£4-08**

(+ 8% VAT 32p)

ROAMER EIGHT Mk I

NOW WITH VARIABLE TONE CONTROL

7 Tunable Wavebands: MW1, MW2, LW, SW1, SW2, SW3 and Trawler Band. Built in Ferrite Rod Aerial for MW and LW. Chrome plated Telescopic aerial can be angled and rotated for peak short wave listening. Push pull output using 400mW transistors. Car aerial and Tape record sockets. Selectivity switch. 8 transistors plus 3 diodes. Latest 4" 2 watt ferrite magnet loudspeaker. Air spaced ganged tuning condenser. Volume/on/off, tuning, wave change and tone controls. Attractive case in rich chestnut shade with gold blocking. Size 9 x 7 x 4in. approx. Easy to follow instructions and diagrams. Parts price list and plans free with parts.

Total building costs **£6-98**

(+ 8% VAT 58p)



ROAMER TEN Mk 2

WITH VHF INCLUDING AIRCRAFT

Now with free earpiece and switched socket.

10 Transistors. Latest 4" 2 watt Ferrite Magnet Loudspeaker. 9 Tunable Wavebands. MW1, MW2, LW, SW1, SW2, SW3, Trawler Band, VHF and Local Stations also Aircraft Band.

Built in Ferrite Rod Aerial for MW/LW. Chrome plated 8 section Telescopic Aerial can be angled and rotated for peak short wave and VHF listening. Push Pull output using 600mW Transistors. Car Aerial and Tape Record Sockets. 10 Transistors plus 3 Diodes. Ganged Tuning Condenser with VHF section. Separate coil for Aircraft Band. Volume on/off. Wave Change and Tone Controls. Attractive Case in black with silver blocking. Size 9" x 7" x 4". Easy to follow instructions and diagrams. Parts price list and plans 50p free with parts.

Total building costs **£9-50**

P P & Ins. 52p
(+ 8% VAT 76p)



"EDU-KIT"

Build Radios, Amplifiers, etc. from easy stage diagrams.

Five units including master unit to construct.

Components include:

Tuning Condenser: 2 Volume Controls: 2 Slider Switches: Fine Tone 3" Moving Coil Speaker: Terminal Strip: Ferrite Rod Aerial: Battery Clips: 4 Tag Boards: 10 Transistors: 4 Diodes: Resistors: Capacitors: Three 1" Knobs. Units once constructed are detachable from Master Unit, enabling them to be stored for future use. Ideal for Schools, Educational Authorities and all those interested in radio construction.

Total building costs **£5-50**

(+ 8% VAT 44p)

P P & Ins. 35p
(Overseas Seamail P & P £2-35)

RADIO EXCHANGE LTD

★ Callers side entrance "Lavelle's" shop.
★ Open 10-1, 2.30-4.30, Mon.-Fri. 9-12 Sat.

To RADIO EXCHANGE CO., 61a HIGH STREET, BEDFORD, MK40 1SA
Tel.: 0234 58267. Reg. No. 788572.

I enclose £..... for

Name

Address

(Dept. EE4.)

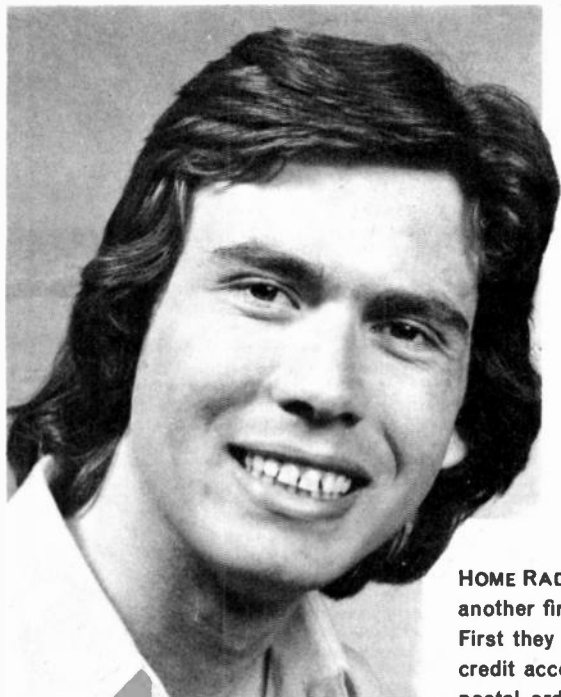

*I know ONE place
where Service
still means
something!*

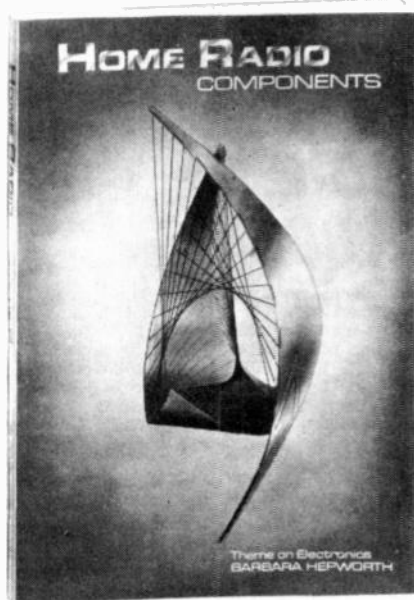

HOME RADIO COMPONENTS LTD. of Mitcham are the people I just don't know another firm that makes life so simple for their mail order customers.

First they devised a system whereby anybody who wanted to could have a credit account and pay monthly, thus saving the cost of several cheques or postal orders. Many credit account schemes are involved and awkward to join, but with Home Radio Components you simply have to complete a very simple form—not even references are called for. Then they send you a supply of order forms and pre-paid envelopes—another worthwhile saving. *Then they really pamper you!* They have installed an Answerphone system, so that you can phone orders through, any time of day or night—Sundays included! Very convenient—no wonder over 700 Credit Account customers use this service.

Of course, to order your components you first need the famous Home Radio Components Catalogue—just about the best catalogue of its kind you've ever seen. It costs 98p (65p plus 33p for post, packing and insurance). But Home Radio help you out even here—with the Catalogue they give you 14 vouchers each worth 5 pence when used against orders, so you can soon get the cost of the catalogue back, plus a bit towards postage! *Just send the coupon below with your cheque or P.O. for 98p.*

By the way, you'll find full details of the Credit Account system inside the catalogue, together with the necessary form. And here's your bonus—once you've joined the scheme you'll receive a new catalogue FREE each year. Yes—Home Radio Components still know the meaning of SERVICE. *To prove it—send that coupon now.*

65p. plus 33p POST AND PACKING

Send off the coupon today. It's your first step to solving your component buying problems.

The price of 98p applies only to customers in the U.K. and to BFPO Addresses.

Please write your Name and Address in block capitals

NAME

ADDRESS

.....

.....

HOME RADIO (Components) LTD., Dept. EE,
234-240 London Road, Mitcham, Surrey CR4 3HD

(Regn. No. London 912966)



CRESCENT RADIO LTD.

11-15 & 17 MAYES ROAD, LONDON N22 6TL
(also) 13 SOUTH MALL, EDMONTON, N.9

MAIL ORDER DEPT.
11 MAYES ROAD, LONDON N22 6TL
Phone 888 3206 & (EDM.) 803 1685

ABS PLASTIC BOXES

Handy boxes for construction projects. Moulded extrusion rails for P.C. or chassis panels. Fitted with 1mm front panels.

1006 - 105mm x 78mm x 45mm - 81p.
1006 - 150mm x 74mm x 47mm - 89p.
1007 - 185mm x 124mm x 60mm - 99p.
1021 - 106mm x 74mm x 45mm - 89p. (sloping front)

CLEAR PLASTIC PANEL METERS

Size 59mm x 49mm x 36mm these meters require a 38mm hole for mounting.

- ME6 - 0 to 50 micro amp Full Scale
- ME7 - 0 to 100 micro amp " "
- ME8 - 0 to 500 micro amp " "
- ME9 - 0 to 1mA " "
- ME10 - 0 to 5mA " "
- ME11 - 0 to 10mA " "
- ME12 - 0 to 50mA " "
- ME13 - 0 to 100mA " "
- ME14 - 0 to 500mA " "
- ME15 - 0 to 1 amp " "
- ME16 - 0 to 50 volts " "
- ME17 - 0 to 300 volts A.C. Full Scale
- ME18 - "5" Meter
- ME19 - "VU" Meter

OUR PRICE



LOW VOLTAGE AMPLIFIER

5 transistor amplifier complete with volume control, is suitable for 9V d.c. and a.c. supplies. Will give about 1W at 8 ohm output. With high IMP input this amplifier will work as a record player, baby alarm, etc., amplifier. £2.00



LIGHT EMITTING DIODES

- TL 209 (Red) with Clip 89p each
- TL 200 (Green) with Clip 89p each
- TL 209 (Yellow) with Clip 99p each
- Mled 500 T092 Type 16p each

LED READOUTS

- Litronix
- DL707 3 Character 14 Pin Dill £2.00
- DL701 As above but ±1 £2.00
- DL747 6 Character £2.62
- Mintron
- 3015 7 Segment 16 Pin Dill £1.18
- 3015G As above but ±1 £1.18

CLOCK CHIP

- OT7001 MOS/LSI Digital Clock/Calendar Chip plus full Circuits and Information Leaflet £6.98
- Chronix and Information Sheet 15p
- L4704 Led Display for above £1.35 Or 4 for £6.35

3 KILOWATTS PSYCHEDELIC LIGHT CONTROL UNIT

Three Channel: Bass—Middle—Trebble. Each channel has its own sensitivity control. Just connect the input of this unit to the loudspeaker terminals of an amplifier, and connect three 250V up to 1000W lamps to the output terminals of the unit, and you produce a fascinating sound-light display. (All guaranteed.) £18.50 plus 38p P. & P.

POWER PACKS

- FP2 Switched 6-7.5-9 volt Battery Eliminator. Approx size 2 1/2" x 3 1/2" x 3 1/2". Ideal for cassette recorders. £8.88 each.
- FP3 Car converter. From 12V Pos. or Neg to 6-7.5-9 volt. Easy to fit and transistor regulated. £8.90 each.

VEROBOARD

	.1	.16	Plain .15
24 x 31	89p	94p	15p
24 x 5	84p	84p	18p
31 x 31	84p	84p	...
31 x 5	89p	89p	...
17 x 24	1.09p	77p	89p
17 x 38	1.48p	1.16p	75p
17 x 5	1.88p	...	1.10p

Pin insertion tool 89p
Spot face Cutter 45p
Pkt 96 pins (state .1 or .15) 89p

10 INCH DUAL CONE L/S

Manufactured by "ELAC" to a very high standard these loudspeakers are a real bargain.

Spec: Size - 10" Dual Cone
Power - 10" Watts
Frequency - 40-12000Hz
Our Price £8.75

WIRE WOUND VARIABLE CONTROL

2500ohm approx diameter - 1 inch long
Standard spindle only 89p each.

ALUMINIUM BOXES

Metal Project Boxes give your work a professional finish.

	L	W	H	Price
AB7	2 1/2	5 1/2	1 1/2	54p
AB8	4	4	1 1/2	65p
AB9	4	2 1/2	1 1/2	54p
AB10	4	5 1/2	1 1/2	63p
AB11	4	2 1/2	2	54p
AB12	3	2	1	45p
AB13	6	4	2	89p
AB14	7	5	2 1/2	94p
AB15	8	6	3	99p
AB16	10	7	3	£1.35
AB17	10	4 1/2	3	£1.02
AB18	12	5	3	£1.20
AB19	12	8	3	£1.50

All size are approx and in inches.

S. G. BROWN "DIPLOMAT" HEADSET

Finest quality British made Lightweight Headphones. Incorporates ceramic piezo electric transducers. Specification: Frequency - 20-17,500 CPS. Impedance - Predominantly capacitive, at 90MFD per earpiece can be regarded as 150K at 1KHz. Weight - 3.5oz. (98 grams). A Bargain at £1.25 each set

CABLELESS SOLDERING IRON WAHL "ISO-TIP"

- ★ Completely Portable
 - ★ Solders up to 150 joints per charge
 - ★ Re-charges in its own stand
 - ★ Fine tip for all types of soldering
 - ★ Only 8" long and weighs just 6 ozs.
- Our Price £9.75. (Spare bits are available)

12-0-12 VOLT 500mA 240 VOLT PRIMARY TRANSFORMER

approx. size 60mm x 40mm x 50mm. Firing centres - 75mm. A REAL BARGAIN AT £1.90 each.

LOW NOISE LOW PRICE CASSETTES

Good quality tape in well made screw type cassettes. Presented in single plastic cases.

060 - 81p
090 - 48p
0190 - 88p
10% discount on ten or more cassettes of one type

CJL PRICES INCLUDE P&P AND V.A.T.

- AERIAL, telescopic, 15-120cm. £1.20
- AERIAL, telescopic, h and w swivel, 15-80cm. . . £1.78
- BIB HI-FI ACCESSORIES**
- CASSETTE TAPE RECORDER CARE KIT . . . £1.95
- CASSETTE SPLICING AND EDITING KIT . . . £1.50
- HI-FI STEREO TEST CASSETTE £2.10
- 1/2" TAPE EDITING KIT £1.35
- GROOV-KLEEN RECORD CLEANER £1.85
- EARPHONE, stethoscope style, 8 ohm dynamic. £1.00
- HAND DRILL, (Laytool), compact precision drill, 5/16" chuck. Gears totally enclosed. S/L bearings. £2.99
- INTEGRATED CIRCUITS**
- AUDIO POWER AMPLIFIER (National) LM380 £1.00
- A.M. RADIO RECEIVER (RCA) CA3123E £1.40
- F.M. STEREO DECODER (Motorola) MC1310P £2.80
- TIMER (Signetica) NE555V £0.78
- VOLTAGE REGULATOR (Fairchild) uA7805 £1.70
- VOLTAGE REGULATOR (Signetica) NE550A £0.80
- D.I.L. SOCKETS (Pk of 3) 8 or 14 pin £0.50
- KEYNECTOR, rapid connect to mains-single/multiple leads. Built-in piano switches, neon & 13A fuse £3.20
- LOCKFLEX RULE (Rebone Chesterman), 3m/10ft precision pocket rule. Easy to read, 13mm/1/2" wide steel tape. Blade length lockable-power return. A superb rule £0.93
- MICROPHONE, lightweight dynamic, remote start stop, 200 ohms, 100-10kHz, 6mV average output . £1.80
- MULTIMETER, attractive design, Vdc-10, 50, 250, 1,000. Vac-10, 50, 250, 1,000. Idc-100mA. R-150k . £4.95
- SIGNAL INJECTOR, audio through video signals, excellent for servicing amplifiers, radio & tv . £3.92
- SOLDERING IRON, 25 WATT, (Antex), X25, 240V. Very low leakage, 1/8" long life bit (interchangeable) £1.85
- 3/32" bit £0.45 □ 3/16" bit £0.45 □ Element £0.95
- STAND, ST3, High grade base, chrome plated spring, sponges and accommodation for spare bits . £0.95
- SPEAKER, miniature, 75mm dia, 8 ohms. . . £0.80

CJL CJL LTD. P.O. BOX 34, CANTERBURY, CT1 1YT

YOUR CAREER in RADIO & ELECTRONICS ?

Big opportunities and big money await the qualified man in every field of Electronics today—both in the U.K. and throughout the world. We offer the finest home study training for all subjects in radio, television, etc., especially for the CITY & GUILDS EXAMS (Technicians' Certificates); the Grad. Brit. I.E.R. Exam.; the RADIO AMATEUR'S LICENCE; P.M.G. Certificates; the R.T.E.B. Servicing Certificates; etc. Also courses in Television; Transistors; Radar; Computers; Servo-mechanisms; Mathematics and Practical Transistor Radio course with equipment. We have OVER 20 YEARS' experience in teaching radio subjects and an unbroken record of exam. successes. We are the only privately run British home study College specialising in electronics subjects only. Fullest details will be gladly sent without any obligation.

To: British National Radio & Electronics School, Dept E.E.C. 45 P.O. Box 154, Jersey, C.I.
Please send FREE BROCHURE to

NAME Block
ADDRESS Caps.
..... Please

BRITISH NATIONAL RADIO AND ELECTRONICS SCHOOL

Sinclair Project 80



**For elegant, versatile, stereo hi-fi systems
designed and built by you!**

Until recently, if you wanted a first-class hi-fi system you had two ways to get it.

You could buy the individual electronic components and build a system from scratch. If you were an electronics genius – fine.

Or you had to buy ready-made units. Expensive – and dull. About the only creative pleasure you'd get would be matching your amp and your speakers, or making your speaker enclosures.

So what's new?

A comprehensive hi-fi system, combining the enjoyment and satisfaction of build-it-yourself (without too much struggle) ... a real value-for-money feeling ... and results of the highest quality.

It's the new Sinclair Project 80.

How does Sinclair Project 80 work?

Project 80 is a comprehensive set of hi-fi modules, or sub-assemblies. Amps ... pre-amps ... FM tuner ... stereo decoder ... control units ... everything you need to assemble hi-fi units. They're all designed to look alike and they're all completely compatible with each other. Simply decide on the specifications of the unit you want to build ... buy the necessary modules ... connect them ... and house them.

No need to buy everything at once for your eventual set-up. All the modules are designed so that you can add to them as your system grows – whether or not it's based on Project 80.

This applies to refinements, like filters ... to up-grading, adding a second set of amps, say, for greater output ... or to real innovation, like quad. (Add a Project 80 quad decoder, a power supply, a pair of amps, and a pair of speakers – and your stereo's gone quad.)

Is it difficult to build?

Not at all. The modules are complete in themselves. All you do is connect them to your turntable ... your speakers ... or to each other. It's absorbing, but if you can solder wires to a 5-pin DIN plug, you can build a complete system with Project 80.

And if you're not so hot with a soldering iron? Use Project 80S. Project 80S uses Project 80 modules, but provides special clip-on tagged wire connections – absolutely *no* soldering required.

And, of course, both Project 80 and Project 80S come complete with instructions for easy, step-by-step assembly. But if you do run into problems, just call our Consumer Advisory Service who are always happy to help.

OK. Where do I go from here?

Over the page! There you'll see for yourself the exacting specifications to which Sinclair Project 80 modules are made, and you'll see some suggested systems.

As you skim the suggestions, remember all Project 80 modules are backed by the remarkable no-quibble Sinclair guarantee. Should any defect arise from normal use within a year, we'll service the modules free of charge. What could be fairer than that?



Choose the Project 80 modules that are right for you.



Project 80 pre-amp/control unit

The control centre of Project 80. With its distinctive white-on-matt-black styling and plastic control sliders, it's a pleasure to look at, as well as to use.

Specification

(9½ in x 2 in x ¾ in.) Separate slider controls on each channel for treble, bass and volume. **Inputs:** PU magnetic - 3 mV (RIAA corrected), ceramic - 350 mV;

Radio 100 mV, **Tape** 30 mV, **S/N ratio:** 60 dB. **Frequency range:** 20 Hz to 15 kHz ± 1 dB. **Outputs:** 100 mV and tape plus AB monitoring. **Press buttons** for PU, radio and tape. **Operating voltage:** 20 V - 35 V.

Price: £13.95 + VAT

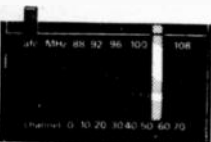

Project 80 FM tuner

Excellent reception from a tuner only 3½ in long x ¾ in deep! Styled to match Project 80 control unit.

Specification

(3½ in x 2 in x ¾ in.) **Tunes** 87.5 MHz to 108 MHz. **Detector:** IC balanced

coincidence (IC equivalent to 26 transistors). **Distortion:** 0.3% at 1 kHz for 30% modulation. **Sensitivity:** 5 µV for 30 dB signal to noise. **Output:** 100 mV for 30% modulation. **Aerial imp:** 75 Ω or 240-300 Ω. **Features:** dual Varicap tuning, 4-pole ceramic filter, switchable AFC. **Operating voltage:** 23 V - 30 V.

Price: £13.95 + VAT



Project 80 stereo decoder

Designed for use with Project 80 FM tuner. Sold separately to

keep down the price of a mono FM system, but also to make the stereo decoder available for use with existing mono FM tuners.

Specification

(1¼ in x 2 in x ¾ in.) 1 IC equivalent to 19 transistors. **LED stereo indicator** glows red.

Price: £8.95 + VAT

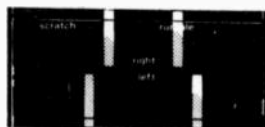

Project 80 active filter unit

Eliminates scratch and rumble (high and low-frequency noise).

Specification

(4¼ in x 2 in x ¾ in.) **Voltage gain:** -0.2 dB. **Frequency response:** filter at zero: 36 Hz - 22 kHz; HF (scratch) out: variable 22 kHz to 5.5 kHz, 12 dB/octave slope; LF (rumble) out: -28 dB at 28 Hz, 9 dB/octave slope.

Price: £7.45 + VAT



Project 80 power amplifiers

Two different amplifiers, designed to be used separately or combined, with Project 80 modules or as add-ons to existing equipment. Protected against short circuits and damage from mis-use.

Z40 Specification

(2¼ in x 3 in x ¾ in.) 18 transistors. **Input sensitivity:** 100 mV. **Output:** 12 W RMS continuous into 8 Ω (35 V). **Frequency response:** 30 Hz - 100 kHz ± 3 dB. **S/N ratio:** 64 dB. **Distortion:** 0.1%

at 10 W into 8 Ω at 1 kHz. **Voltage requirements:** 12 V - 35 V. **Load imp:** 4 Ω - 15 Ω, safe on open circuit. Protected against short circuit.

Price: £5.95 + VAT

Z60 Specification

(2¼ in x 3¼ in x ¾ in.) 12 transistors. **Input sensitivity:** 100 mV - 250 mV. **Output:** 25 W RMS continuous into 8 Ω (50 V). **Frequency response:** 10 Hz to more than 200 kHz ± 3 dB. **S/N ratio:** better than 70 dB. **Distortion:** less than 0.1% at 12 W into 4 Ω at 1 kHz. **Voltage requirements:** 12 V - 50 V. **Load imp:** 4 Ω min, max safe on open circuit. Protected against short circuit.

Price: £7.45 + VAT

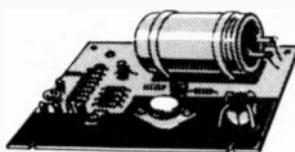

Power supply units

Range of power supply units to match desired specification of final system.

PZ5 Specification

Unstabilised. 30 V output. Including mains transformer.

Price: £5.95 + VAT

PZ6 Specification

Stabilised. 35 V output. Including mains transformer.

Price: £8.95 + VAT

PZ8 Specification

Stabilised. Output adjustable from 20 V to 60 V approx. Re-entrant current limiting makes damage from overload or even shorting virtually impossible. Without mains transformer.

Price: £8.45 + VAT



Project 80 SQ quadraphonic decoder

Combines with and exactly matches Project 80 control unit for true quadraphonics. This unit is based on the CB5 SQ system and is a complete quadraphonic decoder, rear channel pre-amp and control unit.

Specification

(9½ in x 2 in x ¾ in.) Connects with tape socket on Project 80

control unit or similar facility on any stereo amplifier. Separate slider controls on each channel for treble, bass and volume.

Frequency response: 15 Hz to 25 kHz ± 3 dB. **Distortion:** 0.1%. **S/N ratio:** 58 dB. **Rated output:** 100 mV. **Phase shift network:** 90 ± 10° 100 Hz to 10 kHz.

Operating voltage: 22 V - 35 V.

Price: £18.95 + VAT

Some system suggestions from Sinclair

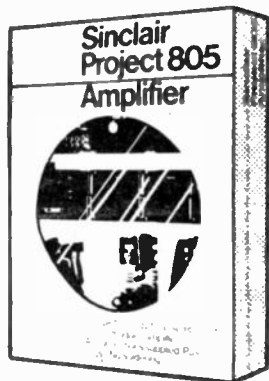

Project 805 amplifier kit

Contains following Project 80 units.

Project 80 control unit
2 x Z40 power amplifier modules
1 x PZ5 power supply unit
Masterlink unit
On/off switch
plus pre-cut wiring loom with clip-on tagged wire connections, nuts and bolts, instruction manual.

Price: £39.95 + VAT



Project 805Q quadraphonic add-on kit

Converts your existing stereo hi-fi system to quad using solderless connections.

Contains following Project 80 units:

Project 80 SQ quad decoder/rear channel pre-amp and control unit
2 x Z40 power amps
PZ5 power supply unit
Masterlink unit
On/off switch
plus pre-cut wiring loom with clip-on tagged wire connections, nuts and bolts, instruction manual.

Price: £44.95 + VAT

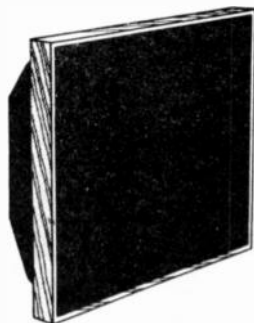

Sinclair Q16 speaker

Original and uniquely designed speaker of outstanding quality.

Specification

(10 3/8 in square x 4 1/4 in deep.)
Pedestal base. All-over black front. Teak surround. Balanced sealed sound chamber. Special driver assembly. Frequency response: 60 Hz to 16 kHz.
Power handling: up to 14 W RMS.
Impedance: 8 Ω.

Price: £8.95 + VAT

1. Quadraphonic system: 25 W per channel RMS
Pre-amp/control unit + quadraphonic decoder + 4 x Z60 amps + 2 x PZ8 mains power supplies + (2 x mains transformers) + (4 x equivalent speakers) + (turntable).
Total Project 80 cost: £79.60 + VAT.

2. Stereo amplifier: 12 W per channel RMS
Pre-amp/control unit + 2 x Z40 amps + PZ6 power supply + 2 x Q16 speakers. Total Project 80 cost: £52.70 + VAT.

3. Stereo tuner/amplifier: 12 W per channel RMS
Pre-amp/control unit + FM tuner + stereo decoder + 2 x Z40 amps + PZ6 power supply + 2 x Q16 speakers. Total Project 80 cost: £75.60 + VAT.

Other applications

4. PA system

(Mic) + pre-amp/control unit + Z40 amp + PZ6 power supply + 2 x Q16 speakers. Total Project 80 cost: £46.75 + VAT.

5. Convert existing mono record-player to stereo
Pre-amp/control unit + Z40 amp + Q16 speaker. Total Project 80 cost: £28.25 + VAT.

What more can we tell you?



The basic facts are covered on these two pages. And you'll find Project 80 at stores like Laskys and Henry's.

But before you look, why not get really detailed information? Clip the FREEPOST coupon for the fully-illustrated Project 80 folder - today!

Sinclair Radionics Ltd,
London Road, St Ives, Huntingdon, Cambs., PE17 4HJ.
Telephone: St Ives (0480) 64646.

sinclair

Sinclair Project 80
a new concept in expandable hi-fi

To: Sinclair Radionics Ltd, FREEPOST, St Ives, Huntingdon, Cambs., PE17 4BR.

Please send me, by return post, a copy of the fully-illustrated Project 80 folder.

Name _____

Address _____

Please print FREEPOST - no stamp needed. EE/4/75

CHROMASONIC electronics

Dept. 3 56, Fortis Green Road,
Muswell Hill, London, N10 3HN.
telephone: 01-883 3705

RECTIFIERS

V	1A	3A	6A
50	IN4001 4p	IN5400 15p	
100	IN4002 7p	IN5401 18p	
200	IN4003 9p	IN5402 17p	BYZ13 58p
400	IN4004 9p	IN5404 27p	BYZ12 66p
600	IN4005 11p	IN5406 26p	BYZ11 73p
800	IN4006 13p	IN5407 28p	BYZ10 85p
1000	IN4007 16p	IN5408 31p	

BRIDGES

V	1A	2A	6A
50	BYX61 -50	E3.21	
100	BYX61 -100	E3.48	
200	BYX61 -200	E3.76	
400	BYX61 -400	E4.29	
600	BYX62 -600	E4.29	

TRIACS

V	1A	2A	6A
50	2N4048 35p	75p	25p
100	2N4049 52p	75p	50p
200	2N4070 58p	90p	100p
400	2N4071 63p	E1.05	200p
600	2N4073 69p	E1.20	400p
1000	2N4075 81p		600p

SOLDERING

Desolder Braid Reel 64p

Multicore
18 swg size 5 32p
22 swg size 15 36p
cotton size 1 50p
" " " " 12E1.57

Adcolva Invector
L70s 19 swg 1/8" bit 62.80
L60s 22 swg 3/16" bit 63.13

DIN CONNECTORS

Pins	Plugs	Sockets	Line Couplers
2	9p	7p	11p
3	10p	7p	11p
4	11p	7p	11p
5 (180)	11p	8p	11p
5 (240)	11p	8p	11p
6	11p	9p	11p
7	13p	9p	11p

4mm.

Available in seven colours

Terminals 15p

Plugs 13p

HEAT SINKS

Transistor covers

TO 3 10p

TO 66 10p

TV2 (TO66) 15p

TV3 (TO 3) 16p

TV4 (TO 126) 14p

TV5 (TO 220) 14p

5F (TO 5) 7p

173 for SL414 SL415 18p

AY-1-4 35p

100 N 400-4

UI (TBA800) 16p

UI (TBA810S) 16p

UI (TBA810AS) 16p

UI (TCA940) 16p

UI (TDA2020) 35p

CO-AXIAL

Plug - Screened	11p
Plug - Plastic	9p
Sockets	
Chassis	10p
Surface	11p
Coupler	25p

PHONO

Sockets	
1 way	5p
2 way	7p
3 way	7p
4 way	8p
Plugs	
Plastic Moulded	7p
Chrome Screened	12p
Coupler screened	15p

JACK

Plugs	Sockets
2.5mm * 20p	12p
3.5mm * 20p	12p
standard * 25p	15p
stereo * 27p	21p
side entry standard	48p

AUDIO I.C.'S

A brand New Audio I.C. Leaflet with Circuits and pin connections for ALL the I.C.'s listed below FREE with orders over £1.00 or 10p without

I.C. SOCKETS

Style	8 pin	14 pin	16 pin	24 pin	28 pin	36 pin	40 pin
TO5	13p	15p	15p	26p	30p	37p	44p

Dual-in Line
8 pin 13p
14 pin 15p
16 pin 15p
24 pin 26p
28 pin 30p
36 pin 37p
40 pin 44p

I.C. PIN SOCKETS

I.C. pins in strips of 100. Just strip off what you need. 65p per strip.

P.C. CONNECTORS

0-1" pin centres 24 way * key supplied with ends 64p

Etch resist from a pen. Draw your own printed circuits, then etch it. 86p

SWITCHES

High Quality 250v 1A	Rotary 2A Mains Switches
S.P.S.T. 25p	35p
D.P.D.T. 45p	
Render	Bulgin
Subminiature Toggle S.P.D.T. 48p	push-to-make 25p
Slide D.P.D.T. 12p	
	Eng Dill Switches
1 pole 8 way 99p	
2 pole 4 way 85p	
4 pole 2 way £1.24	
	LoLin water switches 27p
1 pole 12 way 4 pole 2 way	
3 pole 4 way 4 pole 3 way	

POWER OUTPUT	Supply Volts	Load Ohms	Power I.C.	Price	Tri-amp	Supply Volts
0.25	9	16	C MPC 4008	78p	Dual Low Noise	+24
0.5	9	8	E MC1306P	66p	Dual Low Noise	+24
1	9	8	F TAA300	£1.76	Dual Pre-Amp	+24
2	12	8	G TBA820	74p	Dual Low Noise	+24
2	18	8	A LM380	£1.06	Dual Low Noise	+24
2 1/2	18	8	A LM377	£2.91	General	
3	18	8	J SL414	£1.72	D.C. Controlled attenuator	
5	24	16	J SL415	£2.24	3 stage G.P. amp.	
5	24	8	H TBA800	90p	Tape Pre-Amp	
7	16	4	H TBA810S	£1.07	Bi-Fet	
7	16	4	K TBA810AS	£1.07	Heard/Aid Amp 1.3v	
10	20	4	M TCA940	£1.74	PPL stereo decoder (1)	
15	30	3	O BNA0002	£2.60	4 channel SQ * (1)	
35 driver	25	8	F NE540L	£1.08	4 * pre-amp (1)	
20	+15	4	N TDA2020	£3.24	C85 SQ Logic (1)	

MAINS TRANSFORMERS

secondaries	1A	2A	6A
6-0-6v, 100mA 97p	£1.95	£2.27	£2.64
9-0-9v, 100mA 97p	£2.48	£4.15	-
12-0-12v, 100mA 97p	£5.18	£7.02	-
18-0-18v, 200mA plus	£2.46	£4.18	£6.18
	£2.70	£3.40	£4.53

RENDER INSTA-POWER

safe; inexpensive; quick A.C. mains connector. A 13 amp plug top containing snap connectors £1.75

VAT INCLUSIVE PRICES AT 8%

OVERSEAS CUSTOMERS DEDUCT 27% VAT INVOICES ON REQUEST P&P On U.K. Orders 15p Overseas Orders at Cost



"I MADE IT MYSELF"

Imagine the thrill you'll feel! Imagine how impressed people will be when they're hearing a programme on a modern radio you made yourself.

Now! Learn the secrets of radio and electronics by building your own modern transistor radio!

Practical lessons teach you sooner than you would dream possible.

What a wonderful way to learn—and pave the way to a new, better-paid career! No dreary ploughing through page after page of dull facts and figures. With this fascinating Technatron Course, you learn by building!

You build a modern Transistor Radio . . . a Burglar Alarm. You learn Radio and Electronics by doing actual projects you enjoy—making things with your own hands that you'll be proud to own! No wonder it's so fast and easy to learn this way. Because learning becomes a hobby! And what a profitable hobby. Because opportunities in the field of Radio and Electronics are growing faster than they can find people to fill the jobs!

No soldering – yet you learn faster than you ever dreamed possible.

Yes! Faster than you can imagine, you pick up the technical know how you need. Specially prepared step-by-step lessons show you how to read circuits—assemble components — build things — experiment. You enjoy every minute of it! You get everything you need. Tools. Components. Even a versatile Multimeter that we teach you how to use. All included in the course. AT NO EXTRA CHARGE! And this is a course anyone can afford. (You can even pay for it by easy instalments).

So fast, so easy, this personalised course will teach you even if you don't know a thing today!

No matter how little you know now, no matter what your background or education, we'll teach you. Step by step, in simple easy-to-understand language, you pick up the secrets of radio and electronics.

You become a man who makes things, not just another of the millions, who don't understand. And you could pave the way to a great new career, to add to the thrill and pride you receive when you look at what you have achieved. Within weeks you could hold in your hand your own transistor radio. And after the course you can go on to acquire high-powered technical qualifications, because our famous courses go right up to City & Guilds levels.

Send now for FREE 76 page book – see how easy it is – read what others say!

Find out more now! This is the gateway to a thrilling new career, or a wonderful hobby you'll enjoy for years. Send the coupon now. There's no obligation.

POST TODAY FOR FREE BOOK

TO: ALDERMASTON COLLEGE DEPT. CEE 04 READING RG7 4PF CEE 04

Yes, I'd like to know more about your course. Please send me free details—plus your big, 76-page book that tells about all your courses.

NAME

ADDRESS

POSTCODE



BIET

HOME OF BRITISH INSTITUTE OF ENGINEERING TECHNOLOGY

QUALITY STEREO SOUND.

ALMOST **1/2 PRICE OFFER!** SOLENT AUDIO SYSTEM

MADE TO SELL AT DOUBLE THE PRICE IN CABINET FORM

OUR PRICE **£49.95**

£5 down



*Stereo Tuner Amplifier chassis with AM/FM radio covering long medium short and Stereo FM wavebands. Separate Base and Treble controls. 30 watts total power output (frequency response 25-20,000 Hz) Tape record and playback facilities. Dimensions 18" x 8 1/2" x 3 1/4". The very latest BSR automatic record deck with cue and pause control. Two matching elliptical speaker units.

Order early limited stocks available cash price £49.95. Credit Sale £5.00 deposit 9 monthly payments of £5.75 (Total Credit price £56.75). P. & P. £3.00 Send £3.00 today.

Chassis only available for cash at £35.00.

Full 12 months Guarantee.

CALLERS WELCOME.

Stereo headphones supplied with every complete order.

LEWIS radio EE/4/75 100 CHASE SIDE SOUTHGATE LONDON N14 5PL Telephone: 01-882-1844

ELECTROVALUE

The best of all!

CATALOGUE 7 ISSUE 3

with 25p refund voucher

Up-dated Price & Product Information

112 pages plus cover As comprehensive and up-to-the-minute as possible. Thousands of items from vast ranges of semi-conductors including i.Cs to components, tools, accessories, technical information and diagrams are included as well as a refund voucher worth 25p for spending on orders list value £5 or more **SEND NOW FOR YOUR COPY BY RETURN 30p** post paid it's an investment in practical money-saving and reliability!

PRICES as shown in our latest catalogue (No. 7, issue 3) will be maintained until March 31st next (except in severe cases of market fluctuation) and reviewed only at 3-monthly intervals commencing April 1st. This is instead of making day-to-day price changes.

DISCOUNTS apply on all items except the few where prices are shown NETT. 5% on orders from £5 to £14.99; 10% on orders list value £15 or more.

FREE POST AND PACKING in U.K. for pre-paid mail orders over £2 (except Baxandall cabinets). If under there is an additional handling charge of 10p.

QUALITY GUARANTEE. All goods are sold on the understanding that they conform to maker's specification. No rejects, seconds or sub-standard merchandise.

ELECTROVALUE LTD

All communications to Section 44, 29, ST. JAMES RD, ENGLEFIELD GREEN, EGHAM, SURREY TW20 9NB. Telephone Egham 3603, Telex 284475. Shop hours: 9-5.30 daily, 9-1 pm Sats.

NORTHERN BRANCH: 600, Burnage Lane, Burnage, Manchester M19 1NA. Telephone (061) 432 4848. Shop hours: Daily 9-5.30 pm; 9-1 pm Sats.

everyday electronics

PROJECTS..
THEORY.....

JOB SATISFACTION

One man's hobby might be another man's job. But for some fortunate ones the hobby and the job are one and the same. That happy circumstance spells Job Satisfaction with a capital J and S.

It is remarkable the large number of young persons who are attracted to electronics as a pastime while still at school. Some of these boys (and girls) must often think about the possibilities of becoming involved in this subject professionally, especially when the time comes to start planning for the future. Well, this is sensible thinking, for electronics weaves its way into the whole fabric of life and so really does offer untold career opportunities. At various levels, from technician to scientist, there is a profusion of branches to explore where electronics is applied in diversified areas of specialisation.

Perhaps most important of all, electronics can offer a bonus that no other branch of technology or engineering can really rival. The trained electronic enthusiast is in the enviable position of being able to choose the general environment within which he will pursue his particular trade or profession. A hospital laboratory, a satellite earth station, a radio and television factory, a banking organisation, all have something in common—involvement with electronic equipment.

EVERYDAY ELECTRONICS has played some part in generating interest in this subject amongst members of the younger generation. Now, we

feel, it is right to give some positive guidance to those whose interest in a career in electronics may have been aroused through their happy experiences with electronics as a hobby.

CAREER GUIDANCE

As already hinted, the ramifications of professional electronics are truly amazing: quite bewildering, no doubt, to the young person who has no one of suitable experience to turn to for advice. We have therefore decided to provide a regular series of articles prepared specially for those who in the years or months ahead will have to face up to the harsh realities of life and make decisions that may be binding on them for the future, decisions that will almost certainly influence the pattern of their adult life. The first article in our new series *Your Career In Electronics* appears this month. These articles are written by one who has wide experience of the industry and the professional side of electronics, and who is aware of and is sympathetic to the aspirations of the young enthusiast.

We see these articles as providing a direct service to the industry, as well. Although it is not perhaps fully appreciated, the electronics industry is fortunate in that there is much enthusiastic and knowledgeable young blood eager to enter its ranks. Amongst the youngsters of today are the technicians and engineers of tomorrow. In their hands will rest much of the future of this exciting and expansive industry.

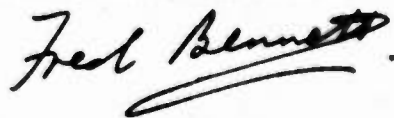

Our May issue will be published on Friday, April 18

EDITOR F. E. Bennett ● ASSISTANT EDITOR M. Kenward ● TECHNICAL EDITOR B. W. Terrell B.Sc.
ART EDITOR J. D. Pountney ● P. A. Loates ● K. A. Woodruff
ADVERTISEMENT MANAGER D. W. B. Tilleard

© IPC Magazines Limited 1975. Copyright In all drawings, photographs, and articles published in EVERYDAY ELECTRONICS is fully protected, and reproduction or imitations in whole or part are expressly forbidden.

All reasonable precautions are taken by EVERYDAY ELECTRONICS to ensure that the advice and data given to readers are reliable. We cannot, however, guarantee it, and we cannot accept legal responsibility for it. Prices quoted are those current as we go to press. Everyday Electronics Fleetway House, Farringdon Street, London, E.C.4. Phone: Editorial 01-634-4452; Advertisements 01-634-4202.

**EASY TO CONSTRUCT
SIMPLY EXPLAINED**



VOL. 4 NO. 4

APRIL 1975

CONSTRUCTIONAL PROJECTS

CAR RALLY INTERCOM A communication system for driver and navigator by Mike Kenward	182
TOUCH SWITCH For feather-light control by A. Russell	188
QUIZMASTER A "first to press" indicator by R. A. Penfold	198
SIGNAL INJECTOR AND LOGIC PROBE Versatile test unit by D. G. Ward	204

GENERAL FEATURES

EDITORIAL	180
READERS' LETTERS From you to us	187
WORKSHOP PRACTICE Part I Cabinets and Enclosures by Mike Hughes	190
WHAT DO YOU KNOW? Construction	195
YOUR CAREER IN ELECTRONICS The Electronics Industry by Peter Verwig	196
COUNTER INTELLIGENCE A retailer comments by Paul Young	197
FOR YOUR ENTERTAINMENT Repeatcorder and discount buying by Adrian Hope	202
PHYSICS IS FUN Home made capacitors by Derrick Daines	203
JACK PLUG AND FAMILY Cartoon	206
QUAD And Other Multichannel Systems. Part 3—Pseudo-quadrphony by Adrian Hope	208
PLEASE TAKE NOTE	211
SHOP TALK Component buying and new products by Mike Kenward	212
DEMO CIRCUITS The Armstrong Oscillator by Mike Hughes	213
PROFESSOR ERNEST EVERSURE The Extraordinary Experiments of. by Anthony J. Bassett	216
DOWN TO EARTH Power dissipation in transistors by George Hylton	222

Publisher's Annual Subscription Rate, including postage Inland £3.55, Overseas £3.60, USA/Canada \$10. International Giro facilities Account No. 5122007. State reason for payment "message to payee". Address to Everyday Electronics, Subscription Department, Carlton House, Great Queen Street, London, WC2E 9PR. Binders for volumes 1 to 4 (state which) and indexes for volume 1 and 2 available for £1.25 and 30p respectively, including postage, from Binding Department, at the above address.

We are unable to supply back copies of Everyday Electronics or reprints of articles and cannot undertake to answer readers' letters requesting designs, modifications or information on commercial equipment or subjects not published by us. An s.a.e. should be enclosed for a personal reply. Letters concerning published articles should be addressed to: The Editor, those concerning advertisements to: The Advertisement Manager, both at the address shown opposite.

SPECIAL NEXT MONTH

**EIGHT PAGE PULL-OUT
SPECIAL SUPPLEMENT
Using Multimeters
A complete beginners guide**

CAR RALLY INTERCOM SYSTEM

By MIKE KENWARD

An in-car intercom for rally driver and navigator.

RALLY drivers in particular and to a certain extent motor cyclists will appreciate this design. It was originally constructed as an aid to communication between driver and navigator, wearing crash helmets, inside a noisy rally car.

The unit is basically a simple amplifier with twin microphone input and twin headphone output. The output to each headset being about $\frac{1}{2}$ watt.

CIRCUIT

The circuit (Fig. 1) is designed around a 1 watt output integrated circuit the MFC6070. This device is designed to operate from a supply of up to 20V, the 14V car supply being quite suitable, and to provide up to 1W output into a 16 ohm load.

In order to drive the integrated circuit from the two cheap crystal microphone inserts used, an extra stage of amplification with a high input impedance is necessary and this is provided by the field effect transistor TR1. This device not only considerably amplifies the input but can easily provide the necessary high impedance.

The two microphones are coupled to TR1 by C1 and the volume control VR1. The output from the amplifier is connected across two 8 ohm magnetic earpiece wired in parallel, thus providing the necessary 16 ohms impedance. Each earpiece is used to supply one headset as described later.

Coupling between the f.e.t. input stage and the amplifier is via C3 and R4. The value of C3

has been kept deliberately low in order to attenuate some of the lower frequencies. This helps to make speech more clear and prevents amplification of some of the unwanted noise inside the car.

Capacitor C7 in conjunction with R9 provides some interference protection so that noise from the car's electrical system will not appear to any great extent at the amplifier output.

If the unit is to be used on a motorcycle with 6V electrics then it should be powered by two fairly large 9V batteries wired in series. In this case resistor R9 can be omitted, keep C7 in circuit as this capacitor will help to keep the supply voltage at a reasonable level when the amplifier draws current to provide a large output peak. The complete unit takes about 5mA when in the standby condition i.e. switched on but not being used, and thus reasonable battery life can be expected from two PP7 type batteries.

FOR
GUIDANCE
ONLY

ESTIMATED COST*
OF COMPONENTS
including V.A.T.

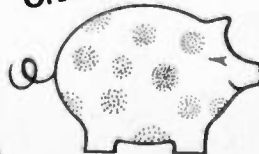

£6.00
excluding case

*Based on prices prevailing at time of going to press

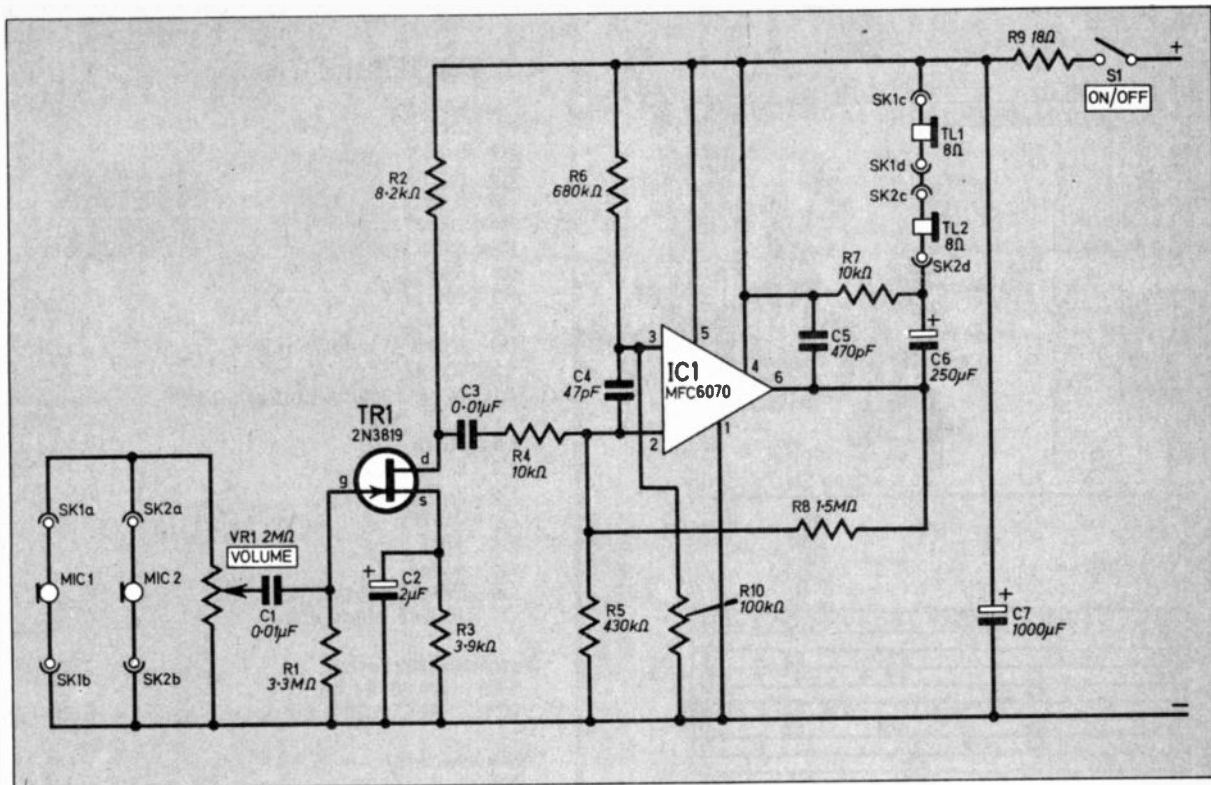

Fig. 1. Complete circuit diagram of the Car Rally Intercom.

OPERATION

In operation each user has one headset, powered either by TL1 or TL2, in addition to a microphone MIC1 or MIC2. The unit is switched on and if either user speaks into his microphone both he and the other user will hear his voice in their headset. Thus no switching is necessary in order to communicate.

CONSTRUCTION

Most of the amplifier components are situated on a piece of 0.1-inch matrix Veroboard. Cut this to size and break the copper strips as shown on the underside view (Fig. 2), all components except TR1 and IC1 should be mounted and soldered in place. Having done this check the construction carefully and connect all flying leads, next solder in IC1 being careful not to overheat the device.

With all the other components in place solder in TR1. This should be done without the unit connected to any other device or to earth and preferably with the soldering iron earthed or disconnected from the mains while the actual joints are made. This will prevent any damage to TR1, which is susceptible to damage caused by iron leakage.

With the board completed, components VR1, S1, SK1 and SK2 can be mounted in a suitable case and wired into the circuit as shown in

Fig. 3. Make sure that screened lead is used for the input and that SK1 and SK2 are wired as shown with an earth connection between the pins. This will help to prevent oscillation of the amplifier due to capacitive coupling of the input and output.

For the same reason SK1 and SK2 are fitted in the case facing opposite directions so that the two inputs from the microphone are as close as possible. If the leads between the two sockets are kept as short as possible (about 20mm) then the screened lead need not be employed at this point.

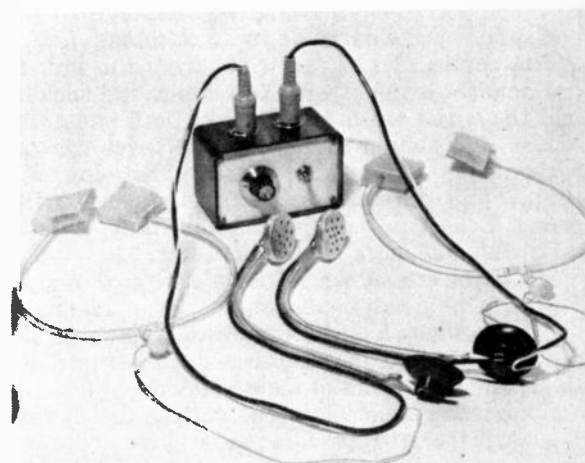

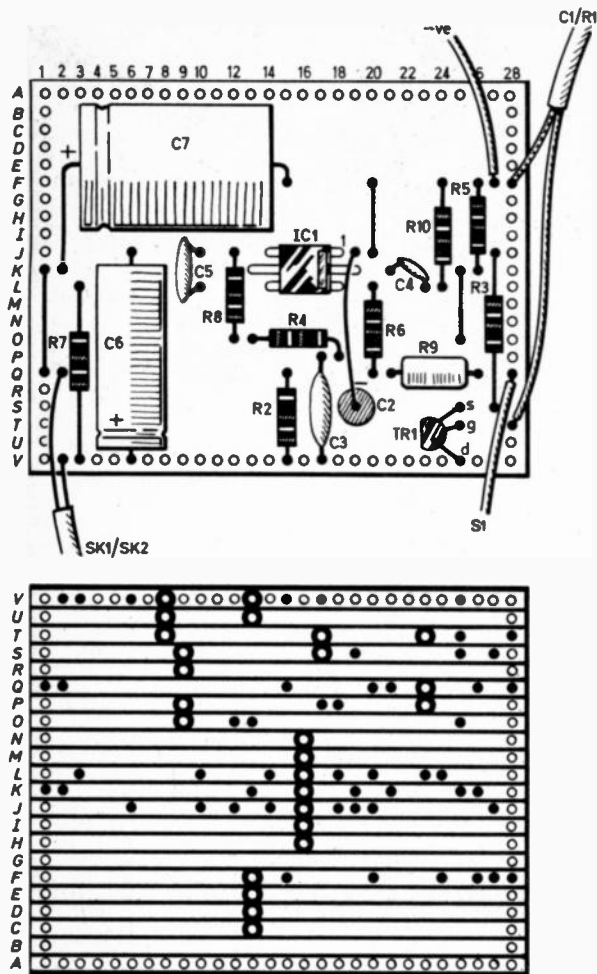

Fig. 2. Veroboard layout and wiring.

HEADPHONE CONSTRUCTION

The headphones have been designed to fit inside the crash helmet in such a way that there is no part actually inside the ear, such as when using ordinary earpieces. This has been done so that the set will not cause any damage to the ear should the wearer be in an accident.

The connection of the wires from the unit to the headset is made with DIN plugs and sockets and the wires are firmly fixed at both ends, this means that should the user try to leave the car without unplugging his headset the plug will simply pull out and automatically release the driver. Positioning of the amplifier unit will also assist this but more about that later.

Headsets are shown in the photograph and in Fig. 4. The headphone consists of a magnetic earpiece, some lengths of plastic tubing a "T" junction as used in windscreen washer connections, and two pieces of foam rubber.

Commence construction by cutting the end off the earpiece so that the plastic pipe will just

Components....

Resistors

- R1 3.3M Ω
 - R2 8.2k Ω
 - R3 3.9k Ω
 - R4 10k Ω
 - R5 430k Ω
 - R6 680k Ω
 - R7 10k Ω
 - R8 1.5M Ω
 - R9 18 Ω 1W wirewound
 - R10 100k Ω
- All $\frac{1}{4}$ W $\pm 10\%$ carbon except R9

Capacitors

- C1 0.01 μ F
- C2 2 μ F elect. 15V
- C3 0.01 μ F
- C4 47pF
- C5 470pF
- C6 250 μ F elect. 25V
- C7 1000 μ F elect. 25V

Semiconductors

- TR1 2N 3819 f.e.t.
- IC1 MFC 6070 integrated circuit amplifier

Transducers

- MIC 1, 2 MC25 or equivalent small crystal microphone inserts (2 off)
- TL1, 2 8 ohm magnetic earphones MR4 or similar (2 off)

Miscellaneous

- SK1, SK2 5 pin DIN plugs and sockets to suit (2 off each)
 - S1 s.p.s.t. toggle switch
 - VR1 2M Ω carbon potentiometer
- Veroboard 0.1 inch matrix 23 strips by 28 holes. Small plastic case approx 100 x 75 x 50mm. Length of screened lead, connecting wire, flexible tubing and "T" junction—see text. Stick on suction hooks, stiff wire, foam rubber, connecting wire, control knob.

SEE
**SHOP
TALK**

The completed component board.

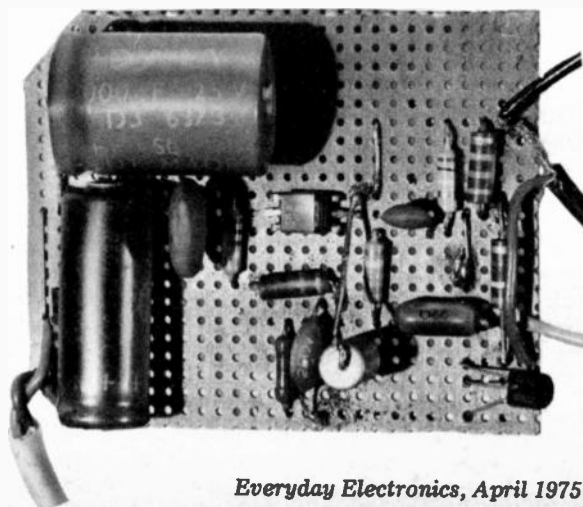

CAR RALLY INTERCOM SYSTEM

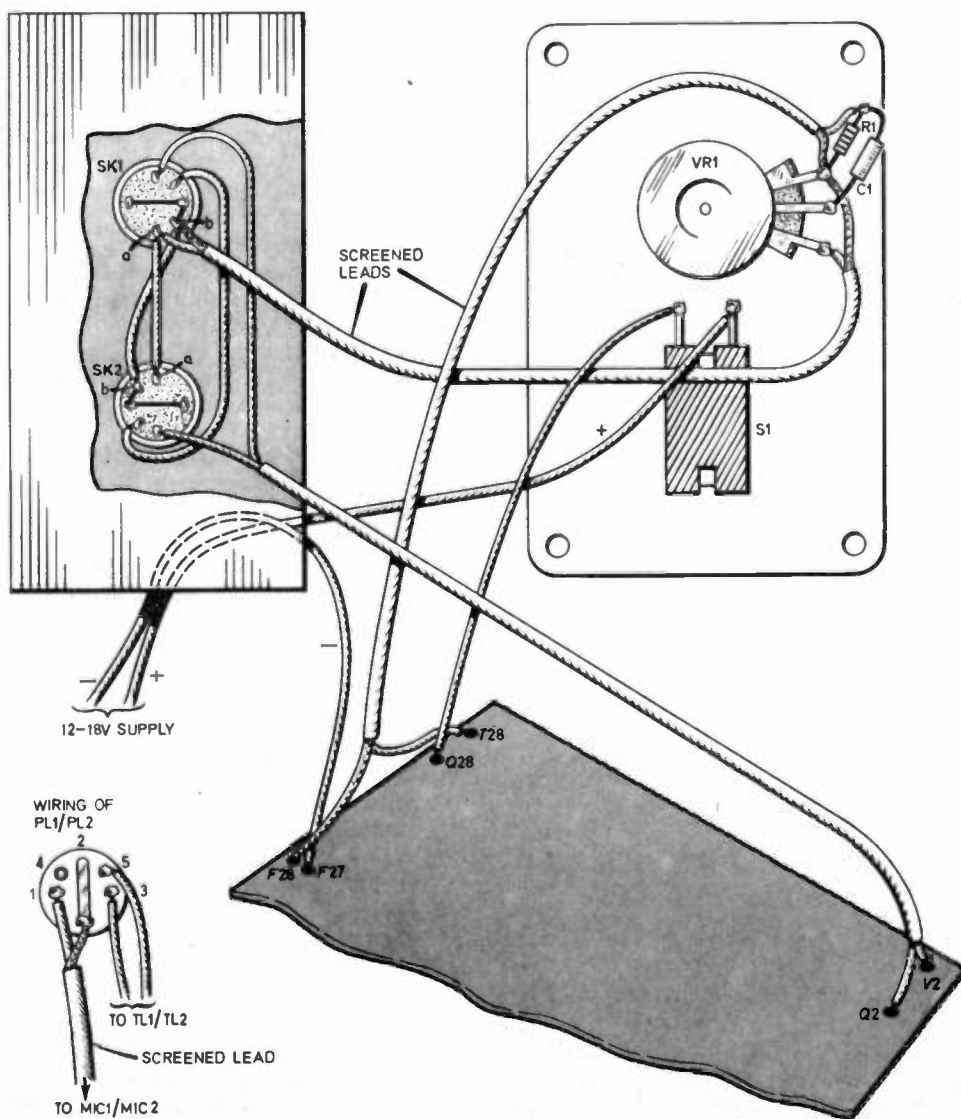
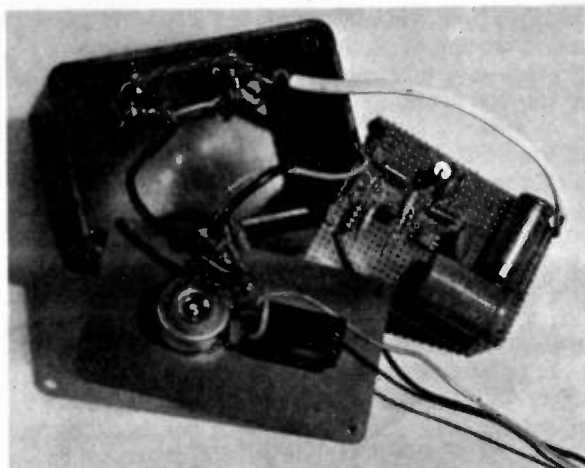

Fig. 3. Layout and wiring of the complete unit in its case.

push into the end. Cut off about 15mm of pipe and push it over the centre of the "T" piece, insert the other end of this piece of pipe in the earpiece but do not push it in further than about 4mm otherwise you may damage the earpiece. Glue the earpiece to the pipe with a dab of suitable glue.

The sound is carried to the ears by two lengths of tube, these should each be about 150mm long. They are joined to the two sides of the "T" piece and the other ends plugged, this was done on the prototype with small pieces of rubber cut from a pencil eraser.

Having done this make a rectangular cutout on the side of each tube about 15mm from the outer ends—these holes allow the sound to reach the ears. Next cut two pieces of 15mm thick foam rubber and slide them over the tube by cutting a small hole—see Fig. 4. Rectangular holes should be cut in the foam to match those in the tube. These pieces of foam should then be glued onto the tube, this completes construction of one pair of headphones.

The two pieces of foam holding the tubes are then glued to the inside of the ear pads inside the helmet such that the holes line up with the ears when the helmet is on. The earpiece hangs below the chin or is fixed to the back of the helmet and the wire is fixed to the helmet strap.

MICROPHONE MOUNTING

The microphone can be mounted in one of two ways depending on the type of crash helmet used. To fit the microphone to helmets with a guard in front of the wearers mouth, simply remove a small section of the foam rubber from this area and glue the microphone in. Run the lead around the side of the helmet and tape it, together with the headphone wire to the fixing strap.

It is a good idea to paint the microphone, being careful not to get paint inside, before fitting as this will provide some protection from moisture.

To fit the microphone to a "normal" type helmet obtain one of the suction type hooks sold

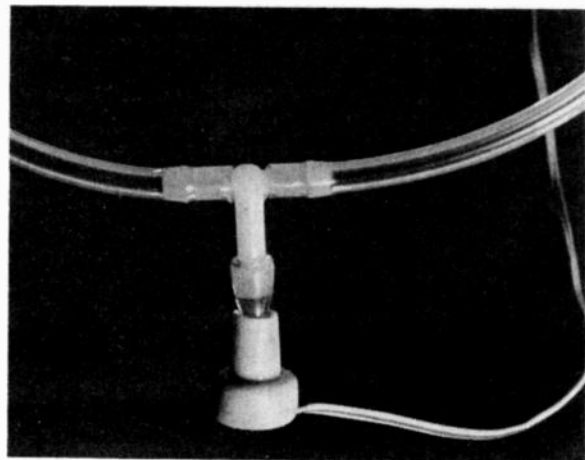

Photograph showing arrangement of the ear-piece.

for domestic use and straighten out the metal hook, next solder a length of fairly stout tinned copper wire to the remaining section of the hook, remove the suction pad to do this. Adjust the length of the wire to suit the wearer so that the microphone which will be attached to the end can be positioned in front of the mouth, and slide a length of plastic tubing over the wire and hook after replacing the suction pad.

The plastic tube should also carry the microphone screened lead which can be taped to the outside, or run along inside the tube and brought out near the suction pad, through a hole in the side of the tube. The microphone can now be soldered to the end of the wire in the tube and the connection lead (stiffening wire to screen connection).

Having done all this, stick the pad to the side of the helmet near the ear and adjust the position of the microphone. Tape the microphone wire, together with the headphone wire to the helmet fixing strap and connect the plug to the free ends of the wires, making sure the cable grip is squashed firmly on the wires. If excessive noise results when the microphone is touched the connecting wires should be transposed e.g. screen and stiffening wire connected to the other terminal.

When the microphones have been fixed and adjusted for position they can be glued in place on the helmet and the "hook" part glued to the suction pad to make it secure. It is not advisable to fix the microphone by drilling holes in the helmets.

INSTALLATION

The amplifier box is best installed in the car between the driver and passenger so that wires from the headsets feed down the side of the wearer and do not get in the way by being in front of him.

It should be noted that the leads must be long enough to facilitate movement of the head

Fig. 4. Headphone earpiece construction.

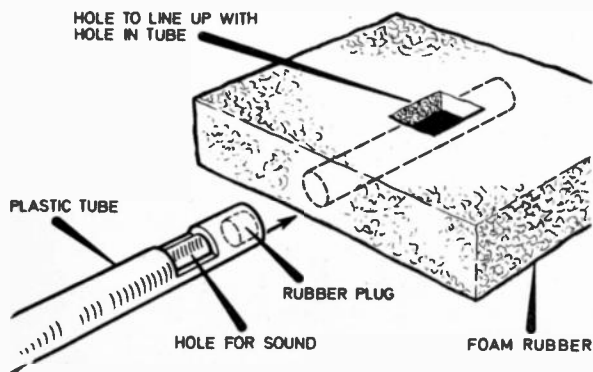

where necessary e.g. turning around for reversing or for map reading by the navigator. It is a good idea to mount the unit in a fairly low position with the sockets on the top so that should the wearer leave the car the plug will simply pull out and no damage will result.

Supply to the unit should be taken from the car wiring after the ignition switch so that the amplifier cannot be accidentally left on when the car is not in use. Supply polarity must be correct—check this before switching on.

For a motorcycle combination the amplifier and supply batteries can be housed in the side-car and a socket for the driver's headset can be mounted in a convenient place on the motorcycle.

If the unit is used on positive earth cars some provision should be made for insulation of the microphones—e.g. two or three coats of paint or insulation tape applied. If this is not done the

supply could be shorted when a microphone touches part of the metal bodywork. □



We would like to thank Everitt W. Vero and Co. Ltd., for kindly loaning us the two Everoak Grand Prix helmets used in the cover and heading photographs.

READERS' LETTERS

Solar Energy

With regard to your editorial, Vol. 4, No. 1, may I point out that even during the most inclement weather that this country can produce, it is still possible to take advantage of solar energy.

Correct orientation of the panels installed on the roof enables the collection of the diffused rays of the sun to provide a moderate amount of energy. However, since the source is free (the sun) and the cost and installation of the collector panels is very reasonable, it could be used in conjunction with one of the present energy supplies.

In summer it could provide a large percentage, if not all the energy required, and in winter a somewhat lesser amount. The economics of the affair should make it a worthwhile investment.

As for that "Maverick Compound" that falls ever so frequently from our skies, this too is an energy source. In fact the total amount of energy released by a summer thunderstorm is

equivalent to that of a large atomic bomb, and could be just as destructive if its total energy were ever concentrated.

L. G. Madden,
Queen Mary College,
London University.

Talking Calculator

Firstly I wish to express my thanks to you and all the staff, and people "in the back room" who bring this excellent magazine to me.

The article by Adrian Hope was most enlightening. Little did I know that calculators send messages. I would like also to tell you of what happens to my calculator.

When switched on in close proximity of a medium wave receiver it emits a whine with a fairly high frequency; not only that, on commencement of a calculation, it changes frequency with each operation.

I have also noticed that if the on-off switch is slowly pushed on at a certain point, the calculator immediately springs into life and starts counting up. The first three digits being a blurr or should that be the last three digits? Anyway, not knowing much of calculators, I wonder if anyone else has had anything like this happen to them?

Alistair Taylor,
Kettering,
Northants.

Cheaper Communication

Shown below is a modification for your 2 Way In-House Communicator, (Sept. '74). It comprises two 100 microfarad electrolytics with negative polarity together. The reason for this addition is that three core cable costs more than twin flex so, this circuit eliminates the third wire. I have not yet tried this in practice, but in theory it should work.

When the call switch is closed, it closes the circuit to activate the oscillator in the main unit, and when open, the audio has a direct path to the main unit. I'm sure some of your readers will like the idea and try it out.

Thanks for the good magazine, and keep the good work up.

W. Brack,
Wamberal,
Australia.

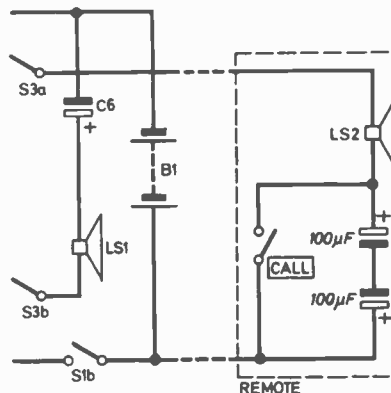

touch switch

for feather-light control

By A. Russell

A switch operated by body resistance rather than pressure.

A SWITCH operated by finger resistance; silent and robust. By a simple modification, the normal on/off function can be changed to a biased on or biased off. The original circuit was built as a novel on/off switch for a transistor radio, but the addition of a relay allows greater loads to be switched, e.g. mains lamps, door bells etc.

CIRCUIT DESCRIPTION

The complete circuit diagram of the Touch Switch is shown in Fig. 1. A finger on the on contact connects the gate of the f.e.t. to the 0V rail of the supply through the resistance of the finger. This biases the gate of the f.e.t. to -9V with respect to the source, and switches the f.e.t. off. The base of TR2 will thus go from 9V to 0V thus turning on TR2 which in turn switches TR3 on and passes the full 9V to the load or to RLA which switches the load.

The 10 megohm resistor R4 connected to TR3 collector, maintains the gate of the f.e.t. at about 0V. The circuit is stable and switched on. All the conditions are reversed when the circuit is switched off.

The circuit was designed for minimum power consumption when switched off. In fact the off current is $50\mu\text{A}$ which should not significantly shorten the shelf life of a large transistor radio

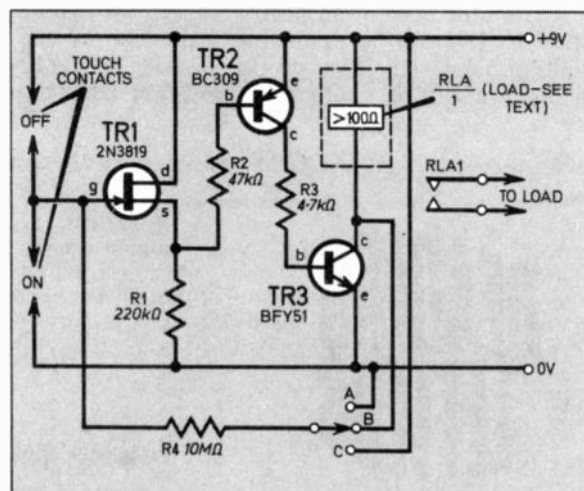
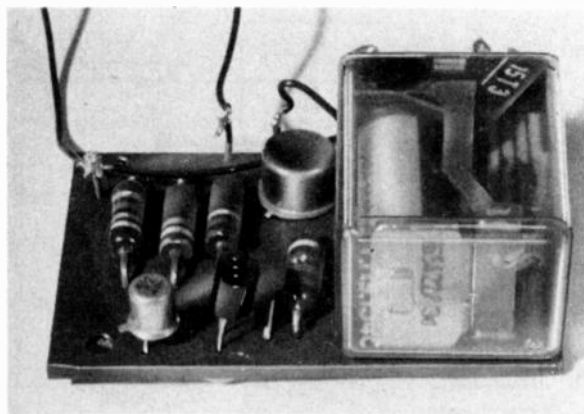

Fig. 1. Circuit diagram of the Touch Switch.

battery. If a relay is used as a load the switch may be used to control greater currents than the 100mA for which the basic circuit was designed.

CONSTRUCTION

The printed circuit board was produced in the standard way. Copper laminate board was cleaned and then painted with quick drying lacquer to protect the copper which was not to be etched away (Fig. 2). Ferric chloride solution was then used to etch away surplus copper, after which the lacquer was cleaned off.



FOR
GUIDANCE
ONLY

ESTIMATED COST*
OF COMPONENTS
including V.A.T.



£2.00

*Based on prices prevailing at
time of going to press

Components....

Resistors

R1 220k Ω

R2 47k Ω

R3 4.7k Ω

R4 10M Ω

All $\frac{1}{4}$ W $\pm 10\%$ carbon

SEE
**SHOP
TALK**

Semiconductors

TR1 2N3819 f.e.t.

TR2 BC309 silicon *pnp*

TR3 BFY51 silicon *nnp*

Miscellaneous

RLA1 Any 9V relay with a coil resistance of more than 100 Ω and at least one pair of normally open contacts rated at 1 amp a.c. (e.g. PC2 CBB/12).

Copper clad printed circuit panel 52 x 36mm, connecting wire.

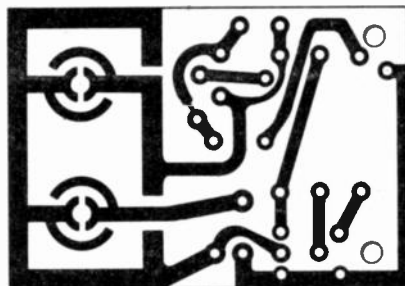
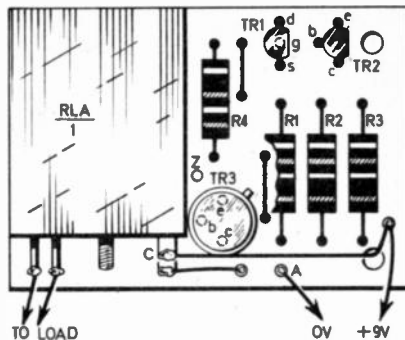

Holes for the component leads were drilled with a number 60 drill. After tinning the copper strips, the components were mounted as shown in Fig. 2 and soldered in position. Solder TR1 in last and make sure that the iron is earthed or disconnected when doing this.

The circuit layout of Fig. 2 makes allowances for the three types of switch available. For the normal on/off function use the circuit layout shown. For the biased on switch cut the printed circuit line at the narrowed section and connect the spare hole (Z) to the 0V pin (A). For the biased off switch connect the spare hole (Z) to the relay contact (C) and break the printed circuit at the narrowed section.

ALTERATIONS

The sensitivity of the circuit may be reduced by using a lower value for the 10 megohm

The completed prototype unit.

Fig. 2. Printed circuit layout and wiring shown full size.

resistor R4. The relay, or any other load (transistor radio etc.), connected to the output transistor must not draw more current than the design maximum of 100mA.

It is not recommended that the circuit be powered from the mains, unless the power supply is connected to the mains by a double wound transformer, and the circuit is well earthed. The circuit can be mounted in any suitable plastic case with a cut out for the contacts or could form the basis of a hidden lock with the touch contacts as inconspicuous brass studs. It must be remembered that any moisture across the contacts will energise the switch.

Using the specified relay, mains loads of up to 200W can be switched. Alternatively d.c. powered loads of up to $\frac{1}{2}$ amp can be switched.

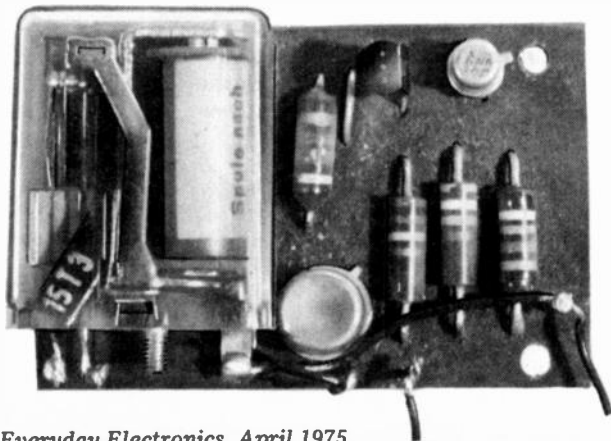

**PRACTICAL
ELECTRONICS**

THE MAGAZINE FOR IDEAS IN ELECTRONICS

Build these top projects—

PE JOANNA A touch sensitive piano with facilities for harpsichord and honkytonk.

CAR INDICATOR/EMERGENCY FLASHER

Plus part two of a special series
TRANSDUCERS

MAY ISSUE ON SALE APRIL 11—30p.

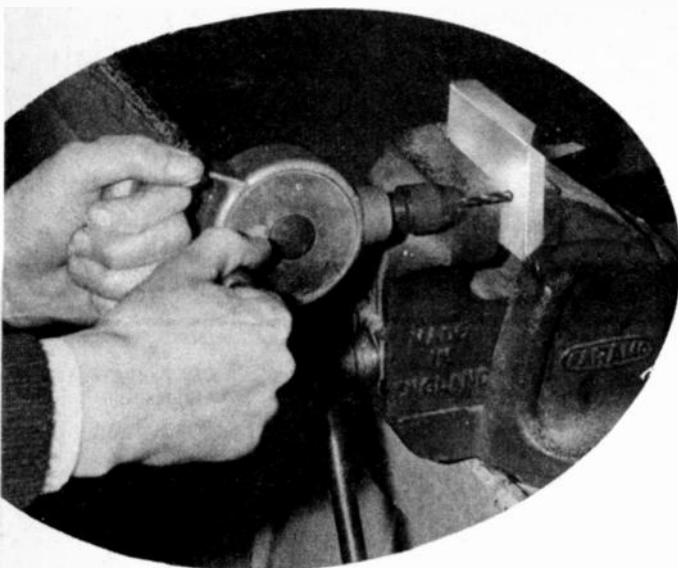

Workshop Practice

By **MIKE HUGHES** M.I.E.R.E

PART ONE
Cabinets & Enclosures

HAVING christened this series with the workshop in mind let us hasten to explain that we appreciate there are very few people who are lucky enough to have a spare room devoted to their hobby; consequently what we have to say will be biased in favour of those who have very limited resources in both tools and space. The only essential commodity has, of course, to be a tolerant matrimonial partner or mother!

CABINETS

We have chosen as the theme for the first part the building of cabinets because these can sometimes be the most expensive single part of any electronic constructional project—particularly when some unthinking author has specified a commercially available box that, while looking nice, is outside the limited budget of the home constructor.

When deciding about an enclosure for a project ingenuity ought to be allowed to run riot. Before embarking on a complex building exercise think a little first and look around you; there are many potential cabinets around the house just waiting to be used rather than ending up in the dustbin. These range from biscuit tins to 35mm film cassette cans, hard plastic containers that once held presents, to disused trinket boxes. While it may be hard to imagine that any of the above list could ever look aesthetically presentable it is amazing what can be done with a little bit of thought.

In the absence of anything suitable around the house do not forget to go round your local hardware store or Woolworths. They often have small plastic boxes that can be bought for a few pence and these are often admirable for housing projects.

PLASTICS

On the whole plastic is not the ideal material for the home constructor; it is usually too soft and flexible or, if based on polystyrene, may be brittle and liable to fracture when cut or drilled. Plastics can also present problems if ever you need to resort to glue or an epoxy resin for holding brackets or other fixtures in place as it is sometimes difficult to get a good bond on its shiny surface. Nevertheless do not discard clean rectangular plastic boxes as they can be most useful.

As already mentioned the hard transparent polystyrene plastics are probably best to use. The boxes can be used in their existing form or alternatively you can, with care, cut the material up into useful panels from which to fabricate other shapes. When cutting use a very fine toothed saw, such as a fret saw, otherwise you will suffer from the edges chipping. When you have cut panels to the right size finish off the edges by rubbing on fine abrasive paper that is held taut on a flat surface.

It is often difficult to drill holes without the material shattering unless you use the minimum amount of pressure; an alternative, and often more satisfactory, method is to use the bit of a small soldering iron (Fig. 1). When



Fig. 1. Using a soldering iron to make small holes in plastic

heated up to normal working temperature this will effectively melt holes through the polystyrene; there will be a slight raising of the edges to the hole but this can be removed with a sharp knife. This technique coupled with a fretsaw allows you to cut out larger sized holes for plugs, sockets and loudspeakers etc.

Once all the sides of the final box have been prepared ordinary polystyrene cement (as used in model kits) can be used to stick the sides together. Make sure you leave the box to harden for at least 24 hours before carrying out any further work on it because the cement stays flexible for much longer than you might imagine. Once dry the box can be painted with conventional polystyrene model paints. If transparent polystyrene was used a very smart finish can be obtained by applying the paint to the inside surfaces of the box.

The usual problem in making a box of this type is to decide on how to fix the lid in position. Again ingenuity is called for but a simple solution is to bolt in four corner brackets that have already been drilled and threaded to take small self-tapping screws (Fig. 2).

PERSPEX

Exactly the same techniques can be applied to boxes made from sheet Perspex however because it is usually thicker (from 3mm upwards) it is considerably easier to machine and will stand drilling and sawing with few problems. The advantage of sheet Perspex is, of course, that you have a ready made finish that can

Fig. 2. Method of fixing front panels to plastic cases.

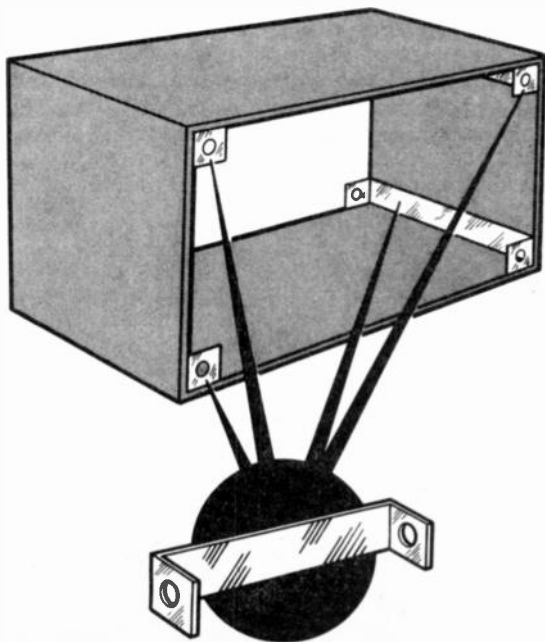

be polished to provide a really attractive box. Also, because of the extra thickness, it is considerably stronger and can be tapped directly (for standard threaded screws).

To get good strong corners using Perspex it is essential that the edges to be stuck together are perfectly flat and smooth—you should, of course, use special Perspex cement which can usually be obtained from the shop which supplies the sheet material.

If you have trouble in obtaining Perspex it is worth making enquiries at a local sign makers—quite often they will have useful sized offcuts that are ideal for our applications and they will not be too expensive. Remember that you should not remove the protective paper coating from the surface of the Perspex until the last possible moment. It is there to protect the surface from scratches and also proves useful for marking out the cutting dimensions.

A big attraction of using Perspex is that you can rely pretty heavily on the strength of cemented joints. This means that you can, with the minimum amount of bother, provide small compartments inside a box that may be used, for example, to hold batteries (Fig. 3).

These compartments can be padded with expanded foam rubber—held in place by double sided adhesive tape. This tape has a multitude of uses around the workshop and it is well worth having a reel available—it can be obtained from most good office stationers or art shops. We shall be suggesting its use again later in this series.

There are, of course, many instances when plastics cannot be used for enclosures either because they lack strength or do not give the right sort of appearance. Perhaps the most common instance for requiring a smart cabinet is for a hi fi amplifier or radio set. The modern style is to have a rectangular wooden box with an inset metal front panel. These may appear so smart that one might think them difficult to make. This is not the case—in fact they are probably one of the most simple types of cabinets.

METAL CHASSIS

Usually one needs a metal internal chassis on which to bolt the various circuit boards and front panel controls but at the same time one wishes to minimise on the number of fixing screws that can be seen from the front of the unit. Obviously metalwork is called for and there are some special purpose tools that really cut down on the hard work and skill—normally required for “metal bashing”.

The most common metal used in amateur electronics is aluminium sheet—probably of 16 to 20 gauge. This can be cut with a hacksaw or metal cutting blades in a fretsaw or coping saw. The only problem with conventional sawing is the difficulty in obtaining smooth straight edges without a lot of filing afterwards.

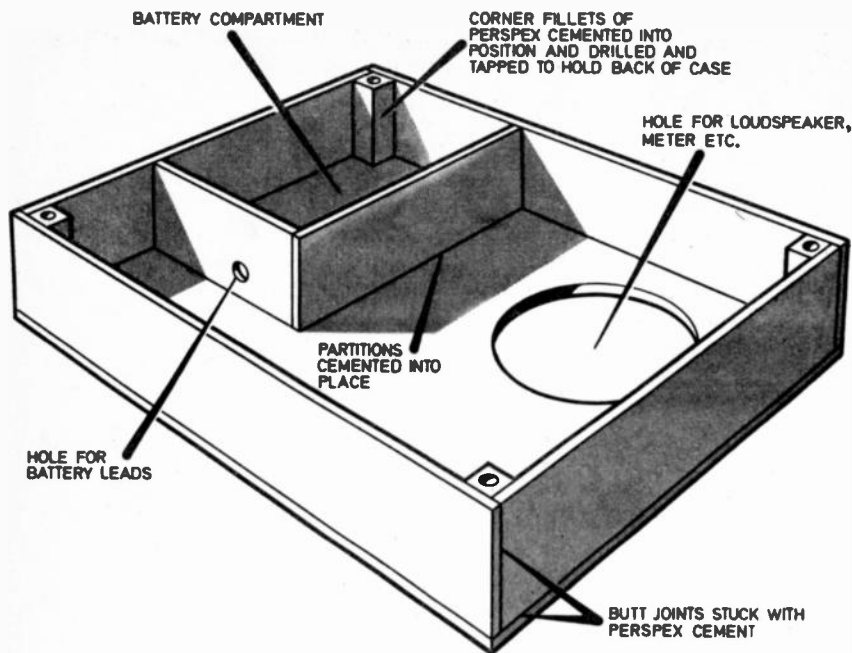

Fig. 3. Case made from Perspex with internal compartment for battery housing.

We would thoroughly recommend the use of one of the patent guillotine tools that are available from most "do it yourself" shops e.g. the Goscut tool. This enables you to cut along lines with ease and have no nasty metal powder to clear up afterwards.

There is the special bonus—to those of us who are basically lazy—that you can do the job sitting down in comfort and there is no need to clean up edges afterwards. The Goscut, in particular, is very good for cutting internal angles because it has one tool which neatly clips off every nibble without leaving you to "wiggle" it out by hand.

Most constructors have hand or electric drills for bit diameters up to about 10mm but above that size there are always problems. Obviously a rat tail file can be used to open up holes a little but these are difficult to use when one is trying to maintain a perfectly circular hole and in any case one needs a good strong bench and a vice which are not always to hand.

For holes up to about 25mm diameter one can use special punches that are operated by locating a die (fixed to a 10mm diameter screw) on one side of a normal 10mm diameter hole with its screw protruding through the hole. A punch is slid over the screw from the opposite side of the panel and a nut tightened up over the punch. By tightening up the nut the punch is literally pressed through the metal sheet and produces an exactly dimensioned circular hole (Fig. 4).

Unfortunately the British punch and die sets (Q-Max cutters) are very expensive indeed and probably out of the range of most do-it-yourselfers. They are expensive because they are

made from the highest grade hardened tool steel and are capable of punching through steel as well as aluminium. Fortunately there are now available small sets of punches that have been brought in from Japan. While they are by no means of as high quality as those made by Q-Max they are perfectly adequate for light gauge aluminium sheet—they can be bought for a pound or two and would make a worthwhile present for any electronics enthusiast.

LARGE DIAMETER HOLES

To make holes of larger diameter there is very little choice apart from the conventional tank cutter (Fig. 5). There are special curved saw blades that fit holders for electric drills but the author has never found these satisfactory—they

Fig. 4. Operation of a typical metal punch.

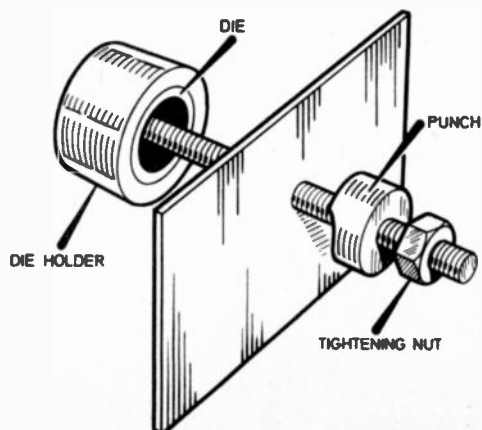

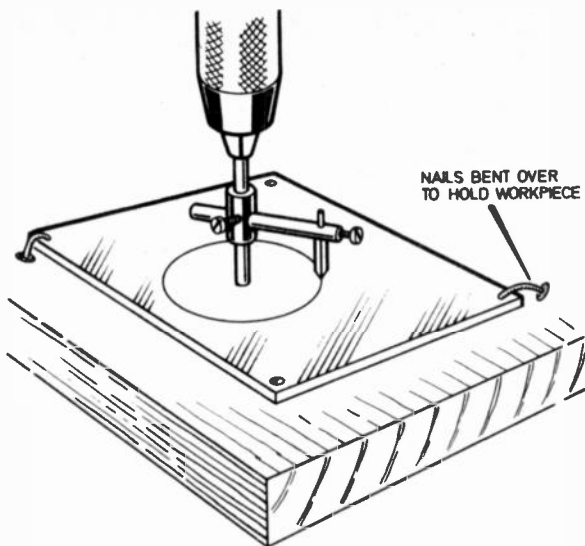

Fig. 5. Operation of a tank cutter.

are difficult to set up and never seem to produce a hole of the diameter you might expect. A tank cutter in a slow speed electric drill or a brace will always produce a better dimensioned hole.

The thing to remember when using a tank cutter is that the workpiece **must** be held very rigidly—for example on a wooden block, held in position with a couple of nails through small holes. Drill half way through from one side keeping the direction of drilling absolutely perpendicular to the workpiece. To finish off turn the workpiece over and cut in from the other side—never try to go right through from one side.

When cutting large diameter holes for bulky objects like meter movements make sure that you allow for any casting taper on the item that has to be set into the hole, as it is infuriating if you have to file out a large hole by even a sixteenth of an inch all round!

Always try to cut all the holes in your chassis before attempting to bend the metal otherwise you will end up with problems in holding the workpiece. It entails you in a little more thought at the marking out stage but a bit of time spent then is worth the extra convenience later.

METAL BENDING

There are no great problems in bending sheet metal but there are, none the less, a few pitfalls for the unwary. Hopefully dimensions of the final chassis are never critical unless you are machining metal to fit a box; it is our suggestion that you make the chassis first and then make the box to suit.

If you have to work to precise outside dimensions you must make allowances for material gained at a bend; this depends on how the metal is held in a vice and how free of curvature the bend is. Typically the top surface of a chassis

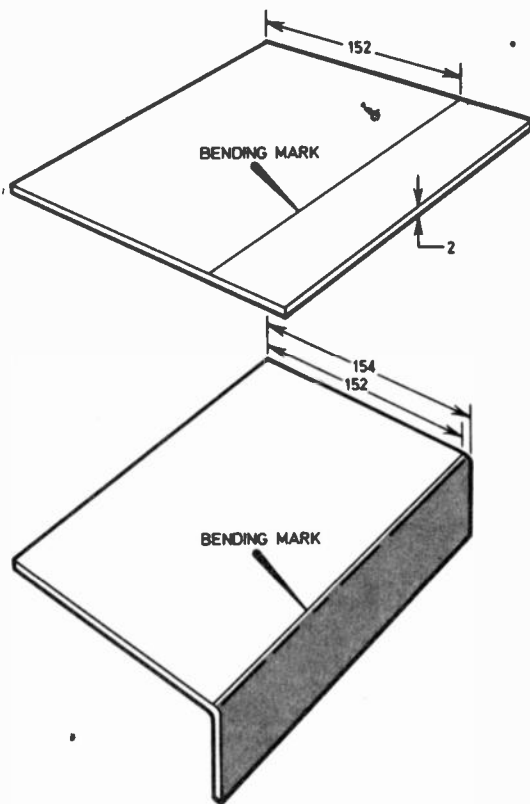

Fig. 6. Allowing for the bend when marking out metal chassis.

can be increased in size by up to twice the thickness of the material if this factor is not taken into account (Fig. 6).

To form a good clean bend it is desirable to use a metal vice. Do not attempt to face the jaws of the vice with wood—this will give a curved bend as opposed to a crisp 90 degree angle. If you only have a wooden vice it is a good idea to line the faces with a couple of pieces of 25mm to 40mm angle iron. Grip the work piece tightly in the vice so that the bending line is either seen with spare metal beneath up to approximately the thickness of the metal, or the line should be below the jaws of the vice by the same amount.

This controls whether you wish to gain or lose dimensions in the bend and, of course, whether you have already taken this factor into account in your original marking out! It is a good idea to have the longest side of the bend out of the vice so that you can get good leverage for the bending operation. Using **both** hands bend the material down flat to the surface of the vice with as even a movement as possible—try to keep the bending pressure uniform along the length of the bend.

For a long edge it might be preferable to apply pressure with a length of 50mm square timber to keep the bending action even. If this is done carefully you should automatically get a clean

corner but if it needs sharpening up a bit you can gently tap the metal down with a mallet or a hammer and a piece of wood.

Unless you have to it is better to avoid bending adjacent sides of a square surface as you are likely to have problems with holding the work in a vice; likewise it is best to keep bends as far apart from each other as possible—particularly if they go in the same direction.

COMPLETE HOUSING

Our illustration (Fig. 7) shows an example of a simple chassis that could be slid into a wooden case. The amount of bending is minimal and is only there to allow clearance for fixing screws underneath the metal surface. The front panel (this is an internal panel and would not be seen from the outside) is fixed into place by a row of pop rivets. These are applied by a special tool which is now commonly available from most hardware shops and is not too expensive. This panel could, of course, be bolted into place or even glued with one of the epoxy resins—e.g. Araldite. Notice the flange that has been bent into the bottom of this panel to allow a fixing point inside the wooden box.

All the controls would be fixed to this internal front panel which needs no surface finish—

unless it is necessary to provide a tuning scale or such like—and the spindles should be long enough to protrude through a single unbent dummy metal fascia panel. This latter panel would be neatly screwed to the front surface of the wooden box or inset slightly and would hide all the unsightly nuts, bolts and rivets.

A subsequent part in this series will deal with ways of producing a professional finish to this panel.

It only remains to make the wooden box in which to house the chassis. You do not have to be a carpenter to make a nice job of woodwork these days. All we need is a rectangular tunnel of plywood the back end of which is blocked off. The simplest way of making this is from plywood that can be butt jointed at the corners with plenty of resin glue (e.g. Evostick Resin W) and panel pins.

The cabinet will have no strain on it and the back and, eventually, the metal front panel will give it ample rigidity. The width of the cabinet should just take the width of the internal chassis but its height should be greater than the height of the internal front panel—to allow for the two fillets of wood that are used to fix the external fascia. The depth should be sufficient to allow the fascia to be set inside the front by about

Fig. 7. Construction of a simple modern chassis and wooden case.

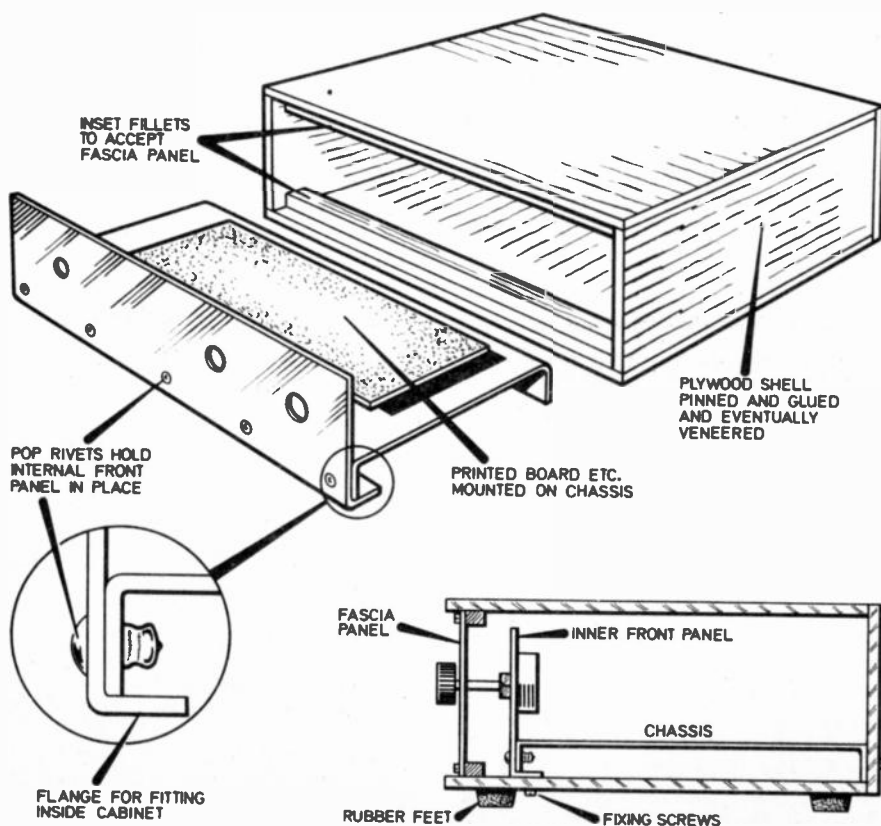

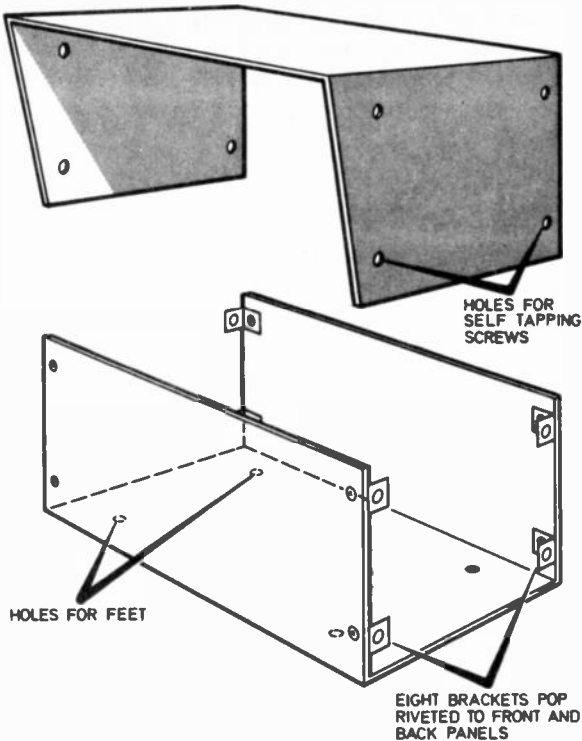

Fig. 8. Simple metal case for test gear.

5mm when the back of the chassis is just touching the inside of the back of the box.

The plywood case can now be covered with either Fablon or, better still, an iron-on wood veneer. The front edges of the plywood can be veneered or, alternatively, painted a nice solid black to hide the grain. When completed it is only necessary to drill holes under the front of the case to tally with the bend on the internal front panel so that self tapping screws can be used to hold the chassis in position.

Similar holes (together with one for the mains lead, if one is used) should be drilled at the bottom of the back panel. To finish the unit off four rubber feet can be screwed to the underside of the box. Small toilet seat buffers are ideal in this role.

FRONT PANEL

You may wonder why we bother to make a metal fascia panel instead of completing the final structure with wood. The answer to this one is simply that we do not advocate wooden front panels in general; they do not take lettering or other designs so well and generally spoil the appearance of the finished product giving it rather an old fashioned look.

In simpler cases you can use the technique suggested above but can omit the internal chassis. For small projects you can often bracket the Veroboard or printed circuit assembly straight on to the front panel with a couple of chromium plated screws; it only remains to drop the whole front panel assembly into the wooden box and secure it with four wood screws, into the two fillets running along the top and bottom.

To house test instruments that may be better off in all metal cases you can make a fairly simple case as shown in Fig. 8. This requires the minimum of bending, looks neat and is reasonably strong.

It is, of course impossible to cover all contingences in this one short article but we have offered a few short cuts and advice on how to take some of the hard work out of making enclosures.

Next month—A professional finish.

What do you know?

CONSTRUCTION

1. On what devices would you use a heat shunt when soldering.
2. What type of solder should you use for electronic construction.
3. What is the difference between Veroboard and plain matrix wiring board.
4. On what types of project should you **not** use Veroboard for construction.

ANSWERS

1. On any device that could be damaged by heat e.g. semiconductors — particularly germanium ones.
2. You should use solder with a resin flux inside it, preferably 18 or 22 s.w.g. Acid flux with ordinary solder **should never be used.**
3. Veroboard has copper strips on one side, plain matrix wiring board does not.
4. Veroboard should not be used on any project where very high voltages or current are employed or where the capacitive effect of the strips would interfere with the circuit operation (unless such a project is designed for Veroboard) e.g. in high frequency receivers or transmitters, capacitance meters etc.

Your Career in **ELECTRONICS**

By Peter Verwig

THE ELECTRONICS INDUSTRY

A career in electronics is an exciting prospect! This month **EVERYDAY ELECTRONICS** starts a regular series of articles on the electronics industry. Month by month our contributor Peter Verwig will explain what working in electronics is all about, how to prepare yourself for a rewarding career, and the job opportunities available in the world's fastest growing industry.

IN forthcoming articles we shall be telling you of courses of instruction that will be helpful, of the professional organisations you might wish to join, and some insights into the life of a marine electronics officer on board ship, a radar technician at an airport, a development engineer in a laboratory, a computer engineer, a TV broadcast engineer and a dozen or more interesting and often exciting occupations in which you can apply your interest in electronics to your own profit. Remember that many of the top personalities in professional electronics were once hobbyists like yourself.

But first we must set the scene by describing electronics as a manufacturing industry and as a service industry. Although *Your Career in Electronics* is based on British practice much of the information will be of value to overseas readers seeking career opportunities in their own countries.

HISTORY

The birth of electronics as an industry came with the filing of the world's first patent for Wireless Telegraphy (British Patent No. 12,039) on June 2, 1896, by a young man of 22, Guglielmo Marconi. He was very much an amateur enthusiast but he had the foresight to see the commercial possibilities of communication without wires. Earlier experimenters such as Heinrich Hertz had only regarded the subject as one of scientific novelty.

For the next 40 years the new science was concerned almost entirely with communications and sound reproduction, and it was

only in the late 1930's that vacuum tube technology (there were no transistors in those days) came to be applied to other uses such as medical radiotherapy. The 1939-45 war period saw tremendous technical advances and it was in the post-war period that the term "electronics" came into general use with radio communication and television as but one important branch of the subject.

The early post-war period saw the development of the first commercially available digital computers and the beginnings of automation in industry. The next big leap forward was the invention of the transistor which paved the way for the completely new technology of solid-state physics which now dominates electronics and has extended its application into almost every human activity.

So deep has been this penetration that from the point of view of an aspiring technician or chartered electronics engineer there are now infinite possibilities of employment. In the old days you needed to work in the radio manufacturing industry, in broadcasting or other professional communications, or as a service engineer at your local radio dealer.

Today the same man might work in a hospital, on an oil rig, in a food manufacturing plant, even at a coal mine. So in the area of job opportunities the spectrum is so large it is difficult to define any limit to electronics.

MANUFACTURING

What can be defined, however, is the electronics manufacturing industry which employs some 500,000 people in the UK with an

annual output of electronic goods worth nearly £2,000 million a year. There are two main divisions, one serving what is called the professional electronics market and the other the consumer market. The consumer market is all the electronics bought by ordinary people for use in their homes, their cars, and their caravans. Domestic radio and TV sets, hi-fi, tape recorders, hand-held electronic calculators, and the electronic watch and clock.

Professional electronics equipment is that classified as capital goods such as broadcast transmitters (both radio and TV), other professional communications (including mobile radio used by the police, fire services, taxis etc.), computers, industrial automation, medical electronics, radar and other navigational aids, and a huge sub-sector of defence electronics for the armed services.

The equipment manufacturers design and build complete equipments or systems and to do so they need to buy millions of components. So within the electronics industry we find some hundreds of manufacturers who specialise in making components, the resistors and capacitors, the transformers, transistors, integrated circuits, plugs and sockets, knobs, printed circuit boards, cables and terminals. The component manufacturers are varied. Some cater for the mass market of low-cost components, others produce fewer components but of very high quality for rather special applications.

Another important sector of the electronics industry is that concerned with the design and manufacture of instruments such as signal generators and oscilloscopes, multimeters and other test gear.

Just over half of all this activity is concentrated in the South-East of England so if you are looking for a job in manufacturing industry the widest choice is in the Greater London and Home Counties areas. The next biggest concentrations are in the East and West Midlands (11 per cent), the North-West (10 per cent) and Scotland (7 per cent). Wales has only 3 per cent of the total electronics manufacturing industry but this figure is now on the increase. The area of electronics famine is Yorkshire and Humberside with only 1 per cent.

PERSONNEL

Electronics assembly work and other light routine duties are conducted almost entirely by female labour, but technical categories are almost exclusively male. In round figures in the manufacturing industry there are 20,000 scientists and technologists (i.e. people with University Degrees or Higher National Certificates), 39,000 other technicians who would certainly be of Ordinary National Certificate standard, 6,500 draughtsmen and 53,000 skilled craftsmen.

The size of firms varies considerably. The Plessey Company, for example, has 60,000 people and GEC-Marconi Electronics, one of the electronic firms within the giant GEC Group, has 30,000. Solartron, whose main interest is in instruments has 1,600 employees, and Membrain, one of the newer companies who specialise in very advanced automated test equipment, has only 130 employees but a very high proportion of these are technically qualified men. There is therefore a very wide choice both for those who value the security of the larger organisations and those who prefer the generally more intimate atmosphere of the smaller concern.

Of course you can still work for the manufacturing industry without working in it. You can be an installation engineer, for example, employed by the manufacturer, and sent out to install and commission new equipment. Or a manufacturer's field service engineer engaged on modifications or servicing of equipment wherever it is installed.

We shall be returning to the

manufacturing industry in future articles in Your Career in Electronics when we look at career structures in closer detail.

Next month we shall discuss the qualifications you will need to get started in a professional career. Yes, it means more exams but remember you have a head start because this time you will be studying a subject which really interests and excites you!



A young Plessey engineer conducting high temperature tests on an advanced type of integrated circuit which is now enjoying good sales in the United States. Performance is being monitored by oscilloscope.



...Counter Intelligence

BY PAUL YOUNG

A retailer discusses component supply matters.

ONE of my more rewarding tasks, when I am not advising you on your component supply, is to offer advice to the management. Not that it is often required, they do a first rate job, bless "em", but in this instance, I would like to voice an opinion and I would particularly like to hear the views of, you, the constructors.

Basically you might say it boils down to i.c.'s (and in this I include modules) versus the equivalent transistors and components. What sparked this off, was when I saw the modules used in the *Modula 3*. Sure, they will save you a lot of work, but this argument, if pursued to its logical conclusion, would suggest you go out and buy a ready made amplifier, and have the great thrill of plugging in a pick-up and loud-

speaker!

It is an inescapable fact, that the i.c. and module are the antithesis of construction. In the case of the *Modula 3*, I am sure that most constructors would have preferred to build the modules and possibly saved money.

Another case in point, (although I hasten to add one that was not sponsored by this magazine) was the Mullard Unilex System. Here was a series of well-made modules, complete with 5 pots mounted on a bracket, all wired with coloured wire, all you needed was a small screwdriver, and you even got that in the kit.

I was invited along to the first demonstration given by Mullards, and I came away very impressed. I even built one for an uncle of mine who wanted a stereo outfit in a hurry. I thought

it would be very popular. I was wrong, it flopped badly and the reason is not hard to seek. You the constructor want something that taxes your skills, something you can construct. It is not overstating the case to say, that to you, this is more important than the finished result!

I am not saying that specialised i.c.'s should not be incorporated in the EVERYDAY ELECTRONICS constructional designs, this would penalise the readers unnecessarily, but a design that consists mainly of an i.c., that just requires a microphone hooked on to one end and a speaker on the other is not what the customer requires. I may be wrong, but that is my view, and I look forward to hearing from the readers.

And so Mr. Editor, please ask your excellent team of designers to be more "discrete" and less "integrated"; in the meantime I will passively await, the consensus of opinion.

LOOKING through the advertisements and brochures of the various electronic component suppliers, one cannot fail to notice the wide availability of logic i.c.s' especially TTL types. For the beginner these can be rather confusing, as the terms used tell the uninitiated little or nothing about the devices, and their functions.

Most of these have been designed for very specialised applications in the computer industry, such as frequency dividers and digital display drivers, and so do not find a very wide use in amateur electronics.

There is however, a family of logic circuits known as "gates", which are more simple than the majority of logic i.c.s, and are suitable for more general use in various switching applications. Because these i.c.s are manufactured in large numbers for use in industry, they are available at very low prices, and thus usually have a cost advantage over alternative types of circuit.

TYPES OF GATE

One factor in common with all types of gate is that they have two or more inputs, and a single output. Both the inputs and the output can be in one of two stable states. Either "high", at a potential of about 3 to 4 volts (often called logic 1), or "low", at a potential of about 0 to 0.5 volts (logic 0). Which of these two states the output assumes is dictated by the combination of states at the inputs, and the type of gate used.

There are four basic types of gate which are known as NAND, NOR, AND, and OR gates.

To show what output state a given combination of inputs will produce for any particular type of gate can be ascertained by reference to the relevant truth table. This is merely a table showing the output states of a gate for all the



possible input combinations, Tables 1 (a-d) give a truth table for each of the four basic types of gate. These tables are for the more simple type of gate having only two inputs.

The way in which the names of the gates are derived is quite straightforward. For instance, an AND gate is so called as the output is only high when input 1 AND input 2 are high.

A NAND gate is the same as an AND gate, except that with input 1 and 2 high, a low or negative output is obtained. An OR gate will have a high output with either input 1 OR input 2 high. A NOR gate will have a low (negative) output with either input 1 OR input 2 high.

These gates are all prefixed with the word "positive", as, with an AND gate for instance, it is when both inputs are positive that a high output is obtained. A negative AND gate has a low output when both inputs are negative. This last complication can be ignored to a certain extent, since one would not normally specify a

FOR
GUIDANCE
ONLY

ESTIMATED COST*
OF COMPONENTS
including V.A.T.

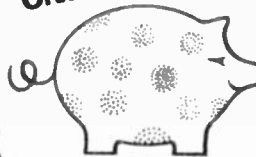

excluding cases
£2.30

*Based on prices prevailing at time of going to press

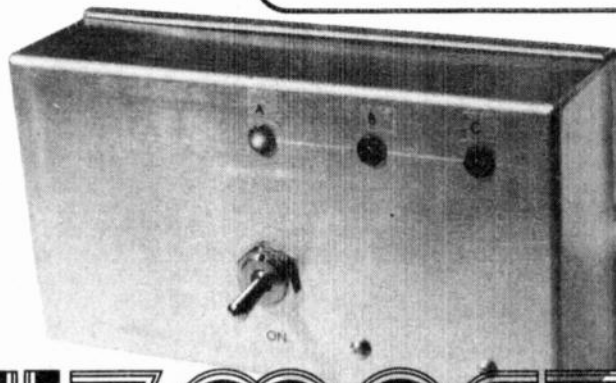

QUIZMASTER

Indicates who presses button first.

By R. A. PENFOLD
Everyday Electronics, April 1975

Table 1 (a): Positive 2-input AND

Input 1	Input 2	Output
LOW	LOW	LOW
LOW	HIGH	LOW
HIGH	LOW	LOW
HIGH	HIGH	HIGH

Table 1 (c): Positive 2-input OR

Input 1	Input 2	Output
LOW	LOW	LOW
LOW	HIGH	HIGH
HIGH	LOW	HIGH
HIGH	HIGH	HIGH

Table 1 (b): Positive 2-input NAND

Input 1	Input 2	Output
LOW	LOW	HIGH
LOW	HIGH	HIGH
HIGH	LOW	HIGH
HIGH	HIGH	LOW

Table 1 (d): Positive 2-input NOR

Input 1	Input 2	Output
LOW	LOW	HIGH
LOW	HIGH	LOW
HIGH	LOW	LOW
HIGH	HIGH	LOW

negative gate for a circuit, as if, for example, a truth table were drawn for a negative AND gate, this would be the same as one for a positive OR gate.

Thus the output is low when input 1 AND input 2 are low, and the output is high when input 1 OR input 2 are high. Thus in order to avoid confusion gates are often just termed NOR, NAND, etc., and it is a positive type that is referred to.

MULTI-INPUTS

A gate can have any number of inputs, and truth tables can be drawn for multi-input gates. These can be derived in much the same way as for a two input gate.

A three-input positive NOR gate will have a low output if input 1, or input 2, or input 3 are high. All three must therefore be low in order to obtain a high output. The resultant truth table is shown in Table 2. Similar truth tables for the other types of gate are not shown as it should be possible (and is a good exercise) for the reader to calculate these for himself.

Table 2: Positive 3-input NOR gate

Input 1	Input 2	Input 3	Output
LOW	LOW	LOW	HIGH
LOW	HIGH	LOW	LOW
LOW	LOW	HIGH	LOW
HIGH	HIGH	LOW	LOW
HIGH	LOW	HIGH	LOW
HIGH	LOW	LOW	LOW
LOW	HIGH	HIGH	LOW
HIGH	HIGH	HIGH	LOW

CIRCUIT DESCRIPTION

The circuit diagram of the Quizmaster (a precedence switching indicator) is shown in Fig. 1. This type of device is used in many television quizzes, where it is necessary to know who was the first person to press a button to indicate that they wish to answer a question.

Such a device consists of a push-button switch

Fig. 1. The complete circuit diagram of the Quizmaster. The three gates, G1A, G1B and G1C are all contained in one package, SN7427.

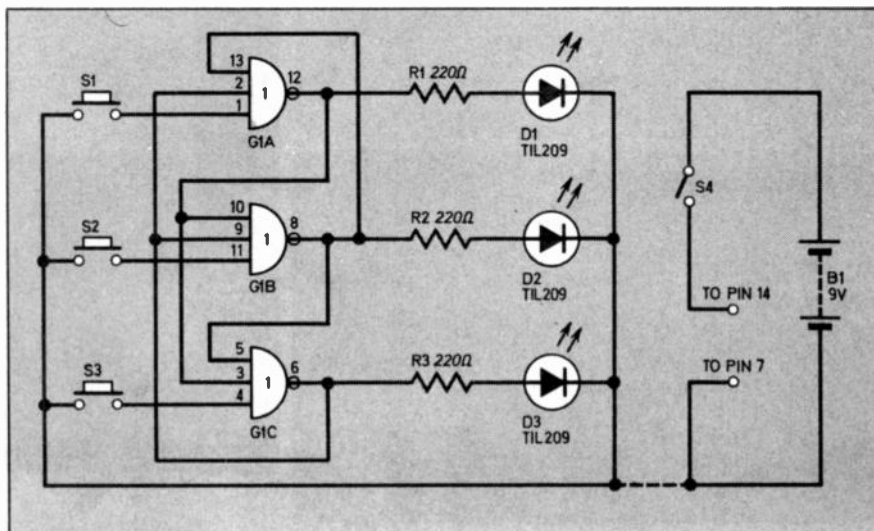

QUIZMASTER

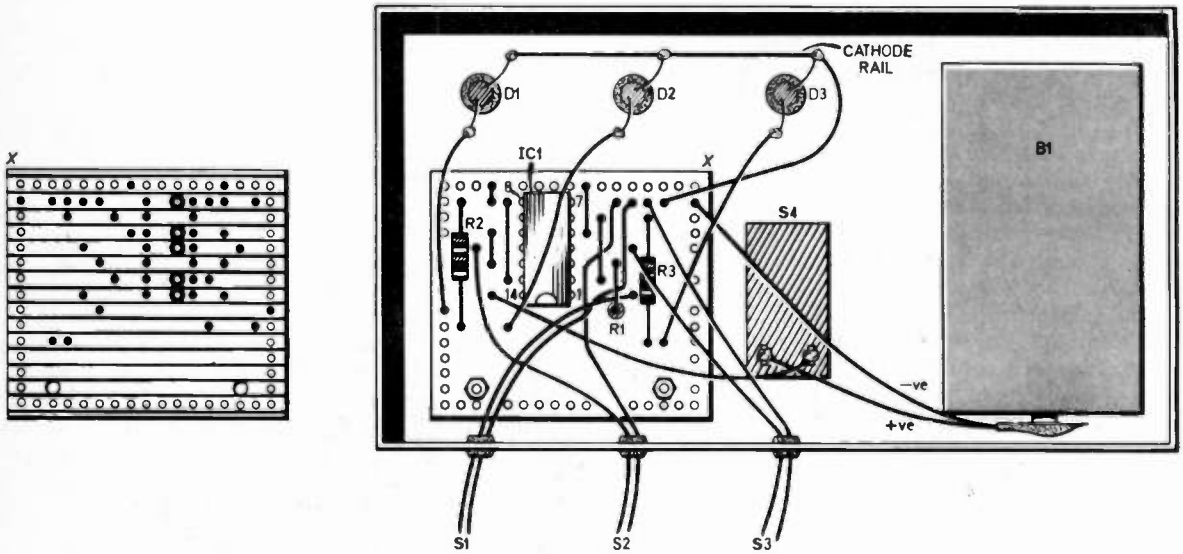
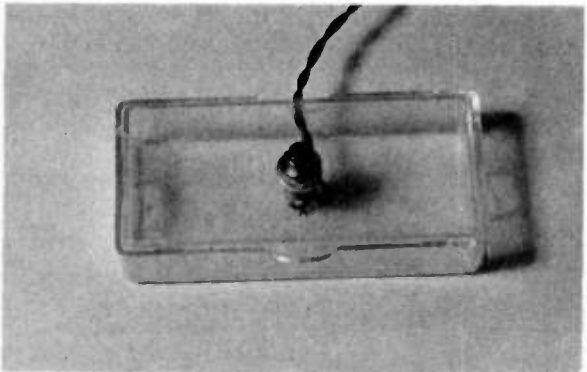
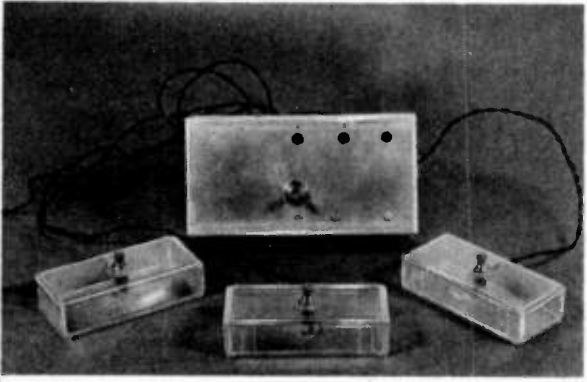

Fig. 2 (above). The layout of the components on the Veroboard and the breaks to be made on the underside. Also shows wiring up details.



Left. Photograph of one of the prototype remote switch boxes.



The completed prototype with remote switches.

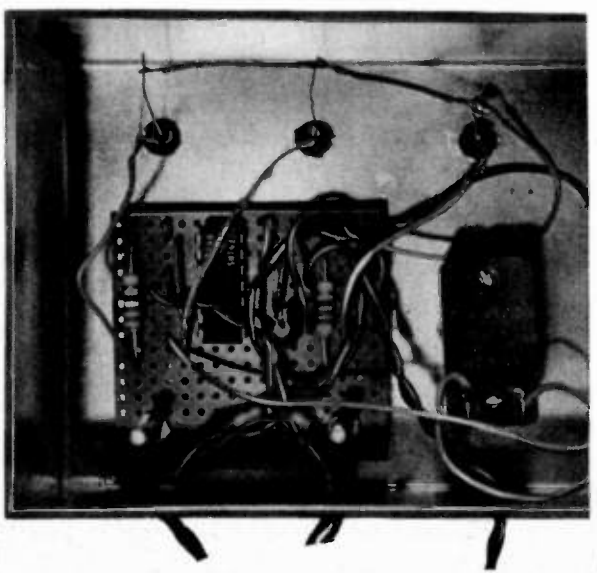

The prototype component board and wiring up details.

for each person, each button operating an indicator lamp when pressed. The circuit is arranged so that when one lamp is lit, the others are blocked, and cannot be illuminated by pressing the appropriate switch.

The circuit uses three 3-input NOR gates which are all contained in a single integrated circuit package type SN7427. The output of each gate is taken via a current limiting resistor to a light emitting diode. These diodes are used as the indicator lamps, and will light when the output of the gate which drives them is high.

One input of each gate is connected to a push button switch, one switch per gate. These are operated by the players, and when closed, earth the input to which they are connected. The other two inputs of each gate go one to each output of the other two gates.

When the on/off switch, S4, is closed, the inputs connecting to S1, S2, and S3 will tend to drift to the high state, due to the type of circuitry used in the i.c. This means that all the outputs will be low (see Table 2). The gates now each have one input high, and two which are low, as they are connected to the outputs of the other gates, which are all low.

If one of the switches, say S1, is closed, all the inputs of gate 1 will be low, and the output will go high, causing the lamp to light. This will cause one input of each of the other gates to go high, and even if S1, and S2 are now closed, one input of these gates will still be high, and the lamps will not light. The circuit is not latching, and the lamp will only light while S1 is closed. Therefore to restart the cycle S1 is merely released.

It is worth noting that although a positive NOR gate is specified, and the 7427 i.c. will be advertised as such, this is in fact being used as a negative NAND gate, as a lamp can only light when input 1, and input 2, and input 3 of its gate are low.

Components

Resistors

R1 220 Ω
R2 220 Ω
R3 220 Ω
All $\frac{1}{2}$ watt $\pm 10\%$

SEE
**SHOP
TALK**

Semiconductors

IC1 SN7427 triple 3-input NOR gates
D1, 2, 3 TIL209 l.e.d. (with fixing clips) (3 off)

Miscellaneous

S1, 2, 3 push-to-make release-to-break type (3 off)
S4 s.p.s.t. toggle
B1 9V PP3
Veroboard: 0.1in. matrix 17 holes \times 15 strips;
aluminium case type AB7 or similar; 14 pin
d.i.l. socket to suit IC1; battery connectors
for PP3; three small cases for remote
switches.

CONSTRUCTION

Some of the components are mounted on a piece of 0.1in. matrix Veroboard size 15 strips by 17 holes, the layout is shown in Fig. 2 together with the breaks to be made on the underside.

Begin by making these breaks and drilling the two fixing holes and then position and solder the components to the board as detailed not forgetting the link wires. Ensure that the i.c. is put in the correct way round; there is an indentation between pins 1 and 14. In the prototype no i.c. holder was used but it is strongly recommended that one is used so as to avoid overheating by the soldering iron.

The prototype used a commercially available aluminium case type AB7 size 135 \times 70 \times 40mm with a removable base, although any size and material will do. Prepare the case to accept the components and then secure the latter in position.

The l.e.d.s. used had a grommet-like fixing that is fitted through a hole drilled in the case and the l.e.d. then pushed in. Do not treat the l.e.d.s. as ordinary bulbs, these must be connected with the correct polarity or they will not light and may be damaged. The case is usually marked with a small dot near the cathode (+ve) terminal.

Solder the flying leads to the component board and then wire up to the case mounted components. Attach suitable lengths of wire to the board that are to go to the push button switches S1, 2 and 3 and pass these out through the case in pairs via small grommets.

The component board is mounted by two 6BA nuts and bolts, and spacers are used to keep the copper strips clear of the case.

REMOTE SWITCHES

The three push button switches (push-to-make release-to-break) should now be mounted in suitable size cases of any material but should be robust enough to stand up to a fair amount of handling from excited contestants. Transparent plastic cases were used in the prototype since they were readily available.

Now wire up the three pairs of wires from the master unit, one to each remote switch, passing the wires through a small hole in the side of each case.

TESTING

Thoroughly check out the construction and when satisfied connect the battery and switch on at S4. None of the l.e.d.s. should be illuminated. Press down one of the remote switches and one l.e.d. should light up. With this switch held down depressing the other two should have no effect. Repeat this procedure with the other two switches to obtain the same result. Each l.e.d. should now be labelled the same as the remote switch that turns it on and the unit is ready to use. \square

for your Entertainment...

By Adrian Hope

A new electronic training aid will be welcomed by musicians, singers and language pupils alike. It takes the form of a cassette player and recorder with an instant playback facility rather like that used by television for sports transmissions. The Canon Repeat-Corder L was developed by the Canon Company of Japan for language learning and speech therapy but anyone playing around with the machine can hardly help thinking up some new use for it.

A rigid document-type carrying case opens up to reveal a cassette recorder with piano-key controls. An ordinary Philips-type cassette is used in the conventional way for record, play-back, fast rewind, and fast forward. But additionally a second, quite separate, cassette can be run alongside the main cassette. This second cassette has a continuous loop of tape of fixed length (anything from 5 to 180 seconds) and when it is running, this second cassette is constantly recording what the main cassette is playing back. The machine has a repeat button and when this is pressed, the main cassette stops and the continuous loop cassette starts to play back what it has been continuously recording. Thus a 5-second cassette will play back over and over again the last 5 seconds it has recorded from the main cassette. When the main cassette is started again, the loop circuitry is automatically switched over to record again. In this way a musician or a language pupil working from a piece of music or a lesson recorded on the main cassette, can snatch any particularly difficult passage and play it again and again until he is satisfied.

Although marketing of the Canon machine was launched in this country around a year ago, by Education Projects International Limited (now at 15 Temple Sheen

Road, London SW14), I have never seen one in any of the usual hi fi or audio shops. But I have checked with the importers and they tell me it is selling well to specialised markets.

As a sign of the times, we are even likely to hear it in public places or on public services, such as the railway. Various different bomb or emergency warnings will be recorded on the main cassette and when necessary the repeat cassette will be switched on to play back the relevant warning repeatedly over the PA system.

DISCOUNT BUYING

Talking of "the usual hi fi and audio shops" brings to mind the perennial problem—should we or shouldn't we buy equipment from cut price or discount dealers? We are all confronted with the same dilemma at some time or another; we want to buy a piece of equipment and we can either go to a shop that sells it at full price, along with helpful advice and demonstrations or we can buy it without demonstration from a discount house for well under the market price but by mail order or from a salesman who probably knows nothing whatsoever about electronics. There really are no simple answers but there are some very clear guidelines.

First and foremost, as electronic equipment gets more complicated, so it becomes more likely to have a fault on when you buy it or to develop a fault in use. Even the American space programme has learned the hard way about zero defect philosophies. For instance, on the first moon landing the computer had to be over-ridden and the ship manually controlled at touch-down.

Most of the cut price shops honour their promises and do replace goods found faulty on

purchase. Most of these shops also honour their promise to repair or replace goods which fail during the guarantee period. But the crunch comes when the guarantee period ends. Quite often a discount dealer can only honour his guarantees by replacing dud items with new ones from his warehouse. Sometimes his original bulk purchase is made at a price which assumes a percentage of duds and thus takes into account a similar percentage of shrinkage or wastage. (This I believe happens a great deal in the calculator market.)

Clearly, if the dealer has no real service facilities and only a warehouse of replacements, he will not be able to help when the guarantee period is passed. And if the equipment is made in the Far East, the proud owner may be left with a beautiful looking piece of junk. For anyone who has tried to find an independent engineer to service a treasured gadget from a far-off land will know what this means in practice. In short, no one will touch it with a barge pole because spares will be difficult or impossible to obtain and anyway a fair price for the job will give the customer a heart attack.

EXCEPTIONS

On the other hand, dealers with a service department and service engineers permanently on their staff (and charging full price for everything they sell to pay the engineers' wages) will probably undertake repairs on anything that they have sold (at a price if out of guarantee of course) for years afterwards.

Of course there are plenty of so-called specialist dealers who sell at full price and offer nothing in the way of advice or after sales service in return. And there are discount merchants who have well equipped service departments. So the golden guideline is to sort out right from the start, without any ifs and buts, whether the source you are buying from will undertake service (at a price) after the guarantee period is over.

Remember that a £100 amplifier bought cheap at £70 is a very expensive bargain indeed if it has to be thrown out after a year. A £100 amplifier bought for £100 that can be repaired for a few pounds later on, is a far better bet.



Physics is FUN!

By Derrick DAINES

HOME MADE CAPACITORS

Cut up some discarded bean tins to provide two sheets of metal of about 15 to 20 centimetres square and nail strips of wood along one edge of each to provide a stand. Stand them on edge facing each other on a sheet of plastic film (plastic tablecloth is ideal) for insulation, see Fig. 1. If tin is not available, cardboard will suffice, provided that silver foil is glued to one face.

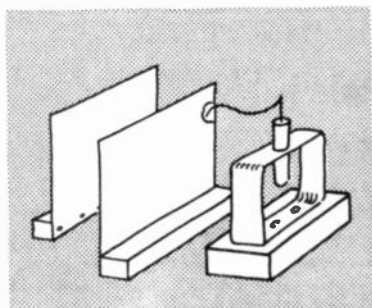

Fig. 1. An experiment with a home-made capacitor.

Solder a thin flexible wire to one face of the home-made capacitor and fasten the other end to your home-made electroscope.

Charge another plastic film by rubbing it with wool, bring it up to the electroscope. You will discover that the electroscope is not so easily deflected—some of the charge is conducted along the wire to charge the plate of the capacitor.

When the electroscope leaves are fully deflected, push the second plate of the capacitor near but not touching the first, (use an insulator—not your hand.) The leaves of the electroscope will show considerably less deflection.

This shows that the capacitance of a capacitor increases when two plates are used and that the closer they are—without touching

—the greater is their capacity to hold charge.

Now earth the second plate by touching it with the hand. Again, it will be found that the capacitance has increased. Finally, place a thick book between the plates and note that the capacitance has increased yet further.

From these experiments we can see that a capacitor has an effect when only one plate is connected into any electronic circuitry, but that the effect is increased when the other plate is also connected. They also show that the material between the plates affects the capacitance.

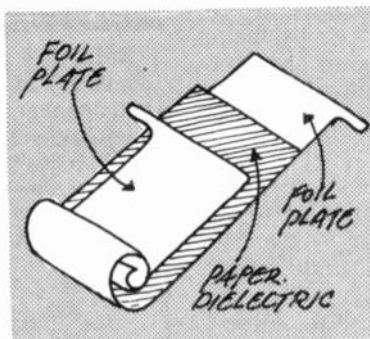

Fig. 2. How a paper capacitor is made up.

Take a discarded paper capacitor and carefully cut the outer covering. Then unroll the "in-nards". You will find that all you have is two strips of aluminium foil separated by paper soaked in a waxy solution, see Fig. 2. The function of the paper is simply that of an electrolyte—the "posh" name we give to the separator between the plates. Our book was an electrolyte; so was air.

As we may guess, different substances have differing ability to increase the possible charge held in a capacitor. Taking air as value 1, paper has the value 2·2

and mica the value of 6. For a given value of capacitance therefore, a mica capacitor will be much smaller than a paper capacitor.

You will often see capacitors that are termed "electrolytic". Strictly speaking, all capacitors are electrolytic, whether the electrolyte is air, mica or what-have-you, but what the manufacturers (and most writers) mean by an electrolytic capacitor is one that has a "wet" electrolyte.

If you have a discarded electrolytic capacitor, dismantle it carefully. The inside is just the same in construction as the paper capacitor, but the paper electrolyte is immersed in a wet paste based (for the record) on ammonium tetraborate.

It is also arranged that one of the spiral sheets of aluminium is in electrical contact with the aluminium can, see Fig. 3. On charge, the wet electrolyte has a chemical reaction that increases the capacitance many times.

Capacitance is the ability to hold a static charge.

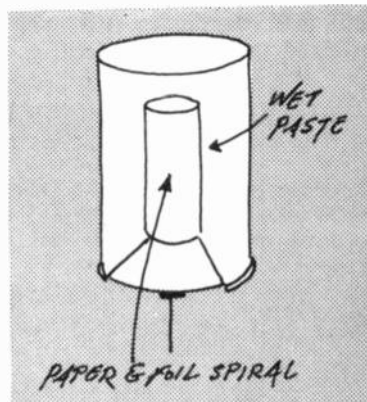

Fig. 3. Internal details of an electrolytic capacitor.

SIGNAL INJECTOR & LOGIC PROBE

By D.G. WARD



A useful pocket instrument for use on audio, radio and logic systems.

WHEN testing radio or audio equipment, a signal injector is an invaluable piece of apparatus to have at hand, as it allows the location of a fault to be rapidly narrowed down to a single stage of the circuit under test.

Also, when testing circuits that make use of TTL devices, it is advantageous to have a device that will provide an audio indication of the logic levels present within the circuit, rather than the visual "transistor-driven lamp indicator" which necessitates the diverting of attention to and from the lamp and circuit board.

The circuit described in this article provides an instrument that will give clear indication of an open circuit, logic "0" and logic "1" or by flicking a switch, an audio frequency signal (approx 1kHz) suitable for injection into audio and radio equipment.

CIRCUIT

The circuit diagram of the Signal Injector & Logic Probe is shown in Fig. 1. As can be seen, it centres around IC1, which is a four-input NAND Schmitt trigger. The Schmitt trigger action is such that if a rising voltage is applied to the inputs of the device, when this voltage reaches a certain level (1.7V in this circuit), the output will fall sharply to 0.4V. If the input is now allowed to fall back towards zero, as it reaches

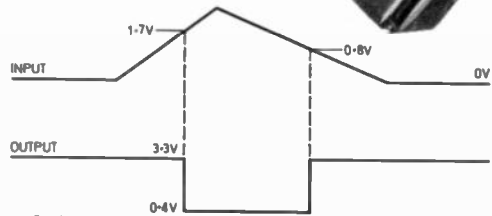

Fig. 2. Input-output characteristics.

0.8V, the output will rise sharply back to 3.3V (see Fig. 2). This delay in the switching action that the device possesses, known as hysteresis, makes it ideal for use as an RC multivibrator.

MULTIVIBRATOR

Referring to Fig. 3, assuming that IC1 output is initially at logic 1 and C1 is discharged, C1 will then charge towards logic 1 via R1 until it reaches the 1.7V threshold, when the output will fall to logic 0. Capacitor C1 then discharges back

FOR GUIDANCE ONLY

ESTIMATED COST* OF COMPONENTS including V.A.T.

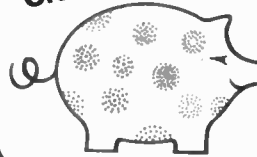

£1.40 excluding case

*Based on prices prevailing at time of going to press

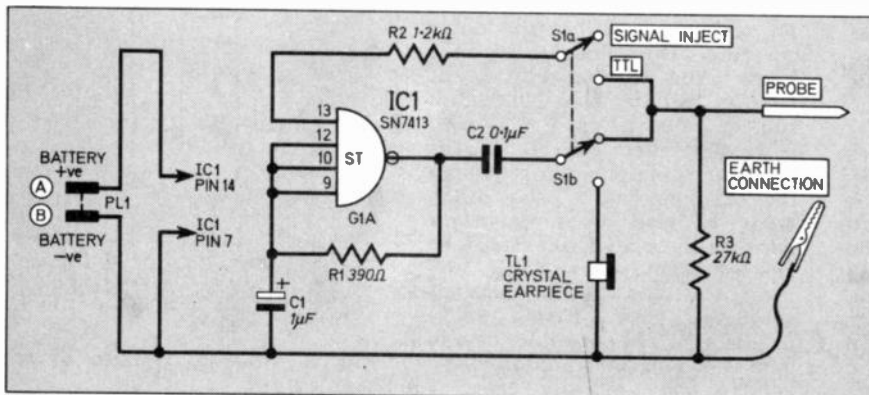

Fig. 1. The complete circuit diagram of the Signal Injector & Logic Probe. Only half of the circuitry in the integrated circuit is used.

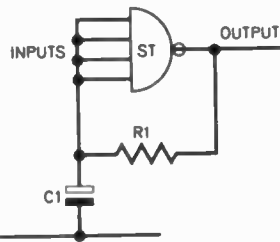

Fig. 3. Details of use of a Schmitt trigger as a multivibrator.

through R1 until the lower threshold of 0.8V is reached, when the output rises back to logic 1. The cycle then repeats itself until the supply is removed.

TTL PROBE

Removing the supply voltage, however, is not the only way of controlling the oscillatory action of the circuit. The device has four NAND inputs, this means that if one of these is held at logic 1 (or left floating) then the output will always be the inverse of the input (as before, when all inputs were connected together).

However, if this input is now taken to ground, then the output will go to a logic 1 and stay there regardless of what appears at the other inputs. Thus one input can be used to switch or gate the multivibrator action of the device.

With switch SI in the "signal inject" position the gating input is left floating and hence the circuit oscillates normally, the output being taken via a d.c. blocking capacitor, to the probe.

With the switch reversed, in the TTL position, the gating input is connected to the probe via a current limiting resistor, R2 and the output goes to the crystal earpiece TL1. When the probe is not connected to any external circuit a note of about 1kHz can be heard through TL1. If the probe is now touched on a point at logic 1 a slightly lower note is heard and if a logic 0 point is touched then the note will cease altogether. Without R3 there would be no difference in the notes of a complete open circuit and logic 1.

SUPPLY

The circuit can be powered either from 4.5V dry cell battery, three 1.5V mercury cells, directly from the supply rail of the circuit to be tested providing it is guaranteed to be *always* less than 5.5V and, with the inclusion of the circuit in Fig. 4, a 9V PP3 battery. The prototype was powered by the first method.

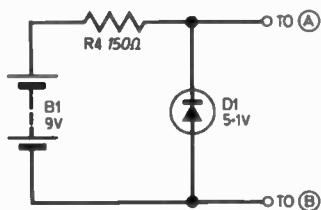

Fig. 4. A suitable power supply for the unit using a PP3 9V battery.

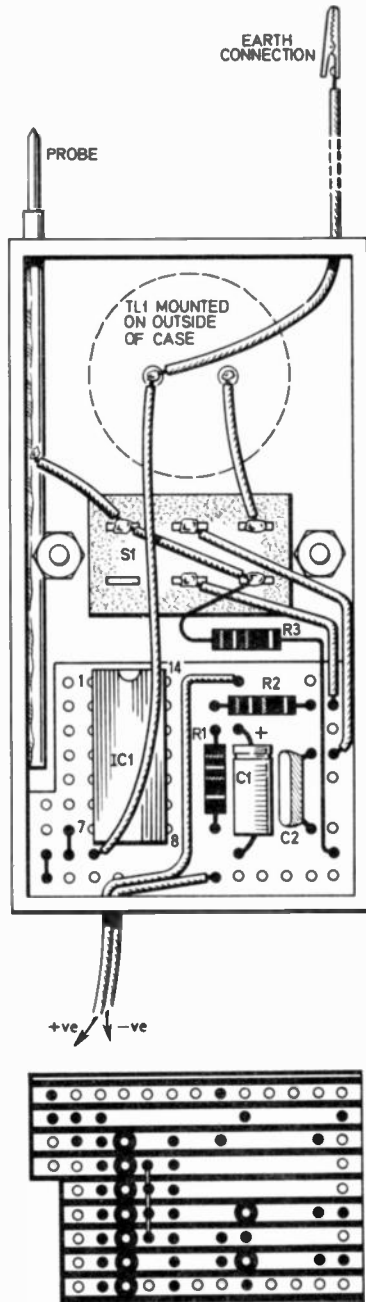

Fig. 5. The layout of the components on the Veroboard, cut-outs to be made and full wiring up details.

CONSTRUCTION

Begin construction by cutting to size the 0.1in matrix Veroboard as shown in Fig. 5. Next break the copper strips where shown by using a small twist drill bit to remove the copper foil. Solder the flying leads, link wire and resistors first. The integrated circuit IC1 is easily damaged by heat so the use of a 14 pin d.i.l. socket is recommended.

Components

Resistors

- R1 390 Ω
- R2 1.2k Ω
- R3 27k Ω
- All $\frac{1}{4}$ W \pm 10% carbon

Capacitors

- C1 1 μ F 15V elect.
- C2 0.1 μ F polyester

Miscellaneous

- IC1 SN7413 dual 4-input NAND Schmitt trigger
- S1 double-pole double-throw slide switch
- TL1 crystal earpiece
- Veroboard: 0.1in. matrix, 13 holes by 9 strips; crocodile clip; socket to suit IC1; 2-pin DIN plug; 50mm 6BA brass studding; small plastic case.

SEE
**SHOP
TALK**

In the prototype the top two sections of an old f.m. aerial were used as the probe, allowing it to be retracted back into the case when not in use, however, a 50mm length of 6BA brass studding filed to a point would serve equally well. The flying lead to the probe is soldered onto one end of the studding prior to fixing.

The whole device was mounted in a clear plastic slide-top case such as those that are used to house throat lozenges and record styli, although any type of case can be used.

Two holes must be drilled for the leads from TL1 and one for its mounting screw. A rectangular hole and two 6BA clearance holes are needed for S1. Three more holes are needed, one 6BA clearance for the probe and two for the supply leads, see Fig. 5.

When all the drilling is complete, the case can be painted from the inside, (this prevents paint scratches on the unit when in use).

The probe should now be fixed in the box with epoxy resin glue, and after this is set, S1 and the component board may be put in place.

The flying leads to the switch and TL1 should then be soldered, and TL1 glued and screwed by means of its cable gland screw, or if this is absent, a small self-tapping screw, to the case.

In the prototype the supply leads were terminated in a 2 pin DIN plug allowing a variety of supply modules to be used, but if only one type of supply is to be used, the leads can be soldered directly to the supply in series with the positive supply rail. In this case, a small push-to-test switch must be mounted in the case (room has been left for this) but the author recommends that in keeping with the simplicity and economy of the device, an Ever Ready battery, type 1289 or equivalent 4.5V battery be used as it has quite a long life and, because it has brass strips as terminals: by soldering one lead to a small brass plate, and glueing it below one terminal this will then serve as a cheap push-to-test switch.

Whatever type of supply is used, do not forget to leave a flying lead, terminated in a crocodile clip from the negative line of the supply to serve as a common chassis connection to the device under test.

NOTES ON USE

The Signal Injector & Logic Probe must not be used on equipment possessing voltage levels greater than the working voltage of C2, eg. some valve equipment. Also, the TTL probe must never be taken to a voltage greater than 5.5V. Failure to observe these two points will result in destruction of the device.

As the TTL probe gives a note when there is open circuit between probe and chassis connector, and no note when this circuit is closed the device can be used in this mode as a continuity tester.

If different frequencies of operation are required C1 can be altered. To increase the frequency, decrease the capacitance and vice versa.

□

JACK PLUG & FAMILY...

THAT VEROBOARD SENSOR THING FOR YOUR RAIN ALARM SYSTEM...



...YOU LEFT IT IN THE GARDEN, SO I PUT IT IN THE SHED TO SAVE IT...



...GETTING WET IF IT RAINS.



Next Month...

SPECIAL 8 PAGE SUPPLEMENT... USING MULTIMETERS

Complete guide for this most useful piece of test equipment.
A must for all beginners.

**EASY
TO BUILD
PROJECTS**

WARNING WINKER

A low current indicator for battery powered equipment.

ANTI-THEFT ALARM

Protect your car with this simple alarm.

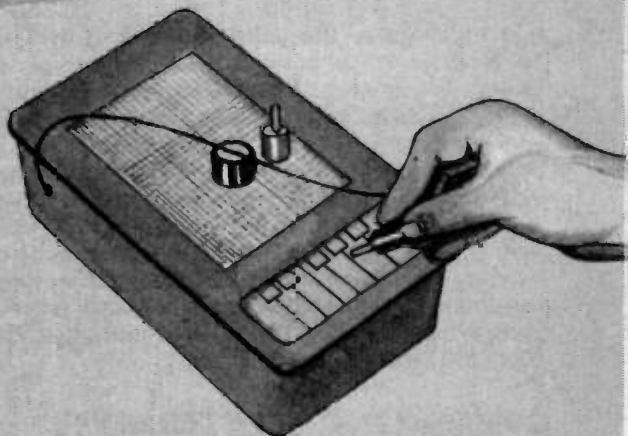

THE MINSTREL

A single octave stylus operated miniature organ.

MW/LW TUNER

Superhet design for use with almost any amplifier.

everyday electronics

MAY ISSUE
ON SALE
FRIDAY APRIL 18

NEW DIMENSIONS IN SOUND

AND OTHER MULTICHANNEL SYSTEMS

PART 3 By **ADRIAN HOPE**

WE CAME to the point last month of seeing how it is possible to produce pseudo-quadraphonic sounds by the simple expedient of wiring an extra loudspeaker across the positive speaker output terminals of an ordinary stereo amplifier. This is the basic technique and with one proviso there is no reason why a reader should not go out now, buy an extra loudspeaker and some wire, connect it (in addition to his existing speakers) across the two positive output terminals of his stereo amplifier and locate it at the back of his room. He would then have a pseudo-quadraphonic set up.

COMMON NEGATIVE TERMINALS

The proviso is that the amplifier must have common negative terminals. In other words, the two negative terminals of the amplifier must be connected together inside, and virtually all modern amplifiers are constructed in this manner. The type of amplifier set-up that would probably not be suitable would be a pair of mono amplifiers wired together in a pair to produce stereo. If anyone is in doubt as to whether their amplifier does have a common negative connec-

tion between the loudspeaker output terminals, they should contact the manufacturer, but in practice it is most unlikely that any modern amplifier will be "unsafe" for Hafler-style connection.

REFINEMENTS

Now for some refinements on the basic Hafler set-up. It is usually better to use two extra loudspeakers rather than one, one extra loudspeaker at the left rear of the room and one at the right rear. It is often better to wire them in series with each other (rather than in parallel) and out-of-phase (rather than in-phase). Thus the set up shown in Fig. 11 is probably ideal.

This series, out of phase connection, will help protect the stereo amplifier from "seeing" too low an impedance across its output terminals and thus perhaps suffering damage, distortion or blowing a fuse. It is also a worthwhile precaution to put an extra quick-blow fuse in series with the rear loudspeakers as additional protection.

The value will depend on the power rating of your own particular set up, but 250 milliamps is a good starting point. Use 500 milliamps instead if it blows regularly on average programme material played at normal domestic levels. The purpose of the fuse is to safeguard the amplifier output stages against untoward current flow from one channel to another under freak programme conditions (such as a massive musical climax on one channel and silence on the other).

The impedance of the extra loudspeakers should generally be the same as the existing loudspeakers. Thus if the existing front loudspeakers are 15 ohms each you would do well to use two 15 ohms speakers at the rear. But within reason impedance is not critical, i.e. 15 ohms at the front and 16 ohms each at the rear is of no consequence.

CONTROL BOXES

Various control boxes are on the market (e.g. made by Eagle, B&O, ScanDyna, Goodwin), which provide for simple DIN plug connection between a stereo amplifier, an existing pair of front loudspeakers and an extra add-on pair of

STEREO AMPLIFIER WITH
COMMON NEGATIVE
LOUDSPEAKER OUTPUTS

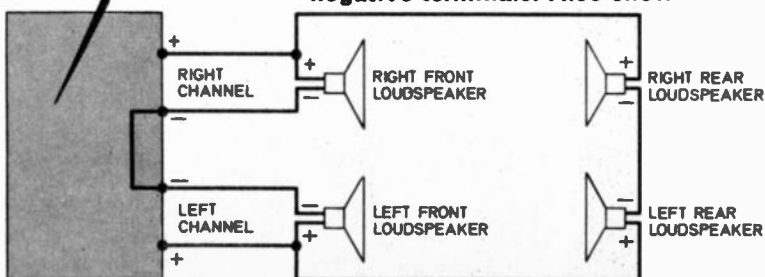
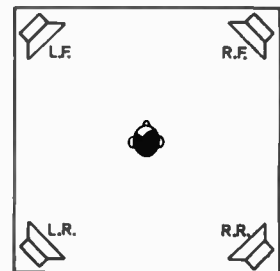

Fig. 11. Adding two more loudspeakers to a stereo set-up to produce pseudo-quadraphony. Note that the amplifier must have common negative terminals. Also shown is domestic arrangement of speakers.



rear loudspeakers. Usually these connection boxes provide a degree of volume control for the front speakers or the rear speakers, but seldom for both.

Some controversy exists over the desirability or otherwise of providing any such volume control. The problem is that putting simple resistors in series with loudspeakers tends in theory to adversely affect their damping. But in practice most problems of this nature tend to be theoretical rather than audible.

In this context it is also worth bearing in mind that the rear loudspeakers can be relatively cheap compared to the existing front speakers. They will be producing sound at lower level than the front speakers and there will generally be less bass content. Thus there is no need to match the rear loudspeakers with the front loudspeakers in terms of price, quality and power handling. But of course if you use junk loudspeakers at the rear and excellent speakers at the front, you will soon become unhappy with the results.

VOLUME CONTROLS

Some of the more expensive control boxes use special volume controls which are intended to safeguard the damping of the loudspeakers but



The Sony SQA100 decoder/amplifier. Can convert existing stereo system for 4-channel listening. (Sony (U.K.) Ltd.)

Everyday Electronics, April 1975

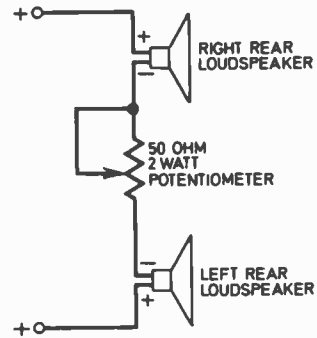

Fig. 12. Using a potentiometer in series with the rear loudspeakers to control rear level.

most of the others use simple series potentiometers. For anyone wishing to build a simple control themselves, the arrangement shown in Fig. 12 will serve to control the rear speaker level.

The potentiometer connected in between the negative terminals of the two rear speakers may be 50 or 100 ohms in value and should be wirewound with 2 or 3 watts handling power. As the circuit diagram shows it is effectively in series with the whole rear speaker arrangement and thus the single potentiometer will control both speakers at the same time and in a ganged manner.

My personal experience, however, is that the kind of power levels which will be produced at the rear loudspeakers will not normally require reduction, as they will seldom be too loud. Likewise it is unlikely that they will be too low in level. In fact one of the beauties of a Hafler arrangement is that it will usually tend (for any volume setting on the main amplifier volume control) automatically to produce a reasonably correct listening level at the rear loudspeakers, relative to the front.

Sometimes a listener may wish to boost the level at the rear, and short of using an extra amplifier to achieve this, the simplest way is simply to cut down the level of the front speakers slightly. This can best be done by using a control as shown in Fig. 13. (The rear loudspeakers and their connections are not shown.) Again the potentiometer is 50 or 100 ohms, but should be of around 5 watt rather than 2 or 3 watt power handling capacity; this is because greater total power is fed to the front loudspeakers than the rear.

RESULTS

With or without the simple embellishments of Fig. 12 and 13, the simple basic circuit of Fig. 11 will produce surprisingly successful results, not only on stereo records with ambient or trick out of phase effects, but also on Sansui QS or CBS SQ matrix discs. It requires virtually no setting up other than making the connections shown and placing the speakers to the left and

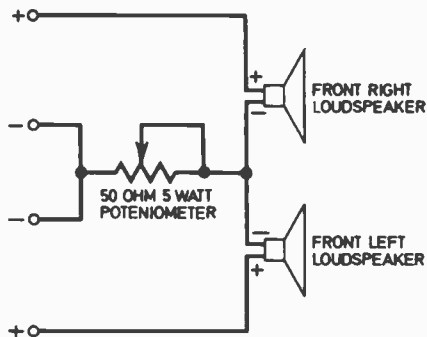

Fig. 13. The potentiometer is used to reduce level of front loudspeakers. Has same effect as boosting rear volume level.

right rear of the listening room, preferably fairly high up on bookshelves.

Because the left and right rear loudspeakers will be producing the *difference* between the left and right front channels (we have seen that this is usually out of phase signal material) they should produce absolutely nothing with the amplifier in the mono mode. This is of course because in the mono mode both the front channels are carrying exactly the *same* signals.

The only occasion when the rear speakers will produce sounds with the amplifier in the mono mode is if the amplifier balance control is not set dead centre, i.e. if more sound is being pushed to the left front loudspeaker than the right, thereby creating an artificial difference.

This in fact is a way to check that a Hafler rig is correctly set up. The amplifier is switched to mono mode and the balance control varied until the minimum sound emerges from the rear loudspeakers (on many amplifiers the true dead centre of the balance control will not be exactly zero on the scale or will vary with volume setting).

With absolutely minimum sound from the rear when the amplifier is in the mono mode, whatever you hear from the rear when the amplifier is switched to the stereo mode is the true difference signal.

Perhaps the most dramatic way to demonstrate pseudo-quadraphonics is to beg, borrow or buy a matrix record. Play it first in the mono mode with mono sound from the front loudspeakers and nothing from the rear, and then in the stereo mode with stereo from the front loudspeakers and the encoded rear sounds roaring out from the rear speakers. The difference, if you will pardon the intentional pun, is quite startling.

QUESTIONS

There are two questions which will inevitably spring to some readers' minds. First, which of the various matrix systems is best? Secondly, why do we need three, four or more channels in the first place?

The answer to the first question is really quite

simple. None of the matrix systems is best (either the major systems discussed or other less well known proposals) as each one is in some respects a compromise. Some systems provide better compatibility than others (produce better stereo or mono when played on ordinary stereo or mono systems) and some are more directionally accurate than others (recreate the recorded sounds in more correct positions on playback). But no matrix system is 100 per cent compatible, especially when used in mono, and no matrix system is 100 per cent accurate in positioning sounds on playback as they were in the original.

And don't be fooled into thinking that mono compatibility is not important. Think for a while of the number of mono radio receivers there are in the world and you will realise why it is essential for any multichannel recording to replay properly in mono (as well as stereo and multichannel).

Rearms of erudite appraisals have been written on the relative merits of the various systems, but all the writing is by definition inconclusive because of the element of compromise inevitably involved. Whichever system prevails in the long run will depend more on commercial skill rather than technical excellence. In the quadraphonic arena the best salesman is more likely to win than the best system.



The Sansui QRX350 quadraphonic receiver.
(Vernitron Ltd.)

NEED FOR FOUR CHANNEL SOUND

As to why we need four channel sound in the first place, the answer is a little more complicated.

Mono bunches all the original sounds into one single channel. If this single channel is played back through one loudspeaker all the original sound will come from that one single source. If several loudspeakers are spread over a wide arc, the apparent sound source will be widened, but there will be no separation in space of the original sounds, e.g. of different instruments.



The Pioneer 4-channel receiver type QX949. Output power 4 x 40 watts r.m.s. (Shiro (U.K.) Ltd.)

In stereo there is a vast improvement. In its simplest form stereo relies on two microphones, of which one picks up sound from the left hand side of the original sound source while the other picks up sound from the right. These are played back through separate loudspeakers spaced apart, with the left hand sound issuing from the left hand loudspeaker and the right hand sound issuing from the right hand loudspeaker, so that there results a spread of sound between the loudspeakers.

Sounds in the centre are recorded equally strongly by each channel and thus are played back equally strongly from both loudspeakers. This produces the illusion of sound emerging from the centre, half-way between the loudspeakers.

Extreme left hand sound issues only from the left loudspeaker and extreme right hand sound from the right loudspeaker. In between these extremes there are an infinite number of half way stages so that when sound moves from left to right on a good stereo set-up, it does so gradually and smoothly. Also on a good stereo set-up, the existence of the loudspeakers can be virtually forgotten.

AMBIENCE

But one thing will always be missing when a stereo set-up is used in a domestic situation. In a concert hall the listener hears the orchestra in front of him not only by way of the direct sounds which come straight from the orchestra to his ears, but also by way of indirect sounds which bounce off the walls, ceiling and back of the hall.

Unless the hall is vastly large, these sounds will not be so delayed by their distance of travel as to sound like real echoes (as in a mountain canyon) and the effect of their late arrival will be subconsciously felt rather than consciously heard. It is this complex of delayed arrival sounds that gives a concert hall its warmth or ambience.

In a domestic set-up the room is too small for the sounds arriving at the ears of the listener from the ceiling, walls or rear to be sufficiently delayed to create any such effect. Any recorded echoes will be reproduced unnaturally from the front of the room. Thus if a concert hall atmosphere is to be recreated in a domestic situation, it must be achieved artificially.

It is usually done by placing extra speakers round the room, especially at the rear of the room, and feeding only ambient sounds to them. These sounds can either be delayed replicas of the sounds issuing from the front loudspeakers, or (and this is where quadrasonics, Hafler pseudo-quadrasonics, surround sound and multichannel come in) they can be true recordings or imitative reconstructions of the sounds which would be heard by the listener if he were in a concert hall.

In its simplest form quadrasonics recording can involve placing a couple of extra microphones at the back of the studio and feeding the sounds recorded from these microphones to the rear channels of the quadrasonics set up. Quadrasonics recordings according to such techniques are usually called "ambience" recordings; many classical recordings in the quadrasonics systems are made in this manner.

YOUR CHOICE

This then is one *raison d'être* for quadrasonics—to simulate reality. But quadrasonics can also be used to create *unreal* sounds.

Some orchestral recordings and many rock and pop recordings use the rear loudspeakers as main sound sources and thereby place the listener artificially right in the middle of the orchestra or group. There is nothing right about the ambience approach or wrong about the unreal surround-sound approach. It is simply a question of paying your money and taking your choice.

If you want simulated concert hall sounds, you buy ambience recordings; if you want the unreal, but exciting, experience of sitting alongside the conductor or in the middle of an electric pop group, then you go for that type of quadrasonics recording. The same hi fi system, of course, copes with either type of record—the element of choice lies in what recordings you choose to play on it. □

PLEASE TAKE NOTE

In the *Soil Moisture Alarm*, EE March 1975, Fig. 3. The underside view of TR1 is incorrect—the emitter and base designations should be transposed

In the *Fuzz Box* article, E.E. March 1975, there was a mistake in Fig. 4, page 151. The two potentiometers are incorrectly labelled; the labelling should be transposed. The circuit diagram of Fig. 1 is correct.

ALTHOUGH there seems to be an abundance of small plastic cases now available, it is always interesting to hear of new types, particularly if they have some unusual features. A new range of polycarbonate moulded cases has recently been introduced by West Hyde Developments Ltd.

The "Boplast" cases have high impact strength, high temperature resistance (140 degrees C), captive stainless retaining screws, internal fixing screws which are outside the enclosed area and internal pads for chassis/circuit board mounting with self-tapping screws. In addition, the cases are sealed with an internal gasket which is recessed for protection and is oil, petrol and water resistant.

**New products and
component buying
for constructional
projects**

SHOP 'TALK

By Mike Kenward

Needless-to-say, with all those features the cases are not cheap, but are good looking with a blue/grey finish that requires no painting. Prices start at about 75p for the smallest 52 x 50 x 35mm and rise to about £9.00. Largest size 250 x 160 x 150mm—some sizes available with clear front covers.

For full details contact West Hyde Developments Ltd., Ryefield Crescent, Northwood, Middlesex, HA6 1NN.

Car Rally Intercom

The amplifier I.C. used in the *Car Rally Intercom* is not at present generally available, and readers will have to write to

Jermyn for the device. The total cost is £1.97 including V.A.T. and postage. Send a cheque or P.O. to Jermyn, Cash Sales Dept, Vestry Trading Estate, Sevenoaks, Kent.

One or two other parts also require a mention—they are the crystal microphone inserts and the earpieces used on the headsets. Almost any small crystal microphone inserts will be suitable, so buy the cheapest—they must be fairly small and light for mounting purposes.

The two earpieces must be of 8 ohms each—no other impedance will do—and they should preferably have hollow ear inserts so that the plastic tubes can be fixed as described in the article.

Case for the prototype was one of the Minos range, available from West Hyde Developments—see above for address—but almost any small case will be suitable.

Quizmaster

A good introduction to logic is provided by the *Quizmaster* and even if you have no interest in this particular unit, a great deal can be gleaned from the circuit and associated description. In fact the same can be said of many of our articles, there is often plenty of technical description that can be applied to many other circuits with the same or similar basic circuit configurations.

No difficulty with buying for this project, in fact, the only parts worth giving a mention to are the cases. Once again, any small plastic or metal cases can be used. And a look around a local hardware store may turn up something that can be used to house the individual pushbuttons.

Most component suppliers now sell reasonable ranges of inexpensive metal cases that can be used for the main unit.

Signal Injector and Logic Probe

Although the *Signal Injector & Logic Probe* article provides an adequate description of the unit's function and use, those who are encountering logic for the first time would do well to read the *Quizmaster* article, which provides a more detailed explanation of basic logic.

Once again, few buying problems for this device, the earpiece must be a crystal type—not a medium or low impedance one.

Suggestions for the case and probe are provided in the text. Of course, any small plastic cases will be suitable and no doubt readers will very quickly find a suitable housing.

Touch Switch

It is possible to build the *Touch Switch* without the relay, in this arrangement the second transistor switches on the load (up to 100mA) and there should be no problems with components. When the relay is used it can be fixed to the board as shown, providing it is small enough. The relay may present a problem when buying but most of the larger suppliers should be able to provide something to suit.

Materials for etching the board should also be available from larger suppliers. In this connection we note that Home Radio have introduced an etching kit containing an etching dish (plastic) some copper clad board, a laminate cutter, a quantity of ferric chloride crystals, plastic spoon and tweezers and a Decon Dalo resist pen. The cost of the kit is £3.50 plus V.A.T. and 35p postage. The kit may be supplied at reduced cost without the plastic items should these not be available.

Also included with the kit is an eight page instruction booklet giving details of how to use the kit and how to lay out the circuit from the diagram. The circuit used for illustration purposes is actually an F. G. Rayer radio design that we published some time ago.

The West Hyde Boplast cabinets.

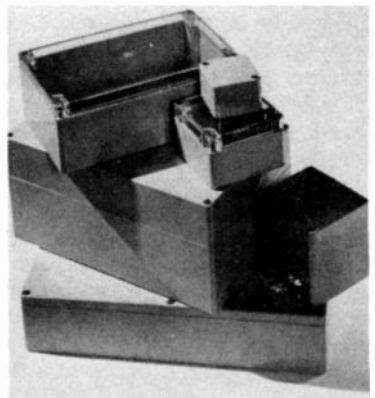

Everyday Electronics, April 1975

DEMO CIRCUITS

By **MIKE HUGHES**

The Armstrong Oscillator

Not many people appear to have heard of the Armstrong Oscillator even though it is probably the most obvious way of getting positive feedback. The reason for this apparent lack of recognition for its originator is the fundamental nature of the circuit and it is more commonly known as a transformer coupled feedback oscillator.

Some people consider it to be a very crude way of producing regenerative feedback but nevertheless it is one of those circuits that can almost be guaranteed to work over very wide limits of component tolerances. It has its shortcomings but whenever you need a good strong signal generated where you are not too fussy about accuracy of frequency or purity of its (nominal) sine wave shape, then this circuit is the one to go for.

INDUCTORS

From the writer's point of view its most distressing feature is that it needs a couple of inductors in the shape of a transformer and, like many lazy amateurs, he is loath to sit down winding coils; however, this is not necessary for the experiment we have in mind because we shall be using a standard readily available transformer to give us the inductance we require.

FREQUENCY

The frequency determining components in the Armstrong Oscillator are an inductance in parallel with a capacitor in the type of circuit shown in Fig. 1a. If signals of different frequencies are applied across the input to this circuit there will be one particular frequency for which the parallel arrangement gives a maximum impedance. This frequency is given by the expression:

$$f = \frac{1}{2\pi\sqrt{LC}}$$

where f is in Hz, L in henries and C in farads (π , of course, is 3.142)

At this frequency, known as resonance, the voltage of the signal developed across $L1$ is maxi-

mum, and although very little current enters or leaves the parallel arrangement quite significant currents flow to and fro between the capacitor and the inductor—these internal currents are caused by the resonance effect and alternate in direction at the resonant frequency.

TRANSFORMER

If we wound a separate coil on the same core as $L1$ —as shown in Fig. 1b, we would be making a transformer. The output voltage across $L2$ would be proportional to the turns ratio of $L1$ with $L2$ and the voltage across $L1$. At resonance of $L1$, we shall get a maximum signal across $L2$ but there is, of course, total isolation between the two windings.

If we assumed that both windings were wound in the same direction and that the starts for each winding are as shown with the black dots in the illustration, then the signal at point B will be exactly in phase with the signal at point A (these signals would be measured relative to the reference lines on either side of the transformer). If the signal at A was rising in a positive direction then the signal at B will also be rising in a positive direction.

TUNING

In theory we must be careful not to load $L2$ with any capacitance because it will affect the tuning of the parallel circuit on the other side of the transformer and hence change the resonant frequency. We can say that capacitance across the secondary is reflected into the primary circuit and modifies the tuning—this is caused by the mutual inductance between the two coils.

Fig. 1a. The tuned circuit used in the Armstrong Oscillator.

Fig. 1b. The tuned circuit with an additional winding to form a transformer.

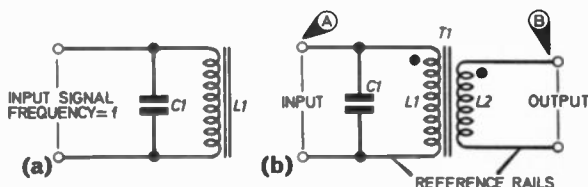

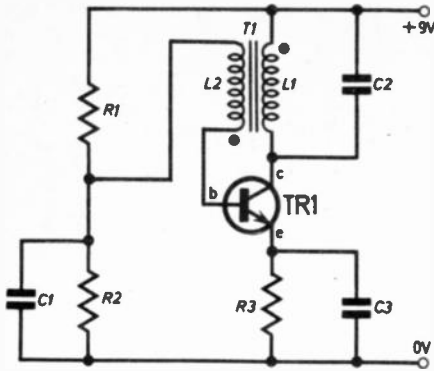

Fig. 2. The Armstrong Oscillator circuit. Winding L2 is the transformer secondary. The dots indicate the start of each winding.

Transformer *T1*, as shown in Fig. 1b, is a single tuned transformer with the tuning capacitor on the primary side. We could, by careful selection of a capacitor, tune the secondary as well—to the same resonance—in which case we would have a double tuned transformer. This would increase the “*Q*” of the circuit as a whole and the transformer would be much more critically tuned to the resonant frequency.

We could have a single tuned transformer with the tuning capacitor connected across the secondary and the output would still be maximum at the resonant frequency, but this time the frequency would be set, primarily, by the capacitor and the inductance of the secondary winding.

COMPONENT FUNCTIONS

The principle of using the tuning of such a transformer circuit and the isolation between primary and secondary turns is put to good use in the Armstrong Oscillator shown in Fig. 2. The primary, *L1*, and *C2* form the parallel tuned circuit and, at the same time, the collector load for *TR1* which is acting as a common emitter amplifier.

Base bias is provided by the potential divide action of *R1* and *R2*. This bias is a d.c. current and is applied to the base emitter circuit through *L2*, the secondary winding of *T1*. Capacitor *C1* is present to ensure that the current giving the bias is not affected at its source by any a.c. signals which will be generated by the oscillator.

Resistor *R3* is present to limit the quiescent collector current through the transistor and also helps to control the gain by introducing negative feedback which can be varied by different values for *C3*.

CIRCUIT ACTION

When the circuit is switched on for the first time, base bias current flows and this causes the voltage at the collector of *TR1* to fall towards

zero. Notice that we have connected the winding of *L2* so that it is 180 degrees out of phase with *L1*. This means that when the signal of *TR1* collector goes in a negative direction then the signal fed back to its base goes positive and adds to the bias current. This, in turn, drives the transistor further into conduction and this will occur regeneratively until, in the extreme case, the transistor is fully turned on (saturated).

An important feature of a transformer is that only changes of current in the primary cause changes in the secondary. Hence once the transistor reaches saturation there will be no further change in signal at the collector therefore there will be no signal fed back to the base to aid the bias current.

Instead the base current will start to revert to the bias level and the transistor starts to turn off. The collector voltage now rises in a positive direction and the effect of phase reversal in the transformer detracts from the bias current and the transistor regeneratively goes into a fully switched off condition.

When that state of affairs is reached there will, momentarily, be no change in collector voltage and the base current starts to rise back up to the bias level in a positive direction starting the cycle over again. This is a cyclic regenerative process and so continuous oscillation occurs.

OUTPUT WAVEFORM

From the explanation, so far, it would appear that the transistor is switching on and off at both extremes and that the output signal at the collector would be a square wave. This could be true unless one takes into account the effect of tuning *L1* with *C2*.

At the resonant frequency of these two components, the collector load has maximum impedance, hence maximum voltage swings will occur at the collector if the circuit oscillated at the resonant frequency. The circuit will automatically oscillate at this frequency because this is when we shall obtain maximum feedback.

If one was to subject the parallel tuned circuit to a single pulse of energy and measure the output of the circuit on an oscilloscope, one would find that after the pulse has finished the circuit will continue to pass current backwards and forwards between the capacitor and inductor for a short while; this will be a decaying a.c. signal at the resonant frequency.

This ringing effect helps to stabilise our circuit to produce a sine wave because an “*LC*” circuit will only ring sinusoidally (it is not possible to get a square wave ring!).

Incidentally, this effect is often put to good use by radio amateurs to generate frequencies that are multiples of lower frequency pulses; they would call the parallel tuned circuit of *L1* with *C2* a tank circuit.

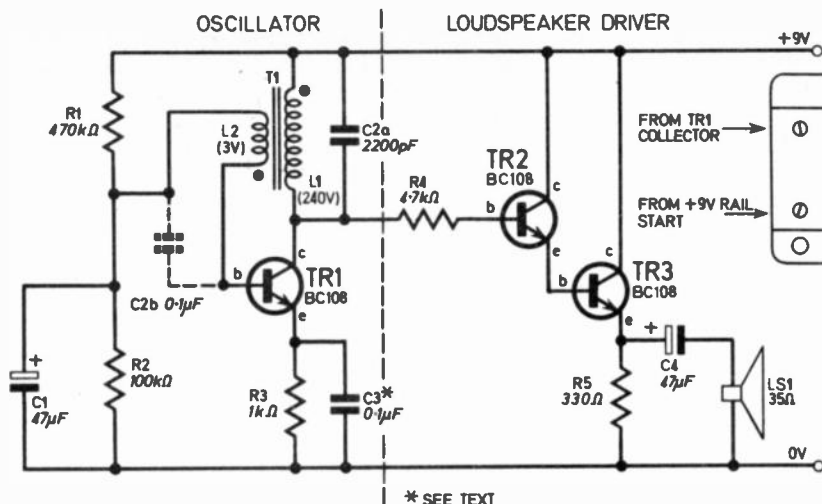

* SEE TEXT

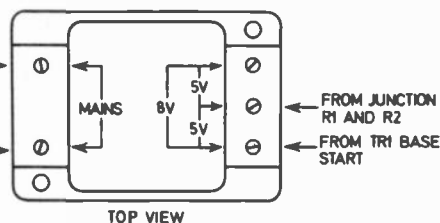

Fig. 3. (left) Practical oscillator and output circuit.

Fig. 4. (above) Connections to the transformer.

GAIN

If we have too much gain in *TR1* we can still drive the transistor into saturation even though we have the stabilising influence of the tank circuit hence it is necessary to vary the gain to get the purest sine wave possible. This is done by increasing the value of *C3* to increase the gain and decreasing it to reduce gain.

If you have too much gain the circuit will sometimes try to oscillate at two frequencies at the same time. These frequencies would be the fundamental frequency of the tank circuit and the frequency of the square wave which is controlled by the level of feedback, the saturation characteristics of the transformer's core and the gain.

You can experience this double oscillation, which is called squeepping, in the experiment that follows.

WORKING MODEL

Shown in Fig. 3 is a working Armstrong Oscillator which is designed to operate at audio frequencies; it has been connected through a loudspeaker driver so that one can hear the output signal. To avoid having to wind a transformer we shall use a standard Friedland bell transformer—the 240V winding for *L1* which has quite a high inductance and hence will enable us to operate at low frequencies).

Feedback needs to be more in the form of current than voltage so we use the smaller number of turns on the 3 volt winding as *L2*. It is important that you get the polarity of the windings correct otherwise you will get negative instead of positive feedback and the circuit will not oscillate.

If you use the transformer specified you can follow the details shown in Fig. 4 but neither we, nor the manufacturers of the transformer can guarantee that every model will have the turns put on in the same direction. The simplest thing to do is try connecting the 240V winding

one way round and if the circuit refuses to oscillate reverse the connections to this winding.

TESTING

Start off with the values of components given (do not put in a capacitor where *C2b* is shown dotted) and you should obtain a strong audio signal. You might experience a siren noise as the oscillator starts off—this is caused by the magnetic material of the transformer's core taking up a preferred direction of magnetisation and this would either not happen at all or would occur much more quickly if we were using a properly designed audio transformer.

Changing the value of *C2* will produce different frequencies of oscillation as you alter the resonant frequency of the tuned circuit. Try varying this in the range of 1,000 to about 4,700 picofarads. You will find that the circuit oscillates with *C2* omitted—this will occur at a much higher frequency and is caused by parasitic capacitance introduced by the reverse biased collector base junction of the transistor.

Try reducing the gain of the amplifier by removing *C3*, the circuit will either stop oscillating altogether or else you will get a considerably reduced signal that may sound more pure. Increasing the value of *C3* will produce a more raucous sound as clipping begins (try 0.33 microfarads).

By putting in a very high decoupling capacitor (say 47 microfarads) for *C3* you will almost certainly introduce squeepping because the gain is excessive.

To see the effect of tuning the base winding of the transformer instead of *L1*, remove *C2a* from its shown position and introduce it where *C2b* is shown dotted. Notice that to get the same order of frequency you have to use a much larger capacitance value in this position; this is because the inductance produced by the 3 volt winding of the transformer is much less. □

The Extraordinary Experiments of Professor Ernest Eversure

by Anthony John Bassett

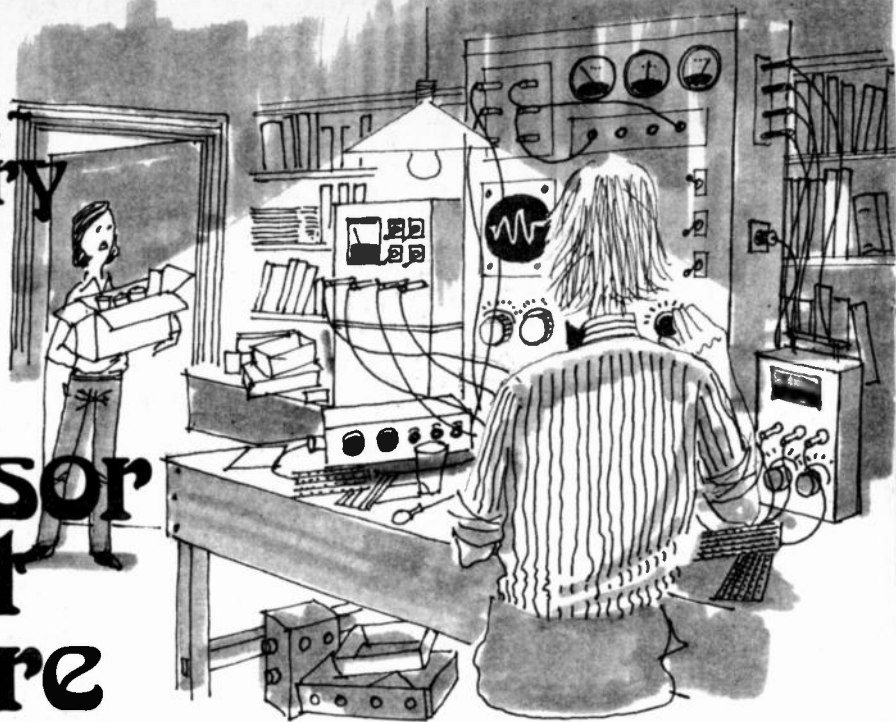

Professor Ernest Eversure, or the Prof. as his friends call him, has been experimenting in electronics for more years than anyone can remember and we thought that you might like to hear of, and perhaps repeat, some of his extraordinary experiments. Anthony J. Bassett recounts some of these experiments every month so why not follow the Prof's work and learn along with young Bob, his friend.

Just as the chaos in the laboratory appeared to have reached its utmost point, the strange helmet fell from the head of their visitor to reveal a rather worried-looking young man. It was the Prof's young friend Paul, a student at the local technical college. As his helmet clattered to the floor, the metal-bending process went into reverse. The Prof. was lowered gently down.

"Prof." said Paul in apology for the chaos which he had caused, "I must say I'm very sorry for what happened in here just now. I'm still trying to make a helmet to boost and amplify metal-bending power. I was hoping to repeat some of Uri's famous demonstrations—but it keeps going out of control!"

Bob was immediately interested. "Could it be your experiments that caused the hands of our school clock to move faster, and let us home an hour early the other day?" he asked.

The Prof. was not quite so enthusiastic. "Could it be that your experiments caused the lead plates in my car battery to bend, and

short out when I was driving near your place last week?" he asked ruefully. "And what can we possibly do about all the bent metal in my laboratory now?" he asked, glancing critically around the room. But to the Prof's surprise, everything appeared to be returning to normal—or was it?

Not quite is seemed, for as his gaze reached the spot where the helmet had fallen, he suddenly noticed that all the aerials on it were bending, and waving back and forth. The helmet itself was also bending, and was cracked in several places. Suddenly many more cracks appeared, and the helmet split into a large number of thin strips of metal and plastic.

Paul looked ruefully at where the helmet had been. "Prof.," he asked, "I came to ask for your advice on mind-over-matter experiments. Either they don't work at all, no matter how I try—or else they go completely beyond my control! That helmet was supposed to amplify the effects—but the helmet itself bent up and split into pieces. What can I do

about it?" He appeared to be very despondent.

"This is a most remarkable situation," replied the Prof., "But just as you entered, Bob and I were about to continue with a series of practical experiments whose results seem to be much more certain. We have just built a number of resistors, a musical note-selector, some microphones and a gramophone pick-up. Next we are planning to try some other vibration pick-ups, which may be attached to musical instruments. Perhaps you would like to stay in the laboratory for a while as we carry on, and we could also give some consideration to some of your problems."

Seeing that the Prof. was not angry with him, Paul cheered up considerably and accepted the invitation to stay. Bob had brought along a small banjo, and also a plastic kazoo, a simple musical instrument. He and the Prof. were about to fit both these instruments with electrical pick-ups using sound-sensitive graphite lines.

The kazoo consists of a plastic tube with a round, narrow opening at one end. The opening at the other end is wider and slightly flattened. This is the mouthpiece. Part way along the instrument, another opening is covered by a diaphragm in the shape of a disc, trapped in place

New. Sinclair IC20.

20 watts stereo amplifier kit

for only £7.95 (plus VAT)

A build-it-yourself stereo power amplifier with latest integrated circuitry...
 10 W RMS per channel output...
 full short-circuit and overheat protection.

Latest from Sinclair – the brand new IC20 power amp. It incorporates state-of-the-art integrated circuits – 2 monolithic silicon chips each containing the equivalent of over 20 transistors! These deliver 10 W per channel into 4 Ω speakers. And the IC20 has integral short-circuit protection and thermal cut-out – it's virtually indestructible!

How should I use the IC20?

Use the IC20 for converting your mono record player to stereo... for upgrading your existing stereo... for improving your car radio/tape player. The IC20 runs off a 9-24 V power supply. If you're running the IC20 off the mains, simply add a Sinclair PZ20 power supply (£4.95 plus VAT).

Using the IC20 to improve your car radio/tape player's quality and volume? Run the IC20 off the car battery direct. You don't need a separate power supply, and you're reducing the drain on the player's dry batteries.

A complete kit!
 6 resistors
 15 capacitors
 2 ICs
 2 heatsinks
 Printed circuit board
 Nuts and bolts

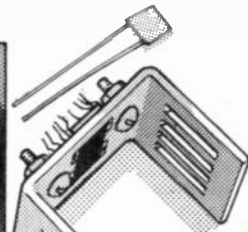
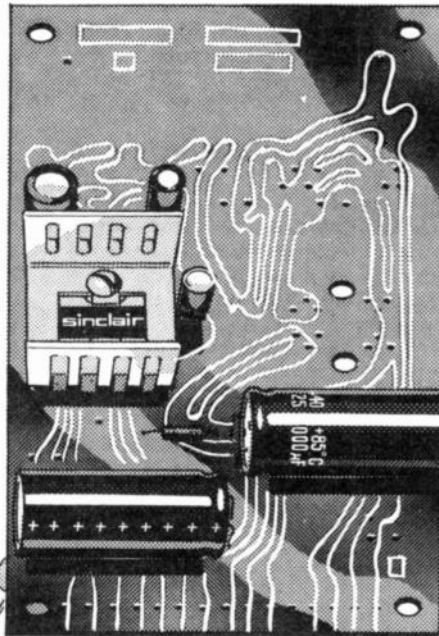

Typical performance of the IC20 stereo amplifier

Supply voltage: absolute maximum 24 V, minimum 6 V.

Current consumption: 24 V, no signal – 20 mA each channel.

18 V, 9 W into 4 Ω – 770 mA each channel.

Power output: 14 V supply, 4 Ω load, 10% distortion – 5½ W RMS per channel, 20 V supply, 4 Ω load, 10% distortion – 10 W RMS per channel.

Total harmonic distortion: at 50 mW, 4 Ω load, 20 V supply – less than 0.1%.
 Input sensitivity: for 9 W into 4 Ω – 90 mV.

Frequency response: –3 dB at 40 Hz and 16 KHz.

Load impedance: 4 Ω or 8 Ω, but device is safe with any load.

Improve your audio equipment – today

Both the IC20 and the PZ20 are covered by the Sinclair one-year, no-quibble guarantee – if absolutely any defect arises, Sinclair will replace the whole unit – unconditionally.

You can find both the IC20 and the PZ20 at stores like Laskys and Henry's. But if you have any difficulty, send us a cheque direct and we'll send you an

IC20 and/or a PZ20 at once. 14-day money-back undertaking, naturally.

Sinclair Radionics Ltd,
 London Road, St Ives,
 Huntingdon, Cambs., PE17 4HJ.
 Tel: St Ives (0480) 64646

VAT Registration number: 213 8170 88.

sinclair

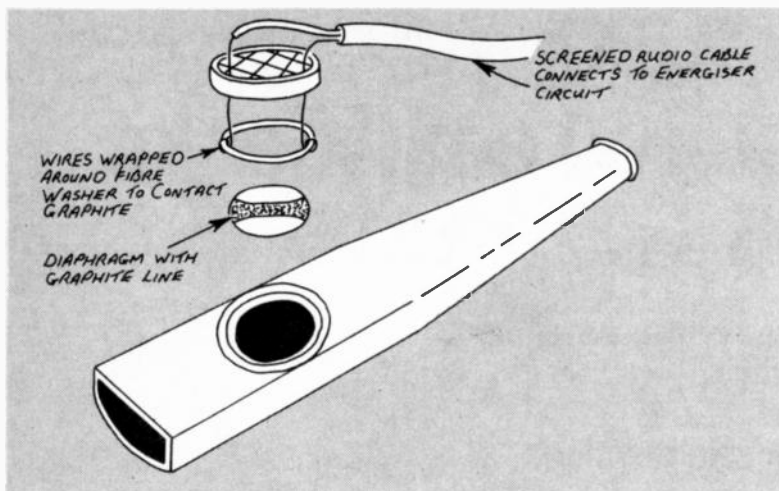

Fig. 1. Construction and wiring of the kazoo pick-up.

by a fibre washer and a plastic ring with a moulded grille. By humming or "tooting" into the mouthpiece, the diaphragm is caused to vibrate, giving a musical buzzing tone.

Bob found that the plastic ring and grille could be easily removed in one piece by pulling it off carefully. This releases the fibre washer and the diaphragm, which appeared to be a disc of "greasproof" paper. He made a line of rubber solution about 3 mm wide across one side of the disc, very thinly applied, and pressed into it some fine graphite powder. Blowing away the surplus graphite, he left the diaphragm in a warm place for a few minutes to allow the rubber solution to set quickly.

Meanwhile he obtained a length of thin screened audio cable several feet long, removed the insulation for a distance of about 20mm along the outer screen. Separating out the inner wire, he removed the insulation from this for a distance of about 10mm. He clipped off a few strands from the outer screen so that several remaining strands could be passed through one of the holes near the edge of the plastic grille (see Fig. 1). The inner wire was passed through another hole opposite and wrapped around the fibre washer. The screen wires were wrapped around the fibre washer opposite to the inner wire.

Now Bob replaced the diaphragm into the instrument with the graphite line upwards, and held it in place with the fibre washer so that the screen wires contacted one end of the graphite line, and the inner wire contacted

the other end. By pressing the plastic ring and grille back into place the whole assembly was made secure, and the cable was taped to the body of the instrument to protect the connections from bending and stress in use.

Bob then connected the other end of the screened wire to the energiser circuit (Fig. 2.) which he had previously used for the microphone and gramophone pick-up experiments, and switched on the amplifier. By "tooting" into the kazoo, he found that loud, clear musical notes came immediately from the loudspeaker, and the tone controls had a very interesting effect on the notes he produced.

Paul had been watching this procedure, and was very impressed. He picked up the instrument

and soon the laboratory was filled with the sounds of melodious tunes from the kazoo, which Bob and Paul could both play quite well with very little practice.

"I can hardly wait until we get that going," remarked Paul, viewing the banjo with sudden interest. He seemed by now to have forgotten the disappointment of his earlier failure to control the metal helmet. "It would be interesting to fit pickups to other instruments too."

Bob was about to apply some rubber solution to the vellum diaphragm of the banjo, but the Prof. stopped him.

"This is not a real hide vellum" he pointed out, "But a plastic substitute, and the solvent in the rubber solution may soften it and cause it to split. I would suggest that you cover a small patch of the vellum with adhesive tape, and apply the graphite to the top of that. If you use double-sided tape there would be no need to apply adhesive to the top side of the tape!"

Bob cut off a length of 10mm wide double-sided adhesive tape about 30mm in length and, without removing the backing-strip, pressed graphite powder into the surface of the adhesive on one side. Then he removed the backing-strip and selected a place on the vellum near to the bridge, and just below the strings, stuck the piece of tape to the vellum and pressed it down firmly by rubbing lightly with a soft graphite pencil. This served also to smooth the surface of the tape into which the graphite powder

Photograph of the modified kazoo.



look!

electronics really mastered

**... practical
... visual
... exciting!**

no previous knowledge
no unnecessary theory
no "maths"

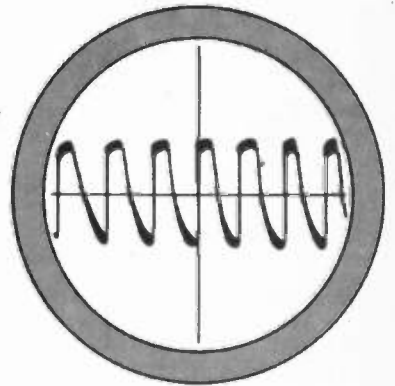
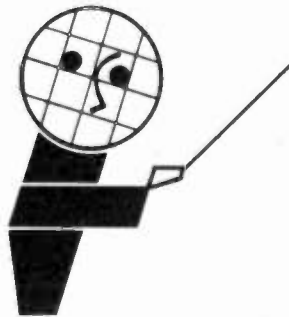

RAPY

BUILD, SEE AND LEARN

step by step, we take you through all the fundamentals of electronics and show how easily the subject can be mastered. Write for the free brochure now which explains our system.

1/ BUILD AN OSCILLOSCOPE

You learn how to build an oscilloscope which remains your property. With it, you will become familiar with all the components used in electronics.

2/ READ, DRAW AND UNDERSTAND CIRCUIT DIAGRAMS

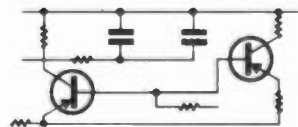

as used currently in the various fields of electronics.

3/ CARRY OUT OVER **40** EXPERIMENTS ON BASIC ELECTRONIC CIRCUITS & SEE HOW THEY WORK, including :

valve experiments, transistor experiments amplifiers, oscillators, signal tracer, photo electric circuit, computer circuit, basic radio receiver, electronic switch, simple transmitter, a.c. experiments, d.c. experiments, simple counter, time delay circuit, servicing procedures.

This new style course will enable anyone to really understand electronics by a modern, practical and visual method—no maths, and a minimum of theory—no previous knowledge required. It will also enable anyone to understand how to test, service and maintain all types of electronic equipment, radio and TV receivers, etc.

FREE POST NOW
for
BROCHURE

or write if you prefer not to cut page

To: **BRITISH NATIONAL RADIO & ELECTRONICS SCHOOL, Dept. EEL 45,**
P.O. Box 156, JERSEY. Please send your free brochure, without obligation, to:

we do not employ representatives

NAME

BLOCK CAPS

ADDRESS

PLEASE

special free gift also to all our students

Marshall's

Everything you need is in our
New 1975 Catalogue
available now price 25p
(100 pages of prices and data)

A. Marshall (London) Ltd. Dept. EE
42 Cricklewood Broadway London NW2 3HD Telephone 01-452 0161/2 Telex 21492
& 85 West Regent Street Glasgow G2 2DD Telephone 041-332 4133

Call in and see us 9-5.30 Mon-Fri
9-5.00 Sat

Trade and export enquiries welcome

Top 500 Semiconductors from the largest range in the UK

2N456	0-80	2N2924	0-20	2N5195	1-46	AF117	0-35	BC214L	0-18	BF178	0-35	8D1L	0-38	OC72	0-25
2N456A	0-85	2N2926	0-20	2N5245	0-43	AF119	0-35	BC237	0-15	BF179	0-43	14D1L	0-40	OC81	0-25
2N457A	1-20	2N3053	0-25	2N5294	0-48	AF124	0-30	BC238	0-15	BF180	0-33	LM710	0-47	OCB3	0-24
2N490	3-16	2N3054	0-60	2N5295	0-48	AF125	0-30	BC239	0-15	BF181	0-36	LM3900	0-70	ORP12	0-55
2N491	4-38	2N3055	0-75	2N5296	0-48	AF126	0-28	BC251	0-25	BF182	0-35	LM723C	0-90	RS3	1-80
2N492	3-00	2N3390	0-45	2N5298	0-50	AF127	0-28	BC253	0-26	BF183	0-55	LM741T099		SL414A	1-80
2N493	5-20	2N3391	0-28	2N5457	0-49	AF139	0-65	BC257	0-15	BF184	0-30			SL610C	1-70
2N696	0-22	2N4938A	1-15	2N5458	0-48	AF186	0-46	BC258	0-16	BF185	0-30	8D1L	0-40	SL611C	1-70
2N697	0-16			2N5459	0-49	AF200	0-65	BC259	0-17	BF194	0-12	14D1L	0-38	SL612C	1-70
2N698	0-82	2N3392	0-15	2N5492	0-58	AF239	0-65	BC261	0-25	BF195	0-23	LM747	1-00	SL620C	2-60
2N699	0-59	2N3393	0-15	2N5494	0-58	AF240	0-90	BC262	0-25	BF196	0-13	LM7488D1L		SL621C	2-60
2N706	0-14	2N3394	0-15	2N5496	0-61	AF279	0-70	BC263	0-25	BF197	0-15	LM7805	2-00	SL623	4-59
2N706A	0-16	2N3402	0-18	2N56027	0-45	AF280	0-79	BC300	0-38	BF198	0-18	14D1L	0-73	SL640C	3-10
2N708	0-17	2N3403	0-19	2N5777	0-45	AL102	1-02	BC301	0-34	BF200	0-40	14D1L	0-73	SL641C	3-10
2N709	0-9	2N3440	0-59	3N128	0-73	AL103	1-00	BC302	0-29	BF225J	0-23	LM7805	2-50	SN76003N	
2N711	0-50	2N3441	0-97	4N139	1-42	AL107	0-107	BC303	0-27	BF241	0-21	LM7812	2-50	SN76013N	2-92
2N718	0-23	2N3442	1-40	4N140	1-00	BC108	0-14	BC307	0-17	BF245	0-28	LM7824	2-50	SN76023N	1-95
2N718A	0-28	2N3414	1-10	3N141	0-81	BC109	0-14	BC308A	0-15	BF246	0-51	MC1310	2-92	SN76033N	1-60
2N720	0-57	2N3415	1-10	3N200	2-49	BC113	0-15	BC309C	0-20	BF247	0-65	MC1330P			
2N714	0-39	2N3416	0-15	40361	0-40	BC115	0-17	BC237	0-27	BF254	0-19	MC1351P		ST2	2-80
2N716	0-28	2N3417	0-21	40362	0-45	BC116	0-17	BC238	0-28	BF255	0-47	MC1352P	0-80	TA30	1-20
2N718	0-32	2N4038	1-15	40363	0-48	BC116A		BC239	0-18	BF257	0-47			TAA30	1-10
2N929	0-37	2N3638A		40389	0-46	BC16A		BC317	0-20	BF258	0-23			TAA350	2-10
2N930	0-22			40394	0-56	BC118	0-14	BCY30	0-80	BF259	0-55			TAA550	0-60
2N1302	0-19	2N3639	0-27	40395	0-65	BC119	0-19	BCY31	0-85	BF293	0-24			TAA611C	1-80
2N1303	0-19	2N3641	0-17	40406	0-44	BC121	0-35	BCY32	1-15	BF297	0-24			TAA621	1-10
2N1304	0-26	2N3702	0-11	40407	0-35	BC125	0-16	BCY33	0-85	BF298	0-24			TAA630	1-10
2N1305	0-24	2N3703	0-15	40408	0-50	BC126	0-23	BCY34	0-79	BF299	0-92			TAA640	1-15
2N1306	0-31	2N3704	0-15	40409	0-10	BC127	0-23	BCY38	1-00	BF561	0-27			TAA650	0-60
2N1307	0-30	2N3705	0-15	40410	0-52	BC134	0-13	BCY39	1-00	BF598	0-25			TAA661B	2-18
2N1308	0-47	2N3706	0-15	40411	2-25	BC135	0-13	BCY40	0-75	BF599	0-25			TAA671	2-03
2N1309	0-47	2N3707	0-18	40594	0-74	BC136	0-17	BCY42	0-28	BFX30	0-27			TAA681B	1-32
2N1671	1-54	2N3708	0-14	40595	0-84	BC137	0-17	BCY58	0-30	BFX84	0-24			TAA690	0-40
2N1671A		2N3709	0-15	40601	0-67	BC138	0-24	BCY59	0-32	BFX85	0-30			TAA700	0-30
2N1671B	1-67	2N3710	0-15	40602	0-61	BC140	0-68	BCY70	0-17	BFX87	0-28			TAA710	1-50
2N1711	0-45	2N3712	0-10	40604	0-56	BC142	0-23	BCY71	0-22	BFX88	0-25			TAA720	1-15
2N1907	5-50	2N3713	1-20	40636	1-10	BC143	0-23	BCY72	0-15	BFX89	0-20			TAA730	1-10
2N1912	0-66	2N3714	1-38	40669	1-00	BC145	0-21	BD116	0-75	BFY50	0-93			TAA740	0-40
2N2147	0-78	2N3715	1-50	40673	0-73	BC147	0-14	BD121	1-00	BFY52	0-21			TAA750	0-30
2N2148	0-94	2N3716	1-80	40674	0-84	BC148	0-14	BD123	0-82	BFY53	0-18			TAA760	0-40
2N2160	0-90	2N3777	2-20	AC126	0-20	BC149	0-15	BD124	0-67	BFY90	0-75			TAA770	0-58
2N2218A		2N3772	1-80	AC128	0-20	BC153	0-18	BD131	0-60	BFY93	0-48			TAA780	0-62
2N2219	0-22	2N3773	2-65	AC151V	0-27	BC159	0-18	BD132	0-50	BSX20	0-21			TAA790	0-74
2N2219A	0-24	2N3779	2-15	AC152V	0-49	BC157	0-18	BD135	0-43	BSX21	0-29			TAA800	0-80
2N2220	0-26	2N3792	2-35	AC153K	0-40	BC158	0-16	BD137	0-55	BK105	2-23			TAA810	0-80
2N2221	0-18	2N3793	1-10	AC176	0-40	BC160	0-60	BD138	0-63	CI06D	0-65			TAA820	1-15
2N2221A		2N3819	0-37	AC176K	0-40	BC168B	0-15	BD139	0-71	CA3180A				TAA830	0-79
2N2222	0-21	2N3820	0-38	AC187K	0-35	BC168C	0-15	BD140	0-87		0-85			TAA840	0-90
2N2222A	0-20	2N3823	1-42	AC188K	0-40	BC169B	0-15	BD529	0-80	CA3202A				TAA850	0-85
2N2222A		2N3904	0-27	ACV18	0-24	BC170	0-15	BF39	0-80	CA3028A	1-80			TAA860	0-80
2N2368	0-25	2N3906	0-23	ACV19	0-27	BC171	0-16	BF979	0-24		1-79			TAA870	0-80
2N2369	0-20	2N4037	0-42	ACV21	0-26	BC172	0-17	BDY20	1-05	CA3035	1-07			TAA880	0-85
2N2369	0-22	2N4058	0-18	ACV28	0-20	BC177	0-28	BF115	0-36	CA3052	1-62			TAA890	0-85
2N2646	0-58	2N4059	0-15	ACY30	0-58	BC178	0-27	BF117	0-55	CA3046	0-70			TAA900	1-40
2N2647	0-98	2N4060	0-15	AD142	0-59	BC179	0-30	BF121	0-35	CA3048	2-11			TAA910	1-60
2N2904	0-22	2N4061	0-15	AD143	0-45	BC182	0-12	BF125	0-35	CA3089E	9-6			TAA920	0-70
2N2904A		2N4062	0-16	AD159	0-66	BC183	0-12	BF126	0-35	CA3090Q				TAA930	0-93
2N2905	0-24	2N4126	0-21	AD150	0-65	BC183	0-12	BF152	0-20	LM301A	4-23			TAA940	0-58
2N2905	0-25	2N4289	0-34	AD161	0-45	BC183L	0-12	BF153	0-25	LM301A	4-23			TAA950	0-58
2N2905A		2N4919	0-95	AD162	0-45	BC184	0-13	BF154	0-16	LM309K	2-50			TAA960	0-80
2N2906	0-26	2N4920	1-10	AD161	pr	BC184L	0-13	BF159	0-27	LM309K	1-88			TAA970	0-80
2N2906A	0-19	2N4921	0-80	AD162	1-05	BC186	0-25	BF160	0-23	LM5T1	1-50			TAA980	0-13
2N2907	0-21	2N4922	0-83	AF106	0-40	BC187	0-27	BF163	0-32	LM380	1-10			TAA990	0-20
2N2907	0-22	2N4929	0-88	AF109	0-60	BC207	0-12	BF166	0-40	LM7831	2-20			TAA992	0-13
2N2907A	0-24	2N5191	0-92	AF114	0-35	BC208	0-11	BF167	0-40	LM709T099	0-80			TAA993	0-20
		2N5192	1-24	AF115	0-35	BC212K	0-16	BF173	0-21					TAA994	0-25
		2N5192	1-24	AF116	0-35	BC212L	0-16	BF177	0-29					TAA995	0-25

PW TELETEENNIS KIT

As featured on BBC Nationwide and in the Daily Mail 2 Oct '74. Ideal game for whole family. No need to modify your TV set, just plug in to aerial socket.

Parts list as follows: A Resistor Pack £1.00 p & p 20p; B Potentiometer Pack £1.25 p & p 20p; C Capacitor Pack £3.10 p & p 20p; D Semiconductor Pack £14.50 p & p 20p; E IC Sockets £4.00 p & p 20p; F Transformer £1.15 p & p 25p; G PCB's £7.50 p & p 20p; H Switches £4.50 p & p 20p; I UHF Modular Kit £7.50 p & p 20p.

Special Prices—complete kit excluding case £42.00 p & p 50p. Sections A-F incl. £23.50 p & p 30p. Assembly instructions with complete kit or 75p on request.

P.C. Marker Pen Dalo 33PC 0-87p

Zeners 400MV-11p; 1W-17p; 1C Sockets 8D1L 16p; 14D1L 17p; 16D1L 20p.

Resistors 1w-2p; 1/2w-3p; 1/4w-9p; 5w-10p; 10w-12p.

Scorpio Car Ignition Kit-£11.50 + VAT

I IMF40V-£1.10; Transformer-BST80246-£1.05; £3.00.

TA30 1-20; TAA263 1-10; TAA350 2-10; TAA550 0-60; TAA611C 1-80; TAA621 1-10; TAA630 1-10; TAA640 1-15; TAA650 0-60; TAA661B 2-18; TAA671 2-03; TAA681B 1-32; TAA690 0-40; TAA700 0-30; TAA710 1-50; TAA720 1-15; TAA730 1-10; TAA740 0-80; TAA750 0-30; TAA760 0-40; TAA770 0-58; TAA780 0-62; TAA790 0-74; TAA800 0-80; TAA810 0-80; TAA820 1-15; TAA830 0-79; TAA840 0-90; TAA850 0-85; TAA860 0-80; TAA870 0-85; TAA880 0-85; TAA890 0-85; TAA900 1-40; TAA910 1-60; TAA920 0-70; TAA930 0-93; TAA940 0-58; TAA950 0-58; TAA960 0-80; TAA970 0-13; TAA980 0-20; TAA990 0-13; TAA992 0-13; TAA993 0-20; TAA994 0-25; TAA995 0-25.

TA30 1-20; TAA263 1-10; TAA350 2-10; TAA550 0-60; TAA611C 1-80; TAA621 1-10; TAA630 1-10; TAA640 1-15; TAA650 0-60; TAA661B 2-18; TAA671 2-03; TAA681B 1-32; TAA690 0-40; TAA700 0-30; TAA710 1-50; TAA720 1-15; TAA730 1-10; TAA740 0-80; TAA750 0-30; TAA760 0-40; TAA770 0-58; TAA780 0-62; TAA790 0-74; TAA800 0-80; TAA810 0-80; TAA820 1-15; TAA830 0-79; TAA840 0-90; TAA850 0-85; TAA860 0-80; TAA870 0-85; TAA880 0-85; TAA890 0-85; TAA900 1-40; TAA910 1-60; TAA920 0-70; TAA930 0-93; TAA940 0-58; TAA950 0-58; TAA960 0-80; TAA970 0-13; TAA980 0-20; TAA990 0-13; TAA992 0-13; TAA993 0-20; TAA994 0-25; TAA995 0-25.

TA30 1-20; TAA263 1-10; TAA350 2-10; TAA550 0-60; TAA611C 1-80; TAA621 1-10; TAA630 1-10; TAA640 1-15; TAA650 0-60; TAA661B 2-1

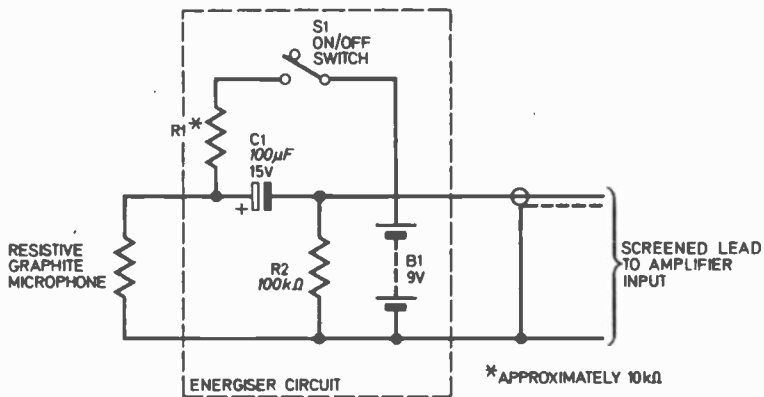

Fig. 2. The circuit diagram of the energiser used for the experimental instruments.

had been pressed, and he blew away the surplus graphite powder from this surface, see Fig. 3.

Now he taped a length of screened audio cable to the surface of the vellum so that the screen wire could be connected to one end of the graphite-covered tape, and the centre wire to the other. Using an adhesive conducting paste of thin rubber solution mixed with graphite powder, Bob bonded the wires to the ends of the tape.

After a few minutes the rubber and graphite composition was nearly set, and he connected the other end of the screened lead to an energiser circuit, switched on the amplifier and turned the volume up a little. Now by strumming on the banjo, the sound of the instrument could be heard quite loudly through the loudspeaker.

Bob could not play the banjo, but Paul picked it up, and adjusted the controls on the amplifier to give just the tone he wanted.

"This is one of the things I really like about electrified musical instruments" he remarked, "Unlike the conventional purely acoustic instrument, you can adjust the tone at the turn of a knob, once a pickup has been fitted: the banjo can be made to sound quite soft and mellow, or else very twangy and sharp."

A few moments later he was plucking away enthusiastically on the strings of the banjo, and Bob was tooting happily on the kazoo. Then they began to discuss the possibilities of fitting the pickups to various instruments.

"Some of my friends will be interested in these pickups," com-

mented Paul, "They are always on the lookout for any low-cost, effective way to improve their instruments."

"My pals at school have a beat group" added Bob, "When they find out about this, they will cover their instruments, even their drums, and cymbals, with sound-sensitive graphite lines!"

"The country music fans will be especially interested in this banjo pickup," observed Paul, "and if graphite lines are applied to the wooden body of an acoustic guitar, mandolin, violin or similarly resonant instrument, it should be possible to pick up the sound vibrations directly from the soundboard and get a really true tone. It is usually very difficult to obtain a true tone from a wooden-bodied acoustic instrument when an electric pickup is used. But this method should prove to be most effective."

The Prof. commented on this. "The tone you pick up will vary

considerably according to the location of the pickup on the body of the instrument. So there is plenty of scope for experiment by applying pickup lines to various places on each instrument in order to obtain variations in harmonic content."

"Also, in some cases, in order to obtain a balanced tone, it will be necessary to use more than one pickup point. This is so with pianos, where if only one pickup is used on the soundboard, it is very likely to emphasise a certain group of notes at the expense of others. By fitting several pickups, with a separate volume-control on each, a balanced sound can be obtained."

"If you paint one side of the piano soundboard with graphite conducting paint, and press contacts against the surface at various points until the best positions are located, you can obtain an old-style honky-tonk sound which should be popular with both the country music connoisseurs and the jazz enthusiasts."

Now once again the flow of information from the Prof. was dramatically interrupted, as a strange helmeted figure appeared at the entrance to the laboratory. "Not again!" groaned Bob as he saw that the helmet looked just like the one which Paul had worn earlier.

But as Paul looked at the figure in the helmet, he was even more horrified than Bob or the Prof. He noticed that the new visitor had the figure of a slim teenage girl, and Paul, pointing at her said in a shaky voice "How could she have got that helmet? That's my sister Suzy!"

Fig. 3. The banjo fitted with a graphite pick-up.

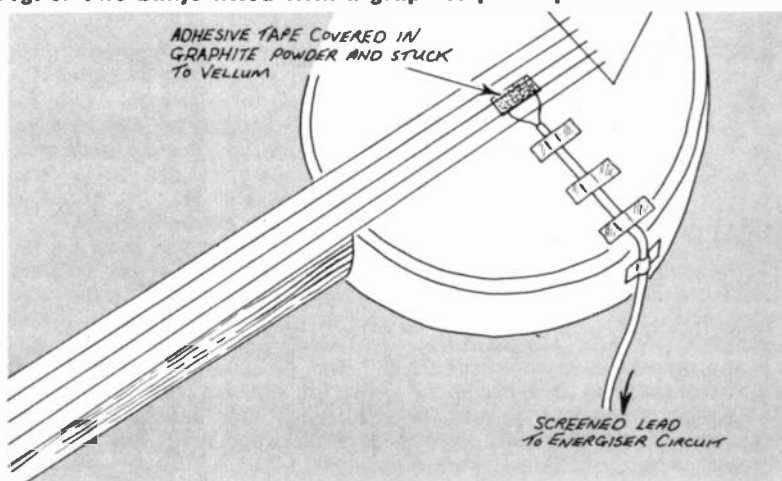

DOWN TO EARTH

By GEORGE HYLTON

"The term P_{tot} or power dissipation completely mystifies me. Is it the maximum a.c. output or what?"

Sooner or later, all the electrical energy which goes into a circuit from a battery or the mains, ends up as heat. If a transistor is in a working circuit—an amplifier, say—then some of the power which goes into the circuit from the power supply is spent in the transistor as heat.

The term P_{tot} (strictly speaking it should be $P_{tot\ max.}$) is the power which a transistor can safely dissipate *when it is kept at a particular temperature*. For example, the data sheet for a particular transistor might give P_{tot} as 30W at a case temperature of 25 degrees centigrade. This means that if you could keep the case of the transistor at 25 degrees centigrade the transistor could dissipate 30W, see Fig. 1. (It could be a.c. or d.c. or a mixture; it all makes heat so it doesn't matter to the transistor.)

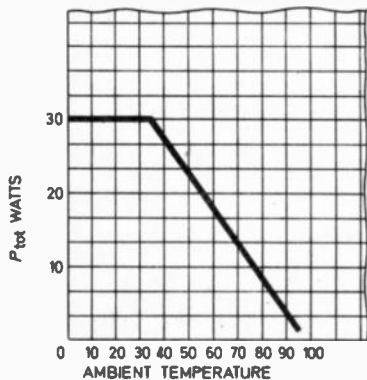

Fig. 1. Typical variation of P_{tot} with ambient temperature.

IDEAL FIGURE

The trouble is that it is not possible to hold the case of the transistor at 25 degrees centigrade because this temperature is in the room-temperature range. If the transistor is in a room at 25 degrees centigrade *before* it dissipates any power then, since no heat sink is 100 per cent

efficient, the temperature must rise above 25 degrees centigrade when power is put into the transistor. This is another way of saying that the transistor can *never* in practice dissipate the 30W which the P_{tot} rating seems to imply it can dissipate.

The term P_{tot} is not a practical figure for the power-dissipating capacity of the transistor (unless it is quoted for a temperature well above ordinary room temperatures so that the transistor can run hot at the rated P_{tot}). Rather, it's an unattainable ideal dissipation which could only be achieved if the transistor were fitted with some highly efficient cooling system like putting it under the cold tap, turned hard on.

IN PRACTICE

The amount of power which the transistor will safely dissipate in practical circumstances, on an ordinary heatsink, say, is always much less than P_{tot} when the latter is quoted at a room temperature.

For a germanium transistor the practical dissipation is very much less than P_{tot} , because with a germanium device the heart of the transistor must not get above 90 degrees centigrade.

In a silicon transistor the internal temperature (called the junction temperature) can be allowed to go to 150 degrees centigrade, so the dissipation of a silicon device can be allowed to get closer to P_{tot} than is possible for germanium.

At this point you may be forgiven for feeling a bit cheated. Why talk about 30W if the transistor hasn't a hope of dissipating anything like 30W?

The reason for quoting P_{tot} is that it enables the designer to calculate how much power the transistor can really handle in his circuit when mounted on a heat-

sink of a particular efficiency. Or rather, P_{tot} is *one* of the things the designer needs to know to make his circuit work.

I said just now that the junction temperature mustn't exceed a certain figure. But the junction (that is the heart of the transistor) is hotter than the case. One of the other things the designer must know is what temperature the case is when the junction is at the highest permissible temperature. This depends on how readily heat flows from the junction to the case. The data gives this information in terms of what is called thermal resistance.

THERMAL DATA

Thermal resistance is the rise in temperature produced by dissipating one watt of power. It appears on data sheets in the disguise of the Greek letter theta, θ : After the theta are some inferior letters which say which thermal resistance is meant. Thus on some data sheets:

- θ_{j-mb} describes the resistance to heat flow from the junction j to the mounting base mb ; i.e. the "bottom" of the transistor, the bit bolted to the heat sink.
- θ_i describes the effect of a standard mica insulating washer in impeding heat flow from the mounting base to the heat sink.
- θ_b describes the flow of heat from the heat sink to the surrounding air; i.e. it is a measure of the heat sink's efficiency.



"Are you sure the computer you constructed has selected you as the ideal marriage partner for me, Mr. Cragg?"

Everyday Electronics, April 1975

Complete the coupon and we'll send you our new catalogue. Completely free.



The new Heathkit catalogue is now out. Full as ever with exciting, new models. To make building a Heathkit even more interesting and satisfying.

And, naturally, being Heathkit, every kit is absolutely complete. Right down to the last nut and bolt. So you won't find yourself embarrassingly short of a vital component on a Saturday evening—when the shops are shut.

You'll also get a very easy to understand instruction manual that takes you step by step through the assembly.

Clip the coupon now and we'll send you your free copy to browse through.

With the world's largest range of electronic kits to choose from, there really is something for everyone.

Including our full range of test equipment, amateur radio gear, hi-fi equipment and many general interest kits.

So, when you receive your catalogue you should have hours of pleasant reading.

And, if you happen to be in London or Gloucester, call in and see us. The London Heathkit Centre is at 233 Tottenham Court Road. The Gloucester showroom is next to our factory in Bristol Road.

At either one you'll be able to see for yourself the one thing the catalogue can't show you.

Namely, how well a completed Heathkit performs. Heath (Gloucester) Limited, Dept. EE-45, Bristol Road, Gloucester, GL2 6EE. Tel: Gloucester (0452) 29451.

A new oscilloscope from the Heathkit range.



Marine direction finder with digital read-out.

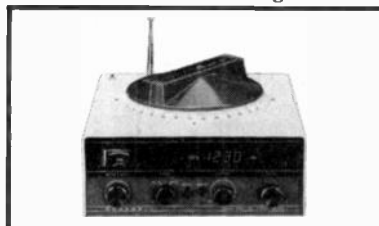

Stereo cassette deck with built-in Dolby.



The new Heathkit catalogue. Out now. FREE.

To: Heath (Gloucester) Limited, Dept. EE-45 Gloucester, GL2 6EE. Please send me my free Heathkit catalogue.

Name _____ Address _____

Postcode _____

Remember easy terms are available with the Heathkit Monthly Budget Plan.



The largest selection

EX-COMPUTER STABILISED POWER MODULES

Complete with circuit diagrams etc. 99p each plus 22p p. & p.

LOW COST CAPACITORS

01µF 400v. 8p. each
500µF 50v. Elec. 10p each

FIBRE-GLASS PRINTED CIRCUIT BOARDS

10½ x 4" approx. 2 for 55p

DECON-DALO 33PC Marker

Etch resistant printed circuit marker pen 99p each

VEROBOARDS

Packs containing approx. 50sq. Ins. various sizes, all 11 mats for 55p

REPANCO CHOKES & COILS

HF Chokes
OH1. 2.5mH 29p OH2. 5.0mH 30p
OH3. 7.5mH 31p OH4. 10mH 33p
OH5. 1.5mH 28p

COILS

DR11 Crystal set 81p DRR2 Dual range 45p

COIL FORMERS & CORES

NORMAN ¼" Cores & Formers 8p
¼" Cores & Formers 10p

SWITCHES

DP/DT Toggle 36p SP/ST Toggle 30p

FUSES

1½" and 20mm. 100mA, 200mA, 250mA, 500mA, 1A, 1.5A, 2A
QUICK-BLOW 5p ea.

EARPHONES

Crystal 2.5mm plug 42p
Crystal 3.5mm plug 42p
8 ohms 2.5mm plug 22p
8 ohms 3.5mm plug 22p

DYNAMIC MICROPHONES

B1223. 200 ohms plus on/off switch and 2.5mm and 3.5mm plugs £1.85

3-WAY STEREO HEADPHONE JUNCTION BOX

H1012 £1.87

2-WAY CROSSOVER NETWORK

K4007. 90 ohms Imp. Insertion loss 3dB @ 121

CAR STEREO SPEAKERS

(Angled) £3.85 per pair.

BI-PAK

CATALOGUE AND LISTS

Send S.A.E. and 10p.

INSTRUMENT CASES



(Black Vinyl covered)

No.	Length	Width	Height	Price
HV1	8"	6½"	2"	£1.35
HV2	11"	6"	3"	£1.75

ALUMINIUM BOXES

BA1	5½"	4"	1½"	49p
BA2	4"	4"	1½"	49p
BA3	4"	2½"	1½"	49p
BA4	5½"	4"	1½"	58p
BA5	4"	2½"	2"	49p
BA6	3"	2"	1"	42p
BA7	7"	5"	2½"	85p
BA8	8"	6"	3"	£1.10
BA9	6"	4"	2"	70p

P & P 10p on each box

BIB HI-FI ACCESSORIES

De Luxe Groov-Kleen

Model 42 £1.95

Chrome Finish

Model 60 £1.50

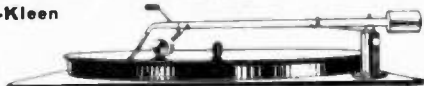

Ref. B Stylus & Turntable Cleaning Kit 34p

Ref. 36A. Record/Stylus Cleaning Kit 33p

Ref. 43. Record Care Kit £2.42

Ref. 31. Cassette Head Cleaner 58p

Ref. 32. Tape editing Kit £1.68

Model 9. Wire Stripper/Cutter 83p

Ref. 46. Spirit level 62p

Ref. P. Hi-Fi Cleaner 81p

Ref. 32A. Stylus Balance £1.37

Ref. J. Tape Head Cleaning Kit 62p

Ref. 66. Hi-Fi Stereo Hinta & Tips 42p

Ref. 45. Auto changer groove cleaner £1.08

ANTEX SOLDERING IRONS

X25. 25 watt £2.05

OCN 240. 15 watt £2.48

Model G. 18 watt £2.26

SK2. Soldering Kit £3.25

STANDS: ST3. Suitable for all models £1

SOLDER: 188WO Multicores 7oz £1.61

228WG 7oz £1.61. 188WG 22oz 51p

228WG Tube 33p

PLUGS AND SOCKETS

PS 1 D.I.N. 2 Pin (Speaker) 0.11

PS 2 D.I.N. 3 Pin 0.18

PS 3 D.I.N. 4 Pin 0.16

PS 4 D.I.N. 5 Pin 180° 0.16

PS 5 D.I.N. 5 Pin 240° 0.16

PS 6 D.I.N. 6 Pin 0.17

PS 7 S.I.N. 7 Pin 0.18

PS 8 Jack 2.5mm Screwed 0.18

PS 9 Jack 3.5mm Plastic 0.12

PS 10 Jack 3.5mm Screwed 0.18

PS 11 Jack 1" Plastic 0.15

PS 12 Jack 1" Screened 0.22

PS 13 Jack Stereo Screened 0.16

PS 14 Phono 0.30

PS 15 Car Aerial 0.22

PS 16 Co-Axial 0.15

INLINE SOCKETS

PS 21 D.I.N. 2 Pin (Speaker) 0.14

PS 22 D.I.N. 3 Pin 0.20

PS 23 D.I.N. 5 Pin 180° 0.20

PS 24 D.I.N. 5 Pin 240° 0.20

PS 25 Jack 2.5mm Plastic 0.16

PS 26 Jack 3.5mm Plastic 0.16

PS 27 Jack 1" Plastic 0.30

PS 28 Jack 1" Screened 0.35

PS 29 Jack Stereo Plastic 0.30

PS 30 Jack Stereo Screened 0.38

PS 31 Phono Screened 0.18

PS 32 Car Aerial 0.22

PS 33 Co-Axial 0.22

ANTEX BITS and ELEMENTS

Bits No.

102 For model CN240 3/32" 42p

104 For model CN240 3/16" 42p

1100 For model OCN240 3/32" 42p

1101 For model OCN240 3/16" 42p

1102 For model OCN240 1" 42p

1020 For model G240 3/32" 42p

1021 For model G240 1/8" 42p

1022 For model G240 3/16" 42p

50 For model X25 3/32" 48p

51 For model X25 1/8" 48p

52 For model X25 3/16" 48p

ELEMENTS

ECN 240 £1.30 EOCN 240 £1.32

EG 240 £1.07 EX 25 £1.16

ANTEX HEAT SINKS 10p

V.A.T. included in all prices. Please add 10p P. & P. (U.K. only). Overseas orders—please add extra for postage.

NEW COMPONENT PAK BARGAINS

Pack

No. Qty. Description Price

C1 200 Resistors mixed values approx. count by weight 0.54

C2 150 Capacitors mixed values approx. count by weight 0.54

C3 50 Precision Resistors 1%, 2% mixed values 0.64

C4 75 ½W Resistors mixed preferred values 0.54

C5 5 Pieces assorted Ferrite Rods 0.54

C6 2 Tuning Gans, MW/LW VHF 0.54

C7 1 Pack Wire 50 metres assorted colours 0.54

C 8 10 Reed Switches 0.54

C 9 3 Micro Switches 0.54

C10 15 Assorted Pots & Pre-Mets 0.54

C11 5 Jack Sockets 3 x 3.5mm 2 Standard Switch Type 0.54

C12 30 Paper Condensers preferred types mixed values 0.54

C13 20 Electrolytics Trans. types 0.54

C14 1 Pack assorted Hardware Nuts/Bolts, Grommets etc. 0.54

C15 5 Mains Slide Switches 0.54

C16 20 Assorted Tag strips & Panels 0.54

C17 10 Assorted Control Knobs 0.54

C18 4 Rotary Wave Change Switches 0.54

C19 2 Relays 6-24V Operating 0.54

C20 1 Pack sheets of Copper Laminates 20 sq. Ins 0.54

SOCKETS

PS 35 D.I.N. 2 Pin (Speaker) 0.08

PS 36 D.I.N. 3 Pin 0.11

PS 37 D.I.N. 5 Pin 180° 0.11

PS 38 D.I.N. 5 Pin 240° 0.11

PS 39 Jack 2.5mm Switched 0.12

PS 40 Jack 3.5mm Switched 0.12

PS 41 Jack 1" Switched 0.20

PS 42 Jack Stereo Switched 0.30

PS 43 Phono Single 0.08

PS 44 Phono Double 0.10

PS 46 Co-Axial Surface 0.10

PS 47 Co-Axial Flush 0.20

LEADS

LS 1 Speaker lead 2 pin D.I.N. plug to open ends approx. 3 metres long (coded) 0.20

CABLES

CP 1 Single Lapped Screen 0.07

CP 2 Twin Common Screen 0.11

CP 3 Stereo Screened 0.12

CP 4 Four Core Common Screen 0.22

CP 5 Four Core Individually Screened 0.80

CP 6 Microphone Fully Braided Cable 0.10

CP 7 Three Core Mains Cable 0.09

CP 8 Twin Oval Mains Cable 0.07

CP 9 Speaker Cable 0.06

CP 10 Low Loss Co-Axial 0.18

CARBON POTENTIOMETERS

Log and Lin
47K, 10K, 22K, 47K, 100K, 220K, 470K, 1M, 2M

VC 1 Single Lead Switch 0.15

VC 2 Single D.P. Switch 0.28

VC 3 Tandem Lead Switch 0.46

VC 4 1K Lin Lead Switch 0.15

VC 5 100K Log anti-Log 0.46

HORIZONTAL CARBON PRESETS

0-1 watt 0.06 each
100, 220, 470, 1K, 2.2K, 4.7K, 10K, 22K, 47K, 100K, 220K, 470K, 1M, 2M, 4.7M

SOLVE THOSE STICKY PROBLEMS!



CYANOACRYLATE C2 ADHESIVE

The wonder bond which works in seconds—bond plastic, rubber, metals, transistors, components permanently immediately!

OUR PRICE ONLY 54p for 2gm phial.

BATTERY HOLDER

Takes 4, HP7's complete with terminal, clip and lead. 34p.

WORLD SCOOP

JUMBO SEMICONDUCTOR PACK

Transistors - Germ. and Silicon Rectifiers Diodes - Triacs - Thyristors - I.C.'s and Zeners ALL NEW AND CODED.

APPROX 100 PIECES

Offering the amateur a fantastic bargain Pak and an enormous saving—identification and data sheet in every Pak.

Only £2 p. & p. 20p

RECORD STORAGE/CARRY CASES

7" EP. 18½" x 7" x 8". (50 records) £2.10
12" LP. 13½" x 7½" x 12½". (50 records) £2.95

CASSETTE CASES £1.80

Holds 12. 10" x 3½" x 5". Lock & Handle

8-TRACK CARTRIDGE CASES

Holds 14. 13" x 5" x 6" £1.95
Holds 24. 13½" x 8" x 5½" £2.70.
Both with lock and handle.

SPECIAL PURCHASE

2N3055. Silicon Power Transistors NPN. Famous manufacturers out-of-spec devices free from open and short defects—every one able! 115v. T03. Metal Case.

OUR SPECIAL PRICE 8 for £1

REPANCO TRANSFORMERS

240v. Primary. Secondary voltages available from selected tappings 4v, 7v, 8v, 10v, 14v, 15v, 17v, 19v, 21v, 25v, 31v, 33v, 40, 50 and 250-0-25v.

Type	Amps.	Price	P & P
MT50/1	1	£1.95	45p
MT50/1	1	£3.49	48p
MT50/2	2	£3.80	60p

CARTRIDGES

ACOB
GP91-18C 200mV at 1.2cm/sec £1.35
GP93-1 280mV at 1cm/sec £1.85
GP96-1 100mV at 1cm/sec £2.80

J-2005 Crystal/Hi Output £1.05

J-2010C " " Compatible £1.20

J-2006B Stereo/Hi Output £1.75

J-2105 Ceramic/Med Output £1.95

J-2203 Magnetic 5mV/cm/sec. including stylus £4.95

J-2203B Replacement stylus for above £2.00

AT-35 Audio-technica magnetic cartridge 4mV/cm/sec £3.80

CARBON FILM RESISTORS

The E12 Range of Carbon Film Resistors. 1/8th watt available in PAKS of 50 pieces. assorted into the following groups:—

R1 50 Mixed 100 ohms-820 ohms 50p

R2 50 Mixed 1K ohms-82K ohms 50p

R3 50 Mixed 10K ohms-82K ohms 50p

R4 50 Mixed 100K ohms-1 Meg. ohms 50p

THESE ARE UNBEATABLE PRICES—JUST 1p EACH INCL. V.A.T.

BI-PAK SUPERIOR QUALITY LOW-NOISE CASSETTES

-the lowest prices!

BI-PAK QUALITY COMES TO AUDIO!

AL10/AL20/AL30 AUDIO AMPLIFIER MODULES

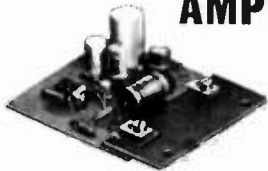

The AL10, AL20 and AL30 units are similar in their appearance and in their general specification. However, careful selection of the plastic power devices has resulted in a range of output powers from 3 to 10 watts R.M.S.

The versatility of their design makes them ideal for use in record players, tape recorders, stereo amplifiers and cassette and cartridge tape players in the car and at home.

Parameter	Conditions	Performance
HARMONIC DISTORTION	Po = 3 WATTS f=1KHz	0.25%
LOAD IMPEDANCE	—	8 - 16 Ω
INPUT IMPEDANCE	f=1KHz	100 kΩ
FREQUENCY RESPONSE ± 3dB	Po=2 WATTS	50 Hz - 25KHz
SENSITIVITY for RATED O/P	Vs=25V. Ri=8 Ω f=1KHz	75mV. RMS
DIMENSIONS	—	3" x 2 1/4" x 1"

The above table relates to the AL10, AL20 and AL30 modules. The following table outlines the differences in their working conditions.

Parameter	AL10	AL20	AL30
Maximum Supply Voltage	25	30	30
Power output for 2% T.H.D. (RL = 8 Ω f = 1 KHz)	3 watts RMS Min.	5 watts RMS Min.	10 watts RMS Min.

AUDIO AMPLIFIER MODULES

AL 10. 3 watts RMS	£2.50
AL 20. 5 watts RMS	£2.85
AL 30. 10 watts RMS	£3.20

POWER SUPPLIES

PS 12. (Use with AL10, AL20, AL30)	95p
8PM 80. (Use with AL40)	£3.25
FRONT PANELS F.P. 12 with Knobs	£1.10

PRE-AMPLIFIERS

PA 12. (Use with AL10, AL20 & AL30)	£4.95
PA 100. (Use with AL60)	£18.15

TRANSFORMERS

T461 (Use with AL10)	£1.60 P & P 22p
T538 (Use with AL20, AL30)	£2.30 P & P 22p
BMT80 (Use with AL60)	£2.75 P & P 37p

PA 12. PRE-AMPLIFIER SPECIFICATION

The PA 12 pre-amplifier has been designed to match into most budget stereo systems. It is compatible with the AL 10, AL 20 and AL 30 audio power amplifiers and it can be supplied from their associated power supplies. There are two stereo inputs, one has been designed for use with ceramic cartridges while the auxiliary input will suit most magnetic cartridges. Full details are given in the specification table. The four controls are, from left to right: Volume and on/off switch, balance, bass and treble. Size 152mm x 84mm x 35mm.

Frequency response—
20Hz - 50KHz (-3dB)
Bass control—
± 12dB at 60Hz
Treble control—
± 14dB at 14KHz
*Input 1. Impedance
1 Meg. ohm
Sensitivity 300mV
†Input 2. Impedance
30 K ohms
Sensitivity 4mV

Look for our

SEMICONDUCTOR ADVERTISEMENTS in
Practical Wireless Wireless World Radio Constructor

ALL PRICES INCLUDE V.A.T.

For The STEREO 20

The 'Stereo 20' amplifier is mounted, ready wired and tested on a one-piece chassis measuring 20 cm x 14 cm x 5.5 cm. This compact unit comes complete with on/off switch, volume control, balance, bass and treble controls, Transformer, Power supply and Power amps. Attractively printed front panel and matching control knobs. The 'Stereo 20' has been designed to fit into most turntable plinths without interfering with the mechanism or alternatively, into a separate cabinet. Output power 20w peak. Input 1 (Cer.) 300mV into 1M. Freq. res. 25Hz-25kHz. Input 2 (Aux.) 4mV into 30K. Harmonic distortion: Bass control ±12dB at 60Hz typically 0.25% at 1 watt. Treble con. ±14dB at 14kHz.

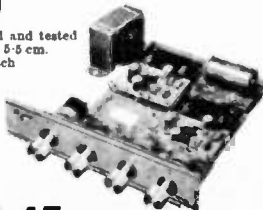

£14.45 p. & p. 45p.

TC20 TEAK VENEERED CABINET

For Stereo 20 (front board undrilled) size 10 1/2" x 8 1/2" x 3", £3.95, plus 45p postage

SHP80 STEREO HEADPHONES

4-16 ohms impedance. Frequency response 20 to 20,000Hz Stereo/mono switch and volume controls £4.95

NOW WE GIVE YOU 50w PEAK (25w R.M.S.) PLUS THERMAL PROTECTION! The NEW AL60 Hi-Fi Audio Amplifier FOR ONLY £4.25

- Max Heat Sink temp. 90°C.
- Frequency Response 20Hz to 100KHz
- Distortion better than 0.1% at 0.1KHz
- Supply voltage 15-50 volts
- Thermal Feedback
- Latest Design Improvements
- Load—3, 4, 8 or 16 ohms
- Signal to noise ratio 80dB
- Overall size 63mm x 105mm x 13mm

Especially designed to a strict specification. Only the finest components have been used and the latest solid state circuitry incorporated in this powerful little amplifier which should satisfy the most critical A.F. enthusiast.



STABILISED POWER MODULE SPM80

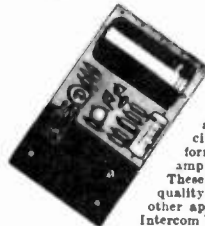

SPM80 is especially designed to power 2 of the AL60 Amplifiers, up to 15 watt (r.m.s.) per channel simultaneously. This module embodies the latest components and circuit techniques incorporating complete short circuit protection. With the addition of the Mains Transformer BMT80, the unit will provide outputs of up to 1.5 amps at 35 volts. Size: 63mm x 105mm x 30mm.

These units enable you to build Audio Systems of the highest quality at a hitherto unobtainable price. Also ideal for many other applications including:—Disc Systems, Public Address, Intercom Units, etc. Handbook available 10p

PRICE £3.25

TRANSFORMER BMT80 £2.15 p. & p. 40p

STEREO PRE-AMPLIFIER TYPE PA100

Built to a specification and NOT a price, and yet still the greatest value on the market, the PA100 stereo pre-amplifier has been conceived from the latest circuit techniques. Designed for use with the AL50 power amplifier system, this quality made unit incorporates no less than eight silicon planar transistors, two of these are specially selected low noise NPN devices for use in the input stages. Three switched stereo inputs, and rumble and scratch filters are features of the PA100 which also has a STEREO/MONO switch, volume, balance and continuously variable bass and treble controls.



SPECIFICATION

Frequency Response 20Hz - 20KHz ± 1dB
better than 0.1%
Harmonic Distortion
Inputs: 1. Tape Head
2. Radio, Tuner
3. Magnetic P.U.
3.25 mV into 50K Ω
75 mV into 50K Ω
3 mV into 50K Ω
All input voltages are for an output of 250mV. Tape and P.U. inputs equalised to RIAA curve within ± 1dB. from 20Hz to 20KHz.
Bass Control ± 15dB at 20Hz
Treble Control ± 15dB at 20 KHz
Filters: Rumble (High Pass) 100Hz
Scratch (Low Pass) 8KHz
Signal/Noise Ratio better than -65dB
+ 25dB
Input overload + 35 volts at 20mA
Supply 292mm x 82mm x 35mm
Dimensions

ONLY £14.25

MK 60 AUDIO KIT

Comprising: 2 x AL60, 1 x SPM80, 1 x BMT80, 1 x PA 100, 1 front panel, 1 kit of parts to include on-off switch, neon indicator, stereo headphone sockets plus instruction booklets. Complete Price: £29.75 plus 45p postage

TEAK 60 AUDIO KIT

Comprising: Teak veneered cabinet size 16 1/2" x 11 1/2" x 3 1/2", other parts include aluminium chassis, heatsink and front panel bracket, plus back panel and appropriate sockets etc. Kit price: £9.95 plus 45p postage

Giro No. 388-7006

Please send all orders direct to warehouse and despatch department

BI-PAK

P.O. BOX 6, WARE · HERTS

Postage and packing add 11p. Overseas add extra for airmail.

Minimum order 55p. Cash with order please.

Guaranteed Satisfaction or Money Back

SCIENTRONICS

greet constructors with EXCLUSIVE INTRODUCTORY MONEY-SAVING OFFERS

SCIENTRONICS is a new company organised to develop and promote electronic designs of especial interest to constructors. We are privileged to offer, as our opening shot, a substantial quantity of selected items no longer part of the manufacturing programme of a famous manufacture. These include transistors by Ferranti, Texas, ITT and others made to stringent specifications, e.g., E 5401 with a guaranteed gain at 1 micro amp. All these transistors are brand new and guaranteed within the terms of our published specifications. S.A.E. brings full list by return. Leads on components are untrimmed.

TRANSISTORS		ONE OFF	VCE	HFE	mA
GENERAL PURPOSE	NPN (N) PNP (P)	PRICE in p		Min.	
FRB 77	P	7.5	*50	100	I
E 5368A	N	7	25	100	I
E 5368B	N	7.5	25	150	I
E 5368C	N	8	25	250	I
E 5369	P	7.5	20	70	I
LOW LEVEL					
E 5401	P	7.5	*30	50	1μA
E 5403	N	7.5	*30	100	10μA
E 5404	N	7.5	*30	100	100μA
E 5405	P	7.5	*30	100	100μA
DRIVERS & SWITCHING (tested for low Vce (sat))					
FRB 772	P	8	40	40	500
E 5370	N	5	20	15	10
				100	60
E 5398	P	8	40	40	100
E 5397	P	8	20	100	
HIGH FREQUENCY (600 MHz F_T)					
E 5399	N	7.5	30	20	3
E 5400	N	8	10	10	I
XK 6116	N	8	20	10	I
HIGH VOLTAGE					
E 5407	P	9	65	50	10
E 5408	N	7.5	65	50	10

QUANTITY DISCOUNTS (prices in pence per device)			
Single	10	100	1000
5	4.5	3.6	3.0
7	7.0	5.5	4.5
7.5	7.2	5.6	4.6
8	7.4	5.7	4.9
9	8	6.5	5.5

* Intended for 10V working guaranteed, but almost all would pass for higher voltage operation as indicated—most can be selected for higher voltage working at an extra charge of ½p per device.

RESISTORS
Most values in E.12 series are available in 5% or 10% tolerances.
Miniature types (½ - ½ watt). Quantity rates apply for orders of same value.
0.8p each; 10 of same value 7p
100 - 55p; 1000 £4.50

CAPACITORS
CERAMICS 1.1p to 2p each in a range of useful values. 10p to 18p for 10; 77p to £1.45 for 100; £6.25 to £11.75 for 1000
ELECTROLYLIC 10-50v; 1 to 220mF from 3p each; 27p for 10; £2.20 for 100; £17.25 for 1000.

NIXIE DISPLAYS/SWITCHES/TRANSFORMERS/KNOBS/NUTS/BOLTS, etc.—Send S.A.E. for full lists and prices—REAL MONEY SAVERS THESE.

ENQUIRIES; TRADE & BULK BUYERS INVITED. SPECIAL QUANTITY DISCOUNTS.

ORDERING & GUARANTEE
All goods guaranteed within terms of specification and in stock at time of going to press. Send cheque or money order with order, or if cash, send reg. post. Please state requirements clearly. Satisfaction guaranteed or your money refunded.
MIN. ORDER £1.00
All goods sent post paid in U.K. Overseas postage charged at cost.
V.A.T.—Add 8% to total value of order in U.K.

SCIENTRONICS
(Dept. EE4)
40 HIGH STREET, SOMERSHAM,
HUNTINGDON, CAMBS PE17 3JA.
Telephone Somersham (04874) 321



VEROBOARD

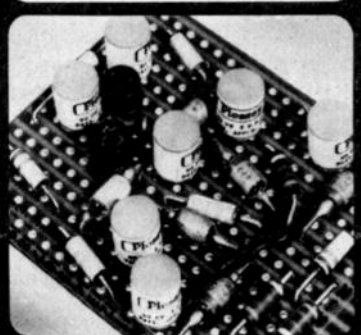

VEROBOARDS GIVE A PROFESSIONAL FINISH TO YOUR WORK

0.1" and 0.15" pitch, plain and copper clad universal circuit boards.

AVAILABLE FROM YOUR LOCAL RETAILER.

TRADE DISTRIBUTOR N. Rose (Electrical) Ltd., London, W.C.1.



VERO ELECTRONICS LTD.
Industrial Estate, Chandler's Ford,
500 32R Tel. Chandler's Ford 282

ENGINEERS
FREE
YOURSELF FOR A BETTER JOB WITH MORE PAY!



Do you want promotion, a better job, higher pay? "New Opportunities" shows you how to get them through a low-cost home study course. There are no books to buy and you can pay-as-you-learn.

This helpful guide to success should be read by every ambitious engineer. Send for this helpful 76 page FREE book now. No obligation and nobody will call on you. It could be the best thing you ever did.

CUT OUT THIS COUPON
CHOOSE A BRAND NEW FUTURE HERE!
Tick or state subject of interest. Post to the address below.

<input type="checkbox"/> Electrical Engineering	<input type="checkbox"/> General Radio and TV Engineering	<input type="checkbox"/> CITY AND GUILDS Electrical Technicians
<input type="checkbox"/> Electrical Installations and Wiring	<input type="checkbox"/> Radio Servicing, Maintenance and Repairs	<input type="checkbox"/> CITY AND GUILDS Telecommunications
<input type="checkbox"/> Electrical Draughtsmanship	<input type="checkbox"/> Transistor Technology	<input type="checkbox"/> Radio Amateurs' Exam.
<input type="checkbox"/> Electronic Mathematics	<input type="checkbox"/> CITY AND GUILDS Installations and Wiring	<input type="checkbox"/> etc. etc.

ALDERMASTON COLLEGE
Dept EEV04 Reading RG7 4PF

NAME (Block Capitals Please)

ADDRESS

POSTCODE

Other subjects Age

Accredited by C.A.C.O. Number of A.B.C.C.

HOME OF BRITISH INSTITUTE OF ENGINEERING TECHNOLOGY

SOUND TO LIGHT UNIT

Add colour or white light to your amplifier. Will operate 1, 2 or 3 lamps (maximum 450w) Unit in Box all ready to work. £7.95 plus 95p VAT and postage.



PORTABLE CABINET OFFER

A nicely made portable cabinet, soft padded black finish intended for portable stereo system. Dimensions as sketch. With motor board cut out for Garrard SP 25. This was obviously a very costly cabinet originally made for a de-luxe record player. Offered at £1.95 plus £1 carriage, free if bought with the Garrard or BBE record decks.



LIGHT DIMMER KIT

For dimming up to 250w without heat sink or 750w with heat sink. This comprises, quadrate, variable control potentiometer, condenser, resistors, tap strip for mounting and data. Price £1.95. 5 amp Industrial Model £3.95.

RELAY BARGAIN

Type 500 relay, 2 changeover one open and one closed contact. Twin 500 ohm coils make this suitable for closing off DC 6v, DC 12v, DC 24v or AC mains using resistor and rectifier, £3p each. Resistor and rectifier 30p extra.



MAINS MOTOR

Precision made—as used in record decks and tape recorders—Ideal also for extractor fans, blowers, heaters, etc. New and perfect. 8hp at 75p. Postage 30p for first one then 10p for each one ordered. 1" stackmotor £1.94. 1 1/2" stackmotor £1.90.

15A ELECTRICAL PROGRAMMER

Learn in your sleep: Have radio playing and kettle boiling as you awake — switch on lights to ward off intruders — have a warm house to come home to. All these and many other things you can do if you invest in an electrical programmer. Clock by famous maker with 15 amp, on/off switch. Switch-on time can be set anywhere to stay on up to 6 hours. Independent 60 minute memory jogger. A beautiful unit. Price £3.95 + 20p p. a. p. or with glass front, chrome bezel, £1.00 extra.

WINDSCREEN WIPER CONTROL

Vary speed of your wiper to suit conditions. All parts and instructions to make. £2.78.



6 DIGIT COUNTER

Resettable. 440 ohm coil up to 25 impulses per second. Ex-equipment but guaranteed perfect, £3.95 each. 4 digit counter as specified for telephone charge calculator 80p.



PRESSURE SWITCH

Containing a 15 amp change over switch operated by a diaphragm which in turn is operated by air pressure through a small metal tube. The operating pressure is adjustable but is set to operate in approx. 10 in. of water. These are quite low pressure devices and can in fact be operated simply by blowing into the inlet tube. Original use was for washing machines to turn off water when tub has reached correct level but no doubt has many other applications £1.78, each.



NUMICATOR TUBES

For digital instruments, counters, timers, clocks, etc. Hi-vac T.N.3. Price 80p each, 10 for £8.

MULLARD AUDIO AMPLIFIERS

All in module form, each ready built complete with heat sinks and connection tags, data supplied. Model 1163 500mW power output 90p Model 1173 750mW power output £1.47 Model EP9000 4 watt power output £2.00 EP 9001 twin channel or stereo pre amp. £1.41



CENTRIFUGAL BLOWER

Miniature mains driven blower centrifugal type blower unit by Woods. Powerful but specially built for quiet running—driven by cushioned induction motor with specially built low noise bearings. Overall size 4 1/2" x 4 1/2" x 4". When mounted by Range, air is blown into the equipment but to suck air out, mount it from centre using clamp. Ideal for cooling electrical equipment or fitting into a cooker hood, film drying cabinet or for removing fume smoke when soldering, etc. etc. A real bargain at £3.50p.



TANGENTIAL HEATER UNIT

This heater unit is the very latest type, most efficient, and quiet running. Is as fitted in Hoover and blower heaters. Comprises motor, impeller, 2kW element allowing switching 1, 2kW, and with thermal safety cut-out. Can be fitted into any metal lined case or cabinet. Only needs control switch, £2.78. Don't miss this. Control Switch, 55p. P. & P. 50p.



SHORTWAVE CRYSTAL SET

Although this uses no battery it gives really amazing results. You will receive an amazing assortment of stations—over ten 19.25 to 39 metre bands—Kit contains chassis front panel and all the parts. £1.25—crystal earphone 50p.



DRILL CONTROLLER

Electronically changes speed from approximately 10 revs. to maximum. Full power at all speeds by finger-tip control. Kit includes all parts, case, everything and full instructions. £2.25 plus 25p post and insurance. Made up model also available. £3.95 plus 30p post & p.



RADIO STETHOSCOPE

Easiest way to find fast traces—signal from serial to speaker, when signal stops you've found the fault. Use it on Radio, TV, amplifier, anything. Complete kit comprises two special transistors and all parts including probe tube and crystal earpiece, £2.20 twin stetho-set instead of earpiece 85p extra post and ins. 20p.

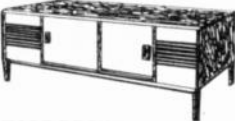
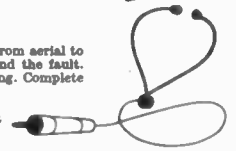

STEREO RADIO CABINET

Long, Low and Modern. Teak veneered with sliding front and tapered legs. Speaker space each end. Size approx. 4ft. 2in x 15in x 15in. Probably cost over £30 to make. Our Price £3.10 each.

TAPE DECK

In metal case with carrying handle, heavy fly wheel and capstan drive. Tape speed 31. Mains operated on metal platform with tape head and guide. Not new but guaranteed good working order. Price £1.95 plus £1 post and insurance.



GENERAL PURPOSE SWITCH

Responds to moisture, heat, light, touch, time delays, etc. etc. Basic kit comprising relay, transistors, diodes, condensers, resistors, etc. and data—only £1.50 + 20p post.



AMMETERS

—moving iron ac/dc—ideal for chargers etc. 2" sq. full vision 0-8 amp 80p. 1 1/2" rounded 0-2 amp 50p. 0-3 amp 85p. 0-4 amp 78p.



DISTRIBUTION PANELS

Just what you need for work bench or lab. 4 x 13 amp sockets in metal box to take standard 15 amp fused plugs and on/off switch with neon warning light. Supplied complete with 6 feet of flex cable. Wired up ready to work. £3.78 plus 25p P. & P.

AM/FM TUNER

Unit made by the American GEC company, 8 transistor, all-wired ready to work. Complete with tuner condenser, needs only scale and pointer. Tunes AM range 540 to 1690 KHz, FM range 88 to 108 MHz. Switches for on-off and AFC. Output for MXP or direct. Special snip price £5.55 plus 90p post. Three or more post free.

7 WATT STEREO AMPLIFIER

Again made by the famous GEC company. This has exceptionally good tone quality and is complete with rectifiers and smoothing, so requires only a mains transformer. Treble, Bass, Volume and balance controls. 15 ohm output. Inputs for tuner, ceramic pickup, etc. Price £8 plus 90p post and insurance.

SPIT MOTOR

200-250V induction motor, driving a Carter gearbox with a 1 1/2" output drive shaft running at 5 revs p.m. Intended for roasting chickens, also for driving models—windmills, coloured disc lighting effects, etc. £3.50 plus 30p post and ins.

EXTRACTOR FAN

Cleans the air at the rate of 10,000 cubic ft. per hour. Suitable for kitchens, bathrooms, factories, changing rooms, etc., it's so quiet it can hardly be heard. Compact, 5 1/2" casing with 5 1/2" fan blades. Kit comprises motor, fan blades, sheet steel casing, plug switch, mains connector, and fixing brackets. £3.78 + 20p P. & P.



NEW ITEMS THIS MONTH

The bargains in this column are just some of the items which appeared in the January supplement to our catalogue. You can receive the next 13 supplements and catalogue when published March or April.

Mains Transformers. We have a good range of mains transformers covering most requirements and we can still supply at reasonable prices. Many are available in large quantities and we will be glad to supply at our usual quantity cash discounts which are as follows:—10-49 10%; 50-99 15%; 100-499 20%; 500 up 25%. Prices as list below. We have not included anything for postage, but you should allow for this when ordering. All standard 230-250 volt primaries.

1v	1 amp (special)	£ 75
2-4v	5 amp	1.05
6-3v	2 amp	1.00
6-3v	3 amp	1.50
9v	1 amp	.95
12v	3.5 amp	1.85
13v	500mA	1.00
13v	1 amp	1.00
13v	1.5 amp	1.25
6-5v-0-6-5v	1 amp	1.25
18v	1 amp	1.25
20v	1 amp	1.00
24v	1 amp	1.50
24v	3 amp	1.50
15v-15v	50mA	1.50
6-0-6v	50mA	1.50
8-0-8v	1 amp	1.50
18-0-18v	2 amp	1.85
25v	1 amp	1.85
50v 2 amp & 6-3v 1 amp		£ 50
60v 5 amp & 6v 1 amp		7.50
27v	8 amp	4.50
40v	2 amp	2.00
80v tapped 75v & 70v	4 amp	£ 50
230v-60mA & 6-3v	1.5 amp	1.75
275-0-275v at 90mA & 6-4v	3 amp	£ 25
EHT Transformer 6000v at 23mA (intermittent)		£ 50

Charger Transformers

6v and 12v	2 amp	1.25
6v and 12v	3 amp	£ 25
6v and 12v	5 amp	£ 50

Room Thermostat. Mercury Switch type with thermometer for low voltage gas central heating systems etc. Made by a famous American Company these are of very neat appearance. In plastic case, easily mounted but the most important feature is that they cut in and out quickly, thus maintaining a very steady temperature. Price £1.85

Flexible heat. You have probably from time to time wanted to warm something by actually winding the heater around it. You can do this now for we have in stock flexible elements comprising fibreglass tape approx. 1/2" wide approx. 4' thick, 15 ft. long. The element is embedded into this, and fully insulated from the outside. The ends can be taken directly into a 13 amp plug or plastic junction box which we can supply at 24p extra. These are rated at 100 watts but you can reduce this if you wish by joining two in series. Price of element is £1.95, no extra for postage if ordered with other items totalling £5 or over.

Self-adhesive paper 45", ideal for marking leads as you take them off, or for providing quick insulation of soldered or twisted joints. 80p per 1,000 or £2 per box of 5,000.

Pick-up cartridges. We have two extra special bargains this month—'Sure' magnetic type number 77DB for £3.50 and 'Roopit' turner mono cartridge standard replacement for DC400 series price £1.50.

Again available—two items which have been held up through supply difficulties: the Domestic light dimmer kit at £1.50 and the industrial 5 amp dimmer at £2.50 are once again available for immediate despatch.

Multi-core cable, 7 cores each pvc insulated and colour coded, screened overall then with pvc outer covering. A miniature cable diameter approx. 1", price 20p per metre available in lengths up to 15 metres.

Fluorescent control trays made for Philips so therefore obviously first-class. These are for two 40 watt 4 ft. tubes and contain quick start transformer, condensers all wired tube ends and provided with Terry clips to hold the tubes. A real bargain at £2.78 each + 80p each post.

Break before make water switch. We are sometimes asked for these but we do not normally keep a range. However, we have some 2 pole 5 way with 1 1/2" water, a substantially well-made switch which we can offer for 85p each. Heavy Duty Mains Power Fask. Output voltage adjustable from 15-40V in steps—maximum load 250W—that is from 6 amp at 40V to 15 amp at 18V. This really is a high power heavy duty unit with dozens of workshop uses. Output voltage adjustment is very quick—simply interchange push on leads. Silicon rectifiers and smoothing by 2,000µF. Price £4.95 plus 80p post. Foot switches. We are producing a range of foot switches of robust construction and suitable for making and breaking circuits of up to 10 amps at mains voltage. Model A operates single changeover switch and the price is £1.78. Model B operates two changeover switches and is £2.85. Model O has three changeover switches and is £2.78. All are fully assembled ready for connection.

A useful power pack giving 250V DC and 6-3v AC mounted on chassis size 9 1/2" x 8" x 5" high comprising double wound fully impregnated mains transformer and full wave rectifier with adequate smoothing condensers. Used but guaranteed in good order. Price only £1.50 + 75p post.

TERMS:—
ADD 8% V.A.T.
Send postage where quoted—other items, post free if order for these items is £6.00, otherwise add 30p.

J. BULL (ELECTRICAL) LTD.
(Dept. EE), 102/3 TAMWORTH ROAD,
CROYDON CR0 1XX

PE SCORPIO Mk 2 ignition system kit new from ELECTRO SPARES

- * 6 OR 12 VOLT
- * + VE AND - VE GROUND

Here's the new, improved version of the original Scorpio Electronic Ignition System - with a big plus over all the other kits - the Electro Spares Kit is designed for *both* positive and negative ground automotive electrical systems. Not just +ve ground. Nor just -ve ground. But both! So if you change cars, you can be almost certain that you can change over your Scorpio Mk. 2 as well.

Containing all the components you need, this Electro Spares Scorpio Mk. 2 Kit is simply built, using our easy-to-follow instructions. Each component is a branded unit by a reputable manufacturer and carries the manufacturer's guarantee. Ready drilled for fast assembly. Quickly fitted to any car or motor cycle.

When your Scorpio Mk. 2 is installed, you instantly benefit from all these Scorpio Mk. 2 advantages:

- ★ Easier starting from cold
- ★ Firing even with wet or oiled-up plugs
- ★ Smoother running at high speed
- ★ Fuel saving
- ★ More power from your engine
- ★ Longer spark plug life
- ★ No more contact-breaker burn.

Electro Spares prices:

De luxe Kit only **£10.85** inc. VAT and p & p.
Ready Made Unit **£13.65** inc. VAT and p & p.
State 6V or 12V system.

Send SAE now for details and free list.

PE FM VARICAP STEREO TUNER

As featured in the May 1973 issue of 'Practical Electronics'. Superb Hi-Fi tuner Kit now available from Electro Spares. Including cabinet and all components - pre-set Mullard modules for R.F. and I.F. circuits. Motorola I.C. Phase Lock Loop Decoder for perfect stereo reception. No alignment needed. Guaranteed first time results - or send it back, and we'll return it in perfect order (for a nominal handling charge). Electro Spares price only **£28.50** inc. VAT and p & p.

PE GEMINI STEREO AMPLIFIER

A superb unit with a guaranteed output of 30 watts RMS per channel into 8 ohms. Full power THD is a mere 0.02%, and frequency response is -3 dB from 20 Hz to 100 kHz into 8 or 15 ohms. Electro Spares have already sold 100s and 100s of these Kits. Get yours now! Depending on your choice of certain components, the price can vary from **£50** to **£60** inc. VAT and p & p.

- ★ All components as specified by original authors, and sold separately if you wish.
- ★ Full constructional data book with specification graphs, fault finding guides, etc. 55p plus 9p postage.
- ★ Price List only. Please send S.A.E. (preferably 9 x 4 minimum) for full details.

ELECTRO SPARES



The Component Centre of the North
288 ECCLESALL RD., SHEFFIELD S11 8PE(B)
Tel: Sheffield (0742) 668888



4 1/4 in x 3 1/2 in METER. 30µA, 50µA or 100µA, £3.85. P. & P. 11p.

TAPE RECORDER LEVEL METER

500µA, 70p
P. & P. 5p.

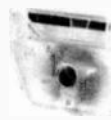

CARDIOID DYNAMIC MICROPHONE

Model UD-130. Frequency response 50-15,000c/s. Impedance Dual 50K and 600 ohms. £6.55. P. & P. 11p.



42 x 42mm METERS 100µA, 500µA, 1mA, 500mA £2.76, 11p P. & P.

60 x 45mm METERS 50µA, 100µA, 500µA and 1mA VU METER £2.92, 11p P. & P.

EDGEWISE METERS, 90mm x 34mm, 1mA £3.40, 11p P. & P.

MULTI-METER

Model 200H
20,000 ohm/volt, £7.65.
P. & P. 15p.



3WATT STEREO AMPLIFIER

1 1/2 W PER CHANNEL
£4.30. P. & P. 10p.



All above prices include 8% V.A.T. LARGE S.A.E. for List No. 11. Special prices for quantity quoted on request.

M. DZIUBAS

168 Bradshawgate · Bolton · Lancs. BL2 1BA



become a RADIO-AMATEUR!

learn how to become a radio-amateur in contact with the whole world. We give skilled preparation for the G.P.O. licence

free! Brochure, without obligation to:

BRITISH NATIONAL RADIO & ELECTRONICS SCHOOL
Dept EEB 45 P.O. Box 156, JERSEY

NAME :

ADDRESS :

BLOCK CAPS please



I.L.P. (Electronics) Ltd

SHEER SIMPLICITY!

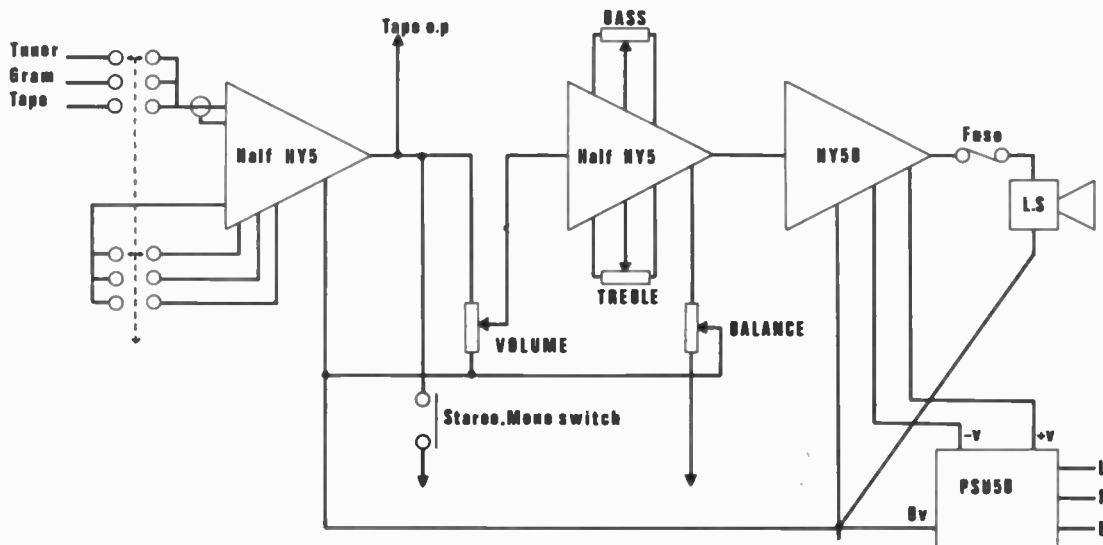

**MONO ELECTRICAL CIRCUIT DIAGRAM WITH INTERCONNECTIONS FOR STEREO SHOWN
POWER CONNECTIONS FROM PFU50 TO HY5 NOT SHOWN FOR CLARITY OF DIAGRAM**

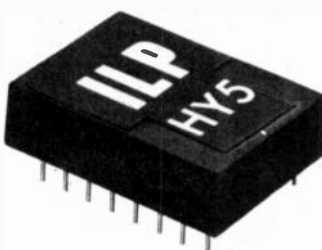

The HY5 is a complete mono hybrid preamplifier. Ideally suited for both mono and stereo applications. Internally the device consists of two high quality amplifiers—the first contains frequency equalisation and gain correction, while the second caters for tone control and balance.

TECHNICAL SPECIFICATION
Inputs: Magnetic Pick-up 3mV RIAA; Ceramic Pick-up 30mV; Microphone 10mV; Tuner 100mV; Auxiliary 3-100mV; Input Impedance 47kΩ at 1kHz. Outputs: Tape 100mV; Main output 0db (0-775V RMS). Active Tone Controls: Treble ± 12db at 10kHz; Bass ± 12db at 100Hz. Distortion: 0.5% at 1kHz. Signal/Noise Ratio: 68db. Overload Capability: 40db on most sensitive input. Supply Voltage: ± 18-25V.

PRICE £4.50 + 36p VAT
P. & P. free

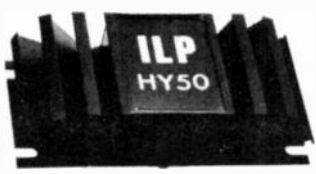

The HY50 is a complete solid state hybrid HI-FI amplifier incorporating its own high conductivity heatsink hermetically sealed in black epoxy resin. Only five connections are provided, input, output, power lines and earth.

TECHNICAL SPECIFICATION
Output Power: 25W RMS into 8Ω. Load Impedance: 4-16Ω. Input Sensitivity 0db (0-775V RMS). Input Impedance: 47kΩ. Distortion: Less than 0.1% at 25W typically 0.05%. Signal/Noise Ratio: Better than 75db. Frequency Response: 10Hz-50kHz ± 3db. Supply Voltage: ± 25V. Size: 105 x 50 x 25mm.

PRICE £5.98 + 48p VAT
P. & P. free

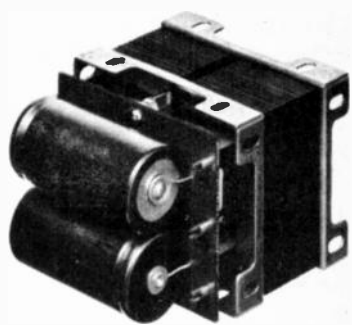

The PSU50 incorporates a specially designed transformer and can be used for either mono or stereo systems.

TECHNICAL SPECIFICATIONS
Output Voltage: 50V (25-0-25V). Input Voltage: 210-240V.
Size: L.70. D.90. H.90mm.

PRICE £6 + 48p VAT
P. & P. free

TWO YEARS' GUARANTEE ON ALL OUR PRODUCTS

I.L.P. Electronics Ltd.
Crossland House,
Nackington, Canterbury
Kent CT4 7AD
Registered Office
Tel (0227) 63218

Please supply,

Total Purchase price

I Enclose, Cheque Postal Orders Money Order

Please debit my Access account Barclaycard account EE 4

Account number

Name & Address

.....

Signature

Everyday Electronics Classified Advertisements

RATES: 11p per word (minimum 12 words). Box No. 30p. extra. Semi-display—£7.50 per single column inch. Advertisements must be prepaid and addressed to Classified Advertisement Department, "EVERYDAY ELECTRONICS," I.P.C. Magazines Ltd., Fleetway House, Farringdon Street, London EC4A 4AD.

SITUATIONS VACANT

SHOP ASSISTANT REQUIRED. Basic knowledge of electronic and electrical essential. 01-546 4099.

SHOP ASSISTANT REQUIRED. Basic knowledge of electronic and electrical essential. 01-579 3979.

EDUCATIONAL

C AND G EXAMS

Make sure you succeed with an ICS home study course for C and G Electrical Installation Work & Technicians Radio/TV/Electronics Technicians. Telecomms Technicians and Radio Amateurs.

COLOUR TV SERVICING

Make the most of the current boom! Learn the techniques of servicing Colour and Mono TV sets through new home study courses, approved by leading manufacturers.

TECHNICAL TRAINING

Home study courses in Electronics and Electrical Engineering, Maintenance, Radio, TV, Audio, Computer Engineering and Programming. Also self-build radio kits. Get the qualifications you need to succeed.

Free details from:

INTERNATIONAL CORRESPONDENCE SCHOOLS,
Dept 171, Intertext House, London SW8 4UJ.
Or Phone 01-822 9911 (all hours)

FOR SALE

MICROPHONES: AKG D109, £12.65; AKG D202E1, £43.45; AKG D190C, £18.70; AKG D190E, £20; AKG D224, £55; Sennheiser MD211N, £49.50; Sennheiser MD413N, £29.70. All brand new and boxed. Send CWO to J. J. Francis (Wood Green) Ltd., Manwood House, Matching Green, Harlow, Essex. Tel: Matching 476.

WANTED

WILL BUY E.E. September '74. Bowman, 8 Brunner Road, London W5 1BA. Tel: 01-998 4713.

SERVICE SHEETS

BELL'S TELEVISION SERVICES for Service Sheets, Manuals, Books on Radio's TVs etc. Service Sheets 40p plus SAE. Free book lists on request. Back issues of PW, PE, EE, TV available, cover price plus 9p post. SAE with enquiries. B.T.S. (Mail Order Dept.), 190 Kings Road, Harrogate, Yorks. Telephone (0423) 55885.

RECEIVERS and COMPONENTS

TUNBRIDGE WELLS. Components from Ballard's, 108, Camden Road, Tunbridge Wells. Tel: Tunbridge Wells 31803. S.a.e. for all enquiries.

LOWEST COST IC SOCKETS. Use Solderroom IC socket pins for 8 to 40 pin DIL's. 70p for strip of 100 pins, £1.50 for 3 strips of 100, £4 for 1000. 10p p&p for orders under £2. Add 8% VAT. Instructions supplied—send s&c for sample. SINTEL, 53e Aston Street, Oxford. Tel: 0865 43203.

3 ASSORTED M.C. METERS £1.30 (40p). **LARGE COMPUTER PANELS 35-50** Transistors, Long Leads, 85p (40p). **COPPER CLAD PAX PANELS 5 1/2" x 5 1/2", 6-85p, c.p. FIBRE GLASS 8" x 7 1/2"** each 80p c.p. **T.V. CONVERGENCE PANELS 2x AC128.3** Slugged Coils, 3 Slide Switches 11 w.w. Pots, 3 Carbon Presents, 2 Ferrite Chokes, etc. £1.20 c.p. **VALU-PACKS Pa. 100** S/mics Caps 67p. c.p. P24, 100 Polyester Caps. Mullard C200 series, £1.18, c.p. Send 12p for lists. Refund on purchase. 71bs **ASSORTED COMPONENTS £2, c.p.**

J. W. B. RADIO

2 Barnfield Crescent, Sale, Cheshire M33 1NL
Postage in Brackets Mail Order Only

VALVES, TRANSISTORS, STYLI. Valves 1930 to 1975. 1,500 types. Many obsolete. List 15p. Transistor list 15p. Diamond styli list 10p. SAE for quotation. Cox Radio (Sussex) Ltd., The Parade, East Wittering, Sussex. West Wittering 2023.

COMPONENTS GALORE. Pack of 500 mixed components manufacturers surplus plus once used. Pack includes Resistors, carbon and W.W., capacitors various, transistors, diodes, trimmers, potentiometers etc. Send £1+10p p. and p. c.w.o. to CALEDONIAN COMPONENTS, Strathore Road, Thornton, Fife.

MISCELLANEOUS

TRANSISTOR TESTER. Ideal for beginners. Measures gain directly. Can be used to test diodes and unmarked transistors. SAE details. Money-back assurance. £9.50 (P&P 15p). Viking, Oak Lodge, Tansley, Derbyshire.

LOUDSPEAKERS

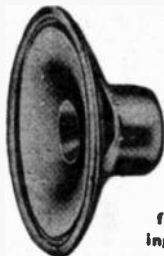

Speakers, kits and cabinets for D.I.Y., Hi-Fi, P.A., Disco, etc. by EMI, Fane, Goodmans, Baker, Kef, Elac, Richard Allan, Wharfedale, etc. Send stamp for free booklet "Choosing a speaker"

WILMSLOW AUDIO

Dept. EE, Swan Works, Bank Square,
Wilmslow, Cheshire SK9 1HF
Tel. Wilmslow 29599

CONSTRUCTION AIDS. Screws, nuts, spacers, etc., in small quantities. Aluminium panels punched to spec. or plain sheet supplied. Fascia panels etched aluminium to individual requirements. Printed circuit boardmasters, negatives and boards, one-off or small numbers. Send 6p for list. **RAMAR CONSTRUCTOR SERVICES,** 29 Shelbourne Road, Stratford-on-Avon, Warks.

LOUD 6v SIRENS for burglar alarms, etc. (new and boxed), £1.20, add 10p P.P. List 6p. Grimsby Electronics, 64 Tennyson Road, Cleethorpes, South Humberside (callers to Lambert Road, Saturdays only).

GADGETS GALORE!!

★ READY BUILT + TESTED ★

Signal Injector £1.95 Signal Tracer £2.95
Logic Probe £4.45 Noise Generator £6.95
Metronome £3.90 Continuity Tester £3.95
Automatic Transistor Checker £15.25

Prices include U.K. Postage and B.A. rates
—Mail Order Only— S.A.E. list to.

G.K. SERVICES, (G2)
83 Westdale Road, London SE18 3BQ

DIGITAL CLOCK CHIP, AY-51224, with data and circuit diagram, £3.66 plus VAT. "Jumbo" LED digits (16mm high), type DL-747, only £2.04 each plus VAT, post free. Greenbank Electronics, 94 New Chester Road, Wirral, Merseyside L62 5AG.

AERIAL BOOSTERS-£3.30

We make three types of aerial boosters B45-UHF-TV, B12-VHF-TV, B11-VHF-Radio.

VALVES BARGAINS

ANY 5-80p, 18-70p, 50-23-30.
ECC82, EF80, EF133, EF184, PCC189, PCF80,
PCF802, PCL82, PCL84, PCL85/805, PFL500,
PL36, PL504, PY800, PY88.

COLOUR TV VALVES—PL508, PL509, PY500— 25p each.

Prices includes VAT, P&P 10p, SAE—leaflet
Electronic Mail Order Ltd, 62 Bridge Street,
Ramsbottom, Bury, Lancs. Tel RAMS 3636.

SUPERB instrument cases by Bazelli, manufactured from heavy duty P.V.C. faced steel. Hundreds of Radio, Electronic and Hi-Fi enthusiasts are choosing the case they require from our range of over 200 models. Largest choice at highly competitive prices, why pay more, prompt dispatch. Free literature (stamp would be appreciated). Bazelli, Department No. 24, St. Wilfrida, Foundry Lane, Halton, Lancaster, LA2 6LT.

MULTIMETER

Type U4324

20,000 Ω/V, Overload protected, Range: 0-6, 1-2, 3, 12, 30, 60, 120, 600, 1200V DC; 3, 8, 15, 60, 180, 300, 600, 900V AC; 0-0.6, 0-6, 6-60, 600mA, 3A DC; 0-3, 3, 30, 300mA, 3A AC; 5 resistance ranges to 5M Ω, 800Ω, —10 to +12. Size 167 x 98 x 63mm. Supplied complete with test leads, clips spare diode and instructions.

ONLY £10.00.

PC ETCHING KIT

Contains 11b Ferric chloride, DALO etch-resist pen, 100 sq ins copper clad board, etching dish, abrasive cleaner and instructions. £3.90

FERRIC CHLORIDE

Anhydrous to Mill-spec in double-sealed 11b packs. 11b 89p; 31b £1.65; 101b £4.40.

VEROBOARD

100 sq ins 0-1, 0-15 & 0-2" good-size offcuts (About 8 pieces) £1.10.

TRANSFORMERS

Miniature type, mains primary, 100mA sec. 6-0-6V 85p; 9-0-9V 99p; 12-0-12V 99p. 16-0-16V with 9V tap @ 11A £2.

COMPUTER PANELS

31bs aasted £1.40; 71b £2.00; 501b £16; 12 high quality panels with trim pots, power transistors, IC's etc. £2.50. Pack of boards with 500 components inc. at least 50 transistors 99p.

GREENWELD ELECTRONICS [EE11]

51 SHIRLEY PARK ROAD,

SOUTHAMPTON SO1 4FX

Tel (0703) 772501. Also at 38 Lower Addiscombe Rd, Croydon & 21 Deptford Bdy SE8.
ALL PRICES INCLUDE 8% VAT AND UK POSTAGE. BAE LIST, ENQUIRIES, CALLERS WELCOME.

BUILD THE TREASURE TRACER MK III Metal Locator



- Variable tuning
- Britain's best selling metal locator kit
- Weighs only 22oz.
- Speaker and earphone operation
- Knocks down to only 17in.
- Prebuilt search coil assembly
- Thoroughly professional finish
- As seen on BBC1 and BBC2 TV
- You only need soldering iron, screwdriver, pliers and snips
- Five transistor circuit

Send s.a.s. for leaflet

Complete Kit **£9.80** P & P 60p
 Built, tested and guaranteed **£13.75** P & P 60p, - £1.10 VAT

MINIKITS ELECTRONICS,
 6a CLEVELAND ROAD,
 LONDON, E18 2AN (Mail order only)

HOME SCIENTISTS

Get the key to a FANTASTIC WORLD of previously UNHEARD-OF-PROJECTS. The NEW Boffin catalogue lists DOZENS of HIGHLY UNUSUAL, LOW-COST BARGAINS, READY-BUILT MODULES. Here are just a few examples, there are stacks more!

Dazzling MINI-STROBE (pocket size) **£2.90**

PEOPLE DETECTOR **£3.20**
 Big-Ear SOUND-CATCHER **£3.20**
 Mini DREAM LABORATORY **£3.20**

Don't take our word for it though! GET A COPY & SEE!
 SEND ONLY 20p, and we'll RUSH YOU A COPY (YOU'LL GET THE GOODIES! JUST AS QUICKLY TOO!)

BOFFIN PROJECTS
 4 Cunliffe Road, Stoneleigh,
 Ewell, Surrey
 (Mail Order U.K. Only)

PLEASE MENTION

Everyday Electronics

WHEN REPLYING TO ADVERTISEMENTS

SPARKRITE MK 2

CAPACITIVE DISCHARGE ELECTRONIC IGNITION KIT



Voted best of 8 ignition systems tested by a leading Motoring Magazine

The Sparkrite Mk 2 is a high performance high quality capacitive discharge, electronic ignition system. Because of the superb design of the Sparkrite circuit it completely eliminates problems of the contact breaker. There is no misfire because contact breaker bounce is eliminated electronically by a pulse suppression circuit which prevents the unit firing if the points bounce open at high R.P.M. Contact breaker burn is eliminated by reducing the current to about 1/50th of the norm. It will perform equally well with new, old, or even badly pitted points and is not dependent upon the dwell time of the contact breakers for recharging the system. Sparkrite incorporates a short circuit protected inverter which eliminates the problems of SCR lock on and therefore eliminates the possibility of blowing the transistors or the SCR. (Many capacitive discharge ignitions are not completely foolproof in this respect.)

Sparkrite can therefore give you:
 up to 20% better fuel consumption. Instant all weather sterling cleaner plugs—they last up to 5 times longer without attention. Faster acceleration. Higher top speeds. Longer coil and battery life. Efficient fuel burning and less air pollution. Smoother running. Continual peak performance.

NOTE—FUEL CONSUMPTION:
 The fitting of a Sparkrite Mk 2 should reduce fuel consumption although the amount of the reduction will vary. A fair estimate of the savings which could be expected, based on reports by our customers and upon our own experience, are as follows:
 any 4-cylinder vehicle, 10% improvement
 any 6-cylinder vehicle, 15% improvement
 any 8-cylinder vehicle, 20% improvement
 It is worth remembering that while fuel saving is important there are many other advantages to be gained from fitting a Sparkrite ignition system.

OPTIONAL EXTRAS
 Electronic R.P.M. limitation
 This can be included in the unit to prevent over revving, an advantage to most companies, hire firms, high performance drivers, etc.
 Electronic conventional ignition switch.
 Gives instant changeover from Sparkrite ignition to conventional ignition for performance comparisons, static timing, etc. and will also switch the ignition off completely as a security device. Includes switch connectors, mounting bracket and instructions. Cables excluded.

PRICES: D.I.V. assembly kit **£10.83***. Ready built unit **£13.86*** (both to fit all vehicles with coil/distributor ignition up to 8-cylinder).
 Switch for instant changeover from Sparkrite ignition to conventional ignition **£2.79***. R.P.M. limiting control **£2.42*** (fitted in case on ready built unit, dashboard mounting on kit).
 *including VAT, post and packing.
 We can supply units for any petrol-engined vehicle (boat, motorcycle, etc.) with coil contact breaker ignition. Details on request.
CALL IN AND SEE US FOR A DEMONSTRATION

ELECTRONICS DESIGN ASSOCIATES of WALSALL

ALUMINIUM BOXES **FLUORESCENT LIGHT KIT** **ORDER NOW**

To: ELECTRONICS DESIGN ASSOCIATES DEPT. E E 4
 82 Bath Street, Walsall, WSI 3DE, Phone 33652

From: Name _____
 Address _____

Please Supply

Quantity	Price
SPARKRITE Mk 2 DIV assembly kits at £10.83	
SPARKRITE Mk 2 ready built negative earth at £13.86	
SPARKRITE Mk 2 ready built positive earth at £13.86	
Ignition changeover switches at £2.79	
R.P.M. Limit systems in the above units at £2.42	
Fluorescent light assembly kits at £3.79	
Fluorescent light built units at £3.79	
Diffusers for the above at 80p	
of number alum. boxes at	
of number alum. boxes at	
of number alum. boxes at	

I enclose cheque/P.O. order for £ _____ Cheque No. _____
 (Send S.A.E. if brochure only required)

These project boxes are manufactured from 18-gauge aluminium and come complete with lids and screws.
 The prices shown include VAT (at 8%) but 18p should be added to the total order value for postage and packing.

Order No.	Length (in)	Width (in)	Height (in)	Price (inc. VAT)
7	5 1/2	2 1/2	1 1/2	47p
8	4	2 1/2	1 1/2	42p
9	4	2 1/2	1 1/2	46p
10	5 1/2	4	1 1/2	49p
11	4	2 1/2	2	46p
12	3	2	1	38p
13	6	4	2	58p
14	7	5	2 1/2	75p
15	8	6	3	83p
16	10	7	3	£1.14

Boxes can be made to any size but the minimum order for special sizes is 500. General trade enquiries welcome.

You can build this reverse polarity protected 12V, 8W, fluorescent light. You will receive all of the necessary parts: white enamelled ready drilled metalwork, ready drilled heatsink printed circuit board, high quality components and transformer, end caps and cable, the fluorescent tube, nuts, bolts and washers, etc. and simple assembly instructions and operating instructions.

When complete the light has a wide variety of uses such as workshop and workbench illumination, garage lighting, emergency lighting, lighting for camping, caravanning or boating, as an inspection lamp and many more.

If you can't spare the time to put the light together then we will supply it ready built (for a few extra pence).

PRICES
 Assembly kit **£3.19** (inc. VAT, post and packing).
 Ready built **£3.78** (inc. VAT, post and packing).
 Diffuser 59p extra (inc. VAT, post and packing).

BI-PRE-PAK

Bargains in Semi-Conductors, components, modules & equipment.

Bargains from our FREE Catalogue

20 large pages, filled with real bargains in transistors, I.C.s, components, equipment, etc. Send large S.A.E. with 6p stamp for your FREE copy of 6th Edition by return. Meanwhile, for prompt delivery order from this month's ad, NOW.

BPP TRANSISTOR PACKS ALL AT 50p EACH TESTED & GUARANTEED

B79	4	IN4007 Sil. Rec. diodes—1,000PIV 1 amp. plastic	H39	6	Integrated circuits 4 gates BMC 962, 2 flip flops BMC 945 BD131/BD132
B81	10	Reed Switches, 1" long 1/8" dia. High-speed P.O. type	H41	2	Complementary Plastic Transistors 43061 Type NPN Sil. Transistors TO-5 can comp. to H66
H35	100	Mixed Diodes, Germ. Gold bonded, etc. Marked and Unmarked	H65	4	43062. Type PNP Sil. Transistors TO-5 can comp. to H65
H34	30	Short lead Transistors, NPN Silicon Planar types	H66	4	43062. Type PNP Sil. Transistors TO-5 can comp. to H65

UNMARKED & UNTESTED

B1	50	Germanium Transistors PNP, AF and RF	B88	100	Sil. Diodes sub. min. IN914 and IN916 types
B64	150	Germanium Diodes Min. glass type	H34	15	Power Transistors, PNP, Germ. NPN Silicon TO-3 Can
B84	100	Silicon Diodes min. glass equivalent to IN4148	H67	10	3819N Channel FET's plastic case type

SILICON POWER TRANSISTORS—PLASTIC

WATT	Type	Gain	VCE	NPN	Price
40	40N1	15	15	NPN	20p
	40N2	40	40	PNP	30p
	40P1	15	15	PNP	20p
	40P2	40	40	PNP	30p
60	60N1	15	15	NPN	25p
	60N2	40	40	NPN	35p
	60P1	15	15	PNP	25p
	60P2	40	40	PNP	35p

NEW X-HATCH GENERATOR Mk.2



Essential for Colour T.V. alignment of 4 patterns. Featuring plug in IC's and a more sensitive sync. pick-up circuit. The case is virtually unbreakable—ideal for the engineer's toolbox—only measures 3" x 5 1/2" x 3". Operates from 3 U.2 type batteries (extra).

Complete kit **£7.93** Ready built unit only **£9.93**

OVER 1,000,000 TRANSISTORS

of all most needed types in stocks including power, diode, rectifier, etc., etc., marked, tested and guaranteed. Hundreds of worthwhile bargains will be found in our FREE CATALOGUE (6th edition). Also Zener diodes, I.C.s, etc.

MAINS TRANSFORMERS TO SUIT STIRLING SOUND MODULES

Type A	18V/1A (SS.103 etc.)	£1.50	Bridge Rectifier	
Type B	25V/2A (SS.110 etc.)	£2.00	Type A	27p
Type C	30V/2A (SS.140 etc.)	£2.25	Type B/C	38p

SUNDRY

Metrication Pocket Charts 12p. 8 assorted relays £1.00. Rev. counter device (for cars) £1.00. U.H.F./TV Tuner Units 625 lines, rotary tuning £2.50. L.M.380 Audio I.C. £1.00 and technical books of all kinds.

TERMS OF BUSINESS

V.A.T. Prices shown do not include V.A.T. Please add 8% to total value of your order including postage. No. V.A.T. on overseas orders.

POSTAGE Except where stated, add 15p for postage & packing in U.K. Overseas—add £1, any difference being charged or refunded.

PAYMENT Cash with order, Cheque or money order. Minimum value—£1. You can also pay by ACCESS.

IMPORTANT—Every effort is made to ensure accuracy of prices and description at time of preparing this advertisement and going to Press. Prices are subject to alteration without notice.

BI-PRE-PAK LTD

Co Reg No B20019

222 224 WEST ROAD, WESTCLIFF-ON-SEA, ESSEX SS0 9DF.

TELEPHONE: SOUTHEND (0702) 46344.

WRITE ORDER SEPARATELY AND ATTACH COUPON IF REQUIRED



challenging values!

Stirling Sound

STIRLING SOUND AUDIO MODULES come to you as basic units assembled on P.C.B.s enabling you to add required components in layouts of your own choice. Modules are tested and boxed before despatched and include well printed instructions.

AMPLIFIER MODULES

Pre-amplifiers; tone control
SS.100 Active tone control unit to provide bass, treble, balance and volume controls **£1.60**

SS.101 Pre-amp for ceramic cartridge, tape and radio **£1.60**

SS.102 Pre-amp for low output magnetic cartridge, tape and radio. With R.I.A.A. correction $\pm 1\text{dB}$ at 1K **£2.25**

POWER AMPLIFIERS

SS.103 Compact I.C. amp. with 3 watts R.M.S. output. Operating voltage 6 to 22. Size 3" x 2" **£1.75**

SS.103-3 Stereo version of above using one I.C. on each channel **£3.25**

SS.105 A compact and useful all-purpose amplifier which will run excellently on a 12V supply. With 5 watt output, two make a good stereo amp. Size 2 1/2" x 1 1/2" **£1.95**

SS.110 Similar in size to SS.103 but with a 10 watt output. Ideal for many domestic and small-size P.A. applications. Operates from 26 to 32V. **£2.40**

SS.140 Excellently designed 40 watt R.M.S. (into 4 ohms) hi-fi amplifier. S/N ratio better than 75dB. THD better than 0.2%. Power requirements—45V. d.c. With 0-15" centre edge connections. Two can be bridged to give 80 watts R.M.S. into 4 ohms **£3.60**

Build a hi-fi stereo tuner with these modules

SS.201 Ganged tuning condenser with accurately engineered slow-motion drive in rugged housing. Excellent sensitivity. Tunes 88-108MHz. With A.F.C. facility. Operates from 6V-16V **£6.25**

SS.202 I.F. stage (with I.C.) Pre-tuned. A.F.C. connection. Operates from 4.5 to 14V **£5.25**

SS.203 Stereo Decoder. Designed essentially for use with SS.201 and 2, this module can also be used in most mono FM tuners. A LED may be attached. Operating voltage 9-16V. d.c. **£5.62**

POWER SUPPLY STABILIZER

SS.300 Add this to an unregulated supply (say typically 45V output) to obtain a steady powerful working output adjustable from 12 to 60V. Essential for your audio and special systems. Money saving and very reliable **£3.25**

● ALL MODULES TESTED AND GUARANTEED

● WITH WELL PRINTED INSTRUCTIONS

● FULL RANGES OF ANCILLARY COMPONENTS AVAILABLE—SEE CATALOGUE

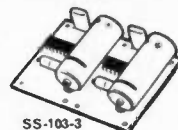

SS-103-3

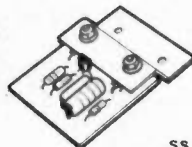

SS.105

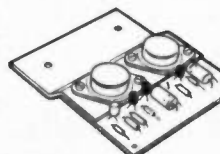

SS.110

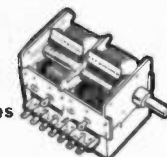

£3.60

Build a hi-fi stereo tuner with these modules

SS.201 Ganged tuning condenser with accurately engineered slow-motion drive in rugged housing. Excellent sensitivity. Tunes 88-108MHz. With A.F.C. facility. Operates from 6V-16V **£6.25**

SS.202 I.F. stage (with I.C.) Pre-tuned. A.F.C. connection. Operates from 4.5 to 14V **£5.25**

SS.203 Stereo Decoder. Designed essentially for use with SS.201 and 2, this module can also be used in most mono FM tuners. A LED may be attached. Operating voltage 9-16V. d.c. **£5.62**

POWER SUPPLY STABILIZER

SS.300 Add this to an unregulated supply (say typically 45V output) to obtain a steady powerful working output adjustable from 12 to 60V. Essential for your audio and special systems. Money saving and very reliable **£3.25**

● ALL MODULES TESTED AND GUARANTEED

● WITH WELL PRINTED INSTRUCTIONS

● FULL RANGES OF ANCILLARY COMPONENTS AVAILABLE—SEE CATALOGUE

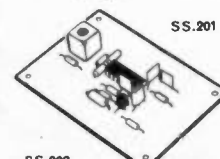

SS.201

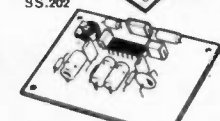

SS.202

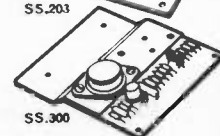

SS.203

SS.300

To BI-PRE-PAK, 222-224 WEST RD., WESTCLIFF-ON-SEA, ESSEX

Please send
for which I enclose.....Inc. V.A.T.

Name

Address

EE.4

FREE!

Over 150 ways to engineer a better future

HIGHER PAY

A BETTER JOB

SECURITY

find out how in just 2 minutes

That's how long it will take you to fill in the coupon. Mail it today and we'll send you full details and a free book. We have successfully trained thousands of men at home—equipped them for higher pay and better, more interesting jobs. We can do as much for YOU. A low-cost home study course gets results fast—makes learning easier and something to look forward to. There are no books to buy and you can pay-as-you-learn.

Why not do the thing that really interests you? Without losing a day's pay, you could quietly turn yourself into something of an expert. Complete the coupon (or write if you prefer not to cut the page). No obligation and nobody will call in on you . . . but it could be the best thing you ever did.

Others have done it, so can you

"Yesterday I received a letter from the Institution informing that my application for Associate Membership had been approved. I can honestly say that this has been the best value for money I have ever obtained, a view echoed by two colleagues who recently commenced the course".
Student D.I.B., Yorks.

"Completing your course, meant going from a job I detested to a job that I love, with unlimited prospects"—Student J.A.O. Dublin.

"My training quickly changed my earning capacity and, in the next few years, my earnings increased fourfold". Student C.C.P., Bucks.

FIND OUT FOR YOURSELF

These letters and there are many more on file at Aldermaston College, speak of the rewards that come to the man who has given himself the specialised know-how employers seek. There's no surer way of getting ahead or of opening up new opportunities for yourself. It will cost you a stamp to find out how we can help you. Write to

ALDERMASTON COLLEGE

Dept. TEE 04, Reading RG7 4PF.

HOME OF BRITISH INSTITUTE OF ENGINEERING TECHNOLOGY



This FREE 76 page book can put you on the road to success through a B.I.E.T Home Study Course. Choose your subject now!

Practical Radio & Electronics Certificate course includes a learn while you build **3 transistor radio kit.**

Everything you need to know about **Radio & Electronics** maintenance and repairs for a **spare time income** and a **career** for a better future.

CUT OUT THIS COUPON
Tick or state subject of interest. Post to address below.

- | | | |
|--|--|--|
| <input type="checkbox"/> ELECTRICAL ENGINEERING | <input type="checkbox"/> Practical Radio & Electronics (with self-build kit) | <input type="checkbox"/> Construction Surveyor's Inst. |
| <input type="checkbox"/> City & Guilds | <input type="checkbox"/> Radio Amateurs' Exam | <input type="checkbox"/> Clerk of Works |
| <input type="checkbox"/> Wiring and Installations | <input type="checkbox"/> Gen. Electronic Eng. | <input type="checkbox"/> Diploma (C. & G. Building Quantities) |
| <input type="checkbox"/> C. G. Electrical Tech-Primary | <input type="checkbox"/> Practical Electronics (with kit) | <input type="checkbox"/> General Building (General Civil Eng. Heating, Ventilation & Air Conditioning) |
| <input type="checkbox"/> Gen. Electrical Eng. | <input type="checkbox"/> AGRICULTURAL ENGINEERING | <input type="checkbox"/> Carpentry & Joinery |
| <input type="checkbox"/> AERONAUTICAL ENGINEERING | <input type="checkbox"/> REFRIGERATOR SERVICING | <input type="checkbox"/> Painting & Decorating |
| <input type="checkbox"/> Air Registration Board Certificates | <input type="checkbox"/> MECHANICAL ENGINEERING | <input type="checkbox"/> Plumbing |
| <input type="checkbox"/> Gen. Aero Engineering | <input type="checkbox"/> Society of Engineers | <input type="checkbox"/> C.E.I. (Part 1) |
| <input type="checkbox"/> AUTO ENGINEERING | <input type="checkbox"/> Inst. Engineers and Technicians | <input type="checkbox"/> Inst. Cost & Management |
| <input type="checkbox"/> City & Guilds Auto Engineering Practice | <input type="checkbox"/> General Draughtsmanship | <input type="checkbox"/> Accountants Works Management etc. etc. |
| <input type="checkbox"/> Inst. Motor Industry | <input type="checkbox"/> Draughtsmanship | |
| <input type="checkbox"/> M.A.A./I.M.I. Management Diploma | <input type="checkbox"/> Institute of Engineering Draughtsmen & Designers | |
| <input type="checkbox"/> Gen. Auto Engineering | <input type="checkbox"/> General Draughtsmanship | |
| <input type="checkbox"/> Auto Diesel Maintenance | <input type="checkbox"/> Architectural Draughtsmanship | |
| <input type="checkbox"/> Motor Mechanics | <input type="checkbox"/> Technical Drawing | |
| <input type="checkbox"/> Service Station and Garage Management | <input type="checkbox"/> RADIO & TV | |
| <input type="checkbox"/> TELECOMMUNICATIONS | <input type="checkbox"/> (Gen. Radio and TV Eng. Radio Servicing, Maintenance and Repairs) | |
| <input type="checkbox"/> City & Guilds Telecommunications | <input type="checkbox"/> CONSTRUCTION & BUILDING | |
| <input type="checkbox"/> Draughtsmanship | <input type="checkbox"/> Institute of Building | |

G.C.E.
—58 'O' & 'A'
Level Subjects
—over 10,000
Group Passes!

POST TODAY FOR A BETTER TOMORROW

To Aldermaston College,
Dept. TEE 04 Reading RG7 4PF.

NAME
Block capitals please

ADDRESS

POSTCODE

OTHER SUBJECTS

AGE

Accredited by C.A.C.C.

Member of A.B.C.C.

Published approximately the third Friday of each month by IPC Magazines Ltd., Fleetway House, Farringdon Street, London E.C.4 4AD. Printed in England by Index Printers Ltd. Dunstable, Beds. Sole Agents for Australia and New Zealand—Gordon and Gotch (A/Sia) Ltd. South Africa—Central News Agency Ltd. Publisher's Subscription Rate including postage for one year, Inland £3.55. Overseas £3.60. U.S.A./Canada \$10.00. International Giro facilities Account No. 5122007. Please state reason for payment, message to payee. Everyday Electronics is sold subject to the following conditions, namely that it shall not, without the written consent of the Publishers first given, be lent, resold, hired out or otherwise disposed of by way of Trade at more than the recommended selling price shown on cover, excluding Hire where the selling price is subject to V.A.T., and that it shall not be lent, resold, or hired out or otherwise disposed of in a mutilated condition or in any unauthorised cover by way of Trade, or affixed to or as part of any publication or advertising, literary or pictorial matter whatsoever.

Henry's Radio

LARGEST SELECTION OF ELECTRONIC COMPONENTS AND EQUIPMENT. LOW PRICES—MEAN LESS VAT.

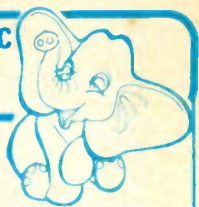

You can build the Texan and Stereo FM Tuner TEXAN 20 + 20 WATT IC STEREO AMPLIFIER

Features glass fibre PC board, Gardners low field transformer 6-IC's, 10-transistors plus diodes, etc. Designed by Texas Instruments engineers for Henry's and, P.W. 1972. Supplied with full chassis work, detailed construction handbook and all necessary parts. Full input and control facilities. Stabilised supply. Overall size 15 1/2" x 2 1/2" x 6 1/2" mains operated. Free teak sleeve with every kit.

£31.00 (Carriage 50p).

(also built and tested £37.50)



HENELEC Stereo FM Tuner Features capacity diode tuning, lead and tuning meter indicators, stabilised power supply—mains operated. High performance and sensitivity with unique station indication IC stereo decoder. Overall size in teak sleeve 8" x 2 1/2" x 6 1/2". Complete kit with teak sleeve

£21.00 (Carriage 50p). (also built and tested £24.95)

JOIN THE LARGE BAND OF HAPPY CONSTRUCTORS!

NEW SPECIAL PURCHASE



Mullard tuner LP1179 and LP1171 AM/FM tuner modules

These two modules together form a high quality AM/FM tuner covering the long, medium and VHF broadcast bands. Requires only 16 resistors and capacitors and a switch to complete. Supplied with circuits and spec. data LP1179

FM Coverage 87-108 MHz
Bandwidth 300 KHz
Selectivity 36 dB
Signal to noise at limiting threshold 40 dB
Audio output 75 mV with built-in tuning gang

AM Bandwidth 6-5 KHz
Sensitivity 1 μ V
Built-in AGC LP1171
Supply 6V negative earth
LP1179 and LP1171 £4 each or £7.50 pr.
Suitable Ferrite aerial £0.75

Mullard Modules
LP1157 AM/Type 2-50
LP1185 10-7 I.F. Unit 4-50
LP1186 10-7 F/M Tuner 4-85
Gorler Perm. F/M Tuner 4-20

Amplifiers with controls
E1210 12 volt 2 1/2 + 2 1/2 watts 8 ohms 8-25
SAC14 Mains 7 + 7 watts 8 ohms 11-75
SAC30 Mains 15 + 15 watts 8 ohms 14-95
CA038 9 volt 1 1/2 + 1 1/2 watts 8 ohms 8-95
CAD68 12 volt 3 + 3 watts 8 ohms 10-50

FM and AM Tuners and Decoders
FM5231 (tu 2) 6 volt fm tuner 7-95
TU312 volt version (FM use with Decoder) 7-95
SD4912 Stereo Decoder for Tu 3-12 volt 7-95
SP82H 6 volt stereo FM tuner 14-80
A1007 9 volt MW-AM 4-95
A1018 9 volt FM tuner in cabinet 13-95
A1005M (S) 8-12 volt Stereo decoder FM for above 7-50
106Z 12 volt Stereo decoder general purpose 6-50

Power Supplies Mains Input (*chassis-rest cased)
470C6/7 9V 300 MA with ad'rs 2-25
P500 9 volt 500 MA 3-20
HC244R 3/6/7 9V 400 MA stabilised 5-50
*P11 2v. \pm amp 3-30
*P15 28V. \pm amp 3-30
*P1080 12V 1A 4-70
*P1081 45V 0-9A 7-80
P12 4-12V 0-4-1 amp 7-15
SE101S 3/6/9/12V. 1 amp stabilised 12-75
P1078 3/4/6/7/9/12V. \pm amp 4-20
SE800A 1-15 VOLT 0- \pm A stabilised 17-50

SINCLAIR MODULES & KITS

SINCLAIR PROJECT 80
ST80 Stereo preamplifier 11-95
Audio Filter Unit 6-95
Z40 15 Watt Amplifier 5-45
Z60 25 Watt Amplifier 6-95
PZ5 Power Supplies for 1 or 2 Z40 4-98
PZ8 Power Supplies (S Tab) for 1 or 2 Z40 7-98
TRANSFORMER FOR PZ5 4-00
FM TUNER 11-95
STEREO DECODER 7-95
IC20 power amp kit 7-95
PZ20 power supply for 1 or 2 IC20 5-45

PACKAGE DEALS (carr./packg 35p)
2 x Z40 ST80 PZ5 25-00
2 x Z60 ST80 PZ8 27-75
2 x Z60 ST80 PZ8-trans 34-40
805 KIT 35-95

Sinclair Special Purchases

*Project 60 stereo preamp £6-75 (post 20p)
*Project 605 Kit £19-95 (post 25p)

TEST EQUIPMENT MULTIMETERS

Carr./packing 35p £ p
U4324 20k Ω /V with case 9-85
U4313 20k Ω /V with steel case 13-80
U4317 20 Ω /V with case 17-00
U4341 33k Ω /V plus transistor steel case 11-00
U4323 20k Ω /V plus 1kHz OSC with case 8-00
U4311 Laboratory meter £52-00
U4312 20K Ω v with case £10-75
U4315 20K Ω v with case £10-00
U4317 20K Ω v with case £17-00
IT1-2 20k Ω /V allm type 5-95
TML33D (L33DX) 2k Ω /V Robust 7-50
TP5SN 20k Ω /V (Case £2) 10-75
TP10S 20k Ω /V 8-50
TW20S 20k Ω /V 13-00
TW50K 50k Ω /V 14-50
S100TR 100k Ω /V plus transistor tester 22-50



NEW REVOLUTIONARY SUPERTESTER 680R

680R Multi-tester 18-50
†TE40 AC Multivoltmeter 19-75
†TE15 Grid dip meter 40kHz-28MHz 19-50
†TE65 28 Range valve voltmeter 22-50
†TE20D RF Generator 120kHz-500kHz 18-95
†TE22D AF Generator 20Hz-200kHz 19-85
*HM350 In circuit transistor tester 19-50
*C3025 Deluxe meter 1-300mA 6-95
*TT145 Compact transistor tester 14-75
†G3-36 R/C osc. 20Hz-200kHz 19-75
*SE35DA De-luxe signal tracer 12-95
*SE400 Mini-lab all in one tester 15-50
C1-5 Scope 500,000KHz (carr. £1-00) 43-00
Radio activity counter G-10r (carr. £1) 9-97
Mains unit for above (carr. 50p) 3-75

EMI SPEAKERS SPECIAL PURCHASE

13 in. x 8 in. chassis speakers (Carr./packing 30p ea. or 50p pr). *150 TC 10 watts 8 ohms twin cone £2-20
15 watt 8 ohms with tweeter £5-25
350 watt 8 ohms with tweeter £7-80 each
*Polished wood cabinet £4-80 carr., etc. 35p each or 50p pair.



UHF TV TUNERS

625 line receiver UHF transistorised tuners UK operation. Brand new. (Post/packing 25p. each).
TYPE C variable tuning £2-50
TYPE B 4-button push-button (adjustable) £3-50

PA-DISCOTHEQUE LIGHTING EQUIPMENT



Without doubt U.K.'s best range of modular and complete equipment. Lighting, mixing, microphones, accessories, speakers, amplifiers, lenses, etc., etc.

FREE stock lists (Ref. No. 18) on request CALL IN AND SEE FOR YOURSELF at

HENRY'S DISCO CENTRE,
309 EDGWARE ROAD,
TEL. 01-723 6963

ALL PRICES SUBJECT TO 8% VAT

TRANSISTORS & INTEGRATED I/C's

TTL "7400 series" IC's from 16p each
Cosmos "4000 series" IC's from 40p each
Linear Op-Amps from 40p each
Signetics Phase Lock IC's; RCA Linear IC's; T03 Power Devices in PNP and NPN; BC107 and "BC range" from 12p
Range of OC71 Types 18p
Plastic Power Devices, Rectifiers, Zener, Power Regulator IC's and many others.
Diodes up to 10 watts

DIL SOCKETS

8 PIN 14p
14 PIN 15p
16 PIN 17p
24 PIN £1-15
28 PIN £1-25

NOMBREX TEST EQUIPMENT

Model 35 Stabilised Power Supply

A short circuit proof power supply delivery up to 30 volts at 1 Amp. Built-in Volts and ammeters. £34-00

Model 40 Wide Range Audio Signal Generator

A high stability signal generator using the low distortion Wien bridge principle. Covering 10Hz to 100 KHz in 4 ranges. Adjustable output from 1mV to 1V. Sine and Square wave output. £34-00

Model 41 RF Signal Generator

Covering 150 KHz to 220 MHz in 8 ranges. Built in AF mod. Output up to 50mV. Crystal calibration facilities. Large linear scale with slow motion drive. £38-00

Model 42 Wide Range RF Signal Generator

Covering 150 KHz to 300 MHz in 8 ranges. Highest range in harmonic. Built in AF mod. Output up to 50mV. Circular scale. £24-50

Model 43 RC Bridge

Null indicating bridge for resistors and capacitors. Resistance range 10R to 10M \pm 2% at Centre Scale. Capacity range 10 μ F to 10 μ F \pm 2% Centre Scale except 1pF to 10pF Range \pm 5%. Power Factor Measurement 0-70% £23-50

Model 44 Inductance Bridge

Measures 1pH to 1,00H in 4 ranges \pm 5% accuracy. Q measurement from 0-1-1,000 \pm 10%. £34-00

Model 45 Direct Reading Frequency Meter

10Hz to 100 KHz in 4 ranges. Input from 10MV to 5V £36-00

All models except Model 35 are internally powered from 9V battery (extra). Carriage and packing all models 37p.

NOW OPEN—SUPERMARKET

Come and browse round the new components supermarket at 404 Edgware Road. Bargains galore. Goodie Bags. Components, etc. WATCH FOR FURTHER DEVELOPMENTS!

FREE:—SEND NOW FOR OUR FREE LIST NO. 36 FOR OUR COMPLETE RANGE OF OVER 10,000 SEMI-CONDUCTOR DEVICES AT NEW LOW PRICES.



EXTRA DISCOUNTS

Semiconductors—Any one type of mixed SN74 Series "IC". 12—extra 10%; 25—extra 15%; 100—extra 20%.

Henry's Radio

Electronic Centres
404 406 Electronic Components & Equipment 01 402 8381
309 PA Disco Lighting High Power Sound 01 723 6963
303 Special offers and bargains store
All mail to 303 Edgware Road London W2 1BW
Prices correct at time of preparation Subject to change without notice £ 6 0 £

Hifi and Electronic Centres Open 9am-6pm