



THE SHAPE OF SCREENS TO COME

- Light emitting plastics ●
- 3-D TV ●
- PODs ●

LOW-COST SIGNAL GENERATOR

From 155kHz to 30MHz
with a 1kHz spot frequency

GETTING MORE OUT OF PICS

Further into PIC programming

HT-8955 DIGITAL ECHO/REVERB

Variable control up to 800 ms

PLUS

- A UHF RADIO CONTROL SYSTEM - PART 2
- EDISON'S 1885 TRAIN TELEGRAPH
- ELECTRONICS PRINCIPLES 5.0



9 770142 722160 06 >

FOR ENTHUSIASTS
BY ENTHUSIASTS
NEXUS

Vol 27 Issue: 6 22nd May - 19th June 1998
£2.75 U.S.A. \$4.95

Electronics Principles 5.0

'A COMPLETE PC BASED ELECTRONICS COURSE'

If you are looking for an easy and enjoyable way of studying or improving your knowledge of electronics then this is the software for you.

Now includes the PIC16C84 & PIC16C71 hardware and instruction set.

The screenshot displays the 'TRANSISTOR THEORY: Equivalent NPN Transistor Circuit' window. It features a circuit diagram of an NPN transistor with a base resistor (R1 = 56k), a collector resistor (R2 = 12k), and a load resistor (RL = 2.2k). The circuit is powered by a 5V supply. The software has calculated the following parameters:

- $h_{fe} = 749.9999R$
- $h_{fe} = 2.5$
- $h_{oe} = 416.6666\mu S$
- $h_{ie} = 0.125$
- $R1 = 56k$
- $R2 = 12k$
- $RL = 2.2k$
- $R_{out} = 2.4k$
- $P_{in} = \frac{1}{R1 + R2 + h_{ie}} = 697.0953R$
- Load $R'L = \frac{R_{out} \times RL}{R_{out} + RL} = 1.1476k$
- Current gain = $\frac{h_{fe} \times R1}{RL} = 1.3043$

The interface also includes a 'Calculations' button, 'Topic Notes', and 'Printing' options. A sidebar on the right allows for selecting resistance values (56k, 12k, 2.2k) and other parameters.

Electronics Principles 5.0 is a significant upgrade of our popular electronics educational software. Now containing even more analogue, digital and microcomputer theory. PLUS over a hundred new mathematics topics to further your understanding of formulae and calculations. Telephone for a comprehensive list or upgrade details.

This software has been developed to teach electronics and is suited to both the complete novice and the more advanced student or hobbyist wanting a quick revision and access to hundreds of electronics formulae. It is extremely easy to use. Just select a topic, which is always presented as a default diagram (no blank screens!) and input your own values. Alternatively, use those from any standard electronics text book to see the results as frequency response curves, calculations, logic states, voltages and currents etc.

Graphics presentation has been enhanced and speeded-up with new menus and Indexing which enables a quicker access and more informative description of the extended range of five hundred and sixty electronics and mathematics topics.

The PIC16C84 microcontroller hardware and instruction set has been introduced and brought to life through colourful interactive graphics where you can study the architecture of this device by changing the data values to simulate all of the registers, direct/indirect addressing, program/data memory and input/output port configuration. Along with those analogue to digital functions of the PIC16C71. If you would like to learn more about the principles of these popular microcontrollers then it could not be made easier.

Electronics Principles software is currently used in hundreds of UK and overseas schools and colleges to support City & Guilds, GCSE, A-Level, BTEC and university foundation courses. Also NVQ's and GNVQ's where students are required to have an understanding of electronics principles.

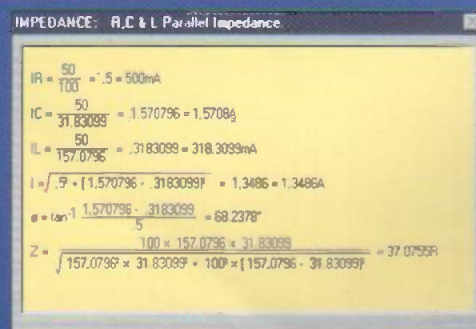
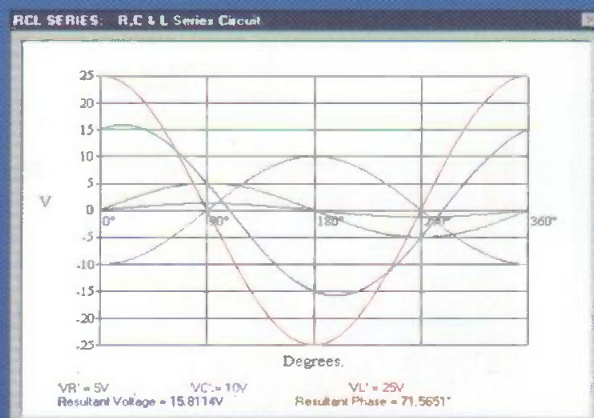

Still only £99.95*

EPT Educational Software, Pump House, Lockram Lane, Witham, Essex, UK, CM8 2BJ.

Tel/Fax: 01376 514008. sales@eptsoft.demon.co.uk <http://www.eptsoft.demon.co.uk>

*UK and EC countries add £2 per order for post & packing. VAT should be added to the total.

Outside Europe £3.50 for air mail postage by return.

Switch, Delta, Visa and Mastercard orders accepted - please give card number and expiry date.

Cheques & Postal Orders should be made payable to EPT Educational software.

Contents

Volume 27 No.6

& Features & Projects

Next Issue 19th June 1998

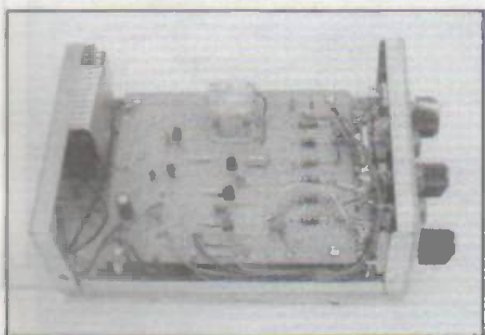
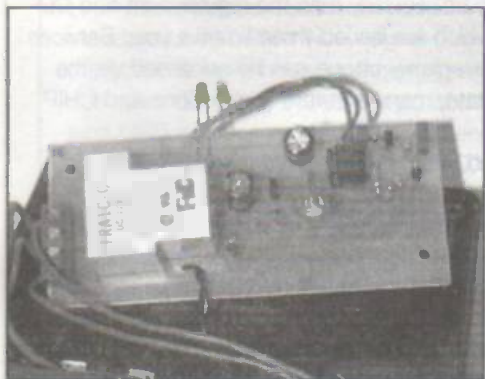

Regulars

News	4,5,6,7 & 8
ETI PCB Service	58
PCB foils	69
Practically Speaking	73
Terry Balbirnie begins a set of short articles on fuses. This month: anti-surge fuses and ratings.	
Round the Corner	74

The Shape of Screens to Come 9

Andrew Armstrong follows up last month's introduction to advanced display screen technologies by reporting on Cambridge Display Technology's Light Emitting Plastics, Brookhaven National Laboratory's Planar Optical Displays (PODs) and Philips' new 3D TV displays.

HT-8955 Digital Echo/Reverb 19

This is a new echo unit by Robert Penfold based on the HT-8955 delay line chip which produces delays of up to 800 milliseconds, and the 41256 D-ram. A variable delay control also enables short echoes down to a reverb effect, giving maximum flexibility.

A Simple Signal Generator 27

This economical unit by Raymond Haigh gives continuous coverage from 155KHz to 30MHz. The output can be modulated, and a 1kHz spot frequency is available for checking audio stages.

Getting MORE out of PICs 37

Robin Abbott begins a new series of more advanced PIC programming, centred around his popular PIC programmer, with additions. In this issue: a development board for 18-pin 16C84 or 16F84 devices.

Headlight Delay 45

Terry Balbirnie's automotive circuit will illuminate you to your door (or out of your garage) after dark by means of your car head headlamps, which will automatically switch off a few minutes later.

Electronic Timing - Part 1: Basic timing 49

"The time constant of a circuit is no more precise than the least precise of the components." RC timing circuits can be more accurate than you might expect, as Owen Bishop describes.

Thomas Edison's 1885 Train Telegraph System 54

George Pickworth describes the short-lived but revolutionary first commercial two-way telegraphy service to passengers on moving trains by a telegraph line or cable.

Review: Electronics Principles 5.0 59

The new, extended version of EPT Software's educational programme now includes PICs and Maths on over 500 screens at substantially the same price as the previous version.

UHF Model Radio Control System - Part 2 62

In the second and concluding part of Geoff Pike G10GDP's UHF radio control project, Geoff describes the construction and casing of the Transmitter and Receiver modules, the testing of the boards and the construction and connection of the antennae.

"Six-and-One" Mini Six-Interval Games Timer 66

Roy Bebbington's little portable LED-driven timer makes games and quizzes fast and friendly. You can select six different time intervals, from a few seconds to half an hour or more, with an alarm at the end and an LED at half time.



Subscribe & Save

Phone the hotline and take advantage of our special offer detailed on page 33

SUBSCRIPTIONS & BACK ISSUES HOTLINES:
01858 435344

ORDERS ENQUIRES:
01858 435322

Lines Open 9am - 6.30pm

Maplin and RS Extend CD-Rom and Web Business

The Maplin catalogue is now on CD-rom as well as its well-known print format.

The latest version of the Maplin catalogue has been redesigned as well as reformatted, and from March '98 it has been available as a CD-rom as well as in the newsagent's catalogue. The new catalogues have over 1,000 new products in them, and the CD-rom allows faster searching and ordering. The CD also has a number of "how to" video features on it to introduce new users to the catalogue.

Information can be called up using the Maplin order code, or using a keyword search. Browsing is easy. Items can be added to the order form by highlighting the item and clicking "add to order". The CD-rom also has information on Maplin's 48 retail stores in the UK, including location maps.

Details of previous orders are stored on the disc for reference. Completed orders can be printed out, and Maplin recommends faxing or posting orders to guard against credit card fraud, which is still a problem with email and Internet commerce.

To order the new catalogue, call 01702 554002, or refer to the Maplin website at www.maplin.co.uk

Meanwhile, RS/Electromail has added to its electronic trading facilities with a new website, rswww.com. The new website provides users with fast search, retrieval and on-line ordering of RS's 100,000-product catalogue, channeling into RS's same-day dispatch system for stock items.

RS's parent company, Electrocomponents plc, is the first UK plc in the marketplace to make an investment in excess of seven figures in the Internet as a major channel for self-service and other business transaction.

Ordering and payment is on-line, and the site recognises customers and tracks their buying habits to offer "tailored incentives" -

bulk discounts and promotions suited to the user's business. The site is VeriSign certified for secure payments, and uses Netscape's industry standard Secure Socket Layer (SSL) encryption protocol. To locate items in the catalogue, Search is by keyword, RS Stock Number, manufacturer's part number or type of product.

A significant advantage of the web site is that information can be updated more regularly than the regular print and CD-rom catalogues, which are issued three times a year. Services previously only available by phone can be accessed via the site, such as RS data, manufacturers' instructions and CHIP sheets.

Internet use and Internet trading are growing fast in the UK. RS estimate that at present only around 25% of customers already have Internet access, but that more than 40 percent have an Internet connection either from their home or via a colleague's PC. Feedback from customers who were consulted while the site was being set up was used to tailor the site's specifications.

RS Components receive on average more than 15,000 phone calls a day, and each day sends out around 25,000 parcels.

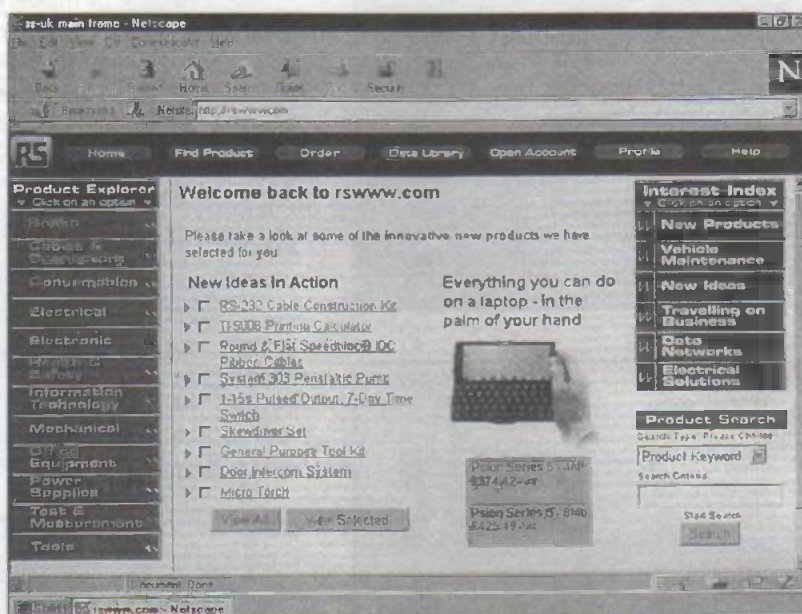

New European Harmonised Amateur Low Frequency at 136kHz

The Radiocommunications Agency has announced the new European Harmonised Amateur Low Frequency spectrum allocation in the UK in the frequency range 135.7 - 137.8kHz.

Modifications to the Amateur Radio Licence (Class A) will make the new allocation available to all holders of a Full Class A licence.

Following the introduction of the new allocation, the UK spectrum allocation at 73kHz will be

withdrawn completely from Amateur use of 30th June 2000. To prepare for this change, new applications to the RA to vary an individual's Class A licence to conduct experimental operations in Low Frequency radio propagation in the 73kHz band in the UK - the current experimental Low Frequency allocation - will not be accepted after 30th June 1998.

Only Amateurs holding Class A licences are permitted to operate at frequencies below 30MHz. Public enquiries: tel 0171 211 0211.

Fujitsu Ultra Miniature Colour CCD Camera

The photograph shows a miniature Fujitsu CCD (charge-coupled device) camera, the GMC-810, which claims to be the smallest high-resolution colour CCD camera commercially available.

All the interface electronics needed to generate a standard composition video signal output are contained in the golf-ball-sized housing, including a 5-volt DC/DC converter supplying both the logic and the CCD. The 0.25-inch CCD array uses 440,000 pixels and 460 horizontal lines in its standard PAL format (380,000 pixels and 470 horizontal lines in its NTSC format), and is complemented by a high quality optical lens.

Weighing only 30 grams, the camera's applications will include video conferencing and multimedia, where a high-quality moving or still colour image is needed, and, of course, discreet uses in the security industry.

For more information, contact Adital Ltd., 30 Ayleswater, Aylesbury, Bucks HP19 3FB, UK. Tel 01296 337755 fax 01296 398085.



DTI Pledges New Bus to Encourage Girls into Science

Science Minister John Battle has announced that his department is offering £25,000 to assist the refurbishment of a new WISE (Women into Science and Engineering) exhibition bus to visit schools and give girls in the 13-14 age range the opportunity to use new technologies and meet women working in science and technology.

This follows a DTI survey to find out what holds girls back from choosing a career in science.

The survey was carried out among 15- and 16-year old girls attending the recent Girls Into Science conference run by the DTI's Development Unit on Women in Science, Engineering and Technology. Many girls felt that physics and physics-related technologies were more interesting to boys, and would opt for biology or medicine if considering a science career. Girls still feel out of place following careers which are traditionally male-dominated, such as engineering.

Said Mr. Battle: "Our survey and video will be available to schools to help us press home the message that there are exciting and good job opportunities for girls in science and engineering."

Public enquires about WISE and Girls Into Science should be directed to the DTI's public enquiries line 0171 215 5377 and 5962.

Low Cost Surface Mount Crystals

The picture shows Advanced Crystal Technology HC-49/U-SMX range surface mount quartz crystals, which come in package sizes down to 2.5mm (H) versions with standard frequencies in the 3.18MHz to 72MHz range.

For information, contact Advanced Crystal Technology Ltd., 9 Kingfisher Court, Hambridge Road, Newbury, Berks RG14 5SJ. Tel 01635 528520 fax 01635 528443.

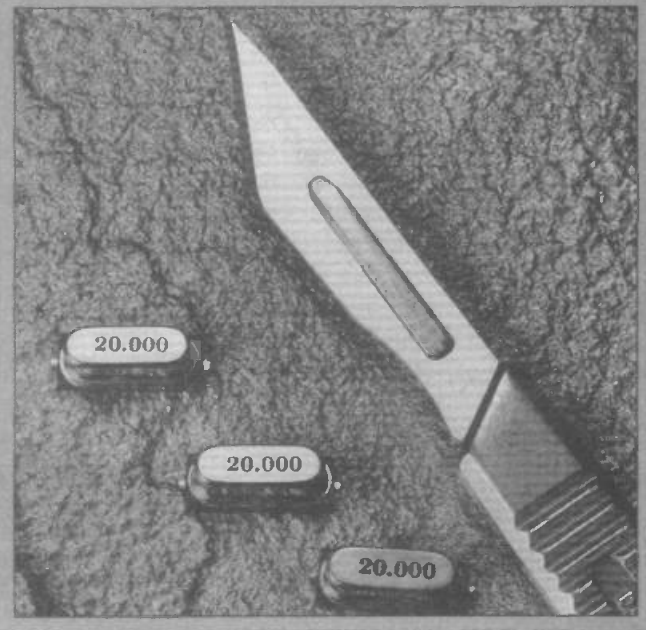

OVERSEAS READERS

To call UK telephone numbers, replace the initial 0 with your local overseas access code plus the digits 44.

Super-TFT Flat LCD Displays Continue Development

The revival of the Super-TFT low-profile LDC display is continuing with Hitachi's release of two new displays. The 14.1-in TX36C01VC0CAA panel has a CMOS interface, and the same-sized TX36D11VC0CAA panel has an LVDS interface. Super-TFT display technology allows a substantially wider viewing angle than conventional TFT without degradation of image quality or contrast, and is becoming an important technology for desktop monitors, allowing a viewing angle of 160 degrees in all directions without colour shift. The improved viewing angle has been achieved by using a technique

known as "in-plane switching" (IPS), where the liquid crystal molecules act as an optical switch, while keeping their long axis parallel to the plane of the substrate.

The displays have contrast ratios of 200:1 with brightness of 200 candelas per square meter and replaceable longlife backlight units. The modules have XGA resolution, 1024 x 768 pixels, Super-TFT technology with 256K colours and a display area of 285.7 x 214.3 mm. Full 8-bit colour can be obtained using frame rate control when using Hitachi's interface board.

Other advantages of advanced LCD technology will be space economy and low power use for applications such as point of sale terminals, bank terminals and information displays. The two models

described here will be ready for use in production quantities in the middle of 1998.

For more information contact Vince Pitt, Hitachi Europe Ltd., Whitebrook Park, Lower Cookham Road, Maidenhead, Berks SL6 8YA. Tel 01628 585000 fax 01628 585160.



"No Limits" Easy-PC Moves to Windows 95 and Windows NT

Number One Systems has announced Easy-PC for Windows 95/NT, the fourth generation of their award-winning family of schematic and PCB design tools.

Easy-PC, whose motto "designed by engineers for engineers", aims to set a new standard in power and usability under Windows95 and NT. The power comes via the removal of limits on the number of layers, components, components pins, tracks, pads and so on dictated by the program; with size and resolution limits ranging from 39 inches down to 10 microns, and "one of the fastest re-draw times ever seen on a Windows system". The limiting factor on track and component capacity is the amount of computer memory available, and can be removed by adding memory as required.

The system's ease of use is derived from an essentially "modeless" editing method that allows any of the elements on a PCB layout to be selected and modified with only two or three mouse clicks. Any track element, from a single segment to an entire net, can be selected, and moving any part of a track "drags" connected segments with it in an

intelligent way. Track corners can be moved in the same way, and converted to mitres by dragging the 45-degree section in and out.

The use of Net Classes and Technology Files makes it easier to set parameters on groups of layout elements by defining a Style and assigning it to them. This feature works in the same way as Style Sheets in a wordprocessor. Active circuit connectivity is derived directly from tracks or connections drawn on the layout, with no difference between tracks that start and end at a component pin and tracks that start or end in the middle of another track.

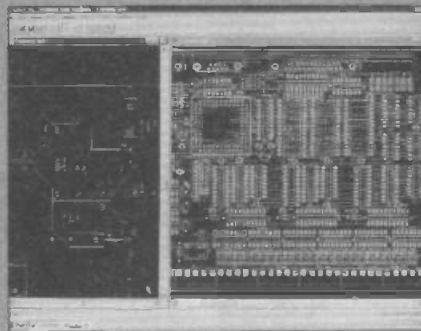

Easy-PC was introduced 10 years ago in 1988, winning a British Design Award in 1989. There are now over 20,000 licences issued in over 100 countries worldwide.

At the same time, Number One Systems are launching new Windows

versions of their MultiRouter family of autorouters, plus Analyser and Layan simulators. Analyser simulates the behaviour of linear analogue circuits drawn in Easy-PC and plots the frequency responses. Layan is a revolutionary electromagnetic simulator program that, used conjunction with Easy-PC and Analyser, plots the frequency response behaviour of an actual physical layout, including all the inductive and capacitive coupling between the copper areas in the layout. Layan can simulate printed inductors and microwave stripline circuits much faster than some workstation-based systems.

Easy-PC for Windows schematic capture and PCB CAD costs £595 ex Vat, with reduced upgrade prices for current users of other versions. Any updates issued within 6 months of purchase will be supplied free of charge, and all other major updates and upgrades will be notified to registered users.

For further information, price lists, brochures etc. contact Number One Systems, Harding Way, St. Ives, Huntingdon, Cambs PE17 4WR, UK. Tel 01480 461778 fax 01480 494042. Web: www.numerone.com Email: sales@numerone.com USA: 126 Smith Creek Drive, Los Gatos, CA 95030. Tel/fax (408) 395 0249.

Young Amateur of the Year Award, 1998

The Amateur Radio Young Radio Amateur of the Year Award has been announced for 1998 by the Radio Society of Great Britain and the Radiocommunications Agency. The Award is for the most outstanding achievement by a young amateur radio enthusiast. It is open to anyone under 18 who has an interest in radio (they do not have to be licence-holders). The following areas will be taken into account when the applications are assessed:

DIY radio construction; radio operation; community service (for example, helping the disabled or assisting in emergency communications); encouraging others to take an interest in radio, for instance through the Novice Licence scheme; projects undertaken at school.

The scheme hopes to generate interest in amateur radio and encourage people to become involved for themselves.

The prize for the most outstanding achievement between 1 August 1997 and 21 July 1998 will be awarded by the RA at the RSGB's annual HF Convention in September 1998. All entrants will receive a copy of the RSGB amateur radio log book, and the winner will receive £300 in cash from the RA and radio equipment from the RSGB.

The closing date for applications is 31 July 1998. The Award is open to any resident of the UK, the Channel Islands or the Isle of Man who has not reached his or her 18th birthday by the closing date. Entrants must be nominated by an adult sponsor.

Applications should be sent to the Young Amateur of the Year Award, RSGB, Lambda House, Cranbourne Road, Potters Bar, Herts EN6 3JE. Tel 01707 659015.

The Government Announces £21 Million Space Investment

A package of £21.2 million invested in European space programmes will help to put the British space industry in a position to share in the multi-million dollar information business of the next century, said John Battle, Minister for Science, Energy and Industry, announcing the UK's investment in three European Space Agency (ESA) programmes at a joint press conference with ESA Director-General Antonio Rodota.

The three ESA programmes benefiting are the ARTES-3 program, the European Remote Sensing (ERS-2) programme and the Earth Observation Preparatory Programme (EOPP).

£6.7 million will go over the next three years to ARTES-3 (Advanced Research into Telecommunications Systems), which aims to develop satellite technologies to provide new services for business and enable recently publicised ideas such as tele-medicine and tele-education to

become reality. The satellites would link experts such as doctors and teachers to people in remote areas, creating a global exchange of knowledge and skills. The satellite superhighway is expected to be an industry worth \$6-12 billion annually by the year 2010.

£8.1 million over the next two years will go to the ERS-2 satellite, which is set to provide data on such subjects as climate, ocean currents and the atmosphere for a range of applications from subsidence monitoring and oil slick detection, and in research in general. Scientific researchers in the UK use more of this data than scientists in any other country. The investment is intended to increase the understanding, assessment and prediction of long-term climate changes.

£6.4 million of five years will go to EOPP to help consolidate the UK's leading role in designing and building instruments for new Earth observation satellite systems. The UK Earth observation business has an annual turnover of around £180 million and employs 2,000 people.

Fast NiCad Chargers for the Hobby Market

A new range of switch-mode NiCad battery chargers meeting the safety requirements of the toy and hobby markets has been introduced by Arlec Power.

The new rapid chargers, part of the company's CB Series, comply with European safety standards, including EN 60-335-2-29, EN 60-742 and NFC 52-290, as well as the 89/336 EMC Directive. The chargers are designed for operation from 230 VAC or 12 VDC supplies. These units incorporate automatic switching from fast charge to trickle charge, with accurate detection of the end of the charging cycle using a delta-peak detection technique. Red, green and yellow LEDs provide indication of fast charge, normal charge and power on, respectively.

The three models are the CB147, offering switch-selectable current ratings from 1.2 to 5A at 10.5 volts; the CB146, providing 5A at 10.5 volts and the CB167, providing 3A at 10.5 volts. The CB147 can charge a pack of four to seven cells, while the other two handle packs of 6-7 cells.

All the chargers include automatic protection against overload, short circuit and wrong polarity, with a security timer which ends quick charging after 40 minutes.

For more information, contact Arlec Power UK Ltd., Kingsway House, Laporte Way, Luton, Beds LU4 8RJ.



New Smart Card Technology Goes into Use in Japan

Leading stripe and smart card makers Gemplus have brought three advanced smartcard technologies onto the market in Japan.

One is a range of environment-friendly contactless smart cards made from paper 0.27mm thick and PET plastic 0.25mm thick. Contactless cards are already in use in applications such as access control and employee identification tags. Until now, the smart cards' embedded processor needed a card thicker than normal magnetic strip cards and made of very rigid material, keeping manufacturing costs up and uses limited. The thinner base material that can now be used includes paper, useful and economic for mass-market prepaid cards such as telephone cards and game cards. In addition, they can be safely incinerated after use, reducing pollution and increasing security.

A second new product is the world's first 32-bit RISC chip card meeting the JAVA Card API 2.0 standard. This

means that several services can be offered on the same card. Conventional smart cards have 8-bit processors with limited memory and processing power. The new card's improved memory and processing allows more complex applications. For instance, when verifying a card-user's identity, 8-bit cards can only check with a PIN number, but the 32-bit card can verify against the owner's fingerprint. In addition, the Java programming language can be used in smart card applications.

The third new product is the EarthCard, made with a low-pollution chlorine- and halogen-free polyester film. The EarthCard will not leach dangerous chemicals into underground water after it has been buried in landfill, and will burn in the same manner as wood or paper. The material also increases the card's durability, extending its use time, which will itself tend to conserve resources.

For more information, contact Lisa Colley, Gemplus Ltd., New Lane, Havant, Hants PO9 2NR. Tel 01705 486444 fax 01705 472081. Web: www.gemplus.com

Highly Integrated Rx/Tx Chip for 1.9GHz

Mitsubishi Electric has introduced a receive-and-transmit front end GaAs (gallium arsenide) MMIC for 1.9GHz applications such as PHS handy phones. The 26-pin surface-mount MGF7136P measures 7 x 5 x 1.1mm and includes an integrated power amplifier. The power gain quoted as typically 38dB for the transmission amplifier and typical adjacent channel power equal to or greater than 55 dBc at +/-600 kHz. The operating current consumption is a low 140mA drain at 21dBm output power. The receive amplifier typically provides 14dB gain with a minimum noise figure of typically 1.8dB, with internal output and external input matching circuits. The receiving mixing circuit, which operates in conjunction with both external input and output matching circuits, has a gain of typically 9dB with a noise figure of typically 7dB.

For more information, contact Linda Butlin at DBI, 31 Chelsea Wharf, 15 Lots Road, London SW10 0QJ. Tel 0990 134275 fax 0171 351 7633. Product reference is MS0101Q.

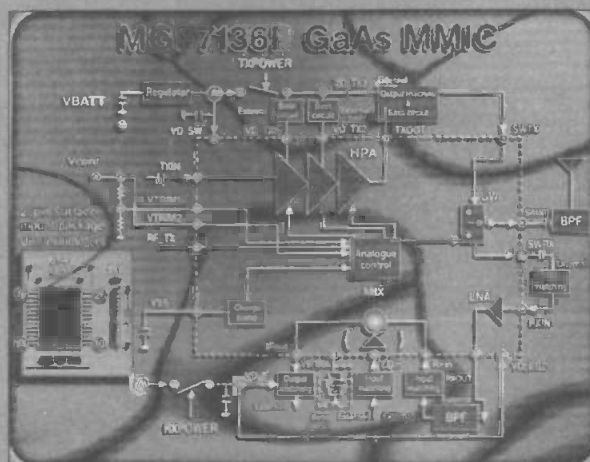

MODMODMODMODMODMOD

Volume 27 Issue 4: Tic Tac Toe. The PCB foil on the Foils Page has been shown from the component side instead of the copper side as usual. Keypad switches for the unit were Maplin KR92A. Anyone who would like a printout of the foil, please write c/o the Editor, ETI, Nexus House, Azalea Drive, Swanley, BR8 8HU. Please mark your envelope "Tic Tac Toe".

The extra query about Smartcam mentioned in our previous issue has been resolved with nothing further to report.

Volume 27 Issue 4: Medium Wave Loop Aerial. For anyone having difficulty finding the 2k pot, R3, a suitable 2k2 variety is listed by JAB Electrical Components, P O Box 5774, Birmingham B44 8PJ. Tel 0121 682 7945 fax 0121 681 1329. Because of the slightly higher track resistance, the value of R4 could be reduced from 1k to 820 ohms to maintain the brightness of the low current LED, but the difference is minimal.

The Shape of Screens to Come

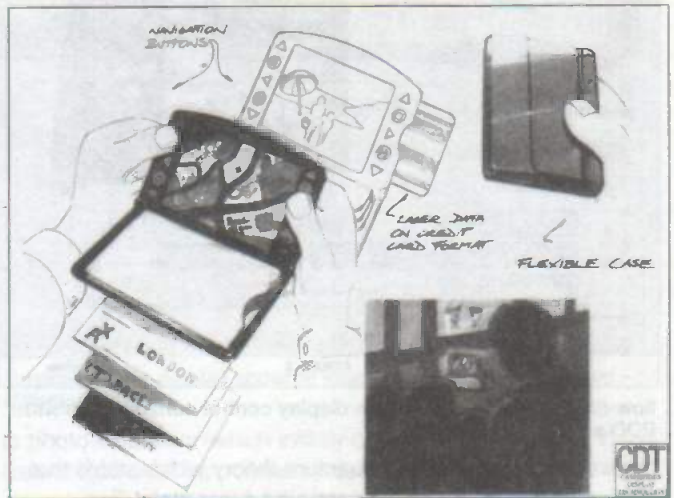

A graphic display outlines a personal organiser application for the future ...

Following last month's introduction to current advanced display screen technologies, Part Two continues with Light Emitting Plastics (LEPs), developed at the Cavendish Laboratories at the University of Cambridge) and commercialised by Cambridge Display Technology; Planar Optical Displays (PODs) developed at Brookhaven National Laboratory, and new 3D TV displays from Philips.

For many years, researchers have been trying to make semiconductors from polymers - in other words, plastic. Cambridge Display Technology (a spinoff company from the Cavendish Laboratories at the University of Cambridge) have succeeded to the extent of making plastic light emitting diodes with useful efficiencies, and have reached the stage of producing a demonstration plastic LED colour television display in co-operation with Japanese corporation Seiko-Epson.

Philips also have a non-exclusive license to use this technology, so that with support from at least two large companies, it is likely that we shall see products on the market using this dramatic new technology.

This uses the principle that light can be emitted when an electron falls from a high energy state to a lower energy state. The frequency of the photon thus emitted is determined by the

energy difference between the two electron states. (The energy of the photon is equal to $h \times f$ where f is the frequency and h is Planck's constant.) In order for visible light to be emitted, there must be a gap between two adjacent energy levels equal to the required energy, which turns out to be around 2 eV (electron volts) for an orange shade of red.

This is a quantity of energy unlikely to be gathered by an electron in a short path length before its next collision. There are materials, including polymers, which have a suitable gap between the bottom of the conduction band and the top of the valence band, but in order to raise electrons from valence to conduction band enormous electric fields are required. It has been possible in the laboratory to make this work, with a layer of polymer between two electrodes, but the high voltages needed are impractical, and the polymer degrades at the interface with the electrodes. The quantum efficiency is also low - typically of the order of 0.01 percent.

What is needed is some means to raise electrons to the required energy level without high voltages, and to increase the proportion of downward transitions which result in the emission of a photon rather than a phonon (that is, merely excitation of the material).

Light emitting diodes using classical semiconductors achieve this by use of a junction, and it turns out that the same idea can be used with polymers.

In silicon, a junction is made between two doped layers of silicon. In a crystal of pure silicon at absolute zero, all the electrons are in the ground state in the valence energy band. At a realistic temperature a few will be raised to the conduction band from the ground state, but only a tiny proportion will accumulate enough thermal energy before a collision dissipates some of that energy. (This is at least partly responsible for the reverse current in a diode.)

To explain the next stage, Pauli's exclusion principle is

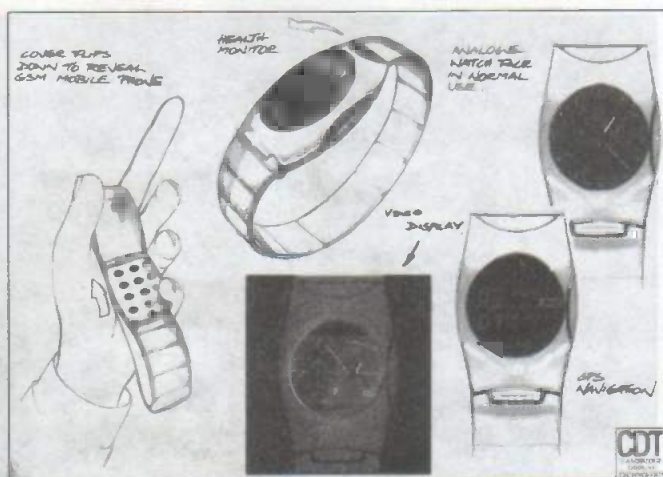

... and one for health monitoring and personal video on a wrist display.

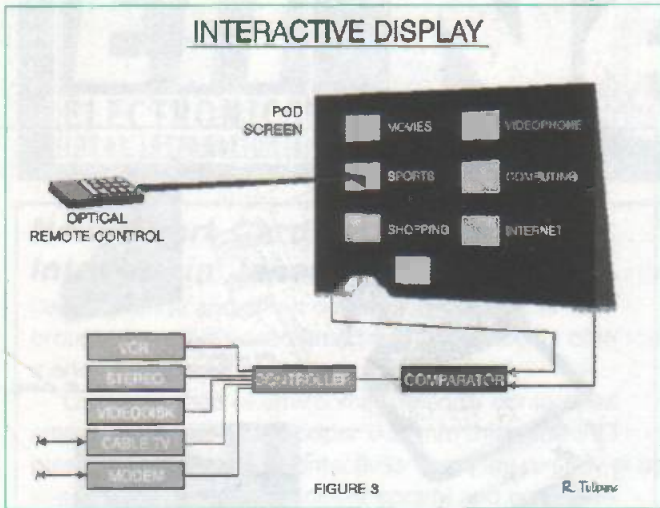

flow diagram for an interactive display control configuration with POD screens

required. This is a piece of quantum theory which states that no two electrons can be in exactly the same state. Two electrons can be at nominally the same energy level if they are of opposite spin, but that is the limit. Further electrons in a material must take up different energy levels. In the above silicon crystal, there are exactly as many ground states available as there are electrons to fill those states, so the electrons have no mobility.

The Junction

If a dopant atom which accepts an electron is added, then a space is created in the valence band. Of course, the electron is still present, but now it is at an energy level just outside what was the valence band. If all the other electrons shuffle around, it can seem as if a space or hole is actually moving around. In semiconductor physics the hole is often treated as a particle, and its effective mass and mobility may be determined.

If an electron donor atom is added instead, there is one more electron than can be accommodated in the valence band. The next available energy level is in the conduction band, so that is where the electron goes. It is available for conduction, and is more mobile than a hole.

If you make a junction between two oppositely doped types of silicon, then at the junction and very close to it, electrons in the conduction band of the N type material (with the electron donor atom) make the transition to the lower energy state in the valence band of the P type material (with the electron acceptor atom). This gives rise to an electric field, because the silicon on each side of the junction no longer has the same number of electrons as it started with. The process continues to the point at which the increase of energy due to the electric field, if an electron crosses the junction, matches the decrease due to the transition from conduction to valence bands. At this point the system has reached its lowest energy state, and nothing further will happen unless an extra electric field is applied.

The electric field keeps the charge imbalance close to the junction. It may be regarded as similar to a capacitor in this respect: there is a separation of charge, and further physical separation of the same charge would increase the voltage, and hence require energy. There is a narrow region, the depletion region, where all the electrons have combined with the holes, with an imbalance of charge immediately either side of it. If a voltage is applied to the diode thus made, attempting to force more electrons from the N type material to the p type, then this happens easily. At the junction, electrons need enough energy

to overcome the electric field of the junction, and then they fall from a higher energy level to a lower one.

If the voltage is connected the other way round, electrons must increase in energy from the valence band to the conduction band in order to cross the junction. The energy which an electron is likely to gain from a reasonable applied electric field between one collision and the next will not approach this level, so that negligible current will flow.

Benzene rings

The class of plastic materials useful as organic semiconductors are called conjugated polymers. These are polymers which possess a delocalised pi-electron system along the polymer backbone; the delocalised pi-electron system confers semiconducting properties to the polymer and gives it the ability to support positive and negative charge carriers with high mobilities along the polymer chain.

This is illustrated in figure 13. The polymer shown here consists of benzene rings linked together by two more carbon atoms. The benzene ring on its own has an electron cloud above and below it - in this particular polymer the cloud is enabled to extend between rings, linking from end to end of the chain.

The benzene ring has a bond structure different from that of other carbon-carbon bonds. The number of covalent bonds available might be expected to give rise to alternating single and double bonds around the ring, but in this case the bonds are shared around the ring, and there is a concentration of electrons above and below it. The alternating double and single bonds in the chain joining the benzene rings enable this electron sharing to continue along the chain.

Benzene has a band gap of the range which may make it useful as a semiconductor. Incorporating it into a polymer has the effect of making a solid material in which the properties may be exploited, and, according to the exact material composition, modifying the band gap of the overall material and adding doping properties.

One of the particularly clever parts is in obtaining a mobile electron, which might otherwise have been expected to form part of a covalent bond, without the material being very unstable and splitting apart readily under thermal or optical excitation.

This is how CDT describe it: "Though the mechanism for charge transport in these materials is not the same as in more traditional inorganic semiconductors (due to the chain distortion of the polymer on charge injection, and therefore the



Jim Velligman at Brookhaven National Laboratory with a prototype small POD screen

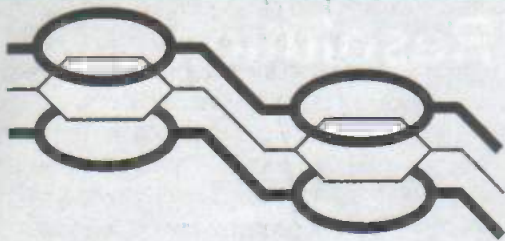

Figure 13: overlap of Pz orbitals leads to the formation of a de-localised pi electron cloud above and below the polymer chain

coupling of the charge carrier and the polymer chain to form a mobile polaron), device engineering of the materials can take advantage of many of the lessons previously learnt from classic semiconductors. Thus device designs and material structures can be copied into the new technology. For example, the use of heterostructures, commonplace in III-V technology, can also be applied to polymer devices for improved carrier confinement, or for varying offsets with respect to injection electrodes."

Polymers offer much easier manufacturing methods than traditional semiconductors. You can't go quite as far as injection-moulding complex electronic parts, but a technique known as spin coating is used to build up layers, and is much simpler than epitaxial growth.

With classical semiconductors, complex multi-doping is tricky, and it can be difficult to make the doped material match the periodicity of the substrate on which it is grown. If it does not match, then microscopic defects in the lattice structure can render it useless.

With polymers, the structure is effectively amorphous, but the defects tend to have energy states outside the bandgap (that is, they are confining), and there are no dangling bonds.

There are disadvantages to polymer semiconductors: lifetime and mobility. Mobilities are low due to the largely amorphous nature of conjugated polymer films. In thin film devices like light emitting diodes and solar cells, the mobility is not the limiting factor.

In Field Effect Transistor devices, however, channel lengths are substantially larger and the total device size has to be comparatively large (with large channel width) to allow reasonable switching times. Therefore polymer devices are more useful in the applications areas where amorphous silicon would otherwise be considered than in most traditional crystalline device types.

The first applications for conjugated polymers have been as conductors. Here is what CDT say on the subject:

"The doping of semiconducting conjugated polymers such as polyaniline and polypyrrole leads to the presence of states in the band-gap (hopping states) and at sufficient dopant concentrations the band-gap effectively disappears and the polymer acts as a metal with high conductivities. Intrinsic conductivities of materials such as PPV are of order 10⁻¹² Ohm⁻¹cm⁻¹; doped conjugated polymers have achieved conductivities of more than 10⁵ Ohm⁻¹cm⁻¹, which is close to that of copper.

A major problem has been producing processible forms of these conducting polymers that are sufficiently stable for commercial applications ... It is interesting to note that most of the challenges did not relate to the stability of the conjugated polymer itself, but more of the doped state."

It well known that most polymers break down in sunlight. Everyday plastics have additives in them to improve resistance

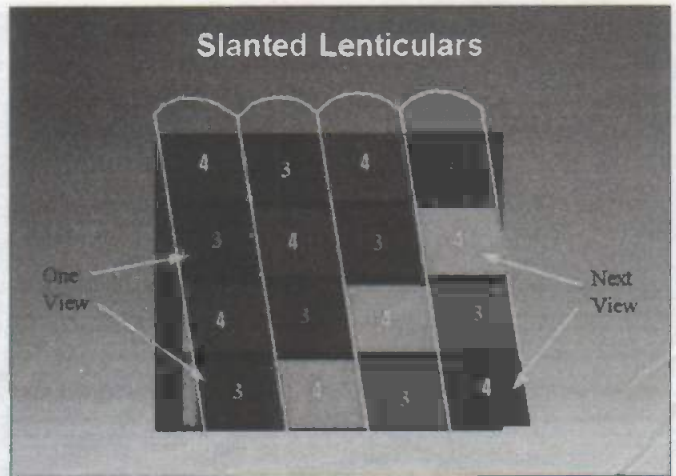

Illustration of a display showing interleaving of the views from different angles

to photo-oxidation, (which initially causes discolouration). In the area of light emitting polymers, research is taking place to improve material lifetimes both through use of materials that are resistant to oxidation and through improved encapsulation.

Display development

Since five years ago, there has been an improvement of four orders of magnitude on the 0.01 percent quantum efficiencies (the number of photons generated in the polymer film relative to the number of carriers injected into the polymer) then achieved. Even if the efficiency which can be achieved in a commercial mass-produced product is not as good as this, the efficiency is now sufficient for a display.

Part of the reason for the rapid improvements has been the application of lessons learned from inorganic semiconductors. The use of a heterostructure that allows carrier confinement at the polymer/polymer interface is significant, in that it has been found to increase the proportion of light to heat produced when the electrons and holes recombine.

Other significant improvements arise from choosing the electron/hole injection barriers to be similar - this can be done through both the choice of the injection electrode material and by modifying the polymer material to be more or less electron withdrawing and therefore to have higher or lower electron affinity. In the example shown the cyano group is electron

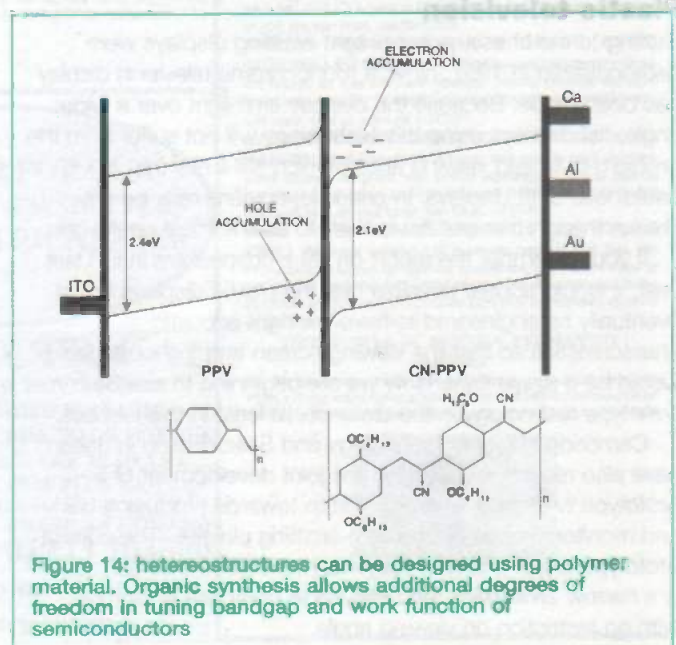
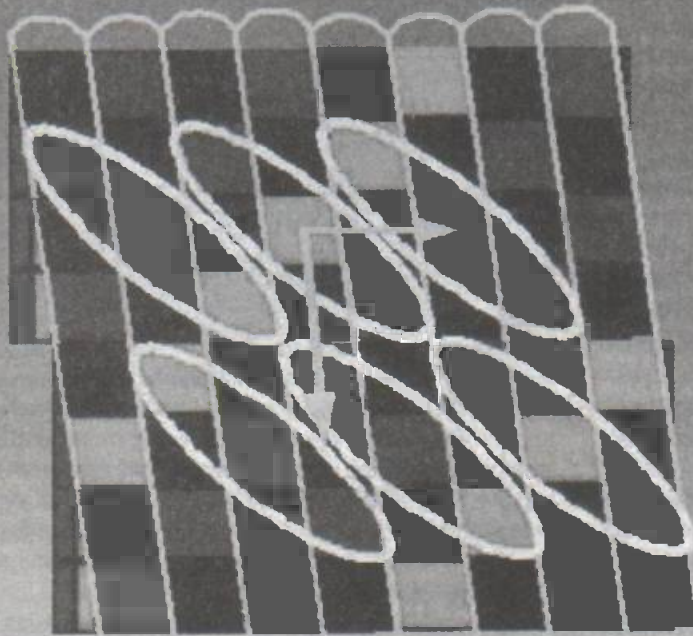

Figure 14: heterostructures can be designed using polymer material. Organic synthesis allows additional degrees of freedom in tuning bandgap and work function of semiconductors

Slanted Lenticular Resolution



Horizontal Pixel Count

$$\frac{1024 \times 3}{3.5 \times 2} = 438$$

Vertical Pixel Count

$$\frac{768}{3} = 256$$

Note:

$$\frac{438 \times 256 \times 7}{1024 \times 768} = 1$$

Calculation of the resolution of a 1024*768 slanted lenticular display with 7 views.

withdrawing and therefore pushes down the barrier to electron injection (see figure 14). The cyanoPPV layer therefore acts as an electron transport layer. Because the bandgap of the cyanoPPV layer is lower than the PPV layer, recombination takes place in this layer. In addition to the increase in efficiency, emission from blue to the near-infrared has been observed, all at efficiencies of over 1 percent.

Therefore in a short time these polymer materials have reached a performance level comparable with inorganic LEDs.

Polymer light emitting devices can be patterned simply by pixellation of the metal (there is no highly doped semiconductor layer required by the inorganic LEDs for ohmic contact). Hence large-area pixellated displays made from one sheet are possible, with added features such as flexibility. The cross section of a couple of pixels is shown in figure 15.

Plastic television

Cutting to the chase, polymer light emitting displays were demonstrated in 1997. Now, a monochrome television display has been made. Because the devices emit light over a wide angle, flat displays using this technology will not suffer from the problem of limited viewing angle, which still limits the usefulness of tft displays. In principle, screens may be any shape, though thin and flat is likely to be the most useful one.

If you remember the report on flat loudspeakers in ETI last year, it would appear possible that the plastic displays could eventually be engineered to have the right acoustic characteristics so that the viewing screen and the loudspeaker would be a single item. Now we are beginning to see Star Trek-type technology in the distance, at least in this respect.

Cambridge Display Technology and Seiko-Epson in Japan have also recently announced the joint development of a prototype tv display as an early step towards producing tvs and monitors based on the light-emitting plastics. The current prototype is just a 50mm-diagonal monochrome screen, but it is a narrow 2mm thick, and can show complete tv pictures with no restriction on viewing angle.

As LEPs can be switched very fast, they avoid the loss of resolution on fast movement that limits STN LCD screens. The mono screen itself could function as a monitor for portable cameras and VCRs, but the processes used to make it are scaleable, so that the path between making the small mono display and a full size full colour screen has already been worked out. A full colour display is planned for later in 1998. Seiko-Epson's polymeric semiconductor inkjet printing and active matrix backplane technologies enable them to print the pixels of the display by ink-jet directly on top of the pixel-switching element in the active matrix, giving a screen with traditional tv quality or better, but made from much thinner and lighter materials.

Further, as light emitting plastics do indeed emit their own light, many of the components (polarisers, colour filters, backlights, etc.) needed in an LCD are not needed for LEP

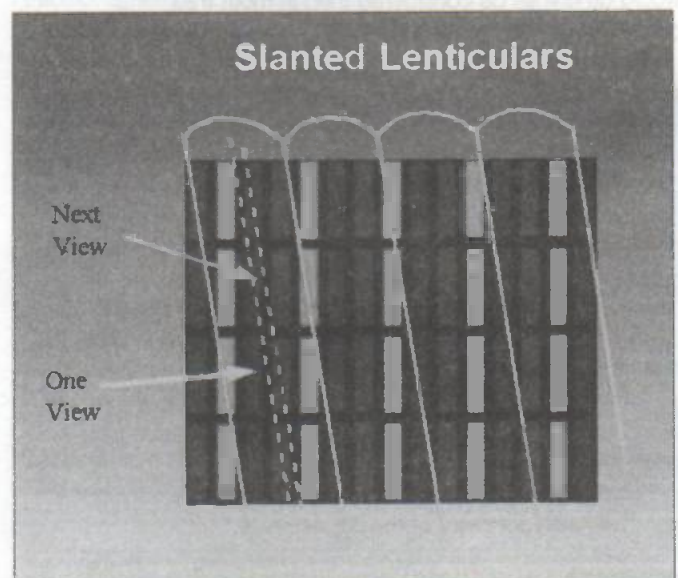

Slanted lenticular display showing the vertical line of a single view.

WIND GENERATORS 380 WATT

1.14 metre dia blades, carbon matrix blades, 3 year warranty, 12Vdc output, 24V version available, control electronics included, brushless neodymium cubic curve alternator, only two moving parts, maintenance free, simple roof top installation, start up speed 7mph, max output (30mph) 380w, £499 ref A1R

HYDROPONICS

DO YOU GROW YOUR OWN?

We have a full colour hydroponics catalogue available containing nutrients, pumps, fittings, environmental control, light fittings, plants, test equipment etc

Ring for your free copy.

PORTABLE X RAY MACHINE PLANS Easy to construct from a simple and cheap way to build a home X-ray machine! Effective device, X-ray sealed assemblies, can be used for experimental purposes. Not a toy or for minors! £6/SET Ref FXP1.

TELEKINETIC ENHANCER PLANS Mystify and amaze your friends by creating motion with no known apparent means or cause. Uses no electrical or mechanical connections, no special gimmicks yet produces positive motion and effect. Excellent for science projects, magic shows, party demonstrations or serious research & development of this strange and amazing psychic phenomenon. £4/SET Ref FITKE1.

ELECTRONIC HYPNOSIS PLANS & DATA This data shows several ways to put subjects under your control. Included is a full volume reference text and several construction plans that when assembled can produce highly effective stimuli. This material must be used cautiously. It is for use as entertainment at parties etc only, by those experienced in its use. £15/SET Ref FEH2.

GRAVITY GENERATOR PLANS This unique plan demonstrates a simple electrical phenomena that produces an anti-gravity effect. You can actually build a small mock spaceship out of simple materials and without any visible means- cause it to levitate. £10/SET Ref FGRA1.

WORLDS SMALLEST TESLA COIL/LIGHTNING DISPLAY GLOBE PLANS Produces up to 750,000 volts of discharge, experiment with extraordinary HV effects, 'Plasma in a jar', St Elmo's fire, Corona, excellent science project or conversation piece. £5/SET Ref FBTC1AG5.

COPPER VAPOUR LASER PLANS Produces 100mw of visible green light. High coherency and spectral quality similar to Argon laser but easier and less costly to build yet far more efficient. This particular design was developed at the Atomic Energy Commission of NEGEV in Israel. £10/SET Ref FICV1.

VOICE SCRAMBLER PLANS Miniature solid state system turns speech sound into indecipherable noise that cannot be understood without a second matching unit. Use on telephone to prevent third party listening and bugging. £6/SET Ref FVSS.

PULSED TV JOKER PLANS Little hand held device utilises pulse techniques that will completely disrupt TV picture and sound! Works on FM too! DISCRETION ADVISED. £8/SET Ref FJTJ5.

BODYHEAT TELESCOPE PLANS Highly directional long range device uses recent technology to detect the presence of living bodies, warm and hot spots, heat leaks etc. Intended for security, law enforcement, research and development, etc. Excellent security device or very interesting science project. £8/SET Ref FBHT1.

BURNING, CUTTING CO2 LASER PLANS Projects an invisible beam of heat capable of burning and melting materials over a considerable distance. This laser is one of the most efficient, converting 10% input power into useful output. Not only is this device a worthwhile candidate as an effective directed energy beam weapon against missiles, aircraft, ground-to-ground, etc. Particle beams may very well utilize a laser of this type to blast a channel in the atmosphere for a high energy stream of neutrons or other particles. The device is easily applicable to burning and etching wood, cutting, plastics, textiles etc. £12/SET Ref FALC7.

DYNAMO FLASHLIGHT Interesting concept, no batteries needed just squeeze the trigger for instant light apparently even works under water in an emergency although we haven't tried it yet! £6.99 ref SC152

ULTRASONIC BLASTER PLANS Laboratory source of sonic shock waves. Blow holes in metal, produce cold steam, atomize liquids. Many cleaning uses for PC boards, jewelry, coins, small parts etc. £6/SET Ref FAULB1.

ANTI DOG FORCE FIELD PLANS Highly effective circuit produces time variable pulses of acoustical energy that dogs cannot tolerate. £6/SET Ref F/DOG2.

LASER BOUNCE LISTENER SYSTEM PLANS Allows you to hear sounds from a premises without gaining access. £12/SET Ref F/LLIST1.

PHASOR BLAST WAVE PISTOL SERIES PLANS Handheld, has large transducer and battery capacity with external controls. £6/SET Ref F/PSP4.

INFINITY TRANSMITTER PLANS Telephone line grabber/room monitor. The ultimate in home/office security and safety! simple to use! Call your home or office phone, push a secret tone on your telephone to access either: A) On premises sound and voices or B) Existing conversation with break-in capability for emergency messages. £7 Ref F/TELEGRAB.

BUG DETECTOR PLANS Is that someone getting the goods on you? Easy to construct device locates any hidden source of radio energy! Sniffs out and finds bugs and other sources of bothersome interference. Detects low, high and UHF frequencies. £5/SET Ref F/BD1.

ELECTROMAGNETIC GUN PLANS Projects a metal object a considerable distance- requires adult supervision. £5 Ref F/EML2.

ELECTRIC MAN PLANS, SHOCK PEOPLE WITH THE TOUCH OF YOUR HAND! £5/SET Ref F/EMAN1.

SOLAR POWERED WIND UP RADIOS BACK IN! These FM/AM radio's have a solar panel and a hand operated charger! £17.95 ref SOLRAD.

PARABOLIC DISH MICROPHONE PLANS Listen to distant sounds and voices, open windows, sound sources in 'hard to get' or

hostile premises. Uses satellite technology to gather distant sounds and focus them to our ultra sensitive electronics. Plans also show an optional wireless link system. £8/SET Ref F/PMS.

2 FOR 1 MULTIFUNCTIONAL HIGH FREQUENCY AND HIGH DC VOLTAGE, SOLID STATE TESLA COIL AND VARIABLE 100,000 VDC OUTPUT GENERATOR PLANS Operates on 9-12Vdc, many possible experiments. £10 Ref F/HVM7/ TGL4.

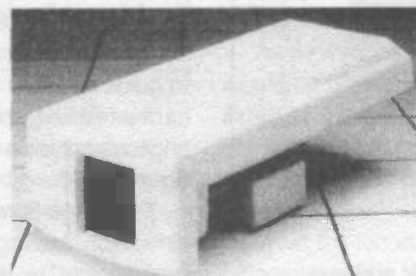

COLOUR CCTV VIDEO CAMERAS,

BRAND NEW AND, CASED, FROM £99.

Works with most modern video's, TV's, Composite monitors, video grabber cards.

Pal, 1v P-P, composite, 75ohm, 1/3" CCD, 4mm F2.8, 500x582, 12Vdc, mounting bracket, auto shutter, 100x50x180mm, 3 months warranty, 1 off price £119 ref XEF150, 10 or more £99 ea 100+ £89

CIRCUIT PACKS Packs of 35 circuit diagrams covering lasers, SW radios, peigars, bugs, char etc. Pack1, Pack2, Pack3 £4.99 each. **SMOKE ALARMS** Mains powered, made by the famous Gent company, easy fit next to light fittings, power point. £4.99 ref SMOX. **CONVERT YOUR TV INTO A VGA MONITOR FOR £26!** Converts a colour TV into a basic VGA screen. Complete with built in PSU, lead and swirve. Ideal for laptops or a cheap upgrade. Supplied in kit form for home assembly. SALE PRICE £26 REF SA34.

***15 WATT FM TRANSMITTER** Already assembled but some RF knowledge will be useful for setting up. Preamp req'd, 4 stage 80-108mhz, 12-18Vdc, can use ground plane, yagi or dipole. £69 ref 1021. ***4 WATT FM TRANSMITTER KIT** Small but powerful FM transmitter kit. 3 RF stages, mic & audio preamp included. £24 ref 1028.

YUASHA SEALED LEAD ACID BATTERIES 12v 15AH at £18 ref LOT8 and below spec by 10AH at £5 a pair. **ELECTRIC CAR WINDOW DE-ICERS** Complete with cable, plug etc. SALE PRICE JUST £4.99 REF SA28.

AUTO UNCHARGER 15x300mm solar panel with diode and 3 metre lead fitted with a cigar plug. 12v 2watt. £12.99 REF AUG10P3.

SOLAR POWER LAB SPECIAL You get 2 6"x6" by 130mA cells, 4 LEDs's, wire, buzzer, switch + 1 relay or motor. £7.99 REF SA27.

SOLAR NICAD CHARGERS 4 x AA size £9.99 ref 6P476, 2 x C size £9.99 ref 6P477.

GIANT HOT AIR BALLOON KIT Build a 4.5m circumference, fully functioning balloon, can be launched with home made burner etc. Reusable (until you loose it!) £12.50 ref HA1.

AIR RIFLES .22 As used by the Chinese army for training purposes, so there is a lot about! £38.95 Ref F78. 500 pellets £4.50 ref EP80.

REGISTER FOR OUR
ELECTRONIC NEWSLETTERS
BULL-ELECTRICAL.COM

BULL ELECTRICAL

250 PORTLAND ROAD, HOVE, SUSSEX.
BN3 5QT. (ESTABLISHED 50 YEARS).

MAIL ORDER TERMS: CASH, PO OR CHEQUE
WITH ORDER PLUS £3.50 P&P PLUS VAT.

24 HOUR SERVICE £5.00 PLUS VAT.

OVERSEAS ORDERS AT COST PLUS £3.50
(ACCESS, VISA, SWITCH, AMERICAN EXPRESS)

phone orders : 01273 203500

FAX 01273 323077

Sales@bull-electrical.com

INFRA RED FILM 6" square piece of flexible infra red film that will only allow IR light through. Perfect for converting ordinary torches, lights, headlights etc to infra red output only using standard light bulbs. Easily cut to shape. 6" square £15 ref IRF2.

HYDROGEN FUEL CELL PLANS Loads of information on hydrogen storage and production. Practical plans to build a Hydrogen fuel cell (good workshop facilities required). £8 set ref FCP1.

STIRLING ENGINE PLANS Interesting information pack covering all aspects of Stirling engines, pictures of home made engines made from an aerosol can running on a candle! £12 ref STIR2. **12V OPERATED SMOKE BOMBS** Type 3 is a 12v trigger and 3 smoke cannisters, each cannister will fill a room in a very short space of time! £14.99 ref SB3. Type 2 is 20 smaller cannisters (suitable for simulated equipment fires etc) and 1 trigger module for £29 ref SB2. Type 1 is a 12v trigger and 20 large cannisters £49 ref SB1.

HI POWER ZENON VARIABLE STROBES Useful 12v PCB fitted with hi power strobe tube and control electronics and speed control potentiometer. Perfect for interesting projects etc. 70x55mm 12vdc operation. £8 ea ref FLS1, pack of 10 £49 ref FLS2.

RUSSIAN BORDER GUARD BINOCULARS £1799 Probably the best binoculars in the world! Ring for colour brochure.

NEW LASER POINTERS 4.5mw, 75 metre range, hand held unit runs on two AA batteries (supplied) 670nm. £29 ref DEC49.

HOW TO PRODUCE 35 BOTTLES OF WHISKY FROM A SACK OF POTATOES Comprehensive 270 page book covers all aspects of spirit production from everyday materials. Includes construction details of simple stills etc. £12 ref MS3.

NEW HIGH POWER MINI BUG With a range of up to 800 metres and a 3 days use from a PP3 this is our top selling bug! Less than 1" square and a 10m voice pickup range. £28 ref LOT102.

BUILD YOUR OWN WINDFARM FROM SCRAP New publication gives step by step guide to building wind generators and propellers. Armed with this publication and a good local scrap yard could make you self sufficient in electricity! £12 ref LOT81.

NEW LOW COST VEHICLE TRACKING TRANSMITTER KIT £29 range 1.5-5 miles, 5,000 hours on AA batteries, transmits info on car direction, left and right turns, start and stop information. Works with any good FM radio. £29 ref LOT101a.

CCTV CAMERA MODULES 46x70x29mm, 30 grams, 12v 100mA auto electronic shutter, 3.6mm F2 lens, CCIR, 512x492 pixels, video output 1v p-p (75 ohm). Works directly into a scart or video input on a tv or video. IR sensitive. £79.95 ref EF137.

IR LAMP KIT Suitable for the above camera, enables the camera to be used in total darkness! £6 ref EF138.

UK SCANNING DIRECTORY As supplied to Police, MOD, MI5 and GCHQ! Covers everything from secret government frequencies, eye in the sky, prisons, military aviation etc. £18.50 ref SCANB.

INFRA RED POWERBAM Handheld battery powered lamp, 4 inch reflector, gives out powerful pure infrared light! Perfect for CCTV use, night sights etc. £29 ref PB1.

SUPER WIDEBAND RADAR DETECTOR Detects both radar and laser, X K and KA bands, speed cameras, and all known speed detection systems. 360 degree coverage, front

Beamwaveguides, 1 1/2"x2.7"x4.6" fits on sun visor or dash. £149 ref

CHIEFTAN TANK DOUBLE LASERS 9 WATT+3 WATT+LASER OPTICS

Could be adapted for laser listener, long range communications etc. Double beam units designed to fit in the gun barrel of a tank, each unit has two semi conductor lasers and motor drive units for alignment. 7 mile range, no circuit diagrams due to MOD, new price £50,000? us? £199. Each unit has two gallium Arsenide injection lasers, 1 x 9 watt, 1 x 3 watt, 900nm wavelength, 2Vdc, 600Hz pulse frequency. The units also contain an electronic receiver to detect reflected signals from targets. £199 for one. Ref LOT4.

NEW LOW PRICED COMPUTER/WORKSHOP/HI-FI RCB UNITS Complete protection from faulty equipment for everybody! Inline unit fits in standard IEC lead (extends it by 750mm), fitted in less than 10 seconds, reset/test button, 10A rating. £6.99 each ref LOT6. Or a pack of 10 at £49.90 ref LOT6. If you want a box of 100 you can have one for £250!

DIGITAL PROPORTIONAL B GRADE RADIO CONTROLLED CARS From World famous manufacturer these are returns so they will need attention (usually physical damage) cheap way of buying TX and RX plus servos etc for new projects etc. £20 each sold as seen ref LOT2DP.

MAGNETIC CREDIT CARD READERS AND ENCODING MANUAL £9.95 Cased with flyleads, designed to read standard credit cards! complete with control electronics PCB and manual covering everything you could want to know about what's hidden in that magnetic strip on your card! just £9.95 ref BAR31.

WANT TO MAKE SOME MONEY? STUCK FOR AN IDEA? We have collated 140 business manuals that give you information on setting up different businesses, you peruse these at your leisure using the text editor on your PC. Also included is the certificate enabling you to reproduce (and sell) the manuals as much as you like! £14 ref EP74.

HIGH POWER DC MOTORS, PERMANENT MAGNET

12 - 24v operation, probably about 1/4 horse power, body measures 100mm x 75mm with a 60mm x 5mm output shaft with a machined flat on it. Fitting is simple using the two threaded bolts protruding from the front.

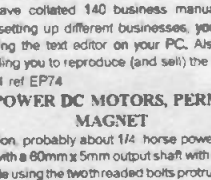

£22ea REF mot4

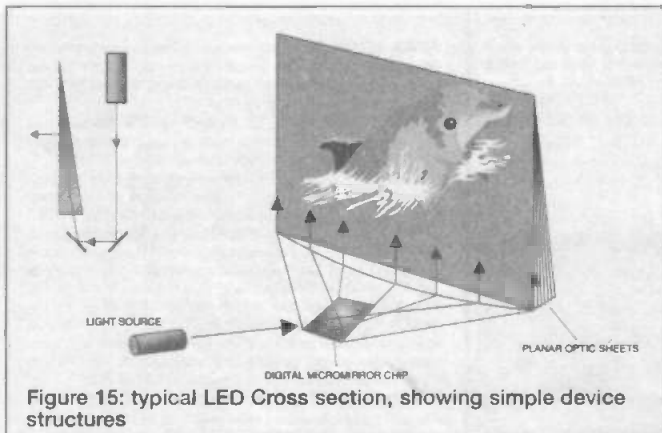

Figure 15: typical LED Cross section, showing simple device structures

displays. Apart from making the display thinner and less complex, this also reduces cost - always desirable. Apart from this, LEP manufacture shares many stages with LCD manufacture - which also reduces costs - and printing the active materials onto the matrix also reduces complexity - and costs.

LEPs are driven from a low DC voltage, compatible with the widely-used TFT active matrix drivers. This fits them for use in the same areas as TFT displays, for example displays for laptop computers. Being solid-state, they are naturally rugged, also desirable for portable equipment, assisting what I believe will be a steady move towards portable rather than fixed electronic equipment in many areas, particularly personal computing. Much of the fabrication of LEPs can be done on existing equipment, which avoids expensive re-tooling for manufacturers who want to use it. Costs again!

Polyplanar optical display

Projection television has not lived up to its early promise, though it is extremely useful in large arenas and suchlike. Conventionally, very bright small cathode ray tubes are used to generate the picture, which is then focussed onto large screens. Catches are that the picture is not bright enough to be seen easily when the lights are on in the viewing room, and that the projector must be a significant distance from the screen to give a large picture. LCD shutter technology has also been used. This can use a bright light source behind, but a significant fraction of the area of the display is opaque, being taken up with the drive electronics and so forth.

Two technological developments have occurred which could revolutionise this type of display, as well as having other applications.

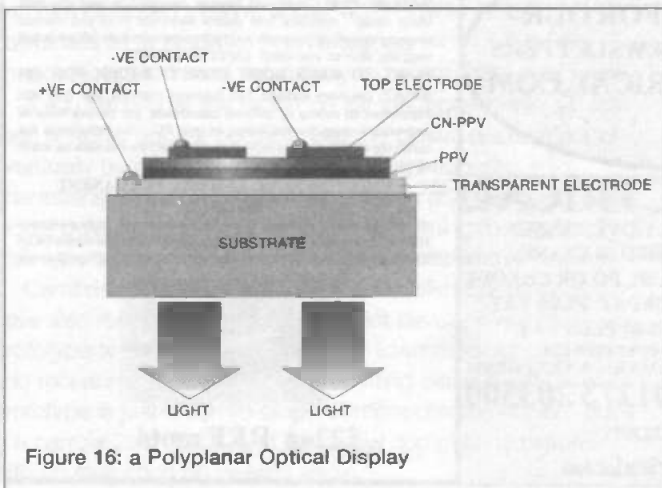

Figure 16: a Polyplanar Optical Display

The first development is the reflective video display. This uses an array of mirrors on a chip. The mirrors can be tilted by means of a piezoelectric activator, and cover almost all the area of the display. Because this, like the LCD shutter screen, can be illuminated by a powerful external light source, it has a higher maximum brightness.

A new and improved means to display the output from a television projector has been developed. It is called the Planar Optical Display, and it uses a sandwich of transparent sheets to guide light to a screen, as shown in figure 16. The sheets form a relatively thin sandwich at the bottom, and are cut at an angle and given a frosted finish to form a screen, as detailed in figure 17.

The image from the projector is compressed in one dimension, making it as thin as the sandwich of transparent laminations. The display decompresses the image to restore it to full size, so that perhaps 4 inches of picture height from the projector is expanded to several feet for viewing. Total internal reflection guides the light from the projector to the screen with little loss. In effect, the transparent sheets are working as optical waveguides.

This is the sort of idea which seems obvious when you have seen it, like many of the best ideas throughout the ages. Some of the important details may not be quite so obvious, however. For example, high contrast is achieved partly by the use of black cladding of a lower refractive index than the transparent material. This is so designed that it does not absorb light from the projector, despite being black, but does absorb light shining onto the face of the screen (because of the different angle of incidence).

Of course, some of the light falling on to the face of the screen must be at a suitable angle for total internal reflection to take place. This light will be guided down to the end where the projector sits, and there mostly dissipated because there is nothing to reflect it back the way it came. The overall effect is to give a black screen, even in a lit room. Light does not reflect off it to the extent which it does from a normal television screen or computer monitor. High contrast, even in high light levels, is a very useful characteristic.

The fact that light will be guided back to the thin end of the wedge can be useful. Optical sensors could be used to detect, for example, a laser pointer shining on the screen. This could work, as another example, as a mouse for software training with a room full of people.

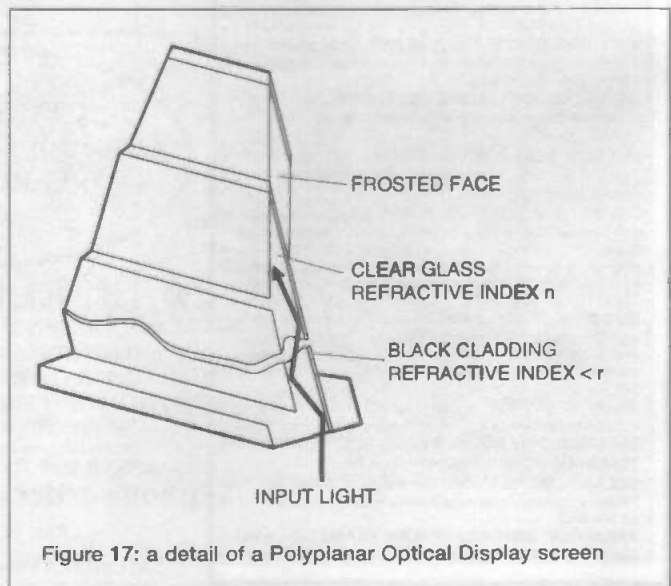
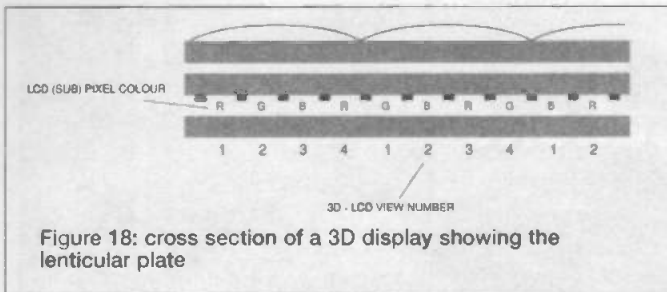

Figure 17: a detail of a Polyplanar Optical Display screen



development from Philips may catch on in the PC community when it comes onto the market.

Since 1994 Philips have been developing a type of 3D display which does not require the viewer to use special glasses. Instead, a lenticular panel is added to a normal colour liquid crystal display, though no doubt it could be added to other types of flat panel display. This is illustrated in cross section on **figure 18**.

As an aside, it is interesting to speculate as to whether it would be possible to make the polyplanar optical display with a lenticular front so that it would become a 3D display. My estimate is that it probably could be done, perhaps at very little extra cost. A 3D display the size of a cinema screen would be spectacular!

What the lenticular panel does is to refract the light from different pixels in different directions, so that each eye sees a different part of the image, as shown in figure 19.

One might expect this to be workable only with one precise head position, and indeed systems using sensors to adjust for head position have been tried. However, the Philips Multiview 3D-LCD is truly autostereoscopic because no head tracking is necessary, and the technology has the potential to be economic for consumer 3D displays the price of liquid crystal displays continues to drop. Because head position is not tracked, the system is suitable for viewing by a number of people at the same time. This may be seen as an advantage over, for example, a VR headset.

To make the picture appear as natural as possible is key. The 3D system uses multiple views, and without special effort the appearance would be of views which flip from one to the

Of course, each line of video display requires its own layer of optical waveguide. For a standard computer resolution of 1024 x 768, at least 768 transparent layers are needed. Efficient manufacturing is necessary if this type of display is to be economic in many situations.

The concept is not limited to large projection video displays. Curved is also an option. If production displays could be made from acrylic sheets, car instrument panels or, initially, aircraft instrumentation could be made more effective and adaptable using these displays. Equally, instead of a console having a screen in it, the whole console could be made as a planar display.

Personally, I look forward to the computer display which forms the desktop. Finally Microsoft's opening windows screen will become literal reality! This would be particularly useful for CAD, as anyone who has worked with mechanical or printed circuit design packages would probably agree.

3D displays

Not so much a display as an addition to a display, this

Multiview Editor

View Mapping

Record / Playback

Online Video

VRML

BMP, AVI, MOV etc

Multiviewing with one video screen in the future



PHILIPS

3D Applications

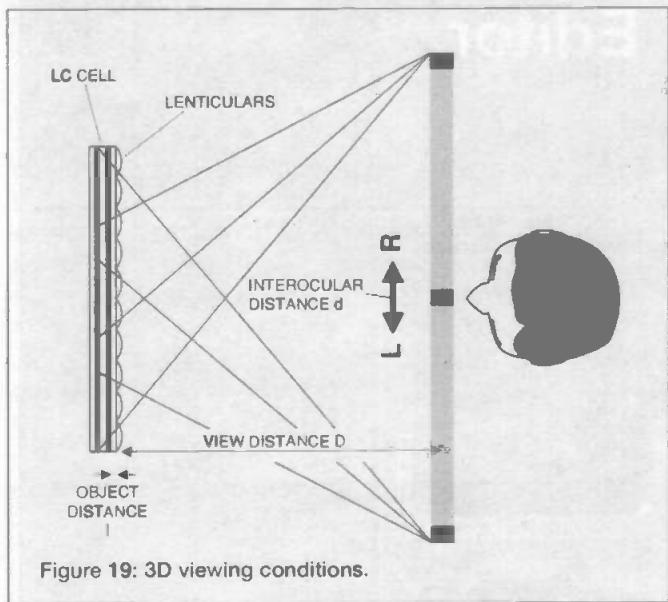
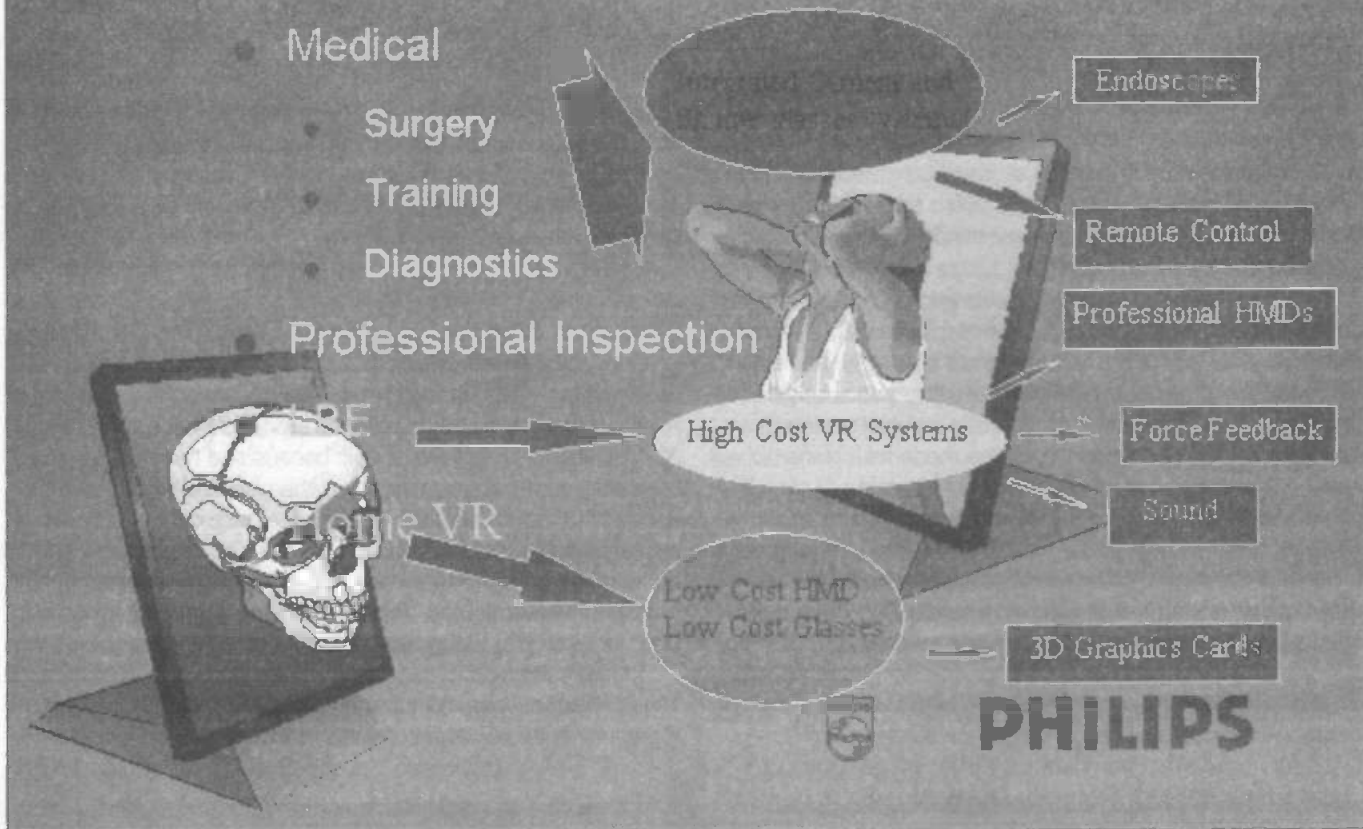

other, rather than a solid object. Also, the division between the images would appear as vertical black lines. The main challenges are to reduce the picket fence effect of the black mask and to try to get away with as few perspective views as possible.

Philips' solution is to 'blur' the boundaries between the views. This hides the black mask image by spreading it out and softens the transition between one view and the next, encouraging the user to perceive 'solid objects' instead of a succession of flipping views. One way to achieve this would be

Applications envisaged for 3D video viewing

to use a new pixel design in which the pixels are slanted with respect to the column direction.

Another way is to place the lenticular at a small (9.46 degrees) angle to the LCD columns. The effect of either method is that, as the observer moves sideways in front of the display, he always 'sees' a constant amount of black mask. This renders the black mask, in effect, invisible and eliminates the picket fence effect.

There is a downside to the ability to display 3D without special goggles. If you have a colour screen of 1024(x 3 for RGB) x 768, and you need seven views to give a fairly natural 3D view, then each picture has only 438 x 256 x RGB resolution. LCD panels with greater resolution become disproportionately expensive, as the yield is reduced. Perhaps the lenticular solution will match well with another display technology, if one is available to give more pixels for less cost. We shall see.

ETI wishes to thank the following in particular for data and background material for both parts of this article: Frank Cornell of JDK (Fujitsu Electronic Devices); Joanne Korosi, MMD and Storm Communications (Pioneer), Blitz and Jonathan Dominic (NEC), Ruth Lloyd (Matsushita/Panasonic), Linda Kandy (Mitsubishi); K Van Berkel (Philips Research Laboratories); James Veligman (Brookhaven National Laboratory); Danielle Leach of The Weber Group (Cambridge Display Technologies); Roger Bassett (GEC Alsthor Engineering Research Centre) - and a number of other people who kindly assisted us.



Station Road, Cullercoats, Tyne & Wear, NE30 4PQ

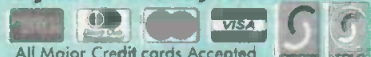

All Major Credit cards Accepted

Prices Exclude Vat @17.5%. Add £1.25 carriage & Vat to all orders. Cheques / Postal orders payable to ESR Electronic Components.

See Next / Last Months Ad. for COMPONENT ACCESSORIES

Table listing various electronic components such as 4000 Series, 74HC Series, and 74LS Series with their respective part numbers and prices.

Table listing various electronic components including AD converters, EPROMs, RAM, and Diodes with their respective part numbers and prices.

Table listing various electronic components including Bridge Rectifiers, Thyristors, PIC Micros, and Transistors with their respective part numbers and prices.

Table listing various electronic components including Diodes, Si. Switch, and Transistors with their respective part numbers and prices.

Table listing various electronic components including Diodes, Si. Switch, and Transistors with their respective part numbers and prices.

Table listing various electronic components including Diodes, Si. Switch, and Transistors with their respective part numbers and prices.

Tel: 0191 2514363 Fax: 0191 2522296 Email: sales@esr.co.uk http://www.esr.co.uk

**OMP MOS-FET POWER AMPLIFIERS
HIGH POWER. TWO CHANNEL 19 INCH RACK**

**THOUSANDS PURCHASED
BY PROFESSIONAL USERS**



**THE RENOWNED MXF SERIES OF POWER AMPLIFIERS
FOUR MODELS:- MXF200 (100W + 100W) MXF400 (200W + 200W)**

**MXF600 (300W + 300W) MXF900 (450W + 450W)
ALL POWER RATINGS R.M.S. INTO 4 OHMS. BOTH CHANNELS DRIVEN**

FEATURES: ★ Independent power supplies with two toroidal transformers ★ Twin L.E.D. Vu meters ★ Level controls ★ Illuminated on/off switch ★ XLR connectors ★ Standard 775mV inputs ★ Open and short circuit proof ★ Latest Mos-Fets for stress free power delivery into virtually any load ★ High slew rate ★ Very low distortion ★ Aluminium cases ★ MXF600 & MXF900 fan cooled with D.C. loudspeaker and thermal protection.

USED THE WORLD OVER IN CLUBS, PUBS, CINEMAS, DISCOS ETC.

SIZES:- MXF200 W19"xH3 1/2" (2U)xD11"
MXF400 W19"xH5 1/4" (3U)xD12"
MXF600 W19"xH5 1/4" (3U)xD13"
MXF900 W19"xH5 1/4" (3U)xD14 1/2"

PRICES:- MXF200 £175.00 MXF400 £233.85
MXF600 £329.00 MXF900 £449.15
SPECIALIST CARRIER DEL. £12.50 EACH



OMP XO3 STEREO 3-WAY ACTIVE CROSS-OVER



Advanced 3-Way Stereo Active Cross-over, housed in a 19" x 1U case. Each channel has three level controls: bass, mid & top. The removable front fascia allows access to the programmable DIL switches to adjust the cross-over frequency: Bass-Mid 250/500/800Hz, Mid-Top 1.8/3/5KHz, all at 24dB per octave. Bass invert switches on each bass channel. Nominal 775mV input/output. Fully compatible with OMP rack amplifier and modules.

Price £117.44 + £5.00 P&P

STEREO DISCO MIXER SDJ3400SE ★ ECHO & SOUND EFFECTS★

STEREO DISCO MIXER with 2 x 7 band L & R graphic equalisers with bar graph LED Vu meters. **MANY OUTSTANDING FEATURES:-** including Echo with repeat & speed control, DJ Mic with talk-over switch, 6 Channels with individual faders plus cross fade, Cue Headphone Monitor, 8 Sound Effects. Useful combination of the following inputs:- 3 turntables (mag), 3 mics, 5 Line for CD, Tape, Video etc.



Price £144.99 + £5.00 P&P

SIZE: 482 x 240 x 120mm

PIEZO ELECTRIC TWEETERS - MOTOROLA

Join the Piezo revolution! The low dynamic mass (no voice coil) of a Piezo tweeter produces an improved transient response with a lower distortion level than ordinary dynamic tweeters. As a crossover is not required these units can be added to existing speaker systems of up to 100 watts (more if two are put in series). **FREE EXPLANATORY LEAFLETS ARE SUPPLIED WITH EACH TWEETER.**

TYPE 'A' (KSN1036A) 3" round with protective wire mesh. Ideal for bookshelf and medium sized Hi-Fi speakers. Price £4.90 + 50p P&P.
TYPE 'B' (KSN1005A) 3 1/2" super horn for general purpose speakers, disco and P.A. systems etc. Price £5.99 + 50p P&P.
TYPE 'C' (KSN1038A) 2" x 5" wide dispersion horn for quality Hi-Fi systems and quality discos etc. Price £6.99 + 50p P&P.
TYPE 'D' (KSN1025A) 2" x 6" wide dispersion horn. Upper frequency response retained extending down to mid-range (2KHz). Suitable for high quality Hi-Fi systems and quality discos. Price £9.99 + 50p P&P.
TYPE 'E' (KSN1038A) 3 1/2" horn tweeter with attractive silver finish trim. Suitable for Hi-Fi monitor systems etc. Price £5.99 + 50p P&P.
LEVEL CONTROL Combines, on a recessed mounting plate, level control and cabinet input jack socket. 85x85mm. Price £4.10 + 50p P&P.

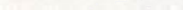
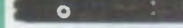
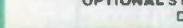
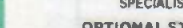
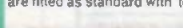
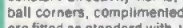
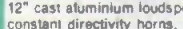
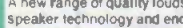
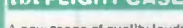

IBI FLIGHT CASED LOUDSPEAKERS

A new range of quality loudspeakers, designed to take advantage of the latest speaker technology and enclosure designs. Both models utilize studio quality 12" cast aluminium loudspeakers with factory fitted grilles, wide dispersion constant directivity horns, extruded aluminium corner protection and steel ball corners, complimented with heavy duty black covering. The enclosures are fitted as standard with top hats for optional loudspeaker stands.



**POWER RATINGS QUOTED IN WATTS RMS FOR EACH CABINET
FREQUENCY RESPONSE FULL RANGE 45Hz - 20KHz**

IBI FC 12-100WATTS (100dB) PRICE £169.00 PER PAIR

IBI FC 12-200WATTS (100dB) PRICE £175.00 PER PAIR

SPECIALIST CARRIER DEL. £12.50 PER PAIR

OPTIONAL STANDS PRICE PER PAIR £49.00

Delivery £6.00 per pair

IN-CAR STEREO BOOSTER AMPS



**PRICES: 150W £49.99 250W £99.99
400W £109.95 P&P £2.00 EACH**

**THREE SUPERS HIGH POWER
CAR STEREO BOOSTER AMPLIFIERS**

150 WATTS (75 + 75) Stereo, 150W Bridged Mono
250 WATTS (125 + 125) Stereo, 250W Bridged Mono
400 WATTS (200 + 200) Stereo, 400W Bridged Mono
ALL POWERS INTO 4 OHMS

Features:
★ Stereo, bridgable mono ★ Choice of high & low level inputs ★ L & R level controls ★ Remote on-off ★ Speaker & thermal protection.

OMP MOS-FET POWER AMPLIFIER MODULES SUPPLIED READY BUILT AND TESTED.

These modules now enjoy a world-wide reputation for quality, reliability and performance at a realistic price. Four models are available to suit the needs of the professional and hobby market i.e. industry, leisure, instrumental and Hi-Fi etc. When comparing prices, NOTE that all models include toroidal power supply, integral heat sink, glass fibre P.C.B. and drive circuits to power a compatible Vu meter. All models are open and short circuit proof.

THOUSANDS OF MODULES PURCHASED BY PROFESSIONAL USERS



**OMP/MF 100 Mos-Fet Output power 110 watts R.M.S. into 4 ohms, frequency response 1Hz - 100KHz -3dB, Damping Factor >300, Slew Rate 45V/uS, T.H.D. typical 0.002%, Input Sensitivity 500mV, S.N.R. -110 dB. Size 300 x 123 x 60mm.
PRICE £40.85 + £3.50 P&P**



**OMP/MF 200 Mos-Fet Output power 200 watts R.M.S. into 4 ohms, frequency response 1Hz - 100KHz -3dB, Damping Factor >300, Slew Rate 50V/uS, T.H.D. typical 0.001%, Input Sensitivity 500mV, S.N.R. -110 dB. Size 300 x 155 x 100mm.
PRICE £64.35 + £4.00 P&P**



**OMP/MF 300 Mos-Fet Output power 300 watts R.M.S. into 4 ohms, frequency response 1Hz - 100KHz -3dB, Damping Factor >300, Slew Rate 60V/uS, T.H.D. typical 0.001%, Input Sensitivity 500mV, S.N.R. -110 dB. Size 330 x 175 x 100mm.
PRICE £81.75 + £5.00 P&P**



**OMP/MF 450 Mos-Fet Output power 450 watts R.M.S. into 4 ohms, frequency response 1Hz - 100KHz -3dB, Damping Factor >300, Slew Rate 75V/uS, T.H.D. typical 0.001%, Input Sensitivity 500mV, S.N.R. -110 dB, Fan Cooled, D.C. Loudspeaker Protection, 2 Second Anti-Thump Delay. Size 385 x 210 x 105mm.
PRICE £132.85 + £5.00 P&P**



**OMP/MF 1000 Mos-Fet Output power 1000 watts R.M.S. into 2 ohms, 725 watts R.M.S. into 4 ohms, frequency response 1Hz - 100KHz -3dB, Damping Factor >300, Slew Rate 75V/uS, T.H.D. typical 0.002%, Input Sensitivity 500mV, S.N.R. -110 dB, Fan Cooled, D.C. Loudspeaker Protection, 2 Second Anti-Thump Delay. Size 422 x 300 x 125mm.
PRICE £259.00 + £12.00 P&P**

NOTE: MOS-FET MODULES ARE AVAILABLE IN TWO VERSIONS: STANDARD - INPUT SENS 500mV, BAND WIDTH 100KHz. PEC (PROFESSIONAL EQUIPMENT COMPATIBLE) - INPUT SENS 775mV, BAND WIDTH 50KHz. ORDER STANDARD OR PEC.

LOUDSPEAKERS

LARGE SELECTION OF SPECIALIST LOUDSPEAKERS AVAILABLE, INCLUDING CABINET FITTINGS, SPEAKER GRILLES, CROSS-OVERS AND HIGH POWER, HIGH FREQUENCY BULLETS AND HORNS, LARGE (A4) S.A.E. (60p STAMPED) FOR COMPLETE LIST.



McKenzie and Fane Loudspeakers are also available.

EMINENCE:- INSTRUMENTS, P.A., DISCO, ETC

ALL EMINENCE UNITS 8 OHMS IMPEDANCE
8" 100 WATT R.M.S. ME8-100 GEN. PURPOSE, LEAD GUITAR, EXCELLENT MID, DISCO. RES. FREQ. 72Hz. FREQ. RESP. TO 4KHz. SENS 97dB. PRICE £32.71 + £2.00 P&P
10" 100 WATT R.M.S. ME10-100 GUITAR, VOCAL, KEYBOARD, DISCO, EXCELLENT MID. RES. FREQ. 71Hz. FREQ. RESP. TO 7KHz. SENS 97dB. PRICE £33.74 + £2.50 P&P
10" 200 WATT R.M.S. ME10-200 GUITAR, KEYBD, DISCO, VOCAL, EXCELLENT HIGH POWER MID. RES. FREQ. 65Hz. FREQ. RESP. TO 3.5KHz. SENS 99dB. PRICE £43.47 + £2.50 P&P
12" 100 WATT R.M.S. ME12-100LE GEN. PURPOSE, LEAD GUITAR, DISCO, STAGE MONITOR. RES. FREQ. 49Hz. FREQ. RESP. TO 6KHz. SENS 100dB. PRICE £35.64 + £3.50 P&P
12" 100 WATT R.M.S. ME12-100LT (TWIN CONE) WIDE RESPONSE, P.A., VOCAL, STAGE MONITOR. RES. FREQ. 42Hz. FREQ. RESP. TO 10KHz. SENS 98dB. PRICE £36.67 + £3.50 P&P
12" 200 WATT R.M.S. ME12-200 GEN. PURPOSE, GUITAR, DISCO, VOCAL, EXCELLENT MID. RES. FREQ. 58Hz. FREQ. RESP. TO 6KHz. SENS 98dB. PRICE £46.71 + £3.50 P&P
12" 300 WATT R.M.S. ME12-300HP HIGH POWER BASS, LEAD GUITAR, KEYBOARD, DISCO ETC. RES. FREQ. 47Hz. FREQ. RESP. TO 5KHz. SENS 103dB. PRICE £70.19 + £3.50 P&P
15" 200 WATT R.M.S. ME15-200 GEN. PURPOSE BASS, INCLUDING BASS GUITAR. RES. FREQ. 46Hz. FREQ. RESP. TO 5KHz. SENS 99dB. PRICE £50.72 + £4.00 P&P
15" 300 WATT R.M.S. ME15-300 HIGH POWER BASS, INCLUDING BASS GUITAR. RES. FREQ. 39Hz. FREQ. RESP. TO 3KHz. SENS 103dB. PRICE £73.34 + £4.00 P&P

EARBENDERS:- HI-FI, STUDIO, IN-CAR, ETC

ALL EARBENDER UNITS 8 OHMS (Except EB8-50 & EB10-50 which are dual impedance tapped @ 4 & 8 ohms)
BASS, SINGLE CONE, HIGH COMPLIANCE, ROLLED SURROUND
8" 50WATT EB8-50 DUAL IMPEDANCE, TAPPED 4/8 OHM BASS, HI-FI, IN-CAR. RES. FREQ. 40Hz. FREQ. RESP. TO 7KHz. SENS 97dB. PRICE £8.90 + £2.00 P&P
10" 50WATT EB10-50 DUAL IMPEDANCE, TAPPED 4/8 OHM BASS, HI-FI, IN-CAR. RES. FREQ. 40Hz. FREQ. RESP. TO 5KHz. SENS 99dB. PRICE £13.65 + £2.50 P&P
10" 100WATT EB10-100 BASS, HI-FI, STUDIO. RES. FREQ. 35Hz. FREQ. RESP. TO 3KHz. SENS 96dB. PRICE £30.39 + £3.50 P&P
12" 100WATT EB12-100 BASS, STUDIO, HI-FI, EXCELLENT DISCO. RES. FREQ. 26Hz. FREQ. RESP. TO 3 KHz. SENS 93dB. PRICE £42.12 + £3.50 P&P
FULL RANGE TWIN CONE, HIGH COMPLIANCE, ROLLED SURROUND
5 1/2" 60WATT EB5-60TC (TWIN CONE) HI-FI, MULTI-ARRAY DISCO ETC. RES. FREQ. 63Hz. FREQ. RESP. TO 20KHz. SENS 92dB. PRICE £9.99 + £1.50 P&P
6 1/2" 60WATT EB6-60TC (TWIN CONE) HI-FI, MULTI-ARRAY DISCO ETC. RES. FREQ. 38Hz. FREQ. RESP. TO 20KHz. SENS 94dB. PRICE £10.99 + 1.50 P&P
8" 60WATT EB8-60TC (TWIN CONE) HI-FI, MULTI-ARRAY DISCO ETC. RES. FREQ. 40Hz. FREQ. RESP. TO 18KHz. SENS 95dB. PRICE £12.99 + £1.50 P&P
10" 60WATT EB10-60TC (TWIN CONE) HI-FI, MULTI-ARRAY DISCO ETC. RES. FREQ. 35Hz. FREQ. RESP. TO 12KHz. SENS 98dB. PRICE £16.49 + £2.00 P&P

TRANSMITTER HOBBY KITS

PROVEN TRANSMITTER DESIGNS INCLUDING GLASS FIBRE PRINTED CIRCUIT BOARD AND HIGH QUALITY COMPONENTS COMPLETE WITH CIRCUIT AND INSTRUCTIONS

3W TRANSMITTER 30-108MHz. VARICAP CONTROLLED PROFESSIONAL PERFORMANCE. RANGE UP TO 3 MILES. SIZE 38 x 123mm. SUPPLY 12V @ 0.5AMP. PRICE £14.85 + £1.00 P&P

FM MICRO TRANSMITTER 100-108MHz. VARICAP TUNED, COMPLETE WITH VERY SENS FET MIC, RANGE 100-300m, SIZE 56 x 46mm. SUPPLY 9V BATTERY. PRICE £8.90 + £1.00 P&P



PHOTO: 3W FM TRANSMITTER



POSTAL CHARGES PER ORDER £1.00 MINIMUM. OFFICIAL ORDERS FROM SCHOOLS, COLLEGES, GOVT. BODIES, PLCs ETC. PRICES INCLUSIVE OF V.A.T. SALES COUNTER, VISA AND ACCESS ACCEPTED BY POST, PHONE OR FAX.



B.K. ELECTRONICS

UNITS 1 & 5 COMET WAY, SOUTHEND-ON-SEA. ESSEX. SS2 6TR

Tel. 01702 527572 Fax: 01702-420243

HT-8955

Digital Echo



This is a new echo unit by Robert Penfold based on the HT-8955 delay line chip which produces delays of up to 800 milliseconds, and the 41256 D-ram. Variable delay control also enables short echoes down to a reverb effect, giving maximum flexibility.

On order to produce an echo effect a delay of at least 60 milliseconds is required, and the delay should preferably be adjustable up to around 500 milliseconds or so. Generating delays as long as these is quite difficult, and in the distant past it required the use of tape machines. More recently the introduction of CCD delay lines has provided a neater alternative, but CCD devices capable of providing long delays are quite expensive. Digital techniques provide another alternative, but until quite recently this route has been both expensive and complex. Fortunately, things are different these days and the introduction of purpose designed chips has made it possible to produce simple but effective digital delay lines.

The digital echo unit featured here is based on the HT-8955 delay line chip which contains most of the circuitry required to produce delays of up to 800 milliseconds. Included in the chip are 10-bit digital-to-analogue and analogue-to-digital

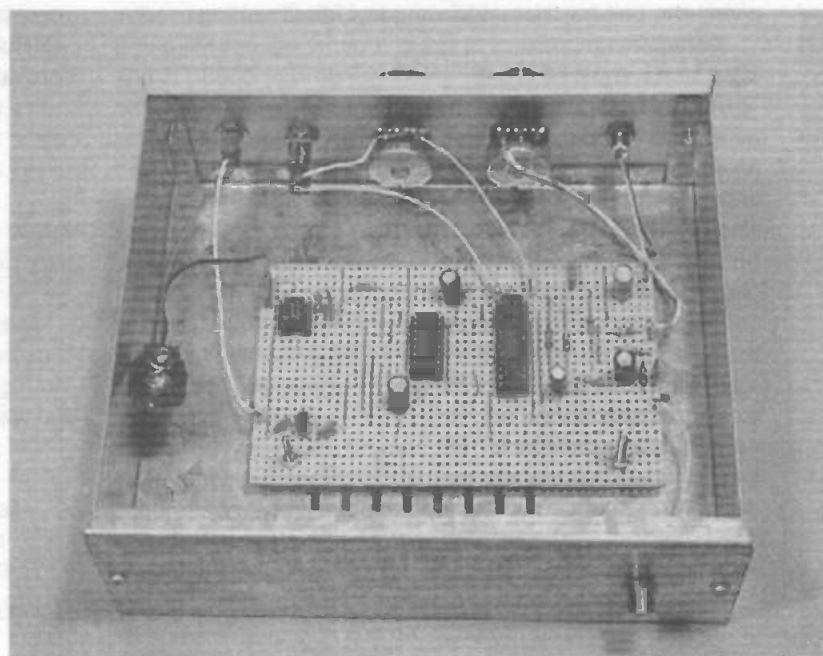

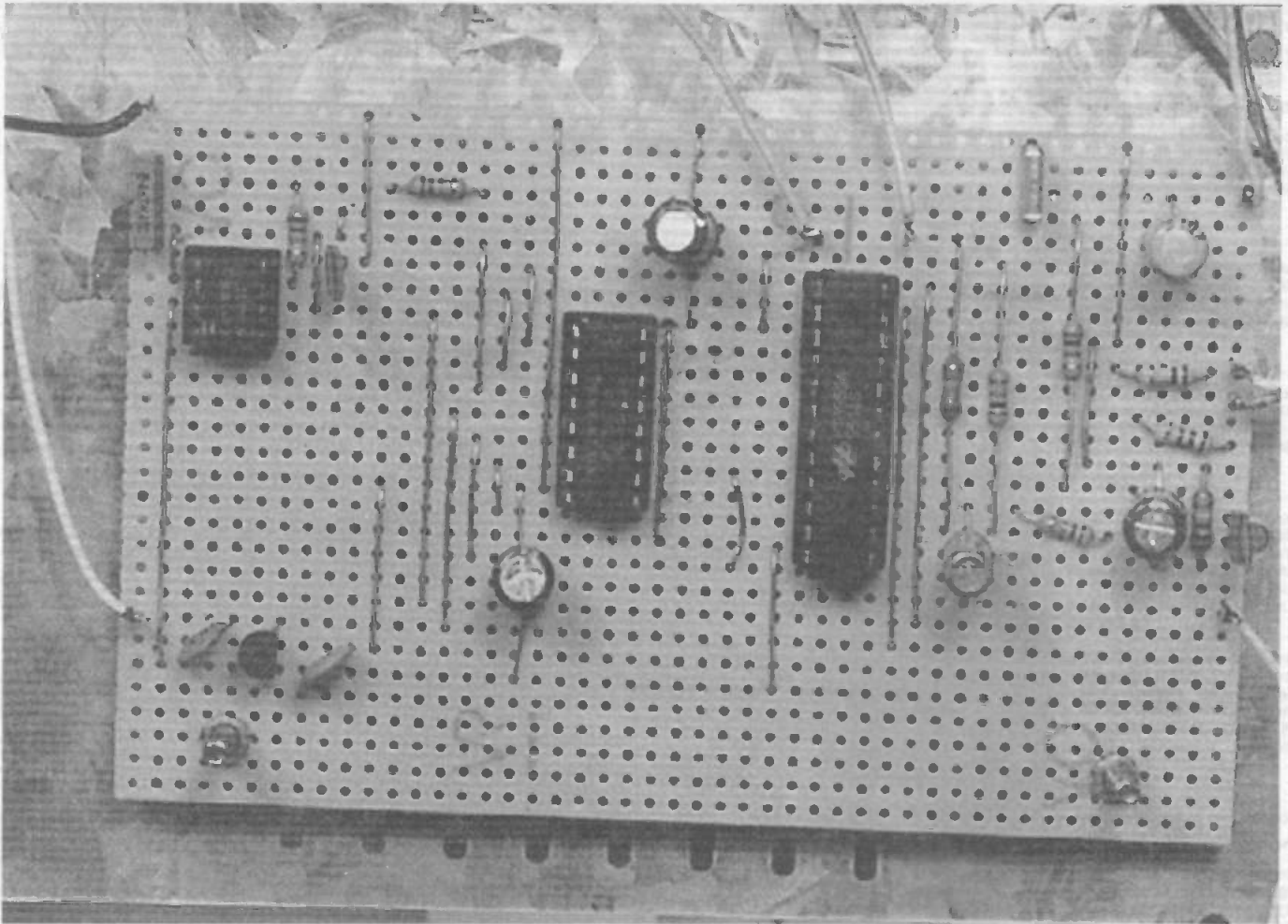

converters, a preamplifier stage, a clock generator, and a large amount of control logic. The only omission is the memory, which must be provided by a standard 4164, or 41256 DRAM chip. These respectively provide maximum delay times of 200 and 800 milliseconds, and it is the 41256 that is utilised in this unit. This makes it possible to obtain quite long echo effects if required, but a variable delay control also enables short echo effects to be produced. At the minimum delay setting the effect is rather more a reverberation type than a normal echo effect, giving the unit for the useful range of effect settings.

System operation

The way in which a digital delay line functions is basically quite straightforward. The essential ingredients are an analogue to digital converter, a digital to analogue converter, and some memory. In a practical unit there must also be a fair amount of control logic to manage the flow of data in and out of memory. The basic action of the circuit is to start by writing the contents of the first memory location to the digital to analogue converter. Next the analogue to digital converter takes a reading which is stored in the first memory location, over-writing the existing contents of that memory location. This general procedure is repeated for the second and third memory locations, and all the subsequent locations, working through them in sequence. Once all the memory has been used the whole process is repeated. In fact this process is repeated for as long as power is applied to the system.

A delay is provided because the samples stored on one complete cycle of the system are not output until the

following cycle. The delay obtained depends on the rate at which samples are taken and the amount of memory used. As with any sampling system, there is definite limit on the minimum rate at which samples can be taken. The sampling rate must be at least double the maximum input frequency, and should preferably be three or more times this frequency. In this case we are using a minimum sampling frequency of about 30 kHz, which provides an audio bandwidth of about 10 kHz. This is something less than the full audio range, but is more than adequate to give good results.

Pinout details for the HT-8955 integrated circuit are provided in figure 1, and the block diagram showing its

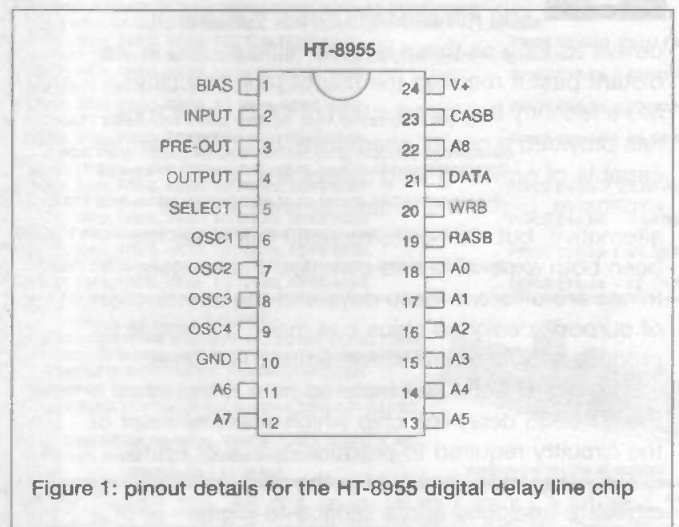

Figure 1: pinout details for the HT-8955 digital delay line chip

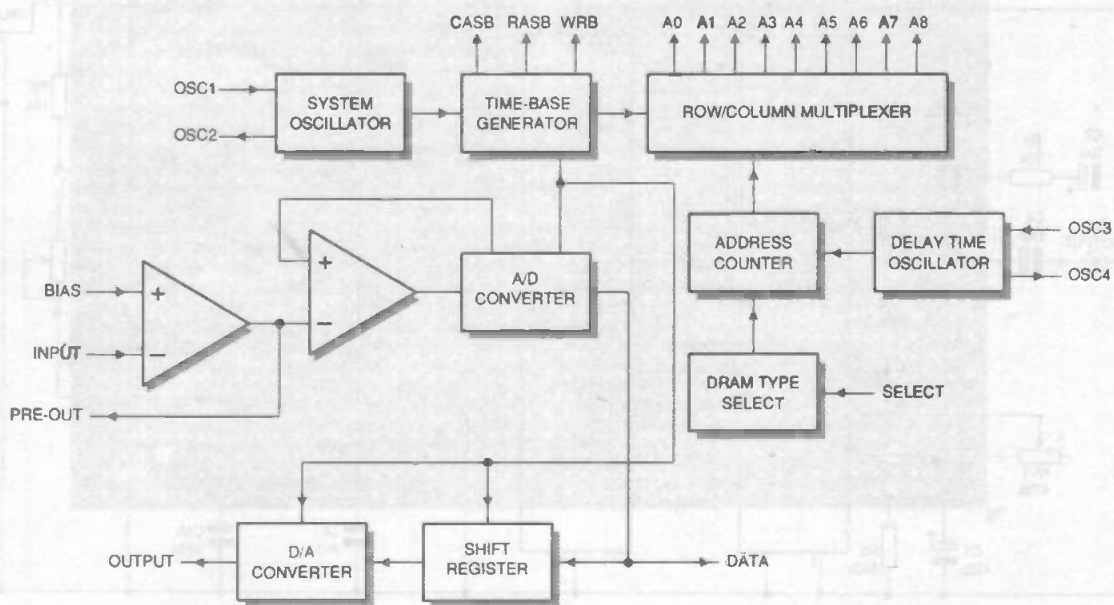

Figure 2: the block diagram showing the internal arrangement of the HT-8955

internal arrangement appears in **figure 2**. As pointed out previously, virtually all the stages needed for a digital echo unit are included in this chip, with the only major exception being the memory. An operational amplifier is included at the audio input, and this is intended for use in the inverting mode. The preamplifier is followed by an analogue to digital converter, which has the usual high-speed comparator input stage. As one would expect, at the audio output of the device there is a digital to analogue converter.

The HT-8955 is designed to operate with standard 4164 and 41256 DRAM chips, and it requires only one memory chip. This brings a slight complication in that these chips provide one bit by 64k or 256k, but the converters are 10-bit types. Each 10-bit word read from the analogue to digital converter must therefore be placed in memory one bit at a time. The shift register is used to provide the parallel to serial conversion. Obviously the single bits of data stored in memory must be re-assembled into complete 10-bit words that can be read back by the digital to analogue converter. This serial to parallel conversion is provided by the same shift register.

The delay time is controlled via the rate at which the address bus cycles through its 262144 addresses, which is in turn controlled by a built-in oscillator. Addressing some 256k of memory requires some 18 address lines, but the 41256 uses a simple method of multiplexing that enables addresses to be written in the form of two 9-bit words. An internal system clock oscillator and timebase generator circuit generates the control signals for the DRAM chip. An internal control logic circuit enables the chip to be set up for operation with the correct type of memory chip via a single input.

Circuit operation

As will be apparent from the circuit diagram of **figure 3**, using a dedicated delay in line chip enables a remarkably simple circuit to be used. Most pins on the HT-8955 (IC1) connect to the corresponding pins on the 41256 memory chip (IC2). Pin 5 of IC1 is connected to ground for operation with the 41256 or left unconnected if the memory will be provided by a 4164 DRAM. In this case a 41256 is used, and pin 5 is therefore connected to the 0-volt earth rail. R3 is the timing resistor for the system clock oscillator. VR1 and R4 perform the same function in the delay oscillator. The delay time varies from about 100 milliseconds with VR1 at minimum resistance to around 600 milliseconds when it is set at maximum resistance. The HT-8955 is probably being operated somewhat beyond its maximum guaranteed clock frequency in order to provide the shortest delay times, but the samples of the device I tested worked perfectly with sampling rates of more double the maximum used in this circuit.

Capacitor C5 and resistor R5 are the discrete components in the bias circuit of the preamplifier. Due to the high value of R5 it is several seconds after switch-on before the input circuitry begins to function properly. During the first memory cycle random values are output to the digital to analogue converter, producing a burst of noise. The switch-on delay provided by C5 suppresses this noise and other glitches that would otherwise find their way into the audio output channel. Resistors R1 and R2 are the negative feedback network for the operational amplifier at the audio input of IC1, and they set the voltage gain at unity. Capacitor C4 couples the output of the preamplifier to output socket SK2, and the input signal therefore appears in non-delayed form at the output

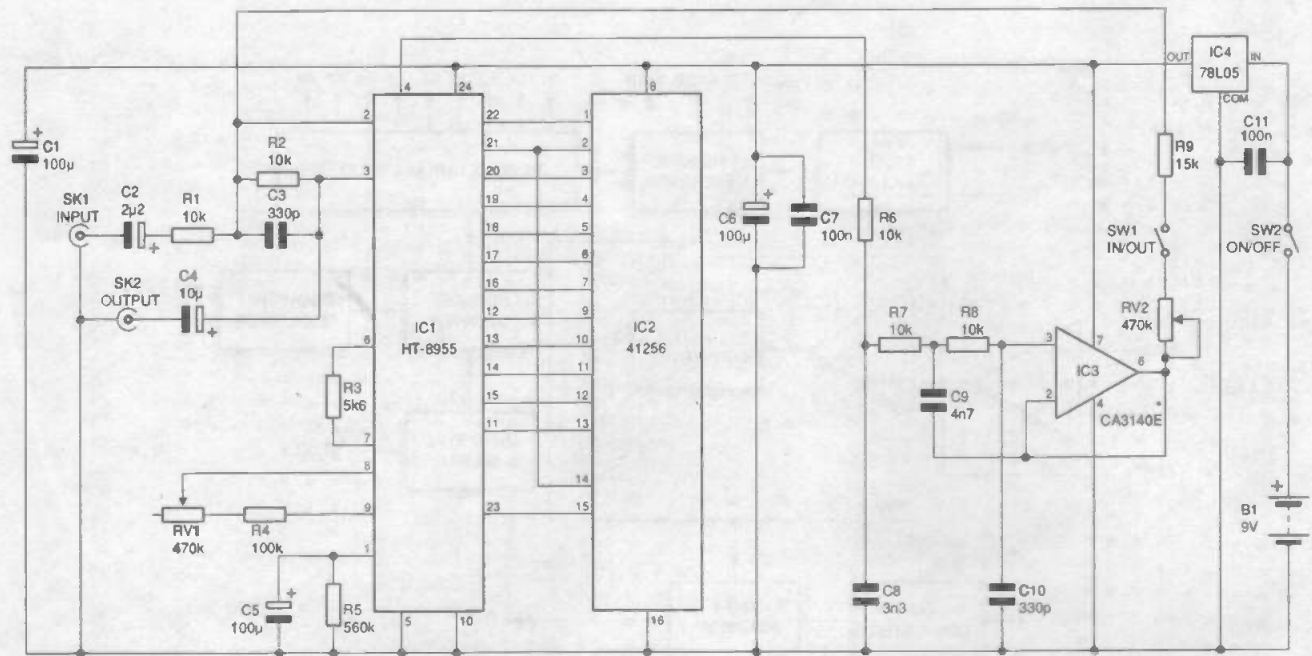

Figure 3: the circuit diagram of the Digital Echo unit

socket. It is important that there are no input signals at frequencies close to the sampling frequency as these could produce heterodyne tones on the audio output signal. In this case we are not trying to push the system to its limits, and the minimum sampling frequency is around 30 kHz. This is well above the upper limit of the audio range, but capacitor C3 is used to provide a small amount of high frequency roll-off. This should be sufficient to

suppress any stray pickup of high frequency noise. Additional filtering should only be necessary if the input signal is not reasonably "clean" for some reason. In order to obtain an echo effect the delayed signal must be mixed with the input signal. As the preamplifier is operating in the inverting mode this mixing action is easily achieved. Simply adding an additional input resistor converts the preamplifier into a simple summing mode

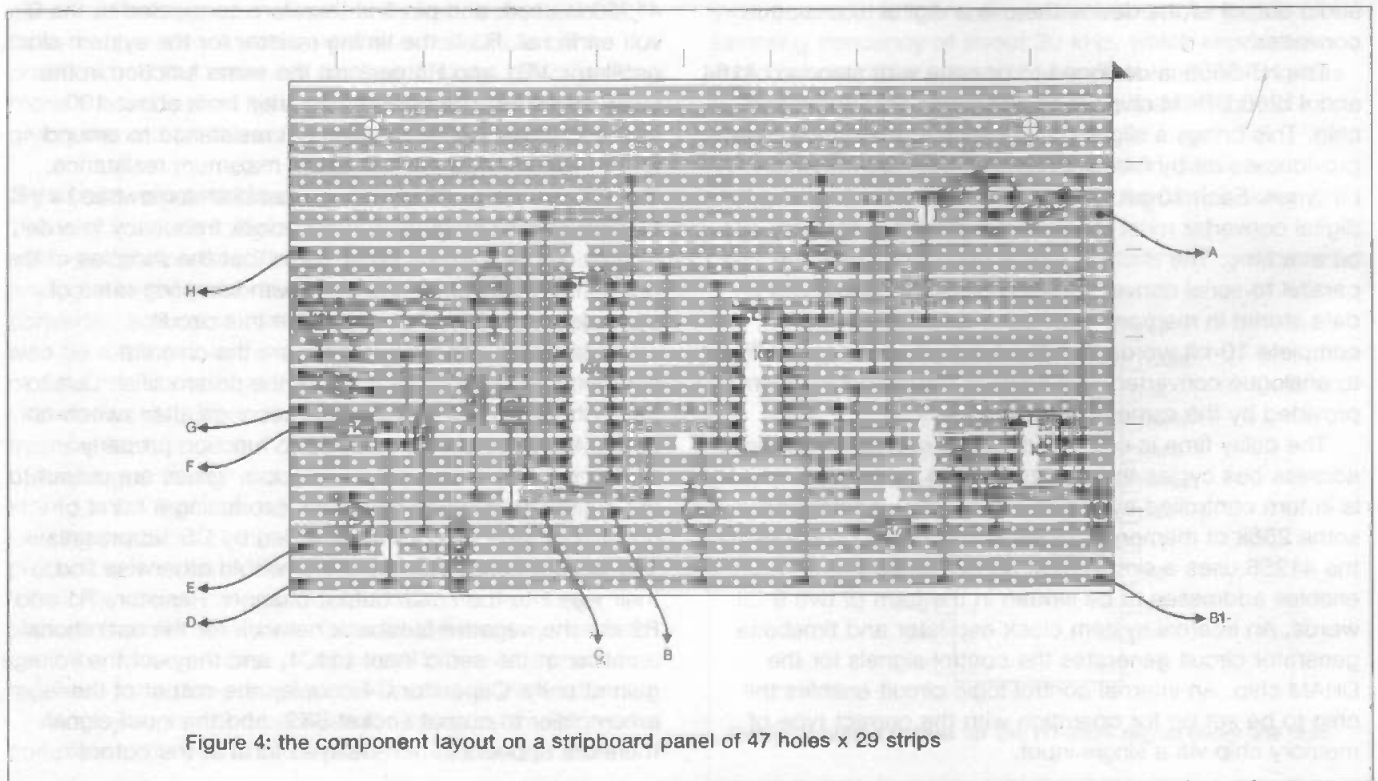

Figure 4: the component layout on a stripboard panel of 47 holes x 29 strips

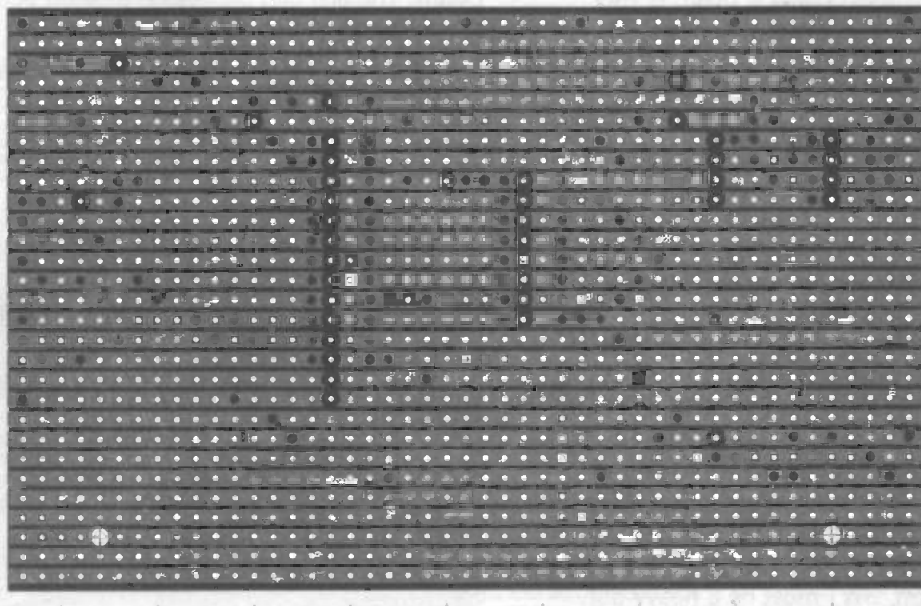

Figure 5: the underside of the component layout showing the cutaways

mixer circuit. The series resistance of R9 and VR2 provides this additional input resistor, and VR2 enables the amount of feedback to be varied over wide limits. With VR2 at minimum resistance the amount of feedback is still less than 100 percent, but this is essential because signals would otherwise circulate around the system indefinitely. Even with slightly less than one hundred percent feedback there would be a problem with excessive noise and a gradual build up in the signal levels. The maximum amount of feedback possible with this system represents a realistic maximum. With VR2 set at maximum resistance the echo effect is so slight as to be barely perceptible, but the effect can be switched out altogether by opening switch SW1.

Like any sampling system, this delay line produces a stepped output signal that jumps straight from one sample level to the next. Some lowpass filtering is all that is needed in order to remove the steps and produce an ordinary audio output signal. In this circuit the lowpass filtering is provided by an active three stage (18 decibels per octave) circuit based on IC3. The cut-off frequency of the filter is approximately 10 kHz.

The circuit requires a single five-volt supply, and this is derived from a nine-volt battery via monolithic voltage regulator IC4. The current consumption of the circuit is about 20 milliamps, making it preferable to use a fairly high capacity battery such as 6 AA size cells fitted in a plastic holder. If the unit is to be built in the form of a small pedal unit it can be powered from a "high power" PP3 size battery, but this is likely to be a more expensive means of powering the circuit.

Construction

The stripboard layout for the digital echo unit appears in figure 4 (component layout) and figure 5 (copper side view). All three integrated circuits are MOS devices, and therefore require the normal anti-static handling

precautions. The most important of these is that they should be fitted in holders, and that they should not be fitted in their holders until the unit is otherwise complete. Until then they should be left in their anti-static packaging, and they should be handled as little as possible when it is time for them to be plugged into the holders. The integrated circuits should obviously be kept well away from any known sources of static electricity such as computer monitors. Note that the CA3140E used in the IC3 position of this circuit is one of the few operational amplifiers that will work properly on a five-volt supply. The use of alternative operational amplifiers is definitely not recommended.

Finding a suitable holder for IC1 might pose problems because 24-pin integrated circuits seem to exist in at least three different encapsulations. Most component retailers seem to offer the 0.6 inch spacing variety, whereas the encapsulation for the HT-8955 has 0.3 inch row spacing. Probably the easiest solution is to use ordinary eight-pin and 16-pin DIL holders butted end-to-end. Provided they are of the same make and type they will effectively

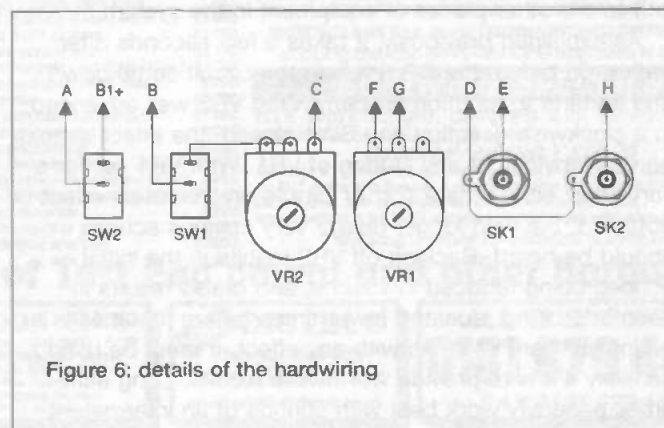

Figure 6: details of the hardwiring

produce a 24-pin holder having the correct row spacing.

In most respects construction of the board is very straightforward, but be careful not to omit any of the numerous link-wires. Some of these are quite long and pass close to other wires. In order to avoid short circuits these wires must either be kept very taut or they must be insulated with pieces of PVC sleeving. The links are shown uninsulated for clarity on the prototype, but it is more secure to include the pieces of insulation. At this stage only fit single-sided pins to the board at the points where connections to the sockets and controls will eventually be made.

The physical form of the unit must be varied to suit its intended purpose. If it is to be constructed as an effects pedal the case must be a fairly tough metal box. A diecast aluminium box is ideal, but cases of this type are relatively difficult to obtain and tend to be expensive. Cases of simple folded aluminium construction are much cheaper and easier to obtain, and I have always found them to be sufficiently strong for this sort of application. If the unit is constructed in pedal form, SW1 must be a heavy-duty pushbutton switch mounted on the top panel of the case so that it can be operated by foot. Standard jack sockets would be more appropriate for an effects pedal than the phono sockets specified in the components list. A metal instrument case is probably the best choice if the unit is to take a more conventional form. Either way, the low voltage gain and medium input impedance of the unit avoid any major restrictions on the general layout. However, try to avoid any long connecting wires to RV2 and SW1, and keep this wiring well clear of IC2. The small amount of hard wiring is shown in figure 6. This should present no problems, and there is no need to use any screened cables.

Testing and use

In order to obtain a good signal to noise ratio from the unit it is essential to use a fairly high input level. The circuit can accommodate input signals having amplitudes of up to at least one volt peak-to-peak, and in most cases signals of almost twice this level will be usable. Ideally the input level should be about one volt peak-to-peak, and most items of equipment supply a signal at about this level. Two obvious exceptions are low output guitar pickups and virtually any type of microphone. In both cases a suitable preamplifier will be needed for successful operation with this echo unit. The voltage gain of the circuit is approximately unity, and connecting the unit between any signal source and an amplifier (or whatever) should give no obvious change in volume. Use good quality screened cables to connect the unit to the other pieces of equipment in the system.

As explained previously, it takes a few seconds after switch-on before the DC levels in the circuit settle down and it starts to function properly. With VR2 well advanced in a clockwise direction and SW1 closed, the effect should be very obvious at any setting of VR1. With VR1 set for a very short echo time a sort of simple reverberation effect is obtained, but with longer delays very obvious echoes should be heard. Backing off VR2 results in the initial echoes being reduced in volume, and it also results in each one being repeated fewer times before it subsides to an insignificant level. As with any effect, it must be used sensibly if it is to provide worthwhile results. Long echo times generally work best with sounds of an intermittent

nature that enable the echoes to be heard reasonably clearly. The unit can be used with short echo times to add reverberation to practically any signal. This effect is very good at making singers with thin voices sound much better than they really are, and it is built into many karaoke units!

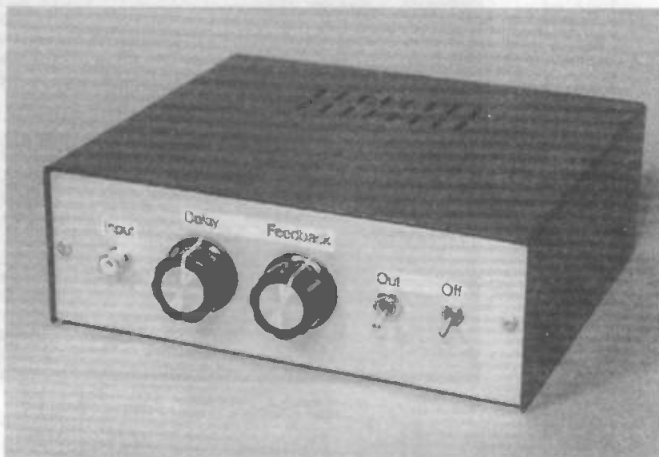

PARTS LIST for the Digital Echo Unit

Resistors

All 0.25 watt 5% carbon film

R1,2,6,7,8	10k
R3	5k6
R4	100k
R5	560k
R9	15k
RV1,2	470k lin rotary carbon

Capacitors

C1,5,6	100u 10V radial elect
C2	2u2 50V radial elect
C3,10	330p ceramic plate
C4	10u 25V radial elect
C7,11	100n ceramic
C8	3n3 polyester
C9	4n7 polyester

Semiconductors

IC1	HT-8955
IC2	41256
IC3	CA3140E
IC4	78L05 (+5V 100mA regulator)

Miscellaneous

SK1,2	Phono socket
SW1;SW2	SPST min toggle
B1	9 volt (6 x AA size cells in holder)
	Metal case, 0.1 inch stripboard having 47 holes by 29 holes, control knob (2 off), 24-pin dill holder (see text), 16-pin dill holder, 8 pin dill holder, battery connector (PP3 type), wire, solder, etc.

Surplus always wanted for cash!

THE ORIGINAL SURPLUS WONDERLAND!

THIS MONTH'S SELECTION FROM OUR VAST EVER CHANGING STOCKS

Surplus always wanted for cash!

LOW COST PC's

SPECIAL BUY 'AT 286'

40Mb HD + 3Mb Ram

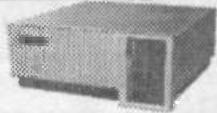

Industrial grade 12Mhz HI GRADE 286 systems Made in the USA to an industrial specification, the system was designed for total reliability. The compact case houses the motherboard, PSU and EGA video card with single 5 1/4" 1.2 Mb floppy disk drive & Integral 40Mb hard disk drive to the front. Real time clock with battery backup is provided as standard. Supplied in good used condition complete with enhanced keyboard, 640k + 2Mb RAM, DOS 4.01 and 90 DAY Full Guarantee. Ready to Run!

Order as HIGRADE 286 **ONLY £99.00 (E)**

Optional Fitted extras: VGA graphics card £29.00
1.4Mb 3 1/2" floppy disk drive (instead of 1.2 Mb) £19.95
Wordperfect 6.0 for Dos - when 3 1/2" FDD option ordered £12.50
NE2000 Ethernet (thick, thin or twisted) network card £29.00

INTEL 486DX-33 SYSTEMS

Limited quantity of this 2nd user, superb small size desktop unit. Fully featured with standard SIMM connectors 30 & 72 pin. Supplied with keyboard, 4 Mb of RAM, SVGA monitor output, 256k cache and integral 120 Mb IDE drive with single 1.44 Mb 3.5" floppy disk drive. Fully tested and guaranteed. Fully expandable. Only **£199.00 (E)**

FLOPPY DISK DRIVES 3 1/2" - 8"

Massive purchases of standard 5 1/4" and 3 1/2" drives enables us to present prime product at industry beating low prices! All units (unless stated) are BRAND NEW or removed from often brand new equipment and are fully tested, aligned and shipped to you with a full 90 day guarantee. Call for over 2000 unlisted drives for spares or repair.

3 1/2" Panasonic JU363/4 720K or equivalent RFE	£24.95(B)
3 1/2" Mitsubishi MF355C-L 1.4 Meg. Laptops only	£25.95(B)
3 1/2" Mitsubishi MF355C-D 1.4 Meg. Non laptop	£18.95(B)
3 1/2" Teac FD-55GFR 1.2 Meg (for IBM pc's) RFE	£18.95(B)
3 1/2" Teac FD-55F-03-U 720K 40/80 (for BBC's etc) RFE	£29.95(B)
3 1/2" BRAND NEW Mitsubishi MF501B 360K	£22.95(B)
Table top case with integral PSU for HH 5 1/4" Floppy or HD	£29.95(B)
8" Shugart 800/801 8" 55 refurbished & tested	£210.00(E)
8" Shugart 810 8" SS HH Brand New	£195.00(E)
8" Shugart 851 8" double sided refurbished & tested	£260.00(E)
8" Mitsubishi M2884-63 double sided NEW	£295.00(E)
8" Mitsubishi M2895-63-02U DS slimline NEW	£295.00(E)
Dual 8" cased drives with integral power supply 2 Mb	£499.00(E)

HARD DISK DRIVES

2 1/2" TOSHIBA (19 mm H) MK2101MAN 2.16 Gb. New	£199.00
2 1/2" TOSH (12.5 mm H) MK1002MAV 1.1 Gb laptop. New	£115.00
2 1/2" to 3 1/2" conversion kit for PC's, complete with connectors	£15.95
3 1/2" FUJII FK-308-26 20mb MFM I/F RFE	£59.95
3 1/2" CONNER CP3024 20 mb IDE I/F (or equiv.) RFE	£59.95
3 1/2" CONNER CP3044 40mb IDE I/F (or equiv.) RFE	£69.00
3 1/2" RODIME R03057S 45mb SCSI I/F (Mac & Acom)	£69.00
3 1/2" QUINTAM 40S Prodrive 42mb SCSI I/F, New RFE	£49.00
3 1/2" WESTERN DIGITAL 850mb IDE I/F New	£185.00
5 1/4" MINISCRIBE 32425 20mb MFM I/F (or equiv.) RFE	£49.95
5 1/4" SEAGATE ST-238R 30 mb RLL I/F Refurb	£69.95
5 1/4" CDC 94205-51 40mb HH MFM I/F RFE tested	£69.95
5 1/4" HP 97548 850 Mb SCSI RFE tested	£99.00
5 1/4" HP C3010 2 Gbyte SCSI differential RFE tested	£195.00
8" NEC D2246 85 Mb SMD interface. New	£199.00
8" FUJITSU M2322K 160Mb SMD I/F RFE tested	£195.00
8" FUJITSU M2329K 2 Gb SMD I/F RFE tested	£345.00

Many other drives in stock - Shipping on all drives is code (D)

THE AMAZING TELEBOX

Converts your colour monitor into a QUALITY COLOUR TV!

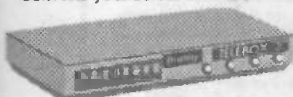

TV SOUND & VIDEO TUNER
CABLE COMPATIBLE

The TELEBOX is an attractive fully cased mains powered unit, containing all electronics ready to plug into a host of video monitors made by makers such as MICROVITEC, ATARI, SANYO, SONY, COMMODORE, PHILIPS, TATUNG, AMSTRAD etc. The composite video output will also plug directly into most video recorders, allowing reception of TV channels not normally receivable on most television receivers* (TELEBOX MB). Push button controls on the front panel allow reception of 8 fully tunable 'off air' UHF colour television channels. TELEBOX MB covers virtually all television frequencies VHF and UHF including the HYPERBAND as used by most cable TV operators. A composite video output is located on the rear panel for direct connection to most makes of monitor or desktop computer video systems. For complete compatibility - even for monitors without sound - an integral 4 watt audio amplifier and low level Hi Fi audio output are provided as standard.

TELEBOX ST for composite video input type monitors	£36.95
TELEBOX STL as ST but fitted with integral speaker	£39.50
TELEBOX MB Multiband VHF/UHF/Cable/Hyperband tuner	£69.95

For overseas PAL versions state 5.5 or 6 MHz sound specification. *For cable / hyperband signal reception Telebox MB should be connected to a cable type receiver. Shipping on all Teleboxes, is code (B)

DC POWER SUPPLIES

Virtually every type of power supply you can imagine. Over 10,000 Power Supplies Ex Stock Call for info / list.

IC's - TRANSISTORS - DIODES

OBSOLETE - SHORT SUPPLY - BULK

6,000,000 Items EX STOCK

For MAJOR SAVINGS - CALL FOR SEMICONDUCTOR HOTLIST

VIDEO MONITOR SPECIALS

One of the highest specification monitors you will ever see - At this price - Don't miss it!!

Mitsubishi FA3415ETKL 14" SVGA Multisync colour monitor with fine 0.28 dot pitch tube and resolution of 1024 x 768. A variety of inputs allows connection to a host of computers including IBM PC's in CGA, EGA, VGA & SVGA modes. BBC, COMMODORE (including Amiga 1200), ARCHIMEDES and APPLE. Many features: Etched bezelplate, text switching and LOW RADIATION MPR specification. Fully guaranteed, supplied in EXCEL-

LENT little used condition. TIR & Swivel Base £4.75 Only £119 (E) Order as MITS-SVGA
VGA cable for IBM PC included.
External cables for other types of computers CALL

As New - Ex Demo
17" 0.28 SVGA Mitsubishi Diamond Pro monitors
Full multisync etc. Full 90 day guarantee. £325.00 (E)

Just In - Microvitec 20" VGA (600 x 600 res.) colour monitors. Good SH condition - from £299 - CALL for Info

PHILIPS HCS35 (same style as CM8833) attractively styled 14" colour monitor with both RGB and standard composite 15.625 KHz video inputs via SCART socket and separate phono jacks. Integral audio power amp and speaker for all audio visual uses. Will connect direct to Amiga and Atari BBC computers. Ideal for all video monitoring / security applications with direct connection to most colour cameras. High quality with many features such as front concealed flap controls, VCR correction button etc. Good used condition - fully tested - guaranteed
Dimensions: W14" x H12 1/2" x 15 1/2" D. Only £99 (E)

PHILIPS HCS31 Ultra compact 9" colour video monitor with standard composite 15.625 KHz video input via SCART socket. Ideal for all monitoring / security applications. High quality, ex-equipment fully tested & guaranteed (possible minor screen burns). In attractive square black plastic case measuring W10" x H10" x 1 3/4" D. 240 V AC mains powered. Only £79.00 (D)

KME 10" 15M10009 high definition colour monitors with 0.28" dot pitch. Superb clarity and modern styling. Operates from any 15.625 khz sync RGB video source, with RGB analog and composite sync such as Atari, Commodore Amiga, Acom, Archimedes & BBC. Measures only 13 1/2" x 12" x 11". Good used condition. Only £125 (E)

20" 22" and 26" AV SPECIALS

Superbly made UK manufacture. PIL all solid state colour monitors, complete with composite video & optional sound input. Attractive teak style case. Perfect for Schools, Shops, Disco, Clubs, etc. In EXCELLENT little used condition with full 90 day guarantee.

20"....£135 22"....£155 26"....£185 (F)

SPECIAL INTEREST ITEMS

MITS. FA3445ETKL 14" Industrial spec SVGA monitors	£245
1kW to 400 kW - 400 Hz 3 phase power sources - ex stock	£60A
IBM 8230 Type 1, Token ring base unit driver	£760
Wayne Kerr RA200 Audio frequency response analyser	£2500
IBM 53F5501 Token Ring ICS 20 port lobe modules	£95
IBM MAU Token ring distribution panel 8228-29-5050N	£550
AIM 501 Low distortion Oscillator 9Hz to 330KHz, IEEE	£50A
Trend DSA 274 Data Analyser with G703(2M) 64 Vo	£6500
Marconi 6310 Programmable 2 to 22 GHz sweep generator	£3750
HP16550B Logic Analyser	£6500
HP3781A Pattern generator & HP3782A Error Detector	£1800
HP6821A Dual Programmable GPIB PSU 0-7 V 160 watts	£875
HP6264 Rack mount variable 0-20V @ 20A metered PSU	£60A
HP54121A DC to 22 GHz, 40 channel test set	£1850
HP7580A A 1 8 pen HPGL high speed drum plotter	£650
F&G Wardrobe test, insurance spec 1 hour rated fire safe	£650
E-B-G Brookdale 95035C Precision lock in amp	£100A
View Eng. Mod 1200 computerised inspection system	£2200
Sony DXC 400A High quality CCD colour TV camera	£2945
CSZ VERY Large 3 cavity thermal shock chamber	£1450
Philips PW1730/10 XRAY generator with accessories	£1150
Kaithley 590 CV capacitor / voltage analyser	£1450
Rack ICR40 dual 40 channel voice recorder system	£3750
Fiskers 45KVA 3 ph On Line UPS - New batteries	£9500
ICI R5030UV34 Cleanline ultrasonic cleaning system	£2200
Mann Tally MT645 High speed line printer	£2945
Intel SBC 486/133SE Multibus 486 system. 8Mb Ram	£1450
Intel SBC 486/125C08 Enhanced Multibus (MSA) NEW	£1150
Zeta 3220-05 A0 4 pen HPGL fast drum plotters	£1450
Nikon HFX-11 (Ephiphot) exposure control unit	£550
Motorola VME Bus Boards & Components List. SAE / CALL	£1950
Trilo 0-18 vdc linear, metered 30 amp bench PSU. New	£1250
Fujitsu M3041R 600 LPM band printer	£2500
Fujitsu M3041D 600 LPM printer with network interface	£3500
Perkin Elmer 2998 Infrared spectrophotometer	£3750
Perkin Elmer 597 Infrared spectrophotometer	£495
VG Electronics 1035 TELETEXT Decoding Margin Meter	£1995
Light Band 60 output high spec 2u rack mount video VDA's	£1995
Sekonic SD 150H 18 channel digital Hybrid chart recorder	£750
Taylor Hobson Talysurf amplifier / recorder	£485
System Video 1152 PAL waveform monitor	£2950
Siemens K4400 64Kb to 140Mb demux analyser	£2950

19" RACK CABINETS

Superb quality 6 foot 40U
Virtually New, Ultra Smart
Less than Half Price!

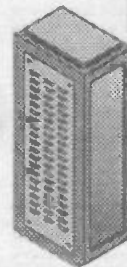

Top quality 19" rack cabinets made in UK by Optima Enclosures Ltd. Units feature designer, smoked acrylic lockable front door, full height lockable half louvered back door and louvered removable side panels. Fully adjustable internal fixing struts, ready punched for any configuration of equipment mounting plus ready mounted integral 12 way 13 amp socket switched mains distribution strip make these racks some of the most versatile we have ever sold. Racks may be stacked side by side and therefore require only two side panels to stand singly or in multiple bays. Overall dimensions are: 77 1/2" H x 32 1/2" D x 22" W. Order as:

OPT Rack 1 Complete with removable side panels.	£345.00 (G)
OPT Rack 2 Rack. Less side panels	£245.00 (G)

Over 1000 racks, shelves, accessories
19" 22" & 24" wide 3 to 46 U high.
Available from stock !!

32U - High Quality - All steel RakCab

Made by Eurocraft Enclosures Ltd to the highest possible spec, rack features all steel construction with removable side, front and back doors. Front and back doors are hinged for easy access and all are lockable with five secure 5 lever barrel locks. The front door is constructed of double walled steel with a 'designer style' smoked acrylic front panel to enable status indicators to be seen through the panel, yet remain unobtrusive. Internally the rack features fully slotted reinforced vertical fixing members to take the heaviest of 19" rack equipment. The two movable vertical fixing struts (extras available) are pre punched for standard 'cage nuts'. A main distribution panel internally mounted to the bottom rear, provides 8 x IEC 3 pin Euro sockets and 1 x 13 amp 3 pin switched utility socket. Overall ventilation is provided by fully louvered back door and double skinned top section with top and side louvers. The top panel may be removed for fitting of integral fans to the sub plate etc. Other features include: fitted castors and floor levers, prepunched utility panel at lower rear for cable / connector access etc. Supplied in excellent, slightly used condition with keys. Colour Royal blue. External dimensions mm=1625H x 635D x 603 W. (64" H x 25" D x 23 3/4" W)
Sold at LESS than a third of makers price !!

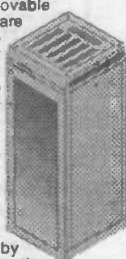

A superb buy at only £245.00 (G)
42U version of the above only £345 - CALL

BATTERY SCOOP - 50% off !!

A special bulk purchase from a cancelled export order brings you the most amazing savings on these ultra high spec 12v DC 14 Ah rechargeable batteries. Made by Hawker Energy Ltd, type SB515 featuring pure lead plates which offer a far superior shelf & guaranteed 15 year service life. Fully BT & BS6290 approved. Supplied BRAND NEW and boxed. Dimensions 200 wide, 137 high, 77 deep. M6 bolt terminals. Fully guaranteed. Current makers price over £70 each! Our Price £35 each (G) or 4 for £99 (D)

RELAYS - 200,000 FROM STOCK

Save ££££ by choosing your next relay from our Massive stocks covering types such as - Military, Octal, Cradle, Hermetically Sealed, Contactors, Time Delay, Reed, Mercury Wetted, Solid State, Printed Circuit Mounting, CALL US WITH YOUR NEEDS. Many obsolete types from stock. Save ££££s

LOW COST RAM & CPU'S

INTEL 'ABOVE' Memory Expansion Board. Full length PC-XT and PC-AT compatible card with 2 Mbytes of memory on board. Card is fully selectable for Expanded or Extended (286 processor and above) memory. Full data and driver disks supplied. RFE. Fully tested and guaranteed. Windows compatible. £59.95
Half length 8 bit memory upgrade cards for PC AT XT expands memory either 256k or 512k in 64k steps. May also be used to fill in RAM above 640k DOS limit. Complete with data.
Order as: XT RAM UC. 256k. £34.95 or 512k £39.95

SIMM SPECIALS	
1 MB x 9 SIMM 9 chip 120ns	Only £8.50
1 MB x 9 SIMM 3 chip 80 ns	£10.50 or 70ns £11.95
1 MB x 9 SIMM 9 chip 80 ns	£10.50 or 70ns £11.75
4 MB 70 ns 72 pin SIMM - with parity	Only £35.00
INTEL 486-DX3 CPU	£19.95 INTEL 486-DX66 CPU £59.00
FULL RANGE OF CO-PROCESSOR'S & STORAGE - CALL FOR £££	
MOTOROLA 25 Mhz 68040 (XC68040RC25M) CPU'S £59.00	
shipping charges for RAM / CPU upgrades is code B	

SOFTWARE SPECIALS

NT4 WorkStation, complete with service pack 3 and licence - OEM packaged.
Special Price ONLY £99.00
Microsoft - Windows for Workgroups 3.11 & DOS 6.22. Supplied on 3 1/2" disks with license & documentation documentation. £39.95
DOS 5.0 on 3 1/2" disks with concise books c/w OBasic. £14.95
Wordperfect 6 for DOS supplied on 3 1/2" disks with manual £24.95
shipping charges for software is code B

Visit our London shop for a full range of Test Equipment and other bargains



ALL MAIL & OFFICES
Open Mon - Fri 9.00 - 5.30
Dept ETI, 32 Biggin Way
Upper Norwood
LONDON SE19 3XF

LONDON SHOP
Open Mon - Sat 9.00 - 5.30
215 Whitehorse Lane
South Norwood
On 66A Bus Route
Nz, Thornton Heath &
Selhurst Park SR Rail Stations

NEW DISTEL ©
Visit our web site
www.distel.co.uk
email: admin@distel.co.uk

ALL ENQUIRIES
0181 679 4414
FAX 0181 679 1927

All prices for UK Mainland. UK customers add 17.5% VAT to TOTAL order amount. Minimum order £10. Bona Fide account orders accepted from Government, Schools, Universities and Local Authorities - minimum account order £50. Cheques over £100 are subject to 10 working days clearance. Carriage charges (A)=£3.00, (A1)=£4.00, (B)=£5.00, (C)=£8.50, (D)=£12.00, (E)=£15.00, (F)=£18.00, (G)=CALL. Allow approx 6 days for shipping - faster CALL. All goods supplied to our Standard Conditions of Sale and unless stated guaranteed for 90 days. All guarantees on a return to base basis. All rights reserved to change prices / specifications without prior notice. Orders subject to stock. Discounts for volume. Top CASH prices paid for surplus goods. All trademarks etc acknowledged. © Display Electronics 1997. E & O.E. 01/8

PINHOLE CAMERA MODULE WITH AUDIO! Superb board camera with on board sound extra small just 28mm square (including microphone) ideal for covert surveillance. Can be hidden inside anything, even a matchbox! Complete with 15 metre cable, psu and tv/rvr connectors. £73.95 ref CC6

BBC SELECTORS WITH SMART CARD SLOT AND VIDEO CRYPT Interesting new item in this week is this Selector. Originally made for the BBC to send encrypted video films to your VCR at night time. The project seems to have failed. Very complex units consisting of a smart card slot in the front plus several switches and an IR receiver. Fully cased and measuring 230 x 430 x 90mm, new and boxed. On the back of the unit is a smart socket plus a UHF input and output. A channel tuning control numbered 28 to 40 and an IR socket. Inside is a comprehensive tuner section, smart card reader mechanism and control electronics plus a power supply section. These units are sold as strippers but we imagine you could use one to convert a monitor into a TV or maybe use the videcrypt side of things for something else. Supplied complete with manual and mains lead. Clearance price just £9.95 ref BBC1X

INLINE RCB UNIT This in-line miniature earth leakage unit instantly shuts off the mains supply in the event of any current flowing between live and earth thus preventing a potentially lethal shock IEC plug one end, socket the other, fitted in seconds, reset button. The ultimate safety aid when working on electronic equipment, computers etc. As these units are fitted with an in-line IEC plug on one end and socket on the other than could even be used to extend standard IEC computer leads. Pack of 3 £9.99 ref LOT5A

THE ULTIMATE ENCLOSURE for your projects must be one of these! Well made ABS screw together beige case measuring 120 x 150 x 50mm. Already fitted with rubber feet and front mounted LED. Inside is a pcb fitted with other bits and pieces you may find useful. Sold either as a pack of five for £10 ref MD1, pack of 20 for £19.95 ref MD2

17 WATT 12V SOLAR PANEL A solar panel designed to give a nominal 12v. The solar cells are laminated within a high quality resin material which offers excellent protection against UV and moisture. Mounted on tempered glass in an aluminium frame. The panel is ideal for charging sealed lead acid batteries and a protection diode in the circuit prevents reversed current flow. Mounting is by four adjustable hooks and connection is by screw terminals. Max power 17 watts, 35 cells, 17vdc peak, 433x402x15mm, 1000mA max, 1.9kg. Solar panel £115 ref SOL4

SOLAR POWERED AM/FM RADIO A compact, AM/FM mono radio complete with earphone and a solar panel that recharges the built-in battery when placed in direct sunlight or under a strong lamp. It features a rotary Volume/On/Off control (which must be set to 'Off' for recharging), AM/FM selector switch, rotary tuning control, metal belt clip and socket for external 3V DC supply. Solar Radio £7.95 ref SR23

MOTOR CYCLISTS RADAR DETECTOR New in is the Whistler 1560 Laser/Radar detector complete with a speaker for motorcycle helmets. Super wide band covering X,K and Ka plus lasers at 950nm +/- 10nm, 360 deg total perimeter protection. Detects laser, radar and VG-2 wherever they come from. £159.95 ref RD4

MAGIC EAR Unlike previous 'sound-magnifiers' we have offered, Magic Ear fits unobtrusively behind the ear itself. Magic Ear's micro technology is very advanced, its built-in microphone is extremely sensitive and there's also a volume control to help you adjust to all conditions in use. Magic Ear is startlingly effective. It'll help you to follow every word of conversation even at a distance, and enjoy theatre, cinema or live music with stunning new sound. Comes fitted with 3 long life batteries, a free travel pouch, plus a choice of 3 different ear pieces designed to fit all shapes of ear. Magic ear £16.99 ref MAGE3

RADIO METER Perhaps the best of the scientific knick-knacks of the past and well overdue for revival! Fascinating, soothing and educational. In the vacuum inside the inverted bulb like container the vanes revolve, driven round by light particles alone (each vane is black on one side white on the other). Radiometer £9.99 ref SC120B

SATELLITE NAVIGATION £119 THE GARMIN - GPS 38 - is the one navigational tool for the great outdoors that offers big features in a small, lightweight package - all at a truly affordable price. Mark your favorite fishing spot, tree stand or camp site. Or retrace your steps back to the safety of your starting point using our all-new TracBack feature. The GPS 38 shows you exactly where you are, where you've been and where you're going. The GPS 38 features easy, one-thumb operation and weighs only 255g. There's a resettable trip odometer, graphic compass and highway steering guidance. And it provides up to 20 hours of use on a set of 4 AA batteries. THE GARMIN GPS 38. The affordable way to bring you back £119 ref GPS1

DIFFERENTIAL THERMOSTAT KIT An electronic self assembly kit designed for use in solar heating systems, heat recovery systems etc. The principle of the kit is that it has two thermostats that are placed on the items to be measured (typically a solar panel and a water storage tank) the controller then operates a relay all the time one temperature is higher than the other. The temperature difference is adjustable. A typical use would be to operate a pump all the time a solar panel was at a higher temperature than the water storage tank. Differential thermostat kit £25 ref LOT93

10 WATT SOLAR PANEL Amorphous silicon panel fitted in a anodized aluminium frame. Panel measures 3' by 1' with screw terminals for easy connection. One of these panels will run our solar water pump in full sunlight although we would recommend that for optimum performance two panels would be preferable. 3' x 1' solar panel £55 ref MAG45

12V SOLAR POWERED WATER PUMP Perfect for many 12v DC uses, ranging from solar fountains to hydroponics! Small and compact yet powerful. Will work direct from our 10 watt solar panel in bright sunlight. Max head 17 ft. Max flow rate: 8.1pm Current: 1.5A (Ref AC8) £18.99

BOOST CELL PHONE RECEPTION ON THE MOVE! Compared to high-powered carphones, hand-portable mobile phones don't always work too well in moving vehicles. Sometimes the signal 'drops out' during a call, other times there's too much interference to get through at all. However, the affordable Cell Patch provides a major improvement, dramatically boosting signal reception without wires or batteries. The 9.5 x 9.5cm (3.7" x 3.7") microthin antenna adheres to your car window sunvisor, ideally within 61-122cm (2-4') of the handset, or can be carried in a pocket. Works with all types of portable cellular phone. Cell Patch £11.99 ref CEL1

CAT SCARER produces a blanket of high sonic and low ultrasonic sound, which is inaudible to humans, birds and fish - so it is ideal where you want to protect your bird table or fish pond against feline predators. It will deter cats from your garden and other protected areas. It will also deter foxes, minks, otters, 10 m of cable. Running cost will be approximately 1 p per day. Garden watcher £42.45 ref GW2

VIDEO PROCESSOR UNITS?/6v 10AH BATT/24V 8A TX Not too sure what the function of these units is but they certainly make good strippers! Measures 390X320X120mm, on the front are controls for scan speed, scan delay, scan mode, loads of connections on the rear. Inside 2x 6v 10AH sealed lead acid batts, pcb's and a 8A? 24v toroidal transformer (mains in), sold as a unit, may have one or two broken knobs etc due to poor storage. £9.95 ref VP2X

SOLAR MOTORS Another new line for us are these tiny motors which run quite happily on voltages from 3-12vdc. We have tried one on our 6v amorphous 6" panels and you can run them from the sun! 32mm dia 20mm thick £1.50 each

TELEPHONES Just in this week is a huge delivery of telephones, all brand new and boxed. Two piece construction with the following features- illuminated keypad, nice clear easy to use keypad, tone or pulse (switchable), recall, redial and pause, high/low and off ringer switch and quality construction. Each telephone is finished in a smart off white colour and is supplied with a standard international lead (same as US or modern card sockets) if you wish to have a BT lead supplied to convert the phones these are also available at £1.55 each ref BT LX Phones £4.99 each ref PH2

INFRARED CAR PHONE KIT £7.99 interesting box of goodies! this kit was designed to convert car phones to enable hands free dialling, the kit contains the following items. 1) A keypad designed to mount in the centre of the steering wheel, it requires a 9v PP3 battery and transmits the numbers using three on board high power infra red LEDs. 140 x 120mm 2) An infra red receiver module containing a IR photo diode, IR filter and control electronics 60 x 30 x 15mm (cased) 3) Control box (nice case) 100 x 170 x 35mm which we understand is the interface between the infra red and the car phone, it is also supposed to adjust the volume of your car stereo at the same time made for Philips car phones (but we don't know the model) complete kit is £7.99 ref CP1

Hi power 12v xenon strobe variable rate flasher modules and tubes £8.95 useful 12v PCB fitted with control electronics and a powerful Xenon tube! just apply 12v DC to the input and the tube will flash. On the board is a small potentiometer which can be used to vary the flash rate! PCB measures just 70x 55mm and could be incorporated into many interesting projects! £6 ref FLS1 Pack of 10 is £49 ref FLS2

WANT TO MAKE SOME MONEY? Stuck for an idea? We have collated 140 business manuals that give you information on setting up different businesses, you peruse these at your leisure using the text editor on your PC. Also included is a certificate enabling you to reproduce the manuals as much as you like! £4 ref EP74

TALKING WATCH YES, it actually tells you the time at the push of a button. Also features a voice alarm that wakes you up and tells you what the time is! Lithium cell included. £8.99 ref EP2BA

POWERBEAM INFRARED LAMP All this lamp gives out is infra red light, and loads of it! perfect for supplementing night sight and surveillance equipment. Most mono CCTV video cameras are infra red sensitive so used in conjunction with this lamp would greatly enhance their operating performance. Water resistant case and rubber covered switch make this unit perfect for all weathers. Krypton bulb 4 D cells required. Powerbeam lamp £29 ref PB1

GIANT SCREEN VIEWERTUM your TV picture into a supesize screen! This high precision Fresnel lens converts even the smallest screen up to a massive 26", giving a crystal clear picture at a fraction of the cost of a big TV. Easily fitted in minutes! Also ideal for PC monitors etc £28.95 ref SVGA2

NOGALIGHT NIGHT VISION £129 Open up a new world of adventures and experiences. Wildlife enthusiasts and adventurers in the wilderness, amateur astronomers, hunters, wargamers, private eyes on surveillance, all find Nightspy indispensable for their use. Nightspy's unique features include a special tube protection device, to eliminate over exposure, and infrared illuminator used in total darkness, such as in cave exploration and operations in dark rooms. The Nightspy is light and hand held, or can be mounted on a standard tripod. It uses two standard AA batteries and can be operated by left or right hand users, with or without optical glasses. Optical Magnification X 1.7 Field of View, 10 Degrees Focusing Range 25cm to infinity objective Focal Length: 50 mm F/N 1.6 Diopter Range +/- 3 Mechanical Length: 182 mm Width: 65mm Height 100 mm Weight 700 g. Electrical Power Source: 3 VDC, 2AA batteries Battery Life: 40 hours Infra-red illuminator built-in Imaging Device: Night Vision Image Intensifier Tube £129 ref NOGA

Register with us at
www.bull-electrical.com
for your free e-mail
NEWSLETTERS!

DRILL OPERATED PUMP Fits to any drill in seconds, uses standard garden hose, will pump up to 40 gallons per hour! £8.99 ref DRL3

BULL ELECTRICAL
250 PORTLAND ROAD, HOVE, SUSSEX.
BN3 5QT. (ESTABLISHED 50 YEARS).

MAIL ORDER TERMS: CASH, PO OR CHEQUE
WITH ORDER PLUS £3.50 P&P PLUS VAT.
24 HOUR SERVICE £5.00 PLUS VAT.

OVERSEAS ORDERS AT COST PLUS £3.50
(ACCESS, VISA, SWITCH, AMERICAN EXPRESS)
phone orders : 01273 203500

FAX 01273 323077

Sales@bull-electrical.com

STEREO MICROSCOPES BACK IN STOCK Russian, 200x complete with lenses, lights, filters etc very comprehensive microscope that would normally be around the £700 mark, our price is just £299 (full money back guarantee) full details in catalogue.

SECOND GENERATION NIGHT SIGHTS FROM £748

RETRON Russian night sight, 1.8x, infra red lamp, 10m-ir, standard M42 lens, 1.1kg. £349 ref RET1

MAINS MOTORS 180 RPM 90X70mm, 50X55mm 50x5mm output shaft, start cap included. £22 ref MGM1

PC POWER SUPPLIES, CUSTOMER RETURNS, ALL FAN COOLED, OUR CHOICE, BARGAIN AT 8 PSU'S FOR £9.99 REF XX17

LOW COST CORDLESS MIC 500 range, 90 - 105mhz, 115g, 193 x 26 x 39mm, 9v PP3 battery required. £17 ref MAG15P1

JUMBO LED PACK 15 10mm bicolor leds, plus 5 giant (55mm) seven segment displays all on a pcb £8 ref JUJ41. Pack of 30 55mm seven seg displays on pcbs is £19 ref LED4, pack of 50 £31 ref LED50

12VDC 40MM FANS MADE BY PANAFLO, NEW £4 REF FAN12

ELECTRONIC SPEED CONTROLLER KIT For the above motor is £19 ref MAG17. Save £5 if you buy them both together, 1 motor plus speed controller rrp is £41, offer price £36 ref MOT5A

RUSSIAN 900X MAGNIFICATION ZOOM MICROSCOPE metal construction, built in light, mirror etc. Russian shrimp farm, group viewing screen, lots of accessories. £29 ref ANAYLT

AA NICAD PACK Pack of 4 tagged AA nicads £2.99 ref BAR34

RUSSIAN NIGHTSIGHTS Model TZ84 with infra red illuminator, views up to 75 metres in full darkness in infrared mode, 150m range, 45mm lens, 13 deg angle of view, focussing range 1.5m to infinity, 2 AA batteries required, 950g weight, £199 ref BAR61, 1 years warranty

LIQUID CRYSTAL DISPLAYS Bargain prices, 20 character 2 line, 83x19mm £3.99 ref SMC20244A, 16 character 4 line, 62x25mm £5.99 ref SMC1640A

TAL-1, 110MM NEWTONIAN REFLECTOR TELESCOPE Russian Superb astronomical 'scope, everything you need for some serious star gazing up to 169x magnification. Send for fax for further information 20kg, 885x800x1950mm ref TAL-1, £249

YOUR HOME COULD BE SELF SUFFICIENT IN ELECTRICITY Comprehensive plans with loads of info on designing systems, panels, control electronics etc £7 ref PV1

PHOTOMULTIPLIER TUBES Boxed and unused straight from the ministry of defence. Made by EMI with a MOD part no of 10C/V/5114 and packed almost 30 years ago. I Do you have a use? do you want to count light particles? They would look nice on the mantle piece! Offered to you at £15 each (we think the MOD paid more than this is 1958! £15 each ref PM3

CLOCK CAMERA WITH AUDIO Discreetly monitor living rooms, reception, office, tills or any other area. Fully working clock houses an invisible spy camera complete with audio. Complete setup includes clock, camera, microphone, clock battery, 15 metres of cable, power supply adapter for either scart or phono. Everything you need, no soldering required. Full instructions included. Easily installed in just a few minutes. Plugs straight into VCR or TV (scart or phono) Clock camera with audio £89.95 ref CC3

AUTO RECORD KIT This automatic system will instruct your VCR to start recording when movement is detected via the PIR. Recording will stop 30 seconds after your visitor has left which saves hours of tapes as the video only records what you want to see. Complete system with PIR, will work with all remote control video recorders. £89 ref CVVC2

TELEPHONE VOICE CHANGER Changes your voice to a new or unfamiliar one. Simply place over the telephone mouth piece and speak into the changer. Fully adjustable for different voices. Supplied complete with batteries, ready to go. Unit measures 90 x 60 x 20mm Telephone voice changer £14.95 ref CC3

EXTERNAL CAMERA introducing the Bulldog model 4 vandal resistant camera in heavy steel case for interior or exterior use. Top quality case housing a 420 line camera module. Each camera is supplied with a 15m cable terminating in Scart and phono plugs. Multi angle bracket for easy installation in any situation. A 12vdc psu is also included. Easily installed in a few minutes, plugs straight into VCR or TV (phono or scart). Bargain price £89.95 ref CC1

GIANT INSULATORS Just in this week are some giant ceramic insulators, each one measures 130mm high and about 170mm diameter. Finished in a high gloss brown and black glaze. In the base of each insulator is a threaded hole approx 1" diameter, rather like a mop/broom head thread. If you are into shortwave radio, crystal sets or high voltage experiments then these are for you. (We've got one as a door stop) Not too sure what their original purpose was, all we know is they were made for export about 25 years ago, never exported and been in store since then. Price is £8 each ref IHSX

NATO RADIATION MONITORS interesting new line! These are small modules that strap on your wrist (strap supplied) and monitor radiation. We have stripped one apart and they contain a small piece of "crystal" this could be something like Naphthalene or any other rare radiation sensitive crystal. When radiation strikes the crystal, it scintillates and a small amount of light is produced in the crystal in reaction to the radiation exposure. That light is then picked up by a micro pv cell measuring about 2mm square! Also in the unit is a sheet of foil, a circular metal plate (insulation between the two) and a small pair of additional parallel metal plates. NATO part no is 8665-99-225-2314 any information gratefully received! Alternatively if you wish to buy one they are just £3 each ref NATOX

WE HAD 38,000 'HITS'
ON OUR WEB SITE
IN FEBRUARY '98....
BULL-ELECTRICAL.COM
See our live camera!

A Simple Signal Generator



This economical unit by Raymond Haigh gives continuous coverage from 155KHz to 30MHz. The output can be modulated, and a 1kHz spot frequency is available for checking audio stages.

Anyone interested in constructing or servicing radio receivers will at some time have felt the need for a signal generator. A unit of this kind is essential for the accurate alignment of a superhet, and the ability to determine tuning ranges with some accuracy can be extremely useful when setting up simple receivers.

The cost of purchasing a new signal generator is substantial, even for a fairly basic model, and second-hand equipment dealers seem to specialise in laboratory instruments which carry an appropriate price tag. Designed with simplicity and the lowest possible cost very much in mind, the unit described here should more than meet the needs of most home constructors and experimenters. The entire MF and HF radio spectrum, from 155kHz to around 30MHz, is covered without a break, and harmonics extend the usefulness of the instrument well into the VHF region. The signal can be modulated, if required, and its amplitude is reasonably constant over the entire coverage. A spot frequency of around 1kHz is available for checking audio stages.

Although not quite small enough to be described as pocket-size (unless you wear a trench coat), it is lightweight and compact and will not take up an excessive amount of space on the workbench.

The oscillators

The heart of any signal generator is, of course, the oscillator. A Butler source-coupled circuit was chosen for this design (first described in 1944, during the valve era, it was originally known as the cathode-coupled oscillator). This circuit oscillates vigorously with coils of modest 'Q', even when they are arranged in tuned circuits with comparatively high ratios of capacitance to inductance. A single-winding coil is all that is required: feedback windings or tapings are not needed. This simplifies range switching and widens the choice of commercially available inductors.

Provision has to be made for modulating the RF output of the generator. If this is not done, it will not produce an audible tone in a domestic superhet. (A beat frequency oscillator is needed to make an unmodulated carrier wave audible, and these are only provided in communications

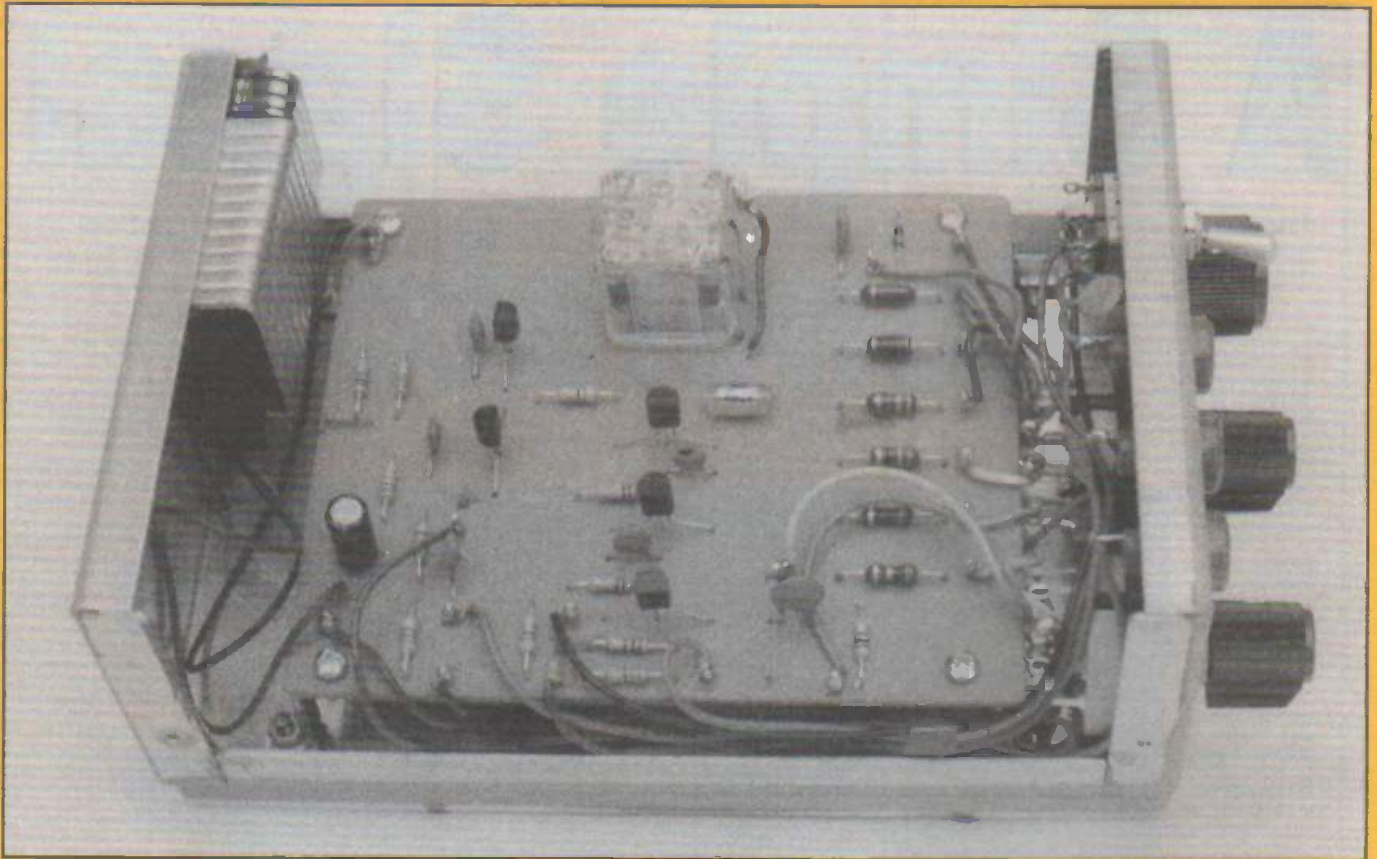

receivers.) A multivibrator is included for this purpose. This is another circuit which oscillates reliably, and it does not require close-tolerance components.

The circuits

The circuit of the unit is given in figure 1. Inductors L1 to L6, tuned by variable capacitor C2, determine the frequency of oscillation of Q1 and Q2, two fets arranged in the source-coupled Butler circuit. Range switch SW1A selects the appropriate coil (miniature RF chokes are used here), and C1 is an optional component, placed in series with the tuning capacitor in order to reduce its swing. More is said about this, and the coil shorting switch, SW1B, later.

Zener diode ZD1 in combination with R2 keeps the supply voltage to the RF oscillator reasonably constant. The operating frequency of a Butler oscillator is not excessively dependant on supply voltage, but the kind of changes encountered with dry batteries (almost 10V with a fresh PP3 battery down to 7V or so at the end of its useful life) will affect the calibration accuracy of the unit. In this circuit, ZD1 only conducts when the battery is fresh, but it does prevent excessive voltage changes noticeably affecting the accuracy of the generator.

C3 and C4 are RF bypass capacitors, and R3 ensures the correct biasing of Q2. The value of feedback capacitor C5 has been chosen to ensure reliable oscillation, at the lowest operating frequency, with all specimens of 2N3819. The 'hot' end of common source resistor, R1, is a convenient low-impedance point for extracting the signal from the oscillator. Coupling capacitor C6 applies it to the gate of a source-follower buffer stage, Q3. Configured in this way, Q3 has a very high input impedance and a low output impedance. This minimises loading on the oscillator and enables the generator to be connected to other equipment by means of screened leads without an excessive drop in signal voltage. Equally important, the

buffer stage isolates the oscillator from the equipment under test and prevents any frequency 'pulling' or other disturbance to its proper operation. R4 ensures the correct biasing of the buffer stage.

Output from the generator is developed across the source load of Q3, which is made up of R7, R8 and R9. SW3 is wired to short out different sections of this resistor chain in order to vary the output voltage. In the maximum position, output is approximately 800mV RMS. This can be reduced to around 400mV (down 6dB) and 200mV (down 12dB) by the operation of the on-off-on type toggle switch. Purists will no doubt point out that the output impedance of the generator changes slightly as the signal level is varied, but this does not detract in any way from the usefulness of the instrument. C9 functions as a DC blocking capacitor.

Bipolar transistors Q4 and Q5 arranged in a conventional multivibrator circuit, provide the audio signal which is used to modulate the RF output of the generator. This arrangement is no more than two amplifier stages coupled together in such a way that the whole of the output is fed back to the input. A square wave with a rounded leading edge is developed across the collector load resistors. This is less than perfect (a sine wave would be ideal), but the modulator does work well in practice, and the need for feedback transformers or close tolerance components is avoided.

The peak-to-peak signal voltage at the collectors is approximately 3.5V. This is too vigorous for our purpose, and the output is accordingly taken from a tapping on the collector load of Q4, at the junction of R5 and R6, in order to reduce it to around 1V. With the component values shown, the operating frequency is in the region of 1kHz. However, the ceramic feedback and frequency determining capacitors, C8 and C10, have a wide tolerance, and the frequency of oscillation can range from around 800Hz to 1.2kHz. R10 and R11 set the bias on the transistors, and

R12 is the collector load of Q5.

Modulation is applied by connecting part of the collector load of Q4 in parallel with R2 in order to impose the audio frequency oscillations on the supply voltage to the RF oscillator. Bypass capacitor C3 and zener diode ZD1 modify the wave form of the AF modulation, but they are not able to suppress it. Indeed, C3 reduces the unwanted harmonic content of the multivibrator output, and the arrangement works well in practice.

Rotary switch SW2 connects the RF and AF sections of the circuit to the power supply and selects the output required: unmodulated RF, modulated RF, and AF. Bypass capacitor C11 is connected across the supply when the multivibrator is operating. C7 is a DC blocking capacitor.

Tuning arrangements

In order to simplify construction and keep the cost of the unit as low as possible, a solid dielectric variable capacitor and miniature RF chokes are used to tune the RF oscillator. Because of their small size, the chokes have a comparatively high self-capacitance, and this reduces the tuning range which can be obtained with individual inductors. Nevertheless, continuous coverage from around 150kHz to 30MHz can be achieved with only six switched ranges and a tuning capacitor with a 10 to 350pF swing.

Polythene dielectric variable capacitors are often available very cheaply on the surplus market, and they can sometimes be salvaged from discarded transistor radios. Individual AM gangs usually have a swing of around 5pF to 270pF, and connecting the aerial and oscillator sections in parallel produces a unit with a 10pf to 540pF swing. A

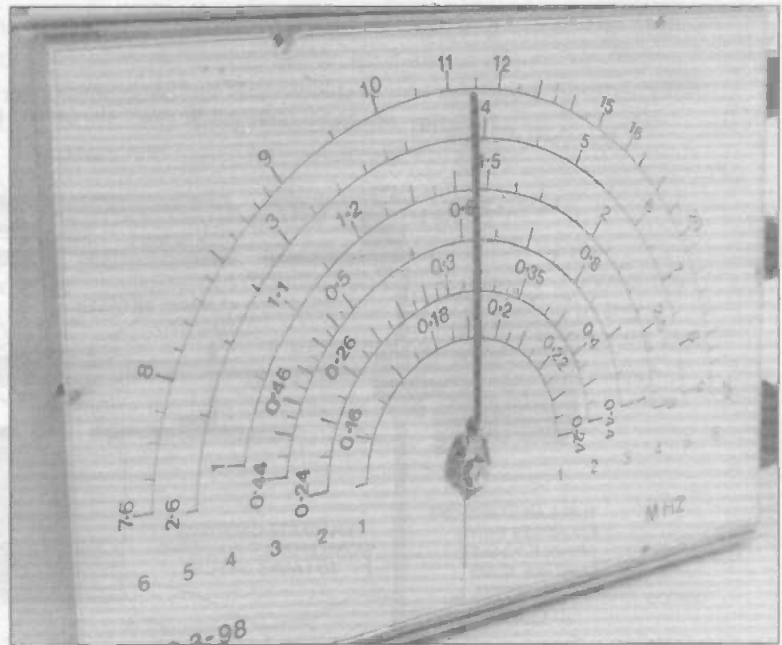

maximum value of 540pF would result in excessive overlapping of the ranges and needlessly critical tuning, and provision is made on the PCB for wiring a fixed capacitor in series with the variable component in order to reduce its fully-meshed value to around 350pF. A capacitor of 1000pF placed in series with one of 540pF will produce the required value of 350pF. This is a useful starting point if a component is to be selected by trial and error. A surplus variable capacitor, connected in this way, was installed in the prototype generator.

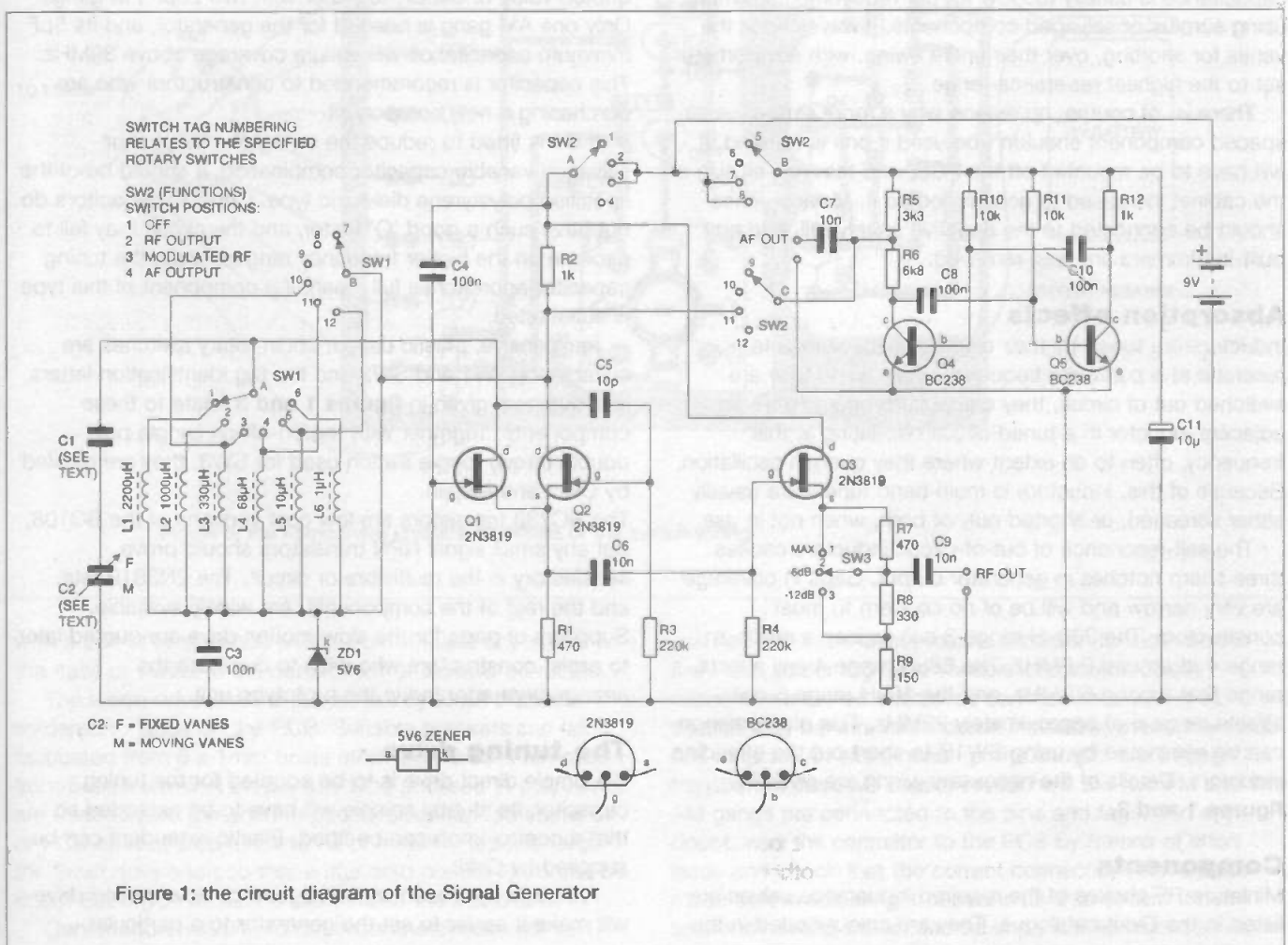

Figure 1: the circuit diagram of the Signal Generator

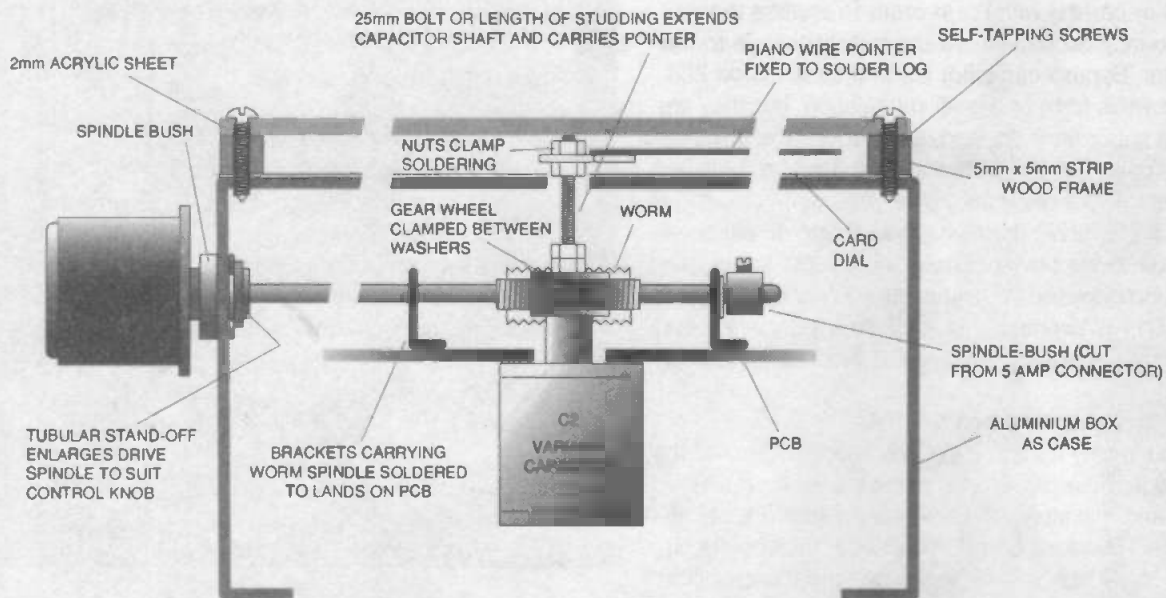

Figure 2: details of the drive, dial and pointer

Tuning capacitors removed from low-cost transistor portables are not likely to be suitable: even when both AM gangs are connected in parallel, the resulting maximum capacitance is usually too low for our requirements. When using surplus or salvaged components, always check the vanes for shorting, over their entire swing, with a multimeter set to the highest resistance range.

There is, of course, no reason why a more expensive air-spaced component shouldn't be used if one is to hand. It will have to be mounted off the PCB, and the over-all size of the cabinet increased to accommodate it. Moving vanes should be connected to the negative supply rail, and any built-in trimmers are best removed.

Absorption effects

Inductors are tuned by their own self-capacitance to resonate at a particular frequency. Even when they are switched out of circuit, they can absorb energy from an adjacent inductor in a tuned circuit oscillating at this frequency, often to an extent where they quench oscillation. Because of this, inductors in multi-band tuners are usually either screened, or shorted out, or both, when not in use.

The self-resonance of out-of-circuit inductors causes three sharp notches in generator output. Gaps in coverage are very narrow and will be of no concern to most constructors. The 330uH range 3 coil causes a notch in range 4 at around 2.8MHz. The 68uH range 4 coil affects range 5 at around 6.2MHz, and the 10uH range 5 coil affects range 6 at approximately 29MHz. This phenomenon can be eliminated by using SW1B to short out the offending inductors. Details of the necessary wiring are given in figures 1 and 3.

Components

Miniature RF chokes of the required inductance values are listed in the Cirkit catalogue. They are colour-coded in the

same way as resistors, and the value is given in uH. Cirkit can also supply a suitable variable capacitor. Manufactured by Toko, it incorporates two AM tuning gangs, each with a quoted value of 355pF, together with two 20pF FM gangs. Only one AM gang is needed for the generator, and its 5pF minimum capacitance will ensure coverage above 30MHz. This capacitor is recommended to constructors who are purchasing a new component.

If C1 is fitted to reduce the swing of a surplus or salvaged variable capacitor combination, it should be of the specified polystyrene dielectric type. Ceramic capacitors do not have such a good 'Q' factor, and the circuit may fail to oscillate on the higher frequency ranges, when the tuning capacitor approaches full mesh, if a component of this type is substituted.

Inexpensive, plastic cased, Lorlin rotary switches are suitable for SW1 and SW2 and the tag identification letters and numbers given in figures 1 and 3 relate to these components. Together with the on-off-on (single pole double throw) toggle switch used for SW3, they are retailed by Cirkit and Maplin.

The BC238 transistors are low cost versions of the BC108, but any small signal NPN transistors should prove satisfactory in the multivibrator circuit. The 2N3819 fets, and the rest of the components, are widely available. Suppliers of parts for the slow motion drive are quoted later to assist constructors who wish to duplicate the arrangement adopted in the prototype unit.

The tuning drive

If a simple direct drive is to be adopted for the tuning capacitor, its stubby spindle will have to be extended so that a control knob can be fitted. Plastic extenders can be supplied by Cirkit.

Although not essential, some form of slow motion drive will make it easier to set the generator to a particular

frequency. An epicyclic reduction drive, or a drum and cord drive salvaged from a transistor radio, could be used. In the prototype unit, a worm and gear wheel drive were fitted. This compact system gave a reduction of 20:1 and made it possible to bring out all of the controls at the side of the case.

Figure 2 and the photographs illustrate the arrangement. The plastic gear wheel is clamped between washers and secured to the spindle of the tuning capacitor by means of a 25mm long bolt or length of studding (2mm diameter metric thread) which also carries the dial pointer. Lock nuts hold the wheel and the pointer firmly in place. When tightening up the fixings, grip the actual capacitor spindle

probably find suitable gears, spindle and brass strip at their local model shops. Maplin list items of this kind in their catalogue, and Greenweld, of 27 Park Road, Southampton, SO15 3UQ (Tel 01703 236363), retail a range of plastic gears and matching spindles.

Constructing the generator

With the exception of the switches and C9, all the components are mounted on a PCB. **Figure 3** shows the layout of the components and the connections to the switches and output sockets. **Figure 4** depicts the foil side of the board. Veropins, inserted at the lead-out points, simplify the task of off-board wiring.

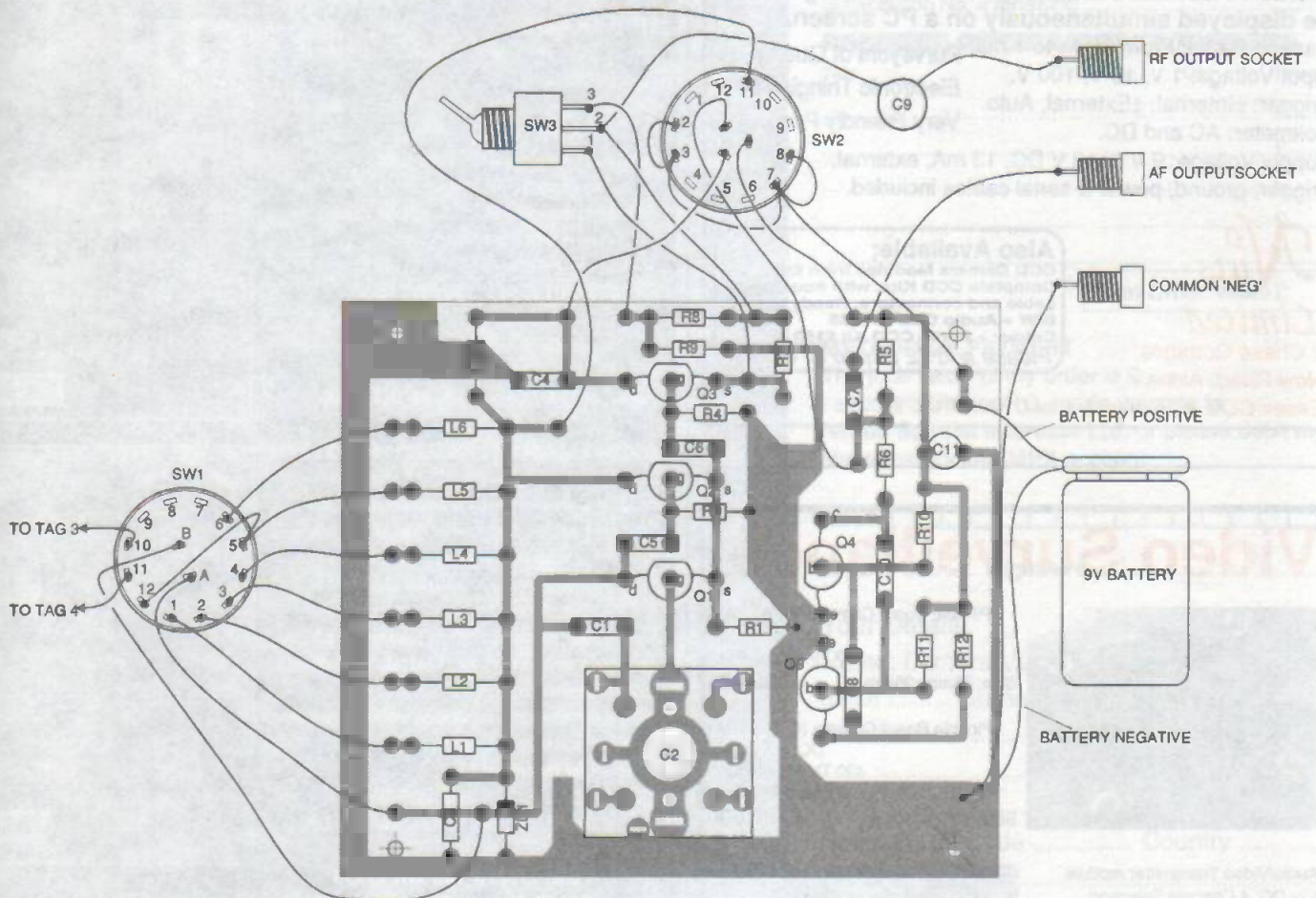

Figure 3: the component layout with details of the switch wiring

with a pair of long-nosed pliers. Do not place any stress on the case or vanes of the component or it could be ruined.

The worm drive shaft is supported by small brackets soldered to lands on the PCB. Suitable brackets can be fabricated from 6 x 1mm brass strip. Connectors removed from 5-amp terminal blocks (the type encased in polythene) are used to hold the shaft in position. A threaded stand-off or PCB spacer, plus a few turns of masking tape, enlarge the 2mm drive shaft so that a standard control knob can be fitted. Superglue locks the shaft inside the stand-off.

Constructors wishing to duplicate the system will

The PCB track layout makes provision for both screw-fixed and solder tag fixed variable capacitors. These capacitors must be orientated correctly or a 20pF FM section may be wired into circuit instead of the higher value AM variable. An examination of the component through its transparent case will usually reveal how the two FM and two AM gangs are connected to the pins and tags. If in any doubt, wire the capacitor to the PCB by means of short leads and check that the correct connections have been made before soldering it permanently into circuit. If two sections have to be connected in parallel in order to

osziFOX

£75
Inc.

A universal 20 MHz storage oscilloscope



A slimline storage oscilloscope and digital voltmeter with a sampling rate of up to 20 MHz. Inclusive software enables the recorded signals to be displayed simultaneously on a PC screen.

Sample Rates: From 50 ns to 1 ms. **Purveyors of Quality**
Input Voltage: 1 V, 10 V, 100 V. **Electronic Thingsies at**
Trigger: ±Internal, ±External, Auto. **Very Friendly Prices**
Voltmeter: AC and DC.
Supply Voltage: 9 V to 13 V DC, 13 mA, external.
Trigger, ground, power & serial cables included.

No Nuts

Limited

2-Chase Cottages,
New Road, Aldham,

Essex CO6 3QT Tel. & Fax 01206 213322

Also Available;

CCD Camera Modules from £60
Complete CCD Kits, with housing,
cable and connectors. Ready to run.
B/W + Audio CCD Kit £85
Colour + Audio CCD Kit £150
Please add £2 p&p to all orders.

Video Surveillance

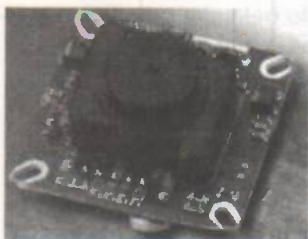

Pinhole Board Camera (B&W) 12v
DC, 0.1LUX,
380 TV Resolution
Size: 35mmx35mm **£35.00**

Pinhole Board Camera (Color) 12v
DC, 0.5 LUX,
420 TV Resolution
2 board foldable
Size: 40mmx40mm **£190.00**

Audio/Video Transmitter module
12v DC, 4 Channel Selection
900MHz-1200MHz, FM Modulation
£120.00

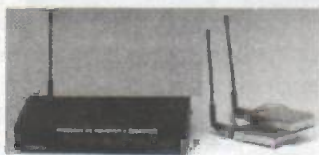

4 Channel Receiver + Switcher
12v DC, Composite Audio/Video
Output **£150.00**



TFT 4" Colour Monitor
12v DC **£150.00**

We also stock:
Time & Date Generator, Miniature PIR etc.

Confidential Communications Limited

344 Kilburn Lane, Maida Vale
London W9 3EF

Tel (44)(0) 181 968 0227 Fax: (44)(0) 181 968 0194
Email: 106075.276@Compuserve.com

ELECTRONICS DIRECT

SUBSCRIBE & SAVE WITH ELECTRONICS DIRECT

Our subscription deals just get better and better - now you can save almost £20 if you subscribe today!

ETI, code: 0215

Electronics Today International - The Project Magazine for all Electronics Constructors.

The single source guide to electronics for today and tomorrow, packed with numerous projects for enthusiasts of all abilities. The detailed features and up-to-the-minute news items keep all readers fully informed of the latest, exciting developments in this ever changing hobby, whilst the equipment reviews ensure that you always know exactly what to buy.

15 issues for the price of 13.

UK: NOW ONLY £35.75 YOU SAVE £5.50

Europe: £44.59, Overseas: £47.84, USA: \$74.00

30 issues for the price of 26

UK: NOW ONLY £71.50 YOU SAVE £13.75

Europe: £89.18, Overseas: £95.68, USA: \$148.00

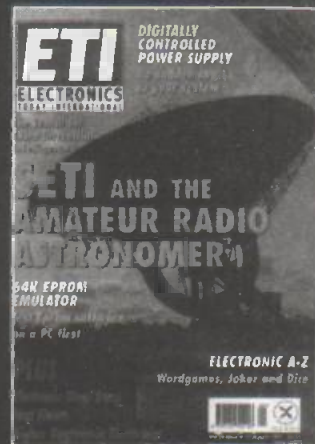

ACORN ARCHIMEDES WORLD, code: 0215

In the constantly changing world of IT, it is vital to keep abreast of all the latest trends and developments. Of course, this is easier said than done. However, you CAN keep fully informed by reading Acorn Archimedes World, Britain's most respected computing magazine devoted to all Acorn 32-bit RISC OS systems. The wide ranging editorial brings you in-depth hardware and software reviews, evaluates new products and forecasts what will happen next, and includes a dedicated educational section. Each issue also comes with a free cover-mounted disc, often containing complete, usable programs as well as workable and playable demos.

15 issues for the price of 13

UK: NOW ONLY £51.35 YOU SAVE £7.90

Europe: £62.40, Overseas: £66.56, USA: \$103.00

31 issues for the price of 26

UK: NOW ONLY £102.70 YOU SAVE £19.75

Europe: £124.80, Overseas: £133.12, USA: \$206.00

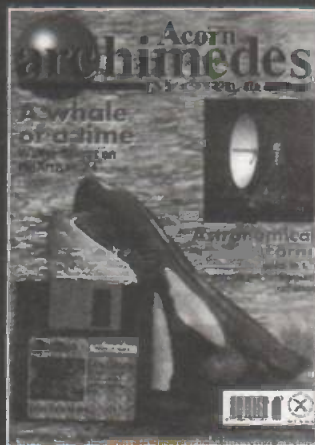

REMEMBER, it's always cheaper to subscribe - and you avoid future cover price increases!

All savings are based upon buying the same number of issues from your newsagent, UK only.

BINDERS

Keep your favourite magazines in mint condition in one of our sturdy binders.

Each binder will hold up to 13 issues.

Code: bind 02

£7.50 U.K. £8.00 Overseas

BINDERS AVAILABLE

● ETI ● ARCHIMEDES WORLD



'Electronics Direct' is the One Stop Shop for all your computing, electronics and amateur radio needs from Nexus Direct. We are offering some sensational deals on Subscriptions, Books & Reader Offers - all available direct by mail order. Remember, all our prices include postage and packing - so there are no hidden extras to add! You can order by phone, fax or use the coupon.

SAVINGS ON BOOKS

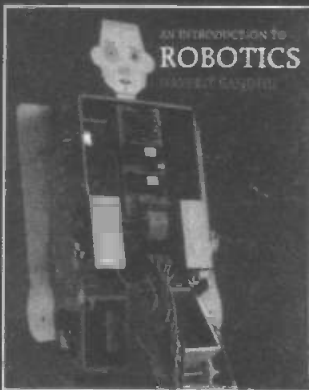

AN INTRODUCTION TO ROBOTICS.

A fascinating and unique book that breaks new ground by exploring the exciting world of robotics in a clear and concise way. Both the theoretical and practical aspects are presented in an uncomplicated fashion using everyday English, which makes this an ideal book for the amateur. Divided into two sections, the first part explains how and why robots work and are controlled, while the second shows you how to make a simple two legged humanoid robot that can be programmed to walk. There are no complicated formulas or equations to grapple with or incomprehensible circuit diagrams to decipher - this robot can be built on your kitchen table and can be run from any personal computer! All you need are model aeroplane servos, a controller, a power supply and some plywood - and all parts are easily available in the UK and the USA. This is a book that will be of interest to modellers and everyone with a fascination for things mechanical and electronic.

Code: NB299

ONLY £11.95 UK £12.95 Overseas

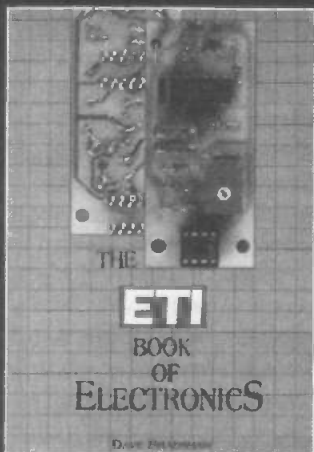

ETI BOOK OF ELECTRONICS

This is the perfect book for beginners, offering a clear and concise introduction to both the theories and principles of electronics. Each chapter also allows you to put this theory into practice with an easy to follow project to make, including a loudspeaker divider, continuity tester, 'brown-out' alarm, freezing alarm, loudspeaker, mini-amplifier and a burglar alarm.

Code: NB214

ONLY £12.95 UK £13.95 Overseas

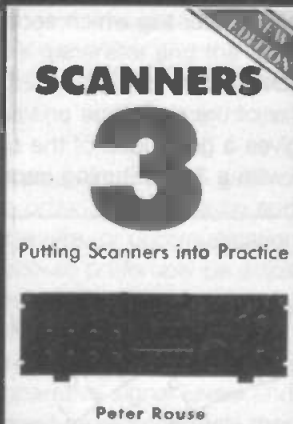

SCANNERS 3 - PUTTING SCANNERS INTO PRACTICE

This is the fourth revised and completely updated edition of Scanners, the complete VHF/UHF radio listeners guide, containing everything you need to know to put your scanner to better use. There is a great deal more information than ever before on frequency listing; in particular, actual frequencies used by coastal stations, airfields and the emergency services. Also included for the first time is a section on the HF (short wave) band as many scanners now cover this range.

Code: NB217

ONLY £11.95 UK £12.95 Overseas



SCANNERS 2 INTERNATIONAL

The companion book to 'Scanners' provides even more information on the use of VHF and UHF communication bands, and gives details on how to construct accessories to improve the performance of scanning equipment. The book is international in its scope and contains frequency allocations for all three ITU regions, including country-by-country variations.

Code: NB216

ONLY £11.95 UK £12.95 Overseas

BOOKS DIRECT

ELECTRONICS DIRECT

Please order all your goods using the coupon below ensuring you fill in all sections OR simply use our order hotline. Thank you.

SUBSCRIPTIONS

Magazine	Code	No. of Issues	Price
.....	£.....
.....	£.....
.....	£.....
Total Subscription Value			£.....

Subscription No. if renewing

READERS OFFERS/BOOKS/BINDERS

Title	Code	Qty	Price
.....	£.....
.....	£.....
.....	£.....
.....	£.....
.....	£.....

Total Order Value £

METHOD OF PAYMENT

The total value of my order is £

I enclose a Cheque/P.O. made payable to Nexus Special Interests Ltd. or please debit my Mastercard/Visa/AMEX account

Card No. [.....]

Expiry/..... Signature

Your Details

Name: (Mr/Mrs/Miss)

Initial Surname

Address:

Postcode/Zipcode Country

Telephone:

Send to:

Electronics Direct
Nexus House
Boundary Way
Hemel Hempstead
Herts. HP2 7ST.

Please Note

All prices include P&P where appropriate. All subscriptions start with the first available issue. Every effort will be made to despatch your order within 14 days but please allow up to 28 days for delivery. Individual items may be dispatched separately. These offers are not to be used in conjunction with any other promotion.

Please tick this box if you do not wish to receive direct mail from other companies



ELECTRONICS DIRECT

Express Order Hotline 01442 266551

9am - 5pm Monday - Friday

Fax order line: 01442 266998

easiest way of calibrating the unit is to connect it to a frequency counter and mark appropriate points on the dial as it is switched and tuned through its ranges. If the constructor has access to an 'all-band' radio with a digital frequency read-out, this will serve just as well, but remember to keep the input from the generator as low as possible or unwanted responses in the receiver may produce misleading dial readings. (Setting the generator to 10MHz will produce harmonics at 20 and 30MHz to which the receiver will respond if the fundamental is strong enough.) If in any doubt, check the results against the prototype dial. The inductors are fixed and of fairly close tolerance, and the calibration should not deviate too far from the original.

The use of a receiver with an analogue dial, unless it is of very high quality, is not likely to result in an acceptable degree of accuracy. However, if a crystal calibrator is available, this can be used in conjunction with an indifferent receiver to obtain results as good as those produced with a frequency counter. The technique involves injecting the calibrator signals into the receiver and setting the generator output to zero beat with them on their fundamentals and harmonics. The procedure takes time and a little patience, but a highly accurate dial can be marked out in this way.

Using the signal generator

Articles describing the construction of receivers, or data sheets covering their servicing, usually give detailed alignment instructions. Some general guidance may, however, prove helpful.

Always keep the generator output as low as possible. Keep reducing the signal level as the state of alignment improves and the receiver becomes more sensitive. A direct connection between the generator and the receiver is not likely to be necessary. Simply place the output lead close to the aerial socket or close to the wiring of the section under alignment.

If a domestic superhet is being aligned, the generator output must be modulated in order to produce an audible tone. Simple regenerative receivers, or communications receivers fitted with a BFO, should preferably be adjusted to render the unmodulated output audible.

A high-impedance test meter, set to a low voltage range and connected across the AGC line, will afford a clear visual indication of comparative signal levels and enable the receiver to be aligned more accurately than it can by ear.

If the IF stages are badly out of alignment, begin by injecting a signal into the base of the transistor (gate of FET or grid of valve) which feeds the final IFT and then work back towards the frequency changer, adjusting transformer cores to peak the output. Modern receivers often incorporate ceramic or mechanical filters and these devices, rather than the tuned transformers, determine the intermediate frequency of the receiver. When these are encountered, gently rock the generator tuning in order to establish the resonant frequency of the filters, then peak up the transformer cores at this setting.

High performance, multiple conversion receivers have complicated alignment procedures which sometimes require specialised equipment. Anyone with the least doubt about their ability would be wise to leave the servicing of sets of this kind to authorised agents.

Resistors

All 0.25W, 5 percent

R1	470R
R2	1k
R3, R4	220k
R5	3k3
R6	6k8
R7	470R
R8	330R
R9	150R
R10, R11	10k
R12	1k

Capacitors

All 10V working or greater

C1	1000pF polystyrene. See text.
C2	2 x 355pF plus 2 x 20pF Toko polyvaricon type FT-2217 (only one 355pF gang used). Cirkit 06-22171. See text for alternatives.
C3, C4, C8, C10	100nF ceramic
C5	10pF ceramic
C6, C7, C9	10nF ceramic
C11	10uF radial lead electrolytic

Inductors

All miniature RF chokes

L1	2200uH Cirkit 35-71225
L2	1000uH Cirkit 35-71105
L3	330uH Cirkit 35-71334
L4	68uH Cirkit 35-71683
L5	10uH Cirkit 35-71103
L6	1uH Cirkit 35-71102

Semiconductors

Q1, Q2, Q3	2N3819
Q4, Q5	8C238
ZD1	5V6 Zener diode

Switches

SW1	Lorlin 2-pole, 6-way
SW2	Lorlin 3-pole, 4-way
SW3	Miniature on-off-on (single pole, double throw) toggle switch

Sundry Items.

PCB making materials, Vero pins, hook-up wire. Control knobs, output sockets, slow motion drive or drive making materials. Aluminium box for case. Battery connector. Nuts, bolts, screws, stand-offs and washers. Card for dial, piano wire for pointer, strip-wood for frame and acrylic sheet for face.

Most parts are widely available. The inductors are supplied by Cirkit Distribution Ltd., Park Lane, Braxbourne, Herts EN10 7NQ. Tel 01992 448899.

£1 BARGAIN PACKS

If you would like to receive the other four £1 lists and a lot of other lists, request these when you order or send SAE.

TEST PRODS FOR MULTIMETERS with 4mm sockets. Good length very flexible lead. Ref: D86.

8 OHM PM SPEAKERS, size 8" x 4", pack of two. These may be slightly rusty and that is why they are so cheap but are electrically OK. Ref: D102.

PAXOLIN PANELS, size 8" x 6", approximately 1/18" thick. pack of two. Ref: D103.

13A SOCKET, virtually unbreakable, ideal for trailing lead. Ref: D95.

PIEZO BUZZER with electronic sounder circuit, 3V to 9V D.C. operated. Ref D78.

DITTO but without internal electronics, pack of two. Ref:D75.

LUMINOUS ROCKER SWITCH approximately 30mm sq. pack of two. Ref D64.

ROTARY SWITCH, 9-pole, 5-way, small size ?? spindle, pack of two. Ref: D54.

FERRITE RODS, 7" with coils for Long and Medium waves, pack of two, Ref: D52.

DITTO but without coils, pack of three. Ref: D52.

MAINS DP ROTARY SWITCH with 1/4" control spindle, pack of five, Ref: D49.

ELECTROLYTIC CAP, 800µF at 6.4V, pack of 20. Ref:D48.

ELECTROLYTIC CAP, 1000µF + 100µF 12V, pack of 10. Ref: D47.

MINI RELAY with 5V coil, size only 26mm x 19mm x 1mm, has two sets of changeover contacts. Ref: D42.

MAINS SUPPRESSOR CAPS 1µF 250V A.C., pack of 10. Ref: 1050

TELESCOPIC AERIAL, chrome plated, extendable and folds over for improved F. M. reception. Ref: 1051.

MES LAMP HOLDERS, slide on to 1/4" tag, pack of 10, Ref: 1054

PAXOLIN TUBING 3/16" internal diameter, pack of two, 12" lengths. Ref: 1056.

ULTRA THIN DRILLS, 0.4mm, pack of 10, Ref: 1042.

20A TOGGLE SWITCHES, centre off, part spring controlled, will stay on when pushed up but will spring back when pushed down, pack of two, Ref: 1043.

HALL EFFECT DEVICES, mounted on small heatsink, pack of two, Ref: 1022.

12V POLARISED RELAY, two changeover contacts. Ref: 1032.

PAXOLIN PANEL 12" x 12" 1/18" thick, Ref: 1033.

MINI POTTED TRANSFORMER, only 1.5VA 15V-0V-15V or 30V. Ref: 1064.

ELECTROLYTIC CAP, 32µF at 350V and 50µF section at 25V, in aluminium can for upright mounting, pack of two. Ref: 995.

PRE-SET POTS, one megohm, pack of five, Ref: 998.

WHITE PROJECT BOX with rocker switch in top left-hand side, size 78mm x 115mm x 35mm, unprinted, Ref: 1006.

5V SOLENOID, good strong pull but quite small, pack of two, Ref: 1012.

FIGURE-8 MAINS FLEX, also makes good speaker lead, 15m. Ref: 1014.

HIGH CURRENT RELAY, 24V A.C. or 12V D.C., three changeover contacts, Ref: 1016

LOUDSPEAKER, 8 Ohm 5W, 3.7" round, Ref: 962.

NEON PILOT LIGHTS, oblong for front panel mounting, with internal resistor for normal mains operation, pack of four, Ref: 970.

3.5MM JACK PLUGS, pack of 10, Ref: 975.

PSU, mains operated, two outputs, one 9.5V at 550mA and the other 15V at 150mA. Ref: 968.

ANOTHER PSU, mains operated, output 15V A.C. at 320mA. Ref: 989.

PHOTOCELLS, silicon chip type, pack of four, Ref: 939.

LOUDSPEAKER, 5" 4 Ohm 5W rating, Ref: 939.

LOUDSPEAKER, 7" x 5" 4 Ohm 5W, Ref: 949

LOUDSPEAKER, 4" circular 6 Ohm 3W, pack of 2, Ref: 951

FERRITE POT CORES, 30mm x 15mm x 25mm, matching pair Ref: 901.

PAXOLIN PANEL 8 1/2" x 3 1/2" with electrolytics 250µF and 100µF. Ref: 905.

CAR SOCKET PLUG with P.C.B. compartment, Ref: 917.

FOUR-CORE FLEX suitable for telephone extensions, 10m, Ref: 916.

PROJECT CASE, 95mm x 66mm x 23mm with removable lid, held by four screws, pack of two, Ref: 876.

SOLENOIDS, 12V to 24V, will push or pull, pack of two, Ref: 877.

2M MAINS LEAD, 3-core with instrument plug moulded on, Ref: 879

TELESCOPIC AERIAL, Chrome plated, extendable, pack of two, Ref: 884.

MICROPHONE, dynamic with normal body for hand holding, Ref: 885

CROCODILE CLIPS, superior quality flex, can be attached without soldering, five each red and black, Ref:886

BATTERY CONNECTOR FOR PP3, superior quality, pack of four, Ref: 887.

LIGHTWEIGHT STEREO HEADPHONES Ref: 898.

PRESETS, 470 Ohm and 220 kilohm, mounted on single panel, pack of 10, Ref: 849.

THERMOSTAT for ovens with 1/4" spindle to take control knob, Ref: 857.

12V-QV-12V 10W MAINS TRANSFORMER, Ref: 811.

18V-QV-12V 10W MAINS TRANSFORMER, Ref: 813.

AIR-SPACED TRIMMER CAPS, 2pF to 20pF, pack of two, Ref: 818.

AMPLIFIER, 9V or 12V operated Mullard 1153, Ref: 823.

2 CIRCUIT MICROSWITCHES, icon, pack of 4, Ref: 825.

LARGE SIZE MICROSWITCHES changeover contacts, pack of two. Ref: 825.

MAINS VOLTAGE PUSH SWITCH with white dolly, through panel mounting by hexagonal nut, Ref: 829.

POINTER KNOB for spindle which is just under 1.4", like most thermostats, pack of four, Ref: 833.

CAMCHARGER CAMCORDER BATTERY QUICK CHARGER (WITH RECONDITIONER & TESTER)

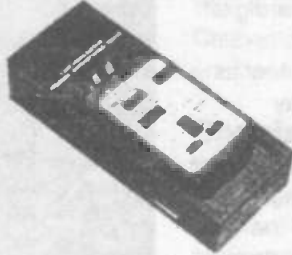

Brand new and boxed. Normal price £35, yours for £15, Order Ref: 15P73.

TOROIDAL MAINS TRANSFORMERS

All with 220/240V primary winding, 0.30V + 0.30V at 120VA, would give you 30V at 4A or 60V at 2A, price £8. Order 8PE2. Order Ref: 8PG2. 0.110V + 0.110V at 120VA would give you 110V at just over 8A or 220V at 1/2A, price £8. Order Ref: 8PG3. 0.35V + 0.35V at 150VA would give you 35V at 4A or 70V at 2A. Price £8. Order Ref: 8PG9. 0.35V + 0.35V at 220VA would give you 35V at 61/2A or 70V at 31/4A, price £9. Order Ref: 9PG4. 0.110V + 0.110V at 220VA would give you 110V at 2A or 220V at 1A, price £10. Order Ref: 10PG5. 0.45V + 0.45V at 500VA would give you 45V at 11A or 90V at 51/2A, price £20. Order Ref: 20PG7. 0.110 + 0.110V at 500VA would give you 110V at 5A or 220V at nearly 3A, price £25, Order Ref: 25PG7.



SUPER WOOFERS. A 10" 4ohm with a power rating of 250W music and normal 150W. Normal selling price for this is £55 + VAT, you can buy at £29 including VAT and carriage, Order Ref: 29P7. The second one is a 8" 4ohm. 200W music, 200W normal. Again by Challenge, price £18. Order Ref: 18P9.

Deduct 10% from these prices if you order in pairs or can collect. These are all brand new in maker's packing.



SOLDERING IRON.

Super mains powered with long life ceramic element, heavy duty 40W for that extra special job. Complete with plated wire stand and 245mm leads. £3, Order Ref: 3P221.

YOU SAVE £40

THE JAP MADE 12V 12A-SEALED BATTERY from regular suppliers costs £50, you can have one from us for only £10 including VAT if you collect or £12 if we have to send. Being sealed it can be used in



any position and is maintenance free. All in tip top condition and fully guaranteed. Order Ref: 12P32. Or if you want a smaller one we have 12V 2.3AH, regular price £14, yours for only £3.50, Order Ref: 3.5P11.

FLASHING BEACON. Uses an XENON tube and has amber-coloured dome with separate bracket. 12V operated. Price only £5. Order Ref: 5P 267.

HIGH RESOLUTION MONITOR. 9" by Philips, in metal frame for easy mounting. Brand new, offered at less than the price of the tube alone. £15, Order Ref: 15P1.

15W 8" SPEAKER AND 3" TWEETER. Amstrad, made for their high quality music centre. £4 per pair. Order Ref: 4P57.

INSULATION TESTER WITH MULTIMETER. Internally generates voltages which enables you to read insulation directly in megohms. The multimeter has four ranges. AC/DC Volts, 3 ranges millamps, 3 ranges resistance and 5 amp range. These instruments are ex-British Telecom but in very good condition, tested and guaranteed OK, probably cost at least £50, yours for only £7.50 with leads, carrying case £2 extra. Order Ref: 7.5P4.

We have some of the above testers but slightly faulty, not working on all ranges, should be repairable, we supply diagram, £3, Order Ref: 3P176.

250W LIGHT DIMMER. Will fit in place of normal wall switch, only £2 each. Order Ref: 2P380. Note these are red, blue, green or yellow but will take emulsion to suit the colour of your room. Please state colour required.

LCD 31/2" DIGIT PANEL METER. This is a multi-range voltmeter/ammeter using the A-D converter chip 7106 to provide five ranges each of volts and amps. Supplied with full data sheet. Special snip price of £12, Order Ref: 12P19.

MINI BLOW HEATER, 1kW, ideal for under desk or airing cupboard, etc. Needs only a simple mounting frame, £5, Order Ref: 5P23.

MEDICINE CUPBOARD ALARM. Will warn when cupboard door is opened. Light makes the bell ring. Neatly cased, requires only a battery. £3, Order Ref: 3P155.

DON'T LET IT OVERFLOW. Be it bath, sink, cellar, sump, etc., this device will tell you when the water has risen to the pre-set level. Adjustable, neatly cased for wall mounting. £3, Order Ref: 3P156.

DIGITAL THERMOMETER. Suitable for outdoors or indoors, has an extra wide temperature range -50° to +70°C, complete with heavy duty battery which should last several years. Its sensor can be outside, but with the read-out inside, £4, Order Ref: 4P104.

SMART HIGH QUALITY ELECTRONIC KITS

All kits are complete with PCB and other components in a blister pack.

If you want more information about them, we have copies of the illustrated Smart catalogue available price £1.

Cat. No.	Description	Price £	Cat. No.	Description	Price £
1003	5 watt electronic siren	2.55	1089	L.E.O. flasher/555 tester	1.61
1005	Touch switch	2.87	1090	Stress meter	3.22
1008	SF function generator	6.90	1093	Windscreen wiper controller	3.68
1010	5-input stereo mixer, with monitor output	19.31	1094	Home alarm system	12.42
1016	Loudspeaker protection unit	3.22	1095	Lead acid battery charger	3.45
1017	Linear CB 30W amp	4.70	1100	2 x 18 watt integrated amplifier	18.39
1020	0.5 min. time switch	4.70	1101	Dollar tester	4.70
1023	Dynamic headphone preamp	2.50	1103	L.E.D. power meter	1.84
1025	7 watt hi-fi power amplifier	2.53	1106	Thermometer with i.e.d.s.	6.90
1026	Running lights	4.60	1107	Electronics to help win the pools	3.68
1027	NiCad battery charger	3.91	1112	Loudspeaker protection with delay	4.60
1030	Light dimmer	2.53	1113	2 x 18 watt power amplifier	5.98
1032	Stereo tone control	3.55	1115	Courtesy light delay	2.07
1035	Space sound effects	2.30	1118	Xxxx-switch, with triac, 0.10 mins	4.14
1039	Stereo VU meter	4.60	1119	Telephone line recording device	5.25
1042	AF generator 250Hz-16kHz	1.70	1123	Morse code generator	1.84
1043	Loudness stereo unit	3.22	1124	Electronic bell	2.76
1047	Sound switch	5.29	1125	Telephone lock	2.68
1048	Electronic thermostat	3.68	1126	Microphone preamplifier	4.60
1050	3-input hi-fi stereo preamplifier	12.42	1127	Microphone tone control	4.60
1052	3-input mono mixer	6.21	1128a	Power flasher 12V d.c.	2.53
1053	Electronic metronome	3.22	1133	Stereo sound-to-light	5.26
1054	4-input instrument mixer	2.76			
1056	8V-20V 8A stabilised power supply	12.42			
1057	Cassette head preamplifier	3.22			
1059	Telephone amplifier	4.60			
1060	+40V 8 A power supply	8.28			
1061	12V 1/2A stabilised power supply	3.36			
1062	5V 0.5A stabilised supply for TTI	2.30			
1063	12V 2A power supply	2.30			
1064	+12V 0.5A stabilised supply	3.22			
1067	Stereo VU meter with leads	9.20			
1068	18V 0.5A stabilised power supply	2.53			
1070	Hi-Fi preamplifier	7.47			
1085	D.C. converter: 12V to 6V or 7.5V or 9V	2.53			
1086	Music-to-light for your car	4.60			

TERMS

Send cash, PO, cheque or quote credit card number - orders under £25 add £3.50 service charge.

J & N FACTORS
Pilgrim Works (Dept. E.T.I.)
Stairbridge Lane, Bolney,
Sussex RH17 5PA
Telephone: 01444 881965

Getting MORE out of PICs

Robin Abbott tackles some PIC functions that give programmers difficulty. This month: a development board for 18-pin 16C84 or 16F84 devices.

Over the past few years there has been increasing interest in projects based on PIC microcontrollers both within ETI and in other magazines. There have also been a number of articles written to introduce beginners to the device. I have been a programming PICs for the last four years, and I have developed a wide range of applications with different needs for functionality and processing power.

In this series I hope to be able to take a design proved in earlier articles and build on them a range of library functions which may be of assistance in a variety of projects. I will be concentrating particularly on functions where I know programmers have had difficulty in the past, or which have a range of uses in different applications.

All of the library functions which I will describe operate as self-contained applications in their own right. Readers may be reassured that they can start with the function, and adapt it to their own use, in the knowledge that it operates correctly in the base application. The functions shown in the articles will also be available on disk, or from the Web.

If people then want another series in ETI introducing readers to the PIC series of microcontrollers, then it may be possible to cover this later in the year.

These are the areas which will be covered in this series:

- Interrupt driven serial communications, and debugging applications in-circuit
- Driving LED displays: multiplexed and non-multiplexed drives
- Driving LCD displays and modules
- Measuring and generating pulses
- Driving the I2C bus
- Using the peripheral functions of the PIC devices
- Using the 8-pin PIC devices

Most of the projects in this series will use a serial port to demonstrate their functions, as this is a cheap and effective method of getting information in and out of a PIC. In this first article we shall consider reading and writing to an RS232 serial interface on a PC.

I shall assume a basic knowledge of PICs and PIC assembler language throughout this series. I shall avoid

unwieldy code listings, instead showing how each application builds up in a series of small modules. All the examples may be compiled and simulated using MPASM and MPSIM, or the PICDESIM program from Forest Electronics.

The 18-pin PIC card

During this series I shall show several applications which run on general purpose development boards. One board is for 18-pin PICs, and the '84' device (16C84 or 16F84) will be used as an example. The other board is for 40-pin PICs, and for these the '74' device (16C74 or 16C74A) will be used as the example.

In this issue I shall consider a small development board for 16C84 or 16F84 devices. The circuit diagram of the board is shown in **figure 1**. It is based on the Basic interpreter module used in ETI over a number of issues in 1995. The component layout is shown in **figure 2**. This board can be easily constructed, and alternatively the circuit can be built on Vero

board. The circuit contains a simple serial interface, which has been shown on a number of projects in the past. It also contains a brown-out reset circuit for protection of the program when the battery is changed, or when connecting or disconnecting a power supply.

The circuit operates with a 4MHz crystal, which is the standard for a low range 84 device. In/Out capability is provided on a 16-pin dual in line socket, which may be used with a short header to connect to an application circuit, or to a prototyping board. Finally the board contains an 8-pin socket for an eeprom device operating from an I2C bus. This allows external storage eeprom, or to provide additional ram.

The circuit is straightforward to construct. Insert the ic sockets first, then the resistors, transistors, capacitors, and the crystal. Finally insert the serial socket, and the power regulator. The board is drilled to accept either a 1A power regulator, or a 100mA regulator.

Delays

There are two methods of generating delays for microcontrollers like the PIC. The first is to use software timing loops, where the delay is introduced by undertaking null operations for a defined period of time to stop the program

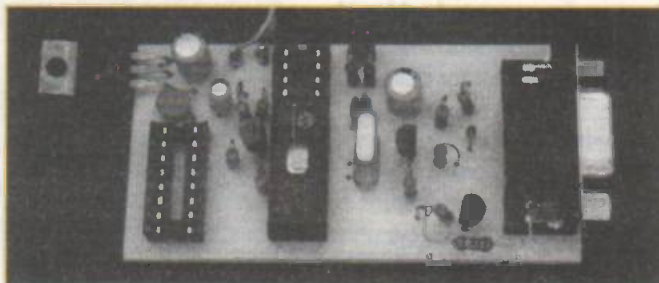

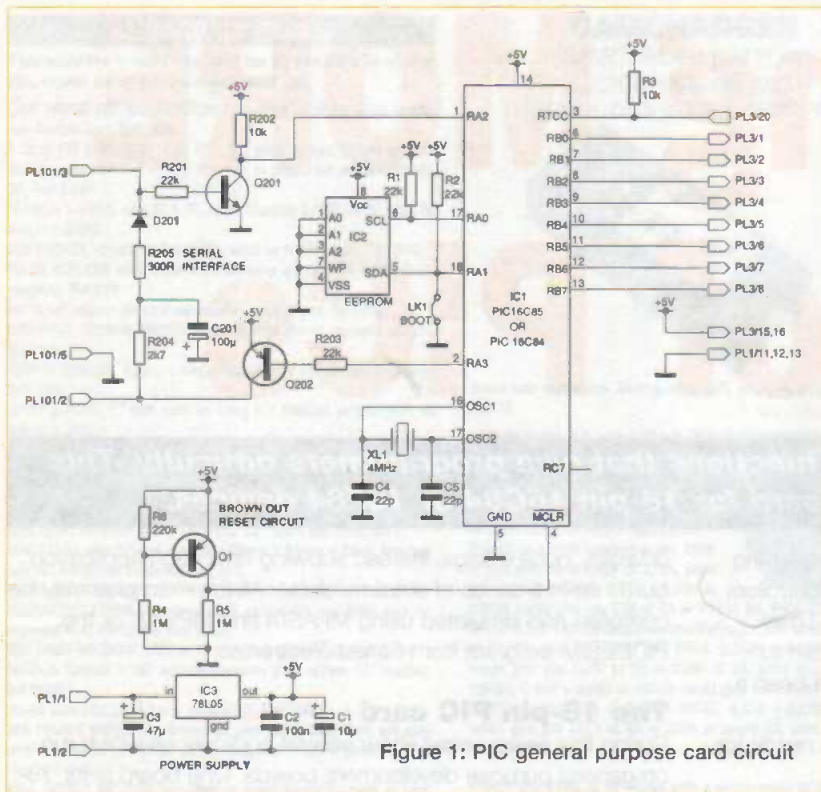

Figure 1: PIC general purpose card circuit

by the main program making the total delay $8+3*(W-1)$.

Listing 1

```

;
; Insert a delay of up to 772 cycles
; Loop time = 5 + 3*(W-1), minimum 5
; Call Delay 1 to add 1 cycle
; Call Delay 2 to add 2 cycles
;
; Remember it takes 2 cycles to call
; this routine, and 1 cycle to load
; W before calling it
;

```

```

Delay2    nop                ; 1
Delay1    nop                ; 1
Delay0    movwf DelayIndex   ; 1
DelayLop  decfsz DelayIndex  ; 1/2
          goto DelayLop     ; 2
Del4      return            ; 2

```

The basic routine (DELAY0) will only delay to the nearest three cycles. To allow any time to be delayed, the routine is preceded by two NOP statements, either of which may be called to add one or two extra cycles.

For the longer time delay it is necessary to use an outer loop. Listing 2 shows a function which calls the short delay function in listing 1 a number of times. In similar fashion to listing 1 the total delay is $730 + (W-1)*728$ cycles.

Listing 2

```

;
; Big delays need an outer loop
; This delays 730 + (W-1)*728 cycles
;
BigDel    movwf DelayIndexH  ; 1
BDLop    movlw 0xf0          ; 1
          call Delay0        ; 724
          decfsz DelayIndexH ; 1/2
          goto BDLop        ; 2
          return            ; 2

```

The routines require two variables to be defined at the top of the program, these are DelayIndex, and DelayIndex1 (shown at the top of listing 3). We now come to the macros shown in listing 3.

Listing 3

```

cblock 0x0c ; Variables in RAM
    DelayIndex
    DelayIndexH ; Delay variables
endc
noexpand
;
; This macro delays an exact
; number of clock cycles between
; 0-at minimum or 186420 at max
;
DELAY macro Cyc
    LOCAL Nx

```

during the delay. This technique has the advantage that the delays may be timed very accurately, normally to within one instruction cycle of the microcontroller. However no other functions may be undertaken during the delay, so this is not a useful technique for long delays.

The second method is to use the device's internal timers, and to detect the end of delay period by the internal counter reaching a pre-set value, or to cause an interrupt when the counter overflows, and to undertake an action as a result of the interrupt. In this article we shall look at the former method, which is used for driving a serial port for the simpler devices. In later articles we shall look at using the internal timer for defining delays.

Software timing loops are quite easy to write for PIC devices, because every instruction takes only one or two instruction cycles. An instruction cycle is four cycles of the device clock, so on the example board the instruction cycle time is 1 microsecond. This allows timing to be determined very simply.

Despite this it can be quite tedious to write exact timing loops for different applications. For this reason the first software that we will look at is a macro which allows a time delay of anywhere between 1 instruction cycle, and 180,000 instruction cycles to be generated within the code automatically. The macro is used quite simply within the program as follows:

```
Delay N
```

Where N is the total number of cycles to delay. We will now examine how the macro operates.

There are two code routines, and the macro inserts calls to these routines. Listing 1 shows the first delay routine which must be included within the program. This routine will delay any period between 7 cycles, and 755 cycles. As shown in the listing, the equation for the total delay is calculated as $5 + 3*(W-1)$. Note that W needs to be loaded and the routine called

Professional Sub-Contract Manufacturing & Suppliers to the Electronics Industry

Do you have a requirement for any of the following services:

- | | |
|---|--------------------------------------|
| PCB Assembly (Conventional and Surface Mount) | Product Design/Consultation |
| Wave & Hand Soldering | Full Procurement Service |
| Complete Equipment Manufacture | PCB Test & "Bum in" Facilities |
| Device Programming from hand written shts or PC 3 1/2" disc | Enclosure Design & Manufacture |
| Cable Harness Assembly/loom Manufacture | PCB Artwork Manufacture |
| Card Cage and Module Wiring | Circuits Drawn Professionally |
| Full Inspection | Kit Procurement & Supply |
| | Component Sales |
| | Refurbishment a speciality |
| | Top Quality Work at Reasonable Rates |

Phone Steve on (01438) 360406 or fax details of your requirements to us on (01438) 352742
EQT LTD, Cromer House, Caxton way, STEVENAGE, HERTS, SG1 2DF

Surplus Electronic Components

Example price each for 25 off quantity:

27256-2	.75	78M09	.16
27C256-120	.75	78M12	.16
27C512-2	1.80	7812	.16
27C1001-20	2.60	7815	.16
CD4046BCN	.20	7906	.20
CD4066BCN	.10	4N25	.10
MC74HC373	.16	LM339N	.09

For a Full List: Write, Phone, e-mail or 24hr Fax-on-demand

Harrison Electronics

Century Way, March, Cambs. PE15 8QW
 email: harrison.electronics@mcmail.com
Tel/Fax:(01354) 651289

Mini waterproof TV camera 40x40x15mm requires 9 to 13 volts at 120mA with composite video output (to feed into a video or a TV with a SCART plug) it has a high resolution of 450 TV lines Vertical and 380 TV lines horizontal, electronic auto Iris for nearly dark (1 LUX) to bright sunlight operation and a small lens with a 92 degree field of view, it focuses down to a few CM. It is fitted with a 3 wire lead (12v in gnd and video out). Now also available with wall mount tilt and swivel case (at the same price). £93.57 + vat = £109.95 or 10+ £89.32 + vat = £104.95

Board cameras all with 512x582 pixels 4.4x3.3mm sensor 9-13 volts power supply and composite video out. All need to be housed in your own enclosure and have fragile exposed surface mount parts. 47MRIR size 60x36x27mm with 6 infra red leds (gives the same illumination as a small torch would) £50.00+vat = £58.75 40MP size 38x38x23mm spy camera with a fixed focus pin hole lens for hiding behind a very small hole. £57+vat = £66.98

40MC size 39x38x28mm camera for 'C' mount lens this gives a much clearer picture than with the small lenses £68.75+vat = £80.83 standard 'C' mount lens F1.8 16mm for 40MC £25.43+vat = £31.06

High quality stepping motor kits (all including stepping motors) 'Comstep' independent control of 2 stepping motors by PC (Through the parallel port) with 2 motors and software. Kit £87.00 ready built £99.00 software support and 4 digital inputs kit £27.00 power interface 4A lot £36.00 power interface 8A kit £46.00 Stepper kit 4 (manual control) includes 200 step stepping motor and control circuit £23.00

DTA30 Hand held transistor analyser it tells you which lead is the base, the collector and emitter and if it is NPN or PNP or faulty (NEW VERSION does not say FETs & SCRs are transistors) DTA30 £38.34

HMA20 hand held MOSFET analyser identifies gate drain and source and if P or N channel HMA20 £38.34

Speaker cabinets 2 way speaker systems with Motorola tweeters

speaker dia	15"	17 1/2"	18"
power rating	250WRMS	175WRMS	100WRMS
impedance	8ohm	8ohm	8ohm
frequency range	40hz-20khz	45hz-20khz	60hz-20khz
sensitivity(1W/1m)	97dB	94dB	92dB
size in mm	500x720x340	450x640x345	315x460x230
weight	21.1kg	16.8kg	7.4kg

price each for:
 black vinyl coating £139.95 £99.99 £54.94
 grey felt coating £159.97 £119.97 £64.99
 (* = not normally in stock allow 1 week for delivery)

Power amplifiers 19" rack mount with gain controls & VU meters

STA300 2x190Wrms (4ohm load) 11kg £339.00
 STA900 2x490Wrms (4ohm load) 15kg £585.00

LED's 3mm or 5mm red or green ... 7p each yellow 11p each cable has 1p each £5.95 per 1000 £49.50 per 10,000

Rechargeable Batteries

AA(HP7) 500mAh £0.99 AA 500mAh with solder tags £1.55 AA 950mAh £1.75 C(HP11) 1.2AH £2.20 C 2AH with solder tags £3.60 D(HP2) 1.2AH £2.60 D 4AH with solder tags £4.95 PP3 8.4V 110mAh £4.95 1/2AA with solder tags £1.55 Sub C with solder tags £2.50 AAA (HP16) 180mAh £1.75 1/3 AA with tags (philipCTV) £1.95 Nickel Metal Hydride AA cells high capacity with no memory, if charged at 100ma and discharged all 250ma or less 1100mAh capacity (lower capacity for high discharge rates) £3.75

Special offers please check for availability stock of 4.42 x 16mm nicad batteries 171mmx16mm dia with red & black leads 4.8v £5.95

5 button cell 6V 280mAh battery with wires (Varta 5x25024) £2.45

Orbitel 866 battery pack 12v 1.6AH contains 10 sub C cells with solder tags (the size most commonly used in cordless screwdrivers and drills 22 dia x 42mm tall). It is easy to crack open and was manufactured in 1994, £8.77 each or £110.50 per box of 14

BCI box 190x106x50mm with slots to house a pcb the lid contains an edge connector (12 way 6mm pitch) and screw terminals to connect to wires and 5 slide in cable blanks £2.95

7 segment common anode led display 12mm £0.45

GaAs FET low leakage current S8873 £12.95 each £9.95 10+ £7.95

BC547A transistor 20 for £1.00

SL952 UHF Limiting amplifier L.C. 16 surface mounting package with data sheet £1.95

DC-DC converter Reliability model V1P25 12v in 5v 200ma out 300v input to output isolation with data £4.95 each or pack of 10 £39.50 Airpax A82903-C large stepping motor 14v 7.5' step 270mm 68mm dia body 8.3mm shaft £8.95 or £200.00 for a box of 30 Polyester capacitors box type 22.5mm lead pitch 0.9uF 250vdc 18p each 14p 100+ 5p 1000+ 1uF 250vdc 20p each, 15p 100+, 10p 1000+ 1uF 50v bipolar electrolytic axial leads 15p each, 7.5p 1000+ 0.22uF 250v polyester axial leads 15p each, 7.5p 100+ Polypropylene 1uF 400vdc (Wima MKP10) 27.5mm pitch 32x29x17mm case 75p each 60p 100+

Philips 123 series solid aluminium axial leads 33uF 10v & 2.2uF 40v 40p each, 25p 100+ Philips 108 series long life 22uF 63v axial 30p each, 15p 1000+ 500pF compression trimmer, 60p Solid carbon resistors very low inductance ideal for RF circuits 27ohm 2W, 68ohm 2W 25p each 15p each 100+ we have a range of 0.25w 0.5w 1w and 2w solid carbon resistors please send SAE for list

P.C. 400W PSU (Initial part 201035-001) with standard motherboard and 5 disk drive connectors, fan and mains inlet/outlet connectors on back and switch on the side (top for lower case) dims 21x145x145mm excluding switch, £25.00 each £138.00 for 8 MX180 Digital multimeter 17 ranges 1000vdc 750vac 2Mohm 200mA transistor Hfe 5v and 1.5v battery test £9.95

Hand held ultrasonic remote control £3.95 CV2486 gas relay 30 x 10mm dia with 3 wire terminals will also work as a neon light 20p each or £8.50 per 100 Verbatim R300NH Streamer tape commonly used on nc machines and printing presses etc. it looks like a normal cassette with a slot cut out of the top £4.95 each (£3.75 100+) Heatsink compound tube £0.95

HV3-2405-E5 5-24v 50mA regulator in 18-264vac input 8 pin DIL package £3.49 each (100+ £2.25)

LM 555 timer ic 16p, 8 pin DIL socket 6p at products advertised are new and unused unless otherwise stated wide range of CMOS TTL 74HC 74F Linear Transistors kits rechargeable batteries capacitors tools etc. always in stock

Please add £1.95 towards P&P (orders from the Scottish highlands, Northern Ireland, Isle of Man, Isle of Wight and overseas may be subject to higher P&P for heavy items). VAT included in all prices

JPG ELECTRONICS

ETI 276-278 Chatsworth Road, Chesterfield S40 2BH
 Access Visa Orders (01246) 211202 fax 550959
 Callers Welcome 9.30am-5.30pm Monday-Saturday



Vann Draper is offering over 30% discount to readers of Electronics Today International on their PM128 3.5 digit LCD panel meter.

The PM128 normally sells at an already low price of £12.87 but is available to readers of ETI magazine for just £8.95 fully inclusive of vat and delivery.

The main features include single 9-12V operation, auto polarity, decimal point selection, high input impedance and an accuracy of 0.5%.

This general purpose panel meter contains high contrast 13mm characters with polarity and over range annunciators. Two on board resistors select either 200mV, 2V, 20V or 200V ranges and the meter may be used for a number of applications including a digital voltmeter, ammeter and frequency meter.

The PM128 digital panel meter is supplied complete with front panel mounting bezel, operating instructions and a 12 month guarantee.

To order simply post the coupon to Vann Draper Electronics Ltd at Unit 5, Premier Works, Canal St, South Wigston, Leicester LE18 2PL. Alternatively telephone 0116 27714000, or fax 0116 2773945.

30% ETI reader offer digital panel meter for just £8.95

Use this coupon for your order

Please supply me:

.....PM128 panel meter(s) at £8.95 inc vat & del

Name:

Address:

Tel no:

Total £.....

Cheques payable to Vann Draper Electronics Ltd
 Or debit my visa, master, access or switch card:

Card type:

Card No:

Expiry date:

Switch iss no:

Signature:

Overseas readers can still obtain this discount but details vary according to country. Please phone or fax.

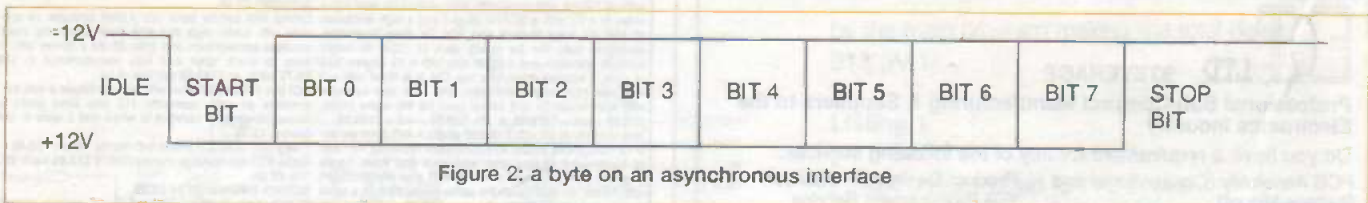

Figure 2: a byte on an asynchronous interface

```

SmallCyc=Cyc
if (SmallCyc<8) ; Short delays
  if (SmallCyc&1)
    NOP
    SmallCyc-=1
  endif
  while (SmallCyc>=4)
    call Del4
    SmallCyc-=4
  endwhile
  if (SmallCyc==2)
    goto Nx
    Nx:
    SmallCyc-=2
  endif
endif

if Cyc>.775 ; Long delays
  BigCyc=(Cyc-.730)
  LoopDelay=BigCyc/.728
  movlw LoopDelay+1
  call BigDel
  SmallCyc=Cyc-(.730+LoopDelay*.728+3)
endif
if (SmallCyc)
  LoopDelay=(SmallCyc-3)-5 ; Delay<=775 Cyc
  movlw LoopDelay/3+1
  call Delay0-LoopDelay%3
endif
endm

```

For delays of less than eight cycles, the macro simply inserts NOP, GOTO, or CALL/RETURN statements to delay the requisite number of cycles. For longer delays the macro inserts calls to the long delay time and/or short delay routines with the correct values loaded to the W register. The number of program words used by the macro is up to three words for delays less than eight cycles, two words for delays between 7 and 775 cycles, and four words for delays greater than 775 cycles.

To use these functions, insert the macro into the program header, or at the top of the first file in the program. The delay functions may then be placed anywhere within the program memory.

Serial interfaces

The standard asynchronous serial interface is quite straightforward to read and to write from a device such as the

PIC. We shall not use any of the hardware flow control signals. (software flow control will be considered in the next article).

Figure 3 shows the waveform for a complete byte sent on an asynchronous serial interface. There are 10 bit periods in total. On the serial interface a voltage of about -12V represents "high", and +12V represents "low". In the idle state the serial interface is high. There is a single low start bit, followed by the eight serial data bits, least significant first. Finally there is a high stop bit. On a typical interface running at 9,600 bits per second at maximum rate, there are actually transmitted 960 bytes per second.

On the general purpose circuit shown in figure 1 the input is inverted and passed to the PIC on pin 1, the RA2 input. The input is also filtered by the negative power supply circuit formed by D20, R204/R205 and C201. This filtered voltage is passed to the output. The idle state is defined by leaving Q202 turned off leaving the output at a negative voltage. To pull it to a high voltage Q202 is turned on by dropping pin RA3 to a low level.

We shall now look at a complete serial application. Listing 4 shows the header and the main loop of a simple application which takes serial character passed to the PIC on the serial interface, and passes it straight back out on the same interface. Note that we will be using the same delay routines as shown above, and therefore the variables DelayIndex and DelayIndex1 are also defined.

In listing 4 the processor frequency and required bit rate are defined. PROCFREQ is the processor frequency in kHz. BIRATE is the required baud rate on the serial interface, this will be one of the standard rates for communicating to a PC, but can be an arbitrary rate if two PICs are communicating. These two values must be set up by the user. From these values the time for a single bit in instruction cycles is calculated in the value BITTIME.

Listing 4

```

#include "p16f84.inc"

cblock 0x20 ; Variables in RAM
  DelayIndex
  DelayIndexH ; Delay variables
  RxByte ; Serial byte received
  Temp ; Temporary variable
  Temp1 ; Temporary variable
endc

```

PROGRAMMER PL1	PC CONNECTOR TYPE:			
	9-WAY FEMALE	9-WAY MALE	25-WAY FEMALE	25-WAY MALE
2	3	2	2	3
3	2	3	3	2
5	5	5	7	7

Figure 3: serial cable connections from the programmer to the host PIC

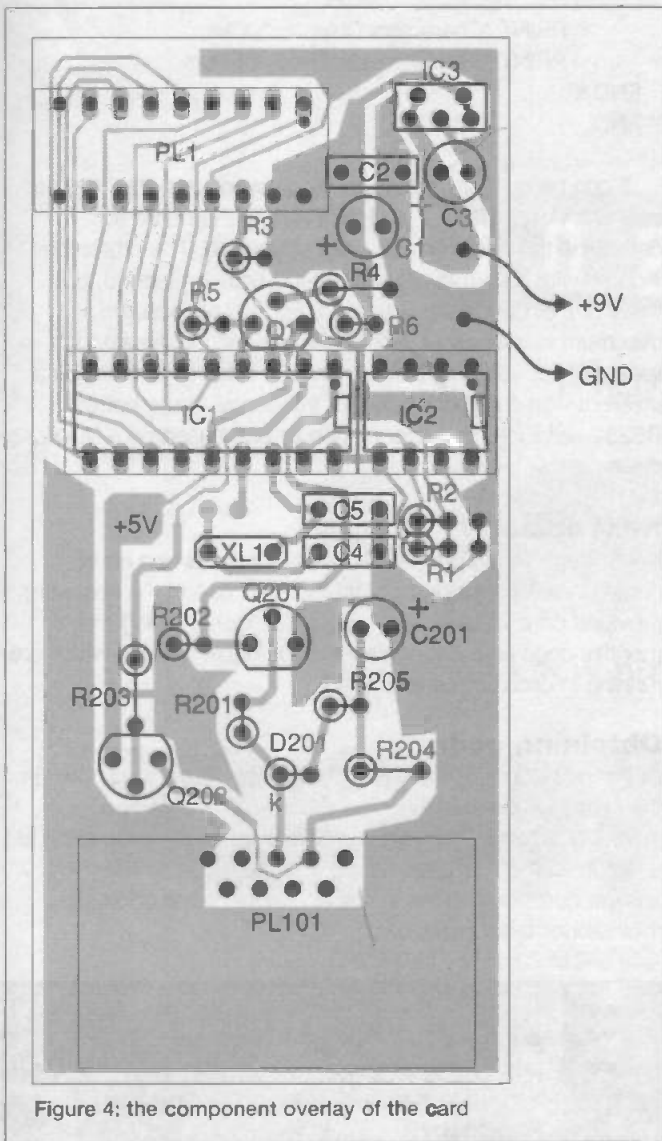

Figure 4: the component overlay of the card

```
RxBit equ 2 ; Receive bit
TxBit equ 3 ; Transmit bit
SerPort equ PORTA ; Serial port
```

```
#define PAGE0 bcf STATUS,RP0
#define PAGE1 bsf STATUS,RP0
```

```
;
;Set up the processor frequency and bit rate
;
```

```
#define PROCFREQ .4000 ; Processor Frequency in kHz
#define BITRATE .19200 ; Baud rate in bps
BITTIME EQU (PROCFREQ*.1000/4)/BITRATE ; Time for a bit in cycles
```

```
start bsf SerPort,TxBit
PAGE1
movlw ~(1<<TxBit) ; set transmit output
andwf SerPort
PAGE0
movlw 'K'
call TxW

lop call Receive
```

```
call TxW
goto lop
```

The main program sets up the ports of the PIC so that RA2 is an input and RA3 is an output. It then calls the function TxW with a letter 'K' in the W register, which sends the letter to an attached PC at power up. The program then enters a continuous loop which waits for a character to be received using the function Receive, the received byte is then transmitted straight back using TxW. The functions Receive and TxW are described below. The function Receive is shown in listing 5.

Listing 5

```
;
;Wait for a byte to be received
;
Receive btfsc SerPort,RxBit ; 1/2 wait for start bit
goto Receive ; 2 Avg. 1.5 cycles here

movlw 8 ; 1 pick up 8 bits
movwf Temp ; 1
DELAY BITTIME*3/2-(BITTIME-7+2+4) ; Wait middle of stop
RxLoop DELAY BITTIME-7 ;
bcf STATUS,C ; 1 sample incoming bit
btfsc SerPort,RxBit ; 1
bsf STATUS,C ; 1
rrf RxByte ; 1 rotate data LSB arrives

first
decfsz Temp ; 1
goto RxLoop ; 2
WaitEnd btfss SerPort,RxBit ; Wait for end of last bit if 0
goto WaitEnd
movfw RxByte
return
```

This function takes only 18 program words. It enters a continuous loop waiting for the input to fall. Once a low is detected, the program waits for half a bit (so that sampling is in the centre of the received bit) and then enters a loop where a single bit delay is incorporated. The input is then sampled and rotated into the variable RxByte which holds the received byte. Once all eight bits are read the function waits for the end of the last bit (to avoid detecting a low bit as a start bit if the function is re-entered quickly). It returns with the received byte in RxByte and the W register.

The function TxW is shown in listing 6. It transmits nine bits in total, the first bit is always 0 (for the start bit), followed by the eight data bits. Finally it waits for at least one bit with the interface in the idle state for the stop bit. Note that some care must be taken to ensure that the bit duration is the same whether a 0 or a 1 bit is to be transmitted.

Listing 6

```
;*****
; Transmit single character in W
;*****
TxW movwf Temp
movlw 9
movwf Temp1
bcf STATUS,C ; first bit is start bit
TxLoop btfss STATUS,C ; 1/2 Set output bit
```

```

goto ZBit ; 2
bsf SerPort,TxBit ; 1
goto NBit ; 2
ZBit bcf SerPort,TxBit ; 1
nop ; 1 Make both arms of loop equal
NBit DELAY (BITTIME-9) ; Wait for next bit
rrf Temp ; 1
decfsz Temp1 ; 1
goto TxLoop ; 2
bsf SerPort,TxBit ; 1 Stop bit
DELAY BITTIME ; 50 Stay idle after Transmit
return ; 2

```

Assembling the application

To make a single file with the complete application ready for assembly the listings shown above are merged as follows. Take listing 4, and add the definition of the DELAY macro shown in listing 3 at the top. Now add the delay routines shown in figures 1 and 2, and the transmit and receive functions shown in listings 5 and 6 at the end of the file. The complete file may then be assembled to create the application. Program a PIC 84 with the code, insert it into the application board, and connect it to a PC on a 9-pin serial interface. The wiring of the cable is shown in figure 4. We are now ready to test the simple serial interface.

Testing and experimenting

The best way to test the interface is to use a terminal emulator. 'Hyper terminal' included with Windows 95 is a good example. Set the emulator to operate on the communications port that you have connected to the PIC, and to set it to 19200 bits per second, 8 bits, no parity, and no flow control. When power is applied to the application board, then characters typed at the PC should be echoed back. A 'K' character should always be received when the board is powered up.

To perform a comprehensive test of the interface, we can use a simple QBasic program, as shown in listing 7. This program transmits random characters to the serial interface, and checks that they are read back correctly.

Listing 7

```
OPEN "COM1:19200,N,8,1,RS,DS,BIN" FOR RANDOM AS #1
```

```
Errors = 0
```

```
Oks = 0
```

```
nc = 0
```

```
CLS
```

```
WHILE ~1
```

```
  RandSend = INT(RND * 64 + 32)
```

```
  PRINT #1, CHR$(RandSend);
```

```
  WHILE LOC(1) < 1: WEND
```

```
  nc = nc + 1
```

```
  in$ = INPUT$(LOC(1), #1)
```

```
  IF ASC(in$) = RandSend THEN
```

```
    Oks = Oks + 1
```

```
  ELSE
```

```
    Errors = Errors + 1
```

```
  END IF
```

```
  IF ((nc MOD 100) = 0) THEN
```

```
    PRINT "Characters OK=" ; Oks;
    PRINT " Characters in Error="; Errors
  END IF
WEND
```

It can be quite instructive to try changing the data rate of interface within the PIC, and then testing the board to determine the maximum bit rates achievable. The prototype worked with no errors at up to 38400 bits per second, but failed at a 57600 bits per second. For safety I assume a maximum rate of about 19200 bits per second is safe for a variety of applications. However higher rates should not be a problem with a higher processor frequency, and a better RS232 serial interface circuit such as one based on a MAX232 device.

Next episode

Next month we shall take a look at interrupt driven serial communications, using both the 84 device, and the hardware provided on a 74 device. We shall also look at using this month's code as a debugging tool to enable devices which are running in circuit to be examined.

Obtaining code

At the end of this series a disk with all the examples shown in the series will be available. The programs may also be downloaded from the web, and a web address will be provided as soon as this has been set up. The author is a happy to answer questions on the series at his own email address: robin.abbott@dial.pipex.com.

PARTS LIST

Parts List for the PIC General Purpose Card

Resistors

R1, R2	22k
R3	10k
R4, R5	1M
R6	220k
R201, R203	22k
R202,	10k
R204	2k7
R205	300R

Capacitors

C1	10u
C2	100n
C3	47u
C4, C5	22p
C201	100u

Semiconductors

IC1	PIC 16C58 or 16C84
IC2	eeprom
IC3	78L05
Q201	BC548
Q1, Q202	BC559
D201	1N4148

Others

XL1	4MHz
PL1	Veropins
PL101	9-pin PCB mounted D connector
PL3	16-pin di1 socket

More than

0 0 2 5 8

Electronic

DESIGNERS

know how to get their

PROTOTYPE PCBs

from their **usual manufacturer** for a

FRACTION of the **COST!**

DO YOU ?

STOP WASTING YOUR MONEY!

CALL NOW: 00353 61 701170

Beta
LAYOUT
PCB-POOL®

get
connected

pcbpool@betalayout.ie
<http://www.pcb-pool.com>

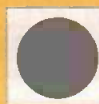

☎ 00353 61 701170
FAX 701164



**8 CAVANS WAY,
BINLEY INDUSTRIAL ESTATE,
COVENTRY CV3 2SF**
Tel: 01203 650702
Fax: 01203 650773
Mobile: 0860 400683

(Premises situated close to Eastern-by-pass in Coventry with easy access to M1, M6, M40, M42, M45 and M69)

OSCILLOSCOPES

Beckman 9020 - 20MHz - Dual Channel.....	£150
Cossor 3102 - 60MHz Dual Channel.....	£250
Gould OS 245A/250/255/300/3000/3351/4000.....	from £200
Hewlett Packard 180A/180C/181A/182C.....	from £200
Hewlett Packard 1740A - 1741A - 1742A - 100MHz dual ch.....	from £350
Hewlett Packard 541000 - 1GHz Digitizing.....	£2995
Hewlett Packard 54200A - 50MHz Digitizing.....	£850
Hewlett Packard 54201A - 300MHz Digitizing.....	£1500
Hiltech V650F - 60MHz Dual Channel.....	£350
Hitachi V152F/V302B/V302F/V353F/V550B/V650F.....	from £125
Intron 2020 - 20MHz Digital Storage (NEW).....	£650
Iwatsu SS 5710/SS 5702 - 20MHz.....	from £125
Kikusui COS 6100 - 100MHz, 5 Channel, 12 Trace.....	£475
Kikusui 5100 - 100MHz - Dual Channel.....	£350
Meguro - MSO 1270A - 20MHz Digital Storage (NEW).....	£650
Nicolet 310 - L.F. D.S.O. with twin Disc Drive.....	£550
Nicolet 3091 - L.F. D.S.O.....	£900
Leroy 9450A - 300MHz/400 Ms/s D.S.O. 2 ch.....	£2250
Philips PM 3211/PM 3212/PM 3214/PM 3217/PM 3234/PM 3240/PM 3243/PM 3244/PM 3247.....	from £125
PM 3262/PM 3263/PM 3540.....	£1750
Philips PM 3295A - 400MHz Dual Channel.....	£1750
Philips PM 3335 - 50 MHz/20Ms/s D.S.O. 2 ch.....	£450
Philips PM 3055 - 50 MHz Dual Timebase.....	£450
Tektronix 434 - 25MHz - 2 Channel Analogue Storage.....	£250
Tektronix 454 - 150MHz - 2 Channel.....	£400
Tektronix 468 - 100MHz D.S.O.....	£750
Tektronix 2213 - 60MHz Dual Channel.....	£425
Tektronix 2221 - 60MHz Digital Storage 2 Channel.....	£1500
Tektronix 2215 - 60MHz Dual trace.....	£450
Tektronix 2235 - 100MHz Dual trace.....	£750
Tektronix 2335 - Dual trace 100MHz (portable).....	£450
Tektronix 2225 - 50MHz dual ch.....	£200
Tektronix 2440 - 300 MHz/500 Ms/s D.S.O. 2 Ch.....	£3750
Tektronix 455 - 50MHz Dual Channel.....	£350
Tektronix 464/466 - 100MHz An storage.....	from £350
Tektronix 465/465B - 100MHz dual ch.....	from £350
Tektronix 475/475A - 200MHz/250MHz Dual Channel.....	from £475
Tektronix 485 - 350MHz - 2 channel.....	£900
Tektronix 5403 - 60MHz - 2 or 4 Channel.....	from £250
Tektronix 7313, 7603, 7613, 7623, 7633, 100MHz 4 ch.....	from £300
Tektronix 7704 - 250MHz 4 ch.....	from £650
Tektronix 7904 - 500MHz.....	from £850
Trio CS-1022 - 20MHz - Dual Channel.....	£125

Other scopes available too

SPECIAL OFFER

HITACHI V212 - 20MHz DUAL TRACE.....	£180
HITACHI V222 - 20 MHz DUAL TRACE + ALTERNATE MAGNIFY.....	£200

SPECTRUM ANALYSERS

Advantest 4133B - 10KHz - 20GHz (60GHz with external mixers) + Ext. Keyboard.....	£7250
Advantest 4131B - 10KHz - 3.5GHz.....	£4950
Ando AC9211 - Spectrum Analyser 1.7GHz.....	£2950
Anritsu MS610B - 10KHz - 2GHz - (Mint).....	£4750
Anritsu MS341A + MS3401B - (10Hz - 30MHz.....	£3995 + £4995
Anritsu MS62B - 10KHz - 1700MHz.....	£2500
Avcom PSA65 S - 1000MHz - portable.....	£1500
Hewlett Packard 3580A - 5Hz-50KHz.....	£995
Hewlett Packard 182T with 8559A (10MHz - 21GHz).....	£3750
Hewlett Packard 35601A - Spectrum Analyser Interface.....	£1000
Hewlett Packard 3562A Dual Channel Dynamic Sig. Analyser.....	£7000
Hewlett Packard 3562A Dual Channel Dynamic Sig. Analyser.....	£7500
Hewlett Packard 853A + 8558B - 0.1 to 1500MHz.....	£3250
Hewlett Packard 182T + 8558B - 0.1 to 1500MHz.....	£2750
Hewlett Packard 8754A - Network Analyser 4-1300MHz.....	£2000
Hewlett Packard 8591A - 9KHz - 1.9GHz.....	£4995
Hewlett Packard 8594E - 9KHz - 2.9GHz.....	£7000
Hewlett Packard 3582A - 0.02Hz - 25.6KHz (dual ch.).....	£2000
Hewlett Packard 3585A - 20Hz - 40MHz.....	£4995
Hewlett Packard 8754A (opt. H26) - 4MHz - 2.6GHz.....	£2950
IFR 7750 10KHz - 1GHz.....	£3250
Marconi 2370 - 110MHz.....	£995
Marconi 2371 - 30KHz - 2000MHz.....	£1250
Meguro MSA 4901 - 1-300GHz (AS NEW).....	£1500
Meguro MSA 4912 - 1-1GHz (AS NEW).....	£1995
Poirad 641-1 - 10MHz - 18GHz.....	£1500
Rohde & Schwarz - SWOB 5 Polyskop 0.1 - 1300MHz.....	£1800
Takeda Riken 4132 - 1.0GHz Spectrum Analyser.....	£2500
Tektronix 7L18 with mainframe (1.5-60GHz with external mixers).....	£2000
Tektronix 495P - 100Hz - 1.8GHz programmable.....	£4950

MISCELLANEOUS

Adret 740A - 100KHz - 1120MHz Synthesised Signal Generator.....	£900
ANRITSU ME 462B DF/3 Transmission Analyser.....	£3000
Danbridge JP30A - 30KV Insulation Tester.....	£1500
Anritsu MG642A Pulse Pattern Generator.....	£1500
Dranetz 626 - AC/DC - Multifunction Analyser.....	£850
EIP 331 - Frequency counter 18GHz.....	£700
EIP 545 - Frequency counter 18GHz.....	£1600
EIP 545A - Frequency counter 18GHz.....	£1600
EIP 575 - Frequency counter 18GHz.....	£1750
Farnell AP70-30 Power Supply (0-70w/30A) Auto Ranging.....	£750
Farnell T5V-70 MKII Power Supply (70V - 5A or 35V - 10A).....	£250
Farnell DSG-1 Synthesised Signal Generator.....	£125
Farnell ESG-1000 Synthesised Signal Generator 1GHz (as new).....	£1650
Fluke 5100A - Calibrator.....	£2500
Guildline 9152 - T12 Battery Standard Cell.....	£550
Hewlett Packard 331A - Distortion Analyser.....	£300
Hewlett Packard 3336C - Synthesised Signal Generator (10Hz - 21MHz).....	£1000
Hewlett Packard 3437A System voltmeter.....	£350
Hewlett Packard 3456A Digital voltmeter.....	£850
Hewlett Packard 3438A Digital multimeter.....	£200
Hewlett Packard 3488A - Switch/Control Unit.....	£650
Hewlett Packard 3560A Dual Ch. Dynamic Signal Analyser.....	£3750
Hewlett Packard 3711A/3712A/3791B/3793B Microwave Link Analyser.....	£2250
Hewlett Packard 325A - 21MHz Synthesiser/Function Gen.....	£1500
Hewlett Packard 3488A - HP - 1B Switch control unit (various Plug-ins available).....	£650
Hewlett Packard 3455A 6 1/2 Digit M/Meter (Autocal).....	£750
Hewlett Packard 3478A - Multimeter (5 1/2 Digit) + HP - 1B.....	£550
Hewlett Packard 3586A - Selective Level Meter.....	£1000
Hewlett Packard 3776A - PCM Terminal Test Set.....	£1500
Hewlett Packard 3779A/3779C - Primary Mux Analyser.....	from £600
Hewlett Packard 3784A - Digital Transmission Analyser.....	£4995
Hewlett Packard 37900D - Signalling Test Set (No 7 and ISDN).....	£6000
Hewlett Packard 4262A - Digital LCR Meter.....	£1350
Hewlett Packard 4275A - LCR Meter (Multi-Frequency).....	£3950
Hewlett Packard 4328A - Millimeter (As New).....	£2000
Hewlett Packard 4342A 'Q' Meter.....	£995

Hewlett Packard 435A or B Power Meter (with 8481A/8484A).....	from £750
Hewlett Packard 4279A - 1MHz C-V Meter.....	£4500
Hewlett Packard 4948A - (TIMS) Transmission Impairment M/Set.....	£1500
Hewlett Packard 4972A - Lan Protocol Analyser.....	£1750
Hewlett Packard 5420A Digital Signal Analyser.....	£350
Hewlett Packard 5335A - 200MHz High Performance Systems Counter.....	£280
Hewlett Packard 5314A - (NEW) 100MHz Universal Counter.....	£500
Hewlett Packard 5316A - Universal Counter (IEEE).....	£1750
Hewlett Packard 5183 - Waveform Recorder.....	£280
Hewlett Packard 5238A Frequency Counter 100MHz.....	£450
Hewlett Packard 5370A - 100MHz Universal Timer/Counter.....	£2650
Hewlett Packard 5384A - 225 MHz Frequency Counter.....	£995
Hewlett Packard 5385A Frequency Counter - 1GHz - (HP1B) with OPTS 001/003/004/005.....	£200
Hewlett Packard 6253A Power Supply 20V - 3A Twin.....	£220
Hewlett Packard 6255A Power supply 40V - 1.5A Twin.....	£225
Hewlett Packard 6266B Power Supply 40V - 5A.....	£1650
Hewlett Packard 6271B Power supply 60V - 3A.....	£1750
Hewlett Packard 6622A - Power Supply, Dual O/P.....	£1500
Hewlett Packard 6623A - Power Supply, Triple O/P.....	£1750
Hewlett Packard 6652A - Power Supply (0 - 20V, 0 - 25A).....	£400
Hewlett Packard 6264B - Power Supply (0 - 20V, 0 - 25A).....	£250
Hewlett Packard 7475A - 6 Pen Plotter.....	£450
Hewlett Packard 7550A - 8 Pen Plotter AS/A.....	£450

HEWLETT PACKARD 6261B Power Supply 20V-50A £450 Discount for Quantities

Hewlett Packard 83555A - Millimeter - Wave source Module 33-50GHz.....	£4250
Hewlett Packard 8015A - 50MHz Pulse Generator.....	£750
Hewlett Packard 8405A - Vector Voltmeter.....	£350
Hewlett Packard 8165A - 50MHz Programmable Signal Source.....	£1650
Hewlett Packard 8350B - Sweep Oscillator Mainframe (various Plug-ins available) extra.....	£2650
Hewlett Packard 8152A - Optical Average Power Meter.....	£1250
Hewlett Packard 8158B - Optical Attenuator (OPTS 002 + 011).....	£1100
Hewlett Packard 8180A - Data Generator.....	£1500
Hewlett Packard 8182A - Data Analyser.....	£2500
Hewlett Packard 8350B - Sweep Oscillator Mainframe (various plug-in options available).....	£2500
Hewlett Packard 8355A - Wave Source Module 26.5 to 40GHz.....	£3500
Hewlett Packard 8620C Sweep oscillator mainframe.....	from £250
Hewlett Packard 8656A - Synthesised Signal Generator (990MHz).....	£2000
Hewlett Packard 8656B - Synthesised Signal Generator.....	£2950
Hewlett Packard 8750A Storage normaliser.....	£375
Hewlett Packard 8756A - Scalar Network Analyser.....	£1500
Hewlett Packard 8757A - Scalar Network Analyser.....	£2250
Hewlett Packard 8903A - Audio Analyser (20Hz - 100KHz).....	£2600
Hewlett Packard 8903E - Distortion Analyser (Mint).....	£2000
Hewlett Packard 8958A - Cellular Radio Interface.....	£3400
Hewlett Packard 8901A - Modulation Analyser.....	£6000
Hewlett Packard 8920A - RF Comms Test Set.....	£9995
Hewlett Packard 8922B - GSM Radio Comms Test Set.....	£280
Hewlett Packard P382A Variable Attenuator.....	£250
Hewlett Packard 1630D - Logic Analyser (43 Channels).....	£2650
Hewlett Packard 16500A - Fitted with 16510A/16515A/16530A/16531A - Logic Analyser.....	£4000
Hewlett Packard 11729B - Carrier Noise Test Set.....	£2000
Krohn-Hite 2200 Lin/Log Sweep Generator.....	£995
Krohn-Hite 4024A Oscillator.....	£250
Krohn-Hite 5200 Sweep, Function Generator.....	£350
Krohn-Hite 6500 Phase Meter.....	£250
Leader 3216 - Signal Generator (100KHz - 140KHz) AM/FM/CW with built-in FM stereo modulator (mint).....	£995
Marconi 2019 - 80KHz - 1040MHz Synthesised Sig. Gen.....	£1450
Marconi 2019A - 80KHz - 1040MHz - Synthesised Signal Generator.....	£1600
Marconi 2022A - 10KHz - 1GHz AM/FM Signal Generator.....	£2000
Marconi 2041 - (10KHz - 2.7GHz) Low Noise.....	£7500
Marconi 2305 - Modulation Meter.....	£1995
Marconi 2610 - True RMS Voltmeter.....	£850
Marconi 2871 Data Comms Analyser.....	£1000
Marconi 2955 - Radio Comms Test Set.....	£3000
Marconi 6960 - Power Meter & Sensor.....	from £950
Philips PM 5167MHz function gen.....	£800
Philips 5190 L.F. Synthesiser (G.P.I.B).....	£2000
Philips 5193 Synthesised Function Generator.....	£1500
Philips 5518 Synthesised Function Generator.....	£350
Philips PM5519 - TV Pattern Generator.....	£525
Philips PM576 - 50MHz Pulse Generator.....	£900
Philips PM6652 - 1.5GHz Programmable High Resolution Timer/Counter.....	£430
Philips PM6673 - 120MHz High Resolution Universal Counter.....	£450
Prema 4000 - 8 1/2 Digit Multimeter (NEW).....	£800
Racal 1992 - 1.3GHz Frequency Counter.....	from £500
Racal Dana 9081/9082 Synth sig. gen. 520MHz.....	£450
Racal Dana 9084 Synth sig. gen. 104MHz.....	£650
Racal Dana 9303 R/F Level Meter & Head.....	£175
Racal Dana 9917 UHF frequency meter 560MHz.....	£375
Racal Dana 9302A R/F multivoltmeter (new version).....	£500
Racal Dana 9082 Synthesised am/fm sig gen (520MHz).....	£300
Racal 9301A - True RMS R/F Multivoltmeter.....	E.P.O.A.
Racal 6116/1615 - GSM Radio Comms Test Set.....	£1600
Rohde & Schwarz LFH2 - 60MHz Group Delay Sweep Gen.....	£300
Rohde & Schwarz Scud Radio Code Test Set.....	£6250
Rohde & Schwarz CMS 54 Radio Comms Monitor.....	£7500
Rohde & Schwarz CMTA 94 GSM Radio Comms Analyser.....	£950
Schaffner NSG 203A Line Voltage Variation Simulator.....	£850
Schaffner NSG 222A Interference Simulator.....	£850
Schaffner NSG 223 Interference Generator.....	£1250
Schaffner WSG 431 Electrostatic Discharge Simulator.....	£4995
Schlumberger 4031 - 1GHz Radio Comms Test Set.....	£350
Schlumberger 2720 1250MHz Frequency Counter.....	from £350
Schlumberger 7060/7065/7075 Multimeters.....	£3500
Schlumberger Stablock 4040 Radio Comms Test Set.....	£2500
Solartron 1250 - Freq. Response Analyser.....	£1200
Stanford Research DS 340 - 15MHz Synthesised Function (NEW) and arbitrary waveform generator.....	£2500
Systron Donner 6030 - Microwave Frequency Counter (26.5GHz).....	£250
Tequipment CT71 Curve Tracer.....	£1500
Tektronix TM5003 + AFG 5101 Arbitrary Function Gen.....	£500
Tektronix 1240 Logic Analyser.....	£500
Tektronix DAS9100 - Series Logic Analyser.....	£500
Tektronix - Plug-ins - many available such as SC504, SW503, SG502, PG508, FG504, FG503, TG501, TR503 + many more.....	£900
Tektronix AM503 + TM501 + P6302 - Current Probe Amplifier.....	£1995
Tektronix PG506 + TG501 + SG503 + TM503 - Oscilloscope Calibrator.....	£1995
Tektronix AA5001 + TM5006 M/F - Programmable Distortion Analyser.....	£1150
Tektronix 577 - Curve Tracer.....	£400
Time 9811 Programmable Resistance.....	£550
Time 9814 Voltage Calibrator.....	£700
Toeliner 7720 - Programmable 10MHz Function Gen (AS NEW).....	E.P.O.A.
Valhalla Scientific - 272A Programmable Resistance Standard.....	£12500
Wandel & Goltermann PFJ-8 - Error/Jitter Test Set.....	£11000
Wandel & Goltermann PCM4.....	£950
Wandel & Goltermann PC95A (+ options).....	£600
Wayne Kerr 4225 - LCR Bridge.....	£275
Wayne Kerr 6425 - Precision Component Analyser.....	£850
Wayne Kerr 8905 - Precision LCR Meter.....	E.P.O.A.
Wavetek 171 - Synthesised Function Generator.....	£250
Wavetek 172B Programmable Sig Source (0.0001Hz - 13MHz).....	£250
Wavetek 184 - Sweep Generator - 5MHz.....	£1250
Wavetek 3010 - 1-GHz Signal Generator.....	£1995
Wiltron 6409 - RF Analyser (1MHz - 2GHz).....	E.P.O.A.
Wiltron 6620S - Programmable Sweep Generator (3.6 - 6.5GMz).....	£650

**MANY MORE ITEMS AVAILABLE -
SEND LARGE S.A.E. FOR LIST OF EQUIPMENT
ALL EQUIPMENT IS USED -
WITH 30 DAYS GUARANTEE.
PLEASE CHECK FOR AVAILABILITY BEFORE
ORDERING - CARRIAGE & VAT TO BE ADDED
TO ALL GOODS**

HEADLIGHT DELAY

Let your car headlamps help you to the door with this add-on car circuit
by Terry Balbirnie

After you have driven home in the dark, this circuit will allow you to walk to your front door using the headlamps to light your way. To use the device, you press a button on the unit before getting out of the car. The headlights will then operate and switch off automatically a short while later.

Owners of garages which do not have mains lighting installed will find this circuit particularly useful. The light reflecting from the interior walls will be more than sufficient to light up your route to the door without stumbling over the tools and garden equipment which you always meant to put somewhere safer.

Dashboard-mounted

The circuit is housed in a small plastic case mounted under the car dashboard or in some other convenient place. On the front edge is the push-button switch which activates the lights and an LED indicator which shows that the circuit is operating (see photograph). A piece of screw terminal block on the rear is used to link the unit to the car electrical system. Connections will need to be made to four points: the headlight main-beam circuit, to a fuse which is active only while the ignition is on, to a fuse which is live all the time and to vehicle "earth".

There is an on-off switch on the rear of the unit but this will not normally be used because the circuit is usually left switched on. The standby current requirement is very small (about 300uA) so it will not drain the battery significantly while the car is left standing, as long as your battery is in reasonable health. (If you are leaving the car unused for a couple of weeks or more, it is prudent to switch the unit off.) The unit will only work while the ignition is switched off, and this prevents inadvertent operation while the car is in motion. If it were possible to do this, the lights would

come on if the button was pressed accidentally and this could be dangerous and confusing to other road users. If operation needs to be cancelled for any reason, it is only necessary to switch the ignition on then off again.

In the prototype unit, the time delay is adjustable between ten seconds and four minutes approximately. This will be found sufficient for most purposes and will be set for the required effect at the end of construction. It would be a simple matter to extend the period, but the user would need to be sure that the car battery was kept in a good state of charge. If it was drained excessively, the engine would not start the following morning. A pair of headlight filaments require some 120W which corresponds to about 10A on the standard 12V system. Two minutes of operation will only drain the battery by some 0.3Ah or about 1 percent of its total capacity.

How it works

The circuit is shown in figure 1. The timing section does not need to be very sophisticated, because the operating period does not have to be particularly accurate. A simple monostable based on CMOS 555 timer (IC1) will do the job well.

The circuit is powered from a continuous feed ("+12V direct") obtained from the car electrical system. This is made via an existing fuse, internal fuse FS1, on-off switch SW2 and diode D3. FS1 provides protection should a wiring error be made. The diode, in conjunction with capacitor C4, smoothes the supply. This may be thought unnecessary because the circuit only works while the ignition is off, so it will receive a smooth feed direct from the car battery. However, the unit is connected to the electrical system all the time and when travelling along a "noisy" supply from the alternator could possibly cause false triggering.

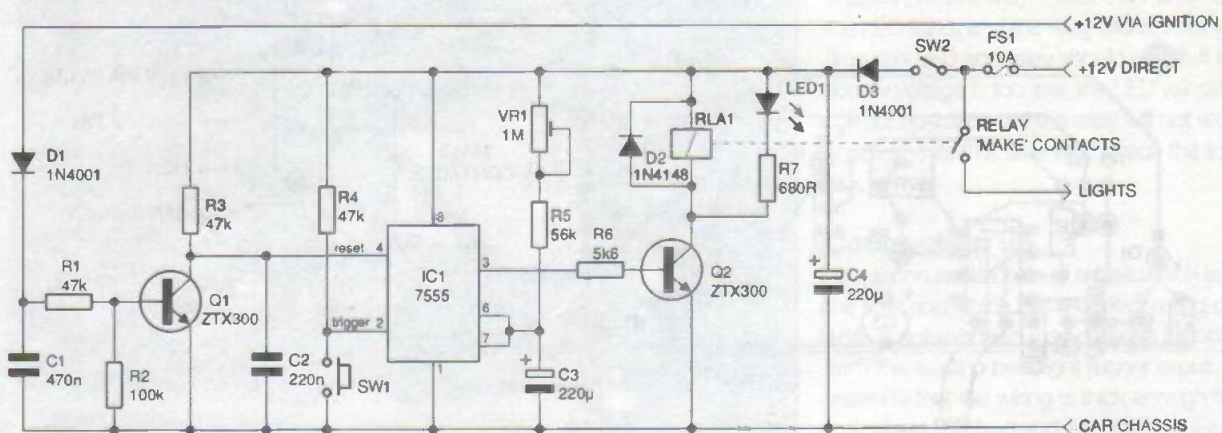
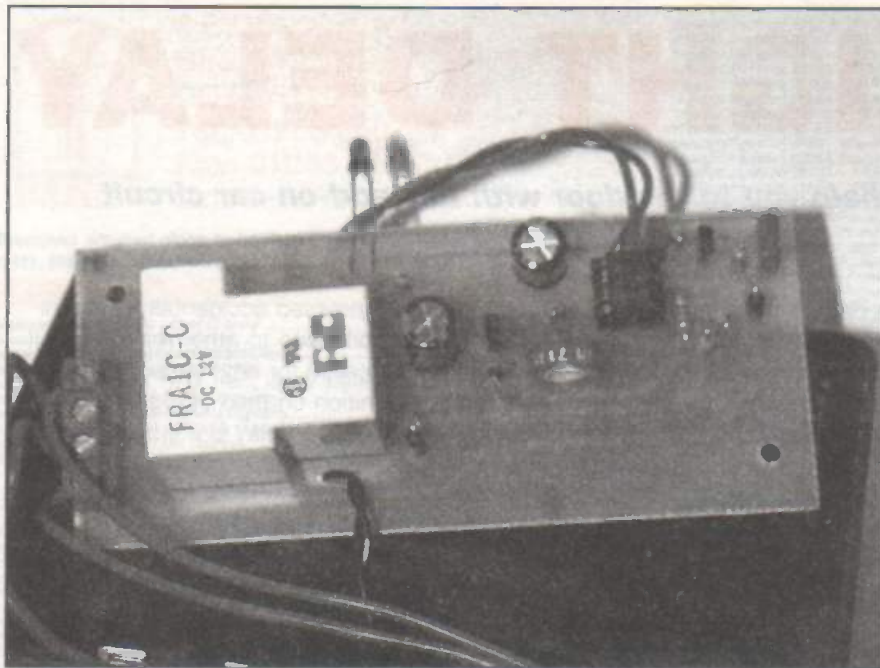

Figure 1: the circuit of the Headlamp Delay



working value by series resistor R7. D2 bypasses the reverse high-voltage pulse which appears across the relay coil when the current switches off. Without this, semiconductor components in the circuit could be damaged.

The time during which the relay remains energised, and the lights on, depends on the time period of the monostable. This, in turn, is related to the values of R5, RV1 and C3. With the values given, this will be some ten seconds (with RV1 wiper at minimum adjustment) and four minutes (when set to maximum). Due to the large tolerance of the electrolytic capacitor used for C3, these timings are subject to fairly wide variation. To extend the timing, the value of C3 could be increased in proportion. However, this would need to be done with caution for the reason mentioned earlier.

Assume for a moment that the ignition is switched off. There is therefore no +12V feed to the anode of D1. Resistor R2 keeps the base of transistor Q1 low so it remains off and no collector current flows. The collector is therefore maintained in a high condition via resistor R3. This high state, when applied to IC1 pin 4 (reset input) enables operation of the monostable. However, nothing will happen until it is triggered by a low pulse applied to the trigger input (pin 2). This is the purpose of push-button SW1. When this is operated for an instant, a low state is transferred to pin 2 and this initiates a timing cycle. R4 keeps pin 2 normally high and this prevents false operation.

While timing, IC1 output (pin 3) goes high and current enters the base of transistor Q2 through current-limiting resistor, R6. Collector current then flows through the coil of RLA1 so energising it. The normally open ("make") contacts then close and direct current from the direct +12V feed to the main beam filaments of the headlight bulbs. At the same time LED1, connected in parallel with the relay coil, operates with current limited to its correct

Feeling Inhibited

When the ignition is switched on, a +12V signal (" +12V via ignition") is applied to the base of Q1 via D1 and R1. The transistor switches on, and the collector goes low. When applied to IC1 pin 4, this resets the ic and inhibits operation. Even if trigger switch SW1 is pressed, nothing will happen. If the ignition is switched on during the course of timing, IC1 will reset and operation will be cancelled. C1 smoothes the signal arriving through D1 to prevent the noisy alternator output from possibly triggering the circuit. C2 keeps IC1 reset input low for a short time when the circuit is powered-up and this prevents possible self-triggering when the supply is first connected.

RLA1 must be chosen with some care and the specified device has worked well. Its "make" contacts must be capable of carrying the large current (about 10A) needed to operate the headlight filaments. However, just as important is their ability to switch the much higher "inrush current" which occurs at the instant of switching on. This comes about because the resistance of the cold lamp

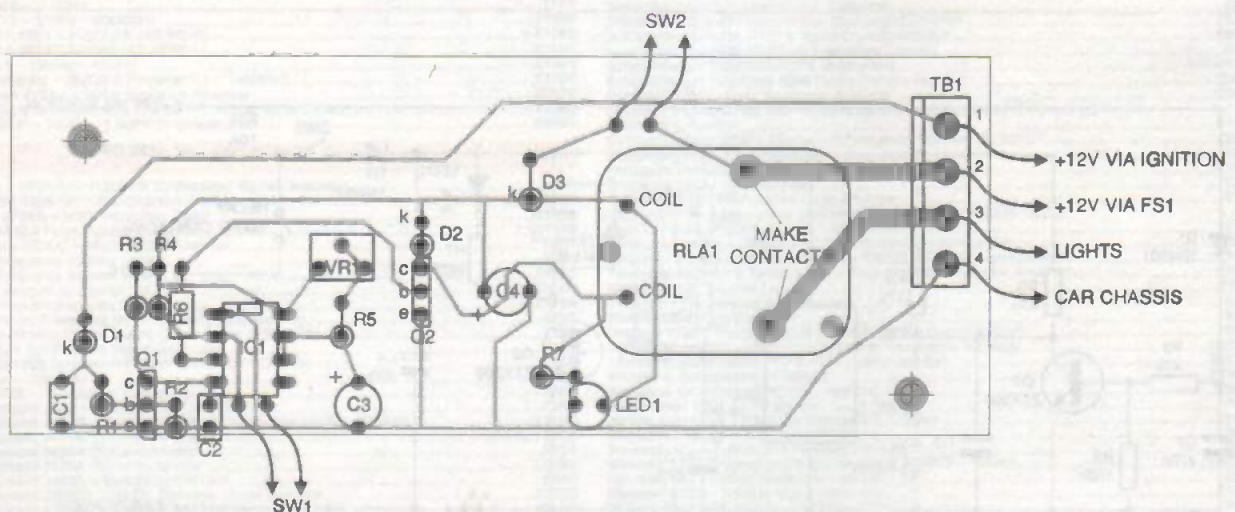

Figure 2: the component layout. Note the reinforced tracks, essential for heavy current-carrying in this project

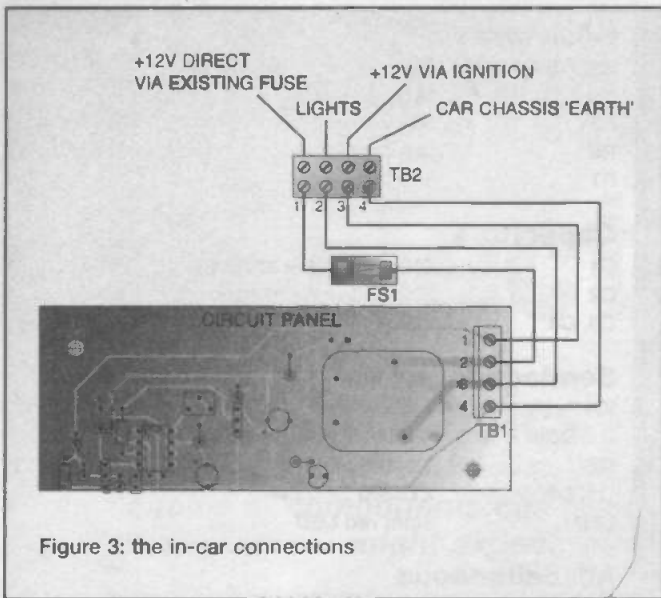

Figure 3: the in-car connections

filaments is much less than at operating temperature. In practice it will probably be necessary to use a relay which has been specially designed for heavy-duty automotive applications (see the Parts List).

Construction

The PCB layout for the Headlight Delay is shown in figure 2. Begin by drilling the two mounting holes in the PCB. Solder the relay, ic socket and PCB-mounting screw terminal block, TB1 in position. Reinforce the tracks from each relay "make" contact pin to the corresponding position on the terminal block. This should be done along the entire length of each track using 18 SWG tinned copper wire as indicated. Doing this is important, because these tracks carry the entire headlight current while the unit is in operation.

Solder all remaining components in place taking particular care over the polarity of the diodes, LED, transistors and electrolytic capacitors C3 and C4. Arrange

for the LED to stand about 15mm above the circuit panel, then bend the leads to right-angles so that the body projects to the front (see photograph). Adjust the preset fully clockwise (as viewed from the top edge of the PCB) to give minimum timing, which will be convenient to begin with. Solder short pieces of stranded connecting wire to the points labelled "SW1" and "SW2".

To prepare the box, begin by drilling a hole in the rear for on-off switch, SW2. Drill two holes to attach the four-section piece of 15A screw terminal block. Allowing space for the fuse holder on the bottom of the box (see photograph), hold the PCB in position bending the LED leads out of the way as necessary. Mark through the mounting holes and drill these through. With the PCB held slightly above the base of the box in its correct position, mark the position of the LED on the front panel. This should be somewhere along the centre line. Remove the PCB and drill a small hole so that the tip of the LED protrudes slightly through it when the PCB is in position. Drill a hole for push-button switch, SW1. Make sure that this and the LED are in a straight line since the final appearance of the unit largely depends on how well this is done. Mount the switches and fuseholder, then attach the PCB using plastic washers on the bolt shanks so that the soldered connections on the underside remain clear of the base of the box. Take care that the top of the relay is not left too high for the lid of the box to be fitted. Wire the "SW1" and "SW2" wires leading from the PCB to the appropriate switches.

Mount the piece of 15A terminal block (TB2) on the rear of the unit. Refer to figure 3 and wire it up. It is essential to use stranded wire of 10A rating minimum for the connections from TB1 terminals 2 and 3. The connections from TB1 terminals 1 and 4 may be made using light-duty wire.

Insert IC1 into its socket. Since this is a CMOS device, it could be damaged by static charge. Touch something earthed (such as a water tap) before handling the pins.

Testing

The circuit can be tested using a bench 12V supply rather than connecting it up immediately to the car system. It will then be easier to correct any small faults. The prototype was even found to work using a 9V battery. Connect the positive and negative terminals of the supply to TB2 terminal 1 (" +12V direct") and TB2 terminal 4 ("car chassis") respectively. Press SW1 and note that the LED lights and the relay clicks. After a short time, the LED and relay should go off. If the supply voltage is too low, the LED will still show correct operation but the relay will not work. If this check shows that all is well, attach the lid of the box.

Connecting up

Locate the outlet side of a fuse which is live all the time and which has a current rating of at least 16A. A suitable feed may perhaps be obtained from the existing headlight flasher circuit. It is essential that the wiring is thick enough to carry the current involved and also that the fuse has sufficient current rating. It may be possible to obtain a supply from the cigarette lighter socket

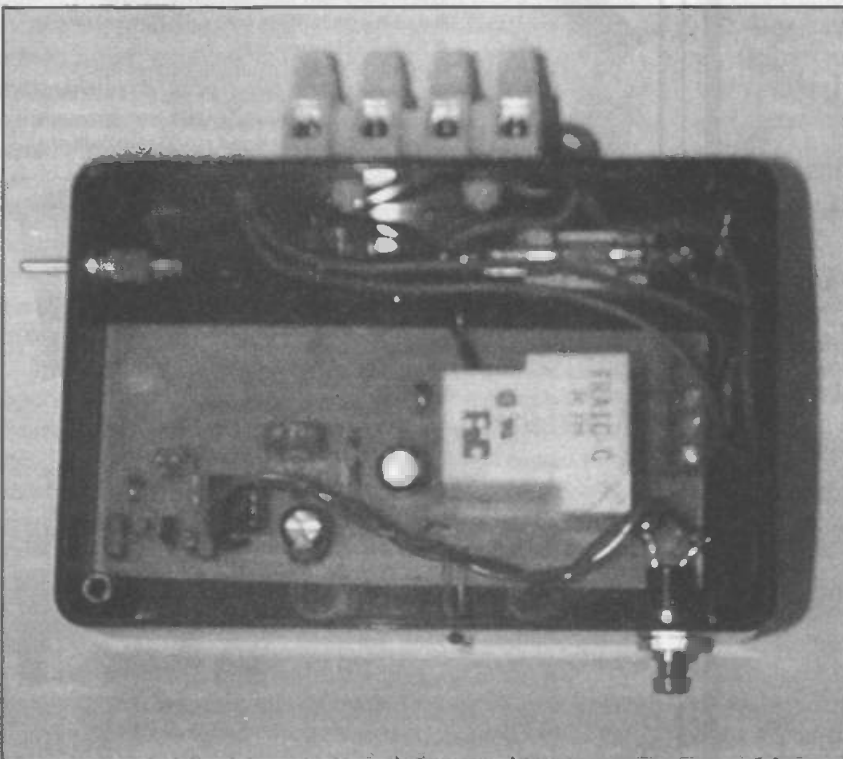

wiring instead, but check that the fuse has sufficient current rating and that the circuit is "live" all the time (that is, with the ignition either on or off). **Do not up-rate a fuse without due care and, if necessary, seeking professional advice.**

Locate the outlet side of a further fuse which only becomes live when the ignition is switched on. Any such fuse will, do because the additional current needed by the circuit is only a fraction of a milliamp. Now, disconnect the car battery positive terminal. This will avoid accidental short-circuits.

Decide on a suitable position for the unit - possibly under the dashboard - and make connections to the terminal block in the following way: From TB2 terminal 1 to the outlet side of the fuse which is live all the time. From TB2/2 to the main beam headlight circuit. This could possibly be made to the output side of the headlamp flasher switch. It is important to make this connection **before** the existing fuses. Use automotive-type wire of at least 10A rating for these two connections. From TB2/3 run a piece of light-duty auto-type wire to the outlet side of the fuse which is live only when the ignition is on. Finally, connect TB2/4 to the vehicle chassis ("earth"). The most convenient method is to find an existing nearby earth point. Again, light-duty wire may be used for this. For all wiring, use automotive connectors of the appropriate type. Also, wherever a wire needs to pass through a hole in metal, a rubber grommet must be used. Do not, under any circumstances, use "twisted and taped" joints. The wiring diagram in the workshop manual will help if difficulty is found with this work. Attach the unit under the dashboard or as required using adhesive fixing pads or a small bracket. Connect the car battery and test the system. Over a period of time, RV1 may be adjusted to provide the required delay.

PARTS LIST for the Headlight Delay

Resistors

R1, R3, R4	47k
R2	100k
R5	56k
R6	5k6
R7	680R

Capacitors

C1	470n 5-mm pin spacing
C2	220n 2.5-mm pin spacing
C3, C4	220u 25V

Semiconductors

IC1	7555
D1, D3	1N4001
D2	1N4148
Q1, Q2	ZTX300
LED1	3mm red LED

Miscellaneous

SW1	Miniature push-to-make switch
SW2	Miniature SPST slide or toggle switch
FS1	20mm 10A "slow blow" fuse and chassis fuse holder
TB1	Four sections of PCB-mounting screw terminal block - 5mm pin spacing
TB2	Four sections of 15A screw terminal block
RLA1	Automotive-type relay with 12V coil and "make" contacts rated at 16A minimum

8-pin dill socket. PCB materials. Plastic box for project. The relay was ordered from Maplin (order code JM26D) as were all other components used in this project.



DISTANCE LEARNING COURSES in:

Analogue and Digital Electronic Circuits, Fibres & Opto-Electronics Programmable Logic Controllers Mechanics and Mechanisms Mathematics

- Courses to suit **beginners** and those wishing to **update** their knowledge and practical skills
- Courses are delivered as **self-contained kits**
- No travelling or college attendance
- Learning is at your own pace
- Courses may have BTEC Certification and Tutoring

For information contact:
NCT Enterprises
Barnfield Technology Centre
Enterprise Way, Luton LU3 4BU
Telephone 01582 569757 • Fax 01582 492928

CONTROL & ROBOTICS from Milford Instruments

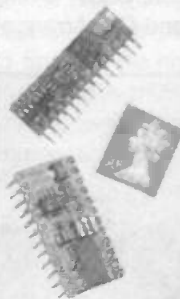

BASIC Stamps-
reprogrammable stamp sized computers
Easy to use BASIC language
● 8 or 16 Input/Output lines each 20mA capability
● 80 or 500 Program lines
● Re-programmable thousands of times from PC or Mac ● 5-12vDC Supply. Stamps from £25.00 each. Development Kits including programming software, Stamp, Cable, Project Board and 25+ Application notes from £79.00.

MUSCLE WIRES
Wires that contract approx 5% when heated (eg 250mA current) -120 page Project book and 3 one metre lengths of wire. £40.00

STAMP BUG
Autonomous roving insect using the BASIC Stamp as its "brain". Approx 300mm overall length. KITS FROM £29.00



LYNX ARM
5 Axis robot arm kit; approx size 300mm. Control from any serial comms port or Stamp. Includes software to run from PC. KITS FROM £85.00



All prices exclude VAT and shipping. For a full catalogue of the above items and other products, please call or fax Milford Instruments at 01977 683665; Fax 01977 681465.

Timing in Electronics

Part 1: The basics - and the workhorse ics

Proper choice of components can make RC timing circuits more accurate than you might expect, as Owen Bishop describes

The concept of time is deeply built into our everyday life, even in such casual phrases as 'Good morning!', 'Hurry up!' and 'Have a nice day!'. All imply the passage of time. Yet the more we probe into the nature of time, the more difficult it is to understand. Does it always run from past to future, or can it sometimes run backward? Does it march relentlessly at a constant rate, or does it pass faster for some people or in some places? But when we emerge, perplexed, from our thoughts on the theories of time and wonder how long it is till tea-time, we have only to glance at the clock to know the answer. Practical time, to us, is real time!

However, this mysterious aspect of the universe can at least be measured locally with a wide range of techniques, some of them of astonishingly high precision. The Earth orbits the Sun, the Moon orbits the Earth and the Earth spins on its axis. These natural physical processes give us our fundamental units of time, the year, the month and the day. Primitive societies do not need any others. With the increasing pressures of agriculture and civilisation, we added hours, minutes and seconds to our timing, and many kinds of instrument to measure them. Some, like the sundial, rely on the spinning of Earth. Others rely on the reasonable constancy of processes such as sand running through a hole, water dripping from a vessel, or a candle burning down. There are sophisticated mechanical devices based on the regular rhythms present in certain physical laws, of which the pendulum and the balance wheel are the two main examples. These are precise enough for almost all everyday timing.

In many fields, electronic clocks have largely replaced mechanical ones. Some of these rely on electrical processes, such as the charging of a capacitor. Some are using electronics only to interface the timing display to a non-electronic process. In a quartz crystal clock, for example, the electronics link the timekeeping circuits to the mechanical vibrations of the crystal lattice. In a caesium atomic clock, electronics are used to probe into the natural time-dependent behaviour of the caesium atom. This will be a practical series, and atomic clocks are a bit too difficult to build at home, so I will direct my attention mainly to charging capacitors and to crystal-based oscillators.

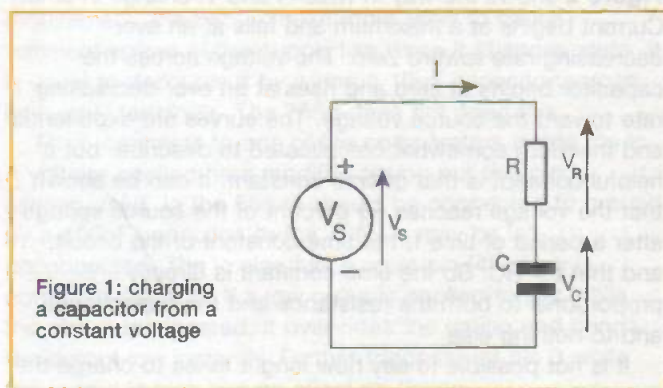

Figure 1: charging a capacitor from a constant voltage

The RC network

In figure 1, current from a constant voltage source V_s is flowing through a resistor of resistance R , and charging a capacitor of capacitance C . At any instant the voltage across the capacitor plus that across the resistor is equal to V_s . At time zero, the capacitor is uncharged, so that $V_C = 0$. The voltage V_R across the resistor is therefore equal to V_s . Current passes through the resistor and, according to Ohm's Law, $I = V_s/R$.

The current begins to charge the capacitor. Over a period of t seconds, the charge in Q coulombs carried by a current of IA is given by $Q=It$. From this we can determine the voltage across the capacitor, which is given by $V_C = Q/C$. All of these equations depend directly on the definitions of the ohm, the coulomb and the farad. Note that if I varies, so do Q and V_C . As current begins to flow into the capacitor, charge builds up and V_C starts to increase. Because of this, V_R starts to decrease, since $V_R = V_s - V_C$. We should therefore re-write the Ohm's law equation as:

$$I = (V_s - V_C)/R.$$

Now we can see what is happening. To begin with, $V_C = 0$ and I has its maximum value, depending on the value of V_s and R . But as soon as charge begins to build up across the capacitor, the voltage across the resistor is reduced to $V_s - V_C$, and there is a corresponding reduction in I .

As I becomes smaller, so the amount of charge carried per second is smaller, and the rate of increase in V_C is

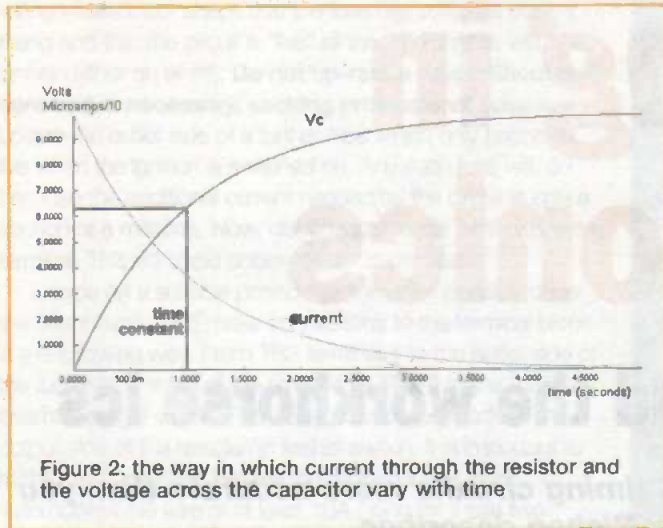

Figure 2: the way in which current through the resistor and the voltage across the capacitor vary with time

smaller. V_c continues to rise but at an ever-decreasing rate. Figure 2 shows the way in which I and V_c change in time. Current begins at a maximum and falls at an ever-decreasing rate toward zero. The voltage across the capacitor begins at zero and rises at an ever-decreasing rate toward the source voltage. The curves are exponential and therefore somewhat complicated to describe, but a helpful concept is that of *time constant*. It can be shown that the voltage reaches 63 percent of the source voltage after a period of time t , the time constant of the circuit, and that $t = RC$. So the time constant is directly proportional to both the resistance and the capacitance, and to nothing else.

It is not possible to say how long it takes to charge the capacitor to the full source voltage. In theory, it never charges completely, such is the nature of an exponential curve. There may be practical reasons too, for most capacitors have a certain amount of leakage and eventually the charging current just equals the leakage current, and no more charge is stored. As a rule of thumb, we can take it that the capacitor is fully charged (actually just over 99 percent) after 5 time constants.

Practical resistors

Since the time taken to charge a capacitor depends on the value of the resistor, any critical timing circuit based on capacitor charging required precise and stable resistors. A 5 percent tolerance resistor gives a timing error up to 5 percent, which may be acceptable in an egg-timer but not in a digital clock. For most circuits, we use 2 percent or 1 percent tolerance metal film resistors, with tempcos (temperature coefficients) in the range ± 50 to ± 200 parts per million per degree Celsius. For more critical circuits, metal film resistors with 0.1 percent tolerance are obtainable with a tempco of only ± 15 ppm/degrees C. For the most precise work (but see next paragraph), there are wirewound 0.1 percent precision resistors with a tempco as low as ± 3 ppm/degrees C at temperatures around room temperature. For the really precise circuits such as digital clocks we abandon the RC network in favour of the crystal oscillator.

Practical capacitors

The time constant of a circuit is no more precise than the least precise of the components. There is no point in using a high-precision resistor in conjunction with a low-

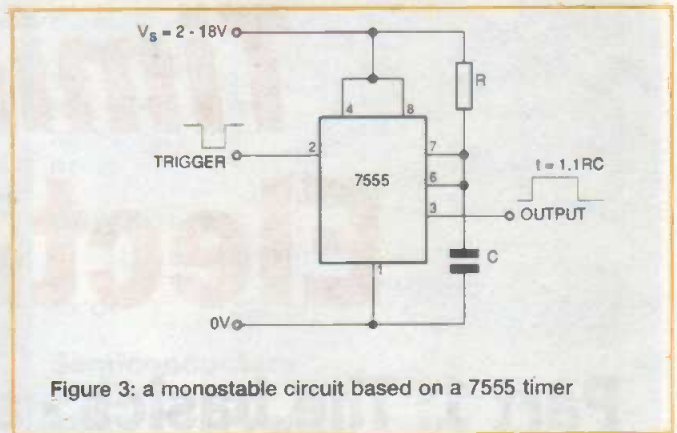

Figure 3: a monostable circuit based on a 7555 timer

precision capacitor. Unfortunately the precision of readily available capacitors does not match that of resistors. The only really precise capacitors are polystyrene foil with a tolerance of 1 percent and a tempco of -125 ± 60 ppm/degrees C. The next most precise are multilayer ceramic capacitors type COG or NPO. These have only 2 percent tolerance but their tempco is low, from zero to 30 ppm/degrees C.

So, if you trim the resistor to match the particular capacitor that you are using, you can obtain a temperature-stable time constant. Note that not all ceramic multilayer types are suitable. The Z5U type, for example, has tolerances of -20 percent to +80 percent and a very high tempco from +22 percent (Yes, percent) to -56 percent. There is no use for this in a timing circuit.

The problem with the capacitor types described above is that they are not available in values larger than about 10nF. This keeps time constants short, in the milliseconds range. If a longer time constant is required, we can use polycarbonate capacitors, which range up to 10uF. These give us time constants of seconds or tens of seconds duration. They generally have 5 percent tolerance and a tempco of less 1 percent/degrees C, and much less at temperatures around room temperature. The relatively poor tolerance can be circumvented by including a variable resistor in the network and adjusting this to adjust the timing. If we need a longer time constant we would need to use capacitors of 100uF or more. The only way to obtain capacitance of this order is to employ aluminium

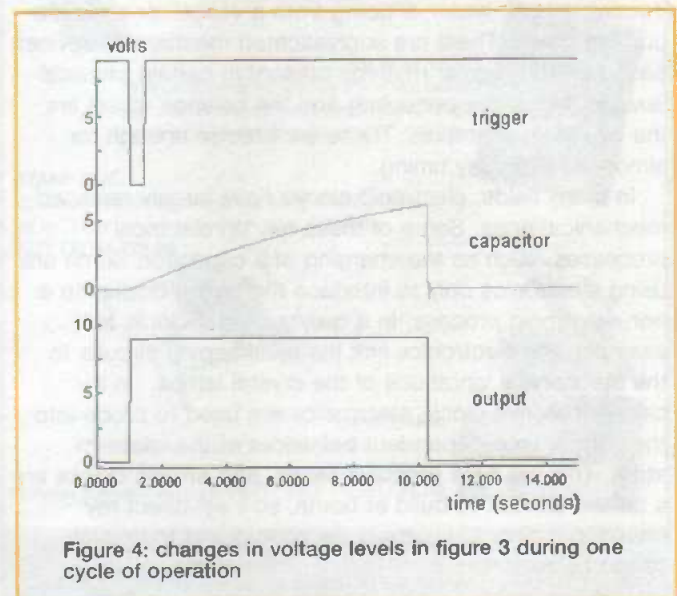

Figure 4: changes in voltage levels in figure 3 during one cycle of operation

electrolytic capacitors or tantalum capacitors. These always have very poor tolerance (+/-20 percent is typical). They also have rather large leakage currents, typically 1uA to 3uA, which compares badly with the types mentioned above which have resistances of the order of 10 gighoms to 1 tera-ohm, making leakage currents at 10V, only 100pA or much less. The capacitance of the aluminium electrolytic type alters appreciable with age, and also depends on the voltages they have been subjected to in use, which means that timing circuits must be readjusted regularly. In summary, these two types of capacitor are suitable only for the most inexact of timing circuits. The choice remains between polystyrene film, COG/NPO, and polycarbonate, of which the latter type is probably the most generally useful. Polyester capacitors can sometimes be used when low precision and stability is acceptable.

The 555 timer ic

The design of timing circuits was revolutionised with the introduction of the 555 timer ic. Since this versatile ic first came on the scene in 1972, it has been put to innumerable applications, many of them only vaguely related to timing. It is possibly one of the most useful ics ever produced. It works on the basis of charging and discharging a capacitor through a resistor, and there are two basic circuits. **Figure 3** shows the simplest of these, in which the ic is connected as a monostable multivibrator, a circuit which produces a single output pulse of specified length when it is triggered.

One of the difficulties in designing reliable timing circuits is detecting when the capacitor has charged exactly to a given level. As **figure 2** shows, the rate of increase of voltage across the capacitor is very slow after 2 time constants, with more scope for error. It is important to restrict the timer to the earlier stages of the charging curve to get a sufficiently precise switching point. The timing period in the 555 (and the 7555 and other more recent CMOS-based timer ics) begins with the capacitor discharged and ends when it is charged to 2/3 the supply voltage.

Treating the ic as a black box, we need only be concerned with what connections need to be made to it. Pins 8 and 1 are connected, respectively, to the positive and ground supply lines. The positive supply may have any value between 4.5V and 15V for the original BJT-based 555 timer, or from 2V to 18V for the CMOS-based 7555 version.

Figure 4 shows the input and output voltage levels during one cycle of operation. This starts when a negative pulse is applied to the trigger pin (pin 2, upper curve). Normally this is held at supply voltage (9V in this example) and is brought down to below 1/3 of the supply for an instant. Pin 6, the threshold input, monitors the voltage across the capacitor. This is plotted as the middle curve in **figure 4**, revealing the exponential rise of charge across the capacitor. The output comes from pin 3 (lower curve). It is normally low but rises almost instantly to the supply voltage when the timer is triggered. When the capacitor charge reaches 2/3 of the supply (6V in this example) pin 7 rapidly discharges the capacitor to ground. At the same time output at pin 3 falls almost instantly to zero. The time taken for one cycle is:

$$t = 1.1RC$$

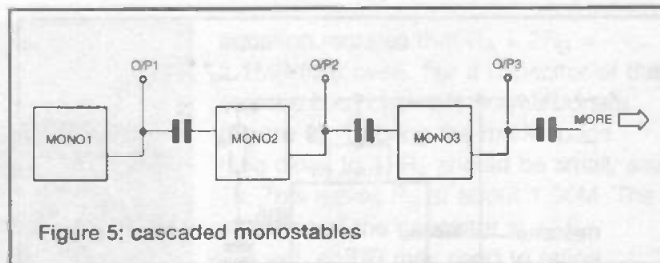

Figure 5: cascaded monostables

where time is in seconds, R is in ohms and C is in farads. The higher the supply voltage the greater the current through the resistor, but the higher the shut-off voltage that is to be reached. These two requirements cancel out so the timing period is completely independent of supply voltage, a important feature in battery-powered circuits.

The output can sink or source 200mA in the 555 or 100mA in the 7555, so this ic has effective driving ability. In general, it is preferable to use the 7555 version because it requires much less operating current (120uA at 18V) than the 555 (10mA at 15V). Because of its higher current requirement, the 555 is much more likely to cause transient spikes of the supply line when it changes state. It is usual to decouple it by wiring a 10uF capacitor across its supply terminals. The 7555 does not need this.

Pin 5 connects to one of the comparators inside the ic. A voltage applied here modifies timing but this pin is seldom used. In the 555 is should be connected to ground by a 100nF capacitor. In the 7555 is may be left unconnected. The ic also has a reset pin (4) which is normally held high. If a low pulse is applied to this while the circuit is triggered, it over-rides the timing and brings the output low instantly. Further triggering at pin 3 while the output is high has no effect on timing.

Monostables are often used in logic and other circuits to produce pulses of predefined length (usually in the microsecond or millisecond range) for co-ordinating the timing in different parts of the circuit.

Cascaded monostables

Multistage process-timing can be obtained by cascading several 555 monostables. All that is needed is a capacitor connecting the output of one stage to the trigger input of the next (**figure 5**). As the output of one monostable goes low the low-going edge produces a downward pulse in the trigger input of the next stage.

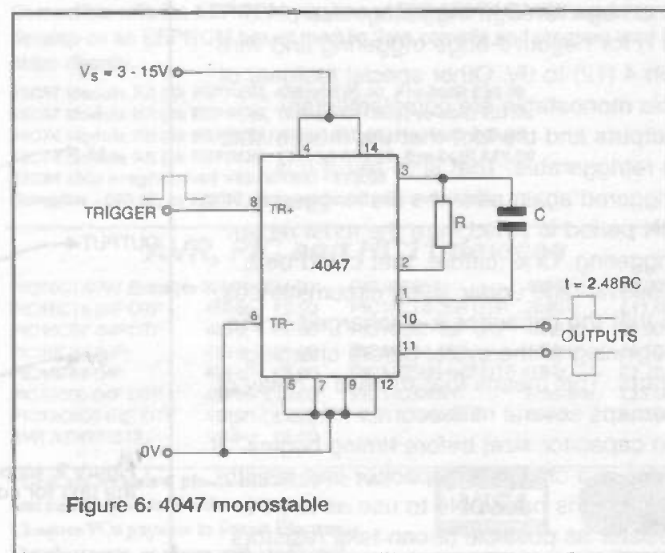

Figure 6: 4047 monostable

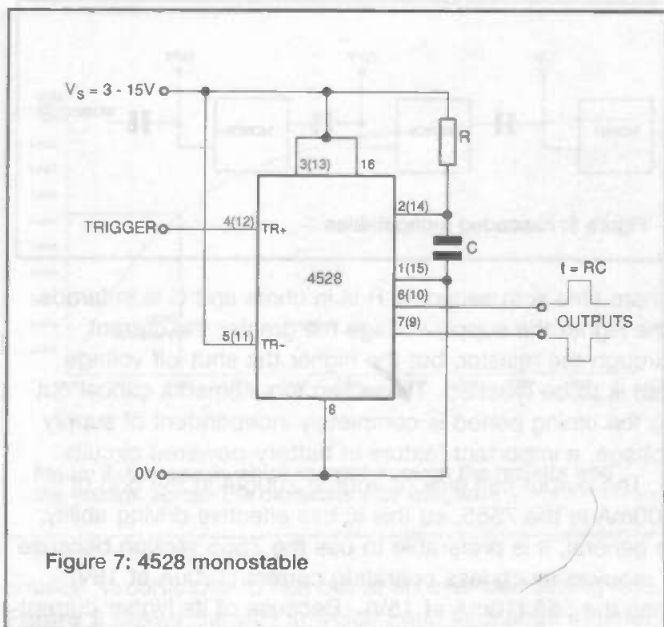

Figure 7: 4528 monostable

4047 monostable

Although the 555 is the standard work-horse for simple timing circuits, there are a few other ICs that perform a similar function and have some special features that are useful in certain applications. A popular example is the CMOS 4047 IC (figure 6). It has two features that the 555 lacks. One is that it is triggerable by either a positive pulse or a negative pulse. The figure shows the connections for a positive pulse applied to pin 8. To use a negative trigger instead, wire pin 8 directly to the positive supply and apply the pulse to pin 6. The second special feature is that the IC has two complementary outputs, delivering a positive output pulse from pin 10 and a negative pulse from pin 11. This IC operates over the range of supply voltage usual for CMOS, 3-15V. The timed period is $2.48RC$.

4528 monostable

The 4528 IC (which has replaced the 4098) contains two identical monostables. In figure 7 the pin numbers in brackets are for the second of these. The timed period is 1 time constant, $t = RC$. The Clear input (pin 3/13), normally held high, resets the timer when pulsed low, and timing can not begin until the Clear input is made high again. The IC has positive-edge and negative-edge triggering. Use pin 5 (11) for negative-edge triggering and wire pin 4 (12) to 0V. Other special features of this monostable are complementary outputs and the fact that the monostable is retriggerable. That is to say, if it is triggered again after the first triggering, the ON period is timed from the most recent triggering. One feature, that could be a disadvantage under some circumstances, is that the capacitor is discharged at the beginning of the cycle, before charging starts. This means that there is a delay of perhaps several milliseconds (depending on capacitor size) before timing begins. If there is a choice of capacitor and resistor values, it is preferable to use as large a resistor as possible (it can take resistors

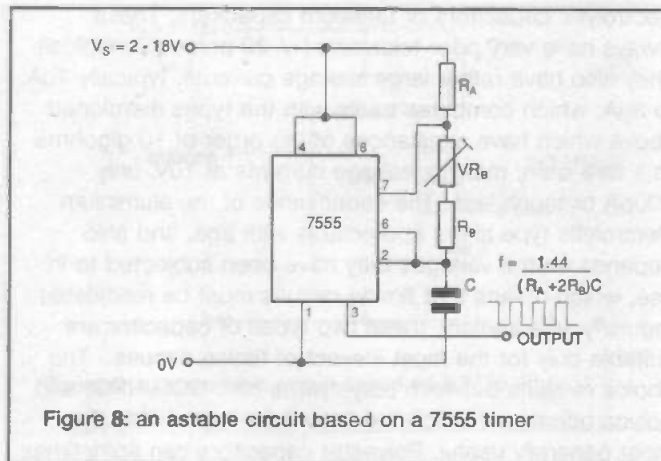

Figure 8: an astable circuit based on a 7555 timer

from 10 kilohms to 10 megohms) so that the capacitor, and hence the start-up delay is as small as possible.

555 astable

By connecting the trigger input of the 555 to its output, we make the IC trigger itself at the end of every pulse. This makes it produce a continuous series of pulses instead of only one pulse. There are two timing resistors in the astable circuit (figure 8). The charging current flows through R_A and R_B in series, charging the capacitor from $1/3$ of V_S to $2/3$ of V_S . The length of the high output is given by $t_H = 0.69(R_A + R_B)C$. At the end of the high period, the capacitor is discharged through R_B only, and output is low. This is not instantaneous discharge as in the monostable and the period of discharge is $t_L = 0.69R_B C$. Combining these two equations we obtain an equation for the frequency of the astable:

$$f = 1.44 / (R_A + 2R_B)C$$

The equations show that the ON time is necessarily longer than the OFF time. In other words, the mark-space ratio is greater than 1. There are ways to produce a ratio less than 1, which we shall discuss in the next part of this series.

A practical astable

This module generates a square-wave signal of a fixed frequency, and mark-space ratio depending on the choice

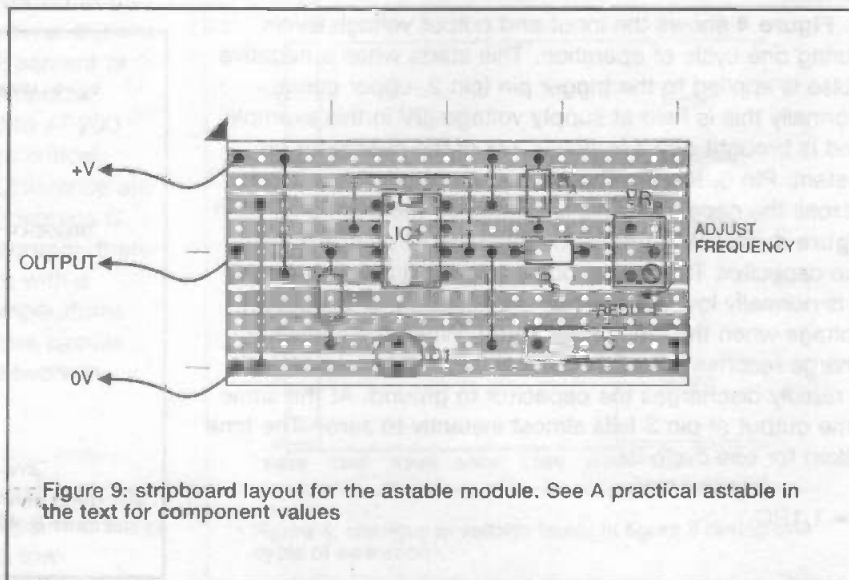
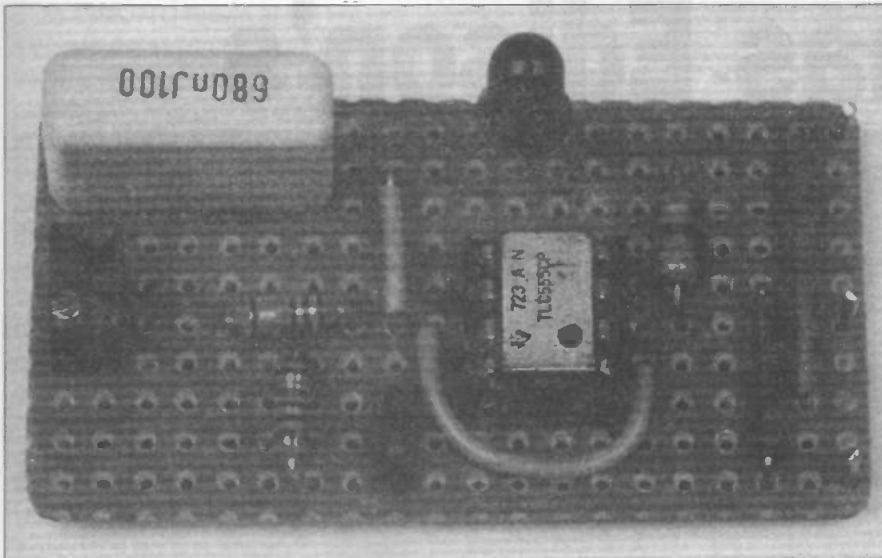

Figure 9: stripboard layout for the astable module. See A practical astable in the text for component values



The stripboard layout for the astable module

of resistor and capacitor values. For the example, we have picked a frequency of about 1Hz, so that it can be used for flashing an LED, or a low-voltage filament lamp, or for pulsing a solid-state buzzer. As an LED flasher, it is an accurate timer for counting seconds, or it can serve as a thief-confuser if disguised as an element in a simulated home or car security device. It could also drive a relay which could then be used to switch other electrical devices on and off at regular intervals.

To obtain a frequency around 1Hz we expect to use a capacitor of about 680nF. Given this capacitor, the

equation requires that $R_A + 2R_B = 2.1\text{MR}$ (just over). For a capacitor of this size the best choice is polycarbonate (figure 9). To bring the mark-space ratio close to 1, R_A should be small, say 1k. This leaves R_B at about 1.06M. The precision of the capacitor is +/-5 percent, so R_B may need to range between 1.01M and 1.11M. Use a 1M fixed resistor (metal film) and 100k preset.

This does not quite cover the required range but it uses easily obtainable standard types and, if you find you can not adjust the timing, try a different 1M resistor. We used a 6-turns preset to allow the timing to be set more easily.

If the astable is intended to drive an LED, a series resistor is required. Given that the supply voltage is 9V, and the LED is to take about 10mA, the required value is $(9-2)/0.01 = 700\Omega$. A standard 680 resistor is suitable. The astable can directly drive a 9V filament lamp, a solid-state buzzer, or a relay rated to operate on 9V. If lamps or relays of other operating voltages are to be driven, the circuit can be powered by any voltage in the range 2V to 18V.

This module is simple to construct and is the basis for other more elaborate circuits that will be described along with other astable devices in subsequent parts of this series.

Microcontroller development Tools from FED

PIC & AVR Microcontroller Programmers

PIC Original - 16C5X, 16C55X, 16C6X, 16C7x, 16x8x. Price : £40/kit £50 built & tested.

PIC Serial - Handles newer PIC devices in a 40 pin multi-width ZIF socket. 16C55X, 16C6X, 16C7X, 16C8x, 16F8X, 12C508, 12C509, PIC 14000. Also In-Circuit programming. Price : £40/kit, or £50 built & tested.

PIC Introductory - Programs 8 & 18 pin devices : 16C55X, 16C61, 16C62X, 16C71, 16C71X, 16C8X, 16F8X, 12C508, and 12C509. Price £22/kit.

AVR - Programs all current DIP devices in a 40 pin ZIF. Price : £40/kit £50 built & tested.

Note : All our programmers operate on a PC, using a standard RS232 serial interface (COM1, 2, 3, or 4). No hard to handle parallel cable swapping ! All programmers are supplied with instructions, Windows 3.1/95/NT assembler and programming software for the AVR or PIC.

AVR, PIC, & HC11 Windows Based Development:

Simulator allows assembly and simulation of your AVR, PIC or HC11 projects in one Windows program. Incorporate multiple files, view help file information directly from the code, edit within project, build and track errors directly in the source, then simulate. Simulator allows 3 breakpoint types, follow code in the source window, set breakpoints directly in code. Run programs, or single step, or step over subroutines. Track variable values and trace for display on the Trace Analyser. Input stimuli include clocks, direct values and asynchronous serial data. Profile your program - examine frequently called routines which are timed and use the information to optimise out bottle necks. PIC Version Simulates up to 50 times faster than MPSIM !

32 bit version allows full use of W'95/NT4.0 facilities & long filenames.

Cost £30.00, or £25.00 for existing and new purchasers of any of our programmers. Please specify Windows 3.1, or Windows '95 (32 bit) and either AVR, PIC, or HC11 version

PIC BASIC

FED's PIC BASIC products - straightforward, capable, powerful, rapid development.

Operating in a Windows Development Environment our modules need no assembler or UV eraser to program your PIC's, and operate from a serial link to your PC. The 16C74 module features - 8k EEPROM, up to 2000 lines of BASIC, 27 lines of programmable I/O, 8 A/D inputs, Interrupt driven serial RS232 interface, Peripheral I²C bus Interface, LCD display driver routines, up to 178 bytes for variables and stack, extendible with optional external RAM and all the standard 16C74 features. Ask about the 16C57 version.

Compiler - The FED PIC BASIC compiler for the 16C74. It produces hex code to program your 16C74 directly with no need for external EEPROM. Compatible with the EEPROM versions of PIC 16C74 BASIC modules - develop on an EEPROM based module then compile and program your PIC chips directly.

16C57 Module Kit (8k EEPROM, 4MHz) £25.00, Pre-built £30.00

16C57 Module KH (8k EEPROM, 10MHz) £31.00, Pre-built £37.00

16C74 Module KH (8k EEPROM, 4MHz) £35.00, Pre-built £42.00

16C74 Module KH (8k EEPROM, 20MHz) £40.00, Pre-built £46.00

16C84 chip programmed with BASIC - £25.00

Compiler - £60.00, or £50.00 when ordered with a module

AVR, PIC and HC11 devices

PIC16C74/JW Erasable	20MHz	£24.00	PIC16C558	4MHz	£5.00
PIC16C74-04POTP	4MHz	£8.00	PIC16C74-20P OTP	20MHz	£11.00
PIC16C57-04POTP	4MHz	£5.00	PIC16C57-10P OTP	10MHz	£6.00
PIC16C84-04P	4MHz	£6.00	PIC16C84-10P	10MHz	£8.00
PIC16F84-04P	4MHz	£6.00	PIC12C508-04P OTP	4MHz	£2.20
PIC14000-04P OTP	4MHz	£10.00	PIC14000/JW Erasable		£23.00
PIC12C508-04P OTP	4MHz	£2.70	AVR AT90S8515	8MHz	£12.00
AVR AT90S2313	12MHz	£8.00			

Prices are inclusive, please add £3.00 for P&P and handling to each order.

Cheques/POs payable to Forest Electronic Developments, or phone with credit card details. Serial Cables - £7.50.



Forest Electronic Developments

15 Springfield Buildings, Chippenham,
Wilts, SN15 1LS. <http://www.lakewood.win-uk.net/fed.htm>
01249-658348 (Voice/Fax)

Thomas Edison's 1885 Train Telegraph System

Long before radio communication with moving trains was attempted, Edison made a system in the USA which appears to have coupled telegraph (Morse code) signals to moving trains by means of capacitance. George Pickworth investigates.

Thomas Edison's 1885 train telegraph provided the world's first commercial two-way telegraphy service to passengers on moving trains; they were able to receive or send messages to virtually anywhere in the world connected by a telegraph line or cable.

Although Edison's train telegraph was patented in England on June 22nd 1885 in the joint names of T A Edison and R T Gilliland, and evolved from systems developed in this country, I have no record of it being employed here; indeed, it seems that its use was confined to the USA presumably because distances and journey times there were much longer than in the UK.

Edison's system was first tried on Staten Island Railway in 1886 and after proving successful was installed on the Chicago, Milwaukee and St. Paul line, a length in the order of 425 km. In 1887 it was installed on the Lehigh Valley Railroad which was linked to Jersey City via Easton.

In 1887 about 230 members of the American Electric Club were invited by the Consolidated Railway Telegraph Company to witness the working of Edison's train telegraph on the Jersey City to Easton section. The Lehigh River valley lay some distance west of Easton.

According to contemporary writer J J Fahie, about 400 messages were sent from and received on the train without difficulty during the 200km journey even though the train was often moving at 80km/h. A long message was also sent to a correspondent in London. The train telegraph service gained much publicity during the winter of 1887 when a severe snowstorm stranded trains in Lehigh Valley. Fortunately, the guards were able to report the exact position of snowed-up trains, expediting the rescue parties. Moreover, stranded

passengers were able to keep in touch with the outside world, which must have been a considerable comfort to them under the circumstances.

But remarkably, shortly after the Lehigh Valley snowstorm, the train telegraphy rapidly fell into disuse. This was simply because nobody wanted to use the service. Business travelers in particular did not want messages from their office disturbing their card games, which seem to have been the great attraction of rail travel in those days! It took almost a century for communication with passengers moving trains to come into common use and this was thanks - or no thanks, if you are not an enthusiast - to mobile phones. And some people are petitioning to ban or restrict the use of mobile phones on passenger trains today!

Evolution

Edison's train telegraph evolved from earlier British experimental systems intended to complement trackside semaphore signals by providing a direct electric telegraph link to the train driver. The earliest system is attributed to W F Cooke, who in 1844 installed his system on the Great Eastern Railway linking Norwich and Yarmouth.

Cooke's system employed an overhead cable and a sliding contact attached to the roof of the rail cars. The rail track completed the circuit. Unfortunately, the sliding contacts were not only mechanically troublesome but generated so much electrical noise that they swamped the signals.

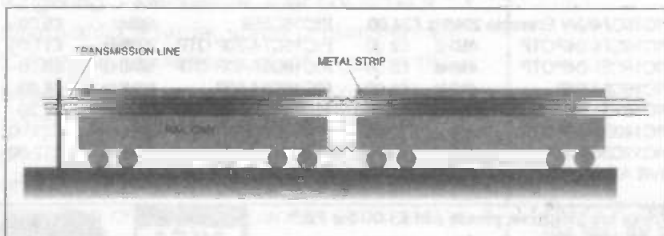

Figure 1: the location of the metal strips and the transmission line

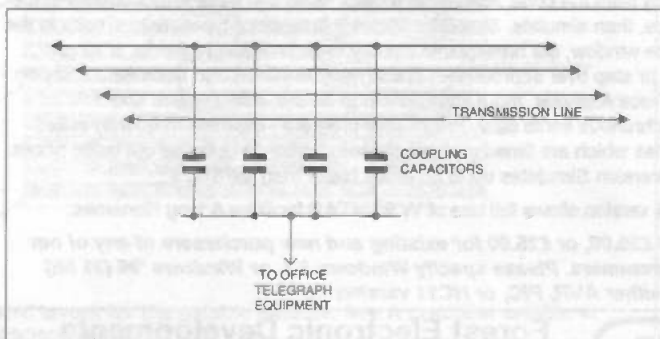

Figure 2: coupling office telegraph equipment to the transmission line

In 1885, A C Brown of the Eastern Telegraph Company replaced the sliding contacts with an electromagnetic induction link employing a track side transmission wire and cumbersome pick-up coil wrapped around the engine. As far as actual signaling was concerned, Brown's system seems to have been successful, but the coil presented insuperable practical problems and the system was abandoned. Remarkably, since then British train drivers have relied almost entirely on trackside semaphore signals and coloured lights.

Brown's system would probably have had a better chance of success had the coil been wrapped around one of the coaches, but presumably this approach was rejected because of problems with linking the coil to the telegraph equipment installed in the cab of the engine.

Passenger service

Unlike Brown's system, Edison's system was designed to extend the landline telegraph service to rail passengers, so it was logical to install signaling equipment in the rail cars. Edison's system employed metal strips attached lengthwise to the wooden rail cars just below the roof line. However, instead of the single wire of Brown's system, Edison employed a stack of four horizontal wires attached to sturdy posts running alongside the track, and arranged to be directly opposite the metal strips (see figure 1). In this study, the stack of wires is referred to as the transmission line. When the train was mobile the distance between the metal strips and the transmission line varied between 2.0 to 8.0m.

The metal strips were attached to both sides of the rail car and brought into use as required; this avoided having to rotate the car if the strips happened to be on the "wrong side" of the car. It also proved advantageous to fit metal strips to a number of rail cars and connect them together.

At telegraph offices, the equipment was connected directly to the transmission lines via four separate capacitors, that is, one for each of the four wires making up the transmission line (see figure 2).

The senders on both trains and at telegraph offices employed induction coil/interrupters to generate high voltage pulses with a repetition rate of about 200Hz; these produced an audible noise in the telephone earpiece which was used as a receiver. Communication between trains and telegraph offices was by producing long and short bursts of pulses to represent Morse code characters.

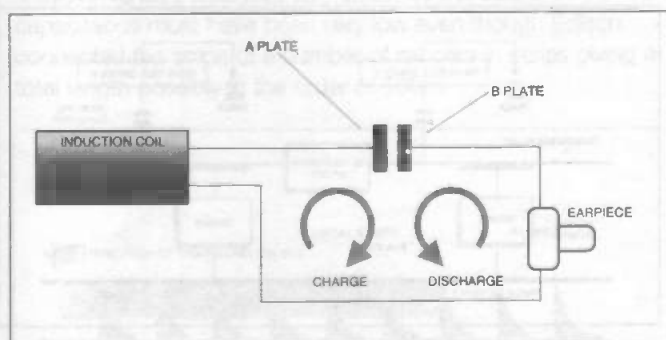

Figure 3: a schematic of a capacitor coupled circuit. The current reverses as the capacitor alternately charge and discharges

Induction coils

The induction coil, which generated the electrical pulses, was fundamental to Edison's train telegraph. So, to help readers who may be unfamiliar with induction coils and interrupters, gain a better understanding of the train telegraph system we

will now take a closer look at these devices.

A high voltage pulse with a very fast rise time develops across the secondary winding each time current through the primary winding is suddenly interrupted and although there is generally a weak oscillation, the rising edge of the pulse is probably of most importance in transferring signal to the receiver on the train. Peak potential is determined by the turns ratio of the primary/secondary windings and the abruptness by which the primary current is interrupted.

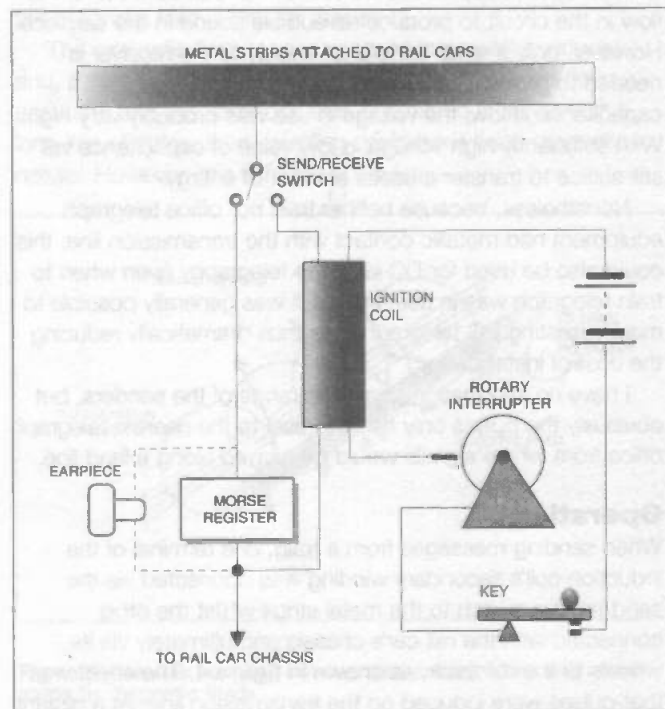

Figure 4: a schematic of send/receive equipment on a train, based on contemporary diagrams

If interruption was instantaneous (which is impossible with ordinary mechanical interrupters) and with no load across the secondary winding, the peak potential of the pulses would theoretically rise to infinity. (The load in use is probably best described as a mismatched transmission line, long enough to have significant loss, and therefore attenuate reflections.)

Indeed, even with ordinary contact breakers, and more especially with electronic interrupters, spark type induction coils should not be operated without a load otherwise the coil's insulation may break down.

Load

The load can be resistive or capacitive; let us now look at the effect of a capacitive load. If a high voltage capacitor is connected across the coil's secondary winding, each pulse charges the capacitor to a certain value in Joules. The actual value of the charge is determined by the amplitude and duration of the pulse. However, after each pulse, the capacitor discharges back through the coil.

Provided that the capacitor has a significant value, the potential across the capacitor is much lower than the open circuit potential across the coil's secondary winding. Indeed, the potential across the capacitor varies in inverse ratio to its value, but the amount of stored energy remains the same.

However, because of the short duration of the pulse, typically 1.0msec, the amount of energy that can be stored in the capacitor during each pulse is limited.

Capacity coupled?

At first sight it would seem that coupling between the metal strips on the rail cars and the transmission line was by capacitance, that is, the metal strips formed one plate of a capacitor and the transmission line the other plate (see figure 3). Indeed, as we have seen this was the case at telegraph offices.

However, the low capacitance value presented by the metal strips and transmission line makes capacitive coupling questionable. It appears to be too low for sufficient current to flow in the circuit to produce an audible sound in the earpiece. However, only a small transfer of energy to the receiver is needed to give an audible response, and although the capacitance is low, the voltage in use was probably very high. With sufficiently high voltage, a low value of capacitance will still suffice to transfer a useful amount of energy.

Nonetheless, because neither train nor office telegraph equipment had metallic contact with the transmission line, this could also be used for DC land-line telegraphy even when to train telegraph was in use. Indeed it was generally possible to modify existing DC telegraph lines thus dramatically reducing the cost of installation.

I have no information about the range of the senders, but obviously the pulses only had to travel to the nearest telegraph office from where signals would be relayed along a land line.

Operation

When sending messages from a train, one terminal of the induction coil's secondary winding was connected via the send/receive switch to the metal strips whilst the other connected with the rail car's chassis and ultimately via its wheels to the rail track, as shown in figure 4. The effect was that pulses were induced on the transmission line. At a distant telegraph office, current pulses flowed from the transmission line via the coupling capacitors, through telephone earpiece and to the rail track. By the same token, when a telegraph office was sending messages, current pulses flowed from the transmission line to the metal strips on the rail car, then via the earpiece to the rail track.

The pulses could also be made to activate a Morse register. However, the commonly used siphon type Morse inkers could not tolerate the vibration of the train, so Edison developed his own register; this was essentially a stylus attached to an earpiece type of diaphragm. Pulses caused the stylus to oscillate laterally along a rotating metal cylinder covered with chalk dust thereby causing the trace to indicate Morse signals. Shades of Edison's phonograph!

DC Telegraph line

Diagrams show the land line telegraph system using wires running alongside the railway to be DC single wire system with earth return (see figure 5). The wires extended the whole length of each specific rail track, for example the St. Pauls to Milwaukee section, and were earthed only at the ends.

Relays, which activated Morse sounders or registers, were inserted in series with the line at intermediate telegraph offices. The line was constantly energised by cells inserted in series at various points along its length, typically at telegraph offices. The Morse keys were connected so that the contacts were normally closed.

So, with no keys pressed, a steady current flowed along the wire, holding all the relays with their contacts in the open position. But as soon as an operator pressed a key, current along the wire was interrupted and relays at all offices on that particular line

changed to the closed position, energising the Morse sounder. So, somewhat paradoxically, signaling was by breaking contact instead of making contact.

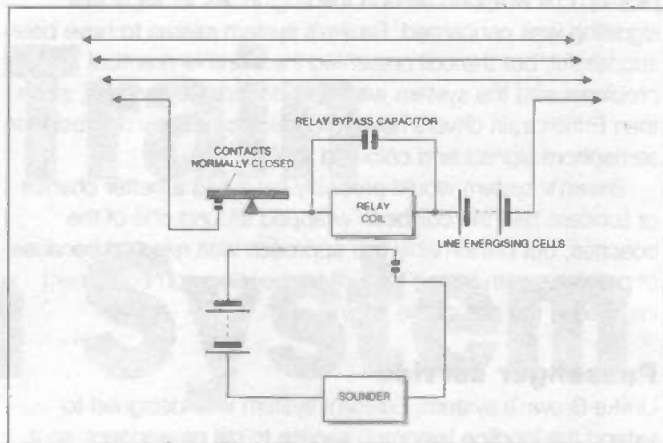

Figure 5: a schematic of a DC railway telegraph station. The three unused wires could be used for other land line telegraph services

The remaining three wires, which collectively made up the transmission line for train telegraph signals, were presumably used for communication with different telegraph offices.

Bypass capacitors

While the relay coils presented a relatively low resistance to DC signals, they presented an almost infinite impedance to the train telegraph pulses riding on the DC along the line. So, a pathway for the pulses was provided by connecting capacitors across the relay's terminals.

However, as I have already mentioned, I can see no reason why train signal pulses should need to extend past the first telegraph office where I would have assumed that signals would have been read and relayed along the DC land line (figure 6). One might think that using the inductance of the relays to confine communication pulses to one section would enhance the utility of the system. However, a relay normally uses a magnetic core which is not optimised for low loss at high frequencies. It is likely that, at the frequencies in use, a relay would have acted more like a resistive load than an inductor. This may be the reason why the relay coils were decoupled with capacitors, so that no high frequency energy would pass through the relays themselves.

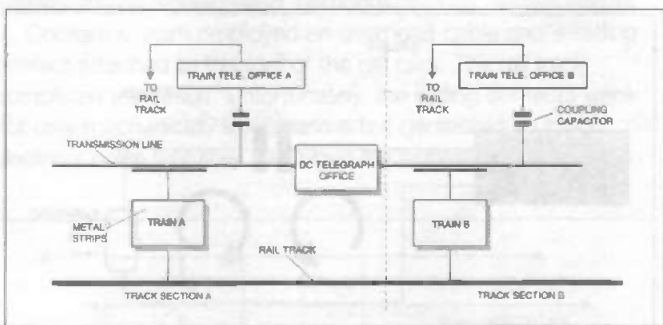

Figure 6: a schematic diagram showing trains and telegraph offices

Capacitance coupling

It is almost certain that Edison's system was a capacitance-coupled; though this cannot be proved without experiment or extensive mathematics. This can be simulated by inserting a telephone earpiece in series with an induction coil and capacitor (see figure 3 above). Charging pulses cause a "click"

to be heard in the earpiece, and then a second "click" is heard as the capacitor discharges through the induction coil. Pulses in rapid succession produce a continuous noise in the earpiece.

Edison employed a rotary Interrupter which was essentially a brush pressing against a wheel with lateral slots filled with insulating material. The wheel was driven by a small electric motor thereby interrupting the current about 200 times/sec. With this arrangement the breaks were far from being "clean".

The magnitude of the sound produced by the earpiece is directly proportional to charging current; this is determined by the potential of the pulse, impedance of the earpiece and the value of the capacitor in Farads.

Obviously, there has to be a minimum product of voltage and capacitance if enough energy is to be coupled to result in an audible response in the earphone.

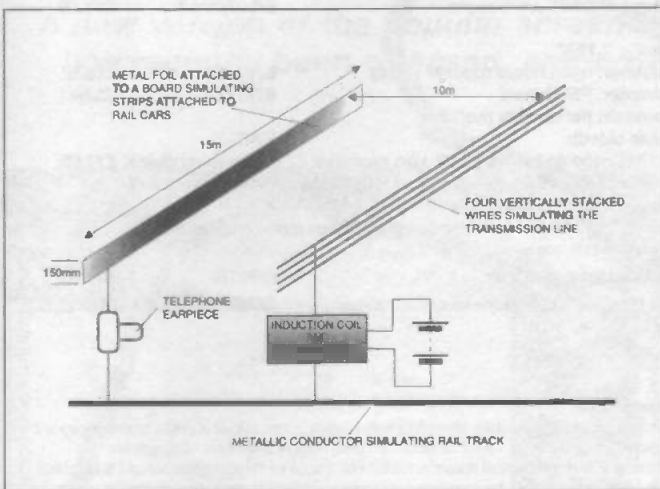

Figure 7: Edison's demonstration to promote his train telegraph system. At first sight, the two elements would seem to be coupled by capacitance as in figure 3

Demonstration

During a publicity demonstration with a mock-up simulating a metal strip along a single rail car together with a similar length of transmission line, Edison boasted that he could make electricity "jump" over a distance of 10m separating the two elements (figure 7).

However, while the four stacked wires of the transmission line had the same overall width as the metal strips, their effective surface area was very small, so the actual capacitance must have been very low even though Edison connected the strips of a number of rail cars in series giving a total length possibly in the order of 100m.

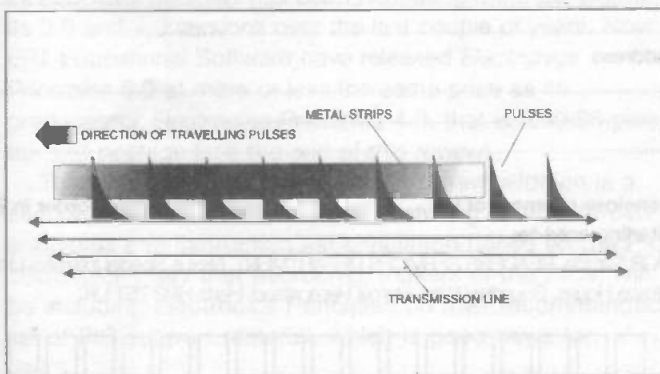

Figure 9: a speculation: pulses propagating along a line of apparently infinite length. The travelling pulses would induce current in the metal strips.

Nonetheless, bearing in mind the short duration of the charging pulse it is still hard to understand, intuitively, how sufficient current would flow through the circuit to give an audible sound in the earpiece. So, let us look for a possible alternative operating system.

Electric and magnetic fields

A conductor carrying alternating current or pulsed DC generates changing electric and magnetic fields which extend into the environment. The electric field extends radially while the magnetic field is circular (figure 8).

The magnetic field causes voltages in parallel conductors, and, if the illustrations of the connection scheme are not accurate, and the earphone was connected in series with a long line of strips, then coupling could have been magnetic in nature. However, this is highly speculative.

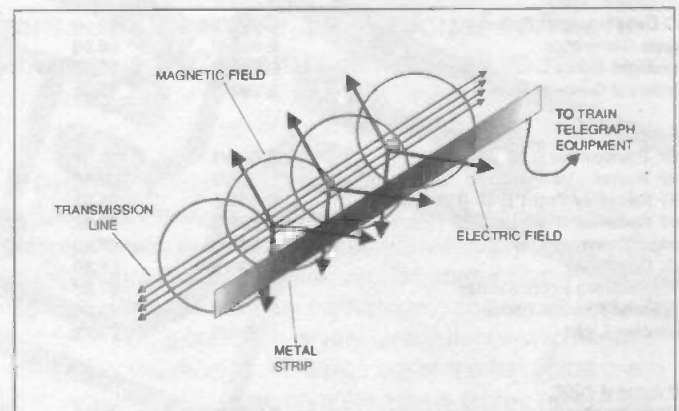

Figure 8: possible coupling between transmission line and metal strips by magnetic fields

Travelling pulses?

It may also be significant that by fitting bypass capacitors across the DC telegraph relays, the effective length of the transmission line, in as far as pulses were concerned, extended to hundreds of kilometers, for example, the length of the Milwaukee to St. Paul railway section.

Moreover, the long effective length of the transmission line and the fact that the fairly high resistance of the galvanised iron wire used for the conductors would have dissipated energy, may well have caused senders to see the transmission line as having infinite length. Train telegraph pulses could therefore have propagated along the transmission line and thereby induced currents on the metal strips as they passed by (figure 9)

The problem is to apply the travelling pulses concept to Edison's demonstration (see figure 7 above) where the transmission line seems to be open ended and of relatively short length!

This idea is quite speculative and I have not been able to test it, but I think it is a good idea to keep the door open on the unexplained. So far, 50Hz pollution has frustrated attempts to conduct experiments with my reproduction of Edison's demonstration. Nonetheless, I hope to repeat these experiments in the future in a place where electromagnetic pollution is minimal. I know of just such a place - in far away New Zealand!

Reference: JJ Fahie A History of Wireless Telegraphy 1901

Electronics Principles 5.0

A new version of the popular screen-by-screen interactive educational software has recently been released, and now includes a PIC menu, as well as maths.

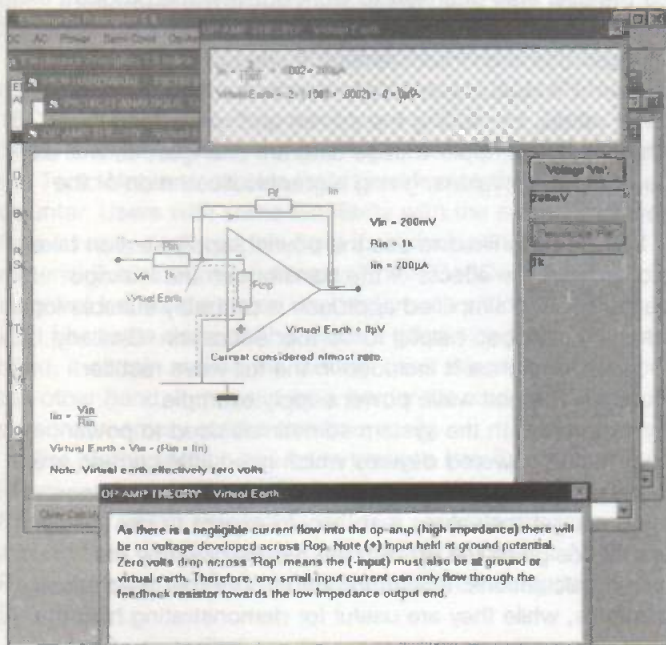

Figure 1: Op-Amp Theory: Virtual Earth box (Op-Amp menu) with Theory Notes and Calculations boxes open. The boxes can be moved round the screen without disturbing other parts of the display. These boxes cannot be open at the same time as the Parameter dialogue boxes, or vice versa

Electronics Principles has been becoming more popular in its 3.0 and 4.0 versions over the last couple of years. Now EPT Educational Software have released *Electronics Principles 5.0* at more or less the same price as its predecessor *Electronics Principles 4.0*, that is, £99.95 plus tax and postage (see the end of this review).

The most obvious (and interesting) new addition is a section on PIC microcontrollers, featuring microcontroller principles and instruction set simulation based on the PIC 16C84. EPT say that Microchip, makers of the PICs, will be including *Electronics Principles* on their recommended list of PIC support material, which is good news for users.

As well as the PIC section, there are now Mathematics principles, and a section on microprocessor hardware, instruction set and addressing modes.

Finding your way around

Electronics Principles is based on a series of pull-down screens which illustrate the operation of different types of components in-circuit. There are also starter screen on some of the basic physics background, and an extensive menu of maths basics. It is very straightforward to look things up: the more basic topics are at the left of the menu bar, working up to more complex topics on the right. There is also a complete menu screen which appears when you open the software. This acts as a master index for all the menu headings, and the screens that can be opened under them - something I felt the lack of in the version of EP 3.0 a year ago. Unfortunately, although it lists all the sub-menu headings and screens, it still does not list the pull-down menu headings. There is no Search facility, so you must continue to rely to some extent on memory and instinct to guide you to a particular screen.

The index also acts as a quick-opener menu, with a single click of the mouse button. The catch is that if you want to move down the menu using the mouse, you quickly find that you have opened the nearest screen instead. Double-clicking would have been useful here. You can however move very quickly up and down the menu

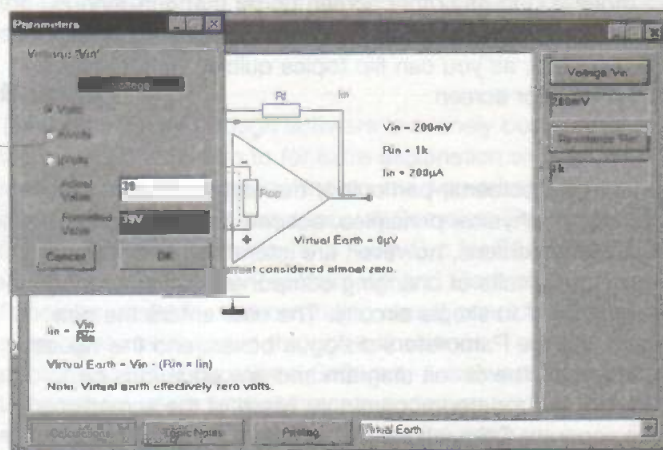
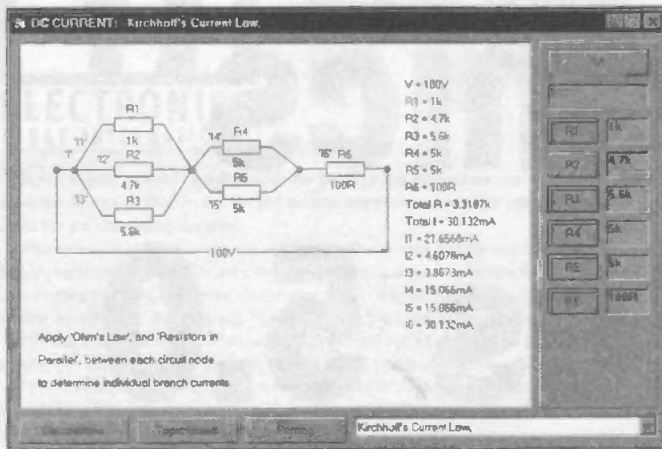

Figure 2: the Op-Amp Theory: Virtual Earth box with a Parameters dialogue box open. The "Formatted Value" box ensures that the figure you enter is converted into the right units for the box. It can indicate if you enter an unacceptable figure - but not necessarily explain it



using the sliding bar - although you may not be able to access this if you already have a screen open. In switching back to the master index, you must click the cursor either on the top bar of the index screen or on part of the frame. If you try clicking inside the index screen (as you can with most Windows software), instead of finding that you have brought the index to the front, presto! you may find that you have opened yet another topic screen, whether you wanted to or not. However, only three topic screens can be opened at once from the master index (after this, you can move up and down without "triggering" extra screens, although each click will put you back into the last screen in use).

Further screens can be opened from the pull-down menu bar, and they cascade neatly, so that you can see at a glance what is open. When the cascading has filled the whole display, any new screens that are opened will start again from the top, forming a new layer. It is unlikely that anyone would want to do this, as the lower layer quickly becomes inaccessible under the new one. But by now there are more than enough different screens open at for people who like to jump from screen to screen. The new V5.0 contains 560 screens under more than 100 screen headings, so you will not be short of choice.

For movement within menus, each screen under a given sub-menu has its own pull-down menu incorporated. This will move you to any other screen under that sub-menu - replacing the screen you are already in quickly and neatly. That is useful, as you can flip topics quickly without filling up the monitor screen.

Some of the screens, particularly the early ones, are simple drawings of physical principles, accompanied by notes. Most of the screens, however, are interactive and will display the results of changing component values and other 'parameters' in simple circuits. The user enters the new values into the Parameters dialogue boxes, and the values displayed on the circuit diagram and any equations on show will be updated accordingly. Many of the screens have separate Calculations boxes where different or more extensive equations are shown. These can be called up separately; in fact, they must be, as *Electronics Principles* is arranged so that Calculations and Topic Notes boxes do not remain open while the Parameters dialogue boxes are

in use (figures 1 and 2).

Take, for instance, the "DC CURRENT: Kirchhoff's Current Law" screen (figure 3) under the DC menu. The voltage, and the values of six different resistors, can all be altered, and the changed values are displayed both on the circuit diagram and on a table of values alongside, with totals. The cumulative Current (I) values at each node are displayed in the Calculations box (which you must open separately, and does not remain open as the changes take place). I believe the voltage (V) value is also intended to be interactive (there is a dialogue box) but it firmly refuses to accept an altered value on my software.

The menu at the bottom right of the screen enables the user to move quickly between the Current Divider, Further Current Divider, Kirchhoff's Current Law and Further Current Law screens.

In the POWER SUPPLY: Half Wave Rectifier screen entering an inappropriate value in any of the Parameters boxes raises the message "Result error - The calculated ripple voltage is greater than the available voltage across the load. Increase the value of C1." In *Electronics Principles 0.3* the user was often left to work out why the program was not responding after entering an unsuitable component value, so this is an improvement. If you are unsure where your error is, you can reset the screen back to the original set of values, by closing the screen and re-opening it. On this screen, the ripple voltage diagram changes, as well as the component values, giving a graphic illustration of the waveform.

I would have liked to see the power supply section take into account the effects of the transformer and leakage reactance. The simplified approach is probably suitable for schools but not so helpful for further education. Similarly, no input resistance is included in the full wave rectifier situation. The half wave power supply example corresponds with the system sometimes used to power small mains powered devices which need little current, are completely insulated from the user, and must be low cost. I could not get the values that I would expect to use in this kind of design to line up with the results given by the screen calculations. It is important to note that theoretical examples, while they are useful for demonstrating how the equations work, are not necessarily an indication of how a specific class of circuit will behave.

Throughout the program, it is necessary to work through the screens sequentially, and make your own notes. There is no help in deciding what values are appropriate and what are not - you must build up awareness of the necessary calculations from earlier in the course.

Under the Micro menu, the Topic Notes for each screen explain briefly what the current instruction does, and the screen will run a simulation of the processes inside a microprocessor when values are entered and the correct keys operated. Explanation of the practical functions of the instructions are left to the course teacher.

The screen INSTRUCTION SET 1: ORA Inclusive OR with Accumulator, under the Micro menu (figure 4), is one of the screens illustrating variations on the operation code working on different registers. You can select which variation to show, then enter the RAM contents and the address to use. When it is all set up, operate the ORA button to simulate the command. The Topic Notes follow

on sequentially from the first screen under Instruction Set 1: LDA (Load the Accumulator) through the subsequent screens, so that gradually a picture of the data movements is built up.

New to Electronics Principles are the Maths section and the section on PICs. The PIC section, courtesy of Microchip Technology, extends step by step over five menus and 60 screens, mainly covering the 16C84, and is a clear indication of the importance of microprocessors in even basic electronics today.

The PIC screens make free use of another of the program's features, extra information boxes that open when you click on the part of the screen concerned. In the screen PIC16C71 ANALOGUE TO DIGITAL: A/D Conversion Block Diagram (figure 5), clicking on the ADRES Register box, or any of the ADCON Register boxes, and various other screen locations, opens a text box explaining that specific location. This is flagged on this screen by the legend "Click box/register top left for details", but it is worth clicking around the screen, as there is more extra information than you might guess. Indeed, it's quite easy to get spoiled by this feature and click around hoping for even more. You never know what you might find.

It is not difficult to feel under-informed in places. To give a very small example, in the second screen under PIC 16C84 HARDWARE, Program Memory Map and Stack, the term PC is introduced, but it is left to screen number six for the Topic Notes to explain that this refers to the Program Counter. Users with some familiarity with the subject may have already deduced this from its inclusion in the mass of material illustrated in screen one (the PIC16C84 block diagram) but as the notes are brief, much sifting of this kind has to be done as the student goes along. On the one hand, it certainly makes the student think things through. On the other hand, it may act as a barrier for students whose personal memory stacks overflow easily.

The Maths section has been brought into Electronics Principles from EPT's original package Mathematics Principles, which was marketed as a separate program at around £50. The Topics run from Simple Numbers: Adding Positive Values up to Complex Numbers: Rectangular Subtraction.

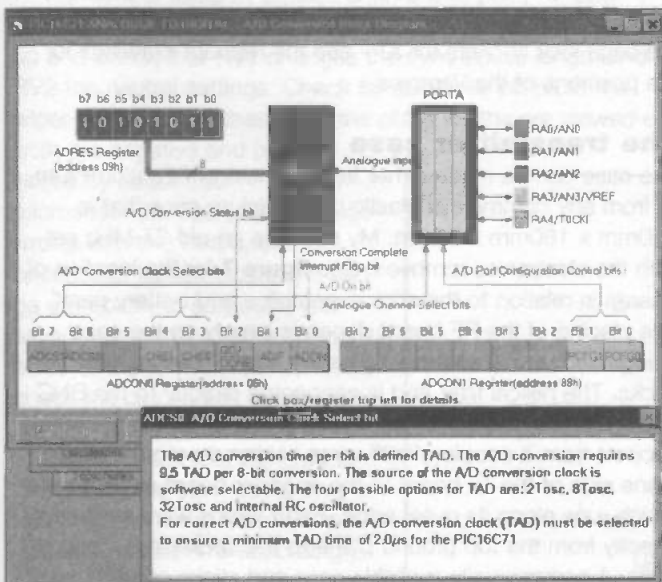

Figure 5: the PIC16C71 Analogue to Digital: A/D Conversion Block Diagram box, with a click box relating to ADCS0 open

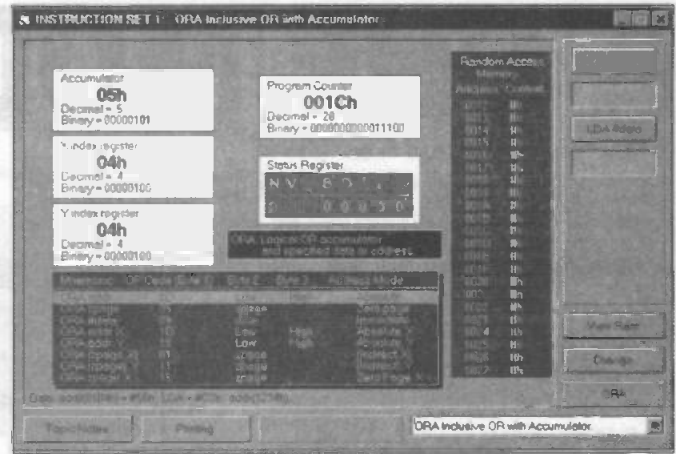

Figure 4: the INSTRUCTION SET 1: ORA Inclusive OR with Accumulator screen, under the Micro menu

Make your own notes

Even without a course teacher, armed with a notebook and pencil to jot down the results of your experiments and anything you want to refer to later, and a lot of concentration (many of the screens are packed with detail and change only small details), you can absorb a good deal from *Electronics Principles*. It would be even easier to use if value changes could be keyed directly into the table of values on each screen, instead of via individual, separately-opened dialogue boxes. The removal of the Topic Notes boxes when the interactive screens are in use can be vexing, but it is possible to print the contents of any box to a wordprocessor by using the Print button on each screen. Window users note: the Print button copies the contents of the last box opened (including Topic Notes and Calculations boxes) to the Clipboard (or off-screen storage area, for those new to computing jargon), from where the Ctrl-V or Shift-Insert command will insert it into any document that is open when you use the command. In this way, you can build up your own notebook, which you can then edit and add to.

This aspect of the program is recommended to course teachers, with the reminder that use for classes requires the Multi-User Site Licence, costing £470 (Inclusive of VAT). This is good value for a licence that allows a unlimited number of users on one site, for a program which for the single user costs £119.97 (inclusive of VAT and carriage) in the UK and other EU countries, and £103.45 (inclusive of carriage) outside the EU. (Prices as at April 1998.)

Backup

Teaching yourself through software is a lonely business if there is no-one to turn to for extra explanation or help. EPT recommend accompanying the course with a basic electronics book, and can supply *A Complete Electronics Course* by Alan Winstanley and Keith Dye for £3.95 (add £1.50 for UK postage). Teachers will find *Electronics Principles* useful for demonstrating circuit principles and allowing students to run through calculations. The publishers, EPT Educational Software, are always interested to hear from users with comments and suggestions, and will also help with technical queries about the program.

Contact: EPT Educational Software, Pump House, Lockram Lane, Witham, Essex UK CM8 2BJ. Tel/fax 01376 514008 email sales@eptsoft.demon.co.uk Web www.eptsoft.demon.co.uk.

A UHF MODEL RADIO CONTROL SYSTEM

Geof Pike G10GDP describes how to build and test the UHF Radio Control transmitter and receiver.

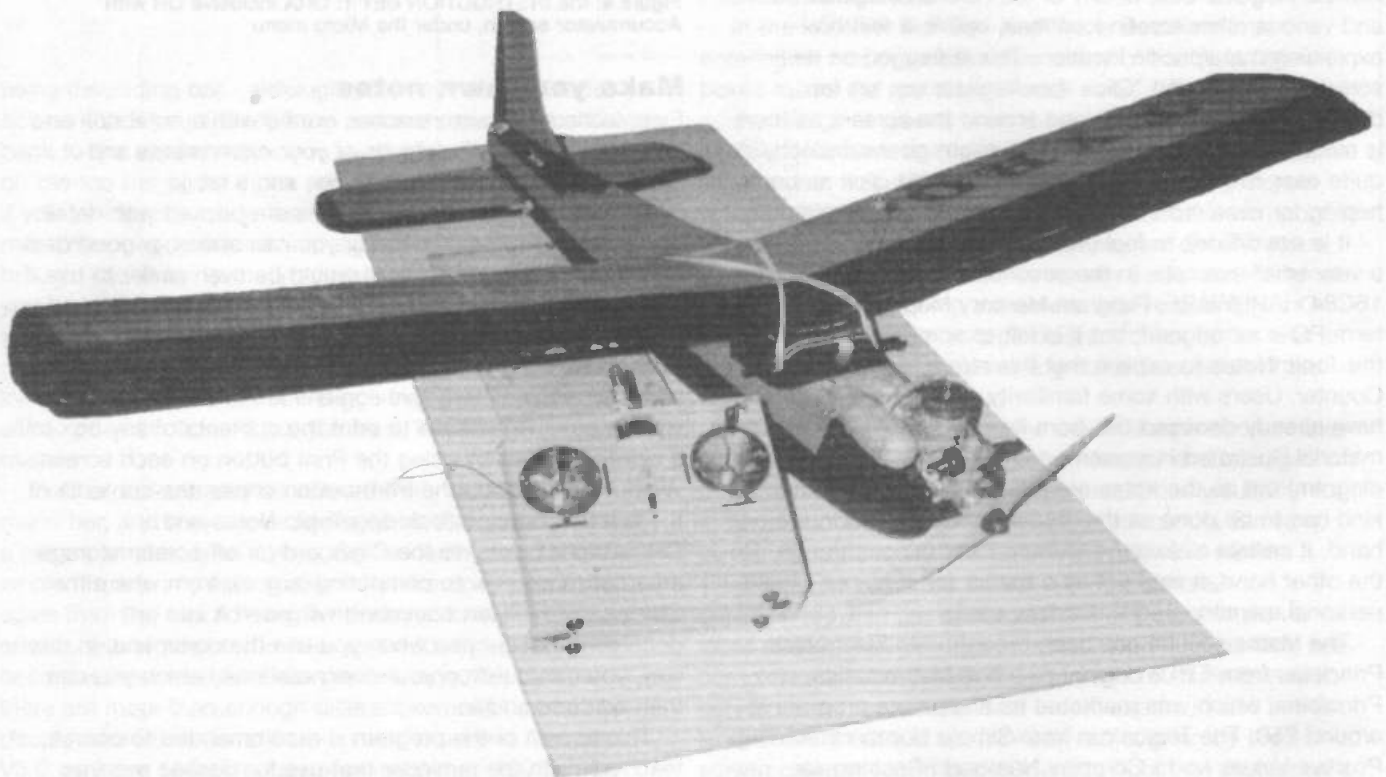

In the previous issue, I described the design and workings of the four transmitter and receiver boards for the UHF radio control system, complete with parts list and component layouts. This month I will complete the construction and antenna information.

Transmitter construction

From the pcb layouts it can be seen that the encoder is a single-sided glass fibre board, and the transmitter by virtue of the uhf circuitry needs to be double sided, with the top foil forming a continuous ground plane.

Both boards were originally made with a Dalo pen and ic pad transfers, and worked using this method. Areas marked with a large dot on the transmitter component layout are upper ground plane connections. Isolated areas are indicated with a dot ".". These areas were cut into the copper with a 3mm drill just to the depth of the copper - no further! Or it will weaken the board. Note that R13 and R14 on the IC3 side should have their respective leads made into loops for the unused channels designated by an x on the circuit

diagram. All holes on the pcb are 1 mm except for L4 and the cage jack sockets for X1 - see the relevant drawings for the positions of the Veropins.

The transmitter case

The case can be made either from a sheet of 22g aluminium, or from any commercial plastic or aluminium case that is 150mm x 180mm x 50mm. My set uses an old 27-MHz set with the electronics removed. See **figure 7** for the location of boards in relation to the stick assemblies and battery pack. The placing of the RF board depends largely on the case being used. In my set, the rf board is fitted between the sticks. The helical filter end is connected directly to the BNC socket on the case, and the crystal end only requires minimal support from a couple of stiff wires soldered onto the ground plane side of the Tx board to the encoder board negative rail, which runs along its outer edge. Earth straps were soldered directly from the top ground plane to the socket mounting bolts. A commercially available case and sticks can be obtained from Micron Radio Control, tel 0115 972 3893. In the case in the parts list, the TX board needs to be mounted

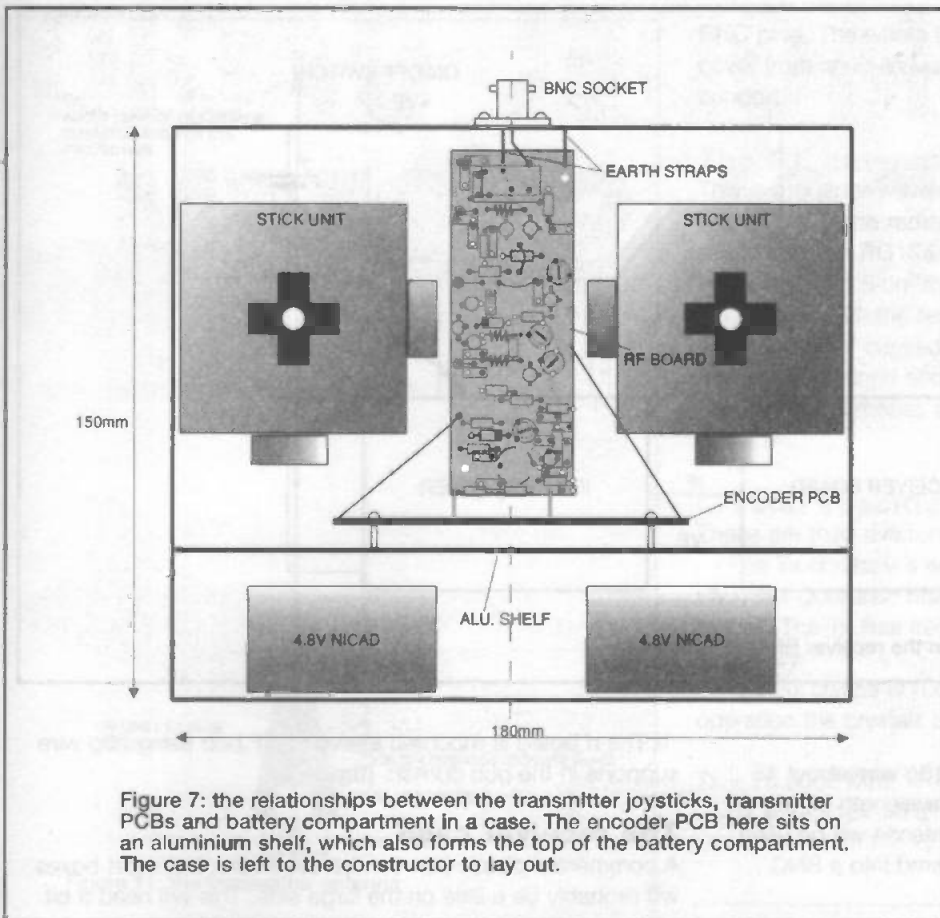

following pre-set before starting: L1: 3mm into coil former; VC1: 30 percent meshed; VC2: 90 percent; VC3: 35 percent; VC4: 30 percent; and VC5 (if fitted) 50 percent. VC5 can if desired be removed and replaced with a 2.2 pf capacitor, and its long lead can form L8. Power up without X1 fitted to the socket. The current drain should be of the order of 30-40 mA. Check for equal voltage drop across R35/R36 and for 7V5 after the voltage regulator. Assuming everything is ok, you will need a dummy load connected to the output, or a very short-leaded 47R resistor. A BNC ethernet terminator would do the job, preferably a 50R type, but 75R is ok. Insert the crystal X1, and the current should rise considerably. If it does not, adjust L1 until the oscillator starts. If the oscillator refuses to start, then change C20 to 15pf. Once running, peak up the trimmers VC2-VC5 and observe a rise in output power either using a uhf power meter or a diode probe. See figure 8. Maplin also sell a diode probe.

directly under the inside of the case top. This will then lie parallel to the encoder board, which sits on a shelf of its own about the battery compartment.

The rear of the board was supported from the encoder using 18 g solid wire. The encoder board was fitted to a dedicated shelf at the bottom of the case, which also serves as a top to the battery compartment, as shown in figure 7.

Testing

The encoder board is best linked up and tested separately to the rf board.

Remember to tie all unused channels to point "x" and connect the control pots between +7V5 and ground. Power up and check that RV1 changes the sync pause length and RV2 the neutral settings. Check for about 4V pk-pk at the wiper of RV3. Also check that the pulse widths are slowed on both the negative and positive edges by about 100

microseconds. There is little to go wrong with this board, but because of its self-clocking it can be a problem to sort out if you have a component in the wrong place or the wrong way round, so check the diodes first for proper orientation.

Finally, check that the control swing from the stick pot is 1ms in total, that is, +/- 0.5ms. If it is not, then adjust R15 accordingly.

The RF board

The RF board will need the

With everything peaked up, a final adjustment using the slugs in the helical filter will be needed. You should have about 350 mW, depending the battery supply voltage used. The current will have jumped to about 180-200 mA.

Check for current balance in Q8/Q9 by checking again the voltage drop across R35/R36. Under no circumstances operate the rf board without a 50R termination, or Q8/9 will most likely fail. With a good dfm and R25 temporarily connected to the 2V test source provided by R37-39 and D13, adjust L1 for the marked crystal frequency. When you are finished, reconnect R25 to the encoder board. With this done, recheck the final output frequency. It will be slightly different from the centre frequency, but close enough to it. This will be more accurately set when the receiver is set up by measuring the IF frequency.

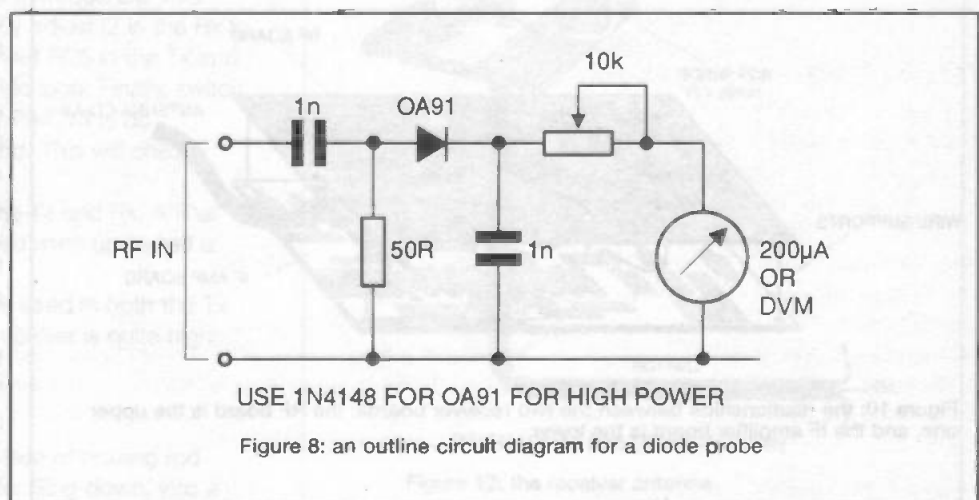

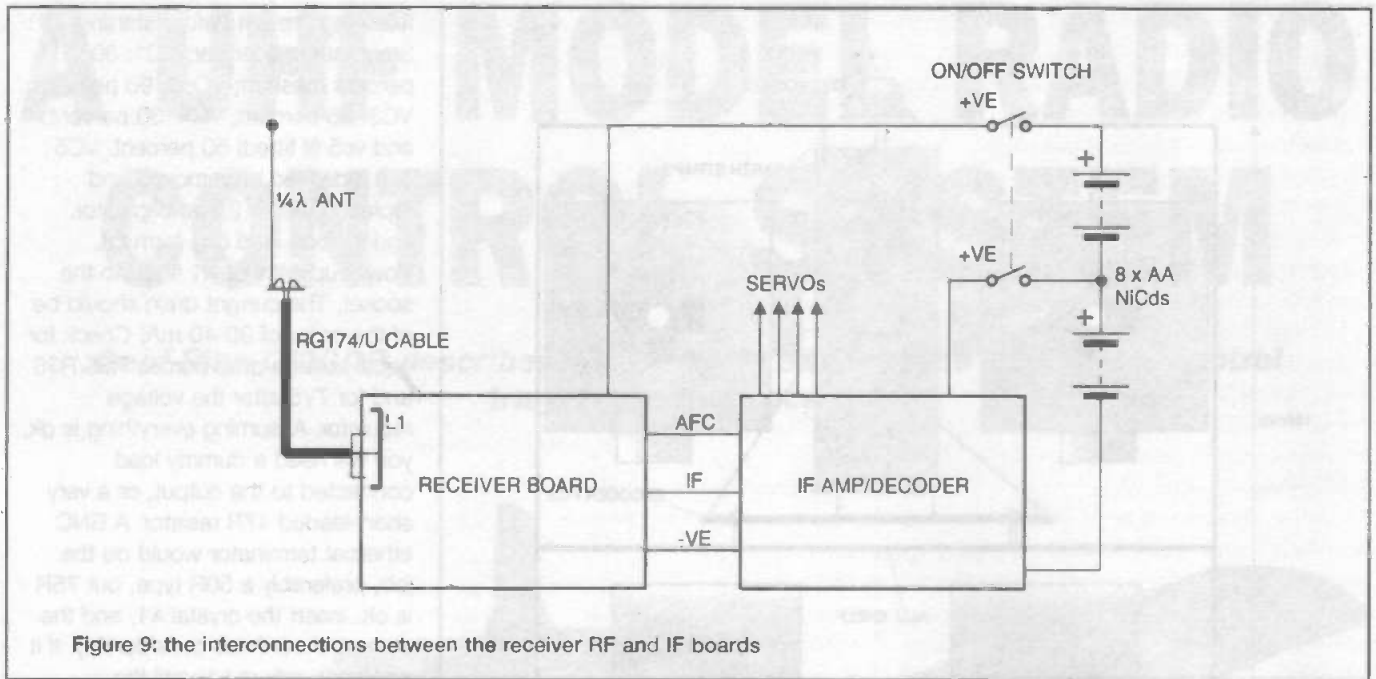

Figure 9: the interconnections between the receiver RF and IF boards

The transmitter antenna

For temporary test purposes a length of 18g wire about 15 cm long can be used. This is a quarter-wavelength at 459 MHz. For final use, a 5/8th-wavelength antenna will be used (see below). The 15-cm wire can be soldered into a BNC plug and connected to the Tx socket.

Receiver construction

This is again split into a double sided rf board and a single sided IF amplifier and decoder section. Note the positions of the Veropins and the connections made direct to the ground plane. All holes are 1mm except for the crystal socket X2.

Note that R10 is fitted under the board, and that R31 is under C17. The link from the top rf board carrying the 10.7 MHz IF to the lower board will need to be short. VC2 is mounted over the top of Q5, and R28/C38 are mounted in air from the junction of D2/C27 through the hole in the pcb near the helical filter. This finally connects with the junction of R11/C17 on the IF board.

R4 is mounted vertically. The longer lead is wound over a 2mm drill as a former for one and a half turns, and stretched out a bit to avoid the turns.

The rf board is mounted above the IF pcb using 20g wire supports in the pcb corners (figure 9).

The receiver case

A commercial plastic box can be used here, but most boxes will probably be a little on the large side. This will need a bit of ingenuity to make a neat job.

Testing

It is probably better to test the complete receiver, that is, with both boards connected together (see figure 10).

Observe that the rf board is fed from +10V, while the if amp board is fed from +5V. Essentially, this is a centre tapped 9V6 nicad pack.

Temporarily attach a piece of solid wire about 15 cm long to L1 where it connects to C2 to act as an antenna.

Temporarily up end R10. Power up without the crystal fitted, and check for 7V5 at the output of IC4.

Next, confirm that R4 drops about 5V across itself, and that about 0.4V is dropped across R6. Insert the crystal and preset I2 to 3mm into its former, and VC2 15 percent meshed. Using a diode probe, confirm that drive is available

at the junction of R25/R26. As before, if the oscillator won't start, change C25 to 15pf. With this done, confirm the lo signal is at the junction of L5/VC2, and measure it with a dfm. It should be 6 x crystal frequency +/- 448.XXX MHz. The preset VC1 should be 45 percent meshed and the helical and T1 as supplied. Measure the voltage at pin 10 of IC1 and set it for about 1.8-1.9V by adjusting T2 slightly.

The next step will assume that the Tx is working correctly. Connect a scope probe to the junction of R7/C8, switch on the Tx and distance it so that the signal is about 50 mV on the

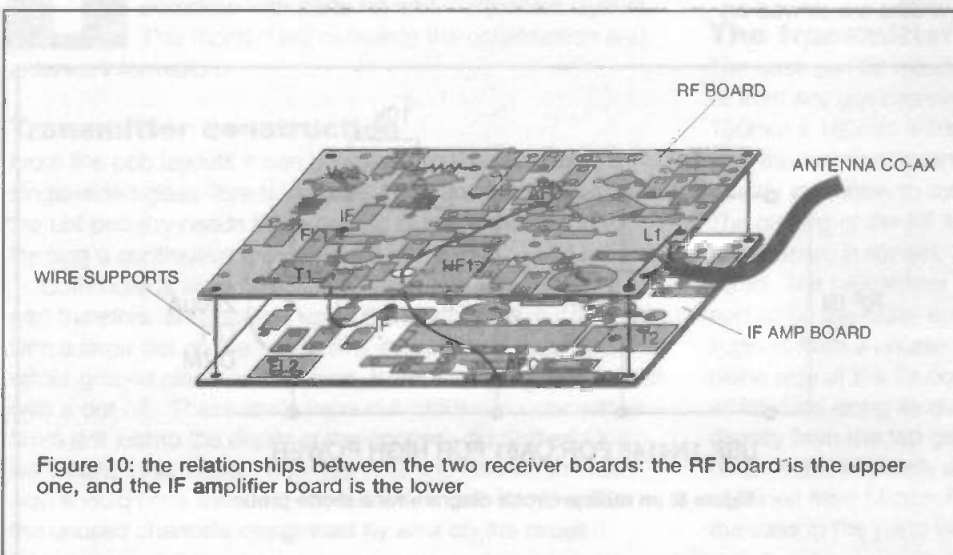

Figure 10: the relationships between the two receiver boards: the RF board is the upper one, and the IF amplifier board is the lower

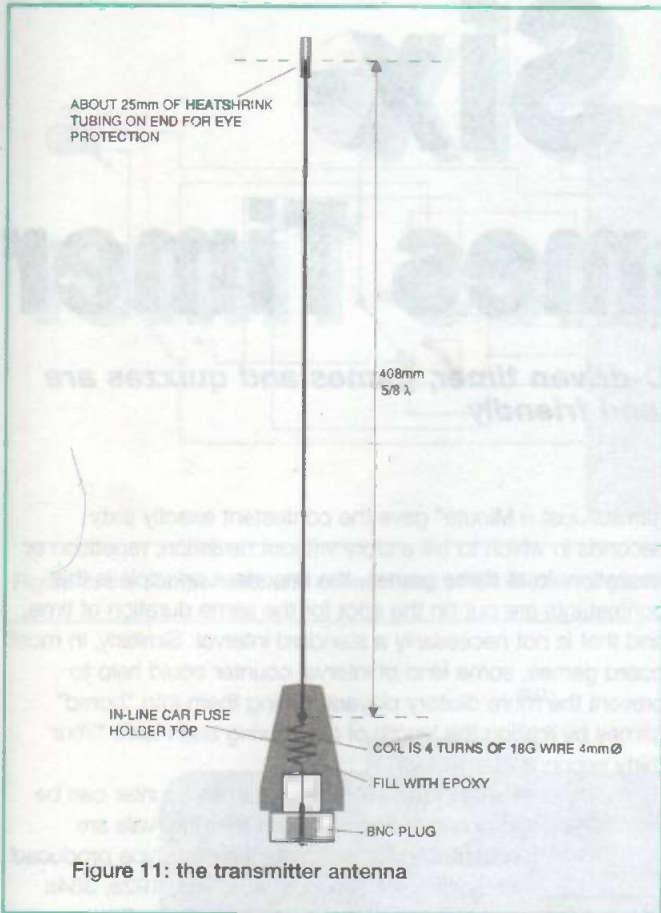

Figure 11: the transmitter antenna

'scope screen. Adjust VC1, the helical filter, and T1 for maximum signal at this point. T1 does not have a sharp peak. Move the scope probe to the junction of R9/C18, and confirm that the second lo is working at 11.155 MHz at pin 1 of IC1 with a dfm.

Ensure that the encoder waveform is present at the junction of R9/C18. This should be about 1V pk-pk, offset from ground by about 1.8V. Adjust with T2, but don't position it too close to ground or vcc. This gives a window over which it can drift without compression.

Setting in the middle will coincide with the maximum output from the discriminator. Move the scope probe to pin 14 of IC3 and observe a squared-up version of the signal. On pin 15 the reset pulse should be seen. Adjust the sync pause in the Tx for this.

Connect a dfm to the junction of R7/C8 and position the Tx for a stable reading. Connect R25 in the encoder to the temporary 2V supply and observe the IF frequency. This should be 10.7 MHz +/- 1 kHz. Slightly adjust I2 in the Rx to achieve this. Switch off and reconnect R25 in the Tx and R10 in the Rx. This will establish the afc loop. Finally, switch on again and check that the signal at R9/C18 is dc referenced at about 1.8V above ground. This will ensure correct afc tracking.

This completes the setting up of the Tx and Rx. A final check on range will be needed. I tested mine up to half a mile.

Ensure that only nicad batteries are used in both the Tx and Rx. Current consumption in the receiver is quite high, and only nicads are suitable for this.

The Tx antenna

See figure 11. This is made from a piece of brazing rod about 408 mm long and soldered, after filing down, into a

BNC plug. The whole thing is filled with epoxy resin and the cover from an in-line car fuse was slid over the top for support.

The RX antenna

This is a quarter-wavelength ground plane antenna without the ground plane radials. See figure 12. Observe that the miniature coax RG174/u must be connected to the receiver in multiples of 21.5 cm to ensure correct impedance matching after tuning with the temporary whip. A final tweak of VC1 can be made if desired, but is generally not needed.

The Rx antenna should be mounted in a prominent position in the model, and must be as near vertical as possible.

Crystal specification

These are third overtones, HC25/u.

The Tx crystal will exceed the current normal limit for third OVT, but Quartslab Marketing Ltd. will make them (see below). The Tx final frequency is 6 times the crystal frequency.

The Rx crystal is $[Tx \text{ freq} - 10.7] / 6$, so for 459 MHz operation the crystals are:

$$Tx = 76.5000 \text{ MHz}$$

$$Rx = 74.7167 \text{ MHz}$$

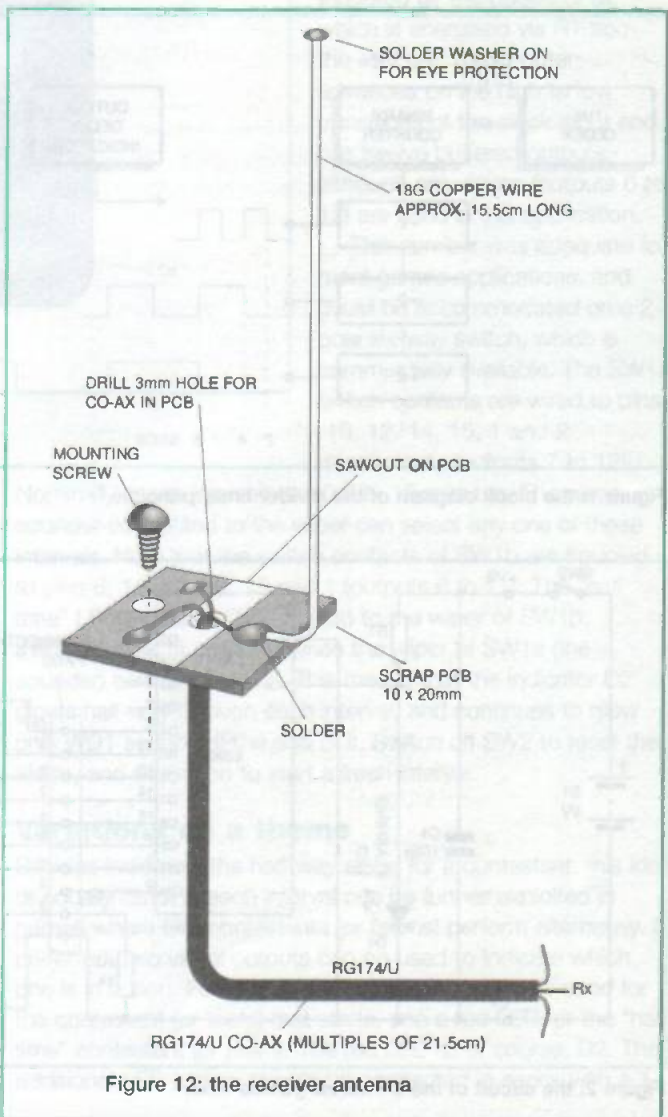

Figure 12: the receiver antenna

Mini Six-Interval Games Timer

Using Roy Bebbington's little portable LED-driven timer, games and quizzes are sure to be fast and friendly

This little circuit allows you to select six different time intervals, from a few seconds to half an hour or more, to be terminated by an audible alarm. As a gentle reminder that time is slipping away, a light-emitting diode (LED) glows when half the selected time interval has elapsed.

Fun and games!
Popular TV word games like "Countdown", "Supermarket Sweep", and so on all depend on interval timers counting away the seconds while contestants make their decisions. The radio

game, "Just a Minute" gave the contestant exactly sixty seconds in which to tell a story without deviation, repetition or hesitation. In all these games, the important principle is that contestants are put on the spot for the same duration of time, and that is not necessarily a standard interval. Similarly, in most board games, some kind of interval counter could help to prevent the more dilatory players turning them into "bored" games by limiting the length of play during each turn. "Your thirty seconds starts now!"

A simple version of this six-interval games counter can be made using just one ic, if non-standard time intervals are acceptable; for example, the prototype produced intervals of 24 seconds, 48s, 96s, 192s, 384s and 768s. For game purposes, this offers a useful range of intervals from a few seconds to over 12 minutes, and if you are culinarily inclined, you could successfully boil an egg in the 192-second interval (as long as it is not your turn to play).

Basically speaking

Probably the easiest way to make an electronic interval timer is to charge up a large capacitor via a resistor in the input of a transistor switching circuit. However, as the tolerance of electrolytic capacitors varies widely, a circuit using a binary counter has the edge for longer intervals of time, as well as the ability to divide. This is illustrated in the block diagram of figure 1. A clock circuit, for

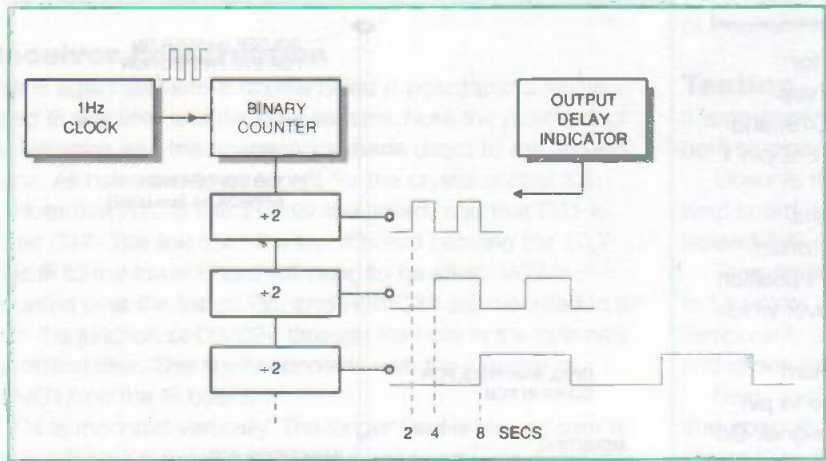

Figure 1: the block diagram of the divider timer principle

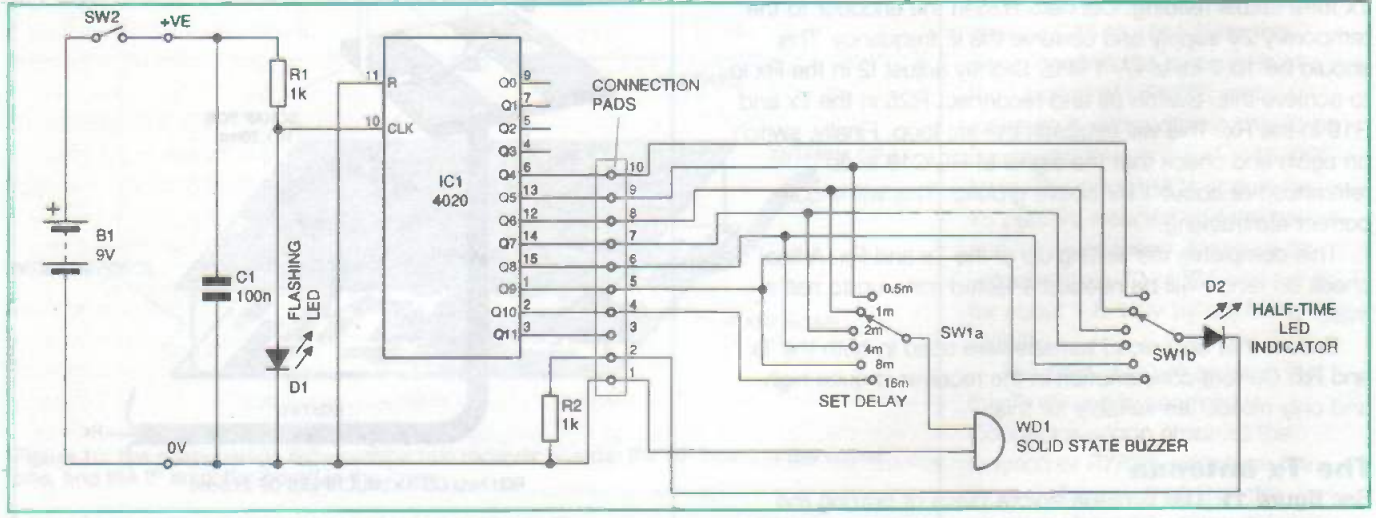

Figure 2: the circuit of the 6-Interval games timer

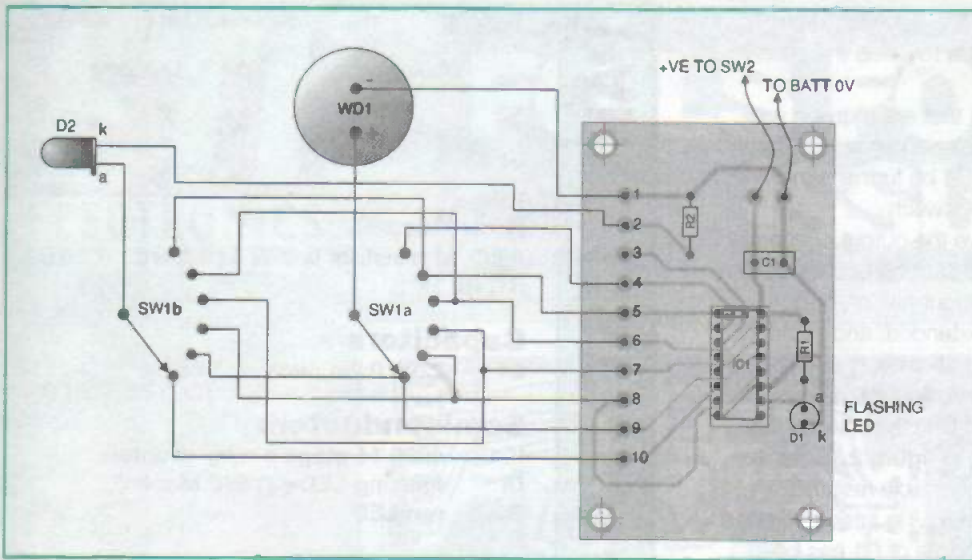

Figure 3: the components and connections of the 6-interval games timer

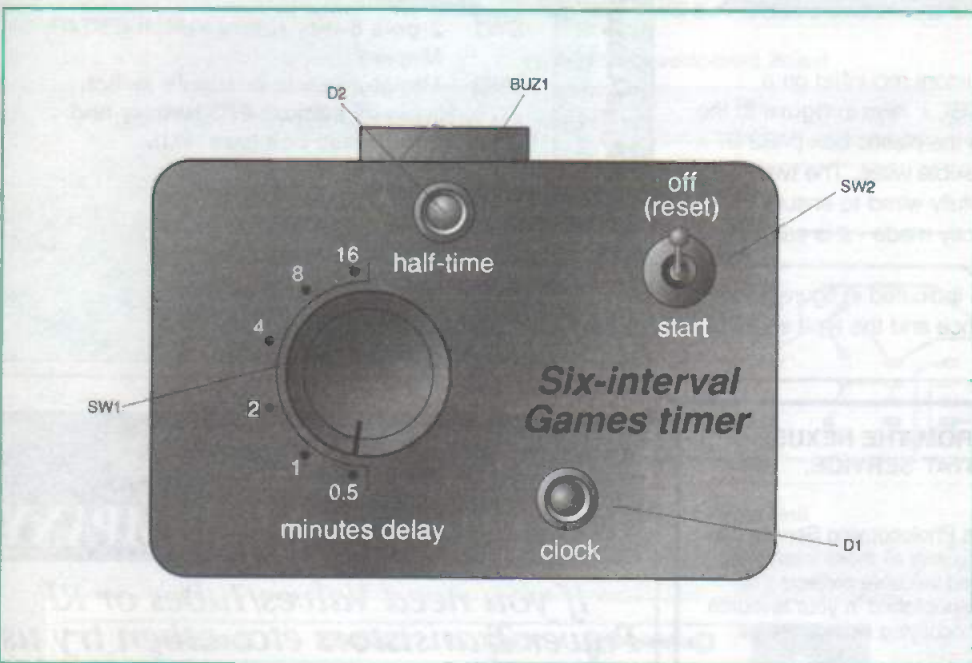

Figure 4: this front panel layout was used in the prototype

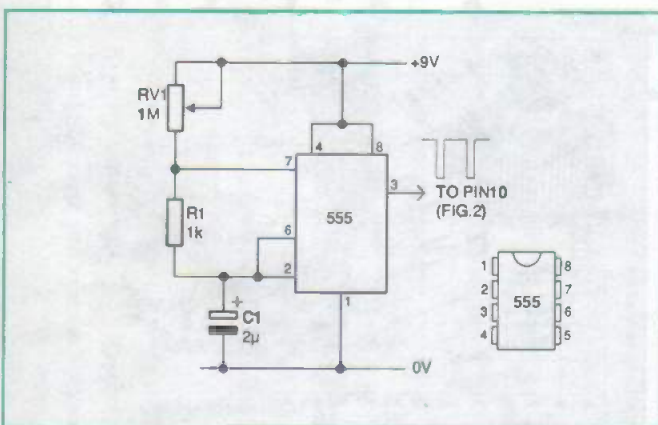

Figure 5: a variable astable circuit to replace D1-R1 (see text)

example an astable giving a train of pulses, is applied to a binary counter. The first divider gives an output after two pulses, the second divider gives an output after four pulses, the third after eight pulses, and so on. Simply select the delay

interval you want and connect it to an output indicator, for example a piezo sounder or a LED. As shown, a free-running astable at a frequency of 1Hz produces delays of 1, 2, 4, 8 seconds, and so on. You may of course connect indicators to one or more of the outputs, as we shall see.

A practical circuit

The simple timer in figure 2 is based on the CMOS 4020 14-stage binary counter, using just six of its divider outputs. The clock input in this case is derived from a flashing LED, with a flash frequency of 2Hz (+/- 1Hz) at 9V. This means that the intervals will depend on the particular LED selected. If you are aiming for "Just a minute", then a 555 timer in astable mode could replace the flashing LED as the clock generator, and much longer time intervals can be obtained.

The clock input on pin 10 is triggered by the pulses of D1, which is energised via R1 from the +9V rail. The counter advances on the high to low transitions of the clock input and has twelve buffered outputs, although only seven (outputs 6 to 12) are used in this application.

This number was adequate for most games applications, and could be accommodated on a 2-pole six-way switch, which is commercially available. The SW1a switch contacts are wired to pins 13, 12, 14, 15, 1 and 2 respectively (outputs 7 to 12)).

Nominally, these intervals are 0.5 to 16 minutes. The piezo sounder connected to the wiper can select any one of these intervals. Note that the switch contacts of SW1b are coupled to pins 6, 13, 12, 14, 15 and 1 (outputs 6 to 11). The "half time" LED indicator, D2, coupled to the wiper of SW1b, therefore selects output 6 when the wiper of SW1a (the sounder) selects output 7. This means that the indicator D2 glows half-way through each interval, and continues to glow until WD1 sounds at the end of it. Switch off SW2 to reset the alarm, and switch on to start a fresh interval.

Variations on a theme

Besides indicating the half-way stage for a contestant, this idea of equally dividing each interval can be further exploited in games where two contestants (or teams) perform alternately. If preferred, two visual outputs can be used to indicate which one is in action. For example, a green LED could be used for the contestant (or team) that starts, and a red LED for the "half time" contestant (or team). The red LED is, of course, D2. The additional LED (green) should be connected in series with a 1-

kilohm limiting resistor, between SW1b wiper and 1d pin 16. Ensure that the anode pin of the LED is towards the positive rail.

If alternating coloured LEDs are all that are required as output indicators, then disconnect the sounder and let them flash in blissful solitude. The timer could be further simplified by replacing SW1 by a single-pole 6-way switch.

If a longer interval is required, move the output connection sequence to outputs 7 to 13. Using a flashing LED as clock input, this should give an interval of about half-an-hour. Obviously, this can be considerably extended, and standard times more precisely determined if a 555 timer is used to provide clock pulses. A suitable circuit using a 555 in astable mode is given in figure 5. This circuit directly replaces the resistor R1 and D1, the flashing LED, in figure 2. Capacitor C1, charging through resistor R1 and variable resistor RV1, enables a wide range of clock speeds, giving intervals from a few seconds to several hours. A low value of R1 has been chosen to sharpen the negative-going edge triggering the counter.

Construction

Apart from the ic socket and two resistors mounted on a single-sided printed circuit board (PCB), shown in figure 3, the other components were mounted on the plastic box (MB2 97 x 73 x 39.5 mm), and connected by flexible wires. The two switch sections need to be very carefully wired to ensure that the staggered connections are correctly made - it is easy to get a wire out of place.

A suggested front-panel layout, is indicated in figure 4, but this will depend on individual preference and the type and size of enclosure available.

PARTS LIST for the Mini 6-Interval Games Timer

Resistors

All fixed resistors 0.25W 5 percent
R1, R2 1k

Capacitors

C1 220n 0.2in pitch

Semiconductors

IC1 4020 14-stage binary counter
D1 flashing LED (QY96E Maplin)
D2 red LED

Miscellaneous

WD1 DC piezo buzzer (eg KU56L Maplin)
SW1 2-pole 6-way rotary switch (FF74R Maplin)
SW2 Miniature slide or toggle switch
PCB; 16-pin dil socket; PP3 battery and connector; plastic box (see text).



NEXUS

NEWS FROM THE NEXUS PHOTOSTAT SERVICE.

The Nexus Photocopying Service can provide you with all those interesting features and valuable projects that have been published in your favourite

magazine. The new costs of our photocopying service are as follows:-

First article: £2.75 inc of VAT. Please note that projects published over several issues must be ordered as a series of individual articles, each for £2.00.

A £2.75 search fee is required if full information is not supplied. Please note delivery could be up to 28 working days.

Please supply photo-copies of the following articles from
(Complete in BLOCK CAPITALS)

Month Year Page (if known).

TITLE

Month Year Page (if known).

TITLE

Month Year Page (if known).

TITLE

I enclose a cheque/postal order made out to Nexus Special Interests to the value of:

£ P&P £1.00 (UK only) 20% Overseas

Total remittance £

Name:

Address:

Post Code:

Send the completed form and remittance to:
Photocopy Service, Nexus Special Interests, Nexus House, Boundary Way,
Hemel Hempstead, Hertfordshire, HP2 7ST



CHELMER VALVE COMPANY

*If you need Valves/Tubes or RF
Power Transistors etc. ...then try us!*

We have vast stocks, widespread sources
and 35 years specialist experience in meeting our
customers requirements.

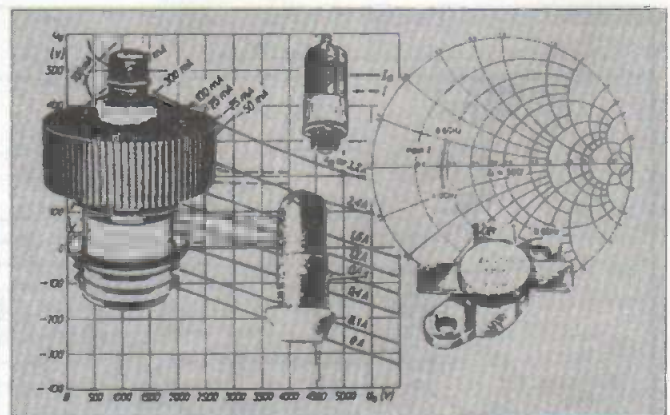

Tuned to the needs of the Radio Amateur

Chelmer Valve Company, 130 New London Road,
Chelmsford, Essex CM2 0RG. England.

Tel: 44-01245-355296/265865

Fax: 44-01245-490064

FOILS FOR THIS ISSUE

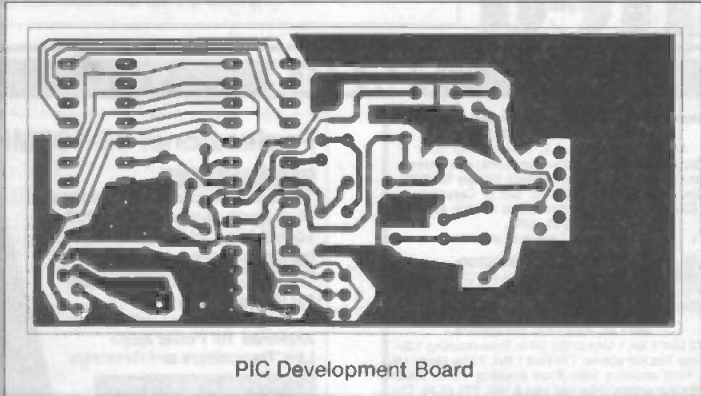

PIC Development Board

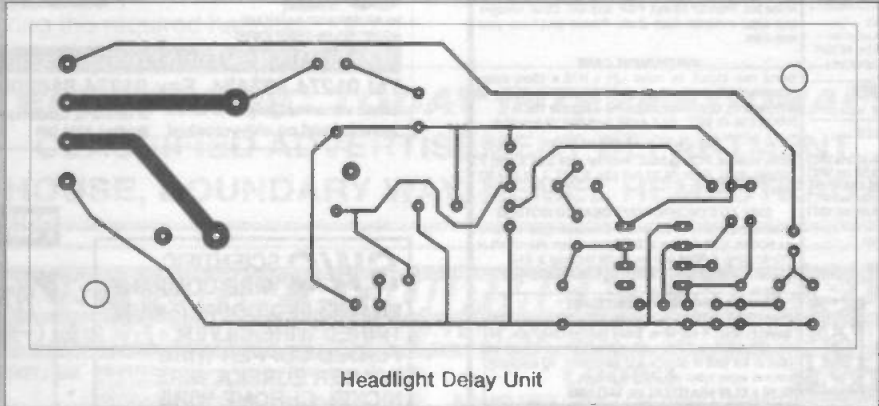

Headlight Delay Unit

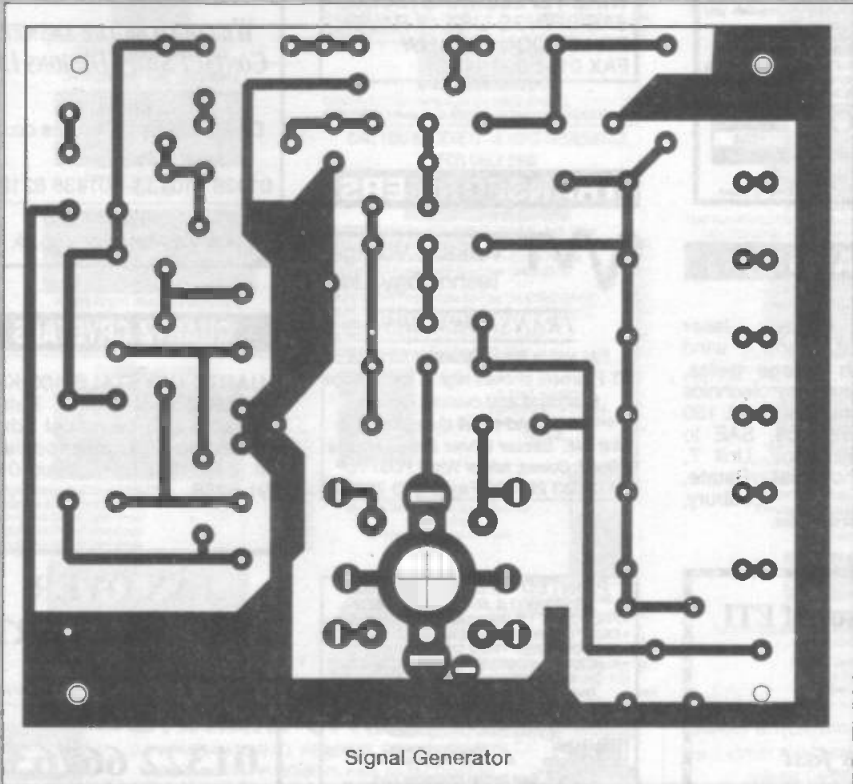

Signal Generator

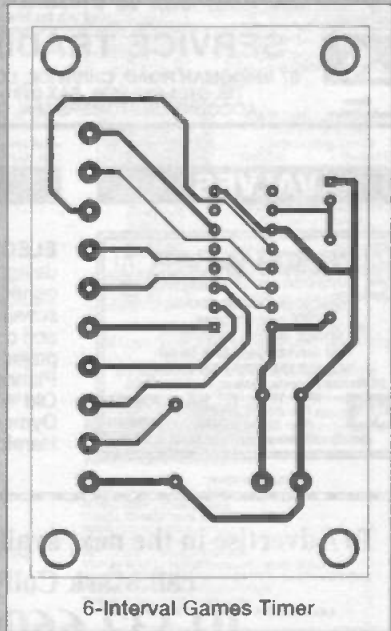

6-Interval Games Timer

Classified



Mark Collyer
01322 660070

Send your requirements to:
ETI Classified Department, Nexus, Nexus House,
Azalea Drive, Swanley, Kent BR8 8HY
Lineage: 85p per word (+VAT) (minimum 20 words)
Semi display: (minimum 3cms)
£12.50 + VAT per single column centimetre



Ring for information on series bookings/discounts.
All advertisements in this section must be pre-paid.
Advertisements are accepted subject to the terms and conditions
printed on the advertisement rate card (available on request).

FOR SALE

VARIABLE VOLTAGE TRANSFORMERS

INPUT 220/240V AC 50/60
OUTPUT 0-250V

Price P&P

0.5KVA 2.5 amp max £33.00 £5.00 (£45.83 inc VAT)

1KVA 5 amp max £45.25 £7.00 (£51.39 inc VAT)

PANEL MOUNTING

0.5KVA 2.5 amp max £34.00 £5.00 (£47.00 inc VAT)

1KVA 5 amp max £46.25 £7.00 (£52.57 inc VAT)

2KVA 10 amp max £65.00 £8.50 (£73.50 inc VAT)

3KVA 15 amp max £86.50 £9.50 (£111.63 inc VAT)

5KVA 25 amp max £160.00 Plus Carriage & VAT

10KVA 45 amp max £300.00 Plus Carriage & VAT

8KVA 3 PHASE Star £205.00 Plus Carriage & VAT

Buy direct from the Importers. Keenest prices in the country

COMPREHENSIVE RANGE OF TRANSFORMERS-LT-ISOLATION & AUTO

(110-240V Auto transfer either cased with American socket and mains lead of open frame type. Available for immediate delivery)

500VA ISOLATION TRANSFORMER

New manuf. surplus 'C' Core' topolicalised with top plate and solder connections. 0.240V AC Prim. 5.0-100-110-120V & Screen Sec. Wt. 10.5K. Size: H195 x 155 x 135mm. Price £35.00. Carn. £7.00 (£49.94 incl.)

RANGE OF XENON FLASH TUBES

Write/Phone your enquiries

ULTRA VIOLET BLACK LIGHT BLUE FLUORESCENT TUBES

4R 40 watt £14.00 (cashiers only) (£18.45 inc VAT)

2R 20 watt £3.99 (cashiers only) (£10.58 inc VAT)

12R 8 watt £4.80 + 75p p&p (£6.52 inc VAT)

9R 8 watt £3.99 + 50p p&p (£5.24 inc VAT)

6R 4 watt £3.99 + 50p p&p (£5.24 inc VAT)

230V AC BALLAST KIT

For either 6R, 9R or 12R tubes £8.00 + £1.40 p&p (£9.75 inc VAT)

The above Tubes are 3500/4000 angstrom (350-400nm) ideal for detecting security markings, effects lighting & Chemical applications.

Other Wave Lengths of UV TUBE available for Germicidal & Photo Sensitive applications.

Please telephone your enquiries.

400 WATT BLACK LIGHT BLUE UV LAMP

GES Mercury Vapour lamp suitable for use with a 400W RFL Ballast

£29.95 INCL. P&P & VAT

12V D.C. BILGE PUMPS

500 GPH 15ft head 3 amp £19.95

1750 GPH 15ft head 9 amp £34.55

Also now available 24V D.C. 1750 GPH 15ft head 5 amp £35.55

All designed to be used submerged. PRICES INCLUDE P&P & VAT

SUPER HY-LIGHT STROBE KIT

Designed for Disco, Theatrical uses etc.

Approx. 16 joules. Adjustable speed £50.00 + £3.00 p&p

(£2.20 inc VAT)

Case and reflector £24.00 + £3.00 p&p (£31.73 inc VAT)

SAE for further details including Hy-Light and Industrial Strobe Kits.

SERVICE TRADING CO

57 BRIDGMAN ROAD, CHISWICK, LONDON W4 5BB
TEL 0181-995 1560 FAX 0181-995 0549
ACCOUNT CUSTOMERS MIN, ORDER £10



Ample Parking Space

VALVES

WILSON VALVES

(PROP JIM FISH G4MH)

Over 50,000 valves stocked,

2000 different types,

vintage, military, audio, etc.

Fast service. Send SAE for list

VALVES WANTED FOR CASH

28 Banks Avenue, Golcar, Huddersfield,

West Yorks HD7 4LZ

Tel: 01484 654650

Fax: 01484 655899

Email: wilsonvalves@surlink.co.uk

PLANS

ELECTRONIC PLANS, laser designs, solar and wind generators, high voltage teslas, surveillance devices, pyrotechnics and com-puter graphics tablet. 150 projects. For catalogue, SAE to Plancentre Publications, Unit 7, Old Wharf Industrial Estate, Dymock Road, Ledbury, Herefordshire, HR8 2HS.

To Advertise in the next available issue of ETI

call Mark Collyer

01332 660070

Remember classified get results fast

Professional 88-108MHz FM Broadcasting Kits

All Our Kits Include
Detailed instructions with Schematics
High Quality Screen Printed PCBs
High Quality Components

Our Product Range Includes
Transmitters from 0.05W to 220W
FM Stereo Coders
Audio Compressor Limiters
Antennas RF Power Amps
Link Transmitters and Receivers

Our Kits Are Also Available
Fully Assembled And Tested

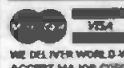

WE DELIVER WORLD-WIDE AND ACCEPT MAJOR CREDIT CARDS

Contact Us Now For A Free Brochure

Tel 01274 883434 Fax 01274 816200

email veronica@legend.co.uk 18 Victoria St, Queensbury

www.legend.co.uk ~ veronica/ Bradford, BD13 1AR

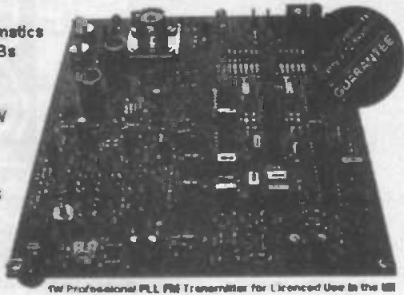

Professional PLL FM Transmitter for Licensed Use in the UK

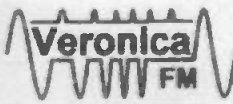

PRINTED CIRCUIT BOARDS

??? PCB DESIGN OVERLOAD ???

- EDWIN -
- EED3 -
- CADSTAR -

WE COULD BE THE ANSWER.
CONTACT SWIFT DESIGNS LTD

Email: Designs@SwiftDesigns.co.uk

Phone: 01438 310133 - 01438 821811

Web: www.swiftdesigns.co.uk

TRANSFORMERS

Variable Voltage Technology Ltd

TRANSFORMERS

For valve and transistor circuits
HT Filament chokes high & low voltage
Standard and custom design
large and small quantities
Unit 24E, Samuel Whites Estate, Medina Road, Cowes, Isle of Wight PO31 7LP
Tel 01983 280592 Fax 01983 280593

QUARTZ CRYSTALS

QUARTZ CRYSTALS 100 KH2 - 100 MHZ at low cost. Full list available and technical advice. Electronic Design Associates. Tel: 0181-391-0545. Fax: 0181-391-5258.

PRINTED CIRCUIT BOARDS

DESIGNED & MANUFACTURED
• PROTOTYPE OR PRODUCTION QUANTITIES
• FAST TURNROUND AVAILABLE
• PCBs DESIGNED FROM CIRCUIT DIAGRAMS
• ALMOST ALL COMPUTER FILES ACCEPTED
EasyPC / Aries / VuTrax / CadStar
Gerber / HPGL / IDraw and many others.
• ASSEMBLY & TEST AVAILABLE
TELEPHONE 01232 738897
INTERNATIONAL +44 1232 738897
agat
Circuit-boards
Fax: 01232 738897
Email: agat@agat.co.uk
Unit 5, East Belfast Enterprise Park,
308 Alberbridge Road, Belfast, BT5 4Gx

FAX OVER
YOUR ADVERT
TODAY
ON
01322 667633

CROWN HILL ASSOCIATES LIMITED

The Old Bakery, New Barns Road,
Ely Cambs. CB4 7PW

Tel: +44 (0)1353 666709 Fax: +44 (0) 1353 666710

Low cost professional quality Smart Card Systems

CHIPDRIVE EXTERN

Intelligent programmer for Smart Cards using the International Standard T=0 or T=1 protocols also Memory and Secure Memory using PC, 2-wire & 3-wire interfaces

Supplied with software to read and write to most popular secure smart cards, inc GSM, PAY PHONE and ACCESS CONTROL cards.

T=0 or T=1 @ 3.579MHz **£69 + VAT**

RS232 @ 9600 - 11500 bps

Internal Supply / Ni-MH

Size: 100x70x60 mm

Weight 660 Gram

Supplied with CardServer API for easy development of SmartCard Applications using Visual Basic, Delphi or C++

Supplied with Sample Memory cards & Secure Smart cards

CE Compliant



Chip Drive Intern

3.5" floppy bay version of the CHIPDRIVE.

Applications are available to provide SmartCard controlled access of data on Hard drives or "PC-LOCK", to control access to the whole PC Fully Compatible with TOOLBOX for systems development. Supplied with cardserver.dll API

£85 + £5 P&P + VAT

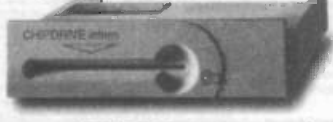

NEW CHIPDRIVE - micro

Fully Compatible with TOOLBOX for application development. Featuring the same functionality as Chip Drive Extern but in a small neat low cost package, similar in size to a smart card. Supplied with cardserver.dll API

£65 + £5 P&P + VAT



Most popular smart cards are plastic, the size of a credit card, with an embedded microprocessor containing an operating system and erasable non-volatile memory.

Physical protection against unauthorised tampering with the card is provided through the following scheme:

The microprocessor and memory are created as a single chip. This ensures there are no data paths that can be monitored or probed. This chip is connected to a thin circuit board and encapsulated with an epoxy. The "module" is then glued within a well milled into the plastic card. This prohibits physical access to the microprocessor and provides a more durable medium than magnetic stripe cards.

ChipDrive Developer Kit
micro, sample cards and Toolbox
£99.95 + P&P + VAT

<http://www.towitoko.co.uk>

<http://www.crownhill.co.uk>

<http://edsim.cambs.net>

T
O
O
L
B
O
X



Driver and application software is available for the CHIPDRIVE family of terminals including the command set DLL for Windows 3.11/95/NT, easy to use 16 and 32 Bit DLLs with just one function call to the "CardServer", a powerful Background task which relieves the application programmer from device and card administration. Featuring automatic protocol and card type detection. Allowing several applications to access one terminal dependent on the type of card inserted. Supplied on CD ROM containing cardserver.dll, applications and source code examples.

£29.95 + £5 P&P + VAT

The microprocessor operates under control of a "built in" program called an operating system. A serial interface - which makes it impossible to access the memory directly - is employed to communicate with the card. An ISO (International Standards Organization) protocol is used to exchange commands and data with the card.

Finally, Holograms, signature stripes, photos, etc can be applied to the card for additional security. And the card can be custom printed with your artwork.

Crownhill can supply OPEN ARCHITECTURE cards, that will allow you, the end user to create your own operating system, to control access to the EEPROM memory of up to 64Kbits (8Kbytes) in size. Crownhill have off the shelf operating systems for Control access. Electronic purse and Portable Document applications. Others can be written to your specification.

SMARTCARDS Available from Stock:

GemPlus, Atmel, Xicor, Siemens, SGS Crownhill and more.....
SLE4442, 4432, 4418, 4428, 4404, AT88SCxx, AT24c01-16.
GPM103, GFM1K, 2K, 4K, GPM416 Phone Cards, Loyalty Cards

THE SMARTEST SOLUTION

Crownhill can offer a broad range of smart cards from just £1.00, and Smart Card sockets for just £1.45 ea. PIC Microchip based Smart Cards now available at just £4.50 ea.....**DEVELOP YOUR OWN SMART CARD!** Crownhill can supply over 150 different types of IC from more than 12 silicon suppliers, which can all be incorporated into smart card format. Some cards are available from stock, most are manufactured to the customers' specification.

SERVICE MANUALS & Technical Books

Available for most equipment, any make, age or model.

Return the coupon for your FREE catalogue

MAURITRON TECHNICAL SERVICES (ETI)

8 Cherry Tree Road, Chinnor, Oxon, OX9 4QY,

Tel: 01844-351694, Fax: 01844 352554 email: mauritron @ dial.pipex.com
Please forward your latest catalogue for which I enclose 2 x 1st Class Stamps, or £4.11 inc. vat for the complete Service Manuals Index on PC Disc plus catalogue.

NAME _____

ADDRESS _____

POSTCODE _____

Photocopy this coupon if you do not wish to cut the magazine

ATTENTION ALL NORTH AMERICAN READERS!

Did you know that you can order an annual subscription to this magazine direct from our official U.S. subscription representative?

For more information and rates contact:

Wise Owl Worldwde Publications

4314 West 238th Street,

Torrance, CA 90505 4509

Tel: (310) 375 6258

ADVERTISERS INDEX

Agar Circuits.....70	JPG.....39
Ambyr Ltd.....72	Labcenter Electronics.....OBC
BETA Layout.....43	Mauritron.....72
B.K. Electronics.....18	Milford Instruments.....48
Bull Electrical.....13,17	NCT.....48
Chelmer Valves.....68	No Nuts.....32
Confidential Communications..32	Plancentre Publications.....70
Crown Hill Associates.....72	Scientific Wire Co.....70
Display Electronics.....25	Service Trading Co.....70
Electronic Design Association 70	Stewarts of Reading.....71
EPT Educational Software.....IFC	Swift Design.....70
EQT.....39	Telnet.....44
Equinox.....IBC	Variable Voltage Technology Ltd
ESR Electronic Components.....2670
Forest Electronics.....53	Veronica FM.....70
Harrison Electronics.....39	Wilson Valves.....70
J & N Factors.....36	Van Draper.....39

Practically Speaking

By Terry Balbirnie

Over the next few months, we shall look at the topic of fuses. The catalogues from major component suppliers present the constructor with a bewildering array of these. Apart from the current rating, there are the physical dimensions, operating speed and material from which the body is made to be taken into account.

Note that a fuse is placed in a piece of equipment to protect against excessive current which could cause overheating of wiring and components and possible fire. It does not provide protection against electric shock. For this, you need a residual current device (RCD) and this will be discussed in a future part of Practically Speaking.

Too hot for comfort

The traditional type of fuse is simply a piece of wire which may be bare (as in older household installations) but is more usually enclosed in a glass or ceramic tube with metal ends. The fuse is connected in series with the circuit so that the current passes through it. If the current exceeds a certain value, the wire overheats, melts and breaks the circuit (that is, the fuse "blows"). This effectively switches off the supply so bringing to a halt (but not curing) the problems above.

The most important parameter of a fuse is its current rating. This is the maximum current which it may carry for a long period of time without blowing. Referring to the manufacturer's data, it may be found that a given fuse cannot carry the rated current for ever. It may blow after a few hours. It may therefore be necessary to use a fuse with a slightly higher value than the maximum current which is intended to flow through it. Catalogues list small fuses with ratings between about 50mA and 10A. The wire in a 10A fuse will be relatively thick while that in a 50mA one will be almost invisible without the aid of a magnifying glass. In every case, the fuse wire must be much thinner than any other wire in the circuit.

Current surge

It sometimes happens that when the circuit is switched on, a larger current than normal flows for a short time. This is likely to happen when inductive components such as transformers are involved. It also occurs in a power supply due to the inrush current to a large-value smoothing capacitor. Motors also pass a large current for a short time until they reach full speed. A further example is a filament bulb. Here, the current-surge is due to the cold filament having a much lower resistance than at operating

temperature. There will therefore be a much larger current flowing until the filament heats up. With a small bulb, this may take such a short time that the fuse wire will not have time to reach its melting point before the current falls to the normal value. However, with larger bulbs the fuse could blow during this perfectly normal surge.

Slow blow

These problems may be avoided by using a slow-blow (time delay) fuse. This will withstand a high current for a short time. Whereas a small quick-blow fuse carrying twice the rated current may blow within about 1 second, the corresponding time delay type would withstand it for some 5 seconds, preventing spurious "blowings" on switch-on and other normal functions. These figures are subject to wide variation and should be taken for illustrative purposes only.

If you look at one of the metal ends of a typical small glass fuse, you will see the value marked on it. This is often expressed in amps rather than milliamps such as 0.2A rather than 200mA. If it is of the time delay type it will be prefixed with a letter "T". So, "T 0.5" means a time-delay fuse having a value of 500mA. If you look inside, you will see that the time-delay type has a "spring" at the end of the fuse wire. There will also be a voltage figure. This is the maximum voltage allowed in the circuit in which the fuse is used. This might be, for example, 250V.

If you are replacing a blown fuse with a new one, it is first of all necessary to try to find out why it blew in the first place. A little investigation will probably come up with the cause. It may be due to a short-circuit somewhere in the wiring. If the cause cannot be found, the fuse may have blown simply due to old age. It should then be replaced with one of the same specification and the equipment tried. If the fuse blows again, a more detailed examination will be needed to find the cause.



Round the Corner

As you know, ETI is a journal which keeps an eye on educational matters, rather than an 'Educational journal'. Now that it is coming round again to the time of year when hard study (or lack of it) will be judged by of results, students and teachers are wondering whether their efforts will be justly rewarded.

Electronics and IT now have a higher profile in schools than for the last couple of decades; since "creative home electronics" gave way to "creative home computing" as the forward-looking hobby in the public mind, in fact. Electronics and Amateur Radio were seen as worthy pursuits for the terminally serious techno-nerd who had no interest in much more important things (free verse and sociology, for instance). Computing fared a bit better, "image-wise" (thanks in part to support from the BBC) but only recently have schools latched on to the way computers are used in offices and industry.

Now technology and craft teachers must teach electronics as part of the "craft" syllabus. Fair enough, you might say - but here's the catch. Suppose your life's work was drafting, or woodwork, or cooking, and somebody told you that you must now master the equivalent of the Radio Amateur's Examination after a two-day course?

Is this an exaggerated comparison? The RAE goes into considerably more depth than first year craft electronics. Even so, somebody with a good working knowledge of maths and basic physics should be able to pick it up pretty quickly. Two days of solid work? A bit tight, maybe.

Well, you all know how much work you invested in learning to put your own projects together - anything involving a handful of components, a lash-up and some calculations. How much do you reckon you could achieve after two days of lectures with a full roster of coffee- and meal-breaks, some course notes - and absolutely no

hands-on? Our mole reckons about 4-5 hours' listening a day, with some more in the evening if you are very lucky. A doorbell? An egg-timer? Anything with logic?

And how much would you expect to pay for this inside information. £200? £400?

Because this, apparently, is what many craft teachers round the country are receiving as their "conversion" from skilled specialists in their own discipline into the resident electronics expert for an entire department, the technical skills pool of the future.

But what becomes of teachers who cannot grasp all the new duties (or, for that matter, the old ones) in Britain in the 1990s? Our mole thinks he has found out.

Many schools run electronics or radio clubs to encourage practical experience. Into one of these clubs comes the school Inspector in charge of determining that the craft syllabus is being properly taught.

The inspector targets one of the students for a closer look. Oddly enough, the chosen student is a slight, very quiet 15-year-old girl. No doubt such a retiring being might appreciate a bit of expert advice. The Inspector begins to explain in detail how the logic circuit the 15-year-old is working on actually works.

"But that's all wrong! It doesn't work like that at all! It works like this!" echoed around the classroom. This was the student talking to the Inspector.

This is not a wry tale of an official who chose the wrong student. It's worse than that. Says our mole: "This Inspector knew virtually nothing. He didn't have a clue how the circuit worked. But he had been sent to report on the club and the students' work."

Pity the teachers who have to teach a technical subject with insufficient background. Pity the teachers and students who are being inspected by non-experts who know even less. It may make it easier for failing teachers and students to conceal their failures this way, but what is it doing for the skills of the future?

Next Month

Volume 27 no. 7 of *Electronics Today International* will be in your newsagents on 19th June 1998 ... Robin Abbott will be looking very closely at the undersized world of Surface Mount ... plus his new series on advanced PIC Programming ... Robert Penfold Investigates the practicalities and pitfalls of putting together your own PC ... an entertaining new circuit from Terry Balbirnie ... and bags more.

Contents are in preparation but are subject to space and availability.

ETI
ELECTRONICS
TODAY INTERNATIONAL

Published by
Nexus Special Interests Limited
Nexus House, Azalea Drive,
Swanley, Kent BR8 8HU
Tel: 01322 660070 Fax: 01322 615636
Sorry, we cannot answer queries about projects or other technical question on the phone. Please write to the address above. Our admin assistant can often help with other queries about this issue.

Don't Worry! All mail will be forwarded from our previous address.

EDITORIAL

Editor
Helen Armstrong
Administration Assistant
Jenny Etheridge
Consultant
Andrew Armstrong

PRODUCTION

Designer
David Rice
Technical Illustrator
John Puczynski
Production Executive
Marie Quilter
Printed By
Wiltshire Ltd., Bristol
Origination by
Ateher, St. Austell

SALES

Midland and Southern Area Sales
Mark Colyer
01322 660070

Northern Area Sales
Denise Barrow
0161 776 4460

Group Advertisement Manager
Diane Farnham

MANAGEMENT

Divisional Managing Director
Tony OeBell

Divisional Managing Editor
Dawn Frosdick-Hopley

Circulation Manager
William Pearson

Copy Sales Manager
David Pagendam

SUBSCRIPTIONS

UK: Orders 01858 435344
Enquiries 01858 435322
USA: Wise Owl Worldwide Publications, 4314 West 238th Street, Torrance, CA 90505-4509, USA. For VISA/Mastercard orders phone: (310) 375 6258, Fax: (310) 375 0548. Pacific Time: 9am - 9pm weekdays 10am - 6pm weekends. Visa/MC/Discover accepted.

READERS SERVICES

Back issues (last 12 months) £3.20 per issue if available. Binders for ETI: £7.50 each including UK post and packing. Overseas please add £1.50. Cheques to Nexus Special Interest at Nexus House, or phone VISA/Mastercard orders to Readers Services Department 01322 660070



© Nexus Special Interests Limited 1998
All rights reserved
ISSN 0142-7229

The Publisher's written consent must be obtained before any part of this publication may be reproduced in any form whatsoever, including photocopyers, and information retrieval systems. All reasonable care is taken in preparation of magazine contents, but the publishers, editors and their agents cannot be held legally responsible for loss howsoever arising from errors or other published material.

The Affordable Solution for 8051 & AVR™ Microcontroller Support Tools

DISTRIBUTORS FOR



IAR Microcontroller Development Tools

C-Compilers, Assemblers, Simulators

8051, Atmel AVR, Hitachi H8



MICRO-PRO DEVICE PROGRAMMER

The complete programming solution!

Supports:

MICROCONTROLLERS

Atmel 89C, 89S, 90S(AVR),
Generic 87C, Dallas 87C520

FLASH MEMORY

Atmel 29C, 49F

SERIAL/PARALLEL EEPROM

Atmel 24C, 25C, 59C, 93C, 28C

CONFIGURATORS

Atmel 17C, Xilinx XC17

Not all devices may be supported within each family.



Only... **£124.95**

Order Code: MPW-PLUS

PROFESSIONAL AVR™ MICROCONTROLLER STARTER SYSTEM

System Contents

- Combined Serial & Parallel Device Programmer
- Evaluation module for 8, 20 & 40-pin DIL devices
- In-System Programming (ISP) Cable
- Integrated Windows™ Development Environment
- AVR™ Basic LITE (1k bytes code) Compiler
- AVR™ Assembler
- Mains Power Supply Adaptor
- PC Serial Cable (Connects to PC COM Port)
- Atmel CD-ROM Datbook
- One AT90S1200 DIL Microcontroller

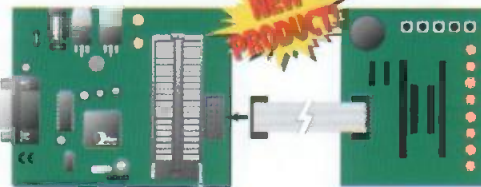

Figure 1

Only... **£124**

Order Code: AVR2-ST

WRITE IN BASIC RUN IN A FLASH

AVR™ BASIC

- Compiled BASIC generates tight AVR™ machine code
- Not a Run-Time Interpreter; NO code overhead!
- Target speeds comparable with assembler
- Breaks the cost barrier for small projects
- Ideal for educational, hobbyist and professional use



Order Codes:
AVR-BAS-LITE
AVR-BAS-8K

Only... **£124**
and **£139**

FLASH 8051 Professional Starter System

System Contents

- Combined Serial & Parallel Device Programmer
- Evaluation module for 20 & 40-pin DIL devices
- In-System Programming (ISP) Cable
- Keil PK51-2K Integrated Windows™ Development Environment (2K code limit). Includes C-Compiler, Macro Assembler, Linker, Hex Creator, Editor & Simulator
- Mains Power Supply Adaptor
- PC Serial Cable
- Atmel CD-ROM Datbook
- One AT89S8252 40-pin DIL Microcontroller

System layout shown in Fig 1 above

Only... **£124**

Order Code: EQ-8051-ST1

Micro-ISP

Series III

Serial Programming System for the Atmel AVR™ & 89S microcontroller families



Typical In-System Programming (ISP) Scenario shown below:

Supports: Atmel 89S, 89LS, 90S(AVR)

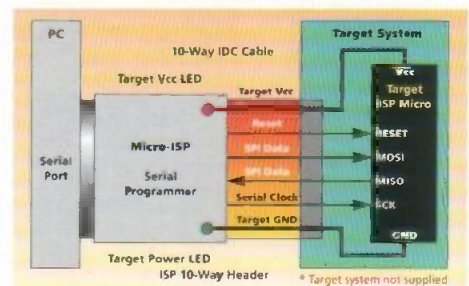

Order Code:
UISP-S3-SYS

Only... **£39.95**



THE ULTIMATE 8051 TOOL SET

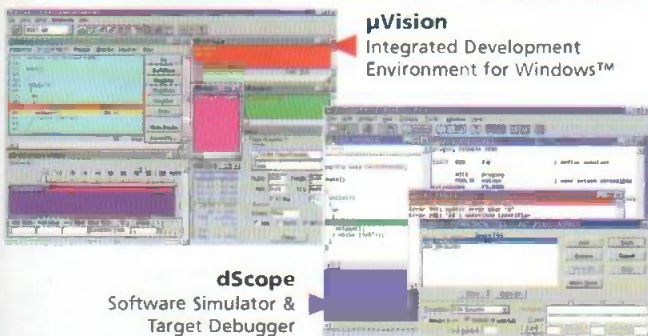

µVision
Integrated Development Environment for Windows™

- Optimising Ansi-C Compiler
- Macro Assembler
- Linker
- Software Simulator
- Integrated Editor
- Hex Creator

Starter Systems supplied with 2K Toolset & Development Systems supplied with 8K Toolset are available for Atmel, Dallas, Siemens, Temic 8051 microcontroller derivatives

dScope
Software Simulator & Target Debugger



The Embedded Solutions Company

3 Atlas House St Georges Square Bolton BL1 2HB England



For sales tel: +44 (0) 1204 529000, fax: +44 (0) 1204 535555, e-mail: sales@equinox-tech.com, Web Site: www.equinox-tech.com

EQUINOX DISTRIBUTORS: AUSTRALIA Farnell +61 2 9645 8888 AUSTRIA Farnell +43 0660 87 75 BELGIUM Alcom Electronics Nv/SA +32 3 227 36 47 Farnell +32 03 227 36 47 BRAZIL Hasteq +55 11 522 1799 Anacom +55 11 453 5588 DENMARK Farnell +45 44 53 66 44 EIRE Farnell +353 1 8309277 FINLAND Farnell +358 9 3455 400 FRANCE Farnell +33 474 65 94 66 Newtek +33 1 4687 2200 GERMANY Elektronik Laden +49 52 32 81 71 Farnell +49 89 61 39 39 Inteltek GmbH +49 7321 93850, MSC Vertreter GmbH +49 08 9945532 12 GREECE Microtec +30 1 5395042 4 HONG KONG Farnell 800 968 280 (HK Direct Toll Free) ITALY Farnell +44 113 231 1311 Grifo Italian Technology +39 51 89 20 52, Newtek Italia +39 2 33 10 53 08 MALAYSIA Farnell +60 3 773 8000 NETHERLANDS Alcom Electronics BV +31 10 4519533 Antratek +31 10 450 4949 Farnell +31 30 241 2323 NEW ZEALAND Farnell +64 9 357 0646 NORWAY ACTE NC +47 63898900 Jakob Hatteland Electronic AS +47 53763000 PORTUGAL Anatronc +35 119 371 634 Farnell +44 113 289 0040 SINGAPORE Farnell +65 788 0200 SPAIN Anatronc SA +34 1 366 01 59 Farnell +44 113 231 0447 SWEDEN ACTE NC +46 8 445 28 70 Farnell +46 8 730 50 00 SWITZERLAND Anatec Ag +41 41748 32 41 Farnell +41 1 204 64 64 UNITED KINGDOM Abacus Polar +44 1925 626626, Farnell +44 113 263 6311 Rapid Electronics +44 1206 751166 Quamdon Electronics +44 1332 332651 USA HTools Inc +1 408 298 9077 Newark Electronics +1 800 718 1997, Peachtree Technology +1 770 688 4002 Pioneer Standard +1 888 832 3976

Equinox reserves the right to change prices & specifications of any of the above products without prior notice. E&OE. All prices are exclusive of VAT & carriage. AVR™ is a trademark of the Atmel Corporation

PROTEUS

Schematic Capture

NEW Version IV

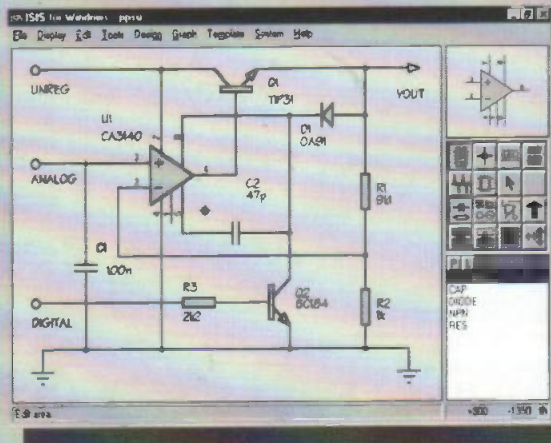

- Produces attractive schematics like you see in the magazines.
- Netlist, Parts List & ERC reports.
- Hierarchical Design.
- Full support for buses including bus pins.
- Extensive component/model libraries.
- Advanced Property Management.
- Seamless integration with simulation and PCB design.

Simulation

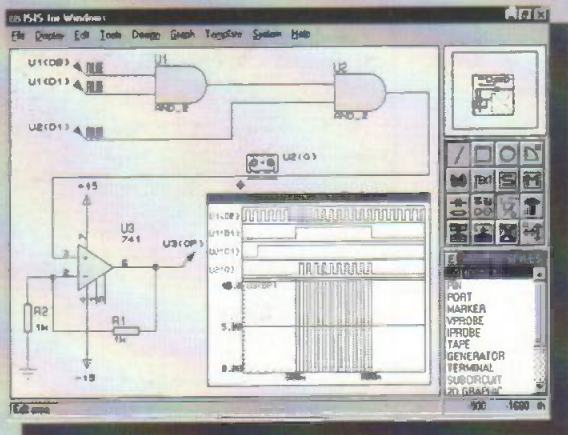

- Non-Linear & Linear Analogue Simulation.
- Event driven Digital Simulation with modelling language.
- Partitioned simulation of large designs with multiple analogue & digital sections.
- Graphs displayed directly on the schematic.

FREE
SOFTWARE
ISIS & ARES Lite
Schematic & PCB
Design

SHAREWARE VERSIONS
AVAILABLE TO DOWNLOAD
FROM OUR WEBSITE

<http://www.labcenter.co.uk>

labcenter
Electronics

The IVth Generation

New Features

- Component Auto-Placer
- Pinswap/Gateswap Optimizer
- Background Regeneration of Power Planes
- Enhanced Autorouting with Tidy Pass
- Full Control of Schematic Appearance
- Extensive New Component Libraries

Available in 5 levels - prices from £295 to £1625 + VAT.
Call now for further information & upgrade prices.

PCB Design

NEW Version IV

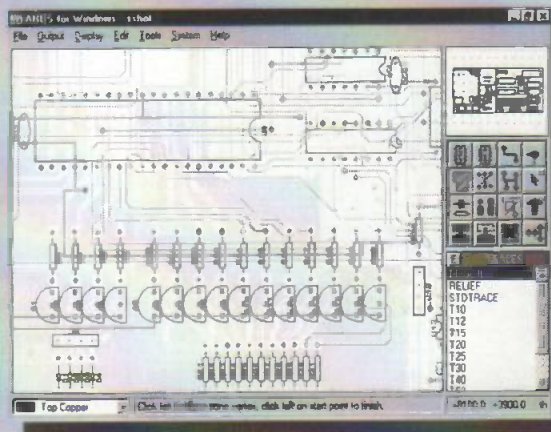

- Automatic Component Placement.
- Rip-Up & Retry Autorouter with tidy pass.
- Pinswap/Gateswap Optimizer & Backannotation.
- 32 bit high resolution database.
- Full DRC and Connectivity Checking.
- Shape based gridless power planes.
- Gerber and DXF Import capability.

"PROTEUS
is particularly good
with its rip-up-and-retry
autorouter" EWW January 1997

Write, phone or fax for your free demo disk, or ask about our full evaluation kit.
Tel: 01756 753440. Fax: 01756 752857. EMAIL: info@labcenter.co.uk
53-55 Main St, Grassington. BD23 5AA. WWW: <http://www.labcenter.co.uk>

Fully interactive demo versions available for download from our WWW site.
Call for educational, multi-user and dealer pricing - new dealers always wanted.
Prices exclude VAT and delivery. All manufacturer's trademarks acknowledged.