



"HUSH" NOISE REDUCTION UNIT

With a self-setting threshold level

A UHF MODEL RADIO CONTROLLER

move to the higher wave bands

WHAT'S FLAT, SHINY AND EXTERMINATES CRTs ?

The Best Telly On The Block

Plasma, plastics and lean screens are coming soon

AVR MICROCONTROLLER PROGRAMMER

Program the new fast Atmel AVR's

PLUS

- *Fridge Thermometer*
- *Mini Swipecard Reader*
- *"Guardian" Security Light*



Vol 27 Issue: 5 24th April - 21st May 1998
£2.75 U.S.A. \$4.95

Electronics Principles 5.0

'A COMPLETE PC BASED ELECTRONICS COURSE'

If you are looking for an easy and enjoyable way of studying or improving your knowledge of electronics then this is the software for you.

Now includes the PIC16C84 & PIC16C71 hardware and instruction set.

Electronics Principles 5.0 is a significant upgrade of our popular electronics educational software. Now containing even more analogue, digital and microcomputer theory. PLUS over a hundred new mathematics topics to further your understanding of formulae and calculations. Telephone for a comprehensive list of upgrade details.

This software has been developed to teach electronics and is suited to both the complete novice and the more advanced student or hobbyist wanting a quick revision and access to hundreds of electronics formulae. It is extremely easy to use. Just select a topic, which is always presented as a default diagram (no blank screens!) and input your own values. Alternatively, use those from any standard electronics text book to see the results as frequency response curves, calculations, logic states, voltages and currents etc.

Graphics presentation has been enhanced and speeded-up with new menus and indexing which enables a quicker access and more informative description of the extended range of five hundred and sixty electronics and mathematics topics.

The PIC16C84 microcontroller hardware and Instruction set has been introduced and brought to life through colourful interactive graphics where you can study the architecture of this device by changing the data values to simulate all of the registers, direct/indirect addressing, program/data memory and input/output port configuration. Along with those analogue to digital functions of the PIC16C71. If you would like to learn more about the principles of these popular microcontrollers then it could not be made easier.

Electronics Principles software is currently used in hundreds of UK and overseas schools and colleges to support City & Guilds, GCSE, A-Level, BTEC and university foundation courses. Also NVQ's and GNVQ's where students are required to have an understanding of electronics principles.

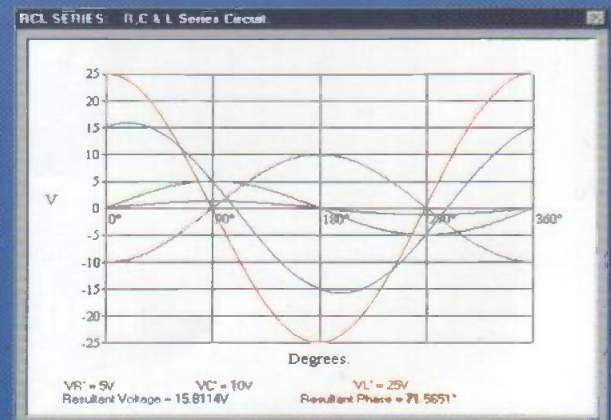

Still only £99.95*

EPT Educational Software. Pump House, Lockram Lane, Witham, Essex. UK. CM8 2BJ.

Tel/Fax: 01376 514008. sales@eptsoft.demon.co.uk <http://www.eptsoft.demon.co.uk>

*UK and EC countries add £2 per order for post & packing. VAT should be added to the total.

Outside Europe £3.50 for air mail postage by return.

Switch, Delta, Visa and Mastercard orders accepted - please give card number and expiry date. Cheques & Postal Orders should be made payable to EPT Educational software.

Contents

Volume 27 No.5

& Features & Projects

Next Issue 22nd May 1998

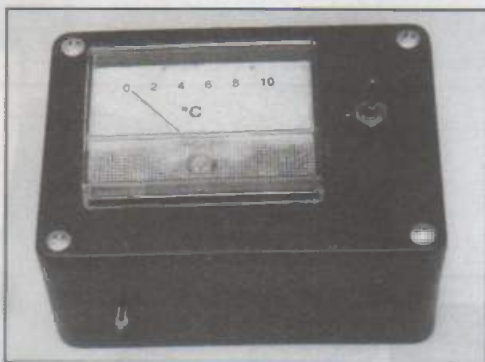
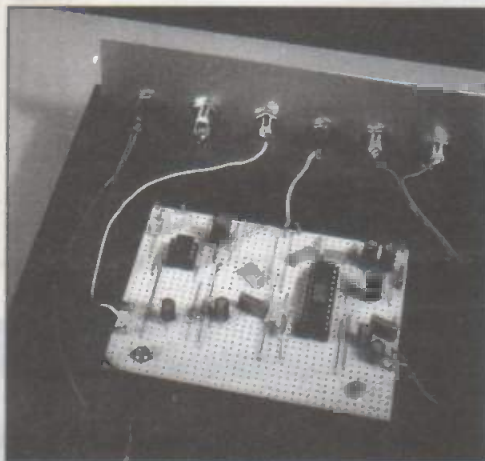
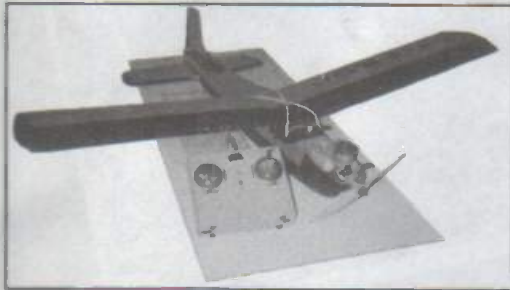

What's Flat, Shiny, and Exterminates CRTs? 9

Cheaper and better flat screen technologies coming in now could knock the conventional cathode ray tube for six. Andrew Armstrong takes a look at some of the more promising ones for computer and television use.

An AVR Microcontroller Programmer 19

The recently-introduced AVR microcontrollers can be very fast, and can be programmed in-circuit. Robin Abbott has designed a new programmer for the AVR's based on his experience with PIC programmers.

Fridge Thermometer 24

Too many people don't know how cold their fridge should be to store food safely, let alone how cold it is. Terry Balbirnie's fridge thermometer/monitor helps to keep the fridge between 2 and 4 degrees Celsius.

"Hush" Noise Reduction Unit 29

Based on "Hush" technology, Robert Penfold's new noise reduction unit requires no manual setting of the threshold level. Circuit stages analyse the input signal and set the most appropriate level.

UHF Model Radio Controller 35

UHF radio can be more effective than the old 27MHz band. Geoff Pike G10GDP decided that "making a UHF radio control system should not pose major problems, given the ease of component availability and new construction techniques", and developed this design.

Fast Fivers 9 - Audible Logic Probe 46

Low-cost quick circuits from Owen Bishop. This logic level probe based on the 4046 phased lock loop means you can keep your eyes on a circuit under test by sounding high and low notes for logic levels.

Guardian Light 51

Emergency lighting systems help people find their way to safety or just sit in peace if the power fails for any reason. The Guardian Light is battery backed and comes on automatically if the mains light fails.

Magnetic Swipe Card Reader 56

A simple ISO track 2 magnetic card reader with PC-based Turbo Pascal software by Magnus Pihl is based on the Omron manual 3S4YR-HNR-4U, but is applicable to other track 2 card readers.

A 27C16 Eprom Programmer 60

Running from DOS commands on a PC via a 9600 baud serial connection, Richard Grodzik's compact battery-powered eprom programmer programs a basic 2kB eprom in two seconds.

Regulars

News & News Extra 4,5,6,7 & 59

ETI PCB Service 66

PCB foils 67, 69, 70

Practically Speaking 73

Terry Balbirnie describes this month how an analogue panel microammeter can be re-scaled to read a higher current range.

Round the Corner 74



SUBSCRIPTIONS
& BACK ISSUES HOTLINES:

01858 435344

ORDERS:

ENQUIRES:

01858 435322

Lines Open 9am - 6.30pm

Subscribe & Save

Phone the
hotline and take
advantage of
our special offer
detailed on
page 45

High-Performance Addressing Advances Passive Matrix Colour

Hitachi Europe has introduced new products based on a new passive matrix colour LCD technology which provides major advances over existing passive matrix colour-STN displays, especially in response times and contrast ratios. The SX3 family of LCDs ranges from 12.1 inches to 15.5 inches in display size, have S-VGA or XGA resolution with conventional or LVDS interfacing.

The new technology, called High-Performance-Addressing (HPA), is aimed primarily at the notebook, mega-notebook and desktop PC markets.

The HPS display family includes initially three products: the SX31S003 12.1-inch SVGA with a conventional interface; the SX33S001 13-inch XGA with an LVDS interface, and, notably, the SX39X, a 15.5-inch XGA with an LVDS interface. A fourth device, the SX39001 15.5-inch XGA panel with a conventional interface, follows shortly.

HPA allows passive matrix technology to be used in applications such as multimedia which were previously forced to use more expensive active matrix displays. The enhanced high-addressing provides response times of 150ms (twice the speed of conventional C-STN) and contrast ratios of 50:1, a significant improvement over existing STN technology. In future, response times of 80ms are expected.

In general, HPA gives response speeds closer to TFT (thin film transistor), a higher contrast ratio and less crosstalk and shadowing. The cost is expected to fall to approximately 60 percent of the equivalent TFT display size.

The more information please contact Vince Pitt, Hitachi Europe Ltd., Whitebrook Park, Lower Cookham Road, Maidenhead, Berks SL6 8YA. Tel 1628 585163, fax 01628 585160.

The following table compares HPA with conventional Colour-STN and TFT displays:

	Colour-STN	HPA LCD	Thin-film Transistor
Technology type	Passive matrix	Passive matrix	Passive matrix
Applications	Data and graphic	Multimedia	Multimedia
Response Time	300-270ms	150-80ms	55ms
Contrast Ratio	30:1	50:1	100:1
Driving Method	Dual scan Enhanced Hi-	Dual scan + Addressing	Single Scan
Shadowing	Low	Negligible	Negligible
Viewing Angle	Good	Excellent	Excellent
Approximate Cost Ratio	50 percent	c. 60 percent	100 percent



MODMODMODMODMODMOD

Smartcam: The outstanding query mentioned in the previous issue has been resolved with nothing further to report.

National Vintage Communications Fair

The National Vintage Communications Fair is coming round again. The next Fair will be on Sunday 10th May in Hall 11, the National Exhibition Centre (NEC), near the M6 motorway, Birmingham, from 10.30am to 4pm.

The Vintage Communications Fair is a collectors fair for antique radio, with rare and collectable examples of radios, tvs, gramophones, value hifi and "all manner of electrical and mechanical antiques and collectables". The Fair is now held twice a year, usually in May and October, and expects over 300 specialist dealers from the UK, the Continent and the USA. Help and advice are on hand from representatives from collectors' clubs, societies and specialist magazines.

Entrance is £5 and includes a copy of The Sound and Vision Yearbook's Collectors' Guide. Anyone who wants to book stand space or requires other details should contact Sunrise Press, Spice House, 13 Belmont Road, Exeter, Devon EX1 2HF (sending an SAE) or tel. 01392 411565.

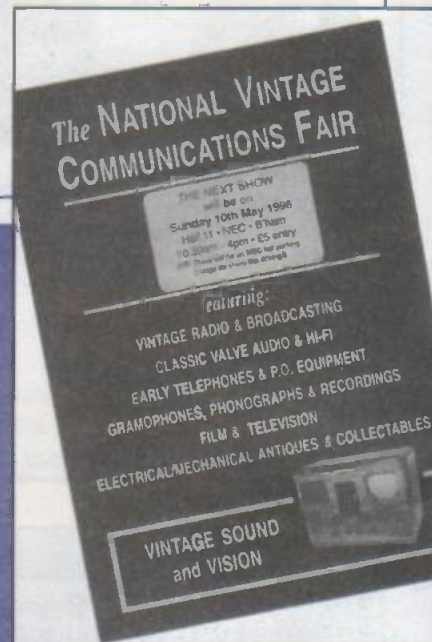

A Cool Million Goes to Multimedia Winners

Part of the DTI's Information Society Initiative Programme for Business is the ISCA's, or Information Society Creativity Awards. Twenty British companies have won financial support from a £1 million pound DTI programme to help turn innovative digital ideas into market leaders.

The twenty 1998 winners include:

Ransom Publishing were awarded £25,000 for *The History of Life*, a multimedia CD-rom with hybrid web access, which covers biological evolution and competing theories of life, creation and biodiversity, and can simulate evolution (visually) on the computer in a number of different environments, to give a better understanding of evolutionary theories. Contact: Lucy Eldridge 01491 613711.

The Barfield Group Ltd were awarded £25,000 for a hybrid CD-rom package encouraging UK companies to take advantage of business opportunities in Russia. It includes photos, maps, sound and video clips and a searchable database. Contact: Paul Wolstencroft 0181 447 1000.

SMS Multimedia were awarded £45,000 for *The Rotary Coping with Life* series, multimedia programs that tackle problems facing young people, such as bullying, crime, stress of family breakdown. Contact: Colin Sawyer 01670 813470.

IIP were awarded £25,000 for *The Palace of Amnesia*, conceived by David Thorpe, author of *How the World Works*, which "marries human psychospace and computer cyberspace with art, music and humour in the quest for identity and nature". (No, it's not *Robot Wars*.) Contact: Dr Will Howard 01792 391290.

Ground Bass Productions were awarded £12,275 for a CD-rom allowing any paper-using company to investigate interactive multimedia as an alternative way of producing the "Interactive Brochure" to promote companies. Contact: Dolly Sanders 0171 288 1833.

JWM Creative were awarded £47,213 for *What Are You Like*, providing teenage girls with information and entertainment on CD-rom. Contact John Worth 01273 488282.

The Mersey Television Company Ltd. were awarded £45,000 for *From Script to Screen*, a hybrid CD-rom providing a behind-the-scenes look at television drama production. Contact Andrew Comie 0151 722 9122.

Cambridge Training and Development Ltd. were awarded £49,980 for *ReadingWrite*, an application to give UK schools an approach to reading and writing using the National Grid for Learning. Contact Martin Good 01223 582582.

Realise Ltd, were awarded £25,000 for *The Knowledge Pool*, an interactive web tool combining the benefits of newsgroups and on-line communities. Contact Richard Ashrovan 0131 538 7344.

Lightspeed Online were awarded £12,480 for *Ariadne*, which allows for secure transmission of sensitive information for

the legal and financial professions. Contact Paul Stokes 01222 235760.

Arq Ltd were awarded £25,000 for *Vision*, a professional journal for managers and decision makers on the subject of sustainable development and the environment. Contact Nick Hart-Williams 01225 312391.

Dataculture were awarded £21,934 for *The 24-Hour Box Office* to enable independent theatres and other venues to sell tickets at any time using touch-tone phones or kiosks. Contact Jonathan Hyams, 01908 232404.

Kenneth Mason Publications Ltd were awarded £49,469 for *Research Exploitation*, a program to match British inventions with manufacturers ready to develop them.. Contact Piers Mason 01243 377977.

WHP Chester Ltd. were awarded £25,000 for a prototype for use in forensic reconstruction using a digitally animated presentation of evidence based on accurate interpretation of data. Contact Kevin Horswood, 01244 344880.

Lightwork Design Ltd. were awarded £50,000 for *The LightWorks StyleMaker* project to create "artist's renderings" directly from 3-D data. Contact Stuart Green, 0114 266 8404.

Notting Hill Publishing were awarded £50,000 for *Dancer DNA Professional* which uses evolutionary theory and 3D graphics to evolve animations to music in real time. Contact 0171 937 6003.

Formance were awarded £21,010 for *4.I.D.*, a hybrid CD-rom/Internet/intranet digital image archiving system operating in three-dimensional space. Contact Alison Murray 0171 729 8808.

Active Adventure Ltd. were awarded £20,075 for *Discovering the National Parks*, a CD-rom that allows PC users to examine information and images of National Parks interactively. Contact: J M Collins 01928 731 791.

Continuum ID were awarded £21,276 for *F.CAD*, an information and design assistance tool for small furniture designers and manufacturers. Contact Roland Whitehead 01403 271888.

AND Software Ltd. were awarded £25,000 for *ProDesk*, an application for designers of microcontroller products to speed design and evaluation, particularly appearance. Contact Valerie Thom 01922 814655.

The ISCA's are sponsored by Sun Microsystems, Macromedia, Demon Internet, Yahoo, The Electronic Telegraph and Computer Arts. "The ISCA's give small and medium sized UK businesses the creative freedom to develop new media-based products," said Robert Youngjohns, MD of Sun Microsystems.

The Information Society Initiative Infoline can be contacted on 0345 152000. The ISI website is on <http://www.sis.gov.uk>

DIY EMC Test Facility in Sussex

Crowborough-based company Feedback Instruments has made its in-house EMC facility available for hire for

EMC (electromagnetic compatibility) testing on a DIY basis, either as a pre-compliance measure or for self-certification.

Feedback describe the facility as a fully-equipped screened room completely lined with rf absorber and suitable for both emissions testing and radiation immunity testing. For emissions testing, the room is equipped with a combination of antenna, preselector, spectrum analyser and appropriate software. The immunity system consists of an antenna, an RF generator, an amplifier, a field probe and GPIB software for automatic field levelling. Other measurements of transients and static discharge can be carried out using readily available systems.

The room has been designed and equipped to be suitable for use by electronics engineers who are not necessarily RF specialists. Feedback's representatives make the point that ease of use is important and that days can be lost during new product development if EMC tests are inconsistent. "Our facility has been designed for the greatest possible consistency of results and cost-effective EMC testing", says Mike Christieson, the Development Manager. At time of writing prices are £540 per day, £280 per half day, ex VAT. For more information, contact Feedback Instruments Ltd., Park Road, Crowborough, East Sussex TN6 2QR. Tel 01892 653322 fax 01892 663719. Web WWW.fbk.com email feedback@fdbk.demon.co.uk



8051 Simulator Can Capture Complete Chip State

A new 8051 simulator running under Windows 95 and Windows NT 4.0 has been released by Crossware Products, a UK-based embedded tools developer. The software creates a virtual 8051 microcontroller on a PC, and provides full source-level debugging facilities without the need for any 8051 hardware.

The software provides full simulation of interrupts, serial port and timers, with graphic displays to show the activity of these on-chip peripherals. Views of memory, registers and disassembled instructions allow observation and control at the microcontroller level. Multiple watch windows show the values of local and global C variables, and context-coloured windows allow debugging at source code level. A unique feature of this simulator is its State Capture facility: one click will capture the complete state of the microcontroller under simulation, including memory contents, register values and program counter. At a later time, the programmer can restore this state and the simulator will reconfigure itself exactly as it was when the state was captured. The programmer can re-start the simulation from this restored state.

Since multiple states can be captured, the state capture facility provides a means of taking giant steps both forwards and backwards through previously executed code without needing to re-execute all the instructions between each point.

Data sheets and a fully working evaluation package can be obtained from the Crossware website at <http://www.crossware.com>

For more information contact Crossware Products, St John's Innovation Centre, Cowley Road, Cambridge CB4 4WS. Tel 01223 421263 fax 01223 421006.

Maplin and CB Radio Representatives Co-Endorse

Maplin Electronics has signed a corporate membership deal with the UK's leading CB radio organisation, the British Citizens Band Confederation (BCBC).

The BCBC, newly formed in 1997, represents the needs of licensed CB radio users, manufacturers and retailers in the UK. The organisation is recognised by the Radiocommunications Agency, who are responsible for all regulation of CB and other radio use in the UK, including the frequencies in use, modes of transmission and technical manufacturing guidelines and regulations.

Purchasers buying CB radio equipment from Maplin will receive information about the BCBC and CB licensing information.

For further information on the BCBC and Maplin's product range and store locations, call 01702 554002 or refer to your current Maplin catalogue.



Joint Development for Digital Imaging ICs

New ICs are being developed to integrate Iomega Corporation's interface for its latest disk drive family, **click!** (sic!) into Atmel Corporation's devices. Iomega's **click!** is expected to be the first true "digital film" that can compete on both price and image quality with conventional film. Various of Atmel's future digital camera products will have the **click!** interface standard integrated. The drive is designed to meet the storage needs of digital imaging with portable equipment, so that data can be passed from portable image-gathering equipment (cameras and any portable peripherals) back to a main computer for handling.

The plan behind **click!** is a family of high-capacity removable storage media using Iomega's mobile technology platform, **n.hand(tm)**. This is part of a move to bring greater levels of removable data storage to portable digital equipment, including digital cameras, hand-held computers, personal organisers and cellular smart phones.

The standard **click!** drive is a portable, low cost external drive that can be used with a wide range of digital portable and desktop equipment and is small enough to fit into a shirt pocket (and, unlike some cheaper mobile data recording solutions, will not leak ink onto the shirt). A

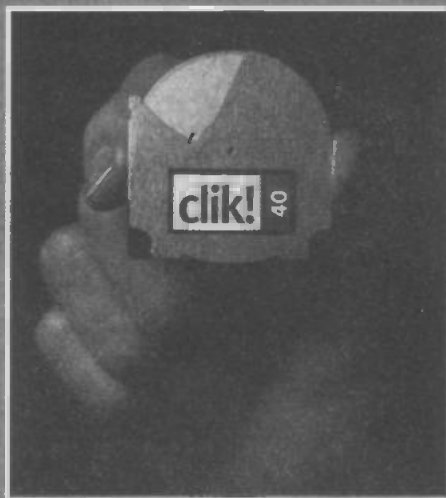

miniature, low-power version of the same drive will be available to original equipment manufacturers (OEMs) to build into equipment from digital cameras to palmtop computers.

Click! 40-megabyte removable disks are about half the size of a credit card and can store approximately 40 high quality (1-megapixel) digital photographs or around 400 10-page Word documents.

Currently digital camera users can take only a few high-resolution photographs before they must download their images from the camera to a computer. Removable storage drives like **click!** free the photographer from having to constantly return to the computer. A 40-megabyte removable disk is expected to retail for about \$9.95 in the USA, so we might expect a price of about £10 when it comes to the UK. The drives as described are reusable.

For more information in the UK contact Bob Henderson at Atmel UK, The Coliseum Business Centre, Riverside Way, Camberley, Surrey GU15 3YL, tel 01276 686677 fax 01276 686697 or Jimmy Tse at Technical Publicity 01582 450054. Web: (Atmel) www.atmel.com (Iomega) www.iomega.com

Wide-Ranging Stepper Materials Catalogue

Parker Hannifin Electromechanical has produced a 72-page catalogue detailing one of the largest ranges of stepper products in the world. The catalogue covers 10 different stepper families, and has full information on compatible motors, controllers and support software. Most applications are catered for: Parker stepper systems are available in torque ratings from 0.5N (Newton) m to 13Nm, drive resolutions from 200 to 50,800 steps per revolution, and speeds up to 3000 rpm.

As well as the ranges of packaged and rack-mount full and half step and ministepping systems, the catalogue has details of Parker's new-generation Zeta advanced microstepping system drives. Incorporating new technology known as active damping and electronic viscosity (patents pending), the drives provide very fast acceleration and settling times, and offer resolutions up to 50,800 steps per revolution.

Every stepper family includes a version with a built-in indexer with capabilities ranging from point to point positioning through to complex continuous path applications. The catalogue also has a range of stand-alone and PC-based indexers for single- and multi-axis applications, together with powerful software support tools running under LabView or Windows.

For more information contact Sharon Beale, Customer Services, Parker Hannifin Plc., Electromechanical Division - Digiplan, Balena Close, Poole, Dorset VH17 7DX. Tel 01202 699000. Email sales@digiplan.com



Stepper drives, motors,
controllers & software

Catalogue 1000 232 01
June, 1997



WIND GENERATORS 380 WATT

1.14 metre dia blades, carbon matrix blades, 3 year warranty, 12vdc output, 24v version available, control electronics included, brushless neodymium cubic curve alternator, only two moving parts, maintenance free, simple roof top installation, start up speed 7mph, max output (30mph) 380w, £499 ref AIR1

HYDROPONICS

DO YOU GROW YOUR OWN?

We have a full colour hydroponics catalogue available containing nutrients, pumps, fittings, environmental control, light fittings, plants, test equipment etc

Ring for your free copy.

PORTABLE X RAY MACHINE PLANS Easy to construct plans on a simple and cheap way to build a home X-ray machine! Effective device, X-ray sealed assemblies, can be used for experimental purposes. Not a toy or for minors! £6/set. Ref FXP1.

TELEKINETIC ENHANCER PLANS Mystify and amaze your friends by creating motion with no known apparent means or cause. Uses no electrical or mechanical connections, no special gimmicks yet produces positive motion and effect. Excellent for science projects, magic shows, party demonstrations or serious research & development of this strange and amazing psychic phenomenon. £4/set Ref FTKE1.

ELECTRONIC HYPNOSIS PLANS & DATA This data shows several ways to put subjects under your control. Included is a full volume reference text and several construction plans that when assembled can produce highly effective stimuli. This material must be used cautiously. It is for use as entertainment at parties etc only, by those experienced in its use. £15/set. Ref FEH2.

GRAVITY GENERATOR PLANS This unique plan demonstrates a simple electrical phenomena that produces an anti-gravity effect. You can actually build a small mock spaceship out of simple materials and without any visible means - cause it to levitate. £10/set Ref FIGRA1.

WORLDS SMALLEST TESLA COIL/LIGHTENING DISPLAY GLOBE PLANS Produces up to 750,000 volts of discharge, experiment with extraordinary HV effects. Plasma in a jar, St Elmo's fire, Corona, excellent science project or conversation piece. £5/set Ref FBTCMLG5.

COPPER VAPOUR LASER PLANS Produces 100mw of visible green light. High coherency and spectral quality similar to Argon laser but easier and less costly to build yet far more efficient. This particular design was developed at the Atomic Energy Commission of NEGEV in Israel. £10/set Ref FCVL1.

VOICE SCRAMBLER PLANS Miniature solid state system turns speech sound into indecipherable noise that cannot be understood without a second matching unit. Use on telephone to prevent third party listening and bugging. £6/set Ref FVSS9.

PULSED TV JOKER PLANS Little hand held device utilises pulse techniques that will completely disrupt TV picture and sound! works on FM too! DISCRETION ADVISED. £8/set Ref FJT5.

BODYHEAT TELESCOPE PLANS Highly directional long range device uses recent technology to detect the presence of living bodies, warm and hot spots, heat leaks etc. Intended for security, law enforcement, research and development, etc. Excellent security device or very interesting science project. £8/set Ref FBHT1.

BURNING, CUTTING CO2 LASER PLANS Projects an invisible beam of heat capable of burning and melting materials over a considerable distance. This laser is one of the most efficient, converting 10% input power into useful output. Not only is this device a workhorse in welding, cutting and heat processing materials but it is also a likely candidate as an effective directed energy beam weapon against missiles, aircraft, ground-to-ground, etc. Particle beams may very well utilize a laser of this type to blast a channel in the atmosphere for a high energy stream of neutrons or other particles. The device is easily applicable to burning and etching wood, cutting, plastics, textiles etc. £12/set Ref FLCT7.

DYNAMO FLASHLIGHT Interesting concept, no batteries needed just squeeze the trigger for instant light apparently even works under water in an emergency although we haven't tried it yet. £6.99 ref SC152

ULTRASONIC BLASTER PLANS Laboratory source of sonic shock waves. Blow holes in metal, produce 'cold' steam, atomize liquids. Many cleaning uses for PC boards, jewellery, coins, small parts etc. £6/set Ref FALB1.

ANTI DOG FORCE FIELD PLANS Highly effective circuit produces time variable pulses of acoustical energy that dogs cannot tolerate. £6/set Ref FIDOG2.

LASER BOUNCE LISTENER SYSTEM PLANS Allows you to hear sounds from a premises without gaining access. £12/set Ref FLLUST1.

PHASOR BLAST WAVE PISTOL SERIES PLANS Handheld, has large transducer and battery capacity with external controls. £6/set Ref FFPSP4.

INFINITY TRANSMITTER PLANS Telephone line grabber/room monitor. The ultimate in home/office security and safety! simple to use! Call your home or office phone, push a secret tone on your telephone to access either: A) On premises sound and voices or B) Existing conversation with break-in capability for emergency messages. £7 Ref FTELEGRAB.

BUG DETECTOR PLANS Is that someone getting the goods on you? Easy to construct device locates any hidden source of radio energy! Swifts out and finds bugs and other sources of bothersome interference. Detects low, high and UHF frequencies. £5/set Ref FBD1.

ELECTROMAGNETIC GUN PLANS Projects a metal object a considerable distance - requires adult supervision. £5 ref F/EML2.

ELECTRIC MAN PLANS, SHOCK PEOPLE WITH THE TOUCH OF YOUR HAND! £5/set Ref F/EMPA1.

SOLAR POWERED WIND UP RADIOS BACK IN! These FM/AM radio's have a solar panel and a hand operated charger! £17.95 ref SOLRAD.

PARABOLIC DISH MICROPHONE PLANS Listen to distant sounds and voices, open windows, sound sources in 'hard to get' or

hostile premises. Uses satellite technology to gather distant sounds and focus them to our ultra sensitive electronics. Plans also show an optional wireless link system. £8/set ref F/PM5.

2 FOR 1 MULTIFUNCTIONAL HIGH FREQUENCY AND HIGH DC VOLTAGE, SOLID STATE TESLA COIL AND VARIABLE 100,000 VDC OUTPUT GENERATOR PLANS Operates on 9-12vdc, many possible experiments. £10 Ref F/VM7/ TCL4.

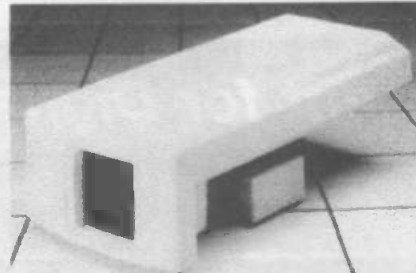

COLOUR CCTV VIDEO CAMERAS,

BRAND NEW AND, CASED, FROM £99.
Works with most modern video's, TV's, Composite monitors, video grabber cards. Pal, 1v P-P, composite, 75ohm, 1/3" CCD, 4mm F2.8, 500x582, 12vdc, mounting bracket, auto shutter, 100x50x180mm, 3 months warranty, 1 off price £119 ref XEF150, 10 or more £99 ea 100+ £89

CIRCUIT PACKS Packs of 35 circuit diagrams covering lasers, SW radios, geigers, bugs, char etc. Pack1, Pack2, Pack3 £4.99 each

SMOKE ALARMS Mains powered, made by the famous Gent company, easy fit next to light fittings, power point. £4.99 ref SMKX.

CONVERT YOUR TV INTO A VGA MONITOR FOR £26! Converts a colour TV into a basic VGA screen. Complete with built in psu, lead and sware. Ideal for laptops or a cheap upgrade. Supplied in kit form for home assembly. SALE PRICE £25 REF SA34

***15 WATT FM TRANSMITTER** Already assembled but some RF knowledge will be useful for setting up. Preamp req'd, 4 stage 80-108mhz, 12-18vdc, can use ground plane, yagi or dipole. £69 ref 1021

***4 WATT FM TRANSMITTER KIT** Small but powerful FM transmitter kit 3 RF stages, mic & audio preamp included. £24 ref 1028

YUASHA SEALED LEAD ACID BATTERIES 12v 15AH at £18 ref LDT8 and below spec by 10AH at £5 a pair

ELECTRIC CAR WINDOW DE-ICERS Complete with cable, plug etc. SALE PRICE JUST £4.99 REF SA28

AUTO SUNCHARGER 155x300mm solar panel with diode and 3 metre lead fitted with a cigar plug. 12v 2watt. £12.99 REF AUG10P3.

SOLAR POWER LAB SPECIAL You get 2 6"x6" 6v 130mA cells, 4 LED's, wire, buzzer, switch + 1 relay or motor. £7.99 REF SA27

SOLAR NICAD CHARGERS 4 x AA size £9.99 ref 6P476, 2 x C size £9.99 ref 6P477

GIANT HOT AIR BALLOON KIT Build a 4.5m circumference, fully functioning balloon, can be launched with home made burner etc. Reusable (until you loose it!) £12.50 ref HA1

AIR RIFLES .22 As used by the Chinese army for training purposes, so there is a lot about! £39.95 REF EF78, 500 pellets £4.50 ref EF80.

REGISTER FOR OUR
ELECTRONIC NEWSLETTERS
BULL-ELECTRICAL.COM

BULL ELECTRICAL

250 PORTLAND ROAD, HOVE, SUSSEX.
BN3 5QT. (ESTABLISHED 50 YEARS).

MAIL ORDER TERMS: CASH, PO OR CHEQUE
WITH ORDER PLUS £3.50 P&P PLUS VAT.

24 HOUR SERVICE £5.00 PLUS VAT.

OVERSEAS ORDERS AT COST PLUS £3.50

(ACCESS, VISA, SWITCH, AMERICAN EXPRESS)

phone orders : 01273 203500

FAX 01273 323077

Sales@bull-electrical.com

INFRA RED FILM 6" square piece of flexible infra red film that will only allow IR light through. Perfect for converting ordinary torches, lights, headlights etc to infra red output only using standard light bulbs. Easily cut to shape. 6" square £15 ref IRF2

HYDROGEN FUEL CELL PLANS Loads of information on hydrogen storage and production. Practical plans to build a Hydrogen fuel cell (good workshop facilities required) £8 set ref FCP1

STIRLING ENGINE PLANS Interesting information pack covering all aspects of Stirling engines, pictures of home made engines made from an aerosol can running on a candle! £12 ref STIR2

12V OPERATED SMOKE BOMBS Type 3 is a 12v trigger and 3 smoke cannisters, each cannister will fill a room in a very short space of time! £14.99 ref SB3. Type 2 is 20 smaller cannisters (suitable for simulated equipment fires etc) and 1 trigger module for £29 ref SB2. Type 1 is a 12v trigger and 20 large cannisters. £49 ref SB1

HI POWER ZENON VARIABLE STROBES Useful 12v PCB fitted with hi power strobe tube and control electronics and speed control potentiometer. Perfect for interesting projects. etc. 70x55mm 12vdc operation. £6 ea ref FLS1, pack of 10 £49 ref FLS2

RUSSIAN BORDER GUARD BINOCULARS £1799

Probably the best binoculars in the world! ring for colour brochure.

NEW LASER POINTERS 4.5mw, 75 metre range, hand held unit runs on two AA batteries (supplied) 670nm. £29 ref DEC49

HOW TO PRODUCE 35 BOTTLES OF WHISKY FROM A SACK OF POTATOES Comprehensive 270 page book covers all aspects of spirit production from everyday materials. Includes construction details of simple stills etc. £12 ref MS3

NEW HIGH POWER MINI BUG With a range of up to 800 metres and a 3 days use from a PP3 this is our top selling bug! less than 1" square and a 10m voice pickup range. £28 ref LOT102

BUILD YOUR OWN WINDFARM FROM SCRAP New publication gives step by step guide to building wind generators and propellers. Armed with this publication and a good local scrap yard could make you self sufficient in electricity! £12 ref LOT81

NEW LOW COST VEHICLE TRACKING TRANSMITTER KIT £29 range 1.5-5 miles, 5,000 hours on AA batteries, transmits info on car direction, left and right turns, start and stop information. Works with any good FM radio. £29 ref LOT101a

CCTV CAMERA MODULES 46x70x29mm, 30 grams, 12v 100mA auto electronic shutter, 3.6mm F2 lens, CCIR, 512x492 pixels, video output is 1v p-p (75 ohm). Works directly into a scart or video input on a tv or video. IR sensitive. £79.95 ref EF137

IR LAMP KIT Suitable for the above camera, enables the camera to be used in total darkness! £6 ref EF138

UK SCANNING DIRECTORY As supplied to Police, MOD, M15 and GCHQ! covers everything from secret government frequencies, eye in the sky, prisons, military aviation etc. £18.50 ref SCANB

INFRA RED POWERBEAM Handheld battery powered lamp, 4 inch reflector, gives out powerful pure infrared light! perfect for CCTV use, night sights etc. £29 ref PB1.

SUPER WIDEBAND RADAR DETECTOR Detects both radar and laser, X K and KA bands, speed cameras, and all known speed detection systems. 360 degree coverage, front

& rear waveguides. 1.1x2.7x4.6" fits on sun visor or dash. £149 ref

CHIEFTAN TANK DOUBLE LASERS 9 WATT+3 WATT+LASER OPTICS

Could be adapted for laser listener, long range communications etc. Double beam units designed to fit in the gun barrel of a tank, each unit has two semi conductor lasers and motor drive units for alignment. 7 mile range, no circuit diagrams due to MOD, new price £50,000? us? £199. Each unit has two gallium Arsenide injection lasers, 1 x 9 watt, 1 x 3 watt, 900nm wavelength, 28vdc, 600hz pulse frequency. The units also contain an electronic receiver to detect reflected signals from targets. £199 for one. Ref LOT4

NEW LOW PRICED COMPUTER/WORKSHOP/HI-FI

RCB UNITS Complete protection from faulty equipment for everybody! Inline unit fits in standard IEC lead (extends it by 750mm), fitted in less than 10 seconds, reset/test button, 10A rating. £8.99 each ref LOTS. Or a pack of 10 at £49.90 ref LOT8. If you want a box of 100 you can have one for £250!

DIGITAL PROPORTIONAL B GRADE RADIO CONTROLLED CARS From World famous manufacturer these are returns so they will need attention (usually physical damage) cheap way of buying TX and RX plus servos etc for new projects etc. £20 each. sold as seen ref LOT2DP

MAGNETIC CREDIT CARD READERS AND ENCODING MANUAL £9.95 Cased with flyleads, designed to read standard credit cards! complete with control electronics PCB and manual covering everything you could want to know about whats hidden in that magnetic strip on your card! just £9.95 ref BAR31

WANT TO MAKE SOME MONEY? STUCK FOR AN IDEA? We have collated 140 business manuals that give you information on setting up different businesses, you peruse these at your leisure using the text editor on your PC. Also included is the certificate enabling you to reproduce (and sell) the manuals as much as you like! £14 ref EP74

HIGH POWER DC MOTORS, PERMANENT MAGNET

12 - 24v operation, probably about 1/4 horse power, body measures 100mm x 75mm with a 60mm x 5mm output shaft with a machined flat on it. Fitting is simple using the two threaded bolts protruding from the front



£22ea REF mot4

It's Flat, Shiny, and Exterminates CRTs

Advanced display screen technologies are becoming cheaper and better all the time. It may not be long before they cause the conventional cathode ray tube to face out. Andrew Armstrong looks at some of the current contenders.

Part One: Liquid crystals; amorphous transistors on glass, and Plasma Discharge Panels (PDPs).

The demise of the trusted and familiar cathode ray tube (CRT) as the main means of displaying video and tv has been predicted for a number of years, but to date none of the many flat screen display technologies have proved good or economic enough to make a significant impression. Today, the main applications for flat screen displays are ones for which a CRT would be quite unsuitable, and therefore for which the extra cost or reduced performance of a flat screen display is not a barrier.

You may wonder why CRTs cannot be made thinner and lighter to compete with true flat displays. After all, they give better picture quality at a lower cost than flat-panel alternatives. CRTs have been slimmed down a good deal over the years, but there is a point at which the problems to be overcome increase so much that it is not economic to proceed.

For example: look at **figure 1**, showing beam deflection. The beam is deflected by means of a magnetic field. If the deflection is truly proportional to the current in the deflection coil - which may not be the case, since different trajectories cause the electron beam to spend a different amount of time in the field - then the deflection of the beam across the screen will be disproportional. It will instead be proportional to the tangent of the deflection angle, which is not at all a linear relationship as the angle becomes large. This effect causes picture geometry errors which must be corrected with more circuitry. **Figure 2** shows the form of an uncorrected picture. It stretches further at the corners, because that is where the path length of the electron beam is longest, as it must be when you consider the three dimensional properties of the deflection system.

Clearly, the thinner the CRT for a given screen size, the worse the error will be. Then there are three different colours to be corrected separately so that they all line up - and it is becomes clear why there is a limit to how thin a CRT can be made.

Electron hopping

Until recently, that is. Last year, Philips Research Laboratories demonstrated experimental flat cathode ray tubes, which they called cathode ray panels (CRPs).



A 42-inch PDP screen showing sharp images at a wide viewing angle

This design incorporates internal supports to avoid the glass envelope having to be made unmanageably thick. The problem with internal supports is that they are likely to interfere with electron transport. The solution has been to use a mechanism of electron transport along the wall of an insulator. When an electron strikes the surface of an insulator, it is absorbed, and this causes the release of secondary electrons.

What is required is that the incident electron causes the release of exactly one secondary electron. To achieve this, the transport voltage has to be set absolutely correctly. Electrons must hop along one wall of the tubes rather than bounce around at liberty.

Figure 3 shows the cross section of a CRP. Electrons travel through the selector plates by hopping and being pulled through holes in the plates. The interesting thing about this is that several layers of selector plates can be cascaded. This, in conjunction with suitable interconnections, reduces the required number of row and column connections required to address each phosphor dot uniquely.

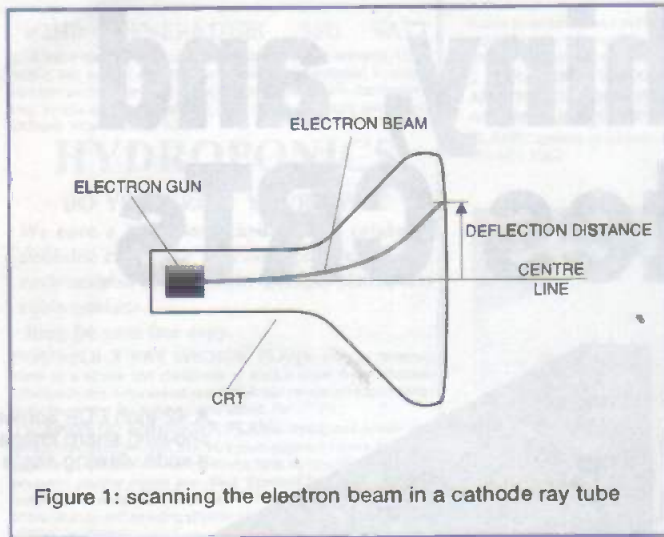

Figure 1: scanning the electron beam in a cathode ray tube

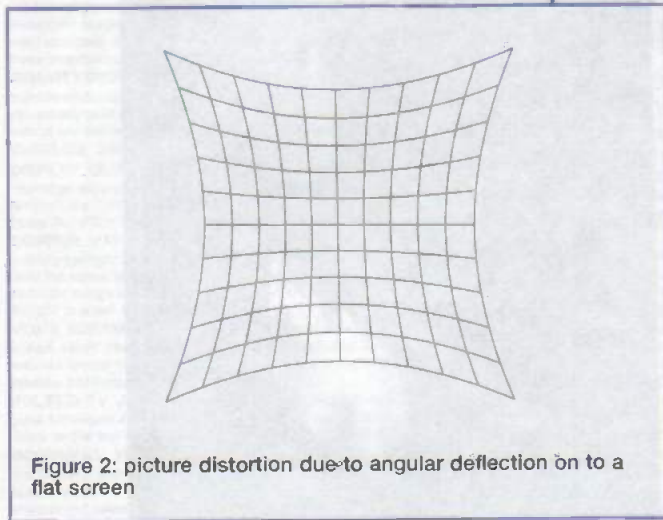

Figure 2: picture distortion due to angular deflection on a flat screen

The detail of this is shown in figure 4: one entrance hole for electrons is routed to the three separate colour dots.

Liquid crystals

Flat displays have been around for years. The first to go public in significant quantities were liquid crystal monochrome displays. In a liquid crystal display, the liquid crystal layer can either rotate or not rotate the polarisation of light passing through it.

With no voltage applied to the display, the liquid crystal molecules line up at the surfaces in a direction determined by the surface finish of the front and back electrodes. When a voltage is applied, the molecules line up (figure 5). Because liquid crystal displays are damaged by direct current, the drive voltage must be an alternating voltage, with front and rear electrodes driven in phase if the pixel is to be un-energised, or in antiphase if it is energised. This is the widely used twisted-nematic type of display.

To convert the change of polarisation to something visible to the human eye, an arrangement such as that shown in figure 6 is used. Here, light cannot pass through the crossed polarisers unless its polarisation is rotated in the liquid crystal cell. If you want to make a vga display panel, you need 640 pixels horizontally and 480 vertically. This, which would be considered a miserable resolution by current standards, needs 640 separately connected vertical strips of electrode, and 480 horizontal strips, in order to address each individual pixel. The interconnection problem is costly to solve, but it can be done,

for example, by using elastomeric connectors which press on to metalised contacts on the edge of the display glass (figure 7). The electronics to address this uses surface-mount ics with multiple pins, or ball grid array connections. This is inherently costly to make.

Still, perhaps the major problem of displays like this is how to make the display visible, when each pixel is only addressed for a tiny proportion of the time. The molecules must line up with the voltage rapidly, but settle back to their un-energised position slowly. It is not surprising, therefore, that the response of this type of liquid crystal display to changes in picture content is a bit sluggish.

At some stage in the development of matrixed twisted nematic displays, techniques for increasing the twist angle were devised, and they became known as Super Twist or STN displays. For a while they looked like going out of use, but improved versions have been developed - see the Hitachi item on the news pages in this issue.

Amorphous transistors on glass

Some years ago, three physicists shared the Nobel prize for work on amorphous materials. The first product seen by the public as a result of this fundamental research was the solar-powered calculator. It was found to be possible to make semiconductors using amorphous materials rather than perfect crystals. The material had to have hydrogen added to all the unattached bonds which would otherwise trap charge carriers.

Crystalline semiconductors gave superior performance, but

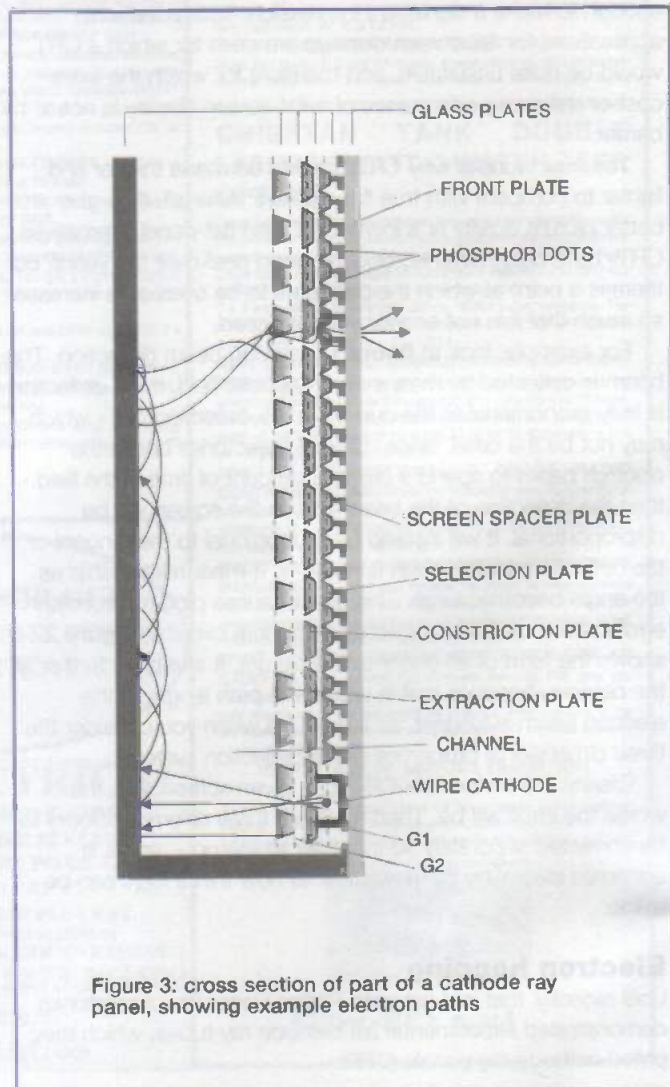

Figure 3: cross section of part of a cathode ray panel, showing example electron paths

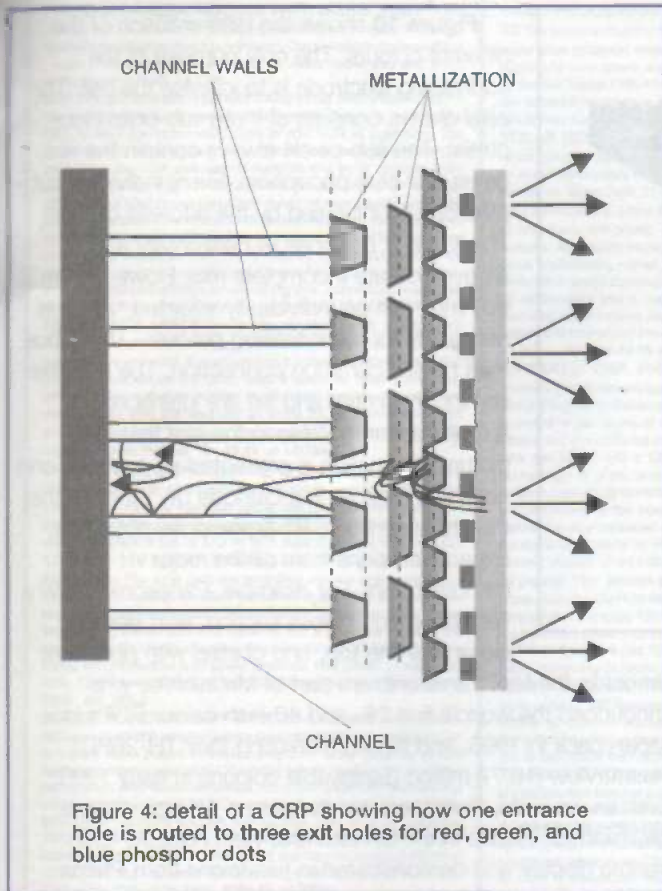

Figure 4: detail of a CRP showing how one entrance hole is routed to three exit holes for red, green, and blue phosphor dots

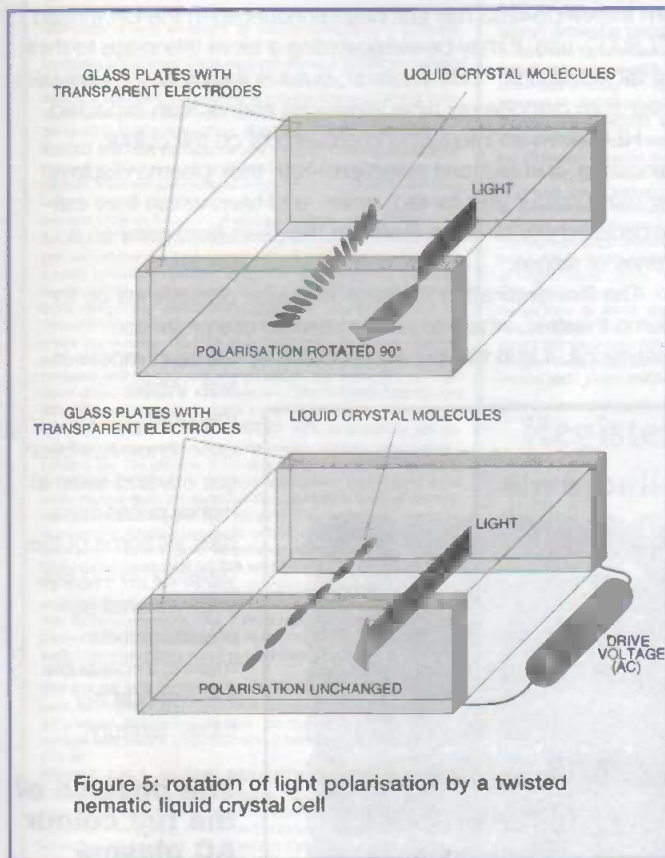

Figure 5: rotation of light polarisation by a twisted nematic liquid crystal cell

even a solar cell of modest efficiency made very cheaply was more suitable to power a calculator than an expensive more efficient crystalline one. It was also possible to make transistors using amorphous semiconductors deposited on glass. This permitted development of the tft (thin film transistor) display, still widely used in notebook computers and portable televisions,

where a transistor is used to improve the drive to each pixel.

Referring to **figure 8**, the circuit on the left here shows that a capacitor is charged to the voltage on the data line when the gate line is energised. The thin film field effect transistor is acting as a sampling switch, and the capacitor holds the sampled voltage until the next time it is addressed.

The performance of liquid crystal displays using this technology is greatly superior to normal stn displays. For a start, the liquid crystal material does not need to be optimised to retain the picture information between scans, so it can be made to respond more quickly. Portable LCD televisions using this type of screen have no visible problems with normal moving tv pictures. However, the delay can be detectable by the eye on some tft computer screens, when the mouse cursor is moved very quickly. To detect it, though, you have to be looking for it. Picture streaking due to crosstalk between pixels in an stn display does not occur on tft displays. Also, because the liquid crystal material is not optimised for one obscure function (slow response) it can be made with a wider viewing angle. The angle is still limited, and it is still necessary to position the screen correctly relative to the viewer, but the problem is eased compared with the typical STN display.

The drawback with tft displays is that there is a lot of electronics for each pixel. Even a single pixel which does not work can be visible, but it is very difficult to manufacture screens with 100% functional pixels. Therefore, quality standards are defined which limit the number of defects in the whole screen area, and further limit the number in the middle area. Even so, many displays do not meet the quality standard and have to be scrapped. This contributes to the relatively high cost of tft displays, particularly large ones with more pixels. Typically, a 1024 x 768-pixel computer display can cost more than a complete machine with a 17-in crt monitor. As an aside, based on news reports which I read at the time, the means of using thin film transistors was first devised by a British engineer. He was unable to get funding to develop this in Britain or elsewhere in the EU, so the technology was developed in Japan, whose industries have made a good return from it.

Plasma discharge

A number of major Japanese development companies, including Fujitsu, NEC and Panasonic, are working on plasma display panels. These are expensive, and best suited for large area displays, partly due to cost and partly because the pixel size does not fit them well for use in small displays. Large screen televisions using this technology are available in Japan, and will soon be available in the UK.

From the current point of view plasma displays are divided into two categories, those which generate visible light by plasma formation (primary), and those which generate visible light indirectly by plasma formation (secondary). In the second case, ultra violet light may be generated by the plasma, and used to excite a phosphor which emits light at visible frequencies. (This is basically how a fluorescent lamp works.) Plasma is generally referred to as the fourth state of matter, after solid, liquid and gas, and it consists of a mixture of ions and electrons. The best known example of plasma technology is the neon tube. By applying high voltage to cause a current flow in the gas, the outer electrons are stripped from the nucleus. The charged particles migrate to the pole with the opposing charge and collide with other electrons on the way, raising their energy level. When the electron returns to the normal lower energy level, the excess energy is emitted as a

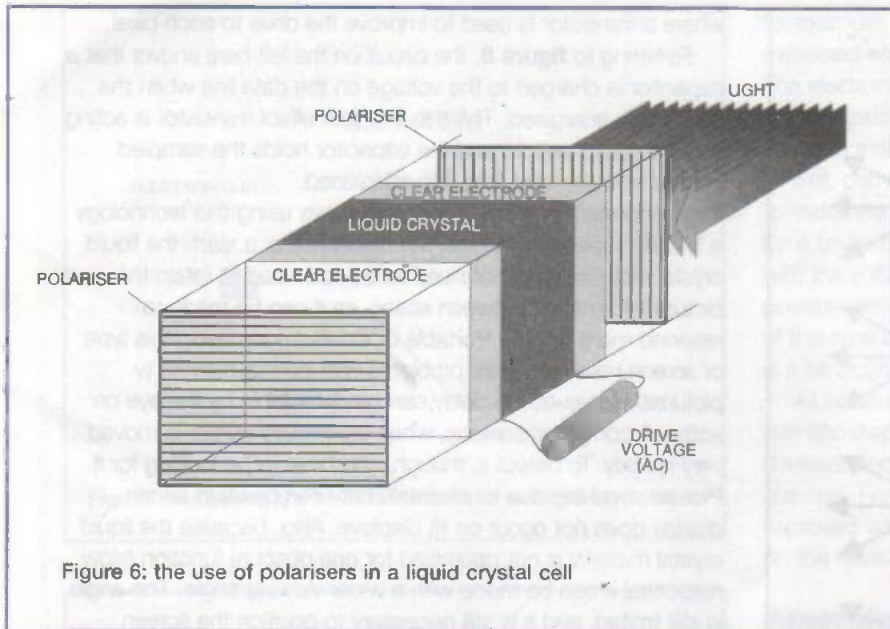

Figure 6: the use of polarisers in a liquid crystal cell

photon.

Depending on the mixture of inert gases and their pressure, the photon may or may not be in the visible range. With primary displays, the emission is in the visible range as red or orange.

A plasma display panel (PDP) is made up of pixels which are actually tiny neon tubes. Presented in a simplified manner, there is a matrix of electrodes in a space between two glass plates, and the space is filled with inert gas.

The crossovers are the pixels. To illuminate a pixel, a voltage sufficient to ionise the gas is applied between the two electrodes. The colours are produced by the light emission of specific phosphor compounds for the spectral ranges red, green and blue in response to ultra violet emitted by the plasma. The electrodes are protected from erosion by the plasma by a magnesium oxide layer.

The phosphor, of course, cannot be behind a protective layer. In order to protect it from damage a special electrode pattern is used (figure 9). The "surface discharge" is between two adjacent bus electrodes, and does not come into contact with the phosphor.

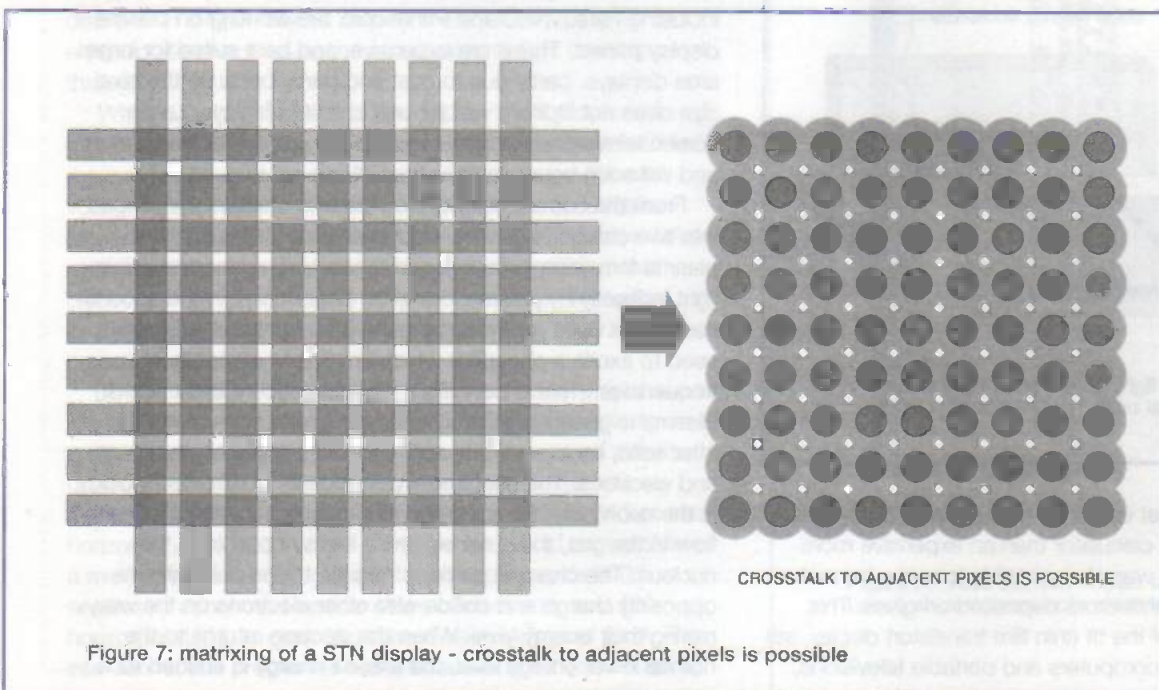

Figure 7: matrixing of a STN display - crosstalk to adjacent pixels is possible

Figure 10 shows the differentiation of the different colours. The only purpose of the addressing electrode is to initialise the cell. The pixel always consists of three sub-units (sub-pixels). The sub-pixels always contain the red, green and blue phosphors. Every individual sub-pixel can be initialised by the address circuitry. The X and Y bus lines lie horizontally and always activate a complete row. However, the X bus lines can be individually selected, which is necessary for the initialising process. The Y bus lines have a common connection. The bus lines coming from right and left are interlaced. A major advantage lies in the fact that the picture information is presented as a whole, and not line by line as in a cathode ray tube, so that the characteristic CRT flicker does not occur. Expect variations from all the major manufacturers. For example, Panasonic show a flat bottomed U cross section, with slanting sides near the top, and coated with phosphor almost to the top. Panasonic are part of Matsushita, who announced the world's first 26- and 40-inch colour PDPs in Japan back in 1995, and began marketing their TH-26PD1 PlasmaView (16.77 million displayable colours) in early 1996. Even as we write, Panasonic are planning a 42-inch plasma television for release in the UK later this year. Fujitsu's 42-in plasma display was demonstrated in televisions from Philips and Grundig at the Cebit-Home Exhibition in March, and the 5-cm thick PDS4203 has just been announced in the UK (priced £7,800 + vat). It may be exaggerating a bit at this stage to think of flat screens as "CRT busters", but it is likely that they will take over from cathode ray tube televisions sooner than expected.

NEC claim an interesting improvement on the colour rendering, and reduced reflections from their plasma displays, by using colour filter for red, green, and blue, which they call capsulated colour filters, built into the glass front pane as a series of stripes.

The first destination for these television displays will be for home theatres, where at present people use projection televisions. It is in this price area that they will be compete at first. When manufacturing experience has been gained, and sales at higher prices have paid for some of the development costs, then we shall see plasma panels making inroads on the cathode ray tubes' territory.

The physics of the full colour AC plasma display

In general, a plasma display consists of a large number of separate cells which contain at least two electrodes and a

PINHOLE CAMERA MODULE WITH AUDIO! Super board camera with on board sound! extra small just 28mm square (including microphone) ideal for covert surveillance. Can be hidden inside anything... even a matchbox! Complete with 15 metre cable, psu and tv/r connectors. £73.95 ref C06

BBC SELECTORS WITH SMART CARD SLOT AND VIDEO CRYPT Interesting new item in this week is this Selector. Originally made for the BBC to send encrypted video films to your VCR at night time. The product seems to have failed. Very complex units consisting of a smart card slot in the front plus several switches and an IR receiver. Fully cased and measuring 230 x 430 x 90mm, new and boxed. On the back of the unit is a smart socket plus a UHF input and output. A channel tuning control numbered 28 to 40 and an IR socket. Inside is a comprehensive tuner section, smart card reader mechanism and control electronics plus a power supply section. These units are sold as strippers but we imagine you could use one to convert a monitor into a TV or maybe use the videocrypt side of things for something else. Supplied complete with manual and mains lead. Clearance price just £9.95 ref BBC1X

INLINE RCB UNITS This in line miniature earth leakage unit instantly shuts off the mains supply in the event of any current flowing between live and earth thus preventing a potentially lethal shock. IEC plug one end, socket the other, fitted in seconds, reset button. The ultimate safety aid when working on electronic equipment, computers etc. As these units are fitted with an in-line IEC plug on one end and socket on the other than could even be used to extend standard IEC computer leads. Pack of 3 £9.99 ref LOTS5A

THE ULTIMATE ENCLOSURE for your projects must be one of these! Well made ABS screw together beige case measuring 120 x 150 x 50mm. Already fitted with rubber feet and front mounted LED. Inside is a pcb fitted with other bits and pieces you may find useful. Sold either as a pack of five for £10 ref MD1, pack of 20 for £19.95 ref MD2

17 WATT 12V SOLAR PANEL A solar panel designed to give a nominal 12v. The solar cells are laminated within a high quality resin material which offers excellent protection against UV and moisture. Mounted on tempered glass in an aluminium frame. The panel is ideal for charging sealed lead acid batteries and a protection diode in the circuit prevents reversed current flow. Mounting is by four adjustable hooks and connection is by screw terminals. Max power 17 watts, 35 cells, 17vdc peak, 433x402x15mm, 1000mA max, 1.9kg. Solar panel £145 ref SOL4

SOLAR POWERED AM/FM RADIO A compact, AM/FM mono radio complete with earphone and a solar panel that recharges the built-in battery when placed in direct sunlight or under a strong lamp. It features a rotary Volume/On/Off control (which must be set to 'Off' for recharging), AM/FM selector switch, rotary tuning control, metal belt clip and socket for external 3V DC supply. Solar Radio £7.95 ref SR23

MOTOR CYCLISTS RADAR DETECTOR New in is the Whistler 1560 Laser/Radar detector complete with a speaker for motorcycle helmets. Super wide band covering K, X and Ka plus lasers at 950nm +/- 10nm. 360 deg total perimeter protection, detects laser, radar and VG-2 wherever they come from. £159.95 ref RD4

MAGIC EAR Unlike previous 'sound-magnifiers' we have offered, Magic Ear fits unobtrusively behind the ear itself. Magic Ear's micro technology is very advanced, its built-in microphone is extremely sensitive and there's also a volume control to help you adjust to all conditions in use. Magic Ear is startlingly effective. It'll help you to follow every word of conversation even at a distance, and enjoy theatre, cinema or live music with stunning new sound. Comes fitted with 3 long life batteries, a free travel pouch, plus a choice of 3 different ear pieces designed to fit all shapes of ear. Magic ear £16.99 ref MAGE3

RADIO METER Perhaps the best of the scientific knock-knocks of the past and well overdue for revival! Fascinating, soothing and educational. In the vacuum inside the inverted bulb like container the vases revolve, driven round by light particles alone! (each vase is black on one side white on the other). Radiometer £9.99 ref SC120B

SATELLITE NAVIGATION £119 The GARMIN- GC38- is the one navigational tool for the great outdoors that offers big features in a small, lightweight package - all at a truly affordable price. Mark your favorite fishing spot, tree stand or camp site. Or trace your steps back to the safety of your starting point using our all-in-one TracBack feature. The GPS 38 shows you exactly where you are, where you've been and where you're going. The GPS 38 features easy, one-thumb operation and weighs only 255g. There's a resettable trip odometer, graphic compass and highway steering guidance. And it provides up to 20 hours of use on a set of 4 AA batteries. The GARMIN GPS 38. The affordable way to bring you back. £119 ref GPS1

DIFFERENTIAL THERMOSTAT KIT An electronic self assembly kit designed for use in solar heating systems, heat recovery systems etc. The principle of the kit is that it has two thermistors that are placed on the items to be measured (typically a solar panel and a water storage tank) the controller then operates a relay all the time one temperature is higher than the other. The temperature difference is adjustable. A typical use would be to operate a pump all the time a solar panel was at a higher temperature than the water storage tank. Differential thermostat kit £29 ref LOTS3

10 WATT SOLAR PANEL Amorphous silicon panel fitted in a anodized aluminium frame. Panel measures 3' by 1' with screw terminals for easy connection. One of these panels will run our solar water pump in full sunlight although we would recommend that for optimum performance two panels would be preferable. 3' x 1' solar panel £55 ref MAG45

12V SOLAR POWERED WATER PUMP Perfect for many 12V DC uses, ranging from solar fountains to hydroponics! Small and compact yet powerful. Will work direct from our 10 watt solar panel in bright sunlight. Max head 17 ft. Max flow rate .8 lpm Current: 1.5A (Ref AC8) £18.99

BOOST CELL PHONE RECEPTION ON THE MOVE! Compared to high-powered carbonones, hand-portable mobile phones don't always work too well in moving vehicles. Sometimes the signal 'drops out' during a call, other times there's too much interference to get through at all. However, the affordable Cell Patch provides a major improvement, dramatically boosting signal reception without wires or batteries. The 9.5 x 9.5cm (3.3" X 3.3") microthin antenna adheres to your car window sunvisor, ideally within 61-122cm (2-4') of the handset, or can be carried in a pocket. Works with all types of portable cellular phone. Cell Patch £11.99 ref CEL1

CAT SCARER produces a blanket of high sonic and low ultrasonic sound, which is audible to humans, birds and fish - so it is ideal where you want to protect your bird table or fish pond against feline predators. It will deter cats from your garden and other protected areas. It will also deter foxes, minks operated, 10 m of cable. Running cost will be approximately 1 p per day. Garden watcher £42.45 ref GW2

VIDEO PROCESSOR UNITS?/6v 10AH BATT/24V 8A TX Not too sure what the function of these units is but they certainly make good strippers! Measures 390X320X120mm, on the front are controls for scan speed, scan delay, scan mode, loads of connections on the rear. Inside 2x6v 10AH sealed lead acid batts, pcb's and a 8A? 24v toroidal transformer (mains in), sold as seen, may have one or two broken knobs etc due to poor storage. £9.95 ref VP2X

SOLAR MOTORS Another new line for us are these tiny motors which run quite happily on voltages from 3-12vdc. We have tried one on our 6v amorphous 6" panels and you can run them from the sun! 32mm dia 20mm thick £1.50 each

TELEPHONES Just in this week is a huge delivery of telephones, all brand new and boxed. Two piece construction with the following features- illuminated keypad, nice clear easy to use keypad, tone or pulse (switchable), recall, redial and pause, high/low and off ringer switch and quality construction. Each telephone is finished in a smart off white colour and is supplied with a standard international lead (same as US or modem card sockets) if you wish to have a BT lead supplied to convert the phones these are also available at £1.55 each ref BTX. Phones £4.99 each ref PH2

INFRARED CAR PHONE KIT £7.99 Interesting box of goodies! This kit was designed to convert car phones to enable hands free dialling, the kit contains the following items: 1) A keypad designed to mount in the centre of the steering wheel, it requires a 9v PP3 battery and transmits the numbers using three on board high power infra red LEDs. 2) An infra red receiver module containing a IR photo diode, IR filter and control electronics 60 x 30 x 15mm (cased). 3) Control box (nice case) 100 x 170 x 35mm which we understand is the interface between the infra red and the car phone, it is also supposed to adjust the volume of your car stereo at the same time! Made for Phillips car phones (but we don't know the model) Complete kit is £7.99 ref CP1

Hi power 12v xenon strobe variable rate flasher modules and tubes £8.95! 12v PCB fitted with control electronics and a powerful Xenon tube! Just apply 12V DC to the input and the tube will flash. On the board is a small potentiometer which can be used to vary the flash rate! PCB measures just 70x 55mm and could be incorporated into many interesting projects! £6 ref FLS1! Pack of 10 is £49 ref FLS2

WANT TO MAKE SOME MONEY? Stuck for an idea? We have collated 140 business manuals that give you information on setting up different businesses, you peruse these at your leisure using the text editor on your PC. Also included is a certificate enabling you to reproduce the manuals as much as you like! £14 ref EP74

TALKING WATCH Yes, it actually tells you the time at the push of a button. Also features a voice alarm that wakes you up and tells you what the time is! Lithium cell included. £8.99 ref EP26A

POWERBEAM INFRARED LAMP All this lamp gives out is infra red light, and loads of it! perfect for supplementing night sight and surveillance equipment. Most mono CCTV video cameras are infra red sensitive so used in conjunction with this lamp would greatly enhance their operating performance. Water resistant case and rubber covered switch make this unit perfect for all weathers. Krypton bulb 4D cells required. Powerbeam lamp £29 ref PB1

GIANT SCREEN VIEWER Turn your TV picture into a supesize screen! This high precision Fresnel lens converts even the smallest screen up to a massive 26", giving a crystal clear picture at a fraction of the cost of a big TV. Easily fitted in minutes. Also ideal for PC monitors etc. £28.95 ref SVGA2

NOGALIGHT NIGHT VISION £129 Open up a new world of adventures and experiences. Wildlife enthusiasts and adventurers in the wilderness, amateur astronomers, hunters, wargamers, private eyes on surveillance, all find Nightspay indispensable for their use. Nightspay's unique features include a special tube protection device, to eliminate over exposure, and infrared illuminator used in total darkness, such as in cave exploration and operations in dark rooms. The Nightspay is light and hand held, or can be mounted on a standard tripod. It uses two standard AA batteries and can be operated by left or right hand users, with or without optical glasses. Optical Magnification: X 1.7 Field of View: 10Degrees Focusing Range: 25cm to infinity objective Focal Length: 50 mm F/N: 1.6 Diopter Range: +/- 3 Mechanical Length: 182 mm Width: 65mm Height: 100 mm Weight: 700 gr. Electrical: Power Source: 3 VDC, 2AA batteries Battery Life: 40 hours Infra-red illuminator: built-in imaging Device: Night Vision Image Intensifier Tube. £129 ref NOGA

**Register with us at
www.bull-electrical.com
for your free e-mail
NEWSLETTERS!**

DRILL OPERATED PUMP Fits to any drill in seconds, uses standard garden hose, will pump up to 40 gallons per hour! £8.99 ref DRL3

BULL ELECTRICAL
250 PORTLAND ROAD, HOVE, SUSSEX.
BN3 5QT. (ESTABLISHED 50 YEARS).
MAIL ORDER TERMS: CASH, PO OR CHEQUE
WITH ORDER PLUS £3.50 P&P PLUS VAT.
24 HOUR SERVICE £5.00 PLUS VAT.
OVERSEAS ORDERS AT COST PLUS £3.50
(ACCESS, VISA, SWITCH, AMERICAN EXPRESS)
'phone orders : 01273 203500
FAX 01273 323077
Sales@bull-electrical.com

STEREO MICROSCOPES BACK IN STOCK Russian, 200x complete with lenses, lights, filters etc etc very comprehensive microscope that would normally be around the £700 mark, our price is just £299 (full money back guarantee!) full details in catalogue

SECOND GENERATION NIGHT SIGHTS FROM £748

RETROIN Russian night sight, 1.8x, infra red lamp, 10m-Inf, standard M42 lens, 1.1kg £349 ref RET1

MAINS MOTORS 180 RPM 90X70mm, 50X5mm 50x5mm output shaft, start cap included. £22 ref MGM1

PC POWER SUPPLIES, CUSTOMER RETURNS, ALL FAN COOLED, OUR CHOICE, BARGAIN AT 8 PSU'S FOR £9.99 REF XX17

LOW COST CORDLESS MIC 500' range, 90 - 105mhz, 115g, 193 x 28 x 39mm, 9v PP3 battery required. £17 ref MAG15PM1

JUMBO LED PACK 15 10mm bicolor leds, plus 5 giant (55mm) seven segment displays all on a pcb £8 ref JUM1. Pack of 30 55mm seven seg displays on pobs is £19 ref LED4, pack of 50 £31 ref LED50

12VDC 40MM FANS MADE BY PANAFLO, NEW, £4. REF FAN12

ELECTRONIC SPEED CONTROLLER KIT For the above motor is £19 ref MAG17. Save £5 if you buy them both together, 1 motor plus speed controller mp is £41, offer price £36 ref MOT5A

RUSSIAN 900X MAGNIFICATION ZOOM MICROSCOPE metal construction, built in light, mirror etc. Russian shrimp farm, ground viewing screen, lots of accessories. £29 ref ANAYLT

AA NICAD PACK Pack of 4 tagged AA nicads £2.99 ref BAR34

RUSSIAN NIGHTSIGHTS Model TZS4 with infra red illuminator, views up to 75 metres in full darkness in infrared mode, 150m range, 45mm lens, 13 deg angle of view, focussing range 1.5m to infinity, 2AA batteries required 950g weight £199 ref BAR61. 1 years warranty

LIQUID CRYSTAL DISPLAYS Bargain prices, 20 character 2 line, 83x19mm £3.99 ref SMC2024A

16 character 4 line, 62x25mm £5.99 ref SMC1640A

TAL-1, 110MM NEWTONIAN REFLECTOR TELESCOPE Russian Superb astronomical scope everything you need for some serious star gazing! up to 169x magnification. Send or fax for further information 20kg, 885x800x1650mm ref TAL-1, £249

YOUR HOME COULD BE SELF SUFFICIENT IN ELECTRICITY Comprehensive plans with loads of info on designing systems, panels, control electronics etc £7 ref PV1

PHOTOMULTIPLIER TUBES Boxed and unused straight from the ministry of defence. Made by EMI with a MOD part no of 10ICV/5114 and packed almost 30 years ago. Do you have a use? Do you want to count light particles? They would look nice on the mantle piece! Offered to you at £15 each (we think the MOD paid more than this is! £95! £15 each ref PM3

CLOCK CAMERA WITH AUDIO Discreetly monitor living rooms, reception, office, this or any other area. Fully working clock houses an invisible spy camera complete with audio. Complete setup includes clock, camera, microphone, clock battery, 15 metres of cable, power supply, adaptor for either scart or phono. Everything you need, no soldering required. Full instructions included. Easily installed in just a few minutes. Plugs straight into VCR or TV (scart or phono) Clock camera with audio £89.95 ref CC3

AUTO RECORD KIT This automatic system will instruct your VCR to start recording when movement is detected via the PIR. Recording will stop 30 seconds after your visitor has left which saves hours of tapes as the video only records what you want to see. Complete system with PIR, will work with all remote control video recorders. £89 ref CV2C

TELEPHONE VOICE CHANGER Changes your voice to a new or unfamiliar one. Simply place over the telephone mouth piece and speak into the changer. Fully adjustable for different voices. Supplied complete with batteries, ready to go. Unit measures 90 x 60 x 20mm Telephone voice changer £14.95 ref CC3

EXTERNAL CAMERA Introducing the Bulldog model 4 vandal resistant camera in heavy steel case for interior or exterior use. Top quality case housing a 420 line camera module. Each camera is supplied with a 15m cable terminating in Scart and phono plugs. Multi angle bracket for easy installation in any situation. A 12vdc psu is also included. Easily installed in a few minutes, plugs straight into VCR or TV (phono or scart) Bargain price £89.95 ref CC1

GIANT INSULATORS Just in this week are some giant ceramic insulators, each one measures 130mm high and about 170mm diameter. Finished in a high gloss brown and black glaze. In the base of each insulator is a threaded hole approx 1" diameter, rather like a mop/broom head thread. If you are into shortwave radio, crystal sets or high voltage experiments then these are for you. (We've got one as a door stop) Not too sure what their original purpose was, all we know is they were made for export about 25 years ago, never exported and been in store since then. Price is £8 each ref INSX

NATO RADIATION MONITORS Interesting new line! These are small modules that strap on your wrist (strap supplied) and monitor radiation. We have stripped one apart and they contain a small piece of 'crystal' this could be something like Naphthalene or any other rare radiation sensitive crystal. When radiation strikes the crystal it scintillates and a small amount of light is produced in the crystal in reaction to the radiation exposure. That light is then picked up by a micro pv cell measuring about 2mm square! Also in the unit is a sheet of foil, a circular metal plate (insulation between the two) and a small pair of additional parallel metal plates. NATO part no is 6665-99-225-2314 any information gratefully received! Alternatively if you wish to buy one they are just £3 each ref NATOX

WE HAD 38,000 'HITS'
ON OUR WEB SITE
IN FEBRUARY '98....
BULL-ELECTRICAL.COM
See our live camera!

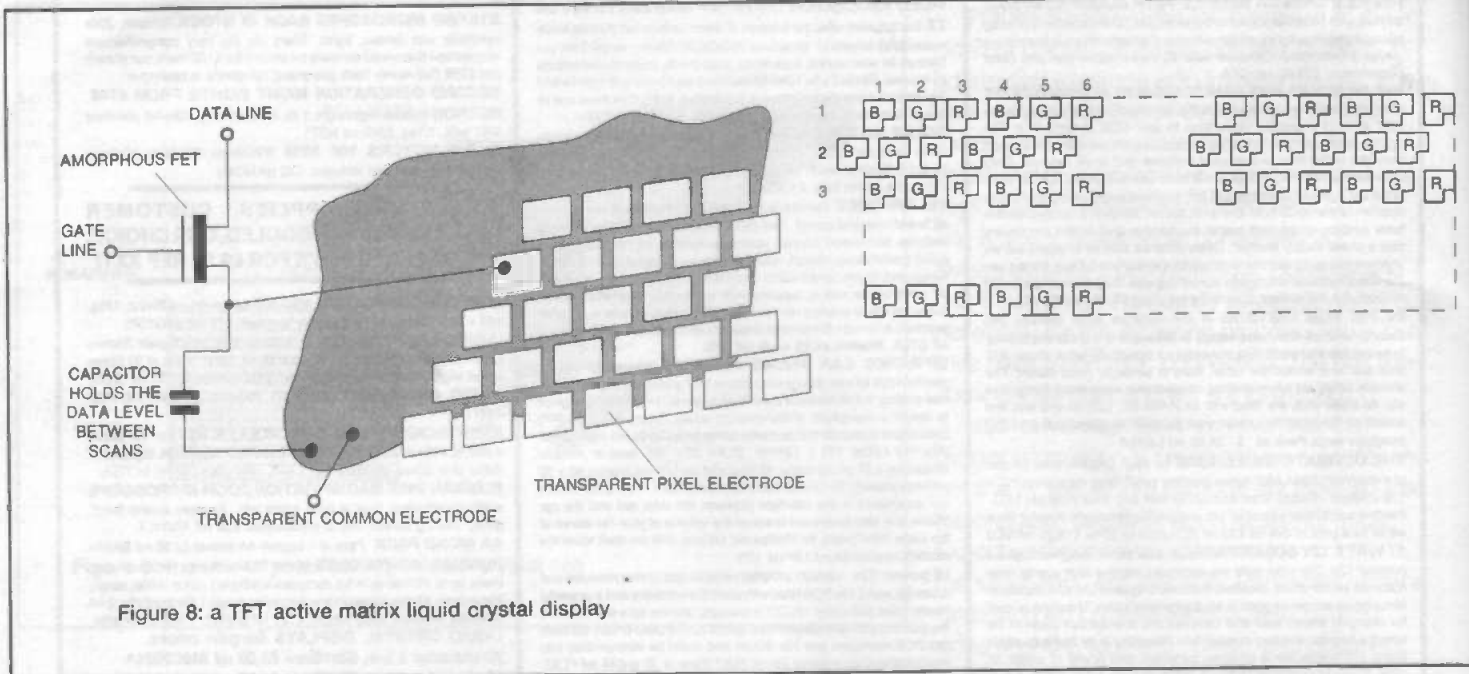

Figure 8: a TFT active matrix liquid crystal display

compound of several inert gases (neon, argon and/or xenon). By applying several hundred volts to the electrodes the inert gas will, as a result of the impact ionisation, assume a plasma state. The result will be a mixture of electrons and ions which, depending on their charge, will flow to one or other of the electrodes.

As a result there will be collisions which are capable of increasing the energy level of the electrons still remaining in the ions. After some time, these will revert to their normal energy level and will emit the absorbed energy as light. Depending both on the inert gas compound and on the pressure of the gas, the emission will be within the range of visible wavelengths or within the range of UV wavelengths. UV is used in colour plasma displays.

Ionisation can be induced by DC or AC, using slightly different electrode arrangements. In the case of the DC display,

the electrodes are embedded in the plasma cell and trigger the plasma formation directly. This creates a simple type of signal and reduces the expenditure on electronics. On the other hand, high voltages have to be generated and the electrodes will be exposed directly to the plasma which leads to their earlier destruction.

If the electrodes are protected, for example, by an MgO coating, and a dielectric medium is incorporated, then the coupling to the gas is capacitive and an AC drive is needed. The electrodes are no longer exposed and have a longer functional life. The disadvantage is that the signal for the triggering voltage is more complex. This technology does, however, offer a further advantage: once the capacitor voltage has been attained it can be utilised to add to the subsequent triggering voltage. In this way the triggering voltage can be reduced to about 180 volts, as against 360 volts in a DC display, simplifying the semiconductor driver circuitry.

The triggering of an AC plasma display occurs basically in three phases, as illustrated in the waveform diagram of figure 11.

The first phase is the addressing or initialising phase. During this phase all the cells which are to become active in the following frame will be preloaded. Cells which are not preloaded will remain dark. The addressing process is completed cell by cell. Current will flow through all the address conductors to cells which have to become active. Then a pulse on bus conductor X1 will cause the

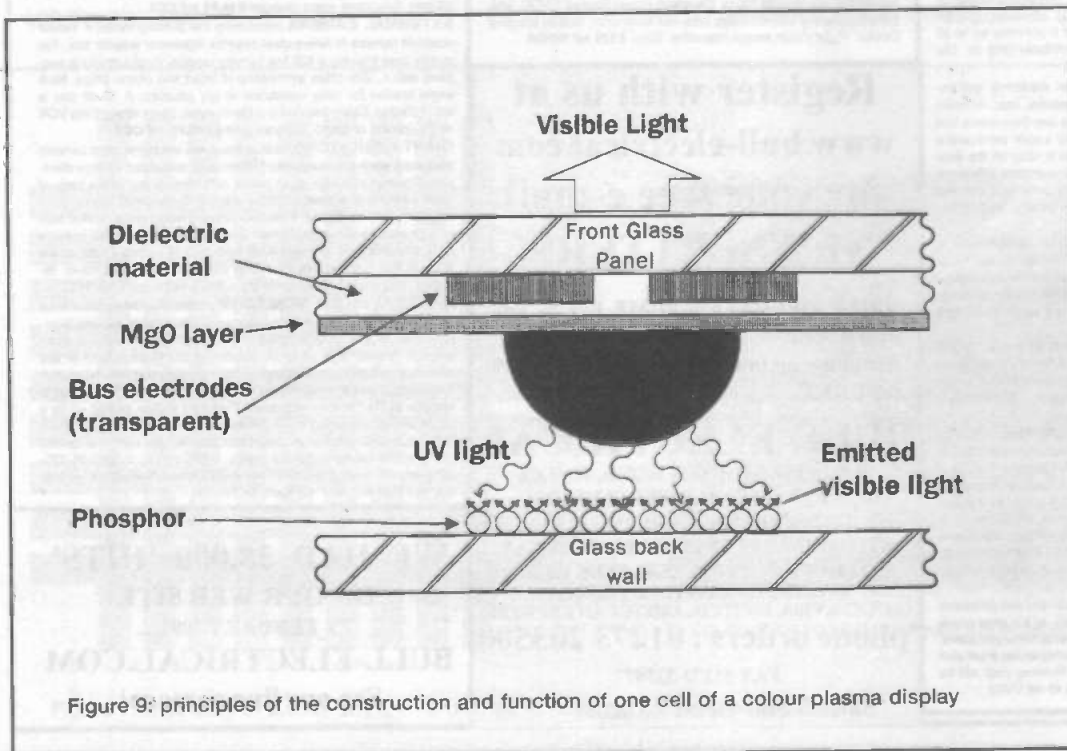

Figure 9: principles of the construction and function of one cell of a colour plasma display

Surplus always wanted for cash!

THE ORIGINAL SURPLUS WONDERLAND!

THIS MONTH'S SELECTION FROM OUR VAST EVER CHANGING STOCKS

Surplus always wanted for cash!

LOW COST PC'S

SPECIAL BUY 'AT 286'

30Mb HD + 3Mb Ram

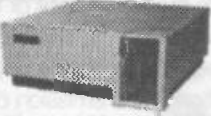

Industrial grade 12MHz HI GRADE 286 systems Made in the USA to industrial specification, the system was designed for total reliability. The compact case houses the motherboard, PSU and EGA card with single 5 1/4" 1.2 Mb floppy disk drive & Integral 40Mb hard disk drive to the front. Real time clock with battery backup is provided as standard. Supplied in good used condition complete with enhanced keyboard, 640k + 2Mb RAM, DOS 4.01 and 90 DAY Full Guarantee. Ready to Run!

Order as HIGRADE 286 **ONLY £99.00 (E)**

Optional Fitted extras: VGA graphics card	£29.00
1.44Mb 3 1/2" floppy disk drive (instead of 1.2 Mb)	£19.95
Perfect 6.0 for Docs - when 3 1/2" FDD option ordered	£12.50
NE2200 Ethernet (thick, thin or twisted) network card	£29.00

INTEL 486DX-33 SYSTEMS

Limited quantity of this 2nd user, superb small size desktop unit. Fully featured with standard simm connectors 30 & 72 pin. Supplied with keyboard, 4 Mb of RAM, SVGA monitor output, 256k cache and Integral 120 Mb IDE drive with single 1.44 Mb 3.5" floppy disk drive. Fully tested and guaranteed. Fully expandable. Only **£199.00 (E)**

FLOPPY DISK DRIVES 3 1/2" - 8"

Massive purchases of standard 5 1/4" and 3 1/2" drives enables us to present prime product at industry beating low prices! All units (unless stated) are BRAND NEW or removed from often brand new equipment and are fully tested, aligned and shipped to you with a full 90 day guarantee. Call for over 2000 unlisted drives for spares or repair.

- 3 1/2" Panasonic JU363/4 720K or equivalent RFE £24.95 (E)
- 3 1/2" Mitsubishi MF355C-L 1.4 Meg. Laptops only £25.95 (E)
- 3 1/2" Mitsubishi MF355C-D 1.4 Meg. Non laptop £18.95 (E)
- 3 1/2" Teac FD-55FGR 1.2 Meg (for IBM pc's) RFE £18.95 (E)
- 3 1/2" Teac FD-55F-03-U 720K 40/80 (for BBC's etc) RFE £29.95 (E)
- 3 1/2" BRAND NEW Mitsubishi MF501B 360K £22.95 (E)
- 5 1/4" Table top case with integral PSU for HH 5 1/4" Flopp or HD £29.95 (E)
- 5 1/4" Shugart 800/801 8" SS refurbished & tested £210.00 (E)
- 5 1/4" Shugart 810 8" SS HH Brand New £195.00 (E)
- 5 1/4" Shugart 851 8" double sided refurbished & tested £260.00 (E)
- 5 1/4" Mitsubishi M2894-63 double sided NEW £295.00 (E)
- 5 1/4" Mitsubishi M2896-63-02U DS slimline NEW £295.00 (E)
- 5 1/4" Dual 8" cased drives with integral power supply 2 Mb £499.00 (E)

HARD DISK DRIVES

- 2 1/2" TOSHIBA (19 mm H) MK2101MAN 2.16 Gb. New £199.00
 - 2 1/2" TOSH. (12.5 mm H) MK1002MAV 1.1 Gb laptop. New £115.00
 - 2 1/2" to 3 1/2" conversion kit for PC's, complete with connectors £15.95
 - 2 1/2" FUJII FK-309-26 20mb MFM I/F RFE £59.95
 - 2 1/2" CONNER CP3024 20 mb IDE I/F (or equiv.) RFE £59.95
 - 2 1/2" CONNER CP3044 40mb IDE I/F (or equiv.) RFE £69.00
 - 2 1/2" RODIME R03057S 45mb SCSI I/F (Mac & Acorn) £69.00
 - 2 1/2" QUANTUM 40S Prodrive 42mb SCSI I/F, New RFE £49.00
 - 2 1/2" WESTERN DIGITAL 850mb IDE I/F New £185.00
 - 2 1/2" MINISCRIBE 3425 20mb MFM I/F (or equiv.) RFE £48.95
 - 2 1/2" SEAGATE ST-238R 30 mb RLL I/F Refurb £69.95
 - 2 1/2" CDC 94205 1.5 40mb HH MFM I/F RFE tested £69.95
 - 2 1/2" HP 97548 850 Mb SCSI RFE tested £99.00
 - 2 1/2" HP C3010 2 Gbyte SCSI differential RFE tested £195.00
 - 2 1/2" NEC D2246 85 Mb SMD interface. New £199.00
 - 2 1/2" FUJITSU M2322K 160Mb SMD I/F RFE tested £195.00
 - 2 1/2" FUJITSU M2392K 2 Gb SMD I/F RFE tested £345.00
- Many other drives in stock - Shipping on all drives in code (D)

THE AMAZING TELEBOX

Converts your colour monitor into a QUALITY COLOUR TV!!



TV SOUND & VIDEO TUNER CABLE COMPATIBLE

The TELEBOX is an attractive fully cased mains powered unit, containing all electronics ready to plug into a host of video monitors made by makers such as MICROVITEC, ATARI, SANYO, SONY, COMMODORE, PHILIPS, TATUNG, AMSTRAD etc. The composite video output will also plug directly into most video recorders, allowing reception of TV channels not normally receivable on most television receivers* (TELEBOX MB). Push button controls on the front panel allow reception of 8 fully tuneable 'off air' UHF colour television channels. TELEBOX MB covers virtually all television frequencies VHF and UHF including the HYPERBAND as used by most cable TV operators. A composite video output is located on the rear panel for direct connection to most makes of monitor or desktop computer video systems. For complete compatibility - even for monitors without sound - an integral 4 watt audio amplifier and low level Hi Fi audio output are provided as standard.

- TELEBOX ST for composite video input type monitors £36.95
 - TELEBOX STL as ST but fitted with integral speaker £39.50
 - TELEBOX MB Multiband VHF/UHF/Cable/Hyperband tuner £69.95
- For overseas PAL versions state 5.5 or 6 mHz sound specification. *For cable / hyperband signal reception TELEBOX MB should be connected to a cable type service. Shipping on all Teleboxes*, code (B)

DC POWER SUPPLIES

Virtually every type of power supply you can imagine. Over 10,000 Power Supplies Ex Stock Call for info / list.

IC's - TRANSISTORS - DIODES

OBSELETE - SHORT SUPPLY - BULK

6,000,000 items EX STOCK

For MAJOR SAVINGS - CALL FOR SEMICONDUCTOR HOTLIST

VIDEO MONITOR SPECIALS

One of the highest specification monitors you will ever see - At this price - Don't miss it!!

Mitsubishi FA3415ETKL 14" SVGA Multisync colour monitor with fine 0.28 dot pitch tube and resolution of 1024 x 768. A variety of inputs allows connection to a host of computers including IBM PC's in CGA, EGA, VGA & SVGA modes, BBC, COMMODORE (including Amiga 1200), ARCHIMEDES and APPLE. Many features: Etched faceplate, text switching and LOW RADIATION MPR specification. Fully guaranteed, supplied in EXCEL-

lent little used condition. Order as MITS-SVGA
Tilt & Swivel Base £4.75
VGA cable for IBM PC included. **Only £119 (E)**
External cables for other types of computers CALL

As New - Ex Demo
17" 0.28 SVGA Mitsubishi Diamond Pro monitors
Full multisync etc. Full 90 day guarantee. **£325.00 (E)**

Just in - Microvitec 20" VGA (800 x 600 res.) colour monitors.
Good SH condition - from £299 - CALL for info

PHILIPS HCS35 (same style as CM8833) attractively styled 14" colour monitor with both RGB and standard composite 15.625 KHz video inputs via SCART socket and separate phono jacks. Integral audio power amp and speaker for all audio visual uses. Will connect direct to Amiga and Atari BBC computers. Ideal for all video monitoring / security applications with direct connection to most colour cameras. High quality with many features such as front concealed flap controls, VCR correction button etc. Good used condition - fully tested - guaranteed
Dimensions: W14" x H12 1/4" x 15 1/2" D. **Only £99 (E)**

PHILIPS HCS31 Ultra compact 9" colour video monitor with standard composite 15.625 KHz video input via SCART socket. Ideal for all monitoring / security applications. High quality, ex-equipment fully tested & guaranteed (possible minor screen bums). In attractive square black plastic case measuring W10" x H10" x 13 1/2" D. 240 V AC mains powered. **Only £79.00 (D)**

KME 10" 15M10009 high definition colour monitors with 0.28" dot pitch. Superb clarity and modern styling. Operates from any 15.625 kHz sync RGB video source, with RGB analog and composite sync such as Atari, Commodore Amiga, Acorn Archimedes & BBC. Measures only 13 1/2" x 12" x 11". Good used condition. **Only £125 (E)**

20" 22" and 26" AV SPECIALS

Superbly made UK manufacture. PIL all solid state colour monitors, complete with composite video & optional sound input. Attractive teak style case. Perfect for Schools, Shops, Disco, Clubs, etc. In EXCELLENT little used condition with full 90 day guarantee.

20"....£135 22"....£155 26"....£185 (F)

SPECIAL INTEREST ITEMS

- MITS. FA3445ETKL 14" Industrial spec SVGA monitors £245
- 1Kw to 400 Kw - 400 Hz 3 phase power sources - ex stock £POA
- IBM 8230 Type 1, Token ring base unit driver £760
- Wayne Kerr RA200 Audio frequency response analyser £2500
- IBM 53F5501 Token Ring ICS 20 port loop modules £750
- IBM MAU Token ring distribution panel 8228-23-5050N £95
- AIM 501 Low distortion Oscillator 9Hz to 330KHz, IEEE £550
- Trend DSA 274 Data Analyser with G703(2M) 64 I/O £POA
- Marconi 8310 Programmable 2 to 22 GHz sweep generator £8500
- HP1650B Logic Analyser £3750
- HP3781A Pattern generator & HP3782A Error Detector £POA
- HP6621A Dual Programmable GPIB PSU 0-7 V 160 watts £1800
- HP6264 Rack mount variable 0-20V @ 20A metered PSU £675
- HP54121A DC to 22 GHz high speed channel last test £POA
- HP5750A A1 8 pen HPGL high speed drum plotter £1850
- F&B Wardrobe size, insurance spec 1 hour rated fire safe £850
- E+G Brookdeal 85635C Precision lock in amp £650
- View Eng. Mod 1200 computerised inspection system £POA
- Sony DXC-3000A High quality CCD colour TV camera £1100
- CSZ VERA Large 3 cavity thermal shock chamber £POA
- Philips PW1730/10 XRAY generator with accessories £POA
- Kaithley 590 CV capacitor / voltage analyser £POA
- Racal ICR40 dual 40 channel video recorder system £POA
- Fikens 45KV4 3 ph On Line UPS - New batteries £9500
- ICI R5030UV34 Cleanline ultrasonic cleaning system £POA
- Mann Tally MT645 High speed line printer £2200
- Intel SBC 488/133SE Multibus 486 system. 8Mb Ram £945
- Intel SBC 486/125C08 Enhanced Multibus (MSA) NEW £1450
- Zeta 3220-05 A0 4 pen HPGL fast drum plotters £1150
- Nikon HFX-11 (Ephiphot) exposure control unit £1450
- Motorola VME Bus Boards & Components List. SAE / CALL £POA
- Trfo 0-18 vdc linear, metered 30 amp bench PSU. New £550
- Fujitsu M3041R 600 PH4 band printer £1950
- Fujitsu M3041D 600 LPM printer with network interface £1250
- Perkin Elmer 2998 infrared spectrophotometer £500
- Perkin Elmer 597 infrared spectrophotometer £3500
- VG Electronics 1035 TELETEXT Decoding Margin Meter £3750
- LightBar 80 output high spec 2u rack mount Video VDA's £495
- Sekonic SD 150H 18 channel digital Hybrid chart recorder £1995
- Taylor Hobson Tallysur amplifier / recorder £750
- System Video 1152 PAL waveform monitor £485
- Siemans K4400 64Kb to 140Mb demux analyser £2950

19" RACK CABINETS

Superb quality 6 foot 40U
Virtually New, Ultra Smart
Less than Half Price!

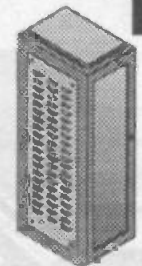

Top quality 19" rack cabinets made in UK by Optima Enclosures Ltd. Units feature designer, smoked acrylic lockable front door, full height lockable half louvered back door and louvered removable side panels. Fully adjustable internal fixing struts, ready punched for any configuration of equipment mounting plus ready mounted integral 12 way 13 amp socket switched mains distribution strip make these racks some of the most versatile we have ever sold. Racks may be stacked side by side and therefore require only two side panels to stand singly or in multiple bays. Overall dimensions are: 77 1/2" H x 22 1/2" D x 22" W. Order as:

- OPT Rack 1 Complete with removable side panels. £345.00 (G)
- OPT Rack 2 Refurb Less side panels £245.00 (G)

Over 1000 racks, shelves, accessories
19" 22" & 24" wide 3 to 46 U high.
Available from stock !!

32U - High Quality - All steel RakCab

Made by Eurocraft Enclosures Ltd to the highest possible spec, rack features all steel construction with removable side, front and back doors. Front and back doors are hinged for easy access and all are lockable with five secure 5 lever barrel locks. The front door is constructed of double walled steel with a 'designer style' smoked acrylic front panel to enable status indicators to be seen through the panel, yet remain unobtrusive. Internally the rack features fully slotted reinforced vertical fixing members to take the heaviest of 19" rack equipment. The two movable vertical fixing struts (extras available) are pre punched for standard 'cage nuts'. A mains distribution panel internally mounted to the bottom rear, provides 8 x IEC 3 pin Euro sockets and 1 x 13 amp 3 pin switched utility socket. Overall ventilation is provided by fully louvered back door and double skinned top section with top and side louvers. The top panel may be removed for fitting of integral fans to the sub plate etc. Other features include: fitted castors and floor levelers, prepunched utility panel at lower rear for cable / connector access etc. Supplied in excellent, slightly used condition with keys. Colour Royal blue. External dimensions mm=1625H x 635D x 603 W. (164" H x 25" D x 23 3/4" W)
Sold at LESS than a third of makers price !!



A superb buy at only **£245.00 (G)**
42U version of the above only **£345 - CALL**

BATTERY SCOOP - 50% off !!

A special bulk purchase from a cancelled export order brings you the most amazing savings on these ultra high spec 12v DC 14Ah rechargeable batteries. Made by Hawker Energy Ltd, type SBS15 featuring pure lead plates which offer a far superior shelf & guaranteed 15 year service life. Fully BT & BS6290 approved. Supplied BRAND NEW and boxed. Dimensions 200 wide, 137 high, 77 deep. M6 bolt terminals. Fully guaranteed. Current makers price over £70 each! **Our Price £35 each (C) or 4 for £99 (D)**

RELAYS - 200,000 FROM STOCK

Save ££££'s by choosing your next relay from our Massive stocks covering types such as - Military, Octal, Credle, Hermetically Sealed, Contactors, Time Delay, Reed, Mercury Wetted, Solid State, Printed Circuit Mounting, CALL US WITH YOUR NEEDS. Many obsolete types from stock. Save ££££'s

LOW COST RAM & CPU'S

INTEL 'ABOVE' Memory Expansion Board. Full length PC-XT and PC-AT compatible card with 2 Mbytes of memory on board. Card is fully selectable for Expanded or Extended (286 processor and above) memory. Full data and driver disks supplied. RFE. Fully tested and guaranteed. Windows compatible. **£59.95**
Half length 8 bit memory upgrade cards for PC AT XT expands memory either 256k or 512k in 64k steps. May also be used to fill in RAM above 640k DOS limit. Complete with data.
Order as: XT RAM UG. 256K. **£34.95 or 512K £39.95**

SIMM SPECIALS

- 1 MB x 9 SIMM 9 chip 120ns Only £8.50
 - 1 MB x 9 SIMM 3 chip 80 ns £10.50 or 70ns £11.95
 - 1 MB x 9 SIMM 9 chip 80 ns £10.50 or 70ns £11.75
 - 4 MB 70 x 72 pin SIMM - with parity. Only £35.00
 - INTEL 486-DX3 CPU £19.95 INTEL 486-DX66 CPU £59.00
- FULL RANGE OF CO-PROCESSOR'S EX STOCK - CALL FOR £59.00
- MOTOROLA 25 Mhz 68040 (XC68040RC25M) CPU'S £59.00 shipping charges for RAM / CPU upgrades is code B

SOFTWARE SPECIALS

NT4 WorkStation, complete with service pack '3 and licence - OEM packaged.
Special Price ONLY £99.00
Microsoft - Windows for Workgroups 3.11 & DOS 6.22. Supplied on 3 1/2" disks with license & documentation documentation. **£39.95**
DOS 5.0 on 3 1/2" disks with concise books c/w QBasic. **£14.95**
Wordperfect 8.0 for DOS supplied on 3 1/2" disks with manual. **£24.95**
shipping charges for software is code B

Visit our London shop for a full range of Test Equipment and other bargains

DISPLAY
-ELECTRONICS-

ALL MAIL & OFFICES
Open Mon - Fri 9.00 - 5.30
Dept ETI, 32 Biggin Way
Upper Norwood
LONDON SE19 3XF

LONDON SHOP
Open Mon - Sat 9.00 - 5.30
215 Whitehorse Lane
South Norwood
On 68A Bus Route
N. Thornton Heath &
Selhurst Park SR Rail Stations

DISTEL ©
Visit our web site
www.distel.co.uk
email admin@distel.co.uk

ALL ENQUIRIES
0181 679 4414
FAX 0181 679 1927

All prices for UK Mainland. UK customers add 17.5% VAT to TOTAL order amount. Minimum order £10. Bona Fide account orders accepted from Government, Schools, Universities and Local Authorities - minimum account order £50. Cheques over £100 are subject to 10 working days clearance. Carriage charges (A)=£3.00, (A1)=£4.00, (B)=£5.50, (C)=£8.50, (D)=£12.00, (E)=£15.00, (F)=£18.00, (G)=CALL. Allow approx 6 days for shipping - faster CALL. All goods supplied to our Standard Conditions of Sale and unless stated guaranteed for 90 days. All guarantees on a return to base basis. All rights reserved to change prices / specifications without prior notice. Orders subject to stock. Discounts for volume. Top Cash prices paid for surplus goods. All trademarks etc acknowledged. © Display Electronics 1997. E & O.E. 01/8

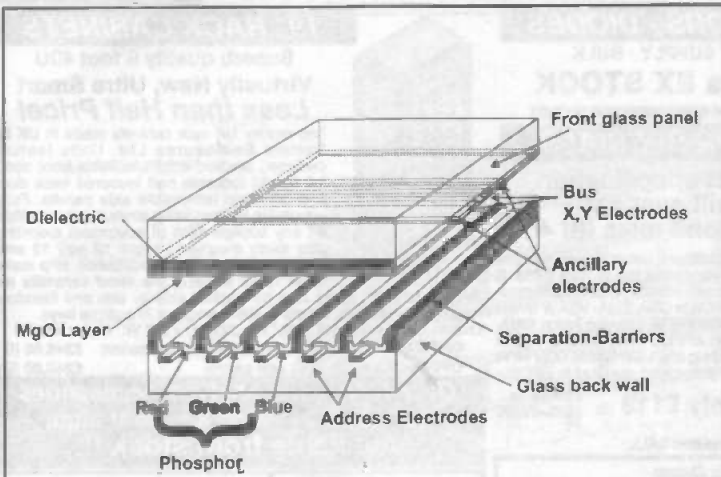

Figure 10: a cross section through the structure of all AC Colour plasma displays (PDPs).

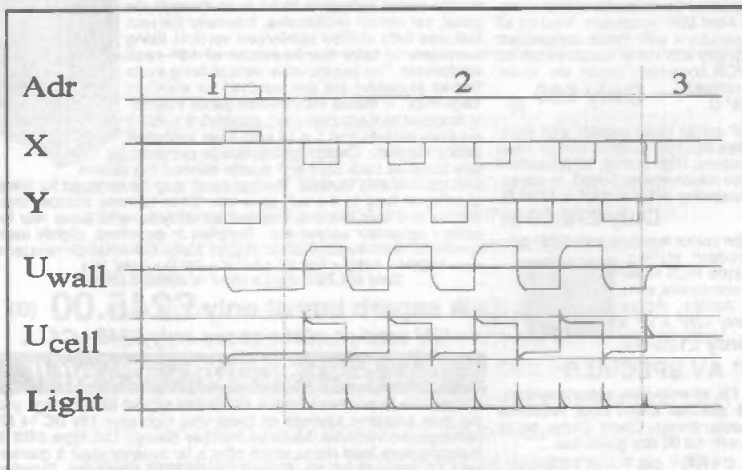

Figure 11: the waveform diagram shows the three-phase triggering of an AC plasma display: (1) cell-by-cell addressing and initialising of active cells for the next frame; (2) stop/display phase during which the build-up of voltage impulses on alternate sides creates the number of light impulses corresponding to the luminance level; (3) extinction phase during which all the cells revert to a neutral state for the next subframe

charge to transfer, pre-initialising the cell. This procedure will be repeated for the remaining cells X2, X3 Xn, etc. A pre-initialised cell will retain its charge for a considerable time. It is

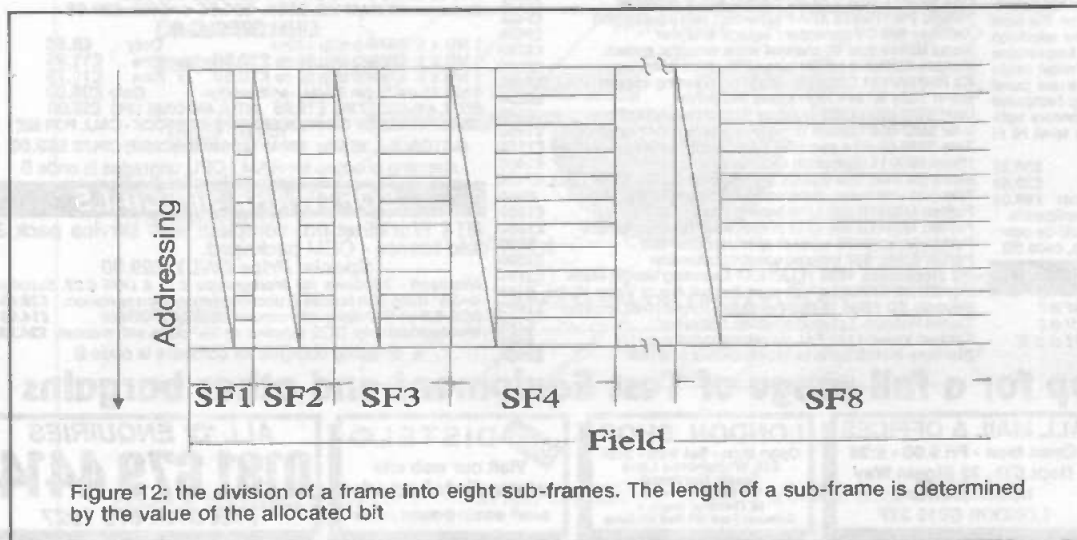

Figure 12: the division of a frame into eight sub-frames. The length of a sub-frame is determined by the value of the allocated bit

this memory effect which makes cell-by-cell addressing possible.

The second phase is the stop phase or the display phase. By applying a voltage alternately to the two bus electrodes, the ions and electrons are forced to move to the opposite electrode. This leads to plasma formation at the emission of light. The more pulses that are applied, the more light is emitted.

In line with the increasing number of alternating pulses a higher light sensitivity occurs. Light impulses always arise when there is a voltage alternation. The externally applied voltage is always directed in such a manner that it will add to the internal voltage, exceeding the trigger voltage of the plasma cell. Cells which are not pre-initialised do not reach the trigger voltage solely as result of the external voltage, and so remain dark. The third phase is the extinguishing phase. This phase is necessary in order to restore a neutral charge distribution to all the cells. The difference between the last two phases and the first is that all the cells are addressed simultaneously. Again, unlike cathode ray tubes, line flickering does not occur in a plasma display.

A further difference between a plasma display and a cathode ray tube is the method used to display different levels of brightness in a pixel. This cannot be done practically by varying voltage or current drive, because each cell would have to be addressed individually. Plasma display brightness variation is best carried out by time division multiplexing (TDM). The human eye is slow to react and will integrate the separate light impulses.

An individual frame is divided in terms of time (figure 12) into eight sections (subframes). In the case of a 21-inch display there will be only six sub-frames. The sections are not all the same length; they correspond to the value of each separate bit in the data word. This also means that with a vertical frequency of 50Hz, each triggering phase will be activated eight times in 20ms. The illustration shows only the addressing and display phases.

In the second part of this article, I will be looking at Light Emitting Plastics (LEPs), first developed at the Cavendish Laboratories at the University of Cambridge) and now commercialised by Cambridge Display Technology; Planar Optical Displays (PODs) developed at Brookhaven National Laboratory, and the new 3D tv displays.

ETI wishes to thank the following in particular for data and background material for both parts of this article: Frank Cornell of JDK (Fujitsu Electronic Devices); Joanne Korosi, MMD and Storm Communications (Pioneer), Blitz and Jonathan Dominic (NEC), Ruth Lloyd (Matsushita/Panasonic), Linda Kandy (Mitsubishi); K Van Berkel (Philips Research Laboratories); James Veligman (Brookhaven National Laboratory); Danielle Leach of The Weber Group (Cambridge Display Technologies); Roger Bassett (GEC Alsthor Engineering Research Centre) - and a number of other people who kindly assisted us.

Serial AVR Microcontroller Programmer

Robin Abbott extends his experience built up with PIC programmers to a programmer for the new fast, in-circuit reprogrammable AVR microcontrollers

It cannot have escaped the attentions of most readers of this magazine that a large number of projects now make use of microcontrollers. The controller which has been used to greatest effect has been the Microchip PIC. Microcontrollers in general include a wide variety of devices offering a variety of capabilities at different prices and in different package sizes. A recent arrival to the microcontroller scene is the AVR series from Atmel. These devices have been hard to obtain until recently, because they have only been in production for a little while. However they are now becoming increasingly available to the amateur and educational market. All the devices have flash eeprom program memory, and can therefore be reprogrammed in circuit, and re-used without the need for an ultra-violet eraser.

Regular readers of this magazine remember that I have designed two programmers for the PIC series of controllers over the past three years. About 1,000 of these programmers have been built by ETI readers. I decided to base a new AVR programmer on a similar circuit, but to improve the circuit on the basis of lessons learned by constructors of the PIC programmers.

Throughout this article I shall make frequent comparisons between the AVR and the PICs, because I believe that currently most constructors who will use the AVR probably already have experience with the PIC. The large amount of source material available for beginners to PIC microcontrollers makes it a better starting point than the AVR. This situation may change as the AVR devices gain in popularity and use.

The AVR microcontroller

Currently there are only four devices readily available in the Atmel AVR series: two devices in 20-pin packages, and two devices in 40- or 44-pin packages. The pinouts of these devices are shown in figure 1.

Like the PIC, the AVR has a Harvard architecture - the program memory is separate from the data memory, enabling the next instruction to be fetched whilst the previous instruction is being executed. Program memory varies in size from 512 words in the 1200 device, to 4096 words in the 8515 device. Each program word is 16 bits in length, enabling most instructions to fit within a single word.

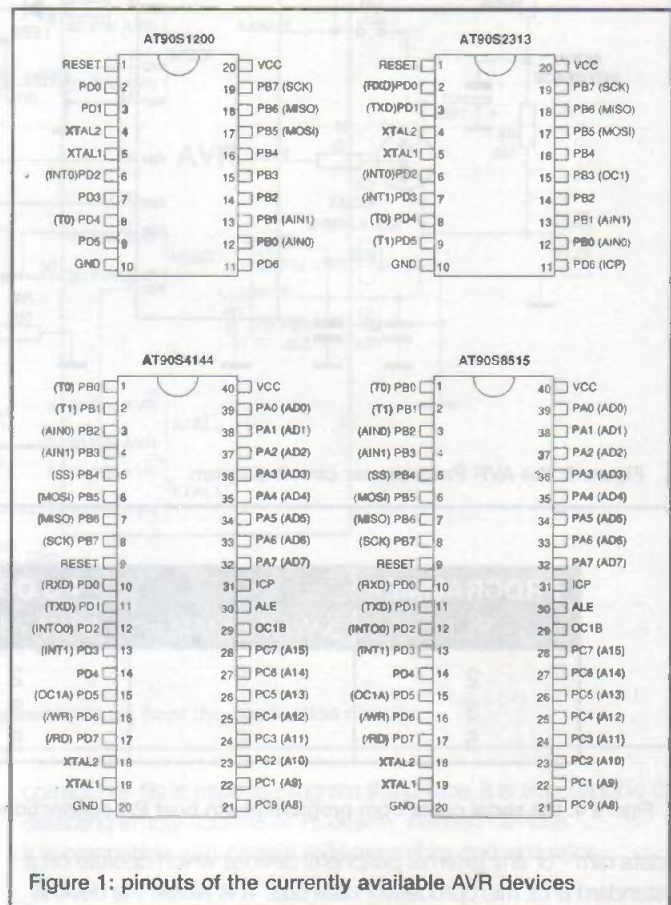

Figure 1: pinouts of the currently available AVR devices

There are 32 general purpose registers, each of which has similar capabilities to the W register in the PIC, and therefore a large number of operations can be performed on and between working registers without having to go to other memory. There are 64 configuration registers which control the ports and peripheral devices of the AVR. The three larger devices all have internal static ram which is up to 512 bytes in length in the 8515. Finally all devices have an eeprom data area which is between 64 and 512 bytes in length.

The 4144 and 8515 devices have the capability to fit external

	PROGRAM MEMORY (WORDS)	WORKING REGISTERS	DATA RAM (BYTES)	MAX RAM (BYTES)	EEPROM	I/O PINS	TIMERS	PWM	UART	ANALOG C/M/P/R	A/D CONVERTER	OTHER BUS
AT90S1200	512	32	0	0	64	15	1	N	N	Y	N	SPI
AT90S2313	1024	32	128	128	128	15	2	Y	Y	Y	N	SPI
AT90S4144	2048	32	256	64k	256	32	2	Y	Y	Y	N	SPI
AT90S8515	4096	32	512	64k	512	32	2	Y	Y	Y	N	SPI
PIC16C84	1024	1	36	36	64	13	1	N	N	N	N	NONE
PIC16C74	4096	1	192	192	0	33	3	Y	Y	N	Y	SPI, IIC, SCI

Figure 2: comparison of AVR and PIC features

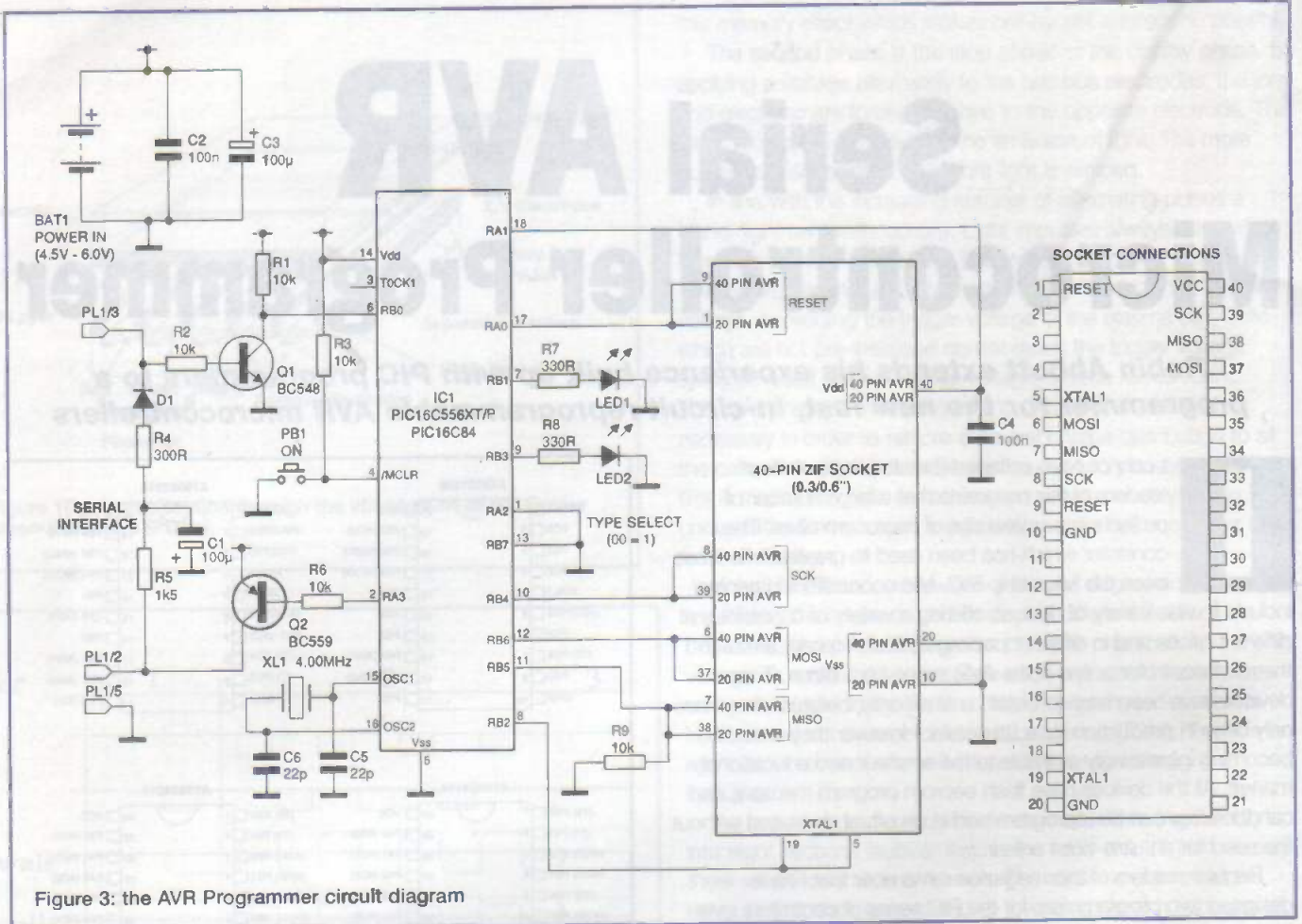

Figure 3: the AVR Programmer circuit diagram

PROGRAMMER PL1	PC CONNECTOR TYPE:			
	9-WAY FEMALE	9-WAY MALE	25-WAY FEMALE	25-WAY MALE
2	3	2	2	3
3	2	3	3	2
5	5	5	7	7

Figure 4: the serial cable from programmer to host PC connections

data ram - or any external peripheral devices which operate on a standard 8-bit microprocessor data bus. This allows the devices to be used at the heart of far more complex systems than simpler microcontrollers.

The most impressive feature of the AVR is its ability to execute most instructions in a single clock cycle. Thus its throughput approaches one MIPS (million instructions per second) per clock megahertz. In simple terms this makes the device on average four times faster than a PIC operating at the same clock frequency. When coupled with the AVR's 32 working registers, this makes the AVR performance notably faster than a PIC in some applications.

In my opinion the AVR architecture and assembler language is easier to use than the PIC. The AVR does not have the difficulty of using paging bits to access different areas of data memory. The AVR has a traditional stack with a stack pointer operating in SRAM which allows data to be pushed and popped, and has far deeper call nesting than the PIC's fixed stack which does not allow data to be saved. In addition, the wide variety of instructions, addressing modes, and the large general-purpose register area on the AVR allow algorithms to be developed with greater ease.

Figure 2 shows a comparison of the capabilities and features of the AVR devices together with the PIC16C84, and the

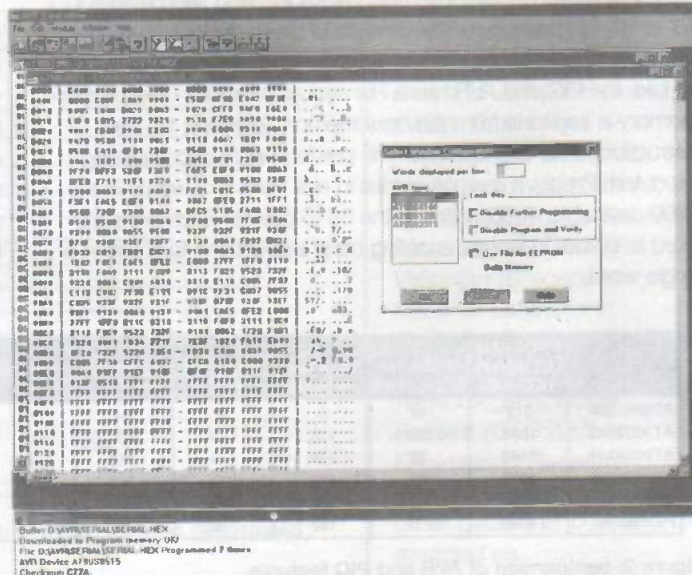

CONNECTOR / CABLE
TO PROGRAMMER
ZIF SOCKET (USE 20
PIN IDC DIL HEADER)
CABLE SHOULD BE AS
SHORT AS POSSIBLE

APPLICATION POWER SUPPLY
SHOULD DRIVE THE PROGRAMMER
POWER SUPPLY IF POSSIBLE

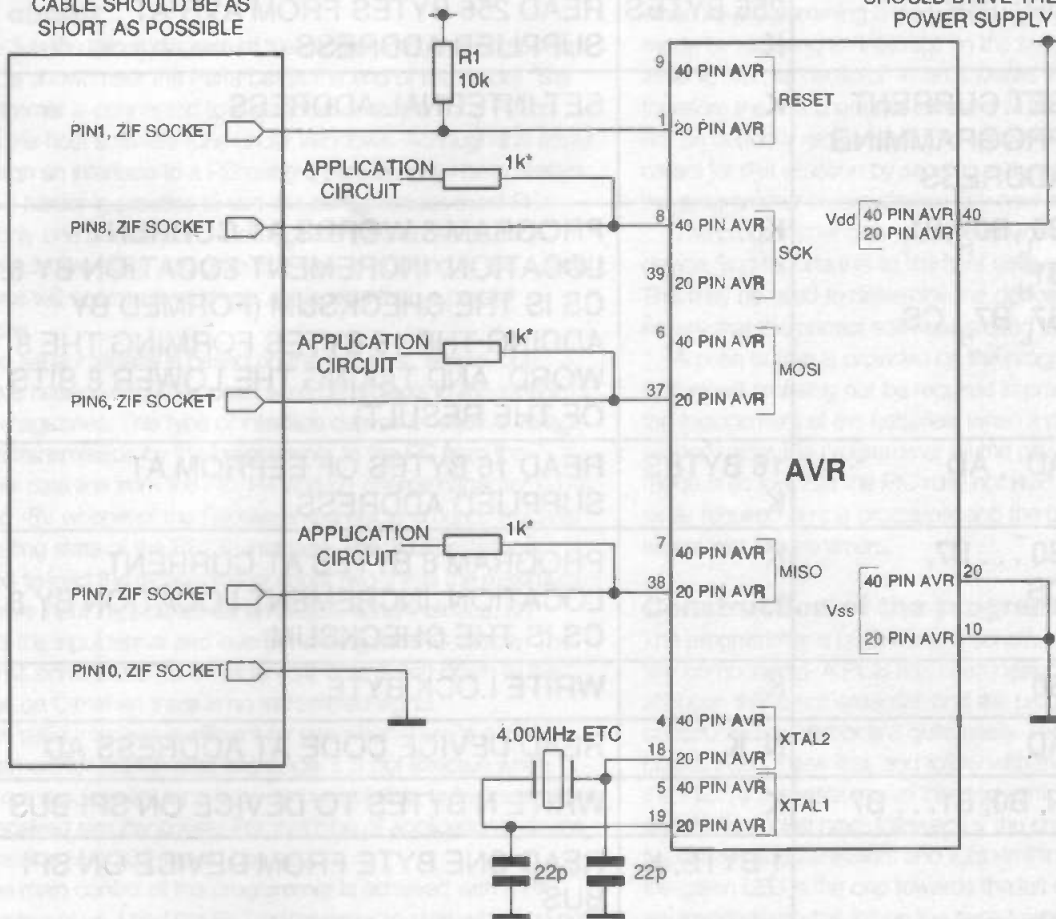

* ONLY REQUIRED IF THE APPLICATION CIRCUIT IS DRIVING THE AVR ON THESE PINS.
RESISTOR MINIMUM VALUE IS 1k, BUT SHOULD BE HIGHER IF POSSIBLE

Figure 6: A typical circuit diagram for programming in-circuit. The power comes from the application circuit

PIC16C74, which are approximately equivalent. At the higher end the AT90S8515 offers more memory and faster program execution than the 16C74 with similar peripherals. Note that at the lower end the PIC16C84 has more memory than the AT90S1200, and is also flash reprogrammable. At the moment this AVR device does not seem to compete too well with the PIC.

In conclusion I believe that the AVR devices are more suited than PICs for applications which require In-circuit programming, large data storage, have a high processing requirement, or which need a large amount of assembler to be written.

The AVR Programmer

This AVR programmer has the following features :

The programmer is battery powered.

It operates on the serial ports of a standard PC running Windows 3.1, '95, or NT.

It automatically detects activity on the serial ports to wake itself up, so it needs no on/off switch.

The programmer uses a zero insertion-force socket, and is capable of programming any of the currently available AVR devices.

The programmer reads the device type from the AVR to allow the correct programming parameters to be used, and ensuring the

correct hex file is used to program the device. It is also capable of detecting empty sockets or incorrectly inserted devices. It is compatible with Atmel's AVR assembler and simulator.

Experience has proved that the earlier programmers were easy to construct, but users had most difficulty with the serial interface. For this reason the AVR programmer offers an additional light emitting diode to show activity on the serial interface. In addition I have included more notes on the use and debugging of the serial interface in this article to assist constructors.

The host software on the PC has also been considerably improved on the basis of comments made by constructors of the PIC programmers. It now offers toolbars and multiple edit windows, each of which allows users to edit hex files within the programmer, and increased status information to show exactly what processes have been undertaken with the programmer.

Programming the AVR

The AVR devices are all programmed in similar fashion. Both the program memory and the internal eeprom memory may be programmed by this project. The AVR is an easier device to program than the PIC microcontroller, because the AVR has much greater commonality among the devices in the range, whereas the PICs have at least four different programming algorithms, and the

LETTER	PARAMETERS	RETURN	DETAIL
A	--	K	PROGRAMMER OK, WAKE UP
B	AD _L , AD _H	256 BYTES K	READ 256 BYTES FROM AVR AT SUPPLIED ADDRESS
C	SET CURRENT PROGRAMMING ADDRESS	K	SET INTERNAL ADDRESS
D	B0 _L , B0 _H , B1 _L B1 _H B7 _L , B7 _H , CS	K	PROGRAM 8 WORDS AT CURRENT LOCATION. INCREMENT LOCATION BY 8. CS IS THE CHECKSUM (FORMED BY ADDING THE 16 BYTES FORMING THE 8 WORD, AND TAKING THE LOWER 8 BITS OF THE RESULT)
E	AD _H , AD _L	16 BYTES K	READ 16 BYTES OF EEPROM AT SUPPLIED ADDRESS
F	B0...B7, CS	K	PROGRAM 8 BYTES AT CURRENT LOCATION. INCREMENT LOCATION BY 8. CS IS THE CHECKSUM.
G	B0	K	WRITE LOCK BYTE
H	AD	N. K	READ DEVICE CODE AT ADDRESS AD
I	N, B0, B1...B7	K	WRITE N BYTES TO DEVICE ON SPI BUS
J	--	1 BYTE, K	READ ONE BYTE FROM DEVICE ON SPI BUS
K	0 OR 1	K	TURN POWER ON OR OFF
L	AD _L , AD _H	CS _L , CS _H , K	RETURN CHECKSUM OF 256 WORDS FROM THE DEVICE, START AT SUPPLIED ADDRESS USING C COMMAND
M	AD _L , AD _H	0, 1, K	BLANK CHECK
N	--	K	ERASE ENTIRE EEPROM

KEY:

- K LETTER K, RETURNED TO ACKNOWLEDGE COMMAND COMPLETE
- B, B_N A SINGLE BYTE
- B_{n_L}, B_{n_H} A WORD SENT, LOW BYTE THEN HIGH BYTE
- AD_L, AD_H 16 BIT ADDRESS SENT LOW BYTE THEN HIGH BYTE

Figure 7: the interface commands for the AVR programmer

differences in programming configuration fuses across the range can make a universal programmer for PICs quite hard to design.

Like the PIC, the AVR can be programmed in either serial mode through an SPI port, or in parallel mode. The serial mode is slightly more limited than the parallel mode, because it does not allow the internal resistor/capacitor oscillator to be selected. This programmer uses a serial mode because it has a lower requirement on for pins than the parallel mode, and more easily

allows all devices to be programmed in a single socket. Although this limits the oscillator type to external crystal, this is not seen as a major problem, because the AVR devices are likely to be used in projects requiring a more powerful microcontroller, for which a crystal oscillator is more appropriate. The other minor disadvantage with a serial programmer such as this one is that programming takes longer than in a parallel mode, and again for a low-cost programmer which is not intended for production runs,

this is not seen to be a serious disadvantage.

Unlike the PIC the AVR does not require a high voltage for programming the eeprom, and therefore only a single power supply is required, which allows a simple programmer such as this one to operate from a battery supply.

The circuit

Figure 3 is the circuit diagram of the programmer (the component layout is shown near the Parts List at the end of the article). The programmer is connected to a standard serial port of a PC on which the host software runs under Windows. Although it is easier to design an interface to a PC using a parallel port, I have always found it harder in practice to use this port, because most PCs have only one parallel port, and because parallel cables and connectors are bulky and difficult to use. In addition to this a serial interface will operate over longer cable runs than a parallel interface.

The serial interface is based on the low-cost, simple, but effective design which has been seen on projects in this, and in other magazines. This type of interface derives a negative voltage for the transmission by the programmer to the PC from the receiver data line from the PC. R4 and D1 charge capacitor C1 to around -8V whenever the Receive line is below ground, which is the resting state of the RS232 interface. The 300R resistor is chosen to load the receive line at about two-thirds the maximum allowable input impedance for an RS232 serial interface. Q1 buffers the input signal and inverts it driving the PIC directly. The Transmit signal switches either to +5V, or is pulled down to the voltage on C1 when there is no transmitted signal.

The serial interface is efficient for use when there is a low requirement for duplex data exchange, it is not effective when there is a requirement for a large amount of data to be transmitted and received simultaneously. For that type of application a device such as the MAX232 should be used.

The main control of the programmer is achieved with a PIC. (Like many of us, I had the PIC programmer to start with, and not an AVR programmer, otherwise I would have tried to use an AVR here.) The power consumption of the AVR during programming is only a few milliamps, and this allows the AVR to be powered from the PIC during programming, reducing the requirement for an external switch transistor for the power supply to the AVR. The PIC may be any of the 18-pin devices with a 1k by 14-bit word memory such as the 16F84, or the 16C556 -see the end of the article for details on obtaining programmed PICs.

The PIC detects and decodes serial input on the interrupt pin. Any received command consists only of a single character followed by a number of parameters. A received command is fully executed, and the programmer reports the result of the operation before any other commands may be sent to the programmer. This obviates the need for duplex serial communications, flow control, or character buffers for the serial port.

The AVR programming interface is a standard SPI port, which is a three-wire interface requiring a clock, data from the PIC to the AVR, and data returned from the AVR to the PIC. As the AVR requires a clock to be operating during programming, the PIC also has a connection to the crystal input of the AVR, and supplies a clock to the AVR during programming. To assist diagnosis or faults on the serial interface, two LEDs are provided and are driven from the PIC. The use of these LEDs is described below in the section on testing.

The power supply for the programmer may be provided from batteries or from a mains battery eliminator. The power supply should be between four volts and six volts at around 20 milliamps. Most alkaline batteries are capable of delivering as much as 1.8 volts each when fresh, and therefore three alkaline batteries are

sufficient for the programmer.

When there has been no serial input for a period of 10 seconds, the PIC enters sleep mode. During sleep mode the total power consumption of the programmer is reduced to 30 microamps. Thus the batteries should last for a number of years when no programming is performed. The PIC is woken from sleep mode by receiving an interrupt on the serial input, the PIC takes a while to start its oscillator when it wakes from sleep mode, and therefore the first character received which wakes up the PIC will not be correctly recognised. The software running on the PC caters for this situation by sending a dummy character to awake the programmer before starting any new operation.

The programmer may read the device code from the AVR device, and reports this to the host software running on the PC. This may be used to determine the device characteristics, and to ensure that the correct software is used to program the device.

A push button is provided on the programmer to reset it. This feature will probably not be required in practice, except following the replacement of the batteries, when it may be necessary to properly reset the programmer as the power consumption in sleep mode is so low that the PIC may not start up properly. It was rarely required on the prototype, and the button has been left off recent test programmers.

Construction of the programmer

The programmer is quite easy to construct as there are relatively few components. A PCB has been designed for the programmer, although this is not essential, and the programmer could be constructed on Veroboard quite easily. There are two links on the board. Insert these first, and follow with the 18-pin dil socket for the PIC. All the resistors are inserted vertically. Insert the resistors and the ic socket next, followed by the crystal resonator, capacitors and transistors and light emitting diodes, noting that the green LED is the one towards the left of the board. The LEDs are inserted with the flat on the case towards the bottom of the board, the diode D1 is inserted with the black band towards the top of the board.

Complete the programmer with the serial socket and the ZIF Socket. On the prototype the ZIF socket was plugged into a 40-pin dil ic socket, although it may be mounted directly on the board. As the ZIF socket is quite expensive, it is possible to use a 40-pin dil socket with a 20-pin dil socket mounted alongside. Pins 1 to 10 of the 20-pin socket connect to pins 1 to 10 of the large socket, and pins 11 to 20 of the smaller socket connect to pins 31 to 40 of the large socket.

Battery clips are available for three AA size cells, with a PP3 style connector. The power supply may be connected to Vero pins, and a standard PP3 battery with connectors wired directly to the pins. Check all of the joints and solder connections on the board, insert the programmed PIC, and the programmer is ready for test.

When the programmer has been fully tested and is proved operational the battery clip can be glued underneath the circuit board with silicone rubber sealant, the entire programmer now sits on the battery case.

Testing the programmer

The programmer must be connected to a PC using a standard serial cable terminating in a 9-pin D plug. The wiring of this cable is shown in figure 4. There are two LEDs on the board. The red LED illuminates when power is applied to the AVR in the socket. The green LED illuminates whenever data is received or is transmitted by the PIC, and flashes briefly approximately once every second when the programmer serial interface is idle.

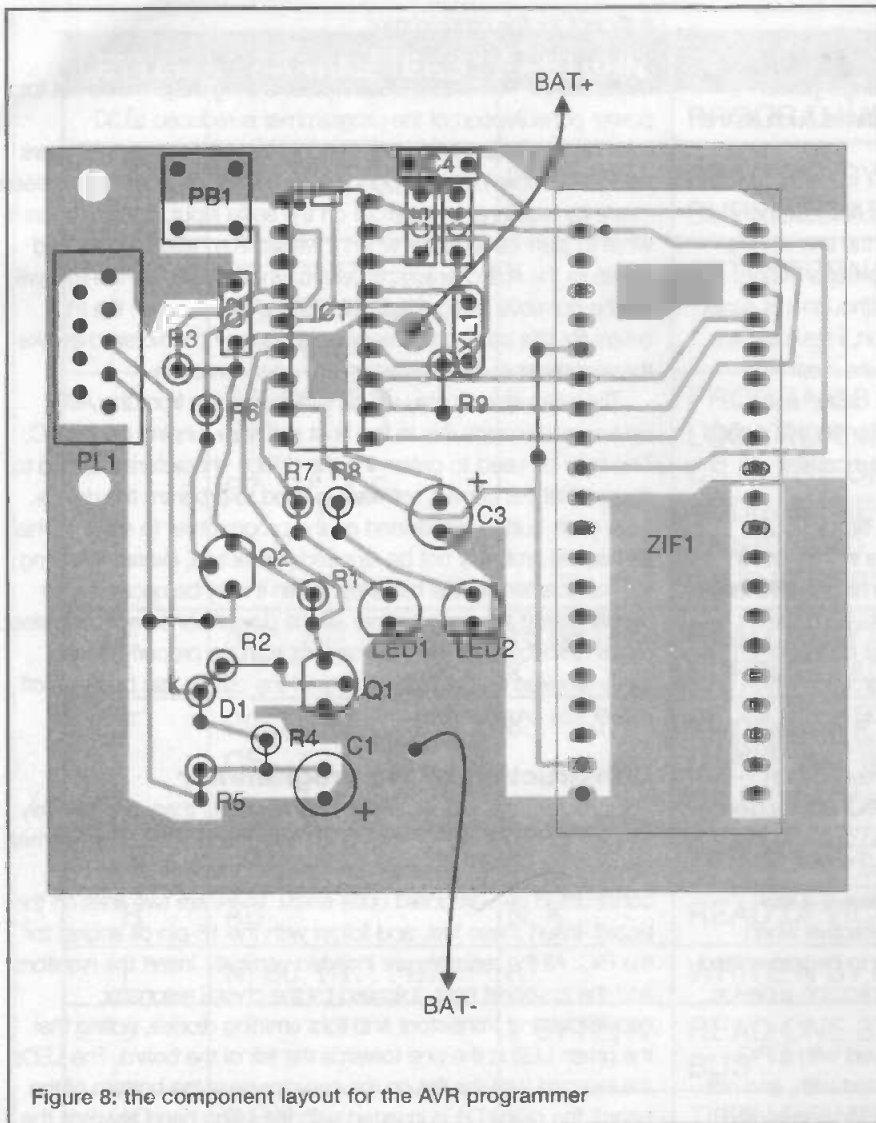

Figure 8: the component layout for the AVR programmer

It is likely that the programmer will operate immediately, so it may be connected to the PC directly. The host software on the PC may be installed as described in the instructions which accompany the program disks. When the host software is initially executed, it will attempt to find the programmer. It may find the programmer immediately, in which case it may be used directly. If the programmer is connected to a serial port which is not serial port number one, then use the Module/Communications menu option to select the correct communications port, at which point the host program will attempt to find the programmer and report back when it is found. Use a serial port rate of 9600bps.

If the programmer does not work straight away, then follow this procedure:

Testing the programmer and PIC oscillator: Press the reset button, and the green LED should flash once every second for approximately 10 seconds. The LED will then be extinguished as the PIC enters sleep mode. Repeat this test with a multimeter inserted in series with the battery pack, and check that the power consumption in sleep mode is less than fifty micro amps.

Checking the serial port : Plug in the serial cable. Check the voltage on pin 3 of the connector underneath the board, it should be around -10V, the voltage on pin 2 should be around -6V. Remove the cable and use a crocodile clip to short pins 2 and 3 on the cable. Start a terminal emulator program on the PC, and set the emulator to operate at 9600bps, no flow control. A suitable

program is hyper-terminal supplied by Windows '95, the serial port set-up dialog box may be found under File/Properties for this program. Check that as you press keys the characters are echoed. If not there is a fault in the cable or the serial card. If keys are received then power down the programmer and remove the PIC, short pins 2 and 6 of the PIC socket, power up the programmer and check again that characters are echoed. If not then there is a fault in the serial circuitry.

Testing the transmit/receive lines from the PIC to the PC: With the terminal emulator in use insert the PIC and power up the programmer. Press the reset button, a 'K' character should be received by the PC. Now press the 'Z' key on the PC, the green LED should flash in sympathy, and 'f' characters will be transmitted back to the PC, the programmer's indication that it has received data which it does not understand.

If the programmer still does not work, then there is either an error with the PIC, or the installation of the host software is incorrect.

Using the programmer

Either the Atmel Assembler, or the Forest Electronics AVRDE assembler/simulator may be used for this programmer. Set the options in the AVR assembler to assemble to Intel Intellec 8/MDS format - this type of file usually ends in a .HEX extension.

The host PC software is accompanied by instructions on its use in a help file. The host software window is illustrated in figure 5. The

40-pin devices are programmed with pin 1 towards the top of the board, the 20-pin devices are placed in the socket towards the top of the socket, again with pin 1 towards the top of the board.

AVR devices should never be removed or inserted while the red LED is illuminated. If multiple devices are connected to the same serial port, then unless full switching is employed it is advisable to remove the programmer when not in use, or it will be repeatedly woken up by received characters.

The AVR devices have a program memory reprogramming life time which is quoted at approximately 1000 cycles - in practice devices operating at normal voltages should achieve much better performance than this, and it is unlikely that this lifetime will be exceeded.

The AVR has a lock byte which prevents the device from being read when set, this is to prevent copying of the internal program. Unlike the newer OTP PIC devices this byte may be set and reset at will, allowing protected devices to be rewritten although they may not be read.

In circuit programming

The AVR programmer has the capability to program devices which are already in-circuit. A typical circuit diagram for programming in-circuit is shown in figure 6. Note that the power is gained from the application circuit - and it is advisable to power the programmer from the same 5V supply as the application. Note that the application has a crystal which must be of greater than 1MHz in frequency. If the circuit has a lower crystal frequency then it must

be arranged to supply a clock from the XTAL1 pin of the programmer, which overrides the application clock - this is likely to be very difficult to arrange in practice and is not recommended.

The lead from the programmer to the application has five wires, one for the reset pin, 3 for the SPI bus, and one for ground. The connection to the programmer should be made by using a 20-pin DIL header on an IDC cable. In the application these pins may need to be isolated by resistors as shown in the figure if the application circuit attempts to drive the pins driven by the programmer. These resistors should be greater than 1k to limit the current drawn from the output pins of the programmer. Mount the resistors close to the AVR to reduce the effect of capacitance on signal timing if this is likely to affect the application. Keep the cable to the programmer as short as possible.

Finally note that the application circuit should be able to operate without damage for short periods with the AVR controller reset and its pins in the high impedance state (this will occur whenever the programmer is connected and powered up).

The serial communications protocol

The interface to the programmer on the serial port is quite straightforward. It is reasonably easy to write an application in Basic to control the programmer from the PC for special purposes. For example the original PIC programmer was used by one small manufacturer to test PICs on manufactured circuit boards on a production line by running a verify algorithm on each circuit board as it passed the test machine.

There are a total of 14 commands available to operate with the programmer from the PC. Each command starts with a capital letter, from letter A to letter N. The commands are shown in figure 7. Most commands are fairly self-explanatory, the key to the table is shown in the Figure. Before undertaking any operation with the AVR it is a necessary to turn the power to the AVR on, this is achieved with the K command followed by a 1 character. The commands required can then be executed, and after operations are complete, the power may be turned off with a K followed by a 0. Note that the red LED will always illuminate while power is connected to the AVR.

To wake the programmer from sleep mode, the A command should be used, this will wake the PIC on an interrupt, and force it to reset itself, the first action undertaken will be to return a K character to the PC. If the PIC is already awake, then a K character will be returned in response to an A command anyway. Once the programmer has been woken up, then all the commands required should be executed with a maximum gap between them of about eight seconds to prevent the programmer returning into sleep mode.

The only commands which are of special note are the commands to send a number of bytes to the AVR on the SPI bus, and the command to read one byte from the device on the SPI bus. These commands may be used for the future devices to implement currently undocumented commands. There may also be some occasional use for these commands in a general-purpose SPI interface.

Please note that any locked device will require the entire eeprom to be erased before any operation will be successfully executed, apart from determining the device code.

AVR development tools and further information

Atmel have a CD describing the complete range of AVR products including data sheets and an assembler/simulator. If you use this CD, make sure that the Include files are dated the 4th of July 1997, or later as earlier Include files were in error.

The entire Atmel AVR product range is described on the Atmel web site which includes assemblers, simulators, and data sheets for the range. The web site is at: <http://www.atmel.com/>. Follow the link to the products page.

Forest Electronic Developments can supply the programmed PIC (see below), and also sell a Windows based integrated Assembler/Simulator, they can also supply the AT90S1200 and AT90S8515 devices. The programmed PIC for the project and the Windows 3.1/95/NT host software is available on 3 1/2" disk. The programmed device and software is £12.00, please add £3.00 for post, packing and handling. Forest Electronics can also supply a complete kit for the AVR programmer for £40.00.

Please send orders payable to:

Forest Electronic Developments, 15 Springfield Buildings, Chippenham, Wiltshire SN15 1LS. They accept also credit card or Switch/Delta orders on 01249 658348.

PARTS LIST for the AVR Programmer

Resistors

All	1 percent 0.25 watt
R1-3, R6, R9	10k
R4	300R
R5	1k5
R7, R8	330R

Capacitors

C1, C3	100uF 25V electrolytic radial
C2, C4	100nF disc ceramic
C5, C6	22pF disc ceramic

Semiconductors

IC1	See Text
Q1	BC548
Q2	BC559
D1	1N4148
LED1	5mm green led 5mm
LED2	red led

Other

XL1	4MHz resonator (Crystal may also be used)
PL1	9 pin D-socket PCB mounted
PB1	PCB mounted button (Maplin KR88)
Bat 1	3 x AA Alkaline Cells
	20-pin dil ic socket
	40-pin multi-width ZIF socket
	PCB; battery clip/box for 3 AA cells (Maplin YR61);
	PP3 battery clip (Maplin HF28); 2 x Veropins (power supply).

Maplin PO Box 3, Rayleigh, Essex SS6 8L can supply the AT90S1200 device. Tel (01702) 554000. Equinox technologies supply a serial/parallel AVR programmer, and can supply the AVR CD and AT90S1200 devices via Farnell, Canal Road, Leeds, LS12 2TU. Tel 0113 263 6311 or 0113 279 0101.

£1 BARGAIN PACKS

If you would like to receive the other four £1 lists and a lot of other lists, request these when you order or send SAE.

TEST PRODS FOR MULTIMETERS with 4mm sockets. Good length very flexible lead, Ref: D86.

8 OHM PM SPEAKERS, size 8" x 4", pack of two. These may be slightly rusty and that is why they are so cheap but are electrically OK, Ref: D102.

PAXOLIN PANELS, size 8" x 6", approximately 1/18" thick, pack of two, Ref: D103.

13A SOCKET, virtually unbreakable, ideal for trailing lead, Ref: D95.

PIEZO BUZZER with electronic sounder circuit, 3V to 9V D.C. operated, Ref: D76.

DITTO but without internal electronics, pack of two, Ref: D75.

LUMINOUS ROCKER SWITCH approximately 30mm sq. pack of two, Ref: D64.

ROTARY SWITCH, 9-pole, 5-way, small size 77 spindle, pack of two, Ref: D54.

FERRITE RODS, 7" with coils for Long and Medium waves, pack of two, Ref: D52.

DITTO but without coils, pack of three, Ref: D52.

MAINS DP ROTARY SWITCH with 1/4" control spindle, pack of five, Ref: D49.

ELECTROLYTIC CAP, 800µF at 6.4V, pack of 20, Ref: D48.

ELECTROLYTIC CAP, 1000µF + 100µF 12V, pack of 10, Ref: D47.

MINI RELAY with 5V coil, size only 26mm x 19mm x 1mm, has two sets of changeover contacts, Ref: D42.

MAINS SUPPRESSOR CAPS .1µF 250V A.C., pack of 10, Ref: 1050

TELESCOPIC AERIAL, chrome plated, extendable and folds over for improved F. M. reception, Ref: 1051.

MES LAMP HOLDERS, slide on to 1/4" tag, pack of 10, Ref: 1054

PAXOLIN TUBING 3/16" internal diameter, pack of two, 12" lengths, Ref: 1056.

ULTRA THIN DRILLS, 0.4mm, pack of 10, Ref: 1042.

20A TOGGLE SWITCHES, centre off, part spring controlled, will stay on when pushed up but will spring back when pushed down, pack of two, Ref: 1043.

HALL EFFECT DEVICES, mounted on small heatsink, pack of two, Ref: 1022.

12V POLARISED RELAY, two changeover contacts, Ref: 1032.

PAXOLIN PANEL, 12" x 12" x 1/18" thick, Ref: 1033.

MINI POTTED TRANSFORMER, only 1.5VA 15V-0V-15V or 30V, Ref: 964.

ELECTROLYTIC CAP, 32µF at 350V and 50µF section at 25V, in aluminium can for upright mounting, pack of two, Ref: 995.

PRESET POTS, one megohm, pack of five, Ref: 998.

WHITE PROJECT BOX with rocker switch in top left-hand side, size 78mm x 115mm x 35mm, unprinted, Ref: 1006.

5V SOLENOID, good strong pull but quite small, pack of two, Ref: 1012.

FIGURE-8 MAINS FLEX, also makes good speaker lead, 15m, Ref: 1014.

HIGH CURRENT RELAY, 24V A.C. or 12V D.C., three changeover contacts, Ref: 1016.

LOUDSPEAKER, 8 Ohm 5W, 3.7" round, Ref: 962.

NEON PILOT LIGHTS, oblong for front panel mounting, with internal resistor for normal mains operation, pack of four, Ref: 970.

3.5MM JACK PLUGS, pack of 10, Ref: 975.

PSU, mains operated, two outputs, one 9.5V at 550mA and the other 15V at 150mA, Ref: 968.

ANOTHER PSU, mains operated, output 15V A.C. at 320mA, Ref: 989.

PHOTOCELLS, silicon chip type, pack of four, Ref: 939.

LOUDSPEAKER, 5" 4 Ohm 5W rating, Ref: 939.

LOUDSPEAKER, 7" x 5" 4 Ohm 5W, Ref: 949

LOUDSPEAKER, 4" circular 6 Ohm 3W, pack of 2, Ref: 951

FERRITE POT CORES, 30mm x 15mm x 25mm, matching pair Ref: 901.

PAXOLIN PANEL, 8 1/2" x 3 1/2" width electrolytics 250µF and 100µF, Ref: 905.

CAR SOCKET PLUG with P.C.B. compartment, Ref: 917.

FOUR-CORE FLEX suitable for telephone extensions, 10m, Ref: 918.

PROJECT CASE, 95mm x 66mm x 23mm with removable lid, held by four screws, pack of two, Ref: 876.

SOLENOIDS, 12V to 24V, will push or pull, pack of two, Ref: 877.

2M MAINS LEAD, 3-core with instrument plug moulded on, Ref: 879

TELESCOPIC AERIAL, Chrome plated, extendable, pack of two, Ref: 884.

MICROPHONE, dynamic with normal body for hand holding, Ref: 885

CROCOOILE CLIPS, superior quality flex, can be attached without soldering, five each red and black, Ref: 886

BATTERY CONNECTOR FOR PP3, superior quality, pack of four, Ref: 887.

LIGHTWEIGHT STEREO HEADPHONES Ref: 898.

PRESETS, 470 Ohm and 220 kilohm, mounted on single panel, pack of 10, Ref: 849.

THERMOSTAT for ovens with 1/4" spindle to take control knob, Ref: 857.

12V-QV-12V 10W MAINS TRANSFORMER, Ref: 811.

18V-QV-12V 10W MAINS TRANSFORMER, Ref: 813.

AIR-SPACED TRIMMER CAPS, 2pF to 20pF, pack of two, Ref: 818.

AMPLIFIER, 9V or 12V operated Mullard 1153, Ref: 823.

2 CIRCUIT MICROSWITCHES, icon, pack of 4, Ref: 825.

LARGE SIZE MICROSWITCHES changeover contacts, pack of two, Ref: 825.

MAINS VOLTAGE PUSH SWITCH with white dolly, through panel mounting by hexagonal nut, Ref: 829.

POINTER KNOB for spindle which is just under 1.4", like most thermostats, pack of four, Ref: 833.

CAMCHARGER CAMCORDER BATTERY QUICK CHARGER (WITH RECONDITIONER & TESTER)

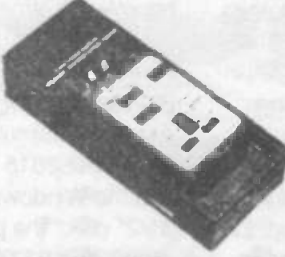

Brand new and boxed. Normal price £35, yours for **£15**, Order Ref: 15P73.

TOROIDAL MAINS TRANSFORMERS

All with 220/240V primary winding, 0.30V + 0.30V at 120VA, would give you 30V at 4A or 60V at 2A, price £8. Order BPE2. Order Ref: BPG2. 0.110V + 0.110V at 120VA would give you 110V at just over 8A or 220V at 1/2A, price £8. Order Ref: BPG3. 0.35V + 0.35V at 150VA would give you 35V at 4A or 70V at 2A. Price £8. Order Ref: BPG9. 0.35V + 0.35V at 220VA would give you 35V at 8 1/2A or 70V at 3 1/4A, price £9. Order Ref: 9PG4. 0.110V + 0.110V at 220VA would give you 110V at 2A or 220V at 3A, price £10. Order Ref: 10PG5. 0.45V + 0.45V at 500VA would give you 45V at 11A or 90V at 5 1/2A, price £20. Order Ref: 20PG7. 0.110 + 0.110V at 500VA would give you 110V at 5A or 220V at nearly 3A, price £25, Order Ref: 25PG7.

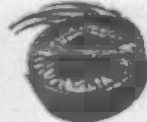

SUPER WOOFERS. A 10" 4ohm with a power rating of 250W music and normal 150W. Normal selling price for this is £55 + VAT, you can buy at £29 including VAT and carriage. Order Ref: 29PT. The second one is a 8" 4ohm. 200W music, 200W normal. Again by Challenger, price £18, Order Ref: 18P9.

Deduct 10% from these prices if you order in pairs or can collect. These are all brand new in maker's packing.



SOLOERING IRON. Super mains powered with long life ceramic element, heavy duty 40W for that extra special job. Complete with plated wire stand and 245mm leads, £3, Order Ref: 3P221.

YOU SAVE £40

THE JAP MADE 12V 12A-SEALED BATTERY from regular suppliers costs £50, you can have one from us for only £10 including VAT if you collect or £12 if we have to send. Being sealed it can be used in any position and is maintenance free. All in tip top condition and fully guaranteed, Order Ref: 12P32. Or if you want a smaller one we have 12V 2.3AH, regular price £14, yours for only £3.50, Order Ref: 3.5P11.



FLASHING BEACON. Uses an XENON tube and has amber-coloured dome with separate bracket, 12V operated. Price only £5, Order Ref: 5P 267.

HIGH RESOLUTION MONITOR. 9" by Philips, in metal frame for easy mounting. Brand new, offered at less than the price of the tube alone, £15, Order Ref: 15P1.

15W 8" SPEAKER AND 3" TWEETER. Amstrad, made for their high quality music centre. £4 per pair. Order Ref: 4P57.

INSULATION TESTER WITH MULTIMETER. Internally generates voltages which enables you to read insulation directly in megohms. The multimeter has four ranges. AC/DC Volts, 3 ranges millamps, 3 ranges resistance and 5 amp range. These instruments are ex-British Telecom but in very good condition, tested and guaranteed OK, probably cost at least £50, yours for only £7.50 with leads, carrying case £2 extra. Order Ref: 7.5P4.

We have some of the above testers but slightly faulty, not working on all ranges, should be repairable, we supply, diagram, £3, Order Ref: 3P176.

250W LIGHT DIMMER. Will fit in place of normal wall switch, only £2 each. Order Ref: 2P380. Note these are red, blue, green or yellow but will take emulsion to suit the colour of your room. Please state colour required.

LCD 3 1/2" DIGIT PANEL METER. This is a multi-range voltmeter/ammeter using the A-D converter chip 7106 to provide five ranges each of volts and amps. Supplied with full data sheet. Special snip price of £12, Order Ref: 12P19.

MINI BLOW HEATER. 1kW, ideal for under desk or airing cupboard, etc. Needs only a simple mounting frame, £5, Order Ref: 5P23.

MEDICINE CUPBOARD ALARM. Will warn when cupboard door is opened. Light makes the bell ring. Neatly cased, requires only a battery, £3, Order Ref: 3P155.

DON'T LET IT OVERFLOW. Be it bath, sink, cellaç, sump, etc., this device will tell you when the water has risen to the pre-set level. Adjustable, neatly cased for wall mounting, £3, Order Ref: 3P156.

DIGITAL THERMOMETER. Suitable for outdoors or indoors, has an extra wide temperature range -50° to +70°C, complete with heavy duty battery which should last several years. Its sensor can be outside, but with the read-out inside, £4, Order Ref: 4P104.

SMART HIGH QUALITY ELECTRONIC KITS

All kits are complete with PCB and other components in a blister pack.

If you want more information about them, we have copies of the illustrated Smart catalogue available price £1.

Cat. No.	Description	Price £	Cat. No.	Description	Price £
1003	5 watt electronic siren	2.55	1089	L.E.D. flasher/555 tester	1.61
1005	Touch switch	2.87	1090	Stress meter	3.22
1008	SF function generator	6.90	1093	Windscreen wiper controller	3.68
1010	5-input stereo mixer, with monitor output	19.31	1094	Home alarm system	12.42
1016	Loudspeaker protection unit	3.22	1095	Lead acid battery charger	3.45
1017	Linear CB 30W amp	4.70	1100	2 x 18 watt integrated amplifier	18.39
1020	0.5 min. time switch	4.70	1101	Dollar tester	4.70
1023	Dynamic headphone preamp	2.50	1103	L.E.D. power meter	1.84
1025	7 watt hi-fi power amplifier	2.53	1106	Thermometer with I.e.d.s.	6.90
1026	Running lights	4.60	1107	Electronics to help win the pools	3.68
1027	NiCad battery charger	3.91	1112	Loudspeaker protection with delay	4.60
1030	Light dimmer	2.53	1113	2 x 18 watt power amplifier	5.98
1032	Stereo tone control	3.55	1115	Courtesy light delay	2.07
1035	Space sound effects	2.30	1118	Xxxx-switch, with triac, 0.10 mins	4.14
1039	Stereo VU meter	4.60	1119	Telephone line recording device	5.25
1042	AF generator 250Hz-16kHz	1.70	1123	Morse code generator	1.84
1043	Loudness stereo unit	3.22	1124	Electronic bell	2.76
1047	Sound switch	5.29	1125	Telephone lock	2.68
1048	Electronic thermostat	3.68	1126	Microphone preamplifier	4.60
1050	3-input hi-fi stereo preamplifier	12.42	1127	Microphone tone control	4.60
1052	3-input mono mixer	6.21	1128a	Power flasher 12V d.c.	2.53
1053	Electronic metronome	3.22	1133	Stereo sound-to-light	5.26
1054	4-input instrument mixer	2.76			
1056	8V-20V 8A stabilised power supply	12.42			
1057	Cassette head preamplifier	3.22			
1059	Telephone amplifier	4.60			
1060	+40V 8 A power supply	8.28			
1061	12V 1/2A stabilised power supply	3.36			
1062	5V 0.5A stabilised supply for TTI	2.30			
1063	12V 2A power supply	2.30			
1064	+12V 0.5A stabilised supply	3.22			
1067	Stereo VU meter with leads	9.20			
1068	18V 0.5A stabilised power supply	2.53			
1070	Hi-Fi preamplifier	7.47			
1085	D.C. converter: 12V to 6V or 7.5V or 9V	2.53			
1086	Music-to-light for your car	4.60			

TERMS

Send cash, PO, cheque or quote credit card number - orders under £25 add £3.50 service charge.

J & N FACTORS
Pilgrim Works (Dept. E.T.I.)
Stairbridge Lane, Bolney,
Sussex RH17 5PA
Telephone: 01444 881965

"Chillright"

Fridge Thermometer

Terry Balbirnie's fridge thermometer/monitor helps to keep the fridge within the temperature at which food should be stored to prevent rapid multiplication of troublesome bacteria.

Some people never seem to get the message. In a recent survey, hardly anyone knew what the temperature inside a domestic fridge should be. Some of them should have known better - they were chefs, housewives, shopkeepers and members of the food processing industry.

What's the answer?

For the very few of you who do have temporarily forgotten the answer, the maximum temperature inside a fridge should be 5 degreesC. Some say that between 2 degreesC and 4 degreesC is better. Above 5 degreesC, potentially dangerous bacteria multiply rapidly and can cause food poisoning. Having the temperature set too high is a major cause of trouble, because people assume that food kept in a fridge is safe, unless it is obviously decaying. However, if the temperature is too low, some foods become very stiff to handle. This fridge thermometer will measure temperatures over the range 0 degreesC to 10 degreesC. Apart from measuring fridge temperatures, it could also be put to other uses such as checking that temperatures outdoors are not low enough to kill sensitive plants.

The fridge thermometer is built in a small plastic box with an analogue (pointer-on-scale) meter fitted on top. There is a centre-off switch for the on-off and battery checking functions. The sensor protrudes from the front. In the prototype, the meter scale reads degrees Celsius: zero corresponds to zero degreesC and full-scale deflection to about 10 degrees. The scale is reasonably linear with each 5uA equivalent to about 1 degree. However, these figures will depend partly on the meter being used.

Some readers might prefer to label the scale with coloured segments, like red for "too high" (say above 4 degrees), green for "correct temperature" (between 2 and 4 degrees) and blue for "too cold" (less than 2 degrees).

Making the test

To use the fridge thermometer, operate the battery check function first. Press the switch to the "test" position. The pointer goes to full scale if the battery is in good condition. Now move the switch to "temp" and place the unit in the fridge. After about 30 minutes take a reading with the unit still inside. Due to the thermal inertia of the sensor, it will take a second or two for it to warm up significantly, so take the reading fairly quickly.

If the temperature falls outside the ideal range, the thermostat should be adjusted accordingly and the fridge left for an hour or two to let the temperature stabilise. You can then recheck it and adjust as necessary. The fridge thermometer should always be used during a period of hot weather. Fridge thermostats are not

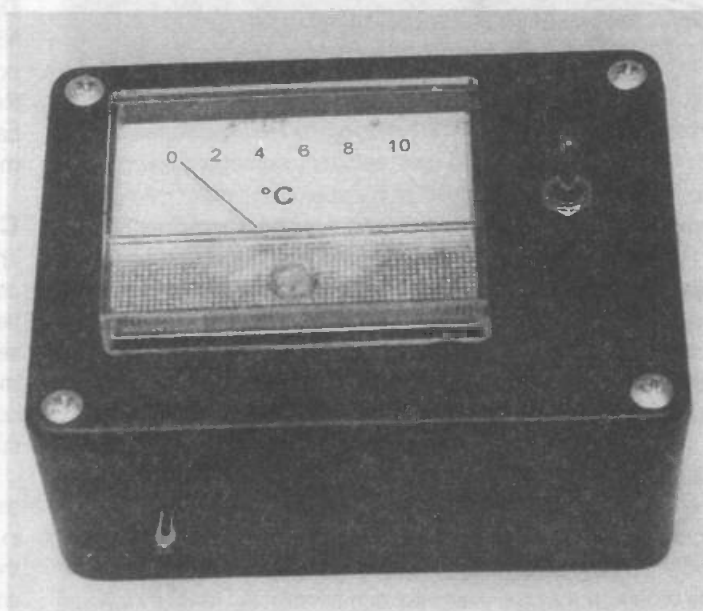

always good at maintaining a constant temperature; when the outside temperature is warm in summer cold in winter, it can affect the fridge accordingly. The thermometer will soon show how the temperature rises if the door is left open too long, opened and closed excessively or not shut completely. Children take note!

You will need a good quality thermometer with which to calibrate the circuit at the end of construction. The best is a standard mercury laboratory type with a resolution of one degree or less. You could probably borrow one from a local school with, perhaps, a payment to charity. An alternative is to use a digital thermometer.

How it works

The circuit for the Fridge Thermometer is in figure 1. S1 is double-pole biased with centre off. It is biased because in one of the on, the lever will spring back to off when released. This is used for the battery check function ("test"). In the other on position, the lever will remain at on until switched off. This is used for the temperature measurement ("temp"). When the switch is set to "temp" or "test", pole b directs current from the 9V battery to the input of IC1, a 5V regulator. This will maintain a steady voltage for the circuit until the battery gives less than about 7V. The circuit only requires about 4mA so, in occasional use, an alkaline PP3 battery should last for at least a year. C1 and C2 are necessary for stable operation of the regulator.

Suppose S1 is set to "temp". The temperature sensor consists of a miniature bead thermistor, TH1, whose resistance falls as the

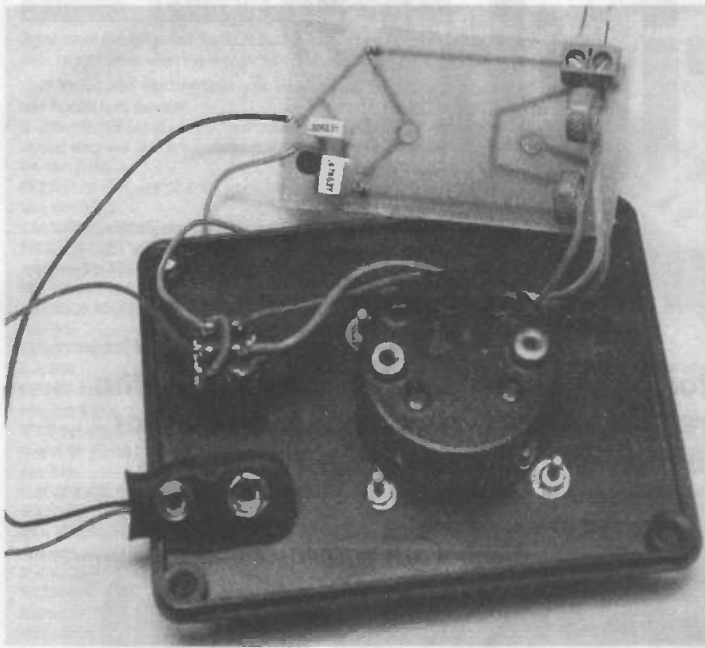

temperature rises. The thermistor and three other resistors (RV1, R1 and R2) are connected as a Wheatstone Bridge. This has not been drawn in the traditional diamond-shape, as this confuses many people. The negative terminal of the microammeter, ME1, is connected to the junction of RV1 and TH1 and the positive terminal to the junction of R1 and R2. Preset RV2 works with S1 in "test" to do the battery-check. Ignore this part for the moment.

Fixed resistors R1 and R2 are connected in series across the 5V supply to form a potential divider. The voltage between the 0V line and the junction between these resistors (that is, the meter positive terminal) will be approximately 3.75V with the values shown. RV1 and TH1 make a further potential divider. Via RV1, the voltage across the thermistor can be adjusted to 3.75V at 0 degreesC; in that case, the voltage at each side of the meter will be equal; no current will flow, and the reading will be zero. The Wheatstone bridge is then "balanced".

Unsteady bridge

When the temperature sensed by the thermistor rises, its resistance falls and so does the voltage across it. The voltage at

the left of the meter is now less than at the right. Current flows through the meter from the positive to the negative terminal (from higher to lower voltage). If the temperature falls below zero, the voltage across TH1 will exceed 3.75V and current will flow through the meter from negative to positive. The pointer will then try to move to the left, but this is of no consequence here.

Often, a Wheatstone bridge is only used in its balanced state where no current flows through the meter. The voltage of the supply is then unimportant. However, when it is unbalanced a complex arrangement of resistors (including the resistance of the meter itself) comes into play to determine the current flowing through the meter. The reading then depends on the supply voltage. Without IC1 to provide a stable supply, the reading would change as the battery aged.

Battery test

The battery-check works as follows: with S1 at "test", current flows through the meter from the R1/R2 potential divider via S1 pole a and RV2 to the 0V line. The preset will be adjusted so that the pointer reaches full-scale deflection for a 5V supply. When the battery voltage falls below about 7V, the regulator is unable to maintain a 5V output and the pointer fails to reach full scale.

Construction

The on-off and "test"/"temp" functions were combined in a single centre-off switch in the prototype. This was neat and avoided the need for two switches. Some constructors may prefer to use separate switches (depending on what is available). The PCB is mounted on the rear of the meter itself (copper track side outwards) using the meter's terminal posts and the small fixings supplied with it.

Drill the holes in the PCB for meter attachment (do not mount the meter yet). Solder the terminal block and all other components in position. The terminal block will be used to connect the thermistor and is essential for two reasons: firstly, it will make it easy to site it remotely for calibration at the end. Secondly, when the thermistor is attached to the PCB, the terminal block avoids the need to solder it. This is significant, as the heat of the soldering iron would permanently alter its operating characteristics. If the specified voltage regulator is used, it will be soldered with its rounded face towards the right-hand edge of the PCB. Note, however, that certain similar devices appear to have their input and output pins interchanged. If necessary, check the supplier's

data. Wire up the switch (if it is the specified type, follow figure 3) and connect the PP3-type battery snap. Adjust RV1 to approximately mid-track position and RV2 fully anti-clockwise (as viewed from the left hand edge of the PCB).

Testing

Mount the meter on the PCB. The terminal marked "+" must be connected to the pad leading to R1 and R2, or the pointer will try to move in the wrong direction.

Connect the thermistor to the terminal block. Connect the battery and S1 to "temp". The pointer will probably deflect - possibly off-scale. This will not harm the meter. Adjust RV1 until the reading is zero. Now warm the thermistor between your fingers - the pointer should move to the right. Move the switch lever to the "test" position. The meter will give a deflection of less than full-scale if RV2 was left adjusted as described. Rotate RV2 sliding contact until full-scale deflection is reached. Switch

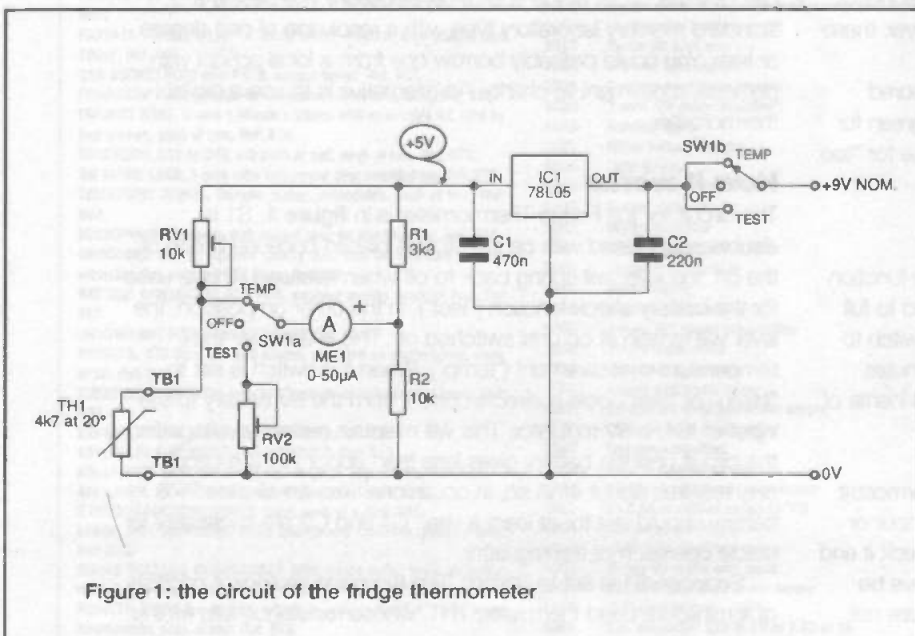

Figure 1: the circuit of the fridge thermometer

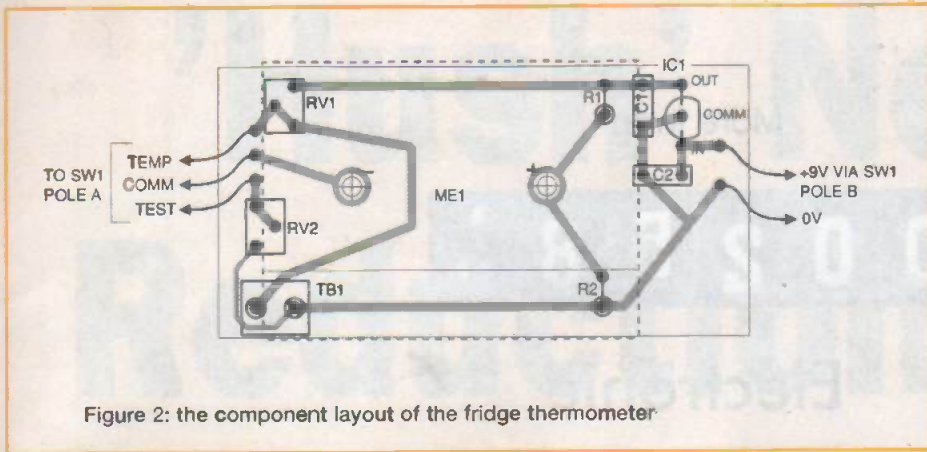

Figure 2: the component layout of the fridge thermometer

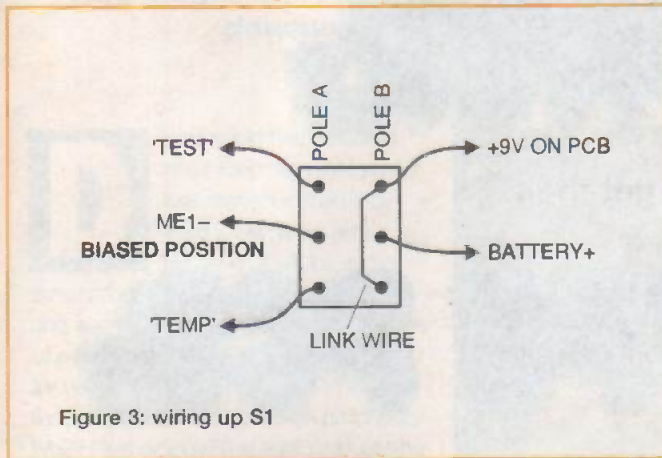

Figure 3: wiring up S1

off. The thermometer must now be set up to read the correct temperatures. If the switch springs back to off while in "test" rather than "temp", reverse the relevant wires on S1 pole a.

Calibration

You will need (in addition to the thermometer), a small drinking glass with some cooking oil in it and access to a freezer (or the freezing compartment of the fridge). You will also need an assistant! Do not use water instead of cooking oil. Water would freeze at 0 degreesC. Also, water conducts electricity and if the thermistor leads were dipped in it, there would be an apparent reduction in resistance. Using a small piece of screw terminal block or other reliable method, connect the thermistor to a short piece of twin wire and the other end of the wire to the terminal block on the PCB.

Remove the oil from the freezer and immerse the thermistor fully. If necessary, wait until it has become more fluid. Keeping the oil well stirred, watch the temperature and when it reaches about minus 2 degreesC, switch the unit to "temp". Keep stirring and when the temperature reaches 0 degrees, adjust RV1 until the pointer reads zero. At each two-degree increment, record the reading. Put the oil back in the freezer and repeat the process, making small adjustments as necessary.

Carefully remove the front cover of the meter by gently prising it up from the body. With the aid of tracing paper or by careful measurement, make a new scale to stick on top of the existing one. Take great care to avoid damage to the pointer while doing this. Attach the new scale and replace the cover, taking care to engage the peg on the adjustment screw with the fork in the meter movement. Do a spot check at 4 degreesC to ensure that the scale is correctly placed.

Remove the wires from the terminal block and attach the thermistor. The thermistor must be the same one used for

calibration, to avoid differences between individual units of the same type. Detach the PCB and drill the lid of the box to mount the meter. The best way to cut the large hole is to drill a circle of small ones, push out the centre, and then file the edge smooth. This need not be very neat, as the meter will cover it up. Mount the meter and re-attach the PCB to it. Measure the position of the thermistor and drill a hole in the side to accommodate it. Bend the thermistor wires so that its body will pass through the hole when the case is assembled.

The thermistor should protrude by a few millimetres. Secure the battery to the side of the box using an adhesive fixing pad or small bracket. Attach the lid of the box, checking for trapped wires.

Using the thermometer

When switched on, the fridge thermometer will give an off-scale reading until the temperature has fallen below about 10 degreesC. This will not harm it. It is essential to leave the unit inside the fridge long enough for it to reach the true temperature. This will take at least 30 minutes, because the temperature sensed by the thermistor is affected by the box until it has cooled down. Make a final check on the fridge to compare the reading of the new unit with that of the laboratory thermometer to make sure that they correspond and that nothing has been disturbed during assembly.

But don't forget, when you are using your fridge, that all food has its use-by date, and it can be unsafe to keep food for too long, even under ideal storage conditions. Always follow the manufacturers' instructions.

PARTS LIST for the Fridge Thermometer

Resistors

R1	3k3
R2	10k
RV1	10k min vertical preset
RV2	100k min vertical preset
TH1	Miniature bead thermistor with resistance 4k7 at 20 degrees approx. (Maplin FX21X.)

Capacitors

C1	470n
C2	220n

Semiconductor

IC1	78L05ACZ regulator
-----	--------------------

Miscellaneous

S1	Miniature double-pole centre-off toggle switch, biased in one "on" position - see text. (Maplin FH06G.)
ME1	Miniature analogue panel meter with 0-50uA movement and a resistance of 4.3 kilohms approx. (Maplin FM98G.)
PCB	materials; alkaline PP3 battery and connector; plastic box; two-section piece of PCB-mounting screw terminal block with 5mm pin spacing.

All components were obtained from Maplin.

More than

0 0 2 5 8 5

Electronic

DESIGNERS

know how to get their

PROTOTYPE PCBs

from their **usual manufacturer** for a

FRACTION of the **COST!**

DO YOU ?

STOP WASTING YOUR MONEY!

CALL NOW: 00353 61 701170

Beta
LAYOUT
PCB-POOL®

get
connected

pcbpool@betalayout.ie
<http://www.pcb-pool.com>



00353 61 701170
FAX 701164

'Hush' Noise Reduction Unit

This single-ended design by Robert Penfold uses dynamic lowpass filtering and downward expansion to give about 25dB of noise reduction.

Digital audio has rendered noise reduction systems of less relevance than they were a few years ago. However, it will be some time before all audio systems are digital, and even then there will be many millions of analogue recordings in our collections for years to come. This stereo noise reduction system is based on proprietary HUSH technology. The audio processing is single-ended, and is applied only during playback. A mixture of dynamic lowpass filtering and downward expansion is used, and together these two techniques give about 25 decibels of noise reduction. This is an unusually high level of reduction for a single-ended system, but the processing is subtle enough to remain unobtrusive. It is normally inaudible even to a trained ear. The harmonic distortion performance of the circuit is very good, with a typical THD figure of 0.02 percent (0.04 percent maximum).

Ups and downs

Of the two new noise reduction techniques used by this system, downward expansion is probably the easiest to understand. It is when the programme material is quiet that background noise tends to be most noticeable and objectionable. One way to reduce the noise is to reduce the volume on quiet passages. Simply turning back the volume control will give the required noise reduction, but it will also reduce the volume during crescendos. Downwards expansion gives the best of both worlds by maintaining high volume levels when the music is loud, but the required reduction in volume when music is quieter. **Figure 1** shows the expansion characteristic used in this application. At the 0dB level there is unity voltage gain through the unit, and even with the input at -20dB there are only minor losses through the circuit. At lower levels the losses become increasingly significant, reaching some 15dB when the input signal is at -70dB. This gives 15dB of downward expansion, which, as one would expect, contributes 15dB to the system's noise reduction.

There is an obvious problem with any form of volume expansion technique, which is simply that it alters the dynamic of levels of the original programme material. What were originally quite subtle changes in the dynamics could easily become exaggerated and

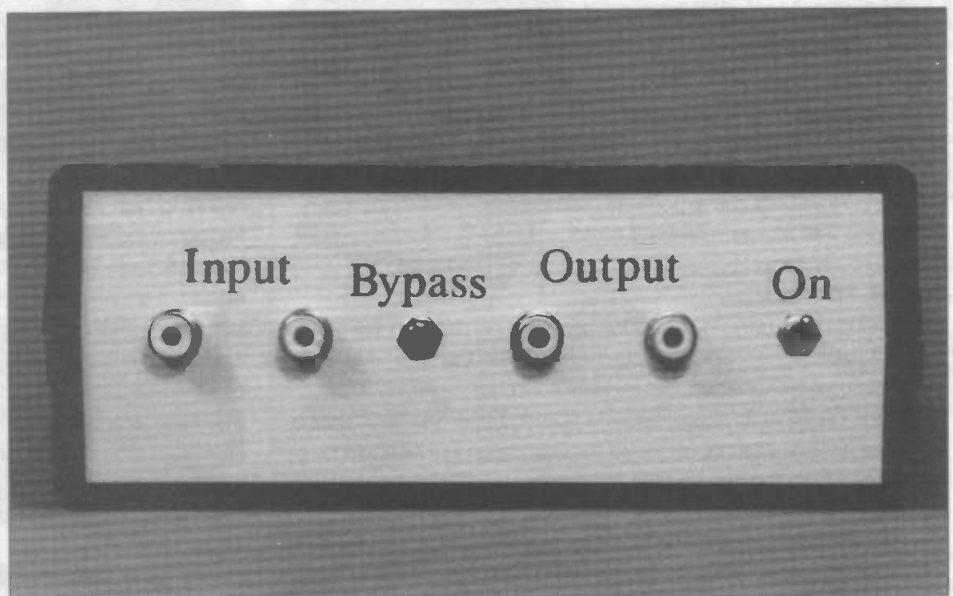

completely over the top. This will certainly happen if more than a modest amount of expansion is used, and 15dB probably represents the maximum amount that can be applied without any undue effects.

Although the dynamic levels are being altered, bear in mind that sound engineers often apply a certain amount of compression when music is recorded or broadcast. This becomes necessary when the

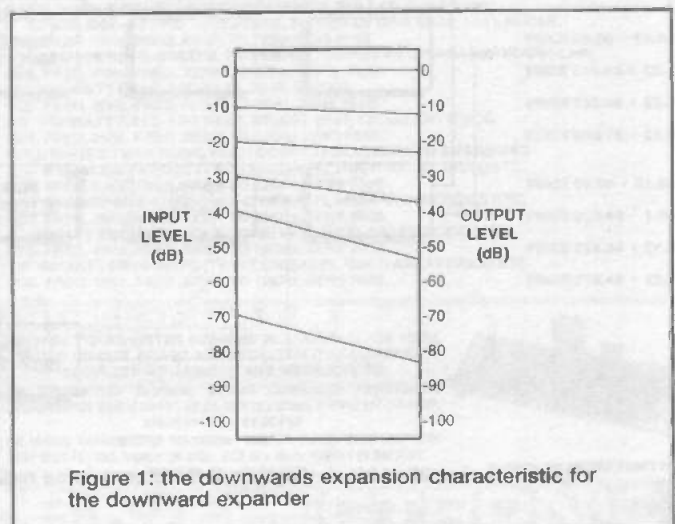
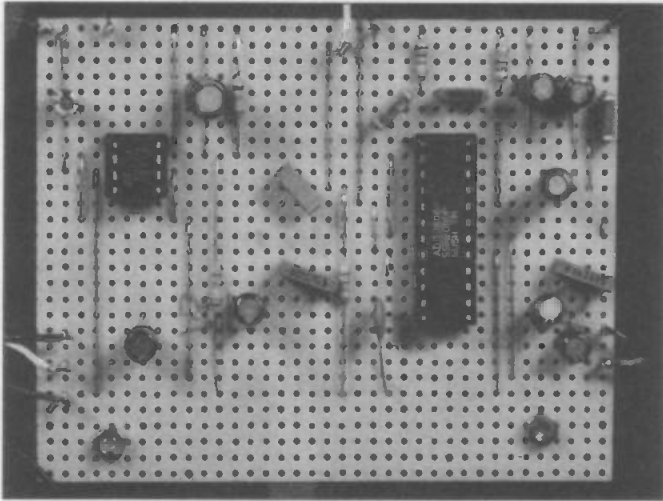

Figure 1: the downwards expansion characteristic for the downward expander



dynamic range of the programme material exceeds the "headroom" of the recording or broadcasting system. Low level signals have to be boosted slightly so that they do not drop down below the noise level. Downward expansion counteracts this process, and more or less restores the dynamic levels. The original dynamic levels can never be precisely restored, because the compression characteristic is unknown, and is unlikely to complement precisely the expansion characteristic used here. However, with some programme sources a small amount of volume expansion gives more realistic dynamics, and music that has more impact.

A cut above

Combating noise using dynamic lowpass filtering relies on the fact that high level signals tend to mask noise. When the volume is low, the noise is all too obvious, but at medium to high volumes it becomes inaudible. In many respects human hearing is very precise, but quiet sounds can not be heard through much louder sounds, especially where the two sounds are similar.

Most readers will probably be aware that applying lowpass filtering can reduce "hiss". This is easily demonstrated by backing off the treble control when listening to any programme material that has a high hiss level. The measured decrease in the noise might not be very great, but the perceived reduction is usually quite significant.

The difference in the perceived and measured noise levels is due to the way human hearing operates, particularly the fact that high frequencies tend to stand out. Signal-to-noise measurements are often weighted using a special filter, which massages the results so that they match our sensitivity to noise.

Simply applying some top-cut filtering will give an improved signal to noise ratio, but it will also reduce the treble content in the signal. The brass section, violins, and many instruments will sound rather dull and lacking in sparkle. Crescendos tend to sound "muddy" and lack impact. Dynamic lowpass filtering provides the noise reduction, but it minimises the amount of treble loss. With low signal levels the full amount of treble cut is applied, but as the signal level is increased, the cut-off frequency of the filter is raised. At the highest signal levels the cut-off frequency is made so high that the filtering is effectively removed, and audio frequency signals are left unaffected. There is no noise reduction at high signal levels, but this does not matter because the noise is not audible at these levels anyway. Maximum noise reduction is applied to low level signals, which is where the noise is most noticeable.

Although one might expect the varying amount of filtering would be all too obvious, in practice it is not noticeable provided a few conditions are met. It is apparently important to control the amount of filtering by altering the cut-off frequency. Using a fixed cut-off frequency and altering the severity of the filtering will not give "transparent" results. It is also essential that the filter responds more readily to high frequency sounds than it does to low and middle frequency signals, because the high frequency noise is masked more efficiently by high frequency signals than by lower frequency signals. If a strong low frequency sound was to lift the filtering, the increased noise would not be properly masked, and it would be clearly heard to increase, producing the aptly named "breathing" effect. Finally, the changes in the cut-off frequency of the filter must be implemented very rapidly so that the unit responds quickly to changes in the dynamic levels. If the filtering does not respond rapidly to sudden falls in volume, short bursts of hiss will be heard, again giving rise to "breathing" effects.

Over the threshold

For the system to work properly it is essential that the filtering and expansion start to operate at the correct threshold level. If the

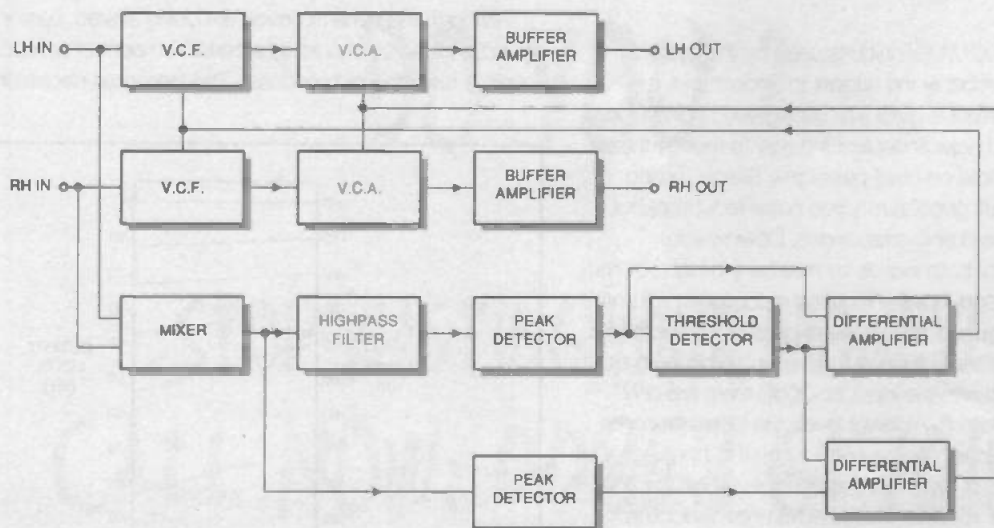

Figure 2: a simplified block diagram of the stereo noise reduction system

POWER AMPLIFIER MODULES-TURNABLES-DIMMERS-LOUDSPEAKERS-19 INCH STEREO RACK AMPLIFIERS

PRICES INCLUDE V.A.T. FREE DELIVERY FRIENDLY SERVICE* LARGE (A4) S.A.E. 60p STAMPED FOR CATALOGUE

OMP MOS-FET POWER AMPLIFIERS HIGH POWER, TWO CHANNEL 19 INCH RACK

THOUSANDS PURCHASED BY PROFESSIONAL USERS



THE RENOWNED MXF SERIES OF POWER AMPLIFIERS
FOUR MODELS:- MXF200 (100W + 100W) MXF400 (200W + 200W)
MXF600 (300W + 300W) MXF900 (450W + 450W)
ALL POWER RATINGS R.M.S. INTO 4 OHMS, BOTH CHANNELS DRIVEN

FEATURES: ★ Independent power supplies with two toroidal transformers ★ Twin L.E.D. Vu meters ★ Level controls ★ Illuminated on/off switch ★ XLR connectors ★ Standard 775mV inputs ★ Open and short circuit proof ★ Latest Mos-Fets for stress free power delivery into virtually any load ★ High slew rate ★ Very low distortion ★ Aluminium cases ★ MXF600 & MXF900 fan cooled with D.C. loudspeaker and thermal protection.

USED THE WORLD OVER IN CLUBS, PUBS, CINEMAS, DISCOS ETC.

SIZES:- MXF200 W19"xH3 1/2" (2U)xD11"
 MXF400 W19"xH5 1/2" (3U)xD12"
 MXF600 W19"xH5 1/2" (3U)xD13"
 MXF900 W19"xH5 1/2" (3U)xD14 1/2"

PRICES:- MXF200 £175.00 MXF400 £233.85
 MXF600 £329.00 MXF900 £449.15
 SPECIALIST CARRIER DEL. £12.50 EACH

OMP X03 STEREO 3-WAY ACTIVE CROSS-OVER



Advanced 3-Way Stereo Active Cross-Over, housed in a 19" x 1U case. Each channel has three level controls: bass, mid & top. The removable front fascia allows access to the programmable DIL switches to adjust the cross-over frequency: Bass-Mid 250/500/800Hz, Mid-Top 1.8/3/5KHz, all at 24dB per octave. Bass input switches on each bass channel. Nominal 775mV input/output. Fully compatible with OMP rack amplifier and modules.

Price £117.44 + £5.00 P&P

STEREO DISCO MIXER SDJ3400SE ★ ECHO & SOUND EFFECTS★

STEREO DISCO MIXER with 2 x 7 band L & R graphic equalisers with bar graph LED Vu meters. **MANY OUTSTANDING FEATURES:-** including Echo with repeat & speed control, DJ Mix with talk-over switch, 6 Channels with individual faders plus cross fade, Cue Headphone Monitor, 8 Sound Effects. Useful combination of the following inputs: 3 turntables (mag), 3 mics, 8 Line for CD, Tape, Video etc.



SIZE: 482 x 240 x 120mm

Price £144.99 + £5.00 P&P

PIEZO ELECTRIC TWEETERS - MOTOROLA

Join the Piezo revolution! The low dynamic mass (no voice coil) of a Piezo tweeter produces an improved transient response with a lower distortion level than ordinary dynamic tweeters. As a crossover is not required these units can be added to existing speaker systems of up to 100 watts (more if two are put in series). **FREE EXPLANATORY LEAFLETS ARE SUPPLIED WITH EACH TWEETER.**

TYPE 'A' (KSN1036A) 3" round with protective wire mesh. Ideal for bookshelf and medium sized Hi-Fi speakers. Price £4.90 + 50p P&P.
TYPE 'B' (KSN1005A) 3 1/2" super horn for general purpose speakers, disco and P.A. systems etc. Price £5.99 + 50p P&P.
TYPE 'C' (KSN1016A) 2" x 5" wide dispersion horn for quality Hi-Fi systems and quality discos etc. Price £6.99 + 50p P&P.
TYPE 'D' (KSN1025A) 2" x 6" wide dispersion horn. Upper frequency response retained extending down to mid-range (2KHz). Suitable for high quality Hi-Fi systems and quality discos. Price £5.99 + 50p P&P.
TYPE 'E' (KSN1038A) 3 1/2" horn tweeter with attractive silver finish trim. Suitable for Hi-Fi monitor systems etc. Price £5.99 + 50p P&P.
LEVEL CONTROL Combines, on a recessed mounting plate, level control and cabinet input jack socket. 85x85mm. Price £4.10 + 50p P&P.

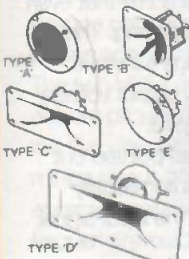

OMP MOS-FET POWER AMPLIFIER MODULES

SUPPLIED READY BUILT AND TESTED.

These modules now enjoy a world-wide reputation for quality, reliability and performance at a realistic price. Four models are available to suit the needs of the professional and hobby market (i.e. Industry, Leisure, Instrumental and Hi-Fi etc.). When comparing prices, NOTE that all models include toroidal power supply, integral heat sink, glass fibre P.C.B. and drive circuits to power a compatible Vu meter. All models are open and short circuit proof.

THOUSANDS OF MODULES PURCHASED BY PROFESSIONAL USERS



OMP/MF 100 Mos-Fet Output power 110 watts R.M.S. into 4 ohms, frequency response 1Hz - 100KHz -3dB, Damping Factor >300, Slew Rate 45V/uS, T.H.D. typical 0.002%, Input Sensitivity 500mV, S.N.R. -110 dB. Size 300 x 123 x 60mm. PRICE £40.85 + £3.50 P&P



OMP/MF 200 Mos-Fet Output power 200 watts R.M.S. into 4 ohms, frequency response 1Hz - 100KHz -3dB, Damping Factor >300, Slew Rate 50V/uS, T.H.D. typical 0.001%, Input Sensitivity 500mV, S.N.R. -110 dB. Size 300 x 155 x 100mm. PRICE £64.35 + £4.00 P&P



OMP/MF 300 Mos-Fet Output power 300 watts R.M.S. into 4 ohms, frequency response 1Hz - 100KHz -3dB, Damping Factor >300, Slew Rate 60V/uS, T.H.D. typical 0.001%, Input Sensitivity 500mV, S.N.R. -110 dB. Size 330 x 175 x 100mm. PRICE £81.75 + £5.00 P&P



OMP/MF 450 Mos-Fet Output power 450 watts R.M.S. into 4 ohms, frequency response 1Hz - 100KHz -3dB, Damping Factor >300, Slew Rate 75V/uS, T.H.D. typical 0.001%, Input Sensitivity 500mV, S.N.R. -110 dB, Fan Cooled, D.C. Loudspeaker Protection, 2 Second Anti-Thump Delay. Size 385 x 210 x 105mm. PRICE £132.85 + £5.00 P&P



OMP/MF 1000 Mos-Fet Output power 1000 watts R.M.S. into 2 ohms, 725 watts R.M.S. into 4 ohms, frequency response 1Hz - 100KHz -3dB, Damping Factor >300, Slew Rate 75V/uS, T.H.D. typical 0.002%, Input Sensitivity 500mV, S.N.R. -110 dB, Fan Cooled, D.C. Loudspeaker Protection, 2 Second Anti-Thump Delay. Size 422 x 300 x 125mm. PRICE £259.00 + £12.00 P&P

NOTE: MOS-FET MODULES ARE AVAILABLE IN TWO VERSIONS: STANDARD - INPUT SENS 500mV, BAND WIDTH 100KHz. PEC (PROFESSIONAL EQUIPMENT COMPATIBLE) - INPUT SENS 775mV, BAND WIDTH 50KHz. ORDER STANDARD OR PEC.

LOUDSPEAKERS

LARGE SELECTION OF SPECIALIST LOUDSPEAKERS AVAILABLE, INCLUDING CABINET FITTINGS, SPEAKER GRILLES, CROSS-OVERS AND HIGH POWER, HIGH FREQUENCY BULLETS AND HORNS, LARGE (A4) S.A.E. (60p STAMPED) FOR COMPLETE LIST.

McKenzie and Fane Loudspeakers are also available.

EMINENCE:- INSTRUMENTS P.A. DISCO, ETC

ALL EMINENCE UNITS 8 OHMS IMPEDANCE
5" 100 WATT R.M.S. ME8-100 GEN. PURPOSE, LEAD GUITAR, EXCELLENT MID, DISCO. RES. FREQ. 72Hz, FREQ. RESP. TO 4KHz, SENS 97dB. PRICE £32.71 + £2.00 P&P
10" 100 WATT R.M.S. ME10-100 GUITAR, VOCAL, KEYBOARD, DISCO, EXCELLENT MID. RES. FREQ. 71Hz, FREQ. RESP. TO 7KHz, SENS 97dB. PRICE £33.74 + £2.50 P&P
12" 200 WATT R.M.S. ME12-200 GUITAR, KEYB'D, DISCO, VOCAL, EXCELLENT HIGH POWER MID. RES. FREQ. 65Hz, FREQ. RESP. TO 3.5KHz, SENS 99dB. PRICE £43.47 + £2.50 P&P
12" 200 WATT R.M.S. ME12-100LE GEN. PURPOSE, LEAD GUITAR, DISCO, STAGE MONITOR. RES. FREQ. 49Hz, FREQ. RESP. TO 6KHz, SENS 100dB. PRICE £35.64 + £3.50 P&P
12" 100 WATT R.M.S. ME12-100LT (TWIN CONE) WIDE RESPONSE. P.A., VOCAL, STAGE MONITOR. RES. FREQ. 42Hz, FREQ. RESP. TO 10KHz, SENS 98dB. PRICE £36.87 + £3.50 P&P
12" 200 WATT R.M.S. ME12-200 GEN. PURPOSE, GUITAR, DISCO, VOCAL, EXCELLENT MID. RES. FREQ. 40Hz, FREQ. RESP. TO 6KHz, SENS 98dB. PRICE £46.71 + £3.50 P&P
15" 300 WATT R.M.S. ME15-300CP HIGH POWER BASS. LEAD GUITAR, KEYBOARD, DISCO ETC. RES. FREQ. 47Hz, FREQ. RESP. TO 5KHz, SENS 103dB. PRICE £70.19 + £3.50 P&P
15" 200 WATT R.M.S. ME15-200 GEN. PURPOSE BASS, INCLUDING BASS GUITAR. RES. FREQ. 46Hz, FREQ. RESP. TO 5KHz, SENS 99dB. PRICE £50.72 + £4.00 P&P
15" 300 WATT R.M.S. ME15-300 HIGH POWER BASS, INCLUDING BASS GUITAR. RES. FREQ. 39Hz, FREQ. RESP. TO 3KHz, SENS 103dB. PRICE £73.34 + £4.00 P&P

EARBENDERS- HI-FI, DISCO, IN-CAR ETC

ALL EARBENDER UNITS 8 OHMS (Except EB8-50 & EB10-50 which are dual impedance tapped @ 4 & 8 ohms)
BASS, SINGLE CONE, HIGH COMPLIANCE, ROLLED SURROUND
5" 50watt EB8-50 DUAL IMPEDANCE, TAPPED 4/8 OHM BASS, HI-FI, IN-CAR. RES. FREQ. 40Hz, FREQ. RESP. TO 7KHz, SENS 97dB. PRICE £8.90 + £2.00 P&P
10" 50WATT EB10-50 DUAL IMPEDANCE, TAPPED 4/8 OHM BASS, HI-FI, IN-CAR. RES. FREQ. 40Hz, FREQ. RESP. TO 5KHz, SENS. 99dB. PRICE £13.65 + £2.50 P&P
10" 100WATT EB10-100 BASS, HI-FI, STUDIO. RES. FREQ. 35Hz, FREQ. RESP. TO 3KHz, SENS 96dB. PRICE £30.39 + £3.50 P&P
12" 100WATT EB12-100 BASS, STUDIO, HI-FI, EXCELLENT DISCO. RES. FREQ. 26Hz, FREQ. RESP. TO 3 KHz, SENS 93dB. PRICE £42.42 + £3.50 P&P
FULL RANGE TWIN CONE, HIGH COMPLIANCE, ROLLED SURROUND
5 1/2" 60WATT EB5-60TC (TWIN CONE) HI-FI, MULTI-ARRAY DISCO ETC. RES. FREQ. 63Hz, FREQ. RESP. TO 20KHz, SENS 92dB. PRICE £9.99 + £1.50 P&P
6 1/2" 60WATT EB6-60TC (TWIN CONE) HI-FI, MULTI-ARRAY DISCO ETC. RES. FREQ. 38Hz, FREQ. RESP. TO 20KHz, SENS 94dB. PRICE £10.99 + 1.50 P&P
8" 60WATT EB8-60TC (TWIN CONE) HI-FI, MULTI-ARRAY DISCO ETC. RES. FREQ. 40Hz, FREQ. RESP. TO 18KHz, SENS 99dB. PRICE £12.99 + £1.50 P&P
10" 60WATT EB10-60TC (TWIN CONE) HI-FI, MULTI ARRAY DISCO ETC. RES. FREQ. 35Hz, FREQ. RESP. TO 12KHz, SENS 98dB. PRICE £16.49 + £2.00 P&P

IBT FLIGHT CASED LOUDSPEAKERS

A new range of quality loudspeakers, designed to take advantage of the latest speaker technology and enclosure designs. Both models utilize studio quality 12" cast aluminium loudspeakers with factory fitted grilles, wide dispersion constant directivity horns, extruded aluminium corner protection and steel ball corners, complimented with heavy duty black covering. The enclosures are fitted as standard with top hats for optional loudspeaker stands.



POWER RATINGS QUOTED IN WATTS RMS FOR EACH CABINET
FREQUENCY RESPONSE FULL RANGE 45Hz - 20KHz

IBTFC 12-100WATTS (100dB) PRICE £159.00 PER PAIR

IBTFC 12-200WATTS (100dB) PRICE £178.00 PER PAIR

SPECIALIST CARRIER DEL. £12.50 PER PAIR

OPTIONAL STANDS PRICE PER PAIR £49.00
 Delivery £6.00 per pair

IN-CAR STEREO BOOSTER AMPS



PRICES: 150W £49.99 250W £99.99
400W £109.95 P&P £2.00 EACH

THREE SUPERB HIGH POWER CAR STEREO BOOSTER AMPLIFIERS

150 WATTS (75 + 75) Stereo, 150W Bridged Mono
250 WATTS (125 + 125) Stereo, 250W Bridged Mono
400 WATTS (200 + 200) Stereo, 400W Bridged Mono
ALL FEATURES INTO 4 OHMS
Features:
 ★ Stereo, bridged mono ★ Choice of high & low level inputs ★ L & R level controls ★ Remote on-off ★ Speaker & thermal protection.

TRANSMITTER HOBBY KIT

PROVEN TRANSMITTER DESIGNS INCLUDING GLASS FIBRE PRINTED CIRCUIT BOARD AND HIGH QUALITY COMPONENTS COMPLETE WITH CIRCUIT AND INSTRUCTIONS
3W TRANSMITTER 90-100MHz, VARICAP CONTROLLED PROFESSIONAL PERFORMANCE. RANGE UP TO 3 MILES, SIZE 38 x 123mm. SUPPLY 12V @ 0.5AMP. PRICE £14.85 + £1.00 P&P
FM MICRO TRANSMITTER 100-108MHz, VARICAP TUNED. COMPLETE WITH VERY SENS FET MIC, RANGE 100-300m, SIZE 56 x 46mm. SUPPLY 9V BATTERY. PRICE £8.90 + £1.00 P&P



PHOTO: 3W FM TRANSMITTER

POSTAL CHARGES PER ORDER £1.00 MINIMUM. OFFICIAL ORDERS FROM SCHOOLS, COLLEGES, GOVT. SOCIETIES, ETC. PRICES INCLUSIVE OF V.A.T. SALES COUNTER, VISA AND ACCESS ACCEPTED BY POST, PHONE OR FAX.



B.K. ELECTRONICS

UNITS 1 & 5 COMET WAY, SOUTHOEND ON-SEA.

ESSEX SS2 6TR

tel 01702 527572 Fax 01702 420243

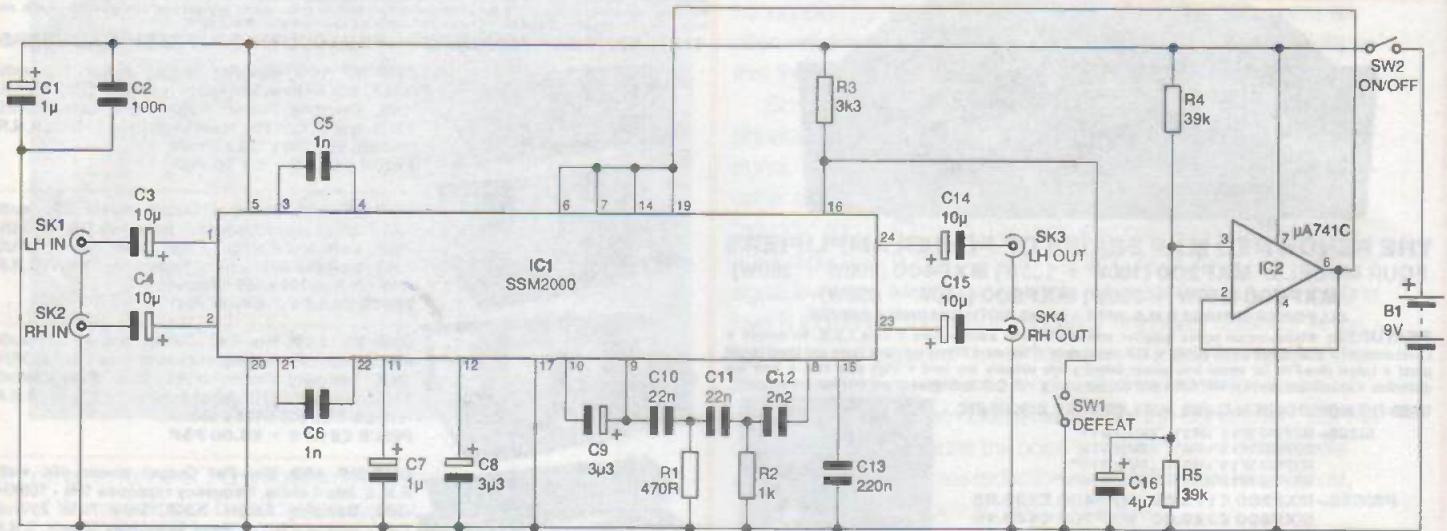

Figure 3: the circuit diagram of the noise reduction unit. IC2 operates as a supply splitter

sensitivity is too low, the full amount of expansion will not be obtained, and the filtering will not be completely lifted at high volume. If the sensitivity is set too high the full expansion will be produced over a relatively small dynamic range, and the filtering will be lifted at middle volumes, either giving less than the maximum noise reduction, or else making the changes in dynamic level and filtering fairly obvious. Either way results leave a lot to be desired, and the programme material would probably sound better without any processing!

Most noise reduction systems of this type require you to select the optimum threshold level carefully, and where necessary readjust the threshold level to suit different programme material. For example, with very noisy signals you may need to use a high threshold level, even if this means that the full amount of expansion is not obtained, and the lowpass filtering is never fully lifted. Otherwise there can be problems with breathing effects, and the action of the system can become apparent to the listener. This unit does not require manual setting of the threshold level, because the circuit includes stages that analyse the input signal and set the most appropriate threshold level. This reduces the play value somewhat, but is more convenient as you can switch from one source to another without having to worry about any manual adjustments to the unit. It automatically adjusts itself to suit the signal source, whether that source is a slightly noisy FM receiver or an old and hissy cassette tape.

System operation

A noise reduction system of this type can either process stereo signals using separate circuits for each channel, or the filter and expander circuits can be controlled by a sort of averaged signal derived from both channels. The discrete approach is probably the more common one, but in this case the two stereo channels are controlled in unison. Each method has its advantages and drawbacks, but in practice both systems can be made to work well. Figure 2 shows the block diagram for this noise reduction system. This actually shows a slightly simplified version of the system, but it includes all the main circuit blocks.

The two stereo channels are fed through identical signal processing stages, each consisting of a voltage controlled filter

(VCF), a voltage controlled attenuator (VCA), and an output buffer stage. As one would expect, the VCF provides the dynamic filtering and the VCA produces the downward expansion. The rest of the unit supplies these stages with a control voltage that provides the required changes in the filtering and attenuation. A mixer stage combines the two input signals, and it is from this signal that the both the VCA and the VCF control voltages are derived. It is probably best to start with the generation of the VCF control voltage. This is produced by first feeding the signal through a highpass filter. As explained previously, the cut-off frequency of the filter must respond to the high frequency components in the input signal, and largely ignore low frequency signals that will not mask the noise very well. This three-stage highpass filter ensures that even the strongest of low frequency signals will not lift the filtering. The filtered signal is fed to a peak level detector. This stage full-wave rectifies the input signal and produces a positive DC output voltage that is equal to the peak (positive or negative) input level. This voltage could be used to control the VCF but, as pointed out previously, the circuit has a threshold detector that automatically adjusts the sensitivity of the side-chain circuit to suit the input signal.

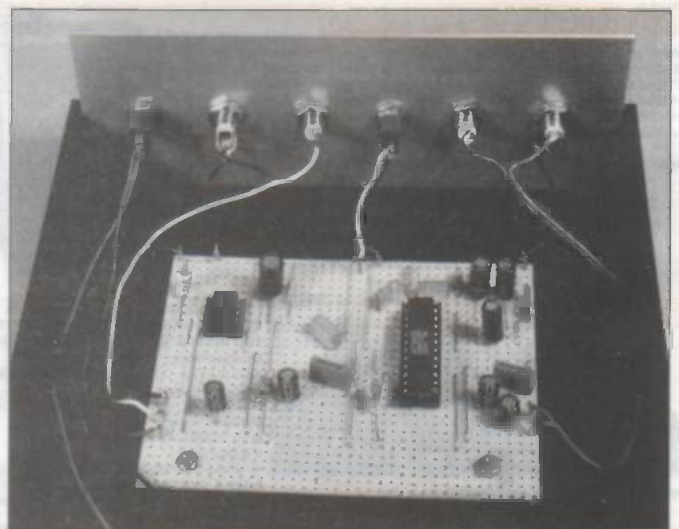

The primary purpose of the threshold detector circuit is to discover the noise level. The input amplitude needed to provide full expansion and lift the filtering is then scaled to this level. This circuit seems to be quite involved, but it is basically just detecting the minimum input level, which occurs during gaps in the main signal when only noise is present. It is high frequency "hiss" type noise that is of primary importance here, and it is for this reason that the threshold detector is driven via the highpass filter circuit. Feeding the outputs of the threshold detector and the peak detector to a differential amplifier produces the control voltage for the VCF. With a high output potential from the threshold detector, the output from the peak detector must also be high before a positive output signal is obtained from the differential amplifier and the cut-off frequency of the filter is increased.

Basically the same method of operation is used for the side-chain that drives the control input of the VCA. The only difference is that no highpass filtering is used ahead of the peak detector in the VCA section of the circuit. The threshold detector is common to the VCF and VCA control circuits.

Circuit operation

Figure 3 shows the full circuit diagram for the stereo noise reduction unit. The circuit is extremely simple due to the use of a specialised integrated circuit, the SSM2000 from Analogue Devices. The only other semiconductor in the circuit is IC2, which is an operational amplifier used as a supply splitter. The half supply potential produced at its output provides a pseudo central supply rail, which is used to bias some of the internal circuits of IC1. The two VCFs are single pole (6dB per octave) circuits that have C5 and C6 as the filter capacitors. These set the minimum cut-off frequency at approximately 3kHz. A lower cut-off frequency would give greater noise reduction, but the affect on the wanted signal would be too great. With strong input signals the cut-off frequency is taken above the 20kHz upper limit of the audio range.

Pin 9 is the output of the mixer stage in the side-chain, and this feeds the peak detector for the VCA via coupling capacitor C9. The VCFs peak detector is driven via a passive three-stage highpass filter comprising C10 - R1, C11 - R2, and C12 plus the input impedance of IC1. C7 and C8 are the smoothing capacitors in the VCF and VCA peak detectors. C13 is part of the automatic threshold detection circuit. There are several pins of IC1 which

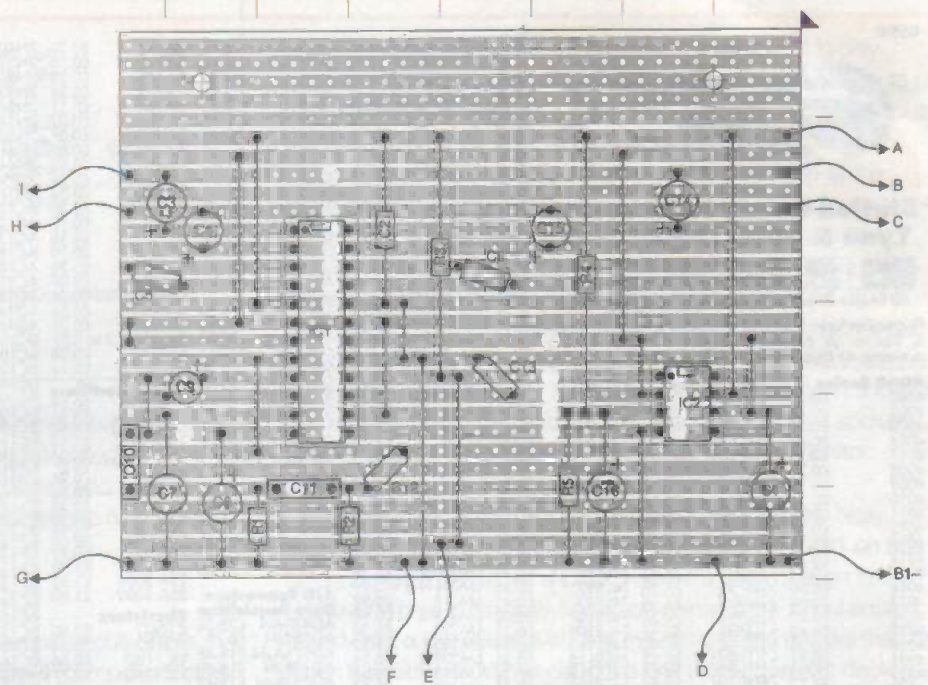

Figure 4: the component layout for the "Hush". The board has 37 holes by 29 strips

serve no purpose in normal use, but the control input at pin 16 is very useful. With SW1 closed this input is taken low, and the unit then functions normally. When SW1 is open, pin 16 of IC1 is taken high by R3, which removes both the expansion and the dynamic filtering. This provides an easy way of switching out the noise reduction.

The current consumption of the circuit is about 10 to 12 milliamps from a 9 to 12 volt supply. A small (PP3) size nine volt battery is just about adequate to power the unit, but a higher capacity battery would be preferable if the unit will receive a great deal of use. Obviously a 12-volt mains power supply unit can be used if preferred, but the supply must have a low output noise level.

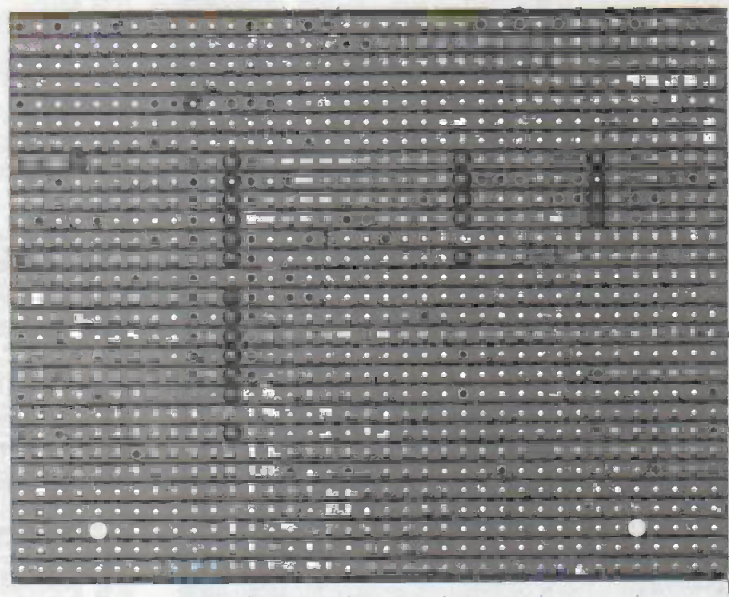

Figure 5: the reverse of the stripboard, with cutaways



Station Road, Cullercoats, Tyne & Wear, NE30 4PQ



All Major Credit cards Accepted. Prices Exclude Vat @17.5%. Add £1.25 carriage & Vat to all orders. Cheques / Postal orders payable to ESR Electronic Components.

See Next / Last Months Ad. for COMPONENT ACCESSORIES

Table listing various electronic components such as 4000 Series, 74HC Series, and 74LS Series with their respective part numbers and prices.

Table listing electronic components including A/D Converters, Voltage Regulators, Diodes, and Linear ICs with their respective part numbers and prices.

Table listing electronic components including Bridge Rectifiers, Transistors, PIC Micros, and Electrolytic Radial capacitors with their respective part numbers and prices.

Table listing electronic components including Electrolytic Axial capacitors, Resistors, and Potentiometers with their respective part numbers and prices.

Tel: 0191 2514363 Fax: 0191 252296 Email: sales@esr.co.uk http://www.esr.co.uk

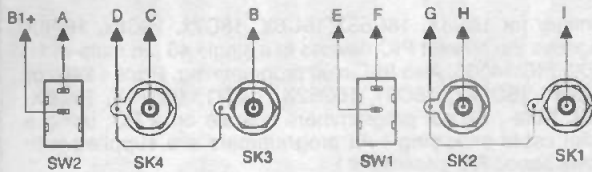

Figure 6: the hard-wiring of the offboard components: use this in conjunction with figure 4

This makes it necessary to use a regulated supply, even though the circuit does not actually need a well-regulated supply. The circuit has been designed to be very tolerant and self-adjusting to any reasonable input signal level around normal hi-fi line level.

Construction

Stripboard construction is well suited to a simple circuit of this type, and a suitable layout is shown in **figure 4** (component side) and **figure 5** (copper side). The board measures 37 holes by 29 copper strips. Construction of the circuit board follows along the normal lines and offers little out of the ordinary. The SMM2000 is not a MOS device, but as it is a fairly expensive component it should be fitted in a holder as a matter of course. It has a rather unusual encapsulation, which is a 24-way DIL plastic type having 0.3-inch (7.62 millimetre) row spacing. 24-pin integrated circuits exist in at least **three** different forms, with row spacings of 0.3, 0.4 and 0.6 inches. In most component catalogues only the 0.6 inch version of 24 pin DIL holders are listed. The easiest solution is to fit ordinary 16 and 8 pin holders on the board, butted together to effectively form a 24-pin holder. This works well provided the holders are of the same make and type. This method is unlikely to give usable results if the holders are of different heights.

The component layout is designed to suit plastic foil capacitors having 7.5mm or 0.3 inch lead spacing, and it could be difficult to fit other types into the layout. The electrolytic capacitors must be high quality components such as aluminium electrolytics. Tantalum bead capacitors are also suitable. Be careful not to omit any of the link-wires, including the small link just below C5. The longer link-wires must either be pulled taut, or fitted with PVC sleeving to ensure that there are no accidental short circuits.

Any medium-sized case should comfortably accommodate this project. As the circuit never has more than unity voltage gain there are no problems with stray feedback, and "anything goes" when designing the general layout of the unit. Phono sockets are specified for the input and output connectors, and these match the sockets used on most domestic hi-fi and video equipment. Obviously these can be changed to any type of audio connector that fits in better with your particular set-up. The sockets are mounted on the front panel of the prototype, but it would probably be more practical to fit them on the rear panel.

The hard wiring is very simple and is shown in **figure 6**. This is used in conjunction with **figure 4** (ie point "A" in **figure 4** connects to point "A" in **figure 6**). As the circuit only handles high level signals, it is not particularly sensitive to stray pickup of hum and other electrical noise, and it is not essential to use any screened leads. However, it must be wired into the hi-fi system (or whatever) using good quality screened leads.

Testing and use

When using this unit, remember that it is a single-ended noise reduction unit only used during playback. It connects between the

signal source and the input of the power amplifier. If it is only required with (say) a cassette deck, simply connect the outputs of the deck to the inputs of the noise reduction unit, and the outputs of the noise reduction unit to the inputs of the power amplifier. Matters are more involved if the unit is to be used with all the signal sources. It should then connect between the outputs of the preamplifier and the inputs of the power amplifier. This is easy enough if the pre- and power amplifiers are separate units, but might not be possible if they are combined into one unit. Some combination pre- and power amplifiers have the necessary input and output sockets marked as such. Many others have them in the form of a tape monitor facility that can be switched in and out. Connecting the unit between the tape input and output sockets enables it to be switched in and out using the tape monitor switch.

The effect of the unit should be very obvious on any hissy signal that covers a wide dynamic range. Switching SW1 on and off during quiet passages should produce a large change in the hiss level. There is relatively little to be gained if the signal source already has a low noise level, and the effect of the unit will then be much less obvious. When using the unit with a cassette deck, it is best to switch off the Dolby B decoding of the deck when playing Dolby encoded cassettes. The dynamic filtering of the noise reduction unit will not provide highly accurate decoding, but it provides a reasonable imitation of a Dolby B decoder. In the chip manufacturer's words, it "effectively decodes Dolby B encoded sources." Using the unit in addition to Dolby B decoding provides a great deal of noise reduction, but the sound might be rather muddy at low signal levels, and the double dose of dynamic filtering may produce very apparent changes in the treble content of the reproduced sound.

PARTS LIST for the Stereo Noise Reduction Unit

Resistors

(All 0.25 watt 5 percent carbon film)

R1	470R
R2	1k
R3	3k3
R4, R5	39k

Capacitors

C1, C7	1u 50V radial elect
C3, C4, C14, C15	10u 25V radial elect
C5, C6	1n polyester
C8, C9	3u3 50V radial elect
C10, C11	22n polyester
C12	2n2 polyester
C13	220n polyester
C16	4u7 50V radial elect

Semiconductors

IC1	SSM2000
IC2	uA741C

Miscellaneous

SK1 - 4	Phono sockets
SW1, SW2	SPST miniature toggle
B1	9 volt (see text)
Plastic or metal case, 0.1-inch pitch stripboard having 37 holes by 29 copper strips, 8-pin holder, 24-pin dil holder (see text), battery connector, wire, solder, etc.	

Microchip PIC and Motorola HC11 based development Tools

PIC Microcontroller Programmers Original - This is our original programmer for 16C5X, 16C55X, 16C6X, 16C7x, 16C8x, 16F8X devices. Price : £40 for the kit, or £50 ready built. **Serial** - This programmer programs the newest PIC devices in a single 40 pin multi-width ZIF socket. Will program: 16C55X, 16C6X, 16C7X, 16C8x, 16F8X, 12C508, 12C509, PIC 14000. Also In-Circuit programming. Price : £40 for the kit, or £50 ready built. **Introductory** - Will program 8 pin and 18 pin devices : 16C55X, 16C61, 16C62X, 16C71, 16C71X, 16C8X, 16F8X, 12C508, and 12C509. Price £22 for the kit (not available ready built). Note : All our programmers operate on a PC, using a standard RS232 serial interface (COM1, 2, 3, or 4). No hard to handle parallel cable swapping ! All programmers are supplied with instructions, Windows programming software, MPASM, MPSIM and PICDE (Windows based PIC assembler)

PIC or HC11 Windows Based Development: PICDESIM and HC11DE allows assembly and simulation of your PIC or HC11 projects in one Windows program. Incorporate multiple files, view help file information directly from the code, edit within project, build and track errors directly in the source, then simulate. Simulator allows 3 breakpoint types, follow code in the source window, set breakpoints directly in code. Run programs, or single step, or step over subroutines. Track variable values and trace for display on the Trace Analyser. Input stimuli include clocks, direct values and asynchronous serial data. Profile your program - examine frequently called routines which are timed and use the information to optimise out bottle necks. PIC Version Simulates up to 50 times faster than MPSIM ! NEW ! - 32 bit version allows full use of Windows '95/NT4.0 facilities. Cost £30.00, or £25.00 for existing and new purchasers of any of our programmers. Please specify Windows 3.1, or Windows '95 (32 bit) and either PIC or HC11 version

PIC BASIC FED's PIC BASIC products - straightforward, capable, powerful, rapid development. Operating in a Windows Development Environment our modules need no assembler or UV eraser to program your PIC's, and operate from a serial link to your PC. The 16C74 module features - 8k EEPROM, up to 2000 lines of BASIC, 27 lines of programmable I/O, 8 A/D inputs, Interrupt driven serial RS232 interface, Peripheral I2C bus interface, LCD display driver routines, up to 178 bytes for variables and stack, extendible with optional external RAM and all the standard 16C74 features. Ask about the 16C57 version.

Compiler - The FED PIC BASIC compiler for the 16C74. It produces hex code to program your 16C74 directly with no need for external EEPROM. Compatible with the EEPROM versions of PIC 16C74 BASIC modules - develop on an EEPROM based module then compile and program your PIC chips directly.

16C57 Module Kit (8k EEPROM, 4MHz) £25.00, Pre-built £30.00 16C57 Module Kit (8k EEPROM, 10MHz) £31.00, Pre-built £37.00
16C74 Module Kit (8k EEPROM, 4MHz) £35.00, Pre-built £42.00 16C74 Module Kit (8k EEPROM, 20MHz) £40.00, Pre-built £46.00
16C84 chip programmed with BASIC - £25.00 Compiler - £60.00, or £50.00 when ordered with a module

PIC and HC11 devices

PIC16C74/JW	Erasable	20MHz	£24.00	PIC16C558			£5.00
PIC16C74-04P	OTP	4MHz	£8.00	PIC16C74-20P	OTP	20MHz	£11.00
PIC16C57-04P	OTP	4MHz	£5.00	PIC16C57-10P	OTP	10MHz	£6.00
PIC16C84-04P		4MHz	£6.00	PIC16C84-10P		10MHz	£8.00
PIC16F84-04P		4MHz	£6.00	PIC12C508-04P	OTP	4MHz	£2.20
PIC14000-04P	OTP	4MHz	£10.00	PIC14000/JW		Erasable	£23.00
PIC12C508-04P	OTP	4MHz	£2.70	Motorola MC68HC811E2		Ring for details	

Ask about other chips!



Forest Electronic Developments

10 Holmhurst Avenue, Christchurch, Dorset, BH23 5PQ 01425-270191 (Voice/Fax)

<http://www.lakewood.win-uk.net/fed.htm> e-mail: fed@lakewood.win-uk.net Prices are inclusive, please add £3.00 for P&P and handling to each order.

Cheques/POs payable to Forest Electronic Developments, or phone with credit card details. Serial Cables - £7.50



Electronic CAD

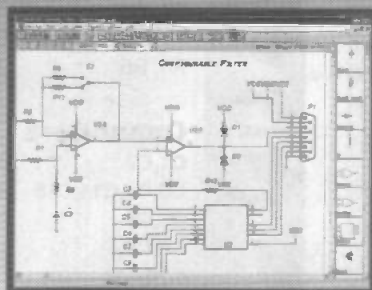

WINDRAFT
Schematics

IVEX™
DESIGN
INTERNATIONAL

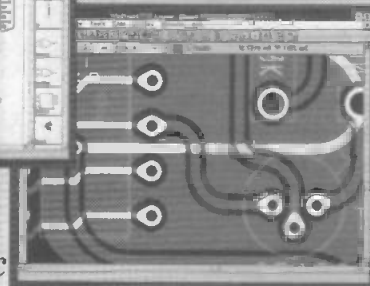

WINBOARD
PCB Layout

cadence
SPECCTRA
Autorouter

The complete,
powerful schematic
and PCB layout
tools for Windows.

① Design your schematic with WinDraft...

- Choose from over 10,000 parts in WinDraft's complete library of components.
- All the utilities you need are included in the package from an Electrical Rules Checker to netlist output to printing and plotting outputs.
- Cut and Paste into other Windows applications such as Microsoft Word. Makes it easy to document your projects!

② Create the artwork for the PCB with WinBoard...

- Quickly route boards on up to 16 layers.
- Use SMD or through-hole components — or mix them for maximum flexibility.
- Unique pad-stack editor can create pads of virtually any size or shape.
- Rotate components in 0.01° increments.

③ Create a Gerber photoplot, NC Drill, pick and place, and other manufacturing outputs!

Tel 0181 926 1161

The PC Solution, 2a High Road Leyton, London, E15 2BP. Fax 0181 926 1160 <http://www.thepcsol.demon.co.uk>

ELECTRONICS TODAY INTERNATIONAL

A UHF MODEL RADIO CONTROL SYSTEM

UHF radio can be more effective for model control than the old 27MHz band ever was. Geoff Pike G10GDP decided to try it from scratch and was pleased with the results



About a year ago, I realised that making a uhf radio control system should not pose any major problems, given the ease of component availability and new techniques in construction.

I made a start, and initially no unforeseen problems were encountered. A first prototype was made and tested in about three months. The design as presented here took a bit longer to finalise, and should not be regarded as the ultimate development of the design, but rather as a basis for others to improve.

A constructor with average experience and some knowledge of radio control should be able to get this going without too many problems, but this project does require the use of an oscilloscope, digital frequency meter, and a diode probe to measure rf. Those of you who are not into uhf radio may be a little puzzled by the things that are done at these frequencies, however, as long as you do it the way it's described, then you should have minimum problems with it. The system is suitable for all forms of model, land, sea, and air. It will drive normal servos, and the only departures from vhf radio control are the particular attention needed to the

installation of the receiver antenna, and the non-standard use of a 9.6-volt receiver (Rx) nicad pack. This is because of the demands made by the Rx local oscillator (Lo). However this in practice will not cause any great weight problems in most models.

A model radio control licence no longer exists. However, the uhf allocation is always changing with respect to power. The current situation, which can be confirmed by ringing the Radiocommunications Agency (RA) low power section on 0171 215 2150 ext. 2058, is as follows:

- 1) 458.5 MHz to 458.8 MHz 1mW
- 2) 458.8 MHz to 459.5 MHz 100 mW erp

Obviously, the second allocation will be used for models or anything needing some distance between the transmitter and the receiver. This gives some 0.7 MHz of space, which would in theory give 28 channels spaced at 25 kHz.

Model radio control articles have been published in the past in both ETI and dedicated modelling magazines and books. Some of the ideas contained in this design as already

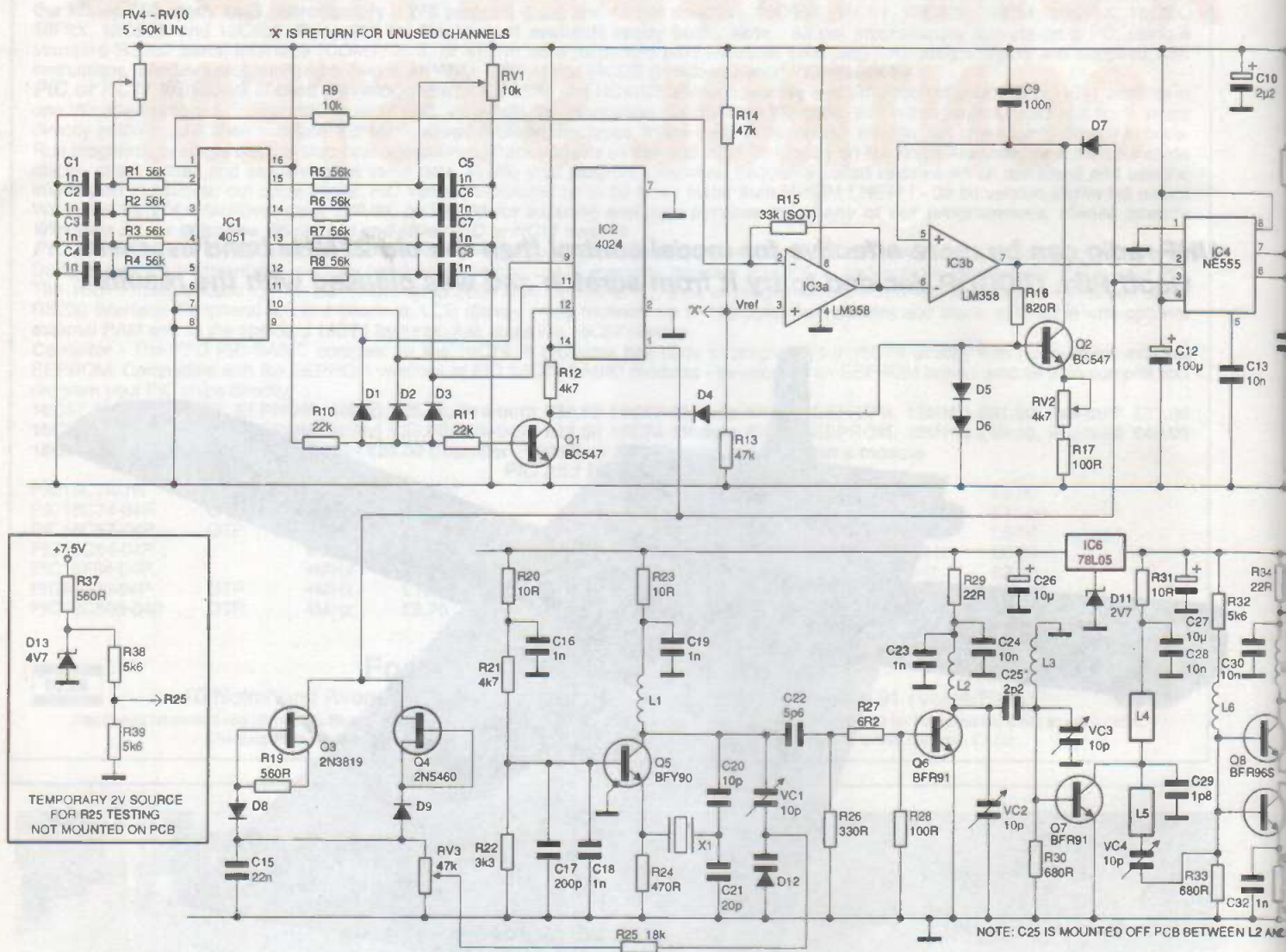

Figure 1: the circuit diagram of the 7-channel UHF model radio control transmitter, including the encoder section (top)

standard. I found Paul Newell's book "Radio Control: A Handbook of Theory and Practice (Radio Modeller Books Ltd., 1981) on radio control useful, especially for the data slicer comparator used in the rx decoder. It is not in print at the moment, but you may find it in libraries.

The circuit The transmitter

The transmitter is in two parts, the transmitter itself and the encoder. Both parts are shown in the circuit diagram in figure 1.

The transmitter follows fairly common practice in model radio control, accepting plug in third overtone crystals and running from a 9.6V nicad pack. The overtone oscillator Q5 is stabilised by the crystal X1, and the frequency is set by adjusting L1. The oscillator is frequency modulated via a varicap diode, D12. This changes the resonant frequency of L1

slightly. The signal is passed to the next stage for frequency doubling (Q6), and then on to Q7, where it is multiplied by three. The total multiplication before the output stage is six times the marked crystal frequency. Final amplification is provided by Q8 and Q9 in parallel. The output of this stage is matched into the helical filter HF1 by L8 and VC5. Harmonic suppression is also provided by this two-chamber filter. The signal at this point is about 250-350 mW, and is then passed to the antenna by either direct connection to the pcb (preferred method) or by a short length of miniature 50R coax cable RG174/U. Stable oscillator performance is helped by the regulated 7V5 supply from the voltage regulator IC6.

The encoder is of the linear ramp type, which was previously available as a dedicated ic for the job. However, here the task is carried out using discrete ics (IC1 - 4) and associated components.

The control stick pots RV4 - RV10 provide a voltage which is dependent on their position. These voltages are fed to the

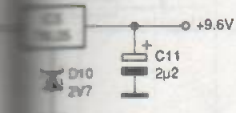

D10	1N4148
D11	2V7 400mW
	BB104
	4V7

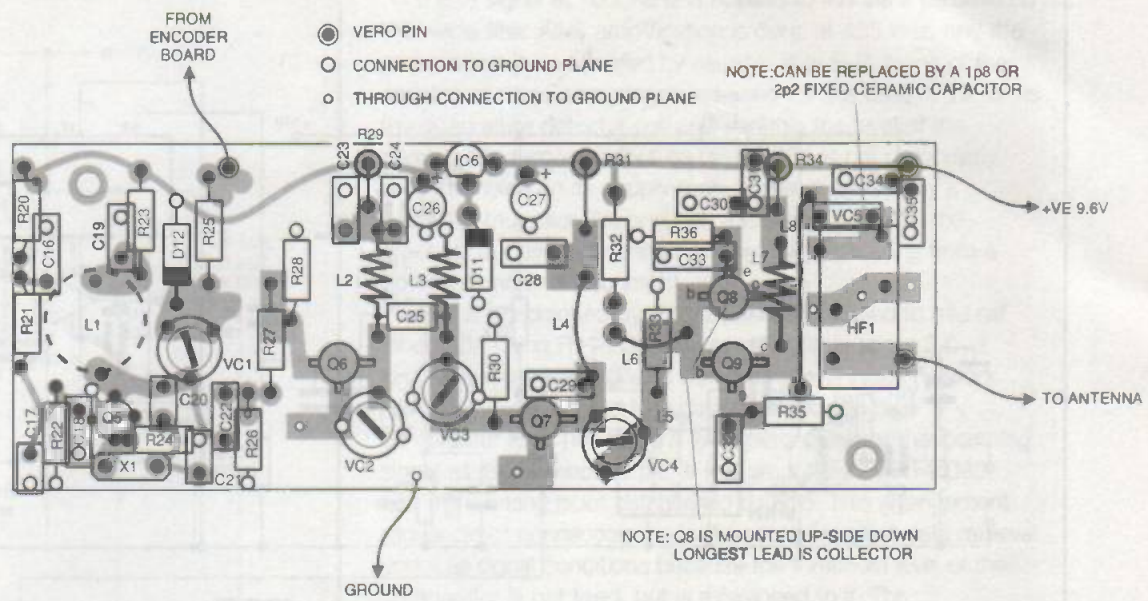
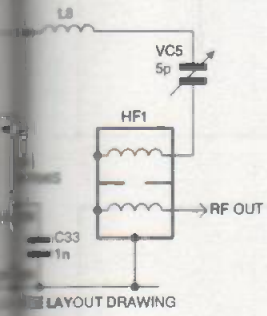
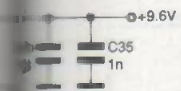

Figure 2: the component layout of the transmitter section

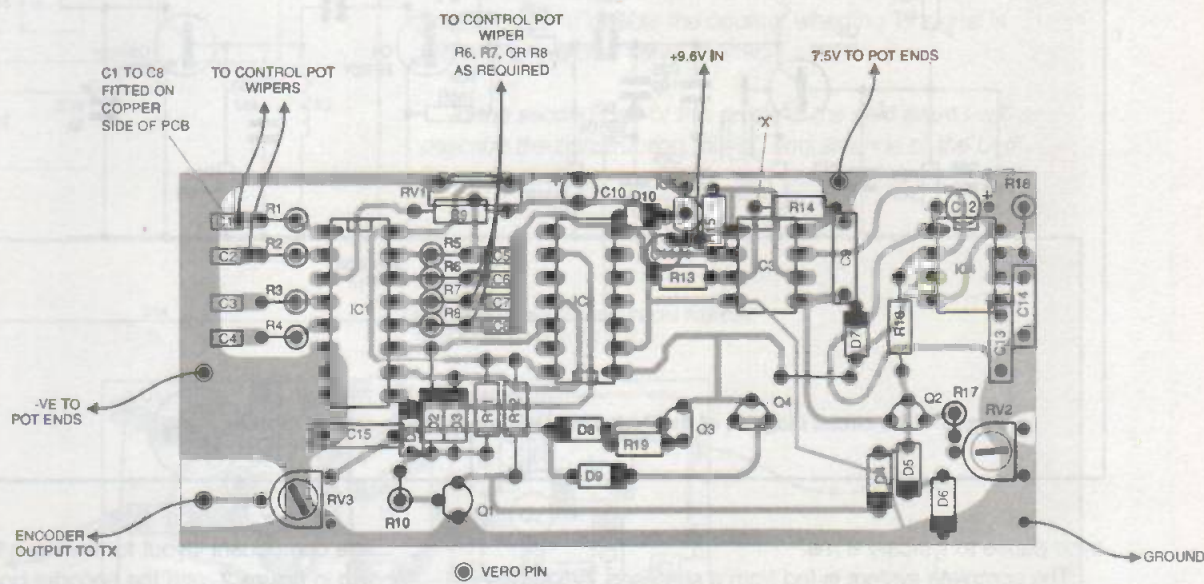

Figure 3: the component layout of the transmitter encoder section

multiplexer, IC1, and are commutated in turn as the address changes from the 7-stage ripple counter IC2.

Considering one channel at a time, at neutral, a stick pot wiper voltage will be approximately 3.75V. This would be presented to op amp IC3a's inverting input. This would allow the integrating capacitor C9 to charge up to this value before IC3b, a comparator, would change state. This would then cause the 555 monostable to produce a short pulse of about 250 us, causing the 7-stage ripple counter to advance and present the next pot wiper voltage to the MUX input and in turn to the op amp IC3a. This would also cause C9 to discharge via D7. The process would start over again, and C9 would linearly charge via Q2 in a time related to the voltage on the selected stick pot.

This process is repeated until the eighth count, when something completely different occurs. Pin 15 of the MUX will select the preset RV1 (sync) and, with the gating of D1, D2 and D3 will cause Q1 to divert Q2's base current. This will mean that C9 will take longer to charge up. This allows a sync pause of up to 20ms to be generated if needed. This has not always been possible with this type of linear ramp encoder.

The process is regenerative. Adjustment of RV2 changes the value of constant current in Q2, which in turn sets the neutral pulse widths. These are typically 1.5 ms in duration. Time constant R18/C14 will control the inter-pulse gap, which is typically 250 us; RV1 sets the

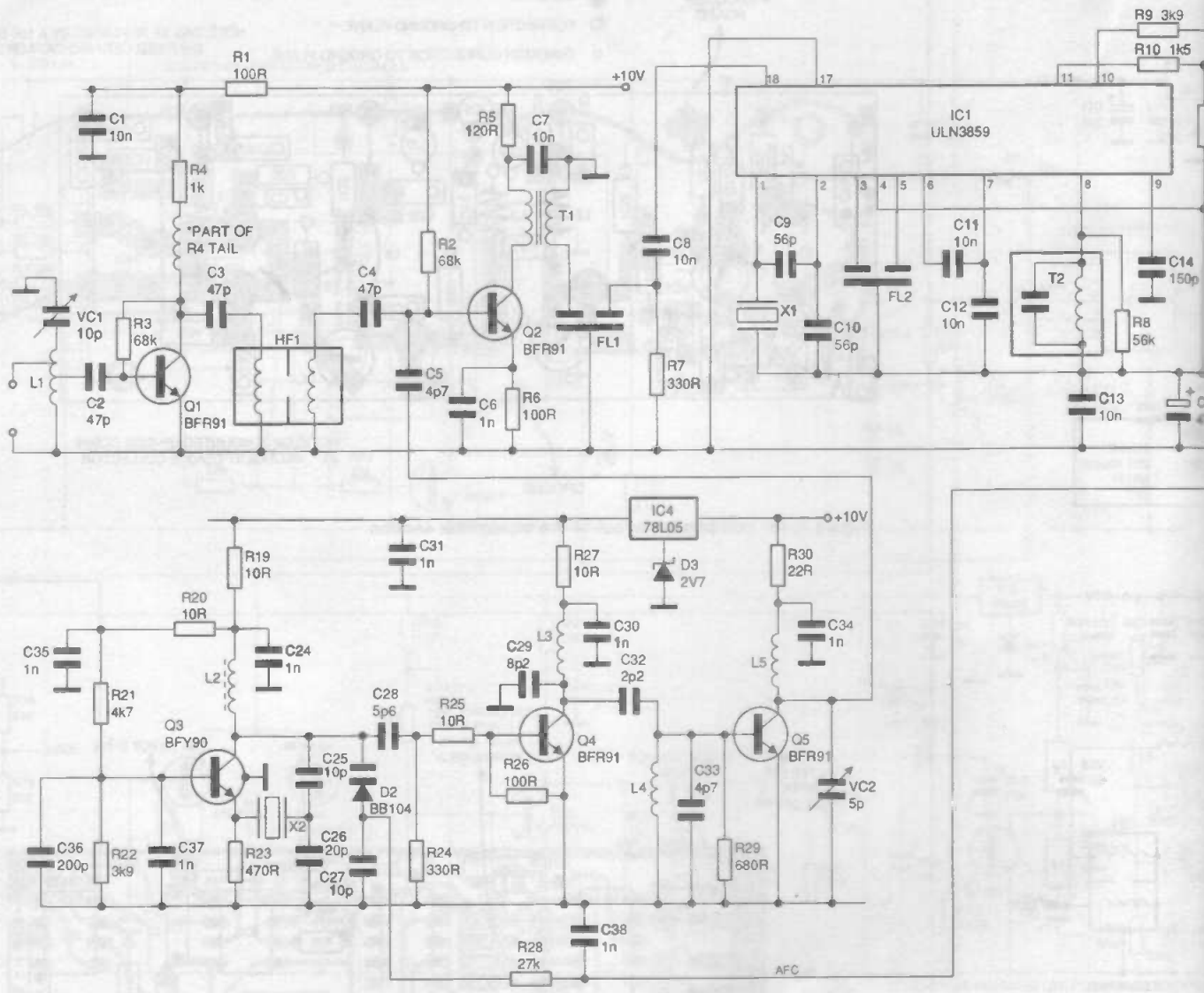

Figure 4: the circuit diagram of the 7-channel UHF model radio control receiver

sync pause to typically 8 ms.

The complete system is fed from a stabilised 7V5 supply rail provided by IC5, the voltage regulator. SMD (surface mount device) type capacitors C1-C8 decouple the rf from the control pot wipers. RF entering an encoder is a real pain, but this design seems to have high immunity against this. Please use the chip capacitors here.

As typically four channels will be used (that is, two control sticks), all unused inputs to IC1 must be connected to the vref point marked "x". The clock signal from the 555 not only advances the 7-stage counter IC2, but is also the modulating signal. This is fed to the bi-directional current device Q3/Q4, an n-channel and p-channel fet (field effect transistor). This ensures approximately equal and near-linear shaping of the pulse edges before they are applied to the varicap diode D12 via R25.

The edge delay is about 100 us on both the rising and falling edges. This shaping is

needed to limit the transmitter signal width. RV3 is used to set the overall deviation to +/- 3.5 kHz.

The component layout for the main transmitter board is shown in figure 2, and the encoder board is shown in figure 3.

The receiver

The receiver (figure 4) is split into two boards, the receiver front end/mixer/LO (figure 5), and the separate pcb with the NBFM decoder and digital processing and decoding (figure 6). The receiver front end consists of an rf pre-amplifier Q1 ahead of a bipolar mixer Q2. Initial selectivity is given by L1/VC1.

Ahead of Q1, this signal is passed to the helical filter HF1, which gives some degree of protection from image signals at 21.4 MHz from the desired signal. After mixing with the lo signal, the difference is selected by T1 at 10.7 MHz and then passed to the nbfm IF amp and demodulator.

The lo signal is generated by a third overtone crystal oscillator, and is multiplied by 6 via Q4 and Q5. Stabilisation is provided by two methods, IC4 supplies Q3 and Q4 with a regulated 7V5 rail, and afc is applied to D2, a varicap, from the discriminator output of IC1.

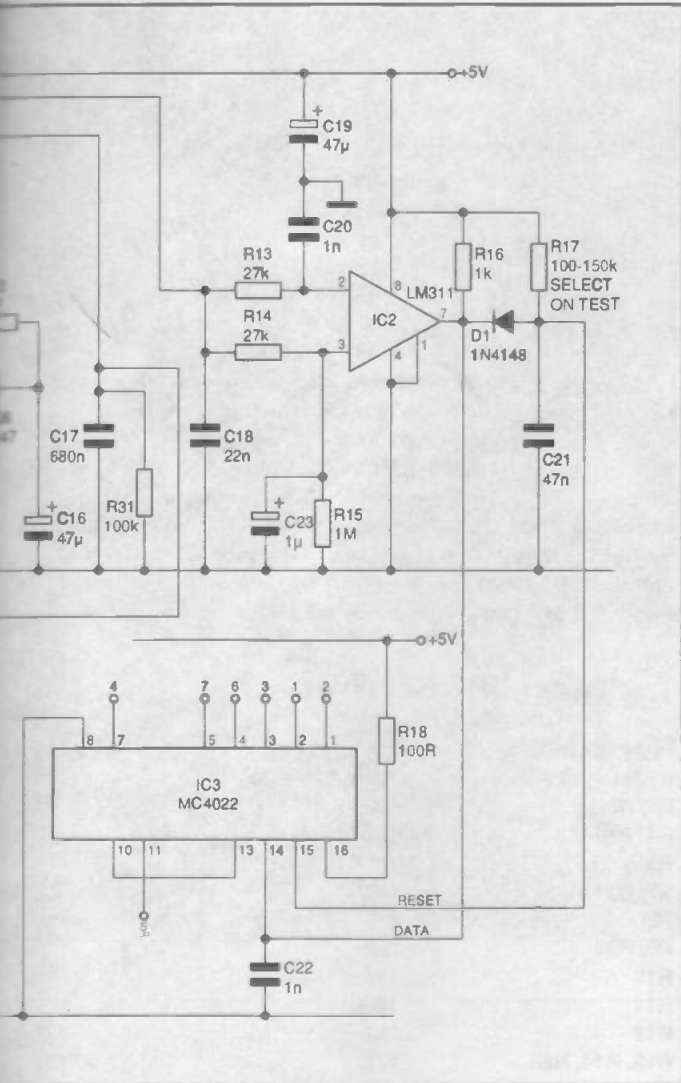

The IF signal at 10.7 MHz is applied to IC1 via a ceramic 50 kHz wide filter. All IF amplification is done at 455 kHz, and the main selectivity is afforded by ceramic filter FL2. None of the squelch or noise amp stages are used for this design. T2 forms the quadrature detector coil and controls the level of the demodulated signal output on pin 10. IC1 is not particularly prone to noise on its supply lines, however it is fed by a capacitor multiplier Q6, and only loses about 0.5V in the process, but effects excellent supply line decoupling from a potentially noisy environment.

AFC is conditioned by R10/C17, and is biased to mid rail (about 2V) using R11/R31. The overall shift is about 2.5 -3 kHz. The recovered signal is de-emphasised in the network R9/C18. This is applied to a data slicer formed by a comparator IC2. This takes a fixed percentage of the incoming signal as its reference at pin 3. It is smoothed by R14/C23, and the working point established by R15. This arrangement allows direct connection, and will ensure excellent data retrieval under all signal conditions because the threshold level of the comparator is not fixed, but is referenced to it. The reconstructed encoder waveform appears at pin 7 and is connected to the clock input of the octal counter IC3. This signal also drives a diode pump D1/C21 and during the sync pause of 8ms +/- R12 will cause C21 to charge up to a level that exceeds the trigger threshold, resetting the counter ready for the next data stream.

The eighth count on pin 10 is connected back to the clock enable so as to disable the counter when no Tx signal is present, preventing servo chatter.

In the second part of this article in the next issue I will describe the construction, casing and antenna of the UHF Radio Controller.

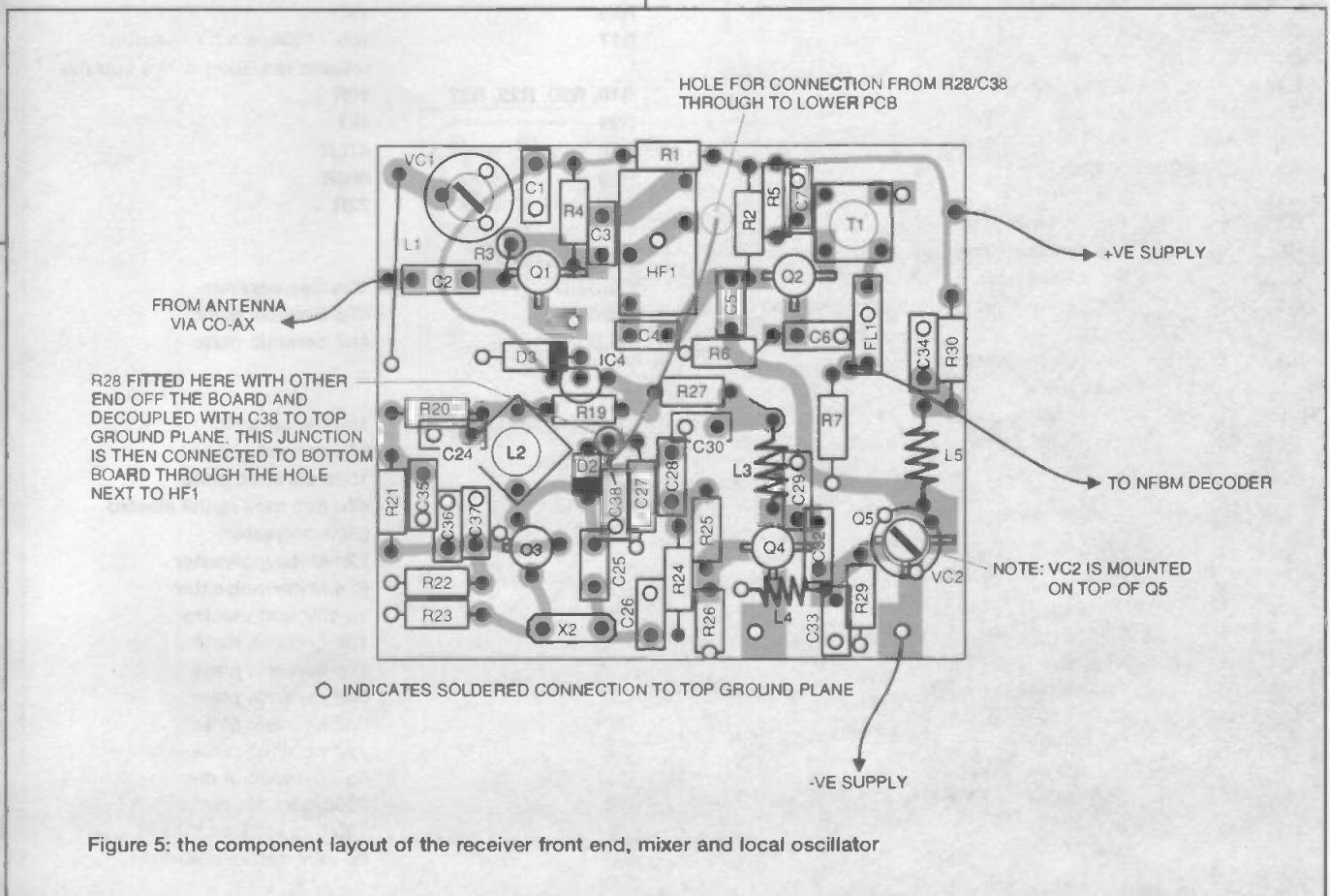

Figure 5: the component layout of the receiver front end, mixer and local oscillator

7-channel UHF Transmitter

Resistors

All 0.25W 5 percent

R1-R8	56k
R9	10k
R10, R11	22k
R12, R21	4k7
R13, R14	47k
R15	33k (select on test)
R16	820R
R17, R28	100R
R18	82k
R19	560R
R20, R23, R31, R23, R35-36	10R
R22	3k3
R24	470R
R25	18k
R26	330R
R27	6R2
R28	100R
R29, R34	22R
R30, R33	680R
R32	5k6
R37	560R temporary for test only
R38, R39	5k6 temporary for test only
RV1	10k vertical
RV2	4k7 horiz
RV3	47k horiz
RV4-10	5-50k linear control stick pots

Capacitors

C1-C8	1n surface mounts F mounted on track side.
C9	100n polyester
C10, C11	2u2 10V tant
C12	100u 10V radial electro
C13, C24,	
C28, C30, C34	10n disc
C14	3900p polyester
C15	22n disc ceramic
C16, C18-19,	
C23, C31-33, C35	1n disc
C17	200p disc
C20, C24	10p ceramic plate
C21	20p ceramic plate
C22	5p6 ceramic plate
C25	2p2 ceramic plate, off board between L2 and L3
C26, C27	10u 16V radial electro
C28, C30, C34	10n ceramic plate
C29	1p8 ceramic plate
VC1-VC4	10p Mullard yellow film trimmers (Cirkit)
VC5	5p ceramic

Semiconductors

IC1	MC4051
IC2	MC4024
IC3	LM355
IC4	NE555
IC5, IC6	78L05
Q1, Q2	BC547 (Maplin)
Q3	2N3519 (Maplin)
Q4	2N5480 (Maplin)
Q5	2N5179/BFY90 (Farnell, Cirkit)
Q6, Q7	BFR91 (Cirkit)
Q8, Q9	BFR96S (Cirkit, Farnell)
U1-U	1N4148

D10, D11	2V7 400mW zener
D12	BB104 (Cirkit)
D13	4V7 zener (temporary)

Inductors and others

L1	S18 green with ferrite core (Cirkit)
L2, L3	3 turns 22SWG, silver wire 1/8th inch ID space wound
L4	Half-turn loop 1 inch of 20SWG wire
L5	On PCB
L6	Long resistor tail from R32, about 3/8th inch
L7	3 turns 22SWG 3/32-in ID space wound
L8	Spare resistor tail mounted about 1/8th inch above PCB
HF1	252MX-1551A helical filter
X1	Third overtone HC25/u (from Quartzlab Marketing (QSL) Ltd. - see below). For 459.500 MHz this will be 76.5833 MHz, which is just above the limit of 75 MHz that the third overtones are normally made to. However, they will make this frequency on request.

7-channel UHF Receiver

Resistors

R1, R6, R18, R26	100R 0.25 watt
R2, R3	68k
R4, R16	1k
R5	120R
R7, R24	330R
R8	56k
R9, R22	3k9
R10	1k5
R11	100k
R12	2k7
R13, R14, R28	27K
R15	1M
R17	100 - 150k: s.o.t. to ensure reliable resetting of the counter
R19, R20, R25, R27	10R
R21	4k7
R23	470R
R29	680R
R30	22R

Capacitors

C1, C7, C8, C11-13	10n disc ceramic
C2, C3, C4	47p ceramic plate
C5, C33	4p7 ceramic plate
C6, C20, C22,	
C24, C30,	
C31, C34, C35, C37, C38	1n disc ceramic
C9, C10	56p ceramic plate
C14	150p ceramic plate
C15, C16, C19	47u 6V3 mini radial electro
C17	680n polyester
C18	22n Mylar/polyester
C21	47n Mylar/polyester
C23	1u 10V tant electro
C25, C27	10p ceramic plate
C26	20p ceramic plate
C28	5p6 ceramic plate
C29	8p2 ceramic plate
C32	2p2 ceramic plate
C33	4p7 ceramic plate
C36	200p ceramic plate
VC1	10p film Mullard (Cirkit)
VC2	5p mini ceramic (Cirkit)

Semiconductors

IC1	ULN3859 or MC3359, or without AFC
MC3361	(Mainline Electronics)
IC2	LM311
IC3	MC4022
IC4	78L05
Q1,Q2,Q4,Q5	BFR91 (Cirkit)
Q3	2N5179/BFY90 (Cirkit/Farnell)
Q6	BC547(Cirkit)
D1	1N4148
D2	BB104 (Cirkit)
D3	2V7 zener

Inductors and others

L1	1.25-in 20SWG silver wire
L2	S18 series coil green with ferrite core (Cirkit)
L3, L4	3 turns 22SWG 1/8 inch ID space wound
L5	Half-turn loop from 0.75-in long 22SWG silver wire
X1	11.155 MHz stock crystal (Cirkit)
X2	To suit frequency: for 459.500 MHz this is 74.800 MHz 3rd overtone (QSL Ltd.)
FL1	50kHz scan filter 10.7 MHz ceramic (Maplin)
FL2	20kHz 455kHz ceramic filter CFU 455D (Cirkit)
T1	119AC 30099R 10.7 MHz IF transformer (Cirkit)
T2	LMC 4100A 455 kHz-transformer (Cirkit)

HF1	252MX-1551A helical filter (Cirkit)
Case	Made from 1-mm plastic card glued with cyano-acrylate adhesive

Custom crystals can be obtained from Quartslab Marketing Ltd., P O Box 19, Erith, Kent DA8 1LH. Tel. 01322 330830. They need to know the frequency required for self-build equipment, or the make and model number for commercial equipment.

Control sticks and case are from Micron Mail Order, 24 Brendon Way, Long Eaton, Nottingham, NG10 4JS, tel. 0115 972 3893. This supplier also supplies servos.

Mainline Electronics PO 235 LE2 9SH Tel. 0116 2777648

Maplin: PO Box 3, Rayleigh, Essex SS6 8L. Tel 01702 554161
Cirkit Distribution Ltd., Park Lane, Broxbourne, Hertfordshire EN10 7NQ. Tel 01992 448899

Farnell Electronic Components: Canal Road, Leeds, LS12 2TU. Tel 0113 263 6311

Silver wire can be obtained from Cirkit. Tinned copper wire is also suitable and is cheaper.

(Where a supplier is mentioned alongside a part without further details it indicates that the supplier listed the part recently, not necessarily that they are the sole or main supplier.)

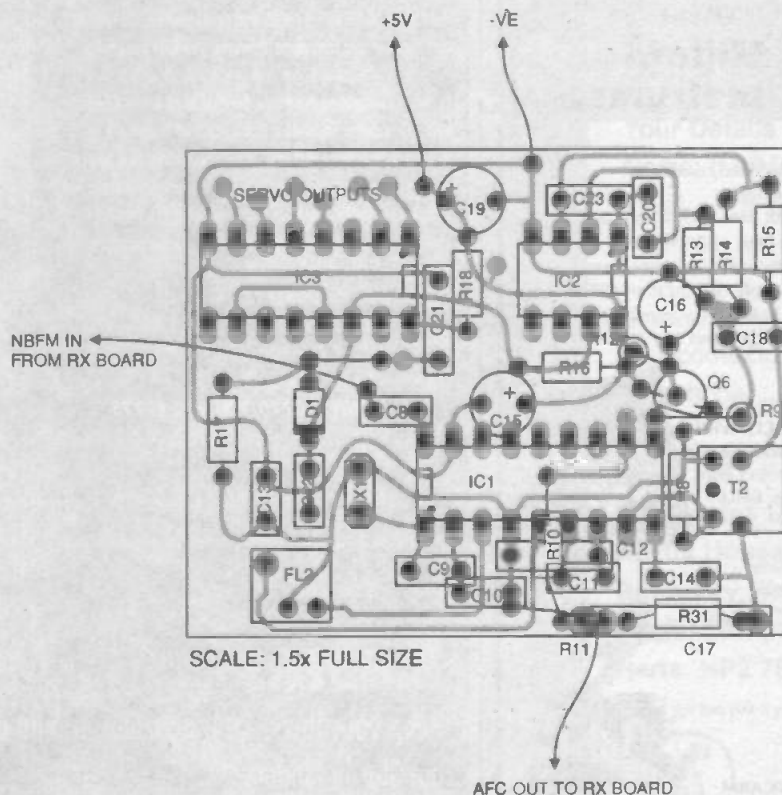

Figure 6: the component layout of the receiver IF amplifier and NBFM decoder

Mini Waterloo TV camera 40x40x15mm requires 9 to 13 volts at 120mA with composite video output (to feed into a video or a TV with a SCART plug) it has a high resolution of 450 TV lines vertical and 380 TV lines horizontal, electronic auto iris for nearly dark (1 LUX) to bright sunlight operation and a small lens with a 92 degree field of view, it focuses down to a few CM. It is fitted with a 3 wire lead (12v in gnd and video out). Now also available with wall mount tilt and swivel case (at the same price). £93.57 + vat = £109.95 or 10" £99.32 + vat = £114.95

Board cameras all with 512x582 pixels 4.4x3.3mm sensor 9-13 volts power supply and composite video out. All need to be housed in your own enclosure and have fragile exposed surface mount parts. 47MR1 size 50x36x27mm with 6 infra red leds (gives the same illumination as a small torch would) £50.00+vat = £58.75 40MP size 39x38x23mm spy camera with a fixed focus pin hole lens for hiding behind a very small hole. £57+vat = £66.98 40MC size 39x38x26mm camera for 'C' mount lens this gives a much clearer picture than with the small lenses £58.79+vat = £68.83 standard 'C' mount lens F1.8 16mm for 40MC £26.43+vat = £31.08

High quality stepping motor kits (all including stepping motors) 'Comstep' independent control of 2 stepping motors by PC (through the parallel port) with 2 motors and software. Kit £67.00 ready built £99.00 software support and 4 digital inputs kit £27.00 power interface 4A kit £36.00 power interface 8A kit £46.00 Stepper kit 4 (manual control) includes 200 step stepping motor and control circuit £23.00

DTA30 Hand held transistor analyser II tells you which lead is the base, the collector and emitter and if it is NPN or PNP or faulty (NEW VERSION does not say FETs & SCRs are transistors) DTA30 £38.34

HMA20 hand held MOSFET analyser identifies gate drain and source and I/P or N channel HMA20 £38.34

Speaker cabinets 2 way speaker systems with Motorola tweeters

speaker dia	15"	2"	8"
power rating	250WRMS	175WRMS	100WRMS
impedance	8ohm	8ohm	8ohm
frequency range	40hz-20khz	45hz-20khz	60hz-20khz
sensitivity(1W/1M)	97dB	94dB	92dB
size in mm	500x720x340	450x640x345	315x460x230
weight	21.1kg	16.8kg	7.4kg

price each for:
black vinyl coating £139.95 £99.99 £54.94
grey felt coating £159.97** £119.97** £64.99
(** = not normally in stock allow 1 week for delivery)

Power amplifiers 19" rack mount with gain controls & VU meters

STA300 2x180Wrms (40hm load) 11kg	£339.00
STA900 2x480Wrms (40hm load) 15kg	£585.00

LED's 3mm or 5mm red or green - 7p each yellow 11p each cable ties 1p each £5.95 per 1000 £49.50 per 10,000

Rechargeable Batteries

AA(HP7) 500mAh £9.99	AA 500mAh with solder tags £11.55	AA 950mAh £11.75	D(HP2) 1.2AH £2.80	D 4AH with solder tags £4.95	PP3 8.4V 1100mAh £4.95
----------------------	-----------------------------------	------------------	--------------------	------------------------------	------------------------

12AA with solder tags £3.55 Sub C with solder tags £2.50 AAA (HP16) 180mAh £1.75 1/3 AA with tags (philipsCTV) £1.95 Nickel Metal Hydride AA cells high capacity with no memory, II charged at 100ma and discharged at 250ma or less 1100mAh capacity (lower capacity for high discharge rates) £3.75

Special offers please check for availability stock of 4 42 x 16mm nicad batteries 171mmx16mm dia with red & black leads 4.8v £5.95

ELECTRONICS DIRECT

SUBSCRIBE & SAVE WITH ELECTRONICS DIRECT

Our subscription deals just get better and better - now you can save almost £20 if you subscribe today!

ETI, code: 0215

Electronics Today International - The Project Magazine for all Electronics Constructors.

The single source guide to electronics for today and tomorrow, packed with numerous projects for enthusiasts of all abilities. The detailed features and up-to-the-minute news items keep all readers fully informed of the latest, exciting developments in this ever changing hobby, whilst the equipment reviews ensure that you always know exactly what to buy.

15 issues for the price of 13

UK: NOW ONLY £35.75 YOU SAVE £5.50

Europe: £44.59, Overseas: £47.84, USA: \$74.00

30 issues for the price of 26

UK: NOW ONLY £71.50 YOU SAVE £13.75

Europe: £89.18, Overseas: £95.68, USA: \$148.00



JPG ELECTRONICS

ETI 276-278 Chatsworth Road, Chesterfield S40 2BH
Access Visa Orders (01246) 211202 fax 550959
Callers Welcome 9.30am-5.30pm Monday-Saturday

CONTROL & ROBOTICS from Milford Instruments

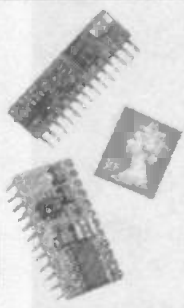

BASIC Stamps
re-programmable stamp sized computers
Easy to use BASIC language

- 8 or 16 Input/Output lines each 20mA capability
- 80 or 500 Program lines
- Re-programmable thousands of times from PC or Mac ● 5-12VDC Supply. Stamps from £25.00 each.

Development Kits including programming software, Stamp, Cable, Project Board and 25+ Application notes from £79.00.

MUSCLE WIRES

Wires that contract approx 5% when heated (eg 250mA current) - 120 page Project book and 3 one metre lengths of wire. £40.00

STAMP BUG

Autonomous roving insect using the BASIC Stamp as its "brain". Approx 300mm overall length. KITS FROM £29.00



LYNX ARM

5 Axis robot arm kit; approx size 300mm. Control from any serial comms port or Stamp. Includes software to run from PC. KITS FROM £85.00



All prices exclude VAT and shipping.

For a full catalogue of the above items and other products, please call or fax Milford Instruments at 01977 683665; Fax 01977 681465.

ACORN ARCHIMEDES WORLD, code: 0215

In the constantly changing world of IT, it is vital to keep abreast of all the latest trends and developments. Of course, this is easier said than done. However, you CAN keep fully informed by reading Acorn Archimedes World, Britain's most respected computing magazine devoted to all Acorn 32-bit RISC OS systems. The wide ranging editorial brings you in-depth hardware and software reviews, evaluates new products and forecasts what will happen next, and includes a dedicated educational section. Each issue also comes with a free cover-mounted disc, often containing complete, usable programs as well as workable and playable demos.

15 issues for the price of 13

UK: NOW ONLY £51.35 YOU SAVE £7.90

Europe: £62.40, Overseas: £66.56, USA: \$103.00

31 issues for the price of 26

UK: NOW ONLY £102.70 YOU SAVE £19.75

Europe: £124.80, Overseas: £133.12, USA: \$206.00



REMEMBER, it's always cheaper to subscribe - and you avoid future cover price increases! All savings are based upon buying the same number of issues from your newsagent, UK only.

BINDERS

Keep your favourite magazines in mint condition in one of our sturdy binders.

Each binder will hold up to 13 issues.

Code: bind 02

£7.50 U.K. £8.00 Overseas

BINDERS AVAILBALE

● ETI ● ARCHIMEDES WORLD



'Electronics Direct' is the One Stop Shop for all your computing, electronics and amateur radio needs from Nexus Direct. We are offering some sensational deals on Subscriptions, Books & Reader Offers - all available direct by mail order. Remember, all our prices include postage and packing - so there are no hidden extras to add! You can order by phone, fax or use the coupon.

ELECTRONICS DIRECT

Please order all your goods using the coupon below ensuring you fill in all sections OR simply use our order hotline. Thank you.

SAVINGS ON BOOKS

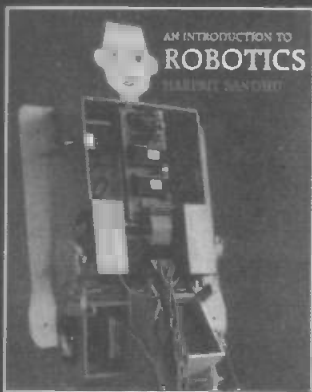

AN INTRODUCTION TO ROBOTICS.

A fascinating and unique book that breaks new ground by exploring the exciting world of robotics in a clear and concise way. Both the theoretical and practical aspects are presented in an uncomplicated fashion using everyday English, which makes this an ideal book for the amateur. Divided into two sections, the first part explains how and why robots work and are controlled, while the second shows you how to make a simple two legged humanoid robot that can be programmed to walk. There are no complicated formulas or equations to grapple with or incomprehensible circuit diagrams to decipher - this robot can be built on your kitchen table and can be run from any personal computer! All you need are model aeroplane servos, a controller, a power supply and some plywood - and all parts are easily available in the UK and the USA. This is a book that will be of interest to modellers and everyone with a fascination for things mechanical and electronic.

Code: NB299
ONLY £11.95 UK £12.95 Overseas

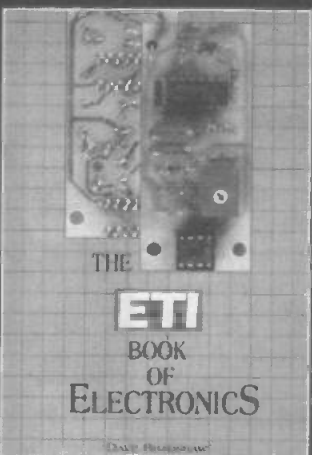

ETI BOOK OF ELECTRONICS

This is the perfect book for beginners, offering a clear and concise introduction to both the theories and principles of electronics. Each chapter also allows you to put this theory into practice with an easy to follow project to make, including a loudspeaker divider, continuity tester, 'brown-out' alarm, freezing alarm, loudspeaker, mini-amplifier and a burglar alarm.

Code: NB214
ONLY £12.95 UK £13.95 Overseas

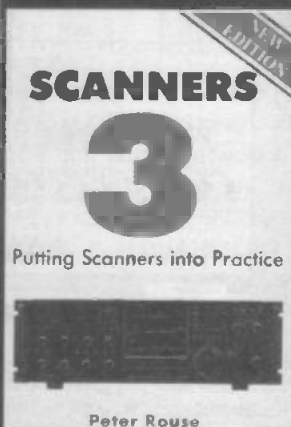

SCANNERS 3 - PUTTING SCANNERS INTO PRACTICE

This is the fourth revised and completely updated edition of Scanners, the complete VHF/UHF radio listeners guide, containing everything you need to know to put your scanner to better use. There is a great deal more information than ever before on frequency listing; in particular, actual frequencies used by coastal stations, airfields and the emergency services. Also included for the first time is a section on the HF (short wave) band as many scanners now cover this range.

Code: NB217
ONLY £11.95 UK £12.95 Overseas



SCANNERS 2 INTERNATIONAL

The companion book to 'Scanners' provides even more information on the use of VHF and UHF communication bands, and gives details on how to construct accessories to improve the performance of scanning equipment. The book is international in its scope and contains frequency allocations for all three ITU regions, including country-by-country variations.

Code: NB216
ONLY £11.95 UK £12.95 Overseas

SUBSCRIPTIONS

Magazine	Code	No. of Issues	Price
.....	£.....
.....	£.....
.....	£.....
Total Subscription Value			£.....

Subscription No. if renewing

READERS OFFERS/BOOKS/BINDERS

Title	Code	Qty	Price
.....	£.....
.....	£.....
.....	£.....
.....	£.....
.....	£.....

Total Order Value £

METHOD OF PAYMENT

The total value of my order is £
I enclose a Cheque/P.O. made payable to Nexus Special Interests Ltd. or please debit my Mastercard/Visa/AMEX account

Card No. [.....]

Expiry/..... Signature

Your Details

Name: (Mr/Mrs/Miss)
Initial Surname
Address:
.....
Postcode/Zipcode Country
Telephone:

Send to:

Electronics Direct
Nexus House
Boundary Way
Hemel Hempstead
Herts. HP2 7ST.

Please Note

All prices include P&P where appropriate. All subscriptions start with the first available issue. Every effort will be made to despatch your order within 14 days but please allow up to 28 days for delivery. Individual items may be dispatched separately. These offers are not to be used in conjunction with any other promotion.

Please tick this box if you do not wish to receive direct mail from other companies



ELECTRONICS DIRECT

Express Order Hotline
01442 266551

9am - 5pm Monday - Friday

Fax order line: 01442 266998

Closing date: 30/06/98

BOOKS DIRECT

PROTEUS

Schematic Capture

NEW Version IV

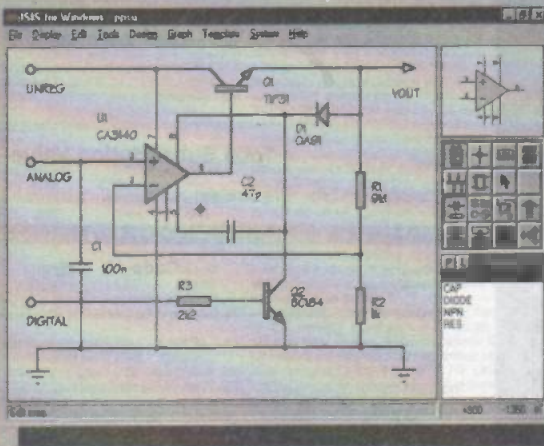

- Produces attractive schematics like you see in the magazines.
- Netlist, Parts List & ERC reports.
- Hierarchical Design.
- Full support for buses including bus pins.
- Extensive component/model libraries.
- Advanced Property Management.
- Seamless integration with simulation and PCB design.

Simulation

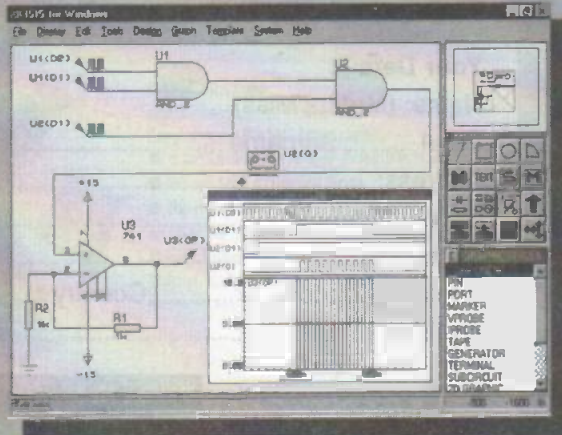

- Non-Linear & Linear Analogue Simulation.
- Event driven Digital Simulation with modelling language.
- Partitioned simulation of large designs with multiple analogue & digital sections.
- Graphs displayed directly on the schematic.

FREE
SOFTWARE
ISIS & ARES Lite
Schematic & PCB
Design

**SHAREWARE VERSIONS
AVAILABLE TO DOWNLOAD
FROM OUR WEBSITE**

<http://www.labcenter.co.uk>

labcenter
Electronics

The IVth Generation

New Features

- Component Auto-Placer
- Pinswap/Gateswap Optimizer
- Background Regeneration of Power Planes
- Enhanced Autorouting with Tidy Pass
- Full Control of Schematic Appearance
- Extensive New Component Libraries

Available in 5 levels - prices from £295 to £1625 + VAT.
Call now for further information & upgrade prices.

PCB Design

NEW Version IV

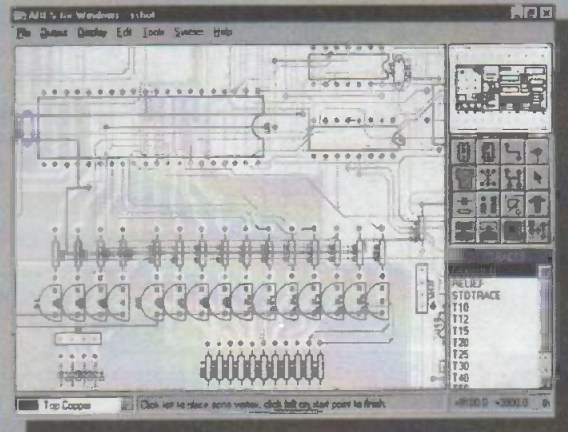

- Automatic Component Placement.
- Rip-Up & Retry Autorouter with tidy pass.
- Pinswap/Gateswap Optimizer & Backannotation.
- 32 bit high resolution database.
- Full DRC and Connectivity Checking.
- Shape based gridless power planes.
- Gerber and DXF Import capability.

**"PROTEUS
is particularly good**

with its rip-up-and-retry autorouter" EWW January 1997

Write, phone or fax for your free demo disk, or ask about our full evaluation kit.
Tel: 01756 753440. Fax: 01756 752857. EMAIL: info@labcenter.co.uk
53-55 Main St, Grassington, BD23 5AA. WWW: <http://www.labcenter.co.uk>

Fully interactive demo versions available for download from our WWW site.
Call for educational, multi-user and dealer pricing - new dealers always wanted.
Prices exclude VAT and delivery. All manufacturer's trademarks acknowledged.

Fast Fivers

Adaptable, affordable - handy circuits for around £5. By Owen Bishop

Audible logic probe

We have described quite a number of logic-based projects in this series so it is high time that we presented a device for checking logic levels. Typically a logic circuit consists of several ics, each with 14 or 16 pins, and checking involves probing the pins one at a time to confirm that the logic levels there are correct. It is more convenient if you can keep your eyes on the test circuit while you do this, so as to be sure that you are contacting the right pin. It is better not have to watch an LED or a meter at the same time. This is where this audible checker is so appropriate. The logic level is indicated by the pitch of the sound produced. A high note indicates a high logic level and a low note indicates a low level. More later about what it means if the note is neither high nor low.

The basis for this circuit is an ic which occupies a kind of borderland between the digital and analogue worlds, though it is a member of the CMOS 4000 series and so qualifies as a logic ic. The 4046 is usually described as a phase locked loop (PLL) ic. It contains several distinct modules which together are used to build a PLL. PLLs are used for locking on to a digital signal of a particular frequency that has become mixed with other signals of other frequencies or perhaps just a noisy background. PLLs can be used for restoring a badly degraded digital signal to its original square-cut form. One of the useful modules to be found in the 4046 is a voltage-controlled oscillator (VCO), and it is this part that we use in this project. We do not need or use the other parts of the PLL. The basic frequency of the VCO is determined by the value of C1 and R1 (figure 1). If the voltage at the control input (pin 9) is exactly half way between the two supply rails, the frequency at the VCO output (pin 4) is $1/RC$. If the voltage at pin 9 drops to zero, the frequency too drops to zero. If the voltage increases to the full supply voltage, the frequency doubles to $2/RC$. With the values given in the figure, the frequency ranges from zero up to about 750Hz.

In this project we need a signal in the audio range when input is 0V. We obtain this by adding a second resistor R2 to produce a frequency offset. The effect depends on the ratio of R2 to R1. In figure 1 the ratio is 82:27, which is approximately 3:1. This raises the zero-input (logic low) frequency from 0Hz to $750/3 = 250\text{Hz}$ (approx). It

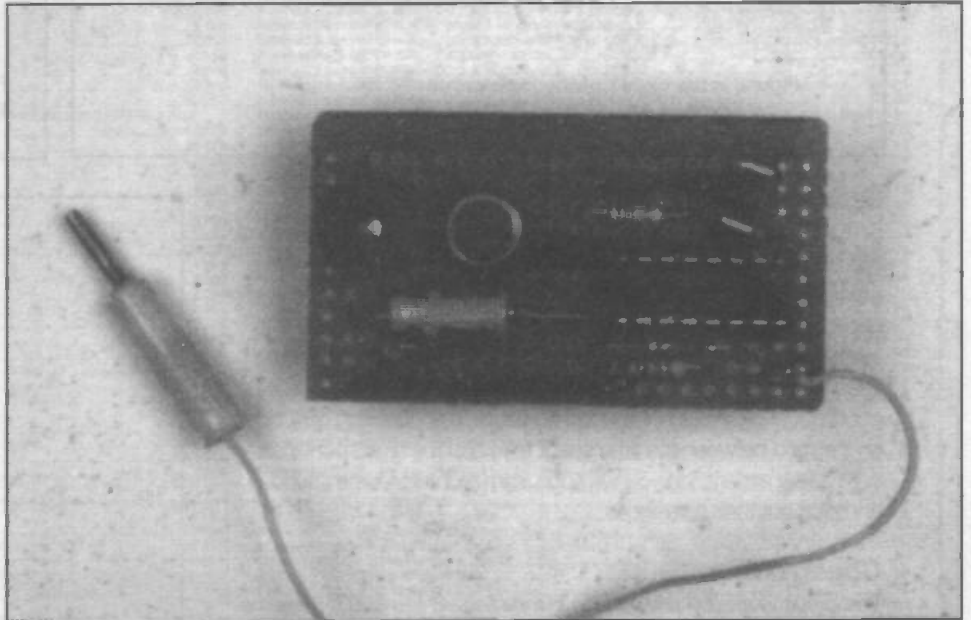

increases the logic-high frequency by the same amount, that is, from 750Hz to 1kHz.

The signal from the VCO is made audible by using it to switch a small magnetic sounder on and off. C2 is needed to prevent the signal from being fed back to the ic through the power lines. The circuit includes a resistor R4 to reduce the volume of sound. The exact value of this depends on the type of sounder used. There is also a push-button in the audio circuit so that the sound is heard only when we want it. As you will discover, the audio output is a depressingly screeching sound unless the probe is connected to a point which is firmly at a steady high or low logical level. Which brings us to the next topic.

In-between levels

In an ideal logical world all points are either at logic-low or logic-high. In-between values do not exist. Unfortunately, in the real world of projects being tested, there may be several points in the test circuit that are hovering somewhere between the two states. If, for example, the connection to one of the supply terminals of an ic is open-circuit so that the ic is receiving its supply unofficially through another input terminal, we find that the voltages at the inputs and outputs are fairly steady, but at some level between low and high. The tone from the probe is steady, but is intermediate in pitch. The same may occur if there are unintended short-circuits between adjacent terminals. If an input terminal has been left unconnected, it 'floats', and its input level varies erratically. The input terminal itself or the output terminal of the same gate produces an

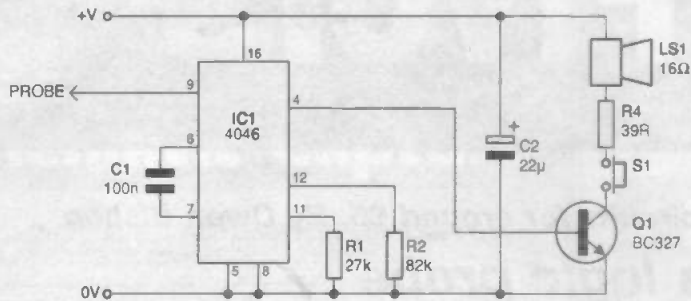

Figure 1: the circuit of the logic probe

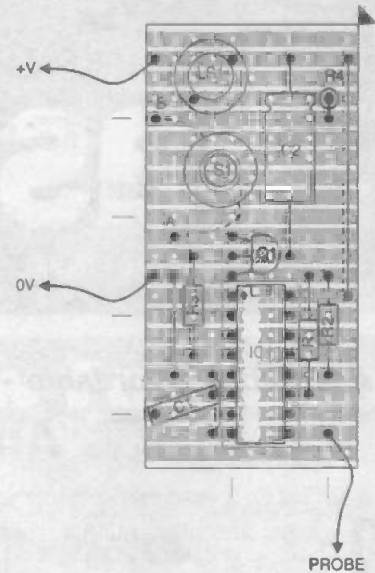

Figure 2: the stripboard layout of the logic probe

unpleasant screeching sound.

Oscillation, either intended or accidental, is a cause of apparently intermediate voltage levels. The levels are alternating between true logic low and true logic high but changing so rapidly that a voltmeter applied to the terminal shows a steady intermediate reading. With this probe this may give a two-tone 'warble' (can sound like a telephone ringing). If the oscillations are faster, it sounds more like a continuous 'high' but not as loud as usual. The loudness depends on the ratio between the time spent high and the time spent low. With a little experience you will soon learn to interpret the sounds and pick out their differences.

Construction

The circuit works on any voltage in the range 3V to 15V (18V is the absolute maximum) and is best driven from the supply of the circuit being tested. It is built on a small rectangle of stripboard (figure 2). We have designed it so that the copper strips run across the width of the board. The board could be housed in a small case with a rigid metal probe at one end and the power leads emerging from the other. The push-button is placed so that the forefinger rests naturally on it as you hold the case in your hand. Then you can easily press the button each time you touch the probe down on a test point.

LS1 is a mini magnetic transducer (not a piezo-transducer) specially intended for PCB mounting. The circuit will also work with a range of miniature loudspeakers if they have a resistance in the range 16 to 64 ohms. Some of these have a diameter of only 2 cm and can be mounted on the board if it is made slightly longer than shown. But do not use a 'buzzer' or any other type of sounder that produces its own tone.

We have mounted the push-switch directly in a hole drilled in the board. The switch is connected to wires soldered in the holes marked A and B. Alternatively you could mount the switch on the case and take leads from it to these two points. R4 in our design is a 39-ohm resistor, which reduces the volume of sound to a suitable level. You may find that you need a resistor of different value or perhaps may omit R4 and replace it with a wire link.

The circuit is so simple that it is best constructed and tested in one session. Connection to the power supply on the test piece is by two flexible wires ending in crocodile clips. We have had no trouble with feedback but, if the tone is 'harsh' when the probe is touched against the +V or 0V supply line, try increasing the value of C2.



Figure 3: the reverse of the strip layout

PARTS LIST

for the Audible Logic Probe

Resistors

(5 percent, 0.25W)

R1	27 k
R2	82 k
R3	10 k
R4	39R (see text)

Capacitors

C1	100nF polyester layer
C2	22nF electrolytic, axial

Semiconductors

IC1	CMOS 4046 phase-locked loop
Q1	BC327 or similar npn transistor
S1	push-to-make push-button switch
LS1	mini magnetic transducer, 16-ohm, or similar

Miscellaneous

Stripboard 58mm x 29mm (22 strips x 11 holes); 3 x 1mm terminal pins; 16-pin dil socket; 2mm wander plug or material for making a rigid probe; miniature crocodile clips (one red, one black).



**8 CAVANS WAY,
BINLEY INDUSTRIAL ESTATE,
COVENTRY CV3 2SF**
Tel: 01203 650702
Fax: 01203 650773
Mobile: 0860 400683

(Premises situated close to Eastern-by-pass in Coventry with easy access to M1, M6, M40, M42, M45 and M69)

OSCILLOSCOPES

Beckman 9020 - 20MHz - Dual Channel	£150
Cossor 3102 - 60MHz Dual Channel	£250
Gould OS 245A/250/255/300/3000/335/4000	from £125
Hewlett Packard 180A/1801/181A/182C	from £200
Hewlett Packard 1740A, 1741A, 1744A, 100MHz dual ch	from £350
Hewlett Packard 54100D - 1GHz Digitizing	£2995
Hewlett Packard 54200A - 50MHz Digitizing	£650
Hewlett Packard 54201A - 300MHz Digitizing	£1900
Hitachi V650F - 60MHz Dual Channel	£350
Hitachi V152FV302B/V302FV353FV550B/V650F	from £125
Intron 2020 - 20MHz Digital Storage (NEW)	£650
Iwatsu SS 5710/SS 5702 - 20MHz	from £125
Kikusui COS 6100 - 100MHz, 5 Channel, 12 Trace	£475
Kikusui 5100 - 100MHz - Dual Channel	£350
Meguro - MSO 1270A - 20MHz Digital Storage (NEW)	£650
Nicolet 310 - L.F. D.S.O. with twin Disc Drive	£550
Nicolet 3091 - L.F. D.S.O.	£900
Leeroy 9450A - 300MHz/400 Ms/s D.S.O. 2 ch	£2250
Philips PM 3211/PM 3212/PM 3214/PM 3217/PM 3234/PM 3240/PM 3243/PM 3244/PM 3261/PM 3262/PM 3263/PM 3540	from £125
Philips PM 3295A - 400MHz Dual Channel	£1750
Philips PM 3335 - 50 MHz/20Ms/s D.S.O. 2 ch	£1500
Philips PM 3055 - 50 MHz DUAL Timebase	£450
Tektronix 434 - 25MHz - 2 Channel Analogue Storage	£250
Tektronix 454 - 150MHz - 2 Channel	£400
Tektronix 468 - 100MHz D.S.O.	£750
Tektronix 2213 - 60MHz Dual Channel	£425
Tektronix 2221 - 60MHz Digital Storage 2 Channel	£1500
Tektronix 2215 - 60MHz Dual trace	£450
Tektronix 2235 - 100MHz Dual trace	£800
Tektronix 2335 - Dual trace 100MHz (portable)	£750
Tektronix 2225 - 50MHz dual ch	£450
Tektronix 2440 - 300 MHz/500 Ms/s D.S.O. 2 Ch	£3750
Tektronix 455 - 50MHz Dual Channel	£350
Tektronix 484/466 - 100MHz An storage	from £350
Tektronix 485/485B - 100MHz dual ch	from £350
Tektronix 475/475A - 200MHz/250MHz Dual Channel	from £475
Tektronix 485 - 350MHz - 2 channel	£900
Tektronix 5403 - 60MHz - 2 or 4 Channel	from £250
Tektronix 7313, 7603, 7613, 7623, 7633, 100MHz 4 ch	from £300
Tektronix 7704 - 250MHz 4 ch	from £650
Tektronix 7904 - 500MHz	from £850
Trio CS-1022 - 20MHz - Dual Channel	£125

Other scopes available too

SPECIAL OFFER

HITACHI V212 - 20MHz DUAL TRACE	£180
HITACHI V222 - 20 MHz DUAL TRACE + ALTERNATE MAGNIFY	£200

SPECTRUM ANALYSERS

Advantest 4133B - 10KHz - 20GHz (60GHz with external mixers) + Ext. Keyboard	£7250
Advantest 4131B - 10KHz - 3.5GHz	£4950
Ando AC8211 - Spectrum Analyser 1.7GHz	£2950
Anritsu MS610B - 10KHz - 2GHz - (Mint)	£4750
Anritsu MS341A + MS3401B - 10Hz - 30MHz	£3995 + £4995
Anritsu MS62B - 10KHz - 1700MHz	£2500
Avcom PSA65 S - 100MHz portable	£1500
Hewlett Packard 360A - 54Hz - 50KHz	£995
Hewlett Packard 182T with 8559A (10MHz - 21GHz)	£3750
Hewlett Packard 35601A - Spectrum Analyser Interface	£1000
Hewlett Packard 3562A Dual Channel Dynamic Sig. Analyser	£7500
Hewlett Packard 3562A Dual Channel Dynamic Sig. Analyser	£7500
Hewlett Packard 853A + 8558B - 0.1 to 1500MHz	£3250
Hewlett Packard 182T + 8558B - 0.1 to 1500MHz	£2750
Hewlett Packard 8754A - Network Analyser 4-1300MHz	£2000
Hewlett Packard 8591A - 9KHz - 1.8GHz	£4995
Hewlett Packard 8594E - 9KHz - 2.9GHz	£7000
Hewlett Packard 3582A - 0.02Hz - 25.6KHz (dual ch.)	£2000
Hewlett Packard 3585A - 20Hz - 40MHz	£4995
Hewlett Packard 8754A (opt. H26) - 4MHz - 2.6GHz	£3250
IFR 7750 - 10KHz - 1GHz	£995
Marconi 2370 - 110MHz	£1250
Marconi 2371 - 30KHz - 2000MHz	£1500
Meguro MSA 4901 - 1-300GHz (AS NEW)	£1995
Meguro MSA 4912 - 1-1GHz (AS NEW)	£1500
Poird 641-1 - 10MHz - 18GHz	£1800
Rohde & Schwarz - SWOB 5 Polyskop 0.1 - 1300MHz	£2800
Takeda Riken 4132 - 1.0GHz Spectrum Analyser	£2000
Tektronix 7L18 with mainframe (1.5-60GHz with external mixers)	£2000
Tektronix 495P - 100Hz - 1.8GHz programmable	£4950

MISCELLANEOUS

Adret 740A - 100KHz - 1120MHz Synthesised Signal Generator	£900
ANRITSU ME 462B DF3 Insulation Analyser	£3000
Danbridge JP30A - 30kV Insulation Tester	£1500
Anritsu MG642A Pulse Pattern Generator	£1500
Dranzet 626 - AC/DC - Multifunction Analyser	£850
EIP 331 - Frequency counter 18GHz	£700
EIP 545 - Frequency counter 18GHz	£1500
EIP 545A - Frequency counter 18GHz	£1600
EIP 575 - Frequency counter 18GHz	£1750
Farnell AP70-30 Power Supply (0.70v/30A) Auto Ranging	£750
Farnell TSV-70 MKII Power Supply (70V - 5A or 35V - 10A)	£250
Farnell DSG-1 Synthesised Signal Generator	£125
Farnell ESG-1000 Synthesised Signal Generator 1GHz (as new)	£1650
Flure 5100A - Calibrator	£1500
Gulldine 9152 - T12 Battery Standard Cell	£300
Hewlett Packard 331A - Distortion Analyser	£1000
Hewlett Packard 336C - Synthesised Signal Generator (10Hz - 21MHz)	£350
Hewlett Packard 3437A System voltmeter	£850
Hewlett Packard 3456A Digital voltmeter	£850
Hewlett Packard 3438A Digital multimeter	£200
Hewlett Packard 3488A - Switch/Control Unit	£650
Hewlett Packard 36600A Dual Ch. Dynamic Signal Analyser	£3750
Hewlett Packard 3711A/3712A/3791B/3793B Microwave Link Analyser	£2250
Hewlett Packard 3325A - 21MHz Synthesiser/Function Gen	£1500
Hewlett Packard 3488A - HP - 1B Switch control unit (various Plug-ins available)	£650
Hewlett Packard 3485A 6 1/2 Digit M/Meter (Arctical)	£750
Hewlett Packard 3478A - Multimeter (5 1/2 Digit) + HP - 1B	£550
Hewlett Packard 356A - Selective Level Meter	£1000
Hewlett Packard 3776A - PCM Terminal Test Set	£1500
Hewlett Packard 3779A/3779C - Primary Mux Analyser	from £600
Hewlett Packard 3784A - Digital Transmission Analyser	£4995
Hewlett Packard 37900D - Signalling Test Set (No 7 and ISDN)	£6000
Hewlett Packard 4262A - Digital LCR Meter	£1350
Hewlett Packard 4275A - LCR Meter (Multi-Frequency)	£3950
Hewlett Packard 4338A - Millionmeter (As New)	£2000
Hewlett Packard 4342A 'Q' Meter	£995

Hewlett Packard 435A or B Power Meter (with 8481A/8484A)	from £750
Hewlett Packard 4279A - 1MHz C-V Meter	£4500
Hewlett Packard 4848A - (TMS) Transmission Impairment M/Set	£1500
Hewlett Packard 4972A - Lan Protocol Analyser	£1750
Hewlett Packard 5420A Digital Signal Analyser	£350
Hewlett Packard 5335A - 300MHz High Performance Systems Counter	£600
Hewlett Packard 5314A - (NEW) 100MHz Universal Counter	£250
Hewlett Packard 5316A - Universal Counter (IEEE)	£500
Hewlett Packard 5183 - Waveform Recorder	£1750
Hewlett Packard 5238A Frequency Counter 100MHz	£250
Hewlett Packard 5370A - 100MHz Universal Timer/Counter	£450
Hewlett Packard 5384A - 225 MHz Frequency Counter	£650
Hewlett Packard 5385A Frequency Counter - 1GHz - (HP 1B) with OPTS 001/003/004/005	£995
Hewlett Packard 6253A Power Supply 20V - 3A Twin	£200
Hewlett Packard 6255A Power supply 40V - 1.5A Twin	£200
Hewlett Packard 6268B Power Supply 40V - 5A	£220
Hewlett Packard 6271B Power supply 60V - 3A	£225
Hewlett Packard 6622A - Power Supply, Dual O/P	£1650
Hewlett Packard 6623A - Power Supply, Triple O/P	£1750
Hewlett Packard 6652A - Power Supply (0 - 20V, 0 - 25A)	£1250
Hewlett Packard 6264B - Power Supply (0 - 20V, 0 - 25A)	£400
Hewlett Packard 7475A - 6 Pen Plotter	£250
Hewlett Packard 7550A - 8-Pen Plotter A3/A4	£450

HEWLETT PACKARD 6261B Power Supply 20V-50A £450 Discount for Quantities

Hewlett Packard 83555A - Millimeter - Wave source Module 33-50GHz	£4250
Hewlett Packard 8015A - 50MHz Pulse Generator	£750
Hewlett Packard 8405A - Vector Voltmeter	£350
Hewlett Packard 8165A - 50MHz Programmable Signal Source	£1650
Hewlett Packard 8350B - Sweep Oscillator Mainframe (various Plug-ins available) extra	£2650
Hewlett Packard 8152A - Optical Average Power Meter	£1250
Hewlett Packard 8158B - Opical Attenuator (OPTS 002 + 011)	£1100
Hewlett Packard 8180A - Data Generator	£1500
Hewlett Packard 8182A - Data Analyser	£2500
Hewlett Packard 8350B - Sweep Oscillator Mainframe (various plug-in options available)	£3500
Hewlett Packard 8620C Sweep oscillator mainframe	from £250
Hewlett Packard 8656A - Synthesised Signal Generator (990MHz)	£2000
Hewlett Packard 8656B - Synthesised Signal Generator	£2950
Hewlett Packard 8750A Storage normaliser	£375
Hewlett Packard 8756A - Scalar Network Analyser	£1500
Hewlett Packard 8757A - Scalar Network Analyser	£2250
Hewlett Packard 8903A - Audio Analyser (20Hz - 100KHz)	£2600
Hewlett Packard 8903E - Distortion Analyser (Mint)	£2000
Hewlett Packard 8958A - Cellular Radio Interface	£2000
Hewlett Packard 8901A - Modulation Analyser	£3400
Hewlett Packard 8920A - R/F Comms Test Set	£6000
Hewlett Packard 8922B - GSM Radio Comms Test Set	£995
Hewlett Packard P382A Variable Attenuator	£250
Hewlett Packard 1650A - Logic Analyser (43 Channels)	£650
Hewlett Packard 16500A - Fitted with 16510A/16515A/16530A/16531A - Logic Analyser	£4000
Hewlett Packard 11729B - Carrier Noise Test Set	£2000
Kroh-Hite 2200 Lin/Log Sweep Generator	£995
Kroh-Hite 4024A Oscillator	£250
Kroh-Hite 5200 Sweep, Function Generator	£350
Kroh-Hite 6500 Phase Meter	£250
Leader 3216 - Signal Generator (100KHz - 140KHz) AM/FM/CW with built-in FM stereo modulator (mint)	£995
Marconi 2019 - 80KHz - 1040MHz Synthesised Sig. Gen	£1450
Marconi 2019A - 80KHz - 1040MHz - Synthesised Signal Generator	£1600
Marconi 2022A - 10KHz - 1GHz AM/FM Signal Generator	£2000
Marconi 2041 - (10KHz - 2.7GHz) Low Noise	£7500
Marconi 2305 - Modulation Meter	£1995
Marconi 2610 - True RMS Voltmeter	£850
Marconi 2871 Data Comms Analyser	£1000
Marconi 2955 - Radio Comms Test Set	£3000
Marconi 8960 - Power Meter & Sensor	from £950
Philips PM 5167MHz function gen	£400
Philips 5190 L.F. Synthesiser (G.P.I.B.)	£800
Philips 5193 Synthesised Function Generator	£1500
Philips 5518 Synthesised Function Generator	£1500
Philips PM5519 - TV Pattern Generator	£350
Philips PM5716 - 50MHz Pulse Generator	£525
Philips PM6652 - 1.5GHz Programmable High Resolution Timer/Counter	£900
Philips PM6673 - 1.5GHz High Resolution Universal Counter	£430
Prema 4000 - 6 1/2 Digit Multimeter (NEW)	£450
Racal 1992 - 1.3GHz Frequency Counter	£800
Racal Dana 9081/9082 Synth sig. gen. 520MHz	from £500
Racal Dana 9084 Synth. sig. gen. 104MHz	£450
Racal Dana 9303 R/F Level Meter & Head	£850
Racal Dana 9917 UHF frequency meter 560MHz	£175
Racal Dana 9302A R/F multivoltmeter (new version)	£375
Racal Dana 9082 Synthesised am/fm sig gen (520MHz)	£500
Racal 9301A - True RMS R/F Multivoltmeter	£300
Racal 6111/6151 - GSM Radio Comms Test Set	£POA
Rohde & Schwarz LFM2 - 60MHz Group Delay Sweep Gen	£1600
Rohde & Schwarz Scud Radio Code Test Set	£300
Rohde & Schwarz CMS 54 Radio Comms Monitor	£6250
Rohde & Schwarz GMTA 94 GSM Radio Comms Analyser	£7500
Schaffner NSG 203A Lin Voltage Variation Simulator	£950
Schaffner NSG 222 Interference Simulator	£850
Schaffner NSG 223 Interference Simulator	£850
Schaffner WSG 431 Electrostatic Discharge Simulator	£1250
Schlumberger 4031 - 1GHz Radio Comms Test Set	£4995
Schlumberger 2720 1250MHz Frequency Counter	£500
Schlumberger 7060/7065/7075 Multimeters	from £350
Schlumberger Stabilcock 4040 Radio Comms Test Set	£3500
Solartron 1250 - Freq. Response Analyser	£2500
Stanford Research DS 340 - 15MHz Synthesised Function (NEW) and arbitrary waveform generator	£1200
Systron Donner 6030 - Microwave Frequency Counter (26.5GHz)	£2500
Tequipment CT71 Curve Tracer	£500
Tektronix TM5003 + AFG 5101 Arbitrary Function Gen.	£1500
Tektronix 1240 Logic Analyser	£500
Tektronix DAS100 - Series Logic Analyser	£500
Tektronix - Plug-ins - many available such as SC504, SW503, SG502, PG508, FG504, FG503, TG501, TR503 + many more	£POA
Tektronix AM503 + TM501 + P6302 - Current Probe Amplifier	£995
Tektronix PG506 + TG501 + SG503 + TM503 - Oscilloscope Calibrator	£1995
Tektronix AA5001 + TM5006 M/F - Programmable Distortion Analyser	£1995
Tektronix 577 - Curve Tracer	£1150
Time 9811 Programmable Resistance	£400
Time 9814 Voltage Calibrator	£550
Toelflner 7720 - Programmable 10MHz Function Gen (AS NEW)	£700
Valhalla Scientific - 2724 Programmable Resistance Standard	£POA
Wandel & Goltermann PFJ-B - Error/Jitter Test Set	£1100
Wandel & Goltermann PCM4 (+ options)	£250
Wayne Kerr 4225 - LCR Bndge	£12500
Wayne Kerr 6425 - Precision Component Analyser	£600
Wayne Kerr 8905 - Precision LCR Meter	£275
Wavetek 171 - Synthesised Function Generator	£850
Wavetek 172B Programmable Sig Source (0.0001Hz - 13MHz)	£250
Wavetek 184 - Sweep Generator - 5MHz	£POA
Wavetek 3010 - 1-1GHz Signal Generator	£1250
Wiltron 6409 - RF Analyser (1MHz - 2GHz)	£POA
Wiltron 6620S - Programmable Sweep Generator (3.6 - 6.5GMz)	£650

**MANY MORE ITEMS AVAILABLE -
SEND LARGE S.A.E. FOR LIST OF EQUIPMENT
ALL EQUIPMENT IS USED &
WITH 30 DAYS GUARANTEE.
PLEASE CHECK FOR AVAILABILITY BEFORE
ORDERING - CARRIAGE & VAT TO BE ADDED
TO ALL GOODS**

Guardian Light

If you lose lighting through a power cut, Terry Balbirnie's Guardian Light provides an automatic, battery-backed lighting system to see you through

You have probably noticed emergency lighting systems in shops and other public places. These are essential to allow people to find their way out if the mains supply fails, especially at night. Emergency lighting helps to prevent people panicking and saves lives, especially in a power failure caused by fire.

Lighting the way

This circuit allows you to build a small emergency lighting unit for your own home. The elderly would benefit, as they could sit comfortably until power was restored. It would also be useful in houses with dark passages, especially where there are frequent power cuts. Note that this system is for use only in private homes and other places where no emergency lighting regulations exist.

The emergency lighting system is a unit that can be placed on a shelf and plugged into a nearby mains socket. There is an on-off switch and a neon indicator which confirms that the supply is on. The lamp itself is plugged into a socket and placed in some convenient position.

Making sense

The unit contains a 12V lead-acid battery which is maintained in a fully-charged state while a mains supply exists. It will then power the lamp when there is a power failure. On top of the unit is a hole which allows light to reach a sensor on the circuit panel. This prevents the lamp from coming on if there is already sufficient light in the room.

The bulb could be of the car type of, say, 5W rating. Such a lamp would operate for about 15 hours using the specified battery, and this would suffice for most purposes. Alternatively, a bulb of lower rating could be used to give a longer operating time. You could also use a small fluorescent light (the 12V caravan or boat type). The nominal 8W variety (which, in practice requires about 1A) would give some 6 hours of operation. **Lamps requiring more than 1A (12W) must not be used with this unit. This is chiefly for the sake of the PCB tracks.**

If lead-acid batteries are left in a deep discharged state (that is, discharged much below a certain low point) they can suffer permanent damage, despite what the supplier's data might say. In the present circuit, this is prevented by an audible warning given below a nominal 10V. The lamp will also become noticeably dimmer. The user must then switch it off using the lamp on-off switch on the front panel.

How it works

The circuit for the Guardian Light is in **figure 1**. The mains supply is connected to transformer T1 primary winding via on-off switch S1 and fuse FS1. LP1 glows while the mains supply is on.

The transformer has two 9V secondary windings which

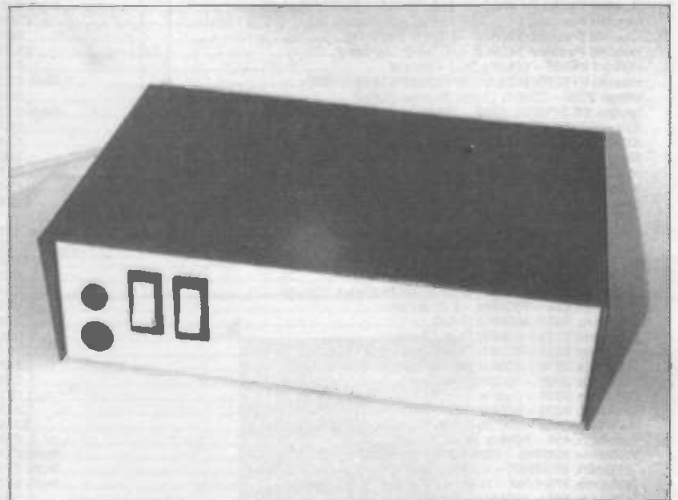

are connected in series to give a nominal 18V ac supply. This is used in conjunction with bridge rectifier REC1 and C1 to provide a smooth dc on-load output of some 18V to 20V. Fuse FS2 provides protection to this part of the circuit.

The supply is applied to the input (pin 1) of IC1, the voltage and current regulator. This provides a fixed voltage output of between 13.5V and 13.8V, which is correct for continuous ("trickle") charging the type of battery used, and limits the current to what is safe to supply to the circuit. The limit used here is 200mA. C2 and C3 are needed for stable operation of the ic.

At a low point

Disregarding the current-limiting aspect for the moment, the charging current would normally be related to the difference between the supply voltage and that of the battery. Thus, with the battery terminal voltage at the low point of 10V, the difference would be about 3.5V to 3.8V and the current would be relatively high. As the battery charges, its terminal voltage rises, the voltage difference decreases and the charging current falls. When fully charged, the difference between the two voltages is very small and only a "trickle" current of a few milliamps remains. This may be left flowing continuously and serves to keep the battery in good condition by overcoming the small loss of charge which inevitably occurs.

However, the process above is modified because, at the beginning of the charging process when the voltage difference is at a maximum, the current is limited by IC1 to a safe working value. This prevents damage to both the battery and power supply. The specified transformer is of the 6VA type and can therefore supply a maximum of 333mA into a resistive load. However, due to the smoothing capacitor, it must be de-rated, hence the chosen current limit of 200mA. During most of the charging cycle, the current will, of course, be much less.

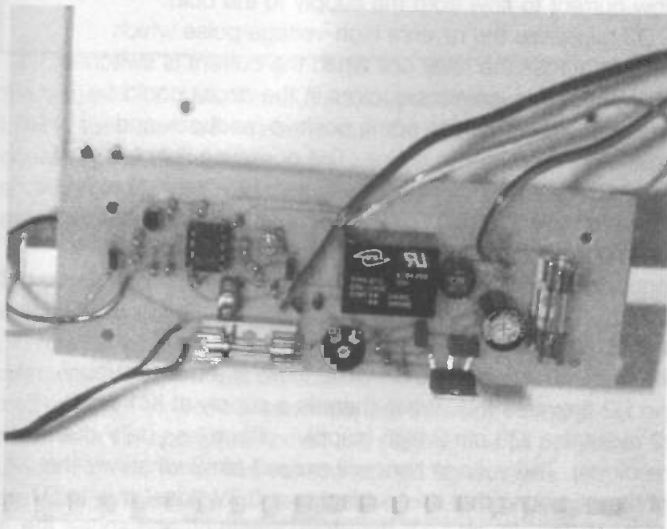
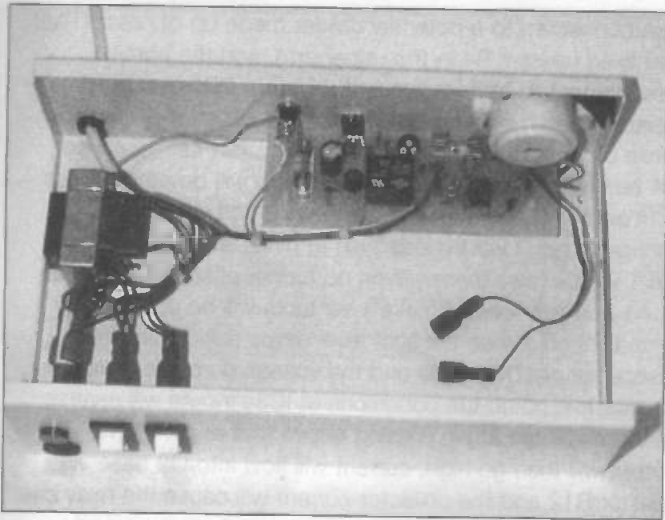

Voltage regulation

R1 connected between IC1 pins 3 and 4 operates with preset pot RV1, connected between pins 2 and 4, to determine the voltage at pin 2. On construction, the preset will be adjusted so that between 13.5V and 13.8V appears at the cathode of D1. Therefore between 14.2V and 14.5V must be provided at pin 2. The voltage difference is necessary to take account of the approximate 0.7V forward voltage drop of the diode.

The pair of resistors R2, connected between IC1 pins 5 and 2, determine the maximum current which can be delivered by the output. The two resistors are connected in parallel to obtain a close match to the value required (2 ohms). The current-limiting aspect of the circuit works as follows: current flows from pin 5, through resistor(s) R2 and develops a small voltage across it. This is sensed by pin 2, and if it exceeds 0.4V, the ic turns the current down to maintain 0.4V. The resistor value required (R) for a given current limit (I) is given by this formula:

$$R = 0.4/I$$

However, the voltage threshold 0.4V is subject to a certain tolerance, as are the resistors. The small resistance of the inter-connecting tracks on the PCB must be taken into account, so the current limit is only a nominal figure.

The voltage difference between IC1 pins 1 and 2

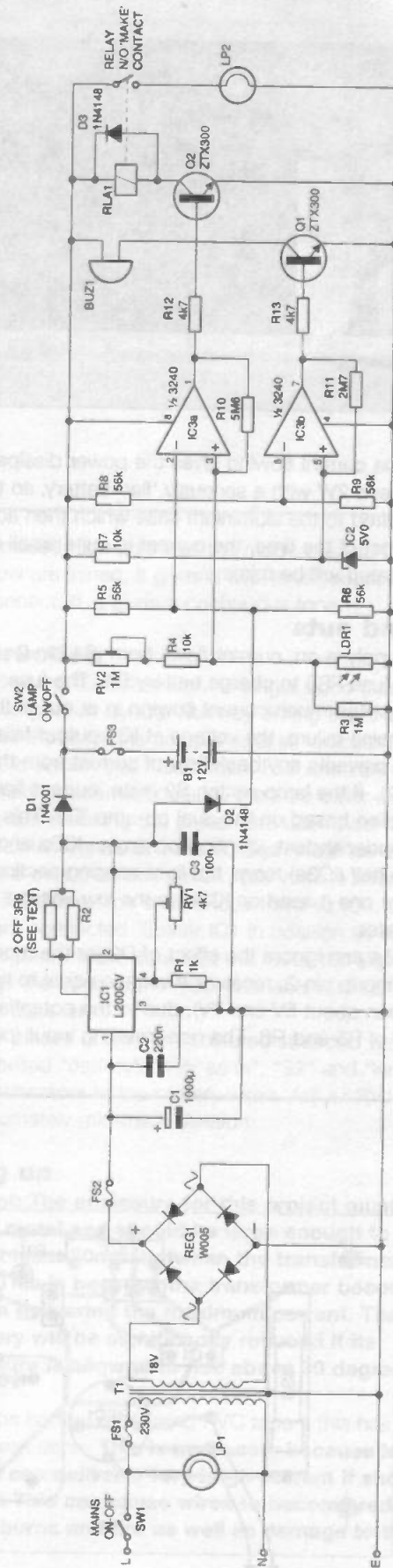
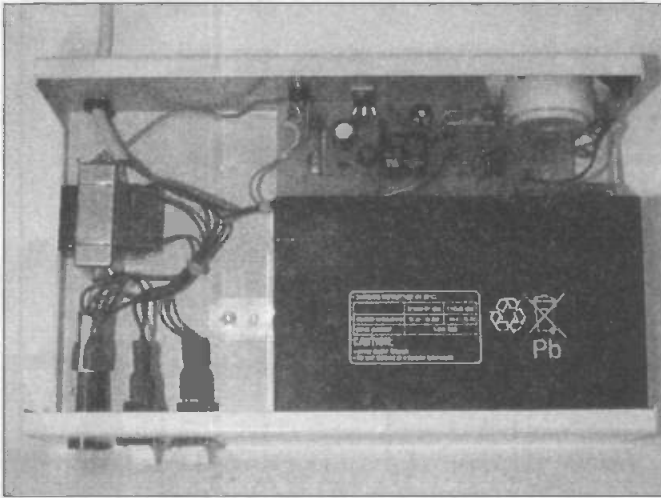

Figure 1: the circuit of the Guardian Light



multiplied by the current flowing gives the power dissipated. This could exceed 2W with a seriously 'flat' battery, so the metal tab is bolted to the aluminium case which then acts as a heat sink. Most of the time, the current is quite small and the heat dissipated will be minimal.

The ins and outs

If the mains supply is on, current flows from IC1 pin 2 via diode D1 and fuse FS3 to charge battery B1. The fuse protects against too much current flowing in or out of the battery. In a mains failure, the voltage at IC1 output falls to zero. D1 then prevents any back flow of current from the battery into IC1. If the lamp switch S2 is on, current flows to the circuit section based on the dual op-amp IC3. This contains two independent, identical op amps, IC3a and IC3b. The top half (IC3a) forms the light-sensing section while the lower one (based on IC3b) is the low-voltage warning indicator.

Look at IC3a and ignore the effect of D2 for the moment. The inverting input, pin 2, receives a voltage equal to half the supply (between about 5V and 7V), due to the potential divider action of R5 and R6. The non-inverting input (pin 3) is

also connected to a potential divider made up of preset RV2 and fixed resistor R4 in the upper arm, and the parallel arrangement of light-dependent resistor LDR1 and fixed resistor R3 in the lower one. Ignore the effect of R3 for now. While there is sufficient light reaching LDR1, its resistance will be low and a relatively small voltage will develop across it. Providing this is less than half that of the supply, the voltage at pin 3 will be less than at pin 2, and IC3a output pin 1 will be low. There will be no further effect and relay RLA1 normally-open ("make") contacts will be open with lamp LP2 off. When the light level drops sufficiently, the resistance of LDR1 rises and the voltage across it increases. At a certain point, the conditions at IC3a inputs will reverse with the voltage at pin 3 rising above that at pin 2. The output will then go high, current will flow into Q2 base via resistor R12 and the collector current will cause the relay coil to energise. The normally-open contacts then close and allow current to flow from the supply to the bulb.

D3 bypasses the reverse high-voltage pulse which appears across the relay coil when the current is switched off. Without this, semiconductors in the circuit could be damaged. R10 provides some positive feedback and sharpens the switching action. The operating light level will remain the same with variations in supply voltage (that is, as the battery discharges). This is because the voltage at each op-amp input falls in the same proportion, so the relative conditions remain unchanged.

A bit inhibited

The bulb must not come on while there is a mains supply, and D2 prevents this. While there is a supply at IC1 pin 2, D2 maintains IC3 pin 2 high (supply voltage less 0.7V due to the diode). The voltage here will exceed pin 3 whatever the light level, noting that it is subject to a 0.7V "loss" due to D1 as usual. The op-amp will therefore remain off and so will the lamp. Most LDRs have a very high resistance in total darkness, almost an open circuit - probably much higher than the stated "dark" resistance. R3 is in parallel with the LDR, so the resistance of the two can never be greater than

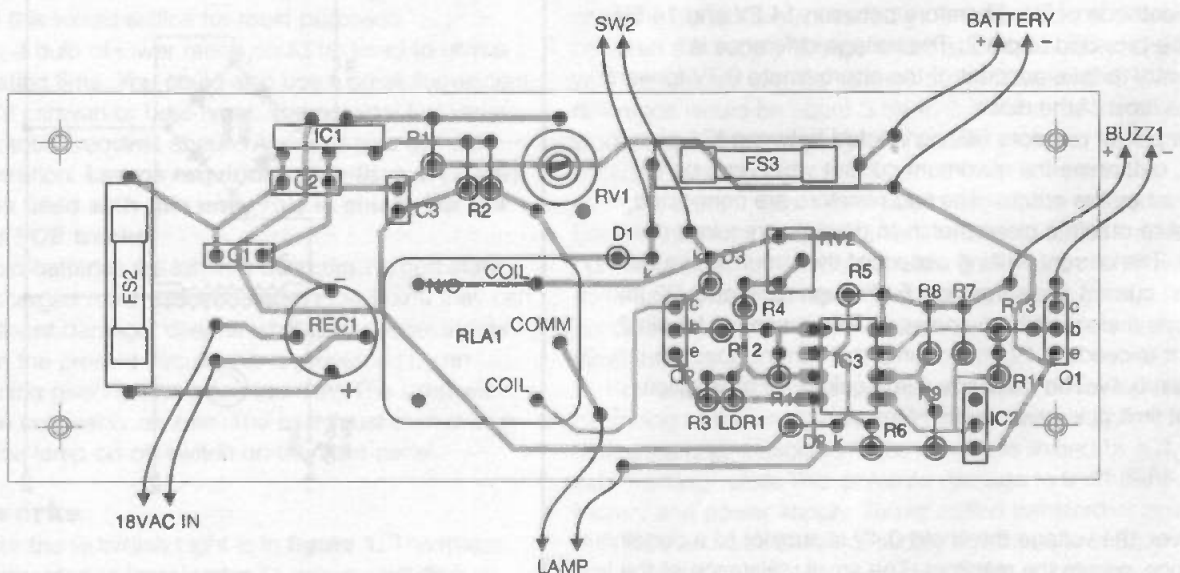

Figure 2: the component layout of the Guardian Light

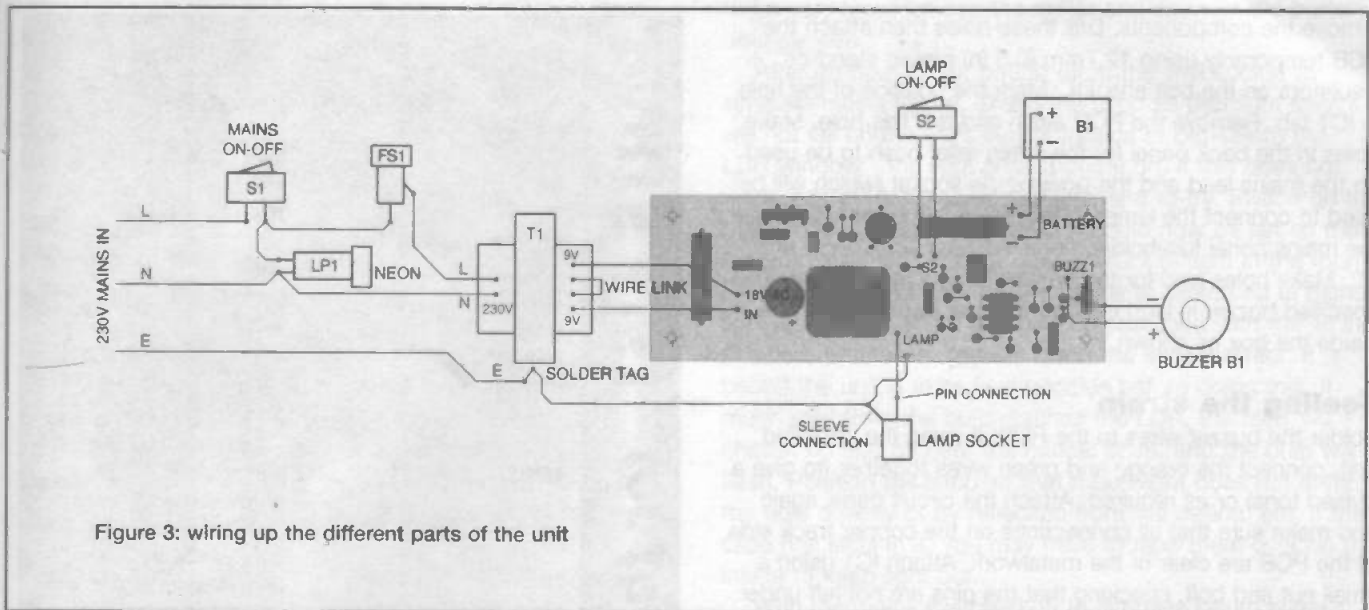

Figure 3: wiring up the different parts of the unit

the value of R3 (1M). Without R3, the voltage across the LDR in total dark would rise to that of the supply, where it could exceed the voltage at pin 2 and switch on the op amp and the lamp. When more light reaches the LDR, R3 has only a small effect.

Sound warning

In the low-voltage warning section, IC3b non-inverting input pin 5 receives a fixed voltage of 5.0V due to the voltage reference IC2. R7 allows sufficient current to flow through it to enable it to work. Meanwhile, the inverting input, pin 6, receives a voltage equal to half the supply, due to potential divider R8/R9. When the voltage across B1 exceeds 10V, the voltage at pin 6 exceeds that at pin 5 and the output, pin 7, will be low. This will also be the case when there is a mains supply. If the supply voltage falls below 10V, the voltage at pin 6 will be less than 5V, pin 7 will go high and current will pass through R13 into the base of Q1. Collector current will then flow through the buzzer, sounding it. R11 provides some positive feedback and, as with IC3a, sharpens the switching action.

It is important to switch off the lamp using S2 soon after the warning sounds. If this is not done, the terminal voltage would eventually fall to the point where the relay "drops out". However, this does not happen until it reaches approximately 2V. The battery is likely to suffer some damage unless re-charged promptly.

Battery specification

The specified battery totally sealed with a nominal capacity of 6.5 amp-hours: it could supply, say, 0.5A for about 13 hours. However, with a bulb of very low rating it will last longer. A larger capacity battery would be more expensive, bulky and probably unnecessary. Note that a battery designed for cyclic use (repeated charging and discharging) will last longer than the ordinary kind. However, the type designed for "float" operation will work well providing the lamp does not discharge it to the low point too often.

The buzzer should be loud while drawing only a small current. The prototype uses a pulsed-tone type (see the parts list). This has the usual red (positive) and black (negative) wires plus three others in green orange and yellow. If the green and orange wires are connected together it

emits a pulsed tone (this was the mode I used). If the green and yellow are joined, it gives a two-tone sound. If they are left unconnected, it gives a continuous tone.

Construction

The PCB of the Guardian Light is single sided (see figure 2 for the component layout). Start by drilling the four mounting holes, and those for the components as indicated. Solder the relay, IC socket and fuseholders FS2 and FS3 into place. Add C1 taking care with polarity, then the other capacitors and resistors including the preset and LDR. Add the diodes, bridge rectifier, transistors and voltage reference device taking care over their orientation. The voltage reference IC has one flat side which should face towards IC3. Only two of its pins are connected. Solder IC1 in position as shown in the photograph. Make sure that the metal tab slightly overhangs the edge of the PCB to enable it to be bolted to the metal case later.

Solder pieces of different-coloured stranded wire to the points labelled "battery", "18V ac in", "S2" and "lamp". Fit spade connectors to the battery wires. Adjust RV1 and RV2 to approximately mid-track position.

Boxing up

Important: The enclosure for this project must be made of metal and should be large enough to allow a gap of at least 50mm between the transformer and battery. This is because the transformer becomes quite hot when delivering the maximum current. The life of the battery will be significantly reduced if its temperature is allowed to rise above 30 degreesC.

Insulate the battery tags using PVC tape if this has not already been done. **This is necessary because lead-acid batteries can deliver a very large current if short-circuited. This can cause wires to become red hot and result in burns and fire as well as damage to the battery.**

Place the PCB, battery and transformer on the base of the box in their final positions (see photograph). Because the battery is fully sealed, it may be mounted on its slide. Make sure that IC1 touches the case so that it can be bolted in position. Mark the PCB and transformer fixing holes and

remove the components. Drill these holes then attach the PCB temporarily using 12.7mm (0.5 in) plastic stand-off insulators on the bolt shanks. Mark the position of the hole in IC1 tab. Remove the PCB again and drill this hole. Make holes in the back panel for the strain relief bush to be used on the mains lead and the power-type socket (which will be used to connect the lamp). Make holes in the front panel for the mains panel fuseholder, neon indicator and for S1 and S2. Make holes also for the buzzer, depending on type. The specified buzzer is loud enough to allow it to be mounted inside the box as shown.

Feeling the strain

Solder the buzzer wires to the PCB. If using the specified unit, connect the orange and green wires together (to give a pulsed tone) or as required. Attach the circuit panel again and make sure that all connections on the copper track side of the PCB are clear of the metalwork. Attach IC1 using a small nut and bolt, checking that the pins are not left under any strain. No mounting kit or heat transfer compound is necessary but you should scrape the paint away from the contact area and attach the ic firmly to make good metal-to-metal contact. Attach the buzzer.

Mount the transformer with the solder tag on one of its fixings. Attach the battery on the base of the box using a small bracket. Do not connect it up yet. Attach also the switches, neon indicator and lamp connector socket. Measure the position of the LDR on the PCB and drill a hole of diameter 8mm approximately in the top section of the box to correspond. Note that the LDR should lie about 50mm beneath the hole. This will make its response very directional and will minimise the amount of light reaching it from the lamp being controlled (which is important).

Refer to **figure 3** and complete the low-voltage wiring. Note that when wiring up the lamp socket, the outer (sleeve) connection must be connected to the negative "lamp" wire on the PCB (that is, the lower one).

Mains section

Now do the internal mains wiring. Use mains-rated wire and follow all relevant safety precautions. In particular, use an insulating cover for the transformer primary tags and a plastic boot on the panel fuseholder. Use fully-insulated spade receptacles on the mains on-off switch, panel fuseholder and neon indicator connections (see photograph).

Make a suitable input lead using 3A three-core wire. Secure it using the strain relief bush leaving a little slack inside the case. Fit a 2A or 3A fuse in the plug if it is of the UK pattern. Hook the earth wire and a further short piece of earth wire through the hole in the solder tag and solder them securely in place. Solder the short piece of wire to the negative (sleeve) connection of the lamp socket.

Before proceeding, check that it is impossible to touch any mains connections at the transformer primary, fuseholder, neon indicator, on-off switch or anywhere else

Finishing off

Insert the fuses into their holders. Note that fuse FS1 (for the panel fuseholder) must be of the mains high-rupture ceramic type as specified. Do not use a glass fuse here. Insert IC3 into its socket. Since this is a CMOS component, it is vulnerable to damage by static charge. To avoid this, touch

PARTS LIST for the Guardian Light

Resistors

All fixed resistors 5 percent carbon film.

R1	1k
R2	3.9R (2 off) - see text.
R3	1M
R4	10k
R5, R6, R8, R9	56k
R7	10k
R10	5M6??
R11	2M7
R12, R13	4k7
VR1	4k7 min horizontal preset
VR2	1M min vertical preset
LDR1	Miniature LDR with nominal "dark" resistance 500k approximately - see text. (Maplin AZ81C.)

Capacitors

C1	1000u PCB electrolytic; 35V
C2	220n metallised polyester 5 mm pin spacing.
C3	100n metallised polyester 2.5 mm pin spacing.

Semiconductors

IC1	L200CV
IC2	REF50Z (Maplin DB 59P.)
IC3	CA3240E
REC1	W005
D1	1N4001
D2	1N4148
Q1, Q2	ZTX300

Miscellaneous

S1	Mains-rated SPST rocker switch
S2	SPST toggle, rocker or slide switch
RLA	Miniature relay with 5A contacts and 12V coil. (Maplin JM18U.)
BUZ1	12V dc buzzer - see text. (Maplin KU60Q.)
B1	12V 6Ah to 7Ah sealed lead acid battery - see text.
FS1	20mm panel fuse holder and ceramic 1A fuse
FS2	20mm chassis fuse holder and 1A fuse.
FS3	20mm chassis fuse holder and 2A fuse

Aluminium box size: 152 x 114 x 44mm; 8-pin dill socket; panel power-in socket and line plug; mains neon indicator; transformer primary cover; fully-insulated spade receptacles; plastic boot; 12.7mm plastic stand-off insulators; small fixings.

Most of the components for this project are freely available.

something which is earthed (such as a water tap) before unpacking it and handling the pins.

Prepare a suitable lead for the lamp and fit the plug. The wire should not be too thin or there will be an excessive voltage drop (especially over a long length) and the bulb will be dim. It seems that suitable bayonet-type holders for small filament lamps are not readily available. You may end up having to solder the wires in position. This is acceptable since the lamp will probably not be on very often and will have a very long life.

Testing

Plug the lamp into the socket. Plug the unit into the mains and switch on. Note that if RV1 has been set to deliver less than 10V to the circuit, the buzzer will sound. It would therefore be wise to cover its hole with some PVC tape until testing is complete! Check that the neon indicator glows. With switch S2 on and with the battery still disconnected, measure the voltage between the battery connectors. Adjust RV1 until it lies between 13.5 and 13.8V (clockwise rotation of the sliding contact increases it). If S2 is off, there will be no load on the system, the forward voltage drop of D1 will be very small and this will result in a figure which is too low. In operation, switch off the mains and connect the negative battery terminal only, taking care over the polarity and observing the precautions to prevent short circuits mentioned earlier. Switch on the mains and measure the charging current to make sure it is below the limit. To do this, set the meter to a suitable current range and connect its leads between the unoccupied battery tag and the free wire. Since the battery is probably well-charged when supplied, the current is likely

to be very low. Remove the meter and connect the battery positive wire.

After an hour or so, switch off at the wall socket to simulate mains failure. Shield the lamp so that light from it will not fall on the LDR. Apply a piece of Blu-Tak to the LDR window - the light should come on. If this does not work, adjust RV2 clockwise a little and re-try. Switch on the mains and it should go off. RV2 should now be set so that the unit operates with the right amount of light in the room. Clockwise rotation causes the circuit to switch on at higher light levels. The effect can only be assessed with the lid in position, otherwise light will reach the sensor direct. It is best if the unit is in its final position before doing this. If much light from the bulb reaches the LDR, the relay will chatter on and off near the critical point, and the bulb will flash. Position the lamp so that much light does not enter the hole directly or by reflection from the ceiling, etc. If the case has slots in it, you may have to tape them over on the inside to keep light out.

With the mains switched off to simulate failure again, allow the bulb to discharge the battery to the low point. Use the voltmeter to monitor the terminal voltage from time to time. At 10V approximately, the buzzer should sound. At this point, re-charge the battery. Check the current again. It should be about 200mA. If it is too high, adjust it by raising the value of R2. Note that the case will become warm, especially at the beginning of the charging cycle when the current is at a maximum.

Normally, the unit will be left in place and forgotten. Remember to switch off the lamp promptly if the warning sounds. Remember also to switch it on again when power is restored.

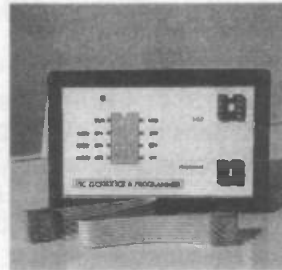

PIC12C508/9 ICE and PROGRAMMER

£59.95

In Circuit Emulator and Programmer. Supplied with Software, Data sheets Manual, leads, 10 breadboard circuits which include DVM, StopWatch, Smoke Alarm, Sound & Light.

PIC ICE II

£59.95

In Circuit Emulator for 54/55/56/57/71/84 PICs. A/D emulated for 16C71. Supplied with leads, manual and hardware projects.

UNIVERSAL PIC PROGRAMMER

£49.95

Read/Write/Copy PIC's 52, 54+A, 55, 56, 57+A, 58A, 61, 62, 64, 65, 71, 73+A, 74, 83, 84, 554, 558, 620, 621, 622, 14000, 12C508/9. Memory 24C01, 2, 16, 32, 65. Universal ZIF socket, best value on the market. FREE Software upgrades.

SERIAL EPROMMER

£34.95

Read/Write all 8 pin Serial EProms, 24, 93, 85 series. 12C. MicroWire etc. Found in Satellite, Digital Dashboards & TVs. Centronics port self powered.

EPROM EMULATOR

£59.95

128k by 8 bit or 2 x 64k by 8 bit. Software to Read/Write when connected to target board. CPU's or Car EM Systems.

PICPOCKET

£39.95

Standalone D2mac/VC2 programmer, computer not required. Supplied with latest D2mac Code. Runs from 9v Battery

All products manufactured in MALTA and carry 12 months Parts & Labour guarantee.

LEADING EDGE TECHNOLOGY LTD

WHITE ROSE HOUSE, XINTILL STR, TARXIEN PLA 11 MALTA
ORDER DIRECT: Tel: (00 356) 678509 Fax (00 356) 667484
SAME DAY DESPATCH

P/P UK. EEC £4.00 NO VAT PAYABLE

ALL MAJOR CREDIT CARDS ACCEPTED

DELUXE SMARTCARD PROGRAMMER

£79.95

Read/Write/Copy ALL types of Smartcard ISO, Memory, PIC, GSM, VideoCrypt, Telephone, D2Mac, Mondex etc. Supplied with interesting Card information, and software.

STANDARD ISO SMARTCARD PROGRAMMER

£25.00

Read, Program ISO7816 Cards (GSM, VC, Mondex etc). Supplied with ISO card information.

MEGAPROM EPROM PROGRAMMER

£69.95

Programs up to 8 Meg devices (32pin), including EProm, FLASH and 24X series. Built in Ram tester. Universal quality ZIF socket, free software updates.

GAL PROGRAMMER

£49.95

Read/Write/Copy SGS / NSC / Lattice etc 16V8A/B/Z and 22V10NSC standard JEDEC files. Smart case with ZIF. Supplied with PSU, Manual & Compiler software.

P87C51/2 PROGRAMMER

£39.95

Read/Write/Copy all makes of 87C51/2 including ATMEL flash 89 series. Universal 40 pin ZIF. Smart case user friendly.

CODEMASTER

£99.95

Hand Held D2mac / VC2 programmer 32 Char LCD screen & Keyboard. Store up to 7 Cards in unit. Supplied with Latest D2mac, VC2 Codes.

ALL PRODUCTS REQUIRE AN IBM PC TO OPERATE UNLESS OTHERWISE STATED.
FOR FURTHER INFORMATION SEE OUR WEB SITE OR TELEPHONE/FAX.
<http://LET.camb.net/> johamorr@mail.keyworld.net

We also manufacture DASH MASTER the handheld Digital Dashboard tool.
Always in stock: Blank SmartCards & PICs, Tel/Fax for current prices.



DISTRIBUTORS
UK CROWNHILL
SPAIN COELMA
FRANCE MULTIPOWER 0033169301379

Telephone
01353 666709
00341 3290523



Magnetic Swipe Card Reader

An ISO track 2 card reader with PC-based Turbo Pascal software, by Magnus Pihl

If you've ever wondered what kind of information is written on the magnetic strip on your plastic cards, or want to build a security system around a card reader, this is for you. The applications of this little card reader are many, from simply exploring the technology used with magnetic card swipe readers, to building a full access control for an alarm system or doorlock. The application example given here is for a PC-based system. No PCB is needed.

How card readers work

There are several types of card reader: there are swipe readers, motor-driven readers and motor driven readers/writers. Swipe readers are the cheapest, and that is what we will use here. There are actually two types of swipe readers, the swipe readers with a TTL interface or swipe readers with an RS232 interface. The swipe readers with the TTL interface (actually just without RS232 interface) are the cheapest, and cost typically about £20, and - guess what! - that's what I have used in this application.

Omron's manual swipe card reader 3S4YR-HNR-4U is the one used in my prototype. This reads the ISO track 2 on the card. The BPI (bits per inch) can be adjusted manually by a switch inside the reader, and it can easily be rebuilt to read ISO track 1 or ISO track 3. Tracks 1 and 3 written at 120bpi, and ISO track 2 is written at 75bpi. When reading ISO track 2, the BPI switch should be set to 75BPI, the ISO standard for track 2.

A card can have several tracks that can be written on. Cards that follow the ISO standard have three tracks. The most used track is Track 2 is most used, so choose a card reader that can read ISO track2, like the Omron's 3S4YR-HNR-4U. The connector has nine pins, configured as follows:

1	N.C.	Not connected
2	N.C.	Not connected
3	N.C.	Not connected
4	RDP	Read data pulse
5	RCP	Read clock pulse
6	CLS	Card loading signal
7	CSV	Current save
8	+5V	Power supply
9	Ground	Ground

In this application I only use RDP, RCP, +5V and Ground. Then, using the PC to read the RCP and RDP signals, and

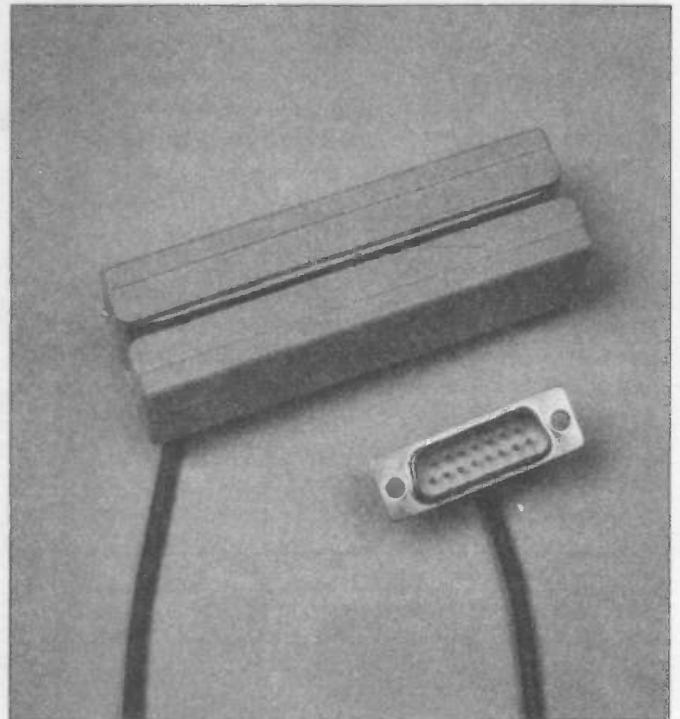

convert them to Ascii, I can read out the information. See figures 1 and 2 to see how the program decodes the data.

You cannot encode (programme) a card with a swipe reader. Encoders cost around £500-£1000, and are always motor-driven.

Construction

I use the PC's games port to interface to the reader. The connector is a 15-pin DSUB connector. Using a four wire shielded cable, connect the reader to the D-SUB

Reader configuration for the Omron 3S4YR-HNR-4U

connector as follows:

Reader	D-SUB
4 (RDP)	7
5 (RCP)	2
6 (CLS)	14
8 (+5V)	9
9 (GND)	4,5,6,12

(Use the cable shield as GND)

The software

Turbo Pascal:

Program CardReader;

Uses Crt;

Const

gameport=\$201;

var

ch,a:array[1..200] of integer;

l:array[1..5] of integer;

i,j,p,x,cn:integer;

end_flag:integer;

Procedure Wait_start;

Begin

Repeat Until (Port[gameport] and 32)=0;

End;

Procedure Wait_clock;

Begin

Repeat Until (Port[gameport] and 16)=0;

End;

Procedure Wait_clock_end;

Begin

Repeat Until (Port[gameport] and 16)=16;

End;

Function data_input:byte;

Begin

If (Port[gameport] and 32)=0 Then

data_input:=1

Else data_input:=0;

End;

Procedure Read;

Begin

wait_start;

for i:=1 to 200 do

begin

wait_clock;

a[i]:=data_input;

wait_clock_end;

end;

End;

Procedure LRC_count;

begin

if end_flag=0 then

begin

if ch[cn]=15 then end_flag:=1+5;

if a[i]=1 then inc(l[1]);

if a[i+1]=1 then inc(l[2]);

if a[i+2]=1 then inc(l[3]);

if a[i+3]=1 then inc(l[4]);

if a[i+4]=1 then inc(l[5]);

end;

end;

Procedure Parity_check;

Begin

if (p mod 2 = 0) and (a[i+4]=0)

then begin writeln('Parity

Error');i:=300;end;

if (p mod 2 <> 0) and (a[i+4]=1)

then begin writeln('Parity

Error');i:=300;end;

end;

Procedure Translate;

Begin

for i:=1 to 5 do

l[i]:=0;

i:=1;cn:=1;end_flag:=0;

while l<200 do

begin

j:=0;p:=0;

if a[j]=1 then begin j:=j+1;inc(p); end;

if a[j+1]=1 then begin j:=j+2;inc(p); end;

if a[j+2]=1 then begin j:=j+4;inc(p); end;

if a[j+3]=1 then begin j:=j+8;inc(p); end;

ch[cn]:=j;

parity_check;

lrc_count;

i:=i+5;

inc(cn);

end;

End;

Procedure Print;

begin

for i:=1 to 40 do

begin

if ch[i]>10 then write(ch[i]);

if ch[i]=11 then write('<');

if ch[i]=13 then write(' ');

if ch[i]=15 then begin

writeln('>');i:=40;end;

end;

end;

Procedure LRC_check;

Begin

for x:=1 to 5 do

begin

if ((l[x] mod 2 = 0) and (a[end_flag+x-1]=1)

then begin writeln('LRC ',x,' Error');

i:=300; end;

if ((l[x] mod 2 <> 0) and (a[end_flag+x-1]=0)

then begin writeln('LRC ',x,' Error');

i:=300; end;

end;

end;

begin

writeln;

writeln("Waiting for card programmed with ISO standard 3554-1976(E)");

writeln("-----");

```

read;
translate;

if I<300 then print else
sound(500);delay(900);nosound;

repeat
until keypressed;

end.

```

Decoding procedure

Cards following the ISO standard are encoded with 5 bits per character, (unless it is alphanumeric, as tracks 1 and 3 are). The first four bits are the actual data and the fifth bit is an even parity check. The last five bits are the longitude redundancy check (LRC). This is how it works:

The Ascii table:

- 0000 = 0
- 1000 = 1
- 0100 = 2
- 1100 = 3
- 0010 = 4
- 1010 = 5
- 0110 = 6
- 1110 = 7
- 0001 = 8
- 1001 = 9
- 1101 = 11 => Start sentinel
- 1011 = 13 => Field separator
- 1111 = 15 => End sentinel

The data is written in 5-bit words, always starting with the least significant bit, then two bits more, then the most significant bit, and finally an even-parity check bit. All even Ascii values should end with a zero, and all odd Ascii values should end with a 1 to be accepted by the system as correct data. When all 40 characters are transferred, the last 5-bit word is a longitudinal redundancy check. This is like a parity check, but longitudinal instead, covering all transferred data. Thus it is easy to check that all data was successfully transferred.

- 1101 0 = 11 =Start sentinel
- 0001 0 = 8
- 1010 1 = 5
- 1000 0 = 1
- 0110 1 = 6
- 1001 1 = 9
- and so on ...

Waiting for card programmed with ISO standard 3554-1976(E)

<8516998749515001 99055142018511111>

xxxxxxxxxxxxxxxxxxxx xxxx

ACCOUNT NR Expires May, 1999

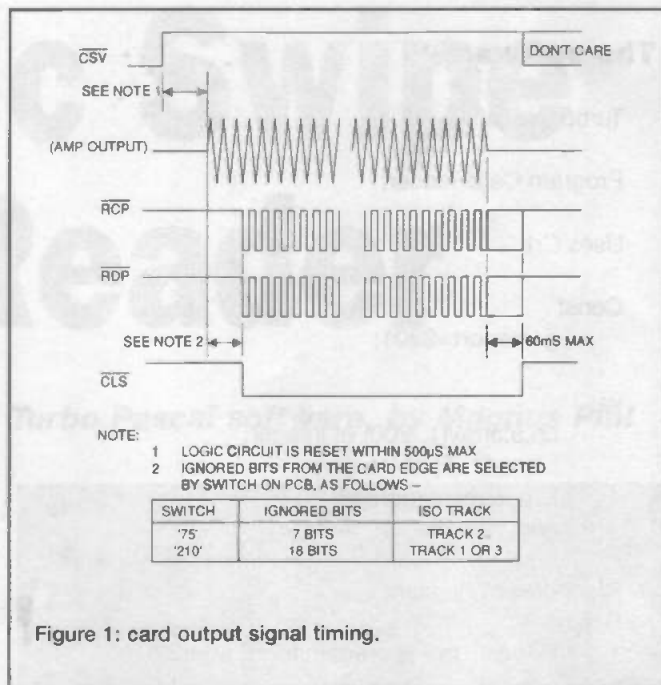

Figure 1: card output signal timing.

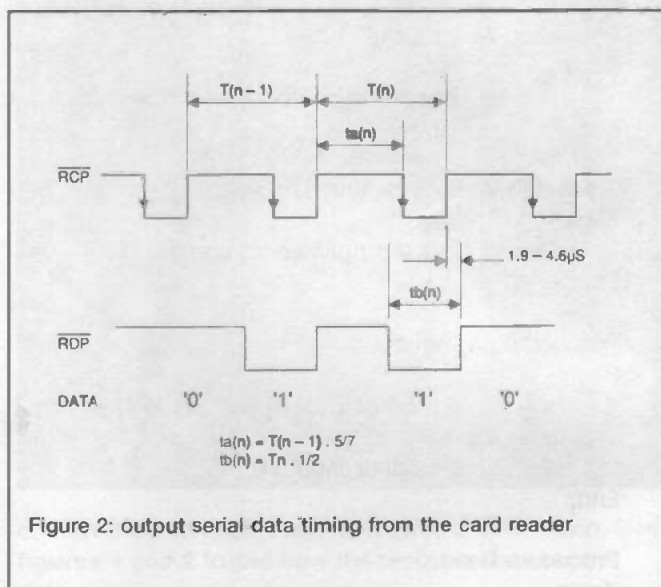

Figure 2: output serial data timing from the card reader

PARTS LIST

Card swipe reader: the Omrom 3S4YR-HNR.
Four-core screened cable
15-pin male DSUB connector (eg Maplin BK58N and cover BK60Q).

The Omrom 3S4YR-HNR card swipe reader is available from Farnell Electronic Components: Canal Road, Leeds, LS12 2TU. Tel 0113 263 6311.

Determined Amateur Designer Seeks Sponsorship for Rocket Development

Daniel Jubb, Britain's youngest participator in the international space race is as we write about to make a bid to put the world's first amateur-built rocket into orbit.

Daniel has been designing, building and launching single- and multi-stage rockets since he was nine. Now aged 13, he is planning to launch his latest rocket, the 14-foot Falcon 7 Mk II in April at the Otterburn Army Field Training Centre in Northumberland, the site of two of his previous launches. The latest rocket is a single-stage, reusable launch vehicle believed to be capable of reaching an altitude of 20,000 feet moving at around 3,000 mph.

The Falcon 7 has an on-board computer guidance and data logging system including components built to Daniel's own design. The details of the system are being kept understandably confidential, but the logging system can process over 200,000 bits of information per second operating at a speed of 19,200 Baud, and can store up to a gigabyte of data. The data will be gathered by sensors throughout the rocket reading information on speed, position, direction and the internal stresses it will undergo during flight. The rocket - prudently - also contains a custom-built radio data link incorporating a modem and transmitter.

The prize of US\$ 2 million offered by a private American consortium for the first independent organisation to put a vehicle into orbit has attracted many competitors into the world of rocket technology.

The space race, including among dedicated amateurs and small-rocket researchers is fraught with uncertainty. Recently Starchaser, a two-year, £70,000 rocket project by the University of Salford Space Technology Laboratory, crashed into a firing range on Dartmoor after only 200 feet of climb when the motors failed to ignite in synch. The rocket's developers are settling back down at the drawing board for the next step in their mission to put a low-cost satellite into low earth orbit. Even Stephenson's Rocket started with James Watt's kettle.

Daniel Jubb has had several successful launches and plans to fit the Falcon 7 with a larger motor capable of taking the rocket 20 miles into the stratosphere following his April launch.

Daniel is looking for sponsorship from any company that may be able to provide specialist components or some modest

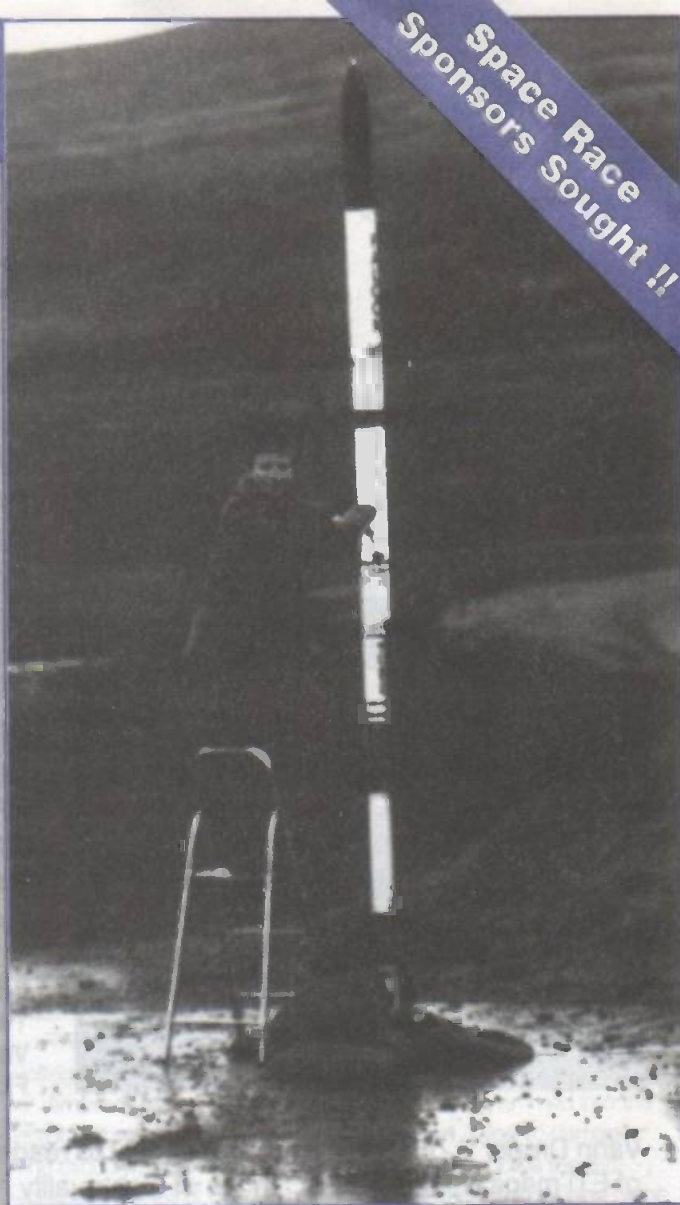

Space Race
Sponsors Sought !!

financial support in his bid to break the records.

Anyone who wants to join the project with some sponsorship and wants more details should contact Robin Gregson at Interface PR, Brook House, 70 Spring Gardens, Manchester M2 2BQ. Tel 0161 907 3075 fax 0161 907 3080

Major New Award Scheme for Technology Students

Eight of Britain's leading industrial companies have joined forces to sponsor the new Science, Engineering and Technology Student of the Year Awards, with the aim of changing attitudes towards technology education.

Prizes worth more than £40,000 will be presented at a ceremony in June 1998. The awards will cover the range of technology education from civil engineering to biotechnology and computer science. Some of the categories include:

Best Aeronautical Engineering student; best Electronic Engineering student; best Physics student; best Computer and Computer Software student; Best Civil Engineering student, and a number of other categories, as well as the Science, Engineering and Technology Student of the Year.

Awards organiser Malcolm Turner says: "there has been an unspoken assumption that making things is less prestigious than dealing in things. This is not the case in the USA, France or Japan, where technical degrees are among the most sought-after, or Germany, where engineering is considered to be more prestigious than medicine."

The awards can be seen as part of a movement in recent years to raise awareness of the importance of engineering and science in the UK.

Entry forms are being delivered to UK Universities and students must be entered by their lecturers, who must be full-time lecturers at universities within the United Kingdom of Great Britain and Northern Ireland. Lecturers must send a completed application form by not later than 15 May 1998.

For more information contact Turner Meredith Ltd., 13A Lower St., Haslemere, Surrey GU27 2NY. Tel 01428 658588 fax 01428-656155.

50% discount for ETI readers on Kenwood power supplies

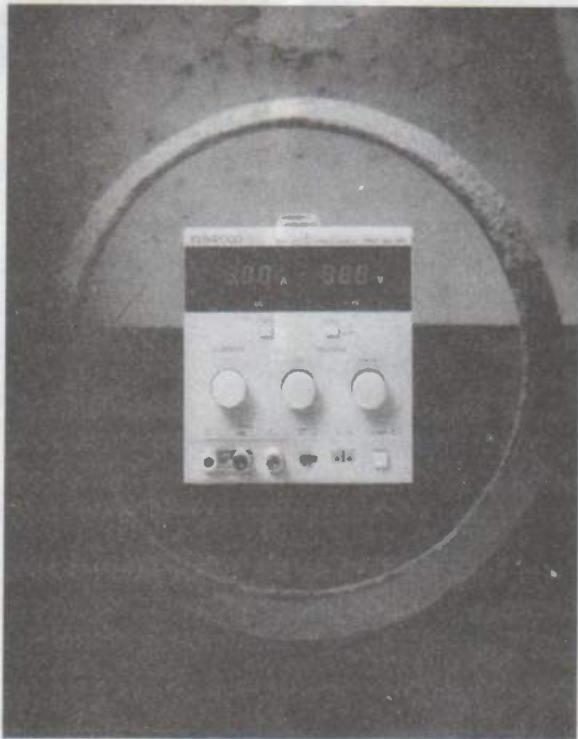

Normal price inc vat exc del

PAC20-3	£264.38
PAC30-2	£264.38
PAC30-3	£287.88
PAC30-6	£464.13
PAC60-1	£346.63
PAC60-3	£464.13

ETI reader price inc vat & del

PAC20-3	£129.00
PAC30-2	£135.00
PAC30-3	£145.00
PAC30-6	£219.00
PAC60-1	£139.00
PAC60-3	£229.00

FEATURES

Twin large led displays
Very low ripple & noise
Floating outputs

Constant voltage/current
Coarse & fine voltage control
Output on/off switch
Constant current check switch

Vann Draper is offering over 50% discount to readers of ETI magazine on the PAC range of high quality Kenwood power supplies until May 31st.

The Kenwood PAC series feature twin led displays for simultaneous display of voltage and current, very low noise & ripple, floating outputs for -ve or +ve grounds and will operate in constant voltage or current modes.

All power supplies are delivered ready to use complete with mains lead, operating manual and a 12 month guarantee.

To order simply post the coupon to Vann Draper Electronics Ltd at Unit 5, Premier Works, Canal St, South Wigston, Leicester LE18 2PL. Alternatively tel 0116 2771400, or fax 0116 2773945.

Key specifications

Model	Rating	Ripple	Line reg'n	Load reg'n
PAC20-3	0-20V 0-3A	0.5mV rms	4mV	4mV
PAC30-2	0-30V 0-2A	0.5mV rms	5mV	5mV
PAC30-3	0-30V 0-3A	0.5mV rms	5mV	5mV
PAC30-6	0-30V 0-6A	1mV rms	5mV	5mV
PAC60-1	0-60V 0-1A	1mV rms	8mV	8mV
PAC60-3	0-60V 0-3A	1mV rms	8mV	8mV

Use this coupon for your order

Please send me :

- PAC20-3 power supply(s) at £129 inc vat & del
- PAC30-2 power supply(s) at £135 inc vat & del
- PAC30-3 power supply(s) at £145 inc vat & del
- PAC30-6 power supply(s) at £219 inc vat & del
- PAC60-1 power supply(s) at £139 inc vat & del
- PAC60-3 power supply(s) at £229 inc vat & del

Name :

Address :

Tel no :

Total £.....

Cheques payable to Vann Draper Electronics Ltd

Or debit my visa, master, access or switch card :

Card type :

Card No :

Expiry date :

Switch iss no :

Signature :

Overseas readers can still obtain this discount but details vary according to country. Please phone or fax.

Compact 27C16 Eprom Programmer

Richard Grodzik's compact 2k eprom programmer runs from DOS commands and programs in two seconds per eprom

The eprom programmer in this article was designed to program 2k 27C16 eprom in 2 seconds, using a 9600 baud serial PC connection and simple DOS commands. It's a handily small-sized board that can be carried around, runs from a 9-volt PP3 battery. An onboard dc-dc converter generates the programming voltage.

The 2k eprom

The 2-kilobyte eprom has been in use for over twenty years and always was a good starting point for eprom-based projects. It is found in countless microprocessor 'trainers' and for a long time has been widely available in the quick-programming 12V75 version, type 2716BQ200. This project was designed to answer the need for a quick and simple solution to programming these devices. No software driver is required. Object code is sent from the PC to the Programmer using the simple DOS copy command. The RS232 protocol used for communication between the PC and the Programmer is 9600 baud, 8 data bits, no parity, 2 stop bits. To set up the PC for this protocol, the DOS 'mode' command is invoked:

```
MODE COM1:96,N,8,2
```

If the COM2 serial port is to be used, COM2 is substituted for COM1. Then it is a simple matter to send the object code 2048 bytes (0800H) in depth using the DOS copy command, that is:

```
COPY FILENAME.OBJ COM1/B
```

A couple of seconds later the eprom is programmed. Multiple eprom programming can be accomplished, as the onboard firmware runs in a continuous loop and is automatically re-configured for each successive eprom. The firmware to drive the Programmer is contained in a PIC, and a pre-programmed PIC is available from the author (see the end of this article)

The eprom

The 27C16BQ200 eprom requires a nominal 100 microsecond programming pulse, a Vpp programming voltage of 12V75 and a Vcc supply of 6V2. Since it takes only 2.5 seconds to program the entire eprom, a battery-based voltage source is practical. I was faced with the problem of generating the various voltages from a

PP3 9-volt battery. Glancing through the component catalogues revealed a 6V2 regulator (7862), available from Farnell electronics. The 13V dc-dc converter is available mainly from the manufacturers' agents. Two of them do one-off orders (see end of article) This works out a bit more expensive than the big catalogues, but only a pound or so plus the postage.

The main requirement for an eprom programmer is that no voltage is present on the eprom socket when the eprom is inserted or removed. At best, random data would be programmed into the eprom; at worst, the eprom would sustain catastrophic damage. The circuitry associated with transistor BD140 supplies the 6V2 voltage to pin 24 of the eprom socket only when the RAO line of the PIC is low. Simple transistor action will then drive the PNP transistor into saturation, the emitter/collector junction attaining a near short circuit and thus applying the full 6V2 voltage to the supply pin of the eprom. The NM0513 is also controlled by the RAO line via a FET (BS170) transistor switch. A low on the gate of the transistor will ensure that the transistor is switched off. The 'open collector' configuration, that is, no load resistor provides a very high impedance (a virtual open circuit) at pin 5 (the control pin) of the dc-dc converter and the full 12V75 is applied to the Vpp pin (21) of the eprom. A high on the RAO line will drive the BS170 transistor into saturation and will reduce the converter output to 1V5. Simultaneously cutting off the BD140 transistor and isolating the 6V2 supply. A standard 78L05 5-volt regulator supplies both the NM0513 and also the PIC chip and 4040 counter.

The communications link between the PC and the eprom socket is based in the PIC16C54XT/P application specific programmable microcontroller which has been programmed to receive RS232 data at 9600 baud. Since at that speed each bit 'cell' is of 104 microseconds duration, a 2-stop-bit protocol has been chosen to create a 208 microsecond buffer zone between each received data byte. A software delay of 104 microseconds is used during this time for the programming pulse, the remainder used for software overhead and 'waiting time'.

The 'MPSIM' PIC simulator was used to develop the firmware and is especially useful in that precise measurements of software execution can be made to verify that a delay loop is of the required time duration. The 4-MHz crystal of the eprom writer produces a clock cycle time of 1 microseconds. The SC 1 command in the simulator will then show real time events as the software runs. Sure

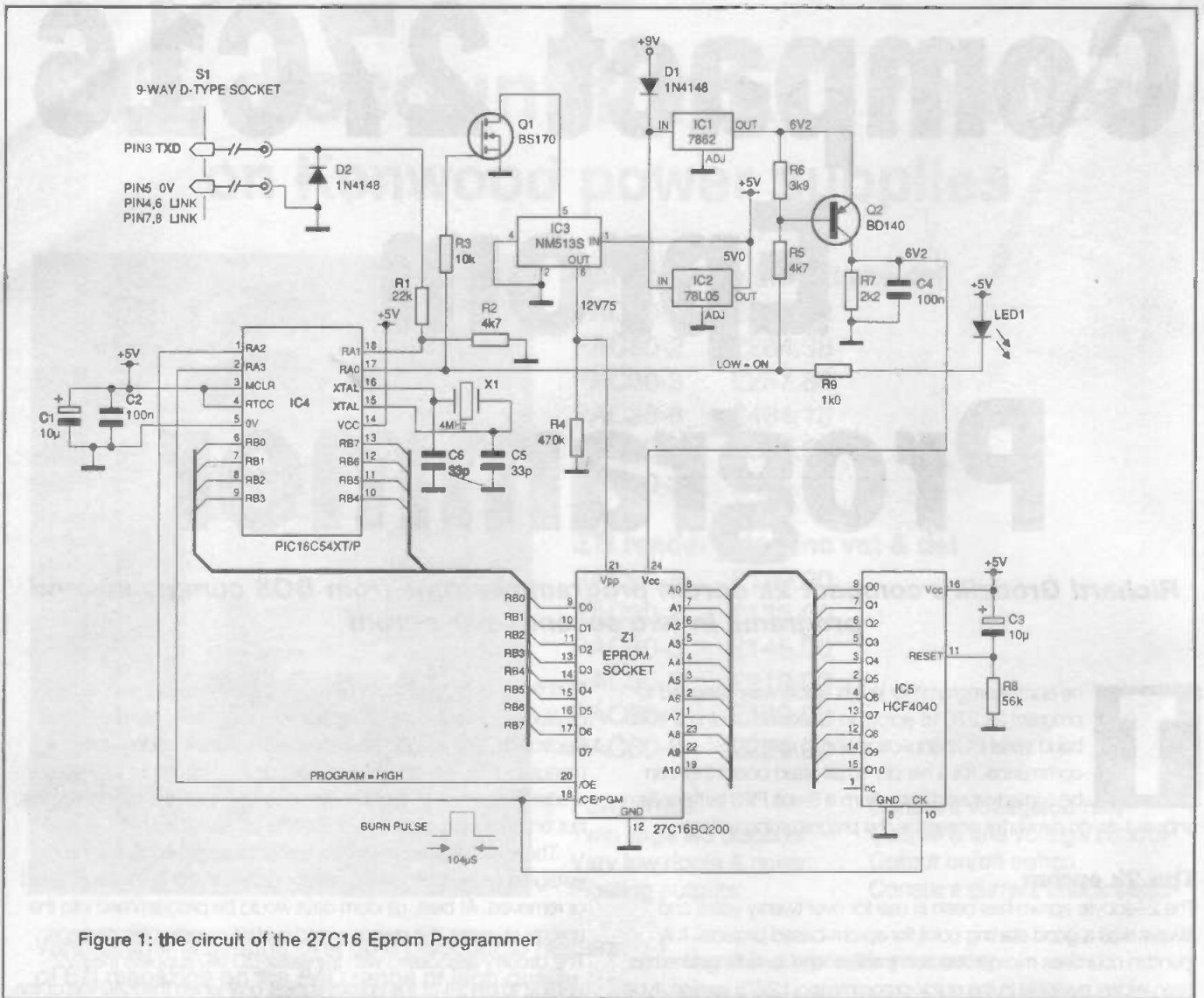

Figure 1: the circuit of the 27C16 Eeprom Programmer

beats the old method of consulting the manufacturer's data sheet to determine the execution time of each instruction and then calculating the total time required for a software loop. I was always a hundred microseconds out. But beware. Simulating a 1-second delay loop on the simulator takes at least an hour!

The purpose of the 4k7 resistor which grounds the RA1 pin of the PIC is to ensure that the RXD input (RA1) is at a logic-low level (a stop bit) if the communications link is disconnected. As successive serial data bytes are received, the PIC's firmware converts them to an 8-bit parallel data byte and presents them to the data bus of the eeprom socket via port lines RB0-RB7. The programming pulse burns the data into the eeprom and increments the eeprom address counter on the falling edge of the pulse. A simple R-C network resets the 4040 counter on switch-on, clearing all Q outputs to zero, that is, address 0000H. If a key is pressed inadvertently on the keyboard, the corresponding character will be transmitted from the terminal emulator to the eeprom Writer - and

the LED will turn on. Re-powering the Writer will re-initialise the system back to zero state. On completion of programming (when 2048 bytes have been received), the LED will go out, permitting the safe removal of the eeprom, since all supply voltages to the socket will have been disabled.

Hints

If frequent use of the programmer is anticipated, then the reverse voltage protection diode (D1) may be omitted, extending the useful battery life. The CR circuit associated with the reset pin of the 4040 address counter has a long time constant to ensure that any glitch

on line RA2 does not activate the counter on switch on. This was found to be the case with the OTP but not the UV version of the PIC!

The PIC Listing (27C16.LST)

```

0001:
0002: ;
0003: LIST p=16C54
0004: ;
0005: 0001 RXD EQU 1 ;PA1
0006: 0003 STATUS EQU 3 ;STATUS REGISTER
0007: 0005 PORT_A EQU 5 ;PORT A
0008: 0006 PORT_B EQU 6 ;PORT B
0009: 0007 MSB EQU 7
0010: 000B COUNTR EQU 0BH
0011: 0009 DLYCNT EQU 9
0012: 000A BUFFER EQU 0AH
0013: 000C BLOW EQU 0CH ;BYTE COUNTERS
0014: 000D BHIGH EQU 0DH
0015:
0016: 0020 BAUD_1 EQU .32 ;9600 BAUD 1 BIT
PERIOD
0017: 0030 BAUD_1ST EQU .48 ;1.5 BITS
0018:
0019:
0020:

```

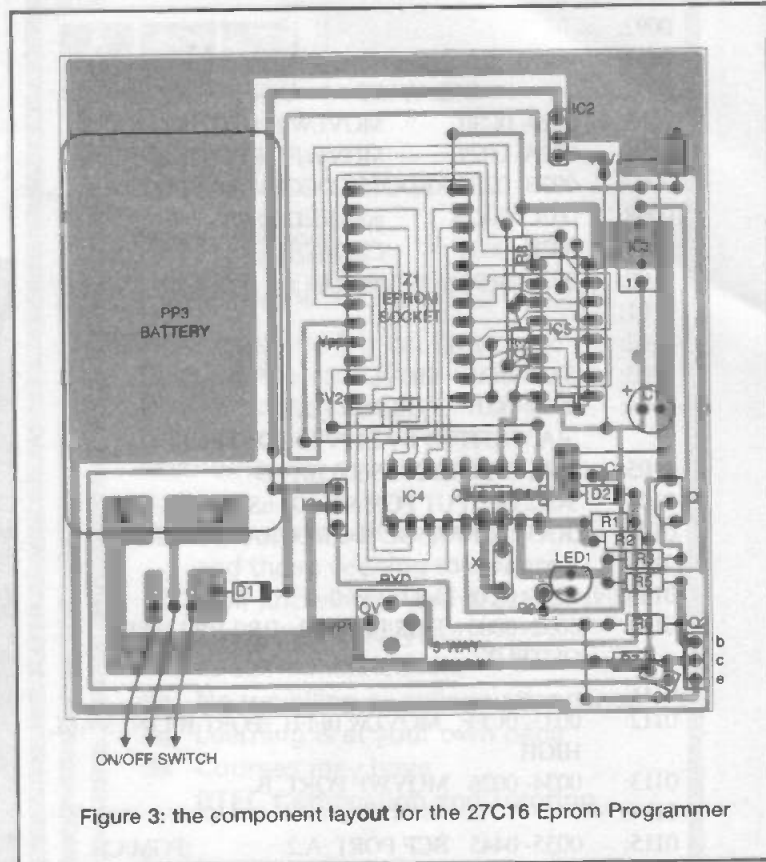
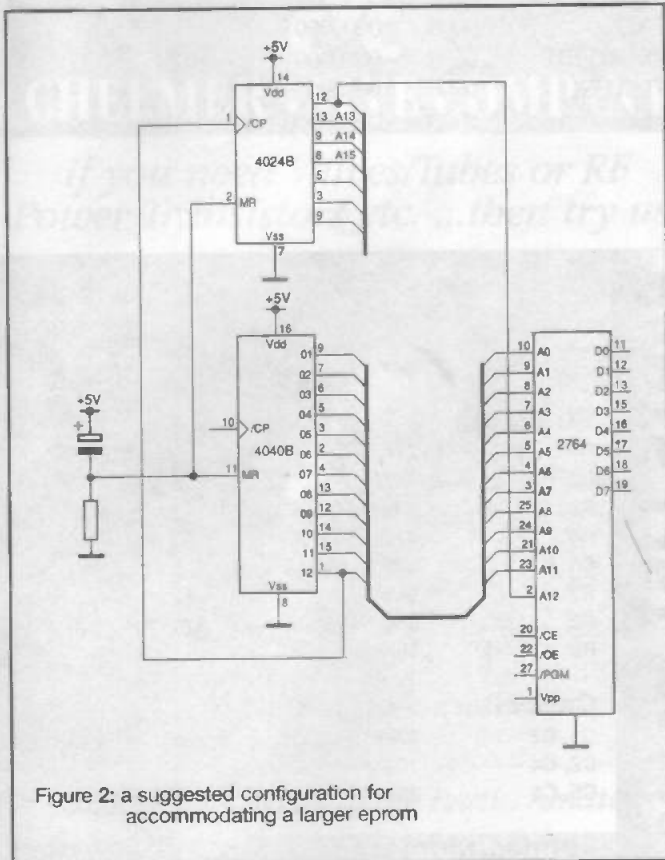
```

0021:
0022:      0000      ORG 0
0023:      start
0024:
0025: 0000- 0000 NOP
0026: 0001- 0000 NOP
0027: 0002- 092F CALL INIT
0028:
0029:      EPROM
0030:
0031: 0003- 0C40 MOVLW .64
0032: 0004- 002C MOVWF BLOW
0033:
0034: 0005- 0C20 MOVLW .32
0035: 0006- 002D MOVWF BHIGH
0036:
0037:      CYCLE
0038:      START_BIT
0039: 0007- 0725 BTFSS PORT_A,RXD
0040: 0008- 0A07 GOTO START_BIT
0041:
0042: 0009- 0405 BCF PORT_A,0 ;POWER ON
0043:
0044: 000A- 0C08 MOVLW 8 ;8 DATA BITS
0045: 000B- 002B MOVWF COUNTR
0046:
0047:
0048: 000C- 0929 CALL DELAY1ST ;1.5 BITS DELAY
0049: 000D- 006A CLRF BUFFER ;CLEAR BUFFER
0050:
0051:      NEXT
0052: 000E- 0403 BCF STATUS,0
0053: 000F- 032A RRF BUFFER
0054: 0010- 0625 BTFSC PORT_A,RXD;
0055: 0011- 05EA BSF BUFFER,7
0056: 0012- 0923 CALL DELAY

```

```

0057: 0013- 02EB DECFSZ COUNTR,1
0058: 0014- 0A0E GOTO NEXT
0059:
0060:
0061: 0015- 0CFF MOVLW 0FFH;INVERT DATA
0062:
0063: 0016- 018A XORWF BUFFER,0
0064: 0017- 0026 MOVWF PORT_B ;SEND TO PORT
B
0065:
0066: 0018- 0545 BSF PORT_A,2 ;CE/PGM HIGH
0067: 0019- 0923 CALL DELAY ;BURN PERIOD 104 uS
0068: 001A- 0445 BCF PORT_A,2 ;CE/PGM LOW
0069:
0070: ;
0071: 001B- 02EC DECFSZ BLOW,1
0072: 001C- 0A07 GOTO CYCLE
0073:
0074: 001D- 0C40 MOVLW .64
0075: 001E- 002C MOVWF BLOW
0076:
0077: 001F- 02ED DECFSZ BHIGH,1
0078: 0020- 0A07 GOTO CYCLE
0079: 0021- 0505 BSF PORT_A,0 ;POWER OFF
0080:
0081:
0082: 0022- 0A03 GOTO EPROM
0083:
0084:
0085:      DELAY
0086: 0023- 0C20 MOVLW BAUD_1
0087: 0024- 0029 MOVWF DLYCNT
0088: 0025- 02E9 REDO1 DECFSZ DLYCNT,1
0089: 0026- 0A25 goto REDO1
0090: 0027- 0004 CLRWDT
0091: 0028- 0800 retlw 0

```

```

0092:
0093:
0094:      DELAY1ST
0095: 0029- 0C30      MOVLW BAUD_1ST
0096: 002A- 0029      MOVWF DLYCNT
0097: 002B- 02E9 REDO1ST DECFSZ DLYCNT,1
0098: 002C- 0A2B      goto REDO1ST
0099: 002D- 0004      CLRWDT
0100: 002E- 0800      retlw 0
0101:
0102:      INIT
0103: 002F- 0C02      MOVLW 2
0104: 0030- 0005      TRIS PORT_A
;RA0 OUTPUT 6V2,12V75 CONTROL
0105: ;RA1 INPUT RXD 9600 BAUD
0106: ;RA2 OUTPUT PGM/CE 100 uS
0107: ;RA3 OUTPUT OE H=PROGRAM, L=READ
0108:
0109: 0031- 0C00      MOVLW 0
0110: 0032- 0006      TRIS PORT_B ;RB0-RB7 DATA
OUTPUT
0111:
0112: 0033- 0CFF      MOVLW 0FFH ;PORT B LINES ALL
HIGH
0113: 0034- 0026      MOVWF PORT_B
0114:
0115: 0035- 0445      BCF PORT_A,2 ;PGM/CE
LOW
0116: 0036- 0505      BSF PORT_A,0 ;POWER OFF
0117: 0037- 0565      BSF PORT_A,3 ;BURN MODE
0118:
0119:
0120:
0121: 0038- 080C      RETLW 0CH
0122:
0123:
0124: ;
0125: 0000      org 01FFh
0126: 01FF- 0A00      goto start
0127: ;
0128: 0000      END

```

Cross Reference.
27

Symbol	Def.	Value
BAUD_1		0016 00000020
BAUD_1ST		0017 00000030
BHIGH		0014 0000000D
BLOW		0013 0000000C
BUFFER		0012 0000000A
COUNTR		0010 0000000B
CYCLE		0037 00000007
DELAY		0085 00000023
DELAY1ST		0094 00000029
DLYCNT		0011 00000009
EPROM		0029 00000003
INIT		0102 0000002F
MSB		0009 00000007
NEXT		0051 0000000E
PORT_A		0007 00000005
PORT_B		0008 00000006
REDO1		0088 00000025
REDO1ST		0097 0000002B

RXD	0005	00000001
START_BIT	0038	00000007
STATUS	0006	00000003
start	0023	00000000

PARTS LIST for the 27C16 Eeprom Programmer

Resistors

R1	22k
R2, R5	4k7
R3	10k
R4	470k
R6	3k9
R7	2k2
R8	56k
R9	1k

Capacitors

C1, C3	10uF
C2, C4	100nF
C5, C6	33pF

Semiconductors

IC1	7862 6.2V regulator (Farnell LM78L62ACZ No. 412-958)
IC2	78L05 5V regulator
IC3	NMF0513S 13V dc-dc converter (see below)
IC4	PIC16C54XT/P (available preprogrammed from the author)
IC5	4040 ripple counter
D1, D2	1N4148
Q1	BS170 fet
Q2	BD140 pnp transistor
LED1	5mA miniature led

Miscellaneous

X1	4MHz crystal
Z1	24-way zif socket
S1	9-way D-type socket
S2/P1	3-way miniature DIN socket and plug

9V battery and connector.

A pre-programmed PIC plus DOS-printable PCB artwork is available, price £17.50 including post and packing, from Mr. R.Grodzik (MICROS) 53 Chelmsford Road Bradford BD3 8QN.

The 27C16 eeprom is available from Farnell Electronic Components, part no. 246-712 (200ns) £3.72 plus vat and carriage, or the faster 150ns (246-700) at £3.82 plus VAT and carriage. Farnell Electronic Components, Canal Road, Leeds LS12 2TU Tel 0113 2636311.

The NMF0513S 13V dc-dc converter is available one-off from Campbell Collins Ltd., Boulton Road, Stevenage, Herts SG1 4QX Tel 01438 369466, price £8.17 plus £2.50 Vat and carriage, or XT Pic, Horseshoe Park, Pangbourne, Berks RG8 7JW Tel. 0118 9845515. Price £12.40 inclusive of Vat and carriage.



CHELMER VALVE COMPANY

If you need Valves/Tubes or RF Power Transistors etc. ...then try us!

We have vast stocks, widespread sources and 35 years specialist experience in meeting our customers requirements.

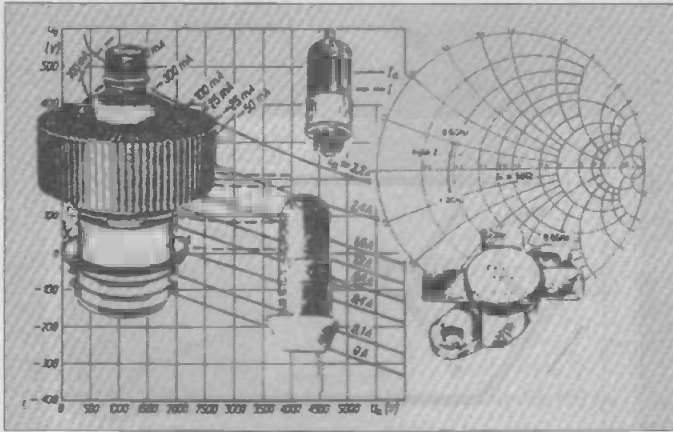

Tuned to the needs of the Radio Amateur

Chelmer Valve Company, 130 New London Road, Chelmsford, Essex CM2 0RG, England.

Tel: 44-01245-355296/265865

Fax: 44-01245-490064



NATIONAL COLLEGE OF TECHNOLOGY

DISTANCE LEARNING COURSES in:

Analogue and Digital Electronic Circuits, Fibres & Opto-Electronics Programmable Logic Controllers Mechanics and Mechanisms Mathematics

- Courses to suit *beginners* and those wishing to *update* their knowledge and practical skills
- Courses are delivered as *self-contained kits*
- No travelling or college attendance
- Learning is at your own pace
- Courses may have BTEC Certification and Tutoring

For information contact:

NCT Enterprises
Barnfield Technology Centre
Enterprise Way, Luton LU3 4BU
Telephone 01582 569757 • Fax 01582 492928

T.I.S.

Midlanbank Farm, Ryelands by Strathaven, Lancashire, ML10 6RD
Tel: 01698 883334 / 884585 Fax: 884825
Send a S.A.E. for your FREE Catalogue & Quote.

T.I.S.

Unconditional replacement or refund on any item if not as requested

TOP SELLING BOOKS

Pract' TV or VCR Repairs-£16.95 (Both £30)
Buy/Sell/Serv/Repair Used Equipment :-
CD, TV or VCR - £10.95 each (All 3 £27)
6 Giant IC Ref' Manuals - £12.95 each
Data Ref' Guide - Identifies/ prices/ cross-ref's
data for most models - £9.95 (3.5" Disk £5)
Microwave Energy & Ovens - £9.95
3.5" Disk Drives - £9.50
The Giant Fault-Finding Guides:-
CTV's £16.95 / VCR's £16.95

SERVICE MANUALS

DESIGNER COLLECTIONS

Comprehensive Circuits Collections of any make of CTV as requested, prices from £8 to £49 (IE. Alba/Bush £20) Full list in Free Catalogue.

Amateur Kit: 10 Service Manuals (as needed), Data Ref', Pract' TV & VCR Repairs, Radio Repairs, Thorn Serv' Set & any 3 CTV Circ Collections. **£199**

Professional Kit: As above + 10 Serv' Man's, Microwave E&D, Buy/Sell/Serv' Collection & 2 More CTV Circ's. **£370**

3 UNIQUE SERVICE MANUAL OFFERS GUARANTEED SAVINGS TO YOU NOW!!

***LIBRARY** Joining fee £65.00
You receive any Service Manuals, no matter how expensive, for £10 each, and you get a £5 credit for any you return.

***PRE-PAY MANUALS**
You get 20 Service Manuals, as and when you need them; as many or few at a time as you want, for a one-off payment of £185.

***SERVICE MANUAL EXCHANGE**
If you have a Service Manual we don't have and need another manual (ie. TV for TV, VCR for VCR), we will exchange it for FREE.

Please add £2.50 to all orders to cover Postage & Handling

WORLD'S LARGEST SERVICE MANUAL COLLECTION

Normal Prices Given (Some Manuals may be Cheaper or more Expensive)



VCR/VIDCAM - FULL MANUALS £16.50 - CIRCUITS £8.00 COMPLETE
CTV's / CD's - FULL MANUALS £12.50 - CIRCUITS £6.00 COMPLETE

AUDIO, CD, COMPUTERS, MONITORS, DOMESTIC / TEST EQUIP', ETC.. FROM £4.00

FOILS FOR THIS ISSUE

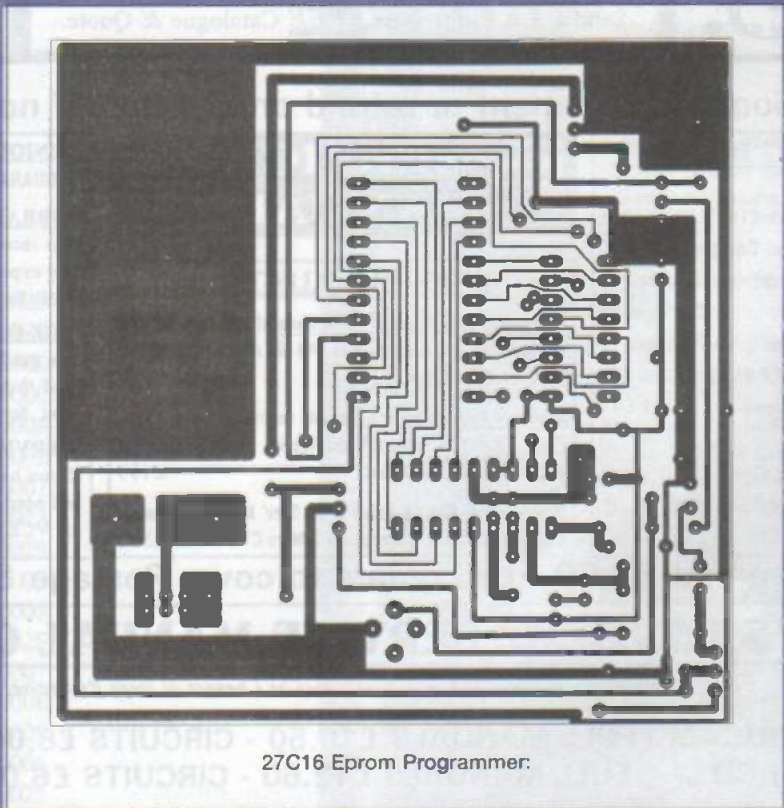
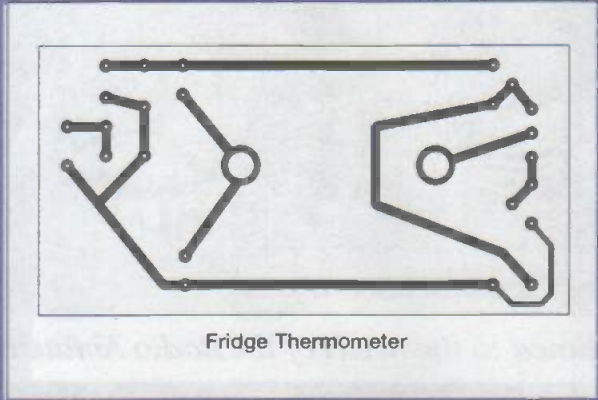
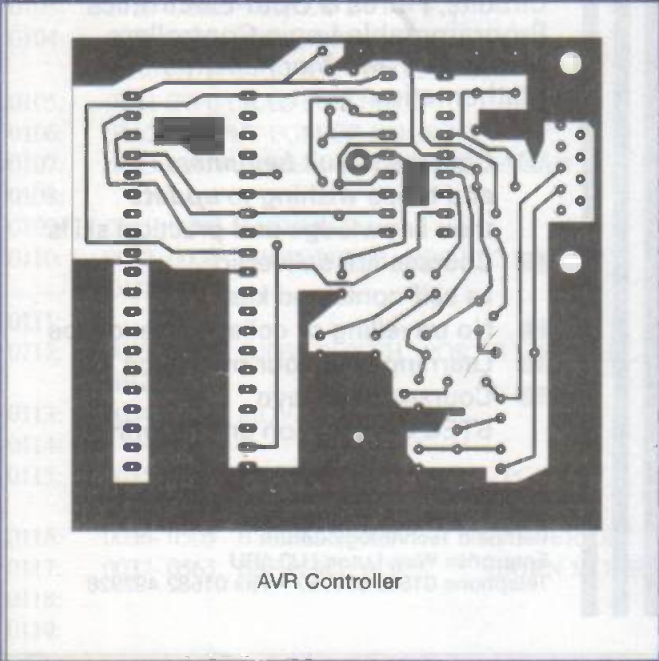

Video Surveillance

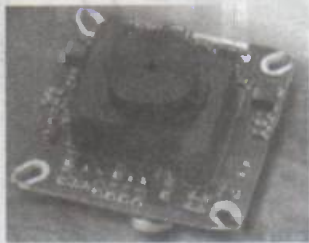

Pinhole Board Camera (B&W) 12v DC, 0.1LUX, 380 TV Resolution
Size: 35mmx35mm **£35.00**

Pinhole Board Camera (Color) 12v DC, 0.5 LUX, 420 TV Resolution 2 board foldable
Size: 40mmx40mm **£190.00**

Audio/Video Transmitter module
12v DC, 4 Channel Selection
900Mhz-1200MHz, FM Modulation
£120.00



4 Channel Receiver + Switcher
12v DC, Composite Audio/Video Output
£150.00



TFT 4" Colour Monitor
12v DC **£150.00**

We also stock:
Time & Date Generator, Miniature PIR etc.

Confidential Communications Limited

344 Kilburn Lane, Maida Vale
London W9 3EF

Tel (44)(0) 181 968 0227 Fax: (44)(0) 181 968 0194
Email: 106075.276@Compuserve.com

osziFOX

£75 Inc.

A universal 20 MHz storage oscilloscope



A slimline storage oscilloscope and digital voltmeter with a sampling rate of up to 20 MHz. Inclusive software enables the recorded signals to be displayed simultaneously on a PC screen.

Sample Rates: From 50 ns to 1 ms. Purveyors of Quality
Input Voltage: 1 V, 10 V, 100 V. Electronic Thingsies at
Trigger: ±Internal, ±External, Auto. Very Friendly Prices
Voltmeter: AC and DC.
Supply Voltage: 9 V to 13 V DC, 13 mA, external.
Trigger, ground, power & serial cables included.

Nuts Limited

2 Chase Cottages,
New Road, Aldham,
Essex CO6 3QT Tel. & Fax 01206 213322

Also Available;
CCD Camera Modules from £60
Complete CCD Kits, with housing,
cable and connectors. Ready to run.
B/W + Audio CCD Kit **£85**
Colour + Audio CCD Kit **£150**
Please add £2 p&p to all orders.

HOW DOES YOUR EQUIPMENT MEASURE UP? AT STEWART OF READING THERE'S ALWAYS 'SCOPE' FOR IMPROVEMENT!

CAN YOU BELIEVE IT 4 TRACE TEXTRONIX 7704A
FOR ONLY £350



2x200MHz, 2x75MHz Sweep Delay, Graphics etc.
OTHER COMBINATIONS AVAILABLE

TEXTRONIX 2215 - DUAL TRACE 60MHz



Sweep Delay, Includes 2 probes
ONLY £100



PHILIPS PM3217 - Dual Trace 50MHz Delay
This really is a very good oscilloscope
Including 2 Probes, Pouch & Front Cover
Only £400

TEXTRONIX 430 SERIES



458 Digital Storage Dual Trace 100MHz Delay
466 Analogue Storage Dual Trace 100MHz Delay
485 Dual Trace 350MHz Delay Sweep
475 Dual Trace 200MHz Delay Sweep
465 Dual Trace 100MHz Delay Sweep



ND 3502
Dual Trace 20MHz, 5mV/20V Div, 0.2u secs-0.5 Sec/Div,
X-Y, X5 Magnifier, TV Sync etc

Hardly Used £150

Un-Used £200

PHILIPS PM3296A Dual Trace 400MHz Dual TB Delay Cursors IEEE £250
FLUXE PM3362 2x200MHz Delay TB Cursors £399
TEKTRONIX 2465 4 Ch 350MHz Delay Sweep Cursors etc £2000
TEKTRONIX 2445/2445A 4 Ch 150MHz Delay Sweep from Cursors etc £1000
TEKTRONIX T45465 Dual Trace 100MHz Delay Cursors £300
TEKTRONIX 2235 Dual Trace 100MHz Delay Sweep £750
HWATSU SS5711 4 Ch 100MHz Delay Sweep £350
PHILIPS 3055 2x1 Ch 50MHz Delay DualTB £175
GONALD CS100 Dual Trace 30MHz £240
GONALD CS300 Dual Trace 20MHz £200

MARCONI 2019 Syn AM/FM Signal Gen 80KHz-1040MHz £1400
MARCONI 2017 Pseudo Lock AM/FM Signal Gen 100KHz-1024MHz £1750

CAN YOU BELIEVE IT - A 1GHz GENERATOR
FOR ONLY £450



H.P. 9640A AM/FM Signal Gen 500KHz-1024MHz - Audio Option £325
FARNELL SS5520 Syn AM/FM Signal Gen 10-520MHz £450
FARNELL PS3520 Syn AM/FM Sig Gen 10-520MHz Portable £450
MARCONI 6311 Programmable Sweep Gen 10MHz-20GHz £1500
H.P. 8656A Syn Signal Gen 0.1 - 960MHz £1500
PHILIPS PM5193 Programmable Syn Func Gen 0.1MHz-50MHz £1000
PHILIPS PM5192 Programmable Syn Func Gen 0.1MHz-20MHz £1250
H.P. 3325A Syn Function Gen 2MHz £400
PHILIPS PM5134 Sweep Func Gen 0.001Hz-20MHz £400
PHILIPS PM5132 Sweep Func Gen 0.1Hz-2MHz £250

CLASSIC AVO METER
A Digital AVO DA116 3 1/2 digit
Complete with Batteries and Leads
Only £30



METROMM
9A - 500V Battery Meggar is useful back-up
for fault finding.
Complete with Batteries and Leads
£30



SOLARTRON 7045
4 1/2 digit Bench Multimeter with leads
£89

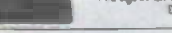

SOLARTRON 7151 DMM 6 1/2 digit IEEE £450
SOLARTRON 7150 DMM 6 1/2 digit IEEE £300
True RMS

LOOK!!
BRAND NEW OSCILLOSCOPES - NEVER
USED LIMITED STOCK



DMS 3850A DIGITAL STORAGE DMM
Hand-held LCD Display 2 Channel 50MS/S Auto range 4 digit
DMM/Capacitance/Frequency Counter Battery Operation or external
7.5-9VDC ac AC Adaptor (Not supplied) RS232 Comes in Black Carrying
Pouch complete with 2 scope probes, DMM leads, Manual
FOR ONLY £400



DTS 40 DIGITAL STORAGE
Dual Trace 40MHz 20MS/S Storage, Cursors + On Screen Readout, Sweep
Delay, Interface etc, etc. Supplied Un-used in original box complete with 2
Probes & Manual
AMAZING VALUE AT £400

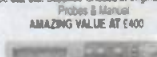

DTA 20 Dual Trace 20MHz AT Mag TV Trig etc.
Un-used & boxed supplied with 2 probes & Manual £225



FARNELL PSG1000 10KHz-1GHz
Am/Fm Synthesised Signal Generator Portable
Un-Used £1500

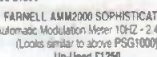

FARNELL AM2200 SOPHISTICATED
Automatic Modulation Meter 10KHz - 2.4GHz
(Looks similar to above PSG1000)
Un-Used £1250

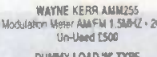

WAYNE KERR AM2255
Automatic Modulation Meter AM/FM 1.5MHz - 2GHz 31/2 Digit
Un-Used £500



DUMBY LOAD 9 TYPE
50ohm 75 Watts
Un-Used £30

NEW & HARDLY USED



PANASONIC VP8177A FM/AM SIGNAL GENERATOR
100KHz-100MHz, FM 0-1000KHz, Output -10dB-60dB AM 0-80%, 32 Preset
Memory, Digital Display Frequency & Output
Un-Used £750

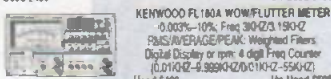

KENWOOD FL100A WOW/FLUTTER METER
0.002%-10%, Preset 30KHz/23.190KHz
RMS/AVERAGE/PEAK, Weighted Filters
Digital Display or ppm, 4 digit Freq Counter
(0.01KHz-0.999KHz/0.0110KHz-55KHz)
Used £400 Un-Used £300

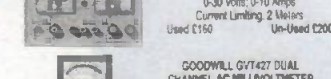

POWER SUPPLY MODEL HSP3010
0-30 Volts, 0-10 Amps
Current Limiting, 2 Meters
Used £150 Un-Used £200

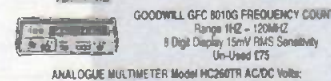

GOODWILL GVT47 DUAL
CHANNEL AC MILLIVOLTMETER
10V/300V in 12 Ranges
Frequency 10KHz - 1MHz
Used £100 Un-Used £125



GOODWILL GFC 8010G FREQUENCY COUNTER
Range 1Hz - 120MHz
8 Digit Display, 15mV RMS Sensitivity
Un-Used £75

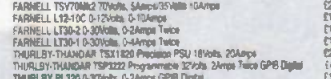

ANALOGUE MULTIMETER Model MC260TR AC/DC Volt;
DC Current 10Amp; 17 Ranges; Continuity Buzzer; Transistor Tester
Un-Used £15

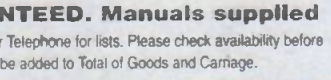

FARNELL LF1
Sine / Sq Oscillator
10KHz - 1MHz
Un-Used £75

POWER SUPPLIES £1000
FARNELL AP18020 3-110Vdc, 0.50Amps Auto Ranging £400
FARNELL PM025 0-600mA, 0.25Amps £200
FARNELL TSY70M2 70Vdc, 5Amps/25Vdc 10Amps £175
FARNELL L12-10C 0-12Vdc, 0-10Amps £175
FARNELL L120-2 0-20Vdc, 0-5Amps Table £150
FARNELL L120V 0-30Vdc, 0-4Amps Table £150
THURLEY-THANDAR TTX1120 Precision PSU 18Vdc, 20Amps £275
THURLEY-THANDAR TSP3222 Programmable 32Vdc, 2Amps Table GPB Digital £450
THURLEY PL320 0-30Vdc, 0-2Amps GPB Digital £150
THURLEY PL310 0-30Vdc, 0-4Amps Digital £110
MANY MORE POWER SUPPLIES AVAILABLE

Access
STEWART of READING
110 WYKHAM ROAD, READING, BERKS. RG6 1PL
Telephone: (0118) 9268041. Fax: (0118) 9351696
Caters Welcome 9am - 5.30 pm Monday to Friday (other times by arrangement)

Used Equipment - GUARANTEED. Manuals supplied
This is a VERY SMALL SAMPLE OF STOCK. SAE or Telephone for lists. Please check availability before ordering. CARRIAGE all units £16. VAT to be added to Total of Goods and Carriage.

FOILS FOR THIS ISSUE

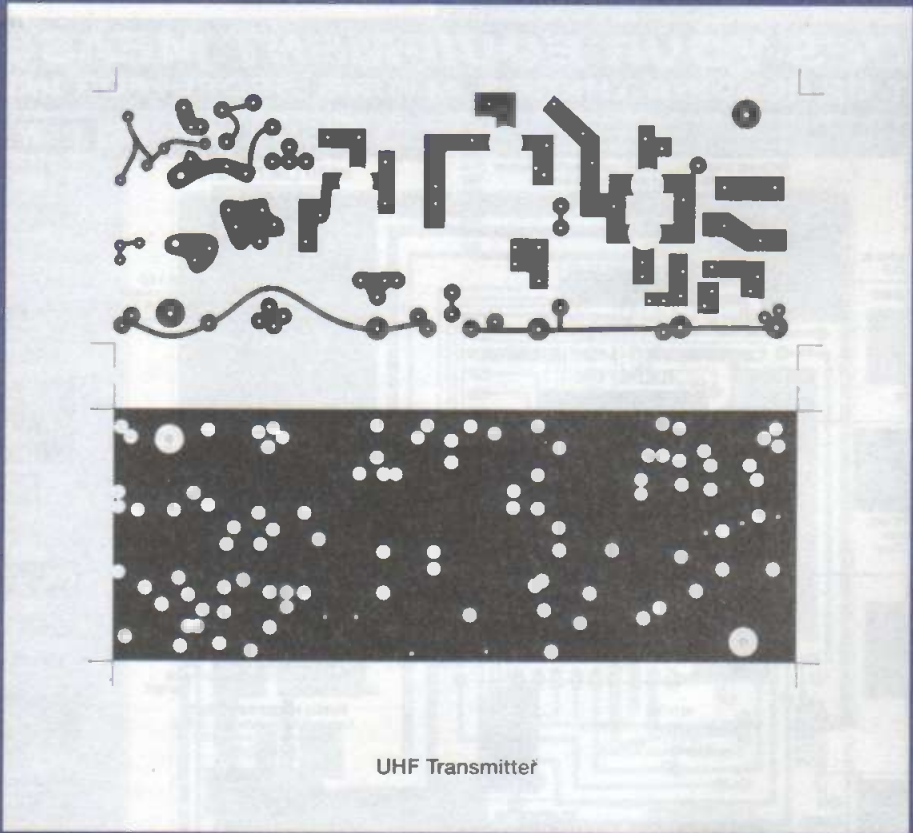
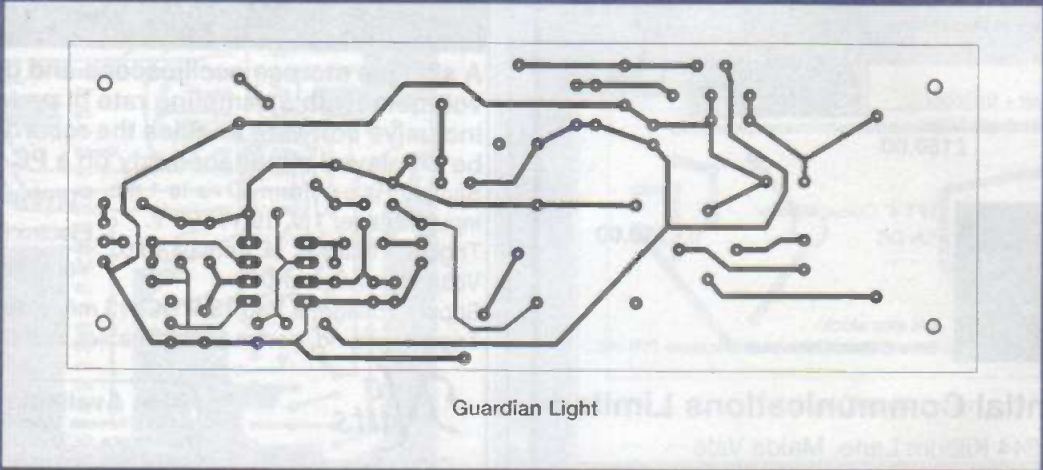

ETI can supply printed circuit boards for most of our current projects - see the list below for boards available. For recent boards not listed, check the constructional article for an alternative supplier.

Please use this order form or a copy of it. Check that all relevant information is filled in, including the Unit Order Code, and that you have signed the form if sending a credit card number. Overseas customers please add postage appropriate to the number of units you are ordering. Make cheques/PO/money orders, in £ sterling only, payable to Nexus Special Interest Limited. Please allow 28 days for delivery. Access/VISA orders may be made on 01443 266551 (ask for Readers Services).

Only boards listed here are available from our PCB Service. For past issues of magazines, copy articles or binders, please see the admin panel (page 74) or contact Readers Services (see below) for information.

Name and issue of project	Unit code	Price
ETI Issue 5 1990		
UHF Transmitter (DS)	E/598/1	£5.07
UHF Transmitter Encoder	E/598/2	£5.09
UHF Receiver Front End (DS)	E/598/3	£5.07
UHF Receiver IF stage (DS)	E/598/4	£5.07
Fridge Thermometer	E/598/5	£5.50
AVR Controller	E/598/6	£5.50
27016 Eprom Programmer	E/598/7	£7.87
5-Interval Games Timer	E/598/8	£5.09
Guardian Light	E/598/9	£6.22
ETI Issue 4 1990		
LED Voltmeter	E/498/1	£5.64
BB Ranger Control Board	E/498/2	£6.22
BB Ranger Score Board	E/498/3	£22.89
Line-Up Oscillator with Glitch	E/498/4	£8.99
Tic Tac Toe	E/498/5	£8.44
ETI Issue 3 1990		
Medium Wave Loop	E/398/1	£5.64
AA Cell Eliminator	E/398/2	£7.32
PIC Based Double Bass Tuner	E/398/3	£5.64
5 Range Capacitor Meter	E/398/4	£6.77
MIDI Drum Pads	E/398/5	£5.64
ETI Issue 2 1990		
Smartcam main board	E/298/1	£5.09
Smartcam opto-sensor board	E/298/2	£5.09
Both smartcam boards	E/298/1&2	£7.00
Switched Mode Internal Power Supply	E/298/5	£7.87
Auto Cupboard Light	E/298/3	£5.64
ETI Issue 1 1990		
Control Centre Desk-Top Unit	E/0198/1	£8.99
Control Centre Main Section	E/0198/2	£7.87
ETI Issue 13 1997		
4-Go Rocket Launcher - main board	E/1397/1	£5.64
4-Go Rocket Launcher - relay board	E/1397/2	£6.22
Mighty Midget	E/1397/3	£8.54
ETI Issue 12 1997		
PC Phonecard Reader: IT Cannon only	E/1297/1	£8.22
Minute Minder	E/1297/2	£13.98
Medium Wave Receiver - RF board	E/1297/3	£11.76
Medium Wave Receiver - Tuning board	E/1297/4	£5.09
Medium Wave Receiver - Audio board	E/1297/5	£5.09
Medium Wave Receiver - PSU board	E/1297/6	£6.77
ETI Issue 11 1997		
Total Harmonic Distortion Meter	E/1197/1	£13.43
Alphanumeric Morse Touchkey	E/1197/2	£5.09
ETI Issue 10 1997		
The IQ Tester	E/1097/1	£5.64
Fake Flasher	E/1097/2	£5.09
DC Motors (Part 2)	E/1097/3	£6.77
Valve Tester - Main Board	E/1097/4	£21.22
Valve Tester - Socket Board	E/1097/5	£5.09
Valve Tester - Heater Regulator	E/1097/6	£5.09
All three Valve Tester boards	E/1097/4/5/6	£30.30
(Due to price breaks there is a small discount on this item.)		
The IQ Tester (previously E/897/2)	E/1097/7	£5.64

ETI Issue 9 1997	Unit code	Price
Eprom Emulator	E/897/1	£16.49
The Power Supply	E/897/2	£5.09
Electronic Door Chimes	E/897/3	£5.09
Digital Power Supply	E/897/4	£10.11

ETI Issue 8 1997	Unit code	Price
The Brake Light Tester	E/897/1	£3.09
DC Motors (3 experimental boards)		
DC Motors: The first Control Unit	E/897/3	£5.09
DC Motors: The 4040 Circuit	E/897/5	£5.09
DC Motors: The Crystal Drive Circuit	E/897/6	£5.09
All three DC Motors boards	E/897/3/4/5	£15.30

ETI Issue 7 1997	Unit code	Price
Eprommer: main board (double sided)	E/797/1	£13.32
Eprommer: PSU board	E/797/2	£3.54
Eprommer: personality modules (double sided)	E/797/3	
Any ONE module board: £2.00; two modules: £7.50; three modules: £11.00; four modules: £15.00; five modules: £18.50; All six modules: £23.70		

Please specify which Eprom module you wish to use for the £1.00 per unit. £1.00 for 27256 or 27512. Other sizes possible but cost extra. Please specify if a replacement of an already used module is to be ordered.

Art Your Lights On?	Unit code	Price
Art Your Lights On?	E/797/4	£3.09
Peak Reading VU Meter	E/797/5	£3.09

Terms of trade

Some items require very little time to make, and many require more, but all require a minimum amount of material. Programs orders will be processed and postage will be added. All materials are supplied from the best sources available. Some items are available from the UK, while others are imported from the USA. Please check that you have a valid UK passport for the importation of goods. The price of postage is included in the price of the goods. We cannot be held liable for any loss or damage to goods in transit. Please check that you have a valid UK passport for the importation of goods. The price of postage is included in the price of the goods. We cannot be held liable for any loss or damage to goods in transit. Please check that you have a valid UK passport for the importation of goods. The price of postage is included in the price of the goods. We cannot be held liable for any loss or damage to goods in transit.

Please supply:

Quantity	Project	Unit Order Code	Price	Total price
.....
.....

Prices are inclusive of post and packing in the UK. Overseas Post and Packing (if applicable): Add £1 per unit

Name
 Address

I enclose payment of £..... (cheque/PO/money order in £ Sterling only) to:
 PCB Service, READERS SERVICES DEPARTMENT, Nexus Special Interests Ltd.,
 Nexus House, Boundary Way, Hemel Hempstead, Herts HP2 7ST UK.

Signature:

Card expiry date:

FOILS FOR THIS ISSUE

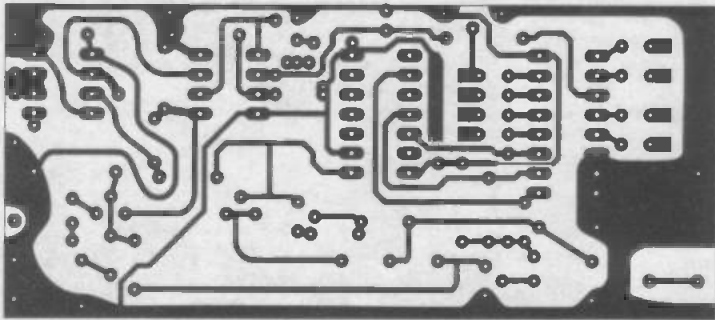

UHF Transmitter Encoder

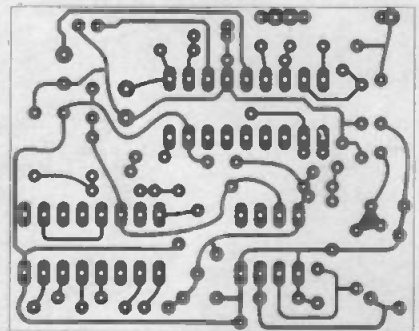

UHF Receiver IF and NBFM Decoder

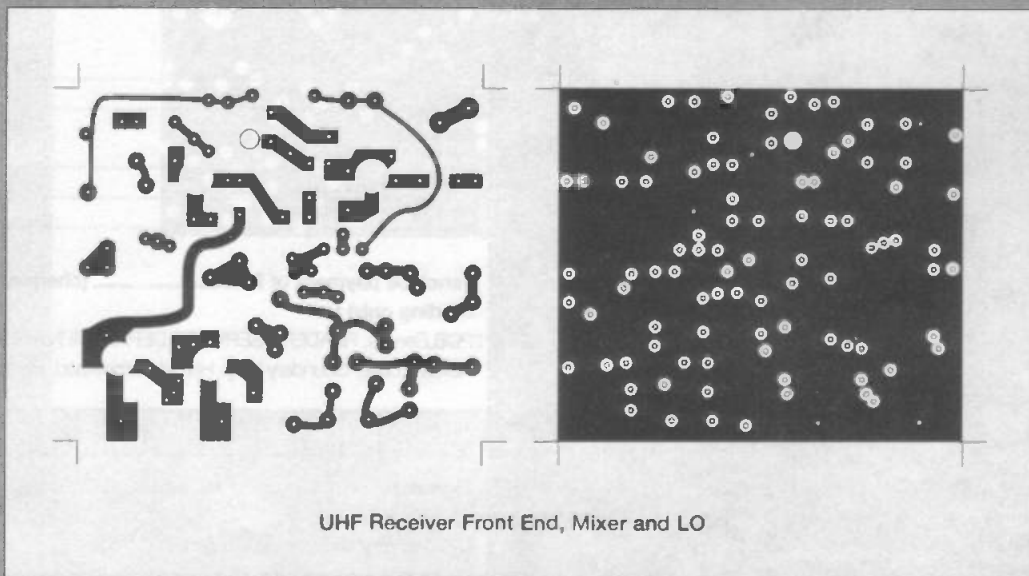

UHF Receiver Front End, Mixer and LO



STEVENAGE

Professional Sub-Contract Manufacturing & Suppliers to the Electronics Industry



Do you have a requirement for any of the following services:

- | | |
|---|--------------------------------------|
| PCB Assembly (Conventional and Surface Mount) | Product Design/Consultation |
| Wave & Hand Soldering | Full Procurement Service |
| Complete Equipment Manufacture | PCB Test & "Burn in" Facilities |
| Device Programming from hand written sheets or PC 3 1/2" disc | Enclosure Design & Manufacture |
| Cable Harness Assembly/loom Manufacture | PCB Artwork Manufacture |
| Card Cage and Module Wiring | Circuits Drawn Professionally |
| Full Inspection | Kit Procurement & Supply |
| | Component Sales |
| | Refurbishment a speciality |
| | Top Quality Work at Reasonable Rates |

Phone Steve on (01438) 360406 or fax details of your requirements to us on (01438) 352742
EQT LTD, Cromer House, Caxton way, STEVENAGE, HERTS, SG1 2DF

Surplus Electronic Components

Example price each for 25 off quantity:

27256-2	.75	78M09	.16	
27C256-120	.75	78M12	.16	
27C512-2	1.80	7812	.16	
27C1001-20	2.60	7815	.16	
CD4046BCN	.20	7906	.20	
CD4066BCN	.10	4N25	.10	
MC74HC373	.16	LM339N	.09	

For a Full List: Write, Phone, e-mail or 24hr Fax-on-demand

Harrison Electronics

Century Way, March, Cambs. PE15 8QW
e-mail: harrison.electronics@mcmill.com
Tel/Fax:(01354) 651289

ADVERTISERS INDEX

Agar Circuits.....	72	JPG.....	44
Ambyr Ltd.....	72	Leading Edge Technology.....	55
BETA Layout.....	28	Labcenter Electronics.....	46
B.K. Electronics.....	31	Milford Instruments.....	44
Bull Electrical.....	8,13	NCT.....	65
Chelmer Valves.....	65	No Nuts.....	67
Confidential Communications.....	67	Plancentre Publications.....	72
Crown Hill Associates.....	71	P.C. Solution.....	36
Dataman Programmer Ltd.....	OBC	Scientific Wire Co.....	72
Display Electronics.....	15	Service Trading Co.....	72
Electronic Design Association.....	72	Stewarts of Reading.....	67
EPT Educational Software.....	IFC	Techno Info Services.....	65
EQT.....	71	Telnet.....	49
Equinox.....	IBC	Variable Voltage Technology Ltd.....	72
ESR Electronic Components.....	34		
Forest Electronics.....	36	Veronica FM.....	72
Harrison Electronics.....	71	Wilson Valves.....	72
J & N Factors.....	24	Van Draper.....	60

CROWNHILL ASSOCIATES LIMITED

The Old Bakery, New Barns Road,
Ely Cambs. CB4 7PW

Tel: +44 (0)1353 666709 Fax: +44 (0) 1353 666710

Low cost professional quality Smart Card Systems

CHIPDRIVE EXTERN

Intelligent programmer for Smart Cards using the International Standard T=0 or T=1 protocols also Memory and Secure Memory using I²C, 2-wire & 3-wire Interfaces

Supplied with software to read and write to most popular secure smart cards, inc GSM, PAY PHONE and ACCESS CONTROL cards.

T=0 or T=1 @ 3.579MHz
RS232 @ 9600 - 11500 bps

Internal Supply / NI-MH

Size: 100x70x80 mm

Weight 660 Gram

Supplied with CardServer API for easy development of SmartCard Applications using Visual Basic, Delphi or C++
Supplied with Sample Memory cards & Secure Smart cards

CE Compliant



Chip Drive Intern

3.5" floppy bay version of the CHIPDRIVE.

Applications are available to provide SmartCard controlled access of data on Hard drives or "PC-LOCK", to control access to the whole PC Fully Compatible with TOOLBOX for systems development.

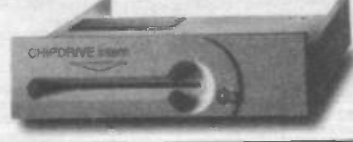

NEW CHIPDRIVE -micro

Fully Compatible with TOOLBOX for application development. Featuring the same functionality as Chip Drive Extern but in a small neat low cost package, similar in size to a smart card



Most popular smart cards are plastic, the size of a credit card, with an embedded microprocessor containing an operating system and erasable non-volatile memory.

Physical protection against unauthorised tampering with the card is provided through the following scheme:

The microprocessor and memory are created as a single chip. This insures there are no data paths that can be monitored or probed. This chip is connected to a thin circuit board and encapsulated with an epoxy. The "module" is then glued within a well milled into the plastic card. This prohibits physical access to the microprocessor and provides a more durable medium than magnetic stripe cards.

The microprocessor operates under control of a "built in" program called an operating system. A serial interface - which makes it impossible to access the memory

<http://www.towitoko.co.uk>

<http://www.crownhill.co.uk>

TOOLBOX



directly - is employed to communicate with the card. An ISO (International Standards Organization) protocol is used to exchange commands and data with the card.

Finally, Holograms, signature stripes, photos, etc can be applied to card for additional security. And the card can be custom printed with your artwork.

Crownhill can supply OPEN ARCHITECTURE cards, that will allow you the end user to create your own operating system, to control access to the EEPROM memory of upto 64Kbits (8Kbytes) in size. Crownhill have off the shelf operating systems for Control access, Electronic purse and Portable Document applications. Others can be written to your specification.

Driver and application software is available for the CHIPDRIVE family of terminals including the command set DLL for Windows 3.11/95/NT, easy to use 16 and 32 Bit DLLs with just one function call to the "CardServer", a powerful Background task which relieves the application programmer from device and card administration.

Featuring automatic protocol and card type detection. Allowing several applications to access one terminal dependent on the type of card inserted.

SMARTCARDS Available from Stock:

GemPlus, Atmel, Xicor, Siemens, SGS Crownhill and more.....
SLE4442, 4432, 4418, 4428, 4404, AT88SCxx, AT24c01-16,
GPM103, GFM1K, 2K, 4K, GPM416 Phone Cards, Loyalty Cards

THE SMARTEST SOLUTION

Crownhill can offer a broad range of smart cards from just £1.00, and Smart Card sockets for just £1.45 ea. PIC Microchip based Smart Cards now available at just £4.50 ea.....DEVELOP YOUR OWN SMART CARD I Crownhill can supply over 150 different types of IC from more than 12 silicon suppliers, which can all be incorporated into smart card format. Some cards are available from stock, most are manufactured to the customers' specification.

ETI Classified



Andy Forder
01442 266551

Send your requirements to:
ETI Classified Department, Nexus, Nexus House,
Boundary Way, Hemel Hempstead, HP2 7ST
Lineage: 85p per word (+VAT) (minimum 20 words)
Semi display: (minimum 3cms)
£12.50 + VAT per single column centimetre



Ring for information on series bookings/discounts.
All advertisements in this section must be pre-paid.
Advertisements are accepted subject to the terms and conditions
printed on the advertisement rate card (available on request).

FOR SALE

VARIABLE VOLTAGE TRANSFORMERS

INPUT 220/240V AC 50/60
OUTPUT 0-260V

Price P&P

PANEL MOUNTING
0.5KVA 2.5 amp max £33.00 £6.00 (£45.83 inc VAT)
1KVA 6 amp max £45.25 £7.00 (£51.39 inc VAT)

SHROUDED
0.5KVA 2.5 amp max £34.00 £5.00 (£47.00 inc VAT)
1KVA 6 amp max £48.25 £7.00 (£62.57 inc VAT)
2KVA 10 amp max £86.00 £9.00 (£96.36 inc VAT)
3KVA 15 amp max £86.50 £9.00 (£111.63 inc VAT)
5KVA 25 amp max £150.00 Plus Carriage & VAT
10KVA 45 amp max £300.00 Plus Carriage & VAT
6KVA 3 PHASE Star £205.00 Plus Carriage & VAT

Buy direct from the suppliers. Lowest prices in the country

COMPREHENSIVE RANGE OF TRANSFORMERS-LT-ISOLATION & AUTO

(110-240V Auto transfer either cased with American socket and mains lead of open frame type. Available for immediate delivery)

500VA ISOLATION TRANSFORMER
New manuf. surplus 'C Core' topicalised with top plate and solder connections. 0.240V AC Prim. 5-0-100-110-120V & Screen Sec. W110.5K. Size H190 x 155 x 135mm. Price £35.00. Car. £7.00 (£49.94 incl.)

RANGE OF XENON FLASH TUBES
Writes/Phone your enquiries

ULTRA VIOLET BLACK LIGHT BLUE FLUORESCENT TUBES

4ft 40 watt £14.00 (callers only) (£16.45 inc VAT)
2ft 20 watt £9.00 (callers only) (£10.58 inc VAT)
12in 8 watt £4.80 + 75p p&p (£6.52 inc VAT)
9in 8 watt £3.96 + 50p p&p (£5.24 inc VAT)
6in 4 watt £3.96 + 50p p&p (£5.24 inc VAT)

230V AC BALLAST KIT
For either 6in, 9in or 12in tubes £8.05 + £1.40 p&p (£9.75 inc VAT)

The above Tubes are 3500/4000 angst. (350-4000nm) ideal for detecting security markings, effects lighting & Chemical applications.

Other Wave Lengths of UV TUBE available for Germicidal & Photo Sensitive applications. Please telephone your enquiries.

400 WATT BLACK LIGHT BLUE UV LAMP
GES Mercury Vapour lamp suitable for use with a 400W P.F. Ballast £39.95 INCL. P&P & VAT

12V D.C. BILGE PUMPS
500 GPH 15R head 3 amp £19.95
1750 GPH 15R head 9 amp £34.55

Also now available 24V D.C. 1750 GPH 15R head 5 amp £36.55
All designed to be used submerged. PRICES INCLUDE P&P & VAT

SUPER HY-LIGHT STROBE KIT
Designed for Disco, Theatrical uses etc.
Approx 18 joules. Adjustable speed £50.00 + £3.00 p&p (£62.28 inc VAT)

Case and reflector £24.00 + £3.00 p&p (£31.73 inc VAT)
SAE for further details including Hy-Light and industrial Strobe Kits.

300V AC BALLAST KIT
Brand new Ovoid Gearbox Crouzet type motors H 65mm x W 55mm x D 35mm 4mm die shaft x 10mm long. 6 RPM anti cw £9.99 incl p&p & VAT. 20 RPM anti cw Depth 40mm £11.16 incl p&p & VAT.

SOLID STATE ENT UNIT
Input 230/240V AC. Output approx. 15KV. Producing 0mm spark. Built-in 10 sec timer. Easily modified for 20sec, 30 sec to continuous. Designed for boiler ignition. Dozens of uses in the field of physics and electronics, eg supplying neon or argon tubes etc. Price less case £8.50 + £2.40 p&p (£12.81 inc VAT) NMS

EPROM ERASURE KIT
Build your own EPROM ERASURE for a fraction of the price of a made-up unit kit of parts less case includes 12in 8 watt 2537 Angst Tube Ballast unit, pair of bi-lead leads, neon indicator, on/off switch, safety microswitch and circuit £15.00 + £2.00 p&p (£19.98 inc VAT)

WASHING MACHINE WATER PUMP
Brand new 240V AC, fan cooled. Can be used for a variety of purposes. Inlet 1 1/2in, outlet 1 in. dia. Price includes p&p & VAT. £11.20 each or 2 for £20.50 inclusive

5KVA ISOLATION TRANSFORMER

As New. Ex-equipment fully shrouded Line Noise Suppression. Ultra Isolation Transformer with terminal covers and knock-out cable entries. Primary 120/240V Secondary 120/240V 50/60 Hz. .005 pF Capacitance. Size L.37 x W.19 x H.16cm Weight 42 Kilos. PRICE £120.00 +VAT

ex-warehouse. Damage on request.

24V DC SIEMENS CONTACTOR
Type 3TH8022 DB 2 x NO and 2 x NC 230V AC 10A contacts Screw or Din Rail fixing. Size H 120 x W 45 x 0.75mm. Brand New Price £7.63 incl. P&P and VAT.

240V AC WESTOOL SOLENOIDS
TT2 Mod 1 Rat. 1 Max stroke 1/4 in. Base mounting 1/2in. stroke 5/8 pull approx. TT6 Mod 1 Rat. 2 Max stroke 1/8 in. Front mounting 1/2in. Front mounting 1/2 in. stroke 1/8 pull approx. Price incl. p&p & VAT. TT2 £5.88, TT6 £8.81. SERIES 400 £7.64.

AXIAL COOLING FAN
230V AC 120mm square x 35mm 3 blade 10 watt Low Noise fan. Price £7.29 incl. P&P and VAT. Other voltages and sizes available from stock. Please telephone your enquiries.

INSTRUMENT CASE
Brand new Manuf. by Imhof L31 x H18 x 19cm deep. Removable front and rear panel for easy assembly of components. Grey finish complete with case feet. PRICE £16.45 INCL. P&P & VAT 2 off £28.20 Inclusive.

DIE CAST ALUMINIUM BOX
with internal PCB guides. Internal size 265 x 165 x 50mm deep. Price £9.93 incl p&p & VAT. 2 off £17.80 incl.

230V AC SYNCHRONOUS GEARED MOTORS
Brand new Ovoid Gearbox Crouzet type motors H 65mm x W 55mm x D 35mm 4mm die shaft x 10mm long. 6 RPM anti cw £9.99 incl p&p & VAT. 20 RPM anti cw Depth 40mm £11.16 incl p&p & VAT.

SOLID STATE ENT UNIT
Input 230/240V AC. Output approx. 15KV. Producing 0mm spark. Built-in 10 sec timer. Easily modified for 20sec, 30 sec to continuous. Designed for boiler ignition. Dozens of uses in the field of physics and electronics, eg supplying neon or argon tubes etc. Price less case £8.50 + £2.40 p&p (£12.81 inc VAT) NMS

EPROM ERASURE KIT
Build your own EPROM ERASURE for a fraction of the price of a made-up unit kit of parts less case includes 12in 8 watt 2537 Angst Tube Ballast unit, pair of bi-lead leads, neon indicator, on/off switch, safety microswitch and circuit £15.00 + £2.00 p&p (£19.98 inc VAT)

WASHING MACHINE WATER PUMP
Brand new 240V AC, fan cooled. Can be used for a variety of purposes. Inlet 1 1/2in, outlet 1 in. dia. Price includes p&p & VAT. £11.20 each or 2 for £20.50 inclusive

Professional 88-108MHz FM Broadcasting Kits

All Our Kits Include
Detailed Instructions with Schematics
High Quality Screen Printed PCBs
High Quality Components

Our Product Range Includes
Transmitters from 0.05W to 220W
FM Stereo Coders
Audio Compressor Limiters
Antennas RF Power Amps
Link Transmitters and Receivers

Our Kits Are Also Available
Fully Assembled And Tested

WE DELIVER WORLD-WIDE AND
ACCEPT MAJOR CREDIT CARDS

Contact Us Now For A Free Brochure
Tel 01274 883434 Fax 01274 816200

email veronica@legend.co.uk
www.legend.co.uk/~veronica/

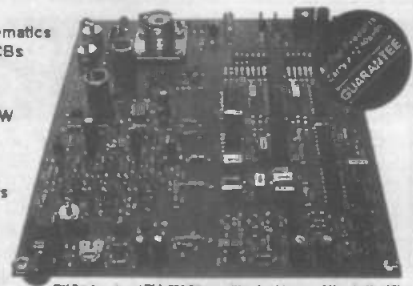

TW Professional PLL FM Transmitter for Licensed Use in the UK



SWC SCIENTIFIC WIRE COMPANY
ENAMELLED COPPER WIRE
TINNED WIRE SILVER
PLATED COPPER WIRE
SOLDER EUREKA WIRE
NICKEL CHROME WIRE
BRASS WIRE LI TZ WIRE
BIFILAR WIRE MANGANIN
WIRE TEFZEL WIRE NICKEL
SAE BRINGS LIST 18 RAVEN
RD LONDON E18 1HW
FAX 0181 559 1114

http://www.dontronics.com is DonTronics Home Page.
Hardware: Atmel and PIC Microcontroller prototype and development boards, Programmers, SimmStick (tm).
Software: Basic Stamp II Windows 95 Front End, AVRBasic for the AT90S1200, BascomLT for the AT89C2051, Multi-media "Pacman-like" Tutorial for the PIC16F84 and lots more

PRINTED CIRCUIT BOARDS DESIGNED & MANUFACTURED
• PROTOTYPE OR PRODUCTION QUANTITIES
• FAST TURNROUND AVAILABLE
• PCBs DESIGNED FROM CIRCUIT DIAGRAMS
• ALMOST ALL COMPUTER FILES ACCEPTED
EasyPC / Aries / VuTrax / CadStar
Gerber / HPGL / IDraw and many others.
• ASSEMBLY & TEST AVAILABLE
TELEPHONE 01232 738897
INTERNATIONAL +44 1232 738897
agar
Circuits
Unit 5, East Belfast Enterprise Park,
308 Albertbridge Road, Belfast, BT5 4GX

PRINTED CIRCUIT BOARDS

??? PCB DESIGN OVERLOAD ???

— EDWIN —
— EED3 —
— CADSTAR —

WE COULD BE THE ANSWER.
CONTACT SWIFT DESIGNS LTD
Email: Designs@SwiftDesigns.co.uk
Phone: 01438 310133 — 01438 821811
Web: www.swiftdesigns.co.uk

CALL ANDY TO PLACE YOUR ADVERT ON 01442 266551

TRANSFORMERS

Variable Voltage Technology Ltd
TRANSFORMERS
For valve and transistor circuits
HT Filament chokes high & low voltage
Standard and custom design
large and small quantities
Unit 24E, Samuel Whites Estate, Medina Road, Cowes, Isle of Wight PO31 7LP
Tel 01983 280592 Fax 01983 280593

QUARTZ CRYSTALS

QUARTZ CRYSTALS 100 KH2 - 100 MHZ at low cost. Full list available and technical advice.
Electronic Design Associates.
Tel: 0181-391-0545. Fax: 0181-391-5258.

SERVICE TRADING CO
57 BRIDGMAN ROAD, CHISWICK, LONDON W4 5BB
TEL 0181-995 1560 FAX 0181-995 0549
ACCOUNT CUSTOMERS MIN, ORDER £10

VALVES

WILSON VALVES
(PROP JIM FISH G4MH)
Over 50,000 valves stocked,
2000 different types,
vintage, military, audio, etc.
Fast service. Send SAE for list
VALVES WANTED FOR CASH
28 Banks Avenue, Golcar, Huddersfield,
West Yorks HD7 4LZ
Tel: 01484 654650
Fax: 01484 655699
Email: wilsonvalves@surlink.co.uk

PLANS

ELECTRONIC PLANS, laser designs, solar and wind generators, high voltage teslas, surveillance devices, pyrotechnics and computer graphics tablet. 150 projects. For catalogue, SAE to Plancentre Publications, Unit 7, Old Wharf Industrial Estate, Dymock Road, Ledbury, Herefordshire, HR8 2HS.

To Advertise in the next available issue of ETI call
01442 266551
Remember classified get results fast

Practically Speaking

TERRY BALBIRNIE

How to adapt a microammeter to read a current range higher than its present full-scale value.

This month we shall continue with more of the calculations used in developing circuits. Last time we looked at the way in which a panel microammeter of the traditional pointer-on-scale (analogue) type could be made to read volts. This time we shall look at how the same type of meter can be re-scaled to read a current range higher than its present full-scale value. For example, how a 0 - 100uA meter could be made to read up to 50mA.

Scaling up

Suppose your meter has a 0 - 50uA scale. You are making a battery charger and want the meter to read up to 5 amps. You know from the manufacturer's or supplier's data that the meter has a resistance of 4300 ohms (4.3 kilohms).

The solution is connect a resistor (called a shunt) in parallel with the meter as shown in figure 1. This resistor has a much lower value than that of the meter so most of the current will flow through it (that is, it will bypass the meter). At full-scale deflection, only 50uA is allowed to flow through the meter while the balance (5A - 50uA) will flow through the shunt. This works out at 4.99995A so, for all practical purposes, we may regard the entire 5A as flowing through the shunt (the error is only 0.001 percent).

Perhaps the easiest way to understand how to calculate the value of the shunt, R, is to find the voltage which exists across the meter when the full-scale current of 50uA flows through it.

Using Ohm's Law and remembering that a current of 50uA (0.00005A) flows through the meter and this has a resistance 4.3k, the voltage across it may be found thus:

$$V = I \times R = 0.00005 \times 4300 = 0.215V$$

Referring to figure 1 again, it will be seen that since the ends of the shunt are connected to the terminals of the meter, the same voltage (0.215V) must exist across the shunt also.

Ohm's Law is used again - this time to calculate the resistance of the shunt. Remember, the shunt may be regarded as carrying the whole 5A and 0.215V exists across it:

$$R = V/I = 0.215/5 = 0.043 \text{ ohms}$$

The problem is finding a resistor having such a low value. Suppliers' catalogues do not list resistors lower than about 0.1 ohm. You could obtain a fairly close value by connecting two 0.1-ohm units in parallel giving 0.05 ohm. However, the error here is about 16 percent and so is not really acceptable. You could "trim" this value and make it a little lower by connecting a relatively high value resistor in parallel with the pair. For example, a parallel arrangement of 0.1, 0.1 and 0.33 ohms gives a very close result - 0.0434 ohms (an error of about 1 percent).

Note: Performing calculation on resistors in parallel was the subject of Practically Speaking in ETI Issue 2 this year.

A further example will make this all clear.

Example:

You require a milliammeter scaled 0 - 250mA and you have available

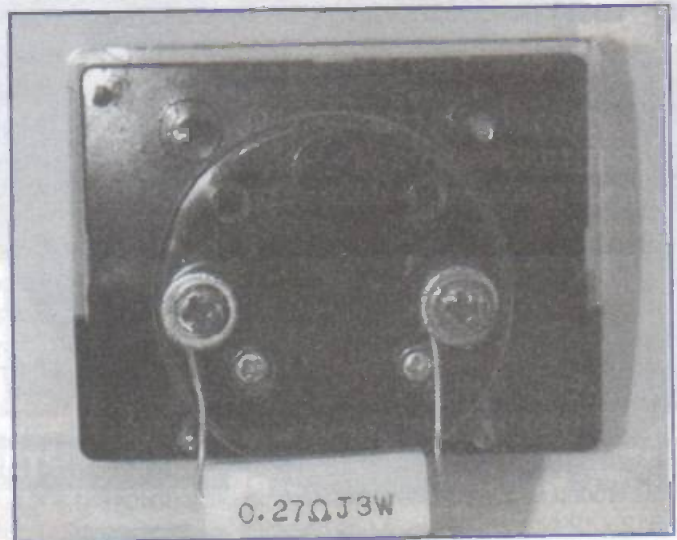

The photo shows the shunt resistor fitted to the rear of the microammeter

a microammeter scaled 0 - 100uA and having a resistance of 3750 ohms.

Referring once again to figure 1, with a total current of 250mA (0.25A) flowing, there will be 100uA passing through the meter. The current in the shunt is then (0.25A - 0.0001A) = 0.2499A. As in the last example, we can regard to whole 250mA as flowing through the shunt. The error is extremely small.

Using Ohm's Law to find the voltage across the meter when 100uA flows through it:

$$V = I \times R = 0.0001 \times 3750 = 0.375V$$

Applying Ohm's Law again to find the resistance of the shunt and (remembering that 0.375V exists across it):

$$R = V/I = 0.375/0.25 = 1.5 \text{ ohms}$$

Fortunately, this value is available "off the shelf".

If the new full-scale deflection is much greater than that of the meter there is no problem in regarding the total current as flowing through the shunt. However, if the new full-scale deflection (fsd) were to be, say, 500uA and the meter had an fsd of 50uA, there would be a considerable error. In this case, you would need to say that 450uA was flowing through the shunt when doing the calculation.

You can make a new scale for the meter by removing the old one, spraying it with matt white paint, and applying the new numbering using dry print lettering.

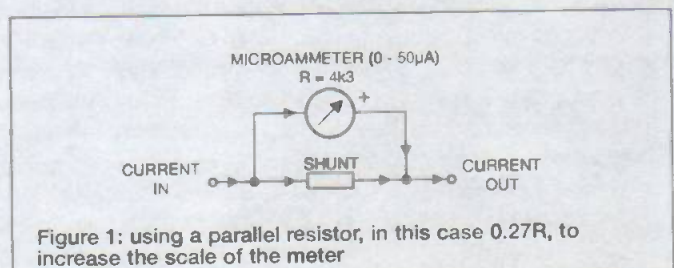

Figure 1: using a parallel resistor, in this case 0.27R, to increase the scale of the meter

Around the

E

ven technophobes in the modern world know that a business called Intel makes a processor called the Pentium II, and dimly realise

that it is one of the most powerful things that you can find inside a computer. Now that even toasters contain microprocessors, what's new at the other end of the range that concerns DIY designers and builders?

It may not surprise anyone that I am thinking of Microchip, makers of the widely used PIC range of microcontrollers. Looking through the new catalogues, I noticed that, since the last time I looked at the section, an 8-pin PIC family has appeared. The basic model, PIC12C508, costs around £1 a piece, and can store up to 512 x 12-bit instructions. It has 25 bytes of data ram, and a completely internal 4MHz clock. As a result, 6 pins are available for I/O. It also contains a timer, a watchdog, and it can be programmed in circuit. Perhaps you could connect your toaster to the Internet and have its software upgraded?

The PIC12C508 is probably more than enough to control a toaster, and is suitable for a number of other appliances which would otherwise use complicated cams and switches, hard-wired logic, or a more expensive processor. Of course, the idea of programming it in Java is probably a non-starter, but where you are going to make hundreds or thousands of something, it is probably worth paying for an extra man-day of programming to avoid the need for a more expensive processor in each one.

Microchip have recently announced the PIC12CE673 and PIC12CE674 processors. These are the same except that the '73 can store 1024 x 14-bit instructions, and the '74 can store 2048. They contain 128 bytes of data ram, 16 bytes of flash memory to store data while powered down, and have a 10MHz internal

clock. They can also be programmed in system, and contain a timer plus a watchdog timer.

In addition, four of the six digital I/O pins can double as 8-bit analogue to digital converter inputs. You could do a lot with that.

Two of the basic models are available from both Farnell and RS/Electromail, so they are accessible to constructors. Now, who is going to design a programmer for this tiny PIC, or a project that uses one?

That is an example of an editorial question which may be looking for an editorial answer. ETI now has a page on the World Wide Web. Initially we have posted some of the basic information which is often requested, such as the contents of forthcoming and current issues, publication dates, contact addresses, and some useful electronics links. In future, we expect to add any MODSMODS or updated component supply information for projects, in advance of the next issue reaching the news-stands.

Also under longer term planning is a master project index, going as far back as is practical, notes for contributors, and possibly letters and technical tips. Tell us what you think. One thing we will lack for the foreseeable future: there is unlikely to be much software on the site, for copyright reasons. The url is <http://www.aaelectron.co.uk/eti/>, and the email address is eti@aaelectron.co.uk.

Please note! This is purely an editorial web site. Enquiries relating to subscriptions, advertising etc. should be sent to Nexus Special Interests' postal address (see the panel on the right of this page), not the email address above. Please do not expect non-editorial enquiries to be forwarded. We have no facilities for forwarding to other departments, and no legions of robot slaves to field messages that we can't deal with. So please, write to the right department if you can't find what you require.

Next Month

Volume 27 no. 6 of *Electronics Today International* will be in your newsagents on 22nd May 1998 ... Advanced Displays describes Light Emitting Plastics, Planar Optical Displays and new 3D strategies ... Part 2 of Geoff Pike G10GDP's UHF-model radio controller touches down ... A request for a good quality echo unit for modern studios prompted a new design from Robert Penfold ... Robin Abbott starts a new introduction to PIC programming for more advanced-programmers, but designed for less experienced PICers to follow ... plus all the regulars, and more.

Contents are in preparation but are subject to space and availability.



Published by
Nexus Special Interests Limited
Nexus House, Boundary Way,
Hemel Hempstead, Herts HP2 7ST
Tel 01442 266551 Fax 01442 266998
Sorry, we cannot answer queries about projects or other technical questions on the phone. Please write to the address above. Our admin assistant can often help with other queries about this issue.

EDITORIAL

Editor
Helen Armstrong
Administration Assistant
Sandra Ballantyne
Consultant
Andrew Armstrong

PRODUCTION

Designer
David Rice
Technical Illustrator
John Puczynski
Production Executive
Marie Quilter
Printed By
Wiltshire Ltd, Bristol
Origination by
Atelier, St. Austell

SALES

Midland and Southern Area Sales
Andrew Forder
01442 266551

Northern Area Sales
Denise Barrow
0161 776 4460

Group Advertisement Manager
Diane Farnham

MANAGEMENT

Divisional Managing Director
Tony DeBell

Divisional Managing Editor
Dawn Frostdick-Hopley

Business Manager
Stuart Cooke

Circulation Manager
William Pearson

Copy Sales Manager
David Pagendam

SUBSCRIPTIONS

UK Orders 01858 435344
Enquiries 01858 435322
USA: Wise Owl Worldwide Publications, 4314 West 238th
Street, Torrance, CA90505-4509, USA. For VISA/Mastercard
orders phone (310) 375 6258. Fax: (310) 375 0548. Pacific Time:
9am - 9pm weekdays 10am - 6pm weekends. Visa/MC/Discover
accepted.

READERS SERVICES
Back issues (last 12 months) £3.20 per issue if available. Older
issues: photocopies of older articles often available. Write to The
Photocopy Service, Readers Services Department, at Nexus
House, Boundary Way, Hemel Hempstead, Herts HP2 7ST.
Senders for ETI: £7.50 each including UK post and packing.
Overseas please add £1.50. Cheques to Nexus Special Interest
at Nexus House, or phone VISA/Mastercard orders to Readers
Services Department: 01442 266551



© Nexus Special Interests Limited 1998
All rights reserved
ISSN 0142-7229

The Publisher's written consent must be obtained before any part of this publication may be reproduced in any form whatsoever, including photocopies, and information retrieval systems. All reasonable care is taken in preparation of magazine contents, but the publishers, editors and their agents cannot be held legally responsible for loss howsoever arising from errors or other published material.

The Affordable Solution for 8051 & AVR™ Microcontroller Support Tools

DISTRIBUTORS FOR



IAR SYSTEMS

IAR Microcontroller Development Tools
C-Compilers, Assemblers, Simulators

8051, Atmel AVR, Hitachi H8

M MICRO-PRO DEVICE PROGRAMMER

The complete programming solution! Supports:

- MICROCONTROLLERS**
Atmel 89C, 89S, 90S(AVR), Generic 87C, Dallas 87C520
- FLASH MEMORY**
Atmel 29C, 49F
- SERIAL/PARALLEL EEPROM**
Atmel 24C, 25C, 59C, 93C, 28C
- CONFIGURATORS**
Atmel 17C, Xilinx XC17

Not all devices may be supported within each family.

NEW PRODUCT!
NOW SUPPLIED WITH LIBRARIES FOR...
29C, 49F, 24C, 25C, 59C, 93C, 28C, 17C, XC17

Only... **£124.95**

Order Code: MPW-PLUS



PROFESSIONAL AVR™ MICROCONTROLLER STARTER SYSTEM

- System Contents**
- Combined Serial & Parallel Device Programmer
 - Evaluation module for 8, 20 & 40-pin DIL devices
 - In-System Programming (ISP) Cable
 - Integrated Windows™ Development Environment
 - AVR™ Basic LITE (1k bytes code) Compiler
 - AVR™ Assembler
 - Mains Power Supply Adaptor
 - PC Serial Cable (Connects to PC COM Port)
 - Atmel CD-ROM Datbook
 - One AT90S1200 DIL Microcontroller

NEW PRODUCT!



Figure 1

Only... **£99.95**

Order Code: AVR2-ST

WRITE IN BASIC RUN IN A FLASH

AVR BASIC

NEW PRODUCT!

- Compiled BASIC generates tight AVR™ machine code
- Not a Run-Time Interpreter; NO code overhead!
- Target speeds comparable with assembler
- Breaks the cost barrier for small projects
- Ideal for educational, hobbyist and professional use

Order Codes:
AVR-BAS-LITE
AVR-BAS-8K

Only... **£24.95**
and
£149.95

FLASH 8051 Professional Starter System

System Contents

- Combined Serial & Parallel Device Programmer
- Evaluation module for 20 & 40-pin DIL devices
- In-System Programming (ISP) Cable
- Keil PK51-2K Integrated Windows™ Development Environment (2K code limit). Includes C-Compiler, Macro Assembler, Linker, Hex Creator, Editor & Simulator
- Mains Power Supply Adaptor
- PC Serial Cable
- Atmel CD-ROM Datbook
- One AT89S8252 40-pin DIL Microcontroller

System layout shown in Fig 1 above

Only... **£109.95**

Order Code: EQ-8051-ST1

Micro-ISP Series III

Serial Programming System for the Atmel AVR™ & 89S microcontroller families

NEW PRODUCT!



Typical In-System Programming (ISP) Scenario shown below:

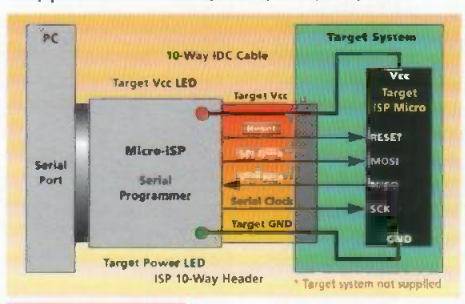

Order Code: UISP-S3-SYS
Only... **£109.95**

KEIL SOFTWARE THE ULTIMATE 8051 TOOL SET

µVision
Integrated Development Environment for Windows™

- Optimising Ansi-C Compiler
- Macro Assembler
- Linker
- Software Simulator
- Integrated Editor
- Hex Creator

Starter Systems supplied with 2K Toolset & Development Systems supplied with 8K Toolset are available for Atmel, Dallas, Siemens, Temic 8051 microcontroller derivatives

dScope
Software Simulator & Target Debugger

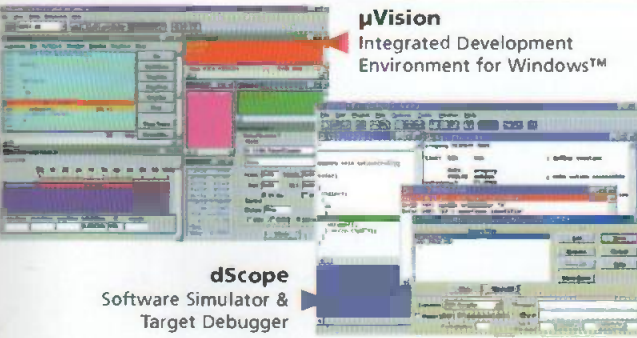

EQUINOX TECHNOLOGIES
EQUINOX TECHNOLOGIES UK LIMITED

The Embedded Solutions Company

3 Atlas House St Georges Square Bolton BL1 2HB England



For sales tel: +44 (0) 1204 529000, fax: +44 (0) 1204 535555, e-mail: sales@equinox-tech.com, Web Site: www.equinox-tech.com

EQUINOX DISTRIBUTORS: AUSTRALIA Farnell +61 2 9645 8888 AUSTRIA Farnell +43 0660 87 75 BELGIUM Alcom Electronics Nv/sa +32 3 227 3647 Farnell +32 03 227 36 47 BRAZIL Hastic +55 11 522 1799 Anacom +55 11 453 5588 DENMARK Farnell +45 44 53 66 44 EIRE Farnell +353 1 8309277 FINLAND Farnell +358 9 3455 400 FRANCE Farnell +33 474 65 94 66 Newtek +33 1 4687 2200 GERMANY Elektronik Laden +49 52 32 81 71 Farnell +49 89 61 39 39 39 Inetek GmbH +49 7321 93850, MSC Wertneis GmbH +49 08 9945532 12 GREECE Mirolec +30 1 5395042 4 HONG KONG Farnell 800 968 280 (HK Direct toll free) ITALY Farnell +44 113 231 1311 Grifo Italian Technology +39 51 89 20 52, Newtek Italia +39 2 33 10 53 08 MALAYSIA Farnell +60 3 773 8000 NETHERLANDS Alcom Electronics BV +31 10 4519533 Animatek +31 10 450 4949 Farnell +31 30 241 2323 NEW ZEALAND Farnell +64 9 357 0646 NORWAY ACTE NC +47 63898900 Jakob Hatteland Electronic AS +47 53763000 PORTUGAL Anatronc +35 119 371 834 Farnell +44 113 289 0040 SINGAPORE Farnell +65 788 0200 SPAIN Anatronc SA +34 1 366 01 59 Farnell +44 113 231 0447 SWEDEN ACTE NC +46 8 445 28 70 Farnell +46 8 730 50 00 SWITZERLAND Anatec Ag +41 41 748 32 41 Farnell +41 1 204 64 64 UNITED KINGDOM Abacus Polar +44 1925 626626, Farnell +44 113 263 6311 Rapid Electronics +44 1206 751166 Quamdon Electronics +44 1332 332651 USA Hitools Inc +1 408 298 9077 Newark Electronics +1 800 718 1997, Peachtree Technology +1 770 888 4002 Pioneer Standard +1 888 832 3976

Equinox reserves the right to change prices & specifications of any of the above products without prior notice. E&OE. All prices are exclusive of VAT & carriage. AVR™ is a trademark of the Atmel Corporation

STILL THE WORLD'S MOST POWERFUL PORTABLE PROGRAMMERS?

£495+VAT

CE

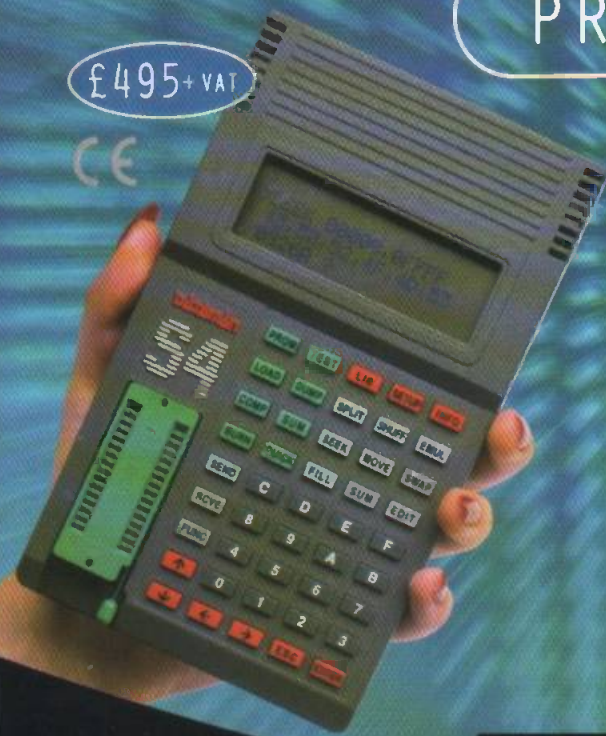

NEW MODEL



£795+VAT

CIRCLE NO. 103 ON REPLY CARD

SURELY NOT.
SURELY SOMEONE SOMEWHERE HAS
DEVELOPED A PORTABLE PROGRAMMER
THAT HAS EVEN MORE FEATURES, EVEN
GREATER FLEXIBILITY AND IS EVEN
BETTER VALUE FOR MONEY.
ACTUALLY, NO. BUT DON'T TAKE OUR
WORD FOR IT. USE THE FEATURE
SUMMARY BELOW TO SEE HOW OTHER
MANUFACTURERS' PRODUCTS COMPARE.

DATAMAN - 48LV

- Plugs straight into parallel port of PC or laptop
- Programs and verifies at 2, 2.7, 3.3 & 5V
- True no-adaptor programming up to 48 pin DIL devices
- Free universal 44 pin PLCC adaptor
- Built-in world standard PSU - for go-anywhere programming
- Package adaptors available for TSOP, PSOP, QFP, SOIC and PLCC
- Optional EPROM emulator

DATAMAN S4

- Programs 8 and 16 bit EPROMs, EEPROMs, PEROMs, 5 and 12V FLASH, Boot-Block FLASH, PICs, 8751 microcontrollers and more
- EPROM emulation as standard
- Rechargeable battery power for total portability
- All-in-one price includes emulation leads, AC charger, PC software, spare library ROM, user-friendly manual
- Supplied fully charged and ready to use

S4 GAL MODULE

- Programs wide range of 20 and 24 pin logic devices from the major GAL vendors
- Supports JEDEC files from all popular compilers

SUPPORT

- 3 year parts and labour guarantee
- Windows/DOS software included
- Free technical support for life
- Next day delivery - always in stock
- Dedicated UK supplier, established 1978

Still as unbeatable as ever. Beware of cheap imitations. Beware of false promises. Beware of hidden extras. If you want the best, there's still only one choice - Dataman.

Order via credit card hotline - phone today, use tomorrow.

Alternatively, request more detailed information on these and other market-leading programming solutions.

MONEY-BACK 30 DAY TRIAL

If you do not agree that these truly are the most powerful portable programmers you can buy, simply return your Dataman product within 30 days for a full refund

hotline
01300 320719



Orders received by 4pm will normally be despatched same day.
Order today, get it tomorrow!

DATAMAN

Dataman Programmers Ltd, Station Rd,
Maiden Newton, Dorchester,
Dorset, DT2 0AE, UK
Telephone +44/0 1300 320719
Fax +44/0 1300 321012
BBS +44/0 1300 321095 (24hr)
Modem V.34/V.FC/V.32bis
Home page: <http://www.dataman.com>
FTP: <ftp://ftp.dataman.com>
Email: sales@dataman.com