

**ELECTRONICS
TODAY INTERNATIONAL**

**PIEZO-ELECTRIC
EFFECT**

**LOCAL OPERATING
NETWORKS EXPLAINED**

Automation control in home and factory

SUPERCOMPONENTS

Perfecting audio standards by John Linsley Hood



LASER RECEIVER

VERSATILE TEMPERATURE CONTROL

Design ideas and project

BACK TO BASICS

Inductances

FIRE DETECTION SYSTEMS



OMP POWER AMPLIFIER MODULES-TURNABLES-DIMMERS-LOUDSPEAKERS-19 INCH STEREO RACK AMPLIFIERS

OMP POWER AMPLIFIER MODULES Supplied ready built and tested.
OMP POWER AMPLIFIER MODULES Now enjoy a world-wide reputation for quality, reliability and performance at a realistic price. Four models available to suit the needs of the professional and hobby market, i.e. Industry, Leisure, Instrumental and Hi-Fi etc. When comparing prices. NOTE all models include Toroidal power supply, Integral heat sink, Glass fibre P.C.B. and Drive circuits to power compatible Vu meter. Open and short circuit proof.

THOUSANDS OF MODULES PURCHASED BY PROFESSIONAL USERS



OMP100 Mk 11 Bi-Polar Output power 110 watts R.M.S. into 4 ohms. Frequency Response 15Hz - 30KHz - 3dB, T.H.D. 0.01%, S.N.R. -118dB, Sens. for Max. output 500mV at 10K, Size 355 x 115x65mm.
PRICE £33.99 + £3.00 P&P.

NEW SERIES II MOS-FET MODULES



OMP/MF 100 Mos-Fet Output power 110 watts R.M.S. into 4 ohms. Frequency Response 1Hz - 100KHz - 3dB, Damping Factor, >300, Slew Rate 45V/uS, T.H.D. Typical 0.002%, Input Sensitivity 500mV, S.N.R. -125dB. Size 300 x 123 x 60mm.
PRICE £39.99 + £3.00 P&P.



OMP/MF200 Mos-Fet Output power 200 watts R.M.S. into 4 ohms. Frequency Response 1Hz - 100KHz - 3dB, Damping Factor >300, Slew Rate 50V/uS, T.H.D. Typical 0.001%, Input Sensitivity 500mV, S.N.R. -130dB. Size 300 x 155 x 100mm.
PRICE £62.99 + £3.50 P&P.



OMP/MF300 Mos-Fet Output power 300 watts R.M.S. into 4 ohms. Frequency Response 1Hz - 100KHz - 3dB, Damping Factor >300, Slew Rate 60V/uS, T.H.D. Typical 0.0008%, Input Sensitivity 500mV, S.N.R. -130dB. Size 330 x 175 x 100mm.
PRICE £79.99 + £4.50 P&P.

NOTE— MOS-FET MODULES ARE AVAILABLE IN TWO VERSIONS, STANDARD — INPUT SENS. 500mV BAND WIDTH 100KHz. PEG (PROFESSIONAL EQUIPMENT COMPATIBLE) — INPUT SENS. 775mV. BAND WIDTH 50KHz. ORDER STANDARD OR PEG.



Vu METER Compatible with our four amplifiers detailed above. A very accurate visual display employing 11 L.E.D. diodes (7 green, 4 red) plus an additional on/off indicator. Sophisticated logic control circuits for very fast rise and decay times. Tough moulded plastic case, with tinted acrylic front. Size 84 x 27 x 45mm.
PRICE £8.50 + 50p P&P.

LOUDSPEAKERS



LARGE SELECTION OF SPECIALIST LOUDSPEAKERS AVAILABLE, INCLUDING CABINET FITTINGS, SPEAKER GRILLES, CROSS-OVERS AND HIGH POWER, HIGH FREQUENCY BULLETS AND HORNS, LARGE S.A.E. (30p STAMPED) FOR COMPLETE LIST.

McKENZIE.— INSTRUMENTS, P.A., DISCO, ETC.

ALL MCKENZIE UNITS 8 OHMS IMPEDANCE

- 8" 100 WATT C8100GPM GEN. PURPOSE, LEAD GUITAR, EXCELLENT MID. DISCO. RES. FREQ. 80Hz. FREQ. RESP. TO 14KHz. SENS. 99dB. PRICE £29.30 + £2.00 P&P
- 10" 100 WATT C10100GP GUITAR, VOICE, ORGAN, KEYBOARD, DISCO. EXCELLENT MID. RES. FREQ. 70Hz. FREQ. RESP. TO 6KHz. SENS. 100dB. PRICE £35.58 + £2.50 P&P
- 10" 200 WATT C10200GP GUITAR, KEYBOARD, DISCO. EXCELLENT HIGH POWER MID. RES. FREQ. 45Hz. FREQ. RESP. TO 7KHz. SENS. 103dB. PRICE £48.67 + £2.50 P&P
- 12" 100 WATT C12100GP HIGH POWER GEN. PURPOSE, LEAD GUITAR, DISCO. RES. FREQ. 45Hz. FREQ. RESP. TO 7KHz. SENS. 98dB. PRICE £37.59 + £3.50 P&P
- 12" 100 WATT C12100TC TWIN CONE HIGH POWER WIDE RESPONSE, P.A., VOICE, DISCO. RES. FREQ. 45Hz. FREQ. RESP. TO 14KHz. SENS. 100dB. PRICE £38.58 + £3.50 P&P
- 12" 200 WATT C12200B HIGH POWER BASS, KEYBOARDS, DISCO, P.A. RES. FREQ. 40Hz. FREQ. RESP. TO 7KHz. SENS. 100dB. PRICE £65.79 + £3.50 P&P
- 12" 300 WATT C12300GP HIGH POWER BASS LEAD GUITAR, KEYBOARDS, DISCO, ETC. RES. FREQ. 45Hz. FREQ. RESP. TO 5KHz. SENS. 100dB. PRICE £87.51 + £3.50 P&P
- 15" 100 WATT C15100BS BASS GUITAR, LOW FREQUENCY, P.A., DISCO. RES. FREQ. 40Hz. FREQ. RESP. TO 5KHz. SENS. 98dB. PRICE £55.05 + £4.00 P&P
- 15" 200 WATT C15200BS VERY HIGH POWER BASS. RES. FREQ. 40Hz. FREQ. RESP. TO 4KHz. SENS. 99dB. PRICE £75.10 + £4.00 P&P
- 15" 250 WATT C15250BS VERY HIGH POWER BASS. RES. FREQ. 40Hz. FREQ. RESP. TO 4KHz. SENS. 99dB. PRICE £82.54 + £4.50 P&P
- 15" 400 WATT C15400BS VERY HIGH POWER, LOW FREQUENCY BASS. RES. FREQ. 40Hz. FREQ. RESP. TO 4KHz. SENS. 102dB. PRICE £96.47 + £4.50 P&P
- 18" 400 WATT C18400BS EXTREMELY HIGH POWER, LOW FREQUENCY BASS. RES. FREQ. 27Hz. FREQ. RESP. TO 3KHz. SENS. 99dB. PRICE £172.06 + £5.00 P&P

EARBENDERS.— HI-FI, STUDIO, IN-CAR, ETC.

ALL EARBENDER UNITS 8 OHMS (Except EB8-50 & EB10-50 which are dual impedance tapped @ 4 & 8 ohm.)

- BASS, SINGLE CONE, HIGH COMPLIANCE, ROLLED FOAM SURROUND**
- 8" 50 WATT EB8-50 DUAL IMPEDANCE, TAPPED 4/8 OHM BASS, HI-FI, IN-CAR. RES. FREQ. 40Hz. FREQ. RESP. TO 7KHz. SENS. 97dB. PRICE £8.90 + £2.00 P&P
- 10" 50 WATT EB10-50 DUAL IMPEDANCE, TAPPED 4/8 OHM BASS, HI-FI, IN-CAR. RES. FREQ. 40Hz. FREQ. RESP. TO 5KHz. SENS. 99dB. PRICE £12.00 + £2.50 P&P
- 10" 100 WATT EB10-100 BASS, HI-FI, STUDIO. RES. FREQ. 35Hz. FREQ. RESP. TO 3KHz. SENS. 96dB. PRICE £27.76 + £3.50 P&P
- 12" 60 WATT EB12-60 BASS, HI-FI, STUDIO. RES. FREQ. 28Hz. FREQ. RESP. TO 3KHz. SENS. 92dB. PRICE £21.00 + £3.00 P&P
- 12" 100 WATT EB12-100 BASS, STUDIO, HI-FI, EXCELLENT DISCO. RES. FREQ. 26Hz. FREQ. RESP. TO 3KHz. SENS. 93dB. PRICE £38.75 + £3.50 P&P
- FULL RANGE TWIN CONE, HIGH COMPLIANCE, ROLLED SURROUND**
- 5 1/2" 60 WATT EB5-60TC (TWIN CONE) HI-FI, MULTI-ARRAY DISCO ETC. RES. FREQ. 63Hz. FREQ. RESP. TO 20KHz. SENS. 92dB. PRICE £9.99 + £1.50 P&P
- 6 1/2" 60 WATT EB6-60TC (TWIN CONE) HI-FI, MULTI-ARRAY DISCO ETC. RES. FREQ. 38Hz. FREQ. RESP. TO 20KHz. SENS. 94dB. PRICE £10.99 + £1.50 P&P
- 8" 60 WATT EB8-60TC (TWIN CONE) HI-FI, MULTI-ARRAY DISCO ETC. RES. FREQ. 40Hz. FREQ. RESP. TO 18KHz. SENS. 89dB. PRICE £12.99 + £1.50 P&P
- 10" 60 WATT EB10-60TC (TWIN CONE) HI-FI, MULTI-ARRAY DISCO ETC. RES. FREQ. 35Hz. FREQ. RESP. TO 12KHz. SENS. 86dB. PRICE £16.49 + £2.00 P&P

TRANSMITTER HOBBY KITS

PROVEN TRANSMITTER DESIGNS INCLUDING GLASS FIBRE PRINTED CIRCUIT BOARD AND HIGH QUALITY COMPONENTS COMPLETE WITH CIRCUIT AND INSTRUCTIONS

- 3W FM TRANSMITTER 80-108MHz. VARICAP CONTROLLED PROFESSIONAL PERFORMANCE. RANGE UP TO 3 MILES, SIZE 38 x 123mm, SUPPLY 12V @ 0.5AMP. PRICE £14.49 + £1.00 P&P
- FM MICRO TRANSMITTER (BUG) 100-108MHz VARICAP TUNED COMPLETE WITH VERY SENS FET MIC, RANGE 100-300m. SIZE 56 x 46mm, SUPPLY 9V BATT. PRICE £8.62 + £1.00 P&P

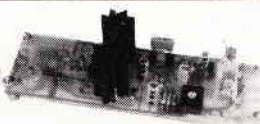

3 watt FM Transmitter

* PRICES INCLUDE V.A.T. * PROMPT DELIVERIES * FRIENDLY SERVICE * LARGE S.A.E., 30p STAMPED FOR CURRENT LIST.

OMP VARISPEED TURNTABLE CHASSIS.



- * MANUAL ARM
- * STEEL CHASSIS
- * ELECTRONIC SPEED CONTROL 33 & 45
- * VARI PITCH CONTROL
- * HIGH TORQUE SERVO DRIVEN DC MOTOR
- * TRANSISTOR CROSSES
- * 12 DIE CAST PLATTER
- * NEON STROBE
- * CALIBRATED BAL WEIGHT
- * REMOVABLE HEAD SHELL
- * 1/2" CARTRIDGE FIXINGS
- * CUE LEVER
- * POWER 220-240V 50-60Hz
- * 390x305mm
- * SUPPLIED WITH MOUNTING CUT-OUT TEMPLATE.

PRICE £59.99 + £3.50 P&P.

OPTIONAL MAGNETIC CARTRIDGES

STANTON AL500
 PRICE £16.99 + 50p P&P

GOLDRING G850
 PRICE £6.99 + 50p P&P

OMP MOS-FET POWER AMPLIFIERS, HIGH POWER, TWO CHANNEL, 19 INCH RACK THOUSANDS PURCHASED BY PROFESSIONAL USERS



NEW MXF SERIES OF POWER AMPLIFIERS

THREE MODELS:— MXF200 (100w + 100w)
 MXF400 (200w + 200w) MXF600 (300w + 300w)

All power ratings R.M.S. into 4 ohms.

FEATURES: * Independent power supplies with two Toroidal Transformers * Twin L.E.D. Vu meters * Rotary indexed level controls * Illuminated on/off switch * XLR connectors * Standard 775mV inputs * Open and short circuit proof * Latest Mos-Fets for stress free power delivery into virtually any load * High slew rate * Very low distortion * Aluminium cases * MXF600 Fan Cooled with D.C. Loudspeaker and Thermal Protection.

USED THE WORLD OVER IN CLUBS, PUBS, CINEMAS, DISCOS ETC.

- SIZES:— MXF 200 W19" x H3 1/2" (2U) x D11"
- MXF 400 W19" x H5 1/4" (3U) x D12"
- MXF 600 W19" x H5 1/4" (3U) x D13"

MXF200 £171.35
 MXF400 £228.85
 MXF600 £322.00

SECURICOR DELIVERY £12.00 EACH



OMP LINNET LOUDSPEAKERS

THE VERY BEST IN QUALITY AND VALUE



MADE ESPECIALLY TO SUIT TODAY'S NEED FOR COMPACTNESS WITH HIGH OUTPUT SOUND LEVELS. FINISHED IN HARDWEARING BLACK NYLON WITH PROTECTIVE CORNERS, GRILLE AND CARRYING HANDLE. INCORPORATES 12" DRIVER PLUS HIGH FREQ. HORN FOR FULL FREQ. RANGE 45Hz-20KHz. 30TH MODELS 8 OHM, SIZE H18" x W15" x D12"

CHOICE OF TWO MODELS

POWER RATINGS QUOTED IN WATTS RMS FOR EACH CABINET

OMP 12-100 (100W 100dB) PRICE £159.99 PER PAIR

OMP 12-200 (200W 102dB) PRICE £209.99 PER PAIR

SECURICOR DEL.— £12.00 PER PAIR

IN CAR STEREO BOOSTER AMPLIFIER



TWO SUPERB HIGH POWER CAR STEREO BOOSTER AMPLIFIERS

150 WATTS (75+75) INTO 4 OHMS
 300 WATTS (150+150) INTO 4 OHMS
FEATURES:
 * HIGH & LOW INPUT IMPEDANCES
 * HIGH & LOW INPUT SENSITIVITIES
 * VARIABLE INPUT GAIN CONTROL
 * SHORT CIRCUIT OUTPUT PROTECTION
 * POWER REQUIREMENT 12V. D.C.
 PRICES: 150 WATT £43.00
 300 WATT £95.00 — £3.00 P&P EACH

PIEZO ELECTRIC TWEETERS—MOTOROLA

PIEZO ELECTRIC TWEETERS — MOTOROLA

Join the Piezo revolution. The low dynamic mass (no voice coil) of a Piezo tweeter produces an improved transient response with a lower distortion level than ordinary dynamic tweeters. As a crossover is not required these units can be added to existing speaker systems of up to 100 watts (more if 2 put in series). FREE EXPLANATORY LEAFLETS SUPPLIED WITH EACH TWEETER.

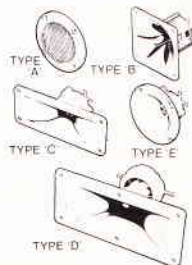

- TYPE 'A' (KSN2036A) 3" round with protective wire mesh. Ideal for bookshelf and medium sized Hi-Fi speakers. Price £4.90 each + 50p P&P
 - TYPE 'B' (KSN1005A) 3 1/2" Super horn. For general purpose speakers, disco and P.A. systems etc. Price £5.99 each + 50p P&P
 - TYPE 'C' (KSN6016A) 2 1/2" x 5 1/2" wide dispersion horn. For quality Hi-Fi systems and quality disco etc. Price £6.99 each + 50p P&P
 - TYPE 'D' (KSN1025A) 2 1/2" x 6 1/2" wide dispersion horn. Upper frequency response retained extending down to mid range (2KHz). Suitable for high quality Hi-Fi systems and quality discos. Price £9.99 each + 50p P&P
 - TYPE 'E' (KSN1038A) 3 1/2" horn tweeter with attractive silver finish trim. Suitable for Hi-Fi monitor systems etc. Price £5.99 each + 50p P&P
- LEVEL CONTROL** Combines on a recessed mounting plate, level control and cabinet input jack socket. 85 x 85mm. Price £3.99 + 50p P&P

STEREO DISCO MIXER

STEREO DISCO MIXER with 2 x 5 band L & R graphic equalisers and twin 10 segment L.E.D. Vu Meters. Many outstanding features 5 inputs with individual faders providing a useful combination of the following:—
 3 Turntables (Mag), 3 Mics, 4 Line including CD plus Mic with talk over switch Headphone Monitor, Pan Pot L & R Master Output controls. Output 775mV. Size 360 x 280 x 90mm. Supply 220-240V
Price £134.99 — £4.00 P&P

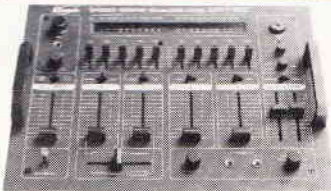

B. K. ELECTRONICS Dept EE
 UNIT 5, COMET WAY, SOUTHEND-ON-SEA, ESSEX. SS2 6TR
 TEL: 0702-527572 FAX: 0702-420243



POSTAL CHARGES PER ORDER £1.00 MINIMUM. OFFICIAL ORDERS WELCOME FROM SCHOOLS, COLLEGES, GOVT. BODIES, ETC. PRICES INCLUSIVE OF V.A.T. SALES COUNTER. VISA ACCESS ACCEPTED BY POST, PHONE OR FAX.





WHY NOT

— subscribe to the best electronics magazine in town

WHEN

— what about NOW!

HOW

— just complete the coupon below and you will receive absolutely FREE this WIRE STRIPPER worth £4.95

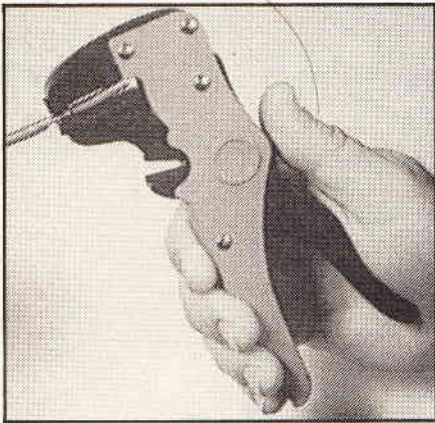

The wire strippers shown here will grip and remove the insulation cleanly from a variety of wire gauges in one easy action. No more gripping and guessing the depth of cut as with other makes, this handy service tool will do the job quickly and efficiently. Any regular electronics project builder would not do without one.

SUBSCRIPTION RATES

U.K. £19.20 EUROPE £24.10 MIDDLE EAST £24.40
 FAR EAST £26.80 REST OF WORLD £25.85 USA \$48.00

This offer closes 31st July 1991 — so don't miss out just complete the coupon and send it with your remittance to the Subscription Manager, Argus House, Boundary Way, Hemel Hempstead, Herts. HP2 7ST.

This offer is open to existing subscribers who wish to extend or renew their subscriptions.

Please commence my subscription to **E.T.I.** with the _____ issue and send me my free **WIRE STRIPPER**. I enclose my cheque/money order for £ _____ payable to ASP or please debit my Access/Visa

Valid from _____ to _____

Name _____ Signature _____

Address _____

_____ Postcode _____

Please allow 28 days delivery for free gift. ETI/11



**ELECTRONICS
TODAY INTERNATIONAL**

EDITORIAL

Editor Paul Freeman

CREATIVE

Art Editor Peter Kirby

Designer Iain Houston

Technical Illustration Jerry Fowler

Photography Manny Cefai

ADVERTISEMENT SALES

Advertisement Manager

Mark Linacre

Advertisement Sales

Michele Donovan

Advertisement Copy Control

Marie Quilter

MANAGEMENT

Managing Director

Terry Pattison

Circulation & Promotions Manager

Debra Stuppel

Production Manager

Tony Dowdeswell

Group Editor

Mark Webb

ISSN
0142-7229

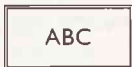

Member of the
Audit Bureau
of Circulation

ETI is normally published on the first Friday in the month preceding the cover date. The contents of this publication including all articles, designs, plans, drawings and programs and all copyright and other intellectual property rights therein belong to Argus Specialist Publications. All rights conferred by the Law of Copyright and other intellectual property rights and by virtue of international copyright conventions are specifically reserved to Argus Specialist Publications and any reproduction requires the prior written consent of the Company © 1990 Argus Specialist Publications. All reasonable care is taken in the preparation of the magazine contents, but the publishers cannot be held legally responsible for errors. Where mistakes do occur, a correction will normally be published as soon as possible afterwards. All prices and data contained in advertisements are accepted by us in good faith as correct at the time of going to press. Neither the advertisers nor the publishers can be held responsible, however, for any variations affecting price or availability which may occur after the publication has closed for press.

• Subscription rates — UK: £19.20. Europe: £24.10. Middle East: £24.40. Far East: £26.80. Rest: £25.85 or US\$48.00.



Argus House, Boundary Way,
Hemel Hempstead HP2 7ST
Tel: (0442) 66551 Fax: (0442) 66998

Features & Projects

Fire Detection Systems 1

Vivian Capel examines the differences between smoke alarm systems.

Towards Tomorrow

Andrew Armstrong looks at the future of Nano-technology.

Back To Basics 5

Paul Coxwell examines the concept of inductance.

Tech-Tips

Some more readers circuits for you to try out.

Lasers 3

In our third and final part, Kevin Kirk introduces an opto receiver for the laser project and suggests some applications.

HDTV 7

James Archer scrutinises another batch of proposed ATV systems.

Cookers and Micros — Alive, Alive-o

Damon Hart-Davis reports on the latest development in Local Operating Networks to automate the office, factory or home.

Circuit File

Ray Marston examines temperature sensor IC circuits.

Versatile Temperature Controller

AJP Williams constructs an accurate temperature control system.

Supercomponents

A controversial issue amongst those within hi-fi circles, John Linsley Hood states his case for component quality and layout.

Piezo Film Technology

An in-depth look at the Piezo-electric effect by Douglas Clarkson.

More on RIAA

The calculations are here for you to discover by Wilfred Harms

Regulars

Open Channel	6
Read/Write	8
News	9
Diary	13
PCB Service	37
PCB Foils	62
Classified Ads	64
Photocopy Service	66

Published by Argus Specialist Publications, Argus House, Boundary Way, Hemel Hempstead HP2 7ST. Tel: (0442) 66551. UK newstrade distribution by SM Distribution Ltd., 6 Leigham Court Road, London SW16 2PG. Tel: 081-677 8111. Overseas and non-newstrade sales by Magazine Sales Department, Argus House, Boundary Way, Hemel Hempstead, HP2 7ST. Tel: (0442) 66551. Subscriptions by Select Subscriptions Ltd., 5 River Park Estate, Berkhamsted, Herts HP4 1HL. Tel: (0442) 876661. US subscriptions by Wise Owl Worldwide Publications, 4314 West 238th Street, Torrance, CA90505 USA. Tel: (213) 3756258. Typesetting and origination by Project 3 Filmsetters, Whitstable. Printed by Acorn Web Offset Ltd, Bradford, W Yorks.

Page

14

17

18

26

29

37

38

43

46

52

57

60

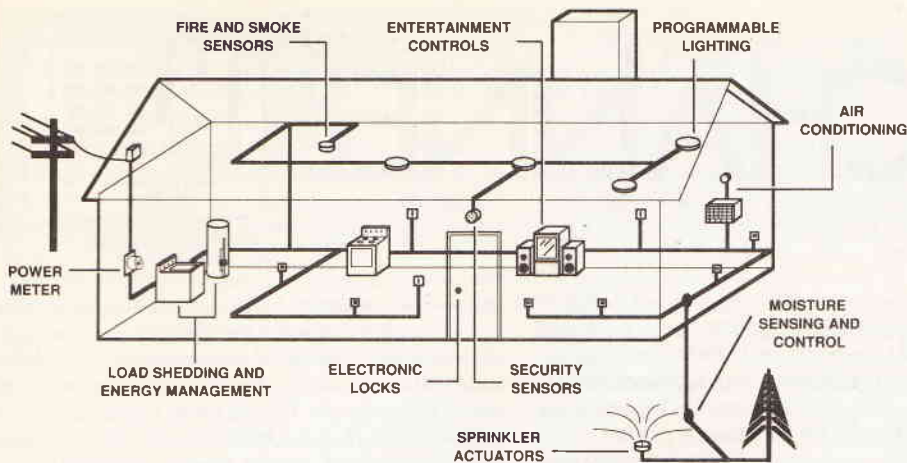

Page 38.

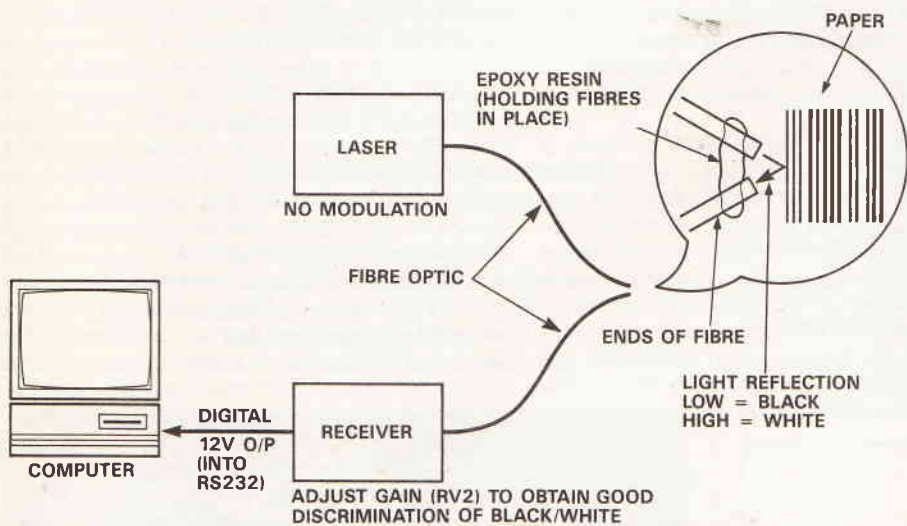

Page 29.

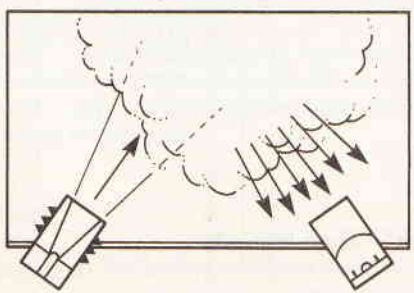
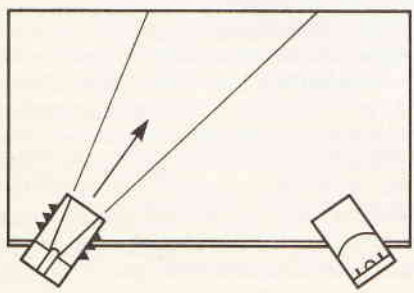

INFRA-RED SOURCE (a)

PHOTO-CELL

INFRA-RED SOURCE (b)

PHOTO-CELL

Page 14

Editorial

The age of the alarm is here! Car alarms, burgler alarms, radio clock alarms and digital watches to name but a few. Affordable technology is now all around us so the media would have us believe. Insurance companies twist our arms to pay up either way through the investment of the latest hardware or with higher premiums. But at what cost. It may just make us more aware that a crime is being committed and be a deterrent to the offender, but what of the social side effects? The false alarm menace could indeed be the price we have to pay for increased security until the alarm becomes more discerning and alert us of a 'real' crime.

The cacophony of communal tonal alert started at the end of the 70s, early 80s when digital watches became affordable and in order to show the world you had the latest technology, the hourly bleeper was left on — and in a hall where there could be 500 of the darned things, you can imagine the effect. They might have been marvellous for stereo sound field experiments but an extreme annoyance to a lecturer in full flight.

Next, enter the car alarm. The social menace at night of this one erupting into a whaling banshee through the night air is bad enough for the owner in wondering whether to face the worst or not and bad for everybody's sleep patterns down the street. These things can be set off by a whole variety of means including wind, rain, cats and of course humans brushing by. Just wait for the whole street of alarmed cars to erupt in the future by a joyride from pranksters, sleep will be a daytime occupation.

And finally, the house alarm. Although they have been around for longer than the others, particularly for high street shops, domestic house alarm installation is on the increase. False alarms in the high street are an even greater problem to solve mainly because keyholders very often cannot be traced. Those who have the misfortune to live in flats along the high street have been known to take their own action in putting the bell out of its misery. People will go to desperate lengths for a peaceful night! You might think an obvious solution is to have have some sort of direct link to the police station so removing the need for audible warning. Just ask a night duty policeman what he thinks about that and you would wish you hadn't asked. If the electronics industry doesn't come up with better and more intellignet systems, it may be that social pressures will cause the downfall of dumb security systems in the future.

Paul Freeman

OPEN CHANNEL

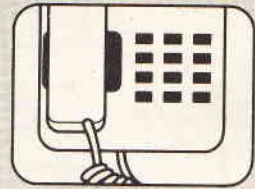

Following the break-up of the old Independent Broadcasting Authority (IBA) into privatised segments, the part which is to hold and operate engineering aspects of radio and television broadcasting — previously the Engineering Division of the IBA — is currently up for commercial grabs. Sale of National Telecommunications (NT) is being handled by Price Waterhouse and several significant prospective bidders have expressed interest.

NT has been looking at methods of diversifying to extend its business, with the aim of moving out of straightforward broadcasting, into technically related and parallel areas. Consequently they are considering such things as networks and satellites, although final details obviously cannot be undertaken until its sale is finalised.

While sale of NT may be valid in terms of economic success for the company, it's worth considering what might happen if it is bought and controlled by a company which does not take into account NT's possible future contributions to the various electronics and communications industries it serves. In the past, as the Engineering Division, the organisation had power to more-or-less actively define telecommunications futures. A power which, incidentally, was not generally abused. In the right hands this function could be continued by NT. In the wrong private hands . . .

VHS Upgrade

A new system of picture enhancement has been developed which promises to improve pictures available from VHS videocassette recorders. The system, known as *active sideband optimum* (ASO), looks set to be used by all VHS equipment manufacturers as an effective replacement for complex high quality (HQ) picture enhancement systems currently used. ASO's significantly less complicated and hence cheaper circuits offer exciting possibilities, so form an attractive manufacturing potential.

ASO works by using a system of automatic tracking, similar to those currently found in some videocassette recorders. Where ASO differs however, is in its optimisation of retrieved automatically tracked signals, to the extent that second and subsequent generation tape-to-tape copies (where copyright restrictions allow) using ASO are said to be clearer than a conventional videocassette recorder's first generation tape recording.

It's not difficult to envisage, therefore, ASO is going to be popular in the new wave of tape-to-tape videocassette recorders which promises to be next year's big consumer spend.

Light At The End Of The Chunnel

Thomson Consumer Electronics has launched its long proposed new television monitor, capable of displaying high definition television (HDTV) pictures. It's expensive — around £3500 — but, as Thomson points out, in relative terms it is less expensive than colour tele-

vision receivers were when they first hit the high street.

There is a difference though. When colour television receivers were developed there was no doubt the system used (conventional 625-line PAL transmission) would be continued. Indeed it has, to this day, and in the foreseeable future. On the other hand, Thomson's telly requires MAC signals (specifically D2MAC) to recreate its HDTV picture, and there is no similar lack of doubt that MAC is going to be the eventually used HDTV standard format.

Thomson is a French state-owned company and as such, allows us to see what French government view on HDTV is. Currently, the future of HDTV standards is unclear and, as it is being defined on a rather ad hoc basis, depends largely on what the consumer wants.

One of the biggest problems in Europe's definition of an HDTV system is the fact the two current Astra satellites (as well as most low and medium power satellites) broadcast mainly PAL transmissions. Consumers moving to satellite television systems as a means of obtaining greater television choice have typically taken to Astra like ducks to water. Apart from a relatively simple receiver and dish, nothing else is required and users can make use of their own television set. Even when the BSB Marcopolo satellite began to operate, with its promise of higher quality pictures, few users took advantage of this through direct RGB connections to the television, instead opting to use conventional UHF connections restricting the picture obtained to a PAL format anyway.

In other countries within Europe the situation is similar. Sales of PAL satellite receivers to pickup Astra and similar satellite transmissions far outstrip sales of MAC receivers. German sales of PAL satellite receivers to take advantage of Astra transmissions are around 60000 per month, while total sales of MAC receivers in France (whose government is actively backing MAC through Thomson, remember) amount to less than 3000. Few people, it seems, want higher definition pictures.

Currently, all broadcast service satellites (BSS) are allowed to transmit only MAC signals. Astra satellites so far have got round this one as they transmit only medium power signals, and are thus classified as telecommunications satellites and are able to transmit using any format. There are moves by European Commissioners though to bring *all* satellites transmitting television signals under the broadcast services banner. But is this what we really want? If the European Commission forces this through (and there's a possibility the decision will have been taken by the time you are reading this month's column) then no account has been taken of the fact MAC as broadcast by satellites so far (DMAC and D2MAC) is only an intermediate standard. It is not by any stretch of anyone's imagination *high* definition television, but merely *higher* definition. In effect, the whole thing is a glorious muddle which prevents the user wanting to buy any new system, in fear of equipment becoming obsolete. Let's face it; there's quite a few BSB equipment users who must feel a bit put out that they bought receivers which have become effectively obsolete within just a few months of purchase.

Question arises, should satellites be allowed to

transmit what they find best fills market requirements until the full high definition television standard (HDMAC, or whatever other whim comes along before then) is operational? Or should a way forward be defined by legislation?

Apart from anything else, if Astra and other satellites are forced to transmit MAC signals, where does that leave the two million owners of PAL satellite receivers who legitimately bought and use their equipment at this moment? Interestingly Nokia, Philips and Thomson have formed a working party to consider the possibility of replacing receivers in such a scenario. While such a cost may seem initially astronomical, it is small enough when you consider a unified European high definition standard is then within grasp.

Dot, Dot, Dash

ASCII's days are numbered, it seems. An 8-bit digital communications code, used by telecommunications equipment, computers and the like for over 24 years now is about to be laid to rest. Many of the world's major computer and telecommunications manufacturers including Apple, IBM, Microsoft and Xerox have joined forces to design and support a new digital code called Unicode.

Unicode is a 16-bit code, capable of 65536 different sequences. This means all characters and symbols from the world's different languages and sciences can be allocated specific sequences within the single code. ASCII, on the other hand, with only an 8-bit format is only ever capable of signifying 256 sequences.

Keith Brindley

Millions of quality components
at lowest ever prices.
Plus Tools, Watches, Fancy Goods, Toys.
Mail order only. UK only.

All inclusive prices
NO post, or VAT etc to add on.

Write or phone for catalogue/clearance list.
At least 2,100 offers to amaze you.

Brian J Reed Electrical
6 Queensmead Avenue, East Ewell
Epsom, Surrey KT17 3EQ
Tel: 081-393 9055

J. VINCENT TECHNICAL BOOKS

Ku BAND SATELLITE TV THEORY, INSTALLATION AND REPAIR

This huge 420 page
3rd Edition by Bay-
lin Publications
covers dish theory,
cables, site survey,
polar mount adjust-
ment, footprints,
now is the time to
learn all about
Satellite TV. £23



SATELLITE AND CABLE SCRAMBLING AND DE-
SCRAMBLING. 2nd Ed. basic theory £19
WORLD SATELLITE TV & SCRAMBLING METHODS By Bay-
lin, Madox & McCormac for the service engineer £27
WORLD SATELLITE ALMANAC by Mark Long. Footprints,
Frequencies, Orbital Assignments, 2nd Edition. £32
WORLD 1990 SATELLITE ANNUAL by Mark Long. Official
supplement to Almanac £31
WORLD 1991 SATELLITE ANNUAL by Mark Long. Includes
transponder loading £34
HOME SATELLITE TV INSTALLATION VIDEOTAPE 40
Minutes VHS PAL. See how 3 meter dishes are installed. £27
SATELLITE INSTALLATION GUIDE second edition by John
Breeds £12
THE SATELLITE BOOK. A complete guide to Satellite TV (the-
ory and practice) by John Breeds £28
TVRO SYSTEM ANALYSIS AND AIMING software 5.25 or 3.5
disk (DOS 3.2). Calculates dish size and lists coordinates of all
satellites in view £35

All items ex-stock, price includes P&P UK, Airmail Europe add 10%. Outside Europe +20%.

Pay by cheque, ACCESS, MASTERCARD, VISA, COD.

J. VINCENT TECHNICAL BOOKS, 24 RIVER GARDENS, PURLEY, READING RG6 8BX.
Tel: 0734 414468 (Answerphone & Fax)

electronize CAR ALARM KITS

MICRO-PRESSURE CAR ALARM

This new type of alarm is triggered by a unique pressure sensing system. As any vehicle door is opened air is drawn out, causing a minute drop in air pressure. A sensor detects this sudden pressure change and sets off the alarm. A sophisticated arrangement of electronic filters and timers provide features to match more expensive ultra-sonic systems.

- ☆ 1 Micro-pressure intruder detection.
- ☆ 2 Operates on all doors and tailgate - no switches needed.
- ☆ 3 Automatically armed 1 minute after leaving vehicle.
- ☆ 4 10 second entry delay with audible warning.
- ☆ 5 Sounds horn intermittently for 1 minute - then re-arms.
- ☆ 6 Easy fitting - only 3 wires to connect - no holes to drill.
- ☆ 7 Compact design can be hidden below dashboard.
- ☆ 8 All solid state Power MOSFET output - no relays.
- ☆ 9 Adjustable sensitivity.

MICRO-PRESSURE ALARM DIY parts kit £15.95 Assembled £22.35

MICRO-PRESSURE TRIGGER

This module adds MICRO-PRESSURE sensing to any volt drop operated alarm simply by connecting two wires across the vehicle's 12v supply. Use it to upgrade an existing alarm or combine the benefits of both systems.

MICRO-PRESSURE TRIGGER DIY parts kit £10.95 Assembled £14.95

VOLT DROP CAR ALARM

This alternative alarm uses the popular voltage drop method of triggering. Based on the timers of the micro-pressure alarm it offers features 3 to 9 above but relies on the existing door switch operation for triggering.

VOLT DROP ALARM DIY parts kit £14.90 Assembled £20.95

120dB SIREN

An ear piercing alternative to using the car horn. This high intensity piezo siren can easily be added to attract even more attention.

120dB PIEZO SIREN £13.35

All the above include cable, connectors and clear, easy to follow instructions. All kits include case, PCB, everything down to the last washer, even solder.

All prices now include post, packing and VAT on U.K. orders. Same prices apply to all European countries. For delivery outside Europe please add £3.

Telephone orders accepted with VISA or ACCESS payment.

Order direct (please quote ref. T16) or send for more details from :-

ELECTRONIZE DESIGN Tel. 021 308 5877

2 Hillside Road, Four Oaks, Sutton Coldfield, B74 4DQ

FUSELODGE LTD

267 ACTON LANE
CHISWICK
LONDON
W4 5DD

Tel:
081-994-6275

READ\WRITE



More on RIAA

In ETI over the last few months there have been articles on the RIAA characteristic.

It was stated that the response of the pre-amp was to correct for the output of the magnetic cartridge to the RIAA standard.

From the information I was given in college and from text books at the time this information is incorrect. This standard is laid down by the RIAA (THE RECORD INDUSTRIES ASSOCIATION OF AMERICA) for the cutting of the master disc which is used during the pressing process,

not for cartridge manufacturing. The frequency response of a magnetic cartridge is flat to say + or - 3dBs.

The signal/noise for good hi-fi reproduction must be that at high frequencies where the signal out-weighs the noise and so the noise can be disregarded.

The response shown in Figure 1 is of the recorded velocity against the recorded amplitude of the master disc with no correction applied. It can be seen that the bass frequencies will be excessive. This can lead to cut-through

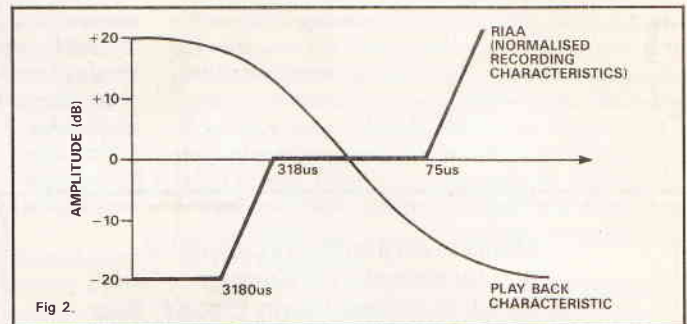

Fig 2.

between grooves on recordings with a high bass content. At high frequencies it results in the signal being corrupted by noise. Therefore low frequencies are attenuated in the recording amplifier before they are applied to the cutting head. Mid-range frequencies are passed through with no correction. The high frequencies are boosted to give good signal/noise ratio (shown in Figure 2) a normalised characteristic. The playback characteristic is also shown. This curve is typical of that which you would normally find in an amplifier if the frequency response is plotted.

The frequencies at which change over takes place are defined in micro seconds and these are 3180μs, 318μs and 75μs.

The turn over frequencies can be found by:-

$$F = \frac{1}{2\pi \times tc} \quad (tc = \text{time constant})$$

At bass = $12 \times 3.142 \times 3180 \times 10^{-6} = 50.04 \text{ Hz}$

At mid-range = 500 Hz

At treble = 2122 Hz

I hope this has helped clear up any misunderstandings.

P. Jackson, Retford, Notts.

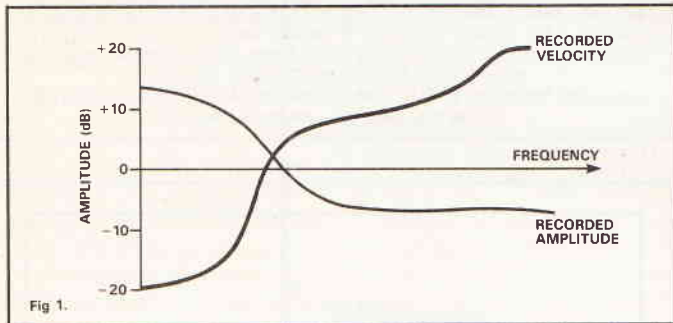

Fig 1.

Alarm Call

I am writing to you with a suggestion for a project which I have not yet seen published in ETI. Last night my wife's car was broken in to and the radio/cassette was stolen for the second time in 18 months. There is an

alarm fitted to the car which I am sure must have sounded, but as false alarms are unfortunately a regular occurrence people generally take no notice.

Therefore when the alarm circuit is triggered, if a coded signal

was transmitted with a range of about 3/4 mile to a small pager type receiver carried by the owner then it would be possible to catch the would be thief in the act.

Can you come up with a design? I am sure many readers

would find it an interesting project.

J. Savin, Southsea.

We may just come up with a design in the future — Ed.

Send in your suggestions to ETI Editorial and we will pass them on.

Have You Seen The Light?

On a recent job vacancy, I set the following question for some interviewees. The idea being, to see the knowledge of my interviewees and to formulate conversation.

A lot of interest had been shown in the question and I therefore offer it to the deliberation of your readers.

As an incentive, I'm offering a free expandable digital wrist-watch for the first correct entry through my door.

A man cuts an 8ft fluorescent fitting in half. The original rating

was 125watt-240volt AC. Using each half with original choke and starter, the person fits two 4ft tubes (40watt each). What will be the rating in watts given by each tube to ±10% at 240V AC.

Will the tubes perform normally at 40watts each or will each overrun giving 125 watts or will both tubes fail to strike?

Keith Lawrence, Ilkley West Yorkshire.

By the way — nobody should attempt to cut any fluorescent tubes in half.

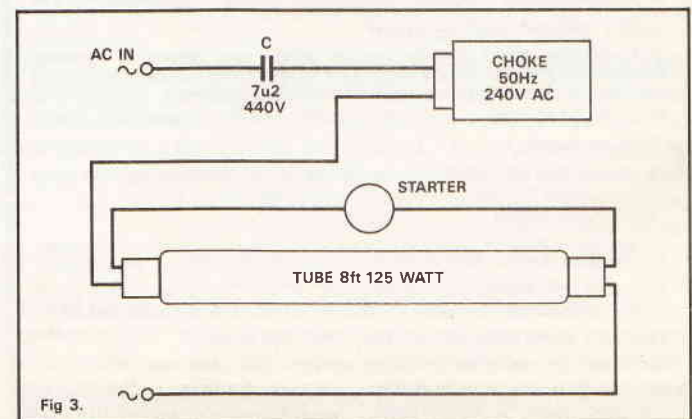

Fig 3.



British Telecom research scientists have responded to a call from North Yorkshire Police to help solve a communications problem which has national implications.

Faced with increasing nationwide pressure on UHF and VHF radio capacity, the Force asked BT to develop an alternative system to link its hilltop radio sites taking advantage of modern digital technologies, provide cost effective options for the future and maximise the use of the Force's integrated digital network supplied by BT.

Dr. Alastair Brydon and Tony Yarwood at BT's Martlesham group technology and development laboratory in Ipswich have succeeded in adapting BT's MegaStream digital technology, currently used in both the Force's private network and the public switched telephone network, and achieved a development which was previously thought impossible.

Dr. Brydon explained: "The problem was that the MegaStream system was not designed to do what the police quasi-synchronous radio system wanted."

"MegaStream's service strength is its ability to automatically take an alternative route when direct route lines are busy. In conventional applications the user is not aware of this, since there is no difference on the line.

"But the millisecond differences that could arise in a police message taking non-direct routes to several different transmitters would render the police communications system useless."

Said Dr. Brydon: "Police VHF radio transmissions are carried throughout a region via relay towers. There are several within each region."

"When a police car is roughly equidistant between two transmitters each carrying the same message, the signals can conflict with each other and the message to the police car becomes garbled." The resulting 'black spot' of non-transmissions can extend to several miles in both rural and urban areas.

This was a major challenge for Dr. Brydon, who, at 27, has a doctorate in radio communications from UMIST. He focused on the timing dilemma and experimented with satellite based timing clocks.

"To start with, I wasn't sure this was possible," he said. "But we met with surprising success and now have refined the system so that two or more potentially competing signals arrive at their transmission destinations and are broadcast simultaneously."

A signal taking a short route between a control room and relay

transmitter might have to be slowed down by several milliseconds so its counterparts, travelling on longer routes, can catch up," explained Dr. Brydon.

The technical term for this is 'quasi-synchronous radio', for which Home Office standards state that signals must be synchronised to better than 50µs if amplitude modulation is used, and to better than 20µs if frequency modulation is used.

In a well set up quasi-synchronous radio system, the radio signal remains clear, no matter where the police car is in relation to relay towers.

The BT solution is now embedded in circuitry attached to multiplexors at the North Yorkshire Police Force Communications Centre and at each relay tower. Signals are automatically adjusted and little ongoing maintenance is likely to be needed.

The system has been welcomed by the North Yorkshire Force, although they have been reluctant to adopt an analogue microwave solution. Much interest has also been generated in the

Police Service nationally.

North Yorkshire Police Head of Information Technology, Superintendent Geoff Garbutt, said: "BT's digital solution will help the Force significantly in moving towards an integrated and digitally based communications/information technology strategy.

"Currently the Force has in place an integrated digital communications network, which carries the Force telephony and computer data traffic. BT's solution, when implemented, will add radio traffic to this network providing the Force with totally integrated communications.

"BT's solution will also provide the Force with a platform which will allow it to cost effectively introduce new technologies and systems as and when they are developed. These include, an automatic vehicle and personal location system; mobile computer data into police vehicles and to police officers on foot and system wide encryption to secure the privacy of police communications."

MOBILE PHONES A TAXING PROBLEM

Chancellor Norman Lamont's assertion that a tax on company mobile phones will "make the roads safer" is an irrelevance, according to NEC, the cellular phone manufacturer.

The company argues that investment in technology, rather than financial penalties, is the most effective way to keep the roads safe, and that the Govern-

ment's proposed levy would not make existing subscribers any more safety conscious than they are at the moment.

"There is no cause and effect between the extra £1.60 a week that subscribers, who are higher tax payers will pay, and their safety consciousness on the road," argues Sandra Richards, the operations and marketing man-

ager for NEC Radio Communications.

"Nor do we believe that the tax will deter new subscribers who have a business requirement for cellular in spite of tax penalties. The effective way to increase road safety in this respect lies in advanced features developed for the telephones such as handsfree, automatic answering and voice

call recognition units, introduced by NEC in 1989."

The company has a Voice Call system that gives a driver hands free operation — even to dial — other than pressing one button once to activate the system and one to end a call.

INDUSTRY NEEDS URGENT ALTERNATIVE TO CFC'S

“Despite the publicity given to ozone depleting compounds, the UK manufacturing industry is largely unaware of the full extent of its dependence on CFCs and other chlorinated solvents and the problems this implies.” This is just one of the challenges confronting the UNEP Solvent Technical Options Committee, working to ensure that the terms of the 1987 Montreal Protocol are met by the 2005 deadline.

The European Update to the

1987 Montreal Protocol added methyl chloroform to the list of CFC and chlorinated solvents to be completely phased out by the year 2005.

This ruling will affect all metal cleaning and manufacturing industries, particularly those requiring precision engineering, such as defence, aerospace, and automotive, and also the dry cleaning and paint industries, which are all heavily dependent on chlorinated solvents.

Alternative cleaning methods

and methods of adapting manufacturing techniques accordingly are being researched, but the cost of changing manufacturing processes, which often involve 20 year plus production cycles, means that there is currently no simple solution in sight. Suggested alternative methods using water as a cleaning agent, are not only unsuitable for the precision engineering industries, but also require extremely high levels of energy consumption in the drying process and thus exacerbate the

problem of global warming.

Government legislation regarding worldwide CFC and chlorinated solvent elimination, differs greatly in different parts of the world. According to UNEP, the European manufacturing industry is under less government pressure to seek alternative solutions and therefore is much less aware of the industrial solvent issue and the wider technology implications than its USA counterparts.

MAPLIN INTRODUCE JUNIOR STEREO MICROPHONE MIXER



Maplin Electronics has introduced a sophisticated, yet easy to use, complete sound mixing system. The unit which combines a tape recorder is designed for children or a budding DJ. The fun unit combines a four channel mixer, sound effects generator and cassette deck. It comes complete with headphones, shoulder strap and electret microphone. Sockets are provided for external 6V DC input, microphone input, auxiliary input and headphone output.

The children's mixer can be used for 'sing alongs' or recording your own music or playing at being a Disc Jockey. The children's mixer provides a good introduction to the basic skills in recording and mixing. It costs £39.95 inc VAT (Maplin code YU 24B).

PM 301 is a new Panel Mounted Transmitting kWh Meter with a wide viewing angle from Northern Design of Bradford. The latest EPROM technology is used in a unit that can measure and display both Power and Energy. When instantaneous power is displayed the energy counting continues.

The 8 digit alphanumeric LCD with permanent back lighting can display kW or MW and kWh or MWh. Automatic and permanent indication of both 'operation' and 'reverse' is via an LED and a pulse output is provided for remote monitoring.

The EPROM technology provides a non-volatile memory that retains the information at power down for up to 10 years. The self-calibrating anti-drift system maintains an accuracy of better than 1%.

Further information contact Ian Hutchinson at Northern Design. Tel: 0274 729533.

POWER METER

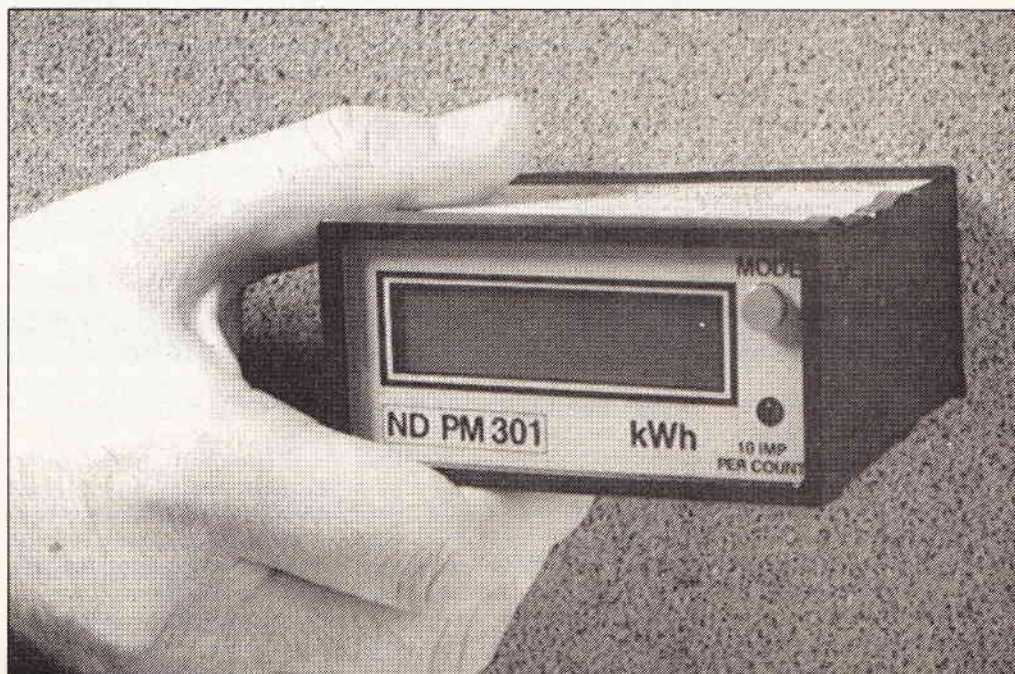

MIXING CONSOLE WINS 1991 DESIGN AWARD

A Hertfordshire based company, Soundcraft Electronics Ltd, has won a coveted 1991 British Design Award in the contracts category for its 200 Delta professional mixing console.

The Design Council British Design Awards are sponsored by National Power PLC. These awards are presented annually to products chosen for their outstanding all-round design, excellent performance, innovation, safety, reliability, value for money and good appearance.

The 200 Delta is a compact console suited to any application, from theatre stage mixing and conferences to home-recording studios and live sound reinforcement.

British professional sound equipment has a high reputation worldwide and is one of the few areas of electronics which has not been monopolised by the Japanese. Soundcraft, learning that Yamaha were planning a compe-



titive product, set about developing the Delta desk. Soundcraft expanded on existing technology, and examined the aesthetics of the product. Design consultants Roberts Weaver were commissioned to work on Delta's styling, moving away from the traditional 'black box' towards a console whose sophisticated look and 'feel' vindicated the high level technology used. Pete Townshend,

who installed 200 Delta in his Eel Pie recording studios, said, "Apart from the performance of the Delta, I was very impressed with the details that Soundcraft managed to include in the design — it looks great!"

Soundcraft sell to 47 countries and 85% of their sales come from

export. Computer based testing equipment has also been employed which again increases throughput and leaves the test engineers free to deal with specific problems.

The company invests heavily in research and development and have a development team which includes engineers, design consultants, manufacturers and distributors.

WOMEN ENGINEERS AND SCIENTISTS DESERVE A BOOST

"More women than ever before are taking up careers in science and engineering, but most will agree that there is still a lack of recognition for their achievements. There is also a general lack of encouragement, particularly for young women, to enter these fields," says Dr Elizabeth Laverick, chairman of the ninth international conference of women engineers and scientists.

"This situation must change," she says. "In the time of demo-

graphic change, professionals and their skills are badly needed by the scientific and engineering communities."

This is just one of the topics to be explored at the conference to be held at the University of Warwick from 14-20 July 1991.

With Communication as its theme, this year's Conference will update women on a wide range of technical and social issues including: transport, telecommunications and satellites, basic science, human communications,

technology transfer education and international demographics. The Conference will also include an important session on career development.

Speakers from over 20 countries will outline current training and employment trends for women in education, engineering and science and there will be a number of keynote addresses from leading women in the field. The Conference programme also includes a number of technical visits as well as an exhibition

demonstrating the latest technical innovations in communications and providing top careers guidance.

"Not enough priority is given to getting the message across that women can succeed in these fields," says Dr Laverick. "ICWES9 will provide an excellent opportunity for us to demonstrate the achievements of women scientists and engineers worldwide."

Contact: Sherrie Simpson, Conference Services, Tel: 071-486 0531.

ROTARY OPTICAL ENCODERS

A new series of rotary optical encoders is now available from Arrow Electronics (UK) Ltd.

These encoders produce a 2-bit quadrature signal which is suitable for digital systems where both magnitude and direction of adjustment must be provided.

The encoders can be used as digital panel controls or as position sensing devices in applications where long life, reliability, high resolution and precise linearity are critical.

The encoder converts rotary

input into electrical signals which can be used by microprocessors without A/D conversion. The encoder output signals are digital which makes it possible to significantly reduce the memory overhead and wiring.

Offering a rotational life from 10 million to 200 million shaft revolutions, the encoders require a 5.0 VDC \pm 0.25 supply voltage and can be servo mounted.

Further information contact Ian Ewin, Arrow Electronics (UK) Ltd. Tel: 0234-270777.



LASER DIODE MODULE FOR HIGH SPEED NETWORKS

Mitsubishi Electric has released a laser diode module that combines a $1.3\mu\text{m}$ diode with a single mode fibre. The module can be used in high speed applications such as local area networks operating at up to 1.5GHz, wide area networks of up to 10km in length, and mainframe computers

with high data throughput requirements.

The diode has a minimum optical power output of 1mW and a typical threshold current of 10mA. Maximum reverse voltage is 2V, and typical operating voltage is 1.2V. The central wavelength of $1.3\mu\text{m}$ is accurate to

within $0.03\mu\text{m}$ and the rise and fall time is typically 0.3ns, with a tracking error (a measure of how the power output varies with temperature) of 0.4dB.

The module also contains a photodiode for monitoring purposes. This has a maximum reverse voltage of 15V, and a

maximum forward current of 2mA.

Further information contact Christine Warren, Mitsubishi Electric UK Ltd. Tel: 0707-76100.

PCB CAD SYSTEM FOR £95

Tsien has released a new upgraded version of BoardMaker-1, a CAD package for printed boards, at £95. The colour software system runs on a standard IBM PC, and offers electronics designers who currently use conventional methods of generating PCB artwork a highly cost-effective entry point to the benefits of computer-aided design.

Comparing the system with manual artwork techniques, most first-time BoardMaker users cite as key benefits the speed with which modifications can be made to PCB artwork following a prototype design, the ease of optimising a PCB's size or shape, and much-improved appearance and overall quality of the tracking. Although there is often little increase in the speed of design cycle for the first couple of applications, most users report very significant gains after this initial period.

The new BoardMaker-1, Version 1.50, provides an integrated PCB and Schematic Editor that will handle artwork for through-hole or surface-mount components with up to 10 circuit and silk screen layers. The user interface is designed for simple, intuitive, operation. Features are controlled via context-sensitive pop-up command menus, in conjunction with a mouse (or cursor keys) for component placement and track routing. High resolution colour graphics simplify the generation of multi-layer artwork.

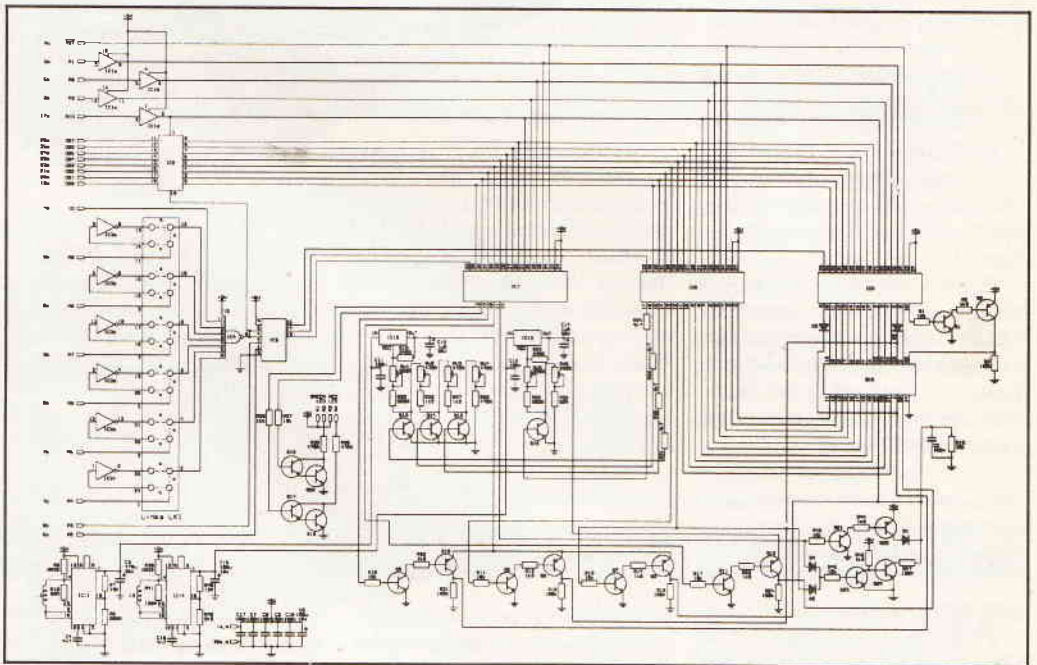

All tracks and pads are drawn so that 'what you see is what you get'.

Tracking is laid out using powerful commands. Pads, vias, text and symbols (user-defined components) are placed by moving the cursor and touching a key. Tracks are then drawn from pad to pad as required, using a 'point and shoot' methodology which gives precise control over positioning. Designs can be generated to a user-defined grid, free-hand to a resolution of two thousandths of an inch, or both. High level editing features allow

you to modify or optimise the size/shape of the artwork — operations that could take hours if performed manually occur in seconds. For instance, block edit and rotate commands allow you to move a component's or orientation while maintaining connectivity, and a mirror command lets you instantly switch a component to another layer.

BoardMaker-1 provides an extensive library of 128 standard track sizes and pad symbols, plus the capability to generate custom shapes and forms. Tracking for

PCBs up to 17 inches (432mm) square can be handled.

Artwork can be output to a wide variety of peripherals, including dot-matrix or PostScript-compatible laser printers, HPGL- or DMPL-compatible pen plotters, or Gerber-compatible photoplotters; NC drill outputs in Excellon format are also available, providing the complete design-to-manufacture package.

Further information contact: David Brooks at: Tsien (UK) Ltd. Telephone: (0223) 277777.

WORLD'S FIRST 64-MEGABIT DRAM

The Central Research Laboratory of Hitachi, Ltd. Has become the first in the world to succeed in developing a 64-megabit DRAM, which was once considered commercially unfeasible until the 21st century.

With the application of 0.3-micron ultrafine process technology, the 64-megabit DRAM

would be able to store up to 4 million Japanese Kanji characters, or the equivalent of a 256-page newspaper, in the 9.74mm by 20.28mm square chip.

The key achievement of the experimental chip, apart from its potential in the circuit density, is in its low power consumption. The experimental chip was success-

fully operated with a 1.5V battery though the use of such a battery was once thought to be unviable since DRAMs consume a great deal more power than SRAMs. By overcoming the negative influence of a reduced power voltage, the introduction of the development of high-speed circuitry technology ensuring high-speed stable

operation under 1.5V of low power consumption led to Hitachi's pioneering work in large capacity battery-operated DRAMs.

This development will encourage the miniaturization of personal equipment such as notebook-size personal computers and portable telephones.

DIARY

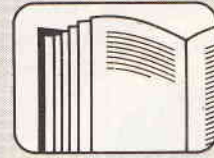

IEE Electronics Meetings May 1991

The following meetings for May 1991 have been organised by the Electronics Division of the Institution of Electrical Engineers (IEE). All meetings will be held at the IEE, Savoy Place, London WC2, unless otherwise stated.

Antenna radar cross section

Colloquium — Tuesday 7 May — 10.30am

This colloquium will review a broad range of topics related to antenna RCS

Signal processing for the restoration of degraded gramophone recordings

Lecture by Dr J W Rayner (University of Cambridge) — Wednesday 8 May — 5.30pm

The lecture will introduce and demonstrate the processing techniques used to remove a number of commonly occurring degradations such as surface scratches and various types of surface noise on early gramophone recordings. Much of the processing is based on the underlying theme of signal modelling in which uncorrupted signal is used to determine the parameters of a mathematical model describing the signal. This model can then be used to replace degraded segment of the original signal.

R&D in advanced communications technologies — Race 2

Colloquium — Thursday 9 May — 10.30am

This meeting will advise and assist potential participants in how to benefit from the European Commission's imminent programme on Telecommunications R&D.

Prospects for digital TV broadcasting

Colloquium — Monday 13 May — 1.00pm

The Colloquium will cover both the picture compression, and RF emission aspects and will attempt to provide a picture of how realistic the prospects for digital television broadcasting really are.

Advances in analogue VLSI

Colloquium — Tuesday 14 May — 10.30am

Presentations will cover novel CAD tools for analogue chip design, GaAs analogue circuit-level design techniques, the use of AI in automated analogue IC design and the rapidly developing field of integrated circuit neural networks. The programme will be balanced with papers reflecting academic and industrial research developments, current industrial applications and design case studies.

Digital sound: low bit rate coding for broadcasting applications

Lecture by Yves-Francois Deherly (CCETT) — Wednesday 15 May — 5.30pm

Recent advances in audio coding algorithms have enabled high quality sound signals for broadcasting

applications to be encoded to 64 to 128bit/s per monophonic channel without noticeable impairment to subjective quality. Some such codecs however may have characteristics (such as a large processing delay) that affect their ease of use in an operational environment. In this lecture Yves-Francois Deherly will describe and demonstrate the coding quality and Simon Shute (BBC) will describe the operational requirements for such codecs.

Design for testability

Colloquium — Thursday 16 May — 10.30am

This colloquium will update engineers on new developments in this field.

EMC in high integrity digital systems

Colloquium — Friday 17 May — 10.30am

This colloquium will address the issues concerned with the effects of EMC on digital systems which are safety critical or must exhibit integrity which is beyond reproach for other reasons. Some of the measures used in design to ensure the required degree of integrity will be described and some methods of recovery from error conditions will be discussed.

Digital audio signal processing

Colloquium — Wednesday 22 May — 10.30am

This colloquium will survey research and recent developments in digital signal processing as applied to audio systems. Topics covered will include room equalisation, PWM for power amplification, parallel multiprocessor architectures for audio, and an overview of current technology.

Adaptive interpolation in images

Colloquium — Tuesday 28 May — 10.00am

Adaptive interpolation methods are some of the most widely used in image processing finding applications in areas as diverse as high definition TV bandwidth reduction, the concealment of lost image data, display scan-rate conversion, a variety of low bit-rate image coding algorithms and television standards conversion.

This meeting will span all these topics to give an insight into the central role being played by recent schemes, such as motion-compensated interpolation.

Film for television: alive or dead?

Colloquium — Thursday 30 May — 9.30am

Broadcast TV has always relied on Motion Picture Film as the prime medium for prestigious production, documentaries, feature film presentation and commercials, also in recent time, 'Pop videos' have relied on film.

With the considerable developments in video and film technology with the potential future of High Definition Television, what does the future hold for Motion Picture Film?

Fire Detection Systems



An electronic guide to fire prevention by Vivian Capel

Detectors

It is a sad reflection on human society, that more time and attention is devoted to defence against other humans who are intent on doing us harm, than to man's age-old enemy fire. Recent cases where elderly couples who had intruder-proof steel doors erected, were burnt to death when the fire services were unable to break through in time, underline this point only too well.

Intruder alarm systems proliferate along with the firms who install them, while security devices are to be found in nearly all business premises and in many homes as well. Advice in magazines and in books as to the various types and their suitability is readily available.

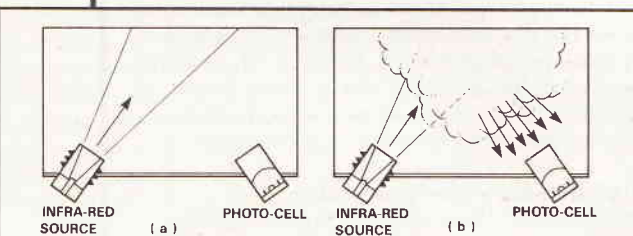

Fig. 1 a Infra-red beam radiates into the matt black chamber of an optical smoke detector; there is no reflection. b If smoke is present the photo-cell receives reflections.

In contrast, little is generally known about fire detection and alarm systems, which types are best for particular situations, and how a system should be planned and installed. It is true that the chances of being burgled are probably greater than that of having a major fire, but the consequences of a fire are far more catastrophic. It can involve loss of premises as well as contents, and possibly, of life too. It is hoped that this series of articles written specially for ETI will go some way to remedying the situation and provide readers with what could prove to be life-saving information.

Firstly then, we will take a look at the various types of fire detector. There are three, each of which responds to its particular fire-generated phenomena. These are, the smoke detector, the heat detector and the flame detector.

Smoke Detectors

There are two kinds of smoke detector. The first which is based on optical principles, relies on the Tindal effect whereby light is scattered by the smoke particles. A detection chamber is coated on the inside with a matt black finish so there is no reflection of light from its walls. A small infra-red radiator projects a pulsed beam into the chamber, while an infra-red photo cell detector looks into the chamber from a different angle.

Owing to the non-reflective interior, it sees nothing, but if smoke enters the chamber, the particles reflect some of the beam to the detector (Figure 1). The effect is rather like that of dust particles in a sunbeam. The first few pulses are ignored so as to eliminate false alarms due to dust, but subsequent ones trigger the system.

Another type of smoke detector uses ionization to detect the particles. It has a small radioactive source which is usually Americium 241, that maintains a flow of ions through the air in the detection chamber to a pickup electrode (Figure 2). Smoke particles impede the ion flow so that the current falls when smoke is present. The drop is sensed by a comparator circuit which signals it as an alarm condition.

A further type uses a set-up similar to that used in many intruder alarms. It consists of an infrared transmitter and receiver facing each other at a distance any drop in the radiation picked up by the receiver due to smoke intervening anywhere along the path of the beam, is interpreted as an alarm, but a delay is incorporated so that momentary beam interruptions due to other causes does not generate a false alarm. Unlike the intruder alarm system, the transmitter and receiver are mounted high up where smoke quickly gathers but where the beam will not be broken by human activity.

Heat Detectors

These sense temperature changes and can be either mechanical or electronic. The mechanical ones use a bimetallic strip consisting of two dissimilar metals bonded together. Like the mechanical thermostat, the strip bends where the temperature increases due to one metal expanding more than the other. At a certain point it releases a latch which tilts its tube of mercury. Contacts in the tube are thus immersed and an external alarm circuit is completed. This arrangement is more positive and certain compared to the normal the normal metal contacts of the ordinary thermostat which could become oxidized or corroded during a long period of disuse.

Most heat detectors are now electronic and they can be of two different types, the fixed temperature heat sensor and the rate-of-rise heat detector. Both use a thermistor in which the resistance changes with temperature.

With the fixed-temperature sensor, we find a thermistor and resistor forming a potential divider that is connected to one input of a comparator. The other input goes to a divider consisting of two resistors. As the temperature rises, the potential difference between the two inputs increases until at a set level it triggers an output circuit into conduction, which in turn activates the system alarm circuit. The temperature at which this is set is usually 135°F (57°C). Mechanical sensors are also usually set to this temperature.

With the rate-of-rise detector, two thermistors are

ALARMS

used, one in each divider, but one responds to temperature change more slowly than the other (Figure 3). If the temperature rise is gradual, they more or less keep in step, and the potential difference between the two comparator inputs is small. So rises due to hot weather, or industrial heat do not affect it, as these usually take a while to develop. When there is a more rapid temperature rise the fast acting thermistor leaves the other behind in its resistance change, and a potential difference appears. A response is generated when the rise is of the order of 40°F (22°C) per minute.

It will be noticed that the slow thermistor has a

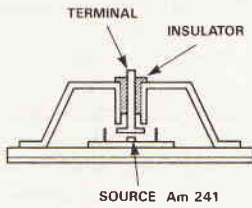

Fig. 2 Ionization smoke detector. Current flows through the ionized air between the radioactive source and an electrode. Smoke particles impede the flow and reduce the current.

resistor shunted across it. This further modifies its response so that at a certain point its resistance is swamped by that of the shunt, and there is very little overall change. Above this point, the circuit reacts even if the rise has been slow, so the device then behaves as a fixed-temperature sensor.

Flame detectors

The third type which is less often used, responds to either the infra-red or ultra-violet light radiated by a naked flame. As other sources of infrared are likely to be around, the detector distinguishes and ignores them, by responding only to a flickering source.

There is much ultra-violet light in sunlight, so just as with the infra-red device, some means of eliminating this ambient light must be incorporated in ultra-violet detectors. Frequencies in the 200-270 nm band are filtered out of solar radiation by the ozone layer, but are present in flames. The detector input is therefore filtered so as to respond only to radiation within this band.

So another possible and unforeseen effect of the continued depletion of the Ozone layer could be a rash of false alarms from fire systems, that is if we are in any fit state to worry about them by then!

One of the first effects of most fires, long before heat is generated to any extent and before even there is much flame, is the production of smoke. As the alarm should be initiated as soon as possible, smoke detectors are the obvious choice. The optical detector is a good choice for smouldering fires that generate a lot of smoke such as those produced by burning fabric, furnishings, PVC, and insulating materials in electrical equipment.

Fires of materials that generate little smoke such as gas, spirits, and solvents, are more quickly detected with flame detectors or ionizing smoke detectors. Where both these and smoke generating materials are present, the ionizing smoke detector is the best choice. It can detect the light, air impurities given off by both types of material at a very early stage of the fire, even before dense smoke appears. It is thus a good all-around detector. Both types of smoke detector can protect an area of approximately 1080 ft² (100 m²) around the device, depending on layout.

The infra-red beam can cover a much larger area as the transmitter and receiver can be spaced up to

300 ft (90 m) apart. Smoke generated at some 20ft (6m) on either side of the beam will affect it, so a total area of 12,000 ft² (1080 m²) can be covered.

It is very effective in detecting smoky fires, but less so in responding to clean burning ones. However, air turbulence caused by rising hot air and gases from clean fires can produce variations in beam intensity. One model analyses turbulence variation patterns and triggers in alarm when the typical turbulence frequencies produced by fire, that is 2-20Hz, are present. It is thus effective for clean and smoky fires.

Where cleaning and machining is carried out there is likely to be high levels of dust or other pollutants in the air. Smoke detectors are unsuitable here as they cannot distinguish between smoke and dust, so false alarms would almost certainly result. Remember that unlike an intruder alarm, the system is not only on at night when work ceases and the air is less contaminated, it is on 24 hours a day. Furthermore, dust would collect inside the detection chamber, especially with the ionizing detector, necessitating frequent cleaning.

Other areas for which smoke detectors would be unsuitable, are those subject to steam or other vapours such as kitchens, bathrooms, laundries, garages and paint-spray shops. The common domestic mis-application is the kitchen, where the self-contained domestic fire alarm that usually employs a smoke detector, can often be found. A heat detector is the better choice here.

Cold storage and refrigeration areas can generate condensation which could also affect smoke detectors, and for which the heat detector should be used. In such conditions though, it may take a long time for the temperature to rise from below freezing to the 135° trigger level, by which time the fire could have taken a firm hold. The best choice here then is a rate-of-rise heat detector, as a temperature increase will trigger the alarm even though the ambient temperature is still low.

Another possible trouble source is a smoke detector on a low ceiling in an area where tobacco is

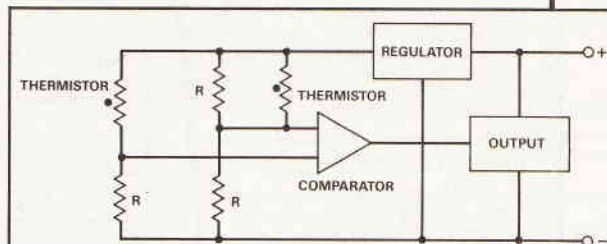

Fig. 3 With a rate-of-rise heat detector, there are two thermistor/resistor networks. One thermistor is shunted by a resistor so that its action is slower than the other. With a slow rise of temperature they keep in step, but a fast rise leaves one behind so producing a voltage difference at the comparator.

smoked. This is less of a problem than it once was, now the smoking habit is dying out, but it still could appear in clubs, pubs or in some domestic situations. An optical smoke detector is less likely to be triggered than an ionizing detector which is sensitive to light products of combustion such as tobacco smoke. Alternatively heat detectors could be used. It is rather ironical that the most effective detector cannot be utilized at locations where the risk of fire is greatest.

BS 5839 Requirements

The BS 5839 which we shall be referring to it subsequently, lays down the requirements for fire alarm systems. Here we consider those relating to fire detectors. The ionizing smoke detector contains a

ALARMS

radioactive material, and health regulations require notification to the Health authority, of such use in a place of work. However, this is only the case if the radio activity is greater than 4 MBq, and the dose rate greater than $1\mu\text{SV}\cdot\text{h}^{-1}$ at 100 mm. Most smoke detectors using Americium 241 have a radiation level much below this so no notification is required.

Self-contained smoke alarms are considered only suitable for domestic use with single-family dwellings, and should not be used for multiple occupation or business premises.

It is necessary that detectors be removable for cleaning and servicing, but if there is the possibility of vandalism and malicious removal, it should be possible only by using special tools.

Call points

Although not strictly detectors, manual call points need consideration too. Detectors trigger the alarm system at an early stage of a fire, whether the premises are occupied or not. There may be an occasion though when a fire is inadvertently started by someone or discovered very soon after it has started. Rather than wait for a detector to be triggered, it is obviously best for the alarm to be raised immediately, and this is the function of the manual call point. It is to the fire system what the panic button is to the intruder alarm.

The normal construction is that of a press button which is held in the depressed position by a glass faceplate. In this position the switch is o/c. In case of fire, the glass must be smashed whereupon the button is released and the switch contacts close. One model has a microswitch that bears on the side of the glass and

so has no visible button to tempt vandals. It is released when the glass is broken just as with the conventional ones.

To reduce the risk of injury when breaking the glass, some are scored so that only light pressure is needed to cleanly break it. Others have a plastic coating which prevents sharp slivers of glass flying free. While any object such as a brick or an elbow can be used, some have a small metal hammer on a chain for the purpose, although this does seem to be inviting trouble!

It may be wondered though, why go to this trouble at all? Why not simply have a button to be pressed like the panic button of the intruder alarm system? As manual call points are installed in buildings in public areas, a simple button would undoubtedly receive the attentions of mischievous small (and not so small) boys. Panic buttons are usually accessible only to staff or in domestic situations, to members of one's own family. The need to break the glass is somewhat of a deterrent to casual mischief-making, and it seems to work as not many false alarms from manual call points are reported.

According to the BS 5839, a manual call point should trigger an alarm not more than 3 seconds after being operated. The maximum distance from anywhere in the building to a call point should be 100ft (30m), but this should be less if inflammable materials are being used.

Call points should be mounted 4ft 6ins (1.4m) above floor level, should be clearly visible, and so should be of contrasting colour to the background, and clearly labelled. They should not be recessed into a wall if approach may be made from the side as in a corridor. Partial recessing is permissible providing the visible side profile is not less than 750mm².

Interak 1

Bare Board
£17.50
(plus postage and VAT)

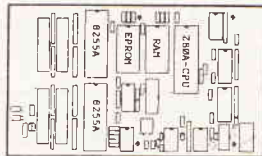

SINGLE BOARD COMPUTER "SBC-1"

A computer doesn't have to look like you'd expect a computer to look. It doesn't have to have a keyboard and a screen and floppy disks and so on.

The SBC-1 has the bare minimum of chips a Z80 computer can have and still be a computer: A 4MHz Z80A-CPU chip, an EPROM chip (up to 32K), a static RAM chip (up to 32K) and a pair of 8255A I/O (input output) chips giving 48 individual lines to wrangle up and down. There are one or two additional "glue" chips included, but these are simple "74LS" or "HC" parts.

A star feature is that no special or custom chips (ie PALs, ULAs, ASICs etc) are used — and thus there are no secrets. The Z80A is the fastest and best established of all the 8-bit microprocessors — possibly the cheapest too!

Although no serial interface is included, it is easy for a Z80A to waggle one bit up or down at the appropriate rate — the cost is a few pence worth of code in the program: why buy hardware when software will do?

Applications already identified include: Magnetic Card reader, mini printer interface, printer buffer, push button keypad, LCD alphanumeric panel interface, 40-zone security system, modem interface for auto sending of security alarms, code converter (eg IBM PC keyboard codes to regular ASCII), real time clock (with plug in module), automatic horticultural irrigation controller.

By disabling the on-board Z80A-CPU this card will plug into our Interak 1 CP/M Plus disk-based development systems, so if you don't fancy hand-assembling Z80 machine code you don't have to!

The idea is (if you are a manufacturer) you buy just one development system and then turn out the cheap SBC-1 systems by the hundred. If you are really lazy we can write the program for you and assemble the SBC-1 cards so you can get on with manufacturing your product, leaving all your control problems to us.

Greenbank

For more details write or phone us.

Greenbank Electronics, Dept. (TEI 06), 460 New Chester Road, Rock Ferry, Birkenhead, Merseyside L42 2AE. Tel: 051-645 3391.

WE HAVE THE WIDEST CHOICE OF USED OSCILLOSCOPES IN THE COUNTRY

TEKTRONIX 2445 Four Trace 150MHz Dual TB	£1200	GOULD O5300 — HIGH QUALITY — 20MHz Dual Trace 2mV/cm Small Light weight. NOW ONLY £215 (far better than some of the New Rubbish available)	
TEKTRONIX 485 Dual Trace 350MHz Delay Sweep	£1000	GOULD OS1100 Dual Trace 30MHz TV Trig	£160
TEKTRONIX 2215 Dual Trace 200MHz Delay Sweep Dual TB	£475	GOULD OS2508 Dual Trace 15MHz TV Trig	£160
TEKTRONIX 475 Dual Trace 200MHz Delay Sweep	£550	SCOPREX 14015 Dual Trace 15MHz	£150
TEKTRONIX 485 Dual Trace 100MHz Delay Sweep	£450	TELEQUIPMENT DE1A Dual Trace 10MHz	£120
SCHLUMBERGER/ENERTEC 5218 Three Trace 200MHz Dual Sweep	£350	SE LABS SM111 Dual Trace 18MHz	£110
SCHLUMBERGER/ENERTEC 5220 Dual Trace 100MHz Sweep	£350	GOULD 1421 Digital Storage Dual Trace 20MHz	£650
PHILIPS PM3217 Dual Trace 30MHz Delay Sweep	£400	GOULD 4035 Digital Storage Dual Trace 20MHz	£850
HITACHI V650F Dual Trace 60MHz Delay Sweep	£500	GOULD OS4020 Digital Storage Dual Trace 10MHz	£450
TELEQUIPMENT D755 Dual Trace 50MHz Delay Sweep	£250	TEKTRONIX 434 Dual Trace 25MHz Tube storage	£250
GOULD OS3000 Dual Trace 40MHz Delay Sweep TV Trig	£250		
GOULD OS1100 Dual Trace 30MHz TV Trig	£160		

BRADLEY Oscilloscope Calibrator 192 with Cal Cert.	£800	LEVELL TM6B Broadband Voltmeter 1Hz-450MHz, 15V-500V	£150
KEITHLEY 224 Programmable Current Source	£1000	LEVELL TM3C AC Microvoltmeter 1Hz-30MHz, 50V-500V	£60
RACAL DANA 1991 nanosecond Universal Counter	£750	LEVELL TM3A AC Millivoltmeter 1Hz-30MHz, 50V-500V	£40
MARCONI TF2008 AM/FM 10KHz-5.10MHz Sig Gen	£450	LEVELL TG200 range 1Hz-1MHz Sine/Sq	£125
MARCONI TF2015 AM/FM 10-250MHz Sig Gen with TF2171	£480	LEVELL Oscillator 1G152 2MHz-30MHz, Sine/Sq	from £75
MARCONI TF2015 without Synchroiser TF2171	£250	LEVELL Oscillator TG155M 1.5Hz-150kHz Sine Wave	£20
MARCONI TF2015 AM/FM 10KHz-120MHz Sig Gen with TF2173	£350	LEVELL Decade Osc TF66A 1.2Hz-1.22MHz Low Distortion	£35
MARCONI TF2016 without Synchroiser TF2173	£175		
H.P.8620C Sweeper Main Frame (Plug-ins available)	£1000		
HITACHI Vectorscope VDBE	£900		
FARNELL PS350H Synthesised Sig Gen 100KHz-520MHz 24V	£200		
12V DC input	£200		
MARCONI/SANDERS 6055E Sig Source 800-2150MHz	£400		
MARCONI/SANDERS 6070A Sig Source 400-1200MHz	£400		
SYSTEM DONNER 1702 Sig Gen 100MHz-1GHz	£350		
H.P.8616A Sig Gen 1.8-2.4GHz	£500		
H.P.8614A Sig Gen 800MHz-2.4GHz	£500		

TEKTRONIX 491 Spectrum Analyser 1.5-12.4GHz	from £1,000-£1,400		
HP 141T Spectrum Analyser Systems	from £2,000		
MARCONI TF2370 Spectrum Analyser 110MHz	£3,000		
WAYNE KERR B424 Component Tester, LCD Display	£125		
RACAL DANA LCR Delabridge 9341	£350		
FERROGRAPH RTS2 Recorder Test Set	from £150		
AVO VALVE CHARACTERISTIC METER VCM163	£300		
FARNELL PSU H50/25 50V 25Amps	£600		
FARNELL PSU H30/100 30V 100Amps	£750		
THORN PSU D-40V, 0-50Amps	£350		
JUST IN: UNINTERRUPTIBLE POWER SUPPLIES Un-used			

GOULD K40 Logic Analyser 32 Channel	£500		
TELEQUIPMENT C771 Curve Tracer	£250		
MARCONI TF2700 Universal LCR Bridge, Battery	from £125		
MARCONI TF237A Auto Distortion Meter 400Hz/1kHz 0.01%	£175		
MARCONI MOD Meters TF2300, TF2300B, TF2303	from £100		
MARCONI TF2803 RF Millivoltmeter 50KHz-1.5GHz	£75		
MARCONI TF2430 Digital Freq Counter 10Hz-60MHz	£60		
MARCONI TF1152/1 RF Power Meter 500MHz 10/25W 50ohm	£25		
MARCONI TF1983A AF Power Meter 20Hz-35KHz 20mW-10W	£20		
RACAL 9915 Freq Counter 10-250MHz Crystal Oper	£150		
PHILIPS PM6822 Universal Timer/Counter 50MHz 8 digit	£140		
FEEDBACK SFG608 Sweep Fun Gen Sine/Sq/Tri 0.01Hz-1MHz	£130		
FEEDBACK FG600 Fun Gen Sine/Sq/Tri 0.01Hz-100KHz	£55		
AVO Valve Characteristic Meter MkIV (no valve data)	£70		
LEADER LMV188A Two Ch Mv Meter 5Hz-500KHz, 1mV-300V	£100		
KIKUSUI AVM23 AC Vmeter Dual Ch 10Hz-500KHz 300V-100V	£75		
SOLAFTON 7945 Multimeter 4 1/2 digit 30 ranges, Auto Man	£95		
FARNELL Pulse Gen System 1Hz-10MHz Sine/Sq Double	£40		
LOGIC PROBE type 33000A TTL/CMOS (p&e £3)	£10		
Large range of BENCH POWER SUPPLIES available	from £40		
VARIAC always available	from £25		
X-Y PLOTTERS Various models	from £25-400		

AVID 8 & AVO 9 MULTIMETERS
GOOD WORKING ORDER — PHYSICALLY NOT BRILLIANT, SUPPLIED WITH BATTERIES. LEADS ONLY £30
Other available Test Set No1: 9Mx5, 6Mx6 from £55 to £120

NEW EQUIPMENT

HAMEG OSCILLOSCOPE HM1005 Triple Trace 100MHz Delay Timebase	£792		
HAMEG OSCILLOSCOPE HM604 Dual Trace 20MHz Delay Sweep	£610		
HAMEG OSCILLOSCOPE HM203.7 Dual Trace 20MHz Component Tester	£336		
HAMEG OSCILLOSCOPE HM205.3 Dual Trace 20MHz Digital Storage	£610		
All other models available — all oscilloscopes supplied with 2 probes			
BLACK STAR EQUIPMENT (PAP all units £5)			
APOLLO 10 — 100MHz Counter, Timer, Ratio/Period/Time Interval etc.	£222		
APOLLO 10 — 100MHz (as above with more functions)	£285		
METEDR 100 FREQUENCY COUNTER 100MHz	£109		
METEDR 600 FREQUENCY COUNTER 600MHz	£135		
METEDR 1000 FREQUENCY COUNTER 1GHz	£178		
JUPITOR 500 FUNCTION GENERATOR 0.1Hz-500KHz Sine/Sq Tri	£110		
ORION COLOUR BAR GENERATOR PAL/TV/Video	£209		
All other Black Star Equipment available			

Used equipment — with 30 days guarantee. Manuals supplied if possible
This is a VERY SMALL SAMPLE OF STOCK. SAE or Telephone for lists. Please check availability before ordering.
CARRIAGE all units £16. VAT to be added to Total of Goods & Carriage

STEWART OF READING
110 WYKEHAM ROAD, READING, BERKS RG6 1PL
Tel: 0734 268041. Fax: 0734 351696. Callers welcome 9am-5.30pm Mon-Fri (until 8pm Thurs)

Towards Tomorrow

The miniaturisation of integrated circuits still uses what can only be described as coarse technology. Photomicrographs of integrated circuits show rough edges, even looking at a scale of many atoms. Clear advantages could be gained if individual atoms, or very small groups, could be manipulated accurately to produce smooth edged features.

The aim of nanotechnology is to make machines with dimensions measured in nanometres (10^{-9} metres), a requirement which presupposes the ability to manipulate with accuracy individual atoms or small molecules.

There are two obvious approaches to this problem — to build small machines which proceed to assemble still smaller ones, and so on, or to start by building molecules, and assembling them into the desired machines.

Can this be done? In 1959 physicist Richard Feynman observed that “the principles of physics, as far as I can see, do not speak against the possibility of manoeuvring things atom by atom”. Since then researchers have spelt out ‘IBM’ in single atoms, so Feynman’s deduction is vindicated.

The next question might be whether practical machinery can result from such atomic manipulation. We have some evidence that it can, because living things use protein nanomachines for self-assembly. In the cell, a nanomachine called a ribosome trundles along RNA molecules building protein according to the command steps encoded in the RNA. This is analogous to a punched tape controlling a simple automated assembly process.

This also answers another question about the utility of nanomachines. We know that they can build structures ranging in size from simple molecules to complete whales. Construction of a three-dimensional integrated circuit should present no problem.

The Story So Far

Progress to date is limited but encouraging. Starting from the macro scale and building smaller, “micro-engineering” devices such as smart silicon sensors for automotive use can be made. These are still made using conventional techniques of lithography, though. A Japanese nanomechanism project has produced a single axis positioning mechanism using a linear motor and a rolling ball guide, giving a positioning accuracy of 1nm and a maximum speed of 200nm/s.

Nanometric measurement is also important. Workers at the National Physical Laboratory at Teddington are reported to have devised instruments able to measure down to 0.05nm.

Imaging of structures consisting of individual atoms is possible using a scanning tunnelling microscope (stm), the device used by the IBM researchers last year to print ‘IBM’ on xenon at liquid helium temperatures, and to read back the image produced.

From the other end, it has so far not been possible to predict reliably how a protein molecule will fold, that is, what shape would be produced by assembling a certain set of small molecule building blocks. Research has been concerned with biological molecules, and it is likely that initial nanotechnological machines will be biochemical in nature. These machines may then be used to assemble more robust

devices using more suitable atoms.

Applications

What may take many people by surprise is the range of possibilities that nanotechnological machines open up. To make a molecular Babbage engine which runs faster and uses less power than any electronic processor we can now envisage is an obvious course. Less obvious is the possibility of building a seamless engine out of elements taken from (say) seawater, and when the engine (with no flaws at all) is complete, leave nanomachines secreted within it to repair damage which may later occur.

Pollution could be cleaned up with minimal side effects by countless nanomachines each removing an atom at a time. In many cases the polluting byproducts could be turned into useful items, or at least decomposed into less dangerous forms for storage or disposal.

Medical nanomachines could totally eliminate the need for surgery, while allowing routine recovery from diseases and accidents which are currently fatal. Death would inevitably be pushed back. Before cardiac resuscitation techniques, when your heart stopped you were dead. Now the heart can be restarted, and the patient can make a complete recovery so long as the delay is brief enough to avoid brain damage. Nanomachines could almost certainly repair some level of brain damage, though there we are likely to meet limits. Nevertheless, at the minimum, the heart could be stopped for longer and a complete recovery still achieved.

Perhaps people who have been frozen in liquid nitrogen in the hope that their fatal illness can be cured in the future will be revived by nanomachines. The major problem with freezing is that crystallisation damages cells beyond conventional recovery. Nanomachines could repair these cells as revival took place, and restore the structure of the brain.

For myself, I look forward to the day when nanodentistry can remove the metal from my teeth and replace it with proper tooth.

Problems

Inevitably, snags exist. First of all, limitations may become apparent, so that not all of the imagined applications are possible. Secondly, and more seriously, accidents and abuses are possible.

One such, the “grey goo” scenario, assumes that nano-assemblers simply replicate using all available raw materials and energy, until nothing is left except nanomachines. This is unlikely, but cannot so far be shown to be impossible.

Nanoplagues could be used in warfare, and the only defence would seem to be further nanomachines to counter the plague. It may be, of course, that in the future everyone will routinely be injected with medical nanomachines to keep them healthy, and that these will automatically confer considerable resistance to nanowarfare. Still, it would do well to attempt to avoid problems before they occur. What we need to do is to develop nanotechnology as soon as possible, and to use it with discretion. The more technologically aware people consider these matters, the more likelihood that we can reap the benefits of this technology without suffering serious problems.

In the second part to this series, Andrew Armstrong examines the extremely small world of Nanotechnology.

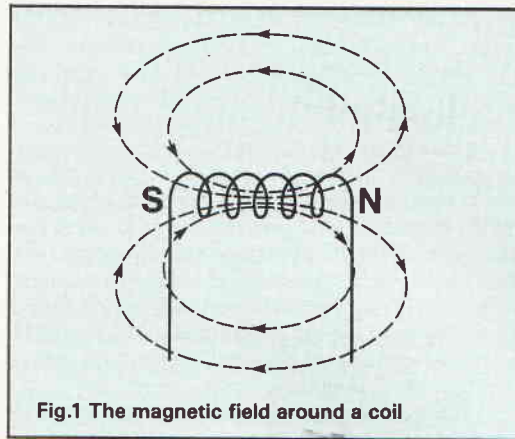

Fig.1 The magnetic field around a coil

This month Paul Coxwell examines the concept of Inductance

At this point in the series you should have a good knowledge of basic electrical circuits. Back in part 2 we examined the link between magnetism and electricity, and saw that a magnetic field is generated around a current-carrying conductor. The electromagnet is a device which puts this field to good use. If a wire is wound into a coil, the magnetic field surrounding each turn of the conductor combines with those next to it. This results in a much stronger magnetic field surrounding the coil (Figure. 1).

The magnetic field may be strengthened by increasing the current flowing through the coil or by adding extra turns to the coil. The amount of magnetic power available is called the magneto-motive force (MMF) and is measured in ampere-turns. For example, if a current of 2A is passed through a 10-turn coil of wire, the MMF is 20 ampere-turns. The same MMF could also be obtained by passing 1A through a 10-turn coil, or 0.5A through a 40-turn coil. Air is

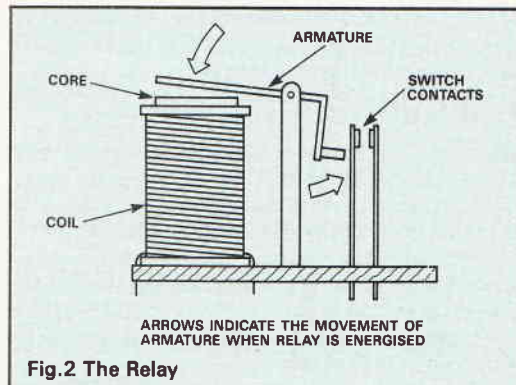

Fig.2 The Relay

not one of the best conductors of magnetic lines of flux, and practical electromagnets are wound with a soft iron core. This core concentrates the magnetic field and the resulting electromagnet can be used in a variety of applications. One application is that of the relay (Figure 2). A relay can be thought of as a remote switch; instead of a small lever being used to open or close the switch contacts, an electromagnet is employed instead. When a current is passed through the coil it generates a magnetic field. This field causes the relay's armature to be pulled down, thus activating the contacts.

Relays are available in many different sizes, from miniature types intended for remote-control of models right up to industrial power relays that are capable of switching very powerful equipment on and off. The relay allows current flow in one circuit to control another, without there being any direct electrical connection between the two. It is, for instance, a common requirement to be able to remotely control a very large electric motor. The cables that supply power to the motor may need to be very thick in order to carry the high current; to run such cables over several hundred yards would be impractical, not to mention very expensive. If a relay is fitted at the motor site, however, much lighter wires can be used to connect to the relay's coil to provide remote control. Figure 3 shows another way in which electromagnets

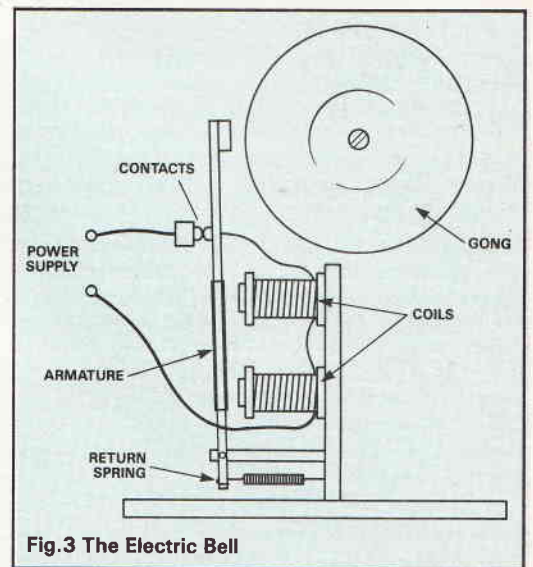

Fig.3 The Electric Bell

are used: a common electric bell. Notice that the bell also has a pair of contacts, just like the relay, only this time they form part of the circuit to the coils themselves. When power is applied, the coils generate a magnetic field which attracts the armature, causing it to strike the bell gong. At the same time, the movement of the armature has opened the switch contacts, thus removing power to the coils. A spring returns the armature to its former position, which closes the contacts and applies power to the coils once again. The whole process is repeated several times a second, with the result that the gong is repeatedly hit to produce a continuous ringing sound.

The relay and the electric bell are just two examples of the way in which a coil may be used to control external events by way of the generated magnetic field. There is another important aspect of the coil, however, in that it can influence the circuit of which it forms a part. This property is called inductance.

Inductance

Recall that when a conductor is moved across a magnetic field (or vice versa), a current is induced. This is the converse relationship to a current causing a magnetic field to be generated. Thinking carefully about the construction of a coil (Figure 4), as current through the coil increases, a magnetic field is formed around each loop of the coil. As this field expands, it cuts across neighboring turns of the coil, and induces

a current in those turns. Each turn of wire forms part of the same conductor, so the induced current will either aid or oppose that already flowing depending on whether the field is rising or falling. This action is known as self-inductance.

Application of the Left and Right-hand Rules shows that the induced current opposes the original current, and the induced voltage is called a counter-EMF, because it is trying to counteract the applied EMF. It is important to remember that this self-induction takes place only when the current through the coil is changing; when the current reaches a constant level the magnetic field around each loop stops expanding, so there is no relative movement between the field and neighbouring loops.

A coil not only opposes any increase in current — it also opposes any decrease in current. As the supply current decreases, the magnetic field around each loop of the coil starts to collapse, cutting across neighboring

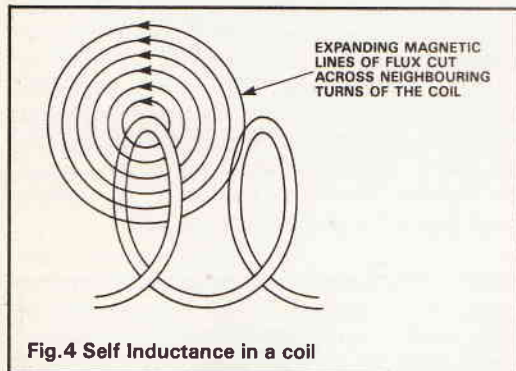

Fig.4 Self Inductance in a coil

loops as it does so. Self induction takes place once again, but this time the induced EMF aids the applied EMF, so the coil tries to keep the current from decreasing.

Figure 5 shows the action of a coil, or inductor, in a simple circuit. The first diagram shows a circuit which should now be familiar: a battery, switch, and load resistor. When the switch is operated, current through the resistor rises almost instantaneously to a value determined by Ohm's Law, as shown in the graph. When the switch is moved back to its original position, current stops flowing straight away — the power source has been removed and a resistor has no way to store power. The second part of the diagram shows how the circuit responds when an inductor (coil) is used. When the battery is connected to the resistor and coil, current starts to flow. As this current builds up, self-induction in the coil tends to oppose the flow of current. The counter-EMF generated is not strong enough to stop the increase in current, but it does slow it down considerably. The result is that current increases much more slowly than it did in the purely resistive circuit. Current is limited to a specific value by the resistor, and once it reaches that level self-induction ceases. Note the way in which the current increases: quickly at first and then more slowly.

When the switch is moved to its other position power from the battery is removed and the resistor is connected as a load across the coil. Self-induction causes the coil to oppose the decrease in current, with the result that current drops gradually rather than instantaneously.

As with any other electrical property, it is necessary to be able to specify how much effect a given coil will have upon a circuit, and the unit for measuring inductance is the Henry. There are two new symbols to remember: 'L' for inductance (it is also used to label coils on schematic diagrams) and 'H' for Henry. The definition of the Henry is that it is the amount of inductance which will cause an EMF of 1V to be induced when the current changes at a rate of

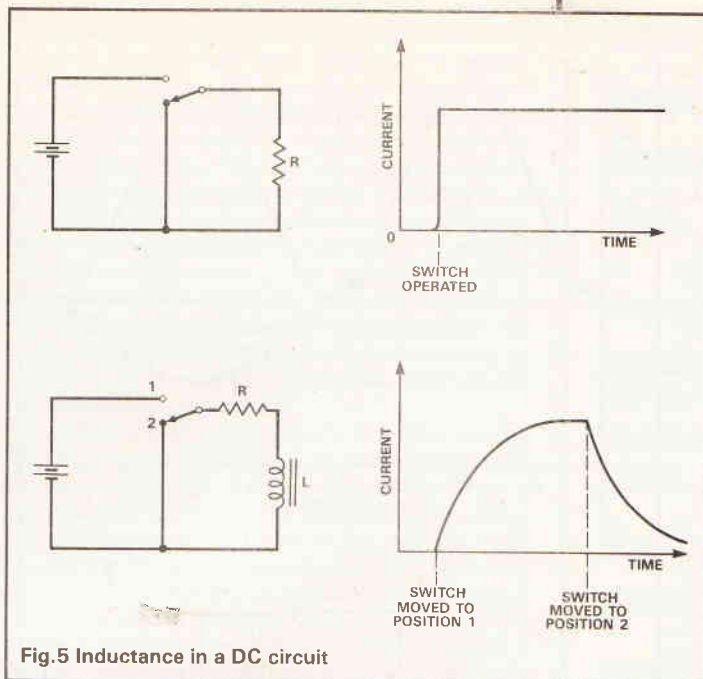

Fig.5 Inductance in a DC circuit

1A per second. In other words, a 1H coil will generate its own EMF of 1V if the supply current changes from, say, 2A to 3A in one second.

The value of the induced EMF is not often required for most work, however, and a more useful measurement is that known as the time constant of a circuit. The time constant is the period of time it takes for the current to increase to 63.2% of its maximum value. In Figure 6, the maximum current value is calculated using Ohm's Law — the result is 100mA. The amount of time taken between the closure of the switch and the current reaching a level of 63.2mA (i.e. 63.2% of 100mA) is the time constant.

The time constant can be calculated by way of a simple formula which states that the time is directly proportional to the inductance and inversely proportional to the resistance in the circuit. The time constant can be lengthened by increasing the induct-

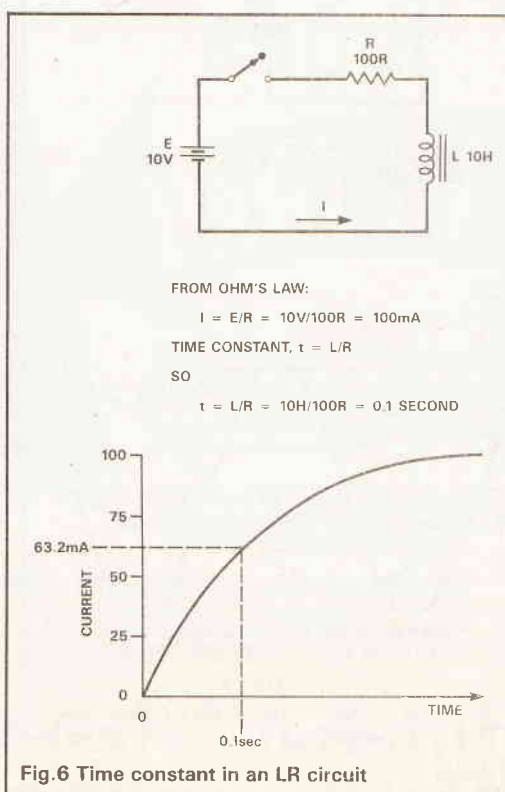

Fig.6 Time constant in an LR circuit

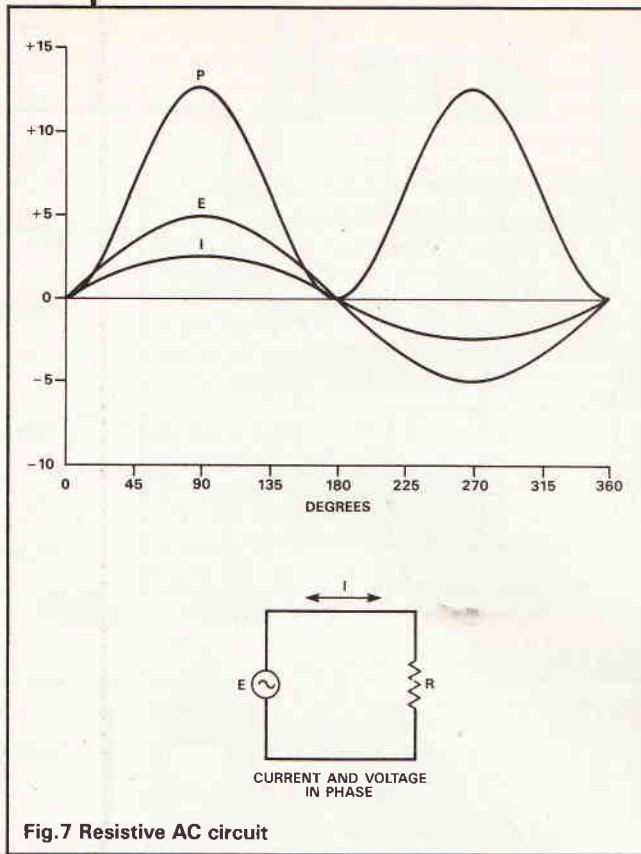

Fig.7 Resistive AC circuit

ance or reducing the resistance. Notice that the time constant is affected by the entire circuit, not just the coil itself. In the circuit shown, the current through the coil will reach 63.2% of its maximum value in one-tenth of a second.

The measurement of the time constant also applies when current through the coil is decreasing. It is the period of time it takes for the current to

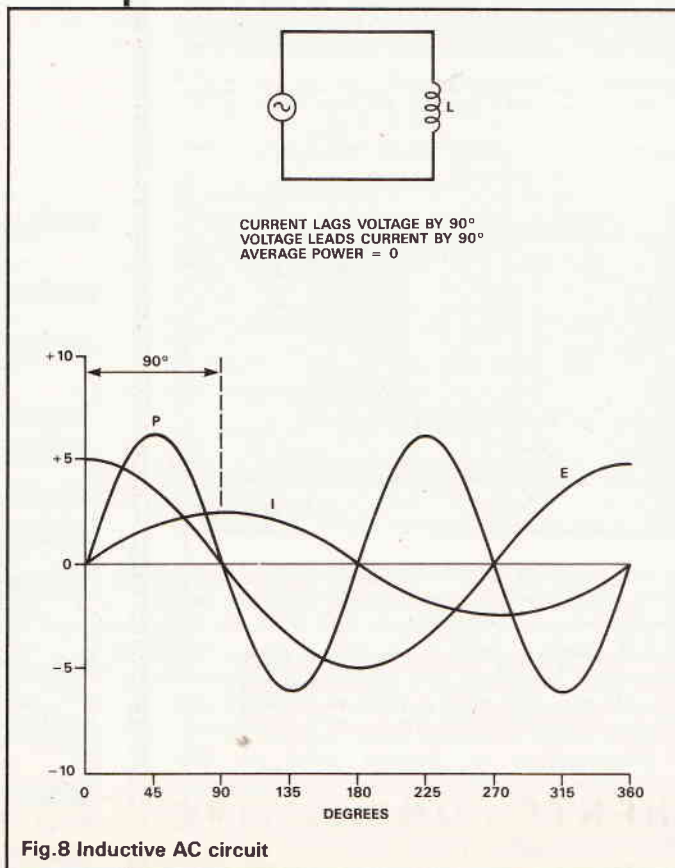

Fig.8 Inductive AC circuit

diminish by 63.2% of its original value (or, to put it another way, the length of time it takes for the current to drop to 36.8% of its starting value). We have covered some important concepts in the preceding section, so it is worth pausing for a moment to recapitulate. Here are the important points to remember: Inductance always opposes a change in current; increasing supply current causes self-induction to generate a counter-EMF; decreasing supply current causes self-induction to generate an aiding EMF; an inductor stores energy in the form of a magnetic field.

Inductance In AC Circuits

So far we have seen how inductance affects DC circuits by delaying the build-up of current to its maximum value. In an AC circuit, the situation becomes a little more complex.

Figure 7 shows a simple AC circuit consisting of just one load resistor and a power source. The graph should look familiar — it is the one we used last month to examine power in AC circuits. Notice how the voltage and current curves, E and I, are in phase with each other (i.e. they both reach their positive peak at the same time, both cross the zero point at the same time, and so on). Recall that the power curve never goes negative, because the product of two negative values (E and I) is always a positive value.

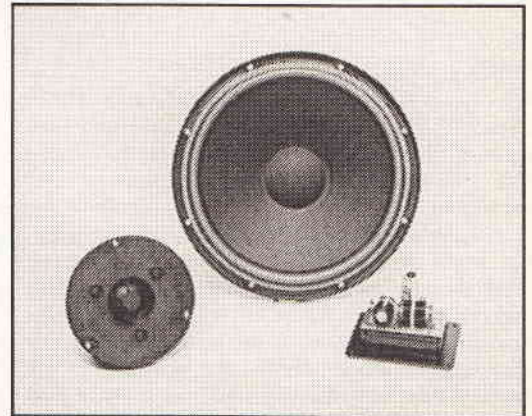

In Figure 8 the resistor has been replaced by an inductor. Look closely at the voltage and current curves and you will see that they are 90° out of phase — as E reaches its negative peak, for instance, I is just crossing zero on its way to the negative peak. We can say either that the current lags the voltage by 90° or that the voltage leads the current by 90°. The descriptions are equivalent and are just two different ways of saying the same thing. The reason for this phase shift is the self-inductance of the coil. The phase of the source voltage is determined by the power supply, but the inductor causes the current to lag behind. The graph in Figure 8 also shows how the power curve would appear. When voltage and current are both positive or both negative, the resulting product (P) is positive. When either E or I is positive and the other is negative, the power curve drops below zero. As has been already stated, a negative power level implies that the circuit is supplying power instead of consuming it. During the positive parts of the power cycle the inductor is creating an expanding magnetic field. During the negative portions, the magnetic field is collapsing and returning its energy to the circuit.

You will see that the power curve is symmetrical and centered on zero, so its average level is, therefore, zero. This leads to an important fact: A purely inductive circuit, such as the one shown, does not consume any power. All the power taken to create a

OHM'S LAW FOR REACTANCE:

$I = E/X$ THEREFORE $E = IX$ AND $X = E/I$

X = REACTANCE
 X_L = INDUCTIVE REACTANCE

$X_L = 2\pi fL$

WHERE L = INDUCTANCE, f = FREQUENCY

EXAMPLE:

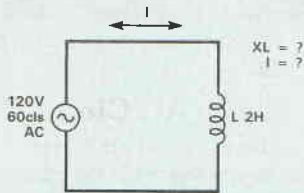

$X_L = 2\pi fL$
 $= 2 \times 3.14 \times 60 \times 2$
 $= 7753.6\Omega$

$I = E/X_L = 120V/7753.6\Omega = 159mA$

Fig.9 Inductive Reactance

it is called inductive reactance (you will come across another type of reactance later in this series). Reactance is not constant for any particular coil — it varies with the frequency of the alternating current. If the frequency of the AC supply is increased, the current does not have as much time to increase before the supply voltage changes polarity. The result is that current decreases as frequency increases, or to put it more formally, inductive reactance is directly proportional to frequency. The inductance value of the coil itself also affects the amount of reactance; more inductance gives a longer time constant for the circuit, thereby preventing current from increasing so rapidly. Inductive reactance, therefore, is also directly proportional to inductance.

The symbol for reactance is 'X' and when referring to inductive reactance it is usual to add the subscript 'L' to avoid confusion. Like resistance, reactance is measured in ohms, and the formula for calculating inductive reactance is shown in Figure 9. For most practical purposes it is accurate enough to take π as 3.14. The example shows a 2H inductor connected directly across a 120V 60Hz supply. Applying the formula for X_L gives an inductive reactance of 753.6 ohms. Although Ohm's Law is stated in terms of current, voltage, and resistance, it may also be applied to current, voltage, and reactance. The current flowing in the circuit may be calculated by dividing the reactance into the supply voltage. The result is a current of approximately 159mA. One may be tempted to multiply the supply voltage and current together in order to calculate the power dissipation — doing so gives a result of just over 19 watts. We have already seen that an inductive circuit does not in theory consume any power. The explanation of this problem forms the basis of next month's installment.

magnetic field around the coil is returned when the field collapses.

Inductance opposes the flow of alternating current but not direct current. In a DC circuit the current will eventually build up to its maximum value, but in an AC circuit the polarity of the supply voltage has changed before the current has had time to reach that same level. The inductor may be considered to have a special kind of 'resistance' to alternating current only. To avoid confusion, this opposition to the flow of AC is called reactance, and when applied to coils



What's so Special about

PAGE 37?

and pages 45, 55, 58 among others

Simply that these are some of the pages which show how exceptionally wide and varied are the ranges of COMPONENTS, PRODUCTS and MATERIALS to be found in our 1991 Catalogue. Much practical information is included and it's all well presented, illustrated and easy to look up — and to order from.

IT'S ALL IN THE NEW, LARGER (A.4) ILLUSTRATED 80 PAGE (PLUS COVERS) 1991 ELECTROVALUE CATALOGUE

WE ARE SPECIALIST SUPPLIERS FOR SIEMENS FINE QUALITY COMPONENTS

Please send £1.50 (cash/P.O./cheque/stamps) for your 1991 EV catalogue (postage paid in UK) We give you a refund voucher for £1.50 usable towards your next order for £5.00 or more.

MAKE YOURS A FREE COPY

ELECTROVALUE

FOR QUALITY COMPONENTS COMPETITIVELY PRICED

Catalogue orders to:—
ELECTROVALUE LTD, 28a ST. Jude's Rd., Englefield Green, Egham, Surrey TW20 0HB
 Phone: 0784 433 603 Fax: 0784 435 216

Supercom

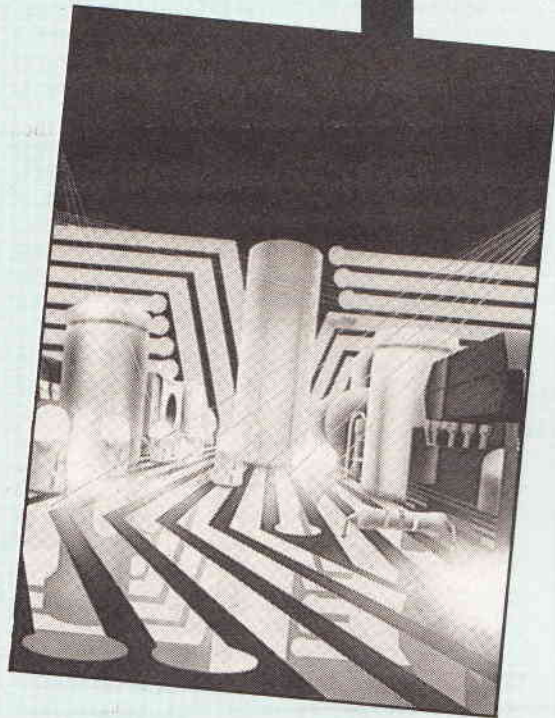

Audible effects of electronic components

Is it really all in the mind?

John Linsley-Hood airs his views on the great audio component debate.

One of the most contentious areas of contemporary debate in the field of audio is whether the components used in constructing the circuitry, or used in joining complete bits together, can or do have an effect on the final sound quality of the system.

The protagonists in this debate tend to be divided as much by what they do for a living as by their natural scepticism or open-mindedness, with the professional designers and engineers tending mainly to a determined view that it is a lot of nonsense that any 'passive' component — provided that it is not inappropriate to its job, faulty or overloaded — will influence the final audio quality.

Their opponents, who tend in the main to be either journalists working for the 'Hi-Fi' magazines, or lay 'hi-fi' enthusiasts with an inclination to experiment, tend to be equally resolute in their view that individual components, cables, or constructional materials, do indeed have an important effect, an idea which is

enthusiastically supported by the commercial suppliers of exotic and expensive 'super grade' components... well, they would, wouldn't they?

As ever, in such debates, there is some truth on both sides of the argument, which is a point I think worth exploring. So I will look at the case of the 'hi-fi' enthusiasts first.

Components do!

My recollection is that, in the days before transistors, and other suchlike unnatural oddities, 'audio' enthusiasts listened fairly contentedly to their hardware, and their debates about sound quality were mainly concerned with whether an open baffle, or a 'corner horn' loaded speaker unit would give the most natural sound, and whether, a closed-box 'infinite baffle' system could give more than a muffled boomy confusion of noise.

There were bands of devotees to the products of the various loud speaker manufacturers, Goodman, Celestion, Elac, Tannoy, Stentorian, Wharfedale, and so on. For the record, in those days, I was a 'Wharfedale' man. However, duelling pistols were seldom called for, and differences in personal preferences were usually just attributed to a slightly comic eccentricity, or perhaps to the possession of 'cloth ears', by the supporters of the other camps.

Occasionally the field of debate would extend into the more esoteric areas of circuit design. On the valve front it was about triode or ultra-linear output stage connections, or the respective merits of possible push-pull 'phase-splitter' circuits, or fixed or 'cathode' bias. However, the debate remained amicable, and as newer and better components were introduced, they were welcomed and used without hesitation — but then, alas, along came transistors.

The advent of the 'solid state'

The decade of the 1950s saw the emergence and development of the transistor from a laboratory curiosity, mainly confined to the United States, into a useful and reliable electronic circuit component, which, at least so far as factory instrumentation was concerned, made it more possible for the instrument engineers desire to 'fit and forget'. However, people have an innate wish to experiment and explore, and before very long, transistor audio amplifiers began to appear.

At first, these weren't very good, and people didn't expect very much from them. They lent themselves to convenient and relatively drop-proof portable bedside radio sets, which worked from small and inexpensive dry batteries, and were fine for listening to the news, but they clearly weren't in competition with the domestic 'hi-fi' audio system. This convenient differentiation of roles also didn't last. Solid-state hi-fi began to appear, and with it the beginning of the parting of the ways between the engineers and the audio enthusiasts.

Components

COMPONENTS

The proud designers of these early solid-state hi-fi units, and the advertising agencies who worked for their employers, proclaimed their achievements — a ruler flat frequency response from 20Hz to 20kHz, and a total distortion below 0.1% at full output power! Overall, a performance which “surpassed the best of the bulky, inefficient, valve designs, and which brought new standards of audio fidelity into the home”. (I quote!) What more could one ask, except, perhaps, that they should be nice to listen to!

The truth, sad to tell, was that these early transistor audio amplifier designs sounded quite nasty. The THD and frequency response data did not tell anything like the whole story. They ignored the unacceptably high amounts of low-level ‘crossover distortion’ making the sound hard and thin. Miserable

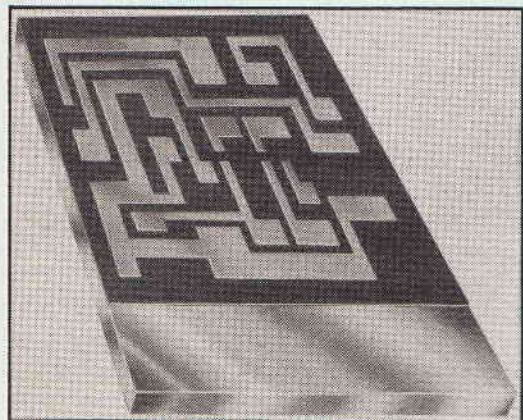

transient response and load stability characteristics made the sound so strident being consequent upon the improper use of negative feedback to try to straighten out the distortions resulting from poor circuit design — and the unsuspected presence of ‘slew-rate limiting’ — which could momentarily blot out whole chunks of programme, following signal transients. This was simply due to bad feedback loop stabilisation procedures.

To use a phrase borrowed from a distinguished

colleague, ‘this allowed the subjectivists to get their foot in the door’. Their case was that the engineers had said their designs were good, and quoted specifications to prove it, but anyone who cared to listen could tell at once their designs were rotten. The moral of this must be, don’t take any notice of what the engineers say, just believe your own ears — or better still the ears of the experienced contributors to your favourite ‘Hi-Fi’ magazine.

As each of these were overlooked, technical faults were revealed by the investigations of other engineers — their colleagues would mainly admit the error of their ways, and strive to do better, until yet another previously unforeseen drawback was revealed.

Uncovering and correcting the design problems did have the effect of making solid-state audio designs a lot better, and by the 1970s most of the contemporary transistor audio amplifiers had achieved a good standard — indeed I recall testing a few high quality, and widely respected, valve amplifiers somewhere around 1972, using the criteria I currently applied to transistor designs, and finding that the actual test performance of the valve designs was not anywhere near as good as I had expected.

Nevertheless, they sounded quite well — not to my mind, any different to a good transistor amplifier, but then the human ear is very tolerant in its acceptance of artificially reproduced sound, provided there is nothing really nasty lurking in the background.

However, the effect on the non-technical user, of the continuing exploration of solid-state design problems, was mainly to give support to the subjectivists ‘only believe your own ears’ campaign, though it also gave a boost to the ‘back to valves’ brigade, since the equally real problems which existed with valve designs were not much explored or publicised.

This feeling about the untrustworthiness of specifications, and the cloth-eared bigotry of engineers, gained ground because most of the ‘Hi-Fi’ fraternity who were concerned with audio standards were listeners rather than circuit designers, and there wasn’t a lot that they could do about it themselves other than to be selective in their purchases.

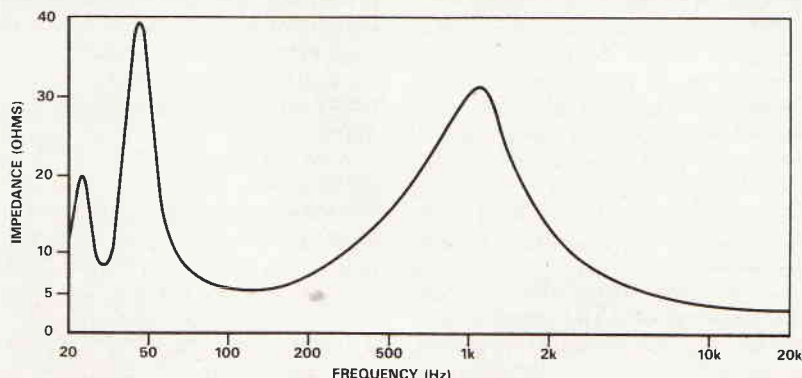
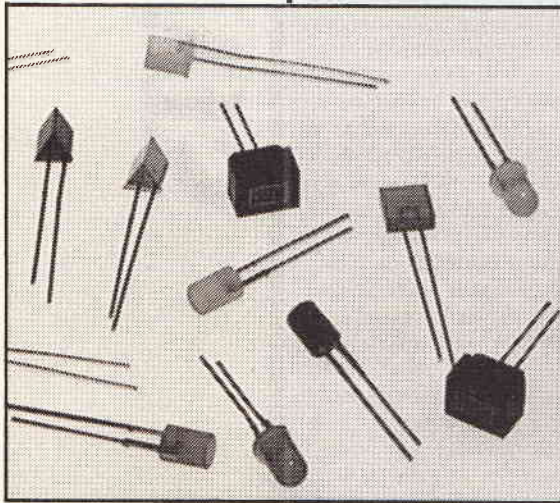

Fig. 1 Measured impedance of 3-way studio monitor LS (nominally 8R).

Wires are wires are wires, or are they?

This situation changed abruptly, when some bright spark observed that changing the wires between the amplifier and the loudspeaker could improve (alter?) the sound of the system. For the first time, here was something the user could do for himself, without the need to delve into the mysteries of his hardware, and with little danger of doing anything harmful or irreversible, if the results were unsatisfactory.

For a period following this observation, there was a spate of suggestions for 'super' connecting wires, ranging from massive, solid-drawn conductors to multi-strand 'Litz' wire, which was designed to have a low impedance at very high (radio) frequencies, though it would be pretty well identical in impedance to any wire of equivalent copper cross-sectional area at lower (audio) frequencies.



A friend of mine, who has a professional interest in human psychology, points out that people usually get a great degree of satisfaction from making their own contribution to the systems they employ, and so in this case, there would be a considerable temptation for them to believe that some benefit really did arise from something which they themselves had done — especially if there was a degree of novelty involved, whether or not any improvement had, in reality occurred.

A rational explanation for this 'speaker cable effect', where it occurred, was given by James Moir, in an excellent article in *Hi-Fi News*, (May 1979), in which he pointed out among other things, that loudspeaker units do not provide a constant load impedance, but rather in the case of a multiple driver unit of contemporary type, the sort of impedance curve I have shown in Figure 1.

It stands to reason that, if the loudspeaker cables have a series resistance which is significant in respect to the overall impedance, the amount of power delivered to the drive unit, and consequently the output sound level, will vary as the impedance of the drive unit changes with frequency. So it is sensible to make sure that the cable resistance is small in relation to the lowest actual impedance offered by the loudspeaker.

At about this time an older generation of equipment reviewers; who had based their judgments on instrument tests assisted by critical listening trials based on classical music played at low to medium sound levels; were succeeded by younger men, who mainly based their performance assessments on 'pop' music, played at much higher levels. Predictably, their preferred drive units were those which would give an exciting reproduction of string bass, and these by pure coincidence, happened to have a very low dynamic impedance, (perhaps less than 2 Ohms), at certain critical parts of the audio range. At these impedance and power levels, not only were low impedance cables very important, if output power was not to be lost, but also those amplifiers which could drive such low impedance loads showed up much better than those which could not, and this factor greatly outweighed all considerations of such trivia as low THD or IM distortion.

I appreciate that I am likely to be denounced by

the PFPS, (the picoBel and femtoBel protection society), but, in normal situations, small changes in loudness level are unlikely to be noticed, and differences in the overall frequency response are even more hard to detect by ear, so if the cable resistance is less than 10% of the loudspeaker impedance, that is probably adequate. For this application, a 7m connecting lead having a resistance of 0.034 ohms/metre, (James Moir's quoted value for standard 1/1.13mm mains wiring cable), is likely to be quite satisfactory.

However, there are other considerations, of which the first is just what source impedance did the loudspeaker designer take as his reference in designing his reproducer. Loudspeaker design is still nearly as much an art as a science, and a lot of final 'tweaking' in the evolution of the system will probably have been done with a specific source impedance, which certainly wasn't zero ohms.

There is also a more sinister reason for the differences which may arise — feedback loop instability. Over the years I have tested quite a few commercial audio amplifiers, and an even larger number of published amplifier circuit designs, which I have built out of interest or curiosity, and I know it is not at all uncommon for quite stable amplifiers with a pure resistive load, or a simulated 'reactive' load consisting of a resistor in parallel with one or two microfarad to burst into oscillation when the load capacitance is in the range 0.5- 22n.

This is just the sort of capacitance value which some of the expensive, interwoven 'super cables' can present to the loudspeaker output terminals, so in some cases-changing the cables will undoubtedly have made a difference — the unlucky amplifier will now be oscillating merrily. If the amplifier had a bit of crossover distortion, a bit of low-level HF oscillation might get rid of this, by straightening out the kink, like the 'bias' waveform in a tape recorder.

Perhaps, if the oscillation is a bit more vigorous, warming up the output transistors may make the crossover kink a bit smaller anyway, so the experimenter may be quite right when he claims that the new cables 'improved the sound quality' A better designed amplifier, in the first place, might have been a preferable solution.

But don't forget the contacts

Some years ago, I made a distortion meter and an oscillator to go with it. It would operate when all was well, down in the range of 0.0001% THD, over the range 100Hz to 10kHz. I said 'when all was well' because this bit of kit abruptly brought me up against the snag that one could only get anywhere near the potential performance of the system when all the cable and meter range switching contacts were scrupulously clean.

Using cheap and cheerful plugs and sockets led to a situation where disconnecting and reconnecting the same contact pair would give a different answer every time. If any current was passed through them, the results could be appalling, adding noise to the distortions due to the metal/oxide rectifying action of the contacting faces. Gold plated contacts, if scrupulously clean, gave more reproducible results, but were still variable in their contact effectiveness.

All this was at levels below 0.005%, meaning this effect would probably be quite inaudible in the presence of the 0.5-2% THD associated with most of the then available programme sources. But then I thought of the cheap tinned copper fuse holders in the loudspeaker circuits of quite up-market audio amplifiers, and the equally rough and ready fuses poked into them, and they might pass an ampere or two of audio output currents. Perhaps the 'super

component' vendors might do a more worthwhile job selling super fuses and super holders than in selling polypropylene film capacitors.

But what about the capacitors?

Throughout the whole of my life in electronics, the capacitor has loomed large as a source of problems, and even now, though greatly improved, it is generally a poorer component compared to a resistor, or any one of the family of solid state devices.

Taking them by and large, capacitors can present any one of the spurious parasitic effects I have illustrated in Figure 2. In the case of the electrolytics, they will suffer from leakage resistance, which is non-linear, asymmetric and variable in its value according to the instantaneous voltage across it. They will also suffer from a significant amount of series resistance and inductance. Tantalum bead types, especially, have a relatively high value of dielectric loss, which can absorb energy in a complex manner, a defect which offsets their many advantages.

Non-polar film dielectric types are better, though bulkier for the same capacitance and likely to have a higher series parasitic inductance. However, these also suffer more from dielectric hysteresis, and 'stored charge' effects, more particularly in the case of rigid, biaxially oriented, films like polyester and polypropylene than in the case of the more limp, solution cast, polystyrene, polycarbonate and polysulphone dielectrics.

The skilled circuit designer needs to know the strengths and weaknesses of the capacitor types available, and specify the correct one for each position, since some places, such as that of a DC blocking capacitor in a negative feedback loop, can be quite critical, whereas a supply-line bypass component is much less so.

Fortunately most of the parasitic effects in non-polar capacitors are only troublesome at very low or very high frequencies, usually well outside the audio range.

If the designer of a circuit has spent some time and thought in deciding just which component type, of the multitudes available, would be the best for any given position, it is unlikely that he will be pleased to be told that some more expensive substitute component will improve his design. If it really does, then he hasn't done his design job correctly.

One must remember the old adage that 'a good engineer can do for a shilling what any dam' fool can do for ten pounds'. Cost effectiveness is also part of the job.

Components don't!

The design of high quality audio amplifiers is a tricky business, with a lot of pitfalls awaiting the unwary, which is probably why there aren't a lot of good designers around. The problem is usually one of achieving, simultaneously, a good steady state (sine wave) performance and a good transient (square wave) response — especially with an awkward LS-type load.

One of the essential characteristics of a good design, if it is to be more than a 'one-off', is that it should be tolerant of small variations in the characteristics of the components used in its assembly. It really isn't any good at all if a circuit will only work with components precisely tailored to the design, and fortunately this situation doesn't often arise.

Nevertheless, it is prudent on the part of the designer to determine by analysis what effects will occur as a result of inadvertent errors in component specification, and to keep well away from critical performance boundaries. If he has done his design work well, all units within a batch will be very similar

in performance, and all within the basic performance specification.

If changing any component for another of nominally identical specification makes a measurable change in performance, then either the design is not a workmanlike effort, or one or both of the components is defective. If the ear of the listener can detect an effect which cannot be measured, then either the listener is deceiving himself or the engineer is looking for the effect in the wrong place, or with the wrong kind of instrument.

But can one measure audible differences anyway?

I am well aware that I differ in my views from many of my fellow engineers, on the score of performance measurements, mainly because I believe that most of the residual problems of audio system design concern errors in the handling of discontinuous waveforms, whereas my peers seem mainly to concern themselves with continuous, 'steady state' effects, in respect of which we have achieved a very high standard of performance anyway.

Where I do not differ is in the need to measure. Progress cannot be made just on the basis that a certain circuit arrangement, or a certain component type 'sounds better'. This approach leads to too many uncertainties, like whether it will sound better after dinner, or whether I have got a cold in the head, or how much have temperature changes effected the frequency response of the loudspeaker units or the gramophone pick-up cartridge, or whether there is an unseen accumulation of gunge on a pick-up stylus or replay head.

At least, in the test laboratory, the instruments can be made to check each other, and the extent of variability in readings can be determined. Sometimes measurable effects can reproducibly affect the quality of the sound, even when their presence is too small

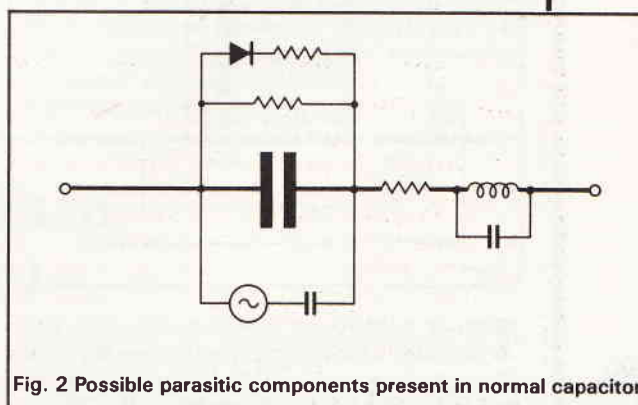

Fig. 2 Possible parasitic components present in normal capacitor.

for it to seem likely, or where they relate to operating conditions which one feels will not arise. In these cases, one must note these facts for future reference and investigation.

In other cases, known defects are overlooked by the ear, when commonsense urges that they should be clearly audible; like the fact that an 'audio quality' perfectionist can live with a pick-up cartridge which gives more than 1% harmonic distortion, over an important part of the frequency spectrum.

There is a lot we know already, and there are things we still need to know, but one thing is certain, our progress will be made in the laboratory, with instruments and with measurements and computation, even if we still need to be told occasionally that we haven't yet achieved perfection — but then, we never will.

Tech Tips

Programmable Tune/Alarm Generator

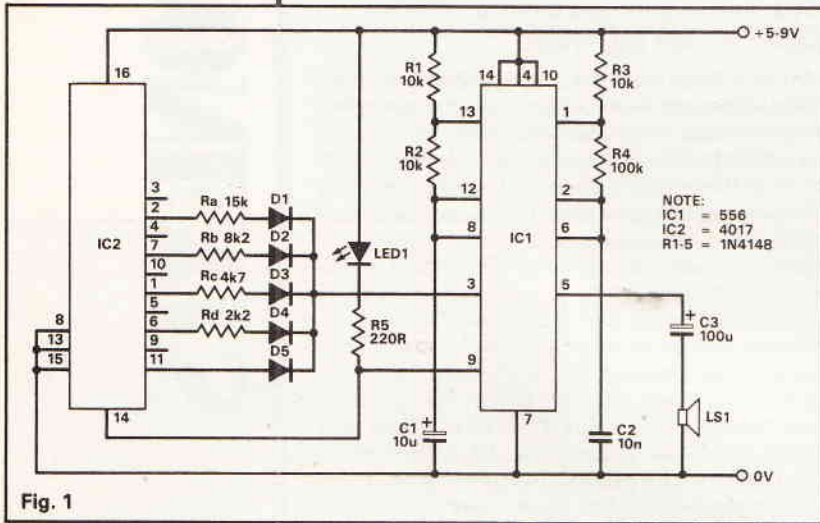

Fig. 1

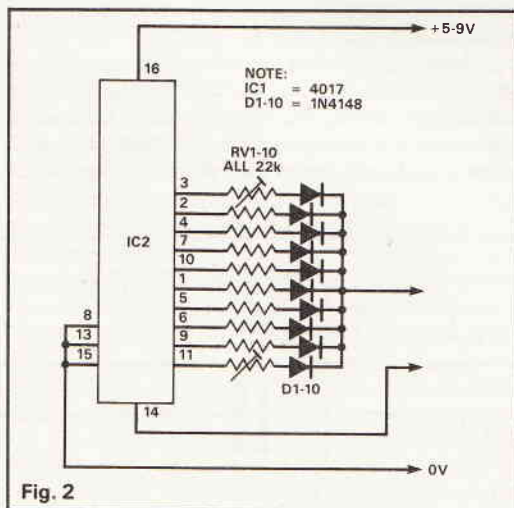

Fig. 2

This is a hardware programmable tune/alarm generator capable of playing 10 notes repeatedly. It is a very simple, low-cost circuit based around 2 ICs (prototype uses 2 × 555 ICs instead of 1 × 556).

The programming requires just 10 resistors giving a different value for each note, or 10 preset resistors which can be adjusted for different sequences. One other resistor controls the speed of operation.

Preset resistors are adjusted to give each required note and the maximum resistance gives the highest pitch. R2 controls the speed (tempo) of the notes, and can be replaced with a 100k preset to make speed variable. All 10 notes are repeated sequentially. The total cost of the main circuit is around £2.15, including battery clip and transducer (microphone element used in reverse), but not including stripboard.

If the flashing LED is not required, then this can be achieved by omitting R5 and LED1. The circuit in Figure 3 shows how to trigger the alarm from a logic circuit. LS1 is an 8-80R miniature loudspeaker, or a

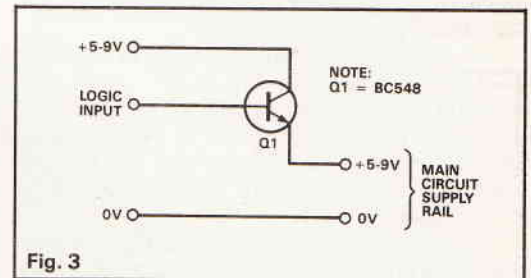

Fig. 3

600R dynamic microphone element as used in the prototype.

Remember to observe CMOS static precautions with IC2 (4017 counter).

It works like this. A low frequency square wave is generated by one half of the 556 timer IC which is used to drive the 4017 counter. This produces a positive output at each of its outputs sequentially. Resistors, in series with these outputs limit the output voltages to various levels. They are wired together via diodes to one output which thus varies its voltage step by step according to the resistors chosen. This output is used to modulate a tone generator formed with the second half of the 556 IC.

The LED is driven in opposite phase to the low frequency square wave which drives the counter.

S Yousaf, Slough.

TECH TIPS

Reducing Electrical Interference On AM Radio

Many of us are affected by interference to radio reception of AM signals; my own interest in DX (long distance) reception of long, medium and short wave was seriously curtailed for some time by a neighbour's faulty central-heating thermostat and by time-base harmonics generated by several neighbouring television sets. Various other forms of domestic interference can ruin reception of even fairly local signals, especially if one lives in a block of flats or a terrace of houses.

Having tried several alternative aerial systems, I arrived at the one described here, which gave quite amazing results. In my own case, I decided to make use of a redundant 405-line television dipole located in the loft but first changed its polarity to horizontal. The existing coaxial downlead, which emerges from a gap in the roof-tiles and comes down the outside of the house, was split at a convenient point near to the radio receiver that it now feeds; just a few feet away from the aerial input and earth terminals. The two free ends of

the download were fitted with coaxial connectors to enable connection to the device which must then be made from a separate piece of coaxial cable about 2 feet long (Figure 1).

The device is simply a convenient method of switching the download so that the entire screening braid is either used to complete a normal dipole arrangement (Figure 2) or is broken so that most of the braid and the dipole arms become one 'long wire' aerial (Figure 3). A linking capacitive effect (C) is provided by the insulated gap between the inner and outer conductors of the coaxial download.

Figure 1 shows how the braiding at one end of the device is cut back, well away from one coaxial connector; the braiding at the opposite end is connected to the shell of its connector in the usual way. A small toggle-switch is then fitted at the open-circuit end of the braiding, one connection to the braiding and one connection to the connector shell. The latter connection can be made by securely tie-wrapping a piece of stripped-back wire to the shell and then covering it tightly with insulating tape. If a small toggle-switch is used, both the switch and the connections can be neatly taped to the 2 feet length of cable with only the toggle arm showing and free to be switched. A coating of clear adhesive can then be added to improve the appearance and to provide extra physical strength.

At times of either minimal or no interference, the switch can be used in the 'off' position so that the coaxial download outside the house functions, with the two

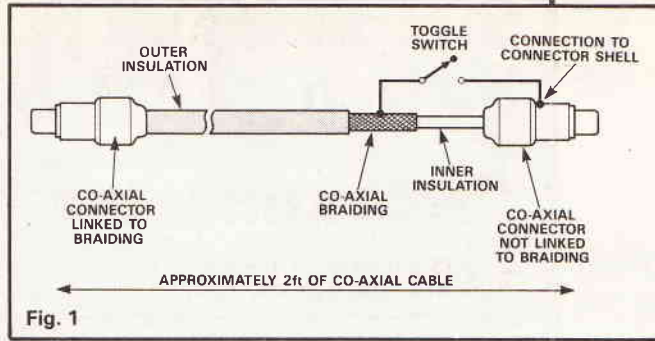

Fig. 1

dipole arms capacitively linked together, as a very efficient long-wire antenna for all bands. The shorter screened lead remaining at the receiver aerial and earth terminals reduces any nearby interference. If severe interference recommences, putting the switch to the

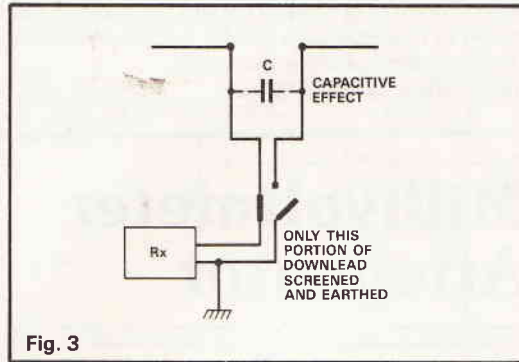

Fig. 3

'on' position reconnects the entire screening all the way to the left dipole. This almost eliminates interference but reduces signal levels on long and medium waves. Short-wave signals are at worst, slightly reduced in strength but are actually increased at some frequencies where the dipole dimensions are appropriate for resonance. Readers may prefer to replace the television dipole with a larger wire dipole, cut to resonate in the bands of their choice. It must be sited well away from any known source of interference.

Ivor Nathan, London

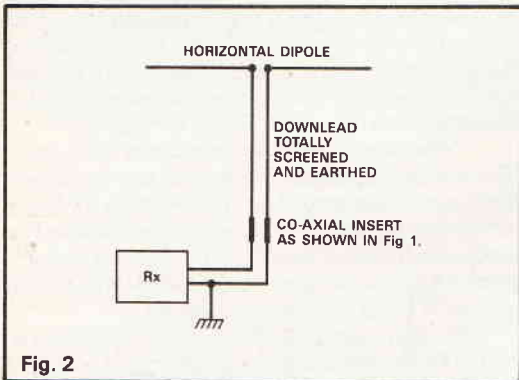

Fig. 2

Rain Alarm. No Rain – No Power Drain

The rain detector operates on the principle of an electronic switch which in this case is a single transistor. The base circuit is normally open circuited. The switch contacts being open lines of interleaving tracks on the sensor board. The resistor in series with the base limits the maximum current to a safe value when one or more of the lines are shorted by rain drops. The diode, placed in series with the emitter lead protects the transistor against accidental reversal of the polarity of the battery feeding the circuit.

The circuit detects rain as soon as the first rain drop falls on the sensor board. The sensor is constructed using high density strip board made of epoxy glass or SRBP with copper tracks spaced at 0.1 in. Alternate tracks are connected in parallel to form an interlaced comb structure. The area of the sensor is not critical. Any size from 50x70mm to 75x100mm will do. Larger areas can be used bearing in mind that it is the first rain drop, per sensor area used, that is detected and the sensor board must be perfectly dry. A damp board will produce some leakage current which may set off the alarm. An adjustment for the sensitivity was

thought to increase the complexity of the circuit, and demand some stand by power.

The audible transducer can be replaced by an LED, relay or any other indicating device if required.

J R Norwicki, Marlborough

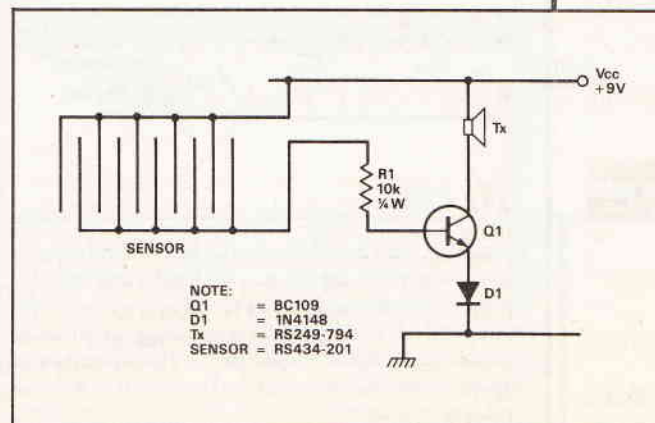

Simple Hand Switch

This simple inexpensive arrangement lends itself to applications where a momentary operation hand held push button switch is required. Construction is straightforward. Wire one side of a miniature SPNO push switch to the centre connector of a 1/4" mono jack plug and the other side to the common connector, the latter must be reduced in length to allow switch fitting. Secure the jack plug cap in place using the switch fixing hardware. A suitable length of two-core cable, extendible cordage being one option, is soldered to a 1/4" mono 'in line' jack socket which mates with the modified jack plug to form the hand switch.

Although not in itself a security circuit, the jack plug may be removed providing a level of protection against unauthorized use if required. A medium size terry-clip mounted on a suitable surface provides a means of stowage where necessary.

Terry Grice, Tyne and Wear.

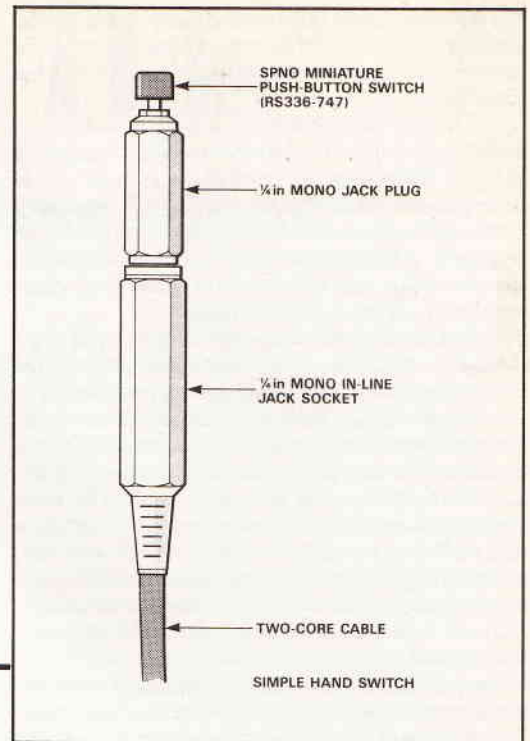

Millivoltmeter Attenuator

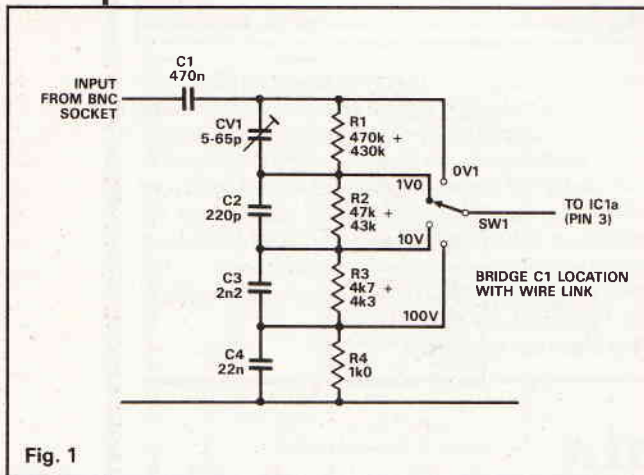

Fig. 1

The AC millivoltmeter circuit (ETI August 1990) can be extended into a stand-alone instrument by adding a compensated attenuator at its input. Figure 1 shows the arrangement. The capacitors are necessary to avoid inaccuracies due to stray capacitance around

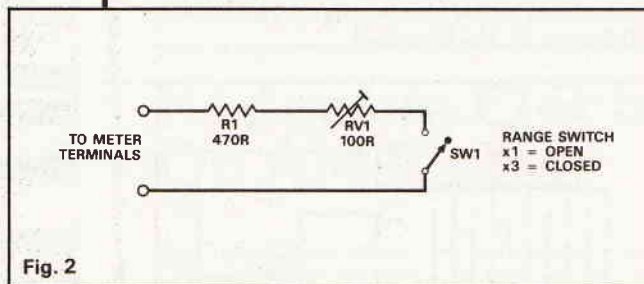

Fig. 2

the switch. The assembly should be hard-wired on a rotary switch with minimum wire length and with the components splayed outwards. The lead from the switch to the board should be screened and as short as possible for minimum capacitance. The whole circuit should be battery-powered and enclosed in a metal case which is connected to circuit ground at the input

terminal (preferably a BNC socket) only. An input impedance of 1M, 22p was chosen as a good match for ordinary oscilloscope probe leads. To maximise the meter resolution, intermediate ranges (300mV, 3V, etc) are useful and these are obtained by shunting the meter movement with the circuit shown in Figure 2.

Calibration is eased with the circuit of Figure 3. This is a low-impedance attenuator, useable at high frequencies without significant error. Initially, the board is calibrated according to the constructional article. The input switch is then set to 100mV. A 1kHz signal is applied from a signal generator at 100mV and 300mV and the $\times 1/\times 3$ meter shunt trimmed.

The signal generator frequency is then raised to 100-200kHz and, using the test attenuator switch to

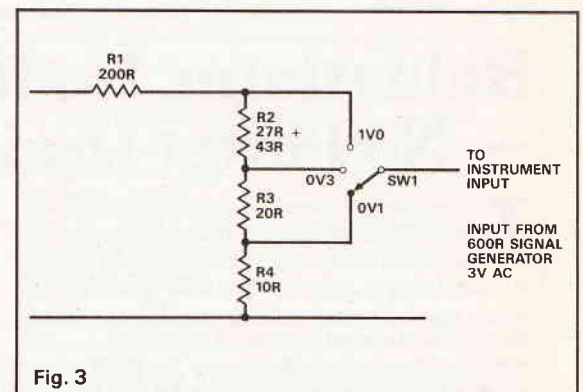

Fig. 3

apply 100mV and 1V alternately, C1 is trimmed for a flat attenuator response. Alternately, a 10kHz square wave input can be applied and the output of IC1a checked with an oscilloscope while the attenuator is trimmed. As this circuit is the simplest possible compensated attenuator and there are several possible paths for stray capacitive coupling, perfect performance is unlikely but it should not degrade the meter accuracy significantly.

If using the millivoltmeter for AC only, insert a 47μ capacitor between the output of IC1a and R5. This will prevent offset error of IC1a affecting the rectifier.

Simon Bateson, Middlesbrough.

Lasers 3

Last month I described the actual laser, which by now some of you will have built. You will have realised that as it stands it isn't much use, except to shine at the wall in a dark room or to put it where Papillon put his money. What is required is some form of receiver, a Ying for the Lasers Yang as it were.

In fact I will describe 2 receivers or optical amplifiers, one which is better suited for analogue signals and the other for digital.

The Circuit

You can always tell when something obeys the law of physics, it becomes difficult to use and gives as many problems as it does benefits when it is actually working. This is especially true of photodiodes, they must be operated reverse biased, will have a thumping DC offset and will have as much useful output as a political debate on the state of the British Electronics Industry. They are better than their predecessors, the photomultiplier though so I suppose we shouldn't grumble. They work by passing different currents at different light levels, for example they may pass $10\mu\text{A}$ when dark and $100\mu\text{A}$ when in strong light. They are also reasonably linear, their speed is pretty impressive

this circuit, then I advise that you lay the board out fairly carefully. There are two gain stages A1,2 and 3 are the input and impedance matching stage and Q4 and Q5 provide the extra gain stage and buffering.

The second circuit is a little more complex, it can however be used to provide a digital or analogue output so it will be more useful when dealing with our laser.

Kevin Kirk outlines the construction of an optical receiver and suggests some uses.

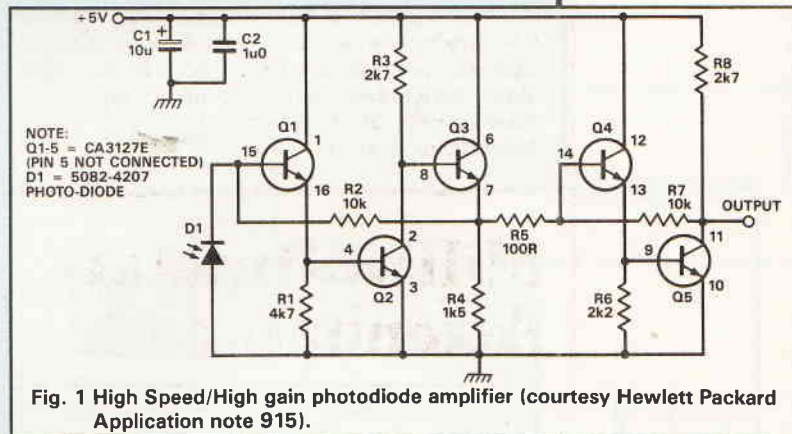

Fig. 1 High Speed/High gain photodiode amplifier (courtesy Hewlett Packard Application note 915).

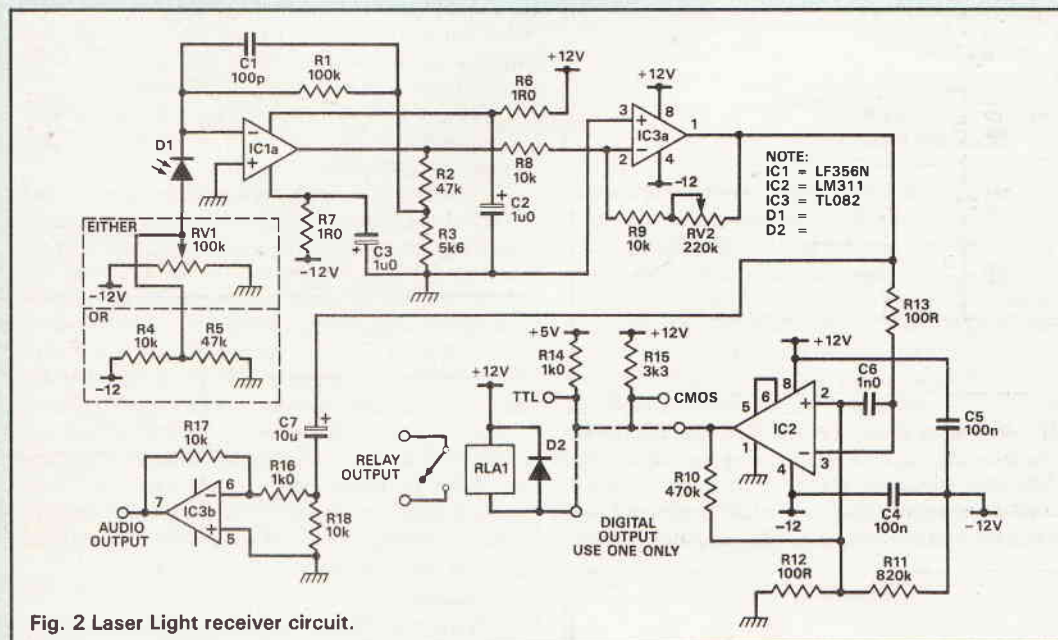

Fig. 2 Laser Light receiver circuit.

too usually under 200ns (the one I have specified though lumbers along like a 12 year old labrador, having a pitiful rise time of $3.5\mu\text{s}$, however this is good enough for our purposes).

As I just mentioned there are two circuits, the first is lifted in its entirety from a Hewlett Packard Application Note (Number 915) and there will be no circuit board for this circuit, it does claim a bandwidth up into the MHz range so it may be useful if you want to continue your experimentation beyond the laser, for example into light pens or very high speed secure signalling. It will work at +5V, single rail which is an advantage, plus it only requires one chip, (I bet you thought they were separate transistors!). If you do use

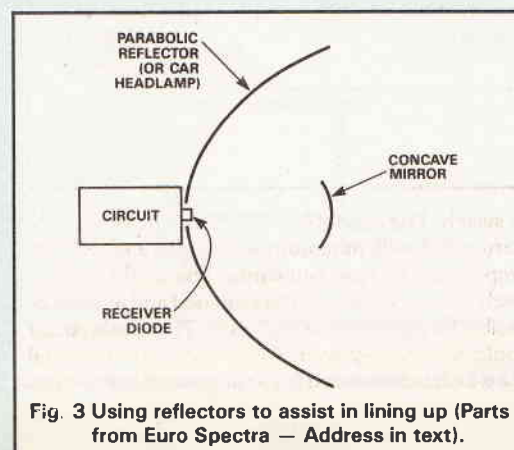

Fig. 3 Using reflectors to assist in lining up (Parts from Euro Spectra — Address in text).

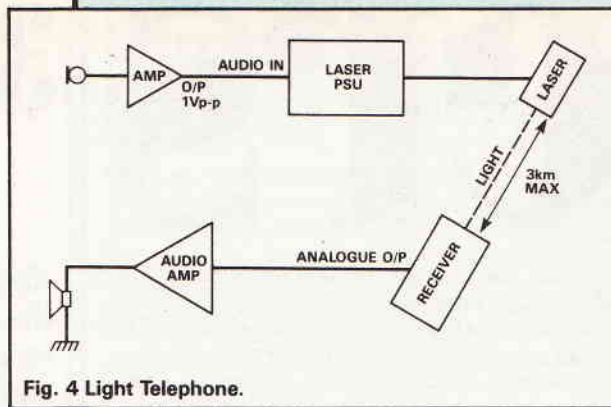

Fig. 4 Light Telephone.

Again the heart of the unit is the photodiode, I have specified the BPW21 as its peak spectral response is at 560nm, with a range from 460-750nm while the laser main output is 630nm, so they are reasonably well matched. Other photodiodes have a closer match but are harder to get hold of (for example the Centronic OSD15-5T which may be used in its place if found).

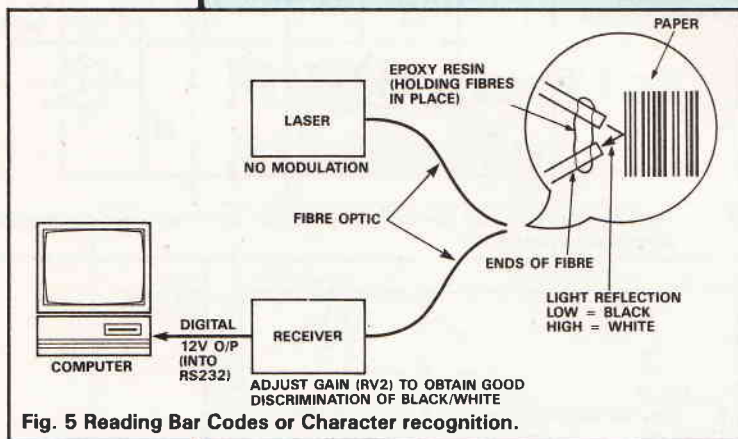

Fig. 5 Reading Bar Codes or Character recognition.

The photodiode requires a negative DC offset which is provided via RV1, this will be in the order of -10V or so and may be set to -10V by replacing RV1 with a 10k resistor and 47k resistor for which provision has been made on the board, having an adjustment is very useful when you are trying to squeeze that extra ounce of output.

The input amplifier is a very low noise op-amp with a JFET input stage. It has a fairly good slow rate with a low input noise current. National, the manufacturer, recommends it for opto amplifiers so it would be churlish not to use it.

The gain of the stage is around 10 and roll off is set below 20kHz to stop instability and improve the

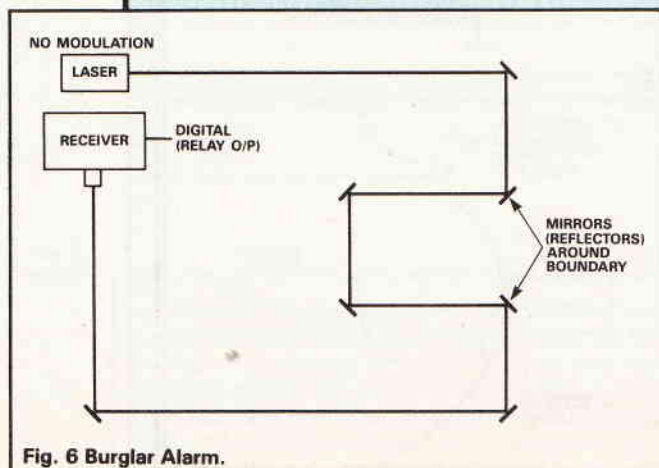

Fig. 6 Burglar Alarm.

HF rejection (we shouldn't be using over 20kHz at any time!). The diodes provide a current output so that must be converted into a voltage so we can all understand it (who's into Norton equivalents anyway, Viva Thevenin!), so that is the job of R1. Note the use of 1R resistors and decoupling capacitors to stop noise (especially from the laser, if used on the same supply) getting coupled back. This is essentially the 'classic' optodiode circuit, ie high input impedance with fairly low output impedance, capable of driving a capacitive load if necessary.

There is one drawback (this is physics after all). This circuit is responsive to sunlight (with this particular photodiode, as it is said to have an 'eye' response ie a response the same as the human eye!) so it must be used with caution as the sun may be stronger than the laser beam at a distance.

The next stage is fairly straightforward, it is a standard op amp with a gain control. This is so the gain of the system can be adjusted to suit the application (more of this later).

The last stage is configured as a comparator to convert the input to a switched output. This is so the circuit can be used in a digital system, such as an alarm or data link. The mass of components around this IC is to stop it bursting into oscillation. In normal operation with input voltages at fairly high levels relative to each other, the device behaves itself. At low levels it becomes about as stable as a central American Government, so we need to bump up the positive feedback (a sort of positive behavioural reinforcement, for all you social workers and child psychologists out there).

This is achieved by R10, 11, 12 with C6 used to reduce the errors caused by instability in the laser.

Note the use of decoupling capacitors C5 and C6 which should be as close as possible to the chip, they may be left off and put on if the circuit becomes susceptible to power supply interference.

The audio/analogue output is a simple amplifier, AC coupled so that only the modulation will get through (hopefully!).

This circuit is not perfect, to be really effective it should have auto biasing and should be better at resolving the variations in amplitude caused by the laser modulation, remember that the laser is kept on all the time and is effectively amplitude modulated. It would also effectively filter out the 70kHz that the laser gets from its power supply, though in truth that should present few problems. What it is though is very simple and the ideal basis for further experimentation, it was designed so that it could be built in schools and colleges by staff or students with limited budgets and of course by home constructors who don't have unlimited amounts of cash to throw around and who want something cheap and effective that can be built on to as the confidence and funds permit.

Construction

This should provide no surprises, try to keep the lead length between the photodiodes and the op-amp as short as possible or you may be plagued by noise or instability. If extra gain is required two or more of the opto diodes may be put in parallel, this may be useful on remote applications. Again the case is left up to you but it may be a good idea to put the diode into a blackened tube to cut down on the reaction from incident lighting. You could try optimising the receiver for remote use by using a couple of reflectors (Figure 3), like a satellite dish, this may be easier to line up in the case of light telephones.

Note, the relay marked on the diagram is not mounted on the board, this is to give you some flexibility on what relay you want to use, it can be used

with a 12V relay coil of >300R so you have plenty of scope.

Applications/Ideas

The idea of this section is to stimulate your imagination, into the possible uses of the laser technology for the experimenter. They are not intended as hard and fast ways of doing things, they may require a lot of modifications to work how you want, they may not even work at all. If the circuit is to be used in schools it may be wise to diffuse the beam so that the possibility of accidents caused by staring into the beam are minimised. This is a Class 1 laser, which means that it is the safest but it must, like mains electricity, be treated with respect. The main rule is don't look at a laser, or a reflection of the beam, directly in the eye.

Light Telephone

Connect the laser up with a modulation input of about 1V peak to peak, which can be obtained from the output of virtually any audio pre-amplifier or mixer (Figure 4). Ensure that the oscillator circuit is not over modulated by adjusting both the modulating input and RV1 (over modulating will cause the oscillator to cease and so the laser will go off).

The laser must be pointed at the receiver, which should be some distance away or have the laser beam diffused to stop swamping the photodiode. It may be a good idea to place a red filter in front of the receiver to cut out interference from room lighting.

This circuit may also be used with some form of simple modem to form the basis of a secure data communications link.

The beam may be sent down fibre optics, though it will require a bit of ingenuity to couple it. It may even be received by the standard fibre optic receiver which is usually peaked around 650nm, so a form of secure broadcast could be arranged whereby the laser could feed many receivers located at different points. This may be used for a secure public address system for example.

Character or Bar Code Recognition

This again could use fibre optics where one laser could feed multiple fibres which are each optically coupled, again via fibres back to receivers. These could be used to scan bar-codes (only one receiver needed) or documents/images to obtain a computer input for a propriety painting/drawing/desk top publishing package. This may be implemented by attaching the fibres to the top of the print head on an Epson compatible printer and using the Epson commands to scan the document which will be fed through like normal paper as the printhead/fibre-optic bundle

PARTS LIST

RESISTORS (all 1/4W 5%)

R1	100k
R2,5	47k
R3	5k6
R4,8,9,17,18	10k
R6,7	1R0
R10	470k
R11	820k
R12,13	100R
R14,16	1k
R15	3k3
RV1	100k
RV2	220k

CAPACITORS

scans across. It may even be possible to recognise the actual words using software such as image in, but again these are just ideas how you do it, is up to you.

Laser Rangefinding

Bit trickier this one, the basis of it is that the laser is modulated with a fixed frequency and when the beam reflects from the object as directed, it will come back phase shifted. The amount of phase shift is dependant on the distance and you then need to use a phase locked loop to resolve the difference into a quantifiable amount which may be metered.

This is essentially how these secret microphones work, the spies use to monitor a conversation inside a closed room. The conversation causes the glass to vibrate which causes a minute phase shift in the receiver, and then resolved into speech. This is a little outside the scope of what we are doing here though. Of course if GCHQ was to make me an offer

Burglar Alarm

There had to be one really, it appears that every piece of electronic equipment has an application in the home security market. It appears we spend half of our money on electronic goodies and the other half on sophisticated electronic alarms to stop it being stolen. So I will be no exception.

Actually this is a cut above the rest as it not only protects your home, but your garden, car, shed in fact anything within the boundaries of your property.

All it consists of is the laser shining through a hole in the wall of your shed/house/garage and hitting mirrors placed around the boundaries of your property, the resultant reflected beam is returned to the receiver.

If the mirrors are tilted right then the beam can be made to go all around the property (except if you happen to be the Duke of Westminster), then back again, so the receiver can be mounted adjacent to the laser. The mirrors can be the reflectors used on the back of cars or bicycles, as they are not so critical to line up.

Ensure that the beam is high enough so your dog doesn't set it off. When it's a misty morning, you can see the beam, so if you use multiple mirrors you can

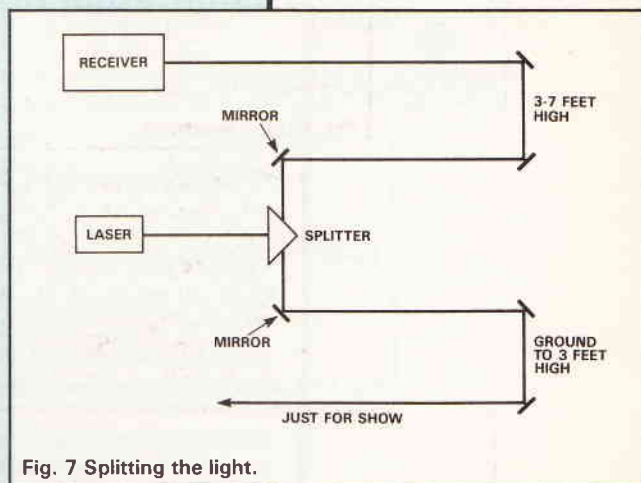

Fig. 7 Splitting the light.

C1	100p
C2,3	1μ0
C4,5	100n
C6	1n
C7	10μ

SEMICONDUCTORS

IC1	LF356N
IC2	LM311
IC3	TC082
D1	BPW21
D2	1N4001

MISCELLANEOUS

RLA1	Relay to suit needs
------	---------------------

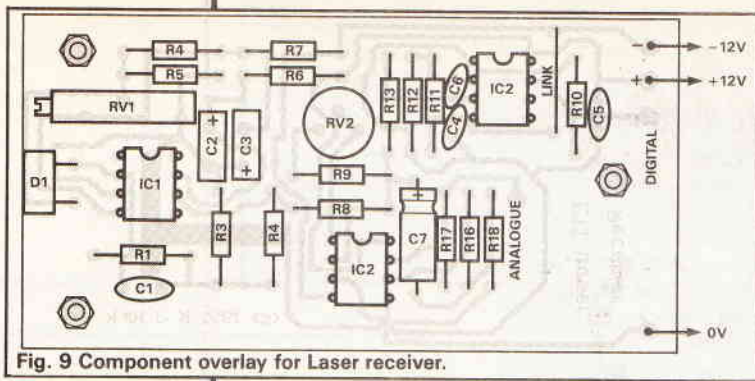

Fig. 9 Component overlay for Laser receiver.



Fig. 8 Fibre-optic woven through fence. CHAIN LINK FENCE

have a network of beams, about 6 inches apart which can be seen. I suggest using a beam splitter, to get beams down to the ground, in this case. The lower 3 foot or so won't work, the upper bit does though. This will act as a deterrent, like the principle of the red laser spot above the heart does to the bad guy. You could also put up a huge great sign saying 'DANGER LASER' or better yet 'DANGER UNLEASHED LASER' which has more of a scientific ring to it than 'beware of the dog', anyway you can

always tame a dog (like I'll show you in a later article) with an ultrasound dog tamer.

On the subject of Lasers I have been accused, especially by the clever people I work with, of treating a complex subject in a superficial way. It's true I'm guilty. They seem to forget that ETI is a hobby magazine (although they buy it, maybe they don't know everything) and part of the pleasure of electronics is experimentation. (We like to appeal to all types you know — Ed).

These articles are really a basis for just such experimentation, they are to stimulate the mind into exploring uses of lasers. The basic circuits can be modified to provide different applications, and better receivers, mains supplies and the like. (ETI has published articles like this in the past).

A range of Lenses and mirrors can be obtained from Euro Spectra Limited, PO Box 60, Crowborough, East Sussex TN6 2YX. Telephone 0892 667700 (Fax 0892 665117).

Errata

Regarding last month's article, it was found that on some supplies with tubes, the combinational component-spreads was too much (so much for theoretical design). This resulted in the power supply getting a bit too 'soggy' to strike the tube.

- The following will rectify the problem:
- 1) Replace the 10k resistor with a 22k or 27k resistor (25k is around the optimum but they don't make one), or even a 33k trimmer plot. This trims the oscillator to the natural frequency of the core and load.
 - 2) Reduce the turns ratio of the transformer primary to 2 or 3 turns, while increasing the wire core area (use 3 or 4 strands together).

★ ★ **8031** ★ ★
LOW COST DEVELOPMENT & TARGET SYSTEM

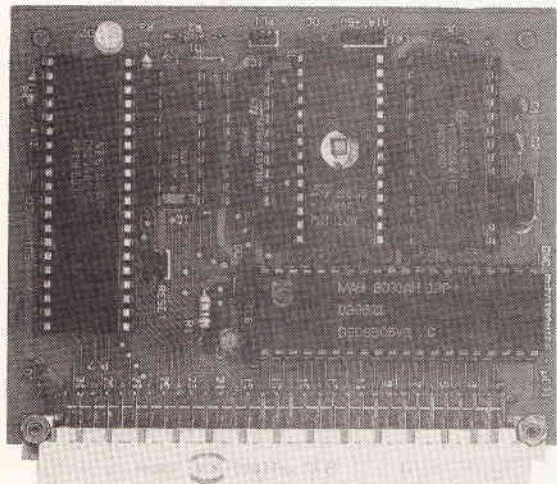

★ ★ **£99.95** ★ ★ + £5.00 Carriage + VAT
Includes 32k RAM, 8K EPROM, 38 I/D Lines,
IBM PC/XT/AT Hosted SB51 Cross Assembler,
Manual and Full Technical Support.

8031 Module only £59.95. 80188 & 64180 modules available

GNC ELECTRONICS
Units 2B-2C Gilray Road
Diss, Norfolk IP22 3EU
TEL: 0379 644285



HALCYON ELECTRONICS

Computers, test equipment, video monitors, amateur radio gear, oscilloscopes, scientific instruments, connectors, printers, power supplies, communications, disk drives, multimeters, component bridges, frequency counters, signal generators, semi-conductors, integrated circuits, etc.

SPECIAL OFFERS
FARNELL E350 VARIABLE STABILISED PSU S C-350V 100MA V A METERS 6.3V 2A C.T. 0-2.5-5-6.3V 3A £49
LINSTEAD M28 MILLIVOLT METERS BATT. OF RANGES 1.2MV-400V AC 120MV-400V DC £19
NICAD BUTTON CELLS 100MAH. 6V FLAT PACK STACKS. EX NEW EQUIPT. £2 STACK. 10 FOR £16

FLUKE 931B RMS DIFFERENTIAL V METER	POA SARTORIUS 2432 ANALYTICAL BALANCE 200G	POA
FLUKE 6160A FREQ SYNTH 1HZ-30MHZ	POA PYE UNICAM SP1800 UV SPECTROPHOTOMETER	POA
FLUKE 7220A F COUNTER 9 DIGIT 1.3GHZ	POA SULLIVAN & G STD DEC AIR CAP 0-1100PF	£495
WESTON STANDARD TWIN CELL TINSLEY	£75 HP 3406A SAMPLING BROADBAND V METER	POA
MICROVITECH L.FST MONS RGB ANAL COMPO SND	£149 RÖHDE & SCHWARZ DPU ATTENUATORS	POA
REDPOINT 65-1 HEATSINKS 1.5" C/W BRAND NEW	£1.50 NEOTRONICS OTOX91 OXYGEN ANAL PRTABLE	POA
BBC-B COMPUTERS	£139 & £179 (DOS) LYONS W3716 16MHZ WORD GENERATOR	£245
NELSON ROSS SPECTRUM ANALYSER 0-20KHZ	£295 MICROWA ANALYTICAL BALANCE	£69
CT491 CABLE TEST SET. 700YDS. CRT DISPLAY	£59 H.P. 5004A SIGNATURE ANALYSER	£95
TEXSCAN 9650 TRACKING SWEEP ANALYSER	£695 EPSON PX4 & TF15D TWIN FLOPPY	£175
RACAL DANA 9341 DIGITAL LCR BRIDGE	£295 WAVETEK 2001 SWEEP SIG GEN TO 1.4GHZ	£1500
AVO CZ 457.5 COMPONENT COMPARATOR	£75 1N4004 6000 OFF (THOMSON-CSE)	£125
MARCONI TF230C FM AM MODULATION METER	£195 B&T LAB OVENS 12x13x14 INTERNAL 210°C	£195
TEKTRONIX 535A 545B, 585 SCOPES FROM	£65 MARCH DPL300S ELECTRONIC LOAD 60A 40V	£175
WANDEL & GOLTERMAN TFPM-43 & TFP5-42 EA	£55 PASCALL BALL MILL VARIABLE SPEED	£95
OLIVETTI 32MB EXT H/DRIVE HDU2432	£149 TEKTRONIX 4662 PLOTTERS GPIB & RS232	£179
ULTRASONIC CLEANING BATH. 5 LITRE	£195 OTHER PLOTTERS From	£95
UV 200W SHUTTER OP. TIMER 240V	£89 HP COMPUTER 9825B 15263A 98032A OPT. 066	£195
B&K 1019 AUTO VIB EXCITER CONT-HEAD	£85 MICROWAVE BY H.P. KELTEC VARIAN ETC.	POA
T-SWITCHES INMAC 1863 RS232 2-WAY	£40 HITACHI CM2073A/301 20" RGB 64kHz CAD DTP	£495
LEAKSEEKER 46 PORTABLE GAS DETECTOR	£95 TECMAR Q1C-60H TAPE STREAMER	£95
TEKTRONIX 834 PROG DATACOMMS TESTER	£495 LEADER LCG 396 NTSC PATT. GENERATOR	£395
AVO 8'S Mk2. 5 & 6 From	£55 CONRAC 7211 HI-RES RGB MONITOR	£395
VARIABLE OUTPUT PSU's From	£35 OSCILLOSCOPES DUAL TRACE From	£75
TEKTRONIX 520 PAL OR NTSC VECTORSCOPE	£475 12" GREEN SCREEN MONITORS From	£39
METROMM 9A 250V MEGGERS	£79 LEADER LBO-9C ALIGNMENT SCOPE	£249
OTHER MEGGERS MEGGER BRIDGES From	£15 SIGNAL GENERATORS. AF TO 12.56GHz From	£20

SEND FOR LIST £1, REFUNDED ON PURCHASE. BUT 1000's OF UNLISTED BARGAINS FOR CALLERS
QUALITY ELECTRONIC EQUIPMENT BOUGHT. ALL PRICE EXC. OF P&P AND VAT

423, KINGSTON ROAD, LONDON SW20 8JR
SHOP HOURS 9-5.30 MON-SAT. TEL 081-542 6383

Reader Survey

It's survey time again and your chance to win one of 50 prizes supplied by Maplin Electronics and ETI.

It's been three years since our last survey and so it is time to update our information. Although some of the questions here may not seem to relate directly to the magazine, please complete the whole questionnaire. Your answers not only help us to steer the editorial content of the magazine in the direction you want but they also help us to build up an overall profile of readers to present to advertisers who require

such data to select suitable magazines for their products.

No names and addresses will be disclosed to any third party and all information will be treated in the strictest confidence.

As an incentive for your hard work, all entries received by 10th June will be entered in the draw for the 50 prizes given by Maplin Electronics and ETI.

1. If you could make one improvement to ETI, what would it be!

2. Please indicate what you think of the following aspects of ETI's coverage:

	Poor	Average	Good	Excellent
Product News	<input type="checkbox"/> 001	<input type="checkbox"/> 002	<input type="checkbox"/> 003	<input type="checkbox"/> 004
Industry/Tech- nology News	<input type="checkbox"/> 005	<input type="checkbox"/> 006	<input type="checkbox"/> 007	<input type="checkbox"/> 008
Advanced Projects	<input type="checkbox"/> 009	<input type="checkbox"/> 010	<input type="checkbox"/> 011	<input type="checkbox"/> 012
Basic Projects	<input type="checkbox"/> 013	<input type="checkbox"/> 014	<input type="checkbox"/> 015	<input type="checkbox"/> 016
General Features	<input type="checkbox"/> 017	<input type="checkbox"/> 018	<input type="checkbox"/> 019	<input type="checkbox"/> 020
Tutorial Features	<input type="checkbox"/> 021	<input type="checkbox"/> 022	<input type="checkbox"/> 023	<input type="checkbox"/> 024
Product Reviews	<input type="checkbox"/> 025	<input type="checkbox"/> 026	<input type="checkbox"/> 027	<input type="checkbox"/> 028

3. Would you like to see a greater or lesser proportion of ETI devoted to the following:

	Less	The same	More
Beginners' Projects	<input type="checkbox"/> 029	<input type="checkbox"/> 030	<input type="checkbox"/> 031
Advanced Projects	<input type="checkbox"/> 032	<input type="checkbox"/> 033	<input type="checkbox"/> 034
Short Projects	<input type="checkbox"/> 035	<input type="checkbox"/> 036	<input type="checkbox"/> 037
Long Projects	<input type="checkbox"/> 038	<input type="checkbox"/> 039	<input type="checkbox"/> 040
Computer Projects	<input type="checkbox"/> 041	<input type="checkbox"/> 042	<input type="checkbox"/> 043
Audio Projects	<input type="checkbox"/> 044	<input type="checkbox"/> 045	<input type="checkbox"/> 046
Music Projects	<input type="checkbox"/> 047	<input type="checkbox"/> 048	<input type="checkbox"/> 049
Radio Projects	<input type="checkbox"/> 050	<input type="checkbox"/> 051	<input type="checkbox"/> 052
Home Improvement Projects	<input type="checkbox"/> 053	<input type="checkbox"/> 054	<input type="checkbox"/> 055
Bio-electronics/Health Projects	<input type="checkbox"/> 056	<input type="checkbox"/> 057	<input type="checkbox"/> 058
Test Equipment Projects	<input type="checkbox"/> 059	<input type="checkbox"/> 060	<input type="checkbox"/> 061
Security/Alarm Projects	<input type="checkbox"/> 062	<input type="checkbox"/> 063	<input type="checkbox"/> 064
Car Electronics Projects	<input type="checkbox"/> 065	<input type="checkbox"/> 066	<input type="checkbox"/> 067
Robotics Projects	<input type="checkbox"/> 068	<input type="checkbox"/> 069	<input type="checkbox"/> 070
Photographics	<input type="checkbox"/> 071	<input type="checkbox"/> 072	<input type="checkbox"/> 073
Novelty/Gimmick Projects	<input type="checkbox"/> 074	<input type="checkbox"/> 075	<input type="checkbox"/> 076
Basic Elementary Theory	<input type="checkbox"/> 077	<input type="checkbox"/> 078	<input type="checkbox"/> 079
Advanced Electronic Theory	<input type="checkbox"/> 080	<input type="checkbox"/> 081	<input type="checkbox"/> 082
General Science/Technology	<input type="checkbox"/> 083	<input type="checkbox"/> 084	<input type="checkbox"/> 085
News	<input type="checkbox"/> 086	<input type="checkbox"/> 087	<input type="checkbox"/> 088
Product Reviews	<input type="checkbox"/> 089	<input type="checkbox"/> 090	<input type="checkbox"/> 091
Letters	<input type="checkbox"/> 092	<input type="checkbox"/> 092	<input type="checkbox"/> 094
Open Channel/etc	<input type="checkbox"/> 095	<input type="checkbox"/> 096	<input type="checkbox"/> 097
Design/Circuit Ideas	<input type="checkbox"/> 098	<input type="checkbox"/> 099	<input type="checkbox"/> 100
Competitions	<input type="checkbox"/> 101	<input type="checkbox"/> 102	<input type="checkbox"/> 103
Others (please specify)	<input type="checkbox"/> 104	<input type="checkbox"/> 105	<input type="checkbox"/> 106

4. Indicate which of the following equipment you use:

	Own	Don't own but regularly use
Home micro	<input type="checkbox"/> 107	<input type="checkbox"/> 108
Professional Micro	<input type="checkbox"/> 109	<input type="checkbox"/> 110
Hi-fi	<input type="checkbox"/> 111	<input type="checkbox"/> 112
Electronic Musical Instrument	<input type="checkbox"/> 113	<input type="checkbox"/> 114
MIDI Equipment	<input type="checkbox"/> 115	<input type="checkbox"/> 116
PA/Recording equipment	<input type="checkbox"/> 117	<input type="checkbox"/> 118
Photographic/Darkroom Equipment	<input type="checkbox"/> 119	<input type="checkbox"/> 120
Ham Radio/CB	<input type="checkbox"/> 121	<input type="checkbox"/> 122
Satellite TV	<input type="checkbox"/> 123	<input type="checkbox"/> 124
Video Camera	<input type="checkbox"/> 125	<input type="checkbox"/> 126
Security/Alarm System	<input type="checkbox"/> 127	<input type="checkbox"/> 128
Oscilloscope	<input type="checkbox"/> 129	<input type="checkbox"/> 130
Multimeter	<input type="checkbox"/> 131	<input type="checkbox"/> 132
Other test gear	<input type="checkbox"/> 133	<input type="checkbox"/> 134

5. Do you read any of the following magazines:

	Never	Occasionally	Regularly
Practical Electronics	<input type="checkbox"/> 135	<input type="checkbox"/> 136	<input type="checkbox"/> 137
Everyday Electronics	<input type="checkbox"/> 138	<input type="checkbox"/> 139	<input type="checkbox"/> 140
Elektor Electronics	<input type="checkbox"/> 141	<input type="checkbox"/> 142	<input type="checkbox"/> 143
Maplin Magazines	<input type="checkbox"/> 144	<input type="checkbox"/> 145	<input type="checkbox"/> 146
Electronics & Wireless World	<input type="checkbox"/> 147	<input type="checkbox"/> 148	<input type="checkbox"/> 149
Music Technology	<input type="checkbox"/> 150	<input type="checkbox"/> 151	<input type="checkbox"/> 152
Home & Studio Recording	<input type="checkbox"/> 153	<input type="checkbox"/> 156	<input type="checkbox"/> 157
Hi-fi News & Record Review	<input type="checkbox"/> 158	<input type="checkbox"/> 159	<input type="checkbox"/> 160
New Scientist	<input type="checkbox"/> 161	<input type="checkbox"/> 162	<input type="checkbox"/> 163
Scientific American	<input type="checkbox"/> 164	<input type="checkbox"/> 165	<input type="checkbox"/> 166
Practical Wireless	<input type="checkbox"/> 167	<input type="checkbox"/> 168	<input type="checkbox"/> 169
Ham Radio Today	<input type="checkbox"/> 170	<input type="checkbox"/> 171	<input type="checkbox"/> 172
Electronics Product News/ Electronics Equipment News/New Electronics/ Electronic Product Review	<input type="checkbox"/> 173	<input type="checkbox"/> 174	<input type="checkbox"/> 175

6. If read, please indicate what you think of the following magazines.

	Not as good as ETI	As good as ETI	Better than ETI
Practical Electronics	<input type="checkbox"/> 176	<input type="checkbox"/> 177	<input type="checkbox"/> 178
Elektor Electronics	<input type="checkbox"/> 179	<input type="checkbox"/> 180	<input type="checkbox"/> 181
Everyday Electronics	<input type="checkbox"/> 182	<input type="checkbox"/> 183	<input type="checkbox"/> 184
Maplin Magazine	<input type="checkbox"/> 185	<input type="checkbox"/> 186	<input type="checkbox"/> 187

7. Which of the following do you buy and how frequently?

	Never ²²²	Sometimes	Regularly
Electronic Components	<input type="checkbox"/> 189	<input type="checkbox"/> 190	<input type="checkbox"/> 191
Complete Electronic Kits	<input type="checkbox"/> 192	<input type="checkbox"/> 193	<input type="checkbox"/> 194
ETI PCBs	<input type="checkbox"/> 195	<input type="checkbox"/> 196	<input type="checkbox"/> 197
Stripboard/Wirewrap Etc	<input type="checkbox"/> 198	<input type="checkbox"/> 199	<input type="checkbox"/> 200
Cases/Case Materials	<input type="checkbox"/> 201	<input type="checkbox"/> 202	<input type="checkbox"/> 203
Tools	<input type="checkbox"/> 204	<input type="checkbox"/> 205	<input type="checkbox"/> 206
PCB making Equipment/Materials	<input type="checkbox"/> 207	<input type="checkbox"/> 208	<input type="checkbox"/> 209
Pre-programmed ROMs	<input type="checkbox"/> 210	<input type="checkbox"/> 211	<input type="checkbox"/> 212
Computer Software	<input type="checkbox"/> 213	<input type="checkbox"/> 214	<input type="checkbox"/> 215
Floppy Disks	<input type="checkbox"/> 217	<input type="checkbox"/> 218	<input type="checkbox"/> 219
Electronic Books	<input type="checkbox"/> 220	<input type="checkbox"/> 221	<input type="checkbox"/> 222
Data Books	<input type="checkbox"/> 223	<input type="checkbox"/> 224	<input type="checkbox"/> 225
Second Hand Equipment	<input type="checkbox"/> 226	<input type="checkbox"/> 227	<input type="checkbox"/> 228

8. Please indicate what you think of the services offered:

	Poor	Average	Good	Not used
PCB Service	<input type="checkbox"/> 229	<input type="checkbox"/> 230	<input type="checkbox"/> 231	<input type="checkbox"/> 232
Photocopy Service	<input type="checkbox"/> 233	<input type="checkbox"/> 234	<input type="checkbox"/> 235	<input type="checkbox"/> 236
Foil Patterns	<input type="checkbox"/> 237	<input type="checkbox"/> 238	<input type="checkbox"/> 239	<input type="checkbox"/> 240
Buylines	<input type="checkbox"/> 241	<input type="checkbox"/> 242	<input type="checkbox"/> 243	<input type="checkbox"/> 244
Subscriptions	<input type="checkbox"/> 245	<input type="checkbox"/> 246	<input type="checkbox"/> 247	<input type="checkbox"/> 248
Back numbers	<input type="checkbox"/> 249	<input type="checkbox"/> 250	<input type="checkbox"/> 251	<input type="checkbox"/> 252

9. Do you watch any of the following TV programmes:

Tomorrows World	<input type="checkbox"/> 253
QED	<input type="checkbox"/> 254
Equinox	<input type="checkbox"/> 255
Horizon	<input type="checkbox"/> 256

10. If you own or regularly used a computer, please indicate which it is:

Spectrum	<input type="checkbox"/> 257
BBC Micro/Master/Electron	<input type="checkbox"/> 258
Commodore 64/128	<input type="checkbox"/> 259
Amstrad CPC	<input type="checkbox"/> 260
Amstrad PCW	<input type="checkbox"/> 261
IBM PC Compatible	<input type="checkbox"/> 262
Atari ST	<input type="checkbox"/> 263
Amiga	<input type="checkbox"/> 264
Archimedes	<input type="checkbox"/> 265
Cortex	<input type="checkbox"/> 266

Other (please specify) 267

11. How many ETI projects have you built in the past 12 months?

None	<input type="checkbox"/> 268
1-3	<input type="checkbox"/> 269
4-6	<input type="checkbox"/> 270
7-12	<input type="checkbox"/> 271
More than 12	<input type="checkbox"/> 272

12. Do you find ETI projects:

	Yes	No
Reliable	<input type="checkbox"/> 273	<input type="checkbox"/> 274
Easy to build	<input type="checkbox"/> 275	<input type="checkbox"/> 276
Useful	<input type="checkbox"/> 277	<input type="checkbox"/> 278
Instructive	<input type="checkbox"/> 279	<input type="checkbox"/> 280
Technically understandable	<input type="checkbox"/> 281	<input type="checkbox"/> 282
Work first time	<input type="checkbox"/> 283	<input type="checkbox"/> 284

13. Do you modify ETI project designs?

Not At All	<input type="checkbox"/> 285
A Few Mods	<input type="checkbox"/> 286
Many Mods	<input type="checkbox"/> 287

14. Do you prefer to build ETI projects from complete kits when they are available?

Yes	<input type="checkbox"/> 288
No	<input type="checkbox"/> 289

15. Do you make your own PCBs?

Never	<input type="checkbox"/> 290
Sometimes	<input type="checkbox"/> 291
Always	<input type="checkbox"/> 292

16. Do you primarily build electronics projects

To save money on commercial goods	<input type="checkbox"/> 293
As a satisfying passtime	<input type="checkbox"/> 294
As an instructional exercise	<input type="checkbox"/> 296

17. As far as electronics design and construction is concerned, do you consider yourself:

Novice	<input type="checkbox"/> 297
Proficient	<input type="checkbox"/> 298
Accomplished	<input type="checkbox"/> 299
Expert	<input type="checkbox"/> 300

18. Estimate the value of your electronics test gear and construction equipment as new:

Under £25	<input type="checkbox"/> 301
£25-£100	<input type="checkbox"/> 302
£101-£200	<input type="checkbox"/> 303
£201-£500	<input type="checkbox"/> 304
£501-1000	<input type="checkbox"/> 305
£1001-2000	<input type="checkbox"/> 306
£2001-4000	<input type="checkbox"/> 307
over £4000	<input type="checkbox"/> 308

19. How much do you estimate have spent on equipment and components during the past 12 months?

Nothing	<input type="checkbox"/> 309
under £25	<input type="checkbox"/> 310
£25-£50	<input type="checkbox"/> 311
£51-£100	<input type="checkbox"/> 312
£101-£200	<input type="checkbox"/> 313
£201-£500	<input type="checkbox"/> 314
£501-£1000	<input type="checkbox"/> 315
over £1000	<input type="checkbox"/> 316

20. Are you responsible for recommending/ specifying electronic equipment in your job?

Yes	<input type="checkbox"/> 317
No	<input type="checkbox"/> 318

21. How long do you keep your copies of ETI for:

Less than one month	<input type="checkbox"/> 319
One month	<input type="checkbox"/> 320
Three months	<input type="checkbox"/> 321
Six months	<input type="checkbox"/> 322
A year or more	<input type="checkbox"/> 323

22. If kept, how often do you refer back to issues of ETI?

Once a week or more	<input type="checkbox"/> 324
About once a month	<input type="checkbox"/> 325
Once every three months	<input type="checkbox"/> 326
Less often	<input type="checkbox"/> 327
Never	<input type="checkbox"/> 328

23. How long do you spend reading you copy of ETI?

Over 2 hours	<input type="checkbox"/> 329
1½-2 hours	<input type="checkbox"/> 330
1-1½ hours	<input type="checkbox"/> 331
½-1 hour	<input type="checkbox"/> 332
Less than ½ hour	<input type="checkbox"/> 333

24. How long have you been an ETI reader?

- Less than three months
- 3-6 months
- 7-12 months
- 1-2 years
- 2-5 years
- Over 5 years

- 334
- 335
- 336
- 337
- 338
- 339

25. How often do you buy ETI?

- Occasional issues
- Most issues
- Every issue

- 340
- 341
- 342

26. How much of ETI do you read?

- Read only some articles
- Read most articles
- Read all articles

- 343
- 344
- 345

27. With regard to the advertisers in ETI, do you?

- Read or look through most or nearly all the ads
- Read or look through some of the ads
- Just read or look through the occasional ad
- Very rarely/never look at the ads

- 346
- 347
- 348
- 349

28. Thinking specifically about the advertising content, would you please rate the two main types of advertisement:

Display Classifieds

- Very useful
- Useful
- Quite useful
- Not very useful
- Not at all useful

- 350 351
- 352 353
- 354 355
- 356 357
- 358 359

29. Which of the following would you most like to see featured with the magazine? (one box only).

- Cover mounted gifts
- Additional supplements
- Competitions
- Money saving offers
- Other (please specify)

- 360
- 361
- 362
- 363
- 364

30. Does anyone else read your copy of ETI?

- No, only myself
- One or two other people
- Three or four other people
- More than four other people

- 365
- 366
- 367
- 368

31. If your copy of ETI is read by other people, please give details of their age and sex:

Person 1 Person 2 Person 3 Person 4

Age:

- 9-14 yrs
- 15-24 yrs
- 25-34 yrs
- 35-44 yrs
- 45-54 yrs
- 55-64 yrs
- Over 64 yrs

- 369 370 371 372
- 373 374 375 376
- 377 378 379 380
- 381 382 383 384
- 385 386 387 388 389 390
- 391 392 393 394

Sex:

- Male
- Female

- 395 396 397 398
- 399 400 401 402

32. Are you aware of the scheduled publication date of ETI?

Yes 405

No 406

33. If the answer to the last question is YES, do you normally attempt to purchase the magazine on that day?

Yes 407

No 408

34. How do you normally obtain your copy?

- Chance purchase
- Newsagent shop collection
- Newagent home delivery
- Subscription
- Passed on copy

- 409
- 410
- 411
- 412
- 413

35. If you are a subscriber, on which date did you receive this issue?

/ /

36. If you are a subscriber, how long have you subscribed to this magazine?

- 1-6 months 414
- 7-12 months 415
- 1-2 years 416
- 3-5 years 417
- 6-10 years 418
- Over 10 years 419

37. If you do not obtain your copy by subscription, is it due to one of the following:

- Subscription too expensive 420
- Not every issue required 421
- Not aware subscription service available 422

38. Are you aware that to subscribe to this magazine in the UK costs the same as purchasing it in a shop?

Yes 423

No 424

39. Would you like to receive further details on taking a subscription?

Yes 425

No 426

40. If you do not subscribe, from which type of newsagent do you most often obtain your copy?

- High Street Shop 427
- Estate shop 428
- Corner shop 429
- Travel point 430

Other (please specify) 431

41. Please tick the box which represents the annual total of your gross income:

- Under £6,500 432
- £6,501-£8,000 433
- £8,001-£10,000 434
- £10,001-£12,500 435
- £12,501-£15,000 436
- £15,001-£19,000 437
- £19,001-£25,000 438
- Over £25,000 439

42. What is your age?

- Under 15 yrs 440
- 15-18 yrs 441
- 19-21 yrs 442
- 22-24 yrs 443
- 25-34 yrs 444
- 35-44 yrs 445
- 45-54 yrs 446
- 55-64 yrs 447
- Over 64 yrs 448

43. Which of the following newspapers do you read?

- The Times 449
- The Daily Telegraph 450
- The Financial Times 451
- The Guardian 452
- The Independent 453
- The Daily Express 454
- The Daily Mail 455
- The Daily Mirror 456
- The Sun 457
- Today 458
- None of the above 459

44. Which of the following Sunday newspapers do you read?
- The Sunday Times 460
 - The Observer 461
 - The Sunday Telegraph 462
 - The Sunday Express 463
 - The Mail on Sunday 464
 - The Sunday Mirror 465
 - The People 466
 - The News of The World 467
 - News on Sunday 468
 - None of the above 469

45. What is your marital status?
- Married 470
 - Single 471
 - Divorced 472

46. Sex:
- Male 473
 - Female 474

47. Are you a member of a book club?
- Yes 475
 - No 476

48. Are you a member of a record club?
- Yes 477
 - No 478

49. Are you:
- In full time employment 479
 - In part time employment 480
 - Not employed at present 481
 - Retired 482
 - Student - full-time 483
 - Student - part-time 484

50. If in full-time employment, please state your occupation:

.....

51. If a student what subjects do you study?

.....

.....

52. If you have children, please indicate their age and sex (give details of the four youngest if you have more than four)
- | Age: | First | Second | Third | Fourth |
|-------------|------------------------------|------------------------------|------------------------------|------------------------------|
| 1-3 yrs | <input type="checkbox"/> 485 | <input type="checkbox"/> 486 | <input type="checkbox"/> 487 | <input type="checkbox"/> 488 |
| 4-8 yrs | <input type="checkbox"/> 489 | <input type="checkbox"/> 490 | <input type="checkbox"/> 491 | <input type="checkbox"/> 492 |
| 9-12 yrs | <input type="checkbox"/> 493 | <input type="checkbox"/> 494 | <input type="checkbox"/> 495 | <input type="checkbox"/> 496 |
| 13-16 yrs | <input type="checkbox"/> 497 | <input type="checkbox"/> 498 | <input type="checkbox"/> 499 | <input type="checkbox"/> 500 |
| Over 16 yrs | <input type="checkbox"/> 501 | <input type="checkbox"/> 502 | <input type="checkbox"/> 503 | <input type="checkbox"/> 504 |
| Male | <input type="checkbox"/> 505 | <input type="checkbox"/> 506 | <input type="checkbox"/> 507 | <input type="checkbox"/> 508 |
| Female | <input type="checkbox"/> 510 | <input type="checkbox"/> 511 | <input type="checkbox"/> 512 | <input type="checkbox"/> 513 |

Thank you for completing the ETI readers' survey. To qualify for entry in the free draw for one of 50 prizes from Maplin Electronics and ETI you must fill in your name and address below, pull out the centre pages, fold as shown and post to arrive not later than 10th June 1991.

Name

Address

.....

..... Postcode

To post, fold on the dotted line A. Fold again at B and C and tuck B into the flap formed by C.

A

Postage will be paid by licensee

Do not affix Postage Stamp if posted in Gt Britain, Channel Islands, N. Ireland or the Isle of Man.

BUSINESS REPLY SERVICE
Licence No. HH37

ETI
Reader Survey,
Argus Specialist Publications,
Argus House, Boundary Way,
Hemel Hempstead
Herts HP2 4BR

2

C

B



PCB SERVICE

June

TELEPHONE
ORDERS
may be made on
**(0442)
66551**
ACCESS or VISA

E9106-1 Laser Receiver F
E9106-2 Temperature Controller — Power Supply G

PCBs for the remaining projects are available from the companies listed in Buylines.

Use the form or a photocopy for your order. Please fill out all parts of the form. Make sure you use the board reference numbers. This not only identifies the board but also tells you when the project was published. The first two numbers are the year, the next two are the month.

Terms are strictly payment with order. We cannot accept official orders but we can supply a proforma invoice if required. Such orders will not be processed until payment is received.

Price code	Price (inc. VAT)
C	£1.80
D	£2.50
E	£3.25
F	£4.00
G	£4.75
H	£5.50
J	£6.62
K	£7.20
L	£8.80
M	£10.60
N	£13.10
O	£15.80
P	£17.90
Q	£21.80
R	£23.90
S	£25.90
T	£29.00
U	£32.20
V	£35.80
W	£37.90
X	£40.70

E9004-2	Bass Amplifier Graphic Equaliser	L	E9104-1	Testmeter Volts	E
E9004-3	Bass Amplifier Micro	N	E9104-2	Active Direct Injection Box	F
E9004-4	Quad Power Supply	O	E9104-3	EPROM Eraser	F
E9005-1	Business Display	O	E9104-4	Digital Tachometer	F
E9005-2	Phone Lock and Logger	F	E9104-5	Radio Calibrator	F
E9006-1	Dark Room Timer	G	E9105-1	Modulator Laser (2 boards)	H
E9006-2	Telephone Extension Bell	C	E9105-2	Thyristor Tester	F
E9006-3	Telephone External Bell	D	E9105-3	Frequency Plotter	K
E9006-4	Fecko Box	G			
E9006-5	Bug Spotter	E			
E9007-1	Guitar Practice Amp	G			
E9007-2	Digital Frequency Meter	M			
E9007-3	Footstep Alarm	E			
E9007-4	Transistor Tester	C			
E9007-5	Decision Maker	J			
E9008-1	AC Millivoltmeter	K			
E9008-2	Temperature Controller	N			
E9008-3	FM Generator	L			
E9009-2	Slide Projector Controller	E			
E9009-2	Ultimate Diode Tester	D			
E9009-3	The Entertainer	G			
E9010-1	Component Tester	F			
E9010-2	Active Contact Pickup	E			
E9010-3	R4X Longwave Receiver	C			
E9011-1	The Autocue (2 boards, 1 double sided)	N			
E9011-2	Infra-lock transmitter (2 boards)	K			
E9011-3	Infra-lock receiver	H			
E9011-4	Four-track cassette recorder (record/playback one channel)	F			
E9011-5	Four-track cassette recorder (Bias/erase oscillator board)	K			
E9012-1	Infra Switch	F			
E9101-1	Remote Control — Main Board	J			
E9101-2	Remote Control — Display Board	H			
E9101-3	Remote Control Timeswitch — Transmit board	E			
E9101-4	SBC Micro-Controller Board	F			
E9101-5	SBC Practice Interface Board	F			
E9101-6	5 in 1 Remote Sensing Switch	E			
E9102-1	Remote Control Timeswitch — receiver board	F			
E9102-2	Anti Theft Alarm (2 bds)	H			
E9103-1	Ariennes Lights	L			
E9103-2	64K EPROM Emulator	N			
E9103-3	SSB Radio Receiver	G			
E9103-4	Active Loudspeaker board	H			

**TO: ETI PCB SERVICE, READERS' SERVICES,
ARGUS HOUSE, BOUNDARY WAY,
HEMEL HEMPSTEAD HP2 7ST**

Please supply:

Quantity	Ref. no.	Price Code	Price	Total Price
----------	----------	------------	-------	-------------

Post and packing

£0.75

Total enclosed

£

Please send my PCBs to: (BLOCK CAPITALS PLEASE)

Name

Address

Postcode

CHEQUES SHOULD BE MADE PAYABLE TO ASP Ltd.

Cookers & Micros Alive Alive-o

Damon Hart-Davis reports on the exciting advance in factory, home and office automation with the \$10 computer.

An important issue of the moment is energy management and conservation; 'smart' electronics can help keep your house or office or factory warmer and more pleasant for less money. Another topic of perennial interest is that of remote and automatic control of electrical and other appliances. A company in the US called Echelon has brought out a product they call the NEURON CHIP™ which will help to pull these strands together with off-the-shelf light bulbs that talk to your PC, timers that talk hot stuff to your heating, and automatic sentries that turn on your lights and your microwave when you turn the front door key.

himself a new home in California. He wanted to wire it up so that appliances could be remote controlled from all over the house, or possibly even outside of the house.

There were existing systems that would run up to 256 or so devices, but Markkula wanted more. Also many commercial controllers weren't 'smart' in the sense that they were only able to drive on/off signals, and usually could not gather data in from remote sites without a great deal of difficulty.

At the same time John Scully, also of Apple, had noticed that computers came in various flavours depending on the power of ten in the price. Supercomputers came in at tens of millions (\$s, £s or Ecu; take your pick!). Mainframe computers such as IBMs for a huge company's payroll came in at millions, minicomputers at hundreds of thousands, and so on down to video games and calculators at around \$100. This was what Scully called the 'Computer Continuum' — see Figure 1. What he also noticed was that there was no general purpose computer for \$10.

There were the sort of devices you might find in 'electronic' washing machines, video recorders or cheap calculators. But these devices were made specially for each application, and had to be sold in the hundreds of thousands to recoup their costs, and were so specialised as to be of no use for anything else except possibly other washing machines or video recorders from the same manufacturer. Alternatively, devices called microcontrollers, often 4-bit microprocessors with a few bytes of memory, were used. Microcontrollers are very simple and didn't really have enough power to talk to the outside world.

So a gap in the market was identified and Echelon was set up in February 1988 to fill it. Markkula put his money where his mouth was, and with other private investors injected \$5 million into development. Another \$30 million has been put in since then, from Apple itself along with venture capitalists and others.

The System

Echelon's system has a number of components. It is what Americans like to call 'total design', meaning Echelon have designed the software and the hardware and the way it will all work together smoothly. This had to happen to keep the cost of the final product down.

Echelon call their system LON (Local Operating Network — a cross between Operating System and Local Area Network, the two components involved). This includes the Neuron Chip itself, and other support such as modems, radio links and the like, and the software.

When Joe Bloggs, or his US cousin Joe Citizen, goes down to B&Q (or K-mart perhaps for Ms Citizen) to buy herself a light fitting, she will look at the price first. So whatever Echelon designs has to be cheap enough not to make a big difference on the ticket. And remember that the cost of something to the consumer is about five times what it cost when it left the factory gate after the wholesaler and retailer (and any others) have had their cut.

"Shall I have an ordinary one, or one that costs

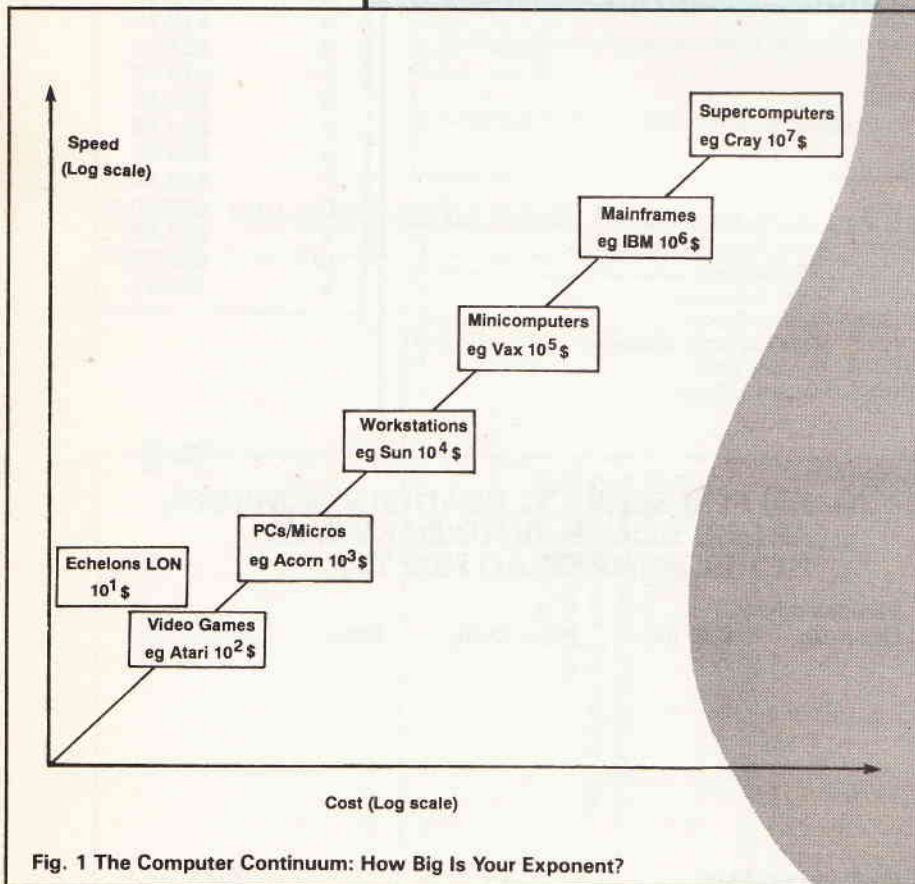

Fig. 1 The Computer Continuum: How Big Is Your Exponent?

LONS

The US company was sent up in 1988 to bring sci-fi into the factory, the office and the home. The parallel processing device is cheap enough to be put into light fittings at \$10 a time, and yet is clever enough to run timers, operate relays, and talk to other Neuron Chips across custom cable or the power lines. It is aimed at products for controlling factory machinery right through to household appliances, integrating all of them into a single intelligent system.

The Idea

The idea was born when A.C. "Mike" Markkula, one of the founders of Apple Computer Inc., was building

twice as much but has this nice gizmo?" is the question to which Echelon want the answer to be "It's not all that much more expensive; let's have the gizmo". Echelon won't be making the gizmos themselves. Motorola and Toshiba have signed up to make the chips, and large manufacturers will put them into their designs. So what is this 'total design'? What is the hardware and the software?

The Hardware

Well, there is the Neuron Chip. It comes in a plastic package about the size of a postage stamp but contains *three* microprocessors sharing the same memory and other facilities. The memory consists of 2K RAM, 1/2K EEPROM (Electrically Erasable Programmable Read Only Memory, ie unlike ordinary RAM it keeps its data when the power goes off) and ROM. On one version of Neuron Chip, the ROM is external so more complex

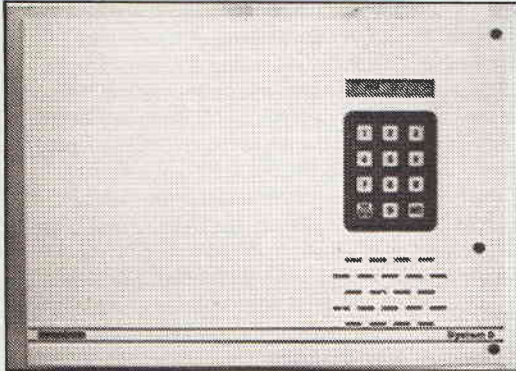

applications in bigger ROMs can be programmed, or so that smaller runs can be cost effective.

In normal use one of the microprocessors is devoted to running the connection between the Neuron Chip and the bus over which they all talk. This bus is a little like an Ethernet, and the protocol for any Neuron Chip to send to any other Neuron Chip over the same piece of wire is as you might imagine quite tricky.

The second microprocessor is devoted to handling such things as authentication (so your neighbour can't turn *your* lights on and off even if his signals get through to your power line), making sure messages actually get across from one Neuron Chip to another, broadcasting and so on. In fact, the communications system is similar in structure to the OSI 7 layer network reference model that is now the world standard. All this in your light fitting!

The last of the microprocessors is dedicated to actually making the system do what the user wants it to — working out when to fade the lights on one Neuron Chip, turn on the stereo on another, and turn on the answering machine with a third. And of course the chips can talk together over your power lines to coordinate this automatically if required.

But some of the hardware that supports the Neuron Chip is designed to make it work in tougher environments such as on the factory floor, where it must perform reliably. Some bus networks like the one that the Neuron Chips use to communicate have a reputation for being unpredictable under heavy load, Ethernet being an example. When Ethernet is heavily loaded, instead of taking the usual microseconds to get data across the network it can take seconds, with most of the available capacity wasted because the protocol does not work terribly well. Echelon has solved this problem with their protocol.

In your home, if a light took an extra second to come on it might be irritating. You might not even notice. In a factory an expensive item of equipment might have fallen off the end of a conveyor belt

because a robot arm hadn't moved over in time to pick it up. So consistent and reliable performance is a must. High performance of the individual Neuron Chip alone, though essential, is not enough — the whole LON has to *interoperate* effectively — another aspect of 'total design'.

And what works in the factory will work also in the office, for example, energy management. This can make dramatic cuts in the company's heating and lighting costs by warming the building to a tolerable though low temperature just before anyone comes in, but then turning on lights and quickly heating the individual rooms in a matter of minutes to a normal working level as people come in. This means power is only used when it is really needed on a room by room basis and yet the building is as functional as if a dumb thermostat and time switch combination was keeping the whole building at working temperature from (say) 8 to 6 even when the caretaker forgets to turn it off on a bank holiday.

A LON system can also provide security by detecting the presence of people when they're *not* expected, and maybe sounding an alarm or talking to a PC to get it to summon the police.

It is possible to connect up to about 32000 Neuron Chips into one LON system if desired, or just one or two, and because the LON can talk over power cable at 9600bps, or over cheap telephone type cable at up to 1.25Mbps, systems can be fitted into old buildings for minimum cost and with minimum disruption, or into new buildings at construction to operate more quickly, or bought item by item as normal electrical goods and plugged in when required.

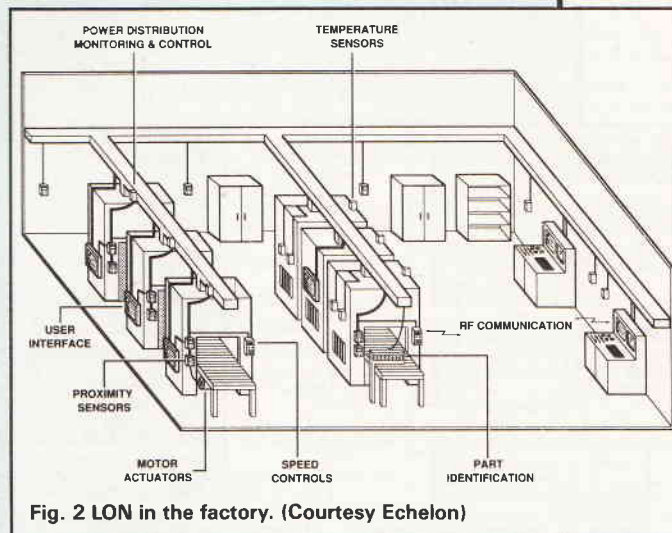

Fig. 2 LON in the factory. (Courtesy Echelon)

Think of the advantages of being able to buy all your electrical products such as your TV and video, or washing machine and tumble drier, or cooker or lights, all with the company's LonTalk logo. You could point your infra-red remote control at *either* the TV or the video and operate *any* of the LonTalk devices in the house from the one control, as well as in the conventional way. But hide the control unit from the cat! (Actually, this is where the authentication might come in useful, to stop the cat reprogramming the video, or flashing all the lights on and off).

And think on. What about having a LonTalk answering machine as well? This could enable you to call home just before leaving work and rather than control the answering machine itself with the supplied bleeper, turn the water on for a bath . . .

All this has been only for the very rich and the very patient until now, but LON and the Neuron Chip are *designed* to do these things as part of their normal

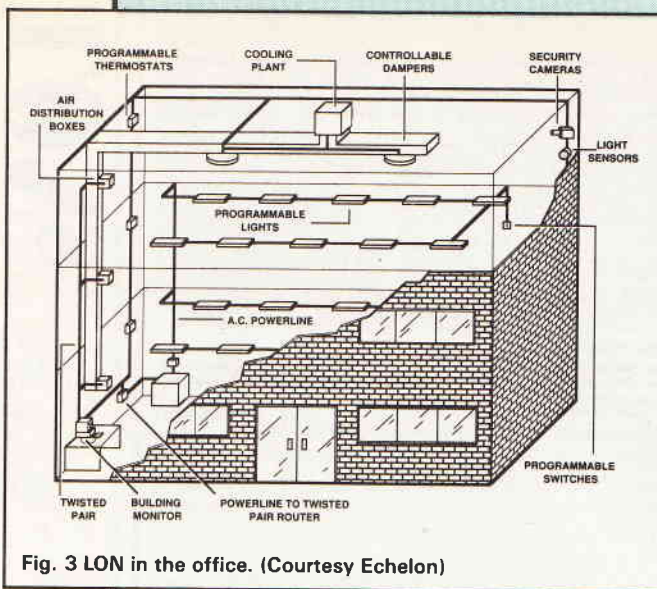

Fig. 3 LON in the office. (Courtesy Echelon)

function. We shall have to see what the Aristons and Zanussis and Sonys of this world do with Echelon's new chip...

The Software

So what Whizzo software is going to support all this put-out-the-cat-from-Los-Angeles hardware? It obviously has to be fairly sophisticated, and yet fairly small to go in a few Kbytes of ROM. Mind you, only a few years ago when CP/M reigned supreme and MS-DOS was but a gleam in Bill Gates' eye, all the normal programs one ran to do accounts or store all those recipes (!) had to fit in the same sort of space, and only got one microprocessor to do the thinking. Simply speaking, Echelon have drawn in two of the most exciting strands of state of the art programming into the LON, which is in fact why it is a LON.

What are these?

The first is distributed processing. As it happens a LON has lots of microprocessors spread out across a bus network (which you may think is what you just paid the electrician to rewire so that plugging in the Hoover didn't burn the house down), all cooperating to control your building or production line. Many systems fail to acknowledge

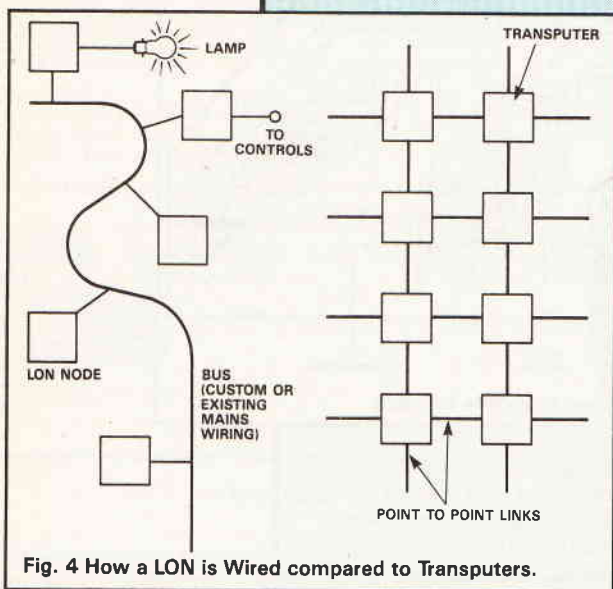

Fig. 4 How a LON is Wired compared to Transputers.

this potential and have a centralised system where some beefy control box has to be powerful enough to control everything, has to be bought before the first device is plugged in, and brings the lot to a halt if it fails. In a LON there need be no central box so you don't have to buy anything expensive up front which anyway is potentially quickly outdated or underpowered. Furthermore, the system can be designed so that failure of a single component need not make the whole building grind to a halt. What can happen is that the system as a whole is just a tiny bit less effective.

Actually, this distributed processing is the same

design concept that has gone into the Transputer, though the Transputer is specifically designed to do fast computation rather than control the real world, and is connected up in absolutely the reverse sort of method to a LON, with each Transputer connected directly to its neighbour rather than the LON where the whole LON shares one piece of wire — see Figure 4.

Imagine the home situation described above with a LonTalk TV and a LonTalk video. Suppose the video's remote control fails. Well it may not matter because you may be able to program it, albeit a little more clumsily, through the TV. So this helps keep LON systems cost effective, and potentially resilient in the face of component failures, which puts Echelon's LON right up with the leading edge developments in more conventional computing systems.

What is this other software technique that the LON uses? It is very fashionable, but in spite of this just right for LON systems — Object Oriented Programming. Rather than sitting down and writing a huge program that sits in a loop saying "Has some one touched a light switch? Has a motion detector detected someone? Is the room too cold? Do we need to turn a light on?" etc, the programmer treats things such as light bulbs and cookers a bit more like the real world, as objects. An instruction can be issued to the cooker object to turn the oven to 200°C, or to the light object from the motion sensor object to say "Switch on please (because I detected someone entering the room)". The Neuron Chips are programmed using a modified version of the C language used by computer programmers for its efficiency and compactness, which is enhanced in this case by the so-called zero-address nature of the microprocessors themselves. (Zero-address means that all operations are done relative to a stack rather than with registers which is good for much C code that does not involve intensive calculation.) In fact, in a way, the LON is programmed as a whole, because one of the functions of the second microprocessor in each Neuron Chip as described above is to allow software objects called network variables to be shared across the whole LON as an integrated whole. This is a particularly clever aspect of the LON.

How Many Sales

Echelon have identified markets in the home, the office, agriculture, car electronics and other areas. They think they have a potential market of more than four thousand million Neuron Chips in 1991 alone, and growing. Echelon themselves do not plan to do other than licence the technology at \$2500 one off to each manufacturer, and with chips ready to roll soon, get designing!

The Future — The High-IQ Home

So are we all going to live in an unfathomable world where the lights go out when you enter a room, or the microwave always overcooks your bacon after 4pm (is Little Brother Bugging You?), or will we all suddenly live and work in almost telepathic homes which practically choose the menu and answer the door at the slightest wave of a hand?

Neither of these obviously. Gradually LON or similar technology will start to turn up in our home and in the office. Just as we take the microwave oven, word processor and portable phone for granted now, we will soon not be surprised by 'interoperable' appliances that adjust the heating in each room as we enter or leave, or let us program the video from the office if we forget to set it up for Neighbours. Actually, if it won't let us miss Neighbours, I'm not sure if I'm ready yet!

LONS

HIGH POWER AMPLIFIER For your car, it has 150 watts output. Frequency response 20Hz to 20 KHz and a signal to noise ratio better than 60db. Has built in short circuit protection and adjustable input level to suit your existing car stereo, so needs no pre-amp. Works into speakers ref 30P7 described below. A real bargain at only £57.00 Order ref 57P1.

HIGH POWER CAR SPEAKERS. Stereo pair output 100w each. 4ohm impedance and consisting of 6 1/2" woofer 2" mid range and 1" tweeter. Ideal to work with the amplifier described above. Price per pair £30.00 Order ref 30P7.

PERSONAL STEREOS Customer returns but complete with a pair of stereo headphones very good value at £3.00 ref 3P83.

2KV 500 WATT TRANSFORMERS Suitable for high voltage experiments or as a spare for a microwave oven etc. 250v AC input. £10.00 ref 10P93.

MICROWAVE CONTROL PANEL. Mains operated, with touch switches. Complete with 4 digit display, digital clock, and 2 relay outputs one for power and one for pulsed power (programmable). Ideal for all sorts of precision timer applications etc. £6.00 ref 6P18.

FIBRE OPTIC CABLE. Stranded optical fibres sheathed in black PVC. Five metre length £7.00 ref 7P29.

12V SOLAR CELL 200mA output ideal for trickle charging etc. 300 mm square. Our price £15.00 ref 15P42.

PASSIVE INFRA-RED MOTION SENSOR.

Complete with daylight sensor, adjustable lights on timer (8 secs -15 mins), 50' range with a 90 deg coverage. Manual override facility. Complete with wall brackets, bulb holders etc. Brand new and guaranteed. £25.00 ref 25P24.



Package of two PAR38 bulbs for above unit £12.00 ref 12P43.

VIDEO SENDER UNIT Transmit both audio and video signals from either a video camera, video recorder or computer to any standard TV set within a 100' range! (tune TV to a spare channel). 12v DC op. £15.00 ref 15P39. Suitable mains adaptor £5.00 ref 5P191.

FM TRANSMITTER housed in a standard working 13A adaptor (bug is mains driven). £26.00 ref 26P2.

MINIATURE RADIO TRANSCIEVERS A pair of walkie talkies with a range of up to 2 kilometres. Units measure 22x52x155mm. Complete with cases. £30.00 ref 30P12.

FM CORDLESS MICROPHONE. Small hand held unit with a 500' range! 2 transmit power levels reqs PP3 battery. Tuneable to any FM receiver. Our price £15 ref 15P42A.



10 BAND COMMUNICATIONS RECEIVER. 7 short bands, FM, AM and LW DX local switch, tuning 'eye' mains or battery. Complete with shoulder strap and mains lead. **NOW ONLY £19.00!! REF 19P14.**



WHISPER 2000 LISTENING AID. Enables you to hear sounds that would otherwise be inaudible! Complete with headphones. Cased. £5.00 ref 5P179.

CAR STEREO AND FM RADIO. Low cost stereo system giving 5 watts per channel. Signal to noise ratio better than 45db, wow and flutter less than .35%. Neg earth. £25.00 ref 25P21.

LOW COST WALKIE TALKIES. Pair of battery operated units with a range of about 150'. Our price £8.00 a pair ref 8P50.

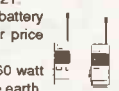

7 CHANNEL GRAPHIC EQUALIZER. plus a 60 watt power amp! 20-21KHz 4-8R 12-14v DC negative earth. Cased. £25 ref 25P14.

NICAD BATTERIES. Brand new top quality. 4 x AA's £4.00 ref 4P44. 2 x C's £4.00 ref 4P73. 4 x D's £9.00 ref 9P12. 1 x PP3 £6.00 ref 6P35.

TOWERS INTERNATIONAL TRANSISTOR SELECTOR GUIDE. The ultimate equivalents book. Latest edition £20.00 ref 20P32.

CABLE TIES. 142mm x 3.2mm white nylon pack of 100 £3.00 ref 3P104. Bumper pack of 1,000 ties £14.00.

VIDEO AND AUDIO MONITORING SYSTEM

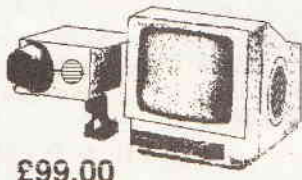

£99.00

Brand new units consisting of a camera, 14cm monitor, 70 metres of cable, AC adaptor, mounting bracket and owners manual. 240v AC or 12v DC operation complete with built in 2 way intercom. £99.00 ref 99P2.

1991 CATALOGUE AVAILABLE NOW IF YOU DO NOT HAVE A COPY PLEASE REQUEST ONE WHEN ORDERING OR SEND US A 6"x9" SAE FOR A FREE COPY.

GEIGER COUNTER KIT. Complete with tube, PCB and all components to build a battery operated geiger counter. £39.00 ref 39P1.

FM BUG KIT. New design with PCB embedded coil. Transmits to any FM radio. 9v battery req'd. £5.00 ref 5P158.

FM BUG Built and tested superior 9v operation £14.00 ref 14P3.

COMPOSITE VIDEO KITS. These convert composite video into separate H sync, V sync and video. 12v DC £8.00 ref 8P39.

SINCLAIR C5 MOTORS 12v 29A (full load) 3300 rpm 6"x4" 1/4" O/P shaft. New. £20.00 ref 20P22.

As above but with fitted 4 to 1 inline reduction box (800rpm) and threaded nylon belt drive cog £40.00 ref 40P8.

SINCLAIR C5 WHEELS 13" or 16" dia including treaded tyre and inner tube. Wheels are black, spoked one piece poly carbonate. 13" wheel £6.00 ref 6P20, 16" wheel £8.00 ref 6P21.

ELECTRONIC SPEED CONTROL KIT for c5 motor. PCB and all components to build a speed controller (0-95% of speed). Uses pulse width modulation. £17.00 ref



17P3.

SOLAR POWERED NICAD CHARGER. Charges 4 AA nicads in 8 hours. Brand new and cased £6.00 ref 6P3.

MOSFETS FOR POWER AMPLIFIERS ETC. 100 watt mosfet pair 2SJ99 and 2SK343 £4.00 a pair with pin out info ref 4P51. Also available is a 2SK413 and a 2SJ118 at £4.00 ref 4P42.

10 MEMORY PUSH BUTTON TELEPHONES. These are 'customer returns' so they may need slight attention. BT approved. £6.00 each ref 6P16 or 2 for £10.00 ref 10P77.

12 VOLT BRUSHLESS FAN. 1/2" square brand new ideal for boat, car, caravan etc. £5.00 ref 5P206.

ACORN DATA RECORDER ALF503 Made for BBC computer but suitable for others. Includes mains adaptor, leads and book. £15.00 ref 15P43.

VIDEO TAPES. Three hour superior quality tapes made under licence from the famous JVC company. Pack of 10 tapes £20.00 ref 20P20.

ELECTRONIC SPACESHIP. Sound and impact controlled, responds to claps and shouts and reverses when it hits anything. Kit with complete assembly instructions £10.00 ref 10P81.



PHILIPS LASER. 2MW HELIUM NEON LASER TUBE. BRAND NEW FULL SPEC £40.00 REF 40P10. MAINS POWER SUPPLY KIT £20.00 REF 20P33 READY BUILT AND TESTED LASER IN ONE CASE £75.00 REF 75P4.

SOLDER 22SWG resin cored solder on a 1/2kg reel. Top quality. £4.00 a reel ref 4P70.

600 WATT HEATERS ideal for air or liquid, will not corrode, lasts for years. coil type construction 3"x2" mounted on a 4" dia metal plate for easy fixing. £3.00 ea ref 3P78 or 4 for £10.00 ref 10P76.

TIME AND TEMPERATURE MODULE A clock, digital thermometer (Celsius and Fahrenheit (9-160 deg F) programmable too hot and too cold alarms. Runs for at least a year on one AA battery. £9.00 ref 9P5.

Remote temperature probe for above unit £3.00 ref 3P60.

GEARBOX KITS ideal for models etc. Contains 18 gears (2 of each size) 4x50mm axles and a powerful 9-12v motor. All the gears etc are push fit. £3.00 for complete kit ref 3P93.

ELECTRONIC TICKET MACHINES These units contain a magnetic card reader, two matrix printers, motors, sensors and loads of electronic components etc. (12"x12"x7") Good value at £12.00 ref 12P28.

JOYSTICKS Brand new with 2 fire buttons and suction feet these units can be modified for most computers by changing the connector etc. Price is 2 for £5.00 ref 5P174.

GAS POWERED SOLDERING IRON AND BLOW TORCH Top quality tool with interchangeable heads and metal body. Fully adjustable, runs on lighter gas. £10.00 ref 10P130.

SMOKE ALARMS ionization type 5 year warranty complete with battery only £5.00 ref 5P206.

ANSWER MACHINES BT approved remote message playback, integral push button phone, power supply and tape. Exceptional value at £45.00 ref 45P2.

CAR IONIZER KIT Improve the air in your car! clears smoke and helps to reduce fatigue. Case required. £12.00 ref 12P8.

6V 10AH LEAD ACID sealed battery by yuasa ex equipment but in excellent condition now only 2 for £10.00 ref 10P95.

12 TO 220V INVERTER KITS supplied it will handle up to 'about 15w at 220v but with a larger transformer it will handle 80 watts. Basic kit £12.00 ref 12P17. Larger transformer £12.00 ref 12P41.

VERO EASI WIRE PROTOTYPING SYSTEM ideal for designing projects on etc. Complete with tools, wire and reusable board. Our price £6.00 ref 6P33.

MICROWAVE TURNTABLE MOTORS. Ideal for window displays etc. £5.00 ref 5P165.

STC SWITCHED MODE POWER SUPPLY 200v or 110v input giving 5v at 2A, +24v at 0.25A, +12v at 0.15A and +90v at 0.4A. £6.00 ref 6P59.

TELEPHONE AUTODIALLERS. These units, when triggered will automatically dial any telephone number. Originally made for alarm panels. BT approved. £12.00 ref 12P23 (please state telephone no req'd).

25 WATT STEREO AMPLIFIER. STK043. With the addition of a handful of components you can build a 25 watt amplifier. £4.00 ref 4P69 (Circuit dia included).

LINEAR POWER SUPPLY. Brand new 220v input +5 at 3A, +12 at 1A, -12 at 1A. Short circuit protected. £12.00 ref 12P21.

MAINS FANS. Snail type construction. Approx 4"x5" mounted on a metal plate for easy fixing. New £5.00 5P166.

POWERFUL IONIZER KIT. Generates 10 times more ions than commercial units! Complete kit including case £18.00 ref 18P2.

MINI RADIO MODULE Only 2" square with ferrite aerial and tuner. Superhet. Req's PP3 battery £1.00 ref BD716.

HIGH RESOLUTION MONITOR. 9" black and white Philips tube in chassis made for OPD computer but may be suitable for others. £20.00 ref 20P26.

BARGAIN NICADS AAA SIZE 200MAH 1.2V PACK OF 10 £4.00 REF 4P92, **PACK OF 100** £30.00 REF 30P16

CB CONVERTORS. Converts a car radio into an AM CB receiver. Cased with circuit diagram. £4.00 ref 4P48.

FLOPPY DISCS. Pack of 15 3 1/2" DSD £10.00 ref 10P88. Pack of 10 5 1/4" DSD £5.00 ref 5P168.

SONIC CONTROLLED MOTOR One click to start, two click to reverse direction, 3 click to stop! £3.00 each ref 3P137.

FRESNEL MAGNIFYING LENS 83 x 52mm £1.00 ref BD827.

LCD DISPLAY. 4 1/2 digits supplied with connection data £3.00 ref 3P77 or 5 for £10.00 ref 10P78.

ALARM TRANSMITTERS. No data available but nicely made complex transmitters 9v operation. £4.00 each ref 4P81.

100M REEL OF WHITE BELL WIRE 8 pattern ideal for intercoms, door bells etc £3.00 a reel ref 3P107.

TRANSMITTER RECEIVER SYSTEM Originally made for nurse call systems they consist of a pendant style transmitter and a receiver with telescopic aerial 12v. 80 different channels. £12.00 ref 12P26.

CLAP LIGHT. This device turns on a lamp at a finger 'snap' etc. nicely cased with built in battery operated light. Ideal bedside light etc. £4.00 each ref 4P82.

ELECTRONIC DIPSTICK KIT. Contains all you need to build an electronic device to give a 10 level liquid indicator. £5.00 (ex case) ref 5P194.

UNIVERSAL BATTERY CHARGER. Takes AA's, C's, D's and PP3 nicads. Holds up to 5 batteries at once. New and cased, mains operated. £8.00 ref 8P36.

ONE THOUSAND CABLE TIES 175mm x 2.4mm white nylon cable ties only £5.00 ref 5P181.

PC MODEMS 1200/75 baud modems designed to plug into a PC complete with manual but no software £18.00 ref 18P12.

ASTEC SWITCHED MODE POWER SUPPLY 800mm x 165mm (PCB size) gives +5 at 3.75A, +12 at 1.5A, -12 at 0.4A. Brand new £12.00 ref 12P39.

VENTILATED CASE FOR ABOVE PSU with IEC filtered socket and power switch. £5.00 ref 5P190.

IN CAR POWER SUPPLY. Plugs into cigar socket and gives 3,4,5,6,7,5,9, and 12v outputs at 800mA. Complete with universal spider plug. £5.00 ref 5P167.

CUSTOMER RETURNED switched mode power supplies. Mixed type, good for spares or repair. £2.00 each ref 2P292.

DRILL OPERATED PUMP. Fits any drill and is self priming. £3.00 ref 3P140.

PERSONAL ATTACK ALARM. Complete with built in torch and vanity mirror. Pocket sized, req's 3 AA batteries. £3.00 ref 3P135.

POWERFUL SOLAR CELL 1AMP .45VOLT only £5.00 ref 5P192 (other sizes available in catalogue).

SOLAR PROJECT KIT. Consists of a solar cell, special DC motor, plastic fan and turntables etc plus a 20 page book on solar energy! Price is £8.00 ref 8P51.

RESISTOR PACK. 10 x 50 values (500 resistors) all 1/4 watt 2% metal film. £5.00 ref 5P170.

CAPACITOR PACK 1.100 assorted non electrolytic capacitors £2.00 ref 2P266.

CAPACITOR PACK 2. 40 assorted electrolytic capacitors £2.00 ref 2P267.

QUICK CUPPA? 12v immersion heater with lead and cigar lighter plug £3.00 ref 3P92.

LED PACK. 50 red leds, 50 green leds and 50 yellow leds all 5mm £8.00 ref 8P52.

FERRARI TESTAROSSA. A true 2 channel radio controlled car with forward, reverse, 2 gears plus turbo. Working headlights. £22.00 ref 22P6.

ULTRASONIC WIRELESS ALARM SYSTEM two units, one a sensor which plugs into a 13A socket in the area you wish to protect. The other, a central alarm unit plugs into any other socket elsewhere in the building. When the sensor is triggered (by body movement etc) the alarm sounds. Adjustable sensitivity. Price per pair £20.00 ref 20P34. Additional sensors (max 5 per alarm unit) £11.00 ref 11P6.

TOP QUALITY MICROPHONE. Unidirectional electret condenser mic 600 ohm sensitivity 16-18kHz built in chime complete with magnetic microphone stand and mic clip. £12.00 ref 12P42.

WASHING MACHINE PUMP. Mains operated new pump. Not self priming. £5.00 ref 5P18.

IBM PRINTER LEAD. (D25 to centronics plug) 2 metre parallel. £5.00 ref 5P186.

COPPER CLAD STRIP BOARD 17" x 4" of 1" pitch 'vero' board. £4.00 a sheet ref 4P62 and 2 sheets for £7.00 ref 7P22.

STRIP BOARD CUTTING TOOL £2.00 ref 2P352.

3 1/2" disc drive. 720K capacity made by NEC £60.00 ref 60P2.

TV LOUDSPEAKERS. 5 watt magnetically screened 4 ohm 55 x 125mm. £3.00 a pair ref 3P109.

TV LOUDSPEAKERS. 3 watt 8 ohm magnetically screened 70 x 50mm. £3.00 a pair ref 3P108.

BBC TRACKBALLS Once again in stock only £4.00 ref 4P86.

CROSS OVER NETWORKS 8 ohm 3 way Japanese made units. Excellent units available at only £2.00 for a pair! ref 2P363.

SPEAKER GRILLS set of 3 matching grills of different diameters. 2 packs for £2.00 (6 grills) ref 2P364.

50 METRES OF MAINS CABLE £3.00 2 core black precut in convenient 2 m lengths. Ideal for repairs and projects. ref 3P91.

4 CORE SCREENED AUDIO CABLE 24 METRES £2.00. Precut into convenient 1.2 m lengths. Ref 2P365.

TWEETERS 2 1/4" DIA 8 ohm mounted on a smart metal plate for easy fixing £2.00 ref 2P366.

COMPUTER MICE Originally made for Future PC's but can be adapted for other machines. Swiss made £8.00 ref 8P57. Atari ST conversion kit £2.00 ref 2P362.

6 1/2" 20 WATT SPEAKER Built in tweeter 4 ohm £5.00 ref 5P205.

5" x 3" 16 OHM SPEAKER 3 for £1.00!! ref CD213.

ADJUSTABLE SPEAKER BRACKETS ideal for mounting speakers on internal or external corners, uneven surfaces etc. 2 for £5.00 ref 5P207.

PIR LIGHT SWITCH Replaces a standard light switch in seconds. Light operates when anybody comes within detection range (4m) and stays on for an adjustable time (15 secs to 15 mins). Complete with daylight sensor. Unit also functions as a dimmer switch! 200 watt max. Not suitable for fluorescents £14.00 ref 14P10.

2 MEG DISC DRIVES 3 1/2" disc drives made by Sony housed in a 5 1/4" frame 1.2 meg formatted. £66.00 ref 66P1.

360K 3 1/2" DISC DRIVES 1/2 height £25.00 ref 25P26.

40 CHANNEL TRANSCIEVER 4 WATT OUTPUT, HANDHELD SQUELCH CONTROL ETC £70.00 EACH REF 70P1.

OR AVAILABLE AS A PAIR WITH NICAD BATTERY PACKS FOR £150.00 REF 150P1 Illuminated channel display, 10 section aerial, Hi-Low power switch, external aerial socket, DC charger socket, 12v DC power socket, carrying strap and owners manual.



BULL ELECTRICAL
 250 PORTLAND ROAD HOVE SUSSEX
 BN3 5QT TELEPHONE 0273 203500
 MAIL ORDER TERMS: CASH PO OR CHEQUE
 WITH ORDER PLUS £2.50 POST PLUS VAT.
 PLEASE ALLOW 10-14 DAYS FOR DELIVERY

FAX 0273 23077

SOME OF OUR PRODUCTS MAY BE UNLICENSABLE IN THE UK

VELLEMAN KITS

Over 100 Project Kits in stock
Send 50p for 1991 Catalogue + Price List

RETAILERS WANTED

Why not be one of our many retailers who carry our top range of high quality kits (Discounts to be arranged)
Send Details and Letterhead to:

HIGH-Q-ELECTRONICS
DEPT ETI, PO BOX 1481 LONDON NW7 4RF

TEL: **0707 263562**

FAX: **081-209 1231**

SCHOOLS AND COLLEGES WELCOME



SUPPLIERS OF AN EXTENSIVE
RANGE OF TOP QUALITY
ELECTRONIC COMPONENTS,
ACCESSORIES & HARDWARE

BOOKS - PCB PRODUCTION AIDS - TEST EQUIPMENT
TOOLS - SELF ASSEMBLE ELECTRONIC PROJECTS

ESR Electronic Components Tel: 091 251 4363
Station Rd, Cullercoats,
Tyne & Wear. NE30 4PQ Fax: 091 252 2296
Schools Colleges and Trade Enquiries Welcome



OPEN: Mon-Fri 8.30-5.00 Sat 10.00-5.00



NEW 1991
COLOUR
CATALOGUE

£1-00

Includes P + P

SURVEILLANCE PROFESSIONAL QUALITY KITS

A range of high quality kits as supplied to leading UK security companies, all in-house designed and produced, not to be confused with cheap imports. All kits come fully documented with concise assembly and setting-up details, fibreglass PCB and all components. All transmitters are fully tuneable and can be monitored on a normal VHF radio or tuned higher for greater security. Build-up service available if required.

MTX Micro-miniature audio transmitter. 17mmx17mm. 9V operation. 100m range **£13.45**

VTR500 Hi-power audio transmitter. 250mW output. 20mmx40mm. 9-12V operation. 2-3000m range **£16.45**

VXT Voice activated transmitter. Variable sensitivity. 20mmx67mm. 9V operation. 1000m range **£19.45**

SCRX Sub-carrier scrambled audio transmitter. Cannot be monitored without decoder fitted to radio. 20mmx67mm. 9V operation. 1000m range **£22.95**

SCDM Sub-carrier decoder unit for monitoring SCRX. Connects to radio earphone socket. Provides output for headphones. 32mmx70mm. 9-12V operation **£22.95**

HVX40 Mains powered audio transmitter. Connects directly to 240v AC supply. 30mmx35mm. 500m range **£19.45**

XT89 Crystal controlled audio transmitter. High performance. 100mW output. Supplied with xtal for 108MHz. Others available to 116MHz. 85mmx28mm. 9V operation. 2-3000m range..... **£37.95**

QTX180 Narrow band FM crystal controlled audio transmitter. 180MHz frequency. Requires Scanner receiver in our QRX180 kit (see Cat) 20mmx67mm. 9V operation. 1000m range **£40.95**

TKX900 Tracker/Beeper transmitter. Transmits continuous stream of audio pulses. Variable tone and rate. Powerful 200mW output. 63mmx25mm. 9V operation. 2-3000m range..... **£22.95**

ATR2 Micro size telephone recording interface. Connects between telephone lines (anywhere) and cassette recorder. Tape switches automatically with use of phone. All conversations recorded. Powered from line. 10mmx35mm..... **£13.45**

TLX700 Micro miniature telephone transmitter. Connects to line (anywhere) switches on and off with phone use. All conversations transmitted. 20mmx20mm. Powered from line. 1000m range..... **£13.45**

CD600 Professional bug detector/locator. Variable sensitivity. Multicolour bar graph readout of signal strength with variable rate bleeper. Second mode AUDIO CONFIRM distinguishes between localised bug transmission and normal legitimate signal such as pagers, cellular etc. 70mmx100mm. 9V operation..... **£50.95**

UK customers please send cheques. PO's or registered cash. Please add £1.50 per order for P&P Goods despatched ASAP allowing for cheque clearance. Overseas customers send sterling bank draft or Eurocheque and add £5.00 per order for shipment. Cred card orders accepted on 0827 714476. Trade enquiries welcome.

Send 2x1st class stamps for the new 1991 Catalogue



THE WORKSHOPS
95 MAIN RD. BAXTERLEY
NR. ATHERSTONE
WARKS CV9 2LE



0827 714476

Cirkit TESTING



TM SERIES MULTIMETERS

D-MM Good Value!

The TM series of low cost meters, with 3½ digit LCDs, full overload protection, strong ABS case and packed with features. Supplied with test leads, battery and manual.

TM 5315	DC current (10A) continuity and diode test	56-05315	£19.99
TM 5365	Capacitance and frequency (200kHz) ranges	56-05365	£37.90
TM 5375	Frequency range (20MHz) and HFE test	56-05375	£36.75
TM 115	AC & DC current (10A), HFE and continuity test	56-00115	£33.67
TM 135	Capacitance and temp. ranges (inc. probe)	56-00135	£45.95
TM 175	Frequency (15MHz) and capacitance ranges and HFE, diode, continuity and LED test.	56-00175	£57.49
7705	Capacitance meter, 1pF to 20,000uF	56-07705	£38.98

BLACK STAR

Top quality, UK made, frequency counters and generators.



Meteor 100	100MHz counter	56-00100	£125.35
Meteor 600	600MHz counter	56-00600	£155.25
Meteor 1000	1000MHz counter	56-01000	£204.70
Apollo 100	100MHz counter/timer	56-10100	£339.25
Nova 2400	2.4GHz counter	56-02000	£343.85
Jupiter 500	500kHz function generator	56-00500	£126.50
Jupiter 2000	2MHz function generator	56-02001	£171.35

HAMEG 'SCOPES

All Hameg scopes are supplied with two x 10 probes, mains lead, manual and 2 year warranty.

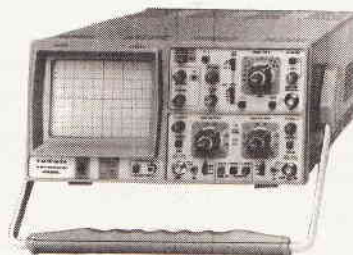

HM203-7	Dual channel, 20MHz	56-52037	£388.70
HM205-3	Digital storage, 20MHz sampling	56-52053	£701.50
HM604	Dual channel, 60MHz	56-56040	£701.50
HM1005	Triple channel, 100MHz	56-01005	£910.85

Full details of all the above are included in our comprehensive catalogue, £1.60 (inc. P&P).

All the above are currently in stock and available for immediate delivery. Standard P&P £1.00, next day delivery £4.50.

Cirkit

All prices include VAT



Cirkit Distribution Ltd.
Park Lane, Broxbourne, Herts EN10 7NQ.
Telephone (0992) 444111.

Temperature Sensor IC Circuits

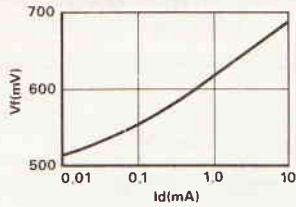

Fig. 1 Silicon diode typical V_F/I_D transfer characteristics.

This article looks at practical applications of modern 'temperature sensor' ICs; all the specified ICs are 'commercial grade' types manufactured by National Semiconductors, and are widely available; they are also made in 'industrial' and 'military' grades, with greatly enhanced specifications.

Sensor Basics

Until fairly recently, electric/electronic temperature sensors were available in only four basic types, none of which were really suitable for use in accurate 'temperature-to-voltage converter' or 'electronic thermometer' applications. Of these four types, the bead thermistor is highly non-linear, carbon rod thermistors have excessively wide tolerances, and thermocouples give very low outputs; none of these three devices gives an output that can be directly calibrated in a known temperature scale.

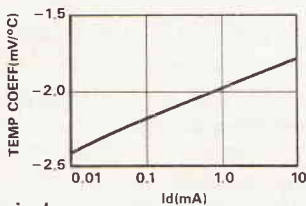

Fig. 2 Typical thermal characteristics of a silicon diode.

The fourth type of sensor is the ordinary silicon diode (or transistor base-emitter junction) which, as shown in Figures 1 and 2, generates a forward voltage of about 610 mV and has a temperature coefficient of about $-2\text{mV}/^\circ\text{C}$ at a forward current of 1 mA, and can thus be employed as a temperature sensing device. Major advantages of this sensor are that it gives repeatable and consistent results and, because of its small physical mass, has a fairly rapid thermal response time. Its major disadvantage is that its normal forward voltage is very large compared to its thermally-induced voltage changes; also, its forward voltage varies with forward current; Figure 3 helps illustrate these problems.

Figure 3 shows, in basic form, an electronic thermometer that uses an ordinary silicon diode as its sensor and is calibrated to span the -10°C to

$+40^\circ\text{C}$ range. The diode is driven via a constant current that is adjusted (during thermal tests) to set D1's thermal coefficient at precisely $-2\text{mV}/^\circ\text{C}$. D1's output is fed to the input of the $\times 10$ op-amp inverting amplifier, which has an offset voltage (V_{REF}) applied to its non-inverting terminal to exactly cancel the effects of D1's forward voltage at -10°C . Thus, the op-amp gives an output that falls to zero at -10°C , has an effective thermal coefficient of $+20^\circ\text{C}$, and rises to $+1\text{V}$ at $+40^\circ\text{C}$.

Once calibrated, the Figure 3 circuit has two possible sources of error. The first is variation in D1's forward current, but here a 10% shift causes only a 3 mV change in forward voltage, so such errors are quite small (equal to an error of 0.15 $^\circ\text{C}$, percent). The second possible source of error is variation in V_{REF} , which has a nominal value of 600 mV. Here a 1% variation (6 mV) is equal to a 3 $^\circ\text{C}$ shift in the D1 temperature, so this can be a major source of error.

Figure 4 shows a useful variation of the basic

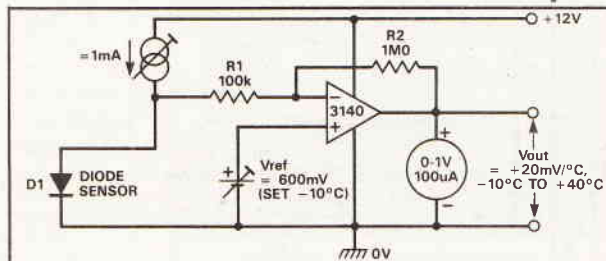

Fig. 3 Basic -10°C to $+40^\circ\text{C}$ thermometer with silicon diode sensor.

diode sensor, using a so-called 'amplified diode' (Q1) as a thermal sensor. Here, ZD1, generates a thermally stable 4.7 volts, and matched transistors Q2-Q3 form a current mirror in which an input current (I_{IN}) fed into diode-connected Q2 inherently generates an almost identical sink current (I_{SINK}) in the collector of Q3. I_{SINK} flows via the Q1-R1-R2 'amplified diode', which generates an output voltage (between its emitter and collector) equal to its base-emitter junction's volt drop multiplied by the $(R1+R2)/R2$

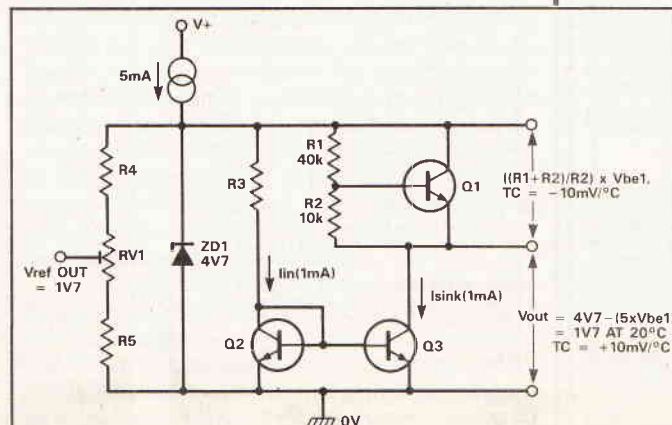

Fig. 4 Thermal sensor using an 'amplified diode'.

Ray Marston looks at modern temperature sensor ICs and shows how to use them.

value, which in this case equal 5; this amplified diode thus acts like five series-connected silicon diodes, and drops approximately 3 volts and has a thermal coefficient of $-10\text{mV}/^\circ\text{C}$ at 20°C . Thus, the circuit's final output taken between Q1's emitter and ground, equals 4.7V minus this value, and at $+20^\circ\text{C}$ approximates 1.7V and has a temperature coefficient of $+10\text{mV}/^\circ\text{C}$. Note that a very stable V_{REF} offset

Practical Temperature Sensor ICs

Temperature Sensor ICs are sophisticated devices that convert temperature directly into voltage. National Semiconductors are one of the major manufacturers of these devices, and produce a range of four widely available ICs of this type; Figure 5 shows details of the low-cost 'commercial grade' versions of these. Here, the LM34CZ and LM35CZ are precision 'micropower' devices that give outputs proportional to $^\circ\text{F}$ and $^\circ\text{C}$ respectively, and the LM335Z is a simple trimmable device that gives an output proportional to $^\circ\text{K}$. Finally, the LM3911N combines a voltage reference, a temperature sensor and an op-amp on a single chip, and can be used to act as either a temperature indicator or as a precision thermal switch.

IC NUMBER	LM34CZ	LM35CZ	LM335Z	LM3911N
TEMP RANGE	-40°F TO $+230^\circ\text{F}$	-40°C TO $+110^\circ\text{C}$	-40°C TO $+100^\circ\text{C}$	-25°C TO $+85^\circ\text{C}$
SPOT ACCURACY (TYP)	$\pm 0.6^\circ\text{F}$ AT $+77^\circ\text{F}$	$\pm 0.4^\circ\text{C}$ AT $+25^\circ\text{C}$	$\pm 2^\circ\text{C}$ AT $+25^\circ\text{C}$	NA
RANGE ACCURACY (TYP)	$\pm 1.6^\circ\text{F}$	$\pm 0.8^\circ\text{C}$	$\pm 4.0^\circ\text{C}$	$\pm 10^\circ\text{C}$
OUTPUT SCALE	$10\text{mV}/^\circ\text{F}$	$10\text{mV}/^\circ\text{C}$	$10\text{mV}/^\circ\text{K}$	$10\text{mV}/^\circ\text{K}$
SUPPLY VOLTAGE RANGE	5-30V	4V-30V	NA	8-35V
QUIESCIENT CURRENT	$70\mu\text{A}$	$60\mu\text{A}$	0.4-5mA	1mA NOMINAL

Fig. 5 Temperature sensor IC selection chart (National Semiconductor 'commercial grade' devices).

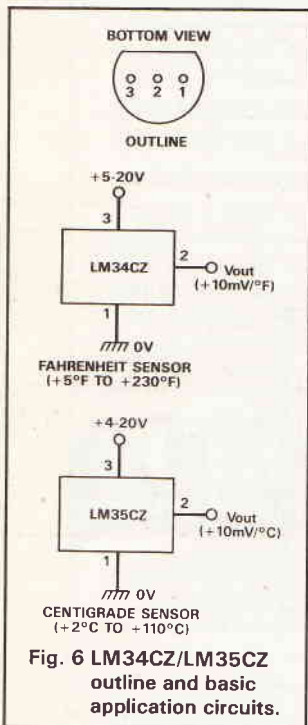

Fig. 6 LM34CZ/LM35CZ outline and basic application circuits.

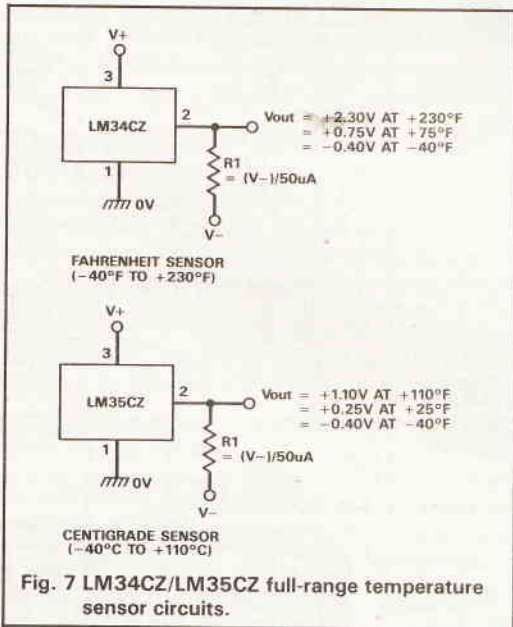

Fig. 7 LM34CZ/LM35CZ full-range temperature sensor circuits.

voltage is available via RV1.

It can be seen from Figure 3 and Figure 4 that the really major snag of using the silicon junction as a precision thermal sensor is that of initially calibrating and scaling its usage circuitry. In recent years, however, advances in manufacturing techniques have made it possible to house a complete sensor and its processing circuitry in a small IC package and, by using very tight production control and on-test trimming, to produce high-performance devices that require a little or no external calibration. Such devices are widely available, reasonably priced, and are simply known as 'Temperature Sensor ICs'.

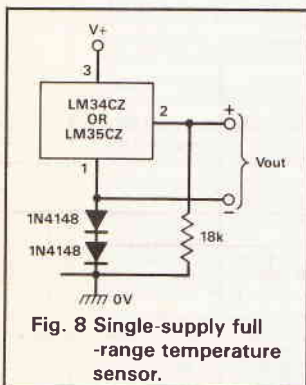

Fig. 8 Single-supply full-range temperature sensor.

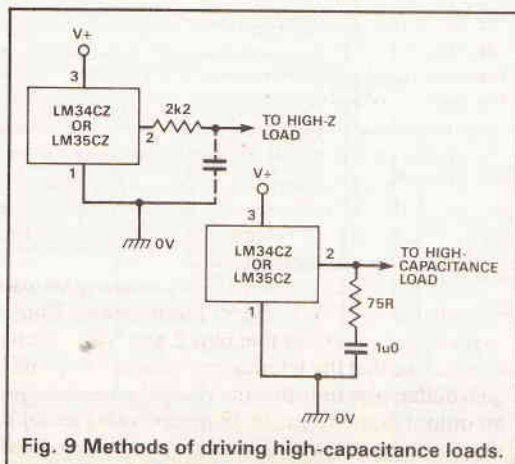

Fig. 9 Methods of driving high-capacitance loads.

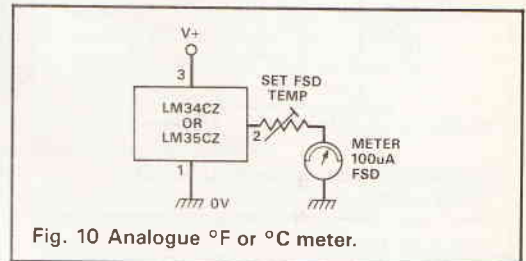

Fig. 10 Analogue $^\circ\text{F}$ or $^\circ\text{C}$ meter.

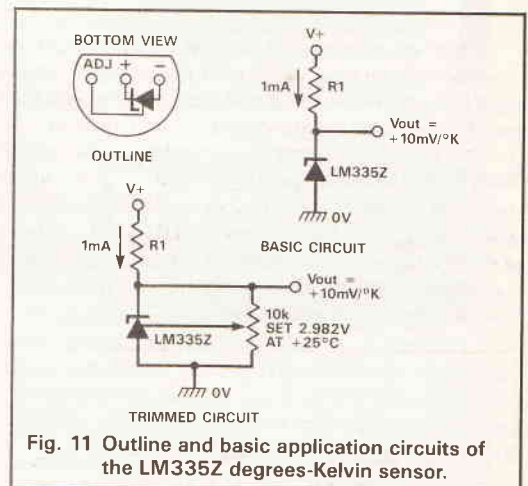

Fig. 11 Outline and basic application circuits of the LM335Z degrees-Kelvin sensor.

LM34CZ/LM35CZ Circuits

The LM34CZ and LM35CZ are housed in 3-pin TO-92 packages, and are designed to consume quiescent currents of only a few dozen microamps, this minimising internal heating effects. Figure 6 shows the outline and basic application circuits of these ICs; note that these basic circuits give minimum temperature readings of $+5^\circ\text{F}$ or $+2^\circ\text{C}$. The ICs can be made to give full-range outputs (i.e., to give

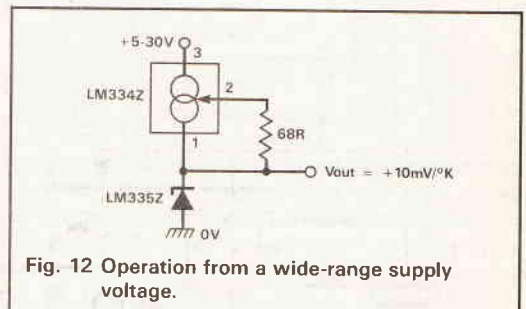
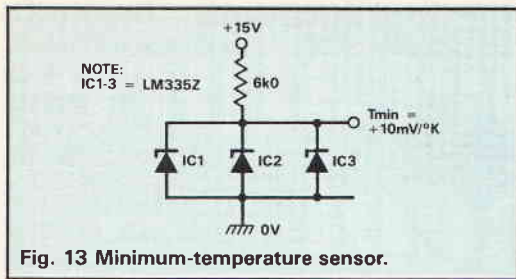

Fig. 12 Operation from a wide-range supply voltage.

temperatures readings down to -40°F or -40°C) by using the two-supply connection shown in Figure 7, or the simulated two-supply connection of Figure 8.

A minor weakness of the LM34CZ and LM35CZ is that, like most micropower ICs, they tend to become



unstable if their outputs are directly loaded by capacitive loads greater than a few picofarad. This snag can be overcome by feeding such loads in either of the ways shown in Figure 9.

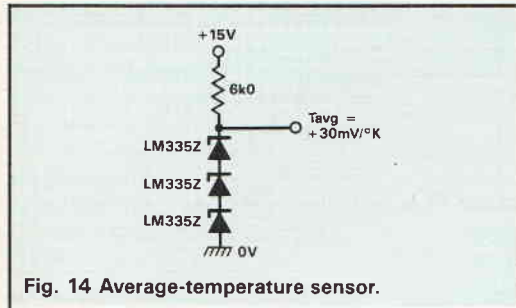

Both of these ICs can be directly used as analogue thermometers by connecting their outputs to a $100\mu A$ moving coil meter via a suitable 'ranging' resistor, as shown in Figure 10. This ranging resistance (which includes the meter's own internal resistance) must equal 100 ohms per degree of full-scale reading e.g., 10k for an F.S.D. reading of $100°F$ or $100°C$, etc. The ICs can be used as digital thermometers, driving a digital display module with a basic 200 mV full-scale sensitivity, by feeding the IC output to the module via a 10:1 attenuator.

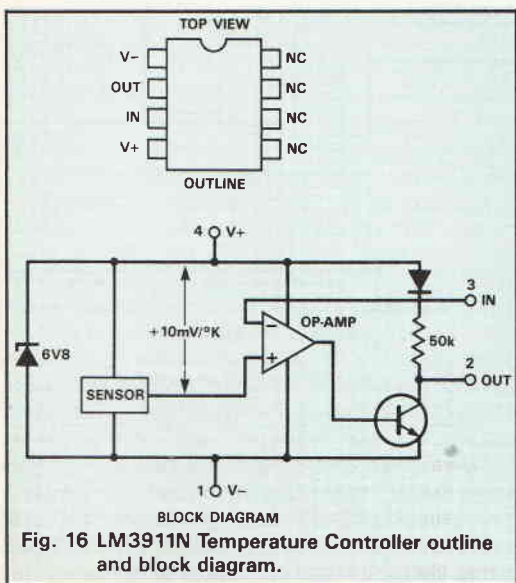
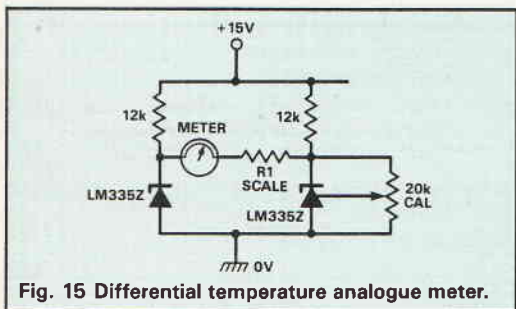

LM3342 Circuits

The LM334Z temperature sensor IC acts like a temperature-sensitive trimmable Zener diode that gives an output of $+10 mV/°K$ (e.g., 2,982 volts at $+25°C$). Figure 11 shows its outline and simple ways of using the device in either the basic (accurate within $+2°C$ at $+25°C$) or the 'trimmable' (precision) mode; note in these circuits that the R1 value is chosen to set the IC's current at about 1mA. Figure 12 shows how the basic circuit can be modified for 1mA operation (via LM334Z constant-current generator) when using a wide-range supply.

Figure 13 shows three LM334Zs used in a circuit that gives an output equal to the lowest of three measured temperatures, and Figure 14 shows a circuit that gives an output proportional to the average of three different readings. Finally, Figure 15 shows how two sensor ICs can be used to make a differential temperature analogue meter; the meter should be a centre-reading ($50\mu A - 0 - 50\mu A$) $100\mu A$ type; the CAL control is initially set to give zero reading when both ICs are at the same temperature, and R1 is chosen to set the desired full-scale differential reading.

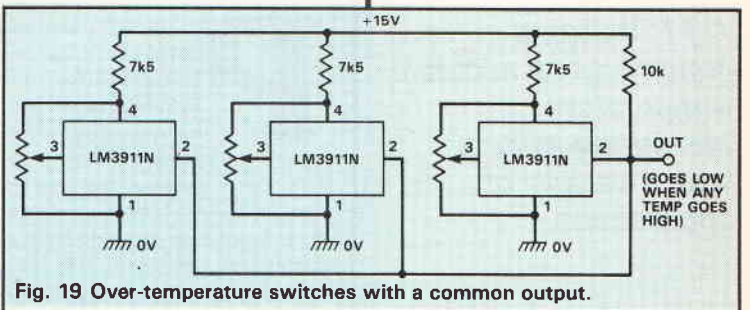
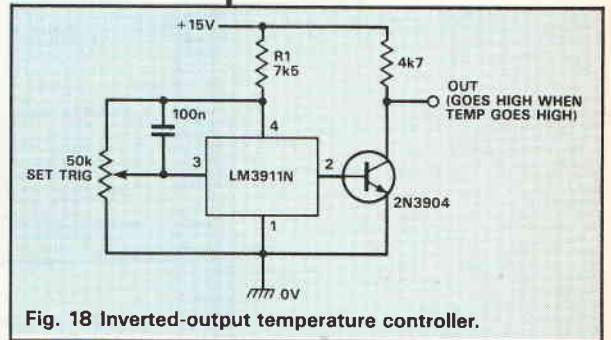
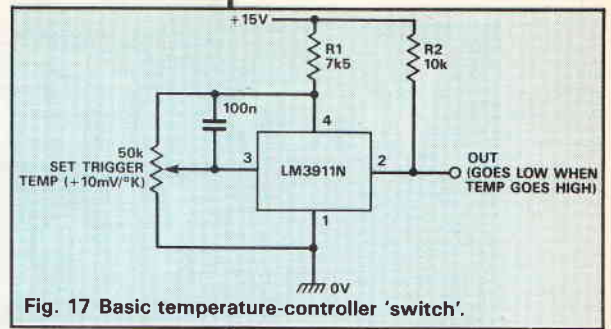

LM3911 Circuits

Figure 16 shows the outline and block diagram of the LM3911N temperature controller IC, which houses a voltage reference, a precision degree-Kelvin temperature sensor, and an op-amp in a single 8-pin DIL package.

Figure 17 shows the basic temperature controller application circuit of the LM3911N. R1 sets a quiescent current of about 1mA in the IC, and the internal op-amp is used in the voltage comparator mode, with pin-3 fed with a stable reference voltage set by the 50k pot. The circuit action is such that the output (pin 2) is normally high, but goes low when the IC's temperature exceeds a threshold value set via the 50k pot. The circuit's action can be reversed, so that the output is normally low but goes high under the over-temperature condition, by modifying the circuit as shown in Figure 18; the outputs of these circuits can be switched from high to low, or vice versa, by temperature changes of only $0.5°C$. Note that several LM3911N ICs can be wired in parallel, as shown in Figure 19, so that the output goes low when any IC reaches its trip threshold.

Finally, Figure 20 and 21 shows alternative ways of using the LM3911N as a $°K$ thermometer. Note in these two applications that pins 2 and 3 are shorted together so that the internal op-amp acts as a unity-gain buffer; also note that the IC can be made to give an output proportional to $°F$ (or any other scale) by simply configuring the op-amp to give an appropriate amount of gain.

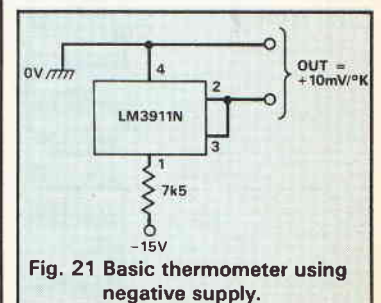
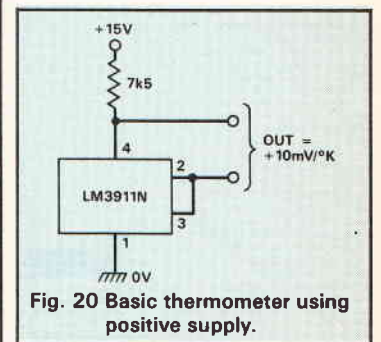

Versatile Temperature Measurement

I

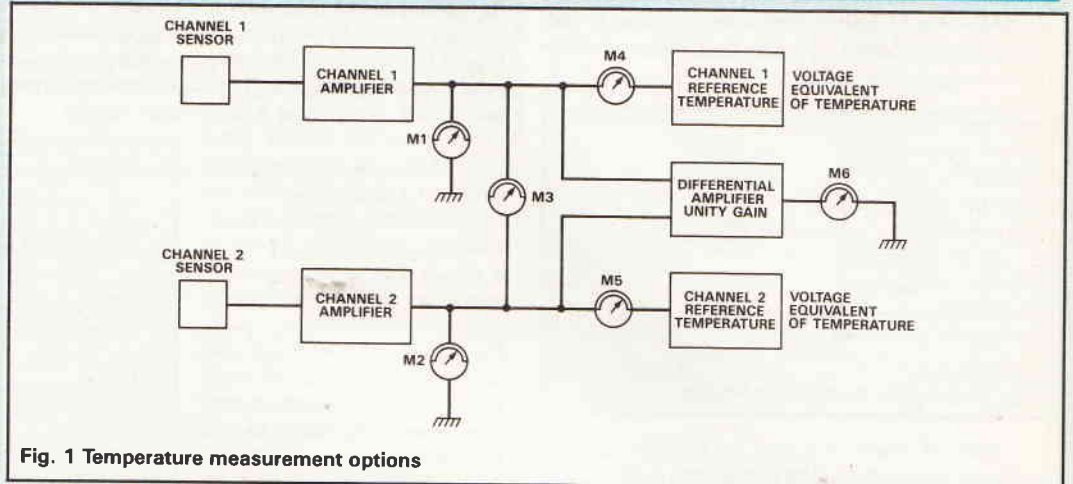

Fig. 1 Temperature measurement options

A J P Williams constructs an accurate temperature measuring system with a variety of applications.

Private, self financed research, very often requires the greatest use from a small amount of equipment. With this in mind a temperature measuring device was designed for use in the solar field, with the possibility of other uses outside this area.

Solar panels of the type used for heating water usually have one or more clear or translucent covers, to prevent heat escaping from a hot absorbing plate, known as a collector. The efficiency of the whole system can be increased by choosing covers that allow a large percentage of the incoming solar radiation to pass through a collector surface that absorbs a high percentage of the sun's rays, and keeps any collector heat losses to a minimum. Some of these requirements are conflicting, for example, more clear covering layers will reduce incident radiation, but at the same time, extra cover plates reduce heat losses

radiation, which means a black body is like an ideal matt black surface.

The fraction of energy absorbed by a real surface compared with that absorbed by a black body is known as the absorption coefficient. Similarly the fraction of energy emitted by a real surface compared with that emitted by a black body is known as the emission coefficient.

My aim was to produce a measuring device which could be used to measure the intensity of solar radiation, the transmission coefficient of clear or translucent cover plates, the absorption coefficient and the emission coefficient of collector surfaces. This measuring device has many other uses as well.

The fundamental concept is based on making measurements so close to the ambient temperature that losses due to convection, conduction and radiation are negligible.

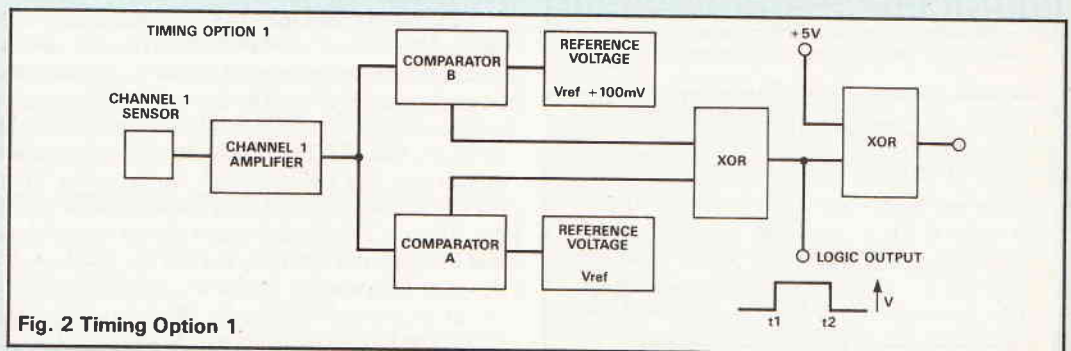

Fig. 2 Timing Option 1

from the collector. Collectors coated with an ordinary matt black paint are good absorbers but they also emit infra red radiation equally well. Some collector surfaces absorb 97% of the incoming solar radiation, while reducing the infra red emission from the hot collector to 10% of the infra-red emission that would have been emitted by a normal matt black paint. These special surfaces are known as selective surfaces. A black body is one that absorbs all the radiation falling upon it, irrespective of the wavelength of the radiation. A black body also emits the maximum possible

To check the performance of the measuring device (and for other tests) it is useful to compare the changes in the one channel relative to the other channel, for example to check the tracking of the two channels over a range of temperatures by having the sensors for both channels mounted side by side on the same test plate, see M3 Figure 1. If a measuring device is used that has one input earthed, for the same purpose as described in the previous paragraph, then it can be connected to the output of a unity gain differential amplifier, see M6 in Figure 1.

PROJECT

The temperature equivalent of each voltage reference is indicated by the setting of three switches and one calibrated variable resistor. When the temperature of a sensor is slightly higher than its equivalent reference temperature, a piezo-electric sounder operates, which enables the temperature of the sensor to be read directly from the setting of the reference switches without using any meters.

Most of my tests are carried out using copper plates 30cm x 16.7cm (500 cm² approx). The size is not that important but it makes calculation a little easier to make the area 1.20m². The copper plates were chosen to be 1mm thick, this ensures that the mass of each plate is sufficient to prevent the plate heating up too quickly when it is exposed to maximum intensity sunlight and the surface has the maximum possible absorption coefficient. This results in the highest rate of rise of temperature, of about 1 degree in 3.4 seconds. The sensor time constant must be in the order of 0.1 second, for the change in temperature to be accurately followed.

To measure the temperature change rate, it is desirable to make the temperature measurement interval as small as possible so measurements can be made as close as possible to the ambient temperature. If the interval is made too small, the electrical noise

output goes to its high state. The logic output changes back again to the low state (t₂) when the sensor temperature reaches the temperature equivalent of $V_{ref} = +100mV$, so comparator B goes to its logic high state. Since 100mV represents one degree Celcius, then the time interval between t₁ and t₂ is the time taken for the sensor to rise through one degree Celcius.

The circuit has a similar operation for measuring the time taken for the sensor to fall through one degree Celcius. In this case the equivalent reference temperature voltage ($V_{ref} = +100mV$) is set initially, slightly below the sensor temperature.

A piezo-electric sounder operates when the logic output is in its high state, this allows the setting up of the equivalent reference temperature. The end of the timing process is indicated by the sound output ceasing.

Timing Option 2

When the temperature of channel 1 sensor is slightly higher than the equivalent reference of channel 1, then the logic output moves to the high state at t₁ (Figure 3). Similarly for channel 2 when the sensor is slightly higher than the equivalent temperature of channel 2, then the logic output moves back to its

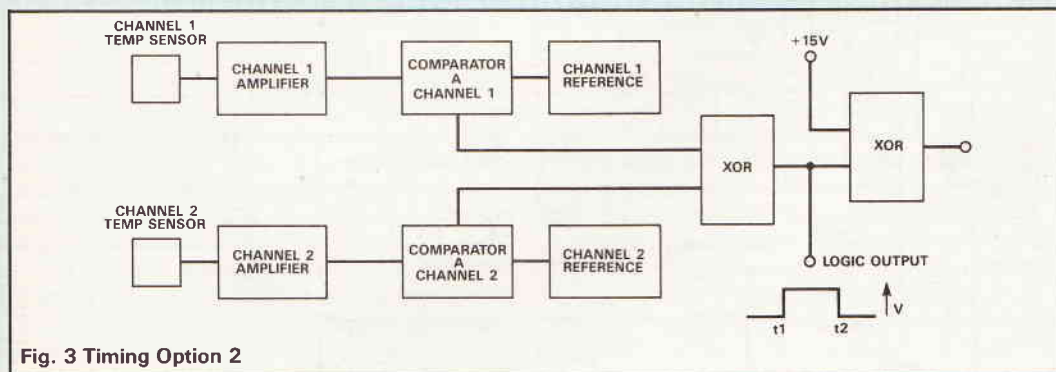

Fig. 3 Timing Option 2

of the system prevents accurate measurement. An interval of 1.00° Celcius was chosen as a good compromise as well as being a very convenient value for calculation purposes. Two identical measuring channels are required so two measurements can be compared under the same conditions. Providing the two channels are calibrated using the same temperature reference then comparative measurements between the two channels are good. If care is taken, measurements of rate of rise of temperature using identical copper plates and surfaces, taken under the same conditions, produce results that are within 1% of each other. Absolute temperature measurements to within $-/+0.5^\circ$ Celcius can be achieved (see meters M1 and M2 in Figure 1).

Before taking a measurement it is useful to know whether the object being measured is in a state of equilibrium with its surroundings, (not changing in temperature). Detecting very small changes in temperature requires the voltage output of the sensor after amplification to be measured relative to the reference voltage. This can be set to the equivalent of any temperature within the range of the instrument (see M4 and M5 in Figure 1). These meters are only indicating a small voltage and therefore can have a good resolution. Changes of one hundredth of a degree are easily observable if the noise and drift of the system is small.

Timing Option 1

The logic output in Figure 2 changes from low to high state (t₁) when channel 1 sensor reaches the temperature equivalent of V_{ref} , ie comparator A

original low state (t₂).

The time interval between t₁ and t₂ indicates the time taken between sensor 1 and 2 reaching its pre-determined temperature.

The situation is similar for falling temperatures, in this case if there is no alteration of the reference settings, t₁ will be determined by the channel 2 sensor and t₂ by the channel 1 sensor.

HOW IT WORKS

The Constant Current Generators and Reference Voltage

A stable voltage reference is required, this being derived by passing a constant current through a known stable resistance. The resistance consists of 3 banks of switched resistors, shown as one resistor RV2 in Figure 1 (see also Figure 5) and one continuously variable resistor RV3, in Figure 1. The constant current generator formed from IC2, Q3, Q4 and R4 provides a current of 5mA by using a 2.5V reference voltage (between the +15V and +17.5V supply rails) across the 500R input resistor R3.

The amplified output voltage from the temperature sensors was chosen so that 100° Celcius provided 10V, this being a convenient voltage for display on any digital or analogue meter. A reference voltage for a 1° change is provided by the constant current of 5 mA also passing through a 20R resistor, R5. The voltage across R5 is 100mV which ensures that it is large compared with any Op-amp offset zero voltages. The value of the constant current was chosen to ensure that the bias currents of the Op-amps would be negligible in comparison and the total value of RV2 and RV3 was low enough to ensure a small value of induced noise. Part of the constant current is fed to the -15V rail via R16 (selected) and R17. By reducing the value of the constant current through RV3, the value of RV3 could be kept to a convenient easily obtainable value.

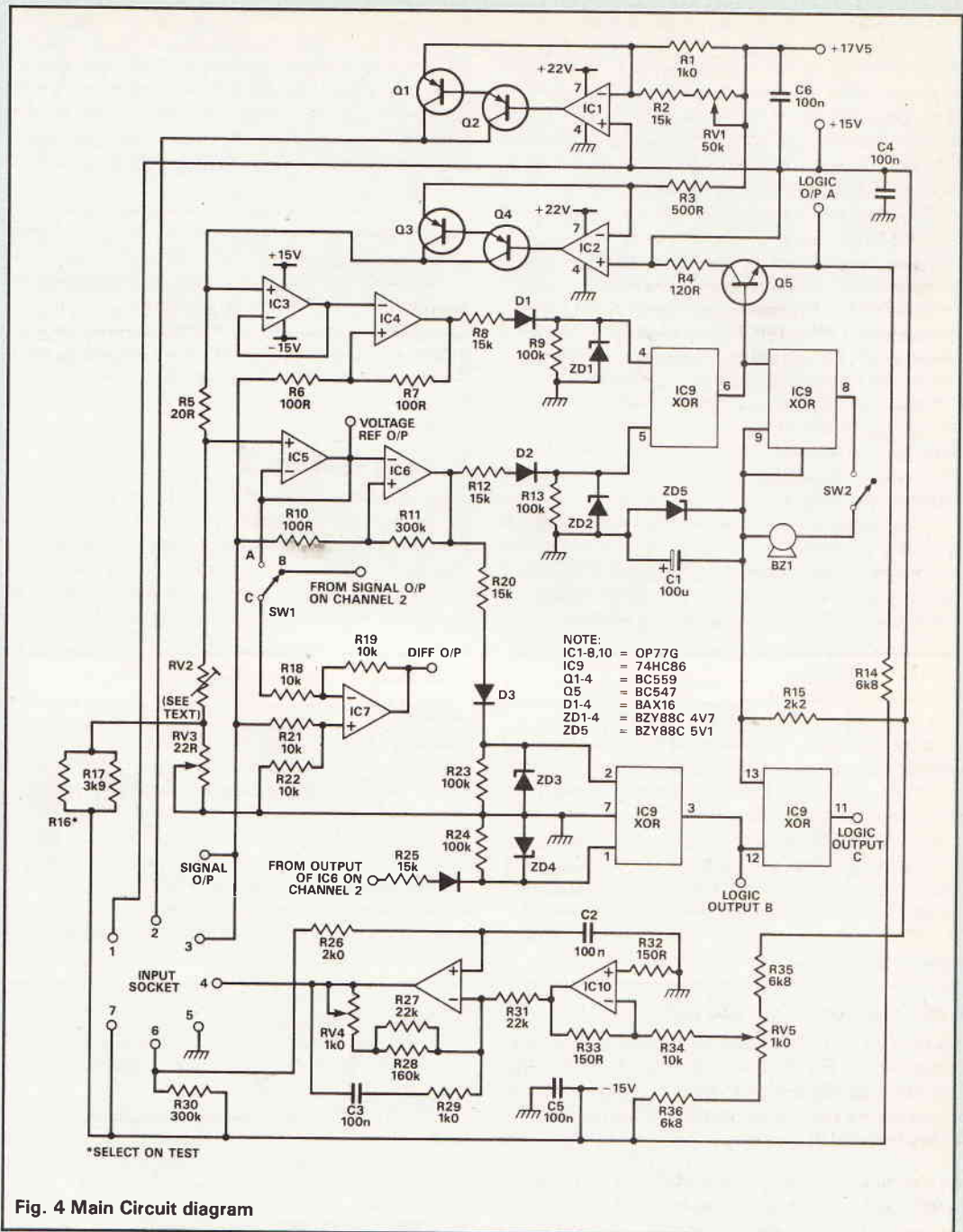

Fig. 4 Main Circuit diagram

The Semi-conductor Probe and Amplifier

The LM35 temperature sensor shown in Figure 7 gives 0V output at 0° Celsius and 1V output at 100° Celsius, ie a sensitivity of 10 mV per °. The line regulation of the LM35 is typically 0.02mV/V and as the 15V supply is regulated the error from this source is negligible. The load regulation of the LM35 is typically 0.5mV/mA. The change in load current over a 100° change in temperature is only 0.5mA ie a 0.025° error in 100° change and this small error can be trimmed out during the line up procedure if required. The error due to self heating is typically 0.08° Celsius in still air.

The output of the LM35 is fed via pin 6 of a 7 pin DIN plug to the semiconductor sensor amplifier IC8. In this non-inverting amplifier, R26 and C2 form an input filter to reduce high frequency noise from the sensor, C3 and R29 reduce the HF gain of the amplifier to also minimise noise.

IC10 provides a stable DC voltage that is applied to the inverting input of IC8. The adjustment of RV5 varies this DC output so that Zero voltage output can be obtained at the output of IC8 when the semi-conductor sensor is at 0° Celsius. The nominal gain of the IC8 stage is 10. This gain can be varied slightly by means of RV4, so that

the output of IC8 is exactly 10V when the temperature sensor is at 100° Celsius. The output of IC8 is fed to pin 4 of the input socket and a strap on the input plug returns the output back to pin 3 on the input socket where it is then fed to the signal output socket and also to a line common to 2 comparator stages and a differential amplifier stage.

The Comparators and Logic Stages

IC3 and IC5 are voltage followers. The difference in the output voltage between these two voltage followers being 100 mV, ie the same as the voltage across R17.

IC4 and IC6 are regenerative comparators. The output resistance of the signal amplifiers being sufficiently low to prevent changes in input current (as the comparator switches) from significantly affecting the value of the signal output.

Assume that the voltage at the junction of RV2 and R5 has been set to 5V by adjusting the value of RV2. This voltage represents 50° Celsius. When the temperature sensor reaches 50° Celsius the signal output will be 5V and comparator IC6 will switch so that its output goes positive. As the temperature rises to 51° Celsius the signal output will reach 50.1V and the output of IC4 will change to its positive state. The feedback resistors on the comparators have been

chosen to give a hysteresis of just under 10mV which ensures that any noise does not give multiple triggering of the comparators.

The output of the comparators changes from approximately -15V to +15V. The resistors and diodes between the output of the comparators and the input of the following XOR gate ensures that the logic level varies between 0V and 4.7V to be compatible with the XOR gate. Using the conditions mentioned at the beginning of this paragraph, when the temperature of the sensor reaches 50° the input to IC9 pin 5 goes to its high state and pin 4 is at its low state thus the output of IC9 pin 6 goes to its high state. When the temperature of the sensor reaches 51° pin 4 also goes to the logic high state so the output of IC9 pin 6 goes to its low state ie the width of the pulse output from IC9 pin 6 indicates the time taken for the temperature to move between 50° and 51°. The output from pin 6 of IC9 is fed into pin 10 of IC9 and since pin 9 is held constantly at logic high then pin 8 provides an inverted output of the pulse at pin 6.

When SW2 is closed the output from pin 8 of IC9 is used to operate a piezo-electric sounder which gives an audible warning when the timing pulse is present.

The logic output from pin 6 of IC9 is fed via an emitter follower (Q5) to an output terminal. This output was used to drive a long coaxial cable feeding a remote computer. The computer being used to time the pulse width.

The XOR gate pins 1 and 2 and inverter pins 12 and 13 operate in a similar manner to that described for the other sections of IC9. In this case the gate is operated from IC6 output from each of two separate identical circuits both as shown in Figure 1. See Figure 3 for details.

The Platinum Resistance Probe

The semi-conductor sensor is very convenient for many measurements being relatively robust and physically small but its time constant was too long to measure accurately a rate of change of temperature of One degree Celcius in 3.6 seconds which was the maximum rate of change that I required. This required response (for surface measurement on metal) was obtained by using a small unshathed platinum resistance sensor.

The sensor has a resistance of 100R at 0° Celcius and 138.5R at 100° Celcius. A constant current generator formed from IC1, Q1, Q2, R1, R2 & RV1 in Figure 4 provides 2.597mA which is passed

through the sensor via pin 2 of the input plus and socket. This value of current was chosen to make the sensitivity of the sensor 1mV per Degree Celcius while keeping the sensor power dissipation down to 0.674mW at 0° Celcius and 0.934mW at 100° Celcius. The self heating coefficient with infinite heat sink is 0.0005° per mW and in still air 0.2° per mW, so for most measurements self heating does not contribute much error. A 4 wire sensing system is used as shown in Figure 6. IC1 and IC3 are both voltage followers, the output of IC1 relative to the output of IC3 being the voltage directly across the sensor. IC2 and its associated resistors form a differential amplifier with a voltage gain of 100.

The 1.26V reference voltage causes a current of 126µA to flow through R8 and also R10, R11 & R12. Resistor R10 is selected so that the potential at the output of IC4 is -0.2597V relative to the output of IC3, ie it has the same magnitude as the voltage across the sensor at 0° Celcius. This results in the output of IC2 (at pin 3 of the input plus) being zero when the sensor is at 0° Celcius. R5, C2, C3 and R9, C5 reduce the gain of stages IC2 and IC4 respectively at high frequencies to minimise noise.

The platinum resistance amplifier is mounted in an external screened probe so that there is a much larger signal to be fed along long connecting screened leads to the main unit. Most of the resistors within the platinum resistance amplifier are 0.1% to ensure a gain close to 100 and to give the required long term stability. For my purposes the accuracy with a fixed gain for IC2 was sufficient, but obviously the gain of this stage could be made adjustable over a small range for a more precise calibration.

The Power Unit

With reference to Figure 8, the lower half of the circuit is a two conventional full wave rectifier circuits, followed by 15V stabilisers to give +15V and -15V relative to the chassis (0V).

The top half of the circuit is a conventional full wave rectifier followed by a variable stabiliser which has been set to give 7V output. This 7V is connected in series with the +15V from the lower half of the circuit to give a stabilised 22V supply which is required for the constant current generators supply voltage. The 7V supply also feeds a voltage reference (REF 03) to give a very stable 2.5V supply which ensures a very stable current from the constant current generators.

Calibration Procedure

Adjust RV1 in the power unit (Figure 8) until the voltage across R5 (Figure 4) is 100mV \pm 0.1%. This automatically ensures that the 2.5V power supply output is very close to its nominal values as R4 and R6 are both 0.1% resistors.

Quick approximate calibration of the semi-conductor sensor (See Appendix 1)

Connect a +1V DC supply between pin 6 of the input socket and the chassis. Adjust RV5 until the P.D from the junction of R31 and R33 relative to chassis is 0V. Adjust RV4 until the PD between pin 4 of the input socket and chassis is 10V. Plug the semiconductor sensor into the input socket and the accuracy for temperature measurement will be within \pm 1.0° using the LM35D sensor and slightly better for the LM35C sensor.

Precise calibration of the semi-conductor sensor (See Appendix 1)

Plug the semi-conductor sensor into the input socket. Keep the sensor at 0° Celcius (see appendix 1) and adjust RV5 until the output of IC8 is 0.00V relative to the chassis. Keep the sensor at 100° Celcius and adjust RV4 until the output of IC8 is 10.00V relative to the chassis. The accuracy will then be typically \pm 0.25° over the whole range.

Quick approximate calibration of the Platinum Resistance Sensor

Plug the platinum resistance sensor into the input socket and temporarily replace the sensor with a 100R \pm 0.1 resistor. Adjust RV1 (Figure 4) until the PD across the 100R test resistor is 0.2597V, make the

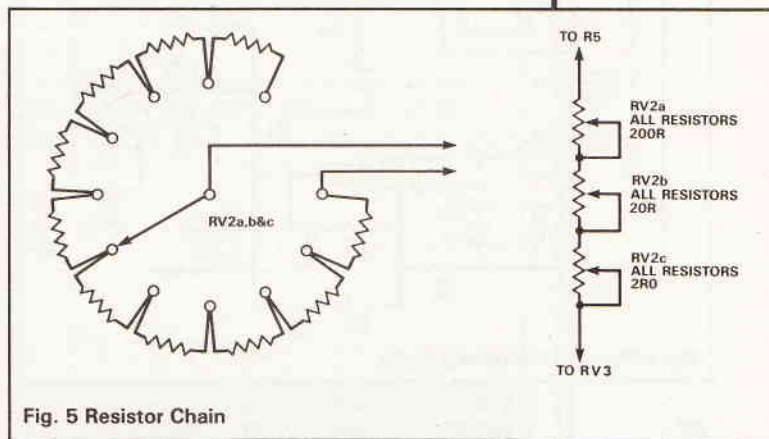

Fig. 5 Resistor Chain

measurement between IC1 output and IC3 output (Figure 6). Select a resistor or resistors for R10 (Figure 6) with a value close to 63R so that the output on pin 3 of the input plug is 0.00V relative to chassis potential.

Replace the platinum resistance sensor, the accuracy will then be typically \pm 0.6° Celcius for class A sensors and \pm 1.0° Celcius for class B sensors. This accuracy could be improved slightly by using a 0.01% tolerance test resistor.

Precise calibration of the Platinum resistance sensor. (See appendix 1)

Plug the platinum resistance sensor into the input socket. Keep the sensor at 0° Celcius and adjust RV1 (Figure 4) until the PD across the sensor (measured

between IC1 output and IC2 output) is 0.2597V. Select a resistor or resistors for R10 (Figure 6) until the output on pin 3 of the input plug is 0.00V relative to the chassis potential. Keep the sensor at 100° Celcius and shunt R4 until the PD between the junction of R3, R4 and the chassis is 9.97V. This should give a typical overall accuracy of $\pm 0.4^\circ$ Celcius

Calibration of R12 (Hundredths of a degree)

Temporarily disconnect R17 (Figure 4), so that the full 5mA constant current flows through RV3. Turn RV3 fully anti-clockwise and mark the dial where the knob pointer is positioned. This mark will enable the knob to be re-positioned after calibration. Turn RV3 clockwise until the PD across RV3 is 5mV, mark this position on the dial. Continue to turn RV3 clockwise marking the dial every 5mV step until RV3 is fully

clockwise. Make the marks longer at 50mV and 100mV as these points will represent 1 and 2 tenths of a degree Celcius. Reconnect R17 and select a value for R16 so that the current through RV3 is 1mA. The other channel can be calibrated in the same way and the dial marks then made more permanent.

Extending the temperature measurement range

The platinum resistance sensor can be used down to -50° Celcius. If the gain of IC 2 in Figure 6 is reduced to 10 then temperatures should be measurable up to 500° Celcius.

The LM35DZ semiconductor sensor can be used from 0 to 100° Celcius and the LM35CZ sensor can be used from -40 to $+110^\circ$ Celcius.

PARTS LIST

Note: All components listed below are for ONE channel only and therefore must be duplicated for both channels.

RESISTORS (all 1/4W 5%)

R1	1k 0.1%
R3	500R 0.1%
R5	20R 0.1%

Metal film resistors 1% 0.6W

R2,8,12,20,25	51k
R4	120R

RV1	50k
RV4,5	1k0
RV3	22R Pot

CAPACITORS

C1	100 μ 12V
C2,3,4,5,6	100n Disk ceramic 50V

SEMICONDUCTORS

IC1-8,IC10	OP77G
IC9	74HC86
Q1,2,3,4	BC559
Q5	BC547
D1,2,3,4	BAX16
ZD1,2,3,4	4.7V Zener BZY88C
ZD5	5.1V Zener BZY88C

MISCELLANEOUS

Rotary wafer switch 1P 12W	Make before break Qty 3
SW1,SW2	SPDT Toggle Switch
BZ1	Piezo Buzzer 3 to 30V dc 7mA max

The following components only are common in both channels. Circuit Equipment Case 21-06202 Maplin Lever Terminals BW71N Qty 3

POWER UNIT

RESISTORS (all 1/4W 5%)

Metal film 1.0% 0.6W

R1,2	2k2
R3	240R
R4	1k1
RV1	5k0 18 turn Cermet Trimmer

CAPACITORS

C1,7,12	10 μ 50V Radial Electrolytic
C4,9,14	1000 μ 35V Radial Electrolytic
C2	330p 160V Polystyrene
C3,6,11	100n 250V Polyester layer
C5,10	2 μ 2 250V Polycarbonate
C8,13	1 μ 0 100V Polyester layer

SEMICONDUCTORS

IC1	Ref 03 2.5V Voltage Reference
IC2	LM317 +1.2 to 37V Voltage Stabiliser
IC3	μ A 7815 15V 1A Positive Voltage Stabiliser
IC4	μ A 7915 15V 1A Negative Voltage Stabiliser
D1,2,3,4,5,6	1N4003 Diode

MISCELLANEOUS

T1	9-0-9V 250mA Transformer
T2	15-0-15V 250mA Transformer
D1,2,3,4,5,6	1N4003 Diodes
L1,L2	470 μ H Inductor
PCB	
SW1	2PST Toggle Switch
F1	200mA Fuse and Holder
14 pin DIL socket	Qty 10

RESISTORS (all 1/4W 5%)

Metal film 1% 0.6W

R3,9	100k
R5	1k0
R7	27k
R10	Select on test (36R initially)

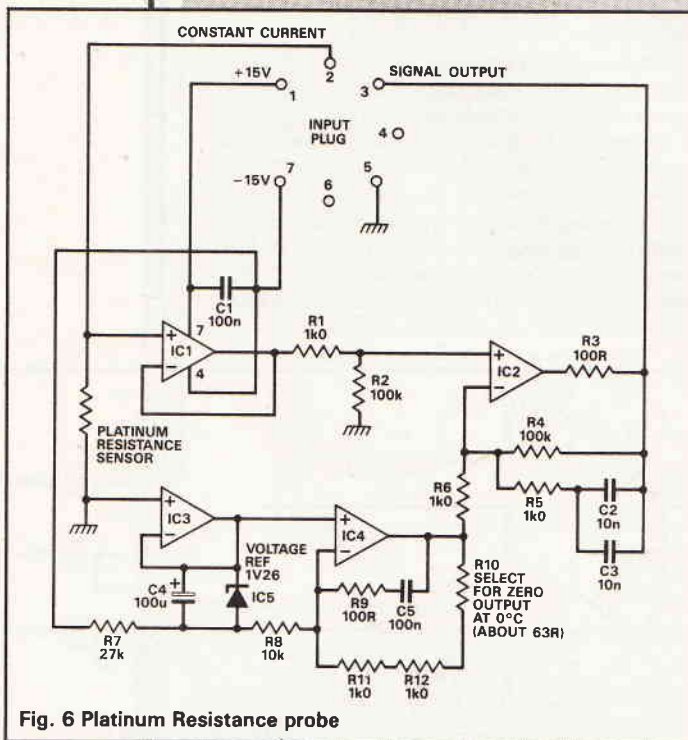

Fig. 6 Platinum Resistance probe

R6,10	100R
R7,11,30	300k
R9,13,23,24	100k
R14,35,36	6k8
R15	2k2
R16	Select on test.
R17	3k9
R18,19,21,22,34	10k
R26	2k0
R27,31	22k
R28	160k
R29	1k0
R32,33	150R
RV2	(See Fig 5) composed of:- 2R Qty 10 20R Qty 10 200R Qty 10 18 or 20 turn Cermet trimmers

PROJECT

PRECISION RESISTORS 0.1%

- R1,6,11,12 1k0
- R2,4 100k
- R8 10k

CAPACITORS

- C1,5 100n 50V Ceramic Disc
- C2,3 10n 25V Ceramic Disc
- C4 100µ16V Radial Electrolytic

SEMICONDUCTORS

- IC1,2,3,4 OP07
- IC5 O4BJ 1.26 V Voltage Ref

MISCELLANEOUS

- Platinum Resistance Sensor (Pt100)
- Electromail Standard 158-238 (Unsheathed) Sheathed 158-244
- 7pin DIN Plug
- Single screened cable
- PCB 14pin DIL socket Qty4
- Diecast Box
- Semiconductor Probe
- Temperature sensor LM35CZ or LM35DZ
- 7pin DIN Plug Qty 1
- Twin screened cable

Appendix 1

```

10 A=B=0
15 TIME=0
20 REPEAT
30 MOUSE xpos%, ypos%, button%, time%
40 CASE button% OF
50 WHEN 1: timeA1%=TIME:A=1
60 WHEN 2: timeB1%=TIME:B=1
70 ENDCASE
80 UNTIL A=1 OR B=1
90 IF A=1 THEN GOTO 100
95 IF B=1 THEN GOTO 165
100 REPEAT
110 MOUSE xpos%, ypos%, button%, time%
120 CASE button% OF
130 WHEN 3: timeB1%=TIME:B=2
140 ENDCASE
150 UNTIL B=2
155 GOTO 220
165 REPEAT
170 MOUSE xpos%, ypos%, button%, time%
180 CASE button% OF
190 WHEN 3: timeA1%=TIME:A=2
200 ENDCASE
210 UNTIL A=2
220 REPEAT
230 MOUSE xpos%, ypos%, button%, time%
240 CASE button% OF
250 WHEN 1: timeB2%=TIME:B=3
260 WHEN 2: timeA2%=TIME:A=3
270 ENDCASE
280 UNTIL A=3 OR B=3
    
```

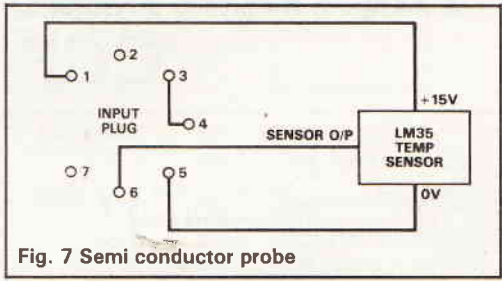

Fig. 7 Semi conductor probe

- 290 IF A=3 THEN GOTO 310
 - 300 IF B=3 THEN GOTO 400
 - 310 REPEAT
 - 320 MOUSE xpos%, ypos%, button%, time%
 - 330 CASE button% OF
 - 340 WHEN 0: timeB2%=TIME:B=4
 - 345 ENDCASE
 - 350 UNTIL B=4
 - 360 GOTO 520
 - 400 REPEAT
 - 410 MOUSE xpos%, ypos%, button%, time%
 - 420 CASE button% OF
 - 430 WHEN 0: timeA2%=TIME:A=4
 - 440 ENDCASE
 - 450 UNTIL A=4
 - 520 PRINT "Channel 1 " (timeA2%-timeA1%)/100 " Seconds"
 - 530 PRINT "Channel 2 " (timeB2%-timeB1%)/100 " Seconds"
1. Load above program
 2. Set temperature reference switches to their required settings
 3. Press escape key: RUN: press RETURN key to obtain timings.

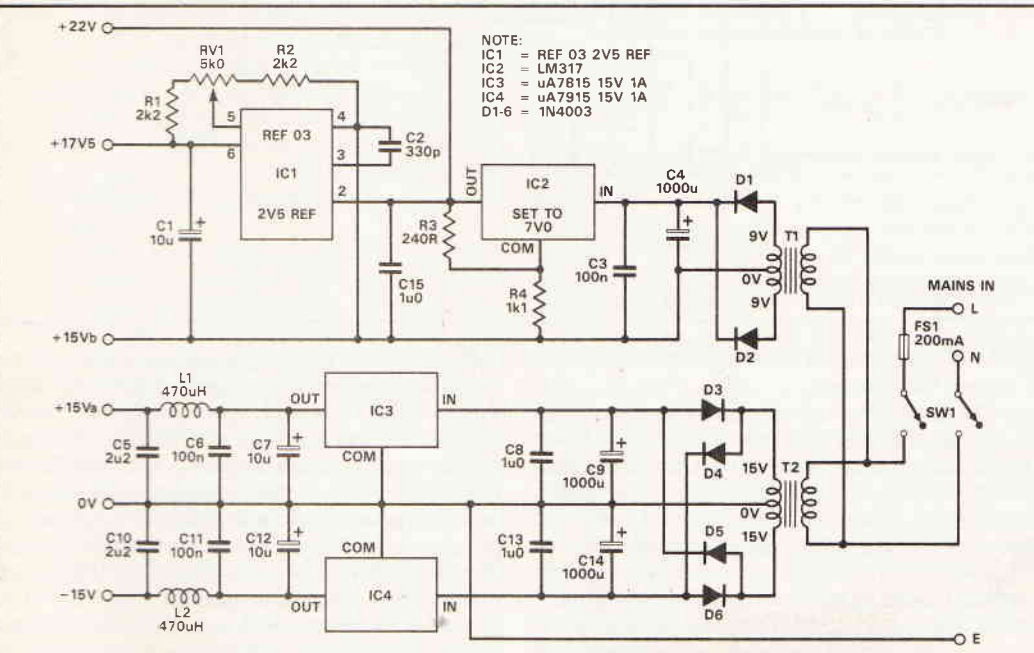

Fig. 8 Power Supply unit

TO BE CONTINUED

High Definition Television

The High Resolution Sciences CCF system

PARAMETER	NTSC	CCF	COMMENTS
NUMBER OF SCANNING LINES	525	525	
INTERLACE	2:1	2:1	
HORIZONTAL FREQUENCY	15,734.26	15,768.79	0.21% FASTER
VERTICAL FREQUENCY	59.94	60.07	0.21% FASTER
SUBCARRIER	3,579.545	3,579.345	
ICLES OF SUBCARRIER PER LINE	227.5	227	0.21% LESS
CHROMA CRAWL	YES	NO	IMPROVED
CROSS COLOUR	YES	REDUCED	IMPROVED

Fig. 1 Differences between CCF and NTSC.

High Resolution Sciences, Inc. is a research corporation dedicated to develop technologies that improve the quality of visual displays. They have not so far put forward a comprehensive scheme for advanced television, but they did submit a paper to the FCC Advisory Committee on Advanced Television Service, and the techniques which HRS have developed look as though they

and frame frequencies in the NTSC system, which were originally chosen to minimise the effects of adding the colour signals to the black and white pictures, it being particularly important to see that the millions of viewers with monochrome receivers were not disturbed. In order to make the spectra of the colour information interleave with that of the luminance information, the colour subcarrier frequency was chosen to be an odd multiple of half the frame and line frequencies. It works out that each NTSC line has 227.5 cycles of subcarrier and each frame 119,437.5 cycles. Since each field ends with the subcarrier 90 degrees out of phase with the one before it, each scanning line will begin with the subcarrier 180 degrees out of phase with the preceding one. In consecutive fields, therefore, the

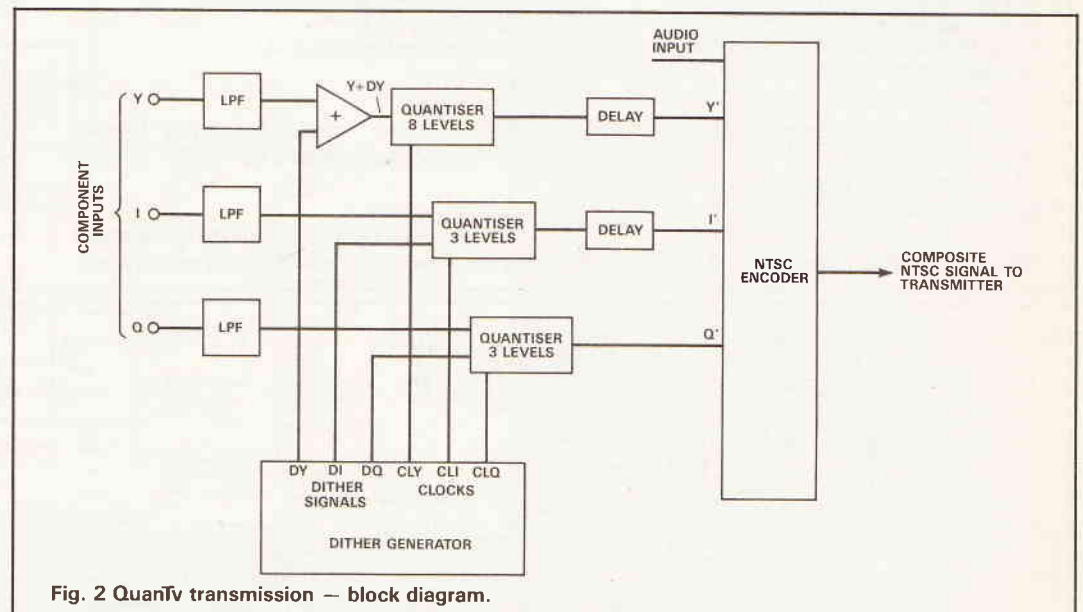

Fig. 2 QuanTv transmission — block diagram.

could make a significant impact if they were applied to various ATV systems.

The heart of the technology developed by HRS is a system called Chroma Crawl Free (CCF). This is a novel method of encoding and synchronising television pictures so that unmodified existing television receivers will display a picture without the effect known as 'chroma crawl', and with greatly reduced cross-colour and cross-luminance artifacts. Chroma crawl can be seen along the edges of brightly coloured parts of NTSC images and in some coloured patterns, as colour dots which move slowly up the picture. The effect can be disturbing, especially when looking at titles in saturated colours, or at detailed patterns. It occurs because of the relationship between the line

colour subcarrier position will appear one line higher, and this causes the 'chroma crawl' or 'dot crawl' effect.

The CCF System changes from the 227.5 cycles of subcarrier per line used in NTSC to 227 cycles, increasing the horizontal frequency by about 2%. This makes every line of the same field have the same subcarrier phase, but an additional half cycle of colour subcarrier is added at the end of each field, with the net effect being that the next field will be 180 degrees out of phase. Fields one and three have the same subcarrier phase on every line, and have the opposite phase from fields two and four, and the resulting in no dot crawl. As an added advantage, the change in the relative phasing of phase has the effect of reducing cross-colour artifacts.

This and next month James Archer looks at the final batch of proposed ATV systems, making some predictions about which are likely to succeed, and those likely to disappear without trace.

HDTV

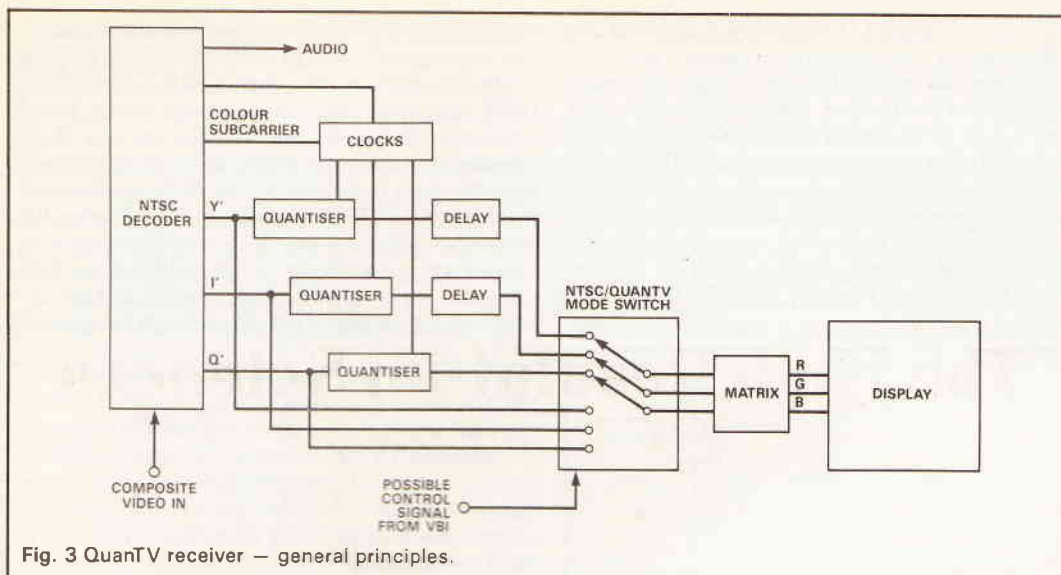

Fig. 3 QuantV receiver — general principles.

Compatibility

The difference between the horizontal and vertical scanning frequencies is small enough to be well within the tolerances of television receivers and video recorders, and tests via satellite and cable systems have resulted in no complaints from viewers. There can be problems in some types of studio equipment such as cameras, special effects units and C-format video recorders which derive their synchronising signals by dividing down from the colour subcarrier.

QuantV — a new technique from the Quanticon company

As the Quanticon submission to the FCC ACTS says, "QuantV is not really a television system, but it is a technique which is applicable to both analogue and digital television systems, and which can reduce noise, distortion, and interference." The signals produced by the system are compatible with existing NTSC receivers and can be carried within the existing 6MHz NTSC radio frequency channel. An advanced receiver could use QuantV signals to rebuild the component parts that provide pictures. They are claimed to be free from all impairments caused by channel noise, interference, cross-modulation, echoes, and colour distortions. The transmitted signal can be recorded on an existing NTSC video-recorder and will play back into a normal NTSC machine at standard NTSC quality; a better quality machine would be required to record the higher quality QuantV pictures. No change in the 4:3 aspect ratio is involved.

The technique used in QuantV is called 'psychophysical compression', and Figure 2 shows what is done at the transmitting end. After filtration, luminance and chrominance components are sampled, and carefully designed dither signals, called 'cinematic dithers' are added to the sampled signals before quantisation takes place. The dither signals vary from pixel to pixel and from line to line, and this technique allows fewer bits to be used in the quantising process without the noticeable contouring effect. If the signals were digitally sent, which is not currently the case, then the bandwidth would be reduced from that required to transmit a standard digital NTSC signal. In the current circumstances, however, where analogue transmission is to be used, the increased bandwidth can be deliberately sacrificed in order to improve the signal to noise ratio of the analogue signals, and to render them more rugged and less susceptible to interference.

The psychophysical compression technique uses luminance sampling having seven or eight levels, but the dither signals cause variations in the level of each picture element between the amplitudes of two adjacent steps. The effect of the dither gives a subsampling effect, i.e. lots of mini-steps for each main amplitude step, and this is especially noticeable in areas of low contrast. The low contrast parts of the

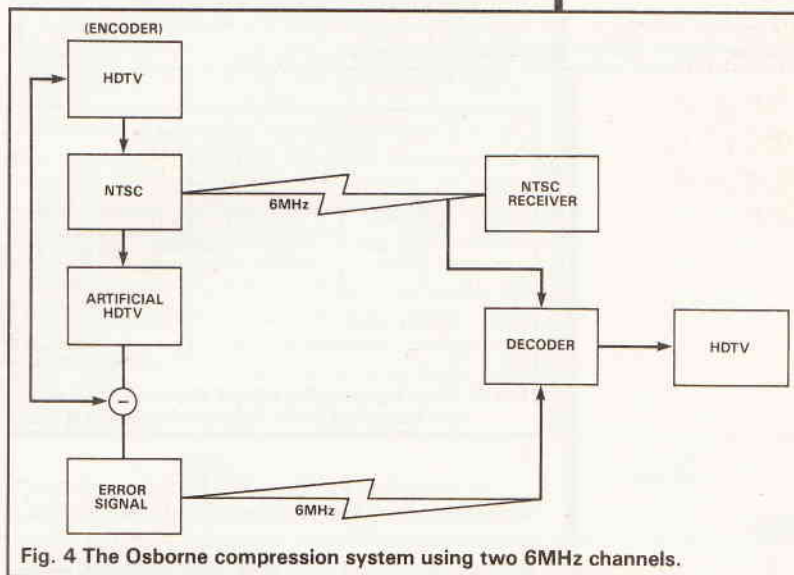

Fig. 4 The Osborne compression system using two 6MHz channels.

picture can use a trade off between spatial and temporal resolution and contrast. This turns out to provide acceptable pictures with improvements in signal to noise ratio, distortion, and ruggedness that were described earlier.

The dither signals are generated by computer techniques, and the transmitter must be modified before QuantV can be incorporated.

Standard NTSC television receivers can make use of the NTSC signal that results from the dithered signals without any problems, but in order to make use of the QuantV signals to generate improved pictures in the home, a special receiver containing frame storage is necessary, and Figure 3 shows the general principles.

The QuantV receiver takes the luminance and colour difference components from the NTSC decoder and then quantises luminance using seven or eight levels and colour difference using three levels. Appropriate delays are inserted in the luminance and chrominance channels, and the regenerated pictures

are free from noise and interference. Clock circuitry in the receiver uses the colour subcarrier to ensure synchronisation between the sampling processes in the transmitter and receiver. The QuantTV receiver has to be a dual-mode design which can switch over to normal NTSC decoding when standard NTSC signals are being transmitted; the diagrammatic changeover switch can be seen in Figure 3. It has been suggested by Quanticon that an ancillary signal carried in the NTSC vertical blanking interval could be used to switch the receiver between QuantTV and NTSC modes.

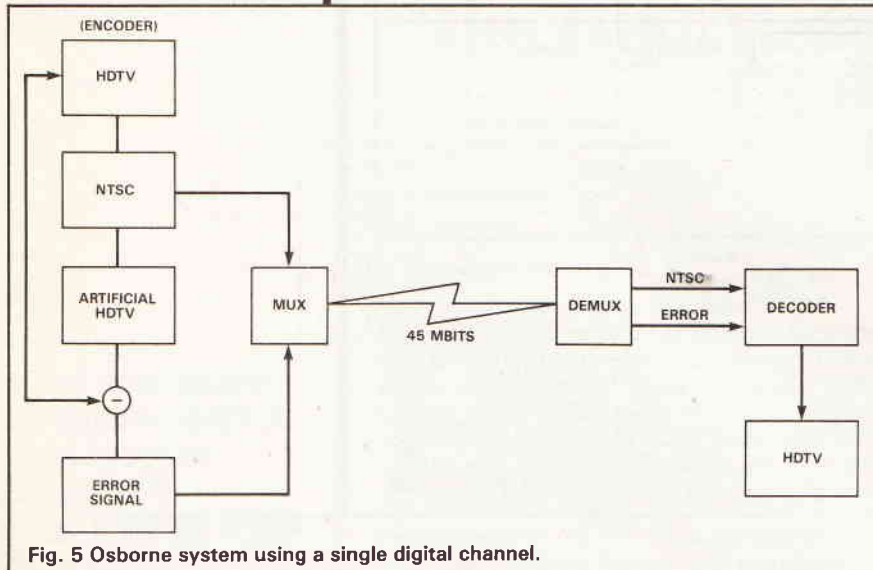

Fig. 5 Osborne system using a single digital channel.

two 6MHz radio frequency channels are available. The subsampled NTSC picture is transmitted directly on the first radio frequency carrier, so that all standard NTSC receivers would receive a normal picture. In the encoding equipment this NTSC signal is then decoded, but using the same adaptive interpolation algorithm as is to be used in the HDTV receiver, so that an 'artificial' HDTV picture signal is present in the encoding equipment, as can be seen from Figure 5. The second radio frequency channel is then used to carry an 'error' or 'difference' signal derived by subtracting the artificial HDTV signal from the original HDTV source signal. When this second signal is received by the HDTV receiver it is added to the NTSC signal received on the first channel, and the receiver can then rebuild a copy of the original HDTV image.

If two 6MHz channels cannot be made available, then it is possible to transmit the NTSC part of the signal in a standard 6MHz channel, the error, or augmentation signal being transmitted in an extra 3MHz wide channel.

Single channel digital system

The third option, shown in Figure 5, is to go for digital transmission, and the Osborne Digital Compression system, using both temporal and spatial compression together with a digital coding system that uses the minimum possible bit rate, allows the complete NTSC signal and the error signal to be compressed to a data rate of 45Mbit/second, and transmitted over a 6MHz wide satellite channel using QPSK coding, which can be considered as a four level code which enables a lot of data to be carried in a limited bandwidth.

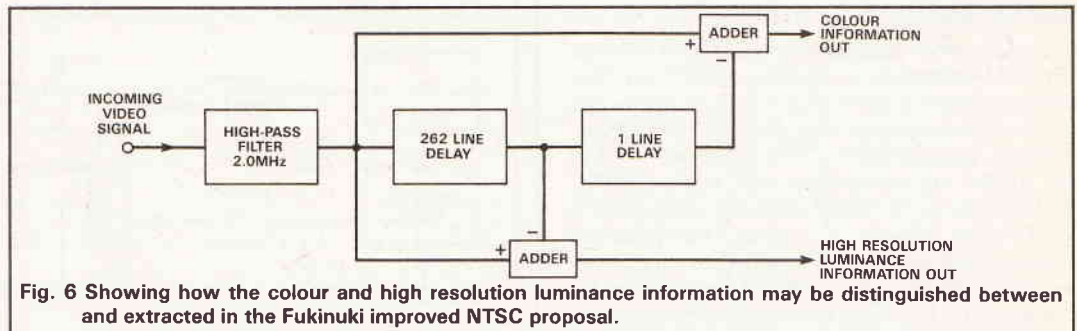

Fig. 6 Showing how the colour and high resolution luminance information may be distinguished between and extracted in the Fukinuki improved NTSC proposal.

It seems that the QuantTV 'cinematic dithering' technique, which brings the benefits of reduced noise and distortion to those equipped with the noise reducing receivers is more likely to be applied to other ATV systems, rather than being adopted as a system in its own right.

The Osborne Compression System

Osborne Associates, Inc. has proposed a flexible system that could be applied to various types of ATV system, and several variants have been detailed. The HDTV signal can be transmitted through a 45 Mbit/sec digital data channel, over a single 9MHz wide channel, or over two 6MHz channels. The aim of the system is to optimise the efficiency of digital transmission by bit rate reduction, and by this means to provide a method of moving to HDTV whilst still providing pictures on standard NTSC receivers. The decoder in the receiver would be the same, whichever of the three transmission methods was used.

In each case, the system subsamples a high definition picture to provide an NTSC picture, and adaptive sampling is used, as in other systems, to make the most of spatial redundancy in the original picture. Figure 4 shows how the system works when

The Fukinuki approach to improved NTSC

Dr Fukinuki of Hitachi Research has already been mentioned in connection with the 'Fukinuki hole', an area or areas of the existing spectrum which are currently being used to carry colour information, but which are not being fully utilised in the NTSC system. Although no official proposal has been submitted to the ACATS, he has suggested a method of carrying the highest definition parts of the luminance signal in these areas, and has shown that such improvements in definition could be achieved in a manner which existing NTSC receivers would find completely compatible.

The proposal can be understood by considering each NTSC television field as a separate plane, so that an NTSC picture will consist of parallel planes separated from one another by one sixtieth of a second. In the NTSC system the colour subcarrier is different in phase by 180 degrees on adjacent lines, and it can be shown that a similar 180 degree phase shift takes place from field to field and from frame to frame. The Fukinuki idea is that when a field starts with one particular phase of subcarrier the information being carried will be the conventional colour infor-

HDTV

mation, whereas when a field begins with the opposite phase of subcarrier high definition luminance information will be carried in the areas normally used for the colour information during that field. In order that the receiver will be able to detect which information is being transmitted at which instant of time, the area of the incoming signals of interest is first selected by filtering, as shown in Figure 6, and the resulting signals are then passed through delays of 262 lines and 263 lines, and the signal phases are then compared with those of the incoming signal. Fukinuki has shown that if the signals are in phase after a 262 line delay then

enhanced picture; the extra information could be used to provide more luminance detail, or to give the same amount of detail on a wider aspect ratio display.

CBS Proposal

An ATV proposal from the Columbia Broadcasting System (CBS), requires the use of two DBS satellite channels, so it cannot be considered compatible with standard NTSC receivers in the same way as other systems, since a special adaptor box would be necessary even to allow NTSC receivers to provide a picture; nevertheless, brief details are included here,

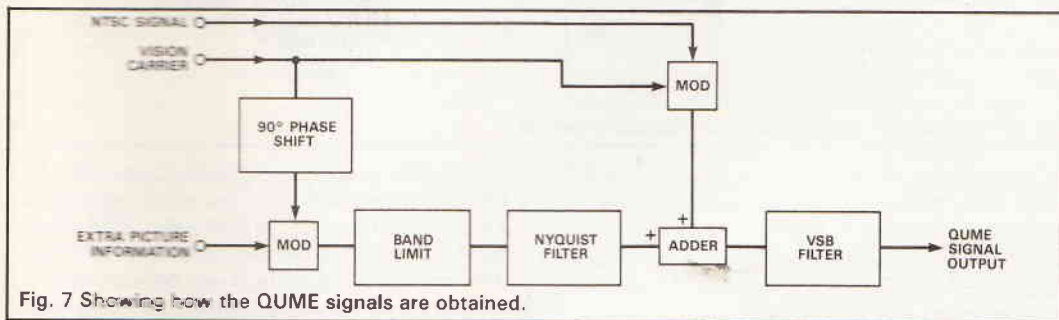

Fig. 7 Showing how the QUME signals are obtained.

the incoming signal will be carrying the colour information, whereas if they are in phase after a 263 line delay the signal will be the higher definition luminance information. The changes taking place from field to field mean that such a system would of course need to utilise some form of motion compensation technique, and the Fukinuki proposal is probably best regarded as a technique to be used in conjunction with some of the other proposed systems that we have discussed.

The QUME system – Quadrature Modulation of the Picture Carrier

Although it has not submitted an official proposal to the ACATS, the Japanese Matsushita company has suggested a method of enabling an NTSC signal to carry additional information which could be used to improve the definition of an NTSC picture or to provide an increased aspect ratio. The technique used is called Quadrature Modulation of the Picture Carrier (QUME), and the name describes the system very well. It is really a development of the way in which a black and white picture was made to carry additional colour information by the addition of a subcarrier. Figure 7 shows the basic idea. The vision carrier signal, before modulation is added, is phase shifted through 90 degrees. This phase shifted signal is then modulated with the extra information which is to be added to the NTSC signal. The resultant modulated signal is then filtered, and it is added to the standard NTSC modulated vision carrier, effectively providing quadrature modulation of the NTSC vision carrier, and giving rise to what is known as the QUME signal.

Figure 8 shows a diagram of the final video spectrum, and it can be seen that the extra information has been slotted into the normal spectrum at the low frequency end, an idea which we have come across in other proposals.

A normal NTSC receiver should ignore this extra low frequency information, and to ensure this, Matsushita have taken considerable trouble to design the filtering circuitry used when producing the QUME signal so that any potential interference is reduced to a minimum for NTSC viewers. Enhanced receivers designed to utilise this system would contain a synchronous detector circuit which could separate out the standard NTSC information and the additional information and the two signals would then be appropriately combined in order to generate an

for the sake of completeness.

The CBS system uses two channels, each of which carries a Multiplexed Analogue Component signal. These transmissions are not called MAC in the CBS system, but TMC, Time Multiplex Components. Figure 9 shows the basic method of operation.

The source picture can be in a variety of formats, but must be converted to a 1050 line 5:3 aspect ratio interlaced before the actual TMC processing begins. To provide a signal suitable for transmission over channel one, the so-called 'compatible channel' every alternate pair of lines from the 1050 line source is averaged, and the result is a 525 line interlaced signal with a 5:3 aspect ratio. The central 4:3 aspect ratio part of this picture signal is then extracted, and it is this signal that is transmitted over the 'compatible' channel.

The second channel carries every other line of the 1050 line 5:3 aspect ratio interlaced picture, and it also contains the information about the 'side panels' which were removed from the pictures in the first channel when the 4:3 portion was selected.

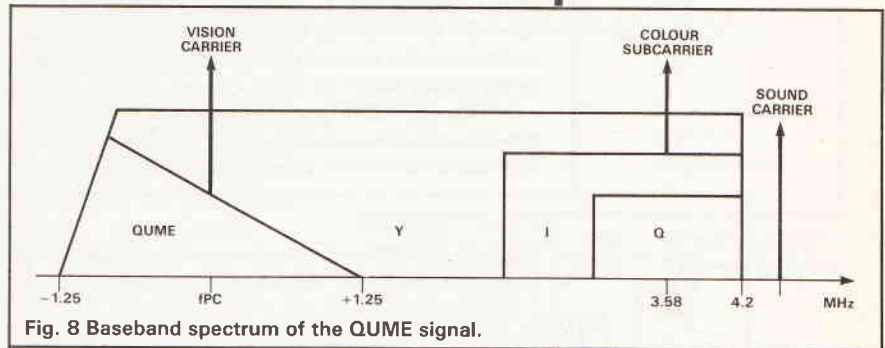

Fig. 8 Baseband spectrum of the QUME signal.

Figure 10 shows the construction of the TMC (MAC) lines used on each of the two channels. The horizontal resolution of the picture in the first channel is about 1.5 times that of NTSC, since the satellite channels for which the system was designed are of wider bandwidth than that available for NTSC, and the final HDTV picture also has the same resolution. The side panels of the 5:3 picture, however, have lower resolution than the central portion because they must be compressed by a greater amount to allow them to be carried along with the extra information in the second channel.

In the home equipped with only a standard NTSC receiver, a satellite receiver feeding an adaptor

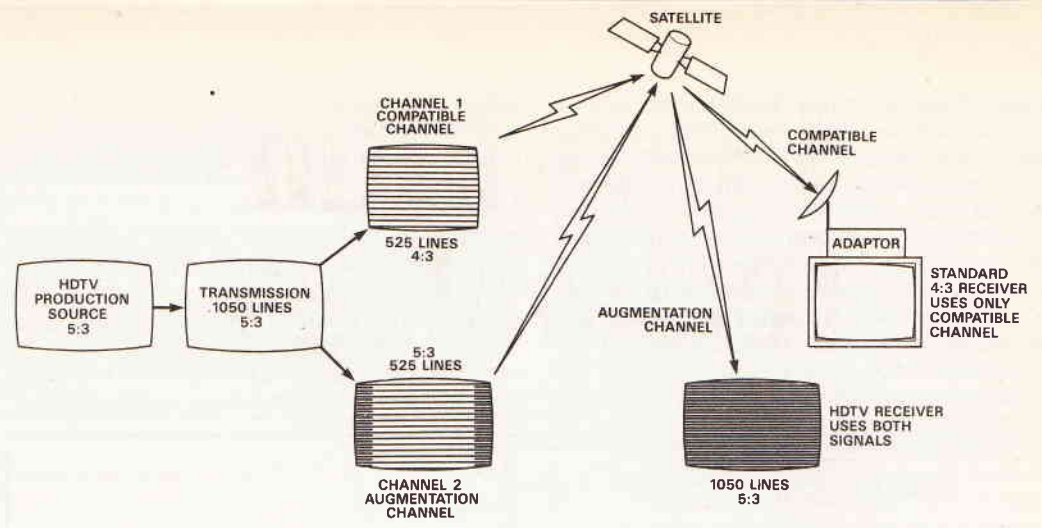

Fig. 9 The CBS ATV system using two satellite channels.

box uses the first channel to provide a 525 line 4:3 aspect ratio picture. Where an HDTV receiver is available, however, both signals will be utilised, and the combination of the two allows the receiver to display a 5:3 aspect ratio 1050 line HDTV picture.

GENESYS – A remarkable proposal from Production Services Inc.

If all the proposed ATV systems are trying to squeeze a quart of information into the pint pot of an NTSC channel, then the GENESYS system from Production Services Inc. (PSI) takes the prize for at least claiming to fit in a whole barrelful. It claims that using its unique processing techniques it can carry a standard NTSC picture and an HDTV picture and four channels of sound within a single 6MHz channel. The system that PSI have put forward is not so much a system, more a method of carrying extra information within the NTSC channel, and they claim that their ideas could be utilised to carry MUSE signals or any of the other HDTV signals that have been proposed by other companies. So far they have demonstrated that they are able to carry an additional 3MHz of information along a standard NTSC channel at the same time as the channel is carrying an NTSC picture, without any visible mutual interference, but it is their remarkable claim that they expect to be able to carry a full bandwidth 1125/60 production standard video picture along the same 6MHz channel that has really caused eyebrows to be raised in the industry, some people being openly sceptical of the claims.

The GENESYS system owes its action to four separate processes or techniques. The first is a 'new' modulation technique, called 'waveform modulation',

and claimed to be completely different from AM, FM, or PM, in that it modifies the shape of the carrier signal in a manner that renders this modulation completely invisible to AM, FM, or PM demodulators in receivers, so that no unwanted artifacts can be seen on the NTSC picture with which such signals are transmitted.

The second technique is an analogue to digital conversion technique which is claimed to provide an infinitely small resolution instead of the usual steps that ADCs provide; it is believed that a modified form of Delta modulation is probably involved.

The third leg upon which the GENESYS system stands is a bit compression system that allows 16 bit digital signals to be sent using only three bits, providing a five times increase in the data that can be transmitted over a particular channel.

The fourth process is a novel method of demodulation of the complex signals produced by the GENESYS system. PSI claim that they have a demodulator containing only a few standard components which can detect the modulation used in the GENESYS system down to very poor carrier to noise ratios, whilst at the same time demodulating standard AM or FM signals.

The system would allow a broadcaster to carry HDTV and normal NTSC signals on his normal transmissions, allowing the viewer to receive either signal, according to whether an NTSC or an HDTV receiver is used. Whilst this sounds to be close to an ideal solution to the American need for a compatible method of providing HDTV, it seems that there is some way to go before the limited demonstrations that have so far been given are supplemented by demonstrations of the full HDTV transmission system, and some engineers have said openly that they believe that the company is extrapolating too far from its proven position, thus seeming to obtain a magical increase in the amount of information that can be squeezed into a given channel.

The Avelex system

A proposal that was submitted to the ACATS but has since received little publicity is a 6 MHz single channel NTSC compatible system 15 from the Avelex company. Known as the High definition and High Frame Rate Compatible NTSC Broadcast Television System, the system uses NTSC as its basis, but incorporates sub-nyquist sampling and uses an eight field sequence. The proposal suggests that up to 1500 pixels could be displayed on each horizontal line, and that 966 lines could be displayed. Aspect ratios of 16:9, 5:3, and 4:3 can be accommodated, and motion vectors are transmitted by multiplexing them with the 'I' colour difference signal, and used to provide motion compensation information for the receiver.

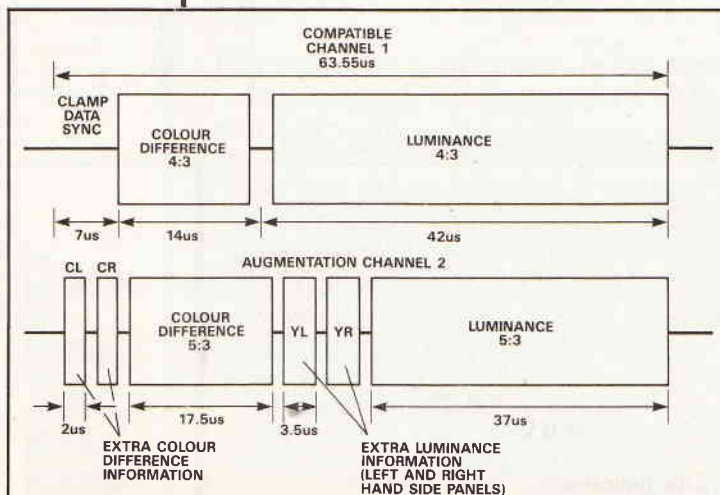

Fig. 10 The TMC signals for the two channels used in the CBS system.

Piezo Film Technology

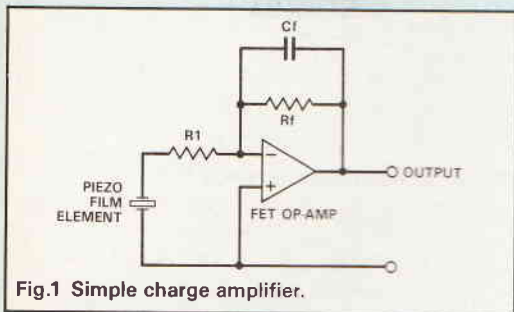

Fig.1 Simple charge amplifier.

A range of natural materials such as quartz and tourmaline exhibit so called piezo-electric (force-electricity) properties. The phenomenon relates to mechanical forces producing electrical effects.

So when a piezo-electric material is subject to forces of compression or tension or is twisted, a corresponding voltage will be developed across surfaces of the material. Conversely, when electrical signals are applied across such materials, they can be driven into mechanical vibration.

From the time when the phenomenon of piezo-electricity was first discovered by Jacques and Pierre Curie in the last century, there has been a search to develop man-made piezo-electric materials. This search has certainly been driven by the need to develop transducers for use in SONAR applications for submarine detection.

The emergence of Barium Titanate and later the PZT range of ceramics provided a stable range of transducer materials which could be used both as detectors and generators of mechanical vibrations over a broad range of frequencies.

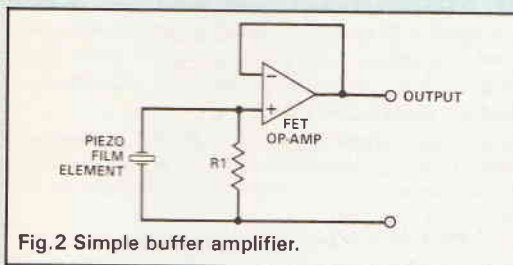

Fig.2 Simple buffer amplifier.

While the PZT range of ceramics were entirely satisfactory as transducer components to create mechanical vibrations, such as in ultrasound transducers in SONAR systems and medical ultrasound diagnostic scanners, there were many applications for which as sensor elements they were not ideal. Lack of mechanical strength was certainly one drawback and the high cost of elements another.

PVDF Films

It had been appreciated for some time that films of plastic polymers could be made to exhibit piezo-electric properties. Early products lacked stability in

their sensing properties. The emergence of so called PVDF films during the 1970's provided an ideal material for the development of sensor devices.

PVDF (or polyvinylidene fluoride) films are essentially a polymer with the basic monomeric unit CH_2CF_2 . The compound is chemically inert and similar in mechanical properties to PTFE.

In the production of the piezo-electric film, the material is initially stretched to between 400% and 500% of its initial size and heated to temperatures between 50°C and 100°C. This encourages the 'beta' phase of the polymer to form. If an electric field is then applied across the material at around 80 volts per micron thickness of film and the film is cooled with the poling field applied, then this process of 'poling' confers on the film permanent piezo-electric properties.

Properties Of Piezo Films

The main properties of piezo film are listed in Table 1. The g_{33} piezo-electric stress constant describes the electric field generated across the film (in the poling direction) for a specific stress (N/m^2) applied to the film (eg squeezing it). The value of g_{31} refers to the effect of applying tension along the film, eg pulling its opposite ends. These values of piezo-electric constants are several times larger than the corresponding values of, for example, PZT-5 ceramics designed for optimum sensitivity.

The value of capacitance of a sensor is important when connecting to electronic circuitry. It is desirable to minimise capacitance to improve voltage sensitivity.

The pyroelectric constant of the PVDF film indicates the sensitivity of the film to temperature changes. Thus a 1cm^2 section of film, having its temperature raised by 1°C should release an amount of charge $Q = -25 \times 10^{-6} \times 10^{-4} \text{ C}$
 $= -25 \times 10^{-10} \text{ C}$

When this charge is distributed across the 380p capacitance of the film (ignoring effects of lead capacitance), using the equation $V=Q/C$, the voltage which should be observed is given by:-

$$= \frac{-25 \times 10^{-10}}{380 \times 10^{-12}} \text{ V}$$

$$= 6 \text{ V}$$

This indicates that the film has a very high potential sensitivity to temperature changes.

Such films are used, in security systems where

The force to electric phenomenon examined by Douglas Clarkson

Typical properties of Piezo-Film (Pennwalt Kynar Film)

Thickness	9, 16, 28, 52, 110 220 and 800 microns (1 micron = 10^{-6} metre)
Piezo-electric stress constant (g_{33} : in poling direction)	$-339 \times 10^{-3} \text{ V/m N/m}^2$
(g_{31} : along length of film)	$216 \times 10^{-3} \text{ V/m N/m}^2$
Operating temperature range	-40°C to 100°C
Water absorption	0.02%
Maximum operating voltage	30 V/micron thickness
Frequency response	0.005 Hz to GHz

Table 1: Main properties of Piezo-film (Pennwalt Kynar)

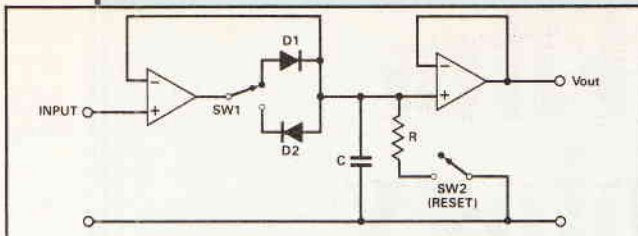

Fig.3 Peak hold circuit to sample either positive or negative peak of waveform.

lenses focus infra red radiation from areas being scanned onto sensitive PVDF film assemblies. Such systems can detect body heat from individuals at distances of 20 feet.

PVDF films are often supplied with metallised contact electrodes which are poor absorbers of infra red radiation. The degree of absorption can be improved by coating the film surface with marker pens. PVDF films are sensitive to wavelengths of infra red radiation greater than about 1.5 microns. (The visible spectrum extends from about 0.4 microns (blue) to 0.7 microns (red)).

The upper limit of 100°C on the operation of PVDF films relates to the breakdown of the organisation of the polymer units. This represents a limitation in relation to, for example PZT ceramic materials which have an upper maximum temperature of around 300°C.

The maximum operating voltage of 30 V/micron indicates, for example, that a 9 micron thick film cannot be operated at driving voltages in excess of 270V.

In many ways, interfacing electronic circuits to PVDF sensors is relatively straightforward. Figure 1 shows a circuit used as a charge amplifier and Figure 2 a direct voltage buffer. The peak positive or negative value of a sensor waveform may be required. Figure 3 indicates how this can be achieved using two low leakage diodes and a conventional operational amplifier. The switch SW1 can be set to select the mode of peak holding required.

Vibration Pick Ups

Perhaps one of the simplest types of application to consider is that of sensory pickup of sound and vibration signals for which the circuit of Figure 2 would be appropriate.

The frequency response of PVDF sensors is

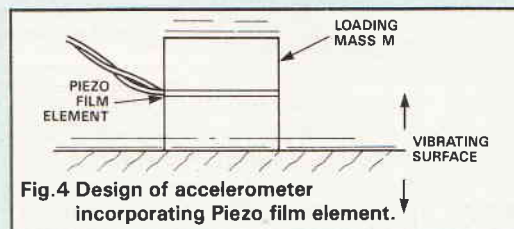

Fig.4 Design of accelerometer incorporating Piezo film element.

superb, certainly better than conventional microphones. This property has been used for pick up devices for guitars and even high tech violins. Part of the skill, however, in using such PVDF films in this way is to efficiently couple the sensor to the vibrating mechanical structure. While a PVDF sensor stuck down with double sided adhesive tape will pick up something, it is not the best way and can certainly be improved.

Piezo-film technology has been used by the Toronto based company Raad Instruments Inc for the construction of a new electric violin.

Part of the advantage of such a system is the low

loading of any vibrating system and the rapid response it provides. An improved signal to noise ratio is also obtained.

Meaningful measurements of the mode of vibration of structures can be obtained using accelerometers as shown in Figure 4. The accelerometer is attached to a vibrating surface and will cause the loading mass, M, to vibrate and so communicate a dynamic force across the PVDF film. The resulting signal from the PVDF film can be used as a measurement of structural vibration.

In industry, there is often a need to 'listen into' systems such as turbines, engine bearings and jet engines in order to detect abnormal vibration patterns before they result in catastrophic failure. While previously PZT ceramic elements have been used for accelerometer systems, PVDF sensing elements can now be used in their construction or as elements directly contacting the vibrating surface.

Impact Measurement

A number of applications using PVDF films involve measurement of impact forces and pressures. Attention has for some time been directed to using PVDF films to detect the 'signature' of coins dropped onto them in vending machines. PVDF films have also been used in research in the automotive industries to record impact pressures on facial surfaces of dummies in car crash situations. Such films have also been used to record pressure distributions on the soles of feet of individuals with walking difficulties. It is very often difficult to isolate various types of mechanical deformation and also temperature effects. If a film experiences pure compression, then one type of effect will be experienced via the g33 stress coefficient. If the

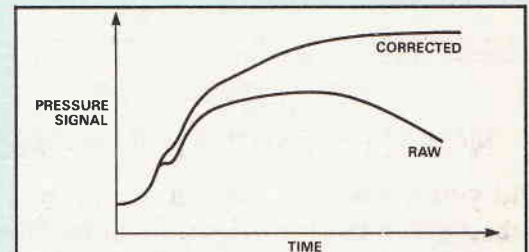

Fig.5 Diagrams of 'raw' and 'corrected' pressure waveforms for Piezo film detector.

film is pulled, then another effect via the g31 coefficient is experienced. If the film is bent upwards it will experience a separate signal. Also if the film's temperature is changed, then it will experience a separate pyroelectric effect.

The way in which a PVDF sensor is mounted must be clearly identified in order to say which signal is to be detected. The support of the film should be as rigid as possible.

Figure 5 indicates the typical waveform recorded for the establishment of a pressure signal to a typical PVDF sensor. As charge builds up on the system due to the piezo-electric effect, it also leaks away again as current leaks across the PVDF film and the amplifier system.

During an interval of time dt, when the voltage present is V, the charge lost will be:

$$\frac{V dt}{R}$$

where R is the leakage resistance of the sensor circuit. This will be equivalent to a fall in voltage of (V dt)/(RC) where C is the equivalent capacitance of the sensor system.

The total 'lost' voltage can be calculated by summing the value of the expression (V dt/RC) over

all the time intervals of the measurement period. In analogue circuitry, this can be undertaken with some form of integration circuit. Where data is sampled using a A/D converter, computer software can readily reconstruct the true pressure trace.

For systems where the impacts are occurring in times appreciably shorter than the time constant RC of the sensor system, then the maximum uncorrected signal is a useful indication of the peak pressure across the sensor. For arrays of sensor elements, however, the time constant RC of each element and its calibration parameters usually have to be separately determined.

'Electronic' pianos make use of such sensor technology to indicate how loud keys should be played when pressed. Impact and pressure sensors are also ideal for use as 'under the carpet' sensors in security systems.

Piezo Film Switches

Extensive ranges of switches have been developed using PVDF film technology. The ability of such switches to generate a significant 'self start' voltage is particularly useful in many applications, particularly those using CMOS components. Switches have to be designed, so that the switch action takes place in a short time. In theory a PVDF switch could be pressed so slowly that the charge is never allowed to build up to attain the necessary threshold value.

Specialised PVDF switches have been developed for rehabilitation engineering projects where disabled individuals are capable of only very limited body movements. PVDF films taped to the forehead of MS sufferers have been successfully used to control interfaces to computer systems which provide a valuable means of communication.

Singing Technology

The development of so called 'singing technology' using PVDF films introduces new techniques to measurement and control systems. Two transducers, one a sensor device and the other a vibrating element driven by an electrical signal allow information about the resonant mechanical frequencies of a structure to be determined. One application could relate, for example, to the change in resonant frequency of a structure as a function of weight loading or immersion depth of a structure in liquid. Control circuitry would maintain the driven transducer at the system's resonant frequency while the value of the resonant frequency would be used as a parameter in a control system.

PVDF film technology therefore provides a range of options for measurement and control in a broad range of applications.

Obtaining PVDF Films

There is nothing like experimentation for developing understanding. Fortunately it is relatively easy to obtain piezo films from Pennwalt in the UK. Initially request a film sample which should be supplied on a business card which allows more information on applications, products and prices to be obtained. Details of various experiments which can be carried out using the sample film and of various kits (basic, switch and vibration sensor) are also provided.

Contact:

Pennwalt Piezo Film Ltd.,
22 Ridge Way, Hillend Industrial Park,
Dunfermline, Fife, Scotland, KY11 5JN.

REFERENCES: Kynar piezo film, technical manual, Pennwalt Corporation.

ATTENTION ALL NORTH AMERICAN READERS!

Did you know that you can order an annual subscription to this magazine direct from our official U.S. subscription representative?

For more information and rates contact:
Wise Owl Worldwide Publications,
4314 West 238th Street,
Torrance, CA 90505
(213) 375 6258

.. PROJECT REPORTS .. TECHNICAL DOCUMENTS ..
.. EDUCATIONAL HANDOUTS .. MANUALS ..

**MICRO
Design₂**

MicroDesign₂ is a new publishing program combining all the essential features of DTP, CAD and Graphic Design in a flexible and easy-to-use package. MicroDesign₂ is ideally suited to the preparation of technical documents (especially those related to electronics), and provides a single and affordable solution to your small-scale publishing needs.

MicroDesign₂ is available for PC-compatibles and the Amstrad PCW series, giving high quality output from 9-pin, 24-pin, Bubblejet and HP-compatible Laser/Inkjet printers. And it costs just £69.95 (PC) or £59.95 (PCW) from ...

Creative Technology 10 Park St Uttoxeter Staffs ST14 7AG Tel 0889 567160

This advert entirely designed & printed using MicroDesign₂ on an Amstrad PCW8512 with HP Deskjet

MICRO BASS

The latest sub bass kit from Wilmslow Audio. Micro Bass measures only 305 x 284 x 382 mm and can be positioned almost anywhere in the confines of the listening room without affecting the stereo image. It can be connected directly into existing systems and requires no extra amplifier. Designed as the perfect partner for most small loudspeakers with a sensitivity of 86 to 89 db.

The Wilmslow Audio Micro Bass kit contains 2 x 8" Bass units, flat pack cabinet kit machined from smooth M.D.F for easy assembly, xover kits and reflex port etc.

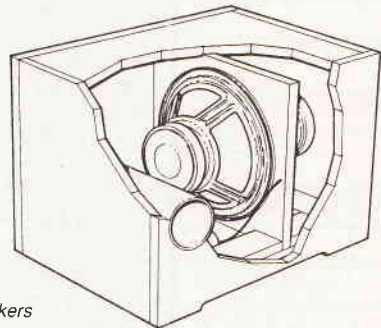

Other subwoofers available to match most types of speakers

Impedance:
8 ohms
AMP Suitability:
20-100w

£110.00 inc VAT
carriage/ins. £10.00

**Wilmslow
Audio**

Wellington Close,
Parkgate Trading Estate
Knutsford, Cheshire
WA16 8DX
Tel: (0565) 650605
Fax: (0565) 650080

DIY Speaker catalogue £1.50
post free (export £3.50)



Telephone credit card
orders welcome



Open Tuesday to Saturday, 4 demonstration rooms available.

Designing Networks for RIAA

Wilfred Harms takes an in-depth mathematical look at RIAA characteristics.

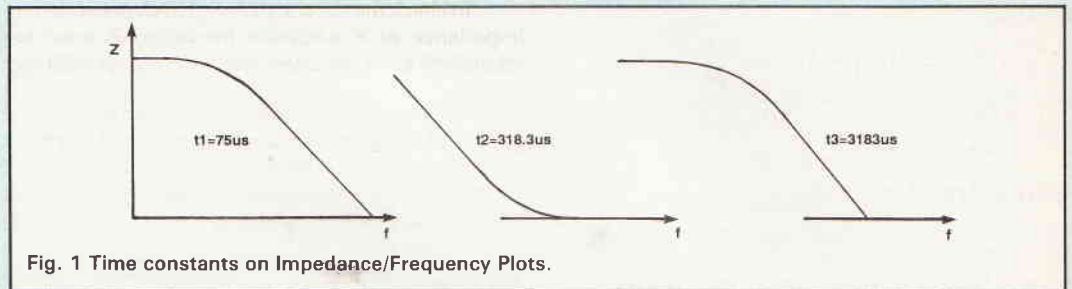

Fig. 1 Time constants on Impedance/Frequency Plots.

The purpose of this article is to explain the design of a network for use in an accurate equaliser based upon the specification. It cannot be achieved by translating three Bode plots (often used for illustration) into simple R/C pairs one by one bundled together. All three need to be considered together and although the resultant calculations are a little long-winded, nothing beyond ordinary algebra is involved and an appreciation of the notation for items 'in quadrature', i.e. the impedance of a capacitor $\frac{1}{sC}$ is shown as $\frac{1}{sC}$ in which 's' represents $j\omega$, the 'j' merely signifies that the item is in quadrature as compared with a normal resistor R.

The Formulae

As a preliminary, consider a passive network to accommodate t_3 and t_2 as Figure 3. The Gain is

$$\frac{R_1 + \frac{1}{sC}}{R + R_1 + \frac{1}{sC}}$$

simplified to

$$\frac{1 + sCR_1}{1 + sC(R + R_1)}$$

This must be equal to

$$\frac{1 + st_2}{1 + st_3}$$

and when the numerators and denominators are equated, we readily see that $R_1C = t_2$ and further development shows

$$\frac{R}{R_1} = 9$$

The Bode plots can be misleading and should be ignored. The following considers a passive network, first including only two time constants, then the three together, and finally, it shows how it can be re-arranged for use in a feedback circuit.

The specification includes the combination of three separate curves corresponding to properties of resistance/capacity combinations (RIAA includes an inductor) with time constants of $t_1 = 75$, $t_2 = 318.3$ and $t_3 = 3183 \mu$ secs and which take the following form in Figure 1.

Frequency is not mentioned but we know that these correspond to $(f = \frac{1}{2\pi t})$ 2122, 500.5 and 50.05 Hz respectively. Realisation of this specification in three separate stages can be achieved thus:-

The GAIN $\left(\frac{\text{out}}{\text{in}}\right)$ of the first stage is:

$$\frac{\frac{1}{sC}}{R + \frac{1}{sC}} = \frac{1}{1 + sCR} = \frac{1}{1 + st_3}$$

Similarly the Gain of the second and third stages is $\frac{1}{1 + st_2}$ and $\frac{1}{1 + st_1}$. The overall output is therefore

$$\frac{1 + st_2}{(1 + st_1)(1 + st_3)}$$

and this is the RIAA FORMULA which any RIAA equaliser must match.

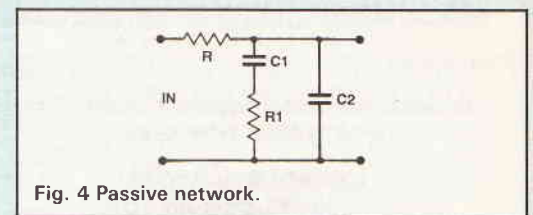

Fig. 4 Passive network.

Any network with these ratios will give an accurate response which includes t_3 and t_2 .

Now consider a network to suit all three time constants as Figure 4, similar to Figure 3 but with an extra capacitor. We must calculate from scratch and starting with the group, $R_1C_1C_2$, if we call the overall impedance 'Z', we have

$$\frac{1}{Z} = sC_2 + \frac{1}{R_1 + \frac{1}{sC_1}}$$

from which

$$Z = \frac{1 + sR_1C_1}{s(C_1 + C_2) + s^2R_1C_1C_2}$$

The overall GAIN of the network is

$$\frac{Z}{Z + R}$$

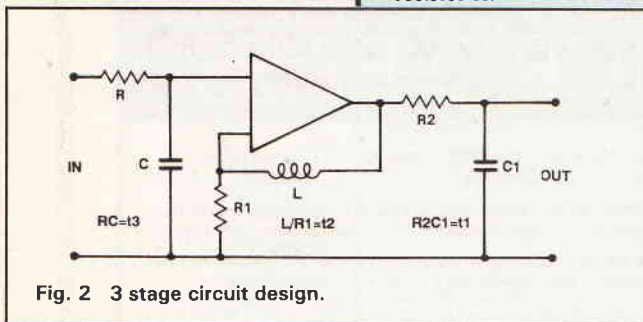

Fig. 2 3 stage circuit design.

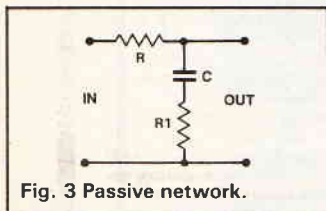

Fig. 3 Passive network.

which works out to

$$\frac{1 + sR_1C_1}{1 + s(R_1C_1 + RC_1 + RC_2) + s^2RR_1C_1C_2}$$

When this is equated to the RIAA FORMULA (numerator and denominators separately) we have three equations:

$$R_1C_1 = t_2$$

$$RR_1C_1C_2 = t_1t_3$$

$$RC_1 + RC_2 + R_1C_1 = t_1 + t_3$$

When these three equations are juggled around we get

$$R_1C_1 = t_2 = 318.3\mu s \quad RC_2 = \frac{t_1t_3}{t_2} = 750\mu s$$

and

$$R = \frac{t_1 + t_3 - t_2 - t_1t_3/t_2}{t_2} = 6.877\mu s$$

Any passive network with these ratios will give an accurate RIAA response.

Consider now the same components as Figure 4 but with resistor R repositioned as Fig 5. The overall impedance from a to b which we call Z_1 can be found

$$\text{from } \frac{1}{Z_1} = \frac{1}{R} + \frac{1}{Z} \text{ or } Z_1 = \frac{RZ}{R+Z} \text{ whilst } \frac{Z_1}{R} = \frac{Z}{R+Z}$$

This is precisely the same as the GAIN of network Figure 4. Thus the overall impedance of network Figure 5 varies in accordance with the RIAA response

and can therefore be used in a feedback arrangement in an equaliser to produce an accurate RIAA response.

The following three networks other than that shown can be used in a RIAA equaliser (Figure 6). Firstly, it can be used as a passive attenuator shown in (A). With R_3 repositioned as in Figure 5, this network and also (B) and (C) are suitable for use in a feedback arrangement. The ultimate value of the components used, must of course be satisfactory for the circuit in which the network is used. The above ratios however are paramount.

To check the accuracy of any RIAA network, the impedance at a particular frequency Z must be compared to its impedance at 1k Hz to give 20 log

$$\frac{Z}{Z_{1k}} \text{ and then compare the result with the accurate}$$

RIAA response which is, at any frequency f,

$$10 \log \frac{441.18(r^2 + 0.2505)}{(100r^2 + 0.2505)(r^2 + 4.503)} \text{ where } r = \frac{f}{1000}$$

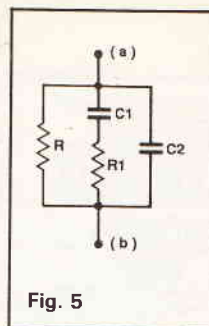

Fig. 5

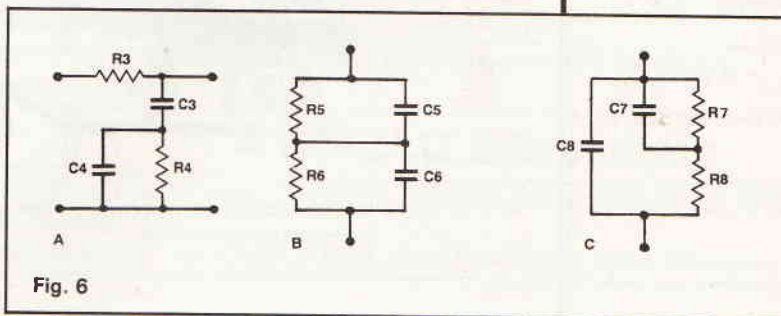

Fig. 6



HART AUDIO KITS — YOUR VALUE FOR MONEY ROUTE TO ULTIMATE HI-FI

HART kits give you the opportunity to build the very best engineered hi-fi equipment there is, designed by the leaders in their field, using the best components that are available.

With a HART kit you not only get more performance for your money but also the added free bonus of your own hands-on experience of modern electronic assembly. The HART combination of innovative circuit techniques, sound engineering design and professional grade components is your recipe for success in the quest for affordable ultimate audio fidelity.

Telephone or write for your FREE LISTS giving full details of all our Kits, components and special offers. Featured this month is:—

AUDIO DESIGN 80 WATT POWER AMPLIFIER



This fantastic John Linsley Hood designed amplifier is the flagship of our range, and the ideal powerhouse for your ultimate hi-fi system. This kit is your way to get EK performance for a few tenths of the cost!

Featured on the front cover of 'Electronics Today International' this complete stereo power amplifier offers World Class performance allied to the famous HART quality and ease of construction. John Linsley Hood's comments on seeing a complete unit were enthusiastic:—

"The external view is that of a thoroughly professional piece of audio gear, neat elegant and functional. This impression is greatly reinforced by the internal appearance, which is redolent of quality, both in components and in layout."

Each power amplifier channel has its own advanced double sided PCB and no less than four power mosfets, directly mounted on the board for superior predictable performance. The sophisticated power supply features not less than six separate voltage rails, all fully stabilised, and the complete unit, using a toroidal transformer, is contained within a heavy gauge aluminium chassis/heat sink fitted with IEC mains input and output sockets. To make assembly very easy all the wiring is even pre-terminated, ready for instant use!

The standard amplifier comes with the option of a stereo LED power meter and a versatile passive front end giving switched inputs, and using ALPS precision, low-noise, volume and balance controls. All inputs are taken to gold plated Phono sockets and outputs to heavy duty 30 amp binding posts. These are also available gold plated as an optional extra.

Another new option is the relay switched front end stage which even gives a tape input and output facility. This means that for use with tuners, tape and CD players, or indeed any other 'flat' inputs the power amplifier may be used on its own, without the need for any external signal handling stages. For your special system requirements our 'Slave' and 'monobloc' versions without the passive input stage and power meter are also available. All amplifiers fit within our standard 420 x 260 x 75mm case to match our 400 Series Tuner range. The case and front plate are finished in textured matt black with white lettering and all parts are precision jig-punched for accuracy.

K1100 STANDARD Amplifier Kit. Total cost of all parts is £503.56
SPECIAL DISCOUNT PRICE ONLY £428.02
If Bargraph Power Meter not required Deduct £32.81
If Relay Input System required Add £39.43
K1100G Option with Gold plated speaker terminals Add £4.40

K1100S SLAVE Amplifier Kit. Total cost of all parts is £382.85
SPECIAL DISCOUNT PRICE ONLY £325.42

K1100M MONOBLOC Amplifier kit. Total cost of all parts is £297.65
SPECIAL DISCOUNT PRICE ONLY £253.00

All HART kits are designed to the very highest standards for easy home construction, and can be built by anyone with reasonable manual ability. If you are still not convinced how easy it is to build it yourself with a HART kit you can order the Instruction Manual to read for yourself and we will refund the cost when you buy your kit!

1100CM Construction Manual. 20+ pages of step by step assembly instructions, circuit diagrams and full parts identification list £5.50

RLH11 Reprints of the latest 1989 articles £1.80

Our FREE LIST has further details of this kit as well as our range of super quality tuners, ALPS precision pots and tape recorder circuits. Send for your copy.

HIGH QUALITY REPLACEMENT CASSETTE HEADS



Do your tapes lack treble? A worn head could be the problem. Fitting one of our replacement heads could restore performance to better than new! Standard inductances and mounting make fitting easy on nearly all machines and our TC1 Test Cassette helps you set the azimuth spot on. As we are the actual importers you get prime parts at lower prices, compare our prices with other suppliers and see! All our heads are suitable for use with any Dolby system and are normally available ex stock. We also stock a wide range of special heads for home construction and industrial users.

HS16 Sennod Alloy Stereo Head. High quality head with excellent frequency response and hyperbolic face for good tape to head contact £17.86

HC40 NEW RANGE High Beta Permalloy Stereo Head. Modern space save design for easy fitting and low cost. Suitable for chrome metal and ferric tapes, truly a universal replacement head from hi-fi decks to car players and at an incredible price too! £6.60

HX100 Special Offer Stereo Permalloy Head £2.85

HRP373 Downstream Monitor Stereo Combination Head £44.39

HQ551 4-TRACK Record & Play Permalloy Head for auto-reverse car players or quadrophonic recording £16.79

TAPE RECORDER CARE PRODUCTS

HART TC1 TEST CASSETTE. Our famous triple purpose test cassette. Sets tape azimuth, VU level and tap speed £5.36

DEM1 Mains Powered Tape Head Demagnetiser, prevents noise on playback due to residual head magnetisation £4.08

DEM115 Electronic, Cassette Type, demagnetiser £8.61

Our new AUTUMN/WINTER '90 List is FREE. Send for your copy now. Overseas customers welcome, please send 2 IRCs to cover surface post, or 5 for Airmail.

We now accept inland and overseas orders by post or telephone on all Access/Mastercharge and Visa credit cards.

Please add post cost of carriage and insurance as follows:

INLAND: Orders up to £20 — £1;

Orders over £20 — £2.50; Next day — £9

OVERSEAS: Please see the ordering information with our lists.

QUALITY AUDIO KITS

24hr SALES LINE
(0691) 652894

ALL PRICES INCLUDE VAT



PCB Foils

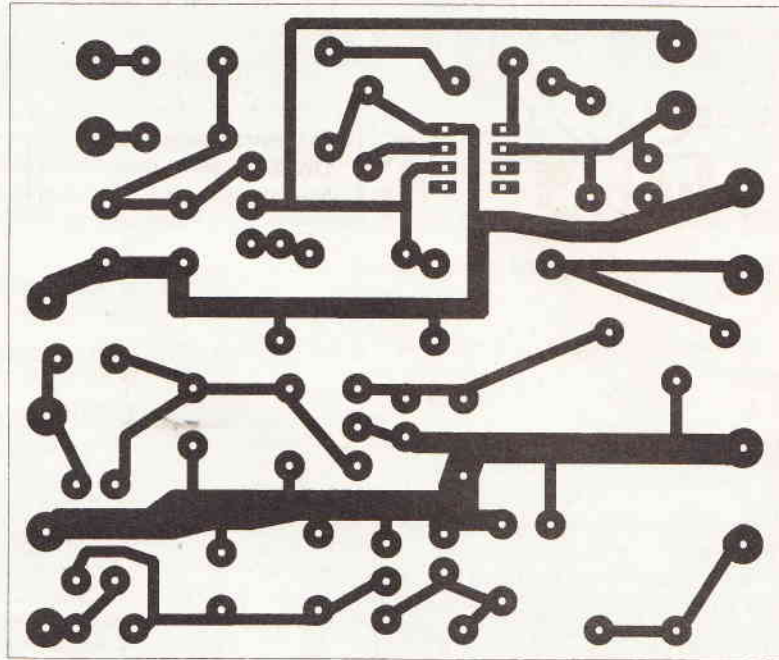

Versatile Temperature Control — Power Supply Foil
(see overlay next month)



Frequency Plotter (May 91)

Polarities have not been set on some capacitors and diodes in Figure 7 the component overlay. The positives for the capacitors are: C11 topside, C12 bottomside, C6 to right, C5 to left, C10 bottomside, C9 topside. Cathodes to diodes are: D1 topside, D2 bottomside, D3 topside, ZD1 topside. In Figure 1 Input polarities of IC2a should be reversed. D2 should be ZD1, D3 and D4 should be labelled D2 and D3 respectively. C5 and C6 polarities to left.

Lasers 2 (May 91)

Figure 1 should read ZD1,2=200V ZENER

SBC09 Part 1 (January 91)

Table 1 on page 49 The fourth row, column 5 should read B7 not 07 column 12 should read EF not ET column 17 should read FB not TO Sixth row column 14 should read 3F not 3T.

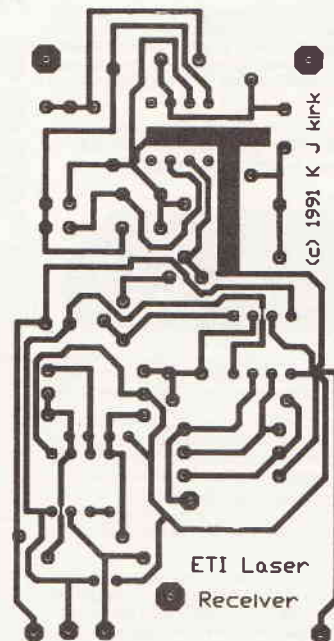

Laser Receiver Foil

EASY-PC, SCHEMATIC and PCB CAD

Over 7500 Installations
in 50 Countries Worldwide!

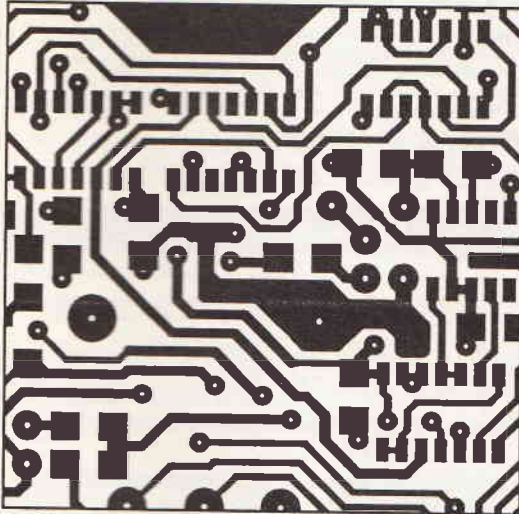

- Runs on:- PC/XT/AT/286/386/486 Herc, CGA, EGA, VGA.
- Design:- Single sided, Double sided and Multilayer boards.
- Provides Surface Mount support.
- Standard output includes Dot Matrix / Laser / Inkjet Printer, Pen Plotter, Photo-plotter and N.C. Drill.
- Superbly easy to use.
- Not copy protected.

Still Only
£98.00!

Plus P&P+VAT

**BRITISH
DESIGN
AWARD
1989**

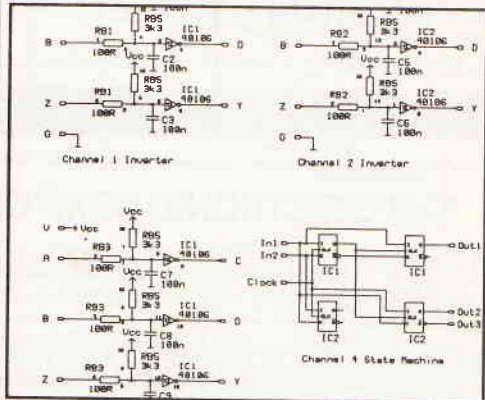

Options: Additional, 1000 piece Symbol library £38.00 (Standard Library includes over 400 Symbols.)
EASY-LINK Gerber files Import facility £98.00

For full info' Phone, Fax or Write to:

Number One Systems Ltd.



The CAD Specialists

REF: ETI, HARDING WAY, SOMERSHAM ROAD, ST. IVES, HUNTINGDON, CAMBS, PE17 4WR, ENGLAND.

Telephone: 0480 61778 (7 lines) Fax: 0480 494042

International: +44-480-61778 Fax: +44-480-494042

ACCESS, AMEX, MASTERCARD, VISA Welcome.

E.T.I.

Powerful Miniature VACUUM CLEANER

— use it everywhere ... for a clean sweep.
Ideal for removing dust from all those small modelling jobs, computer keyboards as well as many other uses.

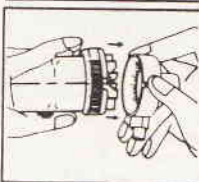
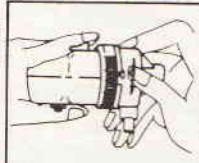

The blower can be opened for cleaning. To do this, detach the interlocking joints as shown.

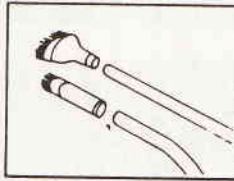

BRUSHES
Two special designed brushes, made of soft pony hair, are included for easy vacuuming.

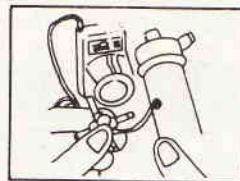

OPERATED BY AC/DC POWER
The unit can be used with common 3 volts adaptor (300mA) which can be plugged into the jack outlet.

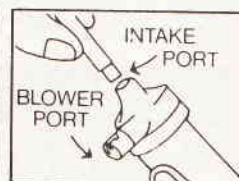

VACUUM & BLOWER ASSEMBLY
For vacuuming, insert end of tube into the intake port. For blowing, face the blower port directly to the target.

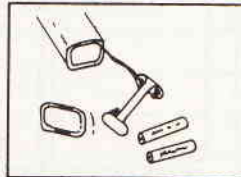

OPERATED BY BATTERY
Slice out the end cap and insert two AA size (UM3) batteries into the battery holder.

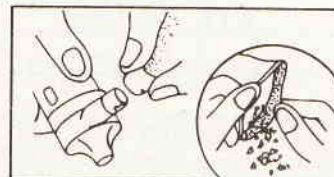

EASY-TO-EMPTY BAG
Join the bag to the blower port in the proper interlocking position. To clean dusts inside the bag, just separate the self-adhesive stripes located at the bottom of the bag.

Please supply ROET/18 @ £5.45 + £1.00 p&p.
I enclose my cheque/P.O. for £ made payable to ASP
or please debit my Access/Visa

Signature Expiry

Name

Address

Postcode

Please allow 28 days for delivery U.K. only (overseas upon request). Please send coupon to ASP Reader Offer, Argus House, Boundary Way, Hemel Hempstead, Herts HP2 7ST.

Please note the above information may be used for marketing purposes.

Telephone orders — call us Now on
0442 66551 (24 hrs)

ASP Reader Offer, Argus House,
Boundary Way, Hemel Hempstead,
Herts HP2 7ST

**Powerful Miniature
VACUUM CLEANER
only £5.45
+£1.00 p&p**

Reader Offer

Courses



MAKE YOUR INTERESTS PAY!

Over the past 100 years more than 9 million students throughout the world have found it worth their while! An ICS home-study course can help you get a better job, make more money and have more fun out of life! ICS has over 90 years experience in home-study courses and is the largest correspondence school in the world. You learn at your own pace, when and where you want under the guidance of expert 'personal' tutors. Find out how we can help YOU. Post or phone today for your **FREE INFORMATION PACK** on the course of your choice. (Tick one box only)

Electronics	<input type="checkbox"/>	TV, Video & Hi-Fi Servicing	<input type="checkbox"/>
Basic Electronic Engineering (City & Guilds)	<input type="checkbox"/>	Refrigeration & Air Conditioning	<input type="checkbox"/>
Electrical Engineering	<input type="checkbox"/>	Car Mechanics	<input type="checkbox"/>
Electrical Contracting/Installation	<input type="checkbox"/>	Computer Programming	<input type="checkbox"/>
GCE / GCE / SCE over 40 examination subjects to choose from <input type="checkbox"/>			

Name _____ Address _____



International Correspondence Schools, Dept. EB551-12/314 High Street, Sutton, Surrey SM1 1PR
Telephone: 081-643 9568 or 041-221 2926 (24 hours) Dept. EB561

Start training now for the following courses. Send for our brochure — without obligation or Telephone us on **0626 779398**

Ref: ETI/06/91

Name _____ **Telecomms Tech C&G 271**

_____ **Radio Amateur Licence C&G**

_____ **Micro-processor**

_____ **Introduction to Television**

Radio & Telecommunications Correspondence School
12 Moor View Drive, Teignmouth, Devon TQ14 9UN

SCOPES

MENDASCOPE LTD
REPAIR & RECALIBRATE
OSCILLOSCOPES
ALL MAKES ALL MODELS
NATIONWIDE COLLECTION
& DELIVERY
FREE ESTIMATES
PHONE: 069 172 597

MISCELLANEOUS

KITS, plans, etc, for surveillance, protection (sonic and HV), "007" gear. Send 2 x 22p stamps. For list ACE(TI), 53 Woodland Way, Burntwood, Staffs.

WANTED

Turn your surplus transistors, ICs etc, into cash. Immediate settlement. We also welcome the opportunity to quote for complete factory clearance.

Contact:
COLES HARDING & CO.
103 South Brink
Wisbech, Cambs.
NOW ESTABLISHED OVER 15 YEARS
Tel: 0945 584188
Fax Number: 0945 588844

SERVICE MANUALS

SERVICE MANUALS

Available for most equipment
TV's, Video's, Test, Audio etc
Write or phone for quote
MAURITRON (HRT),
8 CHERRY TREE ROAD,
CHINNOR, OXON OX9 4QY
TEL (0844) 51694 FAX (0844) 52554

MANUFACTURERS ORIGINAL SPARES

COMPONENTS for TV · Video · Audio · Computer

WE CAN SUPPLY A VAST RANGE FOR MANY MAKES — WRITE (encl SAE please) OR PHONE 0452 26883 FOR A 'PRICE & AVAILABILITY' ON YOUR REQUIREMENTS.

AMSTRAD * SINCLAIR	COMMODORE	OTHER MAKES
PEGATA (PC1640) £32.72	6526 CIA £11.11	Sanyo/Fisher VCR Belt Kit £2.49
40010 G-Array £20.83	8520 (Amiga) £11.22	VTC8500/VBS3500 £2.49
CPC464 Serv Manual £8.49	8565 VIC £29.95	Ferguson SV350/36/08/39 £1.95
Spec 48K Membrane £4.50	8701 Clock Gen £6.90	Tuner contr door £1.95
4120K Membrane £7.99	901225 Char ROM £6.55	Toshiba ST-U2/U2L Power Transformer £9.99
QL Membrane £7.95	C16 User Guide £5.37	TBA530 £1.14 AY38912 £5.74
UL6C001E £16.77	ATARI Basic ROM (XE/L) £4.49	TBA810P £1.40 UPC1378H £2.45
ULA7K010/40056 (+2) £17.99	CO29915 GLUE (ST) £24.84	TBA1001B £2.66 SSC3156 £4.59
ZK 6309 (DL) £16.75	Thermistor (ST-PSU) £7.94	TEA2006 £4.49 2TX650/1 £0.47
ZK 6401 (Spec) £7.94		

This just a small sample of our stock — We are also holding Tools, Connectors, Aerial & Telephone Accs and much more. For our catalogue please send 50p stamps/chg. MAIL ORDER ONLY. Please add 95p (UK) P&P but not VAT. All items subject to availability. Price can change without notice.
MARAPET (TF), 1 HORNBEAM MEWS, GLOUCESTER GL2 0UE

PLANS

ELECTRONIC PLANS, laser designs, solar and wind generators, high voltage teslas, surveillance devices, pyrotechnics and computer graphics tablet. 150 projects. For catalogue. SAE to Plancentre Publications, Unit 7, Old Wharf Industrial Estate, Dymock Road, Ledbury, Herefordshire, HR8 2HS.

SPECIAL OFFER

SPECIAL OFFER TO ETI READERS!

only £17.99 (inc P&P)
A must for all students and hobbyists learning how common electric components work
THE VIDEO
ELECTRONICS FOR THE HOBBYIST
(An excellent 90 minute video using computer-graphic simulations). Send cheques/PO payable to:
ON-LINE VIDEO MARKETING (DEPT EV.3)
The Cottage, Tredown Farm, Bradstone, Milton Abbot, Tavistock, Devon PL19 0QT
Other titles available. SAE for list. Allow 14 days for delivery

RETAIL OUTLETS

EDINBURGH

OMNI ELECTRONICS

stock a wide range of electronic components at
174 Dalkeith Road,
Edinburgh EH16 5DX
Tel: 031 667 2611
Open: Mon-Thur 9.15am-6pm, Fri 9.15am-5pm,
Sat 9.30am-5pm — 1990/91 Catalogue £1.50

LIVERPOOL

PROGRESSIVE RADIO

87/93 Dale Street Tel: 051 236 0154
47 Whitechapel Tel: 051 236 5489
Liverpool 2
'THE ELECTRONICS SPECIALISTS'
Open: Tues-Sat 9.30-5.30

RING JAMES
TROTT ON 0442
66551 TO
REPRESENT
YOUR REGION

SOUTH COAST

ELECTRONIC COMPONENTS
are best seen at

FRASER ELECTRONICS
42 ELM GROVE ★ SOUTHSEA ★ HANTS
Telephone (0705) 815584

Barclaycard Access
COME AND BROWSE BEFORE YOU BUY

LIVERPOOL

ALL PARTS

TV & Video spares emporium
Phone for best price on spares
Ferg Video Heads from £10.95, Panasonic Heads from £10.95
Video Copy Kits £5.99, Amstrad Satellite Spares
All your TV & Video needs here in Liverpool
ALL PARTS, 101 Rocky Lane, Tuebrook,
Liverpool 6 4BB. Tel: 051-260 4825
Mon-Fri 10am-5.30pm, Sat 9am-5.30pm

LONDON

DIRECT ELECTRONICS
ELECTRONICS COMPONENT SPECIALISTS

627 ROMFORD RD,
MANOR PARK
LONDON E12 5AD
Tel: 081-553 1174
Mon-Sat 10-6 pm/Thurs 10-1pm
We stock a large range of TV & Video spares

PHOTO -COPIES

ETI has been published for over 19 years and in this time a great many interesting and valuable projects and features have graced its pages. Although backnumbers are available for only the past 12 months issues we can supply photocopies of any individual article ever published in ETI.

Photocopies cost £1.50 per article regardless of their length. Please note that projects published over several issues must be ordered as a series of individual articles, each for £1.50.

PCB foil patterns (where published) and any errata are included with all photocopies as applicable.

Please supply photocopies of the following articles from ETI (complete in block capitals):

Month Year Page (if known)

Title

Month Year Page (if known)

Title

Month Year Page (if known)

Title

I enclose a cheque/postal order made out to ASP Ltd. to the value of £1.50 per photocopy ordered.

Total remittance £ Date

Name

Address

..... Postcode

Send the completed form and your remittance to:

ETI Photocopy Service
Argus House
Boundary Way
Hemel Hempstead
Herts HP2 7ST



NEXT MONTH

ETI keeps the ever increasing band of readers happy with more for you to enjoy throughout the spring and summer months. We have an introductory feature on Amateur Band microwave equipment (it's all plumbing really!) and continuing the theme of lasers we have a series of two monthly articles on semiconductor laser diodes and lasers for the medical profession. We can give you help on fault finding in some common pieces of equipment, or guide you through projects such as an electronic footpedal for guitarists, yet another Active Loudspeaker project and more construction work on the Versatile Temperature Controller.

And if that wasn't enough, Ray Marston's circuits series ponders over Unijunction and Programmable Unijunction transistors.

Whether its heat from the iron or from the sun, you'll always feel a warm glow reading ETI inside or out. Reserve your copy from your favourite newsagent, out on Friday 7th June.

The above articles are in preparation but circumstances may prevent publication

LAST MONTH

Topics covered in the May issue were:

The Physics of Stereo images
VLF and ELF Loop Antennas Part 2
Modulated He/Ne Laser Project
Thyristor Tester
Frequency Plotter
Constant Current Generator Circuits

Back issues are available from Select Subscriptions (address on contents page).

ADVERTISERS' INDEX

BK ELECTRONICS	IFC	HALCYON ELECTRONICS	32
CIRKIT ELECTRONICS	42	HART ELECTRONICS	61
CREATIVE TECHNOLOGY	59	HIGH Q ELECTRONICS	42
DISPLAY ELECTRONICS	IBC	J&N BULL	41
ELECTRONIZE	7	MAPLIN ELECTRONICS	OBC
ELECTRO VALUE	21	NUMBER ONE SYSTEMS	63
ESR	42	REED ELECTRONICS	7
FUSE LODGE	7	STEWARTS OF READING	16
GNC ELECTRONICS	32	SUMA ELECTRONICS	42
GREENBANK ELECTRONICS	16	WILMSLOW AUDIO	59
		J VINCENT	7

THE ORIGINAL SURPLUS WONDERLAND!

MONITORS

MONOCHROME MONITORS

THIS MONTH'S SPECIAL!



There has never been a deal like this one! Brand spanking new & boxed monitors from NEC, normally selling at about £140! These are over-engineered for ultra reliability. 9" green screen composite input with etched non-glare screen plus switchable high/low impedances input and output for daisy-chaining. 3 front controls and 6 at rear. Standard BNC sockets. Beautiful high contrast screen and attractive case with carrying ledge. Perfect as a main or backup monitor and for quantity users! **£39.95 each (D) or 5 for £185(G)**

CALL FOR DISCOUNTS ON HIGHER QUANTITIES!

Zenith ZVM-1240-EA brand new & boxed 12" amber flat screen with optional swivel and tilt base. Sunflex filter with dark tint. Standard TTL PC compatible. 18 mhz bandwidth. Very attractive "state of the art" tapered grey case. Standard 9 pin D plug (supplied) on 1 metre cord and mains cord terminated with IEC connector. 240 volts complete with operations manual. Free swivel/tilt base. An absolute gift at: **£59 (D) 10/£500 (G)**

COLOUR MONITORS

Decca 16" 80 budget range colour monitor. Features a PIL tube, beautiful teak style case and guaranteed 80 column resolution, features usually seen only on colour monitors costing 3 times our price! Ready to connect to most computers or video outputs. 75Ω composite input with integral audio amp & speaker. Fully tested surplus, sold in little or hardly used condition with 90 day full RTB guarantee. Ideal for use with video recorder or our Telexbox ST, and other audio visual uses. **£99(E) 3/£275(G)**

20", 22" and 26" AV SPECIALS

Superbly made UK manufacture. PIL all solid state colour monitors, complete with composite video & sound inputs. Attractive teak style case. Perfect for Schools, Shops, Disco, Clubs. In EXCELLENT little used condition with full 90 day guarantee. **20"....£135 22"....£155 26"....£185 (F)**

HI-DEFINITION COLOUR MONITORS

Brand new 12" multiline high definition colour monitors by Microvitek. Nice tight 0.31" dot pitch for superb clarity and modern metal black box styling. Operates from any 15.625 khz sync RGB video source, with either individual H & V syncs such as CGA IBM PC's or RGB analog with composite sync such as Atari, Commodore Amiga, Acom Archimedes & BBC. Measures only 14" x 12" square. Free data sheet including connection information.



Only **£145 (E)**

Brand new Centronic 14" monitor for IBM PC and compatibles at a lower than ever price! Completely CGA equivalent. Hi-res Mitsubishi 0.42 dot pitch giving 669 x 507 pixels. Big 28 Mhz bandwidth. A super monitor in attractive style moulded case. Full 90 day guarantee. Only **£129 (E)**

NEC CGA IBM-PC compatible. High quality ex-equipment fully tested with a 90 day guarantee. In an attractive tone ribbed grey plastic case measuring 15" x 13" x 12". A terrific purchase enables us to pass these on at only.... **£79 (E)**

SCOOP! 14" Colour Multisync/Multifunction

Never before has such a deal been struck to bring you this quality Japanese manufactured multisync, multifunction professional grade monitor at an unheard of low price! The Electrohome ECM1311 with its host of inputs will connect to most computer systems including: IBM PC/XT/AT/PS2 (CGA, EGA, VGA modes) Atari, Archimedes (up to SVGA), Commodore, BBC and many more. Many other features include: RGB analog & TTL inputs, separate horizontal, vertical, composite and sync on green inputs; auto 15 to 36khz operation; 0.31mm tube dot pitch; tinted non glare etched screen & 30 mhz bandwidth makes this item an absolute snip! **Current makers list price over £900!** Each supplied with connection data, fully tested in used good condition, some may have screen blemishes. Complete with full 90 day RTB guarantee. Quantity discounts available. Will also function as quality TV with our RGB Telexbox. Full Technical Manual £15.

Only **£149 (E)**

V22 1200 BAUD MODEMS

Master Systems 2/12 microprocessor controlled V22 full duplex 1200 baud modem. Fully BT approved unit, provides standard V22 high speed data comm, which at 120 cps, can save your phone bill and connect time by a staggering 75%! Ultra slim 45 mm high. Full featured with LED status indicators and remote error diagnostics. Sync or Async use; speech or data switching; built in 240v mains supply and 2 wire connection to BT. Units are in used but good condition. Fully tested prior despatch, with data and a full 90 day guarantee. What more can you ask for - and at this price!

ONLY **£69 (D)**

IBM KEYBOARD DEALS

A replacement or backup keyboard, switchable for IBM PC, PC-XT or PC-AT. LED's for Caps, Scroll & Num Locks. Standard 84 keyboard layout. Made by NCR for the English & US markets. Absolutely standard. Brand new & boxed with manual and key template for user slogans on the function keys. Attractive beige, grey and cream finish, with the usual retractable legs underneath. A generous length of curly cord, terminating in the standard 5 pin DIN plug. A beautiful clean piece of manufacturers surplus. What a deal! **£39 (B) 5/£175 (D)**

Brand new and boxed 84 key PC/XT type keyboards in standard IBM grey with very attractive mottled finish and "clacky" solid feel keys. 10 function keys on slide. English layout and £ sign. Green LEDs for Caps, Scroll & Num locks. **£29.95 (B) 5/£135 (D)**

CALL FOR DISCOUNTS ON HIGHER QUANTITIES!

FLOPPY DISK DRIVES BARGAINS GALORE!

NEW 5 1/4 inch from £29.95!

Massive purchases of standard 5 1/4" drives enables us to present prime product at industry beating low prices! All units (unless stated) are removed from often brand new equipment and are fully tested, aligned and shipped to you with a 90 day guarantee and operate from +5 & +12vdc, are of standard size and accept the standard 34 way connector.

TANDON TM100-2A IBM compatible DS **£39.95(C)**
CANON TEC etc. DS half height. State 40 or 80T **£79.00(C)**
TEAC FD-55-F. 40-80 DS half height. BRAND NEW **£79.00(C)**

Specials!

TEAC FD-55 half height series in your choice of 40 track double sided 360k or 80 track double sided 720k. Ex-equipment fully tested in excellent condition with 90 day warranty. Order TE-36 for 360k **£29.95(C)** or TE-72 for 720k **£39.95(C)**

CHOOSE YOUR 8 INCH

Shugart 800/801 SS refurbished & tested **£150.00(E)**
Shugart 851 double sided refurbished & tested **£225.00(E)**
Mitsubishi M2894-63 double sided switchable hard or soft sectors- BRAND NEW **£225.00(E)**

SPECIAL OFFERS!!

Dual 8" drives with 2 megabyte capacity housed in a smart case with built in power supply **Only £499.00 (F)**

Ideal as exterior drives!
End of line purchase scoop! Brand new NEC D2246 8" 85 megabyte of hard disk storage! Full CPU control and industry standard SMD interface. Ultra hi speed transfer and access time leaves the good old ST506 interface standing. In mint condition and comes complete with manual. Only.....**£399(E)**

MAINS SUPPRESSORS & FILTERS

Roxburgh SDC 021 2 amp mains RFI filter. Has an extra wide frequency range of 150 khz to 30 mhz. Can type, solder lug connection. Quality manufactured to BS 613 standards. Dims 1-1/2" x 1-3/4"..... **£3.95 or 3 for £10 (A) 10 for £28 (B)**

Roxburgh SDA 01325. Similar to above rated at 1-1/2 amps. Dims 1-1/2" x 1-3/4"..... **£3.25 or 3 for £8.50 (A) 10 for £25 (B)**

Suppression Devices SD5 A10. Extra compact general purpose suppressor. Plastic moulded case with single bolt fixing and snap connectors. Rated at 230 vac 5 amps. Dims 1-3/4" x 1-1/8" x 5/8"..... **£3.95 or 3 for £10 (A) 10 for £28 (B)**

Belling-Lee type L2127 3 amp mains RFI filters. Has a built in mains cable (English coding), and a three pin miniature non-reversible socket and a mating plug, to go to the equipment. Ideal for those who are bugged by RF interference. Very compact. Dims 3-1/8" x 2.5" x 1.5"..... **£3.95 each or 3 for £10 (A)**

RECHARGEABLE BATTERIES

LEAD ACID

Maintenance free sealed long life. Type A300.
12 volts 12 volts 3 amp/hours **£13.95(A)**
6 volts 6 volts 3 amp/hours **£ 9.95(A)**
12 volts 12 volts 1.8 amp hours. RFE. **£ 5.95(A)**
12 volts 12 volts 38 amp hours. 7-1/2" L x 6" S. RFE **£35.00(B)**

NICKEL CADMIUM

Quality 12v 4ah cell pack. Originally made for the Technicolor video company. Contains 10 GE top quality D nicad cells in a smart robust case with a DC output connector. Ideal for portable equipment. Brand new. **£18.95(B)**
Ex-equipment NICAD cells by GE. Removed from equipment and in good, used condition: D size 4ah **4 for £5(B)**
F size 7ah **6 for £8(B)**

SPECIAL INTEREST

Tektronix 1751 Waveform/Vector monitor **£2750**
Trio 0-18 vdc bench PSU. 30 amps. New **£ 470**
DEC VAX11/750 Inc. 2 Meg Ram DZ and full documentation, in brand new condition **£3900**
Fujitsu M3041 600 LPM band printer **£2950**
DEC LS/02 CPU board **£ 150**
Calcomp 1036 large drum 3 pen plotter **£ 650**
Thurby LA 160B logic analyser **£ 375**
1.5kw 115v 60hz power source **£ 950**
Tektronix R140 NTSC TV test signal standard. **£ 875**
Sony KTX 1000 Videotex system - brand new **£ 790**
ADDS 2020 VDU terminals - brand new **£ 225**
Sekonic SD 150H 18 channel Hybrid recorder **£2000**
Trend 1-9-1 Data transmission test set **£ 525**
Kenwood DA-3501 CD tester, laser pickup simulator **£ 350**



Superb Quality 6 foot 40u

19" Rack Cabinets

Massive Reductions

Virtually New, Ultra Smart!

Less Than Half Price!

Top quality 19" rack cabinets made in UK by Optima Enclosures Ltd. Units feature designer, smoked acrylic lockable front door, full height lockable half louvered back door and removable side panels. Fully adjustable internal fixing struts, ready punched for any configuration of equipment mounting plus ready mounted integral 12 way 13 amp socket switched mains distribution strip make these racks some of the most versatile we have ever sold. Racks may be stacked side by side and therefore require only two side panels or stand singly. Overall dimensions are 77-1/2" H x 32-1/2" D x 22" W. Order as:

Rack 1 Complete with removable side panels.....**£375.00 (G)**
Rack 2 Less side panels.....**£225.00 (G)**

POWER SUPPLIES

Power One SPL200-5200P 200 watt (250 w peak). Semi open frame giving +5v 35a, -5v 1.5a, +12v 4a (8a peak), -12v 1.5a, +24v 4a (6a peak). All outputs fully regulated with over voltage protection on the +5v output. AC input selectable for 110/240 vac. Dims 13" x 5" x 2.5". Fully guaranteed RFE. **£85.00 (B)**

Power One SPL130. 130 watts. Selectable for 12v (4A) or 24v (2A). 5v @ 20A. ±12v @ 1.5A. Switch mode. New. **£59.95(B)**

Astec AC-8151 40 watts. Switch mode. +5v @ 2.5a. +12v @ 2a. -12v @ 0.1a. 6-1/4" x 4" x 1-3/4". New **£19.95(B)**

Greendale 19A80E 60 watts switch mode. +5v @ 6a. ±12v @ 1a. ±15v @ 1A. RFE and fully tested. 11 x 20 x 5.5cms. **£24.95(C)**

Conver AC130. 130 watt hi-grade VDE spec. Switch mode. +5v @ 15a. -5v @ 1a. ±12v @ 6a. 27 x 12.5 x 6.5cms. New. **£49.95(C)**

Boshert 13090. Switch mode. Ideal for drives & system. +5v @ 6a. +12v @ 2.5a. -12v @ 0.5a. -5v @ 0.5a. **£29.95(B)**

Farnell G6/40A. Switch mode. 5v @ 40a. Encased **£95.00(C)**

COOLING FANS

Please specify 110 or 240 volts for AC fans.

3 inch AC. 1 1/2" thick **£ 8.50(B)**
3 1/2 inch AC ETRI slimline. Only 1" thick. **£ 9.95(B)**
4 inch AC 110/240v 1 1/2" thick. **£10.95(B)**
4 inch AC 1 1/2" thick **£ 9.95(B)**
10 inch AC round. 3 1/2" thick. Rotron 110v **£10.95(B)**
10 inch AS above but 230 volts **£24.95(B)**
62 mm DC 1" thick. No. 812 for 6/12v. 814 24v. **£15.95(A)**
60 mm DC 5 v. Papst 8105G 4w. 38mm. RFE. **£19.95(A)**
92 mm DC 12v. 18 mm thick. **£14.95(A)**
4 inch DC 12v. 12w 1 1/2" thick **£12.50(B)**
4 inch DC 24v 8w. 1" thick. **£14.50(B)**

THE AMAZING TELEBOX!

Converts your colour monitor into a

QUALITY COLOUR TV!!

TV SOUND & VIDEO TUNER!



Brand new high quality, fully cased, 7 channel UHF PAL TV tuner system. Unit simply connects to your TV aerial socket and colour video monitor turning same into a fabulous colour TV. Dont worry if your monitor does'nt have sound, the TELEBOX even has an integral audio amp for driving a speaker plus an auxiliary output for headphones or Hi Fi system etc. Many other features: LED Status Indicator, Smart moulded case, Mains powered, Built to BS safety specs. Many other uses for TV sound or video etc. Supplied BRAND NEW with full 1 year guarantee.
Telexbox ST for composite video input monitors.....**£29.95(B)**
Telexbox STL as ST but with integral speaker.....**£34.95(B)**
Telexbox RGB for analogue RGB monitors.....**£65.95(B)**
RGB Telexbox also suitable for IBM multisync monitors with RGB analog and composite sync. Overseas versions VHF & UHF call. SECAM / NTSC not available.

BRAND NEW PRINTERS

TEC Starwriter Model FP1500-25 daisywheel printer renowned for its reliability. Diablo type print mechanism gives superb registration and quality. On board microprocessor gives full Diablo/Quime command capability. Serial RS-232C with full handshake. Bidirectional 25 cps, switchable 10 or 12 pitch, 136 cps in Pica, 163 in Elite. Friction or tractor feed. Full ASCII including E sign. Font and ribbon Diablo compatible.....**£199(E)**
DED DPG21 miniature ball point pen printer plotter mechanism with full 40 characters per line. Complete with data sheet which includes circuit diagrams for simple driver electronics.....**£49(B)**
£ 150
Centronics 150 series. Always known for their reliability in continuous use - real workhorses in any environment. Fast 150 cps with 4 fonts and choice of interfaces at a fantastic price!
150-4 Serial up to 9.5" paper, fan fold tractor.....**£ 99.00(E)**
150-4 Serial up to 9.5" paper, tractor, roll or s/sheet.....**£129.00(E)**
152-2 parallel up to 14.5" paper, tractor or s/sheet.....**£149.00(E)**

CALL FOR THE MANY OTHERS IN STOCK.

VISIT OUR SHOP FOR BARGAINS

LARGE QUANTITIES OF OSCILLOSCOPES AND TEST GEAR ALWAYS AVAILABLE - CALL NOW!

DISPLAY

MAIL ORDER & OFFICES
Open Mon-Fri 9.00-5.30
Dept ET, 32 Biggin Way,
Upper Norwood,
London SE19 3XF.

LONDON SHOP
100's of bargains!
Open Mon-Sat 9-5.30
215 Whitehorse Lane,
South Norwood,
London, SE25.

DISTEL @ The Original
Free dial-up database!
1000's of items-Info On Line
300 bd 081-679-1888,
1200/75 bd 081-679-6183,
1200/1200 bd 081-679-8769

ALL ENQUIRIES
081-679-4414
Fax- 081-679-1927
Telex- 894502



-Electronics-

All prices for UK Mainland. UK customers add 17 1/2% VAT to TOTAL order amount. Minimum order £10. PO orders from Government, Universities, Schools & Local Authorities welcome-minimum account order £25. Carriage charges (A)-£2.00, (B)-£4.50, (C)-£8.50, (D)-£11.50, (E)-£14.00, (F)-£18.00 (G)-Call. All goods supplied subject to our standard Conditions of Sale and unless otherwise stated guaranteed for 90 days. All guarantees on a return to base basis. We reserve the right to change prices & specifications without prior notice. Orders accepted subject to stock. Quotations willingly given for higher quantities than those stated. Bulk surplus always required for cash.



NICAM

...set your sights on a better sound!

Experience a new sensation. An experience that opens up a whole new spectrum of sound.

Put yourself on stage at the Albert Hall, surrounded by a great orchestra. Imagine the sound you will hear, every nuance, every note; or travel up the Nile with an intrepid explorer, a journey not only full of breathtaking beauty and colour, but rich in the sounds of another continent; or capture the hidden gasps of 100,000 hardened fans at Wembley for the F.A. Cup Final, when the ball skims the crossbar with the last kick of the match; follow with your ears as well as your eyes, dodging the bullets, as your favourite hero battles out of yet another tight corner, it's just like being in a cinema!

Nicam hi-fi stereo will turn your living-room into a living room of

sound! You don't settle for second best with television picture quality, why settle for second best in television sound quality? Nicam sound is the new high quality digital stereo sound system, pioneered by BBC, ITV and TV/video manufacturers. In fact so good is Nicam it is comparable to the superb sound reproduction of the compact disc, when played through your existing hi-fi arrangement. If your television hasn't got a built-in Nicam decoder, you will need the Maplin Nicam Tuner System. Ultimately almost all of your favourite programmes will be broadcast in superb hi-fi quality stereo-sound. Without a Maplin Nicam Tuner you won't be able to capture every sound to its full.

Nicam hi-fi stereo. Catch your breath, open your eyes, and pin back your ears! It's what your hi-fi system was made for... It's what your ears are made for!

DIGITAL STEREO TV SOUND FROM YOUR HI-FI

The complete kit contains all the components required to build the unit. However you will also need: a power supply, 12V at 600mA regulated e.g. YZ21X at £9.95; a co-ax Y adaptor e.g. FS23A at £1.20; a co-ax lead to connect to your TV or video; RW36P 2m long at £1.36, JW39N 5m long at £1.98, or JW40T 10m long at £2.95; a phono lead to connect to your hi-fi e.g. RW50E at £1.06 or a SCART Peritel lead JW36P at £5.95. An infra-red remote control kit is also available LP20W at £29.95.

Complete kit LP19W only £149.95 incl. VAT + £1 mail-order handling charge.



IBA

Current
NICAM
Coverage

Maplin ELECTRONICS

**CREDIT CARD HOTLINE
0702 554161**

For a friendly welcome and the very best of service why not visit our shops in Birmingham, Brighton, Bristol, Leeds, London (Edgware and Hammersmith), Manchester, Newcastle-upon-Tyne, Nottingham, Reading, Southampton and Southend-on-Sea.

Subject to availability. Prices subject to change.

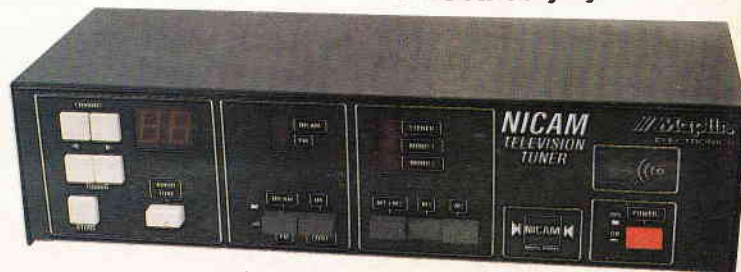

Digital stereo sound companion for your TV set.