



THE ELECTRONICS, SCIENCE & TECHNOLOGY MONTHLY

APRIL 1990 £1.50

NAVIGATE

A guide for aircraft

ELEMENTS OF RADIO

Further designs from
John Linsley Hood



CABLE TV
The complete story

THE BUSINESS
More bass amplification

QUAD POWER SUPPLY
A practical design

POWER SUPPLY THEORY
A comprehensive design

ISSN 0142-7229

9 770142 722009 04

OVP POWER AMPLIFIER MODULES-TURNABLES-DIMMERS-LOUDSPEAKERS-19 INCH STEREO RACK AMPLIFIERS

OVP POWER AMPLIFIER MODULES

Supplied ready built and tested.

OVP POWER AMPLIFIER MODULES Now enjoy a world-wide reputation for quality, reliability and performance at a realistic price. Four models available to suit the needs of the professional and hobby market, i.e., Industry, Leisure, Instrumental and Hi-Fi etc. When comparing prices, NOTE all models include Toroidal power supply, Integral heat sink, Glass fibre P.C.B., and Drive circuits to power compatible Vu meter. Open and short circuit proof.

THOUSANDS OF MODULES PURCHASED BY PROFESSIONAL USERS



OVP100 Mk 11 Bi-Polar Output power 110 watts R.M.S. into 4 ohms, Frequency Response 15Hz - 30KHz - 3dB, T.H.D. 0.01%, S.N.R. -118dB, Sens. for Max. output 500mV at 10K, Size 355 x 115x65mm. **PRICE £33.99 + £3.00 P&P.**

NEW SERIES II MOS-FET MODULES



OVP/MF 100 Mos-Fet Output power 110 watts R.M.S. into 4 ohms, Frequency Response 1Hz - 100KHz - 3dB, Damping Factor >300, Slew Rate 45V/uS, T.H.D. Typical 0.002%, Input Sensitivity 500mV, S.N.R. -125dB, Size 300 x 123 x 60mm. **PRICE £39.99 + £3.00 P&P.**



OVP/MF200 Mos-Fet Output power 200 watts R.M.S. into 4 ohms, Frequency Response 1Hz - 100KHz - 3dB, Damping Factor >300, Slew Rate 50V/uS, T.H.D. Typical 0.001%, Input Sensitivity 500mV, S.N.R. -130dB, Size 300 x 155 x 100mm. **PRICE £62.99 + £3.50 P&P.**



OVP/MF300 Mos-Fet Output power 300 watts R.M.S. into 4 ohms, Frequency Response 1Hz - 100KHz - 3dB, Damping Factor >300, Slew Rate 60V/uS, T.H.D. Typical 0.0008%, Input Sensitivity 500mV, S.N.R. -130dB, Size 330 x 175 x 100mm. **PRICE £79.99 + £4.50 P&P.**

NOTE:- MOS-FET MODULES ARE AVAILABLE IN TWO VERSIONS, STANDARD - INPUT SENS. 500mV BAND WIDTH 100KHz PEC (PROFESSIONAL EQUIPMENT COMPATIBLE) - INPUT SENS. 775mV, BAND WIDTH 50KHz, ORDER STANDARD OR PEC



Vu METER Compatible with our four amplifiers detailed above. A very accurate visual display employing 11 LED diodes (7 green, 4 red) plus an additional on/off indicator. Sophisticated logic control circuits for very fast rise and decay times. Tough moulded plastic case, with tinted acrylic front. Size 84 x 27 x 45mm. **PRICE £8.50 + 50p P&P.**

LOUDSPEAKERS



LARGE SELECTION OF SPECIALIST LOUDSPEAKERS AVAILABLE, INCLUDING CABINET FITTINGS, SPEAKER GRILLES, CROSS-OVERS AND HIGH POWER, HIGH FREQUENCY BULLETS AND HORNS, LARGE S.A.E. (30p STAMPED) FOR COMPLETE LIST.

McKENZIE:- INSTRUMENTS, P.A., DISCO, ETC.

ALL MCKENZIE UNITS 8 OHMS IMPEDENCE

- 8" 100 WATT C1100GPM GEN. PURPOSE, LEAD GUITAR, EXCELLENT MID., DISCO. RES. FREQ. 80Hz FREQ. RESP. TO 14KHz SENS. 99dB **PRICE £29.30 + £2.00 P&P**
- 10" 100 WATT C10100GP GUITAR, VOICE, ORGAN, KEYBOARD, DISCO, EXCELLENT MID. RES. FREQ. 70Hz FREQ. RESP. TO 6KHz SENS. 100dB **PRICE £35.58 + £2.50 P&P**
- 10" 200 WATT C10200GP GUITAR, KEYBOARD, DISCO, EXCELLENT HIGH POWER MID. RES. FREQ. 45Hz FREQ. RESP. TO 7KHz SENS. 103dB **PRICE £48.67 + £2.50 P&P**
- 12" 100 WATT C12100GP HIGH POWER GEN. PURPOSE, LEAD GUITAR, DISCO. RES. FREQ. 45Hz FREQ. RESP. TO 7KHz SENS. 99dB **PRICE £37.59 + £3.50 P&P**
- 12" 100 WATT C12100TC TWIN CONE HIGH POWER WIDE RESPONSE, P.A., VOICE, DISCO. RES. FREQ. 45Hz FREQ. RESP. TO 14KHz SENS. 100dB **PRICE £38.58 + £3.50 P&P**
- 12" 200 WATT C12200B HIGH POWER BASS, KEYBOARDS, DISCO, P.A. RES. FREQ. 40Hz FREQ. RESP. TO 7KHz SENS. 100dB **PRICE £65.79 + £3.50 P&P**
- 12" 300 WATT C12300GP HIGH POWER BASS LEAD GUITAR, KEYBOARDS, DISCO, ETC. RES. FREQ. 45Hz FREQ. RESP. TO 5KHz SENS. 100dB **PRICE £87.51 + £3.50 P&P**
- 15" 100 WATT C15100BS BASS GUITAR, LOW FREQUENCY, P.A., DISCO. RES. FREQ. 40Hz FREQ. RESP. TO 5KHz SENS. 98dB **PRICE £55.05 + £4.00 P&P**
- 15" 200 WATT C15200BS VERY HIGH POWER BASS. RES. FREQ. 40Hz FREQ. RESP. TO 4KHz SENS. 99dB **PRICE £75.10 + £4.00 P&P**
- 15" 250 WATT C15250BS VERY HIGH POWER BASS. RES. FREQ. 40Hz FREQ. RESP. TO 4KHz SENS. 99dB **PRICE £82.54 + £4.50 P&P**
- 15" 400 WATT C15400BS VERY HIGH POWER, LOW FREQUENCY BASS. RES. FREQ. 40Hz FREQ. RESP. TO 4KHz SENS. 102dB **PRICE £96.47 + £4.50 P&P**
- 18" 400 WATT C18400BS EXTREMELY HIGH POWER, LOW FREQUENCY BASS. RES. FREQ. 27Hz FREQ. RESP. TO 3KHz SENS. 99dB **PRICE £172.06 + £5.00 P&P**

EARBENDERS:- HI-FI, STUDIO, IN-CAR, ETC.

ALL EARBENDER UNITS 8 OHMS (Except EB8-50 & EB10-50 which are dual impedance tapped (4 & 8 ohm))

- 8" 50 WATT EB8-50 DUAL IMPEDENCE, TAPPED 4/8 OHM BASS, HI-FI, IN-CAR. RES. FREQ. 40Hz FREQ. RESP. TO 7KHz SENS. 97dB **PRICE £8.90 + £2.00 P&P**
- 10" 50 WATT EB10-50 DUAL IMPEDENCE, TAPPED 4/8 OHM BASS, HI-FI, IN-CAR. RES. FREQ. 40Hz FREQ. RESP. TO 5KHz SENS. 99dB **PRICE £12.00 + £2.50 P&P**
- 10" 100 WATT EB10-100 BASS, HI-FI, STUDIO. RES. FREQ. 35Hz FREQ. RESP. TO 3KHz SENS. 96dB **PRICE £27.76 + £3.50 P&P**
- 12" 60 WATT EB12-60 BASS, HI-FI, STUDIO. RES. FREQ. 28Hz FREQ. RESP. TO 3KHz SENS. 92dB **PRICE £21.00 + £3.00 P&P**
- 12" 100 WATT EB12-100 BASS, STUDIO, HI-FI, EXCELLENT DISCO. RES. FREQ. 26Hz FREQ. RESP. TO 3KHz SENS. 93dB **PRICE £38.75 + £3.50 P&P**
- FULL RANGE TWIN CONE, HIGH COMPLIANCE, ROLLED SURROUND**
- 5 1/4" 60 WATT EB5-60TC (TWIN CONE) HI-FI, MULTI-ARRAY DISCO ETC. RES. FREQ. 63Hz FREQ. RESP. TO 20KHz SENS. 92dB **PRICE £9.99 + £1.50 P&P**
- 6 1/2" 60 WATT EB6-60TC (TWIN CONE) HI-FI, MULTI-ARRAY DISCO ETC. RES. FREQ. 38Hz FREQ. RESP. TO 20KHz SENS. 94dB **PRICE £10.99 + £1.50 P&P**
- 8" 60 WATT EB8-60TC (TWIN CONE) HI-FI, MULTI-ARRAY DISCO ETC. RES. FREQ. 40Hz FREQ. RESP. TO 18KHz SENS. 89dB **PRICE £12.99 + £1.50 P&P**
- 10" 60 WATT EB10-60TC (TWIN CONE) HI-FI, MULTI-ARRAY DISCO ETC. RES. FREQ. 35Hz FREQ. RESP. TO 12KHz SENS. 86dB **PRICE £16.49 + £2.00 P&P**

TRANSMITTER HOBBY KITS

PROVEN TRANSMITTER DESIGNS INCLUDING GLASS FIBRE PRINTED CIRCUIT BOARD AND HIGH QUALITY COMPONENTS COMPLETE WITH CIRCUIT AND INSTRUCTIONS

3W FM TRANSMITTER 80-108MHz, VARICAP CONTROLLED PROFESSIONAL PERFORMANCE, RANGE UP TO 3 MILES, SIZE 38 x 123mm, SUPPLY 12V @ 0.5AMP. **PRICE £14.49 + £1.00 P&P**

FM MICRO TRANSMITTER (BUG) 100-108MHz, VARICAP TUNED COMPLETE WITH VERY SENS FET MIC, RANGE 100-300m, SIZE 58 x 46mm, SUPPLY 9V BATT. **PRICE £8.62 + £1.00 P&P**



3 watt FM Transmitter



POSTAL CHARGES PER ORDER £1.00 MINIMUM. OFFICIAL ORDERS WELCOME FROM SCHOOLS, COLLEGES, GOVT. BODIES, ETC. PRICES INCLUSIVE OF V.A.T. SALES COUNTER. VISA ACCESS ACCEPTED BY POST, PHONE OR FAX.



* PRICES INCLUDE V.A.T. * PROMPT DELIVERIES * FRIENDLY SERVICE * LARGE S.A.E., 30p STAMPED FOR CURRENT LIST.

OVP VARISPEED TURNTABLE CHASSIS



★ MANUAL ARM ★ STEEL CHASSIS ★ ELECTRONIC SPEED CONTROL 33 & 45 ★ VARI PITCH CONTROL ★ HIGH TORQUE SERVO DRIVEN DC MOTOR ★ TRANSIT STROBE ★ 12" DIE CAST PLATTER ★ NEON STROBE ★ CALIBRATED BAL WEIGHT ★ REMOVABLE HEAD SHELL ★ 1/2" CARTRIDGE FIXINGS ★ CUE LEVER ★ MOUNTING 220 240V 50/60Hz ★ 390x305mm ★ SUPPLIED WITH POWER CUT-OUT TEMPLATE

PRICE £59.99 + £3.50 P&P.

OPTIONAL MAGNETIC CARTRIDGES

STANTON AL500
PRICE £16.99 + 50p P&P

GOLDRING G850
PRICE £6.99 + 50p P&P

OVP MOS-FET POWER AMPLIFIERS, HIGH POWER, TWO CHANNEL 19 INCH RACK

THOUSANDS PURCHASED BY PROFESSIONAL USERS



NEW MXF SERIES OF POWER AMPLIFIERS

THREE MODELS:- MXF200 (100w + 100w)
MXF400 (200w + 200w) MXF600 (300w + 300w)

All power ratings R.M.S. into 4 ohms.

FEATURES: ★ Independent power supplies with two Toroidal Transformers ★ Two LED Vu meters ★ Rotary indexed level controls ★ Illuminated on/off switch ★ XLR connectors ★ Standard 775mV inputs ★ Open and short circuit proof ★ Latest Mos-Fets for stress free power delivery into virtually any load ★ High slew rate ★ Very low distortion ★ Aluminium cases ★ MXF600 Fan Cooled with D.C. Loudspeaker and Thermal Protection.

USED THE WORLD OVER IN CLUBS, PUBS, CINEMAS, DISCOS ETC.

SIZES:- MXF 200 W19" x H3 1/2" (2U) x D11"
MXF 400 W19" x H5 1/4" (3U) x D12"
MXF 600 W19" x H5 1/4" (3U) x D13"

MXF200 £171.35
MXF400 £228.85
MXF600 £322.00

SECURICOR DELIVERY £12.00 EACH



OVP LINNET LOUDSPEAKERS

THE VERY BEST IN QUALITY AND VALUE



MADE ESPECIALLY TO SUIT TODAY'S NEED FOR COMPACTNESS WITH HIGH OUTPUT SOUND LEVELS. FINISHED IN HARDWEARING BLACK VINYL WITH PROTECTIVE CORNERS, GRILLE AND CARRYING HANDLE. INCORPORATES 12" DRIVER PLUS HIGH FREQ. HOORN FOR FULL FREQ. RANGE 45Hz-20KHz BOTH MODELS 8 OHM. SIZE H16" x W15" x D12"

CHOICE OF TWO MODELS

POWER RATINGS QUOTED IN WATTS RMS FOR EACH CABINET

OVP 12-100 (100W 100dB) PRICE £159.99 PER PAIR
OVP 12-200 (200W 102dB) PRICE £209.99 PER PAIR

SECURICOR DEL:- £12.00 PER PAIR

IN CAR STEREO BOOSTER AMPLIFIER



TWO SUPERB HIGH POWER CAR STEREO BOOSTER AMPLIFIERS

150 WATTS (75+75) INTO 4 OHMS
300 WATTS (150+150) INTO 4 OHMS
FEATURES:-
★ HIGH & LOW INPUT IMPEDANCES
★ HIGH & LOW INPUT SENSITIVITIES
★ VARIABLE INPUT GAIN CONTROL
★ SHORT CIRCUIT OUTPUT PROTECTION
★ POWER REQUIREMENT 12V D.C.
PRICES: 150 WATT £43.00
300 WATT £96.00 - £3.00 P&P EACH

PIEZO ELECTRIC TWEETERS-MOTOROLA

PIEZO ELECTRIC TWEETERS - MOTOROLA

Join the Piezo revolution. The low dynamic mass (no voice coil) of a Piezo tweeter produces an improved transient response with a lower distortion level than ordinary dynamic tweeters. As a crossover is not required these units can be added to existing speaker systems of up to 100 watts (more if 2 put in series). FREE EXPLANATORY LEAFLETS SUPPLIED WITH EACH TWEETER.

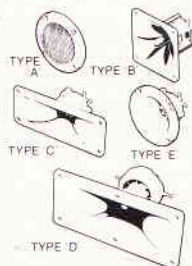

TYPE 'A' (KSN2036A) 3" round with protective wire mesh, ideal for bookshelf and medium sized Hi-Fi speakers. Price £4.90 each + 50p P&P.
TYPE 'B' (KSN1005A) 3 1/2" super horn. For general purpose speakers, disco and P.A. systems etc. Price £5.99 each + 50p P&P.
TYPE 'C' (KSN6016A) 2" x 5" wide dispersion horn. For quality Hi-Fi systems and quality discos etc. Price £6.99 each + 50p P&P.
TYPE 'D' (KSN1025A) 2" x 6" wide dispersion horn. Upper frequency response retained extending down to mid range (2KHz). Suitable for high quality Hi-Fi systems and quality discos. Price £9.99 each + 50p P&P.
TYPE 'E' (KSN1038A) 3 1/2" horn tweeter with attractive silver finish trim. Suitable for Hi-Fi monitor systems etc. Price £5.99 each + 50p P&P.
LEVEL CONTROL Combines on a recessed mounting plate, level control and cabinet input jack socket. 85x85mm. Price £3.99 + 50p P&P.

STEREO DISCO MIXER

STEREO DISCO MIXER with 2 x 5 band L & R graphic equalisers and twin 10 segment L.E.D Vu Meters. Many outstanding features 5 inputs with individual faders providing a useful combination of the following:-
3 Turntables (Mag), 3 Mics, 4 Line including CD plus Mic with talk over switch Headphone Monitor, Pan Pot L & R, Master Output controls. Output 775mV. Size 360x280x90mm. Supply 220-240V.
Price £134.99 - £4.00 P&P



B. K. ELECTRONICS

Dept EE

UNIT 5, COMET WAY, SOUTHEND-ON-SEA, ESSEX, SS2 6TR
TEL: 0702-527572 FAX: 0702-420243

BAKERS DOZEN PACKS

All packs are £1 each. Note the figure on the extreme left is the pack ref number and the next figures is the quantity of items in the pack, finally a short description.

BD2	5	13A spurs provide a fused outlet to a ring main where device such as a clock must not be switched off
BD9	2	6v. 1A mains transformers upright mounting with fixing clamps
BD11	1	6½" speaker cabinet ideal for extensions, takes your speaker. Ref BD137 + 50p.
BD13	12	30 watt reed switches, it's surprising what you can make with these — burglar alarms, secret switches, relay etc. etc
BD22	2	25 watt loud speaker two unit cross-overs
BD30	2	Nicad constant current charges adapt to charge almost any nicad battery
BD32	2	Humidity switches, as the air becomes damper the membrane stretches and operates a microswitch
BD42	5	13A rocker switch three tag so on/off, or change over with centre off
BD45	1	24hr time switch, ex-Electricity Board, automatically adjust for lengthening and shortening day.
BD49	5	Neon valves, with series resistors, these make good night lights
BD56	1	Mini uniselector, one use for an electric jigsaw puzzle, we give circuit diagram for this. One pulse into motor, moves switch through on pole
BD67	1	Suck or blow operated pressure switch, or it can be operated by any low pressure variations such as water level in water tanks
BD103A	1	6V 750MA power supply, nicely cased with input and output leads
BD120	2	Stripper boards each contains a 400v 2A bridge rectifier and 14 other diodes and rectifiers as well as dozens of condensers etc
BD128	10	Very fine drills for p.c.b. boards etc. Normal cost about 80p each
BD132	2	Plastic boxes approx. 3" cube with square hole through top so ideal for interrupted beam switch
BD134	10	Motors for model aeroplanes, spin to start so needs no switch
BD139	6	Microphone inserts — magnetic 490 ohm also act as speakers
BD148	4	Reed relay kits you get 16 reed switches and 4 coil sets with notes on making c/o relays and other gadgets
BD149	6	Safety cover for 13A sockets — prevent those inquisitive little fingers getting nasty shocks
BD180	6	Neon indicators in panel mounting holders with lens
BD193	6	5amp 3pin flush mounting sockets makes a low cost disco panel — need cable clips
BD199	1	Mains solenoid very powerful has 1" pull or could push if modified
BD201	8	Keyboard switches — made for computers but have many other applications
BD211	1	Electric clock mains operated put this in a box and you need never be late
BD221	5	12v alarms make a noise about as loud as a car horn. Slightly solid but OK
BD242	2	6" x 4" speakers 4 ohm made from Radiomobile so very good quality
BD252	1	Panostat, controls output of boiling ring from simmer to boil
BD259	50	Leads with push on ¼" tags — a must for hook ups — mains connections etc
BD263	2	Oblong push switches for bell or chimes, these can mains up to 5 amps so could be foot switch if fitted into pattress
BD268	1	Mini 1 watt amp for record player. Will also change speed of record player motor
BD283	3	Mild steel boxes approximately 3" x 3" x 1" deep — standard electrical
BD305	1	Tubular dynamic mic with optional table rest
BD400	4	Books. Useful for beginners. Describes amplifiers, test equipment and kit sets
BD653	2	Miniature driver transformers. Ref LT44. 20k to 1k, centre tapped
BD548	2	35 volt relays, each with two pairs changeover contacts
BD667	2	4.7uF, non-polarised block capacitors, pcb mounting

There are over 1,000 items in our Bakers Dozen List. If you want a complete copy please request this when ordering.

TOASTERS 2 slice toasters — may need slight attention only. Only £3 each. Ref 3P84.

PERSONAL STEREOS Again customer returns but complete and with stereo head phones. A bargain at only £3 each. Our ref 3P83.

MAINS OPERATED MICROWAVE CONTROL PANEL WITH TOUCH SWITCHES This has a 4-digit display with a built-in clock and 2 relay outputs. 1 for power and 1 for pulsed power level. Could be used for all sorts of timer control applications. Only £6. Ref 6P18.

EQUIPMENT WALL MOUNT. Multi-adjustable metal bracket for speak, etc. 2 for £5. Our ref 5P152.

STABILISED POWER SUPPLY KIT. +-+V/2.0A. Contains PCB, transformer and all components excluding case, etc. Our price is £20. Ref 20P25.

KEYBOARDS. Brand new uncased with 84 keys plus PCB with several ICs. Only £3. Ref 3P89.

SURFACE MOUNT KIT. Only £7.50. Ring for details.

SUB-MIN TOGGLE SWITCH. Body size 8mm x 4mm x 7mm SBDT with chrome dolly fixing nuts. 3 for £1. Order ref BD649.

COPPER CLAD PANEL. For making PCB. Size approx 12in long x 8½in wide. Double-sided on fibreglass middle which is quite thick (about 1/16in) so this would support quite heavy components and could even form a chassis to hold a mains transformer, etc. Price £1 each. Our ref BD633.

POWERFUL IONISER

Generates approx. 10 times more IONS than the ETI and similar circuits. Will refresh your home, office, workshop etc. Makes you feel better and work harder — a complete mains operated kit, case included. £12.50 + £2 P&P. Our ref 12P571.

REAL POWER AMPLIFIER. For your car, it has 150 watts output. Frequency response 20hz to 20Khz and signal to noise ratio better than 60dB. Has built-in short circuit protection and adjustable input level to suit your existing car stereo, so needs no pre-amp. Works into speakers ref. 30P7 described below. A real bargain at only £57.50. Order ref: 57P1.

REAL POWER CAR SPEAKERS. Stereo pair output 100w each. 4-ohm impedance and consisting of 6½" woofer, 2" mid range and 1" tweeter. Each set in a compact purpose built shell mounting unit. Ideal to work with the amplifier described above. Price per pair £29.96. Order ref: 30P7.

STEREO CAR SPEAKERS. Not quite so powerful — 70w per channel. 3" woofer, 2" mid range and 1" tweeter. Again, in a super purpose built shell mounting unit. Price per pair: £27.95. Order ref: 28P1.

VIDEO TAPES These are three hour tapes of superior quality, made under licence from the famous JVC Company. Offered at only £3 each. Our ref 3P63. Or 5 for £11. Our ref 11P3. Or for the really big user 10 for £20. Our ref 20P20.



ELECTRONIC SPACESHIP.

Sound and impact controlled, responds to claps and shouts and reverses when it hits anything. Kit with really detailed instructions. Ideal present for budding young electrician. A youngster should be able to assemble but you may have to help with the soldering of the components on the pcb. Complete kit £10. Our ref 10P61.

12" HIGH RESOLUTION MONITOR. Black and white screen, beautifully cased for free standing, needs only a 12v 1.5 amp supply. Technical data is on its way but we understand these are TTL input. Brand new in maker's cartons. Price: £22. Free delivery. Order ref 25P10.

14" COLOUR MONITOR. Made by the American Display Tek company. Uses high resolution tube made by the famous Japanese Toshiba company. Beautifully made unit intended for console mounting, but top and sides adequately covered by plated metal panels. Full technical spec. on its way to us. We have limited number of these. All brand new still in maker's cartons. Price £89 each plus £6 insured carriage. Order ref 89P1.

COMPOSITE VIDEO KITS. These convert composite video into separate h-sync, v-sync and video. Price £8. Our ref 8P39.

BUSH RADIO MIDI SPEAKERS. Stereo pair. BASS reflex system, using a full range 4in driver of 4 ohms impedance. Mounted in very nicely made black fronted walnut finish cabinets. Cabinet size approx 8½in wide, 14in high and 3½in deep. Fitted with a good length of speaker flex and terminating with a normal audio plug. Price £5 the pair plus £1 post. Our ref 5P141.

3½in FLOPPY DRIVES. We still have two models in stock: Single sided, 80 track, by Chicon. This is in the manufacturers metal case with leads and IDC connectors. Price £40, reference 40P1. Also a double sided, 80 track, by NEC. This is uncased. Price £58.50, reference 60P2. Both are brand new. Insured delivery £3 on each or both.



ATARI 65XE COMPUTER. At 64K this is most powerful and suitable for home and business. Brand new, complete with PSU, TV lead, owner's manual and six games. Can be yours for only £45 plus £3 insured delivery.

10 MEMORY PUSH BUTTON TELEPHONES. These are customer returns and sold as seen. They are complete and may need slight attention. Price £6. Ref 6P16 or 2 for £10. Ref 10P77. BT approved.

REMOTE CONTROL FOR YOUR COMPUTER. With this outfit you can be as much as 20 feet away as you will have a joystick that can transmit and receive to plug into and operate your computer and TV. This is also just right if you want to use it with a big screen TV. The joystick has two fire buttons and is of a really superior quality, with four suction cups for additional control and one handed play. Price £15 for the radio controlled pair. Our ref 15P27.

ASTEC PSU. Mains operated switch mode, so very compact. Outputs: +12V 2.5A, +5V 6A, ±5V .5A, ±12V .5A. Size: 7¼in long x 43/8in wide x 23/4in high. Cased ready for use. Brand new. Normal price £30 +, our price only £12.95. Our ref 13P2.

VERY POWERFUL 12 VOLT MOTORS. 1/3rd Horsepower. Made to drive the Sinclair C5 electric car but adaptable to power a go-kart, a mower, a rail car, model railway, etc. Brand new. Price £20 plus £2 postage. Our ref 20P22.

PHILIPS LASER

This is helium-neon and has a power rating of 2mW. Completely safe so long as you do not look directly into the beam when eye damage could result. Brand new, full spec, £35 plus £3 insured delivery. Mains operated power supply for this tube gives 8kv striking and 1.25kv at 5mA running. Complete kit with case £15. As above for 12v battery. Also £15. Our ref 15P22.

ORGAN MASTER is a three octave musical keyboard. It is beautifully made, has full size (piano size) keys, has gold plated contacts and is complete with ribbon cable and edge connector. Can be used with many computers, request information sheet. Brand new, only £15 plus £3 postage. Our ref 15P15.

FULL RANGE OF COMPONENTS at very keen prices are available from our associate company SCS COMPONENTS. You may already have their catalogue, if not request one and we will send it FOC with your goods.

HIGH RESOLUTION MONITOR. 9in black and white, used Philips tube M24/306W. Made up in a lacquered frame and has open side. Made for use with OPD computer but suitable for most others. Brand new, £16 plus £5 post. Our reference 16P1.

12 VOLT BRUSHLESS FAN. Japanese made. The popular square shape 4¼in x 4¼in x 13/4in). The electronically run fans not only consume very little current but also they do not cause interference as the brush type motors do. Ideal for cooling computers, etc. or for a caravan. £8 each. Our ref 8P26.

MINI MONO AMP on p.c.b. size 4" x 2" (app) Fitted Volume control and a hole for a tone control should you require it. The amplifier has three transistors and we estimate the output to be 3W rms. More technical data will be included with the amp. Brand new, perfect condition, offered at the very low price of £1.15 each, or 13 for £12.



J & N BULL ELECTRICAL

Dept. ETI, 250 PORTLAND ROAD, HOVE, BRIGHTON, SUSSEX BN3 5QT.

MAIL ORDER TERMS: Cash, P.O. or cheque with order. Please add £2.50 service charge. Monthly account orders accept from schools and public companies. Access & Barclaycard orders are accepted — minimum £5. Phone (0273) 734648 or 203500. Fax 23077

POPULAR ITEMS — MANY NEW THIS MONTH

JOYSTICKS for BBC, Atari, Dragon, Commodore, etc. All £5 each. All brand new, state which required.

TELEPHONE TYPE KEY PAD. Really first class rear mounting unit. White lettering on black buttons. Has conductive rubber contacts with soft click operation. Circuit arranged in telephone type array. Requires 70mm by 55mm cutout and has a 10 IDC connector. Price £2. Ref 2P251.

SUB-MIN PUSH SWITCHES Not much bigger than a plastic transistor but double pole. PCB mounting. Three for £1. Our ref BD688.

AA CELLS. Probably the most popular of the rechargeable NICAD types. 4 for £4. Our ref 4P44.

20 WATT 4OHM SPEAKER With built in tweeter. Really well made unit which has the power and the quality for hi-fi. 6½in dia. Price £5. Our ref 5P155 or 10 for £40 ref 40P7.

MINI RADIO MODULE Only 2in square with ferrite aerial and solid dia tuner with own knob. It is a superhet and operates from a PP3 battery and would drive a crystal headphone. Price £1. Our ref BD716.

BULGIN MAINS PLUG AND SOCKET. The old faithful 3 pin with screw terminals. The plug is panel mounted and the socket is cable mounted. 2 pairs for £1 or 4 plugs or 4 sockets for £1. Our ref BD715, BD715P or BD715S.

MICROPHONE. Low cost hand held microphone with on/off switch in handle, lead terminates in one 3.5 plug and one 2.5 plug. Only £1. Ref BD711.

MOSFETS FOR POWER AMPLIFIERS AND HIGH CURRENT DEVICES 40v 100w pair made by Hitachi. Ref 25K413 and its component 25J118. Only £4 a pair. Our ref 4P42. Also available in H pack Ref 25J99 and 25K343 £4 a pair. Ref 4P51.

TIME AND TEMPERATURE LCD MODULE. A 12 hour clock, a Celsius and Fahrenheit thermometer, a too hot alarm and a too cold alarm. Approx 50 x 20mm with 12.7mm digits. Requires one AA battery and a few switches. Comes complete with full data and diagram. Price £6. Our ref 6P12.

REMOTE TEMPERATURE PROBE FOR ABOVE. £3. Our ref 3P60.

A REAL AIR MOVER. Circular axial fan moves 205 cubic foot per min which is about twice as much as our standard 4½in fans. Low noise mains operated 6½in dia, brand new. Regular price over £30, our price only £10. Our ref 10P71.

600 WATT AIR OR LIQUID MAINS HEATER. Small coil heater made for heating air or liquids. Will not corrode. Lasts for years, coil size 3in x 2in mounted on a metal plate for easy fixing, 4in dia. Price £3. Ref 3P78 or 4 for £10. Our ref 10P76.

EX EQUIPMENT SWITCHED MODE POWER SUPPLIES. Various makes and specs but generally ±5, ±12v, ideal bench supply. Only £8. Our ref 8P36.

ACORN DATA RECORDER. Made for Electron or BBC computer but suitable for others. Includes mains adaptor, leads and book. £12. Ref 12P15.

PTFE COATED SILVER PLATED CABLE. 19 strands of .45mm copper, will carry up to 30A and is virtually indestructible. Available in red or black. Regular price is over £120 per reel, our price only £20 for 100m reel. Ref 20P21 or 1 of each for £35. Ref 35P2. Makes absolutely superb speaker cable!

NEW PIR SENSORS. Infra red movement sensors will switch up to 500w mains. UK made, 12 months manufacturers warranty. 15-20m range with a 0-10min timer, adjustable wall bracket. Only £20. Ref 20P24.

MITSUBISHI 3½in DISC DRIVES. Brand new drives, ½ height double sided, double density, warranted. Our price £60. Ref 60P5.

DEHUMIDIFIERS. Domestic mains powered dehumidifiers these are customer returns and sold as seen. Price £30. Our ref 30P9. Callers only please.

SPECTRUM PRINTER INTERFACE. Add a centronics interface to your Spectrum complete with printer cable for only £4. Our ref 4P52.

GEIGER COUNTER KIT. Includes tube, PCB and all components to build a 9V operation geiger counter. Only £39. Ref 39P1.

SPECTRUM SOUND BOX. Add sound to your Spectrum with this device; just plug in. Complete with speaker, volume control and nicely boxed. A snip at only £4. Our ref 4P53.

BBC JOYSTICK INTERFACE. Converts a BBC joystick port to an Atari type port. Price £2. Our ref 2P261.

TELEPHONE EXTENSION LEAD. 5M phone extension lead with plug on one end and socket on the other. White. Price £3. Our ref 3P70 or 10 leads for only £19! Ref 19P2.

LCD DISPLAY. 4½in digits supplied with connection data £3. Ref 3P77 or 5 for £10 Ref 10P78.

CROSS OVER NETWORK. 8 ohm 3-way for tweeter midrange and woofer. Nicely cased with connections marked. Only £2. Our ref 2P255 or 10 for £15 ref 15P32.

REFERSING LIGHT ALARM. Fits to car reversing light and sounds when reversing. Only £2. Our ref 2P248.

BASE STATION MICROPHONE. Top quality uni-directional electret condenser mic 600r impedance sensitivity 16-18KHz — 68db built in chime. Complete with mic stand bracket. £15. Ref 15P28.

MICROPHONE STAND. Very heavy chromed mic stand, magnetic base. 4in high. £3 if ordered with above mic. Our ref 3P80.

SOLAR POWERED NI-CAD CHARGER. 4 Nicad AA battery charger charges 4 batteries in 8 hours. Price £6. Our ref 6P3.

MAINS SOLDERING IRON. Price £3. Our ref 3P65.

SOLDERING IRON STAND. Price £3. Our ref 3P66.

SHARP PLOTTER PRINTER. New 4 colour printer originally intended for Sharp computers but may be adaptable for other machines. Complete with pens, paper, etc. Price £16. Our ref 16P3.

KIT to convert the above Printer to Centronics parallel. £4. Ref 4P.

CAR IONIZER KIT. Improve the air in your car, clears smoke and helps prevent fatigue. Case ref. Price £12. Our ref 12P8.

NEW FM BUG KIT. New design with PCB embedded coil 9v operation. Priced at £5. Our ref 5P158.

NEW PANEL METERS. 50uA movement with three different scales that are brought into view with a lever. Price only £3. Ref 3P81.

STROBE LIGHTS. Fit a standard Edison screw light fitting 240v 40min flash rate, available in yellow, blue, green and red, complete with socket. Price £10 each. Ref 10P80 (state colour reqd).

ELECTRIC SPEED CONTROL KIT. Suitable for controlling our powerful 12v motors. Price £17. Ref 17P3 (heatsink required).

EXTENSION CABLE WITH A DIFFERENCE. It is flat on one side, making it easy to fix and look tidy. 4 core, suitable for alarms, phones etc. Our price only £5 for 50m reel. Ref 5P153.

METAL PROJECT BOX. Ideal for battery charger, power supply etc., sprayed grey, size 8" x 4" x 4½", louvred for ventilation. Price £3. Ref 3P75.

April
1990

VOLUME 19 No 4

Paul Freeman: Editor
Helen Oughton: Deputy Editor
Mark Webb: Group Editor
Pete Baker: Design

Cass Gilroy: Ad Manager
John Brasier: Classified Sales
Jerry Fowler: Technical Illustration
Mannie Cefai: Photography

REGULARS

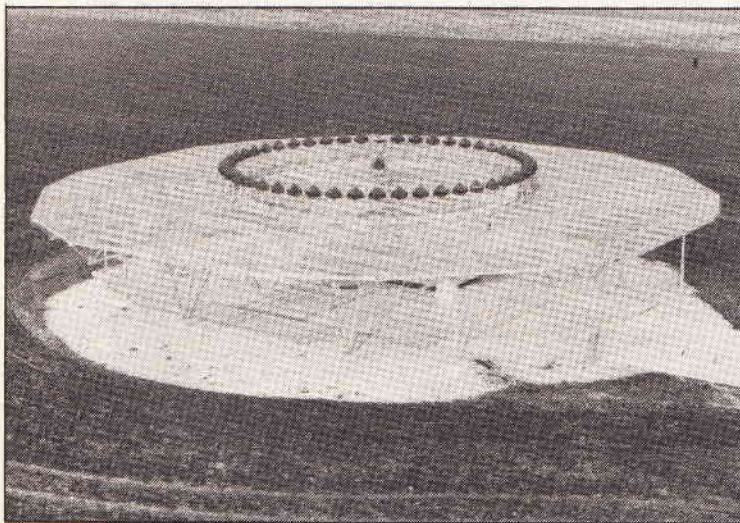

Page 14

ISSN 0142-7229

Member of the Audit Bureau of Circulation

ETI is normally published on the first Friday in the month preceding the cover date. The contents of this publication including all articles, designs, plans, drawings and programs and all copyright and other intellectual property rights therein belong to Argus Specialist Publications. All rights conferred by the Law of Copyright and other intellectual property rights and by virtue of international copyright conventions are specifically reserved to Argus Specialist Publications and any reproduction requires the prior written consent of the Company © 1990 Argus Specialist Publications. All reasonable care is taken in the preparation of the magazine contents, but the publishers cannot be held legally responsible for errors. Where mistakes do occur, a correction will normally be published as soon as possible afterwards. All prices and data contained in advertisements are accepted by us in good faith as correct at the time of going to press. Neither the advertisers nor the publishers can be held responsible, however, for any variations affecting price or availability which may occur after the publication has closed for press.

● Subscription rates — UK: £18.00, Europe: £22.20, Middle East: £22.40, Far East: £24.00, Rest: £22.70 or US\$39.00.



Argus House, Boundary Way,
Hemel Hempstead HP2 7ST
Tel: (0442) 66551 Fax: (0442) 66998

Blueprint

10

Oooooops!

58

ASP Reader Services

53

PCB Service

61

Courses

62

ASP Special Offer

57

Classified Ads

64

News

6

Subscriptions

8

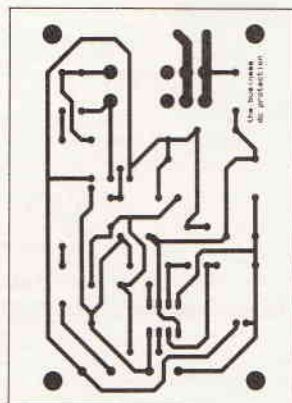

PCB Foil Patterns

58

Next Month

66

Last Month

66

Open Channel

9

Ad Index

66

Published by Argus Specialist Publications, Argus House, Boundary Way, Hemel Hempstead HP2 7ST. Tel: (0442) 66551. UK newstrade distribution by SM Distribution Ltd., 6 Leigham Court Road, London SW16 2PG. Tel: 01-677 8111. Overseas and non-newstrade sales by Magazine Sales Department, Argus House, Boundary Way, Hemel Hempstead, HP2 7ST. Tel: (0442) 66551. Subscriptions by Select Subscriptions Ltd., 5 River Park Estate, Berkhamsted HP4 1HL. Tel: (0442) 876661. US subscriptions by Wise Owl Publications, 4314 West 238th Street, Torrance, CA90505 USA. Typesetting and origination by Project 3 Filmsetters, Whitstable. Printed by Acorn Web Offset Ltd, Bradford, W Yorks.

FEATURES/PROJECTS



Patents in Switzerland

Marc Masson tells of easier Patenting methods in the land of banks and chocolates.

13

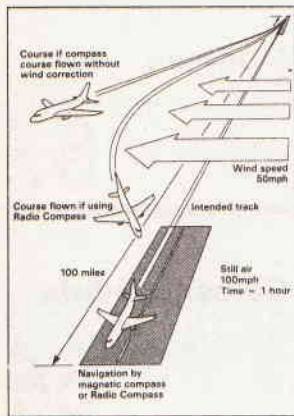

Navigate

Homing beacons are essential for the guidance and safe landing of modern aircraft. Brian Kendall tells the story of close range navigation systems.

14

Cable TV

Jim Slater is back with the first part of a system that's been with us for some time. Will cable TV be developed into a comprehensive national network for all our viewing needs? Find out in these pages.

20

Power Supply theory

If you want a power supply, why not design it from scratch. Mike Bedford takes you through the theory.

26

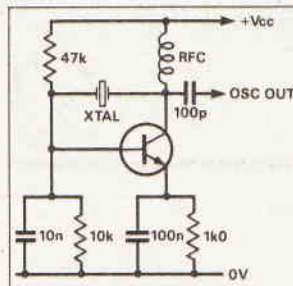

Elements of radio

The second part of our radio serial by John Linsley Hood. This month; Oscillators and superhet problems.

33

Quad Power Supply

Four supplies in one. Paul Brow builds this useful little project.

38

The ETI Superchip

Take part in our first constructional competition.

40

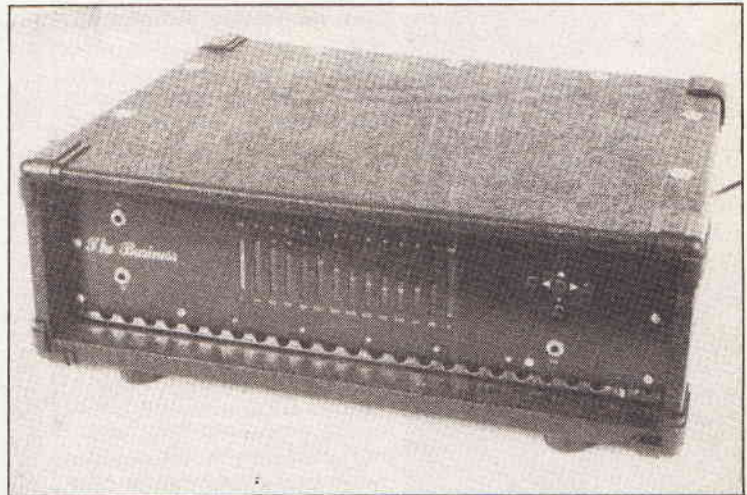

Page 42

The Business

This month Bob Whelan covers more of the vital parts his bass signal has to reach in this high tech amplifier.

42

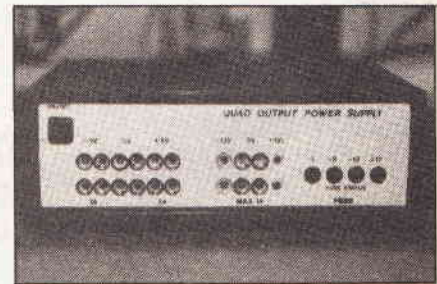

Page 38

Testing Testing

Mike Barwise takes a multimeter to hand and measures some voltages.

50



Earth Current Signals

The third part in the series. George Pickworth detects the signals with his own equipment.

54



Page 20

NEWS

RADIO NEWS

It's beginning to look increasingly likely that Independent Television News (ITN) is going to provide news services for some of the new community radio stations cropping up around the country.

ITN is also applying for a licence to run a national radio, specifically to produce a round-the-clock news and current affairs programme. Problems arise, though, as current rules in the Broadcasting Bill are against cross-media ownership such as this, restricting stakes of no more than 20% in opposing medium types. ITN hopes to get around these problems as a special case.

If it gets the go-ahead, ITN radio news (name as yet unannounced), initially delivered to individual radio stations via satellite links, will be launched on a national basis as soon as possible.

Six commercial stations have shown interest already in the news bulletin service, and more are expected. ITN views this bulletin service as good experience for the full-time news programme which it hopes will be licenced in due course.

GREEN PCB's

New Gallup research, commissioned by Nepcon Europe, suggests that although PCB manufacturers are currently being condemned for their continuing use of CFC cleaning fluids, definite plans to cut down their use and research into safer alternatives are well underway. The new research shows that 66 per cent of manufacturers still using CFC cleaning fluids are planning to discontinue their use in the near future.

The survey was based on 100 manufacturers who currently use a mix of PCB technology applications. 41 per cent stated that instead of using CFCs, a water based cleaning method would be a suitable option for their industry sector. 31 per cent were planning on using terpenes, saponifiers or other alternative solutions to water.

Although cost has been presumed to be the greatest barrier stopping companies from changing over from CFC cleaning fluids, not one of the 34 per cent of companies planning to still use them quoted this as a reason. Instead they stated lack of information on alternatives and also that existing alternatives did not provide industry-required levels of cleanliness.

For more information contact: Sarah Bright/Victoria Howorth Paragon Communications (UK) Ltd 01-734-6030.

TSIEN BOARDMAKER

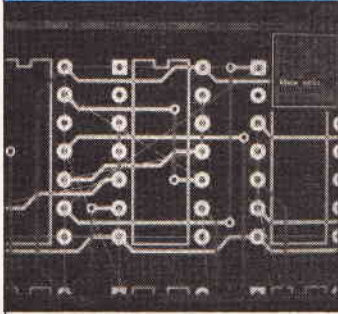

We've got two news releases from Tsiens on the newsdesk. The first explains Tsiens's newest version of *Boardmaker*, the company's printed circuit board CAD software. And if that news release is hot, the second is positively glowing red. Let us explain.

First release shows the new version, *Boardmaker 2* appears to be even more powerful than its predecessor. Where the first version is capable of producing PCB foil designs for original circuits from *netlists* (that is, lists of all the logical connections in the circuit — you know, emitter of transistor Q3 is connected to pin 6 of integrated circuit IC2), *Boardmaker 2* does all this *and* is able to import *netlists* originally performed on other, much more expensive, PCB CAD software.

One of the software's attractions — either version — is its capabilities on an ordinary PC, although it is naturally faster on 286 or 386-based machines. For example, with a faster processor *Boardmaker 2* redraws a typical PCB on screen within around a second. Thus there is no need to have a computer with very high resolution graphics capabilities — simply redraw the PCB at whatever zoom level you require.

It has net-based design rules; all of which means you can tell the computer that particular nets are of specific types. This is useful, because not all PCB tracks have the same specifications. Some are power (needing to be wide) while some are signal (so can be much thinner). In effect, you can specify parameters such as location and dimension where necessary, or just use default parameters, to suit you, not the software.

Second release, on the other hand (you know, *really* hot one) refers to user of *EASY-PC* — main rival of *Boardmaker* and shows them how to switch over at a reduced price. For £155 plus VAT users of *EASY-PC* can upgrade to *BOARDMAKER* and for £225 plus VAT they can upgrade to *BOARDMAKER 2*.

These prices represent a reasonable reduction of the normal price: £195 plus VAT for *BOARDMAKER* and £295 plus VAT for *BOARDMAKER 2*.

Tsiens can be found at Cambridge Research Laboratories, 181A Huntingdon Road, Cambridge CB3 0DJ. Telephone 0223 277777.

HANDHELD TV MONITOR

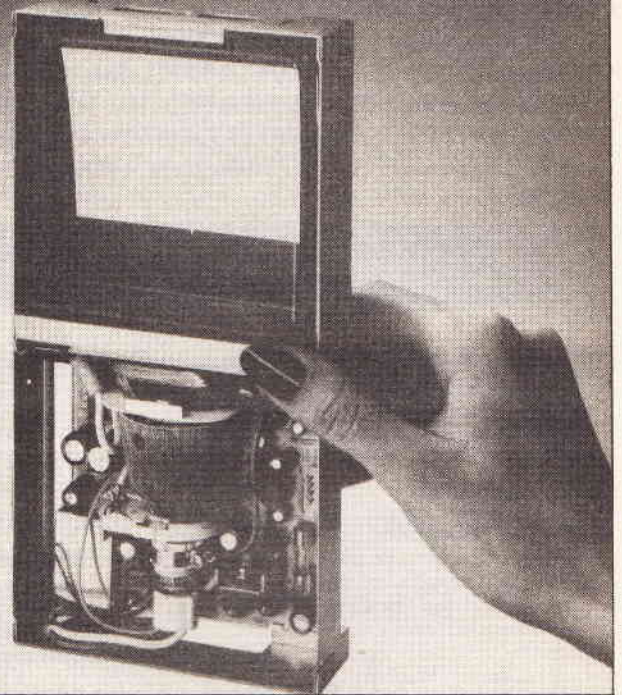

Here's one for the imaginative original equipment manufacturer — Sony Europa has launched a 4 inch flat CRT display module, cryptically known as the FDM-48E. Dimensions of just 41mm depth by 105mm width by 240mm length, with a power consumption of just 4W make the module truly portable.

The module has a high horizontal resolution of 400 lines in PAL mode, and produces a bright high contrast black and white picture allowing a full

grey scale display.

Sony envisages applications in security devices, visual intercoms, TV telephones, rear vision systems for vehicles and portable televisions, applications in-built into walls, desks and so on.

It's also feasible, we suppose, that the module could form the basis of a portable (that is, pocket-sized) flip-topped two-way audio and video communications device. Beam me up, Scotty!

TELEPHONE TAPING

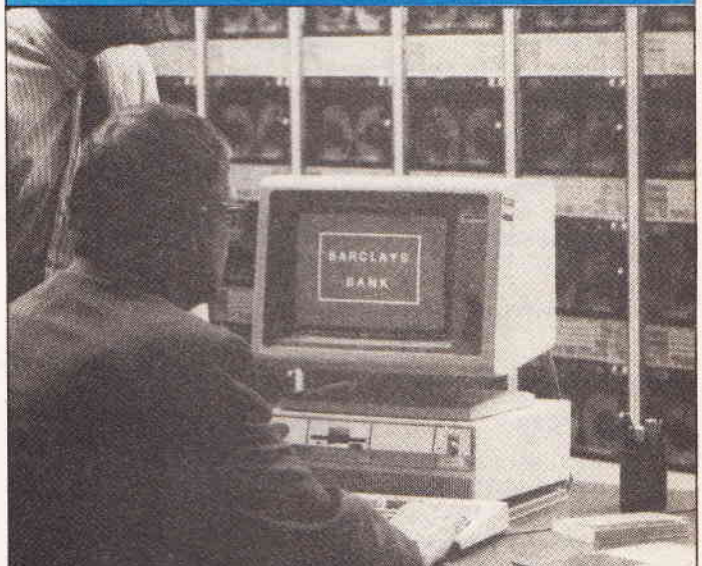

Barclays Bank has placed an order for 30 ICR64 communications recorders with Racal Recorders Ltd. The 64 channel recorders have been installed in the new Barclays treasury dealing room at Royal Mint Court, which houses their 220 London-based foreign exchange and money

market dealers.

The equipment will be used to record telephone transactions vital to bank operations and will be configured with two tape decks running simultaneously in each unit, allowing both archival and quick check operations.

SALARY SURVEY

PA Consulting Group have recently published a survey on Graduate Salaries and Recruitment trends 1989/90. The survey states that starting salary increases predicted for graduates in 1990 are nearly 4% down on last year's increases. Forecasted average salary increases are 7.8% compared to last year's actual increase of 11.2% in 1989. In computers and electronics the starting salary of a graduate in 1990 is forecasted at £11,802 as opposed to £11,095 in 1989.

The survey, involving 130 large UK companies, also showed that engineering is the lowest paid sector and banking the highest. Other findings in the survey include a mismatch of employer demands and graduate supply (49% of organisations failed to fill their vacancies in 1989). Engineering and technology are the most sought after subjects by employers but business administration and the arts are the favourite courses for graduates.

The survey revealed that only half the companies included in the survey have modified their recruitment campaigns to take into account the entry into Europe. Demand for graduates will be greatly increased in Europe because salaries are low in England compared to Europe and also English students leave college earlier and can have 7-8 years experience by the age of 27-28 whereas their European counterparts will have only just started work.

EM SMOG

Childhood cancer, leukaemia and depression have all been linked to electro-magnetic 'smog' generated by computer terminals, domestic wiring and electrical power lines in a recent report.

This report suggests a number of things including the idea that a clustering of spontaneous abortions from September to June occurs among electric blanket users compared to a control population of non users and that pregnant women using computer terminals regularly run an 80% greater risk of miscarriage than with a control population.

Clinical depression and suicides appear in a cluster among those living near UK power lines and exposure to electro magnetic fields causes a partial breakdown of the cell structure.

It was also suggested that 10-15% of all childhood cancers might be attributed to magnetic fields associated with electric cabling inside and outside the home and that a 13 fold increase in brain tumours has been observed in electrical utility workers.

When an analogy was made between these dangers and the dangers of smoking, the risk factor can be stated precisely: the suspicions are more recent than those associated with the effects of smoking but they have been with us for 15 years and a properly funded and executed investigation into the pathological effects seems overdue.

For further information contact: Claire Batten Tel: 01-584 0122.

ECONOLIGHT

A new British invention offers to reduce lighting bills by up to 20% and cut freezer centre electrical consumption by up to 30%. The microprocessor controlled Econolight uses controlled current technology which reduces the voltage necessary to run a variety of lighting systems and electrical inductive motors.

Extensive field tests with a variety of large users including British Rail and British Airways have proved electricity savings of 20% are realistic and so pay for its capital cost over a couple of years.

Econolight is based on a micro-processor controlled sensing circuitry which analyses variations in electrical demand and automatically makes the supply adjustment necessary for optimum efficiency. However, the supply of a carefully controlled voltage is maintained to ensure the necessary voltage levels to start up fluorescent lights or induction motors.

Once in operation there is no discernable loss in lighting level. The heart of the system is a twin transformer which simultaneously maintains power levels and changes in demand.

The Econolight system is available in a variety of sizes to cover power requirements from 10kVA single phase to 60kVA three phase, and is effective with fluorescent tubes, mercury and sodium lights, air conditioners and refrigeration equipment.

The system does not effect computers or other high technology equipment as it employs non-inductive switching methods.

Further details from Econolight Ltd, Tel: 0444 455103.

EMC TRACER



Electromagnetic compatibility (EMC) looks set to be the phrase for the early decade, referring to the interference caused by electronic equipment. New standards soon to be evolved will specify the limits of interference which equipment is allowed to generate. Effectively, anything which is electronic transmits electromagnetic interference to a greater or lesser extent, and EMC regulations will seek to minimise all unnecessary radiations.

In the light of this, equipment to locate EMC sources is going to be popular. First we've seen in ETI is a hand-held interference tracer from Chase EMC, designated the CIT-600. Claimed to be ideal for low-cost initial surveys, the instrument allows interference radiators to be easily located, simply by detecting where transmissions are strongest — the stronger the signal, the closer you are to the source.

A BNC input connector allows a wide variety of probes to be used with the CIT-9600. Useable frequency range is from 50Hz to 500MHz, with a 50dB dynamic range. Powered by a PP3 battery, giving around four hours continuous use, the device has dimensions of 135 by 75 by 35mm.

Sounds like a handy device. ETI's News Editor has suggested to the magazine's Project Editor he must have had a certain premonition when he commissioned the Bug Spotter in next month's issue.

More information on the CIT-9600 from Chase EMC Ltd, St Leonard's House, St Leonard's Road, Mortlake, London SW14 7LY.

FLAT COMPUTER SCREEN



STL (Sygnos) the Hong Kong and UK based flat panel display manufacturers who introduced the EGA flat panel computer screen earlier this year, is expanding its range with the new VGA model.

This new model will meet the demand for industry standard resolution on high performance personal computers and will feature high resolution black and white display in the same casing as the original model. Other features include low power consumption, it is CGA, EGA, MDA,

HGC compatible, has virtually no heat generation and non-flicker scrolling.

They also announce the release of an adaptor card which uses the Sygnos industry standard 25 pin LCD connection and can be bought separately and used with Sygnos flat panel monitor and conventional CRT monitors.

For more information contact: Jens Nielson, Sygnos Technologies Tel: 01-352-1478.

MORE HEALTH COMMUNICATION

Our National Health Service is about to undergo a considerable change in information technology terms, as a new computerised network is planned for the coming decade.

Although much computerisation has already taken place in individual hospitals and doctors' surgeries, there is little inter-communication between separate systems. UK telecommunications and computing company, Racal has already been approached by the Department of Health with the idea of linking initially all general practitioners — obviously a huge task in total NHS data communications.

Currently some 1% of the total health budget is spent on information technology across the board (some £130 million last year), but this is expected to increase to almost match other European health systems. Government intends to double the amounts going to hospitals and general practitioners, specifically for the purpose.



DELIVERED TO YOUR DOOR FREE!*

That's right, if you take out a year's subscription to ETI we will make sure that it is delivered to your door each month at no extra charge*. Just fill in the coupon below and send it to the address given with a cheque, money order or credit card instructions to cover the cost of the subscription. We'll do the rest.

*Overseas subscription rates include postage.

UK:	£18.00
EUROPE:	£22.20
MIDDLE EAST:	£22.40
FAR EAST:	£24.00
REST OF THE WORLD:	£22.70
or USA:	\$39.00

Airmail Rates on Request.

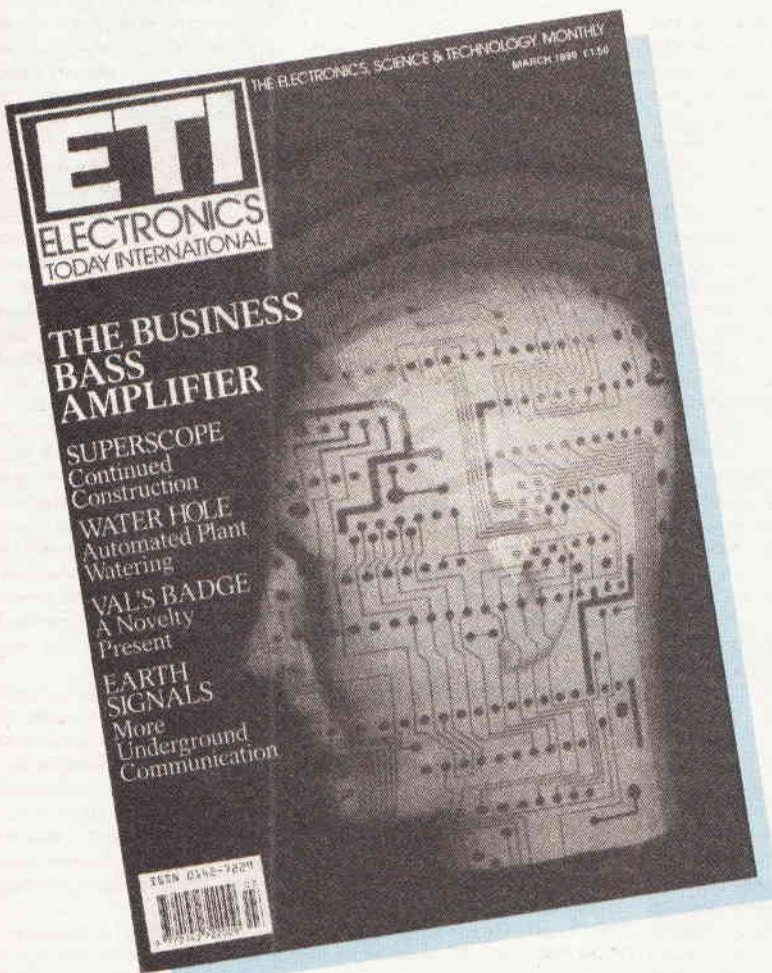

Send this form with your remittance to:
SELECT SUBSCRIPTIONS LTD.
5 River Park Estate,
Billet Lane,
BERKHAMSTED,
Herts. HP4 1HL,
United Kingdom

Please commence my subscription to ETI with the issue. I enclose my cheque/money order for £..... made payable to
ARGUS SPECIALIST PUBLICATIONS

Or Debit my Access/Visa number

Valid from to Signature

Name Address

..... Postcode

New subscriber Subscription renewal/extension (delete as applicable)

OPEN CHANNEL

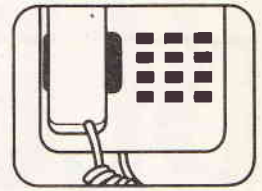

Topic this month doesn't have, strictly speaking I suppose, an obvious link with *Open Channel's* usual predilection to telecommunications. At first sight, it appears to be solely concerned with the somewhat slower communications methods of the postal service. But there *is* a link, and I'll explain it shortly — after explaining the topic.

Rubbish

It's something that affects just about every person in this country (and in all other Western countries, too) to a small or great extent; often forcing its way into our lives with an invasive regularity. Sometimes, whenever the postman calls, it is simply to deliver yet another of its prodigies: often uninteresting; always unsolicited; rarely useful. In fact, as I'm writing this very paragraph, two examples have dropped through my letterbox.

It's known as *direct mail* to those in the know and those who carry it out. To those who don't like it or the principle it relies on, this is a euphemism though, and its preferred title is *junk mail*. A company marketing its wares using direct mail, is said to make a *mail shot* whenever a particular letter is posted out.

In itself, the direct mail principle is quite harmless. Companies and organisations see it primarily as a convenient marketing tool. Rather than spend, say, millions on television, radio and press advertising, a few hundred thousand pounds will allow them to make a mail shot giving straightforward contact with selected individuals throughout the land. And apart from the inconvenience of bending down to pick the letters up, opening them and throwing them in the bin (in fact, when I receive just mail I even sometimes miss out the second stage) who could object to this?

Problem is, though, the underlying methods which direct mail relies on. Before anyone can send a direct mail letter to anyone else, the sender must possess the recipient's name and address. In turn this must mean the recipient's name and address is held on computer file as one record in a database list. This is the first principle which many people, including me, find repulsive. Have I ever been asked if I minded my name and address being put on a list? Never.

Next abhorrent principle is the trading which occurs with (that is, people making money out of, by selling) these lists. It's *my* name and address after all, so why should other people make money out of that, especially since they did not ask my permission in the first place.

Make no bones about this, lists are traded, at around 7½p a consumer's name and address, and around 20p for each business name and address. Further, thousands of such lists are in existence, most with hundreds of thousands of names and addresses.

So how do these lists come into being? In effect, if you are alive and over 18, you will probably be on at least one list, as likely many more. Many companies which form these lists start with the electoral register. Sometimes the names on the electoral roll are classified into sub-lists or even separate lists according to the addresses — this gives a simple but rough classification of economic background on the basis of where people live.

Your name and address may be added to other lists whenever you buy mail order goods, send off a coupon for a holiday brochure, subscribe to magazines, and so on. It seems that if you do just about *anything* which commits you to give your name and address, chances are that someone will extract your details and type them in at a computer keyboard.

Once you have been listed, the matter is out of your control. The owners of those lists have total rights regarding their use. Often, lists are sold outright, transferred as data on a computer disc, to interested companies. Sometimes, the lists are sold simply as adhesive address labels, one name and address per label. Whatever method, people (not you) make money.

Whatever Next?

It is the fact that computers are used, you should realise, which turns the direct mail principle from a purely postal service communications method into a telecommunications method — which simply uses the postal service for final transmission of the information. And it's here where the use of electronic communications combines with the postal service, and where this month's *Open Channel* has a specific interest. Indeed, without the use of computers it would probably not exist at all. As a reminder of this (and perhaps a rude awakener to some) there are organisations which are proud of the fact that they possess so many names and addresses. The next organisation, for instance, is happy to accede to the fact that it has a list which contains information regarding just about every adult in the country. Honourable as such companies' intentions may be, and I'm not suggesting for one minute otherwise, I feel there is a basic flaw in the procedure whereby such a thing can

happen, *without the direct consent of the individual*. After all, Government has required a *law* to force everyone to register on the electoral roll, yet lists such as these exist without even so much as a simple request.

Although I'm sure this will raise a few questioning eyebrows and be more than just a little controversial, I'm going to say it anyway. I believe that existing direct mail procedures bring a bad name to electronics and computing in general. Further, if the situation is allowed to continue in this vein, in the lack of legislation, public acceptance of the real benefits of electronics and computing will be severely dampened.

But what can the individual do about it? Now you've got this unwarranted, unwanted rubbish, how do you get rid of it? Well apart from just throwing it in the bin and wasting the world's resources without reading it, there are three ways. First, is the correct and more long term method.

There now exists an organisation known as the *Mailing Preference Service*. It's a simple matter of writing to the service to have your name removed from mailing lists. The process is carried out when the service enters your details onto a database (yet another list of names and addresses — but at least one which you *have* asked to be on). About every three months the list is circulated to direct mailing organisations to run as a suppression file, deleting all the names on the service list from the organisations' list. However, it is not a legal requirement that direct mailers do this; the service is merely a self-regulatory body set up by the direct mailers themselves. Further, not all direct mailers are members of the service.

Nevertheless, allowing for these doubtful inadequacies, this is a fairly simple procedure which anyone can invoke by applying to the service. One last problem, however, is that every different spelling (or more correctly mis-spelling) of your name and address has to be forwarded. A personal illustration of this is the fact I get some six different variations of mine, including the correct, through

Mr K Brondley, Mrs K Bramley, to Ms K Brindley. Address of the Mailing Preference Service, from which you can get a brochure and application form, is: Freepost 22, London W1E 7EZ. The service has so far removed over a quarter of a million names from mailing lists!

Get Your Own Back

Second method is a bit more drastic, may take a little longer, and is of only short-term benefit — although it makes you feel better. First you've got to ride the tide of junk mail, waiting for those 'free gift' offers with the catch that if you do nothing further, you will continue to receive (and have to pay for) further items. You know the ones; they've usually got a rub-off transfer or sealed extra envelope allowing you to be entitled to the entering of your name into a fabulous prize draw. Always, though, somewhere in the small print will be the clause that allows you to get out of the deal once you receive your free gift. This is usually by sending a letter or postcard which tells the sender this.

There's a simple rule here — make photocopies as your proof. Before you enter into the arrangement, photocopy everything. Reason for this is that you usually have to return the letter which says you *can* get out of the arrangement. Next, when you have received your 'free gift', immediately write to inform the sender that you do not wish to carry on receiving. Photocopy this, too.

I've used this method three or four times and it seems to work. Senders get to realise that you will do this and so they are simply wasting money on you. After a while, your name will be removed from their lists. It is temporary, however, as when new mail shot lists are bought, your name might well be on them, and the process starts again.

Final method will probably never work but it's worth trying if only for the laugh. Write to your MP and complain.

If enough of us tackle the direct mail problem, we'll beat it!

Keith Brindley

If you would like your name removed from the junk mailing service then apply to:

*Mailing Preference Service,
Freepost 22,
London W1E 7EZ*

BLUEPRINT

Blueprint is a column intended to provide suggested answers to readers' electronics design problems. Designs are only carried out for items to be published, and will not be prototyped by the columnist. Circuits published in Blueprint are believed to work, but may need minor alteration by the reader after prototyping. Individual correspondence will not be entered into, save as necessary to prepare items for publication.

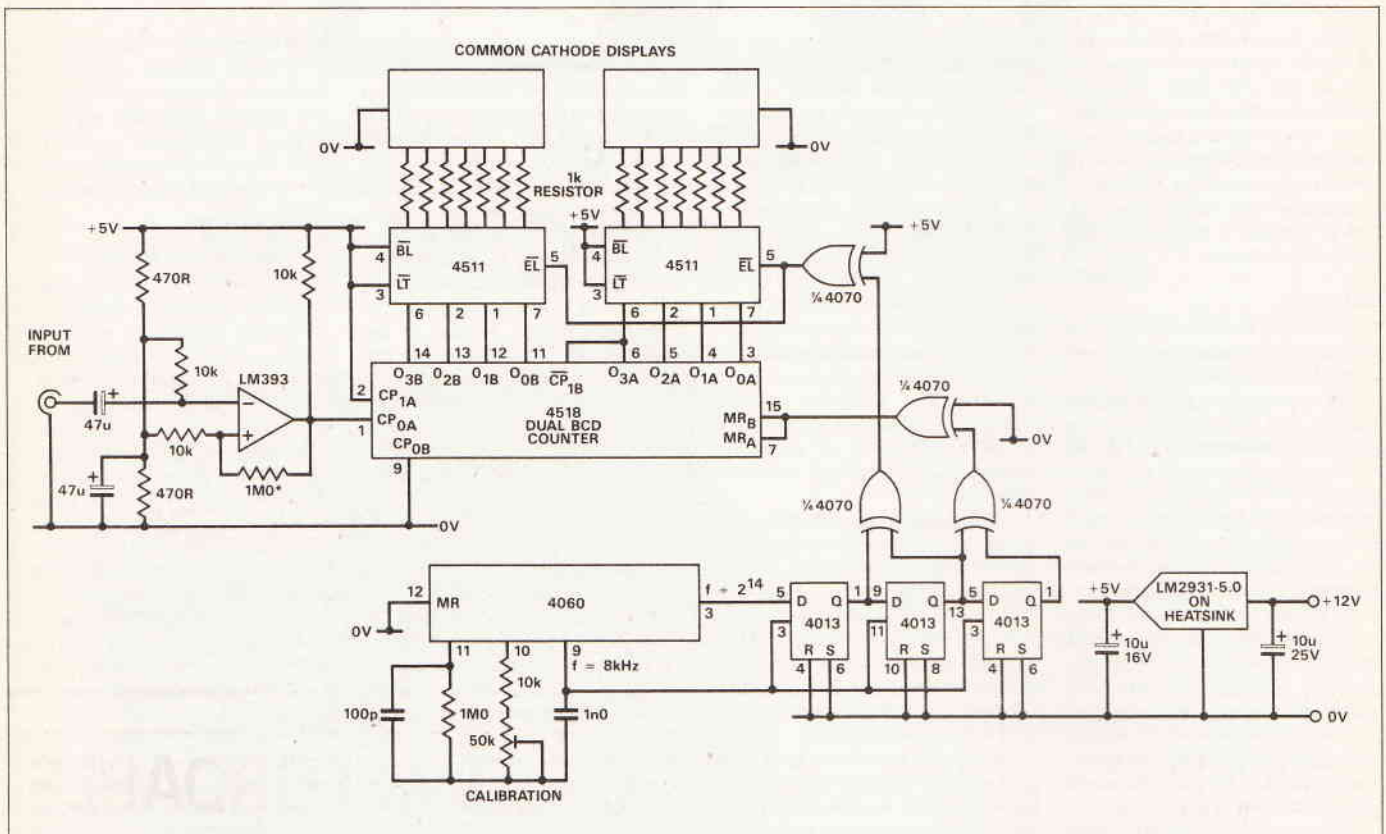

This month's design has been prompted by someone working on a car:

Dear Blueprint,

I am renovating an old car and would like to fit a digital speedometer to it. I would like to use seven segment displays for the readout. I do not know the calibration ratio of the original speedometer, so some form of calibration adjustment will be necessary.

*Yours faithfully
Andrew Leech*

In this design, I am assuming the original speedometer is to remain in use, even though a digital readout is added. A normal car speedometer works in the following manner: a rotary drive cable (from the final drive shaft in the gearbox) drives a rotating magnet in the back of the speedometer. In front of the magnet is an aluminium disc, to which the pointer is attached. When the magnet spins, eddy currents generated in the aluminium disc generate a magnetic field which links with that from the rotating magnet. This generates a torque on the aluminium disc. The

torque is opposed by a spiral spring, like the springs in moving coil meters, so the deflection of the pointer is proportional to the speed of rotation of the magnet.

Obvious way to measure the speed of the car electronically is to start with a magnetic field detector on the back of the speedometer. This may consist of a coil with a small magnetic core, or it may use a Hall effect device. Some experiment is necessary in this area, because the most appropriate pickup may depend on the type of car. However, the output of this detector should be fed to a comparator to convert it to a clean digital waveform, before it is fed to a digital frequency measuring circuit.

Speed Counter

By counting number of revolutions of the magnet and displaying this number, some indication of speed is obtained. The count cycle of the frequency meter must be adjusted though, so the magnet rotates during it once per mile-per-hour of speed to get an accurate display. The time period required is likely to be between 0.5 and 2 seconds, and experiment is necessary to determine the correct setting. The display will, of course, be updated once per measurement period.

A suitable circuit is shown in Fig. 1. At the input of the circuit, the speed detector output is converted to clock pulses by a comparator with positive feedback. Most comparators or opamps will do this job, but don't be tempted to use a slow opamp. Rise and fall times of, for example, a 741 are too slow to clock a counter reliably. In most cases, one part of an LM393 or an LM339 would be a good choice.

The 4518 is a dual BCD up counter, with the two halves cascaded by connecting the most significant bit of the least significant counter to the inverse clock input of the most significant counter. This arrangement counts the second counter on one every time the first counter counts from 1001 to 0000.

This dual counter is clocked up by the pulses from the speedometer detector. When a measurement period is complete, the number on the output of the 4518 is latched in the transparent latches of the 4511 BCD-to-seven-segment latch/driver ICs. The 4518 is then reset to commence a new count.

Latch and reset pulses must be as short as possible otherwise they may encroach on the measurement period. The circuit shown divides a high frequency clock by 214 to provide the required time period, and

uses three D-type flip-flops to generate latch and reset pulses of one clock pulse duration. A timing diagram for this is shown in Fig. 2. Each output transition of the 4060 propagates through the shift register made from three flip-flops at the rate of one stage per clock cycle. If the required output frequency of the 4060 is exactly 0.5Hz then delay in the shift register is 125 μ s per stage. Outputs of the shift register are gated together by exclusive OR gates, which give an output of logic 1 only when the inputs are dissimilar. Therefore, the XOR gates provide output pulses equal to delay in one stage of the shift register.

The latch pulse is inverted by an XOR gate with its other input to logic 1, while the spare gate in the reset pulse channel is solely to equalise gate delays.

Circuit Details

Speed indicating signal may be derived from a coil or a Hall effect device attached to the back of the speedometer. Either way, the resulting signal is likely to be very small so the input of the circuit consists of a comparator with 50mV hysteresis. The input is biased to 2.5V and is AC coupled to avoid disturbing the bias point. The input signal should exceed 50mV, but if it doesn't the value of the

starred feedback resistor, shown as 1M, should be increased. Conversely, if the circuit suffers from noise pickup and the signal is significantly over 50mV, this resistor should be decreased.

Signal pickup itself requires some experiment. An inductive pickup, consisting of a least 500 turns of a thin grade of enamelled wire wound round a ferrous core, should work. A suitable core might be a large diameter bolt, bearing in mind that at the frequency in use eddy current losses in a non-laminated core are unlikely to be a problem.

Alternatively a linear Hall effect device could be used as the pickup. The switching type of Hall sensor is unlikely to receive enough magnetism to switch, while even a small output from a linear sensor can be used to trigger the comparator. A suitable sensor is Electromail part no 304-267, and a suitable sensing circuit using this device is shown in Fig. 3. Circuit is powered by a 5V supply derived from a standard three-terminal regulator. The regulator type specified, LM2951-5.0, is chosen in preference to a 7805 because the LM2931 is characterised for use in an automotive environment. Among other things, it is proof against the spikes which often occur on car electrical systems.

The digital speedometer may be calibrated against the conventional speedometer in the car. Normal speedometers are fairly accurate at low speeds, such as 30mph, but tend

to read high at higher speeds. Therefore a good means of calibration would be for the driver to attempt to drive at a steady speed around 30mph, while the passenger adjusts the digital speedometer to agree with the mechanical one.

Hall Effect

Not everyone may be familiar with the Hall effect. Magnetic effect of current

flow in a wire is familiar to most people, and is used in such devices as electric motors. Same effect is observed in a stream of electrons flowing in a vacuum, where a stream of electrons rather than wire is deflected by a magnetic field — used to provide scanning in television sets.

Because density of charge carriers in a semiconductor is much less than in metal, effect of a magnetic field on

a flow of current is to deflect the current, rather like the effect on an electron beam in a vacuum. In a semiconductor designed for the purpose, this effect is large enough to form the basis of a practical magnetic field sensor. The basic principle is illustrated in Fig. 4, though of course most practical devices will include amplification on-chip to provide a reasonable level of output signal.

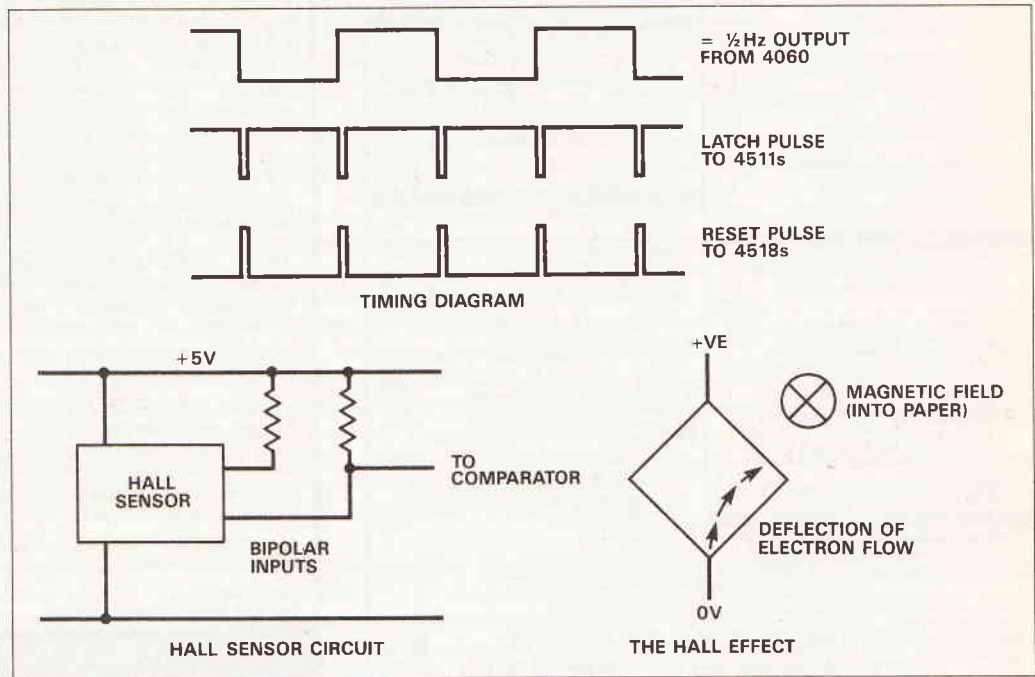

MAKING ELECTRONICS C.A.D. AFFORDABLE

- ★ HAVE YOU BEEN PUTTING OFF BUYING PCB CAD SOFTWARE?
- ★ ARE YOU STILL USING TAPES AND A LIGHT BOX?
- ★ HAVE YOU ACCESS TO AN IBM PC/XT/AT OR CLONE?
- ★ WOULD YOU LIKE TO BE ABLE TO PRODUCE PCB LAYOUTS UP TO 17" SQUARE?
- ★ WITH UP TO 8 TRACK LAYERS AND 2 SILK SCREEN LAYERS?
- ★ PLUS DRILL TEMPLATE AND SOLDER RESIST?
- ★ WITH UP TO 8 DIFFERENT TRACK WIDTHS ANYWHERE IN THE RANGE .002 to .531"?
- ★ WITH UP TO 16 DIFFERENT PAD SIZES FROM THE SAME RANGE?
- ★ WITH PAD SHAPES INCLUDING ROUND, OVAL, SQUARE, WITH OR WITHOUT HOLE, AND EDGE CONNECTOR FINGERS?
- ★ WITH UP TO 1500 IC's PER BOARD, FROM UP TO 100 DIFFERENT OUTLINES?
- ★ WITH AUTO REPEAT ON TRACKS OR OTHER FEATURES — IDEAL FOR MEMORY PLANES?
- ★ THAT CAN BE USED FOR SURFACE MOUNT COMPONENTS?
- ★ WITH THE ABILITY TO LOCATE COMPONENTS AND PADS ON GRID OR TO .002" RESOLUTION?
- ★ WITH AN OPTIONAL AUTO-VIA FACILITY FOR MULTILAYER BOARDS?
- ★ WITH THE ABILITY TO CREATE AND SAVE YOUR OWN SYMBOLS?
- ★ THAT IS AS GOOD AT CIRCUIT DIAGRAMS AS IT IS AT PCB'S?
- ★ THAT CAN BE USED WITH EITHER CURSOR KEYS OR MOUSE?
- ★ WHICH OUTPUTS TO A DOT MATRIX PRINTER, PEN-PLOTTER OR PHOTO-PLOTTER (VIA BUREAU X)?
- ★ WHERE YOU CAN LEARN HOW TO USE IT IN AROUND HALF AN HOUR?

**BRITISH
DESIGN
AWARD
1989**

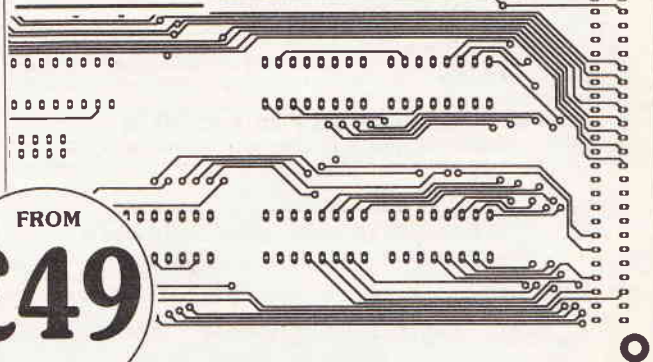

FROM
£49
inc VAT

EASY-PC, TINY-PC, EASY-PC, TINY-PC, EASY-PC, TINY-PC, EASY-PC

Write or phone for full details

Number One Systems Ltd

Ref: ETI, HARDING WAY, SOMERSHAM ROAD
ST IVES, HUNTINGDON, CAMBS PE17 4WR

1

AMEX, ACCESS, VISA WELCOME

Telephone: 0480 61778 (5 lines)

WE HAVE THE WIDEST CHOICE OF USED OSCILLOSCOPES IN THE COUNTRY	
H.P170A Dual Trace 100MHz Delay Sweep Trig	£500
TELEQUIPMENT D83 Dual Trace 50MHz Delay Sweep	£300
GOULD O3300A Dual Trace 50MHz Delay Sweep TV Trig	£300
TELEQUIPMENT O795 Dual Trace 50MHz Delay Sweep	£275
COSSOR CDU150 Dual Trace 30MHz Delay Sweep	£150
GOULD OS1100 Dual Trace 30MHz TV Trig	£210
S.E. LABS SM111 Dual Trace 18MHz	£130
TRIO CS1566A Dual Trace 20MHz	£250
H.P1220A Dual Trace 15MHz TV Trig	£175
GOULD O3255 Dual Trace 15MHz TV Trig	£160
PHILIPS PM3233 Dual Trace 15MHz TV Trig	£150
GOULD OS250B Dual Trace 15MHz TV Trig	£160
THIS IS JUST A SAMPLE — MANY OTHERS AVAILABLE	
TEKTRONIX 2215 Dual Trace 60MHz Sweep Delay with manual, probes, front cover, pouch	only £500
MARCONI TF2015 AM/FM 10-520MHz Sig Gen with TF2171	£450
MARCONI TF2015 without Synchroniser TF2171	£300
MARCONI TF2016 AM/FM 10KHz-120MHz Sig Gen with TF2173	£400
MARCONI TF2016 without Synchroniser TF2173	£250
MARCONI MOD Meters TF2300, TF2300B, TF2303 from	£100
H.P. 620B Signal Generator 7 — 11GHz	£400
H.P. 618C Signal Generator 2 — 16GHz	£400
H.P. 616B Signal Generator 1.8 — 4.2GHz	£400
WOELKE Wov & Fluter Meter ME108	£100
LEADER LMV186A Two Channel Millivoltmeter 5Hz-500KHz 100µV — 300V	£100
FEEDBACK FG601 Sig Gen 0.001Hz-1MHz Sine/Sqr/Tri	£150
MARCONI Automatic Distortion Meter TF2337A	£100
400Hz or 1KHz Measures down to 0.01%	£100
LEVELL OSCILLATORS TG152/7G200 Series from	£75
MARCONI TF2700 UNIVERSAL LCR BRIDGE Battery	from £150
HAMEG MODULAR SYSTEM	
HM8001 Main Frame with HM8032 Sine Wave Generator 20Hz-20MHz, HM8030 2 Function Generator 0.1 — 1MHz Sine/Sqr/Triangle and HM8011 2 Digital Multimeter 4 1/2 digit	only £375
SADELTA MC321 COLOUR BAR GENERATOR RF Bands 1.34 & Video 8 Functions Sound Carrier Unused (P&P £7)	£125
SADELTA COLOUR BAR GENERATOR PAL MIC101 B Patterns Pocket Size Rechargeable Batteries Complete with Battery Charger Adaptor Unused (P&P £4)	£50
LABGEAR COLOUR BAR GENERATOR IGI 8 Test Patterns (P&P £4)	only £40 each
LABGEAR CROSSHATCH GENERATOR Type CM603808 Crosshatch Grey Scale Black Plaster Mains or BATTERY Unused £18, Used £12 (P&P £3)	only £50
TRIO RF SIGNAL GENERATOR Type SG402 100KHz 30MHz Unused (P&P £7)	only £50
ADVANCE SG62B AM 150KHz-220MHz	£45 (P&P £7)
MICROVITEK WB MONITOR 14" COLOUR	£90
TELEPHONES	
Yes real dial type telephones that don't slide around the desk. Type no. 746 supplied with standard BT plug (used). Quantity discount	only £5 (p&p £3)
Used equipment — with 30 days guarantee. Manuals supplied if possible. This is a VERY SMALL SAMPLE OF STOCK. SAE or Telephone for lists. Please check availability before ordering. CARRIAGE all units £18. VAT to be added to Total of Goods & Carriage	

STEWARTS OF READING
110 WYKEHAM ROAD, READING, BERKS RG6 1PL
Tel: 0734 68041. Fax: 0734 351696. Callers welcome 9am-5.30pm Mon-Fri (until 8pm Thurs)

TEKTRONIX OSCILLOSCOPE 2235 Dual Trace 100MHz Delay Sweep	£750
PHILIPS OSCILLOSCOPE PM3217 Dual Trace 50MHz Delay Sweep	£500
GOULD O3300 Oscilloscope Dual Trace 20MHz	£250
GOULD 1421 Digital Storage Dual Trace 20MHz	£750
THANDAR TA2080 Logic Analyser 20MHz 8 Channel	£375
THURBY PL320QMD 0-30V 2A Twice. Quad Mode Digital Meters	£200
FEEDBACK FSG606 Sweep Function Generator 0.01Hz — 1MHz (P&P £7)	£200
SOLARTRON 7045 Multimeter 4 1/2 digit LED 30 ranges Auto/Manual (P&P £7)	£125
LOGIC PROBE type 3300A TTL/Cmos (P&P £3)	£18
FARNELL Oscillator LFM3 10Hz-10MHz Sine/Square	£200
RACAL 9915 Freq Counter 10Hz-520MHz (Crystal Oven)	£150
RACAL 9930 Series Universal Counter Timers from MARCONI ATTENUATORS TF2162 DC-1MHz 600 ohm 0-111dB (P&P £7)	£35
HATFIELD ATTENUATORS 50 ohm DC-250MHz 0-100dB/600 ohm DC-1MHz (New Price £135) (P&P £4) only £50	

AVO MULTIMETERS (P&P £10 all Units)	
Avo 8's 9s and Ministry Versions With Batteries & Leads TEST LEADS for Avos. Red & Black with 2 croc Clips & 2 prods	from £50
(P&P £3) £5	
Black EVER READY Case for Avos. Un-used	(P&P £4) £15
BATTERIES 15V15	£3 each, 10 for £25 (P&P £18)
AVO TRANSISTOR ANALYSER M42. CT446 suitcase style. With Batteries & operating instructions	only £25 (P&P £7)
MARCONI AF Power Meter TF983A 20Hz-35KHz. 20mW-10W With Manual	only £25 (P&P £7)
MARCONI RF Power Meter TF1152A1/ DC-500MHz 0.5 — 25W. 50 ohm With Manual	only £30 (P&P £7)

NEW EQUIPMENT	
HAMEG OSCILLOSCOPE HM1005 Triple Trace 100MHz Delay Timebase	£726
HAMEG OSCILLOSCOPE HM 604 Dual Trace 60MHz Delay Sweep	£375
HAMEG OSCILLOSCOPE HM2036 Dual Trace 20MHz Component Tester	£514
HAMEG OSCILLOSCOPE HM2053 Dual Trace 20MHz Digital Storage	£575
All other models available — all oscilloscopes supplied with 2 probes	
BLACK STAR EQUIPMENT (P&P all units £5)	
APOLLO 10 — 100MHz Counter Timer Ratio/Period/Time Interval etc	£222
SPULLO 100 — 100MHz (As above with more functions)	£295
METEORE 100 FREQUENCY COUNTER 100MHz	£109
METEORE 600 FREQUENCY COUNTER 600MHz	£135
METEORE 1000 FREQUENCY COUNTER 1GHz	£178
JUPITER 500 FUNCTION GENERATOR 0.1Hz-500KHz Sine/Sqr/Tri	£110
ORION COLOUR BAR GENERATOR Pal/TV/Video All other Black Star Equipment available	£209
HUNG CHANG DMM 7030 3 1/2 digit. Hand held 28 ranges including 100mV AC/DC 0.1% Acc (P&P £4) £39.50	£39.50
As above DMM 6010 0.25% Acc	£33.50
Carrying Case for above	£3
OSCILLOSCOPE PROBES Switchable x1, x10	(P&P £3) £11

electronize Car Electronics

MICRO-PRESSURE CAR ALARM

This new type of alarm is triggered by a unique pressure sensing system. As any vehicle door is opened, air is drawn out, causing a minute drop in air pressure. A sensor detects this sudden pressure change and sets off the alarm.

A sophisticated arrangement of electronic filters and timers provide features to match ultra-sonic systems but at a fraction of the cost.

- ★ 1 Micro-Pressure intruder detection.
- ★ 2 Operates on all doors and tailgate.
- ★ 3 No door switches needed.
- ★ 4 Automatically armed 1 minute after leaving vehicle.
- ★ 5 10 second entry delay with audible warning.
- ★ 6 Sounds horn intermittently for 1 minute.
- ★ 7 Easy fitting - only 3 wires to connect - no holes to drill.
- ★ 8 Compact design can be hidden below dashboard.
- ★ 9 All solid state Power MOSFET output - on relays.

MICRO-PRESSURE ALARM KIT £12.95
ASSEMBLED READY TO FIT £18.95

VOLT DROP CAR ALARM

Our latest alarm using the popular voltage drop method of triggering. Based on the timers of the micro-pressure alarm it offers features 4 to 9 above but relies on the existing door switch operation for triggering.

VOLT DROP ALARM KIT £11.75
ASSEMBLED READY TO FIT £17.75

TOTAL ENERGY DISCHARGE IGNITION

Our long established Extended CDI system retains the contacts to allow easy fitting whilst the electronics removes the adverse effects. The unique spark generating system still out performs the latest all electronic systems.

TOTAL ENERGY DISCHARGE IGNITION £18.95
ASSEMBLED READY TO FIT £24.90

All Electronize kits include clear, easy to follow instructions, quality components and everything needed, right down to solder and heatsink compound.

Order direct (Please quote Ref. D05 and add £1 post and packing per item.) or send for more details from:-

ELECTRONIZE DESIGN tel. 021 308 5877
2 Hillside Road, Four Oaks, Sutton Coldfield, B74 4DQ

Wizard Kit-Packs

THIS MONTH'S WIZARDRY
THE WIZARD PRECISION MAINS FILTER
250 volts AC 13 amp, On off switch, 4 IEC output sockets, Merlin made case and USA Potter-Block RFI filter. Price £32.00 VAT paid P&P £1.70

LOOK AT THE SPEC ON THIS WIZARD BENCH POWER SUPPLY
Variable DC Voltage 3.5 to 22 volts at 8 amps continuous rating, twin meters volts and amps. Fine and coarse voltage adjustment, overload protection, mains input and DC output filtered, Merlin made case. Built and tested. Price £66.00 VAT paid P&P £3.00

GEC STEREO CASSETTE UNIT
Record/Playback, Dolby, speed 4.75cm (1.78in) per sec, 40-12,500KHz, Twin VU meters, with service manual. Brand New £12.00 or 2 for £20.00 P&P £3.00

THE WIZARD POWER CUBE

Specification

1 20 Amp Hour Dryfit Battery; 2 Inbuilt Mains Charger;
3 RF Filtered; 4 Solar Cell Input (Cells optional);
5 Compact Size/Portable; 6 Merlin Made

Price £76.00 + P&P £8.00

MORE DATA — Send a 19p Stamp for Latest List.
Ring the Wizard on 0225 706886 Fax 0225 708594 for more information or a visit to the works.
PAYMENT Access, Cheque, PO and Cash. Post and packing on components £1.50 or £1.00 for orders over £20.00. Please add VAT to total.

MERLIN SYSTEMS

Merlin Way, Bowerhill Trg Est, Melksham, Wiltshire SN12 6TJ

19" RACK MOUNTING EQUIPMENT CASES

This range of 19" rack cases features satin black finished 16SWG (1.5mm) steel front panels (no fixing holes visible), with the rear box assembly constructed from 20SWG (9mm) steel. The standard units are 10" (254mm) deep.

NEW FOR 1990 19" project cases only 4" (101mm) deep and are available in the following popular sizes:

PROJECT CASES		
Type	Height	Price
P1	1 3/4" (44mm)	£16.50
P2	3 1/2" (88mm)	£18.50
P3	5 1/4" (133mm)	£20.50
P4	7" (178mm)	£22.50
P6	10 1/2" (226mm)	£26.50

EQUIPMENT CASES		
U1	1 3/4" (44mm)	£20.70
U2	3 1/2" (88mm)	£24.15
U3	5 1/4" (133mm)	£27.60
U4	7" (178mm)	£29.90

Delivery included (UK only).
All prices include VAT.
BLANKING PANELS, RACKING CONSOLES and PACK CABINETS are also available.
Please send SAE for details.
Tel: 0275 823963 for Access/Visa Sales or cheque with order to:

RACKZ PRODUCTS

PO Box 1402 Mangotsfield, Bristol, England, BS17 3RY

Interak 1

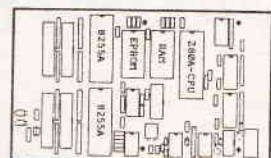

Bare Board
£17.50
(plus postage and VAT)

SINGLE BOARD COMPUTER "SBC-1"

A computer doesn't have to look like you'd expect a computer to look. It doesn't have to have a keyboard and a screen and floppy disks and so on.

The SBC-1 has the bare minimum of chips a Z80 computer can have and still be a computer: A 4MHz Z80-CPU chip, an EPROM chip (up to 32K), a static RAM chip (up to 32K) and a pair of 8255A I/O (input/output) chips giving 48 individual lines to waggle up and down. There are one or two additional "glue" chips included, but these are simple "74LS" or "HC" parts.

A star feature is that no special or custom chips (ie PALs, ULAs, ASICs etc) are used — and thus there are no secrets. The Z80A is the fastest and best established of all the 8-bit microprocessors — possibly the cheapest too!

Although no serial interface is included, it is easy for a Z80A to waggle one bit up or down at the appropriate rate — the cost is a few pence worth of code in the program: why buy hardware when software will do?

Applications already identified include: Magnetic Card reader, mini printer interface, printer buffer, push button keypad, LCD alphanumeric panel interface, 40-zone security system, modem interface for auto sending of security alarms, code converter (eg IBM PC keyboard codes to regular ASCII), real time clock (with plug in module), automatic horticultural irrigation controller.

By disabling the on-board Z80A-CPU this card will plug into our Interak I C/P/M Plus disk-based development systems, so if you don't fancy hand-assembling Z80 machine code you don't have to!

The idea is (if you are a manufacturer) you buy just one development system and then turn out the cheap SBC-1 systems by the hundred. If you are really lazy we can write the program for you and assemble the SBC-1 cards so you can get on with manufacturing your product, leaving all your control problems to us.

Greenbank

For more details write or phone us:
Greenbank Electronics, Dept. (T04E), 460 New Chester Road, Rock Ferry, Birkenhead, Merseyside L42 2AE. Tel: 051-645 3391.

PATENTS IN SWITZERLAND



Although it has been said of Switzerland that it's nothing more than 'chocolates, watches and cheese' there is little further from the truth — at least in respect of patents.

Pat Alley's feature on patenting in Britain makes your system look so confusing that it's obviously a little off-putting to any inventor. Following the Swiss method, however, is simple in comparison and most definitely cheaper. When I saw the feature in January I was fascinated to find just how complicated the British method appears — I've always had a natural interest in patents as my grandfather worked in the Swiss patent office for many years. As patents can be granted for worldwide rights, it seemed to me that ETI readers may like to hear about patenting inventions in Switzerland.

A History of Swiss Patents

Swiss patent laws originate in 1878, so they've been around in one form or another for a long time. It wasn't until ten years after this, however, the first patent was officially registered. Since then, some 660000 patents have been granted through the Swiss patent office.

Up to just a few years ago these patents were protected only in Switzerland itself. However, in 1978 the situation changed with international agreements protecting Swiss patentees rights worldwide. Given the simplicity of obtaining a Swiss patent in the first place, this can make a worldwide patent application for anyone, Swiss or otherwise, altogether much simpler.

Swiss Patent Law

Patent law in Switzerland is pretty clear-cut. There's a booklet available from the patent office (*Erfindungspatente* — not available in English yet, but likely to be soon) which describes it pretty well, along with rules and procedures for application. Costing 12 Swiss francs, it's the only really essential payment anyone applying for a patent needs to make.

A number of exceptions apply to the granting of patents. The main ones relate to inventions which are:

- against *good order* — things which are not necessarily beneficial to the public in general. This is a strict legal term though and, as you may expect, it's meaning is under constant revision in the Swiss courts,

- processes or procedures of surgery, therapy and diagnosis applied on animals or the human body
- not the first of that category — self-explanatory really — if the invention isn't the first of its category, it's not an invention

at all; merely a copy of another

- not public knowledge. Not only does this apply to things which are generally known before the inventor applies for a patent, but also to information which the inventor discloses prior to the patent being granted — in other words, if you have an invention, don't tell anyone (not even your pet parrot) before you get your patent. Your invention is your *gold* and to be a successful *gold-digger* you don't tell anyone where your mine is!

Before we look further at Swiss patenting, though, we've got to clarify a couple of points. First, we need to understand what is meant by an invention — basically, a product of someone's mind; an idea; a creation of oneself. An invention is also often referred to as the actual product which you can see and feel. But it's this distinction between the idea and the product which Swiss patents afford and British patents don't seem to, which makes patenting in Switzerland much simpler. In Britain, patent law requires the invention to be something tangible — a finished product — but in Switzerland, an idea is sufficient.

Second, patenting is the process of officially registering an idea as the inventor of that idea or the inventor's representative. Registering the invention in Switzerland is simply done by completing pre-printed forms and forwarding them to the patents office. Provided the invention can be proved to be original according to the rules we've already considered, the patent will be granted. Compare this with the British procedure!

The purpose and use of patenting lies mainly in protecting one's invention; legally preventing it from being copied and used by others, perhaps for commercial gain. Further, once an invention is patented, the inventor or representative has automatic and full rights to make commercial use of the invention. This is appropriate, when you think about it, so the inventor can reap the rewards of, perhaps, many hours or years of work.

Famous Names

To conclude this first part of our look at the ins and outs of Swiss patenting, it's worth remembering the most famous person who ever worked in the Swiss patent office — Albert Einstein. No proof exists, however, that working there is anything to do with fame, otherwise my grandfather (and perhaps me) would be as famous, too!

Next month we'll look at the actual procedures for patenting an invention.

PATENTS

Following the feature in January's ETI on confusing and costly British patents procedure, Marc Masson writes from Switzerland with an introduction to much simpler patenting rules there

Einstein - Str.
Albert Einstein von Zürich und USA, 1879 - 1955
Physiker und Begründer der Relativitätstheorie
von 1902 - 1909 am Patentamt in Bern tätig

NAVIGATE

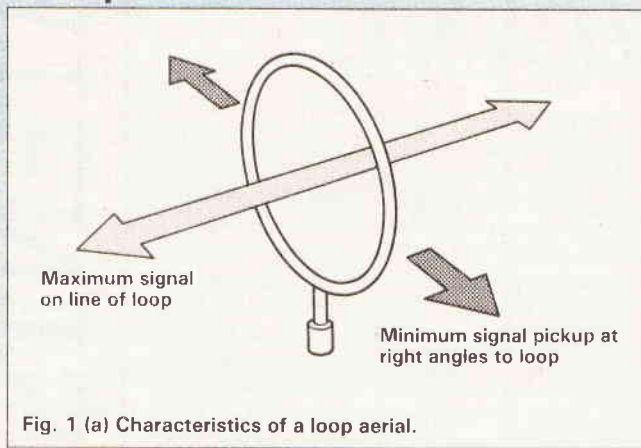
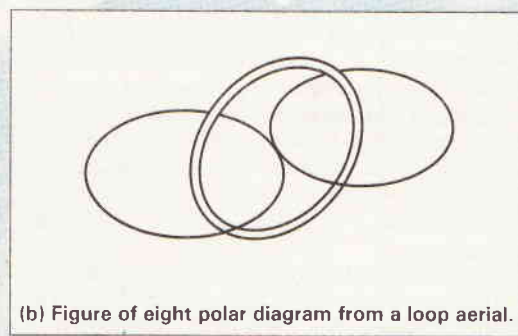
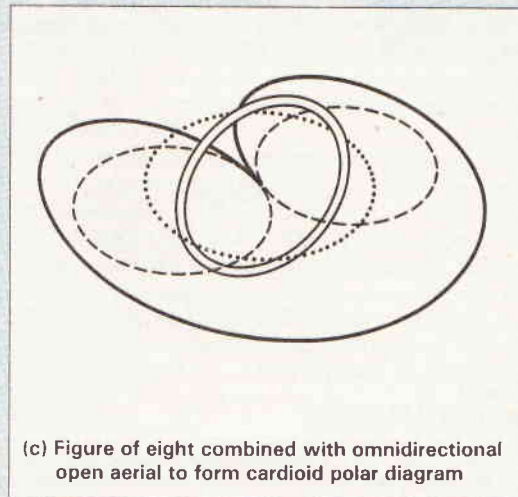

Fig. 1 (a) Characteristics of a loop aerial.



(b) Figure of eight polar diagram from a loop aerial.



(c) Figure of eight combined with omnidirectional open aerial to form cardioid polar diagram

These very problems resulted in the development of air radio navigational aids.

It was the German Airship Service in the first world war which first made use of radio for navigation. In that conflict both states had highly developed and extremely accurate direction finding chains which were used for plotting the origin of the enemy's radio traffic. Very soon, the Germans realised the same D/F chain could also be used for plotting the location of their own airships when engaged on reconnaissance or bombing duties over the United Kingdom.

Von Buttler-Brandenfels, the only airship commander to fly throughout the war, is on record as saying that when above cloud, the D/F chain invariably gave positional fixes within 50 miles, an accuracy which was not possible using star sights with a sextant.

In the years after the war, similar fixer chains were set up around the world but all suffered from the same problems, a minimum of three ground stations were necessary, the system was very labour intensive and expensive, and so the system was very soon overloaded.

By the late 1920s, receiver sensitivity was sufficient to permit the use of small rotating loop aerials which could be fitted on an aircraft. A small loop aerial has a polar diagram like a figure of eight with a null directly opposite the plane of the aerial (Fig. 1). So, if the aerial is rotated until the incoming signal disappears, the direction of the transmitting station is at right angles to the plane of the loop. The only problem being, that there is no way of telling on which side of the loop the station is located.

This was overcome by adding the output of an open aerial to the loop. This modifies the polar diagram of the combination from a figure of eight to a cardioid (or heart shaped) pattern which has only a single null and therefore removes ambiguity.

Armed with such equipment, the aircraft was no longer reliant on bearings taken from ground stations, but could either 'home in' onto a single ground transmission. Alternatively the aircraft would take bearings from several ground stations and determine his own position.

Over the succeeding years, the system has been developed, and has become fully automated, only needing the frequency of the required station to be tuned for the equipment to automatically take a bearing. This is indicated on a meter on the pilot's instrument panel. In this form the system is known either as ADF (Automatic Direction Finder) or Radio Compass.

Although such a direction finding system can be used in conjunction with any radio transmission, it is far more convenient for the aircraft if the ground stations could be located at their destination airports or along the routes. These beacons became known as non-directional beacons (NDBs) and are today the most common navigational aid in use in the world.

The signal radiated by an NDB is a carrier wave modulated by a tone, keyed at frequent intervals with the facility call sign in Morse code. The frequency of operation is between 250 to 400kHz although some operate outside this band. The power radiated varies widely. In Africa or the south Pacific regions where high noise levels exist and long range is necessary, output powers up to several kilowatts into large aerial systems are frequently used. In comparison, many airport locator beacons within Europe only require a range of a few miles. For this the radiated power may well only be a few watts transmitted from a short whip

Brian Kendal guides us through the air and tells of the equipment used to bring our aircraft safely in to land.

GUIDANCE

We are all navigators. Even a walk to the local shop is an exercise in the art of navigation, for we set a course in the correct direction, proceed from waypoint (e.g. street corners, pedestrian crossings, etc.) to waypoint, keeping a mental log of our progress until we reach our destination.

Longer journeys, especially by car, require a more advanced application of the art, for we often need to refer to maps and road signs in addition to accepting restrictions on our progress in the form of diversions, speed restrictions and traffic lights.

The pilot of an aircraft has directly analogous problems except that his roads and motorways are indicated only by lines drawn on a map. If conditions are very clear, he may well be able to fly to his destination by map reading. Often, the ground is obscured by cloud or darkness and even a compass course is of little help if he does not know the strength and direction of the airstream in which he is flying.

aerial system.

In almost every beacon installation, two transmitters are installed with an automatic monitoring and change-over system. Should the monitor detect a reduction in power or a modulation failure of the operational transmitter, the standby equipment is immediately brought into service.

The automatic direction finding system in aircraft used in conjunction with non directional beacons is relatively cheap, effective and has stood the test of time. However, it does have several disadvantages. When using the system for homing, the aircraft will not fly by the most direct course if there is a strong crosswind, (Fig. 2).

Let us consider the case where an aircraft intends to fly to a destination 100 miles distant at a speed of 100mph. In still air conditions the pilot could quite easily use either a compass or the ADF system. After take off, he would set a compass course for his destination or tune in the beacon at the destination airfield and fly a track such that the beacon was directly ahead. In either case, one hour later he would be overhead his destination airfield.

If there was a crosswind of 50mph at right angles to his intended track, the situation would be completely different. Had the pilot been flying a compass course for his destination, after one hour's flying he would be fifty miles to the leeward of his intended destination. If he had used his ADF however, although the nose of the aircraft would at all times be pointing directly at the destination airfield, the wind caused him to drift off the direct track, diverting anything up to twenty or thirty miles off the intended track, covering many more miles than he originally intended. Even more important, had the pilot been flying under air traffic control, his position would have been many miles from where he intended, with consequent danger of collision with other aircraft.

In practice, the pilot would have received a meteorological report before take off and when setting course would have 'aimed off' to allow for the effect of the wind, but forecasts for upper winds are rarely consistent. If a navigational aid could be developed which provided the directional information, then an accurate course could be flown regardless of the strength or direction of the wind. This resulted in the development of the VHF omni range beacon, commonly called VOR.

VHF Omni Range Beacon

VOR is the standard short range navigational aid used throughout the world to mark out the tracks of airways and on some small airports, as an approach aid.

It is known as a rotating beacon and developed in 1907 when the German firm Telefunken introduced their 'Compass'.

Before the turn of the century, many engineers had been studying the characteristics of the inverted 'L' aerial, finding that if the horizontal portion was much longer than the vertical section it showed pronounced directional properties in the direction opposite to the line of the wire. In 1906, Marconi patented a crude direction finder where a number of these aerials were mounted in a circle and by selecting the one with the strongest signal, an approximation of the bearing could be determined. The following year, Telefunken introduced a similar idea called 'The Telefunken Compass' (Fig. 3). Thirty two aerials were arranged at the points of the compass around a central mast which also supported an omnidirectional aerial.

At pre-arranged intervals a 'start' signal was radiated from the central omnidirectional aerial followed by a one second transmission from each of the directional aerials in turn. The navigator used the

Compass with a special stop watch, calibrated in the points of the compass. The compass hand rotated once in thirty two seconds. The watch was started with the first signal and stopped when the signal reached its maximum strength. The radiation pattern was very poorly defined and an accuracy of four or five degrees was claimed for this equipment.

The next development in rotating beacons was by the Marconi Company who realising that only by moving up to the VHF region could accurate polar diagrams be generated, installed a beacon operating on 6.2 metres on Inchkeith Island in 1922.

Two paraboloids were mounted back to back, rotating once every two minutes. The other major breakthrough with this equipment was to key the transmission via a contact ring mounted on the base of the aerial array. In this way, morse code letters were radiated corresponding to the bearing of the aerial. The navigator had only to note which letter was loudest to determine his bearing from the beacon.

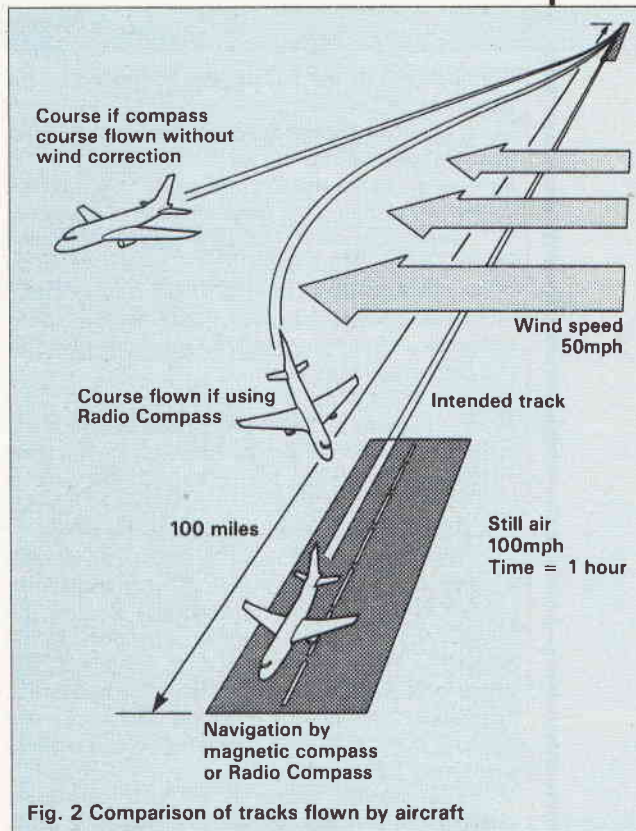

Fig. 2 Comparison of tracks flown by aircraft

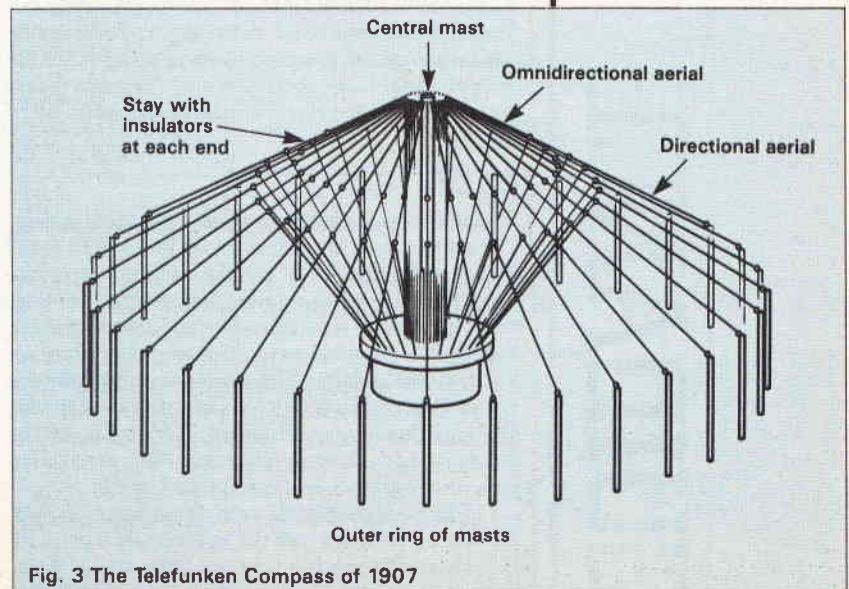

Fig. 3 The Telefunken Compass of 1907

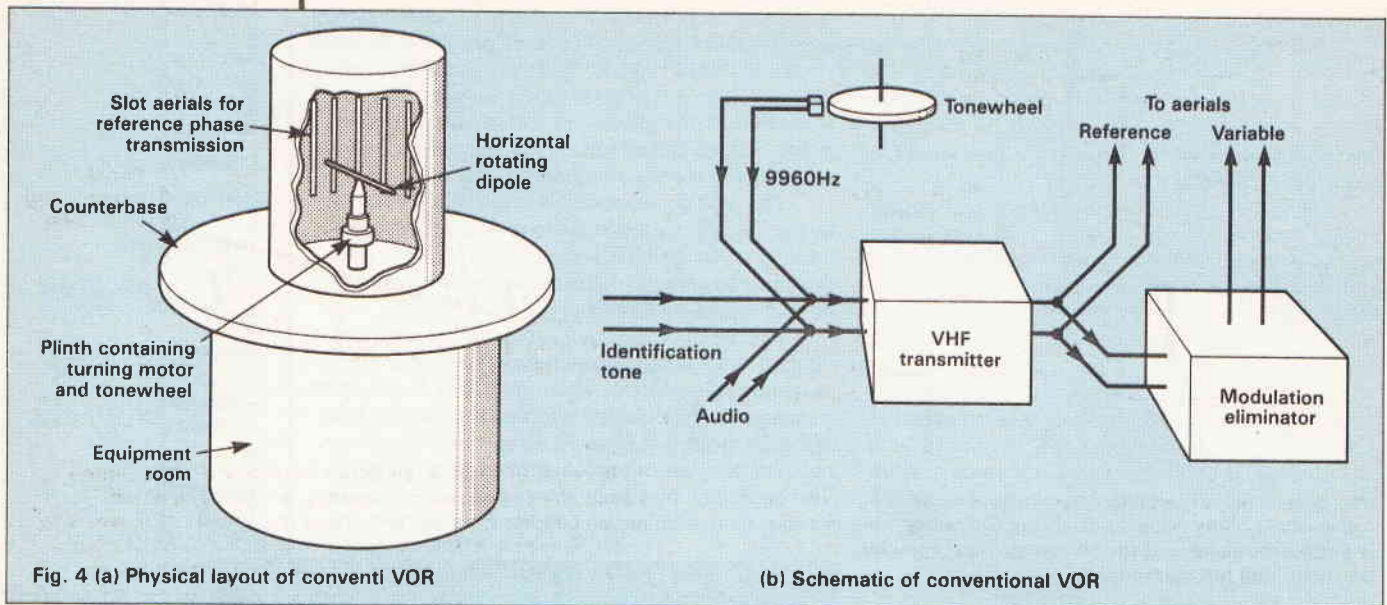

Fig. 4 (a) Physical layout of conventional VOR

(b) Schematic of conventional VOR

Furthermore, as the keying was controlled by the segments on the base of the array, the equipment always gave the correct directions information. Such beacons were satisfactory for marine use, but not so for aviation, as the aircraft could easily have travelled several miles during the determination of a bearing.

During the 1920s and early 1930s, the United States developed the Radio Range system which set out tracks across the country. These only indicated four tracks from each beacon, which although quite satisfactory when flying specified routes, were of little use for general navigation.

In 1937 the decision was made to develop a more modern form of the rotating beacon which was suitable for instrument display. Although the war years intervened, the general principles had been defined by 1949 and the VOR beacon as we know it today was gradually brought into service in the 1950s.

The principle of VOR is that the beacon radiates a signal with two independent 30Hz modulations, known as the reference and variable phases, the phase difference between these correspond to the bearing of the receiving station. In addition to the phase modulations, the facility callsign is radiated at intervals for identification purposes. The equipment operates in the 112.0-117.9MHz region and radiates a power of 220 watts.

The variable phase is a 30Hz amplitude modulation and the reference phase is a 30Hz frequency modulated wave on a 9960Hz subcarrier. There are two ways by which the required modulation can be generated, the older method being called the 'conventional VOR' or CVOR and the more recent using the doppler principle called 'Doppler VOR' or DVOR.

CVOR

The heart of any navigational aid is the aerial system. The earliest, and most simply explained VOR aerial system consisted of a 'dustbin' shaped structure mounted on a metal counterpoise on the roof (Fig. 4a). The 'dustbin' is some six feet in diameter and ten feet high. Around the circumference of the system are a series of slot aeriels which are fed in phase from the reference phase output signal and give a substantially omnidirectional radiation pattern. Inside is a horizontal dipole mounted on a rotating shaft. This aerial is fed with unmodulated RF from the transmitter.

The polar diagram of a dipole is a figure-of-eight, but when combined with the appropriate level of RF in the correct phase from the reference phase RF, the result is a cardioid or heart shaped. If the dipole aerial

is then rotated at 1800 rpm (30 times per second), a distant station will hear a 30Hz modulation (Fig.5a). This is known as 'space modulation'. Furthermore, the phase of this modulation will vary with the position of the receiving station.

There only remains to provide a reference signal with which the variable phase is compared. As stated, this takes the form of a frequency modulation on an amplitude modulated subcarrier.

It is essential the relationship between the reference and variable phases is rigidly maintained at all times. In the original CVOR equipment this was achieved by generating audio for the subcarrier by a tonewheel fixed to the variable phase aerial shaft. (Fig.4b) The most basic tone wheel generator consists of a metal wheel with 332 teeth cut around its circumference. Mounted closely to the teeth is an electromagnetic pick-up which gives an electrical output each time a tooth passes by. If the wheel is rotated at 1800rpm, the output will be at 9960Hz, the subcarrier frequency. In order to provide the necessary frequency modulation, the teeth are arranged in a somewhat staggered manner and this irregularity imparts a cyclic frequency variation between 9480 and 10440Hz, the actual frequency being dependent on the instantaneous position of the toothed wheel.

In order to maintain the correct RF phase relationships between the signals carrying the reference and variable phases, a single transmitter is used.

This is modulated by the output from the tone wheel generator and the output is split two ways. The first of these is connected directly to the omni-direction array of slot aeriels and the second to a circuit which strips the modulation from the transmission. The output of this circuit is then coupled to the rotating variable phase dipole.

The radiated signal is continuously monitored for modulation depth, course alignment and output power and should any divergence from optimum be detected, the operational equipment is switched off and the service is restored by standby equipment.

Over the years, other methods of generating the required has been developed. the most recent by Standard Elektrik Lorenz whose equipment is fully solid state with no moving parts, the necessary waveforms being generated by microprocessor and fed to a slot aerial array.

All CVOR equipment however, suffers from course errors due to the polar diagram of the omni directional polar diagram not being perfectly circular

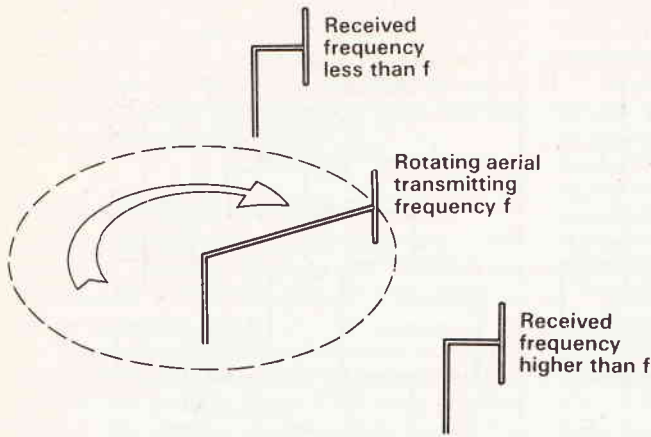
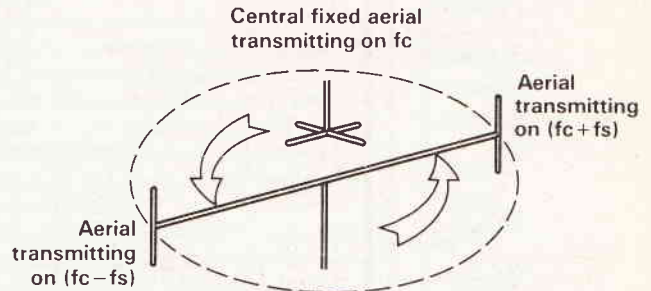

Fig. 5 (a) Effect of rotating a transmitting aerial in a circle. The receiving stations will only receive at frequency f when the transmitting aerial is at the nearest point of approach or farthest from the receiving site.



(b) Principle of a double sideband Doppler VOR. The central aerial radiates the carrier frequency f_c whilst one of the rotating aeriels radiates $f_c + f_s$ and the other $f_c - f_s$ where f_s is the frequency of the subcarrier. In practice a ring of fixed aeriels is used with the signal commutated to each in turn.

and also due to siting difficulties. These problems have been largely overcome by the development of the Doppler VOR system (Fig. 5b).

Doppler VOR (DVOR)

If a signal is received from an approaching transmitter, the frequency will be higher than that transmitted according to the Doppler effect. If the transmitter is receding, the received frequency will be lower. This principle is used to generate the reference phase frequency modulation on the sub carrier. This is achieved by commutating the sideband signals (Frequency +9960 and Frequency -9960Hz) around a ring of aeriels approximately forty feet in diameter. The combination of Doppler effect, rotation at speed of 1800rpm, a distant receiver will receive these signals frequency modulated by ± 480 Hz at a rate of 30Hz, the correct format for the reference phase transmission but with the phase varying with the bearing of the receiving station. The variable phase transmission is transmitted as a 30Hz amplitude modulated transmission from a central omni directional aerial.

In this equipment, the reference and variable phase transmissions have effectively changed places and to allow for this, the direction of rotation around the ring of aeriels is reversed compared with that of the dipole in a CVOR equipment.

The arrangement gives several advantages over CVOR equipment. The more accurate radiation patterns from larger aeriels gives greater bearing accuracy and DVOR is less susceptible to errors due to site conditions.

In practice, the course errors in a CVOR system may add up to three or four degrees on some bearings whilst on a DVOR system less than two degrees would be expected with better than one degree quite commonly achieved.

Aircraft Equipment

The aircraft VOR equipment is a simple superhetrodyne receiver operating between 112.0 to 117.9MHz (Fig. 6). The equipment often also incorporates Instrument Landing System, in which case the frequency coverage extends down to 108.0MHz.

The receiver demodulates the incoming VOR signal and then is applied to two filter circuits, one tuned to 30Hz and the second to 9960Hz. The output from the 9960Hz filter is amplified and applied to a discriminator where the 30Hz reference phase signal is extracted. This is then compared with the 30Hz variable phase signal from the 30Hz filter and the output operates an indicator on the pilot's instrument panel and may also be sent to the aircraft flight director.

The pilot's indicating equipment may take one

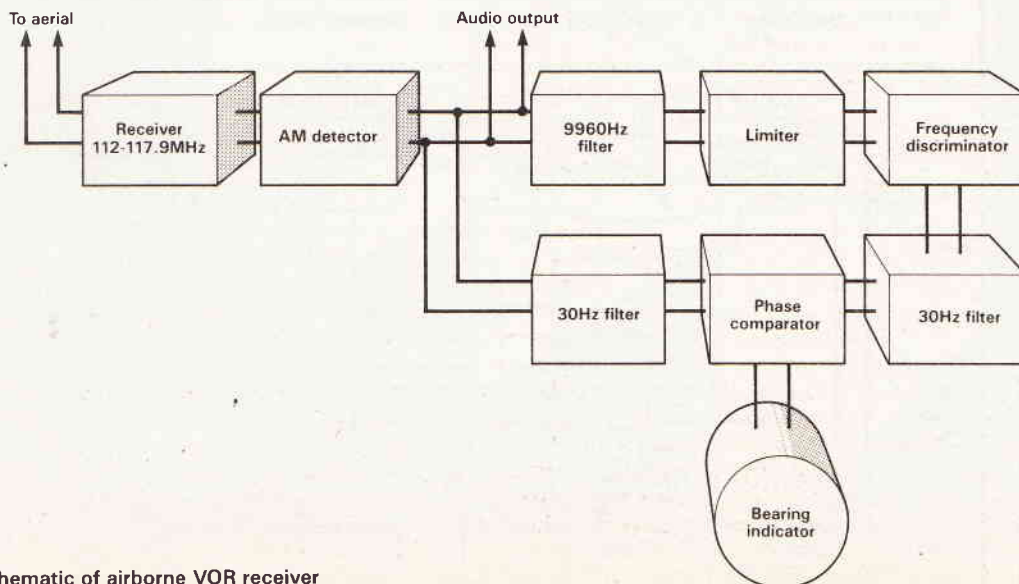

Fig. 6 Schematic of airborne VOR receiver

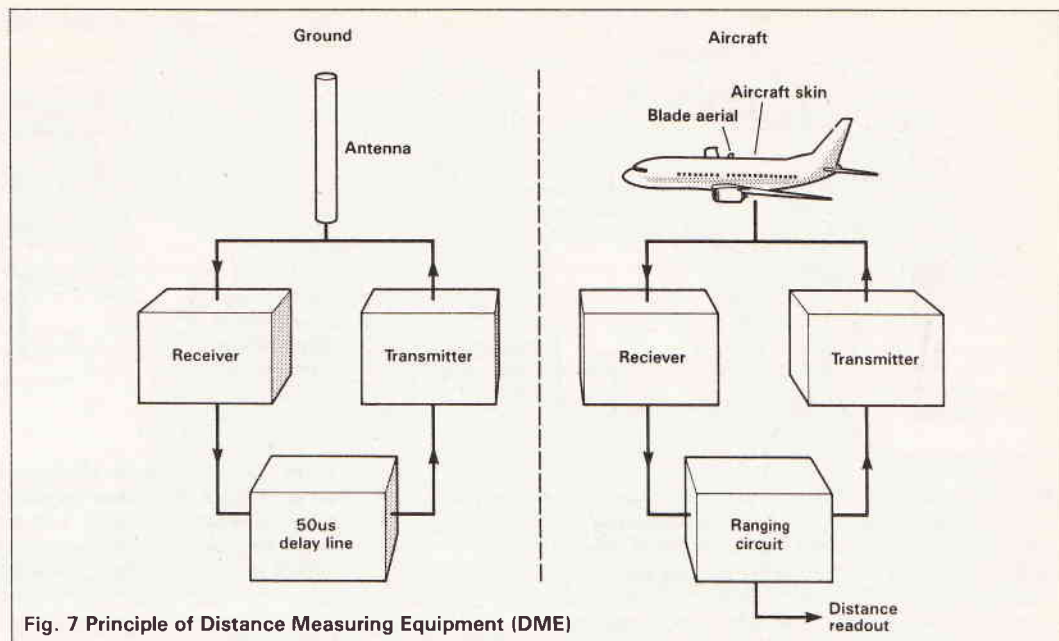

Fig. 7 Principle of Distance Measuring Equipment (DME)

of two forms: either a compass-type instrument in which the bearing of the beacon relative to the aircraft heading is indicated, or a left/right indication on a cross-pointer meter with an adjustable scale. The latter enables the pilot to accurately fly a preset course to or from a VOR beacon following only a simple meter presentation.

The use of VOR enables the pilot to fly accurate tracks between beacons and also by comparing his bearing from several beacons, to determine the plane's position. However, it is easier if a positional fix can be obtained from only one point. This is achieved by co-siting Distance Measuring Equipment (DME) with each VOR beacon (Fig.7).

Distance Measuring Equipment (DME)

DME is a secondary radar device in which the aircraft interrogates a transponder on the ground. From the time interval between interrogation and receipt of reply, the aircraft equipment works out the distance of the beacon. The cockpit will display a direct distance measurement or the information is directly supplied to the aircraft flight director equipment.

Early DME equipment was developed from the wartime Rebecca-Eureka which operated on 200MHz. Soon after the war, Australia developed the first DME operating on a similar frequency which

remains in service to this day but it did not find favour outside that country and was never generally accepted.

In 1959, standards were agreed by the International Civil Aviation Organisation for a DME operating at 1000MHz and these are now currently in use.

Interrogation starts with the aircraft radiating a series of twin pulses, each $3.5 \mu s$ wide, spaced by either 12 or $36 \mu s$, at a rate of about 150 pulse pairs per second.

On receiving a pulsed pair, the ground transponder delays for $50 \mu s$ and then radiates a pulse pair of either 12 or $30 \mu s$ spacing on a frequency 63MHz displaced from the aircraft frequency. The aircraft equipment Fig. 8, receives this pulsed pair, measures the elapsed time between transmission and reception, deducts the $50 \mu s$ beacon delay and calculates the distance between aircraft and beacon.

When the aircraft interrogator has 'locked on' to the beacon, the rate of interrogation is reduced to between five and twenty five pulse pairs per second. This rate remains unless for some reason the beacon is lost. If this happens, the rate is again increased to 150 pulse pairs per second until the beacon is once again acquired. The high rate of interrogation is known as the search mode and the low rate, the tracking mode.

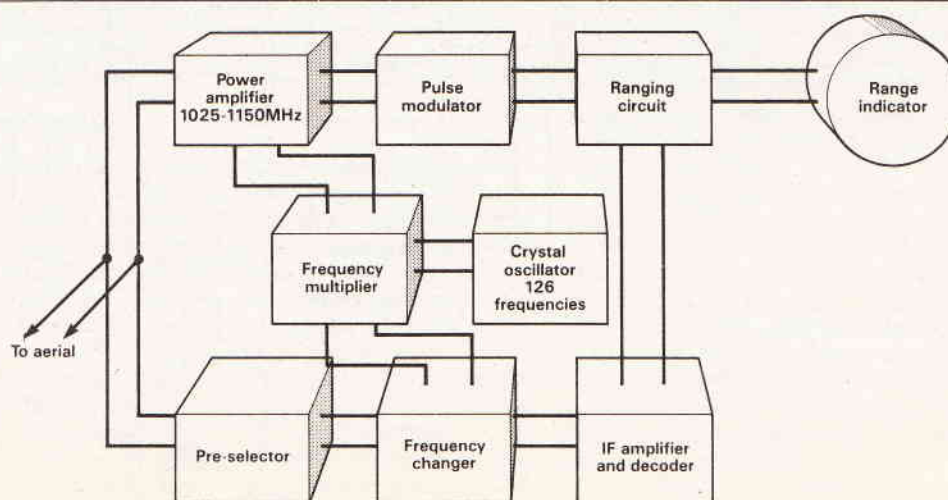

Fig. 8 DME airborne receiver block diagram

With such a simple system it may well be asked how the aircraft can recognise the reply to its own interrogation. This is achieved by making the interrogation rate rather unstable and the aircraft equipment is designed to only accept replies at its own interrogation frequency.

DME Ground Equipment

The basic principle of the ground equipment is quite simple: a receiver, a circuit to validate the interrogation, a $50\mu\text{s}$ delay line and a transmitter to radiate the reply.

There are complications. This simplicity ensures that there is a limit to the number of replies which can be made per second. This is 3000 pulse pairs per second. The receiver is designed to prevent the number of interrogations exceeding this amount and the equipment does not respond until the limit is restored. If the number of interrogations is low, the gain of the receiver is increased until random atmospheric noise causes the transmitter to radiate 3000 pulse pairs. By this means the transmitter duty cycle is kept reasonably constant and the beacon always remains in its most sensitive possible condition. In the case of excessive interrogation, the nearest aircraft is the last to lose contact. An extreme case of this would be if the beacon were to fail whilst being interrogated by one hundred aircraft. Under such circumstances all the aircraft would go into search mode, increasing their interrogation rate to 150 per second. This would hopelessly overload the transponder on its return to service as it would be confronted with 15000 interrogations per second. The transponder would reduce the receiver gain until only 3000 per second were being accepted. This would restore service to the twenty nearest aircraft who would within a minute or so, revert to tracking mode. This in turn would reduce the number of interrogations and allow the receiver gain to increase

and accept more aircraft in search mode. Gradually, all the aircraft would be in track mode with the total number of interrogations below 3000 per minute.

In addition to being used with VOR, DME is increasingly being used on airports to provide the pilot on approach with distance-to-run information. When used in this way, the $50\mu\text{s}$ delay is frequently altered so that no matter where the beacon is located on the airport, the pilot's readout will indicate his distance to the touchdown point of the operational runway and not the distance to the beacon.

Distance Measuring Equipment operates between 960 to 1215MHz. The interrogation and reply frequencies are allocated with 1MHz spacing between adjacent channels and are numbered 1 to 126 in ascending order of airborne interrogating frequency from 1025 to 1150MHz. Each interrogation frequency has two reply frequencies at 63MHz above and below. These vary in frequency in pulse spacing and reply.

When the reply frequency is higher, a $12\mu\text{s}$ pulse spacing is used for both interrogation and reply. These are designated 'X' channels. If the reply frequency is lower, the interrogate pulse spacing is $36\mu\text{s}$ and the reply spacing $30\mu\text{s}$. These are called 'Y' channels.

When DME is operating in conjunction with VOR to from a single facility, their frequencies of operation are paired in a predetermined manner. For example: a VOR on 112.3MHz is always paired with a DME on Channel 70X.

In overcrowded skies of the western world the combination of VOR/DME provides a convenient and accurate means of marking airways and airports. In less crowded areas where lower navigation accuracy is possible, the NDB/ADF system performs a similar task at significantly lower cost. Even with the advent of sophisticated, highly accurate systems such as the satellite based Global Positioning System, it is hard to believe that the current systems will not be still with us until far into the 21st Century.

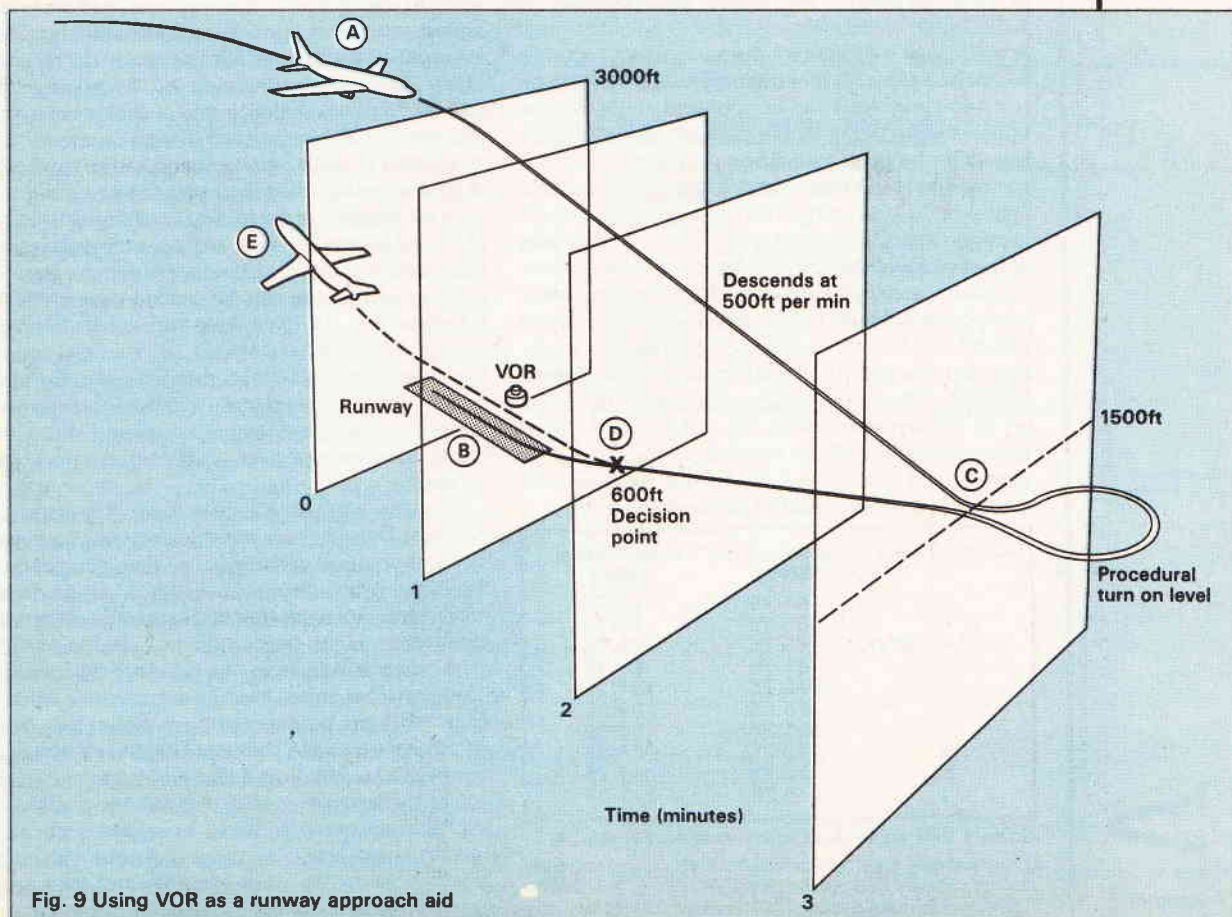
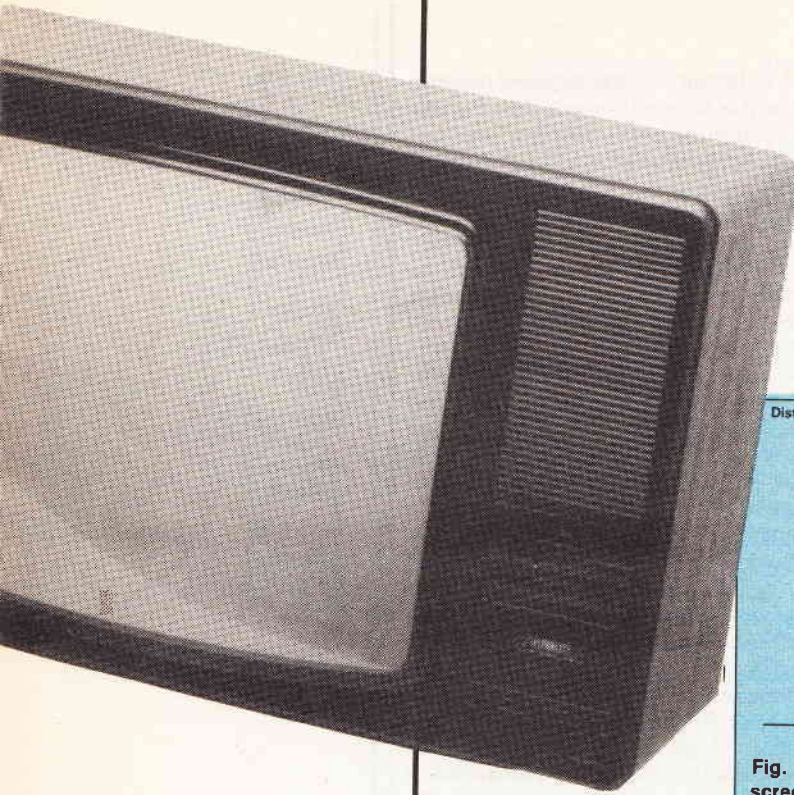

Fig. 9 Using VOR as a runway approach aid



CABLE TELEVISION

Part 1

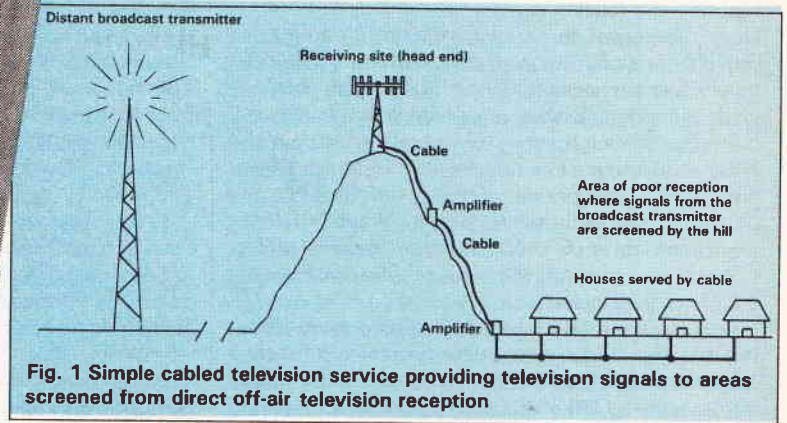

Fig. 1 Simple cabled television service providing television signals to areas screened from direct off-air television reception

Governmental encouragement has brought the subject of cable television into the foreground. Jim Slater explains the technology.

Cable television isn't new — it's been in existence for almost as many years as broadcast television, in various forms. Recent enthusiasm which the UK Government has shown for the information technology-related aspects of cable, however, has brought cable systems into the spotlight, and in particular has concentrated attention on the many exciting new facilities so-called *new technologies* can bring to cable systems.

As with all technical developments the reporting of cable television in the popular press is subject to much misunderstanding, inaccuracy and over-simplification, so it is difficult for the lay reader to obtain a balanced picture of what is actually happening. Even television engineers can be confused about the real impact various technological changes can bring. Cable stories in the press range from a that of a Utopian society where our every need is fed along an optical light-pipe (it is amazing how frequently our need is expected to be 30 channels of television), to scary tales of the upheaval that the installation of cable systems can cause, usually illustrated by American-originated photographs of huge lorries mounted with enormous circular-saw blades that are chewing up our roads. Even in some of the popular technical journals lasers and fibre-optics are generally considered to be a must for all new systems, while the well-proven co-axial systems that have been developed and used over many years are consigned to the technological dustbin, a situation which is far from the truth.

Channel code	Vision carrier (MHz)	Sound carrier (MHz)
A	45.75	51.75
B	53.75	59.75
*R1(B + 2MHz)	55.75	61.75
C	61.75	67.75
D	175.25	181.25
E	183.25	189.25
F	191.25	197.25
G	199.25	205.25
H	207.25	213.25
I	215.25	221.25

Table 1 VHF cable distribution channels in the UK
Channels may be offset to reduce interference, and they should then be referred to as *channel A + + 0.5MHz*
* Channel R1 was adopted before large offsets became common and is not usually specified for new systems

Cable Television — A Whole Range

Cable television distribution has been used for almost fifty years and initially started life as a way of providing television pictures and sound to people living in areas where satisfactory signals could not be received off-air. The situation arose simply because the broadcasting authorities could not provide enough transmitting stations for all those communities that wanted to receive television pictures.

Initially, radio and electrical dealers who were keen to expand into the newly-arrived television business rapidly realised that they wouldn't be able to sell receivers if satisfactory signals couldn't be received. Many dealers experimented by wandering over nearby hillsides, trying to find a spot where good pictures *could* be received. These pioneers then proceeded to tackle the problem: buying a small piece of land to put the *head end* receiving equipment on; running cable down the hillsides and along the streets of many a small town; adding amplifiers where necessary and finally putting wires into the home of every would-be viewer who could be persuaded to subscribe (Fig. 1). Even now, with off-air television coverage approaching almost 100% of the population, there are still large numbers of very small communities, geographically isolated or hidden away in hollows where they are screened from any incoming television signals, which rely on signals being by wire.

In some areas this simple type of system was developed by entrepreneurial dealers who discovered that at their aerial vantage points they could receive television programmes from other, more distant transmitters that were intended to provide services for other areas. Often they could provide one or more extra programmes from the regional independent television companies around the country, while in some parts (the border country of Wales) they could also offer customers a choice of English or Welsh BBC transmissions. Although this proved popular it turned out to be something of a political hot-potato and regulations were introduced to restrict such cable services from supplying more than one extra programme, and they were generally not allowed to provide locally inserted material. Despite this unhelpful regulatory climate, cable services remained

TV

popular in a few areas even after broadcasters built local transmitters because the cable operators could provide a wider choice of programme than the local transmitter did. Such systems are the forerunners of the sophisticated cable services to be developed over the next few years.

Wired networks of the future will be able to receive television signals not only from many different parts of this country but will also be able to pick-up signals from all around the world, thanks to satellite television transmissions. Locally produced services of news and information will be available and the unique two-way capabilities of modern cable systems will allow the viewer to interact with the programme provider, making use of a wide range of hitherto unexplored services such as teleshopping and home banking. Figure 2 shows a possible future wired network. Although such services are often talked about as belonging to an era when fibre-optic cables are universal, it is perhaps worth mentioning at this point that most of these services can be provided by almost any type of well-engineered metallic cable network, and the particular cable technology used is by no means crucial.

Although similar in nature there are differences between the ways in which cable systems of different sizes are engineered. Two major divisions are usually considered as MATV and CATV systems.

Master aerial television (MATV), generally refers to small distribution systems providing services to blocks of flats and maisonettes, to office blocks and even to small housing estates.

Although early MATV systems used VHF distribution, since UHF transmissions have become the norm in the UK and as UHF equipment has improved in performance more and more new MATV cable system builders are choosing the simpler option of distributing television signals at UHF frequencies, without frequency conversion, for their small and medium-sized systems.

Even with small systems frequency conversion is sometimes necessary to avoid strong interfering signals or problems with *pre-imaging* (a form of ghosting caused by signals which reach the receiver by direct off-air pickup, perhaps through the wiring of the receiver, being slightly displaced in time from the signals on the same channel that are being sent to the receiver via the cable distribution system). Interference tends to occur in areas close to a transmitter where strong signals are available and is a common problem encountered when installing MATV systems in many hotels and apartment blocks. Provided too many programme channels do not have to be converted, it's usually possible to find alternative UHF channels for the cable system; far enough away from the off-air signals to eliminate the problems.

Community aerial television (CATV), is the term applied to fairly large systems which distribute television signals to large numbers of homes in towns and villages. Such systems usually contain special compensating equipment to ensure picture quality is not degraded as the signals travel along the length of the system, often many miles. CATV is the modern term for what used to be known colloquially as *television relay*, and when discussing cable television it is usually CATV Type systems that are meant.

Another cable television system which may be encountered is *closed-circuit television (CCTV)*, any system where television signals are generated, distributed and received entirely within a user's own premises. Such systems are frequently used for security purposes in major office complexes and on factory sites and television pictures are often of a lower quality than would be demanded of broadcast television. Signals are cabled to the office where security

guards sit, enabling them to maintain surveillance over many different parts of the site. Cameras responsive to infra-red radiation are sometimes used to monitor the site of night. A typical CCTV system is illustrated in Fig. 3.

Road traffic management systems often use CCTV to allow police to monitor traffic congestion on motorways and at busy road intersections. Systems have even been developed capable of automatically logging licence number plates of moving vehicles.

Closed-circuit systems need not be thought of as unsophisticated as many have been among the first cable systems to make use of fibre-optic technology.

HF Multipair Distribution Systems

Technologies used in cable television systems depend largely on the operating frequencies used for distri-

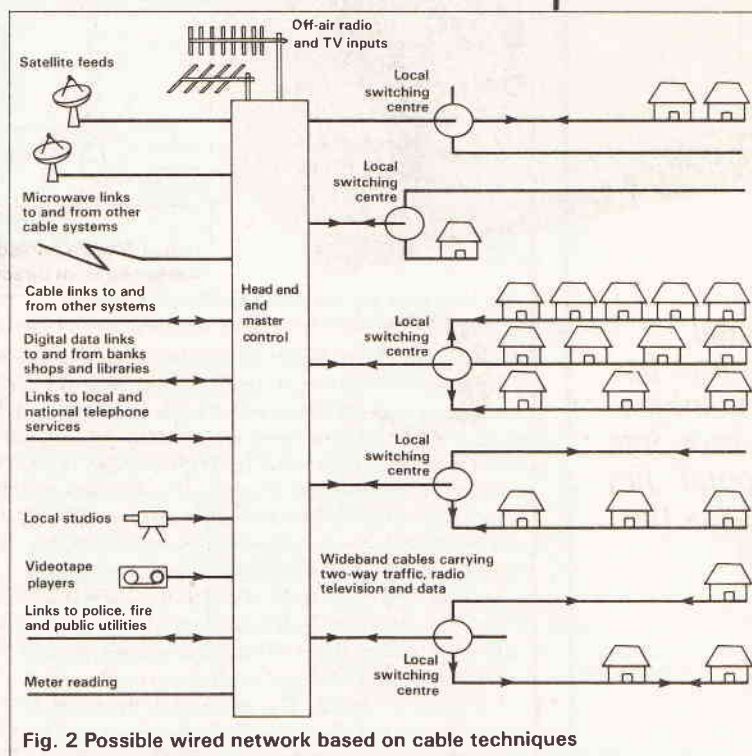

Fig. 2 Possible wired network based on cable techniques

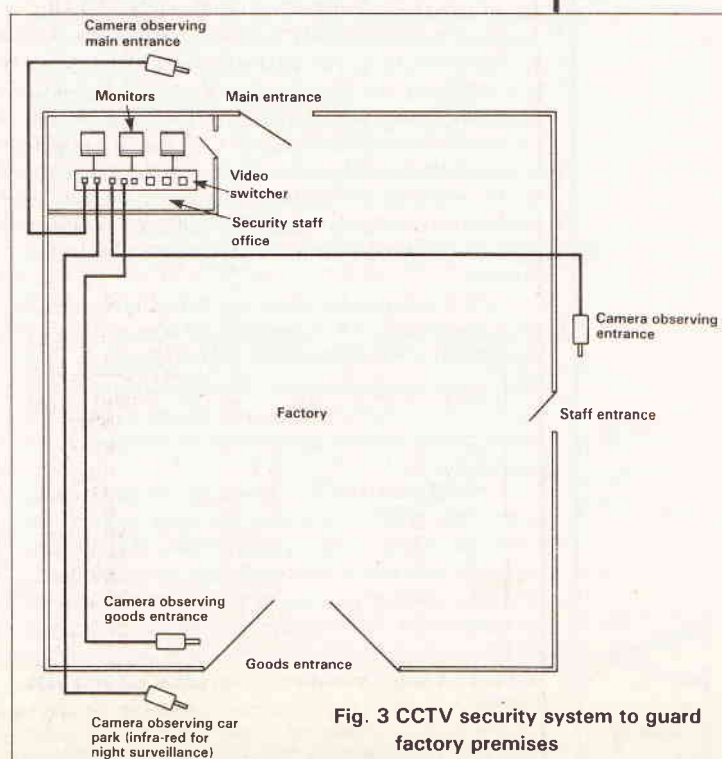

Fig. 3 CCTV security system to guard factory premises

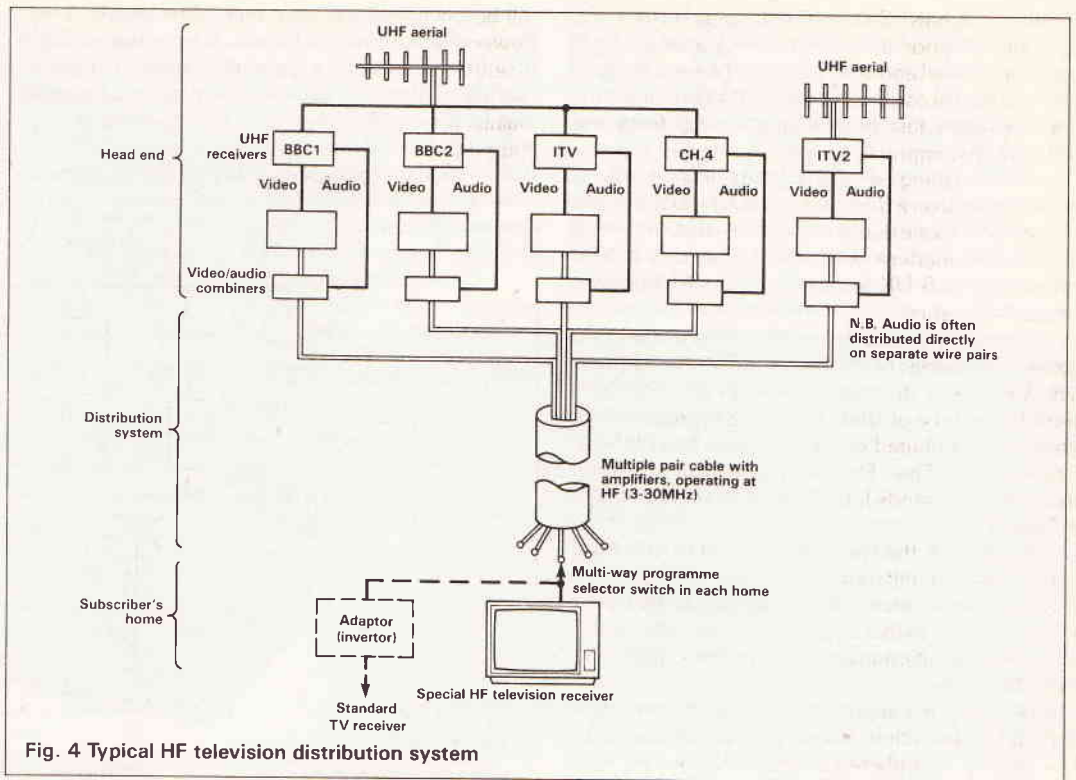

Fig. 4 Typical HF television distribution system

bution. In an HF multipart distribution system each of the television signals received by the aerial at the head-end is converted from the incoming UHF frequency in the band between 3 and 30 Mhz. Usually a carrier frequency of around 10MHz is chosen. Each programme is carried on a balanced pair of wires in a multi-way cable which normally contains up to 12 pairs, and each uses the same high-frequency carrier. If four programmes are being distributed it is necessary for four pairs of wires to be taken into each viewer's home. The viewer selects the channel required by means of a selector switch. This selector switch is often remotely mounted and may contain the mains switch and a volume control. The receiver in the viewer's home is a non-standard model which can receive the HF carrier signals — something which gave rise to a lot of unhappiness in the retail trade at one time, because dealers felt that customers who were connected to one of the HF cable systems had little choice but to buy or rent the special HF receiver from the cable operating company, thereby limiting their own chances of selling conventional receivers. Eventually it became the usual practice for the cable operator to make available an adaptor, sometimes called an inverter, to enable standard UHF television receivers to be used. Figure 4 illustrates a typical HF distribution system.

On these systems sound signals can be translated to an appropriate HF frequency and passed through the system in the same way as television signals, and often radio programmes are distributed this way. It is more usual, however, for sound signals to be distributed directly at audio frequencies on a balanced pair of wires.

HF systems provide excellent distribution quality sound and vision, and they are very suitable for coverage of large areas as signal losses in cables are generally very low at the frequencies which are used, and the number of repeater amplifiers is therefore kept to a minimum. The number of channels which can be transmitted is basically restricted to the numbers of pairs of wires available in the cable, so it is not usually a practical proposition to increase the numbers of channels available once the system has been installed. This limitation, together with the need for

Band	Television	Frequency(MHz)	Notes
I	Television	41- 68	Not used for TV in UK
II	FM sound radio	87.5-108	
III	Television	174-225	Not used for TV in UK
IV	Television	470-613	
V	Television	615-890	

Table 2 Broadcast bands for television and VHF radio (band limits vary in different countries)

for fairly complex head-end equipment and the unpopularity of having to use non-standard receivers or adaptor boxes has rendered HF systems obsolete, and no new systems of this type are being constructed.

VHF Distribution Systems

Radio frequency signals received at the head-end, whether VHF or UHF, are converted to frequencies in the VHF band between about 45 and 225 MHz and these signals are fed to the distribution network which is made up from co-axial cables.

The main reason for VHF conversion is economy. Losses where UHF signals are distributed by cable are great and repeaters must be placed quite close together. VHF signals, on the other hand, are attenuated less so repeaters are spaced further apart: typically a kilometre or so between. Consequently, VHF distribution is used most often in large CATV systems which cover extensive areas.

In the UK the actual distribution frequencies used in any particular system have to be agreed with the Department of Trade and Industry, to minimise possibility of interference to and from other users. Technical standards are laid down for immunity to interference and for radiation from cable systems. Ten channels are officially recognised for VHF distribution purposes, as shown in Table 1, although in some circumstances frequencies may be varied slightly to avoid interference. It is also possible to use special techniques to allow the distribution of more channels.

Factors other than straightforward channel usage must often be considered when allocating suitable frequencies for cable systems. As an example, normal television receivers in use in the UK are not fitted with VHF tuners and can therefore only receive UHF band

IV and V signals. Selectivity of these receivers is generally so poor as to be totally inadequate for adjacent channel and image channel operation: there is so much local oscillator radiation that operation on channels even just five channels away from the wanted one is impracticable, as an adjacent receiver may be radiating significant quantities of local oscillator signal on a frequency of 39.5 MHz (the usual IF in the UK) above that of the wanted channel, which is likely to interfere with any signal at 40 MHz (equivalent to 5 UK television channels) from the wanted frequency.

Television sound transmissions are allocated carrier frequencies 6MHz above the vision frequencies. VHF cable distribution services normally also provide a choice of VHF sound radio programmes which are distributed on their original band II VHF frequencies. The European over-air channel allocations for bands I, II, III, IV, and V are detailed in Table 2.

In the USA the spectrum from 54 to 400 MHz is divided into different segments, and such an arrangement is often referred to by just its upper frequency limit, so that a system might be called a 400 MHz system, alternatively it might be called a 52 channel system.

Similarly, a system with an upper frequency of 300 MHz is sometimes called a 35 channel system. The channels numbered 2 to 13 inclusive are frequently known as the standard VHF channels since these were first to be used, the others being later additions. These standard channels also have the advantage that they can be received on any standard television receiver without a convertor box. This is a powerful economic argument for cable operators to restrict a system to 12 channels. It is also worth noting that the original twelve channels were chosen in such a way as to minimise potential interference caused by intermodulation products generated by the multiple signals. Adding the extra channels has made life far more complicated when trying to minimise the various possible forms of intermodulation interference.

A fairly simple method of providing more than twelve channels without becoming involved in all manner of frequency-extension problems is to put two cables, each capable of carrying 12 channels, around the network instead of one. The two cables work completely independently of one another, but each carries a different set of twelve programmes on the same standard frequency channels from 2 to 13. The customer has a two-way switch in his home, which allows his receiver to be connected to either of the two cables, thus doubling his choice of programme material. This system is widely used in the United States, although it is rare for the maximum possible 24 programme channels to be provided, because in many areas there are a few strong off-air transmissions on VHF frequencies which can sometimes interfere with certain of the cable channels. It is therefore wise to avoid using these channels for cable distribution and in practice, a maximum of about twenty programme channels are normally offered.

Other advantages of the dual cable system are that once the simple and cheap two-way switch has been installed the viewer can receive all the programmes on a standard receiver, whereas if an extended frequency band is used convertors are required costing the operator and, ultimately, the customer money. The dual cable system can also cope with those customers who don't want, or aren't prepared to pay for more than the original twelve channels. Although the second cable cannot really be considered as a back-up system for the first as both carry different programme material, if problems do develop in one of the cables, a restricted service can

still be maintained to customers. This should keep viewers far happier than if they are left totally without a service, and it also gives the cable operator a breathing space to carry out repairs or essential maintenance, without having to shut down the system completely.

The dual-cable system has become so popular

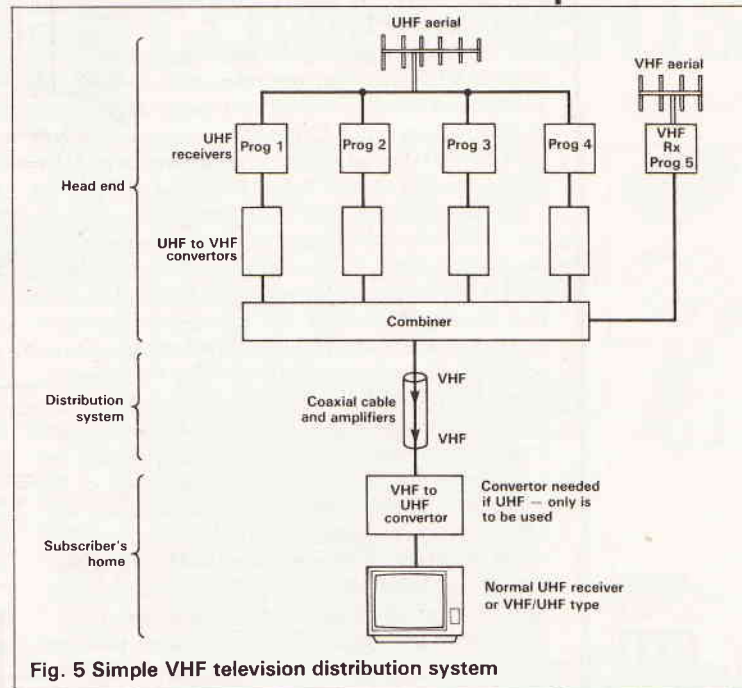

Fig. 5 Simple VHF television distribution system

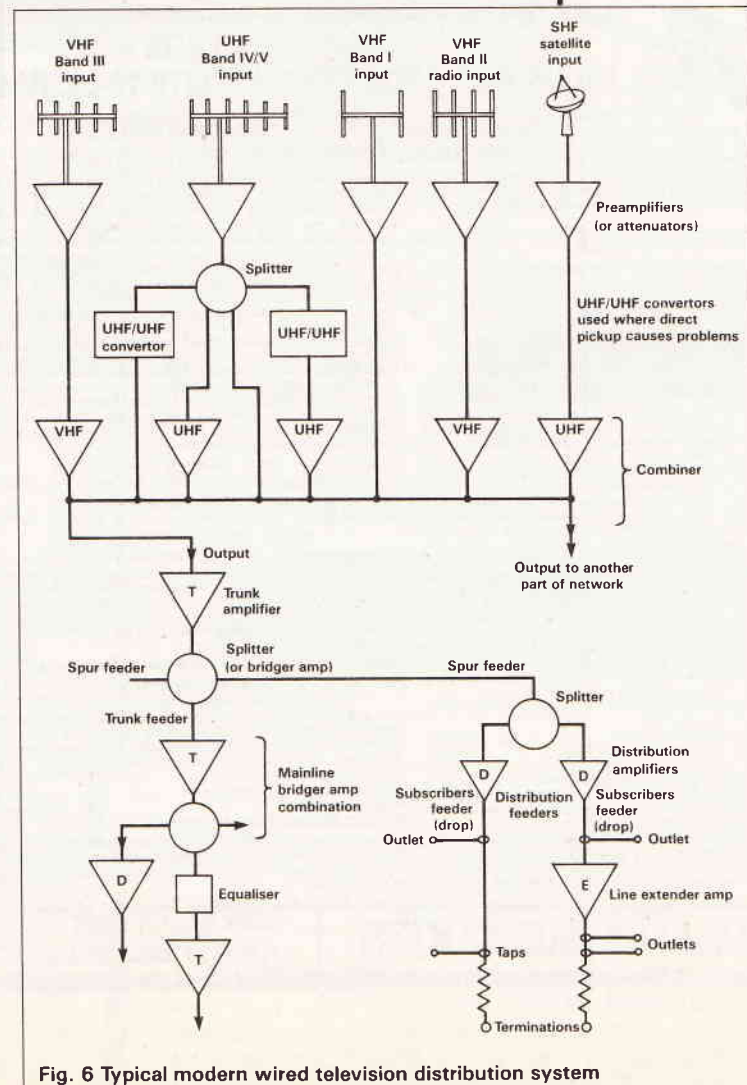

Fig. 6 Typical modern wired television distribution system

with cable operators because of its lack of technical complications that many consultants now recommend two cables should be put into any system using underground cable ducts, right from the start of building a network. The argument goes that cost of the extra cable is minute in comparison with the costs of digging up the ground to insert larger ducts, or even of having to pull extra cables into existing ductwork, should the system need to be extended at any future date. Even though the operator of a new network may have no intention of ever increasing its capacity, history has shown a growing demand for more channels, and a little forethought can save a great deal of money in the long run.

Since the beginning of 1985 there have been no over-air VHF television transmissions in the UK, and portions of bands I and II have been allocated to mobile radio services. Other European countries will continue to transmit television programmes on VHF bands I and III as well as on UHF bands IV and V.

Output signals from a VHF distribution system are, of course, at VHF and although this presented no real problems in the days when dual-standard VHF/UHF receivers were readily available in the UK, now that single-standard UHF receivers are the norm it is necessary to use an adaptor, commonly called an up-converter or translator, to provide a satisfactory signal for the UHF television receiver. When up-converters are used, great care must be taken to see that signal levels available at the system outlets are maintained, as the effective dynamic range of the whole system (that is the range of signal levels with which it can cope) is reduced. In some other countries, including Austria, West Germany, and Switzerland, receivers are fitted with VHF/UHF tuners as standard, and the need for converters does not arise.

British Standard BS6330 recommends that systems using conversion to VHF to overcome the

problems of cable losses over long transmission systems should be designed to reconvert the signals back to UHF at local distribution points, using channels that are not in use for local off-air signals. Such a reconversion allows standard UHF only receivers to be used. The television distribution system shown in Fig. 5 shows the basics of a typical present-day VHF wired network.

Even in large CATV systems the demarcation lines between VHF and UHF are less rigid than was formerly the case, and although the increase in cable attenuation at the higher frequencies makes operation at frequencies above about 450MHz significantly more expensive, some modern systems do make use of the whole of the VHF and the UHF spectrum, right up to about 860MHz. A system in Vienna goes as far as using twin cables each carrying VHF signals in the range of 47-300MHz for the relatively long distance trunk feeders, but converts these signals in substations so that all the signals are available to subscribers over just one cable, which carries as many as 18 TV and 14FM radio signals in the frequency band from 47 to 860MHz.

Layouts of modern UHF systems and VHF systems are almost identical, apart from use of converters at head-ends and viewers' homes, and the greater distances between repeater amplifiers when VHF is used. A fairly typical modern wired system, using VHF and UHF frequencies in television distribution is shown in Fig. 6.

At the present time any such network is most likely to be built using high-quality co-axial cable as its main distribution medium; only the most forward-looking systems use fibre optic techniques.

Next month, the second part of this feature will look at the future of cable television, detailing the possible scenarios.

ETI

HART

HART AUDIO KITS — YOUR VALUE FOR MONEY ROUTE TO ULTIMATE HI-FI

HIGH QUALITY REPLACEMENT CASSETTE HEADS

HART KITS give you the opportunity to build the very best engineered hi-fi equipment there is, designed by the leaders in their field, using the best components that are available. With a **HART KIT** you have direct access to the friendly **HART** service, who are not dealing through, or paying for, any middlemen. Every **HART KIT** is not just a new equipment acquisition but a valuable investment in knowledge, giving you guided hands-on experience of modern electronic techniques. Telephone or write for our **FREE LISTS** giving full details of all our Kits, components and special offers. Here are a few selected items.

AUDIO DESIGN 80 WATT POWER AMPLIFIER



This fantastic amplifier is the flagship of our range, and the ideal powerhouse for your ultimate hi-fi system. Featured on the front cover of the May issue of 'Electronics Today International' this complete stereo power amplifier offers World Class performance with the option of a stereo LED power meter and a versatile passive front end giving switched inputs, volume and balance controls. Tape, CD players, or indeed any 'flat' input may therefore be directly connected to bypass tone controls or give a 'stand-alone' facility. The amplifier can also be supplied in 'slave' and 'monobloc' versions without the passive input stage and power meter. All versions fit within the standard 420 x 260 x 75mm case to match our 400 Series Tuner range. ALL power supplies are stabilised, the heavy current supplies using the same 'moist' devices as the amplifier. The power supply, using a toroidal transformer, is in fact a complete module contained within a heavy gauge aluminium chassis/heat-sink and fitted with EC mains input and output sockets. All the circuitry is on a proper printed circuit with low-resistance blade connectors for the six stabilised DC outputs. **HART KITS** don't leave you to fasten a few capacitors to the floor of the main chassis and wire the power supply the hard way! Remember with a **HART KIT** you get the performance you want at the price quoted through proper engineering design and the right components. We do not insult your intelligence by offering a kit at what seems a fair price and then tell you that you have to spend three times as much to get an upgraded model!

K1100 Complete Stereo Amplifier Kit with LED Power Meter and 3-input Passive Stage. Total cost of all parts is £418.88.
Our Discount Price for the Complete Kit £365.98
K1100S Stereo Slave Version, with plain Front Plate £309.43
K1100M 'Monobloc' mono version, with plain Front Plate £224.15
RLH10 Reprints of latest 'Audio Design Amplifier' articles £2.70
K1100CM HART Construction Manual with full parts lists £4.50
 Reprints and construction manual can be purchased separately and their cost credited against subsequent kit purchase.
 All versions are supplied with dual primary mains transformers for use on 220/240V or 110/115V mains. Monobloc price does not include the construction manual.
SPECIAL OFFER extended until the end of February the K1100 kit will be supplied with the new **ALPS** low noise precision pots at **NO EXTRA CHARGE**.

LINSLEY-HOOD 400 SERIES SUPER HIGH QUALITY AM/FM TUNER SYSTEM

This is the ideal companion tuner to the 80W Audio Design Amplifier in any ultimate hi-fi system with case size, front plate layout and even control pitches unified for stacking. Like the 80W Audio Design Amplifier this is your route to £K+ performance for a few tenths of the cost! Two designs by John Linsley Hood make up this combination of his ultra high quality FM tuner and stereo decoder described in 'Electronics Today International' and the Synchronome AM receiver described in 'Wireless World'. Novel circuit features in the FM section include ready built pre-aligned front end, phase locked loop demodulator with a response down to DC and advanced sample and hold steric decoder together making a tuner which sounds better than the best of the high-priced exotica but, thanks to HART engineering, remains very easy to build and set up. The Synchronome section with its selectable bandwidth provides the best possible results from Long and Medium wave channels, so necessary in these days of split programming. If you want the very best in real Hi-Fi listening then this is the tuner for you. Since all components are selected by the designer to give the very best sound this tuner is not cheap, but in terms of its sheer sound quality it is incredible value for money. To cater for all needs AM only and FM only versions are available as well as the full AM/FM model, with any unit being upgradable at any time. For further details see our full illustrated lists.

K400FM FM Only Version, total cost of all parts is £211.90
 Our special Discount Price for complete Kit Only £169.52
K400AM/FM Full AM/FM version, Discount Price for complete Kit £249.08

STUART TAPE RECORDER CIRCUITS

Complete stereo record, replay and bias circuit system for reel-to-reel recorders. These circuits will give studio quality with a good tape deck. Separate sections for record and replay give optimum performance and allow a third head monitoring system to be used where the deck has this fitted. Standard 250mV input and output levels. These circuits are ideal for bringing that old valve tape recorder back to life. Suitable stereo heads are available at very reasonable prices.

K900W Stereo Kit with Wound Coils and Twin Meter Drive £90.68
RJS1 Reprints of Original Descriptive Articles £2.60

LINSLEY-HOOD CASSETTE RECORDER CIRCUITS

Complete record and replay circuits for very high quality low noise stereo cassette recorder. Circuits are suitable for use with any high quality cassette deck. Switched bias and equalisation to cater for chrome and ferric tapes. Very versatile and easy to assemble on plug-in PCBs. Complete with full instructions.

Complete Stereo Record/Player Kit £57.60
VU Meters to suit £3.99 each
RLH1 & 2 Reprints of Original Articles £2.70

Our latest lists also give details of our ranges of specialist high quality AUDIO CONNECTORS and LEADS, cassette decks and seasonal special offers. Write or telephone for your **FREE** copy. (Overseas 2 IRCs please, or 5 for Airmail.)



Do your tapes lack treble? A worn head could be the problem. Fitting one of our replacement heads could restore performance to better than new! Standard inducances and mounting make fitting easy on nearly all machines and our TC1 Test Cassette helps you set the azimuth spot on. As we are the actual importers you get prime parts at lower prices, compare our prices with other suppliers and see! All our heads are suitable for use with any Dolby system and are normally available ex stock. We also stock a wide range of special heads for home construction and industrial users.

HS16 Sennat Alloy Stereo Head, High quality head with excellent frequency response and hyperbolic face for good tape to head contact £17.86
HC40 NEW RANGE High Beta Permalloy Stereo head, Modern space save design for easy fitting and low cost. Suitable for chrome metal and ferric tapes, truly a universal replacement head for hi-fi decks to car players and at an incredible price too! £6.65
HX100 Special Offer Stereo Permalloy Head £2.86
HRP373 Downstream Monitor Stereo Combination Head £44.39
HQ551 4-Track Record & Play Permalloy Head for auto-reverse car players or quadraphonic recording £16.79
HS24 Standard Erase Head £2.59
SH166 2/2 AC Erase Head, Standard Mount £12.60
HS9510 2/4 Stereo DC Erase Head £8.70
HQ751E 4/4 AC Erase Head, tracks compatible with HQ551 £57.06
 We can supply card reader heads for OEMs at very keen prices.

REEL TO REEL HEADS

999R 2/4 Record/Play 110mH, Suits Stuart Tape Circuits £13.34
998E 2/4 Erase Head 1mH, Universal Mount, Suits Stuart £11.96

TAPE RECORDER CARE PRODUCTS

HART TC1 TEST CASSETTE Our famous triple purpose test cassette. Sets tape azimuth, VU level and tape speed £5.36
DEMI Mains Powered Tape Head Demagnetiser, prevents noise on playback due to residual head magnetisation £4.08
DEM115 Electronic, Cassette Type, demagnetiser £8.61

Our new **WINTER '89** List is **FREE**. Send for your copy now. Overseas customers welcome, please send 2 IRCs to cover surface post, or 5 for Airmail.

We now accept inland and overseas orders by post or telephone on all Access/Mastercharge and Visa credit cards.

Please add part cost of carriage and insurance as follows:

INLAND: Orders up to £20 — £1; Orders over £20 — £2.50; Next day — £9

OVERSEAS: Please see the ordering information with our lists.

QUALITY AUDIO KITS

24hr SALES LINE
(0691) 652894

ALL PRICES INCLUDE VAT

HART
 HART ELECTRONIC KITS LTD
 4 PENYLAN MILL
 OSWESTRY, SHROPSHIRE
 SY10 9AF

HENRY'S Edgware Road,
London, W2

45th ANNIVERSARY

**METEX AND TEST LAB INSTRUMENTS
YOU PAY TRADE PRICES**

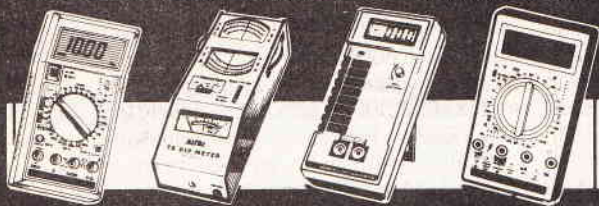

3 1/2 AND 4 1/2 DIGIT Dmms

ALL MODELS WITH CONTINUITY TEST (★ With Capacitance + Hfe test, D with 200KHZ Frequency counter)

METEX PROFESSIONAL*

3 1/2 and 4 1/2 digit Dmm's with hard carry case.

Large LCD Displays, with leads, battery and instructions. 20A AC/DC

BARGRAPH SERIES*

- M3610B 3 1/2 Digit 30 Range 0.3% (+) £46.04
- M3650B 3 1/2 Digit 30 Range 0.3% (+) £51.26
- M4650B 4 1/2 Digit 30 Range 0.05% with Data Hold (+) £78.22

AUTO RANGE SERIES*

- 3 1/2 Digit with Data Hold and Freq. Counter
- M80 21mm Display 20KHZ Counter £46.04
- M81B 17mm Display True Rms. 400 KHZ Counter £58.22
- M81BB Bargraph Version £66.04

NON-BARGRAPH*

- M3800 32 Range 3 1/2 Digit 0.5% (+) £32.13
- M3630 30 Range 3 1/2 Digit 0.3% (+) £41.70

- M4600 30 Range 4 1/2 Digit 0.05% with Data Hold (+) £52.13
- M4360 30 Range 4 1/2 Digit 0.05% with Data Hold (+) £63.43

ALSO STOCKED*

M3610, M3650, M4650, M3630B, M4630B

STANDARD SERIES

- with soft carry case 3 1/2 digit 12mm Displays
- M2315B 17 Range 10 ADC £20.00
- M2318B 23 Range 10 ADC (+) £23.72
- M2335 31 Range 10A AC/DC (+) £27.74
- M2325 32 Range 10A AC/DC (+) £30.42
- M2355 32 Range 10A AC/DC (+) £34.57
- M2365 38 Range 10A AC/DC (+) £37.25
- (2355/2365 HAVE TTL LOGIC TEST)

TEST INSTRUMENTS

- 3000 LCR AC Bridge £103.20
- M3002A AC Millivolt Meter 1MHZ £85.80
- 2020 500 KHZ Function Generator £96.50
- 4162AD 150 MHZ Fr Gen. Plus 6 Digit Counter £172.86
- 2603AD 1 MHZ Af Gen. plus 6 Digit Counter £166.16
- TE200 150 MHZ Rf Gen. (450 MHZ Harmonic) £80.00
- TE220 1 MHZ Audio Generator £81.75
- 3300 Autorange Digital Cap. Meter £64.00
- 6100 Signal Tracer/Injector £52.30
- 5250 150 MHZ 7 Digit Frequency Counter £64.50
- 0ST5M 5 MHZ Bench Scope £168.00
- 243 0/24V 0/3A Variable PSU £56.00
- 245 0/24V 0/5A Variable PSU £69.55
- 154 4/15V 0/4A Variable PSU £40.00

"POCKET" TEST INSTRUMENTS

- YF20 Dual Scale Sound Level Meter 120dB £32.85
- 225V VHS Video Head Tester £30.69
- 1065 Digital Lux Meter - 3 Ranges £46.83
- 07 Logic Probe £7.63
- M625 Logic Probe/Pulsar £14.74
- 300 AC Clamp Meter 600A/300V/Resis £33.50
- M265 Add on AC Clamp Probe for Dmm's £16.48
- 501 Electronic Insulation Tester 500V £53.25
- 504 Electronic Insulation Tester 1000V £70.88
- K0M6 TR Dip Meter 1.5 to 250 MHZ £41.88
- 1062 LCD Temperature & data hold £36.72
- 302K LCD Temperature Two 1/P £32.00
- 3900T0 LCD Dmm With Dwell And Tach Ranges 20A AC/DC £45.17
- KT50 LCD 8 Range Capacitance Meter £36.20
- 6060 LCD Digital True Power Meter 6KW 19 £64.00
- 2070 19 Range Multimeter 10ADC + Buzz £12.00
- 2030ET 27 Range 10A AC/DC. Cap Hfe Temp. Buzz £29.30
- 505DE 41 Range FET mm £26.77
- 0M5 Wallet Autorange Dmm £17.35
- 921 Pen Type Autorange Dmm £24.78
- 850 Mains Phase Tester £21.20
- 260 1000A AC Digital clamp meter £40.25
- 261 Add on insulation tester for 260 £29.35

Henry's are also instrument distributors for HAMEG, FLIGHT, ALTAI, BLACKSTAR, THURLBY, HITACHI, CROTECH, THANDAR. Phone for best prices.

Also stocked
Tools, components, CB, public address, CCTV, security, communications, TV, video, audio, computer accessories.

Prices correct at Dec 89.

TELEPHONE YOUR ORDER WITH VISA/ACCESS
OPEN 6 DAYS A WEEK FOR CALLERS

ADD 15% VAT
(UK ONLY)

HENRY'S AUDIO ELECTRONICS

404 Edgware Road, London W2 1ED
Instruments/Audio 01-724 3564
Security/Communications/CCTV 01-724 0323
Components 01-723 1008 Fax. 01-724 0322
Trade/Education/Export 01-258 1831

(Please note - from 6 May, 1990 the 01 Code changes to 071)

CATALOGUES IN COLOUR

- Instruments
- Security
- Supplements
- Components
- Ask Henry's first
- £1 for callers large SAE £2 stamp UK by post. Free UK Education with Trade Prices

When you need COMPONENTS...

(C.W.O. Post Free U.K.)



You need



Starting with the

FREE 1990 134 PAGE CATALOGUE

WRITE

Electrovalue Ltd, FREEPOST, 28a St Jude's Rd, Englefield Green, Egham, Surrey TW20 8BR (No stamp needed)

PHONE

0784 433 603 • FAX 0784 435216

CALL

Either shop 9.00-5.30pm (Sat 9.00-1.00pm)

NORTHERN BRANCH

680 Burnage Lane, Manchester M19 1NA
Phone 061 432 4945 • Fax 061 432 4127

No postage to pay on UK CWO orders. Access/Visa facilities (min £5). No postage to pay on written enquiries for catalogue when marked Electrovalue Ltd, FREEPOST, 28a St Jude's Rd, Englefield Green, Egham, Surrey TW20 8BR

DESIGNING POWER SUPPLIES

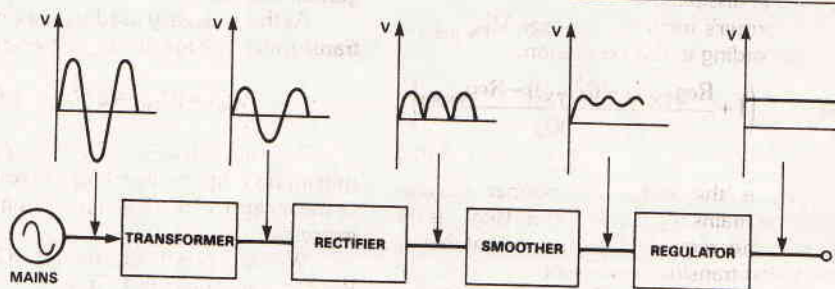

Fig. 1 Block diagram of a power supply showing waveforms at various stages

Often taken for granted, power supplies form the heart of most projects. Mike Bedford shows you how to design your own.

Purpose of a power supply is to convert a mains supply (240V AC in the UK) to a lower DC voltage or voltages. Simply, this involves four basic steps (1) transforming to a lower voltage (2) rectifying (3) smoothing (4) regulating. Figure 1 is a block diagram of a power supply, showing how these steps relate and waveforms at relevant points.

Input power is from a mains source. A transformer changes the 240V supply to a lower voltage, still of an AC nature; the difference is shown in the waveforms in Fig. 1. After rectification the waveform appears as a series of humps, each hump corresponds to one half cycle of the original AC voltage. Rectification is usually performed with diodes. Although the waveform is now of a DC voltage, it is too irregular to be useful and so must be smoothed, generally using a capacitor, to give a more level DC voltage. This value is, however, rather dependent on the current drawn from the circuits at this point so regulation is performed to maintain a constant DC voltage.

The Transformer

A transformer simply converts one AC voltage to another depending on the ratio of the number of turns on the primary and the secondary windings. For a particular mains voltage a transformer is specified according to its power rating, the voltage and current rating of each secondary winding and the regulations. Power rating depends on the number and size of laminations which make up the core and accordingly affects size and weight. Actually, so long as the current rating of each secondary is specified and the transformer has been properly designed, we can forget about the power rating as this is simply the voltage multiplied by the current of each secondary. So, for example a transformer specified as 6VA; 0-6, 0-6; @ 0.5A has two secondary windings each of which can supply 0.5A whereas 12VA; 12-0-12; @ 0.5A specifies a transformer with a 24V centre tapped secondary with a capacity of 0.5A. This second example has effectively two 12V windings which are connected together internally to provide a centre tap.

To complete transformer specification, its regulation specifies the degree to which the secondary voltage varies according to the load. For example a 0-6V; @ 1A; 10% regulation transformer would show a secondary voltage of 6V when 1A is being drawn but this would rise to 6.6V of load. This needs to be considered when working out the maximum voltage rating of the smoothing capacitor — we'll look at this soon. Unless the transformer has some degree of

over-capacity, however, the higher voltage will not apply at the maximum output current and accordingly will not affect the regulator power rating. One other factor which may affect transformer output voltage is variation in mains voltage. In the UK this is generally taken to be 240V \pm 6%.

Touching on the mechanical aspects of transformer design, a particular electrical specification is often available in either a conventional design or as a toroid. Toroidal transformers are smaller for any given power rating but tend to be more expensive. As toroidal transformers represent a relatively new technology, however, price differential is likely to diminish.

Once the required output voltage is known it is only necessary to pick a transformer which gives this output at the required current. Clearly it doesn't matter if the current rating is greater than that required but, unless you want to make use of a transformer you already have, you'll generally select one which gives just the required current — because of size, weight and price considerations. Similarly, while there is a considerable difference in price, a conventional transformer will usually be picked in preference to a toroid unless size is an important criterion.

There are certain measures which could be considered to modify transformer outputs. The example given earlier of a 12-0-12V secondary served to illustrate how two secondaries may be connected in series to provide an output voltage equal to the sum of the two individual windings. Although in this case, the windings are commoned internally there is no reason why multiple secondaries can't be connected together externally. Take note, however, that if two secondaries are connected in series the wrong way round, the result is a voltage which is the difference between the outputs of the individual secondaries rather than their sum. In a similar vein, two secondaries may be paralleled to provide an output with a greater current capacity. Once again the way they are connected is important — to avoid the secondaries working against each other.

To take this custom adaptation further conventional and toroidal transformers are available without secondaries, so the user winds it to suit. With such a transformer, instructions are given in terms of wire gauge and number of turns to be used to achieve the required output voltages and currents. Also it's possible (with a great deal of care) to take a conventional transformer to pieces, re-wind the secondaries and re-assemble it to give a different output. We'll look at this procedure later.

Main design calculations which apply to a

transformer relate to minimum and maximum output voltages, these varying from the stated output due to transformer regulation and load and variations in mains voltage. The transformer's minimum voltage, evaluated for full load, is used for selection of the transformer; maximum voltage evaluated for zero load is used to calculate the smoothing capacitor working voltage. Maximum voltage for full load is also used to determine regulator power dissipation.

A transformer's minimum voltage $V_{TX (min)}$ is calculated according to the expression:

$$V_{TX(min)} = V_{TX} \left(1 + \frac{Reg_{TX} (1 - (I/I_{TX})) - Reg_{mains}}{100} \right) \quad \text{Eqn 1}$$

Where: V_{TX} is the stated transformer voltage; Reg_{mains} is the mains regulation factor; Reg_{TX} is the stated transformer regulation; I is the current drawn; I_{TX} is the stated transformer current.

To be accurate, the ratio I/I_{TX} in this expression should be VA/VA_{TX} . However, we are only talking of a small percentage error and the expression we'll use is much simpler as it only has $V_{TX(Min)}$ on the left hand side.

Similarly, a transformer's maximum voltage $V_{TX (Max)}$ is calculated according to the expression:

$$V_{TX(max)} = V_{TX} \left(1 + \frac{Reg_{TX} (1 - (I/I_{TX})) + Reg_{mains}}{100} \right) \quad \text{Eqn 2}$$

The Rectifier

Examples of rectifiers and corresponding output waveforms are shown in Fig. 2. The simplest possible rectifier is a single diode, shown in Fig. 2a. This merely prevents every alternative half cycle from passing and accordingly gives the output waveform shown. It is referred to as half wave rectification and obviously requires a considerable amount of smoothing so is not generally used. Figure 1b shows a full wave rectifier which obviates this problem, allowing current to pass on every half cycle and thereby giving an output which is more easily smoothed. Disadvantage of such a configuration is that it requires a transformer with a centre tapped secondary and was only really popular in the days when rectifier diodes were expensive. Figure 1c, on the other hand, shows the type of rectifier used in most applications today. The four diodes are arranged in full wave bridge configuration and give an output similar to that obtained in the two diode arrangement but with a straight transformer secondary. From now on we assume use of a bridge rectifier.

Bridge rectifiers don't normally need building up from four discrete diodes as they are available as a single unit. They are specified according to average current rating and maximum reverse voltage and are easily selected once these factors are known. Actually this is simplifying things somewhat as there are times when the currents through individual diodes are much greater than the average DC current. At switch on, for example, the smoothing capacitor is fully discharged and therefore appears as a virtual short circuit across the bridge. This is taken into account by bridge manufacturers who specify the peak one time surge current I_{FSM} of up to 50 times the average current.

Two design expressions cover the bridge rectifier, relating output voltage and current to input voltage and current. Voltage of a transformer secondary is always expressed as an RMS value, this being the average AC voltage rather than the peak level. Rectifier output voltage, on the other hand, is smoothed by a capacitor to the peak voltage which is $\sqrt{2}$ times the RMS value. The current from the bridge has passed through two diodes though and output

voltage must be decreased by two diode voltage drops. Peak DC voltage after smoothing V_{peak} can therefore be calculated from the expression:

$$V_{peak} = 1.414 V_{AC} - 2 V_D \quad 3$$

Where: V_{AC} is the AC voltage (RMS); V_D is the diode voltage drop (0.7V for silicon and 0.3V for germanium diodes).

As this is usually used to work out the required transformer voltage, it can be transposed to:

$$V_{AC} = (V_{DC} + 2 V_D) / 1.414 \quad 4$$

To stay within a transformer's VA rating its maximum output current I_{AC} is reduced by a factor of the reciprocal of $\sqrt{2}$ so this current is given by the expression: $I_{DC} = \sqrt{2} I_{AC}$

Where: I_{DC} is the maximum DC output current. We can transpose this to give:

$$I_{AC} = I_{DC} / 0.707 \quad 5$$

Smoothing Capacitor

Although the output from a bridge rectifier is unidirectional it is certainly not the steady DC voltage required by most electronic circuits. A capacitor connected across the bridge output smooths the

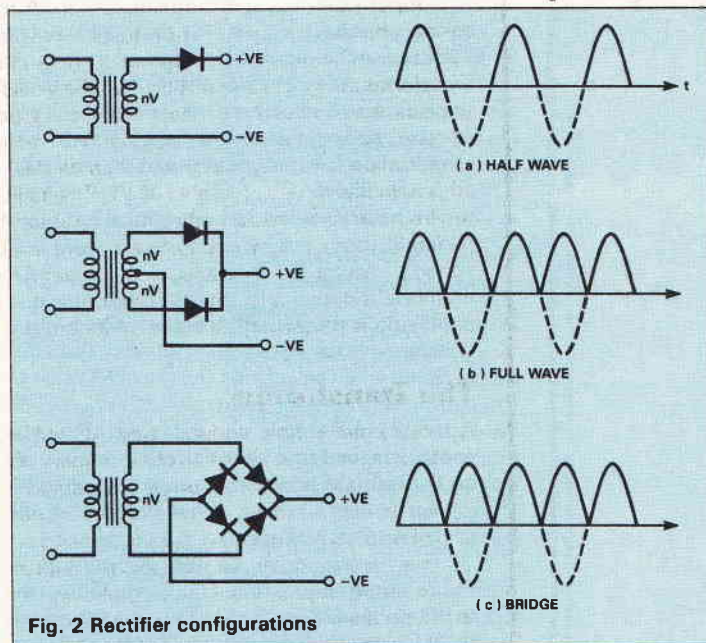

Fig. 2 Rectifier configurations

peaks and troughs of the voltage: working on the reservoir principle — it charges the capacitor during the peaks while discharging during the troughs to give an overall smoothed output. The larger the capacitor, the greater is the effect drawn from the supply, or with an infinitely large value of capacitance smoothing is perfect. In practice the resultant waveform is always similar to that shown in Fig. 3.

This assumes the capacitor charges up instantaneously. The rate of discharge on the other hand, is given by the differential expression shown. This means the minimum capacitor value C is given by the expression:

$$C = \frac{I T}{V_{peak} - V_{reg}} \quad 6$$

Where: I is the current drawn; T is the duration of the cycle which for full wave rectification is .01 s for 50Hz

Regulator

Although there are numerous regulation circuits which can be built from discrete components, the discussion here is limited to the IC regulator. This is a single component which takes in an unregulated input and regulates it to a fixed output voltage. Although other families are available, the 78-series and 79-series are the most common and will therefore be the ones considered here. The device type numbers are of the form 78*ivv* or 79*ivv* where 78 represents a positive output voltage and 79 a negative voltage, *vv* is two digits representing the magnitude of the output voltage and could be 05, 06, 75 (representing 7.5), 08, 09, 10, 12, 15, 18, 20 or 24 and *i* is either omitted in which case the device has a current rating of 1A or is L, S, T, H, J or P for 100mA, 2A, 3A, 5A, 8A or 10A respectively. It should be pointed out that some of the above voltage and current ratings are pretty rare and it's as well to stay with the most common devices (5, 12, 15 and 24V at 100mA, 1A and 5A).

Another family of useful devices is the 317 family: 317L (100mA); 317M (500mA); 317K (1.5A); 338K (5A), which are variable output positive voltage regulators. Output voltage of 317 regulators is adjusted using an external potential divider. The corresponding negative output regulator family is formed by the 337LZ (100mA) and the 337T (1.5A) regulators.

Figure 4 shows the circuit configurations for all these regulators and also shows how a fixed voltage regulator can have its output voltage modified. Capacitors C1 and C2 should be connected physically close to the regulator to aid high frequency stability. Capacitor C1, incidentally, is definitely required even though it is in parallel with the smoothing capacitor and appears to be swamped.

There are two important design considerations regarding the regulator (on top of the obvious output voltage and current considerations); the minimum input voltage required and the power dissipation. Minimum input voltage is specified in the data sheet of any specific device and is shown in Table 1 together with other characteristics of some common regulators. Power dissipation P_D affects the size of heatsink on which the regulator should be mounted (if required at all) and is equal to the product of the output current I_O and the voltage dropped across the regulator. The voltage dropped is the difference between the input voltage (average of peak and trough of ripple) and the output voltage V_{reg} . Power dissipation is calculated from the expression:

$$P_D = I_O ((V_{peak} - (V_{ripple}/2)) - V_{reg}) \quad 9$$

Where: V_{peak} is the peak DC voltage (maximum on-load); V_{reg} is the regulator stated output voltage.

Once the power dissipation is known the heatsink is to conduct heat away from the regulator in order to keep its junction temperature below the maximum stated for that device. This will be 150°C for most regulators. Heat conduction is measured in degrees per watt and a heatsink should be selected such that the required dissipation of the junction θ_{JD} is equal to the sum of the heat transfer co-efficient for the regulator junction to case θ_{JC} , the heat transfer co-efficient for the regulator case to the heatsink θ_{CH} and the heat transfer co-efficient for heatsink to air θ_{HA} .

Required heatsink dissipation also calculated from the expression:

$$\theta_D = \frac{T_J - T_A}{P_D}$$

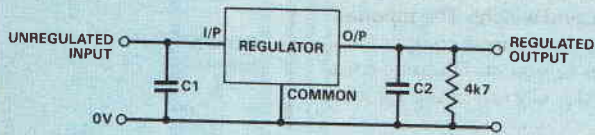

(a) FIXED VOLTAGE 78 & 79 SERIES

	$\geq 5A$	OTHERS
C1	1u0	220n
C2	100n	470n

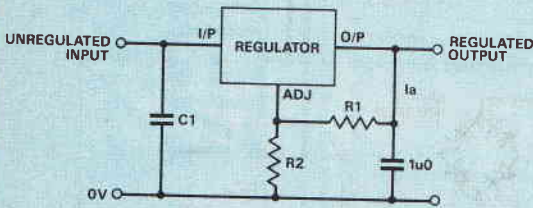

(b) LM317, LM338 & LM337 VARIABLE VOLTAGE REGULATORS

$$V_{out} = 1.25 (1 + R2/R1)$$

C1 (LM317/LM338) = 100n
C1 (LM337) = 1u0
 $I_a \geq 4mA$

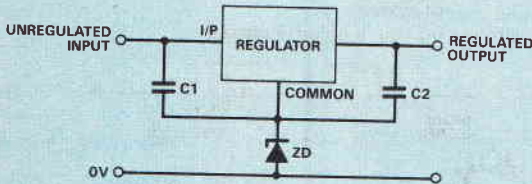

(c) INCREASING VOLTAGE OF 78 & 79 SERIES FIXED VOLTAGE REGULATORS

$$V_{out} = V_{reg} + V_{zener}$$

Fig. 4 Typical voltage regulator circuits using integrated circuit regulators

or 0.0833 for 60Hz; V_{peak} is the peak DC voltage (minimum on-load); V_{reg} is the minimum stated input voltage to the regulator.

In practice, the actual capacitor value should always be the next highest preferred value. This being the case the amount of ripple voltage will be less than the maximum permissible calculated from expression 7. The ripple voltage V_{ripple} is given by the following expression which is really just a transposition of 7:

$$V_{ripple} = IT / C_{actual} \quad 7$$

Where; C_{actual} is the actual capacitor value used.

Tolerance of the smoothing capacitor shouldn't be neglected when calculating the required value as this could easily be in the order of -10% to +30% for capacitors of the type and value which will be employed. The fact that the transformer secondary voltage rises off load according to its regulation factor should be borne in mind when calculating the capacitor's working voltage.

A final design point on the capacitor is its maximum ripple current rating I_{ripple} . By Ohm's law this is the ripple voltage divided by the capacitor's reactance, given by the expression $1/2\pi fC$. This gives a peak value and, as the waveform of the ripple is virtually a sawtooth, should be divided by $\sqrt{3}$ to give an RMS value. Taking all these together gives the following expression:

$$I_{ripple} = \frac{V_{ripple} 2\pi f C_{actual}}{\sqrt{3}} \quad 8$$

Where: f is double the mains frequency.

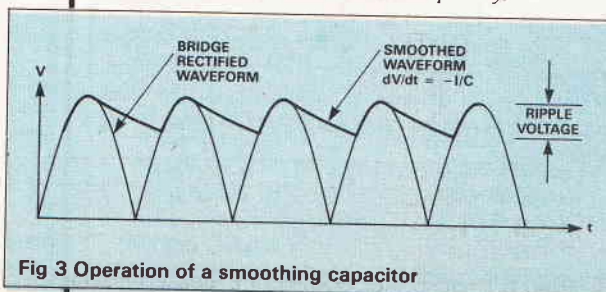

Fig 3 Operation of a smoothing capacitor

Where: T_J is the maximum junction temperature; T_A is the ambient temperature.

This means that the heatsink size is given by the expression:

$$\theta_{H-A} = \frac{T_J - T_A - \theta_{J-C} - \theta_{C-H}}{P_D} \quad 10$$

Values of θ_{J-C} and T_J are functions of the regulator and are listed in the data sheet and Table 1 while θ_{C-H} may be considered to be a constant 2.0°C/W assuming use of a mica washer (for electrical isolation) and heatsink compound (for heat condition). This leaves T_A which will probably reach 50°C inside an enclosed cabinet but may be reduced by use of extra ventilation or a fan. Clearly, reduction of this temperature will reduce the heatsink requirements.

Overall Design

Figure 5 shows two standard power supply circuits. Figure 5a is the circuit of the single polarity output power supply considered in this article. In passing, a dual polarity version is shown in Fig. 5b but we'll say nothing more about it as all component values will be calculated similarly. The design process involves calculating values of each component in this circuit within the constraints of size, weight and cost.

Let's say we require a 5V, 4A supply. First of all the rectifier, as the easiest component, is specified — a 5A version is chosen.

Choice of regulator is also simple. From Table 1 we can see the required type is a 78H05, this being the one which gives 5V at up to 5A. From its data sheet (and Table 1) we see the minimum regulator input voltage required is 8V. So, from expression 4, the minimum transformer output voltage is determined:

$$V_{AC} = 8 + 2 \times 0.7 / 1.414 = 6.65V$$

Also, from expression 5, the transformer output current is determined:

$$I_{AC} = 4 / 0.62 = 5.656A$$

We now have a bit of a chicken and egg situation as we try to determine the stated transformer voltage which ensures the 6.65V AC minimum output voltage is achieved. Expression 1 determines this, but transformer current rating and regulation both appear on the right hand side and this isn't known until we have selected the transformer which, of course, is the whole purpose of using the expression in the first place!

Now if the power supply is to be as small as possible, a home-wound transformer is needed. At this point it's now necessary to carry out a tabulation exercise.

For a range of possible transformer nominal output voltages, calculating; the minimum on-load DC voltage and thereby the smoothing capacitor value; the maximum on load DC voltage and thereby the regulator power dissipation and heatsink requirement; the maximum off-load DC voltage and hence the smoothing capacitor working voltage. The nominal voltage which gives the most acceptable combination of smoothing capacitor and heatsink (these being the other large components) may then be selected. Fortunately, for most power supplies, size is not critical so available transformers may be used. For this example power supply a 0-9, 0-9V; 3.3A, 60VA, 13% regulation toroidal transformer is suitable. Initially this appears to break the rule suggested earlier

of using a conventional transformer if the application does not demand low size and weight. The rationale behind the choice is that the nearest conventional transformer is of a 100VA design and thereby costs more than the 60VA toroid. Choice of the toroidal transformer is confirmed using expression 1:

$$V_{TX}[\min] = 9 \left(1 + \frac{13(1 - 5.656/6.6) - 6}{100} \right) = 8.63V$$

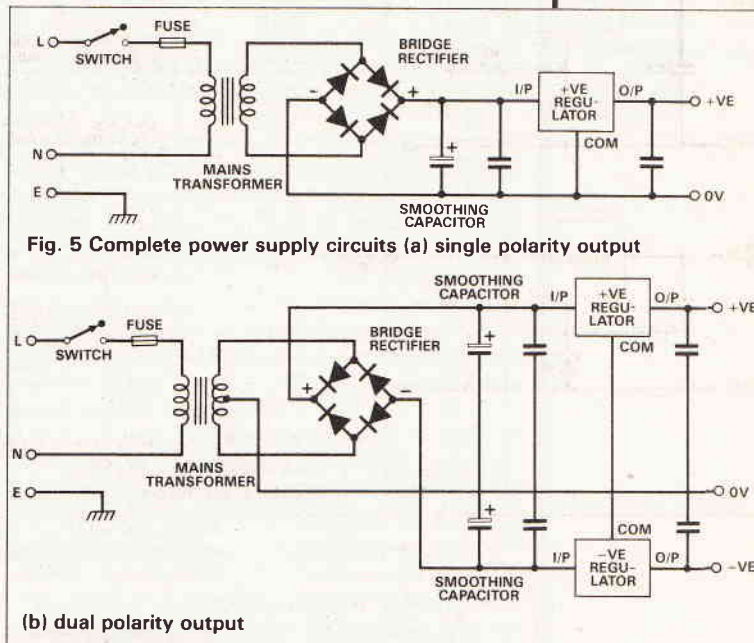

Fig. 5 Complete power supply circuits (a) single polarity output

(b) dual polarity output

This result, 8.63V, is indeed significantly greater than the 6.65V required. Also, of course, the paralleled secondaries give 6.6A which is greater than the required 5.656A.

The next step is to calculate the DC voltage which this transformer will give after full wave rectification. This is given from expression 3:

$$V_{\text{peak}} = (1.414 \times 8.63) - (2 \times 0.7) = 10.8V$$

We now calculate the smoothing capacitor value using expression 6:

$$C = (4 \times 0.01) / (10.8 - 8.0) = 0.014F = 14,000\mu\text{F}$$

and the working voltage is the maximum off-load voltage which is calculated using expressions 2 and 3:

$$V_{TX}[\max] = 9 \left(1 + \frac{13(1 - (0/6.6)) + 6}{100} \right) = 10.71V$$

$$V_{\text{peak}} = (1.414 \times 10.71) - (2 \times 0.7) = 13.74V$$

	TO220 or TO202	PIN VIEW TO92	PIN VIEW TO3
78 -	I/P COM O/P	I/P COM O/P	O/P COM I/P
79 -	COM I/P O/P	O/P I/P COM	
SI7/33B	ADJ O/P I/P	I/P O/P ADJ	I/P O/P ADJ
337	ADJ I/P O/P	I/P O/P ADJ	

Table 1 Common integrated circuits voltage regulator specifications

Device	Output (V)	Current (A)	Min I/P (V)	T _J (Max) (°C)	θ _{J-C} (°C/W)	Max P _D (W)	Package type
78L05	+5	0.1	+7.0	150	180	*	TO92
7805	+5	1	+7.0	150	3	*	TO220
78H05	+5	5	+8.0	125	2.5	50	TO3
79L05	-5	0.1	-7.0	150	180	*	TO92
7905	-5	1	-7.0	150	3	*	TO220
78L12	+12	0.1	+14.5	150	180	*	TO92
7812	+12	1	-14.5	150	3	*	TO220
78H12	+12	5	+15.0	125	2.5	50	TO3
79L12	-12	0.1	-14.5	150	180	*	TO92
7912	-12	1	-14.5	150	3	*	TO220
78L15	+15	0.1	+17.5	150	180	*	TO92
7815	+15	1	+17.5	150	3	*	TO220
78H15	+15	5	+18.0	125	2.5	50	TO3
79L15	-15	0.1	-17.5	150	180	*	TO92
7915	-15	1	-17.5	150	3	*	TO220
317L	+1.2 to +37	0.1	+4 to +40	125	160	0.625	TO92
317M	+1.2 to +37	0.5	+4 to +40	125	12	7.5	TO202
317T	+1.2 to +37	1.5	+4 to +40	125	4	15	TO220
317K	+1.2 to +37	1.5	+4 to +40	125	2.3	20	TO3
338K	+1.2 to +32	5	+4 to +35	125	1	50	TO3
337LZ	-1.2 to -37	0.1	-4 to -40	125	160	0.625	TO92
337T	-1.2 to -37	1.5	-4 to -40	125	4	15	TO220

* = Power Dissipation not listed but internally limited.

Looking through component catalogues, a 22,000µF, 63V capacitor at first sight appears to suit. This is well inside the minimum value so we can forget about capacitor tolerance. As a final check, however, we need to calculate the ripple current which is stated as 14.4A for this component. Using expressions 7 and 8:

$$V_{\text{ripple}} = 4 \times 0.01 / 0.022 = 1.8V$$

$$I_{\text{ripple}} = 1.8 \times 2\pi \times 50 \times 0.022 / \sqrt{3} = 14.36A$$

The regulator itself is already chosen so the only remaining component to specify is the heatsink onto which it will fit. First we use expressions 2 and 3 again, this time to calculate the maximum on-load peak DC voltage:

$$V_{\text{TX}}[\text{max}] = 9 \left(1 + \frac{13(1 - (5.656/6.6)) + 6}{100} \right) = 9.71V$$

$$V_{\text{peak}} = (1.414 \times 10.71) - (2 \times 0.7) = 12.33V$$

Now from expression 9 we can evaluate the regulator power dissipation:

$$P_D = 4 \times (12.33 - (1.8/2) - 8) = 13.72W$$

Finally, equation 10 gives us the heatsink size:

$$\theta_{\text{H-A}} = \frac{125 - 50}{13.72} - 2.5 - 2.0 = 1.0^\circ/W$$

The next best available nearest preferred value of 0.9°C/W is chosen.

Modifying Transformers

Frequently, the ideal transformer is not available off the shelf, or where it is available it may prove expensive. Now, although it wouldn't make sense in any volume production, it's possible to modify

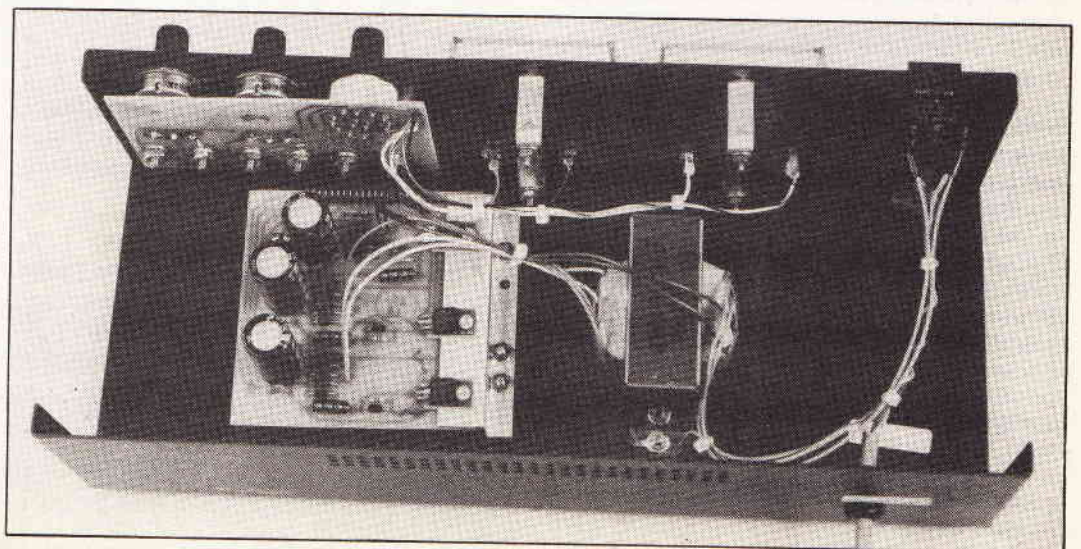

transformer secondaries. For a one-off power supply, modifying a surplus transformer can give a very cost effective solution.

First, a few guidelines. Power rating of a transformer depends on its mass, that is the number of laminations, and cannot be changed. This being so, the secondary shouldn't be modified with the aim of loading it more heavily. Voltage output may be increased by increasing the number of turns but a smaller current is the consequence. Alternatively, the secondary may be completely rewound with thicker wire but then fewer turns may be wound and the output voltage will be decreased. If secondary voltage is to be increased, do this in moderation as a significant increase could result in insulation problems. Final basic guideline is that primary windings should be left well alone — changes should be to the secondary only.

A basic rule in modifying (or winding for the first time) transformers is:

$$\frac{V_{sec}}{V_{prim}} = \frac{T_{sec}}{T_{prim}}$$

Where: V_{sec} is the secondary voltage; V_{prim} is the primary voltage; T_{sec} is the number of secondary turns; T_{prim} is the number of primary turns. So, for a fixed primary, the secondary voltage is proportional to the number of turns on the secondary. For the purpose of this calculation, secondary voltage is considered to be the off-load voltage.

Now for the practical aspects of the operation. The first and most difficult task is to remove the bobbin on which the primary and secondary windings are wound from the core. The core which surrounds the bobbin is a sort of figure-of-eight pattern made up of iron laminates which are usually in the shape of Es and

Is stacked alternately. Laminates in the shapes of Us and Ts are occasionally used. This operation is carried out by first holding the transformer by its core in a vice (but not in the direction which would serve to clamp them even more firmly together). Then, with a flat bladed screwdriver, a hammer and a pair of fine nosed pliers, prize the first laminate off. Next prize the second laminate from the opposite side. Now, alternately prize laminates off — the procedure will get easier as you work towards the middle.

Main objective in all this is to get the laminations out undamaged. The first couple will inevitably get bent but as the chances of getting every last one back in are pretty remote, this probably doesn't matter too much.

The bobbin now being free, the layer of lacquered paper or tape should then be removed to expose the secondary windings. At this point you'll see the method of attaching the leads to the windings this should be adhered to for all new leads created. The next step is to remove the secondary, coiling it neatly as it is un-wound and, most important, counting the turns. When this task is complete calculate the number of turns required for the new windings and the positions of any taps. Carrying out re-winding in the reverse order.

Next, protect the windings with a few layers of insulating tape and a good coat of lacquer or varnish.

Finally, put back the laminations. Although this is a tricky task, do persevere and try to get as many as possible back in. Although missing out a few laminations will only have a marginal effect on the power rating and regulation, it will make the finished transformer emit a significant 50Hz audible buzz. As a final precaution against such an eventuality the laminates should be liberally covered in varnish and well dried out.



C.A.D. SOFTWARE MADE EASY

ISIS SCHEMATIC CAPTURE

An exceptionally easy way to draw circuit diagrams on your PC. Once the design is on the computer, you can generate a parts list, perform an electrical rules check, extract a netlist for PCB design and/or simulation, print hard copy on a wide range of printers and plotters, or else export it to a DTP package to create professional quality documentation.

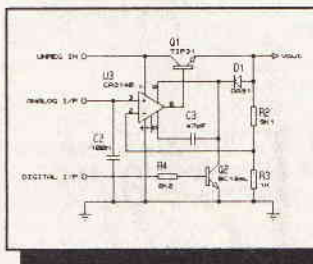

- Auto wire routing.
- Auto dot placement.
- Auto name generator.
- Powerful editing facilities.
- Object oriented 2D drawing with symbol library.
- Support for hierarchical and multi-sheet designs.
- Comprehensive device libraries.
- Output to dot matrix, pen plotters or lasers.

PC-B PRO/AR PCB DESIGN

User friendly PCB layout software with optional auto-router. The layout editor (PC-B PRO) handles 2 copper layers plus overlays and solder resists whilst the auto-router (PC-B AR) will route single or double sided boards on a 25 or 50 thou grid. Together with ISIS, you have an integrated design system that really puts your computer to work.

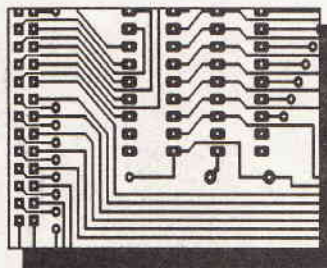

- Auto generation of silk screen/overlay as components are placed.
- Auto generation of solder resists.
- Configurable object sizes.
- On screen overview display.
- On screen pin numbering.
- Connectivity highlight.
- Back netlist verification against schematic.
- Dot matrix, laser, pen plot and Gerber drivers.

labcenter
Electronics

PRICES

ISIS	£399
PC-B (entry level PCB CAD)	£69
PC-B PRO	£229
PC-B PRO/AR	£399
ISIS+PC-B PRO	£599
ISIS+PC-B PRO/AR.....	£749



Call for **FREE** demo disks - 0274 542868.



14 Marriner's Drive, Bradford. BD9 4JT

THE RTC MONITOR II

100 WATT SPEAKER KIT £60.00 +£3.50 P&P (pair)
RESPONSE: 55Hz-20kHz

BASS POLYMER CONE D: 22cm
DOME TWEETER: 14mm

OVERALL SIZE
(HWD): 382,252,204mm

RECOMMENDED AMP POWER:
10-100 watts per channel

The performance standard achieved in this compact design is distinctively superior to anything else available at the price. The drive units used are of sophisticated design and have been carefully integrated with a Complex Crossover.

Stereo performance is exceptionally good with a well focussed sound stage and sharp resolution of detail. Distortion throughout the frequency range is low even at quite high power input and this gives a great sense of dynamic range and openness especially when used in bi-wired mode.

Supplied with:— 2 READY CUT BAFFLES, ALL CROSSOVER COMPONENTS, 2 BASS MID-RANGE, 2 DOME TWEETERS, HOOK UP WIRE, GRILLE CLOTH, SCREW TERMINALS AND SCREWS.

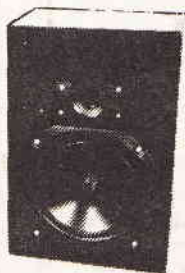

GOODMANS 60W CAR GRAPHIC



As new condition but have been returned by customers or shops, so they may need some attention. Hence the price of only £8.00 each. Order six of these units and you get the seventh one free. Postage £2.90

LCD DIGITAL MULTI TEST METER AC DC

Volts resistance and DC Amps. Most of these units are new but have been returned or rejected by the store and sold with all faults at £11.00 each. Postage £1.00. (Made by Ross Electronics).

ROSS PUSH BUTTON RADIO

Mains and battery operated. High quality VHF/FM, Medium and Long Wave reception. 6 pushbutton selected preset stations. Fully retractable telescopic aerial. Headphone/earphone jack socket.



Size 230H x 150W x 65D.
Ref RE-5500.
Brand new.

Price £14.95
+ £2.80 P&P

EXTRACTABLE HOUSING FOR YOUR CAR STEREO * SIZE DIN E * HANDLE INCLUDED * SPACE FOR MEMORY BATTERY * 4 OR 2 SPEAKER SYSTEM.

ENABLES YOU TO REMOVE YOUR VALUED STEREO FROM YOUR CAR (WITHOUT THE AID OF A HAMMER AND CHISEL, CHAINSAW ETC). £9.95 postage £2.50

HILLS KITS IN STOCK ★ SEND FOR CATALOGUE

MAIL ORDER £1 BARGAIN PACKS BUY 20 GET 1 FREE

Please state pack(s) required

- | No. | Qty. per pack |
|--------|--|
| BP013 | 3 8"x5" Speaker 4Ω 6 watt made by E.M.I. |
| BP015B | 1 30W dome tweeter. Size 90x66mil JAPAN made |
| BP016 | 6 2200µf can type Electrolytic 25V d.c. computer grade made in UK by PHILIPS |
| BP017 | 3 33000µf 16V d.c. electrolytic high quality computer grade UK made |
| BP018 | 3 2000µf 50V d.c. electrolytic high quality computer grade made in USA |
| BP019 | 20 20 ceramic trimmers |
| BP020 | 4 Tuning capacitors, 2 gang dielectric a.m. type |
| BP021 | 10 3 position, 8 tag slide switch 3 amp rated 125V a.c. made in USA |
| BP022 | 5 Push-button switches, push on push off, 2 pole change over. PC mount JAPAN made |
| BP023 | 6 2 pole 2 way rotary switch |
| BP024 | 2 Right angle, PCB mounting rotary switch, 4 pole, 3 way rotary switch UK made by LORLIN |
| BP025 | 4 3 pole, 3 way miniature rotary switch with one extra position off (open frame YAXLEY type) |
| BP026 | 4 4 pole, 2 way rotary switch UK made by LORLIN |
| BP027 | 30 Mixed control knobs |
| BP028 | 10 Slide potentiometers (popular values) |
| BP029 | 6 Stereo rotary potentiometers |
| BP030 | 2 100k wire wound double precision potentiometers UK made |
| BP031 | 6 Single 100k multitune pots, ideal for varicap tuners UK made by PHILIPS |
| BP032 | 4 UHF varicap tuner heads, unboxed and untested UK made by PHILIPS |
| BP033 | 2 FM stereo decoder modules with diagram UK made by PHILIPS |
| BP033A | 4 6"x3/8" High grade Ferrite rod. UK made |
| BP034 | 3 AM/FM modules with diagram PHILIPS UK made |
| BP034A | 2 AM-FM tuner head modules. UK made by Mullard |
| BP034B | 1 Hi-Fi stereo pre-amp module inputs for CD, tuner tape, magnetic cartridge with diagram. UK made by MULLARD |
| BP035 | 6 All metal co-axial aerial plugs |
| BP036 | 6 Fuse holders, panel mounting 20mm type |
| BP037 | 6 In line fuse holders 20mm type UK made by BULGIN |
| BP038 | 20 5 pin din, 180° chassis socket |
| BP039 | 6 Double phono sockets, Paxolin mounted |
| BP041 | 3 2.8m lengths of 3 core 5 amp mains flex |
| BP042 | 2 Large VU meters JAPAN made |
| BP043 | 30 4V miniature bulbs, wire ended, new untested |
| BP044 | 2 Sonotone stereo crystal cartridge with 78 and LP styli JAPAN made |
| BP045A | 2 Mono Cassette Record and play heads |
| BP046 | 4 6-0-6 4VA mains transformers, PC mount UK made |
| BP047 | 1 24V 0.3VA mains power supply. Brand new boxed UK made by MULLARD |
| BP049 | 10 OC44 transistors. Remove paint from top and it becomes a photo-electric cell (or P12) UK made by MULLARD |
| BP050 | 30 Low signal transistors n.p.n., p.n.p. types |
| BP051 | 6 14 watt output transistors, 3 complimentary pairs in T066 case (ideal replacement for AD161 and 162s) |
| BP052A | 1 Tape deck pre-amp IC with record/replay switching No LM1818 with diagram |
| BP053 | 5 5 watt audio ICs. No TBA800 (ATEZ) |
| BP054 | 10 Motor speed control ICs, as used with most cassette and record player motors |
| BP055 | 1 Digital DVM meter I.C. made by PLESSEY as used by THANDAR with diagram |
| BP056 | 4 7 segment 0.3 LED display (R.E.D.) |
| BP057 | 8 Bridge rectifiers, 1 amp, 24V |
| BP058 | 200 Assorted carbon resistors |
| BP059 | 1 Power supply PCB with 30V 4VA transformer. MC7818CT IC & bridge rectifier. Size 4"x2 3/4" |
| BP061 | 5 6.35mm Mono jack plugs |
| BP063 | 5 6.35mm stereo switched jack sockets |
| BP064 | 12 Coax chassis mount sockets |
| BP065 | 1 3mtr Euro-mains lead with chassis socket |

30+30 WATT AMPLIFIER KIT



An easy to build amplifier with a good specification. All the components are mounted on the single P.C.B. which is already punched and backprinted.

■ 30W x 2 (DIN 4 ohm)
■ CD/Aux, tape I, tape II, tuner and phono inputs.

■ Separate treble and bass
■ Headphone jack

Size (H.W.D.) 75x400x195mm

Kit enclosed: case, P.C.B., all components, scale and knobs £36.80, post £3.50
(Featured project in *Everyday Electronics* April 1989 issue). Reprint Free with kit.

TV SOUND TUNER



In the cut-throat world of consumer electronics, one of the questions designers apparently ponder over is "Will anyone notice if we save money by chopping this out?" In the domestic TV set, one of the first casualties seems to be the sound quality. Small speakers and no tone controls are quite common and that really is quite sad, as the TV companies do their best to transmit the highest quality sound. Given this background a compact independent TV tuner that connects directly to your Hi-Fi is a must for quality reproduction. The unit is mains operated. This TV SOUND TUNER offers full UHF coverage with 5 pre-selected tuning controls. It can also be used in conjunction with your video recorder.

£29.50 + £2.50 p&p

As above but with built-in stereo headphone amplifier for the hard of hearing

£35.90 + £2.50 p&p

TV SOUND TUNER KIT £11.50+£1.30 P&P

All parts including Varicap tuner, mains transformer, PCB with IC's capacitors and coils etc., to build the unit illustrated above; without case and scale.

SHURE HIFI STEREO MAGNETIC CARTRIDGE

Fitted with an elliptical diamond stylus supplied with fitting kit and instructions. A good quality unit made to sell for well over twenty pounds due to scoop purchase, we are able to offer these at a fraction of the manufacturers price. All units are brand new and boxed. £7.20 each. If you order in multiples of five you get one free. Postage £1.30 (Made in U.S.A.)

KOSS MINI SPEAKERS

Use instead of headphones on your personal stereo, just plug in instead of headphones. Koss sound cells can be mounted on top of your personal stereo with the holder supplied or simply detach for shelf mounting. This quality unit was made to sell for over seventeen pounds by the KOSS professional headphone company of the U.S.A. Due to a massive scoop purchase we can offer these units for £4.30 each or buy in multiples of ten and you get one free. Postage £1.50.

KOSS STEREO HEADPHONES

High quality light weight stereo headphones fitted 3.5mm jack with adaptor to 6.4mm jack. Ideal use HiFi or personal stereos made to sell for nine pounds. Our price for this unit £4.25. Postage 60p.

Hi-Fi stereo cassette deck transport mechanism, complete with 3 digit rev counter and tape heads, 12V d.c. operation. Unused manufacturers surplus JAPAN made

£6.20 + £1.50 P&P 2 for £10 + £2.50 P&P

MULTIBAND RADIO

VHF 54-176 MHz + AM CB BANDS 1-80

Listen to: AIR TRAFFIC CONTROL,

AIRCRAFT, RADAR

PUBLIC UTILITIES

RADIO AMATEURS AND

MANY MANY MORE

£17.95

POSTAGE

£2.85

SQUELCH CONTROL

"RUBBER DUCK AERIAL"

RADIO AND TV COMPONENTS ACTON LTD

21 HIGH STREET, ACTON LONDON W3 6NG

MAIL ORDER TERMS, POSTAL ORDERS and/or CHEQUES with orders.

Orders under £20 add £1.00 service charge. Nett monthly accounts to

Schools, Colleges and P.L.C. only ACCESS VISA Phone orders between

9.30 & 12pm please. Overseas readers write for quote on delivery

Phone: 01 723 8432 or 01 992 8430

Callers: 323 Edgware Road, London W2

SOLAR POWERED WOODEN MODELS

ATTRACTIVE AND EDUCATIONAL



Now you can experiment with solar energy—the energy source of the future!

Our solar powered static wooden model kits are designed to let you build your own models. Everything is supplied.

A set of pre-cut and marked plywood, PVA cement, instruction sheet, solar cell module, a "music" IC (for the gramophone model) or a small d.c. motor (for the helicopter and aeroplane models), connecting leads and sandpaper.

Helicopter with motor
£8.40 plus £1 p&p

Aeroplane with motor
£8.40 plus £1 p&p

Gramophone model with "music" IC
£8.40 plus £1 p&p

SPECIAL OFFER — BUY ALL THREE and get the postage FREE

ELEMENTS OF RADIO

Part 2

In essence, the superhet receiver uses a high gain radio frequency amplifier tuned to a specific fixed operating frequency (called the Intermediate frequency or IF), while the wanted incoming signal is converted into this chosen frequency for the bulk of the pre-demodulator RF amplification.

Biggest problem with this technique is that when the incoming signal frequency is mixed with a local oscillator signal, both sum and difference frequencies will be produced, so that there are two possible frequencies which can be received at the same time: the desired signal and the unwanted *second channel* or *image* frequency.

The only practical answer to this problem is to ensure that there is adequate selectivity between the aerial input and the mixer, so that the unwanted one of this sum and difference pair can be rejected.

most commonly used second IF value, and bandpass filters with almost any required bandwidth are available for use at this frequency. We'll look at these later. Meanwhile, in contemporary SW band receivers, first IF values as high as 55MHz are often used, to push the image frequency right out of the input pass band. The only requirement of such a way high frequency first IF being that it can adequately reject its own $\pm 900\text{kHz}$ image frequency.

For FM receivers, operating in the 88-110MHz band, the most common IF value is 10.7MHz, and both wide and narrow-band ceramic bandpass filters are available for this frequency. For receivers operating only in the amateur bands, (3.5, 7.0, 14 and 28MHz), 10.7MHz makes a useful and convenient choice of IF.

Oscillator Stability

Other things being equal, drift in operating frequency

Continuing his look into the world of radio, John Linsley Hood explains the problems associated with superhet receivers and presents some oscillator circuits.

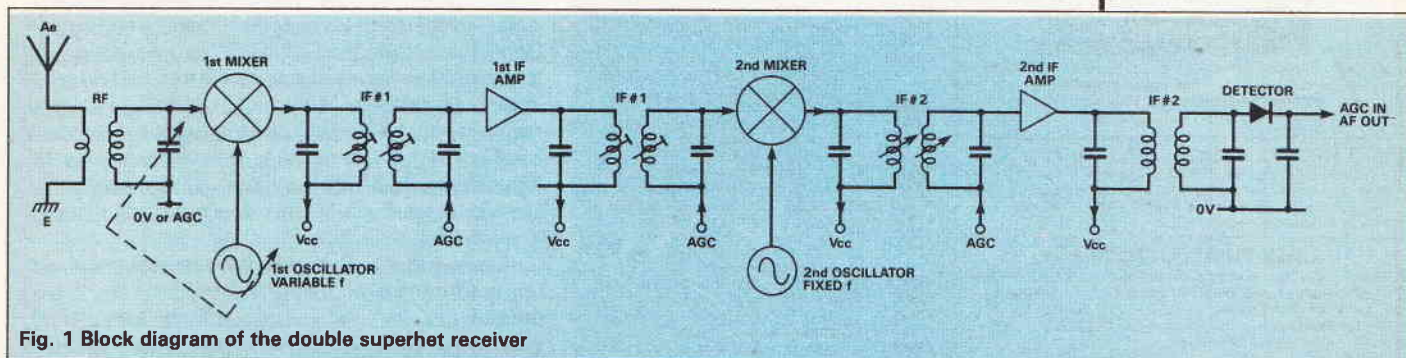

Fig. 1 Block diagram of the double superhet receiver

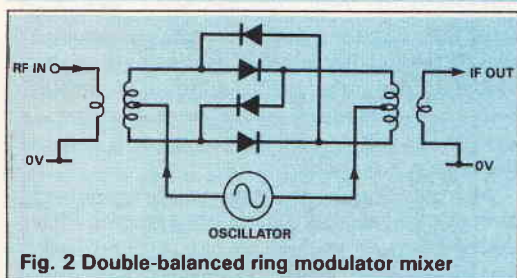

Fig. 2 Double-balanced ring modulator mixer

This is easy to do on the LW and MW broadcast bands, using a 455kHz or 456kHz IF, as the image frequency will be around 920kHz away, and even a simple input tuned circuit can cope with this at signal frequencies in the range up to, say, 1.6MHz. In the short wave band, at frequencies up to 30MHz, the image frequency could be too close for the relatively low selectivity of the input circuit to be able to reject it adequately, and higher IF values are useful.

Before crystal filters and ceramic resonator ladder filters became so inexpensive and easy to get, it was fairly common to find *double superhets* with two IFs, of the type shown in Fig. 1. In such *double conversion* receivers the first IF is, say, 1.2MHz or 1.8MHz, to push the image frequency 2.4MHz or 3.6MHz away from the wanted signal.

This is followed by a second frequency changer and a second, fixed frequency, local oscillator to reduce the signal frequency yet again, before passing to a second IF amplifier stage, operating, perhaps, at 110kHz, where high gain and selectivity are easy to obtain.

In the typical double superhet, 455kHz is the

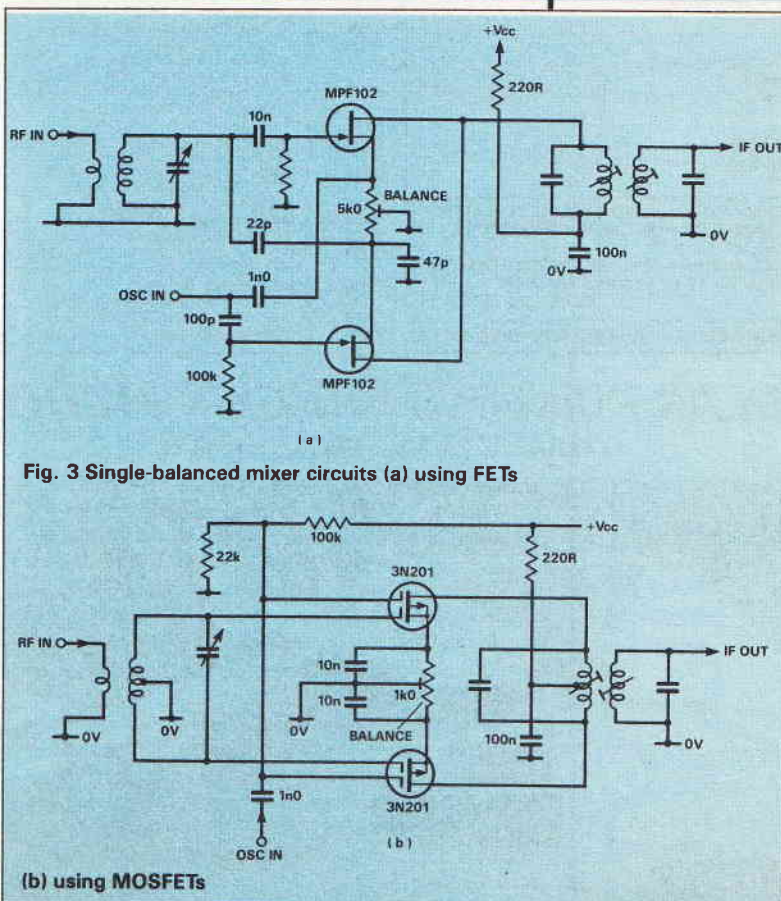

Fig. 3 Single-balanced mixer circuits (a) using FETs

(b) using MOSFETs

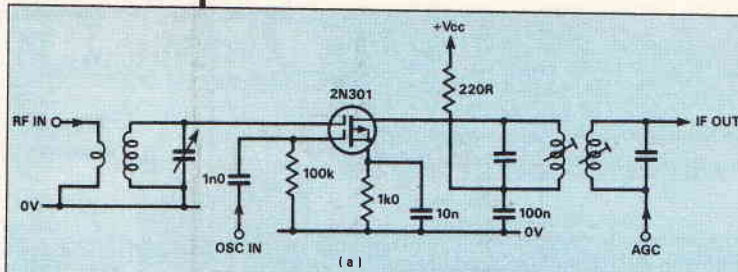
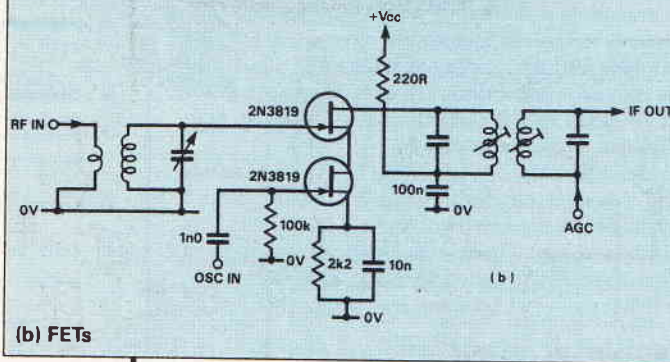

Fig. 4 Simple unbalanced mixer circuits using (a) MOSFET



(b) FETs

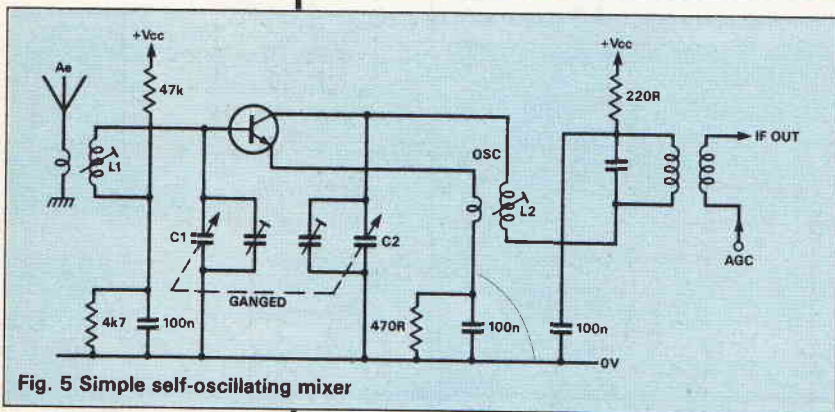

Fig. 5 Simple self-oscillating mixer

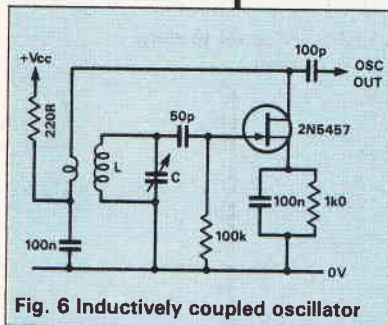

Fig. 6 Inductively coupled oscillator

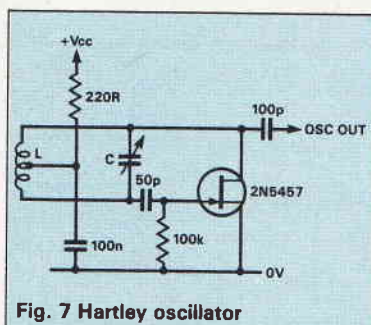

Fig. 7 Hartley oscillator

of an oscillator circuit due to thermal changes, vibration, or component aging, is directly proportional to its operating frequency. A $\pm 1\text{kHz}$ stability is child's play to achieve with a 100kHz oscillator, but exceedingly difficult at 100MHz.

As the custom in superhet design is to run the oscillator at a frequency above the signal frequency, a double superhet receiver tuned to 30MHz with a 55MHz first IF has its oscillator running at 85MHz, so this problem is a real one. On the other hand, the second oscillator for the 55MHz to 455kHz conversion could be a 55.455MHz crystal, which will have an acceptable stability.

For SW amateur use, problem of oscillator frequency drift is made more acute by the wish to receive single-sideband suppressed carrier transmissions; where an internal oscillator is used to replace the missing carrier frequency. In this case, stable and accurate tuning of the signal is essential to achieve and retain intelligibility.

Various schemes have been adopted to avoid the

problem of oscillator instability, including thermally-controlled housings, drift-cancelling systems such as the *Barlow-Wadley Loop*, and quartz crystal-based frequency synthesiser circuits, which we'll look at next month. As large scale integrated circuits become better and cheaper, frequency synthesiser systems are increasingly used in receivers.

On the other hand, for the DIY enthusiast, there's a lot to be said for just plain common sense in design: use of solid, firmly mounted components; discreet use of suitable (usually ceramic) temperature coefficient correction capacitors; minimising oscillator warm-up time by not asking too much output power from it; buffering oscillator output to isolate it from following stages; careful oscillator design; as loose a degree of coupling between the active components and their associated tuned circuit as is practicable.

In FM receivers, where the bandwidth is pretty wide anyway and where automatic frequency control systems can be organised to operate from the frequency-sensitive detector circuit, oscillator stability isn't usually a problem.

Mixer Noise

Another bane of the superhet designer's life is noise introduced by the mixer. This arises partly because the mixer always has a relatively low efficiency in converting the input signal from RF to IF so the input signal is not made as large in respect to the inevitable output noise as would have been the case of a straight RF gain stage, and partly because any noise present in the local oscillator signal will be added straight onto the IF signal output because the system cannot distinguish between signal and local oscillator modulation components.

Hot-carrier or *Schottky diode double-balanced ring modular* systems, of the kind shown in Fig. 2, are undoubtedly the heat mixers in this respect but they take considerable oscillator output power to drive them satisfactorily. They are called double-balanced because both signal and oscillator inputs are cancelled in passing through the circuit. This reduces the noise contribution from the oscillator input. A single-balanced circuit, on the other hand, cancels either the signal frequency or the oscillator components present at the output, but not both.

After diode ring modulators of these types, next best choices are balanced systems using junction-FETs or MOSFETs such as those in Fig. 3. Simple unbalanced dual-gate MOSFET (Fig. 4a) and junction-FET (Fig. 4b) systems provide acceptable alternatives for the amateur constructor.

The single transistor mixer/oscillator of the kind shown in Fig. 5, typically used in the ubiquitous trannie, is well down at the bottom of the league in nearly all respects except conversion efficiency.

There are also some special-purpose integrated circuits such as the MC/LM1496 family which make quite good mixer stages. However, with few exceptions, lower mixer noise and better relative conversion gain (from RF signal in to IF out) always entails rather more circuit complexity and cost.

Oscillator Requirements

Requirements for any superhet local oscillator are good frequency stability, good sinewave purity, low noise level and freedom from spurious parasitic outputs. The first three of these are obvious. Fourth is less so, but consider the case where required signal sensitivity is, say $1\mu\text{V}$, and local oscillator output is 1V, then it is essential there are no unwanted spurious signal components in the 1V oscillator signal which approach $1\mu\text{V}$ in size.

If there are, then somewhere in the spectrum there will be an IF output due to the heterodyning of the spurious signal with the oscillator output resulting in a signal which has not come from the aerial. The only way to avoid this problem is an oscillator wiring layout which minimises occurrence of additional inductance/capacitance loops outside the main LC tuned circuit.

Spurious signals originating in harmonics of the IF or other local oscillator stage of a superhet must also be guarded against, by careful screening, to avoid unwanted whistles when tuning the receiver. This, however, is rather a counsel of perfection, as even the best commercial receivers are not always entirely whistle-free.

Basic Oscillator Types

Although all oscillator circuits here use junction FETs as active devices this is by no means an essential feature of the circuits as they could, in most cases, be built equally well using thermionic valves with appropriate adjustments. Main oscillator types include:

● Inductively coupled oscillators

This is the earliest form of oscillator comprising a simple tuned circuit on the input to an RF amplifier stage with a second small coil, inductively coupled to it and feeding back energy from the output of the amplifier (Fig. 6). This is a similar process to regeneration, applied in the simple one valve receiver shown last month.

If enough feedback is applied, the circuit will oscillate. On the other hand, too much feedback may make the circuit overload and distort the oscillator waveform, giving rise to harmonics in the output.

● Hartley oscillators

Layout of this type of circuit is shown in Fig. 7. This design is basically an inductivity coupled oscillator of the same general type as that of Fig. 6 except the feedback coil is now part of the tuned circuit, which helps rescue the likelihood of spurious output signals.

Its main difficulty in use is in that both ends of the circuit are 'live', and if a tuning capacitor is to be used to alter the oscillator frequency, its spindle and frame will also be live, which can be awkward.

● Electron-coupled oscillators (ECOs)

This arrangement shown in Fig. 8, is sometimes known as a *cathode, emitter or source-coupled* oscillator. In reality, it is just a clever rearrangement of the Hartley oscillator allowing one end of the tuned circuit to be connected to the 0V or earth line. Care should be taken to ensure there is an adequately low impedance return path from the drain to the 0V line at the operating frequency.

Provided the circuit can be made to oscillate sufficiently vigorously, the lower the source tapping

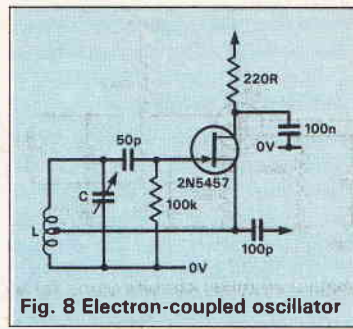

Fig. 8 Electron-coupled oscillator

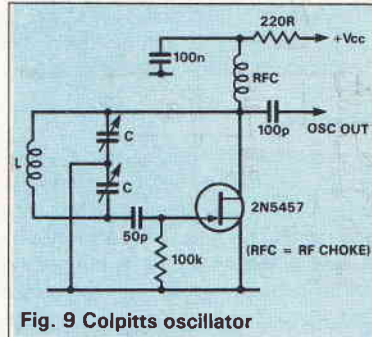
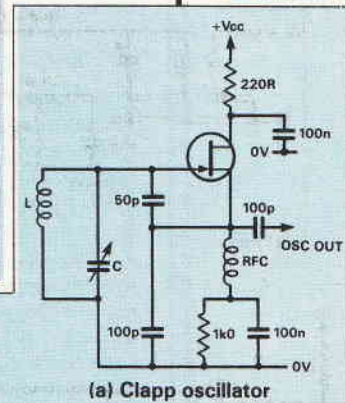
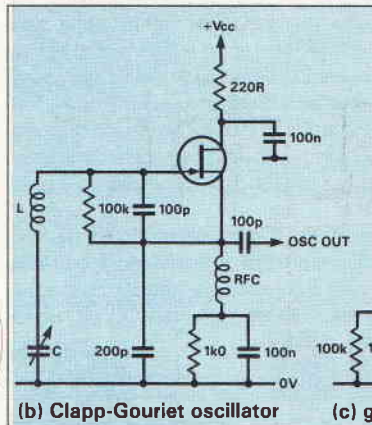

Fig. 9 Colpitts oscillator



(a) Clapp oscillator



(b) Clapp-Gouriet oscillator

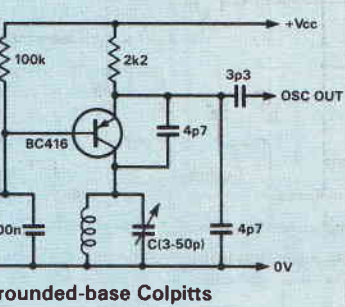

(c) grounded-base Colpitts

Fig. 10 Practical rearrangements of the Colpitts oscillator to allow one side of the tuning capacitor to be earthed

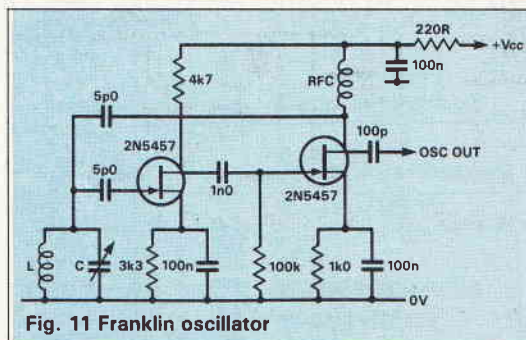
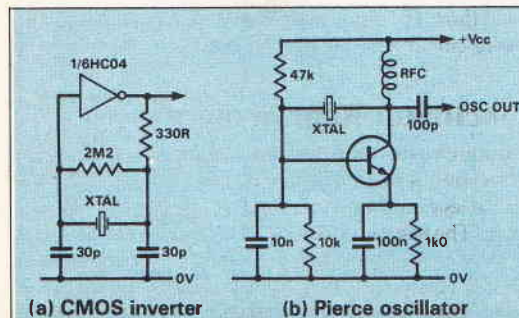
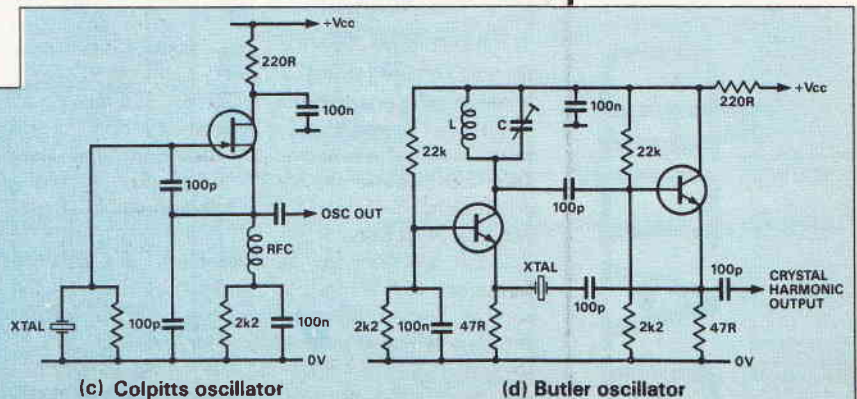

Fig. 11 Franklin oscillator



(a) CMOS inverter

(b) Pierce oscillator



(c) Colpitts oscillator

(d) Butler oscillator

Fig. 12 Various oscillator circuits used with crystal oscillators

point on the coil the better the stability and signal-to-noise ratio will be, so a high Q coil is an advantage in this, as in all other oscillator types.

● Colpitts oscillator

This circuit, shown in Fig. 9, is a companion to the Hartley oscillators, both being invented in the very early days of radio. It is essentially similar to the Hartley oscillator, except the capacitive part of the LC circuit is tapped, rather than the inductive part.

It has rather better stability than the Hartley oscillator because the fairly large tuning capacitance tends to swamp changes in input capacitance of the active device. However, it is a bit awkward to use in a variable frequency oscillator, unless inductors can be tuned or a split-stator tuning capacitor is used.

● Clapp oscillators

This bears the same relationship to the Colpitts oscillator as the ECO has to the Hartley oscillator, in that it is a rearrangement to allow one side of the tuned circuit to be at earth level. This makes capacitor tuning a bit awkward, unless the capacitor is connected across the whole coil/capacitor group, or is connected in series with the coil, as shown in Fig. 10a. Readers may recognise this layout as the circuit which provides regeneration in the two transistor regenerative radio of last month's article. The snag is that as the tuning capacitor is increased in value so the effectiveness of the feedback capacitors C2 and C3 diminishes, and it becomes a bit harder to make the circuit oscillate.

The circuit of Fig. 10b is usually called a Clapp-Gouriet oscillator, and is quite popular in crystal oscillator systems.

The circuit of Fig. 10c is also rearrangement of the Colpitts oscillator but this time in a grounded base form, and has very stable output frequency characteristics, which leads to its popularity in RF signal generators.

● Franklin oscillators

These come under the general heading of *negative resistance* oscillators, comprising a pair of gain stages to provide feedback at 360° that is positive feedback with output and input coupled to the tuned circuit through a pair of small capacitors, as shown in Fig. 11. This leads to a very stable, single coil layout.

There are various other types of oscillator which exploit the negative resistance technique, of which the simplest is just a Gunn diode, connected in series with the coil — neither stable in frequency, nor with a good signal-to-noise ratio, but very useful at VHF/UHF.

● Miller oscillators

Anyone who has ever built an RF gain stage will have come across this — generally as a problem! If an amplifier has a tuned circuit on both input and output, the gain is high enough and there is enough stray capacitance between output and input, then when the two tuned circuits are closely tuned the circuit will oscillate due to the combination of the Miller feedback capacitance effect and of the added phase shift due to the coils being slightly off resonance.

This was used a lot in the old valve days, when it was known as a *Tuned Anode Tuned grid* or TATG layout, and made the simplest single valve transmitter circuit. Nowadays it finds its main application in quartz crystal harmonic oscillators.

● Quartz crystal oscillators

These form a very useful family of highly stable low noise oscillators operating at a fixed though adjustable, frequency. They work because crystalline quartz is piezo-electric, which means that when a voltage is applied across a thin piece of the crystal it will physically deform, slightly. Conversely, if the crystal is deformed, by an applied force, a voltage will appear across the two opposite faces.

Now, as crystalline quartz is a rigid, but very nearly perfectly elastic material, a thin slice of it can be made to 'ring' at a frequency dependent on its shape and thickness. Then if electrically conducting plates are fixed to it or are physically close to it, an AC voltage can be fed to the crystal to maintain oscillation.

Because the mechanical losses in a good quartz crystal are very low it has an exceedingly high value of Q (as high as 2,000,000) which gives very high frequency stability and a very pure sinewave output. On the other hand, activity of the crystal (the ease with which it starts oscillating) decreases as the Q increases, so commercial crystals tend to be designed for Q

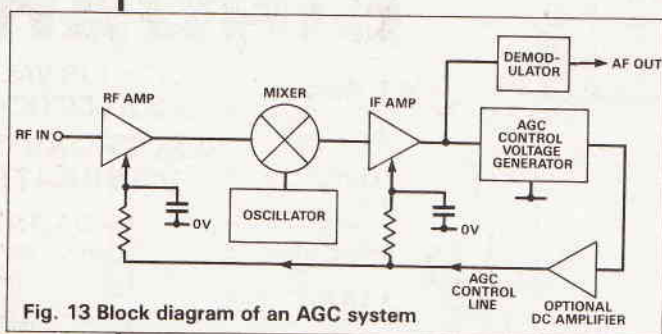

Fig. 13 Block diagram of an AGC system

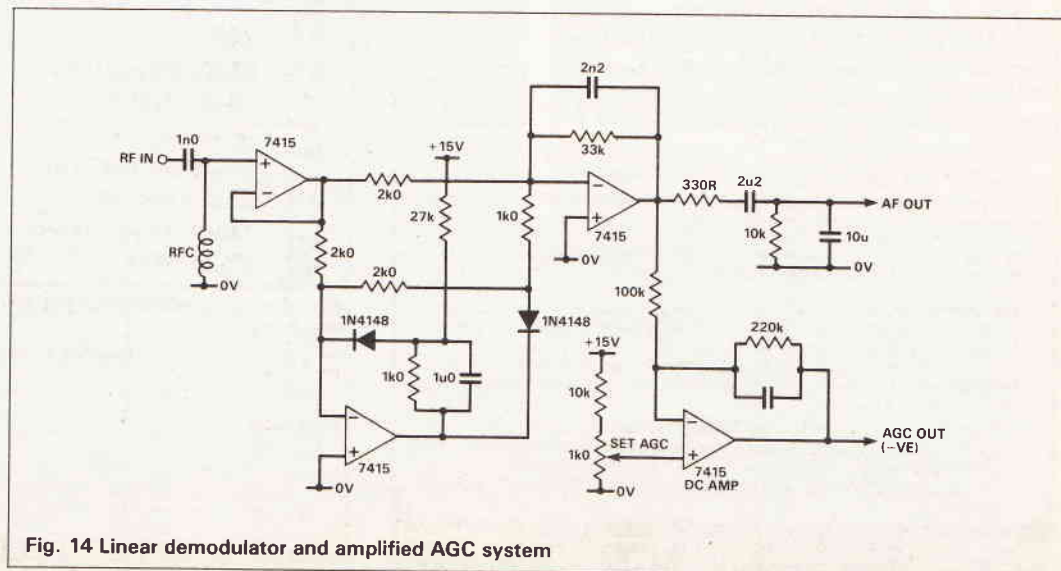
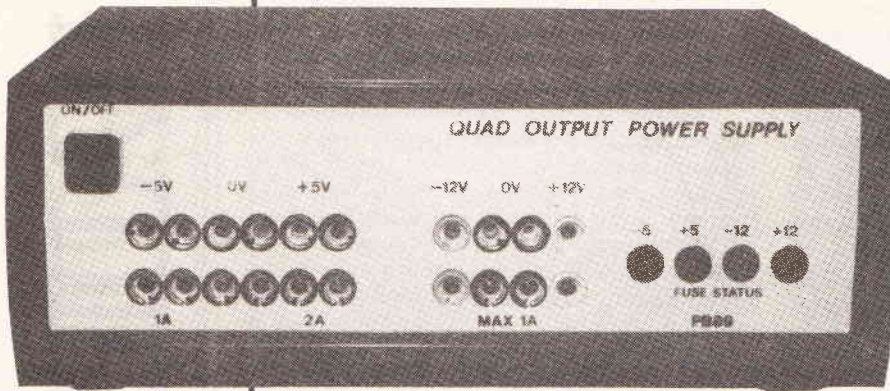

Fig. 14 Linear demodulator and amplified AGC system



QUAD OUTPUT POWER SUPPLY

Having given you the feature on power supply design, we now present a practical example to build: Paul Brow's design for a high-quality laboratory/workshop unit

Anyone interested in electronics — from the dabbling amateur to the full-time professional — knows the importance of good test and service equipment. One of the most used devices is a power supply. Every circuit you design, develop, build or use needs power.

This project uses the same design principles which are discussed and explained in Mike Bedford's article earlier in this month's ETI. However, it's not just a basic single-rail power supply with 0V and a positive DC voltage, but a five-rail supply with 0V and four different DC voltages: $\pm 5V$ and $\pm 12V$. So, just about every voltage you'll ever require for your circuits is catered for.

Same families of components are used in this project as in Mike Bedford's design feature; 78 and 79-type regulators, toroidal transformers and sealed bridge rectifiers, as readers will see from the circuit in Fig. 1, and construction is extremely simple.

Specification of the power supply is pretty good, too. It provides a continuous current of 1A on all power rails except the $\pm 5V$ rail, which is 2A (not, incidentally, a 78-series regulator circuit). Outputs are all fully fused, and the regulators give short circuit and thermal protection, so whatever you do with the supply, you can't damage it. Output rails all have LED monitoring to show individual rail operation.

Construction

PCB has been designed in such a way that all components except the mains switch are board-mounted, making construction both modular and

easy. Method here assumes readers use the case, heatsinks and components specified.

Construction sequence is important for component alignment: from PCB to panels. First, insert printed circuit board pins, wire links, resistors, diodes, capacitors C5 to C12, fuse holders and voltage dependent resistor VDR1. Fit heatsink 2 loosely to the back panel by its two central fixings. Fit heatsink 1 with an M3 16mm CSK screw to the back panel along with the transistor socket SK11 on the inside. Adjust for best fit and tighten. Now, adjust heatsink 2 for good alignment and tighten. Fit the 5V regulator, a T03-type, insulating the pins (a mica washer isn't necessary). Fit the other regulators to the back panel, ensuring that the $-5V$ and $-12V$ regs are insulated with mica and plastic bushes; leaving all slightly loose for adjustment when fitting PCB.

Next, fit the case brackets to the PCB using 14mm M3 threaded spacers. Use metal spacers for safety earthing. Fit the back panel to the brackets while carefully inserting the nine regulator leads into the PCB, but do not solder yet!

Fit output sockets to the PCB following the suggested colour sequence on the PCB overlay (but don't solder yet). Fit the front panel to align the sockets then, at last, solder every thing in place.

Attach 3 and 4 heatsinks to the bridge rectifiers and solder rectifiers in to the PCB. Now solder the T03 socket SK11, rectifiers, capacitors C1 to C4, LEDs (leave long leads) in to the PCB. Next, fit transformers by soldering them in to the PCB and securing with self tapping screws. Securing in this way is important simply because they're heavy — any severe knock

PROJECT

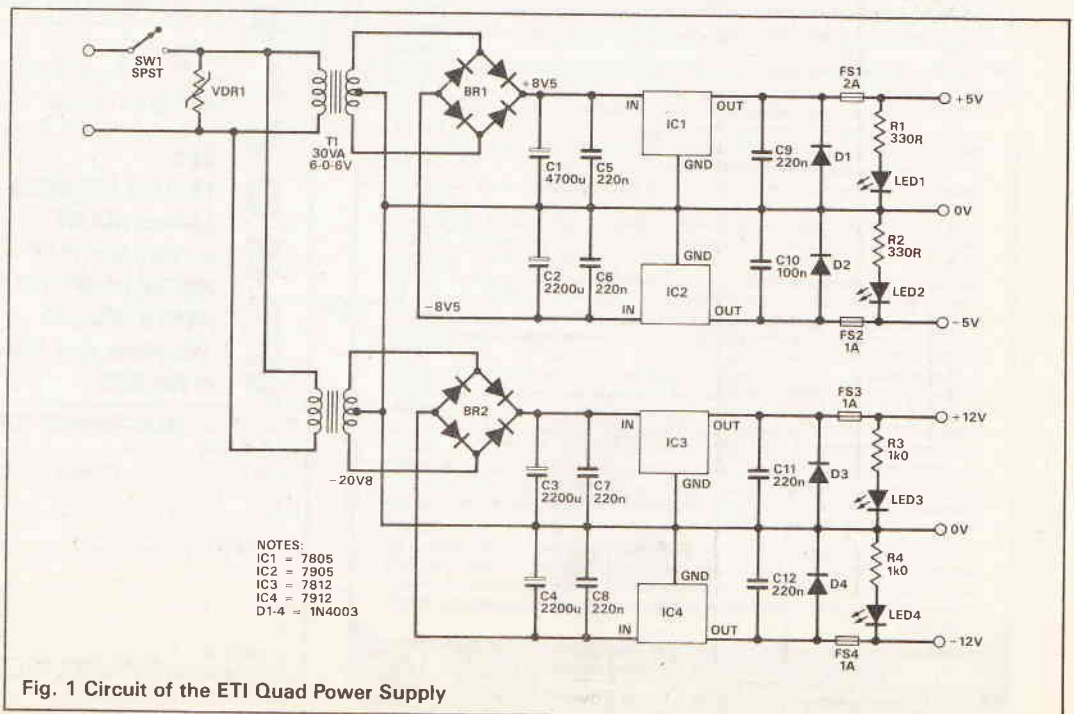

Fig. 1 Circuit of the ETI Quad Power Supply

could otherwise result in the transformer rattling around in the case! Finally, fit mains switch and cable. The cable enters the case side, so drill and file the case to suit a grommet and secure cable with a cable tie. Bend LED leads so LEDs fit into the panel clips, insert fuses and away you go. The result is a single module, easy to build, easy to service, ideal for colleges, schools or home workshops.

BUYLINES

All components are easily obtained, though the author is able to supply any (or all) parts. Case panels and back panel heatsinks can also be supplied pre-drilled and punched, or you may send your own panels for punching (but panels must be from the case specified).

PARTS LIST

RESISTORS (all 1/4W)

R1,R2 330R
R3,R4 1k

CAPACITORS

C1 4700 μ , 16V radial
C2,C3,C4 2200 μ , 25V radial
C5-C9,C11,C12 100n or 220n, 5mm pitch polyester
C10 100n, 10mm pitch polyester

SEMICONDUCTORS

LED1-4 Red LED
D1-4 1N4003
BR1 6A 200V rectifier (Rapid DB602)
BR2 3A 400V rectifier (Rapid BR34)
IC1 323K
IC2 905
IC3 7812

MISCELLANEOUS

F1 2A quick blow 20mm fuse
F2-4 1A quick blow 20mm fuse
Fuseholder (4 off) PCB 20mm
Led panel clip (4 off) 8mm mounting hole
Case Retex RE3 (Rapid 30-0910)
T1 6V 30VA encapsulated transformer
T2 12V 30VA encapsulated transformer
VDR1 275V transient suppression type
SK1,2 Red 4mm double height PCB socket
SK5,6 Blue 4mm double height PCB
SK3,4,8,9 Black 4mm double height PCB socket
SK7 White 4mm double height PCB socket
SK10 Yellow 4mm double height PCB socket
SK11 T03 transistor socket
TO220 washer kits Mica or silicone type
Heatsink 1,2 2.8°C/W Marston 07WN type
Heatsink 3,4 21°C/W Redpoint TV4 type
Spacers (4 off) M3 threaded 14mm long
Mains switch Push button/latching
Grommet, PCB, 1mm PCB pins, various M3 screws, nuts, washers (4BA for T03 socket).

HOW IT WORKS

Nothing much to say here, except that readers should consult Mike Bedford's feature on power supply design. He explains all the main principles better than we could here.

Essentially, the power supply is not just one supply, instead comprising two separate circuits doing similar jobs. One circuit is a $\pm 5V$ supply, while the other does the same for $\pm 12V$.

Each supply features its own transformer, bridge rectifier, smoothing capacitor, positive and negative voltage regulators, fused outputs and indicating LEDs.

PROJECT

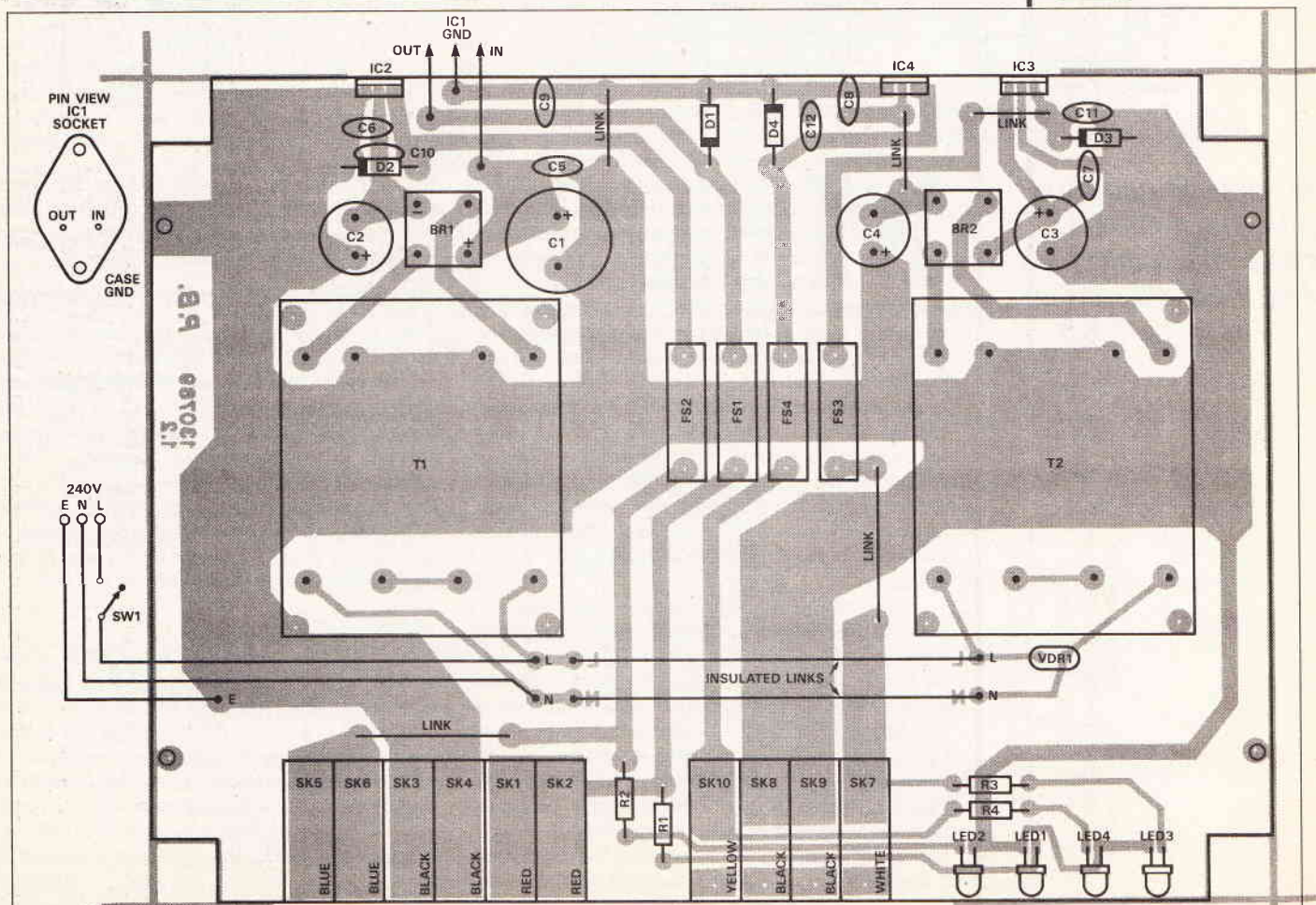

Fig. 2 Component overlay of the Quad Power Supply

THE ETI SUPERCHIP

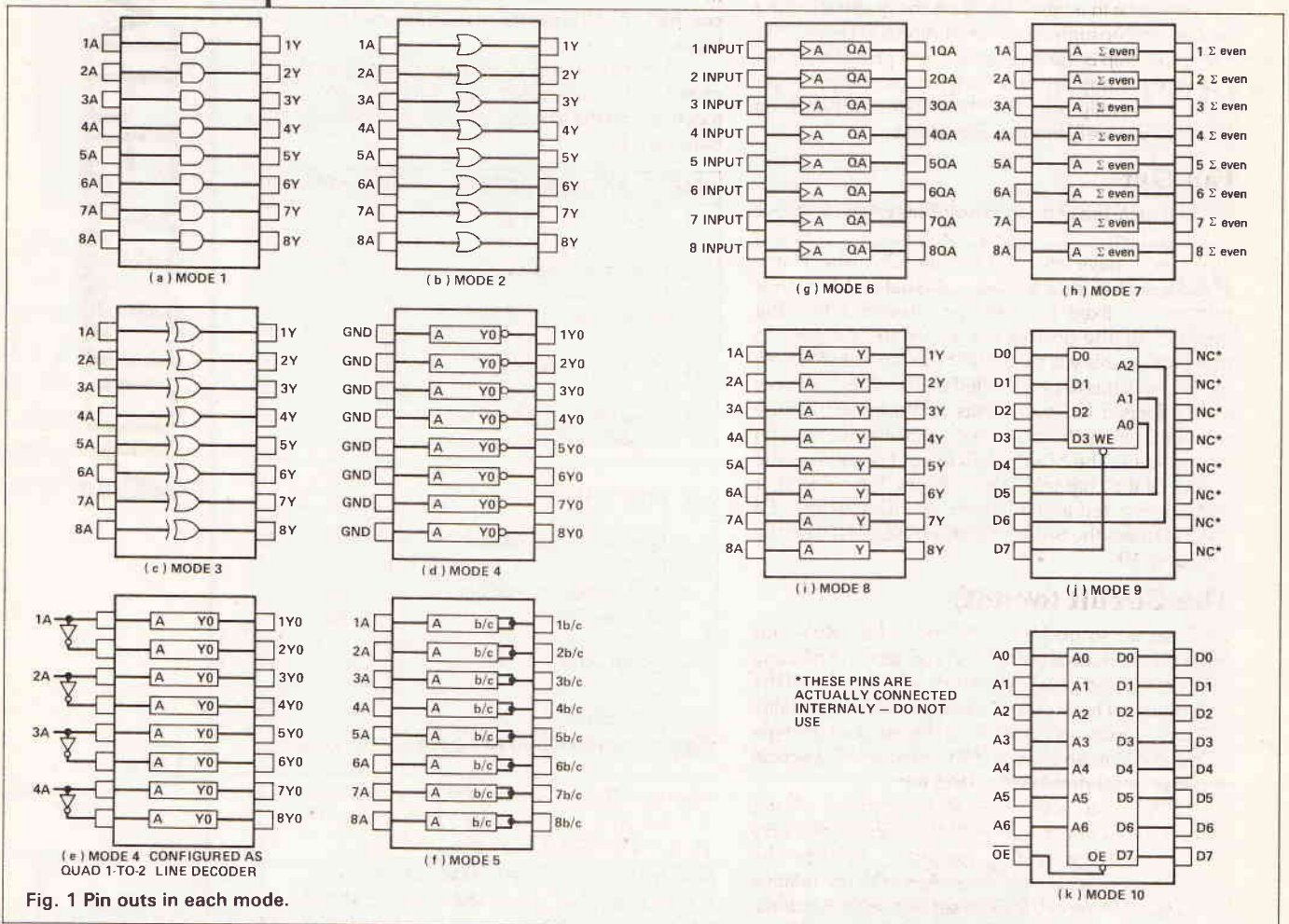

Fig. 1 Pin outs in each mode.

Our first competition and constructional article rolled into one. Mike Bedford explains

Most designers using 7400-series TTL or 4000-series CMOS ICs would probably say that most requirements in terms of functional elements are available, however, there are indeed some drop-offs. Omissions in logic families largely go unnoticed by those designing circuits around them as they have grown up with the situation and have subconsciously learned to use a standard bit of circuitry in place of the missing function. On the other hand, hardly anybody using any of the common logic families can have failed to notice that a whole class of logic elements is notable by its absence. What we are talking about is that group of devices that would be described starting with the phrase 1-input or 1-bit, examples being 1-input AND gates and 1-input OR-gates.

So, where the might of the American and Japanese semiconductor manufacturers have failed, ETI steps in to fill the gap with the ETI Superchip. OK, we have to admit that this is really poetic licence as it isn't truly a chip in the sense of being fabricated on a single piece of silicon but, nevertheless, it can be built up on a 16-pin DIL header and so take up only that space occupied by many 7400 or 4000 series ICs. Those who have followed avidly this far will probably be wondering why we talked about a whole class of functional elements being missing yet have now introduced the concept of a single DIL module. Well, this is the really clever bit of the design. There are numerous other aspects which are unexpected about

the Superchip specification but by far the most unusual is the fact that it can configure itself to carry out one of a number of different functions as will be explained in the specification section.

Specification Logic Functionality

Table 1 shows the various modes of operation of the Superchip and Figure 1 indicates the modules pin-out for each of these modes. As already hinted, the device is able to configure itself to any of these functions. Although this explanation is not strictly correct, to all intents and purposes it may be considered that the chip is able to sense the circuitry around it and automatically configure its functionality depending on the requirements. For reasons which will become obvious later, we intend to be somewhat guarded on this point.

Logic Levels

TTL ICs only operate at 5V, CMOS chips are somewhat more versatile in that they can operate anywhere in the range 3 to 18V although the speed suffers at the bottom end of this range. The Superchip, on the other hand can operate at virtually any logic level, the only constraint being the point at which flashover would occur between the pins (not that anyone would want to operate it at 100KV!). The strange thing about this device is that it does not require a V_{CC} supply and does not even need referencing to ground. This explains how Figure 1 shows all 16 pins as signal inputs or outputs.

Speed and Power Consumption

There is normally a relationship between those as shown in Figure 2. There are exceptions, for example 74LS is both faster and has lower power consumption than 74 series, but generally all the logic families can be seen to lie in a broad band on the graph showing that power consumption is proportional to speed. The ETI Superchip is the exception which proves the rule. Power consumption is negligible yet propagation delay is virtually zero and the maximum switching frequency is well into the GigaHertz.

Fan Out

This is a measure of how many inputs can be fed from an output and to give some comparison, 74LS and 4000 series have fan outs of 20 and 25 respectively. The Superchip is particularly unusual in that it does not have a fixed fan out, but instead this value depends on the devices connected to its inputs. In many cases this will mean that the fan out is almost infinite but it has to be admitted that in other instances a very limited fan out results and a buffer may be required. I think the best way to explain the situation is as follows: The Superchip's fan out is equal to the fanout of the chip feeding it less one for each other input connected to this output. So, for example if a 74LS00 feeds the Superchip and a 74LS138 then the fanout is 19.

The Circuit (or not)

Well, so far so good — until now this article has followed the normal pattern for a project in explaining the concept and going on to give a specification of the equipment. This is where we depart from normality in that we have no intention at this stage of giving a circuit diagram and associated description, practical constructional details or a parts list.

Have you ever noticed how many of the commercially most successful products are very simple in design. As an example, compare the blockbusting success of Trivial Pursuit to the relative obscurity of some of the most sophisticated electronic games. It rather appears that it is the spark of inspiration rather than the detailed design of a product which spells success.

On this basis, having already come up with that inspiration for the Superchip and having realised that it can be implemented with very simple circuitry, it was decided to throw down the gauntlet to our readers. Our challenge is to come up with the circuit for this device and so brings us to our April competition.

Competition

1. Draw a circuit diagram for a device which fully meets the specification of the ETI Superchip as described in this article. Only discrete components may be used.
2. Complete the following sentence in an original and amusing manner:
In the realm of digital electronics, the ETI Superchip will
3. Send your entry complete with name and address to the following address to arrive no later than 12.00 noon on Friday 30th March:

April Competition,
E.T.I.,
Argus House,
Boundary Way,
Hemel Hempstead,
Herts HP2 7ST.

The reader is reminded that the Superchip can be implemented very simply and the competition will be judged on the basis of the simplest entry being the

winner. In order to provide a common basis for comparisons, a complexity factor will be calculated as follows:

$$\text{Complexity} = \text{No. of resistors} + \text{No. of capacitors} + 2 \times \text{No. of diodes} + 5 \times \text{No. of transistors}$$

In the case of a tie for the simplest circuit, the completion of the sentence will be considered as a tie breaker.

A mystery star prize and two mystery runners up prizes will be awarded and the winners' names together with the solution will be published in the June issue of ETI.

MODE	FUNCTIONAL DESCRIPTION	SIMILAR TTL	NOTE
1	Octal 1-Input Positive-AND Gate	08	
2	Octal 1-Input Positive-OR Gate	32	
3	Octal 1-Input Exclusive-OR Gate	135	
4	Octal 1-Input Line Decoder	139	1
5	Octal 1-Bit Binary to 7-Segment Decoder with Zero Suppression	48	
6	Divide-by-1 Counter	93	
7	2-Bit Even Parity Generator	180	2
8	1-Bit Code Convertor (BCD to Binary or Binary to BCD)	184 185	
9	8x4-Bit WOM	-	3
10	128x8-Bit ROM	-	4

Table 1: Fuctionality of each Mode of Operation

Notes: The column headed SIMILAR TTL gives the number of a similar (but with more than 1-input or 1-bit) LS TTL device and is given as a reference to the mode's functionality if not obvious.

Numbers below refer to numbers in the NOTE column.

1. This is, of course, a particularly useless function but is included as these may be used in pairs with the addition of just a single inverter to implement at 1-to-2 line decoder. This is illustrated in Figure 2e.
2. This appears to be an anomaly (2-bit) but does, in fact generate 1 parity bit from a 1-bit input thereby giving a 2-bit word (including parity). A major difference to the LS180 is that it is a parity generator only and does not provide a parity check function.
3. The acronym WOM stands for Write Only Memory.
4. This ROM cannot be user programmed but instead, each location is pre-programmed with data equal to its address.

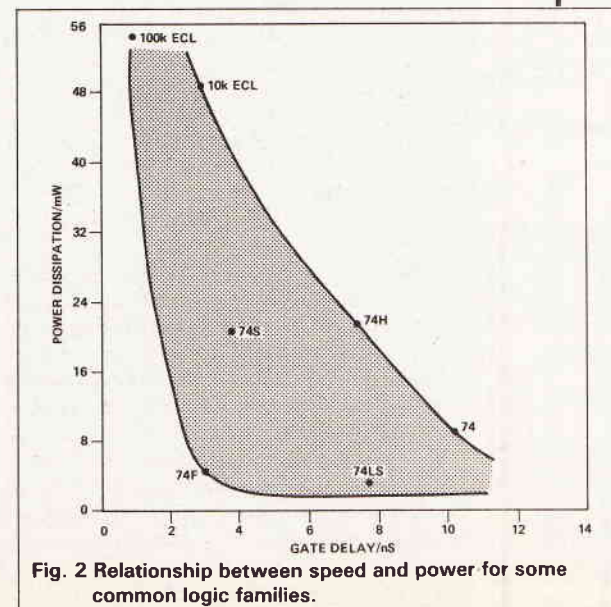
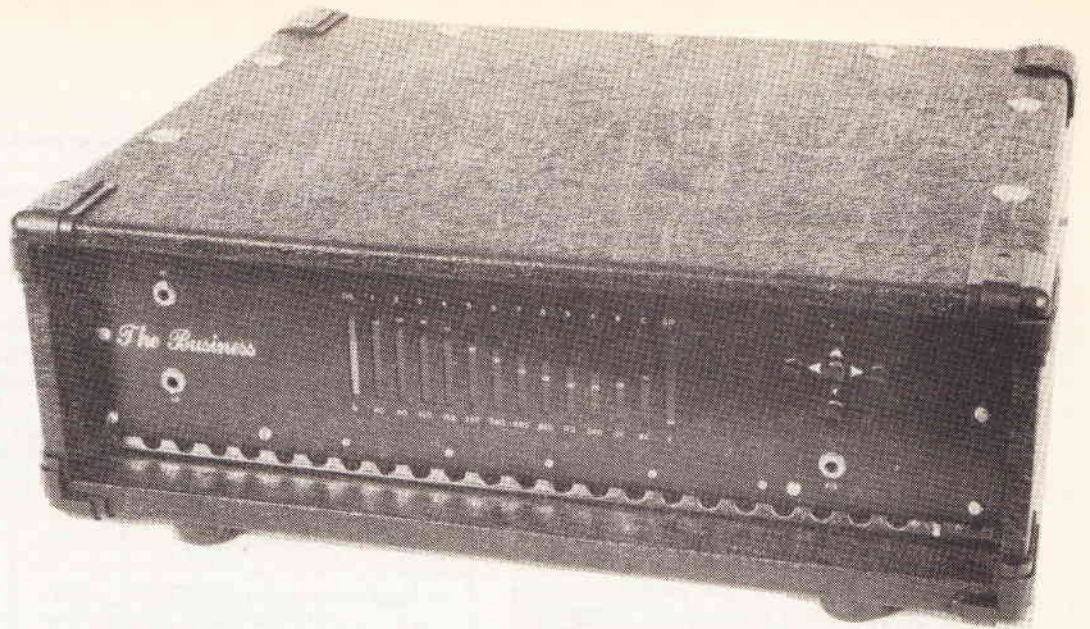

Fig. 2 Relationship between speed and power for some common logic families.



THE BUSINESS AMP

PART 2

Bob Whelan has produced a rugged, high quality, high powered computer-controlled amp and he continues his description of the circuitry

The Business is a custom-built bass amplifier designed for quick on-stage performance changes. At the press of a few buttons all your favourite bass guitar sounds can be there ready without hassle.

We continue with more construction and this month, we cover the graphic equaliser, micro, anti thump and DC protection boards with some extra bits, namely output level detect and DAC volume control that go on the pre-amp board and short circuit protect on the power amp board. The boards were both described last month.

Assembly of the Pre-amp and graphic PCB

The pre-amp and graphic equaliser boards are

mounted in a diecast aluminium alloy box (Maplin Box DCM5006) which serves the double purpose of screening and support. The boards are fixed in the die cast box using M3 x 30 screws and M3 spacers. The graphic board is mounted under the pre-amp board. Four M3 board mounting holes should be drilled in the base of the diecast box using the graphic PCB as a drilling template. Two M4 holes should be drilled in the side and near the top of the box for mounting onto the main amplifier chassis. A hole should be drilled at each end and near the lid of the box for the power supply leads and signal leads. Rubber grommets should be put in these holes. To prevent stressing the solder joints, the 20 pin plug on the pre-amp board should be screwed down using no. 4 x 6.5 self tappers before being soldered to the board.

PROJECT

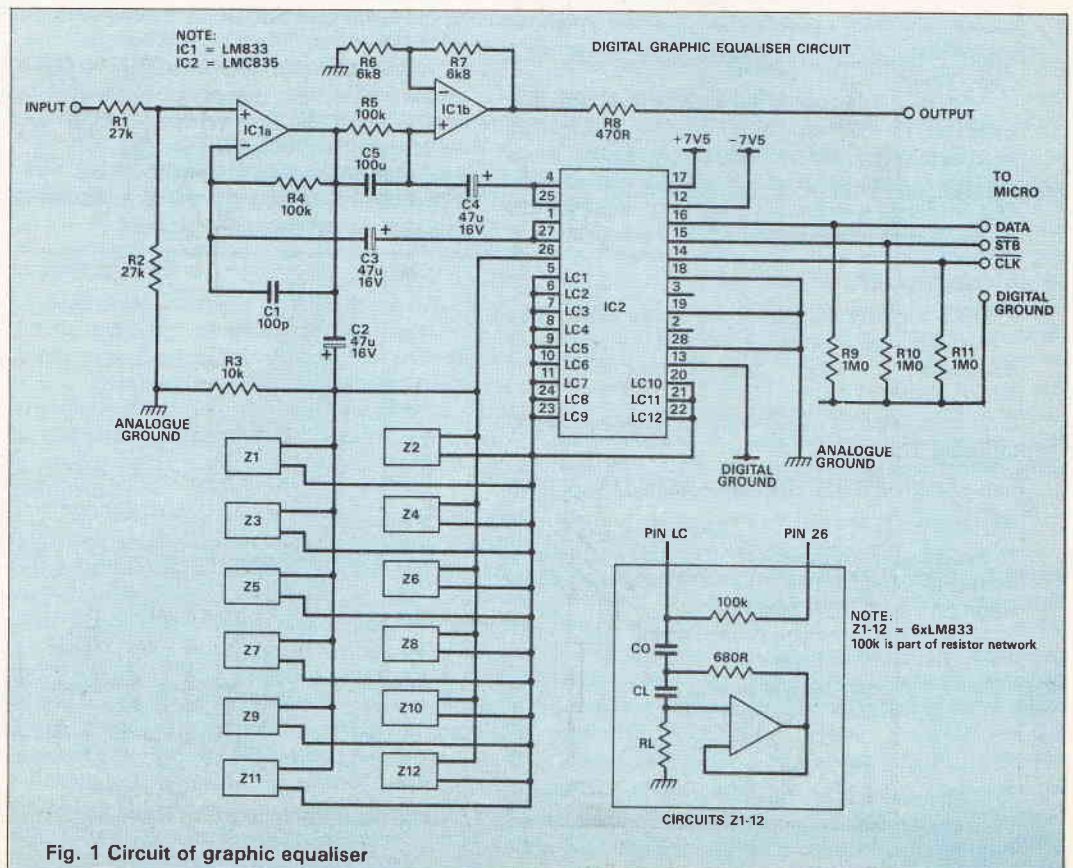

Fig. 1 Circuit of graphic equaliser

Assemble the graphic and pre-amp PCBs according to the overlay diagrams (Fig.3 and Fig.3 last month). Suggested order of assembly being terminal pins, links, IC sockets, resistors, capacitors, semiconductors and finally plug in the ICs. The graphic chip LMC835 and the 7110 attenuator chips are C-MOS types and require careful handling. The pre-amp board can be tested by powering it up with +15, -15V and earth and injecting a 1kHz sine wave into the input while monitoring the output with a scope. A change in gain can be seen by taking the 7110 control lines to earth with a short length of wire. The overload detection circuit should be set up by injecting a 1kHz 10 volt RMS sinewave into its input and adjusting the pre-set until the output from the circuit goes low. Because of the digital control to the graphic, this board can only be tested once it is assembled in the chassis. The boards can be wired together as per the circuit diagrams and overlays then mounted in the die-cast box. The graphic board being mounted below the pre-amp board. Use spacers to ensure that the graphic board does not short to the diecast box base or the pre-amp board. Single core screened cable flying leads for the pre-amp input, output and again switching should be passed through the rubber grommet in the left end of the diecast box. The power supply and earth leads should be passed through the rubber grommet in the right-hand end. Use 16/0.2 wire for the power supply leads and 32/0.2 wire for the earth leads.

Assembly of the Micro

The micro board is mounted in a diecast aluminium alloy box (Maplin Box DCM5006) which again serves the double purpose of screening and support. Four M3 board mounting holes should be drilled in the base of the box using the micro PCB as a drilling template. Two M4 holes should be drilled in the side and near the top of the box for mounting onto the main amplifier chassis as in Fig. 2. A hole should be drilled in the left hand end near the lid of the box for the power supply leads. A rubber grommet should be put

in this hole. To prevent stressing the solder joints, the 20-pin and 16-pin plugs on the micro board should be screwed down into position using no. 4 x 6.5 self tappers using M3 washers as spacers before being soldered to the board to allow for soldering on to the topside. The micro board is a double-sided PCB without plated through holes.

Assemble the board according to the overlay diagram (Fig. 7). Most of the chips are C-MOS types and require careful handling. The Dallas battery socket and RAM chip is quite bulky and should be tied into its turned pin socket with lacing cord for security. Connect up the board supply lines. Use 16/0.2 wire for the +5 volt power supply lead and 32/0.2 wire for the earth lead. The board can be tested by powering up with 5 volts and monitoring the interrupt line. A 1ms pulse should be present on the line. Serial data should also be seen on the display clock and data lines (pins 18 and 19) of the display VIA. If all is well, the board can be mounted in its diecast box. Power supply leads should be routed through a grommet.

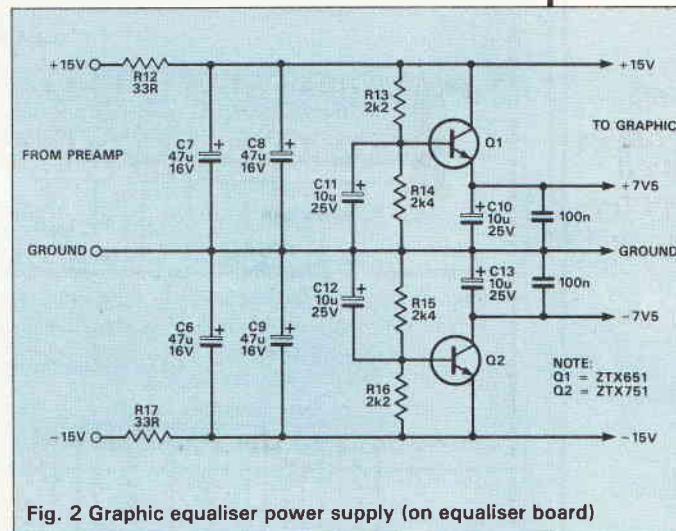

Fig. 2 Graphic equaliser power supply (on equaliser board)

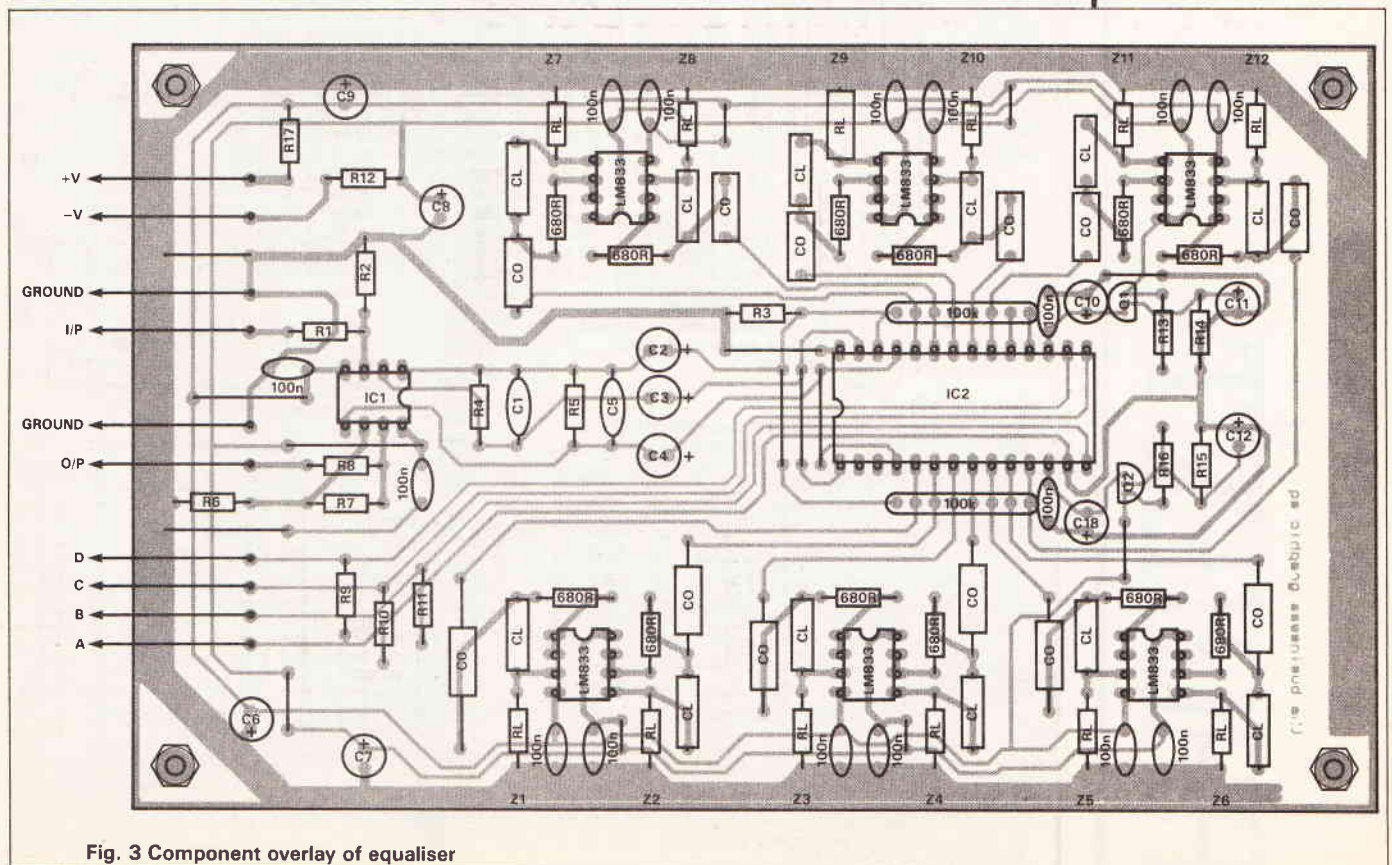

Fig. 3 Component overlay of equaliser

PROJECT

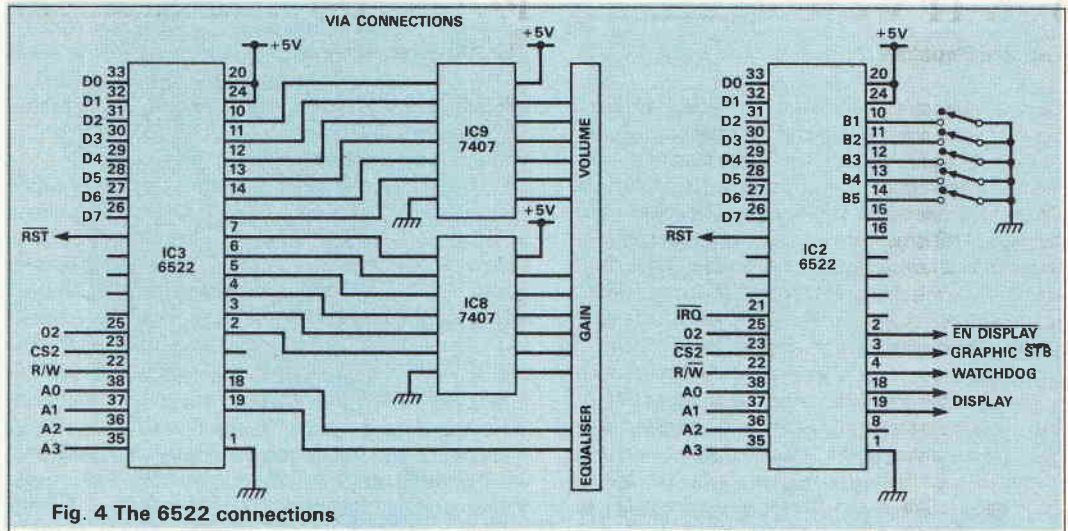

Fig. 4 The 6522 connections

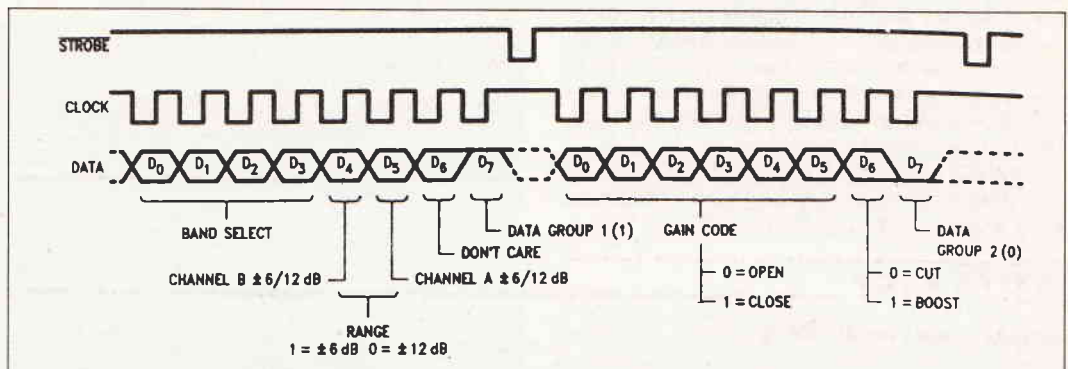

Table 2 Timing diagrams for the LM835

DATA I (BAND SELECTION)

D7	D6	D5	D4	D3	D2	D1	D0	
H	X	L	L	L	L	L	L	CH A ±12 dB RANGE, CH B ±12 dB RANGE, NO BAND SELECTION
H	X	L	L	L	L	L	H	CH A ±12 dB RANGE, CH B ±12 dB RANGE, BAND 1
H	X	L	L	L	L	H	L	CH A ±12 dB RANGE, CH B ±12 dB RANGE, BAND 2
H	X	L	L	L	L	H	H	CH A ±12 dB RANGE, CH B ±12 dB RANGE, BAND 3
H	X	L	L	L	H	L	L	CH A ±12 dB RANGE, CH B ±12 dB RANGE, BAND 4
H	X	L	L	L	H	L	H	CH A ±12 dB RANGE, CH B ±12 dB RANGE, BAND 5
H	X	L	L	L	H	H	L	CH A ±12 dB RANGE, CH B ±12 dB RANGE, BAND 6
H	X	L	L	L	H	H	H	CH A ±12 dB RANGE, CH B ±12 dB RANGE, BAND 7
H	X	L	L	H	L	L	L	CH A ±12 dB RANGE, CH B ±12 dB RANGE, BAND 8
H	X	L	L	H	L	L	H	CH A ±12 dB RANGE, CH B ±12 dB RANGE, BAND 9
H	X	L	L	H	L	H	L	CH A ±12 dB RANGE, CH B ±12 dB RANGE, BAND 10
H	X	L	L	H	L	H	H	CH A ±12 dB RANGE, CH B ±12 dB RANGE, BAND 11
H	X	L	L	H	H	L	L	CH A ±12 dB RANGE, CH B ±12 dB RANGE, BAND 12
H	X	L	L	H	H	L	H	CH A ±12 dB RANGE, CH B ±12 dB RANGE, BAND 13
H	X	L	L	H	H	H	L	CH A ±12 dB RANGE, CH B ±12 dB RANGE, BAND 14
H	X	L	L	H	H	H	H	CH A ±12 dB RANGE, CH B ±12 dB RANGE, NO BAND SELECTION
H	X	L	L	H				CH A ±12 dB RANGE, CH B ±6 dB RANGE, BAND 1~14
H	X	H	L					CH A ±6 dB RANGE, CH B ±12 dB RANGE, BAND 1~14
H	X	H	H					CH A ±6 dB RANGE, CH B ±6 dB RANGE, BAND 1~14

BAND CODE
CH B ±6 dB/12 dB RANGE
CH A ±6 dB/12 dB RANGE
DONT CARE
DATA I

This is the gain if the ±12 dB range is selected by DATA I. If the ±6 dB range is selected, then the values shown must be approximately halved.

Table 1 Values for gyrator circuits

FREQ	CO(μf)	CL(μf)	RL
40	1.5	.22	100K
60	1	.1	100K
100	.68	.068	100K
160	.47	.033	100K
250	.22	.033	82K
380	.15	.015	110K
660	.1	.015	91K
820	.068	.01	100K
1300	.039	.0068	91K
2600	.022	.0033	82K
5000	.01	.0022	91K
8000	.0068	.001	82K

All capacitors are polyester types.

DATA II (BAND SELECTION)

	D7	D6	D5	D4	D3	D2	D1	D0	
FLAT	L	X	L	L	L	L	L	L	
1 dB BOOST	L	H	H	L	L	L	L	L	
2 dB BOOST	L	H	L	H	L	L	L	L	
3 dB BOOST	L	H	L	L	H	L	L	L	
4 dB BOOST	L	H	L	L	L	H	L	L	
5 dB BOOST	L	H	L	L	L	L	H	L	
6 dB BOOST	L	H	L	H	L	L	H	L	
7 dB BOOST	L	H	H	L	H	L	H	L	
8 dB BOOST	L	H	L	H	L	H	H	L	
9 dB BOOST	L	H	L	L	L	L	L	H	
10 dB BOOST	L	H	H	L	H	L	L	H	
11 dB BOOST	L	H	H	L	H	H	L	H	
12 dB BOOST	L	H	H	L	H	H	H	H	
1 dB~12 dB CUT	L	L							VALID ABOVE INPUT

BOOST/CUT
DATA II
GAIN CODE

Coding Information

HOW IT WORKS

Graphic Equaliser

The digital graphic equaliser is implemented using the LMC835. This chip replaces the potentiometers used in a conventional graphic equaliser with digitally controlled step-variable resistors, thereby allowing computer control of an analogue signal. The chip contains enough step-variable resistors for a 14-band equaliser with 1dB steps covering a ± 12 dB range. In the Business amplifier, the graphic is configured for 12 bands of equalisation. To increase signal handling capability the input is attenuated 6dB by two 27K resistors and then equally amplified in the output buffer. With this configuration there is sufficient headroom to handle full boost on a 2Vrms input signal. Each band requires an external op-amp gyrator and the LM833 is used for optimum performance. Gyrator component values are shown in Table 1. There is also a table of values in the Maplin catalogue on page 404 for those wishing to change graphic centre frequencies. Programming is via a three wire interface consisting of a DATA, CLOCK and STROBE line. DATA bits are shifted into an internal serial register on positive CLOCK edges. This data is then latched and executed by a low-going pulse on the STROBE pin. A separate digital ground pin is provided to prevent contamination of the sensitive analogue signal path. Programming requires two 8-bit bytes. The first byte selects a band for adjustment and selects either of ± 6 dB or ± 12 dB control range. The second byte selects boost or cut and the desired level for the band previously selected. A timing diagram is shown in Table 2. Note that bit D0 is shifted in first, D7 last. The table shows the coding used for band and gain selection. With the clock rate of 500kHz, the entire equaliser can be programmed in less than 500 μ s.

PARTS LIST

Graphic Equaliser

RESISTORS (all $\frac{1}{4}$ W 5%)

R1,2 27k
 R3 10k
 R4,5 100k
 R6,7 6k8
 R8 470
 R9,11 1M
 2 off 7 \times 100k resistor networks
 12 off 620R

CAPACITORS

C1,5 100p polystyrene
 C2,4 47 μ 16V radial electrolytic

SEMICONDUCTORS

IC1 LM833
 IC2 LMC835
 Gyrator circuits Z1 to Z12 = LM833 \times 6

MISCELLANEOUS

1 off 28-pin IC socket
 7 off 8-pin IC sockets
 16 off 100n ceramic decoupling capacitors

PARTS LIST

Graphic Power Supply Parts

RESISTORS

(all $\frac{1}{4}$ W 5%)

R12,17 33R
 R13,16 2k2
 R14,15 2k4

CAPACITORS

C6-9 47 μ 16 volt radial
 C10-13 10 μ 25 volt radial
 Q1 ZTX 651
 Q2 ZTX 751

HOW IT WORKS

Microprocessor

The essential connections have been shown in the block form diagrams for the micro circuit. Common data, address and supply connections have been omitted for clarity. The amplifier uses the 6502 microprocessor for control. A 1MHz crystal oscillator module provides the clock signal into pin 37. Figure 8 is a timing diagram for the 6502. The phase 2 clock output from pin 39 together with the read/write line on pin 34 control all data transfers between the microprocessor and peripheral chips. Unused inputs to the 6502 are pulled high by a 1k resistor. The interrupt line is pulled high through a 2k3 resistor. A 74LS138 is used to decode the address lines. The outputs from the 74LS138 form the following memory map:

A15	A14	A13	O/P	CS	Base address
0	0	0	Y0	RAM	0000
0	1	0	Y2	VIA1	4000
1	0	0	Y4	VIA2	8000
1	1	1	Y7	ROM	E000

The system uses a 6264 8K \times 8 CMOS static RAM which is mounted in a DS12138 28-pin socket. This socket has a built-in CMOS controller circuit and a long life lithium battery to provide non-volatile memory. When the internal monitor circuit detects an out of tolerance supply, a lithium power source is switched on to protect the RAM, and the write protection circuit is enabled to prevent the RAM data being scrambled.

Read and write data bus contention between the peripheral chips and memory chips is avoided by gating the O2 clock signal and the R/W signal through 74LS00 NAND gates. This ensures that data transfers are controlled and synchronised by the O2 clock signal from the 6502 micro.

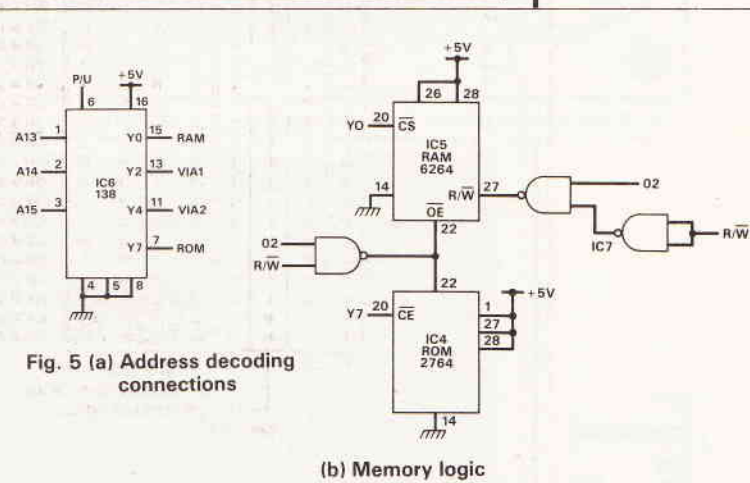
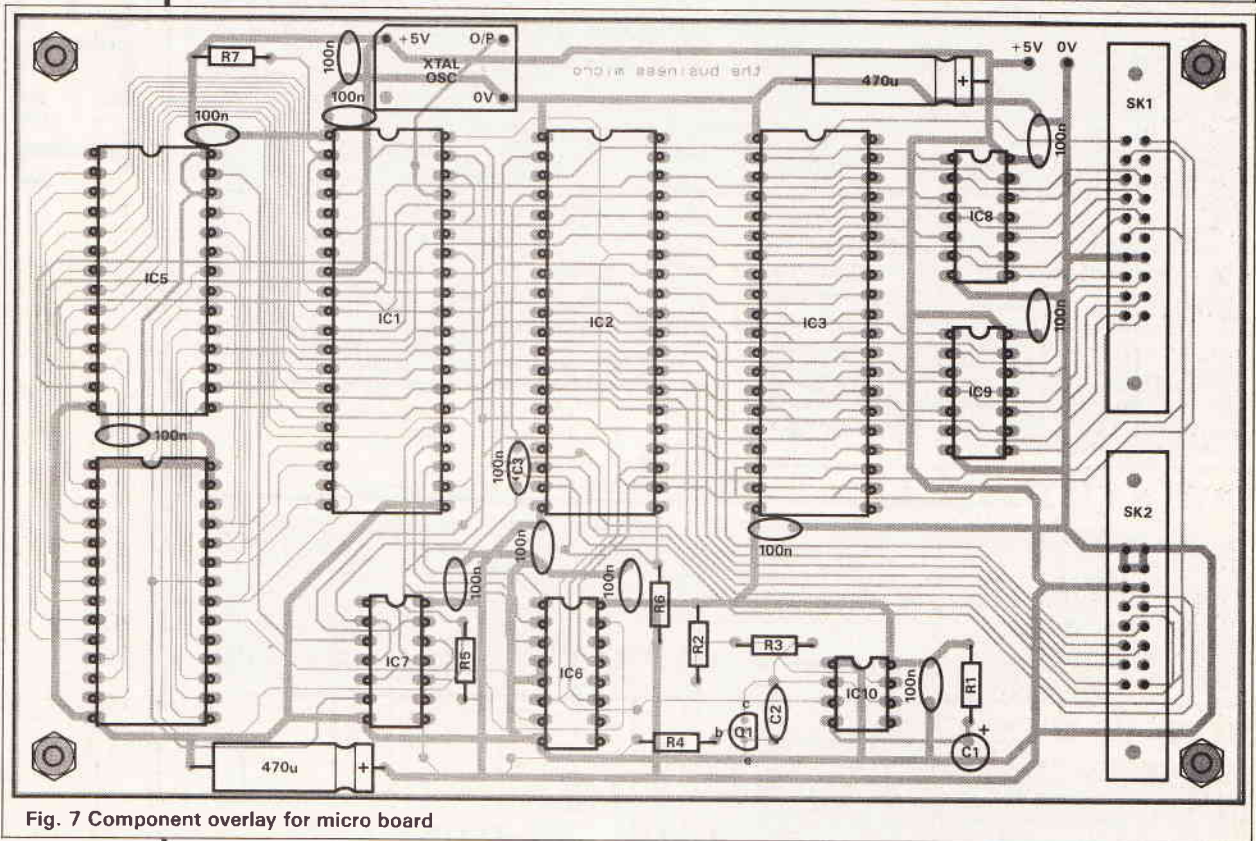
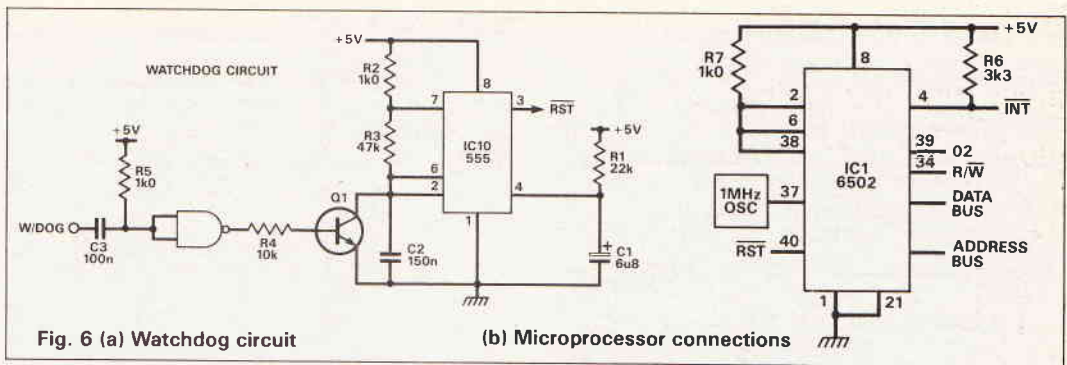

Fig. 5 (a) Address decoding connections

(b) Memory logic

A 6522, VIA1 (Versatile Interface Adapter), controls the amplifier attenuator chips. Port A controlling gain and Port B controlling Volume. A 7407 hex non-inverting open collector driver between the port and the attenuator chip control lines allows level conversion between the 5 volt output of the ports and the 15 volt input requirement of the 7110 attenuator chip.

VIA1 also controls the LMC835 digital graphic equaliser chip using its shift register set to mode 6. In this mode, the CB1 output becomes a shift clock and the serial data is present on the CB2 output. The high order bit D7 being shifted out first. The shift rate is controlled by the system O2 clock divided by two. This gives a 500kHz shift rate, which is the maximum speed of the graphic chip. This mode is enabled by setting bits 3 and 4 in the auxiliary control register of the VIA. Writing a byte to the shift register starts the shift clock. Bit 3 in the interrupt flag register is set on completion of 8 shifts and



cleared on the next write to the shift register.

The front panel display is controlled by the shift register of VIA2. This is again set to mode 6. The rate of updating the display is set by using Timer 1 to free run and generate 1ms interrupts. Each column of the display is on for 1ms in every 14ms. This gives an update rate of 1/0.14 which is approximately 70Hz.

Port B of VIA2 is the input port for the 5 control buttons. On port A, PA0 is the display enable line, PA1 is the strobe for the graphic equaliser and PA2 is the watchdog timer output.

The watchdog circuit uses a 555 timer wired as a missing pulse detector. The reset lines of the micro system being tied to the output from the time pin 3. When powered up, pin 3 is held low until C1 on pin 4 has charged up through R1. Pin 3 then goes high and starts the system. Every 5ms the program outputs a low pulse on PA2 which discharges C2 through T1. If for some reason the program should crash, the 555 times out and pin 3 goes low. After C2 is discharged through pin 7, pin 3 goes high again attempting to restart the system.

The microprocessor system uses CMOS chips where possible for low power consumption and low heat generation.

The program is held in a 2764 8K x 8 CMOS ROM chip.

The program was written using an eeprom emulator. A decent eeprom emulator was recently featured in ETI. An eeprom emulator is an inexpensive way for the electronics enthusiast to unleash the power of the microprocessor.

The business program consists mostly of look up tables for the graphic and display settings and an interrupt routine for updating the display. Control button debouncing is done in software. 12 channels of graphic and gain settings are held in RAM.

Program flow from 2764

Start.
 init 6522 VIA ports.
 Zero Gain and Volume.
 init counters.
 init pointers to look-up tables.
 init Graphic shift register.
 init Display shift register.
 Start timer in 6522 to generate 1ms interrupts.
 Delay for stabilisation of amplifier.
 Select graphic channel 1.
 Set up Graphic EQ and gain for channel 1 from data in ram.
 Set last Volume setting on display but mute the amp.
 Enable interrupts.
 On interrupt, look up display table and update display.
 Loop.
 <
 Wait for button press.
 If North and South button, Zero volume.
 If North button and play mode, step up volume, else step up active graphic band.
 If South button and play mode, step down volume, else step down active graphic band.
 If West and play mode, change channel down, else change active graphic band down.
 If East and play mode, change channel up, else change active graphic band up.
 >

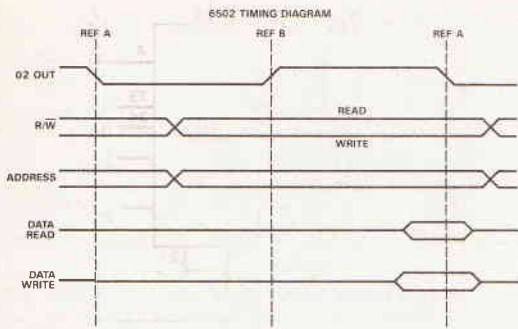

Fig. 8 6502 Timing diagram

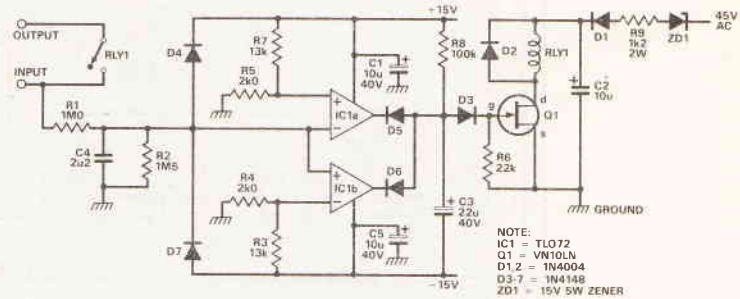

Fig. 9 Circuit diagram for DC protection and Anti thump

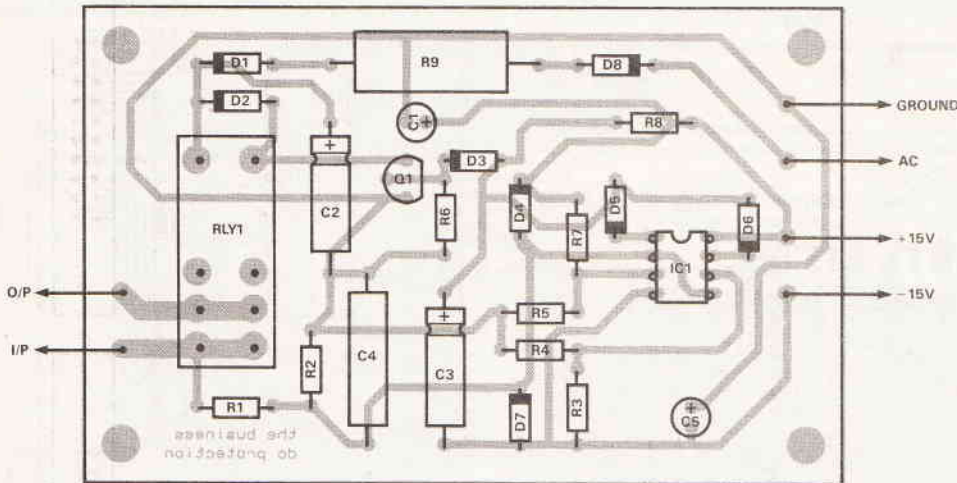

Fig. 10 Component overlay for DC protection and Anti thump

PARTS LIST

Microprocessor

RESISTORS (all 1/4W 5%)

R1	22k
R2,5,7	1k
R3	47k
R4	10k
R6	3k3

CAPACITORS

C1	6 μ 8 tant
C2	150n
2 off	470 μ 10V electrolytic
13 off	100n ceramic capacitors

SEMICONDUCTORS

IC1	65C02
IC2,3	65C22
IC4	27C64
IC5	6264
IC6	74LS138
IC7	74LS00
IC8,9	7407
IC10	55 C-MOS Type
Q1	ZTX650

MISCELLANEOUS

1 off	1MHz Xtal Oscillator
1 off	20-pin IDC plug
1 off	16-pin IDC plug
3 off	40-pin IC socket
1 off	28-pin IC socket
3 off	14-pin IC socket
1 off	16-pin IC socket
1 off	8-pin IC socket
1 off	28-pin Dallas socket DS1213B (Farnell 175-776)

BUYLINES

All the components are readily available. The Dallas socket is available from Farnell or Trilogic on (0274) 684289.

HOW IT WORKS

Anti thump and DC offset protection

The circuit protects the loudspeakers from possibly damaging turn on thumps from the amplifier. If a fault occurs that results in DC potential appearing on the amplifier output, it disconnects the speakers from the amplifier.

At turn on, the gate of the VN10 FET is held low by R6 until C3 charges up through R8. This takes about 2 seconds. Q1 then turns on, closing the relay. Power for the relay coil is provided by the 45 volts AC from the bridge rectifier, dropped through D8 and R9, rectified by D1 and smoothed by C2. As there is no charge stored on the AC when the amplifier is turned off, the relay opens instantly. The DC offset protection is provided by the window comparator circuit of IC1. Upper threshold of 2 volts is set by R7 and R5. The lower threshold of 2 volts by R3 and R4. AC signals at the input are filtered by R1 and C4. If a DC signal appears at the input that exceeds the thresholds, IC1 output goes low discharging C3 and turning off the relay. D4 and D7 prevent the op-amp input from exceeding its rail voltages.

Assembly of the DC protection PCB

The DC protection board components should be soldered onto the board as in overlay diagram (Fig. 10). The board is pretty straightforward and can be tested once it is mounted in the chassis and connected up.

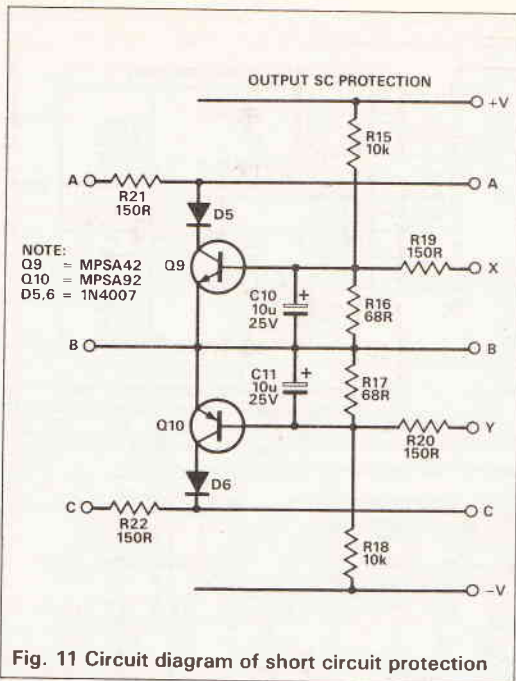

Fig. 11 Circuit diagram of short circuit protection

PARTS LIST

DC Offset/Anti Thump

RESISTORS (all 1/4W 5%)

R1	1M
R2	1M5
R3,7	13k
R4,5	2k
R6	22k
R8	100k
R9	1k2 2W

CAPACITORS

C1,5	10 μ /40V
C2	10 μ /63V
C3	22 μ /40V
C4	2 μ 2

SEMICONDUCTORS

IC1	TL072
D1,2	1N4004
D3-7	1N4148
ZD1	1N5352B 15V/5W
Q1	VN10LN

MISCELLANEOUS

RLY1	Relay single pole 16A 24V coil
1 off	8-pin IC socket

HOW IT WORKS

O/L Detect and DAC Volume Control

The overload circuit monitors the output from the graphic equaliser ahead of the volume control to detect overdrive and distortion in the front end of the amplifier. The overload circuit is a peak detector window comparator with adjustable threshold. This is set to indicate overload on the front panel led when driven by a 1kHz 10V RMS sine wave. In use, the graphic settings for each channel are adjusted and then the gain level is set so the loudest signal from the guitar does not turn on the overload led.

The operation of the volume control works in exactly the same way as the gain control shown on the pre-amp board last month. As can be seen the circuits are the same.

PARTS LIST

Overload Detect

RESISTORS (all 1/4W 5%)

R14	470k
R15	220k
R16,17	15k
R18	510R
RV1	20k Multiturn pot

CAPACITORS

C8	470n
----	------

SEMICONDUCTORS

IC6	TL072
D1,2	1N4148

DAC Volume Control

RESISTORS (all 1/4W 5%)

R11	100k
R12	470R
R13	7 x 48k resistor network

CAPACITORS

C6	470n 100V polyester
C7	47p polystyrene

SEMICONDUCTORS

IC4	AD7110
-----	--------

MISCELLANEOUS

5 off	100n decoupling capacitors for overload detect and volume control
-------	---

Next month, in the final part we discuss the construction of the main power supply, the display and display driver circuits together with a description of how it all fits into the cabinet.

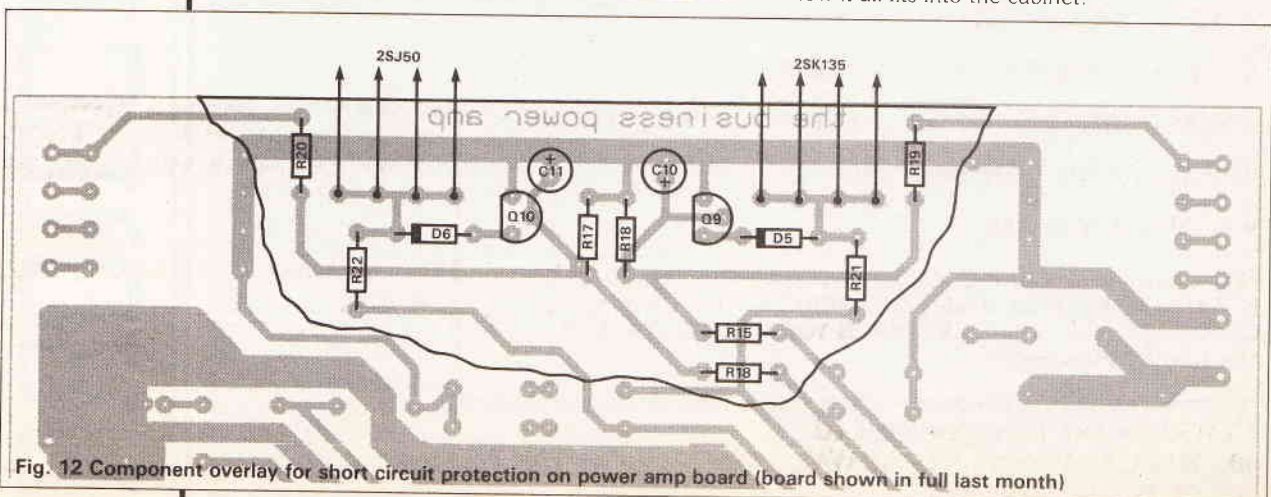

Fig. 12 Component overlay for short circuit protection on power amp board (board shown in full last month)

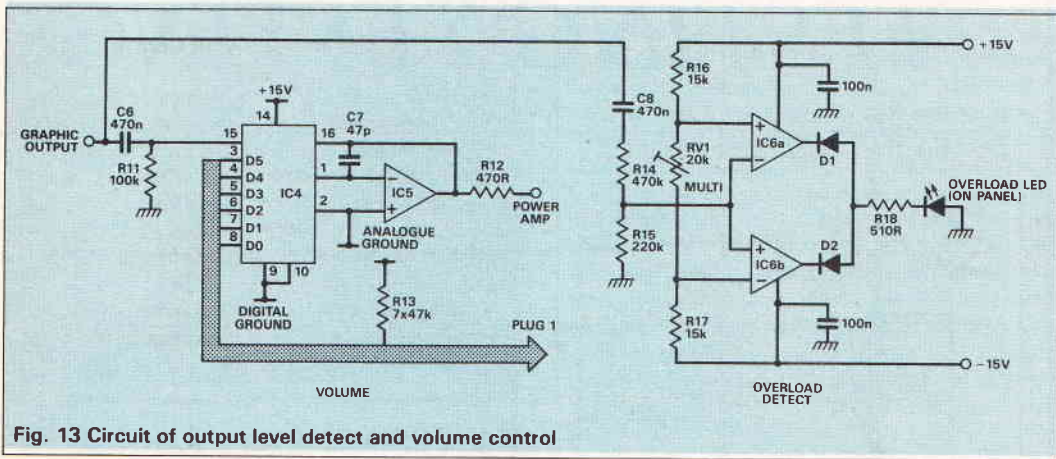

Fig. 13 Circuit of output level detect and volume control

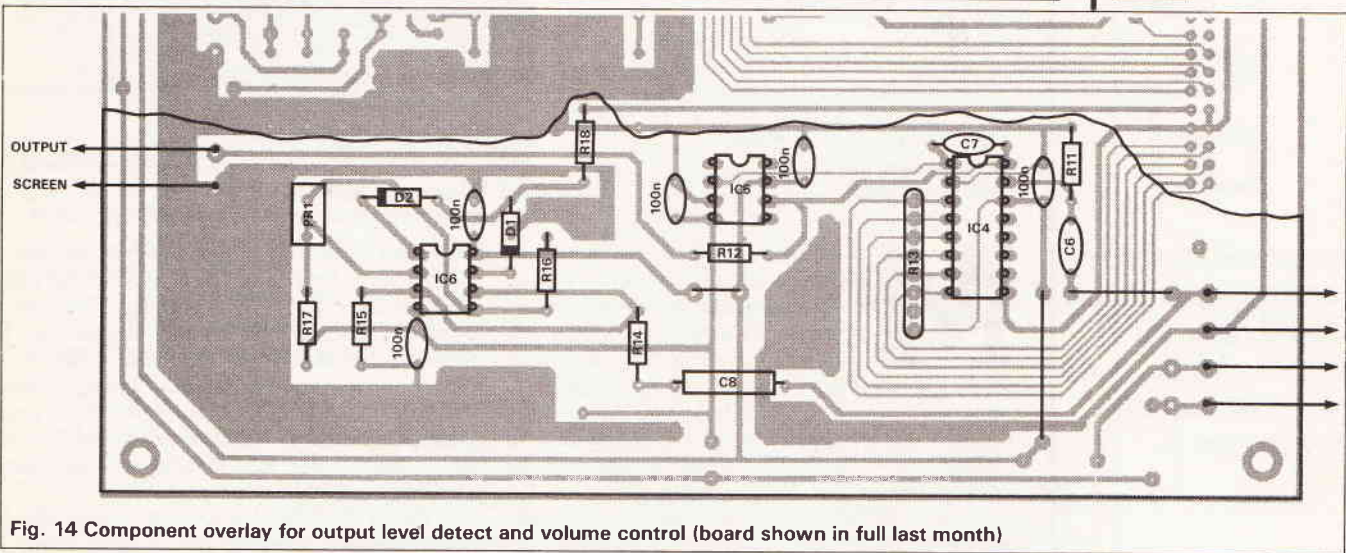
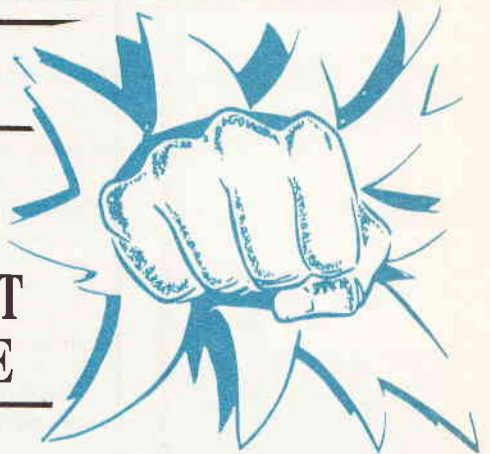

Fig. 14 Component overlay for output level detect and volume control (board shown in full last month)

Remember the new
Component Catalogue
available from
early 1990

CRICKLEWOOD ELECTRONICS



**BIGGER
AND BETTER**

**1990 COMPONENT
CATALOGUE**

- ONE OF THE LARGEST RANGES OF COMPONENTS IN THE UK
- FAST AND EFFICIENT SAME DAY PERSONAL SERVICE
- VERY COMPETITIVE PRICES; QUANTITY DISCOUNTS AVAILABLE
- DISCOUNT VOUCHERS INCLUDED
- NO MINIMUM ORDER

FILL IN THE COUPON AND POST IT WITH YOUR CHEQUE, PO ETC FOR £1.50 TO RECEIVE YOUR 1990 CRICKLEWOOD ELECTRONICS CATALOGUE AND VOUCHERS WHICH YOU CAN USE AGAINST YOUR NEXT PURCHASE

CRICKLEWOOD ELECTRONICS 1990 COMPONENTS CATALOGUE

PLEASE SEND COPIES OF THE 1990
CRICKLEWOOD ELECTRONICS CATALOGUE AT
£1.50 TO:

NAME

ADDRESS

.....

.....

.....

Remittance enclosed £.....

Cricklewood Electronics Ltd
40 CRICKLEWOOD BROADWAY, LONDON, NW2 3ET
Tel: 01-450 0995/452 0161
Fax: 01-208 1441 Telex: 914977

TESTING TESTING

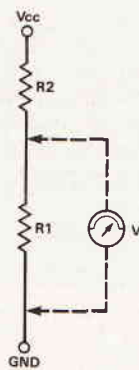

Fig. 1 Illustrating the effects of measuring the voltage across a resistor

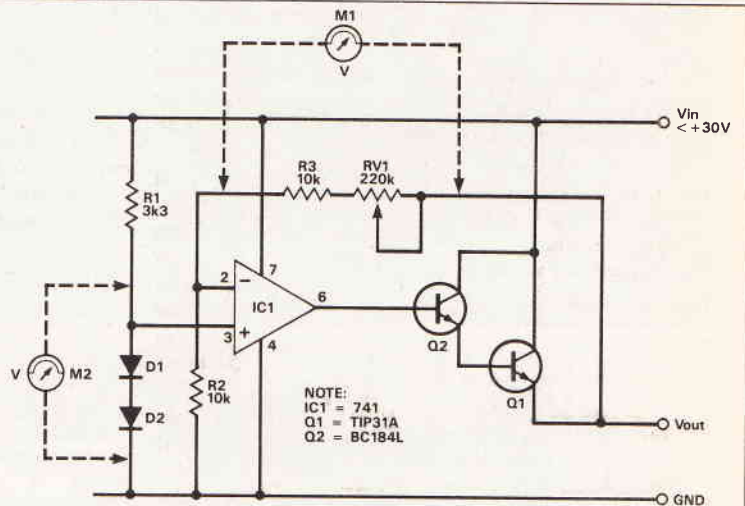

Fig. 2 Basic DC voltage regulator

Having considered the basic test equipment you should have on your bench, Mike Barwise now shows you how to use it.

TEST GEAR

Most fundamental measurements in electronics are those of DC voltages across and currents in passive components. Passive components are generally considered to be those which do not amplify signals such as resistors, capacitors, switches, inductors, rectifier diodes (though these are something of a borderline case, as in some peoples' estimation all semiconductors are active components). Passive components in the presence of DC provide the simplest test and measurement problems you could encounter, but it's still possible to obtain inaccurate results through wrong technique or inadequate precautions.

Simplest measurement of all is the measurement of voltage. A meter is connected in parallel with the relevant part of the circuit under test, and a reading is obtained of the potential difference between two points. Remembering the voltmeter has a finite resistance between its two probes it's easy to see that applying this resistance in parallel with part of a circuit reduces resistance of circuit part. Operating conditions are modified, so the meter reading will never be quite correct and occasionally worse things can happen: the circuit ceases to function or misbehaves in some way while the meter is connected. Let's investigate why. A very simple example is given in Fig. 1, where a meter is used to measure the voltage across the lower resistor of a simple potential divider formed by resistors R1 and R2. Actual voltage can be calculated from the expression:

$$V_{R1} = V_{tot} \left(\frac{R1}{R1 + R2} \right)$$

where: V_{tot} is the input voltage to the whole divider; V_{R1} is the voltage developed across R1. Before the meter is applied, as the two resistors are in series the current in each must be the same. It is the value of R1 and the current flowing through it which defines the voltage developed across it (from Ohm's law). If we now connect a voltmeter across R1, its value is reduced by the resistance of the meter R_m in parallel with it and the effective value R_{1m} is given by the expression:

$$R_{1m} = 1 / (1/R1 + 1/R_m)$$

Measured voltage across R1 will therefore be less than expected and, more important, less than when the meter is absent. In a circuit of this simplicity it's easy to allow for this error: your meter's resistance is

measured using another meter (we're assuming analogue meters here) and Ohm's law can be used to make a correction to the reading. However, the situation is rarely this simple in practice. Total resistance of the whole potential divider is also reduced so more current will flow through it possibly influencing other circuit elements and causing unexpected changes in performance elsewhere in the circuit. We can now look at more practice measurements using a voltmeter.

Figure 2 shows a two-stage voltage regulator circuit capable of delivering about 1A at its output. First stage consists of an opamp used as a DC voltage amplifier. The input signal is a reference voltage derived from a stack of diodes, and the amplification factor is adjustable to provide quite a wide range of output voltage. Second stage is a current amplifier which converts the 10mA or so available at the opamp output into our usable 1A supply current. Note that the current gain stage is included in the feedback loop of the system.

When the regulator is working properly, there should be a constant voltage of about 1.2V (the sum of the forward voltage of the two diodes) between the non-inverting input of the opamp and Gnd, regardless of the supply voltage.

If we attempt to measure this reference voltage using a moving coil meter, we need to know whether the meter makes any significant change in the circuit working conditions. Let's see. By putting the meter in parallel with the diode stack, we added a resistor in parallel with it. Now, the diode stack exhibits its constant voltage drop if a suitable current flows in the diodes. Further, the circuit including the meter is effectively a potential divider with diodes in parallel with the lower resistor. So long as the potential at the most positive anode (defined by the circuit resistor and the meter resistance) would (in the absence of the diodes) be greater than the diode stack drop, current will flow in the diodes and the meter will have no apparent effect on the working of the circuit. The upper resistor has a value of 3k3 and the meter has a resistance of about 20k. Very roughly we have an output potential in purely resistive terms of about 86% V_{in} . Even with a minimum +6V supply, potential divider output is still in the region +5V — sufficient for the diode stack to operate normally. The current drawn by the 20k resistance of the meter is also vastly

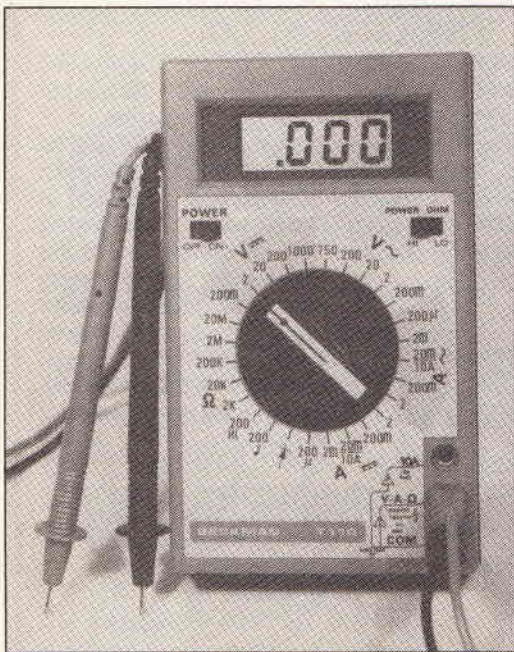

less than the current drawn by the diode stack. The diode stack ON state resistance will be at most a few ohms: the 3K3 resistor in fact effectively defines the diode stack current.

In this measurement, then, the application of a moving coil meter with a 20k internal resistance has no significant effect on circuit performance, and the reading obtained is a valid one.

Suppose, on the other hand, we measure voltage drop across the input resistor at the inverting input of the opamp. This amounts to a reading of voltage at the inverting input, which should theoretically be the same as the reference voltage at the non-inverting input (this is a basic principle of opamps). Applying a moving coil meter, the reading accords with expectations and so everything *looks* fine. But we should also have been monitoring the *output* of the regulator as output voltage increases by quite a lot while the meter is in circuit!

Let's see what happened. Regulator output voltage is defined by the product of the reference voltage and the opamp gain, which in turn is defined by a potential divider formed by the total value of the feedback resistors R_f and the input resistor R_{in} . Opamp gain is calculated for the circuit from the expression $A = (R_f + R_{in}) / R_{in}$.

By applying a meter (internal resistance: 20k) across the 10k input resistor, input resistance is reduced to about 6k6. This *multiplies* the output voltage by a factor of about 1.3. In this case, although a perfectly valid measurement is obtained, the measurement technique does have unexpected effect on circuit performance which *is not immediately noticeable but could do a lot of damage*.

OK, an answer to the problems here is use a digital multimeter with an input resistance of about 10M. But the problem is not *eliminated* by this — merely reduced. The examples use bipolar circuits (essentially low impedance) and a low resistance multimeter, but the digital meter still causes similar problems in high impedance circuits, so a basic rule emerges from this analysis:

Understand the circuit you are testing!

What you must know about the circuit includes:

- what the circuit does
- how it does it
- in-circuit impedances.

Let's look at each of these in turn.

What Does The Circuit Do?

You must be able to define inputs and outputs, analogue and digital sub-systems, supply voltage limits, input voltage limits and so on. You must also have at least a minimal idea of the function of the circuit in black box terms: what kind of input results in what kind of output — the concept of the black box is that you know what the input and output signals of a system are, but you don't care how the system converts the input signal into the output signal. A PCB, say, with a multipole connector at each end and two or three unmarked 40 pin DIL ICs in between is an almost insoluble testing problem. But if you have a list of input and output signals and connector pinouts, the job becomes quite easy (if somewhat tedious!).

Roughly How Does It Do It?

Where the black box of the previous section represents a whole system, at this level the system comprises a set of smaller black boxes, each of which performs one part of the total job. Test and fault finding normally proceeds from a known input signal through the system, stage by stage, towards the output. When an unexpected signal is encountered at a given point, it is probable that a fault is in the black box immediately preceding. This presupposes two things: first you know where each black box starts and finishes, and second you know what the signal *should* be at all tested points.

What Are The In-Circuit Impedances

This information is essential in order to select testing methods which are as far as possible non-intrusive (that is, they don't affect circuit operation). As we discussed when we looked at meters (ETI November '89), the general criterion for adequate measurement dictates that your test probe must have an impedance greater than at least 100 times the circuit impedance at the test point and for critical work, ideally greater than 1000 times. Where this is not possible, you will frequently find that equipment specifications include with nominal test point measurements a record of the test gear used to obtain the measurement. Thus, although the value will not be quite typical of *working* conditions, it will be *replicable* if you use similar test gear.

In the next installment other measurements with meters are discussed, then we'll move on to some more exciting test and measurement scenarios.

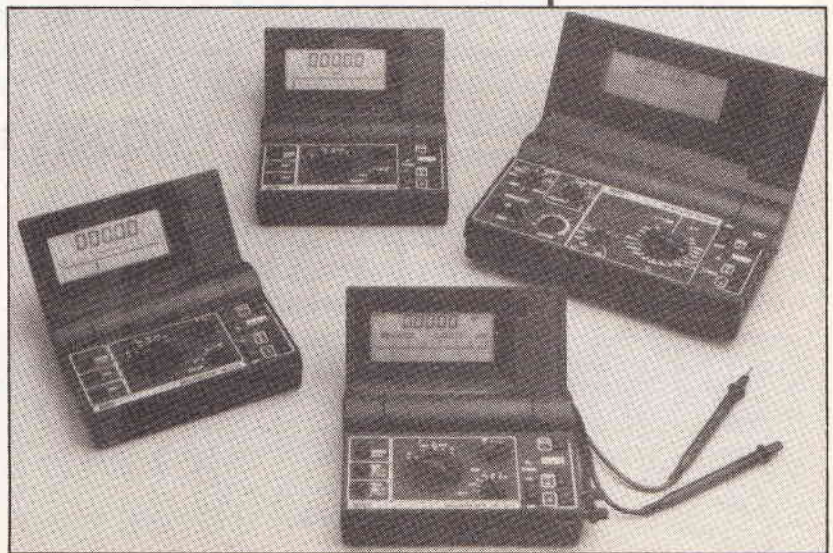

The AVO M2000 range of multimeters

JOIN UP WITH LITESOLD

Professional Soldering Equipment at Special Mail-Order Prices.

SK18 Soldering Kit. £19.75

Build or repair any electronic project. LC18 240v 18w iron with 3.2, 2.4, and 1.6mm bits. Pack of 18 swg flux-cored 60/40 solder. Tweezers. 3 soldering aids. Reel of De-Solder braid. In PVC presentation wallet.



ADAMIN Miniature Iron £8.60

Possibly smallest mains iron in the world. Ideal for fine work. Slim

nylon handle with finger grip. Interchangeable bits available 1.2, 1.6, 2.4, 3.4 and 4.7mm. Fitted with 2.4mm. 240v 12w (12v available). Presentation wallet.

'L' Series Lightweight Irons. 12w £9.20

High efficiency irons for all electronic hobby work. Non-roll handles with finger guards. Stainless steel element shafts. Screw-connected elements. Slip-on bits available from 1.6 to 4.7mm. LA12

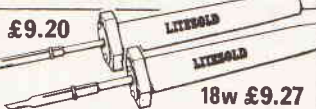

18w £9.27

model, 12w, 2.4mm bit. LC 18 Model, 18w, 3.2mm bit. 240v Std - 12v available. Presentation wallet.

Soldering Iron Stands 3&4 £7.33



Designed specially for LITESOLD irons. Heavy, solid-plastic base with non-slip pads. Won't tip over, holds iron safely. With wiping sponge and location for spare (hot) bits. No 5 stand for EC50 iron No 4 stand for ADAMIN miniature Iron No 3 stand for LA12 and LC18 Irons.

De-Solder Pumps £8.65

High Quality version of increasingly popular type of tool. Precision made anodised aluminium body, plunger guard and high-seal piston. Easy



thumb operation. Automatic solder ejection. Conductive PTFE nozzle - no static problems.

Prices include p&p and VAT. Send order with Cheque/PO. Ring for Access/Visa sales



LIGHT SOLDERING DEVELOPMENTS LTD. DEPT. ET
97-99 GLOUCESTER ROAD, CROYDON CR0 2DN. 01 689 0574

THE DIGITAL 90

A reflex design optimized for CD, the Digital 90 loudspeaker was developed to compete with the best of ready made compact speakers but at a 'DIY' price.

Ideal for use where space is at a premium, the Digital 90 uses Scanspeak's latest Hitech bass unit teamed with the acclaimed Elac metal dome tweeter in a cabinet of only 15 litres. The split-circuit crossover allows biwiring without further modification. The kit comprises of the

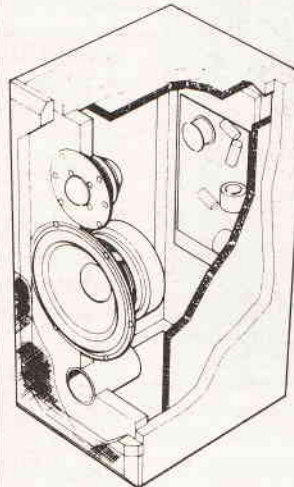

drive units, crossovers, reflex ports, binding posts (8), wadding, grille fabric, flatpack cabinets, (accurately machined from 18mm MDF with all rebates etc. ready cut).

Dims: 480x220x250mm
Response: 45hz - 20Khz
Sensitivity: 87dB 1w/1m
Amp. suitability: 20 - 100 watts.

PRICE: £259 inc. VAT
plus carr/ins £13

telephone credit card orders

WILMSLOW AUDIO LTD

Wellington Close, Parkgate Trading Estate
Knutsford, Cheshire WA16 8DX Tel: 0565 50605
(Closed all day Mondays)

DIY Speaker Catalogue £1.50 post free (export \$6)

Don't miss the LARGEST single day show in the U.K.

NORBRECK

Radio, Electronics and Computing Exhibition

by the Northern Amateur Radio Societies Association at the

NORBRECK CASTLE HOTEL EXHIBITION CENTRE QUEENS PROMENADE, NORTH SHORE, BLACKPOOL

on Sunday, March 18th, 1990

Doors open at 11 a.m.



- * Over 100 trade stands
- * Bring & Buy stand
- * RSGB stand and book stall
- * Restaurant and Bars
- * Organised by over 50 clubs
- * Free car parking (plus free bus service from extra car park)
- * Overnight accommodation at reduced rates (contact hotel directly)
- * Club stands
- * Amateur Computer stands
- * Construction competition
- * Facilities for the disabled
- * Grand Raffle

RADIO TALK-IN ON S22

Admission £1 (OAP's 50p, under 14's free) by raffle ticket and exhibition plan

Exhibition Manager : Peter Denton, G6CGF, 051-630-5790

EXCLUSIVE READERS OFFER

PORTASOL PROFESSIONAL PLUS FREE SUPER "OCTOPUS"

only £39.95 incl p.&p.

(M.R.P. £49.95)

The Portasol Professional is a completely portable gas operated heat tool providing the professional with a four-in-one precision instrument. The unit is adjustable from 10-60 watts and runs for up to an hour on a single fill from standard lighter refills.

Each Portasol Professional comes complete with four interchangeable tips.

- 1) The Soldering Iron is the ideal static free tool for all soldering needs.
- 2) The Blow Torch operates at a temperature in excess of 1300C which makes it the perfect heat tool for heavy soldering jobs, brazing or silver soldering.
- 3) The Hot Blow is ideal for shrink tubing and is adjustable up to a temperature of 500C.
- 4) The Hot Knife cuts and cauterises synthetic materials and is suitable for cutting and shaping plastics, ropes and is adjustable up to a temperature of 450C.

The Soldering and Hot Knife tips use a unique gauze protected catalytic material to give safe, flameless combustion. New and improved exhaust port design makes for increased heat transfer efficiency.

Don't delay - send now! For your Portasol Professional plus **FREE "Octopus"**

Complete and send your form to: Argus Specialist Publications, Reader Offer, Argus House, Boundary Way, Hemel Hempstead, Herts. HP2 7ST. Or telephone your order stating Access/Barclaycard number on 0442 - 66551. Quoting ROMC/1.

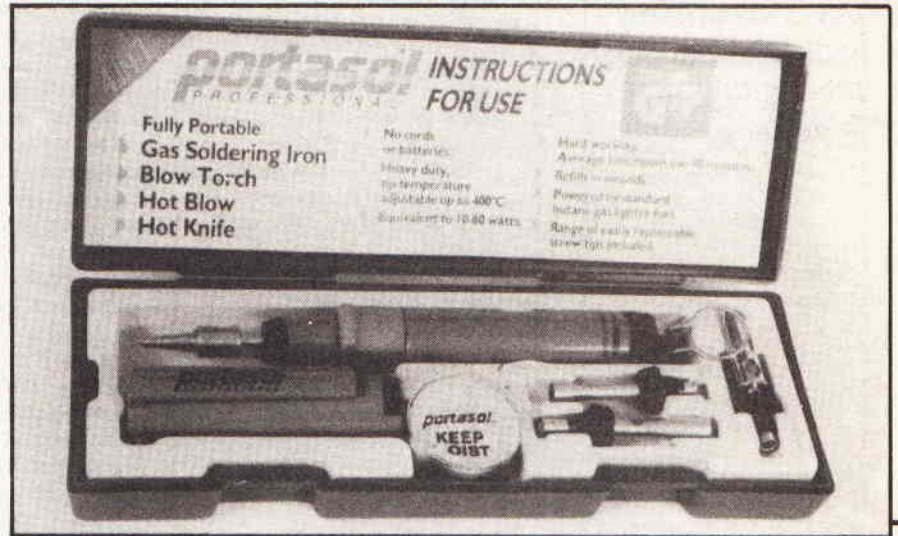

FREE

FREE OCTOPUS WITH EVERY ORDER

RRP £5.95

The extra hands you're always needing.

The Octopus has been designed to give the professional or hobbyist a fine, stable working base that won't slip or wobble under pressure. The base block can be fixed in moments with its own simple C-clamp and it features a padded base to protect table surfaces from marking. Use the Octopus for crafts and model-making, holding delicate parts under the magnifier for fine paintwork or tricky assembly jobs, allowing both hands free for intricate soldering and finishing.

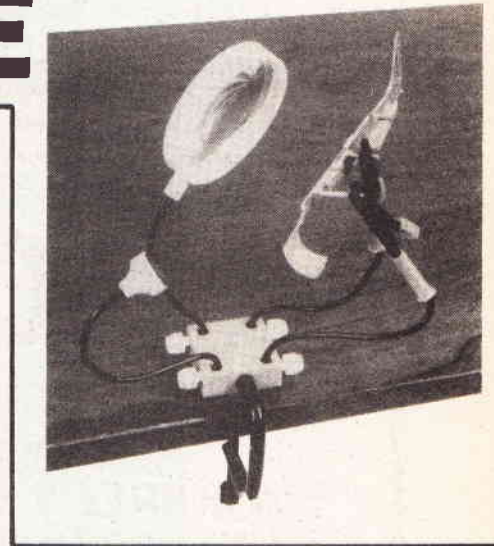

Please supply **Portasol Professional + Free Octopus!** at £39.95 incl. p.&p.
ROMC/1

NAME

ADDRESS

Or charge my **ACCESS/BARCLAYCARD**

Account No:

Expiry Date:

Signature:

EARTH CURRENT SIGNALLING

Part 3: Replication and Results

George Pickworth presents the third part to sending messages through the ground.

In developed parts of the world, earth currents of interest are "buried" under currents leaking from power distribution systems. These pollution currents have a waveform generally identical to those in the power lines: they have spikes and carry other frequencies which extend over a wider frequency range. 50Hz pollution is strongest in urban and industrial areas and filters are therefore a vital part of any present day earth current signalling system.

Natural background currents, such as "whistlers" and other phenomena within the audio frequency range were frequently heard by First World War operators, but now the chances of hearing them depends on locality and the effectiveness of the filters. A variety of man-made signal currents are also present, and of these peculiar "clock pulses" are the strongest at the author's site. These pulses have complex waveform, audible through the low-pass filter as a single low pitched "rough buzz" every second, with "multi-buzzes" every 47 and 9 pulses. So far, the author has been unable to find any way to selectively block these pulses.

Recordings displayed on the oscilloscope suggest that the pulses carry digital information and the author has a feeling that they may possibly originate as ELF electromagnetic waves which are resolved by the base acting as loop antenna and this may well apply to natural currents, some of which are known to have a complementary electromagnetic wave.

There is also a weak fluctuating DC, generated by piezo effect of the enormous pressure on rocks deep within the earth and these currents have long been recognised as a potentially useful tool to give warning of earthquakes. A steady 5-10mV DC appears across the base, the origin of which is unknown.

Steady DC can be generated by the base, when the earth pins become electrodes and the soil moisture the electrolyte. The strength of the current is determined by the nature of the earth pins and the chemical composition of the soil moisture. It is therefore important the earth pins at both ends of a

base be made of the same metal. It was found that clean steel earth pins generate virtually no galvanic current, but this would not necessarily be the case if the pins were to remain in the soil for an extended period and allowed to become rusty.

Simulating early equipment

After successfully experimenting with a car hooter as a replica of the early buzzer systems, it was realised that square waves generated by an asynchronous DC to AC power converter are much the same as those generated by the power buzzer and were used during the trials to simulate a power buzzer. An audio amplifier was used to simulate an audio frequency alternator; an open reel 4-speed tape recorder plays back tapes on which tones have been recorded. Output is boosted to about 20W by a class A transistor stage driving a TDA 20005M IC. In the original trials, the amplifier was matched to the base by a combination of step-up transformer and toroidal variable transformer.

The DC/AC power converter is built around a salvaged mains transformer having a 12-0-12V and 6-0-6V secondary windings and a 250V primary winding. The original converter, with feedback taken from the 6-0-6V winding, could not be induced to operate at frequencies higher than about 400Hz. However, by obtaining feedback directly from the 12-0-12V winding, the converter was found to oscillate readily from about 50Hz to 5.0kHz, but frequency is dependant upon loading. Fortunately a frequency extending from about 1.0kHz to 5.0kHz occurs with loading from 20 to 25W so it is possible to vary the tone over the most useful frequency range without significantly changing the power output. Loading however, is critical, hence the use of the toroidal variable transformer (Fig 1).

A loudspeaker, connected to the 6V winding through a 50R volume control, gives an audible output. Power output was first determined by noting the brightness of a 25W 250V bulb at various frequencies. At full output power, DC input is about 3A. Output is square wave AC whereas the output from the power buzzer is pulsed DC. Attempts to produce pulsed DC, by rectification and syphoning off the negative going half of the cycle, were abandoned because of problems in balancing the bleeder resistor with the base load. All the trials were therefore with square wave AC. Unfortunately the power converter does not take kindly to keying and is thus useless for signalling, nonetheless, it proved to be a useful signal generator.

C type amplifiers

Little information was published on the characteristics of the early A type valves used in the C type amplifiers, indeed such data was deemed unnecessary until the 1920's. Probably one of the earliest valve curves is that for the first valve of the C Mk 1V amplifier when used in slope detector for radio signal. The R valve, which was the successor to the A valve, had, from the best information available to the author, a gain of nine. It would therefore be reasonable to take the gain of the A valve as about eight. British and French valves were

SIGNALS

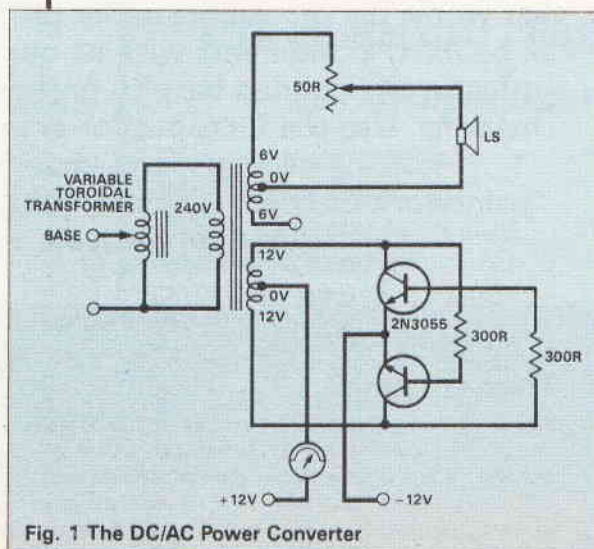

Fig. 1 The DC/AC Power Converter

considered to be slightly better than the equivalent German valves which had a gain of about five. Power gain is however, more meaningful.

To gain some idea of the power gain of a C type amplifier, trials were made with the simulated power buzzer and a simple power meter. Four hundred metres was the limit for the meter to give significantly higher readings, when the transmitter was operating, than background currents: it consists of a 1:1 impedance matching transformer (to by-pass DC) loaded by either a 250 or 350ohm resistor. Voltage across the resistor, measured with a DDM, was converted to μW and was roughly inversely proportional to the square of the distance from the transmitter. Extrapolation suggested that the power transferred from a typical base to a C type amplifier would be about $0.025\mu\text{W}$ at 2000m, and only about $0.006\mu\text{W}$ at 4000m and this was supported by field trials with a simulated C type amplifier. The trials were on clay loam overlying limestone. Unfortunately, because of 50Hz pollution and other man-made currents, it is unlikely that the range of WW1 power buzzer and C type amplifier will ever be replicated with simulated equipment.

As 2000m was the norm for WW1 signalling and taking $500\mu\text{W}$ output from the C type amplifier as sufficient to give a strong signal with the 60R headphones, it seems reasonable to assume that the receivers could give a good signal from an input of $0.025\mu\text{W}$ and a readable signal from inputs as low as $0.006\mu\text{W}$. Power gain would therefore be around 20000. For comparison, when used as a passive receiver, the very best 8000R headphones, required about $50\mu\text{W}$ to give an audible signal.

Filters

To offset the negative gain of the high pass filter, an additional amplifier was incorporated so that the overall gain of the receiver was comparable to that of a WW1 earth current receiver. Input impedance would to all intents and purposes be the same. An IC main amplifier was tried first, but was found to be susceptible to RF pickup: much better results, probably because of the much lower overall impedance, were obtained with discrete transistors. The C type amplifiers did not have a conventional gain control, so presumably gain was reduced by using the rheostat to decrease the voltage to the filament of the first valve.

While the filters effectively block 50Hz sine waves, spikes and other voltages riding on the 50Hz mains leakage are able to pass through the filter and are heard as a sharp buzz rather than hum. Nonetheless, both the high pass and the notch filters allowed signals to be heard that would otherwise have been buried under 50Hz pollution. The power meter, originally used to estimate the sensitivity of a C type amplifier, was also used to give an indication of the efficacy of the high pass filter (see Table 1).

Table 1
BACKGROUND CURRENTS
(Mainly 50Hz - measured with a DMM)

Location	Total AC input across 250R		Filter output across 10kR		NOTES
	mV	μW	mV	μW	
100m from village	60	14	20	0.040	Moderate 50Hz buzz, clock pulses, various on/off tones and morse
Author's receiver site	10	0.33	13	0.017	Very slight 50Hz buzz, otherwise as above. Loud hum with filter not operating

The slope of the high pass filter is almost 18dB/octave and the turnover point is 250Hz. Power is provided by two PPM 9V batteries in series and the filter is able to handle inputs up to 500mV. It is designed for source impedance of less than 6k0 (Fig. 2). Component values for the high-pass filter are not critical provided that filter capacitors are fairly well matched. On the other hand, components for the notch filter (Fig. 3) are critical and as the author does not have a capacitance meter, the values of a number of capacitors were measured in a laboratory so that a pair could be selected. Resistance values were then calculated and the correct value achieved by connecting resistors in series and parallel.

Field trials

The field trials were dominated by the clock pulses which gave strong beats with 1.0kHz square waves generated by power converter at a range of up to 500m. At 2000m, the 1.0kHz tone was just audible between the "clock pulses" and through miscellaneous unidentified on-off tones and morse tones (see Table 2). A 4kHz tone gave stronger beats with the clock pulses at 500m but at 2000m the signal strength was almost the same as with 1kHz.

Using the audio amplifier to transmit recorded

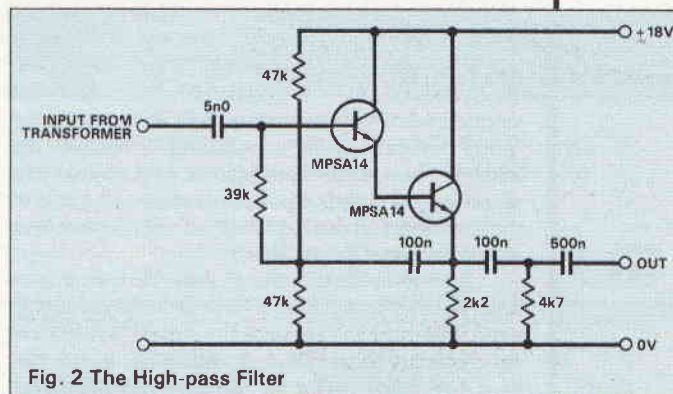

Fig. 2 The High-pass Filter

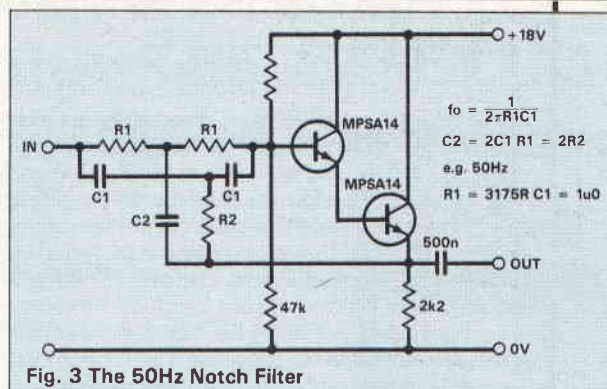

Fig. 3 The 50Hz Notch Filter

speech and music (approx 20W peak), speech was unintelligible at 400m but loud and clear at 200m where the level of softest of the speech signals were above background noise.

The figures for power were obtained by measuring the voltage across the input of the simulated C type amplifier after the signals had passed through the high pass filter and its compensating amplifier, and refer to a particular site at a particular time of the year. The trials have not yet been replicated at different sites (see Table 2 and Fig. 4).

Loop antenna?

Notwithstanding that the "clock pulses", morse tones, and miscellaneous "on/off" tones disappear if the long base lead is disconnected at the earth pin and left lying on the ground, and thus seem to be received as earth currents. As already mentioned they could originate as ELF electromagnetic wave transmissions and are

Table 2
FIELD TRIALS WITH SIMULATED "C" TYPE AMPLIFIER
AND POWER BUZZER

Range m	Amplifier input across 10kohms		NOTES
	mV	µW	
500	70	0.500	Loud tone and strong beats with "clock pulses"
2000	15	0.025	Tone barely audible between "clock pulse" and through background noise

NOTE. Tables 1 & 2. Output from the high pass filter was increased by additional amplifier stage to compensate for negative gain of filter.

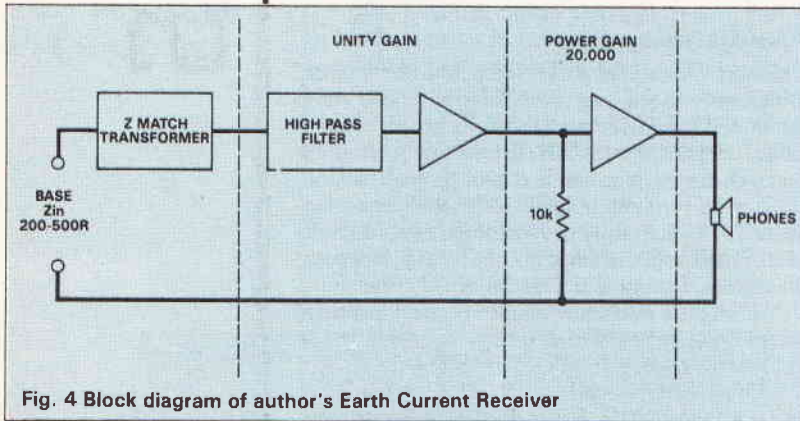

Fig. 4 Block diagram of author's Earth Current Receiver

resolved by the base acting as an ELF loop antenna. Some natural currents, including "whistlers" are known to have an electromagnetic wave counterpart and the loop antenna possibility may well apply to these currents. Indeed, pick-up of radio signals was a problem even during WW1!

Reports indicate that both defence departments and research organisations have experimented with earth antennas and perhaps the largest consisted of earth plates placed in sea water across the narrow part of a peninsula, where the surrounding sea water, having a lower resistance than land, formed a conductive loop.

The base/high pass matching transformer is a single winding auto transformer on a 0.5inch laminated iron core with taps, selected by a rotary switch, to match bases with characteristic impedances ranging from 200 to 500R. Although the transformer performed correctly during bench tests, when connected to a base, the position of the selector switch had a significant effect on the reception of clock pulses and other man-made signals which is not consistent with impedance matching, moreover this effect does not apply to true earth currents generated by the power converter. This supports the loop antenna suggestion and the transformer acts as a variable inductance to form a tuned system with the base.

A further complication is that the transformer seems sensitive to electromagnetic fields. A double-winding transformer with a Faraday screen would probably be better. A potted transformer or toroidal transformer wound on a ferrite core may well be even better. Any amplifiers with a low input impedance so eliminating the transformer and fine matching made with "L" pads may well be the best approach.

The author is keen to determine whether the unidentified man-made currents are in fact earth currents before embarking on trials with more powerful and sophisticated earth/current systems. One approach to resolving the question is to complement the earth current receiver with a low frequency radio receiver.

Although the trials with the power buzzer and C type amplifier (Fig. 5) have been rewarding and

provided much data on which to base trials with more advanced equipment, these trials can only be considered as a simulation of the open radio equipment used during the turn of the century, and before Sir Oliver Lodge demonstrated the advantage of tuned systems. If earth current communication is to have any future, sophisticated communications techniques, similar to those used with radio, will need to be adopted and the development of such techniques could be a worthwhile challenge for amateur investigators.

Footnote

FORK & SPADE

The author found the steel earth pins awkward to insert and extract to he tried using a pair of large spades, which are easy to use. Surprisingly, on compact pasture land, resistance of the base, was slightly less than with the steel pins although the steel pins were superior on fairly loose arable land. The spades were cleaned to bare metal by means of a sanding disc.

The surface area of the spade is greater than the surface area of the steel pins so the results should not have been unexpected: the resistance of a 100m base being only 230. A finding that was rather unexpected, was that large digging forks which are far easier to insert than the spades, were almost as good. However, the soil was much more moist than when the original measurements were made, and the spade and fork may not be so good when drier conditions return.

Background currents preclude measuring the resistance of a base with a DMM: the result is invariably a negative reading. Analogue multimeters also give misleading readings if DC is present, so a special resistance meter is used passing a current of about 0.5amp to swamp other currents present.

Matching

To all intents and purposes, the impedance of a base is the same as its DC resistance and the resistance of the author's bases ranged from about 400R during the dry summer to about 250R after the autumn rains. For maximum transfer of energy, the characteristic impedance of the base has to be matched to the output impedance of the transmitter. As the impedance of the base will vary according to soil conditions and will almost certainly be different at other sites, the matching device should ideally be variable.

An audio frequency amplifier will normally be used as the transmitter: typically a 12V operated device using a low impedance bridged output to provide fairly high power from a low operating voltage. Technically, matching is straight forward, but as transformers dedicated to this operation are unavailable, investigators have the option of winding a custom made transformer, using readily available kits, or adapting a normal commercial transformer.

If the former approach is considered the best match is when:

$$\frac{N_s}{N_p} = \sqrt{\frac{Z_s}{Z_p}}$$

Where N_p and N_s refer the number of turns of the primary and secondary windings respectively, and Z_p and Z_s the impedance of the circuits to be matched. The same applies of course when matching the base to the amplifier input.

If the latter approach is taken, the obvious choice for powers up to about 25W is a transformer designed to match the low impedance output of a normal audio amplifier to a 70 or 100V distribution line. By selecting the optimum input tap, (typically 2.0 to 16R) a reasonably good match can be obtained, but this does require some form of power meter. PA amplifiers with 70 and 100V outputs may well be suitable, but have not been tried by the author. As an expedient, an

ordinary mains transformer having 120/240V input and a range of low voltage outputs may be used. Such transformers work surprisingly well over much of the audio frequency range and one was used by the author during his early experiments.

Taking the maximum loading for the amplifier as 3.0R and the impedance of the base as 350R,

$$\frac{350}{3} = 116.6 \sqrt{116.6} = 10.80$$

The turns ratio should therefore be about 11:1

As the ratio of the voltages is equal to the turns ratio, it follows that the 12V secondary winding tap and 120V primary winding tap should give a good match, and this was confirmed by actual experiment.

Voltage and current figures refer to constant amplitude signals and doubling the voltage does of course, quadruple the power, which in turn can overload the amplifier. For example, 70V across a 250R base will cause a current of 0.28A at 19.6W: increasing the voltage to 100V causes a current of 0.4A at 40W. Matching is therefore quite critical.

For optimum matching, the author is presently trying out a 0.5A toroidal variable transformer and although the upper frequency range of these devices is generally given as 400Hz, which applies to output voltage regulation and not to overall frequency response, tests were found to operate over the virtually the whole of the audio frequency band. However, being auto transformers, only a very small section of the winding is energised when used to step-up very low voltages, which cramps adjustment to tiny sector at the end of the scale and most probably reduces efficiency: this drawback can be overcome by first stepping-up the amplifier output with a normal double coil transformer, to a voltage higher than that required,

a variable stopdown transformer.

Matching to the receiver depends on the amplifier input impedance, but transformers designed to match 300 – 600R microphones to amplifiers with an input impedance of 10 to 20kΩ have been used by the author. While generally satisfactory, the ones tried, were susceptible to saturation by strong 50Hz currents and even by galvanic DC. Other than putting the 50Hz filter ahead of the transformer, probably the best approach is to custom wind a multi-tap transformer on a fairly substantial core: this would also by-pass DC.

An option is to use an amplifier with a low impedance input, about 700R, and match to the base by means of a simple asymmetrical "L" pad. However, the 50Hz notch filter and the band pass filter largely determines input impedance, and of course, the same applies to transformer matching. It would therefore seem logical to integrate the filters with a matching device. Indeed the matching device, together with a changeover switch, when two way working is required, is best considered as part of the base.

The base and the matching arrangement are the only parts of the system that are unique to earth current signalling, and present considerable scope for innovation. Having said that, an efficient matching system will not only allow the use of most ordinary amplifiers as transmitter or receivers, but enable a wide range of measuring equipment to be used.

While battery operated receivers present no electrical hazard, transmitters do. If the soil is dry and the resistance of the base is say 400R, the voltage across the base may exceed 100V. Although this is unlikely to be fatal, normal mains voltage precautions should be observed. The only real hazard is if someone pulls the earth pins out of the ground when transmitting. The open circuit voltage may then rise dramatically and give a nasty shock.



Special ETI Offer

PRE-PUBLICATION BOOK RELEASE £7.95 inc p&p ELECTRONIC POWER SUPPLY HANDBOOK

By Ian R. Sinclair
Published by PC Publishing

- Covers many types of supplies — batteries, simple AC supplies, switch mode supplies and inverters.
- Includes stabilisation and regulators.
- Explains operating principles and gives typical circuits.
- For technicians, students and enthusiasts.

An invaluable book on an often neglected subject.



Offer
Closes
2nd April
1990

ETI READER OFFERS
ARGUS HOUSE, BOUNDARY WAY,
HEMEL HEMPSTEAD HP2 7ST

Telephone Orders
(0442) 66551
Access/Visa

UK only (Overseas on request)
Allow 28 days for delivery

Order to:
ETI READER OFFER, Argus House, Boundary Way, Hemel Hempstead HP2 7ST.

Please supply ROET1/16

Total amount enclosed

Name

Address

Cheques/PO payable to Argus Specialist Publications or debit my Access/Visa

--	--	--	--	--	--	--	--	--	--	--	--	--	--	--	--	--	--	--	--

Signature Expiry



Guitar Tuner (May 1989)

On the PCB overlay: the component labelled IC1 to the right of capacitor C7 should be labelled IC4. IC4 should be labelled IC3. Connection P2 is to the battery +ve supply. Socket SK1 is connected to points P3,4,5, except that these points should be connected via links to the pads directly to their right on the PCB! Diode polarity is not shown. Parts list should contain R5,8,21=47k, R6,22=10k.

Intruderbeam (October 1989)

In the circuit diagram: R9 should read 220R not 220k. Capacitor C1 is shown the wrong way round. Capacitor C2 should be 4 μ 7, not 2 μ 2. In the Parts List for the control unit: R6,8=1M; R7=1k; R9=220R; R10=470R 1/2W.

Virtuoso Power Amplifier (November 1989)

In the circuit diagram: the base of Q49 should go to R46, and not R47. Bases of Q45, 43 should be connected. R44 should be 220k.

Low Voltage Alarm (January 1990)

Resistor R1, shown in the circuit diagram as 1k0, should be 4k7 as in the Parts List. Pins 9 & 11 of IC1 on the PCB should be linked. This is incorporated in PCBs from the ETI PCB Service.

Motorcycle Intercom (January 1990)

On the circuit diagram, R2 and R6 should be 100k, not 100R. Pins 1 & 5 of IC1 should not be connected to earth. Pin 2 should be connected directly to the junction of R2 & 3 — not to earth too. Capacitor C10 should be an electrolytic with positive uppermost. Junction of R39 & 20 should be labelled 1/2Vcc. All references to 0V5 should read 1/2Vcc. On the PCB overlay, R2 and R6 should be transposed. Similarly, R8 & 9 should be transposed.

Digital frequency meter (November 1989)

Regarding Fig. 3. The line from pin 1 of IC1 to pin 2 of IC8 should connect to the Latch/Enable Strobe common line. It is shown crossing.

Fig. 4. The wirelink from IC13 pin 1 to the Latch/Strobe common line for ICs 7-10 is not shown on component overlay. A wire link should be inserted.

If built as shown, ICs 7-10 are held permanently latched and no digits are passed from counters. The display will be a random set of static digits.

Output 7 of IC 15 drives both Q5 and IC12a via D8. If output 7 does not reach a valid high level then the display is not enabled showing a zero with no input. To cure this drive Q5 from output 8 (pin 9) of IC 15. Base resistors of Q5-12 (R's 41-48) may be adjusted to provide sufficient drive depending on the gain of the transistors used. They may be reduced to about 3k3 if necessary.

Eprom Emulator (February 1990)

Under the construction heading, the bracket should include and read: so for example the \$0000-\$1FFF and \$8000-\$9FFF blocks are an illegal pair. The 18th line should read: If you are thinking of using non adjacent blocks. Fig. 5. shows a label LK3.

Oscilloscope (February 1990)

Fig. 3. does not show the polarity of diodes D105,6. The cathodes point up the page. Diode D304 is a 1N4148. Capacitors in the deflection amplifiers parts list are incorrectly numbered and should be C205,206,213 and not C105, 106, 113.

PCB FOIL PATTERNS

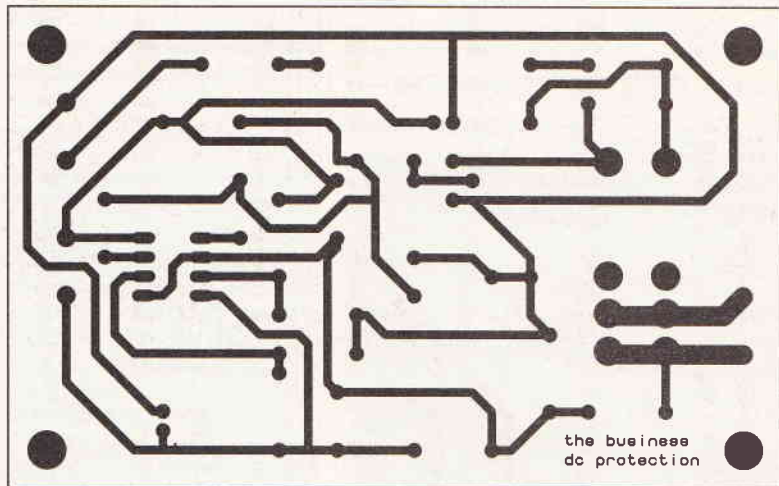

Bass Amplifier DC Protection board

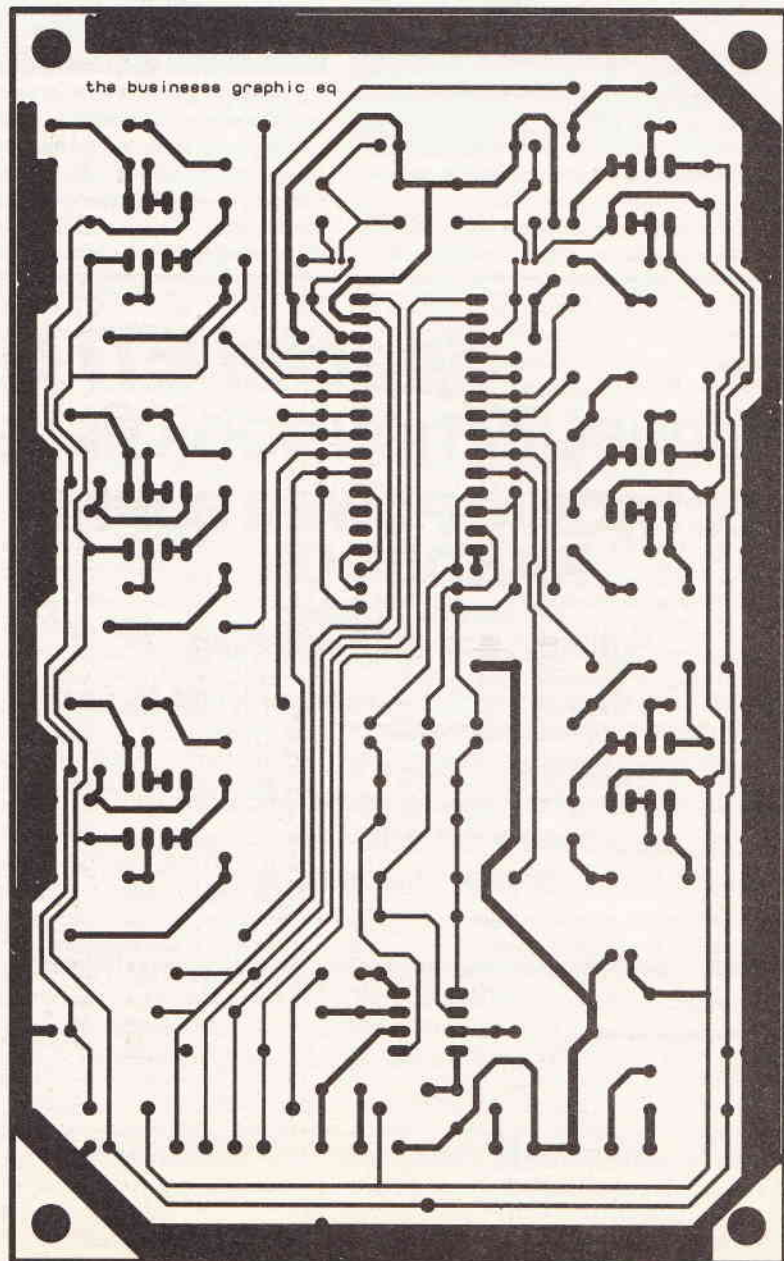

Bass Amplifier Graphic Equaliser

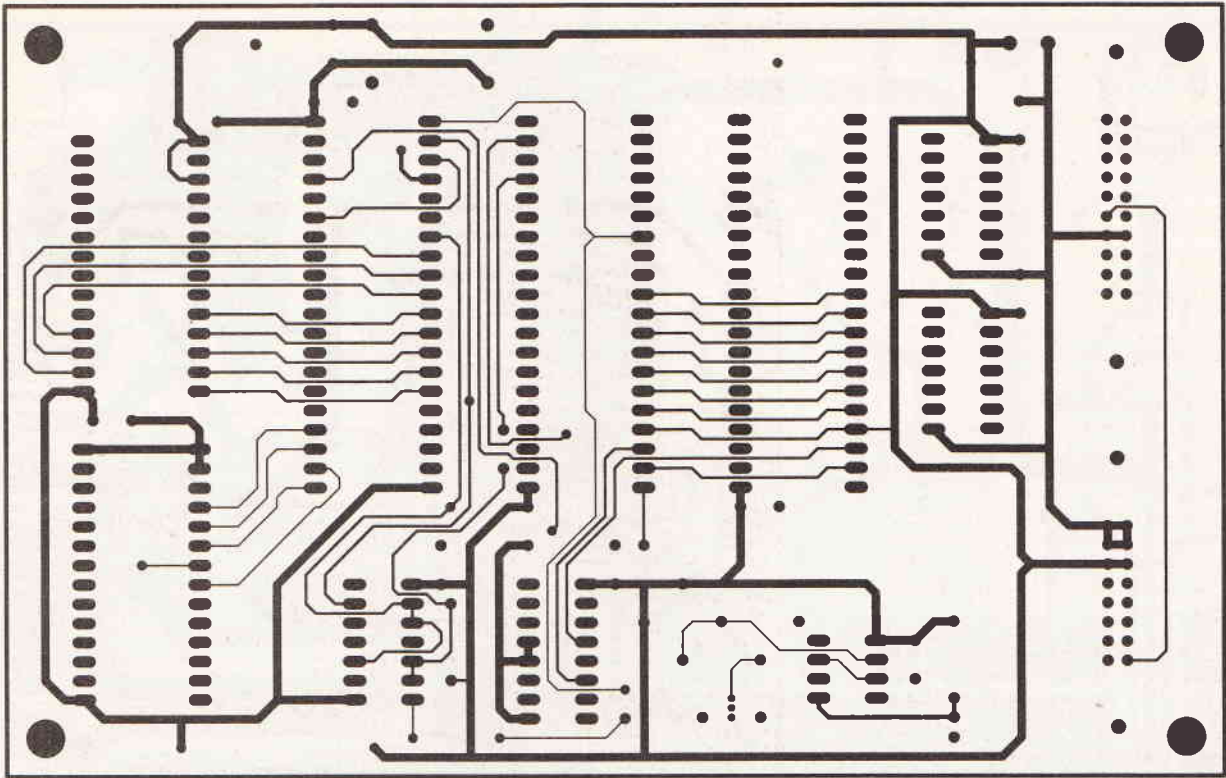

Bass Amplifier Micro (top side)

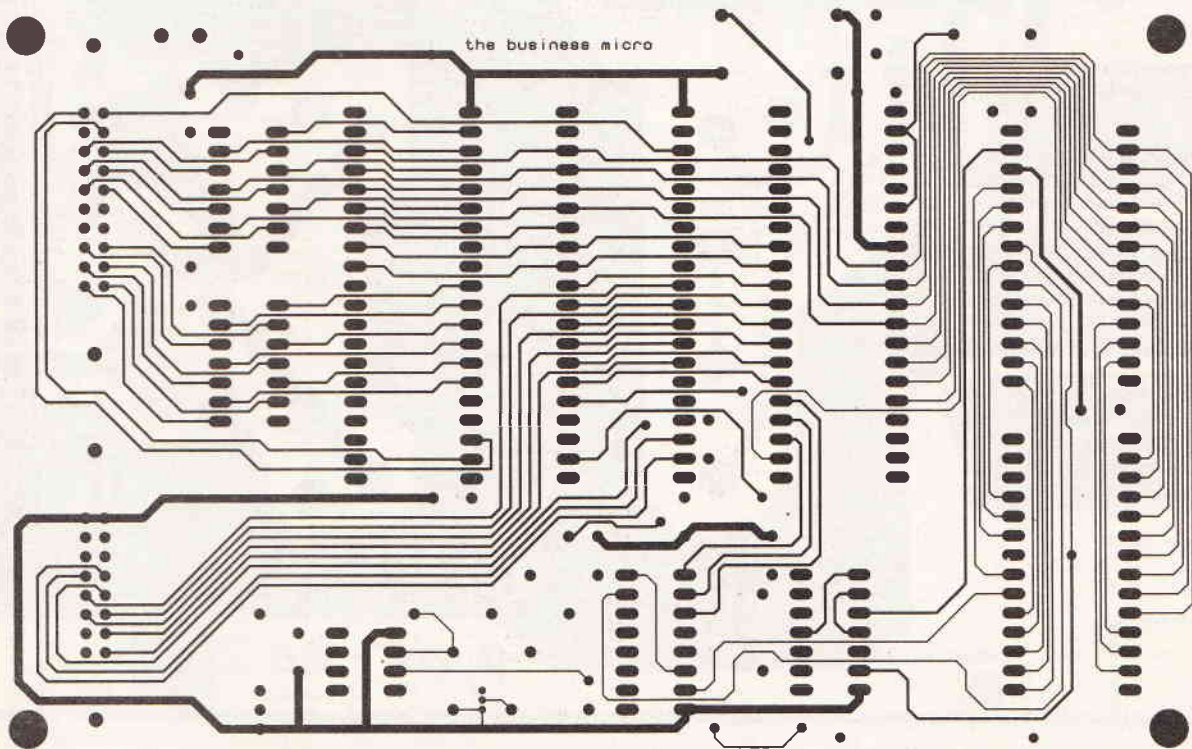

Bass Amplifier Micro (copper side)

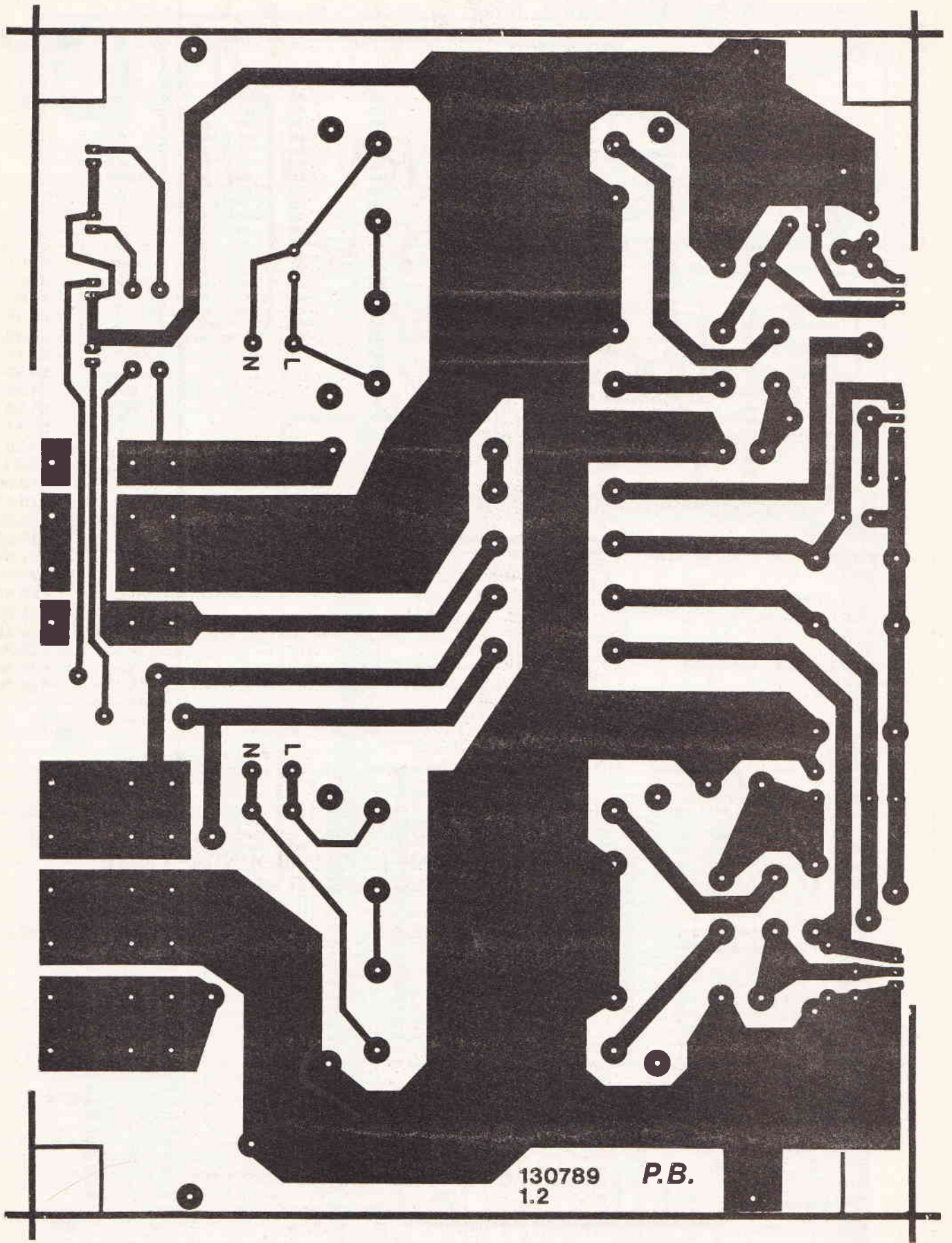

130789 P.B.
1.2

Quad Power Supply foil



PCB SERVICE

April

TELEPHONE
ORDERS
may be made on
(0442)
66551
ACCESS or VISA

- E9004-1 Bass Amplifier DC Protection F
- E9004-2 Bass Amplifier Graphic Equaliser . L
- E9004-3 Bass Amplifier Micro N
- E9004-4 Quad Power Supply O

PCBs for the remaining projects are available from the companies listed in Buylines.

Use the form or a photocopy for your order. Please fill out all parts of the form. Make sure you use the board reference numbers. This not only identifies the board but also tells you when the project was published. The first two numbers are the year, the next two are the month.

Terms are strictly payment with order. We cannot accept official orders but we can supply a proforma invoice if required. Such orders will not be processed until payment is received.

Price code	Price (inc. VAT)
C	£1.80
D	£2.50
E	£3.25
F	£4.00
G	£4.75
H	£5.50
J	£6.62
K	£7.20
L	£8.80
M	£10.60
N	£13.10
O	£15.80
P	£17.90
Q	£21.80
R	£23.90
S	£25.90
T	£29.00
U	£32.20
V	£35.80
W	£37.90
X	£40.70

- | | | | | | |
|---------|---------------------------------------|---|---------|------------------------------|---|
| E8903-2 | MIDI Programmer | L | E9002-2 | Superscope Mother Board | M |
| E8903-3 | Balanced Disc Input Stage | F | E9002-3 | Superscope CRT Driver Board | K |
| E8903-4 | Digitally Tuned Radio | G | E9002-4 | Superscope Timebase Board | K |
| E8904-1 | Camera Trigger | E | E9003-1 | Superscope Y1 input board | J |
| E8904-3 | Intelligent Plotter Main Board | O | E9003-2 | Superscope Y2 input board | J |
| E8904-4 | Kinetotie Tie Board | N | E9003-3 | Superscope switch generator | E |
| E8904-5 | Kinetotie Control Board | E | E9003-4 | Business power amp board | L |
| E8905-1 | Guitar Tuner | H | E9003-5 | Business power supply board | J |
| E8905-2 | Camera Trigger Ultrasonics (2 boards) | F | E9003-6 | Business pre-amplifier board | L |
| E8905-3 | Bench Power Supply (2 boards) | H | E9003-7 | Water hole | G |
| E8906-1 | PC edge connector | F | E9003-8 | Super Siren | D |
| E8906-2 | MIDI converter CPU | N | E9003-9 | Val's badge | F |
| E8906-3 | MIDI converter keyboard | N | | | |
| E8906-4 | MIDI converter control | M | | | |
| E8906-5 | AF signal generator | G | | | |
| E8906-6 | Mini bleeper | C | | | |
| E8906-7 | Caravan heater controller | G | | | |
| E8907-1 | MIDI Patch Bay | G | | | |
| E8907-2 | Priority Quiz Switch | E | | | |
| E8907-3 | Camera Trigger Infra-reds (2 boards) | G | | | |
| E8907-4 | Aerial Amplifier main board | E | | | |
| E8907-5 | Aerial Amplifier power supply | E | | | |
| E8908-1 | Intercom master station | L | | | |
| E8908-2 | Intercom slave station | F | | | |
| E8908-3 | Intercom power mixer | E | | | |
| E8908-4 | Digital joystick-to-mouse conversion | H | | | |
| E8909-1 | Twin Loop Metal Locator | H | | | |
| E8909-2 | Trembler movement detector | D | | | |
| E8909-3 | Field power supply (spec 3) | C | | | |
| E8909-4 | Micro monitors active filter | F | | | |
| E8909-5 | Chronoscope auto-reset | C | | | |
| E8910-1 | Multimeter | H | | | |
| E8910-2 | MIDI Mapper | M | | | |
| E8911-1 | Smoke Alarm main board | F | | | |
| E8911-2 | Smoke Alarm power supply | F | | | |
| E8911-3 | Frequency Meter (3 boards) | O | | | |
| E8911-4 | Serial Logic Scope | L | | | |
| E8912-1 | Mains Failure Alarm | D | | | |
| E8912-2 | Surveillance PCB | D | | | |
| E8912-3 | Slide/Tape Synch | E | | | |
| E8912-4 | Pedal Power | L | | | |
| E8912-5 | Digital Noise Generator | K | | | |
| E9001-1 | 20 metre Receiver | J | | | |
| E9001-2 | Wavemaker FG | L | | | |
| E9001-3 | Motorcycle Intercom | F | | | |
| E9001-4 | Low Voltage Alarm | C | | | |
| E9002-1 | EPROM Emulator | N | | | |

TO: ETI PCB SERVICE, READERS' SERVICES,
ARGUS HOUSE, BOUNDARY WAY,
HEMEL HEMPSTEAD HP2 7ST

Please supply:

Quantity	Ref. no.	Price Code	Price	Total Price
----------	----------	------------	-------	-------------

Post and packing £0.75

Total enclosed £

Please send my PCBs to: (BLOCK CAPITALS PLEASE)

Name

Address

Postcode

CHEQUES SHOULD BE MADE PAYABLE TO ASP Ltd.



Courses

ilea

City Poly
City of London Polytechnic

MUSIC TECHNOLOGY DEPARTMENT

Head of Department T Pamplin

Do you want a career in AUDIO/MUSIC TECHNOLOGY?

In the Music Technology Department we run internationally recognised, BTEC accredited National and Higher national Diplomas in Electronics for the Music Industry.

The courses are two year full time and include elements of design and construction, analogue technology, digital techniques and acoustics.

FACILITIES

2 fully equipped electronics laboratories acoustics lab with analogue and digital analysis facilities 16 track recording studio fairlight, Atari, Digital Mastering, Instruments and outboard equipment.

WHO SHOULD APPLY?

Ideally national Diploma applications should possess the equivalent of 4 GCSE passes at grade C or above and Higher Diploma applications relevant knowledge or experience can be accepted onto the course regardless of qualifications.

INTERESTED?

Then call 01 247 1953 and ask for an application form and further details or write to The Music Technology Department, LCF, 41 Commercial Road, London E1 1LA.



NATIONAL
COLLEGE OF
TECHNOLOGY

PACKAGED SHORT COURSES

The National College of Technology (NCT Ltd) offers a range of packaged short courses in analogue electronics, digital electronics and fibres and optoelectronics for study at home or at work. The advantages are that you may.

— commence at any time— work at your own pace
— have a tutor (optional) and there is no travelling involved. BTEC certificates are available subject to the conditions of the award. These highly popular packed courses contain workbooks, a cassette tape, circuit board and components necessary to provide both theoretical and practical training.

Whether you are a newcomer to electronics or have some experience and simply need updating, there is probably a packaged short course ready for you. Write or telephone for details, quoting ETI to:

NCT Ltd, Bicester Hall

5 London Road, Bicester, Oxon OX6 7BU

or telephone (0296) 613067 Ext. 202

Newark
—technical—
COLLEGE

offers a wide range of full-time Music Industry and Technology Courses including:

B/TEC National Diploma in MUSICAL INSTRUMENT ELECTRONICS (with recording studio option) 2 years

CERTIFICATE in MUSIC INDUSTRY MANAGEMENT 1 year

DIPLOMA in MUSIC INDUSTRY STUDIES 2 years

Details from the Principal, Newark Technical College, Chantry Park, Newark, Notts, Tel: (0636) 705921



Nottinghamshire County Council
Education

ETI

ELECTRONICS TODAY INTERNATIONAL



CLASSIFIED

John Brasier
0442 66651 Ext 310

Send your requirements to:
ETI Classified Department, ASP, Argus House,
Boundary Way, Hemel Hempstead, HP2 7ST.

Lineage: 50p per word (+ VAT) (minimum 15 words)
Semi Display: (minimum 2 cms)

£13.50 per single column centimetre + VAT

Ring for information on series bookings/discounts.

All advertisements in this section must be prepaid.

Advertisements are accepted subject to the terms and conditions printed on the advertisement rate card (available on request).

FOR SALE

CAMBRIDGE COMPUTER SCIENCE LIMITED

10MByte Winchester, used, 3 months wty £42 00 each
5.25" Disk Drives, 80 Tk DSDD £34 00 each
5.25" Drive cases, room for drive psu and fan £10 00 each
Buy a case, Winchester and psu together for £64 00 set
Small cases, to fit 2 half height 5.25" drives £10 00 each
5.25" Drives, used/untested, no warranty £15 00 each
(untested drives are sold on a strictly "as is" basis)

5.25" Disks, DSDD, 48kps, boxes in 10 £3 00 /box
50W PSU, 5V 6A, 12V 2.5A, -5V 0.5A - 12V 0.5A £16 00 each
Gould PSU 0-30V @ 5A, limited quantity only £45 00 each
Dual Data lead (BBC Micro to 2 Disk Drives) £4 00 each
Power lead (BBC Micro to Disk Drive) £2 00 each
Dual power leads (BBC Micro to 2 Disk Drives) £4 00 each
88000 CPUs (the first orders get 10MHz chips) £3 50 each
286A CPU, CTC, PIO £1 20 each, DMA £2 00 £4 50 set 4
74LS TTL, pick and mix, buy 10 or more for £0 12 each

Types available: '00 '02 '04 '05 '11 '13 '20 '21 '26 '27
'30 '32 '38 '42 '74 '83 '86 '107 '109 '122 '152
'136 '139 '145 '151 '153 '157 '158 '163 '164 '191
'193 '288 '365 '670

EPRONS 27128 used £1 50 each 27128-273 new £2 50 each
6264 8K Byte SRAM -15 £3 00 each -12 £3 80 each
65256 32K Byte rams (selling out soon) £7 00 each
8K Byte NV ram chips £3 00 each £10 00 four
20-pin di low profile IC sockets £0 50 /10 £4 00 /100
40-pin di low profile IC sockets £0 80 /10 £5 00 /100
Keyboard, 100 keys on board, LCD & micro 1A £8 00 each
Toroidal mains transformer, 12V 4A & 0.4A, 12-0-12
'1A & 2A, 3-0-3 2A £4 00 /1 £8 00 /2 £8 00 /3

Prices include postage. Add 50p to orders below £5.00
All items new unless stated. Add 15% VAT to all prices.
Send an SAE for our latest list or for more info

Dept ETI, 374 Milton Road, Cambridge, CB4 1SU
Tel: 0223 424602/0831 430496/0831 430552
(Mail order only, no facilities for callers)

BOOKS

MAKE MONEY from your hobby by subcontracting to industry. Our "Home Enterprise Package" show how. Only £12.50 (inc p&p) payable to CBL Associates, 32 Kelvin Grove, Newcastle upon Tyne, NE2 1RL.

WANTED

Turn your surplus transistors, ICs etc. into cash. Immediate settlement. We also welcome the opportunity to quote for complete factory clearance.

Contact:

COLES HARDING & CO.
103 South Brink
Wisbech, Cambs.
NOW ESTABLISHED OVER 15 YEARS
Tel: 0945 584188
Fax Number: 0945 588844

ADVERTISE IN ETI
BY CALLING
0442 66551
TODAY

SWITCHES

VOICE/SOUND ACTIVATED SWITCHES easy to follow diagrams and uses only £1.00. Components and P.C.B's available. Herrington, 63 Home Farm Rd, Hanwell, London W7 1NL.

SECURITY LIGHTING: Save pounds on external passive infra-red detectors. 4KW DIY sensor kit, £18.50. Light and detector kit £18.50, 1KW switching. Full instructions supplied, factory rejects with slight faults. 4KW passive infra-red detector £9.50. 2KW unit £7.50. 240V mains. 10 units for £50. Retail price £45 each. For full list SAE: Decor Lighting, Wavertree Boulevard South, Wavertree Tech Park, Liverpool 7.

CALL
JOHN BRASIER
ON
0442 66551
TO ADVERTISE

SERVICES

B.M.A. CIRCUITS. Prototype printed circuit boards, single and double sided, made to own requirements. Please send for details to: B.M.A. Circuits, 38 Poyning Drive, Hove, Sussex BN3 8GR, enclosing SAE or phone Brighton 720203.

PCB'S

PRINTED CIRCUIT BOARD designs and elec/mech draughting. For a fast efficient service, give us a call on: 01-443 1331.

HPGL PEN-PLOTTING

HPGL FILES on your discs ink-plotted on to top quality film (for PCBs) from £5. 24hr turnaround. A5 to A1 sizes. Send for details or 2x20p stamps for details plus disc mailer (state 5/4/3/2).

White House Systems (Dept ETI)
48 South Terrace, Esh Winning,
Durham DH7 9PS

Sample Our Quality With
A FREE
PRINTED CIRCUIT
BOARD

Single/Double Sided Circuits
or Plated Through Hole

Write to:
PAYNE ELECTROPRINT LTD
Marcus Road, Dunkeswell,
Nr Honiton, Devon EX14 0RA

PLANS

ELECTRONIC PLANS, laser designs, solar and wind generators, high voltage teslas, surveillance devices, pyrotechnics and computer graphics tablet. 150 projects. For catalogue. SAE to Plancentre Publications, Unit 7, Old Wharf Industrial Estate, Dymock Road, Ledbury, Herefordshire, HR8 2HS.

MISCELLANEOUS

HEATHKIT U.K. Spares and service centre. Cedar Electronics, Unit 12, Station Drive, Brecon, Tewkesbury, Glos. Tel: 0684-73127.

SPECIAL OFFERS

JPG Electronics

Resistors 1/4w 5% carbon (E12) 1p, 1% metal film 3p
Resistor Pack 85 different E12 values + zero ohm link, total content 1000 resistors £29.95
LED's 3mm or 5mm red or green 6p each; Yellow 11p each
Cable low 75mm 1p each £9.95 per 1000, £49.50 per 10000
Stepping motor 4 phase 12v 7.5 step 500tms £29.95
SAA 1027 stepping motor driver chip £3.95
FM Transmitter kit good quality sound £7.94
High quality photo resist copper clad epoxy glass boards

Dimensions	Single sided	Double sided
3x4 inches	£0.95	£1.07
4x8 inches	£2.40	£2.68
6x12 inches	£5.37	---
12x12 inches	£10.65	---

Special offers
Computer grade capacitors with screw terminals 38000uF 20v £2.50
87000uF 10V £1.99, 68000uF 15V £2.95, 100000uF 16V £1.50
7 segment common anode LED display 12mm £0.45
LM2931ATS0 low drop out 5v regulator TO220 package £0.85
BS290 P channel MOSFET £0.45
BC558 transistor TO92 PNP £3.95 per 100
74LS05 hex inverter £10.00 per 100; used 8748 Micronroller £3.50
Stereo LNMWFM tuner-pre-ampassy with volume/tone control and tuning scale Brand new in maker's carton £5.95; Faulty £2.50
Circuit etc for above £0.50; 5 digit 6v electromagnetic counter £1.95
Hour counter (use 2) digit 240vac 50hz £0.95
LCD display 16 digit 7x5 dots dot matrix £2.50
QWERTY keyboard 58 key good quality switches £5.00
Wide range of CMOS TTL 74HC 74F Linear Transistor kits, capacitors, tools etc, always in stock

Please add 75p p&p per order VAT included
JPG Electronics,
276 Chateworth Road, Chesterfield S40 2BH
Access orders (0248) 211202 - Callers welcome

RECRUITMENT

THE ROYAL FREE HOSPITAL MEDICAL ELECTRONICS DEPARTMENT

Medical Physics Technicians IV and III Electronics

Salary:

Grade III — £10,122-£12,821
inclusive of London Weighting
Grade IV — £8,882-£11,188
inclusive of London Weighting

To assist with the Design and Repair of Electronic Circuits and Systems in our small and friendly Department.

Applicants should hold an Ordinary TEC Certificate in appropriate subjects, or equivalent or Higher Qualification.

At least three years' experience in circuit design is required for the Grade III post.

Application forms and job description from Personnel Department, The Royal Free Hospital, Hampstead, London NW3 2QG. Tel: 01-794 0500 ext 5053 (24-hour answerphone), quoting reference 799.

Hampstead Health Authority is an equal opportunities employer.

Closing Date: 23 March 1990



John Brasier
0442 66651 Ext 310



Send your requirements to:
ETI Classified Department, ASP, Argus House,
Boundary Way, Hemel Hempstead, HP2 7ST.

SURVEILLANCE

SURVEILLANCE & COUNTER SURVEILLANCE EQUIPMENT

WE MANUFACTURE AND SUPPLY TOP QUALITY SURVEILLANCE AND SECURITY EQUIPMENT



including VHF Transmitters
Automatic Telephone
Recorders, Recording
Briefcases, Bug
Detectors,
Telephone
Counter-Tap Units

We also offer a complete range of accessories, including microcassette recorders, microphones, receivers, cassettes and batteries

CCTV AND SECURITY SYSTEMS SPECIALISTS

Write or phone for a detailed catalogue to:

ESKAN ELECTRONICS LTD.

DEPT. ET, 172 CALEDONIAN ROAD, LONDON, N1

01-278 1768

KITS

SURVEILLANCE. Kits, Built Modules, Plans, Bleep transmitters, Voice switches, Portable EHT, Sonic gun plans etc. SAE list. Ace(TI). 99 Greenheath, Hednesford, Staffs.

NEW VHF MICROTRANSMITTER kit, tuneable 80-115MHz, 500 metre range, sensitive electret microphone, high quality PCB. **SPECIAL OFFER** complete kit ONLY £5, assembled and ready to use £8.95 post free. Access/Visa orders telephone 021-411 1821. Cheques/PO's to: Quantek Electronics Ltd, (Dept ETI), 45a Station Road, Northfield, Birmingham B31 3TE.

FOR MORE
DETAILS ON
COPY
DEADLINES
CALL JOHN
BRASIER
ON
0442 66551

TERMS & CONDITIONS

CLASSIFIED ADVERTISING TERMS & CONDITIONS

Our terms for new advertisers (semi-display and lineage) are strictly pro-forma payments until satisfactory reference can be taken up (excluding recognised advertising agencies) Cheques and PO's should be crossed and made payable to ARGUS SPECIALIST PUBLICATIONS and sent together with the advertisements to:

The Classified Dept.,
Argus House, Boundary Way,
Hemel Hempstead HP2 7ST

There are no reimbursements for cancellations. Advertisements arriving too late for a particular issue will be inserted in the following issue unless accompanied by instructions to the contrary. It is the responsibility of the advertiser to ensure that the first insertion of every series is published correctly, and corrections must be notified in time for the second insertion, otherwise the publishers will not accept liability or offer any reduction in charges. All advertising sales are subject to Government Regulations concerning VAT. Advertisers are responsible for complying with the various legal requirements in force eg. The Trade Description Act, Sex Discrimination Act & the Business Advertisements (Disclosure) Order 1977.

Full Terms & Conditions of Advertising available on request.

EQUIPMENT

- Series X Mixer Kits, up to 1,000 inputs, 6 auxiliaries, versions for PA, recording, radio, disco. From £9.92
- Circuits for: noise gates, compressors, exciters, tape machines, mixers
- 100mm faders, switches



WE REPAIR
AUDIO EQUIPMENT

Send 40p for catalogue to:

K. Tek, P.O. Box 172A, Surbiton,
Surrey KT6 6HN. Tel: 01-399 3990

RETAIL OUTLETS

BIRMINGHAM

"SUPERTRONICS"

Speakers, components and test equipment (new and used) at very competitive prices

Come and see us at
BIRMINGHAM
65 HURST STREET,
BIRMINGHAM B5
TEL: 021-666 6504
9-6pm

LONDON

DIRECT ELECTRONICS

ELECTRONICS COMPONENT SPECIALISTS

627 ROMFORD RD,
MANOR PARK
LONDON E12 5AD
Tel: 01-553 1174

Mon-Sat 10-6 pm/Thurs 10-1pm

We stock a large range of TV & Video spares

SOUTHAMPTON

DIVERSE DEVICES

75 Priory Rd, Southampton

Components, Technical Miscellany

Tel: (0703) 584680

Open 1.00-5.30; Sat 9.30-4.30

FOR MORE INFORMATION
ON SERIES DISCOUNTS
CONTACT

JOHN BRASIER ON
0442 66551

LONDON

CRICKLEWOOD ELECTRONICS

One of the largest component retailers in the UK. Fast and efficient, same day personal service on 'IN STOCK ITEMS'. Very competitive prices. No minimum order. Call Cricklewood Electronics now.
40 CRICKLEWOOD BROADWAY, LONDON NW2 3ET
Tel: 01-450 0995/452 0161

WOLVERHAMPTON

WALTONS OF WOLVERHAMPTON

Established since 1947

Offering a complete range — ICs, transformers, switches, pots, capacitors, resistors, kits, speakers, test equipment, books and lots, lots more!

Come and see us at

55A Worcester Street, Wolverhampton
Mon-Sat: 9-6 pm Tel: 0902 22039

EDINBURGH

OMNI ELECTRONICS

stock a wide range of electronic components at

174 Dalkeith Road,
Edinburgh EH16 5DX
Tel: 031 667 2611

Open: Mon-Fri 9am-6pm, Sat 9am-5pm.
Send 2x18p stamps for latest catalogue.

LIVERPOOL

PROGRESSIVE RADIO

87/93 Dale Street Tel: 051 236 0154

47 Whitechapel. Tel: 051 236 5489

Liverpool 2

'THE ELECTRONICS SPECIALISTS'

Open: Tues-Sat 9.30-5.30

SOUTH COAST

ELECTRONIC COMPONENTS
are best seen at

FRASER ELECTRONICS
42 ELM GROVE ★ SOUTHSEA ★ HANTS
Telephone (0705) 815584

Barclaycard

Access

COME AND BROWSE BEFORE YOU BUY

NEXT MONTH

We've a brand new section to your favourite magazine, the ETI Audio supplement. It contains all the latest news, reviews features and projects in the world of sound reproduction, processing and recording. Along with the launch comes the beginning of a colour section to ETI. These high quality pages will be used to bring our the best in three dimensional aspects our illustrations and realise a first rate quality to our photographic presentation.

Featured in the May issue will be the final part of the Business amplifier, the high quality amplifier with computer connections for bass guitarists and an idea suggested in last month's ETI comes to fruition, a telephone sentinel. It's a concept which makes you wonder why it was never thought of before. Imagine being able to key in your own PIN number to unlock the telephone line and make your calls. It also has some other very handy features (we must keep some secrets!). Geoff Martin's appeal for simple but effective projects last month brought a swift reaction from one of our contributors, Kevin Kirk who designed this little security device as a result of Geoff's suggestion.

We look at the combined heat and power systems now coming onto the market and see the advantages they have to offer for industrial premises over conventional electrical and heating supplies.

There's plenty more to read in our May issue when ETI emerges onto the newstand on April 6th.

The above articles are in preparation but circumstances may prevent publication

LAST MONTH

Sorry to say that you missed the first part of the Business bass amplifier that unique custom built amplifier with a memory to recall all your graphic equalised bass sounds. If you're the type of person that likes plants but somehow manages to forget to water them, you missed a natty little automatic plant watering device. John Linsley Hood started a new series on Elements of radio looking at ways in which radio reception might be improved starting at the front end of course. A limited number of back copies are available from our usual department.

ADVERTISERS' INDEX

BK ELECTRONICS	IFC	MAPLIN ELECTRONICS	OBC
CRICKLEWOOD ELECTRONICS	49.66	MERLIN SYSTEMS	12
DISPLAY ELECTRONICS	IBC	NARSA	52
ELECTRONIC DESIGN	12	NUMBER ONE SYSTEMS	11
ELECTROVALUE	25	RACKZ PRODUCTS	12
GREENBANK ELECTRONICS	12	RADIO & TV COMPONENTS	32
HART ELECTRONICS	24	STEWARTS OF READING	12
HENRYS AUDIO	24	SUMA DESIGNS	37
J & N BULL ELECTRICAL	3	TK ELECTRONICS	66
LABCENTER ELECTRONICS	31	WILMSLOW AUDIO	52
LIGHT SOLDERING	52		

19" RACK CASES

★ Suitable for instruments, high quality amplifiers and many other applications that demand strength and professional finish ★ New improved construction and finish ★ Black anodised aluminium front panels ★ Separate front mounting plate, no fixing screws visible on the front and the side of the enclosure ★ Heavy gauge front panel is of brushed aluminium finish enhanced with two professional handles ★ With ventilation slits and plastic feet ★ Rear box manufactured from 1.1mm steel finished in black. Rack mounting or free standing. Comes in quick assembly flat package

Order Code	Panel Size W H (inch)	Rear Box W H D	Weight kg	Price £
U101	19 x 1.75	17 x 1.5 x 10	2.4kg	26.95
U103	19 x 5.25	17 x 5.0 x 10	3.5kg	29.95

U212	19 x 35	17 x 30 x 12	3.3kg	£29.75
U312	19 x 5.25	17 x 50 x 12	4.0kg	£31.95
U412	19 x 7.0	17 x 65 x 12	4.6kg	£34.95

Please add £3.00 P&P for the first item and £1.50 for each additional item.
Please add VAT to above prices. Overseas orders welcome.



CRICKLEWOOD ELECTRONICS LTD
40 CRICKLEWOOD BROADWAY, LONDON NW2 3ET
Tel: 01-452 0161 Fax: 01-208 1441
SOLE UK DISTRIBUTORS

PROGRAMMABLE ELECTRONIC LOCK KIT

Keys could be a thing of the past with this new high security lock. Secure doors to sheds, garages, even your home or prevent the unauthorised use of computers, burglar alarms or cars. One 4-digit sequence will open the lock while incorrect entries will sound an alarm. The number of incorrect entries allowed before the alarm is triggered is selected by you. Further entries will be ignored for a time also set by you. Only the correct sequence will open the lock and switch off the alarm. The sequence may easily be changed by entering a special number and code on the supplied keyboard. Kit includes: keyboard, alarm buzzer, high quality PCB and all electronic components. Supply: 5-15V d.c. Will drive our Latch Mechanism (701 150 @ £16.50) or relay directly.

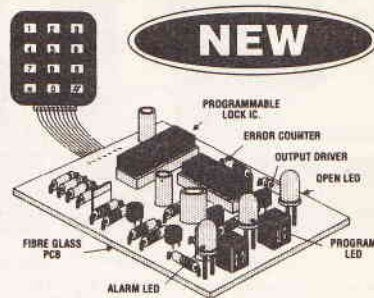

XK131 **£17.35**

DISCO LIGHTING KITS



DL8000K 8-way sequencer kit with built-in opto-isolated sound to light input. Only requires a box and control knob to complete **£34.60**

DL1000K 4-way chaser features bi-directional sequence and dimming 1kW per channel **£21.00**

DLZ1000K Uni-directional version of the above. Zero switching to reduce interference **£11.80**

DLA/1 (for DL & DLZ1000K) Optional opto input allowing audio 'beat' / light response **80p**

DL3000K 3-channel sound to light kit, zero voltage switching, automatic level control and built-in mic. 1kW per channel **£17.00**

POWER STROBE KIT

Produces an intense light pulse at a variable frequency of 1 to 15Hz. Includes high quality PCB, components, connectors, 5Ws strobe tube and assembly instructions. Supply: 240V ac. Size: 80 x 50 x 45. **XK124 STROBOSCOPE KIT** **£15.00**



VERSATILE REMOTE CONTROL KIT



Includes all components (+transformer) for a sensitive IR receiver with 16 logic outputs (0-15V) which with suitable interface circuitry (relays, triacs, etc - details supplied) can switch up to 16 items of equipment on or off remotely. Outputs may be latched to the last received code or momentary (on during transmission) by specifying the decoder IC and a 15V stabilised supply is available to power external circuits. Supply: 240V AC or 15-24V DC at 10mA. Size (exc. transformer) 9 x 4 x 2 cms. Companion transmitter is the MK18 which operates from a 9V PP3 battery and gives a range of up to 60ft. Two keyboards are available - MK9 (4-way) and MK10 (16-way).

MK12 IR Receiver **£17.00**
(inc transformer)
MK18 Transmitter **£7.80**
MK9 4-way Keyboard **£2.40**
MK10 16-way Keyboard **£7.00**
601133 Box for Transmitter **£2.60**

VOICE RECORD/PLAYBACK KIT

This simple to construct and even simpler to operate kit will record and playback short messages or tunes. It has many uses - seatbelt or lights reminder in the car, welcome messages to visitors at home or at work, warning messages in factories and public places, in fact anywhere where a spoken message is announced and which needs to be changed from time to time. Also suitable for toys - why not convert your daughter's £8 doll to an £80 talking doll!!!

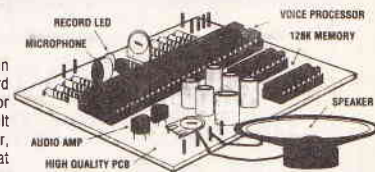

Size 76 x 60 x 16mm
Message time 1 - 5 secs normal speed, 2 - 10 secs slow speed

XK129 **£22.50**

TR ELECTRONICS

13 BOSTON RD. LONDON W7 3SJ
TEL: 01-567 8910.
FAX: 01-566 1916



ORDERING INFORMATION:

All prices exclude VAT. Free P & P on orders over £50 (UK only), otherwise add £1 + VAT. Overseas P & P: Europe £3.50. Elsewhere £10. Send cheque/PO/Visa/Access No. with order. Giro No. 529314002
LOCAL AUTHORITY AND EXPORT ORDERS WELCOME
GOODS BY RETURN SUBJECT TO AVAILABILITY

THE ORIGINAL SURPLUS WONDERLAND!

THIS MONTH'S SPECIAL!

Very high resolution, fully cased 14" green or amber screen monitor with non-glare screen and swivel/tilt base. The very latest technology at the very lowest price! Fully compatible and plug compatible with all IBM PCs and clones fitted with a high res Hercules or equivalent card! Enables superb graphics and resolution, all at a give away price. Has many extra features including aux +5 & 12v DC outputs to power at least 2 disk drives, if your PC power supply is getting hot! Supplied BRAND NEW and boxed. State whether amber or green screen required.

Amber£79 Green£69 (E)

COMPUTER SYSTEMS

TATUNG PC2000. Big brother of the famous Einstein. The TPC2000 Professional 3 piece system comprises: Quality high resolution Green 12" monitor. Sculptured 92 key keyboard and pin-in unit containing Z80A CPU and all control circuits. PLUS 2 integral TEAC 5.25 80 track double sided disk drives. Generous other features include dual 8" IBM format disk drive support. Serial and parallel outputs, full expansion port, 64k ram and ready to run software. Supplied complete with CPM, Wordstar and Basic. Brand new and covered by our famous 90 day guarantee and backup. Normal price of this unit is over £1400!

Our price only£299 (E)

SPECIAL PURCHASE V22 1200 baud modems

We got a tremendous buy on further stocks of this popular **Master Systems 2/12** microprocessor controlled V22 full duplex 1200 baud modem - we can now bring them to you at **half last advertised price!** Fully BT approved unit, provides standard V22 high speed data comm, which at 120 cps, can save your phone bill and connect time by a staggering 75%! Ultra slim 45 mm high. Full featured with LED status indicators and remote error diagnostics. Sync or Async use; speech or data switching; built in 240v mains supply and 2 wire connection to BT. Units are in used but good condition. Fully tested prior despatch, with data and a full 90 day guarantee. What more can you ask for - and at this price!!

ONLY £69 (D)

MONITORS

COLOUR MONITORS

Decca 16" 80 series budget range colour monitors. Features include PIL tube, housed in a beautiful teak style case and guaranteed 80 column resolution, features which are only normally seen on colour monitors costing 3 times our price! It is absolutely ready to connect to a host of computer or video outputs. Manufacturers fully tested surplus, sold in little or hardly used condition with 90 day full RTB guarantee. **Decca 80 COMPO** 75 ohm composite video input with integral audio amp & speaker. Ideal for use with video recorder or our Telexbox ST, or any other audio visual use.

Only £99.00 (E)

HI-DEFINITION COLOUR MONITORS

Brand new **Centronic 14"** monitor for IBM PC and compatibles at a lower than ever price! Completely CGA equivalent. Hi-res Mitsubishi 0.42 dot pitch giving 669 x 507 pixels. Big 28 MHz bandwidth. A super monitor in attractive style moulded case. Full 90 day guarantee.

Only £149 (E)

20", 22" and 26" AV SPECIALS

Superbly made UK manufacture. PIL all solid state colour monitors, complete with composite video & sound inputs. Attractive teak style case. Perfect for Schools, Shops, Disco, Clubs. In EXCELLENT little used condition with full 90 day guarantee.

20"....£155 22"....£170 26"....£185 (F)

MONOCHROME MONITORS

There has never been a deal like this one! Brand spanking new & boxed from NEC, normally selling at about £140! These are over-engineered for ultra reliability. 9" green screen composite input with etched non-glare screen plus swivable high/low impedance input and output for daisy-chaining. 3 front controls and 6 at rear. Standard BNC sockets. Beautiful high contrast screen and attractive case with carrying ledge. Perfect as a main or backup monitor and for quantity users! £39.95 each (D) or 5 for £185 (G)

CALL FOR DISCOUNTS ON HIGHER QUANTITIES!

Wang green screen 12" chassis monitor with composite video input. Adjustable for tilt. Requires 12 vdc. Brand new and boxed in perfect condition. Only £39 each or 2 for £75 (F)

Motorola M1000-100 5" black & white compact chassis measuring only 11.6H x 12W x 2.2D. Ideal for CCTV or computer applications. Accepts standard composite or individual H & V syncs. Needs 12vdc at only 0.8a. Some units may have minor screen blemishes. Fully tested with 30 day guarantee and full data. £29.00 (C)

Fully cased as above in attractive moulded desk standing swivel. Dim 12 x 14.5 x 26cm. £39.00 (C)

JVC 751 ultra compact chassis monitor for 12vdc 0.7a. Dim 11 x 14 x 18cm. Simple DIY data included to convert to composite video input. Full data. BRAND NEW £65.00 (B)

20" Black & white monitors by Aztek, Cotron & National. All solid state, fully cased monitors ideal for all types of AV or CCTV applications. Standard composite video inputs with integral audio amp and speaker. Sold in good used condition - fully tested with 90 day guarantee. £85.00 (F)

FLOPPY DISK DRIVES BARGAINS GALORE!

NEW 5 1/4 inch from £29.95!

Massive purchases of standard 5 1/4" drives enables us to present prime product at industry beating low prices! All units (unless stated) are removed from often brand new equipment and are fully tested, aligned and shipped to you with a 90 day guarantee and operate from +5 & +12vdc, are of standard size and accept the standard 34 way connector.

SHUGART SA405. BRAND NEW £29.95 (B)
TANDON TM100-2A IBM compatible DS £39.95 (B)
TANDON TM101-4 80 Track DS £49.95 (B)
CANON, TEC etc. DS half height. State 40 or 80T £75.00 (B)
TEAC FD-55-F. 40-80 DS half height. BRAND NEW £99.00 (B)

3 1/2 INCH BRAND NEW AT £19.95!!
Never before seen price for a 3 1/2" drive. Standard size believed to be by Canon. Brand new and packaged - mint condition! 40 track SS, run from +5 & +12vdc with standard power connector.....Only..... £19.95 or 2 for £34.50 (B)

CHOOSE YOUR 8 INCH!

Shugart 800/801 SS refurbished & tested £125.00 (E)
Shugart 851 double sided refurbished & tested £195.00 (E)
Mitsubishi M2894-63 double sided switchable hard or soft sectors - BRAND NEW £250.00 (E)

SPECIAL OFFERS!!

Dual 8" drives with 2 megabyte capacity housed in a smart case with built in power supply! Only £499.00 (F)
Ideal as exterior drives!

End of line purchase scoop! Brand new **NEC D2246 8" 85** megabyte of hard disk storage! Full CPU control and industry standard SMD interface. Ultra hi speed transfer and access time leaves the good old ST506 interface standing. In mint condition and comes complete with manual. Only.....£399 (E)

MAINS SUPPRESSORS & FILTERS

The "Flitan" from Crotan is a British made high current mains spike suppressor and RF filter in one, capable of handling up to 10 amps! The attractive case has an integral 13 amp socket for your equipment and a flying lead terminates in a quality plug (to BS 1363A standard) to go to the mains socket. There is an internal fuse plus one in the plug. Two LED indicators, one for power on and the other lights if the internal fuse fails. Dims: 6" x 3" x 2". Brand new. Distributor's price - £65.00! Continental plug version Flit-C. Either only £15.95 each or 2 for £29.95 (B)
Belling-Lee Type L1217 mains RFI filters rated at 250 volts 3 amps maximum. Comes complete with a built in mains cable (English coding), and a three pin miniature non-reversible socket and a mating plug, to go to the equipment. Ideal for those who are bugged by RF interference. Very compact. Dims 3-1/8" x 2-5/8" x 1-5/8".....£3.95 each or 3 for £10 (A)

COOLING FANS

Please specify 110 or 240 volts for AC fans.

3 inch	AC 1 1/2" thick	£ 8.50 (B)
3 1/2 inch	AC ETRI silmline. Only 1" thick.	£ 9.95 (B)
4 inch	AC 110/240v 1 1/2" thick.	£ 10.95 (B)
4 inch	AC 1 1/2" thick	£ 9.95 (B)
10 inch	Round 3 1/2" thick. Rotron 110v	£ 10.95 (B)
62 mm	DC 1" thick. No. 812 for 6/12v. 814 24v.	£ 15.95 (A)
62 mm	DC 12v. 18 mm thick.	£ 14.95 (A)
4 inch	DC 12v. 12w 1 1/2" thick	£ 12.50 (B)
4 inch	DC 24v 8w. 1" thick.	£ 14.50 (B)

RECHARGEABLE BATTERIES

LEAD ACID

Maintenance free sealed long life. Type A300.

12 volts	12 volts 3 amp/hours	£ 13.95 (A)
6 volts	6 volts 3 amp/hours	£ 9.95 (A)
12 volts	Centre tapped 1.8 amp hours	£ 5.95 (A)
12 volts	12 volts 24 amp hours. A200. RFE.	£ 29.00 (B)

SPECIAL OFFER!

100 amp/hours at 6 volt! Brand new Chloride Powersafe 3VB11. Leakproof with additional snap-on security lid. Perfect for uninterruptable power supplies, portable power source, caravans etc. Normally costs £80! £39 (E)

NICKEL CADMIUM

Quality 12v 4ah cell pack. Originally made for the Technicolor video camera. Contains 10 GE top quality D nicad cells in a smart robust case with a DC output connector. Ideal for portable equipment. Brand new. £19.95 (B)
Ex-equipment NICAD cells by GE. Removed from equipment and in good, used condition: D size 4ah 4 for £5 (B)
F size 7ah 6 for £8 (B)

SPECIAL INTEREST

Recal-Redec real time colour drafting PCB layout system. Includes furniture and huge monitor. Complete ready to go! £3950
DEC VAX11/750 inc. 2 Meg Ram DZ and full documentation, in brand new condition! £3900
Calcomp 1036 large drum 3 pen plotter £ 650
Thurby LA 160A logic analyser £ 275
1.5kw 115v 60hz power source £ 950
Wayne Kerr RA200 audio real time freq. res. analyser. £3000
VG Electronics 1033 Teletext Bridge £3750
Tektronix R140 NTSC TV test signal standard. £ 875
Sony KTX 1000 Videotext system - brand new £ 790
DECLS11/02 CPU board £ 150
ADDS 2020 VDU terminals - brand new £ 225

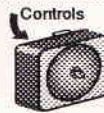

Microwave Speech / Data Links



Made for the US military to the highest possible spec, these units were originally designed as a highly rugged portable point to point distance measuring set. Inbuilt in the unit is a full duplex speech link which may be used as is, or adapted for use as a data link. Many features include 50 km point to point range, approx 10.5 GHz operation for max security, low power consumption (typ. 2 amps at 12 vdc), and small physical size 14w, 15h x 13d including built in dish, fully portable weatherproof case. Supplied in used but tested condition complete with instructions and accessories.

Only £295 per pair (E)

Optional 12v integral nicad pack

(3 hours approximate duration).....£22
Limited quantity - don't miss out this time!!!

May require licence for UK use

POWER SUPPLIES

All PSUs 220-240vac input and are BRAND NEW unless stated. Many types ranging from 3v to 10kv always in stock. Fine OP-8619 20 watts switch mode. +5v @ 2a. +12v @ 1a. -12v @ 0.1a. 5" x 3" x 1-1/2". £15.95 (B)
Astec AC-8151 40 watts. Switch mode. +5v @ 2.5a. +12v @ 2a. -12v @ 0.1a. 6-1/4" x 4" x 1-3/4". £19.95 (B)
Greendale 19A90E 60 watts switch mode. +5v @ 6a. +12v @ 1a. +15v @ 1a. RFE and fully tested. 11 x 20 x 5.5cms. £24.95 (C)
Conver AC130. 130 watt hi-grade VDE spec. Switch mode. +5v @ 15a. -5v @ 1a. +12v @ 6a. 27 x 12.5 x 6.5cms £49.95 (C)
Boshert 13080. Switch mode. Ideal for drives & system. +5v @ 6a. +12v @ 2.5a. -12v @ 0.5a. -5v @ 0.5a. £29.95 (B)
Famell G6/40A. Switch mode. 5v @ 40a. Encased £95.00 (C)
Famell G24/5S. As above but 24v @ 5a. £65.00 (C)

IBM KEYBOARD DEAL

A replacement or backup keyboard, switchable for IBM PC, PC-XT or PC-AT. LED's for Caps, Scroll & Num Locks. Standard 85 keyboard layout. Made by NCR for the English & US markets. Absolutely standard. Brand new & boxed with manual and key template for user slogans on the function keys. Attractive beige, grey and cream finish, with the usual retractable legs underneath. A generous length of curly cord, terminating in the standard 5 pin DIN plug. A beautiful clean piece of manufacturer's surplus. What a deal!

BRAND NEW AND BOXED ONLY..... £49 (B)

THE AMAZING TELEBOX!

Converts your colour monitor into a

QUALITY COLOUR TV!!

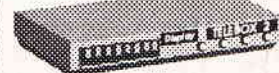

TV SOUND & VIDEO TUNER!

Brand new high quality, fully cased, 7 channel UHF PAL TV tuner system. Unit simply connects to your TV aerial socket and colour video monitor turning same into a fabulous colour TV. Don't worry if your monitor doesn't have sound, the TELEBOX even has an integral audio amp for driving a speaker plus an auxiliary output for headphones or HI FI system etc. Many other features: LED Status indicator, Smart moulded case, Mains powered, Built to BS safety specs. Many other uses for TV sound or video etc. Supplied BRAND NEW with full 1 year guarantee.

Telexbox ST for composite video input monitors.....£29.95 (B)
Telexbox STL as ST but with integral speaker.....£34.95 (B)
Telexbox RGB for analogue RGB monitors.....£65.95 (B)

NOT suitable for IBM or Clone type colour monitors. PAL overseas version please call. SECAM not available.

BRAND NEW PRINTERS

Epson MX-90 FT One of the most popular printers around! Bi-directional printing with full logic seeking. 9 x 9 dot matrix for enlarged, bold, condensed etc. Standard parallel interface. Brand label removed from front. Handles tractor, fanfold and individual paper. OK with IBM PC and most others. A tremendous buy! FOR A LIMITED TIME ONLY.....£129.00 (E)
Hazeltone Esprint small desktop. 100 cps with RS232 and standard parallel. Full pin addressable and 6 user selectable fonts. Up to 9.5" paper. Sheet & tractor feed. SPECIAL SALE £99.00 (E)
Centronics 150 series. Always known for their reliability in continuous use - real workhorses in any environment. Fast 150 cps with 4 fonts and choice of interfaces.
150-SN up to 9.5" paper.....£155.00 (E)
150-SW up to 14.5" paper.....£199.00 (E)

Specify whether serial or parallel required.

CALL FOR THE MANY OTHERS IN STOCK INCLUDING DAISY WHEELS.

Visit our Shop - Technical help always on hand plus many un-advertised specials. You can buy a colour television for as little as £29! Come and join the gang at 215 Whitehorse Lane!

LARGE QUANTITIES OF OSCILLOSCOPES AND TEST GEAR ALWAYS AVAILABLE - CALL NOW!

DISPLAY

-Electronics-

MAIL ORDER & OFFICES
Open Mon-Fri 9.00-5.30
Dept ET, 32 Biggin Way,
Upper Norwood,
London SE19 3XF.

LONDON SHOP
100's of bargains!
Open Mon-Sat 9.5-5.30
215 Whitehorse Lane,
South Norwood,
London, SE25 6RB.

DISTEL © The Original
Free dial-up database!
1000's of Items-Info On Line
300 bd 01-679-1888,
1200/75 bd 01-679-6183,
1200/1200 bd 01-679-8769

ALL ENQUIRIES
01-679-4414
Fax- 01-679-1927
Telex- 894502



All prices for UK Mainland. UK customers add 15% VAT to TOTAL order amount. Minimum order £10. PO orders from Government, Universities, Schools & Local Authorities welcome-minimum account order £25. Carriage charges (A)=£2.00, (B)=£4.50, (C)=£8.50, (D)=£10.00, (E)=£12.00 (F)=£17.00 (G)=Call. All goods supplied subject to our standard Conditions of Sale and unless otherwise stated guaranteed for 90 days. All guarantees on a return to base for 90 days. We reserve the right to change prices & specifications without prior notice. Orders accepted subject to stock. Quotations willing given for higher quantities than those stated. Bulk surplus always required for cash.

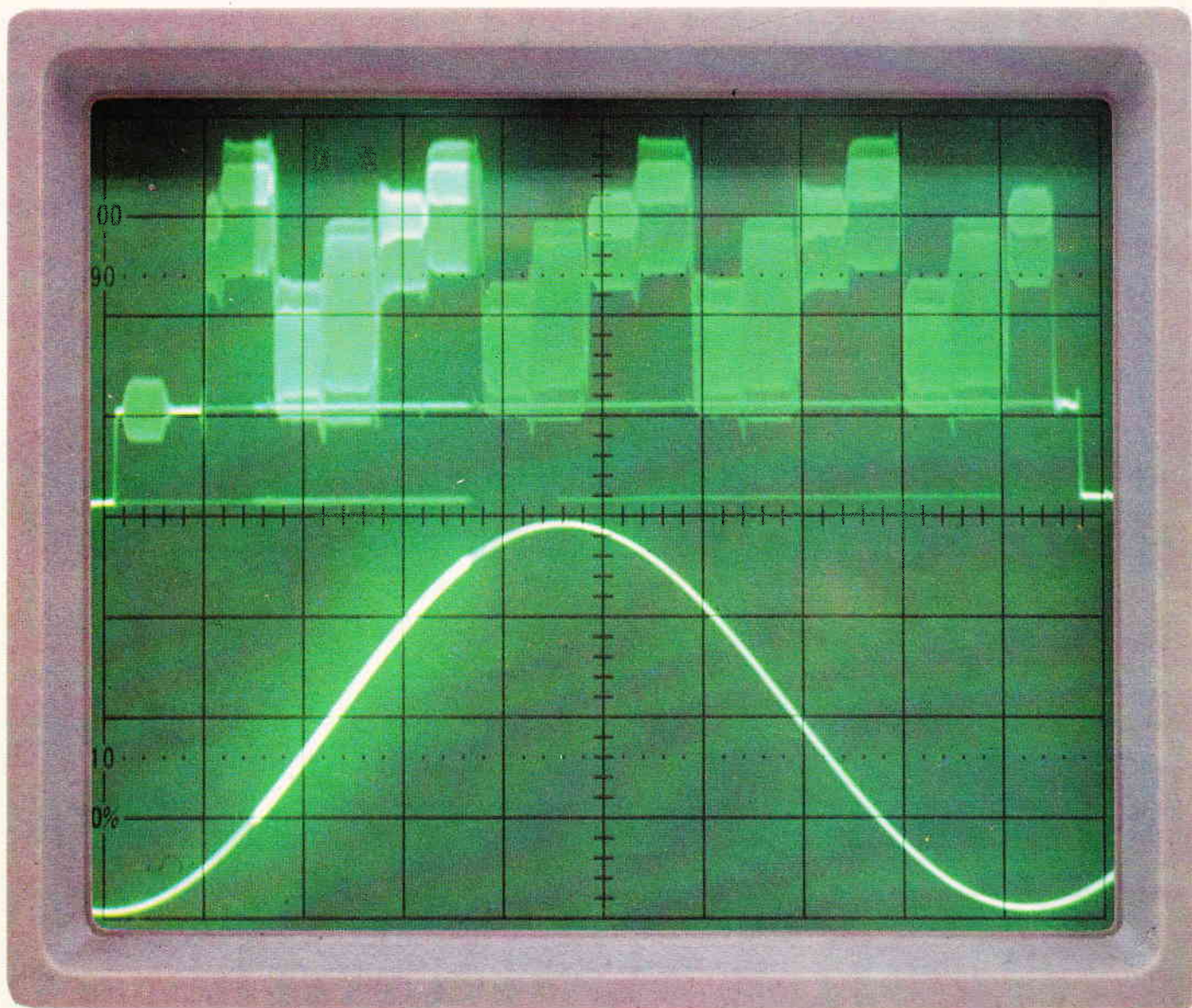

Does yours pass the screen test?

We believe ours do!!!

Precision laboratory oscilloscopes. Triple-trace 20MHz 3 channels-3 trace. XY mode allows Lissajous patterns to be produced and phase shift measured. 150mm rectangular CRT has internal graticule to eliminate parallax error. 20ns/div sweep rate makes fast signals observable. Stable triggering of both channels even with different frequencies is easy to achieve and a TV sync separator allows measurement of video signals. Algebraic operation allows the sum or difference of channel 1 and 2 to be displayed. 50mV/div output from CH 1 available to drive external instrument e.g. frequency counter. Also available, 40MHz triple trace oscilloscope. Similar to the model described above but with 12kV tube that is super bright even at the highest frequencies. This instrument also has a delayed sweep time base to provide magnified waveforms and accurate time interval measurements.

TOA30 (20MHz Triple Scope) £349.95
 TOB30 (40MHz Triple Scope) £549.95

TEST EQUIPMENT - Choose from the extensive range featured in our new 580 page Electronics Catalogue. Available in all our shops or from WHSMITH for £2.25 or £2.75 by mail. No carriage charge if ordering Catalogue only.



CREDIT CARD HOTLINE
0702 554161

PHONE BEFORE 5PM FOR SAME DAY DESPATCH



Maplin ELECTRONICS

P.O. BOX 3, RAYLEIGH, ESSEX, SS6 8LR.

All items subject to availability, all items will be on sale in our shops in Birmingham, Bristol, Leeds, Hammersmith, Edgware, Manchester, Nottingham, Newcastle-upon-Tyne, Reading, Southampton and Southend-on-Sea.

Add Carriage 75p.

ALL PRICES INCLUDE VAT.