

electronics today

INTERNATIONAL

FEBRUARY 1987 £1.30

RADIATION

GEIGER COUNTER AND
RATEMETER TO BUILD

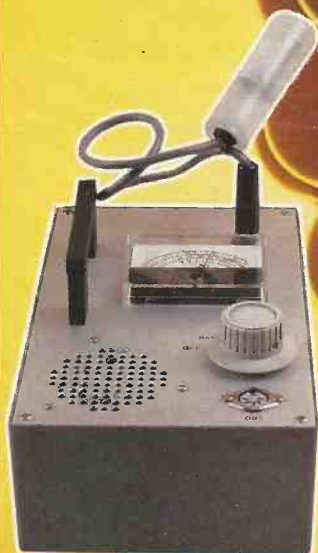

BALANCED CIRCUITS
CELLULAR RADIO

PROJECT:
PHOTO PROCESS CONTROLLER



OMP POWER AMPLIFIER MODULES

* PRICES INCLUDE V.A.T. * PROMPT DELIVERIES * FRIENDLY SERVICE * LARGE S.A.E. 28p STAMP FOR CURRENT LIST

OMP POWER AMPLIFIER MODULES

Now enjoy a world-wide reputation for quality, reliability and performance at a realistic price. Four models available to suit the needs of the professional and hobby market, i.e., Industry, Leisure, Instrumental and Hi-Fi, etc. When comparing prices, NOTE all models include Toroidal power supply, Integral heat sink, Glass fibre P.C.B., and Drive circuits to power compatible Vu meter. Open and short circuit proof.

Supplied ready built and tested.



OMP/MF100 Mos-Fet Output power 110 watts R.M.S. into 4 ohms, Frequency Response 1Hz - 100KHz -3dB, Damping Factor 80, Slew Rate 45V/μs, T.H.D. Typical 0.002%, Input Sensitivity 500mV, S.N.R. -125dB, Size 300 x 123 x 60mm. PRICE £39.99 + £3.00 P&P.

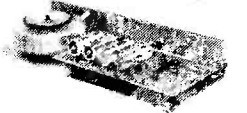

OMP/MF200 Mos-Fet Output power 200 watts R.M.S. into 4 ohms, Frequency Response 1Hz - 100KHz -3dB, Damping Factor 250, Slew Rate 50V/μs, T.H.D. Typical 0.001%, Input Sensitivity 500mV, S.N.R. -130dB, Size 300 x 150 x 100mm. PRICE £62.99 + £3.50 P&P.



OMP/MF300 Mos-Fet Output power 300 watts R.M.S. into 4 ohms, Frequency Response 1Hz - 100KHz -3dB, Damping Factor 350, Slew Rate 60V/μs, T.H.D. Typical 0.0008%, Input Sensitivity 500mV, S.N.R. -130dB, Size 330 x 147 x 102mm. PRICE £79.99 + £4.50 P&P.

NOTE: Mos-Fets are supplied as standard (100KHz bandwidth & Input Sensitivity 500mV) If required, P.A. version (50KHz bandwidth & Input Sensitivity 775mV) Order - Standard or P.A.

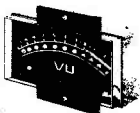

VU METER Compatible with our four amplifiers detailed above. A very accurate visual display employing 11 L.F.D. diodes (7 green, 4 red) plus an additional on/off indicator. Sophisticated logic control circuits for very fast rise and decay times. Tough moulded plastic case, with tinted acrylic front. Size 84 x 27 x 45mm. PRICE £8.50 + 50p P&P.

LOUDSPEAKERS 5" to 15" up to 400 WATTS R.M.S. Cabinet Fixing in stock. Huge selection of McKenzie Loudspeakers available including Cabinet Plans. Large S.A.E. (28p) for free details.



POWER RANGE
8" 50 WATT R.M.S. Hi-Fi/Disco, 20 oz magnet, 1" ally voice coil. Ground ally fixing escutcheon Res. Freq. 40Hz Freq. Resp. to 6KHz Sens. 92dB. PRICE £10.99 + variable with black grille £11.99 P&P £1.50 ea
12" 100 WATT R.M.S. Hi-Fi/Disco 50 oz magnet, 2" ally voice coil. Ground ally fixing escutcheon Die cast chassis White cone Res. Freq. 25Hz Freq. Resp. to 4KHz Sens. 95dB. PRICE £28.60 + £3.00 P&P ea

MCKENZIE
12" 85 WATT R.M.S. C1285GP Lead guitar/keyboard/Disco 2" ally voice coil Ally centre dome Res. Freq. 45Hz Freq. Resp. to 6.5KHz Sens. 98dB. PRICE £29.99 + £3.00 P&P ea.
12" 85 WATT R.M.S. C1285TC P.A./Disco 2" ally voice coil. Twin cone. Res. Freq. 45Hz Freq. Resp. to 14KHz. PRICE £31.49 + £3.00 P&P ea
15" 150 WATT R.M.S. C15 Bass Guitar/Disco, 3" ally voice coil Die-cast chassis Res. Freq. 40Hz Freq. Resp. to 4KHz. PRICE £57.87 + £4.00 P&P ea
10" 60 WATT R.M.S. 1060CP Gen. Purpose/Lead Guitar/Keyboard/Mid. P.A. 2" voice coil. Res. Freq. 75Hz Freq. Resp. to 7.5KHz Sens. 99dB. PRICE £19.99 + £2.00 P&P
10" 200 WATT R.M.S. C10200GP Guitar, Keyboard, Disco, 2" voice coil. Res. Freq. 45Hz Freq. Resp. to 7KHz. Sens. 101dB. PRICE £44.76 + £3.00 P&P
15" 200 WATT R.M.S. C15200 High Power Bass, Res. Freq. 40Hz Freq. Resp. to 5KHz Sens. 101dB. PRICE £62.41 + £4.00 P&P
15" 400 WATT R.M.S. C15400 High Power Bass, Res. Freq. 40Hz Freq. Resp. to 4KHz Sens. 102dB. PRICE £89.52 + £4.00 P&P.

WEM
5" 70 WATT R.M.S. Multiple Array Disco etc. 1" voice coil Res. Freq. 52Hz Freq. Resp. to 5KHz Sens. 89dB. PRICE £22.00 + £1.50 P&P ea
8" 150 WATT R.M.S. Multiple Array Disco etc. 1" voice coil. Res. Freq. 48Hz Freq. Resp. to 5KHz Sens. 92dB. PRICE £32.00 + £1.50 P&P ea.
10" 300 WATT R.M.S. Disco/Sound re-enforcement etc. 1" voice coil Res. Freq. 35Hz Freq. Resp. to 4KHz Sens. 92dB. PRICE £36.00 + £2.00 P&P ea.
12" 300 WATT R.M.S. Disco/Sound re-enforcement etc. 1 1/2" voice coil Res. Freq. 35Hz Freq. Resp. to 4KHz Sens. 94dB. PRICE £47.00 + £3.00 P&P ea

SOUNDLAB (Full Range Twin Cone)
5" 60 WATT R.M.S. Hi-Fi/Multiple Array Disco etc. 1" voice coil Res. Freq. 63Hz Freq. Resp. to 20KHz Sens. 86dB. PRICE £9.99 + £1.00 P&P ea
6 1/2" 60 WATT R.M.S. Hi-Fi/Multiple Array Disco etc. 1" voice coil Res. Freq. 56Hz Freq. Resp. to 20KHz Sens. 89dB. PRICE £10.99 + £1.50 P&P ea
8" 60 WATT R.M.S. Hi-Fi/Multiple Array Disco etc. 1 1/2" voice coil Res. Freq. 38Hz Freq. Resp. to 20KHz Sens. 89dB. PRICE £12.99 + £1.50 P&P ea
10" 60 WATT R.M.S. Hi-Fi/Disco etc. 1 1/2" voice coil Res. Freq. 35Hz Freq. Resp. to 15KHz Sens. 89dB. PRICE £16.49 + £2.00 P&P

PANTEC HOBBY KITS. Proven designs including glass fibre printed circuit board and high quality components complete with instructions.

FM MICROTRANSMITTER (BUG) 90/105MHz with very sensitive microphone. Range 100/300 metres. 57 x 46 x 14mm (9 volt) Price: £8.62 + 75p P&P.
3 WATT FM TRANSMITTER 3 WATT 85/115MHz varicap controlled professional performance. Range up to 3 miles 35 x 84 x 12mm (12 volt) Price: £14.49 + 75p P&P.
SINGLE CHANNEL RADIO CONTROLLED TRANSMITTER/RECEIVER 27MHz. Range up to 500 metres. Double coded modulation. Receiver output operates relay with 2amp/240 volt contacts. Ideal for many applications. Receiver 90 x 70 x 22mm (9/12 volt). Price: £17.82 Transmitter 80 x 50 x 15mm (9/12 volt). Price: £11.29 P&P + 75p each. S.A.E. for complete list.



3 watt FM Transmitter

BURGLAR ALARM

Better to be 'Alarmed' than terrified. Thandar's famous 'Minder' Burglar Alarm System. Superior microwave principle. Supplied as three units, complete with interconnection cable FULLY GUARANTEED.
Control Unit - Houses microwave radar unit, range up to 15 metres adjustable by sensitivity control. Three position, key operated fascia switch - off - test - armed. 30 second exit and entry delay.
Indoor alarm - Electronic swept freq. siren 104dB output.
Outdoor Alarm - Electronic swept freq. siren 98dB output. Housed in a tamper-proof heavy duty metal case.

IDEAL for Work-shops, Factories, Offices, Home, etc. Supplied ready built.



Both the control unit and outdoor alarm contain rechargeable batteries which provide full protection during main failure. Power requirement 200/260 Volt AC 50/60Hz. Expandable with door sensors, panic buttons etc. Complete with instructions.
SAVE £138.00 Usual Price £228.85
BKE's PRICE £89.99 + £4.00 P&P
? Why buy a collection of self assembly boards!



OMP LINNET LOUDSPEAKERS

The very best in quality and value. Made specially to suit today's need for compactness with high sound output levels. Finished in hard wearing black vinyl with protective corners, grille and carry handle. All models 8 ohms. Full range 45Hz - 20KHz. Size 20" x 15" x 12". Watts R.M.S. per cabinet. Sensitivity 1W 1mtr dB.

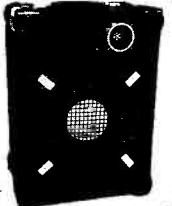

OMP 12-100 Watts 100dB. Price £149.99 per pair.
OMP 12-200 Watts 102dB. Price £199.99 per pair.
Delivery Securicor £8.00 per pair

OMP 19" STEREO RACK AMPS



Professional 19" cased Mos-Fet stereo amps. Used the World over in clubs, pubs, discos etc. With twin Vu meters, twin toroidal power supplies, XLR connections, MF600 Fan cooled. **Three models (Ratings R.M.S. into 4ohms). Input Sensitivity 775mV**
MF200 (100 + 100)W. £169.00 Securicor
MF400 (200 + 200)W. £228.85 Delivery
MF600 (300 + 300)W. £299.99 £10.00

1 K-WATT SLIDE DIMMER

- * Control loads up to 1Kw
- * Compact Size 4 1/2" x 1" x 2 1/2"
- * Easy snap in fixing through panel cabinet cut out
- * Insulated plastic case
- * Full wave control using 8 amp triac
- * Conforms to BS800
- * Suitable for both resistance and inductive loads. Innumerable applications in industry, the home, and disco's, theatres etc.

PRICE £13.99 - 75p P&P

BSR P295 ELECTRONIC TURNTABLE

- * Electronic speed control 45 & 33 1/3 r.p.m.
- * Plus Minus variable pitch control
- * Belt driven
- * Aluminium platter with strobed rim
- * Cue lever
- * Anti-skate (bias device)
- * Adjustable counter balance
- * Manual arm
- * Standard 1" cartridge fixings

Supplied complete with cut out template * D.C. Operation 9-14v D.C. 65mA
Price £36.99 £3.00 P&P.

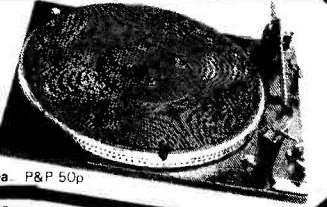

ADC O4 mag. cartridge for above. Price £4.99 ea. P&P 50p

PIEZO ELECTRIC TWEETERS - MOTOROLA

Join the Piezo revolution. The low dynamic mass (no voice coil) of a Piezo tweeter produces an improved transient response with a lower distortion level than ordinary dynamic tweeters. As a crossover is not required these units can be added to existing speaker systems of up to 100 watts (more if 2 put in series) FREE EXPLANATORY LEAFLETS SUPPLIED WITH EACH TWEETER.

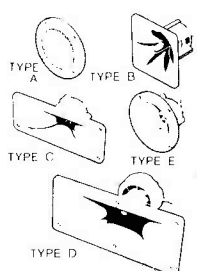

TYPE 'A' (KSN2036A) 3" round with protective wire mesh. Ideal for bookshelf and medium sized Hi-Fi speakers. Price £4.90 each - 40p P&P.
TYPE 'B' (KSN1005A) 3 1/2" super horn. For general purpose speakers, disco and P.A. systems etc. Price £5.99 each - 40p P&P.
TYPE 'C' (KSN6016A) 2" x 5" wide dispersion horn. For quality Hi-Fi systems and quality discos etc. Price £6.99 each - 40p P&P.
TYPE 'D' (KSN1025A) 2" x 6" wide dispersion horn. Upper frequency response retained extending down to mid range (2KHz). Suitable for high quality Hi-Fi systems and quality discos. Price £9.99 each - 40p P&P.
TYPE 'E' (KSN1038A) 3 1/2" horn tweeter with attractive silver finish trim. Suitable for Hi-Fi monitor systems etc. Price £5.99 each + 40p P&P.
LEVEL CONTROL Combines on a recessed mounting plate, level control and cabinet input jack socket. 85 x 85 mm. Price £3.99 + 40p P&P.

STEREO DISCO MIXER

STEREO DISCO MIXER with 2 x 5 band L & R graphic equalisers and twin 10 segment L.E.D. Vu Meters. Many outstanding features 5 Inputs with individual faders providing a useful combination of the following -
3 Turntables (Mag), 3 Mics, 4 Line plus Mic with talk over switch, Headphone Monitor, Pan Pot, L & R Master Output controls. Output 775mV. Size 360 x 280 x 90mm
Price £134.99 - £3.00 P&P

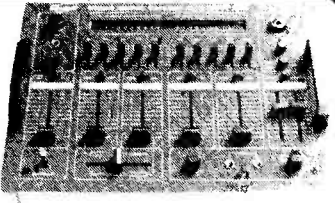

B. K. ELECTRONICS DEPT ETI
UNIT 5, COMET WAY, SOUTHEND-ON-SEA,
ESSEX, SS2 6TR TEL: 0702-527572

POSTAL CHARGES PER ORDER £1.00 minimum. OFFICIAL ORDERS WELCOME, SCHOOLS, COLLEGES, GOVERNMENT BODIES, ETC. PRICES INCLUSIVE OF V.A.T. SALES COUNTER VISA/ACCESS/O.D. ACCEPTED.

electronics today

INTERNATIONAL FEBRUARY 1987 VOL 16 NO 2

EDITORIAL AND ADVERTISEMENT OFFICE

1 Golden Square, London W1R 3AB. Telephone 01-437 0626.
Telex 8811896.

FEATURES

- A QUESTION OF BALANCE 14**
Barry Porter tips the scales in favour of noise-free signals with the low down on balanced lines for stage and home audio systems.
- CELLULAR RADIO 25**
The top telephones of the rich come under scrutiny. Keith Brindley 'phones in his report from a traffic jam on the M1.
- HARDWARE DESIGN CONCEPTS 21**
Mike Barwise takes his design ideas to the workbench and starts to build a top specification pulse generator. We're all invited to watch.
- THE MIDI INTERFACE 31**
This month Alan Robinson takes a look at the control codes used by the Musical Instrument Digital Interface standard.

PROJECTS

- GEIGER RATEMETER AND COUNTER 35**
A general purpose radiation detector to give an accurate reading for anything from a lump of uranium to some dodgy vegetables. Colin Seymour presents this precision instrument.
- LOW DISTORTION STEREO DECODER 46**
John Linsley Hood turns from the theory of the past few months to a practical high quality FM stereo decoder to add to an existing tuner or to keep for his tuner project coming next month.
- PHOTO PROCESS CONTROLLER 41**
Ian Coughlan's photographic enlarger timer is the best design around. With the quality of an SLR and the simplicity of an Instamatic, it's a snap.
- THE ETI LEDLINE ANALYSER... 50**
A fully fledged logic analyser is beyond the reach of most over-drafts. The LEDline analyser does the same job for a fraction of the price.

REGULARS

- NEWS DIGEST 6**
All that's happened.
- DIARY 9**
All that's going to happen.
- READ/WRITE 13**
More of your letters. What's the point of MIDI? What's the future of records? What's the price of a second hand oscilloscope? It's all here.
- TECH TIPS 54**
More of your circuits, and with a decidedly automotive flavour. For those with tow-bars there's a trailer light controller and a 50Hz inverter for the caravan.

INFORMATION

- NEXT MONTH'S ETI 8**
- SUBSCRIPTIONS 11**
- SPECIAL OFFER 30**
- PCB SERVICE 56**
- PCB FOILS 59**
- FREE READERS' ADS 62**
- CLASSIFIED ADS 64**

AN ARGUS SPECIALIST PUBLICATION
electronics today
INTERNATIONAL FEBRUARY 1987 £1.50

RADIATION

GEIGER COUNTER AND RATEMETER TO BUILD

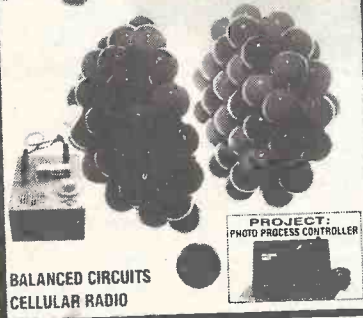

BALANCED CIRCUITS
CELLULAR RADIO

PROJECT:
PHOTO PROCESS CONTROLLER

AUDIO... COMPUTING... MUSIC... RADIO... ROBOTICS...

Geoff Bains: Editor
Ian Pitt: Deputy Editor
Paul Chappell: Project Editor
Jerry Fowler: Technical Illustrator
Alisdair Chisholm: Ad. Manager
Nicola Baty:
Classified Sales Executive
Andrew Selwood: Copy Control
Dave Bradshaw: Group Editor
- Electronics

PUBLISHED BY:
Argus Specialist Publications Ltd.,
1 Golden Square, London W1R 3AB.
DISTRIBUTED BY:
Argus Press Sales & Distribution Ltd.,
12-18 Paul Street, London EC2A 4JS
(British Isles)

TYPESET AND ORIGATION BY:
Design International.

PRINTED BY:
The Garden City Press Ltd.

COVERS DESIGNED BY:
Argus Design.

COVERS PRINTED BY:
Loxley Brothers Ltd.

ISSN
0142-7229



Member of the
Audit Bureau
of Circulation

Electronics Today is normally published on the first Friday in the month preceding cover date. □ The contents of this publication including all articles, designs, plans, drawings and programs and all copyright and other intellectual property rights therein belong to Argus Specialist Publications Limited. All rights conferred by the Law of Copyright and other intellectual property rights and by virtue of international copyright conventions are specifically reserved to Argus Specialist Publications Limited and any reproduction requires the prior written consent of the Company. © 1987 Argus Specialist Publications Ltd □ All reasonable care is taken in the preparation of the magazine contents, but the publishers cannot be held legally responsible for errors. Where mistakes do occur, a correction will normally be published as soon as possible afterwards. All prices and data contained in advertisements are accepted by us in good faith as correct at time of going to press. Neither the advertisers nor the publishers can be held responsible, however, for any variations affecting price or availability which may occur after the publication has closed for press.

■ Subscription Rates. UK: £18.10. Overseas: £22.50. USA: \$29.50. Airmail: £49.50.

BBC Micro Computer System

BBC Master Series

AMB15 BBC MASTER Foundation computer 128K	£395 (a)
AMB12 BBC MASTER Econet computer 128K (only ANFS)	£320 (a)
AMC06 Turbo (65C102) Expansion Module	£99 (b)
ADF13 Rom Cartridge	£13 (d)
ADF10 Econet Module	£41 (c)
ADJ22 Ref. Manual Part I	£14 (c)
ADJ23 Ref. Manual Part II	£14 (c)
ADJ24 Advanced Ref. Manual	£19.50 (c)

ACORN ADD-ON PRODUCTS

6502 2nd Processor	£173 (b)
TORCH ZEP 100	£229 (a)
Multiform 280 2nd Processor	£299 (b)
Acorn Teletext Adaptor	£119 (b)
Acorn IEEE Interface	£265 (a)

BBC Master Compact SYSTEM 1

128K, Single 640K Drive & bundled software	£385 (a)
--	----------

SYSTEM 2

System 1 with a 12" Med Res RGB Monitor	£469 (a)
---	----------

SYSTEM 3

System 1 with a 14" Med Res RGB Monitor	£599 (a)
---	----------

Second Drive Kit..... £99 (c)

UPGRADE KITS

1770 DFS Upgrade for Model B	£43.50 (d)
Basic II ROM	£22.50 (d)
1.2 OS ROM	£15 (d)
DNFS ROM	£17.50 (d)
ADFS Rom (for B with 1770 DFS & B Plus)	£26 (d)

ECONET ACCESSORIES

Econet Starter kit	£85 (d)
Econet Socket Set	£29 (c)
Econet Bridge	£174 (b)
File Server Level II	£125 (d)
Printer Server Rom	£41 (d)
10 Stallion Lead set	£26 (c)
Adv. Econet User Guide	£10 (d)

COMMUNICATIONS ROMS

Terminaler	£25 (d)
Communicator	£49 (d)
Comstar	£28 (d)
DATABEEB	£24 (d)

BBC FIRMWARE & SOFTWARE

Database Management Systems, Word Processors, Languages, Spreadsheets, Utilities

For full details on the wide range of above packages please write to us.

DISC DRIVES

These are fully cased and wired drives with slim line high quality mechanisms. Drives supplied with cables manuals and formatting disc suitable for the BBC computer. All 80 track drives are supplied with 40/80 track switching as standard. All drives can operate in single or dual density format.

PD800P (2 x 400K/2 x 640K 40/80T DS) with built in monitor stand	£249 (a)
PD800 (2 x 400K/2 x 640K 40/80T DS)	£229 (a)
TD800 (as PD800 but without psu)	£226 (a)
TS400 1 x 400K/1 x 640K 40/80T DS	£114 (b)
PS400 with psu 1 x 400K/1 x 640K 40/80T DS	£129 (b)

3.5" DRIVES

1 x 400K/1 x 640K 80T DS TS35	£99 (b)
PS35 1 with psu	£119 (b)
2 x 400K/1 x 640K 80T DS TD35	£170 (b)
PD35 2 with psu	£187 (b)

3M FLOPPY DISCS

High quality discs that offer a reliable error free performance for life. Each disc is individually tested and guaranteed for life. Ten discs are supplied in a sturdy cardboard box

5 1/4" DISCS	3 1/2" DISCS
40T SS DD £10.00 (d)	40T SS DD £20.00 (d)
80T SS DD £14.50 (d)	80T SS DD £25.00 (d)
40T DS DD £12.00 (d)	80T DS DD £16.00 (d)
	80T DS DD £25.00 (d)

DISC ACCESSORIES

FLOPPICLENE Disc Head Cleaning Kit with 20 disposable cleaning discs ensures continued optimum performance of the drives... 3 1/2" £16 (d), 5 1/4" £14.50 (d)

Single Disc Cable	£9 (d)	Dual Disc Cable	£8.99 (d)
10 Disc Library Case	£1.90 (c)	30 Disc Case	£6 (c)
40 Disc Lockable Box	£8.50 (c)	100 Disc Lockable Box	£13 (c)

MONITORS

All 14" monitors now available in plastic or metal cases, please specify.

MICROVITEC: 14" RGB

1431 Std Res	£179 (a)	1431 AP Std Res	£199 (a)
1451 med Res	£225 (a)	1451 AP Med Res	£259 (a)
1441 Hi Res	£365 (a)		

Swivel Base for Plastic 14" Microvitecs £20 (c)

20" RGB with PAL & Audio

2030CS Std Res	£380 (a)	2040CS Hi Res	£685 (a)
TAXAN SUPERVISION II 12" High Resolution	£249 (a)		
TAXAN SUPERVISION III with amber/green option, BBC & IBM	£289 (a)		
MITSUBISHI XC1404 14" RGB Med Res IBM & BBC Compatible	£229 (a)		
MITSUBISHI XC1440C 14" EGA	£460 (a)		

MONOCHROME MONITORS:

TAXAN KX1201G Hi Res 12" Etched Green Screen	£90 (a)
TAXAN KX1202G Hi Res 12" Long Persistence (P39)	£95 (a)
TAXAN KX1203A Hi Res 12" Etched Amber Screen	£95 (a)
PHILIPS BM7502 12" Hi Res Green Screen	£75 (a)
PHILIPS BM7522 12" Hi Res Amber Screen	£79 (a)

Swivel Base for Taxan Monochrome fitted with Digital Clock £21 (c)

PRINTERS

EPSON

LX86NLQ (80 col)	£195 (a)
FX85 (80 col) NLQ 8K RAM	£289 (a)
FX105 (136 col)	£389 (a)
EX800	£399 (a)
EX1000	£579 (a)
LQ800 (80 col)	£439 (a)
LQ1000 (136 col)	£619 (a)
XJ80 4 colour	£229 (a)

TAXAN KP815 (80 col) NLQ £239 (a)

TAXAN KP910 (156 col) £279 (a)

NATIONAL PANASONIC KXP1080 (80 col) £149 (a)

STAR NL10 (IBM interface) £239 (a)

JUKI 6100 Daisy Wheel £289 (a)

BROTHER HR20 £329 (a)

INTEGREX Multicolour £549 (a)

EPSON H180 A4 Plotter £249 (a)

HITACHI 672 A3 Plotter £454 (a)

Paper:

2000 Sheets Fanfold:	
9.5" x 11"	£13 (b)
14.5" x 11"	£18.50 (b)

Labels: (per 1000)

3.5" x 17/16" Single row	£5.25 (d)
27/16" x 17/16" Triple row	£5.00 (d)

ACCESSORIES

EPSON

FX plus sheet feeder	£128.99 (b)
LX80 Sheet feeder	£46.99 (b)
Paper Roll Holder	£17.99 (d)
FX80 Tractor attachment	£27.99 (c)
Interfaces: 8143 RS232C	£26.99 (c)
8146 RS232 + 2K	£27.99 (c)
8132 Apple II	£26.99 (c)
8185 IEEE + cable	£26.99 (c)

Serial & Parallel interfaces with larger buffers available.

Ribbons: RX/FX/MS100 £18.99 (d)

 RX/MS100 £16.99 (d)

 LX80 £25.99 (d)

Spare pens for H180 £7.99/set (d)

FX80 Tractor Attachment £27 (c)

KAGA TAXAN

RS232 Interface + 2K Buffer	£26 (c)
Ribbon KP810/910	£5.99 (d)
JMKL	
RS232 Interface	£26 (c)
Spare Daisy Wheel	£14.99 (d)
Ribbon	£2.99 (d)
Sheet Feeder	£189 (a)
Tractor Feed Attachment	£129 (a)
BROTHER HR15:	
Sheet Feeder	£199 (a)
Tractor Feeder	£299 (a)
Ribbons Carbon or Nylon	£4.99 (d)
Red Correction Ribbon	£2.99 (d)
BBC Printer Lead:	
Parallel (42")	£7.99 (d)
Serial	£7.99 (d)

Printer Leads can be supplied to any length.

MODEMS

All modems listed below are BT approved

MIRACLE 3000:

MIRACLE WS2000 V21/23 Manual £102 (b)

MIRACLE WS4000 V21/23 (Hayes Compatible, Intelligent, Auto Dial, Auto Answer) £149 (b)

MIRACLE WS3000 V21/V23 As WS4000 and with BELL standards and battery pack up for memory £295 (b)

MIRACLE WS3000 V22 As WS3000 V21/V23 but with 1200 baud full duplex £495 (a)

MIRACLE WS3000 V22 bis As V22 and 2400 baud full duplex £650 (a)

MIRACLE WS3022 As WS3000 but with only 1200/1200 £395 (a)

MIRACLE WS3024 As WS3000 but with only 2400/2400 £570 (b)

DATA Cable for WS series/PC or XT £10 (d)

DATATALK Comms Package 'If purchased with any of the above modems' £70 (c)

PACER Nightingale Modem V21/V23 Manual £95 (b)

Serial Test Cable

Serial Cable switchable at both ends allowing pin options to bare-rooted or linked at either end using a 10 way switch making it possible to produce almost any cable configuration on site.

Available as M/M or M/F £24.75 (d)

SPECIAL OFFER

2764-25 £2.00

27128-25 £2.50

6264LP-15 £3.40

ATTENTION

All prices in this double page advertisement are subject to change without notice.

ALL PRICES EXCLUDE VAT

Please add carriage 50p unless indicated as follows:

(a) £8 (b) £2.50 (c) £1.50 (d) £1.00

Serial Mini Patch Box

Allows an easy method to reconfigure pin functions without rewiring the cable assembly.

Jumpers can be used and reused. £22 (d)

Serial Mini Test

Monitors RS232C and CCITT V24 Transmissions, indicating status with dual colour LEDs on 7 most significant lines. £22.50 (d)

GANG OF EIGHT INTELLIGENT FAST EPROM COPIER

Copies up to eight eproms at a time and accepts all single rail eproms up to 27256. Can reduce programming time by 80% by using manufacturer's suggested algorithms. Fixed Vpp of 21 & 25 volts and variable Vpp factory set at 12.5 volts. LCD display with alpha moving message £395(b).

SOFTY II

This low cost intelligent eprom programmer can program 2716, 2516, 2532, 2732, and with an adaptor, 2564 and 2764. Displays 512 byte page on TV - has a serial and parallel I/O routines. Can be used as an emulator, cassette interface. Softy II. £195(b)

Adaptor for 2764/2564. £25.00(c)

UV ERASERS

All erasers with built in safety switch and mains indicator.

UV1B erases up to 6 eproms at a time. £47(c)

UV1T as above but with a timer. £59(c)

UV140 erases up to 14 eproms at a time. £68(b)

UV141 as above but with a timer. £68(b)

CONNECTOR SYSTEMS

I.D. CONNECTORS	EDGE CONNECTORS	AMPHENOL CONNECTORS	RIBBON
(Speedblock Type)	0.1" 0.156"	Solder ZDC	(grey/metre)
No of Header Plug Receptacle Edge Conn.	2 x 6-way (commodore) 150p 2 x 10-way (vic 20) 350p 2 x 18-way 140p 2 x 23-way (ZX81) 175p 2 x 25-way 225p 2 x 28-way (Spectrum) 200p 2 x 36-way 250p 1 x 43-way 250p 2 x 22-way 190p 2 x 43-way 395p 1 x 77-way 400p 2 x 50-way (S100conn) 600p	36 way plug 500p 475p 36 way skt 550p 500p 24 way skt 475p 475p IEEIEE 475p 475p 24 way skt 500p 500p IEEIEE 500p 500p PCB Mtg Skt Ang Pin 24 way 700p 36way 750p	10-way 40p 34-way 180p 16-way 60p 40-way 180p 20-way 85p 50-way 200p 26-way 120p 64-way 280p
D CONNECTORS	EURO CONNECTORS	GENDER CHANGERS	DIL HEADERS
No of Ways	DIN 41612 Plug Socket	25 way D type	Solder IDC
9 15 25 37	DIN 41612 230p 275p 2 x 32 way Ang Pin 275p 320p 3 x 32 way St Pin 260p 300p 3 x 32 way Ang Pin 375p 400p IDC Skt A + B 400p IDC Skt A + C 400p For 2 x 32 way please specify spacing (A + B, A + C).	Male to Male £10 Male to Female £10 Female to Female £10	14 pin 40p 100p 16 pin 50p 110p 18 pin 60p - 20 pin 75p - 24 pin 100p 150p 28 pin 180p 200p 40 pin 200p 225p
MALE: Ang.Pins 120 180 230 350 Soldr 60 85 125 170 IDC 175 275 325 -	FEMALE: St Pin 100 140 210 380 Ang.pins 180 210 275 440 Soldr 90 130 195 290 IDC 195 325 375 - St Hood 90 95 100 120 Screw 130 150 175 -	RS 232 JUMPERS:	
SOCKETS 24-pin £7.50 28-pin £9.90	MISC CONNECTORS	(25 way D)	
	21 pin Scart Connector.200p 8 pin Video Connector.200p	24" Single end Male £5.00 24" Single end Female £5.25 24" Female Female £10.00 24" Male Male £9.50 24" Male Female £9.50	
	4-way 90p 6-way 105p 8-way 120p 10-way 140p		

TECHNOLINE VIEWDATA SYSTEM

Using 'Prestel' type protocols for information and orders phone 01-450 9764. 24 hour service. 7 days a week.

4 SERIES **LINEAR ICs** **COMPUTER COMPONENTS**

Table listing various components in the 4 series. Columns include component numbers (e.g., 74181, 74182, 74183), quantities, and prices. Includes sub-sections for 74LS SERIES, 4000 SERIES, and 74S SERIES.

Table listing linear IC components with part numbers (e.g., A07881, A08008, A08081), quantities, and prices. Includes sub-sections for VOLTAGE REGULATORS (FIXED PLASTIC and OTHER REGULATORS) and SWITCHING REGULATORS.

Table listing computer components including CPUs (e.g., 1802CE, 2650A, 6800), EPROMs (e.g., 2516-5v, 2516-35), ROMs/PROMs (e.g., 2817, 2863), and MEMORYs (e.g., 2101, 2107S).

Real Time Clock, Teletext Decoder, and Profile Sockets section. Lists products like MC8518P, MM58174AN, and MSM5832RS with their respective prices and pin configurations.

Low Profile Sockets by Texas and Wire Wrap Sockets by Texas. Lists various socket types and their prices.

Opto-Electronics section featuring Driver (e.g., BPX34, BPW21), Counters (e.g., 74C925), and Opto-Isolators (e.g., LC74, MCT26).

LEDs, Bar Arrays, and Rect. LEDs section. Lists various LED products and their prices. Includes a note: 'Please note all prices are subject to change without notice.'

TECHNOMATIC LTD logo and contact information. Includes address (17 Burnley Road, London NW10 1ED), phone numbers, and promotional text: 'PLEASE ADD 50p p&p & 15% VAT'. Also includes a small image of a chip.

● The Botswana Technology Centre have written to tell us that their current electronics engineer is leaving in March 1987 and they are looking for a replacement. The work is aimed mostly at creating jobs and aiding rural development. Applicants with a degree in electronics and experience of design and production should contact the Recruitment Executive, ODA, Abercrombie House, Eagle Sham Road, East Kilbride, Glasgow G75 8EA.

● Several ranges of Oak switching products are described in two new catalogues from Diamond H Controls. Keyboards, keyboard switches, membrane panels and programmable rotary switches are covered in one catalogue while the other lists a wide range of rotary switches including PCB-mounting, lever-operated and miniature and subminiature types. Diamond H Controls Ltd, Vulcan Road North, Norwich NR6 6AH, tel (0603) 45291.

● A survey taken at the Internecon exhibition in October reveals that 36% of those visiting the show are already using surface-mount technology and a further 15% are likely to adopt the technique in the coming year. The organisers of the exhibition claim that their visitors represent a broad cross-section of the UK electronics industry, and suggest on the basis of these findings that around 50% of all electronics manufacturers will be using surface mount techniques in 12 months time.

● The range of DIN 41612 PCB connectors manufactured by Bulgin is described in a new 16-page catalogue. The types featured include B, C, D, F, H and R connectors with from 11 to 96 contacts and with pin spacings from 0.1" to 0.4". Included in the catalogue is a selection guide, a series of dimension drawings plus board and panel hole-cutting patterns. A.F. Bulgin & Company PLC, Bypass Road, Barking Essex IG11 0AZ, tel (01) 594-5588.

● Electrovalue, whose new catalogue we mentioned in our December issue, will no longer be sending out each new issue automatically to past customers. Instead, those who require a copy will have to write and request one. However, so that no extra cost is involved for the customer, Electrovalue will be using a Free-post address which removes the need for a stamp on the envelope. Write to Electrovalue Ltd, Free-post, 28 St. Judes Road, Egham Surrey TW20 8BR or telephone (0784) 33603. The catalogue itself is still free.

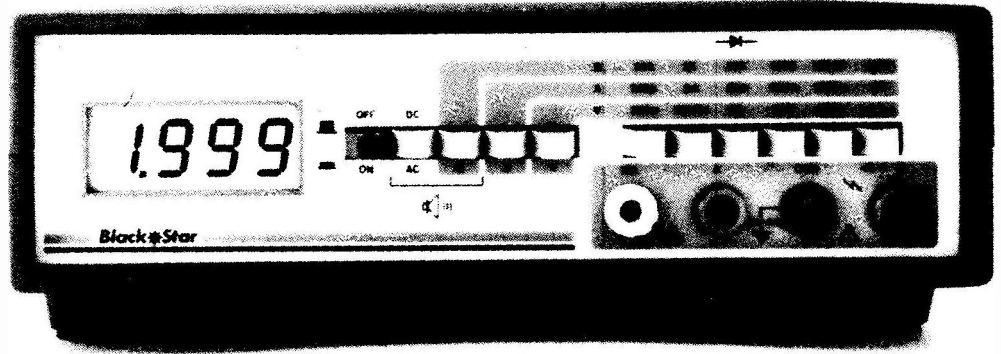

Measuring Time

The latest digital multimeter from Black Star combines a wide range of measuring functions and high accuracy with a typical battery life which is equivalent to over ten months of continuous operation.

Designed as a bench instrument which is none the less extremely portable, the 3225 can operate for around 7,500 hours on one set of alkaline batteries. It has a 3½ digit display, a basic DC accuracy of ±0.25% and includes a diode test function and an audible continuity tester. AC and DC voltages are covered in five ranges with FSDs from 200mV to 1000V (750V AC) while resistance is covered in six ranges from 200Ω to 20M FSD. AC and DC currents are

covered in six ranges from 200µA to 10A FSD and the AC measurements are average responding, RMS calibrated.

The liquid crystal display has 0.5" high characters and includes over-range, polarity and low-battery indication. Connection is made via recessed 4mm sockets and the moulded plastic case is shielded against RF and other electromagnetic interference. The 3225 comes complete with test leads, a set of batteries and a comprehensive manual and costs £89.00 plus VAT. The 3210, an upgraded version of the 3225 offering 0.1% DC accuracy and true-RMS AC measurements, will be available soon at £119.00 plus VAT.

Also new from Black Star is the Jupiter 500 function generator which offers sine, square and triangle waveforms over the fre-

quency range 0.1Hz to 500kHz. Two 600R outputs are provided, one of which delivers up to 30V and can be offset within the range -15V to +15V, and there is also a TTL-level square wave output capable of driving up to 30 standard loads. Coarse and fine frequency controls are provided and all outputs are protected against short circuits. External input signals can be used to control the output amplitude over its full range and to sweep the frequency over a ratio of 1000:1 on any selected range.

The Jupiter 500 comes complete with mains lead and instruction manual and costs £110.00 plus VAT.

Black Star Ltd, 4 Stephenson Road, St. Ives, Huntingdon, Cambridgeshire PE17 4WJ, tel (0480) 62440.

World's Smallest DPM

Datel claim their DM-500 is the smallest digital panel meter in the world. It measures just 48 x 24 x 43mm (1.89 x 0.94 x 1.69") and at around 60mA its power consumption is said to be three times lower than that of comparable DPMs.

The DM-500 has a 3½ digit red LED display with 8mm (0.32") high characters which are designed to be clearly visible even in bright conditions. Different versions provide four DC voltage ranges from ±199.9mV to ±199.9V and four current ranges from ±199.9µA to ±199.9mA. Display accuracy is ±0.1% of reading ±1 digit and each range is provided with over-range signal protection.

The meter samples the incoming signal 2.5 times per second and zeroes automatically. A hold facility allows the sampling to be stopped so that the last signal measured is displayed. Both single-ended and differential signals are accepted and an input impedance of around 1000M ensures that sensitive inputs aren't loaded.

Datel UK Ltd, Belgrave House, Basing View, Basingstoke, Hampshire RG21 2YS, tel (2056) 469 085.

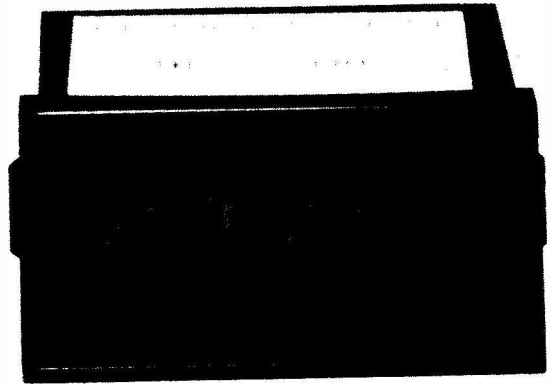

PC-Compatibility For The BBC

A new interface board from Watford Electronics allows BBC B and B+ microcomputers to run PC-type software packages using the Acom Master 512K board.

As well as opening up new possibilities for the BBC as a serious business machine, the interface makes it possible to link-up a Master Turbo co-processor board and so gain extra speed and memory.

Known as the Co-Pro Adaptor, the interface will cost £50.00 and its launch follows a recent price-cut on the Master 512K board to £199.00. This makes it possible to

upgrade a BBC for around £250.00, far less than the purchase price of even the cheapest PC clones.

Watford point out that there are still over 500,000 BBC microcomputers around and claim that the introduction of the new board demonstrates their continuing commitment to the machine. They expect the Co-Pro Adaptor to be popular with schools since almost half of the cost can be claimed back under the DTIs Software In Schools Scheme.

Watford Electronics, 250 High Street, Watford WD1 2AN, tel (0923) 37774.

IC A Picture In A Picture

A new IC from ITT allows a second, one-third size picture to be displayed within the main picture on a TV screen.

The second picture can be placed in any one of four predetermined positions on the screen and is contained within a border which separates it from the main picture.

The IC is part of ITT's Digit 2000 system and is known as the PIP 2250. It works by storing the Y, R-Y and B-Y signals in a DRAM and presenting them to the video controller at the appropriate times. The additional RGB inputs to the controller are used to produce the border and an internal switch allows the PIP2500 to accept external RGB inputs so that Teletext and other picture data can still be used. In keeping with its size, the small picture is sampled at a rate of every third pixel, every third line.

A number of other new ICs have recently been released by ITT, among them a programmable speedometer and mileage indicator system for use in cars and a real-time digital signal processor for digitising audio signals.

The speedometer and mileage indicator consists of two ICs, the SAF1091 and SAF1092, and works by sensing the speed of rotation of the gearbox driveshaft. An LC oscillator drives a coil placed near the gearbox, and a proximity switch within the bipolar SAF1091

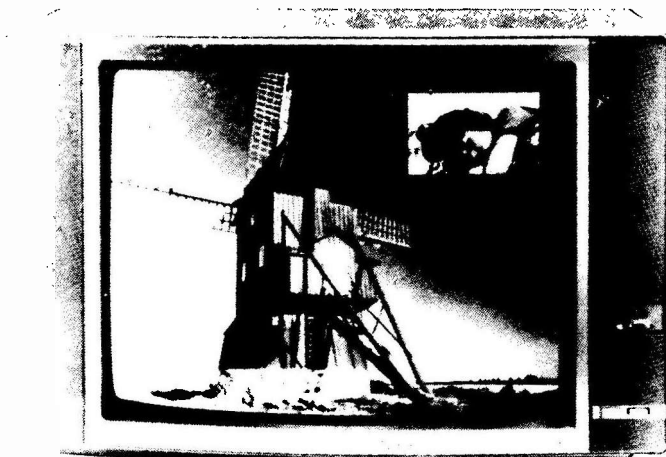

senses drop-outs in the oscillation caused by a small piece of metal attached to the driveshaft. The resulting pulse train is fed to the CMOS SAF1092 for logic processing and then returned to the SAF1091 which drives a moving-coil meter to indicate speed and a stepper motor to register the miles covered. The ICs are suitable for both 12 and 24V electrical systems and are supplied in 18-pin DIL packages.

The digital signal processor IC, the APU 2470, is intended principally for filtering operations which it performs by combining add, multiply and delay functions. It has a sampling rate of 35kHz and handles several calculations and move operations

simultaneously, achieving a maximum of 4.4 million sum-of-product operations each second. A mask-programmed ROM holds the program and a 51 x 16 bit RAM stores intermediate results. Among the other functional blocks within the IC are a fast ALU, digital filters for input PCM conversion, an output DAC and four 16-bit serial I/O channels. Analogue volume adjustment is provided to ensure maximum signal-to-noise ratio. The APU 2470 is fabricated in N-channel MOS and comes in a 24-pin DIL package.

ITT Semiconductors, 145-147 Ewell Road, Surbiton, Surrey KT6 6AW.

● Educational electronics specialist Flight Electronics has issued its latest catalogue of microprocessor, logic and analogue training systems. Packages for the Z80, 8088 and 68K are among those described and the catalogue also lists technical books and a range of training-related equipment such as bench power supplies, breadboards, etc. Flight Electronics Ltd, Flight House, Ascupart Street, Southampton SO1 1LU, tel (0703) 227 721.

● Piezo Products can manufacture small quantities of crystals to a customers' requirements within three working days. The service covers devices in the 1-70MHz range and in most standard packages and offers an accuracy of $\pm 0.001\%$ at normal temperatures. Piezo Products Ltd, Mill-Stream Trading Estate, Christchurch Road, Ringwood, Hampshire BH24 3SD, tel (0425) 479 337.

● A new 40-page A4 catalogue from P. Caro & Associates lists over 170 different slide switches with illustrations and full technical information. Ratings from 0.3 to 3 amps are covered with from one to eight poles and up to ten positions. There are also a small number of toggle, rocker and pushbutton switches with higher current ratings and a few jack-type DC power connectors. P. Caro & Associates Ltd, 2347 Coventry Road, Sheldon, Birmingham B26 3LS, tel (021) 742-1328.

● Three new brochures from Hitachi describe the company's range of liquid crystal dot-matrix displays. One contains specifications on the complete range of devices while the others describe two new product lines, X-Technology displays and LCD modules with built-in LED backlighting. X-Technology is said to offer better contrast and viewing angle than conventional LCDs and is being applied to large displays which would normally lack contrast because of multiplexing. The LED backlighting system is offered as an alternative to high-voltage electroluminescent systems, having longer life and running from a 5V supply. Contact Hitachi Electronic Components (UK) Ltd, 21 Upton Road, Watford, Hertfordshire WD1 7TP, tel (0923) 46488.

● Also available from Hitachi is a 32-page A4 data book on the HG62B series of CMOS gate arrays. A list of macrocell configurations is given, plus notes and examples on the design of logic systems and a guide to the use of auto-diagnosis and other features. Contact Hitachi at the address above.

Pocket Ratemeter

A little something for those who can't be bothered to build this month's Geiger ratemeter project. From Germany comes the DLM-2, a pocket-sized ratemeter complete with GM tube which responds to alpha, beta, gamma and X-rays. It has an LED and a loudspeaker to indicate the detection of radioactive particles and the manufacturers say it is useful for checking food and drink as well as other items such as clothing.

The measurement range is from 1-1999 $\mu\text{R/h}$ (micro-Roentgens per hour) and the result is displayed on a 4-digit, 0.5" high LCD. The current consumption is said to be very low in order to prolong battery life and a low-battery warning is incorporated in the display. The circuit diagram shows a pulse output socket which could be used to drive an external counter, but no mention of this is made in the notes sent to us.

The manufacturers say they are happy to supply the ratemeter to UK customers but do not men-

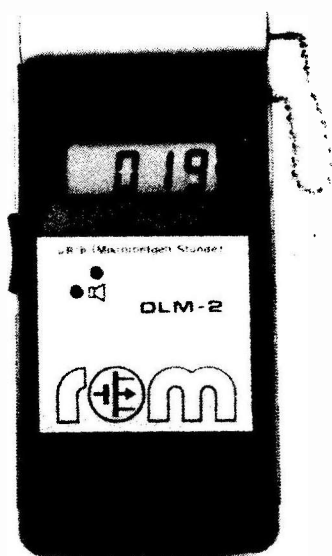

tion a postage charge. Anyone interested in buying one is advised to check this carefully before ordering. The cost of the DLM-2 is DM750 which works out to about £214 at the current rate of exchange.

Rober May Elektronische Geräte, Babenhauser Str.55, D-8908 Krumbach 1, Federal Republic of Germany.

High Capacity All Wound Up

ERA Technology has developed a type of capacitor construction which is capable of delivering 50 farads from a package the size of a cotton reel.

Using a wound double-layer arrangement the company has achieved an energy storage density of six joules per cubic metre at low DC voltages. A prototype capacitor has been shown to be capable of retaining its charge over many months and is said to have stable discharge characteristics. Electric double-layer capacitors are already available in capacitances of a few farads for use in computer memory back-up, and ERA suggests that high value capacitors might be used to allow processing as well as memory to be sustained during power down.

ERA would be interested to hear from other companies involved in the development of large value capacitors for use at low DC volt-ages. Contact them at Cleve Road, Leatherhead, Surrey KT22 7SA, tel (0372) 374 151.

NEXT MONTH

AN ARGUS SPECIALIST PUBLICATION

electronics today

INTERNATIONAL

HI-FI FM TUNER

John Linsley Hood, that last bastion of quality in the British hi-fi market, brings you his latest design in the pages of ETI. JLH's tuner is based on novel principles but those of you who have followed his recent series on tuner design will know to expect the best.

THE ETI CAPACITOMETER

From a few p's to lots of μ 's the ETI Capacitometer can measure the exact value of any capacitor. It's portable and quick to give a reading — a valuable addition to any workshop.

COMPUTER DATA COMMUNICATIONS

Baffled by busses? Perplexed by parallel? At sixes and sevens with serial? All is explained in next month's low down on the world of computer interfacing standards.

AND THE REST

All our regular features will be there too. Projects, features, letters, news, reviews, readers' ads and much much more.

THE MARCH ISSUE OF ETI — ON SALE 6th FEBRUARY YOU'D BE MAD NOT TO GET IT!

All the articles above are at an advanced state of preparation, but circumstances beyond our control may prevent publication.

TRAINEE RADIO OFFICERS

Are you looking for a secure shore-based job which offers rewarding career in the forefront of modern Telecommunications technology... then consider joining GCHQ as a Trainee Radio Officer. Training involves a 32 week residential course, (plus 6 weeks extra if you cannot touch type) after which you will be appointed RADIO OFFICER and undertake a variety of specialist duties covering the whole of the spectrum from DC to light.

We offer you: Job Security · Good Career Prospects · Opportunities for Overseas Service · Attractive Salaries... and much more.

To be eligible you must hold or hope to obtain an MRGC or HNC in a Telecommunications subject with an ability to read morse at 20wpm.

Anyone with PMG, MPT or 2 years relevant radio operating experience is also eligible. The Civil Service is an equal opportunities employer.

Salaries: Starting pay for trainees is age pointed to 21 years. For those aged 21 or over entry will be at £6,572. After training an RO will start at £9,758 rising by 5 annual increments to £14,387 inclusive of shift and weekend working allowance.

Write or telephone for an application form to:-



THE RECRUITMENT OFFICE, GCHQ, ROOM A/1108
OAKLEY, PRIORS ROAD, CHELTENHAM, GLOS GL52 5AJ
OR TELEPHONE (0242) 32912/3

CRICKLEWOOD ELECTRONICS LTD



It's no secret...

... that there is a *real difference* at *Cricklewood Electronics*. That's why you should never be without the **FREE CRICKLEWOOD ELECTRONICS COMPONENTS CATALOGUE**, for sheer variety, *competitive prices* and *service* from the U.K.'s number one 100% component shop. No gimmicks, no gadgets or computers, just components, millions of them, all easily available by mail order, calling or credit card telephone orders. Just pick up the phone (or a pen) to get your **FREE** copy now (no SAE required). You have nothing to lose.

CRICKLEWOOD ELECTRONICS LIMITED

40 Cricklewood Broadway, London NW2 3ET

Tel: 01-450 0995/01-452 0161

Telex: 91 4977



ETI

Standing Up For More Memory

Texas Instruments has found a simple way to get four times as much memory into one IC. Instead of laying chips horizontally within the package, they are stood on end. That way, far more circuitry can be contained in the same amount of space.

The new storage concept is being employed in the 4MB DRAM currently under development. One of the advantages of the

method is that it achieves higher density without the need for new manufacturing tools. TI claims that only one other manufacturer has been able to produce a 4MB DRAM of similar size and a complete new generation of production equipment was needed to do it.

Texas Instruments Ltd, Manton Lane, Bedford MK41 7PA, tel (0234) 63211.

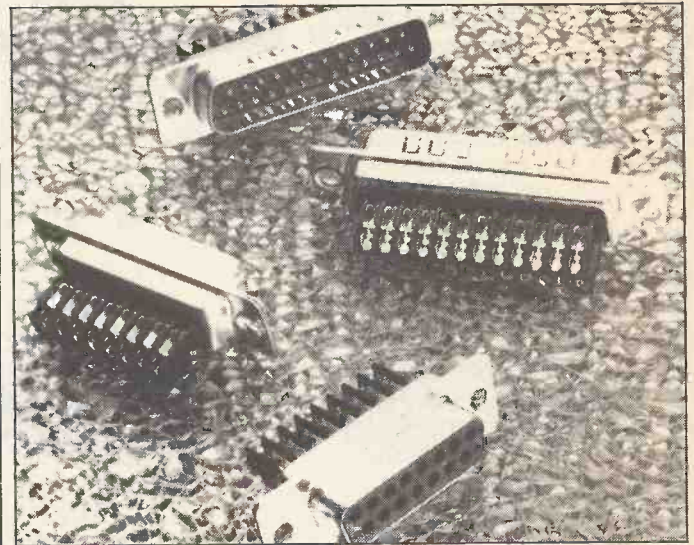

Never A Crossword

Devoted fans of the ETI crossword will be disappointed to learn that it won't be published this month.

We started publishing the crossword just over a year ago, and since then it seems to have drawn praise and criticism in roughly equal measure. We have now used all of the original twelve

crosswords we commissioned but we hope to begin a further series next month. If you have any strong feelings about what we should do with the crossword, why not send a letter in to Read/Write?

Meanwhile, here are the answers to last month's crossword.

ACROSS

- 1) Throat
- 7) Triac
- 8) Algebra
- 9) Switch
- 11) Tesla
- 12) DIN
- 14) Atom
- 15) Address
- 16) Read

17) Bel

- 18) Bench
- 19) Stator
- 22) Flyback
- 23) Spark
- 24) Tweeter

DOWN

- 2) Hall effect
- 3) Overload

4) Turn

- 5) Brown
- 6) Mast
- 9) Siren
- 10) Clock cycle
- 13) Adder
- 14) Assemble
- 17) Board
- 20) Amps
- 21) Blow

DIARY

Television Engineering Course — January 7th

The IBA, London. First of fifteen weekly lectures. Contact the Royal Television Society at the address below.

Satellite Navigation Systems — January 8th

The IEE, London, 5.30 pm. The 22nd Appleton Lecture, given this year by Dr. Peter Daly of the University of Leeds. Contact the IEE at the address below.

Digital Techniques In Television — January 13th

RTS Southern Centre, Newbury. First of eleven weekly lectures. Contact the Royal Television Society at the address below.

The Impact of ASIC on Equipment Design — January 14th

The IEE, London, 6.30pm. Colloquium on Application Specific Integrated Circuits. Contact the IEE at the address below.

Design and Measurement for EMC/RFI Management — January 19th

The IEE, London, 2.00pm. Discussion meeting. Contact the IEE at the address below.

Television Studios from Analogue to Digital — January 21st

The IEE, London, 6.30pm. Contact the IEE at the address below.

The Third High Technology and Equipment in Education Exhibition — January 21-24th

Barbican Centre, London, Exhibition and conference covering all areas of educational and training technology, etc. Contact Christine Smith on 01-608 1161.

Testing and Inspection of Electronic Components and Circuits — January 22nd

The IEE, London, 6.30pm. Contact the IEE at the address below.

Digital Signal Processing — January 26th

The IEE, London, 6.30pm. Contact the IEE at the address below.

SMARTEX '87 — February 10-12th

The Barbican Centre, London. The 2nd Surface Mount and Related Technologies Exhibition. Contact Peter Evans on (01) 855-7777.

The Which Computer? Show — February 17-20th

NEC, Birmingham. Computer show which aims to cover all aspects of business computing from personal microcomputer systems upwards. Contact Cahners Exhibitions at the address below.

Power UK/Enclosures '87 — February 24-26th

Kensington Rainbow Exhibition Centre, London. Exhibition and conference devoted to power sources and supplies, converters, etc and the associated areas of enclosure screening, thermal management etc. Contact TCM Expositions on (0428) 724 660.

The Electronic Data Interchange Conference — April 28-29th

The Barbican Centre, London. Conference which aims to explore the possibilities for improved electronic communication within and between organisations nationally and internationally. Contact Nicky Cross of Online on (01) 868-4466.

British Electronics Week 1987 — April 28-30th

Olympia Exhibition Centre, London. Single event incorporating exhibitions devoted to many different technologies. Contact the Evan Steadman Communications Group on (0799) 26699.

Computer North — May 27-29th

G-Mex Complex, Manchester. Business computer show. Contact Cahners Exhibitions at the address below.

Addresses

Cahners Exhibitions Ltd, Chatsworth House, 59 London Road, Twickenham TW1 3SZ, tel (01) 891-5051.

Institution of Electrical Engineers, Savoy Place, London WC2 0BL, tel (01) 240-1871.

The Royal Television Society, Tavistock House East, Tavistock Square, London WC1H 9HR, tel (01) 387-1970.



THE No 1 NAME FOR ELECTRONICS & COMPUTER PERIPHERALS

STATE OF THE ART POWER AMPLIFIER MODULES

High grade mosfet design for hi fi quality. Each unit comes complete with onboard power supply featuring a toroidal transformer. 3 models to choose from - note these prices are for built and tested units complete. Just plug in and go!!

- 120 WATTS (4 OHMS) ONLY **£39.99**
- 200 WATTS (4 OHMS) ONLY **£49.99**
- 300 WATTS (4 OHMS) ONLY **£59.99**

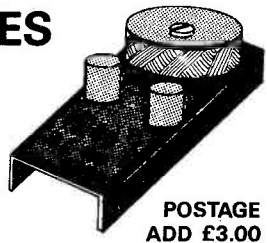

POSTAGE ADD £3.00

SOUND TO LIGHT SYSTEM CONTROLLER



ONLY **£29.99**
+ £2 p&p

5 CHANNEL LIGHT SEQUENCER



ONLY **£39.99**
+ £2 p&p

STROBE LIGHT complete

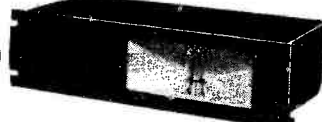

ONLY **£29.99**
+ £2 p&p

Rack mounting or free standing 3-channel sound to light using external connection from speaker lead to eliminate background noise pickup. Bass, Middle, Treble and Master sensitivity controls. 3 LED output mimics on front panel. Fuse protection. Output- 3 x 1000W Max. total load 2800W

Rack mounting or free standing 5-channel light sequencer with additional constant channel. Speed and direction controls for sequencer, with 5 LED output mimics on front panel. Attenuator control for constant channel. Fuse protection. Output- 5 x 1000W Max. total load 2800W

Top quality high output strobe light with parabolic reflector. Housed in rack-mounting case to match other special effect equipment. Variable speed control. On/Off switch. Flash rate- 5-25 Hz.

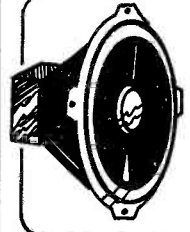

QUALITY LOUDSPEAKERS AT LOW, LOW PRICES!!!

- 12" 50 watts response to 3kHz **£19.99**
- 12" 100 watts response to 7kHz (PA) **£29.99**
- 12" 200 watts response to 3KHz **£34.99**
- BRITISH MADE McKENZIE**
- 12" 85 watts response to 8KHz **£29.99**

- 12" 85 watts response to 15kHz (PA) **£31.99**
- 15" 150 watts response to 4kHz **£54.99**
- 15" 200 watts response to 4KHz **£59.99**

Please Add: £2.00 p&p for 12" model, £4.00 p&p for 15" model. All units are 8 ohms.

4 CHANNEL DISCO MIXER



ONLY **£99.99**
£3.00 p&p

NOW THE ULTIMATE DISCO STEREO MIXER

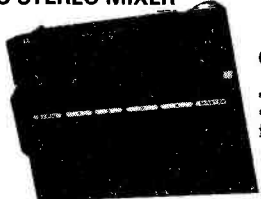

ONLY **£129.99**
£3.00 p&p

5 CHANNEL STEREO MIC/AUDIO MIXER

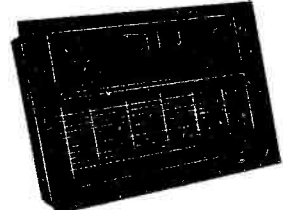

ONLY **£44.99**
£3.00 p&p

4-channel stereo disco mixer with built-in 5-band graphic equalizer. LED display monitored output, fader mix, cue control and equalizer defeat button. 4 inputs.

5-channel stereo disco mixer with built-in twin 5-band graphic equalizer. LED bargraph output monitor. Input and output headphone monitoring. Fader mix channels 1 and 2. Microphone talkover switch. Equalizer defeat button.

STEREO. 5-channel disco mixer. Switchable headphone monitor. Left and right VU meters. On/Off switch. Cabinet mounting. Flush fitting.

DIGITAL SOUND SAMPLING ON YOUR MICRO

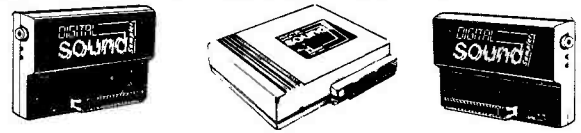

Datel were the first UK company to bring sound sampling to the home micro at realistic prices!! Now we can offer systems for Spectrum/Commodore/Amstrad. Digital sampling allows you to record any sound into the memory of your computer and then replay it at any pitch, forwards, backwards, with echo, reverb, endlessly looped etc. Complete musical pieces can be composed within the sequencer from a single sampled sound. Sequences can be loaded and saved from tape or disc.

- System is complete hardware/software package
- Free microphone supplied Tape or disc (please state)
- Spectrum/Plus/128K only **£49.99** + £1.00 p&p
- Amstrad 464/664/6128 only **£44.99** + £1.00 p&p
- Commodore 64/128 only **£49.99** + £1.00 p&p

ROBOTICS & MODEL CONTROL MADE EASY ON YOUR MICRO

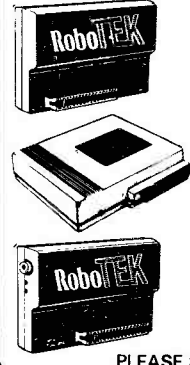

FOR THE SPECTRUM/PLUS/128K ONLY £29.99

- 8 inputs, 4 outputs with onboard relays
- Complete with ribbon connecting cable for mobile projects
- Simply controlled from basic or M/C

FOR COMMODORE 64/128 ONLY £39.99

- 4 buffered inputs 4 outputs via onboard relays
- Analogue input for measurement etc.
- Microphone input for voice control
- Comprehensive software featuring sequencer & measurement modules - very effective
- Complete with cables & microphone etc.

FOR AMSTRAD 464/664/6128 ONLY £29.99

- 8 buffered inputs 4 outputs via onboard relays
- Complete with ribbon cable Through bus
- Simply controlled from basic or M/C

PLEASE STATE WHICH COMPUTER WHEN ORDERING

OTHER COMPUTER PERIPHERALS

- COMMODORE 64/128**
- Action Replay - the ultimate disk/tape/disk backup cartridge - **£24.99**
- Disk Mate 2 - fast load cartridge plus advanced disk user facilities - **£14.99**
- Turbo ROM - advanced replacement kernel with fast load etc - **£10.99**
- Printer IV - for MPS 801 printer contains four improved typefaces - **£19.99**
- 8K pseudo ROM cartridge - battery backed, easy to use - **£16.99**
- 3 slot mother board - accepts 3 cartridges at flick of switch - **£16.99**
- MIDI interface - works with all major MIDI software - **£24.99**
- Snapshot 2 - tape/microdrive/Opus backup system - **£24.99**
- Gamesale - joystick interface - plus delivers sound through TV - **£10.99**
- AMSTRAD**
- Action replay AMX. The most advanced tape/disc/tape system - **£34.99**
- SPECTRUM/PLUS/128K**
- Quickshot 2 including interface (Kempston System) only - **£13.99**
- Interpreter electronics printer interface - laserword compatible - **£24.99**
- Please state tape or disc (if applicable). Please add £1.00 p&p per order.

Please send SAE for Catalogue.

DATEL ELECTRONICS

USUALLY SAME DAY DESPATCH ON ALL ORDERS
SEND CHEQUES/P O'S TO:
UNITS 8/9
FENTON INDUSTRIAL ESTATE
DEWSBURY ROAD, FENTON
STOKE-ON-TRENT TEL: 0782 273815
FAX: (0782) 264510

24 HR CREDIT CARD LINE

FOREIGN ORDERS ADD £2 POSTAGE

BIG

SUBSCRIPTION SAVINGS FOR YOU!

Take advantage of these fantastic money saving subscription offers to these magazines. Hurry, this amazing offer is for a limited period only.

UNITED KINGDOM

OVERSEAS (Accelerated surface post)

	Normal Price	Sale Price	Please Tick	Normal Price	Sale Price	Please Tick
A&B Computing	£21.80	£18.00	<input type="checkbox"/>	£26.00	£20.80	<input type="checkbox"/>
Computer Gamer	£16.00	£13.00	<input type="checkbox"/>	£21.50	£17.20	<input type="checkbox"/>
Your Commodore	£16.00	£13.00	<input type="checkbox"/>	£21.50	£17.20	<input type="checkbox"/>
ZX Computing Monthly	£15.00	£12.00	<input type="checkbox"/>	£18.00	£14.40	<input type="checkbox"/>
Citizens' Band	£16.90	£13.52	<input type="checkbox"/>	£22.00	£17.60	<input type="checkbox"/>
Ham Radio Today	£17.30	£14.40	<input type="checkbox"/>	£21.00	£16.80	<input type="checkbox"/>
Electronics Digest	£11.30	£ 8.30	<input type="checkbox"/>	£14.00	£11.20	<input type="checkbox"/>
Electronics Today International	£18.10	£14.40	<input type="checkbox"/>	£22.50	£18.00	<input type="checkbox"/>
Video Today	£16.90	£13.52	<input type="checkbox"/>	£21.00	£16.80	<input type="checkbox"/>
Which Video?	£16.90	£13.52	<input type="checkbox"/>	£21.00	£16.80	<input type="checkbox"/>
Photography	£16.00	£12.00	<input type="checkbox"/>	£21.50	£16.00	<input type="checkbox"/>
Photoplay	£17.90	£14.32	<input type="checkbox"/>	£21.50	£17.20	<input type="checkbox"/>
Clocks	£30.80	£24.64	<input type="checkbox"/>	£35.00	£28.00	<input type="checkbox"/>
Woodworker	£16.90	£13.52	<input type="checkbox"/>	£21.00	£16.80	<input type="checkbox"/>
Popular Crafts	£17.90	£14.32	<input type="checkbox"/>	£21.50	£17.20	<input type="checkbox"/>
Winemaker & Brewer	£13.70	£10.96	<input type="checkbox"/>	£17.00	£13.60	<input type="checkbox"/>
Aeromodeller	£25.10	£20.08	<input type="checkbox"/>	£29.00	£23.20	<input type="checkbox"/>
Military Modelling	£16.90	£13.00	<input type="checkbox"/>	£21.00	£16.80	<input type="checkbox"/>
Model Boats	£16.10	£13.00	<input type="checkbox"/>	£20.00	£16.00	<input type="checkbox"/>
Radio Control Model Cars	£19.10	£14.00	<input type="checkbox"/>	£21.50	£17.20	<input type="checkbox"/>
Model Engineer	£27.40	£22.00	<input type="checkbox"/>	£32.50	£26.00	<input type="checkbox"/>
Radio Control Boat Modeller	£ 8.50	£ 7.50	<input type="checkbox"/>	£11.50	£ 9.20	<input type="checkbox"/>
R C M & E	£15.80	£12.00	<input type="checkbox"/>	£20.00	£16.00	<input type="checkbox"/>
Radio Control Scale Aircraft						
Quarterly	£ 9.70	£ 8.00	<input type="checkbox"/>	£11.50	£ 9.20	<input type="checkbox"/>
Radio Modeller	£16.10	£13.00	<input type="checkbox"/>	£20.00	£16.00	<input type="checkbox"/>
Sea Classic International	£10.30	£ 9.00	<input type="checkbox"/>	£12.50	£10.00	<input type="checkbox"/>
Scale Models International	£18.00	£13.00	<input type="checkbox"/>	£20.00	£16.00	<input type="checkbox"/>
Your Model Railway	£16.00	£12.00	<input type="checkbox"/>	£25.00	£20.00	<input type="checkbox"/>

(Offer ends 30th April 1987)

Please commence my subscription(s) with the issue.

I enclose my cheque/postal order for £..... made payable to Argus Specialist Publications Ltd.

or debit £..... from my Access/Barclaycard No.

valid from to Signature

Name

Address

Send this form with your remittance to: *Subscriptions Savings Offer (S.087)*

INFONET LTD., Times House, 179 The Marlowes, Hemel Hempstead, Herts. HP1 1BB.

HART

LED DISPLAY DIGITAL ELECTRONIC CLOCK MODULE

Electronic clock module with MOS LSI circuit, 4-digit 0.5" LED display, power supply and other components on a single PCB. Only needs a transformer and switches to construct a complete pretested digital clock/timer for many applications. Suitable for 50 or 60 Hz mains supplies. Direct (non-multiplexed) LED drive eliminates RF interference. Supplied complete with 240v mains transformer and wiring diagram/data. Order as SOL 144 Alarm Clock Module **£6.85**

LIQUID CRYSTAL DISPLAY WATCH MODULE
With LCD display, 2 pieces of Polarising material, backlight diffuser, micro lamp, precision crystal, trimmer, battery contacts and open microcircuit. Untested **5 for £1**

PLESSEY MAINS INTERFERENCE SUPPRESSORS
Filter unit for mains borne interference. Max current 1.5A. Our Price, brand new **only £2.27**
Same item, store soiled **only £1.61**
Similar Unit but 10A. Brand new **£3.49**

10W POWER AMPLIFIER MODULE
Mullard LP1173 Amplifier module. Needs 24v DC Supply to give 10 watts into 4 ohm speaker. Size 112x70x29mm. Complete with heat sink **Only £2.40** complete with Data

ALPS FF317U FM FRONT END
Beautiful precision made High Quality variable capacitor tuned FM Front End with Dual-gate MosFet. Covers full FM range of 87 to 109MHz. 12v supply **ONLY £1.90**
Circuit if required 35p

CAR RADIO FM IF AND STEREO DECODER

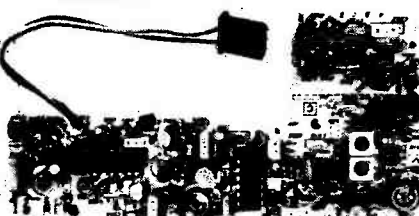

Miniature PCB with 10.7MHz ceramic filters, 2-transformer ratio detector, AX1010 noise suppression IC and TCA4500A advanced stereo decoder IC. Only needs front end to make FM tuner or car radio. Complete with circuit. Incredible value at **Only £1.99**

HART ELECTRONICS are specialist producers of kits for designs by **JOHN LINSLEY-HOOD**. All kits are **APPROVED** by the designer.

LINSLEY-HOOD CASSETTE RECORDER CIRCUITS

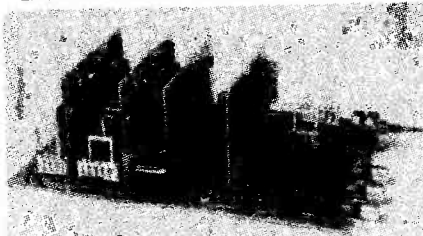

Complete record and replay circuits for very high quality low noise stereo cassette recorder. Circuits are optimised for our HS16 Super Quality Sendust Alloy Head. Switched bias and equalisation to cater for chrome and ferric tapes. Very easy to assemble on plug-in PCBs. Complete with full instructions.

Complete Stereo Record/Play Kit **£33.70**
VU Meters to suit **£2.30 each**
Reprints of original Articles **75p no VAT**
860X Stereo Mic Amplifier **£8.70**

LINSLEY HOOD 300 SERIES AMPLIFIER KITS
Superb integrated amplifier kits derived from John Linsley-Hoods articles in 'Hi-Fi News'.
Ultra easy assembly and set-up with sound quality to please the most discerning listener. Ideal basis for any domestic sound system if quality matters to you. Buy the kit complete and save pounds off the individual component price.

K300-35: 35 Watt. Discount price for Complete Kit **£98.79**
K300-45: 45 Watt. Discount price for Complete Kit **£102.36**
RLH4&5: Reprints of Original Articles from 'Hi-Fi News' **£1.05 no VAT**

LINSLEY-HOOD SYNCHRODYNE AM RECEIVER
Very high quality kit for this recent design featured in 'Wireless World'. This unit represents the first attempt to make a much needed **HIGH QUALITY AM Tuner** since pre-FM days. This will give you Radio 4, or even 1 in better quality than your Eastern 'Tranny'. Advanced construction system, approved by the Author, uses 3 double sided PCBs in a stacked layout for total stability, ease of construction and minimal wiring. This module will form the AM section of an ultra high quality AM/FM switched bandwidth tuner to match our 300 series amplifiers. Power supply and tuning gang will be included with the FM section.
K450 J1H Synchrodyne Kit Special Price **£59.95**

HIGH QUALITY REPLACEMENT CASSETTE HEADS



Do your tapes lack treble? A worn head could be the problem. Fitting one of our replacement heads could restore performance to better than new! Standard mountings make fitting easy and our TC1 Test Cassette helps you set the azimuth spot-on. We are the actual importers which means you get the benefit of lower prices for prime parts. Compare us with other suppliers and see! The following is a list of our most popular heads, all are suitable for use on Dolby machines and are ex-stock.

HC20 Permalloy Stereo Head. This is the standard head fitted as original equipment on most decks **£7.66**
HS16 Sendust Alloy Super Head. The best head we can find. Longer life than Permalloy, higher output than Ferrite, fantastic frequency response **£14.86**
HQ551 4-Track Head for auto-reverse or quadrophonic use. Full specification record and playback head **£14.60**
Please consult our list for technical data on these and other Special Purpose Heads. **MA481 Latest version Double Mono (2/2) Record/Play Head.**
Replaces R481 **£13.35**
SN166 Standard Mounting 2/2 Erase head. Compatible with above or HQ551 4-Track Head **£8.85**
HS24 Standard Erase Head. Semi double gap, high efficiency **£2.25**
HS61 Metal Tape Erase Head. Full double gap **£7.35**

HART TRIPLE-PURPOSE TEST CASSETTE TC1

One inexpensive test cassette enables you to set up VU level, head azimuth and tape speed. Invaluable when fitting new heads. Only **£4.66** plus VAT and 50p postage.

Tape Head De-magnetiser. Handy size mains operated unit prevents build up of residual head magnetisation causing noise on playback **£4.54**
Curved Pole Type for inaccessible heads **£4.85**

Send for your free copy of our **LISTS**. Overseas please send 2 IRCs to cover surface Post or 5 IRCs for Airmail.

Please add part cost of post, packing and insurance as follows:

INLAND
Orders up to £10 - 50p
Orders £10 to £49 - £1
Orders over £50 - £1.50

OVERSEAS
Please send sufficient to cover Surface or Air Post as required.

Personal callers are always very welcome but please note that we are closed all day Saturday

24hr SALES LINE
(0691) 652894

ALL PRICES EXCLUDE VAT UNLESS STATED

HART

HART ELECTRONIC KITS LTD
4 PENYLLIN MILL
OSWESTRY, SHROPSHIRE
SY10 9AF

Complete Parts Sets for ETI Projects

MAINS CONDITIONER FEATURED IN ETI, SEPTEMBER 1986

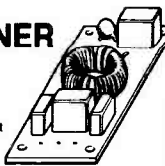

It is astonishing how many people buy or build top-flight hi-fi equipment, and then connect it to a noisy, spiky mains supply. Rather like buying a Ferrari and trying to run it on paraffin, you might think. Expecting crystal clear sound, the poor music enthusiast ends up with a muddy, confused mush, and feels that he has somehow been cheated. 'Is this hi-fi? My music centre sounded just as good!'
The domestic mains supply is riddled with RF interference, noise, transient spikes, and goodness knows what else. Computers crash, radios pop and crackle, tape recordings are spoiled and hi-fi sounds 'not quite right'. Why put up with it when the solution is so simple? The ETI mains conditioner is the lowest cost upgrade you will ever buy, and probably the most effective!
Our approved parts set consists of PCB, all components, toroid*, enamelled wire, fixing ties, fast response VDR*, and full instructions.

ETI MAINS CONDITIONER PARTS SET ONLY **£4.60!**

*Note: the toroid and VDR supplied are superior to the types specified in the article.

TACHOMETER AND DWELL METER FEATURED IN ETI, JANUARY 1987



MOTORISTS QUIZ
You are driving along the road one day when the sound of a horn makes you look behind. The driver of a milk float is cursing you for driving so slowly. A while later, an invalid carriage overtakes you, and just as you turn into your drive you hear a tractor driver mutter 'At last I can get out of first gear!'
Do you:
a) Fit a £500 Pie-in-ear in-car stereo with digital flex-wipers and 24-band ramification?
b) Buy a set of fluty dice and sticker saying 'My other car is a Macaroni'?
c) Give your car in part exchange for a milk float/invalid carriage/tractor?
d) Tune your engine.
The combined tachometer and dwell meter parts set contains: case with battery compartments; printed circuit board; all components; switches; plug, socket and test leads; battery connector; full instructions. The answer to the quiz, by the way, is: a) Buy a bright red Lotus Esprit.

TACHOMETER AND DWELL METER PARTS SET
£12.90 (with terminals for external motor)
£16.40 (with self contained meter)

MAINS CONTROLLER FEATURED IN ETI, JANUARY 1987

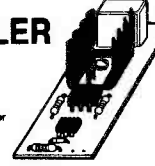

Have you ever wondered what people do with all those computer interfaces? Put your computer in control, say the ads. 'The Spectrabeeb has eight TTL outputs. What on earth can you control with a TTL output? A torch bulb?'
The ETI Mains Controller is a logic to mains interface which allows you to control loads of up to 500W from your computer or logic circuits. An opto-coupler gives isolation of at least 2,500V, so the controller can be connected to experimental circuits, computers and control projects in complete safety. Follow your computer interface with a mains controller and you're really in business with automatic control!
The mains controller connects directly to most TTL families without external components, and can be driven by CMOS with the addition of a transistor and two resistors (supplied).
Your mains controller parts set contains: high quality roller stamped PCB; MOC3021 opto-coupler; power track with heatsink; mounting hardware and heatsink compound; all components, including snubber components for switching inductive loads; transistor and resistors for CMOS interface; full instructions.

MAINS CONTROLLER PARTS SET **£6.20**

POWERFUL AIR IONISER FEATURED IN ETI, JULY 1986

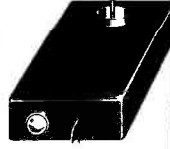

Ions have been described as 'vitamins of the air' by the health magazines, and have been credited with everything from curing hay fever and asthma to improving concentration and putting an end to insomnia. Although some of the claims may be exaggerated, there is no doubt that ionised air is much cleaner and purer, and seems much more invigorating than 'dead air'.
The DIRECT ION ioniser caused a great deal of excitement when it appeared as a constructional project in ETI. At last, an ioniser that was comparable with (better than?) commercial products, was reliable, good to build ... and fun! Apart from the serious applications, some of the suggested experiments were outrageous!
We can supply a matched set of parts, fully approved by the designer, to build this unique project. The set includes a roller stamped printed circuit board, 66 components, case, mains lead, and even the parts for the tester. According to one customer, the set costs 'about a third of the price of the individual components. What more can we say?'

Instructions are included
DIRECT ION PARTS SET **£9.50**

MATCH BOX AMPLIFIERS

20W Single IC parts set **£6.50**
50W Bridge Amplifier parts set **£8.90**
L165V Power Amplifier IC, with data, **£3.90**

LM2917 EXPERIMENTER SET

Consists of LM2917 IC, special printed circuit board and detailed instructions with data and circuits for eight different projects to build. Can be used to experiment with the circuits in the 'Next Great Little IC' feature (ETI, December 1986).
LM2917 Experimenter Set **£5.80**

RUGGED PLASTIC CASE,

suitable for mains controller and mains controller.
ONLY **£1.35!**



SPECIAL CHRISTMAS OFFER!

Until December 31st our best-selling ioniser set is available with a special white case at the same price as the standard ioniser!

WHITE IONISER PARTS SET **ONLY** **£9.50!**

Orders should be sent to Specialist Semiconductors at the address below including 60p towards postage and packing. Please allow up to 14 days for delivery. There is no telephone service at the moment, but all letters or requests for lists will be answered (at top speed if you send SAE!)

Specialist

FOUNDERS HOUSE REDBROOK MONMOUTH GWENT

READ/WRITE

Why MIDI

Now that you are covering the subject I've just got to ask. Why MIDI? I can see that it is awfully clever to send data between musical instruments at around 30K a second, but why would I want to? I should admit I am no musician, but it seems little short of a waste of time to connect up assorted synthesisers and drum machines as indicated in your feature in the January issue.

Surely, if you need a different sound or require lots of noises at once, the answer is to get a different instrument or more musicians, not to connect up all sorts of keyboards together.

I realise I must be wrong because everyone is out there buying these things, but why?

George Beecham,
Morecambe, Lancs.

It would be nice if we could all afford all the instruments (and all the instrumentalists) we ever needed. Instead, MIDI provides a way for a single musician to perform with the help of a computer with all the benefits its programmability allows. The computer can be a micro or just the innards of a synthesiser or a drum machine. Either way, the computer can be programmed to interpret the player's actions as required for that particular song. The interconnectability of MIDI allows, say, half of a keyboard to 'play' one instrument while the other half plays an altogether separate one. This is at the very least much easier than the old Rick Wakeman-esque method of stretching across a great array of keyboards.

While on the subject of MIDI, last month's feature showed a photograph which we incorrectly captioned as showing Hybrid Technology's Music 5000 system. In fact it was a UMI-2B MIDI controller for the BBC Micro. Apologies to both parties for the mix up. Readers interested in music on the BBC Micro will find plenty to interest them in the coming months in ETI.

Collector's Corner

I am a collector of electronic calculators. I am also trying to trace the development of these now common devices since they first began to appear circa 1970. To this end I have been ploughing through many old copies of ETI, which contain a wealth of information in articles and adverts.

It occurred to me that many readers might have info I would find useful, possibly in the form of old instruction booklets and the like, for calculators that have long since 'bit-ten the dust'.

If anyone has any such info they would care to donate to posterity, I would be pleased to hear from them.

Bryan Cloud,
Ipswich, Suffolk.

If any readers have old calculator manuals or even old calculators themselves, they can contact Mr. Cloud on (0473) 44996.

LP RIP

I wonder if other readers regard the advent of Compact Disc with the same concern as I do.

Although I would not deny the technological advances involved, there appears to be no provision for people like myself with large collections of conventional vinyl records.

It is unlikely the majority of these will ever appear as Compact Discs. As conventional record decks and other equipment are taken out of production the supply of replacement parts and spares will dry up.

Personally, I hope the dominance of Compact Disc over the rest of the hi-fi market will not occur, at least until a method of recording Compact Discs at home has been perfected.

Paul Berry,
Accrington, Lancs.

It is true that many of your records will never be issued as Compact Discs (although who would have thought old black and white, and even silent, movies would be commercial candidates for transfer to video — but they are). However, the vinyl record has a good few years left in it yet. Millions of people have 'conventional' record decks and many more millions of records are sold each year. No record company is going to throw away that kind of revenue if it can help it.

There will come a time when vinyl records are no longer produced. However, at that stage people will no doubt be bemoaning the advent of the next leap forward which will make their CD players redundant. Meanwhile, digital cassette systems are only around the corner (no, really!). These will give a quality on a par with CD and allow you to record your old collection.

You cannot stand in the way of progress. CDs will come and eventually go. Some consumers will be left high and dry without spares or musical media but in the long run (as governments say) we will all be better off.

Picture This

Although I am sure you can do without a constant stream of 'suggestions' as to how to improve ETI (excellent as it is already) I feel I must complain about the January issue.

It is not the projects I am winging about. These were as interesting as ever. The features were also up to their usual informative standards. No, what I want to suggest is that you improve the quality of the photographs in ETI. In the January issue they were quite honestly appalling. It looked like there was a heavy fog settling in the photographer's that day!

I won't ask you to pull your socks up. Perhaps they are already pulled over the camera lens!

Malcolm Walmsley,
Sheffield, South Yorkshire.

To be fair to our photographers the fault with the January issue was in the production process of the magazine and not under the studio lights. However, you are quite right in your assessment of the quality of reproduction. We have taken steps and hope that this issue fares better. Incidentally, we always appreciate suggestions (or even 'suggestions') as to how to improve ETI.

Free Praise

I advertised my Hitachi single beam oscilloscope in a Readers' Free Ad in the November issue of ETI. I received and accepted an offer of £47 (I'd put it in for £50) within seven days. Other enquiries continued to come in.

Many thanks for the free advert.
A. Wallwork,
Sutton Coldfield, West Midlands.

The response to the Free Readers' Ads has been a little disappointing. Although by all accounts those readers who have advertised have found suitable buyers, we are not receiving enough advertisements. Don't let your old equipment rust in a corner. Turn it into cash. Post the coupon today!

ETI welcomes letters from readers on any topic. If you disagree with our learned contributors or just think the world is going to pieces, don't just sit there. Tell us all your troubles. We can't promise to solve anything, but we can print your letter.

Write to: Electronics Today International, 1, Golden Square, London W1R 3AB.

A QUESTION OF BALANCE

Barry Porter takes a fresh look at a frequently misunderstood topic — the use of balanced lines for audio signal connections.

To most hi-fi enthusiasts, a 'balanced' system is one which delivers approximately equal amounts of Max Bygraves from each channel while 'unbalance' is a condition brought about by Junior poking an exploratory finger through one of the loudspeaker grilles. It's well known that something called balancing is also important in the world of professional audio, but not many people seem to know what the system does or what advantages it brings. If you fall into this category and would like to know a little more, read on.

The individual units of a domestic system — such as a preamplifier and a power amplifier — are usually connected together with a length of screened cable (Fig. 1). Signal is carried along the inner conductor, and the outer screen joins the earth lines of the electronics in the two items of equipment. This type of interconnection is termed 'unbalanced' and works well enough providing the cable is not of excessive length and does not pass near to a strong source of electrical interference. Although the screen layer gives some protection to the signal carrying conductor, a strong external AC field such as that surrounding a mains transformer will pass through the screen and add its unwanted modulation to the signal.

This problem is obviously at its greatest when the cable carries signals at a low level and is followed by lots of amplification. An example is the connection between a microphone and the input channel of a mixing console, where any hum and noise picked up by the cable may be amplified by as much as 60dB.

One way to minimize the effect of external hum and noise is to keep the line impedance as low as possible and the signal level as high as possible. If the sending amplifier has a very low output impedance — less than 1 ohm is possible with operational amplifiers — the connecting cable appears to be at about earth potential, and external fields will exert very little influence.

This principle works well for cable runs of less than 30 metres or so where the external field is not too intense, but when long interconnections are used, the resistance of the signal carrying wire becomes significant and the line impedance increases as you get further from the sending amplifier. In some cases, it is not possible to achieve a near-zero source impedance.

A typical moving coil microphone has an impedance of 200 ohms, and some equipment which has passive attenuation or equalisation after the final stage may have an output impedance of several kilohms — ideal circumstances for the introduction of noise whenever connected to a few metres of cable.

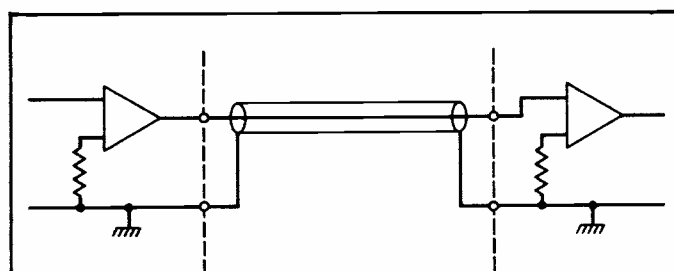

Fig. 1 An unbalanced signal connection, as used on most domestic audio equipment.

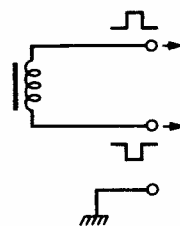

Fig. 2 A balanced output as provided by a moving coil microphone or a transformer.

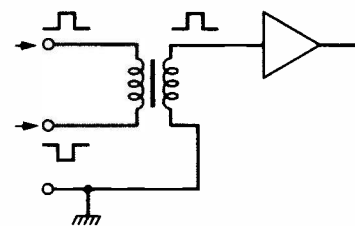

Fig. 3 A differential (or balanced) input using a transformer.

Yet microphones in particular are often required to be at the far end of several hundred meters of conductor, along which a signal with a level of 1mV or less must travel with as little corruption as possible. Can anything be done to minimize the pick-up of hum, noise and Radio 1 that doesn't require considerable lengths of Mu-metal conduit piping? Luckily, it can, and it's called balancing.

The easiest way to understand how balanced connections work is to consider a moving coil microphone. It will consist of a thin foil diaphragm to which is attached a lightweight coil, suspended in a powerful magnetic field. The diaphragm and the coil are vibrated by incoming sound waves, and this vibration is turned into an electrical current by the action of the magnet. The ends of the coil are connected to the microphone output socket (Fig. 2) where the output signal voltage appears with a phase difference of 180 degrees between the two contacts.

For a few minutes, let us turn to a type of input circuit usually referred to as differential and typified by the transformer arrangement shown in Fig. 3. In order to produce an output voltage, the transformer inputs

must receive two signals which are identical in every way except that they must exhibit a 180 degree phase difference — just what the microphone gives out.

If the two outputs of the microphone are now connected to the two transformer inputs, a balanced circuit is created. In practice, the two conductors are enclosed by a screen layer which in the example given would connect the metal case of the microphone to the input amplifier earth. This is shown in Fig. 4 along with the amplification stage which follows the input transformer.

You may wonder what is so different between that and an unbalanced connection. Luckily, there is a big difference. If the cable connecting a balanced output to a balanced input picks up any hum and noise, the unwanted voltages will occur in both conductors at the same level, and most importantly, with the same phase. Since a balanced circuit requires a 180 degree phase difference between its two inputs, any signals arriving which are not in anti-phase are cancelled by the differential action of the input. This removes the hum and noise.

The ability of a balanced input to reject unwanted signals is called the Common Mode Rejection Ratio (CMRR for short), and is measured as shown in Fig. 5. CMRR values tend to be frequency conscious, rejection becoming progressively worse with increasing frequency. By careful design, particularly with solid state inputs, a rejection of 80 or 90dB across the audio band may be achieved.

Transformer Or Solid State?

Until recent years, the standard balanced circuit invariably employed transformers for both input and output coupling. By using transformers the signal can be made to pass from the output of one piece of equipment to the input of another without an earth reference, so removing the risk of hum loops. This is particularly important in radio and TV studios, so transformer balancing is almost universal in these environments.

Transformers do suffer from a number of shortcomings. Without becoming too large for comfort, they will only pass a limited signal level before introducing large amounts of very nasty distortion, particularly at low frequencies. They can also suffer from undesirable phase shifts unless carefully designed. High quality transformers are also rather expensive — 'Professional Grade' versions can cost as much as £50-£60.

Although balancing (and unbalancing) transformers are still used in large quantities, for many applications they are being rapidly replaced with solid state input and output stages. A standard operational amplifier has a differential input, and can be connected to a balanced line, as shown in Fig. 6. To obtain the best common mode rejection, the four resistors must all be of the same value, and it is usual to use a variable and fixed resistor in series for R3 to allow the CMRR to be trimmed at low frequencies. The two capacitors also need to have the same value, and C2 is often a small trimmer in parallel with a fixed component that is lower in value than C1. With careful adjustment, the CMRR can be as high in value as 90dB across the audio band. This circuit can give excellent results, but has a few shortcomings which rule out its use in high quality equipment.

The two inputs have differing impedances because R2 is terminated by a virtual earth whereas R1 is loaded by R3 in parallel with the input impedance of the op-amp. Unequal input impedances may not be

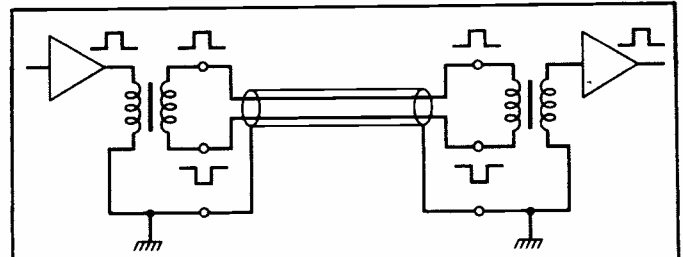

Fig. 4 A balanced interconnection between two pieces of equipment.

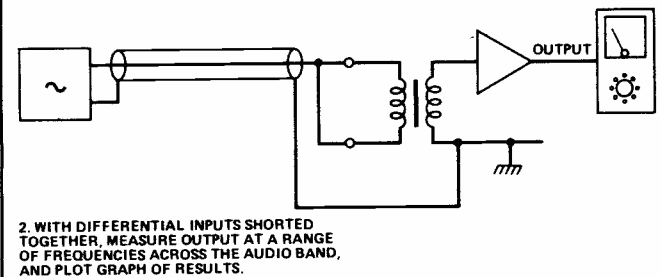
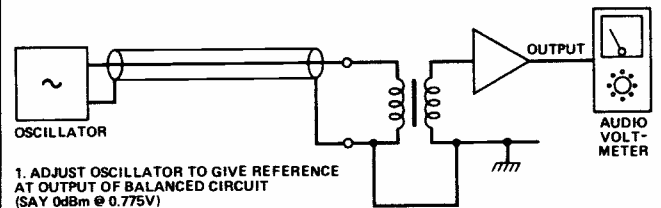

Fig. 5 Measuring the Common Mode Rejection Ratio (CMRR) of a differential input.

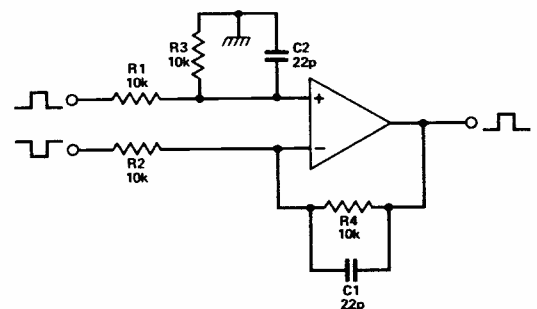

Fig. 6 Balanced input circuit using a single op-amp.

of too much concern depending upon the type of balanced output connected to them, but the actual impedance value may assume a greater importance. It is standard practice to make the impedance of line level inputs 10k ohms or greater so that signal level is not reduced by loading effects, and it is often desirable to present a load of 50k ohms or more to the incoming signal. It will be found that if the value of the resistors is increased sufficiently to give a reasonably high input impedance — say 33k — then thermal noise has to be considered.

The noise voltage of a resistor is given by

$$\sqrt{4kTBR}$$

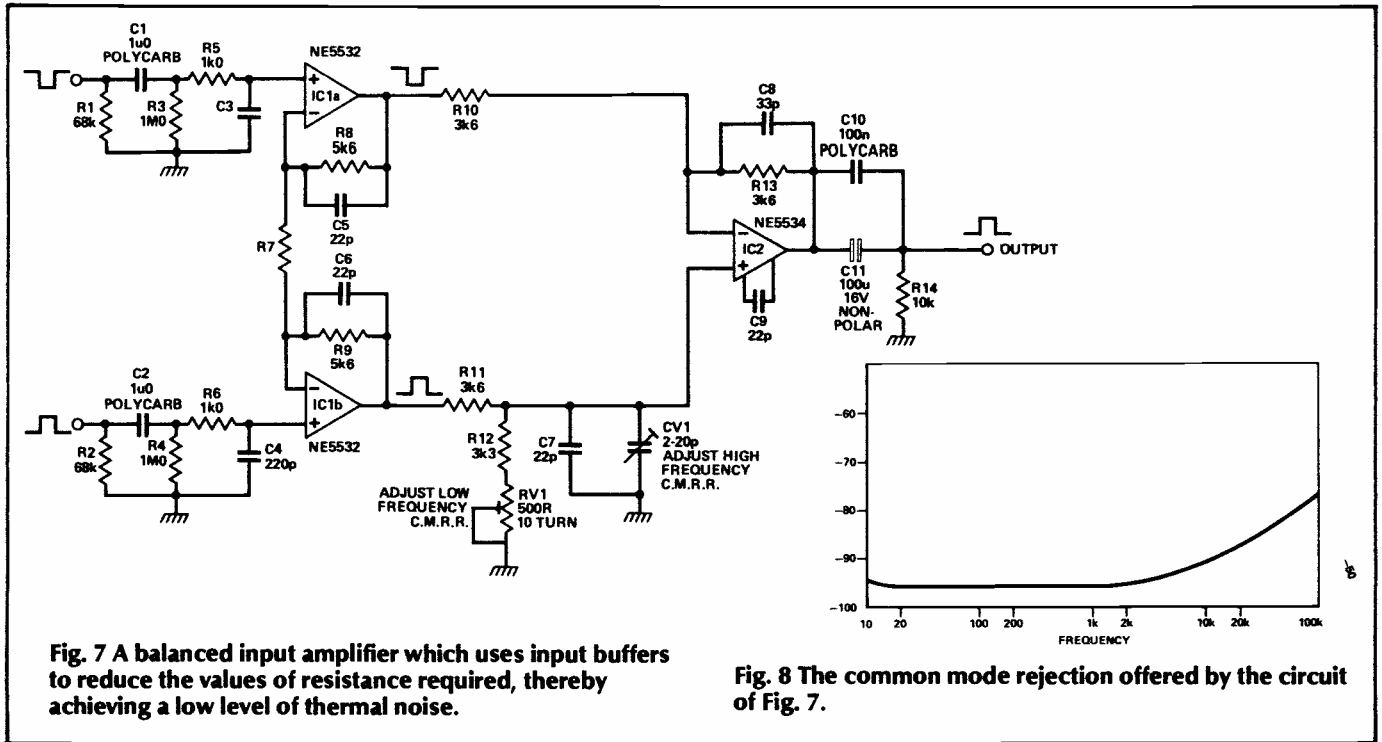

Fig. 7 A balanced input amplifier which uses input buffers to reduce the values of resistance required, thereby achieving a low level of thermal noise.

Fig. 8 The common mode rejection offered by the circuit of Fig. 7.

where k = Boltzmann's constant (1.381×10^{-6})
 T = Absolute temperature ($^{\circ}\text{C} + 273$)
 B = Bandwidth
 R = Resistance in ohms

For a 33k ohms resistor, assuming a band width of 20kHz and an ambient temperature of 25°C , the noise voltage is therefore 3.296×10^{-6} or, in a more recognizable form

$$20 \log \frac{0.775}{(3.296 \times 10^{-6})} = -107.4\text{dBm}$$

which is not particularly brilliant. Now, if the resistor value is reduced by a factor of 10, its noise contribution will be reduced by 10dB, which is a significant improvement.

A practical circuit which takes account of the thermal noise problem is shown in Fig. 7. It is essentially the same as the circuit shown in Fig. 6 except that buffers have been added to each of the inputs. These allow the impedance of each input to be the same and of virtually any value required, yet the resistances around the differential stage may be low enough to avoid noise problems. An additional advantage is that the stage gain can be adjusted by changing one resistor — R7. The gain is calculated from

$$20 \log \left(\left(\frac{R8 + R9}{R7} \right) + 1 \right)$$

or for a required gain,

$$R7 = \frac{R8 + R9}{A \log \left(\frac{Av(\text{dB})}{20} \right) - 1}$$

This stage is ideal for line level inputs operating over a gain range from unity to 20 or 30dB. It has low noise, negligible distortion (typically 0.002% over the audio band) and excellent common mode rejection (see Fig. 8). To adjust RV1 and CV1, use the set-up shown in Fig. 5. With a 100Hz input signal, set RV1 so that the

circuit output voltage is at its minimum level, then reset the oscillator to 15kHz and trim CV1 for minimum output.

This circuit is often referred to as an 'Instrumentation' input. As well as being an ideal balanced input stage for pre and power amplifiers, mixing consoles etc, it also makes a suitable input for many types of high quality test equipment. Audio frequency voltmeters, distortion meters and many other instruments use the circuit because it has very stable and clearly defined gain characteristics and a wide bandwidth with an extremely flat frequency response. With the component values shown in Fig. 7, the -3dB points are at approximately 0.5Hz and 150kHz with less than 2° of phase lead at 20Hz and about 7° of lag at 20kHz.

A number of changes may be introduced to optimize the circuit for specific applications. Input noise may be reduced by replacing C1 and C2 with 10μ or 22μ non-polarized electrolytics (not forgetting to put a 100n polycarbonate in parallel with each one in the interest of sound quality!) This will also give a few more dB of common mode rejection at low frequencies, and the phase shift at 20Hz will be reduced to 0.06. For use in test equipment, C3 and C4 should be reduced to 47p in order to keep the response flat to 100kHz.

Stage gain may be made adjustable by using a single pole switch to select different values of R7 or a potentiometer in series with a fixed resistor (see Fig. 9). Note that AC coupling has been introduced to avoid problems from switch clicks or potentiometer wiper noise which would otherwise arise due to inevitable DC offsets at the op-amp inputs.

If an accurate stepped attenuator is placed in front of this circuit and some additional gain stages added after it, you have the input stage of a professional-quality audio voltmeter which will give FSD readings from 300V to 10uV — a range of 150dB! (When some further development work has been carried out, you may have the pleasure of a constructional article based on it).

So far, we have looked at the balancing of high level signals, but there are far more benefits to be

gained by employing the same techniques when signal levels are in the milli or microvolt region. For a high quality microphone amplifier, the basic configuration of Fig. 7 may be used but with a few important changes.

The biggest single problem with microphone amplifiers is keeping the noise contributed by the active stage as low as possible. The thermal noise of a 200 ohm source is -129.6dBm , so a perfectly silent microphone amplifier with a gain of 60dB and a 200 ohm input load, would have an output voltage of -69.6dBm over a 20kHz bandwidth. If a real amplifier has an output of -67dBm , it is said to have a noise figure of 2.6dB. Some manufacturers claim noise figures as low as 1dB, but 1.5dB is a more realistic aim, and the circuit of Fig. 10 can achieve this providing great care is taken with construction and component choice.

The input impedance is fixed at 1k2 ohms by R4, this being the currently accepted value for loading 200 ohm microphones. It may be changed if a different value is recommended by the microphone manufacturer. R1 and R2 apply 48V phantom power to energise capacitor microphones and should be closely matched, either by purchasing 1% tolerance components or by measuring with an accurate bridge or digital multimeter. If the circuit is only to be used with dynamic microphones, R1, R2 and R3 together with C1 may be omitted, as may C2 and C3. This will give a slight improvement in signal-to-noise ratio and an improvement in sound quality due to the loss of a pair of electrolytic capacitors from the signal path. As the common mode rejection is adjusted at a part of the circuit that comes after the gain setting stage, there will be a variation of rejection with gain.

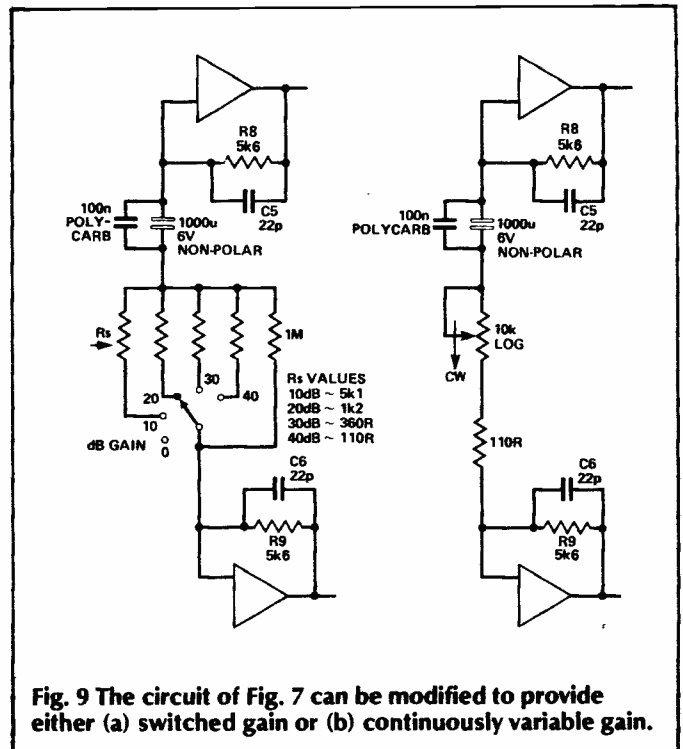

Fig. 9 The circuit of Fig. 7 can be modified to provide either (a) switched gain or (b) continuously variable gain.

Although more impressive rejection can be obtained at 10dB gain than at 60dB it is preferable to carry out the adjustment at the 30dB or 40dB setting.

With a carefully designed PCB layout, this circuit will perform as well as and possibly better than any professional microphone amplifier currently available.

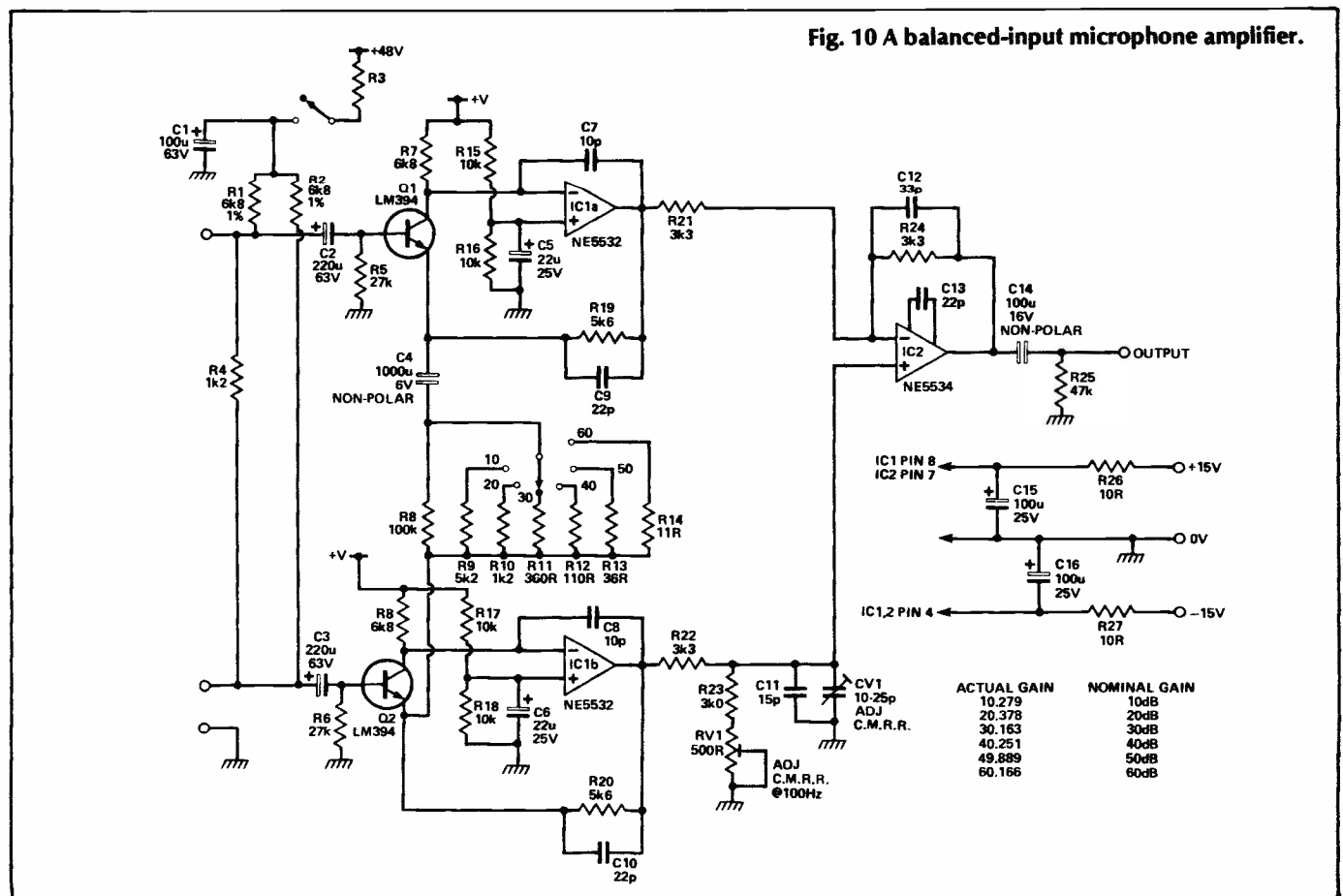
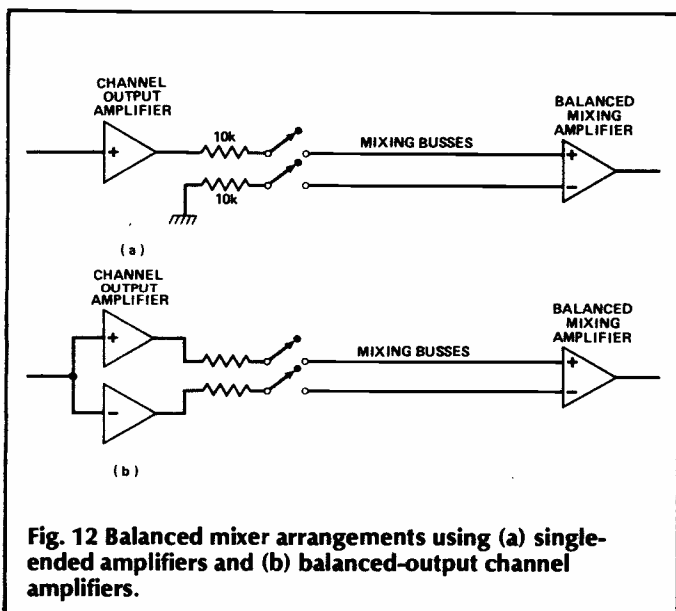
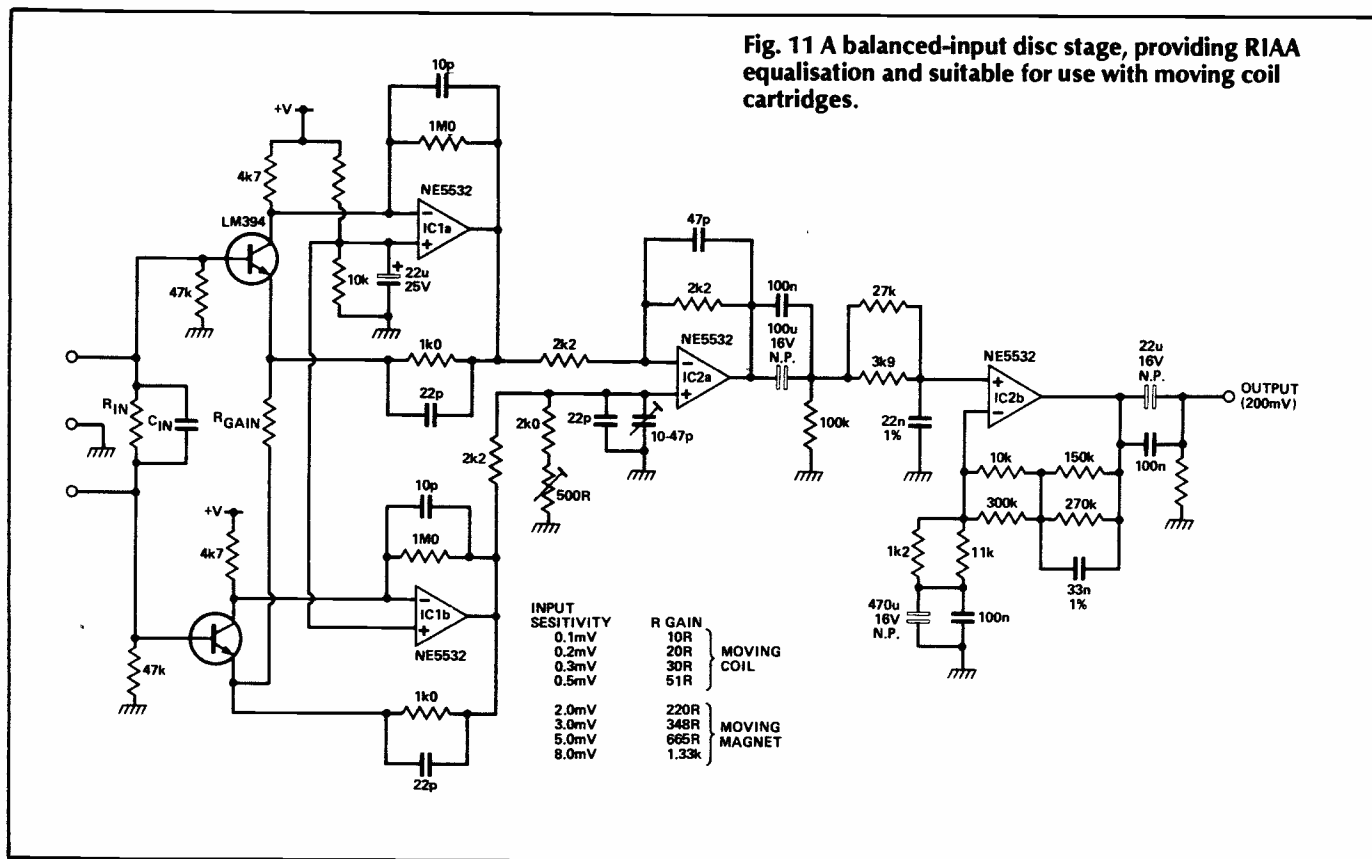

Fig. 10 A balanced-input microphone amplifier.



that of a virtual earth mixing amplifier. Mixing busses are extremely sensitive to hum and noise, but the problem can be greatly reduced by adopting a balanced mixing system. Two basic arrangements are possible, the input channel amplifiers having either single-ended outputs or balanced outputs (Fig. 12). In both cases the signals feed into a differential input, and any noise voltages picked up along the bus lines will appear at the mixing amplifier inputs with the same phase and will be cancelled in the usual way.

A practical circuit for a differential input mixing amplifier is shown in Fig. 13. It resembles the line input circuit of Fig. 7, except that here the incoming signals are taken to the inverting inputs of the op-amps. The use of 3k3 resistors for feedback and mixing helps keep the noise down and the linearity is improved by having the input capacitors inside the feedback loop. With 3k3 input resistors, this circuit will accept up to fifty inputs with no low frequency problems and will attenuate common mode noise from mixing busses ten or twelve feet long by 60-80dB.

Balanced Outputs

Microphones and pick-up cartridges are intrinsically balanced, but amplifier outputs are not. The easy way out is to hang a transformer onto the end of a single-ended output stage, but in this day and age it is rumoured that miraculous things can be done with a handful of chips and a bit of ingenuity.

If a balanced output is just two outputs in phase opposition, there are several ways of obtaining this (see Fig. 14). They all have one failing — namely that if one output is shorted to ground, the output level drops by 6dB because the peak-to-peak voltage swing is halved.

A solution is shown in Fig. 15, a balanced output stage which delivers the same level into balanced

Balanced Disc Stage

Another type of input stage that benefits from balancing is the RIAA pick-up amplifier, particularly when a low output moving coil cartridge is in use. Figure 11 shows the disc input of the Mirage C10 control Unit, which has a balanced input. Using such an arrangement may mean that minor surgery has to be carried out on the wiring of your pick-up arm in order to remove the ground connections from the signal leads, but the results will be found to justify this annoyance. Try it and see.

Balanced Mixing

The final balanced input circuit I have shown is

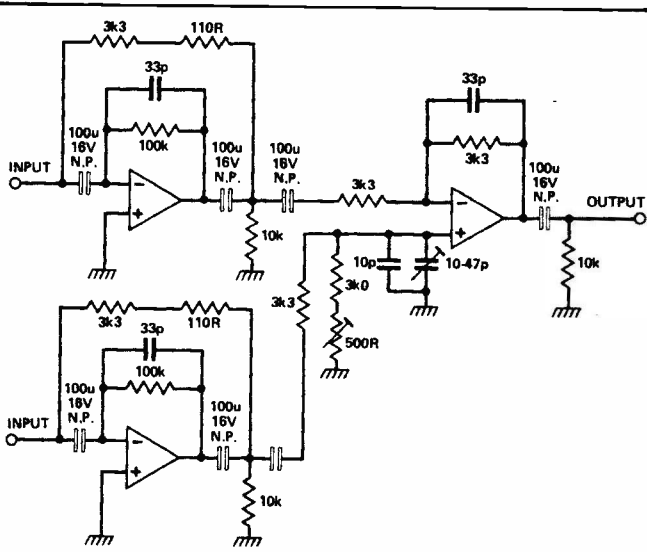

Fig. 13 A practical circuit for a balanced-input mixing amplifier.

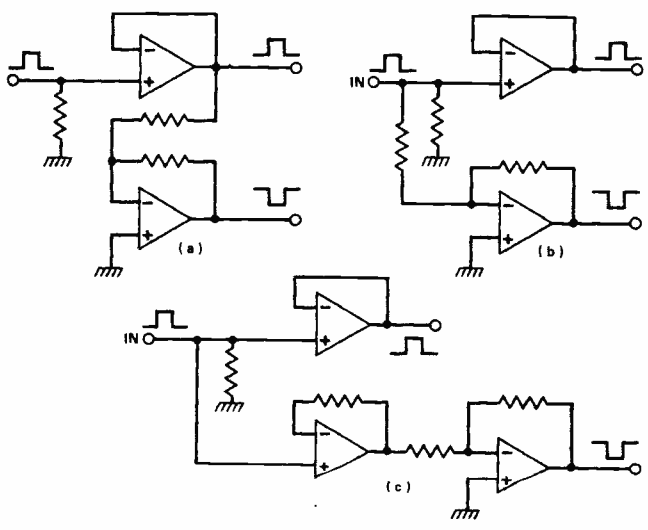

Fig. 14 Some differential (or balanced) output configurations.

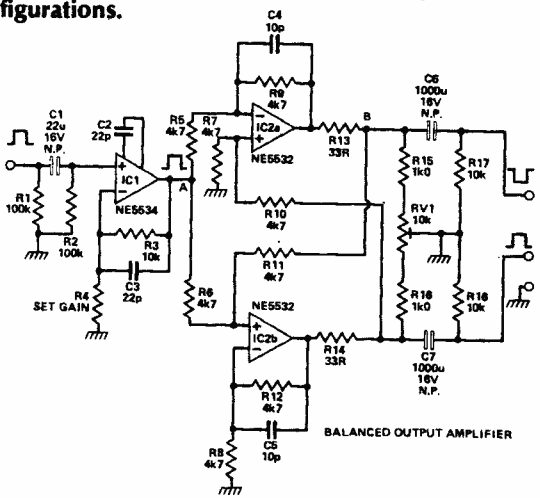

Fig. 15 A balanced output amplifier. The cross-coupled feedback increases the output of either op-amp by 6dBm when the opposite output is shorted to ground, thus allowing the circuit to drive unbalanced inputs as well as balanced ones.

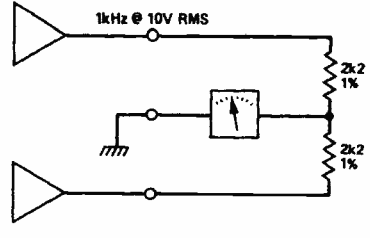

Fig. 16 Adjusting the balance of the circuit shown in Fig. 15. RV1 is set to give a minimum output level.

and unbalanced inputs. When this is used with an unbalanced input, it is essential that the unused output is shorted to ground as distortion and noise will otherwise increase.

The operation of this circuit is fairly obvious. Disregarding the input buffer, assume a 1V input at A which feeds both the inverting and non-inverting op-amps. Taking the inverting stage first (IC2a), you may expect there to be -1V at point B. Instead the cross-coupled feedback through R10 is attenuated by the potential divider R10, R7 and puts +0.25V onto the non-inverting input of IC2a. This is then amplified by 2 (think of R5 as a feedback shunt resistor connected to 0V) so the output becomes $-1 + (0.25 \times 2) = -0.5V$. The non-inverting amplifier (IC2b) has a gain of 2 due to R8 and R12. Its input is held midway between the input voltage and the voltage at B due to the dividing action of R6 and R11. The output of IC2b is therefore

$$2 \left(\frac{-0.5 + 1}{2} \right) = +0.5V$$

The output between B and C is consequently 1V.

In the unbalanced mode with output C grounded, the feedback voltage via R10 no longer exists, so IC2a with its gain of 1 gives an output of -1V at B. If B is shorted to ground, the voltage at the non-inverting input of IC2b becomes +0.5 which is amplified to 1V and appears at C.

Unfortunately, this balance is not so easy to achieve in practice, primarily due to component tolerances. To overcome this, a preset (RV1) is used to load one output more than the other until the balance is exact. This should be set so that both outputs are exactly the same level when measured with respect to ground. An easy way to make this adjustment is shown in Fig. 16.

So, now you know how to balance. The question remains, do you know what to balance? Any interconnection between two pieces of audio equipment can be balanced by the addition of a few op-amps, but it is rarely worth interfering with low impedance unbalanced connections which are carrying high level signals over short distances — say less than 20 metres. Microphones should always be fed to balanced inputs, and it is also worth balancing pick-up cartridges and tape recorder heads. Connections between pre and power amplifiers are often improved by balancing, especially where earth currents from the power amplifier would otherwise find their way into the sensitive parts of the pre-amplifier and cause hum.

In brief, balancing can only bring about an improvement in a situation, so if you have more than your share of the dreaded hums give it a try.

For KITS & COMPONENTS Choose the easy way - with

TRK

Send **50p & SAE**
for **CATALOGUE**
(refundable with first order)
ORDERS: RING (01) 567 8910 - 24 HRS

POWER STROBE KIT
Designed to produce a high intensity light pulse at a variable frequency of 1 to 15Hz this kit also includes circuitry to trigger the light from an external voltage source (eg a loudspeaker) via an opto isolator. Instructions are also supplied on modifying the unit for manual triggering, as a slave flash in photographic applications or as a warning beacon in security applications. The kit includes a high quality pcb, components, connectors, 5Ws strobe tube and full assembly instructions. Supply: 240V ac. Size: 75x50x45
KK124 STROBOSCOPE KIT £12.50

HIGH SECURITY LOCK KIT
Designed for use with our lock mechanism (701 150) this kit will operate from a 9V to 15V supply drawing a standby current of only 50uA. There are over 5000 possible 4-digit combinations and the sequence can be easily changed. To make things even more difficult for an unauthorised user an alarm can be sounded after 3 to 9 incorrect entries - selectable by means of a link. The alarm can sound for a few seconds to over 3 minutes during which time the keyboard is disabled preventing further entries. A latched or momentary output is available making the unit ideal for door locks, burglar alarms, car immobilisers, etc. A membrane keyboard or pushbutton switches may be used and a beep sound when a key is depressed. Kit includes high quality PCB, all components, connectors, high power piezo buzzer and full assembly and user instructions.
KK121 LOCK KIT £15.95
350 118 Set of Keyboard Switches £4.00
KB125 12-Way Membrane Keyboard £9.99
701 150 Electric Lock Mechanism £16.50

VERSATILE REMOTE CONTROL KIT
This kit includes all components (+ transformer) to make a sensitive IR receiver with 16 logic outputs (0-15V) which with suitable interface circuitry (relays, triacs, etc - details supplied) can be used to switch up to 16 items of equipment on or off remotely. The outputs may be latched (to the last received code) or momentary (on during transmission) by specifying the decoder IC and a 15V stabilised supply is available to power external circuits.
Supply: 240V AC or 15-24V DC at 10mA
Size (excluding transformer) 9 x 4 x 2 cms.
The companion transmitter is the MK18 which operates from a 9V PP3 battery and gives a range of up to 60ft. Two keyboards are available MK9 (4-way) and MK10 (16-way), depending on the number of outputs to be used.
MK12 IR Receiver (incl. transformer) £14.85
MK18 Transmitter £7.50
MK9 4-Way Keyboard £2.00
MK10 16-Way Keyboard £5.95
601 133 Box for Transmitter £2.60

PROPORTIONAL TEMPERATURE CONTROLLER KIT
Uses "burst fire" technique to maintain temperature to within 0.5°C. Ideal for photography, incubators, wine-making, etc. Max. Size: 7x4x2.5cms.
MK4 £7.10

DISCO LIGHTING KITS
DL1000K This value-for-money 4-way chaser features by-directional sequence and dimming. 1kW per channel. **£17.50**
DL21000K - A lower cost uni-directional version of the above. Zero switching to reduce interference. **£9.85**
Optional opto input allowing audio beat/light response (DLA1) **70p**
DL3000K - 3-channel sound to light kit features zero voltage switching, automatic level control and built-in microphone. 1kW per channel. **£14.25**

DL8000K
The DL8000K is an 8-way sequencer kit with built in opto-isolated sound to light input which comes complete with a pre-programmed EPROM containing EIGHTY - YES 80 different sequences including standard flashing and chase routines. The KIT includes full instructions and all components (even the PCB connectors) and requires only a box and a control knob to complete. Other features include manual sequence speed adjustment, zero voltage switching, LED mimic lamps and sound to light LED and a 300W output per channel. And the best thing about it is the price: **ONLY £28.50.**

DVM ULTRA SENSITIVE THERMOMETER KIT
Based on the ICL 7126 and a 3 1/2 digit liquid crystal display, this kit will form the basis of a digital multimeter (only a few additional resistors and switches are required - details supplied), or a sensitive digital thermometer (-50°C to +150°C) reading 0.1°. The kit has a sensitivity of 200mV for a full-scale reading, automatic polarity and overload indication. Typical battery life of 2 years (PP3). **£17.00**

HOME LIGHTING KITS
These kits contain all necessary components and full instructions and are designed to replace a standard wall switch and control up to 300W of lighting.
TD300K Remote Control Dimmer £16.45
MK6 Transmitter £4.95
for above **£4.95**
TD300K Touchdimmer £8.50
TS300K Touchswitch £8.50
TDE/K Extension kit for 2-way switching for TD300K £2.70
LD 300K Light Dimmer £4.35

TRK ELECTRONICS
13 BOSTON RD
LONDON W7 2SJ
Tel: 01:567 8910

SEND 9x6" S.A.E. AND 50p FOR CATALOGUE OR CALL AT SHOP MON-FRI 9-5 pm SATURDAY 10-4 pm

ORDERING INFORMATION:
ALL PRICES EXCLUDE VAT

FREE P&P on orders over £20 (UK only), otherwise add 75p + VAT Overseas P&P: Europe £2.75. Elsewhere £6.50. Send cheque/PO/Barclaycard/Access No. with order. Giro No. 5293 14002.

LOCAL AUTHORITY AND EXPORT ORDERS WELCOME
GOODS BY RETURN SUBJECT TO AVAILABILITY

PRACTICAL ELECTRONICS STEREO CASSETTE RECORDER KIT £19.95
+ £2.75 p+p.

★ Noise Reduction System ★ Auto Stop ★ Tape Counter ★ Switchable Eq ★ Independent Level Controls ★ Twin VU Meter ★ Wow & Flutter 0.1% ★ Record/Playback I.C. with Electronic Switching ★ Fully variable recording bias for accurate matching of all tapes, Metal, Chrome, etc.
Kit includes transport mechanism, ready punched and back printed quality circuit board and all electronic parts. i.e. semiconductors, resistors, capacitors, hardware, top cover, printed scale and mains transformer. You only supply the solder and hook-up wire.
As featured in P.E. reprint 50p. Free with kit. **Complete with case.**

125W HIGH POWER AMP MODULES
The power amp kit is a module for high power applications - disco units, guitar amplifiers, public address systems and even high power domestic systems. The unit is protected against short circuiting of the load and is safe in an open circuit condition. Supplied with all parts, circuit diagram & instructions.

AMP MODULE KIT £12.00
+ £1.15 p+p.

AMP MODULE BUILT £17.50
+ £1.15 p+p.

ACCESSORIES: Stereo mains power supply w/transformer - £12.50 + £2.00 p&p. **SPECIFICATIONS:** Max output power (RMS): 125W. Loads: 4 - 16 ohms. Frequency response measured @ 100 watts: 25Hz - 20kHz. Sensitivity for 100 watts: 400mV @ 47K. Dimensions: 205 x 90 and 190 x 36mm.

Built and ready-to-use version with all accessories including power supply and case £42.50 + £2.00 p&p.

VHF STEREO TUNER KIT - £8.95 + £2.50 p+p.

Easy to build 3-band stereo AM/FM tuner kit designed in conjunction with P.E. For ease of construction and alignment it incorporates 3 Mullard modules and an I.C. IF System. **FEATURES:** VHF, MW, LW Bands, Interstation muting and AFC on VHF. Tuning Meter. Two back printed PCBs. Ready made chassis and scale. Aerial: AM - ferrite rod, FM - 75 or 300 ohms. Stabilised power supply with 'C' core mains transformer. All components supplied are to strict P.E. specification. Front scale size: 10 1/2 x 2 1/2" approx. Complete with diagram and instructions.

Mail to: 21 HIGH ST, ACTON Mail or telephone orders by **W3 6NG**. Callers to Acton or **ACCESS. Tel: 01-992 8430.**
323 EDGWARE RD, LONDON W2. (Open 6 days a week).
Please allow 14 days delivery. Payments to RTVC Ltd.

**AUDIO KITS
PRECISION AUDIO COMPONENTS**

BUILD THE ETI VIRTUOSO PREAMP

Standard version Tone controls	Standard version No tone controls	Upgraded version Tone controls	Upgraded version No tone controls
£177	£138	£372	£256
COMPLETE KIT MC stage component pack MM (RIAA) stage pack Tone control board		£12.50 £23	£25 £58
£29.60	Not needed	£89.40	Not needed
Switches & Connectors pack Output stage pack Power supply excl. transformer	£24.95 £11.60	£16.25 £11.60	£77.30 £28.25 £29.50
		£15.50	£29.50

VIRTUOSO preamp case - state whether tone control option. £49
All parts including pcb's available separately. SAE for price list

IAR WONDER CAPS		Holco 0.5% 50ppm/°C resistors 1/4W any E96 value 20R-442K	
uF	V	L x Dia	Price
0.01	630	21 9	£2.25
0.1	425	30 8	£2.50
0.22	630	50 14	£4
0.33	425	40 10	£2.50
0.47	425	50 14	£3
0.68	425	50 16	£3
1	425	57 17	£5
2	425	57 20	£6
3	425	57 25	£8
4	425	57 27	£9
5	310	57 20	£7.50
6	310	57 23	£8.50
8	310	57 26	£10
10	310	57 29	£11

The improvement in sound quality when you replace your caps with Wonder caps or bypass your electrolytics with Wonder caps is WONDERFUL

Top Quality Transistors by Motorola

BC184C	12p
BC214C	12p
BC547C	12p
BC307C	12p
MPSA06	25p
BDS139	25p
BD140	50p
MJ11015	66p
MJ11016	£5.50

BUILD THESE SUPERB ETI PROJECTS WITH AUDIOKITS COMPONENTS

SYSTEM A preamp	SYSTEM A power amp	AUDIO DESIGN preamp	AUDIO DESIGN power amp	VALVE PREAMP Aug 86
-----------------	--------------------	---------------------	------------------------	---------------------

Please ask for our parts price list which includes all electronic parts to build the projects and top quality components which enable owners of these amps to substantially upgrade the sound. Resistor and Capacitor pack for ETI Valve preamp £220.10
Includes Holco resistors, Wonder caps and the best computer grade electrolytics

All prices include VAT. SAE or IRCs with all enquiries.
EXPORT orders. Deduct VAT (multiply by 0.87) and add £2 extra for postage.
Please add 50p P&P for orders under £10.

AUDIOKITS
6, Mill Close, Borrowash, Derby DE7 3GU
Tel: 0332-674929

HARDWARE DESIGN CONCEPTS

Mike Barwise proves his practical approach to hardware design.

Having spent several months discussing theoretical design principles, I would now like to take you through a real project. Rather than present this as a conventional ETI construction project, I will be demonstrating the design process and the step-by-step decision-making culminating in a fully-fledged circuit and PCB. The final design will incorporate both fast logic and an embedded microprocessor.

Test gear is always useful, and for digital and microprocessor work the pulse generator is one of the fundamental tools. Pulse generators tend to be either appallingly expensive or very limited, so I have come up with a DIY solution which is versatile and relatively cheap.

In order of priority, the main requirements of a pulse generator are:

- Reasonably broad range of square wave output (say 100 Hz to 1MHz minimum).
- Provision for delayed short pulse within overall period (Fig. 1)
- Good stability (the ability to remain at the selected settings).
- Reasonably precise setability and repeatability (the possibility of selecting a specific setting or of returning to previous settings after adjustments).
- Auxiliary outputs with shiftable voltage levels.

Most low cost commercial pulse generators use cascaded monostable blocks (Fig. 2a) as the timing chain. With switched capacitors they can easily fulfil the range criterion, and the delayed pulse facility and shiftable levels are standard. However, stability tends to be temperature dependent, and setability and repeatability are poor, normally requiring the use of an oscilloscope to set up critical pulse parameters. This reduces the overall precision to that of the 'scope, ($\pm 3\%$ or so).

The Digital Alternative

The approach which we will adopt is to use digital timing chains instead of analogue monostables (Fig. 2b). If properly implemented, the overall precision will be only marginally less than that of the master oscillator which drives the system. The use of a crystal component will provide a system precision in the order of one part in 1000 or better. As the timing chains use digital counters, setability and repeatability are absolute, and the overall range of the generator depends simply on the maximum count of the digital counter chains.

There is a wide variety of counter devices in each conventional logic family. It is important to choose a

suitable device for the purpose. I have chosen TTL for our pulse generator, simply because 4000 series CMOS (the major alternative) is too slow, operating at about 2MHz max. As we want our pulse generator to work at up to 10MHz, the choice is clear.

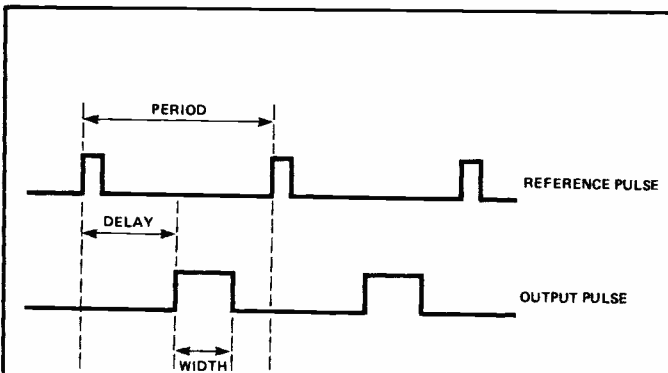

Fig. 1 Pulse delay and width control.

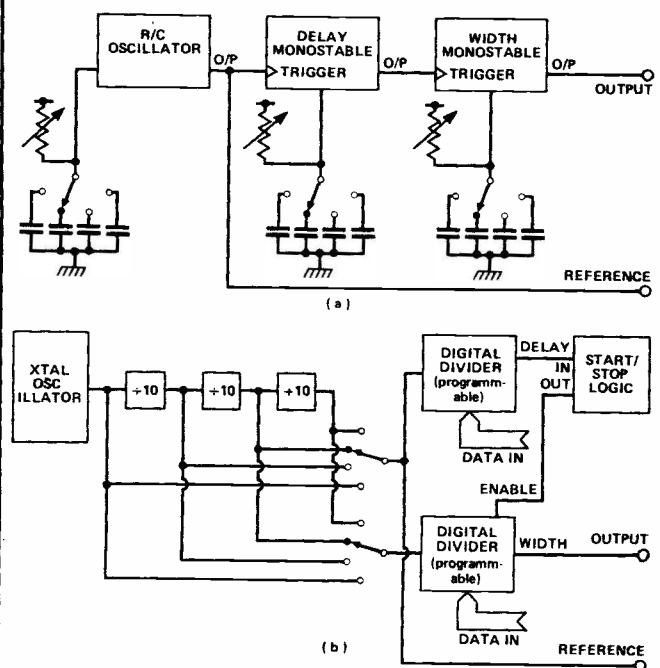

Fig. 2 (a) Analogue pulse generator. (b) Digital pulse generator.

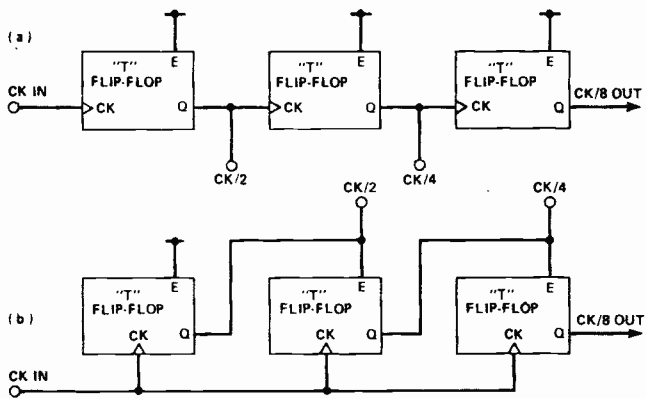

Fig. 3 (a) Asynchronous counter. (b) Synchronous counter.

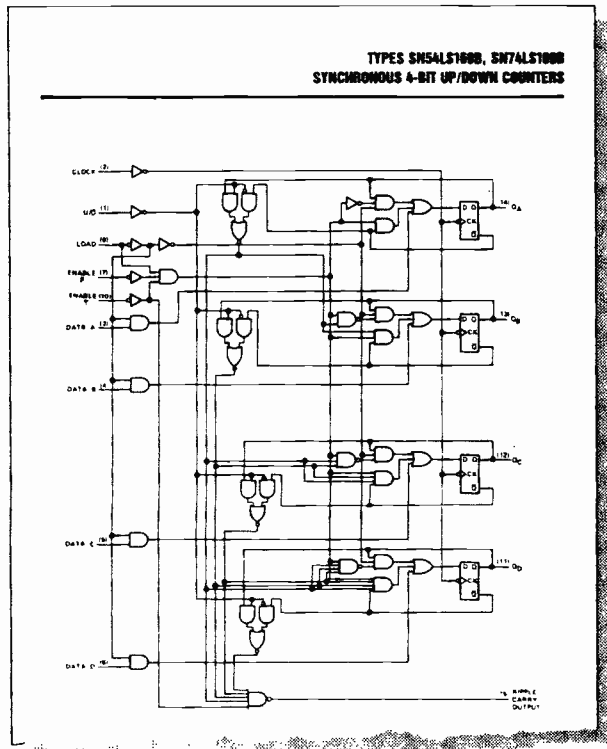

Fig. 4 The 74LS169B synchronous 4 bit up/down counter (courtesy of Texas Instruments).

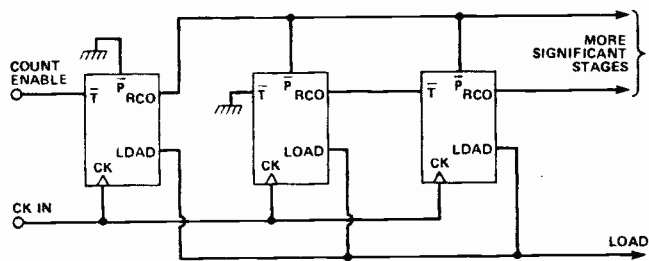

Fig. 5 Look ahead carry for synchronous counter cascading.

Within TTL, there are asynchronous (Fig. 3a) and synchronous (Fig. 3b) counters. Both use chains of bistable flip-flops, each of which divides by two the output from the previous flip-flop.

Asynchronous, or 'ripple' counters use the change in a preceding output to clock the following input, so that the propagation delays (the time between applying an input and getting a change at the output) of all the flip-flops are added together. This causes a phase shift, which depends on the number of cascaded flip-flops, and allows invalid outputs during the transition time between one count and the next. The synchronous counter, on the other hand, uses clocked flip-flops which are enabled or disabled by the outputs of preceding flip-flops, so that when a clock occurs, all enabled flip-flops change state simultaneously, and all disabled flip-flops do nothing.

From this it is obvious that for high modulo counters, synchronous operation is preferable. Most TTL counters are four bit (count of 16) building blocks, so we must physically cascade four bit packages to the modulo we require (about 1000), and care must be taken when doing this to ensure that the inter-package connections maintain synchronisation.

A good choice of counter device for this project is the 74LS169B from Texas Instruments (Fig. 4). This is a four bit binary up/down counter with a maximum speed of 35MHz (typical) and the important facility of 'synchronous loadability'. This means at any time a four bit data word can be presented to the chip, and it will be ignored until the next clock pulse after the LOAD pin is activated. Then the applied word will replace the previous state of the counter. This is crucial, as we will see later. It is worth mentioning in passing that the decade version of this counter (74LS168) is not a good choice, as it has invalid states which cause it to go out of sequence (you can load it with decimal 10 through 15, causing it to revert to its legal 0 through 9 via an unexpected route). However, when the counter is used as a free running maximal count divider, the decade counter has its uses.

The 74LS169B has a ripple carry output (RCO). This is effectively a decade of the terminal count of the device prior to the flip-flop inputs. Thus, as soon as the next state of all counter outputs is low (count zero) when counting down, or as soon as the next state of all outputs is high (count 15) when counting up, the ripple carry output is low. This condition persists until after the next clock. At all other times the RCO is high. Used with this output for cascading are two active-low enable inputs, P and T. P enables the counter chain, and T enables both the counter chain and the ripple carry output.

These signals are very important for synchronous cascading. If you simply take the ripple carry out of the first stage and connect it to the clock input of the next, you create an asynchronous stage in your counter. The proper connection for cascading is shown in Fig. 5. The ripple carry output of the first (fastest) stage is used to enable (P) all subsequent counters, and the ripple carry output of the second stage is connected to the T enable of the third stage, whose RCO is connected to the T of the fourth, and so on. A common clock drives all stages synchronously. The 1000:1 range we require is provided by three cascaded four-bit counters (in fact 4096:1).

Ignoring for the moment the LOAD facility, we have now created a high modulo free-running counter which will count up or down according to the state of its direction select pin. Each output of the counter provides a square wave signal which is half the frequency of the previous output, and the RCO of the last (slowest) stage provides a negative going pulse

(width = input clock period) every time the whole counter chain reaches its terminal count (once in 4096 input clock cycles).

Programming The Counter

If we were to load the counter with a defined value, it would start counting from this point, so the number of input clock cycles between counter start (after the LOAD signal is released) and the output of the RCO from the slowest stage would be determined by the value we loaded. This shows us a way to program the counter. If we feed the slowest stage RCO back into the counter by connecting it to the LOAD pins of all stages (Fig. 6a), every time the whole counter rolls over, it will reload itself. The usable output from the divider is a short 'tick' from the RCO/load feedback loop every time the counter reloads. It is these ticks that are used as clocks or triggers to other systems.

It is simplest to operate in this programmable mode by counting DOWN. You then have to load the value you want (instead of the difference between this and the max. count).

This design is really simple, and looks very elegant. There is, however, one tiny problem. If the slowest (most significant) stage of the chain is programmed to

zero (when using the faster ranges of the divider) the RCO of this stage goes permanently low, inhibiting the whole chain by enforcing a constant LOAD condition. This imposes a severe limitation on the range of the pulse generator, by completely blocking all but the slowest ranges. The solution is shown in Fig. 6b. The RCO outputs of all stages are combined (logical AND) so only when all states are rolling over is a LOAD pulse generated.

As all signals are active low, an OR gate performs the necessary function by DeMorgan equivalence. OR gates with more than two inputs are not readily available in TTL, so the neat answer is to use a three input NOR gate (74LS27) followed by an inverter (74LS04). Note, though, that the propagation delays of these devices in the feedback loop will limit the top end performance of the generator, so we will in due course consider the use of faster devices for this design.

Synchronicity

In these programmable divider chains, synchronous loading is all-important. If the LOAD was asynchronous (happening immediately the RCO signal appeared at the LOAD pins, as in the 74LS191) the counter reload would happen early (between two clock pulses), and the precision of the programmable divider would be spoilt.

As it is, the request to reload is recognised synchronously by the counter at the next clock pulse following the appearance of the RCO signal. This clock pulse, by loading the counter with the user's value, cancels the terminal count causing the RCO signal to go away. The propagation delays in the devices allow the RCO signal to take effect before it is cancelled (Fig. 7). As the clock following the terminal count reloads the counter and counting resumes on the clock following that, the counter modulo is always effectively one more than the loaded user value.

This is no problem when a microprocessor is used to load the modulo, as software is used to subtract one from the intended value before loading it into the counter. However, if we were to use switches, we would have to remember to subtract one 'by hand'.

The important outcome of this is the shortest delay sequence of the counter chain is divide by two. This is generated by loading the least significant counter stage with one and all more significant stages with zero. Loading all stages with zero is still a special case where all counting is inhibited, and this can be used as a stop condition for our pulse generator.

A single programmable counter chain provides us with a variable frequency square wave oscillator (Fig. 8). The RCO output of the final counter stage is fed back to the LOAD pins (via the NOR and invert gates), and also used to trigger a toggle flip-flop. The output from this is a good square wave with a frequency half the repetition rate of the RCO Pulses. This means that for a maximum output frequency of 5MHz, a 10MHz clock oscillator must be used.

Note that some alternative sources of 74LS169 may not operate in this closed loop (with feedback) configuration with a 20MHz input clock. 10MHz is safe, giving a 2.5MHz maximum frequency, or 400ns resolution, but it will prove necessary to go to 74AS or 74F series devices for 10MHz output. Special layout precautions are needed for these families of devices, and I will discuss them in due course. For the time being, the prototype may be run from, say, a 4MHz clock, at which the divider is absolutely guaranteed to operate with a 1µs resolution. For simplicity I have

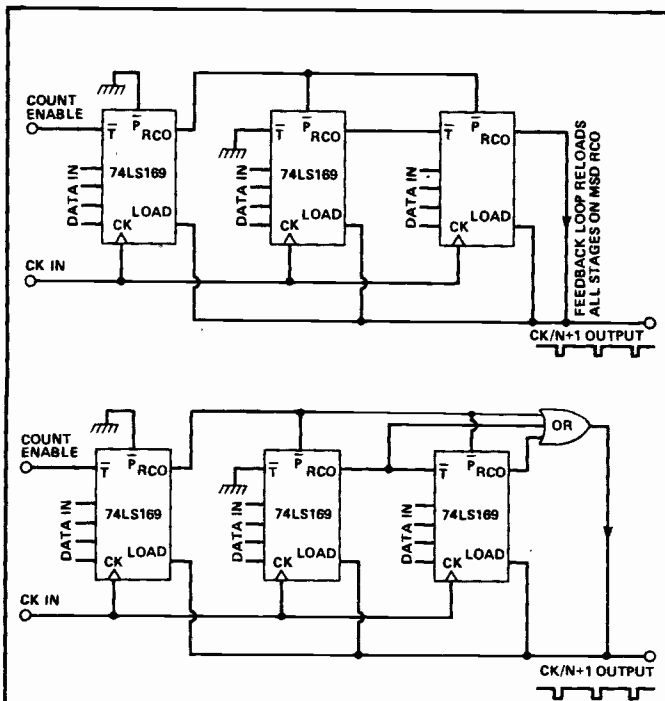

Fig. 6 (a) First attempt at programmable divider. (b) The improved circuit.

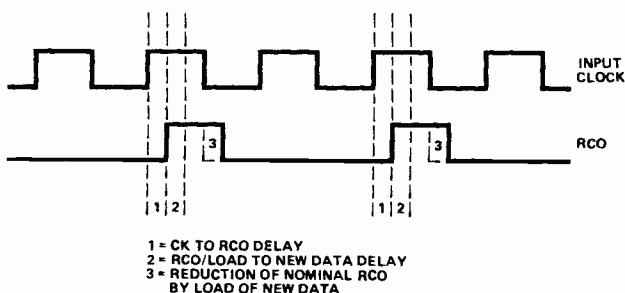

Fig. 7 Propagation delays in the divider chain.

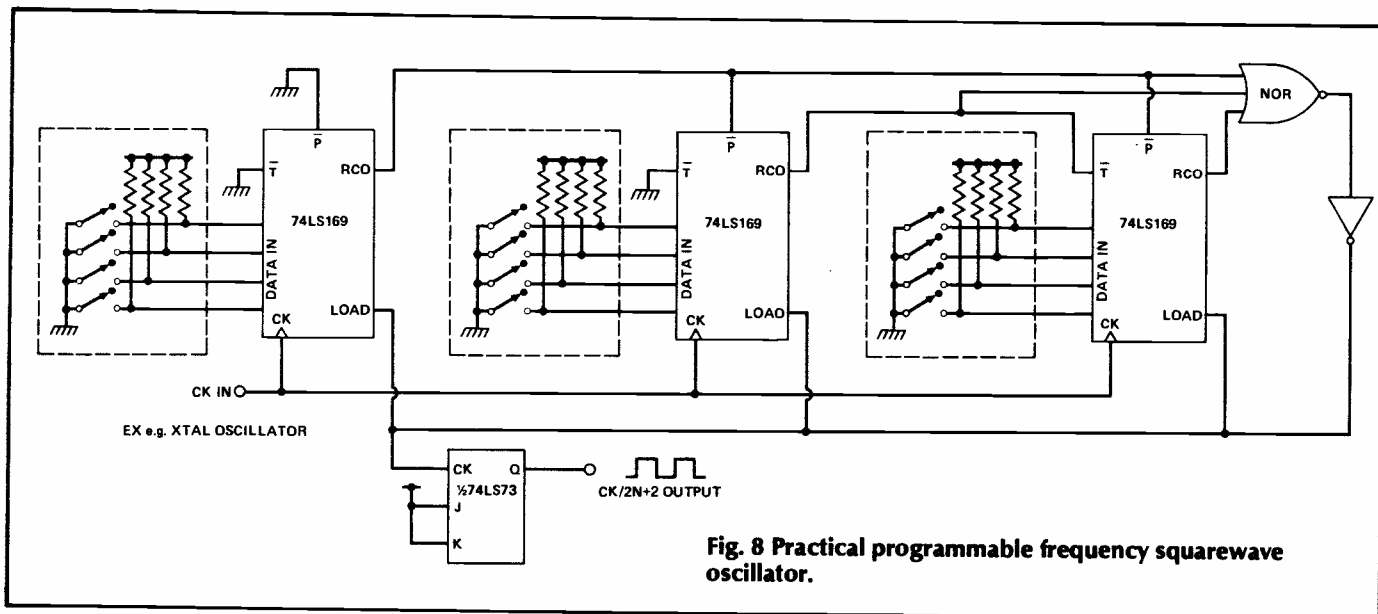

Fig. 8 Practical programmable frequency squarewave oscillator.

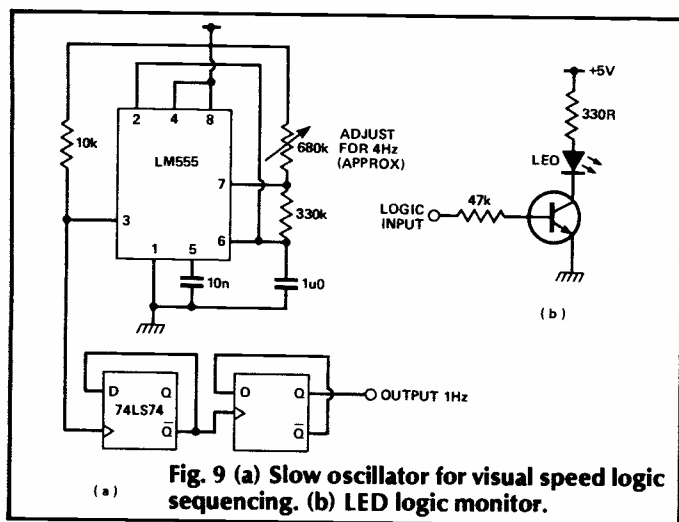

Fig. 9 (a) Slow oscillator for visual speed logic sequencing. **(b)** LED logic monitor.

shown counter programming by switches, but of course in the final implementation, the holding registers will be loaded by a microprocessor.

This is probably a good point to pause and say 'get experimenting'. Next month I will deal with the mechanisms of the pulse delay and width controls for the generators, but in the meantime, try wiring these circuits up on a breadboard. The only test gear you will need is a moderate 'scope (about 10MHz would do for the 4MHz version), or alternatively, you could rig a very slow oscillator using something like a 555 timer (Fig. 9a) and run the prototype at 1Hz. A logic probe or an LED with driver (Fig. 9b) can then be used to monitor the system.

ETI

'Scotlands newest components shop'

OMNI ELECTRONICS

We stock a wide range of components:
transformers, switches, pots, ICs, capacitors, resistors, diodes, boxes, triacs, LEDs, cable, connectors, PCBs-
in fact, all you need for your projects.

Send for our 21 page catalogue - 20p + 12p postage or call at our shop Mon-Fri 9am - 6pm, Sat 9am - 5pm.

**174 Dalkeith Road
EDINBURGH EH16 5DX
031-667-2611**

RACK MOUNTING CABINET

* Suitable for instruments, high quality amplifiers and many other purposes * Black anodised aluminium front panel enhanced with two handles * Aluminium version, wholly made of black anodised aluminium sheets * Metal version, rear box is manufactured from steel painted in black with aluminium front panel. Customer who requires further details, please send SAE.

Panel Size W H (Inch)	Rear Box W H D	Price Steel	AL
19x2.5	17x2x10	22.50	27.50
19x3.5	17x3x10	24.50	29.50
19x5.25	17x5x10	26.50	—
19x3.5	17x3x12	25.50	30.50
19x5.25	17x5x12	27.50	32.50
19x5.75	17x5.5x12	28.50	33.50
* 17x2.5	15.5x2x9	16.50	—
* 17x3.5	15.5x3x9	17.00	—
* 19x3.0	17x2.5x10	—	20.50
* 19x4.0	17x3.5x12	—	22.50

* Discontinued sizes, special price valid while stock lasts. Please add £3.00 P/P for the first item and £1.50 for each additional item. Quantity discount available. A limited quantity of electronic kits at give away prices. SAE for details.

Mail order only. To order send cheque/postal order, please allow up to 7 days despatch for cheque clearance.

T J A DEVELOPMENTS
53 Hartington Road, London E17 8AS.

CELLULAR RADIO

ETI's communications correspondent Keith Brindley casts an eye over cellular communications systems in the UK.

Whatever your point of view, modern electronic communications systems are pretty clever. How we use (or abuse) them is a different matter entirely. Personally, I can imagine little worse than the 'advantage' of a 'phone in my car. I have problems enough at home with the telephone ringing constantly, without having to suffer the same when I drive. Furthermore, I'm committed sufficiently as a serious motorist to feel the distractions of using a 'phone (or any means of telecommunications) in transit are dangerous and should not legally be allowed. Nevertheless, given the fact many people require telecommunications in order to do business, there is a need for a system such as cellular radio.

Mobile communications is not new. Mobile radio has been used by the military for nearly eighty years, and commercial organisations have been in operation providing systems to emergency services such as fire, police and ambulance for nearly as long. There are four other main types of mobile communications, which we should briefly consider before looking in depth at cellular radio itself.

Radiopaging. A call (generally digitally coded) is transmitted on a single frequency radio channel to a large number of receivers (sometimes nicknamed 'bleepers'). The call is headed by a receiver-specific code, triggering only one of the bleepers which correspondingly beeps or otherwise indicates that a call has been received (Fig. 1). The call originator uses a normal telephone to dial the number dedicated to the receiver much as if the receiver is a telephone itself. However, the processing exchange routes the call to the receiver via a radio transmitter. In some sophisticated radiopaging systems a complete message is transmitted to the receiver and the user reads this on an LCD or similar display. Bleepers of more simple systems merely inform the user that a message is waiting. The user must then call a dedicated number via an ordinary telephone to receive the message.

Radiophone. Operating along the citizens' band lines, radiophones or 'walkie-talkies' as they are sometimes nicknamed are simple mobile receiver-transmitters, either hand-held or fixed in a car or base station. These use a single transmission frequency for both reception and transmission (Fig. 2). Use of a single frequency means only one user can transmit at a time, the other user in the communication link must wait until the first has finished before a reply can be made. This one-at-a-time operation is known as 'simplex' communication.

The bands of frequencies which the services use define the type of radiophone system. Citizens' band, for example, is so called because the service uses a band of frequencies which has been allocated for public citizens' use.

As a service, radiophone systems have significant drawbacks in addition to their simplex mode of operation. Users often have to queue, waiting for a free channel on which to transmit. This happens, par-

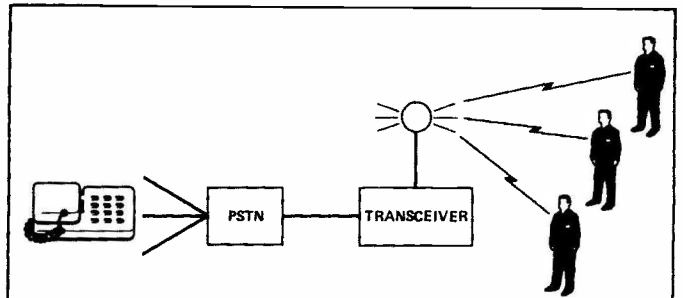

Fig. 1 Radiopaging.

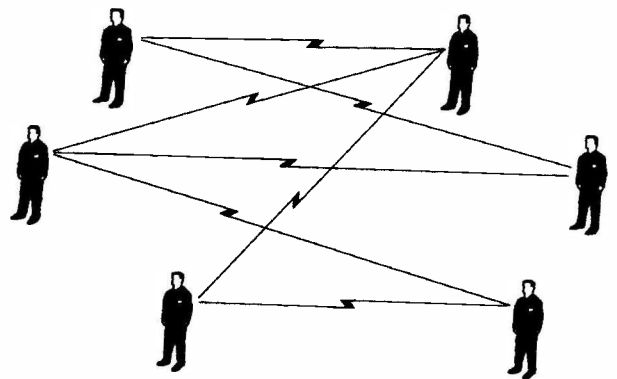

Fig. 2 Radiophone and CB radio.

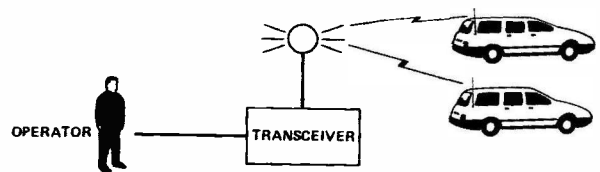

Fig. 3 Dispatch radio services.

ticularly in urban areas where large numbers of users reside, or at busy times. Privacy is also impossible. Anyone with similar equipment can listen into a communication link.

Dispatch radio service. This is the sort of communications system used in taxis, ambulances, service vehicles and so on, in which a central or base station transmits and receives messages to and from mobile users (Fig. 3). The mobile users generally communicate only with the operator at the central station although some systems allow calls to be patched through from one mobile to another by the operator.

The disadvantages are fairly obvious. The number of mobile users on any one system is limited to the number of calls the operator can handle. Communication is simplex. Mobile users' transmitters can only be low powered so the distance over which the system

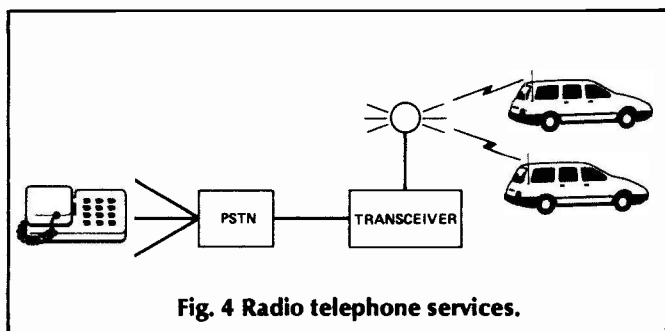

Fig. 4 Radio telephone services.

can be used is limited. Finally, with this service privacy is impossible.

Mobile telephone service. Commonly called radiotelephone services, the mobile telephone is linked over the air to the public switched telephone network (PSTN) so communication links with ordinary telephones can be set-up (Fig. 4). Communications are 'duplex', each user in the link able to talk at the same time.

This would seem the ideal mobile communications system. However, use of the available transmission frequency bands (HF and VHF) is not particularly economical and often a system may be busy, so long waits for a free channel can be expected.

A significant problem arises in the distance which a mobile user is from the central receiving station, and the consequent transmitter power. The further away the user is, the more powerful the transmitters must be. However, the more powerful the transmitters are the wider apart they must be to prevent interference with other transmitters of the same frequency or the fewer the available transmission frequencies. On the other hand, if low powered transmitters are used there is a good chance the mobile user will stray out of the transmission area during the call (the user is mobile, after all). Typically, quite powerful transmitters are used, with a limit to the number of channels available.

Privacy is also not possible in a standard system, although specialised systems can incorporate speech encryption — at a high cost.

One Better

It was the general poor quality of mobile communications and radio channel congestion which, in 1982, prompted the Government to allocate 30 MHz of radio frequency spectrum to a new mobile radio system, known as 'cellular' communications. The system chosen was the 'Total access communications system' (TACS), a derivative of the already existing 'Advanced mobile phone service' (AMPS), developed by AT&T in the US.

Cellular communications systems are essentially an extension of existing mobile services. However, the use of computer controlled technology allows far greater economy of transmitting frequency bands and far greater efficiency. As far as the mobile user is concerned the receiving/transmitting apparatus is effectively an ordinary telephone, with all the usual telephone features (and more besides) and as easy to use.

Computer control of the switching apparatus means tremendous economy of the available frequency bands can be obtained. In turn, this means many more communication links can be made in the same number of frequency bands when compared with other mobile communications systems.

Finally, instead of a small number of relatively high

powered HF or VHF transmitters being used to cover an area (as in radiotelephone systems), cellular communications systems use a very large number of low powered UHF transmitters. Again, it's computer control which allows this to work — calls can be automatically switched from one transmitter to the next as the mobile user moves between different transmitter reception areas.

We will look at each of these features of cellular communications in more depth.

Transmitter Power

Transmitter coverage in a mobile telephone service may be a circle with a radius of x km (Fig. 5). Outside this coverage zone is an interference zone, with a radius of about $5x$ km, in which the same radio frequencies used in the coverage zone cannot be used by another transmitter, otherwise interference of the two transmissions will probably occur. The same frequencies can be used outside the interference zone without interference occurring.

The key to the use of cellular communications is in the reduction in size of the coverage zones of the base stations (the receiver/transmitter) used. A smaller coverage zone means that fewer users will require the use of the base station. As a direct result of this, fewer channels are required to serve those fewer users.

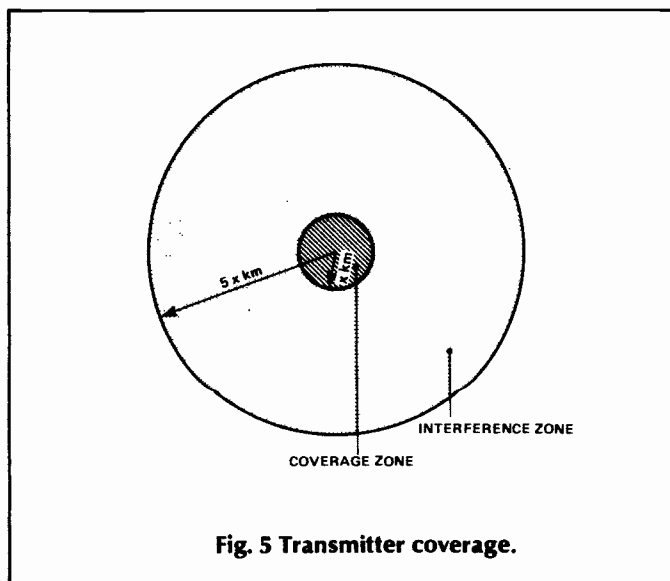

Fig. 5 Transmitter coverage.

In a cellular communications system the coverage areas are so small that they can be looked upon as 'cells' (hence the name) arranged in groups (known as 'clusters') over the land. Figure 6 shows seven-cell and 12-cell cluster arrangements. Others, such as four-cell and 21-cell arrangements, are also possible. Although each cell has a roughly circular coverage zone, they are usually thought of as hexagonal in shape and are much easier to draw because of this. Numbers within the cells merely indicate a particular frequency set of channels which transmitters in that cell use. Clusters are identical, in that correspondingly numbered cells in adjacent clusters use the same transmission frequencies.

The seven-cell cluster arrangement is ideal in terms of interference zones, as each base station is approximately five times the radius of its coverage zone away from the nearest base station with the same transmission frequency (measure it if you don't believe it!). So interference is unlikely. Any fewer cells in a cluster

and corresponding base stations may be too close (and interference might occur). On the other hand, any more cells in a cluster mean that corresponding base stations would be further away than necessary and so transmission frequencies (and hence channels) are apparently being wasted.

However, the number of cells used in a cellular communications system depends on future requirements of the system, too. If more users than an existing arrangement can cope with wish to use the system, then two options are available.

Firstly, each cell can be split into seven smaller cells (ie, the cell itself becomes a cluster) so base station coverage zones become smaller and a greater number of users can be accommodated.

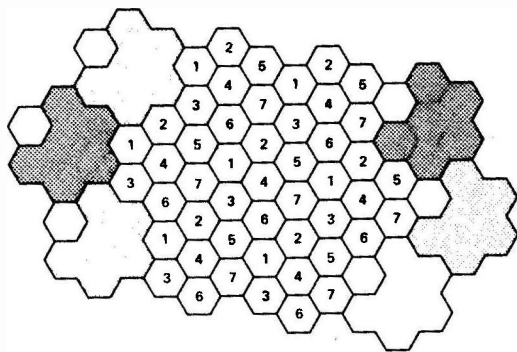
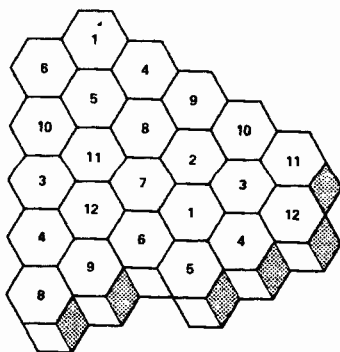

Fig. 6 (a) 7 cell repeating pattern.



(b) 12 cell repeating pattern.

The second alternative is for each cell to be sectored by using directional aerials which only cover one part of the cell. For example, three aerials with 120° each will cover one cell, using the same transmission frequencies, effectively tripling the number of channels which can be used and giving a corresponding increase in the number of possible users.

The two cellular communications systems in use in the UK, Cellnet and Vodafone, illustrate this well. Vodafone uses the seven-cell arrangement, but in urban areas has sectored each cell with three 120° directional aerials, which is about the limit of the system. Cellnet, on the other hand, has a 12-cell arrangement and so can sector its cells more thoroughly (with six 60° directional aerials in each cell) before reaching the system limits. After the sectoring

limits are reached, further users can only be incorporated by splitting each cell into seven or 12 smaller cells.

Future Limits

However, there is a lower limit to cell size when splitting, which depends primarily on system accuracy and where the aerial can be sited. The smallest usable cell (in London, actually) is about 2 km in radius. Smaller than that and it becomes too critical to be able to site an aerial in a convenient position. It's impossible to site an aerial, say, smack in the middle of Tottenham Court Road if that's the ideal spot. Tolerances of a few hundred metres must be built-in to the system to allow convenient aerial siting, which inevitably would cause interference problems unless cell size is sufficiently great. So, in effect, there is a maximum limit to the number of users which can be accommodated on a system.

When the limit is reached will depend on the rate of growth of new users to a system. Eventually, however, the time must come when both existing cellular communications systems are choc-a-block and new systems will have to be built. Even then, unless far more frequency spectrum is allocated to cellular communications, it's not going to be the case that we'll all have our very own cellular telephone in the future — the wired 'phone will be with us for a long time yet!

And talking of the future, it is interesting to note that the UK TACS systems, Cellnet and Vodafone, are each licensed to use only 300 of the 1,000 channels allocated by the Government for present cellular communications purposes (21 of these are allocated for control data purposes, leaving 279 channels each). The remaining 400 are presently allocated for the Europe-wide second generation cellular communications system, planned for the 1990s.

The older mobile telephone services use HF and VHF transmissions which have unpredictable and long propagation ranges. Cellular communications systems, on the other hand, use UHF transmissions which are essentially line-of-sight (communications links can only take place up to a maximum of about 40 km and won't go any further than the horizon), and extremely directional, with highly predictable propagation ranges. Also, because UHF transmissions penetrate deeply into buildings, tunnels, and other physical barriers (unlike HF and VHF transmissions) lower power transmissions can be used, allowing ranges of only a few hundred metres or so. Radiotelephone services operating at HF and VHF must 'swamp' an area to provide the equivalent penetration, creating long propagation ranges.

For reference, the UK TACS cellular communications system uses transmissions at typical effective radiated power (ERP) levels of 50 to 1000 watts for base stations, and 0.6 watts to 10 watts for mobile equipment. The frequency band 935 to 960 MHz is used for 'forward direction' transmissions (from the base station to the mobile) and the band 890 to 915 MHz is used for the 'reverse direction' transmissions from the mobile to the base station).

Cell size is not fixed throughout the country, as you've probably gathered from this discussion already. In rural areas a cell can be quite large (up to 40 km in radius, as we've seen), while in urban areas cells are decidedly small. The general rule-of-thumb is that all cells should have about the same number of users and so have the same number of channels available for those users.

Over To You

The use of quite small cells in a cellular communications system leads to the problem which occurs when a mobile user leaves one cell and enters another. The problem is solved with the use of complex network switches which automatically switch the links through the best base station so that reception and transmission is maintained. The complete national system (Fig. 7) is based around these network switches, which route communications links in the first place and perform the functions of time-keeping and maintenance of tariff data. Finally, the network switches monitor the position of all users so that any call to a mobile user will be quickly routed.

The process of switching from one base station to another when a mobile user goes from one cell to another (and indeed, from one sector of a cell to another) is known as 'hand-off'. This occurs in about 300ms so usually is undetected by the user. Individual cell base stations monitor each communications link in progress, and if communication quality falls below a predefined level the network switch is automatically alerted.

Base station monitoring is remarkably simple. Besides the channels available for telephone communication links, there are some channels reserved for control and signalling communications. The mobile equipment transmits control signals at regular intervals, but when actually in the process of a communications link, it also transmits a tone in a control channel. If the signal-to-noise ratio of the tone falls, indicating the user is moving out of the cell, the base station informs the nearest network switch. It is then up to the network switch to monitor signal strengths at all surrounding cell base stations and switch the link onto a different channel and base station.

Signal strength sensing of this type can also provide the mobile's position to the network switch, at least in terms of the base station which receives the strongest signal. This method of locating the mobile works best in the countryside where signal strength is usually dependent only on the mobile's distance from the base station. In an urban area signal strength sensing is not so useful. A mobile may produce a low signal strength even when comparatively close to a base station because it is being nulled by various fixed and mobile objects. Some cellular communications systems (not TACS) use an alternative form of positional sensing, called 'trilateration', in which the mobile regularly transmits pulses which are received by at least three base stations. The relative delays experienced by the base stations in receiving each pulse indicates the distance the mobile is away from each base station and so gives its position.

Network switches are connected directly to the PSTN so that any fixed telephone subscriber can call any mobile user, or vice versa, and any mobile user can call any other mobile user — world-wide.

Roaming

If a user moves throughout a cellular communications system roaming is said to occur. To roam right throughout the system means hand-off will at some time be required from one cell to another, where the cells belong to adjacent network switches. For this to happen, inter-switch hand-off is required, not just inter-cell hand-off as we've previously considered.

Interestingly, the Vodafone system has not yet got inter-switch hand-off (Cellnet has just been updated to incorporate it). However, Vodafone's network

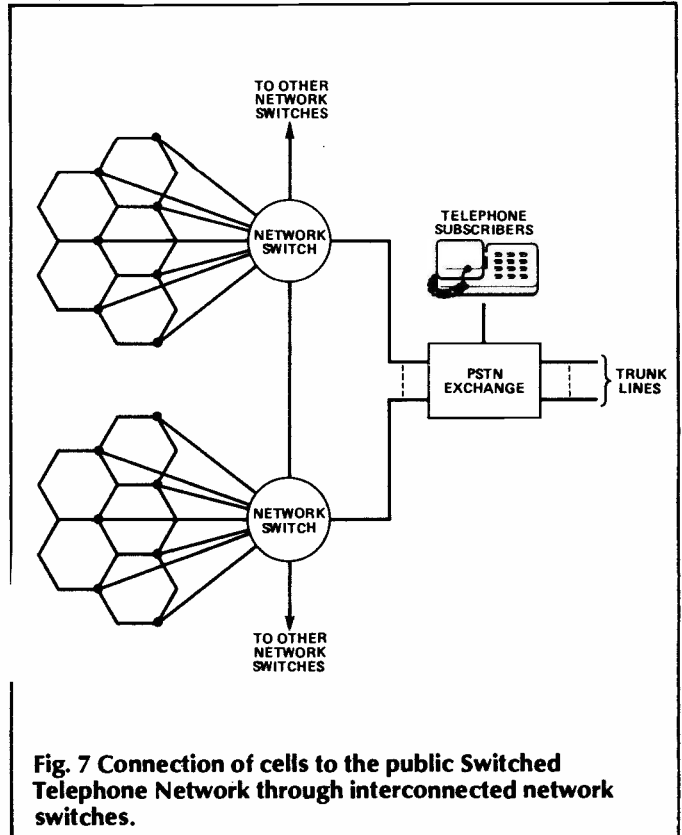

Fig. 7 Connection of cells to the public Switched Telephone Network through interconnected network switches.

switches cover very large areas (each switch can accommodate more than 100,000 users, compared with Cellnet's 30,000 users) so the facility is not so critical.

Features

Now we've described the system, what can it do? First and foremost cellular communications provides a means whereby a mobile user, in a vehicle or on foot, can maintain telephone communication with whoever the user wishes to contact, or whoever wishes to contact the user. So all the features usually taken for granted with the 'phone are available wherever the user travels.

More than this, there are some features which the existing landline telephone network cannot usually provide. These extra features include:

- **Call diversion.** The incoming call can be assigned to an alternative number when the mobile is busy, turned off, or does not reply within a certain period.
- **Three party conference.** Board meetings over the 'phone. A conversation between three or more parties can be heard simultaneously by all parties.
- **Call transfer.** A call can be transferred to another telephone location by the mobile user.
- **Selective call barring.** Certain types of call, such as international calls, can be denied to the mobile user.
- **Alarm call.** The network switch will automatically call a mobile at a time programmed by the user.
- **Camp-on.** If the mobile is in use, an incoming call will be put 'on hold' at the network switch, until the mobile is free. At the same time, the mobile user will be warned a call is being held.
- **Call holding.** An existing call can be put on hold, by the mobile user, while a camped-on call is answered.

Most mobile equipment also has the following facilities:

- **On-hook dialling.** The handset can be left on its cradle until the called party answers.

Cellnet only

British Telecom Mobile Phone Division

Docos House
68-82 Commercial Road
London E1
Tel: (01) 432-6280

Caledonian Communications Ltd

17 Waterloo Place
Edinburgh
Scotland
Tel: (031) 558 1144

The Carphone Company

Vallis House
57 Vallis Road
Frome

Somerset
Tel: (0373) 73220

Cellcom Ltd

Sutherland House
70-78 The Broadway
London NW9

Tel: (01) 202 2322

Cellular One Ltd

114 Windmill Road
Brentford
Middlesex

Tel: (01) 568 1166

Granada Mobile Telephones

Dane Street Chambers
Dane Street
Bedford

Tel: (0234) 55233

Marconi Mobile Radio

Marconi Communications
Systems Ltd

New Street
Chelmsford
Essex

Tel: (0245) 353221

Motorola Communications Services Ltd

Jay's Close
Viabes Industrial Estate
Basingstoke

Hants

Tel: (0256) 58211

Relcom Communications Ltd

Hammersmith Industrial Estate
Winslow Road
London W6

Tel: (01) 741 8581

Securicor Robophone Communications Ltd

Ambassador House
Brigstock Road
Thornton Heath

Surrey

Tel: 9(1) 689 2144

Tactico Ltd

65 Logie Green Road
Edinburgh
Scotland

Tel: (031) 556 6167/8

Racal Vodaphone only

Advance Car Telephones

226 Christchurch Avenue
Kilburn
London NW6

Tel: (01) 328 6514

Automobile Association

AA Vodaphone
Fanum House
52 London Road

Twickenham
Middlesex

Tel: (01) 891 6191

ECT Cellular Ltd

14 Muswell Hill Road
Highgate

London N6

Tel: (01) 368 4321

Ericsson Information Systems Ltd

18 Clerkenwell Road London
EC1

Tel: (01) 251 0187

In-Car Telephones

Unit 19
Acton Business Park
The Vale
Acton

London W3

Tel: (01) 749 9572

London Car Telephones Ltd

9 Lower Addiscombe Road
Croydon
Surrey CR0 6PQ

Tel: (01) 680 4444

Racal-Vodac Ltd

Freeport
Newbury
Berkshire RG13 1BR

Tel: (0653) 69000

Stormo Ltd

110 Grafton Road
London NW5

Tel: (01) 267 5136

Thorn-Ericsson Ltd.

Viking House
Boundary Lane
Horsham

West Sussex

Tel: (0403) 64166

Both Cellnet and Racal-Vodaphone

AirCall PLC

108 Rochester Row
London SW1P 1JP

Tel: (01) 843 9000

Answercall Cellular

Telephones PLC
23 Mount Street
London W1

Tel: (01) 499 2476

Cellcall Ltd

5 St Botolph Street
London EC3

Tel: (01) 283 1122

Digital Mobile

Communications Ltd

Station House

Harrow Road

Wembley

Middlesex

Tel: (01) 903 7753

Europa Communications Ltd

Merevale House

Parkshot

Richmond

Surrey TW9 2HW

Tel: (01) 940 9433

Excell Communications Ltd

Excell House

Hale

Altrincham

Cheshire

Tel: (061) 941 7006

Gazelle Group PLC

Pontoon road

London SW8 5BL

Tel: (01) 627 0000

International Communications

Ltd

Unit 19

Commercial Way

Park Royal

London NW10 1YP

Tel: (01) 964 0065

● **Short code dialling.** Frequently called numbers can be stored and recalled using a code (generally two digits).

● **Electronic lock.** Prevents unauthorised use.

● **Received call indicator.** The equipment indicates a call has been received while the user has been away from the vehicle.

● **Hands free operation.** Conversation can take place without lifting the handset.

● **Last number redial.** The previously dialled number can be redialled, by pushing a single button.

Quality

Overall quality is pretty good. However, it relies mainly on the aerial the user has on the car. It's no good using a bent piece of coat hanger wire and expecting first class results. In a high signal area, with the vehicle stationary you'll have a successful call, but start to move, especially through fringe reception areas, and quality will be lousy. There's no doubt, an incorrect, or even a correct but incorrectly fitted aerial will give poor results.

Research carried out by laboratories, cellular operators, and aerial manufacturers has shown the best position for an aerial is on the roof of a vehicle. So, don't expect to be able to use your existing car radio aerial for cellular purposes. If you don't fancy the idea of defacing your brand new Ford Chevalier RS Turbo GX with an ugly brute of a roof aerial, then cellular communication is not for you.

There are alternatives such as an 'on-glass' aerial or an elevated feed aerial. Unless these are properly installed, you may find you've wasted an awful lot of money. Consult the professionals. That does not necessarily mean the people you obtain the mobile equipment from. Although they will usually only sell you the correct equipment for your needs, they may not be as technically aware of all the aerial considerations as they could be.

The Bottom Line

Finally, how much does all this cost? You can't get something for nothing in this world, and what you get out of your cellular communications telephone will depend on how much you put into it. The 'phones themselves will cost you anything from about £1,000 to £2,500 to buy and from £35 to £70 per month to lease, depending on facilities.

Running costs depend on which of the two systems and which features you use. Typical costs (after the initial connection) run at around £25 per month for rental of service, and around 33p per minute of daytime calls.

From these figures, you'll appreciate that cellular communications is presently a company luxury or a rich man's status symbol. If you're stinking rich or a mobile executive and you think you need easier communications to do your job better, cellular communications could be for you. As time goes on and costs come down (which they are bound to do as the market grows) ordinary consumers may be tempted. For us ordinary mortals my advice is to wait for a year and see what happens. Already, prices are falling.

Some of the data used in this article was taken from Cellular Communications 1986 — A Worldwide Report, produced by Mintel Productions Ltd, and is reproduced courtesy of Cellnet.

LIGHTING

THEATRE — BAND — DISCO — CLUB

At MJL we supply a range of stage lighting equipment within everyones budget. With world wide sales we have the backing and expertise to deliver just the system you need to 'Light Up' that Play, Gig or Dance Floor, from Basic 6 channel dimming to 30 channel rock mixing desks. So if you are a lighting engineer, stage manager or rig technician, or simply an amateur Drama group, we're the Professionals.

FOR FREE COLOUR BROCHURES

Write to:

MJL (International) LTD.
45 Wortley Rd., W. Croydon,
Surrey, U.K. CR0 3EB

or Phone:

01-689 4138

A Great Reverb Amp for £74!



Shown — 45w Reverb Amp with Master Volume

Instrumentalists — do you want a great professional sound without paying the earth? An amp that is at home on stage and in the studio? DELTA PHYSICS' range of built and tested modules sound like vintage valve amps, fit into a 2" high rackable case, and weigh less than 5lb assembled. They are designed for problem-free wiring and assembly into a robust, reliable and good-looking unit.

The system comprises 3 modules:

1. P.66 Reverb Preamp £27.50

Innovative new MOSFET circuit gives remarkable valve-like sound for stage or studio. Complete with long spring and all controls. Works on its own or as part of complete amplifier.

2. P.36 Power Amplifier £14.75

45 watts into 4 ohms with valve-like overload due to part-MOSFET circuitry. Tough and reliable with s/c-protected output.

3. P.45 D.C. Supply £13.45

Power for up to 2 x P.36 and 1 x P.66 in slimline package. Toroidal transformer — fused output — easy fixing.

Accessories

C.11 screened control panel — red, blue or black £6.00

C.22 aluminium chassis (prepared as required) £7.75

C.33 mains-switch unit (switch, fuse, pilot-lamp + 3m of cable in one assembly) £4.50

Please add £1.50 p&p + 15% VAT for each order.

For FREE Brochure, phone or write to:

DELTA PHYSICS

52 Codrington Hill, London SE23 1ND
 Tel. 01-690 1512

RUSH ME A BROCHURE, PLEASE!

Name

Address

SPECIAL OFFER!!

BIO-FEEDBACK PARTS SET

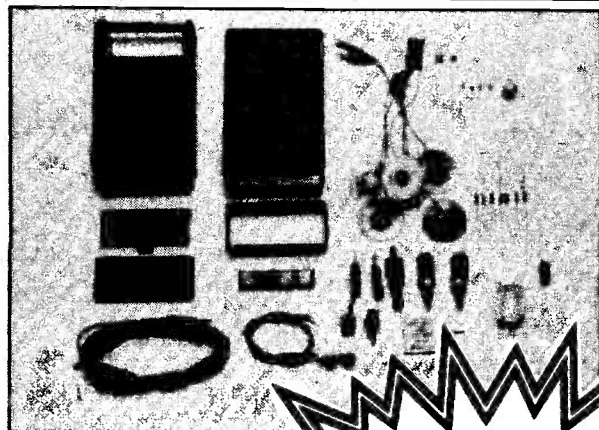

Note: Parts supplied may not correspond exactly to the photograph. Offer while stocks last — order early!

COMPLETE SET
ONLY £13.95
 + 60p p&p

A complete set of parts, including case, professional electrode pads, special conductive gel and full instructions, to make a highly responsive GSR Bio-feedback monitor, as featured in ETI December 1986. By special arrangement, we can offer the complete parts set for ONLY £13.95 + 60p postage (UK only) inclusive of VAT.

* The expansion parts set contains all parts except for the PCB and components given away free with the November and December 1986 issues of ETI.

To order by post, please send the order form (or copy) with your remittance to: ASP Readers Services (RO ET4/7), 9 Hall Road, Maylands Wood Estate, Hemel Hempstead, Herts. Please make cheques payable to ASP Ltd.

Phone ACCESS or VISA only: 0442 211882

Order Code RO ET7. Please supply
 Bio-feedback complete sets at £14.55

Order Code RO ET4. Please supply
 Bio-feedback expansion sets * at £13.55

Name

Address

Or, I authorise you to debit my

ACCESS/BARCLAYCARD No.

of the sum of £ Signed

Please allow up to 28 days for delivery.

THE MIDI INTERFACE

Alan Robinson continues his voyage of discovery in the turbulent sea of the Musical Instrument Digital Interface (MIDI). This month he looks at the confusing array of software codes used by the standard.

Last month I gave a general introduction to the MIDI Interface and described its hardware. In this article I shall investigate the software side of things — the actual meaning of the bytes sent from the transmitter to the receiver. Before diving in to the details, it must be stressed that not all equipment is capable of transmitting or interpreting, all the information the standard covers. Two instruments can only communicate at their lowest common level.

Fortunately, common ground usually covers the basics to the extent that a make A keyboard can drive a make B synth, even if some of its more subtle features do not work properly.

Status And Data Bytes

The bytes transmitted are divided up into two types, called status bytes and data bytes. Status bytes indicate the type of data being transmitted, whereas data bytes contain the data itself. Status bytes are distinguished by having bit 7 set. Data bytes have bit 7 reset. Some of the data uses more than seven bits, so is transmitted as a pair of bytes (low byte first), giving a total of fourteen bits of data.

Information transmitted is sent in batches of bytes called messages. Each message starts with a status byte (with bit 7 set) indicating the type of data about to be transmitted, and then a number of data bytes containing the data itself. However, there is one complication. To speed up transmission there is a feature called 'running status'. Basically, this means a status byte only need be transmitted when it differs from the one at the start of the last message. If a receiver receives data bytes which are not preceded by a status byte, it should assume that the status is the same as last time and the data is more of the same. For example, the transmitter might send information requiring that a chord of three notes be played. This is done by transmitting three 'note-on' messages, but the note-on status byte may be omitted for the second and third messages.

Channel Messages

There are two basic types of message: 'channel' messages, and 'system' messages. Channel messages relate to instrument sounds or voices. They are called channel messages because a transmitter can send out information which is destined for more than one receiver. A sequencer, for example, might control more than one instrument. Each receiver is assigned to a channel number and only responds to messages addressed to it.

MIDI caters for sixteen channels. As far as the user is concerned these are numbered from 1 to 16, but they are actually coded as binary values from 0 to 15. The binary number transmitted is always one less than the user's idea of the channel number — another trap for the unwary. Assignment of channel numbers is covered later. Suffice it to say for now that the channel number is contained in the least significant four bits of the status byte at the start of a channel message. Receivers must examine these four bits to decide whether or not a message is addressed to them, and ignore it if not. Channel messages are further divided into channel 'voice' messages and channel 'mode' messages.

Channel Voice Messages

Channel voice messages are the most frequent. These allow one piece of MIDI equipment (typically a keyboard or sequencer) to make another piece of equipment (typically a synth) to play something. This includes turning notes on and off, but also gives control of pitch bend, and modulation and many other aspects of the sounds produced as well.

Table 1 summarises the channel voice messages. The last four bits of the status byte form the channel number (shown as *n*) and the most significant bit is always 1 to distinguish it from data bytes. The actual function of the status byte is coded into bits 4, 5, and 6. Of the eight possible values of these three bits, seven are used for channel messages: 8*n*, 9*n*, A*n*, B*n*, C*n*, D*n*, and E*n*.

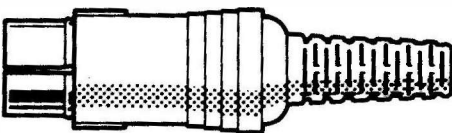

Status Byte Binary	Description Hex	Date Bytes
1000nnnn	8n Note off	1. key number 2. release velocity
1001nnnn	9n Note on	1. key number 2. key velocity
1010nnnn	An Polyphonic key pressure	1. key number 2. key pressure
1011nnnn	Bn Control change (see tables 2-4)	1. control number 2. control value
1100nnnn	Cn Program change	1. program number
1101nnnn	Dn Channel pressure	1. channel pressure
1110nnnn	En Pitch bender	1. pitch bend (LSB) 2. pitch bend (MSB)

Status messages **8n**, and **An** give information relating to individual keys on the keyboard. The first data byte transmitted in all three cases is the MIDI key number. The key numbers range from 0 to 127, so that in theory MIDI can handle keyboards of up to 128 notes, or a span of well over ten octaves.

Middle C is defined to be key number 60 (or 3C in hex), so that key number 0 is the C five octaves below middle C, which at concert pitch has a fundamental frequency of about 8.2Hz. Needless to say it is not used too often! Key number 127 is the G five and a bit octaves above middle C, with a frequency of 12.5kHz at concert pitch. That is not used often either!

Status message **9n** is the 'note-on' message, which is generated when a key is pressed. The first byte transmitted is the key number. The second byte is the key velocity, or how hard it was struck. Many cheaper keyboards are not velocity sensitive, and these transmit a medium value of 64 (40 hex). The exact meaning of the key velocity byte is not defined.

The opposite of the **9n** note-on message is the **8n** 'note-off' message, which is generated when a key is released. This is very similar to a 'note-on' message in that the first data byte transmitted is the key number. The second data byte is the release velocity. As with the key velocity in note-on messages, the release velocity in the note-off message is not precisely defined. Keyboards without velocity sensing again transmit the median value of 64 (40 hex). Every note-on message must be followed eventually by a corresponding note-off message.

There is another potential trap for the unwary with note-on and note-off messages. A note-on message with a key velocity of zero is defined to be a note-off event instead. In this case the receiver has to assume that the release velocity is median value of 64 (40 hex), since this cannot be given. This special case allows note-on and note-off information to be transmitted in the running status mode without re-issuing the status byte, which can sometimes speed things up a bit. Some keyboards will always transmit note-off messages this way though, so beware!

The third kind of individual key related message is the **An** 'polyphonic key pressure' or 'after touch' message. Again the first data byte sent is the key number. The second is the pressure value. The specification says nothing about the relationship between pressure and pressure value sent but in practice a

value of 0 to 1 means virtually none, and a value of 127 means loads of it.

The polyphonic key pressure message is not often used because only the most expensive keyboards have pressure sensing for individual keys. A more common and closely related message is the **Dn** status 'channel pressure' message. This is the same except that the key number is not transmitted, so the message contains only one data byte. The data represents the force applied to all the keys.

Status message **En** is for the pitch bender. In this case the data transmitted is a 14-bit number, transmitted as two data bytes containing seven data bits each. The median value in this case is 8192, or 2000 in hexadecimal, which is transmitted as the three hexadecimal bytes, **En 00 20**. This value corresponds to a pitch bend of zero. Again the MIDI specification is not specific about the relationship between the pitch bend value transmitted and the amount of pitch bend it corresponds to. Often instruments only have seven bit resolution, with the least significant byte containing only dummy information, although fourteen bits of data are always transmitted.

The two different kinds of key pressure message and the pitch bender message are unlike the note-on and note-off messages in that they are continuously variable values which must be repeatedly transmitted many times. The MIDI specification makes no mention of the rate they are transmitted at. This is up to the equipment designer. In practice, these messages are only transmitted when the pressure or pitch bend value changes so transmission rate depends on the resolution of the sensors, the rate they are scanned, and their use at the time.

Status message **Cn** is the 'Program Change' or 'Patch Change' message. These messages contain a single data byte which selects one of 128 'programs' or 'patches', numbered from 0 to 127. Each program is a complete set of control values that define a particular instrument voice or sound. Program change commands instruct the receiver to switch to the new voice selected by the data byte, assuming of course this is something the receiver is capable of. Whenever a new program is selected on an instrument's controls, a program change message is transmitted.

The final channel voice message is the **Bn** 'control change' message used to transmit control parameter changes other than the key pressure and pitch bender values. Each control change message contains two

Number	Function
0	Continuous Controller 0 (MSB)
1	Continuous Controller 1 (MSB)
2-31	Continuous Controllers 3-31 (MSBs)
32	Continuous Controller 0 (LSB)
33	Continuous Controller 1 (LSB)
34-63	Continuous Controllers 3-31 (LSBs)
64-95	On/Off Switches (0 = off, 127 = on)
96-121	Undefined
122-127	Reserved for Channel Mode message

Table 2 Assignment of control numbers

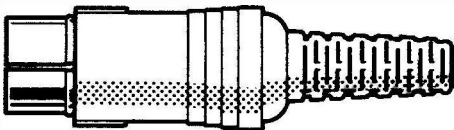

data bytes, the first giving the control number and the second the control value. Table 2 summarises the uses of the control numbers according to the MIDI specification.

Controller numbers 0 to 63 are assigned to 32 'continuous' controllers such as potentiometer inputs. These controllers can have 14-bit resolution if required. One controller number in the range 0-31 is assigned to the most significant byte (MSB), and another in the range 32-63 is assigned to the least significant byte (LSB). The LSB for a controller may or may not be transmitted or received, depending on whether or not seven bit resolution is enough for its function, and entirely at the discretion of the manufacturer.

Controller numbers 64 to 95 are assigned to switches, which can be either on or off. To turn a switch off, a value of 0 is sent, and to turn it on, a value of 127 is sent. How a receiver interprets any other value (1-126) is between is not defined.

Controller 1 is assigned to the modulation wheel. For the others the MIDI specification simply says they may be assigned by manufacturers as they please. An earlier, now out of date, MIDI specification assigned controller 0 to the pitch bender, but this is now done by **En** status messages.

This vagueness about the assignment of the controllers is unfortunate, but something of an unofficial standard has emerged. Table 3 summarises these commonly used assignments.

Channel Mode Messages

Control numbers 122-127 are assigned to an entirely different class of message: Channel 'mode' messages. These are used to define the operating mode of the voices for a particular setup. They are summarised in Table 4. Control number 122 can be used to disconnect an instrument's keyboard from its sound generating circuits so that the keyboard data goes only to the MIDI OUT socket, and the sound generators are only controlled by the MIDI IN data received. This is an optional feature. Not all instruments are capable of being controlled in this way.

Control messages 123 to 127 are all 'All notes off' commands, 123 being different in that it serves no other purpose. However, the MIDI specification says that in no case should these be used to turn off notes previously turned on by 'note on' messages. These should be turned off by specific 'note off' commands. Since there is no possibility of notes otherwise being left on, 'All notes off' commands may safely be ignored. Readers puzzled by this strange aspect of the specification may rest assured they are not alone!

Each instrument is assigned by the user to a channel number, called the instrument's 'Basic Channel', using its own controls. Control messages 124 to 127 control the operating mode of the instrument's voices. These messages control two switches, the **OMNI ON/OFF** switch and the **POLY/MONO** select switch.

OMNI ON, POLY mode. In this case voice messages are received on all channels and routed to the voices according to the instrument's own internal polyphonic assignment algorithm. Voice messages are only

Number	Function
1	Modulation Wheel
2	Breath Controller
4	Foot Controller
5	Portamento Time
6	Data Entry Knob
7	Main Volume
64	Sustain Pedal
65	Portamento
66	Sostenuto
67	Soft Pedal
96	Data Entry Increment
97	Data Entry Decrement

Table 3 Common use of controllers

Message	Status	Data
Local control off	Bn	122,0
Local control on	Bn	122,127
All notes off	Bn	123,0
Omni Mode off	Bn	124,0
Omni Mode on	Bn	125,0
Mono Mode on	Bn	126, No. of channels
Poly Mode on	Bn	127,0

Table 4 Channel mode messages

transmitted on the basic channel.

OMNI ON, MONO mode. In this case voice messages are received on all channels but only routed to one voice, monophonically. Voice messages for one voice only are transmitted on the basic channel.

OMNI OFF, POLY mode. In this case voice messages are only received and transmitted on the basic channel, and received messages are assigned to voices according to the instrument's own polyphonic algorithm.

OMNI OFF, MONO mode. In this case voice messages are received on a number of channels, and each receive channel is assigned to one voice. The number of channels it receives on is given in the last data byte of the 'mono select' message it receives. If, for example, an instrument assigned to basic channel 5 received a MONO mode message specifying four channels, it would receive voice messages on channels 5, 6, 7, and 8 (four channels starting from its basic channel). Each of the four channels would be assigned to one of its voices, assuming of course it has four voices to assign. A special case is where the MONO mode message specifies zero as the number of channels to receive on, when it will assign itself to as many channels as it has voices, again starting from its basic channel number. An instrument in this mode combination will transmit voice messages for a number of voices on the same channel.

Not all instruments are capable of operating in all these modes. Some are assigned to fixed basic channel numbers the user has no control over. On power up, all instruments should default to **OMNI on, POLY mode**. It is also normal for an instrument to initially assign itself to basic channel 1 until told otherwise by its operator.



System Messages

System messages are unlike channel voice and mode messages. They are not related to channels and do not have channel numbers included in the status byte. Particularly important, the system messages include the codes that are used to synchronise sequencer timing so a synth and a drum machine can play along together without any voice messages being transmitted between them. Each sequencer is programmed separately and only the timing codes are needed to make them play together.

System messages are distinguished by status bytes with the four most significant bits set (Fn). They are divided into three types, 'System Common', 'System Real Time', and 'System Exclusive'. Table 5 summarises the system messages.

System exclusive messages are meant for a particular manufacturer's equipment and can contain any data the manufacturer chooses to put in. The status byte is F0, followed by a number of data bytes, the first of which is the manufacturer's ID number. ID numbers are allocated for registered manufacturers by the MIDI Association (for a price!).

The message is terminated by an F7 'end of exclusive' status byte, or any other status except real time codes F8 to FE. An instrument which does not

few instruments actually implement the song position pointer feature.

There are six system 'real time' status codes. These do not have associated data bytes, and with the exception of system reset code FE can be transmitted at any time, even in the middle of other messages. Another little pitfall for the unwary! This aspect of the specification is to allow greater timing accuracy in their transmissions, though this is only really important in the case of the timing clock F8. 'Running status' is not changed by the system timing codes.

F8 timing clocks are sent at the rate of 24 clocks per quarter note or crochet, and are used to synchronise sequencers and instruments with built-in sequencers, a synthesiser sequencer and a drum machine, for example. Timing clocks must be ignored until an FA 'start' or FB 'continue' code is received. This is important to note, because some instruments continuously transmit timing clocks regardless of whether their sequencers are running or not. FC 'stop' codes stop the sequence running.

The 'start' code starts the sequence from the beginning every time, whereas the 'continue' code starts it from where it was last stopped, or if the 'song position pointer' feature described above is used, from where the pointer was set to.

FE codes are for 'active sensing'. This means some transmitters continuously produce this code when nothing else is being transmitted, just so the receiver knows the transmitter is still active and plugged in. The transmitter should transmit this code at least every 300ms (and preferably faster, say every 100ms to 250ms) when there is no other activity on its output. A receiver which does not receive any input for at least 300ms (or perhaps 400ms to be on the safe side) then knows that the transmitter is not longer active and can turn off its voices and return automatically to stand-alone operation. However, not all transmitters produce this code so receivers should not assume its presence until an FE code is actually received in the first place.

The remaining real time code is 'system reset'. This is used to reset the system to the condition of just having been switched on. It should be used sparingly, if ever at all. Instruments must not send out this as part of their cold start routines because this could result in two connected back to back forever resetting each other when switched on and never actually getting to the stage where they could be used!

In some cases it does not seem to make much sense for an instrument to completely reset itself just because a MIDI command has told it to, especially in the case of something like a computer used as a sequencer. Does the user really want it to completely re-boot the sequencer software and quite possibly lose its programmed sequence because its MIDI IN socket told it to? Perhaps the sequencer software disk is no longer in the drive and the computer can then no longer even be a sequencer without changing disks. Not very helpful! In this case a decidedly warm start would make more sense than a cold start. This is one aspect of the MIDI specification that should perhaps be given a somewhat loose interpretation!

Table 5 System messages

	Status	Data	Function
Exclusive	F0	ID data data	Data specific to a particular manufacturer's equipment (any number of data bytes)
Common	F1	-	Undefined
	F2	LSB, MSB	Song Position Pointer
	F3	Song No.	Song Select
	F4	-	Undefined
	F5	-	Undefined
	F6	none	Tune Request
	F7	none	End of Exclusive
Real time	F8	-	Timing Clock
	F9	-	Undefined
	FA	-	Start
	FB	-	Continue
	FC	-	Stop
	FD	-	Undefined
	FE	-	Active Sensing
	FF	-	System Reset

recognise the ID code at the start of a data stream ignores the data until another status byte indicates the end of the exclusive data.

There are four system common messages. F3 status messages are 'song select' messages, which choose between songs, numbered 0 to 127, and F6 'tune request' is used to start analogue synthesiser automatic oscillator tuning. F2 status messages are 'Song Position Pointer' messages. These messages are closely related to the real time 'timing clock', 'start', 'continue', and 'stop' codes, and allow the user to start or continue a sequence from a specified point in the song.

The data given is a fourteen bit value coded as two bytes, the least significant being sent first. It indicates a time within the song in multiples of sixteenth notes, or semiquavers, from the beginning of the song. Very

ETI

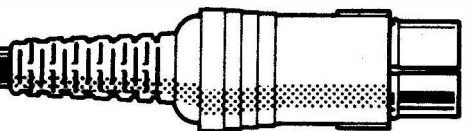

GEIGER RATEMETER AND COUNTER

Colin Seymour describes a cheap, practical radiation monitor which can be used both for instant dose-rate checks and for long-term, accurate counting.

With the present concern about nuclear radiation, especially since the Chernobyl disaster and the sinking of a nuclear submarine, it is not surprising that many people have been trying to obtain Geiger counters or other radiation monitoring devices. Sales of portable detectors have increased and ETI and other magazines have received countless requests for information on radiation measurement and reprints of past articles describing detecting equipment.

We published a basic circuit for a Geiger ratemeter soon after the Chernobyl accident (see p.17, ETI July 1986). Since then several other electronics journals have published ratemeter designs of various levels of sophistication.

The design presented here is the result of a considerable period of development and offers excellent performance and versatility at low cost. It consists of two units, a self-contained Geiger ratemeter and a separate pulse counter which plugs into the ratemeter and uses the same detection circuitry. On its own, the ratemeter is a compact, lightweight instrument which can be used to determine the approximate level of radioactivity being emitted from a source. This is adequate for most practical measurements, but where small changes in background radiation are being compared the accuracy provided by a meter display may not be good enough. Using the counter as well, it is possible to record the total number of pulses detected over long periods of time and so make accurate

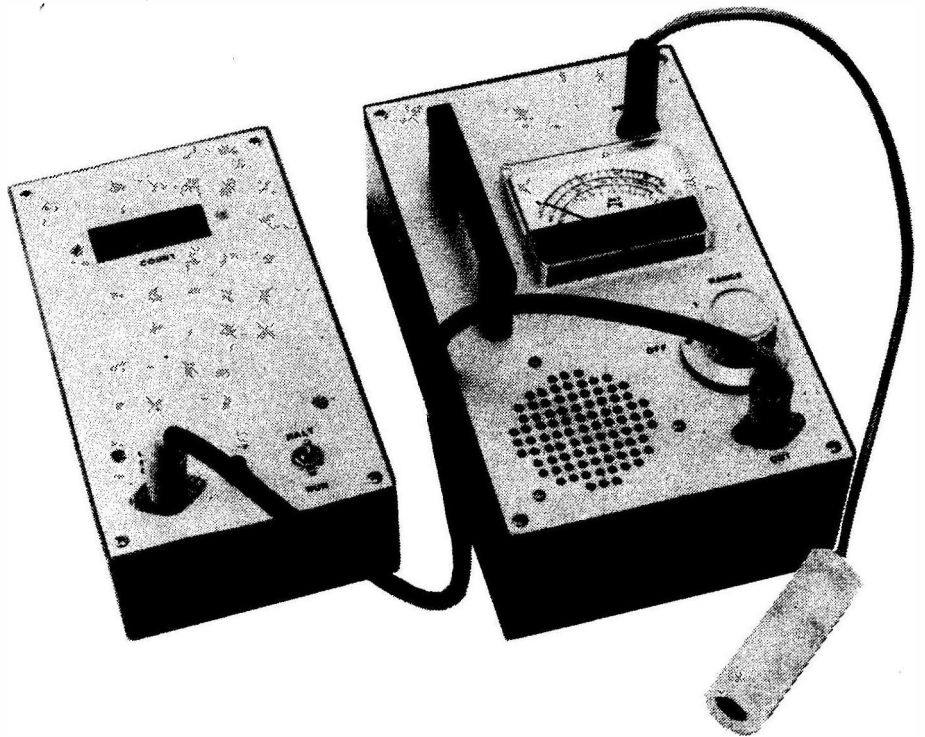

comparisons.

The ratemeter has three count ranges, from 18mR/h (milliRem/hour) FSD up to 2.5 R/h (Rem/hour) FSD. A loudspeaker is provided to give an audible indication of count rate (the traditional 'click-click' sound). The detector is a Geiger-Muller tube which is housed in a small plastic case and which attaches to the ratemeter by means of a length of cable and a plug. The unit is powered by four 1.5V cells and the circuit has been carefully designed to ensure as low a current consumption as possible, allowing the ratemeter to be used 'in the field' for long periods of time.

The separate counter has a four-digit LCD display and indicates the number of pulses detected by the ratemeter within a given time. No timing circuitry was considered necessary — the user simply starts the count when ready and then times it using a watch or timer. When the timing period is complete, the counter is stopped and the total number of pulses noted. A useful feature is the halt switch which freezes the display but allows the count to continue undisturbed. In this way, the count can be taken over a period of, say, ten minutes while the progress of the count can be noted at intervals of one minute or whatever by halting the display long enough to

note the count figure down. The counter draws its power from the ratemeter using the same lead that transfers the pulse information, and even with the two units in operation the battery consumption is low enough to allow long periods of uninterrupted use.

The complete instrument costs under £100 to build (including the Geiger-Muller tube) and uses readily-available components. It is simple to calibrate, straightforward in operation and ideal for use in a wide range of applications from teaching physics through to checking food and drink.

The Geiger-Muller Tube

The first decision to be made when designing a piece of radiation monitoring equipment is the type of detector to use. Most detectors rely on the fact that radiation causes ionization when it interacts with matter, removing electrons from atoms and so creating charged particles. The ions will be attracted to an electric field placed in their path and the resulting fluctuation in the strength of the field can be detected and displayed. This is the

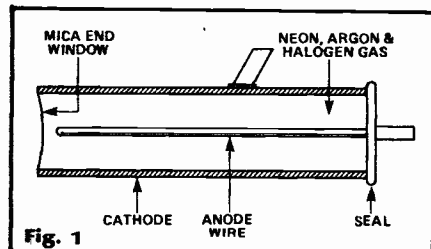

principle on which ionisation chambers work, but the output signals they produce are very small.

If the strength of the electric field is increased, the ions accelerated by it gain enough energy to ionise more gas atoms in collisions. This results in an avalanche of electrons and so-called gas amplification of the original ion pulse. This effect is used in the Geiger-Muller tube (Fig. 1). It consists of a wire anode concentric with a metal cylinder and is filled with gas at less than atmospheric pressure. When the tube is fed from a high voltage supply, a strong field will be present around the anode wire and avalanching will take place whenever ions are present. Ultraviolet photons are created which cause the avalanche effect to spread by the photoelectric emission of electrons. The result is that the tube presents a low impedance to the high voltage

supply and pulls the anode voltage down, creating a large, negative-going pulse which is easy to couple into electronic circuitry.

One problem with this arrangement is that, once initiated, the avalanche may be sustained by slower positive ions which reach the cathode and knock out secondary electrons. This is overcome by means of a 'quenching' agent which absorbs the energy from the positive ions and so prevents further avalanching. In the Geiger-Muller tube specified for this project, the Mullard ZP1400, the quenching agent is a halogen gas.

The mica end window is very thin and bows inward due to the reduced pressure inside the tube. It allows beta radiation to enter the tube and, if sufficiently thin, will also admit alpha particles. Special tubes with a thinner window can be used when alpha particles must be detected. An example of this type is the Mullard ZP1401. Gamma rays are detected in the gas and by scattering electrons out of the cathode material into the gas. Other ionising radiations may also be detected.

The Circuit

The GM tube requires a 500V supply for operation and this is generated by a switching power supply from the 6V battery supply. The current drawn by the tube is only a few microamps so very little power needs to be generated. To minimise battery drain, the transformer is driven with short pulses at long intervals, causing it to generate a characteristic exponentially-decaying 'ring'. The stage using Q1 and Q2 (Fig. 2) is an astable pulse generator. Q3 amplifies and further shortens the

pulse and Q4 drives the transformer.

The stepped up output voltage from the transformer is further increased by the voltage doubling circuit, developing the bias for the GM Tube.

Radiation causes output pulses to appear across the GM Tube when the gas around the anode becomes ionised. The pulse has a rapid rise and a slower decay caused by the stray capacitance in the circuit. Q5 squares the pulse and Q6 further squares and amplifies the signal. The output of Q6 drives the display and output circuits and is also coupled to Q4, the HT driver stage. This feedback causes each GM pulse to provide additional HT drive. Consequently, the output of the GM bias supply is maintained when the GM tube current drain increases due to ionisation by radiation. This method has been used successfully in other designs without any oscillator, relying on the background counts to drive the HT generator. However, if there were no charge on the HT capacitors, the supply would have to be primed to start it up. Hence the provision of the 'idling' oscillator, Q1, Q2.

Each pulse is made audible by Q7 which drives a miniature loudspeaker. The clicking gives a satisfyingly 'authentic' direct indication that the GM tube is detecting background radiation, and an immediate indication when radiation increases. The current amplifier Q8, Q9 charges capacitors for a ratemeter display. Each pulse adds to the charge on a capacitor which leaks away through the indicating meter. The meter gives a reading proportional to the rate of the pulses and is switched to give ranges of different

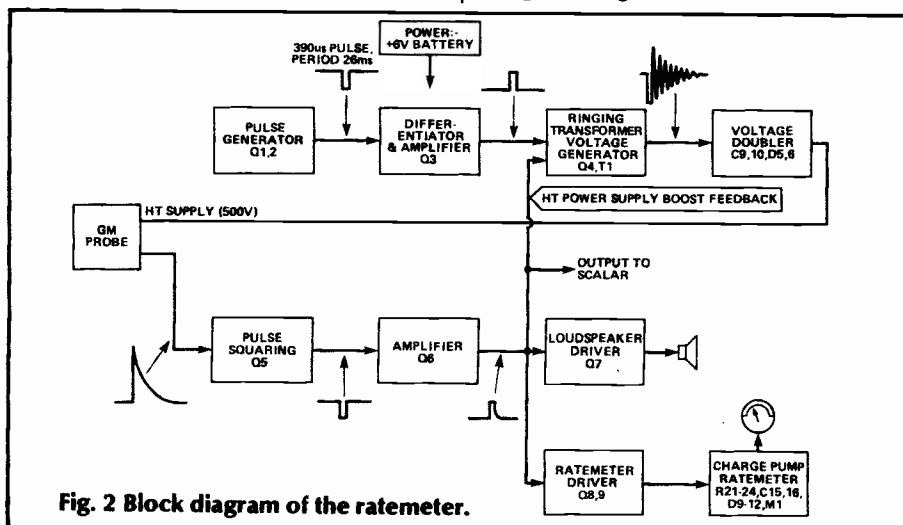

Fig. 2 Block diagram of the ratemeter.

PROJECT: Ratemeter

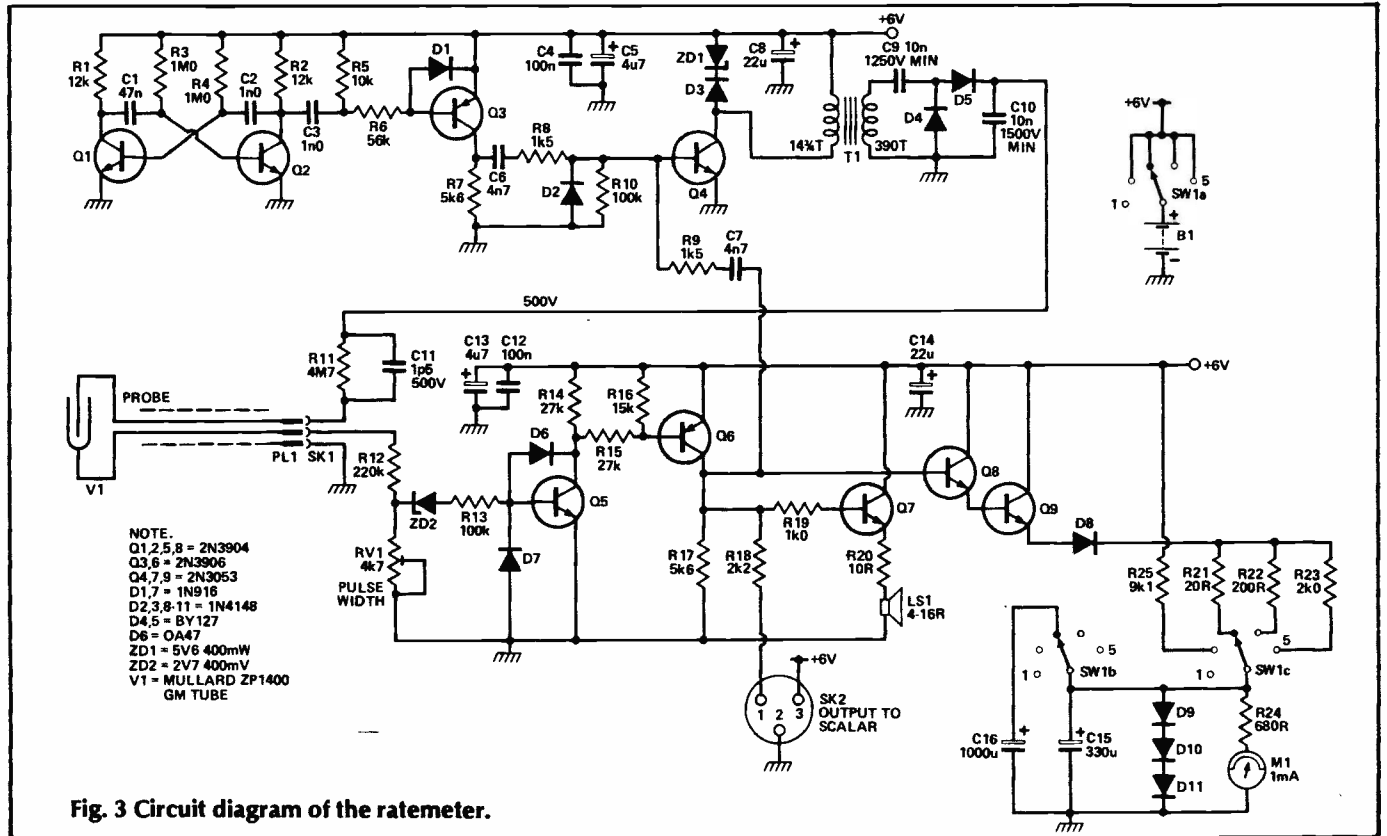

Fig. 3 Circuit diagram of the ratemeter.

HOW IT WORKS

No ICs are used in the detector unit as there is not much need for them and discrete transistors are more resistant to damage by radiation than ICs — although we hope that the user does not encounter such levels of radiation!

The range switch SW1 also acts as an on-off switch for the battery. Due to the low current drain, the unit can be left on to monitor for long periods. A further position on the switch is used for battery checking.

Q1 and Q2 form a conventional astable multivibrator with asymmetrical time periods. C3 shortens the pulse which is squared and amplified by Q3 while D1 prevents Vbe breakdown. C6 and R8 shorten the pulse further to about 25 us. Q4 drives the primary of T1, the current being limited mainly by the inductance of the primary. To provide sufficient inductance, a pot core with a high AI was used in the prototype (Mullard FX2241).

Due to the large step-up ratio, about 250 V peak-to-peak is developed in the secondary and appears across C9 and D4. Voltage stabilisation is achieved by the flyback limiting action of Zener diode ZD1 and rectifier D3.

Voltage doubling occurs as the voltage on C9 is added to that rectified by D5, so 500V appears across C10. These capacitors are generously rated for reliability and must have very low leakage. R11 limits the GM tube current as specified by the data sheet, and C11 helps to shorten the decay of the pulse. The decay time of the pulse is also dependent on the capacitance of the cable connecting the GM tube to SK1. R12 and RV1 attenuate the 100 V or so peak pulse and set the level for the pulse-squaring stage, Q5, reducing the pulse length to 25 us. D7 prevents Vbe breakdown and D6 prevents Vcb breakdown in the vicinity of the 100 V pulse. D6 also limits charge storage which is why it must be a Germanium or Schottky type. ZD2 raises the threshold voltage to a convenient level.

Q6 further amplifies the pulse and enables the distribution of a CMOS-compatible signal to the external socket, the HT feedback input at C7, the loudspeaker driver Q7 and the meter driver Q8/9. D8 prevents Vbe breakdown in Q9.

R21-23 are switched to change meter sensitivity. R24 plus the meter resistance (300 ohms) should be a total of 1kΩ (to within about 2%) to make a 1V FSD meter at 1 mA full load. R24 would have to be changed if a meter with a different resistance were used. D9, 10 and 11 protect the meter from surges. C16 provides additional smoothing capacity on the lowest count rate range.

R21-23 are switched to change meter sensitivity. R24 plus the meter resistance (300 ohms) should be a total of 1kΩ (to within about 2%) to make a 1V FSD meter at 1 mA full load. R24 would have to be changed if a meter with a different resistance were used. D9, 10 and 11 protect the meter from surges. C16 provides additional smoothing capacity on the lowest count rate range.

sensitivity. The capacitance helps to smooth out the variations caused by the random arrival of pulses, especially at low levels.

The pulse is also made available to external circuitry, such as the scalar/counter, by means of an output socket which also carries the supply voltage.

The HT supply and output circuits take large current pulses from the supply, but the duty cycle is very low over the normal range of operation so the standing current drain is also very low. Capacitive decoupling of the

supply prevents malfunction due to the current spikes. The current drain is 0.62 mA with normal background radiation, rising to a few mA on exposure to radiation sources.

Construction

The majority of the components are mounted on two PCBs, a main board which carries the bulk of the circuitry and a smaller board which carries the ranging circuitry and bolts directly onto the back of the meter terminals. The remainder of

the components are attached directly or indirectly to the front panel, with the exception of the battery pack which is secured in the bottom of the case.

The PCBs are double-sided with tracks on one side and a ground plane on the component side. The use of a ground plane is highly recommended for the main board because this helps to isolate the HT supply pulses from the GM tube pulse amplifier and reduces radiation of RF interference from the HT supply. It also helps to reduce sensitivity to spurious

pickup from mobile radio transmitters and other sources which might interfere with the readings. The main board should be of fibreglass, as any leakage current is liable to excessively load the HT supply.

The ground plane on the prototypes was created simply by leaving the reverse side of the boards un-etched. This removed the need to make up a set of ground-plane foil patterns. Boards supplied by our PCB Service will be made in a similar way, so the component lead holes must be isolated from the ground plane using a counterbore tool or drill, and plenty of clearance to the ground plane should be left around the 500V HT circuitry.

None of the components used

present any handling problems so there is no need for any precautions. Begin by soldering into place the passive components (resistors, capacitors, etc) then move on to the diodes and finally the transistors. Take the usual care with the semiconductors and the tantalum capacitors, all of which must be installed the right way around if the circuit is to work correctly. Note that there is no 0V rail on the track side of the main board and that grounded leads must be soldered to the ground plane on the top side of the board.

The coil assembly, T1, cannot be completely assembled at this stage because its turns ratio must be adjusted as part of the calibration procedure. The

secondary is wound first and consists of about 390 turns of 42-48 SWG enamelled copper wire. This should be wound in successive layers of 50-60 turns with an insulating sheet of paper or thin plastic tape between each layer. An initial primary winding of 30-38 SWG enamelled copper wire is then added, consisting of as many turns as will fit on the bobbin in one layer. The number of turns in this winding will later be adjusted to give the correct output voltage. Temporarily fit the coil assembly onto the PCB and solder the leads into place.

The prototype was constructed in a plastic box with an aluminium front panel. The size of the box was determined largely by the size of several key components,

Fig. 4 Component overlay for the main board of the ratemeter.

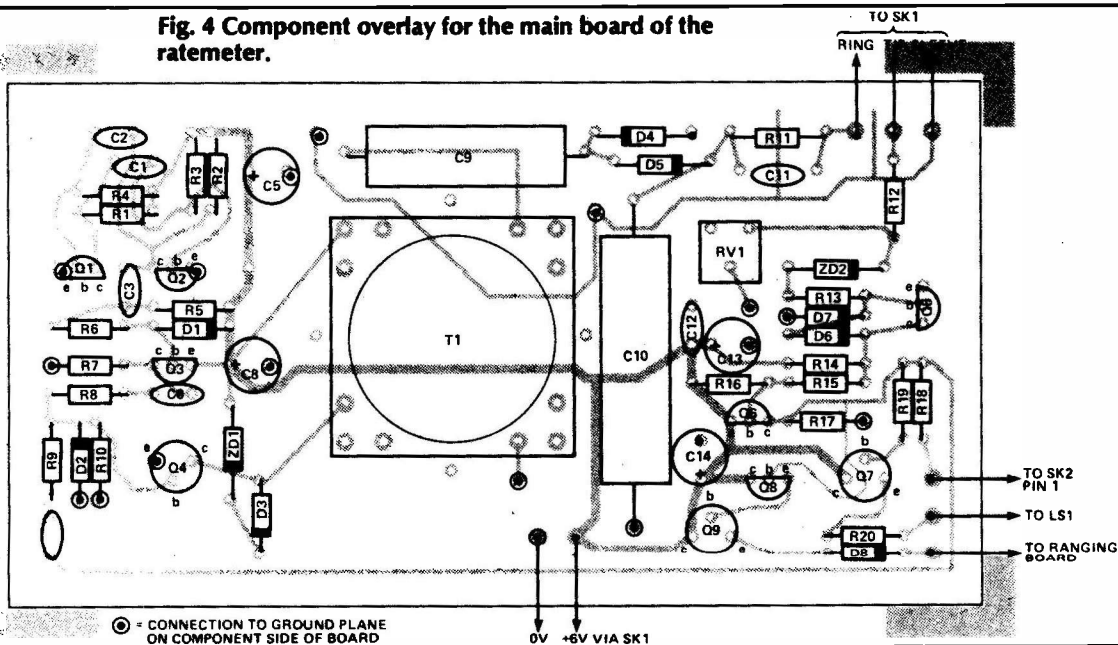

PARTS LIST — MAIN BOARD

RESISTORS

R1, 2	12k
R3, 4	1M0
R5	10k
R6	56k
R7, 17	5k6
R8, 9	1k5
R10, 13	100k
R11	4M7 0.5W
R12	220k
R14, 15	27k
R16	15k
R18	2k2
R19	1k0
R20	10R
RV1	4k7 miniature enclosed horizontal preset

CAPACITORS

C1	47n ceramic
----	-------------

C2, 3

C4, 12	1n0 ceramic
C5 13	100n ceramic
C6, 7	4u7 10V tantalum
C8, 14	4n7 ceramic
C9	22u 10V tantalum

C10

C11	10n 1500V (minimum) polyester, polycarbonate, polystyrene or mylar
	10n 1500V (minimum) polyester, polycarbonate, polystyrene or mylar
	1p5 500V (minimum) ceramic

SEMICONDUCTORS

Q1, 2, 5, 8	2N3904
Q3, 6	2N3906
Q4, 7, 9	2N3053
D1, 7	1N916
D2, 3, 8	1N4148
D4, 5	BY127
D6	0A47
ZD1	5V6 400mW
ZD2	2V7 400mW

MISCELLANEOUS

T1	Mullard FX 2241, core grade A13 (minimum Al = 5815) with clips and tagboard. No trimming core.
	PCB; 30-38 SWG and 42-48 SWG enamelled copper wire for T1.

notably the meter and the loudspeaker which were both purchased ex-equipment in order to keep costs down. Constructors using different sizes of meter and loudspeaker may prefer to use a larger or smaller case. The main PCB was designed so that it would fit neatly into the guide slots of the prototype case, but there is no reason why it should not be mounted on stand-off pillars should a different type of case be used.

The meter, the switch, the loudspeaker, the GM tube socket and the count-output socket were all mounted on the front panel, but it may be preferable to mount some of these components (the two sockets, for example) on the sides of the case. Some sort of handle will also be required, and it is well worth experimenting with the position of this and of the other major components in order to achieve the best distribution of the weight. The complete unit is very light, but it will be far more comfortable to use for long periods if it is well balanced.

The interwiring of the major components is shown in the overlay diagrams. The only difficult item is the switch which has quite a number of wires running to and from it and must also have some of its contacts linked. Note that R25 is mounted between two of the switch contacts. The 6V battery pack can be mounted in the bottom of the case by any convenient means. In the prototype, it was bolted to a spare piece of copper-clad board which was cut so that it would fit into the PCB guide slots.

The probe should be housed in a tubular plastic container with a detachable end cap. The dimensions aren't critical and it should be possible to find something in the kitchen or the medicine cabinet that will do the job. A hole is needed in the bottom of the container to carry the screened cable and a larger hole should be cut in the cap to enable beta particles (and alpha particles if you are using the ZP1401) to reach the GM tube. The lower hole should be fitted with a rubber grommet while the upper hole must be covered with a wire mesh (the type used in tea strainers is ideal) in order to project the fragile end window of the tube.

A new GM tube should be purchased to eliminate any doubts about its efficiency. It will come fitted with a protective plastic cap which should be left on until it has

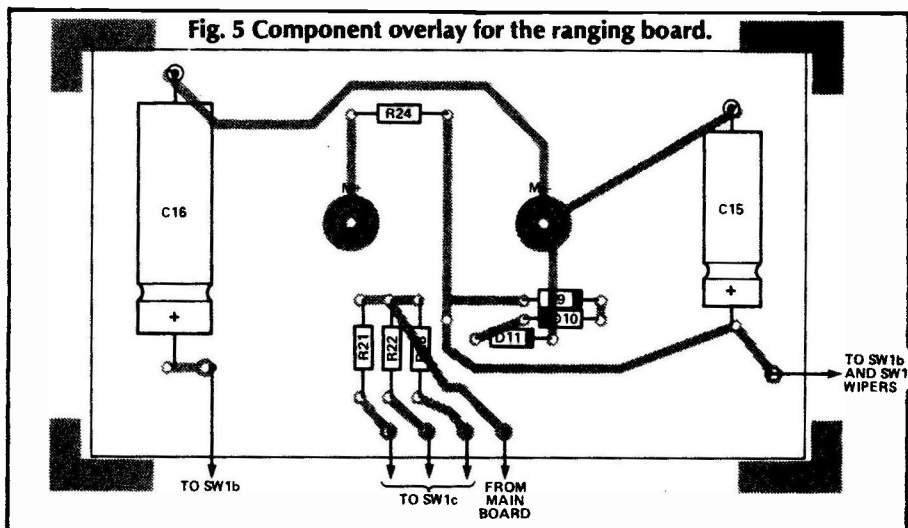

PARTS LIST — RANGING BOARD AND CASE

RESISTORS

R21	20R 1%
R22	200R 1%
R23	2k0 1%
R24	680R (or 1k0 minus meter resistance)
R15	9k1 5%

CAPACITORS

C15	330u 10V tantalum
C16	100u 10V tantalum

SEMICONDUCTORS

D9, 10, 11	1N4148
------------	--------

MISCELLANEOUS

B1	4 x 1.5V AA cells in holder
LS1	4-16R miniature loudspeaker
M1	1mA meter

PL1	movement
SK1	¼" stereo jack plug
	¼" stereo jack socket
SK2	5-pin 180° DIN socket
SW1	3-pole 5-way rotary switch (or 4-pole 6-way MAKKA switch with adjustable end stop, one pole unused)
V1	Mullard ZP1400 Geiger-Muller tube (or ZP1401 — see text)
	PCB; case; handle; knob for SW1; 2-core screened cable, plastic tube with cap, fine wire mesh, mounting foam and rubber grommet, all for probe; connecting wire, nuts, bolts, etc.

been wired to the cable, and drawn into the container cushioned in a foam plastic wrapping. The anode pin is connected via a push-on clip which is supplied with the tube. Take care not to touch the end window with anything when you fit the cap.

Ideally the GM tube should be mounted in low background count materials, but the plastic materials used were found to make no significant difference to background count. The probe assembly should be kept clean and there must be no solder splashes. The box that the GM tube comes in may be adapted with its foam packing as a storage box for the finished probe.

Calibration

The GM tube supply voltage should be 500V ±25V, as measured by a 5% instrument. This

is achieved by adjusting the primary turns of T1. Connect the ratemeter to its battery pack and switch on. If the circuit waveforms are present as shown in Fig. 2, the HT voltage can be checked. This will require an oscilloscope with a 1V/cm range, 1Mohm input, and a 10Mohm x 10 probe. A further x 10 probe must be made from two 33 Mohm and one 22 Mohm resistors in series, or one 90 Mohm 500V resistor. The high impedance enables the oscilloscope to display the voltage when the probe is touched to the HT supply. Even so, because of the low current available the HT capacitor soon discharges, so the probe must be briefly tapped on the HT output while observing the oscilloscope. The effective multiplication is 100 times, so a 5 cm deflection is required. If the HT voltage is out of limits, the primary winding must be rewound. The number of turns

PROJECT: Ratemeter

required will be equal to:

$$\text{original HT voltage} \times \frac{\text{original no. of primary turns}}{500}$$

The primary of T1 should be re-wound to the correct value and replaced on the PCB. Check the voltage again to make sure that it falls within the specified limits, then secure the coil assembly to the PCB using cable ties passed through the holes provided.

Next, the trimmer RV1 should be adjusted so that the output pulse at Q6 collector is 25 us wide at 50% peak to peak. This standardises against variations in GM tube load capacitance.

Now the ratemeter calibration can be considered. The prototype scale (Fig. 7) was calibrated by setting various count rates using an object with radium paint, and referring the count rate to the dose rate graph given in the GM tube data sheet. A range of points were plotted for range 1, giving a curved graph. The output current characteristic calculated for the output circuit showed a similar curve. The non-linearity (due to non constant charging current) can be fitted to the measurements by establishing a highest reading on each scale, and multiplying the rate by a scale factor for each other current value. On range 2 and 3, extrapolation was necessary due to the undesirability of obtaining more powerful sources. Note that the tube specification is limited to 1 R/hr, whereas Range 3 scale ends at 2.5 R/hr.

The method will undoubtedly include sizeable errors. More accurate calibration for a particular counter and probe will require a precise radiation dosimetry set-up with calibrated standard radiation sources. This will only be available

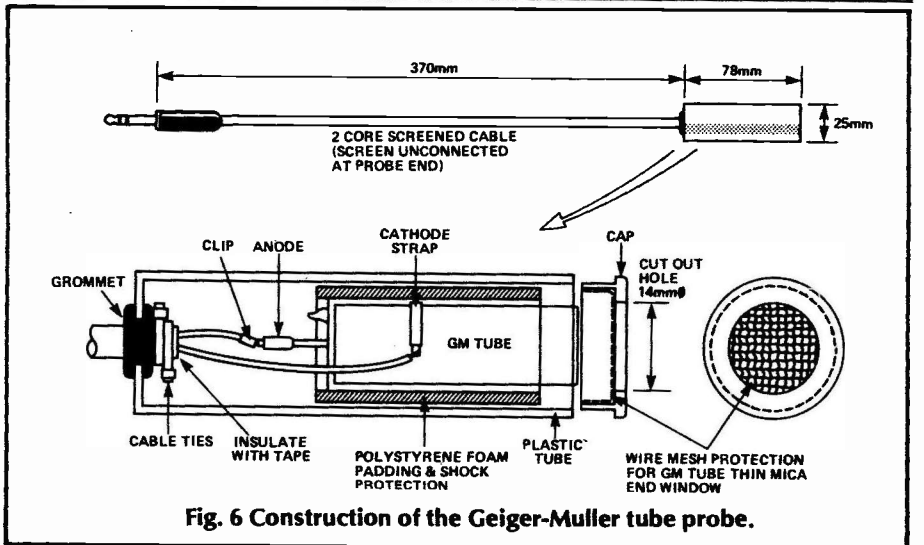
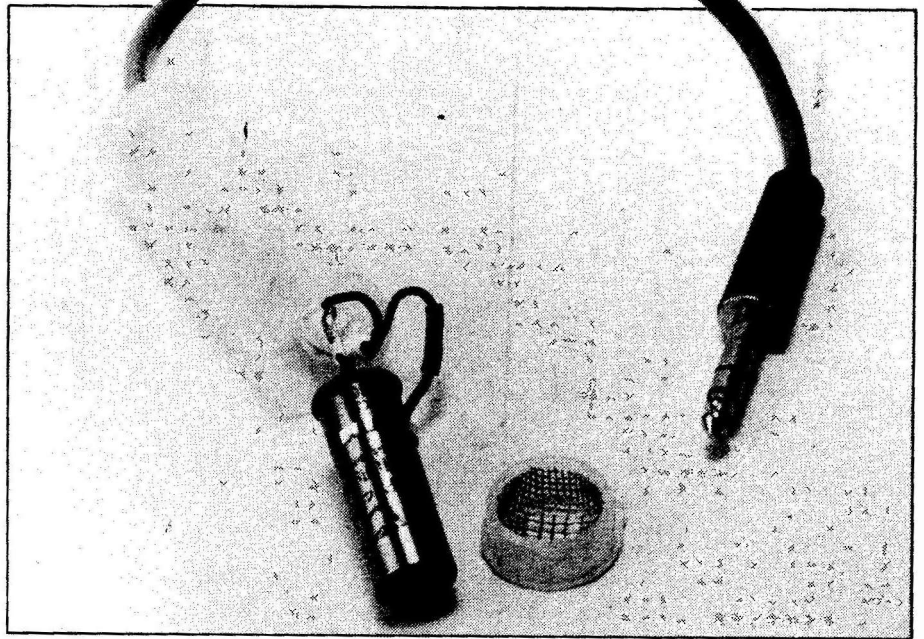

Fig. 6 Construction of the Geiger-Muller tube probe.

to a few specialists. Also, sensitivity can be expected to vary depending on the type of radiation and its energy. However, if the user's main concern is to minimise exposure to radiation then

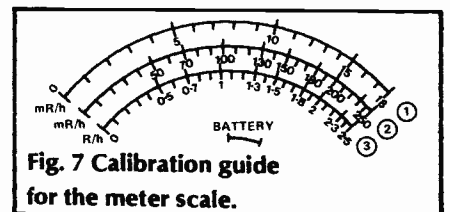

Fig. 7 Calibration guide for the meter scale.

BUYLINES

The resistors, the semiconductors and most of the capacitors are popular types and can be obtained from any number of our regular advertisers and other component suppliers. High voltage capacitors are available from STC Electronic Services (Tel (0279) 441 687), Electrovalue (Tel (0784) 33 603) and MS Components (01-670 4466) among others. Many of the types they stock offer far higher voltage ratings than are needed here, but make sure that the type you buy will fit on the PCB! STC also stock the FX2241 pot core and we suspect that Electrovalue will have an equivalent somewhere among their vast range. Almost any 1mA panel meter should do for M1, but if you want

to use the PCB layout without modifications you must choose a type with 1" (25.4mm) spacing between the terminals. The ZP1400 Geiger-Muller tube (which is sensitive to beta and gamma radiation) and the ZP1401 tube (which also senses alpha particles) can both be obtained from Alrad Instruments Ltd, Turnpike Road Industrial Estate, Newbury RG13 2NS, tel (0635) 30345. As a guide, the latest prices we have for these two tubes are £37.50 and £40.50 respectively plus VAT, but you should check before ordering in case these have changed. The PCBs are available from our PCB Service — see page 56.

measurements are likely to be relative anyway. If a piece of meat has twice the background level of radiation then you would probably not want to eat it regardless of what the measured level in Rems is. In the same way, many radioactivity experiments can be done using count rates as relative quantities.

The accompanying counter unit will be described next month, along with some notes on its operation and on the use of the two instruments.

PHOTO PROCESS CONTROLLER

Okay, so it's just an enlarger timer, but Ian Coughlan's design is the enlarger timer to end all others.

Printing your own photographs is one of the most pleasant aspects of photography. Unfortunately, as with most enjoyable pastimes, there are interesting bits and there are boring bits. One of the more excruciatingly boring bits is timing the exposure when making prints. Peering at a stop clock under safelight for many tens of seconds is no-one's idea of fun. When producing colour prints, it becomes impossible to see the stop-clock, since colour papers cannot practicably be handled under safelight conditions. In any case, colour or monochrome, the safelight ought to be off when making the exposure.

This Photo Process Controller is a neat solution to the problem. Set the desired exposure time on a pair of rotary switches, press the

EXPOSE button, and the enlarger is switched on for precisely the desired time. The exposure time altered can be set anywhere between one and 99 seconds, in one second intervals. In addition to this basic function, the controller has a number of advanced features.

Pressing the FOCUS button will switch the enlarger on, without the timing function, so the enlarger can be set for size, composition and focus. Pressing the RESET button will switch the enlarger off again. The RESET button can also be used to abort the timing function whenever needed. In addition to the power-outlet socket for the enlarger, another is provided for the safelight. Whenever the enlarger is on, the safelight is off. There are two reasons for this. The first is it

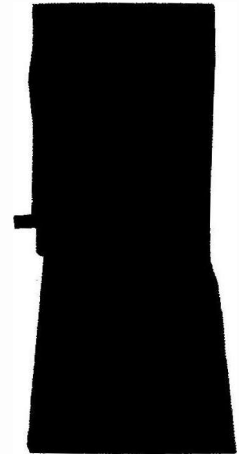

makes focusing much easier. The second is that, although photographic papers are relatively insensitive to the correct safelight, they are not totally insensitive. If a negative requires a long exposure time then switching off the safelight reduces the chances of the paper being 'fogged'. Two LEDs show the status of the power to the enlarger and safelight.

The exposure time set on the rotary switches is shown on a pair of red 7-segment displays. When the paper is being exposed, the displays show the exposure time remaining. When the time is over, the displays revert to showing the settings of the rotary switches.

Fig. 1 Drilling and cut outs for case.

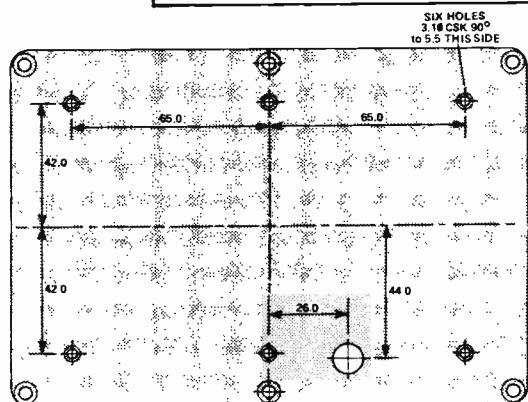
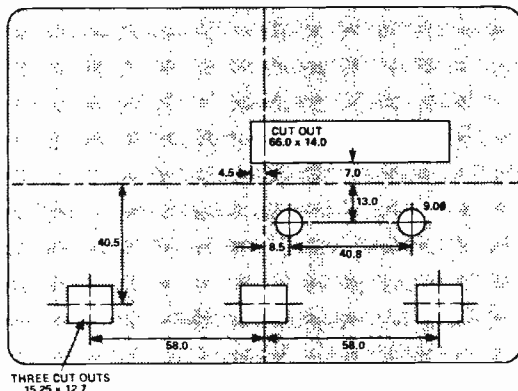
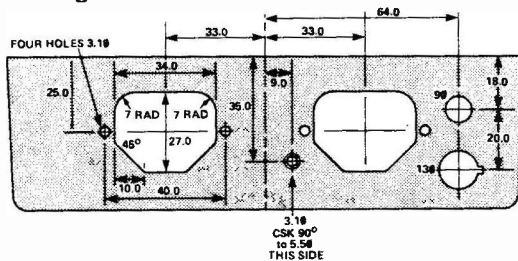

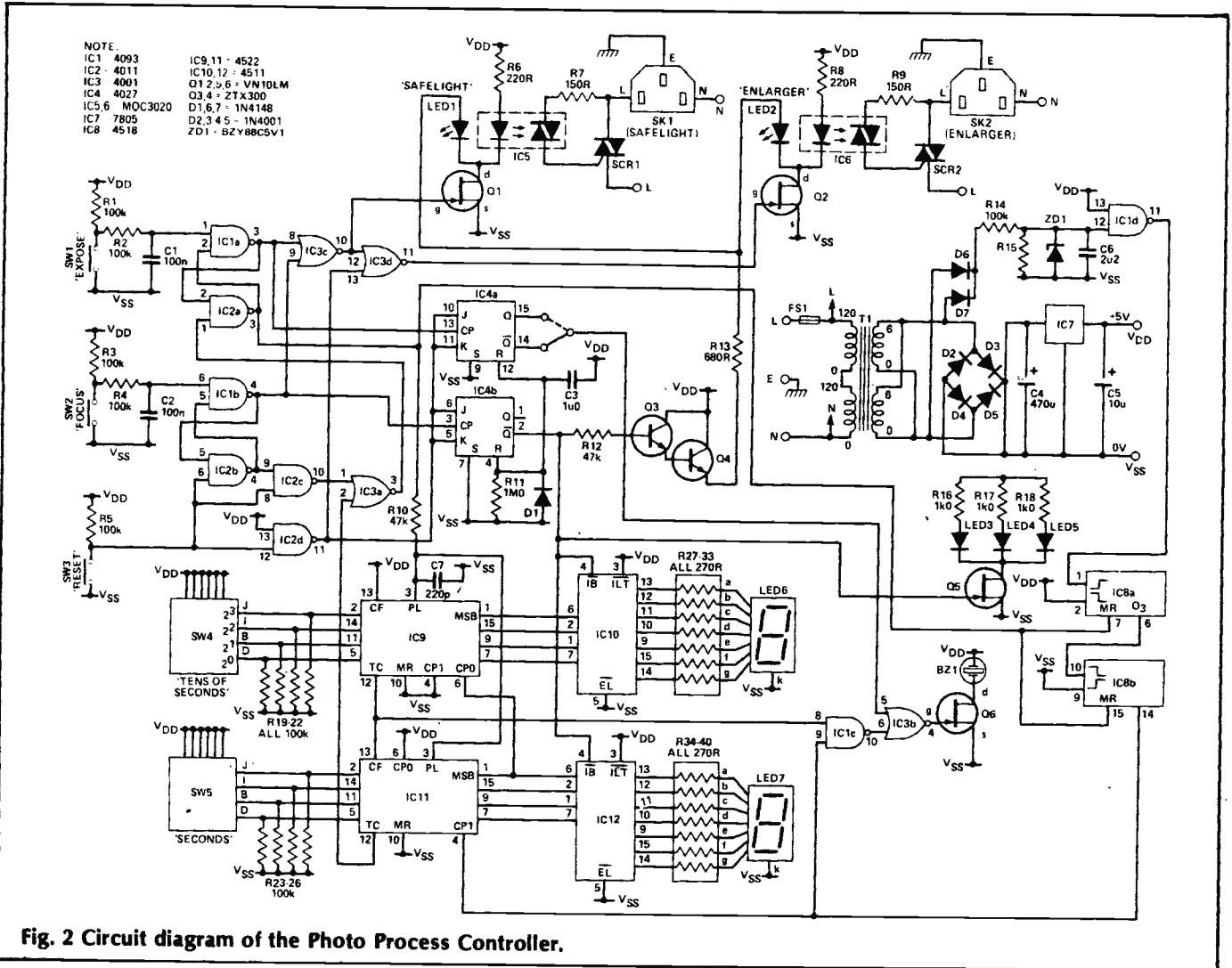

Fig. 2 Circuit diagram of the Photo Process Controller.

BUYLINES

The resistor networks are from RS (stock no. 140-029) and are available through the Electromail service (0563) 204555. Alternatively eight individual 270R resistors may be used in place of each network. The opto-isolator triacs are General Electric H11J1 and are available from RS as 308-196, as are the VN10LM VMOS transistors (RS 295-107). The 7 segment displays (LED 6, 7) are RS 587-917 and the buzzer is RS 249-429. The rotary BCD switches are RS 327-939 and the mains transformer is RS 207-829 although other models would be adequate. The box used for the prototype was also from RS (509-995 but, again, others conforming to the measurements given would serve. The collet knobs should be for a 6mm shaft if the RS BCD switches are used. The push button switches in the prototype are from Roxborough Electronics (no. 8125-185) but others may be used instead. Note the integral LED in these switches should be red. Depending on the box and LEDs used the T0-92 transistor sockets and the DIL turned pin sockets may not be required to raise the LEDs. Any suitably sized display bezel can be used.

The three pushbuttons are illuminated by a further three red LEDs, making them easy to find in the dark. Since monochrome photographic papers are generally insensitive to red light, all these LEDs will not produce a significant fogging effect — so long as the paper is kept at a reasonable distance from the Timer, say a couple of feet or so. However, it may be that it is desirable not to have these LEDs illuminated, such as when printing on colour paper, which is sensitive to red light. The LEDs — including the displays — may be switched off or on as you please by holding down the RESET button and pressing the FOCUS button.

As if this wasn't enough, an audible bleep is produced for each of the last ten seconds of the exposure time. If the bleep becomes irritating, that too can be enabled or disabled by pressing the EXPOSE button with the RESET button held down.

The Controller has been designed to be easy to use even in total darkness, with all the LEDs and displays off. The three

pushbuttons are quite large and widely spaced; and the rotary switches have end-stops, so they can be operated by feel, counting the clicks.

Construction

The prototype was designed around a 171 x 121 x 55 mm die-cast box. If using the foil patterns given, it is recommended you stick with this box size. Drill the box and base as shown in Fig. 2. The rectangular cut-out on the top of the box is for the display bezel. This can be to suit the bezel used. Similarly, the holes for the pushbuttons must be cut or drilled to suit whatever type is used. The box can then be painted and lettered if desired.

Fix the mains connectors and the fuse-holder to the rear of the box. Fix a grommet suitable for 3-core 3-amp mains cable. The earthing screw should be firmly secured to the box, and then four solder-tags attached to the screw. The pushbuttons are a push fit into the box. Fix another grommet to the base, and stick on four plastic

HOW IT WORKS

The timing reference for the controller is the mains supply. Note this design cannot be used on mains supplies with a frequency other than 50Hz.

The 50Hz is doubled by full-wave rectification, clamped by ZD1 to 5 volts, and filtered by R14, R15, and C6 to remove mains-borne interference, before emerging from IC1 pin 11 as a 100Hz square-wave. This is then divided by a pair of decade counters, IC8, to give one pulse per second.

The two rotary switches SW4 and SW5, produce logic levels that depend on their settings. So the binary codes decimal (BCD) equivalents of their settings can be placed on the inputs of a pair of programmable down-counters, IC9 and IC11. As long as the Controller is not in EXPOSE mode, the Parallel Load (PL) inputs to IC9 and IC11 will be at logic 1, and hence the outputs of these down-counters (and the displays, via decoder-drivers IC10 and IC12) will mimic the settings of the rotary switches.

When the EXPOSE button is pressed, the control circuitry will put a logic 0 on the PL inputs, latching the settings of the rotary switches into the counters. Altering the settings of the switches will not affect the counters of the displays. One second later, the first of the clock-pulses will arrive from IC8, causing IC11 — the 'seconds' counter — to decrement its count. The next clock pulse will decrement it again, and so on, until 0 is reached. Assuming the 'tens-of-seconds' counter — IC9 — is not also at 0, the next clock-pulse will change the seconds counter to 9, and the tens-of-seconds counter will decrement, since it is clocked from the most significant bit of the seconds counter. While this is happening, the displays are changing with the counters, showing the time remaining.

Both IC9 and IC11 have a Terminal Count (TC) output, which goes to logic 1 when the counter reaches 0 as long as the Carry Forward (CF) input of that counter is also at a logic 1.

The CF Input of the tens-of-seconds counter is tied to V_{dd}, and so the TC output of that counter will go to logic 1 as soon as 0 is reached. The CF input of the seconds counter, however, depends on the TC output of the tens-of-seconds counter, and so the TC output of the seconds counter will not go to logic 1 unless both counters are at 0, signifying the end of the exposure-time. That logic 1 is passed to the control circuitry which resets the controller and puts a logic 1 on the PL inputs of both counters causing them and the displays, to revert to the sett-

ings of the rotary switches. The PL inputs must not go to logic 1 too soon after the TC output has gone to logic 1, or the TC outputs tend to latch-up. R10 and C7 serve to delay slightly the logic 1 from the control circuitry.

In describing the operation of the control circuitry we start with the Enlarger Timer reset with the enlarger off and the safelight on.

IC1a and IC2a form a latch circuit. IC1 pin 3 will be at a logic 0, and IC2 pin 3 will be at logic 1. IC1b and IC2b form an identical latch circuit with IC1 pin 4 at logic 0 and IC2 pin 4 at logic 1. So IC3 pins 8 and 9 will see a pair of logic 0s making IC3 pin 10 go to logic 1 and turning on Q1. This will light LED1 and activate the optically-coupled triac, IC5 which, in turn, is used to switch a much larger triac, SCR1 to control the safelight.

The logic 1 from IC3 pin 10 is inverted by IC3d, turning off Q2, ICL6, SCR2 and the enlarger.

When the FOCUS button is pressed, IC1 pin 6 will be pulled to logic 0, setting the latch formed by IC1b and IC2b. IC1 pin 4 will go to logic 1, and IC2 pin 4 will go to logic 0. The cross-connection of outputs to inputs will ensure that the latch will remain in this state until the RESET button is pressed. The logic 1 from IC1 pin 4 will be inverted by IC3c (turning the safelight off), and re-inverted by IC3d (turning the enlarger on).

When the RESET button is pressed, the latch will revert to its previous state, and so the enlarger will go off, and the safelight will go on.

When the EXPOSE button is pressed, the result is very similar to that obtained when the FOCUS button was pressed, except now the timing function has to be enabled. IC2 pin 3 will go a logic 0, removing the reset from IC8 pins 7 and 15, allowing the decade counters to start dividing the 100Hz clock frequency down to 1Hz. At the same time, the PL inputs to IC9 and IC11 go to logic 0, locking-out the parallel inputs from the rotary switches, and allowing the counters (and the displays) to step downwards.

When both counters have reached 0, the TC output of IC11 will go to logic 1, and this is inverted by IC3a to produce a logic 0 to reset the latch (IC1a and IC2a) which in turn resets IC8, and puts a slightly delayed logic 1 on the PL inputs to IC9 and IC11, so they revert to the settings of the rotary switches.

The timing function can be interrupted before the exposure-time is over, by pressing the RESET button. This will reset the latch in the same way as the

two counters reaching 0, as described above.

The displays are enabled by a logic 1 on pin 4 of the decoder-drivers (IC10 and IC12). Similarly, LED1 and LED2 are enabled by turning on the Darlington-pair Q3 and Q4. Finally, LED3, LED4, and LED5, are enabled by turning on Q5. Thus the status of all the LEDs will be controlled by the logic level on IC4 pin 2.

IC4 is a dual JK flip-flop. When power is first applied to the controller, both flip-flops will be reset, due to the effect of R11 and C3 on the reset pins of IC4. Pin 2 of IC4 will be at a logic 1, and the LEDs and the displays will be on. The Clock Pulse (CP) input of IC4b will go to a logic 1 each time the FOCUS button is pressed, but since the J and K inputs are both at logic 0, the flip-flop will not change states and the LEDs will remain on.

However, press and hold down the RESET button, and IC2 pin 11 will go to logic 1, as will the J and K inputs. When the FOCUS button is now pressed, the flip-flop will toggle, turning the LEDs on or off as desired.

The CP requires a single pulse each time the FOCUS button is pressed, so the contact-bounce of the button is eliminated by R3, R4, and C2. IC3d prevents the enlarger switching on when both the RESET and FOCUS buttons are pressed.

Remember the TC output of the tens-of-seconds counter (IC9) will be at logic 1 when the contents of that counter are at 0. This logic 1 is used to gate the 1Hz pulses from IC8, so IC1 pin 10 will have a negative-going pulse for each of the remaining ten seconds of the exposure-time. As long as IC3 pin 5 is at logic 0, these pulses will appear inverted at IC3 pin 4, turning on Q6 and the buzzer when positive. If IC3 pin 5 is taken to logic 1, then IC3 pin 4 will always be at logic 0, and the buzzer will not sound.

IC3 pin 5 is controlled by the other JK flip-flop in IC4. This flip-flop functions in exactly the same way as the one controlling the display status, except that in this case, the clock pulse is provided by pressing the EXPOSE button.

This flip-flop will also be reset on power-up, although the constructor can decide whether he wants the buzzer enabled or disabled. In the former case, IC3 pin 5 should be connected to IC4 pin 15, and in the latter case IC3 pin 5 should be connected to IC4 pin 14. A link on the PCB provides for this choice.

feet. These are necessary to provide a gap for the sound of the buzzer to get out.

Using 3 amp mains connecting wire for the high-voltage parts, and any thin insulated connecting wire for the low-voltage parts, connect the case-mounted components as shown in Figs. 3 and 5. Use

sleeving wherever possible. Put the box to one side.

Fit veropins to the three printed-circuit boards. The veropins should be inserted from the foil side of the large PCB, and from the component side of the other two PCBs. Fit the resistors and wire links first, then the

capacitors, transistors, diodes, and the transformer. Note that DIL sockets can be used on both of the single-sided PCBs, but not on the double-sided counter/driver PCB as the IC legs are used as feed-throughs, and must be soldered on both sides. Wherever there is a pad on the component

Fig. 3 Component overlay and wiring for the counter/driver and display boards.

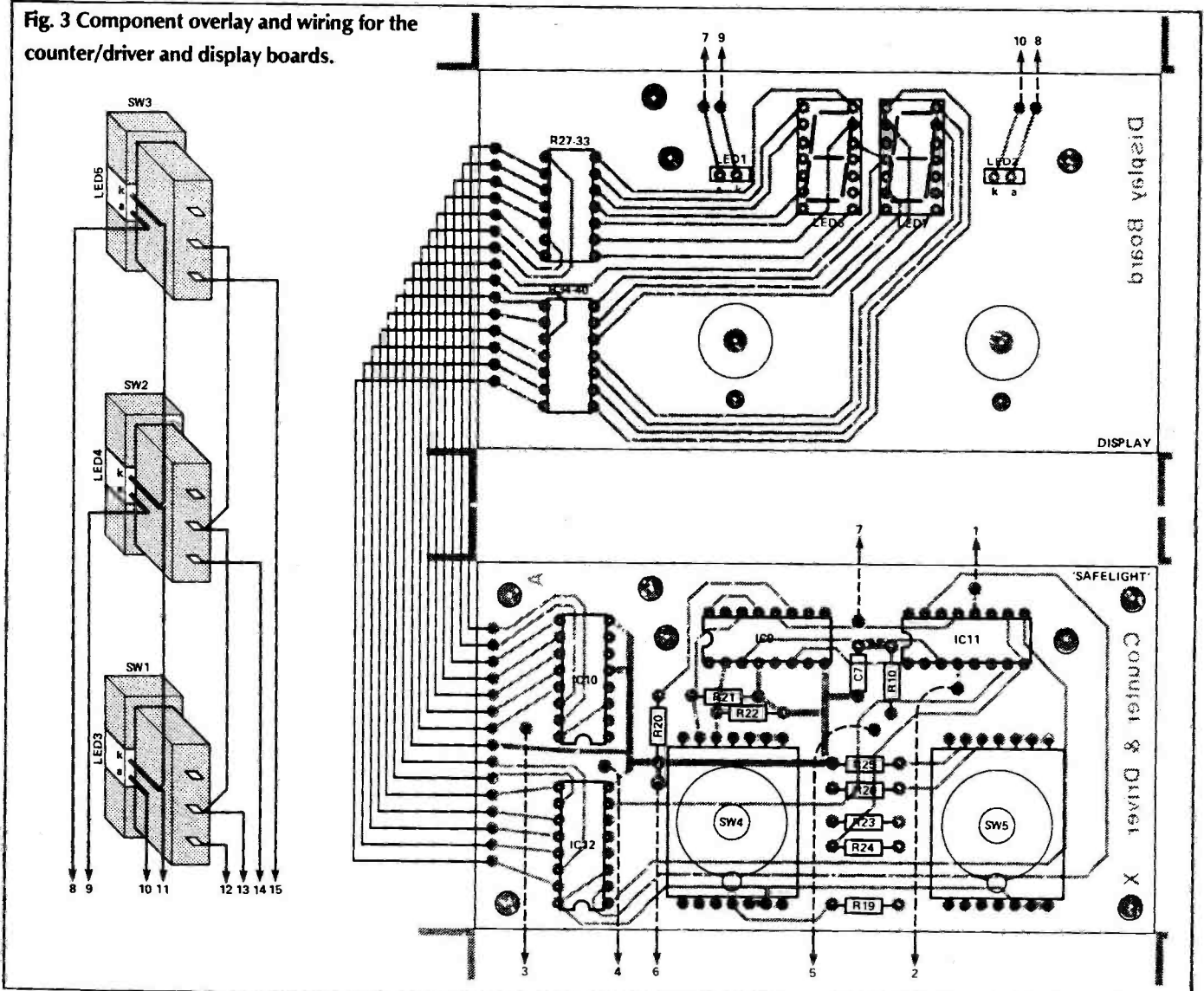

side of the double-sided PCB, this must be soldered on both sides. Use turned-pin DIL sockets for the two LED displays. These will lift the displays up by just the right amount. For the same reason, fit a small transistor mounting pad under each of the two LEDs next to the displays. It is not essential to use resistor networks on the display board — individual 270R ¼W resistors may be used, if preferred.

Connect flying-leads to each PCB and connect and fix the PCBs to each other. The central PCB mounts to the power/control PCB on four 12.7mm insulated stand-offs. The display PCB mounts to the counter/driver PCB on one 12.7mm insulated stand-off, and on the bushes of the rotary switches.

Do not force the boards together. If they don't fit easily, find out why. In particular, do not put any force on the rotary switches. If necessary, file the holes in the PCBs to a slightly larger diameter.

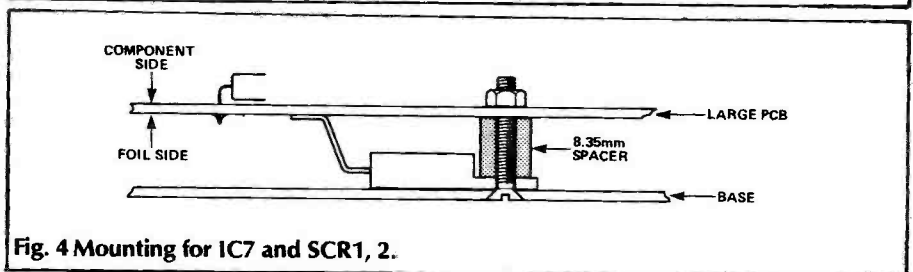

Fig. 4 Mounting for IC7 and SCR1, 2.

The 5V regulator and the two triacs mount in the base of the box, as shown in Fig. 4. Firstly, they must be soldered into place (on the underside of the PCB), so temporarily fix them into position on the PCB with a nut, screw, and an 8.75mm plastic spacer.

The Controller cannot be used to drive inductive loads, unless a snubber-network is connected across each of the triacs. If these are required, they should be soldered in place now, across MT1 and MT2 of each triac. Lay them flat under the PCB. A suitable snubber-network is RS 238-463. Remove the screws from the triacs and the 5V regulator, and carefully

assemble the PCBs to the base. The complete assembly may now be offered up to the box, and the case-mounted components connected. Use cable ties to keep everything tidy. Assuming that the assembly fits into the box without any trouble, screw the base onto the box. Attach the two collet knobs and the Enlarger Timer is now complete and ready for testing.

Testing

Because mains voltages are present in the Controller, the importance of thorough testing cannot be too highly stressed.

PROJECT: Photo controller

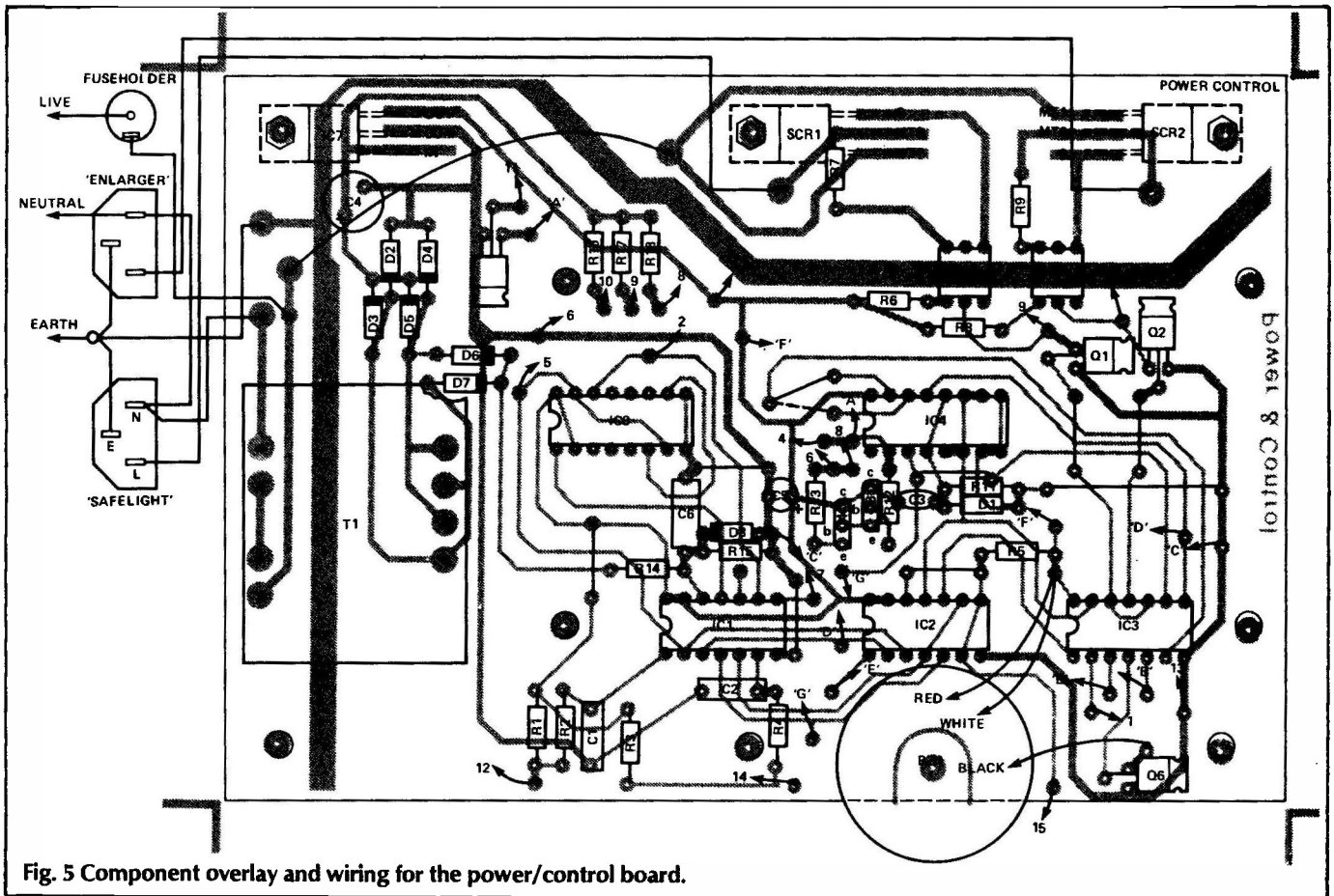

Fig. 5 Component overlay and wiring for the power/control board.

Using a multimeter on its lowest resistance range, check that the earth lead in the mains cable makes good contact with the metal box, and with the central pin of the two mains sockets. Fit a 1A fuse to the fuseholder, and with the multimeter set to its highest resistance range, check that there is good insulation between the

earth wire and the live and neutral connections, including those in the mains sockets. Only when these checks have been made should mains be connected.

If all is well, the LEDs should light, and the display should show the settings of the rotary switches. If the safelight indicator is off, press the RESET button. Check

that the Controller functions in the manner described. An ordinary 240 V lamp can be used to check the outputs of the mains connectors. If everything checks out OK, the Photo Process controller is complete and ready to use.

ETI

PARTS LIST

RESISTORS (all ¼W, 5%)

R1, 2, 3, 4, 5, 14, 19, 20, 21, 22, 23, 24, 25, 26	100k
R6, 8	220R
R7, 9	150R
R10, 12	47k
R11	1M0
R13	680R
R15	470k
R16, 17, 18	1k0
R27-33, 34-40	DIL resistor network, seven individual resistors each 270R

CAPACITORS

C1, 2	100n miniature layer
C3	1u0 35V tantalum bead
C4	470u 16V radial electrolytic
C5	10u 16V radial electrolytic
C6	2n2 polystyrene
C7	220p polystyrene

SEMICONDUCTORS

IC1	4093
IC2	4011
IC3	4001
IC4	4027
IC5, 6	MOC3020
IC7	7805
IC8	4518
IC9, 11	4522
IC10, 12	4511

Q1, 2, 5, 6	VN10LM
Q3, 4	ZTX300
D1, 6, 7	1N4148
D2, 3, 4, 5	1N4001
ZD1	BZY88C5V1

LED1, 2	Rectangular red LED
LED6, 7	0.3" 7 segment LED display, common cathode
SCR1, 2	T2850D 8A 400V triac with insulated heat sink tab.

MISCELLANEOUS

T1	3VA PCB-mount transformer 0-120, 0-120 primary 0-6, 0-6 secondary
SK1, 2	IEC Euro chassis mains outlet socket
SW1, 2, 3	Miniature push button switch (incl LED 3, 4, 5)
SW4, 5	PCB-mounted BCD rotary-switch
BZ1	5V Piezo sander
	PCB; die-cast box, 171x121x55mm; display bezel; collet knobs for 6mm shaft, and caps; cable grommets; fuse holder and 20mm 1A fuse; solder tags; silicone rubber sleeving; nylon spacers 8.75mm (3), 10.0mm (3), 12.7mm (5); DIL sockets, if required; T0-92 transistor pads (2); turned-pin DIL sockets 14-pin, for displays; Veropins; insulated connecting wire; screws, nuts, washers, etc; Plastic feet, paint, lettering, mains cable.

LOW-DISTORTION STEREO DECODER

John Linsley Hood brings you a practical FM receiver design which uses some of the techniques described in his recent theoretical series. To begin with here's the stereo decoder board.

The stereo decoder circuit presented here has been designed to enable the highest practicable audio quality to be obtained from a good FM tuner. In particular, the audio signal path has been kept entirely separate from the 38kHz switching circuitry and uses discrete components rather than ICs. The results include a total harmonic distortion figure of 0.02% over the entire VHF/FM signal bandwidth (30Hz–15kHz) in both mono and stereo modes, more than 20dB attenuation of the 19kHz pilot tone and over 60dB attenuation of the 38kHz switching waveform.

These figures are reflected in the overall sound quality provided by the decoder when used in conjunction with a good quality FM tuner. The stereo image position and stereo separation are particularly good. Because of this, the decoder should prove of interest both to those who are building an FM receiver from scratch and those who already have a receiver and wish to upgrade it.

Stereo Decoding

One of the major advantages of VHF FM radio broadcasting is that the available bandwidth is adequate to allow the transmission of a stereo signal. This is done using the Zenith-GE pilot tone system as described earlier in this series of articles.

The advantage of this method is that the signal is broadcast as a composite. The normal 20Hz–15kHz part of the audio modulation is a perfectly conventional mono (left plus right) transmission, while the necessary additional information required to generate two separate channels is carried as a normally-inaudible suppressed carrier, centred on

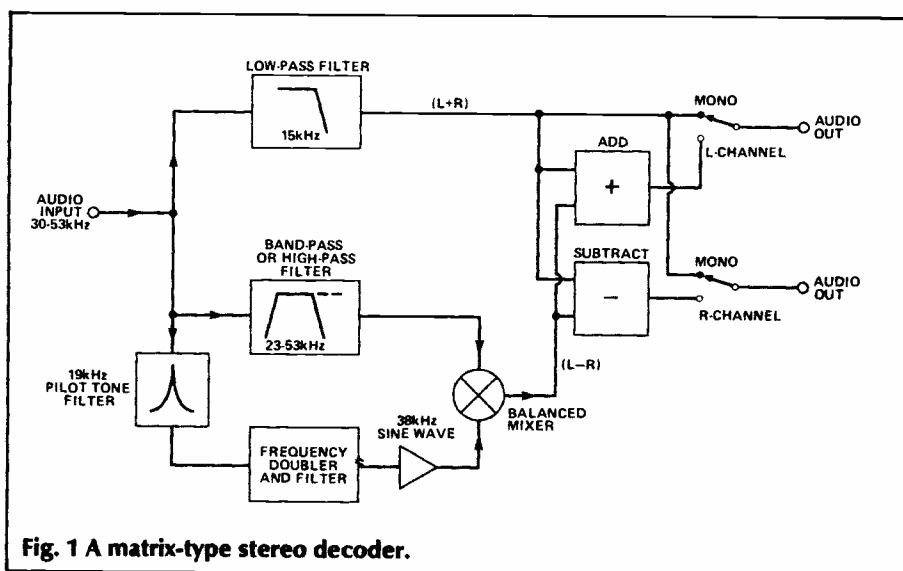

Fig. 1 A matrix-type stereo decoder.

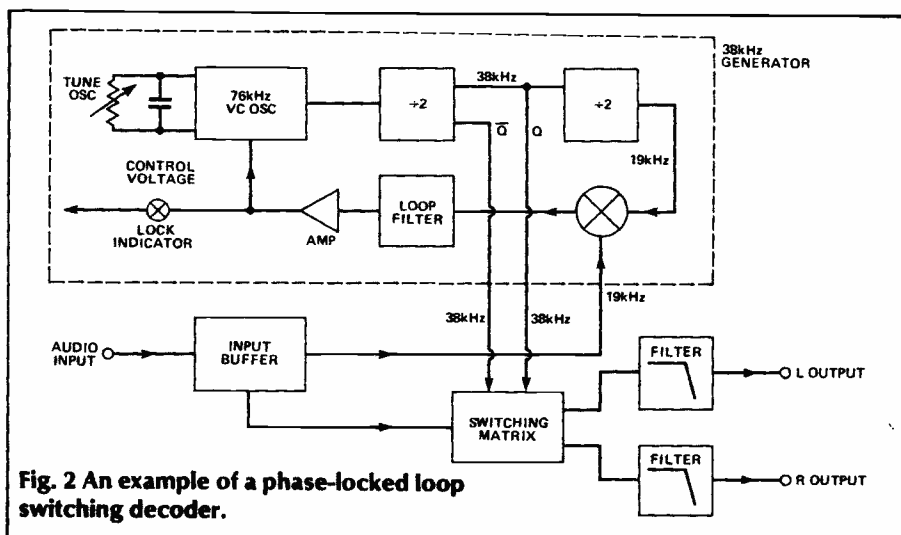

Fig. 2 An example of a phase-locked loop switching decoder.

38kHz and occupying the 23kHz–53kHz part of the AF spectrum.

There are two basic methods of recovering the stereo information from this composite signal (Figs. 1 and 2). The first of these uses the 19kHz pilot tone to regenerate a 38kHz carrier so that the sidebands can be recovered from the 23–

53kHz signal in the normal way. The second method uses a switching system operating at 38kHz, to alternately route the whole signal to the left or the right channel outputs.

Both of these methods effectively do the same thing, but there are differences in the

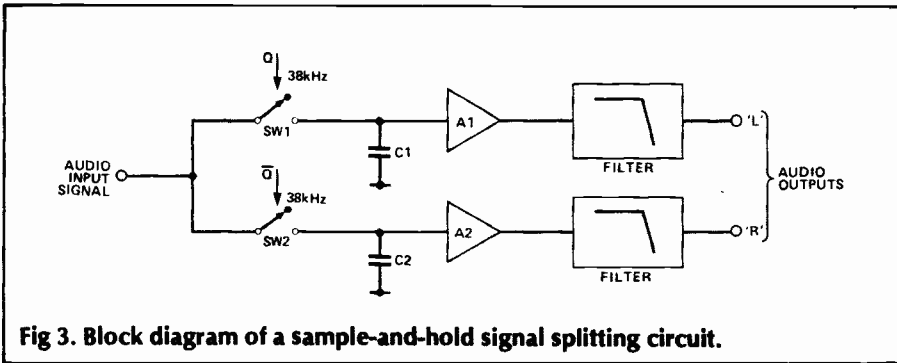

Fig 3. Block diagram of a sample-and-hold signal splitting circuit.

output low-pass filtering, it is necessary to add the network R41/C27. With the PLL tuner part of the article, this is switchable to give a wide or narrow effective bandwidth. Where the signal strength is good, leaving SW2 open gives a slightly better image separation. With it closed, the signal-to-noise ratio is improved by about 6dB with only a small loss of stereo width.

potential signal-to-noise ratio which relate particularly to the effective bandwidth of the decoded signal.

The signal-to-noise ratio of the stereo signal will always be worse than that of the mono signal because it requires more bandwidth. While the magnitude of the signals is the same, the stereo one demands at least a 53kHz bandwidth whereas the mono one only requires 15kHz, and the noise associated with any signal is related to the demodulation bandwidth needed.

However, there is an additional problem with the switching method shown in Fig. 2. If a square wave is used as the switching waveform it will contain a whole series of odd harmonics, at 114kHz, 190kHz, 266kHz etc, and any noise components lying within 19kHz on either side of these will also be commutated down into the audio band.

The matrix system of Fig. 1 is free from this problem — provided that a good quality sine wave is used to replace the 38kHz suppressed carrier. To generate a good sine wave which is accurately locked in phase to the 19kHz pilot tone is not easy, and any error in phase will substantially impair the effective channel separation.

The noise problems associated with the switching decoder can be removed if an effective bandwidth limiting input filter is used to remove any incoming noise signal in the frequency band from 95kHz (38x3-19) upwards. This allows the use of a simpler type of decoder system, which can be built in a form which offers a very low overall distortion of the audio signal.

The Sample And Hold System

Two further requirements of any decoder system, in addition to low noise and low distortion, are that the audio signal output level shall be identical in both mono and stereo modes, and that it is

possible to switch from one to the other noiselessly. Both of these additional requirements are met by the sample and hold arrangement shown in Fig. 3.

In the mono mode, when both SW1 and SW2 are closed, it is evident that the same signal is being fed to both the left and right channels. If the switches are sequentially operated, the holding action of capacitors C1 and C2 will result in an output signal which is identical in amplitude to the incoming one, apart from any

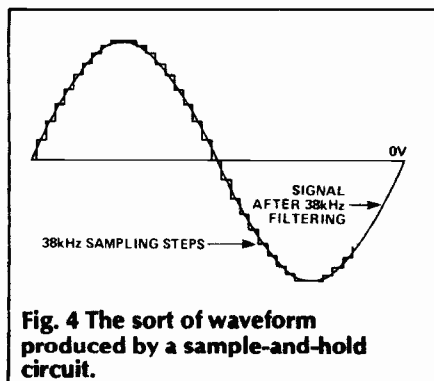

Fig. 4 The sort of waveform produced by a sample-and-hold circuit.

differences in the left and right signals. This is illustrated for a single channel in Fig. 4.

The requirements for correct operation of this circuit are that the switching action should take place at the correct time in relation to the incoming signal waveform, that the time required to charge C1 and C2 from the source through the switching shall be very small in relation to the switching time, and that the discharge time through the input impedances of A1 and A2 shall be very long in relation to the sample period.

In this circuit, Q1 and Q2 form a third-order active low-pass filter. However, only two of the necessary low-pass RC elements are present on the decoder board since the third (5.7us) component was provided by the PLL loop characteristics of the circuit with which it was designed to be used.

Where this decoder is used with a demodulator without AF

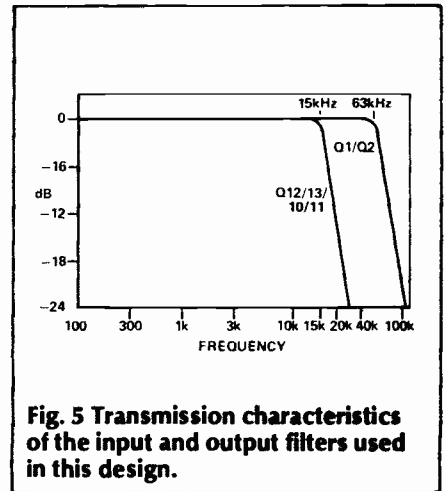

Fig. 5 Transmission characteristics of the input and output filters used in this design.

A similar filter is used after the sample-and-hold switching FETs (Q8, Q9) to produce a rapid attenuation beyond 16kHz. By leaving the 75us de-emphasis network to follow it, the required attenuation of the 38kHz switching waveform ripple is still further increased. The attenuation characteristics of the input and output filter circuits are shown in Fig. 5.

The Switching Waveform Circuit

The 38kHz switching waveform used to drive the FET switches is derived from a standard 1310-type PLL stereo decoder, IC1, which is employed to monitor the incoming signal and extract the 19kHz pilot tone when present.

When the 19kHz pilot tone is present, a 76kHz sawtooth will appear at pin 14 of the phase-locked loop, locked in period to the pilot tone. A DC signal will also be present on pin 6, and can be used to actuate an indicator LED when the 19kHz pilot tone is detected. This DC signal is also used in the circuit shown in Fig. 6 to operate a DC switching transistor, Q4, which controls the supply to IC2. This is a CMOS dual D-type flip-flop, which is used to generate the symmetrical 38kHz switching signal.

In the absence of a DC output current from pin 6 of IC1, Q4 is

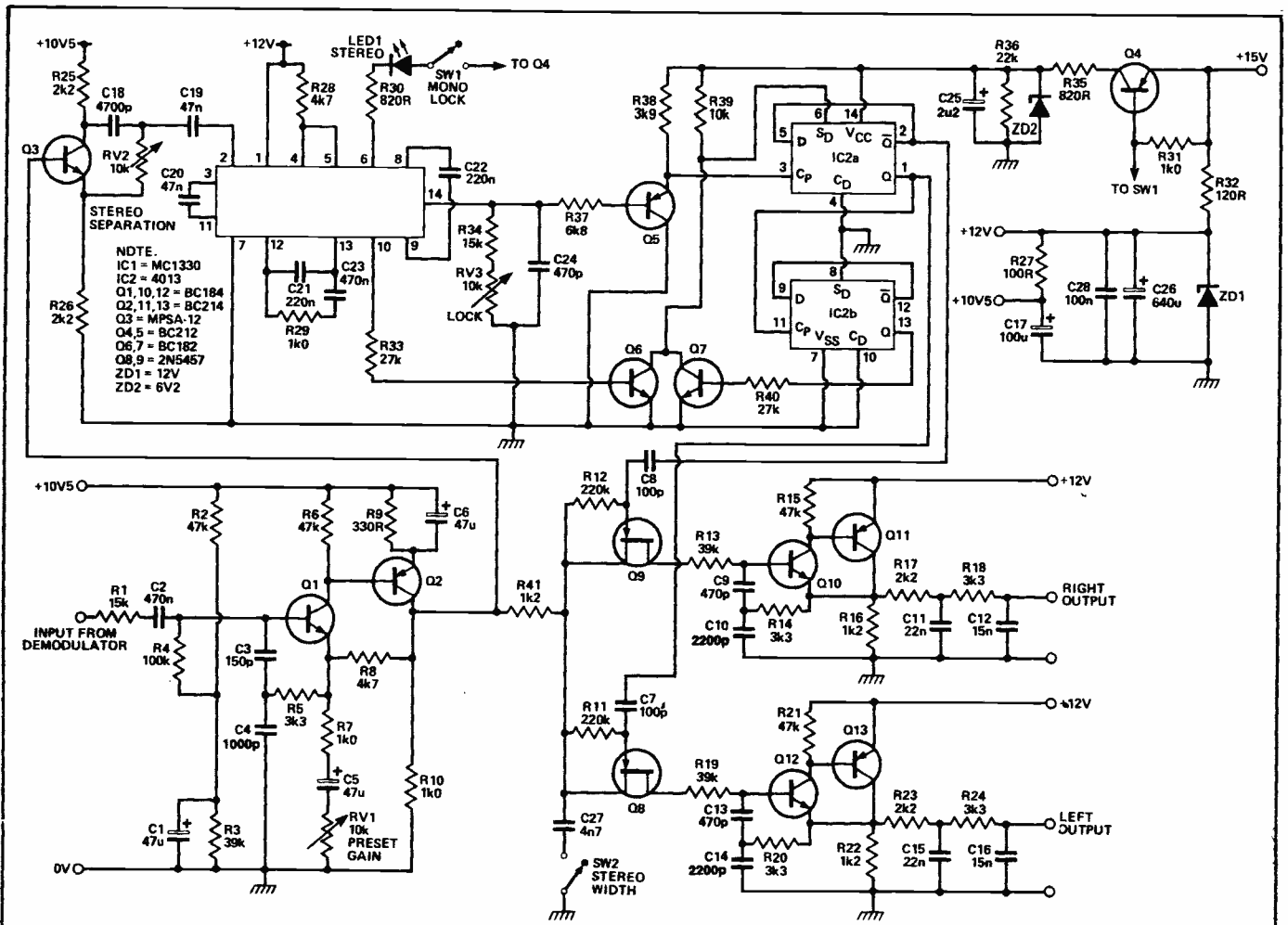

non-conducting, IC2 is inoperative, and both of the switching FETs (Q8 and Q9) are permanently conducting. The incoming signal from the demodulator will thus be passed directly to both the left and right output channels without interference from the switching/decoding circuitry. Opening switch SW1 will maintain this condition even when a stereo signal is present.

Provided that a stereo signal is present and the PLL IC has been correctly tuned, a 76kHz sawtooth waveform will be fed to Q5 and to IC2 as a clock signal. The first divide-by-two output signal pair in IC2 produces a 38kHz signal from this clock and drives Q8 and Q9.

Unfortunately, it would be possible if the circuit were switched off for the left and right channels to be reversed, since their identity depends on the relative phase of the 38kHz waveform. This possibility is removed by using the second-stage (19kHz) output from IC2 to feed a simple two-transistor NOR gate, Q6/Q7. The other input to the gate is taken from the 19kHz output of the 1310. If these should become synchronous in phase, the collectors of Q6, Q7 will rise toward the positive rail and reset IC2 for one half cycle, restoring the correct switching phase.

Because of the sample and hold action of the decoder, the stereo/mono transition is completely noiseless.

The best separation between the two stereo channels is given

when the phase of the 38kHz switching waveform is timed precisely to coincide with the L-R channel transistors at the transmitting station encoder, from which the 19kHz pilot tone is derived.

Since, in this circuit, the audio channel and the switching waveform channels are handled separately, it is possible to feed the 19kHz pilot tone through a phase-angle adjusting all-pass filter, Q3. This allows the phase of the pilot tone fed to the PLL (IC1) to be adjusted to give the greatest L-R separation. The adjustment is provided by RV2.

Construction

The majority of the components for the stereo decoder are mounted on a single-sided PCB. The only exceptions are the panel-mounting components (LED1, SW1, SW2, etc) and the second stage of filtering on the two outputs (R18/C12 and R24/C16).

Begin assembling the board by installing the four wire links (all around Q4 and IC2) and the IC

BUYLINES

A complete kit of parts for the FM stereo receiver will be available from Hart Electronic Kits, Penylan Mill, Oswestry, Shropshire SY10 9AF. They will be supplying parts for both the decoder and the other sections of the receiver which have yet to be published, and they will happily provide individual components or part kits as well as full kits. Prices had yet to be finalised at the time of going to press, so intending constructors should contact Hart on (0691) 652 894. The PCBs will be included in the kits, and since Hart will supply these separately too we will not be offering them through our PCB Service.

PROJECT: Stereo Decoder

sockets if you intend using them. Solder into place the resistors, the presets and the capacitors, then move on to the diodes, the transistors and the ICs. Take the usual care with the electrolytic capacitors and the various semiconductors, all of which must be inserted the right way around if everything is to work correctly.

If you wish to, you can test the audio stages of the board quite simply before fitting it into a receiver. Connect up a +15V supply and apply a signal to the input. You should find that the signal appears at both audio outputs with equal amplitude.

Assuming all is well, mount the board inside the receiver you plan to use it with and make the necessary connections. The off-board filter components, R18/C12 and R24/C16, should be soldered to the far ends of the audio output leads. It will probably be most convenient to mount them on the stereo output sockets.

Switch on the receiver and tune to a station which you know will be broadcasting in stereo. Adjust RV1 to give an audio output level suitable for your amplifier. With SW1 closed, adjust RV3 until the LED lights up and continue turning it until the LED goes off again. Leave RV3 set to the centre of the range over which the LED is on. The outputs of the receiver should now be providing a stereo signal.

Connect a millivoltmeter between the signal connections of the two output sockets and listen for a stereo signal which is fairly random in nature. Something like applause or other crowd noise would be suitable. Set the stereo channel separation by adjusting RV2 until you get a maximum reading on the meter. You should find two maximum positions, one which brings the left and right channels out one way round and one which reverses them. It does not matter which position you leave RV2 at provided you bear in mind that your channel identification may not correspond with that of the broadcasting station.

If you don't have a millivoltmeter, you can set the channel separation roughly by using headphones and adjusting RV2 until the stereo image sounds best.

● The remainder of the circuitry necessary to produce a complete FM stereo receiver will be described next month.

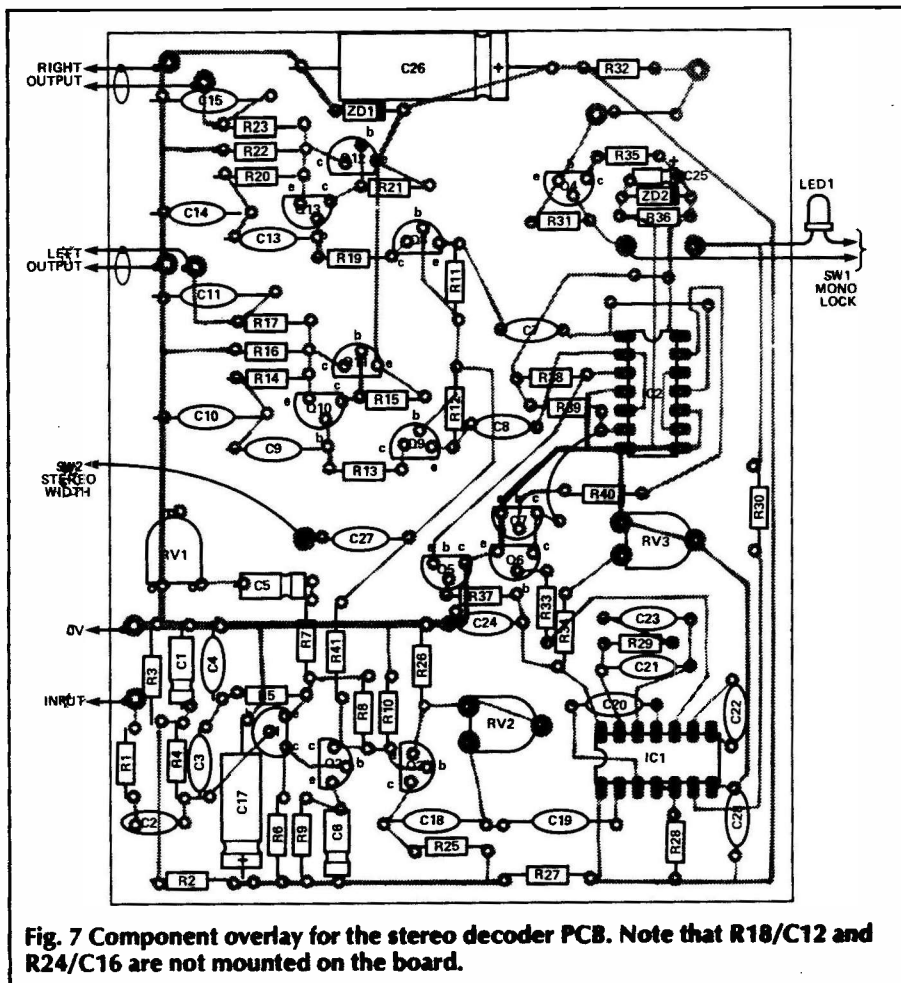

Fig. 7 Component overlay for the stereo decoder PCB. Note that R18/C12 and R24/C16 are not mounted on the board.

PARTS LIST

RESISTORS

R1	15k
R2, 6, 15, 21	47k
R3, 13, 19	39k
R4	100k
R5, 14, 20, 18, 14	3k3
R7, 10, 29, 31	1k0
R8, 28	4k7
R9	330R
R11, 12	220k
R16, 22, 41	1k2
R17, 23, 25, 26	2k2
R27	100R
R30, 35	820R
R32	120R
R33, 40	27k
R34	15k
R36	22k
R37	6k8
R38	3k9
R39	10k
RV1	10k horizontal skeleton preset

CAPACITORS

C1, 5, 6	47u 16V axial electrolytic
C2, 3	270n
C3	150p
C4	1n0
C7, 8	100p
C9, 13, 24	470p
C10, 14	2n2
C11, 15	22n
C12, 16	15n
C17	100u 16V axial electrolytic
C18, 27	4n7
C19, 20	47n
C21, 22	220n
C25	2u2 16V axial electrolytic
C26	640u 16V axial electrolytic

SEMICONDUCTORS

IC1	MC1330
IC2	4013
Q1, 10, 12	BC184
Q2, 11, 13	BC214
Q3	MPSA-12
Q4, 5	BC212
Q6, 7	BC182
Q8, 9	2N5457
ZD1	12V 400mW
ZD2	6V2 400mW
LED1	panel-mounting LED

MISCELLANEOUS

SW1, 2	SPST switches, toggle, push-button, etc as appropriate
--------	--

PCB; screened cable; IC sockets if required; case, mounting hardware, sockets, 15V power supply, etc, according to application.

ETI

THE ETI LEDLINE ANALYSER

This expandable analyser is the logical choice for testing digital circuits.

The ETI LEDline analyser is a powerful aid to testing complex logic circuits. It is the digital equivalent of a multi-channel oscilloscope with storage facilities — at a tiny fraction of the cost!

The circuit diagram for the project is shown in Fig. 1. Each display section consists of a pair of shift registers which clock in logic levels from the device being tested. The levels are displayed on a line of green and red LEDs, representing logic 1 and 0 respectively. The control board contains the trigger circuit, a counter to determine when the displays are full, and a simple interlock to prevent accidental re-triggering.

In use, the clock input of the analyser is connected to the master clock of the board to be analysed. The inputs to the display section are taken from the outputs to be recorded and the trigger is connected to a suitable point to determine the start of the sampling. The switches SW1 and SW2 allow the circuit to be triggered and clocked by either a rising or falling edge, according to the setting.

As an example, suppose you are using a Z80 CPU in interrupt mode 2. In this mode the interrupting peripheral must supply the lower eight bits of an address which points to its service routine. You suspect that the Z80 is receiving the wrong address and would like to check. One way to do this would be to connect the clock of a ten channel version of the analyser to the Z80's clock input, the trigger to INT (with SW1 set so that it fires on the falling edge), eight input channels to D₀ - D₇, a further channel to $\overline{\text{IORQ}}$, and one to M1.

When you are ready, press the READY button (what else?) on the analyser and then arrange for the

peripheral to send an interrupt. As soon as the interrupt request arrives, the analyser will record the logic levels on the data bus and the two control lines over the next sixteen cycles of the clock. It will then stop and the display will remain steady for you to analyse at your leisure. More about this later. First you've got to build the LEDline analyser!

Construction

Initially you must choose the number of data channels you need. I would suggest four as a minimum. You will need at least ten if you intend to use the analyser for serious work with 8-bit microprocessors. This will allow eight data or address lines and two

control signals to be inspected simultaneously.

The display PCB, as supplied by our PCB Service, will record two channels of data. To make a four channel recorder you will need two display PCBs side by side, linked together as shown in Fig. 1. For more channels, just link together as many display boards as you need. If you have a process camera at your disposal (or can talk your local litho printer into doing it for you) you can photograph the foil pattern several times, join the prints together, and then photograph the foil pattern onto transparency to make a master for a single large PCB for the full number of channels you require.

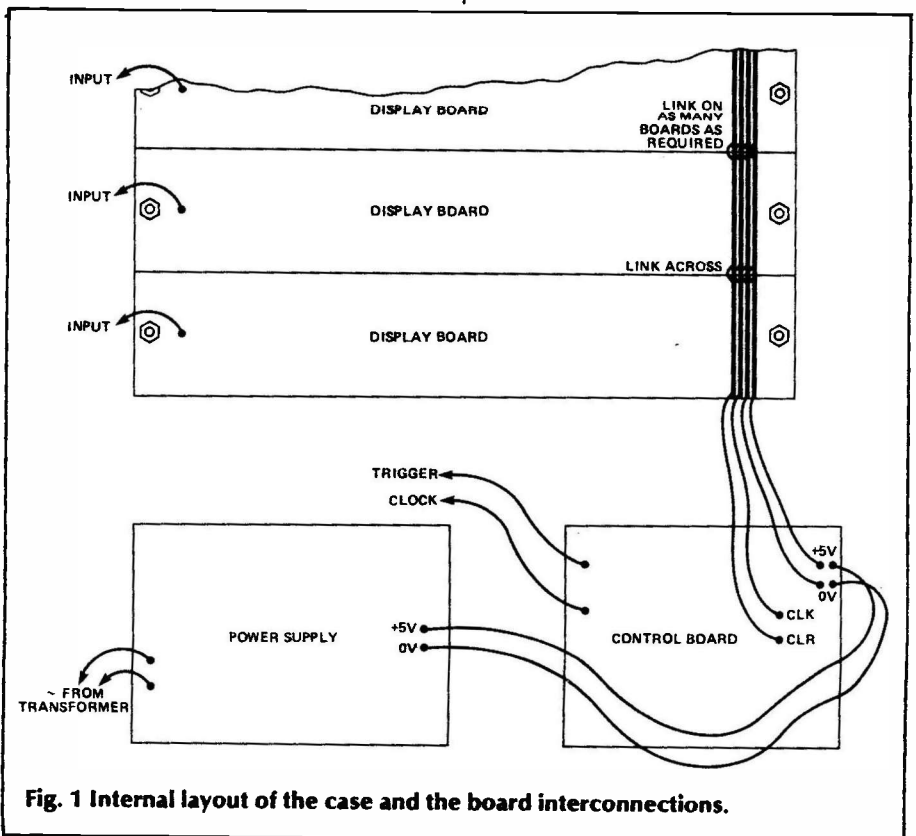

Fig. 1 Internal layout of the case and the board interconnections.

HOW IT WORKS

The display section consists of a pair of eight-bit shift registers, each output lighting a red LED if it is at logic 1 or a green LED for logic 0. As the input is inverted by Q1, the green LEDs indicate a logic 1 input and the red ones a logic 0. Q1 allows the circuit to be driven either by CMOS or TTL. For simplicity, no attempt has been made to match the logic levels exactly. Anything above about 1.5V will be recognised as a logic 1, and anything below will be seen as logic 0. The transistors Q2 and Q3 present a relatively small load to the driving ICs, allowing many more boards to be chained together than would be possible if the clock and clear lines went directly to the inputs of IC1 and IC2.

On the control board, the trigger and clock inputs are once again made compatible with either CMOS or TTL by Q4 and Q7 respectively. IC3a allows the analyser to be clocked by either the rising or falling edge of the input (selected by SW1). IC3b and SW2 perform the same function on the clock input. Transistors Q5 and Q6 and associated components perform a power-on reset function: the circuit powers up with all the displays at 0, IC5 set to zero, and IC4a and IC4b set to 1. In this condition, the circuit will ignore a trigger input, since IC4a is already preset.

Pressing the ready button clears IC4a, and clears down the rest of the circuit as for a power-on reset. It also lights LED33 to show that the analyser is ready for action. Once IC4a is cleared, a rising edge at its clock input (from the trigger) will cause it to change state. When this happens it will be returned to the preset state and will ignore any further trigger inputs until the ready switch is pressed again. LED33 will then be extinguished to show that the circuit has been triggered. IC4b will receive a rising edge at its clock input via IC3c and will change state, enabling the clock input via IC3d. This sets the sampling process in motion. All the display boards are clocked via IC3d and collect data from the board under test.

On the fifteenth clock pulse, pin 15 of IC5 will go high. On the sixteenth it will go low again, at this point clocking IC4b via IC3c. This causes the clock pulses to be cut off and the circuit remains in this state, with sixteen sets of samples displayed, until SW3 is pressed to start another cycle.

BUYLINES

The low current LEDs used for this project were obtained from Electromail, stock no. 588-386 and 588-392. The test probes were from the same source, stock no. 424-175, as was the heatsink for the regulator (stock code 402-989). Note this item comes in packs of 10). In case of difficulty, the 15,000 μ capacitor is also available from Electromail (104-348). The PCBs will be available from our PCB service in due course. None of the other components should present any difficulty.

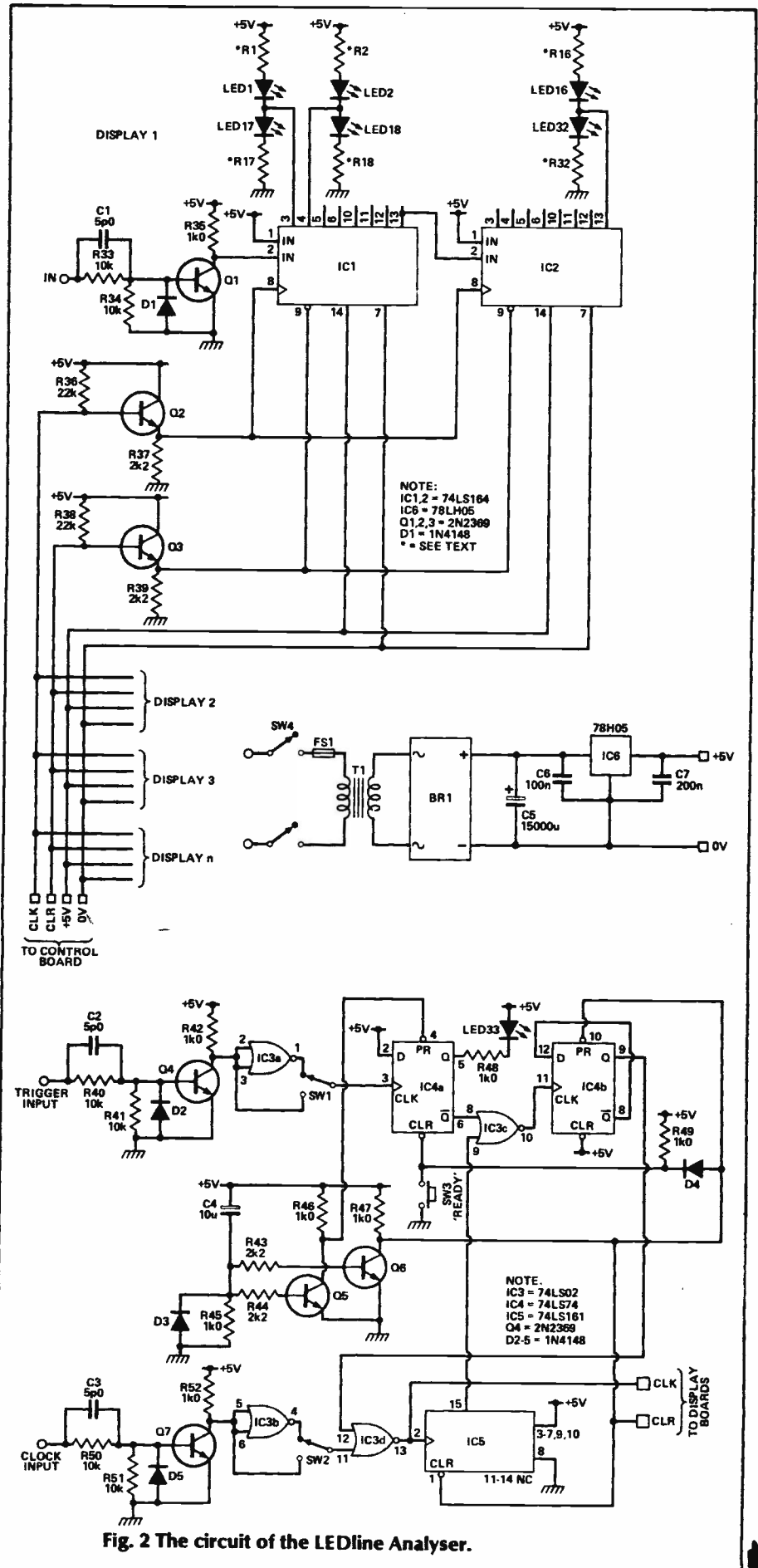
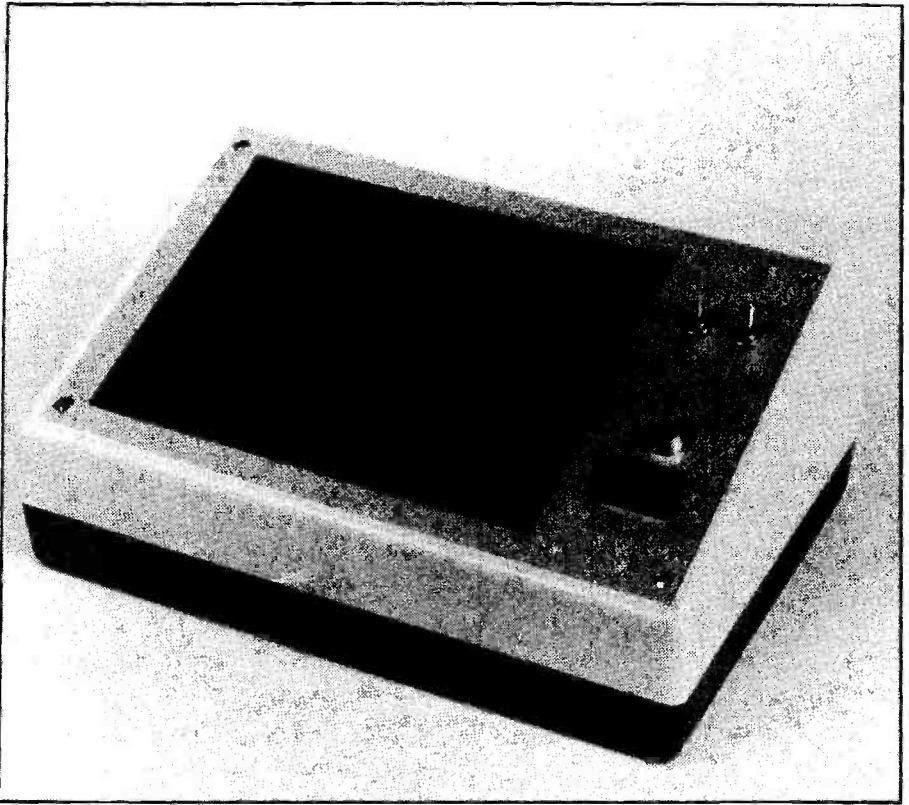

Fig. 2 The circuit of the LEDline Analyser.

The component overlays for the PCBs are shown in Fig. 3. For the display LEDs we used high efficiency, low current types which give a good output at 2mA. If you are building an analyser with only four or so channels, you may prefer to use lower cost LEDs (in which case R1 to R32 must be reduced to 330 ohms). However, for six or more channels, it would be advisable to use the high efficiency types to avoid straining the power supply!

To economise even further, the LEDs 17-32 and the associated resistors R17-32 can be omitted. This would leave just one row of LEDs for each channel. Low logic levels would then be indicated by an unlit LED in the remaining row.

For the analyser inputs you can either have a separate socket on each board (the PCB will accommodate a miniature BNC socket or a 2mm 'banana' socket) or else bring all the inputs to a single connector and make the test connection via a length of ribbon cable. In either case, keep the test leads as short as possible, and pay particular attention to the ground connection.



The prototype LEDline Analyser. This is an eight channel version (with the 256 LEDs behind the central filter on the front panel). The connections to the unit under test are from the rear panel.

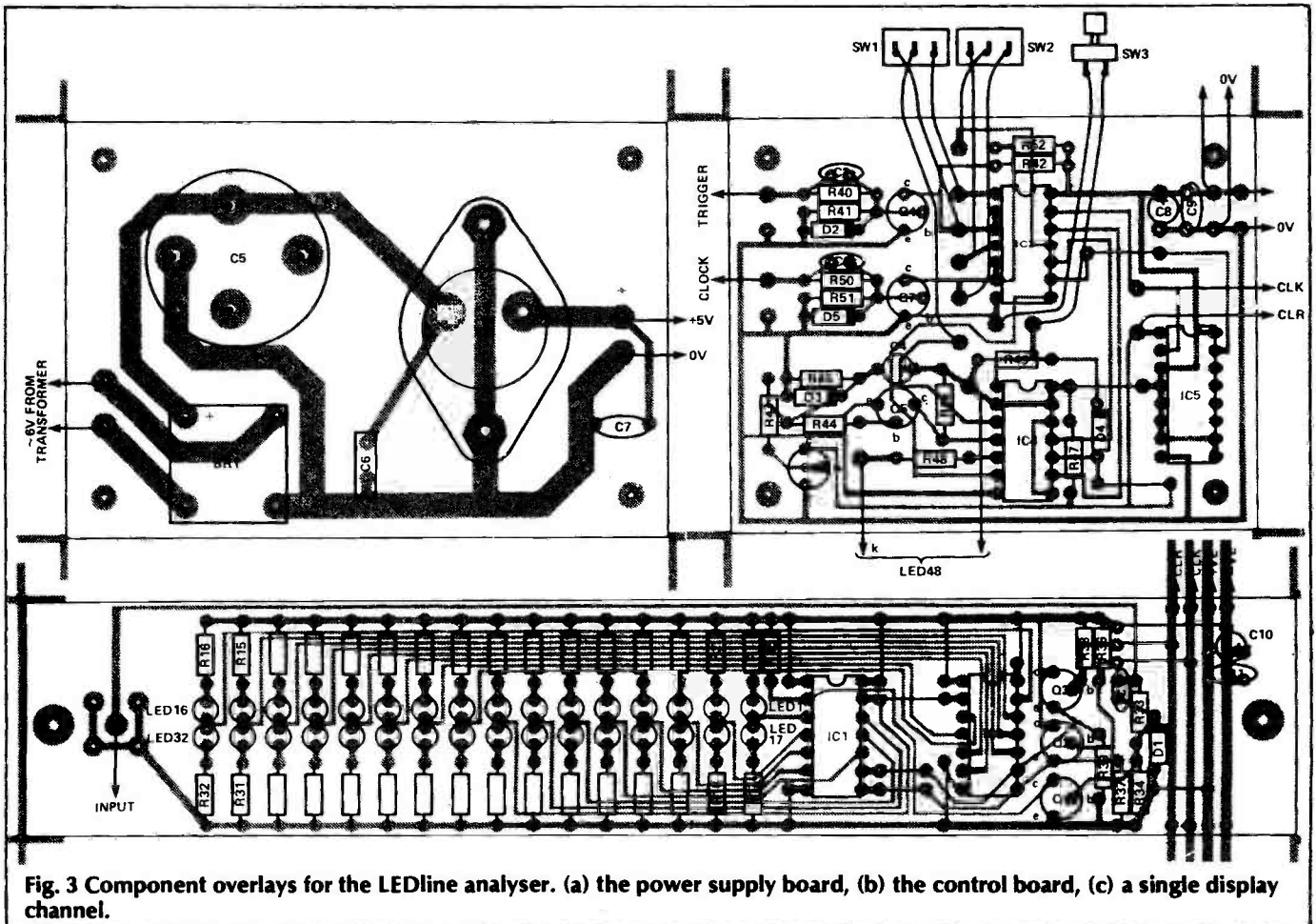
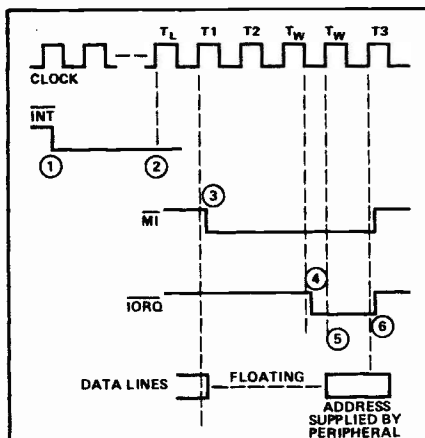

Fig. 3 Component overlays for the LEDline analyser. (a) the power supply board, (b) the control board, (c) a single display channel.

Using The Analyser

A good earth connection between the analyser and the circuit to be tested (the 'unit under test', or UUT, as the ATE trade would have it) is essential, particularly for logic with a clock speed of 1MHz or above. This means keeping the connection short, using relatively heavy gauge wire (32/0.2) and making firm connection to a suitable grounding point on the UUT. Connection test leads to IC pins can be made with a sprung connector such as type 424-175 from Electromail.

I have already mentioned how the analyser might be used to investigate a Z80 interrupt. With this IC, an interrupt acknowledge cycle is identified by both $\overline{M1}$ and \overline{IORQ} going low. Having triggered the analyser from \overline{INT} and captured the data, the next step would be to scan along the line of LEDs until you find the 0 LED lit for both $\overline{M1}$ and \overline{IORQ} . If the analyser has been clocked from the rising edge of the Z80's clock, you will have found point 5 of Fig. 4 — the rising edge of the clock on the second 'wait' cycle. The very next column of LEDs along (captured on the rising edge of T_3) will give you the bits the Z80 will take to be the lower byte of the interrupt vector. If these are not what you intended, you've found the fault!



Note: At point 1 the peripheral takes the Z80 interrupt line low. The Z80 ignores the interrupt until the final clock cycle of the current instruction (T_L) when, at point 2, it tests the interrupt line and prepares for an interrupt acknowledge cycle. At point 3 $\overline{M1}$ goes low (as it would for the opcode fetch which would usually follow the completion of an instruction) and 2½ clock cycles later (point 4) \overline{IORQ} goes low, identifying the cycle as an interrupt acknowledge. At point 6 the bits present on the data lines will be read into the Z80 and used as a pointer to the interrupt service routine. This is the critical point for deciding whether the peripheral is supplying the correct data.

Fig. 4 Simplified timing diagram of the Z80 interrupt acknowledge, mode 2.

However, note that the acknowledge sequence may vary. Extra 'wait' states could be inserted by the hardware, for example.

When using the analyser with asynchronous or 'event driven' logic there is no obvious signal available to connect to the analyser's clock. In fact it is probably better to regard the clock input as the 'sample time' input — even on synchronous logic. If we stick to the Z80 for a moment, a better way to sample the interrupt data might be to use \overline{IORQ} to clock the analyser. Once again, the trigger could come from \overline{INT} , and data would be clocked in whenever \overline{IORQ} went high, so up to 16 interrupts could be sampled. Of course, you would have to be sure the Z80 was not performing any other I/O routines in between, otherwise these would be recorded too. The same principle applies to testing asynchronous logic — find a signal which marks the event you wish to record, and use this to clock the analyser.

Improvements

The analyser was designed to be as simple as possible, consistent with performing a useful function. The Readers' Survey has shown many readers like to modify ETI circuits (How dare you!), so here are a few ideas.

An improved triggering function could be an advantage. To return yet again to Fig. 4, it could be useful to trigger the circuit only when both $\overline{M1}$ and \overline{IORQ} were low. With an extra trigger input and logic gate, this could be arranged without difficulty. An OR triggering function is another possibility — it may sometimes be desirable to set the analyser going when either one of two different events occur.

With intermittent faults, it might be useful to detect the occurrence of the fault and to know the logic states which led up to it. In this case, the analyser could sample continuously and the trigger would be used to stop the recording rather than to start it. When the fault condition appeared, the analyser would then freeze the preceding 16 logic states which could give a clue to the cause of the fault.

Yet another possibility would be a delay in the clock line. If you wanted to record the data clocked into a register, it may be an advantage to clock the analyser from the register's clock input but to record when the data has had a chance to settle at the register's outputs.

There are numerous other possibilities — don't forget our Tech Tips section if you come up with anything good!

ETI

PARTS LIST

CONTROL BOARD AND POWER SUPPLY

RESISTORS (all ¼W, 5%)
R40, 41, 50, 51 10k
R42, 45, 46, 47, 48 1k
R43, 44 2k2

CAPACITORS

C1, 3 5p ceramic
C4 10µ 6V tantalum
C5 15,000µ 16V electrolytic
C6 100n polyester
C7 200n polyester
C8, 10 10µ tantalum
C9 100n Cer.

SEMICONDUCTORS

IC3 74LS02
IC4 74LS74
IC5 75LS161
IC6 78H05
Q4-7 2N2369
D2-5 1N4148
BR1 200V, 6A bridge rectifier

MISCELLANEOUS

Transformer (6V, 20VA), fuse, fuse holder, mains switch, heat sink or regulator, case, PCBs, test leads and connectors, pushbutton and 2 x SPDT switches.

DISPLAY BOARD

One set of the components listed below will be required for each channel.

RESISTORS (all ¼W, 5%)
R1-32 1k0 (see text)
R33, 34 10k
R35 1k0
R36, 38 22k
R37, 39 2k2

CAPACITORS

C1 5p ceramic
C10 10µ 6V tantalum
C11 100n ceramic

SEMICONDUCTORS

IC1, 2 74LS164
Q1-3 2N2369, 2N2222, or similar high speed switching transistor
LED1-16 High efficiency green LED
LED17-32 High efficiency red LED
D1 1N4148

TECH TIPS

Trailer Light Controller

P. J. Dinning
Newcastle-upon-Tyne

A trailer's lights put a heavy demand on the towing car's system and can change the flash rate of indicators, burn out the flasher unit or damage the brake light switch. This circuit will allow extra indicator and brake lights to be safely added to a car's electrical system, typically drawing only 4% extra current.

The circuit also provides for a pilot light to indicate correct functioning of the flashers and another to warn of bulb failure in the brake light circuit.

TIP35 transistors are specified, but any plastic power type is suitable provided it has a collector current rating of at least 15A. This is because bulbs which consume 1.75A when lit have cold surge currents around five times greater. Darlington transistors should not be used.

The base-emitter resistors (R1 and R2) are included because of the high temperatures experienced in cars and trailers. They prevent the transistor turning on due to leakage.

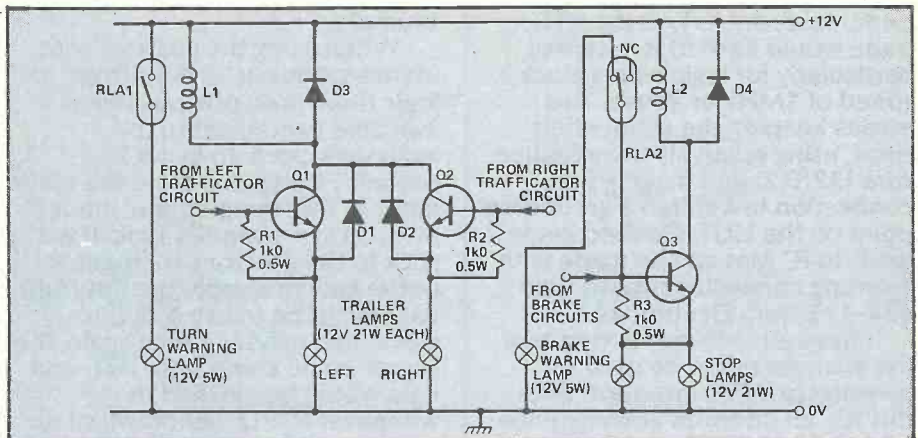

Freewheel diodes D1 and D2 prevent voltage spikes damaging the transistors.

The relays RLA1 and RLA2 are reed switches. In the prototype, an Electromail type 338-147 was used for the flasher circuit and type 338-888 for the brake circuit. These are rated at 40 Ampere turns to operate. With one flasher or brake light bulb the coils L1 and L2 should be 23 turns of 1mm copper wire. For two bulbs 12 turns should be enough. The coil should be wound in one or two layers around the centre of the reed switch and secured with a rubber adhesive (epoxy glues should

not be used as the reed switches are fragile).

Stop light and flasher bulbs use a common return system through the car's bodywork and many weird effects can be traced to poor or rusted earth connections. This should be born in mind when fault finding.

The unit can be easily constructed in a small diecast box, which would also provide heatsinking for the transistors. The TIP35 tabs are connected to the collector and should be insulated with bushes and mica washers. If a steel box is used the reeds should be mounted at least 1" away from the sides.

50Hz Inverter

Andy Armstrong
Leighton Buzzard

This circuit uses an ordinary mains transformer in reverse to give an output of about 220VAC at approximately 50Hz. A toroidal transformer, such as the ILP 30VA type, is suitable.

Darlington power transistors are used to drive the secondary of the mains transformer with a 50Hz square wave. This type of transistor includes an internal anti-parallel diode which catches any spikes due to leakage reactance. Any constructors wishing to make their own Darlings from discrete transistors should add diodes with the cathode towards the transformer to fill this function.

The base drive for the power transistors is provided by a conventional multivibrator. The component values are shown to give operation at just over 50Hz. It is better to run the circuit at just over rather than just under because at lower frequencies there is a danger that the transformer will saturate.

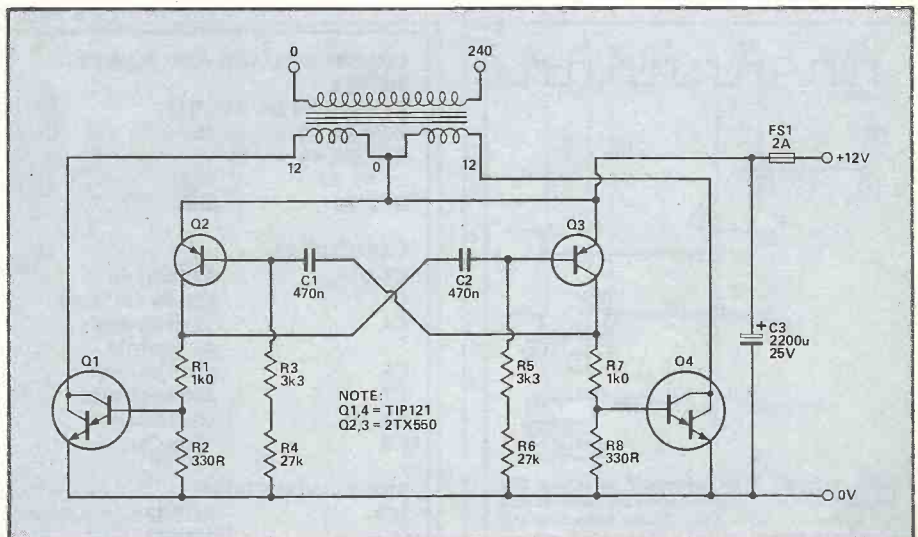

The choice of Q2 and Q3 is important to ensure that the circuit operates reliably, because it is heavily loaded. In some cases BC212s will work but this cannot be relied upon. The circuit will not work reliably unless the connections between the transformer centre tap, the emitters of the power transistors and C3 are all kept short.

This circuit has proved useful as a shaver adaptor to enable me to shave on the way to work while stuck at the traffic lights. There is always enough traffic holdup to allow time for shaving and it means a few minutes more sleep in the morning. This is probably as dangerous as using a telephone on the move, but the unit might be useful for camping.



FROM



ILP Toroidal Transformers are now available through Jaytee. The UK Distributor with the availability and service to match the quality of the toroidals.

Jaytee Electronic Services
 Dept 20, 143 Reclucer Road, Bellinge,
 Heme Bay, Kent CT6 6PL
 Telephone: (0227) 375254

FOR FREE DATA PACK PLEASE
 WRITE TO OUR SALES DEPT.

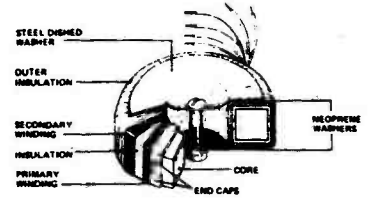

TYPE	SERIES NO.	SEC. VOLTS	R.M.S. CURRENT
15VA Regulation 19% 62 x 34 (See diagram) 0.35 Kgs Mounting bolt M4 x 12	03010	6-6	1.25
	03011	9-9	0.83
	03012	12-12	0.63
	03013	15-15	0.50
	03014	18-18	0.42
	03015	22-22	0.34
	03016	25-25	0.30
30VA Regulation 18% Size A B C 70 35 37 0.45 Kgs Mounting bolt M5 x 50	13010	6-6	2.50
	13011	9-9	1.66
	13012	12-12	1.25
	13013	15-15	1.00
	13014	18-18	0.83
	13015	22-22	0.68
	13016	25-25	0.60
60VA Regulation 13% Size A B C 80 40 43 0.9 Kgs Mounting bolt M5 x 50	23010	6-6	4.16
	23011	9-9	2.77
	23012	12-12	2.08
	23013	15-15	1.66
	23014	18-18	1.36
	23015	22-22	1.13
	23016	25-25	1.00
	23017	30-30	0.83
	23028	110	0.45
	23029	220	0.22
90VA Regulation 12% Size A B C 95 40 43 1.0 Kgs Mounting bolt M5 x 50	33010	6-6	6.66
	33011	9-9	4.44
	33012	12-12	3.33
	33013	15-15	2.66
	33014	18-18	2.22
	33015	22-22	1.81
	33016	25-25	1.66
	33017	30-30	1.33
	33028	110	0.72
	33029	220	0.36
120VA Regulation 11% Size A B C 95 45 50 1.2 Kgs Mounting bolt M5 x 50	43010	6-6	10.00
	43011	9-9	6.66
	43012	12-12	5.00
	43013	15-15	4.00
	43014	18-18	3.33
	43015	22-22	2.72
	43016	25-25	2.40
	43017	30-30	2.00
	43018	35-35	1.71
	43028	110	1.09
43029	220	0.54	
43030	240	0.50	

TYPE	SERIES NO.	SEC. VOLTS	R.M.S. CURRENT
180VA Regulation 8% Size A B C 110 45 50 1.8 Kgs Mounting bolt M5 x 50	53011	9-9	8.89
	53012	12-12	6.66
	53013	15-15	5.33
	53014	18-18	4.44
	53015	22-22	3.63
	53016	25-25	3.20
	53017	30-30	2.66
	53018	35-35	2.28
	53026	40-40	2.00
	53028	110	1.45
225VA Regulation 7% Size A B C 110 50 55 2.2 Kgs Mounting bolt M5 x 60	63012	12-12	9.38
	63013	15-15	7.50
	63014	18-18	6.25
	63015	22-22	5.11
	63016	25-25	4.50
	63017	30-30	3.75
	63018	35-35	3.21
	63026	40-40	2.81
	63025	45-45	2.50
	63033	50-50	2.25
300VA Regulation 6% Size A B C 110 57 62 2.6 Kgs Mounting bolt M5 x 60	73013	15-15	10.00
	73014	18-18	8.33
	73015	22-22	6.82
	73016	25-25	6.00
	73017	30-30	5.00
	73018	35-35	4.28
	73026	40-40	3.75
	73025	45-45	3.33
	73033	50-50	3.00
	73028	110	2.72
600VA Regulation 5% Size A B C 135 60 65 4.0 Kgs Mounting bolt M8 x 70	83016	25-25	10.00
	83017	30-30	8.33
	83018	35-35	7.14
	83026	40-40	6.25
	83025	45-45	5.55
	83033	50-50	5.00
	83042	55-55	4.54
	83028	110	4.54
	83029	220	2.27
	83030	240	2.08

TYPE	SERIES NO.	SEC. VOLTS	R.M.S. CURRENT
625VA Regulation 4% Size A B C 140 70 75 5.0 Kgs Mounting bolt M8 x 90	93017	30-30	10.41
	93018	35-35	8.92
	93026	40-40	7.81
	93025	45-45	6.94
	93033	50-50	6.25
	93042	55-55	5.68
	93028	110	5.68
	93029	220	2.84
	93030	240	2.60

ILP TRANSFORMERS ARE NOW SUPPLIED WITH DUAL PRIMARIES PERMITTING 110V OR 220/240V OPERATION

THE TOROIDAL POWER TRANSFORMER
 Offers the following advantages:-
 SMALLER SIZE AND WEIGHT TO MEET MODERN 'SLIMLINE' REQUIREMENTS.
 LOW ELECTRICALLY INDUCED NOISE DEMANDED BY COMPACT EQUIPMENT.
 HIGH EFFICIENCY ENABLING CONSERVATIVE RATING WHILST MAINTAINING SIZE ADVANTAGES.
 LOWER OPERATING TEMPERATURE.

PRICES

VA	REG.	£	VA	REG.	£
15	0	8.90	160	5	15.64
30	1	10.07	225	6	17.09
50	2	11.21	300	7	18.86
80	3	12.50	500	8	24.63
120	4	13.28	625	9	27.15

SIZES

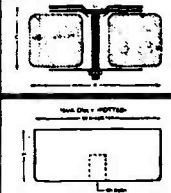

ALL ABOVE PRICES INCLUDE VAT AND CARRIAGE. QUANTITY DISCOUNTS AVAILABLE FOR 6 OR MORE OF ANY ONE TYPE

CROFTON PM101

GREEN SCREEN 9" (P31)
 Metal cased monitor only £45.00 + VAT.
 £51.75 incl. carriage.

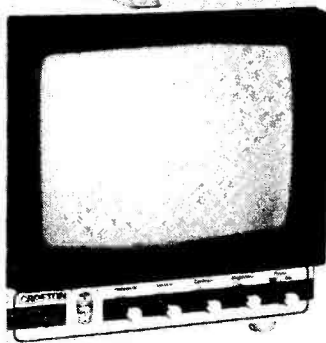

This 9 inch metal cased, monochrome monitor offers you the chance to obtain a high quality product at a budget price!

SPECIAL OFFERS

BRAND NEW professional board and green tube to make 12" T.T.L./comp open home monitor. **ONLY £30 + VAT** and carriage. ZX81 Full sized keyboard in metal case **£13.80**. COMPUTER DESKS **£20**.

THE VIDEO SPECIALISTS

Crofton

(05448) 557

Be sure to ask for our various catalogues. We have a full range of products including:

- 1—Discrete listening devices
- 2—Plugs/sockets/connectors/leads
- 3—Television accessories
- 4—Security products
- 5—Computer products
- 6—NEC cased and uncased monitors

If you would like all our catalogues - Please send a 38p 9 x 12 S.A.E.

THERE'S ALWAYS A SPECIAL DEAL FOR YOU AT CROFTON

If we haven't listed what you are looking for, please ask, we probably have it in stock.

Just starting to refurbish CCTV Cameras, and Monitors, Ask For Details. First Come First Serve, these are very popular items and won't last long.

CCTV camera at attractive prices

PHONE YOUR ORDER NOW!

OFFICIAL ORDERS FROM APPROVED INDUSTRIAL OR EDUCATIONAL ESTABLISHMENTS WELCOME

PHILIPS BM7502
 Also in stock: PHILIPS BM7522
 PHILIPS CT2007

Phone for today's best price

CROFTON ELECTRONICS

KINGSHILL, NEXTEND, LYONSHALL,
 Nr KINGTON, HEREFORDSHIRE HR5 3HZ.

LYONSHALL
 (05448) 557

ETI PCB SERVICE

**Make your project in style -
and avoid bird's nesting
- with a properly designed PCB!**

E8107-1 System A Disc Input bd MC-MM. F	E8405-4 Centronics Interface F	E8508-1 RCL Bridge N
E8107-2 System A Preamp Main ... K	E8405-6 Drum Synth F	E8508-2 EX42/BBC Interface E
E8108-1 System A Power Amp L	E8406-1 Oric EPROM Board O	E8508-3 EPROM Emulator L
E8109-2 System A PSU F	E8406-2 Spectrum Joystick E	E8509-1 Spectrum F
E8201-2 Infant Guard C	E8406-3 Audio Design RIAA Stage ... G	E8509-2 Direct Injection Box E
E8202-5 MM Stage Disc Preamp (Tilsbrook) G	E8406-4 AD Buffer/Filter/Tone H	E8510-9 Sunrise Light Brightener K
E8206-5 Logic Lock F	E8406-5 AD Headphone Amp F	E8511-1 MTE Waveform Generator ... H
E8208-1 Playmate Practice Amp 3bds SA1 K	E8406-6 AD Preamp PSU K	E8511-2 Millifaradometer H
E8212-1 ELCB F	E8406-7 AD Power Amp H	E8511-3 Cymbal Synth J
E8301-2 Analogue to digital conv (ZX81/ Spectrum) E	E8406-8 AD Power Amp PSU J	E8511-5 Chorus Effect H
E8305-3 Dual Audio Power Supply, Linsley Hood G	E8406-9 AD Stereo Power Meter F	E8511-7 Enlarger Exposure Meter F
E8305-5 Balanced Input Preamplifier F	E8406-10 AD Input Clamp C	E8511-8 Switching Regulator E
E8307-2 Flash Trigger-sound or FR F	E8407-1 Warlock Alarm M	E8511-9 Second Line of Defence M
E8308-1 Graphic Equaliser 1/2 Oct/Chnl M	E8408-2 EPROM Emulator N	E8512-1 Specdrum connector F
E8308-2 Servo Fail-safe C	E8408-3 Infrared Alarm Transmitter ... E	E8512-2 MTE Pulse Generator H
E8309-1 NICAD Charger/Regenerator F	E8408-4 Infrared Alarm Receiver F	E8511-3 Specdrum L
E8310-3 Typewriter Interface - EX42 ... F	E8409-1 EX42 Keyboard Interface F	E8601-2 Walkmate L
E8311-1 Mini Drum Synth F	E8409-2 Banshee Siren Unit F	E8601-3 MTE Counter-timer M
E8311-8 Moving Coil Pre-Preamp F	E8410-1 Echo Unit F	E8602-1 Digibaro O
E8312-3 Light Chaser EPROM Controlled (2 Boards) K	E8410-2 Digital Cassette Deck N	E8603-2 Programmable Logic Evaluation Board H
E8402-1 Speech Board M	E8410-3 Disco Party Strobe H	E8603-3 Sound Sampler Analogue Board R
E8402-2 Modular Pre-amp Disc Input Mono F	E8411-5 Video Vandal (3boards) N	E8604-1 JLLH PA PSU H
E8402-3 Modular Pre-amp Stereo Output F	E8411-6 Temperature Controller D	E8604-2 Matchbox Amplifier C
E8402-4 Modular Pre-amp Relay, PSU F	E8411-7 Mains Failure Alarm D	E8604-3 Matchbox Amp Bridging Version C
E8402-5 Modular Pre-amp Tone Main Mono F	E8411-8 Knite Light D	E8604-4 MTE Analogue/Digital Probe M
E8402-6 Modular Pre-amp Tone Filter, Stereo F	E8411-9 Stage Lighting Interface F	E8605-1 Microlight Intercom E
E8402-7 Modular Pre-amp Balanced Output F	E8411-10 Perpetual Pendulum E	E8605-2 Baud Rate Converter M
E8402-8 Modular Pre-amp Headphone Amp F	E8412-1 Spectrum Centronics Interface F	E8605-3 Baud Rate Converter PSU Board G
E8404-2 Mains Remote control Receiver F	E8412-4 Active - 8 Protection Unit F	E8605-4 Portable PA H
E8405-1 Auto Light Switch F	E8412-5 Active - 8 Crossover F	E8606-1 Midi-CV Converter Board ... H
E8405-2 ZX81 EPROM Programmer ... N	E8412-6 Active - 8 LF EQ F	E8606-2 Midi-CV Converter PSU D
E8405-3 Mains Remote Control Transmitter H	E8412-7 Active - 8 Equaliser F	E8606-3 Troglograph F
	E8501-3 Digital Delay (2 boards) T	E8606-4 80m Receiver H
	E8502-1 Digital Delay Expander N	E8606-5 Sound Sampler R
	E8502-2 Data Logger J	E8607-1 Direction E
	E8503-1 Combo Preamplifier F	E8607-2 Upgradeable Amp, MC stage (Stereo) G
	E8503-2 THD Meter mV & oscillator bds (2 boards) K	E8607-3 BBC Motor Controller F
	E8503-3 THD Meter Mains PSU F	E8608-1 Digital Panel Meter G
	E8504-1 Framestore Memory M	E8608-2 Upgradeable Amp, MM stage (mono) H
	E8504-3 Framestore Control N	E8609-1 Mains Conditioner E
	E8504-4 Buzby Meter E	E8609-2 Experimental preamp F
	E8504-5 CCD Delay F	E8609-3 Upgradeable amp, Tone board (mono) H
	E8505-5 Stereo Simulator F	
	E8506-1 Audio Mixer Main J	
	E8506-2 Audio Mixer PSU F	
	E8506-3 Audio Mixer RIAA D	
	E8506-4 Audio Mixer Tone Control ... D	
	E8506-5 EPROM Prog MKII O	

BOARDS AVAILABLE

- E8609-4 Upgradeable amp, Output board (mono)..... F
- E8610-1 Audio Analyser Filter Board L
- E8610-2 Audio Analyser Display Driver..... K
- E8610-3 Audio Analyser Display..... H
- E8610-4 Audio Analyser Power Supply F
- E8611-1 Audio Switcher (2 bds)..... H
- E8611-2 PLL Frequency meter (4 bds)...Q
- E8611-3 Upgradeable Amp PSU J
- E8611-4 Call meter, main bd. O
- E8611-5 Call meter, interface bd..... N
- E8612-1 Bongo Box..... J
- E8612-2 Biofeedback monitor (Free PCB) E
- E8701-1 RGB Converter..... F
- E8701-2 Mains Controller..... D
- E8701-3 Flanger..... H
- E8701-4 Audio Selector main board... M
- E8701-5 Audio Selector PSU F
- E8701-6 Tacho-Dwell..... H
- E8702-1 Ratemeter main board..... K
- E8702-2 Ratemeter ranging board..... F
- E8702-3 Photo Process Controller (3bds)..... O
- E8702-4 LEDline display board (2 off) K
- E8702-5 LEDline PSU and controller (2 bds) C

Please use the form below (or a photocopy of it) to make your order. Be sure to quote the board reference number and price code correctly - mistakes will delay your order.

The board reference number tells you when a particular project was published: the first two numbers are the year and the third and fourth numbers tell you the month; the number after the hyphen indicates the particular project. Re-prints of all articles are available for a small charge from our photocopy service - see the separate page (not printed in every issue of ETI). Please note

that complex projects are usually published in several parts.

Our terms are strictly cash with order. Unfortunately, we cannot accept official orders, but we can supply a pro-forma invoice for you to raise a cheque against. We must stress, however, that your order will not be worked on until payment is received.

The boards listed below are all that are available at the moment. We hope to make more types available in the future, but no details will be available for some while (so please don't phone us to ask!).

Please allow 28 days for delivery

ORDER FORM

**TO: ETI READERS' SERVICES DEPARTMENT
Argus Specialist Publications Ltd,
9 Hall Road, Hemel Hempstead,
Herts HP2 7BH**

Please supply:

No. required per type	Board reference number	Price letter	Price each £	Total for board type £
	E	-	£ . p	£ . p
	E	-	£ . p	£ . p
	E	-	£ . p	£ . p
	E	-	£ . p	£ . p

POSTAGE & PACKING £ 0.75p
TOTAL ENCLOSED £ . p

ORDER TO BE SENT TO: (BLOCK CAPS PLEASE)

Name

Address

Postcode

(Make cheques payable to ASP Ltd)
ACCESS and VISA credit card orders can be taken on 0442 211 882 (office hours only).

Price Code	Price (inc VAT) £
C	1.80
D	2.50
E	3.23
F	4.00
G	4.75
H	5.50
J	6.62
K	7.20
L	8.80
M	10.60
N	13.10
O	15.80
P	17.90
Q	21.80
R	23.90
S	25.90
T	29.00
U	32.20
V	35.80
W	37.90
X	40.70

PCB FOIL PATTERNS

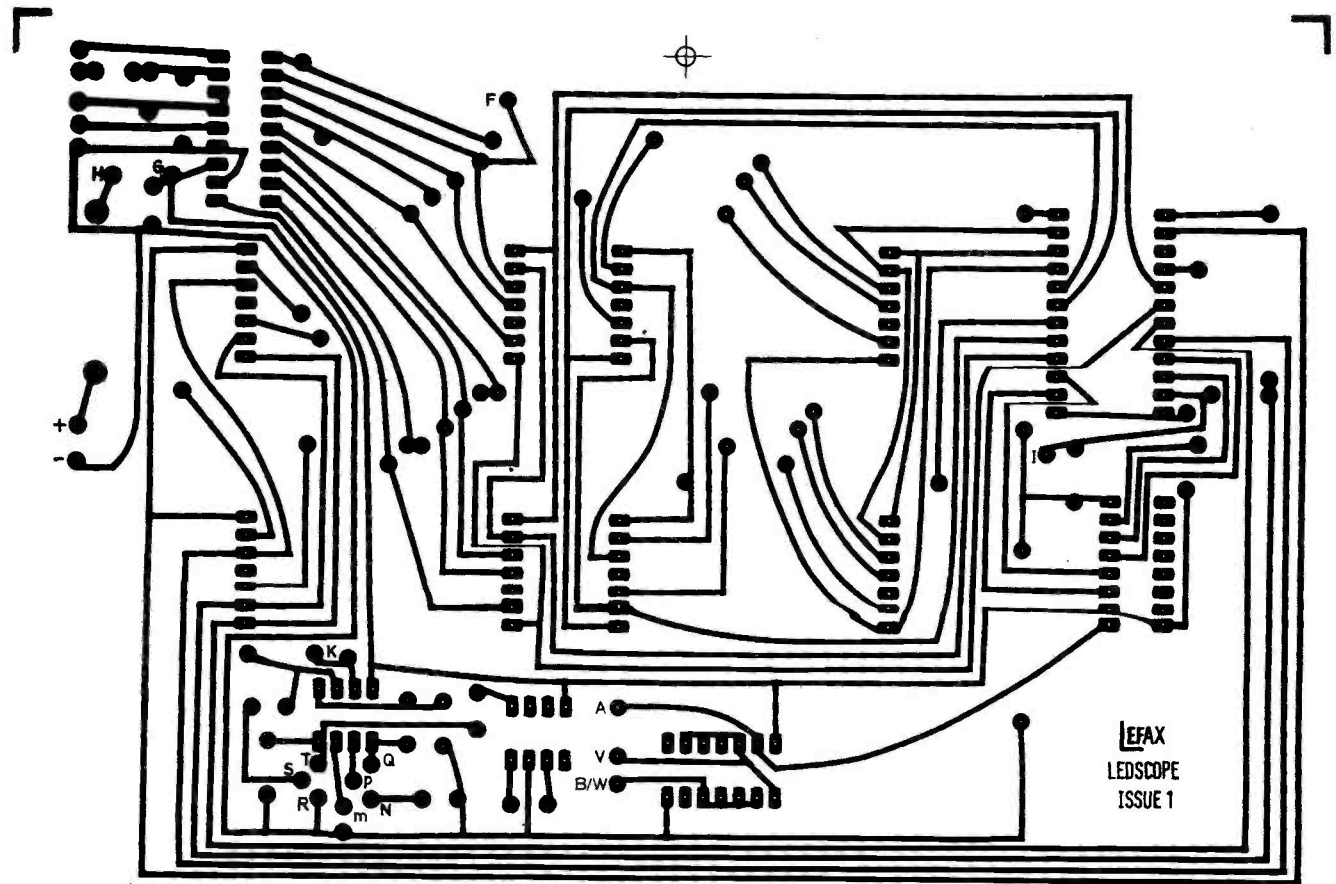

The foil pattern for the LEDscope board, held over from last month.

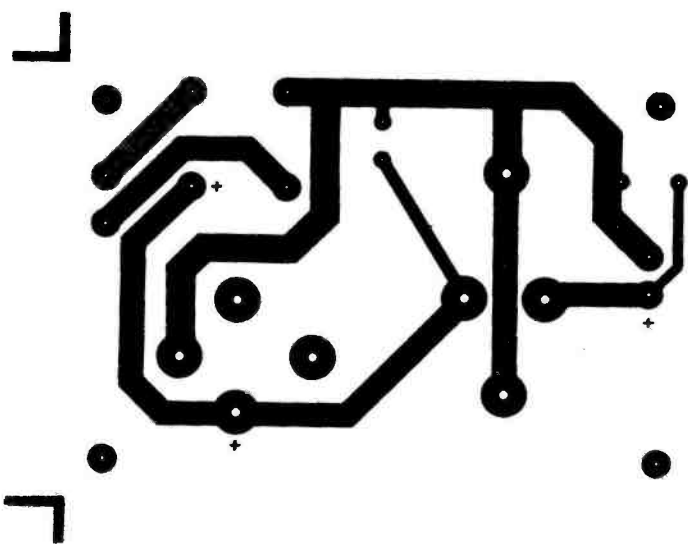

The LEDline PSU board.

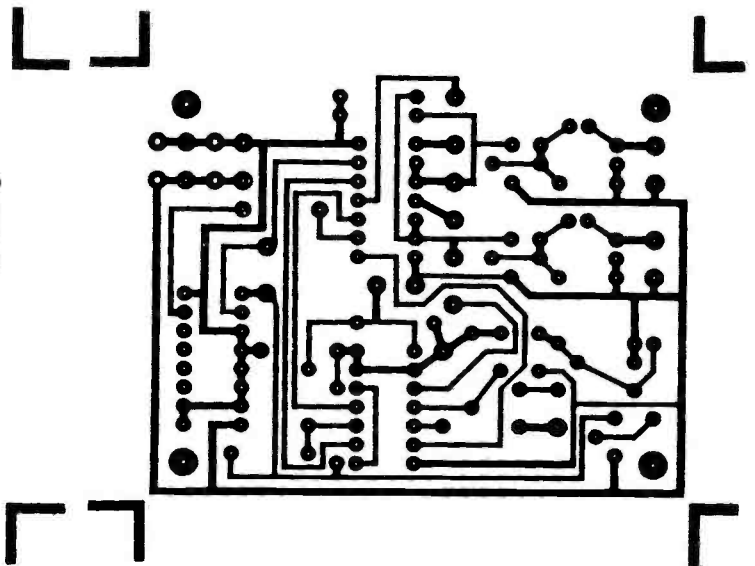

The controller board for the LEDline.

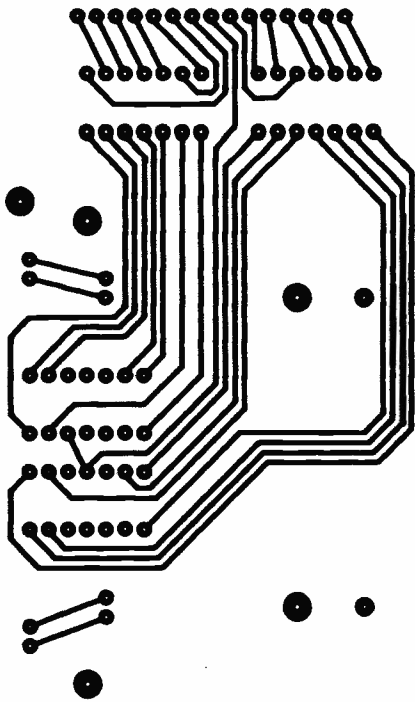

Display Board

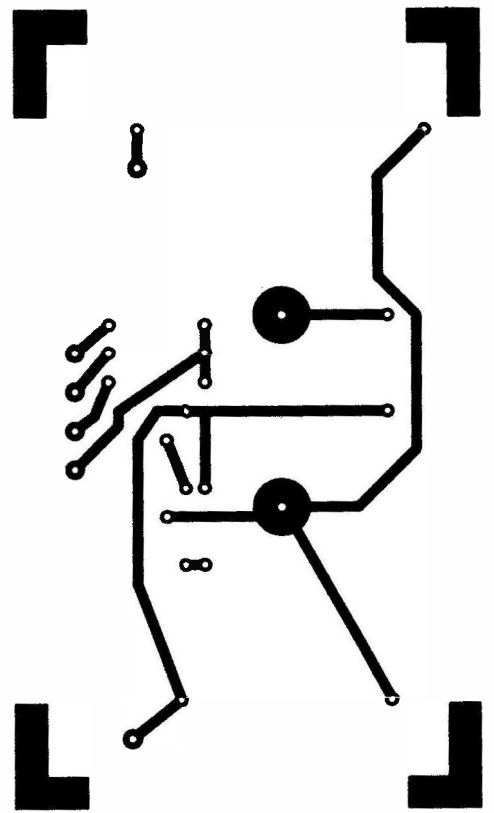

The Geiger Ratemeter ranging board.

The Photo Process Controller display board foil pattern.

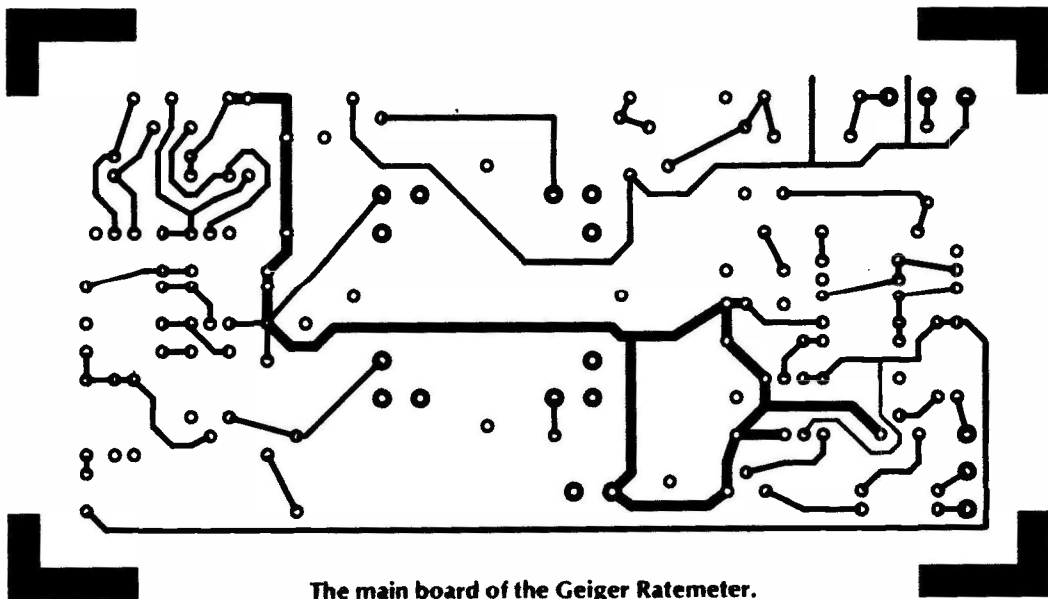

The main board of the Geiger Ratemeter.

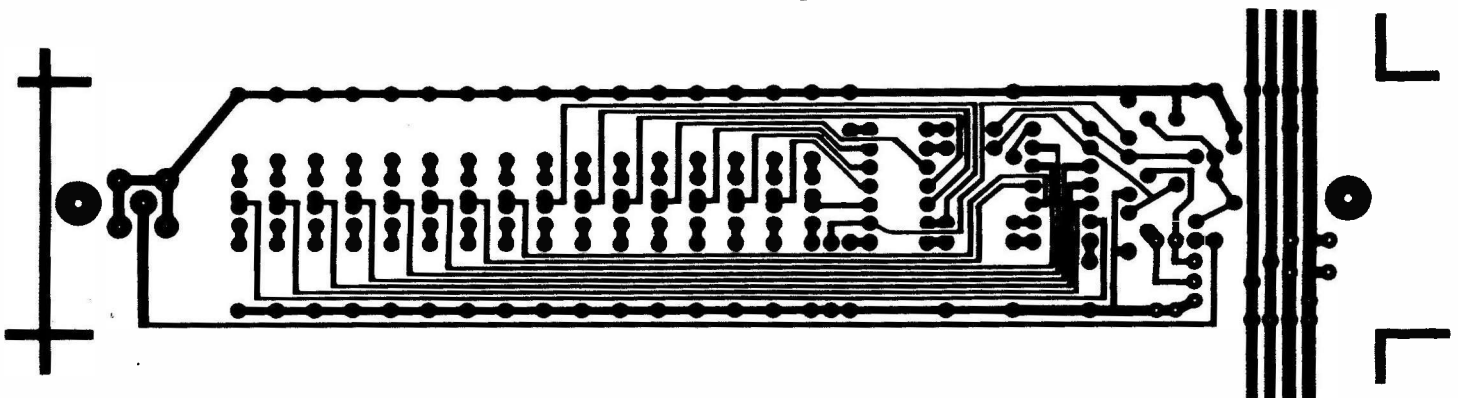

The foil pattern for the LEDline display board.

PCB FOIL PATTERNS

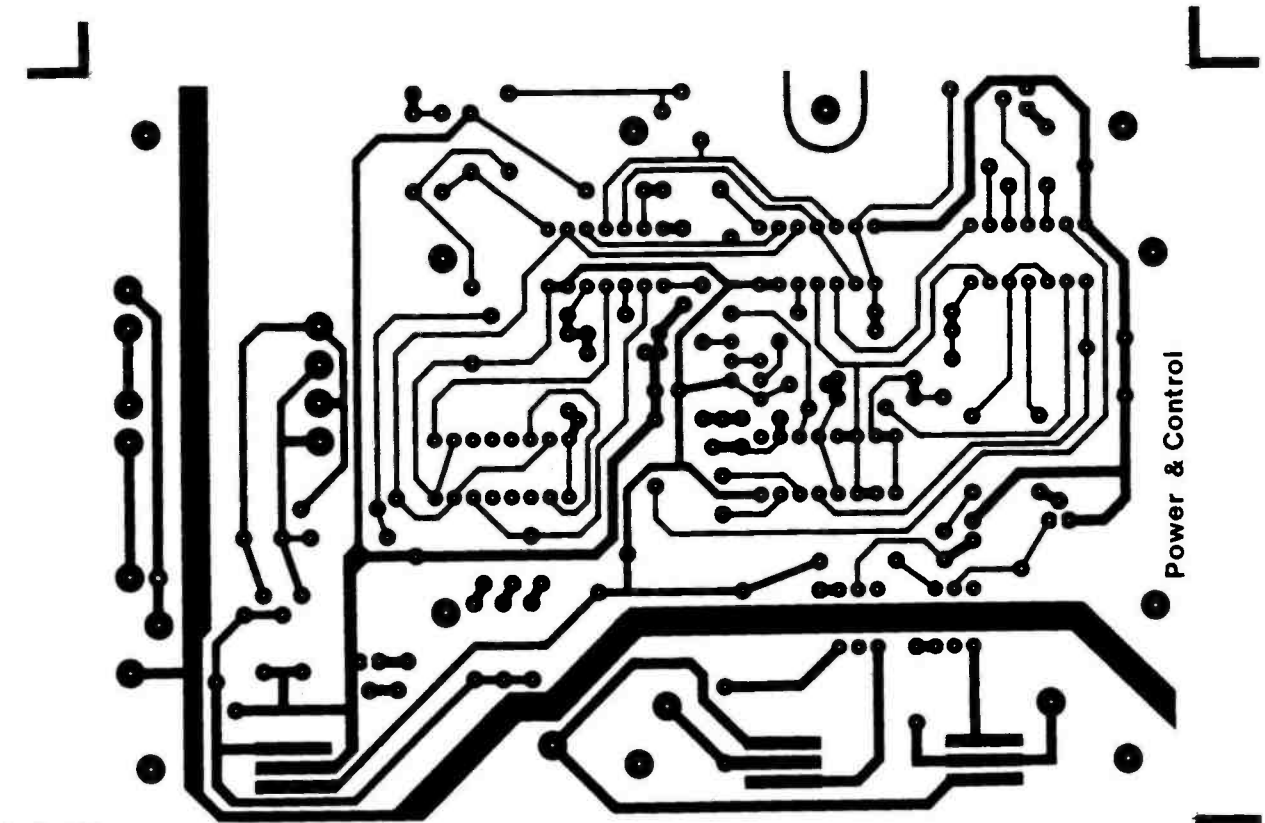

The main board of the Photo Process Controller.

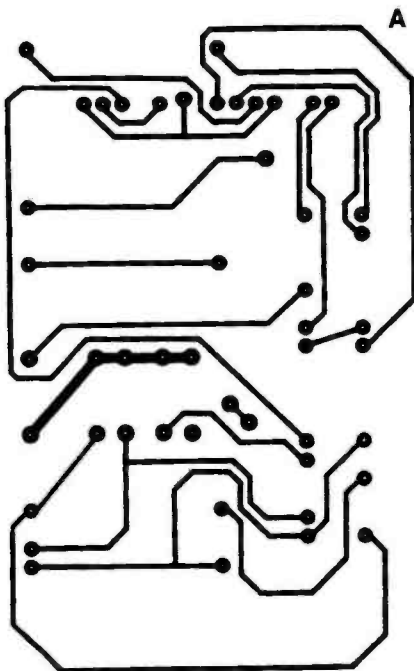

X Counter & Driver

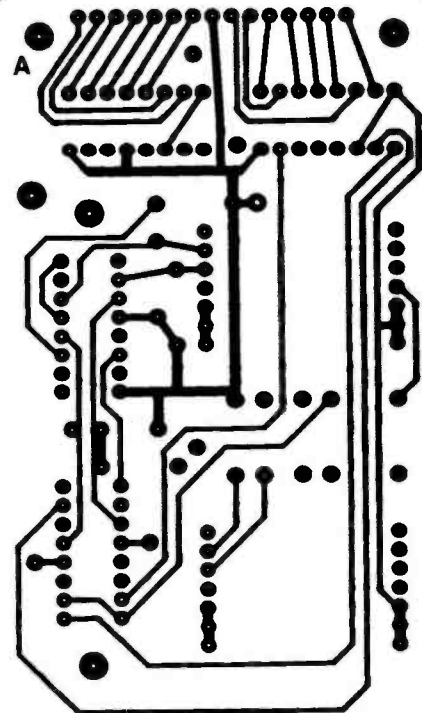

Counter & Driver X

The top and bottom foils for the Photo Process Controller counter board.

<p>OSCILLOSCOPES</p> <p>TELEQUIPMENT 075 Dual Trace 50MHz Delay Sweep £260</p> <p>COSSOR CDU150, Dual Trace 35MHz Solid State Portable 8"x10cm display. With Manual £290</p> <p>GOULD OS255, Dual Trace 15MHz £290</p> <p>TELEQUIPMENT D61A, Dual Trace 10MHz. With Manual £175</p> <p>S.E. LABS SM111, Dual Trace 10MHz Solid State. Portable AC or External DC operation 8"x10cm display. With Manual £160</p> <p>TELEQUIPMENT D43, Dual Trace 15MHz. With Manual £180</p> <p>TELEQUIPMENT S54A, Single Trace 10MHz. Solid State. With Manual £110</p> <p>Philips PM3230 Dual Beam 10MHz. Solid State £180</p>	<p>COMMUNICATION RECEIVERS</p> <p>Racal RA17L 500KHz-30MHz ... ONLY £140 each with manual</p> <p>Eddystone 730/4 480KHz-30MHz only £110 each with manual.</p> <p>SPECIAL OFFERS</p> <p>B + K Precision CRT Restorer/Analyser Model 457 Supplied with 2 bases and Manual. (P&P £7) ONLY £125 each</p> <p>LABGEAR Colour Bar Generator KGI, 8 Test Patterns (P&P £4) ONLY £40 each</p> <p>CROSSMATCH GENERATOR TYT5R</p> <p>Crossmatch/Dots/White RF & Video Outputs. Tuner Control (P&P £4) £20</p> <p>Degaussing Coils (P&P £4) £20</p> <p>ADVANCE AM SIGNAL GENERATOR S662B, 150 KHz-220MHz £45</p> <p>ADVANCE AM SIGNAL GENERATOR Type 62, 150KHz-220MHz £20</p> <p>METRIX WOBBLATOR Type 210, 5-220MHz £20</p> <p>PHILIPS WOBBLATOR GM2677S 5-220MHz & 440-880MHz £100</p> <p>LABGEAR COLOUR BAR GENERATOR CM6037 (P&P £4) £30</p> <p>RACAL 32MHz UNIVERSAL COUNTER TIMER Type 836 £25</p> <p>MARCONI TF2604 (Later version of TF 1041 VTM) 20Hz-1500MHz; AC/DC/Ohms AC 300mV-300V FSD £20</p> <p>MARCONI VALVE VOLTMETER TF2000 10Hz-100MHz; 1mV-300V FSD £40</p> <p>PHILIPS COLOURBAR GENERATOR type 5501 (P&P £5) £100</p> <p>PHILIPS COLOURBAR GENERATOR type 5508. Video out. Many Functions £120</p>
<p>MULTIMETERS</p> <p>AVO 9 Mk 4 (Identical to AVO 8 Mk 4 but scaled differently) Complete with Batteries & Leads £55</p> <p>AVO 8 Mk 2 Complete with Batteries & Leads £45</p> <p>Above items in GOOD WORKING ORDER - appearance not A1 hence the price</p> <p>AVO TEST SET No 1 (Military version of AVO 8) Complete with batteries, leads & Carrying Case £50</p> <p>AVO Model 7x. Complete with batteries, leads & carrying case £40</p> <p>AVO Model 73. Pocket Multimeter (Analogue) 30 ranges. Complete with batteries & leads £18</p> <p>AVO 72 - Similar to above but no AC current range. With batteries & leads £10</p> <p>ADVANCE/GOULD DRYS</p> <p>Auto ranging; max reading 20,000 AC/DC volts - resistance only £20 p&p £5</p> <p>AVO TRANSISTOR TESTER TT108</p> <p>Handled. GO/NO GO for In-situ Testing. Complete with batteries, leads & instructions. (p&p £3) NOW ONLY £12</p>	<p>NEW EQUIPMENT</p> <p>HAMEG OSCILLOSCOPE 605, Dual Trace 60MHz, Delay Sweep - Component Tester £267</p> <p>HAMEG OSCILLOSCOPE 203 G Dual Trace 20MHz. Component Tester With 2 Probes £290</p> <p>All Other Models Available.</p> <p>BLACK STAR FREQUENCY COUNTERS P&P £4</p> <p>Meteor 100 - 100MHz £90</p> <p>Meteor 900 - 600MHz £120</p> <p>Meteor 100 - 1GHz £175</p> <p>BLACK STAR JUPITOR 500 FUNCTION GENERATOR. Sine/Square/Triangle, 0.1Hz - 500KHz. P&P £4 £110</p> <p>HUNG CHANG DMM 7030, 3 1/2 digit. Hand held 20 ranges including 10 Amp AC/DC 0.1%. Complete with Battery and Leads P&P £4 £29.00</p> <p>OSCILLOSCOPES PROBES. Switched x1; x10. P&P £2 £11</p>
<p>ISOLATING TRANSFORMERS</p> <p>240V INPUT - 240V OUTPUT</p> <p>500 VA £15ea P&P £5 100 VA £6ea P&P £2</p> <p>DISK DRIVE PSU 240V 1N; 5V 1.5A & 12V 1.5A out. Size: W125mm, H75mm, D100mm. Case. On-board. Only £10.00 each (P&P £2)</p> <p>Overly keyboard (as in Lynx Micro). Push to make. Cased £5 each (P&P £2)</p> <p>Various 5 1/4" Floppy Disk Drives and Stepping Motors Available</p>	<p>Used equipment - with 30 days guarantee. Manuals supplied if possible.</p> <p>This is a VERY SMALL SAMPLE OF STOCK. SAE or Telephone for Lists. Please check availability before ordering. CARRIAGE all units £16. VAT to be added to Total of Goods & Carriage.</p>

STEWART OF READING

110 WYKEHAM ROAD, READING, BERKS RG6 1PL

Telephone: 0734 68041 Callers welcome 9 am - 5.30 pm Mon.-Fri. (until 8 pm Thurs.)

Readers' Ads

WANTED. Photo-copy of matchbox amplifier, ETI April 1986. Mr. Harries, 17 Eccleshall Ave., Oxley, Wolverhampton WV10 6TN.

ELECTRONICS BOOKS and 'teach-in' courses SAE for list. Anderson, 22 Landaw House, Chatsworth Road, London NW2 4BW.

COMMODORE 64 computer printer, disk drive, cassette, software, Simons Basic ROM. £295 or split. 01-541-3361.

GOOD PRICE paid for someone to assemble/test BATC project. Mr. D.J. Oliver, 100, May Lane, Kings Heath, Birmingham, B14 4AG.

ENGINEER WANTED for RF design/construction to share patent and exploitation. Lewis Santos, 174 Raebush Ave., Surbiton KT5 9ED. 01-4399 6394.

WANTED VHF/UHF Scanner No Gaps. And capacitive discharge car ignition system. Robin (Ilkley) (0943) 608731.

LASER 5mW coherent light spiroscope. £400.00. Ast. lighting controllers. Details: Dave Grubb, 23, Middle St. Worcester. (0905) 29690 evenings.

SPECDRUM INTERFACE £20 or swop for a Trojan Light pen or similar. Phone Tim 5-6pm (0934) 22577. Weston-Super-Mare.

TELEQUIPMENT SCOPES D64 storage and D65 15MHz delay type with manual £180 each. Windsor (0753) 860889.

WANTED. Microtan DOS (Latest). Eprom or tape. Must be reasonable. Tel: (05255) 4848.

WANTED: books/magazines concerning Baird mechanical T.V. (pre-1935). Perth 37165. Write: 17 Pitcullen Terrale, Perth.

ETI CLICK ELIMINATOR January 1979. PCB wanted (blank, complete or partly-constructed). Tewkesbury (0684) 297205.

V.E.L. Argentina Sinclair service. Want information and surplus for Spectrums. Rawson 340, Buenos Aires, Argentina.

COMPONENTS, NEW ASSORTED WORTH £10. £2.50p per bag inclusive post packing. Mr. D.J. Brown, 2 Glentworth Avenue, Whitmore Park, Coventry, West Mids. CV6 2HW. Keresley 3195.

FOR SALE electronic components at greatly reduced prices. Telephone (035 96) 518 for further details.

EPROM 27C64-75 CMOS £4 each. 6264LP 8K SRAM £2 each. Both new, Hitachi. Phone (0705) 454352. Evening/Weekends.

27C64-150ns HITACHI CMOS EPROM. Brand new, full spec. £4 each inclusive. Phone (0705) 454352 evenings.

Universal Semiconductor Devices Ltd.

17 Granville Court, Granville Road, Hornsey, London N4 4EP, England. Tel: 348 8420/8425* Tlx: 25157 uadco g



We offer one of the largest ranges of semiconductors at highly economical prices. The following semiconductor types are available from stock. If we don't stock what you need then we can get it fast from our facilities in West Germany and USA upon request.

TRANSISTORS - Bipolars - Germanium and Silicon
Small signal
Power
Darlington - all shapes and sizes
VHF/UHF devices - all shapes and sizes

FETS - Power Mosfets
Unijunctions

DIODES - Germanium and Silicon
Rectifiers and Bridges
Opto-Electronic devices
LEDs of all shapes and sizes

THYRISTORS and TRIACS - All shapes sizes ratings

INTEGRATED CIRCUITS: Consumer - Digital/Analogue
Microprocessors and Peripherals
IC Sockets

JAPANESE COMPONENTS - Vast range of discrete's and consumer IC's
System A - All semiconductors available from USD. Amp - £75.00 incl. VAT & p&p. Pre-amp - £90.00 incl. VAT & p&p.

Mail order customers: Please send for our comprehensive price list, enclosing £1.00 in stamps. Cheque or postal order.

Catalogue sent free of charge, when requested on official letterhead (without refund), to OEM's, Schools, Colleges, Universities, Government Institutions, Computer Firms, Electronic Repair Firms and Distributors. Special discounts and payment terms are available to above institutions.

Please enquire for quantity discounts.

WE WELCOME TELEPHONE AND TELEX ENQUIRIES!

(SYSTEM A AMP)
All semi-conductors available.
Amp plus pre-amp £90, amp only £75

Free Readers' ADS!

Buy, sell or exchange through our free service to readers

CONDITIONS

1. These advertisements are offered as a free service to readers who are not engaged in buying or selling the same equipment or services on a commercial basis. Readers who are should contact our advertising department who will be pleased to help.

2. Advertisements will be inserted as and when space becomes available.

3. The insertion of advertisements will be on a first-come, first-served basis, subject to condition (2). As a result, it will not be possible to guarantee the inclusion of a particular advertisement in any particular issue of the magazine.

4. Readers should either write out their advertisements in BLOCK CAPITALS or type it, underlining any words that are to appear in **bold**.

The magazine cannot accept any responsibility for printers' errors in the advertisements; however, we will do our best to ensure that legibly written advertisements are reproduced correctly. In the event of a gross error, at the Editor's discretion, a corrected version of the advertisement will be printed (at the advertiser's request) in the earliest issue in which space is available.

6. The magazine or its publishers will not accept responsibility for the contents of the advertisements, and by acceptance of these conditions, the advertiser undertakes to

indemnify the publisher against any legal action arising out of the contents of the advertisement.

7. The magazine reserves the right to refuse to accept or to delete sections of advertisements where this is judged necessary, for whatever reason.

8. Advertisements are accepted in good faith; however, the publisher cannot be held responsible for any untruths or misrepresentations in the advertisements, nor for the activities of advertisers or respondents.

9. Advertisers must fill in their names, addresses and (if available) telephone number in the space provided, and sign the form to indicate acceptance of these conditions (forms returned without a signature will not be used).

10. All that is to be reproduced in the advertisement should be entered in the space provided on the form printed in the magazine — note that a **photocopy is not acceptable**. All advertisements must give either a telephone number and/or address for respondents to contact, and this must be included in the wording of the advertisement.

11. Advertisements must be 15 words or less in length (telephone numbers and names normally count as one word, addresses as two).

Name

Address

.....

..... (tel:))

ENTER YOUR ADVERTISEMENT HERE:

I accept the conditions above.

Signature

Send this form to: Free Readers Ads,
Electronics Today International,
1 Golden Square, London W1R 3AB.

Lineage:
48p (VAT incl) per word (minimum 15 words)
Semi Display: (minimum 2 cms)
£11.60 per single column centimetre
 Ring for information on series bookings/discounts
 All advertisements in this section must be prepaid.
 Advertisements are accepted subject to the terms and conditions printed on the advertisement rate card (available on request)



01-437 0699 Ext 292
Send your requirements to:
Nicola Baty
ETI Class. Dept.,
ASP Ltd.,
1 Golden Square,
London W1.

ALARMS

ALARMS

FREE BOOKLET
on
BURGLAR ALARMS
with
LOWEST U.K. DIY PUBLISHED PRICES
 PHONE OR WRITE FOR YOUR COPY
051-523 8440
AD ELECTRONICS
 217 WARBRECK MOOR
 AINTREE, LIVERPOOL L9 0HU

SPECIAL OFFERS

FREE MEMBERSHIP to a new NATIONAL ELECTRONICS CLUB.
 For details and a free gift of components worth over £10 send only £1.00 p&p to Woodside, Dowsett Lane, Ramsden Heath, Essex CM11 1JL.

VARIABLE POWERSUPPLIES
 £8...12-40 volt stabilised + electronic overload cutout ... TO3/ heatsink & smoothing ... built & tested ... KIA, 8, Cunliffe Road, Ilkley, Mullard resistor pack!!! Post-Ad + 50p Coin (p&p).

SERVICES

FREE PROTOTYPE of the finest quality with every P.C.B. artwork designed by us. Competitive hourly rates, and high standard of work. Halstead Designs Limited, Finsbury House, 31 Head St. Halstead, Essex CO9 2BX. Tel: 0787 477408.

DESIGN SERVICES. microprocessor, special interfaces, analogue, digital, signalling, alarm systems, PCB design and artwork. Prototype and small batch production. **ALAB ELECTRONICS.** Grantham (0476) 860089.

PCB ARTWORK. Lay out your own PCB on screen using a BBC Plot 2:1 on A4 Epson H1-80 40T-80T disc £20. Vinderen Associates P.O.Box 130 Belfast BT9 6NB N. Ireland.

WELDEC ALARMS
 FOR YOUR FREE SIZING GUIDE ON EASY TO INSTAL BURGLAR/FIRE ALARMS WRITE TO OR PHONE:
WELDEC ELECTRONICS
 P.O. BOX 1
 MARPLE
 CHESHIRE 061 449 0395 (24 HOURS)

FOR SALE

2000!
 ... Ex-Pub amusement PCB's for sale. Containing many caps, resistors, i.c.'s, Diodes, Eproms, Z80's, crystals etc. £10.00 each or offers for the lot.
RING (0532) 455685

EX-EQUIPMENT HEATSINKS. Some with components, eg 2.5° C/W £0.75, 10° C/W £0.20, including p&p over £5 order value. Also ex-equipment electrolytics, eg 5600 micro F/63V £0.75, 23000 micro F/40V £1.50. All have screw terminals. Ideal for power supplies or amplifiers. SAE for list or Telephone (0544) 230853. Portable Power, 37 Church Street, Kington, Herefordshire, HR5 3BE.

AUTOMATIC GARAGE DOOR OPERATORS. £65.00. S.A.E. for details to Mulberry Ltd, 116 Grosvenor Road, Aldershot, Hants.

FULL SET OF ETI from 1972 (No. 1) to 1981, excellent condition. Offers please - Tel: 0223 316910.

RING NICOLA BATY
ON 01-437 0699 FOR
ADVERTISING DETAILS

COMPONENTS

PROMs - EPROMs - PALS
ANY PROGRAMMABLE IC SUPPLIED OR BLOWN
PRICES (Including Programming)

2716	£3.45	2732	£3.60
2764	£2.85	27128	£3.20 etc.

BIPOLAR PROMs from £1.35
 e.g. 82S123, 18S030, 74S288
PALS, PLDs etc. from £3.26
 e.g. 82S153, 16L8, EP300

Full design and prototyping service
 Any quantity programmed - SAE or phone for details
P.L.S., 16 Wordsworth Drive,
Cheam, Surrey, SM3 8HF
Phone 01-644 8095

Resistors .25W 5% E12 values ...£0.01
 Eprom 27256-2, 12.5 Vprog£3.90
 Ram 6264LP-15£2.70
 25 way D plug£0.74
 Centronics 36 pin plug£2.10
 DIN plugs & skt's 5.6,7 pin£0.20
 LED's 5mm red, grn, amber£0.10
 5 1/4" disks, RPS unbranded,
 DS 96 tpi£0.46
 All prices inc. P&P, please add VAT at 15%
T-Systems Ltd
Tel: 0689 22196
The Signal Cabin,
61 High Street,
Orpington, Kent, BR6 0JF

I.G.S. Components, No 18 Queensway,
Shelley, Ongar, Essex, CM5 0BN.
 LEDs 5mm:- red, 1 8p, 25 6p, 1005p/
 green, 1 11p, 25 9p, 100 8p/yellow, 1
 11p, 25 9p, 100 8p/ 1N4148, 1 3p, 25 2p,
 100 1.5p/resistors 1/4W 5% carbon film
 E12, 1 2p, 25 1.5p, 100 1p, quantities
 per single value, 4R7 to 10M, 10 of each
 value 770 resistors £4.40. All prices
 include VAT but 50p must be added to
 orders under £5.00.

NEW YEAR BARGAIN 610 carbon resistors, 2, 5, 10, 1/2W, 10 each value E12 Series. £3.00 including P+P. D.M. Evans, 12 Vicarage Hill, Rhostyllen, Wrexham, Clwyd LL14 4AR.

ELECTRONIC COMPONENTS from SCS Components, 218 Portland Road, Hove (Tel: (0273) 770191). Also mail order.

POWER SUPPLIES

220/240v AC Electricity from 12v batteries. Encapsulated modules with screw terminals. Microchip design. Just connect transformer and 8 heat sinked transistors to terminals. 400W/12v £28; 600W/24v £30 p&p £0.75. Detailed assembly instructions provided, Chataigne Products, Green Lane, Great Horkesley, Colchester, Essex, CO6 4HD. (Prop. J.A. Richmond).

WANTED

Turn your surplus transistors, IC's etc., into cash. Immediate settlement. We also welcome the opportunity to quote for complete factory clearance.
Contact:
Coles Harding & Co.
103 South Brink
Wisbech, Cambs.
ESTABLISHED OVER 10 YRS
Tel: 0945 584188

GOOD PRICE for service and/or operating manuals for Sharp SF-780 and/or SF-825 photocopiers. Contact Mr. J.R. Norman, 40 Inglewood Rd, Bexley Heath, Kent DA7 6JS.

TANGERINE OWNERS send s.a.e. to David Cawthorne, 40 Westbourne Rd, West Kirby, Wirral, L48 4DH, for details about a new newsletter.

COILS & CHOKES

MAXI-Q

COILS AND CHOKES
 PREVIOUSLY MADE BY DENCO
 S.A.E. PRICE LIST

8 BRUNEL UNITS, BRUNEL RD,
GORSE LANE IND. ESTATE,
CLACTON, ESSEX CO15 4LU.
TEL: (0255) 424152

TEST EQUIPMENT

COMPONENT TESTER. Turns any oscilloscope with XY input facility into a valuable component tester. Tests all types of semi-conductors, capacitors, resistors etc., in or out of circuit, and displays results on CRT. Ideal fault finding tool complete with test leads and instructions. Only £19.95 (plus £2 p&p). Send cheque/P.O. to: DMR Electronics (ETI), 23 Regent St, Queensbury, Bradford, W. Yorks. BD13 1AU. Tel: (0274) 882892.

BOOKS

PARAPHYSICS Journal (Russian Translation); Psychotronics; Kirlianography, Heliphonic Music, Telekinetics. Computer Software. S.A.E. 4 x 9", Paralab, Downton, Wiltshire.

KITS AND READY BUILT

FM TRANSMITTERS Same day despatch **MINIATURE MODEL** frequency 60-145 Mhz, range 1 mile. Glass fibre P.C.B. All components. Full instructions 9-12V operation, broadcast reception. Super sensitive microphone. Pick up on **FM/VHF** radio. £6.95 inc or ready built £8.95. Size 57 x 19 x 12mm. **HIGH POWER MODEL.** 3 watts 80-108 MHz. Professional broadcast performance. Low drift varicap controlled. Range up to 7 miles. 12V operation. Any input audio/microphone. All components P.C.B. diagrams and instructions. Size 103 x 39 x 29mm. Kit 13.99 inc or ready built £18.99 inc. **TONE GENERATOR** 3-selectable functions; PIP, Warble and pulse tone: All components, instructions & P.C.B., feed into any audio input or transmitter; variable frequency and gating controls. 6-12V operation 53 x 38 x 14mm. £5.50 incl. **TONE GENERATOR POWER AMPLIFIER.** All components, instructions and P.C.B. turnstone generator into a high power siren for alarms; 18 watts max. at 12-15V. 62 x 38 x 14mm £7.00 inclusive **DIGITAL CLOCK/TIMER MODULE.** 12/24 hour & seconds (0.7inch LED) display, 8-functions. Applications: uncommitted output transistor for switching on Tape-recorders: Lighting, Security, etc. External Loudspeaker Output. 84 x 38 x 16.25mm. Full instructions & Modular PCB £17.49 inclusive. **MAINS TRANSFORMER** for above if required: £5.24 incl. **DIGITAL CODE LOCK MODULE: 4 18V.DC** operation; 10,000 combination quality key pad; programmable code; low-power 3-outputs (0.2A); **3-LED** status indicators; All components, instructions & PCB. Applications: Alarms; garage doors; cars, etc. 39 x 62 x 9mm. Kit: £15.95 incl. Ready built; £19.95 incl **ZENITH ELECTRONICS.** 14 Cortlandt Business Centre, Hailsham, East Sussex BN27 1AE. Tel: 0323 847973 or 04353 2647.

ETI KITS assembled and tested* by electronic trainees under supervision within a purpose built electronic workshop for as little as £10* (* depending on type of kit and complexity). Contact:- A.J. Smith, Dept K.A. Electronics Workshop, Lincoln I.T.E.C. Dean Road, Lincoln LN2 4JZ. Tel. 0522 43532.

6808 SINGLE board computer, contains 80 T/D/S disc interface, colour display, 8K monitor etc. Bare P.C.B. or built. Also 6809 micro-set system and tangerine conversions. S.A.E. for details. (state which) Ralph Allen Eng Forncett-End Norwich.

LINSLEY HOOD Designs. Send S.A.E. for details to Teleradio Electronics. 325 Fore Street, London N9 OPE.

TRAINING COURSE

PROFESSIONAL ELECTRONICS TECHNICIANS

Short re-training courses (1-3 weeks)

VCR SERVICING
MICROCOMPUTER SERVICING

(ONC/OND/HNC also available in modules)

* MSC GRANT AID to EMPLOYERS/TRAINEES *

Television/Video/CCTV//
MICROELECTRONICS
Information Technology/
CAD/CAM/ATE
MICROPROCESSORS/
Computers/CONTROL

LONDON ELECTRONICS COLLEGE
Dept (ETI)

20 Penywern Road
LONDON SW5 9SU. 01-373 8721
Next course starts 6th October and 27th October.

COMPUTER ADD-ONS

AMSTRAD OUTPUT PORT

Plugs into printer port and provides seven open-collector outputs. Easy to use from basic or m/c. As detailed in E.T.I. January '87, p9. £14.95 inc. S.A.E. for details.

NCJ Electronics,
13 Binfield Square, Ella Street,
Hull, HU5 3AP.

PLANS & DESIGNS

AMAZING SCIENTIFIC + ELECTRONIC DEVICE PLANS

Lasers, Phasers, Force fields, Tesla Coils, Surveillance, Ultra-sonic, Electronic weaponry, Pyrotechnics, many more.

S.A.E. for catalogue of D.I.Y. Plans.
INFOTECH,
29 Hinton Ave, Alvechurch
B48 7LZ.

ELECTRONIC PLANS, laser designs, solar and wind generators, high voltage teslas, surveillance devices, pyrotechnics and computer graphics tablet. 150 projects. For catalogue, SAE to Plancentre Publications, String Works, Bye St., Ledbury HR8 2AA.

ORGAN KEYBOARDS

ELECTRONIC ORGAN KEYBOARDS and other parts being cleared out. Special Offer: Elvins Electronic Musical Instruments, 40A Dalston Lane, London E8.

SUPPLIES

QUALITY WALKIE TALKIES private. long range satisfaction or refund. £24.95/pair (normally £31.49). Send £3.00 now, pay £21.95 on receipt. 48 hrs delivery. Xenon (Dept ET19) 24 Wharncliffe Street, Barnsley, Yorkshire.

EQUIPMENT

WOULD YOU BUY A CAR WITHOUT A TEST DRIVE? THEN WHY BUY A MIXER WITHOUT A TEST DRIVE?

Thinking about a new project — from a small Mixer to a large studio complex — come and talk over ideas with the people who offer manufacturing and user experience at our new premises:

Unit D, 318 High Road,
Bentley, Essex SS7 5HB
TO TAKE THAT TEST DRIVE —
PHONE 0268-793381

(Weekend Committee visits welcome by prior arrangement)

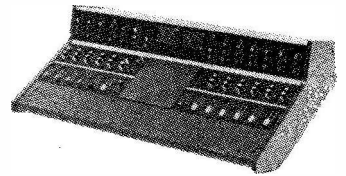

PARTRIDGE ELECTRONICS

Head Office, 56 Fleet Road, Bentley, Essex SS7 5JN
Telephone 0268-793256

SATELLITE

SATELLITE T.V. Receiver Kits £155 - £1,800. For Technical How To Build Manual send £3.50 or catalogue only £1 to: C & S T.V. 11, Wensley Gardens, Leeds 7.

SERVICES

ASSEMBLY SERVICES: PCB/Cable/Harness. Highest standard workmanship. In-Circuit/Functional testing if required. Contact CBA, Dublin (01) 375675.

SCOPES

OSCILLOSCOPES Dual-trace, delay sweep. Hameg 70MHz £415, Tequipment D83 50 MHz £325, Tektronix 545B 24 MHz £135, 585A 85 MHz £235, 556 Eight-Trace 50 MHz £495, 561B 875 MHz Sampling £195. Fine condition Tel. 01-868 4221.

SWITCHES

VOICE/SOUND ACTIVATED SWITCHES easy to follow diagrams and uses only £1.00. Components and P.C.B's available: **Herrington, 63 Home Farm Rd, Hanwell, London W7 1NL.**

ELECTROMART

ELECTROMART

LANCASHIRE



ELECTRO SUPPLIES

NORTHERN COMPONENT SPECIALISTS
Test Equipment, Computers, Peripherals
SEND FOR CATALOGUE Trade Enquiries Welcome

45 LOWER HILLGATE,
STOCKPORT, CHESHIRE.
061 477 9272

also at SHAWCLOUGH ROAD,
WATERFOOT
ROSSENDALE B84 9JZ.
0706 - 215556

LIVERPOOL

PROGRESSIVE RADIO

87/93 Dale Street. Tel 051 236 0154

47 Whitechapel. Tel 051 236 5489

Liverpool 2

'THE ELECTRONICS SPECIALISTS'

Open: Tues-Sat 9.30-5.30

YORKSHIRE

COMPUTERCARE

Electronic Components * Computer Supplies * Repairs.

12 Commercial Road, Leeds LS5 3AQ
(Across from Kirkstall Leisure Centre)

Open: Monday-Friday 9-5.30

(Saturday please phone first)

Phone LEEDS 743356 for stock list

TYNE AND WEAR

ELECTRONIC COMPONENTS AND KITS



STATION RD,
CULLERCOATS
NORTH SHIELDS
TYNE & WEAR
NE30 4PQ
091 251 4363

MON-SAT 9.30 to 5.30
CLOSED THURS.

EQUIPMENT

The Scientific Wire Company
811 Forest Road, London, E17.
Telephone 01-531 1568

ENAMELLED COPPER WIRE				
SWG	1 lb	8 oz	4 oz	2 oz
8 to 34	3.63	2.09	1.10	0.88
35 to 39	3.82	2.31	1.27	0.93
40 to 43	6.00	3.20	2.25	1.61
44 to 47	8.67	5.80	3.49	2.75
48	15.96	9.58	6.38	3.69
SILVER PLATED COPPER WIRE				
14 to 30	9.09	5.20	2.93	1.97
TINNED COPPER WIRE				
14 to 30	3.97	2.41	1.39	0.94
Fluxcore				
Solder	5.90	3.25	1.82	0.94

Please add VAT. Orders under £2 add 20p.
SAE for list of copper and resistance wire.
Dealer enquiries welcome.

GEIGER COUNTERS. Inexpensive gen-purpose portable radiation monitor (Heavy Duty Audiovisual) Kitform (full assembly data) £79.92. Built £89.32. Post incl. Others from £40 send S.A.E. Becker-ET, 8 Finucane Drive Orpington 0689 37821.

COMPLETE GEIGER counter (with Tube) for radiation measurement - Under £50. Send for details: Radiation Detectors 46/47 Pall Mall, London SW1Y 5JG. Tel (01) 839 3143.

MISCELLANEOUS

HEATHKIT U.K. Spares and service centre. Cedar Electronics. Unit 12, Station Drive, Bredon. Tewkesbury, Glos. Tel. 0684 73127.

Our next
copy deadline:
29th January
for the
April Issue.

TERMS

CLASSIFIED ADVERTISING TERMS & CONDITIONS

Our terms for new advertisers (semi-display and lineage) are strictly pro-forma payments until satisfactory reference can be taken up (excluding recognised advertising agencies). Cheques PO's should be crossed and made payable to:

ARGUS SPECIALIST PUBLICATIONS LTD.

and send together with the advertisement to:
THE CLASSIFIED DEPT., L/H,
NO: 1 GOLDEN SQUARE, LONDON
W1R 3AB.

There are no reimbursements for cancellations. Advertisements arriving too late for a particular issue will be inserted in the following issue unless accompanied by instructions to the contrary.



All advertising sales are subject to Government regulations concerning VAT. Advertisers are responsible for complying with the various legal requirements in force eg: The Trade Description Act, Sex Discrimination Act & The Business Advertisements (Disclosure) Order 1977.

FULL TERMS & CONDITIONS OF ADVERTISING AVAILABLE ON REQUEST

electronics today

CLASSIFIED ADVERTISING COUPON

Post to: ETI, 1 Golden Square, London W1A 3RB
Rates:- 48p per word (min. charge £7.20 (VAT incl)). Semi display (min. 2cms) £11.60 (+ VAT) per single column centimetre.

Please debit my Access/Barclaycard No.  
 Expiry date.....

£.....for.....insertions.
Or I enclose my cheque/PO for £.....for.....insertions.

Please use BLOCK CAPITALS and include post codes.

Classification.....

Name (Mr/Mrs/Miss/Ms).....
(delete accordingly)

Address.....

Signature.....Date.....

Daytime Tel. No.

BINDERS

FOR YOUR VALUABLE COLLECTION OF ELECTRONICS TODAY INTERNATIONAL MAGAZINES
• SMART • EASY TO USE • TOP QUALITY
To ASP Readers Services, PO Box 35, Wolsley House, Wolsley Road, Hemel Hempstead, Herts HP2 498 (0442-41221)

£5.20 inc P&P

Please supply.....Electronics Today International Binders @ £5.20 inc. P&P

Total £..... (Please make cheques payable to ASP Ltd.)

Years Required — 198.....198.....198.....198.....

Name.....

Address.....

Please allow 21 days for delivery

INSTRUMENTS FROM STOCK

UK's LARGEST IN-STOCK RANGE

WITH FREE CASE*

DIGITAL MULTIMETERS

- * 105 14 Range 2A DC, 2 Mohm £24.75
- * 528 14 Range 0.2A DC, 2 Mohm H/c test £29.95
- * 615 19 Range 10A DC, 20 Mohm H/c test £34.95
- * 6010 28 Range 10A AC/DC 20 Mohm (0.2MA AC/DC) £38.53
- * 578 20 Range 10A AC/DC 2M. Buzzer Display Hold £39.68
- * 5010 28 Range 10A AC/DC 20 Mohm (20µA AC/DC) £41.98
- * 5010EC 34 Range 10A AC/DC 20 Mohm H/c test
- * ME540 Auto/manual 10A AC/DC 20M Capacitance test. Conductance £59.95
- * ME540 Auto/manual 10A AC/DC 20M £48.30
- * 6013 Digital Capacitance meter 8 ranges 200pf-2000 MFD £63.25



WITH FREE CASE*

ANALOGUE MULTIMETERS

- * 1015 15 Range Pocket 10K/V £8.63
- * 1035 19 Range Pocket 20K/V 10A DC 10 Mohm £11.95
- * 102BZ 19 Range 20K/V 10A DC £14.50
- * 201 19 Range 20K/V 12A AC/DC 10 Mohm £17.95
- * 2010 20 Range 30K/V 10A DC 20 Mohm £21.95
- * 3010BZ 24 Range 30K/V 10A DC Buzzer 10 Mohm £23.95
- * 830A 26 Range 30K/V 10A AC/DC 10 Mohm £28.95
- * 5650E 41 Range 20MEG FET 12A AC/DC 1000 MEG £32.95



POWER SUPPLIES

- DD1c 13.8v 3A DC £14.95
- 243 0/24v 0/3A DC £49.75
- 154 5/15v 0/4A DC £38.25

LOGIC PROBE

- 07 20MHZ Logic Probe £10.95
- TTL cmos etc



STOCKISTS FOR

- Frequency Counters • Generators • Power Supplies • Tools • Computer Equipment • TV/Video Accessories • Nicads • Communications and Security Equipment • Public Address & Audio • (See catalogue)

OSCILLOSCOPES

UK TNT DELIVERY £9.00

- HAMEG Dual trace with component testers 8 x 10cm screen: £342.70
- 203/6 Dual 20MHZ £462.30
- 204 with a sweep delay
- CROTECH with component tester single trace: £224.25
- 3031 5 1/2 x 6 1/2 cm Display £239.20
- 3036 8 x 10cm Display

WITH FREE PROBES

ALL PRICES INCLUDE VAT

If an advertisement is wrong we're here to put it right.

If you see an advertisement in the press, in print, on posters or in the cinema which you find unacceptable, write to us at the address below.

The Advertising Standards Authority. ✓

ASA Ltd, Dept 3 Brook House, Torrington Place, London WC1E 7HN

ORDER BY POST OR PHONE. OPEN 6 DAYS A WEEK FOR CALLERS

VISA **HENRY'S ELECTRONICS** FREE CATALOGUE
301 Edgware Road, London W2 1EN. 01-724 3564 Send s.a.g. (min 12" x 9")
404 Edgware Road, London W2 1ED. 01-724 0323 with £1 stamp UK
EDUCATION/TRAINING & EXPORT SPECIALISTS Callers/export £1.00

COMPUTER WAREHOUSE

1000'S OF BARGAINS FOR CALLERS

THE "ALLADINS' CAVE OF COMPUTER AND ELECTRONIC EQUIPMENT

HOT LINE DATA BASE

DISTEL

The ORIGINAL FREE OF CHARGE dial up data base. Buy, browse or place YOUR OWN AD for goods or services to sell. 1000's of stock items, spares and one off bargains. Updated daily.

ON LINE NOW. CCITT, 8 bit word, no parity.
For 300 baud modems call 01-679 1888
For 1200-75 baud modems call 01-679 6183

FREE

Your monitor from its computer!! For only £24.95 it becomes a SUPERB HIGH QUALITY * COLOUR * TV SET

The fabulous TELEBOX, an INVALUABLE MUST for the owner of ANY video monitor with a composite input, colour or monochrome. Made by a major UK Co. as a TOP QUALITY, stand alone UHF tuner and costing OVER £75 to manufacture, this opportunity to give your monitor a DUAL FUNCTION must not be missed!! The TELEBOX consists of a compact, stylish two tone charcoal moulded case, containing ALL electronics tuner, power supply etc to simply plug in and convert your previously dedicated computer monitor into a HIGH QUALITY COLOUR TV SET giving a real benefit to ALL the family! Don't worry if your monitor doesn't have sound - THE TELEBOX even has an integral 4 watt audio amplifier for driving an external speaker, PLUS an auxiliary output for superb quality television sound via your headphones or HI FI system etc. Other features include: Compact dimensions of only 15.75" w x 7.5" d x 3.5" h, latest technology, BRITISH manufacture, fully tuneable 7 channel push button tuner, AUTO AGC circuit, SAW filter, LED status indicator, fully isolated 240v AC power supply for total safety, Mains ON-OFF switch etc. Many other uses.

LIMITED QUANTITY - DON'T MISS THIS OFFER!!!
ONLY £24.95 OR £19.95 if purchased with ANY of our video monitors. Supplied BRAND NEW with full instructions and 2 YEAR warranty. Post and packing £3.50 *When used with colour crt.

COLOUR & MONOCHROME MONITOR SPECIALS

'SYSTEM ALPHA' 14" COLOUR MULTI INPUT MONITOR
Made by the famous REDIFFUSION Co. for their own professional computer system this monitor has all the features to suit your immediate and future requirements. Two video inputs: RGB and PAL. Composite Video, allow direct connection to BBC/IBM and most other makes of micro computers or VCR's including our very own TELEBOX. An internal speaker and audio amp may be connected to computer or VCR for superior sound quality. Many other features: PIL tube. Matching BBC case colour. Major controls on front panel. Separate Contrast and Brightness - even in RGB mode. Separate Colour and audio controls for Composite Video input. BNC plug for composite input, 15 way 'D' plug for RGB input, modular construction etc.

This Must Be ONE OF THE YEAR'S BEST BUYS. PC USER Supplied BRAND NEW and BOXED, complete with DATA and 90 day guarantee. ONLY £14.95 as above OR IBM PC Version £165.00 15 Day 'D' sct £1.00, BNC sct 75p BBC interface cable £5.50

DECCA 80 16" COLOUR monitor. RGB input.
Little or hardly used manufacturer's surplus enables us to offer this special converted DECCA RGB Colour TV Monitor at a super low price of only £99.00, a price for a colour monitor as yet unheard of! Our own interface, safety modification and special 16" high definition PIL tube, coupled with the DECCA 80 series TV chassis give 80 column definition and quality found only on monitors costing 3 TIMES OUR PRICE. The quality for the price has to be seen to be believed! Supplied complete and ready to plug direct to a BBC MICRO computer or any other system with a TTL RGB output. Other features are: internal speaker, modular construction, auto degaussing circuit, attractive TEAK CASE, compact dimensions only 52cm W x 34 H x 24 D, 90 day guarantee. Although used, units are supplied in EXCELLENT condition. ONLY £99.00 + Carriage.

DECCA 80, 16" COLOUR monitor. Composite video input. Same as above model but fitted with Composite Video input and audio amp for COMPUTER, VCR or AUDIO VISUAL use. ONLY £99.00 + Carr.

REDIFFUSION MARK 3, 20" COLOUR monitor. Fitted with standard 75 ohm composite video input and sound amp. This large screen colour display is ideal for SCHOOLS, SHOPDS, DISCO'S, CLUBS and other AUDIO VISUAL applications. Supplied in AS NEW or little used condition ONLY £145.00 + Carr.

BUDGET RANGE EX EQUIPMENT MONOCHROME video monitors.
All units are fully cased and set for 240v standard working with composite video inputs. Units are pre tested and set up for up to 80 column use. Even when MINOR screen burns exist - normal data displays are unaffected 30 day guarantee.

12" KGM 320-1 B/W bandwidth input, will display up to 132 x 25 lines. £32.95
12" GREEN SCREEN version of KGM 320-1. Only £39.95
9" KGM 324 GREEN SCREEN fully cased very compact unit. Only £49.00

DC POWER SUPPLY SPECIALS

GOULD OF443 enclosed compact switch mode supply with DC regulated outputs of +5v @ 5.5a, +12v @ 0.5a, -12v @ 0.1a and -23v @ 0.02a. Dim 18 x 11 x 8 cm. 110 or 240v input. BRAND NEW only £16.95

GOULD G6-40A 5v 40 amp switch mode supply NEW £130.00

AC-DC Linear PSU for DISK drive and SYSTEM applications. Constructed on a rugged ALLY chassis to continuously supply fully regulated DC outputs of +5v @ 3 amps, -5v @ 0.6 amps and +24v @ 5 amps. Short circuit and overvoltage protected. 100 or 240v AC input. Dim 28 x 12.5 x 7 cm NEW £49.94
Carriage on all PSUs £3.00

KEYBOARDS

Manufacturer's BRAND NEW surplus.

DEC LA34 Uncoded keyboard with 67 quality gold plated switches on X-Y matrix - ideal micro conversions etc. £24.95

AMKEY MPNK-114 Superb word processor chassis keyboard on single PCB with 116 keys. Many features such as On board Micro, Single 5v rail, full ASCII coded character set with 31 function keys, numeric keypad, cursor pad and 9600 baud SERIAL TTL ASCII OUTPUT! Less than half price

ONLY £69.00 with data. Carriage on Keyboards £3.50



DON'T MISS THE CPM Deal OF the CENTURY

The FABULOUS CPM TATUNG PC2000 Professional Business System

A cancelled export order and months of negotiation enables us to offer this professional PC, CPM system, recently on sale at OVER £1400, at a SCOOP price just over the cost of the two internal disk drives!! Or less than the price of a dumb terminal!!!

Not a toy, the BIG BROTHER of the EINSTein computer, the DUAL PROCESSOR PC2000 comprises a modern stylish three piece system with ALL the necessities for the SMALL BUSINESS, INDUSTRIAL, EDUCATIONAL or HOBBYIST USER. Used with the THOUSANDS of proven, tested and available CPM software packages such as WORDSTAR, FAST, DBASE2 etc, the PC2000 specification, at our prices, CANNOT BE BEATEN!!

The central processor plinth contains the 64K, Z80A processor, DUAL TEAC 55F5 1/4" Double sided 40/80 track disk drives (1Mb per drive), PSU, 4K of memory mapped screen RAM, disk controller, RS232, CENTRONICS and system expansion ports, and if that's not enough a ready to plug into STANDARD 8" DRIVE port for up to FOUR 8" disk drives, either in double density or IBM format. The ultra slim 92 key, detachable keyboard features 32 user definable keys, numeric keypad and text editing keys, even its own integral microprocessor which allows the main Z80A to devote ALL its time to USER programs, eliminating "lost character" problems found on other machines. The attractive, detachable 12" monitor combines a green, anti-glare etched screen, with full swivel and tilt movement for maximum user comfort. Supplied BRAND NEW with CPM 2.2, user manuals and full 90 day guarantee. Full data sheet and info on request

PC2000 System with CPM ETC. COST OVER £1400
NOW only £399

PC2000 Business System with CPM and 'Ready to Run' FAST Sales and Purchase ledger, supports up to 9000 Accounts, VAT etc. COST OVER £1700
NOW only £499
Carriage & Insurance £12.00

PC2000 Wordprocessor System with CPM and TEC FP25 daisywheel printer.
NOW only £799

MODEMS

Join the communications revolution with our super range of DATA MODEMS, prices and specifications to suit all applications and budgets.....

BRAND NEW State of the art products.
DACOM DLSL2123 Multi standard 300-300, 1200-75 Auto answer etc. £288.00
DACOM DLSL2123AQ Auto dial, smart modem with multi standard AUTO SPEED detect, and data buffer with flow control etc. £335.00
DACOM DLSL2123GT THE CREAM of the intelligent modems, auto dial, auto call, index, buffer etc etc. £498.00
Stebeck SB1212 V22 1200 baud FULL DUPLEX sync or async optional auto dial. £465.00
TRANSDATA 307A Acoustic coupler 300 baud full duplex, originate only, RS232 interface. £49.00

Ex BRITISH TELECOM full spec, CCITT, ruggedised, bargain offers. SOLD TESTED with data. Will work on any CPM or system with RS232 interface.
MODEM 13A 300 baud unit, only 2" high fits under phone. CALL mode only. £45.00
MODEM 20-1 75-1200 baud. Compact unit for use as subscriber end to PRESTEL, TELECOM GOLD, MICRONET etc. £39.95 +pp £8.50
MODEM 20-2 1200-75 baud. Same as 20-1 but for computer end. £65.00 +pp £8.50
DATL 2412. Made by SE Labs for BT this two part unit is for synchronous data links at 1200 or 2400 baud using 2780/3780 protocol etc. Many features include 2 or 4 wire working, self test, auto answer etc. COST OVER £800. Our price ONLY £199 +pp £8.00
DATL 4800, RACAL MP5A800 baud modem, EX BT good working order, ONLY £295.00 +pp £8.00

SPECIAL OFFER
MODEM TG2393. EX BT, up to 1200 baud full duplex 4 wire or half duplex over 2 wire line. ONLY £85.00 PER PAIR +pp £10.00

For more information contact our Sales Office.

EX-STOCK INTEGRATED CIRCUITS

4164 200 ns D RAMS 9 for £11 4116 ns £1.50 2112 £10.00 2114 £2.50 2102 £2.00 6118 £2.50 EPROMS 2716 £4.50 2732 £3.00 2764 £4.95 27128 £5.50 6800 £2.50 6821 £1 68A09 £8 68B09 £10 8085A £5.50 8086 £15 8088 £8 NEC765 £8 WD2793 £28 8202A £22 8251 £7 8748 £18 280A DART £6.50 Z80A CPU £2.00. Thousands of IC's EX STOCK send SAE for list.

DISK DRIVES

Japanese 5 1/4" half height, 80 track double sided disk drives by TEAC, CANON, TOSHIBA etc. Sold as NEW with 90 day guarantee ONLY £95.00

TUC FB-503 Double sided HH 40 TRK NEW £75.00

SEG SA400 SS FH 35 TRK £55.00

SIEMENS FDD100 SS FH 40 TRK £65.00 carriage on 5 1/4" drives £5.50

Brand NEW metal 5 1/4" DISK CASES with internal PSU.
DSK1 for 2 HH or 1 FH drive £29.95 +pp £4.00
DSK2 for 1 HH drive £22.95 +pp £3.50
DKS3 As DSK1 LESS PSU £12.95 +pp £2.50
DKS4 As DSK2 LESS PSU £10.95 +pp £2.00

8" IBM format TESTED EX EQUIPMENT.
SHUGART 800/801 SS £175.00 +pp £8.50
SHUGART 851 DS £250.00 +pp £8.50
TWIN SHUGART 851's 2 Mb total capacity in smart case, complete with PSU etc. £595.00

MITSUBISHI M2894-83 8" DS 1 Mb equiv. to SHUGART SAB50R. BRAND NEW at £275.00 +pp £8.50

DYSAN 8" Alignment disk £29.00 +pp £1.00
Various disk drive PSUs in Ex Stock SEE PSU section.

HARD DISK DRIVES
DRE/DIABLO Series 30 2.5 Mb front load £525.00
Exchangeable version £295.00. **ME3029** PSU £95.00
DIABLO 44/DRE4000A, B 5+5 Mb from £750.00
CDC HAWK 5+5 Mb £795.00. **CDC9762** 80 Mb RMO3 etc. £2500.00.

PERTEC D3422 5+5 Mb £495.00
RODIME 5 1/4" Winchester ex-stock from £150 CALL

Clearance Items - Sold as seen - No guarantee.
ICL 2314 BRAND NEW 14" Mb Removable pack hard disk drive, cost over £2000 with data. ONLY £99.00

BASF 6172 8" 23Mb Winchester £199.00

Unless stated all drives are refurbished with 90 day guarantee. Many other drives and spares in stock - call sales office for details.

MATRIX PRINTERS

SPECIAL BULK PURCHASE of these compact, high speed matrix printers. Built in Japan for the Hazeltine Corporation this unit features quality construction giving 100cps bidirectional, full pin addressable graphics, 8 type fonts up to 95" single sheet or tractor paper handling, RS232 and CENTRONICS parallel interface. Many other features. BRAND NEW and BOXED. COST £420. Our price ONLY £199.00.

RECHARGEABLE BATTERIES

Dry Fit MAINTENANCE FREE by Sonnenschein & Yuasa

A300 07191315 12v 3Ah NEW £13.95
A300 07191312 6v 3Ah NEW £9.95
A300 07191202 6-0-6v 1.8Ah TESTED Ex Equip £5.99

VDU TERMINALS

Standard VDU data entry terminals at give away prices!!

QUME QVT108, Current product, state of the art terminal with detachable keyboard, 12" Green screen, 2 page RAM, TVI 925, Hazeltine, ADM5A emulations, software setup, 25 x 80, Clock, Swivel and tilt base, Printer port, Function keys etc. BRAND NEW and BOXED AT ALMOST HALF PRICE ONLY £425.00

AJ510 - EX RENTAL, Z80 controlled, 15" green screen 24 x 80 display, graphics, cursor addressing, printer port etc. Very good condition TESTED complete with manual only £225.00

ADDS 520 - Dumb terminal, used, 12" b/w screen RS232 interface and printer port. TESTED. ONLY £125.00. Carriage on terminals £10.00

100's of other terminals in stock. CALL for more details.

All prices quoted are for U.K. Mainland, paid cash with order in Pounds Sterling PLUS VAT. Minimum order value £2.00
Minimum Credit Card order £10.00. Minimum BONA FIDE account orders from Government Depts, Schools, Universities and established companies £20.00. Where post and packing not indicated please ADD £1.00 + VAT. Warehouse open Mon-Fri 9.30-5.30. Sat 10.30-5.30. We reserve the right to change prices and specifications without notice. Trade, Bulk and Export.

32 Biggin Way, Upper Norwood, London SE19 3XF
Telephone 01-679 4414 Telex 894502 Data 01-679 1888

*huge range, low prices, special offers, fast service, top quality components,
 huge range, low prices, special offers, fast service, top quality components,
 huge range, low prices, special offers, fast service, top quality components,
 huge range, low prices, special offers, fast service, top quality components,
 huge range, low prices, special offers, fast service, top quality components,
 huge range, low prices, special offers, fast service, top quality components,
 huge range, low prices, special offers, fast service, top quality components,
 huge range, low prices, special offers, fast service, top quality components,
 huge range, low prices, special offers, fast service, top quality components,
 huge range, low prices, special offers, fast service, top quality components,
 huge range, low prices, special offers, fast service, top quality components,
 huge range, low prices, special offers, fast service, top quality components,*

THE CHOICE IS YOURS, BUT ...



Maplin's on top of the pack

Maplin ELECTRONIC SUPPLIES LTD.

Mail Order: P.O. Box 3, Rayleigh, Essex SS6 8LR. Tel: Southend (0702) 554161

Shops

Birmingham: Lynton Square, Perry Barr. Telephone: 021 356 7292.

London: 159-161 King Street, Hammersmith W6. Telephone: 01 748 0926.

Manchester: 8 Oxford Road. Telephone: 061 236 0281.

Southampton: 46-48 Bevois Valley Road. Telephone: 0703 225831.

Southend-on-Sea: 282-284 London Road, Westcliff-on-Sea, Essex. Tel: 0702 554000.

All shops except Manchester closed all day Monday.



Pick up a copy our 1987 catalogue from any branch of W.H. Smith for just £1.50. Or to receive your copy by post send just £1.50 + 40p p & p to Mail Order address. If you live outside the U.K. send £2.50 or 11 International Reply Coupons.