

JULY 1973

electronics

today

INTERNATIONAL

20p

FREE COMPETITION



THREE ADVANCE
POCKET CALCULATORS
MUST BE WON !!!

BUILD THE
eti
COIN
COLLECTOR

ALSO:

TRANSMISSION LINE
SPEAKERS



GET A FOURTH
TV CHANNEL



TESTING THE
EMPIRE 1000ZE/X

HI-FI ... CONSTRUCTION ... COMMUNICATIONS ... DEVELOPMENTS

ONKYO

**Guaranteed
performance that will
meet or exceed
written specifications...**

SPECIFICATIONS

INTEGRA 725 (illus)

22w/22w RMS

Harmonic distortion less than 0.1

I.M. distortion less than 0.05

Hum and noise better than 75dB (phono)

Phono overload 200mV

***ALSO MODEL 733**

34w/34w RMS

Harmonic distortion less than 0.1

IM distortion less than 0.05

Hum and noise better than 75dB (phono)

Phono overload 210mV

Reviewed Hi-Fi For Pleasure Jan. 73

Available at most leading Hi-Fi and Department Stores. In case of difficulty contact sole UK Distributors:
Parker & Co (London) Ltd, Dept. ET1 2, Parkar House, 1 Beresford Avenue, Wembley HA0 1YX, Middlesex.

electronics TODAY INTERNATIONAL

JULY 1973

Vol 2 No.7

main features

PROCESSORS, PROGRAMS AND PERIPHERALS	14
<i>An introduction to computers</i>	
EXPLORATION ARCHAEOLOGY	26
<i>Electronics in the search for the past</i>	
USING A RESISTIVITY METER	32
<i>Simplified method of interpreting earth resistivity data</i>	
THE AMAZING MAZE	36
<i>Transmission line speakers are in the news — special report</i>	
GET A FOURTH TV CHANNEL NOW	44
<i>General rules on receiving an extra ITV station</i>	
ELECTRICITY FROM WINDMILLS	53
<i>Interest in windmills is reawakening</i>	
TRANSDUCERS IN MEASUREMENT AND CONTROL.....	54
<i>Dr. Sydenham concludes his discussion on pollution</i>	
EARLY WARNING GAS ALARM	65
<i>New detector prevents build up of explosive mixtures</i>	

projects

ETI COIN COLLECTOR.....	20
<i>A simple but sensitive metal locator</i>	
EARTH RESISTIVITY METER	30
<i>How to explore deep under the earth's surface</i>	
ETI MASTER MIXER	63
<i>Getting the best from our project and modifying for individual needs</i>	
AUDIO FREQUENCY METER	66
<i>Units approximates frequency from 50Hz to 10kHz</i>	

product tests

EMPIRE CARTRIDGE TYPE 1000 ZE/X	70
<i>A phono cartridge with excellent trackability</i>	

news & information

EDITORIAL —5; NEWS DIGEST —7; WHAT'S IN NEXT MONTH'S ETI —42; DX MONITOR —68; COMPONENT NEWS —73; EQUIPMENT NEWS —77; AUDIO NEWS —81; TECH-TIPS —82.

FREE COMPETITION: WIN AN ADVANCE EXECUTIVE POCKET CALCULATOR	41
---	----

Cover: Trying out the ETI Coin Collector on Hampstead Heath. Full details on how to build this project on page 20. Colour photography by Francis Graham.



Page 36

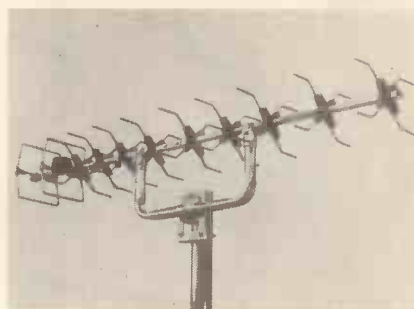

Page 44



Page 20

EDITORIAL & ADVERTISEMENT OFFICES
36 Ebury Street, London SW1W 0LW

Phone: 01-730 2136/9

Published by WHITEHALL PRESS LTD

Printed in England by: Alabaster Passmore & Sons Ltd, London & Maidstone
INTERNATIONAL ASSOCIATES: Modern Magazines (Holdings) Ltd, 21-23 Bathurst Street, Sydney 2000. Phones: 26-2296 22-6129. ACP, Room 401, 1501 Broadway New York, USA. Bancho Media Service, 15 Sanyocho, Shinjuku-Ku Tokyo, Japan. Distributed by: Argus Press Ltd
© Copyright Worldwide
Subscription rates per year: Home—£3.60 Overseas—£4.00.

A few of your friends you wish you could have taken with you.



14" Model TU 75A



9" Model I 89U



12" Model P 32

You can.
With Hitachi, Britain's best-selling black & white portable, they'll follow wherever you go. And for once you can see them all in their true perspective.

Hitachi TV's are small enough to be genuinely portable but large enough to see without strain. Your friends after all should be a sight for sore eyes. Hitachi are also the first to develop fully the latest in solid state circuitry. Whether you're operating the set from AC mains or 12 volt battery, you can be sure of a rock-steady picture and crystal clear reception.

If you want to bring your friends into the open, there's an anti-glare panel especially for

outdoor viewing. And thanks to the instant sound & vision switch, there's no warming-up period. So no one's kept waiting. All controls, especially the ultrafine tuning knob; are effortless, but extremely effective.

Sets come complete with mains/battery leads, personal earphone and loop aerial at no extra cost.

All your problems have been anticipated - except the choice of set. Whether you go for the 14", 12" or 9" tubed model, you know it's the perfect portable. That's why it's Britain's best-selling portable.

Pick one up and take your friends with you.
Hitachi Sales (UK) Ltd. New Century House,
Coronation Road, London NW10



HITACHI The world at your fingertips

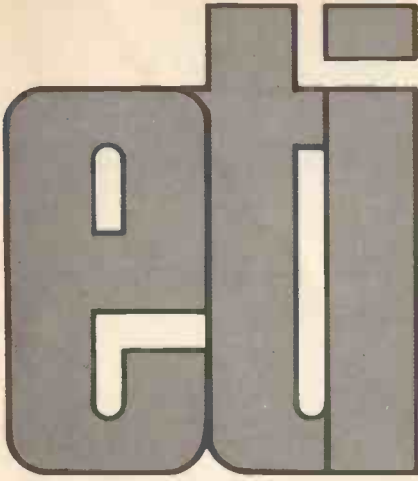

HALVOR MOORSHEAD

Editor

ALEX MELLON

Advertisement Manager

SID GLADWIN

Production Manager

Electronics Today International
36 Ebury Street
London SW1W 0LW
01-730 2136

International Editions

COLLYN RIVERS

Editorial Director

Australia

BRIAN CHAPMAN

Technical Editor

WENDY ROY

Assistant Editor (Hi-Fi)

BARRY WILKINSON

Engineering Manager

Electronics Today International
Ryrie House, 15 Boundary Street
Rushcutters Bay 2011
Sydney, Australia

France

DENIS JACOB

Editor-in-chief

CHRISTIAN DARTEVELLE

Editor

Electronique Pour Vous
International
17 Rue de Buci
Paris, France

boom!

NEWSPAPERS and magazines have one serious drawback in the way that they present information; a development that happens overnight tends to get a massive splash whilst a far more important change that develops over months or years hardly gets mentioned. If a hundred people are killed in an air crash we are concerned (quite rightly) but during the period that this crash is still news a similar number of people are killed on our roads and this rarely gets mentioned.

The big development at the moment is just such a one, but it has developed slowly and lacks the immediate impact necessary to make it a major story in the conventional sense. If it had happened literally overnight we would be talking about it for ages. We are referring to the massive recovery and expansion of the British economy. It is too early to claim that we are undergoing an 'economic miracle' but it is significant that last year our growth rate was higher than almost all of the industrialised countries including Japan, West Germany and the United States. We are reinvesting in our industries, unemployment is falling and the omens are excellent.

For our electronics industry the portents are even better. Even during the slow growth rate of the last decade, this has performed far better than the average and now that things are moving it looks as though we can expect it to do very well. While there was little money about, one of the first departments to feel the pinch was research and development (R&D) but now that things are buoyant money is again flowing in this direction.

It would not be fair to say that the British electronics industry has ever been in the doldrums. One of the main causes for the healthy state of this industry has been colour TV which has made the wheels turn fast. In itself this is of little importance but it has provided the industry as a whole with the money needed for expansion. In recent years most of the interesting developments in electronics have taken place overseas, especially in the United States and Japan. We can now look forward to more major developments originating in Britain. —H.W.M.



EC958 series of receivers 10kHz to 30MHz In world-wide use

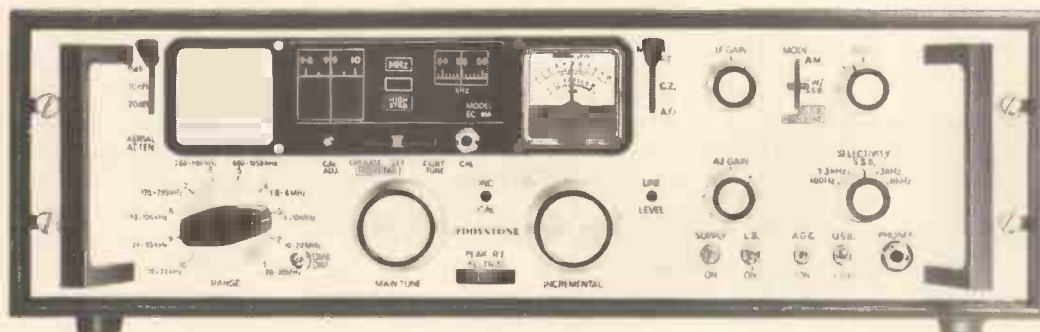

Simplicity
Reliability
Economy

Professional high-stability receiver series for a wide variety of applications. The standard version can be used as a self-contained F.S.K. terminal, or as a dual-diversity terminal with common oscillator control. Variants are available for Lincompex terminal use, for specialized network monitoring surveillance and for marine applications.

Please send for an illustrated brochure to:

Eddystone Radio Limited

Alvechurch Road, Birmingham B31 3PP Telephone: 021-475 2231 Telex: 337081

A member of Marconi Communication Systems Limited.

LTD/ED99

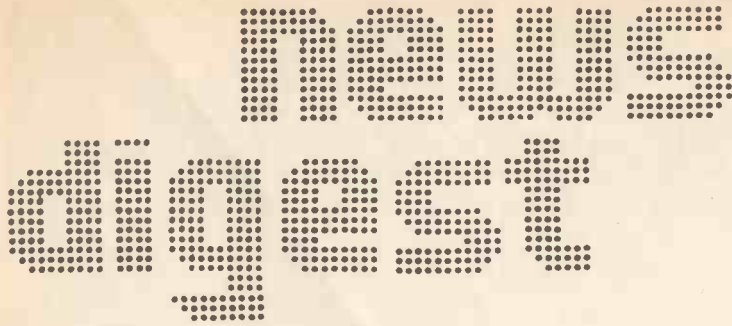

BIG ORDER FOR C.D.I. INTEGRATED CIRCUITS

Deliveries began recently against an order worth over £90,000 for C.D.I. integrated circuits. The order placed by Electrical Remote Control Company Limited with the Electric Components Division of Ferranti Limited is for the custom-designed LR171E integrated circuit timer. The device, manufactured by the Collector Diffusion Isolation process, will be used in a wide range of timing controllers for a variety of industrial, processing and manufacturing operations.

Long, precise, time delays demanded by Elremco Limited could only be produced by using Ferranti C.D.I. technology with its specific capability to combine high performance linear and digital functions side by side on the same chip.

Accuracy is achieved by using an on the chip precision oscillator whose frequency can be selected by the use of an external resistor and capacitor. The output of the oscillator is divided by a 12 stage digital counter which allows delays of up to several days to be produced. Digital outputs are also provided at several stages in the counter to give multiple fractions of total time-out.

The LR171E integrated circuit contains several unique facilities. A shunt voltage regulator and very low

total current consumption enable the timer to be operated directly from a.c. mains via a resistor and rectifier or over a wide range of d.c. voltages. The chip also contains an oscillator and power output stage for direct thyristor and Triac drive. Another feature is a digital to analogue converter which allows the read out of elapsed time by a simple meter. A Schmitt trigger and monostable, which



The timer chip has a vast number of uses. The photograph shows a prototype control panel for controlling various functions in a car.

enable the timing sequence to be initiated by the use of a simple switch or the application of the supply voltage, are also contained in the chip. All these facilities are contained on a single chip only 90 by 70 thousandths of an inch, encapsulated in a 14 lead dual-in-line package.

The LR171E integrated circuit timer will be incorporated into Elremco's own range of timers and will be available from them as a standard product.

One chip looks much like another except to an expert but the LR171E is a device we are likely to hear more of.

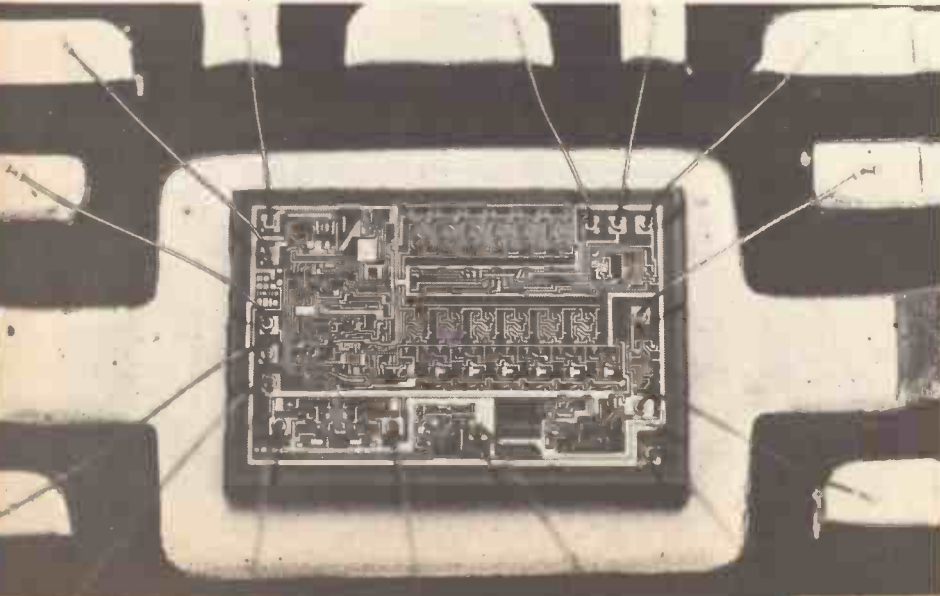

DRAWING MICROWAVE PRINTED CIRCUIT MASKS BY COMPUTER

The layout of printed microwave circuits and the presentation of drawings for the masks can take considerable time and effort; to speed the process used at the Mullard Research Laboratories, Mr. D.H. Paul has developed a method of drawing such masks by computer.

In general microwave circuits are composed of transmission lines of specified lengths and widths which may be either straight lines or arcs of circles. These, together with a method of forming T-junctions, enable any microwave pattern to be specified.

The designer prepares a data list which specifies the pattern in terms of a starting point followed by basic drawing elements having the lengths and widths he requires. The computer attaches these to the starting point in order, builds up the pattern and then produces a scale drawing which can be checked. If necessary the data can be modified until the required pattern is obtained.

A paper tape is then prepared by the computer and fed to a numerically controlled drawing machine which cuts the mask in cut-and-strip material for subsequent photographic processing.

When building up a complete assembly from known component parts these can be copied into specified positions either as plain or mirror copies. Having assembled several patterns into a composite layout an automatic join facility calculates the strip and arc to make the required interconnection in a smooth manner.

The system is now in general use in the Mullard Research Laboratories.

25 PER CENT INCREASE IN U.S. SEMI-CONDUCTOR SALES IN 1973

Total sales volume of U.S. semiconductor manufacturers in 1973 should reach a record high, exceeding last year by approximately 25 per cent, according to Dr. C. Lester Hogan, President and Chief Executive Officer of Fairchild Camera and Instrument Corporation.

"Our earlier projection of a 17 per cent increase now appears too conservative, and we expect U.S. factory sales to increase 25 per cent over 1972, to a record total of nearly \$ 1.83 billion (£425m)," Dr. Hogan told shareholders at the annual meeting. The worldwide consumption of semiconductors is expected to increase about 23 per cent to nearly \$ 3.3 billion (£1¼ billion), also a record.

Awaken to the sound of Teleton

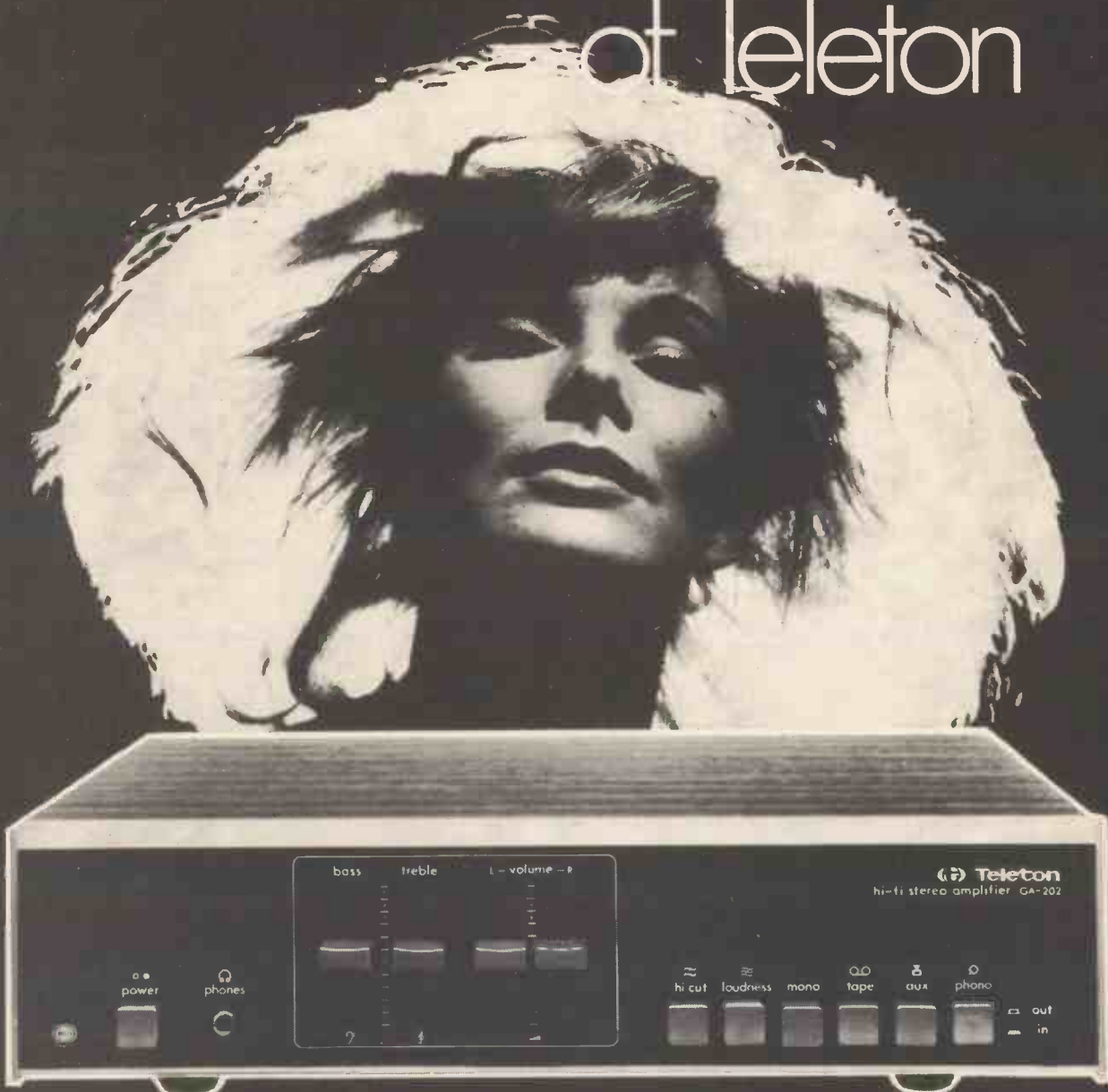

**Join the procession
in Aida.
Smell 1812 gunsmoke.
Shiver
on Bare Mountain.
Awaken to the
sound of Teleton.**

 **Teleton**
Sound Sense

There's a new world of high fidelity in a Teleton sound system, with the GA 202 amplifier at its heart to bring you new standards of purity, new heights of quality in the faithful reproduction of the world's greatest music.

The Teleton GA 202 combines all the latest advances in hi-fi technology—calibrated slider controls for bass, treble and channel volume, hi-cut filter, loudness contour, head-phone socket, tape and auxiliary inputs, to give you 16 watts per channel (RMS) at under one per cent distortion, 30-30,000 Hz—the soaring choruses and the whispers of a cathedral inside an elegant walnut and brushed aluminium cabinet.

Listen to the Teleton GA 202—your ears have been asleep.

Price £50 recommended retail.

Teleton Electro (U.K.) Co. Ltd.,
Teleton House, Waterhouse Lane,
Chelmsford CM1 3DW.
Tel: Chelmsford 62442.

POCKET-SIZE TWO-WAY RADIO

RCA has announced a pocket-size, two two-way radio that incorporates a direct application of space technology to portable commercial communications.

The 18oz radio is the first commercial transmitter-receiver to use the same type of small, highly-reliable I.C. employed in the advanced satellite and missile control systems. It is designed for police departments, industrial firms and other applications requiring high quality, portable communications.

The radio resulted from a major engineering effort which has successfully adapted space technology at a cost suited to the commercial communications market, according to Harold A. Jones, Division Vice President, RCA Commercial Communications Systems.

The new RCA product uses 'beam-lead' integrated circuits that have no wire connections to break and cause failures. This circuit type is used in the newest space and defence control systems to assure high reliability.

One circuit in the new radio is no larger than a pencil point but contains the equivalent of 42 transistors, 41 resistors and 10 diodes — 93 components in all — the RCA official said. They are assembled on a substrate base and their welded interconnections made by employees using microscopes and special machines.

Mr Jones said RCA's continuing engineering efforts will yield other advanced communications products as more new and cost-effective ways are found to adapt space and military electronics to the commercial market.

'This new product opens the way to truly personal two-way communications where the radio is designed for use by the individual, wherever he needs to communicate, rather than accommodated solely to a vehicle or fixed station requirement.

'As one example of its versatility, the new portable can be inserted into a battery charger in the vehicle dashboard and, during the re-charge cycle, operated much like a larger mobile radio. This is made possible by equipping the charger with a separate microphone and speaker, and connecting it to the roof-top antenna.

'When the driver leaves the vehicle, the radio is easily disconnected and slipped into his pocket or mounted on his belt so that communications

contact with home base is never broken'.

The one to six frequency radios are designed for operation in two power ranges in the UHF and VHF bands set aside for land mobile radio service. They will be available with a variety of accessories: battery chargers, multiple tone, external speaker/microphones and antennae, among others.

The weight of 18 ounces is for a single-frequency radio with two watts output and powered by a 250-mill-ampere hour battery.

This model, in a standard case also holding the battery is approximately 6in tall, 1½in deep and 2½in wide, a size which easily fits a shirt or coat pocket.

DIGITAL WATCH

The latest addition to Omega's range of electronic timepieces is a completely solid state electronic digital watch with no moving parts.

Called the Time Computer, it is accurate within five seconds a month — or a minute a year — and has several advantages over existing digital watches.



The Omega Time Computer.

Firstly, because the time is shown by light-emitting diodes in red figures, it can be read in any light. This is an improvement over digital systems using liquid crystal displays which are difficult to read in poor light and impossible in darkness.

Time is shown "on demand" by pushing a command button which illuminates the light emitting diodes covered by a synthetic ruby face, chosen for its hardness and filtering qualities. When the command button is pressed the time in hours and minutes is shown for 1.25 seconds and is then replaced by the seconds for as long as the button remains depressed.

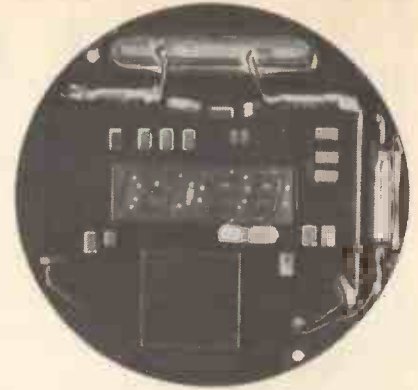

Inside the Time Computer

Another advance in this timepiece is its unique system for resetting time that allows hours or minutes to be changed independently. Time is changed by inserting a tiny magnetic "key" into one of the two timeset recesses in the back of the watch, one linked to the minute digits, the other to the hours. To change the hour only, the magnet is placed into the hour recess, when the face lights up to show the hour digits moving forward.

The Time Computer has 1,238 transistors in a surface area of only 3.8 x 3.8mm. Its brain is an electronically operated quartz crystal vibrating at 32,768 Hz.

The oscillations are counted and the results are fed to the driver decoder circuit, which activates the time display on demand. The watch is powered by two tiny batteries.

Because the watch has no moving parts there is no need for the oiling and cleaning advised for conventional movements. It cannot be damaged by exposure to normal magnetic fields and has been tested at an impact equal to 2500 times the force of gravity to ensure greater shock resistant characteristics. In addition, the computer circuitry is hermetically sealed so that neither dirt nor water can penetrate it, causing damage.

The Omega Time Computer will be available in the shops within a few months at around £300.

UHF TV STATIONS

Five new IBA UHF stations have begun regular transmissions in the last few weeks. The largest is at *Carmel* in South Wales, Channel 60, which brings colour TV to 130,000 more people. The other main station is *Blaen Plwyf*, Cardiganshire, Channel 24, serving about 50,000 people.

Three relay stations have also started: *Blaenavon*, Monmouthshire, Channel 60, *Whitby*, Yorks, Channel 59 and *Maestag*, Glamorganshire, Channel 25.

HENRY'S

Your Complete Audio-Electronic Stores

BUILD THE TEXAN

20 + 20 WATT INTEGRATED I.C. STEREO AMPLIFIER
★ FREE TEAK CABINET with complete kit!

FEATURES. New slim design with 6 - IC's, IC Sockets, 10 silicon transistors, 4 rectifiers, 2 zeners. Special Gardener's low field ultra line transformer. Fibre glass PC panel. Complete chassis work.
HIGH QUALITY & STABILITY ARE PREDOMINATE FEATURES—DEVELOPED BY TEXAS ENGINEERS FOR PERFORMANCE, RELIABILITY AND EASE OF CONSTRUCTION.
FACILITIES. On/off switch indicator, headphone socket, separate treble, bass, volume and balance controls, scratch and rumble filters, mono/stereo switch, input selector; Mag. P.U. Radio Tuner, Aux. Can be altered for Mic, Tape, Tape-head, etc. (Parts list Ref. 20 on request). Constructional details (ref no 21) 30p.



(As featured in "Practical Wireless" May to August 1972)

PW Tricolour as per April/May/June 1973. Parts list on request (52A).

★ SLIM DESIGN WITH SILVER TRIM
Overall chassis size 14½" x 6" x 2" high

SPECIAL KIT PRICE £28.50 P & P 45p

COMPLETE WITH FREE TEAK CABINET
Designer approved kits distributed by Henry's Radio Ltd.

CATALOGUE

IN ELECTRONICS? THIS IS A MUST!

LATEST EDITION!

Fully detailed and illustrated covering every aspect of Electronics—plus data, circuits and information, 10,000 Stock lines at Special Low Prices and Fully Guaranteed.

PRICE **55p** Post Paid (40p FOR CALLERS)

PLUS! FIVE 10p VOUCHERS

For use with purchases

Send to this address—HENRY'S RADIO LTD. (Dept WW) 3 ALBEMARLE WAY, LONDON, E.C.1.—for catalogue by post only. All other mail to '303' and callers to '404' see below.

VAT ALL PRICES ARE EXCLUSIVE OF 10% VAT WHICH MUST BE ADDED TO ALL ORDERS INC. CARR/PACKING. (NOTE: CATALOGUE IS NOT SUBJECT TO VAT).

INTEGRATED CIRCUITS

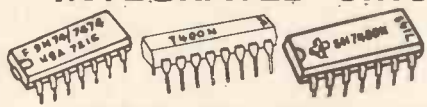

Why buy alternatives when you can buy the genuine article from us at competitive prices from stock?

BRANDED FROM TEXAS I.T.T. FAIRCHILD

Type	1/11	12/24	25/99	Type	1/11	12/24	25/99	Type	1/11	12/24	25/99
SN7400	20p	18p	16p	SN7481	20p	18p	16p	SN74150	£2.35	£2.95	£2.15
SN7401	20p	18p	16p	SN7483	20p	18p	16p	SN74151	£1.10	95p	90p
SN7402	20p	18p	16p	SN7484	20p	18p	16p	SN74152	£1.35	£1.27	£1.20
SN7403	20p	18p	16p	SN7485	20p	18p	16p	SN74153	£2.00	£1.76	£1.55
SN7404	20p	18p	16p	SN7486	20p	18p	16p	SN74154	£1.55	£1.47	£1.35
SN7405	20p	18p	16p	SN7487	40p	37p	35p	SN74155	£1.55	£1.47	£1.35
SN7406	30p	27p	25p	SN7488	40p	37p	35p	SN74156	£1.55	£1.47	£1.35
SN7407	30p	27p	25p	SN7489	40p	37p	35p	SN74157	£1.80	£1.70	£1.50
SN7408	20p	18p	16p	SN7490	55p	52p	50p	SN74160	£2.80	£2.40	£2.25
SN7409	45p	42p	39p	SN7491	75p	70p	65p	SN74161	£2.60	£2.40	£2.25
SN7410	20p	18p	16p	SN7492	80p	75p	70p	SN74162	£3.40	£3.25	£2.70
SN7411	23p	22p	20p	SN7493	£1.25	£1.15	£1.10	SN74163	£3.40	£3.25	£2.70
SN7412	42p	40p	38p	SN7494	80p	75p	70p	SN74164	£2.75	£2.30	£2.10
SN7413	30p	27p	25p	SN7495	£1.00	90p	85p	SN74165	£4.00	£3.50	£3.00
SN7414	30p	27p	25p	SN7496	80p	80p	80p	SN74166	£4.00	£3.50	£3.00
SN7415	30p	27p	25p	SN7497	45p	41p	38p	SN74167	£6.25	£5.60	£5.10
SN7416	30p	27p	25p	SN7498	75p	70p	65p	SN74170	£4.10	£3.55	£3.05
SN7417	30p	27p	25p	SN7499	£1.00	90p	85p	SN74174	£2.00	£1.75	£1.50
SN7420	20p	18p	16p	SN7500	£1.00	90p	85p	SN74175	£1.35	£1.27	£1.15
SN7422	45p	42p	40p	SN7501	80p	75p	70p	SN74176	£1.00	£1.35	£1.20
SN7423	45p	42p	40p	SN7502	80p	75p	70p	SN74177	£1.00	£1.35	£1.20
SN7425	45p	42p	40p	SN7503	80p	75p	70p	SN74180	£1.55	£1.30	£1.20
SN7427	42p	39p	35p	SN7504	80p	75p	70p	SN74181	£2.00	£1.90	£1.60
SN7428	50p	45p	42p	SN7505	80p	75p	70p	SN74182	£2.00	£1.90	£1.60
SN7430	20p	18p	16p	SN7506	80p	75p	70p	SN74183	£2.40	£2.00	£1.80
SN7432	45p	42p	40p	SN7507	80p	75p	70p	SN74184	£2.40	£2.00	£1.80
SN7433	70p	61p	44p	SN7508	£1.45	£1.35	£1.20	SN74185	£2.40	£2.00	£1.80
SN7437	65p	60p	50p	SN7509	80p	75p	70p	SN74190	£1.95	£1.85	£1.75
SN7438	60p	50p	40p	SN7510	80p	75p	70p	SN74192	£2.00	£1.90	£1.80
SN7440	20p	18p	16p	SN7511	80p	75p	70p	SN74193	£2.00	£1.90	£1.80
SN7441A	75p	75p	70p	SN7512	80p	75p	70p	SN74194	£2.50	£2.25	£1.90
SN7442	75p	75p	70p	SN7513	80p	75p	70p	SN74195	£1.85	£1.70	£1.60
SN7443	20p	18p	16p	SN7514	80p	75p	70p	SN74196	£1.50	£1.40	£1.30
SN7444	20p	18p	16p	SN7515	80p	75p	70p	SN74197	£1.50	£1.40	£1.30
SN7445	20p	18p	16p	SN7516	80p	75p	70p	SN74198	£4.40	£3.70	£3.25
SN7446	20p	18p	16p	SN7517	80p	75p	70p	SN74199	£4.80	£3.70	£3.25
SN7448	20p	18p	16p	SN7518	80p	75p	70p	SN74200	£4.80	£3.70	£3.25
SN7450	20p	18p	16p	SN7519	80p	75p	70p				

IC SOCKETS 16 lead 17p 14 lead 15p 8 lead 15p

Prices of 7400 series are calculated on the total number ordered regardless of mix. Larger quantity prices phone 01-402 4891

TEST EQUIPMENT

- SE250B Pocket Pencil Signal Injector £1.90
- SE500 Pocket Pencil Signal Tracer £1.50
- THL33D Robust 2K/Volt £4.55.
- 200H Grid Dip Meter 440 KHz-280 MHz £13.45
- 500 30 K/V Multimeter £28.25 With leather case £18.50
- 200H 20 K/V Multimeter £4.20.
- AF105 50 K/V Multimeter £8.50. With case £9.50
- U4341 A/C/D Multimeter with translator tester. Steel case £16.50
- TE20D RF Generator 120KHz-500MHz £19.95 Carr. 35p
- TE22D Auto. Generator 20Hz-200KHz £17.50 Carr. 35p
- C1-5 3" Pulse Scope, 10Hz-10MHz £30.00 Carr. 50p
- TE65 Valve Voltmeter 28 ranges £17.50 Carr. 40p

ALL NONREX MODELS IN STOCK

"BANDSPREAD" PORTABLE MW/LW Tuner to build Superhet Radio using Mullard RF/M Modules, 600mW o/p. Fibre glass cabinet. All parts £7.90, P. & P. 32p. (Battery 22p extra.)

7 SEG & NIXIE TUBES (Post 15p per 1 to 8)
XN3, XN13, GNE 0-9 side view with data, 85p.
GNP-7, GNP-8 0-9 side view with decimal points and data, 85p.
3015F 7 seg. £2 each, £7 per 4 with data.
12 and 24 hour clock circuits. Ref. No. 31 15p.

ULTRASONIC TRANSDUCERS
Operate at 40Kcps up to 100 yds. Ideal remote switching and signalling. Complete with data and circuits.
PRICE PER PAIR £5.90. Post 10p.

QUALITY SLIDER CONTROLS
60mm stroke singles and ganged. Complete with knobs. 5KΩ, 10KΩ, 25KΩ, 100KΩ, 250KΩ, 500KΩ, 1 meg. Log and Lin. 40p each, 10KΩ, 25KΩ, 50KΩ, 100K Ω, 250KΩ, Log and Lin ganged. 90p each.

MARRIOTT TAPE HEADS
4 TRACK MONO or 2 TRACK STEREO
"17" High Impedance £2.00
"18" Med. Impedance £2.00
"36" Med.-Low Imp. £3.50
Erase Heads for above 75p
"63" 2 track mono—High Impedance £4.75
"43" Erase Head for above 75p.

SILICON RECTIFIERS

WIRE ENDED PLASTIC
Type P.I.V. 1-11
1 amp miniature
IN4001 50 8p
IN4002 100 8p
IN4003 200 8p
IN4004 400 8p
IN4005 600 10p
IN4006 800 12p
IN4007 1000 15p
1.5 amp miniature
PL4001 50 8p
PL4002 100 9p
PL4003 200 10p
PL4004 400 10p
PL4005 600 12p
PL4006 800 15p
PL4007 1000 18p

LINEAR (O/P AMPS)

702C TO5 75p
709C TO99 35p
709C D.I.L. 35p
723C TO99 £1.00
723C D.I.L. 85p
725C (TO99) £4.50
741C TO99 55p
741C D.I.L. 35p
747C TO99 £1.10
747C D.I.L. £1.40
7274P D.I.L. 60p
7274R D.I.L. 50p

SL4030D PLESSEY

3 WATT R.M.S. I.C.
Complete with 8 page Data Booklet and Circuits £1.50.
P.C. Board Stereo 60p; Heat Sink 14p.
Any one type, 11 Watt 5% Miniature Wire Ends Metal Case All voltages 6.8-100 Volts 20p each
25+ 18p
100+ 12p
500+ 10p
Any one type, 2 Watt 5% Plastic 2EZ Range 6.8-33 Volts 25p each.
3 Watt Plastic Wire Ends 3% 3EZ Range All voltages 6.8-100 Volts 30p each.
10 Watt Stud Mounting 5% All voltages 6.8-100 Volts, 40p each.

FREE Stock List Ref. No. 36
Revised Regularly

TRANSISTORS, IC's, DIODES, TRIACS, BRIDGES, SCR's, ZENERS, LDR's.
This advert. contains just a small selection of the thousands of devices kept in stock. Send for Stock List Today! Quantity prices Phone: 01-402 4891.

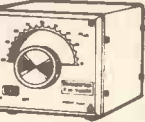

BUILD THIS VHM FM TUNER
5 TRANSISTORS 300 kc/s BANDWIDTH, PRINTED CIRCUIT, HIGH FIDELITY REPRODUCTION, MONO AND STEREO.
A popular VHF FM Tuner for quality and reception of mono and stereo. There is no doubt about it—VHF FM gives the REAL sound. All parts sold separately. Free Leaflet Mk I No. 3 & 7. TOTAL £8.97, p.p. 20p. Decoding Kit £5.97. Built IC Decoder £6.50. Tuning meter unit £1.75. (Mains unit optional).
Mains unit for Tuner and Decoder PS6/12 £3.25. Post 20p.

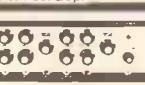

PA-DISCO-LIGHTING
UK's Largest Range—Write phone or call in. Details and demonstrations on request.
DJ30L 3 Channel sound to light unit, 3kw. £20.75
DJ70S 70 watt Disco amplifier. £38.75
DISCOAMP 100 watt amp/mixer. £40.95
DJ105S 30 watt Disco amp/mixer. £86.50
Anti-Feedback Quality M/C. 50K ohm DJ500 50 watt PA. £11.50, £44.00.
DJ700 70 watt DJ1000 100 watt GROUP 200 150 watt rms "Group" Valve Amplifier. £52.75, £63.00, £95.00.
FIBRE OPTICS LIGHTING, MIC'S, EFFECTS, PROJECTORS, SPOTS. DIMMERS—STANDS, MIXERS, SPEAKERS. Everything for PA—Disco—Lighting. FREE Stock List Ref. No. 18. ● PORTABLE DISCO—DETAILS ON REQUEST. ● CREDIT TERMS FOR CALLERS.

SINCLAIR PROJECT 60 MODULES

—SAVE POUNDS!
Z30 £3.57; Z50 £4.37
STEREO 60 PZ5 £3.97
£7.97; PZ8 £4.77
PZ6 £8.37;
Transformer for PZ6 £2.95
Active Filter Unit £4.45
Stereo FM Tuner £16.95
IC12 £1.40; Q1's £15 pr.
Post etc. 20p per item.

ZENER DIODES

400 M/W 5% Miniature
BZY 48 Range All voltages 3.3-33 Volt 15p each.
100+ 8p
500+ 6.5p
Any one type, 11 Watt 5% Wire Ends Metal Case All voltages 6.8-100 Volts 20p each
25+ 18p
100+ 12p
500+ 10p
Any one type, 2 Watt 5% Plastic 2EZ Range 6.8-33 Volts 25p each.
3 Watt Plastic Wire Ends 3% 3EZ Range All voltages 6.8-100 Volts 30p each.
10 Watt Stud Mounting 5% All voltages 6.8-100 Volts, 40p each.

TRIACS

STUD WITH ACCESSORIES
Type Volts Price P.I.V. 1-11
3 AMP RANGE 75p
SC35A 100 75p
SC35B 200 78p
SC35D 400 85p
8 AMP RANGE (TO48) 85p
SC40A 100 85p
SC40B 200 90p
SC40D 400 £1.90
SC40E 800 £1.28
10 AMP RANGE (TO48) 3 Amp
SC45A 100 85p
SC45B 200 £1.90
SC45D 400 £1.25
SC45E 800 £1.45
15 AMP RANGE (TO48) 15 Amp
SC50A 100 £1.25
SC50B 200 £1.35
SC50D 400 £1.45
SC50E 800 £1.95
Additional Types (TO68) 85p 15 Amp
4068 (Plastic) £1.90
4068E (TO5) 80p TO48

NEW BRIDGE RECTIFIERS

SMALL SIZE AND LOW COST
Type Volts Price P.I.V. 1-11
HALF AMP B05105 50 25p
B05110 100 25p
ONE AMP. 1x1in B150 600 35p
ONE AMP (G.I.) TUBULAR W005 50 30p
W005 100 35p
W02 200 40p
W06 600 45p
TWO AMPS B1x1x1x1 B2105 50 35p
B2110 100 40p
B2120 200 45p
B2160 600 50p
B21100 1000 60p

SILICON CONTROLLED RECTIFIERS

Type Volts Price P.I.V. 1-11
ONE AMP CR1105 50 25p
CR1110 100 30p
CR1120 200 30p
CR1140 400 35p
CR1180 800 45p
THREE AMP (TO48) CR3105 50 30p
CR3110 100 30p
CR3120 200 35p
CR3140 400 35p
CR3180 800 55p
FIVE AMP (TO48) CR5100 100 30p
CR5110 100 60p
CR5120 200 85p
CR5140 400 70p
CR5180 800 85p
SEVEN AMP (TO48) CR7100 100 60p
CR7120 200 85p
CR7140 400 70p
CR7180 800 85p
SIXTEEN AMP SCR1100 100 70p
SCR16200 200 70p
SCR16400 400 60p
SCR16800 800 £1.00

HENRY'S RADIO LIMITED

EDGWARE ROAD, W2

All stores within 200 yards—call in and see for yourself
404-406 Electronic Components and Equipment 01-402 8381
354-356 High Fidelity and Tape Equipment 01-402 5854
309 PA-Disco-Lighting High Power Sound 01-723 6963
303 Special offers and bargains store
All mail to 303 Edgware Road, London W2 1BW

Open: 9 am-6 pm 6 days a week

DATA TRANSMISSION SYSTEM

A new low-cost data transmission system developed in conjunction with the Devon River Authority, which uses the normal public telephone network to provide continuous monitoring of river pollution or give early flood warnings, is now available from Delta Controls Ltd. of Kingston-on-Thames.

Known as the Deltrol TeleGen system, the compact solid-state equipment — mains or battery operated — has achieved a price breakthrough. The basic two-channel unit, which can be used to monitor rainfall and river levels, costs only £250. It has been designed to provide functional simplicity with an adequate, but basic, storage memory, which continually up-dates itself.

By using the normal Post Office telephone system, rented tie lines or other costly transmission and storage

methods have been eliminated. Apart from the initial cost of the equipment, the only other expenditure required is a low rental charge for a telephone at each of the remote stations to be monitored and, of course, the normal rainfall, level and pollution sensing devices.

To gain access to the continuously monitored data, all a member of a River Authority, or Water Undertaking, need do is dial the appropriate telephone number. After a 'number unobtainable' tone to deter unintentional callers, the system transmits the latest readings — rainfall, river levels, oxygen counts etc. in the form of easily noted pulse tones. Count these, record the figures transmitted and you have an up-to-the-minute situation report. Each channel in use is dedicated to a function and scanned and transmitted in order. If a reading needs to be double-checked, it is only necessary to replace the receiver and dial the number again. The memory is not reset if interrogated by accident and because it is continually up-dated, the risk of outside interference is

eliminated.

Devon River Authority is able to keep a continuous watch over its catchment area at a fraction of the cost of more conventional methods by using this system. Merely by dialling the telephone numbers of its stations at regular intervals, it is possible to calculate variations in levels, rainfall or any other parameters being monitored.

COOL CONCORDE ON CLOSED CIRCUIT

A television system, operating in worse than Arctic conditions, is helping BAC instrumentation engineers to prove the efficiency of the Concorde de-icing installation. The system, from Marconi-Elliott Avionic Systems Limited, is installed on Concorde 002 for 'worst case' high-altitude icing trials. This will provide not only overall viewing of the ice build up but also detailed close-up shots and data, synchronised for precise laboratory analysis.

The system has been put together by the Company's Electro-Optical Systems Division, at BAC's instigation, as an accurate and flexible scientific measuring instrument, and is capable of measuring ice thickness on wings and air intakes to within 0.5 inches at distances greater than 20 feet from the camera.

Two cameras are used in the installation, one in a fairing in the wing root, and the other in a pressurised zone within the aircraft. The wing-root camera, which views the underside of the wing looking forward, was repackaged into a special short form for the task, and has been sealed and pressurised to operate at altitude. The camera within the aircraft is fitted with a 10:1 zoom lens, and views the wing leading edge and air intake via a mirror.

THAT'S SERVICE FOR YOU!

The Australian edition of ETI of course has its own advertisements and many of these are a real eye-opener to the British reader. Generally components—especially transistors—are rather dearer than in Britain; on the other hand we are not used to the service that some retailers offer.

One of the major component retailers open their head office seven days a week and advertise that free technical advice is available. In addition they offer "a free cup of superlative percolated coffee to every customer". Think about this when you next have to queue to reach the counter of your local components shop!



A girl records readings over the 'phone from a remote TeleGen station. One of the units produced by Delta Controls can be seen on the right.

The largest selection

BRAND NEW FULLY GUARANTEED DEVICES

AC107	0-20	AD162	0-33	BC148	0-10	BD137	0-45	BF188	0-40	OC19	0-35	2G371	0-16	2N2219	0-20	2N3054	0-46	2N4059	0-10
AC113	0-20	AD161	A	BC149	0-12	BD138	0-50	BF194	0-12	OC20	0-38	2G371B	0-17	2N2220	0-22	2N3055	0-50	2N4060	0-12
AC115	0-23	AD162 (MP)		BC150	0-18	BD139	0-55	BF195	0-12	OC22	0-38	2G373	0-17	2N2221	0-20	2N3091	0-14	2N4061	0-12
AC117K	0-20		0-55	BC151	0-20	BD140	0-60	BF196	0-14	OC23	0-42	2G374	0-17	2N2222	0-20	2N3092	0-16	2N4062	0-12
AC122	0-12	AD1140	0-50	BC152	0-17	BD155	0-80	BF197	0-14	OC24	0-56	2G377	0-30	2N2268	0-17	2N3092	0-14	2N4284	0-17
AD125	0-12	AF114	0-24	BC153	0-28	BD175	0-60	BF200	0-45	OC25	0-38	2G378	0-16	2N2269	0-14	2N3093	0-14	2N4285	0-17
AC126	0-17	AF115	0-24	BC154	0-30	BD176	0-60	BF222	0-65	OC28	0-26	2G381	0-16	2N2270	0-14	2N3094	0-14	2N4286	0-17
AC127	0-17	AF116	0-24	BC157	0-18	BD177	0-65	BF257	0-45	OC28	0-80	2G382	0-16	2N2411	0-24	2N3395	0-17	2N4287	0-17
AC128	0-17	AF117	0-24	BC158	0-18	BD178	0-65	BF258	0-60	OC29	0-50	2G401	0-30	2N2412	0-24	2N3402	0-21	2N4288	0-17
AC132	0-14	AF118	0-35	BC159	0-12	BD179	0-70	BF259	0-85	OC35	0-42	2G414	0-20	2N2646	0-47	2N3403	0-21	2N4289	0-17
AC134	0-14	AF124	0-30	BC160	0-46	BD180	0-70	BF262	0-55	OC36	0-50	2G417	0-25	2N2711	0-21	2N3404	0-28	2N4290	0-17
AC137	0-14	AF125	0-25	BC161	0-50	BD185	0-65	BF263	0-55	OC42	0-20	2N388	0-45	2N2712	0-21	2N3405	0-42	2N4291	0-17
AC141	0-14	AF126	0-28	BC167	0-12	BD186	0-65	BF270	0-35	OC42	0-24	2N388A	0-45	2N2714	0-31	2N3414	0-15	2N4292	0-17
AC141K	0-17	AF127	0-28	BC168	0-12	BD187	0-70	BF271	0-30	OC44	0-15	2N404	0-20	2N2904	0-21	2N3415	0-15	2N4293	0-17
AC142	0-14	AF139	0-30	BC169	0-12	BD188	0-70	BF272	0-60	OC45	0-12	2N404A	0-22	2N2904A	0-21	2N3416	0-28	2N4292	0-12
AC142K	0-17	AF178	0-50	BC170	0-12	BD189	0-75	BF273	0-35	OC49	0-10	2N424	0-42	2N2905	0-21	2N3417	0-28	2N4297	0-38
AC151	0-16	AF179	0-50	BC171	0-14	BD190	0-70	BF274	0-30	OC49	0-10	2N427	0-10	2N2906	0-21	2N3418	0-28	2N4298	0-38
AC154	0-20	AF180	0-50	BC172	0-14	BD195	0-85	BF280	0-60	OC72	0-14	2N598	0-42	2N2908	0-15	2N3446	0-09	2N4549	0-40
AC155	0-20	AF181	0-45	BC173	0-14	BD196	0-85	BF289	0-27	OC74	0-14	2N599	0-45	2N2909	0-15	2N3702	0-10	2N4550	0-50
AD156	0-20	AF180	0-45	BC174	0-14	BD197	0-90	BF288	0-22	OC75	0-15	2N696	0-12	2N2910	0-20	2N3703	0-10	2N4551	0-42
AC157	0-24	AF239	0-37	BC175	0-22	BD198	0-90	BF289	0-30	OC76	0-15	2N697	0-13	2N2911	0-22	2N3704	0-11	2N4552	0-42
AD165	0-20	AL102	0-65	BC177	0-19	BD199	0-95	BF288	0-22	OC77	0-25	2N698	0-24	2N2912	0-14	2N3705	0-10	2N4553	0-56
AC166	0-20	AL103	0-65	BC178	0-19	BD200	0-95	BF287	0-24	OC81	0-15	2N699	0-35	2N2924	0-14	2N3706	0-09	2N4554	0-56
AC167	0-20	ASV26	0-25	BC179	0-19	BD205	0-80	BF288	0-22	OC81D	0-15	2N706	0-08	2N2925	0-14	2N3707	0-11	2N4555	0-84
AD168	0-24	ASV27	0-30	BC180	0-24	BD206	0-80	BF289	0-20	OC82	0-15	2N708A	0-09	2N2926	0-12	2N3708	0-07	2N4556	0-84
AC169	0-14	ASV28	0-25	BC181	0-24	BD207	0-95	BF289	0-20	OC82D	0-15	2N708	0-12	2N2926 (Y)	0-12	2N3709	0-09	2N4557	0-84
AD176	0-20	ASV29	0-25	BC182	0-10	BD208	0-95	BF292	0-20	OC83	0-20	2N711	0-30	2N2926 (Y)	0-11	2N3710	0-09	2N4558	0-84
AC177	0-24	ASV50	0-25	BC182L	0-10	BDY20	1-00	BFY53	0-17	OC84	0-20	2N717	0-35	0-11	2N3711	0-09	2N4559	0-84	
AC178	0-28	ASV51	0-25	BC183	0-10	BF115	0-24	BFY55	0-25	OC139	0-20	2N718	0-24	2N2926 (O)	0-10	2N3819	0-28	2N4560	0-84
AC179	0-28	ASV52	0-25	BC183L	0-10	BF117	0-45	BFY56	0-25	OC140	0-20	2N719	0-24	2N2926 (O)	0-11	2N3820	0-28	2N4561	0-84
AC180	0-17	ASV54	0-25	BC184	0-12	BF118	0-70	BFY57	0-15	OC169	0-25	2N726	0-28	2N2926 (R)	0-10	2N3821	0-35	2N4562	0-84
AC180K	0-20	ASV55	0-25	BC184L	0-12	BF119	0-70	BFY55	0-15	OC170	0-25	2N727	0-28	0-10	2N3822	0-35	2N4563	0-84	
AC181	0-17	ASV56	0-25	BC186	0-28	BF121	0-45	BFY58	0-15	OC171	0-25	2N743	0-20	2N2926 (B)	0-10	2N3903	0-28	2N4564	0-84
AC181K	0-20	ASV57	0-25	BC187	0-28	BF122	0-45	BFY59	0-18	OC200	0-25	2N744	0-20	2N3904	0-30	2N3927	0-70	2N4565	0-84
AC187	0-28	ASV58	0-25	BC207	0-11	BF123	0-45	BFY58	0-15	OC201	0-25	2N744	0-20	2N3910	0-70	2N3905	0-28	2N4566	0-84
AC187K	0-20	ASV59	0-25	BC208	0-11	BF127	0-40	BFY59	0-15	OC221	0-28	2N748	0-20	2N3911	0-14	2N3906	0-27	2N4567	0-84
AD188	0-22	BC107	0-09	BC209	0-19	BF152	0-45	BFY58	0-18	OC203	0-25	2N749	0-20	2N3907	0-27	2N3907	0-27	2N4568	0-84
AC188K	0-20	BC108	0-09	BC212L	0-11	BF153	0-45	BFY59	0-18	OC204	0-25	2N750	0-20	2N3908	0-27	2N3908	0-27	2N4569	0-84
ACY17	0-25	BC109	0-10	BC213L	0-11	BF154	0-45	BFY60	0-28	OC205	0-25	2N751	0-20	2N3909	0-27	2N3909	0-27	2N4570	0-84
ACY18	0-20	BC113	0-10	BC214L	0-14	BF155	0-70	BFY61	0-28	OC309	0-40	2N132	0-23	2N3910	0-27	2N3910	0-27	2N4571	0-84
ACY19	0-20	BC114	0-15	BC225	0-25	BF156	0-48	BFY62	0-12	P3467	0-42	2N1303	0-14	AA119	0-08	BY133	0-21	OA10	0-35
ACY20	0-20	BC115	0-15	BC226	0-35	BF157	0-45	BFY63	0-12	P3467	0-42	2N1303	0-14	AA120	0-08	BY134	0-21	OA10	0-35
ACY21	0-20	BC116	0-15	BC227	0-35	BF158	0-45	BFY64	0-12	P3467	0-42	2N1304	0-14	AA121	0-08	BY135	0-21	OA10	0-35
ACY22	0-18	BC117	0-15	BCY31	0-28	BF159	0-60	CI115	0-50	ORP12	0-43	2N1305	0-17	AA129	0-08	BY136/30	0-50	OA70	0-07
ACY27	0-18	BC118	0-10	BCY32	0-30	BF160	0-40	C400	0-30	ORP60	0-40	2N1306	0-21	AA130	0-09	0-42	OA79	0-07	
ACY28	0-19	BC119	0-20	BCY33	0-22	BF162	0-40	C407	0-25	ORP61	0-40	2N1307	0-21	AA123	0-10	BYZ11	0-35	OA81	0-07
ACY29	0-25	BC120	0-25	BCY34	0-28	BF163	0-40	C408	0-25	RT140	0-12	2N1308	0-23	BA100	0-10	BYZ12	0-35	OA85	0-09
ACY30	0-28	BC125	0-12	BCY70	0-14	BF164	0-40	C424	0-50	RT141	0-12	2N1309	0-23	BA101	0-10	BYZ12	0-35	OA85	0-09
ACY31	0-28	BC126	0-12	BCY71	0-18	BF165	0-40	C426	0-35	RT143	0-30	2N1613	0-20	BA126	0-22	BYZ13	0-35	OA81	0-08
ACY32	0-21	BC132	0-12	BCY79	0-14	BF167	0-22	OA28	0-20	UT46	0-27	2N1711	0-20	BA148	0-14	BYZ16	0-40	OA85	0-07
ACY35	0-21	BC134	0-15	BCZ10	0-20	BF173	0-22	C441	0-30	2G301	0-09	2N1889	0-32	BA154	0-12	BYZ17	0-35	OA89	0-08
ACY36	0-28	BC135	0-25	BCZ11	0-25	BF174	0-25	C442	0-30	2G302	0-19	2N1890	0-32	BA155	0-12	BYZ18	0-35	OA89	0-08
ACY40	0-17	BC136	0-18	BCZ12	0-25	BF177	0-35	C444	0-35	2G303	0-19	2N1893	0-37	BA156	0-13	BYZ19	0-28	SD10	0-05
ACY41	0-18	BC137	0-15	BD121	0-30	BF178	0-30	C450	0-22	2G304	0-24	2N2147	0-72	BY100	0-15	CG62	SD19	0-05	
ACY44	0-25	BC139	0-40	BD123	0-35	BF179	0-30	MAT100	0-19	2G306	0-40	2N2148	0-72	BY101	0-15	(Ea) OA91	IN34	0-07	
AD140	0-38	BC140	0-30	BD124	0-35	BF180	0-30	MAT101	0-19	2G307	0-35	2N2149	0-72	BY102	0-15	CG63	IN34	0-07	
AD140	0-48	BC141	0-30	BD131	0-50	BF181	0-30	MAT120	0-19	2G309	0-35	2N2192	0-35	BY114	0-12	CG65	IN34	0-07	
AD142	0-48	BC142	0-30	BD132	0-60	BF182	0-40	MAT121	0-20	2G339	0-20	2N2193	0-35	BY126	0-14	(Ea) OA70	IN1916	0-08	
AD143	0-38	BC143	0-30	BD133	0-65	BF183	0-40	MAT122	0-42	2G339A	0-18	2N2194	0-35	BY127	0-15	OA79	0-06	IN1414B	0-08
AD149	0-50	BC145	0-35	BD135	0-65	BF184	0-25	MAT123	0-37	2G344	0-16	2N2217	0-22	BY128	0-15	OA3	0-35	IN6021	0-08
AD161	0-33	BC147	0-10	BD136	0-40	BF185	0-30	MAT124	0-37	2G345	0-16	2N2218	0-20	BY130	0-16	OA3BL	0-21	IN6031	0-08

FULL RANGE OF ZENER DIODES

VOLTAGE RANGE

2-23V, 400mV (DO-7 Case) 13p ca. 1W (Top-Hat) 15p ca. 10W (SO-10 Stud) 25p ca. All fully tested, 8% tol. and marked. % voltage required.

10 amp POTTED BRIDGE RECTIFIER on heat sink. 100PIV, 90p each

NEW LINE

Plastic Encapsulated 25 Amp BRIDGE RECTS. 50V RMS 32p each 100V RMS 37p .. 400V RMS 46p .. Size 15 mm x 8 mm.

UNIJUNCTION

UT46, EQVT, 2N2646, Evt. 1T843, BEN3000 27p each, 25-99 25p 100 UF 20p.

CADMIUM CELLS

ORP12 43p ORP60, ORP61 40p each

GENERAL PURPOSE NPN SILICON SWITCHING TRANS. TO-18 SIM. TO 2N705A, 2N706, 2N707, A.I.I. usable devices, no open or short circuits. ALSO AVAILABLE IN PNP SIM. TO 2N2906, BCV70. When ordering, please state preference NPN or PNP.

AA119	0-08	BY133	0-21	OA10	0-35
AA120	0-08	BY134	0-21	OA10	0-

-the lowest prices!

74 Series T.T.L. I.C.'S

BI-PAK STILL LOWEST IN PRICE FULL SPECIFICATION
GUARANTEED. ALL FAMOUS MANUFACTURERS



1	25	100+	1	25	100+	1	25	100+			
SN7400	0.15	0.14	0.12	SN7450	0.15	0.14	0.12	SN74123	£2.80	£2.70	£2.60
SN7401	0.15	0.14	0.12	SN7451	0.15	0.14	0.12	SN74141	0.67	0.64	0.58
SN7402	0.15	0.14	0.12	SN7453	0.15	0.14	0.12	SN74145	£1.50	£1.40	£1.30
SN7403	0.15	0.14	0.12	SN7454	0.15	0.14	0.12	SN74150	£2.00	£2.70	£2.60
SN7404	0.15	0.14	0.12	SN7460	0.15	0.14	0.12	SN74151	£1.00	0.98	0.90
SN7405	0.15	0.14	0.12	SN7470	0.29	0.28	0.24	SN74153	£1.20	£1.10	0.95
SN7406	0.25	0.24	0.22	SN7472	0.29	0.28	0.24	SN74154	£1.80	£1.70	£1.60
SN7407	0.25	0.24	0.22	SN7473	0.37	0.35	0.32	SN74155	£1.40	£1.30	£1.20
SN7408	0.18	0.17	0.16	SN7474	0.37	0.35	0.32	SN74156	£1.40	£1.30	£1.20
SN7409	0.18	0.17	0.16	SN7475	0.45	0.43	0.42	SN74157	£1.90	£1.80	£1.70
SN7410	0.15	0.14	0.12	SN7476	0.40	0.39	0.38	SN74160	£1.80	£1.70	£1.60
SN7411	0.25	0.24	0.22	SN7480	0.87	0.84	0.82	SN74161	£1.80	£1.70	£1.60
SN7412	0.25	0.24	0.22	SN7481	£1.20	£1.15	£1.10	SN74162	£4.00	£3.75	£3.50
SN7413	0.29	0.28	0.24	SN7482	0.87	0.86	0.85	SN74163	£4.00	£3.75	£3.50
SN7410	0.43	0.40	0.38	SN7483	£1.10	£1.05	0.96	SN74164	£2.20	£2.15	£2.10
SN7417	0.43	0.40	0.38	SN7484	£1.00	0.95	0.90	SN74165	£2.25	£2.20	£2.15
SN7430	0.15	0.14	0.12	SN7485	£3.80	£3.60	£3.40	SN74166	£2.50	£2.25	£2.00
SN7432	0.50	0.48	0.45	SN7486	0.35	0.31	0.30	SN74174	£2.30	£2.20	£2.10
SN7423	0.50	0.48	0.45	SN7489	£5.50	£5.25	£5.00	SN74175	£1.80	£1.50	£1.40
SN7425	0.50	0.48	0.45	SN7490	0.87	0.84	0.82	SN74176	£2.50	£2.40	£2.30
SN7427	0.45	0.42	0.40	SN7491	£1.90	0.95	0.90	SN74177	£2.50	£2.40	£2.30
SN7428	0.70	0.65	0.60	SN7492	0.67	0.64	0.62	SN74180	£2.00	£1.60	£1.40
SN7430	0.15	0.14	0.12	SN7493	0.67	0.64	0.62	SN74181	£5.50	£5.00	£4.75
SN7432	0.45	0.42	0.40	SN7494	0.77	0.74	0.72	SN74182	£2.00	£1.80	£1.60
SN7433	0.80	0.75	0.70	SN7495	0.77	0.74	0.72	SN74184	£3.50	£3.25	£3.00
SN7437	0.84	0.82	0.80	SN7496	0.87	0.84	0.78	SN74189	£1.95	£1.90	£1.85
SN7438	0.84	0.82	0.80	SN74100	£1.85	£1.60	£1.55	SN74191	£1.90	£1.85	£1.80
SN7440	0.15	0.14	0.12	SN74104	0.97	0.94	0.88	SN74192	£1.95	£1.90	£1.85
SN7441	0.87	0.84	0.82	SN74105	0.97	0.94	0.88	SN74193	£2.00	£1.90	£1.75
SN7442	0.87	0.84	0.82	SN74107	0.40	0.38	0.38	SN74194	£2.70	£2.60	£2.50
SN7443	£1.30	£1.25	£1.20	SN74110	0.55	0.53	0.50	SN74195	£2.00	£1.90	£1.80
SN7444	£1.30	£1.25	£1.20	SN74111	£1.25	£1.15	£1.10	SN74196	£1.80	£1.70	£1.60
SN7445	£1.80	£1.77	£1.78	SN74118	£1.00	0.95	0.90	SN74197	£1.80	£1.70	£1.60
SN7446	0.97	0.94	0.88	SN74119	£1.35	£1.25	£1.10	SN74198	£5.50	£5.00	£4.50
SN7447	£1.00	0.97	0.95	SN74121	0.40	0.37	0.34	SN74199	£5.50	£5.00	£4.50
SN7448	£1.00	0.97	0.95	SN74122	£1.40	£1.30	£1.10				

The AL50 HI-FI AUDIO AMPL 50W pk 25w (RMS) 0.1% DISTORTION! HI-FI AUDIO AMPLIFIER



- Frequency Response 15Hz to 100,000—1dB.
- Load—3, 4, 8 or 16 ohms. • Supply voltage 10-35 Volts.
- Distortion—better than 0.1% at 1kHz.
- Signal to noise ratio 80dB.
- Overall size 63 mm x 105 mm x 13 mm.

Tailor made to the most stringent specifications using top quality components and incorporating the latest solid state circuitry conceived to fill the need for all your A.F. amplification needs. FULLY BUILT—TESTED—GUARANTEED.

BRITISH MADE. only £3.58 each



STABILISED POWER MODULE SPM80

£3.25

AP80 is especially designed to power 2 of the AL50 Amplifiers, up to 15 watt (r.m.s.) per channel simultaneously. This module embodies the latest components and circuit techniques incorporating complete short circuit protection. With the addition of the Main Transformer MT80, the unit will provide outputs of up to 1.5 amps at 35 volts. Size: 63 mm x 105 mm x 20 mm. These units enable you to build Audio Systems of the highest quality at a hitherto unobtainable price. Also ideal for many other applications including—Dirco Systems, Public Address, Intercom Units, etc. Handbook available, 10p.

TRANSFORMER BMT80 £2.15 p. & p. 25p

NUMERICAL INDICATOR TUBES

MODEL	CD46	GR116	3016F Minitron
Anode Voltage (Vdc)	170min	175min	5
Cathode Current (mA)	2-3	14	8
Numerical Height (mm)	16	13	9
Tube Height (mm)	47	32	22
Tube Diameter (mm)	19	13	12 wide
I.C. Driver Rec.	BP41/141	BP41 or 141	BP47
PRICE EACH	£1.70	£1.55	£2.00

All indicators 0-9 + Decimal point. All side viewing. Full data for all types available on request.

STEREO PRE-AMPLIFIER TYPE PA100

Built to a specification and NOT a price, and yet still the greatest value on the market, the PA100 stereo pre-amplifier has been conceived from the latest circuit techniques. Designed for use with the AL50 power amplifier system, this quality made unit incorporates a 15 less than eight silicon planar transistors, two of these are specially selected low noise NPN devices for use in the input stages.

Features switched stereo inputs, and rumble and scratch filters are features of the PA100, which also has a STEREO/MONO switch, volume, balance and continuously variable bass and treble controls.

SPECIFICATION:

Frequency response 20Hz—20kHz ±1dB
 Harmonic distortion better than 0.1%
 Input: 1. Tape head 1.25mV into 50KΩ
 2. Radio, Tuner 35mV into 50KΩ
 3. Magnetic P.U. 1.5mV into 50KΩ
 All input voltages are for an output of 280mV. Tape and P.U. inputs equalised to RIAA curve within ±1dB from 20Hz to 20kHz.

Bass control
 Treble control
 Filters: Rumble (high pass)
 Scratch (low pass)
 Signal/noise ratio
 Input overload
 Supply
 Dimensions

±15dB at 20Hz
 ±15dB at 20kHz
 100 Hz
 8kHz
 better than +65dB
 +25dB
 +35 volts at 20mA
 92 x 62 x 35 mm

SPECIAL COMPLETE KIT COMPRISING 2 AL50's, 1 SPM80, 1 BMT80 & 1 PA100 ONLY £23.00 FREE p.&p

only £13.15

The STEREO 20

The 'Stereo 20' amplifier is mounted, ready wired and tested on a one-piece chassis measuring 20 cm x 14 cm x 5.6 cm. This compact unit comes complete with on/off switch, volume control, balance, bass and treble controls. Attractively printed front panel and matching control knobs. The 'Stereo 20' has been designed to fit into most turntable plinths without interfering with the mechanism or, alternatively, into a separate cabinet.

Output power 20w peak
 Freq. res. 20Hz-20kHz
 Harmonic distortion typically 0.25% at 1 watt

Input 1 (Cr.) 300mV into 1M
 Input 2 (Aux.) 4mV into 30K
 Bass control ±12dB at 60Hz
 Treble control ±14dB at 8kHz

£12.25 free p. & p.

INTEGRATED CIRCUIT PAKS

Manufacturers "Fall Outs" which include Functional and Part-Functional Units. These are classed as 'out-of-spec' from the maker's very rigid specifications, but are ideal for learning about I.C.'s and experimental work.

Pak No.	Contents	Price	Pak No.	Contents	Price	Pak No.	Contents	Price
UIC00	—12 x 7400	0.50	UIC46	—5 x 7446	0.50	UIC86	—5 x 7486	0.50
UIC01	—12 x 7401	0.50	UIC47	—5 x 7447	0.50	UIC87	—5 x 7487	0.50
UIC02	—12 x 7402	0.50	UIC48	—5 x 7448	0.50	UIC88	—5 x 7488	0.50
UIC03	—12 x 7403	0.50	UIC49	—12 x 7450	0.50	UIC89	—5 x 7489	0.50
UIC04	—12 x 7404	0.50	UIC51	—12 x 7451	0.50	UIC93	—5 x 7493	0.50
UIC05	—12 x 7405	0.50	UIC53	—12 x 7453	0.50	UIC94	—3 x 7494	0.50
UIC06	—8 x 7406	0.50	UIC54	—12 x 7454	0.50	UIC95	—5 x 7495	0.50
UIC07	—8 x 7407	0.50	UIC56	—12 x 7456	0.50	UIC96	—5 x 7496	0.50
UIC10	—12 x 7410	0.50	UIC70	—8 x 7470	0.50	UIC100	—5 x 74100	0.50
UIC13	—8 x 7413	0.50	UIC72	—8 x 7472	0.50	UIC121	—5 x 74121	0.50
UIC20	—12 x 7420	0.50	UIC73	—8 x 7473	0.50	UIC141	—5 x 74141	0.50
UIC30	—12 x 7430	0.50	UIC74	—8 x 7474	0.50	UIC111	—5 x 74111	0.50
UIC40	—12 x 7440	0.50	UIC75	—8 x 7475	0.50	UIC154	—5 x 74154	0.50
UIC41	—5 x 7441	0.50	UIC76	—8 x 7476	0.50	UIC193	—5 x 74193	0.50
UIC42	—5 x 7442	0.50	UIC80	—5 x 7480	0.50	UIC198	—5 x 74198	0.50
UIC43	—5 x 7443	0.50	UIC81	—5 x 7481	0.50			
UIC44	—5 x 7444	0.50	UIC82	—5 x 7482	0.50	UICX1	—25 Assorted 74's	1.50
UIC45	—5 x 7445	0.50	UIC83	—5 x 7483	0.50			

Packs cannot be split, but 25 assorted pieces (our mix) is available as PAK UIC X1.

NEW COMPONENT PAK BARGAINS

Pak No.	Qty.	Description	Price
C 1	250	Resistors mixed values approx. count by weight	0.50
C 2	200	Capacitors mixed values approx. count by weight	0.50
C 3	50	Precision Resistors 1%, mixed values	0.50
C 4	75	4th W Resistors mixed preferred values	0.50
C 5	5	Pieces assorted Ferrite Rods	0.50
C 6	2	Tuning Gangs, MW/LW/VHF	0.50
C 7	1	Pack Wire 80 metres assorted colours	0.50
C 8	10	Reed Switches	0.50
C 9	3	Micro Switches	0.50
C10	15	Assorted Pots & Pre-SETS	0.50
C11	5	Jack Sockets 3 x 3.5mm 2 x Standard Switch Types	0.50
C12	40	Paper Condensers preferred types mixed values	0.50
C13	20	Electrolytic Trans. Types	0.50
C14	1	Pack assorted Hardware—Nuts/Bolts, Grommets etc.	0.50
C15	4	Mainz Toggle Switches, 2 Amp D/P	0.50
C16	20	Assorted Tag Strips & Panels	0.50
C17	10	Assorted Control Knobs	0.50
C18	4	Rotary Wave Change Switches	0.50
C19	3	Relays 6—24V Operating	0.50
C20	4	Sheets Copper Laminate approx. 10" x 7"	0.50

Please add 10p post and packing on all component packs, plus a further 10p on pack Nos. C1, C2, C19, C20.

RTL MICROLOGIC CIRCUITS

Epoxy TO-5 case	Price each	
	1-24	25-99 100 up
Buffer	35p	33p 27p
UL914 Dual Bip gate	55p	33p 27p
UL923 J-K Bip-Flip	80p	47p 45p

Data and Circuits Booklet for IC's Price 7p.

DUAL-IN-LINE IC'S. TWO RANGES PROFESSIONAL & NEW LOW COST.	1-24	25-99	100 up
PROF. TYPE No.	30p	27p	25p
TS1 14 pin type	30p	27p	25p
TSO 16 " "	30p	27p	25p

LOW COST No.	15p	13p	11p
BFS 14	15p	13p	11p
BFS 16	15p	13p	11p

LINEAR I.C.'s—FULL SPEC.

Type No.	1-24	Price 25-99	100 up
BP 201C—8L201C	63p	58p	45p
BP 701C—8L701C	63p	50p	45p
BP 702C—8L702C	63p	50p	45p
BP 709—72702	53p	49p	40p
BP 709—72709	38p	34p	30p
BP 709P—8L709C	38p	34p	30p
BP 710—72710	44p	42p	40p
BP 711—8L711	45p	43p	40p
BP 741—72741	75p	60p	50p
BP 703C—8L703C	29p	29p	24p
TAA 263	70p	60p	55p
TAA 293	90p	75p	70p
TAA 380	170p	158p	160p

ROCK BOTTOM PRICES

LOGIC DTL 930 Series I.C.'s	1-24	Price 25-99	100 up
Type	12p	11p	10p
BP930	12p	11p	10p
BP932	13p	12p	11p
BP933	13p	12p	11p
BP935	13p	12p	11p
BP936	13p	12p	11p
BP944	13p	12p	11p
BP945	25p	24p	22p
BP946	12p	11p	10p
BP948	25p	24p	22p
BP951	85p	80p	55p
BP952	12p	11p	10p</

PROCESSORS, PROGRAMS AND PERIPHERALS

Many readers, who may understand quite a lot about electronics, still find the world of computers highly baffling. In this two part feature, Jon Talbot gives an introduction to this field.

DIGITAL computers have always had a poor press. They are well-known to the general public as dispensers of thousand-pound gas bills and it is widely reported that these disingenuous machines, communicating with one another via data links, will soon be swapping secrets culled from our income-tax returns, census forms, hire-purchase agreements and bank accounts and assembling them into one damning dossier. The use of the computer as a scientific tool is rarely published, except in the glamorous context of space shots and supersonic flight, so that the huge field of application of these machines is not widely appreciated.

The advent of the 'mini' computer in the early 1960's has meant that scientific computing facilities have become available to organisations that could not possibly have afforded a full-scale machine. Some computers are manufactured by methods approaching those of mass production and as sales have increased so prices have fallen. Now, the £1000 computer has arrived.

The minicomputer is just what its otherwise rather unsatisfactory name implies. It is a digital data processor

that offers capabilities similar to those of a large installation, but on a smaller scale. Operating speeds are generally lower; core stores are smaller; the range of peripheral devices available, such as cathode ray tube displays and page printers, may be more limited; software (the generic name for the programs that make the hardware 'go') is simpler and less flexible. However, these restrictions do not imply that the small computer is in any way a toy. The smallest machine, when standing alone, is a valuable working tool in any laboratory or plant. When expanded by the addition of extra storage and connected via an interface unit to an experiment or industrial process, so that it monitors or participates in the running of that experiment or process, the small computer can assume an important or even vital role.

A computer may be used in any one of several basic modes. The most easily understood is what might be described as the *static mode*, in which the machine replaces the pencil and notebook and carries out one calculation at a time upon demand. Its operation is then comparable with that of an office calculator, but with the important dif-

The keyboard of an ASR 33 teletypewriter, probably the most widely used computer input/output device. The paper tape on the left hand side is shown emerging from the punch and entering the reader. Each line of up to eight holes across the width is a coded version of a keyboard character. (Photo courtesy of Data Dynamics Ltd.)



ference that the computer has a *stored program*; the act of depressing a certain key or combination of keys on the teletypewriter keyboard calls up a specific sequence of events which requires the operator to do no more than supply the basic data for the calculation.

EXAMPLES

To take a simple example, if the operator typed V,280,332,450 then the computer would recognise that what was demanded was the volume of a box whose height, width and depth were represented by the numbers given. It would immediately print the answer on the typed record. If the operator typed W,280,332,450 then this might produce a figure for the weight of the box when made from a standard material. We can save the user a little more time and trouble (which is what computers are mostly all about) if a small refinement is added: if he wants to know both the volume and weight of the box, let him type VW,280,332,450. (This has also eliminated a possible source of error, since he has to type the numbers once only). It is important to understand that, whereas the above operations would have called for a good deal of button-pushing had a desk calculator been employed, the computer has decided what should be done simply by examining the first character(s) in the message from the keyboard.

Note that the decision was taken, strictly speaking, by the computer *program* rather than by the computer itself. This is because a computer that is working in the box-making business might very well have hardware (transistors, capacitors, nuts and bolts) identical with that of a machine working in air traffic control, but the two programs would undoubtedly be different. It is not inconceivable that the latter machine would interpret 'V' as a request for estimated time of arrival, given air speed, latitude and longitude. If our man from the box factory, while visiting the airport, happened to see a computer just like his old faithful at home and felt the urge to do a few box calculations he would either get some very foolish answers or no answers at all!

We will call the other principal mode of computer usage the *dynamic mode*, in which the functioning of the machine is modified continuously in the light of current events. Computers may be operated 'on line' with data coming in not only from human sources but also from measuring instruments such as pressure gauges and electronic thermometers. For instance, a machine may receive signals representing the torque of an engine and its speed in revolutions per minute and from this

GLOSSARY OF TERMS

<i>Core Store:</i>	A matrix of small magnetic rings or cores upon which electrical pulses may be stored. The presence of a pulse in a train is recorded by magnetising a core, the absence of a pulse by leaving a core unmagnetised.
<i>Peripheral Device:</i>	Any instrument or machine which enables a computer to communicate with the outside world or which otherwise aids the operation of the computer, but which does not form part of the basic installation.
<i>Hardware:</i>	The computer and associated electronic and mechanical devices.
<i>Software:</i>	The lists of instructions which, when converted into electrical signals, dictate the operations carried out by the computer.
<i>Interface Unit:</i>	A device which translates incoming signals that are incompatible with the electrical characteristics of the computer <i>without changing the information content</i> . Also translates outgoing signals for the benefit of associated equipment that is designed to different electrical standards.
<i>Binary Code:</i>	A method of representing numbers in a scale of two (on or off, high level, or low level, one or zero, presence or absence of a signal) rather than the more familiar scale of ten used in normal arithmetic. Electronic circuits designed to work in two defined states are much simpler and more reliable than those working in ten such states.
<i>Accumulator:</i>	The 'scratch pad' section of the computer, in which arithmetic operations are carried out.
<i>Source Program:</i>	The original program, as written by the programmer, from which a working program system is derived.
<i>Teletypewriter:</i>	(Also known as a teleprinter) A keyboard machine, similar to those used for the G.P.O. Telex service, which can transmit and receive alphabetical, numerical and certain control (non-printing) characters as a train of pulses on two wires. Attachments can be fitted for punching paper tape and printing on a roll of paper at the same time, also for reading tape and printing the message that is read.

information it could calculate and print out at regular intervals the shaft horsepower (which cannot be measured directly). It might also monitor bearing temperatures, lubricating oil pressure and the rate of consumption of fuel oil, printing these figures for record purposes at, say, ten minute intervals. At, perhaps, ten second intervals it could test the validity of the results by comparing them with preset limits. A sudden rise in temperature, fall in pressure or increase in consumption would suggest that a defect was developing and it would not be difficult to arrange that the program branched away from its normal routing and instead printed

all measurements at ten second intervals while sounding an alarm. If no action was taken within a specified period then the computer could energise a control valve in the fuel line and stop the engine.

It can be seen that the computer can undertake many boring and repetitive industrial jobs and if it is used properly it can dramatically reduce danger to personnel, wastage of materials and pollution of air and water.

The first step in putting a computer into service is to analyse the work to be done and to try to estimate the scale of future expansion of the system. These and many other factors dictate

PROCESSORS, PROGRAMS AND PERIPHERALS

the choice of machine, not merely the price: performance ratio. As will be explained later, the cost of the machine is dramatically affected by the methods that are to be employed for storing data. This means that a good estimate of the magnitude of the program must be obtained before the programming actually starts. This is not easy: many are the projects that have been converted from profit to loss by lack of attention to this matter. It is helpful to prepare a flow chart detailing all of the required program steps (Figure 1 shows a simple flow diagram for the box-designing operations described earlier). It is also easier if a complicated flow chart can be drawn as a number of smaller diagrams with only a few interconnections between diagrams. The writing of the program can be subdivided in a similar manner and will follow the chart step by step.

THE PROGRAM IS ALL IMPORTANT

The success of a digital computer in pursuing its allotted task is critically dependant upon its program. However, just as a new-born baby cannot understand language so the new-born computer cannot interpret the teleprinter signals and punched paper tape that are its normal means of communication with its user. The machine is inert and useless. Before it can be set to work the rudiments of language must be implanted into its memory and this is achieved by use of an initial (or 'bootstrap') loader.

This series of 15-20 instructions is entered into store directly by means of hand-operated switches or from a read-only memory (ROM), a small section of the computer circuitry that is reserved for this purpose alone. It will only be necessary to repeat this operation later in the life of the computer if the loader is destroyed (erased) or accidentally corrupted.

A computer program is a list of instructions which tell the machine what to do and when to do it. The most efficient programs are written in 'machine language', in which the work to be undertaken has to be reduced to the simplest possible terms. If the so-called electronic 'brain' *must* be considered in human terms then its most significant characteristic is stupidity, for the most advanced computer requires its diet of information to be spoon-fed according to a strict set of rules. It is only able to decide between two courses of action at any one time and then only under the direction of the programmer.

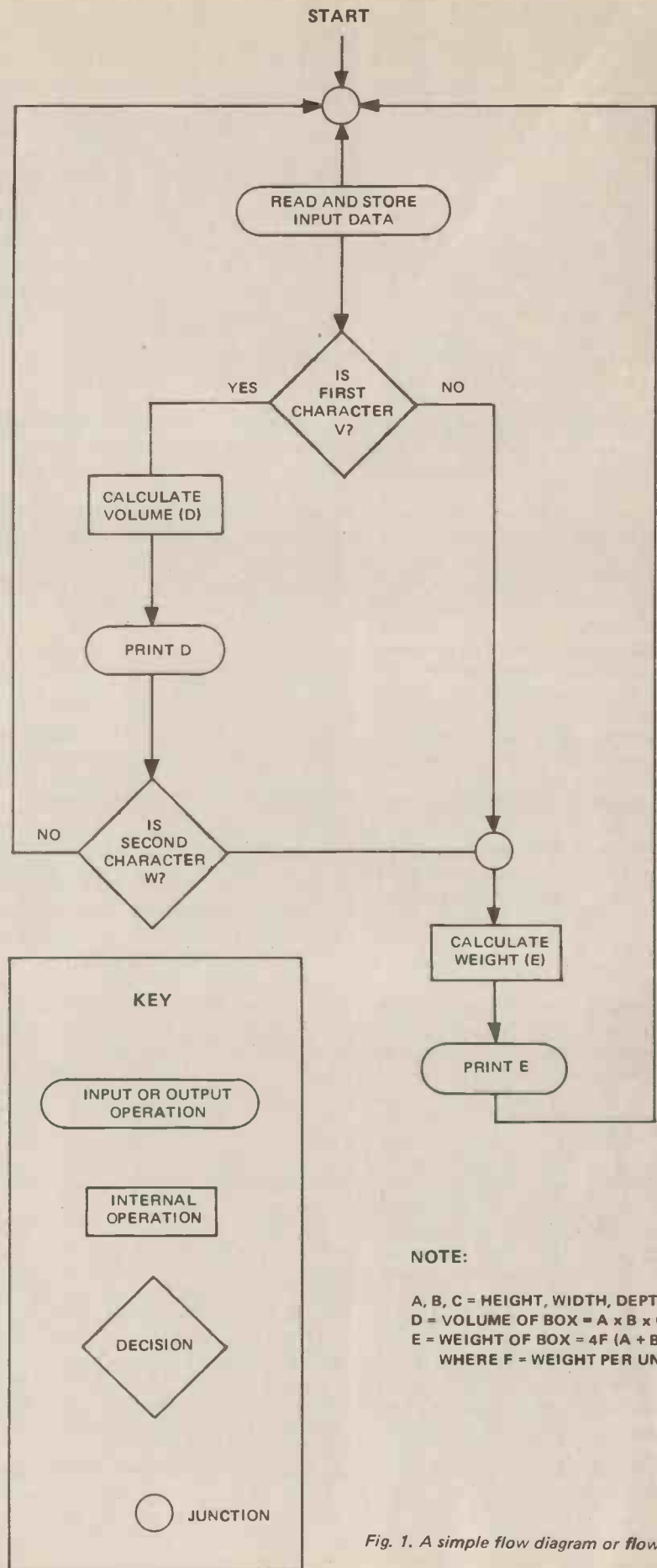

Fig. 1. A simple flow diagram or flow chart

The store of the computer can be likened to a huge snakes and ladders game, in which there is (hopefully!) only one player. The programmer starts at square number one and places his first instruction within that square. He proceeds through the squares in sequence, placing successive instructions. If a piece of information has to be 'remembered' temporarily then he must leave a vacant square somewhere on the board. This stored information is re-introduced as necessary by directing the program to that square by means of a strategically placed snake or ladder. It is possible that a number of instructions that are essential for one operation are unnecessary in another (omitting redundant zeroes in a numerical answer, for example); a ladder can be provided to bypass them. It may be necessary to repeat another series of instructions; the programmer need not waste squares by rewriting them the requisite number of times but instead can install a suitable snake. When the program arrives at a snake or ladder a decision is taken between two alternatives; whether, for example, one number is bigger or smaller than another. Depending upon the conclusion the program either proceeds to the next square or else climbs or slithers to some other unrelated, but specified, location.

The game of snakes and ladders is generally restricted to 100 squares, but the programmer rarely has less than 1024 squares to play with, while most small computers have storage for at least 4096 words or bytes (this curious word derives from the name for the smallest division of a byte, the bit, which is itself a contraction of BInary digiT). Obviously, the complexity of the program can become very great and considerable concentration is needed in order to maintain a firm grip on the problem. Returning to our snakes and ladders analogy, it is only too easy to provide a ladder leading to an empty square or to erase, by overwriting a 'remembering' square, so that when the program arrives at that point the information it seeks is either missing or corrupted.

The 'native' language of the computer is the language of numbers and a program written in machine code comprises, typically, two columns of four digit numbers. The left-hand column contains the number of the location, or address, in the computer's store, while the corresponding number in the right-hand column tells the computer what to do and where in the machine to do it.

TYPES OF INSTRUCTION

There are three basic types of instruction: (1) Memory Reference instructions, in which the right-hand column

includes the address to which the program is to refer, (2) Input/Output instructions, which organise the reception and transmission of data passing between the computer and external devices and (3) Operation Instructions, which specify operations to be carried out on the data in the machine's external registers. The instructions can often be microprogrammed: subtle changes can be made in the action of the machine by altering one or more bits of the 8, 12 or 16 bit word. A block of numbers is allocated to each type of instruction so that the machine can differentiate between the various types by testing certain bits, which act as labels, to see whether they are binary '1' or binary '0'; see Figure 2. (A discussion on binary arithmetic would demand an article on its own and the reader requiring an explanation of this subject is referred to his public library).

Programming in machine language is generally very slow and tedious and is hampered further by the difficulty

in remembering the numbers that constitute the instructions. The programmer must constantly refer to his instruction list. An alternative programming method, called assembly language, replaces the numerical instructions by *mnemonics*: groups of three or four letters which are chosen as an aid to memory (for example, DCA; Deposit and Clear Accumulator). The computer cannot understand these without translation, which is undertaken by a special-purpose program called an *assembler*. This program must be written in wholly numerical form and is usually provided as part of the standard software 'package' that accompanies the computer when it is purchased. The mnemonic programming system still retains close control over the placing of data in store: there is a one-to-one correspondence between the mnemonics and numerical instructions, so that the programmer dedicates each store location individually.



An engineer checks the paper tape output from a data logging system that operates in conjunction with a small computer. This particular type of installation can handle up to 1000 input signals, representing temperatures, pressures, flow rates, mechanical strain, liquid level, acceleration, etc. (Photo courtesy Solartron Electronic Group Limited)

PROCESSORS, PROGRAMS AND PERIPHERALS

When the programmer has completed his work his source program has to be fed into the computer. This may be done either by entering the location numbers and mnemonics directly via the keyboard of a teletypewriter or electric typewriter connected 'on line' to the computer or, alternatively, by preparing a punched paper tape containing the program 'off-line' — on machinery operating independently of the computer. This tape can be read by a high-speed tape reader, operating at speeds of 500 characters per second or more, when computer time is available. Whichever course is adopted the assembler program must be in the store first or the computer simply will not function.

HIGH-LEVEL PROGRAMMING IS EASIER

Programming in low-level languages — those that correspond to machine code — is largely a specialist task. Few potential users of small computers will have experienced programmers available and few will be prepared to expend much time and effort in acquiring a skill that is completely divorced from their normal full-time activities. During the last 25 years a number of high-level languages has been developed to help overcome this obstacle. These make less efficient use of computer storage and are generally slower in execution than their low-level counterparts, but they possess the great advantage that the *statements* that form a program are comprised mainly of familiar English words interspersed with symbols and numbers that resemble normal mathematical notation.

For the 'once in a while' programmer the most useful language is BASIC. The fundamentals of BASIC can be learned in a day or so and it possesses the important advantage that it is a *conversational* language. This means that a program can be typed out on a keyboard and replies obtained as the program proceeds. Again, the program as written must be reduced to machine level in order that the computer can act upon it. This is achieved by a self-contained interpreter program which is provided with the computer and which handles all editing (removal of redundant spaces, etc.), translating and executing processes without additional software.

Other high-level languages such as FORTRAN and ALGOL offer somewhat better flexibility, speed and efficiency in use of storage and are not unduly difficult to learn. Translation into machine code is undertaken by a spec-

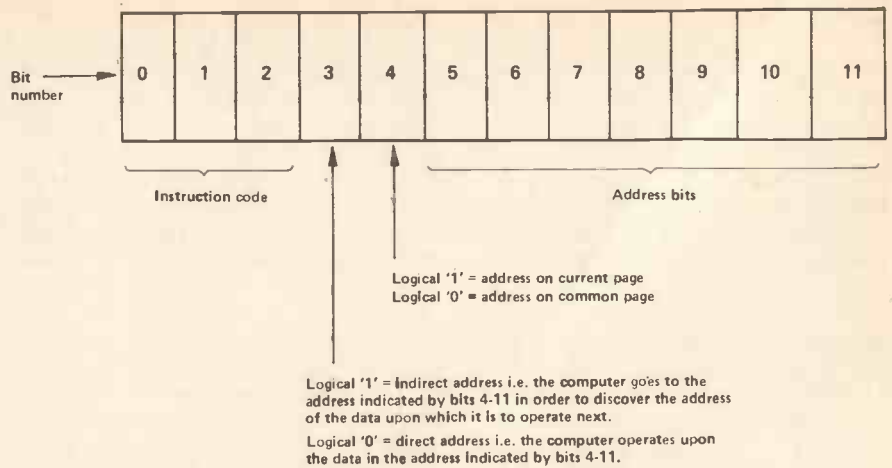
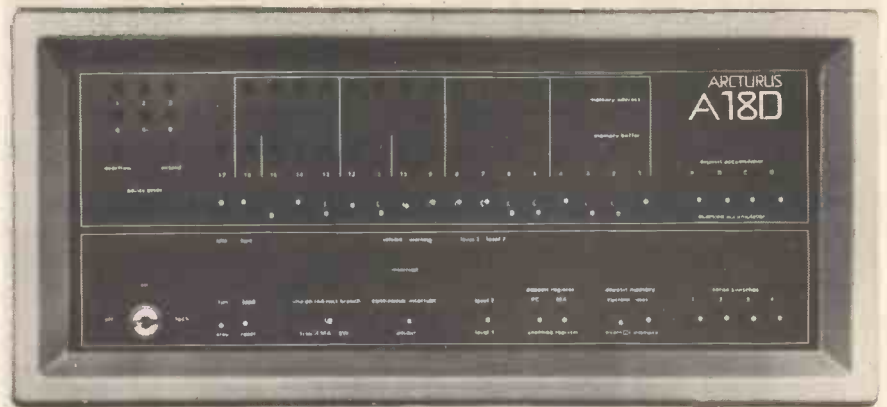

Fig. 2 Indicates the build-up of a memory reference instruction for a mini-computer



The Arcturus A18D, an improved version of a similar earlier machine, the 18C. This British machine is unusual in that peripherals are allowed direct access to the memory without the need to synchronise with the main program. (Photo courtesy Arcturus Electronics Limited)

ial compiler program which on a large-scale computer requires only one *pass*, or reading, of the source program tape. However, a small computer with, typically, 4096 or 8192 words of storage cannot handle work of this type without considerable intervention by the operator.

A number of paper tapes must be read in the correct sequence and placed in selected positions in the machine's core store by manipulation of switches on the control panel. The method of translation from high to low level is very indirect and the programmer is only able to detect a limited number of errors in course of translation. Certain errors may not become apparent until an attempt is made to run the program and then the only course open is to correct the source program and repeat the entire translation process.

The virtual impossibility of relating high-level statements to their corresponding low-level instructions arises from the fact that the high-level programmer is relieved of the chore of handling storage on a word-by-word basis. True, he can reserve a number of locations if he wishes to insert a block

of information in tabular form. However, the use of storage (and choice of instructions) is governed mainly by the interpretation placed upon the source statements by the compiler program. The developers of the language, striving for simplicity and breadth of application, are compelled to restrict the number of available statements and to dispense with much of the subtlety of machine code.

The compiler for a mini-computer usually converts the user's program (the source program) into an intermediate-level language, which is described as *relocatable*. This means that its final placement in the computer's store has not yet been decided and can be changed in accordance with the requirements of the translation process. The compiler also has the ability to produce page linkages and to call external sub-routines (separate small programs which may be incorporated as a programming aid) without direction by the operator.

THE SECOND PART OF THIS ARTICLE WILL BE IN NEXT MONTH'S ETI.

How serious are you about Stereo?



If you're serious at all, cut out this coupon and send it off to Akai. In return, we'll send you lots of information on how to enjoy all that's best in hi-fi stereo—without having to muzzle the dog to do it.

Name

Address

.....

.....

ET10

Please send lots of information on Akai hi-fi stereo equipment.
To: Akai, Rank Audio Products,
P.O. Box 70, Great West Road,
Brentford, Middlesex TW8 9HR.



Akai equipment is made in Japan by Akai Electric Co. Ltd., and is distributed and serviced in the UK exclusively by Rank Audio Products.



eti coin



TREASURE hunting is one of Britain's fastest growing hobbies and a large number of commercial units are now available. What makes this hobby so popular is that it works! It is not only possible to find lost objects - It is almost impossible *not* to find something.

Why do we call it the Coin Collector? Although you can find almost any reasonably sized metal object, coins are the most interesting items you are likely to find. The face value may be low but older coins are often worth considerably more than this. The size

of search coil is ideal for objects the size of coins although it will pick up larger and smaller items.

The presence of metal is indicated by a change in frequency of an audio note and a light headset or ear-piece can be used.

The electronic circuitry is contained in the same cover as the 5 1/4 in. diameter search coil, and operation can be adjusted over a band around 100kHz, which falls within the legal frequencies for such equipment. There are two external controls - the on/off switch, S1, and the knob for adjusting the

heterodyne frequency. The enclosed construction and use of a shielded search coil gives good protection from troublesome external effects such as changes in frequency from rain showers or stray capacitive effects influencing the coil.

DETECTOR CIRCUIT

Figure 1 shows the circuit and L1 is the shielded search coil. Such a shield is known as a Faraday screen and is not usually provided on metal locators of the cheaper type. It is arranged in such a way that inductive coupling changes

ei COIN COLLECTOR

THE CASE

This will be found in many shops and popular stores which include gardening items, and is brown plastic 6½in. in diameter and 1½in. deep ("flowerpot saucer or bowl"). The inside diameter of the open top is 6in. and a disc of 1/16in. paxolin is cut to fit this. Perspex or similar material can also be used. A 4½in or similar drawer handle, also plastic, is bolted to the bowl which is used inverted.

Details of the long handle are shown in Fig. 2. This is a 3ft. length (longer or shorter depending on your height) of plastic piping with an inside diameter of ¾in. This is available from most plumbing shops at low cost. Both polypropylene and PVC piping is available and, while both can be used, the latter is best as it is rather more rigid.

A bicycle handlebar grip will fit nicely onto the outside top of this.

The bottom of the handle is connected to the main casing by means of a bracket made from a length of ¾in. outside diameter aluminium tubing. One end of this is squeezed flat in a vice and the flat part is bent at about 45°. Two holes should be drilled in this and on the case and secured by 4BA nuts and bolts.

An extension lead is necessary for the headphones or earphone. This can be done by adding wire to the existing lead but a neater job is achieved by having a separate wire running inside the tube. A hole should be drilled about 5in. from the bottom of the handle (this is to prevent it being fouled by the bracket) and the extension feeds through this; a 3.5mm jack plug should be fitted to this.

The 3.5mm jack socket at the top is more difficult to fit as it should be about 4in. from the top. A ¼in. hole should be drilled to take this. The wire should be soldered to the socket *outside* the tube and a knitting needle jammed gently into the switching section. This can then be fed down the tube and the thread passed through the ¼in. hole. It is not easy, but it can be done.

Note that the aluminium bracket has an effect on the search coil and if the Coin Collector is converted to the hand held version (or vice versa) realignment is necessary.

The locator is built as a working unit on the 6in. paxolin disc. The cover or casing, with handle, is afterwards attached with two 6BA bolts. The on-off switch and headphone jack are on short flexible flying leads and they can be permanently mounted on the cover.

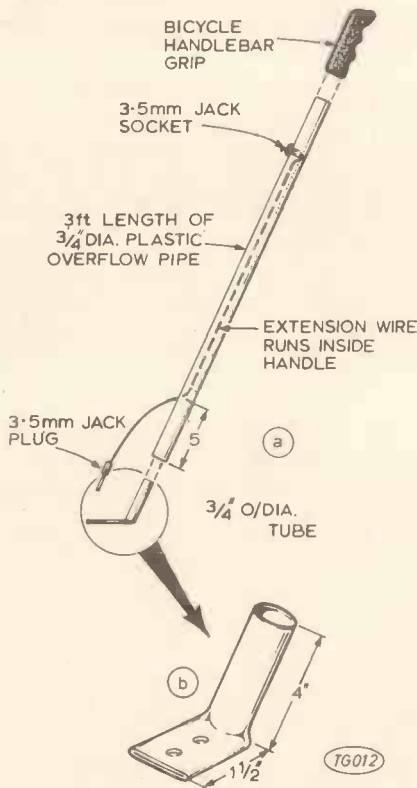
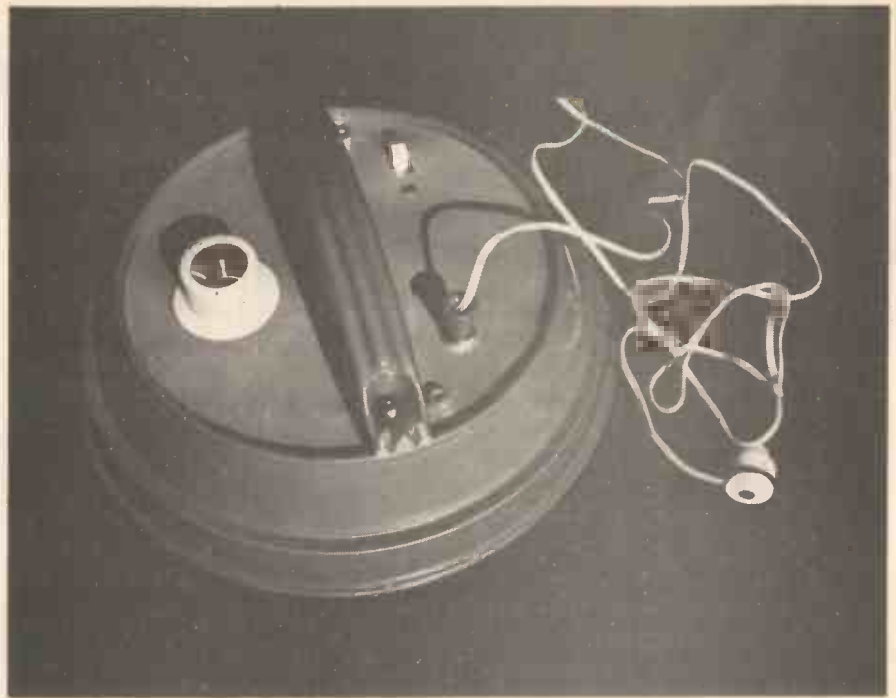

Fig. 2 Details of the long handle and bracket

To change the battery it is necessary to remove the control knob and two 6BA nuts, but the battery has a long working life in this circuit and should only have to be renewed occasionally.

CIRCUIT BOARD

This is cut as in Fig. 3, and the placement of components can then be



The length of the handle should be cut to suit the user's height

exactly as shown. The polarity of D1, D2 and C11 must be as marked.

First locate the circuit board correctly on the 6in. paxolin disc and drill the three holes "A" completely through both. Run 1¼in. countersunk 6BA bolts up through the paxolin, locking them with nuts. Put an extra nut on each bolt, so that the circuit board will be raised about 1in. from the paxolin (to clear the components in Fig 3).

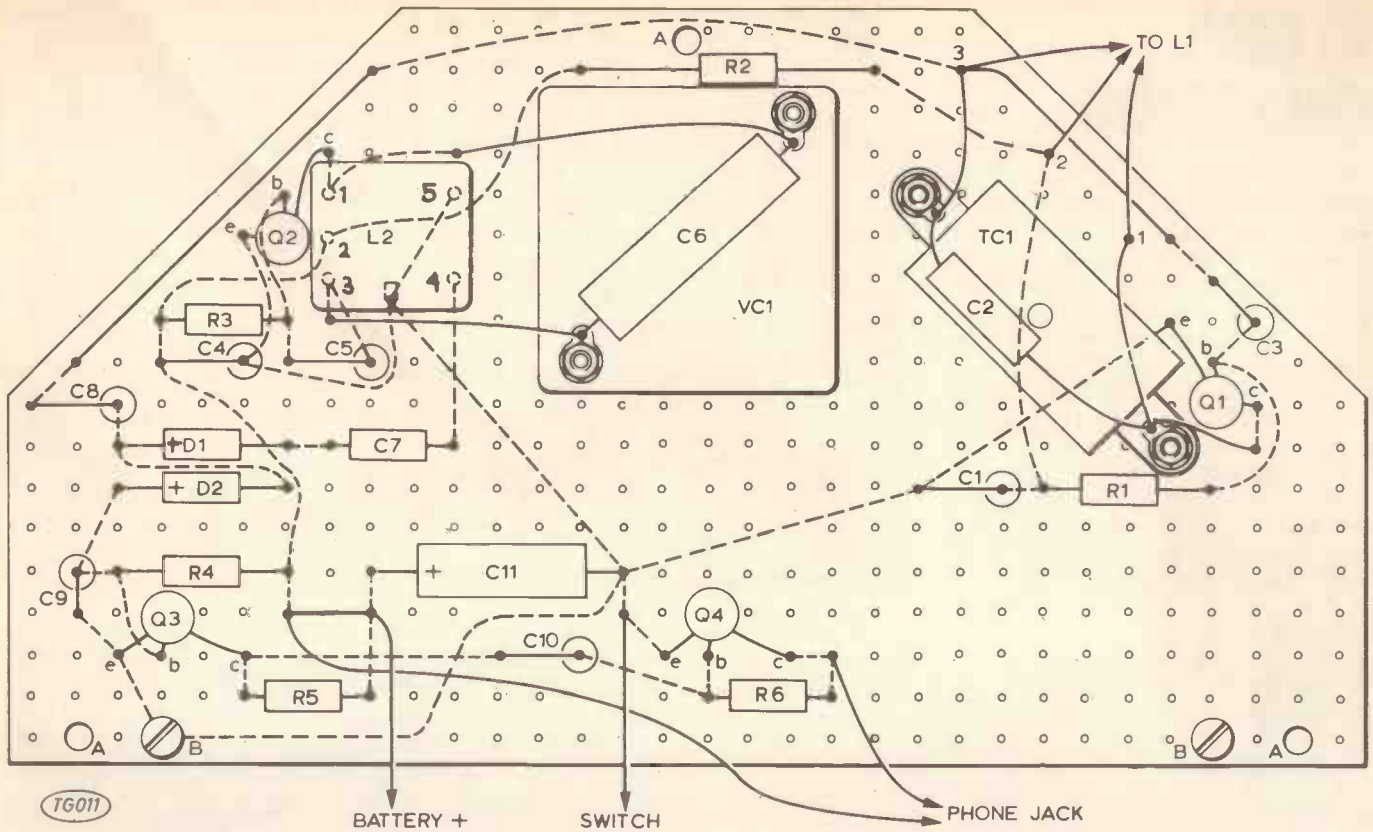

Fig. 3 The component layout — a piece of drilled s.r.b.p. board 4.9 x 2.8 ins with two corners trimmed as shown. The dotted lines represent wiring on the reverse side.

When wiring is completed, the board is fixed in this position by three further nuts.

Drill two holes for the 1/2 in. bolts "B" which secure the cover. Each of these bolts has two nuts, plus a further nut each to hold the cover when it is on.

VC1 is located as shown, with a clearance hole in the cover to match. TC1 is mounted with bolts and spacers or extra nuts, with a hole so that its adjusting screw can be reached from the upper side of the board. A hole allows

the core of L2 to be adjusted from this side also.

Wiring need not run *exactly* as shown in Fig. 3, provided connections are correct. Where the ends of resistors and capacitors are not long enough, use 26swg or similar wire for connecting purposes, with insulated sleeving where necessary to avoid short circuits.

Three Veropins, numbered 1, 2 and 3 are inserted for the leads from L1. A thin flexible lead from positive at C11 is fitted with a positive battery clip. A

lead from negative of C11 runs to the on-off switch. A lead with a negative battery clip is soldered to the second switch stage. Flexible leads from Q4 collector and the positive line are taken to the output jack. Both the switch and jack are left free, and only fixed to the cover when construction is otherwise completed.

SEARCH COIL

This consists of 50 turns, centre-tapped of 26swg enamelled wire, with a mean diameter of 5 1/4 in. An object about 5 1/8 in. in diameter is most suitable as a temporary former for winding. A tapering object (such as a plant-pot) may be used by measuring it and marking the winding position.

Wind 25 turns in a compact pile, and secure with adhesive tape to prevent the turns becoming loose. Form a short loop for the centre-tap, and wind a further 25 turns in the same direction. The coil is then removed and bound in several places as in the photograph to hold the turns together.

Solder a lead to the centre-tap 2, and place insulated sleeving on ends 1 and 3.

Another photograph shows the 6 in. paxolin disc with three 6BA bolts and the coil before the shielding is done.

Cut a ring of aluminium foil 7 in. in diameter and 1 in. wide and place the coil on this. Completely cut away a narrow piece from the foil, opposite the centre tap of the coil.

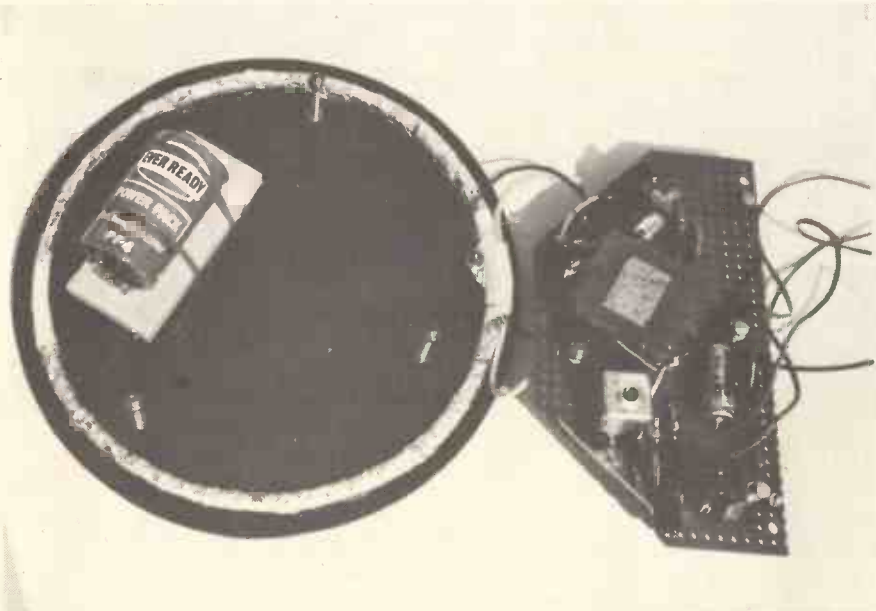

The prototype circuit board wired to the search coil

COIN COLLECTOR

The foil is folded over the winding, from inside and outside, to enclose it. Regular folding of the inner edge outwards will be eased by snipping about 3/8in. into the foil at 1/2in. intervals from the inside. Leave a foil projection near the centre tap. Secure a thin flexible lead to this with a short 8BA bolt and washers and solder this connection to the same lead as is used for the centre tap.

Bind the coil with thread or with adhesive tape. Tape the flying leads, and also the gap in the foil, taking care that the ends of the foil do not touch each other here.

The coil is smeared liberally with adhesive, and is placed onto the paxolin disc. After checking its position, place a few small weights on it to hold it until the adhesive sets. The leads should come near the Veropins to which they will be connected.

BATTERY HOLDER

This is made of a small piece of wood, about 2 1/2 x 1 x 3/8in. A channel is cut for a PP4 or similar battery. Two saw-cuts are made across the wood on its other side. Elastic bands are placed in the cuts round the wood, which is cemented in place. When the cement is dry the battery can then be secured by the bands.

FINISHING ASSEMBLY

Place the circuit board in position and

fix it with the three nuts. Cut the leads from L1 to suit the pins 1, 2 and 3. These are long enough to allow the board to be turned over.

Other photographs show the finished construction before the cover is fitted.

ALIGNMENT

Temporarily fit a knob to VC1 and set this capacitor about half closed. Screw TC1 about half down. With the phones plugged in and the detector switched on, rotate the core of L2 until a loud audio tone is heard. Set the core for about the "zero beat" position.

In these conditions, turning the core either way will cause a tone, which rises in pitch the farther the core is turned. A similar effect arises with VC1: the control knob has a central or zero beat position and turning it either way from this will cause an audio tone

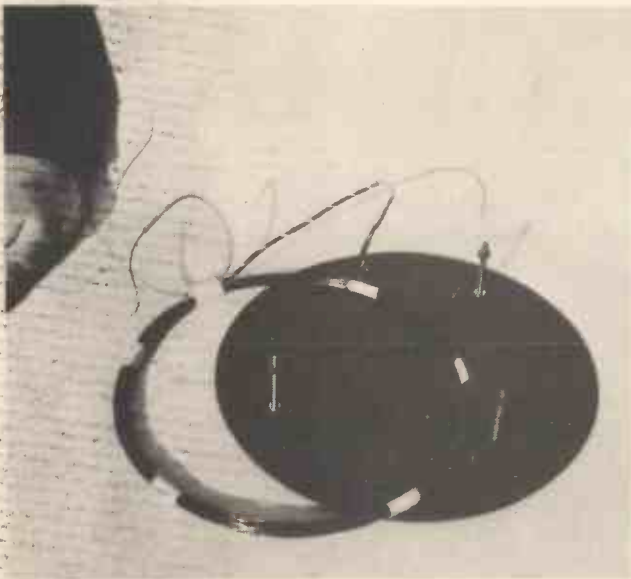

L1 before being screened.

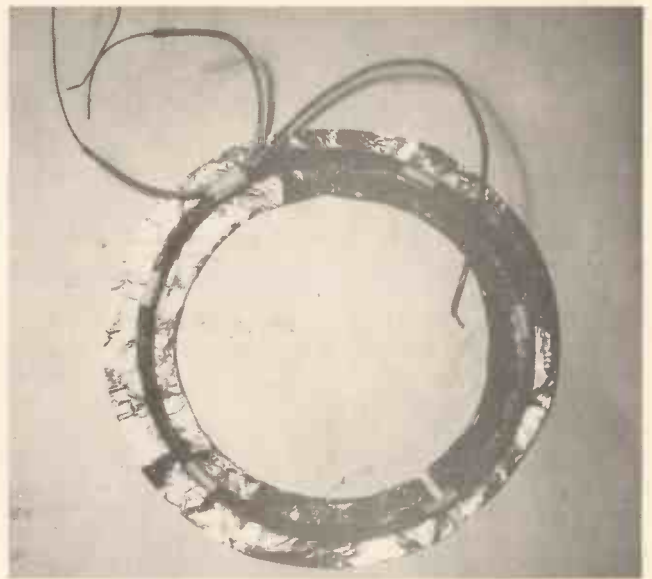

The coil should be laid on the aluminium foil as shown. Note the gap opposite the wire ends.



When screened the coil should be glued to the paxolin disc.

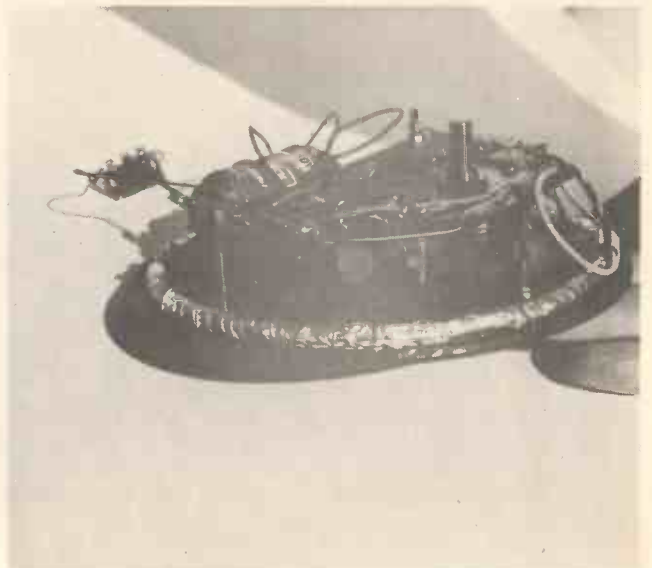

A general view of the prototype out of the case showing the circuit board in position. The extending nuts to the cover can also be seen

which rises in frequency with further rotation of the control knob.

At this time the frequency can be set to whatever may be required, within the range of TC1 and L2. The second harmonic of the oscillators can be picked up by a radio receiver having long wave coverage, and placed near the detector. A frequency a little removed from 100kHz can be chosen, so that possible interference to nearby reception of the 200kHz LW broadcasts does not arise.

The switch and output jack can then be fitted permanently to the cover, which is secured by nuts on the projecting bolts.

LOCATOR USE

Unseen metal is located by a change in the audio tone heard. Initially rotate VC1 so that a steady audio tone is heard. The approach of metal into the vicinity of the search coil will then cause a change in pitch. Most metals

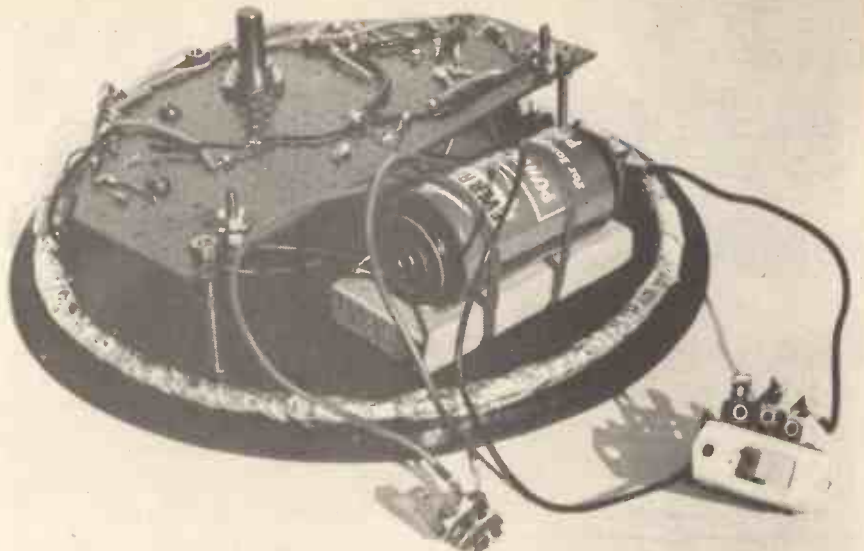

The main assembly without the case. The wires to the switch and earphone socket should be left reasonably long



The completed prototype. Either headphones or an individual earpiece can be used.



The hand held version is ideal for a close investigation of a small area.

vary the tone one way, but certain metals will cause the shift in frequency to be in the other direction. The way in which a particular metal causes a change in frequency can be adjusted by setting VC1 for the wanted effect.

Nearby, or large pieces of metal will cause a very pronounced shift in frequency. For maximum range, a very low frequency audio beat is most suitable, with VC1 adjusted so that this falls in frequency when the coil approaches metal. The limit of detection range is reached when it is no longer possible to observe any change in frequency at all.

It is always difficult to give a binding "maximum range" specification for an instrument of this kind, as this depends so much on individual circumstances of use, such as the size and shape of the metal objects, kind of soil, and even the skill of the user. The actual range

achieved is of course the same as that of other heterodyne locators with a search coil of similar size — this could be a matter of a very few inches for the detection of a small item such as a coin, but up to a foot or more for a large metal object.

HEADSET

Best of all will be a light pair of phones with muffs, such as those listed. These help exclude external noise, and can be carried in a pocket. Headphones of similar type will usually be of about 500 to 2,000 ohms.

A single earpiece is most suitable when there is little outside noise, and the usual medium impedance type can be used.

Great fun can be had with the Coin Collector but it will take you a little while to get used to it and achieve optimum performance.

Resist the temptation of scanning a large area of ground quickly - you will only be wasting your time. If you concentrate on a small area - say 100 square feet - If the area has been frequented by people over the years, even your back garden, the chances are pretty good of finding something - even if it is of no value.

We cannot promise you anything of course and your chances of striking it rich are remote but just bear in mind that there are people who *make a good living* using a metal locator - think about it!

A licence is required to use a metal locator; this costs 75p for five years. Application forms (it is called a Pipe Finder Licence) are available from the Ministry of Posts and Telecommunications, Waterloo Bridge House, Waterloo Road, London, S.E.1. ●

EXPLORATION ARCHAEOLOGY

—searching for the past

by John M. Stanley

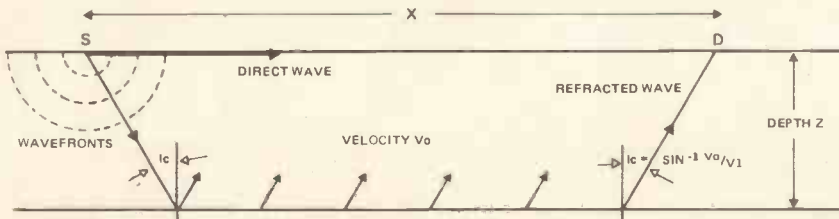

Fig. 1. Paths taken by the direct point S to detector D in two layered earth.



THE ARCHAEOLOGICAL methods used in various parts of the world differ due to the nature of the various civilizations.

European communities produced lasting hardware of baked clay or metals. They built cities of permanent materials with considerable use of stone and bricks, and they often fortified these with substantial walls. Although their civilizations have decayed, they left many remnants now submerged beneath windswept sands or buried by alluvial flood plains. Yet others have been built over by later communities. In common, these folk

considerably altered the landscape where they built their cities. They left permanent relics of their handcraft and they frequently left written evidence of their existence.

The scene in some countries is very different. For instance the Australian aborigines rarely altered their habitat with permanent constructions, and rarely if ever, made use of bricks or metals. Consequently, the only lasting remains of their campsites are fireplaces, shell concentrations and humus-rich deposits where wandering tribes made seasonal camps when food was abundant. These "middens", as they

are generally termed, do however contain small items, usually of chipped stone, which are of interest to natural historians.

These differences require new exploration procedures. In the pursuit for remains of a highly developed community, it is logical firstly to search historic writings for clues as to where a township may have been situated. Aerial photography may then disclose surface formations not normally visible from the ground.

In the past it has been necessary to follow these activities with tedious drilling and trenching, but a great deal

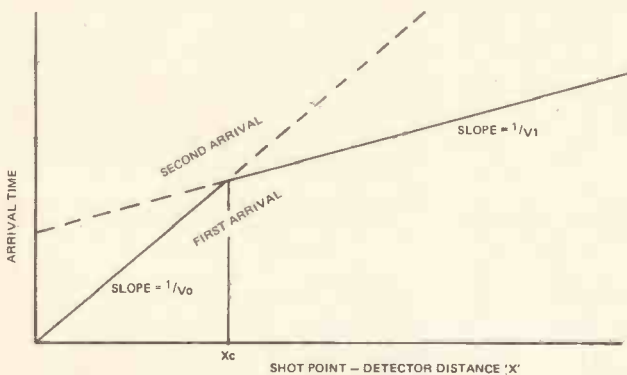

Fig. 2. Plot of first and second arrival times at a detector a distance X from the shot point. Xc corresponds to the point where the refracted wave overtakes the direct wave.

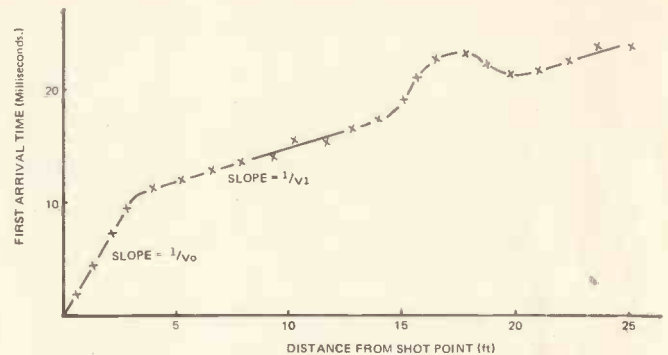

Fig. 3. Experimental refraction plot over a trench filled with silt.





Earth Resistivity meter in use



of this laborious work may now be replaced by the refined use of geophysical methods, and the final excavations commenced with greater confidence of success.

The aborigines left no writings or photographable surface features indicating the whereabouts of their campsites. Fortunately for the archaeologist, much of the countryside in Australia has not changed very much since aboriginal occupation and it is logical that middens be associated with features providing a regular source of food. Lakes, river estuaries, rocky shorelines, natural springs and waterholes are clues to past occupation. They are virtually the only means available of confining the area of search. In fact excavations have only been made in Australia in places where surface evidence of middens has been observed. But if geophysics can be employed successfully, then much older middens may be located buried at greater depths. The author is at present concerned with this possibility.

GEOPHYSICAL METHODS IN PRESENT USE

There are three principle geophysical methods which have been applied to archaeological studies. They are: seismology, resistivity and magnetics. Their use depends upon the nature of the particular environment, the amount of finance available for equipment, and upon the experience of the operating crew.

Combining technology with the classical arts, today's archaeologist is a refined crossbreed of historian and geophysicist.

SEISMOLOGY

The principle of seismology is that shock waves travel at particular and well-defined velocities through material of different types. The denser the material, the faster the speed that shock waves will travel through it. The velocities vary from as low as 600 ft/sec in light and dry top soil, to 20 000 ft/sec in unseamed granite.

If the speed of the shock wave is measured, then the type, hardness and depth of the various strata can accurately be determined. This is relatively easy to do, for when a shock wave strikes an interface between two different types of material it will be refracted along that interface.

With the simplest types of seismographs the shock wave is initiated by striking the ground with a hammer. Figure 1 shows how the shock wave thus generated (at point 'S'), travels out in hemispherical wavefronts. If a detecting instrument is at point 'D' — a distance of 'X' feet from 'S' then the shock wave travelling horizontally through the top material (the 'direct wave') will reach the receiving instrument before any other wave — as long as 'X' is small. For longer distances, the wave travelling along the lower strata (which has a higher characteristic velocity) will

arrive at the receiver before the direct wave.

Angle $1c$ is the 'critical angle' at which the shock wave is refracted along the interface. It is in fact the angle where Sine is V_0/V_1 .

The most convenient way to represent this data is to measure and plot the arrival time of the first refracted wave vs the short distance 'X'. For example with two layered stratum (Fig. 1) we would have the plot shown in Fig. 2. From the gradient of the first arrival segments we can deduce the velocities V_0 and V_1 and hence calculate the depth to the interface. Figure 3 shows the experimental data plotted over a trench buried under a layer of silt.

In the far more complex situation of identifying echos from irregular archaeological objects, interpretation becomes a job for the expert. However, there are many cases when seismology is quite practical to use. These include buried tombs and building sites containing walls or similar large structures. Seismology has been successfully used to locate underground passages and tomb cavities within the Egyptian pyramids, and is ideal for sounding the depth of deposits in caves and rock shelters.

Portable instrumentation has

recently become commercially available, but at a cost of about £1,500! Quite prohibitive for the amateur treasure seeker! Such a "signal enhancement seismograph" is battery operated, weighs only 17 lbs and is exceeding accurate and easy to use. The seismic disturbance is made by simply hitting the ground with a 10 lb hammer.

RESISTIVITY

Another characteristic of differing strata is electrical resistivity — in fact the range of electrical resistivities is enormous. It extends from 10^{-1} ohm/metre to 10^{19} ohms/metre. It follows that if we can measure vertical and horizontal resistivity profiles of the ground, we must be able to detect changes in composition, and hence deduce the existence of buried objects. There are many ways of doing this, some involving ac measurements and others using dc. Generally, the resistivity is far from uniform and so the measurement used is one of "apparent resistivity" — in effect it is a mean value depending on the distribution of rocks and their individual resistivities.

One of the most common electrode arrangements for measuring apparent resistivity is that known as the Wenner Array (illustrated in Fig. 4). Using a Wenner Array (with electrode separation 'a') on the surface of a semi-infinite solid with uniform resistivity p , then $p = 2\pi a V/I = 2\pi a R$ (where R is the resistance between the inner electrodes).

There are two applications of this formula. We may perform "electrical drilling" or "electrical trenching". In the former, a vertical profile of the resistivity may be measured by plotting p as the separation of electrodes 'a' is varied. The depth at which p is measured is approximately $0.6 a$. Apparent resistivity profile curves may be generated by a computing for different models of ground structure. Volumes of standard curves of this type have been published and these facilitate the

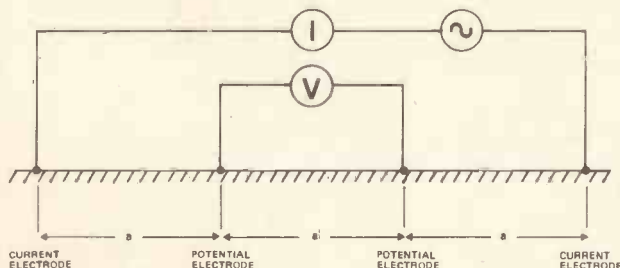

Fig. 4. The Wenner configuration of electrodes used in both "electrical drilling" and "electrical trenching". The electrode spacing used in resistivity calculations is the distance 'a'.

Fig. 5. A typical resistivity traverse over a sandstone wall buried under dry sand.

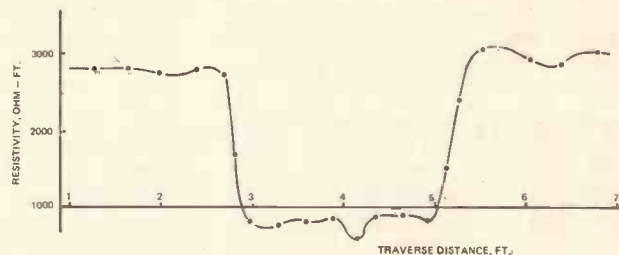

TABLE 1

Material	Magnetic Susceptibility 10^{-6} emu	Resistivity Ohm. M.	Seismic Compressional Velocity M. Sec ⁻¹
Air	0	Infinite	330
Water (fresh)	0	50	1450
Sand (dry)	-1.2	$>10^{10}$	300 - 800
Limestone	5	120 - 400	3,500 - 6,500
Granite	500	$5,000 - 10^6$	4,600 - 7,000
Clay	Variable	1 - 120	1,000 - 3,000
Sandstone	10	35 - 4,000	1,500 - 4,500
Marble	-0.75	$>10^{12}$	—
Basalt	2,000	—	5,000 - 6,500
Alluvium	2,000	Variable	500 - 600

Approximate values of magnetic susceptibility, electrical resistivity and seismic velocity for archaeologically relevant materials. All values tend to be highly variable depending on moisture content and mineral composition.

interpretation of resistivity drilling.

Electrical trenching is achieved by selecting an electrode separation corresponding approximately to the depth of interest, and moving the whole array along the traverse line. Fig. 5 shows a typical set of results plotted over a buried wall.

Resistivity methods are applicable to similar situations as the seismic method. The field skills and interpretation complexity are comparable to those required for seismology but the cost of equipment is very much less. A quite effective ac resistivity meter may be purchased for less than £250 — and a dc operated meter — such as that described immediately following this article — may be home assembled for very much less.

MAGNETICS

The Earth's natural magnetic field is perturbed by the magnetic properties of materials within its influence. If the Earth's field may be measured to an accuracy of the order of 1 part per 1,000 this perturbation can be detected. Information concerning

dimension, location and composition of the perturbing body may be extracted from carefully compiled maps of anomalies in the magnetic field.

During the mid 1950's, a team at Cambridge University developed a magnetometer, having a sensitivity of 1 part per 100,000, specifically for archaeological work. This instrument measured the frequency of protons in an organic fluid as they precessed about the Earth's field. The precession frequency was linearly related to the intensity of the magnetic field. The "proton precession" magnetometer is available now at a cost of about £250. More recently an instrument has been developed which measures the electron-nuclear spin of atoms in an alkali metal vapour. This spin frequency is also linearly related to the magnetic field, but yields an accuracy of 1 part in 1 million. At present these instruments are expensive — in excess of £500 but as refining developments progress, this cost may be expected to decrease substantially.

The magnetic field on the Earth's surface is almost entirely (95%) due to stable sources within the core. The

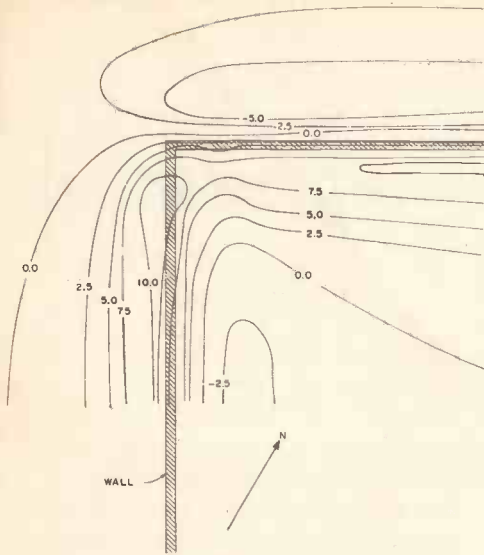

Fig. 6. This is a magnetic contour map over a corner of a stone wall buried at a depth of five metres. The plot was made using a differential magnetometer pair during the search for the lost city of Sybaris in southern Italy.

remaining 5% originates from variable causes, and may be divided into "temporal" (time) or "spacial" (position) variations. The temporal changes result principally from solar-induced currents in the Earth's crust, and magnetic pulsations in the magnetosphere. They range in frequency from a fraction of a second to diurnal. The amplitude of such variations is typically a few gammas but under severe conditions magnetic storms of several hundred gammas may be encountered.

Spacial variations arise principally from the degree of magnetism induced in materials of the Earth's crust. Different rocks and minerals exhibit a range of susceptibilities to magnetization in the Earth's field and this magnetization can readily be detected with modern instruments. A second very significant cause of spacial anomalies results from "remnant" magnetism exhibited by objects containing ferromagnetic minerals which have been heated strongly at some time. Within the crystals of the mineral are small, randomly orientated regions of uniform magnetizations, called domains, which become mobile above the Curie temperature of about 600°C. During cooling, many of the domains align themselves parallel to the Earth's magnetic field and are thus frozen in this alignment. Since they

are parallel to the Earth's field they are also parallel to each other, thus creating a net magnetic effect. Pottery, kilns, hearths and baked rocks will frequently exhibit a measureable remnant magnetism.

If the archaeologist is to distinguish between temporal and spacial anomalies it is usual to use two magnetometers. Both will respond to temporal changes simultaneously so if the difference in field value between the two is measured while one instrument is kept stationary, then only the spacial changes will be recorded. Since the development of the extremely high resolution "Alkali vapour magnetometers" it has been possible to use such two instruments as a "gradiometer". Both field sensors are mounted with a fixed separation on a vertical staff. Again, both respond simultaneously to temporal changes and so the field value difference between the sensors yields the vertical spacial field gradient.

This data is of particular value to the archaeologist who is usually looking for objects buried under a quite shallow layer of sediments. This is because it effectively filters out background magnetic anomalies that originate in the deeper underlying geologic strata. It does this because the magnetic field of a dipole is inversely proportional to the cube of the distance from it. The significance of the inverse cube factor is apparent if we compare the anomalous intensities, at each of two sensors, from a buried wall overlying a geologic magnetic disturbance. Let us suppose that the two sensors are directly above the wall at distances of one and two metres, and that the wall overlies the geologic source at a distance of 10 metres. Then, if the geologic anomaly were even as large as the wall anomaly at the site of the lower sensor, the differential anomaly of the wall would be almost four times that of the geologic strata.

The interpretation of magnetic field and gradient data is certainly a task for the expert if full value is to be extracted from the data. The nature of the anomaly will depend upon a large number of factors such as size, shape, depth, magnetic susceptibility of the object, and its orientation relative to the Earth's field. Mineral and oil exploration research has developed computing prowess in this field and it is now possible to achieve exciting successful results if the right skills are applied to the data. Figure 6 shows an actual magnetic contour map over a corner of a stone wall buried at a depth of 5m. This data was measured with a differential magnetometer pair during the search for the lost city of Sybaris in southern Italy. ●

BUILD THE TREASURE TRACER MK III

METAL
LOCATOR



- Incorporates varicap tuning for extra stability
- Weighs only 22oz and has perfect balance
- Loudspeaker or earphone operation (both included)
- Handle knocks down to only 16in for transport
- Ministry approved design
- Excellent sensitivity and stability
- Kit can be built using only soldering iron, screwdriver, pliers and wire snips
- Drilled, tinned, fibreglass p.c. board with component siting printed on
- Incorporates Faraday screen

Send for s.a.e. for leaflet

Complete kit with pre-built search coil **£9.80**
Plus 35p Post (inc. VAT)

Built, tested and Guaranteed **£13.75**
Plus 35p Post (inc. VAT)

MINIKITS ELECTRONICS,
35d Langley Drive, Wanstead,
LONDON E11 2LN
(Mail order only)

EARTH RESISTIVITY METER

eti PROJECT 212

From gold to archaeological remains — this simply constructed instrument will assist your prospecting.

AS John Stanley's article explains an earth resistivity meter can be used to identify the composition of various earth strata — and the depth at which each strata occurs — and by detecting changes in earth composition, to point to the existence of buried objects.

An earth resistivity meter may be used to locate archaeological objects — to assist in finding conditions favourable for alluvial gold or gestones, or even for such prosaic duties as determining where to locate a septic tank!

These instruments are not expensive compared with most electronic instrumentation. Nevertheless at £250 or so they are way above the budget of most amateur archaeologists or rock-hounds.

But for such people all is not lost — it is possible to construct a simple dc operated resistivity meter for a mere fraction of the price of commercial

units.

For this to be possible we have to accept a few operating limitations — primarily of operating depth — for whereas a commercial unit may be used to depths of several hundred feet our unit is limited to fifty feet or so. But unless you are hoping to locate oil bearing deposits in your garden the limitation on operating depth should not be a problem.

The basic instrument is extremely simple — four equally spaced electrodes are placed in line in the earth. An accurately known current is caused to flow from one outer electrode to the other — and a measurement is taken of the voltage between the two inner electrodes.

Having measured both voltage and current, a simple formula (explained on page 32) is used to establish depth and composition of the strata.

Professional earth resistivity meters

use alternating current across the earth electrodes in order to eliminate the effects of the small galvanic voltages caused by the earth.

This effect cannot be totally eliminated with dc instruments but it can be minimized by switching the battery across the electrodes in alternate polarities — a centre position of the switch (SW2) meanwhile short-circuits the two centre electrodes between readings to discharge the galvanic potential.

Figure 1 shows the circuit diagram of the instrument.

We have not provided any mechanical assembly drawings, for this will depend almost entirely upon the meters used. A pair of cheap multimeters are ideal — but if these are not available then a voltmeter and a milliammeter with switchable ranges should be used. The milliammeter should be capable of measuring from microamps to a maximum of 100 milliamps or so, the voltmeter should cover a range from approximately 100 microvolts to three volts or so and should have a sensitivity of about 20,000 ohms per volt.

Switch SW2 is a three-pole four-way wafer switch. All switching contacts are located on one wafer. Each of the four segments shown in the circuit diagram (ie. SW1 SW2 etc) consists of a wiping contact and three fixed contacts — the connections will be readily apparent when the circuit diagram is compared with the switch.

The ground probes should ideally be made of copper coated steel or brass — however electrodes made from ½" to 1" steel tubing or rod will work quite well as long as they are kept clean. It is of course essential that they make the best possible contact with the surrounding earth. Electrode cable connections must be securely made using proper terminals — remember that you are looking for fairly minor changes in earth resistance.

Operating voltage is not critical — a six or twelve volt dry cell is adequate for most applications. ●

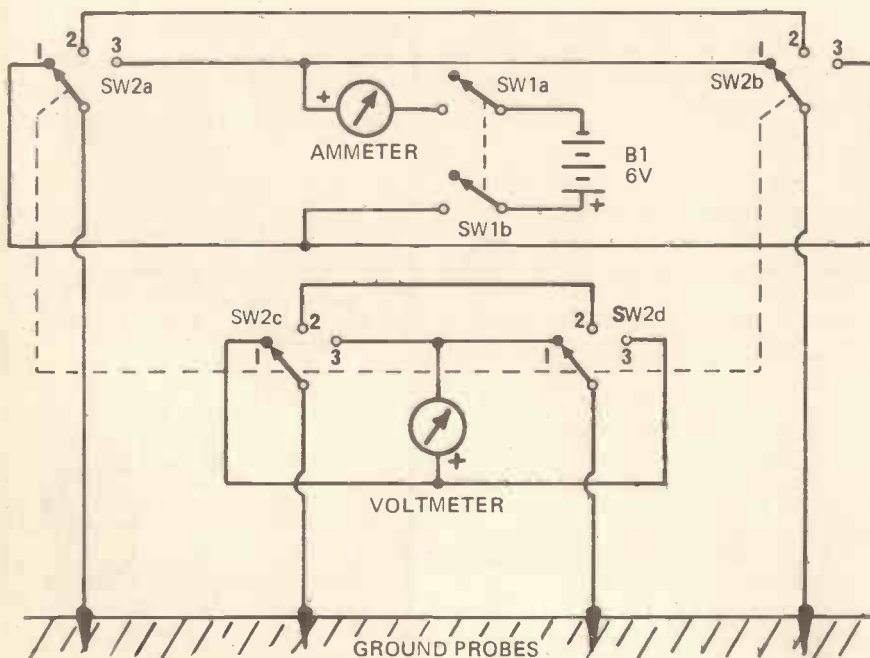
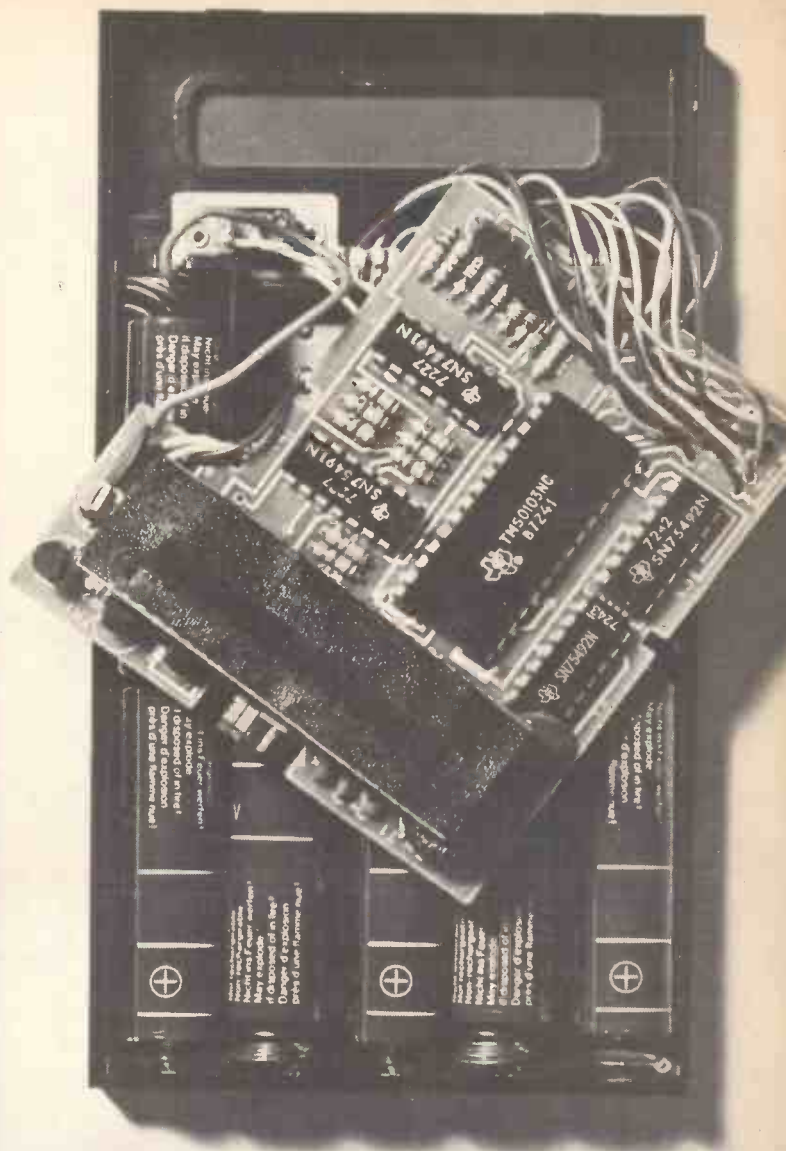

Fig. 1. Circuit diagram of resistivity meter.



Not just a pretty face.

The Advance mini Executive is a beautiful hand-held calculator.

Some, almost as good looking, are as fragile as a butterfly's wings. Ours isn't.

Some are so small you keep mis-punching and get the wrong answers. Ours isn't.

Some aren't made by specialists in electronics but merely imported from goodness knows where. Ours is made right here in Britain by Advance Electronics Limited.

Finally, if you think it's about time you had your very own pocket calculator, ours costs only £52.50.

It's guaranteed for a year.

Has a battery life of 15 hours.

And to remind you, it's called the mini Executive. The coupon will get you literature.

Go on, spoil yourself.

Because at £52.50 (plus VAT) it's the finest pocket calculator in the world.



Name _____

Address _____

Advance Calculators,
Raynham Road, Bishops Stortford, Herts.
Telephone 0279 55155. Telex: 81510.

Using a resistivity meter

JOHN STANLEY EXPLAINS

MEASURING EARTH RESISTIVITY

THERE are several methods of measuring soil resistivities, mostly variations of the original method devised by Wenner. This consists of driving four metal spikes (commonly called electrodes), into the ground, at equal intervals along a straight line as shown in Fig. 1.

A current is passed through the outer electrodes C_1 and C_2 and the resulting voltage drop across the earth resistance is measured across the inner pair ρ_1 and ρ_2 .

If the ground has a uniform resistivity ρ then

$$\rho = 2\pi a^2 \frac{V}{I} = 2\pi a R$$

where 'R' is the apparent resistance measured between the inner potential electrodes.

Generally the current will flow in an arc between the electrodes and hence the depth penetrated will increase as the electrode separation is increased. The effective depth at which R is measured is usually taken as 0.6 times the separation 'a'.

For the greatest accuracy in determining the ratio V/I it is desirable that the current flow I be maximized and hence in dry surface conditions it is common to moisten the soil about the electrodes to reduce the contact resistance. The depth to which the electrodes are inserted must not exceed 1/20th of their separation. This is important if standard curves are to be used for the interpretation of the experimental data.

Having inserted the four electrodes

an average value for both V and I must be determined for both polarities of the battery. Reversing the polarity removes the possibility that the earth may have its own potential due to galvanic reactions underground. From these measurements the resistivity ρ can be calculated.

RESISTIVITY DEPTH SOUNDING

Consider for example the problem of measuring the depth beneath the ground of the water table or perhaps the thickness of soil overlying the bedrock. This type of situation is by far the most common — where a layer of resistivity ρ_1 and thickness 'd' is overlying a layer of different resistivity ρ_2 .

We can determine the depth 'd' with the aid of 'standard curves'. The procedure is to measure the resistivity of the ground each time the electrode separation 'a' is increased about a central point. To use the standard curves provided it is necessary to plot the measured resistivity (ρ) on the vertical axis, against the electrode separation distance on log/log graph paper.

The standard curves provided (Fig. 2), are also constructed on log/log graph paper i.e. graph paper that is ruled in both directions at logarithmic intervals. Each major division on the paper corresponds to a power of 10 and is therefore called a decade. We suggest that for plotting your data you purchase semi-transparent paper that has three decades on either axis and a

decade separation of 2½ inches. The 2½ inch decade separation is most important as paper having other decade separations will not allow your plotted results to be overlaid on the standard curves. This paper should be readily available from major stationary suppliers.

Figure 3 shows a typical plot of field data overlaid onto the standard curve.

To do this, place your plotted curve over the standard curve and slide it horizontally until you find the standard curve that best matches your plotted curve.

When the best matching curve has been found, note where the vertical axis of the standard curve intersects the 'ab' curve of your plotted data. This line extended vertically downwards to intersect the 'electrode separation' axis of your plotted data will show the depth of the first layer — in our example this is 4.25 metres.

We know from our plotted data that the resistivity ρ_2 is about 1000 ohms/metre and the standard curve that is a best match shows a ρ_2/ρ_1 ratio of one tenth, that is ρ_2 equals 0.1 ρ_1 .

Thus ρ_2 is approximately 100 ohms/metre. Relating these figures to Table II we see that the most likely strata formation is two layers of sandstone of different densities — or a top layer of sandstone and a lower layer of limestone.

From the section bc it is possible to calculate the resistivity and depth of the second layer but this requires the use of a second set of auxiliary standard curves. These are very complex and beyond the scope of this article. Similarly section cd provides data on the third layer and so on. There are a number of standard texts on such measurement and the interested experimenter should refer to these for further information.

RESISTIVITY TRENCHING

Another common application of the resistivity meter is in searching for buried objects such as large water mains, buried stream beds or underground sewerage tunnels. The method used is simply to decide approximately at what depth the object is likely to be found, and divide the distance by 0.6 to give a suitable electrode separation. Maintaining this same separation, the array of all 4 electrodes should be progressively moved in a line over the ground being explored. Readings of resistivity should be made at each point and the value plotted against distance moved. (See Fig. 6 page 29) The distance between each reading point should be no greater than half the dimension of

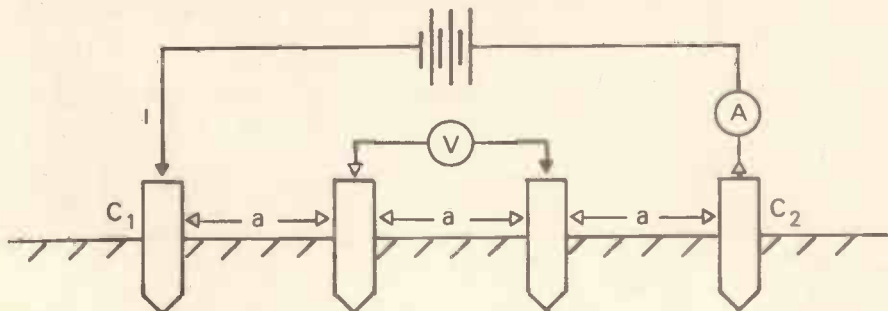

Fig. 1. The electrodes are driven into the ground at equal intervals and in a straight line.

TABLE I

Material	Resistivity (ohms/metre)
Clay	1-120
Water (fresh)	50
Sandstone	35-4000
Limestone	120-400
Granite	5000-10 ⁶
Sand (dry)	>10 ⁶
Marble	>10 ¹²
Alluvium	Variable
Air	Infinite

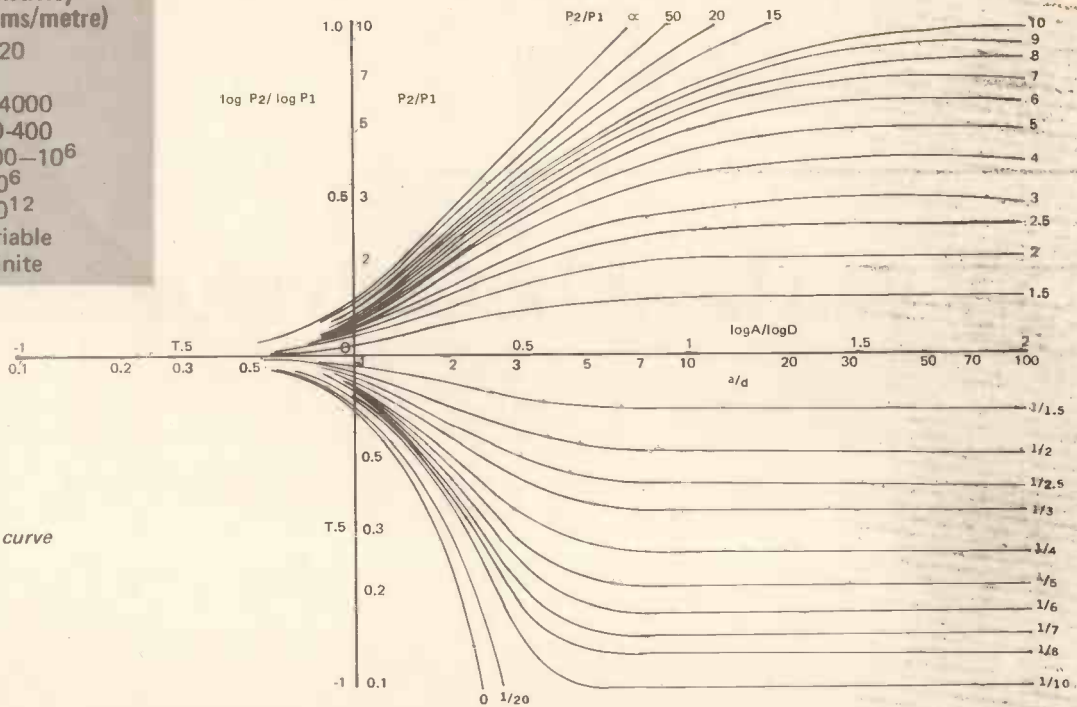

Fig. 2. Standard resistivity curve

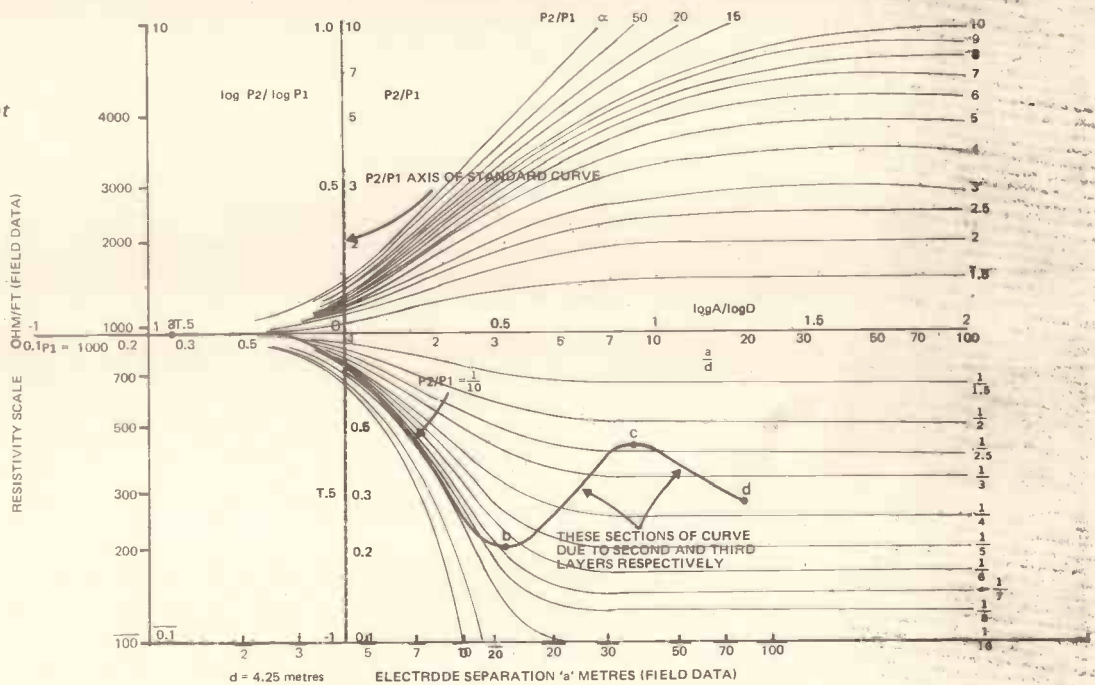

Fig. 3. Typical field data plot superimposed over standard curve shown in Fig. 2.

Earth electrodes should not be inserted into the ground to a depth greater than 1/20th of the probe separation. Because of this, poor electrode/ground contact may result at close spacings. This problem can be reduced by using porous pots filled with copper sulphate solution. Electrodes specifically intended for such work are available from geophysical supply houses.

the object to be located; in fact the closer the readings are taken, the greater will be the resolution.

If it is desired to follow the depth of bedrock beneath the surface, it is best to first carry out a vertical depth sounding to locate the bedrock. Then divide this depth by 0.6 to give the most suitable electrode separation. The depth sound will also tell you whether the bedrock has a higher or lower resistivity (from the ratio

p_2/p_1). If p_2 is greater than p_1 then an increase in your measured resistivity will tell you that the basement is getting shallower and vice versa. Alternatively, if p_2 is less than p_1 an increase in resistivity will indicate that the basement is becoming deeper. This method is most suitable for looking for alluvial gold or heavy gemstones which tend to be concentrated in the hollows of the bedrock along alluvial creekbeds.

Meanwhile, let's tell you about Rotel.

In the past couple of years, the name Rotel has come to mean the best value-for-money hi-fi equipment available.

And we intend to keep it that way.

So we've made the range bigger and better than ever.

There are two new amplifiers – the RA 810 (40W per channel at 8 ohms) and the RA 1210 (60W per channel at 8 ohms). Two new receivers – the RX 600A (30W per channel at 8 ohms) and the RX 800 (40W per channel at 8 ohms). And, for the first time, a 4 channel FM/AM receiver, the RX-154A, that will perform any 4 channel activity.

What's more, all the other models in the range have been brought right up to date.

So now Rotel offer you an outstanding range of amplifiers, tuners, receivers and headphones to suit every hi-fi need.

And every model is designed to give you the finest balance of quality and value.

To show that we mean what we say about value, let's just tell you that a well-known hi-fi writer took us to task last year about the value offered by one of our machines. We checked the facts. He was right. We improved our model.

That's how serious we are about keeping our reputation for value.

The whole of the Rotel range is spelled out in detail in a leaflet that's yours in return for this coupon. Send off for it now. And don't forget that you can hear Rotel right now at your Rotel dealer.



To: Rotel, Rank Audio Products, P.O. Box 70,
Great West Road, Brentford, Middlesex TW8 9HR.

Name _____

Address _____

Please send me the Rotel range leaflet.

ET8

THE AMAZING MAZE

*Transmission line speakers
are in the news
— this report by David B. Weems*

ON MAY 4, 1936, at a meeting of the Acoustical Society of America in Chicago, audio expert Benjamin Olney described a new speaker enclosure. He said that it eliminated the cavity resonance of open-back cabinets, extended low-frequency response, and increased the acoustic damping on the speaker. The enclosure consisted of a mazelike tunnel which Olney and his employer, Stromberg-Carlson, called an "acoustical labyrinth." Stromberg-Carlson produced the labyrinth for several years until it was eclipsed by other, less expensive

enclosures. The labyrinth became a textbook curiosity.

Now labyrinth-derived speaker systems are coming back with a vengeance. The revival started in this country in the mid-sixties and, following the lead of the British made IMF speakers, is now gaining followers around the world. For instance, the US companies, Electrostatic Sound Systems and Infinity Systems, are the most recent converts to labyrinths with the ESS Trans-Static I and Translinear II and the Infinity models Holosonic Monitor, Holosonic I, 2000A, 101, and POS-1. Other British models include the Radford Studio the Cambridge Lab Monitor, and the Bower and Wilkins DM2.

These speakers look "different." Typically, they are floor-standing models, relatively tall and somewhat graceful. Internally they resemble labyrinths, but they are called transmission lines.

If we add to these models another half dozen or more speaker systems which retain the labyrinth idea, the extent of its comeback is even more apparent. Why has this type of enclosure, after lying dormant for many years, suddenly exploded onto the high fidelity scene? And why now, when it must rise against the tide of small quadraphonic systems? Has the labyrinth been vastly underrated until now? Or is its current revival just another example of contemporary nostalgia?

To answer these questions one must look at the history of the labyrinth and its place in the evolution of hi-fi loudspeaker systems. The original labyrinth — more accurately termed a "quarter-wave labyrinth" — was an



open-ended tube that curled back and forth in the cabinet behind the speaker. It offered a high impedance to the speaker at a quarter-wavelength of the speaker's resonant frequency. This technique — borrowed from antenna and electrical transmission line theory — served to dampen the objectionable bass resonance of the stiff-coned speakers of the 1930's. The labyrinth terminated in an opening ("port") that enhanced the bass response of the cone down to about 40 Hz. This was a clear improvement over the boomy but shallow bass of the open-back console radios of that time. The internal walls of the labyrinth were lined with sound-absorbent material to dampen any internal resonances and help smooth the midrange sound.



This sketch shows the original labyrinth designed by Olney in 1936. It was produced commercially by Stromberg Carlson for some years. The labyrinth behind the speaker damped its resonance and the auxiliary port near the bottom of the unit augmented its bass output.

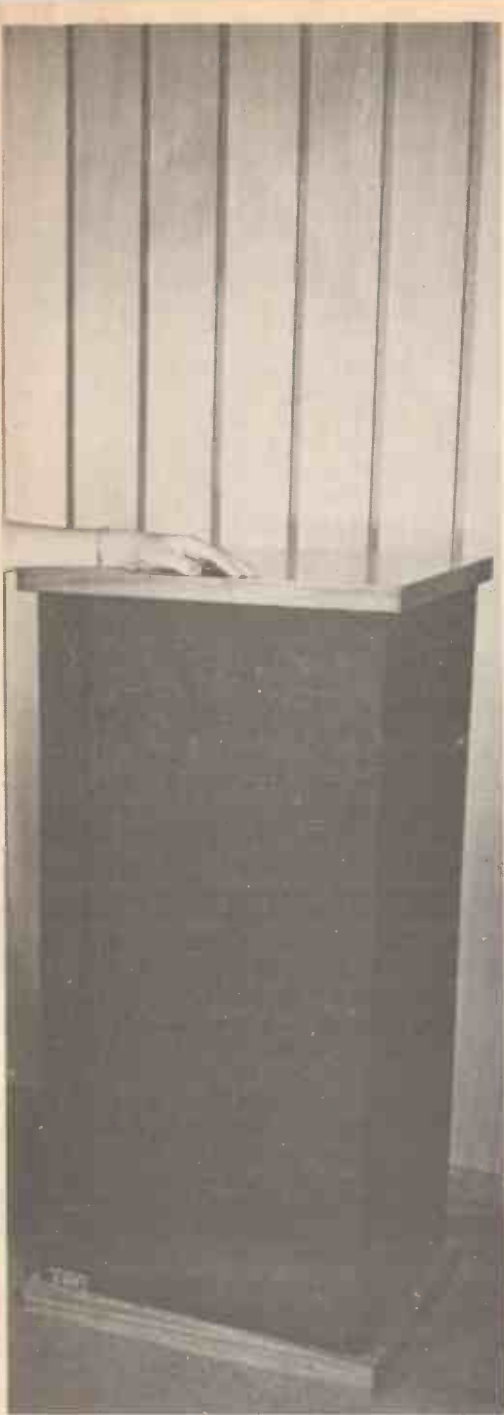

Labyrinth systems met their first competition from the bass reflex cabinet which was simpler, lower in cost, and yet offered the same resonance control as the labyrinth. The bass reflex typically was a box with a port whose area was roughly that of the speaker installed in it. The air in such a box (also known as a "vented baffle" or a "Helmholtz resonator") acted like a huge spring which was compressed and relaxed between the piston effect of the speaker cone and the piston effect of the port air. When properly "tuned" (i.e., precise port dimensions for a specific speaker) the air acted in opposition to the cone at the speaker's resonant frequency, controlling its tendency to move excessively. Again, port radiation supplemented cone

radiation over a selected band of low frequencies.

There were, of course, at least two other "classic" systems for bass loading. One was the large horn — very efficient, but even more complex and expensive to produce than the labyrinth. The other was simply a totally closed large box. The closed box (also known as the "infinite baffle") raised the resonant frequency of the speaker, and also suppressed its back wave entirely. To sound good, therefore, this type of enclosure required low-resonant woofers of rugged construction that could handle relatively high amplifier power.

Then came the revolution known as "acoustic (or air) suspension." During the 1950's the low-resonance woofer arrived, a speaker with a cone of such high compliance that it was useless in the conventional large box. But in a small sealed box the cone's lack of mechanical restoring force was replaced by that of the air in the box. The subsonic resonance of the speaker was brought up to a predetermined point in the audio band, and speaker parameters were adjusted for linear output in the little "pressure box." Since then the acoustic-suspension speaker system has largely dominated the marketplace. Its opponents say that the small size (vis-a-vis the older types) is all that recommends the air-suspension speaker; its proponents insist that size notwithstanding, the air-suspension speaker is a more linear, lower-distorting sound reproducer than the older types.

Throughout these developments and the controversies surrounding them, some audio workers — mostly amateurs but including some engineers in England — continued to play with the labyrinth. American manufacturers ignored it on the grounds that its potential advantages in bass range were too slight to justify its cost. But some experimenters didn't stop at juggling tube dimensions; they began to stuff the tube with various kinds of damping material and the transmission line was born. The labyrinth, a potentially resonant pipe, became one of the least resonant enclosures known. The men who build transmission lines today talk as much about the quality of their bass as its range.

Arthur Radford is one. He began building lines around 1950, but he marketed his first model, the Radford Studio loudspeaker, in 1964. A.R. Bailey, of the Bradford Institute of Technology, called general attention to the new work on labyrinths in a 1965 issue of *Wireless World*. Bailey filled his labyrinth with long-fibre wool that damped the tube resonances and reflections more effectively than

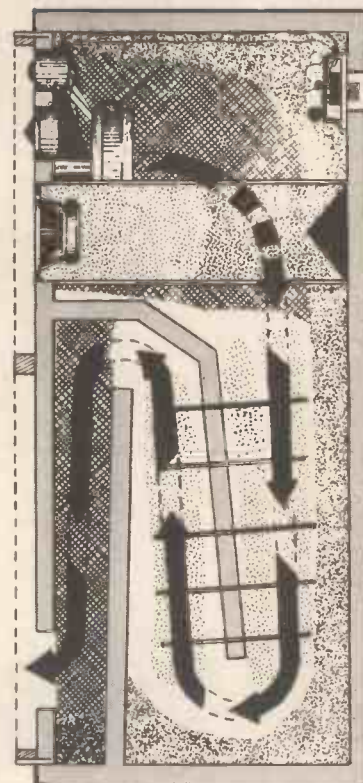

This interior design view of the three-way IMF system shows how a transmission line speaker works. Except for the lowest frequencies, the sound from the back of the woofer is lost in the filtering and bends of the tapered tube. The tapered plug at the end of the midrange line helps to break up the sound from the back and increases the effectiveness of the stuffing.

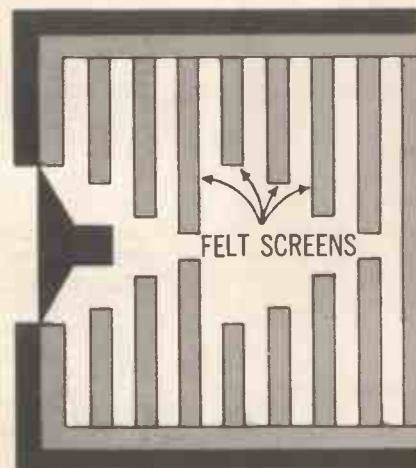

An enclosure of the 1950s, which in some ways resembled today's transmission lines, was the Hartley "Baffle." Its designer, H. A. Hartley, was opposed to reflex or other "resonant" systems. The baffle acted as a low-pass filter. Hartley considered the possibility of bringing the rear bass into phase with that from the front of the speaker but never did so.

THE AMAZING MAZE

Olney's lined walls of thirty years before. Bailey compared his stuffed labyrinth to the ideal electrical transmission line, which is also free of signal reflections, and he showed test results that indicated smooth, extended low frequencies and superior impulse (or transient) response.

Commercial transmission lines development commenced in the U.S. when Irving M. Fried (IMF Products) demonstrated one at the 1965 New York Hi-Fi Show. Fried, who earlier had espoused full-range electrostatic speakers, was won over to transmission lines in the early 1960's after Arthur Haddy and K.S. Spenser of Decca recommended a bass line to match the frequency and dynamic range of their new recordings. Fried followed up the 1965 demonstration with his well-known IMF Monitor and Studio models, speakers that were viewed by the makers of conventional systems as noncommercial, novelty items; until recently that is.

Looking over this history, one is tempted to seek a single compelling reason for the labyrinth's resurgence. In fact the manufacturers of transmission lines do offer a single factor, a partisan one.

"We use the transmission line principle for one reason," says Victor Comerchero, President of ESS. "It is the most faithful bass propagation method available." To be specific, he mentions superior transient response and high definition. Transmission line zealots say that most high fidelity sound is "boxy." They claim that box speakers produce muddy bass, particularly at the lower end of the audio range, due to resonances. Here, they say, is where the transmission line is supreme because its resonance may be put below the audio band. And the port output of a properly designed line will cross over with the output from the front of the cone to maintain a flat response well below that of the speaker alone.

This proficiency of the labyrinth in the low bass may be a factor in the timing of the enclosure's comeback.

As the frequency and dynamic range of recordings improved, better speakers were needed to realize that improvement. The fact that representatives of a recording company were recommending transmission lines in the early 60's, before their current vogue, may be significant.

Another plausible explanation for

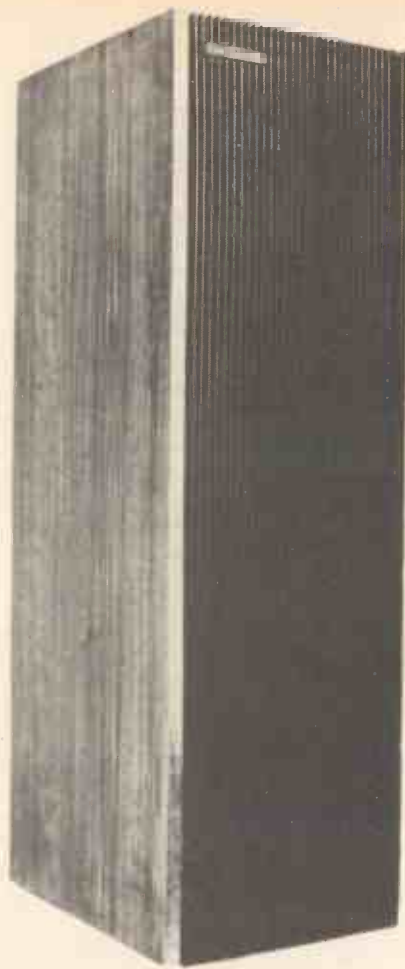

*Cambridge Audio R 50
Monitor speakers*

the revival is the development of drivers that complement the labyrinth's characteristics. Today's transmission line manufacturers stress the importance of good drivers in a nonresonant system because, they say, while poor drivers will sound bad in any kind of enclosure, the colourations of poor drivers are mercilessly exposed in the transmission line system.

Looking again at hi-fi history, there seems to be a parallel between the final triumph of compact speaker systems and the emergence of the transmission line. On the surface this appears to be a coincidence. A causal relationship between the two apparently opposite types doesn't make much sense, but under the skin they have one trait in common. Both are inefficient. One factor that enabled the compact sealed box to conquer the large bass reflex was the development of high-powered amplifiers at reasonable prices. In fact the power demands of the compacts helped to stimulate the development of low-cost electrical power for music reproduction. Now the transmission line people, have seized the opportunity given them to produce a speaker system that seems to be,

philosophically anyway, an anachronism since it is both large and inefficient.

Finally, there may be more well-heeled audiophiles today who can pay the kind of costs incurred in the manufacture of transmission lines. This brings up a related question. If we admit the claimed bass superiority of transmission lines, and both tests and careful listening prove that they are good (if you listen for true fundamental bass rather than the fuller-sounding prominent mid-bass of some systems), how much is this kind of bass worth in terms of money.

However one answers that question, the advocates of transmission lines insist that it's not just a matter of improved bass; the transmission line is better for midrange too.

"The ear," says Irving Fried, "will forgive many more distortions at the bottom and at the top of the musical scale than it will in the midrange where the critical ear hears distortions that are frankly unmeasurable by ordinary laboratory techniques

Indeed, the IMF speakers, as well as the ESS and the Cambridge models, use two transmission lines — one for bass and another behind the midrange driver. Radford uses a separate compartment for its midrange driver that operates as a closed-end acoustic line. These midrange lines, like the bass lines, are stuffed with absorbent material to kill reflections. Makers of line systems see reduction of reflections as one of the significant advantages of line enclosures over simple enclosures. They say that the stuffing in a shallow box (one without a transmission line) produces reflections at certain frequencies, particularly if the stuffing is a roll material with a flat surface exposed toward the driver.

One of the points of diversity between different makes of transmission lines is in the kind of stuffing employed. Radford and Cambridge use the same long-fibre wool that was recommended by Professor Bailey. IMF installs fibre-glass and end-suspended filters and English hemp. ESS and Infinity add Dacron to their mix of materials. Both IMF and ESS employ variable-density filtering which requires careful adjustment. This variable damping in the tapered tube attenuates the sound from the back of the driver in steps until only the lowest frequencies emerge from the

port. Some companies, Bowers and Wilkins for one, substitute heavy damping for tube length. The amount of damping material used must be correlated to the cross-sectional area of the pipe so that the line is not "choked." Fried says that the proper combination of pipe area and damping material provides what he calls "free-flow filtering" for the IMF lines. The filtering critically damps three resonances, those of the air in the top chamber, the tube, and the driver itself.

Although most designers aim at using port radiation to augment cone output at low frequencies, Infinity Systems pursues a different goal. The Infinity lines are stuffed with Dacron, in increasing density toward the port, so that they operate without reflections but also without radiation. This method of loading results in some loss of energy (lower efficiency) which Infinity apparently accepts as the cost of obtaining the kind of results it wants.

Another difference between competing lines is in the driver systems. IMF uses a four-way system of cone drivers. The cones are made of chemically derived material and include a rectangular woofer in the Monitor models. Cambridge also uses a four-way system of cone drivers. Radford has recently changed from a four-way system to three-way, but the three-way system is made up of ten drivers. Two 12-inch woofers drive a single bass line and are crossed over to four 4-inch midrange and four 1-inch soft dome tweeters. The midrange and tweeter units are arranged as a pair per side of the enclosure for 360-degree sound (270-degree against a wall). ESS mixes dynamic speakers with electrostatic tweeters. The bass is handled by a rectangular flat plastic-coned woofer, the midrange by a 5-inch plastic cone, and the highs by three electrostatic tweeters. Infinity also makes use of electrostatic tweeters in its Model 2000A, in addition to the 12-inch mass-loaded woofer and 4-inch midrange cone drivers, but the tweeters radiate both front and rear.

In most transmission line systems the drivers are located near the top of the enclosure while the maze itself exhausts into the room at floor level. One ESS model, the Trans-Static I,



ESS Trans-Static speaker with grille cloth removed.

terminates its line with slots on all four sides of the enclosure, rather than the usual single front port. Victor Comerchero says that the difference between the two types of loading is clearly audible. If you move in close to a line speaker and put your ear to the port, you would hear nothing but the rumble of the lowest frequencies. In the case of the large Cambridge system, you would hear the rumble at the top, for the port is above the tweeters.

Whether the high quality of these systems is due to their use of the transmission line may be debatable, but the makers of conventional systems can no longer pretend that the transmission line doesn't exist. And it doesn't seem to be going away. Perhaps the labyrinth will eventually be adopted by some of the large manufacturers.

One straw in the wind is the recent development of the Aquarius 4 by James B. Lansing Sound, Inc. While not strictly a transmission line system (JBL does not recognize the term as a valid name for a loading technique),

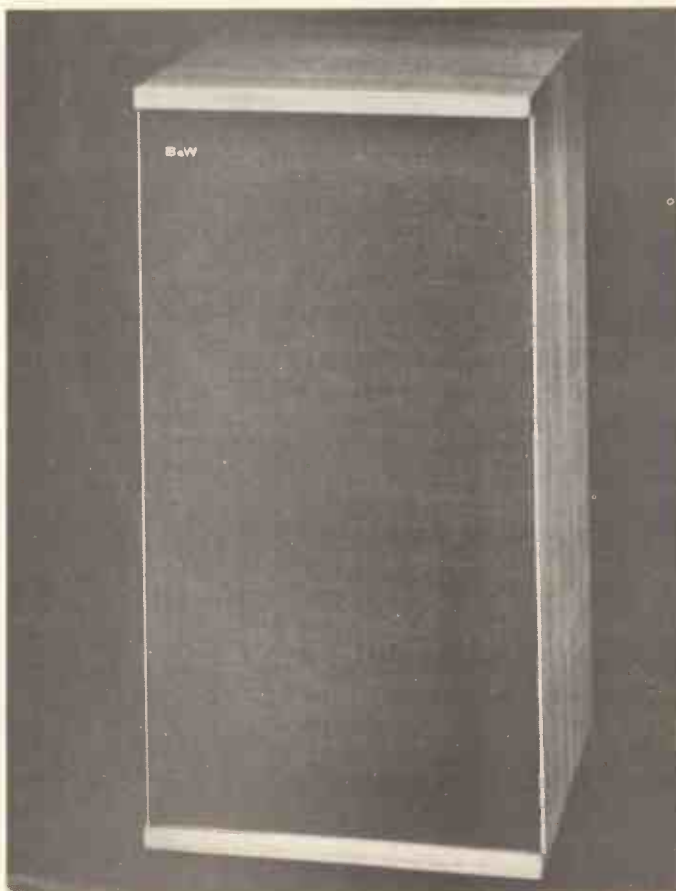

Bowers and Wilkins Model DM2 speaker enclosure uses transmission line loading.

THE AMAZING MAZE

the design of the Aquarius 4 shows similarities to some transmission line techniques. The bass range is reproduced by an upward-facing 8-inch woofer front loaded for 360-degree dispersion. Behind, or rather below in this case, the woofer is a damped pipe. The pipe terminates in an acoustic filter in a second chamber which in turn vents out of a ducted port. JBL classifies the Aquarius 4 as a modified reflex enclosure, but allows that it could be considered a variation of a highly damped labyrinth. One definition of transmission line, as accepted by people who use the term, is "damped labyrinth."

The Aquarius 4 was developed when the firm's marketing staff requested a high-fashion speaker system that would be flexible in its room placement requirements. JBL's engineering department designed the system for omnidirectional sound and minimum floor space requirements; as such it could fit readily into quadraphonic installations.

Fairfax is now producing a large but shallow (52 by 30 by 6½-inch) labyrinth system. This model, the "Wall of Sound," is a four-way system using six 8-inch woofers, two 5-inch

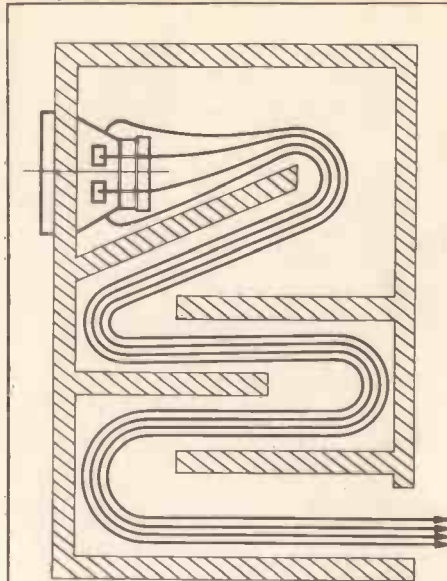

Cutaway drawing shows the construction of the Akai SW 35 unit.

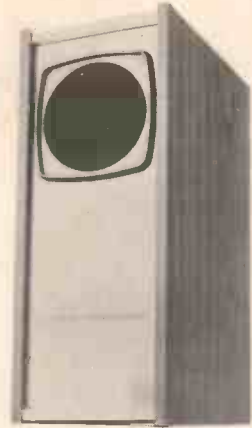

The Akai SW 35 is a miniature labyrinth driven by a single 5¼" diameter speaker.

midrange, two 3½-inch midhigh and two ultrahigh frequency dome tweeters. Fairfax calls the enclosure an integrated labyrinth. It is subdivided into six compartments that feed a labyrinth that is terminated by three round ports. The Fairfax L-34A is a compact (24 by 14 by 12 inch) labyrinth driven by two 8-inch woofers. Other companies that

produce labyrinth-type enclosures are Whiteley (available only in Britain), Admiral, Akai, Crisman, and V-M.

The Admiral "Tunnel Reflex" systems, the V-M "Spiral Reflex" speakers, and two Akai models represent a special kind of small labyrinth or semi-labyrinth. In most of these models the entire music range is covered by a single cone, a high-compliance wide-range speaker. Labyrinth loading was chosen for these models to enable them to reproduce an extra octave of bass over that of a sealed box with the same speaker.

The latest news on labyrinths is the announcement by Audionics of a kit of Radford components for those who want to build their own transmission lines. The kit will consist of a woofer, a midrange driver, a tweeter, a crossover network, and the hard to find long-fibre wool. The kit is designed to work in a transmission line enclosure which was described by Professor Bajley in the May 1972 issue of *Wireless World*.

A few years ago many observers of the high fidelity scene were predicting an ever more narrowing choice of speaker systems. It seemed that the only variety we could expect would be competition between different brands of compact boxes. Instead the last five years have brought us a diversity in kinds of speakers that makes the selection of a system more challenging than ever before. And one of the most important new types is the transmission line. It looks as if the labyrinth is back to stay.

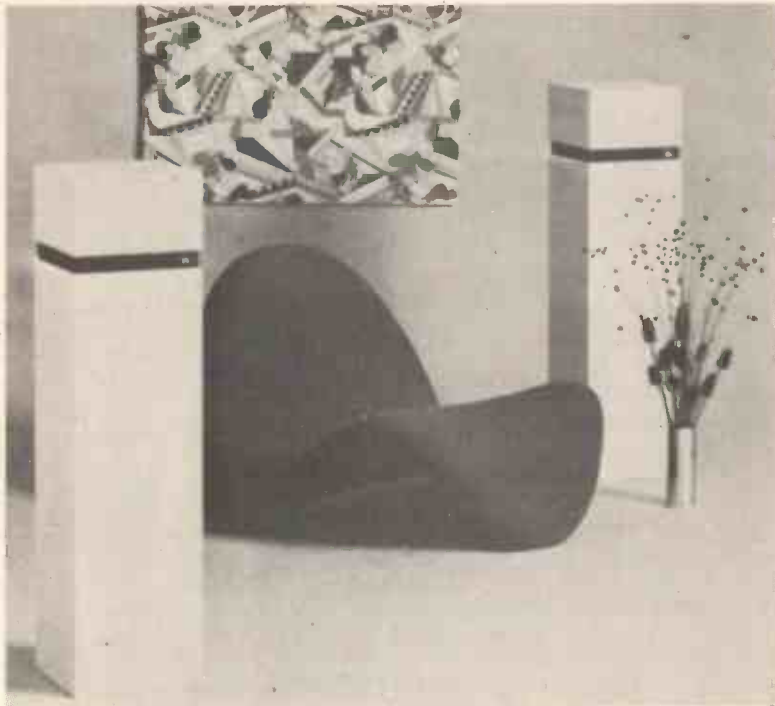

JBL Aquarius 4 speaker system incorporates a damped pipe that is similar in its loading effect to a short transmission line.

Text reprinted by permission from the Winter 1973 issue of Stereo.

FREE COMPETITION

3 ADVANCE CALCULATORS MUST BE WON!



THE ADVANCE EXECUTIVE is a small electronic calculator which is normally operated from dry batteries and may comfortably be held in the hand. In contrast to some other small calculators, it has been rigorously engineered to be truly reliable in continual use.

The Executive multiplies, divides, adds and subtracts with fully floating decimal point to an accuracy of 8 digits and it always underflows. It will chain calculate, square automatically and features the vital 8-digit constant facility in both multiply and divide.

As most calculators are used extensively for financial calculations, provision has been made for optionally fixing the decimal point of the displayed answer to two places (in this mode answers are rounded off).

Power is derived from six dry cells. A separate mains unit is available as an optional extra, designed to operate from 115V or 230V mains. The mains unit is designed to support the calculator in a convenient position for desk-top use. Rechargeable cells are also available and these may be charged through the standard mains unit.

The Advance Executive takes less than a fifth of a second to do its calculations. It is guaranteed for a year. The recommended retail price is £57.75 for the basic calculator including the batteries.

HOW TO ENTER THE COMPETITION

All you have to do is work out the answers to the six mathematical problems set out below; they are not trick questions. Using the Advance Executive, all these can be answered in a few minutes. Note that a slide rule and normal log tables will not give the degree of accuracy we require. The first three entries drawn after the closing date with the correct answers will each win one of the Advance Executive Calculators.

RULES

All entries must be accompanied by the coupon from Electronics Today International. There is no entrance fee, but any entry not accompanied by a coupon will be deemed invalid by the judges.

The prizes will be awarded to the first three correct entries drawn after the closing date. The judges' decision will be final and no correspondence will be entered into concerning the contest.

All entries should be addressed to: Calculator Competition, Electronics Today International, Whitehall Press Ltd, Wrotham Place, Wrotham, Sevenoaks, Kent.

Ensure that your name and address is printed clearly on your entry coupon.

Closing date for the competition is July 31st, 1973.

ENTRY COUPON

When completed this should be sent to:
CALCULATOR COMPETITION, ELECTRONICS TODAY INTERNATIONAL, WHITEHALL PRESS LTD, WROTHAM PLACE, WROTHAM, KENT.

ANSWER THESE QUESTIONS

1. At present a man is earning £1,875 per annum. If his salary increases by 8.5% each year for five years and 7.6% per year for a further five years, what will his salary be after 10 years? The rises are compound; give your answer to the nearest 1p.

£: _____

2. Calculate to two decimal places:

$$\left(\frac{187.632}{7.531} \times \frac{7856.42}{8.437} \right) + 50.485 = \underline{\hspace{2cm}}$$

3. What is the square root of 789 (to five decimal places)

$$= \underline{28.08914}$$

4. If we take the population of England, Scotland and Wales as 54,022,410 and the total area as 88,763 square miles, what is the population density per acre? Give your answer to five decimal places.

= _____

5. What is 1.76413 to the power of six (multiplied by itself six times)? Give your answer to five decimal places.

= _____

6. The resonance of a tuned circuit is given by the formula:

$$f = \frac{10^6}{2\pi\sqrt{LC}} \text{ kHz}$$

Where L is in microhenries and C in picofarads; take π as $\frac{22}{7}$.

If L is 97 μ H and C is 109 pF, what is f? Give your answer to four decimal places.

f = _____

Please find my entry for your Calculator Competition. I have read the rules of the contest and agree to abide by the judges' decision.

SIGNED DATE

NAME (block letters)

ADDRESS

A separate coupon must accompany each entry and entries must not be accompanied by any other correspondence. Closing date is July 31st, 1973.

LASERS

What they are, and how they work



The recent revelations that the armed forces are researching the use of lasers as a possible 'death ray' have put them in the news.

The laser, since it was first developed by Theodore Maiman in 1960, has found large numbers of peaceful uses in industry and pure research. Most of us know that a laser produces light of a single frequency, the beam is coherent, in phase and very nearly parallel but how do they work? Next month's ETI carries a major feature answering these queries.

TRACKING WEIGHT

It is obvious that too heavy tracking weight will damage a record but most makers recommend a range of tracking weights. We have checked out these under laboratory conditions and come up with a surprising result.

WHAT TO LOOK FOR IN AUGUST'S

electronics
TODAY
INTERNATIONAL

ON SALE MID-JULY — 20p

ETI TAKES A PRIDE IN BEING REALLY UP-TO-DATE, SO WE OURSELVES DO NOT ALWAYS KNOW WHAT WILL BE IN THE NEXT ISSUE SO THE FEATURES MENTIONED ON THIS PAGE ARE ONLY SOME OF THOSE THAT WILL BE INCLUDED.

UHF AERIAL PREAMP



Continuing our feature on receiving additional ITV stations, next month we describe a simple, inexpensive project for a one transistor aerial preamplifier which gives about 14dB of gain.

PLUS

REVIEWING THE YAMAHA CA 700

DETECTOR FOR RUSTY CARS —
find out if there's metal or filler under
that coat of paint

FINAL PART OF TRANSDUCERS IN
MEASUREMENT AND CONTROL

NEW AND PATENTED AERIALS FOR STEREO RECEPTION

STEREOBEAM

the best on balance

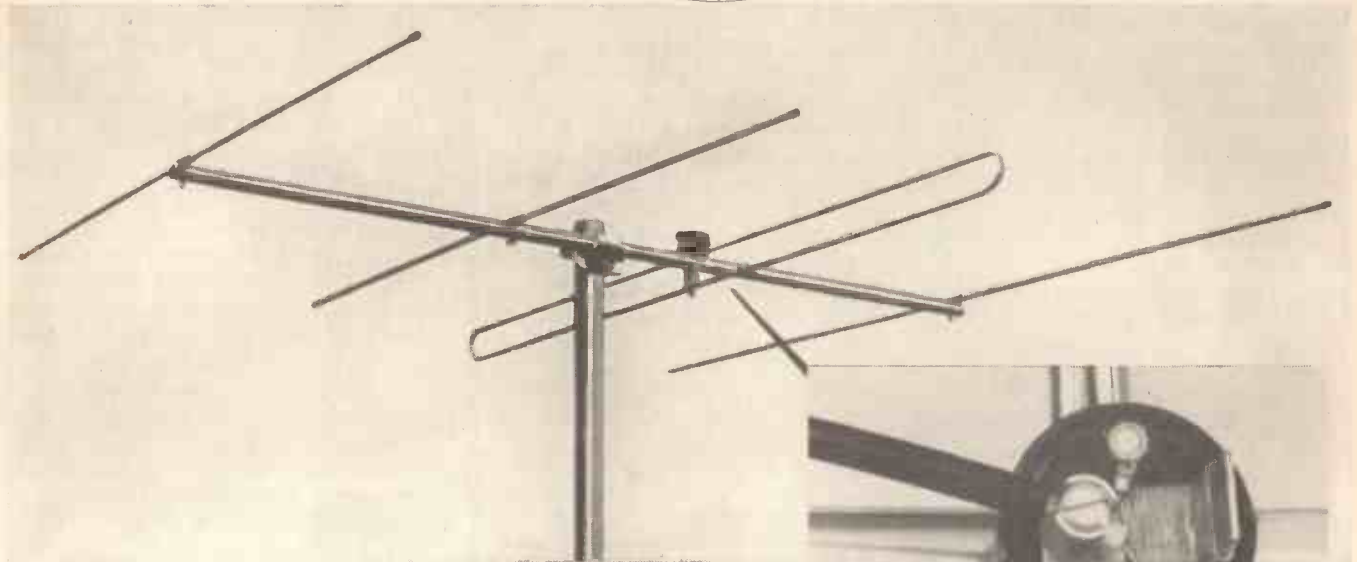

These new and superb "Stereobeam" aerials for FM Stereo or Mono reception provide a wide choice of models ranging from a Dipole to a six Element Array. The folded dipole construction on each model incorporates the patented "Inverse Balun", an exclusive design feature which provides



**PATENTED
INVERSE BALUN**

- * *ELIMINATION OF "PICK-UP" ON DOWN LEAD REDUCING INTERFERENCE AND DISTORTION FROM MULTIPATH RECEPTION.*
- * *REACTANCE COMPENSATION TO GIVE WIDE BANDWIDTH AND EQUAL PERFORMANCE ON ALL STATIONS IN THE FM SPECTRUM.*
- * *MAXIMUM SIGNAL PICK-UP FREE FROM "HISS" AND EXTRANEIOUS NOISES.*
- * *PURE AND SILENT BACKGROUND ESSENTIAL FOR PERFECT STEREO RECEPTION.*



Member of the
J. Beam Group
of Companies

**NOW AVAILABLE
FROM J. BEAM
APPOINTED
DISTRIBUTORS**



NORTHAMPTON NN4 9JD Tel: 0604 63531 (10 lines) Telex 311101

GET A 4th TV CHA

ALTHOUGH there is currently much talk about a fourth channel on British television, many people are already in a position to take advantage of the overlap of different ITV regional services and give themselves a fourth choice today.

To gain adequate coverage it is often necessary to saturate some areas, and the overspill of signal may well spread into the service area of another station from a different region. There are some problems in taking advantage of this and many people who would like to do so could well be unaware of its existence. This article describes the reasons for the choice of the UHF (Ultra High Frequency) system for colour TV and

for the location of transmission sites. It also suggests rules for receiving UHF stations and some of the areas where two, or more, ITV regions overlap.

Britain was ahead of the world in high definition television when the service started in 1936. The 405-line system of 45MHz from Alexandra Palace stopped suddenly in 1939 on the outbreak of war and re-awoke in 1946. In the late forties and early fifties it spread as BBC television (now BBC-1) to cover most of Britain. The stations used 5 frequency sections or "channels" in the very high frequency (VHF) band from 41-68MHz, now known as Band 1.

With the arrival of ITV in 1955, television spread very rapidly and,

technically, broke new ground by using much higher frequencies, Band III close to 200 MHz. There was no room in Band I for any more stations without causing mutual interference. This was because of the way in which VHF waves travel over land. They behave a little like light and are obstructed by rough ground such as hills and mountains. However they do spread very easily over smooth ground or the sea. The average distance covered by a VHF high power station is 40-60 miles according to the geography, but weak signals are often available much further than this. For example, fairly reliable reception was obtained in the early days in Dublin from Holme Moss in Yorkshire, well over 200 miles. It did depend on weather conditions but many people bought sets to receive it. They still take advantage of BBC or ITV from Ulster or Wales in the east of the Irish Republic. Many people now even get acceptable results from British colour stations.

However, the fact that signals can often spread a very long way means that stations on the same channel must be at least 150-200 miles apart on VHF to avoid mutual interference. This puts a relatively low limit on the possible number of stations on Bands I and III for coverage of the U.K. Only 13 channels are available in these two bands limiting national coverage to two networks only. To expand the number of networks would need a new part of the radio frequency spectrum, the UHF bands, IV and V, covering 470-860 MHz. At the same time advantage was taken of the 625-line system with its much higher picture definition than the old 405-line system. Its use had the technical advantage also of making international standardisation easier. Unfortunately, both colour and the 625-line system are very greedy for space in the frequency spectrum (i.e. they require a considerably larger bandwidth than the 405 monochrome system). To make these changes it was also essential to transfer to UHF where 44 of the new broader channels were available. Use of these would permit national coverage with 4 different networks on 625-lines and in colour.

For these reasons, in the 1960's BBC-2 pioneered first UHF in Britain and, later, colour. It was followed into colour at the end of 1969 by BBC-1 and ITV in the major regions. The vast

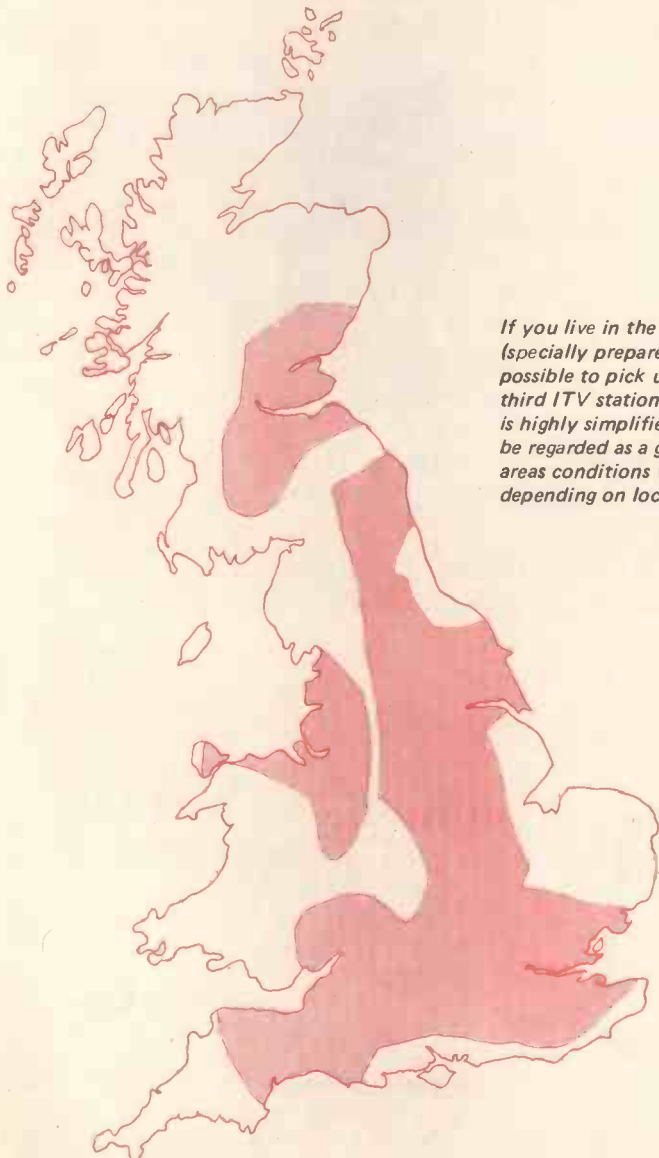

If you live in the shaded area on this map (specially prepared by ETI) it may be possible to pick up a second or even third ITV station on UHF. The map is highly simplified and should only be regarded as a guide; in weak signal areas conditions vary enormously depending on local geography.

CHANNEL NOW

Keith Pitt describes the UHF TV system and gives some rules which should improve your picture and, if you live in certain areas, how you can pick up an additional ITV station with its extra programmes.

job of saturating the UK with UHF transmissions is proceeding rapidly, but, eventually, about 1000 stations will be needed to complete the job. When it is done, the old VHF 405 line system will be abandoned and the airspace made available will probably be re-engineered to give two more national 625-line networks. For the present, however, at least until 1980, the old and new systems will exist in parallel, although virtually no new sets are being made for 405 lines. The fourth channel allocated to each UHF station remains dormant while the various lobbies put their claims for its use.

RECEIVING UHF

As mentioned earlier, radio waves at VHF tend to behave rather like light (this is not entirely surprising as they are relatively long electro-magnetic waves). This means that they have in effect a radio horizon, much like the visual horizon, although they do diffract (or bend) over it to a greater or lesser extent, depending on their frequency. So the higher we put the transmitting aerial, the greater the coverage obtained. Fig. 1 illustrates the effect of using a "smooth earth".

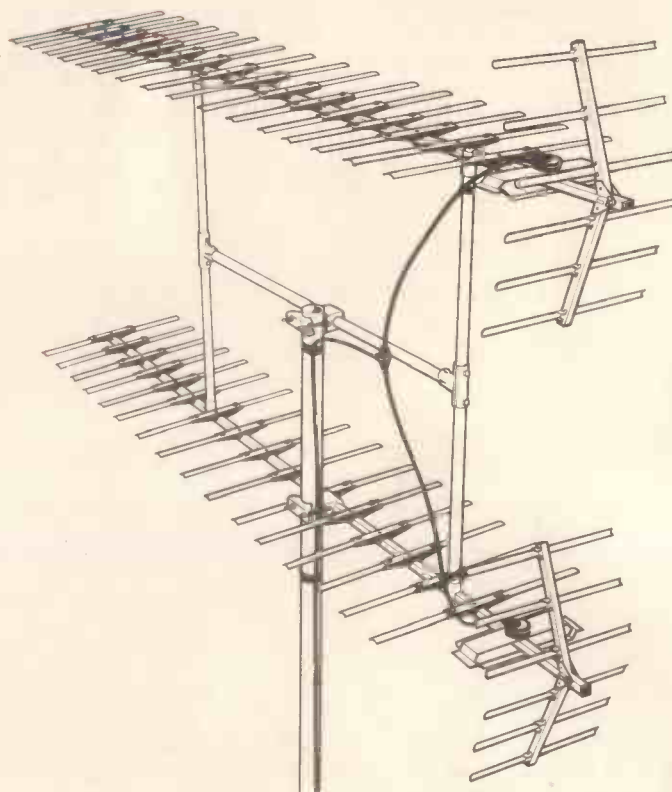

Fig. 1 Radio horizon for a smooth earth

The distance of the radio horizon is approximately given in miles by $1 \frac{1}{3} \times \sqrt{\text{height of aerial in feet}}$. For example, if the transmitter is 625 feet above a plain then the radio horizon is $1 \frac{1}{3} \times \sqrt{625}$, approximately 33 miles. So we could say that the line of sight coverage is about 33 miles in any direction where there is no obstruction. In fact, quite a lot of VHF signal does go over the horizon giving a larger coverage than this theory would predict. The spread or diffraction gets much less as the frequency rises into the UHF bands, 470-860 MHz, and UHF service areas are largely limited to within the radio horizon.



Fig. 2 The effect of hills on transmitter coverage.



In practice the earth is by no means smooth and the situation is complicated by obstructions such as ranges of hills and the service area is never a perfect circle. Fig. 2 illustrates the effect of hills on transmissions. Receiving aerials only a very short distance from a station can sometimes not receive any signal at all from their local transmitter and care has to be taken to find a usable alternative.

Another problem arises from multiple path transmissions - colloquially known as "ghosts". Radio signals reflect off any large body - buildings, gas holders, cranes or hills - and find their way into

the aerial by such an indirect path as in Fig. 3. The resulting ghosts are repetitions of the picture across the screen. This is because the time for the reflected signal to arrive is greater than for the direct path.

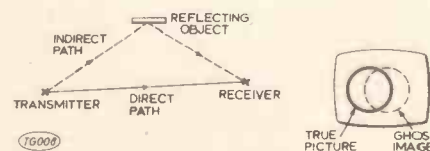

Fig. 3 How ghosting is caused

HOW TRANSMITTERS ARE SITED

To give the maximum possible coverage from one transmitting tower, (which will put out 3, later 4, different programmes) the aerials must be as high above the surrounding countryside as possible. In practice 1000-1200ft. masts are built on suitable hilltops. (This alone requires much care in choice because the best sites for TV stations are often the best scenically and a tall

GET A 4th TV CHANNEL NOW

tower is frequently considered environmental pollution). The transmitted power will be chosen to fit in with the area to be covered, but, in general, main stations send out from about 100 kW up to 1MW. Local area stations to fill in pockets missed by the master transmitter will usually be sited on a local vantage point a few hundred feet above the immediate service area and have a low power somewhere between 80W and about 10kW.

UHF RECEIVING AERIALS AND CABLES

For efficient results a receiving aerial must be tuned to the frequency which it is expected to pick up. It must also pick up as much transmitter signal as needed and discriminate against unwanted noise signals such as electrical interference and distant stations on the same channel in another direction.

At sites close to the transmitter the signal is usually so strong that very simple aerials will give perfectly acceptable results. As the distance increases, we need to pay much more attention to what type of aerial we use and where it is mounted. A simple rule of thumb is: the further away, the more complex the aerial.

What do we mean by more complex? To explain this we can look at some of the more common types of aerial in use. We will examine the simple Bi-Square, the Yagi, Multidirector Yagis and the Log-Periodic aerial.

If we plot the voltage pick up from an aerial against the angle between the

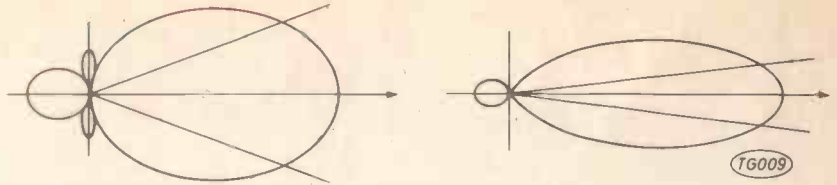
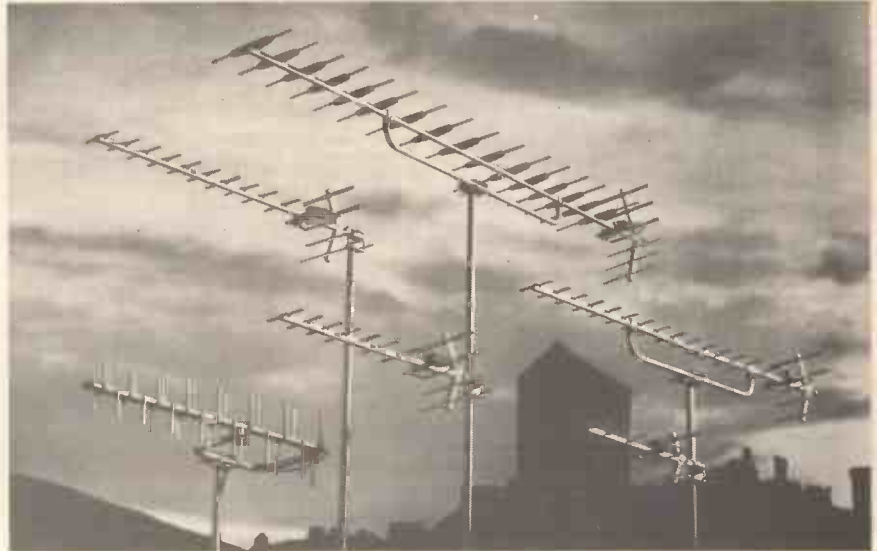

Fig. 4 Simplified aerial polar diagrams. a) (left) shows a low gain, wide acceptance aerial with small side lobes. b) (right) a high gain aerial with narrow acceptance and no side lobes.



Typical UHF aerials, each is designed to serve a particular function. In the centre is the Antiference Hi-Gain Model HG3540 designed for long distance reception.

axis of the aerial and the direction of the transmitter we get a polar diagram. The length of the loop in the forward direction indicates the efficiency, or gain of the aerial relative to a single rod aerial. The width of the loop tells us how closely we must point it at the transmitter before we get a visible loss of picture. Small loops or "lobes"

occur on some aerials allowing stray interference signals in from the side. These, obviously, should not be present in a weak signal strength area although there may not be too much problem if the signal is strong. The front to back ratio tells us what proportion of signal we would get from a source of signal diametrically opposite to the wanted

The Choice of UHF Aerials

Place	Position of Aerial	Type of Aerial	Observations
Local i.e. 10-15 miles from main station or 2 - 3 from fill-in	Outside Loft Set top	6 - 8 element 11 - 18 element As good as possible	Bi-Square is likely to be good only very close to station
Medium i.e. 15 - 25 miles from main station or 3 - 5 miles from fill-in	Outside Loft Set top	11 - 18 element 18 element or Multidirector	Often with a preamplifier Probably not very satisfactory
Fringe and extreme edge of overlap areas	Outside only	Minimum 18 element or Multidirector	Aerial carefully mounted as high as possible, preferably 10 - 15ft above chimney Pre-amplifier may well be needed

Expensive Equipment

Then why not have the aerial it deserves ??

Whether your requirement is simply clean Stereo from a local transmitter, or good recording from Continental stations, our extensive range meets the demand. From the basic 'H' to the superlative 'ARROW SIXTEEN' strict quality control, and design expertise, give specifications to meet every need.

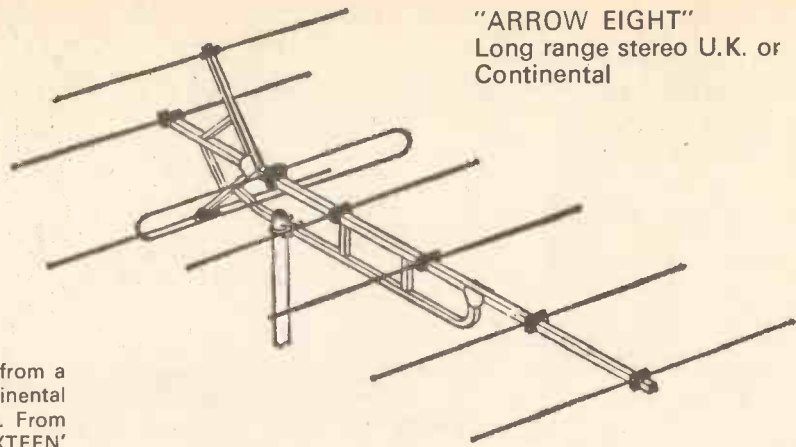

"ARROW EIGHT"
Long range stereo U.K. or Continental

SPECIFICATIONS:	Standard		Economy Arrow				Main Arrow Range			
	H	3EI	4EI	5	6	7	Six	Seven	Eight	"16"
Model	H	3EI	4EI	5	6	7	Six	Seven	Eight	"16"
Gain @ 93Mhz.	2.5	4	5	6.8	7.6	8.8	9.7	10.8	12.3	14.8
F. to B. dB	9.2	13.7	15.9	18	20	22	22.8	23.9	26.5	29
A. Ang. Degrees	78	68	67	66	63	59	58	56	45	38
Length-inches	32	42	72	42	72	102	84	114	162	222
Height "	-	-	-	21	21	21	40	40	58	65
W/load @ 100mph	12lb	16lb	20lb	24lb	27lb	30lb	32lb	38lb	55lb	90lb
PRICE including	£	£	£	£	£	£	£	£	£	£
V.A.T. & Carr.	2.75	3.85	4.95	7.15	8.80	10.45	12.10	13.20	21.45	40.70

ARROW RANGE FEATURES

- *New reflector design giving high gain and good front to back ratio.
- *Narrow acceptance angles and minimal side lobes.
- *Ideal for rotator operation.
- *Suitable for Continental and difficult U.K. areas.
- *Deep support boom for rigid mounting.

NEW ZODIAC ELEVEN MODELS 16 to 142 ELEMENT

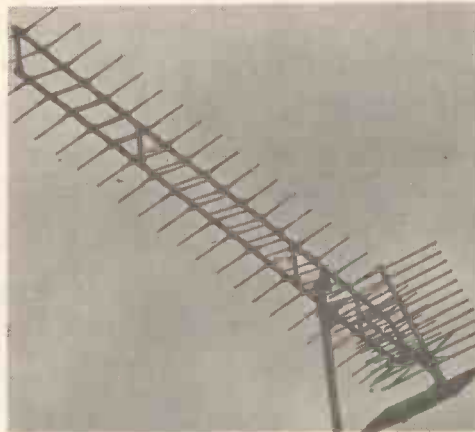

ZODIAC TWENTY-FIVE
WIDEBAND - GAIN - 15 to 19 dB
F. to B. 28-34 dB. A. An. Min. 14°.

- *High Forward Gain
- *Narrow Acceptance Angle
- *Excellent Back Rejection
- *Flat Response
- *Minimal Side Lobes

U.H.F. STANDARD RANGE

- *Good Basic Design
- *Low Weight
- *10, 15, 20 & 30 Elements

AERIAL ROTATORS

We stock Stolle Auto and Memo models.
For heavy duty work we have the C.D.R. A.R.22.

TRADE SUPPLIED
DETAILS ON REQUEST

INSTALLATION SERVICE

- *Fully skilled rigging teams.
 - *Field strength meter alignment.
 - *Special ladders for roof work.
 - *Percussion masonry drills.
 - *Full insurance cover—all risks.
 - *Five years' guarantee parts and labour.
- RANGE—up to 100 miles from LUTON.
Booking—write or phone for details.

LONG RANGE U.H.F. COLOUR GROUP "A" or WIDEBAND

- *British made by Specialists
- *Low Weight and Windloading
- *Twin & Quadruple Booms.
- *Businesslike Appearance
- *Ideal for Rotor Operation

U.H.F. "ARROW" RANGE

- *Efficient Reflector Design
- *Five Models Groups A, B & C.
- *High Performance - Low Cost

ACCESSORIES

Complete range of masts, brackets etc. Send for catalogue of all products.

MAIL ORDER SERVICE

Fast service - goods despatched promptly on receipt of cash or cheque with order. Advice free by post or telephone.

R SMITH AERIALS

T.V.

F.M.

Designers & Manufacturers of Radio and Television Aerials of all Types.

98 ASH ROAD, LUTON, LU2 9AX Telephone: LUTON 36561

For catalogue or information 0582-36561

9.0 to 6.0 Monday to Saturday—callers welcome—5 mins from exits 10 & 11 M.1. motorway

J-BEAM F.M. 6S THE OUTSTANDING BRITISH ENGINEERED F.M. AERIAL
 STILL UNRIVALLED IN ★ PERFORMANCE ★ QUALITY ★ AND PRICE ★



20 Miles Radius
 Professional Installation Service

We also stock the new broadband J-Beam F.M.4S, 1, 2, 3, element F.M. arrays high performance A.M. vertical rod aeriels, all U.H.F. T.V. aeriels, Stolle Memomatic and Automatic aerial rotators, balanced twin feeder, coaxial cables, masts, fixings, amplifiers, baluns, and a host of other accessories. Please send large S.A.E. for catalogue to:

APOLLO AERIALS, STATION FORECOURT, GUILDFORD STREET, CHERTSEY, SURREY
 TEL CHERTSEY 60320 and BYFLEET 43151



THE FREE HEATHKIT CATALOGUE features

NEW 1214 SERIES STEREO HI-FI
 Ideal for use for quadraphonic sound.

the HOW AND WHY OF KIT BUILDING
 Electronics is fun the HEATHKIT way.

BUILD YOURSELF A PAIR OF SPEAKERS
 in an evening - enjoy Stereo sound.

GET THE BEST IN HI-FI
 Enjoy worthwhile kit savings.

SOMETHING FOR ALL THE FAMILY
 even a battery charger for dad.

LOW COST STEREO RECORD PLAYER
 amazing sound value.

NEW MULTI-SPEAKER KIT
 Features Four KEF Hi-fi Drive Units. Offers monitor quality at lowest cost.

NEW AM/FM STEREO RECEIVER KIT
 Solid State FM IF Circuitry, two IC's, two ceramic filters. "Black magic" lighting.

NEW PORTABLE ENGINE ANALYSER KIT
 Versatile automotive testing and trouble-shooting.

LOW-PRICED TESTERS AND INSTRUMENTS
 for the hobbyist and technician.

PLUS
 all the models you have read about in international publications.

Please send me the FREE Heathkit catalogue

Name _____

Address _____

Heath (Gloucester) Limited
 Department ETI / 5/73
 Gloucester GL2 6EE
 Telephone 0452 29451

HEATH
Schlumberger

Post the coupon NOW for a FREE copy
 Heath (Gloucester) Limited, Gloucester GL2 6EE.

transmitter. All these characteristics of an aerial are very important at UHF because there will certainly be a co-channel transmitter near enough to interfere in many places, unless care is taken, when the UHF network is complete.

SET TOP AERIALS

A very popular version is the Bi-Square consisting of two square (or circular) loops of metal mounted on a plastic base. The sides of the square are about 6" and this is also the separation of the two. The smaller square is connected to the cable and should be pointing to the transmitter. (Miniature low gain versions of the Yagi or log periodic are also widely used as set top aerials).

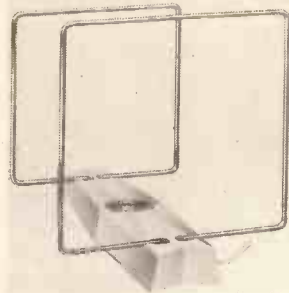
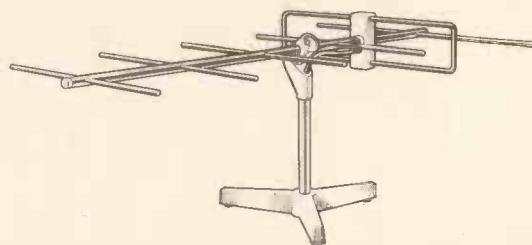

Typical set top aerials; a miniature Yagi on the left and a Bi-Square on the right. These are only suitable for use in areas very close to the transmitter and are of little use for picking up stations some distance away; however they give good results in areas of high signal strength. (Photos courtesy of Antiference)

YAGI AERIALS

Ninety-five percent of the UHF aerials on our roofs are some version of the Yagi. It consists of a resonant loop to which the cable is connected and a slightly larger rod or mesh reflector behind it, with from about 2 to 16 director rods in front, i.e. in the transmitter direction. The gain increases with the number of rods. So does the narrowness of the pick up loop on the polar diagram. Thus we choose a bigger aerial to combat either weak signal or interference.

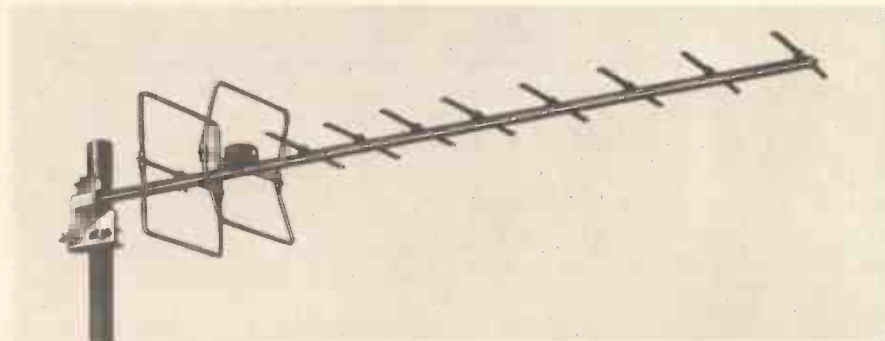

The commonest type of aerial: the Yagi. The one shown is a ten element version though these are available in a wide variety of types. (Photo courtesy of J-Beam)

MULTIDIRECTOR YAGIS

In Europe there are very many overlap areas, often from an adjacent country, and very high gain and directional aerials were developed in which two or more normal Yagis were effectively coalesced into one. These are, in practice, in the U.K., normally a reflector and a receiving loop (dipole) with several sets of director rods in front, carefully placed for maximum efficiency. The version shown has the directors in two planes, while a rival equivalent has the directors all in one plane. There are good arguments for both.

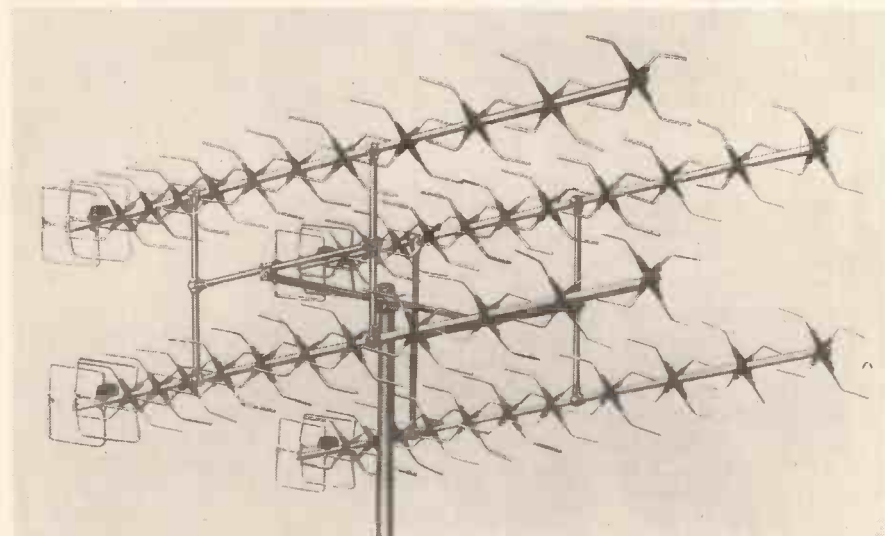

LOG PERIODIC AERIALS

A more recent development is the log periodic aerial; it looks like a Yagi but has two booms rather than one. While the loop dipole is the only active part of the Yagi, all the rods on the log periodic are connected to the cable and contribute to the signal. This aerial has two very remarkable properties. Firstly it can cover much more of the spectrum than a similar sized Yagi (i.e. has a greater bandwidth). One version will work equally over the whole of the UHF bands, whereas Yagis have to be divided up into several groups as explained below. It is however at the expense of lower gain. Secondly, the polar diagram is ex-

The J-Beam Model 4MBM46 (above), a bank of four multi-element, multi-directional aerials designed for long distance reception. On the right is shown the Antiference Troubleshooter TS21 log-periodic aerial.

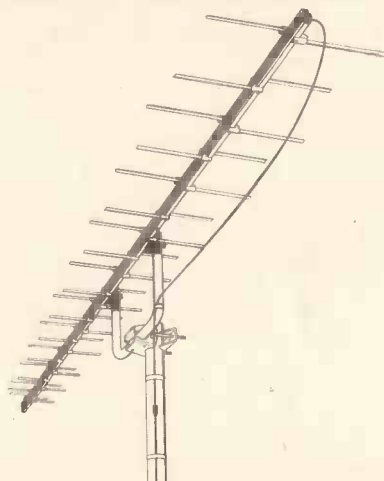

GET A 4th TV CHANNEL NOW

tremely good and there is almost negligible side and rear pick up of stray signals such as "ghosts". One commercial manufacturer calls his range of log periodic aerials "Troubleshooters" and this is a very apt name. This type is used where ghosts and unwanted signals make an ordinary aerial unsatisfactory. They are also made as set top aerials with considerable success in good signal areas. Some versions are slightly different in appearance from the one shown. There is an angle of $10-20^\circ$ between the two booms.

CONNECTING CABLES

A coaxial cable is used to give the correct electrical matching from the aerial to the input of the set. For British television we use a cable with an impedance of about 75 ohms. The cable has to be a low loss sort because, unfortunately, the transfer of the signal along the cable is not perfect and we try to minimise the losses as much as possible. The low loss cable we usually employ for UHF consists of a single thick strand of copper wire inside a plastic sleeving which is large enough to leave some air space between the copper and the sleeve. Outside the insulator is a plaited copper braid outer conductor. Outermost is a tough pvc sleeving. The diameter of the cable is usually about 5/16in. It costs about 10p/yard and can, in long runs, out-cost the aerial itself.

We try to keep the run of cable to a minimum because, even the low loss types do severely attenuate UHF. The manufacturer's specification for one of these cables shows that if we take 100 ft. and pass a signal down it, only 37% of the signal will get to the set at 900 MHz, i.e. at the top of Band V.

The types of cable for VHF are worse than useless at UHF. While at 100 MHz about 56% gets through a 100 feet length, only 14% would reach the set at 1000 MHz. This gives us the golden rule for good UHF reception - never use cheap cable, the only worthwhile type in bands IV and V is an air spaced low loss down lead.

WHICH AERIAL DO WE WANT AND HOW DO WE MOUNT IT?

The UHF bands are divided into 44 channels. Numbers 21 to 34 are in Band IV and, after a gap (35 to 38 inclusive are not available for TV in the U.K.) the remainder 39 to 68 are in Band V. One aerial for all these channels would have to have a flat



The J-Beam Model LBM2, a log periodic aerial

response (bandwidth) of from 470 to 860 MHz. This is a tall order for conventional aerials. (The widely used Yagi, for instance, can cover evenly a band of about 100-150 MHz while still having a high gain. A log periodic aerial can cover the whole of the UHF band easily but at the penalty of a much lower gain.) In practice, each station is allocated 4 channels, usually very close to one another in a suitable part of the band. For example, Rowridge for Southern England has 21, 24, 27 and 31. The first is the spare and the others are, respectively, BBC-2, ITV and BBC-1. The group 21-34 is just the right size to allow aerials to be designed to cover all these channels evenly. This is known as Group A. So, for Rowridge we use a Group A aerial and, as it is a main station, we mount it with its rods horizontal. The Brighton area is only poorly served from Rowridge and a local fill-in station is used. It is designed to cover a limited area within 5-10 miles of the transmitter. Its channels are 53, 57, 60 and 63. This means that we cannot use the same aerial as the main station. So we use one that will cover channels 51 to 66 (Group C), and, being a fill-in station, it has vertical rods.

Other groups of channels are B, 39 to 51, D 49 to 68 (usually combined with C as C/D) and an awkward one, E covering 39 to 68. This latter group requires slightly different design from the others. An example of a station using E is Hannington near Basingstoke, 39, 42, 45 and 66 (at present unused).

The number of rods in the aerial will depend on the local signal strength, so, in general, the further we are from the transmitter, the more rods we are likely to need. Table 1 gives a general guide to the type of aerial that may be needed in any particular place.

Once we know the group and whether it should be horizontal or vertical and how many elements it must have, we have to site the aerial in a suitable position to get a good signal. This should normally be outside and as high as possible. The alignment and location should be done with extreme care because the UHF signal can be unpredictable in its behaviour. In extreme

cases it can lead to one house having no usable signal, while the neighbour is getting perfect colour reception. Moving the aerial a few feet often solves this problem. The largest number of complaints of poor results can be put down to poor aerial choice or installation. Especially on colour a poor input from the aerial to the set can spoil the picture. (If you think you are getting poor results, look at your aerial and those of your neighbours and see which way they are pointing. The complaints come very often from people whose aerials are out of line with the others).

The national networks are planned on the basis of outside aerials of good quality mounted at 25-30ft above surrounding ground, i.e. normally on the roof. Neither BBC nor ITA recommend set top or loft aerials for UHF because of the attenuating effects of building materials. However, many people get perfectly adequate results using them, provided their signal strength is strong in the first place. This brings us to what governs the signal strength reading a set.

HOW MUCH SIGNAL HAVE WE AT OUR AERIAL?

First of all, the signal reaching a receiving aerial is inversely proportional to the square of the distance from the transmitter. This means that one 20 miles away receives only one quarter of that from a similar aerial at 10 miles. Secondly it depends on the heights of both transmitting and receiving aerials - so the higher the receiving antenna (as the Americans call them) the better. Thirdly, it does depend on frequency, but this can be taken care of by the aerial as we shall see below. The fourth main factor is transmitter power. The signal is proportional to only the square root of power and, hence, doubling the output only sends the received signal up to 40%.

Having decided what governs the field strength in which our aerial is placed, we need to collect as much as that voltage as possible and send it to the set. For this we need an efficient aerial

mounted correctly, rods vertical for local stations and horizontal for main ones and cut to the right channel group for the area. In general, the further we go from the transmitter the more aerial rods we need to compensate. Similarly, for the top channels we usually use aerials with many more rods than we would for the low channels, this time to compensate for the fall off with frequency. Normally all we need is as short as possible a length of low loss coaxial cable to take the signal to the set. The cable is a special low loss version for UHF because as explained above, the old sort used for VHF swallows up the signal and is often the cause of unexpectedly poor results. If, after we have done the best we can, the signal is still poor, then we may improve matters with a preamplifier (see next month's ETI)

OVERLAP AREAS

From the above it is fairly clear that to get complete national coverage on UHF demands a very large number of transmitting stations to overcome all the effects of hills and man-made obstructions. This has a side effect in that many places will get a more than sufficient signal from 2 or more stations making a choice possible. In making that choice we must remember that in certain peak conditions (often high pressure areas will cause them) long distance transmission can occur with resulting interference. In general the troubles get worse with increasing distance from your transmitter, so a rule of thumb suggests that most consistent results will come from your nearest transmitter, provided there are no hills in the way. (In some cases, due to the presence of hills in one direction a more distant station will be the better).

Of course, the TV aerial installation team usually has a pretty good idea where to point your aerial for best results and it is best to rely on their judgement.

All this is of only academic interest in most places because usually the rival transmitter will be putting out the same programme. However, on the borders of the IBA regions there are overlaps or - to use their term - "supplementary service areas", where the choice of stations is a real one. In general BBC-1 has some regional variations every day but ITV has a much larger difference from one programme company to its neighbour. BBC-2 does not change with region.

HOW CAN WE PICK UP OUR NEIGHBOURS ITV?

What rules tell us whether we have a fourth or even fifth programme channel available? We normally need a second

aerial located and lined up with care, probably higher above the ground than the local one. It will almost certainly be of a different channel group and will probably have its rods horizontal as the local stations generally have very little overlap. The second aerial will have a second cable and a change over switch (rotary ceramic is best) will be needed, unless we just plug over as required. On the set, if it has continuous dial tuning, this can be operated like the controls tuning a radio. If there are push buttons, the spare can be tuned to the extra ITV. (It is rarely worth going for an adjacent BBC-1 as programme variations are few).

In some good signal strength areas adequate but, rarely good, results are obtained using the normal aerial. These are uncommon, but are the simplest case of all. At the other extreme, even with a good aerial the signal may be too low to give a good picture. Sometimes this can be got over by the use of a preamplifier. This is a one or more stage transistor amplifier which effectively increases the signal entering the set. It is mounted in most cases on the back of the television, between the cable and the aerial socket. However less noise, or "grain", is seen when the amplifier is mounted at the top of the mast by the aerial itself or in between. The reason is that we get best results by amplifying the largest available signal. If the signal has already been cut down a lot by cable losses we tend to amplify noise as well as the information that we want. In addition the true signal is much closer to the noise level of the electronics and the amplifier cannot easily discriminate between the two. The overall results is a much grainier picture.

Nevertheless, a preamplifier at the bottom of the cable has the advantage of accessibility and is not liable to the ravages of weather. Quite often enough extra gain is obtained by using one by the set, but in fringe reception the extra cost and effort for mast mounting pays off in the end product - the quality of the picture.

There are a large number of commercial amplifiers available, most of which give a considerable improvement in the picture. Their costs range from about £3-10 depending on whether they are mains or battery powered and set or mast-head mounted.

WHERE ARE THE OVERLAP REGIONS?

Regions usually extend to natural boundaries and quite often these are hills or mountains. An example is where the Chilterns act as a natural break between Midlands ITV from Oxford and London ITV from Crystal Palace. (Those actually in the Chilterns will have to put



A number of companies specialise in high gain aerials; the one shown here is the Zodiac 30 from R. Smith Aerials of Luton. On Group A this gives more than 20dB gain.

up with poor reception until the promised new chain of boosters is completed in two to three years). Another example is the Pennine ridge dividing the Yorkshire and Granada regions very efficiently. In both these cases the overlap is slight, but, in complete contrast, much of the Thames Valley area such as Maidenhead, while officially served by London, get first rate results from Southern TV at Hannington.

Generally speaking quite good results may be found up to 15-20 miles beyond the official station boundaries, but the actual areas which benefit are very dependant on local geography. As another example, Peterborough, officially in the Anglia "camp" from Sandy Heath, Belmont and possibly, Tacolneston at lower strength, is very much in the service area of the Midlands. Waltham station. Viewers here would use group A aerials for Sandy or Belmont, but group C for Waltham. A little further north parts of Lincolnshire can receive Belmont, Waltham and Emley Moor which adds Yorkshire as a third ITV choice. The map shows some of the areas in the U.K. where overlap between regions gives the possibility of additional ITV choices. If you think you may be lucky, then enquire from your local dealer who will have a fair idea of what can be received in your area. The official overlap areas are well defined, but the purpose of this article has been to show that many more people than one would expect to live in favourable locations for exploiting a fourth TV channel now. (Your author lives in a part of London officially covered from Crystal Palace only. With a high outside aerial usable results are likely from Southern, Anglia and, possibly, Midlands stations in addition to London).

Next month, as a continuation of this article, we shall describe a UHF preamplifier that you can build yourself and also give details of some of the less expensive commercial models available.

BI-PRE-PAK

SUPPLIERS OF SEMICONDUCTORS TO THE WORLD



COMPLETE TELEPHONES
NORMAL HOUSEHOLD TYPE
AS SUPPLIED TO THE POST OFFICE
EX. G.P.O.
ONLY 95p

P & P 35P EACH



TELEPHONE DIALS
Standard Post Office type
Guaranteed in working order
ONLY 25p

P. & P. 15p EACH

TESTED AND GUARANTEED PAKS

B78	4	IN4007 Sil. Rec. diodes, 1,000 PIV lamp plastic	50p
B81	10	Reed Switches. Reed Relay inserts 1 1/2" long	50p
B88	200	Mixed Capacitors. Approx. quantity, counted by weight	50p
H4	250	Mixed Resistors. Approx. quantity, counted by weight	50p
H7	40	Wirewound Resistors. Mixed types and values	50p
H40	20	BFY50/2, 2N696, 2N1613 NPN Silicon uncoded TO-5	50p
H9	2	OCP71 Light Sensitive Photo Transistor	50p
H39	10	Integrated circuits. 6 Gates BMC 962, 4 Flip Flops BMC 945	50p
H30	20	1 Watt Zener Diodes. Mixed Voltages 6.8-43V.	50p
H35	100	Mixed Diodes. Germ. Gold bonded etc. Marked and Unmarked.	50p
H28	20	OC200/1/2/3 PNP Silicon uncoded TO 5 can	50p
H38	30	Short lead Transistors. NPN Silicon Planar types.	50p
H41	2	Complimentary Power Transistors. BD131/BD132	50p

UNMARKED UNTESTED PAKS

B58	150	Germanium Diodes Min. glass type	50p
B63	200	Trans. manufacturers' rejects all types NPN, PNP, Sil. and Germ.	50p
B64	100	Silicon Diodes DO-7 glass equiv. to OA200, OA202	50p
B66	100	Sil. Diodes sub. min. IN914 and IN916 types	50p
B68	50	Sil. Trans. NPN, PNP equiv. to OC200/1 2N708A, BSY95A, etc.	50p
B1	50	Germanium Transistors PNP, AF, and RF.	50p
H8	40	250mW Zener Diodes DO-7 Min. Glass Type	50p
H34	15	Power Transistors. PNP, Germ. NPN Silicon TO-3 Can. P & P 5p extra.	50p
H17	20	3 Amp. Silicon Stud Rectifiers. Mixed volta	50p
H15	30	Top Hat Silicon Rectifiers. 750mA Mixed volta	50p
H18	15	Experimenters' Pak of Integrated Circuits. Data supplied	50p
H26	40	NPN Sil. Planar Trans. 2N3707-11 range. Low noise amp	50p

MAKE A REV COUNTER FOR YOUR CAR

The 'TACHO BLOCK'. This encapsulated block will turn any 0-1mA meter into a linear and accurate rev. counter for any car with normal coil ignition system.

£1 each



OVER 1,000,000 TRANSISTORS IN STOCK

We hold a very large range of fully marked, tested and guaranteed Transistors, Power Transistors, Diodes and Rectifiers at very competitive prices. Please send for Free Catalogue.

600,000 SILICON PLANAR PLASTIC TRANSISTORS. UNMARKED, UNTESTED, FACTORY CLEARANCE. A RANDOM SAMPLING SHOWED THESE TO BE OF REMARKABLY HIGH QUALITY.

AUDIO PNP, similar to ZTX500, 2N3702/3 BCY70 etc.
AUDIO NPN, similar to ZTX300, 2N3708/9 BC107/8/9, BC168/9 etc.
PLEASE STATE "AUDIO PNP" OR "AUDIO NPN" WHEN ORDERING
ALL TYPES:— 500 for £3.00
1,000 for £5.00
10,000 for £40.00
P&P 10p per 1,000

OUR VERY POPULAR 3p TRANSISTORS FULLY TESTED & GUARANTEED

TYPE "A" PNP Silicon alloy. TO-5 can.
TYPE "B" PNP Silicon. plastic encapsulation.
TYPE "E" PNP Germanium AF or RF.
TYPE "F" NPN Silicon plastic encapsulation.
TYPE "G" NPN Silicon, similar ZTX300 range.
TYPE "H" PNP Silicon similar ZTX500 range.

8 RELAYS FOR VARIOUS TYPES P. & P. 25p. £1

VALUE ADDED TO YOU On orders of £4 or over. See below:

Please read very carefully:— We will give a discount to customers who send in an order for £4 or over. This discount will be equal to the V.A.T. rate current at this time. If your order does amount to £4 or over, all you need to send is the total cost of goods and postage as stated in this advertisement. No addition for V.A.T. is needed.

V.A.T. for orders under £4:— If the total cost of goods plus postage and packing is less than £4, kindly add 10% (10p in the £) to your remittance. Incorrect amounts will delay your order.

NPN/NPN will be supplied if not otherwise requested.

A CROSS HATCH GENERATOR FOR £3.50

YES, a complete kit of parts including Printed Circuit Board. A four position switch gives X-hatch, Dots, Vertical or Horizontal lines. Integrated Circuit design for easy construction and reliability. This is a project in the September edition of Practical Television.

This complete kit of parts costs £3.50, post paid.

A MUST for Colour T.V. Alignment.

Our famous P1 Pak is still leading in value for money.

Full of Short Lead Semiconductors & Electronic Components, approx. 170. We guarantee at least 30 really high quality factory marked Transistors PNP & NPN, and a host of Diodes & Rectifiers mounted on Printed Circuit Panels. Identification Chart supplied to give some information on the Transistors.

Please ask for Pak **P.1.** Only **50p**
10p P & P on this Pak.

FREE CATALOGUE

for TRANSISTORS, RECTIFIERS, DIODES, INTEGRATED CIRCUITS AND FULL PRE-PAK LISTS



100,000 Plastic Power Transistors in stock, more on way!

NOW IN TWO RANGES

These are 40W and 90W Silicon Plastic Power Transistors of the very latest design, available in NPN or PNP at the most shatteringly low prices of all time. We have been selling these successfully in quantity to all parts of the world and we are proud to offer them under our Tested and Guaranteed terms.

Range 1. VCE.	Min 15.	HFE.	Min 15.
	1-12	13-25	26-50
40 Watt	20p	18p	16p
90 Watt	24p	22p	20p

Range 2. VCE.	Min 40.	HFE.	Min 40.
	1-12	13-25	26-50
40 Watt	20p	28p	26p
90 Watt	35p	33p	30p

Complementary pairs matched for gain at 3 amps, 10p extra per pair. Please state NPN or PNP on order.

INTEGRATED CIRCUITS

We stock a large range of I.Cs at very competitive prices (from 10p each). These are all listed in our FREE Catalogue, see coupon below.

METRICATION CHARTS now available. This fantastically detailed conversion calculator carries thousands of classified references between metric and British (and U.S.A.) measurements of length, area, volume, liquid measure, weights, etc. Wall Chart 18p. Pocket Size 15p.

LOW COST QUAL IN LINE I.C. SOCKETS

14 pin type at 15p each } Now new low profile type.
16 pin type at 16p each }

BOOKS

We have a large selection of Reference and Technical Books in stock.

These are just two of our popular lines:

B.P.1. Transistors Equivalents and Substitutes 40p, this includes many thousands of British, U.S.A., European and C.V. equivalents.

The Illiffe Radio Valve and Transistor Data Book, 9th Edition 75p. Post & Packing 21p extra. Characteristics of 3,000 valves and tubes, 4,500 Transistors, Diodes, Rectifiers and Integrated Circuits. Send for lists of these English publications.

BUMPER BUNDLES

These parcels contain all types of surplus electronic components, printed panels, switches, potentiometers, transistors and diodes, etc.

2 LBS IN WEIGHT FOR £1
Post and packing 25p.

Please send me the FREE BI-Pre-Pak Catalogue.

NAME

ADDRESS

MINIMUM ORDER 50p CASH WITH ORDER PLEASE. Add 10p post and packing per order. OVERSEAS ADD EXTRA FOR POSTAGE.

BI-PRE-PAK LTD

DEPT. H, 222-224 WEST ROAD, WESTCLIFF-ON-SEA, ESSEX
TELEPHONE: SOUTHEND (0702) 46344

ELECTRICITY FROM WINDMILLS

(Continued on page 61)

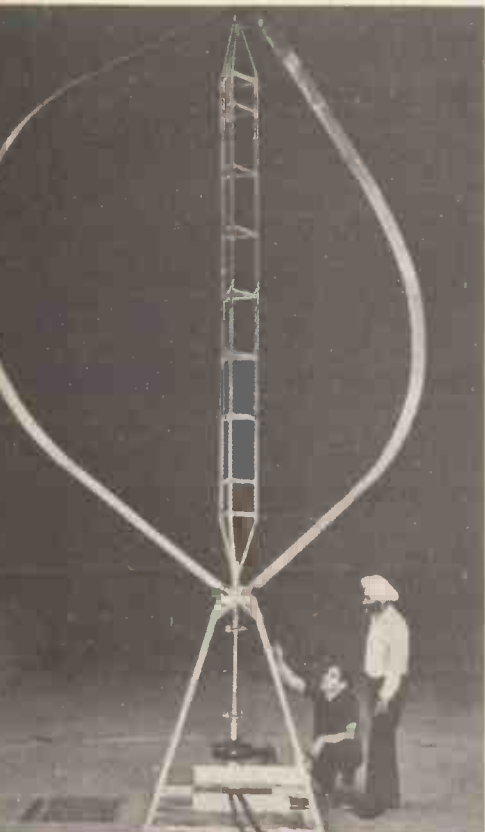

Raj Rahji and Peter South of Canada's National Research Council have developed a wind turbine that rotates around a vertical axis. This avoids gears and shafting. The hope is to provide heating and lighting for Arctic homes.

WITH the world's developed nations becoming more and more worried about diminishing supplies of fossil fuels, engineers in several countries are trying to improve the efficiency of wind-driven power generation, mainly with the aim of providing limited amounts of electricity to isolated settlements and unattended military and scientific outposts, but also with one eye on large-scale power production in the future.

At the Electrical Research Association's Environmental Sciences Research Unit at Cranfield, in Bedfordshire, interest in wind power has been strongly reawakened since arrangements began to be made for the Stockholm Conference on the Human Environment. Ian Harris, in charge of the unit, is already looking at four proposals put to ERA within the past

"The answer my friends is blowing in the wind" – Bob Dylan

two years to design and build wind turbines of varying sizes.

In the developed countries, interest in wind-power last blossomed in and shortly after World War II, with the biggest machine being built by the Americans. Capable of generating 1250 kilowatts of electricity, the project was abandoned after 1000 hours of operation because the blades of the windmill began to crack up. Similar (but generally less spectacular) mechanical misfortunes befell most other wind turbines developed at this time.

Now engineers believe that our knowledge has improved sufficiently to avoid such failures and still squeeze a high amount of energy out of gusts of wind.

The power output of a windmill depends on the wind velocity and the area of blade presented to the wind. In order to maintain continuity of momentum, the maximum amount of energy that can be extracted from the system is just under 60% of the energy flow in the wind. Conventional windmills lose efficiency because their sails can never present an optimum amount of blade area to the wind and because their power generation usually involves some form of mechanical energy transmission by gears and cogs. If X is the maximum that can be extracted from the system, conventional windmills have an efficiency rarely above 15 per cent of X.

The best of more recent designs of windmill, however, can achieve as much as 35 per cent of X. ERA, which has 25 years experience testing other people's wind turbine designs (and some of its own) emphasises that wind turbines have to be built to suit the conditions in which they are to be used. It is of little use to install a windmill designed to give its full rated output in 15 mph winds in an area where the wind speed rarely rises above 10 mph.

Ian Harris explains that almost any cost range is possible with wind turbines, depending mainly on the



8 kw Allgaier experimental windmill built to supply an isolated croft in the Cairngorms, Scotland.

efficiency required: A straight-bladed turbine is simple (and hence cheap) to make, but an aerodynamically more efficient blade has to be twisted along its length and requires considerably more manufacturing skill. At present ERA is looking at three sizes of turbine, all in the low power range and generally suitable for underdeveloped countries. The smallest, capable of producing 250 watts, is intended mainly for charging batteries for telecommunications uses and is ideal for, say, powering a radio telephone in the bush. The intermediate machines, with an output of 500 to 1000 watts, is just large enough to provide lighting. Harris expects this size of wind turbine to sell well in isolated areas in developed countries, where mains electricity supplies have passed small hamlets by and are unlikely to call again.

The largest wind turbine under consideration at ERA will provide an output of 10 to 20 kilowatts – adequate for most household needs, including lighting, heating and driving power-tools. This kind of system can include an arrangement to give pre-selected priorities to certain tasks as power becomes available.

Because the wind does not blow all the time, all of these machines need some form of power storage. For the low-power generating turbine, batteries are adequate. Not lead-acid batteries, explains Harris, because they are not well suited to intermittent duty. The battery should preferably be an alkali cell of some type – perhaps nickel-cadmium, which the National Research Council of Canada favours for the wind turbines it is developing for use in the far North.

Transducers in measurement and control

PART 13

In this article, Dr. Sydenham continues his description of methods used to assess pollution.

POLLUTION of water and air occurs in distinctive groups each requiring different measurement approaches. These groups are unwanted chemicals, particulate matter and radioactivity.

CHROMATOGRAPHY

In the analytical methods described last month, the various chemical constituents of a gas or liquid were identified by separating each, either directly (as in the mass spectrometer), or indirectly, (using the spectrum of radiation). They were then sensed at the different spatial locations.

Chromatography is another procedure by which the chemicals are initially separated in some way so that each may be identified. When a sample mixture, such as a gas or liquid, is passed through, or over, surfaces of another material of different chemical phase (for example, as gas passing over a solid) the transmission times of the individual components of the sample are selectively delayed. They emerge through the column (of different phase material) in a specific time sequence.

In gas chromatography the gas to be analysed is either percolated through a porous solid column (charcoal, silica gel are used) or over a large-area liquid film. The former is known as a gas-solid chromatography, GSC for short, the latter GLC. Other methods used include liquid-solid and liquid-liquid systems. Here, only gas chromatography will be discussed as this illustrates the general principles.

Chromatography had its origins in the mid 19th century. It really became established around 1905 when Ramsey devised a method to separate gases and vapour mixtures, and Tswett used the principle to extract chlorophyll from plant pigments. The latter biochemist coined the name now used because of the coloured bands he obtained down a vertical calcium carbonate column. Chromatography is formed from the Greek words for colour and write. To prevent possible confusion it must be made clear that colour is rarely a parameter in modern chromatography.

The basic essentials of a gas chromatograph (established by James and Martin in 1952) are shown in Fig. 1. An inert carrier gas passes through the separation column to a detector cell. The unknown gas sample is injected into the inert gas carrier flow prior to its entry into the column. The various constituents of the gas arrive at the detector at different times, producing peaks on the recorder chart as the paper moves with time. The sharpness of the peaks, their amplitude and relative time positions identify the sample. It is essential to hold the gas and column at a steady temperature; commercial units enclose the critical areas in a temperature-controlled oven held to 0.1°C limits. Higher than ambient temperatures also enable liquids to be vaporized and treated as gases.

Some components are strongly retained by the column, emerging only after a considerable duration. To speed up the process the temperature is often raised in sequences to follow a preset programme.

Detection sensitivity depends upon the detector used to monitor the emerging gases; it ranges from parts per thousand to parts per billion. To quote a Varian example, one form of detector can sense certain chemicals down to a molecule of sample in every 10^{10} molecules of carrier gas. Such sensitivity has enabled the method to be used in the analysis of odours in foodstuffs. Units are moderately expensive, the one shown in Fig. 2 costs around \$4,000, but less versatile,

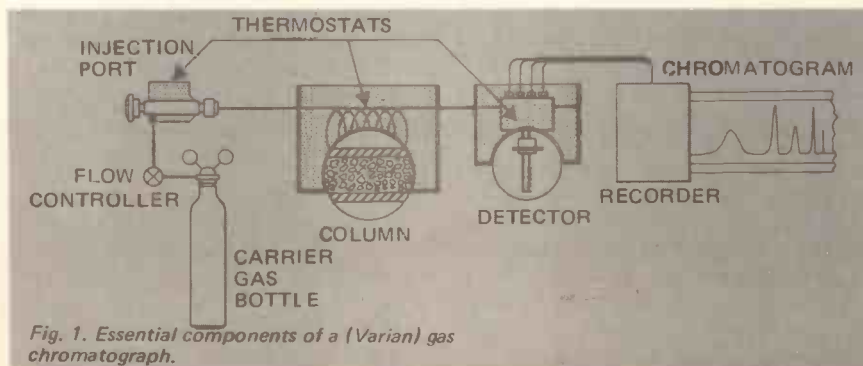

Fig. 1. Essential components of a (Varian) gas chromatograph.

cheaper, units are available.

Detectors in use are varied and numerous, the main two being the ionization detector and the thermal conductivity cell.

FLAME IONIZATION DETECTOR

When a carrier gas of hydrogen is burned it produces a colourless flame. Organic compounds cause it to burn yellow with a height and luminosity proportional to the amount of hydrocarbons present. Flames produce ionized gases in such cases and this effect is used to obtain a more accurate measure of the arrival events out of the column preceding the detector. These cells are called flame ionization detectors (FID). For reasons not fully understood, organic compounds ionize in a flame, and suitably placed electrodes (Fig. 3), detect the minute current flowing. High input impedance amplifiers are needed because the flame resistance is around 10^{12} ohms. Advantages of the FID are that it does not detect water vapour or air, is simple and has a wide response range. These characteristics make it particularly suited for pollution measurements of water and air.

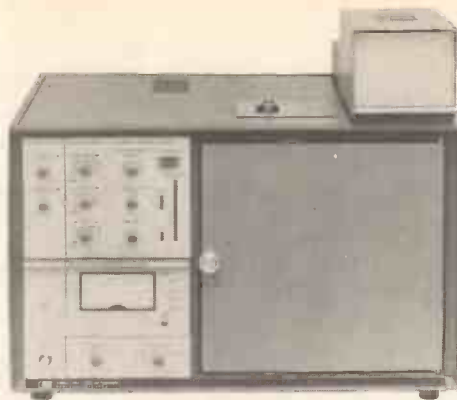

Fig. 2. Gas chromatograph marketed by Hewlett-Packard (series 5700)

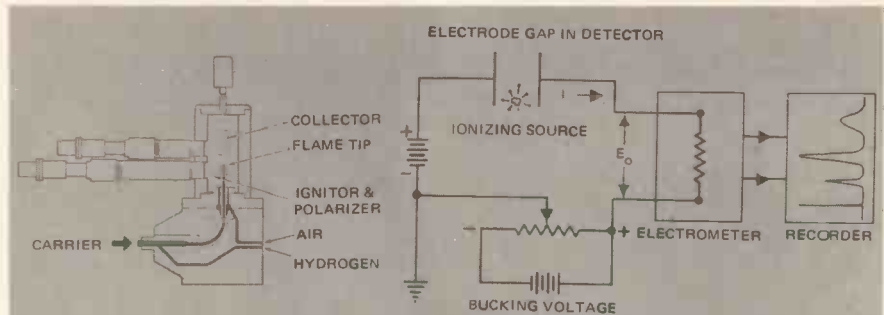

Fig. 3. Cross-section of Varian flame ionization detector and typical electronic circuit used to detect the ionization.

THERMAL CONDUCTIVITY CELL

This detector, introduced by Claesson in 1946, is also commonly employed in chromatographs. It operates by measuring the thermal conductivity of the gas. A heated filament, suspended in the flow, will vary in temperature as the heat is conducted away by the changing conductivity gases emerging from the column, thus changing its resistance. (Very similar in operation to the hot-wire anemometers used to measure flow rates). These are also called katharometers or simply TC units. A schematic of a TC cell is shown in Fig. 4 together with the layout of a typical electrical arrangement. Note that the reference gas passing into the column before injection of the sample is fed across two detector filaments of the bridge and that the outlet gases (carrier plus separated constituent) pass over the other two. This technique makes best use of the properties of a bridge circuit to eliminate unwanted common signal effects existing in the apparatus.

With thermal conductivity cells the gas flow limits the temperature rise of the filaments. Flow is essential, when the detector is energized, to prevent burnouts. Thermistor sensors are sometimes used instead of the tungsten wires.

Flame ionization and thermal conductivity detectors are the more common types used, but others exist that might be more suited. They

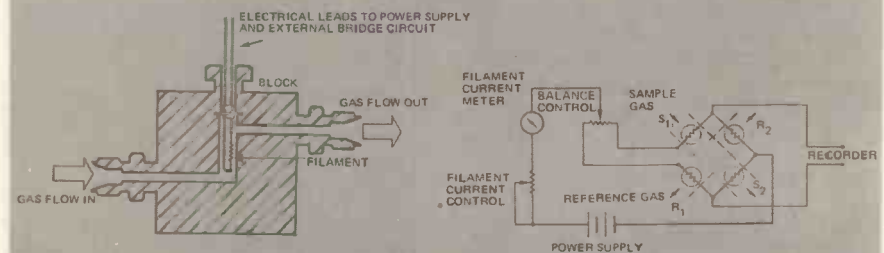

Fig. 4. Schematic diagram of one element of a thermal conductivity detector. The sample gas is made to flow across two resistances, the reference gas across the opposite pair.

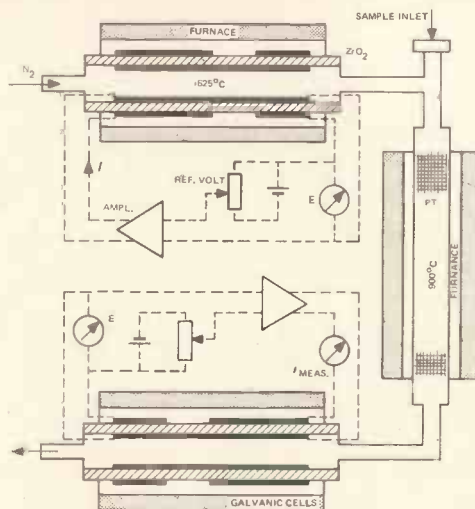

Fig. 5. Layout of a chemical oxygen demand detector using high-temperature galvanic cells.

Transducers in measurement and control

include electron capture cells for detecting alkyl halides, carbonyles, nitrides and nitrates — but not hydrocarbons (useful for pesticides). The helium detector may be used for extremely sensitive analysis of all compounds, provided they are pure enough to begin with; the alkali-flame detector for sensing phosphorous compound (— the newer forms of pesticides that have largely replaced the now unpopular hydrocarbon forms); and the gas-density balance for the analysis of corrosive compounds. Space does not permit descriptions; they are to be found in the listed texts. Where mixture separation is not needed the column can be discarded, passing the gas through the detector only. Several specific analytical instruments operate this way.

The similarity between the amplitude-time recorder plots from a chromatograph and a spectrograph is striking and the use of correlation techniques appears relevant in the

detection process of chromatography (correlation was encountered earlier in the discussion of flow-meters). To date, however, there appears to be little gain when the extra difficulties are accounted for. A study made in 1968 (by Davies) showed that there were two main drawbacks. Firstly, extra gas sample was needed causing the column to operate in a non-linear mode and, secondly, the correlation process was expensive. Since 1968 the latter objection has been lessened by the introduction of commercial units. Even so, a study by Moss and Godfrey in late 1972, concluded that the case is still not strong but might expand in pollution measurements where specific equipments could be marketed thus cutting the cost.

DETECTION OF OXYGEN

Detecting oxygen levels in air, water and industrial processes is a commonly needed measurement. This has led to the development of a number of specific oxygen detectors.

By removing the oxygen (with absorbent columns) from a known volume of gas, and remeasuring the volume, it is possible to determine the oxygen content. This is an old established method but as it does not supply a continuous electrical signal the method has only limited use.

Oxygen analysers exist for use in continuous processes and are mainly of two types; those using electro-chemical principles and those making use of the magnetic properties of oxygen. In principle, one form of the first is based upon a special cell in which oxygen concentration is controlled by an input voltage.

A schematic diagram of a Philips unit devised to monitor the COD (chemical oxygen demand) of possibly polluted water is given in Fig. 5. The special cell consists of a zirconium oxide tube having porous platinum electrodes attached. When hot (the reason for the oven at 625°C) the tube develops a voltage between the electrodes that is related to the partial pressure of oxygen on each side of the tube. A current passed through the cell wall transports oxygen through the wall. With electronic feedback the oxygen partial pressure of an unknown gas can be compared with a known gas. In the COD measurement two such cells are used. The upper provides a constant concentration (p.p.m.) of oxygen in a nitrogen carrier. This enters, along with a minute sample of water to be tested, a furnace at 900°C which oxidizes and removes all oxygen. The gas then enters a second cell where the oxygen demand is met by the electric-servo oxygen transporter. The difference between this requirement and the original concentration is a

measure of the COD of the liquid. The method can measure COD values ranging from 1 to 5000 mg of oxygen per litre in just two minutes. Such detectors are termed high-temperature galvanic cells, and are specifically sensitive to oxygen, so water and carbon dioxide do not upset the analysis. Combustible pollutants, however, may consume more oxygen in the furnace indicating a false COD value.

The polarographic electro-chemical oxygen method, so called because the rate is controlled by the electrode area, uses oxygen diffusion through a Teflon membrane at ambient temperatures to produce a microampere current between two separated electrodes (26.3μ amps/p.p.m. in theory) — the Mackereth cell has a lead anode inside a silver porous cathode, the two having an electrolyte between them. Polarographic electrodes can be made as small as 2mm in diameter.

The second type of oxygen detector operates on a quite different principle — the paramagnetic properties of the oxygen molecule are used. In the O₂ molecule, two electrons are unpaired providing a strangely paramagnetic condition. Faraday discovered this in 1848, but it was not until the 1940s that an oxygen detector was produced using the principle.

The original magnetic detector used an effect known as magnetic wind. Referring to Fig. 6 the incoming gas containing oxygen, parts to both sides with some entering the cross tube. Because of the intense magnetic field, oxygen in the tube is attracted to one side. The heater raises its temperature reducing the magnetic property of the oxygen thus pumping it out; flow of oxygen results across the entire tube and this is detected by monitoring the resistance of the heater winding. Error can occur if the carrier gas is not constant in purity, for this will alter the heat-loss of the filament. The cross tube should also be horizontal otherwise gravity flow will occur. Hydrocarbons upset the method considerably. It is sometimes called a thermal magnetic analyser. In the more advanced Quincke analyser most of these defects are eliminated — at the expense of requiring a continuous supply of nitrogen.

In 1954, Linus Pauling devised another magnetic method that is less prone to errors caused by hydrocarbons. In his detector, two diamagnetic glass spheres, mounted to form a dumbbell, are suspended on a torsional suspension inside a measuring cell. A non-uniform magnetic field is applied across the cell causing the dumbbell to rotate to an equilibrium position. Changes in oxygen level in

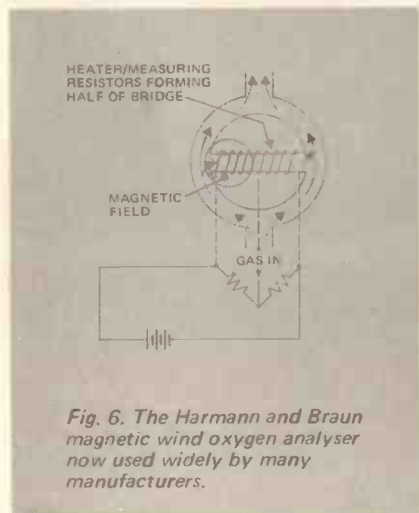

Fig. 6. The Harmann and Braun magnetic wind oxygen analyser now used widely by many manufacturers.

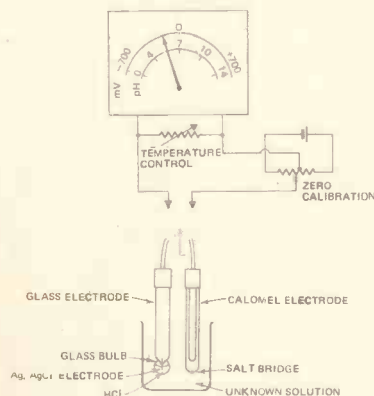

Fig. 7. pH meter using glass and calomel electrodes.

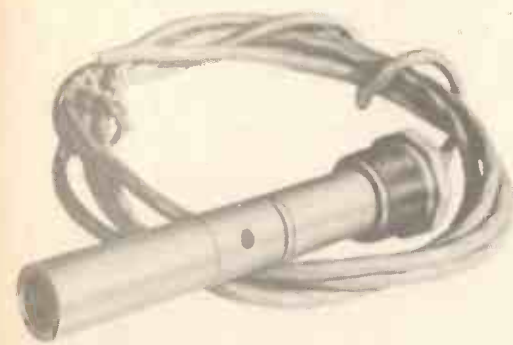
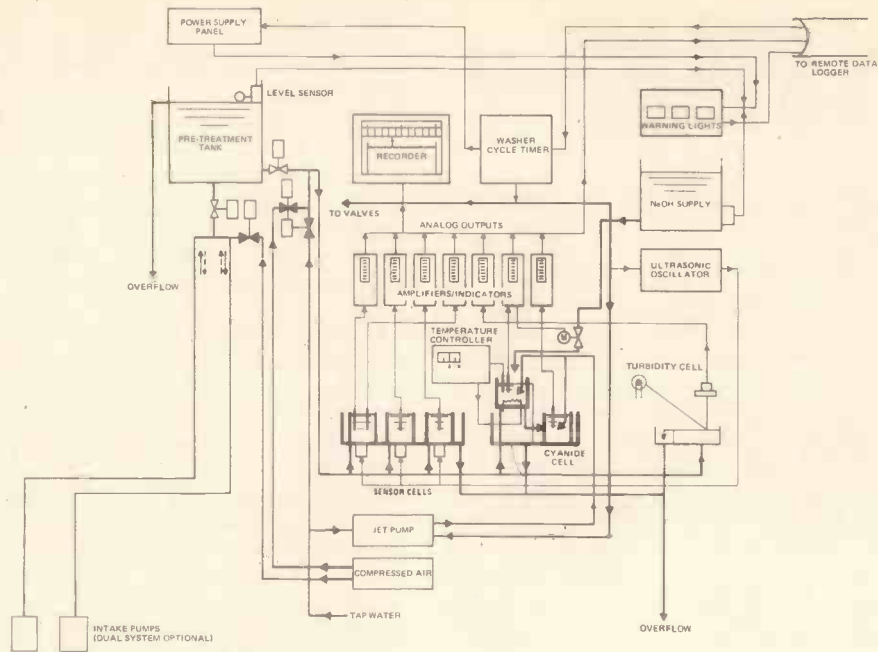

Fig. 8. Conductivity cell by Leeds and Northrup. This immersion design can be used for testing rinse waters.

Fig. 9. Water quality monitoring system (Weather Measure Corp.)



the cell alter the field, causing the beam to rotate. Movement is sensed by a microdisplacement transducer. Suspensions are made of quartz or platinum fibres. More advanced cells of this type use the force-balance technique to restore the beam to a null-position. Many gases are paramagnetic, but oxygen is only approached in magnitude by nitric oxide and nitrogen dioxide; other gases of interest being considerably less paramagnetic.

ELECTROCHEMICAL MEASUREMENTS.

Two plates suspended in a liquid form a primary cell and a voltage occurs between them that depends upon the plate materials used and the liquid composition. This concept can be used in many ways to arrive at the impurity level of the solution. It can be used, firstly, as a battery, measuring the emf with no current flow (potentiometric analysis); as an electrolysis (or coulometric) cell in which current flows consuming energy; or as a resistivity (or conductivity) cell.

In potentiometric analysis, two half cells must always be used, for the voltage of a single plate to liquid half-cell is not meaningful. Quoted electro-potentials are referred against a standard cell to obtain a working calibrate arrangement, the standard hydrogen electrode (SHE) being the arbitrary value assigned for such comparisons. The SHE is not, however, entirely practical and other reference half-cells such as the saturated calomel and silver-silver chloride electrodes are used instead,

having first been calibrated against the SHE. Half-cells are connected to the liquid with salt bridges to enable ions to transfer without diffusion of the electrolytes needed in each half cell.

A common potentiometric measurement is that of pH, the measure of free hydrogen in concentration in a liquid — the degree of acidity or alkalinity. The observed potential of a cell-pair, less that of the reference cell at 25°C, equals 0.05195 times the pH value, the number coming from a simplified form of the Nernst equation explaining the electrochemical process. So called glass and calomel electrodes are used together in pH determinations as shown in Fig. 7. In the calomel electrode a saturated solution of mercurous chloride (calomel) and potassium chloride is placed over a mercury layer electrode. A salt bridge enables the ions to flow. The glass electrode has a silver wire dipping into an hydrochloric solution. This is contained inside a glass bulb that acts as a membrane separating the acid from the sample solution, as well as forming a container. Ions migrate through the glass but as the resistance of the membrane is typically 30 megohm a relatively expensive readout amplifier is needed.

In pH meters, such as that shown diagrammatically in Fig. 7, the electrode pair operate a high input impedance multivolt meter needing a scale of ± 700 mV to cover the 0-14 pH range. Compensation for temperature is essential, for the 0.059 constant is correct only at 25°C. Other electrodes available are the quinhydrone electrode useful in bio-chemical

analysis, the platinum electrode that is non-corrosive, but reads incorrectly in circumstances where chloride ions exist, the mercury electrode suited for chromium potential measurements and bimetallic electrodes made of platinum and palladium or tungsten. Operation of the latter is not completely understood.

In the electrolysis or coulometric analysis, current is made to flow either at a constant value or with a constant applied voltage. Flow is established when the voltage applied exceeds the normal (back emf) cell voltage. For example, a platinum plate and a copper plate in a solution of sulphuric acid has a back emf of 0.87V. Faraday's law states that 96 494 coulombs (a coulomb is an amp per second) of electricity are needed for each equivalent of a chemical reaction. Hence the amount of current consumed enables the substance to be analysed quantitatively. The method is easily automated and is popular for long term analyses.

Conductometry is the third electrochemical method, and, as the name implies, relies on measurement of the specific resistance of the liquid. Cells can be made of glass having platinum electrodes but more modern designs like that shown in Fig. 8 are made of high-impact strength non-corrosive plastics such as polyvinyl dichloride, PVDC, with embedded gold-plated nickel or platinum electrodes. The fluid is either made to flow through the cell or the cell is simply immersed in the sample. Alternating current bridges are usually used, operating at 1-10kHz. Ten MHz units have been marketed under the

Transducers in measurement and control

name Oscillometers. For dc operation, non-polarizing electrodes such as silver/silver chloride might be suitable.

Each electrochemical method can be used to monitor water quality but a number of detector cells are needed if all pollutants of interest are to be monitored. Commercial multi-sensor monitoring consoles exist — Fig. 9 is a block diagram of a versatile unit that will continuously monitor pH, conductivity, dissolved oxygen (DO), turbidity and numerous specific ion concentrations (bromine, chlorine, sodium, cadmium, iodine, cyanide, etc.). Sensing electrodes are automatically cleaned at regular intervals by ultrasonic vibration.

This outline is, by necessity, a brief resume of the chemical analytical instruments used commonly in water and air pollution measurements. Two other powerful analytical techniques, nuclear magnetic resonance (NMR for short) and neutron activation analysis, are applicable but are not used as extensively in routine pollution measurements, being limited by cost or transport factors. They are, nevertheless, worth considering. Details can be obtained in the suggested reading.

PARTICLE MONITORS

The presence of particles suspended in air or water may present a health hazard or impair visibility to such an extent that the air or water is polluted.

Fog, haze, mist, smog, call it what

you may, can be the result of optical dispersion or of suspended particles, ranging in size from smokes with $0.1\mu\text{m}$ diameters to grits of $100\mu\text{m}$. Smoke, airborne bacteria and fine fibres are in the $1\mu\text{m}$ size range, fine dusts from $1\text{-}20\mu\text{m}$ and coarse dusts $20\text{-}80\mu\text{m}$. Devices for measuring the concentration of particles are known as turbidity sensors (in water) or nephelometers (Greek for cloud) in air.

Particles may be permanently suspended by virtue of their small size compared with the molecules of the medium or may be transiently suspended by virtue of an upward velocity, for example, as found in chimney stacks. Coal and oil furnaces are the worst offenders in industrial areas, with cars adding considerably by emitting unburned hydrocarbon particles.

Average particulate concentrations in remote non-urban areas of the United States lie around $10\mu\text{gm}/\text{m}^3$; in urban areas around $100\mu\text{gm}/\text{m}^3$. The heavily polluted areas go as high as $2\text{ mgm}/\text{m}^3$. An accepted safe level of particle precipitation is around $200\text{ mgm}/\text{m}^2/\text{day}$ ($15.4\text{ tons}/\text{mile}^2/\text{month}$). Figures for a medium sized provincial town indicated values of $7\text{-}35\text{ tons}/\text{mile}^2/\text{month}$ indicating that some suburbs were unhealthily polluted in this way. This amount of dust is easy to produce! A 200 MW coal-burning power station operating with only 0.7% dust loss from the chimneys would pour out 20 tons of dust a day. In the 1950s, records for the Pittsburg area in the United States ran as high as $2\text{ gm}/\text{m}^2/\text{day}$ ($170\text{ tons}/\text{mile}^2/\text{month}$).

The cheapest method to monitor

particle fallout rates is to let them fall for a given time onto known size slides or plates which are later examined by counting the particles, using a microscope; or weighing the carrier before and after. Fans or suction are used to increase the yield.

In the airborne bacteria sampler shown in Fig. 10, a culture plate, surfaced with a nutrient solution, is slowly rotated under the dome cover. Air is drawn in by a low-vacuum pump, passing through a slit positioned above the rotating plate. Bacteria come to rest on the plate and a colony begins to grow. After the sample period is complete the plate is removed and incubated. The record obtained of the plates is also shown in Fig. 10. Up to position three the bacteria were freely moving in the air. At three an ultraviolet lamp was turned on — the record shows the diminuation of cultures after the event.

OPTICAL METHODS FOR MEASURING TURBIDITY

The most direct method is to monitor the loss of illumination intensity of an optical beam radiating through the smoke or haze. An installation devised by staff of the CERL (Central Electricity Research Laboratories) in Britain is shown in Fig. 11. Note the Everclean windows that help to overcome signal loss common to viewing windows in such dirty conditions. Air is pumped into the sampling tube at five second intervals to purge the system clean and reset the zero.

Aircraft runways can become clouded and when this happens the pilots desire a measure of the degree of visibility. The Transmissometer is the

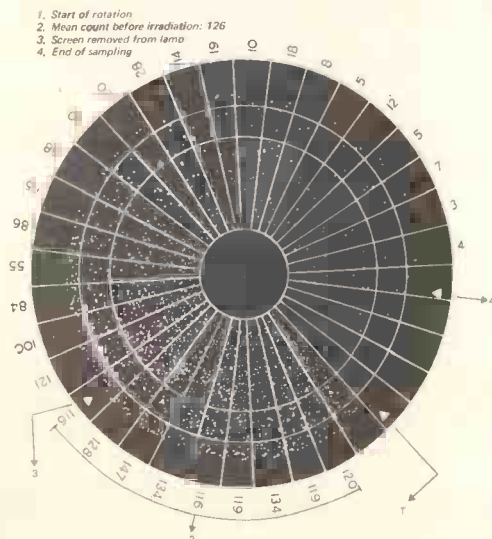

Fig. 10. Casella airborne bacteria sampler MKII and record produced.

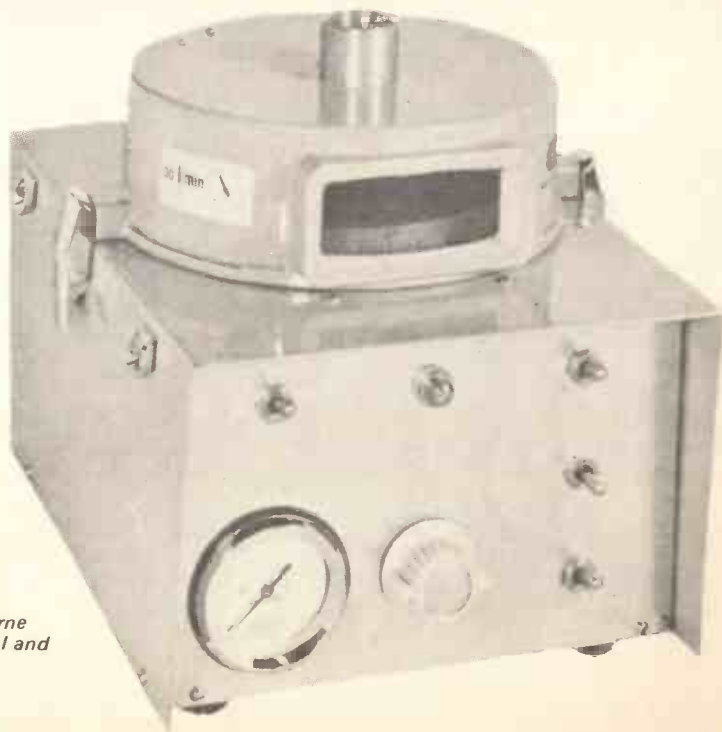
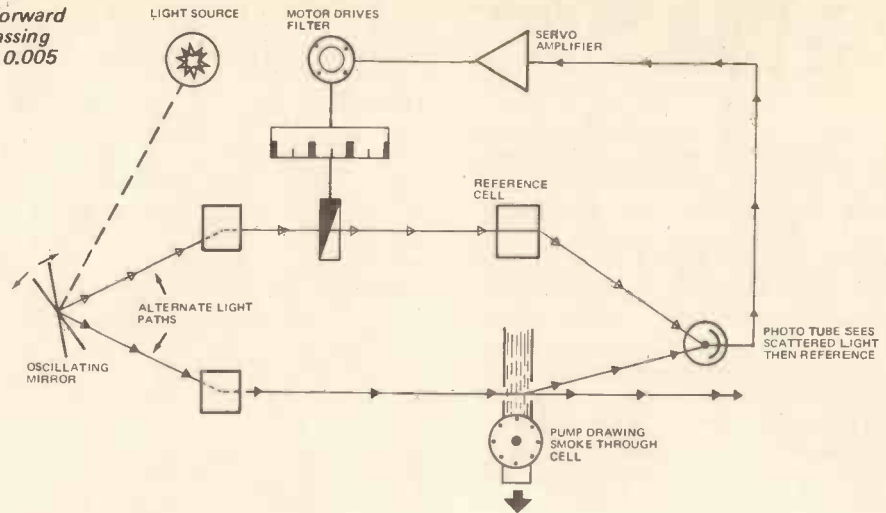

Fig. 12. Sigrist dust monitor operates from the forward scattered stray light produced by a light beam passing a smoke. It can detect concentrations as little as 0.005 mgm/m³.

instrument becoming accepted to perform this task, displacing personnel who make subjective assessments of visibility. In the Transmissometer, a powerful beam of light, often a spark discharge pulse source, is transmitted to a receiver. A telescope gathers the radiation arriving, directing it to a photo-tube or photomultiplier detector. The response of the detector is made to match that of the eye in visual transmission testing. There is an increasing use of this principle on motorways where fog is encountered. Another form of the same concept has the receiver mounted at the detector; back reflected light is used to determine the visible range. Visibility meters can operate over ranges from a hundred metres to 25 km.

In practice, sophistication is needed to eliminate various sources of error. Firstly, it is desirable to modulate the light to overcome the effect of ambient light. Secondly, a portion of the outgoing light is referred back to the incoming to reduce the influence of source intensity variations. Another feature often incorporated, uses the same detector to sense the outgoing and then the returned beam thus eliminating differences in photocell characteristics. The null-balance technique is shown in Fig. 12. The filter wedge attenuator is servo-controlled to obtain a balanced photocell output from each of the two paths as the mirror is rocked from side



to side at 600Hz. The sample cell is compared against a reference until a null is achieved — the position of the optical attenuator is then a measure of turbidity. In some designs light scattered at 90° to the beam is used, for this reduces the errors due to colour or shape of the particles. The turbidity of solutions can be determined in a similar manner, the solution being placed in a test tube that is placed between the transmitter and the detector.

When the particles are large it is the settling rate that is of interest. The CERL dust monitor, as shown in Fig. 13, operates on the principle that the heavy dust will fall out of the flow onto a glass collector plate reducing the transmission. Again, air is used periodically to blast the windows clean.

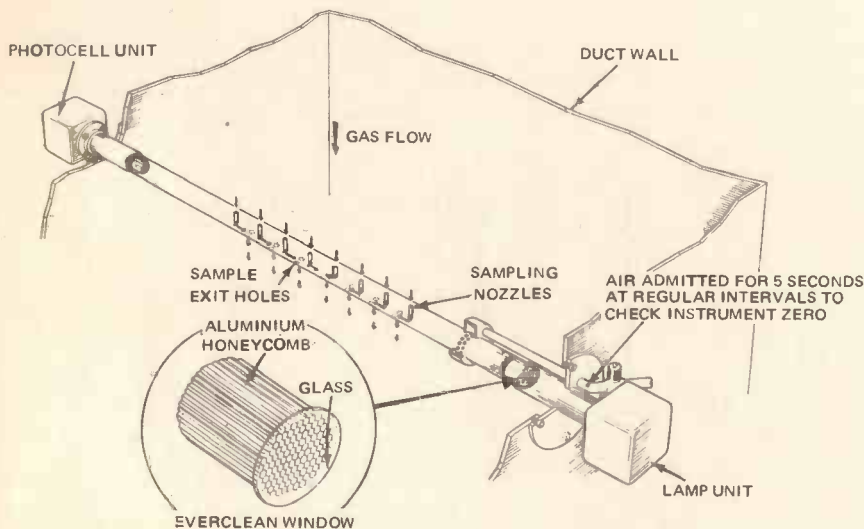

Fig. 11. Smoke density recorder designed at the Central Electricity Research Laboratories CERL in Britain. The patented Everclean windows use a long, thin aluminium honeycomb to prevent the formation of particles on the glass.

PARTICLE COUNTING

An interesting method marketed by Particle Data Inc. makes use of the change in resistance of liquid flowing between electrodes as particles flow in suspension. The particles are first added to a suitable electrolyte that is then drawn steadily through an orifice (with electrodes) that detects resistance changes. The output pulses are amplified and then integrated or distribution analysed into size time charts. Ranges covered go from 0.3µm to 300µm. Flow rate is regulated to reduce coincident occurrences of the particles. As in most nephelometers output is given as a logarithmic scale. Special data processing equipment is available to perform the distribution analysis.

Other non-optical methods include measuring the charge removed from electrodes as the dust passes, and charge carrier rates between electrodes.

When the particles become very large, as in sewage and slurries, they can be detected by capacitance or electromagnetic changes. Certain flow meters (see previously) operating on this principle can yield data on particle size whilst acting as flow sensors.

RADIOACTIVITY

Corpuscular radioactive radiation occurring naturally and synthetically emits packets of energy as alpha, beta and gamma rays. These, and X-rays, lie in the electromagnetic radiation spectrum above 10¹⁷ Hz. Such radiations can be most harmful, especially when it is considered that small doses go undetected only producing symptoms years or generations later. Nuclear radiations have the property of decreasing in radiation strength according to an exponential law. The rate of loss of

Transducers in measurement and control

activity is conveniently described by the time taken to fall to half strength; this is termed the half-life or $T_{1/2}$ and varies enormously from isotope to isotope (the radioactive form of element). For example, of those produced in an atomic reactor, Copper 64 has a half-life of 12.8 hr whilst nickel 59 has a 750,000 years half-life.

The first pollution hazard, therefore, is to be present where radiation leakage is occurring — this is relatively easy to avoid. The second hazard is where long continuous doses are endured at low levels and this is more of a problem. Atomic power stations, ships and nuclear detonations each produce radiation and only the latter is a critically dangerous source of pollution. However, large losses have occurred in power stations, so a constant need for monitoring is vital.

It is hard to believe, but in 1970 it was learned that the U.S. Atomic Energy Commission had in an underground store, some 50.10⁶ gallons of radioactive waste much of which has half-lives measured in hundreds of thousands of years! Some isotopes are particularly dangerous. Strontium-90, for instance, accumulates in our bones encouraging cancer. Nuclear device testing in the early 60s did much to raise the normal background level.

Each radiation presents a different hazard, so the unit of strength is based on the biological effect it produces. This unit is the relative biological effectiveness or rem for short. Normal background levels are around 0.1 rem per annum. Small doses greater than this can cause later-appearing symptoms. Large doses (hundreds of rem) will produce fever and digestive upsets that, if overcome, will lead to tumours and certain death at some stage. It is for these reasons that there is so much opposition to the French nuclear tests in the Pacific.

Alpha particles penetrate the least and are easily shielded or absorbed; Beta rays have the largest range, but gamma are the most penetrating. The relative quantities of each emitted depends upon the isotope.

The simplest detector of radioactivity dosages is the personnel-monitor worn on the lapel. This consists of a piece of photographic film half of which is shielded by a layer of absorber such as lead or aluminium. These cannot be read without processing.

Radioactive particles cause ionization and this is the principle used in the

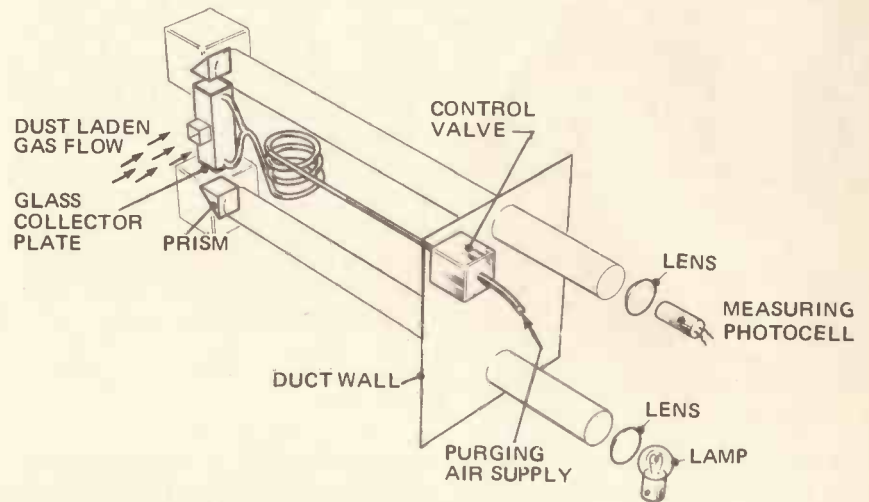

13. Flue dust monitor, developed at CERL and marketed by Kent, uses two horizontal mirrors, the lower collecting dust as it falls.

general purpose ionization detector shown in Fig. 14. Each RA particle entering the chamber ionizes the gas (air, argon, etc.) producing a current pulse that is amplified. The process is random, so a series of noise pulses are counted and averaged over a chosen time-period to be displayed on a meter or used to drive a loud-speaker unit. Certain filling gases have an amplification factor of a million. These, if used, enhance the sensitivity.

The Geiger-Muller tube is of the ionizing type and is typified by a characteristic that provides constant

pulse sizes regardless of particle type. Many variations exist, depending on the shape and the voltage operating, but all are most inefficient using only 1% of the radiation passing through to provide an output signal.

Another disadvantage of ionization cells is that time is essential (0.1-0.5 millisecc) for the anode to become sheathed by charge in readiness for the next particle event.

A superior, but more expensive, method for detecting RA is the scintillometer. Referring to Fig. 15 the incoming particle enters the crystal (of

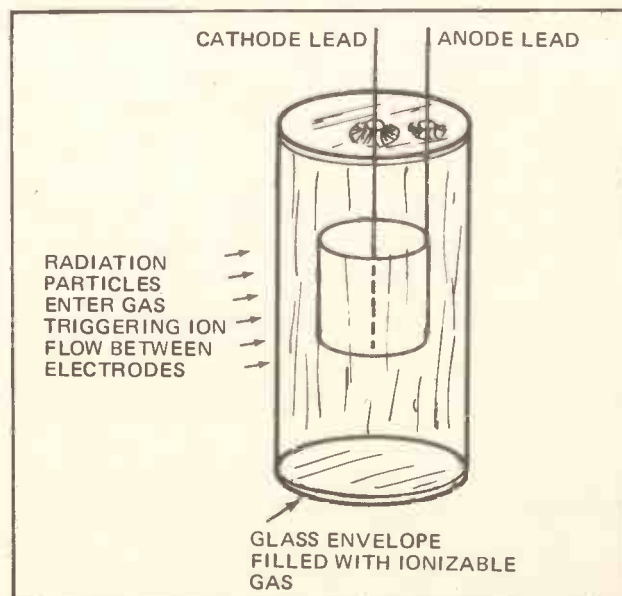

Fig. 14. Simple ionization chamber detects nuclear radiation particles.

Transducers in measurement and control

stilbene or sodium iodide) where it releases photons that scintillate at visible radiation wavelengths. This energy conversion process is reasonably efficient and, furthermore, amplification of light can be had with extremely low-noise addition by the use of a photo multiplier as is shown in the figure. The time delay of scintillometers can be as small as 0.01µsec. so more particles can be detected.

Effective use of these detectors involves the use of pulse processors to discriminate between coincident pulses, to produce averaged rates, and special needs such as pulse height discriminators for the detection of the form of radiation as well as its strength.

FURTHER READING

- "Modern Methods of Chemical Analysis", R. L. Pecsok and L. Donald Shields, Wiley, 1968, London.
- "Basic Gas Chromatography", H. M. McNair and E. J. Bonelli, Varian Aerograph, 1968, California.

- "Practical Manual of Gas Chromatography", J. Tranchant, Elsevier, 1969, Amsterdam.
- "Correlation Techniques Applied to Gas Chromatography", G. C. Moss and K. R. Godfrey, Trans Inst. Meas. Control London, 1972, 5, 351-353.
- "Measurement of Oxygen Content in Gases", F. Tipping, as above, 1970, 3, 145-152.
- "pH Facts - The Glass Electrode; The Industrial Scene", W. Thompson and E. Gill, Kent Technical Review, 1972, 7, 16-22.
- "Variosens - Optronic Instrument for Measurement of Turbidity...", Impulsphysik GmbH, Hamburg.
- "The Transmissometer", G. W. Oddie, Weather, 1968, November.
- "The Continuous Monitoring of Particulate Emissions", D. H. Lucas, W. L. Snowsill and P. A. E. Crosse. Trans Inst. Meas. Control, (London), 1972, 5, 0-21.
- "Neutron Irradiation and Activation Analysis", D. Taylor, Newnes, 1964, London.
- "Radioactivation Analysis", H. J. M. Bowen and D. Gibbons, Oxford, 1963, Oxford.
- "Radioisotope Techniques for Measurement and Control of Industrial Pollution", J. F. Cameron, Trans. Inst. Meas. Control, 1971, 4, 303-307. ●

(Continued from page 53)

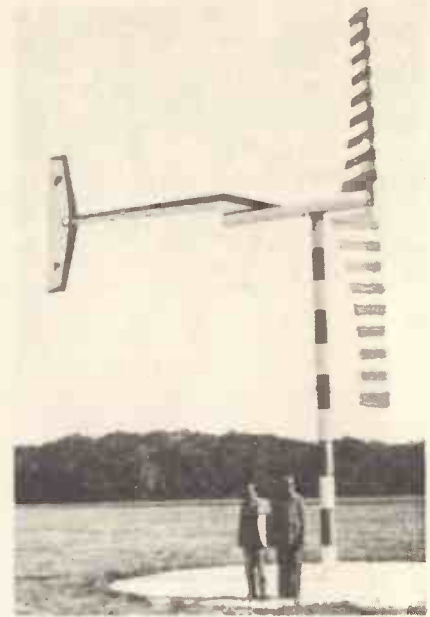

Another shape to wind power: the 40-foot-high Princeton sail-wing.

Above a few hundred watts, however, batteries become cumbersome. Moreover they require the kind of maintenance that is not always available in underdeveloped countries. However, the main power need in underdeveloped countries is for pumping water: hence 'One neat solution' says Harris, "uses the wind turbine for both electricity generation and irrigation. During the day energy from the windmill is used to pump water uphill to a storage tank. At night the water runs back downhill through a small water-turbine generator, giving power when it is wanted for lights. This is an ideal solution for many isolated communities'.

Another solution to the storage problem is most suitable for large wind turbines. Electric current from the turbines. Electric current from the turbine's generator is used to electrolyse water. The hydrogen given off (and possibly the oxygen as well) can be stored to be used later as the fuel to provide heat to drive a conventional gas- or steam-turbine. Alternatively, developments in fuel cell technology might make it possible to recapture the electricity direct by recombining the hydrogen and oxygen.

Conventional windmills are still in use in many parts of the world, and it is there that the new designs of windmill might best make their initial impact. While the capital cost per kilowatt of installed capacity would now be between £500 and £1000 for an advanced wind-turbine prototype, the price would fall greatly with mass production. And, of course, operating costs are almost nil, for the fuel to drive the wind turbine is free. ●

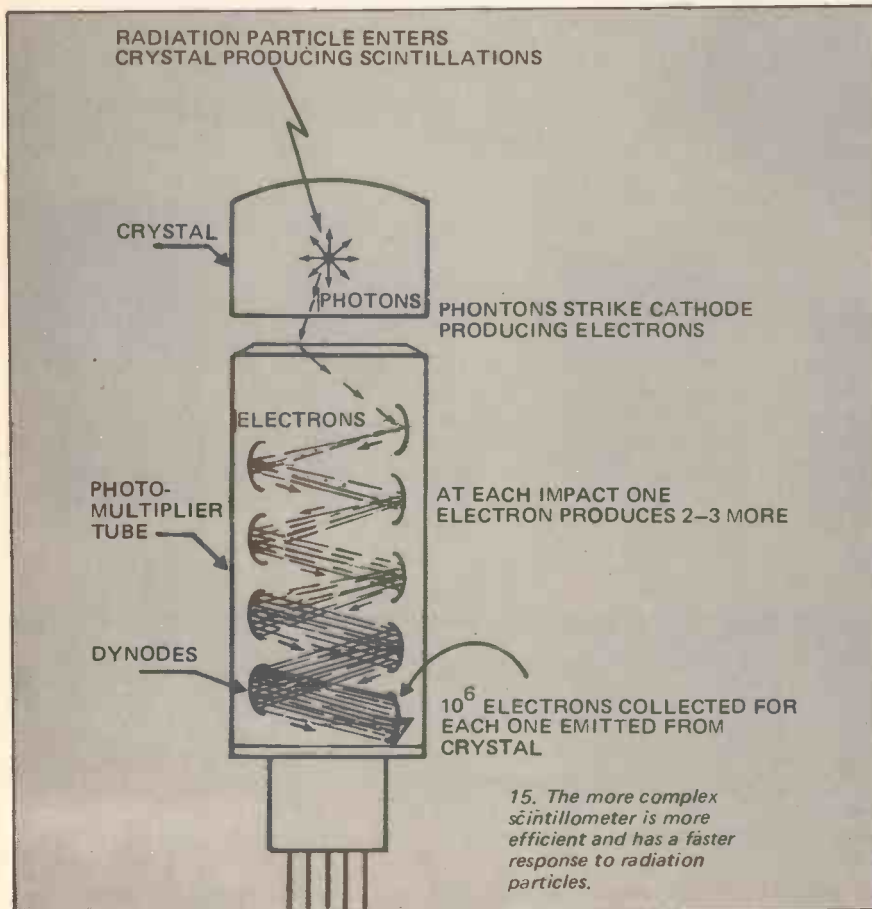

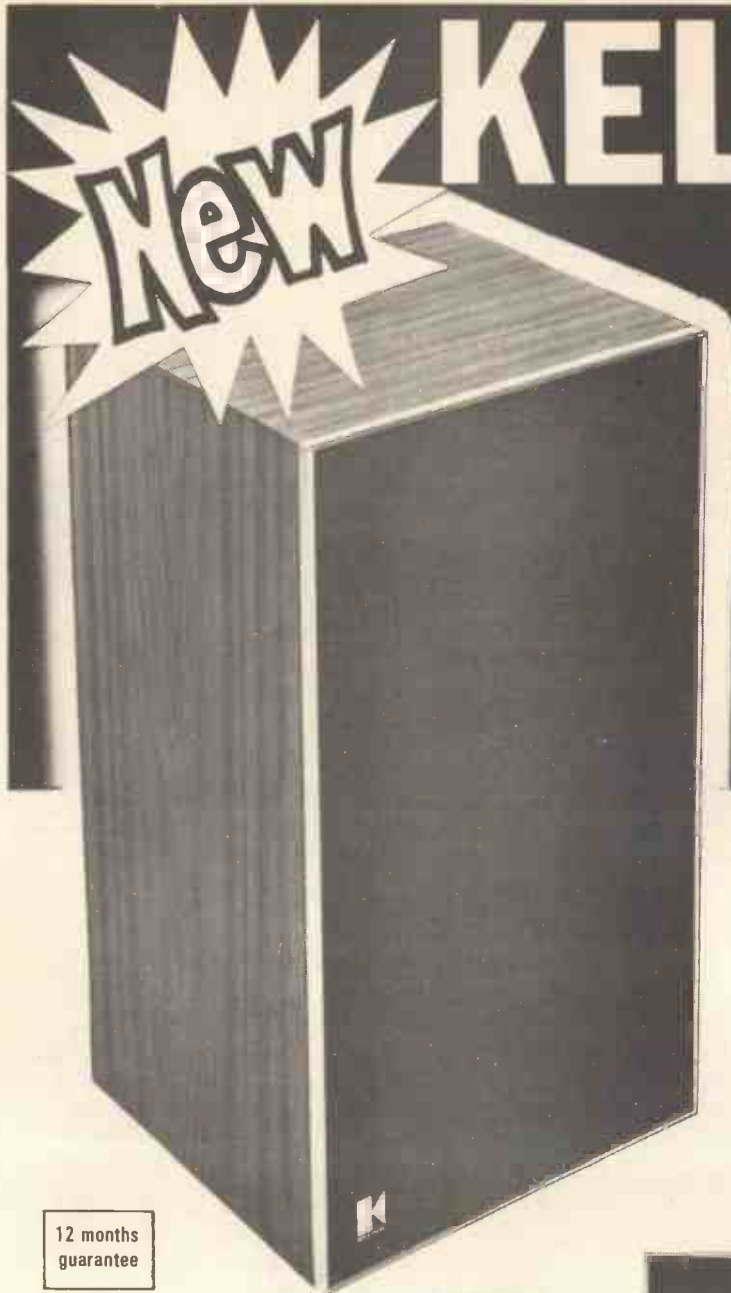

KELETRON speaker systems

We are proud to present our KS range of loudspeaker systems.

They are designed and built on the infinite baffle principle and are fully padded to damp out any panel resonance.

All models are housed in handsome polished-slimline cabinets and are ideal for either shelf or wall mounting.

KS 4 TWO SPEAKER SYSTEM

Power Handling 4 watts RMS
Rec. Retail Price £10.30

KS 6 THREE SPEAKER SYSTEM

Power Handling 6 watts RMS
Rec. Retail Price £12.80

KS 8 THREE SPEAKER SYSTEM

Power Handling 8 watts RMS
Rec. Retail Price £16.50

KS 10 THREE SPEAKER SYSTEM

Power Handling 10 watts RMS
Rec. Retail Price £21.30

KS 15 THREE SPEAKER SYSTEM

Power Handling 15 watts RMS
Rec. Retail Price £31.75

KS 20 THREE SPEAKER SYSTEM

Power Handling 20 watts RMS
Rec. Retail Price £35.80

All prices are exclusive of V.A.T.

12 months
guarantee



KS 4
h11" w6" d6"



KS 6
h15" w8" d7"



KS 8
h19" w10" d9"



KS 10
h23" w13" d11"



KS 15
h27" w13" d11"



KS 20
h31" w13" d11"



Keletron Equipment is manufactured by
K & K Electronics Ltd.
60 St. Marks Rise, London E8 2NR
Telephone 01-254 9941/4

Stockists: Audio Supplies, Comet, F. Cave, Dixons, Global Audio, Henry's Radio, Laskys, Lind-Air, Peak Discount, G. W. Smith, Centre Sound (Dublin), Yorkshire Hi Fi, Smiths (Wolverhampton) and most leading Hi-Fi dealers.

Please send me further details of Keletron Audio Equipment.

Name.....

Address.....

MASTER MIXER

How to use the master-mixer in the most effective way – and how to modify it to suit individual requirements.

eti PROJECT 414

HAVING built the ETI Master-Mixer you will wish to use it in the most effective way, and perhaps modify its performance to suit individual requirements. We cannot possibly cover all eventualities, but this article provides details of a typical installation and some commonly-needed alternative configurations.

BASIC PHILOSOPHY

The unit has been designed to provide master-mixing for the average sized group (which is usually similar to that shown in Fig. 1). It provides a stereo output which may be used to drive the main amplifiers for an auditorium, or may be used for recording purposes. We have taped major performances using our own prototype master-mixer and have achieved very pleasing results indeed. Remember however that a system configuration suitable for recording is not necessarily suitable for auditorium use and vice versa.

Basically the unit should be located in the auditorium so that the operator may judge acoustic quality as the audience hears it – and to make appropriate adjustments as necessary.

Most groups nowadays use half acoustic and half electronic instruments. Instruments such as drums may not need 'miking' at all except in a very large auditorium or out-of-doors. Naturally when making recordings, all instruments have to be 'miked'. In such cases four microphones are usually needed adequately to cover the drums and these are best combined in a sub-mixer. Similarly, an electronic organ with Leslie is perhaps best handled by a sub-mixer. All other inputs will of course go direct to the master mixer.

One of the main problems within the group is that of monitoring. Each player of an electronic instrument needs to be able to hear himself and the drummer particularly needs to hear the bass guitar but there is so much noise on stage that this is usually not possible. As each player usually has his own amplifier/speaker for use in practice, these may be used on stage to provide the necessary monitor facilities. To split the instrument

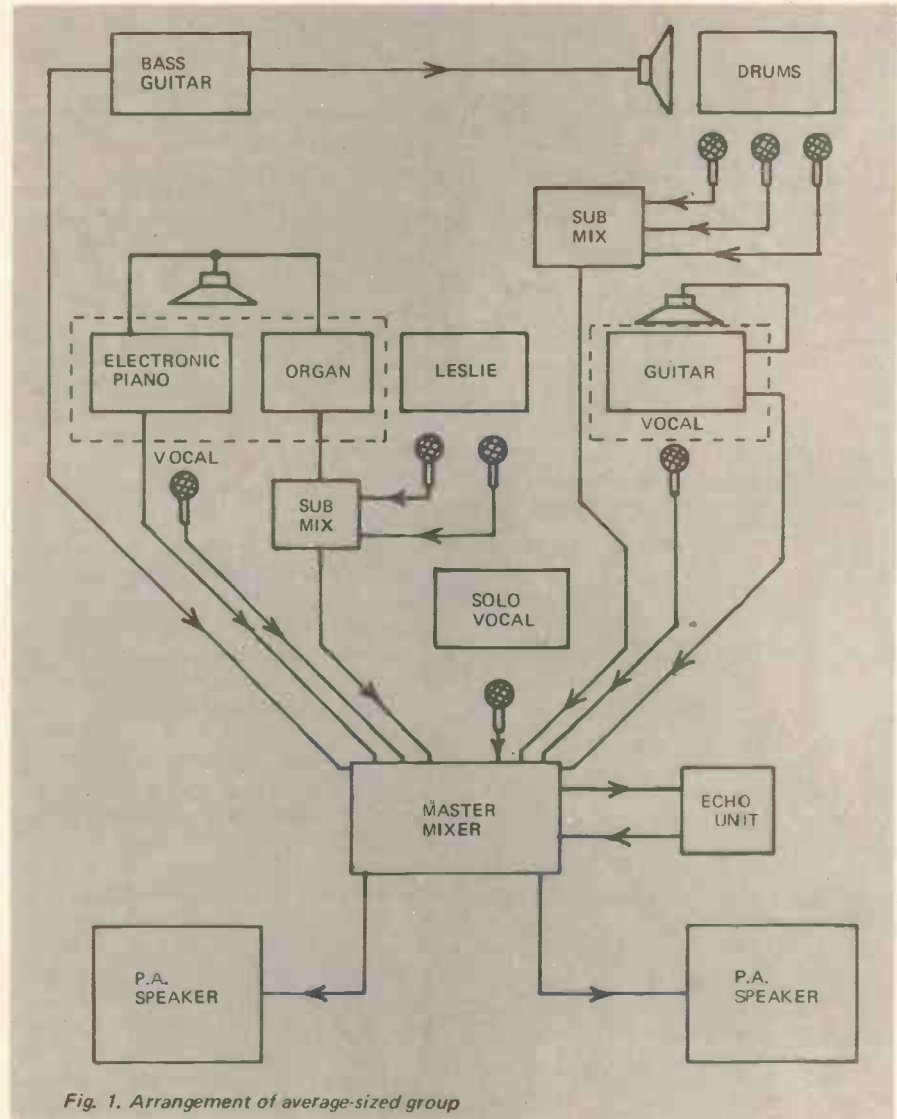

Fig. 1. Arrangement of average-sized group

output for both monitor amplifier and master mixer a simple plug to twin socket adapter may be used. Another method is to use a separate monitor box, as shown in Fig. 2, or monitor outputs may be fitted to the mixer unit itself as explained later.

It is of course possible to 'mike' the output of monitor speakers but this usually results in loss of fidelity. On the other hand such a procedure, together with deliberate overloading, is often used to provide special effects by distorting the output.

SETTING UP THE MIXER

Before connecting any inputs, set each input channel sensitivity switch to low, volume controls to zero, tone controls to centre position.

Switch on, connect the instruments one at a time and perform the following adjustments. Adjust both master-volume and channel volume to position 7 and then switch channel sensitivity for maximum desired level at these settings.

Then adjust the tone controls for the

MASTER MIXER

niciest sound for each instrument — without destroying its natural sound. Bear in mind that to increase the response in mid-range it is necessary to turn down bass and treble and turn up the volume.

If echo is to be used, connect the 'Echo Send' input and output to an echo unit, or alternatively, to a suitable reverberation unit. The echo effect may be increased or decreased by using the echo-send control.

Audibly position each member of the group left or right, by adjusting his channel balance control. Note that a balance control at centre will make the instrument appear audibly centred as well. These controls may need some readjustment when the full group is playing. The master balance control is then adjusted to achieve overall uniformity.

The equalizers may now be used to obtain a level overall frequency response by subjective listening and appropriate adjustments. Note that a five-section equalizer cannot correct major defects in auditorium acoustics, but can compensate for minor problems and for poor quality speakers.

As said before, the unit may be used for recording on stereo tape or disc and this is done by taking direct line outputs from the mixer to the recording equipment. Again, as said before, all instruments need to be 'miked'. Remember that the quality of the acoustics, particularly when recording, is affected very much by the choice of microphone. Most dynamic microphones drop off at the high end and we suggest that, providing sufficient funds are available, a good Electret microphone be used. It is essential that microphones should be as directional as possible to avoid problems with acoustic-feedback.

MODIFYING THE SYSTEM

Innumerable individual variations may be required — a few of those most commonly requested are dealt with here.

Some of these modifications can be performed without changing the basic wood and metal-work, others cannot. Because of the variety of combinations that may be used, details of wood and metal-work must be left to the individual constructor.

These modifications are therefore of necessity presented in a general way and should only be undertaken after careful consideration of exactly what is needed, and only if what needs to be done is fully understood. We regret

that we cannot assist in individual design requirements, however do tell us about your requirements and problems, and, if sufficient people ask for the same thing, we may be able to publish details of a modification at some later date.

Before dealing with specific modifications we will expand on the general theory previously given so that limitations may be more readily understood.

PREAMPLIFIERS

With reference to the circuit diagram on page 33 of the May issue, we see that the input amplifier IC1 has three selectable gains the maximum gain being 500. This means that a one millivolt signal will become 500 millivolts at the output. A higher gain may be obtained by reducing the value of R4/R6 but to maintain input impedance R1/R2 will have to be increased (see How it works — Preamplifier page 32 May issue for gain formula). Note however that the tone-control stage is a standard feedback-type providing a maximum boost of 15 dB which corresponds to a voltage gain of approximately 6. The maximum output voltage of IC2 is 6 volts RMS and the maximum output of the preamplifier must therefore not exceed 1V RMS if clipping under maximum boost conditions is to be avoided. In addition an overload margin of 20 dB should be allowed, and this implies a maximum nominal output of only 100 mV from the preamplifier.

MIXER AND EQUALIZERS

The mixer is simply a summing amplifier, the output voltage being the vector sum of the input voltages

multiplied by the resistance of RV2 divided by 100,000. The maximum gain, one channel only driven, is 3 1/3 and although the individual gain remains constant the power level is greater with all channels driven. Overall gain is controlled by RV1, the master volume control.

Each section of the equalizer is a series LCR filter whose sharpness is determined by the circuit Q and with the coils given, the reactance at resonance is approximately 700 ohms. If more than five sections are required the filter must be made sharper and hence the reactance of the capacitor and inductor must be increased. Note however that phase shift problems limit the number of sections to seven in this type of circuit.

POWER SUPPLY

The current consumption is approximately 10 mA per channel and the power supply has adequate reserve for up to 20 channels, however if more than 10 channels are used a heatsink of about four square inches should be added to Q1.

If meter and overload indicators are required for each channel then a printed circuit board with this section only wired up should be made for each channel. If each channel is required to have a separate LED overload indicator, separate R27 and R28 and use each resistor to drive an LED.

CHANGING THE NUMBER OF CHANNELS

If less channels are required it is simply a matter of deleting the appropriate number of preamplifier/tone control boards and fitting blank panels to the cabinet in

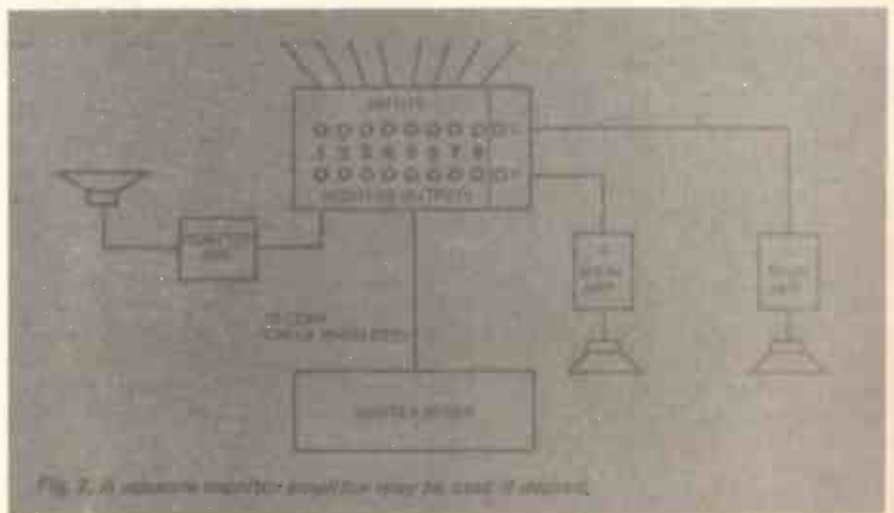

MASTER MIXER

their place.

If more channels are required, the existing metalwork and woodwork will have to be extended to accommodate the extra preamplifiers.

One 100k resistor must be added to the main mixer summing network for each additional channel. These may be mounted by glueing them to the existing resistors with epoxy cement and making flying lead connections. Alternatively a small sub-board may be constructed for them.

In an exactly similar manner the echo mixer may be modified to accommodate the required extra channels. Extra input sockets must also be provided and the appropriate interwiring carried out.

SUB-MIXERS

As discussed earlier, sub-mixers may be required to implement a complete system. A simple sub-mixer may be constructed using the circuit shown in Fig. 3. This circuit is quite simple, is based on the echo mixer, and may be built on veroboard. Alternatively the echo-mixer PC board could possibly be adapted fairly readily.

As the instruments associated with each sub-mixer are usually grouped left-and-right, splitting may be performed after the sub-mixer as shown in Fig. 3. If balance is required before mixing it will be necessary to use two sub-mixers controlled by a ganged potentiometer, and to use balance circuitry similar to that in the circuit on page 31 of the May issue. The outputs of the sub-mixers are taken to the normal inputs of the main mixer.

MONITOR OUTPUTS

The need for monitoring has been explained previously, and if only one monitor channel is required, and echo is not required, the echo channel may be used to provide a monitor output. However two or more monitor outputs are often required and they may need to each have an equalizer for the elimination of microphone feedback. This may be achieved by wiring additional potentiometers in parallel with the echo potentiometers as monitor level controls. The output from these potentiometers may then be fed directly or via additional equalizer/main-mixer boards to the monitor amplifiers. A balance control is not required on monitor, hence R21 and RV7 (page 31 May) may be omitted and the output taken from terminal 19. Again, if equalization is not required, a mixer similar to that of Fig. 3 may be used.

CUEING OUTPUTS

When recording it is sometimes necessary to suppress the main output of the mixer while still monitoring the final mixed sound.

This may be done quite simply by taking an output from the junction of R20 and C8 (page 31 May) of the final mixer to a cue-monitor outlet, and using a good-quality key switch to short terminal 19 to ground.

This allows monitoring of equalizer output whilst inhibiting output to the main amplifier.

That completes our project. We trust that this versatile unit helps you become a good mixer!

NEW, EARLY WARNING, GAS MONITORING SYSTEM

A new system for continuously monitoring from a remote position the atmosphere in potentially hazardous areas, to give an early warning in the event of a build-up of dangerous gases or vapours, has been developed by Detection Instruments Limited, Wokingham, Berkshire.

Designated the 'Gasmonitor', the equipment is designed for permanent installation and operation day in, day out, directly from the mains electricity supply. The unit incorporates safeguards against faults in the detector components or unauthorised interference with its control.

It has applications wherever an early warning of a potential hazard to personnel or plant is necessary – often in zones where it is not safe, practical, expedient or economic for personnel to make routine on-the-spot checks. This applies to ducts, tunnels, tanks, cellars or service rooms and voids such as occur in refineries, sea-going tankers, telephone exchanges and hospitals, or in gas, sewage, effluent, chemical, and many other types of processing plant.

Detector heads can be installed up to 200 metres from the control unit, and multi-point systems can be arranged to monitor various sections of, say, different runs of ducting or a number of basement service areas.



The control unit comprises a main alarm lamp, an indicating meter calibrated 0 – 100 per cent LEL (lower explosive limit), a fault indicating lamp, and a key-operated on-off switch. The level of gas is indicated by the meter and at a pre-set alarm point on the scale – usually 20 – 25% LEL – the main alarm lamp lights. If required, internal relay contacts can be used to initiate at the same time an audible alarm or an automatic shut-down procedure. The fault lamp will light if any fault develops in the detecting head, either in the main element or its compensator, or if the leads or earth connections to them are accidentally cut.

The principle of detection is by catalytic oxidation on an SMRE pellister filament (with another filament compensating for variations in ambient pressure and temperature) in conjunction with a resistance bridge circuit. The design and the components used have been well proved as stable and reliable over many years. The control unit uses plug-in, solid-state, printed circuitry which, if necessary, can be exchanged within a few minutes.

Detection Instruments Ltd., P.O. Box 40, Wokingham, Berkshire, RG11 5S.

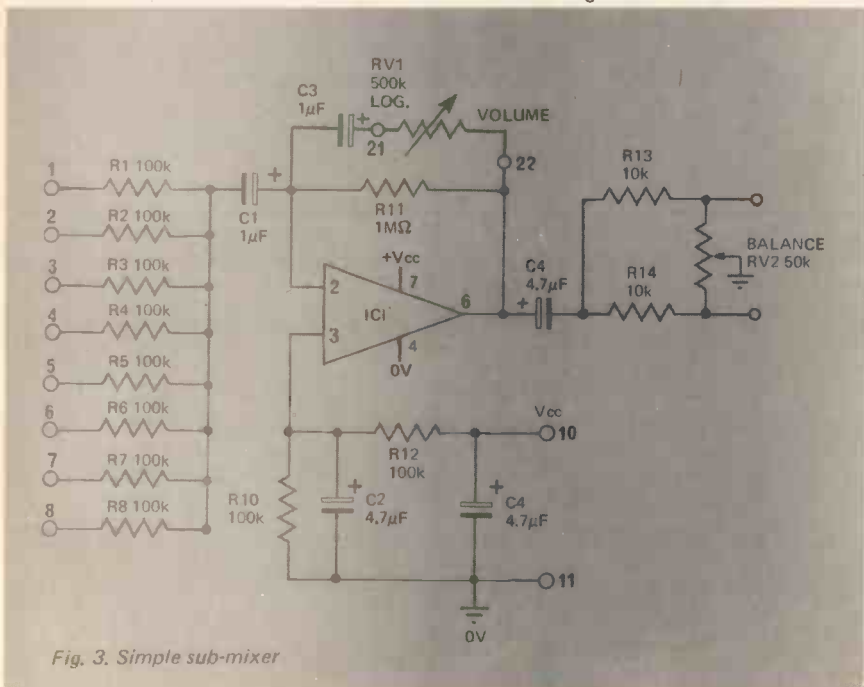
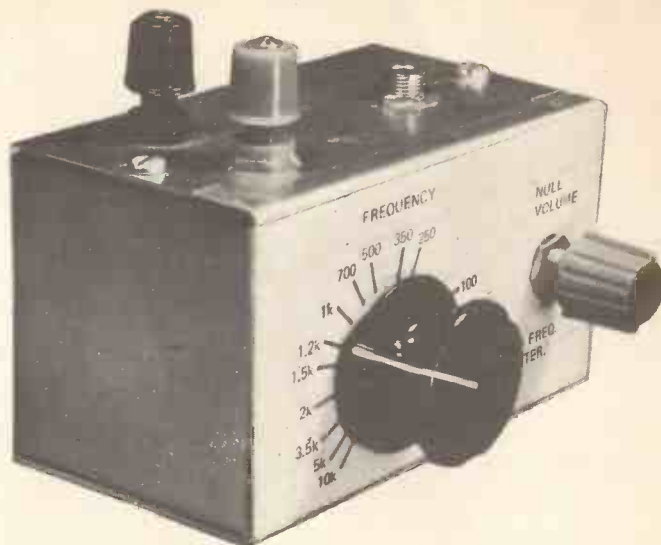

Fig. 3. Simple sub-mixer

Audio frequency meter

PROJECT 211

Simple unit measures frequencies from 50 Hz to 10 kHz



ON MANY occasions it is useful to be able to determine the frequency of an audio signal. Often, the accuracy and expense of a commercial frequency meter is not justified.

This little circuit, using only a few components will provide an indication of frequencies from 50Hz to 10kHz with an accuracy primarily determined by the calibration of the instrument.

The audio signal — of which the frequency is to be established — is fed

into the input terminals of the unit and the calibrated dial adjusted until a 'null' is obtained whilst listening to the signal through a pair of headphones, or even a single crystal earpiece.

We suggest that the components be mounted in one of the small aluminium miniboxes which are available readily at low cost. Our prototype unit had a 4" x 2 1/4" front panel, but a larger box will enable a larger frequency scale to be used hence

providing better resolution. Apart from this a larger box will allow input terminals and output socket to be mounted on the front panel together with the frequency-null controls.

Note that the dual potentiometer is a logarithmic type and is wired such that the frequency scale *increases* with anti-clockwise rotation. This results in a more linear scale (less cramped at the high end) than if wired conventionally. Any type of earpiece or headphone

CALIBRATION CHART

FREQUENCY HZ	RV1 RESISTANCE (one section)
75	21.2 kohm
100	15.9 kohm
150	10.6 kohm
200	8.0 kohm
300	5.3 kohm
400	4.0 kohm
500	3.18 kohm
600	2.65 kohm
750	2.12 kohm
1000	1.59 kohm
1500	1.06 kohm
2000	800 ohms
3000	530 ohms
4000	400 ohms
5000	318 ohms
6000	265 ohms
7500	212 ohms
10 000	159 ohms

HOW IT WORKS

The circuit is that of a Wien bridge which when used for frequency measurement has the form shown below:—

If $C_x = C_s$, $R_x = R_s$ and $R_b = 2 R_a$, then $f = \frac{1}{2\pi C_s R_s}$ or, $R_x = R_s = 0.628 f$

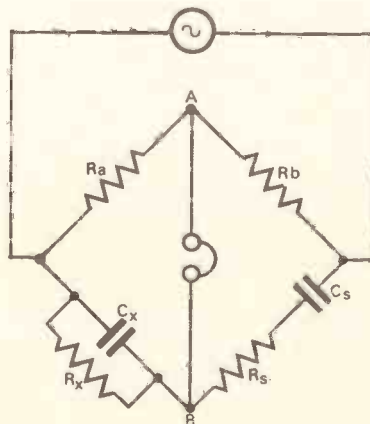

where $C_x = C_s = 0.1\mu f$. Our calibration chart was calculated from this last formula.

At the frequency where the reactance of C_s equals R_s and also $C_x = R_x$, the series network has an impedance of $1.414R$ and phase angle of 45° . The parallel network has an impedance of $0.707R$ and the same phase angle. The signal at point B will therefore be in phase with the input level, but attenuated to $1/3$ of that level. If $R_b = 2R_a$ the signal at A will also be attenuated to $1/3$ of the input. Thus the bridge is balanced and the signals at A and B will be equal in amplitude and phase and a null will occur at that frequency.

At any other setting of the potentiometer the phase angle and amplitudes will be such that an increased output is obtained.

The respective sections of the dual gang potentiometer never track each other perfectly and hence RV1 has been included to obtain best null at any point on the scale.

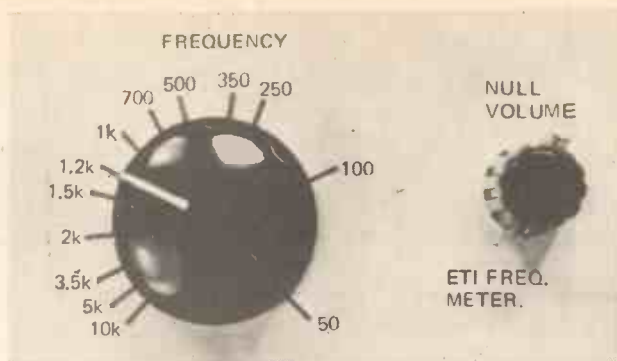
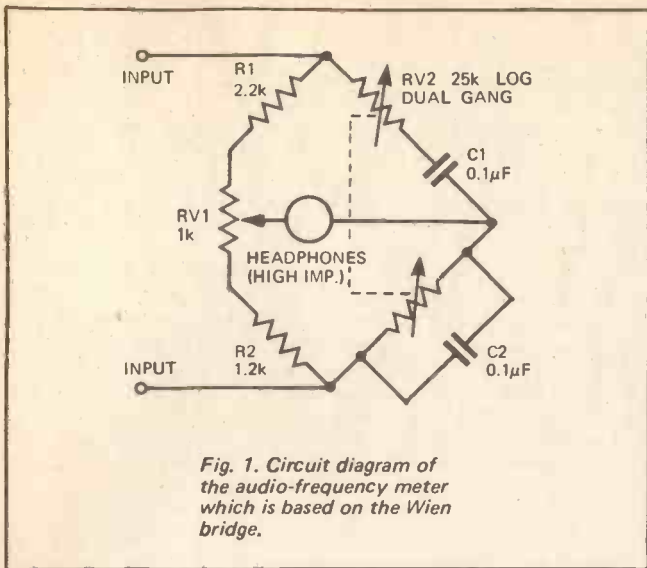

PART LIST

- R1 resistor 2.2 k ohm 5% 1/2 watt
- R2 resistor 1.2 k ohm 5% 1/2 watt
- C1 capacitor 0.1µF 100 volt polyester
- C2 capacitor 0.1µF 100 volt polyester
- RV1 potentiometer 1 k ohm linear
- RV2 potentiometer 25 k ohm log dual gang
- Input terminals
- Output socket to suit headphones
- Metal box
- Headphones earpiece or headset preferably high impedance — 1 k ohm or more.

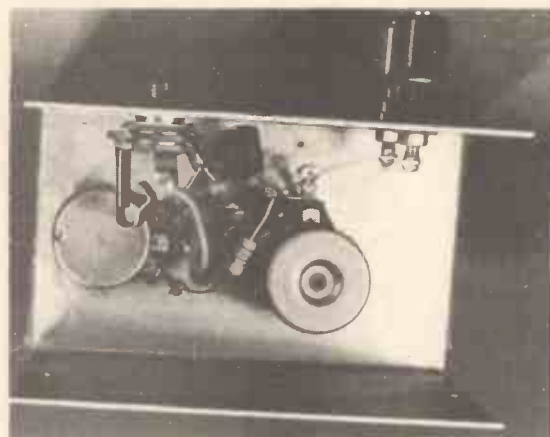

An internal view of the prototype

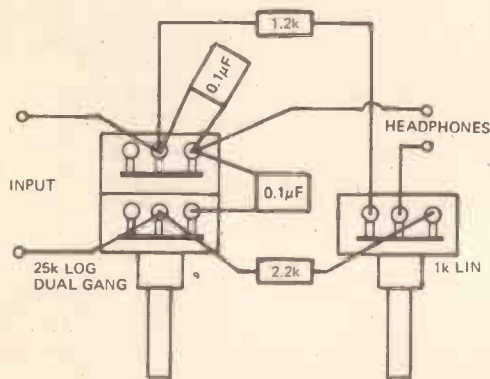

Fig. 2. Follow this diagram to wire the unit.

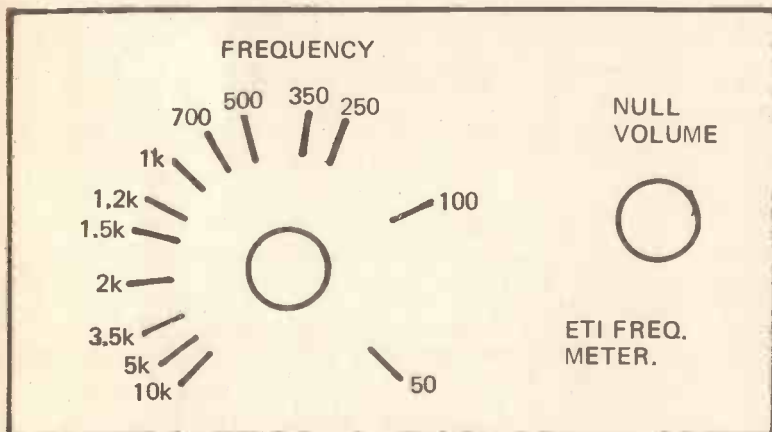

Fig. 3 Front panel of our meter shown for information only — calibration may not suit all potentiometers

may be used to detect the null but best efficiency will be obtained with those having an impedance of around one thousand ohms.

The best way to calibrate your meter is to compare it with a good quality oscillator and mark your scale to suit. Remember that most potentiometers have a manufacturing tolerance of ±20% and hence our front panel drawing may not be correct for your potentiometer.

If an oscillator is not available, but you do have an ohm-meter, then calibration may be carried out by measuring the settings of RV2 (disconnected from the circuit) and marking the scale as shown in Table I.

To use the meter, couple the audio signal into the input terminals and adjust RV2 to a point where the signal drops off. Adjust RV1 to increase the null and RV2 again for the final setting. The frequency of the incoming signal is then read from the front scale. What could be simpler? ●

DX MONITOR

Compiled by Alan Thompson

The time-scale for magazine production is such that, as yet, there has been no chance for any feed-back from readers of 'DX Monitor' in our June issue: however, extremely complicated editorial arrangements will mean that from our August issue this feature will be written very much nearer the date on which ETI appears on the bookstalls with the result that it will be a lot more topical and I shall not have to gaze into my crystal-ball in an attempt to forecast what you might be able to hear!

VALUE OF THE DXer

Is the DXer really valuable to the radio station to which he sends his reports? Of course, DXers would like to believe that they — and their reports on reception — are something that radio stations could not do without, but in all honesty individual reports on a long-distance station are of very little value indeed to the receiving broadcasting station *unless* the programme being reported on was beamed to the area in which the listener lives! To many DXers this will smack of heresy but a few moments consideration of the hard facts will show why this was the case.

TYPES OF STATION

Basically there are two kinds of broadcasting stations or rather two kinds of transmissions put out by them. Firstly, there is the service intended for the local populace; secondly there is the Foreign or International Service which exists to project that country in the area to which the Foreign Service is directed. If we call the stations which carry the Home Service 'local stations' it is axiomatic that they are on the air for the sole purpose of informing, educating and entertaining listeners within the normal service area of the station.

With the vagaries of radio-wave propagation, at times, the signals of such a local station will be heard over immense distances — a classic example is the not too uncommon reception of the Papua and New Guinea Home Service stations in Western Europe. One can be quite sure that a report on such reception is nothing more than a curiosity to the staff of, say, *Radio Wewak*: it certainly doesn't tell them anything of any importance about the type of programme they are broadcasting and they are really only concerned with knowing that they are covering their service area adequately, and that the programmes they broadcast are acceptable in terms of content to those who are their regular listeners.

So, if you are sending a report to one of these 'local stations' then it is essential that one encloses reply postage and writes one's report in terms which make it clear that one is requesting the favour of a reply and/or a QSL card. To be blunt — 'local stations' don't exist in order to deal with DX reception reports, and if they *do* reply (and a lot of them don't!) then it is a courtesy to send a short thank-you letter for the trouble they have taken.

International broadcasters of all descriptions — secular, sectarian, political or non-political — are a very different kind of bird. All have in common a desire, for some reason, to be heard in an area remote from the transmitter. This is not the place for a long discussion on their motives since those are not relevant to this theme. The great majority of international stations have a panel of monitors — usually paid either in money or by means of gifts — which provide them with detailed reports, often on a day-to-day basis, setting out how their signals are being heard in a particular target area. Casual reports from DXers are nothing more than additional information, of very slight value since one has no means of knowing from just one report how 'generous' or 'stingy' a reporter is in his assessment of the station's quality.

However, DXers do have some value to these stations since they may, if there are enough such reports, indicate to the engineers at the transmitter the possibility of treating a service to (say) Africa as also providing a service to Europe at a particular time of day. Broadly: international stations will almost certainly verify any

accurate report they receive even if it is for a non-target area reception, *but* it is worth remembering that, in general, such action is more a gesture of goodwill rather than the result of having received information of considerable value.

What is of use — and it may lead to an invitation to join a monitoring panel — is a series of reports on a particular frequency over a period of a couple of weeks, especially if the reporter takes the trouble to identify the source of interference (if any) and gives adequate details of his equipment, antenna and experience in the DX hobby.

Where does the Shortwave Listener (SWL) come in all this? His reports are usually rather light on the technical side and are not of a lot of use to the engineering staff but they are of a lot of interest to the programme staff, and very often they will get replies — from both 'local' and international stations — where the DXer just waits and waits for the anxiously desired QSL. If you are writing a 'SWL Report' then don't be afraid to say just what you thought of the programmes you heard: if you didn't like them then don't hesitate to say so *but do* say why. Maybe, the amount of propaganda content infuriated you: maybe, you didn't like the fact that 80% of the programme was religious: maybe, you didn't like the 'slant' of their news — whatever your grievance then tell them as they will very surely be interested in what you thought of the programmes they were putting on the air!

WHAT TO LISTEN FOR

Now let's put on the clairvoyant's hat again! *RTV Dominicana* — which last month I mentioned had started using 5970kHz — almost before the script was in the post, decided to reactivate its old frequency of 9505kHz, and has been heard bashing through there most late evenings: ought to stay good for another couple of months. This month, try for some Far East DX and here are a few frequencies to listen on — all round about the 2230 spot (all frequencies in kHz, times GMT).

4845	Radio Malaysia	From Kuala Lumpur in Tamil, s/on 2200
4892	Radio Hanoi	The 2nd Home Service is now here in Vietnamese, from about 2130
4985	Radio Malaysia	From Penang this one: s/on in English at 2230
5010	Radio Singapore	Carefull Garoua (in the Cameroons) is here until about 2200; Singapore s/on in Chinese at 2130 (and there's a Chinese regional station here, too!)
5052	Radio Singapore	In English here from 2230 s/on, usually with nice light breakfast-time music
Changing the time of day (or night).....		
15170	ORTF Tahiti	Try for this one s/on 0300 (some days at 0230) — programmes in Tahitian, and French after 0500. Give 11825kHz a try, too. Nice QSL card with nude mermaid to whet your appetite!
17890	Taiwan (Formosa)	Has English 0200-0350 here, and on 15125, 15345, 17720 and 17780kHz. One of the few stations that still announces the call-sign for each of its many frequencies (that will take the old-timers back!)

And if you manage to log that little lot you'll be waiting for some very nice QSL cards and you will certainly have moved from the beginners-class!!! Last of all: listen round about 3942kHz for the Falkland Islands Broadcasting Service just about 2400 GMT: it's only 500 watts but it *did* make it to the U.K. last summer so keep trying and hoping.

If you have any comments, news and queries for the August issue I shall be glad to have them by 18th June at 16 Ena Avenue, Neath, Glamorgan SA11 3AD, and don't forget to enclose a self-addressed s.a.e. if you want a personal reply. Let's have lots of feed-back, positive or negative!



Wharfedale Hi Fi Isodynamic Headphones.

(Isodynamic, *adj.* Of or pertaining to equal (magnetic) force).

Mission Accomplished: electrostatic quality for less than half the price.

That was our mission. The same superb quality of performance as electrostatic headphones. But for less than half the price.

And by going to the moon we've accomplished it.

Because one of the things that took man to the moon was a unique polyimide film. And we've turned it into a unique



diaphragm. Giving you pure stereo sound at the revolutionary price of £19.95*

Plus. Lightweight comfort. And good looks. Complete with this elegant foam-lined container with transparent lid. It'd look good beside your deck. And let you store the phones neatly and dust free

Unique Diaphragm
In the NASA space capsules polyimide film has to withstand great temperature fluctuations. As low as -269°C or high as 400°C . And it also has to withstand tremendous vibrations. So it has to be flexible. But without destroying the printed circuitry. Which is bonded into the polyimide film.

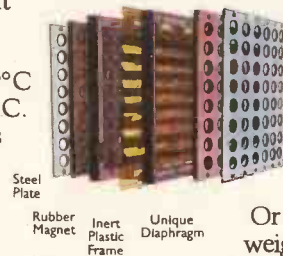

Rubber Magnets
Another Wharfedale Hi-Fi exclusive. Which give you an equal magnetic force from lightweight magnets. And so avoid the heavy iron magnets used in more conventional headphones.

Weightless Capsule
Or almost. For the whole lot weighs a mere 13ozs of sheer lightweight strength. So you can wear the phones for as long as you like. And if you'd like the full inside story then fill in the coupon.

*Manufacturer's recommended retail price at time of printing.

UK and Foreign Patents exist. Further Patents applied for. UK Registered Design No. 956537. Other Design Registrations Pending. Made in England.

Wharfedale Hi Fi. Pure and simple.

Wharfedale Hi Fi, Idle, Bradford, Yorkshire

HET/7

Send me details of Isodynamic Headphones and your nearest recommended dealer.

NAME _____

ADDRESS _____

(BLOCK CAPITALS PLEASE)

Wharfedale Hi Fi

Idle, Bradford, Yorkshire
A division of the
Rank Organisation.



Empire 1000ZE/X phono-cartridge



Testing Empire's top
of the line cartridge.

electronics
TODAY
INTERNATIONAL
product test

THE DESIGNERS of record players and cartridges are faced with a number of difficult tasks, not the least of which is to faithfully transform the mechanical motion of the stylus point into a directly equivalent electrical signal. This complicated conversion is known as "tracking", and with modern music is no easy task.

To be able to perform this task faithfully, the mass of the stylus and all of the associated moving parts must be kept as low as possible, because the

greater the moving mass, the higher its inertia, and its consequent resistance to rapid movements. In addition, it is necessary that sufficient downwards force is applied to the stylus to keep it in the record groove no matter how severe are the forces tending to throw it out. This force is known as the *tracking force*, and if too high, results in accelerated wear rates for your precious records.

For good "trackability", the stylus assembly must have good compliance, which means freedom of movement — or controlled physical resistance.

It is this compliance, or the lack of it, that, amongst other factors, separates good cartridges from average cartridges.

Three main types of cartridge are in common use. These are, moving magnet, moving coil and induced magnet cartridges.

Moving magnet cartridges incorporate a tiny permanent magnet at the centre of the stylus bar. Because this is pivoted in a flexible surround, the magnet follows the motion of the stylus and induces a magnetic field between the pole faces of the pick-up coils (Fig. 1). This type of cartridge is characterized by high signal efficiency and a relatively high output, together with excellent linearity and good channel separation.

With the moving coil system, the magnets are fixed and the two coils move in the magnetic field, thereby having a voltage induced in them. The moving mass of a moving coil cartridge is usually (but not always) lower than that of a moving magnet system, but by contrast its output is so low that a special high sensitivity input has to be provided to boost the signal level. Moving coil cartridges generally provide good frequency response and adequate channel separation, and many of them have built up a reputation for excellent performance.

Induced magnet cartridges are not necessarily the least loved, but it is seldom that much is written about them. They use a simple system (Fig. 3) with two fixed coil assemblies and a fixed magnet. The inner end of the stylus assembly has two minute iron plates attached and these move in the magnetic field thereby causing variations in the magnetic flux. This

results in a modification of the induced voltage in the coils. The protagonists of the induced magnet cartridge claim that it can provide lower mass, higher linearity and improved trackability, although this is generally at the expense of sensitivity and signal to noise ratio.

Notwithstanding, a number of well respected manufacturers have changed from moving magnet systems to the induced magnet system for their top of the line cartridges.

The Empire Scientific Corporation of New York have been producing induced magnet cartridges for years, and it was with real interest that we embarked on reviewing their top of the line model, the 1000ZE/X.

The 1000ZE/X is meant to track in the range 0.25 to 1.25 grams, and is fitted with a 0.2 x 0.7 hand polished bi-radial stylus.

The cartridge uses a black plastic mounting assembly, with the standard 1/2 inch mounting centres, into which is inserted a gold finished metal screen containing the induced magnet assembly. The stylus assembly is inserted into this, and, like a number of other better class cartridges, comes complete with its own flip-down stylus protector. This feature is essential when styli cost more than half the price of the cartridge.

Our first test was to measure the frequency response of the cartridge. This exhibited an essentially flat response to 1kHz, and dropped to -4dB between 8kHz and 12kHz. Not by any means the flattest we have seen, but generally acceptable. Channel separation was 25dB at 1kHz - and always better than 20dB. This is adequate.

We then measured the square wave response of the cartridge at 1 gram tracking weight and at 0.5 grams. The response was quite good, and improved considerably when we used a better tone arm and head shell assembly instead of the heavier one fitted to the automatic turntable required for the automated frequency response curves. This bore out the supplier's comments that the cartridge performs best in an Empire arm.

The measured square wave response in the light-weight transcription arm was equal to the best that we have seen and augured well for the trackability tests that followed.

The trackability tests at 1 gram showed that the 1000 ZE/X is indeed an excellent cartridge and worthy of the title "top of the line". It had no difficulty coping with most record content.

We tried the cartridge out on a number of new records and were gratified

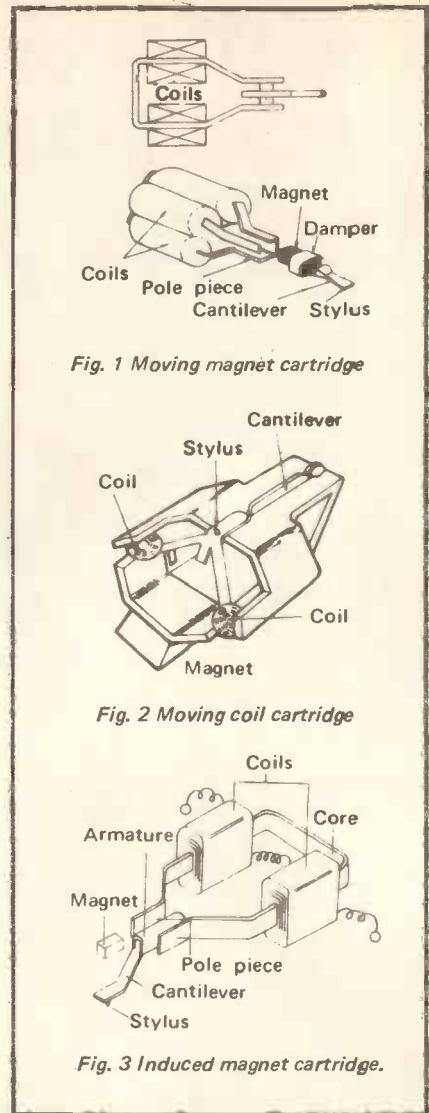

Fig. 1 Moving magnet cartridge

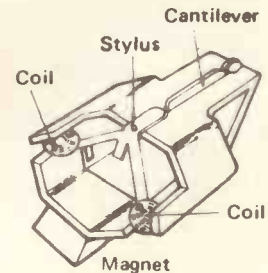

Fig. 2 Moving coil cartridge

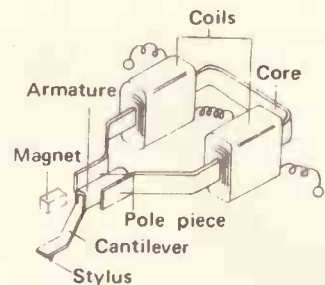
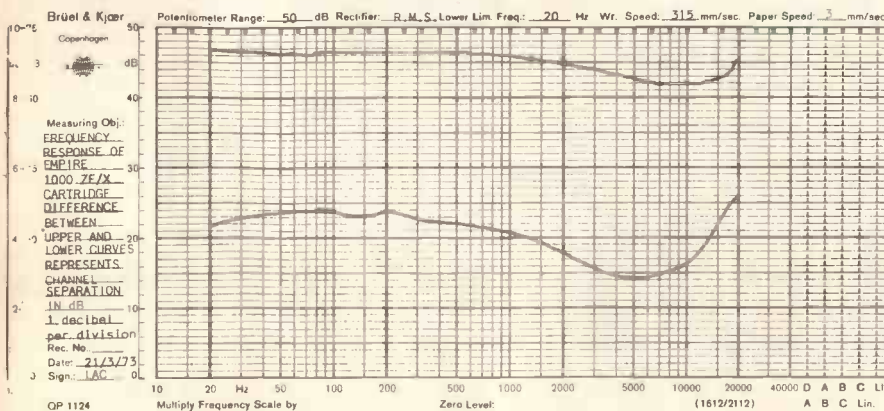
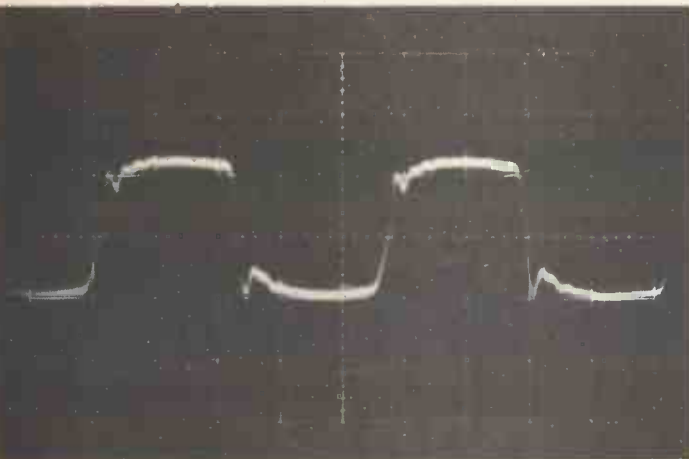

Fig. 3 Induced magnet cartridge.

Response of Empire 1000 ZE/X cartridge to 1000 Hz square wave recorded on special test record.



MEASURED PERFORMANCE

Frequency Response (see Text)
20Hz to 20kHz, +1dB, -4dB
Sensitivity (at 1kHz at 5cm/sec)
5.4mV
Channel Separation (at 1kHz)
25dB

to find that this cartridge could follow and reproduce the most difficult passages; some other good cartridges that we have tried put up rather a poor performance by comparison.

Following this we tried a demonstration record and the cartridge had no difficulty in tracking the many difficult passages.

Our overall impression is that the 1000ZE/X is a fine cartridge offering excellent trackability at low tracking weights and has a reasonably good response.

Recommended Resale Price: £50.50

tomorrows sounds - at 1/2 today's prices

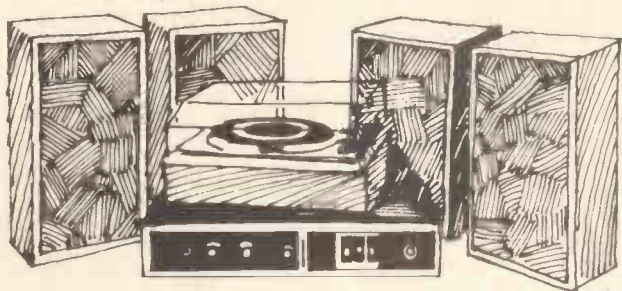

ALBANY HOUSE
20 8 Amp or 108 Amp.
SP25 Package Unit.
4 speakers Analog 8TC
ANALOG PRICE
£51.50+VAT
Post & Packing £3.00
with 4 Analog 8+3
speakers
£60.00+VAT

ROITONE AMPLIFIER SYSTEM

15 watts RMS per channel
1PR ANALOG 152 speakers.
SP25 with G800 in plinth
and cover fully wired.
TODAY'S VALUE £138
ANALOG PRICE
£58.00+VAT

Post & Packing £3

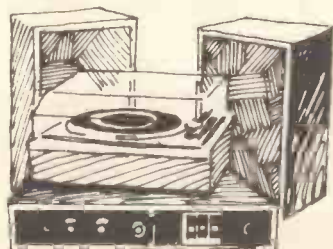
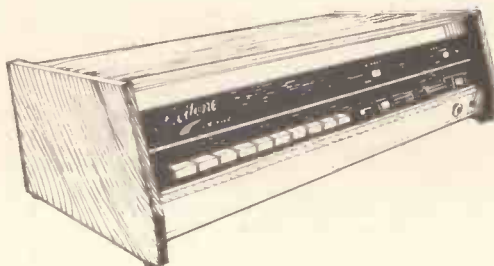

TELETON SAQ 206B/307 SYSTEM

Complete with Garrard
SP2S Mk. III, Goldring
G800 cartridge, plinth and
cover, 2 ANALOG speakers
each with 8" bass+3"
tweeter.

£49.00+VAT
Post & Packing £2.50



TELETON GA202 SYSTEM

Comprising Teleton GA202 amplifier 16x16 watt RMS GARRARD SP25 Mk III with plinth and cover and Shure M75-6 cartridge. One pair of ANALOG 12T speakers or 152 speakers.

TODAY'S VALUE £140
£63.00+VAT
Post & Packing £3.00

RECORD DECK PACKAGES

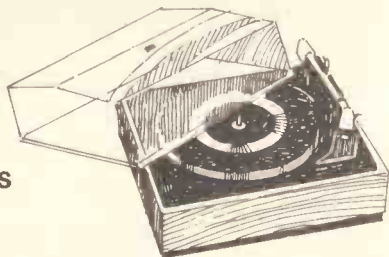

GARRARD SP25 Mk. III

with GOLDRING G800 with diamond stylus. Supplied in Teak veneered plinth with tinted perspex cover. Fully wired i.e. mains lead and 5 pin Din or Phono plug.

ANALOG PRICE £13.20+VAT

Fitted with Shure M75/6 £13.60+VAT
Fitted with Goldring G800H £14.00+VAT

Post & Packing £1

AMSTRAD 8000 SYSTEM

Garrard SP25 Mk III fitted Goldring G800 plinth and cover matched with a pair of Analog 8TC speakers.

£38.00+VAT
Post & Packing £2.50

STEREO AMPLIFIERS

Albany House 108 or 208	£18.60
Amstrad Integra 4000	£21.50
Amstrad IC2000	£26.20
Leak Delta 30	£45.00
Leak Delta 70	£55.00
Metrosound ST20E	£24.00
Metrosound ST60	£45.00
Pioneer SA500A	£33.60
Rogers Ravensbrook Mk III (cased)	£40.50
Rogers Ravensbourne Mk III (cased)	£50.00
Rotel 210	£22.40
Rotel 310	£34.80
Teleton 206B or 307	£21.40
Sansui	P.O.A.
Onkyo	P.O.A.

TUNERS

Amstrad 3000	£23.00
Leak AM/FM	£50.00
Metrosound FMS20 II	£30.00
Rogers R'brook (cased)	£29.00

TUNER AMPS

Goodmans Module 80	£52.50
Goodmans Module 90	£68.00
Goodmans 1-10	£79.00
Goodmans Module 80 Compact	£90.90
Leak Delta 75	£98.00
Philips RH702	£61.50
Philips RH781	£42.00
Rogers Ravensbrook	£60.00
Teleton TSF50 or TSF55	£52.50

TURNTABLES

Garrard SP25 Mk III	£8.00
Garrard AP76	£15.00
Garrard 401	£21.00

TURNTABLE PACKAGES (fully wired)

Garrard SP25 Mk III Goldring G800 P&C	£13.20
Garrard AP76/G800 P&C	£21.00
Goldring G101 P&C	£17.70
Goldring GL75P	£30.90
Goldring GL85P&C	£54.00
Leak Delta	£40.00
Pioneer PL12D	£31.00
Philips GA308	£22.00
Thorens TD125AB	£72.70
Thorens TD160AB&C	£41.00

SPEAKERS priced in pairs

Dentons	£23.50
Lintons	£29.00
Dovedales	£61.00
Ministers	£27.20
Havants	£31.40
Magnum K2	£58.00
Goodwoods	£70.70
Mezzo 3	£45.40
D/Maxims	£36.30
Dimension 8	£89.00
Ditton 10	£26.50
Ditton 15	£42.00
Ditton 25	£83.00
Ditton 44	£68.50
Ditton 120	£31.50
Ditton Counties	£28.00
B&W DM2	£77.00
Philips RH402	£20.00
Leak 150	£30.00
Leak 250	£38.00
Leak 600	£67.00

ADD 10% VAT TO ALL PRICES

Let us quote you on your requirements. Most leading manufacturers supplied: SANSUI, AKAI, ROTEL, TELETRON, PHILIPS GOODMAN, WHARFEDALE, LEAK, METROSOUND etc. Send a SAE with all enquiries.

ANALOG AUDIO

273 PENTONVILLE ROAD LONDON N1 (Beside Kings Cross Cinema)

Tel. 837 6641

779 FULHAM ROAD LONDON SW6 Tel. 731 3348

868A HIGH ROAD FINCHLEY N12 Tel. 01-445 1443 (All mail orders)

DESIGN-IN GERMANIUM TRANSISTORS

Engineers at Motorola are urging their customers to consider using germanium devices in their latest designs rather than automatically selecting a device from the silicon range. The reason for this rather surprising step, which runs against the popular trend, is that in a number of applications germanium transistors perform as well as their silicon counterparts but cost significantly less. In fact there are times when the extremely low saturation voltage of germanium transistors (0.3V at 150A) make them a much better choice than silicon.

Germanium devices *do* have some disadvantages, such as lower peak operating temperature (often offset by the lower V_{SAT} and higher leakage currents.

Advantages of germanium devices which have not already been mentioned include high reliability under temperature cycling conditions, higher gain at high currents, higher gain at low temperature, seventeen years of reliability history and, of course, the fact that all germanium devices are housed in hermetically sealed metal packages.

Motorola manufacture a comprehensive range of germanium devices from small signal to very high power with Jedec (2N) and in-house (M) type numbers. What is not so commonly known is that Motorola also manufacture a range of germanium devices that are registered with Proelectron in Europe. These include such well known types as OC29, OC35, OC36, AD149, ADY26 and the AUY19.

Motorola are asking engineers to look at both silicon and germanium devices before condemning the latter out of hand and to choose the device that meets the specification at the lowest cost. The number of times germanium will come out tops if this approach is adopted will surprise many.

LOW COST HEAT DETECTOR

The new fire regulations require all properties which provide overnight accommodation for more than 6 persons to be fitted with an acceptable fire alarm system. Up to now fire detection has been very expensive, so to meet the need for the sudden increase in good detection equipment Photain Controls Limited have introduced a new low cost heat detector.

Unlike most inexpensive detectors, the Photain Heat Detector eliminates the need for replacement cartridges. The normally closed contacts open when the ambient temperature reaches 60°C and remain open until the temperature drops to 55°C at which point the contacts close again auto-



matically. This closed circuit device is therefore suitable for connection into any fire alarm system using the closed circuit principle. This ensures that the alarm bell sounds if a fault develops with external wiring or if any sensor is removed from the system.

To enable the unit to blend into any decor, the detector is contained in a white circular plastic housing suitable for easy fitting to a standard conduit box. The entire detector is hermetically sealed to eliminate external open contact contamination and increase reliability.

Maximum switching capacity of the contacts is 10W and the operating temperature tolerance $\pm 5^\circ\text{C}$. The unit can be mounted in any position and provides coverage of approximately 400 sq.ft. The Price is £2.00 complete plus 10% VAT.

Photain Controls Ltd, Randalls Road, Leatherhead, Surrey.

HEAT SINKS

A new thermally conductive, electrically isolating silicone pad for mounting power semiconductors or other devices requiring electrical insulations plus high heat dissipation is now available from Steatite Insulations. The new materials, consisting of inorganic fillers dispersed in a silicone binder and known by the tradename CHO-THERM, are available in sheet- or die-cut forms and can be molded to special shapes as desired.

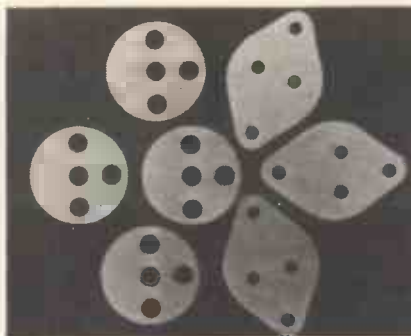

This flexible filled-silicone material is said to have excellent high- and low temperature properties, and represents a significant innovation because of its ability to conform to surface irregularities, unlike the brittle mica/beryllia/alumina materials. CHO-THERM's wholly non-toxic formulation is another important advantage.

Steatite Insulations Ltd, Hagley House, Hagley Road, Birmingham, B16 8QW.

5W AUDIO IC

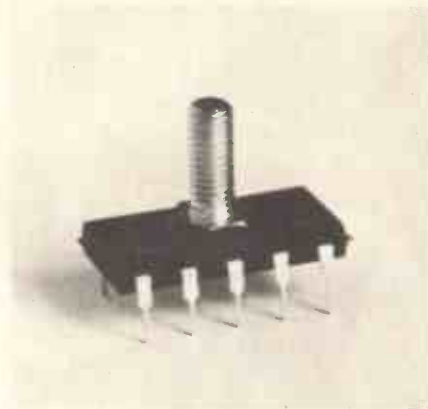

New from Plessey is the SL415 5W audio amplifier, the latest addition to the Plessey Semiconductors range of audio integrated circuits. This and the SL414 are encapsulated in the new plastic power package developed by Plessey to give high reliability. The package utilises currently available stud mounting heat sinks.

VOLTAGE REFERENCE DIODES

A wide range of voltage reference diodes for use in stabilised power supplies, digital voltmeters, etc. is available for immediate delivery from Mullard. Typical examples include families 1N821, BZX90 and BZV10, which have an operating voltage of 6.5V $\pm 5\%$ at currents of 7.5 or 2mA.

In applications where greater voltages are required, new reference voltage assemblies type BZV21 to BZV26 can be used. They have zener voltages ranging from 8.5 to 19V; types BZV21 to BZV23 operate with a current of 7.5mA, and types BZV24 to BZV26 with 2.0mA.

Voltage reference diodes can be supplied with currents other than defined above.

Mullard Ltd, Mullard House, Torrington Place, London W.C.1.

CALCULATOR CHIP PRICE REDUCTIONS

In a move which brings the single chip calculator within the reach of the small volume user or the engineer with a specific

eti component news

computational application in mind, General Instrument Micro-electronics have cut the small quantity prices of their single chip calculator series and are now offering their C500 microcircuit for £13.70.

This £18 reduction is such that an individual engineer can now build a complete calculator, using extensive application notes supplied with the microcircuit, for well under the market price.

The GIM calculator chips are available from Semicomps, Semiconductor Specialists and SDS Components Ltd.

The C550 is a Nitride version of the standard thick Oxide C500 chip. This means it will operate off a 15V supply instead of the present 24V. The C554 4+4 version provides 8 digits of accuracy in a 4 digit display machine. After each calculation the first 4 digits are displayed and then by pressing an interchange key the 4 least significant digits can be displayed.

Prices for the C500 range from £13.70 for one off to £9 each for 100 or more. The C550 ranges in price from £16 to £10.50 in the same price breaks.

Features of all four microcircuits include 8 digit accuracy and constant term facilities on all four functions. Chain calculations involving successive additions and multiplications can be executed with ease and logical simplicity and one feature of the chip which is of particular interest to instrument manufacturers is that it will not overflow or underflow.

General Instrument Microelectronics, 57/61 Mortimer Street, London W1N 7TD.

AUTOMATIC LAMP FADER

A new and versatile integrated circuit announced by Plessey can be employed in a number of useful power control situations. The I.C., type SL440, consists of a triac firing circuit, a timing circuit, an amplifier and a stabilised power supply.

A block diagram of the I.C. and the external components necessary to produce an automatic lamp fading circuit is shown in the illustration.

At each zero crossing of the mains supply capacitor C1 is charged. In between

zero crossings, during each half cycle, C1 discharges at a rate determined by the voltage at pin 13. The voltage across C1 is compared with a reference voltage produced within the chip and, when the capacitor voltage falls below the reference, the triac firing circuit produces a pulse which switches on the triac.

Clearly, the faster C1 discharges the earlier in each half cycle the triac will fire and the brighter will be the lamp.

When both S1 and S2 are open, the circuit functions as a conventional lamp dimmer with the brilliance of the lamp being controlled by R1. R2, together with R1, forms a potential divider between the common (neutral) line and the 11.3V supply provided by the voltage stabiliser on the SL440 chip. The lower the resistance of R1 the lower the potential at pin 13 and the brighter the lamp.

An amplifier on the chip can also be used to vary the potential at pin 13 and hence alter the lamp's brilliance. When switch S1 is closed the highly positive input to the amplifier results in the amplifier's output falling to produce the maximum light output. If S1 is opened light output is determined by the setting of R1.

Switch S2 connects a large electrolytic capacitor, C2, between the input and output of the amplifier to form an integrator circuit.

When both S1 and S2 are closed, the lamp output will be at maximum and capacitor C2 will charge. If S1 is now opened the lamp output will fall at a rate determined by the time constant of the integrator until the lamp's brilliance corresponds to the setting of R1. With the values shown the rate of fade is imperceptible to the human eye and takes between about 20 and 30 minutes. This time period can be shortened by using a smaller value capacitor for C2.

The SL440, is an extremely versatile device. Its use as an automatic lamp fader has been described, but it is also valuable in other TRIAC and SCR circuits. For instance, in motor speed control circuits the amplifier can be used to amplify the error voltage (the difference between a voltage proportional to desired speed and a voltage proportional to actual speed) and at the same

time control the triacs conduction angle accordingly.

Because the amplifier can be looked at as an inverting operational amplifier it is possible to build in all kinds of 'control laws' by integration, frequency response tailoring and the like.

The SL440 is available from SDS Components Ltd, Hilssea Trading Estate, Portsmouth, Hants. The price is £2.08 plus VAT plus postage.

NEW TRANSFORMER CORE

Our picture shows a new type of transformer core now available from Kent Insulations. This design has very real advantage over the traditional 'E' laminations in that it eliminates the time-consuming (and therefore expensive) business of inserting the individual laminations.



Once the coil has been wound, the two halves of the 'Waasner-Ready-Core' are simply pushed together. The wedging action of the centre sections ensures good magnetic continuity right through the core, while built-in clips hold the core securely together.

Kent Insulations Ltd, Power Road, Chiswick, London W4 5PZ

WIND DIRECTION POT

May Precision Components Ltd, are marketing a potentiometer designed for a wind direction indication system for marine and similar applications. The Deswynn System, which is one of the commercial designs available for yachting and in-shore shipping, is a d.c. system in which a mast-mounted

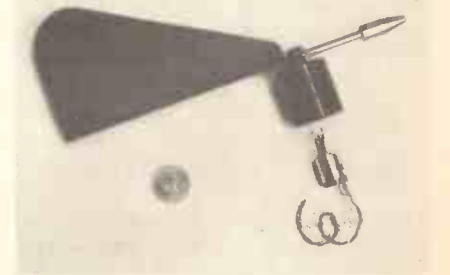

wind vane provides direct drive to a light-weight potentiometer. As the vane reacts to each change of direction, so the potentiometer accurately reflects this on a cockpit console. The potentiometer MR 101 was designed specifically for this application, and features exceptionally low-torque, low-weight factor, high linearity and is environmentally sealed. The company believe the MR 101 to be the smallest component of its type available.

May Precision Components Ltd, Bowlers Croft, Honywood Road, Basildon, Essex. ●

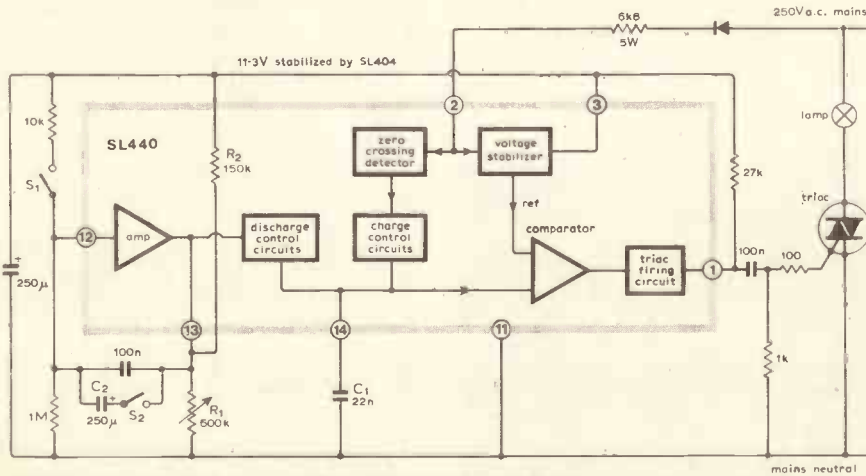

Why take the risk?

of damage to expensive transistors and integrated circuits, when soldering?

Use Antex low-leakage soldering irons

220-240 Volts or 100-120 Volts **Model X25**

The leakage current of the NEW X25 is only a few microamps and cannot harm the most delicate equipment even when soldered "live."

Tested at 1500v. A.C. This 25 watt iron with its truly remarkable heat-capacity will easily "out-solder" any conventionally made 40 and 60 watt soldering irons, due to its unique construction advantages.

Fitted long-life iron-coated bit 1/8".
2 other bits available 3/32" and 3/16".

Totally enclosed element in ceramic and steel shaft Bits do not "freeze" and can easily be removed.

PRICE: £1.75 (rec. retail)
Suitable for production work and as a general purpose iron

Model CCN 220 volts or 240 volts

The 15 watt miniature model CCN. also has negligible leakage.

Test voltage 4000v. A.C.

Totally enclosed element in ceramic shaft. Fitted long-life iron-coated bit 3/32".

4 other bits available
1/8", 3/16", 1/4" and 1/16"

PRICE: £1.80 (inc. retail)

OR Fitted with triple-coated, iron, nickel and Chromium bit 1/8"
PRICE: £1.95 (rec. retail)

A SELECTION OF OTHER SOLDERING EQUIPMENT.



MODEL CN

Miniature 15 watt soldering iron fitted 3/32" iron-coated bit. Many other bits available from 1/16" to 3/16". Voltages 240, 220, 110, 50 or 24
PRICE: £1.70 (rec. retail)

MODEL CN2

Miniature 15 watt soldering iron fitted with nickel plated bit 3/32". Voltages 240 or 220.
PRICE: £1.70 (rec. retail)



MODEL G

18 Watt miniature iron, fitted with long life iron-coated bit 3/32". Voltages 240, 220 or 110.
PRICE: £1.83 (rec. retail)

MODEL SK.1 KIT



contains 15 watt miniature iron fitted with 3/16" bit, 2 spare bits 5/32" and 3/32", heat sink, solder, stand and "How to Solder" booklet.

PRICE: £2.75

MODEL SK.2 KIT

contains 15 watt miniature iron fitted with 3/16" bit, 2 spare bits 5/32" and 3/32",

heat sink, solder, and booklet. "How to Solder"



PRICE £2.40

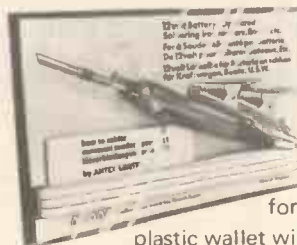

MODEL MES. KIT

Battery-operated 12v. 25 watt iron fitted with 15' lead and 2 heavy clips for connection to car battery. Packed in strong plastic wallet with booklet "How to Solder" PRICE: £1.95



From radio or electrical dealers, car accessory shops or, in case of difficulty direct from:—

ANTEX LTD. FREEPOST
(no stamp required) **Plymouth**
PL1 1BR Tel: 0752 67377

Reg. No. 393594

- Please send the ANTEX colour catalogue.
- Please send the following:

I enclose cheque/P.O./Cash (Giro No. 2581000)
All prices mentioned exclusive of V.A.T.

NAME _____

ADDRESS _____

ET16

Philips set a new high in Hi-Fi



Philips have used advanced technology to develop one of the world's finest integrated audio systems.

It is based on the very sophisticated Philips RH720 tuner-amplifier, which offers a high power output of 2 x 30 watts sine wave, every facility for the precise control of sound, and beautifully clear reception on long, medium, short and VHF/FM wavebands, including FM stereo.

You can select any of six preselected FM stations instantly by just laying a finger on any of six controls that are sensitive to the touch. They make ordinary pushbuttons seem clumsy. There's a switch to silence inter-station noise when tuning on FM, and another for Automatic Frequency Control

to ensure stable FM reception. Variable bandwidth on AM gives a wider range of tones where reception conditions allow, or increases even further the tuner's remarkable ability to separate crowded stations. You can connect two pairs of loudspeaker enclosures, perhaps in separate rooms, selecting either pair for stereo, or all four in one room for Philips STEREO-4 surround-sound.

The GA212 'electronic' record deck sets new high standards in record reproduction, with touch-sensitive speed selectors, photo-electronic switch-off, strobe for precise speed adjustment, electronic brain to keep speed constant during play, SUPER M magneto-dynamic cartridge, and many other top-quality features.

The RH405 enclosures each have three loudspeakers... for low, middle and high notes independently... giving beautiful full-frequency reproduction.

For a free 36-page Audio Guide, write to Philips Electrical Limited, Dept SP, Century House, Shaftesbury Avenue, London WC2H 8AS.

PHILIPS

We want you to have the best.

NEW HIGH – POWER LIGHTING CONTROL DIMMER

Photain Controls have announced the latest addition to their range of lighting control dimmers. The unit Type No. PT5000, is capable of controlling up to 5kW of incandescent lighting or 2kW of mercury or fluorescent lighting. It provides variation from a low output to full brilliance simply by turning a single knob. An on/off switch is also incorporated.

As well as providing the desired lighting effect when the mood or need requires it, prolonged lamp life and considerable savings in current consumption make this unit a useful feature for modern lighting. The dimmer measures 9in x 5in x 5in and a remote controller can also be supplied which can be mounted independently from the dimmer. This allows unobtrusive lighting control in the most luxurious of surroundings.



The PT5000 dimmer is contained in a grey pressed steel housing and operates on the normal mains supply. The unit incorporates a high speed fuse as protection against external overload and special Radio/T.V. suppressors are fitted as standard.

The semiconductor devices incorporated in this unit provide a degree of reliability and safety not found in some other dimmers and are rated far in excess of expected requirements to allow for heating effects and load surges. The dimmer costs £36 plus VAT and the remote control £4 plus VAT.

Photain Controls Ltd., Randalls Road, Leatherhead, Surrey.

DIGITAL MULTIMETER

Fenlow Electronics Ltd have announced the introduction of a new 4½ digit multimeter, Model 705.

The design team have concentrated on producing a sophisticated instrument at a competitive price for the general laboratory



and production line testing market. Recognising that many purchasers of 0.01% instruments are essentially after the certainty of a worst case accuracy of 0.1%, the design concentrated on extending resolution to 1 in 30,000 thus offering a worst case last digit of 0.03%.

Many environments in which DVMs are employed are far from ideal and engineers and technicians are often inconvenienced by the limitations of the instrument performance.

One problem area in high resolution instruments is series mode mains interference. If the last digit is resolving to 1 part in 10,000, then a series mode rejection of 60dB is inadequate if the interfering voltage is greater than 10% of full scale. In order to extend the performance in this area, Fenlow have employed their "strobe locked" technique which improves the rejection figure by 20dB. Further filtering can improve the figure by another 20dB giving a final figure of 100dB.

Continued Overleaf

REMOTE CONTROL BY TELEPHONE



Projex Instruments Ltd are launching in the UK a data monitoring and control system which uses the public switched telephone network. The equipment, manufactured by the Danish company N. Tonnes Pedersen A/S, is designed for the remote control of widely dispersed functions such as exist in electricity distribution systems, pumping stations, relay stations, purifying and heating plants and virtually any other application where centralised control of remote, unmanned operations is required.

The standard system Type NTP 275, which has been tested and accepted by the GPO as permitted equipment, operates over conventional telephone subscribers' lines using a voice frequency PCM system, and consists of one control station and up to fifteen substations. Capacity per substation is: 6 double control facilities ('on/off' or

'increase/decrease'), 6 feedback facilities ('on/off/intermediate'), 6 alarms for change of state since last control operation, 6 separate alarm circuits and 2 x 6 analogue metering circuits.

The control station has an optional VDU which will display all data states of each substation as it is dialled. The display can be held even after the line has been cleared so that a complete picture of all conditions at all substations is given at any time.

The system, which is largely solid state – allowing its use with either mains or battery supplies – is believed to be the first of its type to provide not only remote monitoring and alarm facilities but also positive control functions using public telephone lines.

Projex Instruments Ltd., 303 Morland Road, Croydon, CRO 6HF.

Features of the instrument are: a scale length of 2.9999 giving a resolution of 0.003%; 80dB of series mode and 126dB of common mode rejection at 50Hz, 140dB d.c. Common Mode Rejection.

D.C. voltage may be measured from 10 μ V – 1000V, a.c. voltage from 10 μ V to 600V and a.c. and d.c. current from 10nanoamps to 2A. The resistance measurement capability extends from 100 milliohms to 30 megohms.

The instrument is ruggedly housed in a compact all metal case and is priced at £297.

Bryans Southern Instruments Ltd., 1 Willow Lane, Mitchum, Surrey CR4 4UL.

NEW CONVERTER

New from Datron Ltd. is a true r.m.s. to d.c. converter Type 1110 with a bandwidth of 1MHz – 1Hz (optionally 0.01Hz) and 6 ranges from 10mV to 100V full scale. The unit uses special sensing circuitry which directly computes the *true r.m.s.* values of sinusoidal and non sinusoidal waveforms, thus overcoming many of the shortcomings of conventional thermal r.m.s. to d.c. converters. Its accuracy is stated to be 0.1% of reading + 0.02% full scale, even at very low frequencies with high crest factor signals. Crest factor is given at 5:1 at all frequencies.



The 1110 has an overrange capability of 200%, input impedance of 1M Ω , has optional isolated programming capabilities which are TTL compatible and has an operating temperature range of 0–50°C. List price is given as £199.

Datron Electronics Ltd., Hotblack Road, Norwich, Norfolk.

FLASHER UNIT

AP Electronics has introduced a new electronic flasher unit that has been designed primarily to operate motorway hazard warning lights.

As well as being able to operate these warning lights, the flasher unit can also be used to operate lights for school children's crossings and zebra crossings and for other similar applications, such as at railway level crossings. Furthermore, the flasher units may be remotely controlled from a central point, obviating the need for personnel to visit numerous places.

Two versions of the flasher unit are available – one for 12V battery-only opera-

50MHZ TIMER COUNTER



The Advance TC17 counter timer offers a 6 digit display with decimal point and overflow indicator, and display storage when required.

This instrument measures frequencies from d.c. to 50MHz with a maximum resolution of 0.1Hz. For higher resolutions at frequencies below 1MHz, multiple period measurement facilities are provided. Input sensitivity is 25mV r.m.s. over the full bandwidth, and a three position attenuator provides alternative sensitivities of 250mV and 2.5V. An input impedance of 1M Ω in parallel with 25pF enables the instrument

to be used with standard oscilloscope probes.

The internal 1MHz crystal standard enables a resolution of 1 μ s to be achieved on timing measurements, and positive or negative slope selection allows direct measurements to be made of many waveforms (e.g. pulse widths).

Options for the TC17 timer counter are available offering B.C.D. output and/or an 8 digit display, and a temperature compensated crystal.

Advance Electronics Ltd., Instrument Division, Raynham Road, Bishop's Stortford, Herts.

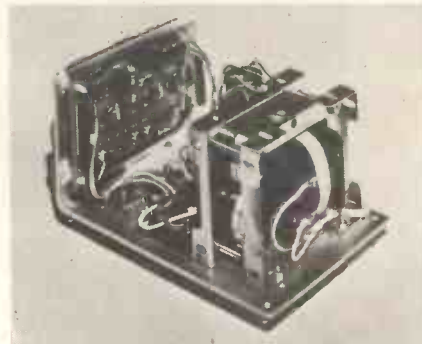

tion, while the other may be powered by mains or battery.

The flashing rate is adjustable from 55 to 70 on/off cycles per minute for each of two outputs, and is virtually constant over the temperature range of –10°C to +50°C. Protective circuits are incorporated to prevent both outputs being in the same state at the same time.

The output power is considered more than adequate for the types of application envisaged. The mains/battery version 36W lamp while the battery-only unit will drive a 48W lamp. Special versions of the flasher unit can be manufactured if required and the flasher can be supplied in a weatherproof case.

AP Electronics Ltd., 270 Acton Lane, Chiswick, London W.4.

DE-SOLDERING GUN

A new de-soldering instrument which eliminates the necessity for air or vacuum lines has been introduced by Adcola Products Ltd.

The R 500 has been designed for simple one hand operation and features an air bulb connected to the barrel by clear PTFE tubing. In use the de-soldering 'gun' reaches operating temperature in two minutes. The air bulb is depressed and the nozzle end of the barrel is then positioned over the joint to melt the solder.



The R 500 is available in a range of voltages from 6V to 250V and has an element rated at approximately 3W for efficient operation. It is robustly constructed for long term trouble-free operation to meet worldwide safety standards, and is priced at £6.72 plus VAT.

Vortexion

50/70 WATT ALL SILICON AMPLIFIER WITH BUILT-IN 5-WAY MIXER USING F.E.T.s

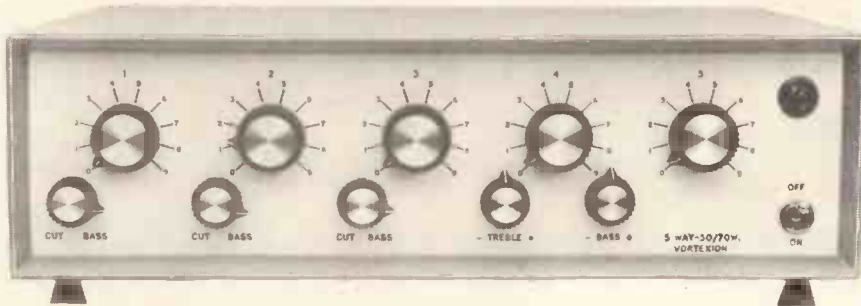

THIS is a high fidelity amplifier with bass cut controls on each of the three low impedance balanced line microphone stages and a high impedance (1.5 meg.) gram stage with bass and treble controls, plus the usual line or tape input. All the input stages are protected against overload by back to back low self capacity diodes and all use F.E.T.s for low noise, low intermodulation distortion and freedom from radio breakthrough.

A voltage stabilised supply is used for the pre-amplifiers

50/70 WATT ALL SILICON AMPLIFIER WITH BUILT-IN 4-WAY MIXER

(0.3% intermodulation distortion) using the circuit of our 100% reliable 100 Watt Amplifier with its elaborate protection against short and overload, etc. To this is allied our latest development of F.E.T. Mixer Amplifier, again fully protected against overload and completely free from radio breakthrough. The mixer is arranged for 2-30/60Ω balanced line microphones, 1-HiZ gram input and 1-auxiliary input followed by bass and treble controls. 100 volt balanced line output or 5/15Ω and 100 volt line.

100 WATT ALL SILICON AMPLIFIER

A high quality amplifier with 8 ohms-15 ohms or 100 volt line output for A.C. Mains. Protection is given for short and open circuit output over driving and over temperature. Input 0.4V on 100K ohms.

THE 100 WATT MIXER AMPLIFIER

with specification as above is here combined with a 4-channel F.E.T. mixer, 2-30/60Ω balanced microphone inputs, 1-HiZ gram input and 1-auxiliary input with tone controls and mounted in a standard robust stove enamelled steel case. A stabilised voltage supply feeds the tone controls and pre amps, compensating for a mains voltage drop of over 25% and the output transistor biasing compensates for a wide range of voltage and temperature. Also available in rackpanel form.

making it independent of mains supply fluctuations and another stabilised supply for the driver stages is arranged to cut off when the output is overloaded or over temperature. The output is 75% efficient and 100V balanced line or 8-16 ohms output are selected by means of a rear panel switch which has a locking plate indicating the output impedance selected. The mixer section has an additional emitter follower output for driving a slave amplifier, phones or tape recorder, output .3V out on 600 ohms upwards.

20/30 WATT MIXER AMPLIFIER

High fidelity all silicon model with F.E.T. input stages to reduce intermodulation distortion to a fraction of normal transistor input circuits. The response is level 20 to 20,000 cps within 2dB and over 30 times damping factor. At 20 watts output there is less than 0.2% intermodulation even over the microphone stage at full gain with the treble and bass controls set level. Standard model 1-low mic. balanced input and HiZ gram. Outputs available 8/15 ohms OR 100 volt line.

CP50 AMPLIFIER

An all silicon transistor 50 watt amplifier for mains and 12 volt battery operation, charging its own battery and automatically going to battery if mains fail. Protected inputs, and overload and short circuit protected outputs for 8 ohms—15 ohms and 100 volt line. Bass and treble controls fitted. Models available with 1 gram and 2 low mic. inputs, 1 gram and 3 low mic. inputs or 4 low mic. inputs.

200 WATT AMPLIFIER

Can deliver its full audio power at any frequency in the range of 30 c/s — 20 Kc/s \pm 1 dB. Less than 0.2% distortion at 1 Kc/s. Can be used to drive mechanical devices for which power is over 120 watt on continuous sine wave. Input 1 mW 600 ohms. Output 100-120V or 200-240V. Additional matching transformers for other impedances are available.

F.E.T. MIXERS AND PPMs

Various types of mixers available. 3, 4, 6 and 8 channel with Peak Programme Meter. 4, 6, 8 and 10 Way Mixers. Twin 3, 4 and 5 channel Stereo, also twin 4 and 5 channel Stereo with 2 PPM's.

VORTEXION LIMITED

257-263 The Broadway, Wimbledon, SW19 1SF

Telephone: 01-542 2814 and 01-542 6242/3/4

Telegrams: "Vortexion, London SW19"

But reel-to-reel quality is what you'll enjoy from TEAC's new A-450 cassette deck.

We call it the "Challenger." And we challenge you to tell the difference between it and reel-to-reel.

We've perfected our new deck to the point of keeping wow and flutter below 0.07%.

We even improved what you can expect from the Dolby* Noise Reduction System.

Of course, we built the well-known Dolby into our A-450 to eliminate tape hiss and noise.

But we also put the system on the monitoring circuit. So you can copy Dolby Cassette tapes and record FM Dolby broadcasts with de-coded monitoring.

Our best cassette deck deserves our best

heads. Which is why you get wear-free High Density Ferrite Heads.

And to assure you of the smoothest possible tape travel, we designed a new tape drive mechanism.

Our A-450 is the only cassette deck we know of that even allows for full mic-line mixing capabilities.

Reel-to-reel supremacy has been challenged by the A-450.

Yet over the years, TEAC has continually developed a quality line of cassette decks.

Both our A-350 and A-250 feature the Dolby System.

Because even on these decks, we knew that you should hear tapes only one way. Perfectly.

They also feature those sophisticated Ferrite Heads.

The A-350 and A-250 are great.

But our challenger is the A-450.

Remember. It's a cassette. But if you didn't see it, you'd swear you were listening to a reel-to-reel deck.



LEGALLY, WE CAN'T CALL THIS A REEL-TO-REEL DECK.

* 'DOLBY' is a trademark of Dolby Laboratories, Inc.

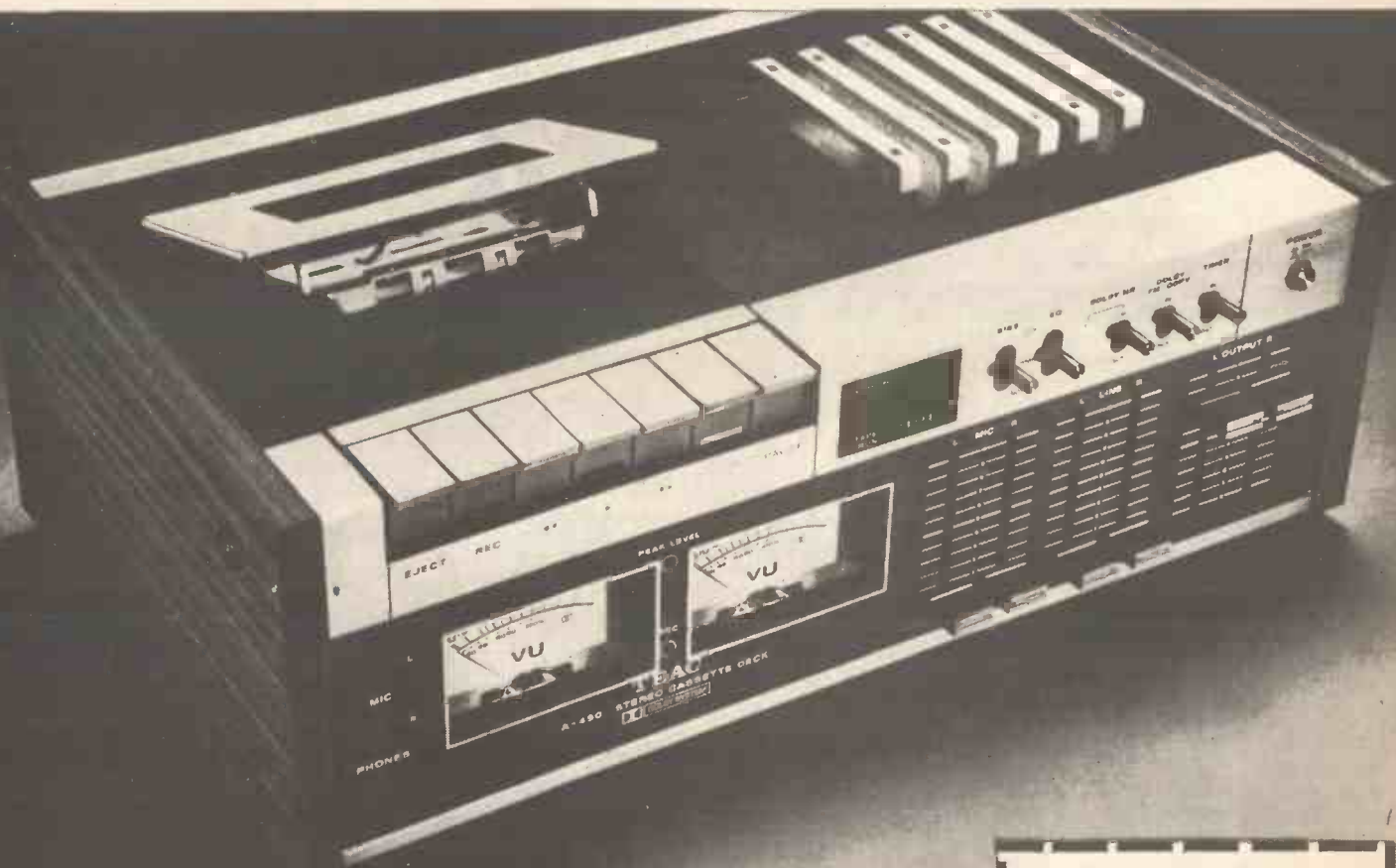

TEAC
The sound of perfection

Dear TEAC:
Please send me more information
about A-450, A-350 and A-250.

Name: _____

Address: _____

Post to Sole U.K. distributors: Acoustico
Enterprises Limited, 6-8 Union Street,
Kingston-upon-Thames, Surrey.
Telephone: 01-549 3471/3

eti

AUDIO NEWS

STEREO CONTROL UNIT

Connect this unit to your existing power amplifier, and at your fingertips you will have a degree of control over the audio spectrum previously unattainable with conventional tone control systems. JVC's unique Model SEA-10 takes the full audio range of 20 to 20,000Hz and divides it up into five discrete frequency bands centred at 40, 250, 1000, 5000, and 15,000Hz. Each band can then be varied independently by ± 12 dB using the professional type slider controls with 2dB click stops.



In addition, the centre frequencies of the bands at either end of the range can be changed from 40 to 60Hz and 15,000 to 10,000Hz at the touch of a button to apply extreme bass and treble cut respectively. This versatile tone control system, so necessary for true high-fidelity reproduction, allows you to tailor the sound just the way you like it and subtly compensate for poor recordings and deficiencies in room acoustics.

The SEA-10 handles signal inputs from a 100 to 800mV level with an input impedance of 100k. The unit possesses approximately unity gain and produces output signals of 1V maximum with a 1k output impedance. A wide frequency response of 20 to 30,000Hz is maintained with the total harmonic distortion kept below a negligible 0.1% at a 1V output level.

Other useful front panel features are a Tape Monitor switch and an S.E.A. Recording switch which allows tape recordings to be made through the S.E.A. Control system. The unit is housed in a compact, wood-finish, cabinet with an attractive satin-silver effect front panel.

EAGLE CATALOGUE

The new 1973 catalogue from Eagle International is designed to reflect the company's simple philosophy — produce a better, more consistent product, tell the truth about it and you have a customer who will return again.

Throughout its 48 pages, the Eagle range of electronic and audio products are amply

illustrated. Almost one hundred new products are featured in the catalogue which carries full specifications augmented with additional technical information.

The range includes high fidelity equipment, loudspeaker systems and drive units, cross-over networks, cartridges, pre-amplifiers, headphones, microphones, mixers, test equipment, accessories and components.

The new catalogue is free and copies can be obtained direct from *Eagle International, Precision Centre, Heather Park Drive, Wembley, HAO 1SU.*

EMI LAUNCHES ITS FIRST STEREO HI-FI AMPLIFIER TO MEET MIDDLE MARKET DEMAND

The introduction of a medium-priced solid-state stereo amplifier and a quadraphonic decoder marks EMI's intention to increase its stake in the mushrooming hi-fi hardware market, after many years as a manufacturer of high quality loudspeaker systems. Both EMI developments, the new 15W per channel amplifier and the decoder, which utilises the popular SQ Quad technique, were launched recently at a trade preview by EMI Pathe, a division of EMI Sound & Vision Equipment Ltd, Hayes, Middlesex.



The photograph shows the new EMI 1515 stereo amplifier and the smaller, EMI SQ 1500 quadraphonic decoder unit pictured with two EMI LE2 15W loudspeakers to form a complete 'add-on' package for converting a suitable existing stereo system for SQ quadraphonic reproduction.

Individual recommended retail prices of the equipment, including VAT, are: EMI 1515 stereo amplifier — £46.50; SQ 1500 decoder — £30; EMI LE2 loudspeakers — £54 a pair.

SURROUND-SOUND ADAPTOR

The Scan-Dyna 4D is an adaptor which is designed for adding to any stereo system to provide, what is claimed to be 'concert-hall' sound. All that is needed is a couple of extra speakers.

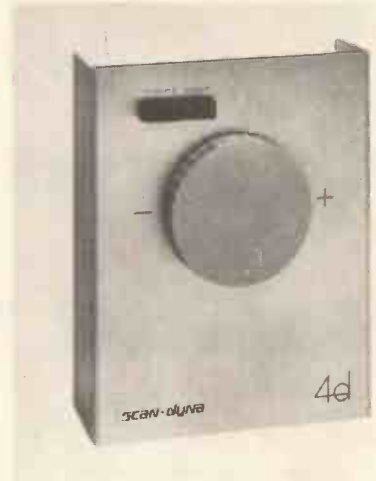

The outputs from the existing speakers are connected to the unit and this provides the four outputs, two to the original speakers and two others for the rear speakers. A level control is provided for the rear speakers. Recommended Resale Price is £12.90 plus VAT.

ITS A RECORD !

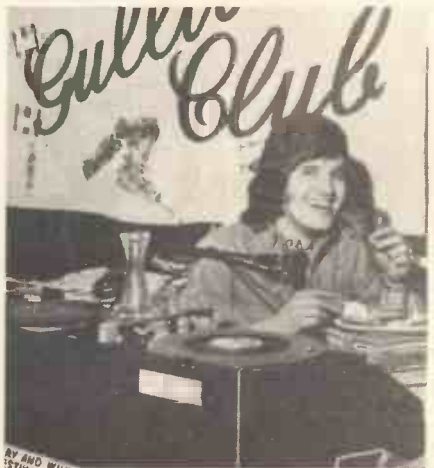

Tony Santos, resident disc jockey at London's swinging Gullivers Club, preparing for his recent successful marathon assault on the world record for non stop disc jockeying.

Using two Garrard SP25 record playing decks, part of a 500W discotheque system supplied by Soundout Systems, Tony played single-play records continuously for a total of 208 hours, breaking the previous record by over two hours.

During the 8½ day marathon, which he afterwards described as "tough", Tony lived on a prescribed diet of eggs, milk, yogurt and tea sweetened with honey. He smoked over 600 cigarettes, lost 10 pounds in weight and at one stage went through a period of hallucinations.

He is now training for an attempt on the world record for long playing records which stands at over 500 hours.

Can YOU improve on C-Scope?

We don't think you can.....
Because.....

C-SCOPE METAL DETECTORS FUNCTION ON THE INDUCTION BALANCE PRINCIPLE WHICH OFFERS A SUPERIOR AND STABLE PERFORMANCE ON ALL TERRAINS..... LAND AND WATER



C-SCOPE Mk I

CONTACT US FOR MORE INFORMATION ON BRITAIN'S BEST SELLING DETECTOR.....

C-SCOPE METAL DETECTOR CO.,
DEPT S3,
82 CASTLE STREET, CANTERBURY,
KENT. TEL: 60518.

eti TECH-TIPS

LOW REGULATED DC VOLTAGES

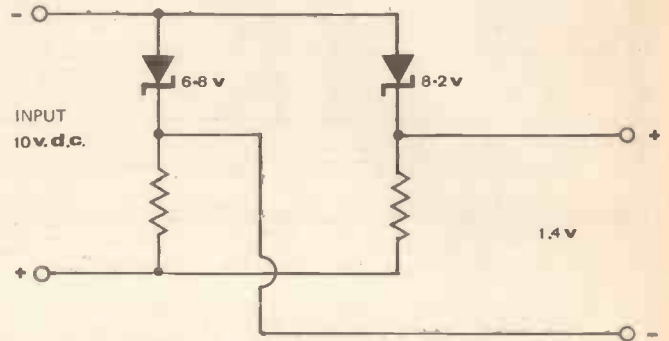

For some purposes it is necessary to use regulated dc voltages lower than can be obtained from commercially available zener diodes.

This can be achieved by using two zener diodes of different voltages and utilising the potential difference between them.

In the example shown, 6.8 volt and 8.2 volt zeners provide the required 1.4 volt difference.

One such application is the supply voltage for gallium arsenide emitters which, typically, require 1.4 volts \pm 0.05 volt.

In general, temperature compensation is excellent as both zeners tend to drift in the same direction — either positively or negatively, depending upon voltage. It is inadvisable to use zeners which bracket 5.6 volts, as below this voltage zeners have a negative temperature coefficient and above 5.6 volts they have a positive temperature coefficient.

SIMPLE SQUARE-WAVE GENERATOR

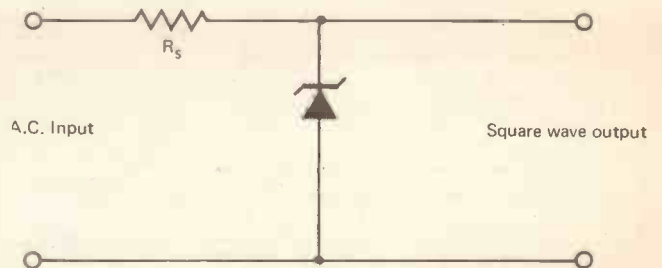

A zener diode clips one half-cycle of the input sine-wave in this simple square-wave generator. The zener voltage must be a small fraction of the input voltage for acceptable results.

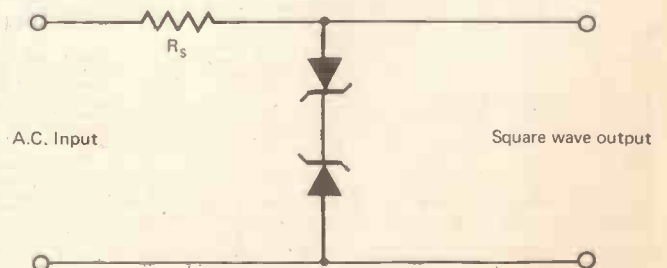

If a larger output is required, opposed zener diodes may be used to clip both halves of the input sine-wave.

SYNTHESISER?

Build your own using . . .

DEWTRON Professional Modules: Voltage-control system, man-size patching facility, Discount offers on quantity.

VOLTAGE-CONTROLLED OSCILLATOR. New VC0-2 gives SINE, SQUARE and TRIANGULAR symmetrical outputs simultaneously. Supplied singly or MATCHED and TRACKED 1v/Octave. All modules obtainable separately, including VC filters, VC amps, Keyboards, contacts, envelope shapers, sample/hold/envelope circuit, VC phaser, white noise, etc.

OTHER MANUFACTURERS USE DEWTRON Professional Modules in their equipment . . . that's sound reasoning! Kits for waa-waa, fuzz, bass pedal units, etc.

Write for catalogue NOW. 15p.

D. E. W. LTD

254 RINGWOOD ROAD, FERNDOWN, DORSET.

LOOK!



We are one of the largest trade stock holders of Semiconductors and if you haven't got one of our catalogues you are missing out.

So send a stamped addressed envelope and we will send you a copy FREE.



Semiconductor Supplies (Croydon) Ltd.
55, Whitehorse Road
Croydon, Surrey. CR0 2JG
Tel. 01-689 0676/7

ETI

THE PRINTED CIRCUIT BOARDS SHOWN IN THIS ISSUE OF ELECTRONICS TODAY INTERNATIONAL ARE AVAILABLE NOW . . .

Top quality fibre glass P.C.B.s drilled ready for assembly will be available month by month as the journal is published. P.C.B.s from all back issues continuously available.

COST? 6p per square inch – just calculate the area and send P.O. or cheque. Telephone orders welcome. 24-hour telephone answering service.

**SCHOFIELD ELECTRONICS,
GILMORTON, RUGBY, Warks.
Tel LUTTERWORTH 3578**

**FAST ECONOMICAL DEVELOPMENT OR
PRODUCTION RUN QUANTITIES.
PROTOTYPE ASSEMBLY.**

ESSENTIAL BOOKS

HOW TO MAKE WALKIE-TALKIES FOR LICENSED OPERATION. Practical working circuit diagrams and constructional details together with explanations on permitted use and operating hints. Only 40p. p.p. 10p.

PROBLEMS IN ELECTRONICS WITH SOLUTIONS. A must for the student, technician, and electronics engineer. Contains 349 problems, answers and how they were arrived at. Includes all aspects of electronics including computers, amplifiers, power supplies, aerials, filters, transmission lines, waveguides, semi-conductors etc. 307 pages. Only 90p. p.p. 10p.

COSMIC RADIO WAVES. Start a new hobby – Radio Astronomy. This big book of 444 pages is an ideal handbook for the beginner and established enthusiast. Numerous photographs and illustrations. Published by Oxford University Press. Price £2.50. p.p. 25p.

THE GOVERNMENT SURPLUS WIRELESS EQUIPMENT HANDBOOK. Gives circuits, data, illustrations and valuable information for British/USA receivers, transmitters, trans/receivers. With modifications to sets and test equipment. Latest impression £3.25 including postage. **DIRECTORY OF GOVERNMENT SURPLUS WIRELESS EQUIPMENT DEALERS.** Gives details of surplus wireless equipment stores and dealers including addresses, plus equipment and spares that they are likely to have available. A valuable book only 40p. p.p. 10p. (Allow 14 days for delivery of this book.)

A NEW GUIDE TO HI-FI FOR BEGINNERS. By J. R. Hey. Tech. (CEI) MSERT. Before buying Hi-Fi equipment you must read this latest publication. It may save you pounds. An excellent guide to the purchase of ready made Hi-Fi equipment. Price only 40p. p.p. 10p.

THE SCATTERING & DIFFRACTION OF WAVES. A goldmine of information for the experimenter, amateur and scientist. Profusely illustrated. Published by Oxford University Press. Price £1.60 post free. **A DICTIONARY OF SCIENTIFIC UNITS.** An important reference book for the student and technician. Lists and defines units which have been or still are being used in the Common Market Countries and throughout the world. Includes all dimensionless numbers and scales used in Science. 204 pages. Only 50p. p.p. 10p.

HANDBOOK OF SATELLITES AND SPACE VEHICLES. A comprehensive working handbook that provides important data both tabular and graphical, enabling space scientists, technicians and engineers to acquire a greater working knowledge of satellite and space vehicle design, launching, orbiting etc. Includes a detailed coverage of COMMUNICATIONS IN SPACE. An imposing book. 457 pages. Published at £8.20 but supplied at the trade price of £6.50 post free.

DEPT. ET, GERALD MYERS, Bookseller & Publisher,
18 SHAFTSBURY STREET, LEEDS LS12 3BT, Yorkshire.

SAVE TIME AND MONEY

LIST PRICE £6.25

OUR PRICE £4.84



As supplied by us to SCHOOLS, TECHNICAL COLLEGES, SHOPS, OFFICES AND INDUSTRY. Silver grey stove enamelled steel cabinet with 48 transparent styrene drawers fitted with moulded handles and label slots. Dividers can be supplied at an extra charge to enable each drawer to be sub-divided into six compartments. Transparent drawers allow swift selection of components at a glance and eliminate duplication of stock. A really first class time saving unit. Size of cabinets 21½" x 11½" x 6½". Size of drawers 6½" x 2½" x 1½". Other sizes available. Callers welcome Mon.-Sat. 9 a.m.-1 p.m. 2 p.m.-6 p.m. NEW as illustrated OUR PRICE ONLY £4.84 plus 25p carriage on orders less than £10. Money back guarantee. SEND FOR FREE COLOUR BROCHURE.

TRADE AIDS

(DEPT. ET.1), 111 CHILTERN DRIVE,
BERRYLANDS, SURBITON, SURREY

01-399 4383

100 yds. Berrylands Railway Station.

Would you spend an hour a day to earn more money in Electronics-Television-Radio?

Study at home, at your own pace, when you choose – for an hour or more a day – and we can turn your interest into the technical knowledge you need for success. Or if you're already in the industry, we'll help you get on! With ICS you get the guidance of the foremost tuition experts in the field. Take your first step to success now – send for your FREE Careers Guide today.

ICS your key to the door
of opportunity

Tick or state subject of interest and post to:
International Correspondence Schools, Dept. 2558
Intertext House, Stewarts Road, London SW8 4UJ.

Subject of Interest:

- | | |
|---|---|
| <input type="checkbox"/> Society of Engineers Graduateship (Electrical Engineering) | <input type="checkbox"/> Audio, Radio & TV Engineering & Servicing |
| <input type="checkbox"/> C & G Telecommunications Technicians Certificates | <input type="checkbox"/> Electronic Engineering, Maintenance, Engineering systems, Instrumentation & Control systems. |
| <input type="checkbox"/> C & G Electrical Installation Work | <input type="checkbox"/> Computer Engineering and Technology |
| <input type="checkbox"/> C & G Certificate in Technical Communication Techniques | <input type="checkbox"/> Electrical Engineering, Installations, Contracting, Appliances |
| <input type="checkbox"/> MPT General Certificate in Radio Telegraphy | <input type="checkbox"/> Self-build radio courses |

Name _____

Address _____

Occupation _____

Age _____

Accredited by the Council for the Accreditation of Correspondence Colleges.

M.Sc. Course in Electrical Engineering

with specialisation in any one of the following:

**Electrical Machines,
Power Systems,
Communication Systems,
Electronic Instrumentation Systems,
Control Engineering and Digital
Electronic Systems,
Design of Pulse and Digital Circuits
and Systems,**

The Course, which commences in October 1973, may be taken on a Full Time, Part Time, sandwich or Block Release basis, and is open to applicants who will have graduated in Engineering or Science, or who will hold equivalent qualifications, by that date. The Science Research Council has accepted the Course as suitable for the tenure of its Advanced Course Studentships.

Research in Electrical Engineering

Applications are also invited from similarly qualified persons who wish to pursue a course of research leading to the Degree of M.Phil. or Ph.D. in any of the above subjects.

Application forms and further particulars from the Head of the Department of Electrical Engineering (Ref: M.Sc. 8), The University of Aston in Birmingham, BIRMINGHAM B4 7PB.



THE UNIVERSITY
OF ASTON
IN BIRMINGHAM

5 DIGIT 32MHz FREQUENCY COUNTER TYPE 301



£75

Exclusive of VAT

SEVEN SEGMENT DISPLAY
CRYSTAL REF OSCILLATOR
RESOLUTION 1Hz
MAINS or 12 VOLT SUPPLY
SENSITIVITY 50mV
AUTO DECIMAL POINT
AUTO LEVEL
LEADING ZERO SUPPRESSION

OTHER MODELS AVAILABLE:--

401 6 DIGIT 32MHz £110
501 8 DIGIT 32MHz £160
701 8 DIGIT 50MHz £170
8012 8 DIGIT 300MHz £260
MEMORY VERSIONS + £25
START STOP FACILITY + £10
DC INPUT TO ORDER

Write for illustrated leaflet. Supplied to and acclaimed by professional engineers everywhere who have purchased our electronic instruments for the past 10 years.

RCS

R. C. S. ELECTRONICS
NATIONAL WORKS, BATH ROAD,
HOUNSLOW, MIDDX. TW4 7EE
Telephone: 01-572 0933/4

sinclair

CREATIVE ENGINEERS

Sinclair Radionics are probably the fastest expanding electronics company in the country. The company, founded in 1961, designs and markets electronic calculators, hi fidelity equipment and digital instruments. To keep pace with the demand for its existing products and future developments, the company requires the following engineers:

SENIOR ELECTRONICS DESIGN ENGINEER Candidates should have at least three years experience of linear circuit design; HF and VHF experience is particularly desirable. The ability to lead a team of highly creative engineers is essential. Ref. SED/SX

TWO LINEAR ELECTRONIC DESIGN ENGINEERS With several years experience of linear circuit designs. Ref. PED/SX

DIGITAL ELECTRONIC DESIGN ENGINEER With experience of digital system design and ideally machine code programming. Candidates should have 3-4 years experience of logic design. Ref. ED/SX

OPTICAL ENGINEER An exceptional engineer is required to design lenses and optical systems for calculators and other electronic instruments. Ref. OE/SX

CHIEF MECHANICAL DESIGN ENGINEER To assume responsibility for all aspects of mechanical and electro-mechanical design. Experience and detailed knowledge of plastic technology and reliable small mechanism design is essential. Ref. CMD/SX

The company is very research and development orientated and engineers have much more responsibility than is usual. The superbly equipped laboratory is located in the former River Mill at St Ives (Hunts) 12 miles north of Cambridge, within easy reach of London. Salaries are based on ability and are among the highest in the country. Interview and removal expenses will be paid.

If you wish to be considered, write or phone Geoffrey King of Cambridge Recruitment Consultants, who have been retained to fill these positions.

Cambridge Recruitment Consultants,
8a Rose Crescent, Cambridge.
Telephone: 0223 64936

BYWOOD

Bywood Electronics, 181 Ebbens Road, Hemel Hempstead,
Herts. 0442 62757

LEDS

TIL302	4 for	£10
	6 for	£14
DL34	4 digits	£15
TIL360	6 digs	£18
TIL209	4 for	£1
	50 for	£10

ICs

MM5311	Clock	£12.50
ZN414	Radio	£1.10
Sig555	Mono/astab	£0.90
CA3082	7-seg driv	£2.10

METERS

Sinclair DM1 £49

KITS (incl IC sockets)

Calculator	£41
Digitronic (6)	£36
Digitronic (4)	£32
Bywood clock kit	£34

CALCULATORS

Advance Mini	£45
Advance Exec 8	£45
Advance Exec 16-1	£95
Advance Exec 16-2	£110

Post & Packing —

ICs, LEDS : 10p

KITs, CALCs, Meter : 50p

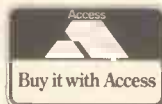

ACCESS — You may telephone your order and pay by **ACCESS**

ANSAPHONE — 24 hour service.

LATEST ! I NEW DIGITAL CLOCK ICs AVAILABLE WITH ALARMS!
SAE FOR DETAILS

team up with the new look e.t.i.

IS YOUR BUSINESS SELLING ELECTRONIC EQUIPMENT?

IS YOUR BUSINESS SELLING QUALITY AUDIO EQUIPMENT?

ARE YOU LOOKING FOR EXPERIENCED STAFF?

THEN

TAKE ADVANTAGE OF OUR NEW CLASSIFIED SECTION
FOR FULL DETAILS OF THE REALISTIC INTRODUCTORY RATES

CONTACT

ALEX G MELLON, ADVERTISEMENT MANAGER
ON 01 - 730 2136/7/8/9

OR WRITE TO: ELECTRONICS TODAY INTERNATIONAL
36 EBURY STREET LONDON SW1W 0LW

INDEX TO ADVERTISERS

Acoustico	80
Advance Calculator	31
Akai	19
Analog Audio	72
Antex	75
Appollo	48
BIET	Cover iii
Bi-Pak	12, 13
Bi-Pre-Pak	52
Classified Ads	83, 84, 85
C-Scope Metal Detector Co.	82
Eagle	40
Eddystone	6
Heathkit	48
Henry's Radio	10
Hitachi	4
J-BEAM Aerials Ltd	43
K & K Electronics Ltd	62
Onkyo	Cover ii
Philips Electrical	75
Rotel	34, 35
RCS	84
Sansui	Cover iv
Smith J	47
Teleton	8
Vortexion	79
Wharfedale	69

NEWSAGENT:

Please deliver **ELECTRONICS TODAY INTERNATIONAL** for 12 months, starting with the.....issue:

NAME

ADDRESS

GIVE THIS COUPON TO YOUR LOCAL NEWSAGENT

USE THIS COUPON



costs no more

delivered to your door ...

...by your local newsagent

For only £2.40 a year (12 issues at 20p each) you ensure that every copy of **ELECTRONICS TODAY INTERNATIONAL** will arrive on your doorstep as soon as it is published — and that you'll never miss out on it if an issue happens to sell out.

electronics TODAY INTERNATIONAL

FREE!

Over 150 ways to engineer a better future

HIGHER PAY **A BETTER JOB**

SECURITY

find out how in just 2 minutes

That's how long it will take you to fill in the coupon. Mail it to B.I.E.T. and we'll send you full details and a free book. B.I.E.T. has successfully trained *thousands* of men at home - equipped them for higher pay and better, more interesting jobs. We can do as much for YOU. A low-cost B.I.E.T. home study course gets results fast - makes learning easier and something to look forward to. There are no books to buy and you can pay-as-you-learn.

Why not do the thing that really interests you? Without losing a day's pay, you could quietly turn yourself into something of an expert. Complete the coupon (or write if you prefer not to cut the page). No obligation and nobody will call on you . . . but it could be the best thing you ever did.

Others have done it, so can you

"Yesterday I received a letter from the Institution informing that my application for Associate Membership had been approved. I can honestly say that this has been the best value for money I have ever obtained - a view echoed by two colleagues who recently commenced the course".— Student D.I.B., Yorks.

"Completing your course, meant going from a job I detested to a job that I love, with unlimited prospects".—Student J.A.O. Dublin.

"My training with B.I.E.T. quickly changed my earning capacity and, in the next few years, my earnings increased fourfold".—Student C.C.P., Bucks.

FIND OUT FOR YOURSELF

These letters - and there are many more on file at Aldermaston Court - speak of the rewards that come to the man who has given himself the specialised know-how employers seek. There's no surer way of getting ahead or of opening up new opportunities for yourself. It will cost you a stamp to find out how we can help you. Write to B.I.E.T. Dept. BE106 Aldermaston Court, Reading RG7 4PF.

Practical Radio & Electronics Certificate course includes a learn while you build **3 transistor radio kit.**

Everything you need to know about **Radio & Electronics** maintenance and repairs for a **spare time income** and a **career** for a better future.

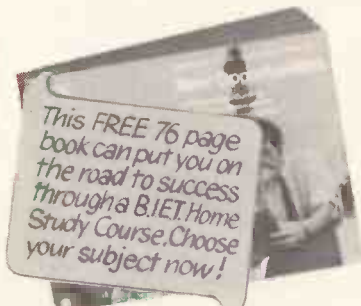

This FREE 76 page book can put you on the road to success through a B.I.E.T. Home Study Course. Choose your subject now!

CUT OUT THIS COUPON

Tick or state subject of interest. Post to address below.

<input type="checkbox"/> MECHANICAL	<input type="checkbox"/> Man. Prod.—cont.	<input type="checkbox"/> Constructional-cont.
<input type="checkbox"/> A.M.S.E. (Mech.)	<input type="checkbox"/> Quality Control	<input type="checkbox"/> Building
<input type="checkbox"/> Boiler Inspect. & Operation	<input type="checkbox"/> Salesmanship	<input type="checkbox"/> Building Drawing
<input type="checkbox"/> C & G Eng. Crafts	<input type="checkbox"/> Storekeeping	<input type="checkbox"/> Build. Foreman
<input type="checkbox"/> C & G Fabricat.	<input type="checkbox"/> Work Study	<input type="checkbox"/> Carpentry & Join.
<input type="checkbox"/> Diesel Eng.	<input type="checkbox"/> Works	<input type="checkbox"/> Civil & Municipal
<input type="checkbox"/> Eng. Inspection	<input type="checkbox"/> Management	<input type="checkbox"/> Engineering
<input type="checkbox"/> Eng. Metallurgy	<input type="checkbox"/> DRAUGHTSMANSHIP	<input type="checkbox"/> Constructional
<input type="checkbox"/> Inst. Eng. & Tech.	<input type="checkbox"/> A.M.I.E.D.	<input type="checkbox"/> Construction
<input type="checkbox"/> Inst. Motor Ind.	<input type="checkbox"/> Design of Elec. Machines	<input type="checkbox"/> Surveyors
<input type="checkbox"/> Mainten. Eng.	<input type="checkbox"/> Die & Press Tool Design	<input type="checkbox"/> Institute
<input type="checkbox"/> Mechanical Eng.	<input type="checkbox"/> Electrical Draughtsmanship	<input type="checkbox"/> Clerk of Works
<input type="checkbox"/> Sheet Metal Work	<input type="checkbox"/> Gen. Draughtsmanship	<input type="checkbox"/> Council Eng.
<input type="checkbox"/> Welding	<input type="checkbox"/> Jig & Tool Des.	<input type="checkbox"/> Health Eng.
<input type="checkbox"/> ELECTRICAL & ELECTRONIC	<input type="checkbox"/> Tech. Drawing	<input type="checkbox"/> Heat & Vent.
<input type="checkbox"/> A.M.S.E. (Elec.)	<input type="checkbox"/> RADIO & TELECOMMUNICATIONS	<input type="checkbox"/> Hydraulics
<input type="checkbox"/> C & G Elec. Eng.	<input type="checkbox"/> Colour TV	<input type="checkbox"/> Inst. of Builders
<input type="checkbox"/> C & G Elec. Inst.	<input type="checkbox"/> C & G Radio/TV/ Electronics	<input type="checkbox"/> Inst. Works & Highway Sup.
<input type="checkbox"/> C & G Elec. Tech.	<input type="checkbox"/> C & G Telecomm. Tech.	<input type="checkbox"/> Painting & Dec.
<input type="checkbox"/> Computer Elect.	<input type="checkbox"/> Pract. Rad. Elec. (with kit)	<input type="checkbox"/> Public Hygiene
<input type="checkbox"/> Elec. Maths	<input type="checkbox"/> Radio Amateurs Exam.	<input type="checkbox"/> Road Engineer.
<input type="checkbox"/> Elec. Science	<input type="checkbox"/> Radio Servicing & Repairs	<input type="checkbox"/> Structural Eng.
<input type="checkbox"/> Electronic Eng.	<input type="checkbox"/> Radio & TV Eng. Trans. Course	<input type="checkbox"/> Surveying
<input type="checkbox"/> Electrical Eng.	<input type="checkbox"/> TV Main. & Serv.	<input type="checkbox"/> GENERAL
<input type="checkbox"/> Install. & Wiring	<input type="checkbox"/> AUTO & AERO	<input type="checkbox"/> Agricultural Eng.
<input type="checkbox"/> Meters & Measuring Instruments	<input type="checkbox"/> Aero Eng.	<input type="checkbox"/> Council of Eng. Inst.
<input type="checkbox"/> MANAGEMENT & PRODUCTION	<input type="checkbox"/> A.M.I.M.I.	<input type="checkbox"/> Farm Science
<input type="checkbox"/> Auto. Control	<input type="checkbox"/> A.E.C. Cert.	<input type="checkbox"/> General Educat.
<input type="checkbox"/> Computer Prog.	<input type="checkbox"/> Auto Engineer.	<input type="checkbox"/> Gen. Plastics
<input type="checkbox"/> Electronic Data Processing	<input type="checkbox"/> Auto Repair	<input type="checkbox"/> Pract. Maths
<input type="checkbox"/> Estimating	<input type="checkbox"/> C & G Auto. Eng. Garage	<input type="checkbox"/> Pract. Slide Rule
<input type="checkbox"/> Foremanship	<input type="checkbox"/> Management	<input type="checkbox"/> Pure & Applied Maths
<input type="checkbox"/> Inst. Cost & Man. Accountants	<input type="checkbox"/> MAA/IMI Dipl.	<input type="checkbox"/> Refrigeration
<input type="checkbox"/> Inst. Marketing	<input type="checkbox"/> Motor Vehicle Mechanics	<input type="checkbox"/> Rubber Tech.
<input type="checkbox"/> Management	<input type="checkbox"/> CONSTRUCTIONAL	<input type="checkbox"/> Sales Engineers
<input type="checkbox"/> Metrication	<input type="checkbox"/> A.M.S.E. (Civil)	<input type="checkbox"/> Tech. Report
<input type="checkbox"/> Motor Trade Man.	<input type="checkbox"/> Architecture	<input type="checkbox"/> Writing
<input type="checkbox"/> Network Plan.	<input type="checkbox"/> Coaching for many major exams. including ONC, C & G, etc.	<input type="checkbox"/> Timber Trade
<input type="checkbox"/> Numerical Cont.		<input type="checkbox"/> University Ent.
<input type="checkbox"/> Operational Research		
<input type="checkbox"/> Personnel Man.		
<input type="checkbox"/> Planning Eng.		
<input type="checkbox"/> Production Eng.		

G.C.E.

58 'O' & 'A' LEVELS SUBJECTS Over 10,000 group passes

POST TODAY FOR A BETTER TOMORROW

To B.I.E.T., Dept. BE106 Aldermaston Court, Reading RG7 4PF

NAME _____
Block Capitals Please
ADDRESS _____

OTHER SUBJECTS _____ AGE _____

Accredited by C.A.C.C.

BRITISH INSTITUTE OF ENGINEERING TECHNOLOGY

The entrancing world
of SANSUI's quadrasonic 4-channel stereo.



The complete range of Sansui's sophisticated
4-channel equipment at your dealer's now!

England : VERNITRON(UK)LTD. Thornhill Southampton SO9 5QF Tel : Southampton 44811

Sansui



4-CHANNEL STEREO

SANSUI AUDIO EUROPE S.A. Diacem Bldg., Vestingstraat 53-55, 2000 Antwerp, Belgium
SANSUI ELECTRIC CO., LTD. 14-1, 2-chome, Izumi, Suglnami-ku, Tokyo, Japan

SANSUI ELECTRONICS CORPORATION 32-17 61st Street, Woodside, New York 11377, U.S.A.

9 Broomfield