

Founded 1925

Incorporated
by Royal Charter 1961*To promote the advancement
of radio, electronics and kindred
subjects by the exchange of
information in these branches
of engineering*

The Radio and Electronic Engineer

The Journal of the Institution of Electronic and Radio Engineers

NEWS AND COMMENTARY

THE INSTITUTION'S TRIBUTE TO LORD MOUNTBATTEN

Admiral of the Fleet Earl Mountbatten of Burma, KG (Honorary Fellow 1965, Fellow 1935), was killed in Ireland on 27th August 1979. Expressions of deep shock and sympathy were received at the Institution from Local Sections, individual members and, speaking for all members in India, from the representative of the Council, Dr P. K. Patwardhan. A letter paying tribute to Lord Mountbatten's great contribution to electronic engineering was sent to his family by the President, Mr D. W. Heightman, on behalf of all officers, members and staff of the Institution.

Following the wishes of the late Earl, the Institution was represented at the funeral service in Westminster Abbey on 5th September by the President Elect, Professor W. Gosling, Mr L. H. Bedford, C.B.E., Past President, The Secretary of the Institution, Air Vice-Marshal S. M. Davidson, C.B.E., and the Clerk to the Council, Mr R. W. Stobbart. Several other members of the Institution were present at the service, including the former Director, Mr G. D. Clifford, C.M.G., and Dr P. A. Allaway, C.B.E., Past President, as a representative of the National Electronics Council.

As a token in memory of the Charter President, a donation has been sent by the Council of the Institution to the World United Colleges, the cause among the many with which he was associated that was closest to Lord Mountbatten's heart.

An appreciation of his life contributed by Mr G. D. Clifford appears on pages 480-482 of this issue.

ANNOUNCEMENTS

Two Opportunities for Engineer-Innovators:

1. National Microelectronics Competition

The Peterborough Prize—estimated to be worth £30 000 in factory premises, cash and back-up to start profitable production—is to be awarded for the individual or firm with the best viable idea for using a microelectronics device. The challenge is to prove that the application is technically sound and that it can be produced economically and sold at a profit.

Entry for the National Microelectronics Competition is open to individuals and to companies with turnover of not more than £2M last financial year.

The overall winner will receive 'The Peterborough Prize', comprising:

- A brand new factory of up to 10 000 sq ft (930 m²) at Peterborough rent free for a year;
- £4000 cash from Barclays Bank and the Industrial and Commercial Finance Corporation (ICFC);
- working capital at preferential rates;
- financial management support from Barclays;

extensive design and marketing advice from Woudhuysen Design and Marketing Consultants; free services of the specialist Electronic Recruitment Company;

full support from Peterborough Development Corporation, including a guarantee of housing to rent or buy for every worker recruited;

immediate consideration for requests of up to £250 000 venture capital from ICFC.

The best entry from an individual already employed in electronics will win: 'The Electronics Times Prize' which is a Gould Instruments OS 400 Digital Oscilloscope (worth £2000) plus a fortnight's holiday for two in California.

The best amateur entry will be given 'The South West Technical Products Prize', namely an SWTP 6809 software development system (a microcomputer system with memory, visual display terminal and printer).

Entry forms can be obtained from Peterborough Development Corporation, P.O. Box 3, Touthill Close, Peterborough PE1 1UJ, by whom completed entries must be received not later than **31st January 1980**.

2. British Microprocessor Competition

The British Microprocessor Competition is being jointly sponsored by the National Research Development Corporation (NRDC) and the National Computing Centre Ltd (NCC). This is a competition for the best invention incorporating a microprocessor, the aim being to encourage British innovation in the use of microprocessors in any type of product, process or service. Eligible products must therefore contain a microprocessor which, for the purpose of the competition, is defined as a programmable microelectronic device. Products must be new and not yet in full scale production.

Total prize money of £20 000 will be awarded in two categories. The first category, for entries that include a working model, will have a £10 000 first prize with £5000 and £2000 for second and third places respectively. The second category is for entries where a working model cannot be demonstrated and will carry a first prize of £2000 and a second prize of £1000. In addition to the cash prizes, NRDC will give favourable consideration to investing up to £500 000 in any of the winning projects, subject to its normal terms, conditions and criteria. There will be no obligation on NRDC to offer such an investment, nor any obligation on the entrant to accept it.

Entry to the competition is open to individuals resident in the United Kingdom, UK registered companies, and other organizations located in the UK such as universities, polytechnics and other institutions engaged in education or research. The closing date for the competition is **14th December 1979** and winners will be notified by 28th February 1980. The official entry form and details of the competition rules and conditions can be obtained from the NCC, Oxford Road, Manchester M1 7ED.

The Derrick Shaw Memorial Award

To commemorate the outstanding contribution made by the late Derrick Shaw (Fellow) to the formation and development of the Yorkshire Section and his involvement with local industry, the Yorkshire Section has established a Memorial Award. This will be offered annually by the Section commencing in the academic year 1979/80. Three prizes of £20 each and testimonials will be awarded to final year undergraduate students who in the opinion of an appointed panel of experts are judged to have submitted electronic engineering projects of outstanding merit. Qualifying conditions are that the student must be following a course of study within the Yorkshire area, and must be a student member of the Institution.

Further details about the Award scheme can be obtained from the Honorary Secretary of the Yorkshire Section, Mr B. Mann, M.Sc., C.Eng., M.I.E.R.E., 65 Westfield Lane, Kippax, Leeds LS25 7JA (Home Tel. Leeds 868586, Work Tel. Leeds 462873).

EITB Training Levy

The Joint Parliamentary Under Secretary of State for Employment, Mr Jim Lester, has approved proposals submitted by the Engineering Industry Training Board to raise the levy on employers within the scope of the Board in the levy base year ending April 5th, 1979. The levy is equal to 1% of an employer's payroll (except in the case of certain establishments engaged in engineering construction activities). The Order (SI 1979, No. 778) has been affirmed by both Houses of Parliament and came into operation on July 17th last.

Employers who employ no more than 60 people will be exempt from the levy, while those who satisfy the Board that they adequately meet their own training needs may seek exemption from the levy. The levy will be used to finance a wide variety of training in the industry. Employers may appeal to an independent tribunal against assessment.

Applications for the 1980 Queen's Award Invited

Applications are now being invited from companies wishing to be considered for The Queen's Awards for Export and Technology 1980. The main qualifications are that companies should be UK-based and have made outstanding achievements in either exports or technology. Application forms are available from the Secretary, The Queen's Awards Office, Williams National House, 11/13 Holborn Viaduct, London EC1A 1EL (Tel. 01-222 2277). The closing date for return of applications is **31st October 1979**.

Correction and Apology



At a late stage in the production of the September Journal, the photograph of Mr Brian Mann, which should have accompanied the note on his career in the feature on Nominations for Election to Council on page 424, was replaced by that of Dr P. B. Johns, author of a paper to be published in a future issue. The Editor wishes to express his unreserved apologies for any embarrassment this may have caused.

FORTHCOMING CONFERENCES

Conference on 'The Changing Patterns in Education for Electronics, Communications and Computer Science'

Organized by the IERE with the association of the Institution of Electrical Engineers, the Institute of Electrical and Electronics Engineers, and the British Computer Society, this conference will be held at the University of Kent, Canterbury, from Tuesday 1st to Friday 4th July 1980.

The rate of technological innovation and development in electronics, communications and computer science makes re-evaluation of education and training patterns in these subjects a continuing necessity. The time is particularly opportune for this forum on curriculum development and course organization for there are presently indications that significant changes are once again required.

The questions which now arise concern the extent to which the engineer in one of the areas of electronics, communications and computer science, need be familiar with other areas and also how much he needs to know about the fundamental disciplines of Mathematics, Physics, Chemistry, Mechanics and Thermodynamics. In particular, the advent of LSI systems components poses a number of problems in education. With increasing trend towards higher-order 'building blocks' how much does the system designer need to know about the physics of components and devices? Indeed, does he need to know anything about traditional electronic engineering? Should most courses now be orientated to supply the increasing demand for systems engineers? How may the discipline of design be taught? What is the best form of course for the minority who wish to enter the highly specialized profession of device engineering?

The Organizing Committee is considering contributions in the following areas relating to these themes:

- Need for interdisciplinary components in courses
- Design as a science rather than an art
- The significance of new technological developments
- The influence of the computer as a design and teaching aid
- Novel systems of teaching, project work organization and course assessment
- Overall course organization, control and administration

Further information about the Conference may be obtained from The Conference Secretariat, The Institution of Electronic and Radio Engineers, 99 Gower Street, London WC1E 6AZ (Tel: 01-388 3071).

International Conference on 'Electromagnetic Compatibility'

In recent years there has been a great proliferation of electronic systems of all kinds and many of these systems have to operate in proximity to one another. Consequently, there is a considerable risk of interference occurring if proper precautions are not taken.

The prevention of potentially interfering signals and the reduction of susceptibility of equipment to interference between and within systems were the main themes of the first IERE conference on 'Electromagnetic Compatibility' held in the spring of 1978.

One result of that first conference was to highlight the growing need for opportunities for engineers to discuss problems (and solutions) of EMC and the Institution decided that there was a requirement for a regular series of conferences on this topic. Accordingly, a second conference is to be held, at the University of Southampton, from 16th to 18th September, 1980. Co-sponsors are the Institution of Electrical Engineers, the Institute of Electrical and Electronics Engineers, the Institute of Marine Engineers, the Institute of Physics, the Institute of Quality Assurance, and the Royal Aeronautical Society.

Systems to be considered include those in civil use in ships, aircraft and other transport vehicles and in control, computing and communication centres. Subjects in the military field will also be considered.

Methods for preventing the generation of potentially interfering signals and for reducing the susceptibility of equipment to interference both within systems and between systems, will represent the main theme of the conference. All types of man-made interference, including radiated, induced and conducted interference, whether from electronic equipment or from electrical plant are to be included and contributions are also being considered regarding protection from natural sources of interference and EMP. It is intended that, in the main, the conference will be concerned with industrial and professional communications, navigation, computing, control and medical subjects. However, the position relating to domestic equipment, both as to its protection from external interference and its own potential for generating it, will also be touched upon.

Further information and registration forms for the conference may be obtained from the Conference Secretariat, Institution of Electronic and Radio Engineers, 99 Gower Street, London WC1E 6AZ (Tel: 01-388 3072).

World's Largest ATE Event

Automatic Testing '79, the seventh in the series of ATE shows and conferences run by Network, will be opened by Air

Vice-Marshal Sinclair Davidson, Secretary of the IERE. The conference and exhibition will be held in Brighton from 11th to 13th December. This event is believed to be the largest anywhere in the world devoted solely to automatic test equipment, the exhibition now covering the whole of the ground floor area of the Metropole Exhibition Centre.

The conference is being supported by the IERE and jointly run by Network with the IERE. During the three days it will cover 'Specification, Management and Ownership of ATE', 'Design Developments and Applications of ATE' and 'Software and Advanced Automatic Test Techniques'. In all some 39 papers will be presented from North America, Japan and Europe.

Programmes and registration forms are being sent to all UK members of the Institution with this issue, or may be obtained on application to: Network, Printers Mews, Market Hill, Buckingham, MK18 1JX (Tel: Buckingham (028 02) 5226/5227).

Electronic Technology

A Conference on the above theme and jointly sponsored by the Institutions of Production Engineers and of Electronic and Radio Engineers is to be held in September 1981.

Contributions are invited in the following general areas:

Integrated manufacturing systems	Process automation and pressure diecasting
Non-destructive testing	Inspection (including metrology)
Maintenance	Microprocessor-based products
Robotics	Low-cost computers as an aid to production and management
Computer aided assembly	Scheduling
Control of machine tools	Production control

Further details may be obtained from the Conference Secretariat, IERE, 99 Gower Street, London WC1 (Tel: 01-388 3071), to whom offers to contribute should also be made.

International Conference on 'The Electronic Office'

The increasing use of such innovations as v.d.u.s, shared data banks, computer networks, user-programmable office machinery and text processors, is gradually leading to the day when most offices will dispense with conventional methods and materials and will use electronic techniques for all business purposes. Office procedures will change to take advantage of the new technologies and new skills will be required in this field.

To provide a forum for discussion of these developments and future trends, the IERE is to hold an International Conference on the 'Electronic Office'. The Conference will be held at the London Penta Hotel from 22nd to 25th April 1980, and associated with it will be the Institution of Electrical Engineers, the Institute of Electrical and Electronic Engineers, the Chartered Institution of Building Services, the British Computer Society and the Operational Research Society.

Contributions will fall under the following general subject headings:

- 'Organization, Planning and Procedures'
- 'Information Processing, Storage, Communications and Reproduction'
- 'Operational Research and Human Factors'
- 'Environmental Services'

Further information and registration forms for the conference will be available in due course from the Conference Secretariat, IERE, 99 Gower Street, London WC1E 6AZ (Tel: 01-388 3071).

An Appreciation of the Life of Admiral of the Fleet The Earl Mountbatten of Burma

K.G., P.C., G.C.B., O.M., G.C.S.I., G.C.I.E., G.C.V.O., D.S.O.,
LL.D., D.C.L., D.Sc., F.R.S., F.Eng., Hon. F.I.E.R.E.

IN 1932 Commander Lord Louis Mountbatten, RN, most certainly did not seek personal advantage by becoming a member of a young society fraught with the difficulties of ensuring its own existence. Indeed, he had his own problems in making certain of his career in the Royal Navy; this he did by first earning his specialist qualification as wireless officer.

There were many reasons for his choice of this branch of the Royal Navy but even in this brief tribute Lord Mountbatten himself would like mention of his father's encouragement in introducing wireless as an aid to defence. George, the elder son, who became the 2nd Marquis of Milford Haven, shared this enthusiasm and greatly influenced his younger brother, Lord Louis, to qualify in the new branch of wireless. George retired from the Royal Navy in order to secure better financial rewards by joining a prominent industrial organization concerned with the applications of radio science. His son, David (the 3rd Marquis) also served in the Royal Navy and became a member of the Institution. Sadly he died suddenly in middle age.

Lord Louis, as he was then known, so directed his thinking of the wider uses of wireless/radio that after succeeding in the Royal Navy's Advanced Courses in Wireless he became a Chief Instructor in the subject and an editor of the Admiralty Handbook of Wireless Telegraphy. So it was that for nearly fifty years Lord Mountbatten maintained a dedicated interest in the welfare of the Institution. On the outbreak of the 1939-45 war he expressed his hope that the Institution, of which he had just been elected a Vice-President, would survive war-time problems. He asked for summaries of Institution happenings to be sent to him and, notwithstanding his subsequent high commands, always found time for personal discussions whenever he was in London. This arrangement had a two-way benefit for whenever he met members he asked for information on any new developments which would help the Navy, Combined Operations, the Burma Campaign and his sojourn in India!

In retrospect, therefore, it is not surprising that at the end of hostilities one of his first public engagements as a newly-elected President was to preside over the Institution's dinner at the Savoy Hotel, London. It was a unique occasion for three reasons: it was the first function of its kind to be held after the war; it was 'covered' by the BBC which, for the first time after the war, kept its radio transmitters open after 22.00 hours; most of all for the contents of Lord Mountbatten's speech which is as relevant today as then on the need for applying electronic solutions to modern problems in communication for industry and commerce.

Almost immediately after this acknowledged newsworthy event, Lord Mountbatten was appointed Viceroy of India. His affection for the Institution, coupled with a deep conviction of the future importance to Great Britain of electronics, made him resolve not to resign his Presidency but (sidestepping all rules and regulations), to appoint L. H. Bedford and W. E. Miller (both subsequently Presidents) to act as his deputies. But, as in war-time, he requested that important reports were still to be sent to him in Delhi!

A great planner, Lord Mountbatten was meticulous in considering policy before taking decisions and applied this principle to all his activities. In doing so he garnered the

opinion of any one possessed of special knowledge or experience of the subjects he had under review; he was, however, angered by incompetence and those who were—as he often expressed it—'anxious to get on his band waggon'. Even so, his innate kindness surfaced and his diplomacy turned away wrath, but he demanded—and gave—loyalty. This was personified by the way he constantly honoured his mother and father, his own family, and his affection for the Royal Navy in which, to his elation, he achieved the same rank as his father and more. In his personal and public life Lord Mountbatten truly lived up to his own motto 'In Honour Bound'.

As a Vice-President he had urged that the Institution should formulate ideas on the future development of radio and electronics and the place of the Institution in that future. This suggestion led to publication of the Institution's Post War Reports.* His main criticism of those Reports were the limitations then imposed on disclosing the potential civil use of certain war-time equipment. He attempted to overcome some embargoes when he gave his first Presidential Address in 1946. Forbidden for security reasons to speak of British war-time development of computer technology and its applications, he persuaded American authorities to allow him to speak on America's progress in developing computers for defence and peaceful purposes. This was the first of the many computer projects that he pursued after forming the National Electronics Council.

A permanent record of Lord Mountbatten's affection for the Institution is shown in our Armorial Bearings. These allude to the pioneers of radio and electronics and in 1955 he was pleased at the idea that some portion of his own Arms be incorporated in the Institution's Armorial Bearings. This was expressed in the sinister supporter which is based on the lion, fork-tailed and crowned, which appears in the first quarter of his own Arms. A full description of the Armorial Bearings is given in the IERE History 'A Twentieth Century Professional Institution'.

Before accepting election as the ninth President of the Institution, Lord Mountbatten reiterated the complaint that he frequently aired in the 1930s about the name of the Institution which was then the British Institution of Radio Engineers. The reason for this is given in the official history but he was adamant that British achievement in the development of radio did not mean that the Institution should seem to be a parochial body. This is but a single example of his international outlook. After reading in the History of the first President's introduction of the term 'electronics' he continually pressed for adoption of the title 'The Institution of Electronic and Radio Engineers' but magnanimously he agreed to await the outcome of the petition for the grant of a Royal Charter. By the terms of the Charter he again accepted election as President—the only member to have twice held that office—and then immediately called a Special Meeting of members at which the change in name was unanimously agreed and subsequently approved by the Privy Council.

Meantime his international outlook was expressed by meeting and addressing groups of members in his journeys

* *J. Brit. IRE*, 4, no. 3, pp. 134-161, October-December 1944.

throughout the world, as for example, when he was in Paris with L. H. Bedford (Past President) and both received gold awards from the Société d'Encouragement pour la Recherche et l'Invention in June 1967. He also accepted an invitation to read his paper on 'Dissemination of Information' to the National Institute of Science of Canada in Ottawa in April 1965 and afterwards presided at a dinner of Canadian members. A repetition of his talk on information distribution and the work of NEC led directly to the formation of the New Zealand Electronics Council—a move subsequently copied in various forms in other countries. During Lord Mountbatten's visit to Delhi in 1963, Jawaharlal Nehru, first Prime Minister of India, accepted an invitation to join him at an IERE dinner to discuss similar problems.

On countless other occasions and in many countries he spoke about his membership of the Institution and what he referred to as his 'electronic life'. He regretted that this side of his life received scant attention in the many stories written about him, including the television series on his life and times. But this was understandable for public interest centred on his many achievements as a war-time Commander, last Viceroy of India, Chief of Defence Staff and advocate of many worthy causes, not least those of Ex-Service men and women.

He frequently repeated that he never lost his interest in electronics. For example, his advocacy of using computer techniques to solve a wide range of commercial manufacturing and defence problems led to his appointment to the Royal Society Committee on Information Processing and he greatly valued his election as a Fellow of the Society in 1966. He was, however, a staunch believer in keeping scientific language as simple as possible and made a plea at the Fourth Congress of the International Federation for Information Processing that computer designers, engineers and programmers should beware of using 'jabberwocky' which added to the problems of students and frightened potential customers.

In or out of office Lord Mountbatten kept himself informed on all Institution activities; he attended many Conventions and other Institution functions, including the Council and Committee Dinners which were used as an opportunity to thank retiring Presidents for their services. Roles were reversed in 1948 when he and the Countess Mountbatten of Burma were

the Institution's guests at a dinner given to express thanks after his first term as President. By then Council and Committee members had seen how easily he assumed command by understanding all the Institution's functions; how its growth had been frustrated by lack of educational and training facilities and the reason for some inhibitions on admitting members. In one instance he criticized the Membership Committee for rejecting the application of a sales engineer in the components field. After being satisfied with the man's academic achievements the President stressed the important role of sales engineers who understood the functions of their wares. He urged approval of the proposal. It was!

Thirty-five years later Lord Mountbatten was still urging all Institutions of the dangers of an 'ivory tower' mentality and of the many advantages of making better use of fully trained engineers who were possessed of marketing skills.

There are countless instances of his realism and humanity—such as supporting the Benevolent Fund and helping to collect funds for a boarding school which accepted children of deceased members, and visiting members of the IERE staff who were in hospital. He also opened several industry exhibitions.

He lived a crowded life but somehow fulfilled the obligations of any office he undertook without, as he put it '... in any way prejudicing my main job'—and that covered the whole of his career in the Royal Navy culminating in an extended term as Chief of the Defence Staff. Just prior to his retirement he received many lucrative offers from commerce and industry but declared that he wanted to use his time to further the application of electronics for the common good, to promote international understanding and to improve educational opportunities for future generations. Memorials to his efforts include his Chairmanship of the Nehru Trust which enables Indian graduates to receive further training in Great Britain and to use that experience on their return to India, and by his Chairmanship of the World United Colleges. Situated in various countries each of these Colleges enrolls students of mixed nationalities. Lord Mountbatten believed that bringing together these youngsters was a tangible way of securing world peace.

But it was by forming in 1964 the National Electronics

Lord Mountbatten with three other Presidents who had worked closely with him during his two presidencies: Mr W. E. Miller (1953–54) and Mr L. H. Bedford (1949–50) who deputized for him while he was in India, and Mr J. Langham Thompson (1963–64) who held office immediately after Lord Mountbatten's spell as Charter President. The occasion of this happy reunion was an Institution reception held at the Savoy Hotel while he was President for delegates to the first Commonwealth Conference on Communication Satellites in 1962.





The last official Institution function which Lord Mountbatten attended was a reception at Scientific Instrument Makers' Hall in the City of London on 18th July 1978 when Honorary Fellowship of the Institution was conferred upon Mr J. Langham Thompson (Past President) and Mr G. D. Clifford (Former Director and Secretary).

Council that he seemed to bring together his main interests. He had been invited by Government and industry to form an organization which would bring together various interested bodies and how he did this is a separate story. It was accomplished without reward of any kind although he welcomed the idea that a history of the National Electronics Council should be published as a testimony of how representatives of so many varied interests would give freely of their time in order to promote the development and use of electronics for 'the common good'. He anticipated antipathy to 'quangos' and believed that by gathering together all interested parties on a voluntary basis it was possible to give honest and impartial advice to Government whilst also monitoring claims or decisions which affected the best use of electronics in the public interest. At the same time he pressed the need for modernizing the teaching of science in schools and urged the introduction of basic electronics as an 'A' level subject. To this end he visited comprehensive and other schools for discussions with teachers and pupils.

Unashamedly he pressed for over thirty years his concept of a national communications grid; many believe that this may still be his greatest memorial.

Only last year the Council passed a unanimous resolution thanking Lord Mountbatten for his sterling work in constituting and leading the Council as the first body of its kind in the world and in his honour establishing an annual 'Mountbatten Lecture'—which he was invited to inaugurate. He enjoyed the compliment but found it a chore to give the First Lecture. Nevertheless, on 28th June 1978, he gave his last public address on electronic matters under the heading 'Electronics—the Lifeline'. In this lecture he summarized the limitations and interdependence of the Institution, the trade associations, Government Departments, Universities and Technical Colleges, the Trade Unions and every manufacturer in developing and applying electronics for the service of man. He ended his address:*

'There is a constant need to monitor all technical

innovations for there is hardly a single development which has not been capable of selfish and sometimes dangerous exploitation. But this proper control should not provide an excuse for us to resist new ideas and processes in order to protect temporary self-interest.

'Science offers us almost unlimited opportunities—but it is up to us, the people, to make the moral and philosophical choices.'

Space is not available to record in detail the tremendous contribution that one of our most illustrious members and outstanding Presidents made towards fulfilling the objects specified in our Royal Charter. Sadly we record that even the manner of ending his life may be the spur for securing peace for the ordinary man and woman which characterized so much of his efforts.

Certainly this thought dominated the crowded assembly in Westminster Abbey on September 5th which gave witness to the incredible scope of Lord Mountbatten's activities. Led by Her Majesty the Queen and the Royal Family, the congregation included his own family and friends, distinguished representatives from many countries, the Prime Minister, political leaders, and delegates from the many charities and institutions with which he had been associated.

In his prayer, the Archbishop of Canterbury expressed thanks for the life of Louis Mountbatten and 'his outstanding gifts, high enthusiasm and liberality of spirit; his integrity, and flair for leadership; his life-long devotion to the Royal Navy; his courage and sense of companionship in times of war; his dedication to the cause of freedom and justice; his service to the peoples of South East Asia, and to India at a critical period in her history; his being so rare a person.'

And to this prayer we all added our fervent Amen.

Lord Mountbatten had been asked to approve arrangements for his funeral. It was significant that the pall bearers from St. James's Palace to Westminster Abbey were volunteers from HMS *Mercury*, the naval signal school; and the last act of lowering his body into his resting place in the church near his home—Romsey Abbey—was entrusted to sailors from the Gosport Naval Communications School.

G. D. CLIFFORD

* Available from the National Electronics Council, Abell House, John Islip Street, London, SW1P 4LN, price 60 pence.

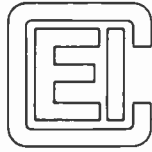

News for Members

Institution Presidents

At the Annual General Meeting of the Institution of Chemical Engineers on 2nd April 1979, **Dr N. L. Franklin**, C.B.E., F.Eng., F.I.Chem.E., Chairman and Managing Director of the Nuclear Power Company, succeeded Mr J. M. Solbett, F.C.G.I., F.Eng., F.I.Chem.E., as President of the Institution for 1979/80.

Dr D. A. Temple, B.Sc., A.R.S.M., Ph.D., C.Eng., F.I.M., F.I.M.M., assumed the Presidency of the Institution of Mining and Metallurgy for the session 1979/80 at the Institution's Annual General Meeting on 17th May 1979.

Rhys Price Probert, C.B., M.A., F.Eng., F.R.Ae.S., who is Director of the Royal Aircraft Establishment, took office as President of the Royal Aeronautical Society on 17th May 1979, immediately after the Annual General Meeting of the Society. He succeeds Professor L. F. Crabtree, B.Sc., D.I.C., Ph.D., C.Eng., A.F.A.I.A.A., F.R.Ae.S.

New Chairman for CEI Trade Union Panel

Sir Sidney Bacon, C.B., B.Sc.(Eng.), C.Eng., F.I.Mech.E., F.I.Prod.E., this year's President of the Institution of Production Engineers, is to succeed Mr G. A. Dummett, M.A., F.Eng., F.I.Chem.E., as Chairman of the CEI's Trade Union Panel. Until his retirement a few months ago, Sir Sidney was Managing Director of the Royal Ordnance Factories.

Mr G. A. Dummett, former Chairman of the CEI in 1976, has been Chairman of the Trade Union Panel since 1975. During his time with the panel he was actively involved in the production of two CEI booklets—'Professional Engineers and Industrial Relations Legislation' and 'Professional Engineers and Trade Unions', the latter of which has recently been updated as a second edition.

Two present members of Trade Union Panel, Mr P. T. Fletcher and Mr R. N. Bruce, will be joined by two elected members of the Board, Mr D. H. Pitcher and Mr E. H. Wakefield.

Fellowship of Engineering Soirée

The Officers of the Fellowship of Engineering, together with Fellows and their guests, numbering well over 250, held the Fellowship's Third Annual Soirée on the evening of Tuesday, 10th July at the Watson House Research Station of the British Gas Corporation, by kind invitation of Sir Denis Rooke, C.B.E., F.Eng., F.R.S., the Chairman of the British Gas Corporation.

The exhibits on display at the Soirée were sponsored by members of the Fellowship to illustrate how engineering developments are being applied to applications in the home. Several of these were concerned with heating and power while others demonstrated new materials. Among the applications for electronics were microprocessor data and information systems, and some of the new systems and devices developed to increase the utility of the ordinary telephone.

The first Annual Soirée was held in 1977 at the National Maritime Institute when the theme was Maritime Technology and the second, in July 1978, at the BBC Television Centre with the theme of Communications.

The Fellowship now has nearly 300 Fellows and the annual Soirée is an important event providing both Fellows and

guests with an opportunity to see some of the advances made in disciplines with which they may not themselves be directly in contact.

The Fellowship objectives are to promote the advancement of the science, art and practice of engineering, to hold meetings for the presentation of papers, delivery of lectures and the discussion of any matter raised by the Executive Committee, to offer advice on engineering issues to other private or public bodies under the guidance of the Executive Committee, and to respond to requests for help and advice from any quarter.

New ERB Publication

The Engineers Registration Board has recently published an 8-page booklet entitled 'Registration—its value to you'. The booklet explains the whole subject of registration for engineers, a highly topical subject, and one of the terms of reference for the Committee of Inquiry into the Engineering Profession. The work of the ERB and its value to all those involved with the profession is explained and details of the three Section Boards and how they operate are given. There is a foreword by Dr D. F. Galloway, C.B.E., F.Eng., Chairman of the Engineers Registration Board General Assembly, in which he urges engineering employers to take advantage of the unique guide to the qualifications and competence of those whom they employ or seek to employ.

Copies of 'Registration—its value to you' are obtainable from CEI, free of charge.

Country's Future Depends upon Young Entrants to Engineering

The whole future of the country depends upon attracting boys and girls of the highest talent into the Engineering Profession, said Dr G. S. Hislop, C.B.E., F.Eng., Chairman of the Council of Engineering Institutions, recently. He was addressing a meeting of engineers and representatives of the industrial and academic worlds in Nottingham organized by the East Midland Branch of CEI.

That requirement, and the need to ensure the proper education and training for the boys and girls entering the profession, was the theme of Dr Hislop's address and the subsequent discussion. He said that the CEI and all the professional engineering institutions which are its Corporation Members are highly involved in these topics and that the council's Regional branches have a most important part to play. He reminded his audience that, although policy decisions are made at the centre, the real impact is only made by the voluntary work of practising engineers throughout the country and who are in close contact with schools, colleges and industry in their own areas.

Employers and academics have the vital role of ensuring that industry gets the engineers and technicians it needs so that British goods and services are the best in the world. Young entrants to industry must have relevant and well organized practical training in addition to their appropriate academic education.

Good engineers and technicians are the most valuable asset of any engineering company, continued Dr Hislop, and much more attention needs to be paid to their recruitment, training and development than is common at present. These are matters which must be handled by people who really understand what engineers do, and not left in the hands of those who have little practical understanding of what is needed.

Members' Appointments

CORPORATE MEMBERS

R. J. Clayton, C.B.E., M.A., F.Eng. (Fellow 1977), Technical Director of the General Electric Company, has been awarded honorary degrees of Doctor of Science by two universities: the University of Aston in Birmingham and the University of Salford, conferred on the 11th and 12th July respectively. Mr Clayton, a Past President of the Institution of Electrical Engineers, is a member of the IERE Council.

A. E. Green, B.Sc., Ph.D. (Fellow 1966, Member 1956, Graduate 1953) received a doctorate in industrial technology at the University of Bradford recently for his research work on reliability strategies. He is currently an honorary Visiting Fellow of the University. Dr Green who is head of the National Centre of Systems Reliability in the Safety and Reliability Directorate of the UK Atomic Energy Authority at Culcheth, near Warrington, was Guest Editor for the special issue of *The Radio and Electronic Engineer* in July 1978 on Reliability. Four years ago Dr Green received the Annual Reliability Group Award of the IEEE, being the first British engineer to be thus honoured.

G. W. MacKenzie (Fellow 1978, Member 1957, Graduate 1956) at present Chief Engineer, Transmitters, with the BBC, has been appointed Chief Engineer, Transmission, with responsibility for both Transmitter Group and Communications Department of the BBC Engineering Division. While holding appointments at Evesham and in Northern Ireland, Mr MacKenzie took an active part in Local Section affairs, serving on the Section Committees, and for a time he was Chairman of the South Midlands Section.

B. J. Slamin (Fellow 1976, Member) has been appointed Chief Engineer (Regions) with the BBC in London; since 1976 he has been Head

of Programme Services and Engineering for BBC Scotland.

P. F. J. Brighty (Member 1967) has joined the press office of Standard Telephones and Cables (STC) as technical press officer. He has recently been working in the technical public relations field and previously held engineering appointments with Post Office Telecommunications, Philips Norway and Associated Electrical Industries.

A. E. Fewster (Member 1979) who has been a Senior Engineer with Plessey Avionics and Communications since June 1976, has now joined Neve Electronic Laboratories as Senior Development Engineer.

J. V. Lindley (Member 1966, Graduate 1961) has recently been promoted to Branch Manager, 600 MW Electrical Engineering, with Atomic Energy of Canada, at its Engineering Company in Mississauga, Ontario. He joined AEC in 1973 as a Design Engineer.

D. F. Meadows (Member 1959) who has been with Normalair-Garrett, Yeovil, for the past 12 years, latterly as Product Engineer (Airborne Electronics), has taken up an appointment in Cairo as Quality Engineering Manager with the Arab British Dynamics Company.

C. J. Peabody (Member 1965, Graduate 1959) has been appointed Managing Director, of Allen-Bradley Numerical Controls. He was previously with Herbert Controls.

Lt Cmdr S. E. Pritchard, RN (Member 1955) has retired from the Royal Navy after 47 years' service; his last appointment was as Weapons Engineer Officer, Fraser Gunnery Range, Southsea. Cmdr Pritchard has been an active member of the Southern Section Committee for many years and has held office in several capacities.

D. P. Sawyer (Member 1975, Graduate 1970) has joined Otto-Simon Carves as an Instrument Engineer. He was previously Systems Design Engineer with the British Steel Corporation, Teesside and Workington Group.

J. W. Stark, C.G.I.A. (Member 1953) has been appointed Assistant Chief Engineer, Communications in the Engineering Division of the BBC. He has been with the Corporation since 1962, and for the past 5½ years he has been Head of Engineering, Communications Operations.

L. W. B. Worrall (Member 1971) has been appointed Programme Controller with M.E.L., Crawley. Since 1971 he has been with Foxboro Yoxall, Redhill, latterly as Manager, Systems Production Control.

NON-CORPORATE MEMBERS

L. W. Kennedy (Graduate 1971) who has been with the Plessey Company since 1970, when he joined the Allen Clark Research Centre as a junior scientist, is now Chief Engineer, Research and Development for micro-electronics process development at Towcester.

W. Maher (Graduate 1967) who has been with the Post Office since 1954 apart from 2 years National Service in the Royal Signals, has been promoted to Assistant Executive Engineer and is currently concerned with trunking, grading and design of telephone exchanges including TXE2 and TXE4 electronic types in the Liverpool area and the Isle of Man.

S. A. Snook (Associate Member 1974) who resigned from the BBC Design Department last autumn to join Oakside Industrial Holdings as Group Chief Engineer, has now been appointed Production Director of Avitel Electronics of Beckenham.

A. Sorrell (Associate Member 1974) formerly Marketing Manager, Far East Operations with Sprague World Trade Corporation based in Hong Kong, has joined Medtronic International as General Manager, South East Asian Operations, also in Hong Kong.



R. J. Clayton



Dr Eric Green is congratulated by the Vice-Chancellor, Professor J. C. West, who had just conferred on him the Doctorate of Bradford University.

Applicants for Election and Transfer

September Meeting (Membership Approval List No. 263)

GREAT BRITAIN AND IRELAND

CORPORATE MEMBERS

Transfer from Graduate to Member

AMARASEKERA, Aviranga Gamini. *London.*
BENNETT, David. *Norihfleet, Kent.*
BENNETT, Gordon Richard. *Meopham, Kent.*
EVANS, David Meurig. *Leatherhead, Surrey.*
MATHIAS, Glyn Edward. *West Wickham, Kent.*
MURPHY, Terence John T. *London.*
PILKINGTON, Roy. *Billinge, Merseyside.*
POPE, William John. *Goring-on-Thames, Oxfordshire.*
PYWELL, Michael. *Preston, Lancashire.*
WHITTON, Melvyn Edward. *Plymouth, Devon.*

Transfer from Associate to Member

*HARRIS, Roger John. *Seaford, Sussex.*

Transfer from Student to Member

HERBERT, Ian. *Mexborough, South Yorkshire.*

Direct Election to Member

PANTELIDES, Antis N. *Brickhill, Bedford.*

* Subject to Mature Candidate Regulations.

THE MEMBERSHIP COMMITTEE, meeting on 9th September 1979, recommended to the Council the election and transfer of the following candidates. In accordance with Bye-law 23, the Council has directed that the names of the following candidates shall be published under the grade of membership to which election or transfer is proposed by the Council. Any communication from Corporate Members concerning the proposed elections must be addressed by letter to the Secretary within twenty-eight days after publication of these details.

NON-CORPORATE MEMBERS

Direct Election to Associate Member

CALLOWHILL, Gerald David Ian. *Shoeburyness, Essex.*
EKPENYONG, Young Ogbonna E. *London.*
GURLING, David James. *London.*
PATEL, Bhikhubhai R. *Coventry, West Midlands.*
PRITCHARD, Keith Bentley. *Welshpool, Powys.*
SHEFFIELD, Ian Walter. *Edinburgh.*

Direct Election to Associate

O'CONNOR, Kerin Leigh. *Chislehurst, Kent.*

Direct Election to Student

TONKISS, Mark Samuel. *Newton Abbot, Devon.*

OVERSEAS

CORPORATE MEMBERS

Transfer from Member to Fellow

PLEVIN, John. *Bailly, France.*

Transfer from Graduate to Member

LUK, Leung Ping. *Hung Hom, Hong Kong.*
SLOSS, Ian. *Munich, FRG.*
WAI, Fung Sang W. *Wanchai, Hong Kong.*

Direct Election to Member

WONG, Kit-Chiu M. *Kowloon, Hong Kong.*

NON-CORPORATE MEMBERS

Transfer from Student to Graduate

KWONG, Chung Ping. *Hong Kong.*

Direct Election to Graduate

SIM, Chew Kwang. *Singapore.*

Transfer from Student to Associate Member

MENON, Vatsan. *Singapore.*

Direct Election to Associate Member

CHEE, Chin Hian. *Johore Bahru, West Malaysia.*

Direct Election to Associate

RAMPUTH, Dawood. *Phoenix, Mauritius.*

Direct Election to Student

LEUNG, Kin On. *Kwai Chung, Hong Kong.*
MOY, Tsap Ming. *Kowloon, Hong Kong.*
SINGH, Balbir. *Singapore.*
WONG, Cheuk Wai. *Kowloon, Hong Kong.*

FORTHCOMING CONFERENCES

Automotive Electronics Developments

The use of electronic systems and in particular micro-electronics in the motor vehicles of the 1980s, will give drivers all over the world vehicles which are more fuel efficient, are safer under both normal and emergency conditions, have a reduced environmental impact, and last but not least, are more comfortable and enjoyable to drive.

The Second International Conference on 'Automotive Electronics', to be held at the Institution of Electrical Engineers in London from 29th October-2nd November 1979 will report and discuss the latest technical developments in these electronic systems and their application to motor vehicles.

Sixty papers in fourteen sessions will be presented covering all aspects of the subject, starting with three keynote review papers from the USA, Japan and Europe and continuing with sessions on microprocessors and microcomputers for engine controls and other vehicle electronic systems; ignition control; fuel control and engine management; power train and transmission control; transducers; vehicle radar systems; comfort, safety and reliability; vehicle communications, navigation and control; driver instrumentation and displays; driver diagnostics; multiplex wiring and control.

There will be a display of equipment and components at the IEE associated with the theme of the Conference and this will be complemented by a display of operating vehicles with functional electronic systems at the Motor Industry Research Association at Nuneaton, where a technical visit is scheduled for the final day of the Conference.

The Conference is being organized in association with seven international technical bodies, including the IERE. The

programme and registration forms can be obtained from the Conference Department, IEE, Savoy Place, London WC2R 0BL.

'Electronics Update'

The Electronics Group of the Institute of Physics is holding its 5th annual Electronics Update colloquium on Wednesday, 31st October 1979, at CEGB, Sudbury House, 15 Newgate Street, London WC1A 7AU. As in previous years, the meeting aims to provide an overview of the current state of development of a comparatively wide range of topics within the electronic device field. Titles of the lectures include, 'The shrinking transistor in v.l.s.i.', 'Silicon-on-sapphire technology', 'Electrochromic displays', 'A reappraisal of solar cells', 'Hybrid integrated circuit technology', 'Chemical vapour deposition of III-V semiconductors', 'Laser annealing of semiconductors' and 'Gallium arsenide integrated circuits'.

The audience will be assumed to have a general electronics background but by the inclusion of tutorial material and the general avoidance of highly specialized terminology, the proceedings will appeal to both senior technical managers responsible for the deployment of resources, and to scientists engaged on other, neighbouring, projects, enabling them to gauge the progress of technologies competing or complementary to their own.

Further details and registration forms from the Meetings Officer, Institute of Physics, 47 Belgrave Square, London SW1X 8QX (Tel: 01-235 6111).

Standard Frequency Transmissions

(Communication from the National Physical Laboratory)

RELATIVE PHASE READINGS IN MICROSECONDS NPL—STATION (Readings at 1500 UTC)

May 1979	MSF 60 kHz	GBR 16 kHz	Droitwich 200 kHz	July 1979	MSF 60 kHz	GBR 16 kHz	Droitwich 200 kHz
1	-0.4	4.5	20.1	1	-2.2	•	41.3
2	-0.3	4.5	20.3	2	-2.0	•	41.6
3	-0.3	4.3	20.5	3	-2.0	•	41.9
4	-0.5	4.4	20.8	4	-2.1	•	42.2
5	-0.7	0.7	21.0	5	-2.1	•	42.5
6	-0.7	1.8	21.2	6	-2.1	•	42.7
7	-0.9	-1.2	21.5	7	-2.1	•	43.0
8	-0.7	4.0	21.7	8	-2.1	•	43.4
9	-0.8	3.9	21.9	9	-2.1	4.0	43.8
10	-0.9	3.5	22.2	10	-1.9	3.7	44.1
11	-1.1	4.0	22.4	11	-1.9	3.9	44.4
12	-1.0	3.9	22.7	12	-1.6	4.8	44.8
13	-1.0	2.9	22.9	13	-1.6	3.8	45.1
14	-1.0	3.0	23.1	14	-1.8	3.7	45.3
15	-0.8	4.9	23.2	15	-1.9	3.8	45.7
16	-0.8	5.0	23.4	16	-2.1	4.1	46.0
17	-0.8	5.2	23.7	17	-2.1	3.6	46.3
18	-0.8	5.3	23.9	18	-1.9	3.7	46.6
19	-1.0	4.9	24.2	19	-1.9	3.7	46.9
20	-1.0	4.8	24.4	20	-1.9	3.5	47.3
21	-1.0	4.4	24.7	21	-1.9	3.6	47.7
22	-1.0	4.1	25.1	22	-2.0	4.2	48.2
23	-1.2	4.3	25.4	23	-1.9	4.4	48.7
24	-1.2	4.0	25.6	24	-1.9	3.4	49.2
25	-1.2	4.8	25.9	25	-2.3	3.6	49.6
26	-1.4	4.5	26.2	26	-2.3	3.7	50.0
27	-1.4	4.3	26.5	27	-2.7	3.6	50.4
28	-1.6	4.7	26.8	28	-2.5	3.5	50.7
29	-1.6	4.3	27.1	29	-2.5	3.4	51.0
30	-1.6	4.0	27.4	30	-2.3	3.7	51.4
31	-1.8	4.0	27.7	31	-2.5	4.0	51.8

June 1979	MSF 60 kHz	GBR 16 kHz	Droitwich 200 kHz	August 1979	MSF 60 kHz	GBR 16 kHz	Droitwich 200 kHz
1	-1.9	•	27.9	1	-2.3	4.0	52.3
2	-1.9	•	28.0	2	-2.5	3.3	52.8
3	-2.1	•	28.1	3	-2.5	3.7	53.3
4	-2.3	•	28.3	4	-2.5	3.8	53.7
5	-2.3	•	28.6	5	-2.4	3.8	54.2
6	-2.3	•	28.8	6	-2.6	4.2	54.7
7	-2.1	•	29.1	7	-2.5	3.6	55.2
8	-2.2	•	29.5	8	-2.5	3.5	55.5
9	-2.2	•	31.6	9	-2.7	3.8	55.9
10	-2.2	•	33.8	10	-2.6	3.9	56.1
11	-2.2	•	35.2	11	-2.8	3.9	56.9
12	-2.1	•	35.4	12	-2.8	4.0	57.4
13	-1.9	•	35.7	13	-2.6	4.0	57.9
14	-1.9	•	35.9	14	-2.8	4.0	58.6
15	-1.9	•	36.2	15	-2.8	2.9	59.1
16	-2.1	•	36.5	16	-2.6	3.0	59.7
17	-2.1	•	36.8	17	-2.8	2.9	60.3
18	-2.0	•	37.1	18	-2.7	•	60.8
19	-2.2	•	37.4	19	-2.7	3.4	61.4
20	-2.2	•	37.6	20	-2.6	3.6	61.9
21	-2.4	•	37.9	21	-2.7	3.7	62.5
22	-2.4	•	38.1	22	-2.7	4.0	63.1
23	-2.2	•	38.5	23	-2.8	4.3	63.5
24	-2.0	•	38.8	24	-2.8	4.0	63.1
25	-2.1	•	39.2	25	-2.8	4.0	62.7
26	-2.1	•	39.7	26	-2.8	4.0	62.3
27	-2.1	•	40.0	27	-2.8	3.8	62.0
28	-2.1	•	40.3	28	-2.9	3.8	61.7
29	-2.1	•	40.7	29	-2.8	3.8	61.5
30	-2.0	•	41.0	30	-3.0	3.5	63.2
				31	-2.8	3.7	65.0

Notes: (a) Relative to UTC scale ($UTC_{NPL} - Station$) = +10 at 1500 UTC, 1st January 1977.

(b) The convention followed is that a decrease in phase reading represents an increase in frequency.

(c) Phase differences may be converted to frequency differences by using the fact that 1 μs represents a frequency change of 1 part in 10^{11} per day.

New and Revised British Standards

Copies of British Standards may be obtained from BSI Sales Department, 101 Pentonville Road, London N1 9ND.

RADIO INTERFERENCE SUPPRESSION

BSI has carried out a further revision of BS 613 **Components and filter units for electromagnetic interference suppression** (£4.70), one of a series of specifications devoted to the abatement of radio interference. This latest publication covers the performance requirements and testing of suppression components for use in electrical machines, appliances and apparatus rated at up to 7 kVA, operating from 50 Hz to 60 Hz supplies above extra low voltage and up to 240 V single-phase or 415 V 3-phase. Although not specifically intended to apply to circuits having a higher rating than 7 kVA many of the requirements will provide guidance in the construction of suppressors for such circuits. The standard will be amended later to include a clause dealing with suppression components for use in motor vehicles.

DATA PROCESSING

A further part of BSI's revised glossary of data processing terms has been issued; it is gradually being developed internationally to provide much more comprehensive information than was available in the 1963 version and will eventually comprise some twenty parts, eight of which have already been published. The latest part is BS 3257 **Glossary of terms used in data processing Part 7 Digital computer programming** (£4.70), which is identical with the corresponding section of the international glossary.

Designed to simplify international communication in this area the revised vocabulary presents terms and definitions of selected concepts and identifies relationships between the entries. In drafting the definitions care has been taken to avoid, wherever possible, individual language peculiarities likely to cause translation problems.

The scope of the complete revised BS 3257 is expected to cover the main data processing areas, including the principal processes and types of equipment used, the representation, organization and presentation of data, and the programming and operation of computers, input-output devices and peripheral equipment, as well as particular applications.

FLAMMABILITY OF PRINTED CIRCUIT MATERIAL

BS 4584 **Metal-clad base materials for printed circuits Part 16 Epoxide glass-reinforced copper-clad laminated sheet of defined flammability: EP-GCA-Cu-16** (£1.90) is one of a series of specifications giving the electrical and non-electrical requirements for properties of base materials used for printed circuits and using the methods of test as specified in BS 4584 Part 1.

Part 16 covers epoxide glass-reinforced copper-clad laminated sheet of defined flammability, whose reinforcement includes non-woven glass filaments in addition to woven glass fabric. Except for the requirements for flexural strength, the requirements are identified with those for epoxide woven glass fabric material as specified in BS 4584 Part 3.

PVC INSTRUMENTATION CABLES INTENDED FOR INTRINSICALLY SAFE SYSTEMS

A further part of BS 5308 **Instrumentation cables intended for intrinsically safe systems** has just been published by the British

Standards Institution. BS 5308 Part 2 **PVC insulated cables** (£1.90) specifies the requirements for and dimensions of PVC cables in multicore and multipair construction, with or without screens and optionally incorporating single wire armour. These cables are suitable for operation at peak voltages up to and including 60 V core to earth or 120 V core to core. The specification includes requirements for conductors, identification of elements, cabling, binder tape, collective screen outer protection, tests and end sealing. Part 1 of this Standard, dealing with polyethylene insulated cables, was published in 1975.

SOUND SYSTEM EQUIPMENT

BSI has issued two further parts of BS 5428 **Methods for specifying and measuring the characteristics of sound system equipment**, the various parts of which deal with different aspects of sound system performance.

The first of the new publications is Part 7 **Automatic gain control devices** (£4.80), which relates to a.g.c. circuits incorporating devices that have limiting/compressing properties in respect of the envelope of the input signal. It does not include devices for clipping or expanding, or those in which the gain is controlled by an external source. Part 7 is technically equivalent to IEC Publication 268-8.

The second new issue is entitled Part 8 **Artificial reverberation, time delay and frequency shift equipment** (£4.80), which applies to signals of acoustical origin and covers devices commonly used to achieve special effects in sound recording, broadcasting and public address systems. Part 8 is technically equivalent to IEC Publication 268-9.

CABLED DISTRIBUTION SYSTEMS

A new specification in a series dealing with cabled distribution systems has been published by BSI. This is BS 5603 **Cabled distribution systems primarily for sound and television signals Part 1 Performance requirements for systems operating between 30 MHz and 1 GHz** (£2.20). The new Standard specifies, for several parameters, the performance limits which should be obtained between the head-end input and any outlet of such systems, operating between the stated frequencies. The values given are intended as a basis for system planning and the performance specified should be maintained throughout the life of the system.

Agreement on an equivalent international standard has not yet been reached, though discussions are in progress within the International Electrotechnical Commission (IEC). Later parts of this standard will cover methods of measurement for the parameters whose performance is specified in Part 1 (i.e. mutual isolation, amplitude/frequency response, noise, etc.) and it is intended that these other parts will also align with IEC recommendations.

BIBLIOGRAPHICAL REFERENCES TO PUBLICATIONS

The British Standards Institution has published BS 5605 **Recommendations for citing publications by bibliographical references** (£1.40). This Standard, which recognizes both the systems of citation permitted by BS 1629 **Recommendations for bibliographical references**, the numeric system and the Harvard system, gives concise guidance to authors and editors on the preferred methods of arranging lists of references in books and journal articles; it includes methods of making attribution within the text.

Letters to the Editor

From: A. D. Booth, D.Sc., Ph.D., C.Eng., F.I.E.R.E.
B. Priestley, B.Sc., C.Eng., M.I.E.R.E.
J. F. Miller, M.Sc.

Education and Training of the Engineer

I have read Professor Lewin's paper* with interest: I felt that he was making debating points rather than saying anything new. The Baconian method is not that actually used by active research scientists. The essence of any research be it in science or in engineering is first to identify the problem. Having done this, the research worker either identifies the parameters from the reported observations if these exist, or designs and conducts such observations as may be needed to provide the data for induction.

No scientist worth the name would hypothesize without consulting nature first. The horrible example of such lack of consultation was Aristotle's theory of vision: he assumed that the eye emitted light something like a radar! Personally I am not a philosopher, I find the writings of philosophers prolix and lacking in common sense, or perhaps I should say, engineering pragmatism.

I believe that the best training for a first-rate student who wishes to become an engineer is to start with mathematics and physics with some chemistry, say about 4:2:1. This would take most of the first two years of a four-year course but, to keep the student aware that he is studying engineering, he should start on a design project in his first year. The design project would commence with graphics, lead to actual construction and evaluation, and, in the fourth year, involve the student in production planning, economic and societal feasibility and so on.

During years 3 and 4 the student would select his engineering option and concentrate on engineering rather than on science. It is worth saying that I introduced a structure of this sort when I was Dean of the College of Engineering at Saskatchewan and the students which it produced have proved excellent engineers as testified by their professional advancement.

An alternative plan, which I personally found satisfactory, is to take an honours physics degree and then to do a two-year graduate apprenticeship in the industry of choice. In my own case the managerial experience of industry stood me in good stead when I eventually ran a university.

So much for the philosophy, the really important point is, however, that for really first-rate students it does not matter what the course structure adopted may be. I believe that engineers are born and not made and that attempts to woo students from science (or worse, sociology!) will only attract the also-rans.

In case these remarks seem to be the ravings of senility it is worth remarking that in retirement I have turned my attention to oceanography which I find to have a number of problems which yield to an engineering approach as I understand it!

ANDREW D. BOOTH

Timberlane,
5317 Sooke Road, R.R. 1,
Sooke, B.C., V0S 1N0, Canada,
21st May 1979

References

* 'The relevance of science to engineering', *The Radio and Electronic Engineer*, 49, no. 3, pp. 119-24, March 1979.

† *The Radio and Electronic Engineer*, 49, no. 3, p. 116, March 1979.

‡ *The Radio and Electronic Engineer*, 49, no. 5, p. 221, May 1979.

I would like to suggest that Professor Lewin's recent article* has considerable relevance to Professor Bell's suggestion† on the education and training of engineers. In particular an education on the methodology of solving the problems met in engineering, or indeed life in general, is more sustaining than an hors d'oeuvre of training in assorted management techniques and the latest 'with it' semiconductor device.

Thus I would suggest to Mr Lomas‡ that a course on the general theory of all active devices (i.e. gain, bandwidth and stability) must be followed by one on the limitations of real devices and when insufficient experience is available on the newest device an older one is acceptable; both will run out of linearity at high level. Having then realized that the 'rules' are only approximate an intelligent student should not have much difficulty in making the mental transition to other devices or to management sciences where the rules are even more approximate and subject to change.

No practicable course of education and training can be expected to match twenty years of experience (even though this sometimes seems to be industry's desire!), however, it should not be difficult to wean students from the idea that problems can be solved completely by looking in the right textbook. The right attitude could well be fostered by courses on Games theory or other probabilistic mathematics with exercises chosen from management as well as engineering.

B. PRIESTLEY

43 Raymond Road,
Langley, Berkshire SL3 8LN
10th July 1979

At least two previous correspondents (Mr. T. Lomas‡ and Prof. D. A. Bell†) have suggested that an element of economic theory be introduced into undergraduate electronic engineering education. From their reasons it seems that they are concerned with money economics; if this is correct then I wish to protest in the strongest possible terms. Money economics is as intellectually challenging as astrology and in the present state of the world about us as relevant as a horoscope.

Consider the money arguments against public transport, for Concorde, for throw-away packaging, rapidly obsolescent consumer 'durables' etc., arguments which run contrary to common sense and most certainly contrary to good husbandry and the needs of future generations. For the economist there is always another rainbow with its crock of gold waiting to be pillaged, another as yet undiscovered resource to be 'substituted' when the present one runs out.

Any author wishing to publish in this journal would not have very much success if his equations violated Kirchhoff's laws or any other of the foundations on which our science is based. Nor would we allow him access to students for the further propagation of his erroneous ideas. However, many economists of high repute (amongst other economists) have in their writings demonstrated a total ignorance of the fundamental laws governing the physical universe (e.g. H. E. Daly in 'Steady State Economics'). It seems totally wrong therefore to include their mythology in science courses.

If we wish future generations to bless us rather than curse us we should add elements of what is popularly known as 'ecology' to our courses. We should stress the total dependence of man on his environment and the long term impossibility of decoupling him from it. 'The World About Us' and 'The Voyage of Charles Darwin' should be compulsory viewing for a start.

J. F. MILLER

Department of Electronic and Electrical Engineering,
The University of Birmingham,
P.O. Box 363, Birmingham B15 2TT
8th August 1979

The Second Mile

W. E. WICKENDEN

On the eve of the publication of the report of the Finniston Committee, members may find food for thought in this abridgement of an address by an eminent American engineer-educator, Dr William Elgin Wickenden (1882-1947).

Dr Wickenden was, from 1929 to just before his death, President of the Case Institute of Technology, Cleveland, Ohio. A former professor of electrical engineering at M.I.T., a Vice President of AT & T and, from 1922 to 1929, Director of the Society for Promoting Engineering Education, he was President of the American Institute of Electrical Engineers in 1945-46, and represented the Engineers Joint Council on the United States' Commission of UNESCO.

First given at the Annual Meeting of the Engineering Institute of Canada in Hamilton in 1941, it was republished in the EIC's Engineering Journal in December 1949 and reprinted in the Journal of this Institution in May 1950. Despite having been written nearly forty years ago, it summarizes the profession of the engineer in a way which seems still highly relevant.

'Whosoever shall compel thee to go one mile—go with him twain'
—The Sermon on the Mount.

Every calling has its mile of compulsion, its daily round of tasks and duties, its standard of honest craftsmanship, its code of man-to-man relations, which one must cover if he is to survive. Beyond that lies the mile of voluntary effort, where men strive for excellence, give unrequited service to the common good, and seek to invest their work with a wide and enduring significance. It is only in this second mile that a calling may attain to the dignity and the distinction of a profession.

Of professions there are many kinds; open professions like music, to which any man may aspire within the bounds of his talents, and closed professions like medicine which may be entered only through a legally prescribed process; individual professions like painting and group professions like law, whose members constitute 'the bar', a special class in society; private professions like authorship and public professions like journalism, artistic professions like sculpture and technical professions like surgery; ameliorative professions like the ministry and social work, and professions which safeguard social institutions through a technique of destruction, like the army and navy. Despite all these differences of pattern, certain characteristic threads run like a common warp beneath the varying woof of every type of professional life and endeavour.

If one searches the authorities for definitions of a profession he will probably find four kinds. One is likely to hold that the determining quality is *an attitude of mind*, that an altruistic motive can lift any honourable calling to the professional level. A second may say that it is a certain *kind of work*, one requiring special skill on a high intellectual plane. A third may state that it is a special *order in society*, as the bar, the bench or the clergy. Still others insist that no work can be professional without a *confidential relationship* between a client and his agent, as that of patient to physician, litigant to lawyer, etc. None of these definitions is self-sufficient. Taken together, like the legs of a table, they give a profession a stable base of support.

What is the distinctive mark of the professional man? First, we may say that it is a *type of activity* which carries high individual responsibility and which applies special skill to problems on a distinctly intellectual plane. Second, we may say that it is a *motive of service*, associated with limited rewards as distinct from profit. Third, is the *motive of self-expression*, which implies joy and pride in one's work and a self-imposed standard of excellence. And fourth, is a conscious *recognition of social duty* to be fulfilled among other means by guarding the ideals and standards of one's profession, by advancing it in public understanding and esteem, by sharing advances in

technical knowledge, and by rendering gratuitous public service, in addition to that for ordinary compensation, as a return to society for special advantages of education and status.

Next, what attributes distinguish the corporate life of a group of persons as professional in character? We may place first a *body of knowledge* (science) and of *art* (skill) held as a common possession and to be extended by united effort. Next is an *educational* process based on this body of knowledge and art, in ordering which the professional group has a recognized responsibility. Third is a *standard of personal qualifications* for admission to the professional group, based on character, training and proved competence. Next follows a *standard of conduct* based on courtesy, honour, and ethics, which guides the practitioner in his relations with clients, colleagues and the public. Fifth, we may place a more or less formal *recognition of status*, either by one's colleagues or by the state, as a basis for good standing. And finally, there is usually an *organization* of the professional group, devoted to its common advancement and its social duty, rather than to the maintenance of an economic monopoly.

The traditional professions of law, medicine and divinity had a common fountainhead in the priestcraft of antiquity. What is professional in modern technical callings such as engineering can be traced back only as far as the mediaeval craft and merchant guilds, which arose out of the breakdown of feudalism.

There being no other effective authority, the guilds took over the regulation of the hours of labour, the observance of holidays, the length and content of apprenticeship, the wage system, the standards of workmanship and the quality of goods. The guilds also tested the progress of novices, apprentices and journeymen, and finally admitted them to the ranks of the masters with imposing ceremonies, of which college commencements and inaugurations are the most picturesque survivors in our modern day.

The guilds naturally took unto themselves considerable monopolies and privileges. As the cities gradually grew strong they usually recognized the guilds and gave them a considerable share of civic responsibility.

Many features of this distinctive type of citizenship are perpetuated in our modern professional bodies. The public grants to a profession more or less tangible monopolies and self-governing privileges, in consideration of which the profession engages to admit to its circle only men of proved competence, to guarantee their trustworthiness, to insist on the

observance of ethical relations and practices, and to protect the public against bungling and extortion.

When a layman comes face to face with the complex and often terrifying specialization of professional skill and knowledge, he is likely to be baffled or easily misled. If you have a problem of mental illness in your family, how can you be sure you are dealing with a qualified psychiatrist and not with a plausible but unscrupulous quack? To protect you in these emergencies the public wisely puts the burden of guaranteeing at least minimum standards of competence and ethics on the profession itself. The physician you can trust is the one who is recognized as well qualified and reputable by his brother physicians of good standing; the same with lawyers, dentists, architects and engineers.

The state may implement the obligation of a profession to guarantee competence by designating a group of its members to conduct professional examinations and to issue public licences to those who pass them successfully, or it may leave professional bodies free to issue their own credentials. Both of these practices may exist side by side, as in the realm of medicine, where the state licenses general practitioners through a board of examiners, while the various groups of specialists have voluntary organizations which examine and certify physicians seeking recognition in their respective fields. In the end, it comes down to the same principle—a profession must guarantee to the public the trustworthiness of its practitioners. In return, the public protects the profession from the incompetent judgment of the layman by a privileged position before the law.

Professional status is therefore an implied contract to serve society, over and beyond all specific duty to client or employer, in consideration of the privileges and protection society extends to the profession. To possess and to practise a special skill, even of a high order, does not in itself make an individual a professional man. Mere technical training, at any level, is vocational rather than professional in nature. The difference between technical training and professional education is no simple matter of length—any difference of two years, or four, or six; nor is it a mere matter of intellectual difficulty. It is rather a matter of spirit and scope. More specifically, it can be described as an overplus beyond the knowledge, however intricate, a man needs to master his daily tasks.

The overplus in professional education, in short, is that which enables a professional man to view his work not only as a skilled service to a client but also in terms of its consequences for society. An engineer, for example, develops a labour-saving process and recommends its adoption; does he see in this act only an immediate saving in the cost of production, and assume that this is adequate justification in itself? Or can he perceive the sequence of effects which will be felt in the lives of individual workers, of the organization which employs them, of the community in which it functions, of the markets which it supplies, and of the wider sector of society which it ultimately serves? In the answer to these questions there is wrapped up much of the difference between a high-grade technician and an engineer of true professional stature. Every professional body counts on its rosters many men who are little more than technicians, and it is well that they are included, since professional development comes so largely through association and indoctrination. But no professional body can be strong and effective unless it contains a substantial nucleus whose intellectual attainments far exceed in depth and breadth the technical demands of its practice.

The ethical obligations of a profession are often embodied in codes and enforced by police powers. Even when no written canons exist, as in the artistic professions, unwritten usages and standards exercise a powerful guiding and restraining influence. The physician and the lawyer are bound by explicit

obligations. As engineers, our codes are less tangible and the means of enforcement less explicit, in proportion as our duties are less definable, but our ethical obligations are no less binding morally.

No professional man can evade the obligation to contribute to the advancement of his group. His skill he rightly holds as a personal possession and when he imparts it to another he justly expects a due reward in money or in service. His knowledge, however, is to be regarded as part of a common fund built up over the generations, an inheritance which he freely shares and to which he is obligated to add; hence the duty to publish freely the fruits of research and to share the advances in professional technique. If the individual lacks the ability to make such contributions personally, the least he can do to pay his debt is to join with others in creating common agencies to increase, disseminate and preserve professional knowledge and to contribute regularly to their support. That is the purpose to which a large share of the membership dues of our professional societies is devoted.

Too many engineers exhibit an unenlightened and petty attitude on these matters; mature men who complain that the direct returns to them of the researches and publications of a professional society are not worth the annual fee, and young men who grumble because membership does not lead to direct preferment in rank and salary. Shame on us! Do we look with envy on the high prestige of medicine or surgery? Then let us not forget that this prestige has been won not merely through personal skill and service, but by magnificent contributions to human knowledge without profit to the seekers and with incalculable benefits to all mankind.

Measured by standards such as these, many men who call themselves engineers and who have proved themselves competent in accepted technical practices, have not attained a real professional stature. Some are victims of a deficient education, not in the sense that school and college failed to teach them all they would ever need to know, but rather failed to inculcate a taste and a capacity for continued learning under self-direction. They are usually the men who have let their scientific training slip away after they have mastered a specific job, who have been unable to surmount the routine of early experience and have gradually grown content with mediocrity. Some of the difficulty may be inherent in the operating routine so often associated with an engineer's work. If these deficiencies exist, they are not solely a reflection on the individuals involved, but also on the professional body. One of its obligations to its younger members is to give effective stimulus and guidance to their growth.

There is a school of thought which has two quick and ready remedies for all the ills and shortcomings of the engineering profession. One is to keep the boys longer in college and to compel them to cover courses in both liberal arts and engineering. The second is to limit strictly the use of the title 'engineer' to men who have obtained a public licence. One need not quarrel with either the aims or the means; so far as they go both are good, but they cover only the first mile.

Registration will probably always be a qualifying standard rather than a par standard for the engineering profession. By its nature, it cannot be a standard of distinction. It will go far toward keeping the wrong men out of the profession, but it will serve only indirectly to get the right men in. Beyond it lies a second mile of growth and advancement for which effective guidance, incentives and rewards can be provided only within the profession itself.

The proposal to compel all engineering students to remain six years or more in college in order to complete combined courses in liberal arts and in engineering is attractive in theory but unworkable in practice. Some young men should do so, but the majority will not. Those who do are likely to find that the

advantage gained comes quite as much, or even more, from sharing the life and spirit of two divisions of education with differing ideals and traditions, as from a more extended range of studies.

The engineer needs his profession for his personal advancement. That is the purpose which brought it into being.* He needs it most at the beginning of his career. Young men need for their advancement wider sources of information, more varied personal associations, broader stimulation to achievement and less formal contacts with their seniors than they usually find in their daily jobs. As men mature they come to value professional rewards—friendships, recognition, responsibility, pride in belonging, evidences of distinction, etc.—no less and often more than money rewards. These are the durable satisfactions of life.

The engineer, in a society based largely on group relations, needs his profession to safeguard his occupational and economic welfare. He needs protection against unethical competition, against indiscriminate use of the title 'engineer', and against all influences which might undermine public confidence in his integrity and competence. He needs protection against those who assume that he is 'just another

* The first professional society, The Institution of Civil Engineers, was organized in London. The official account of its founding begins, 'It was toward the end of the year 1817 that a few gentlemen, then beginning life, impressed by what they themselves felt were the difficulties young men had to contend with in gaining knowledge requisite for the diversified practice of engineering, resolved to form themselves into a society.'

employee' and against sub-professional groups seeking to act for engineers in the process of collective bargaining. He needs protection against the levelling influences of unionism and of civil service. He needs his profession because of his stake in the advancement of knowledge and technical skill.

Few engineers can do much about it alone. Collectively their capacity to advance knowledge is beyond calculation.

Millions of individual, unrelated efforts will not add up to the future that invites our profession. This is no time for engineers to wrap themselves in the mantle of isolation; let us get together and be about our common business.

There are undoubtedly some who feel that the cultural and spiritual interests of society are menaced by a greater dominance of technological education. I am unable to share these fears. We of the engineering schools have no quarrel with liberal education.

We are not indifferent to culture, save that of the dilettante type. Culture is to us not a form of professional interest, nor the fruit of any form of pose or academic exposure, but the fruit of spontaneous activity which all may share on an amateur basis in that second mile which lies beyond the compulsions of one's economic occupation. Expressional activities—sport, music, writing, speaking, dramatics, and the arts of design—also the reading of books, are flourishing on many an engineering campus today quite as vigorously as in many a so-called liberal college. If destiny is to make our technological institutions responsible in the future for a major stem of higher education, and not merely for some of its specialized phases, I have faith that we shall give a good account of our stewardship.

Financial Help for Small- and Medium-sized Enterprises

While it is generally agreed that there are usually considerable obstacles to be scaled by any small or medium-sized business that wants to prosper today, there are nevertheless a number of recognized sources from which funding for projects and expansion can be obtained. One of these is the Industrial and Commercial Finance Corporation which is owned by the Bank of England and the main Clearing Banks and which nowadays is prepared to make loans for amounts between £5000 and £2 million. The Corporation's Report for the year ending March 31st last, shows that its investments on loans and shares totalled a record £67.7 M compared with £50 M in the year ended March 1978.

Long-term finance was provided for 733 small and medium-sized businesses which received an average of £92,000. In money terms this was a record for ICFC but more importantly the numbers of both new applications and existing customers returning for additional funds were the highest ever. During the year the ICFC portfolio rose from 2200 to nearly 2500.

According to the Report, an encouraging trend has been the growing number of cases of managements buying divisions from larger groups which have decided to divest, or from controlling shareholders wishing to realize their investment in family businesses. ICFC has developed expertise in formulating suitable schemes to meet the needs of such situations where,

in many instances, management can contribute only a relatively small proportion of the cash required.

A number of 'Case Studies' are given in the Corporation's Report and the supporting publications and these include a significant number of small and medium-sized companies in the electronics industry. ICFC emphasizes that its mode of operation normally is through the injection of capital either directly or through the purchase of shares and seldom does it appoint Directors to the board of a company unless there is a need for a particular financial expertise, for instance, as is the case of a small company in a high-technology area. A subsidiary, Technical Development Capital (TDC) specializes in financing of this kind.

The Chairman of ICFC, Lord Seebohm, said: 'The financial needs of small, and owner-managed companies can be very complicated and those who provide them require training and skills which are rarely found in other financial institutions. As the economies of size become less important and the complexities of managing a large company increase, ICFC has an evergrowing role to play and its services are in greater demand now than they have ever been.'

Further information about the way that ICFC operates may be obtained from its Head Office at 91 Waterloo Road, London SE1 8XP.

Contributors to this issue*



A Manchester University graduate, **Leslie Forth** has worked with Computer Developments (a joint subsidiary of GEC and ICL) and with the Marconi Company.

He was appointed to his present post of Lecturer in the Department of Electrical Engineering Science at the University of Essex in 1968 where he has been involved in a number of research projects. One was in collaboration with Vickers

Medical to design a computer-controlled blood analyser, another with the Rank Organization to produce an automated cinema system which incorporated a management information system.

With his present co-author, Mr Forth jointly designed and built a novel network for small computers using 'null protocol' techniques, which was supported by the Department of Computer Science and by the Science Research Council.



Peter Kidd, a graduate of the University of Aston, was initially with the Post Office Research Department at Dollis Hill where he worked on the pattern recognition problems involved in sorting mail with handwritten characters. He was seconded to the University of Essex to develop a research interest in the application of pattern recognition philosophy to human speech. Subsequently he was appointed to his present post

of Lecturer in 1970 where he carried out research into the simulation of real-time systems. His interest in computer architecture and peripherals was further enhanced during the creation of the 'null protocol network' which has led in turn to a fundamental re-examination of the ideas concerning the interfacing of peripherals to minicomputers.



Jim Grimbleby graduated in physics at Reading University in 1965 and for the next four years he carried out research into electron spin resonance and spin lattice relaxation in S-state rare earth ions; he was awarded a Ph.D. in 1970. Since completing his doctoral research his interests have been more in the field of electronics and in 1971 he was appointed to a Lectureship. He is now a lecturer in the Department of Engineering.



Bob Holbeche graduated in electrical engineering at the University College of Swansea in 1967. He obtained an M.Sc. for work on geomagnetism in 1969 whilst on the academic staff at Swansea where his research interest in mobile radio began. In 1970 he joined Pye Telecommunications in Cambridge, where his primary concern was the development of area coverage techniques for mobile radio schemes. He was

awarded a Ph.D. in 1972 for work on radio receiver design and subsequently went to the University of Bath in 1974 where he is currently leading a research group concerned with a number of aspects of mobile radio.



Graham Allen received his initial technical training with the Royal Navy and served 12 years with the Fleet Air Arm, specializing in radiocommunications, radar and navigational electronics. After leaving the Navy he became a mature student at the University of Bath and graduated with a first class honours degree in electrical and electronic engineering in 1974. Between 1974 and 1977 he carried out postgraduate research in

mobile radio communications at Bath, and in June 1978 a thesis on sideband diversity gained him his doctorate. After two years as an industrially-sponsored Research Officer, Dr Allen was appointed to a lectureship in the School of Electrical Engineering which he took up on 1st September 1979.

A biography of Professor William Gosling was published in the September issue.



Professor John Beynon (Fellow 1977) graduated in physics in 1960 from the University of Wales, and after obtaining an M.Sc. in electronics at Southampton University, he worked as a Scientific Officer in the plasma physics group at the Radio and Space Research Laboratory (now the Appleton Laboratory), Slough. He joined the staff of the Electronics Department at Southampton University in 1964

where he continued research first in plasma physics and subsequently in microelectronics. He served a three-year term as Assistant Dean of the Faculty of Engineering and Applied Science at Southampton and in 1974 was appointed to a Readership in Electronics. During 1974 and 1975, Dr Beynon was on sabbatical leave in the Department of Electronics, Carleton University, Ottawa, and he has visited Cairo University and the Indian Institute of Technology, Delhi to assist in setting up microelectronics laboratories. In 1979 Professor Beynon was appointed to the Chair of Electronics at the University of Wales Institute of Science and Technology and in July this year he moved to the University of Surrey as Head of the Department of Electronic and Electrical Engineering. He is Guest Editor for a forthcoming special issue of the Journal on Charge Coupled Devices.

* See also page 514

OPTICAL SELF-SCANNED ARRAYS

A Symposium

Edited by Professor J. D. E. Beynon,
M.Sc., Ph.D., C.Eng., F.I.E.E., F.I.E.R.E.*

On 16th January 1979, the IERE Components and Circuits Group organized a one-day colloquium on Optical Self-Scanned Arrays at the Royal Institution, London. As an experiment in reporting colloquium proceedings, Professor Beynon who chaired the meeting, asked all the contributors subsequently to produce shortened versions of their oral presentations for editing into a symposium on this important subject.

In publishing this article the efforts of Professor Alan Pugh are gratefully acknowledged. As chairman of the Components and Circuits Group, Professor Pugh undertook the organization of the colloquium and had hoped to chair the day's proceedings. He was prevented from doing so at the last moment by a national rail strike called for 16th January.

INTRODUCTION

Almost since the advent of integrated circuits enormous efforts have been made to develop an all-solid-state replacement for the electron-beam scanned imaging tube. But despite its obvious disadvantages (fragility, size, necessity for high voltages, etc.), the elegant simplicity of the electron beam has proved a difficult match and it still reigns supreme in the field of high-definition area imaging such as is required for broadcast-standard television. In the last few years, however, notable advances have been made in the development of solid-state (or self-scanned) image sensors and many devices are now available on the market.

The first two contributions to this Symposium deal with the principles of operation of the more important

types of solid-state sensors and with some of the practical considerations relevant to general industrial and aerospace applications. Parts 3 and 4 describe two specific, although very different, areas of recent development: high resolution c.c.d. sensors for the visible and low resolution pyroelectric sensors for the infra-red. Despite considerable progress, most self-scanned arrays currently available suffer from non-uniformities of one sort or another; Parts 5 and 6 are thus topical in that they deal with ways in which the response of such arrays may be improved by using off- and on-chip techniques. The paper concludes with two novel applications of solid-state image sensors.

Part 1 PRINCIPLES OF SELF-SCANNED ARRAYS

Professor J. D. E. BEYNON, M.Sc., Ph.D., C.Eng., F.I.E.E., F.I.E.R.E.*

Self-scanned imaging arrays combine, as the name suggests, the dual functions of detecting the incident radiation and of reading out this information periodically. Fortunately silicon, which is of course the pre-eminent material for the fabrication of integrated circuits, is also a very suitable material for the detection of visible radiation; having a bandgap of 1.1 eV it has a useful working range of 0.4 to 1.1 μm which covers the whole visible spectrum plus the near infra-red. It is helpful, however, to consider the detection and addressing functions separately, at least initially.

1.1 Detection Principle

Detection of light by silicon is based on the creation of a depletion layer in the material. This can be achieved either by means of a reverse-biased pn junction (Fig. 1(a)) or a suitably biased metal-oxide-semiconductor structure (Fig. 1(b)). In each case the field associated with the depletion layer serves to separate any hole-electron pairs generated optically in this region, the

* Department of Electronic and Electrical Engineering, University of Surrey, Guildford, Surrey GU2 5XH.

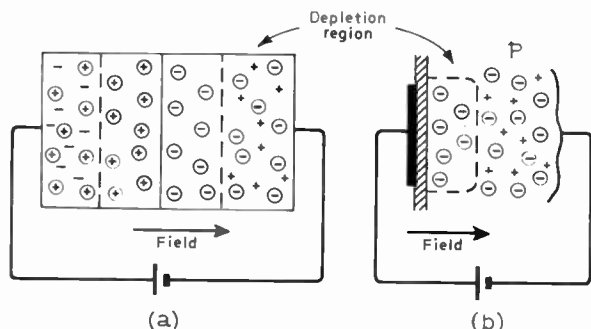

Fig. 1. Principle of light detection by (a) reverse-biased pn-junction and (b) suitably biased m.o.s. structure.

number of charges so generated being proportional to the intensity of the incident radiation.

Unfortunately hole-electron pairs are generated by thermal processes within the crystal as well as by optical stimulation, i.e. a small 'leakage' current will flow even in the absence of light. Leakage currents are very sensitive functions of material quality and processing but a typical value at room temperature is $\sim 10 \text{ nA/cm}^2$. The photo-current is clearly a function of the incident light intensity which in turn is dependent on the scene irradiance and reflectivity, and on the camera optics. Taking a typical outdoor scene under overcast conditions and using $f/2$ optics, the photo current in a silicon detector would be $\sim 10 \mu\text{A/cm}^2$. Although this is a comfortable factor of 10^3 above the leakage, it is clear that leakage effects limit the low-light level performance of arrays. To work at very low light levels advantage can be taken of the fact that the leakage current is a sensitive function of temperature, typically halving for every 9°C . Thus cooling an array by only about 30°C can reduce leakage effects ten-fold. Conversely, however, a sensor's performance may be seriously degraded if its temperature rises—either because of a high ambient or because of dissipation in 'local' circuitry, perhaps on the chip itself.

Before we consider various addressing techniques there is one further aspect of sensing that should be appreciated; i.e. high sensitivity requires that the sensor integrate nearly all the light falling on each element throughout the whole scanning period. The significance of this is easily demonstrated by noting that the area of each sensor in a linear or area array is typically $30 \times 30 \mu\text{m}$, i.e. 10^{-5} cm^2 ; thus a typical photo-current is only $\sim 10^{-11} \text{ A}$ which is not at all easy to measure! Integration of this very small current over a scanning period can readily be achieved in both the arrangements shown in Fig. 1 by utilizing the inherent capacitance of the structures. Both p-n and field-induced junctions have capacitances $\sim 10^4 \text{ pFcm}^2$; thus if charged to 10 V, thermal leakage will (at room temperature) discharge the structure in about 10 seconds. This gives us (at least within an order of magnitude or two) a typical maximum integration time for self-scanned silicon arrays.

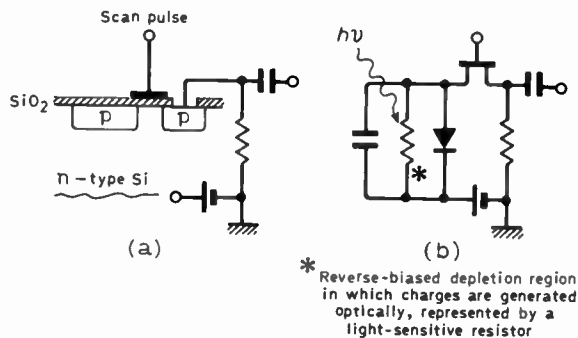

Fig. 2. Photodiode addressing: (a) circuit arrangement, (b) equivalent circuit, (c) waveforms.

1.2 Self-scanned Photodiode Arrays

The basic principle of most self-scanned photodiode arrays is that the multiplexing or commutation previously provided by an electron beam is performed by m.o.s. transistors, utilizing their high ratio of on-to-off conductance. The simplicity of fabrication of m.o.s.t.s and their superb capability for large-scale integration make them very suitable for photodiode addressing. A typical arrangement for one cell, and the corresponding equivalent circuit, are shown in Figs 2(a) and (b); the operation of the circuit should be evident from Fig. 2(c).

Multiplexed scanning of a linear array¹ is effected by using a parallel-output digital shift register, each stage of which is connected to a switching transistor as shown in Fig. 3. As the switching pulse progresses down the register each transistor is turned on in turn, feeding the integrated optical charge into the output bus and resetting the diode-capacitor for the next integration

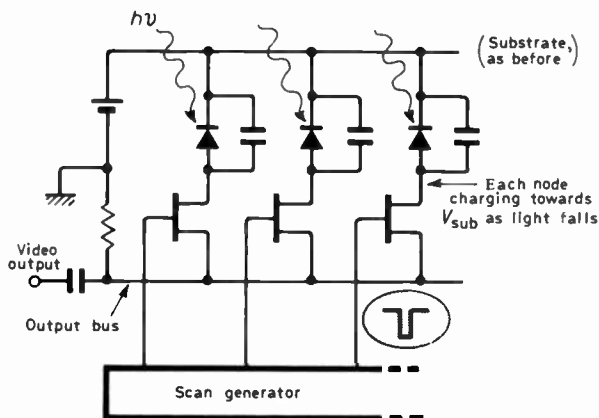

Fig. 3. Linear photodiode array.

period. The resulting video signal current in the output bus is fed to an amplifier preferably located on the same chip.

1.3 Charge Transfer Arrays

Such an arrangement has two disadvantages:

(1) A fundamental problem is that the video signals from all the elements are combined on an extended output bus, the total capacitance of which may exceed the capacitance of each element by several orders of magnitude. The equivalent amplifier noise current would therefore be increased by the square root of this factor beyond its value if it were connected to a single element. The low-light threshold of the device as determined by noise would be correspondingly raised.

(2) A less fundamental disadvantage of multiplexed scanning is the tendency for spurious signals to be introduced into the output signal by capacitive pick-up of the switching pulses. Unfortunately these pulses and the amount of capacitive pick-up inevitably vary along the length of the array making it difficult to filter out the effects.

Despite these problems, however, many linear photodiode arrays with good performance are now available. The number of elements varies from 64 to 2048 the element spacing varying from about $50\ \mu\text{m}$ down to $15\ \mu\text{m}$. Maximum sample rates are typically several MHz but a few devices operate up to 40 MHz. It is

noteworthy that the biggest devices employ a silicon chip over $2.5\ \text{cm}$ long! Linear arrays find wide application for measurement and facsimile, the larger arrays being capable of scanning an A4 page in a fraction of a second.

Area arrays can be fabricated by extending the principles outlined above so that any element can be addressed by orthogonal X - Y conductors—for example as shown² in Fig. 4(a). Clearly the bigger the array, the bigger the output capacitance and thus the poorer the signal-to-noise ratio of large, high resolution sensors. The simple arrangement of Fig. 4(b) is thus confined to small area arrays operating under conditions of high illumination. For large arrays, the common node capacitance is reduced by 'external' multiplexing as illustrated, for example, in Fig. 4(c). Compared with Fig. 4(b) we see that there are as many output busses as there are columns; each bus is addressed in turn so that the total capacitance seen by the output amplifier is substantially less than that in Fig. 4(b).

M.o.s.t.-addressed photodiode arrays of up to 100×100 elements ($60\ \mu\text{m}$ centres in both directions) are available, the fastest device operating at a maximum sample rate of 10 MHz. The Japanese are developing 384×484 arrays primarily for colour-television applications.

An entirely new system of solid-state scanning has resulted from the invention of charge-transfer devices. Basically, these devices permit the fabrication of analogue shift registers along which information is transmitted in the form of charge packets of varying size. By combining an array of sensing elements with such shift registers it is possible to feed all the optically-generated charges to a single output node where they are sensed. There are two types of charge transfer element—bucket brigade devices (b.b.d.s)³ and charge-coupled devices (c.c.d.s).⁴ Their operational characteristics are in many ways similar, as is their application in image sensors; we shall therefore confine ourselves to a description of imaging arrays which employ c.c.d.s.

The principle of charge storage⁵ in an m.o.s. structure was briefly alluded to in Fig. 1(b). Optically (or thermally) generated minority carriers formed in the field-induced depletion region are attracted towards the gate and form (assuming the gate potential exceeds the threshold voltage) an 'inversion' layer at the semiconductor-oxide interface. (It is useful to think of these charges as falling into a 'potential well' at the surface.) Such an inversion charge can be moved along the interface if a series of closely-spaced electrodes on the surface are pulsed in the correct sequence as illustrated in Figs 5(a) and (b).† The most usual technique for sensing these charges at the end of the register is illustrated in Fig. 5(c): a charge packet is 'dumped' on to a suitably reverse-biased diode whose potential is then

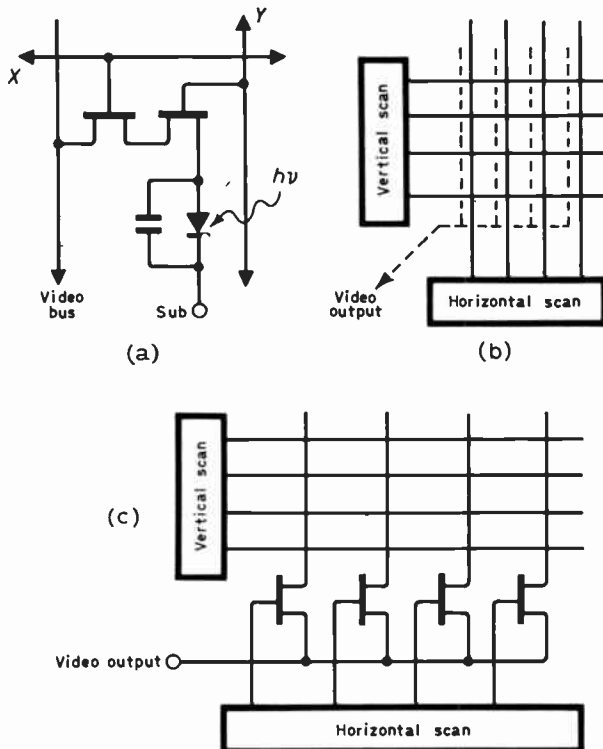

Fig. 4. XY -addressing (a) single element, (b) simple area array, (c) reduction in common node capacitance by multiplexing.

† These diagrams depict so-called 'three-phase' structures but 2- and 4-phase arrangements are also possible.

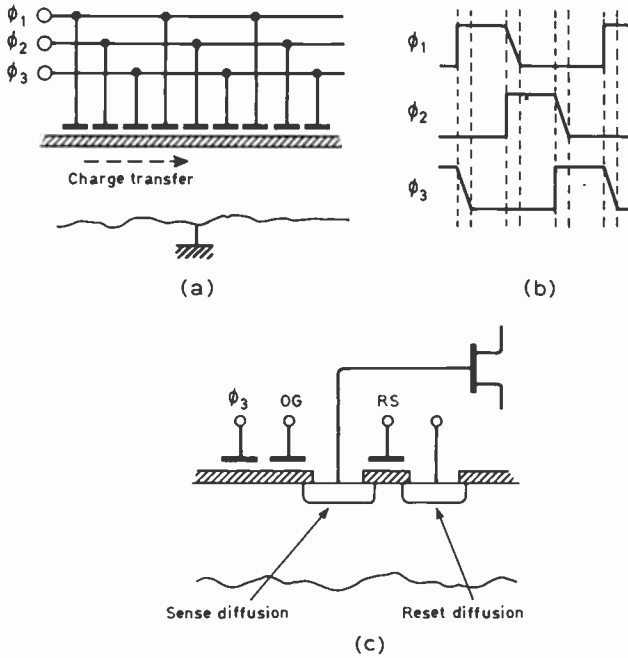

Fig. 5. Charge transfer in a c.c.d.: (a) basic principle. (b) clock waveforms. (c) details of sensing circuitry.

sensed by means of an on-chip m.o.s.t. After sensing, the charge on the diode is removed (and the diode potential reset) by pulsing the gate of the reset transistor of which the diode forms part. The system is then ready to detect the arrival of the next charge packet.

Such a c.c.d. structure forms an extremely simple linear image sensor without the need for any additional components. Suppose, for example, that the ϕ_1 electrodes are held at a high voltage (i.e. compared to ϕ_2 and ϕ_3) for some time. Any photo charges generated in the silicon in the vicinity of each ϕ_1 potential well will be collected in these wells. At the end of the integration period the three phases are clocked so that all the charges are transferred to the output diode and sensed. Note how this approach differs fundamentally from that of the photodiode array. In that system an addressing pulse was moved from element to element on the chip; in the charge-transfer approach the photogenerated charge itself is moved along the transfer channel to the output. The charge-transfer approach overcomes the two biggest drawbacks of the m.o.s.t. addressing technique. Firstly the capacitance of the output node need be no larger than the capacitance of a single sensing element; thus the signal-to-noise degradation discussed previously is eliminated. (We assume that no significant noise is introduced by the charge transfer process itself; this is usually justified since the transfer inefficiency of c.c.d.s is now very small—typically 10^{-4} per transfer.) Secondly, since all the charges emerge at a single node the variations previously introduced by multiple switches and non-identical scan pulses are eliminated. Clock pulses do, of course, appear on the video output but as these have a frequency typically three times the video (i.e.

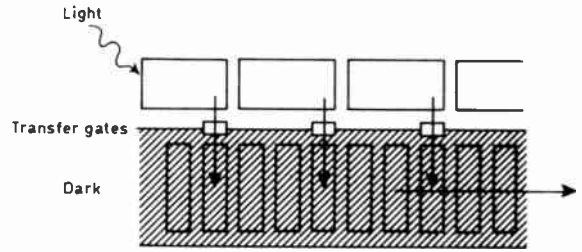

Fig. 6. Separation of charge sensing and charge transfer.

for a three-phase c.c.d.) their removal poses little difficulty.

A significant disadvantage of this simple arrangement is that light continues to fall on the sensor as the charge packets from the previous integration period are being read out. This gives rise to 'smear' which becomes quite objectionable if the scanning period exceeds a few percent of the integration time. The problem is generally overcome by separating the sensing and charge-transfer functions as depicted in Fig. 6. To increase the packing density of the sensors a bilinear arrangement is often used in which the line of sensors is bounded by two c.c.d.s, one on each side, alternate sensors being connected by a transfer gate to each c.c.d. Linear sensors of up to 1728 elements are available on $13 \sim 16 \mu\text{m}$ centres. The maximum bit rate is typically 10 MHz.

There are several ways in which the above principle can be extended to produce an area image sensor. The simplest approach—and the only one to which we shall refer here—is illustrated in Fig. 7. The whole structure (apart from the horizontal read-out c.c.d.) can be regarded as a single vertical c.c.d. having very wide electrodes. By introducing vertical 'channel stop' diffusions, however, the single potential well which one would normally associate with a single electrode is effectively subdivided into many smaller wells which are electrically isolated from one another; thus a large number of vertical, isolated channels are created. In operation the upper half of the structure is illuminated with one phase held 'high' for the integration period.

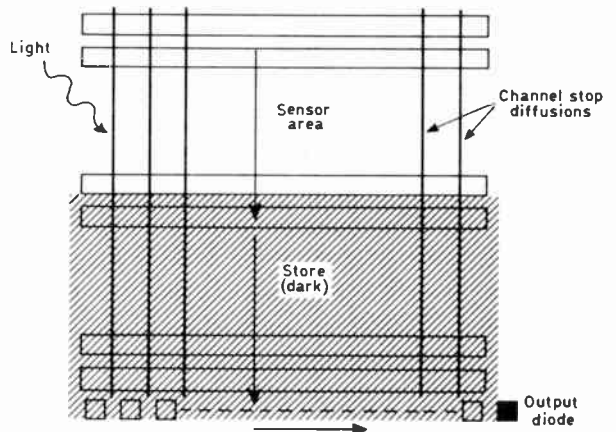

Fig. 7. Frame-transfer c.c.d. array.

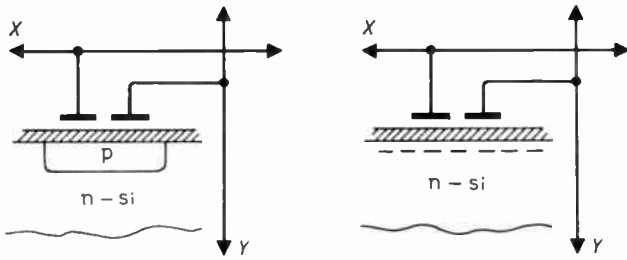

Fig. 8. Principle of charge-injection devices.

Subsequently all the A and B clocks are run so that the whole frame is quickly transferred to the lower non-illuminated store. From here one line of charges at a time is transferred to the horizontal read-out c.c.d. and thence to the output. While this process is proceeding the next frame of information is being integrated in the illumination portion. It is a simple matter to operate such an area array in an interlaced mode, making its output compatible with standard television scan rates. Area arrays are available in sizes ranging from 100×100 to 380×488 , the latter having a resolution approaching that of (U.S.) television. It is perhaps significant, however, that this largest array is available only with 'up to seven partial row or column blemishes' at present. An almost standard feature of c.c.d. imagers now is 'anti-blooming' control which prevents substantial degradation of the image due to local optical overload.

1.4 Charge-injection Devices

One addressing technique which is, in fact, equally applicable—at least in principle—to photodiode as well as m.o.s. image sensors is the charge injection device⁶ or c.i.d., the principle of which is shown in Fig. 8. Confining ourselves to the m.o.s. arrangement (since this is the structure that has received most attention) we see that the basic idea is that each imaging site comprises two charge-coupled electrodes, each of which is connected to row and column address strips respectively. Providing at least one of the electrodes is at a high potential, photogenerated charge collects in the potential well that exists beneath one or both electrodes. When both electrodes are taken to zero bias simultaneously, however, the charges are injected into the substrate where they recombine with majority carriers. This direct injection into the substrate is to be contrasted with the previous techniques in which the charge was returned to the substrate via m.o.s.t. switches (in photodiode arrays) or via an output diode (in charge-transfer sensors).

In early c.i.d. structures read-out was effected by detecting the current resulting from charge injection but more advanced read-out schemes detect the charge by sensing capacitance variations on the electrodes that comprise the storage elements. One example of this technique is shown schematically in Fig. 9 which also includes typical potential well and signal charge distributions. Prior to read-out all row electrodes are

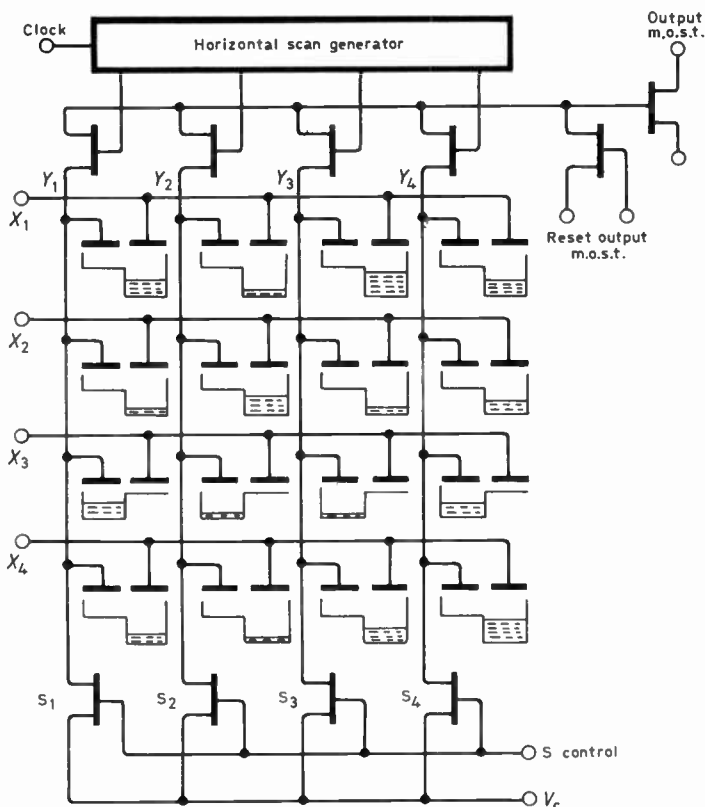

Fig. 9. Area array using c.i.d.s.

biased to a relatively high potential and the column lines are set (via switches S1 to S4) to a somewhat lower potential. To read a row, the relevant row voltage is removed (X3 in Fig. 9) thereby transferring the charges to the wells beneath the column electrodes. The voltage on each column line thus changes by an amount determined by the signal charge and column capacitance, the column voltages being sensed in turn via the horizontal scan register. At the end of each line scan all signal charges in the selected row can be injected into the substrate by driving all column voltages to zero. In general the column capacitance of a c.i.d. is higher than the output node of a c.c.d. and so the temporal noise associated with signal read-out will be correspondingly higher in a c.i.d.

Charge injection device arrays from 100×100 to

248×244 are currently available but only as part of complete cameras.

1.5 References

- 1 Weckler, G. P., 'Operation of p-n junction photodetectors in a photon flux integrating mode', *IEEE J. Solid-State Circuits*, SC-2, no. 3, pp. 65-73, 1967.
- 2 Ando, T. et al., 'Design and performance of silicon integrated imaging sensor incorporating self-scanning integrated circuits', *J. Inst. Telev. Engrs. Japan*, 26, no. 1, pp. 33-46, 1972.
- 3 Sangster, F. L. J. and Teer, K., 'Bucket-brigade electronics—new possibilities for delay, time-axis conversion and scanning', *IEEE J. Solid-State Circuits*, SC-4, no. 3, pp. 131-6, 1969.
- 4 Boyle, W. S. and Smith, G. E., 'Charge coupled semiconductor devices', *Bell Syst. Tech. J.*, 49, pp. 587-93, April 1970.
- 5 Beynon, J. D. E., 'Charge-coupled devices—concepts, technologies and applications', *The Radio and Electronic Engineer*, 45, no. 11, pp. 647-56, November 1975.
- 6 Burke, H. K. and Michon, G. J., 'Charge-injection imaging: operating techniques and performances characteristics', *IEEE J. Solid-State Circuits*, SC-11, no. 1, pp. 121-7, 1976.

Part 2 USING ARRAYS IN INSTRUMENTATION

D. J. PURLL, B.Sc., M.Inst.P.*

2.1 Why use Solid-state Arrays?

The solid-state imaging arrays described in the previous contribution will be increasingly used in a wide variety of optical instrumentation. The questions which the systems engineer must consider in a given situation are the appropriateness of using arrays, the choice of array type, and the design limitations imposed by the properties of the chosen device.

Solid-state arrays offer one of many ways of scanning an optical field, the principal rivals being conventional television cameras and flying-spot laser scanners. Some properties of these different systems are compared in Table 1. In addition to its obvious practical advantages,

such as size and robustness, a solid-state array offers the very important and fundamental advantage for measurement systems (as opposed to visual imaging systems) that the division of space into resolution picture elements (pixels) is defined stably and linearly by the geometry of the chip itself. It has, however, two major performance limitations which cannot be ignored.

The first and most obvious limitation of solid-state arrays is the element count. Although the measurement accuracy can sometimes be increased by interpolation (see later), there is still no alternative to laser scanners when intrinsic resolutions of greater than 1 in 2000 are required, for instance in high resolution defect and shape inspection.

Table 1

Comparison of properties for three types of scanner

Scanner type	Solid-state arrays	Television	Laser scanner
Size and weight	Low	Moderate	High
Supply	Low power and voltage	High voltage	High voltage + motor drive
Reliability and robustness	High	Tube life and fragility	Tube life and mechanical wear
Geometry	Stable, linear	Electron scan distortions and external field interference	Scan angle correction and movement inaccuracies
Spectral range	Broad	Broad	Narrow
Resolution limits	2000 linear 500 matrix	500-1000 per line	10-20,000 per line
Scan patterns	Linear, raster	Raster only	Linear, raster, random access
Non-uniformity	Shading and discontinuous, response and dark current	Shading of response	None due to detector

* Sira Institute Limited, South Hill, Chislehurst, Kent.

The second and perhaps the major problem is non-uniformity. Although there are many industrial applications in which this is not a problem, in low-light-level applications or those requiring faithful grey level representation the device has to be calibrated in the signal processing system. The systems designer will have to trade off the disadvantages of such a calibration requirement against the problems to be found with alternative imaging systems. Typical non-uniformity for

illumination). Dark signal non-uniformity can often be 100% or more of the mean dark signal level, and can therefore be a significant fraction of the illuminated signal level, depending on device temperature and exposure time. Dark signal can be reduced by cooling the device at the expense of extra complexity in the instrument.

Unfortunately, both element count and uniformity are limited by semiconductor process technology, which may not improve as rapidly as the advances in integrated circuit design itself.

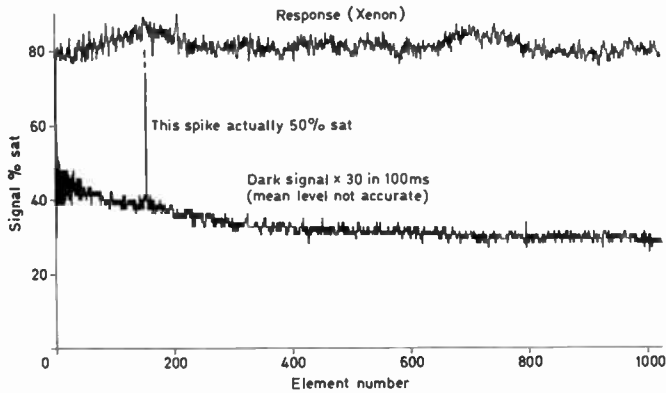

Fig. 10. Typical non-uniformity for a 1024-element c.c.d. linear array.

a long linear array is shown in Fig. 10: response non-uniformity is typically a few percent, but may be up to 30% for long arrays. This is variable with colour, and is usually improved by removing the infra-red (at the expense of losing half or more of the signal with tungsten

2.2 Which Type of Array?

C.c.d. development has attracted (or maybe generated) so much publicity in recent years that people outside the field tend automatically to assume that c.c.d. arrays are the best solid-state solution to any imaging problem. This is not necessarily so. The major properties of the different array types are compared in Table 2. The major advantage of c.c.d.s is their low read-out noise. The read-out noise limit (at 100 electrons/pixel or around 10^{-4} of maximum signal level) is important, however, only for low light level applications; generally it is overshadowed by dark signal non-uniformity. The latter can be reduced substantially by highly cooling the device, or by characterizing the dark current initially and then subtracting it from subsequent total signals. If necessary, special amplification techniques can be used with c.c.d.s to reduce amplifier noise still further, to around 10–20 electrons/pixel.

Table 2
Comparison of properties for different types of array

Type of array	C.c.d.	S.s.p.d.	C.i.d.
<i>Availability</i>			
Linear: resolution	2048	2048	None
spacing	13 or 16 μm^\dagger	15, 25, 100 μm	
Matrix: resolution	488 \times 380	64 \times 64	244 \times 188
spacing	Typically 30 μm	75, 100 μm	35 \times 60 μm^2
<i>Properties</i>			
Noise	Lowest \dagger	Higher than c.c.d.	
Dark current	Highest	Usually lower than c.c.d. \dagger	
Non-uniformity	Highest	Less dark current and spikes \dagger	
Clock fixed pattern	No \dagger	Yes	Yes
Clocks: complex	Yes \dagger	No	Yes
critical	Yes	No	No
Susceptibility to blooming	High	Low \dagger	Low
Surface structures on image area	Yes	No \dagger	Yes
Charge transfer losses	Yes \dagger	No	No

\dagger Indicates mixture of properties for c.c.p.d.

As mentioned previously, the non-uniformities of response and dark current will be the performance-limiting factors in many applications, and these tend to be worse for c.c.d.s than for other solid-state sensors, particularly because of the incidence in c.c.d.s of large dark current 'spikes'. Some of the other properties in Table 2 also show c.c.d.s in rather unfavourable light. For example, the polysilicon electrode structure over the elements in a c.c.d. modifies the spectral response, and the total response can be as low as half that of a photodiode. Moreover, ultra-violet and deep blue response is reduced virtually to zero. In matrix arrays several edges in the overlapping clock electrode structure occur within the boundaries of each element and this modifies the aperture responses (cross-sectional sensitivity profiles) of the elements. The poorer blooming performance of c.c.d.s will cause problems in situations where a very bright object or reflection is within the field of view in addition to the measured object.

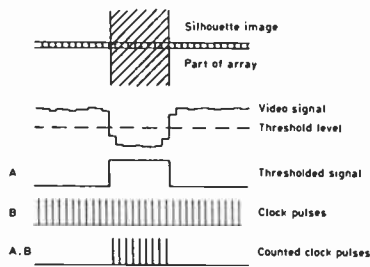

Fig. 11. Basic measurement principle using linear arrays.

The implications for image quality of array design are often overlooked. Small elements sound impressive, but have no advantage in terms of measurement resolution, which is fixed only by the element count and the optical magnification. The main effect of small elements is to complicate the optical design. At 25 μm spacing, an off-the-shelf camera lens can probably be used, but it is asking a lot with readily available lenses to resolve a 13 μm pixel (40 line pairs per mm) with good contrast at the fairly high apertures and field angles which are usually required. The degree of cross-talk between adjacent elements is another factor which degrades image contrast; this is dependent on colour, being worse at the red end of the spectrum. For c.c.d. arrays, charge transfer inefficiency adds a further contrast degradation which is variable across the array. The m.t.f. (effectively the contrast degradation factor) for a c.c.d. array having 13 μm spacing is about 0.5 for visible light at the Nyquist limiting resolution (one line pair per two elements). This falls to around 0.2 with near-infra-red light. This m.t.f. must be multiplied by that of the lens, which for the best readily available lenses will seldom rise above 0.7 at 40 line pairs per mm even at reduced aperture.

To summarize then, the 'old-fashioned' self-scanned photodiode array may well still prove to be the better linear sensor for many applications. In two-dimensional imaging s.s.p.d. cannot compete, but charge injection devices have many advantages although lagging behind c.c.d.s by a factor of around two in resolution on each axis. Reticon claim to have combined the advantages of s.s.p.d. and c.c.d. in their c.c.p.d. range of linear arrays with diode sensors. These would probably compete with the best linear c.c.d. if only the read-out registers were buried rather than surface channel; theoretically the c.c.p.d. design appears optimum for linear sensors. However, for many non-critical applications almost any type of array will suffice and most choices will therefore be made on grounds such as price and availability.

2.3 Basic Measurement Principles

The basic measurement technique is rather obvious but will be described for the sake of completeness. An image of the object to be measured is formed on the array, in silhouette or in reflected light, and the number of elements obscured or illuminated is counted electronically by the sequence of operations indicated in Fig. 11. Knowing the element spacing and the optical magnification, the dimension of the object in the direction of the array axis can be calculated. Optical edges are not perfectly sharp, and the edges in the image will not necessarily be spatially synchronized with the element spacing, so one or more elements in the vicinity of each image edge will give a signal level part way between black and white. This causes a one-element uncertainty in the position of each edge, as defined by the thresholding operation, which translates into a maximum of ± 1 element uncertainty on the width of the image. The measurement accuracy is therefore not absolute, but is determined by the optical magnification and the number of elements which can be disposed across the width of the image; at present up to around 2000 elements can be obtained in linear arrays. The position on the array of an optical contrast edge can of course be used for many other types of measurement than width monitoring.

The accuracy of the position measurement can be increased above the basic element resolution by various interpolation techniques. If the array and image have relative motion then the thresholding error can be averaged out over many successive scans. Alternatively, the shape and therefore the position of an edge can be accurately computed by considering the analogue signal levels from the several elements concerned, rather than by a thresholding operation. These interpolation techniques can readily yield an improvement of about a factor of 10 on element resolution; any further improvement requires calibration of detector properties such as non-uniformity.

2.4 Industrial Applications

The major field of application in industry to date has been in automatic inspection and gauging. It is easy to see how the basic measurement principle just described may be applied to measurement of single dimensions, such as web width, rod and fibre diameter, thickness, level, separation, and so on. Such measurements form an integral part of many plant control and non-destructive testing functions.

Two-dimensional shape inspection is a particularly exciting area. Where a discrete object is moving along a production line a two-dimensional picture can be acquired by a linear array. This is the basis for many on-line pattern inspection (one hesitates to say pattern recognition) systems now made possible by the advent of small and cheap data processing systems based on mini-computers and microprocessors. Figure 12 shows one example, where the output of a linear array has been used to produce a single grey level picture of a plank of wood moving along a conveyor system. Such a picture

for on-line inspection applications. It is therefore usual to employ some hardware data reduction interface between the camera and computer. Data reduction often takes the form of thresholding as in Fig. 12, followed by input to the computer in the form of a few data words per linescan specifying the positions of the contrast edges in that line. In some cases a matrix array must be used to acquire the image because the instantaneous object field is two-dimensional. However, matrix arrays are of lower resolution and more difficult to manufacture with high quality than linear arrays.

Another industrial application is automatic surface inspection, where visible defects on moving strip products (such as metals, paper, plastics, glass and textiles) require detection at production speeds which are increasingly beyond the capability of human inspectors. Solid-state array cameras can in many, though not all, applications replace opto-mechanical scanners which have hitherto been used.¹⁰ Laser scanners must, however, continue to be used for the higher resolution and high speed end of this market.

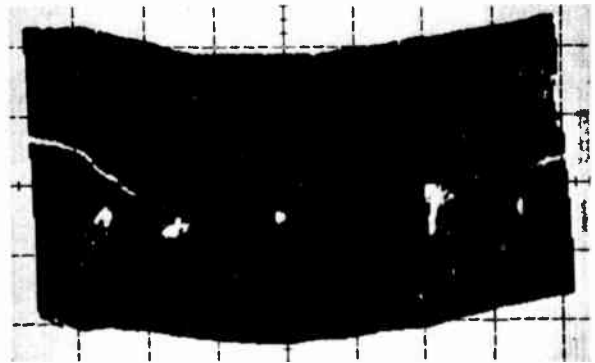
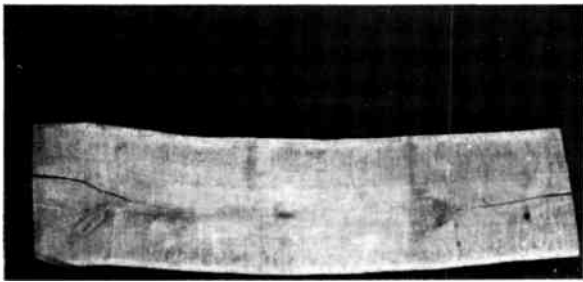

Fig. 12. Photograph of a plank of wood together with the corresponding thresholded picture acquired by a linear photodiode array camera.

can be analysed for shape, area and defect position in order to produce an optimum cutting plan. Other examples of this type of application are the multi-dimension inspection of component parts,⁷ and automatic inspection of packaging. An increasingly important application will be the giving of 'eyes' to robots,⁸ particularly for automatic assembly. One good example of this is the verification of correct parts and their orientation at the output of vibratory bowl feeders,⁹ as an alternative to mechanical tooling which is prone to jamming.

The data input and processing speeds of the computing system still set the limits to the complexity and throughput capability of such instrumentation. The image scanning system may well acquire 1-10 million picture elements per second. Any system based on processing the grey level information from each element of the picture will usually be too slow and too expensive

In addition to viewing an object directly, information concerning its properties may be gathered by analysing an image produced by an intermediate process. Thus solid-state arrays, sometimes of special design, are being used in systems to analyse the patterns produced in interferometry, diffractometry and spectrometry, and an array optimized for spectrometry will be described later in Part 6. Measurements of image quality can be used to inspect optical components and to measure surface texture. Interferometry and moiré grating techniques, with arrays now being used to analyse fringe patterns, are used in displacement transducers for machine tool control. Machine control can also be implemented using more direct measurements, such as imaging the tool position directly or performing in-process inspection of the machined part.

Another important industrial application is in reading machines. Optical character recognition was one of the

chief early spurs to array development. Now arrays are beginning to be used in facsimile transmission and code-reading applications in place of traditional scanning techniques. There will be an increasing need in the future for machines such as automatic banking terminals to recognize human beings for security purposes, perhaps by signature verification.⁷

2.5 Military and Aerospace Applications

The price-sensitive nature of the industrial instrumentation market has meant that, with a few exceptions, only relatively simple problems or those with non-critical optical parameters (such as high light levels) have been tackled so far. More advanced applications are being progressed in the military and aerospace fields, and it is the investment in these spheres, in addition to the search for broadcast-quality television, which drives manufacturers to extend the performance of their devices.

Aerospace applications¹¹ are mainly centred around satellite attitude control (star trackers, sun sensors), earth resources imaging from satellites (using linear arrays scanning across the satellite track direction—the so-called ‘pushbroom’ mode) and astronomical instrumentation such as spectrometers. Many of these applications have their military equivalents, such as target tracking and remote reconnaissance. An example of a position-sensing application in cockpit instrumentation is described later (Part 8). The harsh environments often experienced in such applications have led to investigations of the effects of, for example, radiation damage (bias voltage shifts, increased dark current and transfer inefficiency) and high shock (operation up to

20 000 g has been tested for shell-launched reconnaissance).

The sensitivity of silicon arrays to electron input allows their use in the electron bombarded mode, to detect directly the image at the back end of an intensifier tube without an intervening phosphor. This permits very low light level imaging. Thermal imaging arrays are being built in doped silicon or by interfacing silicon read-out arrays with infra-red detecting elements in other materials. In some cases arrays may be directly fabricated in infra-red sensitive materials.

This general review of the applications of self-scanned image sensors has necessarily been brief. Another review with a more comprehensive reference list is given in Ref. 12. Some specific examples of applications are described later in this symposium.

2.6 References

- 7 Parks, J. R., ‘Intelligent machines—commercial potential’, *The Radio and Electronic Engineer*, **47**, no. 8/9, pp. 355–67, August/September 1977.
- 8 Weaver, J. A., ‘Experiments in visually controlled flexible automation’, *ibid.*, pp. 385–92.
- 9 Pugh, A. and Waddon, K., ‘The prospects for sensory arrays and microprocessing computers in manufacturing industry’, *ibid.*, pp. 377–84.
- 10 Purll, D. J., ‘Automated surface inspection with solid-state image sensors’, *Proc. Soc. Photo Opt. Instrum. Engrs.*, **145**, pp. 18–25, March 1978.
- 11 Samuelsson, H., ‘Space application of c.c.d. image sensors’, *ESA Sci. & Tech Rev.*, no. 1, p. 219, 1975.
- 12 Purll, D. J., ‘Survey of the present state of the art in applications of solid-state image scanners’, *Proc. Soc. Photo Opt. Instrum. Engrs.*, **145**, pp. 9–17, March 1978. (Other applications papers also in this volume.)

Part 3

DEVELOPMENT OF LARGE AREA CHARGE-COUPLED IMAGE SENSORS

D. J. BURT, B.A.*

A variety of prototype c.c.d. cameras are now available from industrial R & D establishments throughout the world. Among the largest devices are a 320 × 512 element frame transfer array from RCA and a 380 × 488 element interline transfer array from Fairchild, alongside which the GEC intends to be competing with a 385 × 576 element frame transfer array later in 1979. These devices are ideal for surveillance, industrial and military applications not requiring the highest resolution but where considerations of long life, small size, precise sensor geometry and low voltage operations are important. Certain problems still exist, however, in realizing devices to meet the more demanding applications such as broadcast television.

3.1 Resolution

The arrays previously described still fall short of the resolution normally expected for European 625-line television, for which an array size of 572 × 576 elements is an absolute minimum. Progress will naturally be made towards this goal, but the manufacturing difficulties in doing so are quite severe. Firstly, to produce such an array within a standard image size (e.g. 11 mm diagonal to be equivalent to a 2/3 inch vidicon), the design will require dimensions that are finer than can be achieved with the resolution currently available from the

* GEC Hirst Research Centre, Wembley, Middlesex.

photolithographic process. Secondly, there will be a certain density of process defects that occur during fabrication and which cause picture blemishes in the display. Hence, as the chips get larger to accommodate more elements, the chance of producing a defect-free array is correspondingly reduced. It will thus be a year or two yet before improved manufacturing techniques become available to make possible the production of full 625-line resolution arrays.

3.2 Signal Levels and Dark Current

Although the output signals from a c.c.d. are generally in the form of voltage pulses, measurement of the output as a current (through the reset drain connection of the output circuit) can give values that can be compared with figures normally quoted for conventional tubes. The following signal levels are fairly typical of the outputs to be expected from a c.c.d. image sensor:

Peak white signal (i.e. saturation)	500 nA/cm ²
Dark current (25°C)	5–10 nA/cm ²
Dark current non-uniformity (25°C)	± 5 nA/cm ²
Output amplifier noise	0.5 nA r.m.s.

Dark current arises from thermal generation of minority carriers. However, the dark current generation tends not to be uniform over a whole array and the fixed pattern noise introduced by the dark current non-uniformity is often the major factor in determining the sensitivity and dynamic range of the sensor. This can be appreciated from the figures quoted: although the output dynamic range is 1000:1 (60 dB), the effective dynamic range is no more than 50:1 (34 dB) as set by the dark-current fixed pattern noise. In addition, many devices show exceptionally high dark-current generation for some elements in the array—the so-called dark-current 'spikes'—probably through contamination picked up during manufacture. These appear as white spot defects in the array.

As previously mentioned (Sect. 1.1), dark current is highly temperature dependent. Cooling is thus a possibility for reducing dark current and its non-uniformity, thereby extending the dynamic range of an array. Furthermore, concealment of a few spike blemishes may be a practical proposition since the output from each c.c.d. element is precisely located in the read-out sequence. Impaired video information at these locations can thus be removed electronically and substituted with values interpolated from the outputs of adjacent picture elements.

3.3 Spectral Response and Sensitivity

The spectral response of the c.c.d. extends over a range 400–1100 nm. However, the performance of the c.c.d.

falls considerably short of that predicted theoretically for silicon, particularly towards the blue end of the spectrum. This is because the polysilicon electrode material is not completely transparent to light, the absorption being greatest towards the blue. Another point is that there are significant ripples in the spectral response curve caused by light interference effects in the dielectric layers that make up the electrode structure. Nevertheless, the wide spectral range of the c.c.d. sensor ensures that the responsivity to white light is reasonably good, with values of 2.5 mA/lumen (3000 K) being typical. Hence, taking the peak signal current as 500 nA/cm², the illumination on the sensor for saturation is typically 2 lux. Thus, with say *f*/4 optics, the c.c.d. can be expected to operate at scene illumination levels of 100 lux and below. This performance compares favourably with other non-intensified vidicon-based cameras and enables daylight imaging under conditions described conventionally as 'twilight' or a 'very dark day'.

Various methods have been proposed for improving the response of the c.c.d., particularly in the blue as is required for colour cameras. Other materials more transparent than polysilicon, e.g. tin oxide, are currently being investigated,¹³ but there are found to be some serious problems regarding compatibility with the other fabrication processes in the silicon chip. An alternative approach is to thin the silicon chip behind the image section and to image the device from the back-face.¹⁴ Light then passes directly into the silicon substrate without being attenuated by an electrode layer. It must be pointed out, however, that the thinning of the silicon chip down to only a few microns (as is necessary for good optical response) is still a very difficult technique and it is unlikely that devices of this type will be commercially available in the near future.

3.4 Blooming Control

Operating a c.c.d. image sensor with signal levels above saturation gives rise to 'blooming' as the excess-generated carriers spread sideways from the area of overload into adjacent picture elements in the array. Blooming thus results in loss of picture information and is subjectively unpleasant to the viewer. On the other hand 'image burn' from an optical overload as found with vidicons does not occur with the c.c.d.

The basic approach to providing anti-blooming for c.c.d.s is that excess charge must be soaked up before it can spread to adjacent picture points in the array.¹⁵ One technique suitable for overload protection up to 10–100 times saturation is to bias the non-integrating electrodes in the array into accumulation during the charge collection period to remove the excess charge by recombination with majority carriers. This does, however, require surface channel operation to be effective and means that fat zeros have to be introduced

via bias light on the array. A superior technique is to use overflow drains positioned between the image sensitive columns of the array. These operate in a manner analogous to the overflow pipe on a domestic bath, being biased so that the excess charge flows into them rather than into adjacent picture points in the array. Experimental 240×300 element arrays produced at GEC have shown that protection can be provided at up to 1000 times saturation. The only disadvantage is some loss of signal current as the drains are non-photosensitive.

3.5 Colour Cameras

Television cameras for colour pictures generally employ three separate sensors for the red, green and blue channels together with the appropriate colour separation filters. A similar approach has been adopted in the few experimental c.c.d.-based colour cameras that have been reported.¹⁶ Sensitivities have not been high, however, with scene illumination levels of typically 3000 lux or more. The sensitivity of any colour camera is always less than a monochrome unit using the same sensors because the colour separation filters are quite narrow (about 40 nm) and only a small fraction of the incident light power is actually available for imaging. In the case of the c.c.d. colour camera, to achieve a performance comparable to that obtained with lead oxide tubes (i.e. < 800 lux at $f/4$), further research will be necessary to reduce dark current considerably so that arrays can be successfully operated at much lower signal currents. For the blue channel, this means peak signal levels of no more than 50 nA/cm^2 (i.e. $< 10\%$ saturation). Corresponding levels in the green and red channels will be somewhat less difficult.

3.6 Operational Problems

The c.c.d. image sensor has a geometric accuracy which is determined solely by the photomasks used in the device fabrication to form the matrix of picture elements.

Geometric accuracy is of particular importance for applications where remote measurements are to be made, i.e. in process control and automation, and also for registration of a number of sensors, as is required in a colour camera. However, to utilize fully the accuracy achievable with such solid-state devices will require a higher tolerance from the optical components in the system. There can of course be no equivalent to the adjustment of scan waveforms to compensate for lens aberrations as is done with tubes.

Arrays will need to be designed for a particular line standard, i.e. separate devices and drive circuitry will be required for 525-line and 625-line cameras. The design of a dual-standard array would be too complex to be commercially viable.

3.7 Future Prospects

Some estimates can be made as to the future development possibilities for c.c.d.-based television cameras. Medium-resolution monochrome cameras are already available. Prototype colour cameras, possibly with only moderate sensitivity and resolution for applications such as home video recorders, will become available in 1980/81, with higher performance units suitable for Electronic News Gathering a little later, say 1981/82. Arrays that can provide full 625-line performance should also be available about this time. However, further development over several more years will probably still be necessary before the very demanding requirements of studio quality television can be met.

3.8 References

- 13 Schroder, D. K., 'Transparent gate silicon photodetectors', *IEEE J. Solid-State Circuits*, SC-13, no. 1, pp. 16-23, February 1978.
- 14 Shortes, S. R. *et al.*, 'Characteristics of thinned backside-illuminated charge coupled device', *Applied Physics Letters*, 24, no. 11, pp. 565-7, 1st June 1974.
- 15 Kosonocky, W. F. *et al.*, 'Control of blooming in charge-coupled imagers', *RCA Rev.*, 35, pp. 3-24, March 1974.
- 16 Ochi, S. *et al.*, 'A device structure and spatial spectrum for checkerpattern c.c.d. colour camera', *IEEE J. Solid-State Circuits*, SC-13, no. 1, pp. 187-92, February 1978.

Part 4

SELF-SCANNED PYROELECTRIC ARRAYS

S. G. PORTER, B.Sc., Ph.D., M.Inst.P.*

All the image sensors described so far operate in the visible (or very near infra-red) part of the spectrum; as such they rely for their operation on radiation reflected from objects. In addition to *reflecting* light, all bodies *emit* radiation which is a function of their absolute temperature and their emissivity. For objects at normal ambient temperatures, around 300 K, this radiation has its energy peak at a wavelength of approximately $10 \mu\text{m}$.

There is much interest at the present time in detecting this radiation in a manner which allows the presentation of a thermal image or thermal 'profile' of an object. There has also been a marked increase recently in the use of infra-red lasers, particularly carbon dioxide lasers which operate at a wavelength of $10.6 \mu\text{m}$. This brings

* Plessey Optoelectronic and Microwave Ltd., Towcester, Northants NN12 8EQ.

with it the requirement of measuring the energy profile of such laser beams. There is the further requirement for measuring the spectral distribution of both thermally-emitted radiation, from various sources, and laser radiation. Thus a considerable need exists for suitable infra-red detectors.

4.1 The Pyroelectric Detector

Silicon detectors generally operate only for wavelengths less than $1.1\ \mu\text{m}$. Lead tin telluride (LTT) photovoltaic detectors and cadmium mercury telluride (CMT) photoconductive detectors both provide excellent detectivity in the infra-red region but have the disadvantage of a non-uniform spectral response and the requirement for cooling below normal ambient temperatures, usually by liquid nitrogen. Pyroelectric detectors, although less sensitive than LTT or CMT, provide a response which is essentially independent of wavelength and will operate at room temperature.

A pyroelectric material is one which exhibits a spontaneous electric polarization whose magnitude varies with temperature. In general the polarization decreases to zero at some temperature, T_C , known as the Curie point.

A pyroelectric detector consists of a capacitor formed by a flake of pyroelectric material with electrodes on opposite faces, the polar axis of the material being perpendicular to these faces. At equilibrium the polarization will be compensated by a surface charge so that no voltage is observed across the capacitor. When the temperature of the flake is changed, however, the polarization changes and a voltage is produced. Typically the charge developed on a pyroelectric detector is of the order of 10^{-16} coulombs, so that a very high impedance low-noise amplifier, such as a junction f.e.t., is needed.

The most sensitive pyroelectric material is triglycine sulphate (TGS). Unfortunately, however, this is a fragile water-soluble material which must be used in single crystal form. It also has a Curie point of only 49°C and so is limited to quite low temperature operation.

A pyroelectric ceramic material has been developed at Plessey Research (Caswell) Ltd. This is a little less sensitive than TGS but is adequate for many applications. It has the advantages of being more robust and inert and has a higher Curie point (200°C). It can also be made electrically conducting ($\sim 10^{12}\ \Omega\ \text{cm}$), a significant advantage when considering arrays of large numbers of elements, each with its associated f.e.t. or other read-out device requiring a bias current.

4.2 Pyroelectric Linear Arrays

Pyroelectric ceramic linear arrays are available with up to 100 elements, each of area in the range $10^{-2}\ \text{mm}^2$ to $1\ \text{mm}^2$. A typical 32-element array for use in thermal imaging applications has elements on a $0.25\ \text{mm}$ pitch,

each with a noise equivalent power of $1.5 \times 10^{-10}\ \text{W Hz}^{-1/2}$ at 80 Hz modulation frequency. At the present time electronic scanning of such arrays can be achieved by c.m.o.s. multiplexers. Direct interfacing of the pyroelectric to the multiplexer, however, gives a badly degraded signal. For most applications it is necessary to include f.e.t. source-followers and some signal processing between the array and the multiplexer.

For maximum sensitivity the radiation from a constant infra-red source is modulated by a mechanical chopper and phase-sensitive detectors are used for amplifying the output of each array element. The resulting direct voltages are then multiplexed to provide a display of the spatial distribution of incident power. A linear pyroelectric array coupled to such a system and designed to be compatible with an infra-red spectrometer (giving an output proportional to intensity as a function of wavelength) has an n.e.p. of $6 \times 10^{-10}\ \text{W Hz}^{-1/2}$ for each element.

For pulsed radiation of relatively high energy density, such as that produced by carbon dioxide lasers, sample-and-hold amplifiers are used in place of the phase sensitive detectors. Using an array of integrating pyroelectric detectors and sampling the peak output, a spatial distribution of the pulse energy is obtained. An instrument of this type can be used for examining a laser beam energy profile or, with the aid of a suitable grating, the spectral distribution of the energy.

4.3 Two-dimensional Thermal Imaging

Two-dimensional thermal imaging is achieved at the present time with either cooled arrays (of lead tin telluride or cadmium mercury telluride) or using a pyroelectric vidicon. The cooled arrays have the obvious disadvantage of requiring liquid nitrogen for cooling, whereas the pyroelectric vidicon has insufficient sensitivity for some applications, is of limited life, and not particularly rugged.

Pyroelectric linear arrays are sometimes used with one-dimensional mechanical scanning to give a two-dimensional image but these are generally of low resolution and of limited application.

The use of c.c.d.s with pyroelectrics will make possible the production of two-dimensional arrays for thermal imaging. The electrical conductivity of the pyroelectric ceramic will be of great benefit in this application in providing a suitable bias to the input gates. It has already been demonstrated that c.c.d.s can be used with pyroelectric arrays to give acceptable signal-to-noise ratios. Further development work is required before two-dimensional arrays can be mated reliably to suitable c.c.d.s.

When this is achieved it should be possible to produce devices which have a performance approaching that of cooled arrays; they will, however, be compact and will operate at normal ambient temperatures.

Part 5 ENHANCEMENT OF THE UNIFORMITY OF RESPONSE OF SELF-SCANNED ARRAYS

P. W. FRY, M.A., B.Sc.*

Normal limitations in the silicon and processing of photodiodes of c.c.d. arrays give a typical non-uniformity of response of $\pm 5\%$ to $\pm 12\%$ for long linear arrays. To a first order, this non-uniformity is independent of clock rate (within limits) and temperature; it is caused by carrier diffusion length variation (due to impurity distribution) and (possibly) minor effects due to photo-engraving errors and undercutting.

The system to be described aims to correct response non-uniformity in a line-array by means of a signal path, subsequent to the video processor circuit, whose gain varies, pixel by pixel, under the control of a p.r.o.m. which has been pre-programmed to suit the particular array with which it is associated. For general purpose it is set up using a standard 2870 K tungsten source with $\pm 1\%$ uniformity over the total array. It is obviously impractical in many applications to achieve illumination of such a high degree of uniformity; in such circumstances the correction can equally well be done to take account of the prevalent lighting conditions in a particular application.

A general target specification for the correction system is shown in Table 3. The worst-case non-uniformity of response of $\pm 3\%$ of mean signal level was set to allow for the predicted error budget of Table 4. Note that, if we keep the same illumination source for setting up and operation, a slight improvement is obtained in the error budget by elimination of item (ii).

5.1 Circuit Design

The system consists of:

- (i) the correction system itself;
- (ii) a programming unit including an r.a.m. to hold the information which will finally appear in the p.r.o.m.;
- (iii) a system for transferring the information from the r.a.m. to the final 'fusible-link' p.r.o.m. (82 S129).

5.1.1 The correction system

This is based on a multiplying d-a converter (DAC-08), which generates an output current which is proportional to the product of an input current and an 8-bit digital input word.

The input current is generated directly from the video signal by R8 (see Fig. 13). Four digits of the 6-digit multiplying factor are programmed for each pixel by the p.r.o.m. P3, whose address lines are driven by counter

Table 3

Array responsivity correction system.
Target specification (Summary)

Max. no. of pixels	256, extendable to 1024
Gain	Proportional to the binary number 11DCBA where D, C, B, A are the correction code bits
	DCBA
Nominal gain	100% for (11) 1000
Minimum gain	87.5% for (11) 0001
Maximum gain	112.5% for (11) 1111 (Gain increment is 1.8%)
Video range (input and output)	0 to +8.5 V
'Killer code'	0000 sets gain to zero
Signal uniformity after correction	$\pm 3\%$ of 5 pC signal (± 0.15 pC)

P6, which is clocked and reset directly by the signals controlling the photodiode array. The two most significant bits are permanently set to '1'. The gain through the d.a.c. is thereby varied in proportion to an integral number between 48 and 63. This gain is set by R8 and R4 so that, for a p.r.o.m. output of 8 (multiplication factor 56), the gain is unity. The 0 to 15 range of p.r.o.m. outputs thus has the capability of varying the gain between 48/56 (85.7%) and 63/56 (112.5%) in steps of 1/56 (1.8%) and the digitization error is $\pm 0.9\%$.

A further facility is provided whereby, at the expense of discarding one level (0000) at the end of the correction

Table 4

Error budget

(i) Array + processor non-linearity	$\pm 0.8\%$
(ii) Light source non-uniformity	$\pm 1.0\%$
Total errors in setting p.r.o.m.	$\pm 1.8\%$
(iii) Array + processor non-linearity	$\pm 0.8\%$
(iv) Photoresponse of array O/P line	$\pm 0.8\%$
(v) Digitization error	$\pm 0.9\%$
Total correction system opn. errors	$\pm 2.5\%$
Therefore maximum possible worst-case overall error = 4.3%	
Probable worst-case overall error by r.m.s. addition = 2.0%	

* Integrated Photomatrix Ltd., Dorchester, Dorset DT1 1SY.

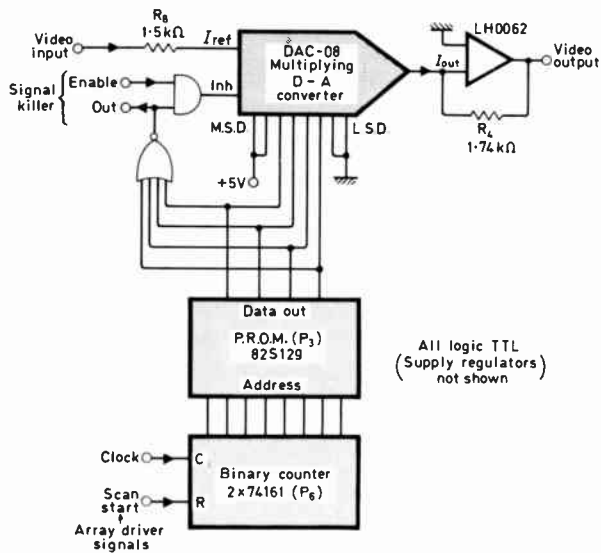

Fig. 13. Array-correction card: simplified circuit diagram.

conditions at 2870 K to $\pm 0.9\%$ uniformity (digitization error limit). The signal was then varied in 1 pC steps between 0 and 5 pC, taking precautions not to vary illumination uniformity or colour temperature, and uniformity of output noted as a percentage of the 5 pC signal at each level. A worst-case error of 1.8%, including digitization error was noted. This is well within the expected error budget already quoted. The experiment was repeated allowing for the digitization error and a worst-case figure of 0.8% obtained.

The correction unit is accommodated on a standard Eurocard which forms an optional part of a general modular system containing up to two linescan cameras and other signal processing units.

5.3 Application of the Video Correction System to a Banknote Inspection System

The responsivity correction system has been applied to an experimental banknote inspection system used in the Danish National Bank printing works.

In the printing process a continuous roll of paper is printed, two banknotes wide, and the inspection system consists of two 256-pixel line arrays in cameras scanning simultaneously two notes side by side. The two camera outputs are scaled with respect to one another and then their difference taken in real time. Any difference signal exceeding a given threshold for a defined period of time is taken to be a printing flaw on one or other of the two notes. As can be imagined, non-correlated responsivity variations in the arrays give rise to substantial apparent difference signals. The application of responsivity correction was therefore considered to be a potentially useful improvement.

Using uniform-light corrections for each camera gave disappointing results, however; comparison of two plain white surfaces similar to the paper on which the banknotes were printed gave a difference signal with amplitude $\pm 6.5\%$ of a camera signal, before correction. After correction, this figure was reduced only to $\pm 4.5\%$. The residual errors were found to be due to:

- (i) different, non-uniform illumination of each camera object plane;
- (ii) fine texture in the paper surface;
- (iii) the addition of digitization errors.

To minimize (i) and (iii) the following procedure was carried out. Using the system correction system on camera 1, camera 2's output was corrected, using the illumination actually present in the inspection set-up rather than a completely uniform light source, to minimize the difference signal rather than the non-uniformity of camera 2's output. Thus errors due to illumination differences should be cancelled by equal and opposite gain adjustments, and only a single digitization error should remain. The residual non-uniformity in the

range, this code can be used for a special function, namely 'killing' the signal to the zero level.

5.1.2 The programming unit

Up to the present time manual programming has been used, although some thought has gone into methods of automatic programming by including a read/write r.a.m. in a feedback loop which sets every array diode output to a predetermined constant level under suitably uniform-light conditions.

The manual programming unit consists basically of an r.a.m. which plugs into the correction unit in place of the p.r.o.m., and is addressed and read by the correction unit in the same way as the p.r.o.m. would normally be. Data input to the r.a.m. is obtained from a hexadecimal switch, so that the number set up on this is written into the address indicated by a bank of 'diode number' switches when a pushbutton is depressed. In operation this unit is used to set the correction unit output as displayed on an oscilloscope to the best straight line with appropriate illumination conditions on the array. The r.a.m. is then unplugged from the correction system and interfaced to a p.r.o.m. programmer to transfer the information to an 82S 129 p.r.o.m.

5.2 Performance

The system described has been supplied to cameras containing IPL 7256 arrays, which contain 256 photo-diodes in line on 0.1 mm centres. Responsivity variation in such a long strip of silicon (over 2.5 cm) can amount to some $\pm 12\%$. A particular array near this worst-case limit was corrected under uniform light

difference signal was then the theoretical $\pm 0.9\%$ as first set up, of course; after a 72-hour period during which the paper object was altered the corrected difference signal non-uniformity had increased to $\pm 2.5\%$. This was found to be due to the uncorrected signals having changed in such a way as to give a $\pm 10.5\%$ uncorrected difference signal.

It is concluded that paper non-uniformity and instability of lighting conditions make difference signals of better than about $\pm 2.5\%$ of little meaning.

5.4 Conclusions

Video signals can be made uniform by this system to about $\pm 2\%$ of maximum signal level over most conditions. Attempts to improve beyond this level are of doubtful validity because of the difficulties in obtaining sufficiently uniform, stable lighting and object surfaces, and because array non-uniformity is a function of light spectrum and hence colour temperature and also of ambient temperature.

Part 6

OPTIMIZATION OF IMAGE SENSORS

A. H. LONGFORD, B.Tech.*

In principle it might be thought that all image sensors fabricated in silicon would have the same spectral response; in particular we might expect photodiode and c.c.d. detectors to be very similar. In practice, however, they are generally quite different. The relatively smooth response of a photodiode (Fig. 14(a)) is very close to the intrinsic response of silicon but the fluctuating response of Fig. 14(b) is characteristic of a c.c.d. imager fabricated (as is usually the case) with polysilicon electrodes. As mentioned in Section 3.3, such electrodes give rise to two problems: (i) multiple reflections in the oxide and polysilicon layers give rise to interference effects causing the response to vary with wavelength in an uncontrollable way; (ii) the polysilicon absorbs preferentially in the blue and so the detector has a relatively poor blue response.

Various techniques have been proposed to overcome these problems, e.g. the use of transparent metal-oxide electrodes, and backside illumination of thinned silicon as has been used in silicon vidicons. These approaches present other problems, however, and are unlikely to become widely used in the near future.

An alternative approach which is now employed in some Reticon devices is to combine the good optical

characteristics of photodiodes with the desirable read-out features of c.c.d.s.

6.1 Charge-coupled Photodiode (C.C.P.D.) Sensors

The principle of separating the sensing and read-out functions was described in Fig. 6 for overcoming smearing. In the c.c.p.d. the functions are once more separated, the m.o.s. sensing sites of Fig. 6 being replaced by photodiodes.

In operation, the photogenerated charge integrated on the photodiode elements is dumped sideways, by the application of the transfer pulse, into odd and even registers lying on each side of the line of photodiodes. These c.c.d. registers transfer the charge to an on-chip charge detection circuit which has a very small capacitance to keep the output signal voltage and thus the signal-to-noise ratio, very high. This configuration thus optimizes the features of the two technologies. It incorporates the low capacitance, low noise output inherent in c.c.d.s with the high quantum efficiency, freedom from blooming and smooth response of the photodiode. As with a conventional all-c.c.d. structure, the outputs of the photodiodes can be combined in the c.c.d. register with an analogue signal inserted into the output register from an external source; this may be advantageous in, for example, cancellation of interference signals.

6.2 Other Possible Improvements

It is not only the technology involved in the manufacture of the chip that is important for optimization; the circuitry external to the photosensor can markedly affect the performance. The choice of type of output circuitry, can, for example, affect the dynamic range of the sensor: the typical recharge output achieves a dynamic range of 50:1 whereas the sample and hold

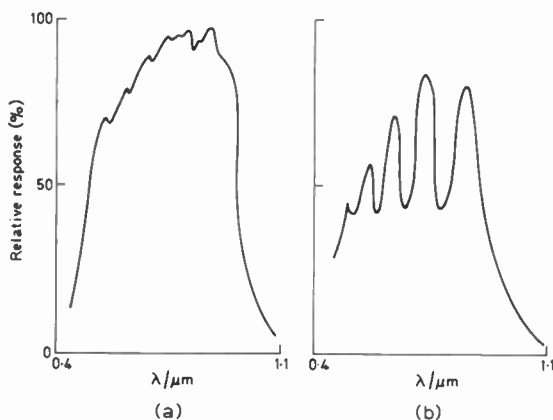

Fig. 14. Typical spectral response of (a) photodiode, (b) c.c.d. (Batelle Institute).

* Herbert Sigma Ltd., Spring Road, Letchworth, Herts. SG6 4AJ.

(or 'boxcar') type output can give typically a 200:1 dynamic range. In many applications the final output will be a.-to-d. converted and then fed to a computer or microprocessor system which can manipulate the sensor data to display results in a manner most suited to the application.

Another way of improving the performance of sensors is to use a fibre optic faceplate to couple the sensor directly to the source,¹⁷ thereby reducing the effects of stray light and other spurious interference. This form of coupling is particularly useful when very low light levels have to be detected. The fibre optic device can also be useful when the detecting area is spread over a wide area or where a wide area is split into more than one device.

Reference to the effects of temperature was made in Section 1.1: Peltier or thermo-electric coolers specially

designed for image sensors can greatly improve the dynamic range.¹⁸ The dark current and leakage of the device reflect the temperature dependence, and cooling the array by 9 degC will improve these characteristics by a factor of 2. However, most coolers are custom designed and only used in the scientific application areas. For general applications, like optical character recognition and facsimile, sufficient dynamic range can be achieved by suitable choice of device and circuits.

6.3 References

- 17 Sandel, B. R. and Broadfoot, A. L., 'Photoelectron counting with an image intensifier tube and a self-scanned photodiode array', *Applied Physics*, 15, no. 12, pp. 311-14, January 1977.
- 18 Horlick, G., 'Characteristics of photodiode arrays for spectrochemical measurements', *Applied Spectroscopy*, 30, no. 2, pp. 113-23, March-April 1976.

Part 7 AN EXPERIMENTAL SOLID-STATE FILM SCANNER

I. CHILDS, B.A., Ph.D. *

At the present time, the application of solid-state image-sensor arrays to television broadcasting is extremely limited. Many firms have introduced, or have announced that they intend to introduce, cameras using c.c.d. arrays designed for the home c.c.t.v. market. These have typically 300 × 200 picture elements. Such arrays have insufficient resolution for broadcast use; even if this were not so, other problems remain.

One application that is feasible, however, is that of using solid state sensors to televise film. This is because the motion of the film itself may be used to achieve one of the scans; the sensor then becomes a single-line array, which is of course easier to manufacture. Such a film scanner has been under investigation at the BBC Research Department. The film is transported by a capstan at a constant speed, controlled by optical sensing of the sprocket holes. It is illuminated by a simple light source (a quartz-halogen bulb) and the image is focused onto the sensor by a lens. Early tests were carried out using photodiode array sensors; later tests have used c.c.d.s with both surface and buried channels. Recently three 1024-element buried channel c.c.d.s have been used to make colour pictures of close to broadcast quality.

Some factors influencing the design of a monochrome film scanner will now be considered.

7.1 Use of Solid-state Sensors in a Monochrome Telecine

The first decision that needs to be made is what type of sensor (photodiode, surface channel c.c.d. or buried

channel c.c.d.) is most suitable. Early work¹⁹ used a photodiode array; this suffered from problems of clock breakthrough and was not suitable for broadcast use. Later work used surface channel c.c.d.s;²⁰ these could be operated at the high clock rates necessary but, at these rates, the transfer efficiency falls. This gives rise to problems of image smearing, especially in dark areas of the filmed scene. For these reasons, buried channel c.c.d.s are probably the most suitable sensors at present; they are not free from problems, however, particularly for colour operation.

The second major problem is that of how many sensor elements are required. The effect of the discrete nature of the image sensing elements is twofold. Firstly, because each element is separate, the overall effect of the sensor is to sample the profile of the incident illumination. By conventional sampling theory, any spatial frequencies above the Nyquist limit (corresponding to a spatial wavelength of two elements) will be converted to aliased frequency components, some of which will lie in the bandwidth of interest.²¹ It is thus important to choose the number of elements so that the frequencies that would cause visible aliasing are so high that they are not present on the film image to any significant extent. Previous tests²¹ have indicated that 512 elements is too small a number; on the other hand 1024 is probably more than adequate. 1024-element sensors capable of working at the required clock frequency (approx. 20 MHz) are available and have therefore been chosen.

* BBC Research Department, Kingswood Warren, Tadworth, Surrey KT20 6NP.

The other effect caused by the discrete elements is that the basic spatial frequency response of the sensor is modified by virtue of the fact that the individual elements integrate the signal over a finite area. Thus the spatial frequency response tends to follow a $(\sin x)/x$ curve with the first zero at twice the Nyquist limit derived above. This response tends to suppress aliasing, especially at very objectionable frequencies, because it occurs before sampling: it is the integral that is sampled, not the samples that are integrated. Other factors affecting the spatial response of the film scanner are multiple reflections in the electrode structure of the c.c.d. and the quality of the lenses used. Neither of these has been found to cause a significant problem.

Another potential problem is that of blooming. If the level of illumination is too high, the charge contained in one well of a c.c.d. can spill over into adjacent wells. The effect can be very unpleasant indeed. Fortunately the maximum level of illumination available in a film scanner is usually fixed (that level when the film is removed). It can be arranged that this light level is just less than that which would cause blooming; thus blooming can always be prevented.

At the opposite extreme, in the absence of light, there will still be a small signal from the sensor due to the generation of carriers by random thermal activity in the silicon substrate. This will cause an added dark current signal in the output and an increase in noise. Both these effects are proportional to the integration time; at the times used in this application (64 μ s) the effects are negligible at room temperature (dark current is less than 0.3% of maximum signal level). Nevertheless the dark current is strongly dependent on temperature, so it is not advisable to place a c.c.d. where it will be subjected to a high ambient ambient. In extreme cases, cooling of the sensor with a small Peltier cooler may be considered.

Because of the mask tolerances and other effects, the sensitivities of the individual photosites are not all identical. The effect of these variations is to modulate the picture information with a fixed pattern which will appear as vertical stripes visible mainly in the lighter areas of the final picture. These stripes can be removed²² by storing the pattern, in digital form, in a read-only memory and re-modulating the signal by the inverse of the stored pattern.

Storage is also required to convert the signals from the c.c.d. into interlaced form. Because the telecine relies on the motion of the film for vertical scanning at 25 frames per second, the signal from the sensor is in a sequentially scanned form unsuitable for display on the UK television system. While this sequential-to-interlace conversion could be avoided by mechanical means (e.g. moving mirrors or rotating polygons) a digital processor using a field store avoids mechanical and optical complication, requires less maintenance, and gives freedom from flicker and from positional errors between odd and even fields.

These advantages may well outweigh the initial cost of such a processor. The use of an 8-bit digital field store for this purpose has been demonstrated and found to work very well.²³

7.2 Colour Operation

There are two additional problems that need consideration in order to use c.c.d.s in a colour telecine. The first is that three devices must be used in order to provide the three signals necessary (red, green and blue) and registration of the three sensors is then needed. Four basic movements must be provided for each sensor; these are focus, vertical shift, horizontal shift and rotation. With care in the design of a suitable mount for a sensor these movements can all be kept independent of each other and registration is a fairly easy task. Problems might arise from chromatic aberration in the imaging lens but no trouble has been experienced in the prototype telecine.

The second problem is that of the colour response of the c.c.d. itself. Examination of the spectral response of the c.c.d. reveals two areas of concern. One is the presence of ripples in the curve (see, for example, Fig. 14(b)). As explained in Part 6 these effects are caused by interference effects in the transparent electrode structure of the c.c.d. (usually made of polysilicon) and will vary between different batches. For a colour telecine these ripples are less serious than for a monochrome machine as the spectral bandwidth in each channel is only about 50 nm. C.c.d.s may therefore be selected to have the best response for each channel; one that is unsuitable for the blue channel may be better in the red channel, for example.

The major problem is, however, very poor sensitivity to blue light. This is due mainly to the poor transmission of blue light by the polysilicon electrode structure. The most satisfactory solution is for the manufacturer to increase the sensitivity. Fortunately, there is now considerable interest in the use of c.c.d.s for home television cameras: thus effort is being spent by manufacturers in improving the blue response and several techniques seem to be possible. Some of these are the use of an alternative material (such as tin oxide) for the electrodes, back imaging through a thinned silicon substrate or the use of a hybrid photodiode/c.c.d. structure.

Fortunately, even in the absence of these improved sensors, increased blue signal amplification can be tolerated because the visibility of noise in the blue channel is relatively low. Preliminary investigations show that an acceptable performance can be achieved with a 150-watt tungsten-halogen lamp. It is necessary to include filters to exclude the infra-red from the light source because of the high sensitivity of silicon devices to near infra-red radiation.

7.3 Conclusions

Solid-state sensors can be used to produce full-resolution broadcast-quality pictures from film. Some of the signal processing required is at present rather expensive; a digital field store, for example, has been used to obtain 50 fields per second interlaced pictures from sequential scanning of the film at 25 frames per second. However, the machine is optically and mechanically extremely simple, and this feature may well outweigh the additional complexity of the signal processing. Alternatively, at the expense of increased mechanical and optical complexity in the form of an oscillating mirror or rotating optical polygon, interlaced scanning could be achieved directly. In this event, however, it is likely that the picture quality would suffer from additional flare and image unsteadiness.

Advantages are numerous. The machine would be virtually maintenance-free with no gradual deterioration of performance due to components aging as at present. There would be completely uniform focus over the entire picture, apart from optical aberration. The electronic compensation for element-to-element sensitivity variations would also result in a uniform signal output over the entire field with no shading or vignetting due to non-uniform illumination. The picture geometry would be perfect, apart from any slight errors that might be caused by the imaging lens. There would be no flicker between the interlaced fields, as can occur at present, and the

running costs would be very low since the only regular replacement would be the light source.

Early tests on colour operation have shown that it is feasible even with the poor blue performance of present day c.c.d.s. Nevertheless improved sensors would be desirable and it is to be hoped that buried channel c.c.d.s with improved blue sensitivity will soon be available.

7.4 Acknowledgement

This contribution is published by permission of the Director of Engineering of the BBC.

7.5 References

- 19 Wright, D. T., 'Solid-state Sensors': The Use of a Single Dimension 512-element Array for Film Scanning', BBC Research Dept. Report no. 1973/32.
- 20 Le Couteur, G. M., 'Performance Tests on a Selection of 100-element Charge-coupled Devices'. BBC Research Dept. Report no. 1978/23.
- 21 Le Couteur, G. M., 'Sampling Frequencies and Structures for Solid-state Image Sensing in Broadcasting'. BBC Research Dept. Report no. 1978/2.
- 22 Le Couteur, G. M., 'Solid-state Image Sensors: Improvements in Signal Processing Techniques'. BBC Research Dept. Report no. 1976/4.
- 23 Childs, I. and Sanders, J. R., 'An experimental telecine using a line-array c.c.d. sensor', *J. Soc. Mot. Pict. Telev. Engrs.* 87, no. 4, pp. 209-13, 1978.

Part 8 A HELMET-MOUNTED SIGHT USING C.C.D. TECHNOLOGY

M. D. STEPHENSON, M.Sc., Ph.D., C.Eng., M.I.E.E.*

Modern fighter aircraft pilots are required to achieve accurate weapon delivery on a first-pass attack. This is made possible by the use of the aircraft avionic systems, which include a head up display (h.u.d.) and more recently the helmet mounted sight (h.m.s.).

The h.u.d. is a system which displays navigational flight and weapon information to the pilot while he continues to look through the windscreen. This is made possible by displaying c.r.t. pictures on a combiner glass in such a way that information is displayed, collimated at infinity.

The h.m.s. can be used outside the restricted viewing area (approx. $\pm 15^\circ$ wide and $\pm 10^\circ$ high) of the h.u.d. system, but with a reduced accuracy. It consists of two parts: the helmet mounted display and the helmet optical position sensor (h.o.p.s.). The h.m.d. is shown in Fig. 15 and consists of a matrix-addressable l.e.d. array (32×32 or 50×50) where the combiner is the visor glass on the helmet. A limited amount of essential information (i.e.

aiming reticule, weapon lock, etc.) can be displayed on this surface, the limit being set by the pilot's inability to assimilate further data.

The h.o.p.s. consists of two triads of l.e.d.s mounted on the sides of the helmet and two c.c.d. cameras mounted in the cockpit. Any combination of one set of l.e.d.s with one camera provides sufficient information to give helmet orientation in roll, pitch and yaw. The appropriate l.e.d.-camera combination is chosen by the computer, based on the previous helmet line-of-sight calculation. This system is shown in Fig. 16. Two cameras and l.e.d. sets are required to meet all possible head positions.

The heart of the system lies in the c.c.d. camera which uses a standard 1728-bit linear imaging c.c.d. By careful retiming of the drive waveforms, three important functions can be carried out.

* Marconi Avionics Ltd., Airport Works, Rochester, Kent ME1 2XX.

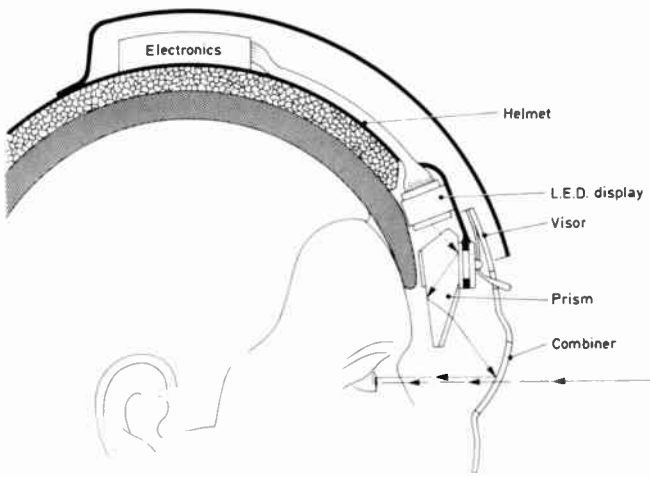

Fig. 15. Helmet mounted display.

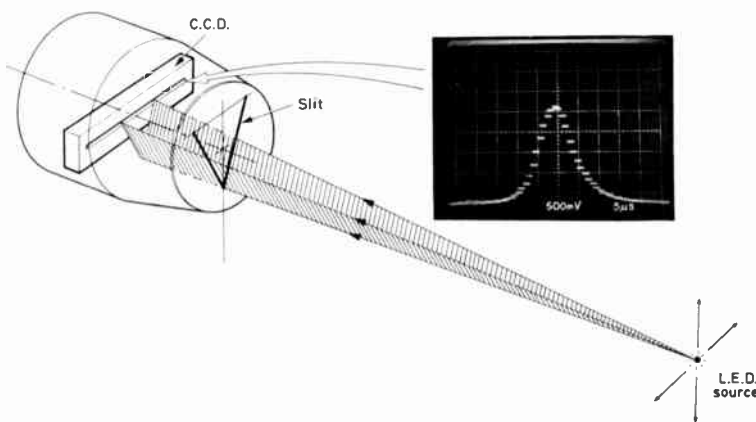

Fig. 17. V-slit camera for h.o.p.s.

The first of these is the establishment of x and y movements using a single axis c.c.d. This is achieved by the use of an optical V-shaped slit in front of the c.c.d. (see Fig. 17) which causes two Gaussian-shaped images to form on the sensor. Movement of the l.e.d. in the x plane causes the images to move across the c.c.d., but their separation remains fixed. Movements of the l.e.d. in the y direction changes the separation of the images. A Gaussian image is shown which was obtained from a prototype GEC Hirst Research Laboratory's 1024-bit linear imaging c.c.d.

At high altitude, bright sunlight can fall directly upon the c.c.d. and due to its sensitivity will make the device saturate. Saturation can be avoided by (i) putting a neutral density filter in front of the c.c.d. or (ii) running the analogue registers at high speed. However, solution (i) reduces the l.e.d. signal and is therefore not desirable while solution (ii) requires a data rate of >10 MHz which is not practical. An approach that has been found satisfactory is to use a narrow-band optical filter to remove much of the sunlight and to pulse the l.e.d. The l.e.d. output is approximately proportional to the

product of pulse time and current and so by using a short but heavy current pulse (typically 20A for 100 μ s) the instantaneous l.e.d./sunlight ratio can be improved; advantage of this improved ratio can be taken by using an exposure control technique on the c.c.d. This is made

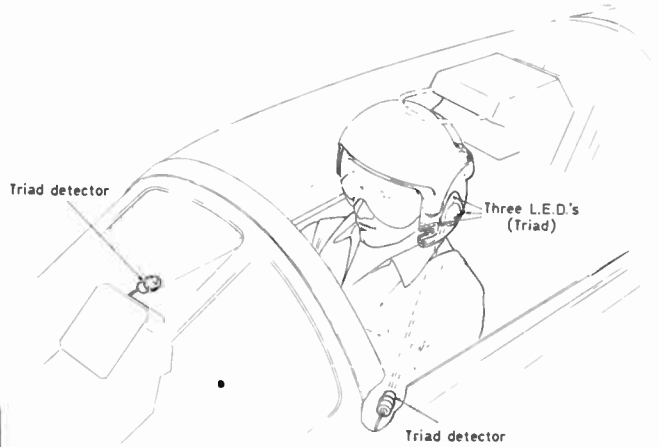

Fig. 16. Helmet optical position sensor.

possible by using the 'B' register of the c.c.d. as a charge dump (see Fig. 18) by holding both ϕ_{1B} , ϕ_{2B} and ϕ_{xB} (the transfer gate) high for the period when exposure is not required. In the first scan of information, odd photosites are read out of the 'A' register and the second scan reads out the even sites. The charge flowing out of the 'B' register is prevented from corrupting good data from the 'A' register by lowering ϕ_{1B} each time information from the 'A' register becomes present.

In general, the signal from the c.c.d. consists of l.e.d. and sunlight. To remove the sunlight signal the l.e.d. is pulsed only on alternate scans. The output corresponding to sunlight only is inverted, delinearized and offset by a level equal to 100% of the charge handling capability of the photosites and fed back into the analogue input of the 'A' register (see Fig. 19). When the next scan of the photosites (corresponding to sunlight and l.e.d.) is transferred to the 'A' register the result is

$$(1 - \text{Sun}) + (\text{Sun} + \text{l.e.d.s}) = 1 + \text{l.e.d.s.}$$

The offset is removed by d.c. restoration and the processed data sent to the pulse-centre detection circuitry and hence to the microprocessor unit. Line-of-sight information is available at 30-50 iterations per

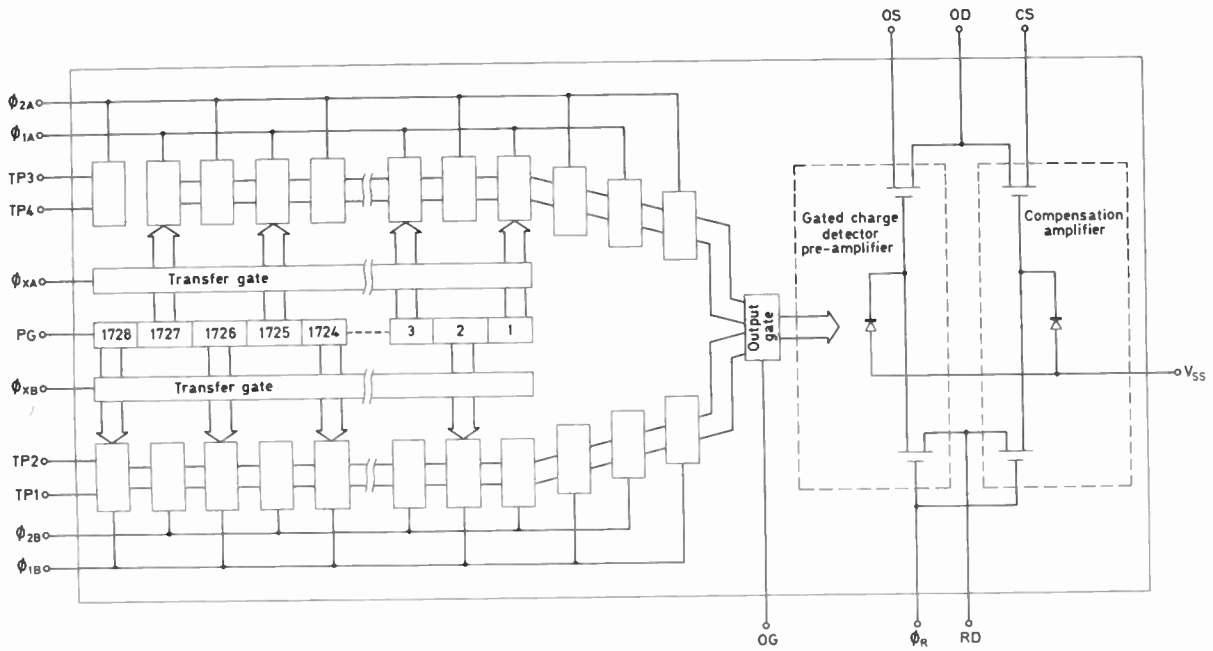

Fig. 18. C.c.d. architecture.

second using a modern 16-bit microprocessor.

Using the c.c.d. to its full capability enables a small compact system to be produced without the need for fast a.-d. converters and a large digital store.

8.3 Acknowledgment

The work described in this contribution is covered by the following British provisional patents: 35518/75, 19735/78, 19734/78; and by US patent 4092072.

CONCLUSIONS

In this paper we have reviewed some of the theoretical and practical considerations relevant to the operation and application of self-scanned image sensors. Although such sensors still cannot compete with electron beam scanned tubes in terms of uniformity and area resolving power, linear solid-state sensors of very high resolution are now available. Moreover, in those applications where uniform response is vital, relatively straightforward signal processing of the sensor output can markedly reduce non-uniformities. As some of the applications have illustrated, an attribute of solid-state sensors which is now beginning to be seriously exploited is the precision with which individual sensor elements can be accessed by virtue of the digital nature of the addressing pulses. This feature and the ease with which it

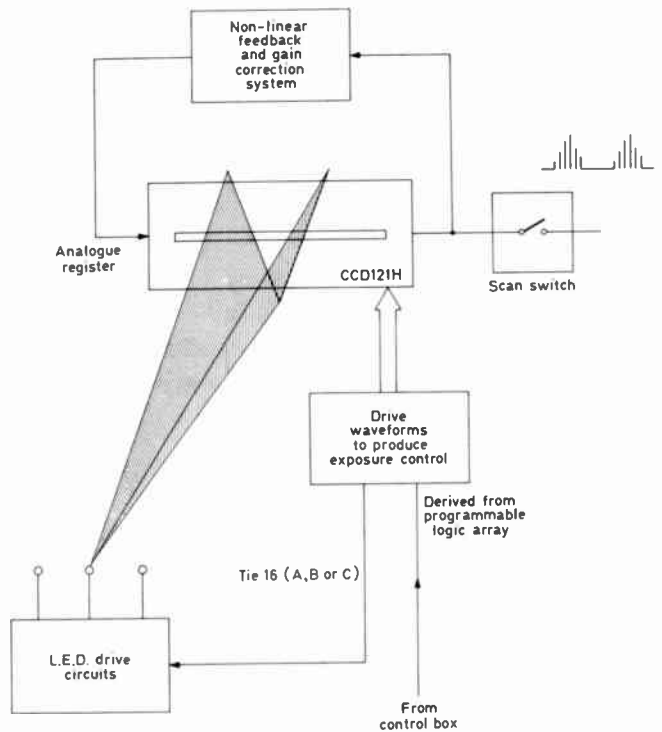

Fig. 19. Block diagram of h.o.p.s. feedback system.

enables the output of a self-scanned array to be coupled to digital signal processing systems is likely to lead to widespread use of such arrays in novel applications.

Manuscripts received by the Institution on 30th April 1979 (Paper No. 1898/CC310)

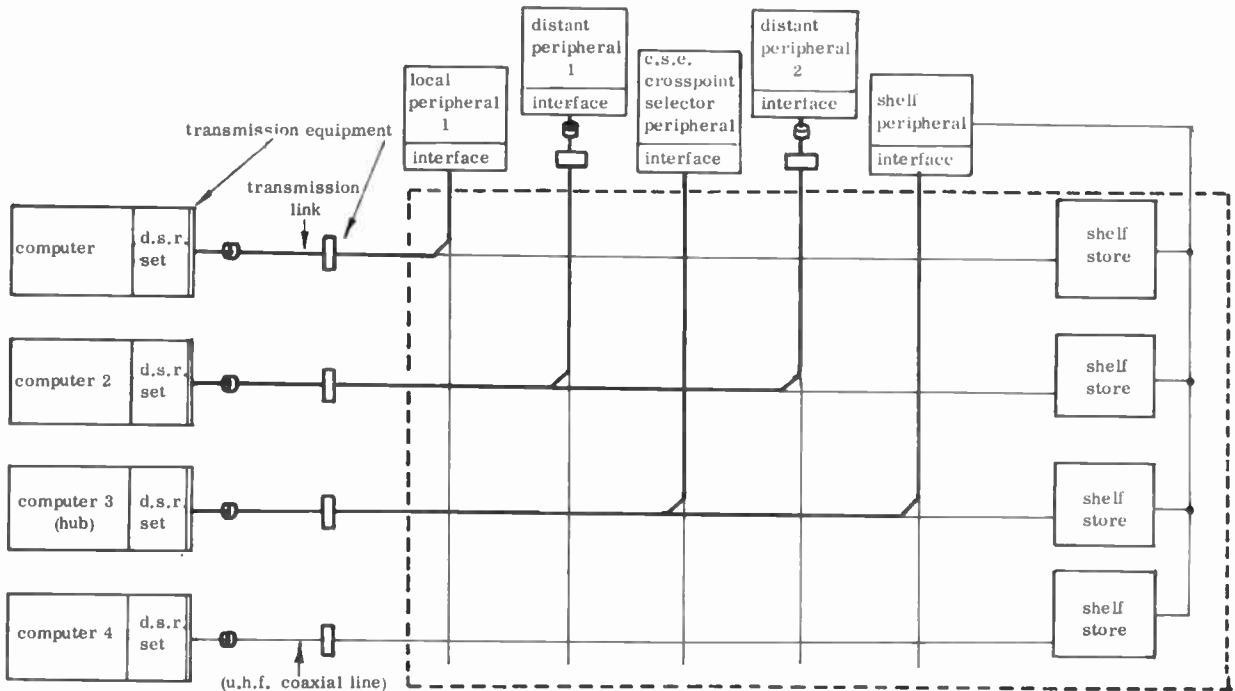

Fig. 1. Architecture of the null-protocol network developed at the University of Essex.

Null protocol systems do not use communications software and must operate as though the peripherals are local. Therefore the only information available to the computer about the state of the peripherals is conveyed by the device status words and flags, which must be duplicated locally at the computer for each peripheral, in order that the timing constraints can be met at both ends. Additionally, a data buffer per input device must be duplicated to meet the timing constraints of the 'input data' command from the computer. Each of the data and sense registers, called a d.s.r. are usually arranged as a set (Fig. 4).

Communication must take place between the sets of registers at each end of the transmission system to periodically update the d.s.r. whenever a change in status occurs in a particular peripheral or when the computer issues an I/O order requiring some action at the peripheral. The short time that register pairs are not identical will not be troublesome provided the transmission delays are small by comparison with the data rate of the peripheral. Data buffering and block transmission techniques may be used to resolve any difficulty for particular peripherals.

It is worth noting that in a situation similar to the



Fig. 2. A conventional computer-peripheral interconnection.

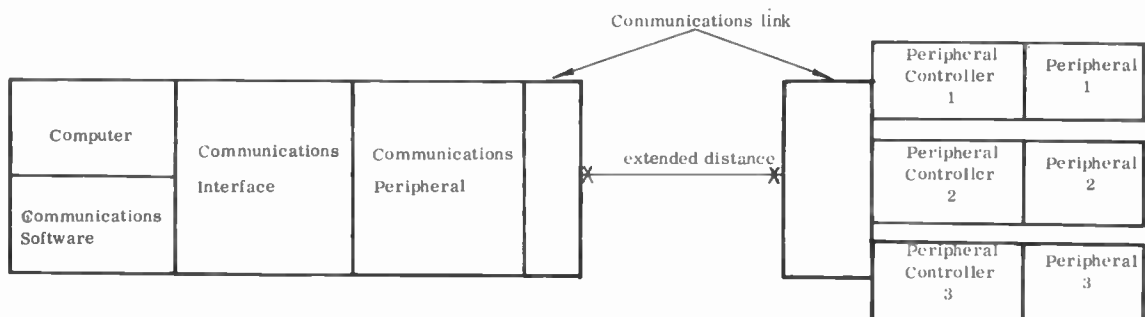

Fig. 3. A computer-peripheral interconnection with remote working.

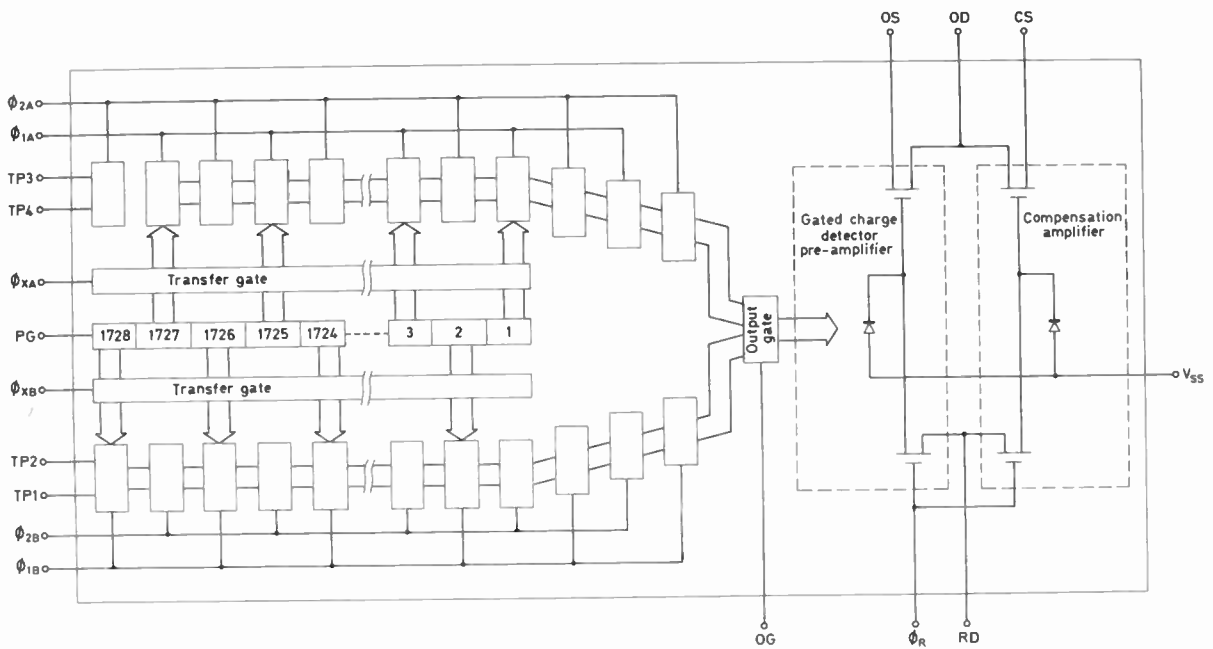

Fig. 18. C.c.d. architecture.

second using a modern 16-bit microprocessor.

Using the c.c.d. to its full capability enables a small compact system to be produced without the need for fast a.-d. converters and a large digital store.

8.3 Acknowledgment

The work described in this contribution is covered by the following British provisional patents: 35518/75, 19735/78, 19734/78; and by US patent 4092072.

CONCLUSIONS

In this paper we have reviewed some of the theoretical and practical considerations relevant to the operation and application of self-scanned image sensors. Although such sensors still cannot compete with electron beam scanned tubes in terms of uniformity and area resolving power, linear solid-state sensors of very high resolution are now available. Moreover, in those applications where uniform response is vital, relatively straightforward signal processing of the sensor output can markedly reduce non-uniformities. As some of the applications have illustrated, an attribute of solid-state sensors which is now beginning to be seriously exploited is the precision with which individual sensor elements can be accessed by virtue of the digital nature of the addressing pulses. This feature and the ease with which it

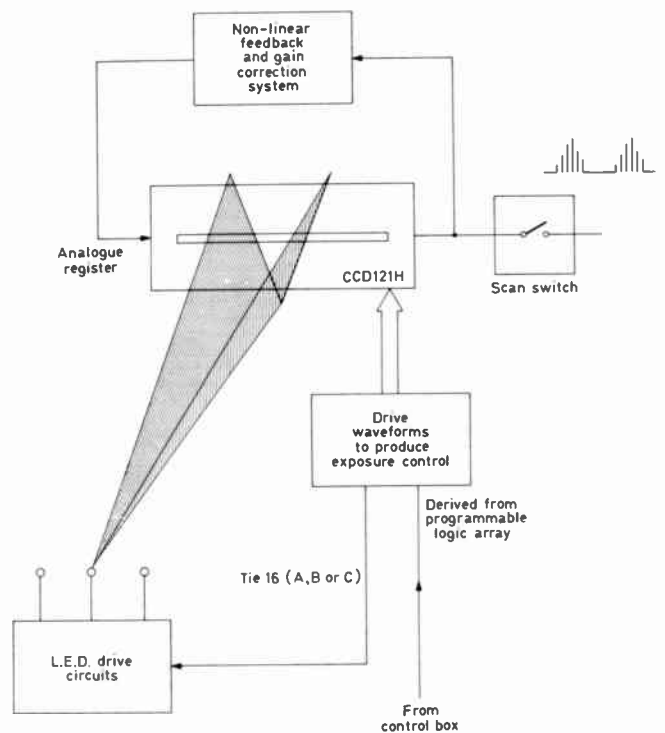

Fig. 19. Block diagram of h.o.p.s. feedback system.

enables the output of a self-scanned array to be coupled to digital signal processing systems is likely to lead to widespread use of such arrays in novel applications.

Manuscripts received by the Institution on 30th April 1979 (Paper No. 1898/CC310)

Contributors to the Symposium on Optical Self-Scanned Arrays

D. J. Purll studied physics at University College London, graduating in 1968. He has since worked at Sira Institute, where he is now a Principal Research Officer, on the application of electro-optics to industrial instrumentation. Mr Purll has many years' experience in the development of automated inspection and measurement instruments in a wide range of industries. He has specialized in the use of solid-state arrays since their emergence, and has recently concentrated on their application to and evaluation for spacecraft instrumentation, through contracts with the European Space Agency.



Stephen Porter gained his B.Sc. and his Ph.D., in solid state physics at Leeds University. He joined the Plessey Company in 1971, where he carried out research on electro-optic and pyroelectric materials before moving on to pyroelectric detector development. He has now been managing the pyroelectric detector development department of Plessey Optoelectronics and Microwave for over four years.



On leaving secondary school **Andy Longford** took up a four-year electronic apprenticeship with Marconi at Chelmsford and graduated from Bradford University with a degree of Bachelor of Technology in electrical and electronic engineering. He spent several years in the Marconi Elliott Microelectronics Unit developing m.o.s. devices and in 1972 he took up a position as Field Engineer with Square D, specializing in development of industrial electronic control systems. Mr Longford joined Herbert Sigma in 1977 as Product Manager for Reticon analogue signal processing and image sensing devices.



D. J. Burt read natural sciences at Cambridge University and on receiving his degree in 1966 he joined Hirst Research Centre, where he worked on m.o.s. device technology. He has been particularly concerned with charge coupled devices since 1971 and he is at present a member of the Leading Scientific Staff and Department Head responsible for c.c.d. research and development.



Ian Childs was at Pembroke College, Oxford, from 1966 to 1969 and obtained a B.A. in engineering science. He then went to Trinity College, Cambridge, and in 1972 was awarded his doctorate. Dr Childs is now with the BBC Research Department where he has worked in the Physics Section on problems connected with holographic recording of digital data and more recently in Image Scanning Section on the use of solid state image sensors to telecine film.



Peter Fry read chemistry at the University of Oxford and received the B.A. degree in 1961 and the M.A. and B.Sc. degrees in 1964. In 1963 he also received the H.N.C. in electrical engineering at Oxford College of Technology. He then joined the Plessey Company at the Allen Clark Research Centre, Towcester, where he worked on new metallization techniques for silicon devices, and from 1965 undertook the first stages of the company's photodetector array work. In 1966, he transferred to the research laboratory of the Automation Group of Plessey at Poole, where he was responsible for the development of transducers and instrumentation techniques. Three years later Mr Fry helped to found Integrated Photomatrix where he is Technical Director, and specializes in photoelectric integrated circuit design.



After completing an apprenticeship in electro-acoustics with Tannoy during which period he studied for National Certificates, **Mike Stephenson** joined Elliott Bros in 1967. Between 1969 and 1973 he was at the University of Southampton on paid leave to study for an M.Sc. degree and subsequently carried out research on semiconductor devices for his doctorate. In March 1973 Dr Stephenson returned to Marconi Avionics, and he is currently a Project Manager in the Flight Automation Research Laboratory leading a team of engineers working on sensor systems for future generation aircraft.



Peripheral interfacing using front-end microprocessors

L. FORTH, B.Sc., M.Sc.*

and

P. A. KIDD, B.Sc.*

Based on a paper presented at the Conference on Microprocessors in Automation and Communications held at Canterbury on 19th to 22nd September 1978.

SUMMARY

This paper is concerned with the design of a microprocessor-controlled interface for use with minicomputers. Originally conceived as part of a network environment, this design concept is applicable to any single computer requiring an easily modifiable interface for multiple peripherals. Employment of this interface has the additional advantage of permitting remote working with no software overheads. It is designed so that all standard software, including operating systems, will run without modification.

* Department of Computer Science, University of Essex, Wivenhoe Park, Colchester CO4 3SQ.

1 Introduction

The main reason for the construction of a computer network is economic. Striking savings can be made if the cost of the two most expensive components, peripherals and software, can be reduced by sharing. At the University of Essex there is currently a small computer network for seven computers of four different types all utilizing the same peripherals, namely, paper tape reader, p.t. punch, line printer and two 10 M byte disks (Fig. 1). Software costs are minimized by insisting that all network computers will issue their normal input/output commands and that this will appear to have the same effect at the shared peripherals as would take place if the manufacturer's own peripherals had been directly connected to that computer. This requirement is termed null protocol.¹

The adoption of null protocol philosophy means that maximum savings can be made in the software area since no changes will be required in most software written for a standard machine configuration. The exceptions are those programs written in a time-dependent manner, for example, where a program executes in the expectation of a certain peripheral speed instead of waiting on the correct flag changes and conditions. No network can ever guarantee the standard time relationships and indeed such programs would benefit from being rewritten.

It should be realized that the principles of null protocol may not only be applied to network operations but to much simpler arrangements of peripherals concerned in the limit with only one computer. It will be shown that null protocol philosophy is a viable technique which should be considered particularly where extended distances are required between computer and peripherals. The system requires an interface structure slightly modified from the usual designs but by the inclusion of a microprocessor great adaptability is obtained to cope with a range of peripherals in a very economic way, both in cost and board space.

2 Peripheral Control

The normal connection between a computer and a peripheral may be thought of as being in two parts, the interface and the peripheral controller (Fig. 2). There are limitations on the separation of these two items due to severe timing constraints which exist in both directions. The computer may require responses from the interface within a few hundred nanoseconds of the issuing of an I/O instruction and the peripheral controller may be similarly constrained by the demands of the peripheral's timing cycle. Remote working would normally be obtained by employing a special peripheral and software whose job it is to obtain status information on the remote peripheral(s) using some suitable communications protocol (Fig. 3).

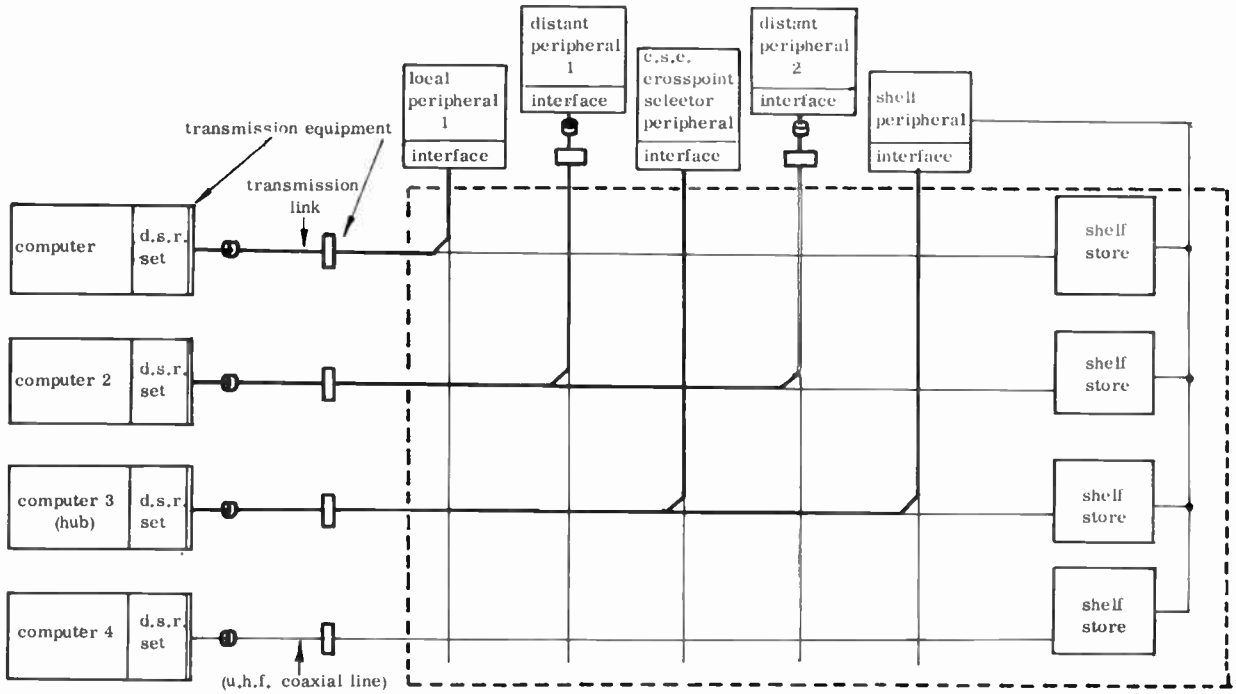

Fig. 1. Architecture of the null-protocol network developed at the University of Essex.

Null protocol systems do not use communications software and must operate as though the peripherals are local. Therefore the only information available to the computer about the state of the peripherals is conveyed by the device status words and flags, which must be duplicated locally at the computer for each peripheral, in order that the timing constraints can be met at both ends. Additionally, a data buffer per input device must be duplicated to meet the timing constraints of the 'input data' command from the computer. Each of the data and sense registers, called a d.s.r. are usually arranged as a set (Fig. 4).

Communication must take place between the sets of registers at each end of the transmission system to periodically update the d.s.r. whenever a change in status occurs in a particular peripheral or when the computer issues an I/O order requiring some action at the peripheral. The short time that register pairs are not identical will not be troublesome provided the transmission delays are small by comparison with the data rate of the peripheral. Data buffering and block transmission techniques may be used to resolve any difficulty for particular peripherals.

It is worth noting that in a situation similar to the

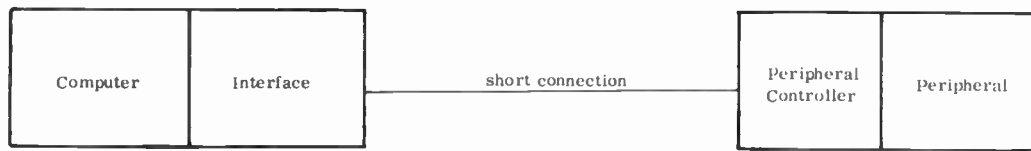

Fig. 2. A conventional computer-peripheral interconnection.

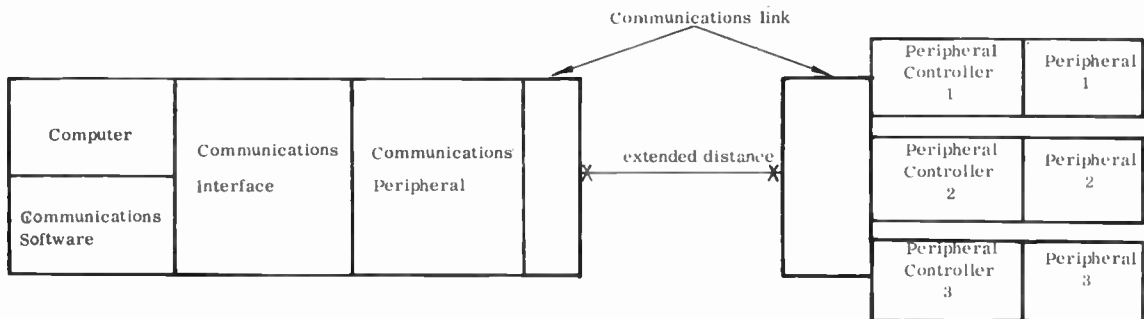

Fig. 3. A computer-peripheral interconnection with remote working.

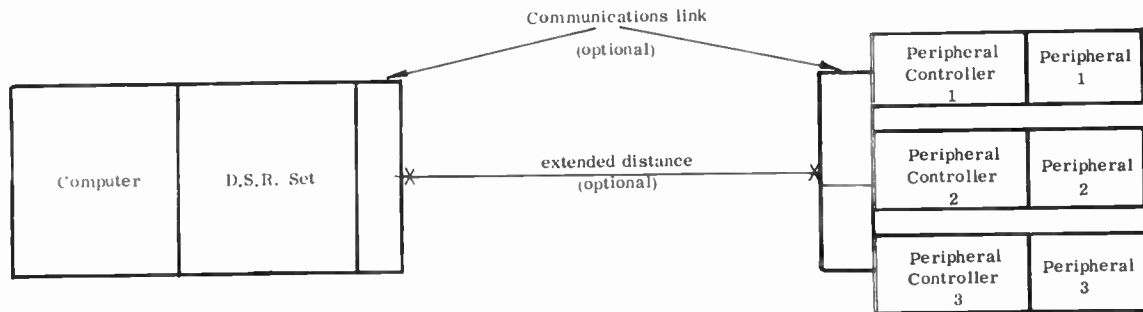

Fig. 4. A computer-peripheral interconnection using a d.s.r. set for remote working.

University of Essex network where multiple computers of different types are employed, the adherence to null protocol provides a means of translating and standardizing the computers' I/O bus signals into, in our case, an asynchronous high-speed serial protocol.

3 Design Considerations of a D.S.R. Set

We have established that each d.s.r. requires duplicate flag and status registers and a data input buffer (if applicable) for each peripheral to be handled. An output buffer is not required provided the transmission system is able to send messages at least as fast as the computer is capable of initiating them. Alternatively, computer activity can be restricted during periods of transmission, for example, by forcing continual databreak output cycles to a simple device which performs no action on the data.

This last course of action is very simple to cause and has a minute effect on the overall efficiency of the computer since the proportion of I/O instructions which generate a message to the peripheral is insignificant. It has been used successfully in hardwired d.s.r. sets but in microprocessor controlled d.s.r. sets its use is mainly in conjunction with output buffers since these are easily provided in r.a.m.

The d.s.r. set must carry out the actions of a normal interface in its relationship with the computer such as recognizing device addresses, decoding I/O instructions, gating data in or out of the machine accumulator, appropriately responding to an attempt at sensing the state of a peripheral device status flag, maintaining correct status information, controlling interrupt flags where appropriate, and providing necessary registers for direct memory access (d.m.a.) devices. All of these operations are specific to the type of computer involved and must form a one-off design effort.

The d.s.r. set also interacts with the communication link, creating messages as well as accepting them; the messages are standardized and therefore nearly all d.s.r. sets conform to a general design pattern. A message

structure has been detailed in a previous paper² but it should be realized that this 24-bit serial structure is most appropriate to our network situation.

Many different protocols can be devised, but essentially it should allow for two main fields, address and information. The address field allows identification of the peripheral concerned and the information field contains either data and/or control information. Return messages acknowledge completion of the operation and are decoded by the d.s.r. set to change the appropriate status bits. Within the message structure, it may be necessary to represent a general reset command which causes a reset to all peripherals; this often is generated during the power-up sequence as well as perhaps by console switch or instruction.

Thus, apart from general reset messages, the system operates on a handshake principle with each outward message sent to a peripheral eventually being matched by a return message from that peripheral. D.m.a. peripherals may also be handled using this system with initial messages setting up remotely-held registers, such as disk address registers. Data transfers take place under the control of local word count and memory address registers, with the process still maintaining handshake signalling. The process finally terminates when the d.s.r. signals to the peripheral that word count has expired and the peripheral responds by sending the final status. The d.s.r. set decodes the message and sets the appropriate status bits.

4 Implementing the D.S.R. Set

Several d.s.r. sets have been constructed for different machines to drive the peripherals on the network. In the case of disk file an appropriate manufacturer's structure is chosen, usually either a fixed head disk or small moving head cartridge disk. Each d.s.r. set has been constructed using hardwired logic according to the principles described, in every case this has operated successfully with their respective manufacturer's operating systems.

Like all interface boards, a hardwired circuit is not

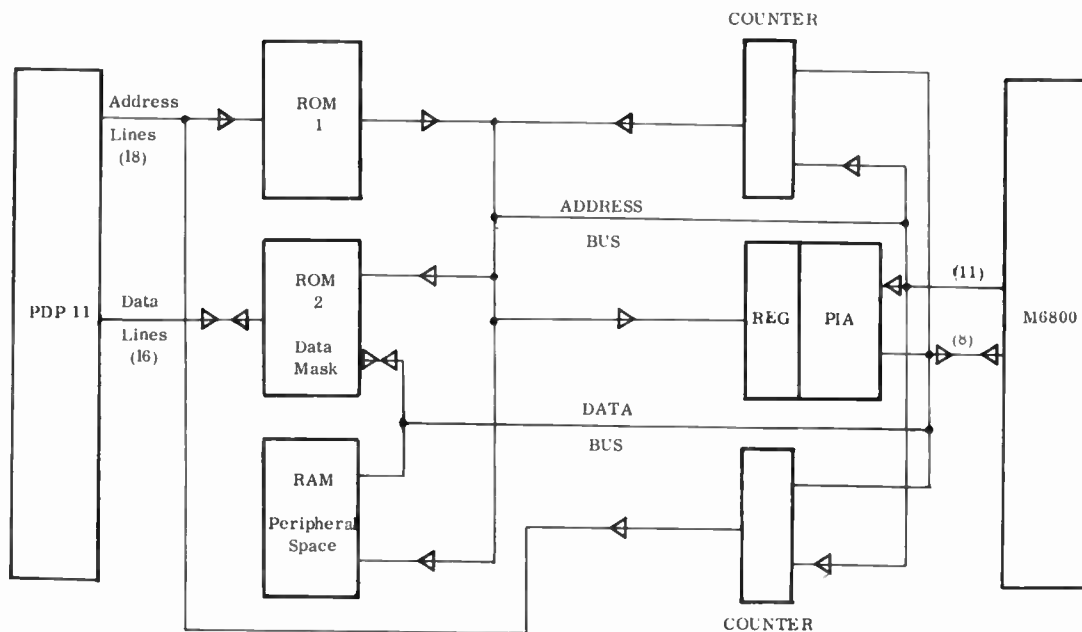

Fig. 5. PDP11/34-M6800 address and data paths.

readily adapted for newly acquired peripherals, neither can it be modified to handle temporarily loaned equipment nor cater for software which is orientated to a different file device. The cheapness and easy availability of microprocessor components enables a different approach to be taken to the problem of implementation. This method has the advantage of being easily changed to cater for a different group of peripherals, indeed provision can be made for the handling of all of the manufacturer's standard devices. As with most microprocessor constructions the chip count is substantially reduced by comparison with their hardwired equivalents.

Two experimental d.s.r. sets have been designed, one for a PDP 11/34 and the second for a DGC Nova 1200. Each one presents difficulties in design which are representative of the class of computer to which they belong, the former being asynchronous, bus-oriented, with variable length instructions, whilst the latter is synchronous, with fixed word length instructions.

The PDP 11/34 d.s.r. set (Fig. 5) employs a read only memory (ROM 1) which maps memory addresses for all peripherals; a legitimate response only occurs for peripherals which are being handled by this interface. The output of ROM 1 is combined with ROM 2 to indicate which bits may be affected, thus giving write protection to parts of those peripheral registers which may be designated read only. Two d.m.a. transfers occur using the specified memory location in the instruction and the mapped peripheral locations in the r.a.m. of the M6800 microprocessor, these also being part of the PDP 11 address space.

The M6800 must now respond to this output command by stalling the miniprocessor for a short

period, whilst it handles any updating of the r.a.m. area connected with this peripheral and then initiates any messages towards the peripheral. Until these actions are complete it is vital that the PDP 11 cannot execute another instruction which might relate to this same peripheral, e.g. branch on a flag condition. The d.s.r. is in an excellent position to stall the processor, since there is a period of approximately 22 μ s during which it must respond with a slave synchronizing signal to indicate that data have been received. The d.s.r., before issuing the synchronizing signal will request 'bus mastership' via the 'non-processor request' line; this signal will be received and evaluated by the priority logic determining circuits on the processor board.

The granting of 'bus mastership' to a peripheral puts the PDP 11 in a waiting state and this is indicated to the d.s.r. by the reception of 'non-processor grant'. This state could be held until the M6800 has completed its tasks, however, it is more appropriate to allow the slave synchronizing signal to be issued after a short time. The time is spent carrying out a dummy d.m.a. transfer from location 0 and meanwhile a new request for 'bus mastership' is made in order that higher priority d.m.a. peripheral devices with their own interface boards are not locked out. The M6800 can carry out its processing tasks in parallel with another active externally controlled device. This gives rise to an interlaced sequence of 'bus mastership' until the M6800 tasks are finished. It finally relinquishes the bus allowing the processor to become 'bus master' once again and carry out the next instruction.

Until such time that a busy peripheral sends a message to clear its status flag, any further test instruction from

the PDP 11 will only cause a transfer of the appropriate data from r.a.m. and will neither initiate further hold-off action of itself nor cause the sending of any outward messages to that particular peripheral. It is convenient in the case of the PDP 11 to use the mechanism for dummy d.m.a. transfers as the basis for real transfers when d.m.a. peripheral devices are in operation. Under these circumstances, the extra counters provided in the d.s.r. set act as word count and memory address registers and are accessible both by the PDP 11 and the M6800.

In a typical disk access using the d.m.a. facility, the total time spent with the PDP 11 'stalled' by the microprocessor is 900 μs. This 'hold-off' time is constant, irrespective of the length of the d.m.a. transfer but with the opportunity for higher priority devices to take control of the PDP 11 bus if they demand it. For our network, the transfer time for a 256-word sector to a remote disk drive is 50 ms, giving an overhead of 1.8% for that instruction. Normal computer operation sees few of these I/O instructions which are capable of generating 'hold-offs' and the overall effect on efficiency is negligible.

Thus it may be seen that the characteristics and architecture of the PDP 11 lend itself fairly readily to the requirements of null protocol. The relationship between the miniprocessor and the microprocessor is a good example of co-operating processes which are assisted by the mechanisms that are available on each device.

The d.s.r. set for the Nova 1200 computer (Fig. 6) has to overcome a number of potential timing problems arising from the synchronous construction of the Nova

processor. The Nova is able to demand input or output of data either separately or in combination with issuing a signal for the peripheral to carry out a specific action. Responses to data transfer are met by the r.a.m., whose locations are mapped by the device selection lines and the encoded combination of the six data transfer instructions. Any signal for peripheral action occurs later in the sequence of execution and is picked up by the microprocessor for subsequent attention. It is necessary that the microprocessor will now hold-off the miniprocessor, so that no further instructions will be executed relevant to that peripheral.

The only means of stopping Nova c.p.u. activity is by requesting dummy d.m.a. cycles, but any request for d.m.a. should be synchronized using the machine signal (RQENB) 'request enable'.³ RQENB only occurs after each store cycle which has the effect of deferring requests until the following instruction cycle. The consequence is that the d.s.r. would permit one more instruction before any d.m.a. request is granted; if this instruction tests the flags of the peripheral concerned it could easily carry out a false operation due to incorrect flags.

It was imperative that a way should be found to exclude this delay and close examination of the d.m.a. mechanism with several computers revealed that d.m.a. requests could be made and obeyed quite late in an instruction cycle. If they are within about 150 ns of the start of the pulse signal action to a peripheral (START or IOPLS) then reliable d.m.a. action does occur.

In other respects, behaviour is very similar to the PDP 11 d.s.r. set. The Intel 8085 handles messages to

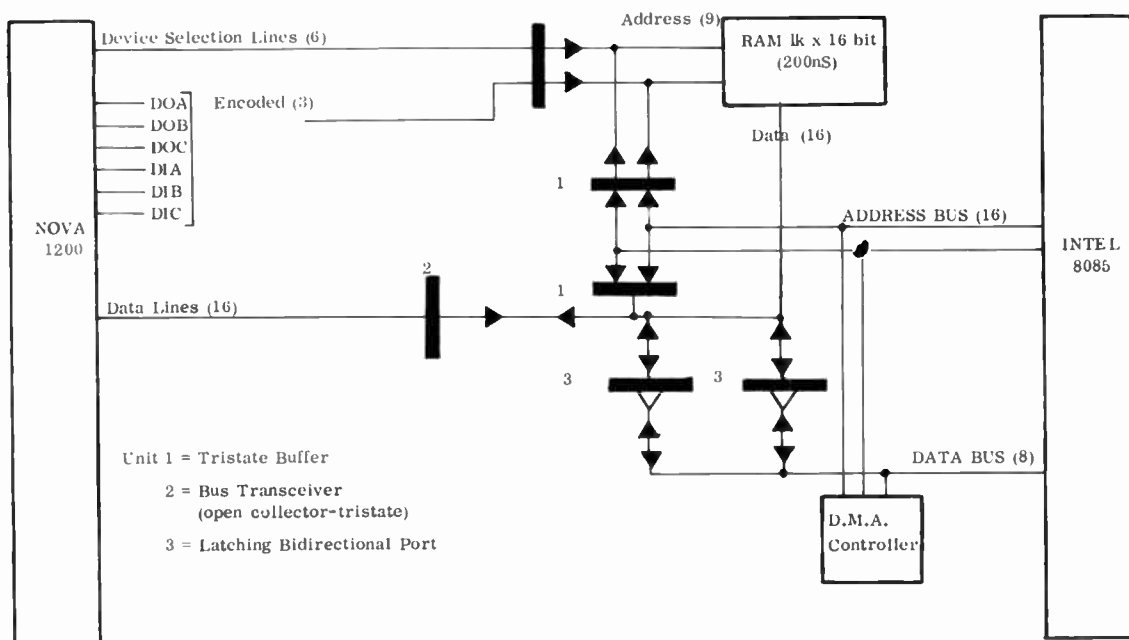

Fig. 6. NOVA 1200 INTEL 8085 address and data paths.

and from the peripherals and when updating in r.a.m. is required, then it waits until d.m.a. is granted so that a conflict of access does not occur. For d.m.a.-oriented devices, the controller for the Intel 8080 series is used to control both the Nova d.m.a. as well as the 8085 d.m.a. transfers, which it is well able to do since it is a four-channel device.

5 Conclusion

It has been shown in practice that null protocol philosophy will successfully allow manufacturers' operating systems and other software to run without modification. The University of Essex network has withstood the energetic endeavours of students in their day-to-day work. This new generation of interfaces takes advantage of the scope afforded by construction partly in hardware and partly in software. The easy alteration of the interfaces to handle peripherals not previously used simply by changing r.o.m.-based data and tables is a considerable step forward over their hardwired counterparts.

The comparison of board size for this composite interface with any group of hardwired interfaces of even one fifth of the peripheral capabilities is startling. For the PDP 11, one hex-wide board is sufficient for a complete d.s.r. set for the entire peripheral device address space. The limiting factor is the availability of r.a.m. space for program handlers which currently permits about ten peripherals to be defined. Extension space may easily be

created, if required, by using a daughter board arrangement to utilize effectively an adjacent slot position. Currently a quad-wide board occupies another slot position and this provides the asynchronous 12.5 M baud serial communication link to the network via twin u.h.f. coaxial cables.

After all physical comparisons, the null protocol d.s.r. set has the distinct advantage of operating with any required separation between the processor and peripherals.

6 Acknowledgments

The authors wish to thank the Department of Computer Science, University of Essex for facilities and development funding and the Science Research Council for the provision of a supporting research grant.

7 References

- 1 Forth, L., Kidd, P. A., Lyons, D. M., Bowden, K. F., Corker, S. W. and Strutt, C., 'Null-protocol network for communication between digital devices', *Proc. Instn Elect. Engrs*, **122**, no. 8, pp. 785-90, August 1975.
- 2 Forth, L., Kidd, P. A., Corker, S. W. and Strutt, C., 'Peripheral sharing under hardware protocols'. *Minicomputers and Small Business Systems* (Minicomputer Forum), November 1976, pp. 156-71.
- 3 'How to use the Nova Computer'. Data General Corporation, Southbro, Massachusetts, 1974.

*Manuscript first received by the Institution on 15th May 1978
(Paper No. 1899/Comp 193)*

An evaluation of a sideband diversity technique for data transmission on the forward path in a mobile radio area coverage scheme

G. ALLEN, B.Sc., Ph.D.,*

R. J. HOLBECHE, Ph.D., C.Eng., M.I.E.R.E.*

and

Professor W. GOSLING,

A.R.C.S., B.Sc., C.Eng., F.I.E.R.E.*

SUMMARY

The technique of sideband diversity has been applied to a quasi-synchronous amplitude modulated area coverage scheme for mobile radio, primarily to improve the error performance of medium-speed data transmissions to vehicles. Results are presented for commercial voice frequency modems using f.s.k. modulation at 1200 baud. Improvements in error performance of between one and two orders of magnitude have been measured. The residual errors after sideband diversity had been applied were heavily dependent upon ignition interference.

* School of Electrical Engineering, University of Bath, Claverton Down, Bath BA2 7AY.

1 Introduction

Area coverage using amplitude-modulated transmitters with overlapping service areas and closely spaced (few hertz) carrier frequencies was developed commercially in 1972 (by Pye Telecommunications) and the first operational scheme was installed for the Lothian and Peebles (now Borders) Constabulary in 1973.¹ This technique of extending the coverage area proved so successful that it is now enjoying widespread adoption by the major UK mobile radio users who have an area coverage requirement.

Much of the success of this approach can be attributed to the simplicity with which schemes of this type can be implemented. All that is required is that the carrier frequencies of the transmitters are maintained to within a few hertz of each other. This has been made possible using a commercially-available frequency drive unit that has long-term stability and exceptionally low phase-noise.

As well as extending the service area, quasi-synchronous operation also intensifies the coverage² by overcoming the shadowing effects of gross terrain features. In signal overlap areas a slow beat occurs between the several received signals which is almost totally eliminated by the automatic gain control of a standard mobile receiver. However, when the resultant signal level nulls to below the receiver threshold there is a consequent loss of audio signal and increase in noise level. As an a.m. receiver produces only moderate background noise level for low input signal, unlike an f.m. receiver, the audible effect of these fades is virtually undetectable during modulation and, because of the redundancy of speech, rarely causes loss of intelligibility.

Quasi-synchronous operation does not in itself overcome fast fading caused by multipath propagation, which is the major impairment to transmissions between base station and the vehicle in the mobile radio environment. Although the fading from geographically well-spaced transmitters will be uncorrelated, interaction between the transmissions ensures that when fading signals are received at the mobile the resultant will exhibit similar fading statistics.

Traditionally, civil land mobile radio has been concerned with speech and, because of its redundancy, satisfactory communications can be established, despite the channel impairments of signal fading and ignition noise. However, there is a growing demand for two-way medium-speed data communications between the base station and mobiles. Data transmissions do not possess the redundancy of speech, however, and signal variability due to either multipath propagation or transmitter interactions in a quasi-synchronous scheme produces a significant number of errors. Sideband diversity³ is a technique that utilizes the redundancy of double-sideband a.m. signals to overcome transmitter interactions and in doing so allows the diversity

advantage offered by multi-transmitter operation to be realized in multi-path fading environments. Substantial improvements on the mobile to base performance can be achieved by using conventional long baseline receiver diversity. A combination of s.b.d. and long baseline receiver diversity produces a system where nearly all the complexity of the diversity system is at the base stations.

2 The Theory of Sideband Diversity

2.1 Conventional QS Schemes

The resultant signal seen by a mobile receiving equal signals from two quasi-synchronous a.m. transmitters operating with a frequency offset of $\delta\omega_c$, and modulated in phase with a frequency ω_m and modulation index of m , is given by:

$$v_r = v_1 \sin(\omega_c - \frac{1}{2}\delta\omega_c)t[1 + m \sin \omega_m t] + v_2 \sin(\omega_c + \frac{1}{2}\delta\omega_c)t[1 + m \sin \omega_m t]$$

where v_1, v_2 are the received signal amplitudes.

This can be written as:

$$v_r = 2v [\sin \omega_c t \cos \frac{1}{2}\delta\omega_c t [1 + m \sin \omega_m t]] \quad (1)$$

if $v_1 = v_2 = v$.

Thus the received signal is amplitude modulated by the slowly varying function $\cos \frac{1}{2}\delta\omega_c t$. It will therefore fall to a null value of zero at a rate determined by the offset frequency and remain below the receiver threshold for a duration determined by the signal level, v .

2.2 Sideband Diversity Scheme

To implement a sideband diversity scheme it is necessary to incorporate wideband phase shift networks in the audio circuits of the fixed transmitters. For a two-station scheme the modulation applied to one transmitter will be shifted by α degrees relative to the other over the entire audio bandwidth. The two components of the signal at the mobile, assuming the same conditions as before, will now be:

$$u_a = v \cos(\omega_c - \frac{1}{2}\delta\omega_c)t[1 + m \cos \omega_m t]$$

and

$$u_b = v \cos(\omega_c + \frac{1}{2}\delta\omega_c)t[1 + m \cos(\omega_m t + \alpha)].$$

Expressions for the combined lower sideband, carrier and upper sideband may be derived as:

Lower sideband

$$u_1 = \frac{1}{2}mv \{ \cos(\omega_c - \frac{1}{2}\delta\omega_c - \omega_m)t + \cos[(\omega_c + \frac{1}{2}\delta\omega_c - \omega_m)t - \alpha] \} = mv [\cos(\frac{1}{2}\delta\omega_c t - \frac{1}{2}\alpha)] \cos(\omega_c t - \omega_m t - \frac{1}{2}\alpha) \quad (2)$$

Carrier

$$u_c = v \{ \cos(\omega_c - \frac{1}{2}\delta\omega_c)t + \cos(\omega_c + \frac{1}{2}\delta\omega_c)t \} = 2v [\cos \frac{1}{2}\delta\omega_c t] \cos \omega_c t \quad (3)$$

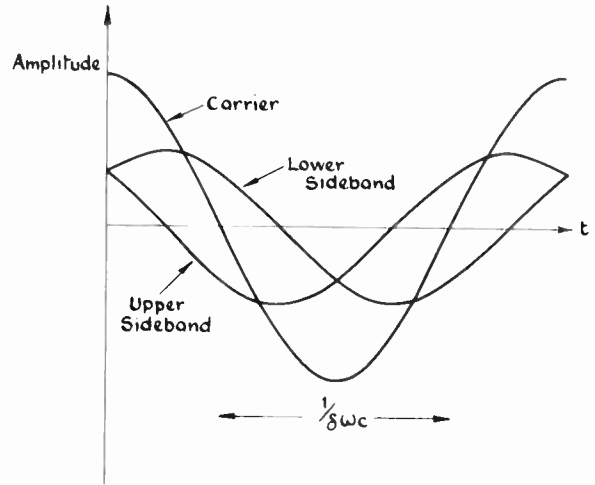

Fig. 1. Resultant relative carrier and sideband amplitudes (100% a.m. with modulation phase angle of 90°).

Upper sideband

$$u_2 = \frac{1}{2}mv \{ \cos(\omega_c - \frac{1}{2}\delta\omega_c + \omega_m)t + \cos[(\omega_c + \frac{1}{2}\delta\omega_c + \omega_m)t + \frac{1}{2}\alpha] \} = mv [\cos(\frac{1}{2}\delta\omega_c t + \frac{1}{2}\alpha)] \cos(\omega_c t + \omega_m t + \frac{1}{2}\alpha) \quad (4)$$

The factor in the square brackets of each of these expressions represents slow modulation caused by receiving two signals with a small frequency offset. The angle α appears with opposite sign in the envelope term of the lower and upper sideband signals thereby ensuring that these signals null at different times provided that $\alpha \neq 0$. The variation of the relative amplitudes of the carrier and sideband components with $\alpha = 90^\circ$ and 100% modulation is shown in Fig. 1, where it can be seen that when one sideband is zero the other is at a maximum.

Thus the effect of introducing a phase shift between the modulation applied to the two transmitters is to ensure that neither the carrier nor either of the two sidebands null to zero at the same instant in time. Because the two sidebands no longer null simultaneously, the information content of the transmission is always available. Therefore if the receiver has the capability of demodulating each sideband independently a simple voting system which always selects the stronger sideband would reduce fluctuation in the level of the demodulated output to about 3 dB only.

3 Received Signal Characteristics with S.B.D. Applied to a Conventional QS A.M. Scheme

It has been shown that an independent sideband receiver with simple voting can minimize interactions between the transmissions in a QS scheme when constant amplitude signals are received at the vehicle. However, the mode of propagation in the land mobile radio environment is predominantly by scattering, and as a

consequence the amplitude and phase of the received signal vary in a random manner as the vehicle moves. The signal may be expected to have a Rayleigh distributed amplitude (with fades of 30 dB below the median value occurring frequently), and a uniformly distributed phase angle.⁴ As the vehicle makes a larger move from one location to another there is a change of structures and terrain which cause a slow variation in the mean level about which the rapid Rayleigh fading occurs. The extent to which an s.b.d. system can improve the signal distribution under multipath fading conditions is obviously dependent upon the correlation of the upper and lower sideband signals.

The geographical spacing of the base stations in conventional QS schemes ensures that the Rayleigh fading characteristics of the individual transmissions received at the vehicle are independent. Under such conditions, and assuming synchronous transmissions, it can be shown that the correlation of the sideband envelopes, ρ , when three transmissions are received is very closely given by:⁵

$$\rho_s \approx \frac{\Omega_1^2 + \Omega_2^2 + \Omega_3^2 + 2\Omega_1\Omega_2 \cos 2\alpha + 2\Omega_1\Omega_3 \cos 2\beta + 2\Omega_2\Omega_3 \cos 2(\alpha + \beta)}{(\Omega_1 + \Omega_2 + \Omega_3)^2} \quad (5)$$

where Ω_n = mean squared value of the n th transmission, and α, β = modulation phase shift angles.

With modulation phase angles of $\mp 60^\circ$ ($\alpha = 60^\circ, \beta = 60^\circ$) or $\mp 120^\circ$, this expression reduces to:

$$\rho_s \approx \frac{\Omega_1^2 + \Omega_2^2 + \Omega_3^2 - \Omega_1\Omega_2 - \Omega_1\Omega_3 - \Omega_2\Omega_3}{(\Omega_1 + \Omega_2 + \Omega_3)^2} \quad (6)$$

Under these conditions there is zero correlation between the sideband signals when the three received transmissions have equal mean values.

When only two transmitters are used (or only two significant transmissions are received at the vehicle) the expression for sideband correlation reduces to:

$$\rho_s \approx \frac{\Omega_1^2 + \Omega_2^2 + 2\Omega_1\Omega_2 \cos 2\alpha}{(\Omega_1 + \Omega_2)^2} \quad (7)$$

In this case the optimum modulation phase angle is 90° , which gives zero sideband correlation with equal mean signals.

The effect on the variance of the signal after sideband selection is illustrated in Fig. 2 for various degrees of sideband correlation. The maximum reduction in variance is obtained with zero correlation with an improvement of 20 dB (diversity gain) over the Rayleigh fading case at the 99.99% reliability point. Even with a high degree of correlation between the sidebands (one transmission predominant) there is a significant reduction in the probability of deep fades. Thus even with $\rho = 0.8$ there is a diversity gain of 15 dB at the 99.99%

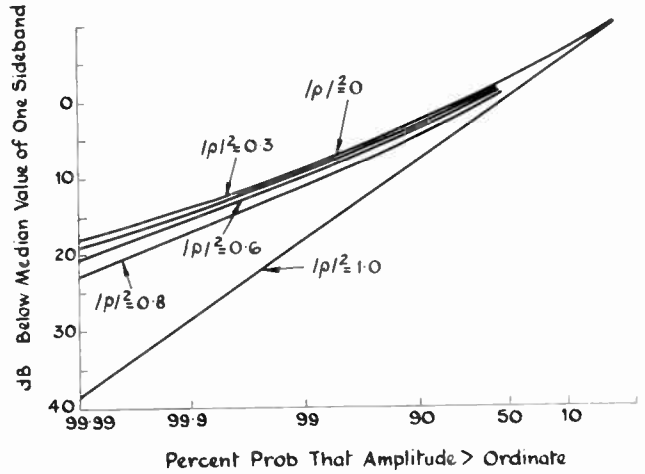

Fig. 2. Sideband diversity distributions with correlated sidebands.

reliability point. This also implies that the phase shift angle α is very non-critical.

In a s.b.d. coverage scheme diversity improvement will vary over the service area because the sideband correlation is dependent upon the relative mean signal levels received from the different transmitters. The maximum improvement occurs when equal mean signals are received; with differing mean signal levels correlation will rise, tending to unity when only one significant transmission is received. This will correspond to a mobile being close to one transmitter, however, when the signal from that transmitter should anyway be large enough to give an acceptable signal-to-noise ratio.

The variation of resultant received power moving along a line between the transmitters in a two-station QS scheme, for a flat urban environment and assuming that the received power is inversely proportional to the cube

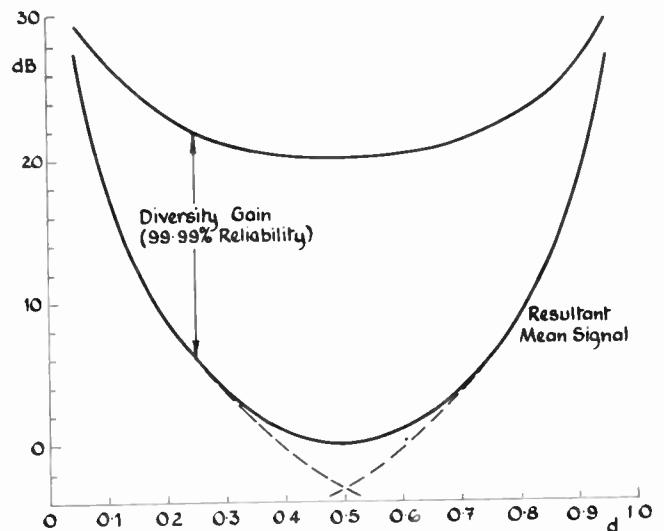

Fig. 3. Resultant mean signal level and sideband diversity gain for normalized transmitter spacing ($P \propto d^{-3}$, 0 dB \equiv resultant mean signal level at the mid-point between the transmitters).

of distance from transmitter to receiver,⁶ is shown in Fig. 3. The 0 dB reference level is the resultant power at the mid-point between the transmitters. The second curve adds the diversity gain for 99.99% reliability, and illustrates how the decrease in diversity improvement, as one transmitter is approached, is closely matched by an increase in the mean received signal. Thus use of sideband diversity in a long baseline QS scheme gives an effect equivalent to a more uniform apparent mean signal level in the coverage area between the transmitters.

Different path lengths from the various fixed transmitters to the mobile will introduce time delays in the transmissions so that the modulation phase angles seen at the mobile will be modified. In conventional QS schemes this can introduce frequency distortion in the demodulated audio if comparable signals are received from two transmitters over excessively different path lengths. Under similar conditions in a sideband diversity scheme the sideband correlation will be modified. Thus a restriction on the scale of a long baseline sideband diversity scheme is imposed by the relative time delay between the received signals when large path differences exist.

For example, in a two-station scheme with a modulation phase angle of $\frac{1}{2}\pi$ radians, the relative time delay, τ , will introduce a modulation phase angle $\omega_m\tau$ and when this angle is equal to $\frac{1}{2}\pi$ the correlation between the sidebands at frequency ω_m will be unity. For a maximum modulating frequency of 2.5 kHz this will

occur when the relative time delay, τ , is 100 μ s which is equivalent to a path difference of 30 km. However, this is only important when the mean levels of the two transmissions are within 20 dB, since if they differ by more than this the correlation will be very near to unity anyway. The likelihood of receiving two signals that are within 20 dB and having a path difference of 30 km depends upon the size of the coverage area and the terrain. For a flat urban area ($P \propto d^{-3}$) and a mobile operating on a line between the transmitters, the base stations would have to be spaced by 50 km for a difference of 18 dB in the signals received with a 30 km path-difference.

In practice, problems arising from this cause are unlikely, since it is only in rare terrain configurations that comparable signals will be received with a path difference approaching 30 km.

4 Experimental System

An experimental three-station QS scheme, operating at 99.55 MHz (± 1 Hz), was established in the geographic region south of Bath and Bristol to study the effectiveness of sideband diversity for data transmission to vehicles. The locations of the base stations and some of the test routes used for the data trials are shown in Fig. 4.

A continuous data signal was transmitted from each site and received by a vehicle travelling over a predetermined route. A schematic of the system is shown in Fig. 5. A 511-bit pseudo-random binary sequence was generated at the Bath control site and used to modulate an audio sub-carrier in a f.s.k. (1.2 kbit/s) modem. The a.f. signal produced by the modem was fed to wideband analogue phase-shifting networks before application to the transmitters. The phase difference between the modulating signals could be selected to be 90° or $\pm 120^\circ$ for two and three-station operation respectively. Although the phase response of the networks was not truly linear with frequency no degradation in error performance over the range of interest, compared with a modem back-to-back test, was measured with the phase shift networks and transmitters and receivers in circuit.

Modulating signals were transmitted to the remote sites over high band v.h.f. radio links. The substantial phase distortion and possibility of frequency offsets of Post Office lines makes this a necessity for any QS a.m. scheme.

A lumped-LC time-delay in the Bath channel compensated for the propagation time of the radio links to the remote sites and an active all-pass network compensated for the phase/frequency characteristic of the link equipment.

A Marina estate car, equipped with only the normal standard of radio suppression, was used for the field tests. The mobile equipment consisted of a modified commercial a.m. receiver, fitted with a 12.5 kHz channel-spacing filter and with the first local oscillator replaced

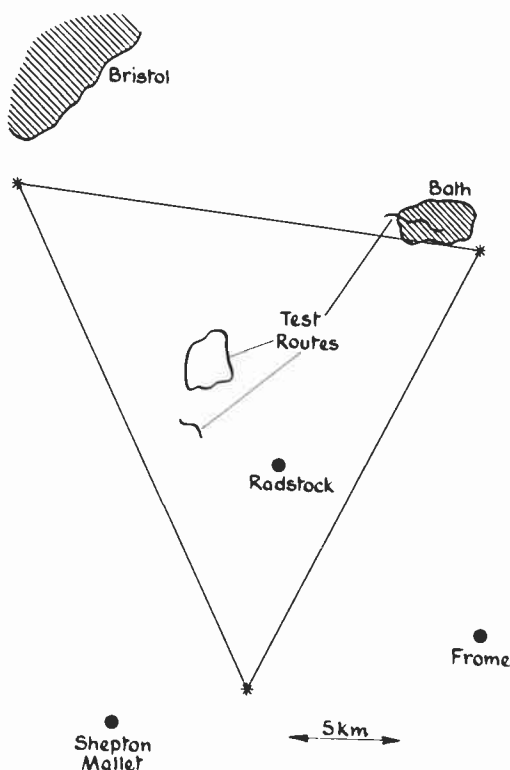

Fig. 4. Location of the base stations.

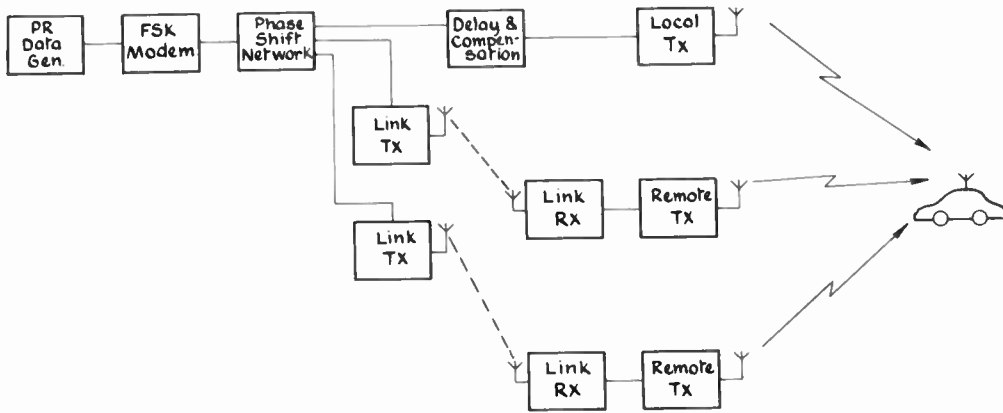

Fig. 5. Experimental QS system.

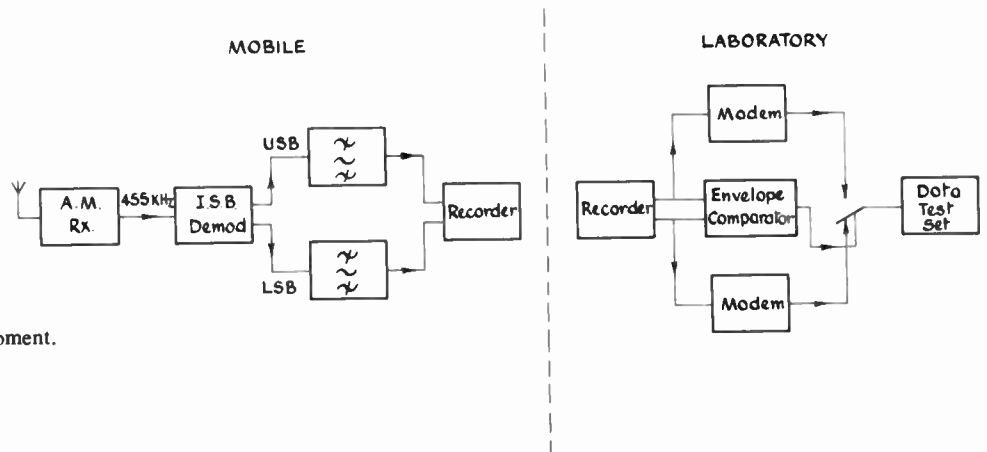

Fig. 6. Mobile and laboratory equipment.

by a much more stable frequency source. The 445 kHz second i.f. signal was fed to a phasing type independent sideband demodulator with a sideband isolation of better than 44 dB. After audio filtering (300-3000 Hz) the sideband signals were recorded on an instrumentation tape recorder.

On replay in the laboratory the sideband signals were applied to independent data demodulators and the envelopes of the two signals compared. A data test-set received data from the demodulator with the largest input, and by comparison with a locally generated 511-bit pseudo-random sequence produced information about error performance and telegraph distortion.

The performance of the complete data system with constant amplitude signals and with no extraneous influences is shown in Fig. 7.

5 Results

The results of tests carried out over three routes, selected to indicate the performance of the system under widely different propagation conditions, are presented. Because transmitter interactions are most significant when the signal levels from the various transmitters are approximately equal, tests were carried out in both rural and urban environments at the centre of the coverage area. Further trials were conducted in an urban area close to one of the transmitters to show how sideband

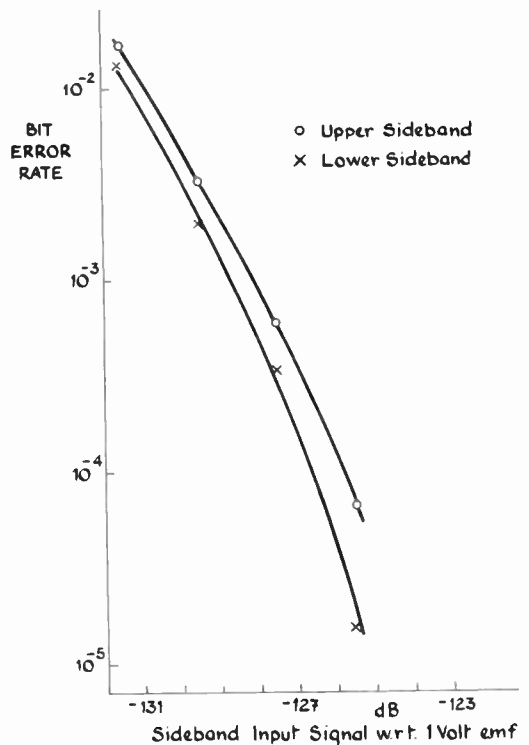

Fig. 7. Static error performance of the system without ignition noise.

diversity performs when one of the transmissions is predominant.

In the tests described the effect of signal level on bit error rate was obtained by simultaneously changing the output power of all the transmitters. In this way the relative mean levels of the transmissions over any section of the route remained the same, thus maintaining the same correlation between the sideband signals. Comparison of the error performance at the different power levels shows the influence of mean signal strength on bit error rate for identical propagation conditions.

5.1 Rural Area—Centre of Coverage Area

The results shown in Fig. 7 were obtained from several test runs over approximately 3 miles of predominantly rural conditions at the centre of the coverage area for QS operation of the three transmitters with modulation phase angles of 0° and ±120°. Line-of-sight propagation from one or more of the transmitters occurs over some sections and multipath propagation was experienced in the two villages on the route. Approximately equal signals from all three transmitters occur for a significant proportion of the time. The mean signal level of the strongest transmission at any time was greater than -98 dB (ref. 1 V e.m.f.) and that of the weakest greater

than -115 dB for an unmodulated carrier power of 5 W delivered to the aerial. Because of the rural nature of the area the tests could be carried out at a reasonably constant vehicle speed of 30 miles/h with only a minor amount of ignition interference from other vehicles.

The bit error rate for single sideband operation (i.e. sideband selection circuitry locked to one sideband) only decreases marginally for an approximately 10 dB increase in signal level. This is because the majority of the errors are caused by fading induced by QS operation. The effectiveness of sideband diversity in reducing the errors experienced under these conditions is clearly demonstrated, with an order of magnitude improvement in error rate at the lowest power level and well over two orders of magnitude improvement with the signal levels increased by 10 dB.

The performance of the sideband diversity system was compared with single sideband performance for convenience. This permitted an experimental procedure in which each recording was analysed twice, once with the selection circuit operative and then with selection circuit locked to one or other sideband. It might be thought that a comparison with envelope demodulated a.m. would be more relevant. However, since the majority of errors in mobile radio data systems are caused by signal fading and ignition interference, the performance of single sideband and conventional a.m. with envelope detection was expected, and subsequently shown experimentally, to be similar. Tests were carried out primarily over the rural test route to compare the performance of a.m. envelope detection and sideband diversity. These tests were carried out with two transmitters operating quasi-synchronously with a 100% modulated 5 W carrier. The modulation phasing was 0° for the a.m. tests and 120° for the s.b.d. tests. The results are given in Table 1.

The improvement in error performance by sideband diversity over a.m. is clearly demonstrated by these results. Amplitude modulation performs slightly better than single sideband, as would be expected, but this difference is small compared with the improvement achieved by the sideband diversity system.

Figure 9 shows the results obtained on a part of the route which included the village of High Littleton and a section of the A39 road where other traffic was encountered. The single sideband error rate falls from

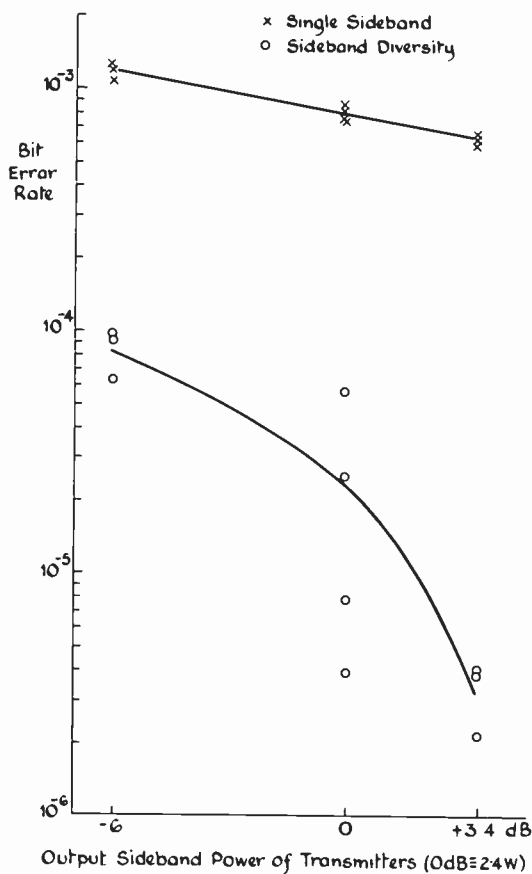

Fig. 8. Rural test route error performance—centre of the coverage area.

Table 1

A.m./s.b.d. comparison trials; f.s.k. (1200 bit/s)

	Bit error rates		
	l.s.b. (120°)	a.m. (0°)	s.b.d. (120°)
Trial 1	1.25 × 10 ⁻³	4.1 × 10 ⁻⁴	8.1 × 10 ⁻⁶
Trial 2	1 × 10 ⁻³	6.8 × 10 ⁻⁴	4.8 × 10 ⁻⁶

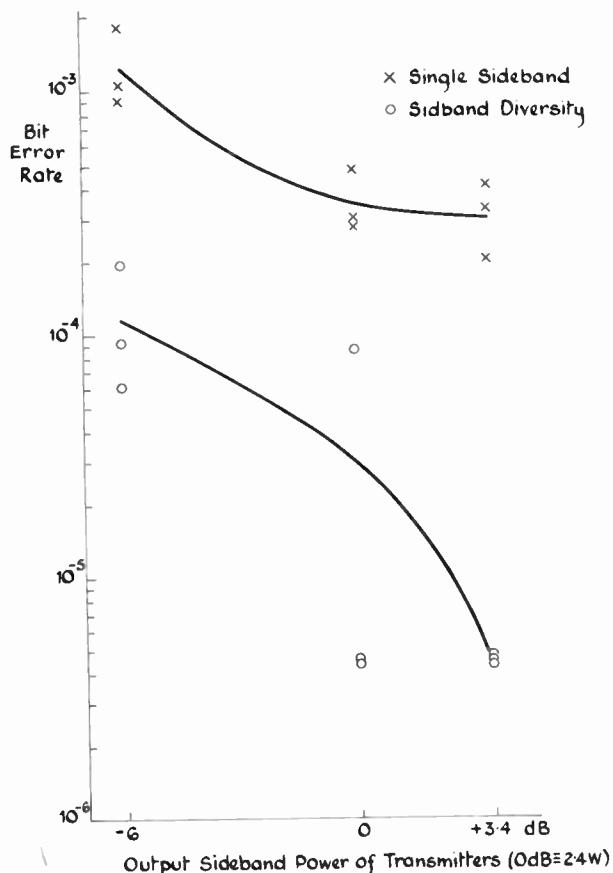

Fig. 9. Rural test route error performance—centre of the coverage area.

1.3×10^{-3} to 3×10^{-4} for a 10 dB increase in signal level. The corresponding rates for the diversity system are 1.2×10^{-4} and 4.5×10^{-6} . At the higher power levels, in the s.b.d. case, only one or no errors were recorded for the majority of the tests, but a burst of 24 errors caused by ignition interference from a noisy vehicle increased the error rate to 8.7×10^{-5} on one test at the 0 dB level. This error burst accounted for all the errors experienced over this section of the route on that occasion.

5.2 Urban Conditions—Centre of Coverage Area

The performance of the system under conditions where all three signals are at a low level but of approximately the same magnitude can be assessed from the results obtained on an urban test route at the centre of the coverage area. Here no line-of-sight path existed to any of the base station sites and multipath fading was experienced for the three individual transmissions for most of the route. The mean signal level of all three transmissions varied in the range -94 dB ref. 1 V e.m.f. to -104 dB for a radiated carrier power of 5 W. The route, which was 1.3 km long, usually suffered from heavy traffic which caused frequent delays.

The results shown in Fig. 10 are heavily dependent

upon ignition interference from other vehicles, particularly at the lower bit error rates achieved by the sideband diversity system. The mean error rate curve for the single sideband performance has a slope of 1 decade/13.4 dB which compares reasonably with measurements made in London⁷ of 1 decade/12 dB for 1200 baud direct frequency modulation. The curve for sideband diversity has a slope of 1 decade/6.5 dB; this is as would be expected for a diversity system which gives a greater improvement at higher signal-to-noise ratios.

5.3 Performance Close to One Transmitter

Tests of the system in an urban environment close to one of the transmitters were carried out in the City of Bath with a test route 4 km long. Conditions varied from suburban at the start of the route on the outskirts of the City to urban in the City centre where traffic congestion usually made progress slow and erratic. Signal strength was dominated by the Bath transmission with the mean signal level, for a radiated carrier power of 5 W, varying in the range -80 dBV to -100 dBV, while the level from the second transmitter varied between -100 dBV and -112 dBV and that from the third was usually lower than this.

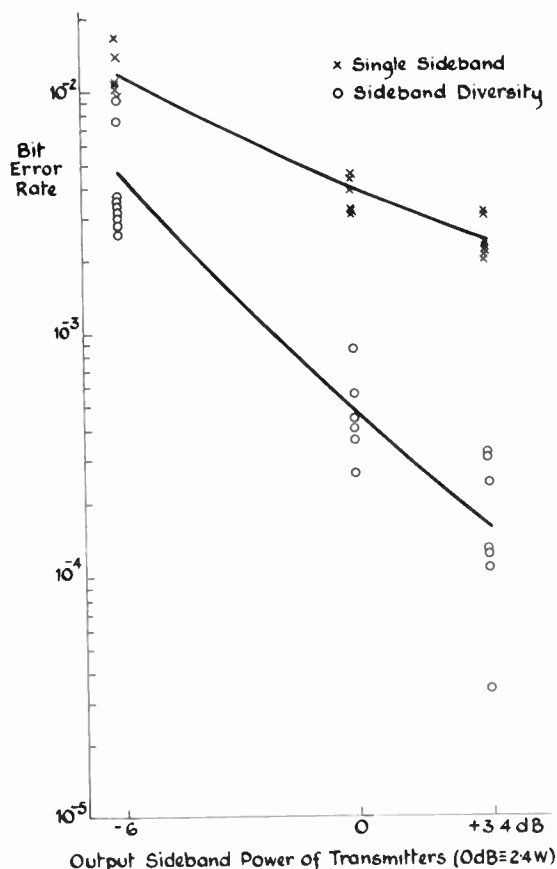

Fig. 10. Urban area error performance—centre of coverage area.

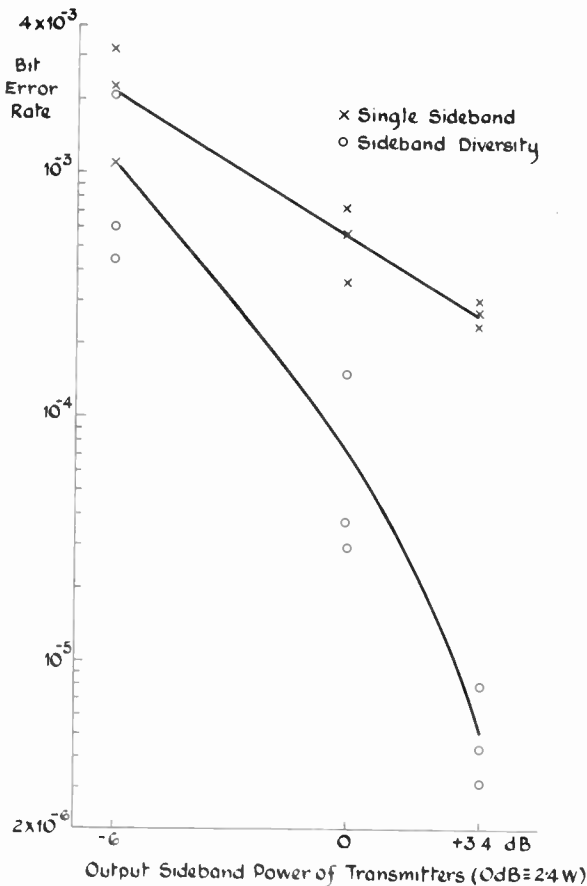

Fig. 11. Error performance—Bath suburban area.

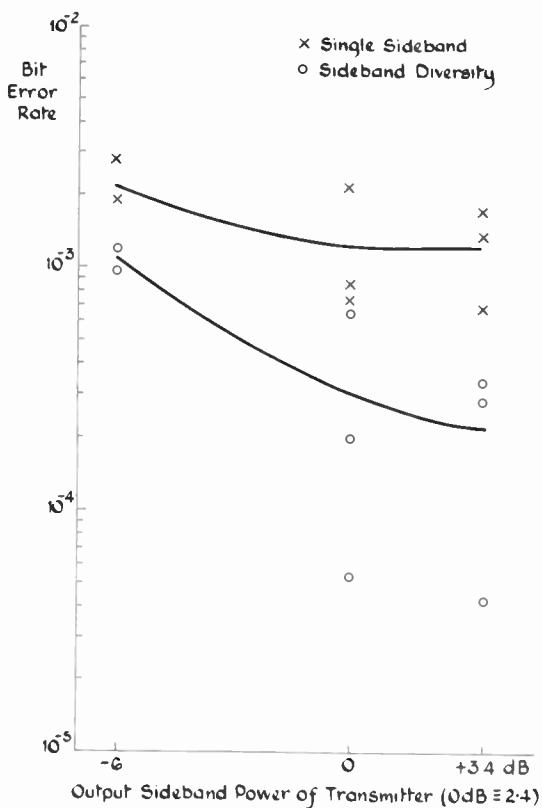

Fig. 12. Error performance—Bath city centre.

The results from the suburban section of the route are shown in Fig. 11 and those for the City centre in Fig. 12, and these results demonstrate the effectiveness of sideband diversity in reducing the error rate even when the vehicle is operating close to one of the base stations. The results from the City centre are heavily dependent upon ignition interference, particularly in the sideband diversity case at the higher power levels where almost all the residual errors occur in the occasional burst caused by the proximity of a noisy vehicle. For example, 84% of all the errors suffered by the diversity system, on one of the test runs at the highest power level, occurred in a burst as the vehicle travelled a short distance of the route where on previous and subsequent tests only the occasional error occurred.

The diversity effect is limited because of the disparity between the mean levels of the signals from the various transmitters. At the higher power levels the transmissions from the remote sites are generally sufficient to maintain the signal above the 'own vehicle' ignition noise during fades but insufficient to give much protection against interference from 'noisy' vehicles.

6 Conclusions

Sideband diversity has been shown to be an effective technique for improving the error performance of medium-speed data transmissions to vehicles in quasi-synchronous area coverage schemes. This is achieved by reducing the undesirable effects of signal variability caused by multipath propagation and quasi-synchronous operation. The diversity improvement will vary over the coverage area, with the smallest improvement occurring in the vicinity of the transmitters where the signal strength will be high anyway. A major advantage of the system is that it requires no extra bandwidth and can operate within the confines of the standard 12.5 kHz channel allocation.

A bit error rate of 1.6×10^{-4} was obtained in an urban environment at the centre of a three-station quasi-synchronous scheme with mean signal levels from the three transmitters of less than $20 \mu\text{V}$ e.m.f. The corresponding non-diversity error rate was 2.4×10^{-3} . With stronger signals an improvement in error rate from 5.8×10^{-4} to 3.3×10^{-6} has been measured.

The introduction of sideband diversity on an existing quasi-synchronous a.m. area coverage scheme requires only the addition of wideband phase-shifting networks and some mobile receiver adaptation. It could thus be implemented cheaply. In a forthcoming publication a particularly simple sideband diversity receiver will be described.

The errors remaining after sideband diversity has been applied are heavily dependent upon ignition interference. In low signal areas 'own vehicle' noise contributes a large proportion of the residual errors and in other areas

'rogue' noisy vehicles produce bursts of errors with long error-free intervals between.

It can therefore be concluded that in order to achieve minimum obtainable error performance greater attention should be given to vehicle suppression generally.

Error correcting codes could be used to overcome the residual errors, but the data throughput would become very low if the codes had to cope with the error bursts caused by the occasional extremely noisy vehicle. An automatic retransmission of the data (ARQ) under these circumstances would be more efficient.

7 Acknowledgments

This work arose out of a research contract placed by the Home Office Directorate of Telecommunications, and we are grateful to the Director for permission to publish. The financial support of the SRC to G. Allen during the course of this work is also gratefully acknowledged.

8 References

- 1 Holbeche, R. J., 'Area coverage techniques for mobile radio', Conference Proceedings, Communications 74, June 1974.
- 2 Gosling, W. and Petrovic, V., 'Area coverage in mobile radio', *Proc. Instn Elect. Engrs*, **120**, no. 12, pp. 1469-76, December 1973.
- 3 Gosling, W., Martin, J. D., Holbeche, R. J. and Allen, G., 'Sideband diversity: a new application of diversity particularly suited to land mobile radio', *The Radio and Electronic Engineer*, **48**, no. 3, pp. 133-9, March 1978.
- 4 Clarke, R. H., 'A statistical theory of mobile-radio reception', *Bell Syst. Tech. J.*, **47**, no. 6, pp. 957-1000, July-August 1968.
- 5 Allen, G., 'The application of sideband diversity to mobile radio', Ph.D. Thesis, University of Bath, May 1978.
- 6 Okumura, T. *et al.*, 'Field strength and its variability in v.h.f. and u.h.f. land mobile radio service', *Rev. Elect. Comm. Lab.*, **16**, no. 9/10, pp. 825-73, September/October 1968.
- 7 French, R. C., 'Mobile radio data transmission—error performance', Conference on Civil Land Mobile Radio, IERE Conference Proceedings, no. 33, pp. 93-100, November 1975).

Manuscript first received by the Institution on 18th December 1978, and in final form on 30th April 1979 (Paper No. 1900/Comm 187)

The Ideal Averaging Filter: Its Applications and Realizations

J. B. GRIMBLEBY, Ph.D., C.Eng., M.I.E.E.*

SUMMARY

The optimum filter for improving the signal/noise ratio in a commonly-encountered instrumentation situation is the ideal averaging filter. Various ways of realizing the ideal response are discussed and rational approximants of order 1 to 6 are given. The circuits required to implement these approximants are considerably less complex than those required for the alternative realizations.

* Department of Engineering, The University of Reading, Whiteknights, Reading RG6 2AY.

1 Introduction

A situation that is frequently encountered in electronic instrumentation systems is where a signal contains a required d.c. or slowly varying component representing some quantity that is to be measured, together with unwanted higher frequency components or noise. Two examples of systems generating such signals are:

- (1) A system for measuring the transmittance of an optical fibre at a number of wavelengths. The monochromatic light that is incident on the fibre input is chopped, and the signal from the detector at the fibre output is amplified and phase-sensitive rectified. The rectifier output will consist of a d.c. component proportional to the fibre transmittance together with noise components which, at frequencies well below the chopping frequency, will be substantially 'white' (that is, the spectral density will be independent of frequency).
- (2) An anemometer. The signal is proportional to the windspeed and its d.c. component can be taken to represent the mean windspeed. Noise superimposed on the d.c. component results from the fluctuation of the windspeed about its mean value.

Some form of signal processing is required to attenuate the noise relative to the d.c. component and this usually takes the form of a low-pass filter. Clearly, the noise components can be reduced to an arbitrarily low level by appropriate choice of filter bandwidth. However, reduction of the bandwidth has the undesirable effect of increasing the time that the filter takes to settle down following a change in its input. This is a consequence of the 'uncertainty principle' that operates between Fourier transform pairs.¹

The extent to which a particular filter design satisfies the conflicting requirements of a short settling time and a good noise reduction is a measure of its suitability in the type of applications being discussed. The rest of this paper is devoted to determining the optimum response, and to obtaining a practical realization of this response.

2 The Optimum Filter

Before deriving the optimum filter response it is first necessary to define more precisely the conditions under which the filter is to be used. Let us suppose that at a time $t = 0$ the required d.c. quantity is established at the input to the filter. A time T_0 is then allowed to elapse before a measurement of the signal at the output of the filter is taken. (This is to allow the filter to 'settle down' following the change in its input conditions.) The level of the d.c. component of the input prior to $t = 0$ is unknown and it is important that this should not affect the accuracy of the measurement of the required signal. In other words, the output at time $t = T_0$ should depend only on the input over the time range $t = 0$ to $t = T_0$.

This (together with the requirement that the filter be causal) leads to the following restriction on $h(t)$, the impulse response of the filter:

$$\left. \begin{aligned} h(t) &= 0 & \text{for } t < 0 \\ h(t) &= 0 & \text{for } t > T_0 \end{aligned} \right\} \quad (1)$$

A convenient quantitative measure of the effectiveness of a filter in attenuating noise is the noise-equivalent bandwidth f_n . This is defined as the bandwidth of an ideal sharp cut-off filter that would attenuate the noise relative to the d.c. signal by the same amount as the filter under consideration. If the noise is white then the expression for f_n in terms of the frequency response function of the filter, $H(j\omega)$, is given by:

$$f_n = \frac{1}{2\pi} \cdot \frac{\int_0^\infty |H(j\omega)|^2 d\omega}{|H(j0)|^2} \quad (2)$$

In some cases, of course, the noise will not be even approximately 'white' and the expression given above will not be appropriate.

It can easily be shown that the signal/noise ratio at the output of the filter is inversely proportional to f_n . The optimum filter is that filter having the smallest value of f_n while satisfying the constraints on $h(t)$ expressed in inequality (1).

$H(j\omega)$ and $h(t)$ are related by the Fourier transform:

$$H(j\omega) = \int_{-\infty}^\infty h(t) \exp(-j\omega t) dt \quad (3)$$

so that:

$$H(j0) = \int_{-\infty}^\infty h(t) dt. \quad (4)$$

Parseval's theorem, applied to this Fourier transform pair gives:

$$\frac{1}{2\pi} \cdot \int_{-\infty}^\infty |H(j\omega)|^2 d\omega = \int_{-\infty}^\infty |h(t)|^2 dt. \quad (5)$$

Substituting equations (5) and (4) into equation (2), and using the fact that

$$|H(j\omega)|^2 = |H(-j\omega)|^2$$

gives the following expression for f_n :

$$f_n = \frac{1}{2} \cdot \frac{\int_0^{T_0} |h(t)|^2 dt}{\left| \int_0^{T_0} h(t) dt \right|^2} \quad (6)$$

where the integration limits have been reduced to take account of the constraints on $h(t)$.

To determine the smallest possible value of f_n we make use of Schwarz's inequality:

$$\left| \int_0^{T_0} h(t)f(t) dt \right|^2 \leq \int_0^{T_0} |h(t)|^2 dt \cdot \int_0^{T_0} |f(t)|^2 dt. \quad (7)$$

This equality holds for $h(t) = k \cdot f^*(t)$ where k is an arbitrary constant. Now, writing $f(t) \equiv 1$, the inequality becomes:

$$\left| \int_0^{T_0} h(t) dt \right|^2 \leq \int_0^{T_0} |h(t)|^2 dt \cdot \int_0^{T_0} dt. \quad (8)$$

Finally, combining this inequality with equation (6) gives:

$$f_n \geq \frac{1}{2T_0} \quad (9)$$

with equality holding for:

$$\left. \begin{aligned} h(t) &= 1/T_0 & \text{for } 0 \leq t \leq T_0 \\ h(t) &= 0 & \text{otherwise} \end{aligned} \right\} \quad (10)$$

where the arbitrary constant k has been removed by choosing $H(j0) = 1$.

3 The Ideal Averaging Filter

A filter with the response given in equation (10) is called an 'ideal averaging filter'. The reason for this can be seen by considering the relationship between the output $y(t)$ and the input $x(t)$ of the filter:

$$y(t) = \int_{-\infty}^\infty x(\tau)h(t-\tau) d\tau$$

$$y(t) = \frac{1}{T_0} \int_{t-T_0}^t x(\tau) d\tau. \quad (11)$$

The instantaneous output is seen to be the mean (or average) of the input over the preceding time T_0 . Integration of the impulse response gives the unit-step response $g(t)$:

$$g(t) = \int_0^t h(\tau) d\tau \quad (12)$$

so that:

$$\left. \begin{aligned} g(t) &= 0 & \text{for } t < 0 \\ g(t) &= t/T_0 & \text{for } 0 \leq t \leq T_0 \\ g(t) &= 1 & \text{for } T_0 < t. \end{aligned} \right\} \quad (13)$$

By Fourier transformation the frequency response $H(s)$ is obtained as follows in terms of the complex frequency variable s :

$$H(s) = \frac{1}{sT_0} \cdot \{1 - \exp(-sT_0)\}. \quad (14)$$

Substitution of this expression into equation (2) confirms that the noise-equivalent bandwidth has its optimum value:

$$f_n = \frac{1}{\pi T_0} \cdot \int_0^\infty \frac{\sin^2 x}{x^2} dx = \frac{1}{2T_0} \quad (15)$$

4 Realization of the Ideal Averaging Filter Using Delays

The ideal averaging filter response is obviously closely related to the delay response:

$$h(t) = \delta(t - T_0)$$

$$H(s) = \exp(-sT_0)$$

and it is worth considering whether a realization based on one or more delays is practicable.

A number of methods are available for generating time delays in the 1 ms to 1000 s range. Time delays can be approximated by linear lumped-element circuits² at a cost of a few operational amplifiers, resistors and capacitors for each delay stage. Alternatively, delays can be produced digitally by an analogue-to-digital converter (ADC) followed by a shift register (SR) and a digital-to-analogue converter (DAC). Finally, charge-transfer devices³ are becoming commercially available although at present these may not possess a sufficiently large dynamic range for the type of application under consideration here.

In principle the ideal averaging filter response could be obtained from a system using a single delay as shown in Fig. 1(a). Here the output $y(t)$ is given by:

$$y(t) = \frac{1}{T_0} \cdot \int_{-\infty}^t x(\tau) - x(\tau - T_0) d\tau$$

$$= \frac{1}{T_0} \cdot \int_{t-T_0}^t x(\tau) d\tau.$$

Unfortunately, if the quantity being integrated is a continuous variable (for example an analogue voltage) then errors in the integrator and subtractor will lead to drift at the output which must remain uncorrected. A possible solution is to integrate and subtract quantized variables; if the delay, subtraction and integration are

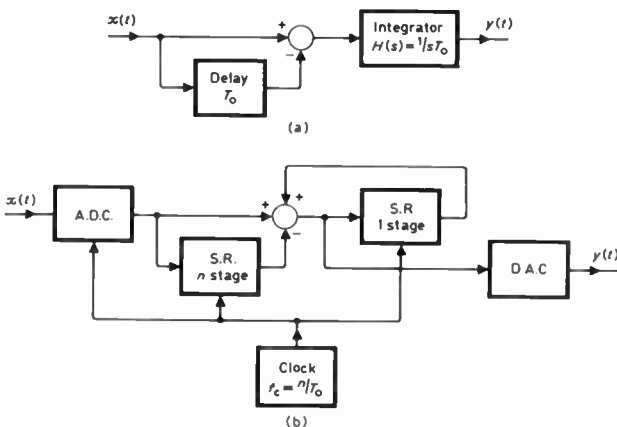

Fig. 1. (a) Delay plus integrator realization of averaging filter. (b) Digital implementation of delay plus integrator realization.

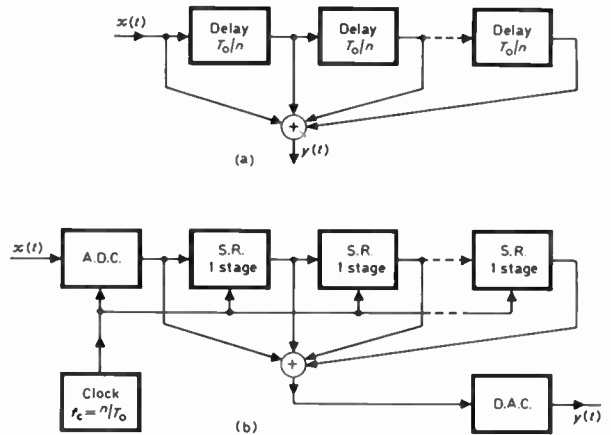

Fig. 2. (a) Transversal realization of averaging filter. (b) Digital implementation of transversal realization.

performed digitally, then the problem of drift does not arise. Figure 1(b) shows such a system. Provided that a sufficiently large value of n is used, the response will approximate that of the ideal averaging filter.

Another approach is to use a transversal filter as shown in Fig. 2(a). Here $n - 1$ delays of T_0/n are used, the outputs of the delays being summed to give the overall output. If a digital implementation is employed, then the additions are also performed digitally so that only one a.d.c. and one d.a.c. are required in the complete system as shown in Fig. 2(b). Again, by the use of a sufficiently large value of n any required degree of approximation to the ideal response can be obtained. On the other hand, the circuit complexity increases with n .

If digital or charge-transfer implementations of the delays are used, then input frequency components at $n/2T_0$ (that is, half the sampling frequency) and above will cause aliasing errors. It is necessary to include a prefilter which will remove these frequency components from the input signal before the point at which the sampling occurs (at the a.d.c. in digital systems).

It seems that no matter which of the realizations using delays is employed, the resulting filter will be of considerable complexity and cost. It is worth considering whether alternative realizations based directly on linear lumped-element circuits are practicable. Before this question can be decided it is necessary to consider how accurately the realization must approximate the ideal response. Some criterion of performance must be devised so that the various types of filter can be compared.

5 The Criterion of Performance

It can be assumed that any reasonable approximant to the ideal averaging filter response will have a finite value for the noise-equivalent bandwidth f_n ; on the other hand, the constraint on $h(t)$ expressed in inequality (1) will never be satisfied exactly. This fact will result in measurement errors due to uncertainty in the value of the

input signal prior to $t = 0$. On the assumption that the input $x(t)$ has constant values of x_0 for $t < 0$ and x_1 for $t \geq 0$, and neglecting for the moment the noise components, the output $y(t)$ will be given by:

$$y(t) = \int_{-\infty}^0 x_0 h(t-\tau) d\tau + \int_0^{\infty} x_1 h(t-\tau) d\tau$$

$$y(t) = x_1 g(\infty) + (x_0 - x_1) \cdot \{g(\infty) - g(t)\}. \quad (16)$$

Provided that $|x_1|$ is greater than $|x_0 - x_1|$, a condition that is usually satisfied, it is possible to define a settling time t_ϵ such that all measurements made after $t = t_\epsilon$ will be subject to relative errors less than ϵ :

$$\epsilon |g(\infty)| > |g(\infty) - g(t)| \quad \text{for all } t \geq t_\epsilon. \quad (17)$$

The value of t_ϵ for various approximants will now be compared with that for the ideal averaging filter:

$$(t_\epsilon)_{\text{ideal}} = T_0(1 - \epsilon) \approx T_0. \quad (18)$$

Clearly comparison is only valid between filters having the same noise-equivalent bandwidth and for convenience the values of t_ϵ quoted will be for filters normalized to $f_n = 1$ Hz.

6 Linear Lumped-element-circuit Realizations

A filter that is often used in the type of application being discussed, but obviously not optimum, is the first-order low-pass filter with the following properties:

$$H(s) = \frac{1}{1 + sT_0} \quad (19)$$

$$g(t) = 1 - \exp(-t/T_0) \quad (20)$$

$$f_n = \frac{1}{2\pi T_0} \int_0^{\infty} \frac{1}{1+x^2} dx = \frac{1}{4T_0}. \quad (21)$$

The settling times for this filter, together with those for the ideal filter are given in Table 1 for measurement errors of 10%, 1%, 0.1%. For $\epsilon = 1\%$ the first-order filter is slower than the ideal filter by a factor of two.

Balslev and Hougs⁴ have published a filter response function which is claimed to be an approximant to the ideal averaging filter response. However, their approximation method is based entirely on the symmetry of the impulse response; there is no reason why it should generate a good averaging filter approximant. The response function published by Balslev and Hougs is of third order:

$$H(s) = \frac{1}{(1 + s/\omega_0)(1 + 2\rho s/\omega_1 + s^2/\omega_1^2)} \quad (22)$$

where

$$\rho = 0.625$$

$$\omega_0/\omega_1 = 0.825.$$

The settling times of this filter are also given in Table 1. It does not approach the performance of the ideal filter and is not markedly superior (according to the criterion used here) to the first-order low-pass filter.

Table 1

Comparison of settling times (in seconds) for filters normalized to $f_n = 1$ Hz

Measurement error	$\epsilon = 10\%$	$\epsilon = 1\%$	$\epsilon = 0.1\%$
Ideal averaging filter	0.45	0.50	0.50
First-order low-pass filter	0.58	1.15	1.73
Balslev and Hougs' filter	0.51	0.89	1.44

The problem of obtaining a satisfactory realization of the ideal response using a linear lumped-element circuit will now be considered. Some approximation method is necessary because the required frequency response function (eqn. (14)) cannot be represented exactly as a rational function.

The approximation method that will be adopted here is that of Padé:⁵ the coefficients a_0 to a_m and b_0 to b_n of the rational function

$$H_a(s) = \frac{a_0 + a_1 s + a_2 s^2 + \dots + a_m s^m}{b_0 + b_1 s + b_2 s^2 + \dots + b_n s^n} \quad (23)$$

are chosen so that the value of this function and its first $(m+n)$ derivatives evaluated at $s = 0$ are equal to those of the ideal response function. This involves the solution of $n+m+1$ equations in $n+m+1$ variables (an arbitrary choice of the value of one of the $n+m+2$ coefficients has to be made; in this case $b_0 = 1$), a task which can easily be performed by a digital computer. The Padé approximant with numerator polynomial of order m and denominator polynomial of order n will be denoted by (m, n) .

If the approximating filter is to have a finite noise-equivalent bandwidth it is necessary that the order of the numerator polynomial be less than that of the denominator polynomial. Consequently, only Padé approximants with $m < n$ will be considered.

For a large proportion of the possible combinations of m and n the approximants (m, n) do not exist. Of those that do exist many are unstable; in fact, it is found there is a single acceptable approximant for each value of n :

$$\text{If } n \text{ is odd} \quad m = n - 1.$$

$$\text{If } n \text{ is even} \quad m = n - 2.$$

In Table 2 the Padé approximants to the ideal averaging filter are given for $n = 1$ to 6. The $(0, 1)$ approximant is, of course, simply a first-order low-pass filter. Although there is no obvious reason why this should be so (except in the case of the $(0, 1)$ approximant), the numerically evaluated noise-equivalent bandwidths of the approximants are found to be equal to that of the ideal filter to an accuracy of better than 0.1%. It seems likely that a detailed mathematical investigation would show that they are in fact identical.

The settling times of the Padé approximants are given in Table 3, and the improvement of the higher order approximants over the first-order filter and Balslev and

Table 2
Padé approximants to the ideal averaging filter

	(0, 1)	(0, 2)	(2, 3)	(2, 4)	(4, 5)	(4, 6)
a_0	1	1	1	1	1	1
a_1/T_0			0	0	0	0
a_2/T_0^2			1/60	1/42	1/36	1/33
a_3/T_0^3					0	0
a_4/T_0^4					1/15120	1/7920
b_0	1	1	1	1	1	1
b_1/T_0	1/2	1/2	1/2	1/2	1/2	1/2
b_2/T_0^2		1/12	1/10	3/28	1/9	5/44
b_3/T_0^3			1/120	1/84	1/72	1/66
b_4/T_0^4				1/1680	1/1008	1/792
b_5/T_0^5					1/30240	1/15840
b_6/T_0^6						1/665280

Hougs' filter is clearly seen.

In Figs. 3(a)–(d) are shown the unit-step responses of the first-order filter, Balslev and Hougs' filter and the (2, 3) and (4, 5) Padé approximants. All filters are normalized to $f_n = 1$ Hz.

The poles and zeros of the Padé approximants are given in Table 4.

7 Conclusion

From Table 3 it is apparent that for the lower accuracies ($\epsilon = 10\%$, 1%) quite low order approximants closely approach the performance of the optimum filter. For example, with $\epsilon = 1\%$ the settling time for the (2, 3) approximant is only 16% longer than that for the optimum filter and is approximately half that for the first-order low-pass filter. It would seem that there is little to be gained by the use of more complex realizations. Although no actual circuits are given in this paper (the circuit design depending on a number of factors not discussed here such as d.c. stability and sensitivity to component values) the (2, 3) approximant response can be obtained from a circuit containing two operational amplifiers, three capacitors and a few resistors. By comparison a digital transversal realization will require a pre-filter, an a.d.c., shift registers, digital adders and a d.a.c.

At the higher accuracy ($\epsilon = 0.1\%$) the (4, 5) approximant is 40% slower than the optimum filter and is more than twice as fast as the first-order filter. Again, the

Table 3

Settling times (in seconds) of approximating filters normalized to $f_n = 1$ Hz

Measurement error	$\epsilon = 10\%$	$\epsilon = 1\%$	$\epsilon = 0.1\%$
Padé approximant (0, 1)	0.58	1.15	1.73
(0, 2)	0.47	0.67	1.26
(2, 3)	0.45	0.58	0.92
(2, 4)	0.44	0.55	0.79
(4, 5)	0.44	0.53	0.71
(4, 6)	0.44	0.52	0.77

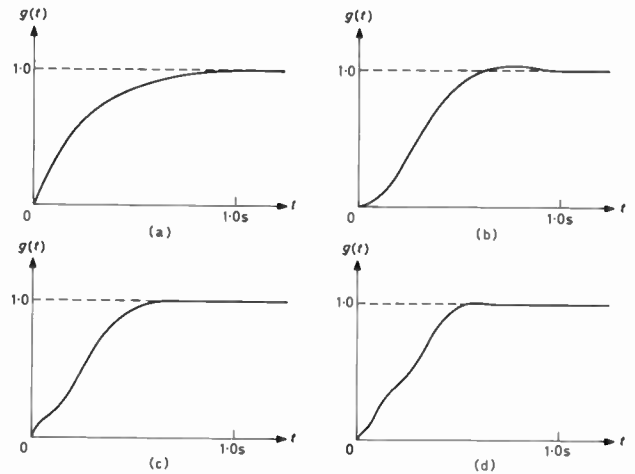

Fig. 3. (a) Unit-step response of first-order low-pass filter. (b) Unit-step response of Balslev and Hougs' filter. (c) Unit-step response of (2, 3) approximant. (d) Unit-step response of (4, 5) approximant.

Table 4

Poles and zeros of the Padé approximants to the ideal averaging filter. The values are given in units of $1/T_0$

Approximant	Poles	Zeros
(0, 1)	-2.00	
(0, 2)	-3.00 ± 1.73j	
(2, 3)	-4.64 -3.68 ± 3.51j	0.00 ± 7.75j
(2, 4)	-5.79 ± 1.73j -4.21 ± 5.31j	0.00 ± 6.48j
(4, 5)	-7.29 -6.70 ± 3.49j -4.65 ± 7.14j	0.00 ± 6.31j 0.00 ± 19.5j
(4, 6)	-8.50 ± 1.74j -7.47 ± 5.25j -5.03 ± 8.99j	0.00 ± 6.28j 0.00 ± 14.2j

complexity of the circuit required to implement this approximant is substantially less than that of a digital transversal realization. If a performance closer to the optimum than the (4, 5) approximant is required, then an alternative realization based on delays will have to be employed; little improvement is to be gained by the use of higher-order approximants.

8 References

- Papoulis, A., 'The Fourier Integral and its Applications', pp. 62–7 (McGraw-Hill, New York, 1962).
- Deliyannis, T., 'Six new delay functions and their realization using active RC networks', *The Radio and Electronic Engineer*, **39**, pp. 139–44, 1970.
- Gersho, A., 'Charge transfer filtering', *Proc. IEEE*, **67**, no. 2, pp. 196–218, 1979.
- Balslev, I. and Hougs, E., 'Filter for continuous averaging', *J. Phys. E (Scientific Instruments)*, **7**, pp. 821–2, 1974.
- Su, K. L., 'Time Domain Synthesis of Linear Networks', pp. 23–37 (Prentice Hall, Englewood Cliffs, N.J., 1971).

Manuscript first received by the Institution on 14th November 1978 and in revised form on 23rd April 1979.
(Paper No. 1901/CC 309)