

The **Walkie-Talkie**

2/6

**CONSTRUCTION
MANUAL**



by **EDWIN N. BRADLEY**

Nº 77

Plans

The WALKIE-TALKIE CONSTRUCTION MANUAL

by
EDWIN N. BRADLEY, A.I.P.R.E.

LICENCE No. G9MO



BERNARDS (PUBLISHERS) LTD.
LONDON

First Published 1948

CONTENTS

	<i>Page</i>
Chapter 1. THE "WALKIE-TALKIE" - - - • -	5
Chapter 2. THE OUTLINES OF THE TRANSCEIVER - - -	8
Chapter 3. THE HANDIE-TALKIE - - - - -	17
Chapter 4. WALKIE-TALKIE TRANSCEIVERS - - - -	23
Chapter 5. LARGER WALKIE-TALKIES - - - - -	37
Separate Transmitter-Receiver Circuits	
The Mains Valves Transmitter-Receiver	
Chapter 6. TRANSCEIVER AERIALS - - - - -	52
Chapter 7. FREQUENCY DETERMINATION - - - - -	61

THE WALKIE-TALKIE CONSTRUCTION MANUAL

CHAPTER 1.

THE "WALKIE-TALKIE"

The events of the last few years have made "Walkie-Talkie" radio as familiar to the general public as was the ordinary broadcast receiver in pre-war days, but highly mobile or easily portable communications gear has a long history. Comic strip cartoonists and even B.B.C. serial plays are somewhat inclined to credit the walkie-talkie with powers which it does not actually possess—as yet—but there can be no doubt that such apparatus has a multitude of uses for both specialised work and in civic services, and it was inevitable that in time of war the walkie-talkie should be developed rapidly into a valuable means of inter-communication.

Mention of but a very few examples of pre-war uses for the walkie-talkie might include the first police radio system, mobile links for B.B.C. outside broadcasts, amateur field day and direction finding activities together with the considerable amount of work performed by amateurs on the exploration and development of the very high frequency bands, whilst at least one "magical" thought reading act depended on miniature concealed transmitter-receivers. Under war time conditions the apparatus was developed no less than was its field of usage, and now the walkie-talkie performs tasks as diverse as maintaining contact between units of firefighters at a blaze and contact between training parachute jumpers and their grounded instructor.

The term "Walkie-Talkie" is used here to cover more than one type of gear, for constructional details are given of both true walkie-talkies and also of a "Handie-Talkie." The handie-talkie, as the name implies, is a personal transmitter-receiver sufficiently small to be held in one hand, whilst the earpiece and mouthpiece are mounted on the case thus giving the instrument the appearance of a rectangular telephone. The aerial, almost always of the rod or whip type, protrudes from or is supported by the top of the case, whilst the chief controls are simply an On-Off switch and a Press-to-Talk switch which is depressed by the hand holding the instrument to the ear when it is desired to transmit. For reception this switch is released.

The walkie-talkie, on the other hand, may be said to be any transmitter-receiver combination sufficiently small and light to be carried, together with its power supply, either in a slung pack or by hand. Once again the aerial employed is generally of the whip or rod type,

and the apparatus, no matter how transported, should be ready for instant operation with no setting up of aerial masts or wires or the need for plugging the power supply into the apparatus. Again the main controls are an On-Off switch and some type of transmit-receive switch, although in the walkie-talkie, as distinct from the handie-talkie, not only may there be a greater tuning range or even provision for band changing, but it may also be possible to tune the transmitter and receiver independently.

Note, however, that the walkie-talkie is essentially capable both of reception and transmission, no matter what the exact circuit arrangements and flexibilities might be, and is in this respect considerably different from a portable transmitter. (Portable Transmitters will form the subject of a future publication in Messrs. Bernards list of Radio Manuals.) The portable transmitter, too, is often scarcely suitable for hand portage, for quite high powers may be entailed together with a large power source so that this type of apparatus is usually carried by car and is set up on the site of operations, together with a more or less elaborate aerial array.

The walkie-talkie, then, is distinct in being easily portable by one person and in its readiness for instant use.

The value of such apparatus both to the amateur and to the administration of many forms of public service is obvious. It must be said at this point, therefore, that such gear cannot be operated save where the operator is a licensed transmitting amateur or is otherwise authorised to use transmitting gear, and where the apparatus is to be used by an already licensed transmitter the rules governing portable transmission gear must be observed, whilst the apparatus must of necessity be tuned to an amateur transmitting frequency.

At the time of writing the permitted frequencies for amateur transmission are as follows:—

1.75 to 2.0 mcs.	10 watts max.
3.5 to 3.635 mcs.	150 " "
3.685 to 3.8 mcs.	150 " "
7.0 to 7.3 mcs.	150 " "
14.0 to 14.4 mcs.	150 " "
28.0 to 30.0 mcs.	150 " "
58.5 to 60 mcs.	25 " "
2,300 to 2,450 mcs.	25 " "

whilst there are in addition two frequency bands where experiments in model control by radio may be performed, namely

27.66 to 28 mcs.
460 to 461 mcs.

with a maximum permitted power on each band of 5 watts.

For work with combined transmitter-receivers, however, the higher frequency bands are by far the more suitable. Apart from the fact that the small coils and tuning capacitors save valuable space in pack sets whilst really efficient receivers for ultra short wave operation can consist, if necessary, of only a single valve stage there is also the

important consideration that a quarter wave rod aerial can easily be mounted on the transmitter if a frequency in the 58.5 to 60 mcs. band is chosen. A rod aerial can also be mounted without much difficulty to work in the 28 to 30 mcs. band.

With regard to the higher frequency bands it should be noted that in the recent Atlantic City Conference on frequency allocations various agreements have been made which will, in the future, have some effect on portable operation. The agreements will in all probability not come into force until Jan. 1st, 1949.

The new allocations mean that in future the 5 metre band from 58.5 to 60 mcs. will be lost to British amateurs although it is hoped that some frequencies may be opened around 60 mcs. by the G.P.O., subject to special conditions. To compensate for this loss, however, a 2 metre band will be opened to the British amateur from 144 to 146 mcs. which for walkie-talkie operation will be full of interest. A 420 to 460 mcs. band will also be open—the 70 centimetres band—besides other higher frequency allocations, so that the British amateur will then be able to take his place in the investigation of these ultra high frequencies.

In comparison with the requirements for the amateur operation of walkie-talkie gear it is interesting to note recent facilities which have been granted to various services and commercial undertakings. Tug-boats on the rivers Tyne and Wear are linked to mobile and central control stations on fixed frequencies in the 80 to 100 mcs. band (3 to 4 metres, approximately), whilst the Press have recently been granted permission to use high frequency two-way links between 1 watt power pack sets, 25 watt mobile stations and a 150 watt control or central station on seven allocated frequencies.

A Cambridge taxi service is thought to be the first in this country to employ radio communications between the cars and a central station, and it is announced that frequencies above 67 mcs. may be allotted to certain applicants when telephonic communication is impossible or is unable to give the necessary service. As a result what is essentially walkie-talkie communication may soon be employed in ports, electrical and other public service undertakings and even as a time saving link between works and sites in large building operations.

In one section of this Manual valves from the Mullard E90 series are included in Walkie-Talkie circuits. Mention of these valves has been made for completeness and to show the trend of modern design; the E90 valves, a newly developed type, are at present in short supply and can be obtained for use only in equipment coming under the heading of Industrial Telecommunications.

An American 6J6, if available, will replace the ECC91, whilst a 6AK6 provides a fair substitute for the EL21. Of the E90 range two valves are available from retailers, the EB91 double-diode and the EF91 R.W pentode.

CHAPTER 2.

THE OUTLINES OF THE TRANSCEIVER

The combination of transmitter and receiver either into a single or into two closely allied circuits has for some time popularly been known as a transceiver, an obvious curtailment of "transmitter-receiver," and the principles and circuitry of such apparatus now require some consideration before actual constructional details are given.

Both transmitter *and* receiver, when 5 or even 10 metre operation is required, have as a basis the oscillating valve. The best possible portable receiver for working at these higher frequencies, in the writer's considered opinion, is without doubt the super regenerative detector with or without audio amplification and, in a few cases, R.F. amplification. Many charges are levelled at this type of receiver on account of its poor selectivity and the re-radiation characteristics of the circuit, but for walkie-talkie operation the poor selectivity is a decided asset, for reasons which will be made apparent when the transmitter is discussed, whilst the area of disturbance set up round a super regenerator is of small moment when, as is the present case, amateur work is under review. For commercial communications where a series of transceivers are operating in a net—i.e., a chain of fixed frequency stations all connecting with a central control transmitter—then interference radiating from the receivers would be serious, but where a single walkie-talkie is in contact with the home station, or where two walkie-talkies are in contact in field operations, the question of interference hardly arises.

The super regenerative detector has probably greater gain than any other single valve stage or circuit so far devised, and although it was designed (by Major Armstrong) as much as 25 years ago it still retains if only for certain limited applications a marked superiority despite some disadvantages. The detector is based on the fact that a regenerative circuit exhibits its best characteristics, for reception, at the point where regeneration becomes oscillation—at the critical point, in other words—and the super regenerator derives its great amplification by continually sweeping the detector into and out of oscillation so that the valve is for all intents and purposes working at the critical point.

The sweeping is performed at a frequency above audibility, and the rate at which the oscillations of the detecting circuit are interrupted (or "quenched") bears a relationship to the signal frequency for best results. The optimum quench frequency for the 5 metre band is of the order of 150 kcs., and this frequency should be lowered when the tuned circuits are adjusted to lower frequencies such as for the 10 metre band, and increased when the detector is tuned to higher frequencies.

The quench frequency may be provided by a separate stage or, more conveniently although slightly less efficiently, may be provided by the detector itself. Whichever system is used, the detector oscillates at the signal frequency in pulses, the oscillations commencing as the valve is swept on to a favourable section of its characteristic, the

oscillations actually starting as a result of some small initiating potential. At the end of the pulse, when no signal is applied to the detector, the oscillations are quenched out. The small initiating potential which causes each pulse of oscillation to commence may be as small as a thermal agitation voltage in the tuned circuit, this proving the remarkable sensitivity of the arrangement which can rise to an aerial input sensitivity of two or three microvolts or better, but no matter what the initiating potential, the result is that with no signal applied the output of the receiver is a fairly strong hiss. This hiss represents the noise output caused by each oscillatory pulse commencing at a random instant, and does therefore, in effect, represent the thermal agitation noise of the tuned circuit considerably amplified.

When a signal is received the random commencement of each oscillatory pulse stops, and the pulses are triggered, instead, by the *instantaneous* power of the received carrier, the audio modulation of the carrier thus being heard. For this reason only audio or tone modulated signals can be received by the super regenerator, but since walkie-talkie transmitters are almost invariably voice modulated this is no drawback. An unmodulated carrier is heard as a "hole" in the quench—the receiver, when tuned to the carrier, is silent—or, if the carrier wave is very weak, the quench or hiss diminishes in volume. Station tuning is thus simple, and equally simple is the setting of the receiver to the required frequency band for a tuned or resonant aerial tightly coupled to the detector will absorb so much energy that once again the quench fails and the detector is silent at the aerial frequency.

Further advantages of the super regenerative detector are an inherent A.V.C. action, the circuit tending to receive signals of widely different strength in such a manner that their respective output volumes are similar, and a strong discrimination against interference, particularly of the staccato type caused by car ignition systems. The super regenerator also receives partially frequency modulated carriers with little difficulty, due to its broad selectivity, and for the same reason is exceptionally easy to tune, no slow motion drive being necessary at any frequency band.

It can be seen, therefore, that the super regenerator is a most suitable detector for walkie-talkie operation, providing as it does a stage with only one tuning control which at the same time can give perfectly adequate headphone strength on all normal signals. By adding an L.F. amplifier to the receiver loudspeaker operation can be obtained but the quench hiss is then rather disturbing between intervals of signal reception. An R.F. amplifying stage between the receiver and aerial has the advantage of blocking the radiated interference and of sharpening the tuning of the receiver to a small degree, but to obtain worthwhile amplification from an R.F. stage at, say, 60 mcs. is far from simple. If the stage is necessary to prevent re-radiation it is most conveniently made as a broad tuned circuit covering the required reception band, having no tuning control, but it is best omitted.

A number of commercial walkie-talkies, as well as portable

transceivers used by the armed forces, provide for superheterodyne reception. The receiver then becomes considerably more complicated especially for high frequency operation, for as the carrier frequency rises so must a high intermediate frequency be used in the receiver to prevent image reception. For work at 5 metres, too, it becomes very desirable, if not necessary, to split the frequency changer into two separate stages, using an oscillator apart from the mixer valve, whilst an R.F. amplifier also is desirable.

The greatest disadvantage, however, especially for handie-talkie and small walkie-talkie transceivers, is that the superhet type of receiver must be apart from the transmitter. The super regenerative detector, on the other hand, is very easily converted via simple switching into the transmitter itself, the one valve thus making up the major part of the whole apparatus.

This, to some Readers, may be a new idea so that the system therefore deserves a full explanation.

A transmitter is, essentially, no more than an oscillator, just as is a regenerative detector, with the difference that the transmitter should oscillate strongly whilst the detector must be controlled, by super regeneration or some less efficient method such as a reaction control, to the region of the critical point at the commencement of oscillation.

A simple oscillatory circuit, the inductively coupled feedback circuit, is shown in Fig. 1. The anode coil is coupled to the grid coil in such

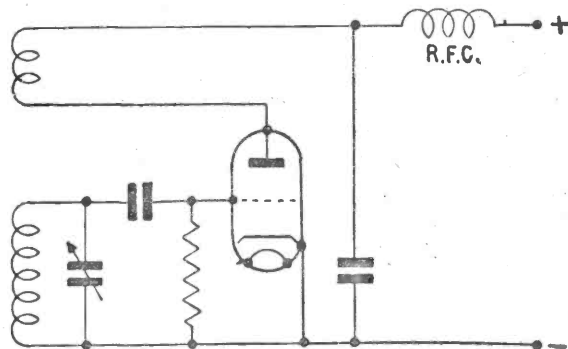

Fig. 1
Simple Tuned
Oscillatory
Circuit with
Inductive Feed-
back.

a manner that any slight change of grid potential causes a variation in the anode current which therefore effects a further change in grid potential in phase with the original change. The effect on the grid thus becomes cumulative and when the feedback from the anode is of a magnitude to supply more energy to the grid circuit than is being lost the circuit oscillates, the energy expended being supplied from the source of H.T.

The energy lost in the grid circuit is expended in the tuned circuit to some degree but chiefly as grid current. The grid is being swung at the natural or tuned frequency of the grid circuit from a negative

to a positive potential, and whenever the grid is positive grid current flows from the cathode to the grid and back to the cathode via the grid leak, since the positive grid will attract and capture some of the electrons flowing towards the anode. The flow of current through the grid leak sets up a potential across the resistance which forces the grid to adopt a negative charge. The potential on the grid is unable to leak away between oscillatory swings and so the oscillator is self biasing, whilst the greater the amplitude of the oscillation so the greater will become the bias on the grid. As the circuit settles down the grid will become negative and the grid leak current will flow only at the peak of each positive swing.

If this oscillatory circuit is driven too hard the bias on the grid will build up to a considerable negative potential and the valve will cease to conduct — the oscillator will be “blocked” — so when the circuit is required for transmission purposes and a high oscillatory amplitude is required the grid leak resistance is made relatively low to prevent blocking. For reception purposes the grid leak resistance is kept high, giving smooth control of reaction if a variable capacitor is connected between the valve anode and the negative or earth line.

A more suitable circuit for high frequency operation is a slightly modified version of the ultradion, shown in Fig. 2, and this oscillator

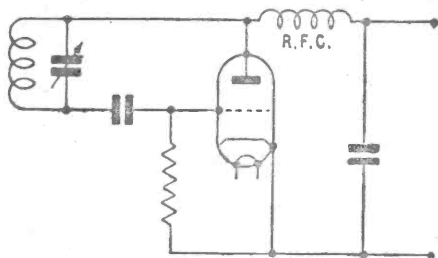

Fig. 2. Tuned Oscillatory Circuit for V.H.F. Operation.

also lends itself well to self-quenching as a super-regenerator. Feedback in this case is not by inductive coupling between grid and anode coils since there is only one coil. Instead the R.F. potential across the single inductance is, in effect, split into two parts by the inter-electrode capacitances within the valve from grid to cathode and anode to cathode. By adjusting the grid leak to a suitable value and by connecting a capacitance from anode to earth—although note that this capacitance is isolated from the anode as far as R.F. is concerned by the R.F. choke—the valve works under two sets of conditions. Oscillation at the tuned circuit frequency occurs but at the same time the circuit is swept over a portion of its characteristic curve by an action akin to the blocking just mentioned. Oscillation is arranged to be sufficiently strong that the whole circuit also oscillates at a low frequency depending on the grid leak and anode capacitance constants, and as a result the valve operation point changes slowly with respect to the tuned frequency but at a rate above audibility. The circuit is thus self quenching and super regenerative, and such a method of

working an oscillator at two differing frequencies at the same time is known as "squegging."

Here again the circuit of Fig. 2 can easily be converted from a super regenerative receiver to a power oscillator by switching in a lower grid leak and, at the same time, switching out the anode capacitor, and a walkie-talkie using this type of transmission-reception circuit has the advantage that communications on a fixed frequency is assured for if a sound design is used both transmission and reception will take place on the same frequency. This means that there is no need to make tuning adjustments between periods of transmission and reception nor any need to search for the contact or control station, for the whole apparatus can be adjusted to frequency at the start of operations with no further adjustments or tuning.

For handie-talkie operation in particular this is an advantage, but at times, using more comprehensive walkie-talkie gear, it may be desired to receive on one frequency and transmit on another—as, for example, when the walkie-talkie is acting as a relay station or central contact. In this case separate receiving and transmitting circuits become necessary for tuning a single circuit back and forth would result in considerable loss of time and, quite probably, in a loss of circuit efficiency also.

The self biased oscillator drops its anode current as the circuit goes into oscillation, for only then is the valve biased. This fact may be shown by connecting a milliammeter in the anode line of such an oscillator, starting or stopping the oscillations by any suitable method such as short-circuiting the inductance with a capacitance of 0.1 mfd., etc. The greater the amplitude of oscillation, therefore, the higher the grid bias and the lower the anode current, and the lower the power input and thus the lower the power output from the valve becomes. For short contact and handie-talkie work this state of affairs is permissible, but where small valves are in use it is sometimes necessary to ensure as great an input as possible in order that the power output shall also be stepped up. This can be brought about by altering the biasing circuit to some degree, and in Fig. 1 the grid capacitor and grid leak might be omitted so that the grid is connected directly to earth through the grid coil. In this case whenever the grid is driven positive with a consequent flow of grid current the negative potential or bias set up at the grid is negligible whilst at the same time what charge does arise is able to leak away directly. As a result the grid attains a considerable positive charge on part of each oscillatory cycle with a corresponding increase of anode current, and the oscillating condition is then shown by a rise of anode current on an indicating instrument connected in the anode line. A valve working under such conditions of grid current in ordinary apparatus, an audio amplifier, for example would, of course, introduce serious distortion, but as an oscillator or transmitter possesses a tuned circuit, the inertia of which smoothes out the energy supplied to it by a distorted current wave, the chief consideration with regard to grid current becomes the necessity to ensure that the valve is not being overrun.

Ideally an oscillator should not be called upon to supply power, but should be a stabilising device to control other transmitting circuits. Disregard of this ruling is a fault inherent in all handie-talkies and most walkie-talkies where the oscillator is either the only transmitting valve or else is coupled to an amplifier without a buffer stage between the two, and as a result frequency stability in this type of set is low. The situation is not improved by driving the oscillator to its limit, for the increase of anode current with every positive grid swing means that the anode voltage on the valve falls even if only slightly, so that the anode voltage is varying and the oscillator tends to shift frequency.

Speech modulation is, moreover, often directly impressed on the oscillator with the consequence that the anode voltage is also varying at speech frequency, and this causes or tends to cause the modulation to be both of the amplitude and frequency type.

In a larger walkie-talkie it is possible to modulate a power amplifier with the speech frequencies, leaving the oscillator merely to drive the following stage, but even then a degree of frequency modulation is probable for the amplifier will present a varying load to the oscillator. If the transmitter is to be compact and have as low a demand as possible on the power supply the situation must be accepted, and it is for this reason that a super regenerative receiver is so suitable for pack set reception. Its wide tuning band at any setting can handle a quite seriously swinging signal which might be unintelligible on a superhet receiver, but at the same time this offers no excuse for poor transmission and an effort should always be made to send a stable carrier with no modulation shift.

Few transceivers are crystal controlled. If, for any reason, it is required to use C.W. transmission then it is practically essential to use a crystal oscillator fed through a buffer stage into a keyed amplifier, the buffer also acting as a doubler for high frequency working, but a keyed transceiver is unusual. At the same time a crystal controlled transmitter could hardly be combined with a receiving circuit, and the self excited oscillator which has the advantage over crystal control of being tunable over its band is therefore more popular.

Just as the transmitter is combined with the receiver, the one circuit being adapted by switching for the two purposes, so may the audio amplifier following the detector be combined with the speech amplifier used to modulate the transmitter, the same valves or valve and the same transformers being used for both operations, switched from one circuit to the other as the detector-transmitter circuit is switched. The modulation system generally used is Heising or choke modulation, which although not suitable for large transmitters can be very satisfactory for walkie-talkie work.

To obtain 100 per cent. modulation, using choke coupling, the speech amplifier must develop half of the power input to the transmitter—i.e., if 1 watt is fed to the transmitter the speech amplifier must have an output of $\frac{1}{2}$ watt—and the basic circuit is shown in Fig. 3a. The output must be derived from a single output valve in the speech

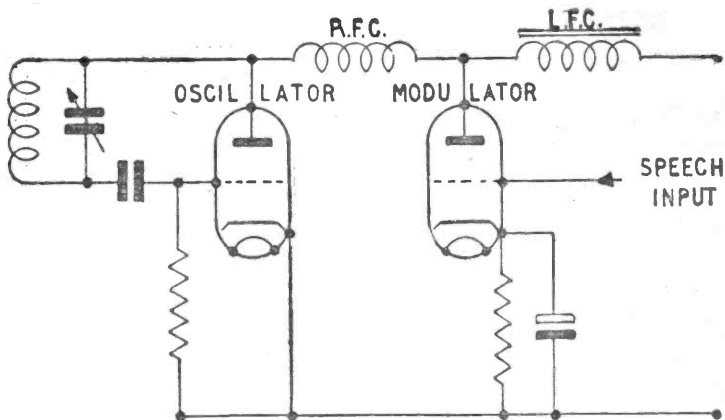

Fig. 3a. Typical Modulation Method for Transceivers.

amplifier operating under "straight" or Class A conditions, and for this reason, if for no other, the circuit can only be used at low power levels.

Even so it is, perhaps, unusual to find a fully modulated transceiver for not only is a lower percentage of modulation beneficial in preventing frequency swing with speech but the rather simplified coupling circuit between the speech amplifier and transmitter prevents perfect operation. The coupling should actually be made as shown in Fig. 3b, with a voltage dropping resistor supplying the transmitting valve, the resistor being by-passed by a capacitance for speech frequencies.

The object of dropping the voltage at the transmitting anode is to allow this valve to be swung (in terms of anode volts) correctly. Speech frequency voltages are set up across the high impedance audio choke and for perfect modulation the peak amplitude of these speech voltages should be equal to the D.C. voltage on the transmitter. The

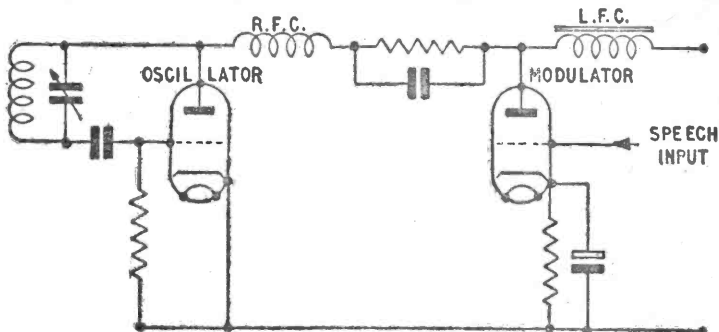

Fig. 3b. Preferred Method of Choke Modulation,

transmitter is then swung over a voltage range for at one instant the speech voltage will be added to the transmitter anode voltage and at another instant the speech voltage will oppose or be subtracted from the transmitter voltage, the transmitter thus having a wide voltage swing at the anode with a correspondingly modulated carrier. The voltage drop required depends on the speech amplifying valve, but in transceivers it is quite usual to omit the voltage dropper altogether in order that the mean carrier power is maintained at as high a level as possible, letting the modulation "look after itself." The oscillator must, of course, correctly load the modulator.

The number of stages in the speech amplifier depend on the required output from the modulating valve (which may be regarded as equivalent to the output stage of an ordinary amplifier) as against the gain necessary to drive this valve correctly. In handie-talkies considerations of power supply and available space mean that the modulation must be carried out using only a single valve, so that a sensitive or high output microphone becomes necessary. The carbon microphone is therefore a popular choice, and whilst it has certain disadvantages in requiring a polarising potential and a microphone transformer, the potential can be supplied quite satisfactorily by the filament battery and the transformer can be combined with the L.F. transformer used to couple the super regenerative detector to the modulator valve when, in reception, the modulator becomes, by switching, the audio amplifier.

In the walkie-talkie as distinct from the handie-talkie the modulator can be rather more elaborate and one or two stages of gain may be employed to enable the use of a crystal microphone or, for real neatness, a small throat microphone. At present many types of Service throat and other microphones are on the surplus market. The extra stages of amplification can utilise midget valves since a voltage gain, not a power gain, is required, so far as the feed to the modulator is concerned, and if required the whole speech amplifier can be switched in to act as an audio amplifier for reception.

Clearly one of the most important considerations in the design of any walkie-talkie apparatus is the power supply, for this part of the gear will contribute most to the weight and require a large proportion of the space within the transceiver case and thus affect the portability of the set to a considerable degree. Where small or miniature valves are to be used—of the button type, for example—dry batteries will serve well for both L.T. and H.T. supplies, but the use even of 2 volt standard battery valves will add weight to the gear for then it will be almost essential to obtain the filament current from an accumulator or storage cell. A "jelly" cell is of course much to be preferred, not only since its celluloid case makes for lightness but also because there is no free acid to leak from the battery compartment. Standard battery valves can be supplied from dry cells, but when two or more valves are in operation the current drain is rather heavy and battery life correspondingly short, although this method of operation can be recommended when gear is only to be used on occasions. Under these

circumstances the transceiver may be fitted with new L.T. cells for each operation period, but when the gear is in regular use, or is reserved as a standby set, a storage cell is to be preferred.

Miniature valves and standard battery valves will not give a great output, however, and the larger walkie-talkies are sometimes fitted with mains type valves. Here the power supply becomes a real problem for besides the relatively high heater demands an H.T. voltage of at least 200 and preferably 300 volts is necessary if full advantage of the valves is to be obtained. A storage battery of 4 or 6 volts must therefore be used unless very high capacity dry cells are employed as an L.T. supply, but H.T. batteries to give 200 or 300 volts are a very uneconomical proposition. The best combination therefore becomes a storage battery for the heaters feeding, at the same time, a vibrator power pack either of the synchronous (or self-rectifying) type or with a cold cathode rectifier to reduce the L.T. drain.

The current demand of a vibrator pack is by no means light and even if 4 volt valves with a 4 volt vibrator are used the storage battery will be rather heavy. Ideally a car type battery should be used but in this case the weight is prohibitive and smaller cells connected in series, or a motor cycle battery, are the only possible solutions. Even so, the construction of a walkie-talkie using mains type valves presents many problems and the gear may almost be classed as "car-talkie."

No matter whether the transceiver is of high or low power, the aerial must be as ready for action as the set and as efficient as possible. Readiness for action means that the aerial must be permanently mounted and as has already been said a quarter wave rod is a popular type of antenna. When the transceiver is to cover a band of frequencies the end section of the aerial may be made telescopic in order that it may be tuned exactly to frequency, but this is an elaboration for single band working. If, however, the transceiver is to work on two bands—for example on 10 and 5 metres—then some form of aerial tuning is essential.

The coupling between the aerial and transceiver is almost always inductive, the aerial terminating in a small coil with the other end of the coil grounded to the chassis, the aerial coil being supported at the optimum distance, determined by test, from the transceiver tuning coil. The optimum distance may be found by adjusting the aerial with the set switched to the receive position, bringing the aerial coil sufficiently near to the tuning coil to have an effect on the quenching of the detector.

When aerial tuning is desirable this may be accomplished by earthing the end of the aerial coil via a variable capacitance instead of directly.

Coupling to a super regenerative receiver is often most effective when the aerial is capacitively coupled through a small capacitance to the anode of the detector, but when the same valve and tuning circuit also have to serve for transmission this method is less satisfactory.

CHAPTER 3.

THE HANDIE-TALKIE.

The handie-talkie, besides being highly interesting on its own account, serves as a useful introduction to the practical and constructional aspect of the whole subject of walkie-talkie radio.

The handie-talkie is a complete transceiver in miniature, so designed that it may be carried comfortably in one hand. The ear-piece and microphone are mounted on the body of the apparatus and the instrument may therefore be likened in appearance to an ordinary hand telephone set with a large square or rectangular body in place of the ordinary moulding. In use the handie-talkie is held in the left hand, earpiece and mouthpiece falling automatically into position and the whip aerial projecting above and to the rear of the left shoulder. The right hand is thus left free. Switching from transmission to reception should be carried out by a "press to talk" switch, which must therefore be in the form of a bar under the fingers of the left hand. Squeezing the bar down brings the transmitter into play; relaxing the pressure allows the bar to rise under spring pressure for reception. A separate on-off switch is necessary.

Rather simpler switch construction is possible if a multi-contact "throwover" switch is used, operated by one finger of the left hand.

It is obvious that the problems encountered in the design and construction of a handie-talkie transceiver are many and various. The apparatus, together with the complete power supply, must be contained in a box sufficiently compact to fit one hand and this means that the H.T. cannot be high with a correspondingly low output power, whilst since a layer type battery must be used the current consumption for either transmission or reception must be kept within limits.

The first difficulty however is the choice of the valves. These must be of the miniature type, the oscillator must work at 60 mcs. or even higher, it is practically essential that the filaments be supplied from a single 1.5 volts cell and, of course, the type chosen must be in good supply. The last consideration puts quite severe limitations on the British constructor who cannot obtain such types as the acorn 958, a 1.25 volt triode with excellent characteristics from the point of view of handie-talkie construction, and recourse must be made to the British 1.4 volt valves with pressed glass bases fitting a B7G holder. For the present circuit the Mullard DL92 output pentode has been chosen to fill both valve positions.

The circuit of the handie-talkie is shown in Fig. 4. V1, the oscillator, has the grid returned to earth through a choke and a 15,000 ohms resistor for transmission when the circuit acts as a power oscillator, the aerial being connected to the tuned circuit L-C2 by a small semi-variable capacitor C1. Note that H.T. is fed into the grid side of the inductance, the aerial being tapped on to this point.

When the oscillator is switched to receive it becomes a self quenching super regenerator. The grid is given positive drive by R1, a 4.7

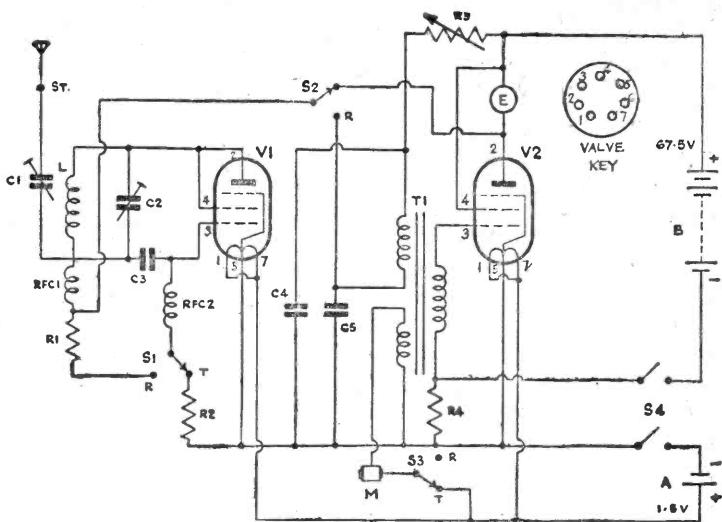

Fig. 4. *The Handie-Talkie.*

megohms resistor, which ensures good quenching and high efficiency, whilst the regeneration is controlled by R3. C5, the quenching capacitor, is automatically switched in with the audio transformer T1, the signal being fed to V2 for amplification.

For transmission V2 becomes the modulator, the earpiece in the anode circuit acting as the modulating choke. The oscillator is fed directly from the anode of V2.

The transformer, T1, is a midget intervalve transformer adapted to act, at the same time, as a microphone transformer. A carbon microphone must be used with a handie-talkie for the audio gain required for the satisfactory operation of a crystal or other non-energised microphone cannot be supplied, the microphone power being supplied from the filament circuit. Depending on the final characteristics of both the microphone used and T1 better modulation may sometimes be obtained by using a 3 volt microphone battery, but this entails the provision of more space in the transceiver case.

T1 is a 3:1 or 5:1 midget transformer with an extra winding to act as the primary of the microphone transformer. To put on this extra winding the transformer must be partially stripped to the extent of removing the core laminations, usually a simple matter with midget audio transformers. On the existing windings is wound a third winding, 50 turns of 30 S.W.G. enamelled wire usually being found satisfactory, and it should be possible to put on this amount of wire in a single thin layer. The winding should have a flexible lead soldered to each end, these leads being firmly anchored and the whole winding covered

with a thin protecting layer of tape or paper. Before removing the transformer core it is necessary to judge the space available between the lamination limbs and the existing windings in order that the microphone primary may be fitted into this space. If a choice between one or two transformers is possible the selection should be made with this in mind.

To ensure good results it is a wise plan to build up the circuit in temporary form before it is finally constructed in the small case, testing for good modulation against a second receiver. In this way the microphone winding may be altered if necessary without having to strip down the apparatus in its compact assembly.

If a compromise between efficiency and space saving is necessary in the elimination of a separate microphone battery, the same is true concerning the bias supply to V2. The audio stage is biased by R4 through which the total H.T. current flows thus causing a voltage drop which leaves the grid of V2 negative with respect to the chassis or "earth" line so that the H.T. finally supplied to the valves is less than the battery voltage by this bias voltage. The H.T. battery chosen is the Vidor L5500 which supplies 67.5 volts. If a separate bias battery is used the power output of the transceiver does rise slightly, but the case dimensions must also be increased.

The size of the L5500 battery is 2 25/32" wide, 3 25/32" high and 1 13/32" deep. Allowing for clearance, therefore, it may be fitted in a space measuring 3" x 4" x 1 1/2" with room to spare for wiring, and these dimensions, together with the valve size, set the overall dimensions of the transceiver case.

The height of the DL92, including pins, is slightly over 2 1/8"—with ceramic B7G holder the total height may be taken as 2 1/4" to allow for clearances—so that the set may be built in a case with internal dimensions of 9 1/2" x 3" x 1 1/2". This case is best made of sheet aluminium cut to size and constructed around 4 corner bars of 1/4" square brass, the aluminium panels being drilled and the brass corner supports being drilled and tapped to take 6 B.A. screws.

This method of construction is shown in Fig. 5 which also shows the positioning of the chassis and the paxolin panel carrying the H.T. connectors. These are spring brass leaves which press down on the two contacts at the top of the H.T. battery.

The L.T. supply, a U2 or any similar cell, is at the bottom of the case, gripped between two further spring brass contact leaves one of which is screwed or riveted directly to the aluminium case for the negative contact whilst the positive contact is insulated from the case by being mounted on a square of paxolin. The position of the "push to talk" switch is also shown, or a throwover switch may be mounted in the same position. The on-off switch, a 2-pole single throw toggle, is mounted in the side of the case above the transmit-receive switch, the body of the toggle switch projecting into the valve compartment.

If the transmit-receive switch is to be of the "push to talk" type it is necessary generally to build this up unless a suitable component

can be taken from a telephone handset. As can be seen from Fig. 4 a 3-pole two-way switch is needed and in the original model this was made up using changeover contacts from an old relay. The switch bar was cut from ebonite and pivoted in the side panel of the case, the relay contacts being shortened and mounted as shown in the sketch. At the bottom of the switch bar projecting pins operated the central switch arms, which were sprung sufficiently to keep the switch bar in the "out" or receive position. Pressure on the bar then forced the central arms over into the "in" or transmit position.

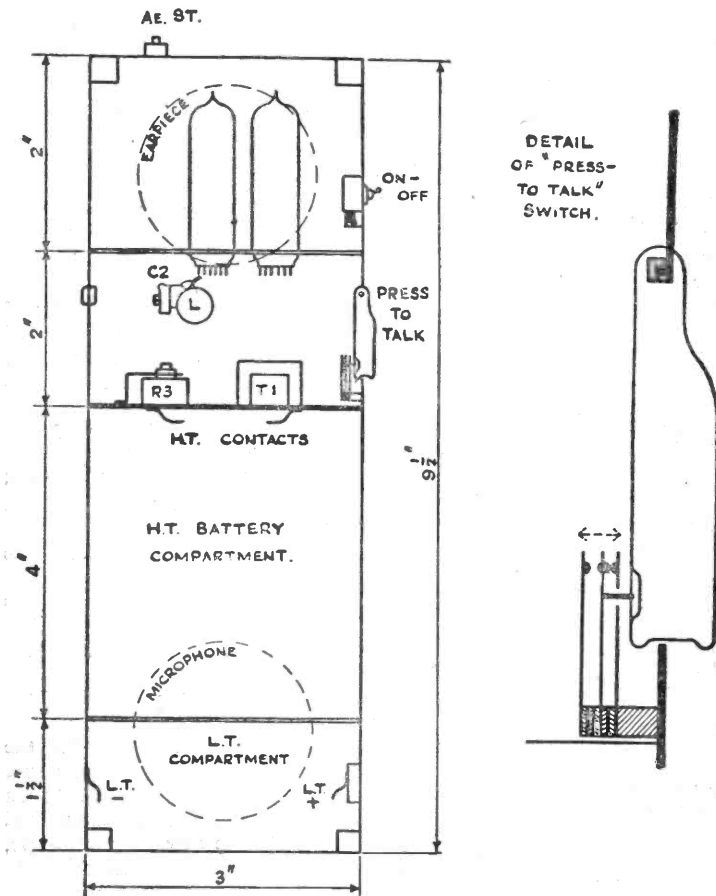

Fig. 5. The Handie-Talkie Layout.

It must be admitted that the construction of such a switch is a time consuming and painstaking matter, and whilst press to talk operation gives a professional appearance to the handie-talkie a throwover switch is much simpler to fit and is less liable to failures.

The earpiece and microphone are mounted on the front panel of the case as shown by dotted lines in Fig. 5. spaced as found most suitable by the constructor. The usual distance between the earpiece and mouthpiece is given by mounting them with their centres separated by 7 inches. The earpiece is positioned directly on the panel, but the microphone should be mounted on a shaped block so that it is tilted towards the mouth—an angle of 30° approximately is satisfactory. Fig. 6.

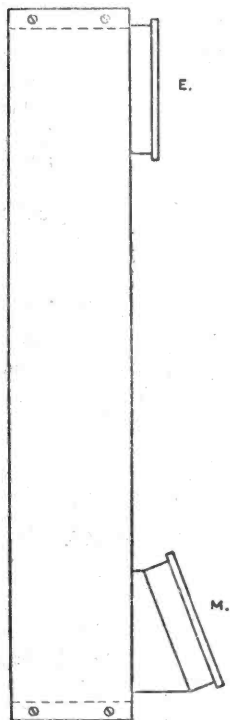

Fig. 6 Earpiece and Microphone Mounting on the Handie-Talkie.

Providing that a really small transformer is used for T1 there is no difficulty in fitting the circuit and components into the space between the chassis and the paxolin shelf. The wire ends of the resistors and capacitors must all be cut short, leaving just sufficient for each joint, and the wire should be gripped by long-nosed pliers between the joint and the body of the component, during soldering, to conduct away heat. The tuned circuit, L, C2 is mounted directly across the contacts of the

holder of V1 (with C3 in series on the grid side) and a hole is drilled in the side panel in order that C2 may be adjusted by a screwdriver. A completely variable tuner could be used in place of the trimmer type tuner, but a good deal of space would then be taken up.

The hole in the side panel through which C2 is adjusted should, of course, be bushed with a rubber grommet.

Since C2 is supported only by the coil this is formed of heavy wire.

If desired R3 may be provided with a control knob and mounted on the rear panel of the case, but this is not really necessary. A midget control should be obtained and mounted, by a strip of bent brass, on the paxolin shelf beside T1. The control spindle of R3 may be shortened and provided with an end slot so that it can be rotated by a screwdriver blade. R3 is then adjusted for optimum operation when the transceiver is first tested, and reset only when the battery voltage drop calls for a slight reduction in resistance.

C1 is adjusted and the aerial trimmed when the transceiver is first built, the transceiver being switched to "receive" and the adjustments being made by increasing the aerial coupling until the quenching action of the detector almost stops, as described in Chapter 6.

A quarter wave whip or rod aerial is employed.

Components List for the Handie-Talkie Transceiver. Fig 4

L (for 60 mcs.),	8 turns 16 S.W.G. enamel $\frac{1}{2}$ in dia., spaced $\frac{1}{4}$ in long.
C1,	3 to 30 pfs. screw adjusted trimmer Aerial coupling.
C2,	3 to 30 pfs. screw adjusted trimmer Tuner.
C3,	50 pfs. Ceramic cup.
C4,	0.1 mfd. 150 v.w. Tubular.
C5,	0.003 mfd. Mica.
R1,	4.7 megohms, $\frac{1}{2}$ watt.
R2,	15,000 ohms, $\frac{1}{2}$ watt.
R3,	100,000 ohms variable. Regeneration control.
R4,	680 ohms, $\frac{1}{2}$ watt.
T1,	Midget L.F. transformer adapted as in text.
E,	Low resistance earpiece.
M,	Carbon microphone, single button.
R.F.C. 1, 2,	70 turns 30 S.W.G. enam. closewound on $\frac{1}{2}$ in. dia. form.
S1, 2, 3,	3-pole two-way Press to Talk switch.
S4,	2-pole On-Off switch.
V1, V2,	DL92.
	2 B7G ceramic valveholders.
A,	1.5 volts cell.
B,	67.5 volts battery Vidor L5500.

Aluminium case. $9\frac{1}{2}$ in. x 3 in. $1\frac{1}{2}$ in. internal.

St. Aerial mount or standoff insulator

Spring brass, paxolin, screws, brass rod, wire, sleeving, etc.

CHAPTER 4.

WALKIE-TALKIE TRANSCEIVERS

The Handie-Talkie described in the previous chapter acts as an introduction to walkie-talkies, especially of the lower powered type. The first circuit to be described is very similar to that of the handie-talkie and, indeed, gives but little more in the way of power output. The power input to the transmitter is 0.4 watt, and the chief difference between this set and the handie-talkie is that the walkie-talkie employs standard 2 volt valves rather than miniature types, together with a standard 90 volt H.T. battery, thus requiring rather more case room. At the same time the circuit may be built up to take rather less room than a normal portable broadcast receiver so that hand portage is perfectly convenient.

Considerable experiment has shown that an excellent valve for combined transmission and reception on the 60 mcs. band is the Type 30, fitting a 4-pin UX holder, or its octal based equivalent, the 1H4G. With the circuit as shown in Fig. 7 the 1H4G takes an anode current of

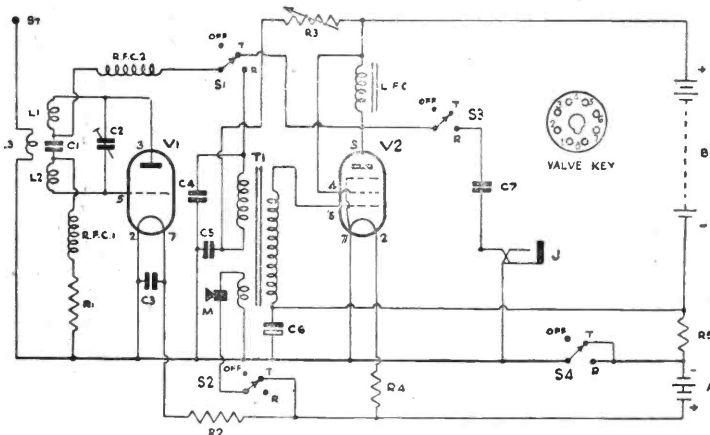

Fig. 7. *The Low-Power Walkie-Talkie.*

approximately 4.5 mAs. with an H.T. supply of 80 volts, so that the load (these figures referring to the valve as an oscillator) may be taken as 20,000 ohms. The transmitter may thus be modulated by a Mullard KL35 driven directly from a carbon microphone.

By switching in a lower grid resistance the anode current of the 1H4G can be forced up considerably until with the grid resistance eliminated and the R.F. choke in the grid circuit grounded directly the anode current is of the order of 15 mAs. at an anode potential of

50 volts. The output power of the transmitter can thus be stepped up a good deal, but the strain on the H.T. battery is correspondingly very heavy whilst modulation becomes much less simple, and since, even with a grid resistance of 100,000 ohms, sufficient R.F. is present at the valve anode to light a low wattage (90 volt type) neon bulb, it is felt that the circuit as shown is quite suitable for most requirements.

The circuit of the oscillator which for reception is changed only to the extent of switching in C4 to provide self-quenching is due to C. S. Franklin although sometimes attributed to other workers. The two coils, L1, L2, are wound to identical sizes and, to preserve the correct sense of the winding, may be made by cutting a larger coil into halves. C1 is a D.C. blocking capacitor and acts as a short circuit so far as R.F. is concerned, feedback being provided over the inter-electrode capacitances within the valve. Since the capacitance of C1 is so much larger than the tuning capacitance C2 and the valve inter-electrode capacitances it may be ignored from the point of view of circuit tuning. C2 in the circuit is shown as a trimmer type capacitor and it is recommended that no provision be made for panel tuning, the frequency being set before the transceiver is put into operation. Nevertheless the trimmer may be provided with a new capacitance-adjusting screw set into a polystyrene rod, the capacitance of C2 thus being variable by turning the rod, or, if speedy tuning across the band is required an ordinary variable capacitor may be used. A standard 40 pfs. tuner is suitable.

With C4 switched in across the anode supply and earth the oscillator acts as a self-quenching super regenerative detector. The value of C4 is lower than that normally required—0.001 mfd.—but different transformers in the position T1 might necessitate a slight change in capacitance for the best results. As a receiver the anode current of the 1H4G drops to approximately half the current drawn by the valve as a transmitter. No switching or change of values is needed in the grid circuit.

The transformer, T1, is adapted in the same manner as that described for the Handie-Talkie. An ordinary intervalve transformer is chosen having sufficient room between its laminations and the winding on the bobbin or former for a further layer of wire, and the microphone primary winding is laid on top of the existing windings, the laminations being removed for the purpose.

As explained, the ratio of the final component, when used as a microphone transformer, is determined practically by chance alone, but it is generally found that 50 turns or so of 30 S.W.G. enamelled wire, taped over for protection, acts as a satisfactory primary. Depending on the characteristics of the intervalve transformer chosen it may be found that the carbon microphone is overloading the modulator valve. In this case a single cell giving 1.5 volts may be used as the energising source, or alternatively a resistance may be placed in series with the microphone and the positive L.T. lead. It is not recommended that overloading by the microphone be corrected by means of a volume control on the grid side of the transformer, for then it would probably

be necessary to change the setting of this control whenever the transceiver was switched from Transmit to Receive and vice versa.

A resistance in the primary microphone circuit should be adjusted to value by trial and error to suit the circumstances obtaining.

The constructional details of the transceiver as a whole may be worked out by the builder to suit the carrying case to be provided, for the gear may be built up in several different ways with no troublesome effects or instability. A recommended layout for the oscillator is, however, shown in Fig. 8, an under chassis view being given. The coils L1, L2, and the aerial coil L3 should be kept an inch or more from a metal chassis or mounting plate, the simplest method of mounting being to secure C1 to the chassis by a small stand-off insulator. The whole tuned circuit is then rigidly fixed and spaced from the chassis, whilst L1 and L2 are automatically spaced by their connections to C1 to provide room for L3, the aerial coil, which lies between them. Alternatively L3 may be mounted at the anode end of L1 if desired, but the position shown is preferred by the author.

It will be seen that the R.F. choke in the anode lead is mounted, in the wiring, close to the feed point on L1. The lead from the choke to the changeover switch should be as short and direct as possible, as should be all the oscillator wiring, but the circuit is very stable and trouble-free.

An added refinement of, perhaps, doubtful merit, is to include R.F. chokes in the filament circuit of the 1H4G, mounting the chokes as close as possible to the valveholder. If chokes are used C3 may be omitted from the circuit. Each choke should consist of 50 turns of 18 S.W.G. enamelled wire wound closely in a single layer on a $\frac{1}{8}$ " diameter rod, or the two chokes may be wound together, the turns laid side by side on a single former.

The L.T. supply may be provided either by a 2 volt storage cell or from a 3 volt dry battery. The storage cell is not really necessary since the total filament drain is no more than 0.2 amp. and the use of a dry battery, with dropping resistors in the two filament positive return leads to reduce the applied voltage to 2 volts on each valve, affords a very well worth while saving in both weight and space. The 3 volt battery may be held in clips cut from tempered sheet brass which also act as connectors, when battery replacement becomes a matter of seconds.

The extra current drawn from the filament battery when the set is switched to Transmit depends on the microphone used, but shortens the battery life only by a little since transmission periods are usually short. If the current is found to be excessive a separate microphone battery may be used.

Grid bias for the KL35 is derived from the H.T. negative line through a dropping resistor, by-passed for audio by C6. The bias voltage will be rather greater when the higher transmitting current is drawn through R5, but, considering the output from the average carbon microphone, this is beneficial.

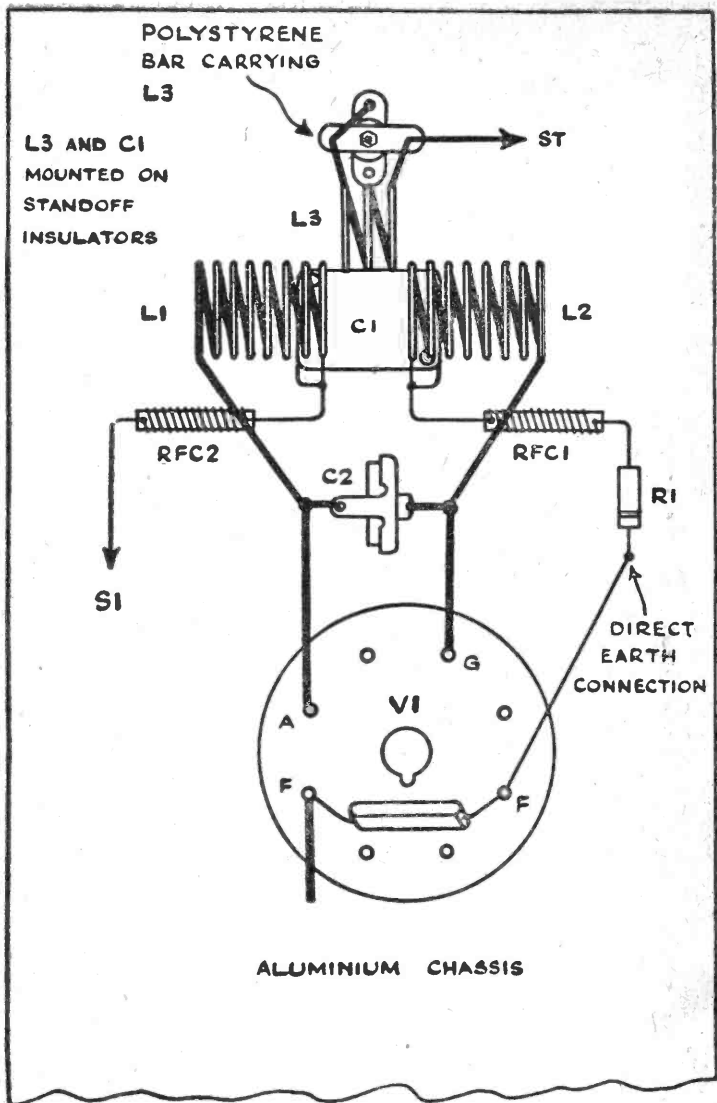

Fig. 8. Oscillator Layout for Low-Power Battery Transceiver.

Components List for the Low Powered Transceiver, Fig. 7.

Coils for 60 mcs.

- L1, L2, Cut halves of 16 turns 18 S.W.G. $\frac{1}{2}$ in. dia., turns spaced own dia. Each coil 8 turns.
- L3, 3 turns 18 S.W.G. $\frac{1}{2}$ in. dia. slightly spaced.
- C1, 0.0005 mfd. Ceramic.
- C2, 3—30 pfs. Trimmer, adapted for tuning if desired. Or 40 pfs. tuner, Raymart VC40X.
- C3, 0.0003 mfd. Mica.
- C4, 0.001 mfd. Mica. Or value varied to suit, as found desirable.
- C5, 1 mfd. 250 v.w. Tubular.
- C6, 25 mfd. 12 v.w. Electrolytic.
- C7, 0.5 mfd. 250 v.w. Tubular.
- R1, 100,000 ohms.
- R2, 16.6 ohms. (2×33 in parallel).
- R3, 50,000 ohms. wirewound variable Regeneration control, reception.
- R4, 6 ohms. (Using standard value resistors, wire two 12 ohm resistors in parallel).
- R5, 470 ohms.
- All resistors $\frac{1}{2}$ watt. type.
- R.F.C. 1, 2, 60 turns 30 S.W.G. enam. on $\frac{1}{4}$ in. dia. former, closewound.
- T1, 5:1 Intervalve transformer, adapted to Transceiver working with microphone primary winding. See text.
- L.F.C., Low resistance high inductance L.F. choke.
- M, Single button carbon microphone.
- J, Closed circuit headphone jack.
- Sl. 2, 3, 4, Main changeover and On-Off switch. 4 pole, 3 way. Yaxley type.
- St, Aerial standoff insulator or mounting.
- V1, Type 30 or 1H4G.
- V2, KL35

2 International Octal chassis mounting valveholders (Or 1 UX4 pin holder, if Type 30 is used).

Small Standoff insulators for L3 and C1. Eddystone Cat. No 1019

2 Control knobs for switch and R3. Knob for tuner if variable is used.

A, 3 volts L.T. Battery. Two Vidor V0007 cells in series.

B, 90 volts H.T. Battery. Vidor L5039.

Aluminium for chassis, cut to suit case. Battery clips and connectors, wire, sleeving, etc.

When receiving, R3 should be used to reduce regeneration to the best receiving level on the signal heard.

If space is at a premium within the transceiver case, the headphones may be connected in series with the anode circuit of the KL35 so that, with the set switched to Transmit, they act as the L.F. choke, the choke in the circuit being dispensed with. The microphone speech is then monitored automatically in the phones. The system is not

recommended, however, and whenever possible a good choke should be used, as shown in Fig. 7.

Whilst the gain from the KL35 is ample for any good carbon microphone it may be found that as an amplifier for reception the audio gain leaves a little to be desired on weak signals, or on signals subject to flutter or fading. Fig. 9 shows a version of the walkie-talkie where an extra stage has been added, the Mullard DAF91 being the new valve. With 90 volts on the anode of the pentode and the circuit arrangement shown an overall gain of 50 is obtainable in this stage alone, and the sensitivity of the amplifier, used as a modulator, becomes sufficiently great to allow a sensitive crystal microphone to be used. The adapted audio transformer becomes unnecessary and since the new valve fits a B7G socket the space formerly needed by the transformer is more than enough for the DAF91. The extra L.T. and H.T. current requirements are negligible. It must always be remembered that the DAF91 needs a filament voltage of only 1.4 volts, so that its positive return lead is taken to the junction of the two single dry cells in series which make up the 3 volt L.T. battery. Neglect of this point, or carelessness in making the connections may well result in ruining the valve.

The volume control shown in the grid circuit of the first audio amplifier is operative only on the set used as a receiver. It may be set for the desired level, full gain being obtained automatically when the circuit is switched to Transmit.

The *extra* components, other than are shown in the previous components list, are as follows (with reference to Fig. 9).—

R6,	33,000 ohms.
R7,	2 meg. variable. Receiver Volume Control.
R8,	10 meg.
R9,	1 meg.
R10,	3 meg.
R11,	47,000 ohms.
R12,	470,000 ohms.
All resistors of the $\frac{1}{2}$ watt. type.	
C8, C9,	0.02 mfd. 250 v.w.
C10, C11,	0.5 mfd. 250 v.w. Tubular.
R.F.C. 3,	Broadcast type choke as Eddystone Cat. No 1066.
Mic. J,	Microphone Jack.
V3,	DAF91.
1 B7G chassis	mounting valveholder.
	Control knob for R7.
	Screened lead for microphone, etc

Note that the diode section of V3 is inoperative, the diode anode being earthed.

For either version of the low power transceiver, a $\frac{1}{4}$ wave whip or rod aerial is mounted on the case, the aerial coupling being adjusted with the set switched to Receive. Aerial lengths and details are discussed in Chapter 6.

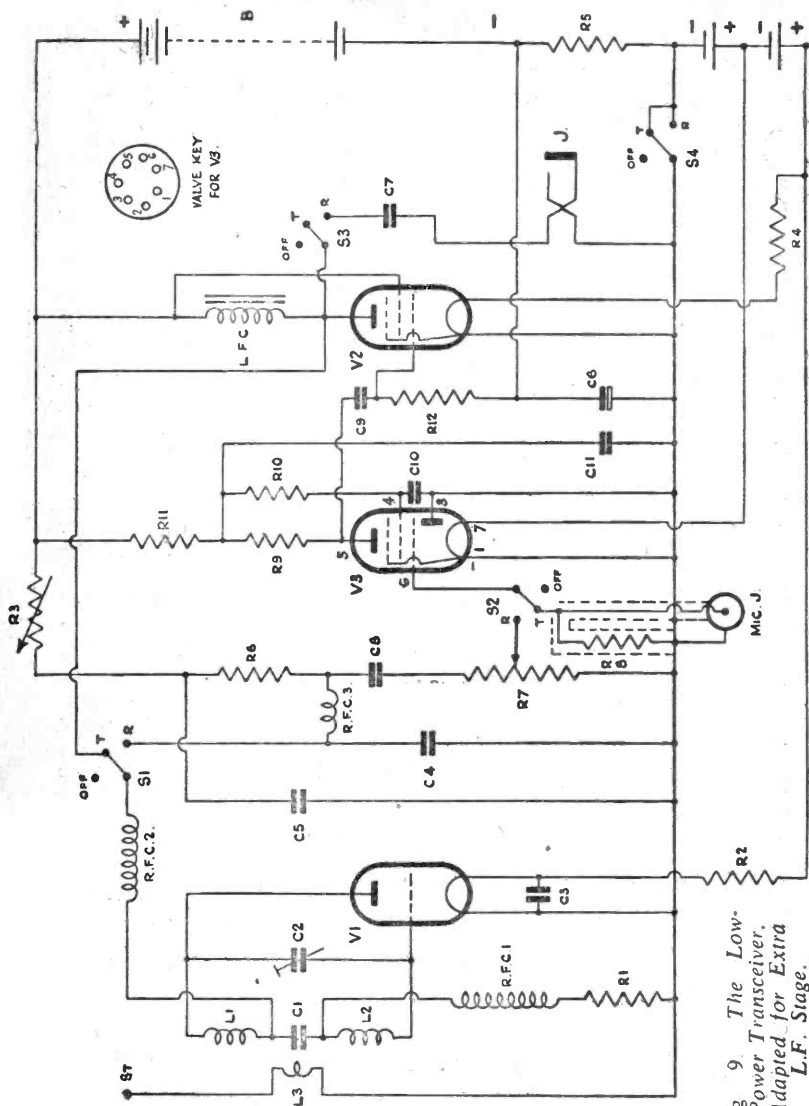

Fig. 9. The Low-Power Transmitter, Adapted for Extra L.F. Stage.

Whilst it is possible to design battery operated transmitters with quite high output powers (relatively), practical limits are set by considerations of valve and battery life. For emergency working these points are not, perhaps, of great importance, but in cases where the transceiver is required for day-to-day operation they must be borne in mind. The problem of developing more power is most easily solved by utilising mains type valves, obtaining the heater supplies from a storage battery which also feeds a vibratory power pack for H.T. This 6 volt battery may be made up by three 2 volt cells connected in series or preferably, is a motorcycle type battery. The power supply thus accounts for most of the weight of the equipment, but if the transceiver is built as a pack set for carrying on the back a quite considerable load can be made comfortably portable.

An example of a medium powered set using mains type valves is shown in the diagram of Fig. 10. The circuit may almost be described as a "trick" circuit, for a double triode is used as the detector-transmitter and modulator, a first L.F. amplifying stage being added to give sufficient gain from a sensitive microphone into the modulator which also acts as the output stage for reception. To attain a satisfactory percentage of modulation the output from the transmitter is kept well below the maximum output available, but at the same time the total anode current of the whole transceiver is also maintained at a low level—below 20 mAs.—so that the demand on the storage battery by the vibratory power supply is reasonable. With the circuit as shown it was found by experiment that very satisfactory results were obtained using an anode voltage on the H.T. line of 200 volts. Advancing the voltage to 250 resulted in a stronger carrier with weaker modulation. The tests were conducted using a sensitive moving coil microphone but a good crystal microphone might also be used. The instrument must have as high an output as possible, however, for the modulator is of necessity running at full gain.

When analysed the circuit is seen to be fairly conventional although it will be noted that the oscillator H.T. feed is to the grid side of the tuned circuit. The aerial coil should also be coupled to the grid side of the tank coil. An ordinary 3:1 intervalve transformer couples the detector output into the first L.F. stage when the set is switched to Receive; for transmission the secondary of the transformer circuit is opened and the primary then acts as a modulating choke common to the two anodes of V1.

The whole input circuit of V2 should be screened as shown in the diagram, otherwise there is some chance of picking up R.F. which is amplified through the stage and causes instability and poor speech quality.

The tank circuit of the detector-transmitter may be tuned by a variable capacitor or by a trimmer set to the desired frequency. The latter method is found preferable since the efficiency of the tank circuit varies considerably with change of capacitance (as with any oscillator) and the values chosen and shown in the components list were deter-

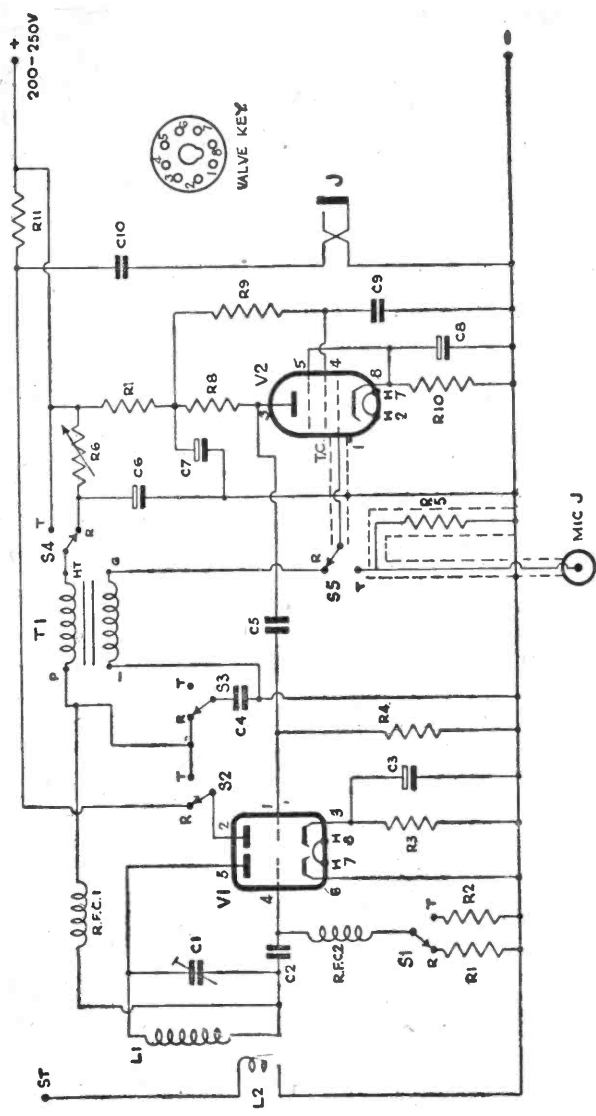

Fig. 10. Two Valve Medium Power Transceiver.

mined by trial for stable operation and good output. The trimmer should be nearly at maximum capacitance with a correctly wound inductance, L1.

Apart from the oscillator section, the circuit may be arranged in any convenient layout form. The oscillator should be built in as neat and compact a manner as possible, but since there is only a single tuned circuit connected directly (via C2) between grid and anode the oscillator falls naturally into shape especially if the valve section designated by the makers as g", a", and k" on their basing chart be used.

To keep the number of controls to the minimum, no volume control for reception is shown in the circuit, and was found unnecessary on ordinary signals. A volume control may be incorporated if desired by connecting the grid side of the transformer secondary to earth through a 1 megohm potentiometer, the sliding arm of the volume control being connected to the point "R" of S5.

R6 which is switched into the detector anode circuit after the transformer is the regeneration control and should be adjusted on a normal signal for most effective reception. Noise as R6 is operated is prevented by the decoupling provided by C6, whilst the second section of the 8 plus 8 mfd. capacitor, C7, provides ample decoupling for V2.

Components List for the Medium Power Transceiver, Fig. 10.

Coils for 60 mcs.

L1,	8 turns of 18 S.W.G. enam., $\frac{1}{2}$ in. dia. $\frac{3}{4}$ in. long.
L2,	3 turns 18 S.W.G. enam. $\frac{1}{2}$ in. dia., spaced own dia.
C1,	3—30 pfs. Trimmer.
C2,	50 pfs. Ceramic cup.
C3, C8,	25 mfd. 12 v.w. Electrolytic.
C4,	0.005 mfd. 500 v.w. Tubular.
C5, C9,	0.1 mfd. 500 v.w. Tubular.
C6, C7,	8 plus 8 mfd. 450 v.w. Electrolytic.
C10,	0.5 mfd. 350 v.w. Tubular.
R1,	220,000 ohms.
R2,	15,000 ohms.
R3,	1,200 ohms.
R4,	680,000 ohms.
R5,	To suit microphone used. Approx. 100,000 ohms. for moving coil types (mic. transformer not shown in diagram) or 2 megohms. for crystal types.
R6,	100,000 ohms. variable. Regeneration Control.
R7,	33,000 ohms.
R8,	300,000 ohms.
R9,	600,000 ohms. (Use 2 × 300,000 ohms.).
R10,	6,200 ohms.
R11,	47,000 ohms.
All resistors $\frac{1}{2}$ watt. type.	
T,	3:1 Intervalve transformer.
J,	Closed circuit headphone jack.

- Mic. J, Microphone jack.
 St., Aerial standoff or mounting insulator.
 S1, 2, 3, 4, 5, 5 pole 2 way main changeover switch.
 1 Standoff insulator as mounting for L2.
 V1, ECC32, Mullard.
 V2, EF37, Mullard.
 2 International octal chassis mounting valveholders.
 Knobs for Switch, R6.
 Aluminium for chassis, wire, screened sleeving, etc.

A suitable vibrator power pack to supply the H.T. for this transceiver is shown in Fig. 16 of Chapter 5. The only change in the components list referring to this pack is to substitute a 250—0—250 volt vibrator transformer such as the Bulgin M.T.5 for the 300 volt transformer specified. The vibrator power pack is shown with a variable ballast resistance incorporated in the circuit by means of which the optimum H.T. potential may be adjusted. The anode voltage measurement on the Medium Power Transceiver should be made with the gear switched to Transmit, the voltmeter being connected between the earth (chassis) of the transceiver and the H.T. side of R.F.C.1, the power pack ballast resistance being set to give a reading of 200 volts.

If desired a commercial vibrator pack may be employed. One suitable model is the Masteradio 6A200S, designed to operate on a 6 volts input to deliver 200 volts at a maximum current of 40 mAs. unsmoothed. The power pack contains its own smoothing circuit, and since the current demand, for the Medium Power Transceiver, is below the rated maximum the smoothed output from this pack will be very close in value to the 200 volts desired..

Readers who use or have a stock of American type valves will find the circuit of Fig. 11 of interest. The oscillator, almost identical with that of the previous transceiver, is built round a 6J5 triode, the one stage acting as both transmitter and self quenching detector, whilst a 6J7 and 6V6 make up the audio amplifier which functions as the modulator when the set is switched to Transmit and the receiver L.F. stages when switched to Receive. The overall gain of the amplifier is high so that loudspeaker operation is possible, in reception, whilst a crystal or moving coil microphone capable of giving 0.05 volt output will amply modulate the transmitter..

With an anode voltage of 200 the input to the 6J5, using the circuit shown, is between 5 and 6 watts with the aerial load applied, the anode current being of the order of 25—30 mAs. The input power can be increased to 10 watts by reducing the grid self-bias resistance to 5,000 ohms, but there is no doubt that the valve is then seriously over-run and such an input should only be used for emergency working. Compared with many small transceivers the output power under even the easier running conditions is still quite high.

For reception the grid resistance is changed to 4.7 megohms and is connected to the positive line to give "positive drive" super regenera-

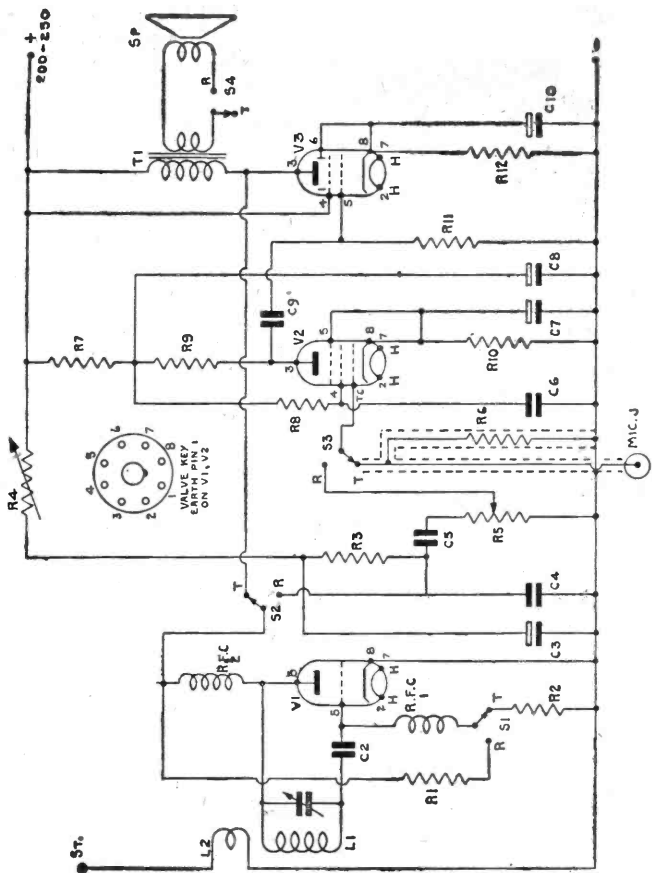

Fig. 11. The American Valve Transceiver.

tion. This method of connection increases the quenching frequency and ensures smooth operation.

A loudspeaker is shown as being used for reception, its output transformer also serving as the modulation choke with the set switched to Transmit, the secondary and speech coil circuit then being broken to allow the oscillator to act as the load on the 6V6. The load matching is quite good, since the oscillator requires about 30 mAs. at 200 volts its load may be taken as a little less than 7,000 ohms providing a quite satisfactory match to the 6V6 anode load at a voltage of 200.

The output transformer must be capable of carrying 60 mAs. at least.

Resistance capacitance coupling is used between the detector and first L.F. stage when receiving, and if headphone reception rather than loudspeaker reception is required the final stage, the 6V6, can be switched out of operation. the headphones being connected into the anode circuit of the first L.F. amplifier. The extra switching is shown in Fig. 12.

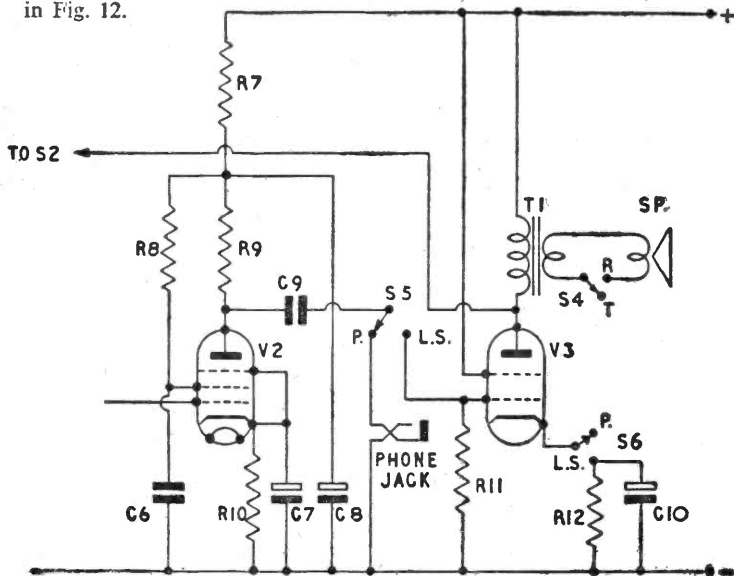

Fig. 12. Adapting the American Valve Transceiver for Headphone Reception.

Components List for the American Valve Transceiver, Fig. 11.

Coils for 60 mcs.

- | | |
|-----|---|
| L1, | 8 turns 18 S.W.G. enam. $\frac{1}{2}$ " dia., $\frac{3}{4}$ " long. |
| L2, | 3 turns 18 S.W.G. enam., $\frac{1}{2}$ " dia., spaced own dia. |
| C1, | 3—30 pfs. Trimmer. |
| C2, | 50 pfs. Ceramic cup. |

C3, C8,	8 plus 8 mfd. 450 v.w. Electrolytic.
C4,	0.005 mfd. 500 v.w. Tubular.
C5,	0.02 mfd. 500 v.w. Tubular.
C6, C9,	0.1 mfd. 500 v.w. Tubular.
C7, C10,	25 mfd. 12 v.w. Electrolytic.
R1,	4.7 megohms.
R2,	15,000 ohms, 1 watt.
R3,	47,000 ohms.
R4,	50,000 ohms variable, regeneration control.
R5,	0.5 megohm, receiver volume control.
R6,	To suit microphone used. Approx. 100,000 ohms for moving coil M/C (transformer not shown) or 2 megohms for crystal microphone.
R7,	33,000 ohms.
R8,	1 megohm.
R9,	220,000 ohms.
R10,	1,200 ohms.
R11,	0.5 megohm.
R12,	270 ohms, 1 watt.
All resistors $\frac{1}{2}$ watt type except for R2 and R12.	
R.F.C. 1, 2,	60 turns 30 SWG enam close wound on $\frac{1}{4}$ " diameter formers.
T1,	Speaker transformer.
Mic. J,	Microphone jack.
S1, 2, 3, 4,	4 pole 2 way main changeover switch.
V1,	6J5.
V2,	6J7.
V3,	6V6.
3 International Octal chassis mounting valveholders.	
1 Standoff insulator as mounting for L2.	
St.,	Standoff or aerial mounting insulator.
Knobs for Switch, R4 and R5.	
Aluminium for chassis, screened sleeving, etc.	

Again the circuit may be built up to any suitable layout providing that the oscillator stage is neatly wired with short leads. No microphone volume control is provided for it is unlikely that overmodulation will occur under any conditions, but if found desirable R6 could be made variable, the lead from point T of S3 being carried to the moving arm rather than to the top of the resistor. R4 should be set, when receiving, for best results, R5 then acting as the volume control.

The transmitter-detector tank circuit is again shown as a fixed tune combination. C1 may be made a 40 pfs. variable if desired but a fixed setting of the trimmer on the chosen frequency is recommended.

The aerial coil, in this receiver, is coupled in to the anode end of the main tank coil.

It will be seen in the adapted circuit for headphone reception that the chief requirement is an extra pair of switch sections, S5 and S6, the former switching the output of V2 into the phones and the latter

disconnecting the cathode circuit of the 6V6 to economise in H.T. current. The only change in the foregoing components list, therefore, is to add J, the headphone jack, and S5, S6, a separate 2 pole 2 way switch, together with its control knob. The rest of the components are as already shown.

The current drawn from the power pack under transmitting conditions is approximately 60 mAs. or a little more, whilst the voltage of the H.T. supply line is not critical. The vibrator power pack circuit shown in Fig. 16 of Chapter 5 may therefore be used if the 300—0—300 volt transformer specified is changed to a 250—0—250 volt transformer. The ballast resistor R5 and the final smoothing capacitor C10 are not required.

If a commercially built vibratory power supply is needed, the Masteradio 6A250S will be found satisfactory. Using this or a similar pack, the total anode current of the whole transmitter should be measured and limited, if necessary, to 60 mAs. A higher current may be reduced most easily by a slight increase in the self bias resistance, R2. Measurements should be made with the transceiver correctly loaded by its aerial.

In the case of these two receivers, as with any gear operated from a storage battery or accumulator supply, the battery should be given a separate compartment in order that no acid spray or fumes may reach either the actual set or the vibratory power unit. The latter should be totally enclosed in a shielding box of metal.

If desired the battery may be carried quite separately in its own battery box and plugged into the transceiver and power supply circuits when needed. Short heavy leads must be used for the battery connections.

CHAPTER 5.

LARGER WALKIE-TALKIES :— SEPARATE TRANSMITTER-RECEIVER CIRCUITS

Versatile as the combined transceiver is, there are occasions and purposes for which it is not sufficiently flexible. Altering the tuning of a combined transceiver when switching from the Transmit to the Receive position and vice versa is, for example, not only time consuming but, in emergency operation, a serious drawback. Where communication with more than one central or contact station is required, the stations working on different frequencies, the receiver and transmitter must for convenience be separate so that transmission and reception can take place on different frequencies. Naturally only the transmitter or receiver can operate at any one time but, as in the case of the simpler transceiver, the only control which need be touched, once the transmitting and receiving frequencies have been set, is the Transmit-Receive switch.

The circuits given in this chapter show two such transmitter-Receiver units, one a low power battery operated set and the other a higher powered unit using mains valves, the heaters being supplied from a 6 volt battery, the same power source energising a vibrator power pack for the

H.T. supplies. This inevitably increases the weight of the gear but, as in the case of the vibrator operated transceiver in the previous chapter, the set and the power compartment may be separated if desired, both sub-units being carried by hand for rapid connection by a battery cord. Alternatively the whole unit may be built as a pack set to be carried, as a haversack, on the back. A 6 volt battery of the motorcycle type may be used, or "smallish" 2 volt accumulators series connected, though it is likely in the latter case, that the rated discharge of the cells will be exceeded. Nevertheless it may be thought worthwhile to over-run the battery somewhat as a price for weight reduction.

The Battery Transmitter-Receiver.

The power supply for the Battery Transmitter-Receiver presents no such problem for 1.4 volt filament valves are used throughout, the circuit being shown in Fig 13. It will be noted that the H.T. positive line is coded as 111 volts positive, this rather unusual figure being accounted for by reason of the fact that a Vidor Battery No. L.5045 is recommended, this battery having an overall voltage of 120 made up of 9 volts G.B. and 111 volts H.T.

V3, the modulator/output valve, is rated to take a maximum of 110 volts on the anode; the other valves with rated maxima of 90 volts are either fed through high resistance loads or, as in the case of the two oscillators, V1 and V2, through a dropping combination.

A push-pull oscillator circuit was used both to ensure stable and certain operation and to increase the output power. A high output with the small valves used is obviously impossible; the input to the oscillator is only slightly above 700 milliwatts so that the output is measured in terms of a few hundred milliwatts rather than in watts. At the same time the oscillator works well, takes up little space and, perhaps most important, is by no means temperamental.

The original circuit was designed to use either American or British valves, the allowance for the duplication being made since a great number of new miniature American battery valves are at present on the surplus market. Thus the oscillator uses either a pair of 1T4's or a pair of Mullard DF91's; the modulator-output valve uses a 3Q4 or, preferably, a Mullard DL33, the only valve which is octal based since the other valves in the circuit have B7G bases, V4, the first audio amplifier, may be either a 1S5 or a Mullard DAF91, the diode section being ignored in each case, whilst the super regenerative receiver, V5, is either a 3S4 or a Mullard DL92.

The only compromise in the substitute lists is the choice between the 3Q4 and the Mullard DL33, and here the English valve is much better. The limiting anode voltage is higher—the 3Q4 will be a little over-run if used in the circuit as it stands—and the rated output of the DL33 assures 100 per cent. modulation, the American valve giving a rather lower modulation figure. Accordingly in the final components list the DL33 alone is specified for the position of V3.

The circuit for the super regenerative receiver, V5, is practically identical with that of the Handie-Talkie although the following stages are

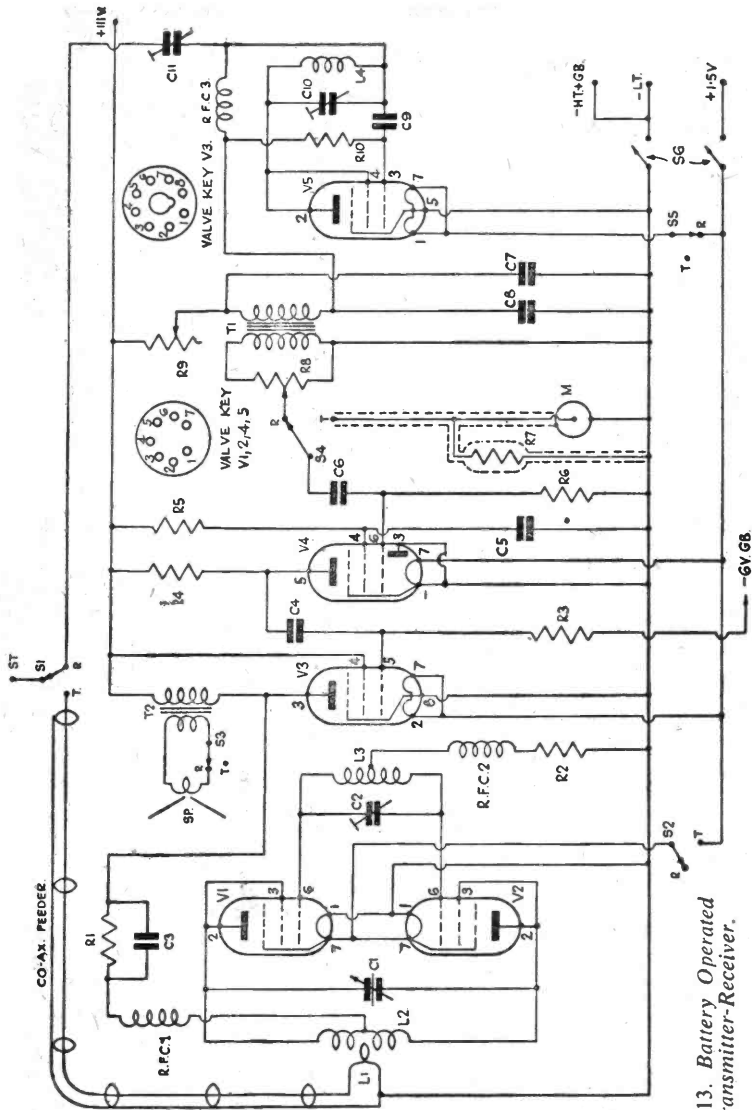

Fig. 13. Battery Operated Transmitter-Receiver.

very different. A high gain amplifier is used in order that a sensitive crystal microphone which should be of the diaphragm type may be used for speech transmission. Close speech into such a microphone is just sufficient fully to load V3 working as a modulator, so that no volume control is needed on the amplifier for transmission.

For reception the amplifier will not require to give so much gain, and the circuit is therefore fed from a volume control across the secondary of the coupling transformer T1. The setting of this control, R8, may be made when the gear is first put into commission and then left alone unless the transmitter-receiver is to be used under varying conditions and with several different contact stations.

Particular note should be made of the screening in the microphone circuit, the screening extending round the microphone load resistor, R7. It is quite possible to pick up R.F. on a high impedance line even though the transmitter output is small, and the lead and microphone circuit should therefore be screened, the microphone cable being preferably of the co-axial type.

When the amplifier is used for reception the output is fed to a small loudspeaker, Sp with T2 in the diagram, the voice coil circuit of the loudspeaker being broken when the apparatus is switched to transmit. The loudspeaker load is thus removed from V3 and the modulator loaded instead by the oscillator which comes into action automatically since it is switched in the filament line by S2.

The oscillator presents no parallel load with the speaker when the gear is switched to receive since S2 opens and cuts filament current, thus switching off the oscillator. V5, the receiving valve, is also controlled in the filament circuit, so that the L.T. battery—which should be a Vidor L.5049 if room can be found for this type in the transceiver case—is used as economically as possible.

If headphone rather than loudspeaker reception is desired, T2 and the speaker should be replaced by a small L.F. choke in the anode line of V3. The transmit-receive switch S3 must then be rearranged so that the push-pull oscillator is connected directly to the anode of V3 for transmission, whilst for reception this connection is transferred to the 'phones through a 0.5 mfd. capacitor. The other side of the 'phones is then connected to the chassis or common negative line.

Whilst the receiver is tuned in the ordinary manner—C10 may be made continuously variable, if desired by replacing the 30 pfs. maximum trimmer by a 40 pfs. tuner—there are two controls to be adjusted on the transmitting oscillator. The frequency is set by C2 L3 in the grid circuit, the anode tank circuit L2 C1 being tuned to resonance. To bring the transmitter onto the chosen frequency it is therefore necessary to adjust first C2, then C1, making the adjustments in small steps until the tuning is correct. Since the transmitter power output is low it is not practical to check the resonance of the anode tank by a loop and lamp, though a small neon bulb rated to fire at 90 volts was used successfully on the original model and gave clear indications not only

of resonance but of relative output powers whilst the sizes of the grid and anode coils were being tested for best results.

Probably the simplest method of setting the transmitter, however, is to use a separate calibrated receiver.

No connection to the rotor of C1 is shown, but if a split-stator capacitor is obtained for use in this position it may be mounted on a metal panel so that the rotor is earthed to the chassis. In the experimental model no change in performance was noted with the rotor earthed and floating. Such a result is to be expected since the rotor of C1, like the R.F. choke tapped onto the centre of L2, is at a point of zero R.F. potential.

L1, the aerial coupling coil, connected to the whip or rod aerial via as short a length as possible of 50 ohms co-axial cable and the section of the transmit-receive switch S1, is a two turn inductance mounted and spaced so that its turns mesh symmetrically into the 3 turns of L2. This means that the two turns of L1 will lie on either side of the central turn and the H.T. tapping point of L2.

A co-axial feed between S1 and the receiver tuned circuit C10 L4 is not required since the aerial is connected directly to the receiver via C11. This capacitor is, of course, adjusted so that the aerial loading reduces the quench almost to quiescence with R9 set at a sensitive receiving position. Further quench control is then given by R9.

The transmitter-receiver may be built up into any carrying case into which may be fitted the H.T. battery and L.T. cell, since the constructed circuit itself takes up but little space.

The layout follows the theoretical diagram in that the transmitting oscillator and receiver can be at opposite ends of the chassis with the speech amplifier between them, and the whole circuit can be fitted without difficulty into a space 9in. long by 4½in. wide—a standard chassis size—with room to spare.

The transmit-receive switch, S1 to S5, is best placed centrally. The only R.F. circuits which are switch controlled are the two aerial couplings, and from the point of view of short and direct leads this is the most important switch section.

If any difficulty is encountered in obtaining a 5 pole 2-way switch, a 6 pole component may be used, one section being ignored.

Components List for the Battery Transmitter-Receiver, Fig. 13.

Coils for 60 Mcs operation.

- | | |
|------------|--|
| L1, | 2 turns 14 S.W.G. enam. 1 in. diam. spaced to fit between turns of L2. |
| L2, | 3 turns 14 S.W.G. enam. 1 in. diam. spaced to ¼ in. long |
| L3, | 8 turns 16 S.W.G. enam. ½ in. diam. spaced to ¼ in. long. |
| L2 and L3, | Centre tapped |
| L4, | As L3, without centre tap. |

- C1, Split stator tuner, 100 pfs. per side, or two Raymart VC100X tuners ganged.
- C2, C10, C11, 3 to 30 pfs. screw adjusted trimmers.
- C3, 4 mfd. paper. Low working voltage.
- C4, 0.01 mfd. 150 v.w. Tubular.
- C5, C7, 0.1 mfd. 150 v.w. Tubular.
- C6, 0.005 mfd. 150 v.w. Tubular.
- C8, 0.003 mfd. Mica.
- C9, 50 pfs. ceramic.
- R1, 2,000 ohms.
- R2, 47,000 ohms.
- R3, 680,000 ohms.
- R4, 1 megohm.
- R5, 3.3 megohms.
- R6, 10 megohms.
- R7, R10, 4.7 megohms.
- R8, 0.25 meg. variable. Receiver volume control.
- R9, 0.25 meg. variable. Quench control.
- All resistors rated at $\frac{1}{2}$ watt.
- R.F.C. 1, 2, 3, 70 turns 30 S.W.G. enam. closewound on $\frac{1}{4}$ in. diam. former.
- T1, 3 : 1 intervalve transformer, small.
- T2 with SP., Electro-Acoustic Industries 5 in. "Elac" speaker with 8,000 ohms matching transformer.
- M, Co-ax microphone lead socket.
- S1, 2, 3, 4, 5, 5 pole 2-way switch. Transmit-Receive.
- S6, 2 pole On-Off switch.
- St., Aerial support or stand-off insulator.
- 1 small stand-off insulator to support L1.
- V1, V2, 1T4's or DF91's.
- V3, DL33.
- V4, 1S5 or DAF91.
- V5, 3S4 or DL92.

4 B7G ceramic valveholders.

1 International octal chassis mounting valveholder.

Chassis to suit carrying case or $9\frac{1}{2}$ in. x $4\frac{1}{2}$ in. x $2\frac{1}{2}$ in.

Co-ax. feeder, wire, sleeving, etc.

3 control knobs for S1-5, C1 and R9.

A typical layout for the push-pull oscillator is shown in Fig. 14. It will be seen that L2 is supported across C1 whilst L3 and C2 are supported by the valveholder contacts and also held rigidly by the choke and R2 connected directly from the centre tap on L3 to the chassis.

The symmetry of this layout should be preserved with all push-pull oscillators whether using separate or combined valves.

THE MAINS VALVES TRANSMITTER-RECEIVER

The battery transmitter-receiver just described is as versatile as could be desired, but at the same time the power output is of necessity restricted, if only for the reason of battery economy. Using the transmitter-receiver now to be described, the circuit of which employs modern mains valves, the restrictions of power no longer apply except insofar as the weight of the 6 volt batteries supplying both heaters and vibratory H.T. powerpack are related to the power consumption.

An output of between 3 and 4 watts is possible, using the Mullard ECC91 double triode as the transmitting valve, although the anode voltage requires to be no greater than 150 volts. The transmitter may thus be supplied through a dropping resistor and modulated under better conditions than are some of the battery transceivers so far described. The modulator, which also acts as the L.F. amplifier for the receiver, employs an EF91 pentode feeding into an EL91 output pentode, and since all these valves are of the midget variety and are based to fit B7G sockets the whole transmitter, including the modulator which has sufficient gain to make possible the use of a crystal microphone of the diaphragm type, can be built into a small space.

The main receiving valve, using the super regenerative principle, is the Mullard EC52 which gives an excellent performance as a self-quenching detector. For convenience the detector is fed into the whole

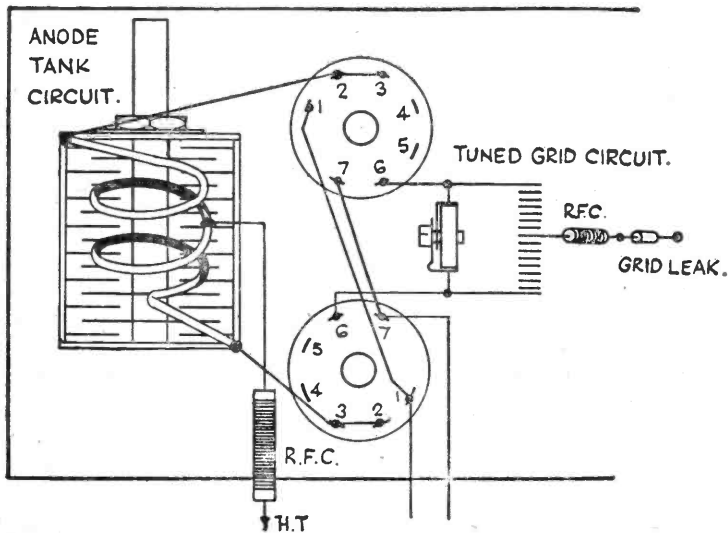

Fig. 14. Typical Push-pull Oscillator Layout, using IT 4's.

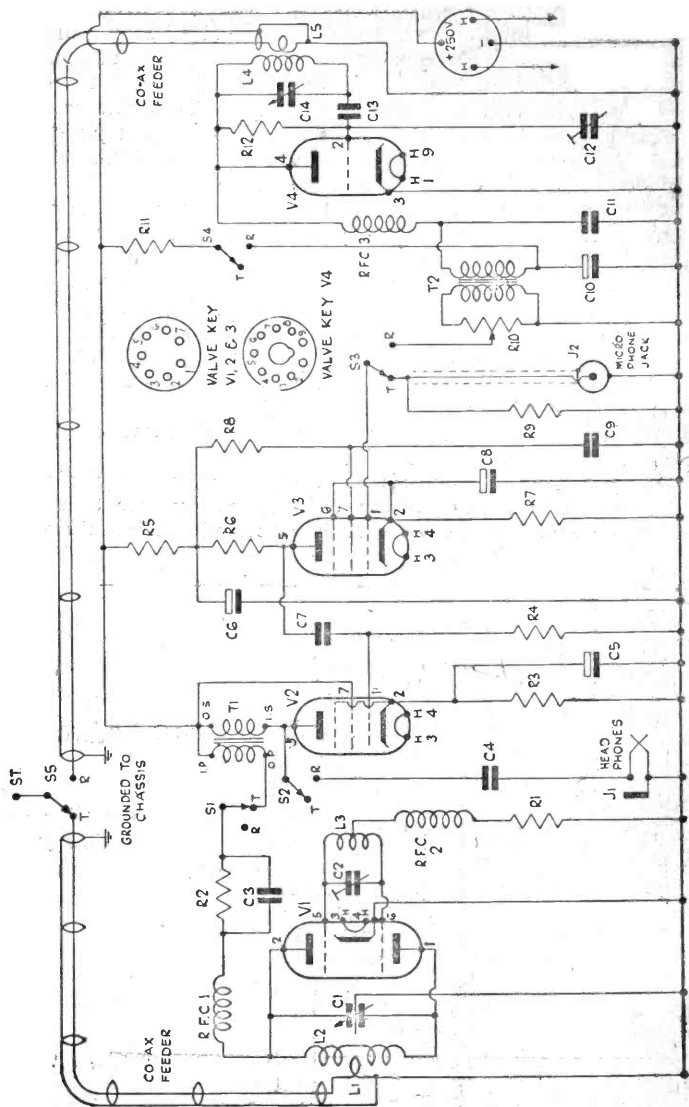

Fig. 15. The Mains Valves Transmitter-Receiver.

of the amplifier-modulator, although the gain will be greater than is needed and the volume control for reception will generally be well retarded. The EC52 is based to fit a B9G socket, and oscillates so powerfully that a small trimmer type capacitor is connected from its grid to earth and adjusted to give optimum reception conditions. Alternatively this capacitor (C12 in Fig. 15) may be omitted and the aerial coupled in tightly to reduce quenching.

The total heater consumption of the transmitter-receiver is 1.38 amps whilst the H.T. consumptions are approximately :—

Transmitting 50 mAs. 250 volts.

Receiving 21 mAs. 250 volts.

The power pack is therefore not called upon to supply any great drain.

The circuit of the transmitter-receiver is shown in Fig 15, the circuit of the power supply being shown separately in Fig. 16. Alternatively a commercially built vibratorpack may be bought, a suitable model for 6 volt operation being the Masteradio 6A250S in which a synchronous vibrator is used.

Since the load of the ECC91 may be taken as 150 volts divided by the total current drawn by the two anodes, or 5,000 ohms, and the modulator, the EL91, requires an anode load of 16,000 ohms the two circuits are coupled not by a plain choke but by a transformer coupling. This has the added advantage that the windings can be connected in such a manner that the core magnetisation can be reduced by some degree. The transformer ratio is, ideally, 1.8 : 1, but a 2 : 1 component may be used. Low resistance windings are desirable.

With the set switched to the Receiver position the secondary winding of the transformer then acts as an output choke, the headphones being capacitively coupled between the anode and earth via a section of the main changeover switch.

The transmitter proper is a push-pull oscillator, the frequency being determined in the grid circuit. The grid coil, in the original model, is tuned by a trimmer type capacitor, and whilst an ordinary variable capacitor could be used, a more speedy change of frequency then being possible, it is felt that for a transmitter which is essentially portable the trimmer is to be preferred since its capacitance, once set, is stable so far as mechanical shock is concerned. A variable capacitor of the split stator type is used to bring the anode circuit to resonance; if a split stator capacitor is not available two ordinary variable tuners may be ganged by a coupling link.

It is, perhaps, not too much to hope that crystals for direct working on 59 or 60 mcs. will be obtainable at some time in the future, since 48 mcs. crystals are now in use. In any case 28-30 mcs. crystals can be bought, and the oscillator can be used as a fixed frequency oscillator on 10 metres by adapting the grid circuit as shown in Fig. 17, the tank circuit constants also being changed to suit the frequency. Generally, however, a variable frequency self-excited oscillator is required, though crystal control is very desirable when the transmitter-receiver is in contact with a control station using superhet reception.

The grid tuner, C2, may be adapted for panel control of frequency by removing the trimmer screw and replacing it by a screw of the same thread tapped into a rod of polystyrene. The trimmer capacitance is then variable by rotating the polystyrene rod which, in turn, may either protrude through the panel for fingertip control or may be slotted across its end for screwdriver control.

The anode or tank coil, to which is coupled the transmitter aerial coil, is wound to have a space between its turns at the centre of the inductance, the aerial coil swinging into this space for close coupling. At the same time the coupling is then balanced and is inductive, capacitive coupling between the coils being reduced since the centre of the tank coil is at a low R.F. potential.

AERIAL SWITCH
VIA CO-AX FEEDER

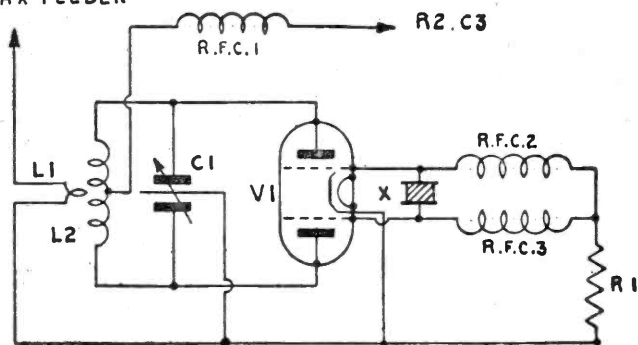

Fig. 17. Adapting the Transmitter for Crystal Control on 10 metres.

The transmitter is fed through its coupling transformer and through R2, bypassed by C3 for audio signals. R2 and C3 are therefore not added to the transmitter load as presented to the modulator. The modulator-amplifier develops sufficient gain for loudspeaker operation, but since headphones are usually preferred for transceiver work, and the coupling transformer would require complicated tappings, headphones are shown in the diagram.

When adjusting the receiver, C12 should at first be set to minimum capacitance and the aerial coupled in to the anode end of the receiver's tuning coil. The capacitance of C12 may then be increased until quenching is satisfactory and further increase of the capacitance puts the receiver out of action. The adjustment is best made on a signal.

It will be seen that the grid leak is of high value and is returned to the positive line to give "positive drive" super regeneration.

Including aerial switching, only five sets of contacts are required for the changeover from Transmit to Receive. A ceramic rotary switch can be used, but perfectly satisfactory operation is obtained with an

ordinary Yaxley type switch. A 5 pole 2-way switching action is necessary.

Several different types of layout are possible for the transmitter-receiver, the choice depending entirely on the carrying case and whether the gear is to be hand portable or built into a back-carried pack or haversack. The 6 volt battery, whether of the moulded and enclosed type or built up of 2 volt cells, provides the major part of the weight and should therefore be placed centrally at the base of the case, unless a separate battery box is to be used. If the battery and transmitter-receiver are to be housed together the battery compartment should be sealed off from the rest of the apparatus to prevent any chance of acid spray or leakage which might cause corrosion.

The battery drain, so far as the vibrator H.T. unit is concerned, will depend to a considerable degree on the efficiency of the particular unit bought or, if made, on the characteristics of the vibrator and transformer. The current required will, however, probably be of the order of 5 amperes so that the storage battery is called upon to supply a fairly heavy load. Nevertheless the transmitter-receiver is rarely in operation for long periods at a time, so that providing the battery is kept well charged and in good condition the power supplies as a whole should give no trouble.

Whilst the provision of a Standby switch as well as a main On-Off switch increases the number of controls it does reduce the battery drain. With the main switch on and the Standby switch open the heaters of all the valves are kept at operating temperature, the vibrator unit coming into action only when the Standby switch is closed, regardless of whether the transmitter-receiver is switched to Transmit or Receive. The Standby

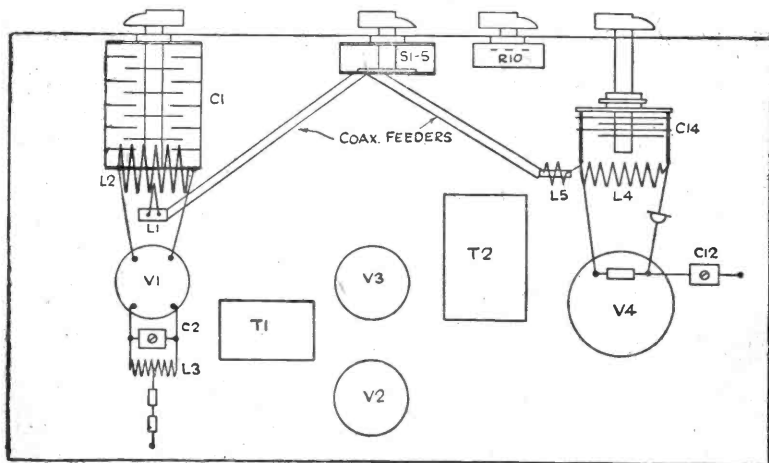

Fig. 18. Skeleton Layout for the Mains Valves Transmitter-Receiver.

switch, therefore, differs in function to the normal Standby switch at fixed stations which usually controls the receiver alone .

In Fig. 18 a layout is shown suitable for inclusion, with the battery and vibrator unit, in a single case. The transmitter-receiver is mounted on a single chassis made from sheet aluminium cut and bent to size, all components being mounted below the chassis with the valves above. If desired the chassis could be provided with a "floor" of sheet aluminium to act as a shield between the set and the battery compartment; alternatively a wooden shelf within the case could retain the set and act as the separating partition at the same time.

The aerial is supplied by coaxial cable with an impedance of 50 ohms, the cable core being the "live" side and the coaxial sheath or outer conductor being earthed at either end of the cable. The aerial switch is, in turn, connected to either aerial coupling coil by lengths of the same cable. The cable run in each case must be as short as possible, the aerial mounting being near the changeover switch to assist in reducing the cable run.

The vibratory power supply circuit, if the unit is to be built up, is conventional as may be seen from Fig. 16, synchronous rectification being employed so that no further heater current is drawn from the battery for a rectifying valve. The output of the unit is filtered for R.F. as well as hum or ripple, and it should be remembered that, using a synchronous vibrator, the electrolytic capacitors should not be connected into circuit until the polarity of the output voltage is checked, the unit being connected to the battery in the correct manner.

A 300-0-300 volt output transformer is used in order that the drop in the smoothing choke shall not cause a low voltage to be supplied to the transmitter-receiver, a ballast resistance being provided to bring the voltage of the main H.T. line to 250 volts. This ballast resistor should be adjusted with the set switched to Receive, for although this must inevitably cause a greater voltage drop in the H.T. line when transmission takes place it is important to see that the EL91 has an anode voltage of not more than 250 volts. The actual drop required on a 300 volt line will depend, amongst other things, on the resistance of the transformer winding through which the EL91 is fed. When a commercially made vibrator unit is employed, some attention must be paid to the regulation of the unit and the makers' instructions and figures studied. Here again, if the anode voltage of 250 volts on the EL91 is exceeded a ballast resistor should be provided. The anode voltage on the valve should be measured with a high resistance voltmeter when ballast adjustments are in progress.

A suitable value for the ballast resistance to be built into a home constructed power pack is 2,500 ohms rated at 3 watts, although a fixed resistance could be used in place of a variable component, the value of the fixed resistance necessary being found by trial.

Components List for the Transmitter-Receiver, Fig 15.
Coils for 60 mcs.

L1,	1 turn 18 S.W.G. $\frac{1}{2}$ in. diam. coupled to centre of L2.
L2,	6 turns 18 S.W.G. $\frac{1}{2}$ in. diam. spaced own diam. with $\frac{3}{8}$ in. gap centrally for L1.
L3,	7 turns 18 S.W.G. $\frac{1}{2}$ in. diam. spaced own diam.
L4,	7 turns 18 S.W.G. $\frac{1}{2}$ in. diam. spaced own diam.
L5,	2 turns 18 S.W.G. $\frac{1}{2}$ in. diam. spaced own diam. coupled to anode end of L4.
C1,	Split stator tuner, 100 pfs. per side, or two Raymart VC100X ganged.
C2,	3-30 pfs. Trimmer. See text.
C3,	4 mfd. 350 v.w. paper.
C4, C9,	0.5 mfd. 350 v.w. Noninductive.
C5, C8,	25 mfd. 25 v.w. Electrolytic.
C6, C10,	8 plus 8 mfd. 350 v.w. Electrolytic.
C7,	0.1 mfd. 350 v.w. Noninductive.
C11,	0.005 mfd. 350 v.w. Tubular.
C12,	3-30 pfs. Trimmer.
C13,	50 pfs. Ceramic.
C14,	40 pfs. Tuner Raymart VC40X.
R1,	620 ohms.
R2,	3,300 ohms, 3 watts.
R3,	680 ohms.
R4,	470,000 ohms.
R5,	22,000 ohms.
R6,	68,000 ohms.
R7,	1,000 ohms.
R8, R11,	330,000 ohms.
R9,	2 megohms.
R10,	10,000 ohms. Receiver Volume Control.
R12,	7.5 megohms.

All resistors are of the $\frac{1}{2}$ watt type unless otherwise stated.

R.F.C.1,2,3	60 turns 30 S.W.G. enam. on $\frac{1}{4}$ in. diam. former closewound.
T1,	1.8 : 1 (or 2 : 1) transformer.
T2,	3 : 1 intervalve transformer.
J1,	Closed circuit Headphone Jack.
J2,	Microphone Jack.
S1,2,3,4,5,	Sections of Main Changeover Switch, 5 pole 2 way
V1,	ECC91
V2,	EL91.
V3,	EF91.
V4,	EC52.
3 B7G valveholders.	
1 B9G valveholder.	
St.	Standoff insulator or other support for aerial connection on case.
1 flexible coupler for halves of C1. Eddystone No. 529.	
2 Standoff insulators to support L1 and L5.	

Insulating bracket to support C14, with extension spindle. Eddystone, 1007, 1008.

Control knobs for C1, C14, R10 and Switch.

Control rod, if desired, with screw for C2. See Text.

Sheet aluminium, screws, wire, etc. Co-axial cable.

Carrying case.

It may be seen from the circuit diagram that the rotor of the split stator capacitor, C1, is earthed. This electrode, as is the centre of L2 at the H.T. tapping, is at low or zero R.F. potential, so that it may be taken to earth thus permitting the tuner to be mounted directly on the chassis, the rear capacitor, when two in gang are used, being supported on a small aluminium bracket.

Some constructors may, however, desire to leave the tuner above earth, and in this case it will be necessary to provide a pair of insulated mounting brackets, such as the Eddystone Cat. No. 1007, driving the capacitor spindle through a short extension control such as the Eddystone Cat. No. 1008.

Components List for the Vibrator Power Supply for Mains Valves

Transmitter-Receiver. Fig. 16.

C1, C2,	0.0005 mfd. Mica.
C3, C4,	0.1 mfd. 1000 v.w. Noninductive.
C5, C6, C7,	0.01 mfd. 1,500 v.w. Mica.
C8, C9,	8 plus 8 mfd. 450 v.w. Electrolytic.
C10,	8 mfd. 450 v.w. Electrolytic.
V,	Vibrator, 6 volts. Bulgin, etc.
R1, R2,	470 ohms, $\frac{1}{2}$ watt.
R3, R4,	100 ohms, $\frac{1}{2}$ watt.
R5,	2,000 ohms variable, 3 watts. See text.
H.F.,	Hash choke. 60 turns 14 S.W.G. enam. closewound on 6in. long wooden rod, 1in. diam.
R.F.C.,	Widerange H.F. choke. Eddystone No. 1022.
L.F.C.,	20 Hys. L.F. choke.
S1,	Standby Switch. (See Text). Q.M.B. Heavy duty type.
S2,	On-Off heater switch. S.P.S.T. Q.M.B.
T1,	Vibrator Transformer, 300-0-300 v. H.T. 6 volts input.
F,	10 amps fuse with holder.
1 Vibrator socket.	
Screened case, wire, etc.	

The vibrator power supply must be built up within a screened case to prevent any chance of radiation interference. The buffer components—C3, C4, C5, C6 and R1, R2, R3, R4—must be positioned close to the vibrator socket and wired into circuit using as short leads as possible. The battery leads must be of stout gauge wire to avoid unnecessary voltage drop which will occur across thin leads by reason of the relatively heavy current flowing.

Components List for Adapting the Transmitter to

Crystal Control on 10 metres.

Fig 17.

- L1,** 2 turns 18 S.W.G. 1½ in. diam. coupled to centre L2.
L2, 6 turns 18 S.W.G. 1½ in. diam. with central gap of ¼ in. for L1. Each half winding spaced to ½ in. long.
C1, Split stator tuner, 120 pfs. each side, or two Raymart MC120X's ganged by coupler.
R.F.C.1,2,3, R.F. chokes, Eddystone Cat. No. 1022.
X, Crystal, 28-30 mcs. band.
R1, 620 ohms.
VI, ECC91.

The receiver can be made to cover the 10 and 5 metre bands by making L4 of Fig. 15 a 16-turn coil of 18 S.W.G. ½ in. diameter, using enamelled wire closewound with turns touching. Such a coil, combined with the 40 pfs. tuner shown will cover both amateur bands, although the tolerance for stray capacitances is not high, and a little experiment may be needed squeezing the turns a little closer or slightly opening the turns as found necessary. The receiver then becomes a very efficient and useful circuit on its own account with very high sensitivity and gain. In a good reception area at suitable times American amateurs who can be identified by the prefix W to their call signs as well as even more distant stations may be received using only the rod aerial on the transceiver. Reception will obviously be improved by a more effective antenna.

CHAPTER 6.

TRANSCEIVER AERIALS

Practically all the transceiver diagrams in this Manual show the aerial as coupled to the tuned or tank circuit via a simple inductive link, one side of the link being connected to the ground or earth of the apparatus formed by the negative chassis, the other end of the link being taken directly to the base of the aerial.

The correct length for the aerial rod is determined from the formula (for quarter wave aerials)

$$L = \frac{2952.5 \times k}{F}$$

where L is the length of the aerial rod in inches and F is the frequency in megacycles. The constant k is only used for rod or whip aerials in use at the very high frequencies and is a correcting factor related to the ratio of the length of the aerial and its diameter. For aerials working at 60 mcs. and thereabouts the value of k may be taken as

- k = 0.94 for ¼ in rod.
 k = 0.93 for ½ in rod
 k = 0.92 for 1 in rod.

so that, as an example, the length of a $\frac{1}{2}$ -wave rod aerial made of $\frac{1}{8}$ in. tubing to work at 59 mcs. is

$$L = \frac{2952.5 \times 0.93}{59} \\ = 48.2 \text{ inches.}$$

The distribution of voltage and current on a Halfwave aerial, usually taken as the standard aerial for theoretical considerations since a half-wavelength wire is self-resonant or tuned to the corresponding frequency, is shown in Fig. 19. The current is at a maximum at the centre of the wire, the voltage being at a maximum at either end, although reversed in polarity at any given instant. The aerial thus shows an impedance gradient along its length, its resistance at the centre being lowest for here potential is low and current high. In actual fact the centre resistance of a halfwave aerial, known as the radiation resistance, is of the order of 72 ohms. Large or small aerials for low or high frequency operation all show a practically constant radiation resistance despite their size, providing that the aerial in each case is a true halfwave in length.

A quarter wave aerial may therefore be supposed to have the characteristics of half of a halfwave aerial, and whilst there are many factors to be taken into consideration as an approximation the assumption is correct. The quarter wave aerial may also be considered as having half of the characteristic current and voltage distributions of the halfwave aerial, one end of the quarter wave having a low and the other having a high impedance, and the simple coupling shown in the diagrams therefore suffices to couple the low resistance end of the quarter wave rod to the tank circuit of the transceiver.

The aerial coil, since it is supplying current to the aerial, usually requires only one turn. It should be mounted beside or near the tank coil, usually at the anode end although there is room for experiment in this matter, and the connections from the coil to the chassis on one side and the aerial on the other should be as short and direct as possible, for long leads may be considered as adding to the aerial length. As has been mentioned the coupling between the aerial and tank coils can be adjusted with the gear in the "receive" condition for combined transceivers, though for separate transmitter-receiving stages, where the aerial is switched, the couplings must be adjusted individually.

To adjust the coupling on combined transceivers, increase the coupling by bringing the aerial closer to the tank coil, tuning the super regenerative detector over the frequency band, until at the aerial resonant point the super regenerative hiss diminishes in volume or ceases. The aerial coupling is then rather too tight, and the degree of coupling should be backed off a little until quenching at normal strength is once more obtained.

The same method is used to adjust the coupling between the aerial and receiver in separate transmitter-receiver circuits, but the coupling to the transmitter must then be adjusted separately. In large transmitters the aerial coupling is judged by measuring both the anode current of the final transmitting valve and the feeder current, but for transceiver

gear it is usually sufficient to use a flashlamp bulb as an aerial current indicator. To test the transmitter for oscillation the bulb may be connected directly across the aerial coil, whilst to adjust the aerial coupling the bulb should be in series with the coil and aerial.

Naturally a low consumption bulb should be used, and a 60 milliamp fusebulb is suitable. Alternatively a bulb rated at 2.5 volts, 60 mAs may be used.

With the bulb in circuit, the aerial coil should be coupled to the tank coil in such a way that the maximum bulb brilliance is obtained. Too tight a coupling may be found to cause a fall off in brilliance, when reducing the coupling will correct the condition.

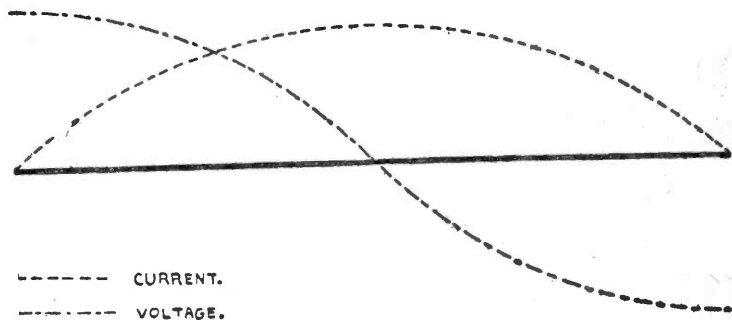

Fig. 19. *Current and Voltage Distribution on $\frac{1}{2}$ -wave Aerial.*

The radiation pattern of a vertical quarter wave rod, as is the case with other vertical aeriels, is theoretically circular—that is the aerial transmits equally well in all directions horizontally. In practice variations will be found although generally in the case of a walkie-talkie, in open country, the radiation pattern is good. The vertical short aerial prevents radiation at high angles to the ground so that the output power is directed in the required manner for greatest effectiveness, but since the aerial is of necessity close to the ground the efficiency cannot be great and where transmission over a distance is required advantage should be taken whenever possible of hills or other geographical features which will lift the gear above the mean level of the surrounding country.

So much depends on the surroundings and terrain where the transceiver is to be used that no endeavour has been made to give performance figures for the sets described. The handle-talkie obviously has a quite short range which for use in towns and built-up areas may almost be measured in terms of "streets" rather than miles, although in open country a good handie-talkie may provide communication over a path a mile or more in length. The walkie-talkie will give communication over greater distances but since very high frequencies are generally used

the line-of-sight ruling may be taken as effective even though it has been proved without doubt that very high frequencies are usable over paths very much longer than were at one time thought possible.

(The line-of-sight, or optical path, ruling states that for certain communication on the very high frequencies the situations of the transmitting and receiving aerials should be visible one from the other.)

Whilst the transceiver, whatever its type, will be used most often with the aerial mounted directly on the carrying case it need not be assumed that a more effective aerial will never be used. For amateur weekend day work, intercommunications at sports meetings, festivals and similar occasions and for other tasks where the transceiver is to operate from a fixed position for an hour or two there is no reason why a simple but effective aerial should not be erected. The essentials of such a system are easy portability and equally simple coupling to the transceiver, whilst to make the extra aerial gear worthwhile some system of increasing the aerial height is essential. Masts, even of a collapsible type, can rarely be carried with ease so that a ball of stout cord or fishing line, with weighted ends for casting over tree branches, etc., becomes an asset.

The portable aerial will usually be of the halfwave type since this is simple to feed, uncomplicated and can be sectionalised for the necessary portability. The type of aerial requires some consideration, however, for where more than one transceiver is operating the aerials should all be polarised in the same plane for the best results—that is all the aerials should be vertical or all horizontal. With higher powered transmitters and more sensitive receivers the question of polarisation is much less important, but work with low-powered apparatus has convinced the author that in this field the maintaining of polarisation is necessary. The transmission, moreover, is along a relatively short path so that polarisation shift which is practically always present on long paths hardly affects the signals.

If horizontal aerials are to be used the simple folded dipole has much to recommend it. A folded dipole may be constructed of 300 ohm twin feeder, now available on the market, thus disposing of central insulators and supports, whilst the aerial can be rolled up for easy carriage. A folded dipole, shown diagrammatically in Fig. 20, has a centre or feed resistance of 300 ohms and can thus be fed from a 300 ohms line without matching. At the transceiver it may be necessary to replace the single turn aerial coil by a 2 or 3 turn coil, determined by trial and error.

To construct a folded dipole for the 5-metre band, taking a central frequency of 59 mcs., the top half wavelength of the aerial should be cut from a single length of 300 ohms line to 7 ft. 10 ins. long. At each end of this "flat top" the twin wires are bared for exactly an inch and twisted and soldered together, reducing the overall length to 7 ft. 8 ins. The feeder is connected in to either one of the top section wires, so that at the centre point of one wire the twin cable must be cut, the cut ends of the wire bent out, and the bared ends of the 300 ohms feeder twisted and soldered to the cut ends of the top section. To cover and

protect this joint scraps of the twin feeder insulation removed when cleaning the ends of the top section may be melted-down and run over the joint by the soldering iron, each scrap being put in place and welded in by gentle heat.

The final form of the aerial is as shown in Fig. 21, where also shown are the end insulators. The whole aerial can be mounted aloft, using tree branches or any other available supports, by lengths of cord or twine weighted as already suggested. The weighted ends of the cords are slung over branches, the free ends attached to the end insulators of the aerial and the gear hoisted.

The feeder or transmission line between the aerial and the transceiver should, of course, be kept as short as possible to avoid undesirable losses.

Where vertical polarisation is to be maintained so that a vertical aerial is necessary, the most suitable type for maintaining a low radiation angle and also for hoisting to a height or for mounting on a mast or pole is the coaxial or skirt aerial, shown in Fig. 22. This aerial is basically no more than a vertical halfwave aerial fed in the usual manner at the centre, but the construction of the aerial is somewhat unusual.

The lower quarter wave of the aerial is formed by a sleeve or skirt which actually surrounds the aerial feeder, the feeder thus being screened

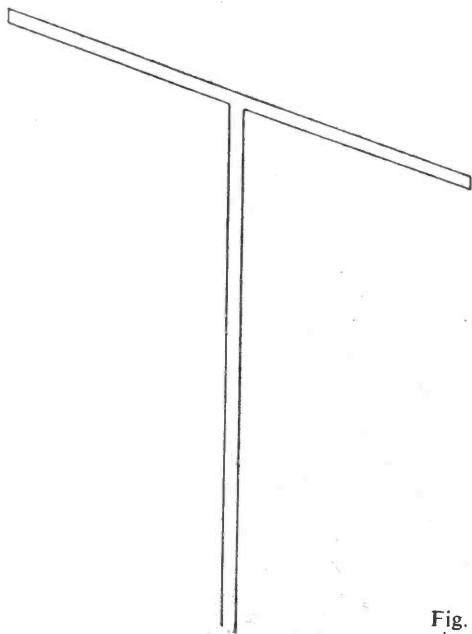

Fig. 20 *Folded Dipole, shown diagrammatically.*

and unable to transmit on its own account over this portion of its length, this precaution reducing the radiation angle of the aerial as a whole.

Here again the feeder or transmission line is automatically matched to the aerial for a 70 or 80 ohms line can be used to match very closely into the aerial impedance. The top half of the aerial acts as an extension of the centre core of the feeder—which, at a characteristic impedance of 70 or 80 ohms. will be of the coaxial type—whilst the sleeve is connected to the outer or cylindrical conductor of the line.

The sleeve may be of any suitable material, copper or brass tubing giving excellent results, and the internal diameter of the sleeve should give clearance to the feeder wire which runs up it to the central junction point. Construction at the central point of the aerial can be "tricky" especially if it is desirable to make the top half of the aerial a dismantlable rod, but one method of attaching the sleeves to the outer conductor of the coaxial line is shown in Fig. 23. A disc of insulating material such as paxolin is drilled centrally to take the coaxial cable, the disc being of a size to fit the internal bore of the sleeving. The braided outer conductor of the feeder is unravelled and brought over radially to the sleeving, being sweated down all round the circumference of the sleeve.

A cap of paxolin or ebonite is now turned to fit over the whole assembly, the centre of the cap being drilled to take a screwed insert which in turn is drilled to take the centre of the coaxial feeder in a sweated joint (the top half of the aerial is of rod die-cut to suit the screwed insert or sweated into a suitable screw) and if desired the joint may be further strengthened by passing two or three pins through drilled holes so that the outer cap is locked through the sleeve and into the

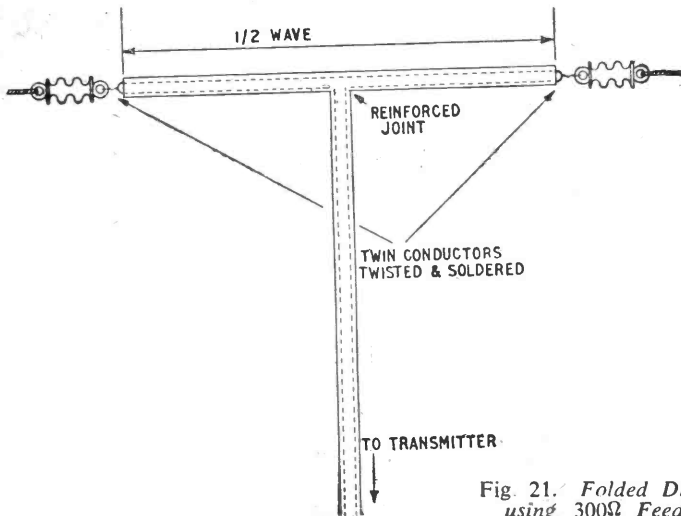

Fig. 21. *Folded Dipole, using 300Ω Feeder.*

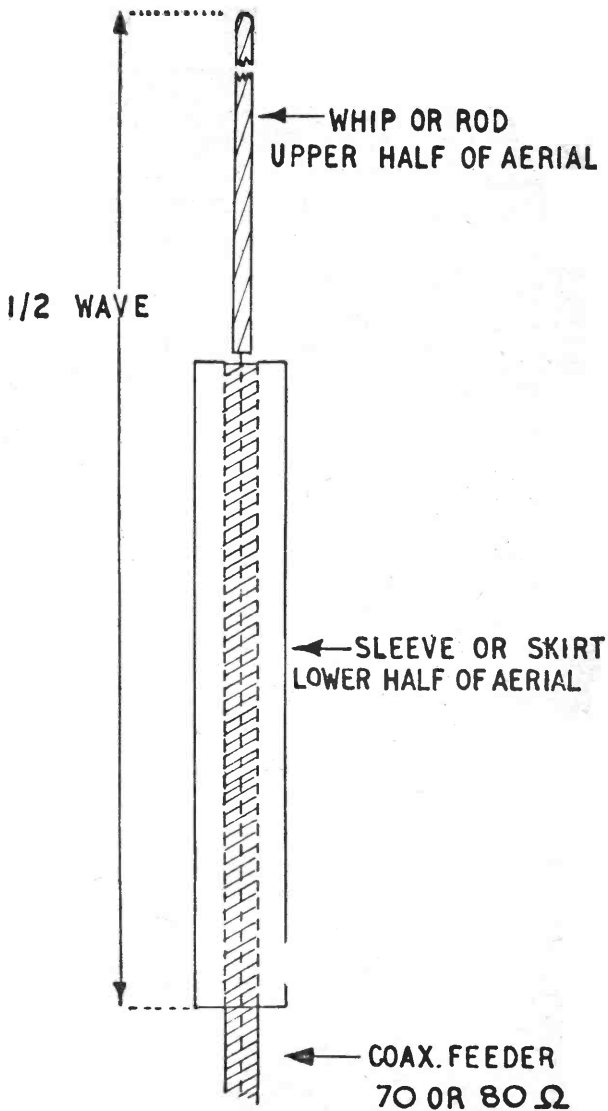

Fig. 22. *The Coaxial or Skirt Aerial.*

disc. A mounting band can then be fastened round the edge of the cap, the band terminating in a bracket or any other mounting fitment by which the aerial may be hoisted or attached to a mast, etc.

The coaxial aerial can be slung from a single cord or line thrown over a branch or projection, as well as mounted more solidly by its mounting fitment, and can also be run to the top of a flagpole. Whatever the mounting, the aerial is kept substantially upright and in position by the feeder line which, as in the case of the folded dipole, should be kept to as short a length as possible. Using coaxial feeder it is possible to make up a variable length line by using co-axial plugs and sockets. Portions of feeder line can thus be added when necessary and disconnected to shorten the whole line when the aerial is low or close to the transceiver.

A single turn aerial coil should provide correct coupling between the feeder and the tank coil in the set.

Each half of the co-axial aerial should be 3 ft. 10 ins. in length to give an overall length of 7 ft. 8 ins. (for the 60 mcs. band).

Whilst transceivers are used for personal work on foot and portable transmitters for car operation are usually more complicated in design and of higher powers there is nothing to prevent the walkie-talkie's being used from a car. In this case, however, the aerial will require mounting on the car itself, and not on the set. Suitable aerial positions vary considerably from car to car, but wherever the aerial is placed it will require feeding by as direct and efficient a route as possible.

The most suitable aerial (for simplicity) is the quarter wave rod or whip as used on the transceiver itself, connected to the apparatus by a coaxial line. A coaxial line is recommended for all transceiver applications where a distant aerial is to be connected to the transmitter-receiver, for besides the desirable low impedance characteristics of such a feeder system there is the advantage that the link between gear and aerial is easily portable and quickly stowed away when not required. For the coupling to the quarter wave whip or rod 50 ohms coaxial cable is suitable.

The circuit is shown in Fig. 24 and is tuned by a variable capacitor between the earthed end of the aerial coil, earth in this instance being the car body, and the earth itself via the outer coaxial conductor. The aerial tuner, C, is so adjusted that the aerial provides the best possible loading on the transmitter or receiver with as little coupling between the aerial coil and tank circuit as can be permitted. The tuner is therefore adjusted with the coupling between the two coils at a minimum, the aerial coil being brought nearer to the tank coil, if desired, once the system is tuned.

Using a combined transceiver the coupling is thus most conveniently adjusted using the receiver quench as a guide, but in cases where the transmitter is separate from the receiver an aerial milliammeter or lamp will give the best indications so far as the transmitter coupling is concerned, an H.F. milliammeter being preferred for the coupling may need to be quite tight if a lamp is relied upon.

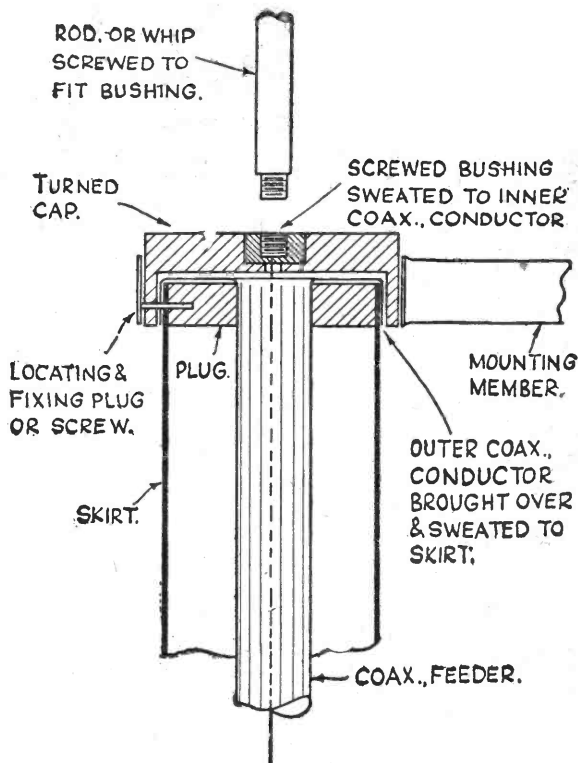

Fig. 23. *Detail of Joint for Skirt Aerial.*

A rod or whip aerial, whether remote from the transceiver as in the last example or mounted directly upon the gear, as in the ordinary walkie-talkie and handie-talkie, should be built up from the widest diameter stock which can conveniently be used, providing that the necessary adjustment to aerial length is made as indicated by the values of k given at the beginning of this chapter. The greater the diameter of the aerial the greater is the bandwidth over which the aerial tunes, and whilst a 59 mcs. aerial will not cause any great fall-off in efficiency at either end of the band, especially so far as reception is concerned, it is worth while to ensure a wide bandwidth so far as is possible. Obviously a wide tube aerial cannot be mounted on a handie-talkie transceiver, but in many cases a two or even three section aerial could be built using wider stock at the base with narrower sections above to give a tapering effect. This also assists to balance hand carried gear and improves the aerial appearance. A clear development from this

is a telescoping aerial which closes down to a few inches long but which can be extended in a matter of seconds to the correct quarter wave length, the top section of the aerial being calibrated for 58.5, 59, 59.5 and 60 mcs. operation. Such a refinement may seem almost pointless, but the amateur has always had a tradition of efficiency!

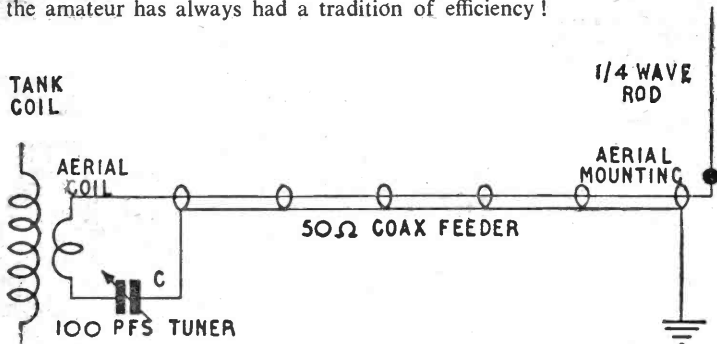

Fig. 24. Feeding a $\frac{1}{4}$ -wave Aerial a short distance from the Transceiver.

CHAPTER 7.

FREQUENCY DETERMINATION

Under the terms of the transmitting licence (Section 3 of Form E-in-C 435) an amateur station must be equipped with a reliable frequency meter of the crystal or other approved type, with which the frequency of transmission may be measured with an accuracy of 0.1%. A frequency meter is always useful, but when it is necessary to adjust high frequency gear, such as a transceiver where a relatively wide tuning band is provided, a frequency meter is found to be essential.

Where the transmitter and receiver are combined as in the small transceiver, the calibration can be made with the gear switched to the Receive position. It is quite a simple matter to receive, on a super regenerative receiver, the harmonics of a simple crystal oscillator such as a Pierce-connected triode, Fig 25, even up to 60 mcs., using a standard 1 mc. crystal. Alternatively the harmonics of a good signal generator may be used (modern signal generators may now be obtained with ranges up to 60 mcs.).

When the transmitter and receiver are separate, however, as in the case of the transmitter-receivers shown in Chapter 5, the problem is a little more difficult to solve. If a good calibrated receiver is in use this may serve as a standard against which the transmitter frequency

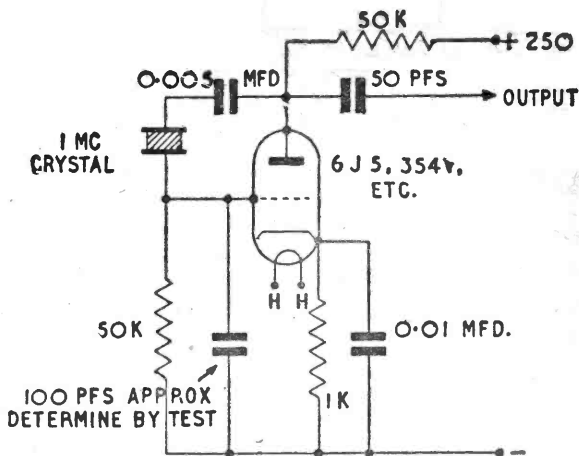

Fig. 25. Pierce Oscillator for Receiver Calibration.

may be adjusted, but since in many cases a roughly calibrated converter is used for very high frequency reception, a frequency meter will probably have to be built—and, of course, calibrated in its turn.

The simplest frequency meter for high frequency operation is a pair of Lecher wires, although for 5 meter measurements Lecher wires are of rather an unwieldy length. The Lecher wires are two bare copper conductors stretched tightly across a space free of conducting or metal masses, the length of the wires being at least one wavelength and preferably greater. The spacing between the wires, which should be absolutely constant, is of the order of 2 inches or a little more, the spacing not being critical. At the end remote from the transmitter the wires are insulated one from the other, whilst at the transmitter end of the system the wires are joined by a single loop which acts as the pick-up loop and which is coupled to the transmitter tank. Also coupled to the transmitter tank is a second loop and flashbulb.

A conducting bar is run along the Lecher wires, the bar being perpendicular to each wire, so that at the position of the bar the wires are short-circuited together. Positions of the bar will be found where the lamp, coupled to the tank circuit, dims suddenly, the distance between two such points being a half wavelength. The coupling, for accuracy, must be loose and using low-powered gear there may be some difficulty in obtaining easily visible brilliancy from the lamp, so that the Lecher wire system has several points of disadvantage. It can be used with good effect as a standard or calibration system, however, if supplied from a temporary oscillator built for the purpose, the circuit giving about 5 or 6 watts R.F. output, the frequency meter to be calibrated being used in place of the loosely coupled bulb.

Several frequency meter circuits are available, but a simple absorption meter is recommended since it can be built up into a small case and so made compact and extremely stable. A suitable circuit is shown in Fig. 26, and it will be seen that the indicator, comprising a moving coil instrument and rectifier, is loosely coupled to the main tuned circuit, the damping on the latter circuit thus being low. A diode rectifier can be used, the diode being either a small 1.4 volt valve with all the electrodes other than the anode strapped down to the negative side of the filament or a very high frequency diode such as the Mullard EA50, but for convenience a germanium crystal rectifier is recommended, or a silicon crystal as made by Messrs. B.T.H. Different crystals have varying frequency limits but all extend well beyond the 60 mcs. band.

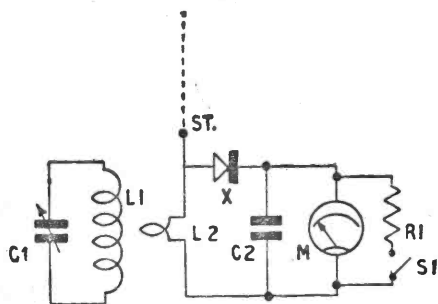

Fig. 26. *Absorption Frequency Meter.*
60 mcs.—28 mcs.

The choice of moving coil instrument sensitivity is far from critical, but if the frequency meter is to be used with various transmitters of widely differing output powers some provision should be made for reducing instrument sensitivity for use with the larger transmitters since a highly sensitive instrument can be burnt out. (The B.T.H. crystal can pass a continuous current of 50 mAs. D.C.) The sensitivity control may well be a shunt or series of shunts selectively switched across the instrument terminals, and if the meter is chosen with a basic range of 0—0.5 mA, or even 0—1 mA, the whole frequency measuring apparatus will be sufficiently sensitive for practically any application, especially if a small rod aerial is connected to the indicating circuit—not, of course, to the calibrated tuned circuit.

In order that the frequency meter may operate without the rod aerial the coils must be mounted outside the case, if this of metal. If the coils are mounted within the case a short aerial will be required as a permanent fixture, although for most applications 3 or 4 inches of wire will provide sufficient pickup.

Components List for the Absorption Frequency Meter, Fig 26.

- C1, 120 pf. Variable Tuner. Raymart MC120X.
- C2, 0.001 mfd. Mica.
- X, Crystal detector, Silicon or Germanium.
- M, 0—0.5 or 0—1 mA. M/C instrument.

- R1, Shunt as required. (5 or 10 mAs).
- S1, Shunt switch, S.P. On-Off.
- St. Standoff insulator or mounting, to take rod aerial.
- L1, 6 turns 18 S.W.G. $\frac{1}{2}$ " diam., wound to $\frac{1}{4}$ " long.
- L2, 2 turns 18 S.W.G. $\frac{1}{2}$ " diam., spaced own diam.

Small metal case or box.

Pointer knob and Dial for C1, Eddystone Cat. No. 62.

Note: L2 may require 3 turns to give the best indications of resonance, since the degree of coupling between L1 and L2 depends to some extent on the characteristics of the crystal in use. The coupling should therefore be adjusted experimentally to give the best results.

If the instrument M reads in reverse, reverse the connections to its terminals.

If a wire ended crystal detector is used, such as the B.T.H. component, the wires should be gripped between pliers during the soldering in order that as little heat as possible is conveyed to the crystal.

The frequency meter is used as is any absorption meter. The instrument is placed near the transmitter and the control of C1 rotated. At some point the moving coil meter will show a sharp rise from zero, falling back as C1 is rotated further. The rise indicates that the frequency meter is in resonance with the transmitter and for the first tests it is wise to shunt the meter until the sensitivity of the instrument is known.

The absorption meter may also be used with super regenerative receiver. When coupled to the receiver coil and tuned to the same frequency, the frequency meter will give no indication on its measuring instrument but a diminution of quench will be heard in the receiver output, indicating resonance.

The frequency meter may be calibrated against Lecher wires, as already described, or against a super regenerative receiver which has already been calibrated against the harmonics of a crystal oscillator. The circuit shown covers the two amateur bands at 5 and 10 meters, and so is suited for the calibration of most transceiver circuits.

OPPORTUNITIES IN RADIO

Get this **FREE** Book!



“ENGINEERING OPPORTUNITIES” reveals how *you* can become technically-qualified at home for a highly-paid key-appointment in the vast Radio and Television Industry. In 108 pages of intensely interesting matter it includes full details of our up-to-the-minute home-study courses in all branches of **RADIO AND TELEVISION, A.M.Brit. I.R.E., A.M.I.E.E., City and Guilds, Special Television, Servicing, Sound Film Projection, Short Wave, High Frequency, and General Wireless Courses.**

We definitely guarantee

“NO PASS — NO FEE”

If you're earning less than £10 a week this enlightening book is for **you**. Write for your copy today. It will be sent **FREE** and without obligation.

BRITISH INSTITUTE OF ENGINEERING TECHNOLOGY

550 SHAKESPEARE HOUSE, 17, STRATFORD PLACE, LONDON, W.1.

HENRY'S

Radio Component Specialists

*We have the most comprehensive range
of Radio Components of every nature.*

Over 10,000 Valves in Stock.

Our reputation is your guarantee.

Situated opposite Edgware Rd. Tube.

If unable to call, please send stamp
for current price list

(Dept. B.P.)

5, Harrow Road, W.2.

PADdington 1008/9.

POST RADIO SUPPLIES

**33 BOURNE GARDENS
LONDON, E.4**

Offer from Stock

COPPER INSTRUMENT WIRES.
ENAMELLED, TINNED, COTTON
AND SILK COVERED. LITZ WIRES.
B.A. SCREWS, NUTS, WASHERS,
SOLDERING TAGS, EYELETS AND
RIVETS.

LAMINATED BAKELITE & EBONITE
PANELS. TUFNOL AND EBONITE
ROD. PAXOLIN type tubes and
coil formers. All diameters.

Permanent detectors, crystals, head-
phones, etc., etc.

Send S.A.E. for List. Trade Supplied

Distributors of Bernard Publications.

BERNARDS RADIO BOOKS

FOR THE HOME & AMATEUR CONSTRUCTOR

3.	SERVICES SIGNALLING MANUAL	1/-
4.	RADIO POCKET BOOK	1/-
6.	ELECTRICAL ENGINEERS HANDBOOK	1/-
22.	MANUAL OF RADIO CIRCUITS	2/-
30.	RADIO VALVE MANUAL	3/6
37.	MANUAL OF DIRECT DISC RECORDING	2/-
41.	WIRELESS AMPLIFIER MANUAL	2/-
42.	SHORTWAVE RADIO HANDBOOK	2/-
43.	MODERN RADIO TEST GEAR CONSTRUCTION	1/6
44.	RADIO SERVICE MANUAL	2/6
45.	RADIO REFERENCE HANDBOOK	12/6
48.	RADIO COIL AND TRANSFORMER MANUAL	2/-
50.	INTERNATIONAL SHORTWAVE RADIO STATION LIST	1/-
51.	CATHODE RAY OSCILLOSCOPE MANUAL	2/-
52.	RADIO TUNER UNIT MANUAL	2/6
53.	RADIO CONSTRUCTORS' MANUAL	3/-
54.	RADIO RESISTOR CHART	1/-
55.	HANDBOOK OF RADIO CIRCUITS NO. 2	2/6
56.	RADIO AERIAL HANDBOOK	2/6
57.	ULTRA SHORTWAVE HANDBOOK	2/6
58.	RADIO HINTS MANUAL	2/6
59.	TELEVISION CONSTRUCTION MANUAL	3/6
60.	RADIO REPAIRS MANUAL	2/6
61.	AMATEUR TRANSMITTERS' CONSTRUCTION MANUAL	2/6
62.	CAR AND PORTABLE RADIO CONSTRUCTORS' MANUAL	2/6
63.	RADIO CALCULATIONS MANUAL	3/6
64.	SOUND EQUIPMENT MANUAL	2/6
65.	RADIO DESIGNS MANUAL	2/6
66.	COMMUNICATIONS RECEIVERS' MANUAL	2/6
67.	RADIO VALVE EQUIVALENTS MANUAL	2/6
68.	FREQUENCY MODULATION RECEIVERS' MANUAL	2/6
69.	RADIO INDUCTANCE MANUAL	2/6
70.	LOUDSPEAKER MANUAL	2/6
71.	MODERN BATTERY RECEIVERS' MANUAL	2/6
72.	EXPERIMENTAL CIRCUITS MANUAL	2/6
73.	RADIO TEST EQUIPMENT MANUAL	2/6

Other Titles in Preparation

- | | |
|-----|--|
| 74. | RADIO VALVE APPLICATIONS MANUAL |
| 76. | RADIO ANTI-INTERFERENCE MANUAL |
| 77. | WALKIE-TALKIE CONSTRUCTION MANUAL |
| 78. | RADIO AND TELEVISION LABORATORY MANUAL |
| 79. | MODERNISING OLD RADIOS |
| 80. | TELEVISION SERVICING MANUAL |