

radio

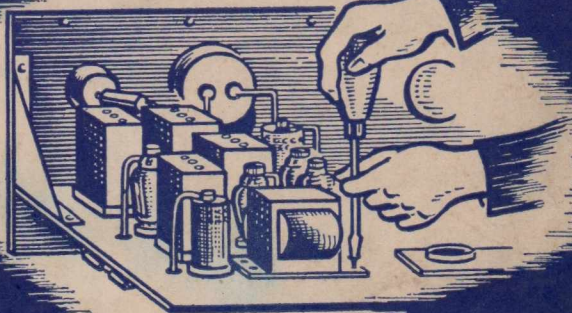

repairs

MANUAL

No. 60

2/6

Copyright

GOOD NEWS

RADIO NEWS, foremost American Radio magazine, can now be obtained direct by post from America; the only sure way of receiving copies regularly.

RADIO NEWS unfolds, month by month, the complete story of radio research and development. Editorially and in presentation, printing and production, it maintains the highest American standards. Each issue contains from 136 to 160 pages of news, articles, pictures and advertisements, brilliantly written and illustrated.

Radio technicians, dealers, business and factory executives, radio specialists in the services, amateurs, "hams," officials, research specialists, constructors, all are fully catered for. The scope of RADIO NEWS, in all that matters, is complete.

For a subscription of £1 5s. 0d., inclusive of postage, payable in advance (equal to 2s. 1d. a copy), the postman will deliver a copy at the door every month for a year. For two years the rate is £2 5s. 0d. and for three years £3 0s. 0d.

Subscription orders may be placed through your Radio dealer or newsagent or, in case of difficulty, send your order (name and full address in BLOCK LETTERS, please) with remittance covering the period required, to us at the address below.

. . . . RADIO NEWS

POPULAR PHOTOGRAPHY, FLYING, PLASTICS.

From the same publishers come these three superb magazines, each completely fulfilling, in its own sphere, the same essential purpose as RADIO NEWS. Informative to the highly skilled operator or technician, yet understandable and interesting to the amateur: intensely practical, yet never dry or stodgy. Brilliantly written, copiously illustrated and beautifully produced, each magazine maintains the highest standards for which American magazines are famous.

Particulars of subscription rates and facilities on request.

ZIFF DAVIS LIMITED,
GRAMPIANS BUILDING, WESTERN GATE, LONDON, W.6.
Telephone: SHEPHERDS BUSH 4794.

RADIO REPAIRS MANUAL

by

“RADIOTRICIAN”

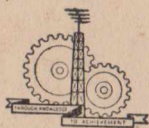

BERNARDS (PUBLISHERS) LTD.
LONDON · W. 6

CONTENTS

	PAGE
INTRODUCTION	5
CHAPTER 1. TOOLS AND WORKSHOP PRACTICE	7
CHAPTER 2. INSTRUMENTS AND TEST-GEAR	12
CHAPTER 3. FAULT-FINDING AND SIGNAL-TRACING	18
CHAPTER 4. FAULTS IN THE POWER PACK	31
CHAPTER 5. FAULT-FINDING—THE RECEIVER AS A WHOLE	37
CHAPTER 6. THE SIGNAL GENERATOR—LINING UP THE RECEIVER	44
CHAPTER 7. VALVE TESTS AND TESTING	52
CHAPTER 8. SOME SPECIAL CONSIDERATIONS	56
CHAPTER 9. THE TELEVISION RECEIVER	62
BIBLIOGRAPHY	64

CONTENTS

1	Introduction
5	Chapter I. The Social Movement
12	Chapter II. The Social Movement and the State
18	Chapter III. The Social Movement and the Church
25	Chapter IV. The Social Movement and the Family
32	Chapter V. The Social Movement and the Education
40	Chapter VI. The Social Movement and the Law
48	Chapter VII. The Social Movement and the Art
56	Chapter VIII. The Social Movement and the Literature
64	Chapter IX. The Social Movement and the Music
72	Chapter X. The Social Movement and the Drama

INTRODUCTION

It is not claimed that perusal of this little book will make the reader a service engineer in any sense of the word, though it is hoped that the service engineer, experienced though he may be, will find something of interest in these pages. On the other hand, it is the author's hope that by following the directions here given the radio amateur, and particularly the beginner, will avoid some of the snags and pitfalls in his path so that he may rectify at first simple, and then more abstruse, radio faults without leaving for the service engineer a practically ruined receiver, as is so often the case.

• The discerning amateur should know when a particular fault is beyond his scope, and call in the trained man, but when this is decided upon, the receiver should be left as it stands, so that the engineer can see for himself the exact state of affairs. Most remarkable cases of misuse and mishandling of radio gear are brought to notice time after time, the setting right of troubles being complicated to the extreme by trial and error "experiments" which more often than not cause even more damage to be done. To quote only one actual case, that of a receiver where a resistor was found to have been replaced by a length of lead pencil held in place by copper wire and chewing gum, will show quite adequately the lengths to which some "amateurs" are prepared to go.

The book is set out in a logical sequence. Commencing with the tool kit and a note on general workshop practices, the author then discusses what instruments and test gear are necessary or desirable; progressing to fault finding, simple tests and precautions, more advanced testing and adjustment, general repairs, valves and valve testing, television, etc.

It should perhaps be noted here that the word "amateur" is used in the script for want of a better term. The true radio amateur is the amateur transmitting man, but here the word is used to indicate collectively the large body of those whose interests and part-time studies are in the realms of all branches of electronics, and whose work has often been of wide value.

INTRODUCTION

The first part of the book is devoted to a general introduction to the subject of the book. It is divided into two chapters. The first chapter is devoted to a general introduction to the subject of the book. The second chapter is devoted to a general introduction to the subject of the book.

The second part of the book is devoted to a general introduction to the subject of the book. It is divided into two chapters. The first chapter is devoted to a general introduction to the subject of the book. The second chapter is devoted to a general introduction to the subject of the book.

The third part of the book is devoted to a general introduction to the subject of the book. It is divided into two chapters. The first chapter is devoted to a general introduction to the subject of the book. The second chapter is devoted to a general introduction to the subject of the book.

CHAPTER I.

TOOLS AND WORKSHOP PRACTICE.

Whenever possible, the service man should have two tool kits, the various items of which are never interchanged. One kit, the larger, will be that attached to the workshop, that is, for most readers, the home bench, the other kit being a portable set of tools carried and kept in a substantial bag or case.

The bench tools can hardly be enumerated, since they will, in all probability, have been built up, as a kit, over some passage of time, but the portable kit should certainly have, as a basis at least, the following tools and accessories: 3 screwdrivers, 1 large, with a $\frac{3}{8}$ " blade, 1 medium, with a $\frac{1}{2}$ " blade, and 1 small instrument driver, of the Starrett type, which has a swivelling flat head, the blade width being $\frac{1}{16}$ ", or even finer, this screwdriver being reserved for fine work and for removing grub screws, etc.

Spanners should always be at hand, preferably both flat steel and box types. A complete set of the flat steel, double-ended spanners from 0 to 10 B.A. is almost essential, a supplementary set of box spanners being kept for the out-of-the-way jobs, the most useful sizes probably being 0, 2, 4, 6, 8 B.A. Component fixing nuts are usually larger than 0 B.A., however, so that a $\frac{1}{2}$ " and a 1" box spanner pair is often useful, especially where variable condensers, chassis mounting electrolytics, volume controls and panel mounting switches are to be dealt with.

A wheel brace with a set of drills is, of course, an integral part of any tool kit, and is perhaps one article that must do double duty in the workshop and portable kits, due to the expense of a good instrument. The chuck especially should receive good care and attention and be of such a size that it will take up to $\frac{3}{8}$ " diameters, while the driving wheel and gears should be substantially made and give good leverage. For the workshop a nest of drills styled in numbered sizes from 1 to 60 is an excellent purchase, but for the portable kit a separate set of drills should be kept. Two of the most useful sizes, in the author's experience, are the tapping and clearing drills for 6 B.A. screws. The tapping drill, No. 44, as its name implies, makes a hole suitable for tapping with a 6 B.A. tap, the clearing drill, No. 32, making a hole which a 6 B.A. screw will enter without fouling. To these may be added tapping and clearing drills for Nos. 4, 5 and 8 B.A., respectively drill sizes 33 and 26, 39 and 29, and 51 and 42.

A small set of taps, made to fit into a bar head, is a most useful asset. A set of dies is not so necessary. The taps should be in the following sizes, 4, 5, 6 and 8 B.A. for portable kits, a more comprehensive set being obtained for the bench if required. Taps are made in three styles for each size, these styles being known as taper, second and bottom, but for radio purposes a taper is all that is really necessary. The tap is centred in the drilled hole and the head rotated in half turns, gently, a slight fraction of a turn back being given after each forward cut to remove the swarf—that is, the threads of metal which are cut from the walls of the drill hole. Even pressure with gentle, but firm, turning must be used, since taps are extremely brittle. If a blind hole is being tapped a second and possibly a

bottom tap, too, will be required, but since most holes are drilled and tapped through panels or chassis, the taper tap will give a perfectly adequate thread. Theoretically, the length of the tapped hole should be at least equal to the screw diameter, for good strength and holding qualities, but in practice most chassis thicknesses will take a 6 B.A. tapping with ease.

Most tool kits contain a variety of pliers, some of which include cutters. Separate cutters are far better, however, 6" side cutters being capable of most radio work, 3½" broadheaded cutters are very useful for small wiring jobs and 5" square nosed pliers will be found a very adaptable tool. Long nosed and round nosed pliers for forming wiring loops are also useful.

Many pliers and screwdrivers are sold as "insulated" tools, but the writer does not advocate their use. It may lead, especially in the case of the beginner, to carelessness in working with live apparatus, since a false sense of security may be engendered, and whenever possible apparatus should not be touched till the supply power has been cut off. This refers especially to the first inspection of apparatus—there are occasions, of course, when work must be carried out with the apparatus in operation, but this should never be done until an inspection has been made and any danger points noted.

Reliance should never be placed on insulated tools, except where, as in the case of trimming screwdrivers, etc., the apparatus would be put out of gear by the use of a conductor. A kit of such trimming tools in a small wallet should be obtained.

Files are not often found in the portable kit, although one or two fairly large smoothing files are useful on the bench. If a set of small files can be obtained, however, they are well worth while carrying. The 6" type, flat, triangular, half round, round or rat tail, take up very little space, but are capable of excellent work.

Too often the tang of a file is used for enlarging holes in panels or chassis. One or two reamers of the taper variety are valuable tools for enlarging or cleaning holes.

The choice of a soldering iron must rest with the purchaser, since the size and wattage rating of the iron depend on the type of work to be done. For wiring purposes a 60 watt iron is perfectly adequate, a pencil bit giving excellent direction of heat to the tag or wire to be soldered, but where the iron is to perform both wire and sheet metal or other heavy soldering work a 90 or 100 watt iron is to be preferred. The shape of bit is also controlled by the work, a broad, heavy bit being necessary for sweating or sheet metal work, and it is possible to obtain irons with a range of interchangeable bits. Such irons should be very carefully inspected when buying, however, and care be taken to see that the bits form a very good junction with the main hot member or element, and are steady and firm in their holder.

The process of forming a soldered joint is to alloy the solder with the metal on which the work is proceeding, the two alloyed surfaces thus adhering firmly through a common bond. For this reason soldering can only take place on really clean metal, or on metals ready coated with solder, that is, "tinned."

For really safe work, however, a resin-cored solder should be used in conjunction where necessary with a resin flux, since this flux does not corrode and, forming round the joint in a hard coating when the metal cools, it

provides a protective layer which will resist moisture and other corrosive agents. Whilst corrosive or slightly corrosive fluxes clean the metal ready for soldering, resin has little cleaning power and the metal therefore should be scraped before jointing. The chief function of a flux is to prevent the metal, when hot, from combining with the oxygen of the atmosphere and thus forming an oxide layer which would prevent the proper forming of the solder alloy. The oxide coat present on practically all metals is removed in the cleaning or scraping process before jointing, and the flux prevents its reforming. Grease, however, will also make a good soldered joint almost impossible to obtain, and a resin flux made by dissolving powdered resin in methylated spirit will help to remove this impurity. The best resin should be used, and dissolved in the spirit to make a slightly viscous fluid. The amounts of resin to spirit are not critical, and a thick, dark brown paste should be avoided. A clear amber solution (using uncoloured spirit) gives perfectly good protection. The resin cored solder should be melted directly on to the joint, not first on to the iron and then transferred. Only sufficient solder to run over the joint should be used, and the resin will be seen to melt and run just before the solder itself. A joint over which the solder does not run, but from which it drops off or collects in blobs, is not sufficiently clean.

The solder should not be relied upon for mechanical strength. All joints should first be made strong, the wire being hooked through the holes provided in soldering tags, valve-holder legs, etc., the solder then being applied to make the electrical joint good. No attempt should be made to solder plated metals. Some platings are said to take solder well, but almost invariably an unsatisfactory joint results. All plating should be scraped off, exposing clean metal underneath, for proper soldering to take place. Tinned coatings solder well when new, but old coatings should also be scraped off.

The same remarks apply also to the bit of a new soldering iron. On its first heating file one face of the tip of the bit down to bright copper and immediately tin this face before it has time to oxidise by rubbing it on a sheet of tin or copper on which have been melted down some scraps of resin-cored solder, so that a coating of solder and resin flows over the bit. Repeat with each side of the bit, cleaning the metal as the work proceeds and only immediately before tinning, since the hot copper oxidises rapidly. The use of resin flux keeps the tinning of the bit in good condition, for, although a coating of dark scale forms over the bit as work proceeds, it will be found that this burnt resin will wipe off on a cloth, leaving the tinning below it bright and clean.

If the bit becomes misshapen or has hollows forming in one or more of the sides, it should be refiled to shape before the wear proceeds too far and retinned in the same way.

Whenever possible it is a good plan to provide both the workshop and portable kits with their individual electric soldering irons, a large iron being kept on the bench and a small wiring iron being carried in the kit. The bench iron is best kept in a cage of perforated zinc bent into U shape and screwed below the bench, so that the iron rests in the hollow of the U. In this way the iron is out of danger, there is no risk of burns and the temperature of the iron is kept at the correct level.

A stand should also be provided for the portable iron, and may be made

of sheet brass with a vertical projecting end. In this end piece a V shaped cut will hold the iron safely. A sheet of asbestos fastened to the bottom of the brass sheet will protect the surface on which the whole arrangement is set down.

GENERAL WORKSHOP PRACTICE.

The quality of the worker at the bench may generally be assessed by studying the manner in which he uses tools. The correct tool for the job should always be selected, screwdrivers, for example, being chosen to fit the head of the screw to be turned, the blade being neither longer nor shorter than the screw slot. Nuts should always be turned with the aid of spanners, the pliers never being used for this purpose since correct gripping cannot be obtained and the nut is marked, the work possibly scored, and a poor fixing result. In the same way all the electrical accessories on the bench should be in good working order, and the plugs and sockets feeding the iron, lights, etc., properly wired and insulated. In particular, inspect plugs for complete entry into sockets, since incomplete entry, due to poor fittings or bent pins leaves a gap between plug and socket into which wire or sheet metal scrap might easily fall, causing a fuse. Wherever sheet metal is to be worked, as in the making of chassis, etc., a vice should be fitted to the bench, preferably as a fixture. A large parallel jawed metal vice will accommodate most types of work, although a carpenter's vice, built into the bench itself is extremely useful. To use the vice for bending the sides of chassis, cut two hardwood battens to the length of the inside of the chassis, which should be ready cut and marked to shape, and two further hardwood battens cut to the inside width of the chassis. The sheet metal is then gripped in the vice between these battens, the bending edge coinciding with the batten edges. The metal is then bent over in degrees, by light tapping with a smooth headed hammer.

When drilling aluminium speed should be kept down so that the swarf clears easily. For the workbench a set of chassis punches is a real asset for making holes to take valveholders in one clean operation, or if a set is not obtainable, a $1\frac{1}{8}$ " diameter punch will suit practically all types of valve holders. The punches are of two kinds, the drawbar type, where a cutting head is drawn through the sheet metal by a screw action, and the true punch type where the punch is driven through into the die by a hammer blow.

Another tool for making large holes is the tank cutter, obtainable from hardware stores. The adjustable cutter has a wide range of sizes from about 1" up to holes as large as $2\frac{1}{2}$ ", which will take meters, etc., and is made to fit the ordinary square chucked wood-brace. The tank cutter revolves about a centre pin of $\frac{3}{16}$ " or $\frac{1}{4}$ " steel, so that a hole must first be drilled of the correct size to take this centrepin.

A small cabinet with a supply of screws and nuts of assorted sizes is also a great help. Compartments for components such as soldering tags can be provided. A supply of cheese-headed brass screws of 6 B.A. gauge is useful, with nuts to suit, whilst it will be found that 5 B.A. screws are used by many manufacturers, especially in studding lengths supporting terminal boards, etc., so that 5 B.A. nuts should also be to hand. In larger components, such as loudspeakers, fixing bolts and nuts are commonly of the

2 and 4 B.A. gauges. There seems to be no common size of grubscrew, and no broken or damaged knob should be discarded until its grubscrew has been salvaged for further use.

There will scarcely be room or need for saws in the portable tool kit, although a hacksaw blade has many uses and takes up no room. On the bench, however, beside the woodsaw, there should also be a fretsaw, since the ordinary fretsaw blade, handled with care and worked slowly without dragging, will cut practically any sheet metal. The writer has frequently worked $\frac{1}{8}$ " aluminium and $\frac{1}{16}$ " brass sheet with a 12" fretsaw with ease, and a neat finish is easily obtainable. The fretsaw, naturally, should be brought into play only for shaped or circular holes, the hacksaw being used for straight cuts. Lubricants should always be used, of course, turpentine for aluminium and an oil for brass. Tools should be kept lubricated, especially the saws which are best kept hanging on a peg over the bench, and, therefore, have not the protection against damp of the toolbox.

It should be remembered that with the hacksaw the cut takes place on the forward or push stroke, and the sawblade must be inserted accordingly.

The workbench should always be kept clean, especially with regard to swarf from drilling and metal dust, which can cause havoc in the radio chassis. When possible a separate bench should be kept for the radio work proper, though this would probably be a luxury for most amateurs. One end of the bench, therefore, should be reserved for receivers and chassis, and a felt mat should be kept for protection to cabinets and polished surfaces. Apart from this mat, a rubber pad for actual work on chassis is of great help when it can be obtained. A sheet of white rubber two feet square greatly aids visibility and also keeps tools in place, whilst giving perfect insulation and freedom from leakage effects. Where high voltage circuits are being worked on, or where it is necessary to keep the apparatus switched on as work proceeds, a further precaution is a tough rubber mat on the floor in front of the bench, particularly where the floor is of concrete. Failing a rubber mat a wooden duckboard gives a good measure of protection.

The bench should be adequately lit both by overhead lamps fitted with plain white shades and also by at least one adjustable lamp of the flexible neck type, in order that light can be directed as required. Above the bench, in a corner of the room, should be a loudspeaker mounted on a baffle, the accompanying transformer being at bench level with several ratios brought out to a connecting board. The ratios should, of course, include a centre tapped primary winding for push-pull or paraphase output circuits.

A self-contained power pack giving at least 100 ma. at 350 volts of smoothed D.C. and low voltage A.C. outputs at 4 and 6.3 volts for heater circuits is a desirable unit in any workshop, not only for receiver testing but also for working auxiliary apparatus and experimental purposes. The outputs should be terminated in terminals, also in a 4-pin socket for 4-volt apparatus, and in an octal socket for 6.3-volt units, this enables auxiliary apparatus to be plugged in directly by having their power leads terminating in suitable plugs made from old valve bases.

A self-contained power pack, giving at least 100 ma. at 350 volts of smoothed D.C. and low voltage A.C. outputs at 4 and 6.3 volts for heater circuits is a desirable unit in any workshop, not only for receiver testing but also for working auxiliary apparatus and experimental purposes. The

outputs should be terminated in terminals also in a 4-pin socket for 4-volt apparatus and in an octal socket for 6.3-volt units, this enables auxiliary apparatus to be plugged in directly by having their power leads terminating in suitable plugs made from old valve bases.

A turntable and pickup provide an excellent test signal source for all amplifiers and radiogram amplifier sections, and the tests can be made of real value if a set of frequency recordings is obtained. Such recordings, used with a level response pickup and a good output meter, or, better, a small oscilloscope, can give a searching test to any amplifying gear.

One small point, often overlooked, is the provision of test leads. A hook at the test end of the bench can carry a large number of such leads, which should be of rubber covered flexible wire, provided with various terminating devices such as clips, prods, spade ends and plugs, there being a variety of lengths for convenience. At least one length of shielded two-core cable should also be provided, clips at one end and plugs at the other being found a useful combination, the screen at either end being brought out by a few inches of flex to a clip.

A nest of drawers holding tools and spare components, with at least one stout shelf for the instruments and gear to be described will provide the outline of what can be built up, to suit individual taste, into an excellent workroom. It may seem that a very ambitious layout has been described, but work under the correct conditions is so much more pleasant, as well as efficient, that an effort in making the workroom a tidy, shipshape place is never wasted.

One important point, that of mains power supply, has been left till last. The manner in which the cable carrying the main supply is brought to the bench must naturally depend on the exact location of the workroom, and very often it will not be possible to bring the cable from the house fusebox. The best alternative is to run a line from the nearest power point in lead covered cable, maintaining good earth connections throughout, the power being fed into a small iron clad switch and fuse box at the more accessible end of the bench. The fuses should be made to take the estimated bench load and no more (remembering that if the power is brought from a point that the maximum permissible load is 15 amps.) and the bench should be disconnected from the supplies whenever work is not in progress.

All wiring must conform to the rules of the local authority, whether carried out by their officials or privately.

CHAPTER 2.

INSTRUMENTS AND TEST-GEAR.

Probably very few radio amateurs or engineers are satisfied with their collections of test gear, and it is certain that a good kit of instruments takes time to acquire. The beginner, indeed, should make do, at first, with restricted testing facilities in order that he may gain experience in the use of simple instruments before progressing to more complicated equipment. A circuit analyser or multiple test gear is essentially simple, although expen-

sive to buy and, in some cases, easy to damage, but there is no reason why a quite good analyser should not be built by any amateur who knows the rudiments of electrical theory—and considerably more than the rudiments should be learnt by anyone aspiring to the title of amateur.

The basis of all measuring test gear is the milliammeter, and whilst full details regarding the construction of analysers are to be found in others of Bernards' publications, the outline details are here repeated.

Firstly, any instrument measuring either voltage or current must be considered as a current measuring device, the measuring of voltage being accomplished by inserting a large series resistance into the circuit and discovering what current is forced by the applied potential through both resistance and instrument. The measuring of larger currents than those for which the instrument was designed is accomplished by passing the bulk of the current through a very low resistance "shunt," leaving only a definite proportion to pass through the instrument, the whole current being gauged by knowledge of the proportions of the resistances of the shunt and the instrument.

The circuit of a simple D.C. analyser is shown in Fig. 1. It will be seen that provision is not made in the diagram for taking A.C. readings although most commercially made analysers include A.C. scales. It is presumed, however, that an ordinary D.C. milliammeter will be used in the analyser, with the linear scale common to such instruments—that is a scale

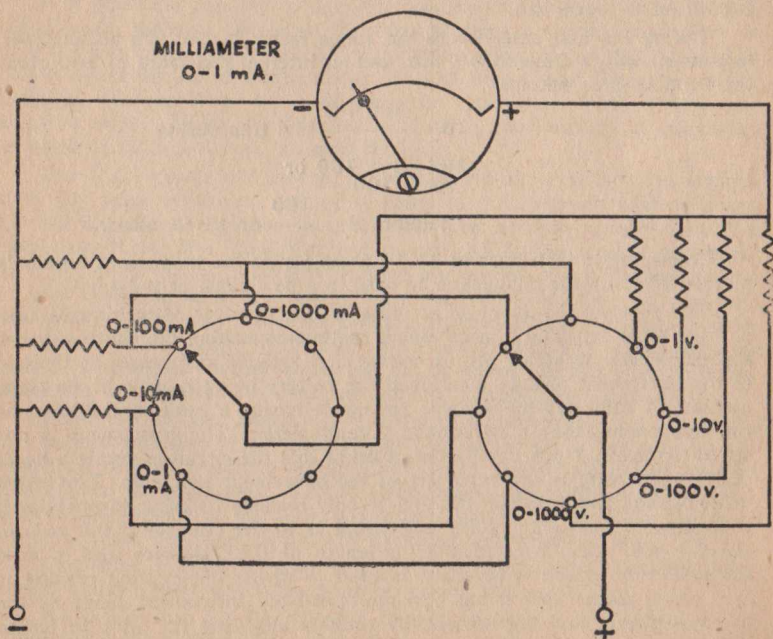

FIG. 1.—Simple D.C. Analyser.

with equal divisions throughout its length, from 0 to the top mark of say 1 or 5 milliamps. When an instrument rectifier is placed in circuit with such an instrument and the combination is used for reading A.C. these linear markings unfortunately no longer hold good on the lower voltage ranges, which, to the service man, are the more important ranges, the linear scale being only approximately true at voltages of at least 100 or 200. The service man, however, requires an A.C. range of from 0 to 10 volts in order that heater voltages, transformer windings, etc., might be tested, and here the instrument would require to be recalibrated before anything like accuracy is obtained.

Accordingly, it is advised that at least a two-range, and if possible a multi-range, A.C. voltmeter be obtained as a separate unit.

So far as the D.C. analyser is concerned there are two methods of adjusting the shunts for the various current ranges. If the internal resistance of the milliammeter is known, the shunt resistance for any higher current range is given by the formula

$$X = \frac{R + S}{S}$$

where X is the factor by which the range of the instrument is to be multiplied, R is the resistance of the milliammeter and S is the required shunt resistance. It is wise to step up the current ranges by factors of 10 so that a 1 milliamp. instrument should be made to read, besides 0.1, 0.10, 0.100 and 0.1,000 mA.

Taking the first case, where the range factor is 10, and an imaginary instrument with a range of 0.1 mA. and an internal resistance of 100 ohms, the formula then becomes

$$10 = \frac{100 + S}{S} \text{ and transposing}$$

$$10S - S = 100 \text{ or}$$

$$9S = 100$$

$$\text{Therefore } S = \frac{100}{9} \text{ or } 11.11 \text{ ohms.}$$

Connecting a resistance of 11.11 ohms across the instrument terminals, therefore, allows the milliammeter to read to a new value of 0.10 mA.

This requires the use of an accurate bridge, however, if such a resistance is to be measured, and a more simple method of making the shunt is to put the milliammeter in series with a battery and variable resistance, in the case of the instrument already mentioned the battery being capable of supplying a steady 4 volts and the variable resistance having a value of 5,000 ohms, the component being a wirewound potentiometer. The instrument is now set to top mark, 1 mA., and after ensuring that the circuit is steady a length of resistance wire is connected across the instrument terminals. The instrument reading will naturally fall and it only remains to bring the pointer to a position of one tenth of full scale, that is to the reading of 0.1 mA. on the 0.1 mA. scale, by adjusting the length of the resistance wire to make the 0.10 mA. shunt. The shunt is used to divide the existing reading by ten, which means that it has also multiplied the instrument range by ten. The process is best carried out by roughly adjusting the wire to length, spooling it, or winding it on a paxolin sheet, and finally adjusting when this

has been done. It should always be remembered that if resistance wire is wound or spooled after adjustment the stretching which will occur will change the resistance value. The 100 factor shunt will be made by adjusting the instrument to full scale with the 10 mA. shunt in place, reshunting with a further piece of resistance wire to again reduce the reading to one tenth of full scale. It will be seen, therefore, that in using this method any error in one of the shunts will be multiplied up in the other shunts, so that very careful work is required.

The calculation of the series resistors for the volts ranges is simple, since it merely depends on the current range of the unshunted instrument. An 0.1 milliammeter is best for voltage work, since the higher the current required by the voltmeter the greater will be the effect on any circuit whose voltages are being measured. An 0.1 mA. instrument is said to be a 1,000 ohms per volt instrument, since passing 1 mA. through 1,000 ohms sets up a potential difference across the ends of the circuit of 1 volt.

Similarly a 0.5 mA. instrument is a 200 ohms per volt instrument. Taking the 0.1 mA. instrument, then, it may be seen that to measure 1 volt its resistance must be increased to 1,000 ohms. The instrument resistance has already been supposed to be 100 ohms, and thus to measure 1 volt 900 ohms must be added in series with the instrument. Again, to measure 10 volts the instrument resistance must be increased to 10,000 ohms, to measure 100 volts the resistance must be 100,000 ohms, and so on.

It is generally possible to omit the instrument resistance from the calculation—for instance 100 ohms in 100,000 ohms is a very small error of only 0.1 per cent., better than the instruments accuracy, so that resistances of the round figures of 1,000 ohms, 10,000 ohms, 100,000 ohms and 1 megohm will enable a 0.1 milliammeter to read 0.1, 0.10, 0.100 and 0.1,000 volts. These resistors are obtainable commercially to accuracies of better than 1 per cent. at small expense.

The D.C. voltage and current instrument and the A.C. volts instrument have now been mentioned, and the question of A.C. current readings arises. On the commercial analyser these readings are generally provided but the home constructor of a simple analyser cannot include them in his instrument. It is not often that A.C. current readings are needed, but a thermo-ammeter is very useful although it is easily burnt out, and thus must be used with the greatest care. It is wise to shunt a thermo-ammeter through a push-button circuit, the range of the instrument being multiplied by ten until the button is depressed and the shunt put out of action. In this way the instrument can be inspected for overload without damage being caused.

Continuity testers, consisting of a sensitive instrument in series with a dry battery with test leads brought out to insulated prods can also be calibrated as resistance meters, and give very quick and simple circuit tests for broken wiring, bad joints, shorting condensers and faulty resistors, etc., and further details of all these instruments are to be found in *Bernards' Modern Radio Test Gear*, No. 43 in *Bernards' list*, price 1s. 6d.

The same publication gives details of the construction of signal generators, audio signal generators, bridges, output meters, etc.

No service man can be without a signal generator, and if such an instrument is bought it should have wide frequency ranges, 30 per cent. modula-

tion by a 400 c.p.s. audio signal which is also available for audio testing, and a calibrated output in millivolts up to 1 volt. It may be mains or battery driven in order that it may be included in the portable kit, so that the power supplies chosen will depend on the district in which the work is to be done.

It is interesting to note, however, that Messrs. Bulgins have produced a neon oscillating I.F. liner which works at a set frequency of 465 KCs, thus covering many receivers, a second model being available for 110 KCs. These liners work from a 200-volt or more D.C. supply, and may be connected to the H.T. supply of the set under test. A modulated I.F. signal is fed from the liner in the ordinary way to the frequency changer and I.F. circuits of the receiver. Such a device is highly portable, and may be carried in place of a heavy and bulky signal generator, since it is relatively simple to trim the R.F. circuits of a superhet by ear, working on broadcast signals, once the I.F. has been adjusted. A neon output meter can also be obtained from the same manufacturers, the list figures being VT17 for the 465 KCs. liner, VT20 for the 110 KCs. liner and VT19 for the neon output meter. Naturally these liners cannot take the place of a full range signal generator, and are of value only with a set whose I.F. is exactly that of the liner.

A good valve testing set is, of course, useful for the service man, but is really a shop instrument. The amateur can perform tests just as searching—indeed, often more so—by the use of one or two instruments in a temporary hook-up on the bench, and whilst the valve tester saves time and trouble in that it is always ready for action its expense is not warranted unless a real business is being built up.

A small cathode ray oscilloscope, on the other hand, is always of use to any amateur, experimenter or dealer, especially if it has an auxiliary "wobbulator," the term given to a frequency modulated test oscillator. This is similar to a signal generator which, instead of giving an output on one set frequency, sweeps over a narrow band of frequencies in the I.F. range, this sweep being applied to the I.F. transformers and circuits of the receiver under test. The output from the I.F. circuits is taken to the oscilloscope, whose time base is keyed in with the wobbulator, and as a result an actual pattern of the frequency response of the receiver's I.F. circuits is shown on the screen, the pattern being corrected for the required response by the I.F. transformer trimmers in the usual manner.

An oscilloscope and a modulated test oscillator can be built by any experienced experimenter or amateur, and full details are to be found in the Cathode Ray Oscilloscope Manual, No. 51 in Bernards' list, price 2s.

By the exercise of a little ingenuity, and by using a 1" tube when these again become available, even an oscilloscope can be made portable in any district where A.C. mains are common.

For the service engineer capacity and inductance bridges are available commercially, some of which also measure resistance, but here again these are not really practical for the amateur, unless a home-made article is considered, when the trouble of calibration arises. This is a very real drawback to the construction of much apparatus, since the calibrating of bridges, signal generators and the like is not simple. The best method is to borrow a similar commercial instrument and calibrate the constructed article by direct comparison methods.

Reviewing the situation, the portable kit will consist of the tools, a simple D.C. analyser at least, preferably a more comprehensive instrument, and a circuit tester, including continuity and resistance measuring capabilities. These parts of the portable kit may be packed into the bottom of a stout carrying case, the tools in clips and the test instruments in a covered partition, the signal generator, if of any size, being carried separately. Into the lid of the carrying case may be fitted racks or compartments for the carriage of spare components, together with a six feet reel of resin cored solder, a six feet reel of No. 22 tinned connecting wire and several lengths of insulated sleeving, together with a coil of rubber-covered flex. A reel of insulating tape should also be carried, but its use should be avoided whenever sleeving can perform the work, since tape is liable to dry and crack, giving the impression of a poor job, besides making a bulky covering to a joint.

The spare components should certainly include a representative set of valves, the district power supply again dictating the choice of types, and it is not easy to provide a list of valves all of which are likely to be of value on an outside job. The variety of base connections and pin arrangements complicate the task, and only experience in the district will show what to carry. The choice of components is simpler and the kit should contain at least the following:—

- 2 8 mfd. Electrolytic condensers, 500 v.w.
- 4 0.1 mfd. Non-inductive condensers, 350 v.w.
- 4 0.01 mfd. Non-inductive condensers, 350 v.w.
- 2 0.0005 mfd. Mica condensers.
- 2 0.0001 mfd. Mica condensers.
- 3 60 mmfd. max Trimmers.
- 2 500 mmfd. max Padders.
- 2 500 ohms 1-watt resistors.
- 2 2,000 ohms 1-watt resistors.
- 4 10,000 ohms $\frac{1}{2}$ -watt resistors.
- 4 30,000 ohms $\frac{1}{2}$ -watt resistors.
- 4 50,000 ohms $\frac{1}{2}$ -watt resistors.
- 4 100,000 ohms $\frac{1}{2}$ -watt resistors.
- 2 0.5 megohm $\frac{1}{2}$ -watt resistors.
- 2 1 megohm $\frac{1}{2}$ -watt resistors.
- 1 0.25 megohm volume control, less switch.
- 1 0.25 megohm volume control, with switch.
- 3 American type top grid clips, shielded.
- 3 American type top grid clips, unshielded.
- 3 British type top grid clips, shielded.
- 3 British type top grid clips, unshielded.
- Valveholders, chosen to suit the valves carried.
- 2 short paxolin group boards, fitted with tags.
- 1 range of small tuning coils, such as the Wearite P type, including oscillator coils. Naturally any faulty coil should be replaced by a maker's replacement type, since the substitution of a different coil will upset the receiver's ganging and may, indeed, prevent it from operating at all, but on many occasions it may be possible to keep a set working, at least on the local stations, by fitting a temporary coil whilst awaiting replacements.

2 Screened I.F. transformers, 465 KCs. The same remarks apply, although in the majority of cases the I.F. transformers will have sufficient adjustment to allow their being trimmed into line with the receiver, thus providing a permanent repair.

1 Screened broadcast choke.

2 6.3 v. .3 amp dial lights.

2 lengths of screened, insulated sleeving, 2 m.m.

Assorted soldering tags.

Assorted nuts and bolts, 4, 6, 8 B.A. gauges.

Replacement mains transformers and chokes can hardly be carried in the portable kit, and in any case where such a component has broken down the receiver should be given a thorough bench test to ascertain that no other components have been affected. An output transformer may be carried, if there is room, but since it should be a multi-ratio instrument for temporary insertion into the receiver while a replacement is being obtained, it may be found rather bulky.

One further item of test gear still remains to be described, namely, the signal tracer. The use of such an instrument is still not so widely known in this country as it might be, however, and accordingly the signal tracer is dealt with separately under the next chapter heading. The simplest signal tracer of all, however, the ordinary pair of headphones, should be in every portable kit, since these provide a ready test for all amplifiers and radio audio stages, not only as a sound detector but as a dynamic microphone for giving a quickly applied input speech signal.

CHAPTER 3.

FAULT FINDING AND SIGNAL TRACING.

Servicing, either on the bench or in the home, commences with a general inspection of the faulty receiver, attention being concentrated on the power supply side to ensure that the set can be connected to the mains without further damage either to itself or to the house system. The owner's report is often of little value in tracing the trouble, but it will at least show whether the fault was accompanied by fusing of the circuit, heating in the receiver, etc., and naturally whenever mains circuits faults are suspected great care should be taken to trace any shortcircuit or other dangerous condition which might exist. In a doubtful case the continuity tester is of value, since it can be connected across the mains lead from the receiver. When the receiver is switched on (the mains lead, of course, being connected only to the continuity tester, not to the mains as well), there should be a reading somewhat below top mark, due to the D.C. resistance of the mains transformer. In an A.C./D.C. receiver the same conditions hold, since there is now the resistance of the voltage dropper and heaters in circuit with the tester. If the continuity tester shows a top mark reading, the receiver should not be connected to the mains supply until the short circuit or other faulty condition is rectified.

With the receiver clear, so far as the mains input side is concerned, switch on and allow the valves to reach their operating temperature, listen-

ing for hum. Loud hum shows trouble on the rectified D.C. side of the power pack, and the set should be switched off immediately for investigation.

Presuming, however, that the power pack is in order, it now remains to discover in which stage of the receiver the fault lies.

Probably the first test a radio amateur learns in making up a simple receiver is that for reaction—tapping the grid connection of the oscillator valve gives a loud click when the valve is oscillating and a soft click for the non-oscillating condition. The same test can be applied to the receiver, since any mains set will give a hum or purr when the grid of any valve is touched. Testing by this method should always be carried out stage by stage, working from the loudspeaker back towards the aerial input, and by touching each grid connection in turn will immediately isolate the faulty stage.

Once the stage itself has been found, it too must be tested from output to input side; the output stage, for example, which gives no response to the simple grid check, must be tested from the speech coil of the transformer through the transformer secondary, the transformer primary, the anode circuit of the valve, to ensure that H.T. is flowing, the cathode circuit, to ensure that the biasing resistor has not open-circuited, so that whilst H.T. is on the anode no current can flow, through to the grid resistor which might have short-circuited the grid to earth and made response impossible.

These tests can be carried out by headphones and the D.C. analyser, but headphones are of no use in the R.F. stages, since they are unable to detect frequencies other than audio frequencies. It is here that the signal tracer is of value, and in Fig. 2 is shown the circuit for this instrument.

The majority of commercially made signal tracers are no more than valve voltmeters, sometimes with an audio stage attached, whilst some models are signal generators and signal tracers in one. The input to the radio receiver, however, can be supplied by the aerial, and what is really required is a device that will pick up a signal at any point in the receiver circuit, whatever type of signal is obtainable, ether as a modulated R.F. wave or a demodulated audio signal, amplify that signal and give either an audio output or a visual indication when there is no audio modulation on the wave. The latter case, for example, is met in the case of the oscillator section of a superhet, where an audio indication is of no value since there is no modulation on the oscillator.

The signal tracer, therefore, consists essentially of an input valve which can work on either R.F. or audio signals, a visual indicator of R.F. energy, which can take the form of a Magic Eye tuning indicator, and an audio amplifier feeding into a loudspeaker.

The unit can be provided with its own power pack, or can be plugged into the workshop power pack described in Chapter 1.

For easy connection to the circuit under test valve voltmeter practice is copied insofar as a probe is used for tapping on to the circuit, the probe being an insulated handle containing a prod, the prod being connected to the tracer via screened cable. In order that the probe can be connected to any circuit, irrespective of H.T. voltages, a condenser is inserted into the probe between prod and cable, acting as a D.C. blocking condenser, whilst leaky grid rectification of R.F. signals is provided by a further condenser, and a grid leak which is also the volume control. The Magic Eye is fed from the

diodes of the first valve, a double-diode-triode, which in turn are fed back from the second stage of the tracer in order that a measure of R.F. amplification is obtained.

As may be expected, the whole input wiring as far as the grid of the first valve must be of shielded cable, preferably of co-axial cable but, if this is unobtainable, of single core screened cable. The input valve must also be screened with a valve screening can, since the circuit is highly sensitive and is open to pick up of hum. Further sockets, also wired with screened cable, are provided for the introduction of microphone or pickup leads.

The probe head may be cut from ebonite tubing of diameter sufficient to take the condenser, the head being covered with a shield of sheet copper, or the probe may be made from copper tubing. However it is constructed, it must be shielded and connected to the earthed shield of the cable, the test prod protruding about half an inch and insulated from the shield. One convenient method of connecting the probe head and cable to the tracer is to terminate the probe cable in a telephone jack, a corresponding socket being used on the panel of the tracer, the probe thus being detachable from the main instrument for carrying or storing.

The input valve provides automatic grid biasing through a grid current characteristic, the valve thus dealing with both R.F. and audio frequencies without trouble.

Components for the Circuit of Fig. 2:—

C1, C5, 0.0002 mfd. Mica.

C2, C3, 50 m.mfd. Ceramic.

C4, 8 mfd. Electrolytic, 350 v.w.

C6, C9, 0.01 mfd. Noninductive, 500 v.w.

C7, 0.05 mfd. Noninductive, 500 v.w.

C8, C10, 25 mfd. 12 v.w. Electrolytic.

R1, 1 megohm potentiometer.

R2, 33,000 ohms, $\frac{1}{2}$ watt.

R3, R7, 56,000 ohms, $\frac{1}{2}$ watt.

R4, 2 megohms, $\frac{1}{2}$ watt.

R5, R8, 0.5 megohms, $\frac{1}{2}$ watt.

R6, 1 megohm, $\frac{1}{2}$ watt.

R9, 1,500 ohms, $\frac{1}{2}$ watt.

R10, 0.25 megohms, $\frac{1}{2}$ watt.

R11, 220 ohms, $\frac{1}{2}$ watt.

V1, AC/HL. DD.

V2, AC/HL.

V3, Pen 45.

V4 VME4.

1 7-pin valveholder, chassis mounting, UX type.

1 7-pin valveholder, chassis mounting, British.

1 5-pin valveholder, chassis mounting, British.

1 Mazda Octal valveholder, chassis mounting.

Loudspeaker and transformer, chassis, wire, etc.

The whole signal tracer should be built up in a compact form on a metal chassis, and provided with an overall screen by making a chassis cover of sheet metal such as perforated zinc, an excellent material for covering gear

although it must be worked carefully since, when it is bent along the lines of the perforations it becomes somewhat brittle. Making the bend along a curved edge rather than a sharply cut edge helps, however, both in preserving the strength of the metal and in appearance. These zinc covers can be made and easily fitted to any gear which has its controls on the front of a deep chassis, and all bench gear, as used in the workshop, should have a protective covering not only to exclude dirt and dust but to prevent tools or apparatus from striking the valves or other components mounted on the chassis.

Testing with the signal tracer once again proceeds stage by stage, and for the sake of experience the instrument should first be used on a receiver which is working correctly and connected to an aerial, with a broadcast signal tuned in. The signal tracer is switched on, its earthed lead is connected to the chassis of the receiver and the probe used for the second connection. It should be noted here that in all cases where A.C./D.C. power packs are used, that where two pieces of apparatus are to be connected together, and they both have an A.C./D.C. power pack, there is a grave risk of shorting the mains supply by making such a connection as has just been described. If pieces of apparatus have to be connected under these conditions, the connection in the first case should be made by a neon lamp of 250 volts rating which has leads terminating in insulating prods. If the lamp lights it is immediately shown that the mains leads are crossed, the situation being corrected by reversing one of the main plugs feeding the apparatus. This state of affairs which can only be met within D.C. or A.C./D.C. apparatus, is shown in Fig. 3, and careful note must be made of this point. So far as A.C. apparatus is concerned the transformer integral with each piece of apparatus isolates the mains from the connecting points, and there is consequently no chance of trouble whilst the transformers are in good working order.

With the signal tracer earthed to the receiver, then, the probe is first placed on the aerial input socket. The tracer can rectify, or detect, signals but cannot tune to any particular frequency, so that the tracer loudspeaker will give a jumble of stations. Transferring the probe to the grid of the first valve puts the receiver tuned circuit into circuit with the tracer, and now the station to which the set is tuned will also be heard in the tracer loudspeaker. It should be noted that connecting the tracer to the tuned circuit will alter the loading on that circuit, so that whenever the tracer is coupled to the tuned stages of the set, the tuning dial should be "rocked"—that is, turned back and forth through a small angle, to ascertain whether the tuning is still correct.

For work on the early stages of the receiver the volume control of the signal tracer will require to be fairly well advanced, but as the signal is amplified in the successive receiver stages the control can be turned back to keep the signal within comfortable limits.

Presuming the first valve of the set under test to be the frequency changer, transfer the tracer prod to the anode of the oscillator section. No sound will be heard in the tracer's loudspeaker, except that in some cases there will be a low hiss, but the Magic Eye of the tracer will close, showing the presence of an unmodulated R.F. carrier.

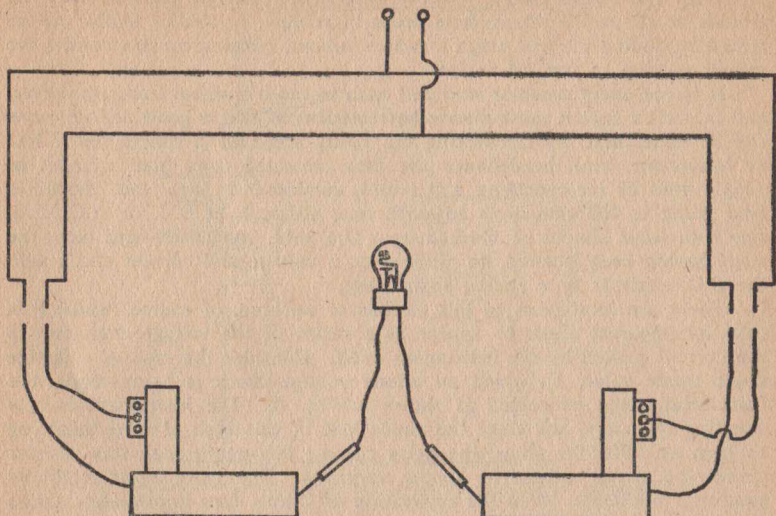

FIG. 3.—Showing mains crossed by connecting two pieces of A.C./D.C. apparatus with Neon check 1 amp. in use.

The Eye, of course, will flutter on all sound signals, but where R.F. is also present, that is, in circuits where the sound is carried as modulation on R.F. energy, the Eye will both flutter and close to a degree dependent on the strength of the carrier R.F. Thus it enables R.F. bypassing and leakage to be tested.

The test now proceeds through the circuit, the probe being applied to the primary and secondary windings of the first I.F. transformer, the grid and anode of the I.F. valve, the windings of the second I.F. transformer and so to the diode detector, where the R.F. indication of the Eye will give place to the audio flutter. As the amplifying stages of the receiver are reached, either the triode of a double-diode-triode, or the output valve, the signal will be so strong that merely approaching the probe to the anode of the valve will probably give quite good loudspeaker output from the tracer.

The output transformer can also be tested using the probe, of course, although in some receivers it may be necessary, when testing the secondary, or speech coil side of the output transformer, to remove the tracer's earth clip from the receiver chassis and connect it to one side of the transformer secondary, touching the probe to the other.

The signal tracer, then, is a rapid and certain tester of a receiver, for not only can the incoming signal be traced up to the stage where it disappears, and all the signal circuits of that stage tested to isolate the component or circuit wherein the fault lies, but a check on distortion throughout the set can be made at the same time, which, as any service man will agree, is a real asset. In general it may be said that a set which refuses to work at all is a simpler servicing job than the receiver which develops distortion, or which has intermittent volume changes.

With the signal tracer, however, distortion can be tracked with no trouble at all, whilst intermittent drops of volume, or similar faults, can be traced by finding the first stage in which volume remains constant whilst the output volume of the set varies.

It is not every amateur who will wish to build a signal tracer, however, and in such a case it must always be remembered that a good deal of work can be done, first, by discovering the faulty stage by a simple touch test or headphone trial—headphones are best protected from high voltages or supply lines by incorporating a 0.1 mfd. condenser in one lead, the other lead going to the chassis as an earth line, although in D.C. or A.C./D.C. sets both leads should be blocked by a 0.1 mfd. condenser—and then, the stage having been isolated, to proceed on a voltage and current check with the D.C. analyser or a similar instrument.

There are limitations to this method of working, of course, whilst it is easy for apparent faults to appear as a result of the voltage drop due to the current passed by the instrument itself. Consider the case of a double diode triode valve, on which an anode voltage check is being made, the instrument being connected as shown in Fig. 4. The instrument is now shunting the valve, and since the anode load of this type of valve might be as high as 100,000 ohms, the extra current flowing through this resistor causes the anode voltage to appear very low. The valve itself might be passing 1 milliamp., when the application of Ohm's Law immediately shows that the voltage drop in the anode resistor is $V = R.I.$, or, remembering to express the current, I , in terms of *amperes* (not milliamperes)

$$V = 100,000 \frac{1}{1000} \text{ which gives}$$

$$V = 100 \text{ volts.}$$

Therefore, presuming the supply line voltage to be 200 volts, with the drop in the load resistance, as shown, 100 volts, 100 volts are on the anode.

This is not the figure, however, that will be shown by a voltmeter. The shunt circuit, shown in Fig. 4, draws its own current through the anode resistor too, and in a 1,000 ohms per volt instrument, switched to the 100 volts range, this resistance across the valve is 100,000 ohms. That means that there are now two resistances in parallel, the resistance of the meter and the internal resistance of the valve, which, since the valve is taking 1 milliamp. at 100 volts may be taken as 100,000 ohms also.

The total resistance of two equal resistances in parallel is

$$R_t = \frac{R^2}{2R}$$

so that the total resistance of the valve and the voltmeter in parallel is 50,000 ohms. The total load across the 200-volt supply, counting in the anode resistor, is therefore now 150,000 ohms, so that across each 50,000 ohms of the chain of resistances there appears a potential difference of

$$\frac{200}{3}$$

or, in other words, the anode voltage of the valve, immediately the voltmeter is connected to it, becomes, not 100 volts, the true working figure, but 66.6 volts, a high percentage of error.

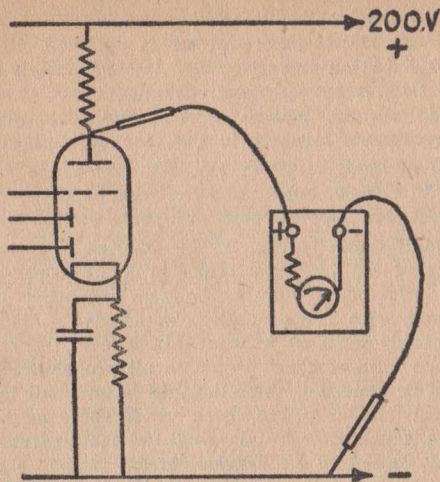

FIG. 4.—Voltmeter giving parallel circuit and causing error in voltage drop.

The position is improved, however, by switching the voltmeter to a higher range, for the shunt resistance becomes higher. Using the 1,000 volt range of the analyser containing a 1 mA. instrument the range resistance is 1 megohm, so that, considering the valve's D.C. resistance to be still 100,000 ohms, the total resistance of the parallel circuit is

$$\frac{1}{R} = \frac{1}{100,000} + \frac{1}{1,000,000} \quad \text{or } R = \frac{1,000,000}{11}$$

or $R = 90909.09$ ohms, very nearly the resistance of the valve alone. The total resistance across the 200-volt supply is now 190,909 ohms, and the voltage shown at the valve anode when the instrument is connected in circuit is, therefore, 95.2 volts, are figures much nearer to the working figure of 100 volts. The extra accuracy, however, is off-set by the fact that the voltmeter is reading over only one-tenth of its scale.

When measuring anode and screen voltages, therefore, or when measuring voltages in any circuit containing high resistances, the effects caused by the instrument current must be allowed for, and it must be remembered that an error is introduced into the circuit with the connection of the voltmeter, the error decreasing with each higher voltage range of the instrument.

In the same way it is not possible to check the bias voltage of valves with a high degree of accuracy. Connecting the voltmeter across the bias resistor puts the voltmeter resistance in parallel with the bias resistance, thus reducing the overall resistance and reducing the bias voltage, whilst connecting the voltmeter across the grid and cathode pins of the valve tends to cause a flow of grid current through the relatively low resistance path of the voltmeter, which, of course, upsets the whole working of the valve.

Undoubtedly the best method of taking readings in a valve circuit is to break the cathode circuit before power is supplied, to introduce the milliammeter, switched to the correct range, into the break and then, with the power on, to take cathode current readings of the valve. These can then be compared with the makers' figures for that valve, adding the anode and screen currents together in the case of multi-electrode valves.

The deduction of likely faults or troubles from these figures calls for the exercise of a little logic, but a good deal can be done, especially when the obtained readings are supplemented with some continuity tests.

Consider the fault shown in Fig. 5, the diagram of a simple I.F. stage with the secondary of the I.F. transformer broken or open-circuited. The touch test on the grid would now be far from conclusive since the valve itself is working and, with a floating grid, would give a loud hum—indeed, the set would probably have an increased hum level before the grid was touched. A cathode current check would in all probability show a higher current than would be expected, since the grid is unbiased by the break in the circuit, whilst an anode voltage check would show an even lower voltage than might be expected even allowing for the instrument drop, this lower voltage being caused by the heavier current causing a greater voltage drop in the anode load circuit. All these points taken into consideration would direct attention immediately to the grid circuit, and the continuity tester applied between grid and earth would show an open, or at least a very high resistance, circuit.

The tracing of distortion, or intermittent volume changes, when the work is to be done without a signal tracer, is not at all simple, although

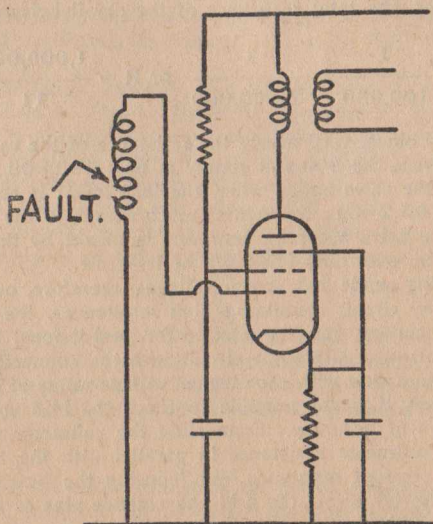

FIG. 5.—Simple I.F. Stage with opened grid circuit.

the output or audio stages should always be suspected first and tested with the headphones. The writer was recently shown a receiver in which distortion had suddenly arisen after it had been out of use for a week or two, and from the quality of the sound the emission of the output was suspected, since the characteristic overloaded tone was present. As a quick and simple test the output valve was removed from its holder, headphones were plugged into the grid and cathode sockets and it was found that the signal from the diode detector as fed into the output valve was faultless. A resistance check across the cathode socket and the earthed chassis showed that the bias resistance was in order (it was thought that the bias condenser might possibly have short circuited and thereby removed bias from the grid of the output valve) whilst, with the valve in place again the anode voltage was checked and found to be correct.

A new valve was straightaway plugged in, and the receiver once more functioned correctly.

This, however, was a perfectly straightforward case of distortion caused by the age of the valve, which had dropped emission, and the trouble is not always found so easily. One point in the circuit which should always be checked early in the proceedings, however, when distortion arises, is the coupling condenser to the output grid from the anode of a preceding valve. In the case of the diode detector set, just quoted, it was known that there could be no leakage of H.T. onto the output valve's grid through a faulty condenser, but where a double-diode-triode feeds the output stage the condenser is then in a position to make the grid of the last stage positive, should a fault or leak occur in it. Often a slight leak can make the grid of the output stage positive only to a slight degree, when the biasing of the valve saves it from harm even though distortion may arise, but anything more than a very slight leak will cause the bias to be overcome by the positive potential applied to the grid, grid current flows, bad distortion arises, and, more often than not, the valve is ruined by the greatly increased emission of electrons from the cathode.

The age of the valves should often provide a useful pointer in the tracing of distortion. Obviously, in a receiver which has been running properly, the introduction of distortion means that some deterioration is present, the valve being the least robust and the most hardworked component to suspect. Bypassing condensers, however, especially on the audio side, should be next on the list for inspection, especially where H.F. pentodes are used for audio amplification as in so many gramophone and microphone amplifiers. This type of valve should normally have at least a 0.5 mfd. condenser from the screen to earth, and very bad distortion will be caused should the condenser become open circuited.

Ordinary H.T. bypassing, however, can cause as much trouble when a fault develops in the condensers which, in the case of the larger sizes, are not simple to test. Possibly the best test for a suspected 8 mfd. condenser when the work is being done away from the bench and more elaborate test gear, is to test the condenser across a 200-300 volt D.C. line which can be provided by the power pack of the receiver under test, as long as there is no other fault in the circuit which makes it impossible to run the set. The condenser should be connected across the supply, making sure that the

polarities are correct, of course, in series with a 200 volt neon lamp. As the condenser charges the lamp should flash, the light rapidly diminishing to extinction, the condenser then being passed as good. If there is no flash from the lamp, the condenser is undoubtedly open circuited, but the testing of a leaky condenser is not so simple. The electrolytic condenser always passes a small current which, in some cases, may be sufficient to keep the neon lamp barely alight, so that judging in such a case is rather difficult. A bad leak, however, will allow the lamp to flash up at full brilliance and stay in that condition, when the condenser may be immediately condemned.

If a neon lamp is not available, the D.C. analyser may be used, switching in the highest current range in series with the condenser, a series resistance of 500 ohms also being in series with the circuit for the first test. As the condenser charges a flick of the instrument pointer will be seen, the pointer returning to zero. If this occurs, the condenser may have a slight leak, which can be observed by leaving the circuit connected and the condenser charged and switching the milliammeter to higher sensitivities stage by stage, watching the pointer reading. If the 1 mA. range is reached, and a current of only a few microamps is shown, the condenser is in perfect condition. No flick of the pointer as the condenser is connected up shows an open circuited component, whilst a steady reading on the first test when a high range is being used shows a bad leak.

The milliammeter, in these tests, must be used with extreme caution since charging or discharging an 8 mfd. condenser through the instrument can easily result in a burnt out movement. The series resistance of 500 ohms is a safety measure which, in conjunction with the highest range of 1,000 mA. should protect the instrument in all eventualities. It must also be remembered, however, that should this circuit of series resistance and instrument be shorted inadvertently across the power pack supplying the test voltage, a high current would flow, and possibly damage the supply source.

In all these tests, therefore, the greatest care must be used at all times.

Testing the smaller type of condenser, the 0.1 mfd. and 0.5 mfd. condensers, for leaks, is still more difficult since in their case the charging current is hardly sufficient to cause a flick on the instrument and the leaks themselves are generally of such high resistance that no more than a microamp or so is flowing.

Where a leak through to the grid of a valve is suspected perhaps the best test is to remove the valve and to conduct a voltage check from the grid socket of the valveholder to earth, the set being switched on, using various ranges of the voltmeter, working from the highest to the lowest range. At no time should any reading be given by the instrument, and if a reading is shown the condenser should be replaced and the test given to the new component.

Intermittent volume changes are generally traceable to condensers although this fault may occur in any stage of the receiver. Soldered joints are often suspected when volume changes occur, but in the majority of cases, in the modern set at least, the joints are above suspicion. In the last resort the receiver may be switched on and tuned to a signal, the

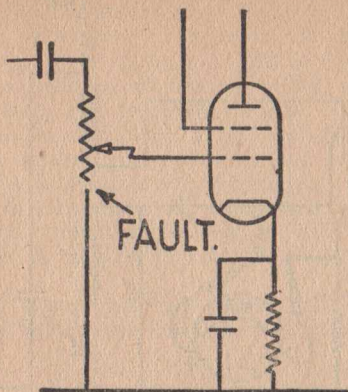

FIG. 6.—Unearthed grid.

condensers being lightly tapped one by one to discover any faulty components. Resistors do not generally deteriorate unless they are overrun, when the resistor in question will immediately be traced by its charred appearance, but even when quite a heavy overload is imposed the resistor usually operates, although with a change of resistance value, until it burns out and its circuit goes dead.

Distortion and overloading can be caused, especially in an audio circuit, by the failure of a grid resistor, but the writer has rarely seen an open circuit resistor of the carbon type other than burnt out resistors, nor an open circuit wire-wound resistor which has not been subjected to physical stresses.

Potentiometers and volume controls cannot be included in these last remarks, of course, since both the carbon composition track and the wire-wound types are subjected to a good deal of wear. The carbon track potentiometer used in a current carrying circuit—as a tone control or regeneration control, or as a bias control in a cathode circuit, for example, often shows signs of pitting if the moving arm commonly takes up the same or about the same position on the track, when noise will be caused, but potentiometer faults are recognisable by the effects heard when the control is moved and rarely cause distortion or intermittent volume changes. A break in continuity at one end of the track will put the control out of action, but may not necessarily cause the signal to disappear. The break in a volume control as shown in Fig. 6, for example, will cause distortion and overloading effects, which might be described as a harsh, choked quality in the reproduced sound, but since volume will be up and the control without effect the trouble would be simple to trace.

Another circuit position in which the milliammeter can immediately call attention to a fault which would prevent any superhet from working is in the grid leak of the oscillator portion of the frequency changer valve, the point of insertion of the instrument being shown in Fig. 7. Practically all

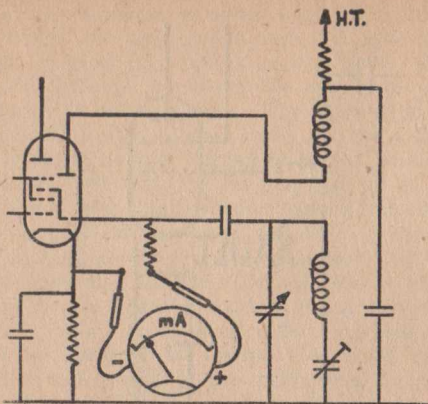

FIG. 7.—Milliammeter Test of oscillator self bias.

superhet oscillators, as may be seen from a glance at a series of circuit charts or blueprints are self biased—that is to say that in each cycle of oscillation the grid of the oscillator becomes momentarily positive so that grid current flows. Since the current flow must be through the grid resistor, generally of a value of about 50,000 ohms, a voltage drop is set up across the resistance between grid and cathode which serves to bias the grid negatively, the relationship between the resistor value, the grid condenser value, and the frequency of oscillation being arranged in such a way that the bias, so obtained, is held on the grid and does not fluctuate with the oscillating voltage on the grid condenser.

If the oscillator, then, ceases to function for any reason at all the bias on the grid immediately disappears, allowing a rather greater current to flow through the anode circuit with a correspondingly greater voltage drop. As we have seen, however, it is not simple to obtain a valuable reading from the anode of the valve, and if the oscillator is suspected the one definite test is to break the junction of the grid resistor with the cathode line, inserting a milliammeter switched to the 1 mA. range, and then to switch on the receiver. If no reading is obtained it is then certain that the oscillator is not functioning, but any reading however small indicates that the oscillator is probably working. Again, first suspect the valve itself, since in many receivers the frequency changer is the first valve to show a bad emission loss. Provided that there is no obvious circuit defect (i.e., quickly check that there is voltage on the oscillator anode, and, with the continuity tester, prove that the oscillator grid coil and anode coil are not open circuited) insert a new valve of the same type into the frequency changer socket. In the majority of cases this will cure the trouble.

Often a set will be reported to fail to operate when first switching on, although if the receiver switch is rapidly turned off and then on once more the set will work well. Here again the oscillator valve is immediately suspect, since the first sign of failing emission is that it requires an electrical

shock or jerk to set the oscillator going. Switching off and then on again provides this, since at the first switching on the valve heater warms up slowly, the anode current rising slowly so that no sudden supply of power is provided. At the switching off and on for the second time, however, the cathode is hot and ready to supply electrons, so that it is the anode circuit which receives the slight surge caused through the switching process. This is sufficient to set the circuit oscillating, and thus to bring in signals.

Again, all that is required is a new frequency changer valve. It may be, of course, that in such a case the switch itself is faulty, but obviously this is checked without trouble by watching the valve heaters, since if they come into operation at the first turn of the switch the power supply is clearly faultless.

So far, isolated examples of fault tracing have been given. The following chapters deal with trouble tracking on circuits as a whole.

CHAPTER 4.

FAULTS IN THE POWER PACK.

It has already been said that before any faulty receiver is switched on the power pack should be inspected for trouble, and that it should be ascertained as far as is possible that switching on the set will cause no further damage.

Unfortunately it often occurs that where a fault has arisen in the power supply unit no more damage can possibly be inflicted for the simple reason that the unit is "burnt out"—that is, either the transformer has been ruined or the valve has broken down or both together.

In Fig. 8 the simplest A.C. power pack circuit is shown, the basic circuit for any power unit designed to operate solely on A.C. mains. All too often the fuse bulb shown in the main H.T. negative lead to the chassis is omitted, so that its inclusion in the diagram might be questioned, but it is such an essential component in the writer's view that it is shown here as a reminder. The writer always includes such a fuse when rewiring or attending to power pack troubles, and on all his personal equipment.

The weakest link in any power pack is the reservoir condenser C1, generally of 8 mfd. capacity. The working voltage of the condenser should be the highest obtainable, as a measure of safety, and also any condenser used in this position should have an A.C. rating of 100 mA. A.C. at least.

The condenser has across it a peaky voltage, so that it is charged not by a steady current flow but by impulses, its discharge into a constant impedance presented by the smoothing choke and the rest of the receiver or gear, being more constant. Conditions are such that there is a flow of alternating current, measured in milliamps, through the reservoir condenser, and a poor component will heat up, break its insulation and ultimately short circuit.

When this state of affairs arises the two halves of the transformer secondary are alternately short circuited to the centre, or earthed point, through the valve, so that the valve has to stand a full load current which,

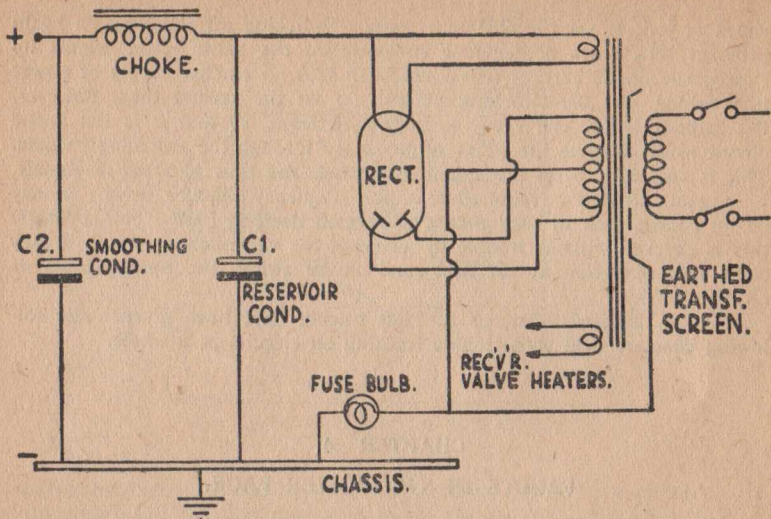

FIG. 8.—The A.C. Power Pack.

since its internal impedance is low, will rise to a very considerable figure. Generally the rectifier arcs over, the current rises still higher in a split second, and the transformer windings, tremendously overloaded, fuse.

This happens when the fuse is not in circuit. As can be seen, all the current drawn from the transformer H.T. secondary has to flow through the bulb, so that when any short circuit, either in the condenser or in the receiver, draws a high current, the fuse bulb is now the weakest link and blows before damage is done. On the other hand the fuse bulb must not be too conservatively rated, since as the rectifier valve heats and passes current there is a surge caused by the preliminary charging up of the condensers, and the fuse must be capable of withstanding this first flow of current.

In general, the writer has found that a 2.5 volt flashlamp bulb gives excellent protection to any ordinary circuit where the rated H.T. current is up to the usual figures of between about 75 to 100 mA.

The smoothing condenser, C2, of a value ranging from 8 mfd. to as high as 32 mfd. with a working voltage of about 500 volts is rather less likely to give trouble since it is working under less arduous conditions than is C1. It may dry up, in an old set, and become to all intents and purposes an open circuit, so that a very high hum level is imposed on signals, but this will cause no actual damage and all that is required is a new condenser. If the smoothing condenser should become internally short-circuited the current flow will be reduced by the choke, which is often the energising, or field, winding of the loudspeaker, the D.C. resistance in such a case being fairly high—seldom less than 1,000 ohms, and sometimes as

much as 2,000 ohms. The current which will flow, therefore, in the event of a shortcircuited smoothing condenser, may or may not be sufficient to blow the fuse bulb, depending on the resistance of the choke, although in general the current will be rather higher than the valve's rated load, so far as the rectifier is concerned, and higher than the rated load of the transformer. In general, however, this fault does little damage since the set refuses to operate and is switched off, whilst the first inspection will reveal the trouble if the simple precaution of a voltage measurement across the output lines of the power pack is made. The voltmeter across C1 will show about the normal voltage, or a little lower, whilst across C2 there will be only a negligible reading, so that the smoothing condenser is shorting or the choke is open-circuit. The choke, however, will probably warm up so quickly that a current test will be unnecessary.

It may be as well to mention here that if a power pack is disconnected from its receiver or other gear and then switched off, the condensers are left charged and capable, for a time at least, of giving a bad shock to an unwary hand. Several manufacturers fit a bleeder resistance to the power pack, which not only discharges the condensers rapidly when the apparatus is switched off, but also assists in regulating the power pack output. The bleeder resistance is connected directly across the power pack output lines, that is in parallel with C2, and should have a resistance such that it consumes about 10 per cent. of the receiver load. Thus, if the receiver requires 80 mAs. for its operation, the bleeder resistance should draw a further 8 mAs. so that its resistance is given by

$$R = \frac{V}{I}$$

I, the current, again being stated in amperes as is required by Ohm's Law.

Thus for a power pack with an output voltage of 300 volts the bleeder resistance in the above case is

$$R = \frac{300}{0.008} = 37,500 \text{ ohms.}$$

The watts rating of the resistance may be taken as voltage multiplied by the current 300×0.008 or 2.4 watts, so that a 3 watt component would suit. This resistance is rather higher than that of some bleeder resistances and values down to 10,000 ohms are quite common.

One fault which may prove difficult to trace, but which is not common, is a short circuit to earth inside the choke or speaker field. At first it would appear as a shorting smoothing condenser, particularly since the field winding would heat up to some degree, but current tests on either side of the field winding would show that current was flowing into the choke but not out along the proper path, leaving only one deduction to be made.

Transformer faults are possible, the most likely troubles being leaks or short circuits between the rectifier heater winding and the H.T. secondary or shorting turns in any winding.

A short circuit between the two windings mentioned causes a high voltage, generally the full secondary voltage, to appear directly across the

rectifier valve which arcs and breaks down, the transformer probably burning out at the same time. In this case the fuse is of no use, since all the current flow is in the closed circuit of valve and transformer windings, but the fault should not arise unless the transformer has been damaged in some way that has broken down the inter-winding insulation. The testing of transformer insulation requires a megger working at a fairly high voltage for the test to be of real use, but a component which broke down in such a way would be poor indeed. The transformer with shorting turns is not too uncommon, and the only remedy is to have it rewound. Discovering the winding in which the shorting turns are present is simple, the fault first showing itself as poor operation of the receiver with the generation of heat in the transformer. In a severe case the transformer will burn out with the emission of a great deal of smoke and melted waxes and varnishes.

When any turns short circuit on any winding, they form a closed circuit of very low resistance. In this closed circuit, therefore, a very high current is generated which heats the shorting turns often to red heat. Insulation breaks down, further turns short into circuit, the resistance falls again, and so the effect is cumulative. The output voltage of any secondary falls, when it contains shorting turns, whilst if they occur in the primary all the secondary voltages fall below normal. The faulty winding is thus traced without difficulty, but in any case the transformer must be removed and replaced.

The A.C. power pack shown is known as a condenser input filter type, since the valve rectifier feeds into a condenser, C1. In some cases, however, C1 is omitted and the power pack becomes a choke input filter type, although this is generally used on apparatus other than the ordinary receiver, and in consequence is not often seen in the ordinary course of radio servicing.

The metal rectifier type of A.C. power pack may or may not include an H.T. transformer, but the remarks concerning the valve rectifier power supply also apply insofar as the choke and condensers are concerned.

The A.C./D.C. power pack with valve rectification is shown in Fig. 9. Apart from the absence of the transformer the chief differences are in the insulation between the rectifier valve's cathode and heater, which must be perfect, in the provision of a dropping resistor which controls the supply to the heater chain of the receiver valves, this resistor generally being rated as an 0.2 amp or 0.3 amp resistor depending on the valves being used, all of which, of course, must take the same heater current since they are all in series.

One other change may be in the reservoir condenser which may now rise above 8 mfd. in capacity, whilst the smoothing condenser will almost certainly be of 24 mfd. capacity at least, since the rectification is now only half wave instead of the A.C. power pack's full wave rectification, so that greater smoothing is consequently required.

So far as the condensers and choke are concerned the same faults as already discussed may arise, and the same tests may be used, the additional chance of trouble lying in the possibility of a failure in the rectifier's heater-

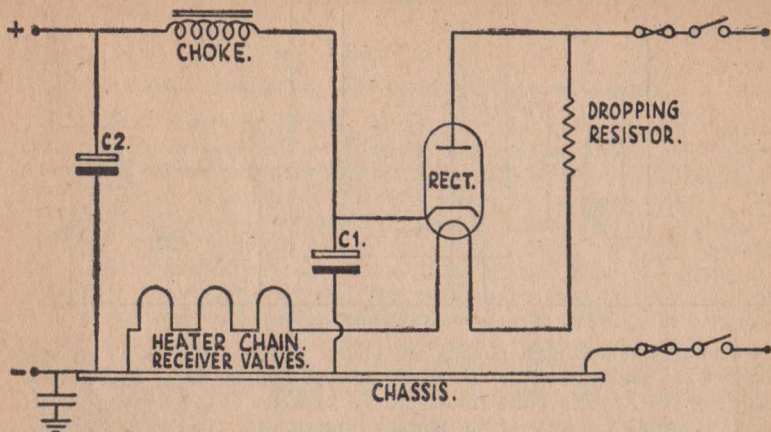

FIG. 9.—A.C./D.C. Power Pack.

cathode insulation. If this should occur the mains supply is shorted through the rectifier valve, with its immediate failure and the probability of the blowing of the mains fuse. Others of the valves in the heater chain may also be damaged if this fault does arise, but generally the rectifier heater breaks before other harm is done.

It must always be remembered that the A.C./D.C. set is "alive" to the mains, and must never be connected directly to earth. A condenser not higher than 0.1 mfd., and preferably of 0.01 mfd. capacity, rated at 400 volts working or more must be in series with any earth lead, whilst when using an A.C./D.C. amplifier or similar gear it must again be remembered that microphones or pickups may be "alive" to earth.

The fitting of a fuse to the A.C./D.C. power pack is less simple than was the case with the A.C. power pack, since it is difficult to protect the heater chain and H.T. side at the same time. Possibly the best method is to fit fuses into the two mains leads using a double way fuse box of small construction such as is provided by one or two manufacturers, fitting fuses of 0.3 amp ratings where 0.2 amp valves are used, and 0.4 amp ratings where 0.3 amp valves are used, this allowing a further 0.1 amp in either case for the H.T. flow. In many receivers a dial light in series with the heater chain acts also as a fuse.

A metal rectifier used in place of the valve obviates the weak link of cathode-heater insulation, the dropping resistor feeding directly into the receiver heater chain, the power circuit otherwise remaining as shown. The A.C./D.C. power pack, when used on D.C., will only supply current when connected properly, the valve or metal rectifier then acting merely as a resistance. Reverse the mains plug when such a receiver will not operate on D.C.

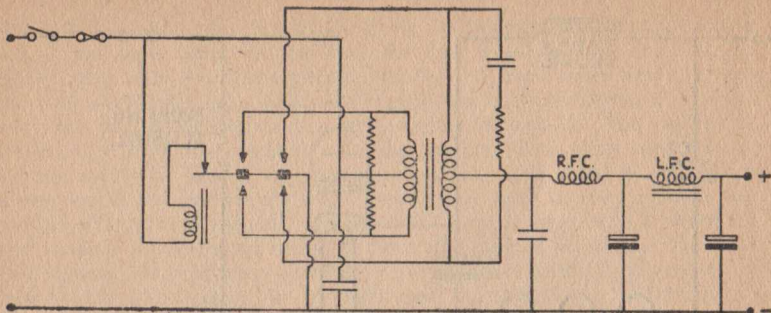

FIG. 10A.—Synchronous vibratory power pack.

Vibratory power pack circuits are shown in Figs. 10a and 10b, one being of the synchronous or self rectifying type and the other of the valve rectifying type. The chief trouble to be expected in a vibratory power supply is ageing and wear of the vibrator contacts with consequent sparking, inefficient operation and the introduction of hash to the receiver. In a vibrator where the wear is bad the contacts may finally arc to such a degree that they weld together, causing a short circuit on the heavy current primary side and most probably fusing the transformer in a very short time. The valve rectifier, like that used in the A.C./D.C. power pack, has an insulated heater and cathode, a short circuit of H.T. being caused if this insulation breaks down.

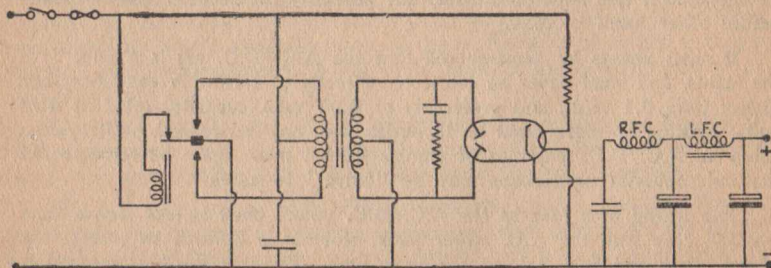

FIG. 10B.—Valve rectified vibratory power pack.

In the self rectifying vibrator supply, it is possible under some conditions to reverse the output voltage polarity. If this should occur the filter condensers, if of the electrolytic type, will suffer, and whilst they may not break down in such a way as to cause a short circuit and overload damage to the transformer and the vibrator contacts, they will require to be replaced.

Arcing at the contacts, due to age or wear, cannot be remedied, and a new vibrator must be fitted. Any endeavour to reset the contacts will only result, in all probability, in causing more damage through arcing and welding.

The condensers and chokes of the power pack filter may be tested as already described, whilst if any of the buffer condensers or resistors are replaced, the same valves must be adhered to strictly.

CHAPTER 5.

FAULT FINDING—THE RECEIVER AS A WHOLE.

Of great assistance to any service man are manufacturers' Service Sheets, which are printed, with circuit diagrams and details, to outline the technical data concerning each separate radio receiver model which is built. Generally speaking such service sheets are available only to the accredited service man or radio engineer, or to others in a professional capacity. (Many technical schools and night schools now run evening classes with examinations connected with the British Radio Manufacturers' Association, the certificates gained by passing such examinations giving status to a service engineer.) In general, however, many repairs can be given purely on inspection alone, but access to makers' information must be found when receivers are to be lined up since the original intermediate frequency must be known, whilst there may be special points of consideration for individual receivers.

These, however, are personal problems for personal solution.

The circuit shown in Fig. 11 is of a typical superhet receiver, and it is proposed to go through this circuit, imagining a whole array of faults, affecting every stage, to see what the behaviour of the set would be in each case. It is not suggested, of course, that all the faults to be described would or could occur all at once!

The testing will be by inspection and an analyser instrument, with the help of headphones or a signal tracer, together with a continuity tester or ohmmeter. It should, perhaps, be pointed out that the circuit shown is not that of either a commercial or a home-built receiver, since it was "designed" for the purposes of this chapter, but there is no reason why the set, as shown, should not give a good account of itself, properly ganged and trimmed.

The aerial feeds through an isolating condenser to aperiodically coupled tuning coils, A.V.C. being applied to the frequency changer signal grid via a resistor, a blocking condenser isolating the A.V.C. circuit from the tuning coils. In the oscillator section the anode circuit is tuned instead of the grid, the wavechange switches S1, 2, 3 and 4 being ganged, as, of course, are the tuning condensers of 0.0005 mfd. capacity. Wearite P type coils are shown, with their recommended padding and trimming values. A.V.C. is applied to the I.F. stage in the usual series connection rather than the shunt connection as used for the first stage, and the signal passes by way of the second I.F. transformer to one of the diodes of a double-diode-triode. The triode section, however, is not used on radio signals, since it would provide a feed strength sufficient to overload the output valve. It is reserved for the gramophone as a pre-amplifier, and there will be sufficient gain in the two valves to permit of a simple tone filter across the pickup if desired. The volume control is therefore switched either to radio or gram by a two pole two way switch which, when the gramophone circuit is in use, earths the output from the second I.F. transformer, whilst disconnecting the pickup from the circuit still leaves the triode biased through its 1.5 megohm grid resistor.

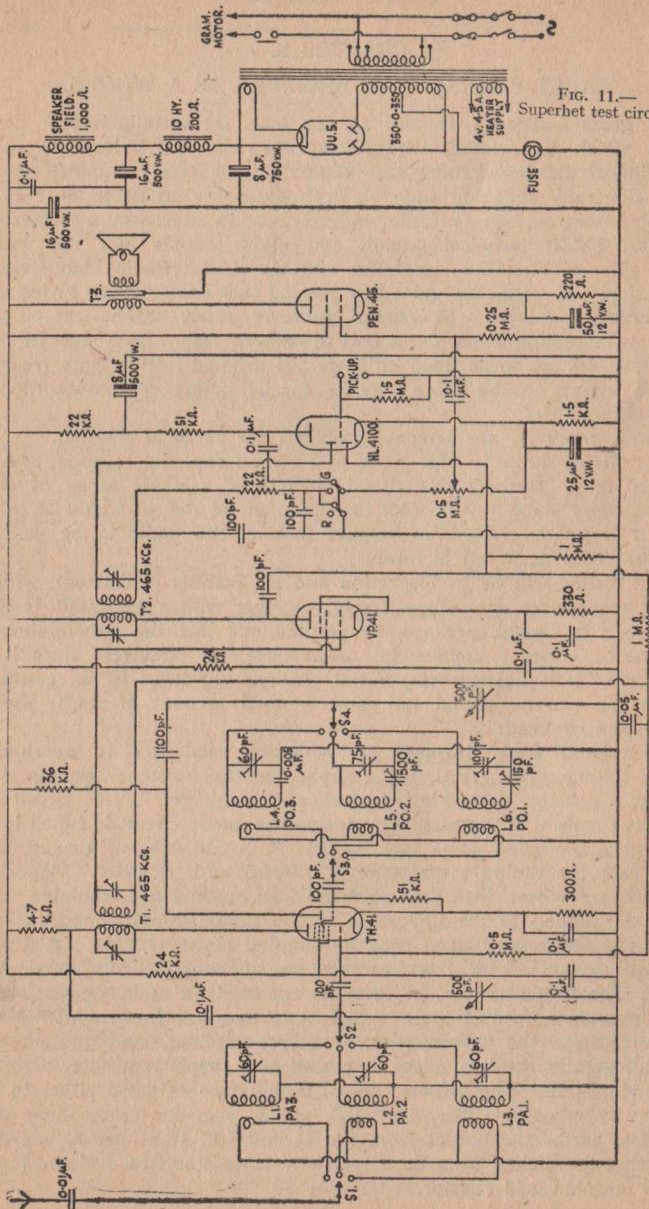

FIG. 11.—
Superhet test circuit.

The A.V.C. voltage is derived from the second diode which is fed directly from the I.F. valve's anode through a 0.0001 mfd. condenser.

The output stage is purely conventional, although there is more H.T. filtering than usual to give a low hum level.

This receiver, then, to which a whole chapter of accidents has occurred, is brought in for servicing.

The report states that the set is 5 years old, has had no service work performed upon it previously, and that no signals can be obtained on either Radio or Gram.

The set is removed from its cabinet for servicing, and given a visual inspection before switching on, and it is discovered that the fuse bulb has blown.

The means obviously that there is a short circuit or low resistance path to earth, possibly in the power pack, so that the continuity tester or ohmmeter is used across the points of final H.T. supply, that is from the earthed chassis on one side to the top of the output transformer primary on the other. A resistance of about 1,100 ohms is read, and since there are no voltage dividing circuits in the receiver the low resistance path is probably in the power pack. A second resistance reading, taken from the junction of the loudspeaker field and the 10 henry choke to earth, reveals a resistance of only 100 ohms, so that it would appear that the trouble is in the choke. When removed from circuit, this is verified. Its frame, mounted on the chassis, is naturally earthed, and a fault has developed in the winding so that a short circuit to earth is made. There are no signs of burning, but the component cannot be used without its being rewound. A temporary choke of about the same characteristics is inserted into the circuit.

Note that if a replacement choke is not to hand the output from the rectifier could be fed directly to the speaker field, but in this case it must be remembered that the first of the two 16 mfd. condensers must be disconnected. Leaving it in circuit with the 10 henry choke shortcircuited would place a total of 24 mfd. across the rectifier valve, which would lead to trouble.

The failure of the choke will have placed a heavy load on both the transformer and rectifier, but since the fuse has blown they were probably protected from ill effects. An inspection shows that this appears to be so—there is no burning visible, and the valve heater shows continuity, so the fuse is replaced and, the temporary choke in circuit, the power pack is again tested with the ohmmeter across its main output points. This time the resistance is shown as nearly Infinity on the scale, so that the receiver can be connected to the mains supply and switched on. The fuse is watched as the switch is contacted, but all is well, and the rectifier and receiver valves heat up with no other faults appearing in the power pack.

The voltmeter, switched to a high range, is left coupled across the main H.T. supplies as a further check, however, and shows a steadily rising voltage as the rectifier comes up to operating temperature, but no sound is heard in the loudspeaker, although a slight hum might be expected. Removing the voltmeter connection from the positive line does not cause any click.

It now appears that the set must be inspected with the power supplies on, and the appropriate precautions are borne in mind hereafter. An aerial is now connected to the receiver's aerial socket, the waverange switch being set to "medium."

Operation of the Radio-Gram switch still causes no sound to be heard, so that there is obviously a fault in the output stage. The voltmeter, connected to the output valve's anode, shows the expected reading, and there are also volts on the screening grid. A quick check on a lower range across the bias resistor shows that the Pen 45 is drawing current since a reading only slightly below the correct 8.5 volts is obtained, the drop being due to the voltmeter shunting effect, so that the voltmeter is switched back to the high range and put to one side. (Always switch back to the high range when the analyser is not in use, even after making a milliamp. check.)

The signal tracer, or at least headphones, are required for the next check. If headphones are used, make sure that one lead has an isolating condenser of 0.1 mfd. capacity in place. The signal tracer or headphone set is clipped directly across the primary of the output transformer, and immediately valve noise is heard whilst the receiver's own loudspeaker is still dead.

This means that the output valve is working into a dead load of some description, so that the receiver is switched off whilst further investigations are made. The output transformer primary is obviously in circuit, since it is passing current, and is probably not short circuited since there are signals, i.e., valve noises and hum, across it. This is checked by the ohmmeter, however, and a reasonable reading obtained across the primary—the figure is quite low.

The continuity tester must now be tried across the secondary of the transformer and the speaker voice coil, one of the connections between the two being broken for the purpose so that they can be tested separately. The output transformer is found to be in good condition, its secondary registering practically a short circuit, but the speaker voice coil is found to be open circuited. Inspection shows that the break has occurred at one of the anchoring points where the flexible leads are attached to the fine voice coil wire. The joint is remade very carefully, the fine wire being cleaned of enamel by the use of methylated spirit and extremely light scraping. The circuit is reconnected, and the receiver switched on again.

A faint hum is now heard in the speaker and when the grid connection to the output valve is touched the characteristic *purrr* is heard, although there is a slightly harsh quality present. Switching from Radio to Gram, however, gives a click in the speaker although no radio signals can yet be tuned in. Touching the gramophone grid input socket also causes hum, so that it is decided to check the quality of the feed and output stages, as well as the loudspeaker, by playing a record, connecting in the pickup by long screened leads.

Quality is poor, since there is a distinct cracking on high notes together with a choked effect on loud passages so that, with the pickup off the record, tests are carried out from the output stage forward. The volume control is in operation, but since the grid resistor of the Pen 45 is not acting as this control and is isolated from it by a condenser, the grid is not earthed through the volume control. When this 0.25 megohm grid resistor is

checked, however, its resistance is found to be very high, although not open-circuited. This explains the reason why the hum level was only low, for the grid is not floating and a degree of bias is being applied, although the valve of the grid resistance is such that the valve cannot operate properly. Replacing the component, and again testing with the record, now gives excellent quality although the volume is definitely lower than might be expected with the valves shown. Attention is thus directed to the biasing of the triode portion of the double-diode-triode. Tests show that the bias is approximately correct, and as a trial a new 25 mfd. condenser is coupled across the existing bias condenser whilst the pickup is still feeding the amplifier. The volume immediately rises to the proper level, the old condenser is replaced by a new one. Later tests prove that the condenser was open circuit. This would introduce a degree of negative feedback into the triode stage; this explains the low volume.

The gramophone section, and therefore the whole audio side of the receiver apart from the detector itself is now working correctly, so that the investigation must now be carried on into the radio stages, the double switch being turned to Radio and left there.

A touch test, however, on the top grid connection of the I.F. valve brings no response, even when the grid clip is removed and the grid left floating. The first trouble to be rectified must therefore be in the I.F. transformer secondary or diode circuits.

The first point to suspect is of course the Radio-Gram switch, which may be working on the gram side only. Touching the junction of the 22,000 ohm resistor and switch connecting lug, with the volume control turned well up proves the switch is working, however, since clicking and hum results. Touching the further side of the resistor also gives clicking, but at a very low volume. A signal generator and signal tracer would show up the defect with ease, but since they are not being used the valve itself is suspected, since a touch test on the diode side of the resistors should give greater response. The valve is rocked gently in its holder, when scratching and clicking result, and on withdrawing the valve it is found that the solder on the diode pin has a greyish-white appearance, indicating the possibility of a dry joint. The pin is given a touch of soldering paste (not resin) such as Fluxite, and the joint is freshened by applying the well tinned iron to the end of the pin for just as long as is required to allow the solder to melt inside the pin and the flux to penetrate. The joint is then allowed to cool and any excess flux cleaned off the pin and valvebase with a rag dampened with methylated spirit. The valve is replaced, and on its heating up the touch test is remade on the diode socket. The healthy response shows that a dry joint was present and is cured.

When the grid of the I.F. valve is touched, however, there is still no corresponding hum or noise produced. A signal tracer will find the fault with ease but presuming that such an instrument is not to hand, proceed with analyser checks. The voltmeter, switched to a high range, shows the correct voltage on the I.F. anode and also on the screen, whilst a bias check on a low range shows that the valve is passing a current as near to normal as can be determined. This would appear to isolate the trouble in the I.F. transformer, since even if the grid connection of the valve were

broken internally there would still be valve noise. The anode is not short circuited to earth, since the correct voltage is shown at its connection, and for the same reason the primary of the I.F. transformer is not open circuited or broken. The one alternative is a short circuit across the I.F. transformer primary, and on inspection, after switching off the set, this is found to be the case. The trimmer condenser of the screw type has mica dielectric separating the plates, the mica having cracked and shifted, so that whilst H.T. is passed to the anode of the I.F. valve the signals are bypassed straight to the H.T. line, and thus, in the usual manner, to earth. The short circuit is simple to rectify, a small sheet of mica being obtained from any old trimmer condenser or the faulty trimmer being replaced, but the I.F. transformer will now be out of alignment. It will of course be necessary to re-align the set in any case, but the transformer must be brought roughly to adjustment before the tests can proceed. After the repair is effected replace and rewire the transformer into circuit, switch on the receiver once more and allow it to warm up. On touching the I.F. grid there is now a hum, although the volume is low. Trim the I.F. transformer primary till the hum comes up in volume—the adjustment is very rough and ready, but it will permit of the servicing to go forward.

There is now only the first stage, the frequency changer, left to deal with, but signals from the aerial are still lacking. A touch on either side of the first I.F. transformer secondary, that is, in the grid circuit of the I.F. valve shows that the winding is in good order, whilst, bearing in mind the previous I.F. transformer fault a quick check is taken on the primary of the first I.F. transformer by shorting it with a length of insulated wire, bared at the ends. A click at each contacting of the shorting link shows that signals are being transferred from the primary to the secondary, and that the transformer has current flowing through it. Nevertheless the TH41 is tested on a high range of the voltmeter for voltages at the screen and the two anodes, when it is found that the oscillator anode voltage appears to be a little low, indicating a rather higher current than might be expected. Using a signal tracer, of course, the probe would be applied directly to the anode and it would be found that the Magic Eye would not close indicating that there is no oscillation, but with a D.C. analyser it would be necessary for a satisfactory check to break the connection of the triode grid leak to the cathode, inserting a milliammeter switched to the 0-1mA. range in the break. No current reading would show the same fault, as already described.

This may mean, of course, that only the medium wave range is refusing to oscillate, so with either test still in progress, rotate the waverange switch, the valve still refuses to oscillate, either the H.T. supply is low or the valve has lost its emission. The supply voltage has been checked so a replacement valve is tried. The replacement on test oscillates correctly.

With the volume control fully up, there is now a degree of hiss or valve noise to be heard in the loud speaker, although no stations are tuneable when the tuning condenser is rotated. The same result is obtained when the wavechange switch is operated, and there are slight clicks as the switch turns, so that the lead from the signal grid of the first valve to the switch arm is suspect. The lead is found to be broken from the lug, and when the soldered joint is remade, the switch being reset to the medium wave

band, stations are tuned in at good volume. The long wave band is also in operation, but when the short wave band is tested, whilst there is a certain "liveness" the only signals heard are weak and in the background. The oscillator section has been tested and is correct so the fault must be in the aerial tuning circuit, whilst weak signals in the background indicate that the short wave tuning is operating with very small, or no feed from the aerial.

Inspection of the first switch, S1, shows that the contacts which should grip the rotor arm have opened up and are failing to touch when the arm is in position. These contacts are reset in place, and tested for springiness, any weakness which shows as being liable to cause the fault to re-occur being the deciding factor as to whether the switch leaf shall be replaced or not.

Signals are now available on all waveranges, although the stations do not fall on their correct dial markings. This, however, will be rectified in the lining and trimming of the receiver, and before this takes place the local stations are tuned in as a test for the general response of the receiver. Immediately the good tone deteriorates, an overloading effect being apparent, although when the aerial is removed from the input socket the volume falls and the tone is corrected, the station still being received. This means that the A.V.C. line is either out of action or is at fault in one section, so that, with the receiver switched off, a continuity test is made from the grid of the frequency changer to earth and the grid of the I.F. valve to earth. Only a low reading will be obtained, of course, due to the high resistance circuits (if an ohmmeter is used for this check it must be a high reading instrument), but approximately correct indications are found. Other possible failures are in the diode and in the feed condenser from the anode of the I.F. valve to the diode, and since the double-diode-triode has already been inspected attention is directed at the condenser. It is not simple to test a 0.0001 mfd. condenser so that the best method of discovering whether the fault lies in this component is to replace it with a new condenser and switch on. This time, the receiver, with aerial coupled, brings in the local station at good strength with no overloading, showing the A.V.C. to be back in operation. Inspection of the faulty condenser shows a loose tag connection where one set of plates is brought out.

The specimen receiver has been run through, then, with a characteristic fault in every stage, and whilst the writer has (fortunately!) never serviced a receiver with so many faults, all those described have been seen and traced by the methods described in different sets.

It will be realised that where a multiple fault exists the signal tracer method of servicing is very valuable, but the testing should not always be from the aerial back, for convenience. In the example just given, the best plan for any type of servicing would be to work first on the power pack and then to get the audio stages running, taking signal tracer tests from the aerial back afterwards.

It would of course be impossible, if not impracticable, to list all the faults which might arise in a receiver, and those dealt with are intended to be broadly characteristic, the emphasis being placed not on the fault but on the method of tracing it. Nor does the writer place much faith in a list of "Causes and Effects" since such a method not only tends to make

the novice go from stage to stage and circuit to circuit, possibly putting several adjustments out of line at the least, but also may concentrate attention on the list itself so that the service man's deductive powers are not used as much as they should be. Radio servicing is akin to crime detecting—an understanding of the instruments to hand and their proper use, the working out of their findings by logical investigation—that is the best method especially for the beginner. As experience is gained some faults will be recognised immediately, but such knowledge is only to be gained on the workbench, not through a printed list of possibilities.

It is the writer's personal opinion that no intending service man should commence the repair of receivers or gear until he has constructed a wide range of sets and apparatus, either functional or experimental. Certain correspondence courses which are widely popular in the U.S.A. send the student a kit of parts and valves for the construction of receivers and test gear, but even at its best this would seem to be directed, repetitive work, and a more personal approach on the part of the student himself, with personally thought out experiments and designs is probably more satisfactory in the long run.

The need for the complete understanding of the test instruments has already been stated, but one example may help to show what is meant. The case occurred where a small mains receiver was faulty in the output stage, a headphone test showing that signals were present on the grid of the output valve although there was complete silence so far as the loudspeaker was concerned. A voltage test on the anode of the valve showed volts to be well up, so that a test on a low voltage range was made across the bias resistor. Immediately the voltmeter was connected into circuit signals, though weak and distorted, were heard in the loud speaker, and some time was spent on working out the obvious solution—that the bias resistor had burnt out, since it was of a very low wattage rating, the valve being brought back into circuit by the voltmeter itself. Naturally the resistance of the voltmeter was far too great to allow the circuit to work properly, but it worked after a fashion.

To return to the specimen receiver. The set is now in operation, but it is yet to be trimmed and aligned. The process is described in the following chapter.

CHAPTER 6.

THE SIGNAL GENERATOR—LINING UP THE RECEIVER.

After a little experience the signal generator can be one of the most useful pieces of gear on the test-bench, for not only can the radio side of a receiver under test be trimmed and aligned, both as regards superhet and straight receivers, but with any good model of generator the audio or gramophone amplifier section of the set can be supplied with a useful 400 cycle signal, which is often an advantage over the varying type of signal provided by the pickup and a record.

The superhet is adjusted as follows:—

Switch on the receiver and allow it to reach operating temperature and remain working for 10 minutes at least. If the receiver is of the type where

the base of the cabinet can be removed for easy access to the trimmers and padders mounted below the chassis, and there is room in the top of the cabinet for work on the I.F. transformer trimmers to proceed, the receiver should be replaced in its cabinet for the aligning operations so that it is firmly fixed and the chassis unable to warp in any degree. If the cabinet will not allow of the trimming and adjusting operations to be carried out with the chassis in place, then the chassis should be stood on end and supported in any manner necessary so that no strain is placed on wiring and components. It is quite possible to trim a receiver out of its cabinet only to find, when it is remounted, that the adjustments are now out of line. Remember the rubber mat if the chassis is to be worked on without the cabinet, or, if the set is rehoused, remember to protect the polished wood-work by placing the cabinet on its side on the felt mat.

Whenever possible, use an output meter for the aligning, since a visual reading is much more satisfactory than an aural indication. The 400 cycle note which will be heard in the speaker tends to "desensitise" some ears, so that after a few minutes the note appears to vary when no adjustment has been made. The output meter can be quite simple, and need not read in terms of actual output, since for this work only comparative readings are required—that is to say it is only necessary to know whether an adjustment has caused the meter indication to rise or fall. If a commercial output meter of the neon or instrument type is not to hand the A.C. voltmeter or voltmeter range of the analyser can be put to good use, switching it to a low A.C. range and coupling it across the output transformer secondary, in parallel with the speaker voice coil. If the speaker is of low impedance, however, only a very low reading will be obtained, and in that case the A.C. voltmeter may be connected across the primary of the output transformer so long as a condenser of 0.1 mfd. capacity and of good insulation is in series with the circuit, to protect the instrument and its rectifier from D.C. The receiver volume control should be kept at the full-on position. All reductions in volume being made at the signal generator.

The two methods of connection are shown in Fig. 12, and in the second case, where the A.C. voltmeter is connected across the transformer primary, it should first be switched to a high reading range, the sensitivity being increased in steps with the range switch, since quite a high reading can be obtained in some cases.

With the output meter in place, switch on the signal generator so that it too may warm up to its operating temperature.

The I.F. circuits in the receiver are the first for attention, and the usual practice is for the oscillator section of the frequency changer to be put out of action by shorting the oscillator to earth for R.F., which is accomplished by temporarily wiring in a 0.1 mfd. condenser from triode grid to earth. This prevents the oscillator from working, and it has been pointed out that the bias of the triode section, and thus, to some degree the characteristics of the whole valve, are changed by doing this. In practice, however, no draw-back appears to attend this way of working.

Some signal generators are provided with two output sockets, one being marked A.A. or artificial aerial, the other marked Output, or similarly. For the I.F. work the generator should be connected to the receiver from

the Output socket, not via the artificial aerial. The generator is usually provided with a screened output lead, the screen clip being attached to the receiver chassis and the core, for the first tests, to the signal grid, generally the top cap, of the frequency changer valve.

The signal generator is now tuned to the I.F. of the receiver—in the case of our specimen set of Fig 11, to 465KCs., and a modulated carrier is thus introduced to the I.F., detecting and output circuits with a consequent note in the receiver loudspeaker.

If no note is heard, either the connections are faulty, the receiver has developed another fault, the signal generator batteries, if it is of the battery operated type, are low, or more likely than any other cause, the receiver is so far off trim that the I.F. circuits are not responding. A slight variation of the generator tuning will probably bring in the signal on the receiver. In general, however, the signal is heard on the receiver, and registered on the output meter as soon as the generator is tuned to the I.F.

The signal generator has an attenuator or output control, and this should now be reduced as far as is possible, whilst keeping a readable indication on the output meter, and the trimming of the I.F. transformers commenced by adjusting the second secondary, that feeding the detector diode, and working forwards, setting each trimmer for maximum possible output and reducing the signal generator output whenever possible to keep the output of the receiver down to as low a value as can be worked with. Using a cathode ray oscilloscope and a "wobbulator" enables the actual response curve of the I.F. circuits as a whole to be adjusted into a clean shape, the oscilloscope, for this operation, being connected to the signal diode of the detector through a small condenser, so that the actual I.F. envelope is traced on the screen. Using the output meter, however, the shape of the response curve can only be guessed at, testing by the following method. With the I.F. transformers trimmed to maximum volume, set the signal generator right off tune, so that the output meter reading falls to zero, and then in one steady, slow movement, tune the signal generator right through the I.F. resonant point of, in this case, 465 KCs., watching the output meter closely. As the signal comes into tune the pointer will rise to a peak, probably fall back very slightly and then rise to another peak, falling back to zero as the generator once more goes off tune. These two peak readings should be the same, whilst the sweep up from zero and the sweep back to zero should be smooth with no hesitating points which indicate a "slipped" peak in the response. If the peaks do not agree in reading, the I.F. transformers are not exactly aligned and probably the quality of the reproduced sound will suffer whilst sensitivity and selectivity will probably be lacking to some degree. It is worth while spending some time on the trimming of the transformers and getting the peaks to agree in height so far as the output meter reading is concerned. It may be, of course, that a double peak is not obtained in any case, due to a different degree of transformer coupling having been chosen by the manufacturers, in which case the sweep up and down to the single peak should be made smooth and even. Naturally, all these tests depend on the steadiness with which the signal generator is swept through the resonant frequency.

Once the I.F. transformers have been trimmed satisfactorily they must not be touched again, but left set. If thought desirable, the trimming screws

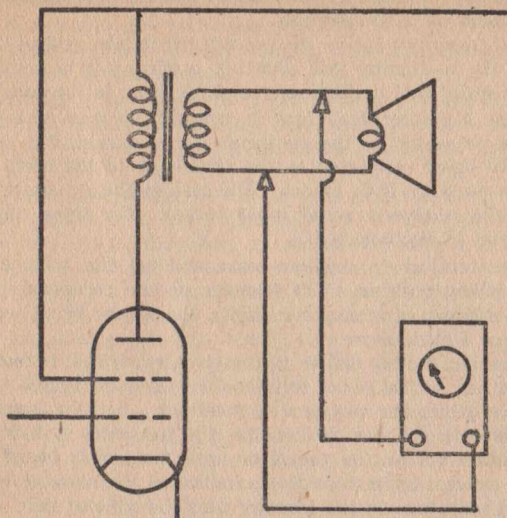

FIG. 12A.—A.C. Voltmeter used as output meter. High impedance voice coil.

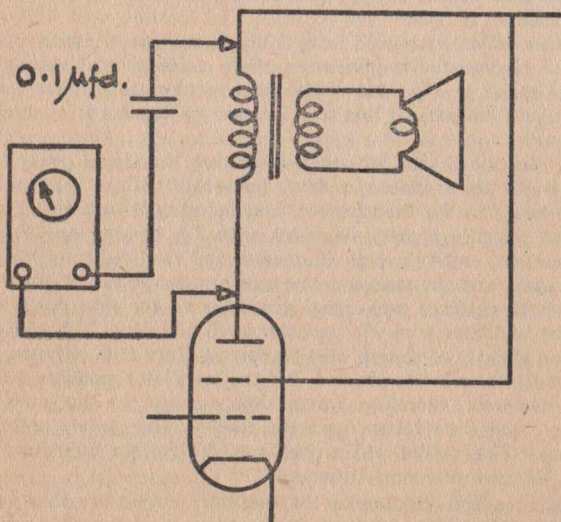

FIG. 12B.—A.C. Voltmeter used as output meter. Low impedance voice coil.

can be secured with a touch of soft wax or some similar substance, but any such agent should be used sparingly.

The signal generator is now disconnected from the grid of the frequency changer, and the oscillating grid shorting condenser is also removed from the circuit, in order that oscillations may take place in the usual manner.

The signal generator feed lead is transferred from the plain output socket of the generator to the Artificial Aerial socket, the screened lead screen clip still being connected to the chassis or to the earth terminal of the receiver in an A.C./D.C. model. The core of the generator lead is now plugged into the receiver's aerial input socket. For these alignments the aerial, of course, is disconnected.

Switch the receiver to medium wave and set the trimmer on L2 to roughly its midway position. The trimmer on the corresponding oscillator coil, L5, should be set at minimum capacity, the padder being set to the half-way position, or a little more.

Set the receiver tuning dial to 200 metres, or, if that is too low a wavelength for the set, to as low a wavelength as can be tuned. 200 metres should be well within the range of a good set. Set the signal generator to the same wavelength (for 200 metres the frequency is 1,500 KCs) and turn up the attenuator on the generator until a signal is heard or recorded on the output meter. Quite possibly no indication will show or no sound will be audible. Slowly turn in the trimmer on the oscillator coil, reducing the signal generator output as the oscillator comes into trim, and adjust the oscillator trimmer for full volume. If the trimmer is turned further in after the first point of full volume, another peak position will probably be found. This position is incorrect, and the first setting of the oscillator trimmer is the correct setting.

With the oscillator trimmed in at 200 metres, the trimmer on the aerial coil may now be adjusted to give any further increase in volume—that is the trimmer across L2 in Fig. 11. Remember to keep the signal generator at the lowest useful output, so that any increase of volume is apparent on the output meter.

Now retune the set to 500 metres, setting the signal generator to the same wavelength, the frequency reading being 600 KCs. The signal may or may not be heard in the loudspeaker, and to bring it in adjust the padding condenser to 500pF capacity in series with L5 turning up the generator output if necessary until the signal is heard, and then reducing the output as the volume rises and the output meter reading increases. With the padder set, return both receiver and signal generator to the first position of 200 metres. The oscillator trim will probably need adjusting, although the aerial coil trimming should, of course, still be correct since it is only the oscillator trimming which has been affected by the oscillator padding adjustment. Retrim the oscillator, therefore, for maximum output on the loudspeaker or output meter, and then return both the receiver and generator to the 500 metre setting. The padder will probably need a further adjustment to compensate for the new oscillator trimming.

The trimming and padding of the oscillator circuit are thus brought to a nice balance, the adjustment of the first one and then the other being continued, perhaps switching from the 200 metre trim to the 500 metre pad four or even five times, until the circuit is stable and the balance point is

found. The oscillator is now tracking properly over the medium wave band—that is, the frequency of the oscillations generated by the triode section of the frequency changer is always 465 KCs. higher than the frequency of the station to which the aerial circuit is tuned.

The procedure is now repeated exactly as before on the long wave range, the oscillator and aerial coil trimming being carried out on a wavelength of 800 metres, or 375 KCs. and the oscillator padding at 2,000 metres or 150 KCs.

On the short wave range, as will be seen from the diagram of Fig. 11, the oscillator padder is a fixed condenser of 0.005 mfd. capacity. The alignment of this range, therefore, is carried out merely by the trimming, and since the coils as specified cover a range of from 16 to 47 metres, the trimming should be at a wavelength of 17 metres. A tracking test, however, should be made at 30 metres, tuning both receiver and generator to that wavelength, and another tracking test is then made at 45 metres. At both of these latter wavelengths the signal should be received as a properly tuned signal, but if the receiver should be a little off tune the addition of an extra padding condenser of, say, 0.0005 mfd. capacity connected in parallel across the present padder of 0.005 mfd. should be tried. If the off-tune effect is worse, the 0.005 mfd. condenser might be replaced by a 0.004 mfd. condenser, and the tracking tested once more. Any necessary retrimming on the oscillator side should be carried out before the tracking tests. By trial and error in this way the oscillator padding on the short waves can be made as accurate as that of the longer wavelengths, another virtue of the signal generator, since it is only by the use of a known fixed frequency signal that such tests can be made.

The set is now trimmed and adjusted and ready for work, and at this point the majority of service men consider the work to be finished. It is possible, however, to make a series of tests on the receiver based on the manufacturers' tests, using the signal generator and a properly calibrated output meter. The sensitivity of the receiver, for example, is measured by setting all controls to give maximum output into an output meter and then applying a test signal from the signal generator sufficient to show an output of 50 milliwatts, or, on receivers capable of giving 1 watt output, of 500 milliwatts. The 50 milliwatt figure is accepted for all sets, however.

The test is conducted at 200 metres on the medium wave range and the signal from the generator slowly brought up until the required output is obtained. The output should actually be measured into a standard dummy load, but for the test bench it will be necessary to use the loading of the loudspeaker.

When the output is obtained the signal generator reading in microvolts shows the sensitivity.

Another useful test, particularly on the short wave ranges, is that relating to the image frequency. The signal to which the aerial section of the set is tuned is heterodyned by the local oscillator to give the I.F., or, in other words, the set generates a frequency separated from the station frequency by, in the case of the specimen receiver, 465 KCs. There are thus two frequencies possible at any one tuning point. When, as in the present case, the oscillator frequency is higher than the signal frequency, a station or signal generator signal at 200 metres, or 1,500 KCs., being tuned in on

the receiver dial would mean that the local oscillator was working at 1,965 KCs., the subtraction of the two frequencies leaving the I.F. of 465 KCs.

A second signal might break through the aerial circuit at 2,430 KCs., however, and the difference between this and the oscillator frequency still gives the I.F. of 465 KCs., the only safeguard against such an occurrence being the selectivity, or sharpness, of tuning of the first tuned circuit.

To discover the Image Ratio of the receiver, first take the sensitivity by the last test described with both receiver and generator tuned to a convenient test frequency, then, with the receiver tuning left set, retune the signal generator to the signal frequency plus twice the I.F. if the oscillator frequency is higher than the signal frequency, or to the signal frequency minus twice the I.F. if the oscillator frequency is lower than the signal frequency. The former is the more usual case. Now increase the generator output to bring the receiver output back to the test level of, say, 50 milliwatts, the Image Ratio being obtained by dividing the new microvolt reading of the signal generator by the old sensitivity figure already obtained. Correct test points are as before, 200 or 500 metres on the medium wave band and 17, 30 and 45 metres on the short wave band.

Other tests may be made, but they are chiefly of value to the designer or the experimenter. A full description of such tests, however, may be found in the "Radio Designer's Handbook," published by Iliffe.

Where an ordinary "straight" set is to be ganged up, the process when using the signal generator is simple. As before, switch on both receiver and generator to allow them to attain their operating temperatures, set the receiver to the medium wave range and turn up the volume control to the maximum output position. Use an output meter for indications whenever possible.

Tune the receiver to 200 metres and set the generator to the same frequency, with its output as low as possible. Trimming proceeds from the detector tuned stage back towards the first R.F. stage, each circuit, as usual, being trimmed for maximum output, the generator output being reduced as much as possible. With all the stages in line at 200 metres, a test should be made for the trimming at 500 metres—in a well-designed set with good coils the circuits should still be in alignment, but in some cases it may be necessary to retrim one stage, endeavouring to strike a balance so that results at 200 and 500 metres are on a level so far as the ratio of input signal to output power is concerned.

If the straight or T.R.F. receiver has only one wave range the trimming will most probably be provided on the tuning condensers, but a multi-range set will have each coil provided with its own trimmer in the majority of cases.

Another obvious use of the signal generator is in the calibration of new or home-built receivers. When the commercial receiver is being re-aligned the original calibration as given on the tuning dial is adhered to, but the new receiver can be fitted with a dial made specially for it or else can be adjusted to suit a dial which may be supplied by the manufacturer of the tuning coils used.

The majority of signal generators, too, can be used for testing at the very high frequencies, since even if they are not calibrated for use above, say, 20 metres, a strong harmonic should be obtained at 10 and even 5

metres. When harmonics are being utilised for testing the attenuator, if supplied calibrated in microvolts, will not be giving a true reading of absolute output, but it will still be possible to obtain comparative readings.

Where a signal generator of a high quality is used it may be provided with a variable degree of internal modulation. The frequency of modulation, as already stated, should be 400 cycles, and the test signal for all ordinary purposes should be set at 30 per cent.

In an emergency it is possible to line up a superhet without the use of a signal generator, when the receiver is a commercial model which has been repaired so that the I.F. circuits, at least, are working somewhere near their true frequency. A new set should be adjusted with the aid of the generator.

The alignment of a receiver when no generator is available should be carried out as follows:—

Switch on the set, with aerial and earth connected to their appropriate sockets, and allow the receiver to warm up to operating temperature.

Turn up the volume control and tune in a weak, but steady, signal as near to 200 metres as possible, identifying the station if this can be done so that trimming at the correct wavelength on the dial can be carried out.

Set the oscillator trimmer to its minimum position and the aerial coil trimmers to halfway positions, retuning the chosen station.

Trim the I.F. condensers in the opposite manner to that usually employed, commencing with the primary of the first transformer and working back to the diode secondary of the second or last I.F. transformer, adjusting for maximum volume.

Tune the receiver to a second weak, but steady, signal at 500 metres, or as near to that wavelength as possible, and trim the aerial coil condensers for maximum volume, then trimming the oscillator or coil for maximum volume. If the station, identified, is registered at an incorrect reading on the dial, correct this by a slight adjustment of the oscillator padder, and whilst all these adjustments are made, gently rock the tuning condenser through the station.

Re-adjust the I.F. transformers, in the same sequence, for maximum volume.

Return to the original station at about 200 metres and re-adjust the I.F. transformers again, repeating the process once more at 500 metres, thus balancing the transformer response over the waverange.

The long wave tuning range should now be adjusted in by the aerial coil trimmers and the padding condenser.

Where such an instrument as the Neon I.F. oscillator is available, the I.F. transformers can be aligned without trouble, the neon oscillator being used in the same way as a signal generator.

With the I.F. transformers properly trimmed, the set is connected to its aerial and earth and a weak station tuned in at 200 metres. The oscillator section of the frequency changer is now trimmed from its minimum position up to the first peak of maximum volume, and the aerial coils trimmed for maximum volume, the tuning dial being set to the true wavelength reading of the station being received.

The set is then retuned to a station giving a weak signal at about 500 metres and the oscillator is padded, the trimming and padding being carried out in steps, just as with the signal generator, to give the correct tracking.

The procedure is repeated with the other waveranges, the I.F. transformers, once being set by the small neon tester, being left alone throughout all the other adjustments.

It must be re-emphasised, however, that the neon oscillator can only be used when the intermediate frequency of a receiver coincides exactly with that of the neon oscillator, and that when a receiver is to be re-aligned with the aid of a signal generator, the intermediate frequency for which the set was designed must be used, and no other.

CHAPTER 7.

VALVE TESTS AND TESTING.

The service man who undertakes radio work as a profession will probably acquire a valve testing panel such as are made by several firms, whilst the radio shop should not be without such an instrument, but for the amateur or the part-time service man the valve tester is an expensive piece of apparatus, and must be replaced, as far as possible, by testing suspected valves with the gear already to hand.

Nor is it advised that a valve testing panel be made up, since the multiplicity of valve types would make such a task highly complicated. In some cases the owner of a good analyser or multi-range test instrument may find that the manufacturers can supply a simple and relatively inexpensive set of adaptors, designed for use with their instrument, but failing this it is suggested that valves be given the tests outlined in this chapter by arranging a simple "hook-up" circuit as and when desired.

Before any other tests are applied it is necessary to check the continuity of the valve's filament, or heater, and to ascertain that there are no inter-electrode short circuits.

With regard to this last point an interesting case was brought to the writer's attention, where a new output valve of reputable make had been fitted to a receiver. On switching on the set signals were received after the warming up period for approximately 30 seconds, when there was a click and the loudspeaker went dead. An inter-electrode short circuit test when the valve was cold showed no fault, but on closely inspecting the internal structure of the valve through the glass envelope it was seen that the cathode was slightly bent. As the cathode heated up the bend was accentuated until it was sufficient to contact firmly with the grid, thus bypassing the input to the valve to earth.

This is not a usual fault, of course, and it is generally sufficient to make the short circuit test with the valve cold.

The ordinary continuity tester is not suitable for the test, however, since a rather higher voltage should be applied between the valve electrodes, and the usual method is to test from pin to pin on the base with a neon lamp supplied either from a battery or a transformer with about 100 volts, the neon lamp therefore being of the smaller 95 volt type, not of the household type, which requires a high striking voltage. The same test will, of course,

show heater or filament continuity, whilst should there be a slight residual glow on the neon, as is sometimes the case with A.C. working, due to capacitance effects in the wiring of the tester, a small condenser of 0.01 mfd. capacity coupled directly across the lamp will allow only short circuits and high resistance leakages to show an effect.

A hot cathode test for shorting electrodes is not quite so simple to apply, since the valve is ready to pass current. The simplest method of overcoming the effect of ordinary current flow is to use a battery or other D.C. source for the supply in series with the neon lamp, coupling the circuit up in opposition to the tending current flow in the valve.

Whilst conducting hot cathode tests it is wise to test for emission between heater and cathode in either direction in the case of power output valves especially, since in some cases a stubborn degree of hum in a receiver or, more particularly, an audio amplifier, is occasionally caused by such a defect.

The test is made simply by connecting between either end of the heater and the cathode a milliammeter in series with a D.C. source of supply, noting the current registered by a low voltage. The polarity of the test D.C. source is then reversed, and the new current noted. No current in either direction indicates that there is neither leak nor interelectrode emission, a varying current (that is a current of a different value for one direction of flow) indicates emission from the cathode to the heater, or vice versa, whilst a current which gives the same indication for either direction of flow indicates a leakage.

An emission tester, which is the basis of most commercial test sets for valves, indicates an "end of life" point when the emission falls below a certain accepted percentage of the valve's rated figure, but since the manufacturers' tables are required, giving accepted emissions for valves and the electrode voltages at which their calculations are made, the building of such a test set is not of great use to the amateur, and a more useful piece of gear is a mutual conductance tester. The mutual conductance of a valve (or Transconductance) is measured either in microamperes per volt or milliamperes per volt, and is the relationship between the grid voltage and corresponding plate current of the valve. Two possible methods of making the test exist, the Static and the Dynamic methods, but whilst the Dynamic test is made with the valve in conditions closely approximating to its working conditions, the Static test is more simple to make, both as regards gear and the instruments used, although a little more time is required.

The Static test consists of setting up the valve in a simple circuit with the heater fed either from a large capacity battery or from a tapped transformer, so that all types and voltages of heaters can be accommodated. A transformer, if used, should have good loading characteristics, so that the heater is properly fed and is neither over nor under-run. The plate and screen voltages are most satisfactorily drawn from batteries, each electrode being supplied from a potential divider, although a good power pack could do the work and would more easily and cheaply supply current for large power valves.

The instruments required, which must remain in circuit and cannot be combined in a multi-range analyser, are a low voltage grid voltmeter, two high-reading voltmeters, one for screen and one for anode indications, and a

multirange milliammeter in the plate line, capable of reading the anode currents drawn by the whole range of valves upon which work has to be done.

The test is conducted by setting up the valve according to the manufacturer's conditions as found in any valve manual—the Valve Manual, No. 30, in Bernards' List, price 3/6, is highly recommended, especially for details of American type valves, the grid, plate and screen voltages being as listed. The grid voltage is then set to 0.5 volt lower than the rated figure, the anode and screen voltages are checked for accuracy, and the anode current read and noted. The grid voltage is now reset to 0.5 volt higher than the rated figure, the anode and screen voltages again being adjusted to the accurate figure and the new anode current read and noted.

The grid voltage has been varied over 1 volt, so that the change in anode current is immediately given as the mutual conductance of the valve in milliamps or microamps per volt, or, where the mutual conductance is stated as the transconductance, the change in milliamps multiplied by 1,000 shows the transconductance in micro-ohms.

The circuit for the test is shown in Fig. 13, where the supply source is shown as an A.C. operated power pack, a battery being used as a grid bias source for convenience.

The "end of life" point for power and voltage amplifiers, which includes the vast majority of ordinary radio valves, H.F. and output valves included, is generally reckoned to be the point where mutual conductance has dropped to 75 per cent of the rated figure, or, in the case of frequency changers, when the oscillator section mutual conductance has fallen to 60 per cent. of its original value. The static test is not of great value where frequency changers are concerned, however, since the design and arrangement of the oscillating circuits connected to the valve have such a great bearing on the valve's efficiency of working. Any figure obtained by a static test of a frequency changer oscillator should, therefore, be used in conjunction with an observation of the valve's actual working under receiver conditions, and decisions taken accordingly.

Diodes need to be tested under rather different conditions, of course, and here something more in the nature of a simple emission test is required. Most diode types of valve are given a maximum A.C. voltage per plate, with a maximum D.C. rectified current, and in cases where a variable source of A.C. is to hand a test along these lines can be made, or, in the case of power rectifiers, the valve may be run at the full stated current output load and the voltage across the load compared with the maker's tables.

The testing of small diode types and large power rectifying diodes is not simple for the amateur, however, and possibly the simplest method is to substitute a suspected valve by a new valve of the same type, noting the difference in the working of the receiver or other apparatus in which the substitution is made and rejecting or passing the valve accordingly.

Blue glow inside a valve, generally to be seen between the cathode and the plate, is due to the ionisation of a residuum of gas, and usually indicates trouble, whilst fluorescence which takes place on the glass (particularly in heavy duty types) is caused by electron bombardment of the envelope, and is not indicative of trouble.

Very few valves are microphonic under present manufacturing conditions, and this should be remembered when a case of ringing or similar noise is

FIG. 13.—Mutual conductance test.

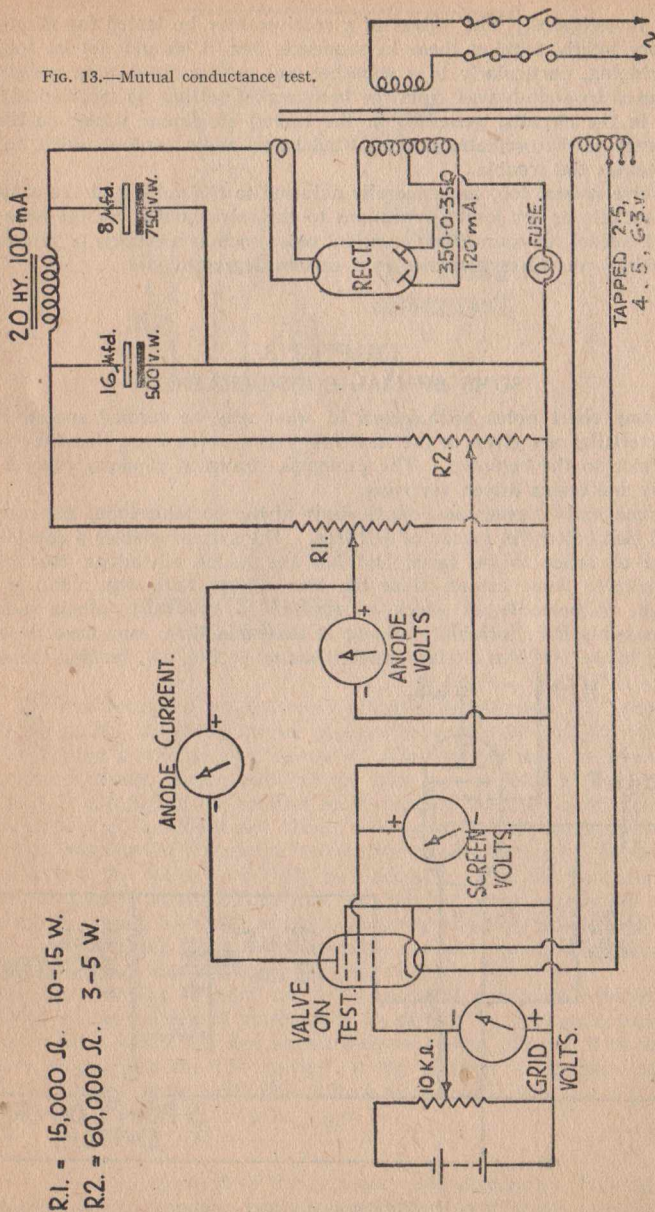

R1. = 15,000 Ω . 10-15 W.
R2. = 60,000 Ω . 3-5 W.

being investigated. The valves of a receiver may be tested for microphony by very lightly tapping them in sequence, but it should not be forgotten that ringing, particularly in a superhet and on the short wave ranges, can be caused by soundwaves from the loudspeaker setting up mechanical vibrations in the circuits, generally in the tuning condenser vanes, so that the frequency of the oscillator is modulated by an audio content which, in turn, accentuates the trouble.

Valve noises, too, are generally external to the valve and are caused by dirty sockets or dry joint connections to the valve holder. By the term valve noise is meant, of course, any transient noise such as a crackle or pronounced scratching—all valves give rise to a certain degree of hiss.

CHAPTER 8.

SOME SPECIAL CONSIDERATIONS.

Some short notes with regard to what may be termed special circuit characteristics are given in the next few pages in the hope that they will be of service to the beginner. The examples, drawn at random, concern both battery and mains driven receivers.

Some battery sets, more particularly of the portable type, dispense with a grid bias battery in favour of self bias. The system enables a considerable degree of space to be saved and has the added advantage that bias is automatic to some extent, since the bias voltage falls with a fall in H.T. voltage. A portable set which is reported to have lost volume suddenly, with possibly R.F. instability arising at the same time, may have developed a fault in the self bias circuit, which is shown in Fig. 14, feeding the output

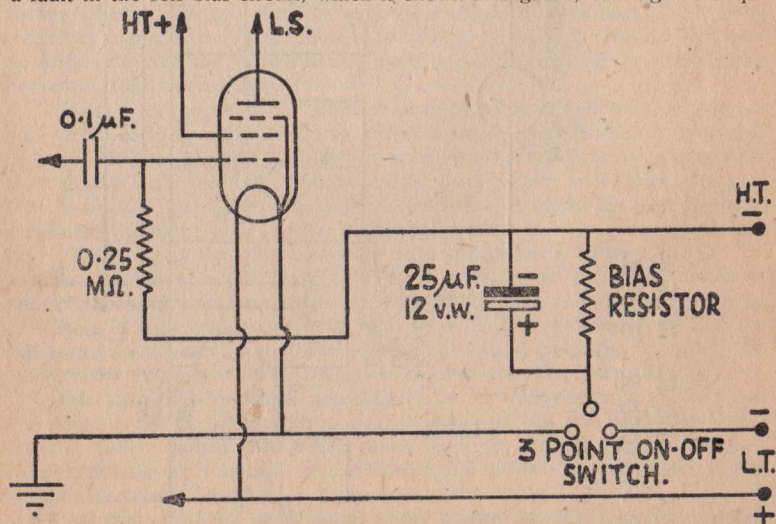

FIG. 14.—Self bias in a battery receiver.

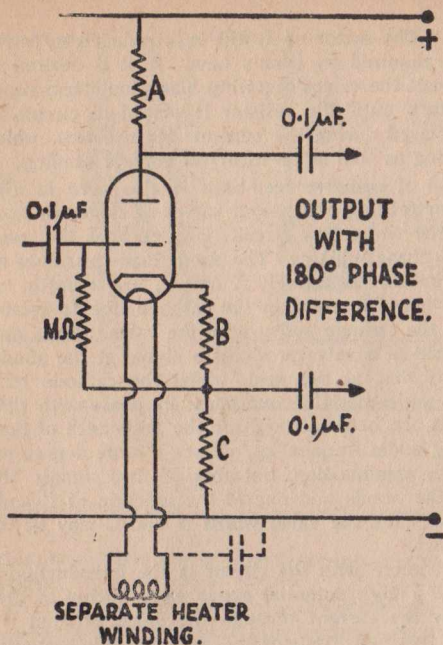

FIG. 15.—Phase splitter circuit.

valve. The bias voltage is set up across a resistor in the main H.T. negative line, all the current drawn by the set necessarily passing through the resistor and thus causing a voltage drop across it. The resistor must be by-passed by a large condenser, conveniently of the bias type as used in mains sets, since the A.F. currents of the receiver must circulate together with the supply current, so that if the condenser should develop a fault or become disconnected it is possible for the audio frequency currents to develop fluctuating voltages across the resistor on their own account. The net result is that there is a degree of negative feed-back into the last stage, which will cause some drop in output, although in most cases reproduction will be pure and possibly even of better tone; in other cases, however, positive feed-back to earlier stages occur and motor-boating will result.

Two different bias voltages can be obtained by using two resistors in series with a bias condenser across each to earth. To replace a damaged self bias resistor which has lost its marking or coding colours, it is merely necessary to calculate the full current of the receiver as supplied by the H.T. battery and then to apply Ohm's Law in the usual way.

$$R = \frac{V \times 1,000}{I}$$

where R is the necessary bias resistance, V is the bias voltage required by the valve and I is the current in milliamps supplied by

the H.T. battery. The factor of 1,000 is introduced to convert the current to amperes as is required by Ohm's Law. If it is desired to measure the current in the circuit the valves requiring bias should temporarily be supplied from a bias battery until the resistor is placed in circuit, otherwise they would be left unbiased during the current measurement, which would result in their overrunning as well as an incorrect current reading.

The utilisation of negative feed-back is also seen in Fig. 15, a phase splitting circuit for feeding two output valves or stages in push pull. Sometimes known as the concertina circuit, it is perhaps the most efficient and trouble free of all phase splitters. The anode load resistance and the cathode load resistance, marked respectively A and C, are equal in value, the small bias resistance B being inserted in the cathode line to establish a working potential between the cathode and grid of the valve. As is generally known, a signal on the grid of a valve produces a signal at the anode 180 degrees out of phase with that at the grid, whilst the cathode of the valve can produce a signal, under certain conditions, in phase with that on the grid.

The conditions are here satisfied for the resistance of the cathode load, C, unby-passed for audio frequencies, causes a large degree of feed-back, so that the valve loses amplification, but provides two signals 180 degrees out of phase, one at the anode and one at the junction of C and B. B should have the value usual for the valve whilst A and C may be of the order of 50,000 ohms each.

One possible trouble with the circuit is the introduction of hum. The cathode is at quite a high potential above earth owing to the voltage drop along C caused by the current through the valve, so that if the heater is supplied from an earthed transformer winding this potential is directly between heater and cathode. It is advisable, therefore, whenever possible, to use a separate, unearthed heater winding on the mains transformer to supply the heater of the phase splitter, and it is generally under these conditions that hum arises. Earthing the winding will remove the hum, but defeat the object of supplying the separate winding, but a 0.1 mfd. condenser from either side of the heater to earth, or a 50,000 ohm resistor from heater to earth will cure the hum whilst providing no direct current path to make a breakdown likely.

Another well-known method of phase splitting is the use of a centre tapped transformer, the centre tap on the secondary being earthed. A temporary repair in such a case where the transformer has failed can be made by using an ordinary transformer of low ratio, providing it with an "artificial" centre tap as shown in Fig 16, where two resistors of equal value are connected across the secondary, their junction being earthed.

Negative feed-back can sometimes be used very simply with a pentode or tetrode output valve, which shows a tendency to introduce distortion. A small mica insulated condenser between anode and grid may be tried, or a larger noninductive condenser with a series resistance to be found by experiment. A combination, in the latter case, of a 0.1 mfd. condenser and a 1 megohm resistance makes a good starting point. There should be no need to stress that the condenser insulation must be perfect. The two circuits are shown in Fig. 17. Of the two methods, the larger noninductive condenser with a series resistance is recommended, since it gives relatively constant feed to all audio frequencies, the use of a small condenser with no resistor,

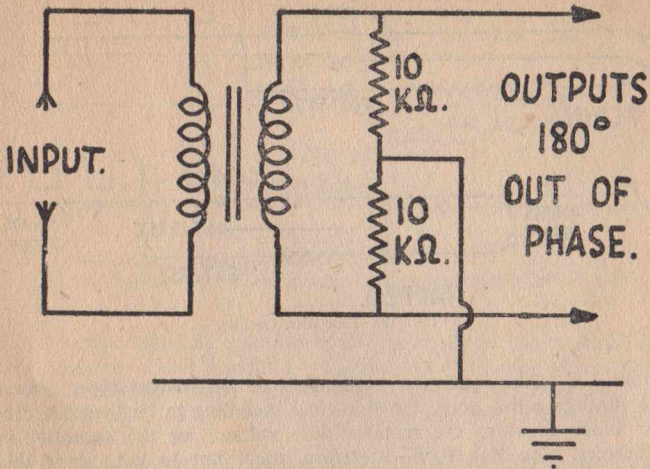

FIG. 16.—Phase splitting with an “artificial” centre tapped transformer.

however, will give most feed-back at high frequencies, resulting in a serious loss of top response.

Instability in R.F. and I.F. circuits is generally caused by feed-back between anode and grid wiring, and may become apparent in a receiver which has been rewired or partially rewired. Even a stubborn case can usually be cured by screening the anode wiring, especially where I.F. circuits are at fault, and in some cases merely rearranging the offending wiring will prevent the feed-back. Where the trouble is bad, however, it is possible that the screens of the H.F. pentodes connected with the circuit are either overrun or else are not sufficiently by-passed to earth. Changing the screen feed from series to voltage divider is often a great help, whilst screens which draw current (for two or more valves) from one voltage divider can often be separated with good effect, each screen being supplied with its own voltage divider.

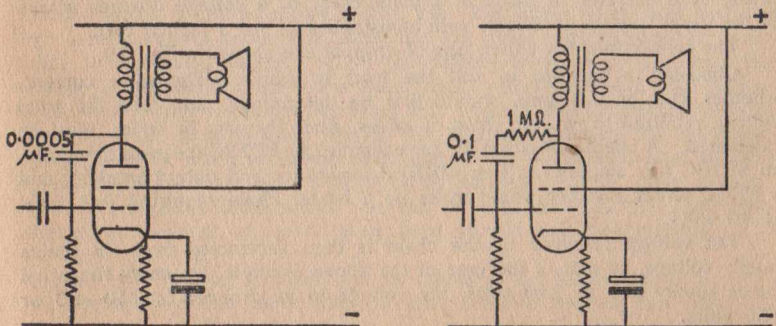

FIG. 17.—Simple negative feedback.

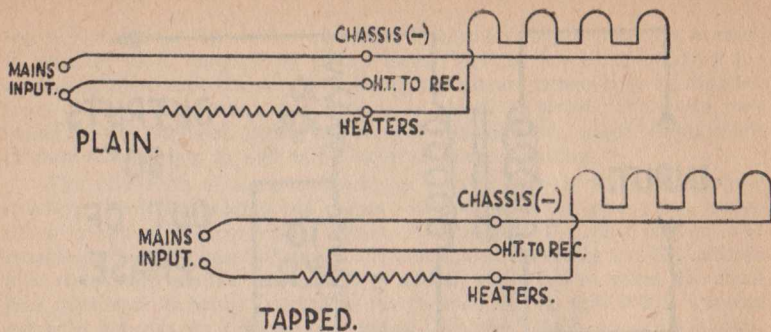

FIG. 18.—Line cord circuits.

Some A.C./D.C. receivers, particularly of the midget type, draw mains current through a line cord. The line cord including in its length a dropping resistor which provides the required low voltage for the operation of the valve heaters. The line cord, therefore, must not be cut, since this will change its resistance and result in the overrunning of the valve heaters, but despite the warning labels attached to new line cords, many set users cut the cord to length to suit their power plug position. When replacing line cord it is necessary to discover whether it is of the plain or tapped variety, since the tapped cord has a third wire running to a tapping on the resistor element, providing for a reduced H.T. potential, generally of about 110 volts, this being the working voltage of the smaller types of power rectifier, especially those enclosed in the same envelope as a small power pentode.

In Fig. 18 are shown the two types of line cord. Since this type of dropping resistor runs hot and the cord is therefore inclined, if not actually, to char, then to deteriorate in insulation and flexibility, it is wise to use a different dropping resistor when possible, depending on the cabinet space and ventilation available in the set itself. With the midget receiver it is generally impractical to make any alteration, so that a new line cord must be fitted in the event of accidental damage or a breakdown in the existing cord, but where the receiver has spare cabinet space it is worthwhile to consider the fitting of a barreter in place of a plain cord, or a voltage dropper wound in the usual way on porcelain, with adjustable taps for a tapped cord.

The connections for either type of dropper are shown in Fig. 19.

Choosing a barreter to suit the load is simple. The valve current, whether 0.2 or 0.3 amp, should first be determined, and then the total voltage required to run the chain of valves, since they are in series, must be calculated. A chain consisting of, for example, an FC13C frequency changer, an SP13C I.F. amplifier, a Pen 40DD demodulator and output amplifier and a UR1C power rectifier would make up a heater chain requiring 0.2 amps at 90 volts.

The voltage required by the chain is then subtracted from the mains supply voltage, so that in the case of the above example, assuming the usual mains supply line at 240 volts, the voltage to be dropped is 240—90 or 150 volts.

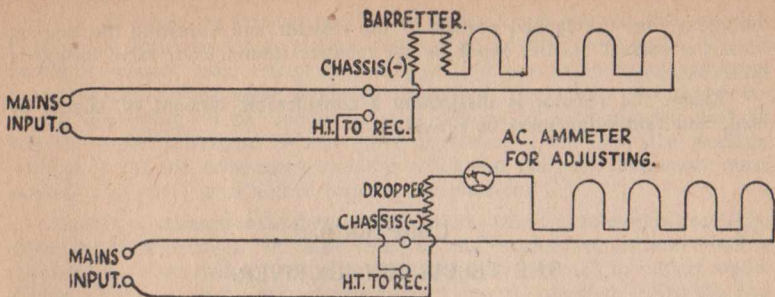

FIG. 19.—Substitution barretter or wire-wound voltage dropper for line cord.

Barretters are listed as covering a voltage range at the required current, so that a barretter for 0.2 amps is required, with a range of voltage which covers the determined figure of 150 volts. The Osram type 202 barretter is listed as covering 120 to 200 volts at 0.2 amp, so that this would be a suitable barretter.

The barretter should not be mounted close to the loudspeaker, since it has an iron filament suspended in an atmosphere (usually) of hydrogen, so that magnetic fields cause undue strains on the filament. Moreover, in this case the barretter will be dissipating 150×0.2 watts, or 30 watts, so that it requires ventilation.

The properties of a barretter are such that the filament will pass a current of 0.2 amp (or whatever rating it is given) even though the voltage across the filament varies within wide limits. Thus the barretter supplies a regulated current to the valve heaters, and does so, moreover, without adjustment or settings of any sort.

Where it is necessary to use the wirewound voltage dropper, adjustments must be made, and these can only be set safely by the use of an A.C. ammeter, which will read with accuracy the required current of the valve chain. Suppose the chain of valves to be as in the above example. A dropper rated to take 0.2 amp would be chosen, and the first adjustable tapping be set a little below halfway along the resistor. The second adjustable tap would be set at the far end of the resistor, the ammeter being included in the circuit as shown in Fig. 19. The valves would now have too high a resistance in series with them, and the chain may be connected with safety to the mains supply. Allow the heaters to warm up and read the current on the meter when it has steadied—it will always read high at first, as the valve heater resistance increases with heat, as does almost any resistor element. The current, when steady, will be low. Advance the adjustable tapping little by little, preferably switching off for adjustments and allowing the circuit to warm up again before taking the new reading, until, with the valves at operating temperature, the current registered is 0.2 amp. For other types of valves, of course, their rated current must be registered. The tapping is then set.

The H.T. tapping is finally set by allowing the receiver to draw H.T. from the tapping into the rectifier, so that a load is applied, measuring the

voltage across the tapped portion of the resistor and adjusting the tapping until the correct R.M.S. input to the rectifier (found from valve tables) is indicated.

Again, the resistor is dissipating a considerable amount of energy as heat, and ventilation must be provided.

CHAPTER 9.

THE TELEVISION RECEIVER.

It must straightaway be said, with regard to the servicing of a faulty television receiver, that the amateur, and even the professional service engineer, should not undertake such work until a course of training in television servicing has been passed. Not only is it easy to cause more harm than good by inexperienced handling of such a set, but, unless the equipment is thoroughly understood, the service man himself is in quite considerable danger whenever the apparatus is switched on. It must always be remembered that the final high voltage line of the cathode ray tube section is at a potential of several thousands of volts above earth, and in some circumstances can kill.

The first precaution to take whenever a television set is to be inspected is to make sure that the mains supply is off, and, secondly, to discharge the high voltage reservoir and smoothing condensers, not, of course, by directly short circuiting these components, but by allowing them to discharge through a half-megohm resistor. If the receiver is in working order the condensers will automatically discharge through the potential dividing chain to which the tube is connected, but often the resistance of this chain is so high that the discharging process is lengthy. A breakdown in the chain will, of course, leave the condensers charged, so that in any case it is only wise to ensure a discharge, connecting the resistor into circuit by insulating prods and keeping it there for several seconds.

The only work the partially experienced service man should undertake on a television set is the testing of valves, the replacing of cathode ray tubes which have deteriorated through age (not those which have suddenly developed a fault or have broken down for no apparent reason) and the testing of H.T. transformers and condensers, always with the high voltages in view in the latter case.

The most likely points of trouble in a television set are the condensers and the valves, together with the tube itself. The old tube can generally be identified by a discolouration over the picture area, since when it is withdrawn from the mask the unused edges will show their original creamy white colour, the picture area being a shade darker, or even brown. In such a case, when the tube is reported to be giving a poor picture with no contrast and with poor overall luminosity, it should be safe to specify a new tube. A tube failure, however, even of an old tube, should be regarded with suspicion. If an attempt is made to check the heater voltage or the heater circuit insulation, it must be remembered that high voltages can appear on this side of the power circuit if the earthed positive type of power pack is used.

The replacing of condensers can be carried out only in the untuned portions of either sound or picture receiver, and in the power pack. Never attempt to change tuned circuit capacitors or time-base components. In many cases the capacitance value is absolutely critical, the whole working of the circuit depending on the condenser, and failures in such circuits must be left for expert attention. If any other condenser is replaced, the working voltage of the old component must be noted and the new component must possess the same, or a higher, voltage specification.

Burnt out mains transformers are sometimes found in television receivers, since the high voltages can cause leakages and breakdowns in inter-winding insulations. Such damaged transformers should be returned to the set manufacturers in order that a correct replacement may be supplied, whilst the rest of the power pack must be carefully inspected for damage which might have arisen through the failure.

Valves in the tuned circuits of the vision receiver particularly are working at low efficiencies, so that loss of mutual conductance through age has serious effects. A poor picture, though still properly framed on the screen, possibly indicates failing valves in the H.F. or I.F. stages, whilst a good, bright picture which persists in losing its locking, either vertically or horizontally possibly indicates a failing sync. separating valve, so long as it is known that the effect has appeared gradually.

A picture in which some of the lines flick to the right when movement takes place on the edge of the picture is demonstrating a fault akin to pulling on whites, and which once more indicates sync. separating trouble if the effect has newly appeared. A picture which has a bas relief effect, or in which a black shape is edged or followed by a white smear, and vice versa, is showing the effect of instability in the tuned circuits, once again, the expert's job.

A jerking picture, one in which the picture suddenly jerks to right or left or up and down, resuming its correct place slowly, is a warning, so far as electrostatically deflected tubes are concerned, that the line or frame condensers are breaking down. The effect is less likely with magnetically deflected tubes, although in some cases, where a condenser is in series with a deflecting coil, a similar effect with a similar meaning can be observed.

BIBLIOGRAPHY

There are, of course, a great number of books suitable for the service man whatever his experience, but for everyday reference and general reading he should at least be conversant with the following:—

“Foundations of Wireless,” A. L. M. Sowerby, published Iliffe.

“Wireless Servicing Manual,” W. T. Cocking, published Iliffe.

“The Amateur Radio Handbook and Supplement,” published by the Incorporated Radio Society of Great Britain.

“The Radio Amateur’s Handbook,” published by The American Radio Relay League.

“The Radio Designer’s Handbook,” published by Iliffe.

“Testing Radio Sets,” J. H. Reyner, published by Pitman.

“The Cathode Ray Oscilloscope,” W. E. Miller, published by The Wireless and Electrical Trader.

“Radio Data Charts,” R. T. Beatty, published by Iliffe.

Bernards’ Radio Manuals.

BERNARD'S RADIO BOOKS

FOR THE HOME AND AMATEUR CONSTRUCTOR

3.	SERVICES SIGNALLING MANUAL	1/-
4.	RADIO POCKET BOOK	1/-
6.	ELECTRICAL ENGINEERS HANDBOOK	1/-
22.	MANUAL OF RADIO CIRCUITS	2/-
30.	RADIO VALVE MANUAL	3/6
37.	MANUAL OF DIRECT DISC RECORDING	2/-
41.	WIRELESS AMPLIFIER MANUAL	2/-
42.	SHORTWAVE RADIO HANDBOOK	2/-
43.	MODERN RADIO TEST GEAR CONSTRUCTION	1/6
44.	RADIO SERVICE MANUAL	2/6
45.	RADIO REFERENCE HANDBOOK	12/6
48.	RADIO COIL AND TRANSFORMER MANUAL	2/-
50.	INTERNATIONAL SHORTWAVE RADIO STATION LIST	1/-
51.	CATHODE RAY OSCILLOSCOPE MANUAL... ..	2/-
52.	RADIO TUNER UNIT MANUAL	2/6
53.	RADIO CONSTRUCTORS' MANUAL... ..	3/-
54.	RADIO RESISTOR CHART	1/-

In Preparation or Printing—Order Now

55.	RADIO CIRCUITS HANDBOOK No. 2	2/6
56.	RADIO AERIAL HANDBOOK	2/6
57.	ULTRA SHORTWAVE HANDBOOK	2/6
58.	RADIO HINTS MANUAL	2/6
59.	TELEVISION CONSTRUCTION MANUAL	3/6
60.	RADIO REPAIR MANUAL	2/6
61.	AMATEUR TRANSMITTERS' CONSTRUCTION MANUAL	2/6
62.	CAR AND PORTABLE RADIO CONSTRUCTORS' MANUAL	2/6
63.	RADIO CALCULATIONS MANUAL	2/6
64.	SOUND EQUIPMENT MANUAL	2/6
65.	RADIO DESIGN MANUAL	3/-

"TECHNI-GEN"

CONSTRUCTORS' ENVELOPES

Correspondence with many thousands of purchasers of our well-known Radio books has revealed a considerable demand for Radio designs in sheet form, and has indicated the types of sets desired.

The new "TECHNI-GEN" series of Radio Constructors' Envelopes is based upon this information.

Each envelope has an attractive cover design in two colours and contains a broad-sheet, size 22½ in. by 17½ in., giving a chassis blueprint, a picture of the set which, in each case, has been built and fully tested, circuit diagrams and explicit instructions.

Lewis George, the well-known Radio designer and author, is responsible for the production of the Series and British component manufacturers have co-operated in developing the designs.

- No. 1. **HOW TO MAKE A 3-VALVE PLUS RECTIFIER AC/DC T.&F. RECEIVER.** For medium waves (200-557 M. only). This receiver is provided with a tone control and a method of using an energised loudspeaker is illustrated and described.
- No. 2. **HOW TO MAKE AN "ECONOMY" 4-VALVE PLUS RECTIFIER AC/DC SUPER-HET. RECEIVER.** For medium waves (200-557 M. only). A.V.C. and Tone Control is incorporated.
- No. 3. **HOW TO MAKE "ALL-DRY" 4-VALVE BATTERY SUPER-HET. PORTABLE RECEIVER.** For medium waves (200-557 M. only). A.V.C., Tone Control and a Frame Aerial are incorporated. Provision is also made for the use of an outside aerial.
- No. 4. **HOW TO MAKE AN AC/DC "QUALITY" RECEIVER.** For medium and long waves. This receiver is suitable for both local station reception and for the more powerful Continental stations. Approximately 8-watts push-pull output is provided.
- No. 5. **HOW TO MAKE A 20-WATT "QUALITY" AMPLIFIER.** Separate treble and bass tone controls are incorporated and the output stage comprises two tetrodes in push-pull with negative feedback.
- No. 6. **HOW TO MAKE A PORTABLE AC/DC PUBLIC ADDRESS AMPLIFIER.** 10-watts output with provision for mixing two microphone inputs and a gramophone pick-up. A suitable carrying case is illustrated.

Retail price 2s. each

Obtainable from your dealer or, in case of difficulty, write direct

BERNARDS (PUBLISHERS) LIMITED,
GRAMPIANS BUILDING, WESTERN GATE,
LONDON, W.6.

Telephone : SHEPHERDS BUSH 2581.