

No. 51 *Copyright*

CATHODE RAY OSCILLOSCOPE

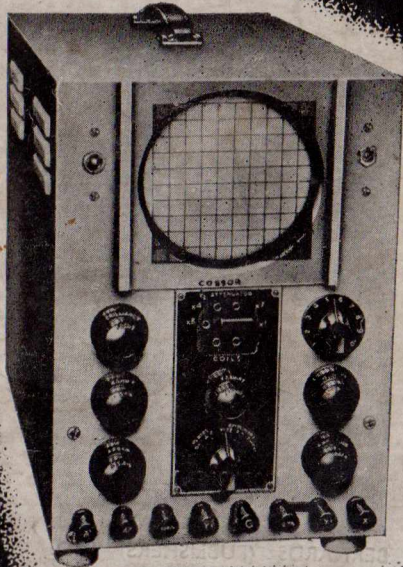

MANUAL

**CATHODE
RAY
OSCILLOSCOPE
MANUAL**

No. 51

COPYRIGHT.

1945

BERNARDS (PUBLISHERS) LTD.

LONDON, W.6

THE CATHODE RAY OSCILLOGRAPH CONSTRUCTION MANUAL.

Introduction.

With the recent developments made in the cathode ray tube and its associated components the most modest experimenter can now afford to build an oscillograph, an instrument which can be invaluable in a host of applications. A three inch tube, obviously the most expensive single unit of the whole instrument, may be obtained for from about £3, and the tube alone with its power pack can immediately prove its use before such accessories as deflection amplifiers and time base are added. The tube alone can measure voltages of practically any frequency (provided that a hard tube is used), can show phase angles and compare frequencies, whilst, with the time base and amplifiers added to it, the range of experiments and uses of the apparatus is almost unlimited.

Before construction of an oscillograph is commenced, there should be a careful consideration of the performance which it is desired to obtain, and the ultimate uses of the instrument should be tabulated. Two types of cathode ray tubes are obtainable, the soft and the hard tube, and on several points they differ appreciably. The soft tube will work very efficiently at a much lower anode voltage with a well-defined spot, but its frequency response falls off badly as radio frequencies are approached due to defocussing. Moreover, other things being equal, the life of the soft tube may be of shorter duration than that of the hard tube as the cathode undergoes a bombardment of heavy ions. (See Chapter 1).

The soft tube, therefore, will be used primarily by those who have only a low voltage supply available - users of D.C. mains or batteries - and as the subsidiary apparatus for both types of tube is practically identical, the hard tube will receive more attention in the following chapters.

The oscillograph, when made commercially, is generally a self-contained instrument, all the circuits and power supplies being mounted inside one case with a battery of controls on the front panel below the screen aperture, and this method of construction is undoubtedly the best for the serviceman who requires a compact and portable instrument, as well as for the experimenter or engineer interested in such work as routine testing of samples, etc., where the tube is working under practically the same conditions for a length of time as well as for all cases where the tube is used purely and simply as an indicator.

For experiments with the tube itself, however, or for time base testing and development and for general radio laboratory work, it is very useful to have each circuit separately mounted on a small chassis with the controls on a panel, each chassis and panel being of a standard size. They may then be arranged side by side with simple plug and socket connectors, and are easily broken down for the extraction of any one circuit or for the addition of new units.

To summarise, then, the soft tube will be cheaper, easier to run, will have good focussing and sensitivity, but

radio frequency work will be impractical and tube life will be shorter than that of the hard tube. The hard tube will be dearer, the power supply will need greater attention, but virtually any oscillograph work at all frequencies will be possible.

Chapter 1.

THE CATHODE RAY TUBE.

The cathode ray tube, hard or soft, works in much the same manner as the ordinary radio valve; that is by control of an electron stream. It contains electrodes varying in number with the type of tube, but in all cases consisting of a cathode, a shield which can be regarded as corresponding to the triode's grid and an anode or system of anodes. (Figs. 1a and b).

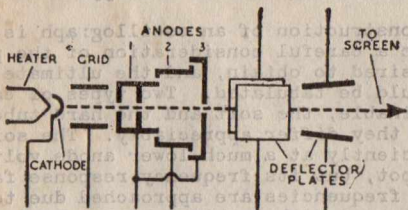

FIG 1b. ELECTRODE ASSEMBLY OF THE HARD TUBE.

The cathode may be either directly or indirectly heated and differs from the usual valve cathode only in the fact that the active element is smaller - either the emissive substance is held in a small cup or similar device for indirectly heating or it may be mounted on the end of a short stub projecting from the filament in the case of directly heated cathodes, the aim being to obtain as nearly as possible a point source of emanation. The electrons emitted from the cathode or filament immediately come under the influence of the shield, grid or Wehnelt cylinder. This electrode is generally held at a potential negative to the cathode so that the electrons are repelled from the walls of the cylinder by ordinary electrostatic action and bunch tightly together into a beam running up the tube. This beam is strongly attracted by an anode held at a relatively high positive potential, the anode being in the form of a disc or shallow cup pierced with a central hole. Through this hole the beam passes to travel on up the tube, any stray electrons being trapped by the anode if they are sufficiently wide of the aperture to cause the boundaries of the beam to be ill-defined.

At this stage the main difference between hard and soft tubes become marked.

In the soft tube this first anode, just mentioned, is the only anode. Inside the glass bulb of the cathode ray tube a small quantity of an inert gas such as argon is introduced after the evacuation of the air and before sealing off, and it is the action of the electron beam leaving the anode upon this gas which focusses the beam and keeps it in a well-defined ray until the screen is reached. The gas disperses throughout the tube and is so attenuated as to appear as electrically neutral molecules which, when bombarded by the electron stream have electrons knocked from them, leaving a positively charged "heavy" ion in place of the molecule. This ion, appearing as it does in the electron stream from the anode, attracts the electrons forming the beam, causing them once again to bunch inwards, whilst any stray electrons on the fringe of the beam are attracted back into the main stream. The chief disadvantage of the system, as already noted, is the loss of focus suffered under high frequency conditions for the "heavy" ions are unable to move as fast as the light electron beam and thus above certain speeds fail to maintain their concentrating effect. The higher the frequency, therefore, the more blurred will the spot become. At the same time the ions drift back against the electron flow, attracted by the negatively charged source, and some find their way as far as the cathode itself, accelerating as they approach it until they bombard it at high speed. Modern soft tubes have screens to prevent cathode bombardment but often the life of the cathode is shortened by this effect. Moreover, on some directly heated cathodes, the active element can be divided as it ages into two or three separate parts with the consequent reduction of cathode efficiency and particularly in its function as a point source.

It may be stated here that directly heated cathodes are best worked on D.C. and they should be connected as in Fig. 2, that is through a rheostat, with the obvious refinement of an ammeter, so that the best operating point (for sharpest focus) can be found and recorded, the setting probably needing slight adjustment as the tube ages. Indirectly heated cathodes are treated as in ordinary radio valves but A.C. modulation of the beam can be caused by operating the heater on A.C., although this is unusual. The remedy, obviously, is once more to use D.C. for the heater.

In the soft tube, then, the electron beam passes through the anode, is focussed by ionisation of gas molecules and finally impinges on the sensitive screen coated on the inside of the glass bulb. This screen consists of a chemical layer very thinly spread on to an adhesive base, the compounds used varying with makers' patents and also to control the colour of the light emitted. The first screens were generally of Willemite, which is still widely used to give the well-known green image, but a blue emitting screen is often used for making photographic records and this consists of cadmium or calcium tungstate, these compounds fluorescing when struck by electrons. The screen is easily damaged by "burning", that is by allowing the focussed beam to fall on one point for any appreciable time, and the spot should always be switched off or reduced in intensity to a

very low brilliance or shifted right off the screen by the shift controls if it must remain still, that is, with no deflecting signals on the tube.

A "burnt" tube rarely shows discolouration. Actually the chemical activity of the compound is greatly reduced at the affected point which ever afterwards gives out much less light than the surrounding screen. Even a brilliant line or trace can burn the screen if it always covers the same ground, and great care must be taken, therefore, to treat the screen with all due precautions.

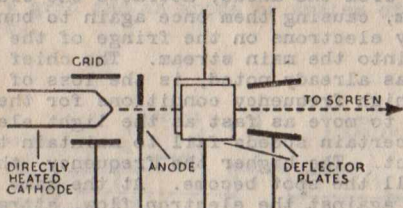

FIG. 1b. ELECTRODE ASSEMBLY OF THE SOFT TUBE.

In the hard type of tube the vacuum is high and no gas is present so that the beam carries out no bombardments. Instead the first anode is followed usually by two other anodes of varying shape but generally of the forms shown in Fig. 1b, from which it will be seen that the first anode also has its shape slightly changed. The shape of these anodes influences the distribution of electrical charge on their surfaces and thus the concentration of electrical fields through which the beam passes. The net result is to focus the beam, the action of the fields upon the electrons being almost identical with the action of glass lenses upon light rays. The first and third anodes are often joined to the same potential point, being connected inside the tube, whilst the second anode is not so positively charged and gives control over the focussing. For this reason it is connected to a potentiometer contained in the supply system (Figs. 3 and 4) and swinging the variable arm of the potentiometer gives the same effect on the screen as turning the focussing knob of a camera.

Both types of tubes have the same types of screens.

In both hard and soft tubes the beam, after leaving the anode or system of anodes, encounters on its way to the screen an arrangement of four deflector plates situated in pairs perpendicularly (Figs. 1a and b), their purpose being to move the beam in any direction according to the voltages fed to the plates. In almost all cases one plate of each pair is earthed to the cathode ray tube anode, either

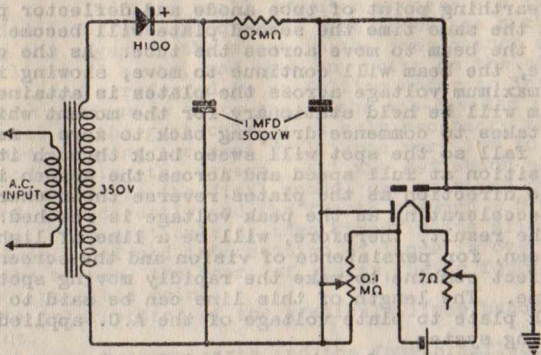

FIG. 2. POWER SUPPLIES FOR SOFT TUBE.

directly or through a shift system of potentiometers (Fig 3), the other plate of each pair being connected to the work or apparatus under test. This second plate is also earthed to the cathode ray tube anode but through a resistance of about five megohms, the work voltages being applied through condensers (Fig. 3).

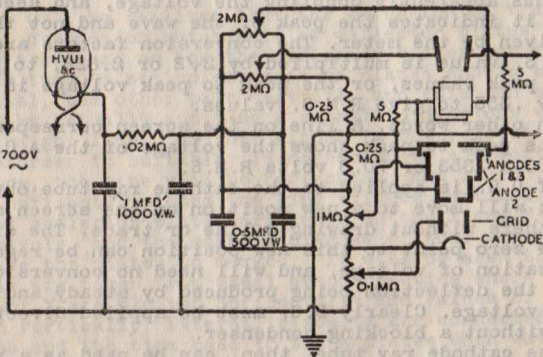

FIG. 3. POWER SUPPLY AND SHIFT NETWORK FOR HARD TUBE

The electron beam obviously carries a negative charge. If a deflector plate is made positive, therefore, the beam will be attracted towards it, and if the plate is made negative, the beam will be repelled from it, the spot of light on the screen moving in either case to a new position. Consider then an A.C. voltage applied to either pair of plates. At one instant the voltage will be zero on each plate relative to the tube's anode, the beam remaining in a central position, but immediately one plate will commence to gather a positive charge so that the beam will move towards

it. The other side of the A.C. line is connected to the common earthing point of tube anode and deflector plates, so that at the same time the second plate will become negative, helping the beam to move across the tube. As the charges increase, the beam will continue to move, slowing its speed as the maximum voltage across the plates is attained. The beam will be held stationary for the moment which the charge takes to commence dropping back to zero. As the charges fall so the spot will sweep back through its central zero position at full speed and across the screen in the opposite direction as the plates reverse their charges, again decelerating as the peak voltage is reached.

The result, therefore, will be a line of light across the screen, for persistence of vision and the screen's after-glow effect combine to make the rapidly moving spot appear as a line. The length of this line can be said to represent the peak plate to plate voltage of the A.C. applied to the deflecting system.

The relation of peak to peak A.C. voltages to the more usual measurement of Root Mean Square (R.M.S.) voltages must be fully understood. An A.C. voltmeter may read, for example, 40 volts - this is the R.M.S. value which is the figure generally required. Applying the same voltage source to the cathode ray tube would result in a trace on the screen, the length of which would correspond to a voltage of 113.1. This is because, in the first place, the tube measures each half of a full cycle in two directions from zero, thus apparently doubling the voltage, and secondly because it indicates the peak of the wave and not the mean value given by the meter. The conversion factors are simple; the R.M.S. value is multiplied by $2\sqrt{2}$ or 2.828, to give peak to peak values, or the peak to peak voltage is multiplied by .353 to give R.M.S. values.

In other words, a line on the screen corresponding to 200 volts peak to peak shows the voltage of the A.C. source to be $200 \times .353$ or 70.6 volts R.M.S.

If D.C. is applied to the cathode ray tube obviously the spot will move to a new position on the screen and remain there without drawing a line or trace. The distance from the zero point to this new position can be regarded as an indication of voltage, and will need no conversion factor, the deflection being produced by steady and unvarying voltage. Clearly D.C. must be applied direct to the plates without a blocking condenser.

The cathode ray tube, then, can be used as a peak reading voltmeter for practically any frequency of supply (using a hard tube) subject to none of the errors of the mechanical type of instrument which rapidly becomes inaccurate as the higher frequencies are reached and, also of great value, taking no power whatsoever from the circuit under inspection, for it must be realised that no current flows from deflector plate to deflector plate.

Calibrating the tube is simple, supposing it to be firmly mounted and lined up in its case. Almost all oscillographs for serious work are fitted with graticules in front of the screen. As close to as possible is fixed a sheet of celluloid, generally in slides which hold it firmly

but allow it to be removed for uninterrupted viewing. This celluloid is ruled into small, regular squares and further sub-divided into further squares. The lines are numbered off along the edges of the sheet in the same manner as are the grid lines of a map, and thus any point on the cathode ray screen can be referred to as falling under an inter-section of two lines or below one of the sub-divided squares.

To set up the graticule it is only necessary to switch on the tube, keeping the spot brilliance very low to avoid any risk of burning the screen. All the deflector plates should be earthed to the final anode, one pair and one of the second pair directly and the fourth through a 5 megohm resistance. The graticule is then fixed in its slides so that a clearly defined intersection of lines is over the spot on the screen, the beam, of course, being focussed to the finest possible point.

This intersection of the graticule lines becomes the zero point.

Now apply between earth and the fourth deflector plate a D.C. voltage from batteries. The movement of the spot across the screen will immediately be readable on the graticule as a distance between points, the distance corresponding with the voltage applied. An A.C. voltage which moved the spot to the same point (and, of course, to a point the same distance away on the opposite side of the zero point), would have a peak to peak voltage, measuring the trace from end to end, of twice the D.C. voltage applied.

It will be realised that the direction of travel of the spot depends on which pair of deflector plates is chosen for the test, and on how the deflector plates are arranged. When the tube is set up one pair of plates should be horizontal, the other pair vertical, and this can only be checked by actually applying a signal to draw out the spot to a straight line. If this signal (a 50-cycle voltage from a transformer is suitable) is connected to the vertical pair of plates, the line will be horizontal, and if it is applied to the horizontal plates the line will be vertical. These pairs of deflector plates are known as the X and Y plates respectively, and the maker's diagram of tube connections will have the plates so marked. It will be seen that these initials are taken from usual graph practice where the values of X are plotted horizontally and values of Y are plotted vertically. External circuits are connected to the Y plates and the time base to the X plates when waveforms are being drawn (Chap. 3).

If, as above, D.C. is connected across each pair of plates, in turn it will be found that the spot is deflected a greater distance when using one pair of plates than is the case with the other pair. This introduces the question of sensitivity for clearly one pair of plates is more sensitive, that is; gives a greater deflection, than the other. Several factors influence this, chiefly the distance between the deflector plates, the distance from the plates to the screen and the anode voltage used.

The closer the plates can be brought to the beam the greater effect will they have over it, but they cannot be

too close together or the beam will be deflected to such an extent that it will hit the plates and so be cut off altogether from the screen. They are therefore tilted as shown in Fig. 1 a and b to give the beam a greater angle of emergence.

The electron beam acts as a pointer or lever after passing between the plates and therefore, if the deflecting system is near the screen, the pointer, as it were, is only a short one with a small arc of movement. A long tube to allow good travel to the beam after leaving the deflector plates will give a far wider range of movement for the spot on the screen for the same deflecting voltages and thus will be a more sensitive tube, although the longer the tube the more liable to outside interference will the beam become.

Finally, the anode voltage controls the speed at which the electrons travel, and a slowly moving beam will give the deflecting plates more opportunity to exert their influence than will a fast beam, but again the voltages lie between limits which must be observed.

The chief problem of the oscillograph user so far as sensitivity is concerned is the voltage necessary across either pair of deflector plates to make the pattern or trace comfortably fill the screen. With the time bases described in Chapter 3 a sufficient sweep will be given for a three-inch tube of either soft or hard type, but for the Y deflector plates either the makers' notes may be consulted or the sensitivity of the plates measured just as in the D.C. voltage calibration mentioned above.

Earth the X and one of the Y plates directly to the tube anode, the other Y plate being earthed through a 5 megohm resistance. Apply D.C. from batteries till the spot is deflected to the top or bottom of the screen and read the voltage applied. Twice this voltage will be the peak to peak A.C. voltage necessary to carry the spot from top to bottom of the screen. Since the screen is circular, a little less voltage will be required in practice to prevent the pattern being run off the screen at the corners. This will probably be of the order 50 to 70 R.M.S. volts, or about 150-180 volts peak to peak. It can then be determined whether any signal to be applied to the tube needs amplification or not before a worthwhile pattern is obtained.

To obtain greater sensitivity the anode voltage of the tube might be reduced to its lowest limit but there will then be a risk of the bulb charge becoming troublesome.

When the electron beam impinges upon the screen the compound acquires a charge itself, freeing electrons which leak away along the inside of the bulb and are finally led off by the tube anode. If the anode voltage is brought to too low a value, however, perhaps in an attempt to exaggerate sensitivity, the electrons will form a layer over the screen which will prevent the beam from reaching the screen either locally or uniformly, and thus many strange effects may arise. In one such case the screen of the author's tube glowed green all over with something like a black beetle wandering about in the middle!

The remedy, of course, is to increase the anode voltage when the positive charge will again become

sufficient to break up the electron clouds and the trace will again appear in the normal way.

External interference, which can completely upset the results from an otherwise perfectly adjusted tube, can be of two kinds, electrostatic and magnetic. As the beam is already being moved inside the tube by electrostatic means it is easy to understand that any accumulation of charges or any sudden electrical impulses outside the tube could also add their own effects to the beam, causing it to give a distorted image on the screen. Electrostatic interference can be fairly easily avoided for a metal screen round the whole tube will trap charges in the same way as an radio type of screen, the metal being earthed to the tube anode, but magnetic interference is more difficult to prevent and cure.

The electron beam is deflected by magnetic fields in the same manner as by charges, and indeed can be completely controlled by electromagnetic means instead of electrostatic fields. Most television types of cathode ray tubes are focussed magnetically and have magnetic deflecting coils mounted outside the tube, round its neck, instead of internal deflecting plates. It is well known that a wire carrying an electric current has a magnetic field set up around it, and that this field will interact with other surrounding fields. The electron beam of the cathode ray tube is just such a current, minute though the flow might be, and therefore if a magnetic field is set up parallel to the beam the electrons will be deflected one way or the other depending on the polarity or direction of the field. Magnetic deflection is not so suitable as electrostatic deflection for oscillograph work and therefore will not be treated in any greater detail, but the effect must be understood so that sources of interference may be traced. Unfortunately the oscillograph must contain a sure source of magnetic interference if the apparatus is to be A.C. operated - the mains transformer. The transformer chosen should have good metal shrouding all round it, to minimise stray fields, and if it is at all possible the transformer should be mounted directly at the rear of the tube so that lines of force which might emanate from it run centrally along the tube with the beam. Magnetic interference will generally tend to draw the spot from side to side in one plane or another, and so may be observed if, with no signals applied and with brilliance right down, the spot is focussed on the screen not to a small point or circle but to an oval or short line. Magnetic interference, however, can also modulate the beam, that is, instead of a steady flow of electrons, they will, at some point depending on the field, be changed to spurts in accordance with the frequency of the field, generally 50 cycles when the field is caused by A.C. apparatus. This will not be detectable on a stationary spot but only when a full pattern is being observed, when parts of the wave form will remain at full brilliance whilst other parts will either be dim or even blacked out if the interference is sufficiently strong. The same effect will be caused by imposing an A.C. ripple on to the shield or grid supply, for the more negative the grid becomes the less

electrons will be passed. A.C. on the grid, therefore, will modulate the beam strength in the same way and it should be noted that this effect can be masked on an A.C. waveform of 50 cycles where the pattern will be synchronised with the interference.

Besides mounting the transformer behind the tube, therefore, the tube should be mounted into a cylindrical shield, preferably of Mumetal, or as good a magnetic iron as can be obtained. If possible it is better for the shield actually to fit the tube, that is, for it to be of small diameter about the neck widening with the tube up to the screen, but such an undertaking would probably be a very expensive one. It must also be remembered that heater leads carrying A.C. have an alternating magnetic field round them quite capable of causing a hum ripple on the beam. Such leads should be twisted and allowed to follow a direct route away from the other leads whilst all the wiring should be as short as possible although along enough to give the tube a little play in its mounting.

Both soft and hard tubes have inherent faults which can be avoided in various ways. Gas focussed tubes suffer from 'origin distortion' which appears as a kink in any waveform or pattern in the centre of the tube and is due to a type of space charge between the deflector plates owing to the presence of the gas. This space charge reduces the sensitivity of the tube at low deflecting voltages, but it is now generally overcome by special methods of construction of the deflecting system. Some tubes have one plate of each pair split into two with different 'bias' voltages fed to the halves of the plates from the resistance chain of the power pack, whilst other tubes have the deflector plates so mounted that, at low voltages, the spot is directed into one corner of the screen instead of the centre. The pattern under inspection is then re-centred by shift controls and the kink can only occur where it will cause no confusion.

Trapezium distortion is generally found only in hard tubes and is caused by the signals on one pair of plates effecting the sensitivity of the other pair. Once again in some tubes it is avoided by special methods of construction, and the effect appears on the screen as a distortion of the length of one or two edges of the pattern. It is especially noticeable on a television screen where the rectangle of light becomes a partial trapezium. If the deflecting plates of the tube are not corrected for the effect it can be overcome by using a push-pull time base which ensures that both of the X plates are rising and falling in potential at equal and opposite rates. (This time base is dealt with in greater detail in Chapter 3). Wherever these distortions are allowed for in the making of the tube the alterations, if any, to the circuit will be described by the manufacturer's leaflet.

A short tube of the hard type can show a loss of focus on one side of a wide image, the trace becoming fuzzy or thicker. This is due to variations in the voltage of the second or focussing anode with respect to the deflecting plates, but should not affect results unduly unless the tube is very insensitive. In this case a push-pull time base will be of benefit.

POWER SUPPLIES.

It must be understood that where, in the text and diagrams, the tube anode and deflector systems, together with apparatus connected to them, are described or shown as being 'earthed' what is meant is a connection to the metal chassis of the oscillograph, not a physical earth connection like that of a radio receiver. A direct earth connection would impose high voltage strains across the power transformer if one side of the mains were earthed and in any case a direct earth connection should be totally unnecessary.

There are two points of major importance to be observed in the design of power packs for cathode ray tubes; high voltages are used and therefore insulation must be perfect. Moreover, the anode, as just shown, is earthed for the reason that the chassis will then be at a safe potential level with respect to the deflector plate system and electrostatic interference will be less readily picked up. The cathode and heater of the tube, with their supply systems, will thus be floating at a high potential to the chassis and dangerous in direct contrast to conditions obtaining in normal radio technique. Except for the controls no part of the tube's base and holder and power supply circuit should be touched or adjusted without first switching off. Even should a shock so obtained not be serious physically, the muscular contraction bound to result might easily smash the tube if the hand were near it.

Although the power pack deals with higher voltages than usual it is simple to construct because of the very low currents flowing. The tube itself passes only a few micro-amperes and if a half to one milliamp or so is flowing through the whole resistance chain of Figs. 2, 3 and 4, it will be sufficient. If the potentiometers of this chain are to be mounted on a metal panel they must have insulated variable arms, and as an added precaution it is wise to mount them on an insulating sub-panel with their spindles protruding through holes in the main panel drilled to give adequate clearance. Alternatively, insulating bushes might be used.

All the condensers of the power pack must be in perfect condition and of adequate working voltage. The reservoir condenser, that nearest the rectifying device, must bear not only the R.M.S. voltage supplied to the external circuit, but the peak voltage of the A.C. half cycle, so that the voltage rating for condensers should for safety be twice the D.C. voltage the power pack is designed to supply. It will be seen that a smoothing choke is not used in the circuit for the current flow is so small that resistance smoothing is perfectly suitable and the voltage drop is negligible. Resistors rated at one watt are all that are required. Obviously any instrument used for testing the power supplies for the tube must be of the high resistance type. A cheap low resistance voltmeter, even if it embraced the necessary ranges, would have such a potential drop across its own terminals when connected to any two points on the resistance chain that the reading obtained would be meaningless. The best type of instrument for the purpose is, of course, an electrostatic voltmeter

which consumes no power on D.C. but a high grade moving coil instrument with a resistance of 2,000 ohms. per volt or more could also be used.

The half wave rectifiers of Figs. 2 and 3 will supply the power needed by the cathode ray tube itself but very often the Time Base (Chap. 3) is driven from the same supply and then provision must be made for the extra current drain. A gas relay time base which will give ample output for any three-inch tube will consume about ten milliamperes, a current which several high voltage rectifiers cannot supply. A voltage doubling rectifier, however, has the advantages not only of supplying a high voltage output from a low voltage input but also of giving ample current.

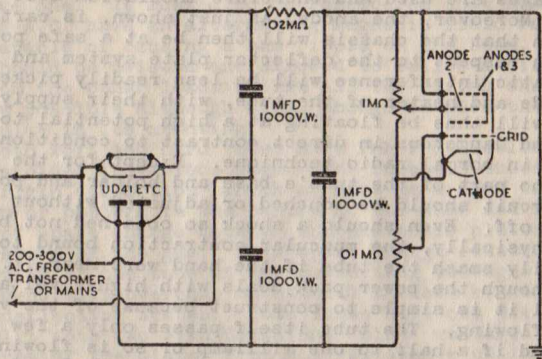

FIG 4. VOLTAGE DOUBLING POWER SUPPLY.

The circuit shown in Fig. 4 will give 600 volts or more when the H.T. input terminals are connected to a 250-volt secondary of a small transformer, or even directly to the A.C. mains, but it must be remembered that, in this latter method of connection, the tube will be isolated from the mains supply only by the valve and condensers, not by insulated transformer windings. Great care must be used therefore, when using such a circuit with any other mains apparatus, and a transformer to supply H.T. to the rectifier is much more desirable. A transformer for heater supplies will still be needed in any case and it is good practice to use separate heater transformers for high voltage work. The whole voltage exists across the H.T. and heater secondaries, and if they are wound on separate cores the problem of insulation between them is solved.

Where the time base is driven from the same power pack its supply voltage may need to be lower than that to the tube, so that a dropping resistor or potential divider will be necessary. Since the time base must be directly earthed to the tube anode a dropping resistor must be inserted into the negative supply lead.

Constructors used to ordinary radio technique must always bear in mind that the chassis is positive, and wire negative leads accordingly.

Deflection amplifiers (Chap. 4) are generally driven from their own power packs. The current drain is only small and a simple supply system with good choke smoothing will suffice, the chief reason for separate supplies again being that once again the input circuit of the amplifier would be positively earthed if it was driven from the tube supply and consequently not so simple to connect to outside apparatus. It must be said, however, that more than one commercial oscillograph has its amplifiers fed in this way, and providing a good power transformer is used, no undue trouble should be encountered.

The resistance chain to which the tube is connected needs nothing special in the way of resistors as the current and thus the watts dissipated are so low, but wire wound potentiometers are to be preferred simply because they are likely to be more trouble free than the composition type.

There is a constant potential slope along the chain from negative to positive ends and it must be remembered that the tube cathode is connected after the first potentiometer, not directly to negative H.T. The first potentiometer supplies the negative bias to the tube and if it is desired that this bias cannot fall to zero a fixed resistance inserted between this potentiometer and the cathode tap of, say, 5,000 ohms. will ensure a minimum bias of one or two volts.

A very few tubes use positive bias which can be obtained by reversing the cathode and grid connections to the resistance chain but the makers' instructions must be rigidly observed on this point. Any mistake in the biasing circuit can easily ruin the cathode's emission or badly burn the screen.

The method of obtaining shift control is shown in Fig. 3, where it will be seen that two extra potentiometers are connected to the resistance chain. To their variable arms are led one of the X and one of the Y deflector plates. The method of connection is such that these X and Y plates, instead of being at the anode potential, can have a voltage varied by the sliders to about 100 volts above and below the voltage of the anode. As the deflecting voltages are always relative to the tube anode voltage this means that the spot can be moved over the screen either horizontally or vertically, whilst external signal voltages (often called the "work") can still be applied. In this case, of course, the whole trace or pattern moves across, up or down, according to the shift control in use, and if there should be any defect in the centring of the spot on the screen due to small constructional faults in the deflecting system, the shift controls provide an excellent means for correcting the defect. With a small tube, however, shift controls are by no means essential except in the case of the soft tube where, as already mentioned, the spot has deliberately been de-centred to prevent origin distortion at the centre of the screen.

Chapter 2.

THE TUBE IN USE.

In Chapter 1 it has already been shown that an A.C. voltage applied to either pair of plates will cause the spot

to move in such a way that a straight line will be drawn on the screen, the length of the line being directly controlled by the voltage applied. The pair of Y plates is generally used so that the line is vertical, the X plates simply being earthed so that they are taking no part in producing the trace on the screen.

Consider, however, a second A.C. voltage of the same frequency applied to the X plates. The spot is already travelling up and down in response to the Y plates' charges; it will now also be drawn from side to side by the charges on the X plates and the two movements must of necessity be amalgamated in some way - the spot can no longer travel purely vertically or purely horizontally. The way in which the spot moves depends on the phase relationship of the alternating voltages.

A.C. voltages, as is well known, may be shown as sine waves, and two voltages are said to be in phase when the positive peaks of the one voltage are occurring at the same moment as the positive peaks of the other - if graphs of both voltages were drawn on paper one graph would exactly fit the other so long as the voltages were equal. Moreover the sine wave can be numbered off in degrees. In Fig. 5, with respect to the X plate voltage curve, the point A, a positive maximum, can be called 0 degrees. The sine wave curve is derived from a rotating vector whose movement is measured in angular degrees, the voltage at any moment being proportional to the sine of the angle through which the vector has rotated (see any A.C. text book for full theoretical details), so that point B corresponds to 90 degrees, point C to 180 degrees, point D to 270 degrees, and the second positive maximum to 360 degrees, the two positive maxima being thus separated by one complete revolution of 360 degrees.

Now consider the voltage shown in Fig. 5 as being applied to the Y plates. Point A occurs at the same instant

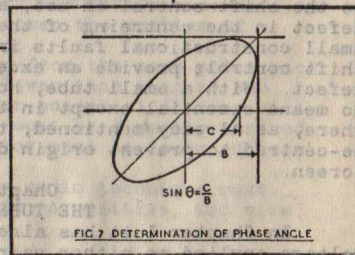
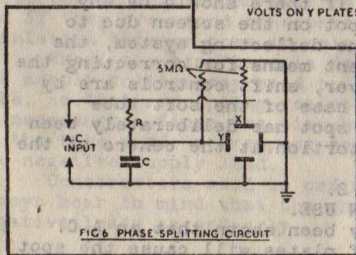
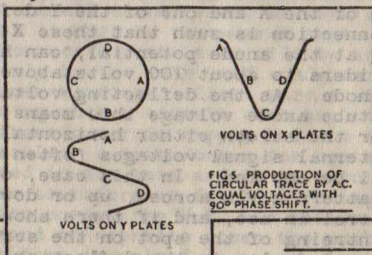

of time as point A in the X plate voltage, but now the voltage is not at a maximum, it is at zero level. As the voltage on the Y plates rises to point B the voltage on the X plates falls to point B and clearly the one sine wave will never be in step with the other. The Y plate voltage is lagging behind the X plate voltage, and if it is remembered that point A in both cases is at the same moment of time it can easily be seen that the Y plate voltage lags by a quarter of a wave or, in other words, the Y plate lags the X plate voltage by 90 degrees.

How, then, will these two waves combine to move the spot? Study of Fig. 5 will immediately make this plain. On the circle point A shows the spot at the right centre of the screen - full X plate charge and no potential across the Y plates. At point B the X plate potential has fallen to zero so that the spot has endeavoured, so far as the X plates are concerned, to return to the centre of the screen, but the rising Y voltage has caused it to fall as well so that it is now at bottom centre. As the Y voltage falls back to zero the spot is carried over to the left by the reversed and growing charge on the X plates until it reaches point C, and so on until the spot has traversed the full circle and left a circular trace. Only for phase differences of 90 and 270 degrees of equal voltages does the spot describe a circle. As the phase difference grows or decreases the circle narrows to an ellipse inclined either to the left or the right, whilst at phase differences of 0 and 180 degrees the trace becomes a straight line running diagonally across the screen. Where the two voltages are equal the ellipse will be inclined at 45 degrees, more steeply for a greater Y plate voltage and more flatly for a greater X plate voltage. The phase relationship cannot be changed by voltage variation, however, and no matter how the pattern is inclined, a simple method of measurement will enable the actual phase difference of the two A.C. supplies to be obtained.

Fig. 7 shows an ellipse as it might appear on the screen, preferably using a graticule to set the horizontal and vertical base lines. Then, calling the angle of phase difference θ , measurement C divided by measurement B equals $\sin \theta$ from which the angle can be found by reference to sine tables. Clearly there are several possibilities for errors in such a method and results will not have spot accuracy especially when the figure opens out to a near right circle, but at the worst a good indication is obtained.

It will be seen that measurement C is from the centre of the ellipse to the cutting point of the horizontal base line and measurement B is from the vertical base line to the vertical tangent at the side of the figure.

One important application of this method of phase angle determination is the measuring of phase shift in amplifiers. A signal is fed to the X plates of, say, a sliding frequency between 30 and 10,000 cycles, sufficient to give a good trace. A portion of this same frequency signal is then fed into the amplifier under test, the amount being controlled by a resistance network or potentiometer, and the output from the amplifier is then led to the Y plates. If no phase shift is present the trace on the

screen will be a straight line, but where the amplifier introduces phase shift the line will open to a loop. One possible source of error in using this method of amplifier testing is in the potentiometer which supplies the input circuit of the amplifier which might itself introduce phase shift. Instead of using a voltage sufficient to give full X plate deflection the frequency used for testing could be fed at low voltage directly to the amplifier input circuit, thus avoiding the potentiometer network. The Y plates could be supplied as before by the amplifier output circuit whilst the X plate supply comes from the low voltage source via a deflection amplifier. Naturally such an amplifier must be beyond reproach both as regards phase shift and frequency response, and the subject of deflection amplifiers is dealt with in Chapter 4.

A simple method for experimenting with phase shifts is shown in Fig. 6, which is the circuit, with deflector plate connections, of a phase splitting device. The terminals marked A.C. Input are fed from a transformer giving about 200 volts (it may be necessary to connect a potentiometer across the winding so that the voltage can be adjusted). It is not safe to use the mains supply without a transformer to isolate the circuit from the mains. Then the voltage across the resistance R is in phase with the current flowing through R whilst the voltage across the condenser C is lagging behind the current, so that, by adjusting C or R, the amount of phase shift can be controlled. Where $R = \frac{1}{\omega C}$ the trace on the screen will be circular ($\omega = 2\pi f$

or, for 50 cycle mains, 314 ; R is in megohms and C in microfarads). Suitable values, therefore, for a circular trace would be .1 microfarad and $31,500$ ohms., although the trace will not be a true circle as one pair of plates is slightly more sensitive than the other and thus need a slightly lower voltage.

So far the phase shift effects considered have been phase shifts of one fundamental frequency, but it will be realised that where two different frequencies are compared one with the other the effect is that of a constantly changing phase shift between the two. For example, where two waves are compared, one having twice the frequency of the other, they will be in step at the zero point and again in step at zero, although one will have passed completely through 360 degrees whilst the other has passed through 180 degrees. If two such waves were applied to the cathode ray tube, one on the X plates and the other on the Y plates, the result would be a rapidly changing phase shift pattern until one frequency was an exact multiple of the other. At such points a steady and recognisable pattern would appear on the screen, and from such patterns unknown frequencies can be compared with standard frequencies and measured with very great accuracy. These patterns are known as Lissajous' figures and a few of them are shown in Fig. 8. No. 1 shows two frequencies which are equal but 180 degrees out of phase; No. 2 is of two equal frequencies 90 to 270 degrees out of phase; No. 3 is of two equal frequencies about 130 degrees out of phase.

Frequencies of two to one ratio produce figures such as those of Nos. 4 and 5, the exact shape depending on the

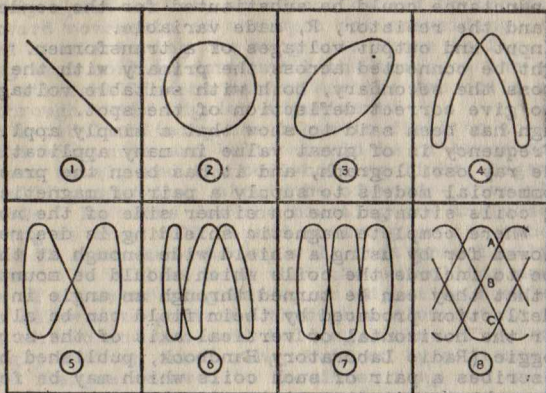

FIG. 8. LISSAJOUS FIGURES.

phase difference, whilst figures such as are shown in Nos. 6 and 7 are produced by frequency ratios of three to one. It should be noted that inverted ratios - sub-multiples instead of multiples, such as one to two or one to three - produce exactly the same figures but they will be turned through 90 degrees, or "lying on their sides". It will be noticed from the figures that the ratios of the frequencies which produce them can actually be read off from the patterns by counting the number of complete wave peaks along the top of the pattern and comparing the figure thus obtained with the number of loops appearing at the end of the pattern. Using this method with Figs. 8 (4 and 5) immediately gives the ratio of 2:1 in each case, and with Figs. 8 (6 and 7) the ratio 3:1 is also found without difficulty. The clarity of Lissajous' figures breaks down, however, as ratios of 10:1 are approached, and at even lower ratios the number of end loops is sometimes difficult to determine. In such cases it may be easier to read off the number of line intersections as at a, b and c in Fig. 8 (8), remembering to add one to the number to make up the required figure. Thus, for a pattern having seven horizontal wave peaks and four end intersections, the frequency ratio would be 7:5.

Although the method becomes of less value for ratios above about 10:1, it is still possible to read with great accuracy frequencies of up to 500 cycles per second by using the mains frequency of 50 c.p.s., and if a variable audio oscillator is available the ratio limit is extended to a very great degree, the accuracy being dependent on the calibration of the oscillator which can be checked in its turn, of course, against the mains frequency.

Further examples of phase shift between currents drawn

from the same source or from the same fundamental frequency are:-

1. The voltage and current across an inductance.

Here the inductance could be substituted for the condenser in Fig. 6 and the resistor, R, made variable.

2. Input and output voltages of a transformer. The X plates might be connected across the primary with the Y plates across the secondary, both with suitable voltage controls to give correct deflection of the spot.

Enough has been said to show that a simply applied 50-cycle frequency is of great value in many applications of the cathode ray oscillograph, and it has been the practice in many commercial models to supply a pair of magnetic deflecting coils situated one on either side of the neck of the tube. Where complete magnetic shielding is desired this can be allowed for by using a shield wide enough at the neck of the tube to include the coils which should be mounted on a ring so that they can be turned through an angle in order that the deflection produced by their field can be aligned with either the horizontal or vertical axis of the screen. M. G. Scroggie (Radio Laboratory Handbook, published by Iliffe) describes a pair of such coils which may be fed from a transformer heater winding giving 4 volts, to produce an

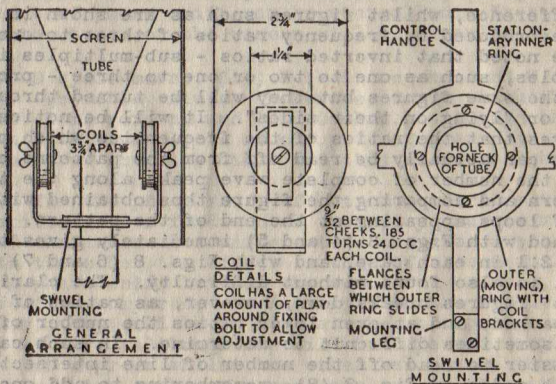

FIG 9. COILS & SWIVELLING MOUNTING FOR MAGNETIC MOUNTING.

adequate trace on the screen, and Fig. 9 shows the dimensions of the coils, together with a suggestion for their mounting.

This magnetic deflection can be used in several ways, and provides a very good test signal for the tube. The spot is kept moving so that it need no longer be reduced to a very low brilliance, and when the coils are properly set in position (generally to give a horizontal trace), the test frequencies or voltages may be applied to the Y plates as before, to obtain phase shift or other patterns.

The coils are aligned by coupling all the deflector plates to earth and connecting the coils to the 4-volt A.C. source, which should also be earthed on one side. The line is probably split in two, an effect caused by the forward and backward movements of the spot not coinciding. This is corrected by slackening the wing nuts shown in Fig. 9 and adjusting each coil in turn until the trace on the screen is a single straight line no matter how the two coils are turned through their angular adjustment.

To avoid localising the magnetic field to too great a degree the wing nuts and bolts should be of brass or some non-ferrous metal, and the coil-holding limbs, together with the swivelling mounting, should be of wood - five ply would be suitable. No sizes for the mounting are included with the drawing as they will depend entirely on the tube used, but the coil sizes and spacing will suit practically any small tube. It will be seen that the swivelling mounting consists of an outer ring having an adjusting handle which could be allowed to protrude through a slot cut in the magnetic shield and two coil holding limbs. This outer ring fits snugly upon an inner ring, held on by a flange on each side, the flanges screwed to the inner ring and one of them extended into a mounting leg.

No details can be given of exactly where along the tube the coils should be, for once again different tubes will need different adjustments. It should be a simple matter, however, to run the coils up and down in the vicinity of the deflector plates until a good trace is obtained using the energisation suggested. The most likely cause of trouble will be deflector plate cut off - that is, the coils are too far behind the deflector plates so that the swinging electron beam is pulled over till it is interfered with by the plates - but little trouble should be encountered in practice.

A second valuable use for the coils is a direct deflection from current effects. To study the waveform or phase of current, as distinct from voltage, it is necessary generally to pass the current through a resistor and to use the voltage drop so obtained across the resistor, as the deflecting potentials or "work". In most cases, however, this resistor must be small in order that it shall not interfere seriously with the current flow, which means that the voltage must first be amplified by a deflection amplifier. With the coils this is no longer necessary except for very small currents, whilst with too large currents the coils can be shunted to give the correct amplitude. It should be remembered that the inductance of the coils may have an effect on A.C. signals, but at audio frequencies this should not be sufficient to be troublesome.

The coils may also be used to provide a sinusoidal time base for quick checking of "work" frequencies or waveforms. If a greater voltage, for example, 10 volts, is fed to the coils, the trace will extend beyond the limits of the screen so that only the centre portion of the 50 c.p.s. trace is occupying the screen. For all practical purposes this portion of the wave can be considered linear, so that, if the coils are arranged to give a horizontal trace and the

"work" is applied as usual, to the Y plates, an almost correct waveform will result so long as the frequencies are in synchronisation. Actually two waves will be shown, one on the forward and one on the back trace, but these can generally be separated by the eye. Time base work and synchronisation are fully dealt with in Chapter 3.

Chapter 3.

THE TIME BASE AND WAVEFORMS.

All radio and audio frequency effects are due to alternating, or waveform, voltages and currents, the frequency of the alternations ranging from about 20 to 15,000 or 20,000 c.p.s. in the audible band and up to several million cycles per second in the radio bands, and much of the information necessary for the solving of problems in the audio-radio electrical sphere can be gained by study of these waveforms.

The cathode ray oscillograph is the only instrument on which the shape of the wave at all frequencies can actually be seen. Mechanical oscillographs, those where a mirror or filament is caused to vibrate in a magnetic field, soon fail to respond as the frequency rises because of the inertia of the moving element, no matter how light it is made, but a moving beam of electrons is to all intents and purposes weightless, and without friction or inertia.

The theory of drawing out a wave form on the oscillograph screen is simply understood. Suppose, once again, that an alternating voltage is applied to the Y plates so that the spot traces a vertical line on the screen. Now, if a positive charge is given to one of the X plates, the spot will also be attracted towards that plate and the vertical line will shift from the centre of the screen over to one side. Thus the line can be moved across by applying a steady potential to the X plates and further, if this potential were arranged to grow slowly from zero to full deflection value, the line would move slowly across the screen in accordance with the rising X plate charge. If, when this voltage reached a maximum, it suddenly dropped back to zero and then commenced to grow again in the same way, clearly the line would fly back to its starting point and then recommence its slow movement across the screen.

Now suppose this process to be accelerated so that the X plate potential grows rapidly and thus forces the Y plate trace to move quickly.

The Y plate trace is caused by the spot moving up and down - the spot is further along its course at one moment than at the preceding moment. If the growth of the X plate charge is sufficiently rapid the spot will move horizontally while endeavouring to trace out the vertical line and as a result the line will curve and resolve into the waveform of the Y plate voltage.

Actually, of course, certain conditions must be met for the waveform to be visible as a steady trace on the screen for it will at once be seen that the horizontal and vertical movements of the spot must bear some fixed relationship to maintain the wave picture, just as a Lissajous' figure will remain steady only when the frequencies are multiples or sub-multiples. For example, if

the Y plates are connected to a 50 c.p.s. supply and the X plate potential grows from zero to maximum in one-fiftieth of a second, then curve traced will show one complete wave of the Y plate supply voltage; that is one positive and one negative half cycle.

This supposes that the X plate voltage drops from maximum to zero at the end of each sweep across the screen instantaneously, which is, of course, impossible. The drop

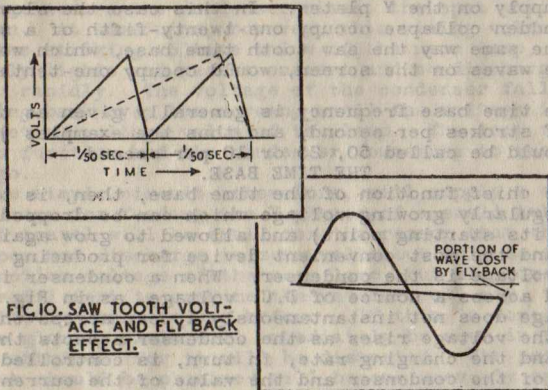

**FIG. 10. SAW TOOTH VOLT-
AGE AND FLY BACK
EFFECT.**

takes a short time, which must be allowed for so that the whole cycle of operations is performed in one-fiftieth of a second in the above example. This drop back to the zero position is known as the "fly back" and as a result of the time taken up in returning the spot to the start of its run, the waveform is cut short as in Fig. 10.

To obtain one complete wave on the screen, therefore, it is necessary to show at least two or preferably three waves, which means an alteration to the time base frequency.

The time base voltage, if drawn as a graph of volts against time takes the form of saw teeth and is known as a "saw tooth" voltage, such a voltage also being shown in Fig. 10. The full line shows two sweeps of the time base, each occupying one-fiftieth of a second, so that, during the first sweep, a wave like that shown is drawn on the screen when the Y plates are connected to a source of 50 c.p.s. supply. At the end of the sweep, however, the spot has just returned to its starting point and so, during the second sweep, the trace on the screen will again be that of one cycle of the supply voltage and, moreover, it will fall exactly on the trace of the preceding cycle. In this way 50 waves are drawn on the screen each second but they combine to form the steady picture of a single wave. If the frequency of either the supply or the time base altered by even a minute amount the spot would not quite return to its starting point - it would either fail to reach it or overshoot it, and so the wave would slowly drift through a series of phase changes. The waveform would be retained but

the wave would appear to wander across the screen, and the frequency changes needed to give this effect are so slight that it is generally necessary to synchronise the time base with the voltage under inspection. Methods of obtaining synchronisation, or "synch", are explained later in the chapter.

The dotted line of Fig. 10 shows the saw tooth re-adjusted to give two waves on the screen, still using a 50 c.p.s. supply on the Y plates. In this case the slow build up and sudden collapse occupy one-twenty-fifth of a second, and in the same way the saw tooth time base, which would show five waves on the screen, would occupy one-tenth of a second.

The time base frequency is generally given as the number of strokes per second, and thus the examples just quoted would be called 50, 25 or 10 per second.

THE TIME BASE.

The chief function of the time base, then, is to provide a regularly growing voltage which can be dropped to zero (or its starting point) and allowed to grow again as before, and the most convenient device for producing such a growing voltage is the condenser. When a condenser is connected across a source of D.C. voltage, as in Fig. 11, the voltage does not instantaneously appear across the condenser; the voltage rises as the condenser accepts the charge, and the charging rate, in turn, is controlled by the capacity of the condenser and the value of the current which is allowed to flow as a surge. The resistance R in the figure has the task of controlling the current flow taken by the condenser C, and thus across C there will be a rising voltage, which, if connected to the Deflecting plates, will draw the spot across the screen.

It is also necessary, however, for the voltage to fall back if not to zero then at least to some suitable minimum value, and of several devices capable of this switching effect the neon tube is the most valuable so far as this circuit is concerned. As is well known the neon tube has a "striking voltage" - that is the tube must have a certain

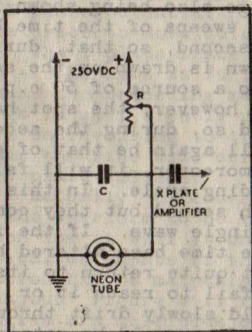

FIG. 11. NEON TIME BASE.

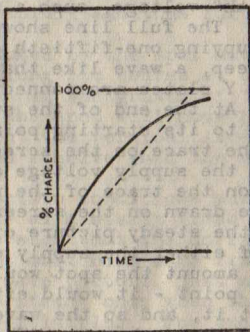

FIG. 12. CONDENSER CHARGE CURVE.

voltage across the electrodes before the gas will ionise and pass current, but once this ionisation has been accomplished and the tube is glowing, the voltage may be dropped well below the striking voltage before the tube fails to pass current. This new voltage is known as the "extinction voltage".

Consider, therefore, the action of the whole circuit of Figure 11. C charges at a rate controlled by R and so the voltage across the condenser rises, the spot moving over the screen. At some time, however, this rising voltage reaches the striking voltage value of the neon lamp, which immediately lights and passes current and so discharges the condenser rapidly. The voltage of the condenser falls, the spot flying back over the screen, until the voltage is below the extinction voltage value of the lamp. The lamp then ceases to function and the condenser commences to restore its charge.

This simple circuit, therefore, will supply a saw tooth voltage for feeding the X plates of a small tube. The amount of travel will be small for the reason that the condenser does not discharge to zero volts but only so far as the extinction voltage of the neon lamp, but the time base will be sufficient to examine the waveform of, say, the A.C. mains suitably connected as before. If this is done, however, one glaring fault will immediately be seen in the waveform obtained, for it will be distorted. The pure sine wave which should be obtained will become unevenly spaced, the waves far apart at one side of the screen and closed up at the other. Clearly this is the fault of the saw tooth voltage itself, and can only mean that the straight lines of the voltage graph shown in Fig. 10 have become curved. Such is indeed the case, and Fig. 12, which is the graph of a charging condenser, reveals the cause.

A condenser does not accept charges in a linear fashion. The dotted line in Fig. 12 shows the ideal charging characteristics of a condenser which would make a time base circuit such as that of Fig. 11 practicable, but in actual fact the charge is accepted as indicated by the full line. The condenser has 63% of its full voltage across its plates in a time equal to the reciprocal of CR where C is in microfarads and R is in megohms, but the charging rate is steadily falling and, even after three times the above period, the charge has only reached 95% of its full amount. This, then, accounts for the uneven movement of the spot along the horizontal axis, and whilst there are some few methods of combating this defect, undoubtedly the best way is to use a constant-current device. The resistance of Fig. 11 is allowing a sudden current surge to flow as the condenser commences to charge, and if this could automatically be regulated so that a constant current was flowing right up to the moment of discharge, the non-linearity of the condenser could be neutralised.

One convenient constant-current device is the diode valve. When the filament of a directly-heated valve is run at a reduced rate only a relatively small number of electrons are emitted, so that a positive potential on the anode of the valve of a few volts can easily draw all the avail-

able electrons from the filament to the anode. Under these conditions the valve is said to be "saturated", that is no matter how the anode voltage is increased, no more electrons will flow and thus the current which can be passed by the valve is strictly limited. This is just what is required to charge the condenser of the time base, and if a diode is inserted in place of the ordinary resistance, its filament being run at a reduced rating, the condenser will be forced to charge up in a linear manner.

This, however, will mean that the diode's filament must be run from some easily controlled source, such as batteries, while the setting of the filament current may be rather sensitive, and a much better substitute for the diode is a pentode valve which has similar characteristics when the voltages of the grid and screen are kept constant. The current flowing through the valve is practically unaffected as the anode rises in potential over about 60 or 70 volts and the charging rate of the condenser can be controlled by varying the voltages on the pentode's control grid or screen grid. One of the most efficient circuits using the pentode valve is shown in Fig. 13. Here the condenser C of Fig. 11 is replaced by a block of four condensers brought into the circuit by a switch so that, beside the control of the charging rate given by variation of the screen grid potential, the frequency of the time base is also controlled by selecting a suitable condenser capacity for the work. The circuit is fed from a potential divider across the supply, the control grid of the charging valve, as the pentode is called, being earthed. The selected condenser, when charging, must draw its current through the pentode.

The second valve of the circuit, a triode shown shaded, now needs explanation. It was seen that, with the circuit of Fig. 11, the neon lamp, when discharging the condenser, only allowed the charge to fall to the extinction voltage of the lamp which might be quite high - say 150 volts. Thus the circuit is very inefficient, added to which there is no control over the characteristics of the neon lamp. The shaded triode of Fig. 13 takes the place of the neon lamp, and is known as a gas relay or, in the Mazda range of valves, a thyatron. The internal construction is similar to that of the ordinary triode, but instead of a vacuum within the bulb, a small amount of inert gas is allowed to enter, the gas being, perhaps, neon or argon, so that in the first case the valve appears little better than the neon tube. When a current flows from the cathode to the anode, however, as in an ordinary valve, it bombards the gas molecules between the electrodes and the gas ionises so that the current immediately grows to a high value. Even if the anode voltage falls the current still flows until the anode potential is either removed or at a very low value, often below 20 volts, the exact figure depending on the valve used. Obviously the gas relay is much more efficient than the neon lamp for the purpose of discharging a condenser, for the high current will give a very rapid discharge, allowing the fly back time to be short, whilst for all intents and purposes the condenser will be completely discharged, and not left with a considerable potential across

The time base amplitude, or the length of the trace on the screen, is varied by varying the grid bias. The chief effect of this is to increase or decrease the potential difference through which the cathode voltage swings, thus controlling the percentage of charge of the condenser. A large degree of negative bias means a greater cathode swing and thus a longer time of charge for the condenser and therefore a longer trace on the screen. Obviously this will also change the frequency of the time base but this can always be corrected by the Frequency Control.

It will be seen that the anode circuit of the gas relay includes a resistance of 1,000 ohms. Different gas relays require different values of resistance, but it should not rise above this value, as given in Fig. 13, as too high a resistance in the circuit at this point will cause a delay in the discharge of the condenser and thus add to the length of the fly back. The function of the resistance is to prevent too high a current from passing through the gas relay, for as the condenser discharges through the valve in a short time, the current can rise to a high figure. Quite a small gas relay can carry half an ampere without damage, however, so that, if it is thought that this resistance is adding appreciably to the fly back time, it may be dropped to 500 ohms. with safety.

The charging condensers for the time base can be chosen by using the approximate formula for time base

frequency $f = \frac{I}{CV}$ where I is the charging current in microamps, C is the condenser capacity in microfarads, and V is the difference in voltage of the condenser charged and uncharged. It will probably be of more use, however, to suggest capacitivities for a general purpose time base, and a good, overlapping frequency range will be given with Fig. 13 by switching in condensers of 0.5, 0.05, 0.01, 0.001, 0.0005 microfarads capacity.

SELF CENTRING.

From the descriptions of the spot movement across the screen given earlier in the chapter it might be difficult to imagine how the time base trace extends from one side of the screen to the other. It would appear, since the spot commences its travel from the centre of the screen that the fly back would carry it once more to the centre of the screen so that the line would halve the screen width in length.

This is indeed the case with the first sweep of the spot, but the cathode ray tube, connected in the usual way with leaks from the deflecting plates to the anode and fed through isolating condensers is a self-centring device. The condensers prevent D.C. from reaching the deflector plates and so the charges transmitted to the deflector plate are affected by the time constant of the condenser and leak circuit. The result is that, in television parlance, the D.C. component is lost. The tube reaches a condition where impulses take up a symmetrical position about the centre point with the result that the trace extends across the screen. Operation of the Amplitude Control of Fig. 13 shows the effect well; shortening the trace causes it to shorten

at one side only, and it then drifts across the screen until it is once more symmetrical.

As has been mentioned in Chapter 1 trapezium distortion can be cured in a cathode ray tube by using a push-pull time base which supplies the two X plates with equal and opposite deflecting potentials, but the circuits of such time bases are, in general, not only more complicated but also uneconomical in valves and, since the trouble is hardly likely to arise with the smaller type of tube, the push-pull time base is not dealt with here.

Details are available from such works as "Cathode Ray Oscillographs", by J. H. Reyner (Pitman), "The Cathode Ray Tube", by G. Parr (Chapman and Hall), "Time Bases", by O. Puckle (Chapman and Hall), and a small volume containing several photographs of actual screen traces is published by the Furzehill Laboratories, Boreham Wood, at 1/-, entitled "How to Use the Cathode Ray Tube", by J. H. Reyner.

SYNCHRONISATION.

With Lissajous' figures it was shown that, at exact multiples of the two frequencies under comparison, a pattern was obtained which would remain stationary on the screen, and similarly with the time base, when the frequency of the sweep voltage bears a definite relationship to the work frequency a waveform is obtained on the screen, the number of complete waves shown depending on the time base. Even for relatively slow waves, however, such as the A.C. mains sine wave the time base sweep frequency is of such an order as one-twentyfifth of a second, and clearly, when waves of frequencies approaching the radio bands are under inspection, the time base frequency becomes very fast indeed, and therefore very delicate in adjustment. What is needed is a "locking device" - some circuit which will cause the time base to run steadily at some chosen sub-multiple of the work frequency.

This is the function of the "Sync." control of Fig. 13. A small voltage is tapped from the Y plate on which the work potential appears and is fed into the grid circuit of the gas relay. This will mean that the relay, besides bearing the bias due to its own circuit, will also have a small fluctuating bias tending at each full cycle to bring the relay's grid to a point where the valve will fire. Whilst the bias is running down to the firing point this additional bias will be far too small to take effect, but when the grid is almost at the firing potential, the injected voltage will be sufficient just to trigger the time base circuit into action at the right moment. The time base sweep will thus be locked or synchronised to the work frequency and the waveform will remain steady on the screen without drifting. Too much synchronisation, however, will lead to over-strong locking. The tube will fire too soon, and the wave pattern on the screen will suddenly jump to one wave less than it was showing formerly. The best method, then, of applying "sync." is to set the control to a low value whilst the time base is being adjusted for amplitude and frequency, when the pattern will probably show a tendency to drift across the screen; then, when the adjustments are as nearly correct as possible, the synchronisation

control is advanced only as much as is necessary to hold the waveform or trace steady. The action will generally be quite definite, and no more sync. than is necessary should be given.

HARD VALVE TIME BASES.

At frequencies of over about 20,000 c.p.s. the gas relay ceases to operate in a satisfactory manner, due not only to delays in the action of the valve, but also to circuit characteristics. For example, the heater and cathode of the relay in Fig. 13 are tied together to prevent any chance of flash-over between these two electrodes, and are both connected to an isolated transformer winding. At high frequencies this might give rise to a capacity effect which would also tend to limit the efficiency of the circuit,

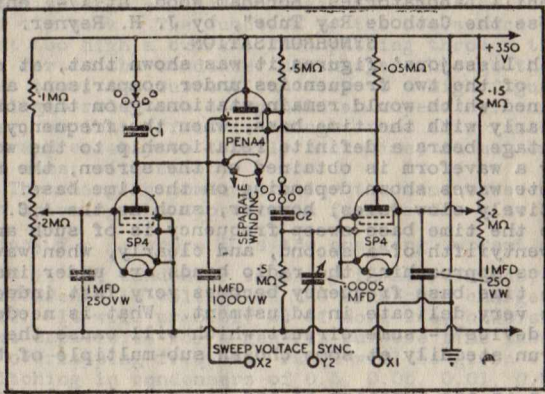

FIG 14. PHILIPS TIME BASE.

although at lower frequencies no trouble will be found. In any case the amplitude of the voltage swing from a gas relay circuit falls as the frequency rises, and for such considerations as these it is found very convenient to use hard valve (that is normal vacuum type valves) time bases for high frequency work.

The Philips Company have developed a hard valve time base which, it is claimed, has a frequency range of up to 150,000 c.p.s. and the circuit is shown in Fig. 14.

V1 is the usual constant current charging valve, the condenser in its anode circuit being the main charging condenser. Connected across the condenser is the discharging valve, V2, whose grid is connected to the anode of V3, the grid of V3 being coupled back via a condenser to the screening grid of V2.

As the circuit goes into operation current flows through V3, causing a voltage drop across the anode resistor and thus a bias on the grid of V2, sufficient to prevent V2 from taking current. As the charging condenser accepts its charge, however, the potential across V2 gradually rises

until V2 passes current. This causes a change in the screen potential which, being passed on to the grid of V3, causes it to become more negative and thus reduce the current flowing in V3. This causes the bias on the Grid of V2 to drop so that the current in V2 can rise and the action is therefore cumulative, the swift cycle of events causing the discharge of the main condenser. The cycles of operation, of course, repeat themselves automatically as long as the circuit is switched on.

Synchronisation is included in the circuit by connecting the grid of V3 to the work frequency by a small variable condenser.

The frequency control, as before, is the screen potentiometer of V1, whilst the amplitude can be controlled by the screen potentiometer of V3 since this ultimately controls the bias limits of V2, and thus the degree to which the main condenser is discharged. The selecting switches of the main condenser bank and the coupling condenser bank should be ganged so that the correct degree of coupling is automatically obtained.

Values for the condensers to be switched into the position C1 are 1.0, 0.5, 0.1, 0.05, 0.01, 0.001, 0.0005, 0.00005 microfarads, whilst the coupling condensers for the position C2 should be half these values.

Since the circuit works on an H.T. of 350 volts and there are three valve heaters to supply, it is best to run the hard valve time base from a separate power supply, the same remark also applying to the circuit of Fig. 15.

A suitable power pack is shown in Fig. 16, driving an amplifier.

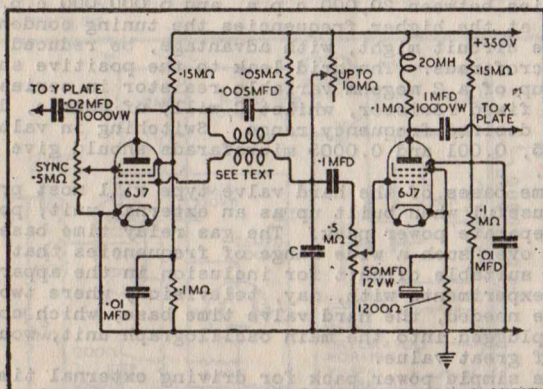

FIG 15. MARCONI TIME BASE WITH AMPLIFIER (FOR USE WITH SEPARATE POWER SUPPLY)

Figure 15 shows the hard valve time base developed by the Marconi Company. The time base proper consists of only one valve which has included in its circuit a pair of oscil-

lating coils, the grid coil of which is returned to earth through the charging condenser C. The grid is also given positive bias through a high resistance leak of between two and ten megohms. The action of the circuit is as follows. When the valve is switched on and goes into action the circuit oscillates and rapidly charges the condenser C negatively to such a degree that the oscillations cease as the valve is biased to cut-off. The positive grid leak then slowly neutralizes the negative charge on the condenser until the valve operates again, once more oscillating and running the condenser up to a negative charge. It will be seen that the circuit is in reverse when compared with the normal time base for the saw tooth voltage is generated, so that the fly back is given by the condenser rapidly charging whilst the working slope of the voltage is obtained whilst the condenser discharges. This is no inconvenience, however, but the author found it necessary to include an amplifier with the circuit to give adequate sweep. This is shown in Fig. 15 and is of slightly unconventional design when compared with the usual audio amplifier, having a small choke in the anode circuit. Further details of such amplifiers are given in Chapter 4.

This oscillating time base works well at high frequencies but obviously care must be taken when using it as interference might easily be picked up from the oscillating coils and injected into the circuit under examination if the two frequencies are similar, whilst broadcast interference might also be caused. The coils should be chosen with regard to the work in hand but their characteristics are by no means bound by narrow limits, the author having used frequencies between 20,000 c.p.s. and 5,000,000 c.p.s., although at the higher frequencies the tuning condenser in the anode circuit might, with advantage, be reduced to about .0005 microfarads. The grid leak to the positive supply may be made up of a 2 megohm variable resistor in series with a 2 megohm fixed resistor, whilst C will, of course, depend upon the desired frequency range. Switching in values of 0.1, 0.05, 0.001 and 0.0005 microfarads should give good coverage.

Time bases of the hard valve type will most probably be more useful when built up as an external unit, possibly with a separate power pack. The gas relay time base is so reliable over such a wide range of frequencies that it is the most suitable circuit for inclusion in the apparatus, but for experiments with, say, television, where two time bases are needed, the hard valve time base, which could be quickly plugged into the main oscillograph unit, would prove itself of great value.

The simple power pack for driving external time bases or amplifiers, as shown in Fig. 16, needs no explanation.

Points to watch in the building and operation of time bases are:-

(1) Linearity.-Use only good condensers of proven insulation and suitable working voltage ratings; clean, high insulation valve-holders; decouple the H.T. circuits when operating from the cathode ray tube's power supply (see Fig. 17); avoid overloading amplifiers where used.

(2) Time Base Hum.-Gas relays are prone to hum pick-up, necessitating good power supply smoothing and screening of the grid circuits from stray fields. Keep deflector plate leaks near to the tube with short earthing leads.

(3) Intermodulation between the time base and work frequencies. Sometimes caused in Y plate amplifiers by feed back through the power supply. Decouple or use separate power packs.

Chapter 4. DEFLECTION AMPLIFIERS.

In discussing the applications of the Cathode Ray Oscillograph so far it has generally been supposed that the applied work or waveform voltages have been sufficient to give full deflection of the spot across the screen.

Very often, however, this is not the case. The signals under inspection may easily be at very low voltage levels and will need amplifying before a useful trace is obtained, and this amplifying system, known as a deflection amplifier, may consist of one or more valves, whilst there may be identically similar circuits for both the X and Y plates. For general work, however, the time base will adequately be feeding the X plates so that a Y plate amplifier will be all that is required.

Plainly the amplifying system must have good characteristics for one of the oscillograph's main uses is the tracing of faults in radio or allied apparatus, and if distortions are arising within the amplifier itself, the results will be totally misleading. For this reason it is desirable to keep the amplifier circuit simple and to design it with due regard to the exclusion, as far as possible, of phase shifts, harmonic distortion and narrow frequency ranges.

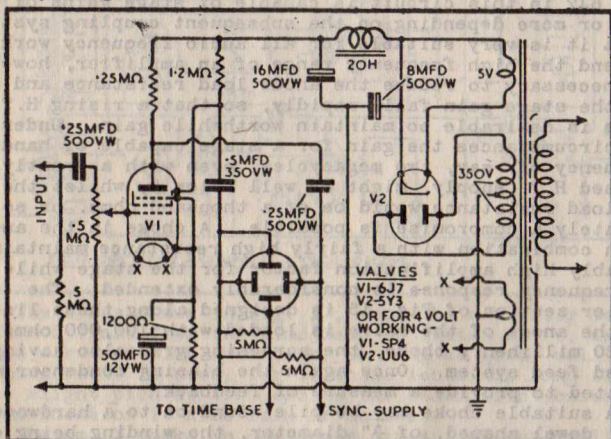

FIG 16. GENERAL PURPOSE AMPLIFIER SHOWING C.R.O. TUBE CONNECTIONS.

The frequency range of the amplifier is, of course, restricted by the circuit as a whole. In the single valve

amplifier of Fig. 16 the range extends from a low value of about 30 c.p.s. to a top limit of about 10,000 c.p.s., although there will be a falling off of output at the extremes. The oscillograph, however, will respond to frequencies of the order of megacycles so that this circuit will not be suitable for work on radio frequencies, but since the deflection amplifier has to supply a voltage output rather than the power given by the output stage of a conventional audio amplifier, certain circuit modifications can be introduced.

One method of straightening the characteristics of an amplifying circuit is to use negative feedback, but for high frequency work the feedback might easily become more of a hindrance than a help, since phase shift due to shunt capacities across the valve would alter the circuit constants to such a degree that parasitic oscillation might occur. The effect could be prevented by arranging for a reduction in the total amplification, but as the feedback circuit is already uneconomical in this respect such a measure would negate any advantages which might be gained.

A certain small measure of feedback, however, is useful in helping to prevent amplitude distortion and a simple method of obtaining such a degree of feedback is to remove the bias by-pass condenser in the cathode lead (the 50 mfd. condenser) of the amplifying valve in Fig. 16. In the absence of this condenser the signal currents flowing through the bias resistor set up fluctuating voltages which oppose the input voltages due to the signal under amplification, and whilst this reduces the overall stage gain the loss is not serious.

There is still the question of extending the high frequency limit of the circuit, however. As given in Fig. 16 the 6J7 in this circuit is capable of stage gains of up to 140 or more depending on the subsequent coupling system, so that it is very suitable for all audio frequency work. To extend the high frequency range of an amplifier, however, it is necessary to reduce the anode load resistance and once again the stage gain falls rapidly, so that a rising H.T. voltage is desirable to maintain worthwhile gain. Under these circumstances the gain for a stage capable of handling a frequency of, say, two megacycles, even with a greatly increased H.T. supply, might be well below 5, whilst the anode load resistance would be of a thousand ohms. or so. Fortunately a compromise is possible. A choke in the anode line in combination with a fairly high resistance maintains a reasonably high amplification factor for the stage while the high frequency response is considerably extended. The amplifier section of Fig. 15 is designed along these lines where the anode of the valve is loaded with 100,000 ohms. and a 20 millihenry choke, the screening grid also having a modified feed system. Once again the biasing condenser may be omitted to provide a measure of feedback.

A suitable choke may be pile wound on to a hardwood former, dowel shaped, of $\frac{3}{8}$ " diameter, the winding being of 2,900 turns of No. 30 enamelled copper wire (S.W.G.) and arranged to fill a length along the rod of $\frac{3}{8}$ " with a height of $\frac{3}{8}$ ". This winding may be protected and held by cheeks or

the wire may be dipped in melted paraffin wax which, when set, will hold the winding firmly.

When using an amplifier with a time base the frequency range must be suitable to respond to the fly back frequency. Even if the time base is running at slow speeds and it seems permissible to use an audio type amplifying circuit, the fly back is operating at a very much higher rate, and if the amplifier fails to respond, the sweep on the screen will be hampered by a dragging fly back.

Apart from the differences in design, deflection amplifiers may be regarded as equivalent to audio amplifiers so far as constructional methods are concerned. The usual rules hold good, that is to say, the amplifier should be adequately screened, especially from the time base circuits. If possible the transformer is best mounted below the chassis (a deep chassis is of great advantage for oscillograph work) and should have good metal shrouding around it to cut down stray fields. The sub-chassis components of the amplifier should be screened by sectionalising a part of the space by an iron screen so that the leads, resistors and condensers, etc., are separated from the other apparatus both electrostatically and magnetically, whilst all leads to the grid circuit, together with such grid circuit components as volume controls should have their metal covers earthed.

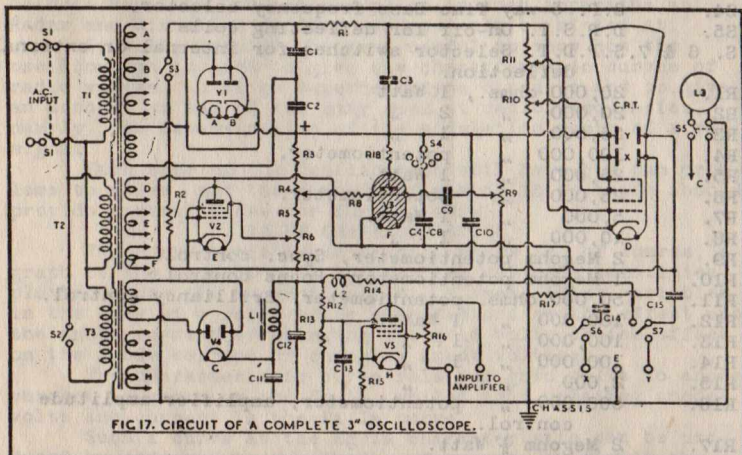

The leads shown in Fig. 17, from the amplifier to switch No. 7 and from the Time Base to switch No. 6, may also be screened with advantage, so long as good, well insulated cable is used, for if these leads are long there may be slight pick-up from one to the other with consequent cross-modulation in some form or another.

The small choke in the anode circuit of the amplifying valve should also be individually screened in a copper can, such a can having an internal diameter of at least twice that of the coil, the length also being at least twice as

long as the coil, the coil being mounted centrally inside the can.

Again, it is necessary to remember that, whilst the chassis of the oscillograph is negative to the amplifier circuit, it is positive to the other sections of the apparatus. Good insulation and careful separation of circuits must be maintained, and it is on these considerations that the plan of splitting up the oscillograph into separate units scores.

Figure 17 shows the suggested circuit of a completed oscillograph suitable for most three-inch hard tubes. For the sake of efficiency in operating both 4 and 6-volt heater valves are included in the same circuit, and arranged to operate from separate power packs.

COMPONENTS FOR FIGURE 17.

- T1. 250 volt, 50 m/a, 4v 2a, 4v 2a, 4v 2a Mains Transformer.
- T2. 4v 1a, 4v 1a, with third winding to suit tube filament, high insulation Mains Transformer.
- T3. 350-0-350 volt, 100 m/a, 5v 2a, 6.3v 1a Mains Transformer.
- S1. D.P.S.T. Mains switch.
- S2. S.P.S.T. " " "
- S3. S.P.S.T. On-off for H.T. to Time Base.
- S4. S.P. 5-way Time Base frequency selector.
- S5. D.P.S.T. On-off for deflecting coils.
- S. 6 & 7. S.P.D.T. Selector switches for internal or external deflection.
- R1. 20,000 ohms., 1 Watt
- R2. 20,000 " 2 "
- R3. 25,000 " 1 "
- R4. 100,000 " potentiometer.
- R5. 25,000 " 1 Watt.
- R6. 25,000 " potentiometer.
- R7. 5,000 " 1 Watt.
- R8. 10,000 " 1 "
- R9. 2 Megohm potentiometer, Sync. control.
- R10. 1 Megohm potentiometer, Focus control.
- R11. 50,000 ohms. potentiometer, Brilliancy control.
- R12. 150,000 " 1 Watt.
- R13. 100,000 " 1 "
- R14. 100,000 " 1 "
- R15. 2,000 " 1 "
- R16. 500,000 " potentiometer, amplifier amplitude control.
- R17. 2 Megohm $\frac{1}{2}$ Watt.
- R18. 1,000 ohms., 2 Watt.
- C1, 2 & 3. 1 mfd. 1,000 volts working.
- C4. .5 mfd. -
- C5. .05 mfd.)
- C6. .01 mfd.) Paper or Mica, 600 volt working, Time
- C7. .001 mfd.) Base Charging Condensers.
- C8. .0005 mfd.)
- C9. .02 mfd., 500 volt working.
- C10. 4 mfd., 600 " "
- C11. 8 mfd., 600 " "
- C12. 16 mfd., 500 " "

- C13. .5 mfd., 350 volt working
- C14 & 15. 1 mfd., 1,000 " "
- L1. 20 Henry, 20 m/a Smoothing Choke.
- L2. 20 Millihenry Choke. See chap. 4.
- L3. Deflection Coils. See Fig. 9.
- V1. Voltage Doubling Rectifier. UD41.
- V2. VP41.
- V3. T41.
- V4. 5Y3G.
- V5. 6J7.

Tube Type:-3" Electrostatic Deflection Hard Tube,
4 or 5 volt heater.
Chapter 5.

TESTING WITH THE OSCILLOGRAPH.

The Cathode Ray Oscillograph is now used to perform such diverse and widely ranged tests that it is difficult to select a small number of typical examples more suited to the interests of the radio serviceman and amateur experimenter. As has already been noted, the oscillograph is able to give useful information in all matters pertaining to waveform signals, but beside these such measurements as gas pressures in cylinders, the time duration of sudden (i.e., transient) discharges, the thickness of materials, explosive forces and many other industrial applications now commonly use the Cathode Ray Tube, whilst its place in such apparatus as Radar and direction finding can now only be hinted at.

It will, perhaps, be most useful to show how the oscillograph is used to give the characteristic curves of radio valves, to align superhetrodyne circuits and to give an account of one of its many uses at radio frequencies, namely, the determination of the modulation depth of a radio signal.

Each user of the Oscillograph will have his own problems to solve, and the methods of making these tests should provide several ideas for further work.

VALVE CHARACTERISTICS.

The characteristic curve of a valve is, of course, a graph of the relationship between two variable quantities plotted along the conventional X - Y axes, these variables in the case of a valve being such factors as the effect upon the anode current of changing the grid volts or the effect on the anode current of changing anode voltages.

The characteristic curve relating grid volts to anode current is known as the E_g/I_a , whilst that relating anode volts and current is the E_a/I_a curve.

Such a curve as the E_g/I_a characteristic can be produced by ordinary test methods, of course, by giving the grid various bias voltages and reading the corresponding anode currents obtained from a milliammeter, the series of points then being plotted on graph paper, but the method is laborious. Besides this there are certain conditions of the valve (running well into grid current, for example) where it is most undesirable for such a state of affairs to exist for any length of time for fear of damaging the valve.

Since the Cathode Ray Oscillograph produces a trace with the necessary X - Y axes it can also draw a graph so that the characteristic curve of a valve can actually become

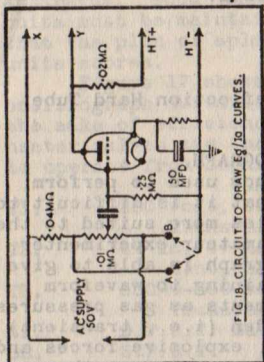

FIG. 18. CIRCUIT TO DRAW E_g/I_a CURVES.

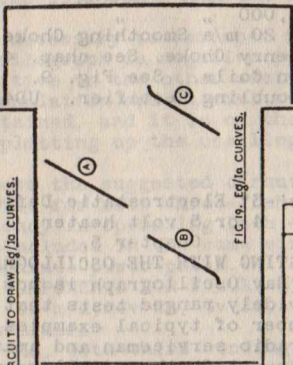

FIG. 19. E_g/I_a CURVES.

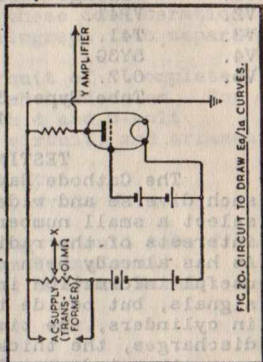

FIG. 20. CIRCUIT TO DRAW E_g/I_a CURVES.

visible upon the screen. All that is required is to "sweep" the valve through the suitable set of electrical conditions and to pass on the information to the tube.

Suppose, for example, it is required to draw the E_g/I_a curve of the triode shown in Fig. 18 (after "Cathode Ray Oscillographs", J. H. Reyner, Pitman). All that is necessary is to sweep the grid through a continuous voltage change - say from -6 to 0 volts and record, against this sweep, the corresponding change in anode current. To do this with the Cathode Ray Tube the spot must sweep between the X plates at the same rate as the bias voltage changes on the grid - that is, the horizontal spot deflection must be synchronized with the grid voltage change, and this is most easily done by running both the bias and the X plates deflecting voltage from the same source. One obvious method is to drive the valve grid from the time base, a suitable method where E_g/I_a curves only are required, but since in some cases actual power is required from the sweep source, which the time base is unable to supply, it is a much better method to switch out the time base and to drive both the valve and the X plates from a source of 50 cycles power. One advantage of this method of testing is clear already, for, since the grid voltage changes are taking place once every 1/100 second, the valve can be run into far from normal conditions without damage.

Since the grid of the valve under test requires, in this example, only -6 volts and the X plates of the tube require, perhaps, a 100-volt sweep, it is plain that the grid must be supplied from a potentiometer across the source of supply which should be the secondary of a suitable transformer.

Alternatively a 6-volt transformer could drive the valve and the X plates also through a deflection amplifier, but it is very advisable to use the first method to obviate errors due to amplifier characteristics.

The change in anode current due to the changing grid volts must now be recorded by the Y plates as a vertical deflection, and since this deflection must be caused by a voltage change a resistor is included in the valve's anode lead so that the changing current may set up changing voltages, these voltages actually being recorded via the usual condenser and leak system to the Y plate.

Consider, then, the operation of the circuit shown in Fig. 18. Along the X axis the dot moves (conventionally) from left to right as the grid voltage sweeps from -6 to 0 volts, whilst at the same time the anode current rises, causing the spot to rise. What would have been a horizontal line, therefore, is progressively tilted up until the valve grid is at 0 volts and the anode current at its peak. The A.C. cycle then reverses, the valve grid commences to run negative, the spot sweeps back and the anode current falls, all in synchronism, so that the line is retraced backward over the same ground, giving a single curve on the screen even though there is no swift fly back. This effect does not, of course, hold good if there is capacity or inductance in the valve's anode circuit. In such cases the anode voltage and current undergo a phase shift and, instead of a single line, the trace will open out into an ellipse. This ellipse, however, still shows all the forms of distortion dealt with later, and can present a valuable picture of the characteristic curve of the valve working into a transformer load, for example. The phase shift effect can be overcome, if necessary, by driving grid and tube from the time base as already mentioned.

With the circuit of Fig. 18 the trace on the screen may appear in four different ways on the screen, depending on how the deflecting plates are connected (for all Cathode Ray Tube work it must be remembered that the deflecting plates are non-polarized, that is, they respond to negative or positive charges, inverting the image in the process), the four ways being:-

1. Correctly.
2. Upside down.
3. Inverted right to left.
4. Upside down and inverted right to left.

If the trace is inverted (the line should slope up to the right) the cathode of the valve circuit should be connected to the opposite end of the grid feed potentiometer, i.e., if it is connected at A it should be transferred to B and vice versa.

If the trace is upside down the connections to the Y plates should be changed.

When both faults are present the trace will appear to be correctly positioned so that a sure method of identification is needed. This can be obtained by deliberately over-biasing the valve under test, which will then give bottom bend distortion as in Fig. 19b. If both sets of connections are wrong the bend will appear at the top of the trace so that the faults can be rectified.

A valve running into grid current shows distortion at the top of the curve, and for the correct operation of the valve as an amplifier the curve should be approximately a

straight line as in Fig. 19a.

In Fig. 18 the valve is shown supplying its own bias, and if apparatus is to be made up permanently for conducting these tests, it will be convenient to arrange the cathode resistor as a rheostat, the bias voltage being read by a high resistance voltmeter in parallel, so that different values of bias are readily obtainable.

The A.C. voltage on the grid of the valve is also controllable from 0 to any desired maximum reading, the range depending on the ratio of the potentiometer to its fellow resistor in the A.C. supply circuit and it should be remembered that some output valves require quite high bias and therefore high grid, voltages. The A.C. (peak value) volts applied to the grid for E_a/I_a characteristics should be equal to the grid bias, the bias itself being the normal working value or halfway between 0 and the cut-off voltage.

The circuit for drawing E_a/I_a characteristics is shown in Fig. 20, where the anode voltage of the valve is swept from 0 to full potential by the transformer voltage, alternatively opposing and assisting the H.T. supply. Battery operation is very helpful in this case in order that adjustments to the applied voltages may easily be made, whilst the battery and transformer should each supply half the full H.T. voltage. Interesting E_a/I_a characteristic curves are those of valves in oscillating circuits, particularly the dynatron oscillator. When the anode resistor is not a part of the load circuit, it should be of as low a resistance as will adequately feed the amplifier - say 200-500 ohms.

CIRCUIT ALIGNMENT.

To the Serviceman the most useful function of the oscillograph is in the recording, with the aid of a Frequency Modulated Oscillator, the frequency response of tuned circuits such as I.F. Transformers. The method has

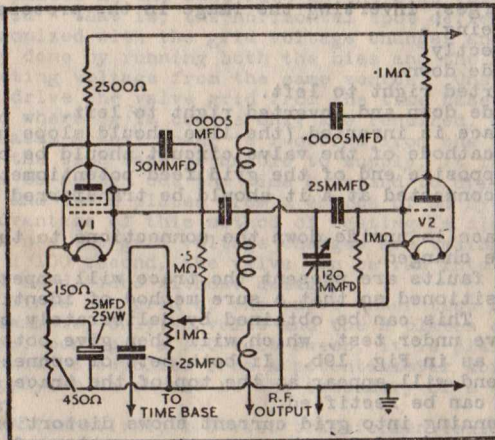

FIG. 21. SIMPLE SWEEPING FREQUENCY GENERATOR.

points of similarity to the method of tracing valve curves, for the tuned circuit under investigation is swept through a frequency range, so that it develops its greatest response at the centre of the sweep. At the same time the oscillograph spot is swept horizontally across the screen while the output of the tuned circuit is fed to the Y plates.

The response curve of a tuned circuit appears as in Fig. 22 and this is the curve shown on the oscillograph screen.

In superhet receivers the curve is double humped in the usual band pass response, and it is this double humping which is so difficult to adjust even with a good output meter. On the oscillograph, however, the I.F. Transformers may be adjusted to whatever degree is needed.

A simple form of Frequency Modulated Oscillator is shown in Fig. 21, the circuit being taken from "The Cathode Ray Tube" by G. Parr (Chapman and Hall). Briefly, a simple oscillator circuit is tuned partly by a variable condenser and partly by the inter-electrode capacity of a pentode coupled in a manner which utilises the Miller effect (the input capacitance varying with the gain of the valve). The grid voltage of the Miller valve is varied by the time base to which it is connected, the frequency being only 25 or 50 sweeps per second, and the consequent steady and repeated variation in input capacitance of the valve sweeps the oscillating circuit through a range of frequencies. A tuned circuit fed from this oscillator will thus be swept through its maximum response point when the oscillator range is centred about this point, and the output of the tuned circuit, the I.F. Transformer in this case, is tapped off as shown in Fig. 23 and applied to the oscillograph through an amplifier, since only a few volts will be obtainable.

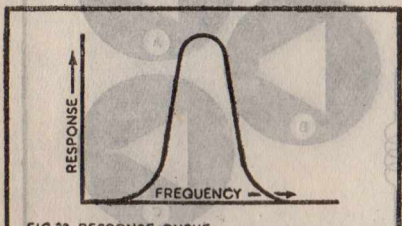

FIG 22. RESPONSE CURVE OF TUNED CIRCUIT.

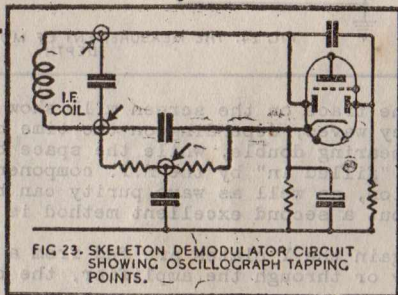

FIG 23. SKELETON DEMODULATOR CIRCUIT SHOWING OSCILLOGRAPH TAPPING POINTS.

The whole subject of Frequency Modulated Oscillators and superhet alignment covers a wide field, and only the elementary considerations can be touched upon here.

For the circuit shown any suitable coils can be used, suited to the frequency range desired, the pick-up or output coil being of about the same size as the anode coil. V1 may be a 6J7 for 6-volt working or an SP41 for 4-volt working, while V2 may be a 6J5 or 354V.

DETERMINATION OF MODULATION DEPTH.

One of many uses of the oscillograph to the amateur transmitter is the measurement of modulation depth and purity of the audio signal. It is, of course, possible actually to show a picture of the transmitted wave on the screen, with the modulated side-bands, the method being to modulate the oscillator with a constant tone signal and to run the oscillograph with the time base connected as usual to the X plates, the time base running at some sub-multiple of the modulating frequency. The Y plates are fed from a pick-up coil of a few turns situated close to the tank coil and connected to the oscillograph by the usual twisted cable. Whether or not the pick-up coil will supply sufficient potential to drive the oscillograph direct will depend on the power transmitted, but if not the signal may be passed through the amplifier.

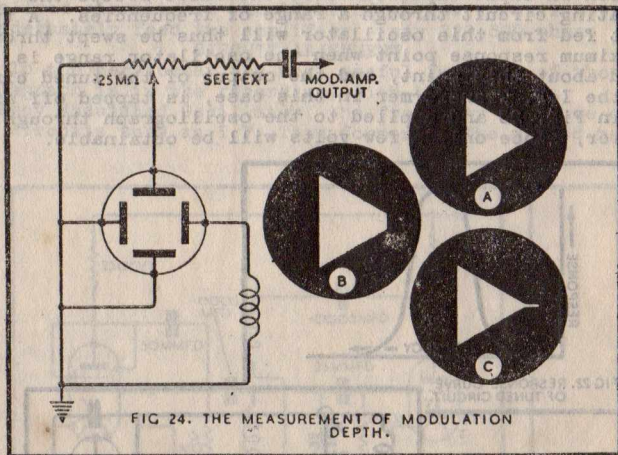

FIG 24. THE MEASUREMENT OF MODULATION DEPTH.

The trace on the screen will show two or three audio frequency waves, depending on the time base frequency, the wave appearing double, while the space between the waves will be "filled in" by the R.F. component. The depth of modulation, as well as wave purity can be gauged from such a trace, but a second excellent method is illustrated in Fig. 24.

Again the Y plates are fed from a pick-up coil, either directly or through the amplifier, the coil being connected

by twisted leads (these are not shown in the theoretical circuit). The X plates, however, instead of being fed from the time base are fed from the modulating amplifier output, which is also supplying the transmitter. The value of the condenser in the figure should be suitable for the test frequency - not below .1 mfd. and the total resistance of the voltage dividing circuit, as given by the A.R.R.L. Handbook, should be .25 megohm for every 150 volts at the output side, the unmarked resistor being adjusted to a suitable value to maintain this law.

With this arrangement the figures shown are obtained, that at 'a' being for a 100% modulated signal, that at 'b' for an under modulated signal and that at 'e' for an over modulated signal. The depth of modulation can be calculated from a figure such as 'b', calling the maximum vertical height 'm' and the minimum vertical height 'n' the percentage modulation is $\frac{100 (m-n)}{(m-n)}$

Distortion in the modulation amplifier is shown by curved sides to the figure, whilst phase distortion causes the figure to appear as though wrapped round a cylinder - an effect often found in several oscillograph applications and unmistakable when once understood.

BERNARDS' TECHNICAL BOOKS.

No. 1	Amalgamated Engineering Ref. Tables ...	1/-	No. 26	Tanks at War—Friend or Foe? ...	2/-
" 2	"Little Marvel" Vegetable Ref. Book ...	1/-	" 28	Income Tax for the Working Man ...	1/-
" 3	Services Signalling Manual ...	1/-	" 30	Manual of Radio Valves, British and American ...	3/6
" 4	Radio Pocket Book ...	1/-	" 31	Explosives.—Nature, variety and uses as Projectile Fillings, Propellents, Mines, Demolition Charges, etc., etc. ...	2/-
" 5	Elements of Mathematics ...	1/-	" 32	You can Fly. Flying made easy, fully illustrated ...	2/-
" 6	Electrical Engineers Handbook ...	1/-	" 33	Invasion Tactics. Here and on the Continent ...	2/-
" 8	Manual of Modern Automatic Guns ...	1/-	" 34	Guerillas v Tanks ...	2/-
" 9	Manual of Photography ...	1/-	" 35	Mathematical Dictionary ...	2/-
" 10	Manual of Mathematical Tables ...	1/-	" 36	Defence against Gas ...	2/-
" 11	Manual of Cycle Maintenance and Hints ...	1/-	" 37	Manual of Direct Disc Recording ...	2/-
" 12	Manual of Commando and Guerilla Tactics: ...	1/-	" 38	Aeronautics Illustrated ...	2/-
" 13	Manual of Commando and Guerilla Tactics: ...	1/-	" 39	Tool Makers' and Engineers' Manual ...	1/-
" 14	Manual of Small Arms and Special Weapons ...	1/-	" 40	Carpenter's Handbook ...	1/6
" 15	Manual of Wartime Household Repairs ...	1/-	" 41	Wireless Amplifier Manual ...	2/-
" 16	Illustrated Engineering Practice ...	2/-	" 42	Short-Wave Radio Handbook ...	2/-
" 17	Manual of Rifles, usual series ...	1/-	" 43	Modern Radio Test-Gear Construction ...	1/6
" 18	Weapons and Armaments of the Modern German Army ...	2/-	" 44	Radio Service Manual ...	2/6
" 19	Manual of Map and Compass Reading ...	2/-	" 45	Radio Reference Handbook ...	10/6
" 20	Manual of Gliding and Motorless Flight ...	2/-	" 46	Motor Car Queries ...	2/6
" 21	Manual of Science. Mechanics, Physics, etc. ...	2/-	" 48	Radio Coil and Transformer Manual ...	2/-
" 22	Manual of Radio Circuits. ...	2/-	" 49	Shoe Repairing at Home ...	1/-
" 23	Manual of Hand Grenades, Mines and Bombs ...	2/-	" 50	World-wide International Short Wave Radio Station List ...	1/-
" 24	Uniform, Rank Badges and Intelligence Data on the Modern German Armed Forces ...	2/-	" 51	Cathode Ray Oscilloscope Manual ...	2/-
" 25	Strategy and Tactics of the German Army ...	2/-	" 52	Radio Tuner Unit Manual ...	2/6