

## BERNARDS RADIO BOOKS

10. Manual of Log and Maths. Tables ... ..	1/-
35. Dictionary of Mathematical Data ... ..	2/-
39. Tool Makers and Engineers Manual ... ..	1/-
56. Radio Aerial Handbook ... ..	2/6
57. Ultra-Shortwave Handbook ... ..	2/6
58. Radio Hints Manual ... ..	2/6
61. Amateur Transmitter's Construction Manual ... ..	2/6
63. Radio Calculations Manual ... ..	3/6
64. Sound Equipment Manual ... ..	2/6
65. Radio Designs Manual ... ..	2/6
66. Communications Receivers' Manual ... ..	2/6
68. Frequency Modulation Receivers' Manual ... ..	2/6
69. Radio Inductance Manual ... ..	2/6
70. Loudspeaker Manual ... ..	2/6
71. Modern Battery Receivers' Manual ... ..	2/6
73. Radio Test Equipment Manual ... ..	2/6
78. Radio and Television Laboratory Manual ... ..	2/6
80. Television Servicing Manual ... ..	4/6
81. Using Ex-Service Apparatus ... ..	2/6
82. AC/DC Receiver Construction Manual ... ..	2/6
83. Radio Instruments and their Construction ... ..	2/6
86. Midget Radio Construction ... ..	3/6
90. Wireless Amplifier Manual No. 2 ... ..	3/-
91. Handbook of Radio Circuits No. 3 ... ..	2/6
93. Power Pack Manual ... ..	4/6
94. Practical Circuits Manual ... ..	3/6
95. Radio Data Book ... ..	1/6
96. Crystal Set Construction ... ..	1/-
97. Practical Radio for Beginners, Book 1 ... ..	5/-
99. One Valve Receivers ... ..	1/6
100. A Comprehensive Radio Valve Guide, Book 1 ... ..	5/-
101. Two Valve Receivers ... ..	1/6
102. 40 Circuits Using Germanium Diodes ... ..	3/-
103. "Radiofolder" A. The Master Colour Code Index for Radio and Television ... ..	1/6
104. Three Valve Receivers ... ..	1/6
106. Radio Circuits Handbook No. 4 ... ..	2/6
109. High Fidelity Radio; Design and Construction by N. Bonavia Hunt ... ..	3/6
111. "Radiofolder" B. A Practical Oscilloscope ... ..	2/6
114. "Radiofolder" E. An Inexpensive Tape Recorder ... ..	2/6
115. Constructors' Handbook of Germanium Circuits ... ..	2/6
117. The Tele-King: Constructional Envelope ... ..	6/-
118. Practical Coil Construction for Radio and Television ... ..	3/-
119. The Practical Superheterodyne Manual ... ..	3/-
120. Radio and Television Pocket Book ... ..	2/6
121. A Comprehensive Valve Guide Book 2... ..	5/-
122. Wide Angle Conversion: for Home Constructed Televisors: Constructional Envelope ... ..	3/6
123. "Radiofolder" F. The Beginners' Push-Pull Amplifier ... ..	1/6
124. "At a Glance" Valve and Tube Equivalents for Radio and Television ... ..	5/-
125. Listeners' Guide to Radio and Television Stations of the World ... ..	2/6
A Magnetic Tape Recorder ... ..	3/6
The Electronic Photographic Speedlamp: How to Make it and How to Use it ... ..	3/6
Universal Valve Guide ... ..	15/-
International Radio Tube Encyclopædia, 1954 Edition ... ..	42/-

# PRACTICAL RADIO FOR BEGINNERS (Book 1)

3/-

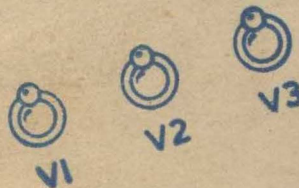

**EDWIN N. BRADLEY**  
**BERNARDS RADIO MANUALS \* No. 97**

MCGILL'S AGENCY  
 BOOK DEPOT  
 18 AND 19, ST. MARK'S PLACE, LONDON, E.C. 4



PRACTICAL RADIO  
FOR BEGINNERS

*(Book One)*

by E. N. Bradley

LONDON

BERNARDS (PUBLISHERS) LTD



BERNARDS RADIO MANUALS No. 97

General Editor: W. J. MAY

★★★★★★

First published, 1950  
Second Edition, May 1953

Printed for the publishers Bernards (Publishers) Ltd., The Grampians,  
Western Gate, London, W.6, by Reynard Press Ltd., Flitcroft Street,  
London, W.C.2

CONTENTS

<i>Chapter 1</i>	<i>Page</i>
RADIO WAVES AND WHAT THEY ARE ... ..	7
 <i>Chapter 2</i>	
COMPONENTS ... ..	14
 <i>Chapter 3</i>	
THE BEGINNERS' PROGRESSIVE RECEIVER ... ..	36
 <i>Chapter 4</i>	
DETECTION: TWO SIMPLE RECEIVERS ... ..	40

## LIST OF ILLUSTRATIONS

FIG.	PAGE
1. Section through a radio wave ... ..	8
2. Representation of a wave ... ..	9
3. A. Plain or unmodulated carrier wave. B. Representation of a sound wave. C. Sound wave impressed as modulation on a carrier wave ... ..	11
4. An A.C. waveform ... ..	16
5. A. Proving current flow in a diode. B. How the diode rectifies	20
6. Theoretical valve symbols. The numbers correspond to the pin numbers on the holder when viewed from the underside. TC indicates top cap ... ..	22
7. Methods of connecting valve heaters in receiver circuits ...	23
8. Showing the symbols and uses of resistors ... ..	25
9. Resistor colour coding ... ..	26
10. Behaviour of a capacitor ... ..	29
11. An electrolytic condenser used for smoothing cathode bias ...	30
12. Capacitor colour coding ... ..	31
13. Chassis dimensions for the Progressive Receiver <i>facing page</i>	32
14. Symbols associated with coils of different design and application	34
15. The waveform of Fig. 3C after rectification ... ..	41
16. Showing the effect of capacitor C on the waveform of Fig. 15, the RF carrier being effectively bypassed to earth ... ..	42
17. Basic circuit of a grid bias or anode bend detector ... ..	42
18. A 2-valve plus rectifier AC/DC receiver with anode bend detector ... .. <i>facing page</i>	48
19. Under chassis layout and practical wiring of Fig. 18 <i>facing page</i>	48
20. Showing how the top cap of VI is connected ... ..	55
21. The grid leak detector ... ..	58
22. Modified connections to the top cap of VI for grid leak detection ... ..	58
23. A 2-valve plus rectifier with grid leak detector and reaction	60
24. Under chassis layout and practical wiring of Fig. 23 ...	63



## INTRODUCTION

*PRACTICAL RADIO FOR BEGINNERS* is designed for the newcomer to the hobby of radio who wishes to commence the construction of receivers.

There are numerous publications available, large and small, which discuss at some length the theory and mathematics of radio. This book comprises brief descriptions of the main components employed in the building of receivers, with the greater part devoted to constructional details.

For the first time there is described a "Progressive" receiver—a radio set which starts as a simple two-valve receiver and which is developed into a progressively ambitious receiver by clear-cut easy-to-follow steps. Each stage of the constructional work ends with a complete working radio set; each stage is illustrated with theoretical and practical diagrams. In the succeeding volumes it is intended to cover all classes of receivers and radio equipment for both P.A. work and gramophone reproduction.

## CHAPTER 1

### RADIO WAVES AND WHAT THEY ARE

Radio waves are a form of electro-magnetic radiation similar in many ways to other forms of radiation, such as light. Radio waves travel at the speed of light (approximately 186,000 miles per second or 300,000,000 metres per second in free space), but have a wavelength considerably greater than the wavelength of light. Like light, however, radio waves can be reflected, refracted or bent, diffracted and polarised, and can also be blocked, like a light ray, by an "opaque" object when the object's opacity refers to radio waves. It is well known that broadcast signals can be passed through many objects such as buildings which are opaque to light rays.

It is difficult to form a mental picture of a radio wave, especially since science has disposed of the "ether" (a medium supposed to fill all space and act as an ubiquitous transporter of light and other electro-magnetic radiations), and the old analogy of the effect of a broadcasting station and the dropping of a pebble in a pool, although leaving much to be desired, is still a convenient way of visualising the transmission of radio waves. The stone tossed into the centre of a pond disturbs the water and sets up a wave motion which rapidly spreads until the whole pool is disturbed; at the same time there is no movement of the water along with the wave. A stick floating on the pond will rock up and down as the wave reaches and passes it but will not move forward with the wave. The wave can therefore be said to be a form of energy which is transmitted or carried across the surface of the water; in the same way a radio wave is a form of energy which is transported through space.

Most newcomers to radio will be aware of the idea of lines or fields of force. A magnet when presented to a compass needle, causes the needle to swing and to take a position so that it points



along the "lines of force" which are supposed to exist in the space about the magnet between pole and pole. In the same way it may be supposed that fields of force exist about a radio transmitting aerial, set up by the currents which are caused to flow back and forth in the aerial wire at very high speeds, the fields of force so generated spreading out, like the waves across the surface of the pond, though at a very much greater speed. The radio wave, however, consists of two composite fields: lines of electrostatic force existing in one direction and lines of magnetic force existing at right angles to the electrostatic lines of force. A section through a radio wave travelling directly towards an observer would appear as in Fig. 1 if the wave were transmitted from a horizontal aerial; if the wave were transmitted from a vertical aerial the electrostatic force lines would be vertical.

The wave shown in Fig. 1 is thus said to be horizontally polarised; the polarisation always refers to the electrostatic lines of force. For medium and long wave broadcasting the polarisation

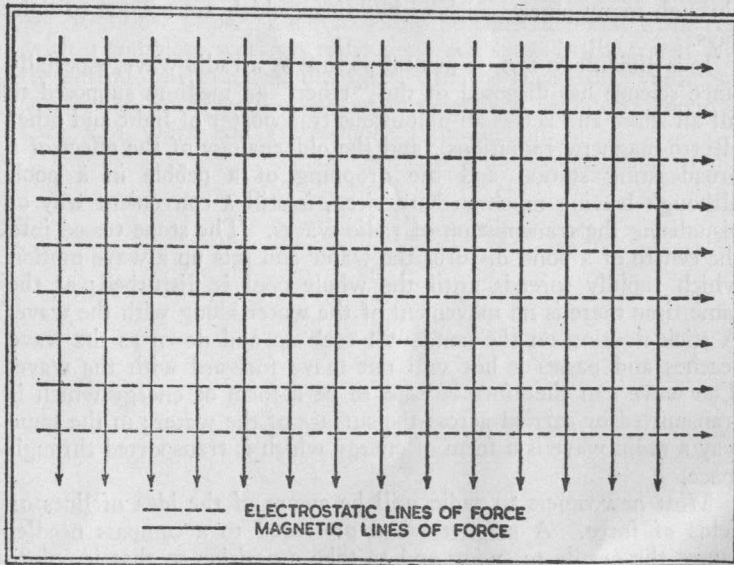

Fig. 1. Section through a radio wave

of the wave is not of great importance; for example, the long wave Light Programme, transmitted from a vertical aerial and thus vertically polarised, and medium wave Home Programme transmitted from a horizontal aerial and thus horizontally polarised, can be received equally well on a vertical or horizontal aerial. In short wave reception the polarisation of the receiving aerial becomes more important however, and in very short wave working—television, for example—it is essential that the receiving aerial be on the same plane as the transmitting aerial, which is vertical for the British system.

A wave can be drawn as in Fig. 2. Imagine, first, that Fig. 2 illustrates a section through a wave on the surface of a pond; then the straight line drawn centrally across the wave represents the undisturbed water surface and the curved line represents crests and troughs above the surface and below the surface. It can be said that the straight line represents the water surface when no energy is being transmitted, i.e., zero power, and the peaks and troughs represent the transmission of power.

The power at a peak is obviously acting in a different manner from the power at a trough—the power at a trough is "pulling in the opposite direction"—and when Fig. 2 is translated into terms of electrical waves the same holds good. The peaks above the zero line are said to be positive—in a radio wave they would be due to currents flowing in one direction along the transmitting aerial—

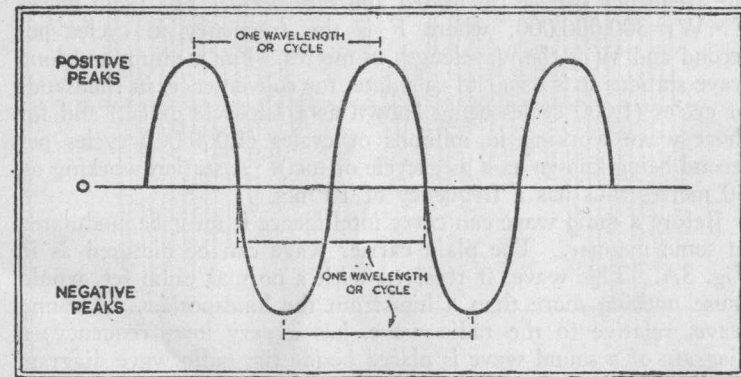

Fig. 2. Representation of a wave



and the troughs (or peaks below the zero line) are said to be negative; these, in the radio wave, would be caused by the current reversing its flow and travelling back along the aerial. If, in Fig. 1, the arrows show the direction of lines of force during a positive peak, the lines of force would reverse, and the arrows point in the opposite direction during a negative peak.

Wavelength is measured between two similar peaks, i.e., between two positive or two negative peaks, or between two similar zero points, as shown in Fig 2. One wave—or, to give the correct name, one cycle—contains one whole positive and one whole negative peak. The distance between two positive peaks can be measured in metres, yards or feet (it would be a fairly simple matter to measure the wavelength set up by dropping the pebble in the pond), but the distance can also be measured in terms of time. A stick stuck upright in the bottom of the pond could be used as a marker, and the interval between two positive peaks or wave crests timed as the waves passed the stick. If the wavelength was short the time interval would be short; for long wavelengths the time intervals would be long. The rate at which waves passed the stick could be called the frequency, and a little thought will soon show that the wavelength, multiplied by the frequency at which the waves pass the stick, is equal to the speed of the wave.

The speed of a radio wave is the speed of light, 300,000,000 metres per second, so if the wavelength of a radio wave is known, the frequency can be calculated and *vice versa*. For radio waves  $F \times W = 300,000,000$ , where  $F$  is the frequency in cycles per second and  $W$  is the wavelength in metres. For medium and long wave stations it is usual to calculate, for convenience, in thousands of cycles (1,000 cycles being known as a kilocycle or kc.) and for short wave working in millions of cycles (1,000,000 cycles per second being known as a megacycle or mc.). A station working on 30 metres thus has a frequency of 10 mcs.

Before a radio wave can carry intelligence it must be modulated in some manner. The plain carrier wave can be pictured as in Fig. 3A. This wave, if received with a normal radio set, would cause nothing more than a hiss from the loudspeaker. A sound wave, relative to the radio wave, has a very low frequency; a diagram of a sound wave is placed beside the radio wave diagram in Fig. 3B; but the difference in frequency is actually very much greater than can be shown in a drawing. A sound wave can be

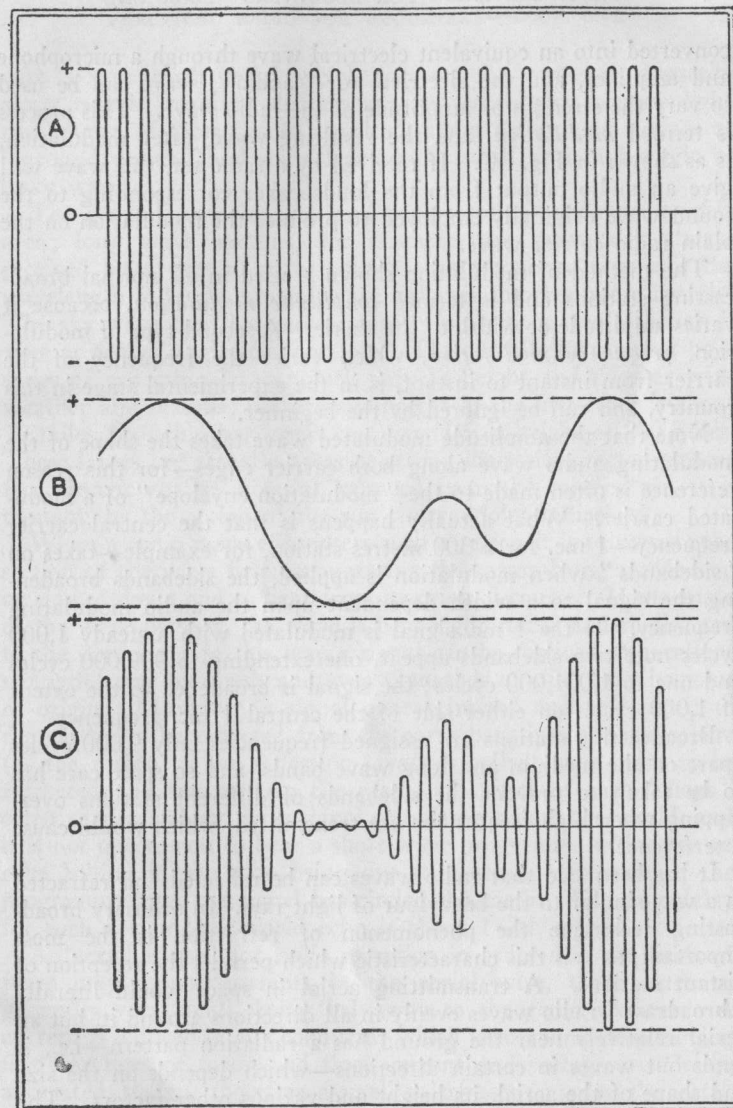

Fig. 3. A. Plain, or unmodulated carrier wave. B. Representation of a sound wave. C. Sound wave impressed as modulation on a carrier wave.



converted into an equivalent electrical wave through a microphone and amplifier, and the electrical (or "audio") wave can be used to vary the strength or amplitude of the radio wave. This process is termed *modulation*, and the resulting wave, after modulation, is as shown in Fig. 3C. If received by a radio set, this wave will give an audio output from the loudspeaker corresponding to the sound wave originally employed to produce the modulation on the plain radio carrier wave.

The method of modulation shown is used in all normal broadcasting stations and is termed *amplitude modulation*, because it varies amplitude or width of the carrier. A second type of modulation, *frequency modulation*, which varies the frequency of the carrier from instant to instant, is in the experimental stage in this country, and can be ignored by the beginner.

Note that the amplitude modulated wave takes the shape of the modulating audio wave along both carrier edges—for this reason reference is often made to the "modulation envelope" of a modulated carrier. What actually happens is that the central carrier frequency—1 mc. for a 300 metres station, for example—takes on "sidebands" when modulation is applied, the sidebands broadening the signal to a width dependent upon the audio modulating frequency. If the 1 mc. signal is modulated with a steady 1,000 cycles note two sidebands appear, one extending to 999,000 cycles and one to 1,001,000 cycles; the signal is broadened to the extent of 1,000 cycles on either side of the central 1 mc. frequency.

Broadcasting stations are assigned frequencies only 9,000 cycles apart on the medium and long wave bands, and so some care has to be taken to prevent the sidebands of different stations overlapping when high frequencies are transmitted, which would cause interference.

It has been said that radio waves can be reflected and refracted in a way similar to the behaviour of light rays. In ordinary broadcasting technique the phenomenon of refraction is the most important, as it is this characteristic which permits the reception of distant stations. A transmitting aerial in space would literally "broadcast" radio waves evenly in all directions around it, but an aerial relatively near the ground has a radiation pattern—i.e., it sends out waves in certain directions—which depends on the size and shape of the aerial, its height and various other factors. The waves leave the aerial in roughly defined beams (not to be confused

with a true beam aerial which focusses the waves it transmits along certain required directions as a searchlight focusses light rays), some of these beams travelling along the ground surface as "ground waves" and some leaving the earth at a high angle as "sky waves."

The ground waves can be used for reception over quite a wide area; long wave stations, for example, are practically always received by a ground wave; but as the frequency rises and the wavelength falls, the ground wave becomes absorbed more rapidly. The sky wave then becomes of major importance, for although it rises at a high angle it is not lost. The earth is surrounded by a series of reflecting layers which vary in height and number with weather and seasons; the average height of the first layer is about 70 miles, though other layers can extend to a height of 200 miles. These layers are actually areas of strong ionisation, regions where free electric charges abound, released from the rarefied air, it is thought, by the action of the sun's ultra-violet radiation.

When a radio wave encounters such a region it is refracted; the section of the wave first encountering the region being speeded up or slowed down and so bent from its original course. If the angle of the wave permits, the wave is bent right round and re-directed to the earth, and in this way a signal can be received at excellent strength many hundreds and even thousands of miles from its point of origin. Moreover, a signal once refracted and re-directed to the earth can be reflected from the earth back into the ionosphere (as the region of the reflecting layers is called) once more to be refracted and returned to the earth. A series of such "hops" often carries a short wave signal completely round the world, and it is not uncommon to hear a short wave programme which has an echo behind it, the echo being due to a second reception of the programme after the signal has circled the earth. The time delay for such a round-the-world echo is about 1/7th second.

An aerial is used for radio reception in order that the fields of force may induce currents in the aerial wire, these currents, generally very small, being led away to the radio receiver. A current is induced in any conductor which is surrounded by moving fields or lines of force, and since current and voltage are always associated, there is therefore a small voltage set up across the aerial.

The field strength of a radio wave is expressed in millionths or thousandths of volts per metre, and is measured by the voltage set



up across a metre of wire, acting as an aerial, suspended in the fields of force. The voltage induced either by the electrostatic or magnetic field can be taken: that induced by the electrostatic field is generally employed for the test.

For preference, an aerial should be high and in the open, so that it is not shielded by surrounding objects, and should be well insulated at each end to prevent losses of the minute currents and voltages set up. The aerial wire may be bare or insulated; the presence of an insulating covering has no effect on the process of induction.

The currents are led from the aerial to the receiver by the lead-in which should be as direct as possible and clear of all earthed metal objects such as gutterings, wastepipes, etc.; the lead-in should also be insulated and should enter the house through a protected or insulated tube, to prevent losses.

The lead-in brings us to the main point of interest—the receiver; but before we can commence to build even a simple set, it is necessary to make at least a quick survey of the parts and components used, so that their actions and operations may be understood.

## CHAPTER 2

### COMPONENTS

Any radio receiver (apart from crystal sets) is built up from no more than four main types of components, if the purely mechanical parts of the receiver are omitted. Each main type of component may be present in several forms—outwardly, for example, there is little similarity between a tuning coil and a loudspeaker although a coil of wire is the important factor in each. The four main components are valves, resistors, condensers or capacitors, and coils or inductors.

A source of electrical power is necessary to supply the energy to make the components operate.

#### ELECTRICITY.

Electrical power for the operation of a radio receiver may be drawn from batteries or from mains supplies. The input voltage for the majority of mains sets is from 100 to 250 volts; the current drawn from the supply system depends on the type and number

of valves. The power must be supplied from a smooth D.C. source so that receivers operating from the A.C. mains must have a system or "power pack" which will turn alternating current into direct current.

A battery supplies direct current—one pole is positive, the other is negative, and the current flows steadily from one pole to the other whenever they are connected by an external circuit. It was at one time thought that current flow was from the positive pole to the negative pole and for some electrical applications this flow is still presumed; for all radio purposes, however, it must be assumed that an electric current is a flow of electrons from the negative pole through the external circuit to the positive pole. Electrons may be visualised as particles of negative electricity, or negatively charged particles, which together with protons or positive particles, make up atoms.

Electrons can move freely through conductors such as silver, copper and aluminium; but move with difficulty through a metal such as iron, and alloys such as manganin. The impeding effect of poor conductors is termed "resistance"; a common material used to manufacture resistors, suitable for radio receivers, is carbon.

The current flowing between the poles (or "electrodes") of a battery connected together through an external circuit depends on the battery voltage and the resistance of the circuit. If two of these values are known the third can be calculated from Ohm's Law, which states:

$$E = IR \quad \text{or} \quad I = \frac{E}{R} \quad \text{or} \quad R = \frac{E}{I}$$

where E is the voltage (or "electro-motive-force"), I is the current in amperes; and R is the resistance in ohms. For radio work the ampere is too great a unit of current for many purposes and currents are often expressed as thousands of an ampere; i.e. as milliamperes (also called milliamps. and abbreviated to mAs.). When applying Ohm's Law to radio, care must always be taken to convert a current in mAs. to amperes. 1 milliamperere is, as the name implies, equal to 0.001 amp (one thousandth), 100 mAs. to 0.1 amp (one hundredth), and so on.

A well known law both of magnetism and electricity is that like poles repel and unlike poles attract. Thus, just as a north magnetic pole repels another north pole but attracts a south pole, so does an



electron repel another electron, though all electrons, being negative, are attracted towards positively charged bodies.

An alternating current is a current which starts at zero strength, increases to a maximum in one direction of flow, decreases to zero strength and then again increases to a maximum, but flows in the opposite direction. Such a current, or the voltage associated with such a current, can be illustrated by the wave form already shown in Fig. 2. The alternating voltage supplied by the A.C. mains can be shown in graph form as in Fig 4. An alternating voltage has a peak value reached only by each positive and negative crest, and for all ordinary purposes this peak value is seldom quoted, since it is attained only twice in each cycle. A mean value must be chosen or calculated to show the equivalent voltage over a period of time, and this value, known as the Root Mean Square or R.M.S. value, calculated by taking the mean of all the instantaneous squares of the voltage values over a cycle, is the value always quoted. The R.M.S. value is, for the A.C. mains, 0.707 of the peak value—i.e., the peak voltage is 1.44 times the R.M.S. voltage. Thus the mains supply, rated at 230 volts R.M.S. attains a peak value of  $230 \times 1.414$  volts twice each cycle, or 324.22 volts, which helps to explain the apparently greater severity of an A.C. shock.

The frequency of most A.C. mains in this country is 50 cycles per second (c.p.s.), so that the current reverses its direction of flow, and the voltage reverses its polarity, 100 times per second. The waveform of the A.C. mains is termed sinusoidal, and the wave is

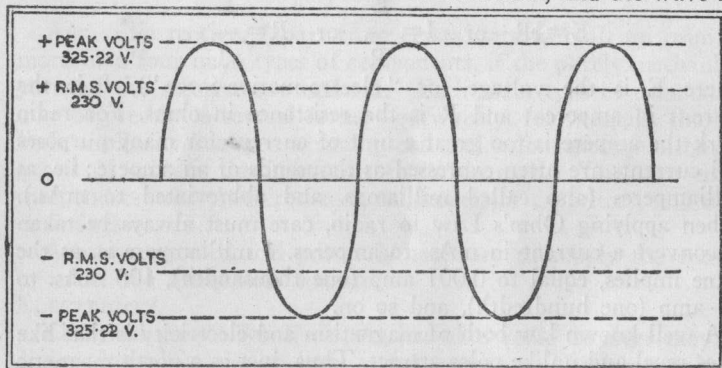

Fig. 4 An A.C. waveform

called a sine wave, since the manner in which the current and voltage grow and decrease is governed by the rotation of a generator armature and thus by a trigonometrical law introducing the sines of angles. If a complete armature rotation through 360 degrees produces one complete cycle, then clearly distances along a cycle may also be measured in degrees— $90^\circ$  equals  $\frac{1}{4}$  of a full cycle,  $180^\circ$  equals  $\frac{1}{2}$  of a full cycle, and so on.

It will already have been realised that the current flowing up and down the transmitting aerial to produce the fields of force mentioned in Chapter 1 is an alternating current, though in this case the alternations are very much faster than are those of the A.C. mains. Very fast alternating currents are generally termed oscillatory currents the word giving a better idea of the manner in which the current swings back and forth.

The term "electrostatic" has been used in describing the force fields of radio waves. "Static" electricity is an electrical field or an electrical charge upon a conductor not associated with a flow of current through a conductor. A simple way of generating static electricity is to rub the barrel of a fountain pen, or a bakelite comb, upon the sleeve of a woollen garment. The pen or comb will become charged with electricity to such an extent that it will attract small scraps of paper by inducing an opposite charge on them, the two unlike charges then being attracted, but the current flow associated with these high voltage charges is infinitesimal.

This simple experiment is of value in demonstrating how charges can be held on materials which are employed as insulators. Such charges can also be set up on conducting bodies, but they will then leak away rapidly unless special precautions are taken.

In radio practice the holding of charges in this way is met with in the study of condensers.

#### VALVES.

The science of radio is based on the valve and it is essential that the beginner should have a clear understanding of how they are constructed and how they function. Whilst electrons normally flow along and through conductors, early experimenters found that electrons could also be thrown off by some substances and caused to travel through space. Sir Ambrose Fleming discovered that the incandescent filament of an electric lamp threw off or "emitted" electrons. He introduced a metal plate into an ordinary lighting bulb and attracted the electrons from the



filament to the plate by charging the latter positively and in this way made the first valve. A short time after this discovery, Dr. Lee de Forest, an American, found that a third electrode could be placed between the filament or "cathode" and the plate or "anode" to control the flow of electrons from one to the other. This third element was called a "grid," due to its physical resemblance to the grid of a stove. The insertion of this grid resulted in the most versatile of all valves, the triode. During the past twenty years, other grids have been added to produce various characteristics, and these later types are called multi-element valves. The names for these types are obtained by adding the Greek prefix for the number of electrodes to the root—ode; so we have diode, triode, tetrode, and pentode, for valves having two, three, four and five electrodes.

The most important electrode in the valve is the cathode, since it supplies the electrons necessary for the valve to function. Whereas the remaining electrodes consist of plates and wire meshes, the cathode must be able to throw off or emit vast quantities of electrons.

To enable the cathode to "emit," it is necessary to apply external energy in the form of heat and the resultant activity is termed thermionic emission. Different forms of cathode have different operating temperatures and it is proposed to describe each of the several types in common use, separately.

Cathodes used to-day may be divided into two classes: the directly heated or filament pattern and the indirectly heated or heater-cathode variety. The former type may be sub-divided into three main groups: the tungsten, thoriated-tungsten and oxide coated filament.

Nearly all the valves of the early 1920's used pure tungsten filaments operating at bright white heat (about 2,500° K) with the result that the listener could read a book comfortably from the light radiated by a 2-valve receiver.

Nowadays their use is confined to a few specialised high-powered types where other forms of cathode have proved unsuitable. After some experiment with tungsten it was found that filaments made from tungsten containing a small amount of thoria (thorium oxide) had a much greater emission than the pure tungsten pattern. Subsequent improvements have provided the modern carburized thoriated-tungsten filament which is used in the

majority of medium power transmitting valves. The filament is processed to allow the thorium to diffuse to the surface of the wire in the form of a layer. It is this layer which emits electrons thousands of times more rapidly than an equivalent pure tungsten filament operating at the same temperature. During operation the thorium evaporates from the wire heater and new thorium is constantly diffusing to the surface. The operating temperature is about 1,900° K, which is a bright yellow heat.

The most efficient of all modern cathodes is the oxide-coated type which consists of a mixture of strontium and barium oxides coated on wire or strip usually of a nickel alloy. This cathode operates at a dull red temperature some 1,100° K and is used for all normal receiving valves; it is, however, unsuitable for use in valves operating at high anode potentials, i.e., over 600 volts. With this type, the thoriated-tungsten cathode is a more satisfactory proposition. The heater-cathode or indirectly heated cathode was developed to provide a valve that could be operated from A.C. mains supply without introducing unwanted hum into the circuit and consists of a nickel alloy cylinder coated in a manner similar to the oxide coated filament. Mounted inside the cylinder and heavily insulated is the heater wire, usually of tungsten.

If a cathode is placed in an evacuated envelope together with an anode (Fleming's metal plate), such a two electrode valve is called a diode. This is the simplest of all valves and is the basic type from which all others are derived.

If a diode is wired up to an external power source as shown in Fig. 5A, the presence of the electrons will be detected by the meter "A" which will indicate the strength of the current flowing. The cathode is heated by the LT battery and the anode is made positive with respect to the cathode by the HT battery. The higher the anode potential the greater the electron stream until saturation point is reached and no greater flow of electrons is available from the cathode, however much the anode voltage is increased. Now if the potential of the HT battery were to be reversed, i.e., positive to cathode and negative to anode, the electrons would no longer be attracted, in fact they would be repelled and the current flow would cease. From this it will be realised that the diode is a true valve, since it permits current to flow in one direction only.

Fig. 5B illustrates the behaviour of a diode when presented with an A.C. input. It will be observed from the characteristic curve



that as the input voltage rises from zero to peak A so the electron flow increases and peak A is reproduced at the output. The input voltage now falls back to zero and proceeds to peak B, this time the diode has no response and there is no electron flow. This principle is used when it is required to obtain a D.C. supply from A.C., as is necessary with any receiver fed from A.C. mains, and is called rectification. It is also used for rectification or detection of radio signals.

From the following paragraphs it will be realised that the advent of the triode, i.e., the introduction of a third electrode into the valve, had a profound effect on its operation as an electronic device.

This new electrode, called the grid, is composed of a mesh of wires, and is placed between the anode and the cathode so that the electrons from the cathode pass through the grid before reaching the anode. If the grid is given a positive charge with respect to the cathode it captures a few of the electrons passing, but attracts many more from the cathode. The increased electron stream passes through the grid and reaches the anode; charging the grid positively therefore increases the current through the valve.

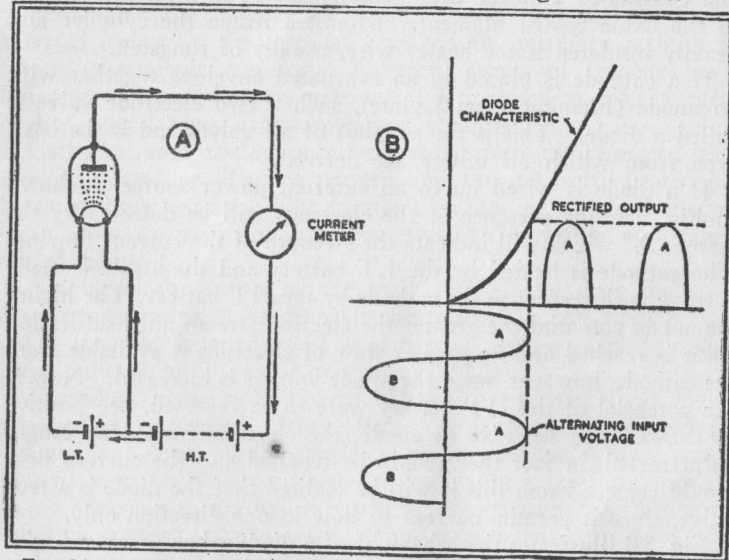

Fig. 5. A. Proving current flow in a diode. B. How the diode rectifies

If, on the other hand, the grid is charged negatively with respect to the cathode, this negative charge relatively near to the cathode repels electrons about to leave the cathode's surface with the result that fewer electrons pass across the valve and the current is therefore reduced. The more negatively charged the grid becomes, the fewer are the electrons which pass through it and reach the anode, so that the grid forms a most valuable control electrode which can affect a relatively large current with only a small controlling charge or voltage. The triode valve is thus an amplifier, and small variations at the grid can cause large variations at the anode.

It was soon discovered that the triode worked well at low frequencies but poorly at the higher frequencies, owing to the grid and anode of this type of valve forming a condenser (explained in following paragraphs) and other grids were added to the triode to shield the control grid from the anode. A valve with one other grid is termed a tetrode (four electrodes) and this type of valve, with modern developments, is now chiefly employed for amplifying sound frequencies. A third grid added to the tetrode makes the valve a pentode, and pentodes of various types are now used in almost all stages of radio receivers. Some are adapted to give very high amplification to high frequencies. These are known as R.F. or H.F. pentodes (Radio or High Frequency pentodes) and other types are adapted to allow the grid to have a wide control on quite a heavy valve current; these are output pentodes designed to drive loud speakers.

The symbols for mains-operated diodes, triodes, tetrodes and pentodes are shown in Fig. 6. Battery types are drawn similarly, but with the cathode omitted.

Different valve types have different bases, but the majority of the valves described and employed throughout the constructional chapters of this book all have what are known as International Octal bases, which fit into octal—i.e. 8-hole—valveholders. The valve base is fitted with a peg or spigot which has a projection running down it; before the valve can be fitted into its holder this projection must be turned to correspond with a channel in the holder. The valve is therefore located correctly into its holder.

In the theoretical drawings the valve contacts are usually numbered with the pin numbers, and a key of the valve holder given, as in Fig. 6. This allows the valveholder to be wired up correctly without reference to valve tables; it is necessary only to

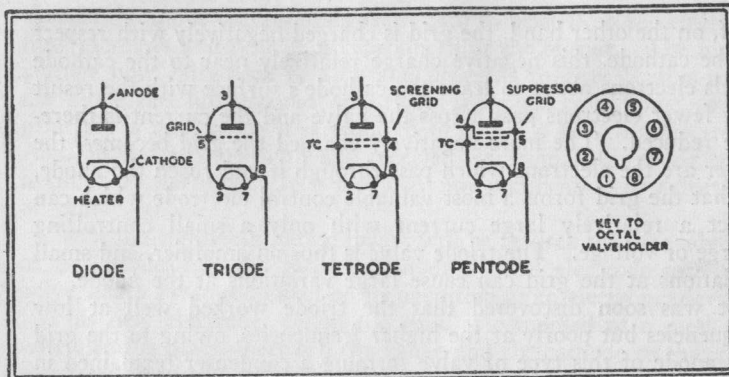

Fig. 6. Theoretical valve symbols. The numbers correspond to the pin numbers on the holder when viewed from the underside. TC indicates top cap.

remember that the key is drawn looking at the free end of the valve pins and at the underside of the valveholder where the connecting tags are found.

Some types of valve, chiefly R.F. pentodes, have a top cap contact, which is generally used as the grid connection. The three grids of a pentode are referred to generally as the "grid" for the main control grid, or first grid, the "screening grid" for the second grid and the "suppressor grid" for the third.

The term "suppressor grid" is used, since this third grid was introduced to suppress secondary emission from the anode. Secondary emission consists of electrons which are knocked out of the anode of a valve by the arrival of high speed electrons from the cathode. In the triode this effect is unimportant; but in the tetrode valve the secondary electrons were drawn to the screening grid and this "backwards flow," as it might be called, upsets the valve characteristics.

The screening grid was found to be of such value that the suppressor grid was introduced between it and the anode, and given a negative charge to repel the secondary emission electrodes back to the anode.

The heaters of valves can be connected in series or parallel, as shown in Fig. 7. When the heaters are connected in parallel, as they are in receivers designed to operate only from A.C. mains, each heater must require the same voltage across it, though the

heaters may draw different currents. For series operation, a form of heater connection found in D.C. mains and Universal mains receivers, each heater must pass the same current, though then the heater voltages may vary. In a valve which passes a heavy cathode-anode current the cathode must be more massive than that of a smaller valve, so that the cathode will in consequence require more heating. A typical Universal mains output valve, the CL33, draws 0.2 amp. at 33 volts for its heater, and a typical R.F. pentode, the EF39, draws 0.2 amp. at 6.3 volts.

The wide range of figures and numbers by which various valves are identified can be rather intimidating to the beginner; but there is, especially at first, no need to remember more than one or two of the many available types.

It will be noticed from a valve table or catalogue, that some valves in the R.F. pentodes range are classed as variable-mu types. Mu is the symbol denoting a valve characteristic which controls the amplification given by the valve, and a variable-mu valve is one in which the grid is specially wound to give a variable ampli-

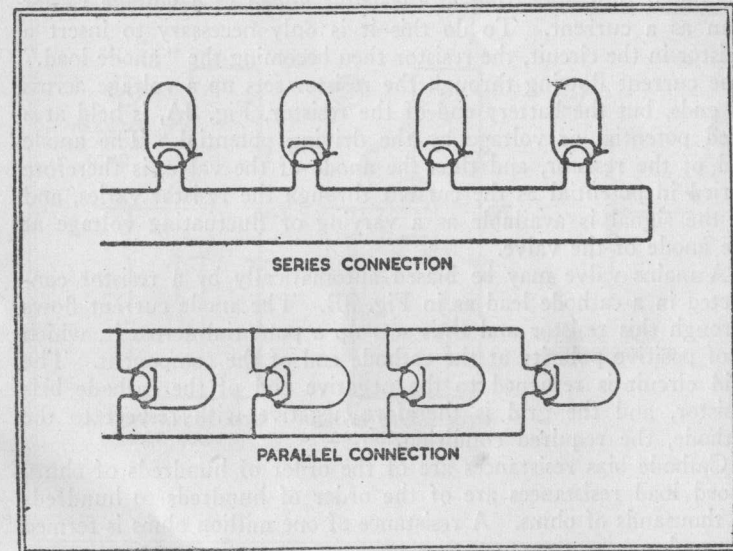

Fig. 7. Methods of connecting valve heaters in receiver circuits



fication factor. Most valves must be "biased," that is, have a small negative potential on the control grid to hold the valve at the most favourable operating condition, and in a variable-mu valve the variable amplification factor is controlled by varying this "grid bias" in one of several simple ways.

#### RESISTORS.

Resistors are components that possess the quality of resistance, and are found in all radio circuits in considerable numbers. It has already been shown that the current through a resistor depends on the voltage across its ends; similarly, from Ohm's Law, a current flowing through a resistor sets up a Potential Difference expressed in volts across the ends, the voltage depending on the current and resistance. A current of 1 mA. through a 1,000 ohms resistor sets up a P.D. or voltage of 1 volt across the resistor; 10 mAs. through the same resistor would set up a potential difference of 10 volts.

It has been shown that the control grid of a valve controls the anode current of the valve; but it is generally necessary to take off the signal thus appearing at the valve anode as a voltage rather than as a current. To do this it is only necessary to insert a resistor in the circuit, the resistor then becoming the "anode load." The current flowing through the resistor sets up a voltage across its ends, but the battery end of the resistor, Fig. 8A, is held at a fixed potential or voltage by the driving potential. The anode end of the resistor, and thus the anode of the valve, is therefore varied in potential as the current through the resistor varies, and so the signal is available as a varying or fluctuating voltage at the anode of the valve.

A mains valve may be biased automatically by a resistor connected in a cathode lead as in Fig. 8B. The anode current flows through this resistor and thus sets up a potential across it, which is of positive polarity at the cathode end of the component. The grid circuit is returned to the negative end of the cathode bias resistor, and the grid is therefore negative with respect to the cathode, the required condition.

Cathode bias resistances are of the order of hundreds of ohms, anode load resistances are of the order of hundreds to hundreds of thousands of ohms. A resistance of one million ohms is termed a megohm.

Resistors are rated at the power which can safely be lost across

them—there must be a loss of power whenever a current flows through a resistance. The power is expressed in watts, the product of the potential in volts and the current in amperes. Thus 1 volt at 1 amp. represents a power of 1 watt, as also does 1 mA. at 1,000 volts. The ratings most commonly employed in radio work are  $\frac{1}{4}$  watt and  $\frac{1}{2}$  watt resistors.

The symbol for resistance has already been shown in Figs. 8A and B. A further symbol, that for a potentiometer, is shown in Fig. 8C. A potentiometer is a resistor with a connection at each end and a variable connection which may be slid along the resistive track. If a potential is set up across the ends of such a device the variable contact can tap off any required fraction of that potential, so that potentiometers are used for bias control, volume control and for similar applications.

#### RESISTOR COLOUR CODE.

Present day resistor colour coding is carried out by one of the two methods illustrated in Fig. 9.

In method A the colours are read from the end of the resistor

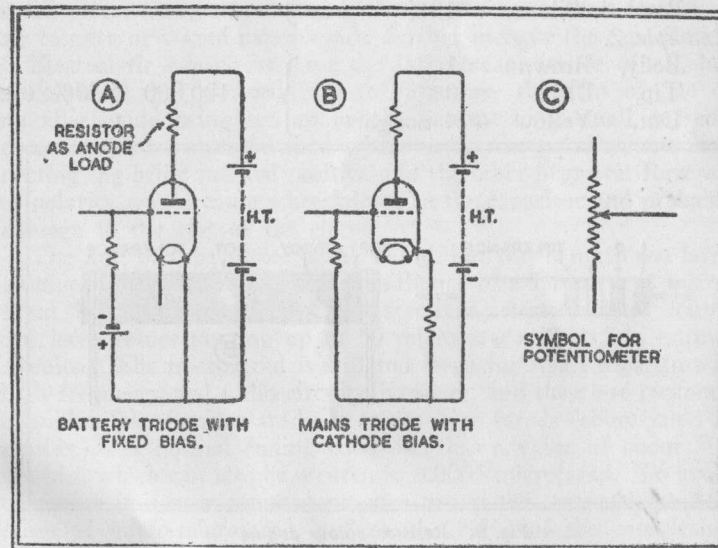

Fig. 8. Showing the symbols and uses of resistors

adjacent to the colour bands. Band 1 is the first significant figure; Band 2, the second; Band 3, the number of noughts to be added to the first two numerals. In method B the sequence is as follows: body colour, tip colour and spot or band colour. This third or spot colour indicates the number of noughts following the two numerals. The code is as follows:—

Black 0    Red 2    Yellow 4    Blue 6    Grey 8  
Brown 1    Orange 3    Green 5    Violet 7    White 9

When a fourth band is added on resistors coded by method A, or an additional tip in method B, it indicates the tolerance by the following code:—

Gold  $\pm$  5% Tol.                  Silver 10% Tol.

Where this fourth metallic indication is absent the tolerance is assumed to be 20%.

*Example 1.*

Band 1, Yellow	= 4	} = 47,000 $\Omega$ 10% tol.
Band 2, Violet	= 7	
Band 3, Orange	= 3 noughts	
Band 4, Silver	= 10%	

*Example 2.*

Body, Brown	= 1	} = 100,000 $\Omega$ 20% tol.
Tip, Black	= 0	
Dot, Yellow	= 4 noughts	

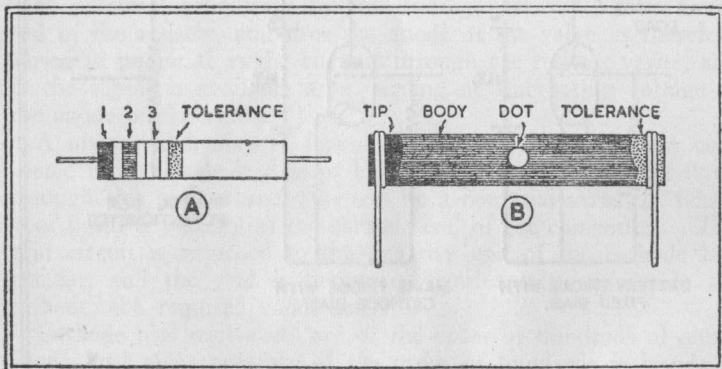

Fig. 9. Resistor colour coding

#### CAPACITORS.

Condensers, now generally called capacitors, since these com-

ponents possess the quality of capacitance, appear as often, and in even more widely different forms in radio circuits, than resistors.

A capacitor is, basically, two conductors, or two sets of conductors, spaced apart by an insulating medium. Inspection of an air-spaced tuning capacitor will allow the construction to be seen clearly.

The conductors are generally in the form of plates, and the separating medium can be air, waxed paper, mica or similar insulators, or can be made of fabric soaked in chemical solution when the insulation between the plates is finally formed by a thin film of gas or a thin layer of metallic oxide on one plate. Capacitors in which such a separator is used are known as "electrolytic" capacitors, since an "electrolyte" or conducting solution is employed between the plates.

The capacitance of a capacitor depends on the size of the plates, the number of plates in each set, and the distance of the plates apart, as well as on the characteristics of the separating medium. Large plates very closely spaced give a higher capacitance than small plates far apart; changing the separating medium from, say, air to mica or waxed paper would further increase the capacitance.

Electrolytic capacitors have the largest capacitance of all, but since these are "formed" in manufacture, the film of gas or metallic oxide being set up by the passage of a small current, these capacitors must be used with the correct polarity, one connecting tag being marked positive and the other negative. Reversal of polarity would cause a breakdown in the capacitor and probably damage to the rest of the circuit.

The unit of capacitance is the Farad, but this is much too large a value for radio purposes and a millionth of a Farad, or 1 microfarad, becomes a more convenient standard; electrolytic capacitors can have values ranging up to 50 microfarads (mfd.) in normal circuits. The microfarad is still too large for small capacitors in high frequency and radio circuits, however, and these are reckoned in millionths of microfarads, or micro-microfarads (abbreviated to mmfds.). A normal tuning condenser has a value of about 500 mmfds., which can also be written as 0.0005 microfarad. To avoid confusion it is now common practice to use the term picofarad in place of micro-microfarad, and so the value of the capacitance just mentioned is usually written as 500 pFds.

The function of a capacitor is to hold a charge. If a capacitor



is connected across a battery or other source of D.C. potential, no steady current can flow, since the plates of the capacitor are separated by an insulator; nevertheless there is a momentary flow of current from the battery into the capacitor which charges up the plates. The current at first flows heavily; but as the voltage on the plates rises the current flow diminishes and finally ceases as the plates attain battery potential. If the capacitor is now disconnected from the battery the plates are left in the charge condition until they are connected through some external circuit, when a current will flow in the external circuit, strongly at first but more and more weakly as the plates lose potential, until the plates are finally totally discharged when the current ceases.

On an A.C. circuit the behaviour of a capacitor is, of course, basically the same; but, in this case, the potential applied to the plates is constantly varying. As the potential applied to the plates rises from zero to full in one direction there is a flow of charging current into the capacitor, but then the potential commences to fall and the current must therefore reverse and flow back in the opposite direction. We therefore have the peculiar effect of a reversing current at the point where the circuit voltage reaches maximum and starts to fall, with the consequent further peculiar effect of maximum current at zero voltage.

The chief point to be noted, however, is that the current flowing into a capacitor on an A.C. circuit flows out again, so that there is no final power loss; unlike the D.C. circuit, where the current flows from the battery into the capacitor giving, so far as the battery is concerned, a loss of power, though this power is stored up for use in the capacitor.

The second important point is that a capacitor connected to an A.C. circuit always has a current flowing in or out of it—the current does not die away as on the D.C. circuit. We therefore say that a capacitor acts as a “block” or insulator to D.C. but passes A.C.—the terminology is perhaps rather loose but does make obvious the fact that if two currents, one D.C. and the other A.C., are flowing in a single circuit the A.C. can be tapped off through a capacitor without the D.C. This condition is met with at the anode of a valve. There is a D.C. current and thus a D.C. voltage at the anode of the valve, due to the driving potential supplied by a battery or power pack, and at the same time there is a fluctuating voltage set up by passing the varying anode currents (controlled by

the signals on the grid) through an anode load resistor. We need these fluctuating voltages clear of the D.C. driving voltage and so we connect the following circuits to the valve anode via a capacitor. The fluctuating voltages appear much the same to the capacitor as an alternating voltage; indeed we obtain an alternating voltage on the other side of the capacitor, in the manner shown in Fig. 10.

Another use for a capacitor is as a “smoother.” Refer to Fig. 8B where a resistor in the cathode lead of the valve is supplying a bias voltage. When a signal is applied to the grid of the valve the current through the resistor will vary and thus the bias voltage will vary with the signal, which is generally undesirable. If we connect a capacitor across this resistor as in Fig. 11, using a fairly high value electrolytic component, currents will flow into the capacitor when the voltage across the resistor tends to rise, and flow out of the capacitor when the voltage tends to fall, and the result will be that the bias voltage remains constant.

The same scheme is used for smoothing out the spurts of current which flow through a diode connected to an A.C. circuit; each spurt of current can be used to charge up a capacitor which will then supply quite a steady current when the diode is not conducting.

It was mentioned that the triode valve was not of great use when employed on high frequencies since the grid and anode formed a small capacitor. It can now be understood that energy from the anode was “fed back” through the valve to the grid, thus upsetting the working of the whole circuit.

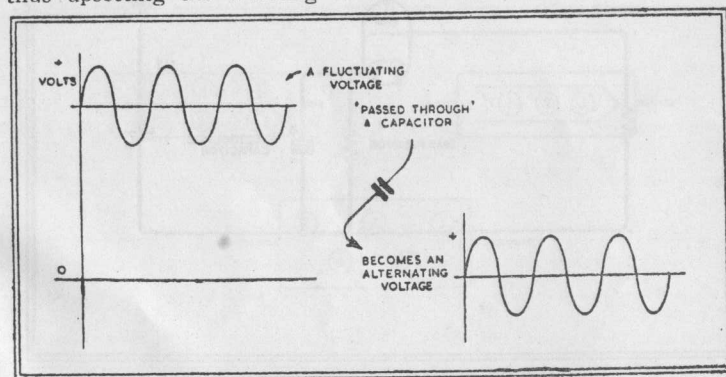

Fig. 10. Behaviour of a capacitor

The higher a frequency, the more readily do currents at that frequency "pass through" a capacitor; it is as though a capacitor has less resistance to high frequencies. The term resistance cannot very well be used since the true resistance of a good capacitor is practically infinite as the plates are separated by an insulator, so the term reactance is used instead, though its value is calculated in ohms. All capacitors are rated at a working voltage which must not be exceeded otherwise the insulating medium will break down and the component will be ruined. A common type of electrolytic capacitor used in most power packs is coded as 8 mfd. 450 v.wg.—v.wg. is the abbreviation for Volts Working.

Electrolytic capacitors are clearly coded with the polarity of their electrodes, but tubular paper capacitors merely have a black band at or near one end. This indicates the connection to the outer electrode which is conventionally connected to the more negative or "earthy" side of the circuit.

Practically all British capacitors are stamped or marked in some way with their values, but some small capacitors are colour coded. This colour code is shown in Fig. 12. The two symbols for

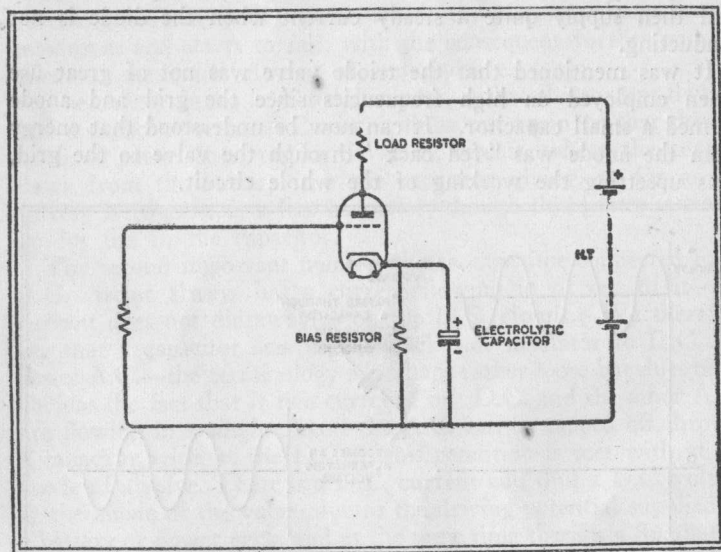

Fig. 11. An electrolytic condenser used for smoothing cathode bias

capacitance are shown in Figs. 10 and 11; note how the electrolytic capacitor is distinguished from a plain non-polarised capacitor. CAPACITOR COLOUR CODE.

Up to six colours are sometimes used to indicate the capacity in micro-microfarads or picofarads, the direct current voltage rating and the tolerance. The sequence is shown in various ways, usually by an arrow or some such device as shown in Fig. 12.

The code is as follows:

Colour	1 1st Fig.	2 2nd Fig.	3 3rd Fig.	4 Multiplier	5 D.C. Voltage Rating	6 Tolerance +
Black ..	0	0	0	0	—	—
Brown ..	1	1	1	$\times 10$	100	1%
Red ..	2	2	2	$\times 10^2$	200	2%
Orange ..	3	3	3	$\times 10^3$	300	3%
Yellow ..	4	4	4	$\times 10^4$	400	4%
Green ..	5	5	5	$\times 10^5$	500	5%
Blue ..	6	6	6	$\times 10^6$	600	6%
Violet ..	7	7	7	$\times 10^7$	700	7%
Grey ..	8	8	8	$\times 10^8$	800	8%
White ..	9	9	9	$\times 10^9$	900	9%
Gold ..	—	—	—	$\times 0.1$	1000	5%
Silver ..	—	—	—	$\times 0.01$	2000	10%
No colour	—	—	—	—	500	20%

Note.— $10^2 = 10 \times 10$ .  $10^4 = 10 \times 10 \times 10 \times 10$ , etc.

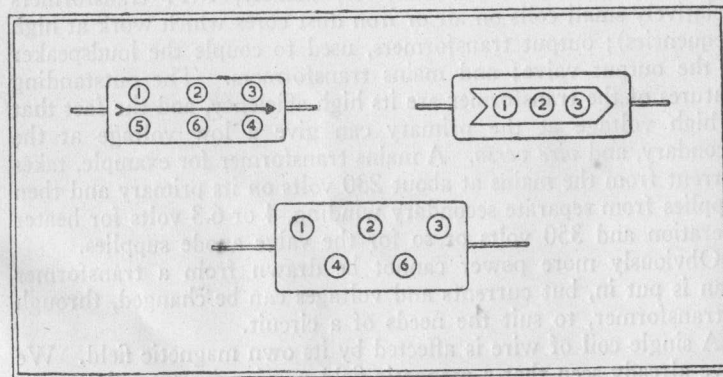

Fig. 12. Capacitor colour coding



### COILS.

The fourth main component employed in radio receivers is coils of wire of various types and sizes. Some coils are wound on iron cores and consist of many turns; others are wound on open formers with air cores and consist of a few turns.

If any coil is connected across a battery, current flowing through the turns of wire sets up a magnetic field within the coil, the strength of the field depending on the value of the current and the number of turns in the coil. Many turns will set up a strong field, a few turns, with the same current, will set up a much weaker field. Faraday discovered that if two coils are placed close together and current is made to flow through one coil by connecting it across a battery, a current is set up in the neighbouring coil. This is the process of induction, the current in the first coil setting up a magnetic field which in turn affects the second coil and causes a "secondary" current to flow.

The secondary current flows only while the magnetic field is changing in value. A stable field does not cause current. Thus the secondary current flows only at the moments when the first or "primary" coil is connected and disconnected to the battery; at these moments the current in the primary coil is either reaching maximum or falling to zero.

The effect can be improved by placing both coils on a common iron core. Two coils on a common core are termed a "transformer," and of the many types of transformer possible three are chiefly common to radio receivers, namely, R.F. transformers (relatively small coils on air or iron dust cores which work at high frequencies); output transformers, used to couple the loudspeaker to the output valve; and mains transformers. The outstanding features of the transformer are its high efficiency, and the fact that a high voltage at the primary can give a low voltage at the secondary, and *vice versa*. A mains transformer for example, takes current from the mains at about 230 volts on its primary and then supplies from separate secondary winding, 4 or 6.3 volts for heater operation and 350 volts or so for the valve anode supplies.

Obviously more power cannot be drawn from a transformer than is put in, but currents and voltages can be changed, through a transformer, to suit the needs of a circuit.

A single coil of wire is affected by its own magnetic field. We have already seen that a magnetic field varying in strength can set

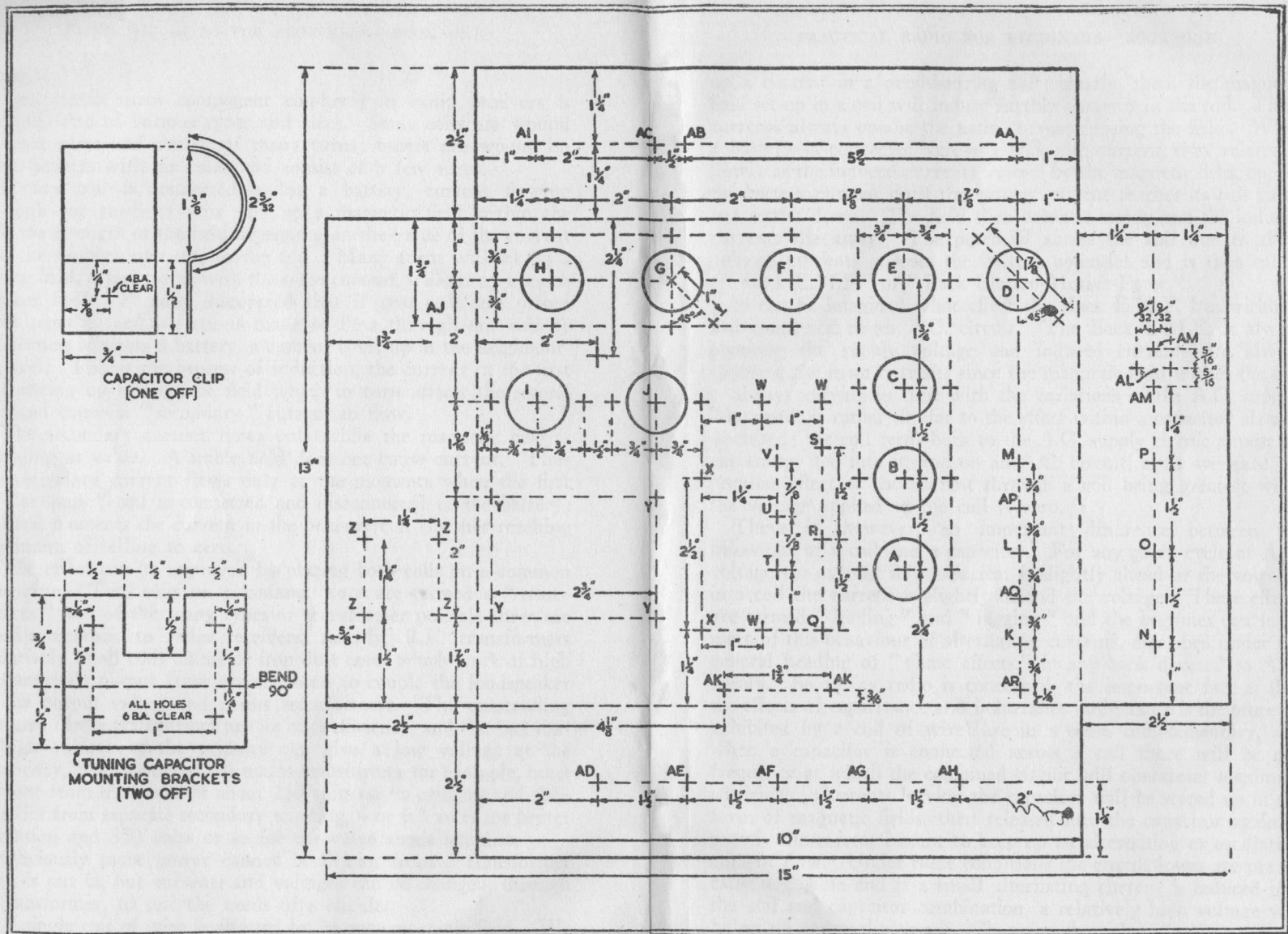

Fig. 13. Chassis dimensions for the Progressive Receiver



up a current in a neighbouring coil; clearly, then, the magnetic field set up in a coil will induce further currents in the coil. These currents always oppose the main current causing the field. When a battery is connected across a coil, the current rises relatively slowly as the induced currents, caused by the magnetic field, oppose the battery current until the battery current reaches its full value and settles down. The field then becomes steady and the induced currents die away. The potential across the coil due to these induced currents opposes the battery potential and is thus called a "Back E.M.F." or "Back Electro-Motive-Force."

It can be imagined what effect the Back E.M.F. has within a coil connected to an A.C. circuit. The Back E.M.F. is always opposing the supply voltage and induced currents are always opposing the main currents since the magnetic field within the coil is always varying in time with the variations of the A.C. supply. The result is rather similar to the effect within a capacitor already discussed; the coil feeds back to the A.C. supply circuit almost all the energy fed into it, and on an A.C. circuit, again we have the peculiar effect of the current through a coil being greatest when the voltage applied to the coil is zero.

There is, however, an important difference between the behaviour of a coil and a capacitor. For any given cycle of A.C. voltage the current in a capacitor is slightly ahead of the voltage; in a coil the current is slightly behind the voltage. These effects are termed "leading" and "lagging" and the beginner can learn more of this behaviour of alternating currents, described under the general heading of "phase effects," in any book devoted to A.C. theory. So far as radio is concerned, the important fact is that the effects of capacitance and inductance (inductance is the property exhibited by a coil of wire) are in a sense complementary, and when a capacitor is connected across a coil there will be one frequency at which the combined circuit will operate at maximum efficiency. Currents leaving the capacitor will be stored up in the form of magnetic fields, then released into the capacitor again at exactly the correct instant to keep up an alternating or oscillating current flow. Under these conditions the circuit losses are practically negligible and if a small alternating current is induced into the coil and capacitor combination, a relatively high voltage will be set up across the circuit. Changing the value of either the coil or the capacitor will change the frequency at which the effect is

observed. A coil and capacitor so connected form a "tuned circuit" which is "resonant" to one certain frequency. A coil and variable capacitor are therefore used to tune to the frequencies at which radio signals are transmitted; on either side of the tuned frequency neighbouring signals have much less effect on the tuned circuit and so one station can be selected out of many.

The symbols for coils of various types are shown in Fig. 14.

The coil is found in many different positions in a receiver. The output transformer has already been mentioned. This transforms the relatively low current (at relatively high voltage) flowing in the anode circuit of the output valve into a heavy current at low voltage which is then fed to a small coil of wire attached to the cone of the loudspeaker. Within this small coil, therefore, magnetic fields are set up whose strength and direction depend finally upon the signal applied to the grid of the output valve. The small coil of the loudspeaker is arranged to work over a powerful magnetic pole, and thus the fields set up within the coil by the varying currents interact with the steady strong magnetic field of the pole-piece. Quite powerful forces are thus set at work, and since the magnetic polepiece is rigidly fixed in position the small coil moves back and forth, carrying the speaker cone with it. The cone in turn moves the air, and thus sets up sound waves.

The property of inductance is measured in units called Henrys, and the inductance of coils employed in radio receivers vary so widely for different types of work that it is also necessary to use

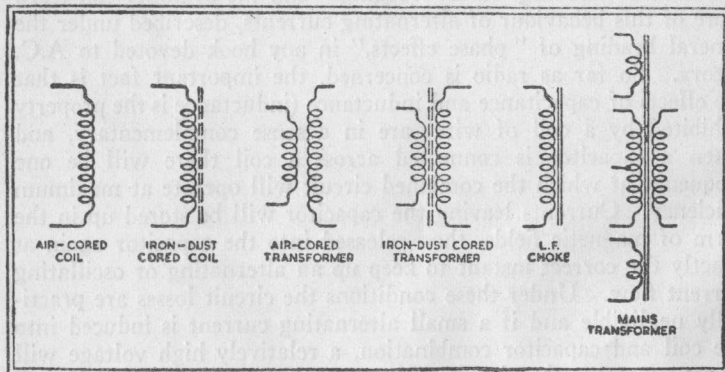

Fig. 14. Symbols associated with coils of different design and application

thousandths of a Henry, termed millihenrys, and millionths of a Henry, termed microhenrys. Thus 1,000 microhenrys (the Greek symbol  $\mu$  often takes the place of "micro," so that microhenrys can be written  $\mu$  Henrys or  $\mu$ H) are equal to one millihenry.

Short wave tuning coils have inductances of 2 or 3  $\mu$  Henrys, medium wave coils have inductances of about 150  $\mu$  Henrys and long wave tuning coils have inductances of the order of 2 millihenrys or mH. In the power pack, at the other end of the receiver, will be found a low frequency choke or L.F.C. which has an inductance generally of the order of 10 to 30 Henrys.

This choke has many turns of wire on an iron core and passes the current from a diode power rectifier to the receiver. It has already been shown that a capacitor connected across the diode rectifier helps to smooth out the spurts of current passed by the valve from an A.C. supply. The current still needs further smoothing however, and the choke greatly assists in providing such smoothing. We have already seen that any change in current in a coil, is accompanied by a corresponding change of magnetic field within the coil; the change in field causes a back E.M.F. and a back current which opposes the original current changes. The choke, therefore, passes a smooth current without opposition; but any change in current value is strongly opposed. The remaining spurts, or ripples, of current from the diode-capacitor circuit are thus blocked by the choke and cannot pass through its winding, although a steady unvarying current is passed readily. The output from the choke is thus quite smooth D.C., and a second electrolytic capacitor gives a final degree of smoothing to the current eventually passed to the receiver.

High frequency chokes, which are usually air cored, are small coils which have a similar choking action at the radio frequencies.



## CHAPTER 3

## THE BEGINNERS' PROGRESSIVE RECEIVER

The following chapters and companion volumes introduce a number of receivers, the construction of which will take the beginner progressively through various types of radio sets from the simplest 2 valve circuit up to an advanced superhet. The complete work will present an intensive practical course.

The circuits have been chosen and designed so that they can be built up, one after another, on a single chassis, with little, if any, wastage of parts. Commencing with a 2 valve receiver, complete in itself, the constructor will add parts and valves as experience is gained, so that the expense is spread over a period and the final high quality receiver is built up piece by piece.

Many beginners in radio are under the impression that it is easier and much cheaper to built battery receivers than mains operated sets. This is an entirely erroneous idea and provided the constructor has mains facilities, he may proceed with every confidence to construct a mains driven receiver. The chassis on which the receivers are to be constructed is shown in Fig. 13 and to avoid complication the same design is used for constructing all the receivers. Punching and drilling should be completed before any constructional work is undertaken.

The radio designs shown in this volume utilise an A.C./D.C. power pack (this type of supply is sometimes called a Universal power pack) and the necessary conversions to full-wave rectification for A.C. operation only will be discussed in a later volume.

*Drilling the Chassis.* The chassis is made of stout sheet aluminum and measures  $10" \times 8" \times 2\frac{1}{2}"$ . This is a stock size and a ready-made chassis can be procured from any good radio dealer

should the constructor not wish to bend his own sheet metal into shape.

Hole sizes are as follows:—

A to J inclusive,  $1\frac{1}{8}"$  diameter.

K to S inclusive, and holes W, 6 B.A. clearance.

T, U, V,  $\frac{1}{8}"$  diameter.

X, and holes AD to AI inclusive,  $\frac{3}{8}"$  diameter.

AA, AB, AC,  $\frac{5}{16}"$  diameter.

Y, Z and hole AJ, 4 B.A. clearance.

AK, AL, 6 B.A. clearance.

AM to AR inclusive,  $\frac{1}{4}"$  diameter.

Unmarked holes, 6 B.A. clearance.

Holes to clear 6 B.A. bolts should be drilled with a No. 32 twist drill, and 4 B.A. clearance holes are drilled with a No. 26 twist drill.

The  $1\frac{1}{8}"$  diameter holes are made with a chassis punch, which can be obtained in one of two styles. One type of punch has the die and bed drawn together by a bolt, whilst a second type of punch has the die hammered through the chassis material into the bed. In either case, a hole  $\frac{1}{4}"$  or  $\frac{3}{8}"$  diameter is drilled through the chassis dead centre with the large hole, in order that the punch bolt or locating pin may be passed through the chassis. The punch is then operated and the hole taken out cleanly.

The large holes of  $1\frac{1}{8}"$  diameter are for the valveholders and, later, for I.F. transformers and, in the case of hole D, for an electrolytic capacitor.

Throughout all the radio receiver designs it is intended that one or two components shall remain permanently in place on the chassis; these components are the power pack parts, whether for A.C. or Universal mains, and the tuning capacitor which is mounted in a central position and supported a little above the chassis on two end brackets. These brackets are shown in Fig. 13 and they should be cut from stout sheet aluminium or brass. The purpose of mounting the tuning capacitor above the chassis is to provide for the easy fixing and coupling of a tuning drive and scale when this becomes desirable.

In all designs a three-gang tuning capacitor is needed (the Jackson Bros. Type MG). This should be ordered by name, since the chassis drilling is shown to suit this type. The term three-gang capacitor means that there are three variable capacitors ganged

together in one framework, so that three tuned circuits can be tuned simultaneously.

The preliminary designs use only one section of this capacitor and the three sections are not used together until the final design. Nevertheless, it will be found economical to buy the three-gang capacitor at the start.

The capacitor is mounted so that its spindle points to the front of the chassis and falls over the chassis centre line. The moving vanes of the capacitor must open on to the left hand side, and it will be found that each set of fixed vanes has a small connecting tag to each end. The moving vanes are automatically connected to the chassis through the frame and metal supporting brackets.

At the bottom of each end plate or end frame of the capacitor two small holes will be found. The upright tabs of the supporting brackets are bolted to these holes, the bolts being passed through the end frames of the capacitor with their heads inside, so that there are no long bolt shanks which might touch the fixed or moving vanes of the capacitor. 6 B.A. bolts and nuts are used. The two supporting brackets are then bolted down to the chassis, using the holes marked Q, W, W, W. This places the capacitor in the correct position. In the designs, connections are made to the underneath tags of the capacitor sections, but it takes only a moment's work to unbolt the fixing brackets, raise the capacitor for the wires to be soldered to the tags, and then bolt the component back in place.

Other components permanently fixed to the chassis are the low frequency choke, employed for smoothing in the power pack which is fitted below the chassis and bolted in place by holes Z, Z, Z, Z, with 4 B.A. bolts and nuts. The rectifier valveholder is bolted below hole I; all valveholders are bolted beneath their respective holes and secured by 6 B.A. bolts and nuts.

For smoothing purposes a double electrolytic capacitor is employed. The first section, value 8 mfd, is the capacitor connected across the rectifier valve and is known as the reservoir; the second section, value 16 mfd, is the smoothing capacitor. This double component is bolted to the side wall of the chassis by a clamp bent up from sheet aluminium or brass; the clamp is shown in Fig. 18 and the hole AJ provides the fixing position.

Hole H has a British 4 or 5 pin valveholder bolted below it to hold a Barretter valve (which is explained in the following chapter).

The valve holder may need drilling with new holes to fit the  $1\frac{1}{2}$ " fixing centres of the 6 B.A. clearance holes on each side of hole H; but this is a simple matter.

One or two rubber grommets should be obtained as bushings for some holes. Grommets may be described as thick rubber washers with a central hole for the passage of a lead or cable and a circumferential slit which grips the edge of hole in the chassis, the hole thus being completely bushed and insulated. The holes marked AI for the mains lead; AN for speaker leads; XX for transformer or choke leads; and AO beside hole G should be grommetted in this way.

Note that there is no provision on the chassis for mounting a loudspeaker. If the chassis is mounted in a cabinet the speaker may be bolted to the front of the case above the chassis; if no cabinet is used at first, as will be most likely, the speaker may be fastened to a separate baffle board or in a separate cabinet.

A loudspeaker should always be provided with a firm, strong mounting as large as possible, and secured with large bolts or screws. In a veneer or plywood cabinet the speaker should have a thick board screwed or glued to the interior of the case to act as a mount, this board being cut with a circular aperture of suitable size.

The ideal mounting for a loudspeaker is a flat baffle board about 4 feet square, the speaker being mounted centrally if the baffle board can be suspended or raised above floor level, or rather above the centre line if the bottom edge of the board is at floor level.

For the designs shown in this volume the loudspeaker must have its output transformer mounted on the loudspeaker framework; the speaker should not be positioned too far from the receiver. A length of no more than a yard for the speaker leads should give ample flexibility.



## CHAPTER 4

## DETECTION: TWO SIMPLE RECEIVERS

A radio wave passing a receiving aerial, sets up oscillatory currents in the wire which are supplied to the input circuits of the receiver connected to the aerial lead-in. The currents in the first circuit of the receiver may therefore be represented as in Fig. 3C, they will rise and fall in value from positive to negative peaks and the strength of the currents at any instant will be dependent on the modulation or sound content of the radio wave.

It is obvious that the tiny currents will need considerable amplification before they can operate a loudspeaker; not so obvious, perhaps, is the fact that in their present form (Fig. 3C) no matter how amplified they may be, they are quite useless for operating any mechanical reproducer.

The positive peaks and the negative peaks of the current follow exactly the same curve imposed upon them by the modulation; they increase and decrease together in amplitude. If such a waveform were to be supplied to a loudspeaker, these currents, operating in the voice coil to produce magnetic fields, would cancel each other out, for no sooner would the coil commence to move to a position dictated by a positive peak, than it would have to reverse and move to a position dictated by a corresponding negative peak. In fact the coil would not move at all, for the mechanical system could not respond to the immensely fast reversals of current flow.

The waveform must therefore be rectified or, to employ an old term still in use, "detected," by passing the currents through a device such as a diode. If this is done only half of the peaks of current will flow, the opposite peaks being blocked, and the result on the waveform of Fig. 3C can be seen in Fig. 15 which shows the same modulated wave after detection. Refer also to Fig. 5B.

The effect of this waveform on a mechanical device such as a loudspeaker is very different. The current is still rising from zero value to peak value every half-cycle; but there are no opposite

peaks and so a mechanical system could respond to the overall slow variations in the peak value of the current. These variations of peak value, however, constitute the sound wave originally used to modulate the radio wave, and so the chief requirement—that of separating the sound wave from the radio wave—is satisfied.

There are, however, the rapid fluctuations of current from zero to peak value still to be dealt with; but if a small capacitor is connected across the diode circuit as in Fig. 16 it will present a small reactance to these very rapid changes of current while presenting quite a high reactance to slow current value changes. (The general term "impedance" is more usually employed than the term "reactance"). The rapid current fluctuations will thus be "by-passed to earth" through the capacitor, and the sound waveform will be set up across the capacitance as a varying charge in the way shown.

A diode is not the only detector which can be used and, indeed, it is rarely employed in simpler sets, since it gives no amplification to the signal; a detector often employed is shown in Fig. 17. In this circuit a pentode valve is used, but instead of a normal and fairly low bias resistance, the cathode resistance  $C_r$  has quite a high value. This has the effect of making the anode current through the valve very small, since the grid voltage is very negative—the valve is said to be "biased back to cut off," that is, has such a high negative bias that anode current almost ceases.

Imagine now that currents of the waveform shown in Fig. 5B

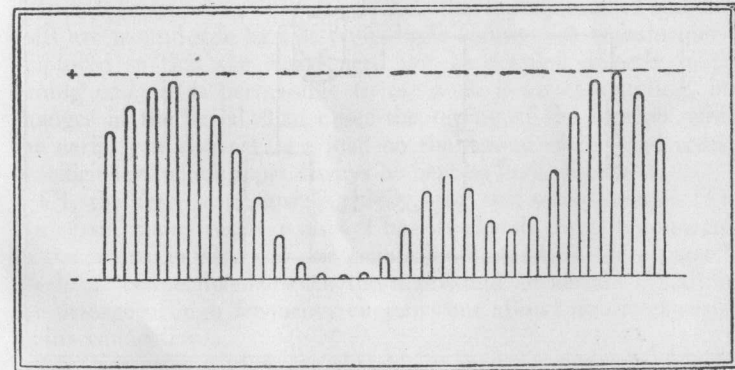

Fig. 15. The waveform of Fig. 3C after rectification

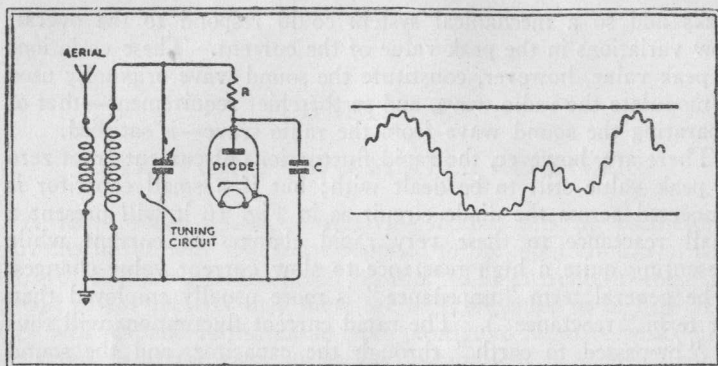

Fig. 16 Showing the effect of capacitor C on the waveform of Fig. 15, the RF carrier being effectively bypassed to earth

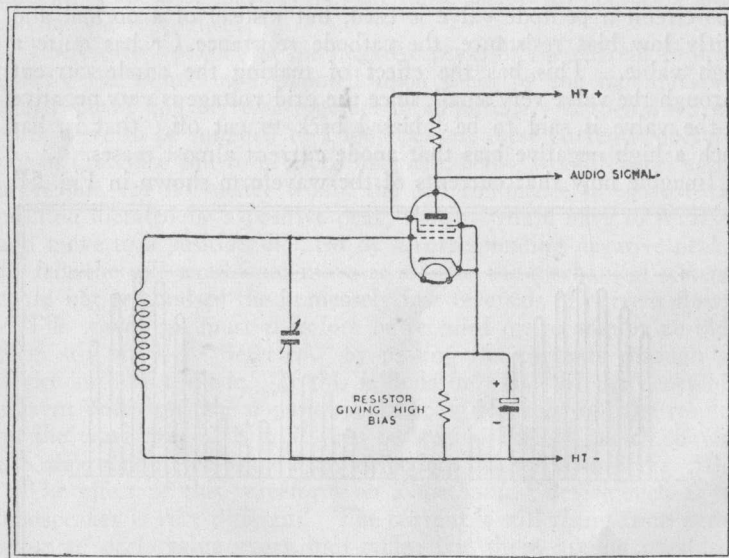

Fig. 17. Basic circuit of a grid bias or anode bend detector

applied to the grid of the valve from the tuned circuit shown. On each positive peak the bias will be neutralised to some degree so that the negative bias on the grid will drop a little. This allows the anode current to rise and so produce a signal at the valve anode. On the negative peaks the negative bias on the grid is augmented so that the already high negative bias becomes more negative still. In a normal circuit this would have the effect of reducing the anode current below its original level; but in this circuit the anode current is already so low that it cannot fall further. On negative peaks, therefore, the anode current simply falls to its original level, rising once more when a positive peak follows the negative. The signal at the anode is thus produced by positive peaks only, and once again the waveform is rectified and, moreover, is amplified through the valve.

The first simple circuit has such a detector, known as the Grid Bias Detector or Anode Bend Detector—the latter name describing the curve of a graph which depicts the behaviour of the anode current of the valve. The detector is followed by an output stage which gives the rectifier signals further amplification, enabling a loudspeaker to be operated. Since it is anticipated that most constructors will have a source of mains power available, the first receivers to be described are mains operated and are suitable for A.C./D.C. mains.

The receiver is shown in theoretical form in Fig. 18. The currents from the aerial flow through L1, an air-cored coil, and induce corresponding currents in L2, the tuning coil. These two coils are wound side by side on a single former. A transformer is employed so that the aerial need not be coupled directly to the tuning coil; it is permissible to use such a direct coupling, but changes in the aerial then upset the tuning of the receiver while the aerial can also act as a load on the tuning circuit and reduce its efficiency, which must always be kept as high as possible.

C1, the aerial capacitor, is chiefly used as a safety device. The Universal mains receiver always has its chassis directly connected to the mains supply, and one regulation states that there must be no direct connection between the mains and an aerial. C1 allows the passage of high frequency currents but allows no direct aerial-mains connection.

C2 (note the symbol for variable capacitor) tunes the coil L2 to any required frequency within the medium wave band, since a



medium wave coil is employed, and V1, a Mullard EF37 pentode, acts as an anode bend detector. The cathode resistor, R3, is by-passed by a high value electrolytic capacitor and the rectified signals appear at the anode as changes of voltages across R2, the anode voltage rising and falling with the signal.

A small capacitance, C6, by-passes the radio frequency signal from the anode of V1 to earth, leaving the audio signal for transfer to V2.

Note the connection of the suppressor grid of V1 to the cathode and also the method used to feed the screening grid of the detector valve. The screening grid is directly connected to the earth line by a capacitor, so that any voltage fluctuations on this grid are smoothed out, the grid thus operating on a fixed voltage.

It will have been noticed that the base line of the theoretical diagram is termed the "earth" line; in British circuit drawings this line is also taken as the chassis of the receiver, and the connections to it in the diagram are taken to the chassis in the actual receiver.

No direct earth connection is shown to the earth line or chassis in the diagram, the earth line being shown, instead, taken through a capacitor. This is a point of the utmost importance, for the chassis is indirectly earthed through the mains leads, and a direct earth to the chassis could mean a serious short-circuit across the mains if the mains plug were inserted in such a way as to connect the chassis to the line or "live" side of the mains.

C11, the earthing capacitor, must have a rated working voltage of 750 volts, and must not be higher in capacitance than the 0.01 mfd shown.

To return to the operation of the circuit. The audio signal from V1 is taken via C7 to a potentiometer whose other end is earthed. The signal is thus set up as a fluctuating voltage across this potentiometer and the variable contact can tap off any desired percentage of the signal voltage, so that the final voltage presented to the grid of V2 is variable from maximum to zero. R5 is thus a volume control operating on the audio signal.

R6, in series between the potentiometer variable contact and the grid of the output valve, acts as a filter in co-operation with the input capacitance of V2, the input capacitance of a valve being the small capacitor-effect set up between the grid of the valve and earth. The resistance and capacitance together acts as a filter

which has very little effect on the audio frequencies; but which blocks quite effectively any stray radio frequencies not by-passed to earth through C6.

Another type of filtering circuit is formed by R1 and C5. At the anode of the output valve a large voltage swing is set up, and should any of this energy be fed back to V1 through the H.T. line serious instability could result. In a 2-valve circuit there is, in fact, small chance of trouble arising in this way; but as a safety measure the "decoupling circuit," R1, C5, is included. Note that R1 supplies the H.T. current to both the anode and screen of V1. Any "feedback" from V2 will vary the voltage of the H.T. supply line in time with the fluctuations of voltage on the anode of V2; but with R1 in circuit, these fluctuations of voltage must be set up across R1 before they can affect the anode and screen voltage of V1. R1 is, however, by-passed to earth by C5, a large value capacitor which smooths the voltage at the junction of R2 and R4 with R1 and so prevents feedback from affecting the operation of the first valve.

V2, like V1, is self biased; R7 in the cathode circuit of the valve makes the cathode more positive than the grid. The bias voltage is smoothed by C8.

The output valve is coupled to the loudspeaker by the output transformer T1. The required load of the valve, for optimum working conditions, is given by the manufacturers as 4,500 ohms and the voice coil impedance of a normal loudspeaker is 3 ohms. The transformer must, therefore, match a load of 3 ohms into a load of 4,500 ohms. We have already seen that a transformer can "match" one voltage into another with a corresponding change of current; matching one load resistance into another is much the same thing. For example, a transformer of 100% efficiency might be used to drop a 200 volts line supply to 100 volts from the secondary. If the current drawn from the secondary is 1 amp the current drawn by the primary from the supply line will be  $\frac{1}{2}$  amp, for in halving the voltage we double the current so that the power used in or supplied from each winding is the same. The circuit impedance on the two sides of the transformer are by no means the same, however. It is not proper to use Ohm's Law for A.C. circuits without corrections but, as an example, we may say that the resistance coupled to the secondary of the transformer is 100 divided by 1, i.e., 100 ohms, and the resistance connected to the

primary of the transformer is 200 divided by  $\frac{1}{2}$ , i.e., 400 ohms. The transformer is thus matching two resistances and this is exactly the task of an output transformer.

In dealing with the output transformer, so far we have employed two terms—resistance and impedance—and it will be as well to define these two properties. In dealing with direct currents we are concerned only with one circuit characteristic, that of resistance—a coil will present to direct current the actual resistance of the wire in its windings, a good capacitor will present a resistance of infinity and a resistor will present to the current just the actual resistance in ohms marked upon it. On A.C. circuits, however, both coils and capacitors present a reactance to the current, the reactance being measured in ohms and varying with the frequency of the alternations, falling in value as the frequency rises. A resistor still presents to A.C. the resistance marked upon it.

Reactance and resistance cannot be directly added together, for we have seen that in coils and capacitors the behaviour of the current and voltage change differs from what would be expected. In a resistor the current and voltage rise and fall together—they keep in phase—but in coils and capacitors the phase varies and in different directions. When resistance and reactance are present in a circuit they must be added by taking the square root of the sum of the squares of the values, and the result is known as impedance still measured in ohms. (When both types of reactance are present, both inductive and capacitive, the calculation becomes more involved.)

We must, therefore, speak of the impedance of a voice coil, for this is made up of the resistance of the wire and also the inductive reactance of the coil, and since the reactance varies with frequency a particular frequency must be specified. For all voice coil calculations a frequency of 400 cycles per second is understood.

To discover the ratio of the transformer required (by ratio we mean the number of turns in one winding compared with the number of turns in the other winding) we use the formula:

$$\text{Ratio} = \sqrt{\frac{\text{Load resistance}}{\text{Voice coil impedance}}}$$

and if we evaluate this for the actual circuit of Fig. 22 the output transformer ratio for a 3 ohms impedance voice coil is found to be 38.7 to 1. One winding is therefore made of a few turns of heavy gauge wire; and is connected to the voice coil. The other winding

is made of many turns of finer wire, and this is generally brought out to connecting tags on the transformer, which is connected into to the output valve's circuit.

The power supply circuit, consisting of R8, V3, C10 and C9 and the low frequency choke L.F.C. is of the half-wave type, so called since the rectifier valve, V3, supplies one pulse of power per cycle. Power packs operating from A.C. only are termed full-wave packs, since they supply two pulses of power per cycle.

The pulse charges up C10, which then supplies a smoother flow of power to the choke and the smoothing capacitor C9, the output to the receiver circuit being drawn from the charge on C9 and thus being fully smoothed.

R8 is not always found in half-wave power packs, but it serves to give valuable protection to V3 and C10. Since the power is fed to C10, the reservoir capacitor, in separated pulses there is a heavy ripple voltage across this capacitor which therefore passes quite a heavy alternating current to earth. This ripple current, as it is termed, might damage the capacitor by overheating it, and might also damage the rectifier valve, so that a limiting device of some sort is desirable. R8 acts as such a limiter. For a normal current flow the voltage drop across R8 is negligible; but for a heavy pulse of current the voltage drop across the resistor is much higher. This causes a drop of voltage on the anode of the rectifier, and in this way heavy current pulses are smoothed out to a useful extent. The smoothing cannot, of course, be carried out beyond a certain limit, otherwise the ripple on C10 will be increased and the final output current will be less smooth than is desirable. This would lead to objectionable hum from the loudspeaker.

Special attention must be paid in all A.C./D.C. circuit drawings to the manner and order in which the valve heaters are connected in the chain shown between V4 and the earth line. Note that VI has one side of its heater earthed, V2 and V3 following in sequence. The detector/first audio stage (in a receiver, a stage consists of a valve and its associated components) in a Universal mains set, is always the stage to have one side of its heater earthed, and there is very little difference in potential between the heater and cathode. A high potential strain across these valve elements would almost certainly again cause an annoying hum.

V4, although included with the valves in the components list and coded as a valve in the diagram, is actually a special type of



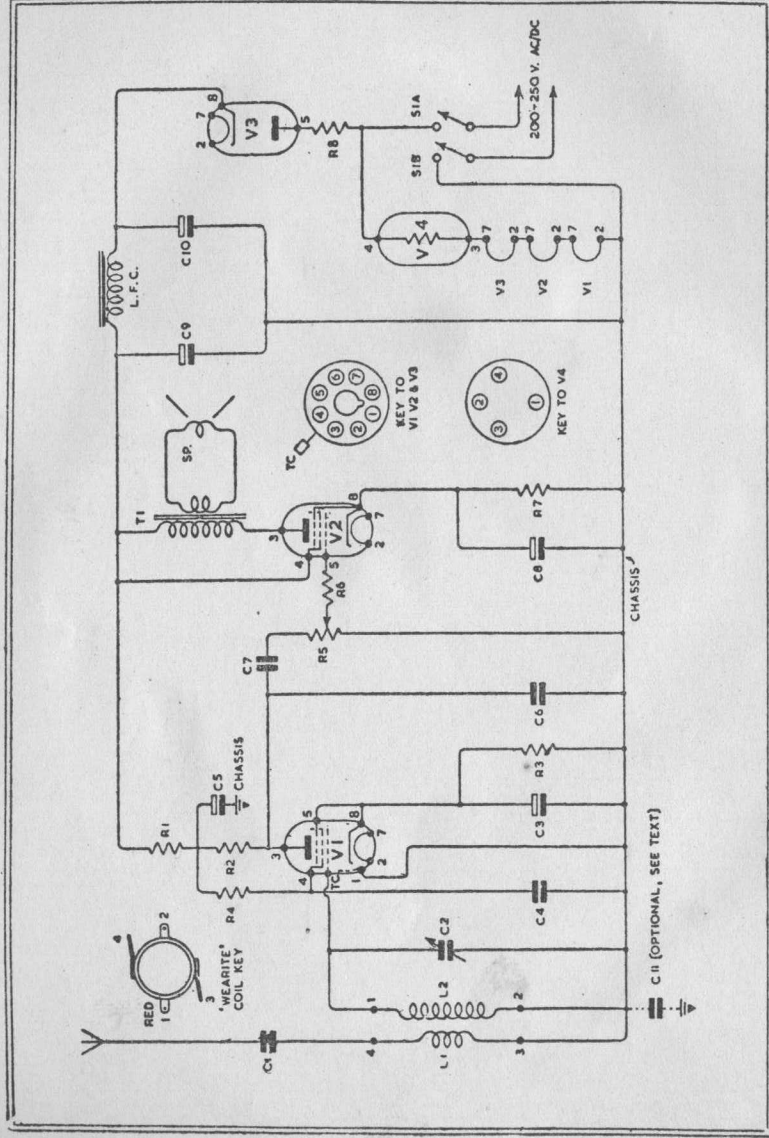

Fig. 18. A 2-valve plus rectifier A.C./D.C. receiver with anode bend detector

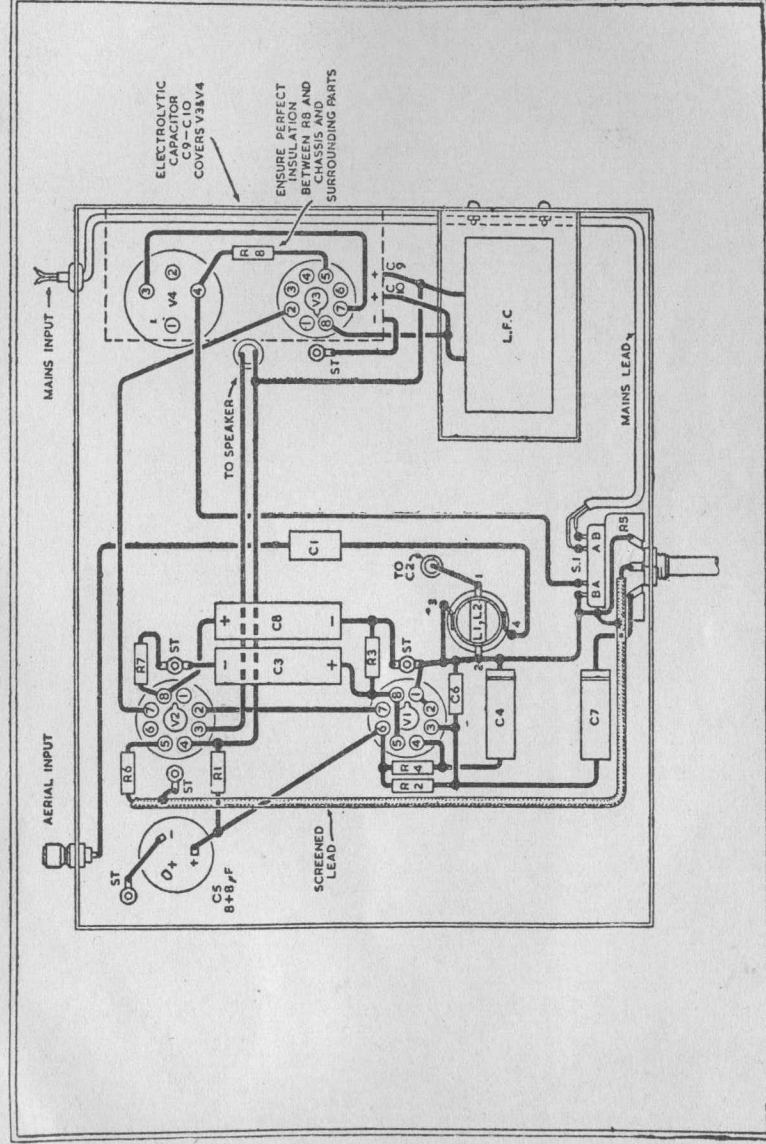

Fig. 19 Under chassis layout and practical wiring of Fig. 18

resistor enclosed in a glass envelope. In a Universal mains receiver, where the valve heaters are connected in series, the total voltage across the heaters will not amount to the mains voltage, and there is thus a surplus voltage which must be "dropped." A normal resistor or a resistor made up to look like ordinary connecting cable and called "linecord" can be used to drop this voltage, but the supply mains are liable to quite wide voltage fluctuations, so that when a dropping resistor is employed in an A.C./D.C. receiver there are times when the valve heaters will be over-run and other times when they will be under-run; both conditions are to be avoided.

A barretter or regulator lamp, as V4 is called, has the great advantage that it is self-regulating. It is made up of an iron wire held in an atmosphere of hydrogen gas within the glass envelope, and it is found that such a device will pass a certain fixed current although the voltage across the ends of the wire varies between surprisingly wide limits—between about 100 and 200 volts in the case of the chosen barretter. The barretter is chosen to pass the 0.2 amp required by the series-connected heaters, connected as shown, and the constructor can then be sure that the valves are always running at the correct rating, no matter how the mains voltage may be fluctuating. This great advantage is gained at the expense of one small disadvantage, since the barretter filament is of iron wire the valve must not be placed anywhere in the stray fields of a choke or, more especially, of the permanent magnet of the loudspeaker. The filament is carrying a fairly heavy current and thus has a magnetic field around it and if this field interacts with a second magnetic field the filament will be made to move. When the barretter is passing A.C. the effect is very serious, since the filament will then vibrate at the mains frequency and soon break down. The effect is avoided in the progressive receiver, as the loudspeaker is not mounted on the chassis.

The mains switch of the set, S1a and S1b, as shown is of the double pole type, and is ganged with volume control arm, one component thus serving for two functions. A double pole switch should always be used in a Universal mains receiver for, if a single pole switch is used, the set is left connected to one side of the mains, which is definitely unsafe.

In the constructional diagrams the switch poles are drawn to show the connections clearly, but on the actual component, depend-

ing on the make, it may be difficult to decide by visual inspection, the pole connections, when the switch is closed.

If this is the case the constructor should test the connections with a torch bulb and battery, and code them before connecting the switch into the receiver circuit.

If, for any reason, only a single pole switch can be obtained, this pole should be arranged to break the line or live side of the mains circuit.

Throughout the description of the receiver it has been assumed that power is being drawn from A.C. mains. If the set is connected to D.C. mains the receiver works in the same way, and the mains lead marked "Line" in the diagram must be connected to the positive side of the supply before the receiver will operate. The working of the power pack is also rather different, for V3 acts only at quite a low resistance, the anode always being positive with respect to the cathode, so that current is always flowing through the valve. Nevertheless, V3 serves to protect the electrolytic capacitors C10 C9, for, if the mains plug were incorrectly inserted into a D.C. supply socket, no current would flow through V3. A direct connection under such circumstances would ruin the electrolytic capacitors, as well as blowing the mains fuses.

The operation of this simple receiver has been described in some detail in order that the passage of the signal from the aerial to the detector, and the separation of the audio modulation from the carrier, with its subsequent amplification and presentation to the loudspeaker, may be thoroughly understood. In the case of the following receiving circuits such detailed discussion will be unnecessary.

There follows a components list of the parts required to build the set. As further developments are described, each will be accompanied by a list of further components required, so that it will not be necessary to sort out from each list those parts already possessed. Where parts are specified by maker's names and code numbers, there is good reason for making the specification which should be adhered to rigidly; but such parts as resistors, valveholders, etc., can be purchased at practically any radio store. Components such as tubular and electrolytic capacitors should be bought as required and not obtained from surplus stocks, since it is essential that these components are in perfect condition; but it is sometimes possible to buy mica capacitors, resistors, valveholders, etc., in bulk at favourable prices.



COMPONENTS LIST FOR THE SIMPLE 2-VALVE PLUS  
RECTIFIER SET. FIG. 18.

- L1, L2, Wearite PA2 tuning coil.  
 C1, 0.01 mfd. 750 v. w. Tubular TCC 743.  
 C2, 3-gang 500 pFds tuning capacitor, Jackson Bros.  
 Type MG (one section only used in this set).  
 C3, C8, 25 mfd. 25 v.wg. Electrolytic TCC CE32C.  
 C4, C7, 0.01 mfd. 350 v.wg. Tubular TCC 346.  
 C5, 8 mfd. One section of an 8 plus 8 mfd. 450 v.  
 wg. Electrolytic TCC CE27P.  
 C6, 100 pFds. 350 v.wg. Mica TCC CM20N.  
 C9, C10 16 plus 8 mfd. 450 v.wg. Electrolytic TCC  
 CE28P.  
 R1, 33,000 ohms,  $\frac{1}{2}$  watt.  
 R2, 330,000 ohms,  $\frac{1}{2}$  watt.  
 R3, 15,000 ohms,  $\frac{1}{2}$  watt.  
 R4, 680,000 ohms,  $\frac{1}{2}$  watt.  
 R5, 0.5 megohm potentiometer, with switch.  
 R6, 10,000 ohms,  $\frac{1}{2}$  watt.  
 R7, 180 ohms,  $\frac{1}{2}$  watt.  
 R8, 47 ohms, 1 watt.  
 V1, EF37A }  
 V2, CL33 } Mullard.  
 V3, CY31 }  
 V4, C1C }  
 3 International octal chassis mounting valveholders.  
 1 British 4-pin chassis mounting valveholder.  
 T1 with Spk. 8" loudspeaker, Rola, permanent magnet,  
 with output transformer to match into 4,500  
 ohms.  
 L.F.C. 10 henrys 80 mAs. 300 ohms. Partridge  
 EEC/3/VDL.  
 Sla, b, 2 pole on-off switch, ganged with R5.  
 2 Round control knobs.  
 1 Grid clip.  
 Aerial socket, Belling-Lee L315 with plug L378/3.  
 Capacitor clip for C5, TCC "V3."  
 Mains lead and plug.  
 4 and 6 B.A. nuts and bolts. Connecting wire, sleeving, etc.

## CONSTRUCTION.

An under chassis view showing the wiring of the 2-valve plus rectifier receiver for A.C./D.C. operation is given in Fig. 19. Before wiring up, the various components should be bolted in place in the positions given as follows:—

Bolt the 4-pin valveholder below hole H.

Bolt the octal valveholders below I, B and E.

Before bolting the variable capacitor in place, solder a 6" lead to the underside tag of the centre section fixed plates, passing the lead down through U, then fasten the capacitor by its brackets as already described, using a long 6 B.A. bolt through hole Q. In later receivers this long bolt supports a coil below the chassis.

Bolt the choke to the Z holes, and clamp the 16 plus 8 mfd capacitor to the side chassis wall by hole AJ.

Bolt the capacitor clip type V3 over the chassis hole D.

Through hole R pass  $\frac{1}{2}$ " 6 B.A. bolt so that the bolthead is above the chassis and the screwed shank is below. This can be done before the tuning capacitor is in place, although the bolt can easily be slipped in place by using long-nosed pliers. The PA2 coil, like all P type coils, will be found to have a brass fixing plate near the base of the former, and the coil is secured below the chassis by means of the  $\frac{1}{2}$ " bolt and this plate.

Note the coil key diagram shown in Fig. 22, which shows the numbering of the coil tags viewed from above. The two long upright tags are connected to the main tuned winding of the coil, and the red tag is No. 1.

The volume control/on-off switch is mounted through the hole AF in the front chassis wall. If the component has a small locating pin or lug, a small hole should be drilled for this beside the main hole. The threaded spindle bushing is then passed through the chassis, fixed by the shakeproof washer provided, and the nut.

Remember to tighten all nuts with spanners; never use pliers. Large nuts can be tightened with an adjustable spanner.

Many connections to this chassis will have to be made in the course of constructing the series of receivers. Below each 4 and 6 B.A. mounting nut a suitable soldering tag should be fastened; each valveholder, for example, will then have two soldering tags fixed under its securing nuts. The tags are, of course, mounted like the components, below the chassis.

The soldering tags should not be included below the fastening

bolts of the rectifier and barretter holders, however; it is a wise precaution to keep earthed connections away from the power points and in any case only one main earth is required in the power circuit. This is provided by a tag bolted down with the capacitor clamp at hole AJ.

#### SOLDERING.

With the main components in place, the wiring can now commence, all joints being soldered. The constructor who has no soldering experience should first practise on some scraps of wire and metal; the secret of good soldering is to keep all the tools and materials absolutely clean.

An electric iron with a medium or small sized bit should be obtained. For radio work a pencil bit is excellent, since it can be applied to a joint without touching nearby wiring or components mounted in the wiring. An ADCOLA miniature iron is highly recommended. The solder used should include its own flux, and Ersin Multicore cannot be bettered; this should be bought by the pound reel.

For wiring up, use 22 S.W.G. tinned copper, bought in  $\frac{1}{4}$  or  $\frac{1}{2}$  lb. reels, insulating each length of wire with  $1\frac{1}{2}$  millimetre insulating sleeving.

To make a joint, measure off the wire required, and add a half inch to the length for jointing before cutting off the wire. Pass the first end of the lead to be joined through the hole in the connecting tag, for example—bend the end of the wire round and clamp it down on the tag tightly. Remember that a joint must be mechanically sound before it is soldered; the solder is to make an electrically efficient joint, not to add mechanical strength. Apply the end of the solder to the joint, then the soldering iron. As the solder melts the resin core runs out over the joint as a flux, and the solder follows it, running smoothly. Remove the end of the solder and keep the iron in place, heating up the joint for a few seconds, then remove the iron. Allow the joint to cool naturally without disturbing it in any way. The final cooled joint should have a smooth bright appearance; a dull joint is probably "dry." In a dry joint, dirt or too little heat or some disturbance of the part joined has spoiled the flow of solder and the joint will soon give trouble, owing to a high resistance being set up.

Note that no other flux is used with cored solder, and that the resin within the solder itself is sufficient. Many other fluxes will in time cause corrosion of the joint and should be avoided.

With the wire joined at one end, measure off the correct length of sleeving needed to insulate the lead, slip it over the wire, then join up the other end. Care must now be taken not to char or heat up the sleeving. This may be found difficult at first, but practice in soldering soon makes perfect.

Avoid blobs of solder on joints, using only as much as is required to flow smoothly over the metal. Watch the body of the iron as a joint is made, so that it does not accidentally touch a resistor or capacitor.

With new components there is no need to clean the metal before soldering. The plating on soldering tags, valveholder lugs and similar connecting points is designed to take solder well. If the metal looks dull or discoloured, tin it first before making the joint by flowing a little solder over it and applying heat until the solder runs smoothly and takes perfectly.

When using cored solder, never melt the solder on to the iron and transfer it to the joint. This burns up the flux before the iron reaches the joint. Always apply the solder to the joint first, then the heat to melt both solder and flux together on to the parts to be connected.

#### WIRING.

In any receiver, no matter what its type or design, the first wiring job should be the complete heater chain. The heater leads should be as short and direct as possible, and kept well pressed up against the underside of the chassis. On A.C., the leads have an alternating field around them and could thus cause hum if brought into proximity with other circuits. Keeping the leads against the chassis provides a measure of shielding. These leads, like all others, must be perfectly insulated.

After the heater circuit, wire up the power supply circuit including the mains lead. Support R8 between the correct tags of the barretter and rectifier valveholders, ensuring that the resistor is well spaced both from the chassis and the body of C9, C10, so that there is not the slightest chance of a short circuit.

The wiring of C9, C10 cannot conveniently be shown in Fig. 19, but the leads are coded. Remember that the black (negative) tag of the capacitor must be connected to a soldering tag under the bolt holding the capacitor clamp. The red tag is C9, the yellow C10.

When wiring resistors and capacitors into circuit, remember first to cut their leads to the correct length, then to slip on a



suitable piece of insulating sleeving before making the joint.

With the heater and power supply circuits completed—the H.T. supply line from the power pack to the circuits should not be included yet—transfer the attentions to the cathode circuits of each stage in turn. Note that in the case of V1 the No. 1 tag of the valveholder must be earthed to connect the metallised coating of the valve to the chassis. This coating acts as a screen to protect the valve electrodes from external fields. Connect tag 5 to tag 8 on the V1 holder, then take tag 8 to the nearest earthed soldering tag through R3. Support C3 between tag 8 and earth as shown in Fig. 19. Although C3 is a large component it will be easily supported in the wiring.

Wire the cathode circuit of V2.

Now wire up the screen and anode by-passes. On V1 this means taking C4 to earth from tag 4. Before applying the solder, wire in the end of R4 to the same tag. From tag 3 of V1 run C6 direct to earth, adding R2 and C7 to the tag before applying solder.

On the V2 holder, wire R6 right at the grid pin, which is No. 5. Note by-pass capacitors and grid stoppers, such as R6, must always be connected right at the appropriate valveholder pin to be fully effective.

Tag 6 on the holder of V1 is not used for any valve connection, and the pin on the valve base has no connection to any valve electrode. This tag may therefore be employed as a "tie-point," that is a tag or connector where a number of leads may be brought together, joined and anchored. R2 and R4 anchored together with the lead to C5, as shown.

Tag No. 4 on the V2 holder connects the screening grid of the output valve to the main H.T. line and can thus also be employed as a tie-point for components taken to the main H.T. line. R1, one speaker lead and the lead from the power pack therefore meet at this tag.

The speaker leads are best made of light rubber-covered flex, the two cables being twisted together and carried across to their grommetted hole.

The grid circuits of the two valves are now wired up.

The lead of the grid of V1 is taken from the upper tag of the fixed plates of the tuning capacitor's centre section, and so is the only lead above the chassis. Thin rubber-covered flex wire should be used for the lead, measured and cut to length with V1 in its

holder. Taking the lead to the top grid cap from the capacitor in this way keeps the lead short and direct, and also ensures that the grid circuit is as isolated as possible from the anode and power circuits of the stage. This connection is shown in Fig. 20.

The lead from the volume control to the output valve is rather long, and should therefore be screened. 22 S.W.G. wire can be used, screened sleeving being used as a covering for the wire instead of plain sleeving. Screened sleeving is insulated sleeving of normal type with a loosely woven wire mesh surrounding the sleeving, and the lead carrying the signal is thus protected from stray fields and external influences which might induce small potentials on the grid of the output valve.

At each end of the screened sleeving the wire mesh should be unravelled for a short distance and twisted up into a pigtail. The pigtail at each end of the screen is then taken to a convenient and nearby earthing point.

Add the H.T. supply line from the power pack.

Wire up the aerial connection through C1 between L1 and the aerial socket on the rear of the chassis. No earth socket is shown and C11 is deliberately omitted from the parts list, since the earth provided by the mains connection in the A.C./D.C. set is invariably perfectly satisfactory. If the constructor wishes to experiment with an earth connection he may add a second socket by the aerial socket, remembering that this earth socket must be connected to the chassis via C11, which has the same value and v.wg. as C1.

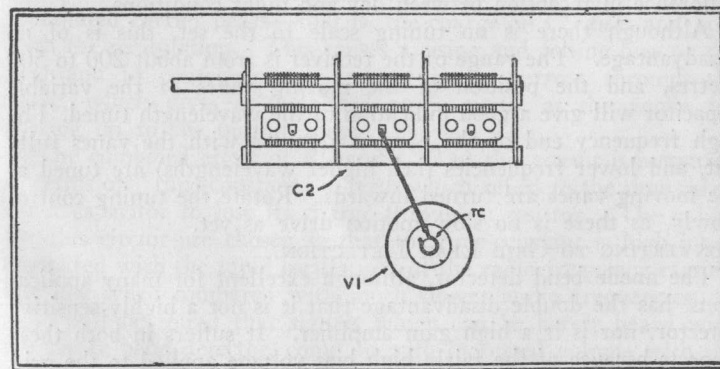

Fig. 20. Showing how the top cap of V1 is connected

Connect the speaker leads to the output transformer on the loudspeaker before the valves are inserted. The receiver must never be switched on and the valves powered without the speaker connections being made, otherwise the anode of V2 will draw no current and the screen of the valve will have to carry a heavy load, which might well result in serious damage to the valve.

Before inserting the valves, carefully check over every wire.

Insert the valves and, before connecting up the mains plug, fasten the two control knobs to the two spindles—those of the tuner and volume control. Connect up the mains plug. From now on do not touch the chassis of the set until the mains plug is connected in the correct sense. Switch on by turning the volume control knob right up. Let the set warm up until a faint hum is heard from the speaker—allow a minute for this, then reverse the mains plug in its wall or lamp socket. The hum heard from the set will either increase or decrease. Connect up the mains socket in the way which gives least hum from the receiver; this will mean that the chassis is connected to the earth line and may be handled with safety.

Connect a good aerial to the aerial socket, and then rotate the tuning capacitor through its whole travel. Reception with this set will depend on the nearness of a radio transmitter and the efficiency of the aerial; in remote and country areas it is probable that reception will be rather weak. That, however, can be improved very rapidly as will be explained shortly. Note the difference in reception between day and night conditions.

Although there is no tuning scale to the set, this is of no disadvantage. The range of the receiver is from about 200 to 500 metres, and the position of the moving vanes of the variable capacitor will give a good indication of the wavelength tuned. The high frequency end of the band is received with the vanes fully out, and lower frequencies (i.e., higher wavelengths) are tuned as the moving vanes are turned inwards. Rotate the tuning control slowly, as there is no slow motion drive as yet.

#### CONVERTING TO GRID LEAK DETECTION.

The anode bend detector, although excellent for many applications, has the double disadvantage that it is not a highly sensitive detector, nor is it a high gain amplifier. It suffers in both these respects because of the fairly high bias voltage applied to the grid of the valve. If the anode bend detector is found to give poor

results in the constructor's reception area, the circuit can be changed in a few moments to a grid leak detector. The simplicity of the change over is illustrated in Fig. 21 where the new detector circuit is shown.

R3 and C3, the biasing components of Fig. 18, are removed and the cathode of V1 is taken directly to earth by being connected to the nearby soldering tag. The direct lead from the upper tag of the section of the tuning capacitor to the top cap grid of V1 is also removed, and in its place is connected C12, a 100 pFds. mica capacitor, with a grid resistor or grid leak R9. The earthed end of R9 is taken directly to the earthed soldering lug on the tuning capacitor, as shown in Fig. 22.

The grid leak detector operates by the grid and cathode of the valve forming a diode and rectifying the modulated carrier by passing the positive peaks and blocking the negative peaks, as shown in Fig. 15. Since the grid of the valve is not biased by any circuit components but is originally at earth potential, each positive R.F. peak sends the grid positive and as a result current flows through the 1 megohm resistor R9. This causes a voltage drop across the resistor which makes the grid end of R9 negative. This negative potential or charge is held by the grid capacitor, C12, and so can only leak away to earth through R9—which is therefore called the grid leak. As the charge leaks away it is replenished by following positive peaks, and the values of C12 and R9 are so chosen that the charge present on the capacitor, and so on the grid of the valve, varies with the variations in potential of the modulated carrier peaks—that is, the charge on C9 rises and falls with the modulation. This causes a rising and falling bias on the grid and in consequence a varying anode current through the valve, which gives an amplified audio signal at the anode for passing on to the output stage.

The combined effect of R9 and C12 in this circuit is measured in terms of "time-constant," a term which refers to the time taken for a capacitor to lose its charge through a resistor. The values for this circuit are chosen so that the time-constant is high when compared with the rapid oscillations of the radio frequency carrier, but low when compared with much slower audio frequencies.

It will be found that signals which can be barely heard with the anode bend detector, come up with increased volume with the grid leak detector. In many areas, results may still be un-



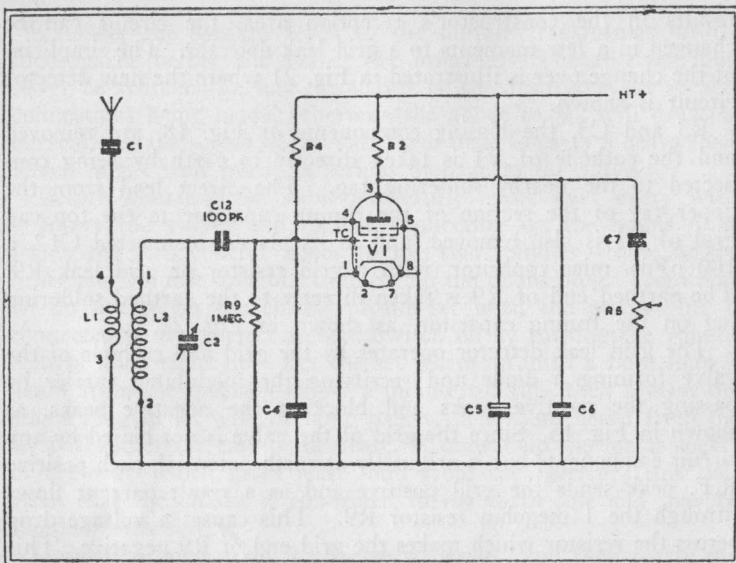

Fig. 21. The grid leak detector

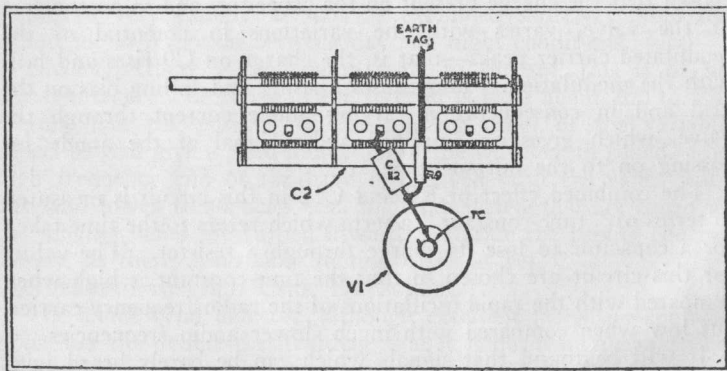

Fig. 22. Modified connections to the top cap of V1 for grid leak detection

satisfactory, however, and for a further improvement in output (and a remarkable extension of reception range) the grid-leak detector can be converted into a regenerative or reacting detector.

Extra Components for the Grid-Leak Detector, Fig. 21

C12 .. 100 pFds. 350 v.wg. Mica TCC CM20N

R9 .. 1 megohm,  $\frac{1}{2}$  watt.

CONVERTING TO A REACTING DETECTOR.

The grid-leak detector converted for reaction is shown in Fig. 23 with the rest of the receiver and power pack circuits. The main circuit change to be noted is the new arrangement of L1, now connected via a capacitor between the anode of V1 and earth; and the aerial connection through a small capacitor to the grid coil L2.

We have already seen that at the anode of a detector valve there appears a rectified version of the carrier wave, the audio frequency section of which is transferred to following stages and the high frequencies are bypassed to earth. The high frequencies then, shown in Fig. 23, will flow through C13 and L1 on their way to earth.

L1 is coupled to L2 by being wound on the same former in close proximity to the main tuning coil—it was formerly employed in coupling the aerial to the tuned circuit. Now, however, it is coupling the high frequencies from the anode of V1 back into the grid circuit of V1, that is, there is induced into the grid circuit a signal corresponding to that already fed into the grid circuit from the aerial.

If the signal is induced into the grid circuit in the correct sense it will obviously add to the signal already there, so that at the grid of the valve there will be presented for rectification and amplification, a more powerful signal than that supplied by the aerial alone. The sense of the induced signal is made correct by connecting L1 in the correct sense to the anode. Induction from anode to grid is called "feedback," for obvious reasons, and since the induced signal is made to agree with, and add to, the original signal, the effect is further described as "positive feedback," "regeneration" or "reaction." Reversing the connections of L1 would give "negative feedback" or degeneration with a resultant loss of signal strength.

In any circuit where currents are flowing, losses must occur and this holds good for the tuned circuit L2-C2 connected to the grid of V1. As more and more energy is induced into L2 from the anode circuit, however, the losses of the grid circuit are increas-

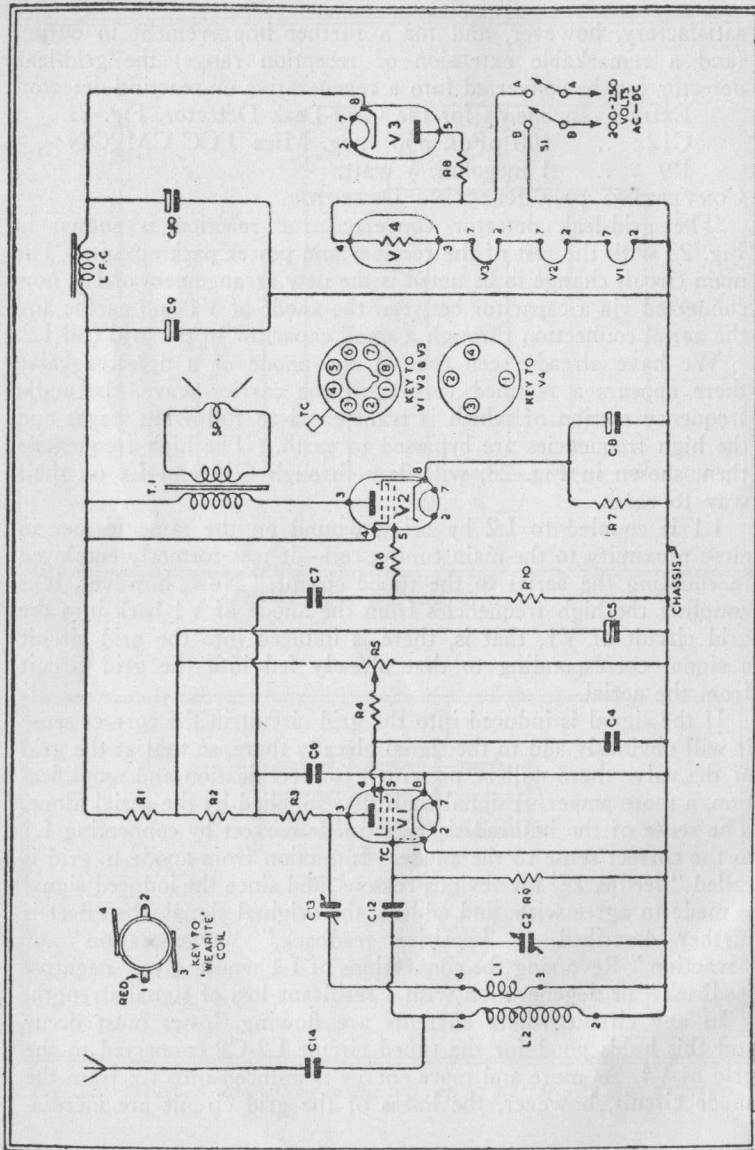

Fig. 23. A 2-valve plus rectifier with grid leak detector and reaction

ingly made good until a point is reached where more energy is fed into the grid circuit than is being lost. The valve then goes into oscillation and generates a radio carrier at a frequency dependent on the setting of C2 and the inductance of L2—the detector becomes, in fact, a midget transmitter.

If the constructor has a milliammeter this can be connected in the supply line to the valve's anode circuit, when it will be found that there is a marked drop in anode current as the valve goes into oscillation. This is because the grid is now driven strongly positive on half of each oscillatory cycle, and the grid current through the grid leak and the grid bias, are increased. This type of oscillatory circuit is therefore "self-biased."

For reception the efficiency of the circuit is at its greatest just at the point where oscillating conditions are reached, when the circuit is said to be at the "critical point." It is very desirable, therefore, that there should be some method of controlling the reaction so that the detector can be brought up to, or near, this critical point to give high amplification to weak signals. In some circuits this control is effected by making C13 a fully variable capacitor with a panel control, and increasing the capacitance of C13 causes more and more energy to be bypassed from the anode through the coupling or reaction coil. In the present circuit where V1 is an R.F. pentode, the control is obtained by varying the potential on the screening grid of V1.

R5 is taken from its position as a volume control into the grid of V2 and replaced by a resistor R10. The potentiometer is joined between the end of R1 and earth, and so has a steady potential set up across it from which the screening grid of V1 is supplied. R5 still acts as a volume control as well as a reaction control, for, as the potential on the screening grid of V1 is reduced, the valve gives less and less amplification. This controls reaction for, if the amplification of the detector is reduced, there will be less energy available at the anode to feed back.

The screening grid requires a fairly high potential for best results so that the valve is working well as an audio amplifier, and only a very low feedback capacitance is required at C13. This capacitor is accordingly a small semi-variable component, which is indicated by the T-shaped line passing through the symbol, and is known as a trimmer.

C13 is set by trial and error for best results.



It will be noted that R3 separates the audio coupling capacitor C7 from the anode. This resistor is acting as a filter in conjunction with C13 and C6, in the same way that R6 acts as a filter for the grid circuit of V2. The high frequencies are thus prevented being passed on for amplification along with the audio frequencies.

As the coupling coil L1 is being used for reaction, the aerial must now be tapped directly on to the grid coil through C14, a low capacitance being used to reduce the loading of the aerial on the tuned circuit as much as possible. It will be found, nevertheless, that the receiver tunes a little differently, and that the tuning capacitor vanes will not need to mesh so far in to receive stations. With a good aerial and favourable receiving conditions the range of the receiver will be found to have increased by hundreds of miles through the use of reaction, and several foreign stations should be heard at good strength. When tuning the set the reaction/volume control should be gently advanced until the critical point is reached, when the detector will be heard to go into oscillation, and whistles will indicate the position of signals as the tuning capacitor is rotated. R5 is then turned back just sufficiently to stop oscillation. This critical state should be reached with R5 turned well up towards the full position, and if the detector oscillates too readily, C13 must be reduced. This capacitor has two concentric cylinders, one riding over the other, and the movable cylinder must be unscrewed a little—i.e., moved outwards—to reduce the capacitance. A suitable starting point for C13 is with the cylinders meshed about half way.

Extra Components for the Reacting Detector Receiver, Fig. 23.

C13 .. 3-30 pFds. concentric trimmer, Mullard-Phillips.

C14 .. 100 pFds. 750 v.wg. Mica TCC M2U.

R10 .. 470,000  $\Omega$   $\frac{1}{2}$ w.

#### CONSTRUCTION.

Only a few minor changes in the wiring of the grid-leak detector receiver are required, and the new arrangement is shown in Fig. 24. C13 has connections made to a centre spindle and a side lug, which can be soldered directly to tag No. 4 on the coil-former, as shown. When adjustments are made to C13 the receiver should be switched off.

Never use the set with the detector actually oscillating, for this causes serious and perhaps widespread interference in neighbouring receivers. Always keep R5 below the critical point, and tune slowly,

as the tuning of the receiver will be found sharper, that is each signal is tuned in and out with a smaller rotation of the tuning knob than in either of the two circuits previously described. This is due to losses in the tuning circuit being made up, and the coil and capacitor are therefore working more efficiently.

The greater the range of a receiver becomes, so should its tuning become sharper, in order that neighbouring signals may not interfere one with another. The range can be further extended and its selectivity (i.e., sharpness of tuning) increased by amplifying the received signal in a stage before detection. Such a stage also prevents interference from a reacting detector as the oscillations do not reach the aerial. A stage placed before the detector, and used to give amplification to the small potentials set up across the first tuned circuit is known as an "R.F. Amplifier" or, more generally, an "H.F. Stage." This together with other improvements will be fully dealt with at a later stage.

