

# TANDY

Handbook of  
**Radio Receiver  
Construction**

Using  
**IC's and  
Transistors**

by **B. B. Babani**

NO. 62-9010

60p

**HANDBOOK OF**  
**RADIO RECEIVER**  
**CONSTRUCTION**  
**USING**  
**IC'S & TRANSISTORS**  
**BY**  
**B. B. BABANI**



**TANDY CORPORATION**



Although every care is taken with the preparation of this book the publishers will not be responsible for any errors that might occur

© 1974

I.S.B.N. 0 85934 017 1

First published February 1974  
Reprinted November 1974

Printed by C. Nicholls & Company Ltd, Manchester M11 4AU

## CONTENTS

|   |    |
|---|----|
| Solid State Fremodyne .....                           | 5  |
| 3 Transistor Receiver with FET Detector .....         | 19 |
| Two Simple Receivers .....                            | 31 |
| An "All Wave Two" Receiver .....                      | 34 |
| Short Wave Converter .....                            | 47 |
| RF Preamplifier for Short Wave Receivers .....        | 56 |
| Experiment with your own Integrated Circuits (IC's).. | 66 |
| EA160 Multi-waveband Receiver .....                   | 75 |

BRITISH OR  
U.S.A. TYPE

TANDY - ARCHER TYPE

BF115  
2N5485  
TAA300  
EM401  
BZY88 /C6V2  
2N4360  
BA100  
2N3568  
BC108  
OC71  
2N5459  
MPF106  
OA91  
BZY88 /C9V1  
UA703C  
AN1101

RS276-2009  
RS276-2028  
RS276-016  
RS276-1139  
RS276-621  
RS276-2028  
RS276-1102  
RS276-2009  
RS276-2009  
RS276-2004  
RS276-2028  
RS276-2028  
RS276-1102 or 1136  
RS276-622  
RS276-008  
RS276-1102

## A SOLID STATE FREMODYNE

Experimenters who have experienced the thrill of short-wave reception on simple two and three stage regenerative sets frequently inquire whether there is an equivalent set which will allow them to explore the VHF bands. The nearest approach is the superregenerative set, of which the Fremodyne is our favourite version. And of the Fremodynes, we tip that this solid state design will prove most popular.

Before embarking on the description, perhaps it would be wise to look at the VHF part of the spectrum and see what is available for the interested listener. This is summarised for the benefit of newcomers to this field.

The table shows that quite a lot of use is now being made of these frequencies. First and foremost, a dozen or so television channels are located in this part of the spectrum. While the average experimenter will generally have access to local TV stations by way of a receiver in the lounge their sound carriers are also available as a source of powerful signals for a simple sound receiver.

Elsewhere are channels allocated to two-way radiotelephones operated by government services, public utilities and private companies, some using amplitude modulated signals and some frequency modulated. While the content of such telephone conversations is of no immediate concern to the casual listener and, in fact, must be treated as confidential, their presence can serve both as guide to the performance of the receiver and as an indication of the extent to which such communications are used in day-to-day activities.

One point that should be emphasised is that, for the most part, the signals to be heard in this part of the spectrum are of a local nature, VHF signals, particularly above 50MHz, are not often heard beyond about 20 or 30 miles from their source. This is a valuable characteristic for short-range systems as it means that the same set of frequencies can be used over and over again in suitably separated centres of population.

However, it also means that there will be little to be heard by an enthusiast living in areas remote from such activities.

Before discussing the circuit, it might be interesting to examine the reasons for its choice.

Initially, we decided to make a solid state VHF receiver based on the simple and well-tried superregenerative principle. A typical circuit is shown in figure 1. A tuner was made up which was a slight elaboration

of figure 1. This arrangement worked very well, as far as reception of signals was concerned, and it covered the range from 30MHz to about 250MHz. The sensitivity was little short of amazing, considering the simplicity of the circuit.

Superregenerative receivers in the past, using valves, always presented the problem of radiation at the received frequency, which could cause serious interference, to others receiving the same signal. This often led to more elaborate designs, such as the introduction of an isolating stage, to reduce the radiation nuisance to a minimum.

We were aware of this problem but we also reasoned that transistor equivalent circuits were operated at considerably lower power levels than those of the former valve circuits. Hopefully, after having tested the receiver for its reception qualities, one of our staff took it home to try it under typical listening conditions.

It was a rather sad-faced individual who appeared on Monday morning, with said receiver under his arm. He intimated that the little monster worked very well as far as reception was concerned but it blacked out his television receiver — and possibly others in the neighbourhood.

And so our theory on reduced radiation was dashed to the ground. This naturally led to a complete re-thinking of the project and another look at the Fremodyne approach. Here, a superregenerative detector is used on a fixed frequency of 27MHz, where any radiation is not so important. Ahead of this detector is a mixer and local oscillator, which converts the incoming signal from the VHF region to 27MHz, where it is further amplified and detected. The audio from the detector is then fed to a conventional amplifier.

These requirements did not seem unreasonable in the light of current solid state techniques. The audio amplifier would be no problem and could be considered as routine. The superregenerative stage could presumably be that which we had used for the initial VHF receiver but changed to be fixed-tuned to 27MHz. It only needed the addition of a mixer and local oscillator to convert the wanted signal to 27MHz.

With an audio system already available, the next logical step was to tune the superregenerative stage to 27MHz. This was achieved by simply changing the coil and capacitor of the tuned circuit and making some circuit value changes to give optimum performance at this frequency.

The mixer was the subject which called for our closest attention. We tried a "ring" mixer first, which we have used with much success recently. Unfortunately it soon became evident that we needed very high speed switching diodes. Recovery time of the order of a very few

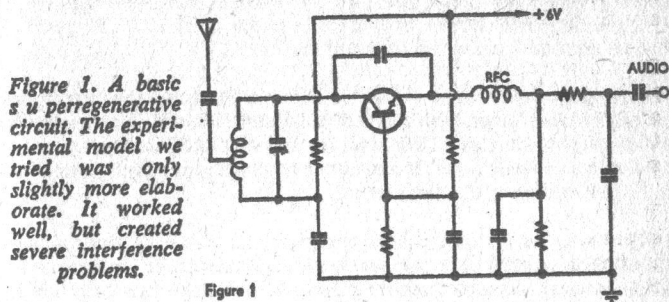

Figure 1. A basic superregenerative circuit. The experimental model we tried was only slightly more elaborate. It worked well, but created severe interference problems.

Figure 1

#### BASIC SUPERREGENERATIVE RECEIVER

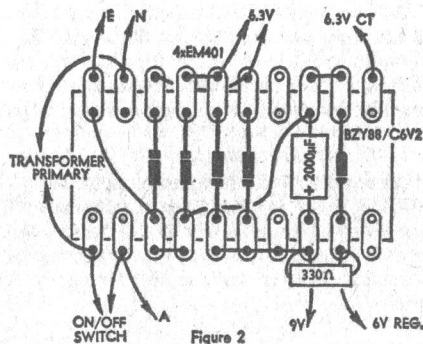

Figure 2. The main power supply board. All the power supply components are accommodated on this board. Make sure that the power flex is connected correctly.

Figure 2

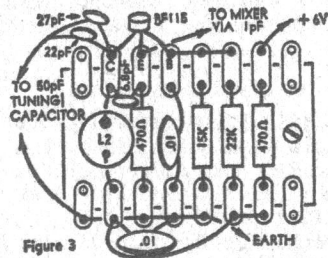

Figure 3. Wiring and component layout for the local oscillator board. A 2-pin socket is provided for the oscillator coil.

Figure 3



nanoseconds was essential if we were to handle signals up to 200MHz or so. Here, we were faced with the problem of availability and cost of high speed diodes. We tried the fastest which we could obtain, consistent with reasonable cost, and they did function but not really to our satisfaction. It appeared that we must look elsewhere for a suitable mixer.

Still clinging to the idea of a balanced mixer, we replaced the four diodes of the original ring mixer, with a pair of junction FETs, still retaining the input and output transformers. This mixer worked very well, holding its efficiency to at least 200MHz and gave a small amount of gain, compared with the insertion of the diode mixer.

Still not satisfied that this was the complete answer, on the grounds that it was rather more elaborate than we considered suitable for a relatively simple receiver, we considered the possibility of a single junction FET in a conventional mixer circuit.

A junction FET, type 2N5485, was set up and this proved to be quite satisfactory, although the gain was not as good as the balanced FET mixer using the same type of FET. As we were looking for a satisfactory mixer, consistent with low cost and simplicity, we decided that the single FET was the best choice. The only other point to be settled for the mixer was the best method of injection from the local oscillator. The most convenient method turned out to be gate injection, which is efficient and easy to put into operation.

The result of all this is the receiver portrayed in the photographs and circuit diagram. In spite of the fact that it makes no use of reflexing, as did the valve versions, it has a sensitivity which, on a side by side test, appears to be at least as good as the earlier ones. Also, we believe, the absence of reflexing will make the set a good deal less critical and much easier for the home constructor to duplicate.

The circuit is worth studying in some detail. At the aerial input terminals is a "balun" or balanced-to-unbalanced transformer. This is an optional item, about which more will be said later. Next is the aerial tuned circuit, consisting of a coil (L1) and variable tuning capacitor. To cover the tuning range three coils are necessary, and we have used the well tried plug-in principle.

The mixer is a junction FET, type 2N5485, which is rated into the VHF range. In common with this type of mixer it is biased well back, with a 4.7K resistor in its source. The drain load is a tuned circuit on 27MHz, suitably damped.

This damping resistor was needed to maintain stability, using the particular combination of components in our prototype. Its value may need to be

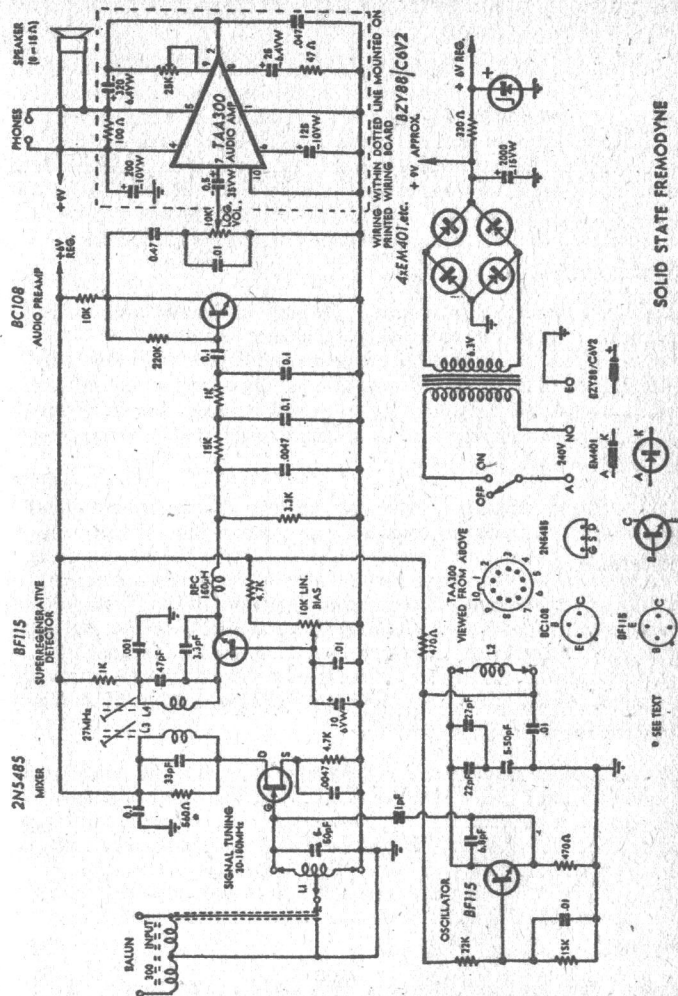

The circuit uses a FET mixer in conjunction with a local oscillator to convert the incoming signal to approximately 27MHz. It is then fed to a superregenerative detector which causes little interference when operating at this frequency.

SOLID STATE FREEMODYNE

SEE TEXT

varied with individual sets and should be determined experimentally. The simple rule is to make it as large as possible (or omit it altogether) consistent with stable operation.

The main tuning of the receiver is by means of the local variable oscillator, L2 and its associated tuning capacitor. At the lower signal frequencies the oscillator operates on the high side of the incoming signal. At the high frequencies it operates on the low side. Also, by using the plug-in coil designed for the highest frequency range, but setting it on the high side of the incoming signal, we are able to cover the middle frequency range. This means that although we have three ranges, requiring three plug-in coils for the signal frequencies (L1), we need only two plug-in coils for the oscillator (L2).

To achieve a measure of band spread, the range of the oscillator tuning capacitor is restricted by connecting capacitance in series with it. Two fixed capacitors, 22pF and 27pF are connected in parallel, giving a total of 49pF which is about right for our purpose. By using two capacitors in parallel, we are able to reduce slightly the inductance of the circuit due to connecting leads. The output of the oscillator is injected into the gate of the mixer via a 1pF capacitor.

At this stage, some readers may be comparing the frequency coverage of this receiver with previously described valve Fremodynes. An upper frequency limit of around 250MHz was achieved with the valve versions, whereas we are only claiming about 180MHz for the transistor version. Actually, the upper limit of the prototype is about 189MHz. This may vary from one unit to another. The limiting factor appears to be the minimum capacitance in the circuit, contributed largely by the tuning capacitor associated with L2. Attempts to offset this by reducing the inductance of L2 resulted in an L/C combination which would not oscillate at the higher frequencies at which we were aiming.

The output of the mixer is magnetically coupled to the following stage, by means of L3 and L4 which are tuned to 27MHz. This is the superregenerative stage. More precisely it is a squegging oscillator, designed to squegg or "quench" at about 20KHz. Comparing this with the local oscillator feeding the mixer reveals a marked similarity. Both have their collectors tuned, both have a feedback capacitor from collector to emitter, both have their bases grounded to RF, and the output is taken from the emitter circuit in both cases.

However, there are also differences. While the bias to the base of the VHF oscillator is fixed, the bias to the superregenerative oscillator is adjustable. This is important in that it enables the user to set the bias on this oscillator so that it performs its complex functions properly.

There is also a difference in the time emitter circuit of the superregenerative detector. This consists of a 3.3K resistor, shunted by a .0047uF capacitor. This time constant causes the superregeneration effect, which amounts to switching the oscillator on and off at a supersonic ("quench") rate dictated by the time constant.

To understand this better, envisage this circuit without the .0047uF capacitor. In these circumstances the circuit would not oscillate. If we now replace the .0047 capacitor it will, at the moment of connection, act as a short circuit across the 3.3K resistor. Thus the circuit commences to oscillate. At the same time the capacitor commences to charge, since there is a voltage developed across the 3.3K resistor due to the current flowing in the emitter circuit. As the capacitor charges, its ability to "short out" the 3.3K resistor becomes less until, eventually, the presence of this resistor causes the circuit to cease oscillating.

When this happens the emitter current through the 3.3K resistor drops to a very low value. There is now nothing to maintain the charge across the capacitor and it discharges into the 3.3K resistor, eventually reaching a point where it once again effectively "shorts out" the 3.3K resistor. The circuit then commences to oscillate again and the whole cycle is repeated. The rate at which this happens can be controlled by selecting the values of R (3.3K) and C (.0047uF). In this set the quench frequency is in the region of 20KHz.

This type of circuit has a very high sensitivity and, although it has little application in the high frequency range, it is still useful in the VHF range, particularly where economy is paramount.

Immediately following the detector, is a two-section low pass filter. Its function is to remove any RF component, as well as the supersonic quench of the detector.

The low level audio emerging from the filter is amplified by the audio pre-amplifier. This is a simple transistor amplifier with some negative feedback.

The output of the preamplifier is passed through a volume control and then to the main audio amplifier. This uses a Mullard/Philips TAA300 IC mounted on a small printed board with its associated components. The power output is about 1 watt into an 8 ohm speaker, which is the lowest value which can be used. A 15 ohm speaker may be used, with a reduction in power output.

The power supply is quite simple. It consists of a readily obtainable transformer, with a secondary of 6.3 volts rated at about 2 amps. This feeds a bridge rectifier for four silicon power diodes. The main filter is a 2000uF electrolytic capacitor and the voltage at this point is very near to 10 volts.





the coil. More will be said on the subject of suitable aerials later on.

The tunable oscillator coils (L2) may be wound next. We used two-pin miniature speaker plugs and sockets for the oscillator coils. The coil proper is wound with the two ends running at right angles to the coil and these are terminated by soldering them to the plug pins. The lower frequency coil consists of 7 turns of 22 gauge tinned copper wire,  $\frac{1}{4}$ in diameter and spaced to  $\frac{3}{8}$ in long. The high frequency coil consists of 2 turns of 18 gauge tinned copper wire,  $\frac{1}{4}$ in diameter and spaced to  $\frac{3}{8}$ in long.

The aerials coils (L1) are wound in a similar manner but using four-pin miniature plugs and sockets. The coil for the range 30 to 70 MHz consists of 8 turns of 18 gauge tinned copper wire,  $\frac{3}{8}$ in diameter and spaced to  $\frac{1}{2}$ in long. The leads from the ends of the coil are terminated in the two pins with the greatest spacing. The coil is tapped at 2 turns from the earth end and this tap is brought across to one of the remaining pins.

The coil which covers from 70 to 130MHz consists of 4 turns of 18 gauge tinned copper wire,  $\frac{1}{4}$ in diameter and  $\frac{3}{8}$ in long. The aerial tap is one turn from the earth end. The coil for 120 to 180MHz consists of two turns of 18 gauge tinned copper wire,  $\frac{1}{4}$ in diameter,  $\frac{5}{16}$ in long and tapped at  $\frac{1}{4}$  turn from the earth end.

Coils L3 and L4 are for the output of the mixer and the input to the superregenerative detector, respectively. Both are tuned to 27MHz with their associated capacitors. Each coil consists of 12 turns of 24 SWG enamelled wire, wound directly on to the grooves of a 7mm slug,  $\frac{1}{2}$ in long, of grade 900 Neosid material.

The power supply board is built on a piece of miniature tag board, which accommodates all the components as shown in the wiring diagram of figure 2. The completed assembly will finally be supported on screws through the two holes, one at each end. Meanwhile, a solder lug is screwed over each of these holes and connected to the nearest earth leads on the board. The board is wired into the rest of the set as shown. Points worthy of note are that the centre tap (if any) of the 6.3 volt winding should be terminated as shown. Also points marked "A" (active) and "SW" are taken to the on/off switch. Points "A", "N" and "E" terminate the three leads of the power flex.

The tunable oscillator assembly is accommodated on a piece of miniature tag board, with eight pairs of tags. This is wired according to the circuit and the wiring diagram of figure 3. It would be a good idea to wire up all the components except the transistor and the 2-pin coil socket. Then drop a  $\frac{1}{8}$ in Whitworth x  $\frac{1}{4}$ in long mounting screw through the hole immediately under where the coil socket is to be placed. Put a solder lug

on the screw and under the board and screw a nut down on it. The lug is soldered to the nearest earth point on the board. Provide another identical screw, without a lug, at the other end of the board.

Now wire the socket across the pair of lugs on the board as indicated. To make a solid joint, we suggest that you get some tinned copper wire of about 22 gauge. Thread it through the appropriate lugs on the board and socket. Then solder the joints with a sufficient amount of solder to make a firm joint. The wire will give added strength to the joints, as solder alone may not stand up to the coil changing for very long.

To further support the socket on the board, make two pillars of heavy tinned copper wire and run them through the two holes of the socket normally used for screwing down. The other ends of the pillars are run to the end lugs of the board. Solder the four points and the socket will be quite firm. The transistor is then soldered in.

A large tag board, with 15 pairs of tags, accommodates the FET mixer at one end, followed by the superregenerative detector, with its low pass filter and the audio preamplifier at the other end. This assembly should be made up carefully and according to the circuit and wiring diagram. Before starting the wiring, two  $\frac{1}{8}$ in Whitworth x  $\frac{1}{4}$ in long screws should be dropped through the third hole from the end near the mixer and the fourth hole from the other end. A nut is run down each screw, after providing a solder lug in each case. Tighten each nut, remembering that the solder lugs must be finally connected to the nearest earth point in each case.

Wire up this board in a similar manner to the oscillator unit. A few points are worthy of note and particular care. The two coils, L3 and L4, must be placed as shown in the wiring diagram. Care should also be taken not to distort the windings. The coil socket is fixed and strengthened with wire as before, but only one pillar is used. This runs from the lug on the board, second from the end on the side nearest to the edge of the chassis, to the nearest screw fixing hole on the socket.

The printed board for the audio system has only nine items to be soldered into place and the job is done. The diagram of figure 5 should be followed carefully and a few important points should be observed to ensure success. Make sure that all the electrolytic capacitors are in their correct positions and that correct polarity is observed. When fixing the IC, make sure that it is done with due respect for the correct orientation of the connections. The tag on the IC is between connection 1 and 10 and these should be soldered to the appropriate band of copper on the board. The other connections will automatically be correct.

Although this completes the wiring of the board, it is still necessary to provide a heat sink clip for the IC. We made one up from a piece of

aluminium sheet, measuring 2in x ½in. One end was wound around a 5/16in diameter drill and the resulting loop was adjusted by hand so that was a neat fit over the case of the IC. Although aluminium is excellent for this job, other metals such as brass, copper, or steel would be satisfactory.

At this point we are in a position to carry out the final assembly. The front panel is held to the chassis with the two headphone terminals, the speaker socket and the on/off switch. The dial assembly, volume control and aerial from the audio board are also run to the volume control.

From the stator and rotor plates of the aerial tuning capacitor run leads in heavy tinned copper wire to the appropriate points adjacent to the coil socket. From the rotor plates of the oscillator tuning capacitor run a similar lead to the appropriate earth point near the aerial coil socket. From the rotor plates, run a 22pF and a 27pF capacitor in parallel to the appropriate lug on the board. A 1pF ceramic capacitor is run from the emitter of the oscillator transistor to the gate of the FET. This completes the wiring.

Before switching on, plug the lowest frequency aerial coil into its socket. Set the detector bias potentiometer to about one-third of its travel from the earth end. Set the slug in L4 about halfway out — this may be adjusted more closely later. Set the rotor of the pre-set potentiometer on the audio board to about one-third of its travel from the input end of the board.

Open the volume control just a little and switch on. Make sure that there are no signs of distress. All being well, you should be greeted with a strong "hissing" or "rushing" sound. This is a sign that the superregen detector is functioning. If this sound is not forthcoming, adjust the rotor on the 10K pre-set potentiometer until this condition is established. Ignore any squeals in the process.

If you have a signal generator, set it to 27MHz, feed it into one of the aerial terminals and adjust L4 until the signal is heard. It may be necessary to make a fine adjustment to the 10K pre-set potentiometer for optimum sensitivity. At this point, you may also adjust the slug in L3 for the best signal, i.e. lowest noise. If you do not have a signal generator leave the L4 slug in the mid position and adjust the slug in L3 on a received signal later on.

If you have a multimeter, set it to a range somewhat above 10mA and insert it in series with the +9 volt lead from the power supply to the audio amplifier. With the volume control right off, switch on and adjust the 25K preset potentiometer so that a quiescent current of 8mA is drawn. Switch off and remove the multimeter.

At this stage we are ready to try the new receiver but it is necessary to pro-

vide it with a suitable aerial. This could be anything from an elaborate multi-band TV array to a simple dipole. However, with a simple set of this kind, with limited sensitivity, the aerial plays an important part in the final performance. Use the best you can.

If reception is desired around one particular band of frequencies, say, one of the mobile bands or several TV stations closely related in frequency, it would be possible to use a simple folded dipole aerial cut and made according to the instructions in figure 6. This aerial consists of a piece of 300 ohm TV ribbon, with both ends shorted and one lead cut in the centre to connect in another length of ribbon, which acts as a feeder. The length is calculated by dividing the desired frequency in MHz into 55,400. This gives the length of the dipole in inches.

Before we can tune in any signals, we must understand the method of selecting the right set of coils for any frequency range.

To cover from 30 to 70MHz use the largest of the aerial coils. The oscillator must run from about 57MHz to about 97MHz and the larger of the two oscillator coils is used. To tune from 70 to 130MHz use the middle of the three aerial coils. The oscillator must now tune from about 97MHz to 157MHz and the smaller oscillator coil is used.

With these first two ranges the oscillator frequency has been to the high side of the wanted signal, by 27MHz. To tune from 120 to 190MHz the smallest of the aerial tuning coils is used, with the same oscillator coils as for the previous example. The oscillator will now be tuned from about 93 to 163MHz, i.e., on the low side of the signal.

A little practice will be required to get the feel of tuning this receiver. Set the aerial or signal tuning capacitor about halfway meshed and turn the oscillator tuning until a station is heard. If it is an AM station you can tune to the centre of the carrier. Should it be an FM station (as with the sound on TV channels) you will need to tune slightly off to one side for "slope" detection to occur. Having tuned the signal, you can peak the aerial circuit to give the clearest signal. If necessary, readjust the oscillator tuning slightly as you go.

## PARTS LIST

- 1 Chassis 8in x 5¼in x 2in.
- 1 Front panel 9in x 6-5/8in.
- 1 Power transformer 6.3V at 1 to 2 amps.
- 1 Slow-motion dial and knob.
- 2 Knobs.
- 4 Terminals.
- 2 2-pin miniature speaker sockets.
- 1 4-pin miniature speaker socket.

- 3 2-pin miniature speaker plugs.
- 3 4-pin miniature speaker plugs.
- 1 SPST toggle switch.
- 1 Miniature tag board, 8 prs. tags.
- 1 Miniature tag board, 10 prs. tags.
- 1 Miniature tag board, 15 prs. tags.
- 1 Balun former.
- 1 Miniature tag strip, 1 tag required.
- 5 Rubber grommets.
- 1 Cable clamp.
- 2 Slugs, 7-8mm, grade 900, Neosid or similar.
- 1 RF choke, 150uH.
- 2 Transistors, BF115 or similar.
- 1 FET, 2N5485.
- 1 IC, TAA300.
- 4 Power diodes, BA100 or similar.
- 1 Zener diode, BZY88/C6V2.

#### RESISTORS (all ½ watt)

- 1 47 ohms.      2 1K.
- 1 100 ohms.    1 3.3K.
- 1 330 ohms.    2 4.7K.
- 2 470 ohms.    1 10K.
- 2 15K.          1 560 ohms.
- 1 22K.          1 220K.
- 1 10K preset potentiometer.
- 1 10K log potentiometer.
- 1 25K preset potentiometer.

#### CAPACITORS

- 1 1pF NPO ceramic.      1 10uF 6VW electrolytic.
- 1 3.3pF NPO ceramic.    1 25uF 6.4VW electrolytic.
- 1 6.8pF NPO ceramic.    1 125uF 10VW electrolytic.
- 1 22pF NPO ceramic.    1 200uF 10VW electrolytic.
- 1 27pF NPO ceramic.    1 320uF 6.4VW electrolytic.
- 1 33pF NPO ceramic.    1 2000uF 15VW electrolytic.
- 1 47pF NPO ceramic.
- 2 5-50pF miniature variable.
- 1 .001uF High-K ceramic.
- 2 .0047uF 25V ceramic.
- 1 .01uF 25V ceramic.
- 1 .01uF low voltage polyester (volume control).
- 2 .01uF high-K ceramic (oscillator).
- 1 .047uF 25V ceramic.
- 4 0.1uF 25V ceramic.
- 1 0.47uF 25V ceramic.
- 1 0.5uF 35VW electrolytic.

## THREE-TRANSISTOR RECEIVER FEATURES FET DETECTOR

Here is a circuit for those who like experimenting with small receivers. Using a FET (Field Effect Transistor) in the first stage, it invites comparison with the time-honoured valve "Reinartz" circuit. It can be built up and used as a one-transistor receiver, or equipped with an audio amplifier to operate a loudspeaker at modest volume.

The idea of using a field effect transistor as a regenerative detector is just about as old as the device itself but very few were able to give it practical expression while FETs remained as scarce, as expensive and as fragile as once they were.

Recently, mass production techniques have brought the price of FETs more in line with consumer transistors generally and they can now be considered for a variety of projects of potential interest to home-builders.

The point of particular interest about a FET is its naturally high input impedance. Ordinary transistors have a normal input impedance of only a few thousand ohms, which means that the source from which they derive their signals "sees" their input circuit as a resistive impedance of a few thousand ohms. Typically, if a transistor were connected directly to a tuned circuit, the shunting effect of its input impedance would be such as to ruin the performance of the circuit in terms of signal transfer and selectivity. To overcome this, transistors are connected, almost invariably, to a tapping well down towards the "cold" end of the tuned circuit.

A FET, on the other hand, has a high natural input impedance and, in this respect, is comparable with a valve. Just as the grid-cathode circuit of a valve can be connected right across the tuned input system, so also can the gate-source circuit of a field effect transistor. The need for a tapping is thus avoided.

In a general sense, this is a step in the right direction because a device which does not load the signal source is more convenient to use than one that does. However, that is not the end of the story.

At the present time, the FETs which are available cheaply on the market vary tremendously in their individual characteristics. Any given circuit normally has to be optimised for the particular FET sample but some will work better than others in any case. Over and above this, the gain available from FETs is likely to be less than that available from conventional transistors in the same — or a lower — price range. Thus, while the FET has certain inherent advantages and a somewhat subjective appeal as being "more like a valve", it may not end up doing a particular job either as well or as predictably as a conventional transistor in a suitable circuit arrangement.





For purely headphone listening to the stronger stations there may, in fact, be not much point in operating more than the one transistor and our circuit suggests a wiring arrangement by which only one transistor is in operation while ever the phones are plugged into their jack. Since the other transistors are inoperative, best battery economy is realised in this way.

We shall have more to say about some of these points towards the end of the article.

The power output available from the FET detector is really not enough to operate a loudspeaker and, for constructors who may want loudspeaker operation, we have incorporated a simple audio amplifier. It is a two-stage class-A system with an output of approximately 40mW at a current drain of around 12mA. This order of power is quite sufficient for "hobby" listening and is the most economical approach to obtaining a simple amplifier. The circuit details have been worked out to make the best use of the 18V supply already made necessary by the FET detector.

DC stabilisation is provided by DC feedback from the 150-ohm emitter load resistor of the 2N3568 transistor to the base of BC108. If the current through the 2N3568 had a tendency to rise due to temperature, for example, the voltage across the 150-ohm resistor increases which causes the BC108 to conduct more. This decreases the voltage across the BC108 and biases the output transistor back to a lower current. While DC stabilisation involves extra circuitry, it minimises the risk of a build-up in the operating current, which is not good either for transistors or batteries!

Because the FET detector also has an amplifying function, the addition of two audio stages produces quite high overall gain at audio frequencies. With such gain comes some risk of instability, particularly when the impedance of the supply batteries increases as they age. For this reason, the circuit specifies electrolytics of generous value for bypassing and decoupling.

A step circuit consisting of a 220 ohm resistor and a .047uF capacitor rolls off the response above the audio range to minimise the risk of high frequency instability arising from possible resonance effects in the output transformer. A high frequency roll-off can also be quite a help in the event of poor layout bringing the output and input wiring too close together.

The diode connected from emitter to base of the BC108 is necessary to prevent the transistor being driven to destruction by large negative "swings" of the input signal. This does not happen under normal conditions but, if the regeneration control is advanced too far with a coil having over-generous feedback, the FET stage may motorboat or "squegg" at low frequencies. This can result in a signal with an amplitude of around 9 volts peak-to-peak. The diode clips this to a safe level of about 1 volt peak-to-peak. The diode must be a BA100 or similar silicon type, as germanium types will upset the

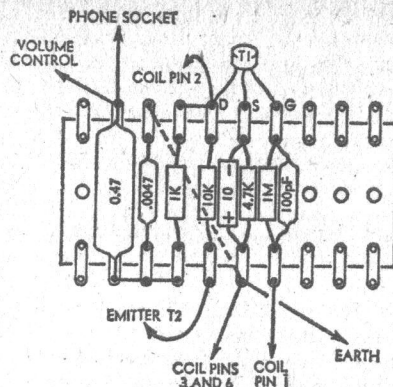

*Most of the small components mount on two tagstrips. Shown above is the tagstrip holding the detector and its various components. It mounts close to the coil.*

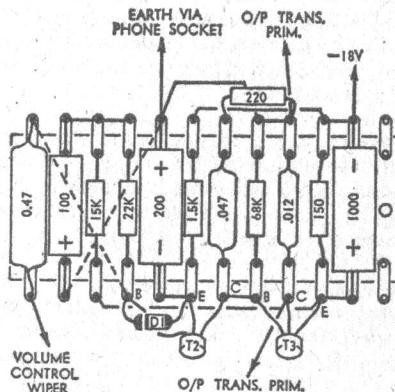

*The audio board, which is virtually a complete amplifier, other than the volume control and output transformer. The receiver can be built without the audio amplifier, if desired.*

bias conditions.

Under normal conditions the output transistor will be running just within its dissipation ratings at which it will be warm to the touch. Those readers who feel so inclined could fit a "flag" heat sink fashioned from brass shim. We must warn against allowing the FET stage to squegg for any length of time with the volume control fully advanced. While the first transistor is protected by the diode, the current through the second transistor may increase sufficiently to exceed its dissipation rating. If left in this state for too long, which is perhaps unlikely because of the unpleasant sound, the transistor may be destroyed.

The volume control can be regarded as a refinement to the circuit rather than an absolute necessity. The actual loudness of the signal will vary greatly with the setting of the reaction control and, to some degree, it can serve as a volume control. However, as the reaction is backed off to reduce volume, there is an accompanying reduction in selectivity and this can be a nuisance to anyone operating the receiver close to one or more powerful stations. In such circumstances, there is an advantage in operating the reaction control very close to the point of oscillation and relying on a separate volume control to set the loudness of the signal from the speaker.

As mentioned earlier, our prototype FET receiver was built up on a chassis that had been used for previous project. The chassis measures 8 inches long by 4 1/4 inches wide, by 1 1/4 inches deep, with a 1/2-inch lip along the rear edge. The panel size is 9 by 6 5/8 inches — a size which happens to correspond with one of our standard instrument boxes. None of these dimensions is critical, however.

In fact, the set could be assembled on a simple baseboard or dressed up as elaborately as the individual constructor may wish. Whatever the method, however, it should be provided with a metal front panel, which would be connected to earth to prevent hand capacitance from affecting the tuning of the setting of the reaction capacitor.

As already explained, the circuit is designed so that the FET RF stage may be used alone, driving high impedance (2000-ohm) headphones, or as a modest loudspeaker set. The jack which accommodates the phones is so wired that it switches off the amplifier section when the phones are plugged in.

This switching function may be performed with one of the simpler type jacks, wired as shown in the circuit. However, the frame of the jack **MUST** be insulated from the chassis. Alternatively, one may use a jack in which the two switch contacts are completely insulated from the signal contacts, in which case there is no need for additional insulation.

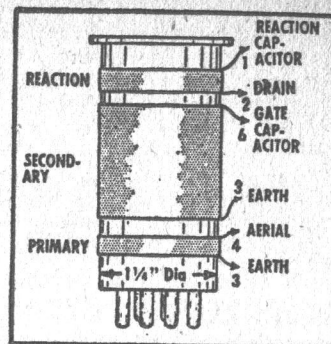
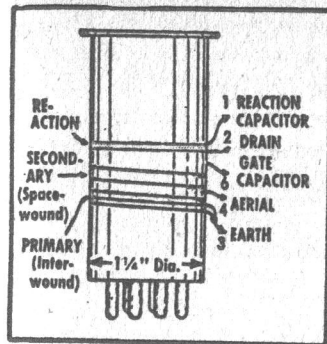

Left: The style of winding for high frequency coils, showing spaced winding and interwound primary. Right: The style of winding for the low frequency close wound coils.

| BAND              | AERIAL PRIMARY  | SECONDARY                           | REACTION  |
|-------------------|---|-------------------------------------|---|
| 570KHz to 2MHz    | 15T. of 32SWG. Spaced 3/16in from earth end of secondary. | 100T of 32SWG. Close wound.         | 40-60T. 40SWG. Spaced 1/8in from gate end of secondary. |
| 1.8MHz to 4.7MHz  | 11T. 32SWG. Spaced 1/8in from earth end of secondary.     | 38T. 25SWG. Close wound.            | 20-35T. 32SWG. Spaced 1/8in from gate end of secondary. |
| 2.9MHz to 11.2MHz | 5T. 32SWG. Spaced 1/16in from earth end of secondary.     | 13T. 25SWG. Spaced to occupy 1/2in. | 9-15T. 32SWG. Spaced 1/8in from gate end of secondary.  |
| 8.2MHz to 30MHz   | 1T. 32SWG. Interwound from earth end of secondary.        | 4T. 25SWG. Spaced to occupy 1/2in.  | 4-6T. 32SWG. Spaced 1/8in from gate end of secondary.   |



For the original receiver, the amplifier and FET stage were assembled on separate tagboards, as shown in the accompanying diagrams. Readers using these diagrams and the under-chassis photograph should have no trouble in duplicating the lay-out.

The tuning capacitor is a standard miniature (so-called when it was first introduced) type but any serviceable 400pF (approx.) broadcast tuning gang could be used with only one stator actually connected. The regeneration capacitor is a standard 100pF type connected in series with an additional 100pF to reduce its maximum effective capacitance to 50pF. Again, any available small capacitor could be used in this position giving an effective maximum capacitance of between 50 and 100pF.

For the tuning coil, we used a standard valve type bought over the counter. Coils like this have been plentiful in the past, being variously known as "Reinartz" or "reaction" or "aerial with reaction" As far as we know they have never been graced with the modern term "regenerative". Such coils are usually branded in some way to identify the connections; in this case "gate" substitutes for "grid" and "drain" for "plate", all other connections being as normal.

If the coil is of a type having the pins arranged in a plastic moulding, do not heat the connections more than is necessary to make a good soldered connection.

Home-wound coils could doubtless be used in the circuit and any coil or winding specifications that have been salvaged from a valve situation would be worth a trial.

Incidentally, if you have a close look at the photographs, you may spot where we moved the coil slightly to one side to make room for the battery.

The battery we used was an Eveready 2512 which is actually a dual nine-volt battery which can be inter-connected for nine volts, 18 volts or 18 volts with centre-tap. Care must be taken in wiring the plug for the battery as the two individual internal batteries are connected diagonally to the terminals at one end of the case; the battery used in the prototype gave no clear indication as to how plug connections should be made. To effect a series connection, the plug should bridge an adjacent pair of plus and minus connections. The remaining two connections become plus and minus 18 volts.

Readers who have other batteries on hand may connect them in series to obtain the required 18 volts, but they must be capable of supplying the necessary 12mA.

As can be seen in the photograph of the rear of the chassis we used a slow

motion planetary drive for the dial. This enables the set to be tuned with far greater ease than with the tuning knob connected directly to the gang.

The output transformer is a small 400-ohm primary type, as commonly used for small transistor sets. The secondary impedance should suit the speaker voice coil.

Ideally, the speaker should be as large as possible with a large magnet to make the best use of the power output. The small speaker in the prototype gave quite satisfactory volume for listening in the hobby room or by the bedside.

Having described the construction of the receiver it is appropriate to discuss the performance it should give. In spite of the reservations expressed earlier in comparing it to similar high-gain transistor designs, the receiver does give a very good account of itself.

In the author's home in a western Sydney suburb, all the local broadcast stations were received at good loudspeaker strength with about five feet of wire connected to the aerial terminal. To be completely satisfactory, though, the set must have an earth connection both to complement the function of the aerial and to eliminate hand capacity effects. With the addition of the earth connection the set performed very well and, with critical tuning, brought in many country stations.

Again, with the same aerial and earth connections, the set performed well with just the FET detector driving high impedance headphones. All the local stations plus a few of the nearer country stations were brought in at good headphone volume. Better performance could conceivably have been obtained by experimenting with the length of aerial. The further the set is operated from local stations, the longer will be the aerial which it is practical to use.

The frequency coverage of the prototype was from 530KHz to almost 2-MHz.

If readers have a pair of low impedance headphones (say 8 ohms) they would be best connected across the secondary of the output transformer. Again low impedance headphones of about 200 ohms could be connected to the output transistor in place of the output transformer. Both schemes will mean drawing full power from the battery.

For the benefit of those readers who have not had experience using regenerative sets the following appended notes should be helpful:

Regeneration—or reaction—is a circuit principle which has been very widely used to increase the gain and selectivity of small receivers (typically from

1 to 3 valves or transistors) which would otherwise be notably lacking in these respects. It involves coupling some of the amplified RF energy present in the detector output circuit back to the input in such a way as to add to the strength of the input signal.

In the present circuit, this is done by coupling the RF output via the 100pF regeneration capacitor to a separate winding, L3, which is magnetically coupled to the main tuned circuit, L2. Winding L3 is arranged so that its field reinforces the field produced in the tuned circuit. If the regeneration capacitor is adjusted so that the field produced in the tuned winding is above a certain minimum level, the FET stage will oscillate. This is because it doesn't need an input any more—it is supplying its own from the regeneration winding. It oscillates at the frequency at which the tuned circuit is adjusted to resonate.

In this condition it will not amplify properly. Signals picked up by the aerial will beat with the self-generated oscillations to produce a heterodyne whistle which will vary in pitch as the receiver is tuned. The voice of musical signals modulating the carrier will be heard as distorted and even unintelligible noises.

It is not a good idea to leave the set in a state of oscillation, since it can cause interference in other sets in the nearby area due to radiation from its aerial.

If the regeneration capacitor is adjusted so that the stage is just below the state of self-oscillation, the positive feedback will greatly increase the sensitivity by almost cancelling losses in the circuit. At the same time, it increases the sharpness of tuning and therefore the selectivity.

Thus, best performance is obtained with the reaction (or regeneration) adjusted so that the stage is on the verge of oscillation. This condition will require different and critical setting of the reaction control for each station. If sufficient reaction cannot be obtained with a particular combination of FET detector and coil, the series capacitor can be eliminated from the reaction circuit, making available the full 100pF of the reaction capacitor.

The addition of plug-in coil facilities to the receiver extends its frequency coverage into the short-wave region. The next logical step was to ascertain the performance above the broadcast band. This article gives details on plug-in coils for the receiver.

The data are suitable for nearly all small regenerative receivers, except those with a separate RF stage.

The coil details given presume the use of a tuning capacitor with a maximum capacitance of around 400-pF. The coils have considerable overlap at each end of their allotted band. This is to allow for variation in maximum

and minimum capacitance.

Readers who wish to do so could restrict the overlap at either end of the bands by the use of a trimmer capacitor connected in parallel with the main tuning capacitor.

All coils are wound on 1/4in diameter formers, which is a popular size for plug-in coils. The coils have the 6-pin base, with two large pins to effect polarisation. Looking at the base of the coil, the pins are numbered clockwise from one to six, the two thick pins being one and six.

For the sake of convenience, only three popular enamelled wire gauges (SWG) have been specified. Wires of slightly different thickness and/or different insulation could be used but allowance must be made for the different space occupied by the windings and the resulting effect on the inductance.

The arrangement of the windings on the former is shown in the accompanying diagrams, one applying to three of the coils while the other, with interwound primary and secondary windings applies to the coil for the highest frequency band. All coils are wound in the same direction.

Exact coil requirements for any individual set are affected by the components and the reception conditions generally, so that a little experimenting will often result in greatly improved performance.

A typical example is the reaction winding: If the receiver fails to oscillate toward the low frequency end of the band, it may be necessary to increase the number of turns on the reaction winding and/or move it closer to the secondary winding. If the reaction cannot be easily controlled then reverse the above procedure.

In the prototype, we found it advantageous to increase the amount of available regeneration by using the full range of the variable 100pF capacitor instead of only an effective 50pF as in last month's version.

Because of the different orientation of the coil connections on the socket as compared to the "can-type" coil used in last month's version we found it necessary to rearrange the components on the RF board in order to keep leads, and thus stray capacitance to a minimum. We also removed the "leaky-grid" components (LM resistor in parallel with 100pF). These were included in last month's version.

The only other information regarding the use of plug in coils is that, since they have no shielding, the battery cannot be positioned close to the coil. This same fact also means that the set can be used without an aerial on the broadcast band in strong signal areas. However, it needs an earth connection

to reduce the effects of hand capacitance, which can make tuning very difficult.

Set up and using an aerial about 40 feet long slung seven feet above ground, the set gave a good account of itself. Reception was good up to around 10MHz where the performance began to taper off. We have included the information for winding the higher frequency coil for the benefit of those who may want to experiment further.

## PARTS LIST

1 Chassis and panel to suit components used.  
1 Dial scale and perspex panel.  
1 400 ohm impedance loudspeaker transformer.  
1 Speaker, of impedance to suit transformer secondary.  
1 Planetary drive.  
1 18-volt battery, 9V + 9V.  
1 phone jack, insulated mounting type, with pair of normally open contacts (optional).  
1 Valve type reaction  
1 Plug to suit battery.  
Miscellaneous: Hook-up wire, knobs screws, nuts, expanded aluminium mesh for speaker. terminals for aerial and earth connections, on-off switch, etc.

### RESISTORS (all 1/2-watt rating)

1 x 1M, 1 x 68K, 1 x 22K, 1 x 15K, 1 x 10K, 1 x 4.7K, 1 x 1.5K,  
1 x 1K, 1 x 220 ohm, 1 x 150 ohm, 1 x 10K (log) potentiometer.

### CAPACITORS

1 100uF/6VW electrolytic.  
1 200uF/18VW electrolytic.  
1 100uF/18VW electrolytic.  
1 10uF/6VW electrolytic.  
2 0.47uF low voltage polyester.  
1 0.047uF low voltage polyester.  
1 0.0047uF low voltage polyester.  
1 0.012uF low voltage polyester.  
2 100pF low voltage polyester or ceramic.  
1 Tuning capacitor, Roblan single section, 10-415pF.  
1 100pF variable capacitor for regeneration (see text)

### SEMICONDUCTORS

1 2N4360 field effect transistor (FET).  
1 BC108, 2N3565 or similar silicon NPN  
1 2N3568 or similar silicon NPN transistor.  
1 BA100 or similar silicon diode.

## TWO SIMPLE RECEIVERS USING FETs

"Here are two RF circuits using FETs, which may be of interest to experimenters. The first circuit is an adaptation of a standard valve circuit, the main difference being the inclusion of a source ('cathode') resistor to provide bias for the FET. Bias appears to be necessary for the circuit to operate at its best, and has a further advantage of reducing battery current.

"Due to the large spread of tolerances for the type 2N4360, I cannot guarantee that all units will work satisfactorily. The one I used had an Id of 4mA at Vgs=0, and a Vgs of only IV was needed to reduce this figure to 0.4mA, thus placing this unit in the high-gain category. The bias resistor (marked with an asterisk) should be adjusted for best performance, although this may be at the expense of battery drain.

"By changing the coil it should be possible to make this circuit operate in the amateur or short-wave bands, although I have not tried this.

"Prompted by the success of this circuit, I decided to try the FETs in the VHF band. Gate-drain capacitance is the biggest problem here, but I reasoned that this would be of little consequence in a super-regenerative circuit where oscillations are meant to be developed, Stability in the RF stage is achieved by using the common gate mode.

"Bias is used in this circuit for the same reasons as in the first circuit, and the resistors marked with asterisks will again need to be adjusted for best performance. The remarks about the tolerance spread and the suitability of individual units also applies.

"The circuit was built on a piece of tag strip as shown in the accompanying layout diagram, and is housed in a metal box. Acceptable reception was obtained on channels 0 and 2 using about four feet of wire laid out in a horizontal direction and connected to terminal 'A' as an antenna. Better results can be obtained by removing link 'L' and connecting terminals A' and 'B' to a TV aerial.

"It is imperative that the unit be housed in a metal box, or else direct radiation from L4 will interfere with nearby TV sets. When housed in this fashion the units, including aerial, can be brought within a few inches of a TV set or feeder without causing any noticeable interference.

"It is important that all leads associated with the RF section be as short and rigid as possible. Philips air trimmers are used as variable capacitors and some kind of insulating shaft will be needed to operate them. One possible method is illustrated. In practice, the RF







"front end," then, but what about the audio section? To return to the Fet-Three for just a moment, this used a straightforward two-stage audio amplifier, capable of sufficient output to drive a loudspeaker. This would still make a satisfactory arrangement. However, with progress in the solid state field, microcircuit or "IC" audio amplifiers are now available. The Mullard/Philips device type TAA300 is a typical example, an audio amplifier made up around this device giving approximately 1 watt of audio, with an input sensitivity of 8mV or less, and with a modest supply of nine volts.

Armed with the new advantages of the latest FET's together with the new audio IC's we recently set ourselves the task of improving the Fet-Three. The goals which were voluntarily set included such things as the use of one FET and one IC, the idea being simplicity together with optimum use of these devices. Also, if at all possible, the receivers should cover from the broadcast band, right up to 30MHz. Battery operation would be the prime mode but operation from a mains power supply could be an alternative. To keep construction simple, plug-in coils would be used, rather than a switching system.

In considering all these points, the Reflex receiver also came to mind, as this receiver is a very high performer. Basically, it consisted of a regenerative RF amplifier, followed by a voltage-doubler detector. The audio from the detector was then fed back into the transistor, which functioned this time as an audio amplifier. (This is called "reflexing").

It would be possible to use the reflex approach in a new design, and a regenerative RF amplifier too, but using an FET, instead of a transistor. The voltage-doubling detector could also be used as this gives virtually double the audio output voltage, for the modest outlay of an extra germanium diode. However, the reflexing would pose considerable problems on the short-wave bands, and in any case can sometimes involve the beginner (and the more experienced constructor!) in obscure instability problems.

We have therefore decided to reject the reflexing idea, while adopting the idea of combining the regenerative FET amplifier with a voltage-doubling diode detector. And so we have the basis for our new design already. It is just a matter of explaining the details.

Let us have a look at the circuit and see just how it has all worked out. As mentioned before, the first stage is a regenerative RF amplifier. Each plug-in coil consists of three windings, a primary, a tuned secondary, and a feedback, "tickler" or reaction winding. The aerial is connected to the primary winding and the secondary is tuned to the wanted signal with a variable capacitor of 400pF or so maximum capacity. Feedback via the third winding is controlled by the variable reaction capacitor of about 100pF.

It may be noticed that there is a self-bias resistor of 100 ohms in the source circuit of the FET. This is a design centre value for this type of FET and should not be varied. The resistor is shown bypassed to RF as would normally be expected. It may be worthwhile to experiment here, however, by omitting the 0.1uF bypass, as the resulting degenerative effect opposes the regeneration and can sometimes make regeneration smoother. We found it better in our case to leave the bypass in circuit.

Due to the relatively high current taken by the FET and the modest supply voltage, it is necessary for correct operation to have a drain load which is high to the RF signals, yet which does not cause an excessive DC voltage drop. This is achieved by using a 2.5mH RF choke in this position.

Following the RF stage is a half-wave voltage doubling detector comprising the .0015uF and .220uF capacitors and the two germanium diodes. The detector circuit is identical with that of the half-wave voltage doubler rectifier used in power supplies, the only difference being in terms of component values. Where one has to deal with low frequencies as in a power supply, the capacitors are generally high value electrolytics, and the diodes are of the power type.

Instead of being connected to the secondary of a power transformer, the detector obtains its signal from the output of the RF amplifier. At the output end of the detector, the equivalent load is the 10K volume control.

The audio amplifier which follows is built around the TAA300 IC previously mentioned. Assembly is on a printed wiring board, and all the components shown within the dotted lines are accommodated on the board. This includes an extra component, a 560pF capacitor, which is suggested by Mullard/Philips to restrict the high frequency response and thereby avoid any possibility of high frequency instability.

The audio amplifier is designed to feed into a loudspeaker of 8 ohms. This is the minimum impedance which should be used, but the impedance may be increased if desired to 15 ohms with a small reduction in audio output.

Perhaps the last item of main interest on the circuit is the decoupling introduced in the supply line from the 9 volt source, to the RF amplifier. The decoupling consists of a 100 ohm resistor, a 100uF capacitor and a 0.1uF capacitor, the latter capacitor normally being required to ensure a low impedance RF path across the power source. However, to eliminate a small amount of instability due to interaction between the RF amplifier and the audio amplifier, we found it necessary to introduce the additional 100ohm resistor and 100uF electrolytic.



For those readers who wish to use a pair of headphones either additionally or instead of a loudspeaker, we have made provision for this. The circuit modification involved is shown separately, and the jack involved is fitted to the front panel, just below the slider battery on/off switch. It will be noted that there is a 100 ohm resistor shunted across the speaker circuit and wired directly to the jack. This is to provide for the minimum load to be presented to the audio IC output, in the event of an otherwise open circuit or more likely, for when a pair of high impedance headphones are used.

While on the subject of headphones, it might be worthwhile to note that these fall into two broad categories, high and low impedance. The type which was common years ago and more particularly those used on crystal sets, were of high impedance, usually between 2,000 and 4,000 ohms. On the other hand, low impedance types are nowadays quite common and these are generally around 8-40 ohms. Either type would be suitable for use on this receiver.

The prototype set was built up on a chassis and panel. The chassis measures 8in long by 4 $\frac{1}{4}$ in wide, by 1 $\frac{3}{4}$ in deep, with a  $\frac{1}{2}$ in lip along the rear edge. The panel size is 9in by 6.5-8in and this size corresponds with one of our standard instrument boxes. It is of course up to the builder to decide whether or not he fits the finished set into a box.

As an alternative to the chassis just described, the set may be built up breadboard style using a piece of board to mount the components which would otherwise be fixed to the chassis. However, an earthed metal front panel is a "must" in order to minimise hand capacitance effects when tuning.

The dial is mounted directly to the front panel, along with the 3in loudspeaker. Whilst on the subject of speakers, it is worth noting that although such a small speaker gives a satisfactory account of itself, the larger types are generally more efficient and one of these could be used to advantage if desired. This would probably dictate the use of a larger case unless the speaker were housed separately.

The front panel is fixed to the chassis simply by mounting the volume control, reaction capacitor, on/off switch and headphone jack. When mounting these components, it is important to remember to insulate the headphone jack from the chassis and panel.

The headphone jack is normally insulated with a pair of fibre washers. If no means are provided for stopping the bush from touching the metalwork inside the hole, then care must be taken to see that the hole is oversized and that the bush is centred so as not to allow a short circuit.

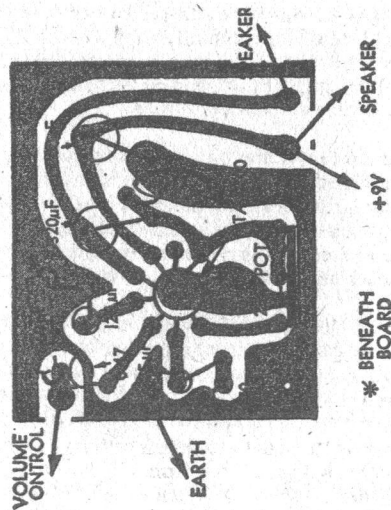
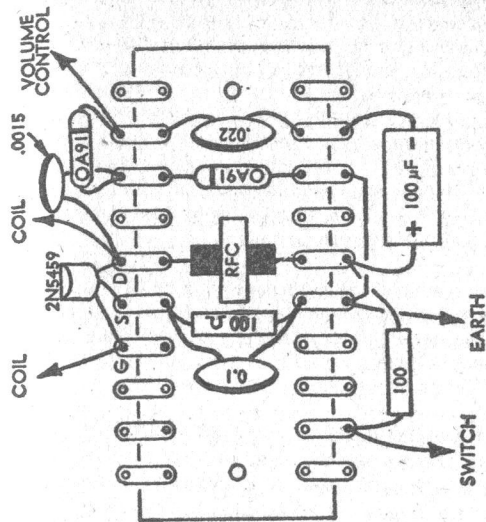

*At left is the audio board shown from the component side, with the copper shown as it would appear when held up to the light. The RF amplifier and detector tag board is at right.*

The reaction capacitor which we used is mounted by two screws threading into metal blocks in the end insulating material. This method insulates the capacitor from the panel and so a lead must be run from the rotor plates to an earth lug nearby. If you use a capacitor with the familiar rotor bush mounting, then it will be automatically returned to earth.

A further word about the reaction capacitor. We used one with a maximum capacitance of 100pF and to make adjustment somewhat easier, we connected a 100pF NPO ceramic capacitor in series with it. If a variable capacitor of 50pF is available, then it may be used and there will be no need for the 100pF series capacitor,

The main tuning capacitor has a maximum capacitance of 415pF. This is not really essential and if you have an old one in good condition which approximates the size required, electrically and physically, then it would be in order to use it. This capacitor is mounted on the top of the chassis and immediately behind the dial mechanism.

Immediately behind the tuning capacitor, is a six-pin valve socket, for the set of plug-in coils. The coils are all wound on moulded formers, 1 1/4in diameter and with a six pin base. More will be said about winding the coils later on.

We used a nine volt battery for the prototype and this is held to the chassis with an "L" shaped aluminium bracket. The aerial and earth terminals are fixed to the back skirt of the chassis. The earth terminal should make good electrical contact to the chassis, whereas the aerial terminal must be insulated with the washer provided.

The FET RF amplifier and detector are wired up on a piece of tag board, in our case, a piece with 10 pairs of tags. This is not really necessary and a shorter board may be used, provided it has enough tags for the job. Details of this board are given in the wiring diagram. It is also important to note that the board is mounted adjacent to the six pin coil socket, so that leads may be kept as short as possible.

The IC audio amplifier is built on a board, The assembled board is mounted in a convenient position underneath the chassis. The position is not vital, so long as it fits in conveniently with other components. At the same time, if you consider moving it from the indicated position, it would be wise to keep the input end as far as possible from the active detector circuitry.

The overall construction and assembly order is not really vital, but perhaps a good place to start would be with the audio amplifier board. There are only ten items to be soldered in place and the board

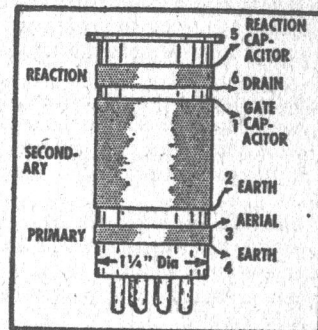
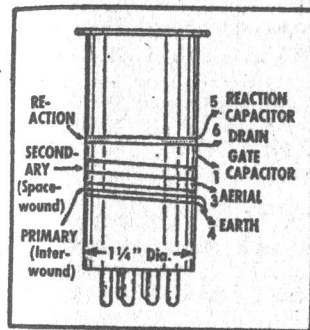

| BAND           | AERIAL PRIMARY  | SECONDARY                              | REACTION   |
|----------------|---|--|--|
| 550KHz to 2MHz | 15T. of 32SWG. Spaced 3/16in from earth end of secondary. | 100T of 32SWG. Close wound.            | 40T. 40SWG. Spaced 1/8in from gate end of secondary. |
| 2MHz to 6MHz   | 11T. 32SWG. Spaced 1/8in from earth end of secondary.     | 27T. 25SWG. Close wound.               | 13T. 32SWG. Spaced 1/8in from gate end of secondary. |
| 6MHz to 15MHz  | 5T. 32SWG. Spaced 1/16in from earth end of secondary.     | 10 1/2 T. 25SWG. Spaced to occupy 3in. | 5T. 32SWG. Spaced 1/8in from gate end of secondary.  |
| 15MHz to 30MHz | 1T. 32SWG. Interwound from earth end of secondary.        | 4 1/2 T. 25SWG. Spaced to occupy 3in.  | 3T. 32SWG. Spaced 1/8in from gate end of secondary.  |

At top left are details for the high band coils, showing interwinding for top coil. At right, details for the close wound lower band coils. Immediately above are complete coil winding details.

circuit diagram, with the extra circuitry for headphones.

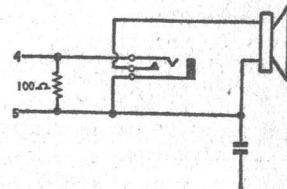

is complete. The diagram should be followed carefully and a few important points should be observed to ensure success. Make sure that all the electrolytic capacitors are in their correct positions and that the correct polarity is observed. When fixing the IC, make sure that it is done with due respect for the correct orientation of the connections. The tag on the IC is between connections 1 and 10 and these should be soldered to the appropriate band of copper on the board. The other connections will automatically be correct.

Before leaving the audio board, there is one extra component which has to be added, making the tenth, and this is the 560pF capacitor across the input. It is wired underneath the board, from pin 7 of the IC to a convenient point on the earthed part of the copper.

Although this completes the wiring of the board, it is still necessary to provide the heat sink clip for the IC. We made one up from a piece of copper sheet, about 24 gauge and measuring 2in x 1/2in. One end was wound around a 5/16th diameter drill and the resulting loop was adjusted by hand, to the correct diameter, such that it was a neat fit over the case of the IC. Although copper is excellent for this job, other metals such as brass, aluminium, or steel, would probably be satisfactory.

The next job could be to wire up the tag board which supports the RF amplifier and detector components. This is straightforward and no trouble should be experienced in following the diagram. It may well be at this point to mention that when making all the soldered joints on this and elsewhere, that care should be taken to ensure a good joint but at the same time, avoid overheating of the components.

The bracket to hold the battery in place can be fashioned from a strip of 16-gauge aluminium, about 6 1/2in long and 3/4in wide. This is formed into an "L" shape, or rather that of a "U", with one long leg and one only about 3/4in long, and can be fashioned by actually bending it around the battery to be held. The general idea can be obtained from the picture. A hole is required near the end of the long leg, with a matching hole on the back skirt of the chassis.

There are four plug-in coils and these may now be wound. The coils are wound on 1 1/4in diameter moulded formers which include a standard six-pin base.

It may be noted that there are two thick pins on these formers, the pins being numbered clockwise from one to six with the two thick pins being "one" and "six". All of the winding details are given in the table and this is backed up with two diagrams, showing just how the windings are placed on each former.

For the sake of convenience, only three popular enamelled wire gauges (SWG) have been specified. Wires of slightly different thickness and/or different insulation could be used but allowance should be made for the different space occupied by the windings and the resulting effect on the inductance.

The arrangement of the windings on the former is shown in the accompanying diagrams, one applying to three of the coils while the other, with inter-wound primary and secondary windings, applies to the coil for the highest frequency band. All coils are wound in the same direction.

Exact coil requirements for any individual set are affected by the components and the reception conditions generally, so that a little experimenting will often result in greatly improved performance.

A typical example is the reaction winding. If the receiver fails to oscillate towards the low frequency end of the band, it may be necessary to increase the number of turns on the reaction winding and/or move it closer to the secondary winding. If the reaction cannot be readily controlled then less reaction is probably in order, and the above procedure should be reversed.

We have shown pin numberings on the circuit, for the coil terminations.

These are suggested and are what we actually used, as they make for reasonably short leads which need to be run to other points. If you alter these connections, then it should be done with short leads in mind.

The dial knob spindle may be just a little too long and this point should be checked. If necessary, cut off no more than is necessary with a hacksaw. A convenient way to do this, is to hold the spindle in a vice, which steadies the assembly while the unwanted end is cut off.

Having done all this preparatory work, the reader should now be in a position to take on the final assembly. As mentioned previously, the front panel is fixed to the chassis by means of the front controls and this may therefore be the first operation, to bring the chassis, panel and front controls together. The loudspeaker and dial may be next. The tuning capacitor, which has its spindle fixed to the dial drive, is mounted next. Before doing so, make sure that you have soldered, a lead to the lug to the fixed plates. The lead should be long enough to reach the coil socket.

Mount the coil socket and the aerial and earth terminals. Then follows the RF amplifier and detector board. This is stood off from the chassis with a pair of 1/2in spacers, 3/4in diameter and tapped to 1-8in Whitworth. Before similarly mounting the audio board, it would be advisable to



solder leads to the appropriate points, which run to other parts of the receiver. This only leaves the battery to be fixed, with the clamp all ready made for it.

We are now in a position to do all the wiring between units and other individual components, such as the switch, phone jack, loudspeaker, volume control, coil socket, etc. When carrying out this part of the job, +9V supply should only be run to the audio amplifier, omitting the run to the RF amplifier.

At this point, we are just about ready to carry out the first test and adjustment. But before doing so, make a thorough check of the assembly and wiring, to make sure that there are no errors or omissions. When satisfied about this and if one is available, connect a multimeter in series with +9V supply lead to the audio amplifier. Set the multimeter to the 100mA, or a higher range and switch on. Adjust the 25K potentiometer on the audio board, for a quiescent current of 8mA. If a meter is not available, then we suggest that you set the potentiometer to mid range.

With the battery switch off, disconnect the meter from the circuit and restore the lead to the battery plug. Leave the plug disconnected from the battery. Run the lead which was omitted earlier, from the +9V supply to the RF amplifier. The set is now ready for final testing and any calibrations which may be considered necessary or desirable.

In any case, the next thing is to check that the receiver is functioning normally. This can be done by plugging in preferably the lowest frequency coil and connecting the aerial. More will be said about aerials later on. Having established that all is well, those who do not have to do any calibrating may skip over the next few paragraphs and read what then follows.

For readers who wish to calibrate their own dial scales, we will first assume that you have a signal generator or calibrated oscillator at your disposal. This is an operation which can be both easy and interesting, and we suggest that you proceed as follows:

Unscrew the four screws holding the perspex plate which covers the dial scale, remove the perspex and replace the screws. Plug in the coil for the broadcast band and connect the signal generator to the aerial and earth terminals.

Set the signal generator to say 600KHz and set the output level no higher than is necessary for an easily detected signal. Adjust the regeneration almost to the point of oscillation and find the signal on the receiver. Mark this position in pencil on the appropriate scale on the dial. Repeat this process at frequencies differing by 100KHz steps, right across the dial to 2MHz.

Plug in the 2 to 6MHz coil, and calibrate this range with points at say 500KHz intervals. Next, plug in the 6 to 15MHz coil and calibrate the appropriate range in the similar manner. Finally, with the 15 to 30MHz coil in position, calibrate at intervals of say 1MHz.

Now remove the dial scale and carefully mark each point with a lining pen and black drawing ink. Figures corresponding to the calibrations are filled in and the scales then refitted to the dial. The reproduction of our scale will serve as a guide to the finished scales.

Finally, here are some pointers which should be a useful guide to the tuning and operation of this kind of receiver.

When the reaction or "regeneration" in the RF amplifier is increased, the sensitivity is also increased and selectivity is sharpened as well. Sensitivity and selectivity reach a maximum just at the point of oscillation. For the reception of AM signals, the regeneration should normally be set just below the point of oscillation. However, when attempting to receive very weak signals which are not satisfactory under these conditions, it is often possible to copy them if the RF amplifier is made to oscillate and the signal carefully tuned so that there is no whistle.

For the reception of morse code or "CW" signals, the RF amplifier is brought to the point of oscillation and then the signal is tuned slightly to one side or the other, thus producing a whistle or beat note. The note is selected to suit the convenience of the listener. The side selected does not matter but if interference is present, it can often be avoided by selecting a particular side.

Again, for SSB reception, the RF amplifier is made to oscillate and the signal is resolved by carefully tuning for the best speech quality. Note that when the RF amplifier is made to oscillate for all the conditions just mentioned, there is no point in advancing the regeneration control beyond the position where reliable oscillation is achieved.

Another important point concerns adjustments for volume with strong AM signals. Do not back off the regeneration control if the volume is too high. This practice will certainly reduce the volume, but the selectivity will be seriously degraded as well. The correct procedure is to leave the regeneration at maximum and use the volume control. For CW and SSB reception, the question does not arise, since the volume level can be adjusted only with the volume control.

Suitable aerials could be quite a topic in itself. For best results over the full coverage of the receiver, a number of different types of aerials would be desirable. The needs will vary according to the location and the frequencies on which most interest rests.

As a guide, for broadcast band and frequencies up to about 3MHz, a random length of wire would be suitable. This may be inside or outside and of such a length as suits local conditions, proximity of wanted stations, etc. For general short wave reception, a Doublet Aerial would be very suitable. If on the other hand the amateur bands are of prime interest, then an aerial designed specially for these bands would be the logical choice.

The IC audio amplifier operates under class "B" conditions and briefly, this means that the louder the volume, the higher will be the current drawn from the battery. Therefore, only use sufficient volume for the prevailing conditions.

## PARTS LIST

- 1 Chassis and panel to suit
- 1 Dial scale and drive assembly
- 1 Speaker to suit, 8-15 ohms VC
- 1 9-volt battery
- 1 Switch, on/off
- 1 Plug to suit battery
- 1 Phone jack, insulated mounting, with normally open contacts
- 1 6-pin valve socket
- 4 6-pin coil formers, 1½in dia.
- 2 Terminals, aerial and earth
- 1 Wiring board
- 1 Tag board, length to suit
- 1 2N5459 or MPF105 junction FET
- 1 TAA300 audio microcircuit
- 2 OA91 or similar germanium diodes
- 2 Brass spacers, ½in long, ¼in dia., tapped 1/8in Whit.
- 1 2.5mH RF choke

### RESISTORS

- 1 47 ohms, ½w
- 2 100 ohms, ½w
- 1 10K (log.) potentiometer
- 1 25K preset potentiometer

### CAPACITORS

- 1 100pF NPO ceramic
- 1 100pF miniature variable (see text)
- 1 415pF single gang variable
- 1 560pF low voltage polystyrene
- 1 .0015uF low voltage polyester
- 1 .022uF low voltage ceramic
- 1 .047uF low voltage ceramic
- 2 0.1uF low voltage ceramic
- 1 0.47uF low voltage ceramic
- 1 25uF 6.4VW electrolytic
- 1 100uF 12VW electrolytic
- 1 125uF 10VW electrolytic
- 1 200uF 10VW electrolytic
- 1 320uF 6.4VW electrolytic

### MISCELLANEOUS

Hookup wire, solder, lugs, screws, nuts, expanded aluminium for speaker, heat sink for IC, knobs, etc.

## SHORTWAVE CONVERTER USES ONLY 2 TRANSISTORS

A simple converter using two transistors which will mate with almost any normal broadcast for reception of shortwave signals in the range 6-19MHz.

From time to time, we receive requests for a converter to listen to any one of a number of segments of the short wave and very short wave bands.

Clearly, any one converter cannot be made to do all the jobs which have been asked for. However, after considerable thought, we have come up with a printed wiring board which we hope to use as the basis for a wide range of converters. A kind of "universal" board has been arrived at, which may be used as a simple short wave converter covering the range 6-19MHz. Both of these may be arranged to feed into a first IF of 1.6MHz, which means that they may be fed into any reasonable broadcast band receiver.

By changing the output IF to say 3.5MHz or 5MHz, the converter may be fed into a suitable receiver capable of being set to one of these frequencies. More than likely such a receiver would be capable of receiving such modes as CW and SSB in addition to normal AM.

It may also be possible to extend the upper frequency limit to include say the 52-54MHz amateur band, to the various services around 80MHz and even to the 118-136MHz aviation and 144-140MHz amateur bands. Perhaps the last two bands may be stretching the friendship somewhat, but we hope to have a look at them in the not too distant future and see if they are a practical proposition.

So far, we have only considered tuning over a band of frequencies, with a variable oscillator in the converter and a fixed first IF. An alternative method is to use an oscillator on a fixed frequency, with the tuning done by the receiver at the first IF. This method has a number of advantages. One is that the oscillator may be crystal controlled, resulting in a high order of frequency stability.

A further simplification is possible if the converter is to be used for reception of one particular channel or station only. Here the RF tuning of the converter may be fixed and the first IF also fixed at some suitable frequency.

The frequency of the crystal controlled converter oscillator will depend upon the frequency of the wanted signal and the first IF. This could involve the use of an oscillator on frequencies between say 1MHz and 100MHz or so. Crystal oscillators are available to cover this wide range but the appropriate circuit varies somewhat over the range. This presents a problem when designing a "universal" board. In spite of this and other problems we have been able to come up with a board which provides for a variable oscillator for use over the range under consideration, as well as the variations in circuitry for crystal oscillators over the same range.

For the mixer transistor, there are at least three different type numbers which we know to be suitable. These are 2N5485, FE5485 and MPF106, all having substantially the same characteristics. The oscillator transistor is a bipolar and such types as BF115, TT1002, SE1002, or similar should be satisfactory in this position.

As mentioned before, we have attempted to make this a multi-purpose board and during assembly, you will notice that there are a number of unused holes. To avoid any possible errors due to the extra holes, we suggest that extra care be taken during assembly.

The output transformer is a broadcast aerial coil connected in reverse.

The dial assembly calls for special comment, particularly as the "Jabel" dial used on the prototype is no longer available in this form, having recently been modified. The actual mounting centres have been retained but the height has been increased by about 1/2 in. This would mean that the front panel would have to be increased in height to accommodate the new unit. This has been taken care of in the dimensions given in the parts list, and the metalwork drawing which we have prepared has also been altered to suit.

A good place to start construction would be to wind the aerial and oscillator coils. The aerial coil consists of a primary and a secondary winding, with the secondary wound first. This consists of 18 turns of 22SWG enamel wire. The start and finish of this winding may be anchored in position with a small piece of adhesive tape. This is slipped under a few turns at each end during winding. The end protruding is then folded over the top of the winding when completed. The primary winding of 2 turns of 28SWG enamel (22SWG enamel may be used) is wound over the bottom end of the secondary, after having placed a piece of tape over that part of the secondary. Again, tape is used to anchor the winding in place.

The oscillator coil is treated in much the same way as the aerial coil, bearing in mind that the frequency stability of the oscillator largely depends on this coil. It should therefore be wound firmly and finished in a workmanlike manner. The secondary is wound first and consists of 16 turns, centre tapped, of 22SWG enamel wire. The tap on the coil may be effected in a number of ways. One simple method is to scrape the enamel from about 1/8 in of the wire at the tapping point. Another short piece of the same wire is soldered on to act as a lead. To avoid a short circuit, a small piece of adhesive tape should be placed under that turn at the tap. The primary winding of 3 turns of 28SWG enamel (or 22SWG) is wound over the bottom end of the secondary.

To ensure that the windings stay firmly intact, they should now be given a coat of cellulose lacquer or other suitable material. When dry, the leads should be terminated such that when the coil is fitted to the board, the pins correspond with the relevant parts of the circuit. This is shown in the diagram.

Before the 2-gang variable capacitor can be fitted to its board, leads must be soldered to the two bottom lugs of the fixed plates. About

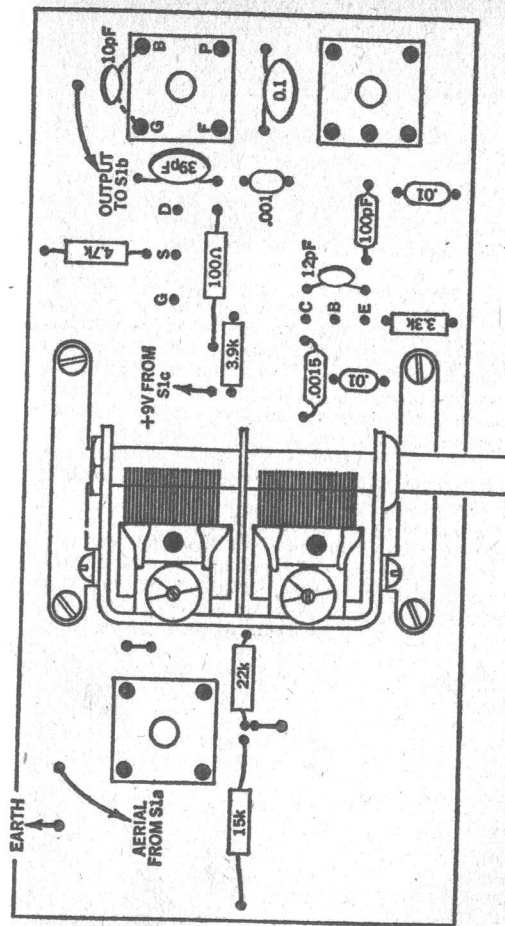

The wiring board of the converter, with the copper pattern shown as if viewed through the laminate. Using this diagram it should be a simple matter to mount all components correctly.

three inches of 20 gauge tinned copper wire should be used, with a loop wound firmly around each lug before soldering. This will prevent the soldered joint from coming adrift when the other end of the lead is finally soldered to the board. A trimmer must also be soldered to each section of the gang and as may be seen from the picture, we used the new solid dielectric type. If you have the old type "beehive" trimmers, then use them by all means. Care should be taken when soldering the former trimmers in place, making sure that a good soldered joint is made in each case, without damaging the trimmer by burning or overheating.



Possibly the most interesting part of the construction is assembly of the printed board. Although this is a straightforward task, it is advisable to approach it in a systematic manner. A good place to start is with the resistors, followed by capacitors and other small items, including the transistors. Do not forget the two links, which may be a piece of tinned copper wire or even a scrap of pigtail from a resistor. Note that the 10pF top-coupling capacitor on the output transformer is mounted underneath the board.

Due to the fact that the board was made to accommodate Neosid coil formers, some care is needed in fitting this transformer. The following fitting procedure is suggested.

Cut off the fifth pin close to the moulding so that there is no chance of it being short circuited later on. This pin is the one close to one of the can mounting lugs and is normally a tap from one of the windings. Now bend each of the remaining four pins over so that they lie across the corners of the can. Then the pins are bent in dog-leg fashion such that they will enter the four holes in the printed board. The can mounting lugs must also be bent inwards and in a similar manner so that they will also pass through the respective holes in the board. This done, the can may be mounted—but care must be taken to ensure that it is orientated correctly, according to the code on the circuit and that moulded adjacent to the pins.

Having mounted the aerial and oscillator coils in their cans and bent the lugs over, each assembly may be fitted to the printed board, again taking care that it is orientated correctly. Each coil is fixed to the board with two 6BA screws. If 6BA screws are unprocurable in your case, the alternative is to re-tap the holes to 1/16 Whitworth.

The two-gang variable capacitor is fixed to the board with four screws and in our case, we added a half inch long brass mounting spacer under the board, to two of the screws, one nearest the front panel and adjacent to the oscillator circuitry, with the other diagonally opposite. The other four spacers may be fitted at each corner of the board.

This completes assembly of the board, except for some leads which must be provided to go to external points. Leads of sufficient length are soldered to the earth point near the earth terminal on the back skirt of the chassis, the aerial point of the coil to the switch, the +9V point to the switch, the IF output braid on the coax.

The two terminals, rubber grommet, switch and dial assembly may now be fixed to the chassis-panel. As we mentioned earlier, the dial used is no longer made but if you have one on hand, then it may be used, as the mounting holes remain the same. Alternatively, the new dial may be used as suggested, or you may make your own arrangements as you see fit, possibly by still making use of the dual ratio dial drive by Jackson Bros.

The complete dial assembly is supplied with a scale, having in addition to a 0-100 logging scale, four blank ranges which may be calibrated according to actual needs.

At this stage, a careful check should be made to ensure that no errors have been made on the board assembly and elsewhere. Satisfied that all is well, the board may now be screwed to the chassis, not forgetting the flexible coupling between the gang and the dial drive. A short spindle is required between the drive and the coupling and this may be obtained from an offcut of a potentiometer spindle.

All interconnecting leads are now terminated. The switch connections should be carefully studied to ensure correct operation. We used the centre section to switch the +9V supply and the other two were used for the aerial and IF output respectively. We arranged the wiring such that when the switch toggle arm is uppermost the converter is switched off and the aerial is fed directly into the broadcast receiver. With the switch operated, the converter is switched on, with the aerial fed to it and the output of the converter is then fed to the receiver. The coax cable and a lead for the +9V supply are passed through the rubber grommet. If desired, a separate negative lead for the supply may be provided and connected to the earth copper of the board.

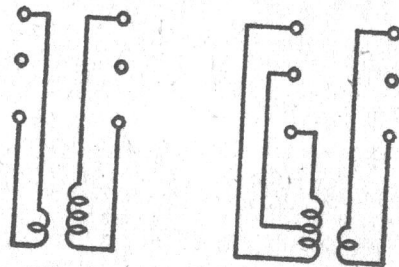

COIL CONNECTIONS VIEWED FROM ABOVE  
*Correct connection details for the coils, to match the wiring board pattern.*

Having completed the mechanical work, the converter is ready to be put into operation. Quite a number of items must be considered here. We will assume that you have a suitable broadcast receiver into which to feed the converter. A source of 9 volts DC at a couple of milliamps should also be available. Ideally, if the receiver has a suitable supply, then the converter may share it. On the other hand, a separate 9V battery may be used just as well. We will also assume at this stage that there is a suitable aerial.

Connect the converter to the receiver, a suitable source of power and an aerial. Assuming that no signal generator is available, set the receiver to 1600kHz on the dial or preferably, by tuning in station 3NE in Wangaratta before connecting the converter. Switch on the converter and tune in any station that may be audible. Adjust the slug in the output transformer for maximum response. This tunes the transformer to the IF of 1600kHz.

Now tune to a signal towards the low frequency end of the dial and one whose frequency is accurately known. Unless you have another choice, we suggest that you tune to the standard frequency station VNG on 7500kHz. We have marked this point on the dial specially for this purpose. Having tuned the station, more than likely it will not be in the right place on the dial. In this case return to the correct frequency and adjust the slug in the oscillator coil until the station is again being received.

Now tune to a station of known frequency towards the high frequency end of the dial. Once again, having tuned in the reference station, it is not likely to be in its correct position. Set the pointer to the correct point and adjust the trimmer on the oscillator section of the gang until the station is retuned. As always, when aligning a superhet receiver, this process must be repeated several times until the stations are set at the correct points at each end of the dial respectively.

Each time the oscillator coil slug or trimmer is adjusted, the slug or trimmer on the aerial coil should also be adjusted.

If you have a signal generator or you have access to one, then the process of alignment is made that much easier, but the principles are the same. With an accurately calibrated signal generator, you may also calibrate your own dial scale.

If you are located close to a broadcast station on 1600kHz, you may have trouble with breakthrough. In this case we suggest that you move the tuning of the broadcast receiver just enough to avoid the problem. The output transformer of the converter must also be reset to the new frequency, and if necessary the converter alignment touched up.

Given a broadcast receiver of reasonable sensitivity and a good aerial system, this little converter, although about as simple as it could be, can give a very good account of itself. A point not always understood, is the fact that due to technical reasons, a converter of this type does not have as much gain at the low frequencies as it does at the higher frequency end of the band. However in spite of this it works out well in practice.

Before concluding, it may be worthwhile to give a few words on the use of this converter with receivers using ferrite rod aerials, as most modern receivers will probably be in this category. A number of points arise when it is intended to use any converter with a receiver of this type.

If your receiver has a rod but is also fitted with aerial and earth terminals for an external aerial, then all you have to do is to connect the centre conductor from the converter to the aerial terminal and the braid to the earth terminal or its equivalent. However, many receivers do not have this facility and it will be necessary to gain access to the rod to add an extra coupling winding.

I suggest that you wind on say three turns of a light hookup wire over the earthy end of the coil on the rod, tape the winding and connect the

end nearest the earthy end of the main winding to some convenient earth point. The other end goes to the centre conductor of the coax from the converter.

So much for the actual connection itself. However, when using converters with ferrite rod aerials, there is a potential problem caused by the fact that the rod continues to pick up broadcast stations, regardless of the fact that the converter is connected to it. This can cause interference, particularly at night. If happily you do not have a problem here, then all is well.

If trouble is experienced, then the receiver may be retuned slightly to avoid interference. Should this prove unsatisfactory, then most receivers will tune higher than 1600kHz and we suggest that you therefore shift the first IF out of the band. All that is necessary, after finding a suitable spot, is to make sure that the output transformer is peaked to the new frequency.

### Parts You Will Need

- 1 Chassis-panel, 6½in long x 5½in high x 5in deep
- 1 Cabinet to suit
- 1 Dial assembly, Jabel 6/36N
- 1 Flexible coupling, ¼in x ¼in, Jabel
- 1 Miniature toggle switch, 3-pole, 2-position
- 2 Terminals, 1-red, 1-black
- 4 Rubber feet
- 1 Rubber grommet for coax cable
- 6 Spacers, ¼in long x ¼in diameter, tapped 1/8in in Whitworth
- 1 Printed board, 6in x 3in, 73/3C
- 1 Aerial coil, RCS type 221
- 2 Neosid coil formers, 7.6mm x 1-3/8in, with grade 900 slug can
- 1 Transistor, 2N5485, FE5485, MPF106
- 1 Transistor, BF115, or similar

### RESISTORS (¼W)

- 1 100 ohms
- 1 3.3k
- 1 3.9k
- 1 4.7k
- 1 15k
- 1 22k

### CAPACITORS

- 1 10pF NPO ceramic
- 1 12pF NPO ceramic
- 1 39pF NPO ceramic
- 2 60pF Philips trimmers
- 1 100pF 630V polystyrene
- 1 415pF Roblan 2-gang variable
- 1 .0015uF 630V polystyrene
- 1 .001 uF 100V polyester (or polystyrene)
- 2 .01uF 100V polyester
- 1 0.1uF 25V ceramic

## RF PREAMPLIFIER FOR SHORT-WAVE RECEIVERS

Here is an RF preamplifier, which covers from 1.4MHz to 30MHz, in four switched ranges. It will prove a useful addition to many receivers deficient in the input stage, or it could be the basis for the RF amplifier for any solid state communications receiver.

From time to time we are asked for details of some means of improving the sensitivity, front end selectivity, image response etc. of receivers which are lacking in one or more of these qualities.

If your receiver is reasonably modern and has an RF stage, more than likely it will be adequately, designed for good sensitivity and signal to noise ratio, as well as such other considerations as image rejection. Such being the case, you are unlikely to be interested in an outboard RF preamplifier. On the other hand, if your receiver is an old one with an old type valve in the RF stage, or if it does not have an RF stage at all, the unit we are about to describe will be a worthwhile addition.

Before going into the details of this amplifier, perhaps it would be worth while to consider some design aspects. Regardless of whether the amplifier is to be used with valve or transistor receivers, we felt it desirable to use a solid state device, rather than a valve. Admittedly, at the present state of the art, valves still seem to have the advantage when it comes to signal handling ability with freedom from cross-modulation, blocking and AGC characteristics. However with careful design and the observance of suitable precautions, the solid state counterparts can be made to perform quite well. This is particularly the case when short-wave listening is being considered.

Having decided in favour of the solid state device, the next question is just what this will be. The now familiar bipolar transistors are capable of high gain but there is a problem of impedance matching between the input tuned circuit and the transistor base, normally achieved by tapping down on the coil. Besides having to make the tap, the tuned circuit is somewhat loaded by the transistor input resistance.

On the other hand, junction type field effect transistors have somewhat less intrinsic gain, but they have a much higher input impedance, so much so that the tuned circuit coil does not need to be tapped and the resultant loading by the FET is less than for the bipolar transistor. All other things being equal, the resulting loaded Q of the tuned circuit will be higher and the gain of this part of the circuit will be greater. In short, the field effect transistor advantages cannot be over-looked. Of the types available, the 2N5459 was finally chosen as being best suited to our purpose.

Next, should we use one or two tuned circuits? Two tuned circuits will give a greater degree of selectivity and gain but the extra cost and complexity makes one wonder whether it is worthwhile. If we give enough consideration to the input tuned circuit, and retain a relatively high Q factor, then one tuned circuit should be sufficient. The output (drain) circuit will not be tuned.

In order to preserve maximum gain, we must have a suitable step-down in impedance from the drain to the aerial terminal of the receiver. This can be done quite conveniently with an emitter follower stage.

Although we have just made a case for the FET (or other solid state device) the fact remains that, under strong signal conditions, there is the possibility of cross-modulation. So that a not so strong signal may be received, in the presence of a very strong adjacent one, the FET must be protected from overload. This can be done simply by introducing a 1K potentiometer in the aerial input circuit. By judicious use of this control, the wanted signal can usually be sorted out from possible interference.

With the circuit diagram before us, let us go over it in detail and explain the various parts. We start off with a 1K potentiometer between the aerial input terminal and the primary of the aerial coil. Experience has shown that the value of 1K is about optimum for this function and gives a very smooth control. From the rotor of the potentiometer, the signal passes to the first section of the range selector switch.

In order to restrict the frequency coverage from each coil, using a 415pF tuning capacitor, a fixed capacitor is connected between the tuning capacitor and each coil, individual values being selected to suit the range involved. These capacitors are interposed between each coil and its switch contact.

The signal level across the variable capacitor is limited to the ratio of the variable and fixed capacitor, and is less than the full value as measured across the coil. It is therefore necessary to take the signal from across the coil. This involves using a third switch on the range selector switch, the rotor feeding directly to the gate of the FET.

To further restrict the frequency coverage of each band, this time at the high frequency end, a 22pF fixed capacitor is located between the gate and chassis. There are also two OA91 germanium diodes, one in each direction, from the gate to chassis. These are added as a precaution against excessive RF being fed to the gate of the FET, which could cause damage. This applies particularly where the unit is operated



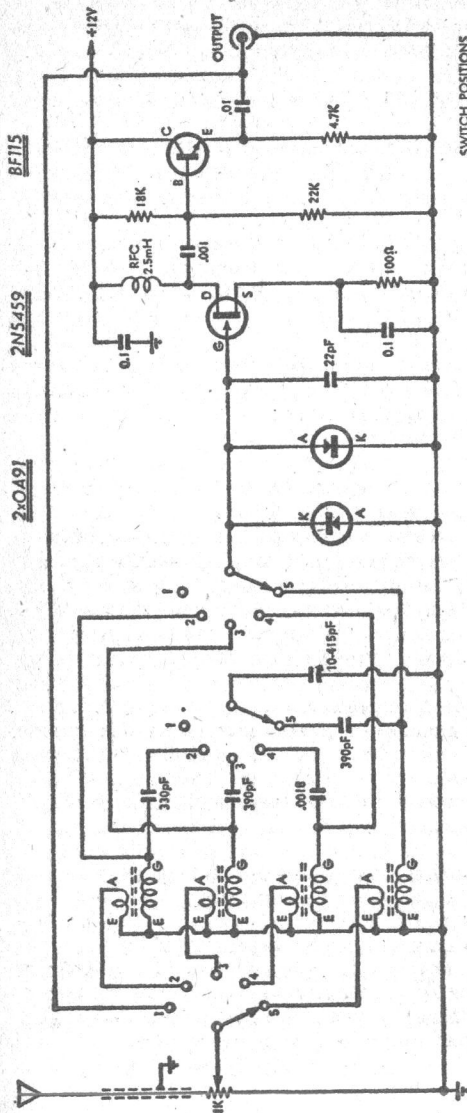

SWITCH POSITIONS

- 1 -- DIRECT TO RECEIVER
- 2 -- 1.5-3MHz
- 3 -- 3-6MHz
- 4 -- 6-15MHz
- 5 -- 15-30MHz



FET RF PREAMPLIFIER

*Use of only a single tuned circuit for each band greatly simplifies the circuit. The FET operates into a fixed load and an emitter follower.*

very close to a transmitter, as in a two-way system. Although these diodes will limit the signal level into the FET to about 300 millivolts, they do not affect normal signals in any way. If you intend to use this unit only for ordinary listening, you may omit these diodes.

The source resistor and by-pass are the equivalent of the cathode resistor and by-pass capacitor of a valve circuit. The value of 100 ohms is about optimum to accommodate the spread likely to occur with the 2N5459 FET.

As we have elected not to tune the drain circuit, but need to present as high a load to the drain as possible, a 2.5mH RF choke is used. Generally speaking, the impedance of the RF choke will rise with increasing frequency, so holding up the gain where it would otherwise tend to fall.

As this high impedance circuit will need to be connected to a low-impedance aerial terminal of a receiver, we have interposed an emitter follower stage. A BF115 transistor is used and the circuit is so straight-forward that no further comment is needed.

The circuit shows position 1 of the range selector switch wired to direct the aerial around the preamplifier to the output terminal. This is most useful if the receiver is to be used on a band not covered by the preamplifier, such as the broadcast band. While satisfactory for the broadcast band, it produces a noticeable insertion loss on the short-wave bands, due mainly to the presence of the emitter follower across the output terminal. In practice, the preamplifier is unlikely to be switched out of circuit on those bands where it can function.

While on the subject of the extra switch position, in cases where it is desired to make the preamplifier cover the broadcast band, it is only necessary to add a suitable broadcast aerial coil. Such a coil would be one designed for valve use and with a tuning capacitor of 10 to 415pF. No series capacitor is needed for this band and this will simply be omitted and a piece of wire substituted.

As mentioned earlier, the short-wave coils need to be high Q types. To achieve this, we looked at a number of alternatives. A well-designed helix, on a low-loss former, can result in quite a high Q. However, this type is generally some what larger than we had in mind for this application and it has another disadvantage which we will mention later. A promising alternative is to use a ferrite core of some type. Pot cores are excellent, though rather expensive. They also provide for limited adjustment of the inductance, but this is not necessary here.

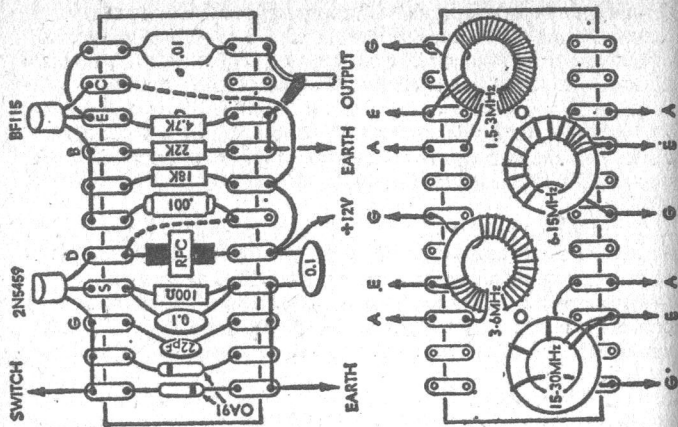

*These two panels are shown correctly orientated,*

*Below, The circuit of a suggested power supply which uses a 6.3 volt heater supply with one side grounded.*

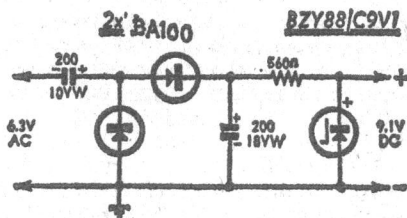

Ferrite toroids appeared more attractive. After some investigation, we found that unloaded Q values ranged from about 120 at the lowest point, to about 360 at the other end of the scale. These were obtained with Q2 toroids, which are only about  $\frac{3}{4}$ in diameter. The price is somewhat less than that for a pot core.

Although there is no real provision for varying the inductance of a coil wound on one of these toroidal formers, it is possible to make small variations under conditions where the full length of the circle is not used for the winding. If the inductance needs to be increased, then the turns should be pushed closer together. On the other hand, the inductance can be reduced by spreading the turns. We mention this as a matter of interest, since there should not be any need to make adjustments in this case, as no ganged circuits are involved.

Another advantage which is to be gained from the use of a magnetically enclosed former, such as the toroid, is the fact that practically all the magnetic field is enclosed, with very little stray. This means that the coils for the various ranges can be grouped together with little mutual coupling to cause "suckout." In the helical coils first mentioned, this problem necessitates an extra section on the switch, to short out the coils not in use.

In short, by using coils wound on toroids, we have been able to achieve a high Q at small cost and with a minimum of space. This leads to an efficient and compact assembly.

The coil winding details are given in the table. The number of turns on each winding and the disposition of the winding should be closely adhered to. However, the gauge of wire specified is simply a guide. If you do not have the exact gauge specified, then something close to it should suffice. At the same time, particularly for the higher frequency coils, the gauge of wire should be as heavy as practicable. This will reduce the resistance of the coil and so give a higher Q.

With the exception of the 1K aerial attenuator potentiometer and the tuning capacitor, all components are integrated into one assembly. Most of the components are mounted on a strip of tag board, with 11 pairs of tags. The four toroidal coils are mounted on another and similar size tag board. Both of these are shown in the respective sketches.

A logical place to start is winding the four toroidal coil units. This task is straightforward but an odd comment or two may make the job a little easier. The number of turns quoted in the coil table may be considered as the number of times the wire passes through the hole of the toroid. It is a good idea to make an estimate of the quantity of wire required for the secondary winding and then locate the centre of the length. Pass one end through the toroid and bring the wire to the centre point, thus leaving equal amounts to be wound with half the number of turns each way. This means that there is less wire to thread through each time. Care should also be taken not to scrape the enamel from the wire against the edges of the toroid.

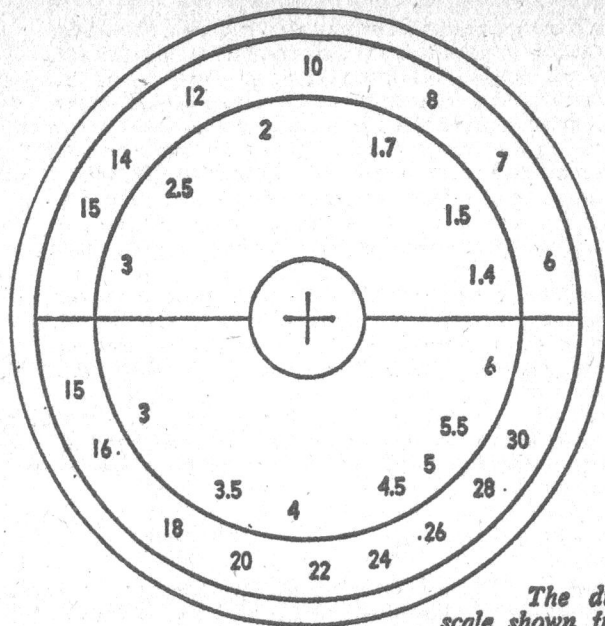

*The dial scale shown full size.*

At one end of the secondary winding, which will become the earth end, the primary is wound on. The common earth ends of the two windings should be bared, tinned and soldered together.

With the four coils wound, they are mounted on the tag board in the relative positions as shown in the diagram. The respective ends of the windings are terminated at convenient adjacent tags on the board. In the case of the lower frequency coils, which are wound with relatively fine wire, this is not enough to fix the coil securely to the board. This is best done by simply trying the toroid to the board with a piece of nylon cord. While not so necessary with the coils wound with heavy wire, it is a good idea and ensures that they do not shift about.

The main component board is next and is wired up according to the diagram. The usual care should be taken not to overheat any of the components, in particular the transistors and diodes. Make sure that all the interconnecting wires are complete, before any attempt is made to take the assembly of this board any further. The four capacitors in series with the tuning capacitor are not wired in at this stage.

The two above sub-assemblies are mounted on the end of the range selector switch and separated from each other and the switch with  $\frac{1}{2}$ in long spacers. The first step in assembly involves fitting the first pair of spacers to the rear ends of the two switch retaining screws. Generally, there is about  $\frac{1}{16}$ in of thread protruding beyond the nuts. The screws used in MSP switches are 5BA and the threaded spacers which are readily available are  $\frac{1}{8}$ in Whitworth. These dissimilar threads do not mate very well but, due to the short length of  $t$  thread, it is possible to screw the spacers on, provided due care is taken. If you can substitute Whitworth screws, so much the better.

Having mounted the spacers, check the centre-to-centre dimension between the spacers with that of the third hole from each end of the two boards. More than likely you will find that the two holes are too close together. A little filing with a slim taper file will put this right.

The board with the coils is mounted against the spacers at the end of the switch, with the coils away from the switch. The second board is spaced away from the coil board with the second pair of  $\frac{1}{2}$ in spacers.

Two roundhead screws,  $\frac{1}{8}$ in x  $\frac{3}{4}$ in are used to secure the two boards to the spacers on the switch.

The assembly is now ready for the outstanding wiring and components. The various sections of the switch are used as follows. Only one section is used on the wafer nearest the clicker plate, and is employed to switch the aerial into the primaries of the coils. The corresponding section on the other wafer switches the tuning capacitor to the relevant series capacitors. The third section selects the top of the secondary of each coil.

The wiring involves the interconnections between the various contacts on the switch and coils, together with the series capacitors. One connection not mentioned is the one from pin 1 of the aerial section to the output point at the end of the  $.01\mu\text{F}$  capacitor. This is optional.

Now we have three items, the coil-switch assembly, the potentiometer for the aerial attenuation and the tuning capacitor. If you have a box which you have to drill yourself, there are a couple of points worth watching. The hole for the coil-switch assembly should be carefully placed so that the assembly will not foul any parts of the case when it is slid into position. Having located this hole, the position for the potentiometer is then established.

The placement of the tuning capacitor needs care, so that it does not foul the coil-switch assembly. At the same time it should be as close as possible. This will keep vital leads to a minimum length. There are



three untapped holes on the front of the tuning capacitor. These are tapped and used to mount the capacitor to the panel, using countersunk head screws. Spacers must be used to keep the spindle bearing from fouling the panel. We found that four flat washers on each screw were sufficient to give the proper spacing.

With these items mounted, the interconnections can be made. It is wise to run an earth wire between the tuning capacitor frame and coil wiring, as well as the earthed lug and metal case of the aerial attenuator potentiometer. Input and output leads, which can be conveniently located at the back of the case, complete the wiring. Any convenient terminals may be used but we are inclined to prefer coaxial sockets. However, this is up to the individual.

A dial scale is needed for the front panel.

This completes the unit proper, assuming the availability of a 12V DC source to power it. This can be a battery or a simple power supply. Details operated from the 6.3V line of the main receiver, will be described later in the article.

The unit may now be tested. Connect the aerial to the RF preamplifier and connect the output of the RF preamplifier to the receiver, preferably via a short length of coaxial cable. Select the appropriate range to suit, the frequency to be tuned on the receiver. Tune the wanted station on the receiver and then peak the signal by tuning the preamplifier. As a preliminary check, this procedure should be carried out across the full coverage of the system. More than likely, signals will not be available over such a wide range at any given time. If a signal generator is available, it could be used to advantage.

Assuming that all is well we can calibrate the dial scale. The extent and accuracy with which this is done, will depend on the ideas and needs of the individual. At least, the salient points towards each end and in the middle of the scale should be marked in.

For more extensive calibration a signal generator would be most useful. If this is not available the next best thing is to use stations of known frequency. Tune the receiver to the generator or other signal first, then peak this signal carefully with the RF preamplifier. This position should then be marked on the dial scale.

The RF preamplifier is now complete and the method of using it should be clear. At the same time, a little experience will soon show the best way to use this device. In some cases, it will be possible to tune the RF preamplifier to the "image" signal, rather than the wanted one. This must be carefully guarded against, where this condition exists.

Such a condition can occur, in single conversion receivers using an intermediate frequency of 455KHz (or lower), and at signal frequencies from about 7MHz, getting progressively worse as the frequency is increased. In the case of a 455KHz 1F, with the local oscillator tuned to the high side of the wanted signal, another signal at twice the 1F, or 910KHz higher, will also get through the system and cause interference. However, with the RF preamplifier, extra RF selectivity is achieved and the image frequency will be either eliminated, or reduced in severity.

We touched briefly on the subject of power supplies earlier and here is a suggested alternative to the use of batteries. When the preamplifier is being used with a receiver having a 6.3 volt heater supply, this may be used as the source for a half wave voltage doubler supply. The circuit is shown.

## PARTS LIST

- 1 Metal case, 5in, with sloping panel.
- 1 Variable capacitor, 10-415pF, single section.
- 1 Potentiometer, 1K linear.
- 2 Coaxial sockets.
- 1 Switch, 2 wafers, 2-pole 5-position.
- 2 Tag boards, 11 pairs of tags.
- 4 Ferrite toroidal formers.
- 1 Field effect transistor, Motorola type 2N5459.
- 1 Transistor, type BF115.
- 2 Diodes, type OA91.
- 1 RF choke, 2.5mH.
- 2 Spacers, 1/2in long, 1/4in diam. brass, tapped 1/8in Whit.
- 2 Spacers, 1/2in long, 1/4in diam. brass, 1/8in clearance
- 1 Dial scale.
- 1 Knob dial;
- 2 Knobs.
- 1 22pF NPO ceramic.
- 1 330pF Styroseal.
- 2 390pF Styroseal.
- 1 .001uF plastic.
- 1 .0018uF plastic.
- 1 .01uF low voltage plastic.
- 2 0.1uF low voltage ceramic or plastic.
- 1 100 ohms 1/2W.
- 1 4.7K 1/2W.
- 1 18K 1/2W.
- 1 22K 1/2W.
- Hook-up wire, solder, screws, nuts, coaxial cable, etc.

## COIL DETAILS

1.5MHz-3 MHz Secondary, 50 turns 26 SWG enamel, wound to occupy about 90 per cent of former. Primary, 5 turns, interwound at earth end of secondary.

3MHz-6MHz Secondary 24 turns 24 SWG enamel, wound to occupy about 60 per cent of former. Primary, 3 turns, interwound at earth end of secondary.

6MHz-15MHz Secondary, 9 turns 18 SWG enamel, wound to occupy about 50 per cent of former. Primary, 2 turns 26 SWG enamel, interwound at earth end of secondary.

15MHz-30MHz Secondary, 4 turns 48 SWG enamel wound to occupy about 33 per cent of former. Primary, 1 turn 26 SWG enamel, interwound at earth end of secondary.

## EXPERIMENTS WITH YOUR OWN IC.

Still a little in awe of integrated circuits? Here is an ideal opportunity for you to gain valuable practical experience, by actually trying out a modern linear IC in some simple and easy-to-build circuits.

The IC which we have chosen as the basis for this article is the Fairchild uA703, a silicon monolithic device which although designed especially for use as an RF amplifier and limiter, can also be used for a variety of other purposes. The word "monolithic" simply means that all of the circuitry in the device is fabricated as part of a single tiny chip of silicon.

You can perhaps appreciate that this involves by looking at figure 1, which shows the uA703's internal circuit. The five transistors and two resistors all consist of combinations of microscopic P-type and N-type regions within the same tiny chip of silicon, measuring only a tenth of an inch or so square. The connections between these regions of the chip are formed by a tiny pattern of aluminium film deposited on the surface of the chip. Finally the chip is mounted in a metal can similar to a normal transistor, to produce the final IC.

Basically, the amplifier circuit configuration used in the uA703 is that of a current-limiting long-tailed pair. Tr5 is essentially a constant current source which provides the 'tail' current to the amplifier transistors Tr3

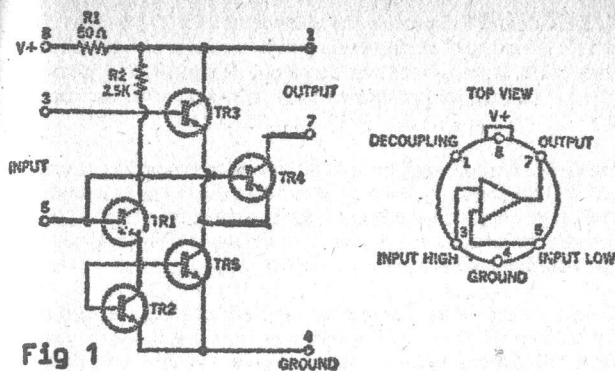

Fig 1

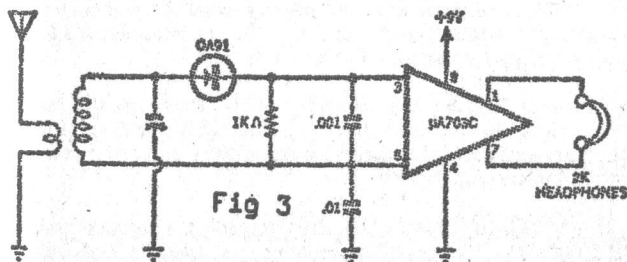

Fig 3

Figure 1, shows the schematic of the uA703 and the pin connections while figure 3, shows the method of connection to use it as a simple "crystal set" amplifier. Note that the type number on the IC will not simply be uA703 but the numerals 703 will be contained in a longer part number.

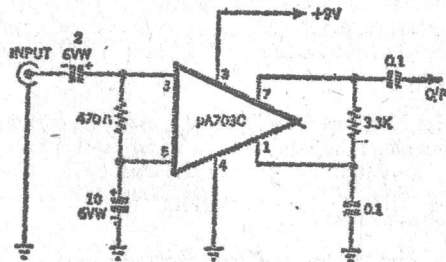

Figure 2. An AF amplifier stage.

and Tr4, R1, Tr1 and Tr2 provide the bias voltages for Tr5 and also for Tr3 and Tr4. No external biasing components are necessary. R1 is for decoupling of the supply. Note that transistors Tr1 and Tr2 are shorted from collector to base, so that they actually function as forward-biased diodes.

Under small signal conditions, the uA703 can be considered as an emitter-follower (Tr3) driving a grounded base amplifier (Tr4). Input impedance is low and output impedance is high which is ideal as far as high-Q output tuned circuits are concerned. Normally the input signal is applied from a transformer winding to pins 3 and 5.

Under large signal conditions, where the input signal is greater than about 300mV peak-to-peak, the circuit operates by switching the "tail" current into Tr3 or Tr4, depending on which has the more positive base potential. This means that the collector currents of Tr3 and Tr4 are square waves which are 180° out of phase with each other. A parallel-tuned circuit across the output terminals (pins 1 and 7) rejects the harmonics of the square wave and produces a sine wave at the output.

As can be imagined, under large signal conditions, the circuit thus has excellent limiting characteristics, making it ideal for use in IF amplifiers for FM sound systems. Under small signal conditions, the device acts like a normal linear amplifier.

While the uA703 is intended for use mainly at radio frequencies up to 100MHz, there is no reason why it cannot be used at audio frequencies, although the special biasing arrangements do make things a little tricky. Figure 2 shows how the uA703 can be used as an audio amplifier, for small signals.

Instead of coupling the signal into the input with a transformer winding, a 470 ohm resistor is connected between pins 3 and 5. Pin 5 is grounded with respect to AC signals by the 10uF capacitor and the input signal is capacitively coupled into pin 3. A similar approach is used at the output with the signal being developed across a 3.3K resistor and capacitively coupled to the output.

The resistor values shown are a compromise. Lower values at the input result in too low an input impedance while higher values increase the current drain. At the output the resistor value must be low enough to ensure correct operation of Tr4 but not low enough to cause undue loading and resultant distortion.

The voltage gain of this circuit is typically about 30, and while the low input impedance is a little restrictive, there are a number of applications to which such a circuit can be put. One suggestion is as a low impedance microphone preamplifier: the reader will no doubt think of many others.

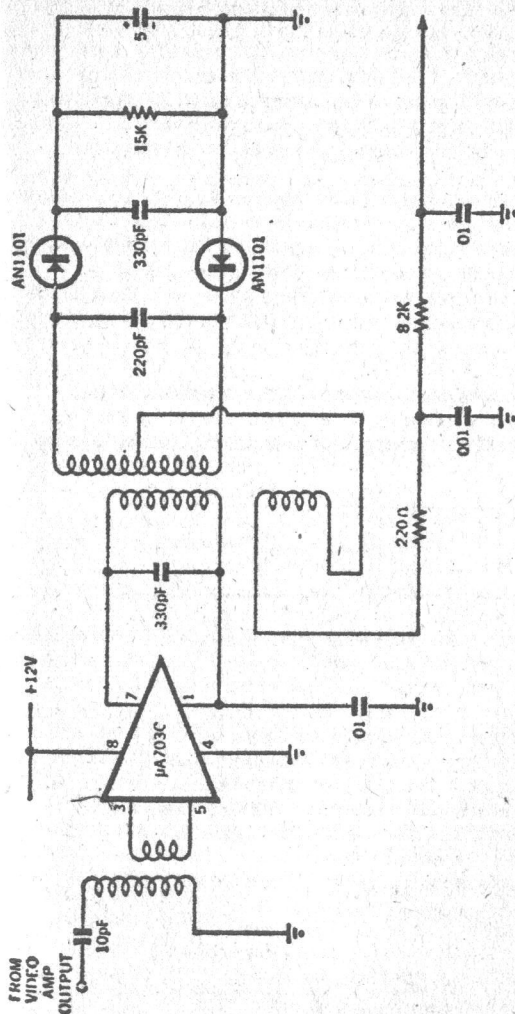

Figure 4. This circuit shows the primary use of the uA703, as a limiting amplifier combined with a ratio detector, in FM sound systems.



Maximum output voltage is 1V RMS. Attempts to obtain more output voltage will merely drive the circuit into the switching mode described earlier.

Figure 3 shows basically the same configuration used as an audio stage in a so-called "crystal" set using a germanium diode. The .001uF capacitor across the 1K input resistor shunts detected RF signals to ground via the 10uF capacitor. The amplifier load is provided by a pair of 2K dynamic headphones. Lower values should not be used.

It is probably true that equal or better performance could be obtained from a single common-emitter transistor in the audio stage. However the circuits presented here are mainly an exercise in ingenuity — how many circuit functions can be performed by what is basically a specialised RF device? Any reader who buys the device will no doubt want to experiment with it in as many applications as possible, just for interest's sake.

Figure 4 shows the major use of the uA703, as the manufacturer originally intended: as a limiting IF amplifier followed by a radio detector. As such, it will perhaps be of only passing interest to most

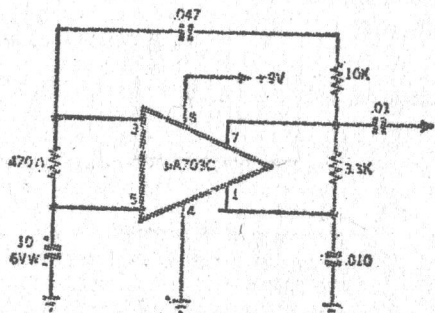

Figure 5, above, shows the uA703 in an AF oscillator circuit which has square wave output at 1KHz.

readers since their only access to FM sound is via television. Because of this, we have not tried the uA703 in such a circuit and cannot supply coil details.

Another "different" use for the uA703 is shown in figure 5. This may look very similar to figures 2 and 3, but in fact it works quite differently. Here, the circuit operates as an oscillator in the switching mode, rather like a multivibrator. Pin 7 is coupled back to pin 3 via a 10K resistor and .047uF capacitor. This RC network is alternatively charged in one direction and then the other as Tr4 and Tr3 switch on an off. The output wave form at pin 7 is a square wave at a rate of 1KHz.

Current drain of this square wave oscillator circuit is 0.5mA at a voltage of 9V. As such, the unit makes a handy signal injector. The repetition rate or frequency can be changed merely by varying the size of the capacitor between pin 7 and 3. Increasing it decreases the frequency, and vice versa.

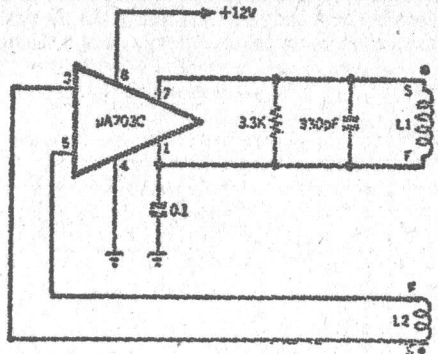

Figure 6 shows that the uA703 used in a simple LC oscillator at 3MHz.

L1 turns 32 SWG on neosid SMS type 'A' assembly with grade 900 slug cup and ring. L2 6 turns 32 SWG.

The uF703 also functions very well as an RF oscillator. Figure 6 shows the circuit for a remarkably simple LC oscillator requiring only four components in addition to the uA703.

Inductor L1 and the 330pF capacitor form the tank circuit. L2 is coupled very tightly to L1 so that sufficient of the output signal is fed back to the input (i.e., positive feedback) to ensure switching action of Tr3 and Tr4 as described earlier. As with limiting amplifier operation the current waveform applied to the parallel-tuned tank circuit is a square wave. The resonant circuit provides a sinusoidal voltage waveform at the output whose amplitude is greater than the value for the supply voltage.

With a 12V supply the sinusoidal waveform has a value of 15 volts peak-to-peak. The output can be coupled via a further winding on the L1/L2 transformer, or capacitively coupled from pin 7. The tank circuit shown has been chosen for an oscillator frequency of 3MHz.

The tuned transformer is wound on a miniature Neosid coil former assembly. This uses a ferrite cup and ring assembly to couple the windings together, along with a grade 900 slug.

Handwinding these miniature coil assemblies is tricky, to say the least. Use 30SWG or thinner, enamelled or cotton-covered copper wire. First, glue the former to the bakelite base. Then slip the ring assembly on to the former. The primary, L1 can then be wound and terminated (28 turns). It must be neatly layerwound (this is the tricky bit) so that the ferrite cup assembly fits neatly over the ring. After the primary is finished, the secondary is wound directly over it and the ferrite cup

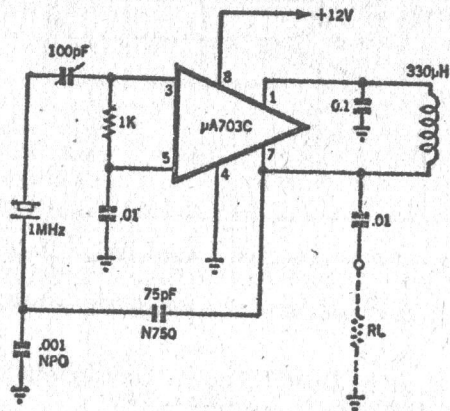

Figure 7 shows the uA703 in a crystal oscillator circuit at 1MHz. The tank circuit may be modified for other frequencies.

pushed over the whole winding and ferrite ring. It can be held in place with a spot of glue.

The starts and finishes of both windings should be marked on the coil assembly base. If the windings are not correctly phased the oscillator will not function.

The uA703 also works well as a crystal controlled oscillator as shown in figure 7. This has been tried with a variety of crystals and found to be quite reliable. The load capacitively coupled to pin 7 should be less than 2.7K for correct switching operation of Tr4. The output voltage with this load is 7V peak-to-peak.

The final use presented for the uA703 is as an RF amplifier. The basic circuit is shown in figure 8. The input is tuned and the output is taken from across a fixed RF choke of 2.5mH. This ranges up to 30MHz. While the uA703 will function up to 100MHz, the performance is reduced

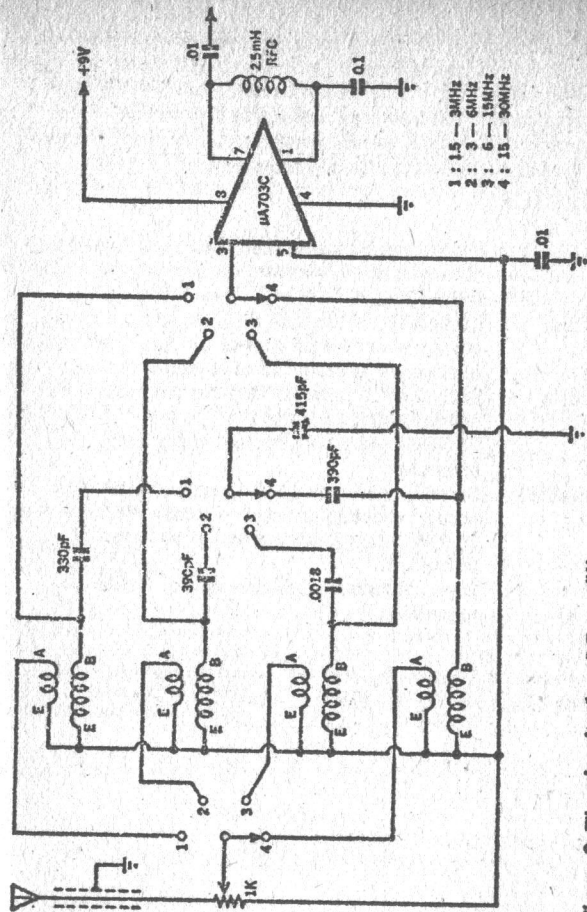

Figure 8. The circuit of an RF amplifier covering the range from 1.5 to 30MHz. The coil details are shown immediately above.

above 30MHz. The coils are wound on toroids which has the effect of minimising isolation problems. The toroids can simply be mounted on tagboard, with wires running off to the double-pole switch.

Finally, a word or two about construction techniques. Perhaps the easiest way of making connections to the IC is to mount it on a short section of miniature tagboard. All wiring, especially earth returns, should be kept as short as possible. It may be necessary, in some cases, to use a "groundplane" technique, with all earth connections made to a metal chassis.

Well there you have it, A number of interesting and easily built-up circuits which will let you experiment with the uA703 device and thereby gain valuable practical experience with modern linear IC's. No doubt a few more applications will have suggested themselves to you as you have been reading this article, so take your confidence in both hands and try them out too. There is little to lose, and plenty to gain!

## COIL DETAILS

- 1.5MHz-3.0MHz** Secondary, 50 turns 26 SWG enamel, wound to occupy about 90 per cent of former. Primary, 5 turns, interwound at earth end of secondary.
- 3MHz-6MHz** Secondary, 24 turns 24 SWG enamel, wound to occupy about 60 per cent of former. Primary, 3 turns, interwound at earth end of secondary.
- 6MHz-15MHz** Secondary, 9 turns 18 SWG enamel, wound to occupy about 50 per cent of former. Primary, 2 turns 26 SWG enamel, interwound at earth end of secondary.
- 15MHz-30MHz** Secondary, 4 turns 18 SWG enamel, wound to occupy about 33 per cent of former. Primary, 1 turn 26 SWG enamel, interwound at earth end of secondary.  
Each coil uses a toroidal former of ferrite Q2 material.

## THE EA160 RECEIVER

THIS NEW, NOT TOO COMPLICATED DESIGN PROVIDES FOR AM, SSB, CW RECEPTION

This receiver features a ceramic BFO, amplified AGC with variable time-constants, S-meter, fine tuning and an RF stage. In all, we see this unit as appealing to the more serious short-wave listener, with an interest in SSB reception.

The front end of the Communications Receiver uses a self-excited oscillator switched to the various frequencies required. Inevitably, this must degrade the overall frequency stability but past experience suggested that the degradation would be well within tolerable limits and, happily, this proved to be the case.

Contrary to the usual practices, the higher frequency bands are covered with the oscillator set on the low side of the incoming signal. Thus, and by way of example, for the highest or 20 to 24MHz range, the first oscillator is at only 16MHz, instead of about 25MHz. The lower frequency tends to result in less oscillator drift, other things being equal.

For the first mixer, we have a junction FET picking up a useful amount of gain in the process.

Additional gain has also been realised by the use of bipolar transistors in the IF amplifiers.

The method adopted for controlling the gain of amplifiers for AGC involves introducing a transistor in the emitter circuit of each stage to be controlled, to give variable degeneration. As a method, it gives one of the best AGC characteristics obtainable. Admittedly, it involves the use of extra transistors, but they are modestly priced and we consider the addition well worth while.

The block diagram shows the basic format of the receiver. The reader would be wise to study this before now turning to the main circuit.

At the aerial input, we have an attenuator in the form of a potentiometer. Where necessary, a series capacitor may be included to further attenuate the lower frequencies, particularly the broadcast band, to reduce break-through interference.

Three aerial coils are used to cover the ranges 0.5-1.5MHz, 1.5-4MHz and 8-24MHz. This leaves a gap of 4-8MHz, which is the range of the tunable IF. For simplicity, the front end is not used for this range, the aerial input being switched directly into the first tuned circuit of the tunable IF. The three aerial coils are wound on ferrite toroid formers, giving compact coils with a high Q and thus permitting the use of a single tuned circuit.

The aerial tuned circuit selected by the range selector switch is connected to the gate of the 2N5485 junction FET RF amplifier. The drain of this amplifier is broadbanded by using 1mH RF choke for its load. This stage is coupled via a 100pF capacitor, to the gate of the 2N5485 mixer, with a 10K resistor between gate and earth. The drain of the mixer is



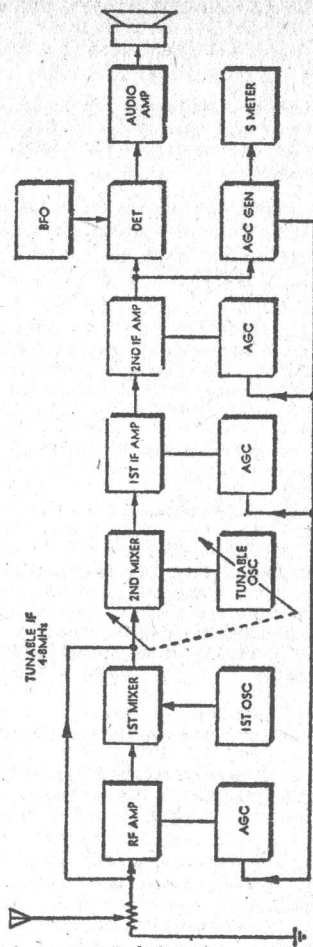

The block diagram shows the function of each part of the receiver and this should make the circuit diagram easier to understand.

also broadbanded by using a 2.5mH RF choke for its load. As a high to low impedance transformation is desirable to couple from the mixer drain to the following stage, an emitter-follower is used at the output of this stage.

Inspection of component values thus far will show that they favour the higher frequencies. The interstage coupling capacitors are small values and, in addition, the 1mH and 2.5mH RF chokes in the drain circuits have reduced reactance at the low frequencies and so contribute to the overall effect.

There are two reasons for this. Firstly, there is a natural tendency for the RF gain to fall as the frequency is increased, so that the suggested approach has a levelling effect. The second is perhaps peculiar to this design. As mentioned earlier, we have used only one tuned circuit in the input to the first stage. Although the circuits are of quite high Q, there is not sufficient discrimination to prevent strong local broadcast stations from breaking through in some circumstances. By reducing the gain at these frequencies this problem is minimised.

The self-excited oscillator associated with the first mixer uses an adaptation of the oscillator circuit which we employed in a recent wide-range dip oscillator. The tuned circuit of this oscillator, which determines the first injection frequency, is switched. As the oscillator is run at the final injection frequency and not multiplied as in some instances with the previous crystal oscillator, spurious responses are thereby reduced. Switching of the oscillator is carried out by ganging it with the switching for the aerial tuned circuits at the input of the RF amplifier.

An extra winding of low impedance has been added to the oscillator coil to provide source injection to the mixer. Bias for the mixer is provided by means of a bypassed 4.7K resistor in series with the injection winding.

This arrangement of the first oscillator tuned circuit and injection permits the use of a single oscillator coil. It is only necessary to switch appropriate capacitors for band changing and this makes for the simplest and most conveniently aligned front end circuit we could devise.

Injection frequencies for the first mixer are 4MHz, 8MHz, 12MHz and 16MHz. The 4MHz injection is used for both the 0.5-1.5MHz and 1.5-4MHz ranges, 8MHz is used for the 12-16MHz range, 12MHz for the 16-20MHz range and 16MHz is used for both 8-12MHz and 20-24MHz. These figures may be clearly seen from the table.

| Signal Freq. MHz | Injection Freq. MHz | Tunable IF MHz |
|------------------|---------------------|----------------|
| 0.5-1.5          | 4                   | 4.5-5.5        |
| 1.5-4            | 4                   | 5.5-8          |
| 8-12             | 16                  | 8-4            |
| 12-16            | 8                   | 4-8            |
| 16-20            | 12                  | 4-8            |
| 20-24            | 16                  | 4-8            |

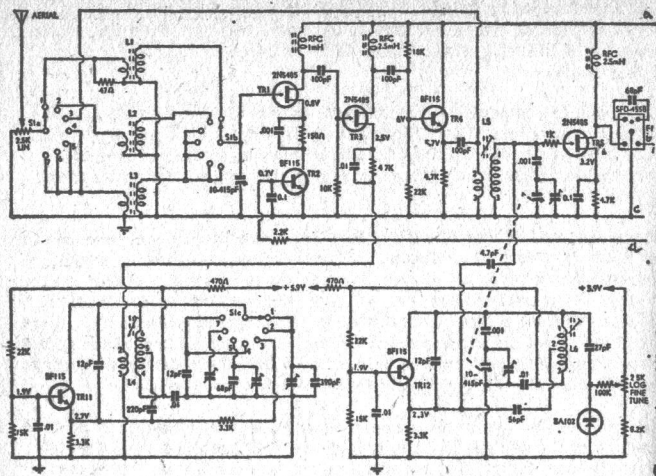

Connects with drawing on Page 78

ALL TRANSISTERS 1-100P

2 POSITIONS

- 1 6S - 1.0MΩ
- 2 12 - 4.0MΩ
- 3 44 - 100P
- 4 45 - 100P
- 5 46 - 100P
- 6 12 - 100P
- 7 16 - 100P
- 8 16 - 100P
- 9 16 - 100P
- 10 16 - 100P

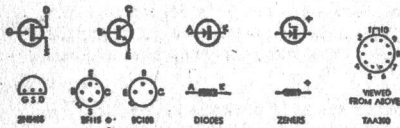

NOTE: VOLTAGES AS MEASURED ON PROTOTYPE, WITH RANGE SELECTION SWITCH SET ON 100Ω AND ON 5V PER VOLT MULTIMETER. NOT DESIGN CENTRE VALUES.

SHIELD ON BF115 NOT CONNECTED, EXCEPT ON THIS

Connects with drawing on Page 78

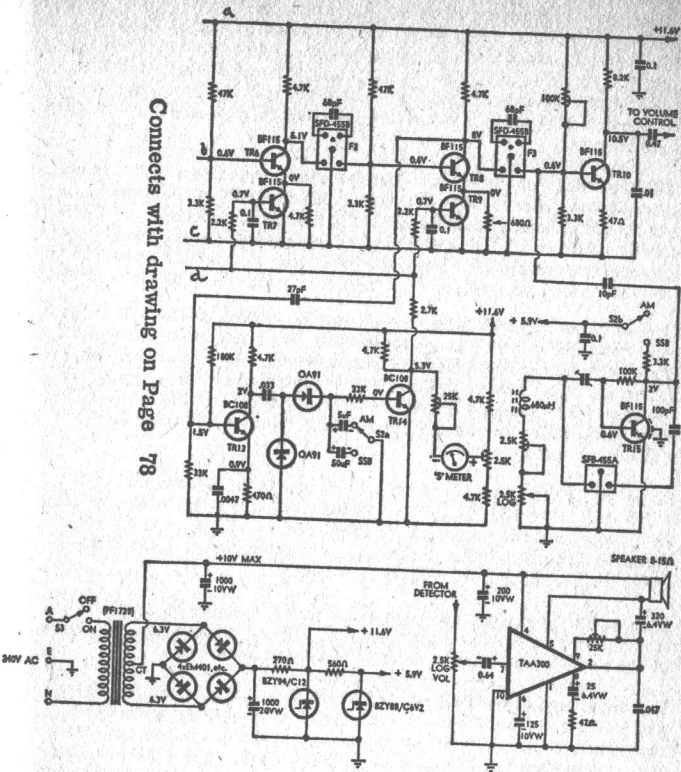

It may be noted from the table that all ranges but that from 8-12MHz tune "forward", i. e. from 4-8MHz on the tunable IF dial. While the "odd band out" could conceivably have been made to tune in the same direction, it would have meant using an injection frequency of 4MHz, with a likely problem of spurious responses from the broadcast band. A reverse tuning mode is considered a small price to pay for improved performance.

The "front end" which we have just described, in addition to being suitable as part of a complete receiver, could conceivably from the basis to a converter which could be used in a number of applications. Variations could be made in the oscillator frequencies, the RF tuned circuits and the tunable IF, to suit the particular need. Such a design could be readily adapted for spot frequencies "amateur bands only" etc.

We now come to the tunable IF section. From here on the system is really a single conversion receiver in its own right, albeit one which tunes only the 4-8MHz range. The tunable IF does not have an amplifier in the strict sense, in that there is no transistor or other active device at this frequency range. However, the coil used has a tuned secondary, with a low impedance primary input, the step up giving a useful amount of gain.

Immediately following the tunable IF circuit is the second mixer, which is another 2N5485 FET. The tunable oscillator associated with this mixer uses the same basic configuration as the first oscillator the main difference being the changed circuit values to make it tunable over the range 4.455MHz to 8.455MHz.

Also, a BA102 varicap has been added with a suitable bias adjusting circuit to provide a fine tuning facility. Injection from this oscillator is via a small capacitor to the gate of the second mixer.

The drain load of the FET second mixer is again a 2.5mH RF choke. The load requirement here is such that it must present a low DC resistance to the +12 volts DC supply and at the same time present a source impedance of 3K ohms at 455KHz, to the SFD-455B ceramic resonator which follows. The readily available 2.5mH RF choke meets this requirement quite satisfactorily.

The next two stages are the 455KHz IF amplifiers, and here silicon bipolar transistors of type BF115, BF184, BF185 or similar may be used. Collector load in each case is a 4.7K resistor and these are followed by two more SFD-455B ceramic resonators, similar to the first one. Each of the resonators is top coupled with a 68pF capacitor. This value largely determines the bandwidth of the IF system and, unless you have good reason for making a change, we suggest that you adhere to this value.

After the third 455KHz ceramic resonator is another transistor which can be a similar type to the two previous amplifiers. This device is biased in class B consistent with its role as the detector. The circuit shows a 100K potentiometer in series with a 3.3K resistor, as the divider for the detector base bias; when the bias is adjusted on completion, the potentiometer may be replaced with a fixed resistor, if desired.

The detector collector load is an 8.2K resistor, with a .01uF shunt capacitor which functions as an IF filter, audio being recovered from this point. It will be noted that there is an unbypassed 47 ohm resistor in the emitter of the detector. The main purpose of this resistor is to give some degeneration to reduce the audio output, as only a fairly low level is required for the IC audio section.

For AGC purposes, part of the IF signal is taken from the collector of the second IF amplifier. This is fed via a 27pF capacitor to an amplifier, the output of which is rectified by the two OA91 diodes, connected as a half-wave voltage doubler. The output of the rectifier charges either a 5uF capacitor for AM reception, or a 50uF capacitor for SSB reception, the capacitors being switched according to the mode of reception.

As the source impedance for the rectifiers is relatively low, the capacitor in circuit will be charged rapidly, in proportion to the strength of the signal being received. The only path for discharge of the capacitor when the signal level is reduced or disappears, is via the 33K resistor and the emitter junction of the following transistor. The time constants are so arranged that discharge will be fast for AM reception but slow for SSB reception.

When no signal is being received, there will be no charge on either the 5uF or 50uF capacitor and consequently no forward bias on the following transistor. This means that the transistor will not be conducting, producing no voltage drop across the 4.7K collector load resistor. The collector of this transistor, is the source point of forward bias through a 2.7K resistor, to the bases of the three AGC transistors. Under these conditions, these transistors will be saturated, so there will be very little collector-emitter resistance. Consequently, the AGC transistors will have negligible effect on their associated amplifiers.

When a signal is received, one of the AGC capacitors will be charged, the following transistor will conduct according to the signal strength and there will be a resultant voltage drop across the 4.7K collector load. This means, in turn, that there will be less current fed to the bases of the AGC transistors, causing the collector-emitter resistance to increase and producing the same effect as placing a resistor of equal value in each amplifier emitter (or source) circuit. The resulting degeneration produces a reduction in amplifier gain.

It may be noted that each IF amplifier control transistor is shunted by a fixed resistor. The choice of these resistors determines the shape of the AGC characteristic and the values given should be adhered to unless you have good reason for making any changes.

Since the collector voltage on the AGC DC amplifier falls with a increase in signal strength, this can be used as the reference for an S-meter. So that the meter will be forward reading, it is included in a bridge circuit, with 2.5K preset potentiometer to set the zero reading of the meter under no-signal conditions. In series with the meter coil is a 25K preset potentiometer which is provided to set the limit of travel of the meter to just full scale, under the very strongest signal conditions. This potentiometer will suffice for any meter with a sensitivity ranging from about 200uA to 1mA.



The BFO is a new design and this is the first application of it in a complete receiver. The unit is built on a printed board and, in spite of the low cost of the parts required, is virtually as stable as a crystal. It presents no trouble to get going. The frequency is variable over sufficient range to be able to resolve either upper or lower sideband SSB transmissions. The BFO is switched on and off with the same toggle switch assembly which determines the AGC time constants for AM and SSB reception. The output of the BFO is fed to the base of the detector via a 10pF capacitor.

Output from the detector is fed via a 2.5K volume control to the main audio amplifier. The Philips TAA300 IC used in this amplifier is mounted on a small printed board with its associated components. The power output is about 1 watt into an 8 ohm speaker, which is the lowest value which can be used. A 15 ohm speaker may be used, but with a reduction in power output.

The power supply is quite an interesting one. We were faced with a number of problems which, at first, looked as though they might be difficult to solve at low cost. Firstly, we had the need for an audio supply of 9 volts with a maximum of 10 volts. The current requirement would vary from a quiescent value of 8 milliamps to a maximum of about 180 milliamps with full audio output. This is brought about by the fact that the TAA300 amplifier operates under class B conditions.

In addition to this, we needed a supply of 12 volts, reasonably well regulated, for all other parts of the receiver except the oscillators. The latter needed a supply of 6 volts, well regulated. All this adds up to quite an exacting need, considering the modest receiver which we aimed to produce. However, we were able to come up with a relatively neat solution by adapting an old idea used for multiple voltage power supplies.

This involves using a bridge rectifier across the total transformer secondary supply, for the highest voltage need. A lower voltage may be had by taking the output from the centre-tap of the transformer secondary. This is effectively fed from a full-wave rectifier system, using only two of the four diodes of the bridge rectifier system, but with the diodes in the negative, rather than the positive side of the supply. With a secondary supply of about 6.3 volts AC, each side of the centre tap, we thus obtain between 9 and 10 volts DC for the audio amplifier while at the output of the bridge we obtain something close to 20 volts. This is fed through a dropping resistor of 270 ohms to a BZY94/C12 zener diode, which gives a regulated supply of 12 volts, nominal.

The well regulated supply of 6 volts (nominal) required for the oscillators is obtained by a further dropping resistor of 560 ohms and a BZY88/C6V2 zener diode. Thus the supply voltage requirements of the receiver have been met in a very satisfactory way. In fact, although the supply current to the audio amplifier is constantly fluctuating, the other two supply voltages remain virtually unaffected.

To reduce the hum to an acceptable level, we found it necessary to use a minimum of 1000uF for each of the two main power supply electrolytics. Readers who wish to reduce the hum to an even lower level, could increase these two electrolytics to 2000uF each.

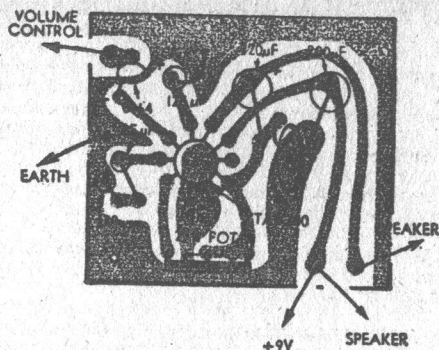

*The audio board is shown from the component side. Note the polarity of electrolytics and orientation of the IC.*

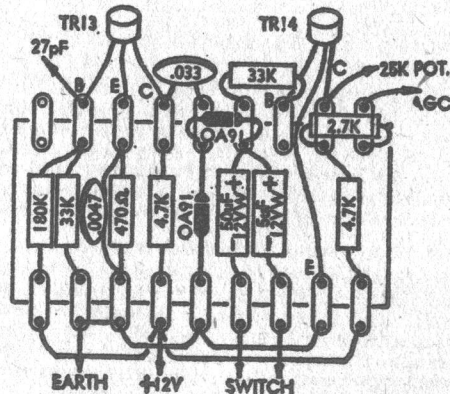

*Wiring details for the AGC generator board. This board is fixed on the same panel as the IF strip.*

So much for the design. In the description which follows we hope to supply sufficient details to ensure that readers will have no difficulty in duplicating the prototype.

A good place to start construction is the power supply for, by starting here and working backwards, one can finish off each section and test it immediately. The power supply, less transformer, is built in a piece of miniature tag board, with 12 pairs of tags. It is a simple item to wire, particularly when reference is made to the wiring diagram. Note that, as there is not a great deal of room around the wiring board, the relatively large 1000uF capacitor on the 9-10 volt supply is located between the loudspeaker socket and the audio amplifier.

There are a number of small power transformers available which should do the job. The prime need is for one having a secondary of 12.6 volts, centre tapped, and rated at between 500mA and 1A.

The printed board for the audio system has only nine items to be soldered into place and the job is done. The appropriate diagram should be followed carefully and a few important points should be observed to ensure success. Make sure that all the electrolytic capacitors are in their correct positions and that correct polarity is observed. When fixing the IC make sure that it is done with due respect for the correct orientation of the connections. The tag on the IC is between connections 1 and 10 and these should be soldered to the appropriate band of copper on the board. The other connections will then automatically be correct.

Although this completes the wiring of the board, it is still necessary to provide a heat sink clip for the IC. We made one up from a piece of aluminium sheet, measuring 2" x  $\frac{1}{2}$ ". One end was wound around a 5/16" diameter drill and the resulting loop was adjusted by hand so that it was a neat fit over the case of the IC. Although aluminium is excellent for this job, other metals such as brass, copper or steel would be satisfactory.

Having completed the audio board, the other board for the BFO may be attended to next. It is very simple to make up and reference to the special picture should be sufficient guide. Every care should be taken to make sure that the transistor is correctly orientated. And, while care should be taken at all times not to overheat components, the requirement applies particularly to the ceramic resonator, transistor and trimmer.

The next assembly is the largest of the whole project. It consists of two boards and includes the second mixer, two IF amplifiers, detector and AGC system. Wiring is again based on tag strips, one with 19 pairs of tags and a smaller one which accommodates the AGC system, with 9 pairs of tags. The small board is secured with two screws, one of these screws being common with one of the three screws used to secure the large board - all to an aluminium panel,  $4\frac{1}{4}$ " long, 1 7/8th" high and with a 5/16" foot. This panel serves as a mounting bracket for the complete assembly. There is a screw at the extreme end of each board, with one at an intermediate point on the large board.

The boards are spaced from the panel by about  $\frac{1}{4}$ ". Instead of spacers, we used extra nuts to perform the same job. At each screw, we fixed a solder lug and soldered to the nearest earth point.

The three ceramic resonators are mounted directly on the tag board. Care must be used in mounting, as it is necessary to drill five small holes fairly accurately. Only holes large enough to pass the leads should be drilled. The resonator leads are passed through the holes and the other leads and components are then soldered to the opposite side. This is sufficient to hold the resonators in place. Make sure that the "dots" on the resonators are orientated correctly.

Most of the remaining assemblies involve the use of one or more coils so this would be a good time to wind all the coils.

The aerial tuning coils L1 - L3 are wound on Ducon toroids, which are about  $\frac{3}{4}$ " outside diameter, and of Q2 material. These coils have a high Q, can be wound readily and have the added advantage of being compact. The coil winding details are given in the table. The number of turns on each winding and the disposition of the windings should be closely adhered to but the gauge of wire specified is simply a guide. If you do not have the exact gauge, something close to it should suffice. At the same time, particularly at the higher frequencies, the gauge of wire should be as heavy as practicable. This will reduce the resistance of the coil and give a higher Q.

The switched oscillator coil L4 is wound on a Neosid former with a diameter of 7.6mm. The secondary should be wound first, with the primary wound over the earthy end of the secondary. Do not forget to make the centre tap on the secondary winding. When this point is reached, we suggest that you carefully remove the enamel for about 3/16", tin the bared copper and place a small piece of insulation tape under the wire at this point and continue winding. Later on, a small piece of the same wire can be soldered to the centre point and this can serve as the extra lead.

The means of anchoring each end of the windings is largely up to the reader. We have used a couple of different methods of anchorage. In one, a loop of linen thread is placed lengthwise on the former, with the loop near the start of the winding. The end of the wire is passed through the loop, a few turns made, and then the linen ends are drawn tight, causing the loop to anchor the wire at the start. A similar method is used at the finish. The loose ends are cut off and the anchorages reinforced with a small blob of cellulose glue.

An alternative, though not quite as neat a method, is to use a small strip of plastic adhesive tape, in a manner similar to that for the linen thread. In any case, when the secondary is wound, it is a good idea to place a layer of plastic adhesive tape over the secondary, where the primary will be wound, to minimise the possibility of a short-circuit between windings.

Coils L5 and L6 are wound on longer formers of the same type as used for L4, and in a similar manner to L4. Although care should be taken to make all windings in a firm and workmanlike manner, this applies more particularly to L4 and L6, which are oscillator coils. These must be wound tightly and precautions taken so that there will be no movement of the turns. If this is not done then the stability of the whole receiver could be prejudiced.

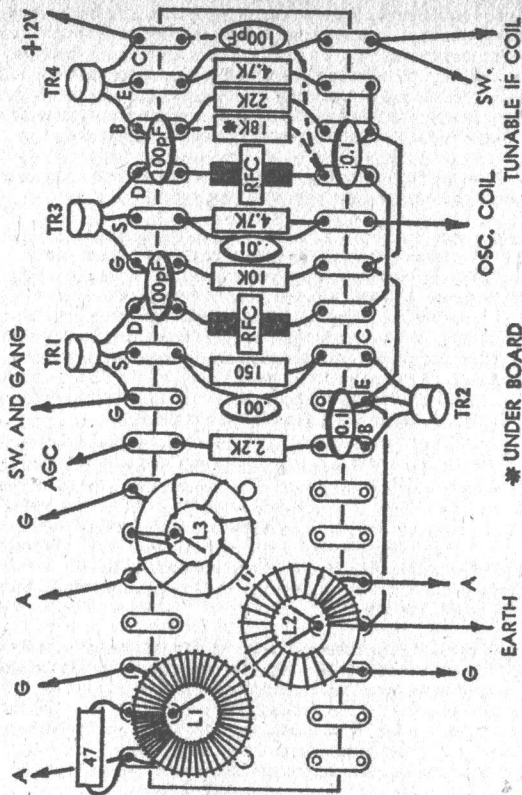

*When wiring the RF amplifier board, special care should be given to the switching details.*

When coils L4, L5 and L6 are wound and terminated, each winding should be placed in a can, ready for use in the final assemblies. The Neosid cans are provided with a pair of lugs and the intention is that these lugs be bent over to hold the coil former in position. Two screws through the holes anchor the coil and the can to the chassis. This system is excellent but it requires a very special set of punched holes in the chassis. An alternative method which we used, is to bend the lugs outwards, rather than inwards. The former is firmly held in the can by crimping the aluminium over with a screwdriver, at a couple of spots which do not interfere with the terminating pins. The assembly is then held to the chassis with a couple of screws and nuts.

The next board to be wired is that containing the three toroidal coils, with the RF amplifier, first mixer and the emitter-follower. This is wired up in the usual way, according to the wiring diagram. When the coils are wired in place, it will be noted that they are more or less loose, according to the gauge of wire used for winding. To keep the coils held firmly in place, it is a good idea to tie each one to the board, with a piece of nylon or linen thread.

The last board to be wired is that for the first oscillator. It cannot be over-stressed that this board must be wired with the greatest care, making sure that all components are held firmly in place. Failure to do so will result in an unstable receiver or one which is more susceptible to shocks than it should be. Details are shown in the wiring diagram, which also includes the coil which is mounted separately. The new Philips dielectric film trimmers fit quite nicely between adjacent tags on the board, as may be seen from the photograph.

Having completed all the sub-assemblies, we are now in a position to undertake the final assembly and wiring. The unit is built on a chassis 10" x 6" x 2" with a front panel, 11" x 6". As the order of assembly and wiring can affect the ease of the job, here are some suggestions as to how it may be done.

Fit the chassis partition first, making sure that a rubber grommet is fitted at least to the hole which must pass the 240V AC lead to the switch. Next, fix the speaker socket and aerial and earth terminals to the back skirt of the chassis. A solder lug is fitted under each of the terminals, making contact with the chassis for the earth and insulated for the aerial.

Solder trimmers to the top of the 2-gang capacitor and, to the bottom lugs, solder two pieces of hookup wire about 4" long. Fix a similar piece of wire to the single gang and mount both units to the chassis. Mount coils L4, L5 and L6, making sure that the pins are so orientated as to give the shortest wiring leads. Under one mounting screw of L6, fix a 5-tag strip and under the corresponding screw of L5 fix a 2-tag strip.

Mount the power transformer with the low voltage leads nearest the back of the chassis. Make sure that the two holes in the chassis are fitted with rubber grommets, to protect the transformer leads. Fit another grommet to the hole in the back skirt of the chassis, for the power flex.



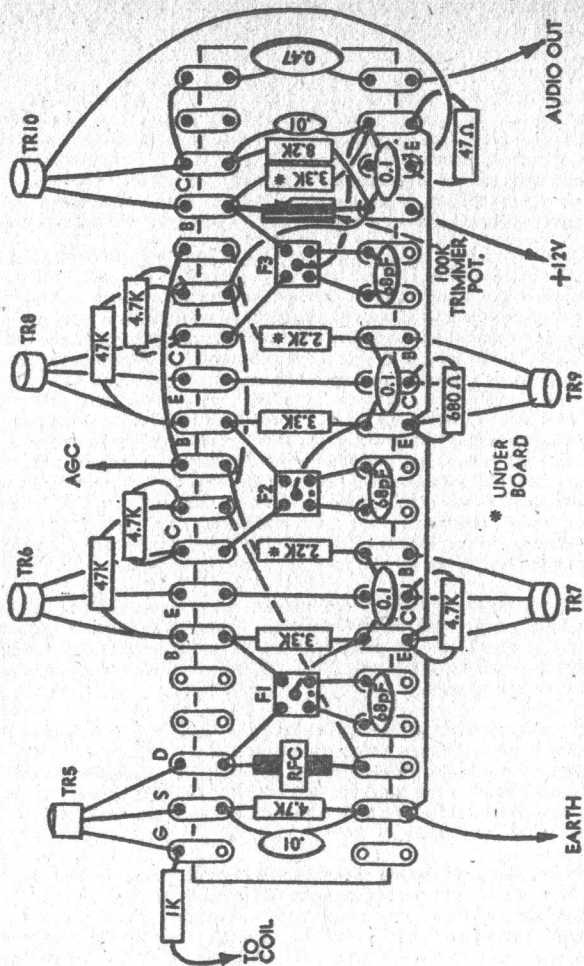

The IF amplifier strip is relatively easy to wire, when the above drawing is followed, in conjunction with the circuit.

Mount the power supply board assembly. We used a couple of 1/8" Whitworth screws, one at each end hole of the board. Three nuts are used on each screw, so that a spacing of about 1/2" is effected between the board and the chassis skirt. The board is orientated so that the vacant terminals for the 240 volt wiring is nearest the dividing partition. It is a good idea at this stage, to wire up the leads of the transformer, power supply and switch. This gets rid of flying leads, which can be a nuisance when doing the rest of the assembly.

Now the audio amplifier board can be next. It is also held off the chassis, by about 5/8" with a couple of 1/8" Whitworth screws, using the three-nut technique as before. Before finally fitting the board, make sure that all leads from it are fitted, with sufficient length so that each will comfortably reach its intended destination. Under each fixing screw and next to the board, provide a solder lug for earthing purposes. At this point, you may fit the 1000uF electrolytic capacitor between the speaker socket and the nearest earth lug of those just referred to. The 9 volt lead may also be run from the power supply.

The IF strip assembly is the next logical step but this must be considered with the BFO assembly. The BFO is mounted above the chassis as shown in the photograph and in such a position that the output lead to the detector is kept short and direct. At the same time, its mounting screws must not foul any part of the IF strip assembly. In mounting the BFO, we placed the screw heads under the chassis and by using three nuts on each screw, the BFO is held clear of the top of the chassis by about 1/4". The 6 volt supply and injection leads are passed through a hole in the chassis just near the 10pF capacitor. The leads to the 2.5K potentiometer are run along the top of the chassis.

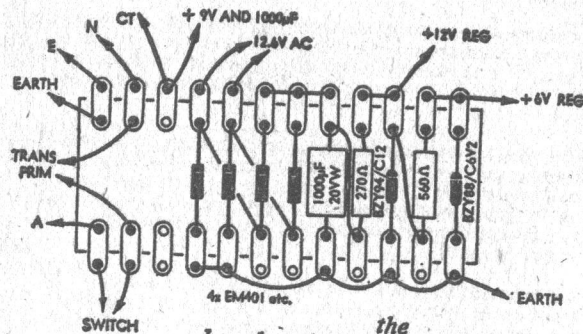

the board for the power supply. Note that the 1000uF electrolytic for the audio supply is mounted at the speaker socket.

The IF strip assembly is mounted with a gap of only about  $\frac{1}{4}$ " between the end of the panel and back skirt of the chassis. The detector must be at this end. Before fixing, provide leads for the 12 volt supply and the audio output to the volume control. The 12 volt lead may be run to the power supply but the audio lead must wait until the front panel is in place.

Now the tunable IF can be wired up. This involves coils L5 and L6, with associated components to the two tag strips previously fixed. The wiring here is largely a matter of common sense. Best use should be made of the tags available, together with vacant pins on the two coil formers. Once again, the oscillator components must be firmly fixed. In some cases, it is difficult to avoid some components having leads a little longer than we would like. However, this is of no serious consequence. The IK "stopper" resistor, from L5 to the gate of the second mixer must be so mounted that the resistor is hard up against the gate tag on the board. The other lead should run direct to the coil.

Having completed the tunable IF, it is interesting to note that we have completed 4-8MHz tuning range, and the unit at this point is a receiver in its own right. We now move on to the "front end".

Perhaps the next most convenient board to fit would be that of the first oscillator. This is fixed to the end skirt of the chassis and stood off the chassis by about  $\frac{3}{8}$ ", once again using the same technique with screws and nuts. As with other units, it is well to consider any leads from it which may be difficult to fit later. Make sure that you run the 6 volt supply to this oscillator, as we hope you have already done with the second oscillator for the tunable IF.

Some readers may be wondering about the purpose of the 3.3K resistor which runs from the band switch to the emitter of the first oscillator transistor. It is simply there to stop this oscillator when the receiver is set to the 4-8MHz position, avoiding the possibility of any unnecessary "birdies".

Before attempting to fit the board with the toroidal coils, drop the 2.5K aerial attenuator pot through the hole in the chassis. The nut could be just run up finger tight at this stage. Stand the board off the chassis, by about  $\frac{5}{8}$ ". The mounting screws are run through the extreme end hole nearest the aerial attenuator, with the other one through the fifth hole from the other end.

We are now in a position to attach the dial to the front panel and to fix the panel to the chassis. The panel is held in place with the nuts of the band change switch, aerial attenuator, toggle switches and volume control. The drive from the dial to the tuning capacitor is via a flexible coupling. To connect the coupling to the dial movement, it is necessary to provide a short length of  $\frac{1}{4}$ " diameter steel or brass rod. This needs to be about  $\frac{1}{4}$ " long and can be obtained from an offcut of one of the controls, such as the switch or a potentiometer.

When fixing the band switch, it should be orientated such that the rotor lugs are nearest the top of the chassis. This done, the switch may be completely wired. A piece of light coaxial cable is run from

the aerial and earth terminals, to the aerial attenuator. A convenient earth point for this end is a lug under the nearest fixing screw for the single gang capacitor.

A careful check should be made at this stage, to make sure that all leads have been properly terminated, and that there are no wiring errors or omissions. Assuming that all is well, we are ready to carry out final adjustments and alignment.

The first check which should be made is to see that the three supply voltages are correct. With the volume control turned right down the voltage to the audio amplifier should read between nine and ten volts. The 12 volt supply to other parts of the receiver, should read 12 volts within of course the tolerance of the zener diode. The supply to both oscillators should read 6.2 volts, with a similar tolerance.

Unsolder the 9V lead between the power supply and the audio amplifier. Connect a multimeter in series with this lead and set the multimeter to the 100mA range, or a higher one and switch on. Adjust the 25K potentiometer on the audio board, for a quiescent current of 8mA. If a meter is not available, we suggest that you set the potentiometer to mid range. With the volume control partly advanced, a finger on the active lug of the potentiometer should now give a healthy noise from the speaker.

Set the 100K potentiometer in the base of the detector so that the full resistance is in circuit. Check the voltage at the collector then reduce the 100K potentiometer resistance until the voltage drops by about half a volt on the previous reading. Later on, the final setting can be determined to give best detection.

With no signals being fed into the receiver, set the S-meter to zero with the 2.5K tab pot. The 25K tab pot. determines the full scale limit of the pointer. This can be set arbitrarily such that the strongest signal just reads full scale.

The IF strip should need no adjustment at all. This is a good thing as it simplifies the procedure considerably. With the three Murata type SFD-455B ceramic filters, top coupled with 68pF, we obtained very good results. The top of the band pass shape is almost flat with only a slight dip in the middle. The bandwidth has been measured at 4.4KHz, at the 6dB points. The skirt selectivity is very good and is borne out by the receiver's ability to separate cleanly, adjacent signals about 5KHz away.

Fit a slug each to L4, L5 and L6. To ensure that the slug remains in its final position it is necessary to use some sort of locking arrangement. This can take the form of a locking compound which looks rather like a heavy grease, but the method which we prefer is the use of a short length of elastic. The elastic which we used is available from drapery stores in reels and it is just under  $\frac{1}{32}$ " in diameter. It is generally double cotton covered like some of the copper winding wires but the cotton should be removed. A length of about 1" is introduced into the former tube before screwing in the slug, providing a reliable locking action.

Set the dial pointer to 100 on the logging scale or to the ends of the scale arcs. With the gang fully meshed, tighten all grub screws. The Fine Tuning knob should tentatively be set to its mid travel and left in this position while the tunable IF is aligned.

Set the dial pointer to 4MHz or 95 on the scale. Set the band switch to the 8-4MHz range. Feed in a signal from a signal generator, set precisely to 4MHz and adjust the slug in L6, followed by the slug in L5, for maximum response. Set the dial pointer to 8MHz or 6 on the scale. Adjust the trimmer for L6, followed by the trimmer for L5, for maximum response. Return to 4MHz and make a further adjustment. This procedure must be repeated until both points are correct.

The front end is aligned as follows:- Set the dial pointer to 4MHz corresponding also to 12MHz on the scale, then set the band switch to the 8-12MHz range. Feed in a signal from the signal generator, set precisely to 12MHz and adjust the slug in L4 for maximum response making sure also to peak up the tuning of L3. Once set, the slug in L4 MUST NOT BE TOUCHED AGAIN.

With the dial pointer still in the same position, corresponding to 16MHz, set the band switch to 20-16MHz. Feed in a signal from the generator, set precisely to 16MHz and adjust the appropriate trimmer across L4 for maximum response followed by peaking of the tuning of L3. If a generator is not available, we suggest that you tune in a station within this range and on a known frequency and adjust the trimmer across L4 to bring the station to the correct position on the dial.

With the dial pointer again set to 4MHz, corresponding also to 12MHz on the scale, set the band switch to 16-12MHz. Feed in a signal from the signal generator, set precisely to 12MHz and adjust the appropriate trimmer across L4 for maximum response also peaking the tuning of L3. If a generator is not available, use can again be made of VNG on 12MHz as before.

Set the band switch to 1.5-0.5MHz and tune in a broadcast station of known frequency. Adjust the appropriate trimmer across L4 to bring this station to the correct position on the dial.

So far, we have not set the Fine Tuning control. Ideally the point of travel of the rotor should be found, such that, turning the control either way gives equal frequency change from the reference. Having done this, it may be necessary to adjust the trimmer across the tunable IF oscillator section of the gang, so that the 8MHz point on the dial is correct.

To adjust the BFO tune in a steady signal between 4 and 8MHz. Tune slightly to the low frequency side of the signal and switch to SSB. Set the 2.5K tap pot. and the BFO Tune pot. With all resistance in circuit. Now adjust the Philips trimmer on the BFO for zero beat. Re-tune by an equal amount, to the other side of the signal and set the BFO Tune pot. With all resistance in circuit. Now adjust the Philips trimmer on the BFO for zero beat. Re-tune by an equal amount to the other side of the signal and set the BFO Tune pot. to the other end of its travel. Adjust the 2.5K tap pot. for zero beat. It will now be necessary to repeat the procedure for the low frequency side, and so on, until both sides are set correctly.

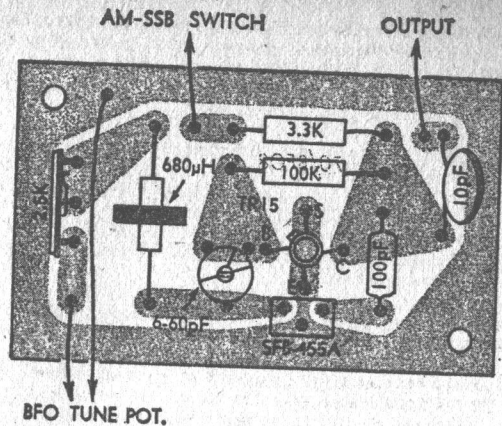

*This shows the BFO layout from the component side of the board.*

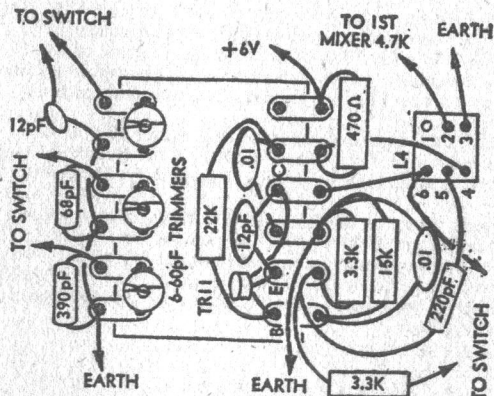

*The first oscillator should be firmly wired, again with care given to switching accuracy.*



It is not easy to lay down the exact positions where the BFO should be set. This can best be determined experimentally, such that the best SSB reception is obtained. When tuning from one extreme to the other, the "hiss" should sound much the same. This indicates that the BFO is tuned equally about the IF pass band.

This completes the adjustment and alignment and your new receiver should now be ready for full operation. Although it is of modest size and design, it is capable of quite a surprising performance. The selectivity is adequate for all normal listening and the overall frequency stability is better than we originally hoped for. It must be emphasised, of course, that the stability is not as good as an equivalent crystal locked front end.

As the design is very simple, it is reasonable to expect that there would be a number of spurious responses. This is so in practice but they usually fall in such a position as not to cause much if any, inconvenience. Also, because of the simplicity of the front end design, it is vital that the RF Tune control be set to the wanted frequency and not otherwise, which can result in an unwanted signal overriding the wanted one. However, a little practice is all that is required to get used to this situation.

#### COIL WINDING DATA

- L1 Secondary, 120 turns 30 B & S or 32 S.W.G. enamel on Q2 toroidal former. About 90 turns occupy full former length. Overwind remainder back. Primary, 10 turns, interwound at earth end of secondary.
- L2 Secondary, 43 turns 24 B & S or 24 S.W.G. enamel on Q2 toroidal former, wound to occupy about 90 per cent of former. Primary, 5 turns interwound at earth end of secondary.
- L3 Secondary, 7 turns, 18 B & S or 28 S.W.G enamel on Q2 toroidal former, wound to occupy about 90 per cent of former. Primary, 1 turn 24 B & S enamel, interwound at earth end of secondary.
- L4 Secondary, 30 turns centre tapped 26 B & S or 28 S.W.G. enamel close wound on 7.6mm (0.300in) x 1½" Neosid former. Primary, 5 turns over earth end of secondary. Grade 900 slug.
- L5 Secondary, 35 turns, 26 B & S or 28 S.W.G. enamel close wound on 7.6mm (0.300in) x 2½" Neosid former. Primary, 7 turns over earth end of secondary. Grade 900 slug.
- L6 One winding, 32 turns centre tapped, 26 B & S or 28 S.W.G. enamel close wound on 7.6mm(0.300in) x 2½" Neosid former. Grade 900 slug.

#### PARTS LIST

- 1 Chassis 10" x 6" x 2" (with partition).  
 1 Front panel 11" x 6"  
 1 Dual ratio dial assembly (Jabel)  
 1 Rotary switch, 3 wafers, 1 pole, 11 position  
 1 Toggle switch, miniature SPST.

- 1 Toggle switch, miniature DPDT  
 6 Knobs  
 1 Power transformer, 2 x 6.3V or 12.6V at 1A  
 1 2-pin miniature speaker socket  
 1 Aerial terminal  
 1 Earth terminal  
 1 ½" flexible coupling (Jabel).  
 1 ½" extension shaft  
 1 Miniature tag board, 6 pairs  
 1 Miniature tag board, 9 pairs  
 1 Miniature tag board, 12 pairs  
 1 Miniature tag board, 17 pairs  
 1 Miniature tag board, 19 pairs  
 2 Veroboards of suitable size  
 1 2-tag strip  
 1 5 tag strip  
 5 Rubber grommets  
 2 2.5mH RF chokes  
 1 1mH RF choke  
 1 680uH RF choke  
 1 S-meter  
 3 Ferrite toroidal formers, Q2 material preferably  
 2 Neosid coil formers, 7.6mm x 2½" with grade 900 slug and can.  
 1 Neosid coil former, 7.6mm x 1½" with grade 900 slug and can  
 3 Murata ceramic resonators, type SFD-455B  
 1 Murata ceramic resonator, type SFB-455A  
 Mounting panel for IF strip, Hookup wire, solder screws, nuts, power flex and plug, solder, lugs, etc.

#### TRANSISTORS

- 3 2N5485  
 10 BF115, BF184, BF185 etc.  
 2 BC108  
 1 TAA300 IC  
 DIODES

- 4 EM401, BY126/100, BA219, 1N4002  
 1 BZY94/C12 ZENER  
 1 BZY88/C6V2 ZENER  
 1 BA102, BA103, BA101, 109, BB103  
 2 OA91, OA81, OA161, AA117, AA132, IN63, SFD108.

#### RESISTORS (½ WATT)

- |            |            |                   |
|------------|------------|-------------------|
| 3 47 ohms  | 1 150 ohms | 2 33K             |
| 1 270 ohms | 3 470 ohms | 2 100K            |
| 1 560 ohms | 1 680 ohms | 1 2.5K linear pot |
| 1 1K       | 3 2.2K     | 2 2.5K pots       |
| 1 2.7K     | 7 3.3K     | 1 100K pot        |
| 10 4.7K    | 2 8.2K     | 2 47K             |
| 1 10K      | 2 15K      | 1 180K            |
| 1 18K      | 3 22K      | 3 2.5K log pots   |
|            |            | 2 25K pots        |

## CAPACITORS

|                             |                              |
|-----------------------------|------------------------------|
| 1 4.7pFNPO ceramic          | 1 10pF NPO ceramic           |
| 3 12pF NPO ceramic          | 2 27pF NPO ceramic           |
| 1 56pF NPO ceramic          | 4 68pF polystyrene           |
| 4 100pF polystyrene         | 1 220pF polystyrene          |
| 1 390pF polystyrene         | 3 .001uF polystyrene         |
| 1 .0047uF 100V polyester    | 3 .01uF 25V ceramic          |
| 4 .01uF 160V polyester      | 1 .033uF 100V polyester      |
| 1 .047uF 25V ceramic        | 5 0.1uF 25V ceramic          |
| 1 0.47uF 25V ceramic        | 1 0.64uF 64VW electrolytic   |
| 1 5uF 12VW electrolytic     | 1 25uF 6.4VW electrolytic    |
| 1 50uF 12VW electrolytic    | 1 125uF 10VW electrolytic    |
| 1 200uF 10VW electrolytic   | 1 320uF 6.4VW electrolytic   |
| 1 1000uF 10VW electrolytic  | 1 1000uF 20VW electrolytic   |
| 6 6-60pF trimmers, Philips  |                              |
| 222 808 01001               |                              |
| 1 10-415pF variable, single | 1 10-415pF variable, 2-gang. |

## TANDY RADIO BOOKS

|         |  |     |
|---------|--|-----|
| 62-9001 | First Book of Transistor Equivalents and Substitutes   | 40p |
| 62-9002 | Handbook of Radio, TV, Industrial and Transmitting Tube and Valve Equivalents                      | 60p |
| 62-9003 | Worlds Short, Medium and Long Wave FM and TV Broadcasting Stations Listing – International Edition | 60p |
| 62-9004 | Radio and Electronic Colour Codes and Data Chart   | 15p |
| 62-9005 | Practical Transistor Novelty Circuits  | 40p |
| 62-9006 | Electronic Novelties for the Motorist  | 50p |
| 62-9007 | Second Book of Transistor Equivalents and Substitutes  | 95p |
| 62-9008 | Constructors Manual of Electronic Circuits for the Home  | 50p |
| 62-9009 | Handbook of Electronic Circuits for the Amateur Photographer                                       | 60p |
| 62-9010 | Radio Receiver Construction Handbook using IC's and Transistors                                    | 60p |
| 62-9011 | Boys and Beginners Book of Practical Radio and Electronics   | 60p |
| 62-9012 | The Boys Book of Crystal Sets  | 25p |
| 62-9013 | Coil Design and Construction Manual  | 50p |
| 62-9014 | Radio, TV and Electronics Data Book  | 60p |
| 62-9015 | Handbook of Practical Electronic Musical Novelties   | 50p |
| 62-9016 | Handbook of Integrated Circuits (IC's) Equivalents and Substitutes                                 | 75p |
| 62-9017 | IC's and Transistor Gadgets Construction Handbook  | 60p |
| 62-9018 | Second Book of Hi-Fi Loudspeaker Enclosures  | 60p |
| 62-9019 | First Book of Hi-Fi Loudspeaker Enclosures   | 60p |
| 62-9020 | Practical Transistor Circuits for Modern Test Equipment  | 60p |