

# Multi-circuit Board Projects

R. A. PENFOLD



## ALSO BY THE SAME AUTHOR

- No. 222 Solid State Short Wave Receivers for Beginners
- No. 223 50 Projects Using IC CA3130
- No. 224 50 CMOS IC Projects
- No. 226 How to Build Advanced Short Wave Receivers
- No. 227 Beginners Guide to Building Electronic Projects
- No. BP45 Projects in Opto-electronics
- No. BP49 Popular Electronic Projects
- No. BP56 Electronic Security Devices
- No. BP59 Second Book of CMOS IC Projects
- No. BP65 Single IC Projects
- No. BP69 Electronic Games
- No. BP71 Electronic Household Projects
- No. BP74 Electronic Music Projects
- No. BP76 Power Supply Projects
- No. BP80 Popular Electronic Circuits — Book 1
- No. BP83 VMOS Projects
- No. BP91 An Introduction to Radio DXing
- No. BP94 Electronic Projects for Cars and Boats
- No. BP95 Model Railway Projects
- No. BP96 CB Projects
- No. BP98 Popular Electronic Circuits — Book 2
- No. BP99 Mini-Matrix Board Projects
- No. BP105 Aerial Projects
- No. BP106 Modern Op-Amp Projects
- No. BP107 30 Solderless Breadboard Projects — Book 1

## MULTI-CIRCUIT BOARD PROJECTS

# MULTI-CIRCUIT BOARD PROJECTS

by  
R. A. PENFOLD

BERNARD BABANI (publishing) LTD  
THE GRAMPIANS  
SHEPHERDS BUSH ROAD  
LONDON W6 7NF  
ENGLAND

Although every care has been taken with the preparation of this book, the publishers or author will not be held responsible in any way for any errors that might occur.

© 1982 BERNARD BABANI (publishing) LTD

First Published – August 1982

**British Library Cataloguing in Publication Data**  
Penfold, R. A.

Multi-circuit board projects.

1. Printed circuits – Amateurs' manuals

I. Title

621.381'74 TK 7868.P7

ISBN 0 85934 078 3

Printed and bound in Great Britain by Cox & Wyman Ltd, Reading

## CONTENTS

	Page
INTRODUCTION . . . . .	1
MAKING THE PCB . . . . .	3
Tracing . . . . .	3
Etchant . . . . .	5
Reusing the PCB . . . . .	7
PROJECT 1 Electronic Doorbuzzer . . . . .	8
The Circuit . . . . .	8
Construction . . . . .	12
PROJECT 2 Light Detector . . . . .	15
The Circuit . . . . .	15
Construction . . . . .	18
PROJECT 3 Darkness Detector . . . . .	20
The Circuit . . . . .	21
Construction . . . . .	22
PROJECT 4 Latching Light Detector . . . . .	24
The Circuit . . . . .	24
Construction . . . . .	25
PROJECT 5 Continuity Tester . . . . .	29
The Circuit . . . . .	30
Construction . . . . .	32
PROJECT 6 Bent Wire Game . . . . .	34
The Circuit . . . . .	34
Construction . . . . .	35
PROJECT 7 Morse Practice Oscillator . . . . .	39
The Circuit . . . . .	39
Construction . . . . .	40
PROJECT 8 Low Voltage Alarm . . . . .	44

	Page
The Circuit .....	45
Construction .....	46
<b>PROJECT 9 High Voltage Alarm</b> .....	<b>48</b>
The Circuit .....	48
Construction .....	50
<b>PROJECT 10 Water Activated Alarm</b> .....	<b>52</b>
The Circuit .....	52
Construction .....	53
<b>PROJECT 11 Transistor Checker</b> .....	<b>57</b>
The Circuit .....	57
Construction .....	59
<b>PROJECT 12 Simple Signal</b> .....	<b>63</b>
The Circuit .....	63
Construction .....	66
<b>PROJECT 13 Electronic Heads or Tails</b> .....	<b>68</b>
The Circuit .....	68
Construction .....	69
<b>PROJECT 14 Signal Injector</b> .....	<b>72</b>
The Circuit .....	72
Construction .....	73
<b>PROJECT 15 Computer Voice</b> .....	<b>77</b>
The Circuit .....	77
Construction .....	80
<b>PROJECT 16 Games Timer</b> .....	<b>82</b>
The Circuit .....	82
Construction .....	84
<b>PROJECT 17 Guitar Preamplifier</b> .....	<b>87</b>
The Circuit .....	87
Construction .....	88

	Page
PROJECT 18 Guitar Treble Booster . . . . .	91
The Circuit . . . . .	91
Construction . . . . .	93
PROJECT 19 General Purpose Preamplifier . . . . .	95
The Circuit . . . . .	95
Construction . . . . .	98
PROJECT 20 Signal Tracer . . . . .	100
The Circuit . . . . .	101
Construction . . . . .	101
PROJECT 21 Quiz Monitor . . . . .	105
The Circuit . . . . .	105
Construction . . . . .	107
SEMICONDUCTOR LEADOUTS . . . . .	109



## INTRODUCTION

This book provides twenty one electronics projects, most of which have practical uses, but a few are primarily intended to demonstrate certain electronic principles and are included for their interest and novelty value. All the projects are easy to construct, and they can all be built onto the printed circuit design which is illustrated actual size in Figure 1. Furthermore, wherever possible the same components have been used in each design so that with a small number of components and the printed circuit board it is possible to make any one of the projects, or those who like to experiment could build all the projects in turn by reusing components. The components needed are listed below (these are the main electronic components only, and items such as cases, plugs, sockets, etc. are not included).

*Resistors* (any small types such as  $\frac{1}{4}$  or  $\frac{1}{3}$  watt components)

120 ohms  
390 ohms  
2.2k (2 off)  
4.7k (2 off)  
47k  
100k  
220k  
470k (2 off)

*Capacitors*

22nF polyester (C280)  
470nF polyester (C280)  
10 $\mu$ F 25V electrolytic  
100 $\mu$ F 10V electrolytic

*Semiconductors*

555 integrated circuit  
BC109C transistors (2 off)  
TIL209 (3mm red LED)  
TIL211 (3mm green LED)

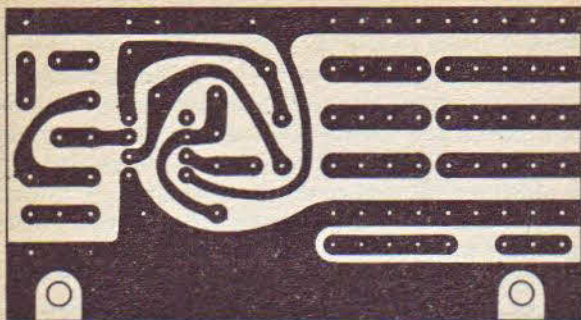

*Fig. 1 The foil pattern of the printed circuit board*

2N5777 Photo Darlington transistor  
BZY88C10V 400mW 10 volt zener diode

### *Switches*

Miniature SPST toggle switches (2 off)

### *Miscellaneous*

Miniature loudspeaker having an impedance in the range 40 to 80 ohms.

A circuit description, circuit diagram, printed circuit component layout diagram, components list, and construction notes are provided for each project. It should not be beyond the capabilities of a beginner at electronics to build any of the projects featured in this book since construction of the projects is almost invariably very straight forward and uncomplicated, and none of the projects are at all complex. All the projects operate from a 9 volt battery supply (usually a small, PP3 size battery) and none connect to the dangerous mains supply, making them an ideal and safe introduction to electronics.

## MAKING THE PCB

Obviously it is necessary to have a printed circuit board (PCB) before constructing any of the projects described in this book, and building your own printed circuit board is a reasonably easy task provided it is tackled in the right way. Before proceeding to the projects we will therefore first consider the home-production of printed circuits for the benefit of readers who are unfamiliar with the techniques employed in this process. There are actually a number of similar ways of producing your own printed circuit boards, and the method that is described below is the one usually utilized by the author, and one that is also very simple and easy in practice.

### Tracing

First it is necessary to have a full size drawing giving the positions of the holes in the board, and this drawing must be actual size as it will be used as a drilling template. This can be traced from Figure 1 using either proper tracing paper or any thin paper such as typing copy paper, after cutting the paper down to the same size as the board. Some double-sided tape or Bostik Blue-Tak can be used to keep the paper in place while the tracing is being made.

Next a board of the appropriate size (approx. 78 x 42mm) must be cut out. Various types of copper laminate board are available, and in this non-critical application any single sided board should be perfectly suitable (i.e. any board coated with copper on one side, not one having both sides coated). For the home-constructor SPBP board is probably better than one having a fibre-glass base since the glass in fibre-glass tends to blunt drills, saws and files used to work the material, and the extra strength of this type of board is not usually needed in home-constructor projects. The board is cut to size using a hacksaw, and if necessary a file can be used to tidy up the sawn edges.

Now the holes in the board should be drilled, and in order to achieve this the tracing is fixed to the copper side of the board using double-sided tape or Bostik Blue-Tak. The holes

are then drilled through the drilling point marks on the tracing being as accurate as possible. Ideally a miniature drill fitted in a stand should be used to do this, but a hand drill can also be used, as can a full-size electric drill (although the latter is not recommended unless it is mounted in a stand). Accurately positioning the holes is likely to be very difficult without a stand for the drill, and one way around this problem is to use a bradawl or similar tool to make small indentations in the board at the points where the holes must be made. These will then tend to keep the drill bit in the correct place while each hole is drilled. However, be careful not to press too hard when making the indentations or the board could be damaged.

The ideal size for the holes for the component leadout wires is about 1mm or 3/64in. Using a diameter much larger than this is likely to make it difficult to solder the components into place neatly and reliably, while a diameter much less than this is quite possibly going to be too small to take the leadout wires of some of the components! Drills of such a small diameter are inevitably rather brittle and easily broken when compared to the larger types with which most people are more familiar. Treat them reasonably gently so as to avoid unnecessary breakages. The two larger holes in the board are the mounting holes and are 3.3mm in diameter. 6BA or M3 mounting bolts can be used.

The next step is to thoroughly clean the copper side of the board, and a simple way of doing this is to use a scouring pad, being sure to rinse off any soap from the board by running it under hot water (which will also help to remove any grease as well). The point of cleaning the board is that this helps to speed up the etching process, and it might otherwise be found that the etch resist will not take to the board properly. Once the board has been cleaned try not to handle the copper surface as this would tend to make the board greasy again.

The board is now ready for the etch resist to be applied, and the resist is simply paint or ink which is applied to the board over the areas where copper tracks are required. The board is then placed in the etchant which removes the copper from other areas of the board, leaving only the required copper tracks. You can use virtually any paint as the etch resist, but

it must of course be a water resistant type, and a quick drying type is preferable. The etch resist can be applied with a small brush, or an exhausted fibre-tip pen can be used in the same way as a brush. As the track pattern is fairly complex, on this PCB it is essential to apply the etch resist with a very fine brush or pen. Etch resist pens are available at quite low prices, and using one of these is almost certainly the easiest and most convenient way of applying the resist to the board. The copper track pattern is simply copied from Figure 1, and the finished result does not have to look as neat as the diagram. Provided there is a small pad of copper around each hole, and the tracks connect the holes together in the correct fashion the finished board should be perfectly usable. Make quite sure that the resist covers the appropriate areas properly and that the tracks are not excessively thin, otherwise on the etched board it is possible that there will be breaks in the tracks. If the resist should bridge two points that should not be bridged, simply let the resist dry and then scrape off the unwanted resist using a compass point or something of this nature.

### Etchant

The etchant normally used by home-constructors is ferric chloride, and this is available from a number of the larger component suppliers and it comes in three forms. The easiest way of obtaining it is as a ready made solution which is almost ready for use as supplied. It only needs to be diluted with water in a one to one ratio (or, at least, the solutions obtained by the author have always been of this type – if the solution is supplied with instructions stating other than this then these instructions should obviously be followed).

Anhydrous ferric chloride powder is available, but is not recommended as it is hard to make it into a solution. Ferric chloride is also available in crystalline form, and in this form it looks like chunks of yellow-brown rock. 500grms of ferric chloride crystals is sufficient to make about 1 litre of solution, and it is quite likely that the crystals will not dissolve very quickly. Using warm water and stirring the mixture will considerably speed up the process. One or two points must be

borne in mind here, and the most important of these is that ferric chloride is poisonous. It should therefore be treated carefully, wiping up immediately any that is spilt and disposing of the paper or rag used to soak it up. If you get any on your skin always wash it off at once using plenty of water. Do not use containers that are used for food when mixing or using the etchant. Another important thing to remember about ferric chloride is that it attacks many metals, and not just copper. In practice this means that you should not use or store it in a metal container, or even in one having a metal lid or cap. Use tweezers when manipulating boards in the solution, but plastic tweezers not metal ones.

Do not place the board in the ferric chloride solution until the resist has dried properly. Make sure that the etchant properly covers the copper side of the board with no air bubbles on the board. The board will etch more quickly if it is held upright or up-side-down in the solution, although it might be difficult to achieve this in practice. The board can usually be positioned up-side-down if the solution is held in a round bowl of a suitable size. When using this method it is essential to have some clearance between the underside (copper side) of the board and the container used to hold the etchant, or the etching process will be severely slowed down rather than speeded up. Using warm etchant and occasionally agitating it also helps to speed up the etching process.

The time taken for the etching to take place depends on numerous factors, but usually takes between about 5 minutes and an hour. Do not leave the board in the etchant any longer than necessary as this could result in the wanted copper being slowly removed along the edges of the resist and at any points where the resist is weak. Rinse the etched board to remove any ferric chloride solution and then remove the resist. It is possible to obtain resist remover, but a scouring pad is also suitable and will also make sure that the copper track is very clean so that good soldered joints can be made easily when fitting components onto the board.

It is not essential to buy the items needed to produce printed circuit boards one at a time, and a few etching kits and printed circuit kits are available and worthy of consideration.

For those who prefer not to make their own PCB's, a ready made PCB is available from Maplin Electronic Supplies Ltd., P.O. Box 3, Rayleigh, Essex SS6 8LR, Part No. GA79L, price £1.25 including V.A.T. at time of publication.

### Reusing the P.C.B.

Reusing the printed circuit board should not present any great difficulties, and provided component leadout wires are not bent over on the underside (copper side) of the board it should be very easy to remove components. With the board held in a vice or PCB support frame, simply apply the iron to the appropriate joint while gently pulling the body of the component so that the leadout is pulled clear of the board. Removing the integrated circuit is somewhat more difficult as it is not possible to pull a single pin clear of the board; they must all be pulled clear together. One way around this problem is to mount the integrated circuit on Soldercon pins. The integrated circuit can simply be unplugged from these, and then the pins can be removed one at a time.

An alternative method of removing the integrated circuit is to use desoldering equipment of some kind to take away the solder holding each pin in place so that the component can then be pulled clear. It is also a good idea to use desoldering equipment to remove any excess solder from the board prior to reusing the board. The cheapest method of desoldering (unless a great deal of desoldering is to be done) is to use desoldering braid or wick. This consists of copper braiding which is applied to the joint together with the iron and it draws up the molten metal. There are a number of simple desoldering tools which rely on suction to draw up the molten solder from the joint, and any of these should be usable here. Whatever method you use, be careful not to over-heat the integrated circuit, allowing it time to cool off between the desoldering of each pin if necessary. Also bear in mind that applying heat to the board for prolonged periods might damage the adhesive that holds the copper track to the board, causing the copper tracks to lift from the board.

## PROJECT 1

### ELECTRONIC DOORBuzzer

We are all probably familiar with the callers who take it out on the doorbuzzer if they are not answered within a few seconds of first operating the bell push. This is something that can easily be defeated using an electronic doorbuzzer as it is an easy matter to incorporate circuitry that inhibits the doorbuzzer for a certain period once it has been operated, and also prevents the unit from sounding for more than a certain period of time.

This simple doorbuzzer project produces an audio tone when the bell push is operated, but the tone automatically cuts out after about one second or so of operation, even if the bell push is activated continuously. Releasing the bell push and then immediately operating it again will give no output from the unit. Leaving only a brief pause before reoperating the bell push will give an audio tone from the unit, but only for a very short period before it will be cut off by the built-in inhibiting circuit. Thus the unit can fulfil its task as a doorbuzzer, but cannot cause annoyance by being operated incessantly.

#### The Circuit

This is one of the many circuits in this book which is based on a 555 timer integrated circuit, as can be seen by referring to the circuit diagram of the unit which appears in Figure 2. As the 555 device is used in so many of the designs featured in this book it would perhaps be as well to briefly look at this device before proceeding further. The block diagram of Figure 3 shows the arrangement of the stages within the 555 device in slightly simplified form. It also shows the basic method of connection used to operate the device in the astable (oscillator) mode. The stages and components within the broken lines represent the 555, and the components outside the broken lines are discrete components.

Initially the transistor will be switched off and capacitor Ca



will be totally uncharged. However, Ca immediately starts to charge from the supply rails by way of Ra and Rb, and this continues until the charge on Ca exceeds two thirds of the supply potential. The voltage supplied by Rc to Re is then less than that supplied by Ca to the other input of comparator 1, and the output of this comparator therefore changes state. This changes over the output state of the flip-flop (which has one of its inputs fed from the output of comparator 1) so that the transistor is now switched to the on state. The output stage formerly gave an output which was virtually equal to the positive supply rail potential, but this now changes to a potential only marginally higher than the negative supply voltage. The output stage is capable of sourcing or sinking fairly substantial currents incidentally (up to about 200mA in each case).

With the transistor now switched on the charge current which previously flowed through Ra is now directed straight to the negative supply rail through the transistor. The charge on Ca is leaked away through Rb and the transistor. This continues until the voltage across Ca falls below one third of the supply voltage, and the voltage fed to one input of comparator 2 by Rc to Re is then less than that fed to the other input from Ca. This results in the output of comparator 2 changing state, and this in turn resets the output of the flip-flop back to its original state. The transistor is thus back in the off state and the output stage gives an output which is practically at the positive supply potential.

Ca then starts to charge up by way of Ra and Rb, just as it did originally. This whole sequence of events thus continues indefinitely with a low impedance rectangular waveform being produced from the output at pin 3. The output signal is not a true squarewave having a mark-space ratio of one to one since Ca charges up through both Ra and Rb, but it only discharges through Rb (plus the insignificant resistance of the transistor). This obviously must give a charge time which is at least marginally longer than the discharge time, and therefore a high output period which is at least a little longer than the low output time. Of course, in many applications the output waveform is of no great importance and this basic 555 astable configuration has a great many practical uses.

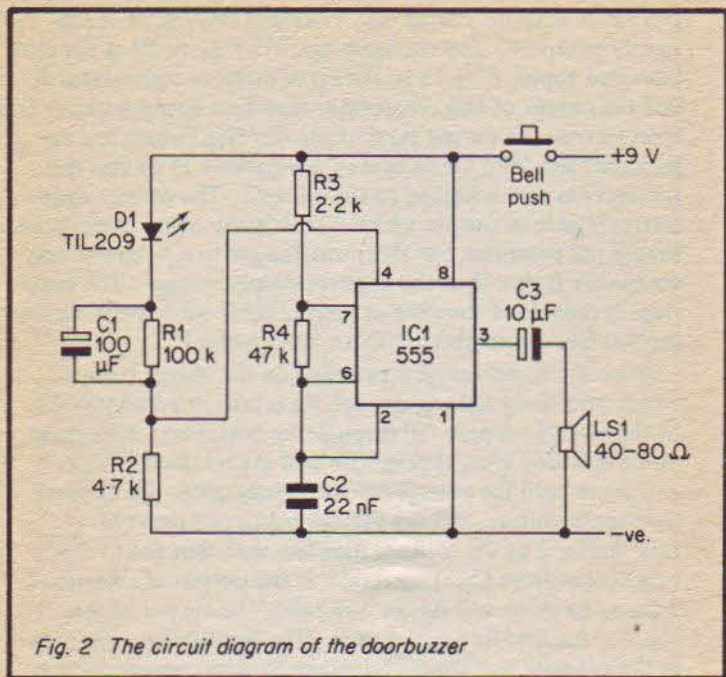

Fig. 2 The circuit diagram of the doorbuzzer

If we return now to the circuit diagram of the Doorbuzzer which appears in Figure 2, it will be seen that this uses what is virtually the same configuration as that shown in Figure 3. The timing components are R3, R4 and C2; the operating frequency of the unit being set at about 450 Hertz by the values given to these components. As R3 has a low value in comparison to that of R4 the output at pin 3 is very nearly a squarewave. This signal is applied to a high impedance loud-speaker via coupling capacitor C3, and although the output power fed into the speaker is only about 400mW RMS, this produces quite a loud audio tone from the speaker. The squarewave output is rich in harmonics which helps to avoid masking of the output by other sounds and makes the unit

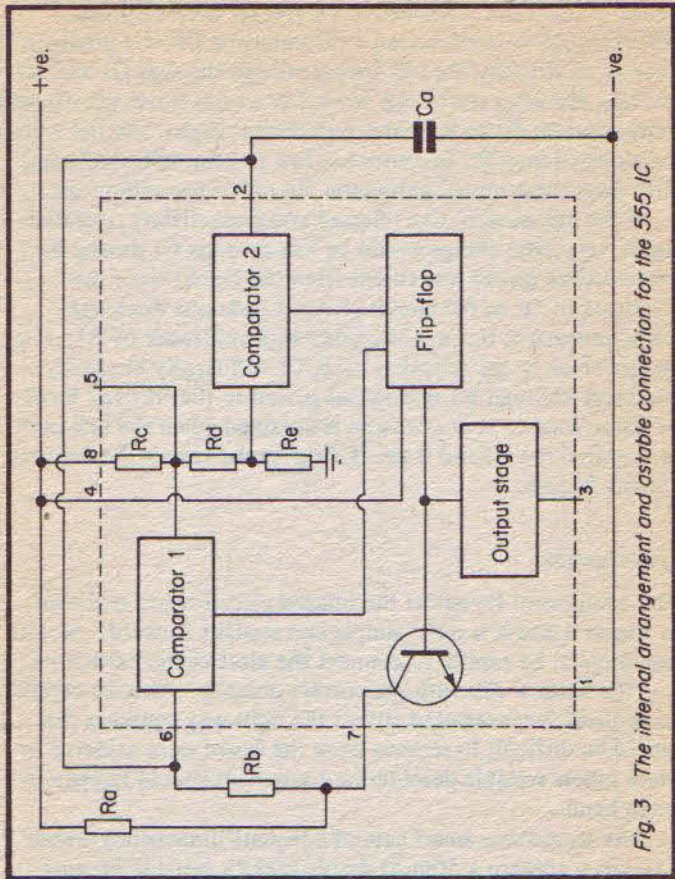

Fig. 3 The internal arrangement and astable connection for the 555 IC

nearly as effective as a modulated tone generator. It certainly seems to work well in practice.

The oscillator can only function if pin 4 of the 555 is taken to a potential of more than about 0.5 volts, since the internal discharge transistor of the device will otherwise stay in the on state and the output will go low continuously. When the bell-push is operated the circuit will indeed function properly because  $C_1$  will be uncharged, and pin 4 of IC1 will be taken

to the positive rail potential, less a voltage drop of about 2 volts through forward biased LED indicator D1. C1 gradually charges to virtually the full supply voltage through D1 and R2 though, and after about one second or so this leaves insufficient voltage across D1 to keep this component alight, and the voltage developed across R2 becomes too low to keep IC1 oscillating. This gives the required automatic cut off of the audio tone.

If the bell-push is now released and immediately operated again, very little charge would be lost through C1 during the period when power was absent from the circuit since the inclusion of D1 in the circuit gives C1 only one discharge path, and that is through the fairly high resistance of R1. If a longer break in the supply is used, C1 will largely or totally discharge through R1 during this period so that the full burst of audio tone or very nearly so is obtained when the bell-push is operated the second time. This gives the circuit the required inhibit feature.

## Construction

The component layout of the printed circuit board is shown in Figure 4 and it is quite simple and straight forward. As with any project, be careful to connect the electrolytic capacitors and the battery clip with the correct polarity. Also, be careful to connect the integrated circuit the right way round as this would be difficult to remove from the board once soldered in place unless suitable desoldering equipment should happen to be to hand.

Any reasonably smart case of adequate dimensions (about 150mm x 100mm x 50mm) should make a suitable housing for this project. The loudspeaker and the LED indicator are mounted on the front panel, and the LED is mounted in a panel holder of the appropriate size and type. Mounting miniature loudspeakers is not usually quite so easy as they only very rarely have any provision for screw fixing, and it is usually necessary to carefully glue them in place. First it is necessary to make a speaker grille of some kind in the correct part of the front panel, and one method of achieving this is to make a circular cutout using a fretsaw or coping saw. A piece of speaker

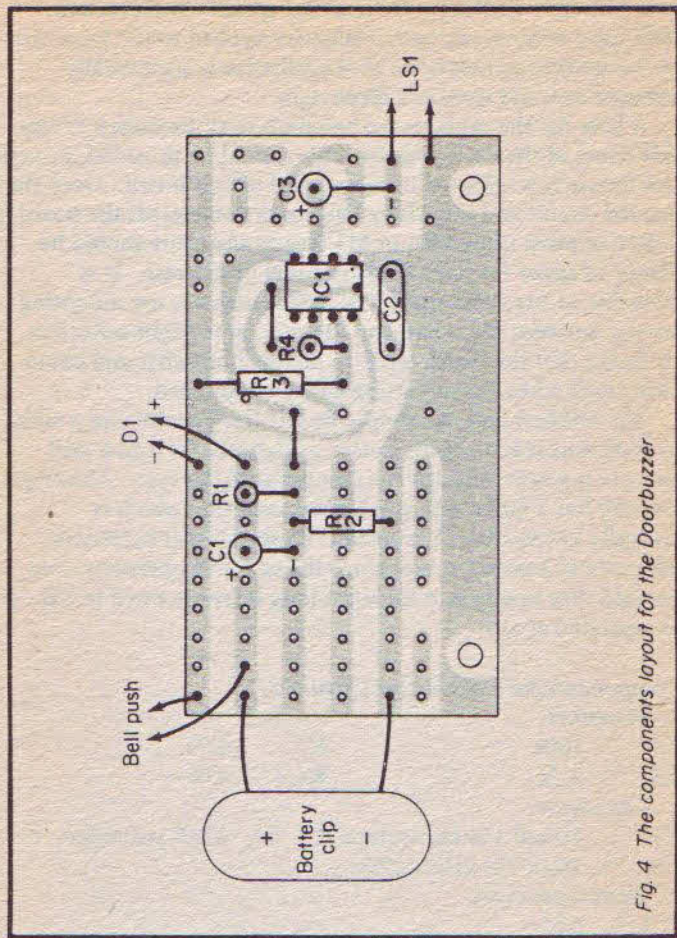

Fig. 4 The components layout for the Doorbuzzer

fret or speaker material is then glued in place behind this. A much easier alternative is to drill a neat group of holes in the panel to produce the grille. One word of warning though, with this second method it is necessary to be very careful and accurate with the positioning of the holes as the finished grille will otherwise look very untidy and scrappy. Use a strong

general purpose adhesive to bond the speaker in place, and only use a modest amount of adhesive applied to the front rim of the speaker so that none of the adhesive is accidentally smeared over the speaker's diaphragm.

A hole for the cable to the bell-push must be drilled in one side panel of the case, and the cable should be threaded through this before it is soldered to the printed circuit board. Once the printed circuit and the wiring have been completed, the board is bolted in place using 6BA or M3 fixings and there should be plenty of space for it on the base panel of the case. It is advisable to use short spacers or extra nuts over the mounting screws, between the board and the case, as it might otherwise be found that the board tends to distort somewhat and could even crack when the mounting nuts are tightened.

The finished unit can simply be left free-standing on a table or shelf, but it is probably better to securely fix it to a wall using two screws through the rear panel of the case. Although the unit has a fairly high current consumption which is typically around 40mA, a small (PP3 size) 9 volt battery is adequate as a power source since the unit will obviously only be used very briefly and there are long intervals when it will not be operated at all.

### *Components for Doorbuzzer (Figure 2)*

#### *Resistors*

R1	100k	R2	4.7k
R3	2.2k	R4	47k

#### *Capacitors*

C1	100 $\mu$ F 10v electrolytic	C2	22nF polyester
C3	10 $\mu$ F 25v electrolytic		

#### *Semiconductors*

IC1	555
D1	TIL209

#### *Miscellaneous*

- Case,
- Miniature loudspeaker having an impedance in the range 40 to 80 ohms (LS1)
- Printed circuit board
- PP3 battery and connector to suit
- Bell push, connecting wire, solder, etc.

## PROJECT 2

### LIGHT DETECTOR

There are a great many types of light operated circuit, and the most simple types are those where either an audio alarm is generated or a relay is activated when the photocell receives a light intensity which is above some threshold level. This simple project is a circuit of this type, and the unit sounds an audio alarm tone if the photocell is subjected to a reasonably high light intensity (the light level in a normally lit room should be sufficient to activate the unit).

#### The Circuit

The circuit diagram of the Light Detector unit appears in Figure 5 and this is another 555 astable based project, as will be obvious from the circuit diagram.

As was the case with the previous project, the operating frequency of the 555 oscillator is set at about 450 Hertz by the values used in the timing circuit. The output waveform is a string of brief pulses in this case though, since the value of R3 is low when compared to that of R2. This gives quite a loud and penetrating alarm signal but gives only a fairly low current consumption. C2 couples the output signal to the loudspeaker, and although there is no obvious need for a DC blocking capacitor, this capacitor does in fact have an important purpose. A high current load direct across the output of a 555 device can sometimes result in a malfunction of the circuit, and in this circuit the output is normally high (virtually equal to the positive supply potential) and only goes low (almost at the negative supply voltage) during the brief negative output pulses. This would give a high average current through the speaker and consequently a high average current consumption when the alarm was operating. This could be overcome by connecting the speaker between pin 3 of IC1 and the positive supply rail, but as the output of IC1 does not go fully positive this would still leave a substantial current

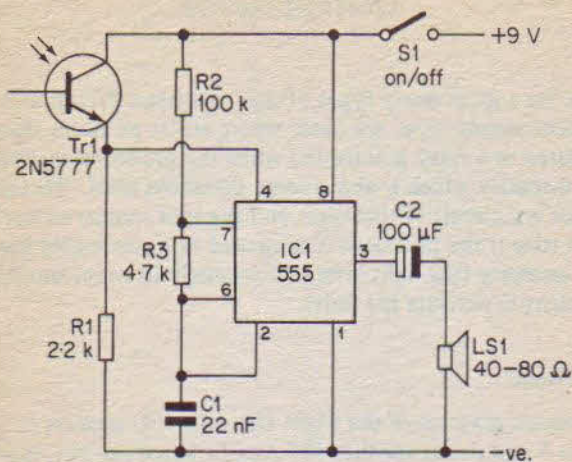

Fig. 5 The circuit diagram of the light detector

through the loudspeaker during the positive output periods. The use of a DC blocking capacitor at the output overcomes this problem, and such a capacitor is used in all the circuits in this book which have a 555 device driving a loudspeaker.

As in the previous circuit, the 555 is gated on or off by means of a control voltage applied to pin 4 of the device. The control voltage is derived by a potential divider which consists of the collector-to-emitter resistance of Tr1 and the resistance of R1. Tr1 is a photo-Darlington transistor, and this is basically just an ordinary photo-transistor connected in the Darlington configuration with a second device so as to give a considerable boost in sensitivity. In this circuit the base terminal of the device is not used and we are simply using the collector and emitter terminals to give a sort of light dependent resistance. The resistance between these two terminals will be very high



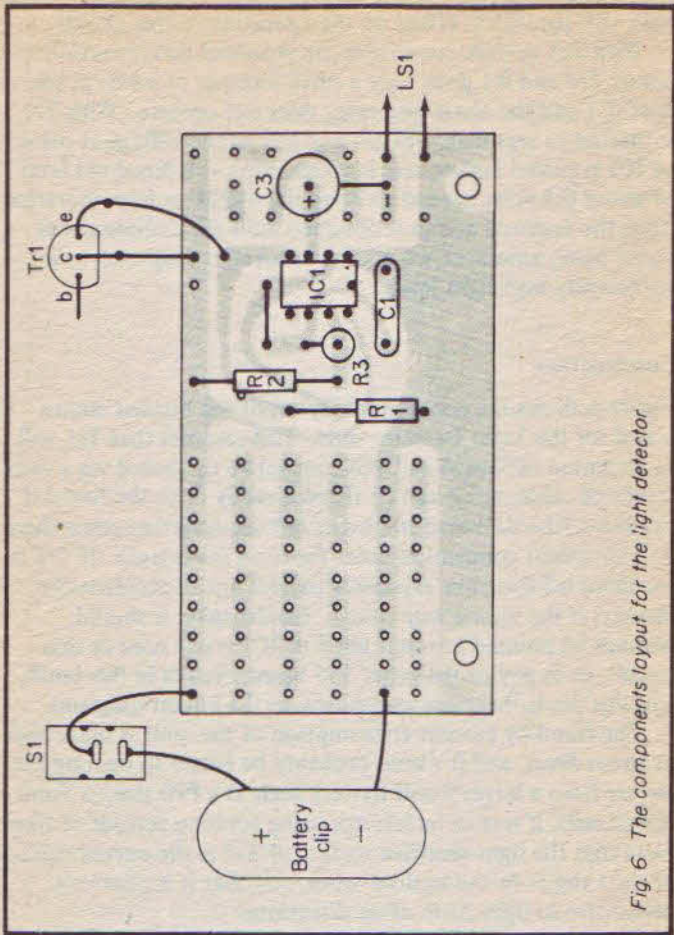

Fig. 6 The components layout for the light detector

(typically many megohms) if the device is placed in total darkness, but only a few hundred ohms if the photo sensitive surface is subjected to a very high light intensity. Strictly speaking the device does not have pure resistance as the effective resistance varies somewhat with changes in the voltage applied to the device, but this effect is too limited to

have any significant effect on the operation of this circuit.

With Tr1 in dark conditions the potential divider action across Tr1 and R1 gives only a small fraction of a volt at pin 4 of IC1 and the alarm generator does not operate. With Tr1 subjected to reasonably bright conditions the voltage at pin 4 of IC1 is pulled higher, and is taken above the threshold level of about 0.5 volts needed to bring the oscillator into operation. Thus the required action is obtained with the audible alarm signal being generated when the photocell is subjected to a sufficiently high light level.

### Construction

Figure 6 shows the component layout of the printed circuit board for the Light Detector unit. This assumes that Tr1 will be mounted off-board and will connect to the board via a twin insulated cable, but it can be fitted directly onto the board if preferred (the base lead still being left unconnected since there is no convenient connection point for it on the board). If Tr1 is mounted off-board be especially careful not to accidentally connect it the wrong way round. Incidentally, it should perhaps be pointed out that pin 5 of IC1 is not used in this circuit, or in any of the other 555 based circuits in this book, and this pin is therefore not shown on the circuit diagrams.

The stand-by current consumption of the unit is quite high at about 8mA, and it would probably be better to operate the circuit from a larger 9 volt battery such as a PP9 size, or from NiCad cells, if it is to be left operating for long periods of time. Note that the light sensitive surface of Tr1 is the curved surface at right angles to the leadout wires, and that it is relatively insensitive to light from other directions.

If necessary, the sensitivity of the circuit can be boosted somewhat by increasing the value of R1 to 4.7k. Similarly, the sensitivity can be reduced somewhat by reducing the value of R1, or by connecting another 2.2k resistor in parallel with it.

### *Components for Light Detector (Figure 5)*

#### *Resistors*

R1	2.2k	R2	100k
R3	4.7k		

*Capacitors*

C1      22nF polyester                      C2      100 $\mu$ F 10v electrolytic

*Semiconductors*

Tr1      2N5777

IC1      555

*Switch*

S1      SPST miniature toggle type

*Miscellaneous*

Case

Printed circuit board

PP3 size battery and connector to suit

Miniature loudspeaker having an impedance in the range  
40 to 80 ohms (LS1)

Wire, solder, etc.

## PROJECT 3

### DARKNESS DETECTOR

This circuit is really just a slight modification of the previous one, and the unit sounds the audible alarm when the photocell is subjected to a light level which is quite low, rather than when it is subjected to a fairly high light level. In a normally lit room the light level is quite sufficient to prevent the alarm from being activated, but the light intensity does not have to fall very far below this level in order to trigger the unit.

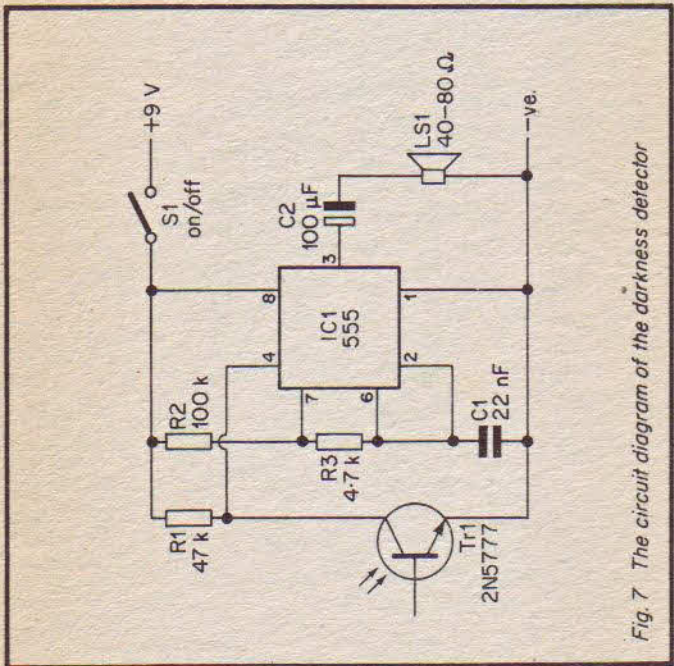

Fig. 7 The circuit diagram of the darkness detector

## The Circuit

The circuit diagram of the darkness detector unit is given in Figure 7. The oscillator section of the unit is exactly the same as the oscillator circuit used in the previous project of this book, and this will not be considered in detail here.

The light level detector part of the circuit only differs from

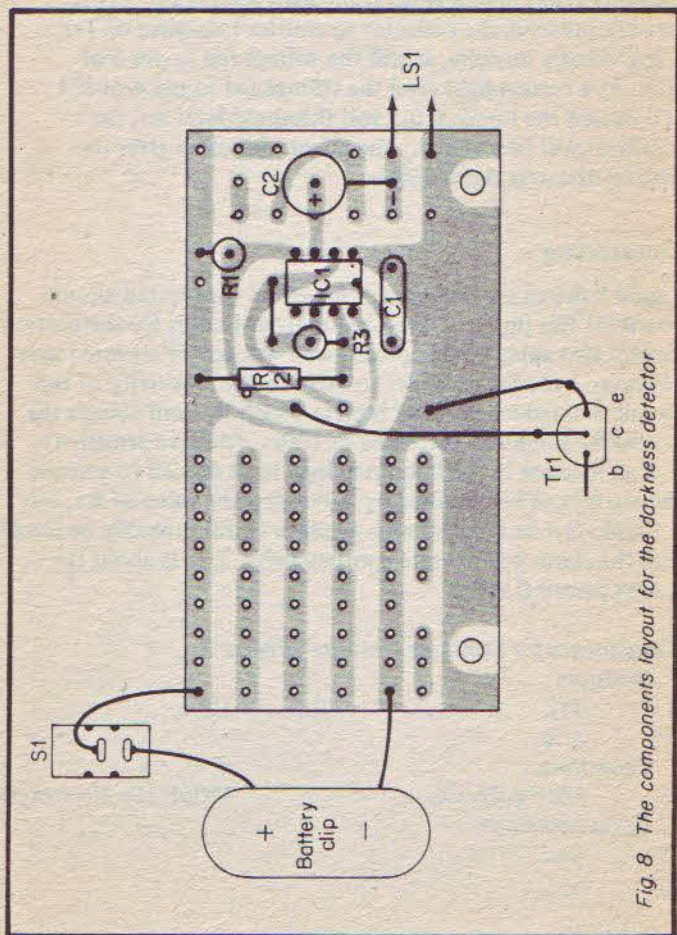

Fig. 8 The components layout for the darkness detector

that employed in the previous circuit in that the positions of the transistor and resistor have been reversed, and the resistor has been made higher in value so that the light threshold level of the circuit is at a more useful level for this application.

If Tr1 is subjected to a high light level, its collector to emitter resistance is quite low and due to the fairly high value of R1 it pulls the voltage at pin 4 of IC1 down to only a minute fraction of a volt. If the light level fed to Tr1 is steadily reduced, the collector to emitter resistance of Tr1 will gradually increase, as will the voltage fed to pin 4 of IC1. At a certain light level the voltage fed to pin 4 of IC1 will exceed the nominal 0.5 volt threshold level and the oscillator will be enabled. The circuit therefore gives the desired darkness alarm action.

### Construction

Figure 8 shows the component layout of the printed circuit board for this project. The constructional notes for the previous project also apply to this project and will not be repeated here. However, note that in order to increase the sensitivity of this circuit (i.e. reduce the light level at which the unit sounds the alarm) R1 should be increased to 100k. Reduced sensitivity (i.e. an increase in the minimum light level needed to activate the alarm) can be obtained by decreasing the value of R1, but it should not be reduced very much or it will probably be found that the alarm will operate continuously. 2.2k is about the lowest practical value.

### *Components for Darkness Detector (Figure 7)*

#### *Resistors*

R1	47k	R2	100k
R3	4.7k		

#### *Capacitors*

C1	22nF polyester	C2	100 $\mu$ F 10v electrolytic
----	----------------	----	------------------------------

#### *Semiconductors*

Tr1	2N5777
IC1	555

*Switch*

S1 SPST miniature toggle type

*Miscellaneous*

Case

Printed circuit board

PP3 battery and connector to suit

Miniature loudspeaker having an impedance in the range  
40 to 80 ohms (LS1)

Wire, solder, etc.

## PROJECT 4

### LATCHING LIGHT DETECTOR

The light detector circuit described earlier in this book does not have a built-in latching action, and it therefore switches off the audible alarm signal when the light level falls back below the triggering threshold level. This can be a severe drawback in some applications, and a latching action that keeps the alarm operating after the light level has returned below the trigger threshold is a useful feature that is easily achieved.

Such a latching action is incorporated in the light activated switch which is described below.

#### The Circuit

The complete circuit diagram of the latching light detector unit can be found in Figure 9.

As in the previous two light activated switch circuits, the unit is built around a 555 astable which is controlled by means of the voltage applied to pin 4 of the 555. In this case the control voltage is obtained from the output of a simple bistable multivibrator which uses Tr1 and Tr3 in a conventional bipolar bistable arrangement.

At switch-on the base of Tr1 will be at zero volts since C1 will initially have no charge, but Tr3 will be biased hard into conduction by the base current it receives through R1 and R2. Therefore the circuit stabilises with Tr1's collector at virtually the full positive supply potential and the collector of Tr3 at practically zero volts. The voltage fed to pin 4 of IC1 is therefore practically zero as well, and the oscillator is inhibited. This all assumes that Tr2 is subjected to a fairly low light level, since it will exhibit a low resistance if it is subjected to a reasonably high light intensity. The potential divider action across R1, R2 and the collector to emitter resistance of Tr2 then prevents the voltage at the base of Tr3 from reaching a high enough level to bias this device into conduction. Tr3 is then cut off and its collector voltage rises to virtually the full



supply potential so that the 555 astable is able to function normally.

With Tr3's collector at this potential, Tr1 is biased hard into conduction by the base current it receives from Tr3's collector via R3. As a result of this, Tr1's collector voltage falls to practically zero, and Tr3 can no longer be biased into conduction by way of R3. Once in this state the circuit therefore latches in it and the light level received by Tr2 becomes irrelevant.

The circuit can be reset to the opposite state with the alarm switched off by simply closing S1 momentarily. This short circuits the base of Tr1 to the negative supply so that Tr1 switches off and its collector potential rises to virtually the full positive rail voltage. Provided Tr2 is not subjected to a high light level, Tr3 is then biased into conduction from Tr1's collector via R2 so that Tr3's collector returns to practically zero volts, cutting off the oscillator and the base bias current to Tr1 via R3. The circuit therefore latches in this state when S1 is opened since the bias for Tr1 is no longer available.

Apart from ensuring that the circuit initially assumes the correct state with the audible alarm muted, C1 also helps to prevent spurious triggering of the circuit to stray pick-up of noise spikes caused by car ignition noise, lighting, thermostats, etc.

## Construction

The printed circuit layout for this project is shown in Figure 10, and although this is somewhat more crowded than most of the other printed circuit layouts in this book, it is still quite easy to construct and there should be no problems here. Like most of the printed circuit layouts in this book there are link wires which must be soldered to the board, and there are three of them in this layout. It is probably easiest to add the link wires before soldering the other components in place, and it is not necessary to use insulated leads. Bits of wire trimmed from resistor or capacitor leadouts should be ideal.

Like the other two light detector circuits this one has a fairly high current consumption of about 8mA, and it is

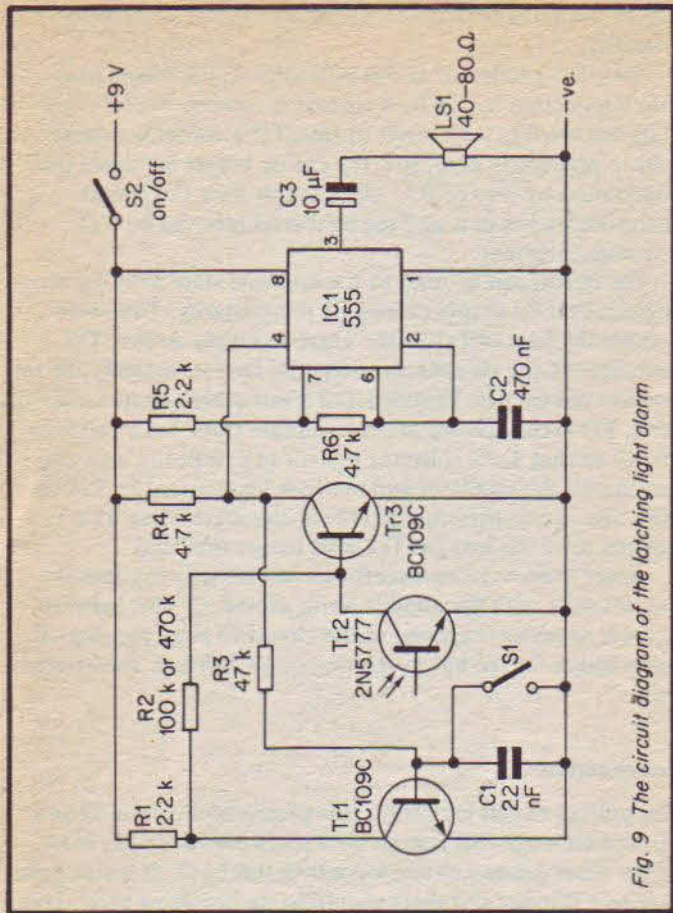

Fig. 9 The circuit diagram of the latching light alarm

recommended that a large 9 volt battery or NiCad cells should be used as the power source if it is to be used for long periods of time.

The value of R2 controls the sensitivity of the circuit, and with a 100k component used in this position the unit will probably not quite trigger in a normally lit room. Using a 470k

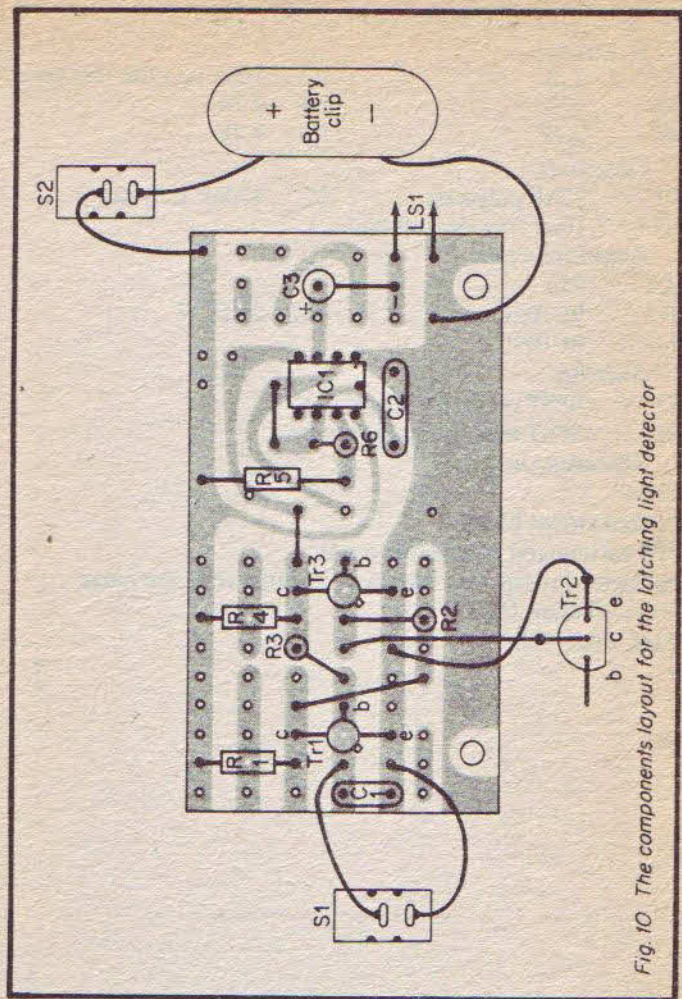

Fig. 10 The component layout for the latching light detector

component for R2 considerably reduces the light threshold level at which the alarm is activated, and the unit will then probably trigger even in the light of a very dimly lit room.

## *Components for Latching Light Alarm (Figure 9)*

### *Resistors*

R1	2.2k	R2	100k or 470k (see text)
R3	47k	R4	4.7k
R5	2.2k	R6	4.7k

### *Capacitors*

C1	22nF polyester	C2	470nF polyester
C3	10 $\mu$ F 25v electrolytic		

### *Semiconductors*

IC1	555		
Tr1	BC109C	Tr2	2N5777
Tr3	BC109C		

### *Switches*

S1	SPST miniature toggle type
S2	SPST miniature toggle type

### *Miscellaneous*

Case

Printed circuit board

PP3 battery and connector to suit

Miniature loudspeaker having an impedance in the range 40 to 80 ohms (LS1)

Wire, solder, etc.

## PROJECT 5

### CONTINUITY TESTER

A continuity tester is simply a device which indicates in some way whether or not there is electrical continuity between two test prods. Units of this type usually provide either a visual indication in the form of a meter or a LED indicator, or an audible indication in the form of an audio tone. The second method is generally the better one since it does not require the user to look away from the test prods, and this can often be of importance since the test prods may well be awkwardly placed when making tests, especially when checking complex circuit boards.

Continuity testers are useful for simple tests, such as checking fuses and cables, and can also be used for checking circuit boards for accidental short circuits between copper tracks due to pieces of excess solder or faulty components. When checking circuit boards in this way a common problem is false alarms due to diodes or other semiconductor junctions (part of an integrated circuit or transistor for example) providing a low impedance path between the test prods. This problem is easily overcome using a continuity tester which will only indicate continuity if there is a very low voltage drop across the two test prods. Silicon semiconductor junctions produce a voltage drop of about 0.6 volts when forward biased, and this drop is thus sufficient to prevent continuity being indicated and a false alarm being produced.

This simple continuity tester is designed so that it will not indicate continuity if the test prods are connected so as to forward bias a silicon semiconductor junction, and it will only respond if there is a fairly low resistance between the test prods. The unit might indicate continuity if a germanium semiconductor junction is connected across the test prods so that it becomes forward biased by the current that flows, and this is due to the relatively low voltage drop across a germanium junction (usually only about 0.1 to 0.2 volts). This is not really a significant shortcoming these days since the majority of

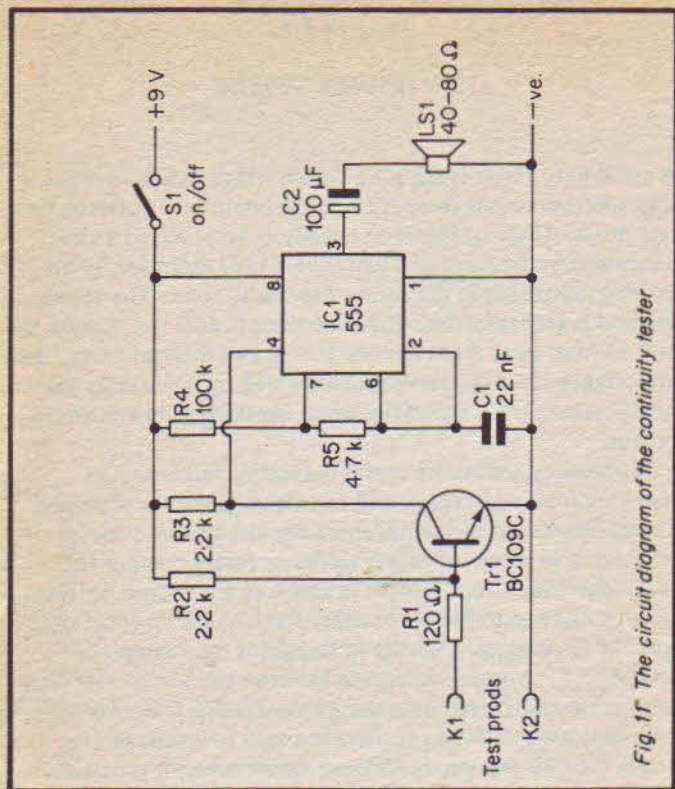

Fig. 11 The circuit diagram of the continuity tester

germanium devices are now obsolete and are unlikely to be encountered very often, if at all.

### The Circuit

The circuit is a type which produces an audible tone to indicate continuity, the tone being generated by a 555 astable circuit. Figure 11 shows the complete circuit diagram of the Continuity Tester.

The tone generator circuit is the same as that used in some of the previous projects, and it gives a nominal 450 Hertz pulse

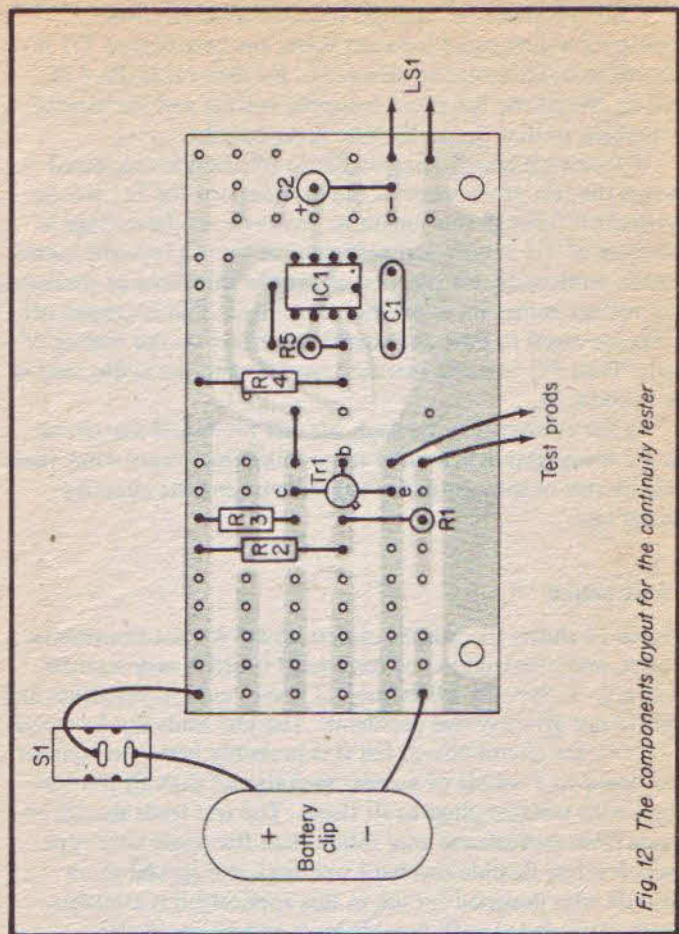

Fig. 12 The components layout for the continuity tester

signal to the loudspeaker. Also in common with some of the previous circuits the 555 astable is controlled by a voltage fed to pin 4 of the 555. Under stand-by conditions this voltage will be only fractionally higher than the negative supply rail potential because Tr1 will be biased hard into conduction by R2. The astable is therefore switched off.

If the test prods are shorted together, or a very low resistance is connected between them, the base bias to Tr1 is cut off and this device switches off. R3 then takes pin 4 of IC1 to almost the full positive supply voltage and the astable is enabled so that the audio tone is produced.

If a forward biased semiconductor junction is connected across the test prods some of the base current for Tr1 will be tapped off through this junction. However, as the voltage at the base of Tr1 is only just sufficient to bring a forward biased silicon semiconductor junction above the threshold of conduction, the voltage across R1 and hence the current that is tapped off is far too small to have any significant effect on the biasing of Tr1. Thus Tr1 remains switched hard on and the audio tone is not produced.

As the current flow through the test prods and the circuit under investigation is limited to no more than about 4mA there is little risk of the continuity tester damaging the circuitry under test.

## Construction

Figure 12 shows the printed circuit layout for the Continuity Tester, and construction of the circuit board is very straight forward. In fact the whole project is very easy to construct and should not give any real problems. The test leads can be wired direct to the circuit board, but it is probably better to connect the board to a couple of wander sockets and then fit the test leads with suitable plugs to fit these. The test leads should be made from multistrand wire rather than the single core type (which is less flexible and hard wearing), and special extra flexible wire designed for use in this application is available. Prods ready fitted with flexible leads and plugs are also available.

### *Components for Continuity Tester (Figure 11)*

#### *Resistors*

R1	120 ohms	R2	2.2k
R3	2.2k	R4	100k
R5	4.7k		



*Capacitors*

C1 22nF polyester

C2 100 $\mu$ F 10v electrolytic

*Semiconductors*

IC1 555

Tr1 BC109C

*Switch*

S1 SPST miniature toggle type

*Miscellaneous*

Case

Printed circuit board

PP3 battery and connector to suit

Miniature loudspeaker having an impedance in the range  
40 to 80 ohms (LS1)

Test prods and leads

Wire, solder, etc.

## PROJECT 6

### BENT WIRE GAME

The bent wire game is by no means a new idea, in fact it is a very old one. Probably most readers will already be familiar with this game where a small metal ring with a lead attached is passed along a length of wire. The wire is bent into a very irregular twisted shape to make it difficult to pass the ring along the wire without touching the two together, which is of course, the point of the game.

There has to be some method of showing when the ring and the wire are in contact, and the traditional method is to connect the wire and the ring into a simple circuit so that a bell rings or a light bulb switches on when the two are touched together and the circuit is completed. A modern equivalent of this could simply consist of an electronic buzzer or a LED indicator connected so that it would switch on if the wire and the ring were brought into contact. However, it is possible to add a simple refinement to an electronic version of the game in the form of a simple timer circuit which causes the alarm signal to stay on for a second or two even if the wire and the ring are only touched together momentarily. This avoids the possibility of the two being touched together so briefly that the alarm does not have time to operate effectively, or is not noticed.

The simple circuit described here has such a timer built-in and gives an audible alarm signal when the wire and ring come into contact.

#### The Circuit

Figure 13 shows the circuit diagram of the bent wire game, and this is another circuit which uses a 555 astable to drive a loud-speaker and produce an audible tone. The oscillator is in fact very much the same as the one used in several of the previous projects, and also in common with some of these projects, the oscillator is controlled by means of a voltage applied to pin 4 of the 555.

Pin 4 of IC1 is fed from the junction of timing components C1 and R1, and these components are connected across the supply rails. At switch-on C1 will be uncharged and pin 4 will be taken to the positive supply rail voltage. However, C1 will soon charge up to the point where the voltage fed to pin 4 of IC1 is no longer sufficient to permit oscillation, and the audible tone signal therefore cuts off about one second or so after switch-on.

The bent wire and the ring are connected in parallel with C1, and if they should short circuit together, even very briefly, C1 will be almost instantly discharged and the audible tone signal will again be produced for about a second until C1 almost fully charges again. This gives the required clear indication that the two have been touched together.

## Construction

Electrically the unit is very simple to construct, and the component layout for the printed circuit board is shown in Figure 14.

Mechanical construction is somewhat less straight forward since it is necessary to incorporate the bent wire and the ring in the unit. Probably the best way of doing this is to use a plastic case with the loudspeaker and the on/off switch fitted on the front panel. The bent wire can then be mounted on top of the case, and one way of achieving this is to drill small holes at opposite ends of the top panel and then thread one end of the wire through each hole. The ends of the wire can then be bent flat against the underside of the top panel and glued in place using a good quality gap filling adhesive. An epoxy adhesive is probably the best type to use for this. The wire must be fairly thick, and a piece of wire cut from a wire coat-hanger was used on the prototype. However, it does not have to be quite as thick as this and a piece of 16swg (or thereabouts) tinned copper wire would be a suitable alternative, and can be obtained from most of the larger electronic component retailers. Of course, the wire must not be insulated, but a small length at each end should be insulated so that the ring can be rested at either end of the wire without the alarm signal sounding. This insulation can

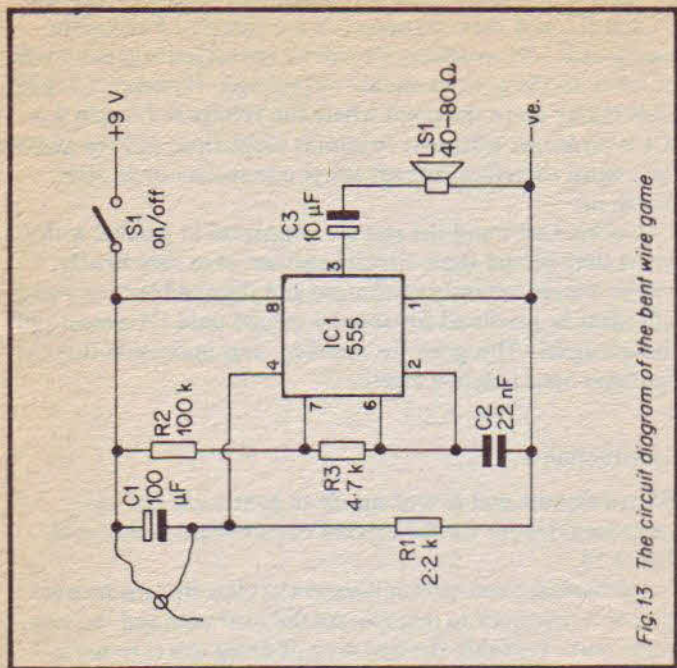

Fig.13 The circuit diagram of the bent wire game

simply consist of a couple of bands of insulation tape applied to the wire at the appropriate place. The connection to the wire can be made using a direct soldered connection, although this might be difficult in some cases. Another method is to use a small crocodile clip to make this connection.

The ring and the lead attached to it can actually be made from a single piece of single strand PVC covered wire; one end being threaded through a hole drilled in the case and then connected to the circuit board, and the other having about 50mm of insulation removed. The bare wire is then looped around the bent wire, and the bare wires are then twisted together to reduce the size of the loop to the required level. The loop can then be carefully bent into a neat circle. The final size of the loop is best determined by trial and error since

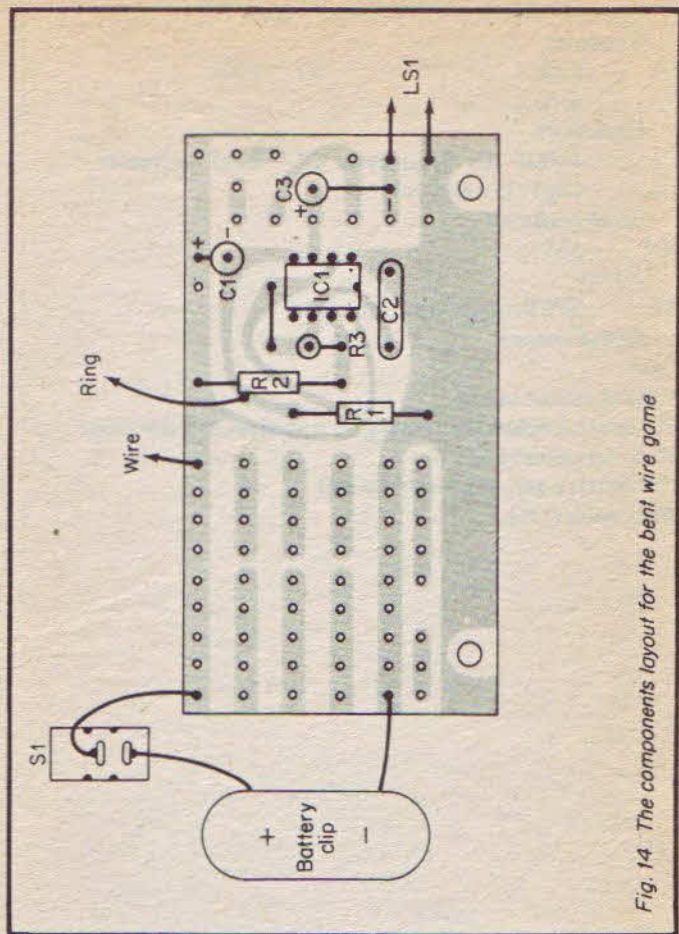

Fig. 14. The components layout for the bent wire game

this largely controls the difficulty of the game. Making the loop only slightly too small makes the game practically impossible while making it only a little on the large side makes the game extremely easy. This method of producing the loop makes it quite easy to alter the size of the ring if necessary.



## PROJECT 7

### MORSE PRACTICE OSCILLATOR

The ability to read and send Morse coded messages is an extremely useful asset, especially for anyone interested in radio DXing, boating, and a number of other activities. When learning Morse code it is extremely useful to have a simple Morse practice oscillator of some kind, preferably together with a good quality Morse key and a tape recorder. The latter is useful for making your own Morse practice tapes to help you to learn to read Morse code. Although not generally realised, the ability to send Morse coded messages and the ability to read them are two quite different things, and simply learning to send Morse coded signals does not automatically give one the ability to read Morse as well.

#### The Circuit

A 555 astable circuit is the obvious choice for a unit of this type, and as can be seen from the circuit diagram of Figure 15 this unit is basically just a 555 astable feeding a high impedance loudspeaker.

Ideally a device of this type should provide a reasonably pure output signal as the output signal might otherwise become rather tedious to listen to after a while, and a pure sinewave signal is the type of output obtained from a radio receiver when receiving Morse coded signals. In this case a reasonably pure output signal is obtained by making R2 high in value when compared to R1 so that a mark space ratio of virtually one to one is obtained at the output, and C3 is used to attenuate the higher frequency harmonics on the output signal. Further attenuation of these harmonics could be obtained by using a higher value component in the C3 position, but this is probably not advisable as it could greatly increase the current consumption of the unit. The Morse key is connected in the positive supply lead so that it simply switches the unit on when depressed, and switches it off when released.

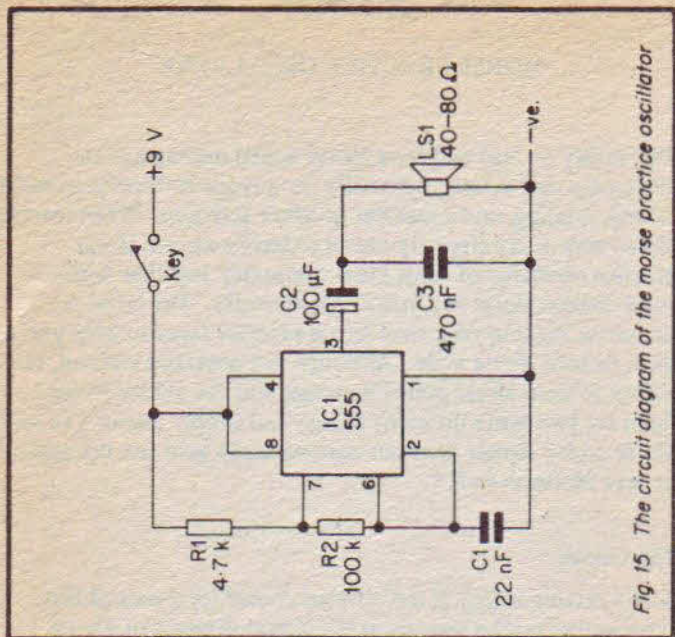

Fig. 15 The circuit diagram of the morse practice oscillator.

### Construction

The printed circuit board layout for the Morse Practice Oscillator is given in Figure 16, and both mechanical and electrical construction of the unit are quite easy and straight forward. The Morse key can be permanently wired to the printed circuit board with an entrance hole for the lead being drilled in the front panel of the case, but it is probably better to connect the appropriate two leads from the circuit board to a two way socket, and then fit the cable from the Morse key with a matching plug. A 3.5mm jack is a suitable type of connector.

If the unit is used to make recordings to help with Morse decoding practice, one way of achieving this is simply to use a microphone to pick-up the sound produced by the unit and thus give an acoustic coupling from the oscillator to the recorder.



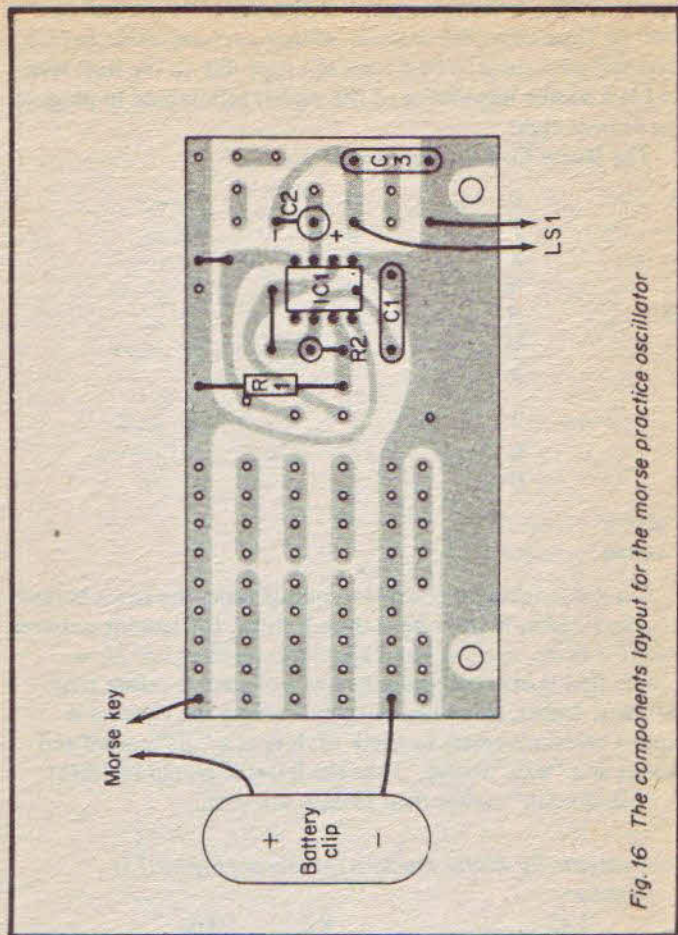

*Fig. 16 The components layout for the morse practice oscillator*

An alternative method is to couple the output of the unit (which can be taken from across the loudspeaker terminals) direct into a high level input of the recorder (not a microphone input as this would probably be overloaded). If the second method is used it will be more convenient in use if the output signal from the speaker terminals is taken to a 3.5mm jack



Printed circuit board

PP3 battery and connector to suit

Miniature loudspeaker having an impedance in the range  
40 to 80 ohms (LS1)

Morse key

Wire, solder, etc.

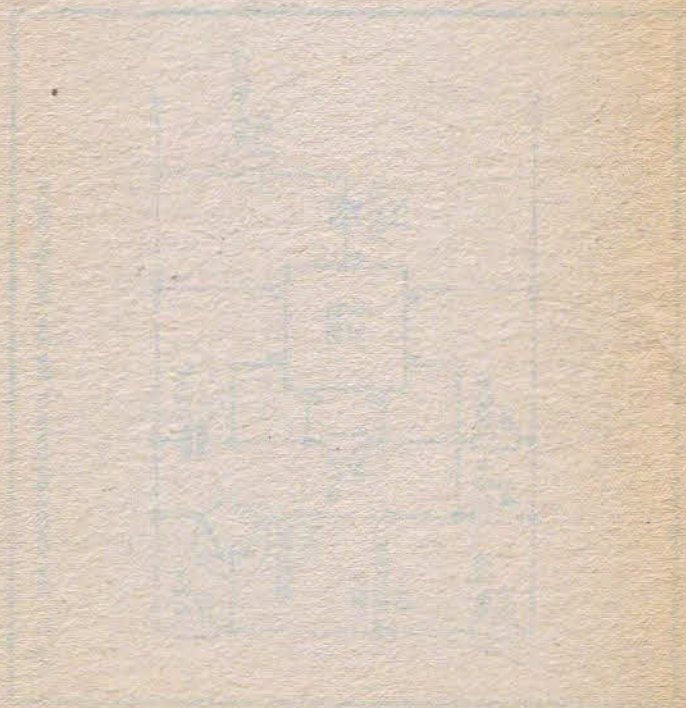

## PROJECT 8

### LOW VOLTAGE ALARM

This alarm circuit is primarily intended for use in cars or boats, and it gives a warning if the battery voltage of the car or boat falls below a nominal level of 10.5 volts. This threshold level can be changed slightly if desired. Units of this type often give the low supply voltage warning in the form of an indicator light that switches on, but the warning light is easily overlooked. In this design, therefore, the warning is given by an audible alarm signal which cannot easily be missed.

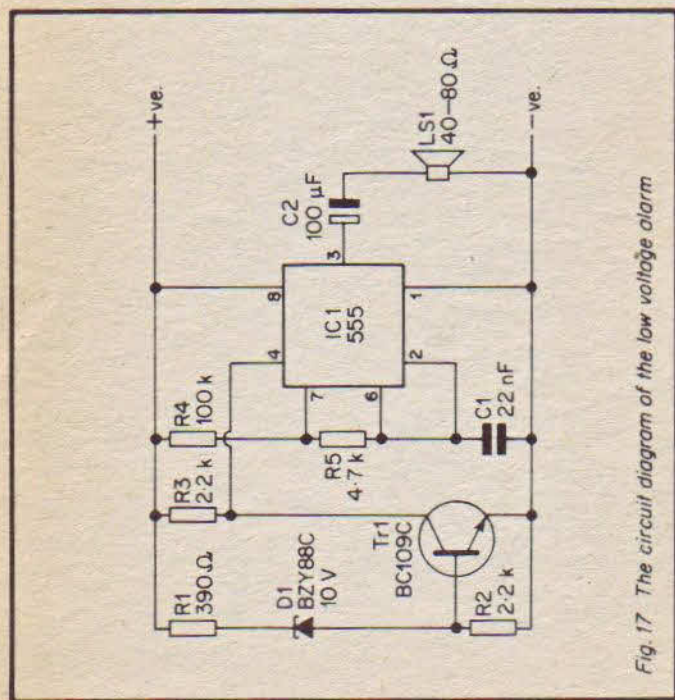

Fig. 17 The circuit diagram of the low voltage alarm

## The Circuit

Figure 17 shows the complete circuit diagram of the low voltage alarm unit, and once again this uses a 555 astable driving a high impedance loudspeaker to generate the alarm signal, with the astable being controlled using a voltage applied to pin 4 of the 555.

If the supply voltage is at more than about 10.5 volts D1 will be biased beyond its avalanche voltage and will conduct,

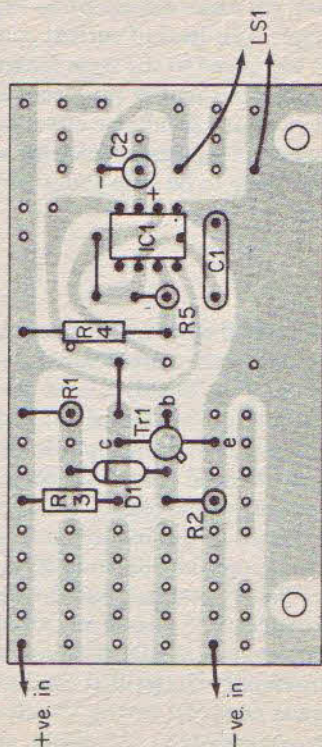

Fig. 18 The components layout for the low voltage alarm

and there will be sufficient voltage developed across R2 to bias Tr1 hard into conduction. This gives a matter of only a few tens of millivolts at the collector of Tr1, and this voltage mutes the astable circuit.

A supply voltage of less than about 10.5 volts may keep D1 in a state of conduction, but the voltage developed across D1 then leaves a potential across R2 that is too small to bias Tr1 into conduction. With Tr1 cut off R3 takes pin 4 of IC1 almost fully positive and the astable is enabled. Thus the alarm signal is produced when the supply falls below the 10.5 volt threshold level.

The circuit has a current consumption of around 10mA under stand-by conditions, the exact consumption depending on the actual supply voltage. This level of current consumption is insignificant when compared to the large capacity of a 12 volt car battery, and adding this unit to the electrical system of a car or boat should not have an adverse effect on the battery. The current consumption increases somewhat when the alarm operates, but is still likely to be only about 20mA or so and of no real significance.

## Construction

Figure 18 gives the printed circuit component layout for the Low Voltage Alarm unit, and there should be no problems with the construction of the board, or with the mechanical construction of the unit for that matter. If desired, an on/off switch can be inserted in one of the input leads of the unit so that the alarm can be silenced once it has come into operation.

As mentioned earlier, within reason the threshold voltage of the unit can be altered to suit individual requirements. It is merely necessary to change the operating voltage of the component used in the D1 position, and the threshold voltage of the unit is approximately 0.5 volts more than the voltage of the zener diode employed in the D1 position. Obviously there are limits to the threshold voltages that can be handled by the circuit, and the upper one is set by the 16 volt maximum permissible supply voltage of the 555 device, and the unit should obviously not be used in situations where there is a

real danger of this supply voltage being exceeded. The circuit will not operate very well with supply voltages of much less than about 6 volts, and the minimum acceptable voltage rating for D1 is therefore 5.1 volts.

Of course, the actual threshold voltage obtained is dependent on component tolerances and errors of up to about 0.5 volts might occur, but in most applications, including the intended one of a car or boat battery monitor, an error of this magnitude is quite acceptable.

### *Components for Low Voltage Alarm (Figure 17)*

#### *Resistors*

R1	390 ohms	R2	2.2k
R3	2.2k	R4	100k
R5	4.7k		

#### *Capacitors*

C1	22nF polyester	C2	100 $\mu$ F 10v electrolytic
----	----------------	----	------------------------------

#### *Semiconductors*

IC1*	555
Tr1	BC109C
D1	BZY88C10V (400mW 10 volt zener, see text)

#### *Miscellaneous*

Case

Printed circuit board

Miniature loudspeaker having an impedance in the range 40 to 80 ohms (LS1)

Wire, solder, etc.

## PROJECT 9

### HIGH VOLTAGE ALARM

This circuit is a modification of the previous one, and it is designed for use in situations where a warning is needed if the supply voltage should exceed some critical threshold level, rather than fall below a threshold level as was the case with the previous design.

#### The Circuit

The circuit diagram of the High Voltage Alarm unit is shown in Figure 19, and the astable section of the unit is exactly the same as that employed in the previous design. However, the

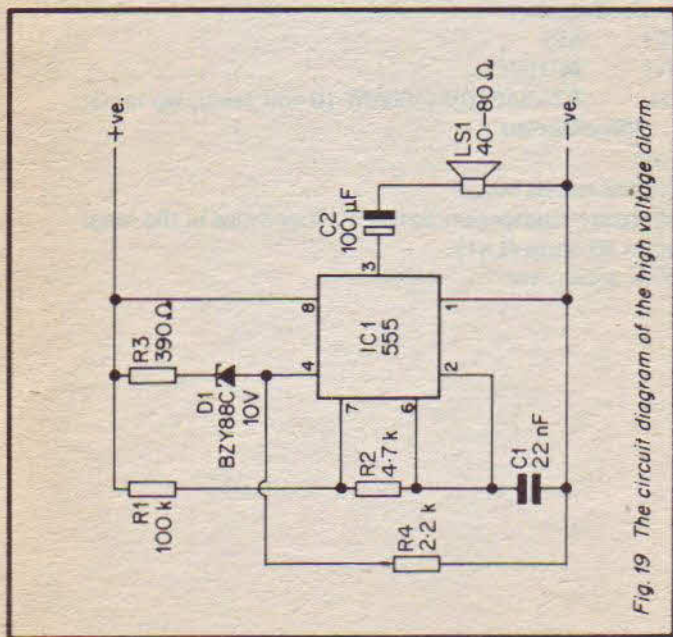

Fig. 19 The circuit diagram of the high voltage alarm



method of deriving the control voltage for pin 4 of the 555 is much more simple in this circuit.

If the supply voltage is below about 10.5 volts D1 will probably not be biased into conduction, or it will only just be biased into conduction so that less than 0.5 volts is developed across R4. The astable will therefore be inhibited and the alarm will not sound.

If the supply voltage goes above about 10.5 volts D1 will be strongly biased into conduction and the current flowing

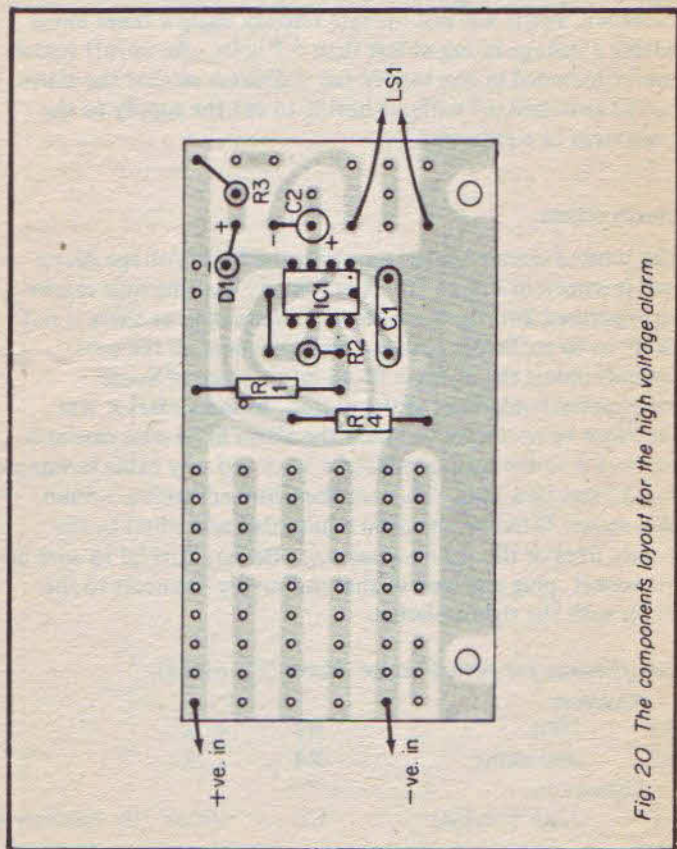

Fig. 20 The components layout for the high voltage alarm

through R3, D1 and R4 will be sufficient to produce the nominal potential of 0.5 volts that is needed across R4 in order to bring the astable into action and sound the alarm.

As was the case with the Low Voltage Alarm unit, the threshold voltage can be altered by changing the voltage rating of the component used in the D1 position, and the threshold voltage is approximately 0.5 volts more than the voltage rating of the zener diode utilized. Also as before, the unit should not be used where there is a risk that the maximum permissible supply voltage rating of IC1 (which is 16 volts) will be exceeded, and it will not operate reliably using a zener diode having a voltage rating of less than 5.1 volts. An on/off switch can be included in one supply rail if desired, so that the alarm can be switched off without having to cut the supply to the main item of equipment.

### Construction

The printed circuit board layout for the High Voltage Alarm unit is shown in Figure 20. It is unlikely that the unit can be incorporated into the main piece of equipment as there is not likely to be sufficient space to accommodate all the components unless the alarm is fitted into a piece of home-constructed equipment at the outset. In most cases it will therefore be necessary to house the alarm in its own case and connect it to the main equipment via a two way cable terminated in a 3.5mm jack plug. This can then connect with a 3.5mm jack socket fitted on the main equipment and wired to the supply lines of the main equipment. Be very careful to wire up the socket, plug and lead so that the supply connects to the alarm with the right polarity.

### *Components for High Voltage Alarm (Figure 19)*

#### *Resistors*

R1	100k	R2	4.7k
R3	390 ohms	R4	2.2k

#### *Capacitors*

C1	22nF polyester	C2	100 $\mu$ F 10v electrolytic
----	----------------	----	------------------------------

*Semiconductors*

IC1 555

D1 BZY88C10V (400mW 10 volt zener, see text)

*Miscellaneous*

Case

Printed circuit board

Miniature loudspeaker having an impedance in the range  
40 to 80 ohms (LS1)

Wire, solder, etc.

## PROJECT 10

### WATER ACTIVATED ALARM

Probably the most common application of water activated alarms is as rain alarms, but they can be used in other applications around the house, and are sometimes used in boats. Another application, for example, is as a cistern alarm for use with a cistern that is unreliable and apt to overflow in the middle of the night.

Although pure water is quite a good insulator, rain water, tap water and sea water all contain impurities which make them conduct electricity reasonably well. This makes it very easy to produce a water sensor since all that is required is two strips of metal separated by a thin layer of insulation. Normally there will be a very high resistance between the two pieces of metal due to the insulating layer, but if water containing suitable impurities should bridge the two strips of metal there will then be a fairly low resistance between them. Thus a water alarm circuit using a sensor of this type just has to detect the large fall in resistance when the sensor is activated, and produce an alarm signal of some kind.

This simple water alarm produces an audible alarm signal when water is detected, and it has an extremely low stand-by current consumption that makes battery powered operation extremely economic even if the unit will be left running for long periods of time.

#### The Circuit

The full circuit diagram of the water alarm is shown in Figure 21. The audible alarm signal is generated by a 555 astable driving a high impedance loudspeaker, as in the previous alarm projects in this book. However, although the sensor could be used to directly control pin 4 of the 555 and give the required action, this would be impractical in this case as the circuit would make operation from a small 9 volt battery too expensive due to the consequent short battery life. Therefore, in this

design the astable is controlled simply by switching its supply on and off rather than gating it by means of pin 4.

While it is possible that connecting the sensor in one of the supply rails would give the desired effect, this is by no means certain. With no water on the sensor there would definitely be no significant current to the oscillator and it would not operate. With the sensor bridged by suitably impure water a substantial current would flow to the oscillator, but the resistance through the sensor might be too high to give sufficient current and voltage to the oscillator for good results. If the sensor was a fairly inefficient type or the water bridging it contained only a modest amount of impurities it is quite likely that the oscillator would fail to operate at all.

The supply to the oscillator is therefore obtained by way of Tr1 which is used in the emitter follower mode and is inserted in the positive supply rail. With no water on the sensor Tr1 is cut off and only a minute leakage current of less than one microamp is passed to the oscillator. This is far too low to produce oscillation, and is also far too low to drain even a small 9 volt battery significantly. In fact the battery should have virtually its shelf life even if the alarm is used continuously (and provided it is not left running for long periods with the alarm operating).

When the sensor is bridged by water a small base current is provided for Tr1, and due to the high gain of Tr1 the oscillator is fed with virtually the full supply voltage. S1 is the on/off switch and is included so that the alarm can be silenced once it has been activated — due to the extremely low quiescent current consumption of the unit the position of the on/off switch is irrelevant when the unit is not in use.

## Construction

The printed circuit board layout for the Water Activated Alarm is provided in Figure 22, and electrically there is nothing difficult about this project. The only unusual aspect of the mechanical side of constructing the unit is that it is necessary to construct a water sensor since ready-made sensors are not available. This does not really present any difficulties since a

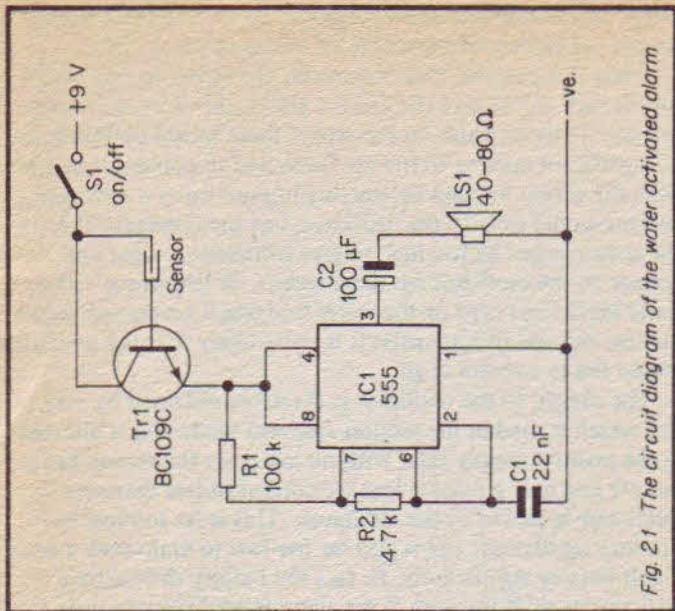

Fig. 21 The circuit diagram of the water activated alarm

suitable sensor can be constructed very easily. One possibility is to use a piece of stripboard with alternate strips connected together and acting as one section of the sensor. The other metal strips are then connected together and act as the other section of the sensor. Any water touching two adjacent copper strips will bridge the two sides of the sensor and activate the unit. This is a good method to use if the unit is to be used as a rain alarm since a sensor having a large surface area (so that the unit is quickly activated when it starts to rain) is easily produced. Of course, there are many other possible ways of producing a water sensor, such as using printed circuit board techniques, or simply gluing a couple of pieces of wire to a piece of insulating material with a small gap being left between the wires. You can use anything that gives the desired result.

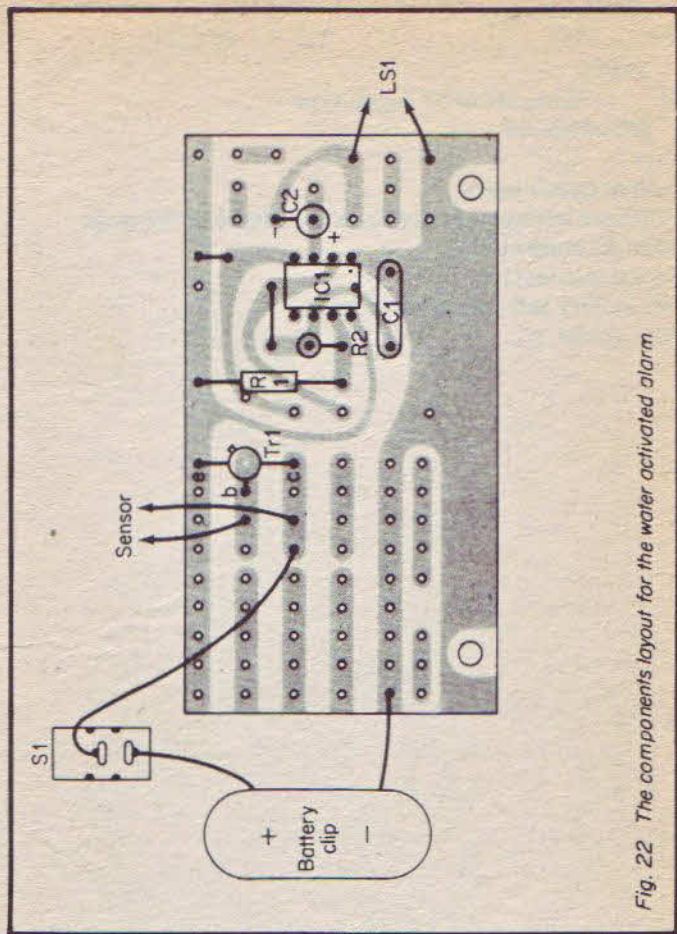

Fig. 22 The components layout for the water activated alarm.

*Components for Water Activated Alarm (Figure 21)*

*Resistors*

R1 100k

R2 4.7k

*Capacitors*

C1 22nF polyester

C2 100 $\mu$ F 10v electrolytic





## PROJECT 11

### TRANSISTOR CHECKER

While transistors are not used in every item of modern electronic equipment, there can be relatively few items of electronic hardware that do not use at least one discrete transistor. This makes a transistor checker of some kind an extremely useful piece of test gear for the electronics enthusiast, even if it is only a simple checker of the go/no-go type. In fact a checker of this type is all that most people really need, and the cost of a complex transistor analyser or tester is probably not justified in the majority of cases. Normally one simply needs to know if the device in question is a serviceable device having low leakage and reasonable current gain or a total dud.

This very simple transistor checker is suitable for testing NPN or PNP silicon devices, but is not recommended for checks on germanium devices where misleading results might be obtained. This is not much of a drawback though since germanium devices are not often encountered these days, and most germanium transistors are in fact obsolete now. The unit has two three way sockets on the front panel, one for NPN devices and the other for PNP types. With the transistor under test connected to the appropriate socket correctly a LED indicator lamp should flash on and off at a rate of about two times per second. There are separate indicator lights for PNP and NPN devices incidentally. If the transistor being checked is a closed circuit device the LED indicator will simply switch on all the time the device is connected to the tester. If the test transistor is an open circuit or very low gain device the LED indicator will either not switch on at all or will only flash on very dimly.

#### The Circuit

Figure 23 shows the basic way in which the tester functions, and the unit is really just an oscillator and a couple of indicator lamps. Figure 23(a) shows the arrangement used for testing NPN devices, and here the base of the test transistor is fed from

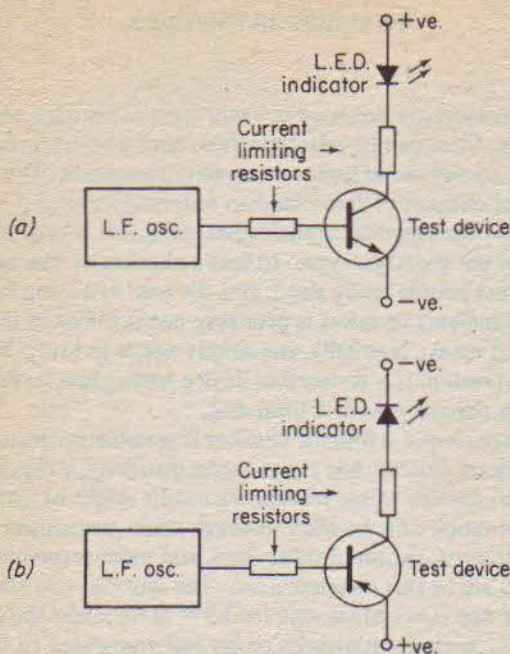

*Fig. 23 (a) The basic arrangement for NPN testing and (b) the arrangement for testing PNP devices*

the output of the oscillator via a current limiting resistor. The test device is fed with a base current when the output of the oscillator is high (almost equal to the positive supply voltage) but is cut off when the output of the oscillator is low (at or little higher than the negative supply rail potential). The LED indicator forms the collector load for the test transistor, and this should be switched on when the transistor receives a base bias current, and switched off when the transistor is cut off. Of course, if the test device is a closed circuit type then the base bias will be irrelevant and there will be a permanent low impedance path between the collector and emitter terminals of

the device so that the LED indicator will be switched on while the test device is connected to the checker. An open circuit test device will not conduct even when it receives a base current and the LED indicator will then fail to switch on at all. The base bias current is made quite small so that a very low gain test device will only produce a very low collector current during the periods when it is biased into conduction, and its low gain will be indicated by the LED only flashing on quite dimly. The low base current also ensures that a false indication cannot be obtained if the test device has a short circuit between its base and collector terminals. This could cause the LED to flash on when the output of the oscillator went low, and switch off when it went high, but this cannot happen since the current flow is limited to a level which is insufficient to make the LED indicator visibly glow.

Figure 23(b) shows the arrangement used for testing PNP types, the only real difference being that the supply polarity and the polarity of the LED indicator have to be reversed for PNP devices.

If we now consider the full circuit diagram of the unit which appears in Figure 24, the astable uses a 555 IC in the standard configuration. The values of timing components R1, R2 and C1 have been chosen to give a mark space ratio at the output of virtually one to one and an operating frequency of roughly 2 Hertz. The use of separate test sockets, LED indicators, and current limiting resistors for the latter avoids the cost and complexity of NPN/PNP switching. R3 limits the base current for the test device to a suitable level of a little under  $200\mu\text{A}$ , and this is used in both the NPN and PNP modes. D1 is the LED indicator for NPN test devices and D2 is the indicator lamp for PNP test transistors. R4 and R5 are their respective current limiting resistors.

## Construction

The printed circuit component layout and wiring for the Transistor Checker project are shown in Figure 25. Once again, electrically and mechanically the unit is quite straight forward to construct.

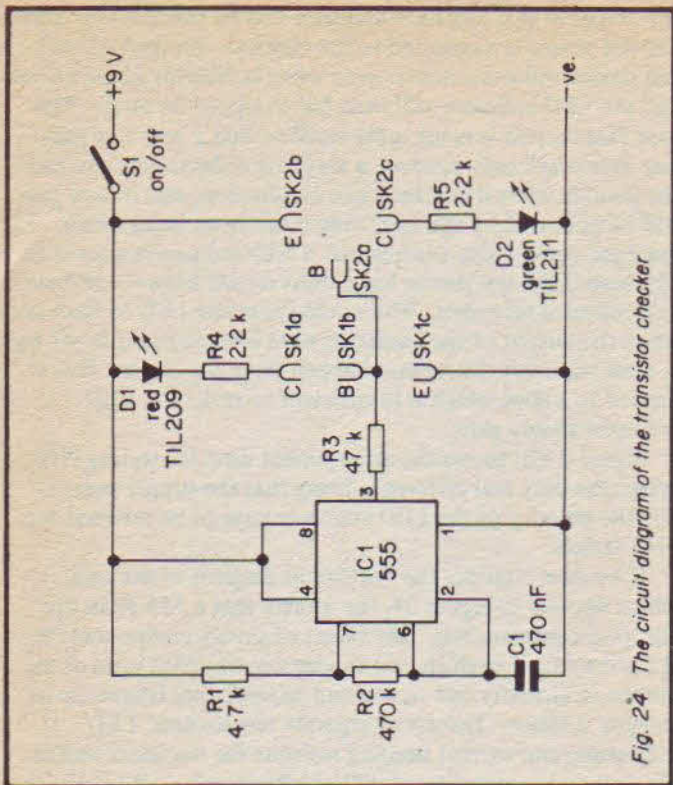

Fig. 24 The circuit diagram of the transistor checker

SK1 and SK2 are both 3 way DIN sockets, and most small transistors will plug directly into these without any problems, but always make sure that all three leadout wires are in proper contact with the socket, the device is connected correctly, and it is connected to the right socket! Obviously there are some devices which will not connect direct to the appropriate socket, and it is necessary to have a set of test leads so that devices of this type can be accommodated. A suitable set of test leads merely consists of three short insulated leads which should be of different colours to permit easy identification. These are fitted with a 3 way DIN plug at one end and small crocodile

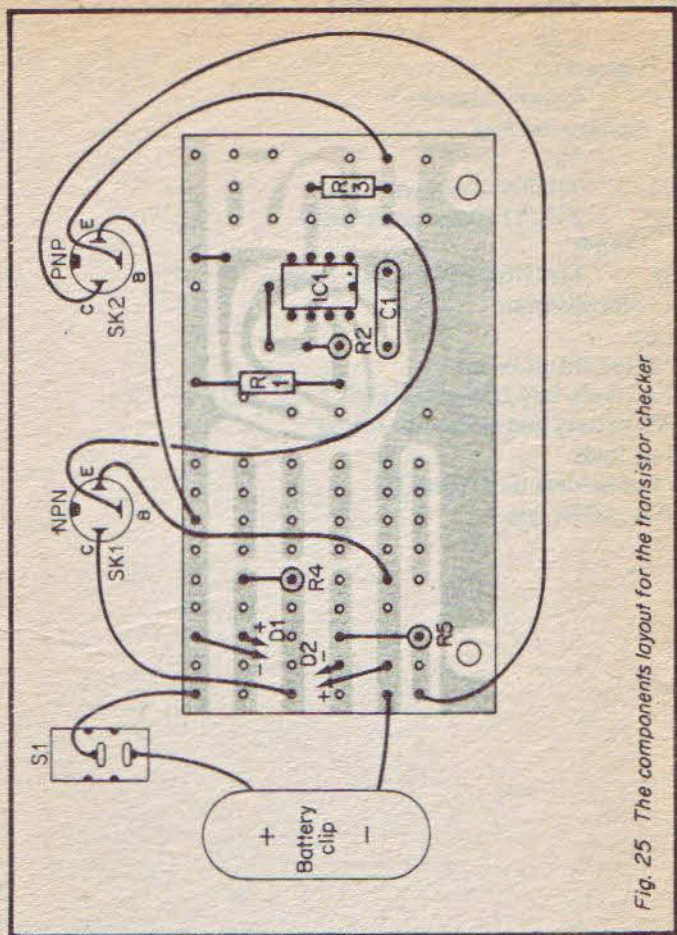

Fig. 25 The components layout for the transistor checker

clips at the other end to permit easy attachment to the leadout wires of the test device.

### Components for Transistor Checker (Figure 24)

#### Resistors

R1 4.7k

R2 470k

R3      47k                      R4      2.2k  
R5      2.2k

*Capacitors*

C1      470nF polyester

*Semiconductors*

IC1      555

D1      TIL209 (3mm red LED)

D2      TIL211 (3mm green LED)

*Switch*

S1      Miniature SPST toggle type

*Miscellaneous*

Case

Printed circuit board

Two three way DIN sockets (SK1 and SK2)

PP3 battery and connector to suit

Test leads

Panel holders for D1 and D2

Wire, solder, etc.

## PROJECT 12

### SIMPLE SIGNAL

There are several types of automatic signal for model railway layouts (or for model car layouts), and some of these are quite complex and expensive affairs. However, even a simple and inexpensive automatic signal can greatly enhance the realism and effectiveness of a model railway layout. This very simple design is of the type where the signal is switched to green for a certain period of time, then to red for a certain length of time, then back to green for the appropriate period, and so on. The red and green signal times are made different, with the red time being substantially shorter. One reason for doing this is merely that a real signal usually spends a far greater length of time showing a green signal than it does showing a red one. In a model train context it is undesirable to have the train stopped for a substantial proportion of the time as this could make the signal add boredom to the layout rather than interest. Of course, there is no reason why several signals cannot be incorporated in a layout, and this should in fact give even greater realism, and add to the fun of the layout. The cost of several signals is still quite low and should add very little to the overall cost of a layout.

#### The Circuit

The circuit diagram of the automatic signal can be found in Figure 26, and this is another circuit which is based on a 555 astable. The 555 is ideal for this application as it is easy to obtain a mark space ratio at the output of other than one to one, and it is also easy to set the mark space ratio at any desired figure. As pointed out earlier, the mark space ratio must be other than one to one with a basic 555 astable since the output is low while C1 discharges through just R2. All things being equal in other respects, the charge time and high output period must be longer than the discharge time and low output period.

In this circuit R1 has been made roughly twice as high in

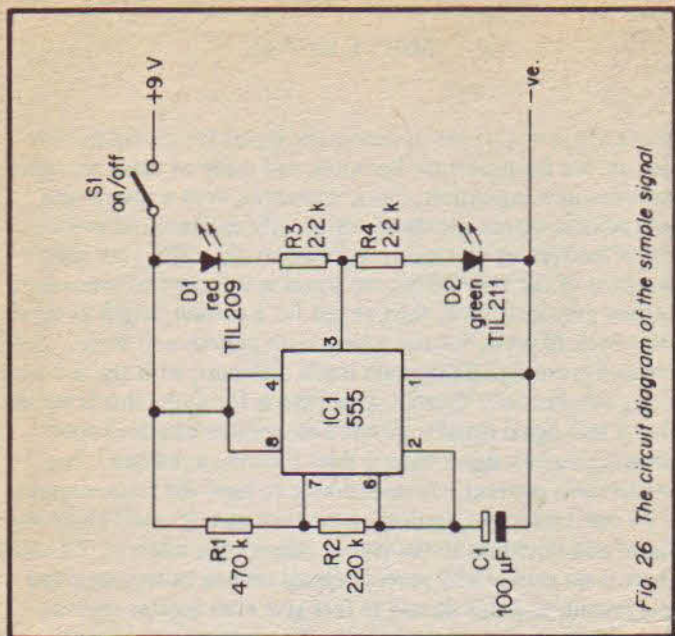

Fig. 26 The circuit diagram of the simple signal

value as R2, giving a charge resistance approximately three times as high as the discharge resistance. This gives a high output time which is about three times longer than the low output time, and the red LED indicator (D1) is therefore connected between the output of IC1 and the positive supply rail. It then switches on during the comparatively brief periods when IC1's output is low. D3 is the green LED indicator and it is connected between the output of IC1 and the negative supply rail so that it switches on during the comparatively long periods when IC1's output is high. R3 and R4 are simply the series current limiting resistors for D1 and D2 respectively.

The actual time for which the red LED is switched on is set by R2 and C1 at approximately 15 seconds, while the green LED on time is set by R1, R2 and C1 at about 47 seconds, but these times are only very approximate due to the tolerances of



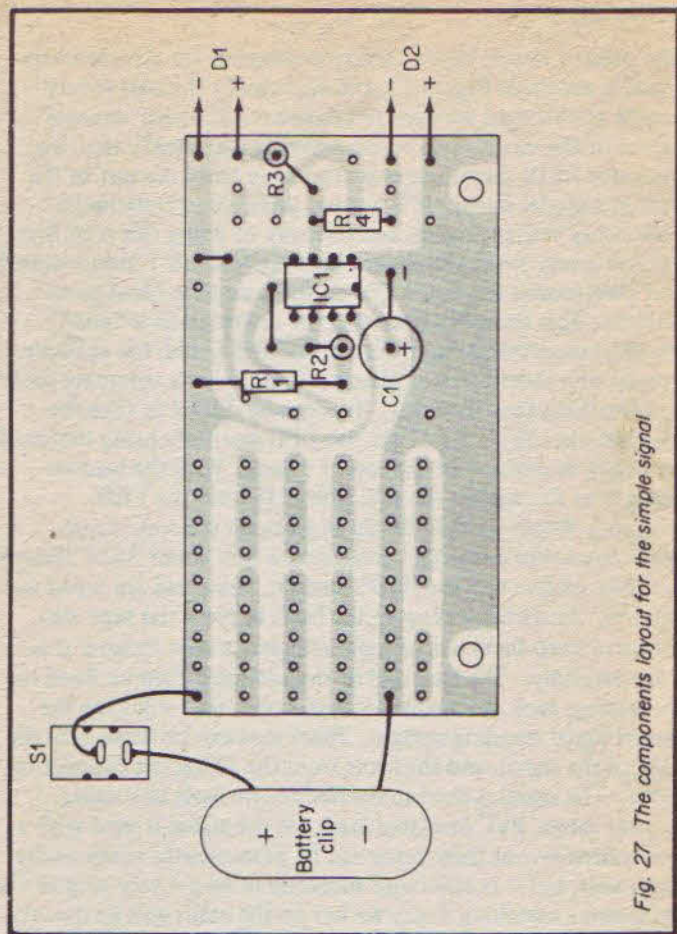

Fig. 27 The components layout for the simple signal

the components used (especially C1 which is likely to have a tolerance of something like +50% and -20%). These times can be changed to suit individual requirements if desired, as will be explained later.

## Construction

The printed circuit board component layout for the automatic signal is shown in Figure 27, and electrically the unit is very simple and straight forward to construct. The only unusual aspect of the mechanical construction is that ideally the two indicator LEDs should be mounted away from the rest of the unit in a model signal. It is not too difficult to construct a reasonably realistic signal, and one way of doing this is to first cut out a very small aluminium panel (say about 12mm x 6mm) and then mount the two LEDs on this using the usual panel holders. This assembly must then be mounted on a "post" made from an insulating material, and this could, for example, consist of a short piece of plastic rod cut from a trimming tool or something similar to this. This can be drilled to take the leadout wires from the LEDs, the LED assembly being mounted vertically at one end of the rod of course. With the leadout wires bent flat against the rear side of the rod the LED assembly should be held firmly in place on the rod. Leads made from thin enamelled copper wire (say about 34 or 36swg) are then soldered to the LED's leadout wires, and are taped to the rod. Apart from keeping the leads in place the tape also serves to keep them out of sight and gives a neat finish if it is done carefully. The base end of the rod must then be fixed to something, such as a small block of wood, that will keep the model signal standing upright. Panel pins can be fitted into the base of the signal, and the leads from the LEDs can connect to these. The signal is then connected to the main unit using heavier gauge, PVC insulated leads. If the signal is used with a permanent layout these leads can be permanently wired to the main unit, but it is otherwise advisable to fit a 4 way plug to the leads and a matching 4 way socket on the main unit so that the signal and main unit are easily detached from one another when the layout is not in use.

### *Components for Simple Signal (Figure 26)*

#### *Resistors*

R1	470k	R2	220k
R3	2.2k	R4	2.2k

### *Capacitors*

C1 100 $\mu$ F 10v electrolytic

### *Semiconductors*

IC1 555

D1 TIL209 (3mm red LED)

D2 TIL211 (3mm green LED)

### *Switch*

S1 SPST miniature toggle type

### *Miscellaneous*

Case

Printed circuit board

PP3 size battery and connector to suit

Panel holders for D1 and D2

Wire, solder, etc.

## PROJECT 13

### ELECTRONIC HEADS OR TAILS

This novelty circuit simulates the tossing of a coin and gives either a "heads" or a "tails" indication. The unit has two light emitting diode inductors; one red and one green. When a switch is closed both LEDs appear to glow continuously at moderate intensity, but when the switch is opened only one LED will remain on (and will glow at full intensity) and the other will be switched off. There is no way of predicting which will be the LED that remains on when the switch is opened, and there is an evens chance as to which one it will be. Thus, by using (say) the red LED to indicate "heads" and the green LED to indicate "tails" the required coin tossing simulation is obtained.

#### The Circuit

Figure 28 shows the full circuit diagram of the heads or tails simulator, and this is yet another circuit which uses a 555 timer IC used in the astable mode.

If S2 is switched to the "on" position and S1 is closed, the oscillator circuit will operate normally and will oscillate at a frequency of about 40 Hertz. D1 and D2 are driven from the output of IC1 via current limiting resistors R3 and R4 respectively. D2 will switch on when IC1's output is high, and D1 switches on when IC1's output is low. This switching action occurs just too fast for a human operator to perceive it, and it looks as though both D1 and D2 are switched on continuously, but they glow at less than normal brightness since they are switched off for 50% of the time and the average LED current is half its normal level.

The mark space ratio at the output of IC1 is very nearly one to one as R2 has been made low in comparison to the value of R1. Thus the charge and discharge times of C1 are practically the same; the error being less than 1%, and D1 is switched on for virtually the same length of time as D2.

When S1 is set to the open position C1 can no longer charge by way of R1 and R2, or discharge via R1 and IC1. It therefore remains with whatever charge it happened to have at the instant S1 was opened. This halts the action of IC1, and it remains in whatever state it happened to be in at the moment S1 was opened. Thus, if D1 was switched on at this instant it remains switched on, and if D2 was switched on it is D2 that remains on. The action of the circuit is so fast that it is not possible for the operator to operate S1 when one particular LED is switched on, and there is no significant bias to one LED or the other due to the virtual one to one mark space ratio at the output of IC1. It is therefore a matter of pure chance as to which of the LEDs remains switched on when S1 is opened, and the required simulation is produced.

### Construction

This unit is very simple to construct and should give no problems with either the mechanical or electrical construction. The component layout for the printed circuit board is shown in Figure 29. The unit, complete with PP3 size battery, should readily fit into any of the inexpensive metal or plastic cases that are readily available from any of the larger component retailers.

In use S1 is briefly set to the closed position to "spin" the coin and it is opened to stop oscillation and produce a result on the display. Do not be surprised if the unit gives the same result each time after a few operations of S1, as the same thing could easily happen when tossing a coin several times. "Heads" and "tails" should occur virtually the same number of times, but not after only a few operations of the unit. After a large number of operations though, say after one or two hundred, "heads" and "tails" should have occurred virtually the same number of times if the unit is functioning correctly.

### *Components for Electronic Heads or Tails (Figure 28)*

#### *Resistors*

R1	470k	R2	4.7k
R3	2.2k	R4	2.2k

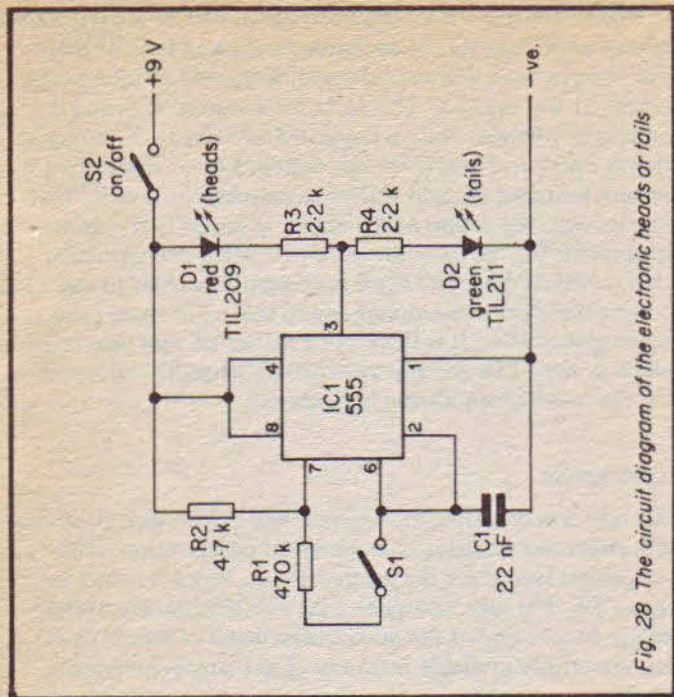

Fig. 28 The circuit diagram of the electronic heads or tails

#### Capacitors

C1 22nF polyester

#### Semiconductors

IC1 555

D1 TIL209 (3mm red LED)

D2 TIL211 (3mm green LED)

#### Switches

S1 Miniature SPST toggle type

S2 Miniature SPST toggle type

#### Miscellaneous

Case

Printed circuit board

PP3 battery and connector to suit

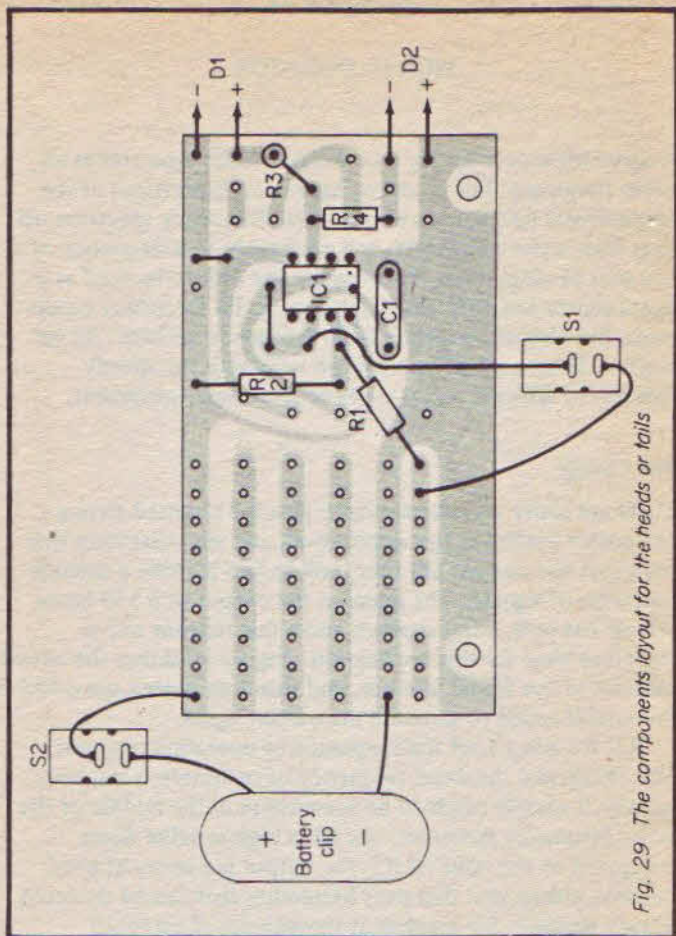

Fig. 29 The components layout for the heads or tails

Panel holders for D1 and D2  
Wire, solder, etc.

## PROJECT 14

### SIGNAL INJECTOR

A signal injector is simply an oscillator which operates at an audio frequency, but produces harmonics (multiples) of the fundamental frequency over the radio frequency spectrum up to at least a few megahertz, and preferably to a frequency of a few tens of megahertz. This enables the unit to be used as a signal source not only when checking audio frequency equipment, but also when testing radio frequency circuits. As we shall see later, a signal injector can help with the speedy location of faults in many types of electronic equipment.

#### The Circuit

There are many waveforms which give the required strong harmonics needed in this application, and any waveform that has a fast rise and (or fall time) will in fact provide a suitable spectrum of signals. The signal at the output of a 555 based astable has both a fast risetime and a fast falltime and is therefore ideal for this application. Figure 30 shows the circuit diagram of the Signal Injector, and this does indeed use a 555 in the astable mode to generate the output signal.

R1, R2 and C1 set the frequency of operation at about 500 Hertz, and the exact frequency of operation is not very critical; it merely needs to be somewhere in the middle of the audio frequency spectrum. As R1 is high in value when compared to the value of R2, the output is a series of brief negative pulses, and this gives harmonics that can be detected using a sensitive SW receiver at frequencies of up to 30 megahertz (the upper limit of the SW spectrum) with no difficulty whatever. The unit is therefore suitable for the majority of AF and RF signal injection tests.

The output signal level at pin 3 of IC1 is around 8 volts peak to peak, and this signal is coupled to SK1 via C3. This signal level is considerably too high for most signal injection applications, and this could often make the unit difficult to



use with misleading results being obtained quite frequently. An attenuated output is therefore available at SK2, and it is advisable to use this output when testing sensitive audio or RF equipment, especially when the signal is being injected at or near the input of the equipment.

R3 and R4 provide the attenuation, and C2 couples the attenuated signal to output socket SK2. The attenuation provided by R3 and R4 is about 41.5dB (the signal voltage is reduced by a factor of about 120 times), and this gives a peak to peak output voltage of roughly 66mV (0.066 volts).

## Construction

This is another project which is very easy to construct and is not likely to give any difficulties in this respect. The printed circuit layout is provided in Figure 31. Virtually any small plastic or metal case should be adequate to accommodate all the components and the PP3 size 9 volt battery. With SK1, SK2 and S1 fitted on one edge of the unit (which then acts as the front panel of the unit) there should be plenty of space for the printed circuit assembly and the battery at the rear of these.

In use the idea is to first inject a signal at the output of the circuit under test. With a typical audio amplifier the first test would be to apply the signal to the loudspeaker just to make sure that the fault does actually lie in the amplifier and is not simply a damaged speaker, and then if all is well here, the next test would be at the other side of the output coupling capacitor to check that this is providing a suitable signal path and is not faulty. An important point to bear in mind when making a test such as this to a low impedance part of the circuit under test is that loading of the signal injector's output will greatly reduce the output signal level. Only a low volume signal from the speaker would therefore be expected unless the end of the coupling capacitor which connects to the amplifier circuitry is disconnected so that the loading is eliminated. The output impedance of the signal injector is quite low, and with low level stages it is not likely to be a significant problem.

Subsequent tests are made at the input of the output stage,

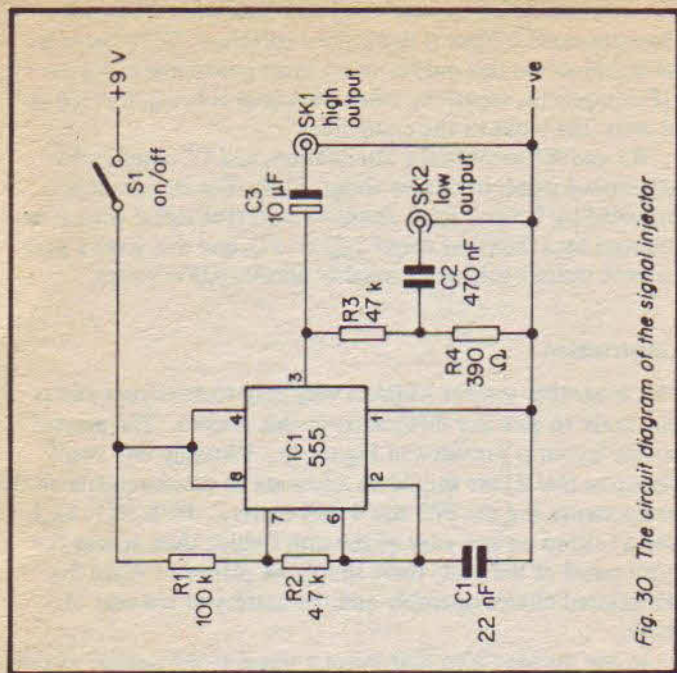

Fig. 30 The circuit diagram of the signal injector

the input of the driver stage, the output of the preamplifier stage, and so on, working backwards through the circuit towards the input. When the signal fails to be produced from the output the approximate position of the fault has been located. It probably lies in the circuitry between the last and penultimate tests, but it is possible that it exists in the circuitry in the immediate vicinity of the last test. Voltage measurements and other normal test procedures are used to find the exact nature of the fault; the signal tracer is intended merely as an aid to initially locate the part of the circuit under test that is faulty, and to enable this to be done quickly.

When injecting a signal into the input circuitry of a sensitive amplifier it is better to use the output from SK2 rather than the normal output from SK1. This is merely because only a small amount of a high level signal needs to leak through to the

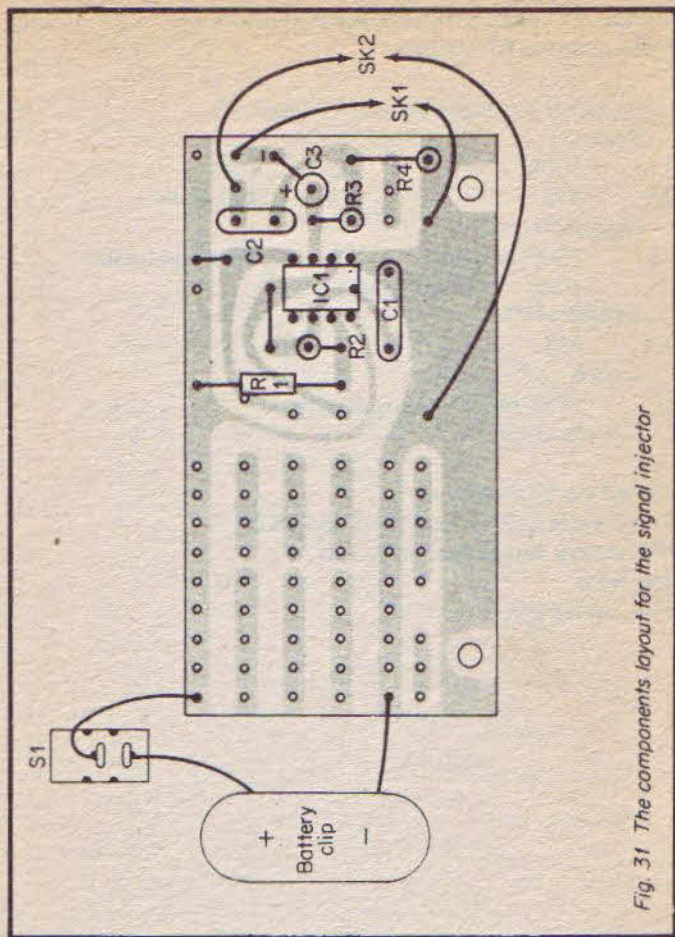

Fig. 31 The components layout for the signal injector

subsequent stage in order to give a strong audio output, and possibly misleading results. If a low level signal is used a small leakage through to the next stage of the circuit will give little audio output. The harmonics, especially those at quite high radio frequencies, are far less strong than the fundamental signal and it might be necessary to use the output from SK1

in order to obtain sufficient signal injection even when testing quite sensitive RF circuits.

*Components for Signal Injector (Figure 30)*

*Resistors*

R1	100k	R2	4.7k
R3	47k	R4	390 ohms

*Capacitors*

C1	22nF polyester	C2	470nF polyester
C3	10 $\mu$ F 25v electrolytic		

*Semiconductor*

IC1 555

*Switch*

S1 SPST miniature toggle type

*Miscellaneous*

Case

Printed circuit board

Two 3.5mm jack sockets (SK1 and SK2)

PP3 battery and connector to suit

Test leads

Wire, solder, etc.

## PROJECT 15

### COMPUTER VOICE

This simple circuit can be used in amateur dramatic productions, etc., to produce computer type voice effects from an ordinary voice signal input. There are several ways of producing simple computer voice effects, but probably the most simple method that gives good results is to amplitude modulate the ordinary voice signal input using a squarewave as the modulating signal. This is similar to the well known tremolo effect which is sometimes used with guitars and other electronic instruments, but tremolo units normally use a triangular or sinewave modulation signal to give a smoother form of modulation. In this application a squarewave gives better results, and a sinewave or triangular waveform would be ineffective. In effect, the unit is switching the input signal between being passed straight through to the output, and being attenuated by around 20dB or so, and a switching rate of a few Hertz is used.

#### The Circuit

The circuit diagram of the computer voice unit is given in Figure 32, and this really consists of two sections; an oscillator to provide the modulation signal, and the modulator itself.

The oscillator uses a 555 astable, and the frequency of operation has been set at about 10 Hertz by the values given to R1, R2 and C1. The mark space ratio is virtually one to one as R2 has been made high in value relative to R1.

A very simple modulator is used, but this is quite alright in this application where a small amount of distortion is quite acceptable. In fact a certain amount of distortion is desirable since it produces new frequencies that help to change the voice signal and make it sound less like the original, although a large amount of distortion is obviously not desirable as it would severely impair the intelligibility of the signal.

Tr1 is used as a sort of voltage controlled resistor, and in conjunction with R4 it forms a voltage controlled attenuator.

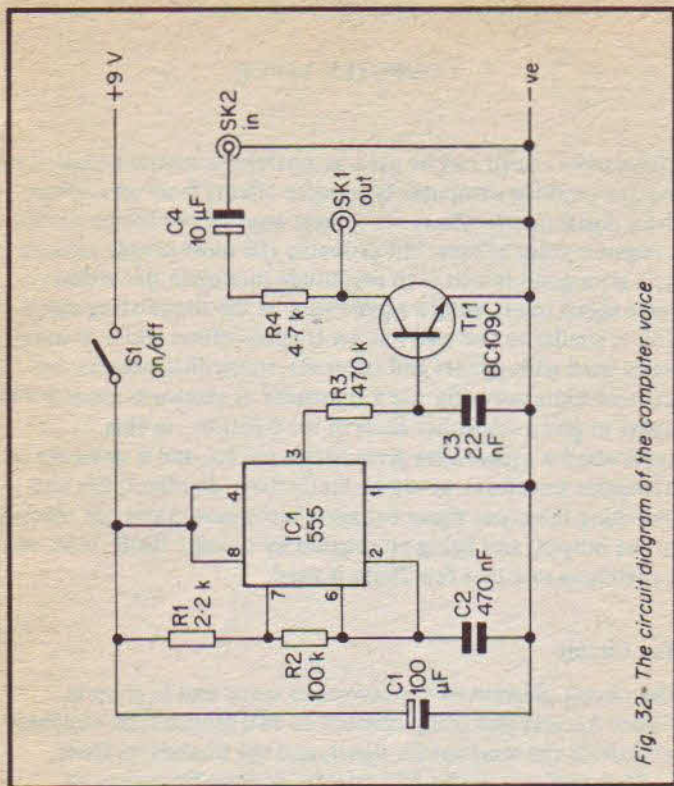

Fig. 32- The circuit diagram of the computer voice

C4 is merely a DC blocking capacitor at the input and R3 is used in the base circuit of Tr1 to effectively make Tr1 a voltage controlled device rather than a current controlled one. During the periods when IC1's output is high Tr1 is biased into conduction by the base current it receives via R3, and effectively has a collector to emitter resistance of only a few hundred ohms. This gives losses of around 20dB or so through R4, and attenuates the signal fed to the output by this amount. When IC1's output is low Tr1 is switched off and the input signal can pass straight through R4 to the output. The only attenuation is due to the potential divider action between R4 and the

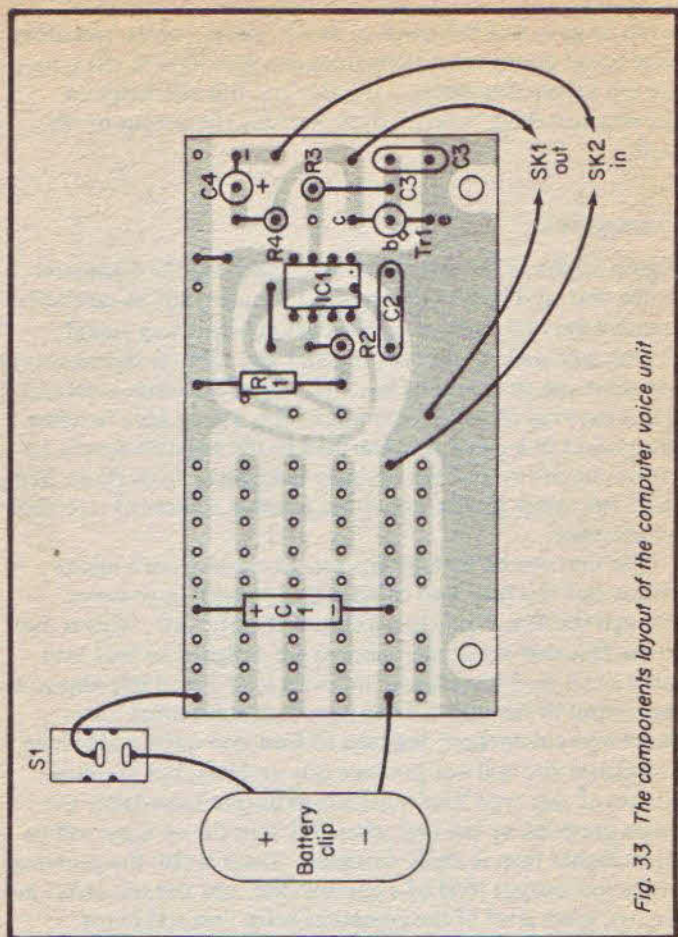

Fig. 33 The components layout of the computer voice unit

input impedance of the equipment to which the output signal is fed. This should produce minimal losses.

Thus the output signal is switched up and down in amplitude, producing the required computer type voice effect. C3 is included in the circuit to slightly slow down the sharpness with which the signal is switched between the two

levels of gain, and this helps to avoid "clicks" which can otherwise occur during transitions from one gain level to the other. C1 is a supply decoupling capacitor and this also helps to prevent switching "clicks" from reaching the output of the unit.

## Construction

Figure 33 shows the printed circuit layout for the Computer Voice unit, and this is quite straight forward, but be careful to connect the two leads to each socket the right way round. 3.5mm jack sockets are used for SK1 and SK2 on the prototype, but these can of course be any two way audio connectors and it is not essential to use 3.5mm jacks. It is a good idea to house this project in a metal case (earthed to the negative supply rail of the circuit) so that the circuitry is screened from mains hum, radio frequency signals, and other possible sources of electrical interference.

The unit can be used to process the signal from a microphone, but this may well cause problems with large losses through the unit even when Tr1 is in the off state. This is due to the fact that some microphones are designed to feed into quite a low load impedance, and with such a load impedance at the output of the unit R4 will introduce substantial losses. Some microphones are designed to feed into quite a high load impedance and will not produce this problem, but as microphones of this type have quite a high output impedance the losses provided by the unit when Tr1 is in the on state will be much higher than is really desirable. There is also the problem of the low output level of a microphone, and this can result in the low noise level of the computer voice unit still being inadequate due to the high level of gain that would follow it.

It is better to feed the microphone signal to the unit via a preamplifier so that a fairly high signal level is fed to the unit. There should be no problems if the unit is fed from a tape recorder or some piece of equipment which provides a similar signal level (a few hundred millivolts RMS). It is not advisable to use the unit to process a signal having an amplitude of more than about 1 volt RMS as quite severe distortion could then be produced.



## *Components for Computer Voice (Figure 32)*

### *Resistors*

R1	2.2k	R2	100k
R3	470k	R4	4.7k

### *Capacitors*

C1	100 $\mu$ F 10v electrolytic	C2	470nF polyester
C3	22nF polyester	C4	10 $\mu$ F 25v electrolytic

### *Semiconductors*

IC1	555
Tr1	BC109C

### *Switch*

S1 SPST miniature toggle type

### *Miscellaneous*

Case

Printed circuit board

PP3 battery and connector to suit

Two 3.5mm jack sockets (SK1 and SK2)

Wire, solder, etc.

## PROJECT 16

### GAMES TIMER

Some games, such as chess or draughts, can tend to become rather boring if one (or both) of the players take a long time over each move. The obvious way to avoid this is to impose a time limit to prevent competitors taking more than a reasonable amount of time to make their move, and thus keep the game moving and interesting. A simple electronic timer such as the one featured here is ideal for this application. This unit is switched on at the beginning of the game, and the first competitor then has about 25 seconds to make his or her move. After 25 seconds an indicator light on the timer switches on to indicate that the first competitor must make his or her move immediately. The timer is then momentarily switched off, and a new timing run starts when it is switched on again. If the first competitor makes his or her move within the allotted time, the unit is still switched off and then immediately switched on again to commence a new timing run. The game then progresses with the timer being reset in this way after each move has been made.

Although the timing period is 25 seconds using the specified values for this project, this length of time may well be inappropriate for many games. However, the length of the time delay is easily altered to suit individual requirements, as will be explained in greater detail a little later on.

#### The Circuit

The full circuit diagram of the Games Timer is shown in Figure 34, and this is another circuit that is based on a 555 timer IC. In this case though, it is not used in the astable mode, but is used as a monostable multivibrator. This type of circuit is not an oscillator, but instead produces a single output pulse when an input trigger pulse is received. When used in the monostable mode pin 2 of a 555 device is the trigger input, and this should normally be high (at virtually the positive supply potential). In order to trigger the device it is necessary

to take pin 2 to less than one third of the supply voltage, but only very briefly or the trigger pulse will affect the length of the output pulse by a significant amount.

In this circuit R1 normally takes pin 2 of IC1 high, but at switch-on C1 will not hold any charge and it will take pin 2 low so that IC1 is triggered. This negative trigger pulse is only very brief though since C1 soon charges up to the full supply potential via R1.

The output at pin 3 of IC1 is normally low, but it goes high once the device has been triggered, and it stays high for a length of time that is controlled by the values of R2 and C2 (only two timing components are needed in the monostable mode of operation). The output pulse length is approximately  $1.1 CR$  seconds (with the capacitance value in microfarads and the resistance value in megohms). With the specified values for R2 and C2 an output pulse of about 25 seconds (24.2 seconds is the calculated figure, to be precise) is obtained, but by changing the value of R1 any other pulse length within reason can be obtained. R2 needs to have a value of about 9.1 kilohms for each second of the required output pulse length. Thus a value of 91k for example, would give a pulse length of about ten seconds, or a value of 180k would give a pulse length of around 20 seconds. Due to component tolerances the output pulse duration cannot be set with a very high degree of accuracy, and quite large errors could be produced. In this application a high degree of accuracy is obviously not of great importance, and it is more important to have good repeatability of the output pulse length. This is achieved since any errors in the values of the timing components will produce the same error in the output pulse duration each time the unit is operated.

C2 tends to rapidly discharge through IC1 when the unit is switched off so that it automatically starts a new timing run from zero charge, and it is unnecessary to incorporate circuitry in the unit to discharge C2 at switch-off.

D1 is the LED indicator, and it is connected between the output of IC1 and the positive supply rail by way of current limiting resistor R3. As IC1's output goes high at switch-on D1 does not light up at first, but it does do so when IC1's output goes low at the end of the timing period.

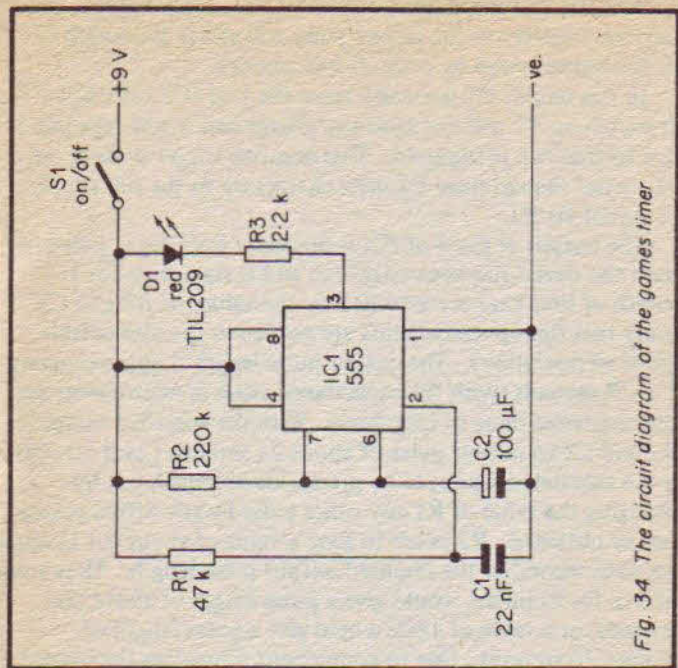
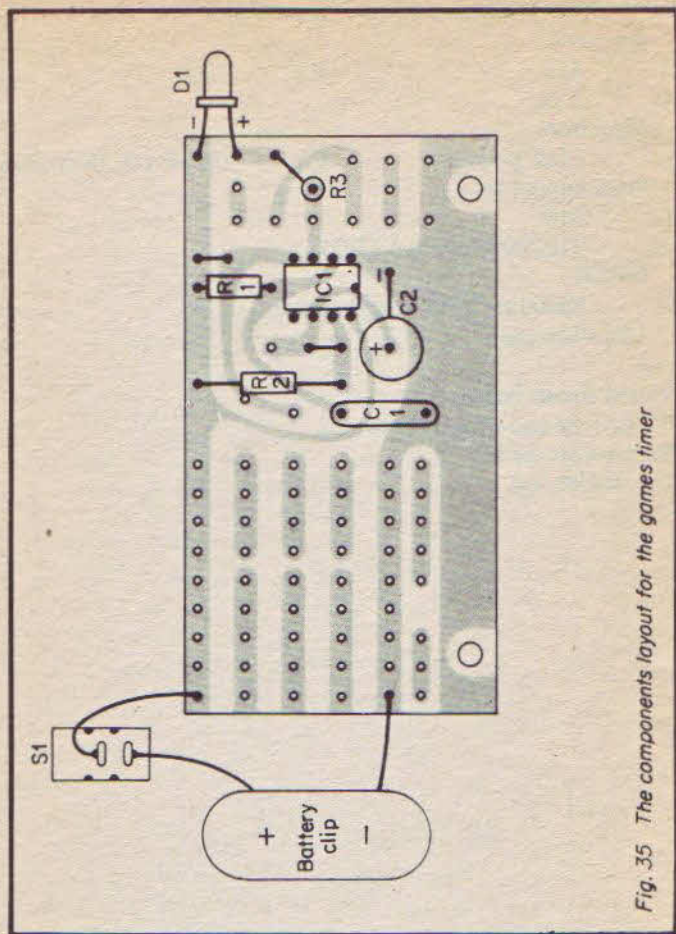

Fig. 34 The circuit diagram of the games timer

### Construction

The printed circuit component layout for the Games Timer unit is given in Figure 35. The board is constructed in the normal way and is bolted in place inside the case once it has been completed and wired to the rest of the unit. D1 is fitted in a suitable LED panel holder, and it can be mounted off-board if necessary and connected to the component board via a couple of short insulated leads. However, if the layout of the timer can be arranged so that D1 is fitted directly onto the board and not fitted into a panel holder, this will give optimum constructional strength and reduce the risk of D1 getting knocked out of its holder (especially if the unit is to be used by youngsters).



*Fig. 35 The components layout for the games timer*

If the timing period of the finished unit seems to be considerably elongated, and perhaps very inconsistent as well, this would suggest that the component used in the C2 position has a rather high leakage level, and it would be advisable to change it for a low leakage component.



## PROJECT 17

### GUITAR PREAMPLIFIER

Amplifiers specifically intended for use with guitars usually have a fairly high sensitivity, this being necessitated by the fairly modest output from a guitar pick-up. This lack of output can cause problems if you try to use an electric guitar with an amplifier which is primarily intended for some other purpose, such as a hi-fi amplifier. It is quite likely that an input of adequate sensitivity will not be available, and if a suitably sensitive input is present (such as an input for a magnetic cartridge) it is likely to be equalised and will give a far from flat frequency response when used with a guitar pick-up.

The obvious solution to this problem is to use a pre-amplifier between the guitar and the power amplifier so that output level of the signal from the pick-up is effectively boosted to a level that is high enough to drive a high level amplifier input satisfactorily. The preamplifier described here has low levels of noise and distortion, has an input impedance of about 50 kilohms (which is a good match for a normal guitar pick-up) and provides a little over 20dB of voltage gain (a little more than a tenfold increase in signal level). This degree of amplification should provide a sufficient boost to the signal to enable any normal power amplifier or hi-fi amplifier to be fully driven.

#### The Circuit

Figure 36 shows the full circuit diagram of the Guitar Preamplifier, and as will be apparent from this, the unit uses a single transistor. This is used in a straight forward common emitter amplifier configuration which has R2 as the collector load resistor and R1 as the base bias resistor. Emitter resistor R3 is used to introduce negative feedback which reduces the otherwise excessive voltage gain of the unit, and increases the input impedance of the unit to a suitable figure. The negative feedback also has the beneficial effect of reducing the noise

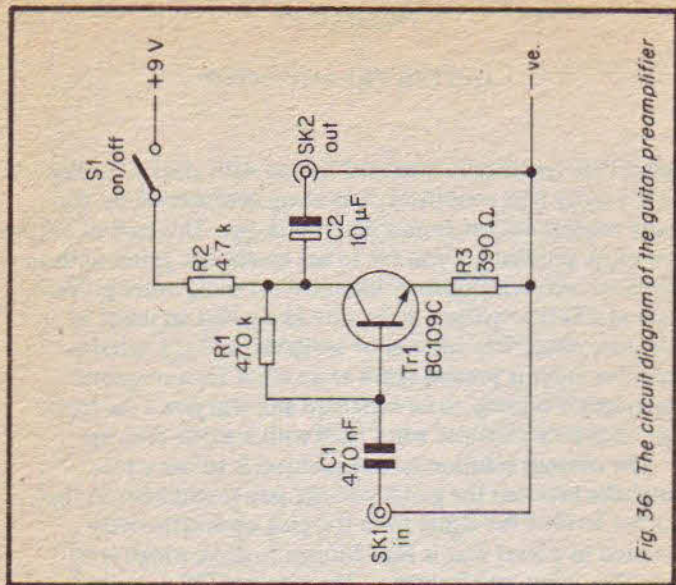

Fig. 36 The circuit diagram of the guitar preamplifier

and distortion levels of the circuit. C1 and C2 are the input and output DC blocking capacitors respectively.

The current consumption of the circuit is only about 1mA or so, and even a small 9 volt battery such as a PP3 type will give very many hours of use from the unit.

### Construction

It is advisable to house this project in a metal case earthed to the negative supply rail so that the circuitry is fully screened from sources of mains hum, radio frequency signals, and other possible sources of signals that could be picked up by the unit. A diecast aluminium box is ideal for a unit such as this because it provides a rugged housing as well as one having good screening properties. However, an inexpensive folded aluminium box also makes a suitable casing for the unit.

The layout of the unit is not critical since the input and output of the amplifier are out-of-phase, and any stray feedback



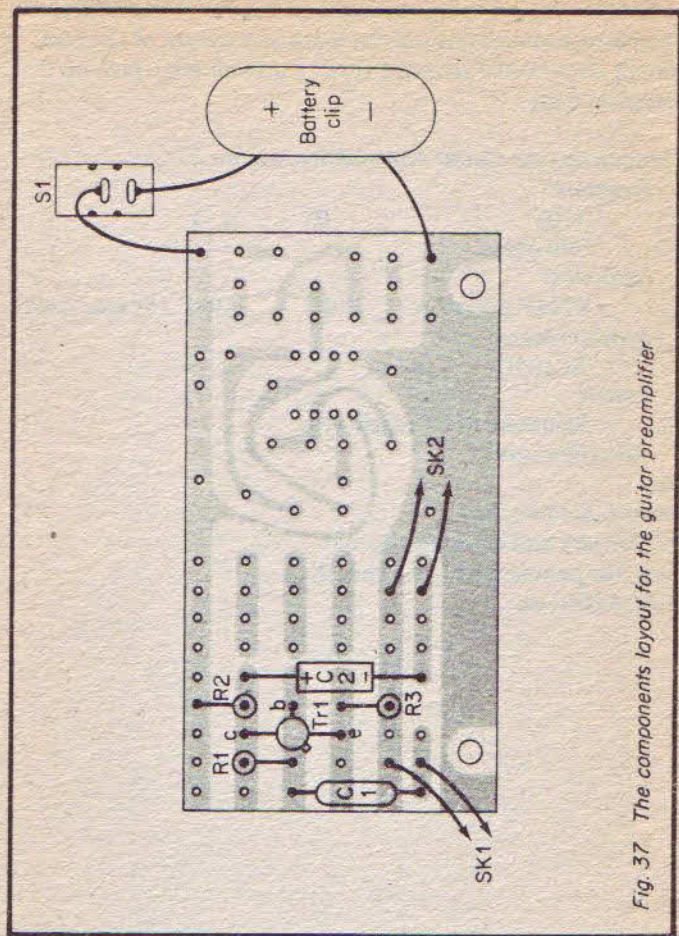

Fig. 37 The components layout for the guitar preamplifier

from the output to the input is not likely to cause instability.

The component layout for the printed circuit board for this project is shown in Figure 37, and this is perfectly straight forward. There is no need to use screened leads to connect the printed circuit board to SK1 and SK2 as overall screening of the unit is provided by the case, and as explained earlier, stray feed-

back from the output to the input of the unit is not a problem. Of course, external leads at the input and output of the unit should be the usual screened type to prevent stray pick-up of electrical noise.

*Components for Guitar Preamplifier (Figure 36)*

*Resistors*

R1	470k	R2	4.7k
R3	390 ohms		

*Capacitors*

C1	470nF polyester	C2	10 $\mu$ F 25v electrolytic
----	-----------------	----	-----------------------------

*Semiconductor*

Tr1 BC109C

*Switch*

S1 Miniature SPST toggle type

*Miscellaneous*

Case

Printed circuit board

PP3 battery and connector to suit

Two  $\frac{1}{4}$ in jack sockets (SK1 and SK2)

Wire, solder, etc.

## PROJECT 18

### GUITAR TREBLE BOOSTER

A treble booster is used with a guitar to give a "brighter" sound to the instrument, which can sometimes give very effective results. As the name implies, a treble booster simply gives increased gain at treble frequencies. The amount of boost produced at the fundamental frequencies of the notes is not very great, or non-existent, and it is normally only the higher frequency harmonics on the signal that are significantly boosted. Thus the booster does not greatly change the volume level obtained when it is switched in, but does change the sound of the instrument quite significantly.

#### The Circuit

Figure 38 shows the circuit diagram of the unit, and as will be apparent from Figure 38, the unit is very similar to the guitar preamplifier unit which was described in the previous section of this book. It is basically just a common emitter amplifier with an emitter resistor to produce negative feedback that boosts the input impedance of the stage and reduces its voltage gain. However, in this circuit a higher value emitter resistor is used, and this gives greatly reduced voltage gain. In fact the voltage gain of a circuit of this type is roughly equal to the collector load resistance divided by the emitter feedback resistance, and with the specified values this obviously gives a voltage gain of only about unity. The unit therefore simply acts as a buffer amplifier and has no effect unless the treble boost action is switched in by closing S2.

This brings C2 into circuit, and it is shunted across R3. At low and middle audio frequencies the impedance of C2 is very high in relation to that of R3, and C2 therefore has very little shunting effect on R3 and the gain of the circuit remains at about unity. At higher frequencies the impedance of C2 reduces and becomes comparable to that of R3 so that there is a significant boost in gain. At the highest audio frequencies

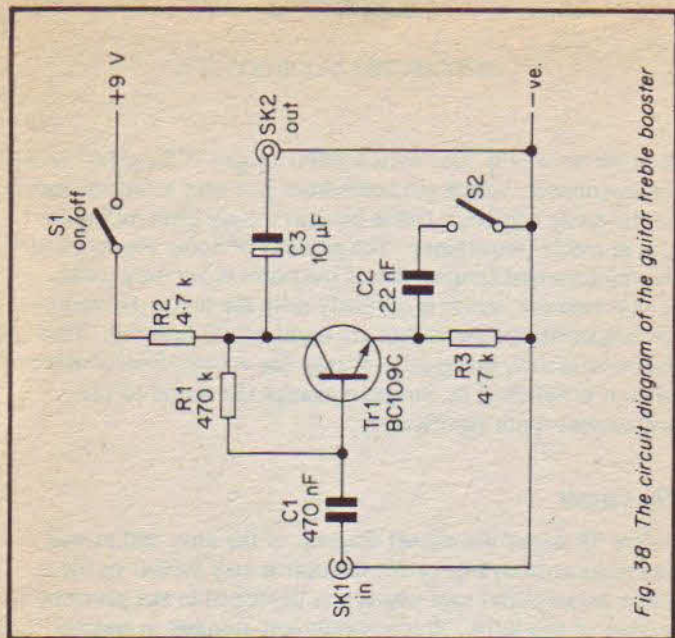

Fig. 38. The circuit diagram of the guitar treble booster

C2 has an impedance which is much lower than that of R3, and its shunting effect on R3 results in the gain of the unit being greatly boosted. Thus the treble boost is provided by the circuit.

The gain of the circuit rises to 6dB (i.e. 2 times) at a frequency of approximately 2kHz, 18dB (i.e. about 8 times) at approximately 10kHz, and is over 20dB (i.e. 10 times) at frequencies above about 15kHz. This degree of boost gives a good effect when used with a guitar, but if preferred, increased treble boost can be obtained by making C2 a little higher in value, or reduced treble boost can be obtained by using a slightly lower value here.

The unit is left in circuit when the treble boost is switched out, but as the unit has a current consumption of only a little in excess of 1mA this does not result in excessively high running costs, and the noise and distortion levels of the unit

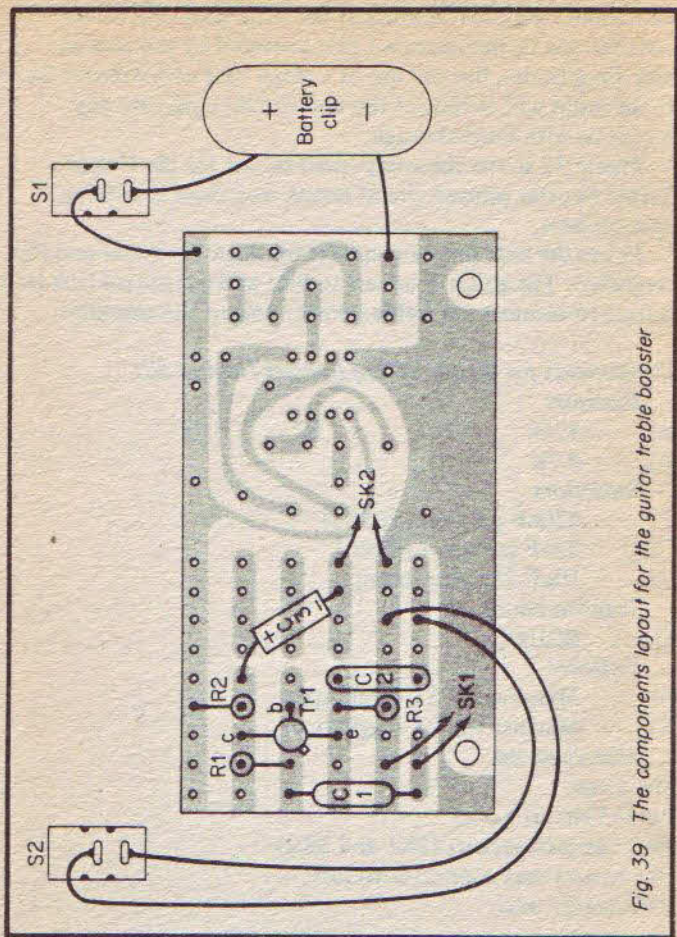

Fig. 39 The components layout for the guitar treble booster

are too small to be of significance.

### Construction

The unit should be housed in a metal case (earthed to the negative supply rail) so that stray pick-up in the circuitry is

minimised. RF breakthrough is the main problem in this instance due to the increased gain provided by the unit at high frequencies, but the use of a metal case and screened leads at the input and output of the unit should eliminate any problems with breakthrough.

Figure 39 shows the component layout for the Guitar Treble Booster printed circuit board, and there is nothing unusual here.

In use the unit simply connects between the guitar and the amplifier. The guitar connects to SK1 and a standard jack lead is used to connect the treble booster unit to the amplifier.

### *Components for Guitar Treble Booster (Figure 38)*

#### *Resistors*

R1	470k	R2	4.7k
R3	4.7k		

#### *Capacitors*

C1	470nF polyester (C280)
C2	22nF polyester (C280)
C3	10 $\mu$ F 25v electrolytic

#### *Semiconductor*

Tr1	BC109C
-----	--------

#### *Switches*

S1	Miniature SPST toggle type
S2	Miniature SPST toggle type

#### *Miscellaneous*

- Metal case
- Printed circuit board
- Two  $\frac{1}{4}$ in jack sockets (SK1 and SK2)
- PP3 battery and connector to suit
- Wire, solder, etc.

## PROJECT 19

### GENERAL PURPOSE PREAMPLIFIER

A common problem in electronics is that of matching a low level signal to an insensitive input. A typical example of this would be trying to use a high impedance dynamic microphone with a hi-fi amplifier. The output from a microphone of this type is typically no more than a few millivolts RMS, whereas a hi-fi amplifier normally requires an input level of a few hundred millivolts RMS at the "aux", "tape" and similar inputs.

This general purpose preamplifier gives low levels of noise and distortion, and has a voltage gain in excess of 40dB (100 times). The prototype actually requires about 3.8mV RMS at the input in order to give a level of 500mV RMS at the output. It has a low output impedance and an input impedance of approximately 47k. It is therefore ideal as a preamplifier to match a high impedance dynamic (or similar) microphone to a hi-fi or other type of power amplifier, or in applications of a similar nature. An output level of up to about 2 volts RMS is possible before clipping and consequent serious distortion are produced. By making a simple modification to the circuit it is possible to slightly boost the gain and input impedance of the unit. The modified unit requires an input level of only about 1.8mV RMS in order to give an output signal of 500mV RMS, and has an input impedance of approximately 200k.

#### The Circuit

The unit uses a two stage direct coupled circuit, as can be seen from the full circuit diagram of the unit which appears in Figure 40.

Both stages of amplification are of the common emitter type. Tr1 has a high value collector load resistor as it operates at a low collector current of only about 60 microamps, and the reason for using a low operating current through the input transistor is that this gives the unit a low noise level. The low noise level is also aided by the use of low noise transistors in

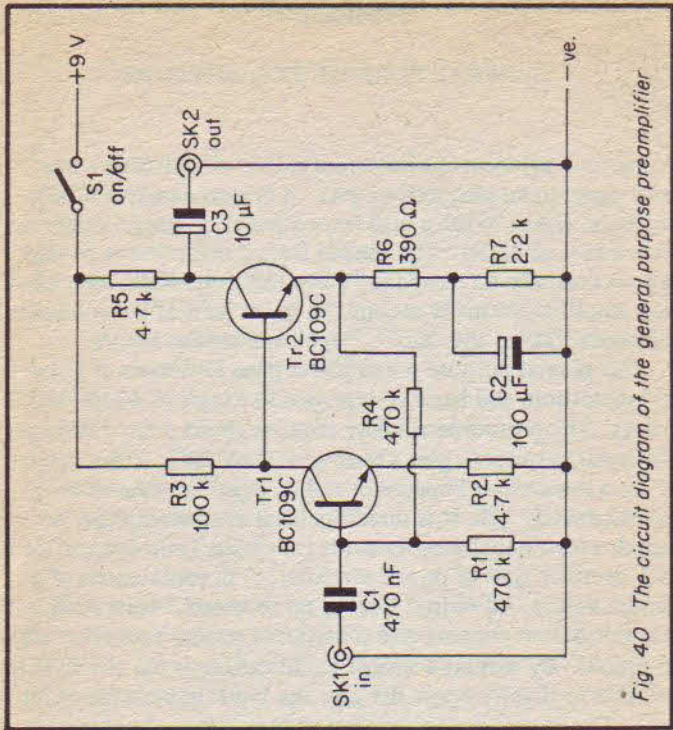

Fig. 40 The circuit diagram of the general purpose preamplifier

both stages of the circuit. R2 provides local negative feedback over Tr1 which reduces the otherwise excessive gain of the input stage, boosts the input impedance, and reduces noise and distortion. Tr1 is biased from the emitter of Tr2 via the potential divider which consists of R1 and R4, and the biasing is stabilised by a certain amount of DC negative feedback.

As the two stages are direct coupled Tr2 is, of course, biased from the output of Tr1. R5 is the collector load resistor, and R6 plus R7 provide DC negative feedback in the emitter circuit of Tr2 which helps to stabilise the DC biasing conditions of the circuit. This feedback is undesirable at AC since it would reduce the gain of the unit by an unacceptable amount, and a substantial amount of the feedback is decoupled at AC by C2.



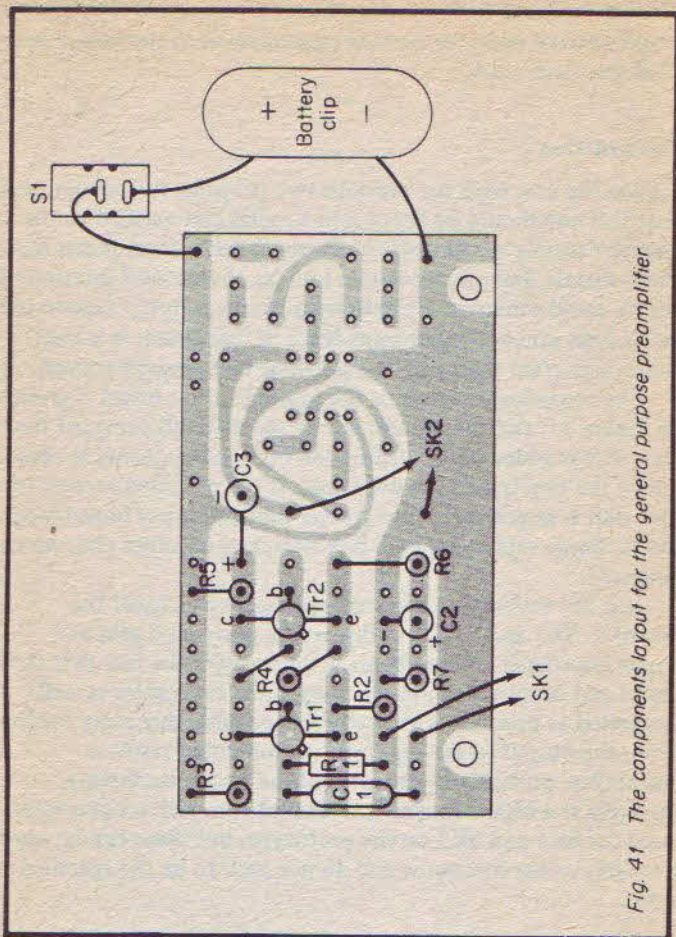

Fig. 41 The components layout for the general purpose preamplifier

R6 is not decoupled though, and a small amount of feedback remains at AC. The gain and input impedance of the circuit can be boosted, as mentioned earlier, by removing the local feedback around Tr2, and R6 is simply shorted out in order to achieve this.

C1 and C2 are the input and output DC blocking capacitors.

The unit will run for very many hours from a small (PP3 size) 9 volt battery since the current consumption of the circuit is a little less than 1mA.

## Construction

As was the case with the previous two projects, it is recommended that this one should be fitted into a metal case earthed to the negative supply rail in order to screen the unit from mains hum, radio signals, and other possible sources of electrical interference which could otherwise breakthrough to the output. Due to the fairly high gain and input impedance of this circuit it is even more important than with the previous two projects though.

The component layout of the printed circuit board is given in Figure 41, and this should not be too difficult provided the link wire is added before fitting the other components in place. Leave the two transistors until last. If the modified version of the unit is required (to give greater gain and input impedance), R6 is simply replaced with a link wire, and no other changes are required.

It is not essential to use screened leads to connect the board to SK1 and SK2, but due to the fairly high gain and input impedance of the circuit, together with the fact that the input and output are in-phase, keep these two cables as well separated as possible. Otherwise it is possible that stray feedback from the output to the input of the unit could result in instability, probably in the form of the circuit oscillating strongly at a high frequency. Standard  $\frac{1}{4}$ in. jack sockets were used for SK1 and SK2 on the prototype, but these can be any two way audio connector and do not have to be the specified type.

### *Components for General Purpose Preamplifier (Figure 40)*

#### *Resistors*

R1	470k	R2	4.7k
R3	100k	R4	470k
R5	4.7k	R6	390 ohms
R7	2.2k		

### *Capacitors*

- C1 470nF polyester (C280)
- C2 100 $\mu$ F 10v electrolytic
- C3 10 $\mu$ F 25v electrolytic

### *Semiconductors*

- Tr1 BC109C
- Tr2 BC109C

### *Switch*

- S1 Miniature SPST toggle type

### *Miscellaneous*

- Metal case
- Printed circuit board
- Two  $\frac{1}{4}$ in jack sockets (SK1 and SK2)
- PP3 battery and connector to suit
- Wire, solder, etc.

## PROJECT 20

### SIGNAL TRACER

The purpose of a signal tracer is much the same as that of a signal injector (such as the one described earlier in this book). However, a signal tracer is, in a way, used in the opposite manner to a signal injector. Instead of injecting a signal at the output of the equipment under investigation and then working towards the input, a signal tracer is used to first verify that an input signal is present, and further tests are then made at strategic points working towards the output of the equipment. When the signal can no longer be traced (or is obviously at too low a level, seriously distorted, or in some other way incorrect) the approximate area of the fault has been located. As is the case with a signal injector, normal voltage testing and similar checks are then used to precisely locate the fault.

A signal tracer for use on audio equipment simply consists of an audio amplifier driving a loudspeaker or an earphone, so that the traced signal, if present and correct, will give the appropriate audio output from the tracer. For RF or IF signal tracing the signal tracer must additionally have a suitable demodulator built-in so that an audio signal is produced from the tracer, provided a suitable input signal is present, of course.

This signal tracer has good sensitivity so that it can be used for any normal type of audio signal tracing. The circuit gives AM demodulation, and the unit can therefore be used for IF and RF testing on AM radios provided a suitably strong signal is available. The unit has an integral loudspeaker, and although the maximum output power is only a few tens of milliwatts, the volume level obtained is more than adequate for this application. If preferred though, the loudspeaker could be replaced by an earpiece or headphones, and a crystal earphone, low, medium and high impedance headphones are all suitable for use with the unit.

## The Circuit

The circuit diagram of Figure 42 is that of the Signal Tracer, and the circuit is basically just two common emitter amplifiers with capacitive coupling.

Tr1 is used in the input stage, and this has C1 to provide DC blocking at the input, R2 as the bias resistor, and R3 as the collector load resistor. An input signal direct to the input of the amplifier may well be sufficient to overload the amplifier in many cases, and a second input having lower sensitivity is therefore provided (SK1), and the necessary attenuation (of nearly 40dB) is provided by R1 and the input impedance of the amplifier. The input impedance of the amplifier at the high sensitivity input (SK2) is several kilohms, but R1 provides a useful boost in input impedance so that the input impedance at SK1 is approaching 500 kilohms.

C2 is used to roll-off the high frequency response of the circuit in order to aid stability. It also gives the circuit a simple AM demodulator action by providing RF filtering. The rectification that is also needed in order to produce AM demodulation is provided by Tr1 which, like any amplifier, does not give perfect linearity. It tends to amplify more during positive input half cycles when the collector current increases than it does on negative input half cycles when the collector current decreases. This form of non-linearity is typical of any normal bipolar transistor, and gives the required rectification. There is no need to have any AF/RF switching since the circuit will properly process either type of signal.

The output from the collector of Tr1 is coupled to the input of Tr2 by C3. Tr2 is used as a straight forward common emitter stage, but it is run at a fairly high collector current of around 15mA so that a strong enough output signal to give reasonable volume from a high impedance loudspeaker can be obtained. C4 couples the output signal to the loudspeaker.

## Construction

Once again, it is advisable to fit this project into a metal case earthed to the negative supply rail so that the circuitry is

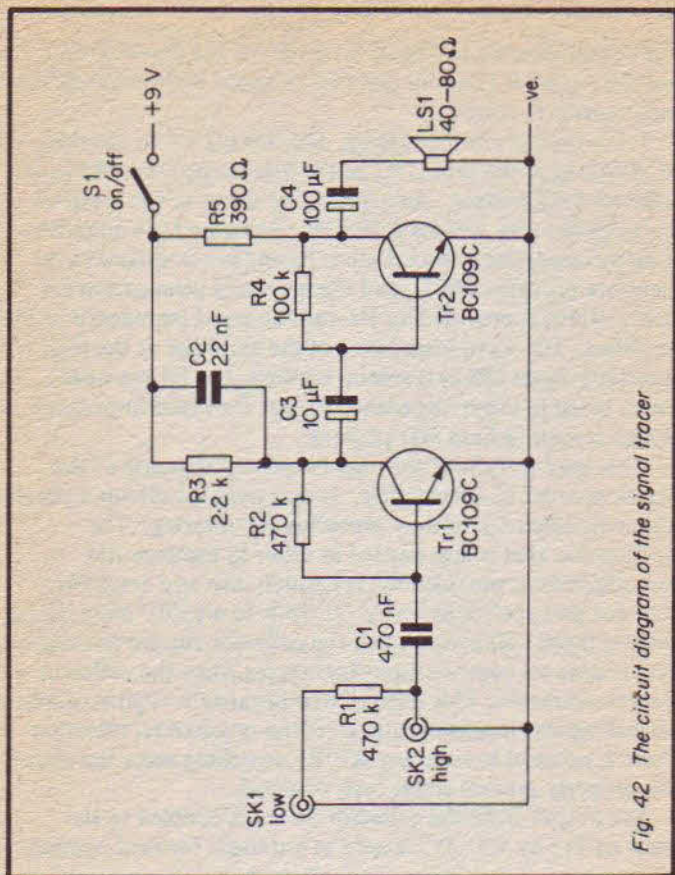
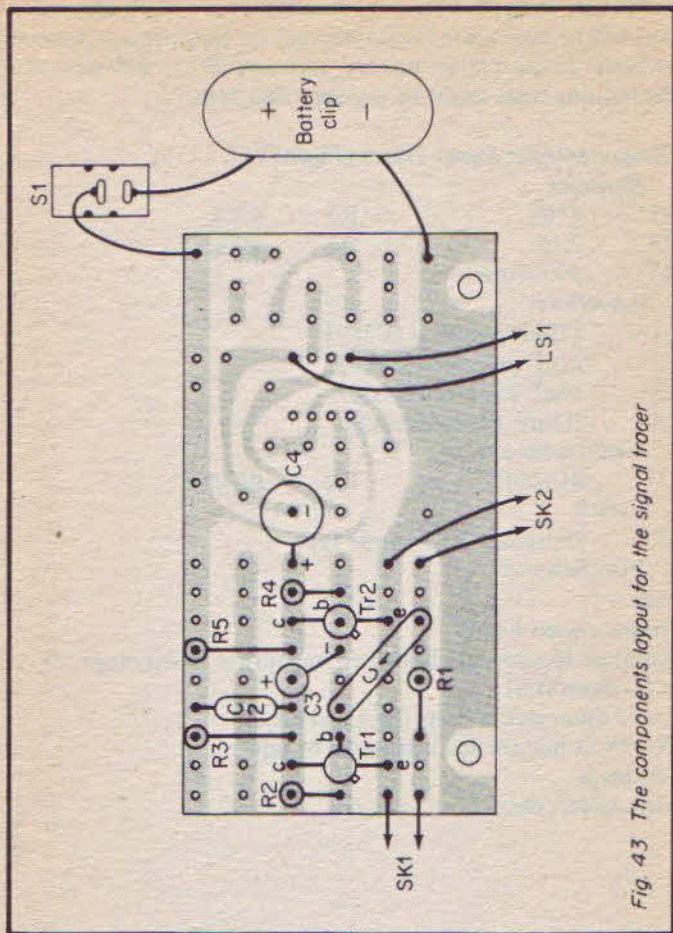

Fig. 42 The circuit diagram of the signal tracer

screened from stray electrical signals. Construction of the unit is quite straight forward in other respects, and the component layout of the printed circuit board for this project is shown in Figure 43. As the input and output of the unit are in-phase, keep the speaker leads reasonably well separated from the input leads in order to minimise stray feedback and give good stability. It should not be necessary to use screened leads to connect the board to SK1 and SK2 in order to obtain stability,



*Fig. 43 The components layout for the signal tracer*

but the external lead which connects to these sockets should be a screened type or severe breakthrough of unwanted signals will almost certainly result.

The current consumption of the unit is about 17mA, and a PP3 size battery will not give many hours of operation, although this will not matter in many cases since the unit is not likely to

be used for long periods. However, if it is envisaged that the unit will be used quite frequently and for long periods it would be better to use a larger battery, such as a PP7 or PP9 size, or the running costs might be unacceptably high.

### *Components for Signal Tracer (Figure 42)*

#### *Resistors*

R1	470k	R2	470k
R3	2.2k	R4	100k
R5	390 ohms		

#### *Capacitors*

C1	470nF polyester (C280)
C2	22nF polyester (C280)
C3	10 $\mu$ F 25v electrolytic
C4	100 $\mu$ F 10v electrolytic

#### *Semiconductors*

Tr1	BC109C	Tr2	BC109C
-----	--------	-----	--------

#### *Switch*

S1	Miniature SPST toggle type
----	----------------------------

#### *Miscellaneous*

Case

Printed circuit board

Miniature loudspeaker having an impedance in the range 40 to 80 ohms (LS1)

Two 3.5mm jack sockets (SK1 and SK2)

PP3 9 volt battery and connector to suit

Test leads

Wire, solder, etc.



## PROJECT 21

### QUIZ MONITOR

There are a number of games, such as snap and TV type question games, where it is necessary to know who was first to notice the snap, to indicate that they wished to answer the question, or whatever. It may often be uncertain who was first, and arguments can occur in consequence. In TV quizzes the problem is overcome by each contestant having a push button which operates an indicator light, and when one light comes on all the others are blocked. Thus, only the light of the first person to operate his or her switch can come on, and disputes about who was first to operate their switch are avoided.

This unit provides this action and is for two players. It is simple to use as it automatically resets when the switches are opened, and the two switches are in fact the only controls.

#### The Circuit

The circuit of the Quiz Monitor unit is shown in Figure 44, and the unit is basically just a conventional bistable multivibrator using a couple of bipolar transistors.

If we assume that S1 is closed, Tr1 will receive a base current by way of D2, R4, S1 and R2, and it will therefore be biased hard into conduction. D1 then lights up as it receives a strong current via Tr1 and current limiting resistor R1, but D2 does not light up since the only current it passes is the minute base bias current of Tr1.

If S2 is now closed, no significant base current will flow into Tr2 via S2 and R3 as the voltage at the collector of Tr1 is very low while this device is biased into conduction. This gives the required blocking action with S2 unable to switch on D2 once S1 has been operated and D1 has switched on. If the switches are opened again Tr1 will switch off and the circuit will be back in its original state.

If S2 is now operated, obviously D2 will switch on and S1 will be blocked from operating D1. The circuit operates

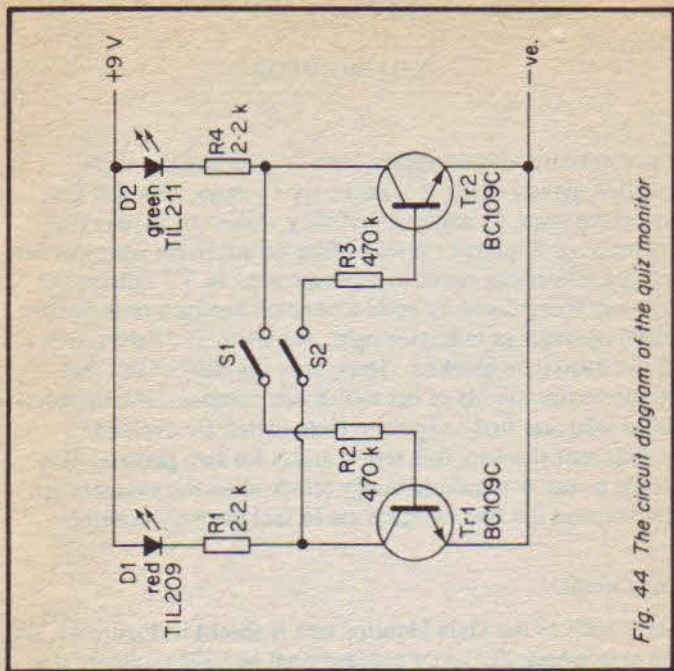

Fig. 44 The circuit diagram of the quiz monitor

extremely rapidly indeed, and even the slightest delay between the two switches being operated will result in the first one operating the appropriate LED indicator and the second one being blocked.

The unit does not need an on/off switch because the only current that flows when S1 and S2 are open is the small leakage current that Tr1 and Tr2 pass. This current will only be a fraction of one microamp and is far too small to have any effect on the operating life of even a small 9 volt battery. The current consumption of the unit is only a few milliamps when one of the lamps is operating, and a PP3 size battery should have virtually its shelf life when used to power the unit, even if it receives a great deal of use.

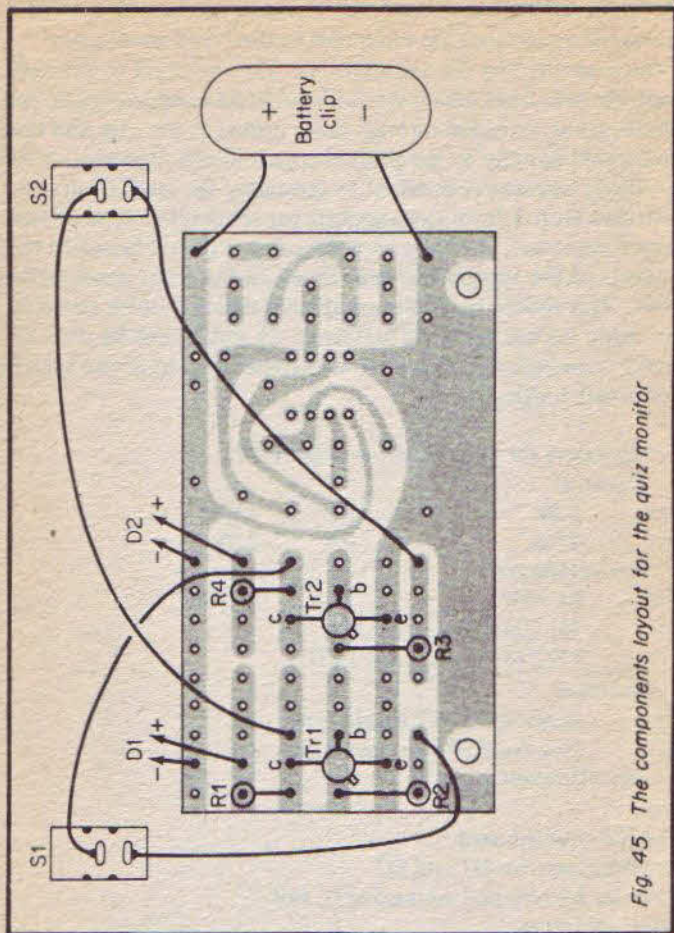

Fig. 45 The components layout for the quiz monitor

### Construction

Figure 45 shows the printed circuit component layout for the Quiz Monitor unit, and this aspect of construction is perfectly straight forward. D1 and D2 can be mounted on the front panel of the unit, but in order to make the unit convenient

to use it will almost certainly be necessary to have S1 and S2 mounted away from the main unit in their own small cases (which are held by the contestants). They connect to the main unit via twin leads which do not have to be screened types, and these can be threaded through holes drilled in the case and then connected directly to the printed circuit board. However, it will probably be more convenient to terminate the leads from the switches with 3.5mm jacks sockets (or some other type of two way connector), and then wire the printed circuit board to two sockets of the appropriate type fitted on the front panel of the unit. This should make the equipment easier to store and set up ready for use again. If preferred, S1 and S2 can be push to make (non-locking) push button switches instead of the specified miniature toggle type.

#### *Components for Quiz Monitor (Figure 44)*

##### *Resistors*

R1	2.2k	R2	470k
R3	470k	R4	2.2k

##### *Semiconductors*

Tr1	BC109C	Tr2	BC109C
D1	TIL209 (3mm red LED)		
D2	TIL211 (3mm green LED)		

##### *Switches*

S1	Miniature SPST toggle type
S2	Miniature SPST toggle type

##### *Miscellaneous*

Case  
Printed circuit board  
Panel holders for D1 and D2  
PP3 size battery and connector to suit  
Wire, solder, etc.

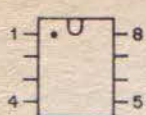

555

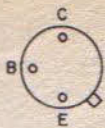

BC109C



2N5777



BZY88C10V

Fig. 46 Semiconductor leadouts  
(IC top view, transistor base views)

## OTHER BOOKS RECOMMENDED FOR BEGINNERS

**227: BEGINNERS GUIDE TO BUILDING  
ELECTRONIC PROJECTS** price £1.50

Author: R. A. Penfold

ISBN 0 900162 68 6

1977

Approx. size: 180 × 108 mm

112 pages

The purpose of this book is to enable the complete beginner to tackle the practical side of electronics, so that he or she can confidently build the electronic projects that are regularly featured in the popular magazines and books.

Subjects such as component identification, tools, soldering, various constructional methods (Matrixboard, Veroboard, P.C.B.), cases, legends, etc. are covered in detail and practical examples in the form of simple projects are given.

**228: ESSENTIAL THEORY FOR THE  
ELECTRONICS HOBBYIST** price £1.25

Author: G. T. Rubaroe, T.Eng.(C.E.I.), Assoc.I.E.R.E.

ISBN 0 900162 69 4

1977

Approx. size: 180 × 108 mm

128 pages

In any hobby activity a background knowledge of the subject can considerably increase the enjoyment and satisfaction one derives from it. This point of view applies, without any reservations whatsoever, to electronics.

The object of this book is to supply the hobbyist with a background knowledge tailored to meet his or her specific requirements and the author has brought together the relevant material and presented it in a readable manner with minimum recourse to mathematics.

Many formulae having a practical bearing are presented in this book and purpose-designed examples are employed to illustrate their applications.

**BP48: ELECTRONIC PROJECTS  
FOR BEGINNERS** price £1.95

Author: F. G. Rayer, T.Eng.(C.E.I.), Assoc.I.E.R.E.

ISBN 0 85934 054 6

1978

Approx. size: 180 × 108 mm

128 pages

Another book written by the very experienced author — Mr F. G. Rayer — and in it the newcomer to electronics, will find a wide range of easily-made projects. Also, there are a con-

siderable number of actual component and wiring layouts, to aid the beginner.

Furthermore, a number of projects have been arranged so that they can be constructed without any need for soldering and, thus, avoid the need for a soldering iron.

Also, many of the later projects can be built along the lines of those in the "No Soldering" section so this may considerably increase the scope of projects which the newcomer can build and use.

## ELEMENTS OF ELECTRONICS

— an on-going series                      price (each volume) £2.25

- BP62: BOOK 1 — The Simple Electronic Circuit  
and Components**  
ISBN 0 0900162 82 1    1979
- BP63: BOOK 2 — Alternating Current Theory**  
ISBN 0 900162 83 X    1979
- BP64: BOOK 3 — Semiconductor Technology**  
ISBN 0 900162 84 8    1979

**Author: F. A. Wilson, C.G.I.A., C.Eng., F.I.E.E., F.B.I.M.**

Approx. sizes: 180 × 108 mm    each 224 pages

The aim of this series of books can be stated quite simply — it is to provide an inexpensive introduction to modern electronics so that the reader will start on the right road by thoroughly understanding the fundamental principles involved.

That the books are inexpensive is perhaps obvious. By accepting their modest size the total information is that which in normal size text books would cost some 2–3 times as much.

Although written especially for readers with no more than ordinary arithmetical skills, the use of mathematics is not avoided, and all the mathematics required is taught as the reader progresses. There is little doubt that some skill in electronics and mathematics will be an asset to almost everybody in the future, destined as we are to be controlled more and more by computers, microprocessors and the like. There is also much to offer those who need revision or to be brought up to date with fundamentals, with those grown-up children asking awkward questions or preparing for entry to a college or even those who may find a different approach refreshing.

The course is not written to a specific syllabus but concentrates on the understanding of the important concepts central to electronics rather than continually digressing over the whole field on the basis that once the fundamentals are mastered, the

technicalities of most other things are soon revealed. The author anticipates where the difficulties lie and hopefully guides the reader through them.

Each book is a complete treatise of a particular branch of the subject and, therefore, can be used on its own with one proviso, that the later books do not duplicate material from their predecessors, thus a working knowledge of the subjects covered by earlier books is assumed.

**BOOK 1:** This book contains all the fundamental theory necessary to lead a full understanding of the simple electronic circuit and its main components.

**BOOK 2:** This book continues with alternating current theory without which there can be no comprehension of speech, music, radio, television or even the electricity mains.

**BOOK 3:** follows on semiconductor technology, leading up to transistors and integrated circuits.

Books 1-3 therefore constitute a complete but inexpensive basic electronic theory course on inestimable help in either career or hobby. Other books following are on specialised electronic subjects, they are all built on this earlier groundwork.

Two further books are available:

**BP77: BOOK 4 – Microprocessing Systems and Circuits**

**BP89: BOOK 5 – Communication**

These two volumes are priced at £2.95 each.

**BP97: IC PROJECTS FOR BEGINNERS** price £1.95

**Author: F. G. Rayer, T.Eng.(C.E.I.), Assoc.I.E.R.E.**

**ISBN 0 95934 072 4**

1982

**Approx. size: 180 X 108 mm**

112 pages

This book has been especially written for the less experienced hobbyist and offers a range of fairly simple projects based on a number of popular and inexpensive linear and digital integrated circuits.

It covers such items as power supplies, radio and audio circuits, oscillators, timers and switches, etc.

With many of the projects, complete layout and/or point-to-point wiring diagrams are included to help simplify construction. It is hoped that most of the designs should be well within the capabilities of practically anyone who can use a soldering iron and a few other simple tools.



# BERNARD BABANI BP103

## Multi-circuit Board Projects

- This book contains information to allow the reader to build 21 fairly simple electronic projects, all of which may be constructed on the same specially designed printed circuit board. Furthermore, wherever possible, the same components have been used in each design so that with a relatively small number of components and hence low cost, it is possible to make any one of the projects or by re-using the components and P.C.B. all of the projects.
- A circuit description, circuit diagram, printed circuit component layout diagram, components list and construction notes are provided for each project. All the projects operate from a 9 volt battery supply making them an ideal and safe introduction to electronics for the beginner.

ISBN 0 85934 078 3



BERNARD BABANI (publishing) LTD  
The Grampians  
Shepherds Bush Road  
London W6 7NF  
England

£1.95