

An Introduction to Video

D. K. MATTHEWSON

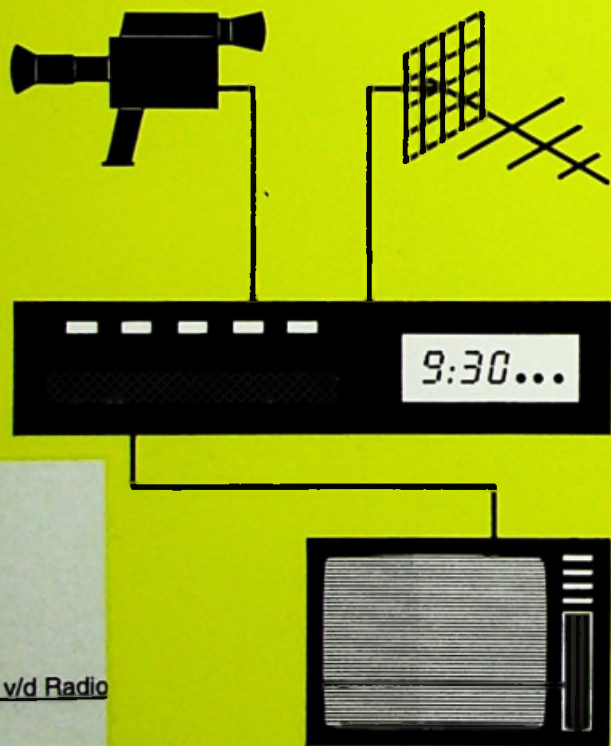

R
S
Historie v/d Radio

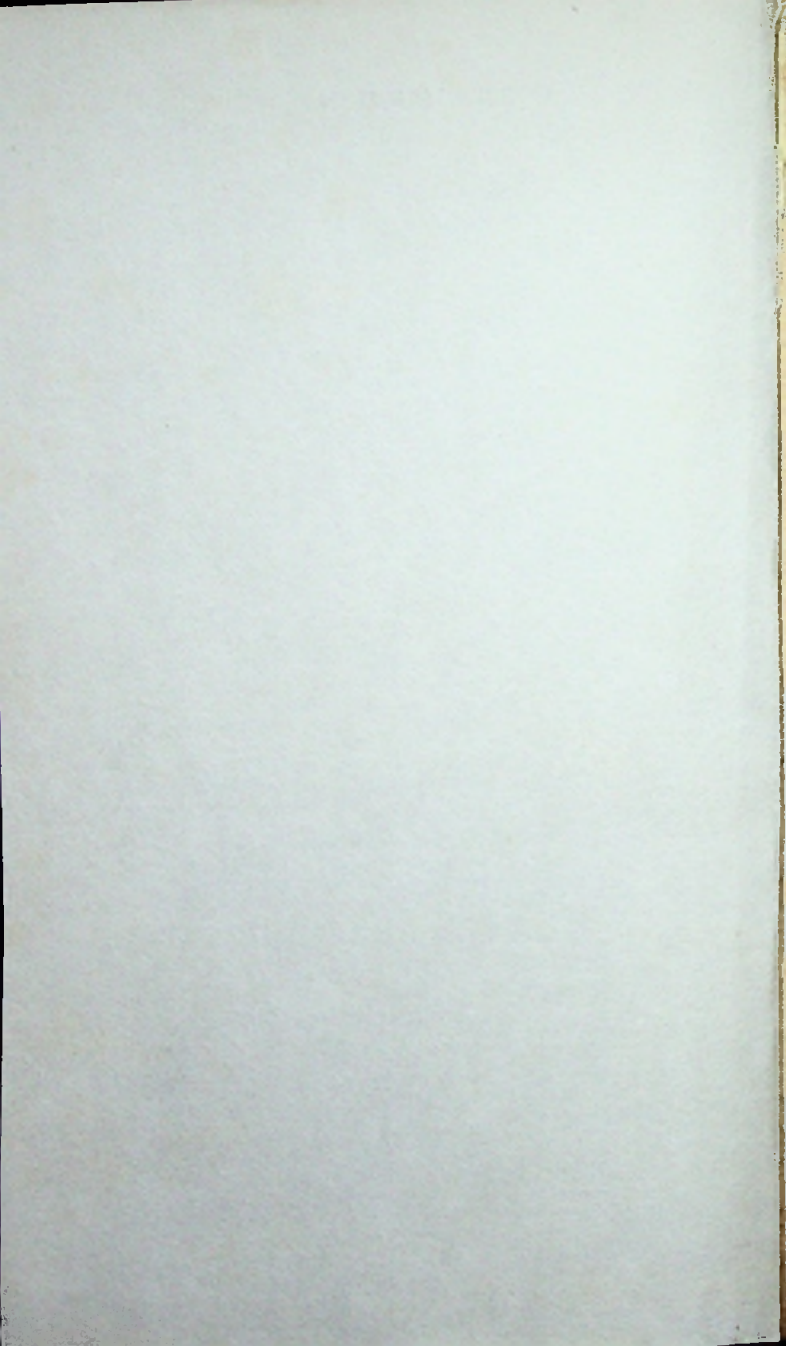

AN INTRODUCTION TO VIDEO

BIBLIOTHEEK
N.V.H.R.

ADVANCE PRODUCTION SAMPLE

NOT FOR RE-SALE

*This book is dedicated to
the A.P.'s - both sets*

AN INTRODUCTION TO VIDEO

**BIBLIOTHEEK
N.V.H.B.**

by
DAVID K. MATTHEWSON
Ph.D., B.Sc., M.R.T.S.

BERNARD BABANI (publishing) LTD
THE GRAMPIANS
SHEPHERDS BUSH ROAD
LONDON W6 7NF
ENGLAND

Although every care has been taken with the preparation of this book, the publishers or author will not be held responsible in any way for any errors that might occur.

© 1983 BERNARD BABANI (publishing) LTD

First Published -- February 1983

British Library Cataloguing in Publication Data
Matthewson, D. K.

An introduction to video. (BP100)

1. Video-tape recorders and recording
– Amateurs manuals

I. Title

621.389'32 TK6655.V5

ISBN 0 85934 075 9

Printed and bound in Great Britain by Cox & Wyman Ltd, Reading

CONTENTS

BIBLIOTHEEK
N.V.H.R.

	page
INTRODUCTION	1
Background	1
Questions and Answers	2
USES OF VIDEO	4
TV, Images and Eyes	5
Video Tape Recorders	8
Basic Video System	10
Video Tape Recorders	14
Video Cameras	21
Video Discs	25
Which System?	32
Videotext	33
CHOOSING THE HARDWARE	40
Features	41
Specifications	43
Video Tape Recorders	43
Video Bandwidth	43
Signal to Noise Ratio	44
Chroma Noise	45
Hue Accuracy	45
Chroma/Luma Delay	45
Impedance, Signal Levels and Plugs	46
Audio Inputs	46
Audio Outputs	47
Attenuators	48
Video Sockets	50
Camera Connectors	50
Rent or Buy?	52
USING YOUR VIDEO	54
Getting Started	54
Connection of a Vtr to Several Tvs	55

	page
Copyright	57
Basic Tape Copying and Editing	58
Maintenance and Care of Your Video System	63
Using Video Cameras	66
International Tape Exchange and Related Problems . . .	72
THE FUTURE	76
Glossary of Common Video Terms and Abbreviations	80

INTRODUCTION

Only a few years ago a large colour television set in the corner of the living room was the ultimate in status symbols, but this is no longer the case. Instead the video cassette recorder, the latest high technology product to reach the consumer market has replaced it.

If anyone doubts that Video Cassette Recorders and Video in general is the boom industry of the 1980's then let them look at the magazine shelves in any newsagents where they will find a proliferation of magazines on video. Interesting and well written as some of these journals are, it seems that they either ignore the practical aspects of video and concentrate on the wide range of pre-recorded video cassettes available or else they are full of reviews on the latest recorders etc. It is difficult to find much information on the basic principles of, say, a video recorder or camera, and also how different bits of video equipment can be used to the best advantage.

This book is an attempt to meet this need and aims to present information on video equipment in a non-technical manner. No knowledge of electronics or engineering is assumed or required, nor will much 'hard' technical information be given. This is a book for the person who is just about to buy or rent some video equipment but is not sure what to choose, or for someone who already has, say, a recorder and wants advice on what to look for in suitable cameras. I also hope that this book will be useful to anyone interested in the history, current state and future developments of home video.

BACKGROUND

The term 'video' is often used, rather inaccurately, to describe a whole range of items related to television. For instance, it

can mean video cassette recorder, pre-recorded video tape, to shoot a sequence on video tape and so on. In fact the derivation of 'video' is from the Latin and means 'to see'. In this book we will be using it in terms of 'video recorder', 'video tape' and to refer to other items of non-broadcast television equipment.

All the current domestic video recorders, cameras and disc units can trace their origins back to equipment first developed for the broadcasters, in other words they are all off-shoots of professional television equipment. We will look at this development in more detail in the appropriate sections which are devoted to specific types of equipment. Video tape recorders as such are a relatively new innovation, as the first practical broadcast machine was developed only in 1956.

QUESTIONS AND ANSWERS

Before we really get started let us try to answer some of the more frequently raised questions concerning video. More detailed explanations will be given in the appropriate section of the book.

What is a Video Tape Recorder (vtr)?

A vtr is a type of magnetic tape recorder which records both sound and vision simultaneously. The tapes can then be played back on the same machine and watched and listened to on a standard tv set. All domestic mains operated vtrs have a tv tuner built in, so can be used to record programmes without a separate tv set.

It sounds a complex process -- is a vtr easy to operate?

All current vtrs are similar in operation to hi-fi cassette audio decks, although some do have special features which take some getting used to. There are no knobs to adjust or meters to watch.

Are they as good as they sound?

The picture quality of all vtrs is acceptable, but of lower quality than a good off air received tv signal displayed on a good tv set. The sound quality of vtrs is not as good as an audio cassette recorder, but acceptable to all but hi-fi enthusaists.

Will I have to buy a new tv set to use with my new vtr?

No. Vtrs will work with almost all tv sets, although some of the older valve sets will need a small modification to get a stable picture.

Can any video cassette be replayed on any video machine, just like an audio cassette?

Unfortunately no. The format of the tape differs between the different systems from various firms and there is no international standard. At present there are three main incompatible formats, VHS, Beta, and V2000.

What length of programme can I record without changing tapes?

Again, this depends on format, but around four hours for the longest playing tapes -- which will cost about £7-£10.

What is all this going to cost?

New vtrs cost from around £300 to over £700. As far as running costs are concerned a vtr uses less electricity than a 100 watt light bulb and is therefore cheap to run.

Can I use a vtr in my caravan or boat?

Mains operated vtrs need a stable mains supply, that from a generator will not suffice. Battery operated vtrs are available.

USES OF VIDEO

Probably the major domestic use of video tape recorders is to 'time shift' broadcast television programmes. By 'time shift' I mean to record a programme when it is broadcast and play it back at a more convenient time — either later the same day or weeks later. Besides this basic use video tape recorders can also be used to play back pre-recorded video cassettes of movies, educational and general interest programmes. This area of the industry is at present booming even though pre-recorded cassettes cost around £25–£35 in the shops.

Video disc players can not be used to record at all and are limited to playing back the material which various software manufacturers (i.e. the programme producers) have decided to market.

Low cost colour and black and white video cameras have now become widely available, and they are being used by people to record weddings, family events, amateur drama, sports and so on. Whilst not giving results equivalent to broadcast television they are still quite good. The ease of use and low cost of tape has seen domestic video recorders and cameras make considerable inroads into the amateur Super 8mm market. As recorders become smaller and more portable, and as combined camera/recorder units become available then this trend is bound to increase.

Videotext is a word which is currently in vogue and which refers to the information services which are available on television screens, such as Prestel, Ceefax and Oracle. The former is provided by British Telecom and uses the telephone lines to link a number of large computers to modified television sets in home or business premises. This allows the tv set to function rather like a computer visual display unit. The other two services, Ceefax and Oracle are provided by the BBC and

IBA respectively and provide a similar but more limited type of information to tv viewers along with normal tv programmes. Again, a special tv set is needed to extract the information from a tv signal and to display it on the screen.

In the following sections we will look at some of the various facets of video technology and, more importantly, how they can be used.

One of the main functions of this book is to try to take the mystery out of video and to provide the necessary information with which the consumer can make a sensible choice of what equipment to buy – or not to buy as the case may be.

TV, IMAGES AND EYES

One of the good things about domestic video equipment is that it is all designed to be operated by almost anybody – no understanding of electronics is necessary, although it can be helpful for the prospective user to understand some of the general principles that are involved.

Before we go on to look at video hardware in detail it will be helpful to take a brief, and, hopefully, not too technical look at the basic principles of television and how images can be displayed on a tv screen.

When we sit and watch a tv picture, what exactly are we looking at? What I mean is that if we go to the cinema to watch a movie, what we see projected on the screen can clearly be related to what is running through the film projector. It is a series of still images – like colour slides – each one projected for a very brief interval. The illusion of a smooth moving scene is produced because the changes from one still picture to the next are so rapid that the human eye/brain perceives a moving picture.

Television is very similar, a series of stills are 'projected' on to

the front of a tv cathode ray screen, (the tv 'tube') and the eye/brain smooths out these stills into a moving picture. Each of these stills is built up from a series of lines, again the persistence of the tv tube combines with the eye/brain to give the impression of an evenly illuminated tv screen.

In the UK colour tv pictures are composed of 625 lines making a single frame and 25 frames or images per second are flashed on to the tv screen. If all this seems a bit esoteric, it is an important point to grasp, if for no other reason than because the corresponding figures for American tv are 525 lines and 30 frames per second. It is for this reason that US video cassettes can not easily be replayed in the UK and vice versa, but more about this later!

A typical video system, be it domestic VHS camera and recorder or a broadcast tv camera in a studio linked to a tv transmitter works in a similar manner.

The light reflected from the object at which the camera is pointed is focused by the camera lens into the camera tube and on to a light sensitive target or screen. This screen becomes electrically charged according to the brightness of the light falling upon it. In this manner the scene is dissected and can then be scanned to turn these differences in electrical charge into a complex electronic signal – the video signal. This signal can then be recorded on to video tape or transmitted as required. The scanning process in the camera is almost identical to that used in the tv receiver to reconstruct the picture. If you consider it, you will see that the more horizontal lines into which the scene is broken down then the higher the resolution the system will be. In other words, finer detail will be shown up. Consider how much of an improvement today's 625 line system is to the old 405 one, or even the pre Second World War 30 lines system!

In order to improve the image quality as much as possible each frame of 625 lines of picture information is in fact built up on the tv screen as two separate 'fields', each of 312½ lines.

(Fig. 1 illustrates principles.) The first field has the odd numbered lines whilst the second field, which is interwoven or interlaced with the first is composed of the even lines. As the whole frame is transmitted 25 times a second there are 50 fields per second. This figure is well above what is called the 'flicker fusion frequency' at which the eye/brain merges a sequence of stills into a smoothly moving picture.

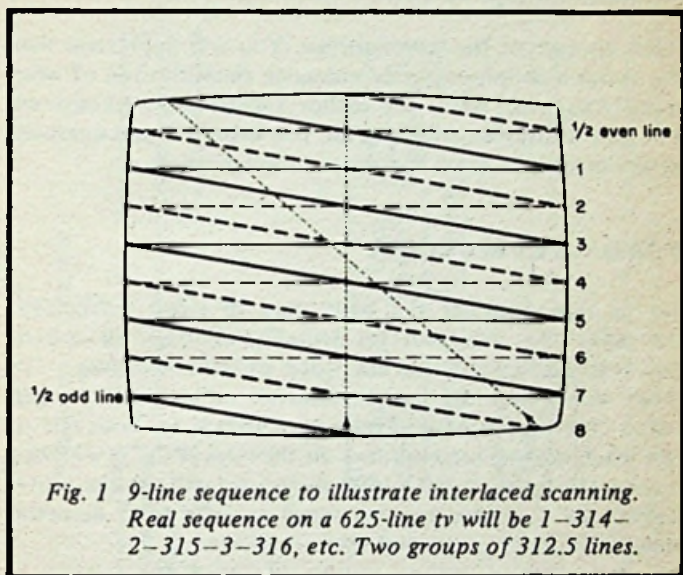

The final technical point to appreciate is that along with the picture information, the video signal also contains synchronising information, which is essential to ensure that the image recreated on the tv screen is identical to that scanned by the original camera. This synchronising signal is important in domestic video as we shall see when we look at tape copying and editing.

At the receiver end of the system, i.e. the tv set, the picture is reconstructed into an image of what the camera was pointed

at, Fig.2. The tv picture tube has a luminescent coating on its inside face which means that when it is struck by an electron beam it will emit light. This electron beam is guided by the video synchronising signal and its intensity controlled by the video signal level. The more electrons that fall on an area of the tv screen the brighter the image will be. In this manner, line by line, and frame by frame, a replica of the scene the camera is looking at is built up on the tv screen.

O.K., enough of the technicalities. You will appreciate that the above description is a considerable simplification of what actually happens, but it will suffice. Incidentally, although we have not mentioned colour at all, it is treated in an essentially similar manner to black and white tv transmission.

VIDEO TAPE RECORDERS

Let us now consider the basic core of video technology, the video tape recorder. Incidentally, although all current domestic video recorders are video cassette machines – in other words they use tape in cassettes rather than on open reels – the functional principles are identical for both reel to reel machines and cassette ones. As the term 'VCR' is a Philips trade mark for their $\frac{1}{2}$ " N1500 system we will use the abbreviation 'vtr' – (video tape recorder) to refer to all domestic video recorders.

Most people use a vtr for recording off-air television programmes and replaying them at a later date. To do this the vtr must receive the broadcast signal, process it so that it can be recorded on magnetic tape and then replay it, reprocess it and turn it into a suitable signal for feeding into the aerial socket of a tv set. Ideally what comes out of a vtr should be identical to what goes in. In practice this isn't quite the case, but for domestic purposes it is near enough.

Such a vtr could be very basic in character, so why do some of the current vtrs have such a bewildering array of features with

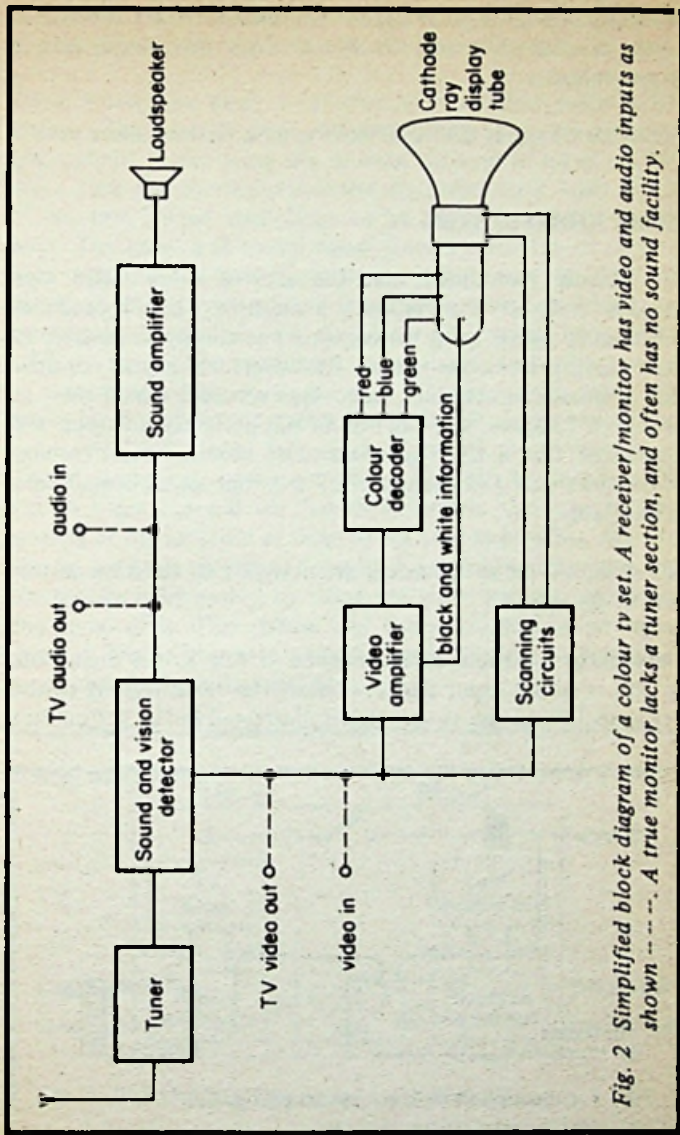

Fig. 2 Simplified block diagram of a colour tv set. A receiver/monitor has video and audio inputs as shown - - - -. A true monitor lacks a tuner section, and often has no sound facility.

a corresponding range of prices? The answer to this question is partly because many vtrs will do a lot more than simply record tv programmes.

Let us now look at the basic video system in some more detail.

BASIC VIDEO SYSTEM

I've already mentioned that the aim of every video tape recorder designer is to produce a machine which reproduces the original signal, (and hence, scene) as closely as possible to that coming from the studio. However, when you consider that a broadcast standard video tape recorder which costs in excess of £30,000, still can not do this perfectly then you will appreciate that a £300 domestic video recorder must employ some short cuts and consequently a certain signal degradation is inevitable.

All domestic video recorders are designed to function in this sort of set-up.

Only three connections are needed — one to the mains, one to the tv aerial input and one from the aerial output to the aerial socket on the tv set, this is illustrated in Fig.3. Couldn't

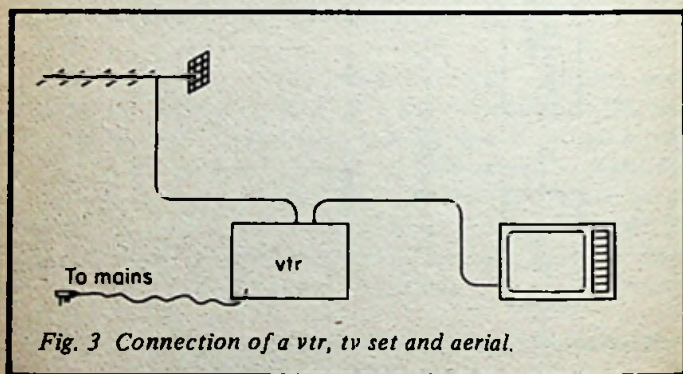

Fig. 3 Connection of a vtr, tv set and aerial.

be simpler, could it? Let us now look at the 'building blocks' of a domestic video tape recorder, as shown in Fig.4.

The vtr contains what is in effect a tv set, but without the screen. This means that tv programmes can be recorded without the tv set being on, or even with no tv set at all. The video tape recorder's tuner is usually linked to a timer which allows unattended recordings to be made, but more of this later. The video and sound signal from the built-in tv tuner is then processed so that it can be recorded on to the tape. On playback, the reverse process is undertaken and the video and sound signals are fed to a modulator for turning back into a UHF tv signal. The modulator is, in effect, a very low power tv transmitter. You will note that most vtrs have video and audio input and output sockets on them, which allows cameras, other vtrs and special tv receiver/monitors to be connected. The audio sockets also mean that a hi-fi can be linked to the vtr. In Fig.4 you will see that these sockets feed into the electronics of the recorder as close to the tape as possible. In other words, on both record and playback a considerable amount of electronics is by-passed by using the video sockets, instead of the aerial ones. This means that the signal will be of higher quality. This is important when considering tape copying, but more about this in that section.

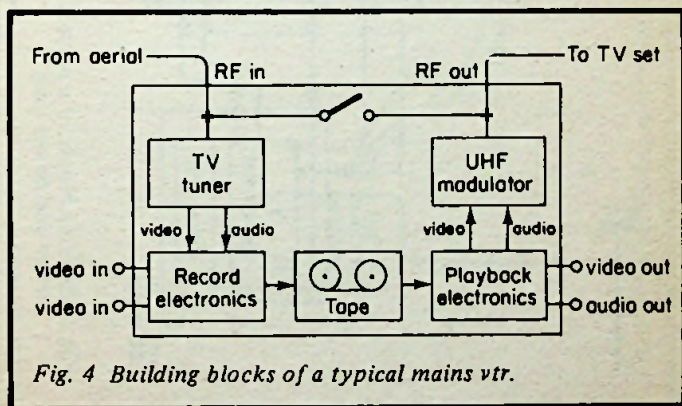

Fig. 4 Building blocks of a typical mains vtr.

Besides the basic mains operated vtr you can also buy portable units which will run from either batteries or mains. These vtrs do not contain a tuner/timer section and so can only be used for recording from a camera or other recorder via the 'video in' socket. It is possible to buy an add on tuner-timer power supply so that you can have the equivalent of a conventional mains vtr as well as the advantages of a portable unit – the best of both worlds. See Fig.5.

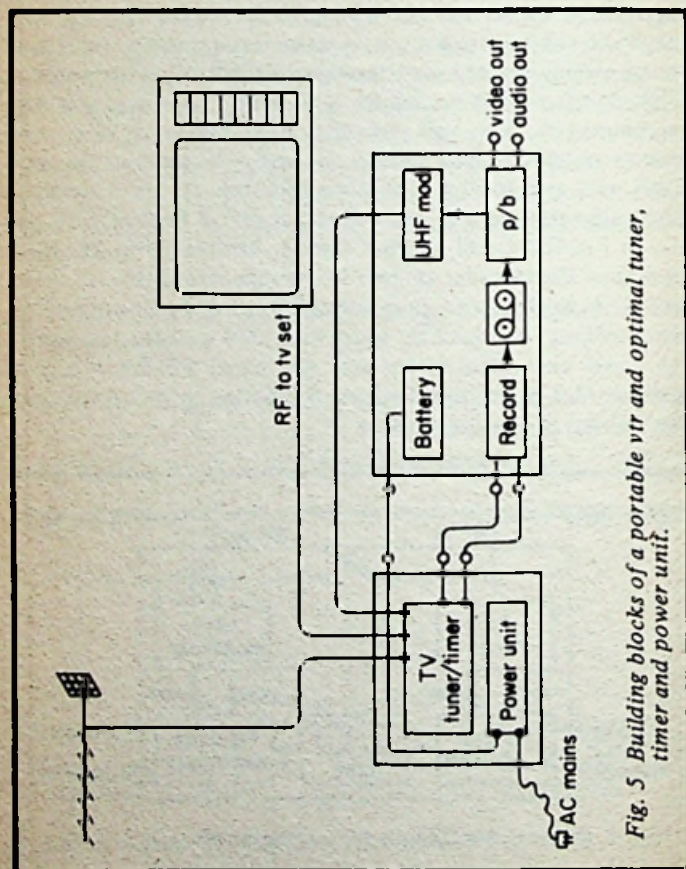

Fig. 5 Building blocks of a portable vtr and optimal tuner, timer and power unit.

The cameras which are designed to be used with these portable vtrs usually plug into a complex multi-pole socket in the vtr which allows the camera not only to be powered from the vtr battery but also allows the recorder to be started and stopped from a trigger on the camera. See Fig.6.

Having talked briefly about the basic video systems, let us go on to look at their history and development, basic technical background and some of the different formats which are around.

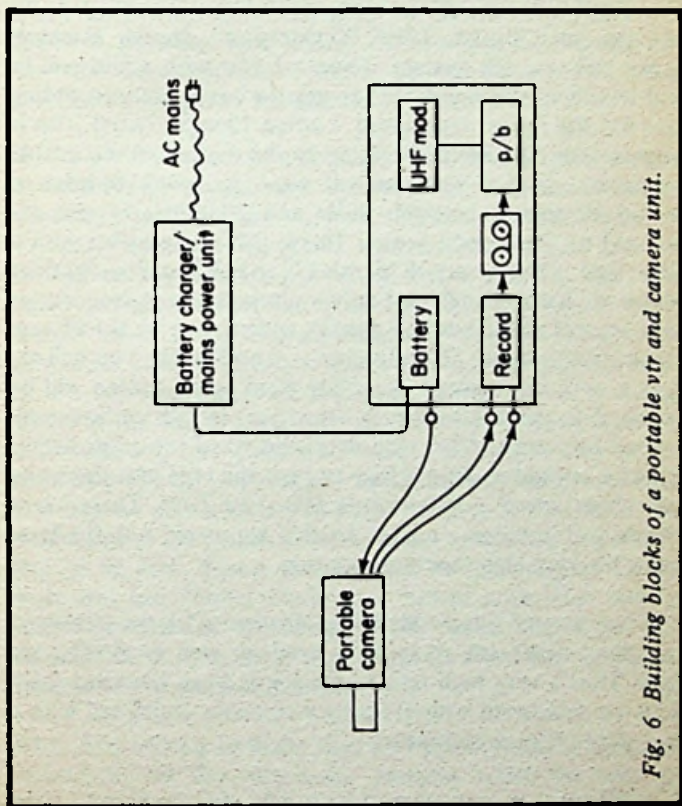

Fig. 6 Building blocks of a portable vtr and camera unit.

Video Tape Recorders

I've already said that vtrs as a whole are quite recent innovations, with the first practical one being built in 1956. This was done in the USA for the broadcasters who, until that date, could only record tv pictures with difficulty, using a special type of 16mm film camera. When you consider how many time zones the USA is divided into you will appreciate how useful the vtr was for the nationwide networking of programmes.

The first black and white broadcast vtrs used 2" wide tape, in an open reel format, called "Quadruplex". Similar machines today still use this system. Those of you with audio reel to reel recorders will know that to get the best quality recording you use the fastest tape speed – often 19cm/s ($7\frac{1}{2}$ i/s). This is because the tape speed is related to the maximum recordable frequency. Hi-fi enthusiasts will want an audio recorder to record all sounds between 30Hz and 20,000Hz (cycles per second) to give a good sound. This is just not possible with a slow tape speed – say 4.75cm/s ($1\frac{7}{8}$ i/s). When you consider that a vtr has to handle not only a similar range of frequencies as it records sound but also a much wider range for the picture signal, from around 50Hz to almost 5 million Hz, you will see that a very fast tape to recording head speed indeed will be required to get a satisfactory recording. In fact early experimental broadcast video recorders used fixed recording heads, as per a normal audio machine and ran the tape past them at a very high speed – 30–40m/s (90–120 ft/s). There are a number of problems related to this approach, not the least being the very high tape consumption.

The way around this problem is to dispense with the stationary recording heads and to spin the heads as well as moving the tape. Thus a very high tape to head speed can be maintained, with an associated wide frequency response combined with a reasonable tape consumption.

2" wide tape on a spool may be suitable for the broadcasters,

(although even they are turning to smaller 1" vtrs) but it is not really practical for the home market and so nowadays $\frac{1}{2}$ " wide tape loaded into easy to handle cassettes has become commonplace. Some machines use $\frac{1}{4}$ " tape, either as such or as a double sided cassette, like an enlarged audio cassette. Normal VHS and Beta cassettes can only be played on one 'side'. With such narrow tapes running at very slow speeds various electronic tricks have to be employed to get a good picture and in practice the colour and black and white information from the tv signal is recorded separately. As a consequence of this sometimes problems occur with the colour and black and white images not quite lining up correctly on playback – a form of ghosting. This system of recording also means that even the most expensive domestic vtr will never reproduce all the fine detail of the transmitted tv picture.

In the 1960's industrial and commercial users of video created a demand for smaller and cheaper units than the broadcast standard 'Quad' vtr and the first $\frac{1}{2}$ " black and white open reel recorders appeared. By 1970 around £350 was all that was needed to buy a black and white reel to reel vtr, but home video needed another ten years to mature before it really caught on. It is worth considering why this was the case and how these reasons influence current design and practice. First of all, the recorders were black and white only even though BBC2 in the UK was transmitting in colour. The vtrs were also open reel and like open reel audio recorders needed careful threading up. Being essentially industrial machines these early vtrs had no off-air tuners built in, no timer and often no RF modulator so that a special tv set with video in and out sockets had to be used. Some of these early tv sets designed for use with vtrs had cooker clock type timers built into them to enable unattended recordings to be made. Such sets were manufactured by a number of Japanese firms but they never became very popular in the UK.

What was needed to make domestic video practical was a vtr embodying all the easy-to-use features which we take for

granted in vtrs today, i.e. cassette loading, timer, off-air tuner and RF modulator, enabling almost any tv set to be used with the vtr. It was Philips in October 1970 who announced that they were working on just such a machine, although it was not until 1973 that the VCR as it was known went on sale in the UK for £350. This machine, the N1500, gave up to an hour's recording on a ½" cassette and allowed recordings to be set on any one channel up to 24 hours in advance. A primitive cooker type mechanical clock was employed so accurate start times were difficult to achieve. The cassette format was a dual concentric one, which throughout its life often gave mechanical problems — quite why the firm who invented the Compact Audio Cassette did not develop a similar video cassette until 1979 seems obscure. Even so, the N1500 series worked well most of the time and was purchased on quite a large scale by institutional users such as schools, colleges and so on, as well as some domestic users. The video revolution was beginning! The N1500 was improved and refined through the N1501/2 but the cost of around £15 hr. for recording tape was still too much for many users and coupled with the one hour maximum recording time served to limit the appeal of the VCR format.

It was thus no real surprise when in 1975 the Japanese got on to the bandwagon with Sony's original one hour Betamax format vtr, marketed only in Japan and the USA. This system employed some clever electronics to cram more information into the same length of tape, almost doubling the Philips playing time to tape length ratio. Philips countered with a system employing the same tricks but based on their N1500 cassette. This was called the N1700 and was launched in the UK in 1977. It was now possible to get 2 hours 10 minutes recording on to a tape which ran for only 1 hour in the N1500 vtr. Tape recorded on either format did not play in the other vtr of course, even though the cassettes were physically identical. Even thinner tapes eventually raised this to 3 hours, although these very thin tapes were rather prone to breakage and damage. Sony's predictable response was to increase the playing time of their Beta system to 3hr 15min. before it was

introduced on the European market. Unfortunately for them they were "pipped at the post" when in March 1978 a similar but incompatible $\frac{1}{2}$ " cassette system called VHS (Video Home System) was launched by the giant Matsushita Corporation of Japan, more familiarly known by its various trade names such as JVC, National Panasonic, Technics etc. VHS gave a maximum playing time of 3 hours, which has now been increased to 4 hours by employing very thin tape. Sony launched their Beta format in the UK some 6 months after VHS, in autumn 1978 and they have never recovered their lead. By this time the cost of home recording had fallen to around £5 hour. Since then a few other incompatible video tape formats have appeared or been mooted, but VHS and Beta have, between them, some 90% of the UK market. At present this is split about 70%–30% in favour of VHS although exact figures are difficult to estimate.

Other formats which have reached the market have included Grundig's SVR-Super Video Recorder, which was based on the Philips dual concentric cassette but gave 4 hours recording time, and Funai's $\frac{1}{4}$ " micro cassette portable deck which at present gives only 30 mins. recording time but on a very small and lightweight vtr – 7 lbs. More interestingly Philips V2000 format vtrs also use $\frac{1}{2}$ " tape but loaded into a double-sided cassette like an enlarged Compact Audio Cassette. This allows the VCC (Video Compact Cassette) to be played to the end, turned over and played back to the beginning, so in effect only $\frac{1}{4}$ " of the $\frac{1}{2}$ " tape is used in each direction.

V2000 has a number of interesting possibilities from the technical point of view, such as noise free still picture and slow motion. This is possible because of the highly accurate manner in which the video heads follow the tracks of video information which were laid down on record. Incidentally, this system is called DTF – Dynamic Track Following – and is another feature borrowed from broadcast equipment. Unfortunately it looks as though V2000 has arrived a bit too late to make a large impact on the domestic market which is already dominated by VHS and Beta vtrs. It is also interesting to note

that V2000 may even lose the advantages of its unique near-broadcast quality still picture in the near future as Beta prototype machines in Japan are achieving this trick by using an extra video head in the head drum. It can only be a matter of time before these hit the consumer market.

The race between the manufacturers to produce the vtr with the lowest possible cost per hour seems at last to have petered out, so, hopefully, the existing formats will not be made obsolete by even slower running vtrs. Four hours playing time tapes are available in the UK for VHS machines as are $3\frac{2}{3}$ hour tapes for Beta users. In the States both VHS and Beta vtrs come in multi-speed versions, giving around 6 hours maximum playing time per tape, but it seems unlikely that these systems will appear in the UK. For one reason the picture quality is very much reduced at these very slow running speeds and it seems that this would not be acceptable to European users. Another reason is that auto-changers for changing cassettes are available for Beta vtrs and a similar device for V2000 machine will soon become available. These devices allow four or five cassettes to be stacked in the loader and the vtr then programmed to do up to twelve hours or so unattended recordings. A similar system for VHS must also be available soon. Comparisons of the various tape formats are shown in Table 1.

Table 1 Comparison of video tape formats

Format	Tape width (mm)	Tape speed (cm/s)	Writing speed (m/s)	Max cassette length	Supported by
VHS	12.7	2.339	4.8	4 hours	JVC, Thorn, RCA, National Panasonic, Technics, Matsushita, Hitachi.
BETA	12.7	1.873	6.6	$3\frac{2}{3}$ hours	Sony, Sanyo, Toshiba, Fisher, Zenith.
V2000	12.7*	2.44	5.08	4 hours	Philips, Pye, Grundig, Bang & Olufson.
VCR	12.7	14.29	8.1	$1\frac{1}{2}$ hours	Now obsolete.

* but used as 2 X 6.35 tracks

Let us now go on to look at some of the various features offered on some vtrs and how these can affect your choice, details are illustrated in Fig. 7.

All mains operated vtrs have some sort of tv tuner and electronic timer to allow you to make recordings in your absence. The type of timer varies between machines, but tends to fall into either the basic – one programme on one channel up to one week in advance of the setting date – or the advanced.

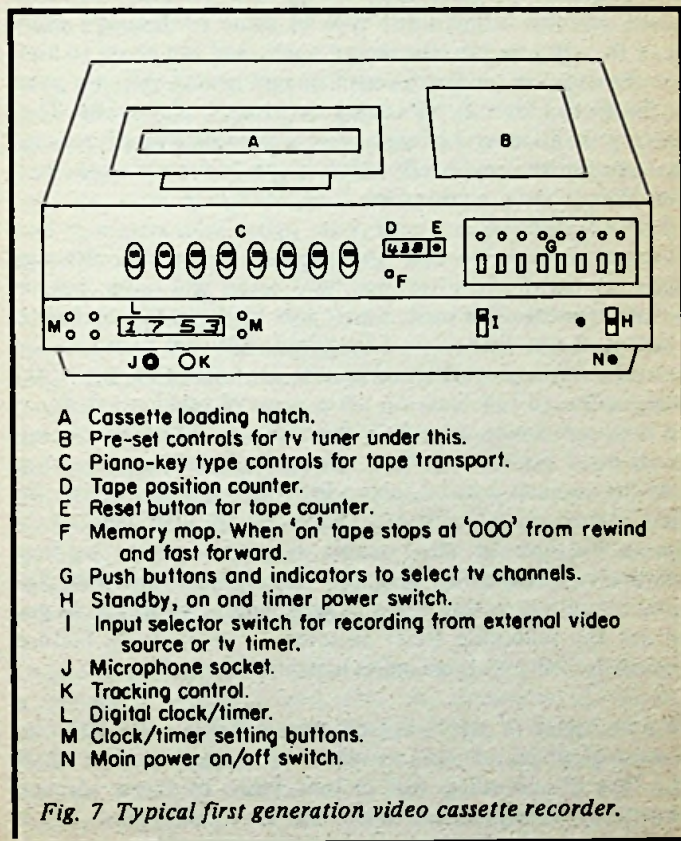

Fig. 7 Typical first generation video cassette recorder.

The latter type can allow for quite a range of recordings, such as 7 recordings on 5 different channels, set up to 14 days in advance. It is even possible to get vtrs which allow for even more recordings, set up to 99 days in advance! Even with automatic cassette loaders that should be enough for absolutely anyone. Having recorded such a large number of programmes in your absence you may then find that you have a problem in locating quite where they are on the tape. Well, with some of the more sophisticated vtrs this is no longer a problem due to the inclusion of Automatic Programme Location Systems. These circuits record some type of pulse on the tape every time the vtr goes into the record mode, and can be set to hunt for these pulses on fast forward or fast rewind. When a pulse is found the vtr will either stop or go in to play mode. Thus finding the beginning of various recordings on a four hour tape becomes quite simple. Like a lot of special features this one is found only on up-market vtrs.

Remote controls are now almost standard on vtrs, although again the more expensive ones have better and more comprehensive remotes. On some simple vtrs all that you may have is a simple pause button on a long lead. You can go up-market through more complex wired remote controls to the top of the range infra-red full function units, some of which are designed to work in conjunction with the same manufacturers tv sets to control both vtr and tv. Generally speaking, the wired remote controls can be rather frustrating to use due to the long lengths of cable that are trailing around. Like many of the special features of vtrs, remote controls tend to be used relatively infrequently once the novelty has worn off. The only exception to this is the type of remote which allows you to set the recording timer remotely, a most useful feature, especially if the vtr is normally located near the floor!

Various types of trick play are now common. By trick play I mean playback of tapes at speeds other than those at which the tape was recorded. Still picture, frame by frame advance, shuttle backwards and forwards are all commonplace. Again the true value of these options is limited, although shuttle

backwards and forwards is useful for locating the exact start of a programme or for skipping the adverts! If you use your vtr for recording your local football team then still and slow motion can be useful, but for most people it is probably a gimmick. The quality of still and slow motion also generally leaves something to be desired, as a bar of noise often distorts the picture. V2000 machines can however give a near perfect still and slow motion picture.

Video Cameras

After vtrs the camera must be the next most popular item of video hardware that is purchased. Simple black and white cameras are available for around £100 whilst colour ones cost from around three times as much. When you consider that in 1973 the price of the cheapest colour camera was £1,500 and that its results were rather poor, then it is gratifying to realise that not everything is going up in price!

With a simple camera you can use it with either a mains operated vtr or a battery portable, or even, with a suitable adapter, straight into a tv set as a surveillance system.

As with vtrs, cameras come in a whole range of shapes, sizes and prices, all offering various features. We will leave black and white cameras out of our discussion, as the current low cost of domestic colour cameras coupled with the fact that we are all accustomed to thinking of black and white tv as 'old fashioned' means that most people who buy domestic cameras will be interested in colour ones.

Unlike vtrs where the problem of different tape formats arises, a camera is a camera, and with one exception, all current cameras can be used with all current vtrs, although adapter leads will be required for some combinations of recorder and camera. The one exception to this guide line is a Philips camera and recorder, which do not have separate video level signal plugs, but rely on RF signal transmission, just like a vtr

modulator. This means that if you want to use any other camera with a Philips V2000 vtr you will need to buy an adapter unit for either the vtr or the camera. Similarly the camera which Philips specify for the VR 2023 vtr can only be used with this recorder.

Let us look at two cameras, a low cost simple one and a more expensive full feature one and try to determine what the differences are and what they mean to the user.

Fig. 8 shows a typical low cost basic colour camera, weighing around 1.8kg only and looking very like a super 8mm cine

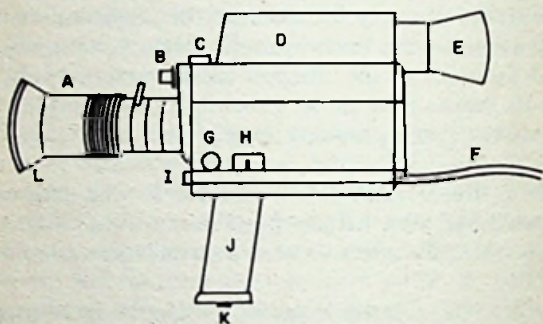

- A Zoom lens.
- B Omni-directional microphone.
- C Shoe for high quality directional microphone.
- D Viewfinder
- E Rubber eye-cup
- F Captive cable to link camera to video recorder or to mains power unit.
- G Colour temperature adjustment control.
- H Colour temperature meter.
- I Trigger to stop and start associated video recorder.
- J Pistol grip.
- K Socket to attach camera to tripod.
- L Rubber lens hood.

Fig. 8 Simple low-cost colour camera.

camera. A single multi-core lead connects the camera to either a portable vtr or a mains power unit for using the camera with other vtrs. The camera is lightweight, easy to use, has few user controls and is almost totally automatic in operation. Like most 8mm cine cameras, this camera has an optical viewfinder, which allows you to see, more or less, what the camera is pointing at. It loses its accuracy when the camera is pointed at a very close object due to the fact that although the viewfinder is close to the lens, it does not actually operate through it. Three light emitting diodes are fitted in the viewfinder to act as warning indicators, one to show that the associated vtr is running, one to show that the video level from the camera is satisfactory and a final one that warns you that the vtr batteries are running low. A simple 3x zoom lens is fitted, allowing a reasonable range of shots to be established from one camera position. Although the lens has a manual iris diaphragm (f stop ring), an electronic automatic sensitivity control will compensate for most changes in lighting levels. Although around 500 lux of illumination is required to enable the camera to deliver its best results, a high gain switch on the rear of the camera allows for reasonable pictures to be obtained at lighting levels around 100 lux. (almost average sitting room lighting levels.) The camera has a built-in pistol-grip with a stop/start switch for operating the vtr from the camera, once you have set it to 'record'. The final user control is for white balance — that is, to adapt the colour response of the camera to the prevailing lighting conditions. To adjust this you point the camera at a white card, centre zero the meter and the camera will then remember what is 'white' in all subsequent shots. You only have to alter this control when you alter the lighting conditions, such as when you go from shooting outside to inside under artificial lights. A small built-in omni-directional microphone ensures that synchronous sound is recorded along with the vision, although there is also provision for plugging in an additional microphone of higher quality. An ear-piece socket allows for monitoring the recorded sound quality on location. As the camera runs from a 12 volt power supply and draws only 6 watts it can be run from the vtr battery for quite a long time.

Although I have been talking about an actual camera, its features are common for a number of similar products.

The specification of a 'simple' camera as compared with that of a more expensive, versatile one is detailed in Table 2.

Table 2 Camera specifications

	<u>Basic</u>	<u>Advanced</u>
Pickup tube	2/3" tri-electrode vidicon	2/3" tricon vidicon
Scanning system	625/50 lines/fields	625/50 lines/fields
Video output	1v pp/75ohm	1v pp/75ohm
Horizontal resolution	230 lines	300 lines
Signal : Noise ratio	42dB	45dB
Minimum illumination	100 lux	35 lux
AGC range	100-100,000 lux	35-100,000 lux
Power	12v/5.8 watt	12v/8.3 watt
Weight	1.8kg	3.2kg

The 'advanced' specification refers to a domestic camera which comes from the top end of the range and which is almost double the price of the basic one. The differences in specification, of course, tell only some of the story, for besides giving a higher performance the 'advanced' camera has a whole host of extra features. First of all, though, on the performance side, not only can it operate satisfactorily under lower lighting conditions but it also allows for finer detail to be recorded, due to its improved horizontal resolution. The signal-to-noise ratio is better as well, which not only helps with improved detail but also allows for more copying without excessive noise becoming apparent.

As far as features go, the up-market camera has everything you could reasonably ask for — it has all the features of the basic model and more besides. For a start, a 6x zoom lens, not a 3x, is employed which is electrically driven to allow for very smooth zooms. A manual over-ride is possible for very fast or very slow special effects. The lens also has macro capability which means that you can focus on to objects almost touching

the glass, as opposed to the more normal 3/4 metre or so. As well as a more stable and sophisticated automatic gain control to match changes in illumination, the lens comes with an auto iris as standard to return optimum performance under all lighting conditions. All these automatic controls may be manually over-ridden for creative camera work when required. However, probably one of the most useful extra features is the electronic viewfinder in place of the simple optical one. This is in effect a miniature black and white tv monitor attached to the top of the camera. Thus everything the camera sees, as well as exposure and contrast levels is relayed to the cameraman. Best of all, this type of viewfinder will double as a playback monitor so that after a 'take' you can check it on location and retake any shots as required. A socket on the camera body also allows for the monitoring of sound playback.

Other features which you are likely to find on up-market cameras include an auto-fader, which allows you to automatically fade in and out of takes, so as to minimise the visual disturbance between them on recording. Zoom microphones are also appearing, which alter their angle of reception as the camera zoom lens angle is altered. In this way they are also omni-directional when the zoom is on wide angle and go into highly directional microphones as the zoom lens zooms in to a tight shot.

As to which type of camera you should buy you will have to decide what you want — either a low cost simple point-and-shoot type or a more costly but more versatile and creative one.

VIDEO DISCS

Video discs are one of the latest innovations to hit the consumer video market, even though the idea of recording tv pictures on to a disc has been around since the late 1920's. A video disc is in effect a gramophone type record which has pictures as well as sounds recorded on it, and which can be

watched and listened to by playing it on a suitable video disc player attached to a tv set.

J.L.Baird, that indefatigable pioneer of television, developed a primitive video disc in the late 1920's and it even appeared on sale in Selfridges for a time, but it was not until the 1960's that serious interest was revived in the video disc. Not only were the consumer electronics industry interested but like so many home video developments the broadcasters were also interested. The broadcast companies wanted a device to enable them to produce action replays, slow motion and stills for sports use, which the then current vtrs were incapable of doing. The video disc system which eventually evolved for broadcast use was, unlike all domestic ones, capable of recording and playing back a short length of programme material, such as a football goal, etc. All the domestic disc players are replay only devices, that is, like a gramophone they are restricted to reproducing what software (programmes) the manufacturers make available. This in turn means that for any disc system to be a commercial success then a large range of low cost interesting software must be made available.

Unlike audio record players, the current video disc players do not rely on a conventional pressure sensitive stylus tracking a spiral groove to pick up the sound and vision information. Video disc systems have been developed which *do* function like this, including Baird's system, but they were very prone to mechanical problems such as dust, fingerprints and scratches. When you consider how delicate an audio disc is you will appreciate this point for after all, a video disc has to contain far more information than an audio disc.

So instead of pressure sensitive styli other techniques are used, and it is here that things start to get complicated. Just as with video cassettes there are several different and incompatible video disc systems, which have arisen due to the marketing policies of the different electronic companies. So far there are three commercial systems, one from Philips of Holland, one from RCA in the USA and one from JVC in Japan.

As I've mentioned before, a disc designed for one system, say the RCA 'Capacitive Electronic Disc' – CED, cannot be played on a JVC 'Video High Density' – VHD player and so on. Beside the parent companies there are a number of firms who have taken up licences to produce players to one format or the other. A few firms are even going to produce machines to two systems, presumably to hedge their bets! For example, Pioneer of Japan produce Philips 'Laservision' type disc players, whereas Hitachi make RCA type ones. Thorn-EMI market their version of the JVC VHD player, as do several other firms. Toshiba, who are affiliated to JVC's parent company, however market an RCA CED player, not the expected VHD one! This state of affairs must be guaranteed to confuse the public even more.

Before we look at the pros and cons of the three different systems let us briefly look at some of the technical features and how these affect what you can use the various disc players for.

The Philips 'Laservision' system has been on the market the longest, having been launched in the USA in 1978. As its name implies, 'Laservision' relies on laser technology and uses a low powered laser to 'read' the information which is encoded on the video disc, as opposed to a more conventional stylus. Although this means that there is no physical contact between the disc and the pickup on playback – and hence no wear and tear, it also means that it is the most high technology player of the three systems. This high technology approach allows for several very advanced features to be offered but also is reflected in a high price for the hardware. The lack of wear is probably the most significant feature and if the disc is handled with reasonable care its life is infinite. This is something which can not be said about either of the other two disc systems. The 300mm/12" disc is immune to fingerprints, dust and even small scratches, as the information which is needed to reproduce the pictures and sound is not on the disc surface like a gramophone record but actually in the body of the disc and thus protected by a thin layer of transparent plastic, through

which the 'reading' laser beam is focused. Fig. 9 shows how the 'Laservision' disc is scanned by the laser.

Other features of 'Laservision' include very high quality still picture facility — far superior to that from any domestic vtr — as well as noise free fast and slow motion. Indeed, the overall picture quality is as good as the best off-air one. A

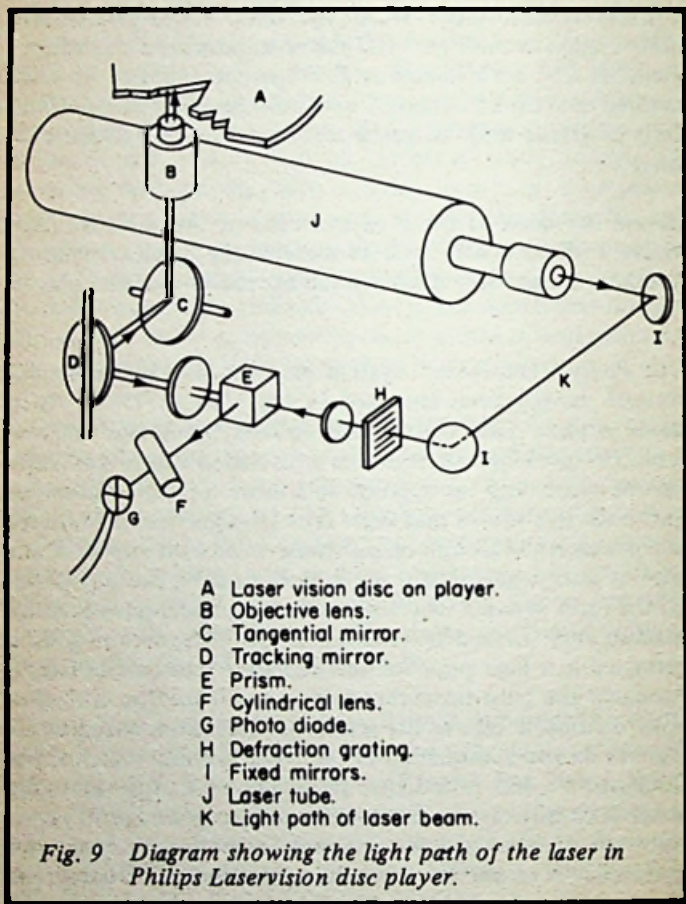

neat trick with 'Laservision' is the ability to have still and moving pictures on the same disc, so that with an add-on microprocessor complex sequences can be built up. This makes 'Laservision' ideal for instructional and educational use. Altogether around 54,000 stills can be recorded on one side of a disc, with an access time to any one of around 2 to 5 seconds. Each still or moving frame is given a number which allows the user to tell the disc player to 'go to' frame number say 45,897 either directly or via a fast forward mode which gives fast motion pictures en route from the current location to the new one.

As it is very early days yet for all the video disc systems and many of their more esoteric uses have still to be explored. All three systems are relying on their large catalogues of big budget movies to arouse the general public's interest in discs, after which they will move on to the more specialist markets. Whether all three systems will survive is yet to be seen.

Philips have developed a very clever way of apparently achieving the impossible, combining a long playing time, (60 minutes per side) with a wide range of special effects — still, fast and slow motion in either direction, and so on. The two rival systems do not offer this type of versatility. What Philips have done is to produce two types of disc, a Long Play and an Active Play version. The Long Play is suitable for movies and so on and although it will provide fast motion this is of an inferior quality to that provided on the Active Play disc. This is because Active Play discs play for only 30 minutes per side as opposed to the 60 minutes of the Long Playing discs. This is done for technical reasons to allow for the special effects. Although this might seem a bit of a problem in practice it is not really so. After all, a movie is designed to be watched all the way through at one sitting — any slow motion and so on will be provided by the movie makers in the first place. As far as operating the disc player goes it is also not a problem. There are no switches to set or whatever, as detection of what type of disc has been loaded is automatic and the player handles it accordingly.

RCA's CED – Capacitive Electronic Disc – was the second system to appear, in March 1981 in the USA. In contrast to 'Laservision' CED is a low technology approach to video discs and this is reflected in its lower cost – around £250 as opposed to the £350 for 'Laservision'. Instead of relying on laser optics, CED uses variations in capacitance in the surface of the disc and a groove following stylus, made of sapphire. In some respects this technology is more closely related to normal gramophone records, although the grooves are considerably finer and thus closer together. Consequently CED discs are very prone to damage from scratches, dust, fingerprints and all the normal things which cause damage to audio LPs. To minimise these problems RCA supply the disc, not in a normal sleeve or box like Philips but in a thin plastic caddy, which is 'posted' into the player which then unloads the disc. In this way human fingers never need to touch the disc surface. No fancy effects are possible with CED – a limited sort of still is possible, with the stylus playing a complete revolution of the disc for a length of time, but what you get is a short repeating sequence of tv picture, not a true still. This mode of play is not recommended as it can cause excess wear on the disc. Incidentally RCA reckon that a CED disc is good for a few thousand plays, if treated with care. RCA are relying on the large range of interesting titles in their catalogue to make their system a success, combined with its low cost and simple servicing.

The third contender for the video disc prize comes from Japan, and is the JVC designed 'VHD' – Video Home Disc. In terms of complexity this falls midway between 'Laservision' and 'CED', as it is a capacitance system but does not use grooves to guide the stylus, relying instead on sophisticated electronics to control the tracking arm across the surface of the disc, Fig. 10 illustrates. Like 'CED' discs, 'VHD' ones are susceptible to dust and scratches and thus also come in a protective caddy. 'VHD' has some of the special features of 'Laservision', such as high quality fast and slow motion although the production of still frames seems at present to be a bit of a problem.

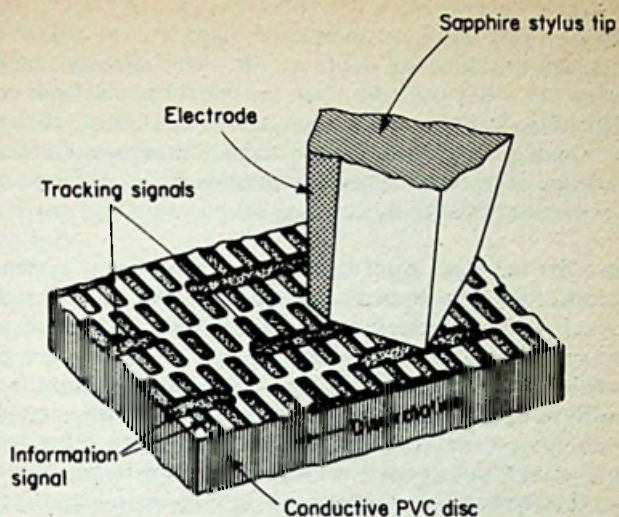

Fig. 10 VHD stylus assembly, showing grooveless disc.

Table 3 summarises the features of the three disc systems.

Table 3 Comparison of video disc formats

	Laservision	RCA CED	JVC VHD
disc diameter	305 mm	305 mm	260 mm
disc material	plastic/metal	conductive PVC	conductive PVC
stylus material	none – optical	diamond or sapphire	diamond or sapphire
playing time	2 hours	2 hours	2 hours
operating system	optical – laser	capacitive	capacitive
disc life	unlimited	'several thousand plays'	
sound	stereo	stereo	stereo
cost of player	high	low	medium

Which System?

This is a very difficult question to answer — as indeed are all aspects of predicting the future. It seems unlikely that the market can really support three incompatible playback only video disc players systems on a world wide basis. It therefore seems probable that one of them will become dominant in Europe at least, although it is possible that a different one may win out in the USA.

From the technical point of view the 'Laservision' system is without doubt the most elegant and versatile, as well as the one capable of giving the highest quality results. It is also the only one really capable of true interactive use as a programmed stills store, educational tool, etc. It is also indisputably the most expensive and technically the most complex of the three systems. The RCA 'CED' is, on the other hand, the cheapest and simplest, with 'VHD' falling in between the two. 'Laservision' will probably be with us for a long time to come if for no other reason than that it is being adopted by governments and industry in both the UK and USA as an archiving and training system. 'CED' will be widely purchased by the public, especially in the USA, due to its low selling price. In the UK RCAs name is not familiar to the public in the consumer electronics field but even so with a price tag of around £200 the CED player is about £150 cheaper than a 'Laservision' one. As far as the prices of video discs go, there is little to choose as all the manufacturers are aiming at around £10—£20 depending on contents and running time. As most people will primarily be interested in watching the big budget movies a lot will depend on how large and varied a catalogue the manufacturers can produce and maintain. This latter is very important if a sustained public interest in, and enthusiasm for, video discs is to be maintained.

On a personal level I must confess to considerable doubts about the long term future of domestic discs and agree with Sony who feel that vtrs are all that the public either need or want and who are concentrating their disc marketing on the

commercial and industrial sectors.

VIDEOTEXT

Videotext is the over-all name given to the various systems which display pages of text, as opposed to pictures, on tv screens. Many of you will have seen tv sets in shop windows displaying this type of page and may have wondered what was going on.

Videotext services, of all types, are computer based information systems, allowing an individual access to various types of data from remote computers and which use the conventional tv set as a means of presenting this data to the inquirer. There are two fundamentally different branches of videotext, called Teletext and Viewdata, respectively. These two systems have much in common, both in terms of mode of operation and use, as well as common electronics. There are, however, fundamental differences. Teletext data is transmitted by the various broadcast companies along with the normal tv programmes, riding piggy-back on some unused space in the tv picture. Viewdata, on the other hand, employs the existing telephone wires to transmit data and the tv set is used as a means of displaying it, thus making Viewdata independent of broadcast tv programmes.

This major distinction is very important, as we shall see. We'll begin by looking at Teletext, which is the simplest and most limited of the various videotext systems.

Teletext, as transmitted in the UK, is organised as CEEFAX, (See Facts) by the BBC and ORACLE (Optical Reception of Announcements by Coded Line Electronics) by the IBA. Technically both services are identical and thus a standard package of electronics can be used at the viewer's location to decode and display the information. The actual type of information available is quite varied, but tends to be based around current news and immediately relevant information

— weather, roadworks, stocks and shares, agricultural news and so on. All the data is organised into pages of text and stored on a computer before being inserted into the main tv signal from the studio in an appropriate sequence. This sequence starts at the first page, runs through all the pages in turn to the last one and then restarts at the beginning. As each page is transmitted as part of a sequence all that the viewer has to do is to use his teletext decoder to “grab” the required page the next time it is transmitted. As all the pages are transmitted in turn by the broadcast company, the individual viewer has no control over when a specific page is transmitted. In his home or office he will have either a modified tv set containing a Teletext decoder or else a separate Teletext decoder, which, like a vtr, plugs into the acrial socket of the tv set, either black and white or colour. Incidentally in the UK all videotext services are in colour, and so will give a colour display on a colour set and a black and white one on a monochrome set. To obtain a desired page all that the viewer needs to do is to press the required page number in to a simple calculator style keyboard attached to his decoder. The next time the decoder receives, say, page 207 it will grab it and then display it. The maximum time that you will have to wait between requesting a page and having it appear on your screen is about 23 seconds but the more frequently used pages are arranged so that waiting time is reduced. The index pages appear within a few seconds. Table 4 shows the indices for some of the UK Teletext services, which gives you some idea of the range of information.

Besides pages of text, simple graphics can also be produced, for example, a weather map.

There are also a number of other features which Teletext can offer the viewers. For example, most decoders can be set to allow you to watch normal tv programmes until the latest Teletext Newsflash is received when this is shown on the screen instead. Incidentally, this ability to update Teletext pages very rapidly is very useful for allowing up to the minute information to be displayed. You can also arrange to have

your normal tv picture interrupted by Teletext at a specified time — set to remind you to switch the oven off, etc.

In essence, with Teletext you are restricted not only in the range of information — for technical reasons only a few hundred separate pages can be transmitted on each tv channel — but also in terms of when you can access the information, remembering that it is transmitted along with normal tv programmes.

Viewdata systems on the other hand, although being closely related to Teletext, can have an almost infinite number of pages of information and are interactive in nature. In other words, they only transmit a specific page in response to a specific request for that page from an individual viewer. That viewer and he alone will be receiving that actual page. You will recall that Viewdata systems use the telephone lines to connect the viewer directly to a remote computer and only use the tv set to display the desired page of information. From the users point of view all that he has to do is to decide what page he wants — either from an on-screen index or a printed directory — and again press out the page number on a simple keyboard. The required page will then be retrieved from the computer and transmitted along the 'phone wires' to the viewer almost instantly.

What sorts of information do Viewdata systems provide and in what way does it differ from that provided by Teletext? In the UK a national public Viewdata system — as opposed to private ones for use within certain firms — is provided by British Telecom and is called Prestel. The data-base, number of pages, of Prestel is huge and increasing all the time. Around 100,000 pages existed in 1981. Unlike Teletext, the information on Prestel is not provided by the system organiser, in this case British Telecom, but by separate information providers. All British Telecom does is to provide the computer systems and the telephone hardware. This means that an enormous range of information is available covering an equally large range of interests and topics. Besides news, weather, train

CEEFAX ON BBC1

Contents: Page 100

<p>NEWS Headlines 101 News in detail 102-116 News diary 117 People in the News 118 Charivari - a lighter look at the News 119 News Index 190 Newsreel 199</p>	<p>FINANCE Headlines/Index 120 News and Reports 121-126 Market Reports 127-129 FT Index Report 130 Stocks and Shares 131-133 Money Markets 134 Exchange Rates 135-136 Commodities 137-138 Diary 139</p>	<p>SPORT Headlines 140 Sports News 141-159 CEEFAX provides a rapid service of news, results and background. On Saturdays, Sport Plus takes over some of the Finance pages to provide full coverage of the sporting scene.</p>
<p>FOOD GUIDE Headlines/Index 161 Shopping Basket 162 Meat Prices 163 Fish & Egg Prices 164 Vegetable Prices 165 Fruit Prices 166 Recipe 167 Farm News 168</p>	<p>ENTERTAINMENT Today's TV - BBC1 171 BBC2 172 ITV 173 Radio Highlights 174 Films on TV 175 Top Forty plus 176 Top Ten L.P.s 177 TV Choice 178 Tomorrow's TV 179 Viewers' Questions 179</p>	<p>WEATHER AND TRAVEL Headlines/Index 180 Weather Maps 181 Weather Forecast 182 Temperatures 183 Travel News 184-188 Tourist Rates 189</p>

<p>NEWSFLASH 150</p> <p>Turn to this page to watch television programmes – when something important happens a NEWSFLASH will appear on the screen.</p>	<p>ALARM CLOCKPAGE 160</p> <p>This page can change every minute. It can also be used as a silent alarm clock. Turn to page 160 for instructions.</p>	<p>NO NEED TO SHOUT 169</p> <p>A mini-magazine of news and views of particular interest to those with hearing difficulty.</p>
<p>OTHER PAGES</p> <p>News about CEEFAX 191</p> <p>Transmitter News 196</p> <p>Engineering Tests 197-198</p>	<p>FULL INDEX</p> <p>A – F 193</p> <p>G – O 194</p> <p>P – Z 195</p>	<p>SUB-TITLES 170</p> <p>A small number of BBC programmes have experimental CEEFAX subtitles to help the deaf.</p>

Table 4 The indices for some of the UK Teletext services

times, sports and so on, Prestel is well suited to holding information of a long term interest such as basic reference data, encyclopaediae, scientific information etc. Again, like Teletext, Viewdata allows for a very rapid updating to be carried out, so situations vacant, road conditions, airline seat reservations and so on can easily be maintained in up-to-date order. As Viewdata systems are interactive, i.e. they allow true communications between the user and the computer, various forms of direct response are possible. Prestel will allow you to book a holiday, reserve hotel rooms etc. all from a simple calculator style keypad. Let us look at how you might order some books using Prestel. A series of pages will be devoted to reviews of the current "Top 10" best sellers so you can browse through these and decide what interests you. Another related page will then allow you to order it. This is done by keying in responses to a series of questions put to you by the computer, such as what is the number of the book you want, how many copies, your user code number, and your credit card number. The system will then check that the book is currently in stock, and if so then advise you that it will be despatched to you. Incidentally, your user number is a code known only to you to ensure that you and only you order items in your name.

Hotel reservations work in a similar way and can be updated to reflect the changes in availability.

Moving on from looking at what Videotext can do for you, let us see how much it all costs. Teletext is certainly the cheapest, as once you have purchased either a special tv set or an add-on decoder then you have no continuing costs. There is no additional licence fee for Teletext in the UK at present. A Teletext capable colour tv set costs maybe around £100-£150 more than a similar up-market remote control version, with add-on adapters being similar in price. With Prestel however, not only do you have to either rent or purchase the hardware, but you also have an on-going cost. The modified tv set or adapter cost slightly more than a Teletext model although it should be born in mind that most

Prestel tv sets can also display Teletext. The running costs are quite considerable, as not only do you have to pay an increased phone bill for the time you are connected to a Prestel computer but also a charge for computer time and a charge for every page accessed. This latter figure can vary from nothing — free pages — to 50p for 'hot' information on and shares, gold prices etc. This page charge is not levied by British Telecom but by the organisation which provides the information. It is almost impossible to estimate how much Prestel would cost an 'average' user, as it all depends on how much you use it, but a 30% increase in your phone bill would be a low minimum figure.

Without doubt Viewdata systems are here to stay. The UK business community has taken to Prestel in a bigger way than expected, whilst domestic sales have been rather slower than anticipated. As the hardware costs decrease it seems likely that Videotext systems will spread even more.

CHOOSING THE HARDWARE

Before tackling the 'rent or buy' question, let us look at how to decide just what you want or need in the way of hardware — we'll look at what is usually the first acquisition of any video enthusiast, the video tape recorder (vtr or vcr).

There is a bewildering array of vtrs, offering a whole host of features at a wide range of prices, from around £300 to £700 and upwards. What does it all mean and just what do you get for your money?

First of all, there is the problem of Tape Format, which of the three systems which are currently available is the best for you; VHS, Beta, or V2000? The answer to this depends to some extent on what you intend to do with your vtr. If off-air recording of tv programmes is going to be your main use and interest then the question of format becomes rather secondary. The cost per hour of all three systems is similar, at present around £3—£4 per hour. The technical quality of the systems in terms of picture quality is very similar and all three systems have high and low priced machines offering similar features. All three are backed up by major international firms so spares and service should prove no real problem, or to put it another way, should be an equal problem regardless of format.

If, however, you wish to purchase pre-recorded software or to exchange tapes with friends then the Philips V2000 system does become rather an outsider, as only a few firms produce programmes on V2000 cassettes and the format holds only a small percentage of the UK market. Also, only about 4 firms are marketing V2000 machines, as opposed to around a dozen for VHS and half a dozen for Beta.

If we rule out V2000, even though it does have considerable technical merit over both its rivals, then we are left with VHS and Beta. If you talk to some engineers they will tell you that

Beta gives better pictures than VHS and although this is my opinion too, for most people it is not really relevant, as the average picture quality of a VHS or Beta vtr is very similar.

If we now go on to look at the availability of software, then without doubt VHS leads Beta, even though most of the programmes which are available on VHS are also available on Beta. As far as software sales go, it seems that VHS outsells Beta by about 2/3 VHS to 1/3 Beta. If this is an important factor for you then VHS must be the one for you. If, however, software is not of prime importance, then look at the features which are available on various vtrs and see what you need and what is available, and at what price.

FEATURES

Mains operated vtrs tend to come in two categories – low cost basic machines and more expensive full feature ones. The former will give you just as good pictures as the latter – at a lower price – but will not have all the special features of the latter. A basic vtr, for example, will not have a wireless remote control, nor all the variable speed playback features and will possibly have a less advanced timer unit. On a full feature vtr you can usually make several recordings on several channels over a two week period, a basic machine will be limited to maybe one recording on one channel set up to 7 days in advance.

What you have to do is to try to decide how much you are willing to pay for these extra features and how often you are really likely to use, say, reverse play at three times speed. It is easy to be impressed by such features but you will probably find that your interest in them wanes after the first few weeks. Let's face it, the number of times that you will need still frame as a domestic user is rather limited, regardless of what the manufacturers' advertisements might say. If a sports still is needed then the broadcasters usually provide it. On the other hand, if you travel away from home a lot then an advanced

timer will be a useful feature for you.

An alternative to a mains vtr is to buy a battery portable. With its optional tuner/timer unit this will do all that a mains unit will do and some more besides, although it will be a little dearer in price. If one of your interests is in producing home video movies, say of the local amateur drama group or football team, then a portable could be the answer for you.

Moving on from vtrs, the different arguments for and against the various video disc systems have already been outlined in the appropriate section. Again it comes down to how often you are likely to use any particular feature and how much you think it is worth paying for it, although the technical quality argument is a bit more valid here.

Moving on now to cameras, again you tend to get what you pay for. It is possible to buy low cost rather basic cameras and whilst these will not have all the features such as electronic viewfinders, auto focus, sound zoom microphones and so on, the picture quality that the camera is capable of giving will not be greatly different from a higher priced camera with a range of extra features. These extras may make the camera easier to use and more versatile, but will probably not affect the intrinsic picture quality. The argument again becomes a matter of features and how much you want to pay for them. Try to decide what you are going to use your camera for in the main, and select those features you really need. For example, if you intend to use it indoors a lot then a camera with a good low light sensitivity is a good idea. If you are going to be carrying it up mountains, then not only does it need to be rugged but also as light as possible. A camera is probably a more personal decision than a vtr, so try to borrow one to try out for a few days before parting with your hard earned cash. If a dealer will not let you do this then try shopping around or even hire a camera for a few days. This may cost £20 or £30 but it could save you money in the long run.

SPECIFICATIONS

Like hi-fi, video manufacturers make a considerable fuss of the published specifications of their equipment and at times this serves to confuse rather than clarify the issue. We will try to demystify some of the more common specifications and to indicate just what is important and what isn't, as well as trying to indicate how relevant they are to your needs.

VIDEO TAPE RECORDERS

The most important 'specification' is the tape format – VHS, Beta, V2000 etc. an area which we have already covered. Following on from this terms like bandwidth, resolution, signal to noise ratio, chroma noise, hue accuracy and chroma/luma delay are all likely to be found in manufacturers' data sheets, and refer to various facets of the video, i.e. picture side of the vtr. The audio side will have terms more familiar to hi-fi enthusiasts, such as frequency response, wow and flutter, distortion, signal to noise ratio, and so on – in fact, very similar to those terms found applying to an audio cassette deck. For easy reference a definition of these and other video terms is given at the end of the book. You will also find that the input and output impedance of both the audio and video connectors will be given as well as specifying what type of sockets are used. Other specifications will include the tv system for which the recorder is designed – (in the UK this will always be CCIR I/PAL), tape speed, (which will be dependant on format), maximum playing time, time taken to rewind a cassette and so on. We will go through these terms one at a time and explain what they mean as well as their relevance.

Video Bandwidth

This is in effect the frequency response of the picture side of the recorder. Ideally this should cover the whole width of the

colour tv signal, from 50Hz-cycles per second to over 5MHz-million cycles per second, but due to the recording system which all domestic vtrs use this will not be the case. For complex technical reasons the colour part of the signal is recorded separately from the black and white detail part. It is the amount of black and white detail which the recorder can handle which is the most important. The more detail the recorder can produce the better, as a sharper picture will be the result. The familiar BBC type F test card, the one with the girl on it with the blackboard, has down one side of it a series of vertical gratings of different fineness of line. If you look at your tv set you will see, working from the top, that you can see separate lines on maybe the first four squares, whereas the last two seem to be blocks of solid grey. This is because these last two contain very fine detail indeed. However, if you now record the test card on a well set up VHS or Beta vtr and play back the result you will be lucky to resolve even the third grating from the top. These gratings are equivalent to 1.5, 2.5, 3.3, 4.0, 4.5 and 5.25MHz, and most domestic vtrs are pushed to resolve 3MHz. Thus a video bandwidth or resolution figure of anything in excess of 3MHz can be considered acceptable – anything below 2.5MHz definitely not.

Signal to Noise Ratio

This means just what it implies – the amount of noise that the recorder adds to the incoming signal during its recording and subsequent replay. In practice the larger the signal to noise ratio the better. Figures of around 42dB are quite common, whilst 45dB would be better. A poor signal to noise ratio will mean that detail of the original scene will become blurred and the colour reproduction will also suffer. When the vtr is in the monitor mode, i.e. passing a tv signal from its tuner to the output but not playing back, a signal to noise figure of at least 45dB should be obtained. This would drop to around 40dB on playback, indicating that the tape added around 5dB of noise.

Chroma Noise

Again this one is self explanatory and refers to the amount of noise the vtr adds to the colour portion of the signal. This will show up as flecking and noisiness in areas of very highly saturated colour, for example, a bright red motor car. A figure of 20dB or better is quite acceptable.

Hue Accuracy

This refers to how much distortion of the colour of an object the recorder adds to the original picture. For example, how blue the vtr turns a pink face and so on. It is obvious that only small hue errors can be tolerated before an unacceptable picture results. Colour hue is measured in terms of phase, i.e. angles of degree and a figure of around 4° or smaller is acceptable. With the use of automatic colour phase circuits being prevalent in most vtrs this parameter is often omitted from data sheets.

Chroma/Luma Delay

This is the final video parameter to which we will refer. It is a measure of how accurately the colour and black and white parts of the original scene are recombined on play back and manifests itself as a colour ghost image around the black and white one, almost invariably to the right hand side. A delay value of $\frac{1}{2} - 1\mu\text{second}$ is OK, any more and the vtr is in need of some attention.

Other points of the specification cover points such as describing the tuner and timer arrangements, giving the weight and size of the machine, power requirements and so on.

The audio parameters which are often included are very similar to those for an audio cassette deck and need no further explanation.

IMPEDENCE, SIGNAL LEVELS AND PLUGS

This section of the specification should not really cause much in the way of problems as there are few differences between machines from different manufacturers. A feature common to all vtrs is that they have sockets for aerial input for connecting to a tv aerial and another similar socket for connection to the aerial input of a tv set. These two sockets are called 'aerial in and aerial out' or 'RF in and RF out' – (RF standing for Radio Frequency to distinguish it from video in and out.) The RF sockets on vtrs designed for the European market will be of a standard type, once called "Belling-Lee" after their manufacturer, but now adopted by the European standards organisation and hence called DIN Antenna Plugs. You will normally find that the input plug is a DIN female, whereas the output is a DIN male, thus simplifying the connection of the vtr to existing aerial leads which are always terminated in a DIN male plug. (The aerial socket on the back of a tv set is always a DIN female). American vtrs are slightly different as they are often designed for a 300 ohm aerial instead of the 75 ohm European type.

Many, but not all, vtrs have additional sockets for connecting extra audio inputs and outputs to the machine, such as a microphone for adding additional commentary, or for playing the existing audio back through a hi-fi system. The types of plug and socket used as well as their electrical characteristics do vary considerably between individual machines.

Audio Inputs

The "microphone in" specification is one of the simplest as well as the one that is used most often. Most, but not all, manufacturers use a 3.5mm "mini-jack" socket for the microphone, but not all microphones fitted with this type of plug will work equally well with all vtrs! This is because although the socket may be the same, the electrical characteristics may be different. By electrical characteristics I mean both the impe-

dence and signal level that is required to correctly drive the vtr's audio circuits. There is, unfortunately, no "standard" vtr audio level or impedance for domestic machines so it is essential to ensure that the microphone you choose will match the characteristics of your recorder. As a generalisation, most microphone inputs are high impedance ones designed for microphones with an impedance of more than 680 ohms and giving an output of around -60 to -70 dB. i.e. around 3mV. The term dB is simply a way of comparing signal levels which have a very wide range. In this case 0dB is equal to a standard signal level of 0.775 volts, and thus signals above and below this can be easily related.

Besides the microphone input there will also be sockets for connecting a higher level signal to the vtr, such as from a hi-fi amplifier or radio tuner. This can be used for adding music to existing video recordings via the dub switch as well as being the sockets which you use when copying tapes from one recorder to another. Again there is no standard type of socket used, but RCA phono and DIN 3 and 5 pin types are quite common. Also, there is as yet no standardisation on the signal levels or impedance, although a few generalisations can be made. The signal level will be quite high, either 10dB (.25V) or maybe -5 dB (.4V) and will have a high impedance, maybe around 50K ohms or more. This means that anything connected to these audio outputs will need to be of a similar impedance. In practice this should work out fine as most hi-fi amplifiers present an impedance of 10K ohms or more on their "auxiliary" outputs. The RCA type plugs are easy to wire up but the multi-pole DIN types may prove more of a problem, especially as many manufacturers combine audio inputs and outputs on the same socket. Generally the rules are like those for connecting up an "audio in/out" socket on a tape recorder. The most common audio plugs are illustrated in Fig. 11.

Audio Outputs

These are the sockets you will need to get at to connect your

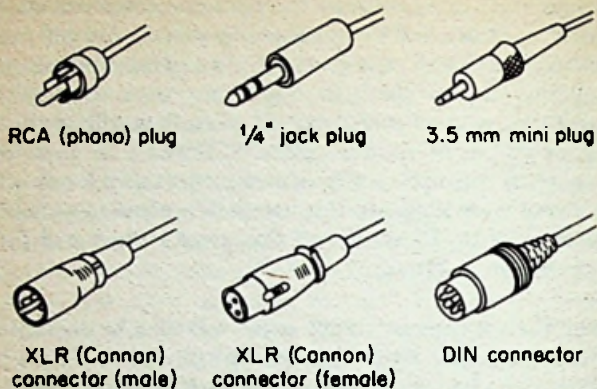

Fig. 11 Audio plugs.

vtr to another one for tape copying or for playing back your tapes through a hi-fi set up. Again there is no standardisation on either sockets or electrical characteristics. DIN and phono plugs are common, with 3.5mm mini-jacks not being unheard of either. Electrically, outputs will be of a high signal level, 0dB (.775V) or maybe -5dB (.4V) and of a low impedance of around 10K ohms or less. This means that they need to be connected to a higher impedance at either the other recorder or hi-fi amplifier. See Fig. 12.

Attenuators

Some recorders do not have separate line input sockets, which makes things a bit difficult, as often the only way of getting a signal in will be via the "mic in" connector. This can be done, but if you just connect up a lead and try a recording when you play it back you will find it very distorted, as the signal will have been of too high a level. Remember that mic

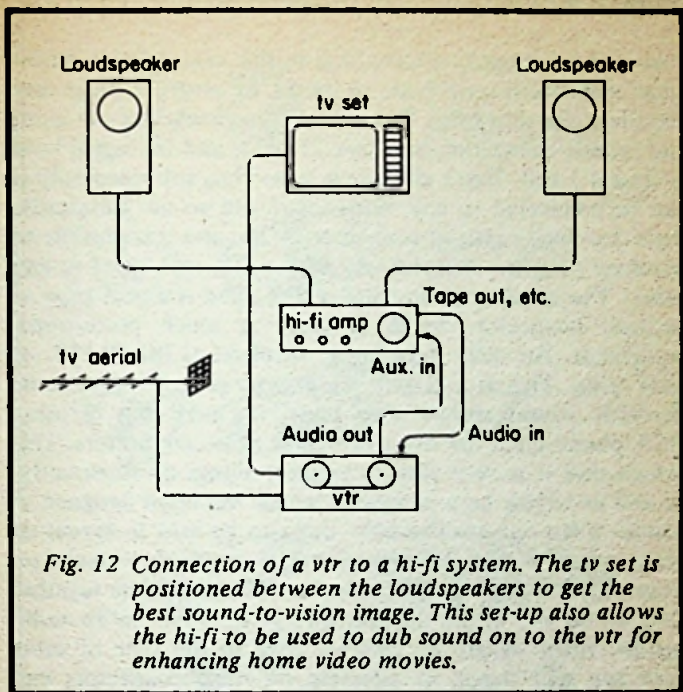

Fig. 12 Connection of a vtr to a hi-fi system. The tv set is positioned between the loudspeakers to get the best sound-to-vision image. This set-up also allows the hi-fi to be used to dub sound on to the vtr for enhancing home video movies.

sockets are designed to accept a -60 or -70 dB level and a line in -10 dB. The solution to this is to connect an attenuator in line with the lead, to reduce the signal level to something that the vtr can handle, as shown in Fig. 13.

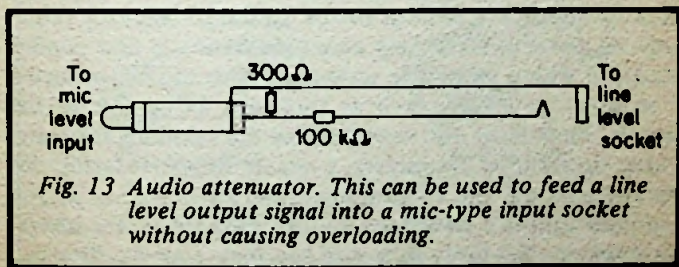

Fig. 13 Audio attenuator. This can be used to feed a line level output signal into a mic-type input socket without causing overloading.

Video Sockets

You will be pleased to know that in this area there is almost total standardisation, both in terms of physical plugs and electrical characteristics. The electrical impedance of the input and output connectors is always 75 ohms and the signal level is always 1 volt. That's all there is to it. Thus any video output can be connected to any video input and so on. Physically, there are three types of connector in use, and it is possible to purchase adapters to match any of the different types to any other. The commonest is called a BNC, and is a neat type of bayonet connector, which is used on much professional equipment. An older type, now obsolete, is the PL259, or UHF plug. This is a larger, screw type plug. Finally, some domestic manufacturers have taken the odd step of using RCA phono plugs for video as well as audio connectors. This means that it is very easy to connect things up incorrectly, as well as relying on a connector which was never designed to handle video signals. The only thing to be said in favour of phone plugs is that they are cheap. If you wish to make up your own leads to connect, say, two video recorders together then do be sure to use the correct type of cable. Unlike audio signals, video signals are very sensitive to the type of cable they are sent down. A selection of video connectors and adapters is shown in Fig. 14.

Camera Connectors

The final type of plug and socket I want to look at are those used for connecting cameras to vtrs. Although originally found only on portable vtrs, many mains machines are now coming equipped with a multi-pole socket to which can be connected a suitable camera. As well as supplying DC power to the camera, these plugs also have pins for the incoming video and sound signals from the camera, a remote stop/start facility for the recorder and also a return sound and vision feed to let you use your camera's viewfinder and earpiece socket for instant playback in the field. It is obvious that a single "live and



Screw type:
UHF,
F. & E.,
PL 259/50 239

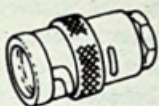

Bayonet type:
BNC



Aerial type:
Belling Lee,
DIN



RCA Phono:
essentially an audio
connector used for video
to reduce costs

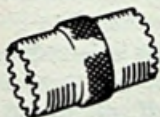

Back-to-back for joining
two leads ending in PL 259s



T-connector
for PL 259s



UHF to BNC



BNC to UHF

Fig. 14 Video connectors and adaptors.

earth" type cable cannot carry out all these roles so various types of multi-core cables are used. Although different manufacturers have again adopted different types of plug, this is not as bad as it might at first seem, for there are only two common types, one from the VHS group and another from the Beta group of companies. The VHS type plug is a 10 pin design and is used by Hitachi, JVC, Ferguson, National Panasonic etc. The cameras designed by these manufacturers will all fit each others products with no problems. It is only when you want to use, say, a Sony camera with a VHS recorder from National or a JVC camera with a Sony recorder that you run into snags. The Beta type plug is a 14 pin one and so the only way to match up the various possibilities is to either buy or make up adapter leads. In fact this is done by various manufacturers as well as video accessory companies and means that almost any camera can be used with any recorder. So if you really want to use a Sony camera with a JVC recorder then you can. Indeed just as in hi-fi, people often want to mix components from different companies to get the best possible results, a similar pattern of use is emerging for video equipment.

RENT OR BUY?

The question of whether to rent or buy video equipment is a difficult one. With rental, not only are you protected against maintenance bills and against being left with an old fashioned machine, but also against the format you have chosen becoming obsolete. You are, however, committed to a regular monthly outlay for a vtr which never becomes your property. With outright purchase, on the other hand, once the one year warranty is over you have to pay all the bills yourself and even if anything goes wrong during the guarantee period you won't have the rapid service you would expect from a rental firm such as replacement vtr whilst yours is being serviced etc. So which is best? This is a very difficult choice and although outright purchase may look more financially attractive in the long term, rental does have a number of benefits. The following examples outline some of the financial considera-

tions of the two options.

It is possible to buy a perfectly adequate vtr for around £400. If at the end of two years you sold it you would probably get around £200 for it. The loss of interest on laying out the £400 capital to start with might be around £100. Add to this the average of £40 which people spend on service in the second year of ownership, to give a total of £540, less the resale value of £200 leaves a cost of £340. A comparable sum for rental on a similar vtr might run like this: assume a rental of £16 approx a month or £200 p.a. In two years this gives £400, add on loss of interest of £30 giving a total of £430 and because the vtr is on rental you have no resale value. In other words, rental over 2 years is around £100 more expensive than purchase. However, although more expensive, rental ensures that not only do you get first class maintenance and probably a loan vtr if yours fails but also that you can trade 'upmarket' to a more sophisticated vtr when your needs change with a minimal outlay. It should also be borne in mind that unlike a colour tv set, a vtr is certain to need replacement video heads after about 1,000 hours use, and that if you own the vtr then you will be faced with a bill of between £60-£100. Rental schemes of course cover these costs. For those of you who would still like to purchase their own vtrs then many dealers run insurance type maintenance schemes.

So, for most people the answer would seem to be a matter of personal choice, depending mainly on the extent to which you intend to use the vtr. For a first time user, rental is probably the best answer, as it allows a vtr to be tried out without too large a financial commitment. Rental is also the answer if the vtr will be subjected to heavy family use, with outright purchase being best for the committed user with well researched requirements and who is not intending to subject the vtr to heavy use.

USING YOUR VIDEO

GETTING STARTED

Once your new video arrives, your first reaction will be to rip open the box and get the thing plugged in and working. But wait, before you do this, unpack the instructions and read them first. Unlike a lot of hi-fi equipment video recorders and cameras come with very comprehensive sets of instructions, covering not only the best way to use the item but also how to connect it up as well as simple fault finding. Also unlike hi-fi, most vtrs come with all the required leads to connect it to your existing tv set and tv aerial.

The first thing that you will need to do is to fit a mains plug on to the vtr lead or the power supply lead for a portable unit. It is essential that you wire the plug up correctly. If you have any doubts then do consult a qualified electrician. Also remember to have the correct fuse installed. The fuse is to protect both you and your vtr against faults so make sure that you get it right. Having done this then check that the voltage selector on the vtr is set to your local voltage, 240 AC in most of the UK. In practice this adjustment will, hopefully, have been carried out by either the manufacturer or dealer, but it is just as well to make sure. The final thing to do is to connect your tv aerial to the vtr and your vtr to your tv set and either playback a pre-recorded tape or if there is one, use the "test" switch in the vtr to help you tune your tv set into the output of the vtr. If your tv set has pre-set channel selectors and one of these is marked "vtr" then do use this one, as it will be designed to ensure that you get the best possible picture on playback. If your tv set has a rotary tuner or no specific button for vtr, then it will probably still work OK, but don't worry too much if you get some waviness in the picture at the top of the screen. This will be due to the rather poor quality of the tv synchronising signal which your vtr will be giving. A simple modification to your tv set will solve this problem —

just consult your local tv dealer. Incidentally, this problem occurs most often with the older type of valve tv set.

That rounds off the basic information on getting started, so we will now go on to look at some of the more interesting things that you can do with your vtr besides recording off-air tv programmes.

CONNECTION OF A VTR TO SEVERAL TVS

In some situations you may find that you wish to playback a video tape to several tv sets, either in a commercial situation for advertising purposes or at home, so that you can watch your vtr in either your living or bed rooms.

Unfortunately you can not do this by simply cutting the aerial cable from the vtr to the tv set and splicing in another length to the second set. This would result in an imbalance in the signal levels and ghosting of the picture would occur, if not worse problems. In the UK the aerial cable used on tv sets is of 75 ohm impedance and it is essential that that characteristic value is maintained under all circumstances. To achieve this special aerial splicing units are needed. See Fig. 15.

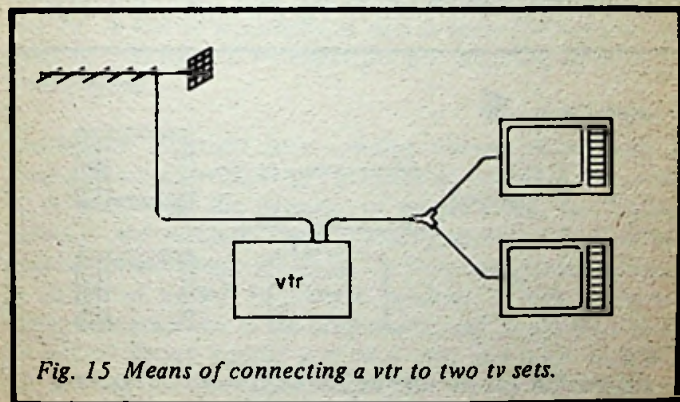

Fig. 15 Means of connecting a vtr to two tv sets.

The trouble with this type of simple splitter is that they reduce the level of the tv signal in the cable and you may find that your tv set gives poor results with a noisy picture, particularly with colour signals. If this is the case then an aerial splitter/amplifier unit will be needed, which not only divides the signal in two but also maintains the level as well. Your local tv aerial contractor will be able to advise you on what to buy.

If you already have two tv sets installed, then your existing aerial wiring may well look like that shown in Fig. 16, which can present a bit of a problem. If you want to playback the vtr to your second tv only occasionally, then try connecting the aerial input lead to the vtr output instead. You may find that an adapter plug may be needed. Now try tuning tv 2 in to the vtr output. With luck you should be able to pick up the vtr signal. Interestingly, you will technically be breaking the law by doing this, as half the vtr signal will be being fed to the tv aerial and then out into space! In practice the signal levels are so small that all should be well.

If you want to undertake this type of replay quite often, then you will need to fit a switch unit in the aerial lead to select which set you feed the vtr to, or else have the aerial system rewired as in Fig. 15.

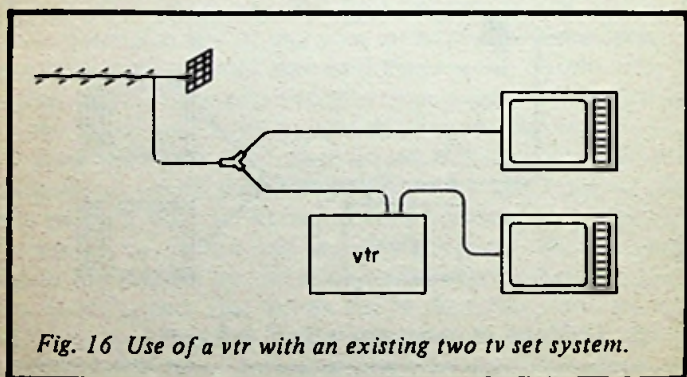

Fig. 16 Use of a vtr with an existing two tv set system.

COPYRIGHT

Contrary to popular opinion the UK copyright laws are quite clear, although admittedly complex. Basically you are committing an illegal act if you videotape almost any broadcast programme. The need for copyright is due to the fact that once any sort of production has been committed to video tape or disc, it can be replayed without reference to the actors, producers and other people who might have an interest in the production. In this way their financial interests can be prejudiced. Normally with broadcast tv or book sales etc. the actors and authors etc. get paid not only a one-off fee for the original production but also repeat fees depending on the number of times that the programme is repeated. One of the reasons that pre-recorded video cassettes are the price that they are is due to the need to build this "repeat fee" element into the sale price.

You may have noticed that the end credits of most BBC and IBA programmes have the © symbol and a date, thus signifying that the over-all programme is the property of the production company. Even in programmes which do not have the © symbol, you will probably find that some of the lines of actors' dialogue, incidental music or film inserts are protected by a separate copyright, even though the entire programme may not be. A few sports events as well as some live news broadcasts are not covered by copyright and thus may be recorded with impunity.

Unlike the copyright laws covering printed matter such as books, those covering tv programmes do not allow for copies to be made "for the purposes of private study, fair dealing, criticism and research", and so strictly speaking the fact that you are timeshifting a broadcast for your own private purposes is no excuse in law. In practice, however, so long as you are genuine in your use of the programmes and do not show them to school classes, paying audiences etc., and most definitely do not try to sell copies, then your venture into illegality will probably be overlooked.

A possible solution to this problem could take the form of either a revision of the law to allow for private time shifting, the introduction of a private recording licence such as used to exist for audio tape recording, or the raising of a levy on blank recording tape such as exists in West Germany.

Until the matter is resolved remember that by time-shifting broadcast tv programmes you are breaking the law, but are unlikely to run into trouble unless you try to profit by your illegality.

BASIC TAPE COPYING AND EDITING

Now that you have got your vtr set up and working, you may soon be faced with wanting to copy a tape. Maybe you have a tv programme in the middle of a tape which you want to keep whilst recording over the others. Awkward, isn't it? If we were talking about audio tape on open reels then you could always sit down with a razor blade and cut out the section that you wanted to keep. Although this was the way in which video tape was originally spliced it is not recommended now-a-days!

One solution to this problem would be to borrow a friend's recorder and copy the desired section of tape from your vtr on to a blank tape in his. Remember however, that you can run into problems concerning copyright in this field.

There are two ways that you can link the vtrs up for copying, as shown in Fig. 17. In Fig. 17a the vtrs are joined by their aerial sockets, with a single lead. A single tv set is connected to the master recorder to show what is being recorded. You will need to tune the tv tuner of the master recorder in to the output of the slave — use a spare preset. If you seem to be getting interference on the tv screen then this is probably due to the RF modulators in both vtrs being set to identical channels. If you consult the vtr handbooks you will find out how to shift one of them slightly to get rid of the problem. You will remember that in the section on vtrs we talked about

how the video and audio signals have to pass through extra circuitry when routed through the modulators and tuners and so become more distorted. With a copy of a tape this is something we want to avoid so Fig. 17b shows the preferred way of copying, via separate sound and vision leads. The signal to be recorded will now be of the highest possible quality that the vtrs are capable of giving.

Even so, when you come to playback the new copy you will find that it is not quite as good as the original. This is because it is a second generation tape — a copy of the master. You will find that there is more noise in the picture, small flashes of

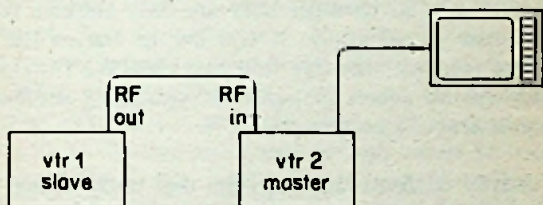

Fig. 17a Copying video tapes via the aerial sockets.

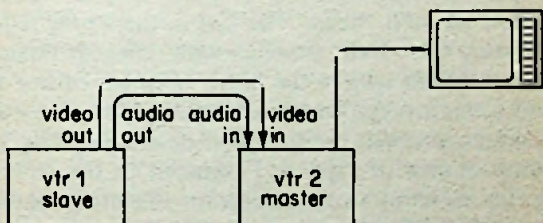

Fig. 17b Copying video tapes in the preferred manner, via separate audio and video leads.

colour, and that strange edges appear around vertical lines, and that in extreme cases the picture wobbles or "hooks" at the top of the tv screen. If this second generation was then copied again to produce a third generation then that would exhibit all these faults but to a higher degree. With all domestic vtrs a third generation tape is just about watchable — if you are determined!

If you intend to do a lot of tape copying, say producing copies of amateur dramatics on a regular basis, then it may be worth considering the purchase of one of several accessories which are designed to improve the copy of second generation copies. These devices can be inserted in the video lead from the slave to the master and reduce the apparent noise level, increase the picture stability and so on. As these accessories can cost anything from £120 upwards they are only suitable for the real enthusiast. Incidentally, if you live in one of the UK's larger cities you will probably find that there is a firm in your area who will do copies of tapes for you using professional grade equipment at a modest price.

Having briefly outlined tape copying, that really brings us on to tape editing. By editing I mean re-arranging sections of tape, containing either sound or vision, or both, in to a desired sequence. For example, if you have shot some footage with a home video camera then maybe one of your "takes" includes somebody accidentally walking in front of your camera or maybe some of your "takes" are just in the wrong sequence for your story line. Well, although with domestic equipment it is not possible to achieve the highly accurate editing which the broadcasters manage, with modern equipment and a degree of care, quite reasonable results are possible. By editing, I refer to copying chunks of tape as I outlined in the section on copying. Let us set up two recorders for an editing session and see how things work out. As before, you will need to borrow a second vtr and also a second tv set, and link them up as in Fig. 18.

If we tried to copy by starting both vtrs from "stop" then for

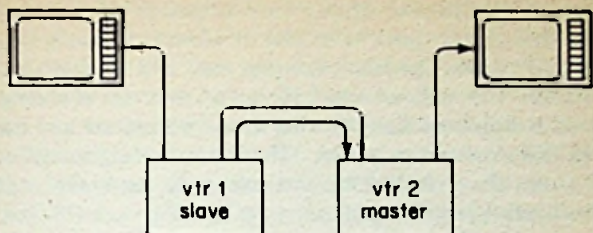

Fig. 18 Simple video tape editing.

the first "take" this would be OK, but at the join between the first and second "takes" there would be a great deal of picture disturbance. This is caused by both master and slave recorder taking several seconds to get from "stop" to their operating speed. When you play the tape back, at its correct speed, the starting up section will now run too fast, thus causing picture roll etc. as all the line and frame timings would be incorrect. What is needed is for the master vtr not to be put in to "record" until both it and the slave have reached running speed. This in turn means that both vtrs must be started *before* the point at which you want to do the edit. This is not as easy as it at first appeared to be! To overcome all these problems is not possible with existing domestic vtrs, but we can go some way to minimising them. The first thing to do is to "pause" the master vtr after a "take" rather than stopping it. The second thing to do is to rewind the slave vtr past the start of the required take, and then to let it run up to speed before the bit of tape you want appears. In this way, if you release the "pause" on the master as the picture you want appears on the slave monitor, then a reasonable edit should occur. If your vtr is one of the newer types which have fast function edit controls or even back wind editing, then even better results are possible. By "back wind editing" I mean the type of vtr which when you are in record and press "pause", not only pauses, but also rewinds for a few cms. When the

“pause” key is released the vtr runs forward, but only goes in to record at the end of the first sequence of vision. This means that it only goes in to record when the tape is running at its true speed. The result is a first class edit, with no picture roll at all. The only adverse effect you may see is a series of horizontal coloured lines moving down the picture and maybe taking 3-4 seconds to vanish. These are the colour information from the last “take” and can only be erased with a professional type editing vtr.

An effect often seen in broadcast tv is the superimposition of a title or name over a program beginning, newscaster, and so on. This type of effect adds a great deal of professionalism to a finished tape but until recently it has been very expensive to produce. An interesting device from Sony has changed this and now, for around £70, you can add coloured captions to either live or recorded material as well as being able to fade in and out pre-recorded tapes. Fig. 19 shows how this vision mixer/caption colouriser and down stream keyer can be wired into a video set-up. It can be fed with either a suitable colour

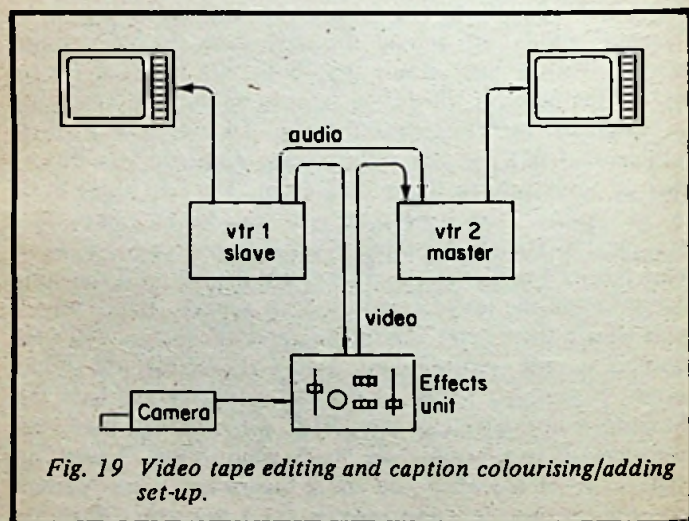

Fig. 19 Video tape editing and caption colourising/adding set-up.

camera for adding captions to live recordings or a video recorder for adding them to existing material. In this mode a second recorder would be needed to record the final result, so it would be ideal for use in an editing session. The unit is designed for use with a special Sony black and white camera, which can be pointed at titles made from rub down lettering etc. This signal can then be mixed with the existing one coming off tape, or given an electronically generated colour, so that, for example, red lettering can be superimposed over an existing scene. Strange artistic effects can be produced by pointing the black and white camera, not at lettering, but at a scene or an object and artificially colouring that!

MAINTENANCE AND CARE OF YOUR VIDEO SYSTEM

If you have spent several hundred pounds on video equipment you will want to make sure that it stays in good operational condition.

Video equipment on the whole is complex and expensive, so it is worth taking heed of the "No user serviceable parts inside" notices which are often found stuck to vtr cabinets etc. If you get any faults then it really is a good idea to take your equipment along to a qualified dealer, as he will have all the expensive test gear, the service manuals and the experience necessary to put it right. If you use your recorder a fair amount — a couple of hours every night — then it is a good idea to have it serviced at least once a year. Cameras, power units and similar devices really do not require much attention as they, unlike vtrs, do not have any moving parts. But besides this annual service there are a number of ways by which you can make sure that you get the best from your vtr.

First of all, consider where you are going to put it in the house. Not on a thick pile carpet where the vtr's fan will suck up dust and fluff into the machine. Although special vtr cabinets are available, any solid surface or shelf will suffice.

Not only will this keep the vtr away from the dust but it will also get it out of the reach of small children and the dog! Vtrs don't like coffee, beer, ash etc., nor do they appreciate pens, chewing gum or fingers pushed into the cassette loading slot. Many vtrs come supplied with a dust cover which is worth using when not recording or playing back a tape. An occasional dust and polish with an aerosol silicon furniture polish will help to keep your vtr looking like new. Do not use any solvents on the plastic cases or you may damage the finish.

The only other maintenance that a user can undertake is that of cleaning the tape path and video heads on the recorder. As those of you who own domestic audio recorders will know, as tapes are played a layer of oxide rubs off the tape and on to the recording heads and tape guides. With time this reduces the performance of the recorder significantly and in the case of a video recorder can prevent recording and playback totally. A solution to this can be found in the form of various cleaning cassettes which are available. These are very easy to use, as no dismantling of the vtr is needed. The only problem arises if they are incorrectly used as this can lead to excessive wear on the vtr which in turn can lead to the need for expensive repairs, so do be careful.

Cleaning cassettes come in two forms: abrasive and chemical. The former work by grinding down the oxide and binder which have accumulated on the tape guides and delicate video heads. As well as removing the waste oxide these abrasive tapes have a tendency to grind down the video heads if you clean excessively, necessitating an expensive bill for their replacement. The other type of cleaning cassette is really to be preferred, and is of the chemical type. This is essentially non-abrasive and consists of a strip of soft feltlike material which is moistened with a solvent. The cassette is then "played" in the vtr and the dirt transferred from the heads and guides on to the felt strip. Problems can occur if too much or too little solvent is used but so long as the manufacturer's instructions are followed then a satisfactory result will be obtained.

So, how often should you use a cleaning tape, and how do you know when its use is needed. Like fading brakes on a car, the gradual degradation of a vtr picture is often difficult to detect and so preventative rather than reparative maintenance is a good idea. In this respect a good clean about every 40-50 hours use, or every couple of months is reasonable. Do make sure that you read the cleaning tape instructions carefully and stick to them. Clogged video heads can be recognised by black streaking on peak white parts of the tv picture on playback — i.e. a window in the background of an interior shot. Excessive buildup of oxide on the audio heads can degrade the sound signal performance and if it also builds up on the control track head then picture roll can result. If any of these symptoms occur then a head cleaning session is in order. If, however, after the requisite cleaning there is no improvement then don't continue but stop and take your recorder to a good dealer, as something other than dirty heads may be at fault and need rectifying. The only problem with both types of cleaning cassettes mentioned is that there will still be old oxide and dust in the recorder after a period of use. Even the chemical cleaners do not clean all the parts of the tape path. For this reason a dealer overhaul once a year is a good idea. If, however, you are really determined and reasonably skilled you can buy a cleaning kit which consists of swabs and solvents. To use these you have to take the lid off your recorder and as this can invalidate the warranty you must think carefully before you decide to try it! These cleaning swabs are used by soaking them in a suitable, supplied, solvent (often a trichloro-ethylene compound) and gently rubbing the guides and heads clean. The actual video heads are very delicate and should only be cleaned in this way with the recorder switched off, and even then only in a right to left motion, never up and down.

Other simple faults which can occur are due to the tracking control on the vtr being accidentally moved, so that the old recordings no longer play back correctly. Faults resulting in no picture are often due to leads having been pulled out or being faulty. Often, repeated plugging and unplugging of the

aerial lead can cause it to break, sometimes inside the plastic covering so that from the outside there is no visible sign of damage — check this type of fault by substituting the lead with a similar one.

Another source of problems is damaged video cassettes. Sometimes a vtr will “eat” a tape and when it is eventually recovered the tape is either broken or badly crumpled. Don't be tempted to try to play crumpled tapes as they can shed oxide easily and damage the video heads. If you want to salvage the cassette there are two options open to you: either open the plastic cassette up, decide which spool has most tape on it, unwind the other spool and throw the tape away and re-join the two spools, or else try to splice the tape to keep the full length. The former option is the safest, although you do end up with a non-standard cassette. If the material on it really is worth saving then splicing may be the only possible solution. Be warned, however, a badly spliced tape may damage the video heads, so if you have any doubts about your abilities in this area leave it to your dealer. If you want to go ahead on your own, you will need to buy some pressure sensitive splicing tape and a single edged razorblade. A proper ½” splicing block is useful but not essential. You can not use clear sticky tape, masking tape or any tape other than proper video tape pressure sensitive splicing tape. Proceed as follows: Cut the ends of the tape clean, discarding any damaged or crinkled tape. Butt the ends together, making sure not to overlap them as this will cause a lump in the tape. Apply the splicing tape and press firmly down. Finally trim the excess tape away, do not wrap it round. Make sure that the splicing tape is on the non-oxide side of the tape — in other words, the side which does not come into contact with the video heads. Fig. 20 illustrates.

USING VIDEO CAMERAS

Although all the current domestic video cameras, whether colour or black and white, are easy to use, to get the best

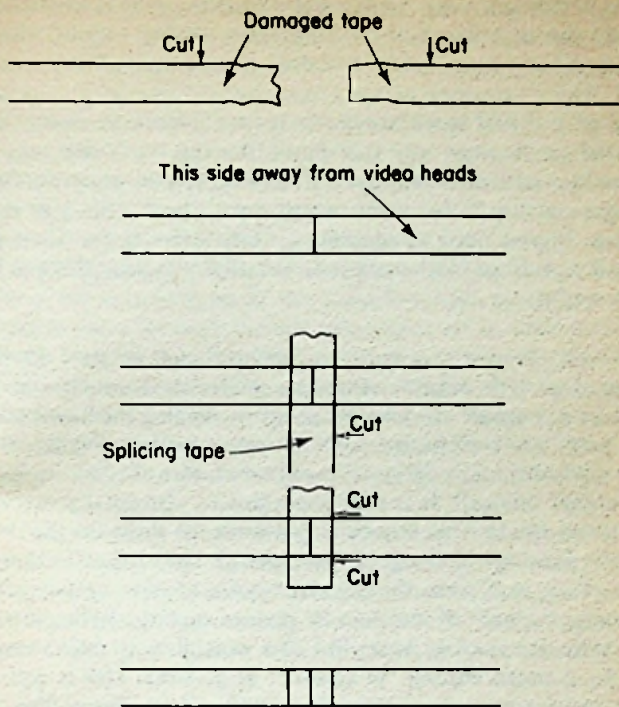

Fig. 20 Series of diagrams to illustrate video tape splicing.

possible results from them you need to do a bit more than "point and squeeze the trigger".

In the UK we all know what tv looks like, after all our broadcast tv is reputedly the best in the world. This can at times present a problem. After all, people are used to watching tv of a very high standard, both in terms of production and technical quality, and if your home-produced video movies are full of out of focus shots, jerky zooms, over exposed

green faces and so on, your audience will soon lose interest, even if they are your friends and relations. So it is important to do the best that you can to achieve quality results, which can be done even with low cost domestic equipment.

One of the first ideas to take in is that video tape cannot be wasted in the same way that 8mm film can be. Video tape is re-usable, and after all, even if it wasn't, you are recording images on "rust" (magnetic tape) not "silver" (film) so it is cheap. If you need to practice a "take" five times, then go ahead and do so. With instant on-location playback this can be very useful.

However, before you go on a "shoot", let us start at the beginning. It is essential that you understand your tools, as it is in any trade. An hour or so spent reading the handbooks on your vtr, camera and microphone as well as playing with the equipment in your garden will save hours of frustration on an actual "shoot". It is also important to plan what you want to shoot and in what sequence you want the shots for the final result. Editing video tape is an expensive and time consuming operation, and, from the domestic point of view, best avoided if only because of the loss in picture quality. With current portable vtrs having backwind edit capability it makes sense to do as much editing "in camera" as possible. This is one of the main areas where video tape differs from 8mm film, in which editing is both easy and produces no loss in quality. So if you want, say, a village name board followed by an exterior of a church, then an interior shot followed by an exterior of the bells ringing then shoot it in that order. You may well find it useful to prepare a rough script or story board — i.e. sketches of shots required along with notes on the associated sound track, before you start on a shoot.

When you actually go out, what do you need to take with you? Well, besides the portable vtr and camera you may well need a whole host of accessories, including an AC adapter or extra batteries if you intend to shoot for more than about 3/4 hours or so. With 3 and 4 hour cassettes being widely

used you will probably only need one of these, but a spare in case of accidents can be a good idea. An additional microphone to the one built in to the camera will improve the sound quality and an earphone will allow you to check your sound on location. If your camera has an electronic viewfinder then you can check your recorded picture in black and white on site, but not in colour. To do this you can use one of the battery operated small colour tv sets which are now obtainable. Some of these, with around a 5" screen, have input sockets for both video and sound signals so can be very useful for checking colour balance of the camera on location. A range of assorted extension leads can come in useful, ranging from a simple mains extension for use of a mains vtr in your garden, through extension microphone cables for using a microphone off-camera to an extension camera lead itself. This latter will allow you to leave the vtr and move about in relative freedom. Although all domestic cameras are designed for either hand or shoulder mounted operation you will find that some type of tripod will enable you to produce far steadier pictures, especially when you are using a long-range zoom lens. If a tripod is impractical for some reason then try resting the camera on a car roof or even on a foam rubber cushion on top of a wall. Unsteady wobbling shots are one of the quickest ways to make your audience feel ill and then to lose interest.

It is also probably a good tip to avoid panning the camera too much — moving it from left to right and vice versa, or overusing the zoom lens. It should be remembered that with all types of movie camera, it is mainly the subject, not the camera which is supposed to do most of the moving. Unless you want a special dramatic effect then try to be gentle in all your camera movements.

Remember, also, that whilst your camera will come equipped with a built-in microphone this will be of relatively low quality and will usually be of the type which picks up sounds from all around it equally well, as opposed to those sounds directly in front of it. Although there are a few cameras on the market which have microphones where the angle of coverage alters

in response to the setting of the zoom lens, most users will find that the addition of an extra external microphone will be the best solution. If you use one of the more directional type, the microphone will pick up the sounds at which the camera is pointed as opposed to the noise of the zoom lens and the cameraman's breathing, etc. Sound is often the neglected area of tv production but this should not be the case.

If you are intending to shoot indoors then you will probably find that on some occasions there will not be enough light around for the camera to function properly and you will have to supply some extra. There are a few problems here, not the least being that the battery operated lights are very expensive and have only a short operating time between rechargings. However, in most cases when the amateur is shooting indoors he will be near to a source of mains power and so AC mains lights can be used. Although correct lighting of a subject is a topic for a book in its own right, you will be mainly concerned not with artistic effects but with raising the over-all lighting levels sufficiently to enable the camera to give a respectable picture. An easy way to do this is with one of the 1000 watt bar lights of the type often sold for use with super 8mm cameras. This will be fine. Some of these types come with a built-in cooling fan enabling them to be used for extended periods but those without fans should not be used for more than about 15 minutes at a stretch as they can get extremely hot. The life of this type of bulb is not very long, about 12 hours continuous use. If you find that the lights of this type are too harsh you might try bouncing it off a wall or ceiling on to your scene to soften it.

Beside the type of light there is another problem concerned with its colour temperature. By colour temperature I mean the proportion of red, blue and green light which the light source emits. Those of you who have used colour video cameras will know that they all have a control to enable them to give the correct colour pictures under different lighting conditions, including daylight, tungsten artificial light, fluorescent tubes and so on. In effect this is the electronic equivalent of indoor

and outdoor film for Super 8mm or 35mm slide cameras. The human eye and brain can compensate for this effect and ensure that, say, a white sheet of paper looks white under almost any lighting conditions but film and tv cameras cannot do this. Colour temperatures of common light sources are shown in Table 5. If the paper is reflecting a lot of blue light it will appear blue and so on. Balancing for any one type of lighting is not too difficult but problems do arise where a mixture of different types of illumination are falling on to a scene you wish to record. For example, in a room you may well have daylight coming in through the windows and a mixture of fluorescent tubes and ordinary tungsten bulbs. Those cameras with the click stop type of colour temperature adjustment will not be able to cope with this situation and an approximation will be the best you can do. Those with fully variable colour balance controls will do better although a well set up colour tv or monitor will come in useful for making sure that you have the balance right.

Table 5 Colour temperatures of common light sources.

Light Source	Colour Temperature ($^{\circ}$ K)
Tungsten lamps	2600 - 2900
Quartz Iodine lamps	3200 - 3500
Morning and evening daylight	5600 - 5700
Hazy daylight	5700 - 5800
Overcast daylight	6000
Clear noon sunlight	6700
Mediterranean sunlight	10000 - 12000

To sum up then, probably the most important thing to try to consider when using a video camera is to plan what you are going to do in as much detail as possible and to practise before the event.

INTERNATIONAL TAPE EXCHANGE AND RELATED PROBLEMS

One problem which the more ambitious video enthusiast will encounter is that concerned with either buying video equipment outside of the UK and then trying to use it here, or the reverse. A related problem is that of exchanging video tapes with friends overseas.

These problems arise because a number of different television systems are in use around the world, and hence problems of lack of compatibility arise. For example, you will already know that in the UK we use a colour system called PAL and have tv pictures made up from 625 lines. In France, however, even though 625 lines are used, a different colour system called SECAM is employed. The situation in the USA and Japan is even more complex where 525 lines and a colour system called NTSC is used. Thus a PAL video cassette will only play back in colour when played on a PAL vtr and when connected to a PAL colour tv set and so on. Table 6 shows

Table 6 Matrix table showing what results will be obtained when playing different standards of video tape on different standard vtrs into various colour video monitors.

vtr	Tape type	Standard of colour video monitor for display		
		PAL	NTSC	SECAM
PAL	PAL	colour	b & w?	b & w
	NTSC	---	---	---
	SECAM	b & w	b & w?	colour?
NTSC	PAL	---	---	---
	NTSC	b & w?	colour	b & w?
	SECAM	---	---	---
SECAM	PAL	colour?	b & w?	b & w
	NTSC	---	---	---
	SECAM	b & w	b & w?	colour

- (1) ? indicates that playback should be possible, but results will be dependant on the models of vtr, monitor used.
 (2) --- indicates that no playback at all is possible.

what will happen when different standard video cassettes are replayed on different combinations of vtr and tv set.

Essentially what this means in practice is that you can happily use PAL tapes in any other PAL country but no others. Table 7 shows which tv systems are in use in some of the major countries of the world. If international tape exchange is of great interest to you then it is possible to buy multi-standard vtrs and tv sets which will, for example, allow PAL, SECAM and NTSC tapes all to be replayed in colour. Such equipment is more complex than conventional video hardware and this is reflected in its premium price and restricted choice, although both VHS and Beta formats are catered for. If you have, say, an NTSC tape from the USA it is possible to have it converted by a professional video facilities house to a PAL format, via a standards convertor. This device allows, say, an NTSC tape to be played back on an NTSC vtr, the signal to be converted to PAL and then re-recorded on a PAL vtr. Conversion to and from all systems is possible, with only a small amount of signal degradation. The cost of these operations is however very high, often being over £100 per hour, due to the very high cost, £100,000 – of the complex electronic standards convertors. For this reason it is rarely economical to have tapes purchased on holiday in the USA converted for PAL systems.

Moving on from the different line and colour systems used

*Table 7 Which countries use which tv systems
– major examples only.*

System	No of lines per picture	Pictures per second	Major countries using system
PAL	625	50	UK, West Germany, Spain, Scandinavia, Australia, China, S.Africa, Pakistan.
NTSC	525	60	USA, Japan, Canada, Chile, Peru, Venezuela
SECAM	625	50	France, USSR, Eastern Europe, UAR, Zaire.

around the world there are even more complications, in that both Beta and VHS formats in NTSC countries come in three different speeds. This means that, rather like reel to reel audio recorders, a tape recorded at one speed will not play back correctly at any other. The reason for these various speeds is to get very long playing times from the cassettes and hence a very low cost per hour of recording tape. The VHS formats are called: SP – Standard Play, (2 hours) LP – Long Play, (4 hours) and SLP – Super Long Play or EP – Extended Play, (6 hours). All the times given are for a T-120 cassette, equivalent to the PAL E-120. Beta in NTSC areas is similar, with Beta I, Beta II and Beta III, giving recording periods from 1 to 5 hours. In practice, VHS SP and Beta II seem to be the most commonly used speeds, especially for pre-recorded movies. The PAL/NTSC multi-standard vtrs available in the UK work at the Beta II and VHS SP speeds only.

Moving on to equipment now, it will be obvious that an NTSC vtr purchased in the USA will be of little use to you in the UK and vice versa. Don't be fooled by any salesman who tells you that all you need is a different transformer to make it work in the UK – it won't! But what about a PAL vtr purchased in Germany or Australia, will that work in the UK? Well, yes and no. All three countries use the PAL colour system and 625 line colour picture scans, so if you restrict your use of the vtr to the video/audio in and out connectors then all will be well. But if you want to use the tv tuner and UHF modulator in conjunction with a normal tv set then you will have some more problems, as different frequency transmission standards are used in the different countries. In this case you will find that you can tune the picture or sound coming from your German vtr on to your UK tv set, but not both. The same will apply to the German tv tuner in the vtr – sound or vision, not both. This is because the space between the frequencies upon which the sound and vision are transmitted in the UK and Germany are different. The modification to the German UHF modulator is an easy one, but that needed for the tuner is a more complex matter. Table 8 shows the transmission systems for some of the major countries which use PAL.

Table 8 RF transmission standards for some countries using PAL.

Transmission system	Sound carrier/ vision carrier spacing (Mhz)	Major countries used in
B/G	+5.5	Most PAL users, except for ex-British colonies, etc., W. Germany, Scandanavia, Australia, Spain, Switzerland.
I	+6	UK, South Africa, Hong Kong, Ireland.

Don't let these technical points put you off what is a fascinating hobby. There is little more satisfying than for distant friends and relatives to receive not merely colour slides but full colour home video movies. But first of all check on the local tv standards and systems to avoid disappointment.

THE FUTURE

One of the problems with video is the speed at which new developments can make existing hardware obsolete. Look at the original Philips VCR N1500 system or its successor, the N1700. Indeed, it was the boss of Sony in Japan who said, "We are in the market to obsolete our own products." Although this can be frustrating at times, it does ensure that the future of video is without doubt very exciting.

Trying to predict this future is as difficult as any form of prediction, but by looking at existing trends in research and development we can glean some interesting possibilities.

One certainty is that all solid state colour cameras, with the conventional glass vacuum vidicon tube being replaced by some type of semi-conductor imaging device will appear. Such a camera will not only be smaller and lighter than existing ones but more immune to their problems, such as image stick and burn on the tubes. It is probable that some of these light-weight cameras will be linked with very small lightweight $\frac{1}{4}$ " vtrs, some examples of which are already on the market. This sort of package could well rival the cine camera for weight and quality. A development from this would be to combine both recorder and camera in to one shoulder mounted unit, as has been demonstrated in prototype form by several Japanese manufacturers. Fig. 21 shows the suggested system from Sony.

Here a solid state – CCD (Charge Coupled Device) – camera is coupled with a very small but otherwise reasonably conventional vtr. Sony envisages that tapes recorded on this "Video-Movie Cam-Corder" would be edited on to a Beta format vtr for storage and subsequent use. It would be pleasant to think that a common standard for the "Cam-Corders" from all manufacturers could be arrived at but this seems unlikely.

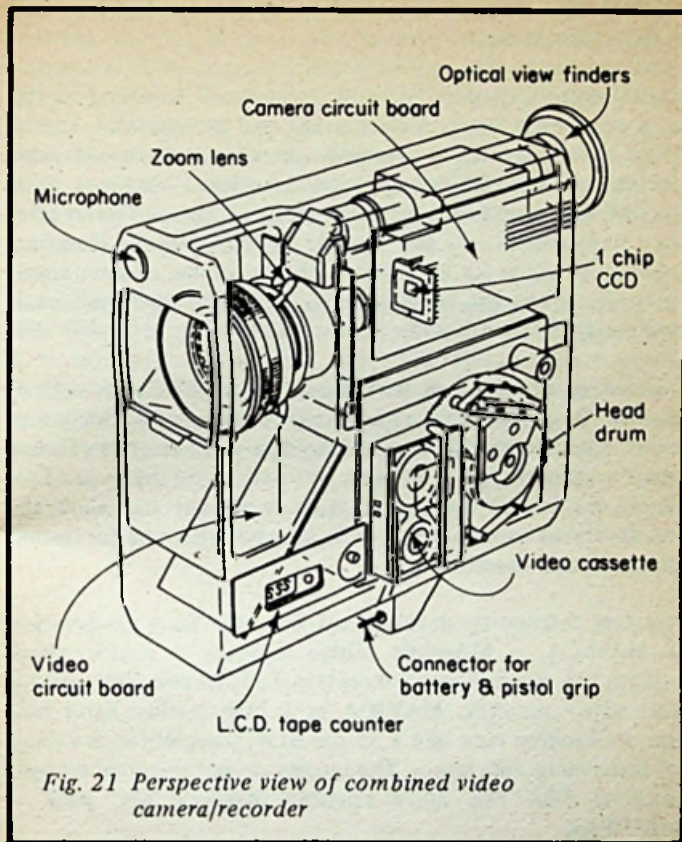

Another interesting development will be the use of vtrs, not for recording pictures but very high quality digital sound — Super Hi-Fi. This will allow totally noise free stereo or ambisonic recordings to be made and replayed. A special adapter would be used to fit in between either an FM radio tuner or audio mixer to turn audio signals in to a form suitable for feeding in to the "video in" socket of a vtr. These techniques of digital recording are already used on a small

scale for the production of some very high quality discs and radio transmissions.

Digital recording of tv pictures, as opposed to sound, is still in a very early experimental stage and is restricted to the broadcasters at present. However, as all current home video equipment was developed from broadcast hardware it is possible that domestic vtrs will go "digital" about 5 years after the broadcasters — say around 1990. Digital recording techniques allow for an almost infinite number of generations of a tape to be produced with no increase in the noise levels and no signal degradation.

Flat screen tv, although strictly not video, will also be with us shortly. By flat screen I mean a tv set employing not a conventional cathode ray tube to display the pictures on, but some other very thin type of display. Not only could this type of set herald the era of the wall hanging tv set but also allow the possibility of screens being built into portable vtrs for instant playback and monitoring.

Another fascinating development from the Sony Corporation is MAVICA — MAGnetic VIdeo CAmera, a device which bridges the gap between conventional 35mm still photography and video cameras. MAVICA is a high quality hand held camera looking very like a 35mm SLR, complete with a range of interchangeable lenses. The images are not recorded on light sensitive film but on a reusable magnetic disc pack — MAVIPAK.

The light which enters the camera through the lens is converted into electrical signals by a solid state CCD. The signals are processed into colour and brightness components and then recorded on the magnetic disc. This can store up to 50 separate pictures and once used can be erased for further use. The pictures can be viewed on a domestic tv set by playing the MAVIPAK in a special viewer unit. If actual hard copies of the stills are required then these can be produced by a printer unit. The stills can also be recorded on normal

video tape recorders if desired. MAVICA has the capability of shooting pictures at up to 60 a second and can also be used as a standard video camera. The actual disc pack is very compact, being 60 x 54 x 3 mm and is also quite cheap – it should cost around £2 with the camera being about the same price as a good 35 mm SLR. Although the overall picture quality is not quite as good as normal photography MAVICA does have a number of advantages. Sony hope to have this system on the market in about 2 years.

One of the major Japanese companies is developing a domestic laser videodisc system that allows a recording to be made. Also it is believed that another laser videodisc system is being developed in Japan which can be recorded and erased as many times as the user wishes. However, it will remain to be seen how the cost of these systems will compare with the domestic vtr.

GLOSSARY OF COMMON VIDEO TERMS AND ABBREVIATIONS

AC

Alternating current, the sort of electricity normally supplied by household mains in the UK.

AFC

Automatic Frequency control.

AGC

Automatic Gain Control.

ALC

Automatic Level (or Light) Control.

AM

Amplitude Modulation. The variation of amplitude of a carrier signal without altering its frequency.

Amplitude

The 'strength' of a signal, as can be measured on an oscilloscope.

Assemble edit

A method of electronically editing video tapes, where new sound and vision signals are recorded simultaneously.

Attenuate

To reduce the level of a signal.

Audio dub

To add new audio signals to existing video ones.

Azimuth

A measure, in degrees, of the angle between a video head and the plane of that head relative to the direction of travel of the video tape.

B & W

Black and White – monochrome.

BNC

Type of bayonet fitting video connector.

Bandwidth

Amount of frequency spectrum occupied by a signal.

Beam

The stream of electrons emitted by the electron gun in a crt or camera tube.

Belling Lee

Name often used for a type of high frequency plug, as used on tv aerial leads.

Beta

Domestic video tape cassette system developed by Sony in Japan.

Burn

A condition caused to a video camera tube by exposure to excessively strong light, normally resulting in the retention of a black area on the tube.

Capstan

A motor driven shaft which controls the speed of tape travel in a vtr.

Cardioid

One of several types of pick up patterns of microphones. Heart shaped.

CED

Capacitive Electronic Disc, a video disc system developed by RCA in the USA.

CCD

Charge Coupled Device. A form of solid state imaging device.

CCTV

Close Circuit Television. TV picture transmission by cable as opposed to broadcast.

CRT

Cathode Ray Tube, as used for the picture display in tv sets.

Ceefax

(See Facts), Teletext service transmitted by BBC.

Chroma

The colour information part of a video signal.

Coaxial cable

Special type of cable used for transmission of high frequency tv signals.

Colour temperature

A measure of the proportions of various colours in a particular type of light, the more blue in it the higher the temperature.

Composite video

A type of video signal containing synchronisation information as well as picture information.

Control track

A track on a video tape that carries the servo information needed to control the speed of tape and video head on recording and replay.

Crash edit

Simple type of editing, where no attention is given to synchronisation.

Crispener

Electronic gadgetry used for improving the horizontal resolution of a tv picture.

DC

Direct Current, the sort of electricity normally supplied by a battery.

DIN

Deutsche Industrie Norm. German equivalent of British Standards.

Decibel

An estimate of relative sound levels, expressed on a logarithmic scale.

Dichroic mirror/prism

Type of mirror/prism used in some colour tv cameras, which reflects light of one frequency (colour) only.

Drop out

Damaged portion, where no signal can be recorded, of metal oxide coating on magnetic tape.

Dubbing

Adding sound to existing vision on a video tape.

EFP

Electronic Field Production. TV programme production done on location, usually with one camera and recorder.

ENG

Electronic News Gathering. Coverage of news stories with a single camera/recorder unit.

Edit

To join together sections of tape, usually electronically.

Electron gun

The assembly in a crt or camera tube which produces electrons for scanning the tube face or target.

FM

Frequency Modulation, variation of the carrier frequency whilst the amplitude remains constant.

Field

Half a frame of a tv picture. Two fields, odd and even, interlace to produce a complete frame.

Format

Way of describing to which group of vtrs a specific model belongs, i.e. VHS format or BETA format.

Frame

A complete tv picture, consisting of 2 interlaced fields.

Frequency

Number of cycles per second, the unit is Hertz.

Gain

The amount of amplification of a signal.

Gap

Space between the pole pieces of a recording or replay head, across which a magnetic field is produced.

Generation

Number of times a tape has been copied from the original. A copy of a master tape is 1st generation, a copy of this is 2nd, etc.

Head drum

Video head housing in a vtr.

Helical scan

Form of vtr recording where the video information is placed in diagonal tracks across the tape.

Hertz (Hz)

The unit of frequency, cycles per second.

Impedence

The measurement of a.c. resistance to a signal. Important for matching the input and output signal levels in vtrs.

Insert

Electronic editing technique where new sound and/or vision is inserted into a programme with clean 'in' and 'out' transition.

Interlace

The method by which the 2 fields of odd and even lines of a tv picture are fitted together.

Kelvin

As in '°K' the unit of measurement of colour temperature.

Laservision

Name used by Philips for their optical laser type of video disc player, (also made by Pioneer under licence in Japan).

Line

As applied to the scanning lines of a tv picture. 625 in the UK, 525 in the USA.

Lumen

A unit for measuring light intensity.

Luminance

The brightness information of a tv signal, sometimes abbreviated to luma.

Lux

Measure of light level.

MHz

Measure of frequency. 1 million cycles per second.

Modulator

Part of a circuit that is used for turning a video signal into an RF tv signal.

Monitor

Type of tv set that has no tuner but which accepts signals at sound and video levels.

NTSC

National TV Standards Committee. Colour tv system as used in USA, Japan, etc.

Off air

TV programmes that are transmitted and received by the Broadcast Companies.

Omnidirectional

Type of pick up pattern of a microphone which receives sounds from all around equally.

Oracle

Optical Reception of Announcements by Coded Line Electronics. Teletext service transmitted by IBA.

PAL

Phase Alternate Line. Colour tv system used in UK, W. Germany, etc.

Prestel

A viewdata service operated by British Telecom.

Quadruplex

Professional broadcast vtr format.

RCA

As in 'RCA plug', a type of audio connector often used for carrying video signals on some domestic vtrs.

RF

Radio Frequency.

Raster

Pattern of lines displayed on a tv set when no picture is displayed.

SECAM

Colour tv system as used in France.

Scanning

The process whereby the electron beam traces out a pattern over a crt or camera target.

Sync

Synchronising pulses as in a tv or vtr.

Telecine

Device for transferring film and slides onto video tape.

Teletext

Videotext data transmitted by various broadcast companies 'piggy back' with the actual tv programme pictures.

Track

A band of information recorded on magnetic tape or disc.

UHF

As in 'UHF plug', a type of screw thread video connector.

Unidirectional

Type of pick up pattern from a microphone designed to detect sounds from one direction only.

VCR

Name Philips use for their domestic vtr. Also sometimes used as an abbreviation for Video Cassette Recorder.

VHD

Video High Density or Video Home Disc, a video disc system developed by JVC in Japan.

VHS

Video Home System. Tape format originated in Japan by JVC for domestic vtrs.

VTR

Video Tape Recorder.

Video

Picture element of a tv signal — also used generally to cover non-broadcast tv.

Video cassette

The complete plastic unit, which is placed in a vtr, that contains the video tape for recording.

Video disc

A disc on which video and audio signals are recorded.

Video 2000

Name used by Philips for their double-sided domestic video cassette format.

Videotext

Over-all name given to various systems which display pages of text, as opposed to pictures, on a tv screen.

Viewdata

Videotext data transmitted via telephone lines to a tv set.

Zoom lens

Type of lens on a video camera that can vary from wide angle to telephoto (i.e. change its focal length) whilst not altering its focus.

205	First Book of Hi-Fi Loudspeaker Enclosures	85p
221	28 Tested Transistor Projects	1.25p
222	Solid State Short Wave Receivers for Beginners	1.75p
223	50 Projects Using IC CA3130	1.25p
224	50 CMOS IC Projects	1.35p
225	A Practical Introduction to Digital IC's	1.25p
226	How to Build Advanced Short Wave Receivers	1.95p
227	Beginners Guide to Building Electronic Projects	1.95p
228	Essential Theory for the Electronics Hobbyist	1.95p
RCC	Resistor Colour Code Disc	20p
BP1	First Book of Transistor Equivalents and Substitutes	1.50p
BP6	Engineers and Mechanists Reference Tables	75p
BP7	Radio and Electronic Colour Codes and Data Chart	40p
BP14	Second Book of Transistor Equivalents and Substitutes	1.75p
BP24	52 Projects Using IC741	1.25p
BP27	Chart of Radio Electronic Semiconductor and Logic Symbols	50p
BP32	How to Build Your Own Metal and Treasure Locators	1.95p
BP33	Electronic Calculator Users Handbook	1.80p
BP34	Practical Repair and Renovation of Colour TVs	1.25p
BP36	50 Circuits Using Germanium, Silicon and Zener Diodes	1.50p
BP37	50 Projects Using Relays, SCR's and TRIACs	1.95p
BP39	50 (FET) Field Effect Transistor Projects	1.75p
BP40	Digital IC Equivalents and Pin Connections	3.50p
BP41	Linear IC Equivalents and Pin Connections	1.50p
BP42	50 Simple L.E.D. Circuits	1.95p
BP43	How to Make Walkie-Talkies	1.95p
BP44	IC555 Projects	1.95p
BP45	Projects in Opto-Electronics	1.95p
BP47	Mobile Discotheque Handbook	1.35p
BP48	Electronic Projects for Beginners	1.95p
BP49	Popular Electronic Projects	1.95p
BP50	IC LM3900 Projects	1.35p
BP51	Electronic Music and Creative Tape Recording	1.95p
BP52	Long Distance Television Reception (TV-DX) for the Enthusiast	1.95p
BP53	Practical Electronic Calculations and Formulae	2.98p
BP55	Radio Stations Guide	1.75p
BP56	Electronic Security Devices	1.95p
BP57	How to Build Your Own Solid State Oscilloscope	1.95p
BP58	50 Circuits Using 7400 Series IC's	1.75p
BP59	Second Book of CMOS IC Projects	1.50p
BP60	Practical Construction of Pre-amps, Tone Controls, Filters & ATN	1.45p
BP61	Beginners Guide to Digital Techniques	95p
BP62	Elements of Electronics - Book 1	2.25p
BP63	Elements of Electronics - Book 2	2.25p
BP64	Elements of Electronics - Book 3	2.25p
BP65	Single IC Projects	1.75p
BP66	Beginners Guide to Microprocessors and Computing	1.75p
BP67	Counter Driver and Numerical Display Projects	1.75p
BP68	Choosing and Using Your Hi-Fi	1.65p
BP69	Electronic Games	1.75p
BP70	Transistor Radio Fault-Finding Chart	50p
BP71	Electronic Household Projects	1.75p
BP72	A Microprocessor Primer	1.75p
BP73	Remote Control Projects	1.95p
BP74	Electronic Music Projects	1.75p
BP75	Electronic Test Equipment Construction	1.75p
BP76	Power Supply Projects	1.75p
BP77	Elements of Electronics - Book 4	2.95p
BP78	Practical Computer Experiments	1.75p
BP79	Radio Control for Beginners	1.75p
BP80	Popular Electronic Circuits - Book 1	1.95p
BP81	Electronic Synthesiser Projects	1.75p
BP82	Electronic Projects Using Solar-Cells	1.95p
BP83	VMO5 Projects	1.95p
BP84	Digital IC Projects	1.95p
BP85	International Transistor Equivalents Guide	2.95p
BP86	An Introduction to Basic Programming Techniques	1.95p
BP87	Simple L.E.D. Circuits - Book 2	1.35p
BP88	How to Use Op-Amps	2.25p
BP89	Elements of Electronics - Book 5	2.95p
BP90	Audio Projects	1.95p
BP91	An Introduction to Radio DX-ing	1.95p
BP92	Electronics Simplified - Crystal Set Construction	1.75p
BP93	Electronic Timer Projects	1.95p
BP94	Electronic Projects for Cars and Boats	1.95p
BP95	Model Railway Projects	1.95p
BP96	CS Projects	1.95p
BP97	IC Projects for Beginners	1.95p
BP98	Popular Electronic Circuits - Book 2	2.25p
BP99	Mini-Projects Board Projects	1.95p
BP100	An Introduction to Video	1.98p
BP101	How to Identify Unmarked IC's	65p
BP102	The 8009 Companion	1.95p
BP103	Multi-Circuit Board Projects	1.95p
BP104	Electronic Science Projects	2.25p
BP105	Aerial Projects	1.95p
BP106	Modern Op-Amp Projects	1.95p
BP107	30 Solderless Breadboard Projects - Book 1	1.85p
BP108	International Diode Equivalents Guide	2.25p
BP109	The Art of Programming the 1K ZX81	1.95p
BP110	How to Get Your Electronic Projects Working	1.95p
BP111	Elements of Electronics - Book 6	3.50p
BP112	A Z-80 Workshop Manual	2.75p
BP113	30 Solderless Breadboard Projects - Book 2	2.25p
BP114	The Art of Programming the 18K ZX81	2.50p
BP115	The Pre-Computer Book	1.95p
BP116	Electronic Toys Games and Puzzles	2.25p
BP117	Practical Electronic Building Blocks - Book 1	2.25p
BP118	Practical Electronic Building Blocks - Book 2	2.25p
BP119	The Art of Programming the ZX Spectrum	2.95p
BP120	Audio Amplifier Fault-Finding Chart	65p
BP121	How to Design and Make Your Own PCBs	2.25p
BP122	Audio Amplifier Construction	2.25p
BP123	A Practical Introduction to Microprocessors	2.25p
BP124	How to Design Electronic Projects	2.25p

BIBLIOTHEEK

N.V.H.R.

BERNARD BABANI BP100

An Introduction to Video

- This is a book for the person who has just, or is just about to buy or rent some video equipment but is not sure what it is all about.
- The author's aim is to present, in as non-technical a way as possible, how a video recorder works and how to get the best out of it and its accessories. No knowledge of electronics or engineering is assumed or required.
- Among the items discussed are the pros and cons of the various formats – VHS, Beta and V2000, Video disc systems, Videotext, renting or buying?, tape copying and editing, international tape exchange, understanding specifications, a look into the future, etc. A comprehensive glossary of video terms and abbreviations completes this book.

ISBN 0 85934 075 9



BERNARD BABANI (publishing) Ltd
The Grampians
Shepherds Bush Road
London W6 7NF
England

blitheek Ned. Ver.

£1.95