

50 PRACTICAL HINTS for GOOD RECEPTION

# Amateur Wireless

and  
Radiovision

WIRELESS  
MADE *8 page*  
EASY-Supplement

Every  
Wednesday

3<sup>d</sup>

Vol. XXI. No. 546

Saturday, November 26, 1932

# 50 PRACTICAL HINTS for GOOD RECEPTION



SPECIAL  
BEGINNER ARTICLES  
A·B·C·OF GRAMO-RADIO  
IMPROVING SELECTIVITY  
SET BUILDING MADE EASY

**INSIST ON**  
**"PROVED PERFORMANCE"**  
**WHEN BUYING GRID LEAKS & RESISTANCES**

Though they are the smallest components in a Wireless Set, grid leaks and resistances are as vital as the largest part. It pays, therefore, to exercise the same care in their selection—the performance of your Set depends on their performance. You run no risks when you choose the new Dubilier Grid Leaks and the now well-known Dubilier Metallized Resistances. Millions are now in use. They have been proved by critical technicians to be unmatched in their performance—and absolutely reliable. Yet they cost no more than components of less repute. You can buy the new Dubilier Grid Leak for only 1/-, while the Dubilier Metallized Resistances cost only 1/- per watt.

**DUBILIER**

**METALLIZED RESISTANCES AND GRID LEAKS**



**DUBILIER CONDENSER CO. (1925) LTD.**  
 Ducon Works,  
 Victoria Road,  
 North Acton,  
 London, W.3



Type E.L.M.4.  
 45 a/h capacity  
 Price 8/-

**Designed on a NEW PRINCIPLE**

to give **LONGER LIFE and HIGHER AMPERE HOUR EFFICIENCY**



Type E.L.S.7. 60 a/h capacity Price 12/6



Type E.L.9. 80 a/h capacity Price 12/3

The new Ediswan "balanced capacity" accumulator cell is an entirely new development. Careful re-designing of the positive and negative elements to ensure an exact electrical "balance" between them obviates the uneven charging inevitable with "unbalanced" accumulators and greatly prolongs their life. Consequently they are especially suitable for slow discharge work.

Every feature of the new Ediswan cell bespeaks attention to detail. British containers of clear glass, moulded ebonite lids, screwed vents, non-corrodible and non-interchangeable connectors and a carrier which fits neatly under a moulded projection of the glass container. In addition the E.L.S. types are fitted with "grease-cup" pillars to prevent acid creeping. See them at your radio dealers.

**EDISWAN**  
**EXTRA LIFE**  
**ACCUMULATORS**



THE EDISON SWAN ELECTRIC CO. LTD.  
 155 CHARING CROSS ROAD, LONDON, W.C.2

B.197

# STAGGERING OFFER!

from. E. J. HERAUD Ltd.,  
the famous Mail Order House.

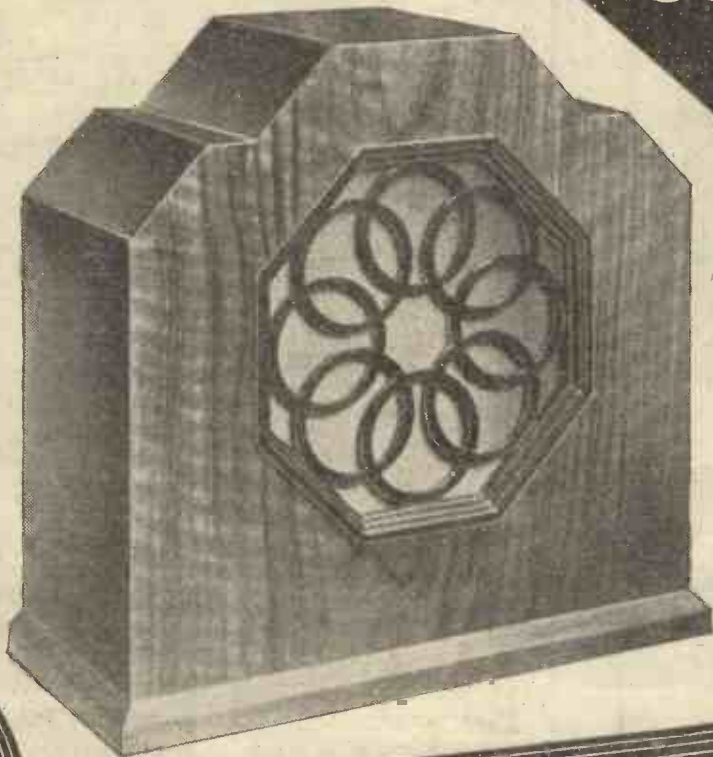

## 1933 BROWN

*Permanent Magnet*

## MOVING COIL SPEAKER

Just consider! An entirely new 1933 BROWN PERMANENT MAGNET MOVING COIL Cabinet Speaker at TWO POUNDS BELOW LIST PRICE! This is not merely a bargain, it is *sensational value*, and, moreover, you can pay by monthly instalments of only 5s.

SEND ONLY

# 2'6

DEPOSIT

LIST PRICE  
**£3-19-6**  
OUR  
PRICE  
**39'6**

The Moving Coil Unit with tapped Transformer is extremely sensitive and highly suitable to work with any set from 2 valves upwards, giving deep, rich tone, and extraordinary volume without distortion. The pole faces of the Unit are entirely protected to prevent dust and metal particles entering the gap. The beautiful Walnut Cabinet is of splendid modern design, 13 in. high, 13½ in. wide, 6½ in. deep, with handsome ebony finish vulcanite fret. Let us send you this magnificent Speaker for 7 days' trial for only 2s. 6d. deposit; if satisfied, pay further 2s. 6d. at once, then complete purchase by 8 monthly payments of 5s. 0d. (Cash in 7 days, 39s. 6d.)

*What could be fairer than our offer to let you have one of these superb Speakers for 7 days' trial for only half a crown deposit? Post the Coupon at once.*

### Glorious Tone!

A Radio Set is only as good as the Speaker which is used in conjunction with it. This Brown Moving Coil Speaker makes any Set a much better Set by true reproduction and full-bodied tone. Speech comes through with smooth, unspoiled clarity, music is reproduced with that deep, rich tone that is only obtained with a first-class Moving Coil Speaker. Try this Speaker and realise the hitherto hidden and unsuspected possibilities of your Set. Send the Coupon TO-DAY.

### POST THIS FOR 7 DAYS FREE TRIAL

To E. J. HERAUD, Ltd., Dept. A.W.15, NUMBER ONE, EDMONTON, LONDON, N.18

Please send me a Brown Permanent Magnet Moving Coil Cabinet Speaker, for which I enclose 2s. 6d. deposit. If after 7 days' trial I am satisfied, I will

- (1) Send further 2s. 6d. at once, and 8 monthly payments of 5s. 0d.
- (2) Send 37s. 0d. at once to complete purchase.

(Please strike out which does not apply)

Please fill in here  
Number of Postal  
Order

Name.....

Please make Post-  
al Order payable  
to E. J. Heraud,  
Ltd., and Cross it

Address.....

£ Co.

The above is our full postal address. Branches at 78/82 Fore Street, Edmonton; 77 West Green Road, Tottenham; 34 St. James Street, Walthamstow; and 139 Hertford Road, Enfield Wash.

Please Mention "A.W." When Corresponding with Advertisers

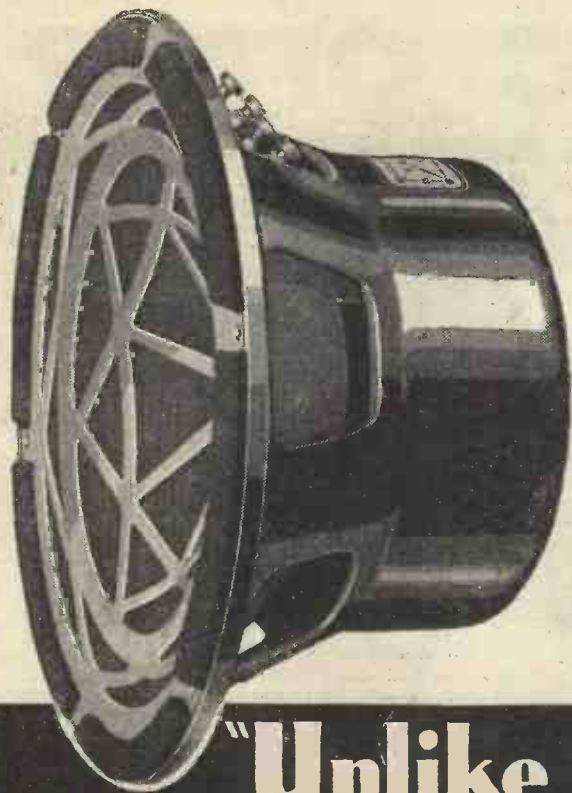

**"Unlike the majority"**

which "rely on a resonance in the vicinity of 100 cycles to give a false impression of sensitivity" WIRELESS WORLD

The *Wireless World* Test Report on the R & A 'Victor' states—

"The outstanding feature . . . is the uniform distribution of the output energy over the frequency range . . . especially noticeable in the bass, where the majority of P.M. units rely on a resonance to give a false impression of sensitivity . . . The important range . . . between 75 and 400 cycles is free from objectionable resonances . . . The 60 cycle resonance is helpful in correcting the loss of amplification below 100 cycles which occurs even in some of the best amplifiers. In the upper register there is no sharp cut-off . . . there is still an appreciable output at 12,000 cycles."

Ask your dealer to demonstrate

The **R & A "VICTOR"**

**P.M. MOVING COIL PRODUCER DE-LUXE**

The R & A "Victor" is amazingly sensitive, the massive cobalt steel magnet having a flux density of 8,000 lines per square centimetre, giving a total flux of 33,000 lines. The cadmium plated grille protects the diaphragm. The magnet and 6-ratio FERRANTI Transformer are totally enclosed. Chassis is finished black enamelled. Dimensions: 10 3/4 in. dia. x 5 3/4 in. deep. Weight: approx. 12 1/2 lb. Will accept 5 watts undistorted A.C.

**REPRODUCERS AND AMPLIFIERS LTD. WOLVERHAMPTON**



Holders

**RADIOPAK**  
TRADE MARK  
THE ONLY COMPLETE BAND-PASS TUNER

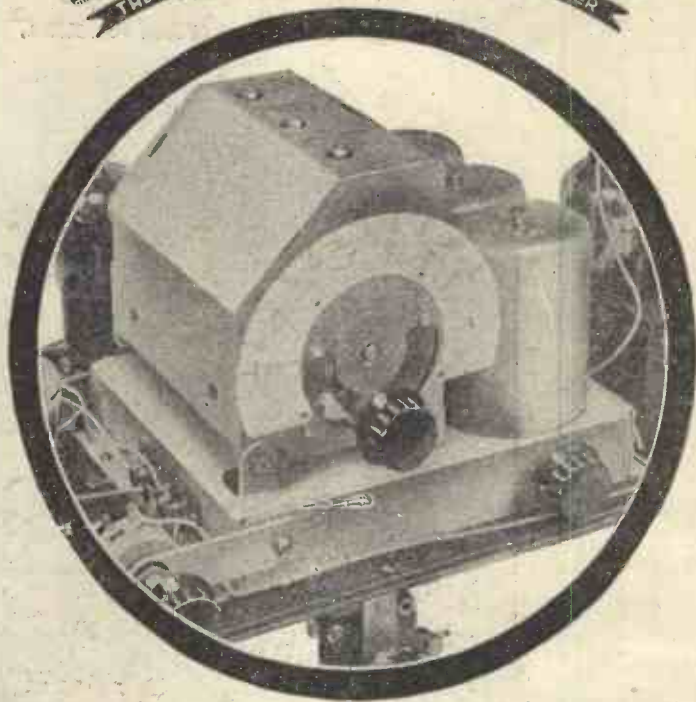

**T**HE band-pass "Radiopak" simplifies set construction as well as it simplifies selectivity. No development in modern component design is so important as this to the amateur constructor. Revolutionary in conception and design, neat, compact, and robust, above all the "Radiopak" is efficient.

Consisting of screened coils, with provision for reaction ganged condenser with drive, combined volume control, and on-off power switch, mounted neatly on a metal chassis, the "Radiopak" needs only the addition of valves, low-frequency circuit, loud-speaker, and batteries or mains unit to form a complete receiver.

Because the coils and condenser are matched with the highest possible degree of accuracy before leaving our factory, all ganging difficulty is eliminated, and each unit is supplied with a tuning scale calibrated in wavelengths.

Width along front of baseboard, 9 3/4 in.  
Depth " " " " 6 in.  
Height " " " " 6 1/2 in.  
Supplied with full-size fixing template.

STANDARD TYPE 535A, fitted with 10,000 ohms potentiometer .. £3 0 0  
TYPE 535A/50,000 for use with reaction, fitted with 50,000 ohms potentiometer and extra knob for reaction condenser .. £3 0 6

**THE BRITISH RADIOPHONE LTD.**  
Aldwych House; Aldwych W.C.2  
Telephone: Holborn 6744

**TELSEN**

# SCREENED TUNING COILS

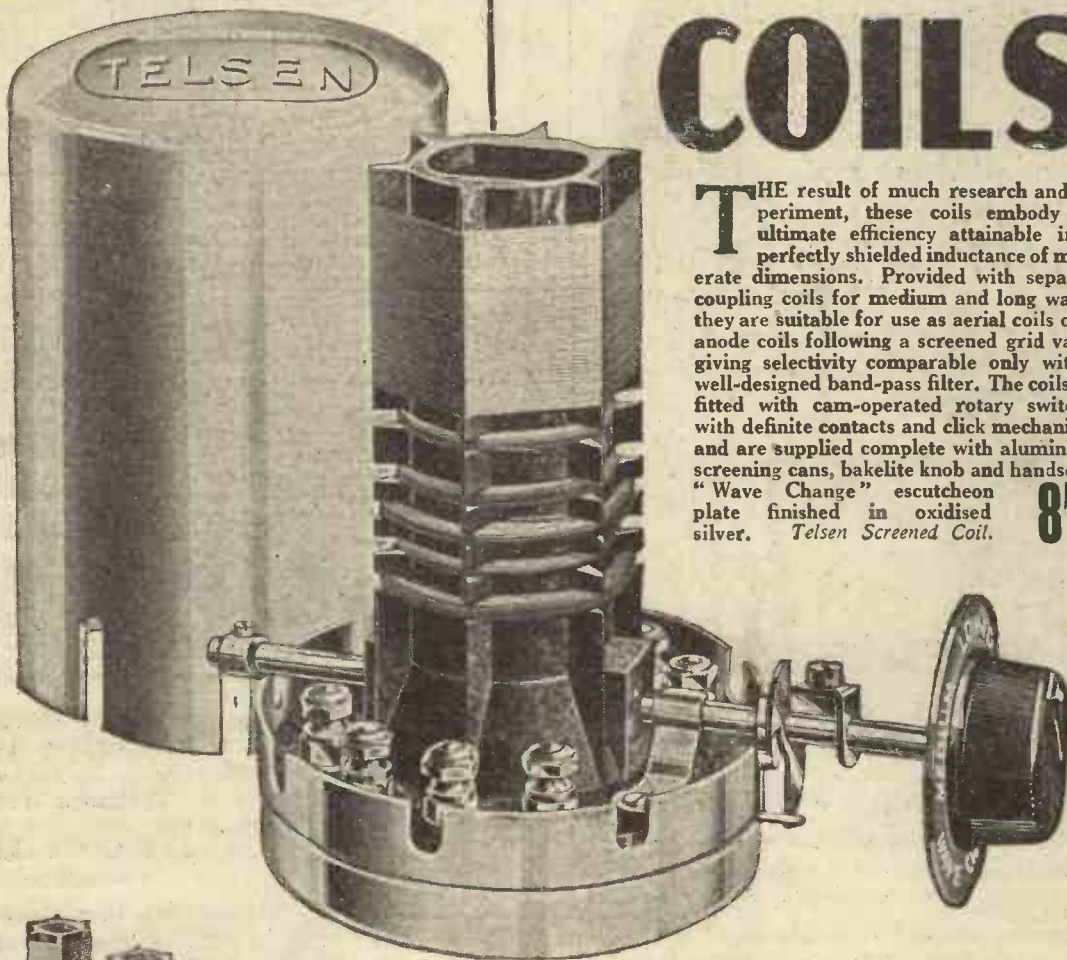

**T**HE result of much research and experiment, these coils embody the ultimate efficiency attainable in a perfectly shielded inductance of moderate dimensions. Provided with separate coupling coils for medium and long waves, they are suitable for use as aerial coils or as anode coils following a screened grid valve, giving selectivity comparable only with a well-designed band-pass filter. The coils are fitted with cam-operated rotary switches with definite contacts and click mechanism, and are supplied complete with aluminium screening cans, bakelite knob and handsome "Wave Change" escutcheon plate finished in oxidised silver. **8'6**  
Telsen Screened Coil.

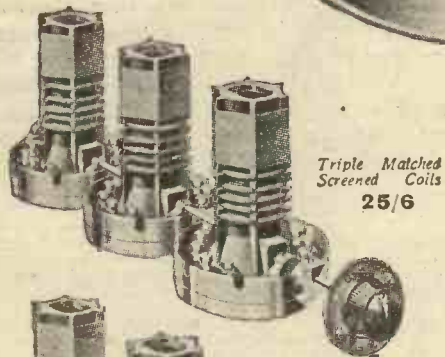

Triple Matched Screened Coils  
25/6

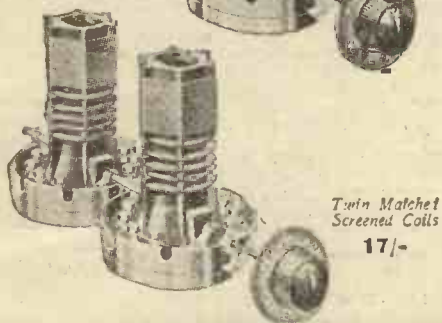

Twin Matched Screened Coils  
17/-

Full instructions are supplied with every Telsen Screened Tuning Coil, showing you the alternative methods of mounting the coils, either singly or in twin-matched or triple-matched form, as required.

**TELSEN**  
**RADIO COMPONENTS**

**TELSEN RADIO COMPONENTS ARE 100% BRITISH**

ANNOUNCEMENT OF THE TELSEN ELECTRIC CO., LTD., ASTON, BIRMINGHAM.

Mention of "Amateur Wireless" to Advertisers will Ensure Prompt Attention



Now, at a price no higher than you would pay for an ordinary condenser you can buy a Utility .0005 condenser complete with the Utility Straight Line Dial.

The Utility condenser is the standby of every discerning expert and amateur and needs no explanation. The Straight Line Dial makes every other type of tuning obsolete. A moving pointer traversing a stationery scale which is always in full view is surely the best method of tuning; but you can only get it with the Utility Dial.

From your dealer or post free from the Makers.

And look at the **PRICE**  
**9/6**  
complete as illustrated.

**WILKINS & WRIGHT LTD.**  
UTILITY WORKS, HOLYHEAD RD., BIRMINGHAM  
London Agents:  
E. R. Morton, Ltd., 22, Bartlett's Buildings, Holborn Circus, E.C.4.



"We're Fluxite and Solder, The reliable pair, Famous for Soldering—Known everywhere!"  
Wherever there's Wireless—There you'll find US, We SOLDER ALL CONNECTIONS Without any fuss!"

See that Fluxite and Solder are always by you—in the house, garage, workshop—anywhere where simple, speedy, soldering is needed. They cost so little, but will make scores of everyday articles last years longer! For Pots, Pans, Silver, and Brassware; RADIO; odd jobs in the garage—there's always something useful for Fluxite and Solder to do.

All Hardware and Ironmongery Stores sell Fluxite in tins, 8d., 1/4 and 2/8. ANOTHER USE FOR FLUXITE Hardening Tools and Case Hardening. Ask for Lealot on improved method.

**NEW "JUNIOR" SIZE, 4d. per tin FLUXITE SOLDERING SET**

Simple to use and lasts for years in constant use. Contains special "small-space" soldering iron, with non-heating metal handle; pocket blow-lamp, Fluxite, Solder, etc.; and full instruction.

COMPLETE, 7/6, or LAMP only, 2/6.

FLUXITE, LTD. (Dept. 326) ROTHERHITHE, S.E.15



ALL MECHANICS WILL HAVE  
**FLUXITE**  
IT SIMPLIFIES ALL SOLDERING

**USED IN THE B.B.C. STUDIOS**

**How the B.B.C. has ended "Boominess"**

There is only one way to cut out Resonance and boom which spoils the lower notes and distorts speech—fit the patented Howe Box Baffle to your Loud Speaker.

This latest development, as used by the B.B.C., can now be obtained complete ready for use with your own Speaker. It will give you purity and perfection such as you never realised was possible. Complete in case, ready for use, from 30/-.

Home Constructor's Kit, from 20/-.

Let us send you full details.

F. McNEILL & CO., LTD. (Radio Dept. 8), Lamb's Passage, Bunhill Row, E.C.1.

**The HOWE BOX BAFFLE**

**7 DAYS FREE APPROVAL!**  
**H.T. BATTERY ELIMINATORS**  
**BRITISH THROUGHOUT** 2 Years Guarantee

Westinghouse rectifiers in A.C. Models.

D.C. MODEL	Send for literature to actual manufacturers.	A.C. MODEL
<b>15/-</b>	V.M.C. RADIO COMPANY, Mail Order Dept. 198 Goswell Road, London, E.C.1	<b>37/6</b>

A New "Amateur-Wireless" Handbook

**THE HOW AND WHY OF RADIO**  
By ALAN HUNTER

2/6 net Of all Newsagents and Booksellers, 2/0 post free, from "Amateur Wireless," 58/61, Fetter Lane, London, E.C.4.

Don't Forget to Say That You Saw it in "A.W."

# Micromesh

## THE MODERN VALVE FOR MODERN RADIO



Outstanding in design and construction—outstanding, too, in the results they give—Micromesh Valves make a moderate set good and a good set better! Fit Micromesh in your receiver and listen to real radio!

Type H.L.A.I, Detector	... ..	List Price	13/6
Type P.A.I, Power Output	... ..	" "	17/6
Type R.1, Indirectly-heated Full-wave Rectifier	... ..	" "	12/6
Type R.2	... ..	" "	15/-

Write for the Micromesh Valve Leaflet: also for details of Standard Sets and Loud-speakers.

Standard  
**Micromesh** TRADE MARK  
**VALVES**

Standard Telephones  and Cables Limited

Radio Merchandise Dept., St. Chad's Place, 364 Gray's Inn Road, London, W.C.I.  
 Telephone: Terminus 6255.

Mention of "Amateur Wireless" to Advertisers will Ensure Prompt Attention

### Is your Loud Speaker cheating you ...



### ...of vital parts of the Broadcast

The illustration above shows the monster magnet of special steel, the secret of such faithful reproduction.

**PRICE**  
**42/-**  
 including Baffle and Transformer

If, when you listen to your Loud Speaker, you are aware that you are hearing reproduced music, you need the Lamplugh Silver Ghost P.M. M.C. Loud Speaker.

So crisp, so human, so absolutely life-like is the reproduction of this "Loud Speaker with the monster magnet," that you are literally unaware that you are listening to anything but the actual artistes.

Your dealer will be pleased to demonstrate the Silver Ghost.

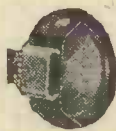

**JUNIOR**  
 The new Lamplugh Junior "Silver Ghost" P.M. Moving Coil Dynamic Loud Speaker, including transformer costs only

29/6



**INDUCTOR DYNAMIC**  
 This is the most natural reproducer on the market. Made under Farrand patents. Refuse imitation types. Price 50/-

HEAR IT ALL ON THE

# silver ghost

P.M. MOVING COIL LOUD SPEAKER

S. A. LAMPLUGH LTD., 89, LITTLE PARK ST., COVENTRY  
 London Office: Mr. F. G. Billett, 19/20 Holborn Viaduct, London, E.C.1

Buckingham

**FREE 16-PAGE  
SUPPLEMENT**

# Buyers' Guide to Sets for 1933

**SPECIAL OFFER!**  
FREE to new Set buyers, a 2/6 Book, "The How  
and Why of Radio." See Page Nine of Set  
Buyers' Supplement in the Christmas "Wireless  
Magazine."

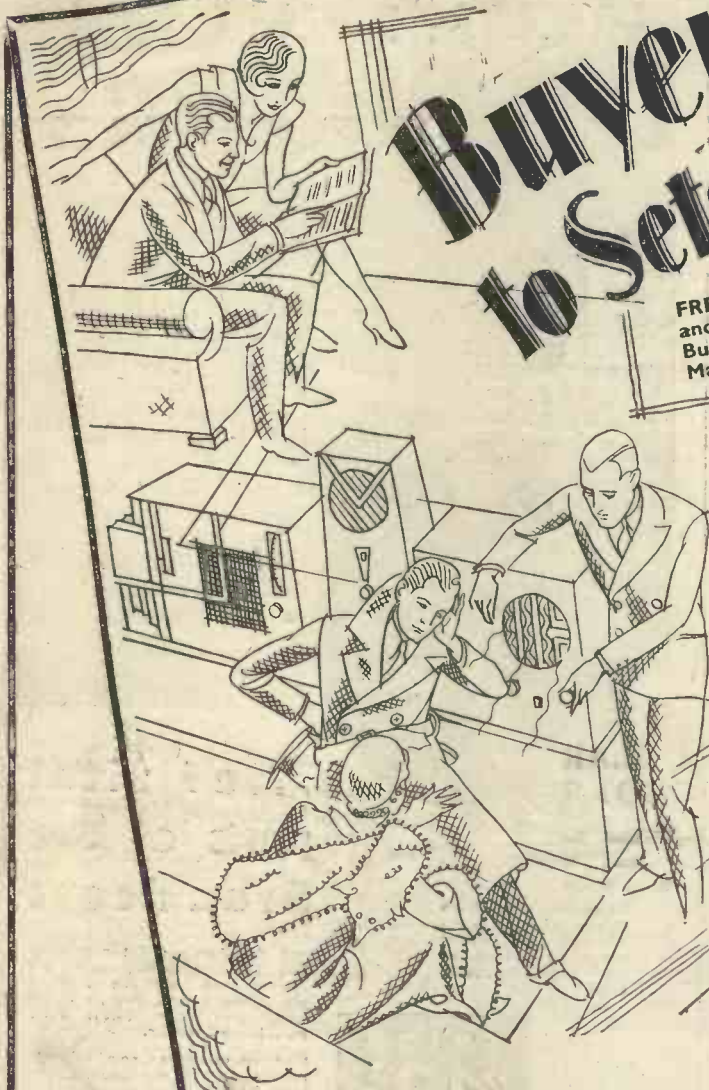

## DOUBLE CHRISTMAS

★ ★ NUMBER ★ ★

The December "Wireless Magazine" more than ever lives up to its reputation, the "Best Shillings-worth in Radio." EVERY SET BUYER, before making a purchase, should take advantage of the guidance offered by the illustrated Supplement, which gives details of more than 300 sets, made by nearly 70 leading manufacturers.

### TWO NEW SETS for CONSTRUCTORS

An absolutely up-to-date A.C. one-knob super-het Radiogram. It will get over 70 stations, all at good strength. Full instructions for building the 1933 ECONOMY S.G.3—complete with valves, batteries, cabinet and speaker—for Five Guineas.

#### OTHER CONTENTS—

Buyers' Classified Guides to 1933 Sets for Batteries, A.C. and D.C. Mains—GENERAL ARTICLES—Guide to the World's Broadcasters—World's Broadcast Wavelengths—Radio "Juggles" for Christmastide—The Story of a Radio Play, by Whitaker-Wilson—Adventuring on the Short Waves! by J. Godchaux Abrahams—TECHNICAL ARTICLES—Valves to Use in Your Set—Can You Design a Three-valve Set? by W. James—Some Low-frequency Modifications, by Percy W. Harris—Rejuvenating an Old Set, by E. H. Chapman, M.A., D.Sc.—GRAMO-RADIO SECTION—Your Choice of New Records, by Whitaker-Wilson—Something Unusual in Gramophone Records.

**ON SALE TO-DAY**  
**148 Pages - Price 1/-**

# Wireless Magazine



# TELSEN

## H.F. CHOKES, PUSH-PULL SWITCHES & VALVE HOLDERS

### TELSEN TWO-POINT SWITCH

For use as battery switch, or as wave-change switch, with the dual-range S.W. Coil unit. Employs a "knife" type self-cleaning contact, and a positive snap action, a series gap reducing self-capacity to a minimum ... **1/3**

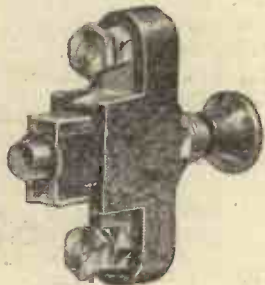

### TELSEN THREE-POINT SWITCH

The perfect wave-change switch for use with a dual-range aerial coil or for breaking L.T. and H.T. currents simultaneously ... **1/3**

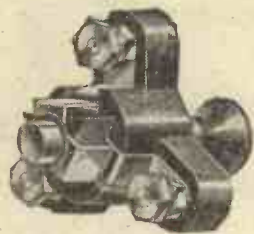

### TELSEN FOUR-POINT SWITCH

Highly suitable for use in wave-changing on two coils or an H.F. Transformer, or for switching pick-up leads or an additional speaker. ... **1/6**

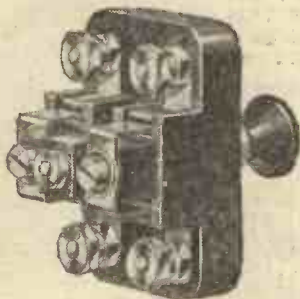

### TELSEN VALVE HOLDERS

An improved range of valve holders in both solid and anti-microphonic types. Employ special contact sockets of one-piece design with neat soldering tabs and terminals. Extremely low self-capacity.



Rigid type  
4 pin ... **9d.**

Anti-Microphonic  
4 pin ... **1/3**

Rigid type  
5 pin ... **1/3**

Anti-Microphonic  
5 pin ... **1/3**



### TELSEN STANDARD H.F. CHOKE

Covering the entire broadcast band, and occupying only the minimum of baseboard space, the Telsen Standard H.F. Choke has proved deservedly popular ever since its introduction. With an inductance of 150,000 microhenrys, a resistance of 400 ohms, and an extremely low self-capacity, it is highly suitable for use in reaction circuits, and is constantly being specified in this respect by the leading set designers ... **2/6**

### TELSEN BINOCULAR H.F. CHOKE

In H.F. amplification, the performance of a choke is of supreme importance. Where the very highest efficiency is the primary requisite, the Telsen Binocular H.F. Choke is the inevitable choice. It has a high inductance of 250,000 microhenrys, with a very low self-capacity and a practically negligible external field (due to its binocular formation). It is from every point of view the ideal choke—and where high-class circuits are concerned definitely the essential choke **5/6**



# TELSEN

RADIO COMPONENTS

**TELSEN RADIO COMPONENTS ARE 100% BRITISH**

ANNOUNCEMENT OF THE TELSEN ELECTRIC CO., LTD., ASTON, BIRMINGHAM

To Ensure Speedy Delivery, Mention "A.W." to Advertisers

# PETO=SCOTT for

## DON'T DELAY—ORDER NOW

### TELSEN JUPITER S.G.3

Sent Carriage Paid on first payment of

**7/-**

Complete Kit as advertised, less Valves and Cabinet. Cash Price, Carriage Paid, £3/17/0.

Balance in 11 monthly payments of 7/-.

**PETO-SCOTT**—the largest Radio-by-Mail House in the world—have carefully selected these popular items to give you Better Radio this XMAS.

### SLEKTUN SCOUT S.G.3

S.G., Detector and Power. Kit "A," less Valves and Cabinet. Cash or C.O.D., Carr. Paid, £3/19/6.

Sent Carriage Paid on first payment of

**7/3**

Balance in 11 monthly payments of 7/3.

**BLUE SPOT SPEAKER UNIT AND CHASSIS. TYPE 100U.** Cash Price £1/12/6. Carriage Paid.

Balance in 6 monthly payments of 5/2.

Send **5/2** only

**EPOCH "20C" PERMANENT MAGNET MOVING-COIL SPEAKER.** (New Edition). With 5-ratio input transformer. Cash Price £1/15/0. Carriage Paid.

Balance in 5 monthly payments of 6/6.

Send **6/6** only

**W.B. PERMANENT MAGNET MOVING-COIL SPEAKER.** Type PM4. Complete with transformer. Cash Price £2/2/0. Carriage Paid. Balance in 7 monthly payments of 5/9.

Send **5/9** only

**BLUE SPOT UNIT AND CHASSIS, Type 99 P.M.** Including matched transformer. Cash Price £2/19/6. Balance in 11 monthly payments of 5/6.

Send **5/6** only

**ROLA PERMANENT MAGNET MOVING-COIL SPEAKER F.6.** With universal tapped input transformer. Cash Price £2/9/6. Carriage Paid. Balance in 11 monthly payments of 4/6.

Send **4/6** only

**R & A "VICTOR" PERMANENT-MAGNET MOVING-COIL SPEAKER DE LUXE.** With 6-ratio input transformer and protecting grille. Cash Price £3/10/0. Carriage Paid. Balance in 11 monthly payments of 6/5.

Send **6/5** only

**R & A "CHALLENGER" PERMANENT MAGNET MOVING-COIL SPEAKER.** With special Ferranti multi-ratio input transformer. Cash Price, Carriage Paid, £1/15/0. Balance in 5 monthly payments of 6/6.

Send **6/6** only

**W.B. PERMANENT-MAGNET MOVING-COIL SPEAKER P.M.2.** With 3-ratio input transformer. Cash Price £4/5/0. Carriage Paid. Balance in 11 monthly payments of 7/10.

Send **7/10** only

**CELESTION P.P.M. PERMANENT MAGNET MOVING-COIL SPEAKER** with impregnated diaphragm and dual-impedance input transformer. Cash Price, Carriage Paid, £2/7/6. Balance in 11 monthly payments of 4/6.

Send **4/6** only

**SONOCHORDE PERMANENT-MAGNET MOVING-COIL SPEAKER,** with universal input transformer. Cash Price £1/12/6. Balance in 5 monthly payments of 6/-.

Send **6/-** only

**BLUE SPOT 66R UNIT AND MAJOR CHASSIS.** Cash or C.O.D. £2/10/0. Carriage paid. Balance in 11 monthly payments of 4/7.

Send **4/7** only

## THIS YEAR'S WINNER LISSEN "SKYSCRAPER"

### COMPLETE WITH VALVES S.G.3

Chassis kit with (Lissen) S.G., Detector and Pentode Valves. Cash Price, Carriage Paid, £4/9/6. Delivered, carriage paid, on first payment of Balance in 11 monthly payments of **8/3**.

Cabinet Kit with (Lissen) Valves, Walnut Cabinet and special Balanced Armature Loudspeaker. Cash Price, Carriage Paid, £6/5/0. Delivered, carriage paid, on first payment of Balance in 11 monthly payments of **11/6**.

**ONLY FROM PETO=SCOTT ON GENEROUS EASY TERMS**  
*Carriage paid to your door*

**BLUE SPOT PICK-UP.** With arm, rotating head and volume control. Cash Price £3/3/0. Carriage Paid. Balance in 11 monthly payments of 5/9.

Send **5/9** only

**MARCONIPHONE PICK-UP K.17.** Send With counter balanced arm and rotating head. Cash Price £2/2/0. Carriage Paid, only. Balance in 7 monthly payments of 5/9.

Send **5/9** only

**ATLAS ELIMINATOR, Type A.C.244.** Three tappings. S.G., Detector and Power. Output: 120 volts at 20 m/A. Cash Price £2/19/6. Carriage Paid. Balance in 11 monthly payments of 5/6.

Send **5/6** only

**HEAYBERD H.T. UNIT D.150.** Tapped variable 60/120 v., variable 0/150 fixed. Max., 25 m/a. at 150 v., 20 m/a. at 120 v. Cash Price, Carriage Paid, £4/6/0. Balance in 11 monthly payments of 8/10.

Send **8/10** only

**EKGO A.C.18 H.T. ELIMINATOR** for A.C. mains. Tapped S.G. 80 v. 120/150 v. at 12 m/a. Cash Price, Carriage Paid, £3/7/6. Balance in 11 monthly payments of 6/3.

Send **6/3** only

**GARRARD INDUCTION GRAMOPHONE MOTOR.** For A.C. mains. Model 202. Mounted on 12-inch nickel motor plate with fully automatic electric starting and stopping switch. Cash Price £2/10/0. Carriage Paid. Balance in 11 monthly payments of 4/7.

Send **4/7** only

**GARRARD JUNIOR "B" SPRING MOTOR.** Complete with turntable. Cash Price £1/13/0. Carriage Paid. Balance in 5 monthly payments of 6/1.

Send **6/1** only

**EKCO H.T. ELIMINATOR A.C.25.** for A.C. mains. Tapped S.G. variable, 50/80 volts and 120/150 volts max. at 25 m/A. Cash or C.O.D., Carriage Paid, £3/17/6. Balance in 11 monthly payments of 7/-.

Send **7/-** only

**REGENTONE W.I.F. H.T. ELIMINATOR** for A.C. mains. Tapped for S.G., Detector and Power, 120/150 volts max. at 12 m/a. Cash or C.O.D., Carriage Paid, £2/15/0. Balance in 11 monthly payments of 5/1.

Send **5/1** only

**GARRARD AUTOMATIC RECORD CHANGER** for A.C. mains. Mounted on unit plate complete ready for fitting in position, including Garrard pick-up and tone-arm. Cash Price £10/0/0. Carriage Paid. Balance in 11 monthly payments of 18/6.

Send **18/6** only

**COSSOR MELODY MAKER MODEL 334**

With Metalised Variable-mu S.G. and Detector Valves, Power Valve and Cabinet. Cash Price, £6 7 6. Balance in 11 monthly payments of 11/10.

Delivered, carriage paid, on first payment of **10/-**

**RADIO FOR THE MILLION "STATION MASTER 3"**

Delivered, carriage paid, on first payment of **10/-**

**MODEL "A" BATTERY TYPE** With Valves and Cabinet for Battery use. Cash Price £5/11/0. Carriage Paid. Balance in 11 monthly payments of 10/2.

**READY RADIO "METEOR" S.G.3.**

Three-valve screened-grid receiver. Covers short, medium and long waves without coil changing. Cash Price, £3/15/3. Balance in 11 monthly payments of 7/-.

Delivered, carriage paid, on first payment of **7/-**

**COSSOR MELODY MAKER MODEL 335**

Complete with Valves, Speaker and Cabinet. Employs Cossor Variable-mu S.G., H.F. stage, Detector and Power Valves. Cash Price, £7 17 6. Balance in 11 monthly payments of 14/10.

Delivered, carriage paid, on first payment of **10/-**

**RADIO FOR THE MILLION "STATION MASTER 3"**

Delivered, carriage paid, on first payment of **10/-**

**MODEL "B" BATTERY TYPE** As Model "A" but with Speaker in attractive Cabinet. Cash or C.O.D. Carriage Paid. Cash Price £7/10/0. Balance in 11 monthly payments of 14/-.

**READY RADIO "METEOR" S.G.3.**

Three-valve screened-grid receiver, WITH VALVES, CABINET, and PERMANENT-MAGNET MOVING-COIL SPEAKER. Covers short, medium and long waves without coil changing. Cash Price, Carriage paid, £8 17 6. Balance in 11 monthly payments of 16/3.

Delivered, carriage paid, on first payment of **16/3**

**STRICT PRIVACY GUARANTEED—WE DEAL WITH YOU DIRECT**  
*Mention of "Amateur Wireless" to Advertisers will Ensure Prompt Attention*

# EVERYTHING RADIO

IMMEDIATE DELIVERY CASH, C.O.D. or H.P.

PILOT AUTHOR KITS - Exact to Specification

## 1933 WALNUT ADAPTAGRAM

Constructed in Walnut with inlaid Walnut Veneers. Trade Mark



MODEL A converts your existing set to a Radiogram. Comes to you with vignette front as illustrated and motor-board, ready to take your own set. Gramophone Motor and Pick-up. No skill or expensive tools are required to transform your Radio into a combination instrument, presenting the professionally finished appearance of the most luxurious Radio Gramophone money can buy. 12 monthly payments of 5/9.

63/-

Carriage and Packing 2/6 extra. England and Wales.

MODEL B with Garrard Double Spring Motor. 12-in. Turntable. Automatic Stop. B.T.H. Tone-arm with Pick-up, and Volume Control Complete. Automatic Needle Cup. Cash or C.O.D. or 12 monthly payments of 12/-.

6 G S.

MODEL C with Collaro Induction Electric Motor with Tone-arm, Pick-up and Volume Control in one Unit. 12 in. Turntable. Automatic Stop. Automatic Needle Cup. Cash or C.O.D. or 12 monthly payments of 13/6.

7 G S.

In Console Form for Radio only. With flat lift-up lid. Otherwise exactly as illustrated. Cash or C.O.D. 62/- or 12 monthly payments of 5/8. Carriage and packing 2/6.

## NEW CENTURY SUPER

As described in "Amateur Wireless" October 29, 1932.

### STRUCTAKIT FOR NEW CENTURY SUPER

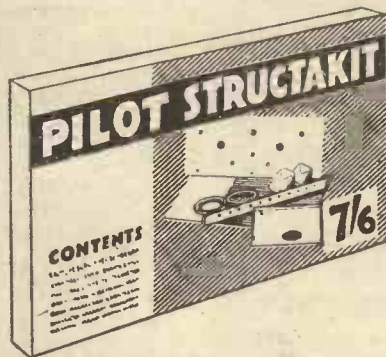

Containing RED TRIANGLE first-quality 16 by 8-in. ready-drilled ebonite panel; PETO-SCOTT 3/8-in. foil-covered non-warping ply baseboard, necessary fixing screws, insulated connecting wire and twin flex for building PANEL ASSEMBLY for NEW CENTURY SUPER.

7/6

CASH or C.O.D. Postage 6d. extra.

**KIT A**  
DELIVERED CARRIAGE PAID  
ON FIRST PAYMENT OF  
**12/9**  
Balance in 11 monthly payments of 12/9

### IMPORTANT

Parts, Kits, Miscellaneous Components, Finished Receivers or Accessories for Cash, C.O.D., or H.P. on our own system of Easy Payments. Send us a list of your wants. We will quote you by return. C.O.D. orders value over 10/- sent carriage and post charges paid.

### KIT "A"

Complete kit of Author's first specified components as listed, excluding panel and foil-covered baseboard.

Cash or C.O.D. Carriage paid.  
**£7.0.0**  
or 12 monthly payments of 12/9

KIT "B."—As Kit "A." WITH oak-faced ready-drilled panel, foil-covered baseboard, and valves. Cash or C.O.D. (Carriage Paid), 21/5/6, or 12 monthly payments of 20/9.

KIT "C."—As Kit "A." WITH oak-faced ready-drilled panel, foil-covered baseboard, valves, and cabinet. Cash or C.O.D. (Carriage Paid), 21/2/0/6, or 12 monthly payments of 22/3.

## THE BEST OF 1933 RADIO

ULTRA 1933 BLUE FOX. A.C. or D.C. Mains. Detector and Pentode Valves. Moving-coil Speaker. Complete with Valves and Cabinet, ready for use. Cash Price, Carriage Paid, £10/10/0. Balance in 14 monthly payments of 15/9.

ULTRA 1933 TIGER. A.C. or D.C. mains. S.G., S.G. Detector and Pentode. Moving-coil Speaker. Complete with Mazda Valves. Ready for use. Cash Price, Carriage Paid, £15/15/0. Balance in 17 monthly payments of 20/-.

AERODYNE SCREENED GRID 3. With Variable-mu. Complete and ready to play, with Valves, Batteries and Accumulator. With Moving-coil Speaker. Cash Price, Carriage Paid, £9/9/0. Balance in 14 monthly payments of 14/3.

AERODYNE ALL-MAINS VARIABLE-MU S.G.3. Complete and ready to play, with Moving-coil Speaker. Cash Price, Carriage Paid, £15/15/0. Balance in 17 monthly payments of 20/-.

LISSEN S.G.3. PENTODE BATTERY SET. In walnut cabinet, complete with Speaker, Valves and all necessary Batteries. Wave-length calibrated. Cash Price, Carriage Paid, £8/17/6. Balance in 14 monthly payments of 13/4.

PHILIPS TYPE 830A. For A.C. mains. 4-Valve Receiver. Two Screened-grid, Power-grid Detector and Pentode. With Moving-coil Speaker. Provision for Pick-up and external Speaker. Cash Price, Carriage Paid, £16/16/0. Balance in 17 monthly payments of 21/6.

TELSEN MACNAMARA. S.G., Detector and Pentode. Complete, ready to play, with Moving-coil Speaker. In Walnut Cabinet. Cash Price, Carriage Paid, £15/15/0. Balance in 17 monthly payments of 20/-.

## 2 GUINEA FAMILY 3

As described in last week's issue.

KIT 'A' Author's Kit of Cash or C.O.D., panel, baseboard, valves and cabinet. Carriage Paid, 42/-

Or 3 monthly payments of 5/9.

KIT 'B' As Kit "A" but with panel, baseboard, and valves. Cash or C.O.D., Carriage Paid, £3/13/0. Or 12 monthly payments of 6/9.

KIT 'C' Author's Kit, complete with panel, baseboard, valves and cabinet. Cash or C.O.D., Carriage Paid, £4/4/6. Or 12 monthly payments of 7/9.

PILOT STRUCTAKIT, comprising ready-drilled oak-faced ply panel, 10 in. by 7 in., baseboard, 10 in. by 10 in. necessary fixing screws, insulated connecting wire and flex for TWO GUINEA FAMILY THREE. 5/-

## "NEW CENTURY SUPER" OAK TABLE CABINET



Figured hand-french polished Oak cabinet with panel ready drilled to specification and complete with foil-covered baseboard. 19/6

IMPORTANT Parts, Kits, Miscellaneous Components, Finished Receivers or Accessories for Cash, C.O.D., or H.P. on our own system of Easy Payments. Send us a list of your wants. We will quote you by return. C.O.D. orders value over 10/- sent carriage and post charges paid.

PETO-SCOTT CO. LTD. 77 City Rd. London, E.C.1, Telephone: Clerkenwell 9408/7  
West End Showrooms: 62 High Holborn, London, W.C.2 Telephone: Holborn 3243

Dear Sirs, Please send me CASH/C.O.D./H.P. ....  
for which I enclose £.....s.....d. CASH/H.P. Deposit. Also send your FREE 1933 Radio Catalogue.  
NAME .....  
ADDRESS .....  
A.W. 26/11/32.

ANY ITEM SUPPLIED SEPARATELY—ORDERS OVER 10/- SENT C.O.D. CARRIAGE AND POST CHARGES PAID

You will Help Yourself and Help Us by Mentioning "A.W." to Advertisers

# IGRANIC QUALITY COMPONENTS

The quality of your reproduction depends upon the quality of your components. You can be certain of both if you use Igranic components. Nothing is left to chance in the designing, construction and finishing of this Igranic T.24B Transformer. The primary inductance of this transformer is high, permitting a high amplification of bass notes, whilst at the same time reproducing faithfully all notes over the whole scale of musical frequencies.

Supplied in two ratios 3:1 and 5:1  
Price **5/6**

SPECIFIED FOR THE "£2 2s. FAMILY THREE"

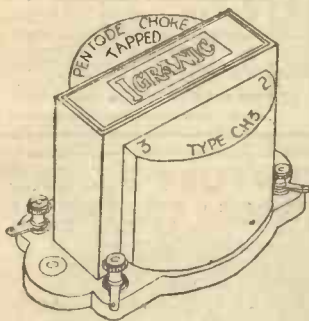
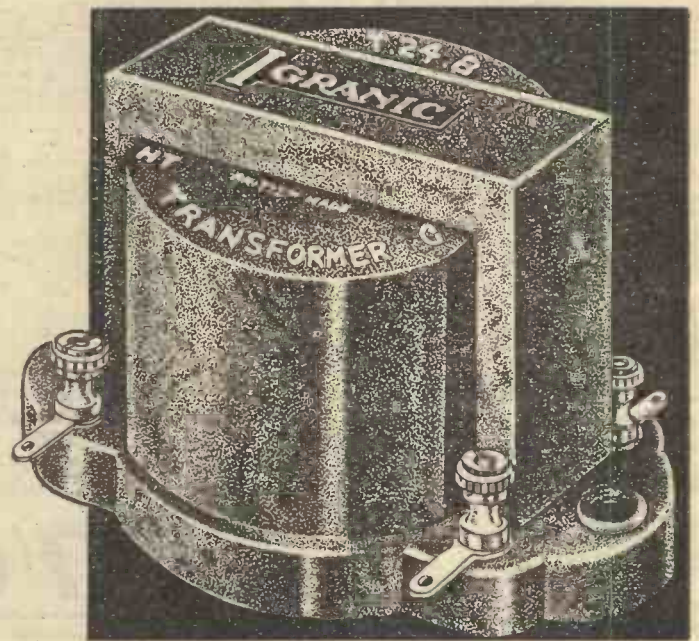

### PENTODE TAPPED CHOKE

The Igranic Pentode Choke is designed so that the impedance of various types of loud-speakers may be matched to that of the pentode valves whilst keeping the inherent self-capacity of the choke at a minimum.  
Price **10/6**



### TAPPED "C.C." OUTPUT UNIT

Invaluable for receivers employing a power output valve. It prevents de-magnetisation and makes possible a closer adjustment of loud-speaker movement. Designed to pass a maximum current of 30 milliamps.  
Price **12/6**

**IGRANIC  
COMPONENTS WILL  
BE THE MAKING  
OF YOUR SET.**

Write to-day for fully-illustrated Catalogue No. D.175 of complete new range of Igranic Quality Components.

The Igranic Electric Co., Ltd., 149 Queen Victoria Street, London, E.C.4.

**SEND FOR THE 1932 CATALOGUE**





BRITAIN'S LEADING RADIO WEEKLY FOR CONSTRUCTOR, LISTENER & EXPERIMENTER

EDITOR: BERNARD E. JONES.

TECHNICAL EDITOR: J. H. REYNER. B. SC. AM.I.E.E.

RESEARCH CONSULTANT: W. JAMES.

ASSISTANT EDITOR: H. CORBISHLEY.

NEWS & Gossip of the Week

THIS WEEK

THIS issue is full of good things for set users. If you want to know how to work your set from the mains, to do away with high-tension batteries, or merely to charge your present accumulator from the mains, then you will find the whole question very explicitly dealt with on pages 1170-1172. Another practical feature is a selection of fifty useful hints and tips for good reception. They may not all apply to your set, but many of them will! They will help you to get better results.

CHRISTMAS IS COMING

A SEASONABLE thought is that next week is "A.W.'s" Christmas Bumper Number. It makes you realise that the festive season is near at hand! Further details of this specially enlarged issue are given elsewhere this week. Just two points to note. It is specially enlarged, but not enlarged in price; usual price 3d.; also, order your copy now. There will be a rush on it.

TO CATCH A THIEF

WIRELESS has been used by the police on many occasions to assist in catching criminals, but it is doubtful whether the aerial itself has ever played much part in these activities. A day or two ago, however, a number of articles stolen from a neighbouring house were found underneath the direction-finding wire near the 5xx re-broadcast receiver at Belfast. Apparently, the thief ran into the wire while escaping with his booty and dropped them in his fright!

DANCE MUSIC IN DECEMBER

DURING December the B.B.C. Dance Orchestra, Ambrose and the bands of the Savoy Hotel will between them share half the total number of late dance-music periods. Other bands during this Christmas month will include Roy Fox, Lew Stone,

Maurice Winnick and Bertini. A good mixture!

NEW PLYMOUTH TRANSMITTER

YOU will remember that the Edinburgh relay station was closed down when the high-power Falkirk twins came into operation some months ago. This 1/2-kilowatt plant is shortly to be taken down to Plymouth, where it will replace the 120-watt transmitter now serving this out-of-the-way locality. B.B.C. engineers are searching for a new wavelength for Plymouth around 200 metres, and it is thought that the installation of the Edinburgh plant will be a good opportunity to try out the new wavelength, while the old low-power relay is simultaneously transmitting on its present wavelength of 288.5 metres.

Also in this issue

FEATURES YOU SHOULD NOT MISS

50 Hints and Tips for good Reception.

All About Working Your Set from the Mains.

Getting Results with the "£2: 2: 0 Family Three."

ALSO SPECIAL EIGHT-PAGE SUPPLEMENT FOR BEGINNERS

PROVINCIAL STUDIO DEVELOPMENTS

THE large studio that has been built at the old transmitting building at Sheffield is now in use and the old studio has been dismantled. Work is progressing on the new Leeds studio in the Quaker building, as mentioned some time ago. This should be ready in a few weeks.

B.B.C. RIVALS THE POST OFFICE

WHEN the B.B.C.'s short-wave stations are in full operation at Daventry, there will be a series of reliable point-to-point contacts with various parts of the world. It has been suggested that the reliability of the directional aerials at Daventry, in maintaining good contact with distant countries, might become a serious menace to the Post Office's beam telephony service. For example, there would be no reason why America should pay high rates for a Sunday afternoon transatlantic talk relay through the Post Office system when it could obtain satisfactory reception from one of the Empire aerials at Daventry. From inside information received we think it is highly improbable that the B.B.C. will take advantage of its position.

TAKE IT WITH YOU!

IF—and it is a big "if" in these hard times—you are taking a Continental holiday at Christmas, you should make a note of the fact that the Italian officials have recently relaxed the regulations on using wireless sets in Italy.



B.B.C. Ambassador leaves for the Empire! Mr. Malcolm Frost (left) is being seen off by Mr. Cecil Graves, the Empire Service Director of the B.B.C., at the start of his lengthy trip covering the Empire. He will make contacts with distant Empire transmitters and will also investigate markets for the special records of B.B.C. programmes

NEXT WEEK: SPECIAL XMAS NUMBER WITH FOUR-COLOUR PHOTOGRAVURE COVER

# NEWS & GOSSIP OF THE WEEK —Continued

British visitors can now take their sets into Italy and they have only to pay a licence fee of five lire (about 1s. 6d.) a month. You pay this fee to the Italian Broadcasting Company through the Customs Offices at the frontiers, in the same way as car licences.

## SPECIALLY FOR THE MIKE

ALTHOUGH the B.B.C. has a number of musicians, such as Hely-Hutchinson, who write music specially for the microphone, it is rare to find special talent being employed at Continental stations. Honegger, a modernist musician and one of the once-famous "Six," has written some special radio play music for broadcasting and it will be given through one of the French short-wave stations. If you don't like modern music, then be prepared for something of the "King David" or "Pacific 231" nature.

## BROADCASTING MANUFACTURED MUSIC

ONE of the German station chains recently gave a series of lectures on electric organs and similar gadgets which produce music by valve oscillators. The lectures were illustrated with tunes broadcast on one or two of these organs. Now the Poste Parisien station is giving regular weekly broadcasts of an electric organ fitted with four hundred valve oscillators.

## TELEVISION DISTORTION

IT has long been recognised that television images are much more susceptible to line distortion than are ordinary broadcast speech and music currents. It is for this reason that long land-line links between the television apparatus and the transmitter are impossible. Even between London and Brookmans Park some distortion is introduced, and the B.B.C. is considering the idea of using ultra-short waves for the television link. It has been found

that no appreciable distortion is introduced by the 7-metre transmitter on the top of Broadcasting House when it is sending out television. On the other hand, interference from cars and other machinery might easily counteract any of the advantages of this ingenious idea.

## OUR CHRISTMAS BUMPER NUMBER—NEXT WEEK!

Make a note of the fact—next week is "A.W.'s" Christmas Bumper Number, a specially enlarged issue full of good things and with a very attractive four-colour cover, printed by the photogravure process. This Bumper Number of "A.W." will be as attractive as its specially designed cover—it will be packed full of seasonable radio advice, topics and general articles of outstanding interest. It will be a genuine Christmas Bumper Number and a wonderful threepennyworth. Tell your friends about it, and don't forget to order your own copy now!

OUT NEXT WEDNESDAY

copy now!

USUAL PRICE 3d.

## GERMAN PRODUCTION IDEAS

GORDON McCONNEL is a great believer in the German system of studio productions. He is using only one studio—the large No. 10 wharf studio—with a variety of microphones and a number of screens, and he is obtaining some extremely interesting results. At present he is working on operatic shows due to start during Christmas week. One advantage of the single-studio idea is that the producer can exercise direct supervision over all those taking part in the broadcast, instead of relying on a dramatic control panel and studio managers dotted about the building.

## ON CHRISTMAS DAY

DURING the afternoon, when listeners have had time to digest their Christmas fare, the B.B.C. will broadcast its "Round the Empire" programme. It will make contact with Canada, Australia, New Zealand, Egypt, Gibraltar, and several ships at sea. It would be rather appropriate if His Majesty the King would graciously consent to allow his Christmas greetings to be broadcast during this "re-union" of the Empire.

moderation for his department. This will be the first productions breakaway from Broadcasting House. Seeing that the accommodation is only just enough at the present time, it is rather inevitable that any future developments must find room to expand outside the new building—unless the building itself is enlarged.

## ALL SOULS' BROADCAST

THE B.B.C. will make use of what must surely be its shortest outside broadcast link on New Year's Eve, when the service from All Souls' Church at Langham Place—opposite Broadcasting House!—will form part of the B.B.C.'s end-of-the-year programme.

## B.B.C.'S GIANT LOUD-SPEAKERS IN ACTION

DURING the Armistice Day services the B.B.C. made full use of the giant loud-speakers fitted on the roof of Broadcasting House. Big Ben and the Last Post were clearly heard by people in the vicinity of Portland Place. The near-by All Souls' Church relayed the Cenotaph service through loud-speakers. For the first time in history a cinema—in Essex—also relayed this service by means of its "talkie" equipment.

## LOOKING DOWN ON FRANKFURT



An unusual glimpse of the new Frankfurt station, which shows the base of one of the huge masts, the water-cooling tower for the valves and the elaborate lead-in arrangements. You can now hear Frankfurt on 259 metres with increased power

## GOING BACK 150 YEARS

YOU remember that interesting programme arranged by Mr. Leslie Bailey, taking listeners back over events during the last thirty years? After a good deal of research work Mr. Bailey has now prepared another programme on similar lines, but this time he goes back a hundred and fifty years.

## FOR SAVOY OPERA LOVERS

ALL lovers of Gilbert and Sullivan comic operas will be cheered at the news that the B.B.C. is to broadcast excerpts from *The Mikado* on December 3, and from *The Gondoliers* on December 9. Later in the month the B.B.C. will be relaying a complete opera. These relays will come from the Savoy Theatre.

## A B.B.C. STAFF REVUE

AT the Fortune Theatre, on December 5 and 6, the B.B.C. Dramatic Society is producing a staff revue. This is intended mainly for the amusement of the staff, and in it nobody is spared, from the Director-General downwards! The last revue of this kind, given two or three years ago, provided a great deal of material for subsequent broadcasting. As is only fitting, the B.B.C. Dramatic Society is full of talent.

**A**RTISTES in the London and Manchester studios have had, during the last week or so, to face a galaxy of microphones!

The engineers are trying out all kinds of new "mikes" not only in the hope of getting better quality and a wider frequency response, but also with the idea of finding more stable microphones for outside broadcasts, and for getting a really silent background.



the old Reisz microphones. The O.B. engineers are very keen on the new Reisz job. It may be used at sports broadcasts throughout the winter.

The Western Electric people have introduced the new moving-coil "mike," and in spite of the polarising supply it needs, it will probably be used in big studio broadcasts. It is more directional than some of the condenser microphones which the B.B.C. engineers have tried. Some artistes

# The NEW B.B.C. MICROPHONES

The heading photograph shows the new condenser microphone (in the centre), in use in the television studio of Broadcasting House

If you listen on an ordinary Post Office telephone you can always hear a kind of rushing background noise, which is the result of the intermittent passage of current through the carbon type microphone which is at the transmitter end of the phone.

All carbon microphones give this background in a more or less noticeable degree, and the engineers have found it very difficult to cut out all trace of hiss, so that when nothing is happening in a studio and when the microphone is switched on, there is a silent background with no carbon hiss.

Condenser microphones have no noticeable background, but unless worked in the right way, they have other faults. In the past the carbon "mikes" have been more reliable.

Now leading manufacturers of microphones have put up some new ideas to the B.B.C., and so the studios have been fitted out with all kinds of "mikes," some positively fearsome in shape, and the announcers never know into or at what curious object they will have to address their fond "Good-night, everybody—good-night."

### Different Types

The "mike" experiments are being tried at all the B.B.C. studio centres, and in the London studios alone there are six different microphones working. Some of these instruments represent a long step from the days when the old British Broadcasting Company used Post Office telephone microphones (complete with handles!) hanging on cables from the ceiling. These early carbon "mikes" were followed by an instrument known as the Marconi-Sykes microphone, which was really an energised moving-coil speaker working in reverse. The magnets were energised by a large car-starter type battery. The diaphragm of the microphone was much smaller than a moving-coil speaker diaphragm, and the moving-coil itself was connected to the first valve of the L.F. amplifiers.

Then came the popular Reisz carbon microphone which displaced the Marconi-Sykes because it was easier to work and gave a better frequency response.

*Kenneth Ulyett explains why better studio and "O.B." broadcast quality is now obtained owing to the new microphones employed.*

The Reisz microphone is the familiar white marble cube which you often see in a prominent position at outside broadcasts. The marble cube has grooves on one face, filled with carbon granules and covered with a diaphragm. It has few of the disadvantages of the old P.O. type carbon "mikes."

Now by a curious trick of technical design, a moving-coil microphone, very much like the old Marconi-Sykes, is coming into B.B.C. studio use after a long career in the Hollywood film studios, and it looks like replacing the carbon microphones to a large extent. In some of the London studios and in most of the provincial studios the old type Reisz microphone is still used. There is a new Reisz microphone being tried out at London which gives less hiss, which is more compact and which does not need mounting in such a resilient suspension as

like Henry Hall, prefer a directional microphone, although they have had a lot of experience with a non-directional microphone, such as the Edison Bell.

The Edison Bell microphone was first used at the B.B.C. by Jack Payne. It is (Continued on page 1182)

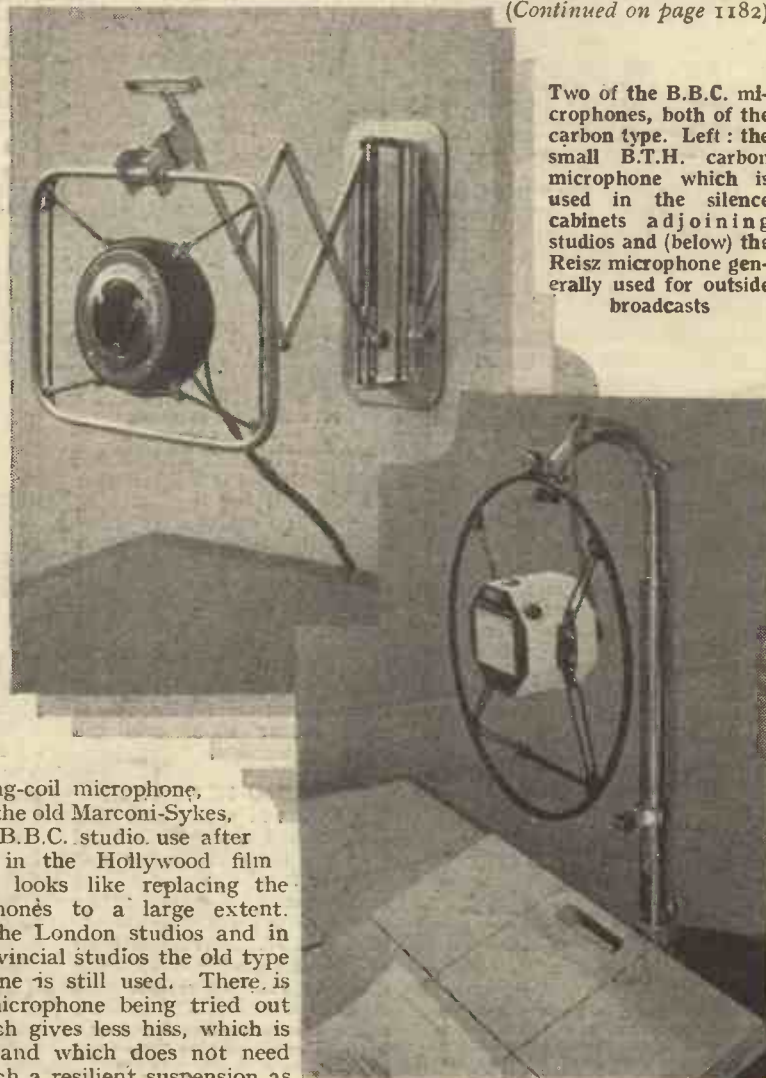

Two of the B.B.C. microphones, both of the carbon type. Left: the small B.T.H. carbon microphone which is used in the silence cabinets adjoining studios and (below) the Reisz microphone generally used for outside broadcasts

# 50 PRACTICAL HINTS



**RESULTS WITH A FRAME**  
**I**F you don't want to lose performance when working your set from a frame aerial, you must keep the frame leads just as care-

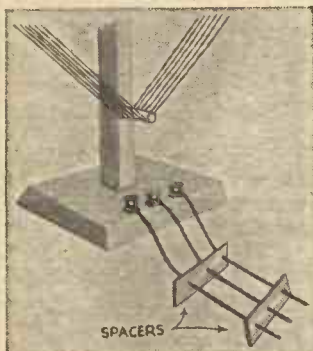

This diagram shows how ebonite spacers can be used to space the wires connected to a frame aerial, in order to cut down high-frequency loss

fully spaced as you would if they were the aerial and earth leads of a normal aerial arrangement. Don't let the frame flexes run too close. Cut small strips of ebonite to act as spacers for the leads running between the frame and the set. This will cut down high-frequency loss.

**NOT TOO MUCH BIAS**

**I**F you have recently replaced your power valve by one of the latest types of small power valves, you must make sure that you are not using *too much* grid bias. Whereas most of the older types of power valves required about 9 to 12 volts grid bias, at 120 to 150 volts H.T., most of the new small power valves need only 4½ to 7½ volts, and distortion will result unless you reduce the grid bias to this voltage. These remarks do not, of course, apply to super-power valves and the golden rule is to

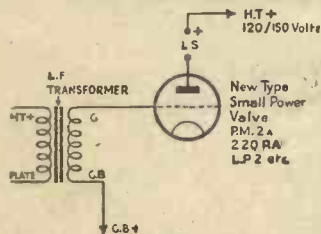

This diagram gives a suitable arrangement and values for a well set-up power output stage of the type dealt with in the accompanying paragraph

follow the instructions as given on the leaflet issued with the valve, for the particular H.T. voltage you may be using.

**IS IT EARTHED?**

**Y**OU will find that a mains transformer or choke is automatically earthed in many cases, when it is mounted on a metal chassis or on a foil-covered baseboard. Either the feet or, in some cases, the metal core itself, make contact with the chassis. Of course, sometimes this is helpful, especially in the case of ordinary transformers, where earthing the shrouding or core cuts down interaction and stabilises a set. But in the case of mains parts, it is dangerous and you should cut a piece of cardboard to the size and shape of the base of the transformer, taking care also to cut away the foil so that when the transformer is clamped down on the insulating card the screws do not short-circuit to the chassis.

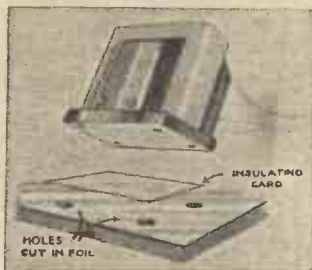

If you are troubled with interaction owing to the earthing of some component which should have its core or casing insulated, fit an insulating card beneath the component as shown

**SHORTENING FLEXES**

**A**LTHOUGH it is a bad plan to have flex leads trailing about near a set, it is nevertheless hardly advisable to cut them so that (especially in the case of speaker flexes), the components connected cannot be moved about. The best plan is to have the flexes only as long as is ever needed and to shorten them by looping them backwards and forwards and slipping a couple of small rubber bands over the loops.

**KEEPING IT STABLE**

**H**AVE you ever found that when a new valve is fitted in a set the performance goes "up the loop"? The whole set seems unstable, just because one new valve is fitted. This is particularly the case with a detector or low-frequency valve. The difficulty may be serious in a detector stage and may need the fitting of a decoupling circuit or a by-pass condenser to "anchor" the set. It is much easier, how-

ever, to stabilise a low-frequency stage. As a last resort you can always fit a decoupling circuit of a 30,000-ohm resistance and a 2-mfd. condenser. But before going to all that trouble, try, first, an ordinary grid leak of about ¼ megohm in the wire going to the grid of the low-frequency valve. If that fails, try a grid leak connected directly across the transformer secondary terminals.

**TWO WAYS OF CONNECTING BY-PASS**

**A** BY-PASS condenser in a detector stage generally consists of a .0001-mfd. condenser, one side of which is connected to the anode of the valve, and the other to negative high-tension. In this position it has to stand up to the full high-tension voltage on the detector, a good condenser must therefore be used. A useful tip, if a by-pass is needed in a hurry and one is not quite sure of the working voltage of the condenser, is to connect a small fixed condenser across the primary of the transformer in the detector anode circuit. In this position it will generally act quite efficiently as a by-pass, and will not have to withstand the full high-tension voltage.

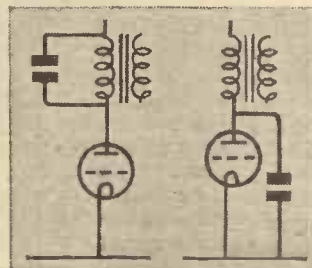

Two ways of connecting a by-pass condenser. On the left, the condenser is shown across the anode load component, and on the right connected directly between anode and earth

**SPEAKER RATTLE**

**W**HEN the cone of a reed type speaker is butted against a baffle board or cabinet front, it is advisable to glue felt all round the speaker opening. The cone can then be pushed gently against the felt and the speaker unit mounted to shat the cone presses gently against its fixing, without causing rattle. Strips of felt, as used as draught excluders on doors, can be bent to fit the speaker opening.

**KEEPING THEM NEAT**

**W**HEN the insulation of battery flexes is bared and turned back so that an easy connection can be made to wander plugs or spade tags, the

fabric covering is apt to fray out and make an untidy lead. Slip a length of cycle valve rubber over the wire before clamping on the spade terminal. This will keep the outer covering in place.

**IS IT RUN DOWN?**

**I**F you are using a trickle charger in conjunction with a super-het., or other multi-valve set, do not overlook the possibility of the L.T. accumulator becoming run down. A six-valve set with a super-power valve in the output stage will consume about 1 ampere of L.T. current in one hour, so that if the set is in use for six hours per day, 6 amperes are taken out of the L.T. accumulator. The average trickle charger charges at a rate of about ½ ampere per hour, so the L.T. accumulator must be charged for twelve hours to make good the amount consumed by the set in six hours. If the set is used for ten hours per day, the accumulator should be charged for twenty hours. As this is not possible, the accumulator will gradually run down, and it should, therefore, be sent to the charging station, periodically, to be given a full charge.

**CENTRING A MOVING COIL**

**I**F the coil of your moving-coil speaker tends to chatter and rub against the centre pole piece, you may find it difficult to effect a cure unless a centring

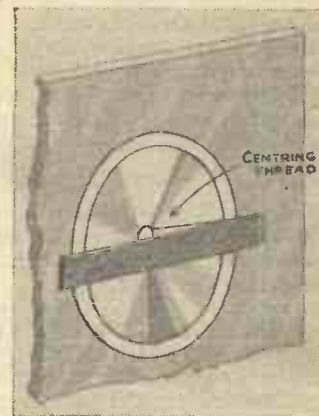

A tensioning thread can be fitted to a moving coil speaker which rattles owing to faulty positioning of the moving-coil with respect to the pole pieces

device is provided. This can easily be done by putting a narrow strip of fibre or plywood across the front of the diaphragm and tensioning the cone piece to one side or the other by means of a fine thread, one end of which is attached to the diaphragm and the other to the centring strip. The method is



# FOR GOOD RECEPTION

crude, but quite an effective one where there is any side strain on the diaphragm.

## SPEAKERS AND INPUT TRANSFORMERS

**L**ISTENERS who wish to use a loud-speaker, which has its own input transformer incorporated in it, some distance from the receiver, will not get satisfactory results unless they either disconnect the transformer from the speaker and arrange it in the set or arrange another output system in the receiver to make good the losses which will otherwise occur in the long leads to the speaker transformer.

As it is not always wise or practicable to disconnect the speaker transformer from the actual speaker, the best plan to adopt is to use a normal choke-filter output arrangement in the set itself and to connect the output terminals from this to the speaker extension wires.

A 30-henry choke with 2- or 4-microfarad capacity condenser will usually be found to be best with ordinary power valves, but whatever choke is used it must have a reasonably low D.C. resistance.

## SHORT-WAVE SELECTIVITY

**Y**OU will not get good short-wave results if a long aerial is taken direct to a short-wave coil or to a tapping on it. A series aerial condenser must be used and, in the case of a short-waver, this should be a neutralising condenser. If an ordinary preset condenser is used, its maximum value should not exceed .0001-microfarad,

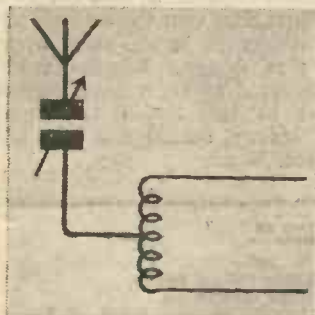

In a short-waver a neutralising condenser should be used as the series aerial condenser. This should be connected between the aerial and the tap on the short-wave coil

but it is always better to use an air-dielectric neutralising-type condenser.

## FOR WET H.T.'S

**L**ECLANCHE type wet high-tension batteries are apt to "creep"—that is, the electrolyte spreads over the tops of the

cells and covers the metal parts on top of the electrodes. A few drops of fine oil put in each of the cells will form a protective film above the electrolyte and will in most cases prevent it spreading up the sides of the cell.

## METAL WIRE FOR PICK-UP LEADS

**I**T is possible to buy special metal sheathed wire of comparatively small size, and this is very useful for pick-up wiring in a radiogram. The sheath leads should be carried direct from the pick-up, through the radiogram switch, to the set. In some cases it is worth while earthing the metal sheathing, which can be done by twisting a piece of bare wire over the outer covering, binding the joint with insulating tape and taking the wire to earth or low-tension negative. The metal sheathing of the wire prevents interference—a specially useful point in a radiogram with an electrically driven turntable.

## MOUNTING YOUR OWN COILS

**I**F you wind your own coils, take care in the mounting of them. If you want to fix a coil with its axis parallel with the baseboard, do not clamp it down so that the wire touches the wood. Support the coil away from the baseboard on small feet. The best way of doing this is to slip 1/4-in. lengths of ebonite tubing over the clamping screws,



Here is a good coil-mounting hint. Small feet are cut from lengths of ebonite to stand the coil away from the baseboard

thus forming small pedestals on which the coil rests.

## LABELLING THE LEADS

**I**F you haven't any engraved wander plugs or spade tags handy, do not risk connecting up a set, with the battery flexes unmarked. As a rough and ready guide, for say, the high-tension leads, tie one knot in the H.T. plus 1 lead, two knots in the H.T. plus 2 lead, three knots in the H.T. plus 3 lead, and so on, leaving the H.T. negative wire unmarked.

## LOOSE MOVEMENT

**Y**OU will never get good results from a set having solid dielectric condensers in

which there is any loose movement or end play of the bearings. The slightest movement of the knob up or down will affect the capacity, before one has a chance to turn the knob. Sometimes the bearings can be packed to prevent end play, but it is generally better to scrap the condenser and get a new one.

## INTERFERENCE FROM THE MAINS

**A** GREAT deal of interference experienced with mains-driven sets comes from the electric-light wiring itself and is of a high-frequency nature. If you are troubled with this kind of interference, try putting an ordinary high-frequency choke in each mains lead. Make sure that the wire of which the choke is wound will stand up to the current consumed by the set, and take care that the chokes are insulated, for they will have the full mains voltage across them.



Two high-frequency chokes can be connected, one in each mains lead, in order to cut out interference induced by the mains

## THOSE JAMMING TRIMMERS

**T**HЕ trimmers on some ganged condensers consist only of leaf springs, separated by a small piece of mica insulation. The capacity is varied by screwing down a small ebonite adjuster, closing the gap between the leaf springs. You may sometimes find that the springs jam and do not return properly when the adjusting screws are slacked off. Watch this point, for otherwise the set will not be properly ganged.

## CORRECTING A PICK-UP

**Y**OU will sometimes find it an advantage to correct the tone of a pick-up, or to reduce the peak voltage. An easy way to do this is to fit a fixed resistance across the pick-up terminals, preferably as close to the pick-up as possible.

## ARE YOUR VALUES RIGHT?

**I**N sets where a stage of resistance-capacity coupling immediately follows the detector,



best results can be obtained by taking care that the correct type of valve is used as the detector and that the correct value of resistance is used in the anode circuit of the detector valve. Generally speaking, the detector valve should have a fairly high impedance, between about

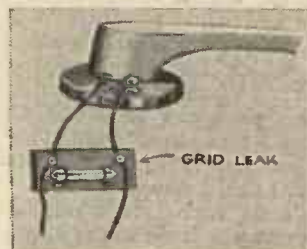

Tone correction is possible with a pick-up. All you have to do is to connect a grid leak across the output terminals as shown by this sketch

18,000 and 35,000 ohms, and the anode resistance should be approximately three times this value: i.e., 50,000 to 100,000 ohms.

If your detector valve happens to be one of the "special detector" type, with the rather low impedance of 10,000 to 14,000 ohms, and your anode resistance is 100,000 ohms, you can improve the results, particularly on the long waves, by reducing the value of the anode resistance to about 30,000 or 40,000 ohms.

## DOPING CONES

**I**T is often said that a loud-speaker cone, doped with some preparation to increase its rigidity, gives a better frequency response. You can easily try this on your speaker cone. A useful dope to employ is amyl acetate, in which celluloid cuttings have been dissolved.

(Continued on page 1178)

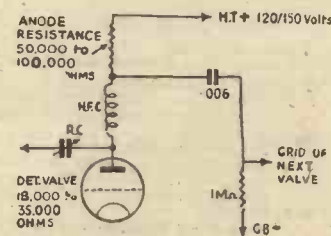

These are the connections for the resistance coupling arrangement described

# COMPLETING YOUR "£2 2s. FAMILY THREE"

Some further notes for constructors of this economical and very low-priced three-valver, first constructional details of which were given in last week's issue

ONE of the outstanding features of the "£2 2s. Family Three" is that it is easy to build.

The use of the concentrically-mounted tuning control unit simplifies the panel layout. There is only one part to fix on the panel. The escutcheon is bolted on the panel front and gives the set an attractive and unusual appearance.

The layout on the baseboard is just as simple as that of the panel. As you can see from the photographs shown last week, there are only a few parts to be screwed down and wired together.

A full-size blueprint, showing the layout and wiring has been prepared by the AMATEUR WIRELESS Technical Staff. Copies of this print can be obtained, price one shilling, post free, from the Blueprint Department, AMATEUR WIRELESS, 58-61 Fetter Lane, London, E.C.4.

A scale reproduction of this full-size blueprint was given in the form of a wiring diagram last week. Of course, it is possible to measure off from this the positions of the baseboard parts and the drilling centres for the tuning-control unit, but naturally it is much quicker and easier to work with a blueprint. It also helps in the wiring.

Keep the transformers and valve holders in the positions shown, for if you attempt to make the set any more compact you are almost certain to get feedback. The set layout, as shown, results in stable working, especially as there are separate high-tension tappings for each anode circuit.

## WIRING

When wiring it is a good plan to put on the leads in the order shown on the blueprint. The leads are numbered numerically in a practical wiring order. You cannot go wrong if you follow the blueprint and cut each length of wire, slip it through its insulating tubing, and connect up in the order recommended.

The use of battery flexes direct to the various baseboard parts makes an easy job of the wiring. If you like you can clamp down the battery flexes with insulated staples to prevent the wiring being pulled by accidental movements of the batteries. Don't attach spade tags or wander plugs to the battery leads after the leads have been twisted together. Try out the set first of all and then fix the connectors before tidying up the battery wires.

Recommended accessories in the way of batteries and speaker are given in the accessory section of the components list.



The "£2 2s. Family Three"

## HOW TO TUNE

Tuning is very easily carried out, thanks to the concentric controls. The dual-range coil covers an exceptionally wide band from 185 metres up to well above 2,000 metres. All the switching is done by the small lever on the tuning escutcheon, control of selectivity being effected by the preset condenser.

It is not advisable to take the detector tapping to anything higher than 70 volts, nor is there any need, for this anode potential results in the detector stage being very sensitive.

The control is easy because the concentric knobs enable you to adjust reaction to a nicety and so make the most of the set's range and selectivity. The preset condenser is used in the normal way to control selectivity.

Screwed down hard, it gives maximum performance with the standard selectivity provided by the coil. When slacked off the selectivity is improved, but there is, of course, a tendency for volume to be reduced, unless reaction boosting is resorted to.

The design of this receiver for an economical three-valver is rather unusual it being the first time that the controls have been made concentric in the same way as shown in this design. London readers may be interested to know that they can see the set in the Radio Department windows of Messrs. Selfridge & Co., Ltd., Oxford Street, W.1.

## SUITABLE 2-VOLT VALVES FOR THE "£2 2s. FAMILY THREE"

Mullard	PM1HL	PM2DX	PM202
Marconi	HL2	L210	P2
Osram	HL2	L210	P2
Mazda	HL2	L210	P220A
Cossor	210HL	210LF	220P
Six Sixty	210HL	210LF	220P
Lissen	HL210	L210	P220
Eta	BY2020	BY1814	BW1304
Dario	Super HF	Super Det.	Super Power
Triotron	HD2	SD2	202
Tungsram	L210	LG210	P220

A great deal of the success obtained with this set depends, naturally, upon the valves chosen. This is particularly the case with the detector valve, which has a most important effect upon performance. A good detector will give sensitive results without making the set unstable. Stability is assured in all normal circumstances by the separate anode feeds, and by the resistance across the secondary of the low-frequency transformer. A valve with an unsuitable impedance will, however, make the set unstable and it is therefore wise to follow the specifications given in the accompanying table. This shows suitable battery-type two-volters for all three positions in the set.

## COMPONENTS REQUIRED FOR THE "£2 2s. FAMILY THREE."

### PANEL

1—3-ply wood panel, 10 in. by 7 in. (Peto-Scott).

### BASEBOARD

1—Baseboard, 10 in. by 10 in. (Peto-Scott).

### VARIABLE CONDENSER

1—Twin condenser tuning unit and switch (Lissen).

### TUNING COIL

1—Dual-range screened coil (Slektun).

### PRESET CONDENSER

1—.0001-mfd. maximum preset condenser (Sovereign, Telsen, Formo, Igranic, Lissen, Goltone, Polar).

### FIXED CONDENSERS

2—.0002-mfd. fixed condensers (Lissen, Telsen, Dubilier, Goltone, Graham-Farish, T.C.C., Formo, Sovereign).

### H.F. CHOKE

1—High-frequency choke (Graham-Farish, Lissen, Lewcos, Telsen, Slektun, Goltone, Igranic, Ready Radio, R.I., Wearite, Bulgin, Varley, Tunewell).

### VALVE HOLDERS

3—4-pin valve holders (Lissen, Telsen, Graham-Farish, W.B., Igranic, Ready Radio, Lotus, Benjamin).

### GRID LEAK

1—2-megohm grid leak (Graham-Farish, Dubilier, Erie, Lissen, Claude Lyons)

### RESISTANCE

1—250,000-ohm resistance (Erie, Dubilier, Claude Lyons).

### L.F. TRANSFORMERS

1—Low-frequency transformer (Igranic, type T24B, Telsen, Lissen, Sovereign, R.I., Ferranti, Lewcos, Lotus, Varley).

1—Low-frequency transformer (Telsen Ace, Lissen, Sovereign, Igranic, Ferranti, R.I., Lewcos, Lotus, Varley).

### SUNDRIES

2—Terminal blocks (Telsen, Lissen).

6—Yards thin flex (Lewcoflex).

2—Spade terminals, marked L.T.+ , L.T.— (Belling-Lee, Clix, Eclex).

Connecting wire and sleeving (Lewcos, Jiffilix, Quickwyre).

### WANDER PLUGS

7—Wander plugs, marked: H.T.—, H.T.+1, H.T.+2, H.T.+3, G.B.+ , G.B.—1, G.B.—3 (Belling-Lee, Clix, Eclex).

### Recommended Accessories

Loud-speaker (Lissen LN5077, Epoch, Rola, Bfuo Spot, W.B.).

120-volt H.T. battery (Lissen, Pertrix, Ever Ready, C.A.V., Fuller).

9-volt G.B. battery (Lissen, Pertrix, Ever Ready, C.A.V., Fuller).

Cabinet (Peto-Scott).

"Fit" earthing device (Graham-Farish).

Electron aerial wire.

# RELIABILITY

Valves that you can depend on, that never fail you, that always give of their best. That is the reputation of Mullard 2-volt valves, a reputation proved by public choice; another reason why you should re-valve with Mullard and get the best that radio can give. There's a valve for every valve holder and every radio purpose. If you have an eliminator, use the P.M.202 Super Power Valve in your output stage; if you use batteries, then there's the P.M.2A power valve. Do it now, re-valve with Mullard.

The valves specified for the "New Century Super" are:—  
 (1) Mullard P.M. 12. (2) Mullard P.M. 12V.  
 (2) Mullard P.M. 1HL. (1) Mullard P.M. 22A.

ASK T.S.D.—Whenever you want advice about your set or your valves—ask T.S.D.—Mullard Technical Service Department—always at your service. You're under no obligation whatever. We help ourselves by helping you. When writing, whether your problem is big or small, give every detail. Ask T.S.D.

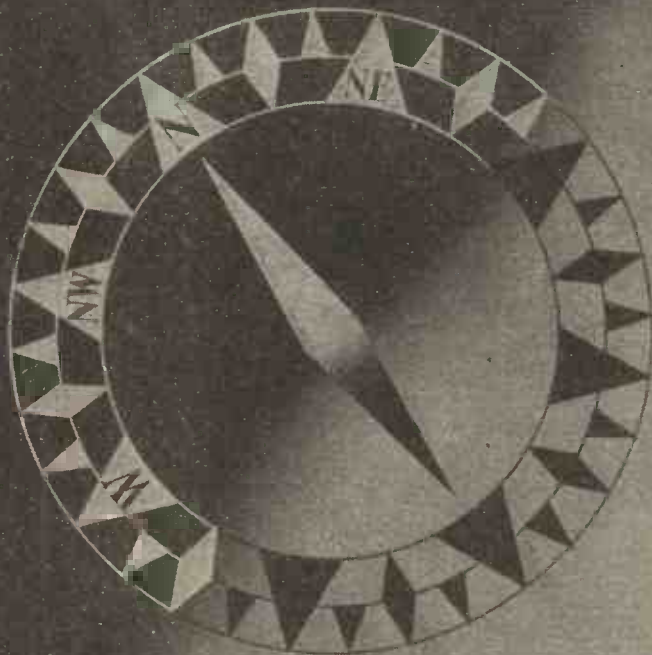
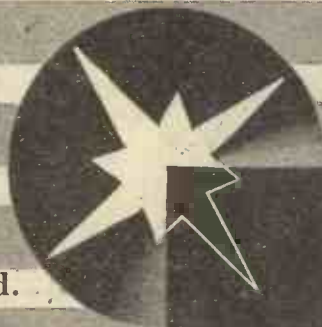

**Mullard**  
 THE MASTER VALVE

Advt. The Mullard Wireless Service Co., Ltd., Mullard House, Charing Cross Road, London, W.C.2.

Arks

Don't Forget to Mention "A.W." to Advertisers



**WHEN** first cost is not the only consideration choose

**ULTRA CAPACITY**  
**PERTRIX**  
TRADE MARK  
**H.T. BATTERIES**

Ultra Capacity means extra large cells—plentiful power for greedy sets—longest life and cheapness in the long run. Pertrix patent construction makes sure there is no deterioration when out of use. Next time, fit Ultra Capacity and end battery disappointments. There is a size for EVERY set—prices from 8/-, 60 volts.

BRITANNIA BATTERIES LTD., 233 Shaftesbury Avenue, London, W.C.2  
Telephone: Temple Bar 7971 (5 lines) Works: Redditch (Worcs)



The Famous **WEARITE**  
OT2 INTERMEDIATE COILS  
are essential for the  
**NEW CENTURY SUPER**

Send for your copy of our latest illustrated booklet (A.I.) dealing with the full range of components.

The heart of a super-het. is in its intermediates—upon them the set's efficiency depends—and the designers have specified Wearite. Prompted by the experience of past triumphs, including the original "Century Super"—with a knowledge of the careful and exclusive tests which every OT2 undergoes before release—the designers pinned their faith in the perfect functioning of their set to these coils. To ensure results as the authors intended you must use the Wearite OT2's. Before you start building write for a copy of the new Wearite Booklet No. A.I.

**OTHER WEARITE PARTS FOR THE "NEW CENTURY SUPER"**

- One 50,000-ohm Potentiometer (Q.V.C.) combined with switch (G.40) ... Price, complete 6/6
- Eight Four-pin and One Five-pin Valve Holders (S.1). Price, each 1/3
- One Super-het. Choke (H.F.S.) ... Price 4/6
- One 20,000-ohm Resistance (2 watt), (R.D.) ... Price 2/-
- One 50,000-ohm Resistance (4 watt), (R.D.) ... Price 2/9

And for a good earth tube, use the Wearite. "No tool" earth tube price 3s. 6d.

THE WEARITE INTERMEDIATE COILS  
**PRICE 10/6 each**

**WEARITE**  
COMPONENTS

WRIGHT & WEAIRE, LTD., 740 High Road, Tottenham, N.17. Telephone: Tottenham 3847/3/3.

Advertisers Appreciate Mention of "A.W." with Your Order

# TELSEN SELF-SEALING CONDENSERS

**D**ESIGNED in accordance with the principles formulated as a result of the most recent research, and manufactured by the most modern plant in the world from the finest materials it is possible to obtain, these Telsen Self-Sealing Condensers represent a very definite advance on current condenser practice, embodying numerous features of outstanding importance. Only genuine Mansbridge foil paper and the finest linen tissue are employed in the exclusive method of manufacture, each individual plate being self-sealing and the case itself being finally triple-sealed with a newly discovered bitumastic compound, for permanent efficiency. Every condenser is subjected to rigorous tests up to Post Office and Admiralty standards, the exclusive method of construction making them genuinely non-inductive. It is only because of this unique combination of research, plant, materials, method of manufacture and rigorous testing that Telsen Self-Sealing Condensers give such high insulation with such freedom from breakdown—such lasting efficiency under all conditions of use.

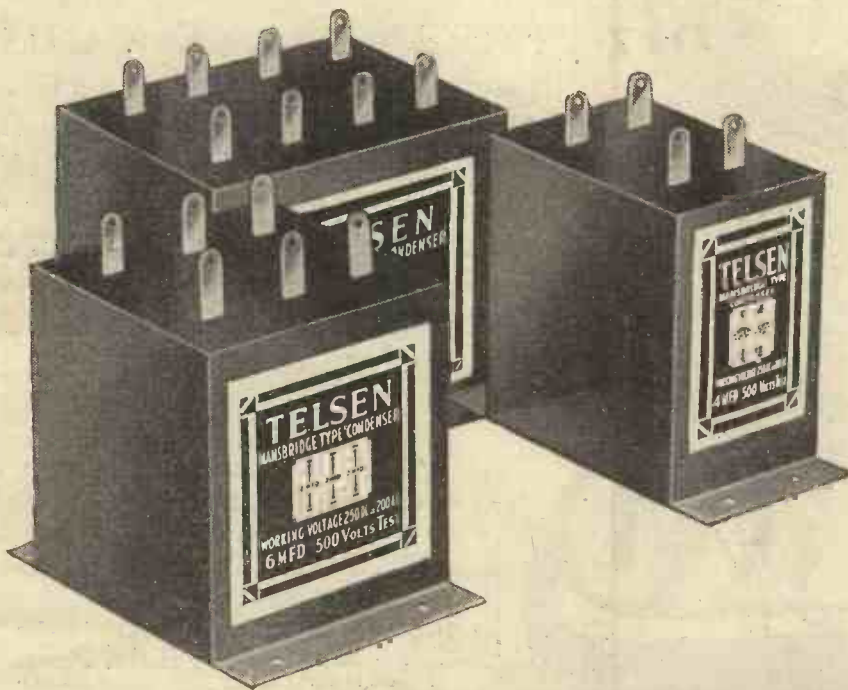
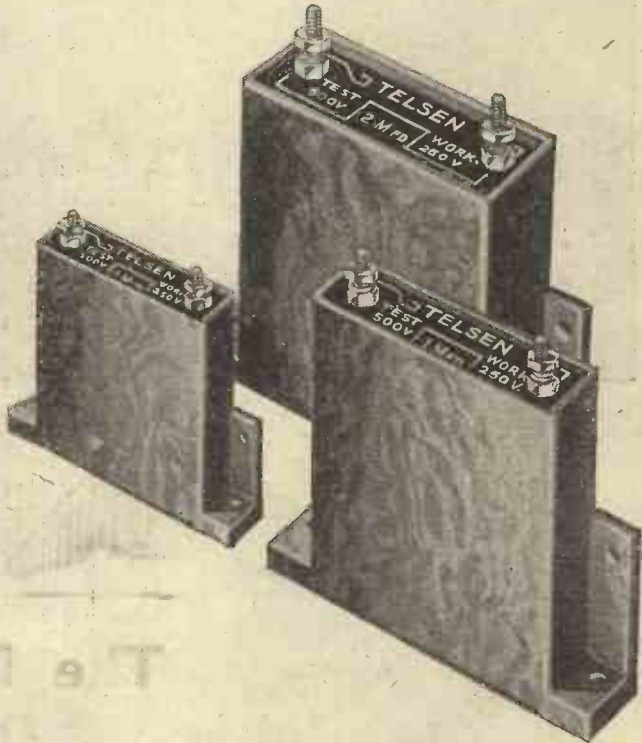

In attractive moulded bakelite cases, specially designed for 2-way fixing...

Cap. Mfd.	500 Volt Test.	1000 Volt Test.
.01	1/6	2/6
.04	1/9	2/9
.1	1/9	2/9
.25	2/3	3/3
.5	2/3	3/6
1.	3/-	5/-
2.		

In metal cases with soldering tags...

Cap. Mfd.	500 Volt Test.	1000 Volt Test.
4.	5/6	9/6
6.	8/-	14/6
8.	10/6	



**IT'S THE 'LASTING EFFICIENCY' THAT COUNTS**

ANNOUNCEMENT OF THE TELSEN ELECTRIC CO., LTD., ASTON, BIRMINGHAM

To Ensure Speedy Delivery, Mention "A.W." to Advertisers



Prices from  
**39/6**  
 or by Easy  
 Payments

All models are similar in external appearance. Size, 9 in. by 5 in. by 3 1/4 in.



**RADIO POWER UNITS**

\* "I've saved over two pounds ten on the running costs of my three-valve set this year. It used to need four batteries a year, costing over fifty shillings. Nowadays I use an EKCO Power Unit—and the cost is one shilling a year."

Whatever your set, providing you have electric light, there is a suitable EKCO Unit. All you have to do is to connect the Unit in the place of your H.T. battery, plug into the electric light or power supply, and switch on—that's all! No alterations to set; valves, or wiring. Ask your dealer or post coupon now for full details.

\* Based on three hours daily use of an average three-valve set.

To E. K. COLE LTD., Dept. K.27,  
 EKCO Works, Southend-on-Sea

Please send me Illustrated FREE literature of EKCO All-Electric Radio.

Name.....  
 Address.....

Mention of "Amateur Wireless" to Advertisers will Ensure Prompt Attention

# On Your Wavelength!

## FOR SHORT-WAVERS

**I**F you are not a short-wave enthusiast already, you will no doubt become one ere long, for as soon as the Empire station gets under way, there is sure to be something like a boom in this fascinating department of long-distance wireless reception. By all the rules of the game, we should have a splendid time on the short waves for the next three or four years, for we are now definitely entering upon a sunspot minimum period. One rather curious result of this will probably be a marked increase in the optimum wavelength for distance-spanning purposes at night time. Old hands may remember that during the last sunspot minimum period, when short-wave reception had its beginnings as a popular hobby, the outstanding transmission was that of KDKA, which used a wavelength of about 65 metres. Though the power was comparatively small, reception in this country was so good that full loud-speaker volume was obtainable night after night with simple two-valve sets.

## MORE WAVELENGTH PROBLEMS

**D**URING the next year or two the lengthening of the optimum wavelength, which is almost certain to accompany the sunspot minimum period, may raise some pretty problems for commercial long-distance stations that make use of the short waves. Including the various beam and telephone services, there are a good many of these, and it seems probable that they will have to adopt longer wavelengths—at any rate, during some parts of the twenty-four hours—if they are to maintain uninterrupted communications. This may even necessitate the re-designing of some of the transmitting plants. One wonders whether the five wavelengths allotted to the Empire broadcasting station will prove to be sufficient. Personally, I hardly think they will, and I shall not be at all surprised if it is found necessary to lay claim to a certain number of wavelengths a good deal higher than those that have already been acquired.

## WORTH THINKING ABOUT

**T**HERE is, by the way, one tip with regard to the simple short-wave set consisting of a detector and either one or two low-frequency valves that readers may find useful. This kind of set has usually to be worked very close to the point of oscillation, with the result that quality is apt to suffer considerably, owing to the way in which the low notes drown those of high pitch. I have known this effect so marked when a feeble signal was being received that absolutely nothing could be heard of an orchestra but the drums and the bass instruments. There is a very simple way of setting matters right, and that is to incorporate in the short-wave

set a tone-correcting low-frequency transformer. These devices are useful enough in the ordinary medium- and long-wave set, but they are doubly useful in the short-waver.

## A LONG, LONG NOTE

**H**AS it ever struck you what an enormous length a note is, so to speak, stretched when the corresponding modulation is mounted on the carrier wave of a broadcasting station? Take our old friend the middle C, whose sound waves and their electrical copies have a frequency of, roughly, 256 a second, and think what happens to this note in the process of transmission from the London Regional station. As the frequency of the station is 843,000, no less than 3,293 ups and downs of the carrier are required to trace out the shape of a single middle C wave occupying 1/256th part of a second. The wavelength of the station is 356 metres; so that to trace out just one middle C wave, no less than 1,172 kilometres, or about 730 miles, are required. And that is just one of the waves. You can work out for yourself just how far the middle C is stretched if the note is sounded for, say, one-fifth of a second.

## AN ASTONISHING FEAT

**W**HAT a marvellous piece of work the H.M.V. people have done in bringing an old Caruso record up to date. So amazing is it in fact, when you come to think it over, that it almost savours of magic. The original record, remember, was made by mechanical means before the days of electrical recording. If you have an old Caruso record and play it over on your radiogram, you will see at once how far it falls short of modern standards. The orchestral accompaniment is thin and not all of the great singer's voice is there. After spending no less than six years in laboratory experiments, H.M.V. have found a process, still a close secret, which enables them to perform something like miracles. First of all, the old orchestral accompaniment was filtered out altogether, leaving

nothing but the voice. The next process was to give a proper balance to the recording of the voice. Then a new accompaniment had to be put in. To do this, the record of the voice alone was played and a real live orchestra accompanied the singing. I have not yet heard one of the transformed records, but I understand that they are completely successful, and that others are likely to be dealt with in the same way. Once more science has achieved the impossible.

## STILL AT IT

**T**HERE is still no news of any progress from Madrid, where the Radio Conference continues to talk and talk. No sooner, it appears, is a proposal made by someone than half a dozen delegates spring to their feet to say that their country will never stand anything of the kind. Everybody wants more wavelengths, though even now there aren't enough to go round properly, and none of the delegates will admit (though each of them knows it well enough in his heart of hearts) that if European broadcasting is not to reach a state of chaos in the near future, all countries must be prepared to adopt a policy of sacrifice. There is not the slightest question that many countries have far more stations at present than they really need to give a proper service to their inhabitants. Why, for example, should France require six stations in Paris alone? She has them, though, in Radio-Paris, the Eiffel Tower, Paris PTT, Radio LL, the Poste Parisien, and Radio Vitus. This kind of thing is simply absurd.

## PLENTY TO HEAR

**F**OR all the congestion that prevails on the broadcast band, there is plenty to hear at the present time with any reasonably good set. During the mornings or the early afternoons you will find that quite a number of the bigger stations can often be picked up with good strength, and from about 4 p.m. onwards the choice is very large. Amongst the best of the foreigners at the moment of

## PERSONALITIES IN THE WEEK'S PROGRAMMES

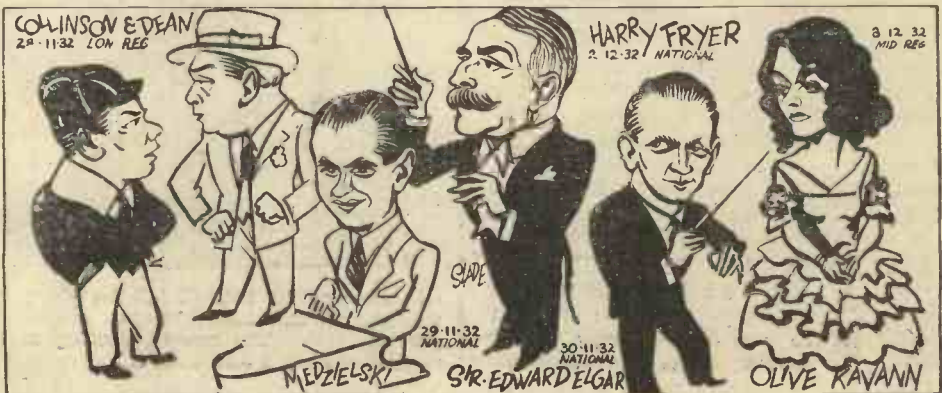

## On Your Wavelength! (continued)

writing are Budapest, Vienna, Florence, Brussels No. 1, Prague, and Langenberg, near the top of the band. In the middle part, Rome, Stockholm, Leipzig, the Poste Parisien, and Breslau are first-rate. Lower down, Hilversum, Bratislava, Heilsberg, Turin, and Trieste are always ready to oblige. I am not saying that you will obtain perfect reception of every one of these whenever you like to try for them. On the contrary, some of them may possibly be interfered with by sparks or by heterodynes. Still, most of them will come in well, and there are a good many other stations in addition that will provide first-rate entertainment.

### SPONSORED PROGRAMMES

**T**HERE is still a certain amount of feeling that the B.B.C. ought to increase its revenue by indulging in advertising. It is contended that if we had sponsored programmes we should obtain very much better entertainment, since advertisers would vie with one another in putting on the best items that money can buy. There is undoubtedly something in this, and no one can deny that American stations, generally dependent largely upon advertising revenue, give a marvellous service and put on some splendid programmes. Still, if you read the American papers you will find that even in the "Land of Publicity," people are beginning to get sick of broadcast advertising. Personally, I should be very sorry if our programmes were interspersed with entreaties to buy so-and-so's goloshes, somebody else's tooth paste, and so on. I don't think that even the rich and rare talent that advertisers might provide would be sufficient compensation for that kind of thing. Taken as a whole, our programmes, as they are, are pretty good, though we do grouse a good deal about them. And almost everybody nowadays has plenty of alternatives from abroad if he does not like the fare that is being served up by his local station.

### INGENIOUS

**A**N ingenious idea for battery users is the accumulator H.T.B. which can be charged from the filament battery. I have not used one myself, though a friend installed one some time ago and has found it quite satisfactory. Charging from the L.T.B. is done by means of a switch which throws blocks of H.T. cells into parallel. The amount of current taken is not large, and one big advantage is, of course, that you have only one battery to take to the charging station. Unfortunately, you cannot do your charging from a 2-volt L.T. battery, which is what most people use nowadays. Instead, a 6-volt battery is required.

### FREQUENCY OR WAVELENGTH?

**I**N spite of the agitation on the part of technically minded gentlemen for the use of frequency rather than wavelength in designating wireless transmissions, the practice of refer-

ring to stations by their wavelength still remains with us. True, the B.B.C. always quotes the kilocycles as well as the wavelength in metres, and in most tables of stations it is customary to quote both the frequency and the wavelength, but the average user still regards the frequency as a subsidiary effect and the wavelength as the really important factor.

In point of fact, the state of affairs is exactly the reverse. The fundamental property is the rapidity with which the electric currents vibrate, and because of this vibration they produce electric waves. These waves travel a certain distance in one second; so that the more waves there are in a second—i.e., the higher the frequency—the closer will the individual waves seem to each other, so that the wavelength will be less. Hence we have the well-known

**Full of Good Things—Our  
Bumper Christmas Number  
Next Week**

relation that high frequencies produce short wavelengths and vice versa.

For the ordinary electro-magnetic wave the frequency and wavelength are connected by the expression:—

$$\text{Frequency (kilocycles)} \times \text{wavelength (metres)} = 300,000.$$

Hence, a frequency of 750 kilocycles corresponds to a wavelength *in air* of 400 metres. It must be emphasised that this only applies in air. An interesting example of this was brought to light the other day by a writer who propounded the following proposition.

### AN ANOMALY

**I**F one has a receiver tuned to 12,000 metres on land and takes this on board a submarine, what will be the wavelength to which the receiver is tuned? You will obviously answer, in a slightly bewildered frame of mind, 12,000 metres. If you do, you will be quite wrong,

### IMPROVING SELECTIVITY

Why not fit your home-wound tuning coils with plugs and sockets so that quick tappings can be taken to vary the inherent

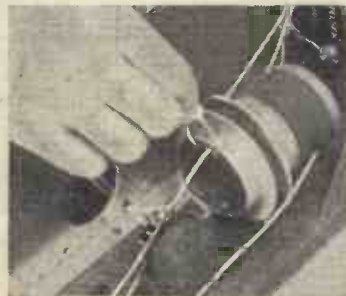

selectivity of the tuning? Battery-type wander plugs and sockets can quite well be used for this. The arrow indicating a tapping made on a dual-wave coil.

for the wavelength to which the receiver is tuned will be nearer 12 metres than 12,000.

Twelve thousand metres corresponds to 25 kilocycles, and we are really tuning the receiver to respond to a frequency of 25 kilocycles. Now, electro-magnetic waves in water travel at a very much lower rate than in air; something nearer 300,000 metres per second instead of 300,000,000 metres in air. Consequently, at a wavelength corresponding to a vibration of a frequency of 25 kilocycles in water is only about 12 metres.

Thus we have the fact that a receiver tuned to one wavelength in air is tuned to a different wavelength under water.

### RADIO IN THE AIR

**W**IRELESS first made its mark at sea—long before the days of broadcasting—and afterwards in aerial navigation where it is still finding new applications. I am not referring so much to ordinary air-to-land communication, or even to direction-finding systems, although these are rapidly becoming indispensable for long-distance flights. The kind of thing I have in mind, for instance, is the use of a radio transmitter operated by the pilot for automatically lighting up the landing field as he approaches the aerodrome. By sending out a certain sequence of signals he is able to operate a selective relay which in turn controls the floodlighting switch.

In America they are developing an even more ingenious plan which is designed to allow an aviator to land in the densest fog. This involves televising from the aerodrome to the machine a picture of the landing field, showing any dangerous obstacles, and also a bright mark which moves across the picture to indicate the track of the machine from moment to moment. The latter effect is obtained by first "spotting" the plane from the land by D.F. wireless and then superposing its position on the televised picture. The whole scheme can be carried out when "visibility" is at its worst.

### THE NEW COILS

**T**HE appearance of iron-cored tuning-coils is really a revival of an old idea, although, of course, it has been dressed up in new clothes. Coils with finely laminated or powdered cores were used in the intermediate-frequency stages of some of the earliest types of superhet, whilst the use of a finely powdered iron core for low-frequency work, in order to reduce eddy-current loss, is well known in telephony practice. The merit of the latest development is that the grain of the iron is made so fine that it has to be specially protected from contact with the air—otherwise it would burst into flame. In this form there is practically no eddy-current loss in the iron, and a shorter length of thick, low-resistance wire can be used to produce a given inductance. This, of course, is all to the good where selectivity is one consideration and compactness another.

THERMION.



# Direct Radio

# CENTURY SUPER

159 BORO HIGH STREET LONDON BRIDGE

THE ONLY KIT WITH A GUARANTEE

The New "CENTURY SUPER" Table Model

1 J.B. Untune twin-gang .0005 variable condenser, fully screened	18 6
1 J.B. Untune single .0005 variable condenser	9 6
1 Bulgin 50,000-ohm potentiometer and combined switch, type VS36	5 6
3 Wearite super-bet intermediates with pigtailis	11 6
1 Set Lisen ganged oscillator and band-pass coils and combined on-off switch	10 0
8 Four-pin and 1 five-pin valve holders	4 8
2 Dubilier 1-mfd. condensers, type 9200	5 6
1 Dubilier .02-mfd. fixed condenser, type 9200	2 0
1 T.C.C. .0001-mfd. fixed condenser	1 3
1 T.C.C. .0002-mfd. fixed condenser	1 3
1 T.C.C. .001-mfd. fixed condenser	1 6
1 Erie 1-megohm grid leak	1 0
1 Erie 2-megohm grid leak	1 0
1 R.I. Paraflex low-frequency coupling unit	11 9
1 Sovereign .0005-mfd. pre-set condenser	1 3
1 Ready Radio high-frequency choke	5 6
2 Sovereign terminal blocks	1 0
4 Belling Lee terminals, marked: Aerial, Earth, L.S., L.S.—	10
9 Belling Lee wander plugs, marked: G.B., G.B.—1, G.B.—2, H.T., H.T.—1, H.T.—2, H.T.—3, H.T.—4, H.T.—	1 2
2 Belling Lee spade terminals, marked: L.S., L.S.—	3
1 Sheet aluminium foil, 16 in. by 10 in.	1 6
1 Ready Radio fuse and holder	1 0
1 Erie 20,000-ohm fixed resistance	1 0
1 Erie 50,000-ohm fixed resistance	1 0
1 Aluminium bracket	3
6 Yards flex	4
1 Special Direct Radio "159" cabinet, with Easyfix baseboard and panel drilled to specification	1 1 0
6 Mullard valves: PM12 Met. 2 PM12V Met., 2 PM1HL Met., 1 PM12A	4 0 0
1 Callibrator Easy Station Finder (no charge)	
<b>£12 2 0</b>	

"Century Super" Short-Wave Adaptor

Complete kit as specified, Price £3, can be purchased on easy terms if included with any "Century Super" Table Model or Radiogram Kit.

Terms: 5/6 per month extra on 12 monthly payments.

KIT MODEL 1 (Less Valves and Cabinet)	£7:0:0
---------------------------------------	--------

Or twelve monthly payments of 13/-.  
 With Valves (less Cabinet) £11:1:0

KIT MODEL 2	£11:1:0
-------------	---------

Or twelve monthly payments of £10/6.

KIT MODEL 3 (With Valves and Cabinet)	£12:2:0
---------------------------------------	---------

Or twelve monthly payments of £12/6

KIT MODEL 4 (Complete kit as specified, with "159" Console Cabinet, Valves, and Epoch Twentieth Century Moving Coil Speaker)	£15:0:0
--	---------

Or twelve monthly payments of £17/6

## Convincing Proof!

## "AMATEUR WIRELESS" TEST

## DIRECT RADIO'S CENTURY SUPER

READ THEIR REPORT

"A MODEL of the "New Century Super" supplied complete by Direct Radio, Ltd., was taken for a test in the West Riding district of Yorkshire—some twenty miles east of the Northern Regional transmitter.  
 The first impression justified the well-known slogan of "One station for every degree of the dial." Making allowance for interference and a natural slight spread on the higher powered stations, this slogan is certainly an apt description of the "Super's" performance in the North. A short test brought in a host of foreigners, including French, German, Italian, Spanish, and Russian.  
 No attempt was made to keep a detailed log, as in the short time available for testing the "New Century Super" there was no opportunity for definitely logging the call signs and announce-

ments of some of the fainter stations heard; only an account could be kept of the total bevy of stations.  
 One or two late sittings showed that America was "on tap"—if not every night, at least on every occasion that the set was given a test.  
 In ordinary working a striking feature was that the usual bugbear of super-bets—second-channel interference—was entirely absent. Some idea of the "Super's" capabilities can be gauged from the fact that during the preliminary try out, which took only a little over an hour, forty stations were logged on the medium waves and eight on the long. Of course, this log was considerably extended in later trials.  
 Muhlacker could be cleared from London Regional and Konigs-wusterhausen from Daventry. Need more be said for selectivity?"  
*Amateur Wireless, 12-11-32*

### NOW TEST FOR YOURSELF

OFFICIAL DEMONSTRATION: 159 BORO HIGH STREET, LONDON BRIDGE, S.E.1. "Amateur Wireless" in co-operation with Direct Radio invite you to a demonstration of the "Century Super" constructed from Direct Radio guaranteed kits. Everyone who hears it is astounded. Before you definitely decide on any new receiver come to 159 Borough High Street and test the remarkable "Century Super" yourself.

#### "CENTURY SUPER" NEW RADIO-GRAM

KIT RG1 Full kit with all radiogram accessories, as below but excluding valves and cabinet. Price	£12:3:6
Or 12 monthly payments of £1 4 0.	
KIT RG2 As RG1, but including valves. Price	£16:4:6
Or 12 monthly payments of £1/10/0.	
KIT RG3 As RG1, including valves and radio-gram. Price	£19:14:6
Or 12 monthly payments of £1/17/6.	

RADIOGRAM ACCESSORIES

1 Collaro B.30 clockwork gramophone motor with turntable and automatic stop	1 13 0
1 Bowyer-Lowe A.E.D. Mark III gramophone pick-up	1 10 0
1 Bulgin radio-gramophone switch	1 9
1 Lewcos 50,000-ohm volume control potentiometer	3 0
1 Special "159" radio-gramophone cabinet	3 10 0
1 Belling-Lee wander plug, marked G.B.—3, 1 length of screened connecting wire and 1 yard thin flex (Lewcoflex)	9
1 Epoch Twentieth Century permanent-magnet moving-coil loud-speaker	1 15 0
Bulgin dual needle cup	2 6

#### "CENTURY SUPER" SHORT-WAVE ADAPTOR

1 Direct Radio cabinet with baseboard, 10 in. by 9 in.	15 0
1 Drilled panel, 10 in. by 8 in.	2 0
1 Covert dual-range screened short-wave coil, type KSW	9 6
1 J.B. .00025-mfd. short-wave variable condenser, type 2045, with slow-motion disc drive No. 1085	10 9
1 Ready Radio .0005-mfd. reaction type bakelite dielectric	2 6
1 J.B. neutralising condenser	3 6
1 Ready Radio on-off switch	10
1 4-pin valve holder	6
1 T.C.C. 1-mfd. condenser	2 10
1 T.C.C. .0001-mfd. and one .0005-mfd. fixed condensers	2 6
1 Ready Radio 400-ohm baseboard mounting potentiometer	2 9
1 Erie 1-megohm grid leak	1 0
1 Slektan short-wave H.F. choke	2 9
1 Sovereign terminal block and 2 Belling Lee terminals marked Aerial and Earth	11
2 Yards thin flex, connecting wire, screws, etc.	4
1 Bulgin 4-pin adaptor plug, P.9.	2 0
1 Belling Lee S.G. anode connector, type 1030	4
<b>£3 0 0</b>	

#### "TWO-GUINEA FAMILY THREE"

Kit Model 1 (less valves and cabinet). Price	£2:8:0
Or 7 monthly payments of 7/9	
Kit Model 2 (with valves, less cabinet). Price	£3:14:0
Or 10 monthly payments of 8/6	
Kit Model 3 (With valves and cabinet). Price	£4:11:6
Or 12 monthly payments of 8/6	
Kit Model 4 (with valves, special walnut console cabinet and Epoch Twentieth Century Permanent-magnet moving-coil speaker.) Price	£7:5:0
Or 12 monthly payments of 13/6	

ACCESSORIES

1 Siemens 120-volt H.T. battery	13 6
2 Siemens 9-volt G.B. batteries	1 0
1 Epoch Twentieth Century permanent-magnet moving-coil chassis with input transformer	1 15 0
1 Graham Farish "Flit" earthing device	2 6
1 Selectanet aerial	2 6
1 Cop lead-in tube and lightning arrester	2 6

any Component can be supplied separately

COMPLETE CATALOGUE OF ALL SETS, ACCESSORIES & GADGETS, PRICE 1/6, POST FREE.

### CASH, C.O.D. AND EASY PAYMENT EXPRESS ORDER FORM.

To DIRECT RADIO, LTD., 159 Borough High Street, London Bridge, S.E.1.

Please dispatch to me at once the following goods.....

for which (a) I enclose {cross out line} (b) I will pay on delivery {not applicable} (c) I enclose first deposit of £.....

NAME..... ADDRESS..... Amateur Wireless, 26/11/32

Please Mention "A.W." When Corresponding with Advertisers

# THE 'BLOCK' PLATE-LESS ACCUMULATOR



DOUBLES  
YOUR  
BATTERY  
CAPACITY

2v. 80 AMP. HRS. 1/6<sup>D</sup>.

THIS is the power source of a new era—a neat, richly coloured cylinder in place of the admittedly crude, present-day accumulator. It is the independent patent of Mr. Leonard Fuller, M.I.E.E. (whose father and grandfather made world-famous accumulators from the days of Faraday on). Called the Block plate-less Accumulator, it gives 80 amp. hours at little more than the cost of a modern 40 amp. hour accumulator. It will not run down when out of use (no waste of

the charge). And how it lasts! (It is almost unbreakable). The diagram shows its secret—the inefficient “plates” of the modern accumulator are avoided by a special process that enables the accumulator cylinder itself to be made the negative electrode, the positive electrode being a central core. (Hence the ideal of unimpeded active surface, and even radial action.) Consider the result—twice the life per charge; more compact; simpler; immeasurably stronger. More than a battery-de-luxe—a revolution! Get a Block Accumulator from your dealer to-day, and be rid of old-time battery inefficiency.

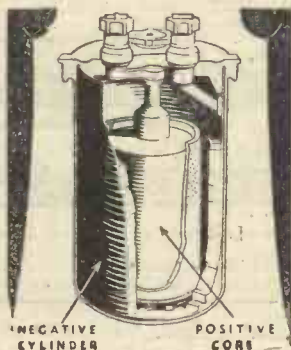

**BLOCK BATTERIES LTD ABBEY ROAD BARKING**

TAS/BB.6

*Don't Forget to Say That You Saw it in "A.W."*



# THE AERIAL TAP AND SELECTIVITY

The customary tapped aerial coil has the aerial connection about one-quarter of the way up the coil or an equivalent effect is produced by means of a separate coupled aerial winding. What exactly is the effect of reducing this tapping point? First and foremost the signal strength is reduced, but it is popularly believed that the selectivity is greatly improved. Is this assumption correct?

IN order to obtain some practical data on aerial taps, some tests were made recently on a simple form of tuning circuit. Voltage was introduced into the dummy aerial circuit from a signal generator as shown in Fig. 1, and the low-frequency voltage was measured in terms of the input voltage for various tappings on the coil. From this it was possible to determine the

point is too large then the aerial damping begins to have quite a marked effect, but for any point less than about one-quarter of the way up the coil the aerial effect is quite small and the selectivity of the circuit is dependent upon the resistance of the tuning coil itself.

In order to demonstrate this point Fig. 2 has been plotted. This shows the ratio of the strength at resonance to the strength 30 kilocycles off tune for various tappings. Such a figure gives an immediate indication of the selectivity without having to plot resonance curves and analyse them afterwards, and it will be clear that the larger this figure the more is the selectivity. Tapping down the coil will be seen to increase

the selectivity very slightly and the curve shows every indication of reaching a limit which is that determined by the "goodness" of the coil itself.

It remains, therefore, to carry out the tests again with reaction applied to find out whether there is any material difference in the results. This was done accordingly and it was found at once that there was quite an appreciable difference between the conditions with a large aerial tap and one with a small tap.

Tapping down the coil reduces the signal strength. With no reaction applied it is not possible to make up for this reduction, and it is largely because of this that there is no material gain in the selectivity. If

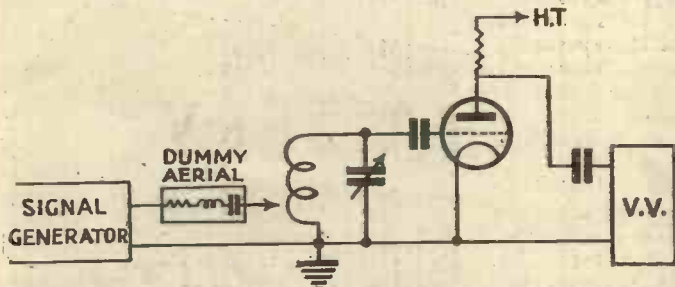

Fig. 1. Here are the circuit arrangements, which were used in order to obtain data on the question of the aerial tap position and selectivity

sensitivity of the arrangement, and also to estimate the selectivity by the following method.

The circuit was tuned to resonance and the output noted. If the frequency of the signal generator is now altered by a known amount on either side the output will fall

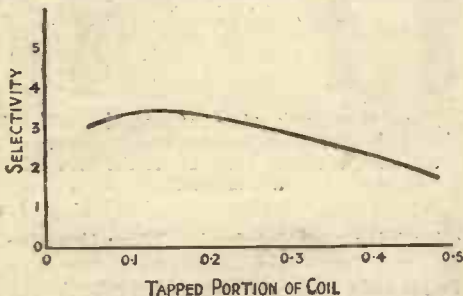

Fig. 2. Without reaction, tapping down the coil makes little difference to selectivity

off and a resonance curve can be plotted without any difficulty. Tests were made to find both the sensitivity and selectivity with various aerial tappings and also with various types of valve used as the detector.

The results were interesting. They indicated that the actual tapping point had little effect on the selectivity provided it was reasonably small. If the tapping

the selectivity very slightly and the curve shows every indication of reaching a limit which is that determined by the "goodness" of the coil itself.

### Valve Types

It is also interesting to note that the type of valve has no appreciable effect on these results. The valve, of course, introduces damping of its own but this damping remains constant irrespective of the position of the aerial tap. Therefore the actual type of valve in use does not affect this question of the aerial tap, although of course the actual selectivity and sensitivity varies quite considerably with different types of valve. With a pentode detector, for instance, the selectivity is remarkably improved as compared with the ordinary three-electrode valve.

All these results have been taken without reaction. This is an important point because there are two distinct cases which arise in practice. Firstly, we can have a simple detector circuit, followed by one or more low-frequency valves, and in such an arrangement we inevitably use reaction in order to increase the sensitivity for distant reception. It does not follow that the results so far obtained necessarily hold good if reaction is applied.

The second case is the ordinary high-

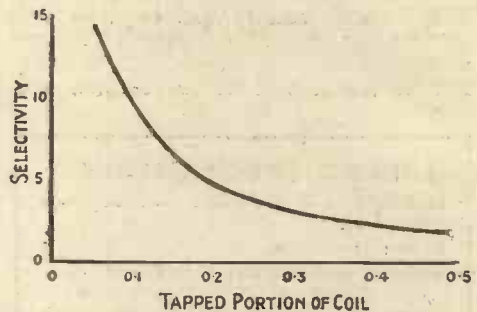

Fig. 3. With reaction the selectivity is greatly improved by tapping down the coil

we are able to use reaction, however, the signal strength can be brought up again to a value equivalent to that with the higher tap, and if this is done there will be found to be a distinct improvement in selectivity. Fig. 3 illustrates this point quite clearly.

Hence we can say that as long as reaction can usefully be applied there is a distinct improvement in selectivity due to tapping down the coil. Beyond a certain point, however, no further progress can be made because the reaction adjustment becomes too critical. We can increase the strength of a weak signal without much difficulty, but if the signal becomes too weak then, in order to bring the strength up, we have

(Continued on page 1180)

## SETS OF THE SEASON

# COLUMBIA RADIOGRAPH FOUR



COMING within the price reach of many thousands of listeners, the "Radiograph Four" is, I think, one of the most notable of the new season's radio-gramophones. At 32 guineas it is excellent value for money in this particular field.

The basis of the instrument is a chassis already well known to me, as indeed it must be to many readers. It comprises the powerful band-pass three-valve chassis of the Columbia, H.M.V. and Marconiphone table sets.

### Valve Sequence

With subtle improvements in sensitivity, power, and selectivity this chassis, acknowledged last season as outstanding, is now accepted as a standard of what can be done with three straight valves arranged as high-frequency amplifier, detector, and pentode power output.

As I say, this chassis is but the basis of the new inexpensive radio-gramophone. The fourth valve? That is the rectifier, used to convert the A.C. mains supply into direct current for the anodes of the three receiving valves.

On taking the back off the really high-class walnut cabinet, which is 34 in. high, 23½ in. wide, and 16½ in. deep, we find the chassis mounted on one side, a large moving-coil loud-speaker fitted behind the fret of the cabinet at the bottom, and

of a three-point switch, which gives you three degrees of aerial coupling to suit all conditions. There is a mains-aerial plug nearby.

The top part of the instrument, seen on lifting up the felt-lined lid, which incidentally cuts out all trace of surface noise when records are being played, is exceptionally well arranged. The fittings are liberal, indeed, and would do justice to a radiogram costing much more.

In addition to one of the latest Columbia pick-ups and an induction-type motor, there is a foolproof automatic brake-stop device, a fast and slow adjustment, and two needle cups.

The controls are arranged on a neat escutcheon on the right of the motor board; here again we find luxury worthy of the most de-luxe of sets. There is a combination switch knob, called the control knob, which works the mains switch, the wave-change switch and the gramophone switch.

As the set comes on, the bulb behind the tuning scale lights up, "floodlighting" not only the medium- and long-wave scales, which are rotatable with the switch, but also the panel on the left engraved with most of the powerful medium- and long-wave stations.

### Simplified Calibration

This simplified station calibration is masterly in its conception and admirable in operation, as my tests soon proved. Tuning is done with another knob, which works the three-gang condenser connected to the aerial band-pass and inter-valve coupling, and also a pointer that moves along whichever scale is brought into play by the control switch knob.

The only other control is for volume, and this knob works on both radio and gramophone reproduction, being in fact two separate controls ganged on the common spindle. The radio volume control has the additional novelty that at its maximum travel reaction is applied.

### Wonderful Results

As soon as I got this instrument working, which was a simple job of installation that even a non-technical listener could tackle quite easily, I realised what a "hot" radio circuit I was dealing with.

Even on an indoor aerial, I was able to get twenty stations at concert strength and without any background of interference. Well, such a number of programme alternatives on three valves in the present

state of the ether is very good going.

Local stations did not spread unduly. I got Scottish Regional clear above London Regional, and Milan was quite clear below. The London National was even more limited, and stations two channels away from this local came through clearly.

On the long waves, thanks to the band-pass action again, the high standard of

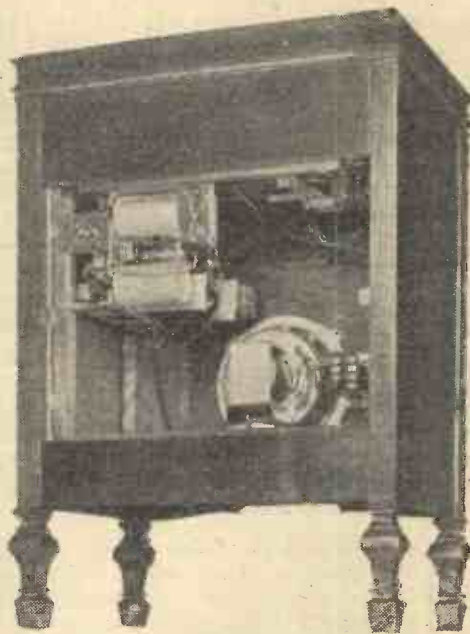

Here is a rear view of the Columbia Radiograph: note the somewhat unusual disposition of the receiver at the side of the cabinet

selectivity is maintained. When listening to Zeesen, all I could hear of the Daventry and Radio Paris programmes on each side of the German was sideband twitter—and not much of that.

Switch over to gramophone and you realise what a thoroughly good job is the "Radiograph." The quality from records, and the volume, should give the vast majority of listeners great pleasure. The energised moving-coil, with its ample baffle in the pedestal cabinet, does justice to the full output of the power pentode valve.

SFT TESTER.

### BRIEF SPECIFICATION

**Makers:** The Columbia Graphophone Co., Ltd.

**Price:** 32 guineas.

**Valve Combination:** Screen-grid (Marconi MS<sub>4</sub>B), detector (Marconi MH<sub>4</sub>), pentode (Marconi MP<sub>4</sub>), and valve rectifier (Marconi U<sub>12</sub>).

**Power Supply:** A.C. and D.C. mains of usual voltages.

**Controls:** Single knob tuning, dual volume control with reaction at maximum setting on radio, combination mains switch.

**Type:** Radio-gramophone, needing only an external aerial and earth to complete the installation.

**Remarks:** One of the best designs yet tested this season. Luxury performance at a moderate price.

underneath the top panel is the gramophone motor and accessories.

A neat little panel in the top left-hand corner of the back of the cabinet provides a convenient connection for the aerial and earth. The aerial socket forms the centre

# OUR BROADCAST CRITIC

ON  
NON-STOP VARIETY



JOHN DRINKWATER, author of the play *BIRD IN HAND*

THE Non-Stop Variety timed programme last Monday was, to my way of thinking, the most unmitigated tosh we have had for a long time. I hope the B.B.C. is ashamed of it.

The "Man with Wink in Voice" (I am quoting the humour of the published programme) surely did not imagine he was being funny, did he? At four minutes past eight the "Uncrowned Queen of Ditty" was good enough to "step up and sing." I should not have minded her doing that if she had sung something worth hearing. At nine minutes past the hour the members of a "Zither Banjo Society" began to "enjoy themselves with enthusiasm." I am so glad, for their sakes.

At 8.15 Clarice Mayne was billed to "charm us with songs." She left me uncharmed with her new songs, but I liked some of the old ones. The Maestro Singers sang well; I liked their bass especially. I was sorry when they stopped. However, John Charman came to the microphone "with laughter in his sleeve." Pity he kept it there, though! Stale schoolboy howlers do not make a good vaudeville turn.

After that they all had a second shot but I was not there. If this non-stop idea was meant to hide the dull patches in the usual type of vaudeville, all I can say is that it failed miserably. If anything, it accentuated the weak spots. Better to have only one vaudeville a month and have it good—anything rather than bore us to extinction with this sort of thing.

John Drinkwater's West Country comedy *Bird in Hand* made very good broadcasting. It needed only a few words of introduction to set it going. After that it played itself, so to speak. I should like to congratulate Cyril Wood on his splendid producing. This comedy—surely a specimen of the type of play the Productions Director has said he is seeking—shows the power of a practised hand. I admired its technique intensely. I was also greatly struck by the casting. I do not remember having heard a play in which as many as eight people spoke so distinctively; nobody could have been uncertain about the characters at any moment of the play. I listened to it both times—a rare thing for me to do!

Mr. Gerald Heard, in the fourth of the "Un-named Listener" series, addressed a doctor, or perhaps it might be more accurate to say the medical profession. I was quite entertained by what he said,

but I could not avoid a feeling that if I had been a doctor I should have been distinctly irritated. Doctors are busy people and not given to writing letters except when they must. Were it otherwise I am inclined to think Mr. Heard might have received a few letters. Perhaps he has!

Things are looking up at Broadcasting House. The Wireless Military Band led off with two Bach fugues in its programme on Thursday evening. We shall have Bach in a vaudeville yet! I enjoyed the G major, but the speed of the Great G Minor was ridiculous. What made Mr. O'Donnell take it at that rate? He completely destroyed its dignity. Moreover, the players fuddled their semiquavers. Please don't do that again.

I hope you heard the Witch Programme

## PROGRAMMES POINTERS

*I have listened to several relays of opera recently. They have generally been whole acts and relayed from some theatre. Comparing them with a recent broadcast under the attractive title of "Popular Opera," I think their value in the broadcasting sense is considerably less. I have held for a long time that listeners need much training before they can appreciate opera without seeing it. Comparing again, I feel that whereas listeners have greatly advanced in appreciation where radio drama is concerned, the very nature of opera is such that the difficulties are much greater. Although I make no suggestion that these isolated acts of operas should be discontinued, I do urge that the type of broadcast mentioned above should be given regularly. It is from them that the listener will learn most. In the programme of the one I have in mind there were splendid performances of (1) the Prologue from "Pagliacci"; (2) the Street Scene from the fourth act of Gounod's "Faust"; (3) the Inn Scene from the second act of "Carmen"; (4) the final scene from "Cavalleria Rusticana." Those four items were very well chosen. Without tiring or bewildering the listener, they gave a very good idea of opera at its best.*

("Fire Burn and Cauldron Bubble") even if only for its superb English. I thought it beautifully produced. The music also was most suitable. I did not seem to recognise any of it, but I thoroughly enjoyed the effects Leslie Woodgate brought about. I have noticed before that these smaller orchestras at Portland Place behave themselves particularly well when he is conducting.

There was an attractive recital by a soprano and a flautist—Noel Eadie and John Amadio—on Thursday evening. A flute broadcasts delightfully, to my way of thinking. Whether a flute and a soprano is as good as a flute and a tenor is another matter.

I happened to be at home on Armistice morning. Switching on a few minutes before eleven I heard the bands playing Chopin's funeral march. Although not in the slightest mood for criticism, I could not avoid a sense of surprise and regret that the march should sound so bad. Either the bass instruments were too near the microphone or else the march should be re-scored. Nothing but bass and inner parts came through. Rather sad at such a time.

Birthday Week began well with Gielgud's production of *Romeo and Juliet*, which I consider to be one of the finest dramatic productions ever given on the wireless. Harman Grisewood as Romeo was superb. Moreover, I am definitely of opinion that the best microphone writer we have is a certain Will Shakespeare!

The case for sedition having been disposed of without our hearing it—just as well, perhaps—I think most listeners must have followed the perjury trial with interest. It taught me a good deal. That is why I am so keen on this series: one gets to know something about law without having to read a treatise on the subject. Law should be everyman's subject, but I am afraid it is not so in reality. This particular case worked out simply enough. The doctor was clearly guilty of perjury even though he may have committed it with honourable intentions. The fact remains that if you are in a court of law and you are on oath you must tell the truth or take the consequences. I imagine the learned judge, after plainly directing the jury to find him guilty, would be leniency itself when it came to actual judgment.

WHITAKER-WILSON.

# ALL ABOUT WORKING YOUR SET



A survey of the most common methods of obtaining power from the mains for high-tension

## A SIMPLE ACCUMULATOR CHARGER FROM A.C. MAINS TENSION UNIT :: A HIGH TENSION UNIT

### A SIMPLE ACCUMULATOR CHARGER FOR A.C. MAINS

OWNERS of battery-driven sets who do not wish to go to the expense of converting an A.C. mains supply for the low-tension can economise by making up a little battery charger to work off the mains and to charge up the existing accumulator.

You can use a charger no matter whether you have a mains eliminator or a high-tension

rectifier unit by Heyberd has further simplified the construction and lowered the cost.

It is not necessary to search about finding special transformers to match up with any type of metal rectifier unit that may be chosen for the particular charging requirements. In this present unit a complete rectifier and trans-

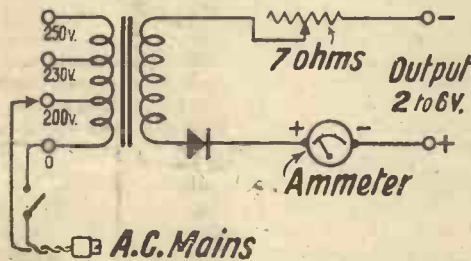

The circuit of the A.C. charger. The wiring diagram is given overleaf

former is incorporated. This has three terminal tappings on the mains input side for 200, 230 and 250 volts. The most suitable tapping for your voltage should be chosen.

In the present unit a type of combined rectifier has been used which has separate terminals for an additional rheostat which can be added to control the charging rate and in the unit illustrated by the accompanying photograph this additional resistance—a 7-ohm job—is mounted on the panel. The output terminals are mounted at the back of the unit and these are connected up to the accumulator output terminal and to the ammeter on the panel.

For convenience in connection there are two terminals on the small strip at the back and these are clearly marked positive and negative. It is very important to get the connections the right way round, for a reverse charge would damage the plates of the accumulator.

The mains supply connects up to the unit by means of a length of flex terminating in a plug or socket for connection with the mains point.

The wiring can most easily be done with tinned copper wire enclosed in insulating sleeving. Note the two short lengths of flex which connect up to the mains input side and which can easily be changed from one terminal to another, so that the most suitable tapping for the voltage can be chosen.

On a 6-volt accumulator a charging rate of approximately 1/2 ampere is obtained and the

ammeter on the panel can therefore be of the 0.1 ampere type. On a 2-volt accumulator, however, the charging current rises to just over 1 ampere and a 0.3-ampere type ammeter is advisable in order to give an accurate reading without any danger of damaging the instrument.

The charger is extremely simple to use. Just plug it into the mains, connect up the accumulator and switch on.

### CHARGING BATTERIES FROM D.C. MAINS

While a rectifier is needed to convert alternating current into pulsating direct current for accumulator charging from A.C. mains, no rectifier is needed when you want to charge an accumulator from D.C. mains.

All you need is some means of cutting down the mains supply to a suitable charging current which, in the case of trickle charging, for most accumulators, is in the neighbourhood of 1/2 ampere.

An elaborate unit for charging from D.C. mains would use tapped resistances for limiting the charging current, but for all ordinary purposes it is quite sufficient to use a carbon filament lamp for current regulation.

A D.C. charger is therefore one of the simplest pieces of radio apparatus it is possible to arrange. The charger should be mounted on a piece of plywood in order to prevent short-circuiting in any of the mains wiring.

On the wooden strip should be mounted a lamp holder to carry the current limiting bulb.

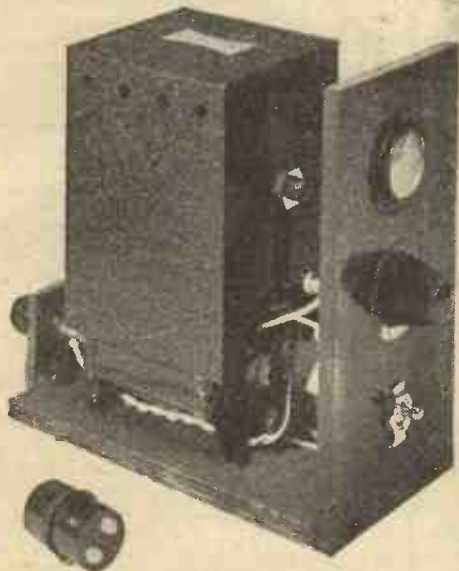

The trickle charger for A.C. mains employing a metal rectifier

battery for the H.T. supply. It makes no difference. The charger is quite a separate gadget. It is connected up only when you need it. It will save you those tiring journeys to the charging station.

Now that price reductions have been made in metal rectifiers, there is no great expense involved in a charger for 2-, 4- or 6-volt batteries and to charge them at a nominal rate of 1 ampere or so. The production of a special combined power transformer and

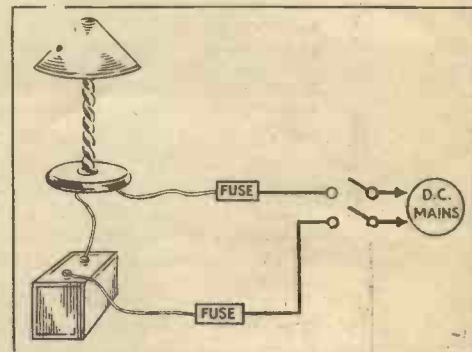

A simple method of charging accumulators from D.C. mains

# FROM THE MAINS

Convenient methods of obtaining power  
 tension supply and for battery charging

CHARGER FOR A.C. MAINS :: ACCUM-  
 D.C. MAINS :: MAKING A D.C. HIGH-  
 TENSION UNIT FOR A.C. MAINS ::  
 NG MAINS VALVES

A fuse should be included in the circuit and it is really a good plan to have a fuse in each mains lead so that if there is an accidental short-circuit to earth, the mains fuses will not be blown. A switch to cut the charge out of circuit is an optional fitting, as is also an ammeter to show the charging current.

It should be remembered that whereas the charging side of an A.C. charger is insulated from the mains wiring (on account of the insulation between primary and secondary of the mains transformer) a D.C. charger is not so insulated.

Fuses are therefore wise fittings, for the actual leads going to the accumulator are directly connected (one through the charging bulb) to the mains wiring.

Wire up the fuses, lamp holder and switch or ammeter with stout rubber-covered wire. It is a good plan to have lead tags on the ends of the leads going to the accumulator to make good contact and to prevent corrosion eating away the insulation of the wire. The acid is apt to creep along brass connectors and damage the wire insulation.

If the wiring is well carried out, it is possible to use the charging bulb in a reading lamp or in some similar way so that use is made of the light it gives.

An accompanying table shows the charging current passed by typical carbon-filament lamps.

Charging Current Passed by Typical Carbon-filament Lamps

200 volts	50 candle-power	1.0 amp.
" "	32 " "	.64 "
" "	16 " "	.32 "
" "	8 " "	.16 "
220 "	50 " "	.9 "
" "	32 " "	.6 "
" "	16 " "	.3 "
" "	8 " "	.15 "
240 "	50 " "	.83 "
" "	32 " "	.53 "
" "	16 " "	.26 "
" "	8 " "	.13 "

## MAKING A D.C. HIGH-TENSION UNIT

Those with direct-current mains are fortunate, for they are able to replace the high-tension side of their sets with a simple unit which

get can be, there is nothing to prevent you making up a D.C. high-tension unit in an easy evening's work to replace your present high-tension battery.

The unit is made as small and as compact as possible and therefore the parts on the baseboard are close together. As a little closer inspection will show you, however, the construction is easy, and there are no expensive parts, just variable and fixed resistances, a few condensers, and a mains smoothing choke.

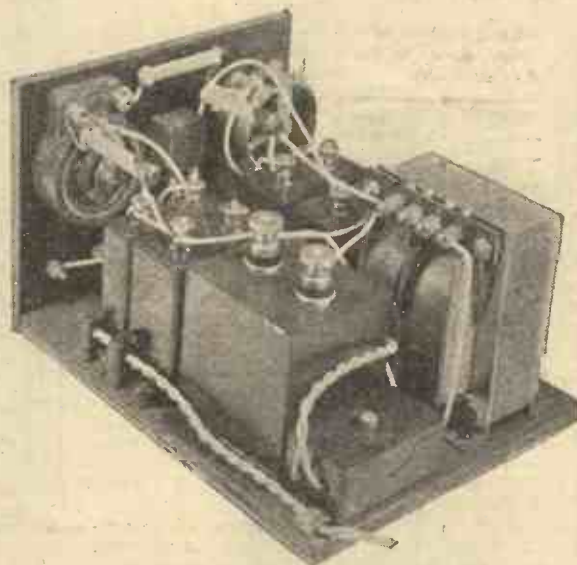

A high-tension unit for D.C. mains

If you want to see how the unit works then look at the circuit diagram which shows the wiring in the theoretical form. This will convince you that the specification of this unit is first rate.

You could always build a very cheap mains unit, but it is false economy in the long run. There are not many parts in this outfit, so use the best. Then you won't risk breakdowns.

A direct-current mains unit is really very simple. The mains supply enters the unit via fuses and a double-pole switch which entirely cuts off the mains supply when the unit is out of use.

Then there is a smoothing choke and a large

costs very little to make and which does not need a rectifier, as is the case with mains units for alternating current supplies.

As you can see from the accompanying photographs of a typical direct current mains unit which has been made up to show you how simple such a gad-

condenser (a 4-microfarad condenser in the case of this unit). The combination of the choke and condenser forms a smoothing circuit which prevents the ripple of the mains supply being heard in the receiver. If there were no smoothing and if the mains supply were connected directly to the set the commutator

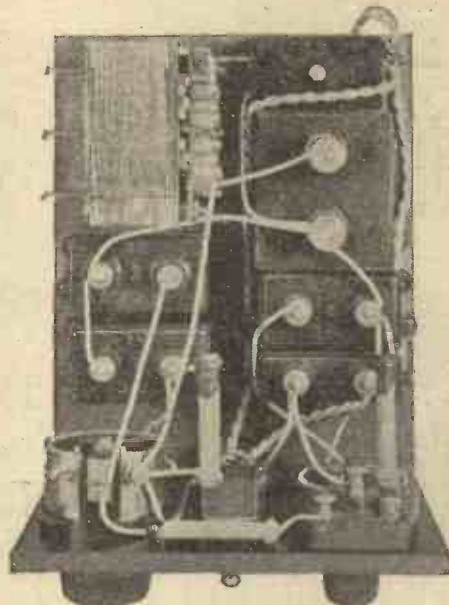

A plan view of the D.C. mains high-tension unit

ripple of the D.C. supply would be heard in the loud-speaker and spoil the set's silent background.

There are some people who will tell you that in order to get over this mains ripple you must have as large a choke and condenser as possible. Well, this is a mistake. The choke and condenser form a tuned circuit. The values given are correct for all normal working and ensure a nice smooth high-tension supply with virtually no more background noise than you get from a high-tension battery.

The mains supply, having been smoothed, must be reduced in voltage for the various tappings. This voltage reduction is carried out by fixed and variable resistances with, in each case, a fixed condenser connected between the voltage tapping point and high-tension negative. This decouples each tapping and prevents motor-boating.

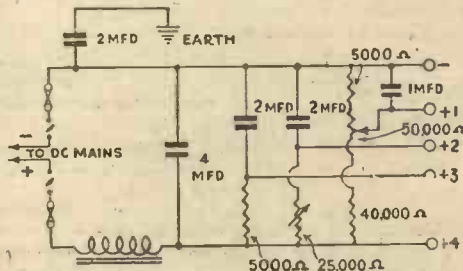

The circuit of the D.C. high-tension circuit

Well, there you are. A smoothing choke, a few condensers and resistances;

ALL ABOUT WORKING YOUR SET FROM THE MAINS—Continued

that is all you need to get high tension from direct-current mains.

There is no need to guess at the constructional details, for the photographs show an excellent way of arranging the parts.

There is a small ebonite panel, carrying the six terminals, the on-off switch, and the two variable voltage controls. On a plywood

(and the leads should not be too long) there will be little possibility of interaction between

condenser is not very involved. You must remember that with a direct-current mains supply, one side of the wiring is connected at the power house and at intermediate points to earth. Without making a test, you cannot tell which side of the wiring is earthed. If accidentally the other mains wire is also connected to earth, then there will obviously be a short-circuit. Therein lies the reason for the safety condenser. When a direct-current mains unit is connected to the set, the low-tension negative wiring, connected to the high-tension

(Continued on page 1176)

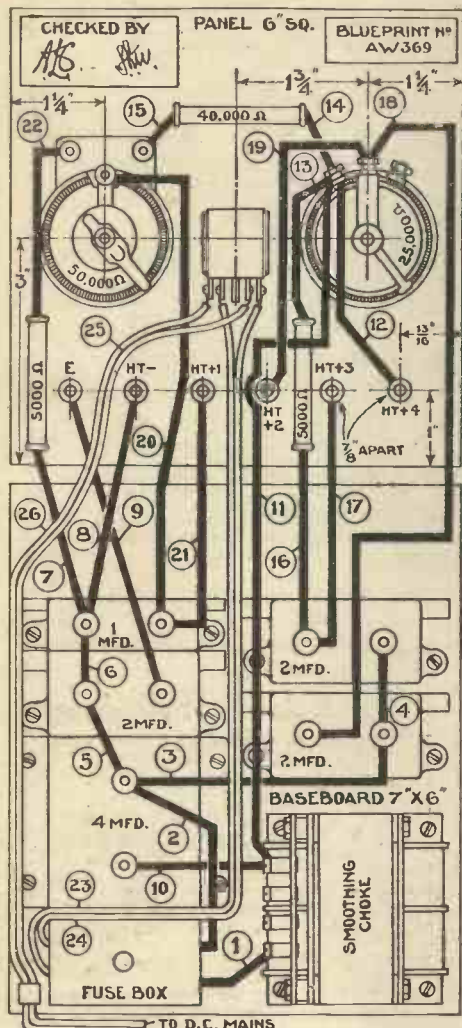

The wiring diagram of the D.C. mains high-tension unit

strip forming the baseboard are carried the smoothing choke, fixed condensers, and fuse-holder block.

There is no special point to note in mounting the parts, except perhaps that the smoothing choke is put at the back of the baseboard so that if the unit is worked near the receiver



The rectifier and transformer unit which will allow of the D.C. unit being used on A.C. mains

the smoothing choke and any other iron-cored component in the set itself.

The panel carries six terminals. Only five of these are taken up by the high-tension

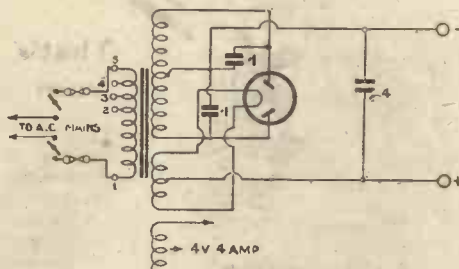

The circuit of the A.C. high-tension unit

tappings, one being the high-tension negative tapping and the other four for the high-tension positive tappings. You will therefore be wondering what purpose is served by the sixth terminal which is marked E and which is connected only to a fixed condenser on the baseboard.

It serves an important purpose. The condenser connected to it is a safety condenser. The whole arrangement prevents fuses being blown owing to a wrong connection.

An explanation of the working of the safety

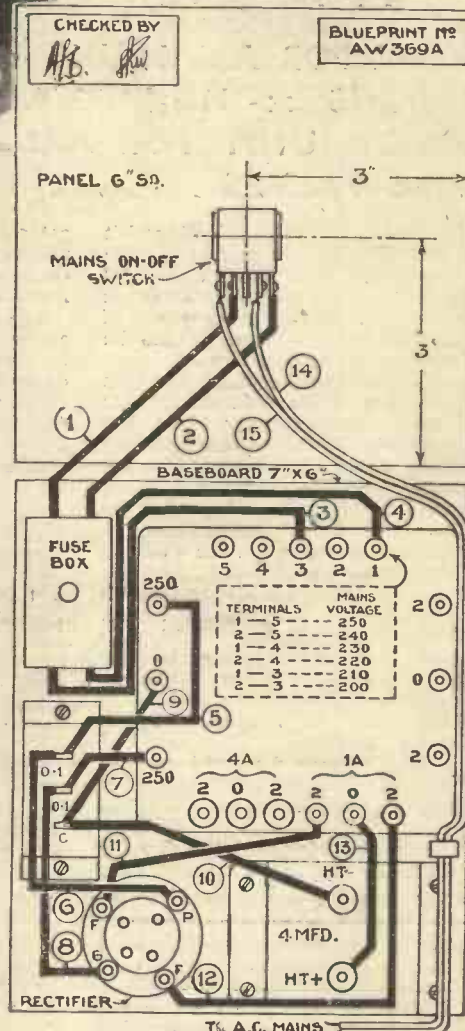

The wiring diagram of the A.C. unit which, coupled to the D.C. unit, will furnish high-tension from A.C. mains

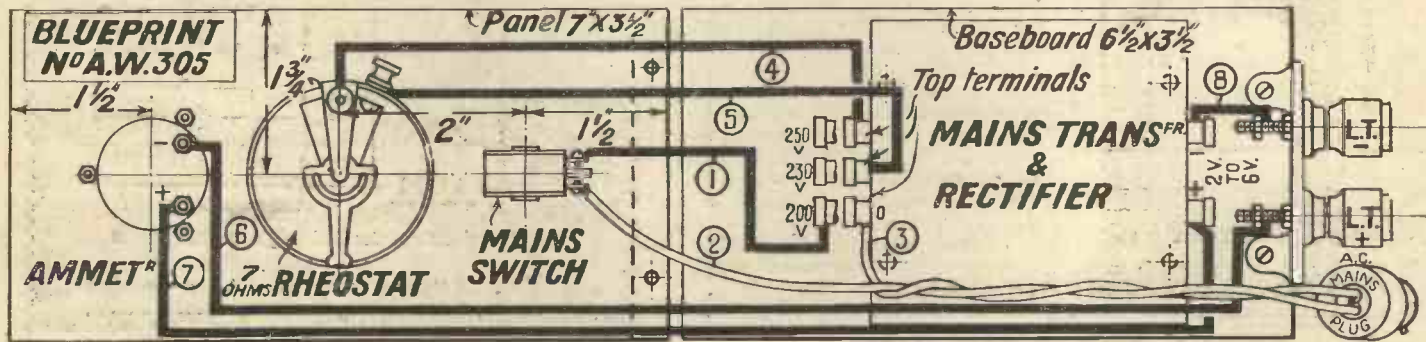

The wiring diagram of the trickle charger for A.C. mains



**High  
Tension  
Current for  
1<sup>p</sup>/<sub>2</sub> A  
2 WEEK**



**YOURS  
for  
5/-  
DOWN**

**That's all your H.T. current costs from this Lissen H.T Power Unit**

Low first cost is practically your only outlay because the cost of running a Lissen Eliminator is so small that your meter will hardly register the current it takes. No current from any eliminator is smoother or more silent than the current of a Lissen Eliminator. No eliminator output is more constant, none is so free from hum. Every Lissen Eliminator will deliver 20 m/A OUTPUT IN PERPETUITY—sufficient H.T. current to feed the largest receiver, with the biggest power valves you are ever likely to use.

Large smoothing chokes—big condensers—no chance of motor-boating. Decoupling arrangements incorporated in every eliminator—you connect the Lissen Eliminator almost as you would an H.T. battery. Everything has been thought out for you—you simply put the eliminator in. Lissen have made eliminators safe by totally enclosing all the current-carrying parts in high-grade insulating material—see also the thickly insulated “cab-tyre” flex.

From the four types of Lissen Eliminators mentioned on this page you can choose one which exactly suits your set. The type you want is easy to choose. Your dealer will help you, or write direct to factory.

**4 MODELS TO SATISFY REQUIREMENTS OF ANY SET**

Every Lissen Eliminator is available for a small initial payment and easy gradual purchase terms.



**D.C. Model “A”**  
100/110, or 200/250 volts. Cash price 27/6. Or 5/- down and 5 monthly payments of 5/6.

**D.C. Model “B”**  
100/110, or 200/250 volts. Cash price 39/6. Or 5/- down and 8 monthly payments of 5/6.

**A.C. Model “A”**  
100/110, or 200/250 volts. Cash price 60/-. Or 5/- down and 10 monthly payments of 6/6.

**A.C. Model “B”**  
100/110 or 200/250 volts. Cash price 75/-. Or 5/- down and 10 monthly payments of 8/6.

**LISSEN**

**AC HIGH TENSION DC  
POWER UNIT**

To Ensure Speedy Delivery, Mention “A.W.” to Advertisers

**USE YOUR  
OWN HANDS  
AND  
SAVE  
POUNDS**

# Build yourself LISSEN

**GREATEST SET  
EVER  
BUILT**

*Yours*

**THE ONLY SET YOU CAN  
BUILD YOURSELF EMPLOYING  
METALLISED S.G.-HIGH-MU  
DETECTOR & ECONOMY  
POWER PENTODE VALVES**

*for*

**8'6  
DOWN**



**COMPLETE IN CABINET WITH LOUDSPEAKER £6.5s**

This new Lissen SKYSCRAPER Kit set is the only one on the market that you can build yourself employing a Metallised Screened Grid Valve, High Mu Detector and Economy Power Pentode. Around these three valves Lissen have designed a home constructor's kit the equal of which there has never been before. Why be satisfied with whispering foreign stations when you can BUILD WITH YOUR OWN HANDS this LISSEN SKYSCRAPER that will bring in loudly and clearly distant stations in a profusion that will add largely to your enjoyment of radio?

**KIT COMPLETE  
INCLUDING  
METALLISED S.G.  
HIGH MU DETECTOR &  
ECONOMY POWER  
PENTODE VALVES**

**89'6**



To-day you can buy the LISSEN SKYSCRAPER KIT on Gradual Payment Terms. Skyscraper Chassis Kit, complete with Valves, CASH PRICE 89/6. Or 8/6 down and twelve monthly payments of 7/6. Skyscraper Kit complete with Walnut Cabinet and inbuilt Loudspeaker, as illustrated, £6 5s. CASH. Or 11/6 down and twelve monthly payments of 10/6.

*You will Help Yourself and Help Us by Mentioning "A.W." to Advertisers*

# the great SKYSCRAPER

USE YOUR OWN HANDS AND SAVE POUNDS

**GREATEST CHART EVER PUBLISHED**

*Free*

**TELLS YOU EXACTLY WHAT TO DO WITH EVERY SINGLE NUT AND SCREW**

**TO "A.W." READERS**

Lissen have published a 1s. Constructional Chart, giving the most detailed instructions ever printed for the building of a wireless set. You can't go wrong—you are told what to do with every part, every wire, every terminal—everything is identified by photographs. Everybody without any technical knowledge or skill can safely and with complete certainty undertake to build this most modern of radio receivers from the instructions given and the parts Lissen have supplied.



*You can get the Lissen Skyscraper chart Free from any radio dealer, or by posting the COUPON on right direct to factory.*

**ASK YOUR DEALER OR POST THIS COUPON**

# LISSEN SKYSCRAPER 3 KIT

To— **COUPON**  
LISSEN LTD., Dept. A.W.12,  
WORPLE ROAD, ISLEWORTH,  
MIDDLESEX.

Please send me FREE copy of your 1/- Skyscraper Chart.

Name.....

Address.....

*Please Mention "A.W." When Corresponding with Advertisers*

## "ALL ABOUT WORKING YOUR SET FROM THE MAINS"—(Continued from page 1172)

negative side of the unit, the earth return circuit, is in nearly every case completed. The earth of your receiver is connected to low-tension negative and thus to the high-tension negative side of the unit.

Should it so happen that the positive wiring of your mains supply is earthed, then there will be continual short-circuits until you discover the fault. In any case, no matter which mains wire is earthed, it is generally forbidden by the power supply regulations to add any additional direct earth to the wiring.

To get over all these troubles a safety condenser is fitted in the mains unit. When you connect the unit to the set, dis-

### COMPONENTS FOR ACCUMULATOR CHARGER

- BASEBOARD**  
1—Baseboard, 6½ in. by 3½ in. (Camco, Peto-Scott, Readi-Rad).
- PANEL**  
1—Panel, 7 in. by 3½ in. (Becol, Peto-Scott, Readi-Rad).
- RECTIFIER**  
1—Transformer rectifier unit (Heayberd, type AO-2).
- AMMETER**  
1—0-3 ammeter (Bulgin).
- RHEOSTAT**  
1—7-ohm rheostat (Lissen, Ormond, Wearite).
- SWITCH**  
1—O.M.B. switch (Bulgin type S.80, Claude Lyons).
- SUNDRIES**  
Terminal mount (Sovereign, Junlt).  
Two terminals, marked: L.T.—, L.T.+ (Belling-Lee, Eelex, Burton).  
Connecting wire (Lewcos).  
Sleeving (Lewcos).  
Mains flex (Lewcoflex).  
Mains adaptor (Goltone).

connect the set's earth lead and take it to terminal E on the mains unit, leaving the set's earth terminal free.

Switch on and see if there is any high-tension coming through to the receiver. If the set appears dead then you will find that the mains plug is the wrong way round, thus putting a negative potential on to the valve anodes. Simply reverse the mains plug and all will be well. Adjust the variable tappings to suit your receiver. Don't forget to switch off when leaving the set. The mains switch on the unit must be turned off, together with the low-tension switch on the receiver.

### A HIGH-TENSION UNIT FOR ALTERNATING CURRENT MAINS

In order to get a high-tension supply from alternating current mains, you need first of all a rectifier to convert the A.C. supply to pulsating direct current, and then a smoothing supply to eliminate the ripple which would otherwise be heard in the set.

You can easily make up a simple valve rectifier to convert A.C. to D.C., and the smoothing side of the direct current high-tension unit just described will do excellently for smoothing out the ripple.

If at present you are on direct-current mains and are informed that you will soon be changing over to A.C., you can safely make up the D.C. unit just described, knowing that it can easily be converted to A.C. when the mains supply is changed over. If you already have an A.C. supply, then you can make up this rectifier as a separate unit, or you can mount it on the one baseboard with the D.C. high-tension unit.

A rectifier to convert A.C. to D.C. is just as simple as the smoothing side of the D.C. unit. A valve is used for rectification. There is a power transformer which gives the correct A.C. voltage to the valve anodes and also supplies

### COMPONENTS FOR THE D.C. HIGH-TENSION UNIT

- BASEBOARD**  
1—Baseboard, 7 in. by 6 in. (Peto-Scott).
- PANEL**  
1—Ebonite panel, 6 in. by 4½ in. (Peto-Scott).
- CHOKE**  
1—Low-frequency smoothing choke (Igranic constant inductance, type C.H.Z., Lissen, Telsen, Varley, Ferranti, Tunewell, Bulgin, R.I., Heayberd, Slektun).
- CONDENSERS**  
1—4-mfd. fixed condenser, 400-volt working (T.C.C., Telsen, Lissen, Dubilier, Ferranti, Peak, Formo).  
3—2-mfd. fixed condensers, 200-volt working (T.C.C., Telsen, Lissen, Dubilier, Ferranti, Peak, Formo).  
1—1-mfd. fixed condenser, 200-volt working (T.C.C., Telsea, Lissen, Dubilier, Ferranti, Peak, Formo).
- RESISTANCES**  
1—50,000-ohm resistance (Eric, Dubilier, Claude Lyons).  
1—5,000-ohm resistance (Eric, Dubilier, Claude Lyons).  
1—1,000-ohm resistance (Eric, Dubilier, Claude Lyons).
- POTENTIOMETERS**  
1—50,000-ohm variable potentiometer (Watmel, Lissen, Graham Farish, Colvern, Wearite).  
1—25,000-ohm wire-wound variable potentiometer (Colvern, Watmel, Wearite).
- SWITCH**  
1—Double-pole mains on-off switch (Bulgin type S.88, Claude Lyons, Igranic, Utility, Wearite).
- FUSES**  
1—Double-pole mains fuse holder and fuses (Bulgin, type F.9, Belling-Lee).
- SUNDRIES**  
5—terminals, marked: E, H.T.—, H.T.+1, H.T.+2, H.T.+3, H.T.+4 (Belling-Lee, type R, Eelex, Clx, Bulgin);  
Length twin flex (Lewcos).  
Connecting wire and sleeving (Lewcos, Jiffilix, Quickwyre).

switch in the D.C. unit. One side of the negative high-tension wire is connected to one output condenser terminal and the free smoothing choke terminal is connected to the other output condenser terminal.

The special power transformer has a number of secondary windings and a tapped primary winding to suit the various A.C. mains supplies. The main tapped secondary winding gives the

### COMPONENTS FOR THE A.C. MAINS HIGH-TENSION UNIT

- BASEBOARD**  
1—Baseboard, 7 in. by 6 in. (Peto-Scott).
- PANEL**  
1—Ebonite panel, 6 in. by 5½ in. (Peto-Scott).
- TRANSFORMER**  
1—Mains transformer (Tunewell type M.V.50, Heayberd, R.I., Parmeko, Varley, Bryce).
- CONDENSERS**  
1—4-mfd. fixed condenser, 400-volt working (T.C.C. type No. 80, Lissen, Dubilier, Telsen, Ferranti, Peak, Formo).  
1—0.2 centre-tapped fixed condenser (T.C.C. type No. 87A/02, Ferranti, Dubilier, Peak).
- FUSES**  
1—Double-pole mains fuse holder and fuses (Bulgin type F.9, Belling-Lee).
- VALVE HOLDER**  
1—Four-pin valve holder (Lissen, Telsen, Graham Farish, Igranic, W.B., Bulgin, Wearite).
- SWITCH**  
1—Double-pole mains on-off switch (Bulgin type S.88, Claude Lyons, Igranic, Utility, Wearite).
- SUNDRIES**  
Length twin flex (Lewcoflex).  
Connecting wire and sleeving (Lewcos, Jiffilix, Quickwyre).  
Rectifying valve (Mullard DW2).

high-tension output, while a second winding lights the filament of the rectifier valve. The following rectifier valves are suitable for use in this unit: Mullard DW2, Marconi and Osram Uro, Cossor 506BU.

### MAINS VALVES

A third secondary winding gives a 4-volt 4-ampere supply, centre tapped, so that if you want to modify your set and fit mains-heated valves, thus doing away with the accumulator, you can do so, taking the A.C. low-tension supply from this special 4-volt winding.

This will mean a number of alterations to the low-tension side of the receiver, and further decoupling may be needed in the set itself, owing to the greater "punch" given by mains valves.

This A.C. unit, used in conjunction with the D.C. smoothing unit, is quite suitable, without any other set alteration, for providing an economical high-tension supply and thus doing away with dry batteries.

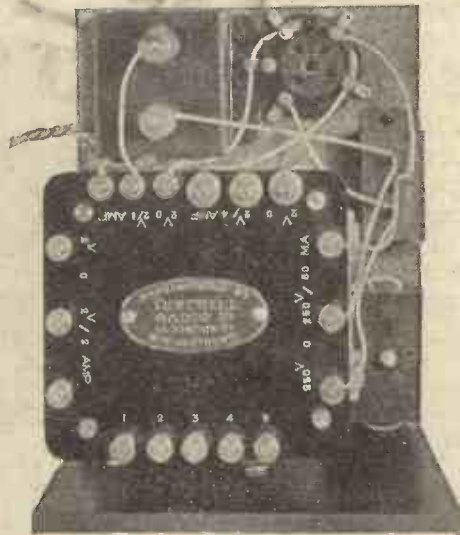

A plan view of the rectifier and transformer unit for use in conjunction with the D.C. H.T. unit

the heating current for the filament circuit of the rectifier valve. Therefore you do not need any batteries to work the rectifier valve and so it can hardly be counted as an additional valve in the outfit.

A large condenser (in this case of 4 microfarads) is put across the output side of the rectifier. Two other small condensers, of .1 microfarad capacity, are connected in the rectifier valve circuit.

The output condenser of the rectifier is connected to the smoothing side of the direct current mains unit. In this case there is no need to have the fuses or double-pole on-off

### WHEN SUBMITTING QUERIES

Please write concisely, giving essential particulars. A Fee of One Shilling (postal order), a stamped addressed envelope, and the coupon on the last page must accompany all letters. The following points should be noted.

Not more than two questions should be sent with any one letter.

The designing of apparatus or receivers cannot be undertaken.

Modifications of a straightforward nature can be made to blueprints, but we reserve to ourselves the right to determine the extent of an alteration to come within the scope of a query. Modifications to proprietary receivers and designs published by contemporary journals cannot be undertaken.

Readers' sets and components cannot be tested at this office. Readers desiring specific information upon any problem should not ask for it to be published in a forthcoming issue, as only queries of general interest are published and these only at our discretion. Queries cannot be answered by telephons or personally.

Readers ordering blueprints and requiring technical information in addition, should address a separate letter to the Query Department and conform with the rules.

**IF YOU ACTED ON OUR  
ADVICE LAST WEEK - YOU KNOW!  
IN CASE YOU DID NOT -  
WE REPEAT**

**There is NOTHING  
you can do that  
will so CERTAINLY  
improve your radio  
as to give it the  
pure power of a**

**LISSEN  
H.T. BATTERY**

**NEW  
VALVES  
ARE NECESSARY  
BUT  
NEW BATTERIES  
ARE  
MORE SO!**



**LISSEN LIMITED. WORPLE ROAD, ISLEWORTH, MIDDLESEX.**

*Mention of "Amateur Wireless" to Advertisers will Ensure Prompt Attention*

## 50 PRACTICAL HINTS (Continued from page 1157)

**PREVENTING THEM FROM SLIPPING**

**O**RDINARY grub screws do not sometimes suffice to prevent knobs from slipping on control shafts. This is particularly the case if the grub screws have flat or rounded ends. If you are troubled with knob slipping, file the small grub screws to a point, so that a positive grip is obtained on the brass control shafts.

**SHORTENING SPAGHETTIS**

**O**RDINARY flexible resistances are made in standard lengths, and if you want to put a long flexible resistance between two terminal points close together, you should tie a very loose knot in the resistance. Do not, on any account, cut the resistance to shorten it, for not only will you find it extremely difficult to make an end contact to the loose resistance, but you will alter the resistance value.

**FIT A SPARK GAP**

**I**F you have a long aerial which is liable to collect a heavy static charge, it is a good plan to fit a spark gap across the aerial and earth terminals so that the static electricity can be discharged through to earth. A very small gap of less than  $\frac{1}{8}$  in. should be allowed between two brass strips, one clamped under the aerial terminals and the other under the earth terminal. Make sure that there is only an "edge" gap and that the faces of the brass strips do not increase the capacity between aerial and earth.

**DECOUPLING COMPONENT VALUES**

**A**RE you sure that you have the right values for the resistance and condenser in the decoupling of your set? A decoupling condenser will sometimes work if it has a value of only 1-microfarad, but a 2-microfarad condenser is usually safer. In the case of a transformer-coupled stage, the decoupling condenser can generally have a value of 200,000 or 300,000 ohms. It should have a larger value, up to about 5,000 ohms, in the case of a resistance-coupled stage.

**STABILISING THE DETECTOR**

**Y**OU sometimes get poor results with a set in which the high-tension supply has a fairly high internal resistance. The detector stage of a set which operates satisfactorily from batteries may be unstable, when the set is worked from the mains. Try connecting a 1- or 2-microfarad condenser across the detector tapping and H.T.—

**PROTECT THE PANEL**

**W**HEN you are doing any work on a new ebonite panel, hack-sawing or drilling,

clamp the panel in a vice between two or three sheets of thick paper to protect the polished surface of the panel. Don't clamp the vice too tightly or you may crack the panel.

**STOP THEM ROTATING**

**T**HERE is nothing more annoying than terminals which rotate when the clamping top is turned, twisting the shank and so probably pulling loose some of the wiring beneath. If you want to stop this trouble, file flats on the terminal shank at the point where it passes through the panel and cut a slot instead of a round hole in the panel, so that the filed shank fits into it, and cannot rotate.

**METALLISING YOUR VALVES**

**T**HERE are some aluminium and similar paints which contain a large amount of metal and which are therefore suitable for metallising valve bulbs. If you have an unstable screened-grid or detector valve, paint it with a coating of metal paint, taking care that in the case of a screen-grid valve the paint does not make contact with the top terminal. If you want to earth this metal covering, twist some bare wire round the bulb and take it to one of the filament pins.

**WHICH WAY-ROUND?**

**E**VEN when an output choke is fitted to a set, it sometimes makes a deal of difference which way round the speaker is connected. This is particularly the case if any other leads, battery wiring, or pick-up leads, run close to the set. With the speaker connected one way round, interaction may result, while in the other there may be no noticeable self-oscillation.

**REACTION ON THE LEFT**

**I**F you are making up a set to your own design and are puzzled where to place the panel controls, remember that it is generally advisable to have the tuning knob in the centre, for the sake of symmetry, with the reaction knob on the left hand, so that the main tuning knob can be operated with the right hand.

**ANCHORING MAINS TRANSFORMERS**

**S**OMETIMES the low-tension secondary of a mains transformer gives a voltage higher than is required for the number of valves in the circuit. It pays sometimes to put a resistance in parallel with the L.T. secondary to increase load and regulate the voltage. The resistance should, of course, be of the power-type, capable of carrying up to about 1 ampere, depending on the value required.

**FUSES AND MOTOR-BOATING**

**Y**OU must remember that even a short length of fuse wire has an appreciable resistance. If it had no resistance it could not very well function as a fuse! This resistance may be disturbing at times, and in the case of some sets, a high-resistance fuse in the negative battery lead is sufficient to cause the circuit to motor-boat.

**SHIELDS ON CONDENSERS**

**S**OME variable condensers are provided with shields covering the fixed vanes. When mounting a condenser of this type, arrange it so that the fixed vanes are uppermost, and so that the shield prevents dust forming between the vanes.

**LOCK NUTS ON PRE-SETS**

**O**RDINARY screw-down type pre-set condensers are generally fitted with a lock nut so that once the correct value of capacity has been set, the control can be locked. Don't forget to slack off this lock nut before the pre-set condenser is again adjusted, for otherwise the thread of the adjusting screw will be damaged.

**COLOURING THE CANS**

**R**ESISTANCES are colour coded nowadays to indicate at once what the value is. Certain coils and couplers are also coloured to show in what part of the circuit they function. This is quite a good tip for amateur use. A few minutes spent with a brush and a few paints will help you to identify at once the stock of components in your junk box.

**WIRING MAINS SETS**

**F**EW constructors fully realise what a large current the wires from a mains transformer to the valve heaters in a mains set have to carry.

If there are three valves in the set, then the wire has to carry 3 amperes.

The wire usually employed for connecting up electric radiators is designed to carry up to five amperes and, if used for connecting valve heaters to the appropriate transformer terminals, will have a satisfactory safety margin and will also be efficient.

**METAL SCREENS**

**Q**UITE a number of amateurs and, indeed, a few earnest experimenters, appear to think that screening of any form between the circuits of a receiver or around the components tends to reduce or eliminate inductive interaction. This idea, of course, is quite wrong.

Metal screens only act as electro-static or capacity shields and do not prevent or minimise inductive effects.

It is therefore essential, when assembling wireless components

which are separated or shielded by metal screens, to bear in mind that inductive coupling will occur unless steps are taken to keep magnetic fields at right angles to each other.

**BATTERIES AND DAMPING**

**T**HERE is a fairly general failing in some amateur circles, when placing batteries in the cabinet which holds the receiver, to arrange the grid-bias or H.T. battery close to the end of the receiver which holds the tuning coil. A moment's thought will make it clear that, as a battery possesses a large mass of metal, damping will occur, due to the field of the coil interacting with the zinc of the cells.

This damping gives rise to flat tuning and often spoils the efficiency of an otherwise satisfactory receiver.

Batteries should be kept well away from the tuning coils in a set and the best place to put them is at the L.F. end of the receiver baseboard.

**GOOD R.C. VALUES**

**I**DEAS of what constitute good values for the condenser and leak in a resistance-coupled circuit have changed considerably, as valve design has improved. Average values nowadays are 60,000 ohms for the anode resistance, .006-microfarad for the fixed condenser, and about  $\frac{1}{2}$  megohm for the grid leak.

**SHORT-WAVE COIL SPACING**

**A**LITTLE trouble sometimes experienced with short-wave coils is that the spacing between the turns of air-spaced coils can vary. This will affect the tuning. Any mechanical vibration will upset the tuning point, and strips of notched fibre or ebonite should be inserted to keep the turns rigid.

**TRACING A CRACKLE**

**R**ECEPTION is sometimes marred by crackling noises which you know are due to partial contact between the vanes of a multi-gang condenser. The best plan to trace the source of these noises is to disconnect all the sections of the ganged condenser, replacing the wires to the sections, one at a time. This will make it obvious which section is short-circuiting.

**A GANGED COIL TROUBLE**

**W**HEN two dual-range coils are ganged together with the wave-change switches linked, you must make sure that the switches open and close together, for otherwise you will get poor reception, owing to one coil working on the long waves, while the other is on the medium waves! The links between the ganged coil switches are sometimes adjustable. If no such

(Continued on page 1180)

# New Times Sales Co

EVERYTHING  
RADIO-EASIEST  
OF EASY TERMS.

## ULTRA "TIGER"



A.C. or D.C. Mains. S.G., S.G. Detector and Pentode. Moving-coil Speaker. Complete with Mazda Valves. Ready for use. Cash Price, Carriage Paid, £15/15/0.

**20/-**

WITH ORDER

Balance in 17 monthly payments of 20/-.

ULTRA "PANTHER" Cash or C.O.D. £18:18 Or 18 monthly payments of 24/3

## ULTRA 1933 "BLUE FOX"

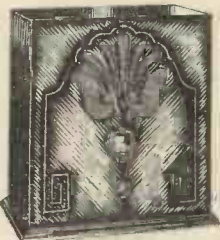

A.C. or D.C. Mains. Detector and Pentode Valves. Moving-coil Speaker. Complete with Valves and Cabinet. Ready for use. Cash Price, Carriage Paid, £10/10/0.

**15/9**

WITH ORDER

Balance in 14 monthly payments of 15/9 only.

## AERODYNE SCREENED GRID 3

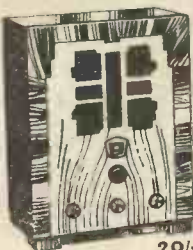

With Variable-mu. Complete and ready to play, with Valves, Batteries and Accumulator, with Moving-coil Speaker. Cash Price, Carriage Paid, £9/9/0.

**14/3**

WITH ORDER

Balance in 14 monthly payments 14/3

ALL-MAINS MODEL with Variable-mu S.G. Valve. Cash Price, Carriage Paid, £15/15/0.

20/- WITH ORDER  
Balance in 17 monthly payments of 20/-

## S.T. 400 FINISHED INSTRUMENT

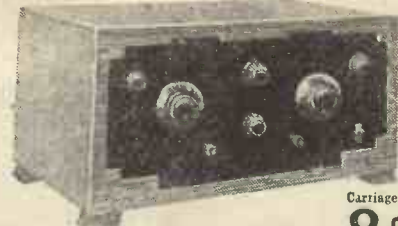

Carriage Paid.

**8 Gns.**

Assembled with "Easybilt" S.T.400 Kit. Cash or C.O.D. Every component guaranteed. Aerial tested. Complete with set of Valves and Table Model Oak Cabinet. Batteries extra.

Or 12 monthly payments, 15/6

## STRICT PRIVACY GUARANTEED

### "LISSEN SKYSCRAPER 3"

CHASSIS MODEL, with Lissen S.G., Detector, and Pentode Valves. Cash Price £4/9/6. Carriage Paid. Balance in 11 monthly payments of 8/3.

**8/3**

WITH ORDER

CABINET MODEL. Complete with Lissen Speaker and Lissen S.G., Detector and Pentode Valves. Cash Price £6/5/0. Carriage Paid. Balance in 11 monthly payments of 11/6.

**11/6**

WITH ORDER

### COSSOR MELODY MAKER Model 335

Complete with Valves, Speaker, and Cabinet. Employs Cossor Variable-mu S.G., H.F. stage, Detector and Power Valves. Cash Price £7/17/6. Balance in 11 monthly payments of 14/10.

**10/-**

WITH ORDER

BLUE SPOT SPEAKER UNIT AND CHASSIS. Type 1000. Cash Price, £1/12/6. Carriage Paid. Balance in 6 monthly payments of 5/2.

With 5/2 order

BLUE SPOT UNIT AND CHASSIS. Type 99 P.M. Including matched Transformer. Cash Price, £2/19/6. Balance in 11 monthly payments of 5/6.

With 5/6 order

EPOCH "20 C" PERMANENT MAGNET MOVING COIL SPEAKER. (New Edition). With 3-ratio input transformer. Cash Price, £1/15/0. Carriage Paid. Balance in 5 monthly payments of 6/6.

With 6/6 order

W.B. PERMANENT-MAGNET MOVING-COIL SPEAKER. Type PM4. Complete with Transformer. Cash Price, £2/2/0. Carriage Paid. Balance in 7 monthly payments of 5/9.

With 5/9 order

ATLAS ELIMINATOR. Type A.C.244. Three tappings. S.G. Detector and Power. Output: 120 volts at 20 m/a. Cash Price, £2/19/6. Carriage Paid. Balance in 11 monthly payments of 5/6.

With 5/6 order

GARRARD INDUCTION GRAMOPHONE MOTOR. For A.C. mains. Model 202. Mounted on 12-inch nickel motor plate with fully automatic electric starting and stopping switch. Cash Price, £2/10/0. Carriage Paid. Balance in 11-monthly payments of 4/7.

With 4/7 order

## TELSEN JUPITER S.G.3

Complete Kit as advertised, less Valves and Cabinet. Cash Price £3/17/0. Sent Carriage Paid on first payment of ...

**7/-**

Balance in 11 monthly payments of 7/-

R. & A. "VICTOR" PERMANENT-MAGNET MOVING-COIL SPEAKER DE LUXE. With 6-ratio input transformer and protecting grille. Cash Price, £3/10/0. Carriage Paid. Balance in 11 monthly payments of 6/5.

Send 6/5 only

EKCO H. T. ELIMINATOR A.C.25 for A.C. mains. Tapped S.G. variable, 50/80 volts and 120/150 volts max. at 25 m/A. Cash or C.O.D., Carriage Paid, £3/17/6. Balance in 11 monthly payments of 7/-.

Send 7/- only

R. & A. "CHALLENGER" PERMANENT-MAGNET MOVING-COIL SPEAKER. With special Ferranti multi-ratio input transformer. Cash Price, Carriage Paid, £1/15/0. Balance in 5 monthly payments of 6/6.

Send 6/6 only

## PYE "G" For A.C. Mains

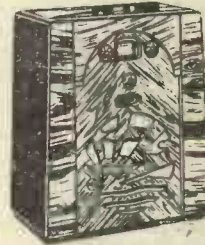

Three-valve with Bandpass Tuning. Variable-mu, Power grid and Pentode. Complete ready to play, with Moving-coil Speaker. Walnut Cabinet. Cash Price, Carriage Paid, £18/18/0.

**24/3**

WITH ORDER

Balance in 17 monthly payments of 24/3.

## LISSEN S.G.3 PENTODE BATTERY SET

In Walnut Cabinet, complete with Speaker, Valves and all necessary Batteries. Wave-length Calibrated. Cash Price, Carriage Paid £8/17/6.



**13/4**

WITH ORDER

Balance in 14 monthly payments of 13/4.

## TELSEN MAGNAMARA

FOR A.C. MAINS S.G., Detector and Pentode Complete, ready to play, with Moving-coil Speaker. In Unstained Cabinet. Cash Price, Carriage Paid, £12/12/0.



**16/-**

WITH ORDER

Balance in 17 monthly payments of 16/-.

In Polished Walnut Cabinet: Cash or C.O.D. £15/15/6. Carriage Paid. Or by 18 monthly payments of 23/-.

## PHILIPS TYPE 830A VALVE RECEIVER

For A.C. Mains. Two Screen-grid, Power-grid Detector and Pentode. With Moving-coil Speaker. Provision for Pick-up and external Speaker. Cash Price, Carriage Paid, £16/16/0.



**21/6**

WITH ORDER

Balance in 17 monthly payments of 21/6.

## NEW TIMES SALES CO., 56 LUDGATE HILL, LONDON, E.C.4

Dear Sirs: I enclose £ ... s. ... d. as first payment for .....

NAME .....

ADDRESS .....

A.W. 26/11/32

**EVERYTHING CARRIAGE PAID**  
Pioneers of Radio on Easy Terms in 1924. We shall be pleased to quote you by return for all your Radio requirements. We carry stocks of all leading manufacturers' products advertised in this journal. Any parcel of components or accessories over £2 supplied on Easy Terms. Send for NEW CATALOGUE.

Don't Forget to Say That You Saw it in "A.W."

**HOW IT IS DONE:****FEEDING THE AMPLIFIERS**

**T**HERE are over four hundred valves in the amplifiers at the London studio headquarters, and these are fed from batteries for H.T., L.T., and grid bias. So, in order to feed the dozens of separate amplifiers there is a battery room at the side of the control room at the top of Broadcasting House. The number and size of these accumulators makes interesting comparison with the batteries the average amateur uses—and this is particularly so as battery valves are used in all the speech amplifiers.

The B.B.C. uses six-volt valves, and there are two big banks of low-tension accumulators in the battery room. The bank for the main speech amplifiers has a capacity of 2,100 a.h. There is a separate set of accumulators for the delicate "A" amplifiers—the first amplification stages in the microphone chain. Separate batteries have to be used to prevent the "clicks" in the transmission which would be heard if there was any voltage variation on the filaments of the valves in the early stages of amplification.

There is a 300-volt bank of high-tension accumulators which gives the H.T. for all the amplifiers.

There are heavy copper leads running

from the high-tension accumulators to the amplifier racks, so that there is no voltage drop or additional internal resistance which would cause motor-boating. Most of the B.B.C. amplifiers are decoupled, however.

The grid-bias batteries are in a section of the battery room which is close to the amplifier panels, and so the leads are very short. This saves having grid decoupling circuits. There are two sets of batteries which are for special jobs in connection with the microphones

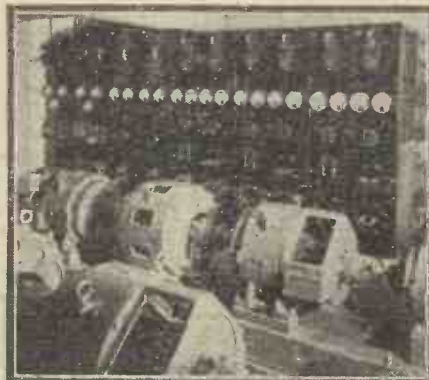

Just one corner of the battery charging equipment in Broadcasting House

and amplifiers. The new carbon microphones need a polarising voltage, and there is an 8-volt bank of batteries to supply this. All the switching in the control room amplifiers and in the landline equipment is done with relays, and there is a 24-volt bank of batteries of 600 a.h. capacity to feed the relay operating coils.

Each bank of batteries is duplicated so that one set is on charge, while the other is on loan. They are charged from motor generators driven by induction motors, but the small grid-bias batteries are charged through metal rectifiers. Even the charging equipment is in duplicate to prevent breakdown! It is a full-time job for the control-room engineers to keep all the batteries topped up and properly charged. One of the engineers keeps a log of the voltage readings taken from the battery control panel, and there is a regular daily schedule for the battery charging. One of the advantages of having accumulators instead of rotary converters for supplying the amplifier is that there is less chance of commutator ripple or any other interference. The charging apparatus is so arranged that no noise is induced into the amplifiers when the motor generators are working.

**"THE AERIAL TAP AND SELECTIVITY"**

(Continued from page 1167)

to adjust the valve right to the edge of oscillation and apart from the adjustment being very critical the side-bands are badly cut off and quality becomes very distorted. Consequently we cannot carry this tapping-down process too far, but it is certainly

possible to go down to one-eighth or even one-tenth of the total coil provided the reaction adjustment is reasonably smooth.

We may summarise the results, therefore, by saying that where a simple detector circuit with reaction is being used it does pay to tap rather lower down the coil and to bring up the strength with reaction. The circuit does not appear so lively at first sight because without reaction the

signal strength is reduced, but the application of a judicious amount of reaction enables the strength to be recovered with considerably better selectivity than is possible with a higher tap.

On the other hand where no reaction is applied to the aerial circuit, as is usually the case in a high-frequency stage, tapping down the coil does not make any great improvement in the selectivity.

**50 PRACTICAL HINTS (Continued from page 1178)**

adjustment is provided with your coils, then remount one of the coils so that the wave-change switches open and close together.

**DON'T LET IT OSCILLATE**

**I**N spite of the constantly repeated advice not to let a receiver oscillate continually, there are still enthusiasts who put their receivers in a state of oscillation before searching for foreign stations. The ability on the part of the set to oscillate gently, without too much background noise, is a great help in making final adjustments when tuning, but it is a mistake to let the set oscillate all the time the tuning knobs are turned.

**IS IT NON-INDUCTIVE?**

**N**ON-INDUCTIVE fixed condensers are sometimes specified at certain points in the set.

Non-inductive condensers are generally used, for instance, for bypassing in the screening-grid circuit of an S.G. valve. Never use a plain type fixed condenser, where a non-inductive condenser is specified.

**HOW TO FIND THOSE STATIONS**

**U**SUALLY the easiest station to receive is the local "Regional"; the London Regional will be found in the middle of the tuning dial, at approximately 100 degrees. A little higher up, round about 112 degrees, is the Scottish Regional, followed by the Midland at approximately 120 degrees. The North Regional is quite easy to find, as the dial reading is usually 20 degrees or so below the maximum, that is 160 degrees on a 180-degree dial. About 2 degrees above and below will be

heard Prague and Langenberg respectively. Descending to the lower end of the scale, we find the London National programme approximately 20 degrees from the bottom. If we tune still lower to approximately 5 degrees, this will be about the correct setting for Fecamp on 225.3 metres.

The North National can be identified very easily as the programme is the same as that of the London National. The dial reading is approximately 10 or 12 degrees above that of London.

**THAT IMPORTANT DETECTOR VOLTAGE**

**O**NE of the easiest valves to overload in a set is the detector stage. This is sometimes accentuated by the fact that the detector has too low a high-tension voltage applied to it.

**GRID CONDENSER VALUES**

**H**AVE you ever tried altering the value of the fixed condenser in the detector grid circuit? The value used often makes a big difference to sensitivity and tone. The conventional value, of course, is .0003 microfarad. But you will generally find that with a .0001-microfarad condenser the high notes are stronger than with a larger grid condenser in circuit.

**IMPROVING YOUR POTENTIOMETER**

**I**F the rotating arm of a potentiometer does not make contact with the winding over the whole distance of travel, try fitting a double arm—the additional arm being mounted also on the control shaft, but consisting of a piece of leaf spring, bearing on the actual contactor arm of the "pot."



# READY RADIO KITS CATER FOR EVERY CONSTRUCTOR

## READY RADIO S. T. 400

Complete Kit,

**£4 : 17 : 6**

Or deposit of 9/6 and 11 monthly payments of 9/9

**MODEL A**

Complete Kit, with four specified valves and beautiful walnut cabinet fitted with moving-coil speaker.

**£10 . 10 . 0**

Or deposit of 20/- and 11 monthly payments of 21/-

**MODEL B**

Complete Kit, with four specified valves,

**£6 . 16 . 9**

Or deposit of 12/6 and 11 monthly payments of 13/9



**BUILT IN THREE HOURS  
TWENTY MINUTES**

A new four-valve set which will give you over one hundred programmes—more than fifty at “local” strength. Amazing selectivity and sensitivity; wonderfully fascinating to build and operate. You must build it.

*Full-size blueprint and complete instructions free with every kit.*

## READY RADIO “METEOR S.G.3”

Complete Kit,

**£3 : 15 : 3**

Or 9 monthly payments of 9/9

**MODEL A**

Complete Kit, with set of three Mullard valves and beautiful walnut cabinet fitted with permanent magnet moving-coil speaker.

**£8 . 17 . 6**

Or 12 monthly payments of 17/-

**MODEL B**

Complete Kit, with set of three Mullard valves (metalised screened grid, detector, and power).

**£5 . 7 . 6**

Or 10 monthly payments of 12/6. (A pentode may be used if desired, 8/9 extra.)



**BUILT IN TWO HOURS  
TWENTY MINUTES**

The only kit set to give you all the wonderful features of the S.T.300 plus the additional advantage of ultra-short-wave reception of stations in all parts of the world. Super-sharp selectivity; huge volume; a minimum of thirty stations guaranteed. Moving-coil reproduction.

*Very easy to build. Full instructions, diagrams, and photo-plans with every kit.*

## READY RADIO “THREE-O-THREE”

Complete Kit,

**£2 : 7 : 3**

Or deposit of 9/6 and 5 monthly payments of 9/-

**MODEL A**

Complete Kit, with set of three Mullard valves and beautiful walnut cabinet fitted with permanent magnet moving-coil speaker.

**£6 . 17 . 6**

Or 10 monthly payments of 16/-

**MODEL B**

Complete Kit, with set of three Mullard valves,

**£3 . 10 . 0**

Or 7 monthly payments of 11/9



**BUILT IN TWENTY MINUTES**

The most efficient type of detector-two L.F. set. Remarkably selective and sensitive, giving an excellent choice of home and foreign programmes with superb moving-coil quality. Incorporates the unique Ready Radio dual-range coil, fitted with four-in-one control (on-off, wavechange, selectivity, and volume control all operated by one knob). Only five components to mount and five wires to connect—you will build it in twenty minutes.

*Full instructions, diagrams, and photo-plans with every kit.*

Obtainable from all leading Radio Dealers.



Announcement of READY RADIO, LTD., Eastnor House, Blackheath, S.E.3.  
Telephone : Lee Green 5678. Telegrams : Readtrad, Blackvil, London.

To READY RADIO (Book Dept.), Eastnor House, Blackheath, S.E.3.  
Please send me full details of your Kits and tell me about your Registered Users' Scheme. I enclose 1½d. stamp to cover postage.

NAME .....

ADDRESS .....

..... A.W.15.

Mention of “Amateur Wireless” to Advertisers will Ensure Prompt Attention



# What Our Readers Think

The Editor does not necessarily agree with the views expressed by readers and does not accept responsibility for the letters published. Letters cannot be published which do not bear the sender's full name and address



length. Meanwhile our licences are rendered useless.

R. R. (Sunderland).

## The "Century Super"

SIR,—May I once again encroach on your valuable space for the purpose of praising the original "Century-Super"? I find the short-wave band extremely interesting, for it has brought to me items of interest from all over the world. On one recent Sunday afternoon I heard a relay of the Belgium *v.* Holland football match from Bandoeng, PLV, on 31.86 metres. Surely listening to a programme from the distant Dutch East Indies at loud-speaker strength is an excellent tribute to the designer! Another great thrill is to hear VK2ME (Sydney), the "Voice of Australia." I have been fortunate enough to hear it nearly every time I have tried to receive it.

F. A. B. (Ridgewell, Essex).

## What Is the Cause?

SIR,—I had rather a curious experience the other day, which I have written below:—

I have a battery-operated set which has extension wires into other rooms, but has no output filter. The other day when I had tuned in the Regional programme I connected up the extension wires. What was my surprise to see the fuse bulb light up! I changed the valves for some old ones and then investigated. Eventually I found that the cause was that the extension wires were connected to a crystal set's 'phone terminals. The crystal set also had its aerial and earth connected up. As soon, however, as I disconnected the earth wire from the crystal set, the bulb went out; when the earth was connected up the bulb lit up. I fell upon this rather by chance as both the earths are in different positions. One goes into the garden and the other to a pipe in another part of the house.

F. C. (Wallington).

## Radio Paris

SIR,—I was relieved to read in "On Your Wavelength" in "A.W." of November 12 that "Thermion" has also experienced fading on the long as well as the medium wavelengths. At the moment of writing (10.30 p.m.) I am listening to Radio Paris, and the strength fades to

The Editor invites letters from readers on all interesting radio subjects. For the most interesting letter published each week a general-purpose valve or other component to the same value will be given.

## Controls—A Useful Suggestion

SIR,—May I request you to use the influence which your publication undoubtedly has over the radio trade in order to bring about some revision of the present position regarding component controls. At the moment, any constructor who wishes to build a set which will have an ornamental as well as a practical value is greatly handicapped by the fact that almost every manufacturer uses a different type of control knob for his variable components; some, in fact, use several. This means that, even though a constructor may purchase all his panel components from the same maker, his set will probably possess a heterogeneous collection of knobs which, although they may fulfil their primary purpose admirably, will certainly not enhance its value as an *objet d'art*.

It is obviously neither feasible nor desirable to standardise control knobs but surely this could be done with regard to the dimensions of spindles. The components might then be sold alternatively without knobs, leaving the way clear for an enterprising bakelite manufacturer to produce a range of standard knobs. The intending constructor would thus be enabled to choose knobs whose shape and colour were suited to his particular taste or requirements.

W. C. M. (Haverfordwest).

## Newcastle's Troubles

SIR,—Referring to H. S. R.'s letter in your issue of October 29 with regard to Aberdeen's "shortish" wavelength, I wish to endorse his remarks, in so far as they equally apply to Newcastle's reduction of wavelength from 288 to 211 metres.

In the course of my many inquiries from users of multi-valve sets as to how the new wavelength is working, I have invariably received the reply, "Oh, I don't bother with Newcastle now; it's useless; besides, if I want this programme, there is always the North Regional."

Judging by correspondence which has appeared in the Press, both here and in Newcastle, the great majority of listeners appear to be dissatisfied with the change, which nobody apparently wanted but the B.B.C.

Here in Sunderland, twelve miles from the transmitter, crystal sets have been rendered useless, no one having, so far as I can ascertain, been able to find a means of adapting their set to the new wave-

almost inaudibility, which is most extraordinary as Radio Paris is a most consistent performer in these parts. Remarkable as it seems, although London Regional has faded slightly at times this evening, Rome has maintained a steady strength. I have never known the long-wavers to be so poor.

E. J. H. (Ilford, Essex).

## Typed by a Blinded Operator from his own Braille Shorthand Notes

SIR,—As you will understand from the above heading, I am unable to see and at the same time am very interested in wireless, but under the circumstances it is very difficult to obtain the necessary knowledge from AMATEUR WIRELESS when a non-expert reads it to me.

I wonder if you know of any keen amateur in the neighbourhood of 41 Eardley Crescent, Earls Court, S.W.5, who would, and could, help me to build the set which you are explaining in your supplement.

I shall be very pleased if you can help or advise me in any way.

T. E. CLARKE, (St. Dunstan's.)

## "THE NEW B.B.C. MICROPHONES"

(Continued from page 1155)

the smallest of the microphones, being no larger than an ordinary domestic thermometer, and having the same shape. It is a condenser microphone; that is to say it has two electrodes, the distance between which is varied by the sound waves, and the resulting capacity change alters the tuning of the sensitive amplifier to which it is coupled.

A "mike" which has often struck terror in the heart of an initiate artiste is the R.C.A. condenser microphone, which is housed in a curious metal baffle, making it look for all the world like a bomb. This "mike" is famous more for its excellent frequency response than for its suitability under O.B. conditions. It has nevertheless made its appearance at the Queen's Hall, where it has helped still further to improve these fine O.B. relays.

A small stable microphone which is in some of the news studios and studio silence cabinets is the B.T.H. carbon. This is a fairly directional microphone, giving a crisp reproduction very suitable for speech. It has a comparatively silent background, considering its sensitivity.

With its present wide range of "mikes," old and new Reisz, R.C.A. "bomb," Western Electric moving-coil, B.T.H. carbon and Edison Bell "thermometer," the B.B.C. is well equipped to tackle studio and outdoor broadcasting under all conditions.



**Graham Farish says**

# YOU CAN'T BE MORE CRITICAL THAN I AM

I don't know what tests you make of the Components you buy, but I do know that every one I sell is tested far more stringently before it leaves my factory. It has to be not only capable of doing the job for which it is designed—but it has to bear electrical stresses greater than will ever be required in practice before I allow it to bear my name. That is why you can trust every Graham Farish product to the limit.

**Graham Farish**  
**LIT-LOS**  
SOLID DIELECTRIC  
VARIABLE CONDENSERS



A very carefully constructed instrument, compact in size and efficient in design, with accurately gauged bakelite dielectrics and solid brass pigtail connection to moving vanes. Made in all capacities up to .0005 mfd. in tuning straight line capacity and differential types. Used by many leading manufacturers and specified in sets by famous designers. One hole fixing; supplied complete with terminals.

**2/6**  
EACH

**Graham Farish**  
**OHMITE**  
RESISTANCES

The popular and efficient resistances for all general purposes. All values 300 ohms to 5 megohms. 1/6d. each.

**1/6**  
EACH



**BETTER THAN WIRE WOUND**

## GRAHAM FARISH COMPONENTS

GRAHAM FARISH LTD., MASONS HILL, BROMLEY, KENT.



Export Dept. : 11-12 FENCHURCH STREET, LONDON, E.C.3

Mention of "Amateur Wireless" to Advertisers will Ensure Prompt Attention

Some Notes on Present

day Short-wave Conditions

# Around the Short-wave Dial



TELEVISION sponsored by the Columbia Broadcasting Company is now being broadcast through W2XAB on 105.3 metres for vision and 109 metres for sound. The times usually are between 1 and 4 a.m., so little difficulty should be experienced in receiving this station. I should like to hear from anyone who has picked up these transmissions.

Madrid EAQ, on 30.43 metres, broadcasts quite a good programme between 11.30 p.m. and 12.30 a.m. each night. If anyone is interested, bull-fighting notes can be heard at 12.30 a.m., followed by a final news bulletin. A special programme for the benefit of South American listeners is sometimes broadcast during the evening on a wavelength of 15.198 metres.

The introduction of Empire broadcasting will cause a certain amount of rearrangement in the colonies. The New Zealand authorities have made arrangements for 1YA Auckland, 2YA Wellington, 3YA Christchurch and 4YA Dunedin to broadcast these special programmes throughout the whole country.

SUV Cairo on 29.84 metres, which was intended primarily for the telephone service, transmits concerts at regular intervals, reproduction being particularly good; there is also a marked absence of fading and static.

Batavia on 26 metres broadcasts from 11 a.m. to 1 p.m. a light concert from a local hotel. Occasionally a gramophone concert is given instead, the records being only of local interest.

On Sunday evenings at 6 p.m. the Columbia Broadcasting Company have arranged talks to be broadcast via the Atlantic 'phone. These, usually sent out from GBS on 33.25 metres, or GBU on 24.1 metres, are given by eminent English and Continental experts and are mainly political.

During the past week, reception has not been altogether satisfactory. On Tuesday, November 1, Zeesen on 31.38 metres was relaying a Bach concert from Witzleben. Skanleback on 31.56 metres was comparatively poor and although signal strength improved rather in the evening, it was

jammed by an Atlantic 'phone station. Radio Coloniale is scheduled to close down at 7 p.m.; at 8.30, however, it was still an R6 signal relaying the P.T.T. programme.

On Wednesday, Moscow was the best station of the day and a lady announcer was reading a propaganda talk in French for nearly an hour. This was followed by a so-called musical programme, which consisted mainly of a harmonium. Prague has now recommenced its short-wave transmissions and is usually a strong signal on 58 metres. The main programme is usually a relay from 9 p.m. until the closing down.

Thursday was notable for being one of the worst days for some weeks. Atmospherics were particularly bad, and signal strength of stations received was greatly below par. After midnight, as the reception was not worth listening to, I tuned in on my medium-wave super-het and received eight North and South American stations between 200 and 300 metres.

The conditions on the following day, however, were distinctly better. Boundbrook and W8XK were both R8 and the conditions were distinctly above the average for nearly all the North American stations.

Curiously enough, on Sunday, although W8XK and W3XAL were R8, W2XAF was almost inaudible; lower down on the tuning scale Radio Coloniale was good 'phone strength. There is no accounting for this very erratic reception of the North American stations.

## "NEW CENTURY SUPER" NOTES

By RUTHERFORD WILKINS

I HAVE been asked by a number of people what are the advantages of the "New Century Super," or any super-het. for that matter, over an ordinary three-valver, when they only intend to use the set for listening to the locals or for an occasional foreigner to provide an alternative programme.

It is perfectly true that a straight three can provide excellent results from the Regional stations and can also be relied upon to give good reception from a fair number of high-powered foreign stations. What is generally overlooked, however, is the amazing degree of selectivity that can be obtained from a super-heterodyne with comparative simplicity of tuning. The "New Century Super" has no less than nine tuned circuits and thus is capable of giving a degree of selectivity which could only be obtained by a straight three employing four band-pass circuits before the H.F. stage. At the same time, owing to the fact that a system of fixed tuning is employed in the intermediate transformers of the "New Century Super," there is no necessity for trimming or other tuning complications which would lead to insurmountable trouble if a three-valve set with a large number of band-pass circuits be used.

Only a set with this degree of selectivity can possibly separate Muhlacker from London Regional or Frankfurt from London National. It is, therefore, easy to realise

that a super-heterodyne type of set is really essential to even a local-station listener if he wishes to enjoy absolutely interference-free reception. This point of view must be stressed in view of the present tendency of foreign stations which often operate within a few kilocycles of each other to raise their powers to 50 and 60 and even 100 kilowatts.

Another point worthy of notice is the fact that the high degree of H.F. amplification given by the super-heterodyne enables the listener to forget the power difference between the local station and the fairly distant foreigner. By means of judicious use of the volume control, it is easily possible to tune in 30 or 40 foreigners at "local station" volume.

If a greater power output is needed than that which is already given by the "New Century Super," it is a good plan to replace the present single output valve by a pair of pentodes or medium power valves in push-pull. This conversion can be quite easily effected and it is not absolutely essential to change the existing intervalve transformer. The one that is at present in the set can be used if the grids of the two valves are connected to the two ends of the secondary winding, with two  $\frac{1}{4}$ -megohm grid leaks connected in series across it. The bias lead feeding the two valves can then be taken from the junction of the two resistances.

It is better practice, however, to use a proper split secondary input transformer in this position. The output device can consist of either a centre-tapped L.F. choke or a push-pull output transformer, but care should be taken to isolate the speaker from the H.T. circuit by means of two 2-mfd. condensers if a centre-tapped choke is used. If you have not already purchased your speaker and intend to use push-pull output on your "New Century Super," it is a good plan to apply to the manufacturers for a speaker that is already fitted with an input transformer having a centre-tapped primary.

Before finally deciding upon fitting push-pull output to your super, it is essential to ascertain whether your H.T. mains unit, if one is used, will deliver enough H.T. current to feed the two output valves.

### PETO SCOTT KITS

IN the announcement of Peto Scott, Ltd., on page 1095 of AMATEUR WIRELESS No. 545, the description of the Peto Scott kits for the new "A.W." set, the "Two Guinea Three," were unfortunately given under the incorrect heading of the "Two Guinea Two."

It should be understood that three kits are available for the "Two Guinea Three." The kit A, consisting of the specified parts, but without panel, baseboard and valves, costs only 42s. The kit B, comprises panel, baseboard and valves, with the rest of the components, but excluding the cabinet, the cost being £3 13s. The kit C is a complete outfit, comprising components, valves and cabinets, the total cost being only £4 4s. 6d. Deferred payment terms are available for all three kits.

**TELSEN**

# L.F. TRANSFORMERS COUPLING UNITS and OUTPUT CHOKES

## TELSEN "ACE"

### L.F. TRANSFORMER

The Telsen "Ace" is eminently suitable for Receivers where highest efficiency is required at low cost and where space is limited. Its characteristic curve bears comparison with that of the most costly transformers.

Ratio 3-1 5/6  
Ratio 5-1 5/6

## TELSEN "RADIOGRAND"

### (Ratio 1.75-1) TRANSFORMER

For use in high-class receivers employing two stages of L.F. amplification. When used following an L.F. stage employing choke or resistance coupling, it gives ample volume with remarkable reproduction.

10/6

## TELSEN "RADIOGRAND"

### (Ratio 7-1) TRANSFORMER

Gives extra high amplification on receivers employing only one stage of L.F. amplification. Not recommended for use with two L.F. stages, as overloading is likely to occur.

10/6

## TELSEN INTERVALVE

### L.F. COUPLING CHOKES

Primarily designed for use as coupling chokes but may be used in any circuit carrying not more than the stipulated maximum current. The 100H type is for H. or H.L. type valves and the 40H for L. types.

Rating.	Normal Current.	Max. Current.
40 H.—	5 m.a.	10 m.a.
100 H.—	3 m.a.	8 m.a.

5/-

## TELSEN TAPPED PENTODE

### OUTPUT CHOKE

For mains and battery operated pentodes taking an anode current of up to 20 m.a. The single tapping provides (by reversing) ratios of 1-1, 1.4-1, 2.5-1, ensuring perfect matching under widely varying conditions. Also suitable for matching a low impedance speaker with an ordinary power valve, a 1-mfd. coupling condenser being recommended for this purpose.

7/6

## TELSEN OUTPUT CHOKE

Designed for use with power or super-power valves taking an anode current of up to 40 m.a., this output filter provides an ideal response curve under all conditions. For use with a condenser of not less than 1 mfd. capacity.

7/-

## TELSEN POWER PENTODE

### OUTPUT CHOKE

For mains operated pentodes taking an anode current of up to 40 m.a. Serves both to prevent direct current passing through the speaker and to match the speaker to the pentode valve, with the choice of three ratios—1-1, 1.3-1, 1.7-1. Used with a 1-mfd. condenser it gives a great increase in both quality and volume.

10/6

## TELSEN 10-1 INTERVALVE COUPLING UNIT

A filter-fed transformer using a high permeability nickel alloy core, securing a 10-1 voltage step-up while preserving an exceptionally good frequency characteristic. The response is compensated in the higher frequencies for use with a pentode valve giving an amplification greater than anything previously achieved, equal to two ordinary L.F. stages but with better quality of reproduction.

12/6

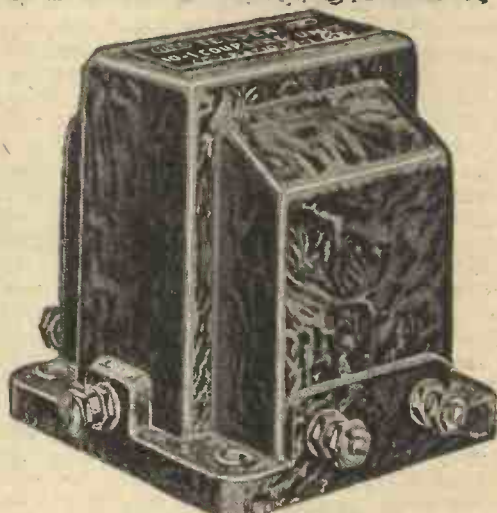
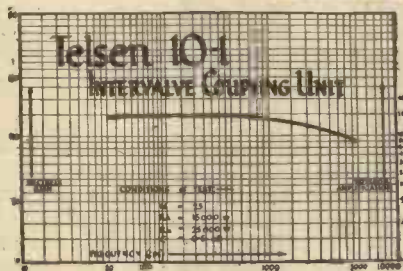

## TELSEN RADIOGRAND (Ratio 5-1) L.F. TRANSFORMER

Telsen Radiogrand Transformers have signified to expert designer and enthusiastic constructor alike all that is finest in British Radio craftsmanship. They are designed in accordance with recent research, constructed on the soundest engineering principles and tested rigorously under broadcast conditions for enduring efficiency. The excellence of their characteristic curve is only the logical result of this insistence on perfection, revealing the fact that they give a performance equal to

that of the most costly transformers; Ratio 3-1 Ratio 5-1

7/6

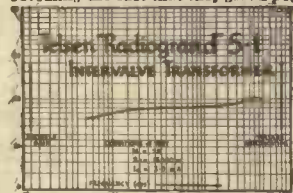

## TELSEN 1-1 INTERVALVE COUPLING UNIT

A modern development of the deservedly popular R.C. unit incorporating a low pass filter feed in its anode circuit, thus preventing "motor-boating," "threshold howl" and other instability due to common couplings in eliminator and battery circuits. Used with an H.L. type valve it gives an amplification of about 20 and a

perfect frequency response on a negligible consumption of H.T. current.

7/6

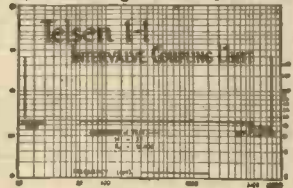

## TELSEN MULTI-RATIO

### OUTPUT TRANSFORMER

For use with moving-coil speakers, having a low impedance speech coil winding, and suitable for anode currents of up to 40 m.a. Three ratios—9-1, 15-1, 22.5-1—allow for correct matching of speakers of widely varying characteristics.

10/6

## TELSEN OUTPUT TRANSFORMER (Ratio 1-1)

For connecting the speaker to the output stage, using a triode valve. Avoids saturation by isolating the D.C. from the speaker windings. Also keeps H.T. voltage from the speaker and its lead, which is specially important where a D.C. eliminator is being used. Suitable for anode currents of up to 40 m.a.

10/6

**TELSEN**  
RADIO COMPONENTS

**TELSEN RADIO COMPONENTS ARE 100% BRITISH**

ANNOUNCEMENT OF THE TELSEN ELECTRIC CO., LTD., ASTON, BIRMINGHAM

Mention of "Amateur Wireless" to Advertisers will Ensure Prompt Attention

# MORE ABOUT TESTING YOUR VALVES

BY PERCY W. HARRIS

Last week it was shown how to make up a simple valve-testing panel from parts you have by you. While not intended to cover an elaborate series of tests of valves, it does give a "check up" on the faults that are likely to occur in the great majority of cases—burnt-out filaments, loss of emission, reduction of emission, shorting of electrodes. The following are some further instructions for using the tester

YOU will see from a study of the circuit diagram reproduced here that we have high-tension and low-tension supplies, a milliammeter in the plate circuit of the valve, and two flashlight bulbs which serve the double purpose of protecting our H.T. and grid-bias batteries and revealing short circuits of electrodes. The valve, by the way, looks in the diagram like a screen-grid valve with the screening grid connected to maximum high-tension positive—actually, however, it is drawn in this way just to show how, in the case of a pentode, the auxiliary screen voltage is applied without any further connection. Only the control grid and the screening grid are shown, the further grid connected inside the valve not being indicated in the diagram. It is *not* intended that this set should be used for testing screen-grid valves. I mention the point at once in case this diagram may possibly mislead anyone.

## The Milliammeter

Owing to a figure having been rubbed off the diagram, the milliammeter in the wiring diagram last week was shown as if it were a 0-2 milliammeter. This, of course, is much too low a reading instrument for the purpose and a 0-20 milliamperes type or higher should be used. It is not, however, essential that this particular range should be adopted as any range milliammeter sufficient to cover the plate current of the valve to be tested can be used if such an instrument is available. A low-reading meter with a shunt may also be used, provided it is recalibrated with the shunt in position.

The use of the switches is quite easy to understand. The on-and-off switch for the accumulator explains itself and the change-over switch is so arranged that in one position the valve is given zero grid bias and the other whatever negative grid bias we like to decide upon. Let us start then by making a test of an output valve; say one of the power type (not super-power) I have before me as I write, a valve which, with 120 volts anode voltage and a grid bias of  $4\frac{1}{2}$  volts gives about 6 milliamperes plate current. At zero grid bias, however, it gives nearly 20 milliamperes. Let us see what happens in our tester. Adjust your high-tension voltage to 120, connect up your accumulator, and set the grid bias at  $4\frac{1}{2}$  volts. Insert the valve in the holder with the switch in the position to give grid bias, switch on and the needle of the milliammeter will immediately indicate 6 to  $6\frac{1}{2}$  milliamperes. Now momentarily push the switch the other way (only momentarily) and the needle will shoot up to near the 20 mark. Switch back again at once.

Suppose when you buy a new valve, or

when you know your valve is a good one, you adjust this instrument with the correct grid bias and take a reading. You will be getting the correct plate current for the voltage (you can check this up with the makers' curve and particulars given in the box) and the change-over switch will show you that the control grid is properly connected up and functioning. If you stick a label on your valve and mark the figures found, you can always return it to the tester and see if it is "up to scratch."

Now take an H.L. type of valve, which is very popular for the detector circuit. One particular make of valve of this kind I know gives about  $4\frac{1}{2}$  milliamperes at zero grid bias and at  $1\frac{1}{2}$  volts grid bias just over 1 milliamperes. The test on such a valve will normally be made with zero grid bias, but you should arrange your tester to give

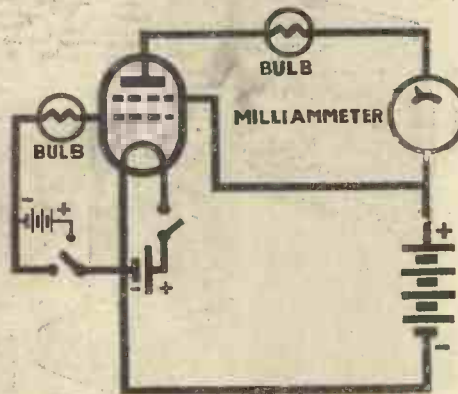

Here is a reproduction of the circuit diagram which will make clear the instructions given for using the valve tester

$1\frac{1}{2}$  volts grid bias so that you can be sure the control grid is functioning correctly. When testing power valves it is usually sufficient to test the plate current with the correct grid bias and without changing over to zero voltage, but in the case of detector valves the procedure just mentioned is adopted.

## Mechanical Defects

Now let us suppose that we have a valve in which the grid is touching the filament. With our switch on the position with no grid bias nothing will happen, but immediately we switch over to a grid bias position the bulb will light up for the current will pass from the grid-bias battery through the bulb and the contact between the grid and the filament, back again to battery. If you see any glow at all in your bulb, switch back at once to "no grid-bias" position.

Let us imagine we have one of those rare cases where grid and plate are touching, immediately we put the valve into the socket, whether or not the L.T. is switched on, the bulb in the plate circuit will glow, for there will be a direct path from the high-tension battery through the milliammeter bulb, plate and grid, back to H.T. negative. The milliammeter needle will, of course, swing right over and you must be careful to pull out the valve immediately, otherwise your meter may be injured. From this you will gather that whenever a valve is inserted in the tester the two bulbs should be watched.

In the case of a pentode, I suggest you test only in the grid-bias position.

In the case of a valve where the grid is disconnected inside the valve itself, no change of plate current will take place when the grid bias is switched on and off.

## OUR LISTENING POST

By JAY COOTE

GENERAL ELECTIONS in Germany and the United States recently provided many late nights to listeners on both medium and short waves. On the Continent all German transmitters worked throughout the Sunday night and could still be heard broadcasting a Berlin orchestral concert and gramophone records interspersed with Election results until the early hours of the morning. It was an excellent opportunity for securing accurate dial readings of each individual transmitter and, much to my delight, I received the signals from many of the smaller relays at excellent volume.

The matter, of course, was facilitated by the fact that in cases where the smaller relays worked on wavelengths common to other foreign stations, as the latter were closed, the Germans enjoyed undisputed possession of the shared channel. In the case of the American broadcasts, Nature was kind on two nights out of three, and transmissions from stations on medium waves provided readable loud-speaker signals. Such well-known stations as WIOD (Miami Beach), WPG (Atlantic City), WCAU (Philadelphia), WTIC (Hartford), and a number of others were easily logged between 3 and 4 a.m., as were four Buenos Aires studios. On the short waves, curiously enough, conditions were not so favourable and, in addition to the usual Schenectady, Pittsburg and Boundbrook relays, little else was received satisfactorily.

Possibly, for this eventful occasion, WCAU (Philadelphia) had hurried forward the launching of its new 50-kilowatt transmitter; without doubt on those nights it was the loudest signal captured.

For those who wish to test the range of their sets, a search might be made for YVIBC, a 5-kilowatt at Caracas, Venezuela, working on 312.3 metres (960 kilocycles). It is, in reality, an exclusive Canadian wavelength, and will be found on the dials just between the readings of KDKA (305.9 metres) and those of LR3 (Radio Nacional, Buenos Aires) on 316 metres. I cannot guarantee success, but in radio miracles *do* happen.

A new 150-kilowatt station is now on the point of completion on the Mexico-United States border; its call sign is XENT, its wavelength 268.9 metres (1115 kilocycles). As it possesses three times the voice power of any of the present U.S.A. stations, there is just that possibility—shall I say probability?—that we may hear it on this side of the Herring Pond.

"Selectivity is of a high order..

Volume is enormous..  
Quality is excellent.."

writes Yorkshire user

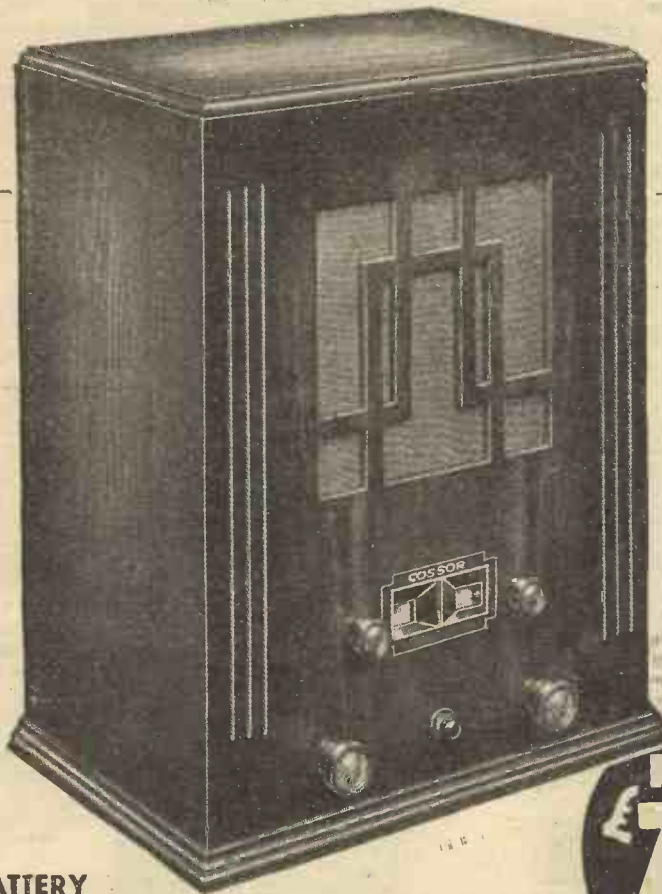

YORKS.  
21/9/32.

Dear Sirs,  
..... I feel bound to send you a note of appreciation.  
Selectivity is of a high order, comparing very well with a well-known set using a band-pass input filter and costing 20 gns.  
Volume is enormous, I have to use the volume control for fear of making myself unpopular with neighbours!  
Quality is excellent, as would be expected.  
My aerial consists of 25 feet of wire round the picture rail. The number of stations I get would take much room to list.  
I consider it to be far the best set for the price.  
Yours truly,  
Signed .....

The originals of the testimonials here reproduced may be inspected at our Head Office, Cossor House, Highbury Grove, London, N.5.

PRICE  
**7.17.6**

EVERY day we receive letters like the above. Other users write... "logged 49 stations"... "tone excellent—38 stations"... "not heard any Set so pure"... etc. etc. —overwhelming evidence of the efficiency of this remarkable Receiver. Equipped with Cossor Variable-Mu Valve — individually shielded coils — graded volume control — every up-to-date feature of design—the Cossor Melody Maker is undoubtedly to-day's greatest value in Screened Grid Radio. Send at once for full details—use the coupon.

**BATTERY**

**MODEL 335** with Self-Contained Loud Speaker

Kit of Parts includes Cossor 220 V.S.G. Variable-Mu Metallised Screened Grid, Cossor 210 H.L. Metallised Detector and Cossor 220P. Output Valves; Individually Shielded Coils, Cossor L.F. Transformer; All-Metal Chassis and all parts for assembling the Receiver as illustrated; handsomely finished cabinet 18½ in. high, 13½ in. wide, 10½ in. deep and 10 in. Balanced Armature Loud Speaker with rear adjustment. Provision is made for fitting Gramophone Pick-up Socket and Plug. Price **£7.17.6**

Hire Purchase Terms: 17/6 deposit and 9 monthly payments of 17/6

**ALL-ELECTRIC MODEL 337**

with Self-Contained Loud Speaker

Kit of Parts includes Cossor M.V.S.G. Variable-Mu Metallised Screened Grid, Cossor 41M.H. Metallised Detector, Cossor 41M.P. Output and Cossor 442 B.U. Rectifier Valves; Individually-Shielded Coils; Cossor L.F. Transformer; All-Metal Chassis; Cossor Mains Transformer and all parts necessary for assembly. Handsomely finished cabinet 18½ in. x 17½ in. x 10½ in., Balanced Armature Loud Speaker with rear adjustment. Provision for fitting Gramophone Pick-up Plug and Jack. Price **£11.15.0**

Hire Purchase Terms: 25/- deposit and 11 monthly payments of 21/-

All-Electric Models for A.C. Mains only. 230 to 250 volts (adjustable), 40-100 cycles.

**BATTERY MODEL 334**

Kit of Parts, similar to Battery Model 335 except that no loud speaker is supplied. Handsomely finished cabinet 9½ in. high, 13½ in. wide, 10½ in. deep. Price **£6.7.6**

Hire Purchase Terms: 14/- deposit and 9 monthly payments of 14/-

**ALL-ELECTRIC MODEL 336**

Kit of Parts, similar to All-Electric Model 337 except that no loud speaker is supplied. Handsomely finished cabinet 10½ in. high, 17½ in. wide and 10½ in. deep. Price **£9.15.0**

Hire Purchase Terms: 19/6 deposit and 10 monthly payments of 19/6

**COSSOR MELODY MAKER**

**ALL-ELECTRIC MODEL 338**

Kit of Parts for building Cossor All-Electric Melody Maker Model 338 Chassis. Specification identical with Model 336 except that no cabinet is supplied. Kit includes escutcheon and template for drilling your own cabinet. Price **£8.15.0**

Hire Purchase Terms: 32/6 deposit and 8 monthly payments of 20/-

Prices do not apply in I.F.S.

A. C. COSSOR LTD., Highbury Grove, London, N.5. Deposits at Birmingham, Bristol, Glasgow, Leeds, Liverpool, Manchester, Newcastle, Sheffield, Belfast and Dublin.

To A. C. COSSOR LTD., Melody Dept., Highbury Grove, London, N.5.

Please send me free of charge a full size Constructional Chart, which tells me how to build the Cossor <sup>\*Battery</sup> Melody Maker. <sup>\*All-Electric</sup>

(\* Strike out type not required.)

Name.....  
Address.....  
A.W. 26/11/32

My usual Retailer is.....  
Address.....

**COUPON BRINGS YOU FULL-SIZE CONSTRUCTIONAL CHART**

1785

Mention of "Amateur Wireless" to Advertisers will Ensure Prompt Attention



A weekly review of new components and tests of apparatus conducted by J. H. Reyner, B.Sc., A.M.I.E.E.

**USEFUL INSULATED TERMINALS**

WE have received for report samples of a new line of insulated terminals manufactured by Messrs. S. Lilley & Sons, Ltd. These terminals are of the all-insulated variety, the insulating parts being made from moulded bakelite. Each terminal is provided with a non-rotating bakelite nameplate, all the usual markings being available. The head of the terminal can be removed, but the nameplate remains fixed. The terminal is arranged to take spade connectors, pin connectors, or bare wire.

These terminals, which are known as the B.B.C. All-Insulated Terminals, retail at 2½d. each and can be recommended.

**BRYCE MAINS TRANSFORMER**

A WELL-MADE mains transformer which we have tested recently is that manufactured by Messrs. W. A. Bryce and Co. This transformer resembles the other Bryce models which we have reviewed in

these columns as far as general appearance goes. It has, however, the additional

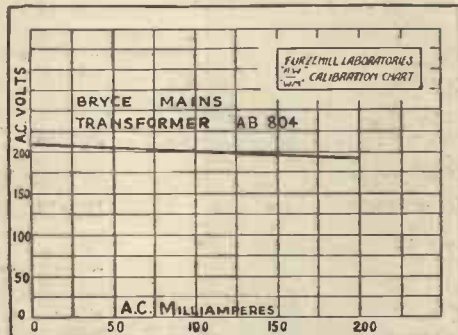

This curve shows the variations of voltage with load in the case of the 200-volt winding of the Bryce transformer tested

feature that the windings are completely enclosed in a brown crackle-finished metal casing. All the various windings are

terminated on terminals mounted on a red fibre board bolted to the top of the transformer. These terminals are very clearly designated and no trouble should occur from wrong external connections. Three secondary windings are provided, one rated to give 200 milliamperes at 200 volts specially for use with metal rectifiers, another rated to give 4 volts at 4 amperes, this winding being centre tapped and designed for use with the heaters of A.C.-type valves. The third winding is a 1-ampere 11-volt winding and designed for accumulator-charging purposes.

On test the transformer was found to be well up to its rating, the curve accompanying this report showing the variation of voltage with current in the case of the 200-volt winding. It will be seen that the voltage is well maintained right up to full load. On the 4-volt winding the voltage was just a shade under 4 volts on full load,

(Continued on page 1190)

# 99 P.M. 59 1/6

The most AMAZING Moving Coil ever produced

BRITISH MADE

There are many moving-coil speakers and marvellous claims are made for them. Disregard all these and fix your attention on Blue Spot 99 P.M.

There has never been a moving-coil speaker of such stupendous achievement—never one that has genuinely earned the right to claim perfect reproduction. The main features of 99 P.M. are as follows:

Write for Catalogue No. A.W.58.S.

- 1 Heavy magnet forged from highest grade magnet steel.
- 2 Powerful and permanent energy.
- 3 Magnetic energy in air gap is exceptionally high—1,320,000 ergs.
- 4 Pole pieces cadmium plated to prevent rusting.
- 5 Side plates are fitted to the magnet to exclude dust and magnetic particles from being attracted into the air gap.
- 6 Specially designed cone and speech coil. Astonishing faithful reproduction.
- 7 Valve-matching transformer incorporated. Undistorted output, 3½ watts.

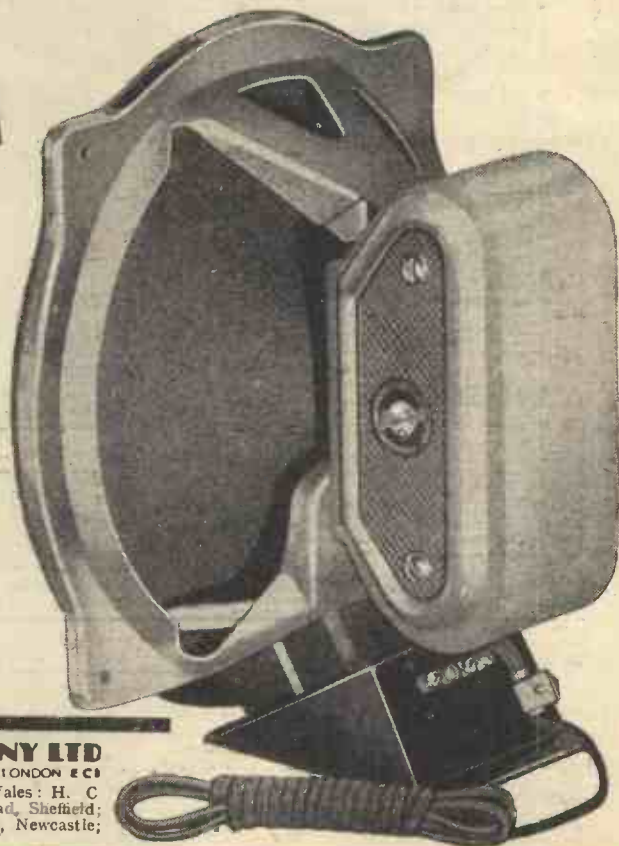

**THE BRITISH BLUE SPOT COMPANY LTD**

BLUE SPOT HOUSE, 94/96 ROSOMAN STREET, ROSEBERY AVENUE, LONDON E.C.1  
 Distributors for Northern England, Scotland, and Wales: H. C. RAWSON (Sheffield and London), Ltd., 100 London Road, Sheffield; 22 St. Mary's Parsonage, Manchester; 44-46 High Bridge, Newcastle; 37, 38, 39 Clyde Place, Glasgow.



**TELSEN**

# DIFFERENTIAL, REACTION & TUNING CONDENSERS

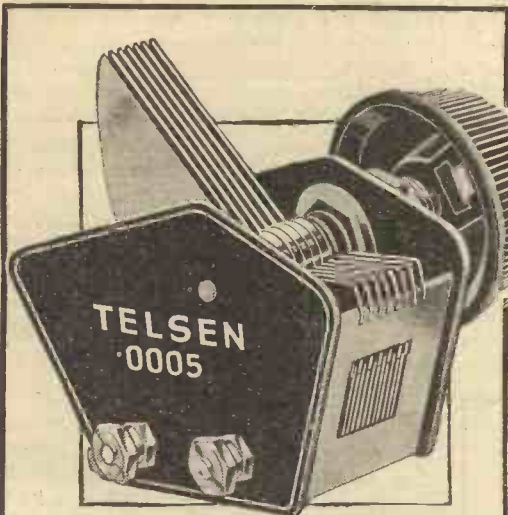

**TELSEN DIELECTRIC TUNING CONDENSERS**

New design of great rigidity and exceptional compactness, ensuring the utmost efficiency in use even where space is very limited. The well-braced vanes are interleaved with a minimum of the finest solid dielectric, giving absolute accuracy of tuning. Supplied complete with knob.

In capacities '0005 and '0003 **2/6**

**TELSEN DIFFERENTIAL CONDENSERS**

Improved type of exceptionally rigid construction. The rotor vanes are keyed to the spindle and fitted with definite stops. A strong nickel silver contact makes connection to the rotor, a positive connection being made to the stator vanes. Supplied complete with knob.

In capacities '0003, '00015 and '0001 **2/6**



**TELSEN REACTION CONDENSERS**

Built to the highest standards of efficiency, embodying every improvement and refinement indicated by the latest research. The vanes are interleaved with the finest solid dielectric, the construction throughout being of great rigidity and exceptional precision. Supplied complete with knob.

In capacities '0003, '00015 and '0001 **2/-**

In capacities '00075 and '0005 **2/6**

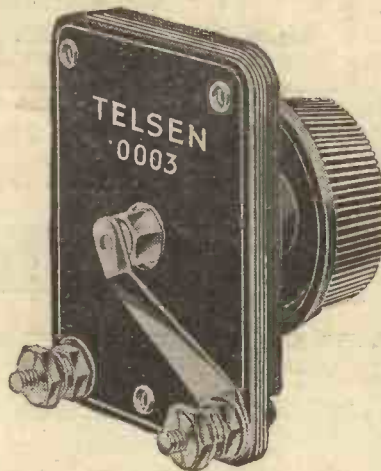

**TELSEN AERIAL SERIES CONDENSER**

The ideal volume and selectivity control, solidly constructed, with very low minimum capacity. The externally keyed switch-arm when rotated to a maximum position, connects with a contact on the fixed vanes, thus short-circuiting the condenser for maximum volume. Supplied complete with knob.

Capacity '0003 **2/3**



**TELSEN**  
**RADIO COMPONENTS**

**TELSEN RADIO COMPONENTS ARE 100% BRITISH**

ANNOUNCEMENT OF THE TELSEN ELECTRIC CO., LTD., ASTON, BIRMINGHAM

Advertisers Appreciate Mention of "A.W." with Your Order

**"WE TEST FOR YOU"**

(Continued from page 1188)

while on a load of 1 ampere the remaining winding gave exactly 11 volts. On no load the power consumed was only 1.5 watts, thus giving a very high overall efficiency.

This transformer can be thoroughly recommended and it retails at 36s. 6d. as described, or 30s. in a "stripped" condition.

**NEW GOLTONE AERIAL WIRE**

READERS will remember that we recently reviewed in these columns the Goltone Lektrite aerial. The same firm have now introduced a new aerial known as the Goltone Ultrite aerial. This new aerial has been introduced with the idea of providing an aerial absolutely universal in use. The insulation provided is sufficient to enable it to be used as an outdoor aerial with no additional insulation. This aerial is actually composed of eleven copper strands of best electrolytic copper wire tinned to give protection against corrosion. The large number of strands, which are of about 30 gauge, provide a good pick-up surface, and as all the conductors are pure copper, the aerial is quite flexible and has no inherent springiness.

The insulation of the aerial is in two parts. Firstly, over the strands a vulcanised rubber covering is formed, this giving the necessary very high insulation to prevent leakage and to protect the strands against the weather conditions. Over this rubber covering a strong cotton braid is placed, the whole forming a very strong job.

The insulation of this aerial is extremely good and the manufacturers state that a coil of 100 ft. has a resistance of some 3,000 megohms when tested at 500 volts,



A good mains transformer—the Bryce

after having been immersed in water for twenty-four hours.

This aerial may be obtained in coils of 25, 50, 75, and 100 ft.

**UTILITY CONDENSER DRIVE**

AN interesting slow-motion condenser drive which we have received for review is that recently placed on the market by the makers of the Utility condensers. The main feature of this control is that the pointer moves over a flat stationary scale

marked with 100 divisions. The pointer is given the necessary parallel motion by means of two arms and an eccentric drive, which is fixed to the main spindle. The reduction gearing is such that the pointer moves in the same direction as that in which the control knob is turned, approximately four turns being necessary to give a complete lateral movement of the pointer. The scale itself, which is of ivory, actually forms one side of a rectangular metal box in which is located a small illuminating lamp.

We have found this control quite good in use, the drive being absolutely positive, with no trace of back-lash, and since this full-vision type of indication is becoming very popular, we have no doubt our readers will be interested.

It should be noted that in the announcement of the new Marconiphone Model 95 speaker, given in the Marconiphone announcement last week, the price was incorrectly given as 49s. 6d. This new speaker, which is a permanent-magnet moving-coil unit, fitted with a massive cobalt-steel magnet and a universal input transformer, costs actually 47s. 6d.

Full details can be obtained free on mention of "A.W." from the Marconiphone Co., Ltd., 210 Tottenham Court Road, London, W.

In order that Midland Regional listeners may know something of legends, Mr. G. Clifford Leather is to give a talk on Folk Lore and Legends, on November 23.

**Don't Forget to Order  
"A.W." for Next Week  
OUR BUMPER CHRISTMAS  
NUMBER**

**BUILD  
YOUR**



**OWN  
ELIMINATOR**



THE only way to ensure constant output from an eliminator is to see that it incorporates a Westinghouse Metal Rectifier. No other form of rectifier possesses the all-round efficiency of Westinghouse. The construction is robust, efficiency is high, and the output does not deteriorate, so that the rectifier will not need renewing even after years of use.

Full particulars, prices, and circuits showing you how to build an eliminator to meet your own needs, are given in the new and enlarged 1933 edition of "The All-Metal Way." Threepence in stamps and mention of this journal will bring you a copy by return.

**METAL RECTIFIERS**

The Westinghouse Brake & Saxby Signal Co. Ltd.  
82 York Road, King's Cross, London, N.1

# ERIE

**GRID LEAKS  
and  
RESISTORS**  
*Safest  
for your  
Set*



**ERIE  
RESISTORS**  
carry an Unqualified  
**GUARANTEE**  
against  
**Open-Circuiting**



Erie Grid Leaks and Resistors are positively guaranteed never to break down—that is why they are used exclusively by the leading British manufacturers. Absolutely stable, safe and silent, ERIE offer a degree of satisfaction in service not previously available to the constructor and amateur. Watch them being specified by the leading technical papers!

All values from 50 ohms to 4 megohms. Tag identified and colour coded.

Write for leaflet with Colour Code Chart.

**PRICE**

**1/-** PER WATT  
in all values

THE RADIO-RESISTOR CO., 1 Golden Sq., Piccadilly Circus, London, W.1

**What's born in the record  
Comes out via the Mark III**

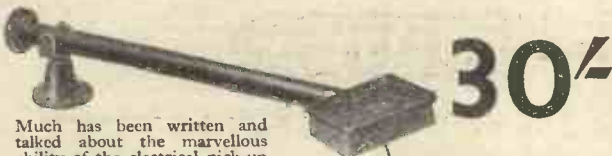

Much has been written and talked about the marvellous ability of the electrical pick-up to reproduce music which was never suspected on the record. Perfectly true, but the real test for a pick-up is to reproduce the record as it was originally recorded. It takes a Bowyer-Lowe Mark III to do this.

Send for catalogue.

**Bowyer-Lowe & A.E.D. Ltd.**  
Diamond Works, Brighton.

**BRITISH GENERAL**

**OUTPUT  
TRANSFORMER**



Enables the speaker to be correctly matched to the valve giving increased volume and better tonal balance. Prevents damage to the loud-speaker due to sudden switching on and off of large currents.

Price **9/6** Multi Ratio.

From all dealers or direct.

**British General Manufacturing Co., Ltd., Brockley Works :: London :: S.E.4.**

# SPECIFIED for the "NEW CENTURY SUPER"

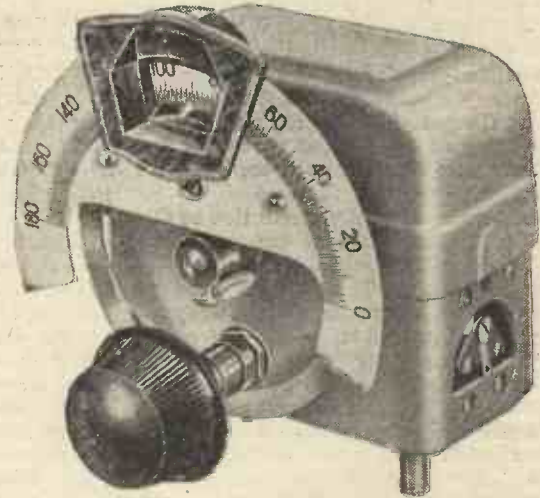

**J. B. NUGANG TYPE AI. 10/6**  
Complete as illustrated  
(or 9/6 without screening lid).

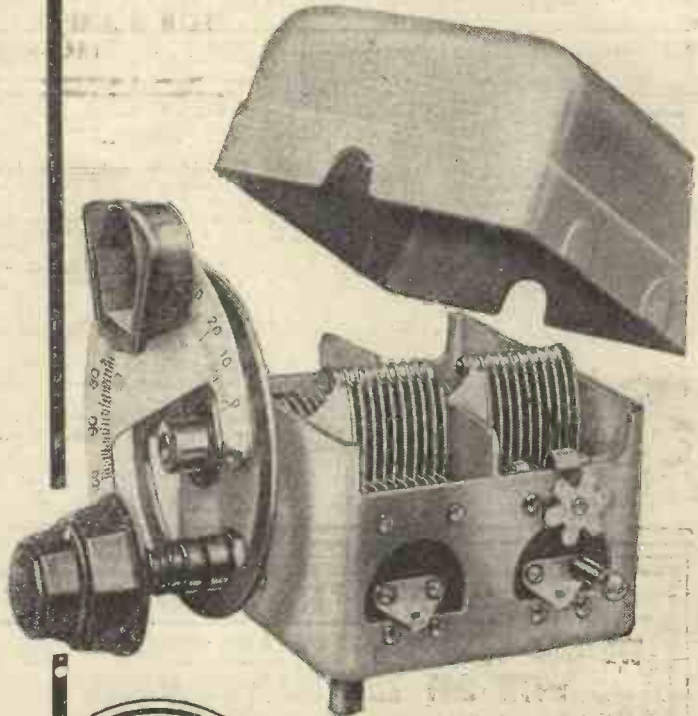

**J. B. UNITONE 2 GANG  
Type D - - 18/6**

Write for complete catalogue.

**PRECISION  
INSTRUMENTS**



Advertisement of Jackson Brothers, (London) Ltd., 72 St. Thomas' Street, London, S.E.1  
Telephone: Hop 1929

You will Help Yourself and Help Us by Mentioning "A.W." to Advertisers

# IN MY WIRELESS DEN

WEEKLY HINTS —

CONSTRUCTIONAL



& THEORETICAL

BY W. JAMES

## TAPPING YOUR RESISTANCE

IT is possible to make a tapped resistance at small cost if a little care is taken.

You obtain a wire-wound resistance of the flexible type and having the right resistance. Carefully remove the covering. Then at the proposed tapping points wrap a few turns of fine copper wire over the resistance wire to make good contact with it.

Do not make a lengthy connection as this will short-circuit some of the resistance wire, but wrap a length of the copper wire about one point. There is no need to solder the wire, but cotton may be wrapped over the joint to hold it.

A resistance unit may roughly be divided into equal sections by making the contacts equal distances apart. If you have a 20,000-ohms resistance, for example, sections of about 5,000 ohms will be obtained by making three contacts, the first, one-quarter of the length along, the second in the middle of the resistance, and the third, three-quarters of the length along.

I find tapped resistances very useful and

made in the way described they are cheap and serviceable.

## DID YOU KNOW THIS ?

WHEN you adjust the high-tension voltage applied to a leaky grid detector you probably alter two things.

The first is the sensitivity of the detector and the second is the amount of the signal which the valve will handle without overloading. The tendency is to adjust for maximum sensitivity, a weak signal being used during the test. This is all very well, but the handling capacity of the detector must be kept at or above a certain amount or the detector will overload before the power valve is fully loaded.

An increase in the voltage applied to the anode circuit of the detector will usually reduce the danger of overloading.

This also increases the anode current. Some detector valves pass 5 or 6 milliamperes when the high tension is as much as 120 volts. Such a high value of current is usually wasteful and a lower voltage may be used with satisfactory results. The object should, therefore, be to use no more

high tension than is necessary, consistent with the avoidance of overloading.

## TESTING WITH A METER

WHEN you are testing with a meter connected in the anode circuit of a leaky grid detector you will notice that the current falls below normal when a signal is tuned in.

This is because the signal has the effect of making the grid of the valve more negative, as the negative bias of the valve is increased, so the anode current is reduced. A strong signal will produce a greater effect than a weak one, but if the anode current is reduced to too low a value by a signal, then the valve is being overloaded.

A milliammeter connected to the detector is of great assistance, especially when first trying a set. Adjustments may be made which produce a difference in the results more easily seen than heard and very often it is possible to gang a set more accurately by making adjustment to the tuning and watching the meter than by listening.

## A MATTER OF BIAS

THE usual method of obtaining grid bias for the grid circuit of a mains set is to connect a resistance in the cathode return, as shown in the accompanying sketch, where the resistance is marked r.

Now the anode current passed by the valve also flows through this resistance with the result that there is a fall in voltage across it. The value of the voltage is

(Continued on page 1194)

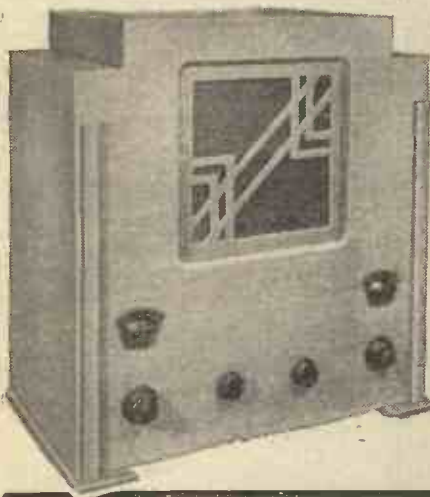

## RECOMMENDED for YOUR "NEW CENTURY SUPER"

The "Whitehall de Luxe" is a fine solid piece of furniture, and is available in three finishes: natural, golden, Jacobean. The use of solid wood does away with any troublesome boom effect, plywood only being used for decorative purposes, namely, the fret and detachable back.

Make certain that your "New Century Super" is housed in a worthy cabinet—the "Whitehall de Luxe," price 30s. cash or C.O.D. Obtainable at all good-class Radio Dealers, or direct from the sole manufacturers.

State style of finish required when ordering. Money refunded if not completely satisfied.

The Myers-Hunt Cabinet Co., 7 Austin Street, Shoreditch, London, E.2

## A SUPER-SELECTIVE AERIAL

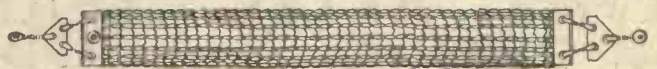

## THE SELECTANET

Reg. No. 520797  
Pat. No. 371534

Super-selective Aerial has a collective surface area of over 800 ft. of pure copper ribbon wire, woven into a tubular net only 9 ft. long. No other aerial has such a ratio. It reduces interference and overlapping to a minimum; and gives sharper tuning. Get one to-day and improve your set. Of all Dealers or direct, postage 3d. extra, from

Spong & Co., Ltd., Woodville Grove, London, N.15.



## "NEW RADIOS FOR OLD—FOR CHRISTMAS"

WE BUY YOUR OLD SET AND SUPPLY YOU WITH ANY NEW SEASON'S MODEL

Liberal Allowances and Balance Payable by Cash or Hire Purchase.

HUNDREDS OF TESTIMONIALS FROM SATISFIED CLIENTS

EVERY MAKE OF KIT, SET OR RADIOGRAM SUPPLIED

It will pay you to write for particulars of our amazing exchange offer, enclosing 1½d. stamp, naming your old set and the new model you fancy. A FREE QUOTATION WILL FOLLOW. Complete transaction executed by mail.

FREE Wireless set to introduce the Radialaddin Club.

Please forward this INQUIRY FORM (without obligation) Please quote me free your allowance for the new set:

Make..... Model and list price.....

My Present Set is: Make..... Batteries or Mains.....

Date of Purchase..... Original Cost of Set.....

Balance of purchase price would be payable by me as follows:

Plan A. Whole of balance in cash.

Plan B. Whole of balance over six, nine, twelve \* months.

\*Delete unwanted words.

NAME (in full)..... (Block letters)

ADDRESS .....

**RADIALADDIN, Limited**

THE LARGEST RADIO EXCHANGE IN THE UNITED KINGDOM. (Dept. A.W.), 47-48 Berners Street, London, W.1.

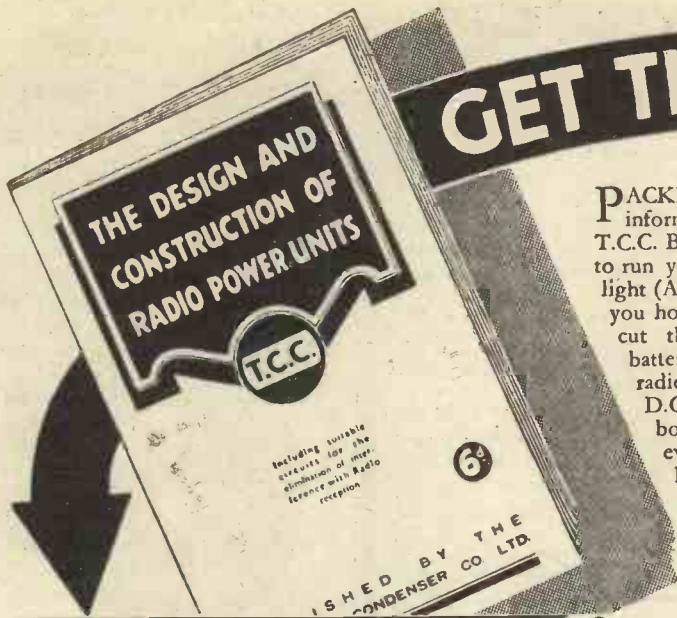

# GET THIS NEW BOOK

**P**ACKED full of real useful information and data, this T.C.C. Booklet shows you how to run your set off the electric light (A.C. Supply)—It shows you how, once and for all, to cut the cost of expensive batteries, and to get better radio. With a chapter on D.C. mains apparatus, this book should be in every electric light users hands. Get your copy now!

## IT TELLS YOU ALL ABOUT

- RADIO POWER UNITS—and how to build them.
- NOTES ON A.C. POWER UNITS.
- OPERATING RECEIVERS ON D.C. MAINS.
- ABOUT T.C.C. ELECTROLYTIC CONDENSERS.
- ELIMINATION OF INTERFERENCE.
- FOUR T.C.C. POWER UNITS with full-constructional Details.
- ROTATING RESISTANCE CALCULATOR.

**COUPON**

To The Publicity Dept., The Telegraph Condenser Co. Ltd.,  
Wales Farm Road, N. Acton, London, W.3

Please send me a copy of your book "The Design and Construction of Radio Power Units," for which I enclose six penny stamps to cover cost and postage.

Name.....

Address.....  
A.W. 26/11/32

Please write in Block Letters

## Ask your Dealer

If you have any difficulty in obtaining a copy of this book. Fill in the coupon and post to us with six penny stamps. We will send you a copy by return.

# T.C.C.

ALL-BRITISH  
**CONDENSERS**

1804

## YEAR AFTER YEAR IT GIVES UNFAILING SERVICE

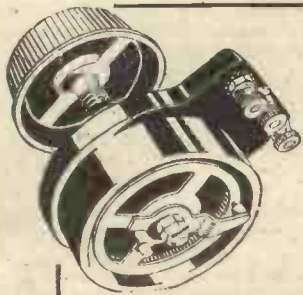

**D**ESIGNED and manufactured by experts from first quality materials, the Sovereign Volume Control will give you years of unfailing service. Its patented construction ensures smooth silent action all round the resistance. A bakelite dust-and-damp proof cover (not shown here) protects the spring diaphragm contact. The Sovereign Volume Control is sold complete with bakelite pointer-knob and protecting cover and is obtainable from all dealers. To assure satisfaction—fit Sovereign.

## SOVEREIGN VOLUME CONTROL

In all values from 50,000 ohms to 2 megohms **4/6**

Manufactured by  
**SOVEREIGN PRODUCTS, LTD.,**  
SOVEREIGN HOUSE, ROSEBERY AVENUE, E.C.1.  
Makers of Good Components

MAKE YOUR SET  
SELECTIVE

## EFFICIENT BAND-PASS FILTER



### Band-Pass Unit

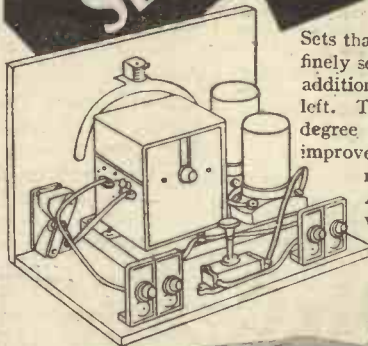

Sets that are a year or so old can be made finely selective without any alteration by the addition of the Band-Pass Filter shown on the left. This highly selective unit provides the degree of selectivity required to-day and improves tonal quality. It requires little more than a Formo Band-Pass Tuning Assembly and has been designed by a well-known expert as a simple and inexpensive way to bring any set up to date.

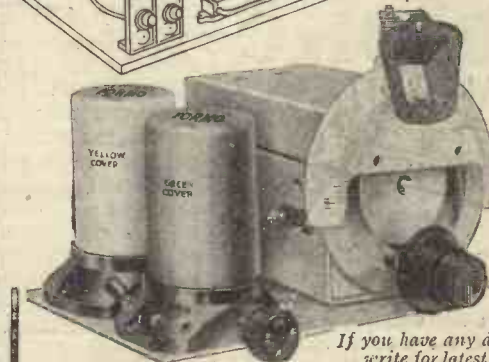

Write for a copy of the designer's Article describing the Filter in detail.

Formo Dual Gang Band-Pass Unit Complete **33/6**  
Triple Gang Band-Pass Unit **46/6**

If you have any difficulty in obtaining, write for latest Formo Catalogue.

**FORMO** London Showrooms: 23 Golden Sq., Piccadilly Circus, W. 1.  
Head Office: Crown Works, Regents Park, Southampton

Don't Forget to Say That You Saw it in "A.W."

# FOR 8/6

YOU CAN BUY THE

*Simplest  
Safest &  
Cheapest*

**KIT  
TO ABOLISH  
BOOM  
RATTLE &  
RESONANCE**

**B**ANISH distortion in your loud-speaker with "Melotone" Kit, the cheapest, most efficient, and simplest treatment yet devised. The best known method of mounting any Moving Coil or good Cone Speaker, based on the system developed by the B.B.C. for dispensing with the cumbersome and unsightly baffle-plate. Modernised by the introduction of a featherweight sound-absorber recommended and used by leading authorities on Radio and Acoustics.

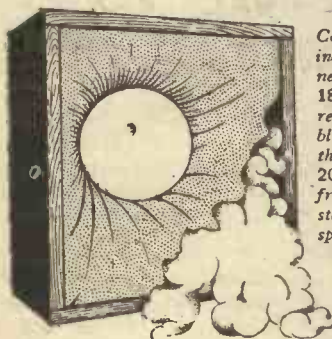

Complete Kit, including Cabinet 18 in. by 18 in. by 9 in., ready for assembling, supplied at the low cost of 20/- only, post free. Please state diameter of speaker.

## Melotone LOUD SPEAKER KIT

**KILLS  
REPRODUCTION  
IRRITATION**

**8/6**  
POST FREE

This featherweight Kit—costing only 8/6—comprises noise-absorbing Acoustic Down, special covering, and everything for treating existing Cabinets.

Secure YOUR Kit without delay by sending postal Order NOW

Simple Instructions supplied for fixing  
**H. L. WILLIAMS, ELLIS & COMPANY (R.I.),**  
72 Oxford Street, LONDON, W.1. 8 Gt. George Street, LEEDS.  
99/101 Clarendon Street, Hulme, MANCHESTER.

### "IN MY WIRELESS DEN"

(Continued from page 1192)

easily worked out, being given by the value of the resistance in ohms, multiplied by the value of the current in amperes.

Usually, anode current is expressed in milliamperes. A milliampere is one-thousandth part of an ampere. The above result must be divided by 1,000, therefore, in order to allow for the difference between milliamperes and amperes. Thus a current of 10 milliamperes and a resistance of 1,000 ohms produce a voltage drop of 10 volts.

The bottom of the resistance at A is clearly more negative than the end joined to the cathode of the valve and so the grid circuit is connected to A.

Sometimes it is necessary to add to this simple circuit. Thus a condenser of 1 or 2 microfarads may be joined across the resistance. But when hum is introduced into the grid circuit by the bias circuit, or when

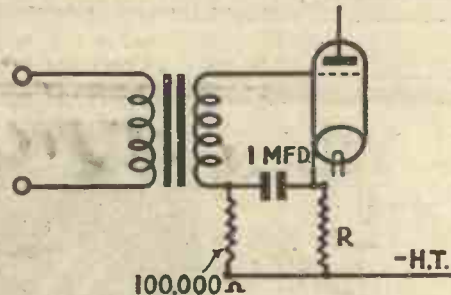
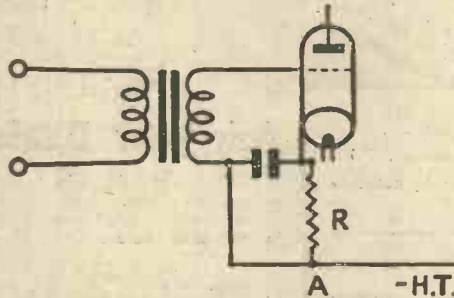

Two bias arrangements. (Top) the standard voltage-dropping circuit, and (below) automatic bias and grid decoupling

decoupling is necessary, a further resistance and condenser must be used to act as a filter. Usual values are 100,000 ohms and 1 or 2 microfarads.

This filter circuit is effective in avoiding difficulties from couplings with other circuits and also stops hum from entering the grid circuit of the valve.

### A SPEAKER OFFER

There is no type of speaker more popular than the moving-coil and it is therefore of interest that in the Heraud announcement this week there is an offer by this well-known mail-order house of 1933 Brown permanent-magnet moving-coil speakers, complete in cabinet at £2 below this price. Deferred payment terms are available and readers are offered one of these moving-coil speakers on seven days' trial for only half a crown deposit, the balance being payable in small monthly instalments.

**TELL YOUR FRIENDS**  
Our Special Christmas Bumper  
Number—Next Week

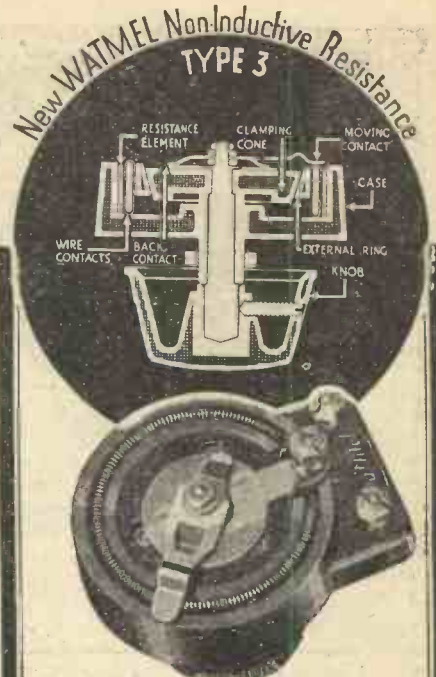

## NEW NON-INDUCTIVE RESISTANCE

### ADVANTAGES:

- 1 NON-INDUCTIVE.** This is because the resistance element is not wire.
- 2 Furthermore,** the wire contacts shown make contact with the resistance element so that the moving contact does not wear out the element. This guarantees even and true contact always.
- 3 The extremely firm and even contact** with the element. This is obtained by a new patented clamping cone which directly it is screwed down forces the sprung external ring against the wire band. The pressure is so great that perfect all-round contact is made with the element which will not vary under any circumstances.
- 4 Self-cleaning wiping contacts.** This ensures perfectly clean contact always.
- 5 Silent in operation.**
- 6 PRICE . . . . . 4/6**

We recommend this Resistance (Type 3) only for values above 50,000 ohms, where wire-wound potentiometers are not required. Patents for this new Resistance have been applied for. Type 1. Wire Wound, any value up to 50,000 ohms.

Write for Free Component Catalogue and also for our Free Calculation Resistance Chart.

If you have any difficulty in obtaining Watmel Components, WRITE DIRECT TO US.  
TRADE ENQUIRIES INVITED.

**Watmel  
COMPONENTS**  
GET THE BEST OUT OF ANY SET

Watmel Wireless Co., Ltd., Imperial Works,  
High Street, Edgware.  
Telephone : Edgware 0323.

POST CARD

# POSTCARD

## RADIO LITERATURE

**GET THESE CATALOGUES FREE**  
 Here "Observer" reviews the latest booklets and folders issued by well-known manufacturers. If you want copies of any or all of them FREE OF CHARGE, just send a postcard giving the index numbers of the catalogues required (shown at the end of each paragraph) to "Postcard Radio Literature," "AMATEUR WIRELESS," 58/61, Fetter Lane, E.C.4. "Observer" will see that you get all the literature you desire. Please write your name and address in block letters.

**New Moving-coil Unit**  
 I AM very pleased to see that the Marconi-Phone people have brought out a new moving coil unit which costs only £2 7s. 6d., including universal input transformer. They have just sent me details of this new job, the type 95, and I advise you to write for information about it right away. **886**

**No Modulation Hum!**  
 Mains hum is only too often due to a poorly designed input transformer. For that reason I am all the more interested in the design of some mains transformers described in a folder sent me by Sound Sales, Ltd., and copies of which you can have free. The folder is particularly handy, for it gives all the technical particulars you need to know when choosing a transformer—voltage ratings of the windings, tappings, fixing arrangements, and what-not. **887**

**The "Compleat Tester"**  
 Most of you know the Avometer, the universal testing meter used by many professional men for circuit testing. The Avometer people have just brought out a new radio gadget known as the AvyDapter, which enables circuit tests to be made without altering any of the set's wiring. Four-pin or five-pin valves can be tested at will. It impresses me as being a very useful accessory for the keen experimenter, and many of its uses are described in the new AvyDapter folder. **888**

**Lissen's "Three"**  
 Remembering what great interest there was at Olympia-time in Lissen's new battery-operated three-valver, I was keen to have a copy of the folder giving details of this set. Its striking appearance seems to me to be in keeping with its specification, and the folder gives full details. It has all the characteristics of a good mains set, and the H.T. consumption is under 10 milliamps, so you don't need immense batteries! **889**

**A Useful Valve Card**  
 Here is something which will interest all valve users—a pocket card giving a comparative table of receiving valves, showing the types of Eta valve which correspond to other popular makes. Thus an Eta valve for any position in the set can be chosen at once. **OBSERVER 890**

# AMPLION

MC 22

39/6

## MOVING COIL PERM-MAG-SPEAKER

"... the finest permanent magnet moving coil speaker the industry has yet produced."  
 AMPLION (1932) LTD. 82/84 ROSOMAN STREET, LONDON, E.C.1. CLERK. 5440-1

Every Thursday

## TEST YOUR SET

Makes all the difference to Enjoyment and Economy. No skill required with this instrument. "The Wireless World" describes it as "the most comprehensive." The ONLY popular priced instrument testing resistances, as well as voltages of H.T. and L.T. batteries, valves, transformers, coils, condensers, short circuits, distortion, etc. FOUR readings on one dial (1) 0-150 v. for H.T.; (2) 0-6 v. for L.T.; (3) 0-30 milliamps.; (4) resistance test 0-2,000 ohms. Of all wireless Dealers, Ironmongers, etc., including 4-page instruction leaflet.

## WATES 126 Universal Meter

British Made by Emicol, London  
 3-IN-1 POCKET METER L.T. (0-6v.) H.T. (0-150v.) and 0-30 milliamps. Pocket Case for same 1/3 **8/6**

Explanatory Leaflets Post Free.  
**WATES RADIO LTD.,**  
 184-8 Shaftesbury Av. London, W.G.2

## MOUNT YOUR TERMINALS NEATLY ANYWHERE—

With the Belling-Lee Bakelite Terminal Mount, terminals may be mounted anywhere, anyhow—vertically or horizontally. On the baseboard or screening box, the window ledge, wall or skirting board, etc.

An exceptionally neat bakelite moulding designed to take two terminals of any make, particularly suitable for our "B" Type Terminal.

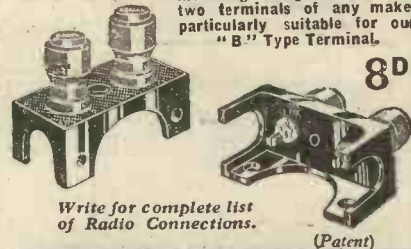

Write for complete list of Radio Connections.

(Patent)

# BELLING-LEE

FOR EVERY RADIO CONNECTION

Advt. of Belling & Lee Ltd., Cambridge Arterial Road, Enfield Middlesex.



MAINS POWER for your Radio

HEAYBERD Transformers are available for either Metal or Valve rectification—whichever you prefer.

They are sturdily built from the finest British materials. Voltage regulation is excellent, whilst temperature rise is negligible—even on maximum output.

HEAYBERD 805 TRANSFORMER SECONDARY OUTPUTS: 350-250 +250-350 v. 120 ma. 2+2 v. 2.5 amps., 2+2 v. 5 amps and 2+2 v. 2 amps.

Price ... 55/-

POST COUPON NOW

I enclose 3d. stamps for 1933 Handbook "Mains Power for your Radio." Packed with hints, tips and diagrams.

Mr. Address. A.W.



MONARCH OF THE MAINS.

10, FINSBURY STREET, LONDON, E.C.2. One minute from Moorgate Und. Station

EASY PAYMENTS

"There's no place like HOLMES." The first firm to supply wireless parts on easy payments. Eight years advertiser in "Amateur Wireless." Thousands of satisfied customers.

We unhesitatingly recommend EPOCH 4/10 20th CENTURY P.M. Speaker Deposit 7 payments of 4/10 The best in its Class Any Epoch Speaker supplied on Hire Purchase.

Table with columns: Kit Name, Price, Deposit, Monthly Payments

Parts for any Kit Set. Any make of Speaker. New Goods Obtained for Every Order. Send us a list of the parts you require and the payments that will suit your convenience, and we will send you a definite quotation. Anything Wireless.

H. W. HOLMES, 29, FOLEY STREET Great Portland Street, London, W.1 Phone: Museum 1414.

BROADCASTING STATIONS

Broadcasting Stations classified in order of wavelengths. For the purpose of better comparison, the power indicated is that of the carrier wave.

Large table listing broadcasting stations with columns for Kilo-Metres cycles, Station and Call Sign, and Power (Kw.).

LET "A.W." SOLVE YOUR WIRELESS PROBLEMS



EXACT AERIAL Tuner, 250-2,000 metres. Works in conjunction with .0005 mfd. variable condenser. 14/- Post Free

EXACT INDUPAS Aerial Tuner, 200-2,000 metres. Gives good selectivity when tuned with .0005 2-ganged condenser. No screen or special components required.



20/- Post Free THE EXACT MANUFACTURING CO. Croft Works, Priory Street, Coventry.

THE MOST POPULAR RADIO-GRAM CABINET ON THE MARKET

Reduced to 39/6 Carriage Paid!! Quality Guaranteed Improved Soundly constructed in selected oak, etc., and hand polished. SPECIFICATION.—3' 3" high, 1'10" wide, 1'6" deep. To take panels up to 18" x 7". Panel opening to suit set. These cabinets allow ample room for the following:—Pick-up, Motor, Speaker, Batteries, etc., all for the reduced price of 39/6.



Catalogue Post Free. From one of the Largest Mail Order Works in England: W. S. WILKIN, Cabinet Manufacturer, 12-26 Nelson Mews, Gt. Gt. Street, Dept: Messrs. Leale Southend-on-Sea, Essex. Ltd., 7, Bondage, Guernsey.

REPAIRS to Loudspeakers 4/-. Blue Spots 5/-. Transformers 4/-. Moving Coils, etc. quoted for. Prompt Service. 12 months guarantee. Trade Invited. Streatham 6618. Loud-speaker Repair Co., 2 SHIPKA ROAD, Balham, London



# EXPRESS EASY PAYMENT SERVICE

Prompt Delivery Guaranteed.  
Price List Free on Request.

### MANUFACTURERS' KITS

- NEW LISSEN "SKYSCRAPER" KIT**, including Valves. Cash Price, £4/9/6. **With 8/3** order
- And 11 monthly payments of 8/3
- TELSEN "JUPITER" S.G.3 KIT**, complete kit less valves. Cash Price, £3/17/0. **With 7/-** order
- And 11 monthly payments of 7/-
- TELSEN "AJAX 3,"** complete kit less valves. Cash Price, £3/1/6. **With 5/8** order
- And 11 monthly payments of 5/8
- READY RADIO "METEOR" S.G.3 KIT**, including cabinet, valves, and moving coil unit. Cash Price, £3/17/6. **With 11/-** order
- And 11 monthly payments of 16/8. This Receiver also tunes to Ultra-short Waves.

### ACCESSORIES

**NEW BLUE SPOT 99 P.M. MOVING-COIL UNIT.** The finest of the new Permanent Magnet Units. Cash Price, £2/19/6. **With 5/-** order

And 11 monthly payments of 5/6.

**12 EXIDE W.H. HIGH TENSION ACCUMULATORS.** (120 Volts, 5000 M.A.). The cheapest and best High Tension Supply where Mains are not available. Cash Price, £3/15/-. **With 7/-** order

And 11 monthly payments of 7/-.

**NEW EPOCH 20c PERMANENT MAGNET MOVING-COIL UNIT.** Cash Price, £1/15/-. **With 5/6** order

And 6 monthly payments of 5/6.

Rola Speakers Supplied on Similar Terms. All above carriage paid.

To avoid delay, will customers kindly send first payment with order.

Goods ordered C.O.D. are dispatched by return of post. Post charge paid by us.

The **LONDON RADIO SUPPLY COMPANY** ESTD 1925

11, Oat Lane, Noble St., LONDON, E.C.2

Phone NATIONAL 1977

**EMPR D.C. or A.C.**

2-Valve All-Electric Chassis ready wired and tested, £4 - 12 - 6 complete

Send for particulars.

**MAINS POWER RADIO, LTD.**  
EASTERN ROAD, ROMFORD

**MATERIALS SUPPLIED FREE**

in Profitable Spare Time Employment making Leather Matting at Home

Finished Work Bought at Fixed Rates.

Write for particulars, Dept. D420.

**ARNOLDS (Wellingborough) Ltd., Wellingborough.**

**TAYLEX WET H.T. BATTERIES**

Give long service, improved volume and tone. Very economical. Replacements for Taylex or Standard batteries at low prices; details post free. Also Bargain List; Radio Kits and parts at lowest prices.

**A. TAYLOR, 57 STUDLEY ROAD, STOCKWELL, LONDON.**

## FULL-SIZE BLUEPRINTS

When ordering, please send Postal Order, NOT STAMPS.

### CRYSTAL SET (6d.)

1931 Crystal Set .. .. . AW308

### ONE-VALVE SETS (1s. each)

Easy to Build One .. .. . AW304  
Short-wave One-valver .. .. . AW327  
B.B.C. One-valver .. .. . AW344  
Portable Short-wave One .. .. . AW354

### TWO-VALVE SETS (1s. each)

25/- Two (D, Trans) .. .. . AW330  
Ten-Station Two (D, Trans) .. .. . AW336  
Inexpensive A.C.2 (D, Trans) .. .. . AW346  
Midget Two (D, RC) .. .. . AW348  
Mascot Two (D, Trans) .. .. . AW353  
Ideal Regional 2 (D, Trans) .. .. . AW357  
Quality 30s. Two (D, Trans) .. .. . AW361  
Economy A.C. Two (D, Trans) .. .. . WM286  
A Two for 7 Metres (D, Trans) .. .. . WM295  
New-style Radiogram (D, Trans) .. .. . WM299

### THREE-VALVE SETS (1s. each)

New Favourite Three (D, RC, Trans) .. .. . AW334  
Home-Lover's All-electric 3 (SG, D, Trans) .. .. . AW335  
P.W.H. ("Mascot" D, RC, Trans) .. .. . AW337  
Home-Lover's Battery 3 (SG, D, Trans) .. .. . AW341  
8 Radiogram (SG, D, Trans) .. .. . AW343  
New Regional Three (D, RC, Trans) .. .. . AW349  
World-Ranger Short-wave Three (D, RC, Trans) .. .. . AW355  
Wizard (SG, D, Trans) .. .. . AW360  
£2 2s. Family Three (D, 2 Trans) .. .. . AW368  
Percy Harris A.C. Radiogram (D, RC, Trans) .. .. . WM294  
Prosperity Three for Batteries (SG, D, Trans) .. .. . WM296  
1933 Economy S.G. Three (SG, D, Trans) .. .. . WM306

### FOUR-VALVE SETS (1s. 6d. each)

Four Star 4 (SG, D, RC, Trans) .. .. . AW318  
Up-to-the-Minute Four (2 SG, D, Trans) .. .. . AW356  
Your Home Radiogram, (SG, D, RC, Trans) .. .. . AW358  
Economy Radiogram (SG, D, RC, Trans) .. .. . WM276  
Triple-tune Four (2 SG, D, Trans) .. .. . WM293  
Calibrator (SG, D, RC, Trans) .. .. . WM300  
Table Quad (SG, D, RC, Trans) .. .. . WM303

### FIVE-VALVE SETS (1s. 6d. each)

James Short-wave Super (Super-het) .. .. . AW328  
Simple Super (Super-het) .. .. . AW340

### SIX-VALVE SETS (1s. 6d. each)

A.C. "Century Super" (Super-het) .. .. . AW295  
Mains Unit (1/-) .. .. . AW295A  
New Century Super (Super-het) with copy of A.W. 4d., post free .. .. . AW363  
Ideal Home Super (Super-het) .. .. . WM280  
Easytune 60 (Super-het) .. .. . WM284  
1932 A.C. Super 60 (A.C. Super-het) .. .. . WM272

### SEVEN-VALVE SETS (1s. 6d. each)

Super Senior (Super-het) .. .. . WM256  
Seventy-Seven Super (A.C. Super-het) .. .. . WM305

### PORTABLES (1s. 6d. each)

Hiker's Two (D, Trans) (1/-) .. .. . AW345  
General-purpose Portable (SG, D, RC, Trans) .. .. . AW351  
Town and Country Four (SG, D, RC, Trans) .. .. . WM282  
Everybody's Portable (5-valve super-het) .. .. . WM291

### AMPLIFIERS (1s. each)

Universal Push-pull Amplifier .. .. . AW300  
"A.W." Record Player (L.F. Push-pull) .. .. . AW319  
The Battery-operated Amplifier .. .. . AW362  
A-P-A (Power Amplifier for A.C. Mains) .. .. . WM275  
A-P-A Radio Unit (SG, D.) .. .. . WM281

### MISCELLANEOUS (1s. each)

Short-wave Plug-in Adaptor (6d.) .. .. . AW326  
Short-wave Super-het Adaptor (6d.) .. .. . AW329  
Ether Searcher Radio-gramophone Motor Board .. .. . AW333  
"A.W." Short-wave Adaptor .. .. . AW339  
"Mascot" Mains Unit .. .. . AW350  
"A.W." Trickle Charger .. .. . AW352  
Add-on Band-pass Unit .. .. . AW359  
Short-wave Adaptor for New Century Super .. .. . AW367  
A Simple Mains Unit .. .. . WM385  
Voltage Regulator .. .. . WM287

Copies of the "Wireless Magazine" and of "Amateur Wireless" containing descriptions of most of these sets can be obtained at 1s. 3d. and 4d. respectively, post free, under letters "A.W." refer to "Amateur Wireless" sets and "W.M." to "Wireless Magazine." Address letters:

**Amateur Wireless Blueprints Dept., 58-61 Fetter Lane London, E.C.4**

"Amateur Wireless and Radiovision." Price Threepence. Published on Wednesdays and bearing the date of Saturday immediately following. Post free to any part of the world: 3 months, 4s. 6d.; 6 months, 8s. 9d.; 12 months, 17s. 6d. Postal Orders, Post Office Orders, or Cheques should be made payable to "Bernard Jones Publications, Ltd."

General Correspondence is to be brief and written on one side of the paper only. All sketches and drawings to be on separate sheets. Contributions are always welcome, will be promptly considered, and if used will be paid for. Communications should be addressed, according to their nature, to The Editor, The Advertisement Manager, or The Publisher, "Amateur Wireless," 58-61 Fetter Lane, London, E.C.4.

You can build ANY Set BETTER -at LESS COST!

8 FREE BLUEPRINTS



**TUNEWELL VOLUME CONTROL**

Increases power of reception! Losses much less than with ordinary types. Logarithmically wound with double silk covered wire. Paper laid between windings. Type V. All sizes up to 50,000 ohms, 5/6. From 50,000 to 100,000 ohms, 7/6. Type P. Variable Resistance or Potentiometer. Equal resistance between studs. Max. Dissipation 3 watts, 5/6.

The new Tunewell Components have been specially designed to give you Super Radio, but by lowering our profits amazing values are offered. Use Tunewell Components wherever you can, for any set, and be sure of Super results.

Send Coupon below NOW for Tunewell "Guide to Super-Radio"

which gives full details, and eight FREE CIRCUITS, including Kit Eliminator and All Mains Band Pass 3 etc.

## ★ The Amazing TUNEWELL A.C. RADIOGRAMOPHONE

This new instrument has created a sensation with its truly amazing tone—quality of reproduction never before attained.

No "mass-produced" Radiogramophone can compare with this individually made instrument.

Before you buy a Radiogramophone, hear this latest Tunewell achievement. 27 gns. (plus 25/- Royalties).

Send coupon now for full details.

# TUNEWELL

To Tunewell Radio Ltd., 54 Station Road, London, N.11.

Please send me:—

- \*(a) "Guide to Super-Radio."
- \*(b) Radiogramophone Brochure.

Name .....

Address .....

\*Cross out if not required. A.W.9.

**PREPAID ADVERTISEMENTS**

Advertisements under this head are charged **THREEPENCE PER WORD**, minimum charge **THREE SHILLINGS**. DEPOSIT SYSTEM.

As the publishers cannot accept responsibility for the bona fides of advertisers in this publication, they have introduced a system of deposit which it is recommended should be adopted by readers when dealing with persons with whom they are unacquainted. It is here explained.

The amount of the deposit and fee must be remitted by Postal Order or Registered Letter (Cheques cannot be accepted), addressed to "AMATEUR WIRELESS" ADVERTISEMENT DEPARTMENT, 58/61 FETTER LANE, LONDON, E.C.4

**THE RADIO INDUSTRY.**—During the past twenty years I have placed nine hundred students in good permanent posts. I have devised a Home Study course, followed, if desired, by two weeks practical training. Prospectus free.—H. F. Yardley, M.I.R.E., A.I.E.E., Northern Counties Wireless School, Preston.

**COMPLETE KITS** for the "£2:2:0 Family 3," or separate components supplied on special terms; also Speakers, Batteries, Mains Units; cash or C.O.D.—Highbury Supply Stores, 44 Highbury Hill, N.5.

**1933 RADIO SETS, Kits, Speakers, Components.** Your old Radio equipment taken in part payment. Top prices allowed. Coupons accepted.—Rad-Auto-Gram Co., Tulketh Street, Southport.

**NEW EDITION RELIABILITY WIRELESS GUIDE**, incorporating Station Log, sent post free.—J. H. Taylor and Co., 3 Radio House, Macaulay Street, Huddersfield.

**"UNIVERSAL" RADIO BARGAINS.**—S.T.300 Coils, 5/11 pair; air-spaced variables, 1/11, with slow motion, 3/6; fixed condensers, 6d.; leaks, 6d. Ear transformers, 2/7; Stal, 2/11; chokes, 1/-; pick-ups, 5/11; triple-gang, 7/11; speaker units, 2/11; P.M.M.C. speakers, 19/11; Inductors, 92/11; Selected kits, Wizard 49/-; New Century Super 55/12/-; S.T.400 kit at keen price. Keen quotations for any journal kit. Thousands of other bargains. Lists free. Trade supplied.—"Universal," Peckham, S.E.15.

**MAINS TRANSFORMERS REWOUND**, promptly and efficiently. Satisfaction guaranteed. Keenest terms.—The Sturdy Electric Co., Derwent View, Dipton, Newcastle-on-Tyne.

**COMPLETE H.T. AND L.T. HIRE SERVICES.** Express delivery over wide area. Charging contractors to Camberwell Council and Oldham Service Station.—Aneloy Radio, 36 Hindmans Road, East Dulwich, S.E.22. Phone: New Cross 4074.

**THE "TONIC"** keeps any make 2-volt Accumulator fully charged at home. Electric mains unnecessary. Ideal for remote places. 7/- each, postage 9d. Particulars, copies of testimonials, etc., with pleasure.—Williams, Netherend, Cradley, Birmingham.

**SERADEX RADIO.**—Lists for stamp. Range includes Meters, Chargers, Condensers, Resistances, Chokes, Transformers, etc. Trade supplied.—48 Wake Green Road, Birmingham.

**GOSMIC RADIO SERVICE** purchase high-class components up to one-third list price. Send full particulars and ask for details of part exchange service.—14 Chapel Street, Liverpool.

**READY RADIO METEOR S.G. 3 KIT, £3/15/3.** Terms 10/3 monthly. New Century Super alternative kit, £5/15/- S.T. 300 author's kit, £2/15/-. Slightly soiled Ekco D.C. Eliminators (8 only), £1/8/6. Old sets taken in exchange for 1933 models. Send for quotations.—Servwell Wireless Supplies, 74 Gough Street, London, E.14.

**£5/10/- 111**—Power Pentode Two Edlswan A.C. mains receiver, listed at £12/10/-, guaranteed brand new, complete with new Mazda valves, A.C./E.L., A.C./PEN., and U.U.60/250 rectifier valve, a modern receiver with a high output, suitable for operating a moving-coil speaker on radio or gramophone; carriage paid, cash with order, or c.o.d.—Seekamp, 46 Farringdon Street, E.C.4.

**30/-**—B.T.H. B.K. Moving-coil Speakers, guaranteed new, unused manufacturers surplus; original price, 6 guineas. These are highly sensitive and have a wonderful response to high and low notes, will handle heavy outputs. Available for 6 volts, 100 volts, 200 volts, D.C. A.C. models, £2/10/-; Ask for list of other unused bargains; carriage paid, c.o.d., or cash with order.—Seekamp, 46 Farringdon Street, E.C.4

**Met-Vick A.C. Eliminators.** Guaranteed new, with U.U. 60/250 Mazda valve, manufacturers surplus. Suitable for screened-grid 3- or 4-valve sets. Output 40 m/A., 200 volts automatic bias, 4 volts 4 amps. A.C., early stage and S.G. tapping. Carriage paid, c.o.d., or cash with order. Send for list of other unused bargains.—Seekamp, 46 Farringdon Street, E.C.4.

**SUPPLY YOUR FRIENDS'** wireless requirements and make money. Particulars from "Wireless," 76 Wiverton Road, London, S.E.26.

**EVERYBODY KNOWS SIMMONS.**—Sale of Showroom Samples. Gram 4, £7/10/-. P.M. Speakers, Valves, Components. Stamp for list.—Simmons Radio Supplies, 9 Alfracombe Avenue, Southend-on-Sea.

**CHARGE YOUR H.T. FROM YOUR L.T. AT HOME.**—Combination trickie. Charges efficiently 1 to 12 H.T. 10-volt accumulators, 10/6. Postage 6d. Diagram only, 1/6.—R. Fox, 188 Camberwell Grove, S.E.5.

**ALL OF US NEED A TONIC** occasionally, but your 2-volt accumulator needs a "Tonic" always.—See advert.

**CONSTRUCTORS' BARGAINS!** Eliminators, D.C. 25/6; A.C. 42/6. P.M.M.C. speakers, 22/3. Quotations for anything.—Childs, 29 Moray Road, London, N.4.

**NEARLY NEW GOSBOR SET, S.G.3, 37/6.** Also Marconi, Etc. Perfect order.—Advertiser, 106 Elmstead Avenue, Wembley Park, Middlesex.

**ENGINEERS—IMPORTANT NOTICE.**—After months of intensive effort and research, we are pleased to announce that our new Hand-book is now out of the publishers' hands and ready for distribution. Containing 250 pages of practical guidance, this book is beyond argument the finest and most complete Handbook on Successful Engineering Careers ever compiled. It is a book that should be on the bookshelf of every engineer, whatever his age, position, or experience. The book contains, amongst other intensely interesting matter, details of B.Sc., A.M.I.C.E., A.M.I.Mech.E., I.E.E., A.M.I.A.E., F.S.I., G.P.O., and every other important engineering examination; outlines courses in all branches of civil, mech., elec., motor, radio, aero, and "talkie" eng., and explains the unique methods of our Appointments Department. We alone guarantee "No Pass—No Fee." The new "Engineering Opportunities" is bound to create a mild furore in engineering circles. See that you get your copy by writing to-day. Free and post free.—British Institute of Engineering Technology, 109 Shakespeare House, 29-31 Oxford Street, W.1.

**RECOMMENDED** Fully qualified Radio Technician, with 10 years' experience as service engineer to foremost radio manufacturers. Immediate attention to all inquiries. Greatly reduced terms to "A.W." readers.—Sparks Radio Consultants, 173b Merton Road, S.W.10. Phone: Sutton 4860.

**TRANSFORMERS.**—Large quantity of genuine Ericsson Transformers. New and guaranteed. List price, 17/6 each. Ratios 2-1 and 4-1. Our price, 3/3 each, carriage paid U.K., cash with order. Speakers, genuine "Six-sixty" Speaker Units, brand new and guaranteed. Limited number only. Original cost, 6/6; to clear, 1/9 each. Don't waste time. Save money whilst you can!—Pioneer Radio Manufacturing Co., Ltd., Coptic Street, New Oxford Road, W.C. Museum 9607. Trade inquiries invited.

**No H.T. Batteries needed with a SUPERSEDER even if you are not on the mains**



**37/6**  
from us only.

1,000 other bargains in our SALE LIST

S. G. Brown's device gives you 80 v. D.C. from your 2-volt battery and lasts indefinitely. A boon and blessing to all H.T. battery users. Reduced from £3/15/- to 37/6.

**MICROPHONES**

Highest grade, for all purposes. £20 Brown's P.A. Sale, £12. No. 5 Announcers, 65/- No. 12 Ring Pedestal, 18/6. Hand Transmitting, 15/- Solo Pendant, No. 11, in armoured case, 6/6.

Deaf Aid Sets. Solo, 18/6. Brown's Aural Box, £5/10/-. Ossiphones, 30/- See lists.

**CONDENSERS**

1 mfd., 220 v., 10d. 2 mfd., 220 v., 1/3. 2 mfd., 440 v., T.C.C., 1/6. 4 mfd., 3/6. 8 mfd., 5/6. 10 mfd., 10/6. T.C.C. 8 mfd. electrolytic, 6/3. L.T., 500 mfd., 12 v. only, 10/- .01 mfd., 1,000 v., Dubilier, 1/8. .25 mfd., 4,000 v., 6/- Grid .0001, .0002, .0003, .0004, .0005, .0006, or .001, etc., all mica, 6d. For other condensers up to 50,000 volts, see Sale List.



**14/- New Cobalt Steel SPEAKER-MAGNETS**

Owing to Messrs. S. G. Brown's liquidation we are able to offer some 1933 Four-claw M.C. Speaker Permanent Magnets at manufacturers' price. A great opportunity for constructors. Large Horse-shoe, 1/-, 1/6, 2/-, and 2/6.

**PARCELS.**—For the Experimental Amateur who wants a useful junk-box of oddments, our famous Bargain Parcels of Electrical and Radio Sundries from dismantled W.D. sets—surplus stocks, etc., with Switches, Wire, Chokes, Condensers, and Coils, and a host of useful parts, post free, 10 lb., 7/-; 7 lb., 5/-.

**ELECTRADIX RADIOS, 218 Upper Thames St., E.C.4**

**WHARFEDALE M.C. SPEAKERS.**—Assemble your own and save 33 per cent.. Complete kits ready for assembly in an hour. Full instructions; first-class results guaranteed.

**BRONZE WHARFEDALE STANDARD MODEL (2) watts undistorted;** latest 6-lb. P.M. 7-in. moulded cone, etc., £1, complete. Three-ratio Transformer (30 m. amps.), 7/6; carriage 2/6.

**COMPONENTS SCIENTIFICALLY MATCHED;** 3 days' approval; guaranteed 12 months.—Wharfedale Wireless Works, 92-96 Leeds Road, Bradford.

**SILVER WHARFEDALE SUPERPOWER MODEL (5-6 watts undistorted);** massive four-claw magnet (57,000 effective lines), linen cone, leather surround, etc., 50/-, complete. Three-ratio Transformer (50 m. amps.), 10/6; carriage 3/6. Equals any speaker, regardless of price. Complete Speakers, 3/6 extra.

**PERSEUS RADIO, Burton-on-Trent,** for Kits, Receivers, and Speakers, all kinds. Trade supplied. Catalogue 6d.

**PRINTED NOTEPAPER AND ENVELOPES,** 1/6 25, carriage paid.—Senior, 6 Tanfield Road, Birkby, Huddersfield.

**WIRELESS COMPONENTS.**—All makes supplied. Special discount home constructors. Also Cabinets.—Imperial Radio, 18 Summerhill Street, Birmingham.

**1933 RECEIVERS, KITS, COMPONENTS.** Cash or H.P. Amazingly high part exchange allowance; any type of set or component accepted. Send description, also details of receiver or components required; quotation immediately.—Wood, Fowlcotes Buildings, Holcombe Brook, near Bury, Lancs.

**BUILD SETS FOR FRIENDS** and make money.—Page, 42 Moray Road, London, N.

**SEND FOR COMPLETE RADIO CATALOGUE,** 128 pages, 1/6, post free. Oak Cabinets, beautifully finished, hinged lid, 14 by 7 by 10 in., 7/6; 16 by 7 or 8 by 10 in., 8/-; 18 by 7 by 10 in., 8/6. Baseboard, 9d., C.P. Hundreds sold. Other sizes made. Cabinet lists free. Speaker Cabinets from 5/6; Stand, 30/- Radio-gram, in oak, 37/- State nearest station.—F. S. Gibson, 99 Burnley Road, Alnsdale, Lancs.

**A BETTER OPPORTUNITY** awaits you in Radio and Talking Pictures. Introductions to employers given after practical home-study courses.—Particulars free from Radio Training Institute, Union Buildings, St. John Street, Newcastle-on-Tyne.

**BANKRUPT BARGAINS.**—List free with 3-valve diagram. If you have some usable components on hand or a set that you want to change, get my offer against a New Century Super kit, S.T.400 kit, or any "A.W." kit. Keenest prices offered against a new kit or any set. All parts supplied for any kit. M.C. speaker, P.M. or D.C. mains, Triotron valves, full range in stock. Triotron units, 7/6. A.C. and D.C. eliminators, accumulators, transformers, coils, cabinets, all small parts in stock. No order too large or too small. Advice free. Sets assembled. If you want a cheap A.C. mains set I have them complete from £7/10/- with M.C. speaker. I am always getting good second-hand parts and supply at low prices. Quotations per return for anything radio.—Butlin, 143b Preston Road, Brighton.

**BARGAINS.**—Westinghouse Metal Rectifiers, 180 volts 30 m.a., 6/6, post 6d. A.C. Eliminators incorporating Westinghouse metal rectifiers, a perfect job, 200-250 volts input, 150 volts 25 m.a. output, 30/- each, post 1/- Mains Chokes C.I. for eliminators or choke output, 30 henries 75 m.a., 6/- each, post 6d. Special Notice: We shall be marketing in the next few weeks a patent Universal Electric clock running on A.C. or D.C., 100-250 volts, any cycles, and will also work off a 3-volt battery. We shall be pleased to receive inquiries from those interested. D.C. Eliminators, 200-250 volts, 2 pos. tap, 1 variable, output 150 volts 25 m.a. or 30 m.a., price 15/-, post 1/- Also a large stock of All-mains Transformers and other mains apparatus, Cables, M.C. Speakers, Conversion Units for converting your D.C. Speaker to A.C. with Westinghouse metal rectifiers, price 10/6 with diagram.—T. W. Thompson & Co., 14-17 Strutton Ground, Westminster, S.W.1. Telephone: Franklin 6355.

**PHOTO ELECTRIC CELLS** potassium, guaranteed, for home talks, light-sensitive relays, etc., 15/- each, postage paid. Sound Installation Services Ltd., 14 Carlisle Street, W.1.

**DESIGNS FOR APPARATUS FOR ANY RADIO PURPOSE, INCLUDING TRANSMISSION. OVERSEAS ENQUIRIES INVITED; ANY APPARATUS SUPPLIED. CONSTRUCTIONAL WORK UNDERTAKEN.**

We undertake to solve your Problems, including obtaining Amateur Transmitting Licence. Whatever your difficulty, write us. Charges: 3/- per query, four or more, 2/6 each, with diagrams.

**Radio Technical Agency, (Dept. A.W.), 2, Westgate Chambers, Newport, Mon.**

**Famous Maker's Offer!**

**£5 Radio-Gram CABINET for 65/- 7 DAYS' FREE TRIAL (OR 10/- MONTHLY.)**

Polished Oak and Piano built The acoustic Tone-brings finest. Makers to Radio Press, B.B.C., 3,000 clients. Other Models 35/- to £15. Photographs and List Free.

**PICKETTS** Piano-Tone Cabinets, (A.M.) Albion Road, Bexleyheath.

**RADIO SUPPLIES**

Send your list of Radio needs for our quotation. Kits, Parts, Sets, etc. Everything in Radio stocked. Prompt delivery; seven days' approval. Catalogue free. Taylor and Standard Wet H.T. replacements stocked.

**A. TAYLOR, 57 STUDLEY ROAD, STOCKWELL, LONDON**

**Amateur Wireless**

**INFORMATION BUREAU COUPON**

Available until Saturday  
**DECEMBER 3, 1932**

FEE 1/-

**"RADIO  
AS IT SHOULD  
BE"**

means a good set and  
an **R.K.**



**Senior A.C. Unit  
for  
mains operation  
Price - £7-15-0**

Now that R.K.'s are available at such low prices, there is no longer any need to put up with second-rate reproduction. In the R.K. range of speakers at prices from £2.17.6 there are models to suit all purses and purposes. Each is designed to give in its particular sphere of operation, the characteristic R.K. balanced reproduction and fine sensitivity. All good radio dealers will be glad to demonstrate R.K.'s. A range of output transformers, specially designed for use with R.K.'s, is available.



**Minor R.K. Permanent Magnet Model  
Prices:—**  
Fumed Oak "ARUNDEL" model £2.17.6  
Walnut "ARUNDEL" model - £3.9.0

**Senior R.K. Permanent Magnet Model  
Prices:—**  
"WARWICK" model in Oak - £8.10.0  
"WARWICK" model in Walnut £8.17.6

**Senior R.K. Permanent Magnet Model  
Price:—**  
"WINDSOR" model in Oak - £8.10.0

*The above mentioned speakers are supplied complete with multi-ratio transformer.*

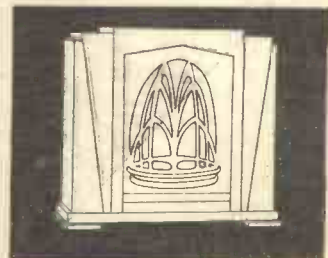
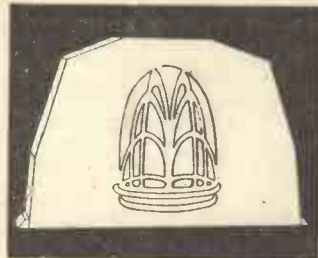

*Specified by the B.B.C. for Broadcasting House.*

**B.T.H.**

**MOVING COIL  
EDISWAN RADIO**



**REPRODUCERS**

**100% BRITISH  
MODELS**

The Edison Swan Electric Co. Ltd.



155 Charing Cross

*Don't Forget to Say That You Saw it in "A.W."*

# FACTS YOU SHOULD KNOW

## ... ABOUT THE MAZDA RANGE OF POWER OUTPUT VALVES

LOOK  
FOR "EDDY"  
IN YOUR  
DEALER'S  
WINDOW

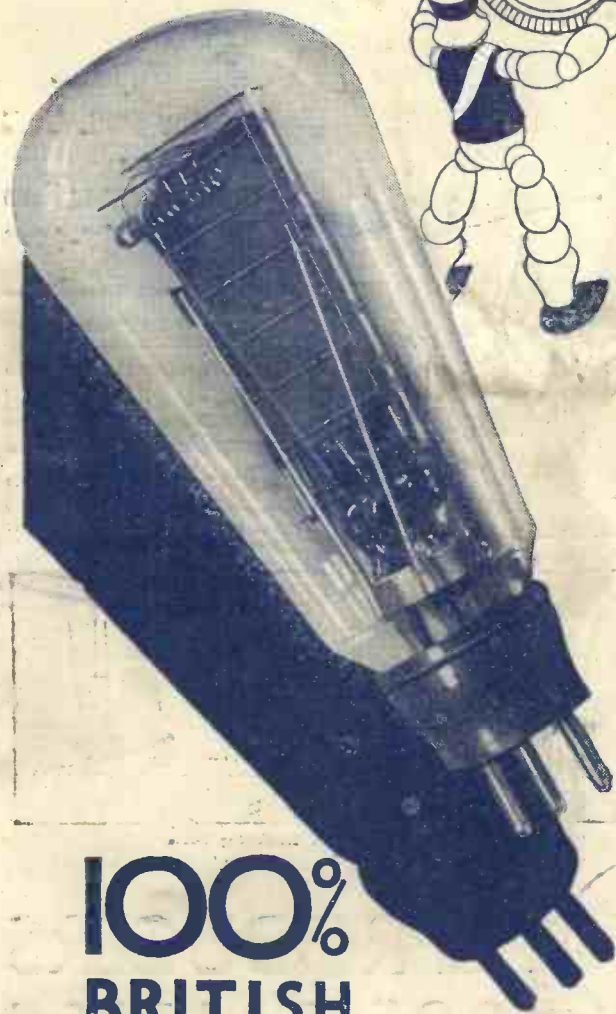
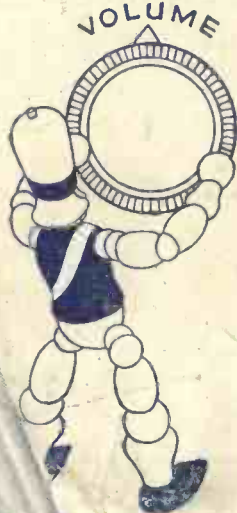

A good receiver, whether battery or mains operated, can be made or marred by the power valve. Each type of Mazda Power valve has been designed to give its most efficient performance under specific conditions. Here is a guide to the selection of the correct Mazda Mains Power Valve for your particular purpose.

**THE AC/P**—a low consumption power valve for operating balanced armature speakers. It is sensitive to comparatively small inputs, and will give good results on anode voltages as low as 150.

**THE AC/P1** will handle a bigger signal input and will satisfactorily operate a moving coil speaker. It requires 200 volts H.T.

**THE PP5/400** is a heavy power output valve capable of fully loading a large moving coil speaker. The anode current at 400 volts is 60m/a with 30 volts bias.

For Battery operated receivers there are the following:

**P220 and P220A**, both capable of giving ample volume with a reasonable input. The former valve is particularly recommended where economy of anode current is a consideration.

Full details of these and other useful Mazda types will be found in the Mazda catalogue, sent FREE on request.

**Mazda valves are fitted by all the leading receiver manufacturers. All good radio dealers stock them.**

The amazing

# MAZDA THE BRITISH VALVES

100%  
BRITISH

Designed by British Engineers

Electric Co. Ltd.



155 Charing Cross Rd. London. W.12

Manufactured in Britain for

The British Thomson-Houston Co. Ltd., London and Rugby.

V.169



# WIRELESS MADE EASY

## SUPPLEMENT

THIS WEEK'S  
"HIGH SPOTS"

THE A.B.C. OF GRAMO-RADIO—  
page Seven.  
"BUILD AS YOU LEARN"—pages  
Two, Three and Six.

A PAGE OF SELECTIVITY HINTS  
FOR BEGINNERS—page Eight.  
ELEMENTARY WIRELESS COURSE  
—pages Four, Five and Six.

### THE PRACTICAL MAN GETS DOWN TO THE JOB

:: SET-BUILDING MADE EASY ::

**M**AKING a wireless set to-day is a very easy job if you make good use of the AMATEUR WIRELESS blueprints, which are full-size layouts of the components, as well as guides to the wiring between the components.

A blueprint gives you a full-size view of the set as it looks

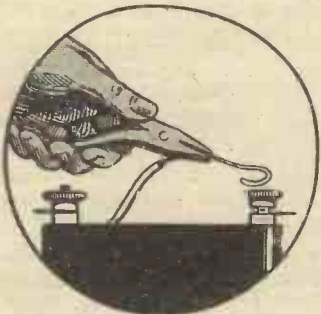

Make your wires loop so that the terminal nut closes them up

when all the components have been mounted in their correct positions on the panel and on the baseboard, and when all the leads between the components have been secured under the component terminals.

Right at the start, then, you can see your way towards the completed job. This alone should be an encouraging help. It will be still more of a help if you realise just how great an aid the print can be while you are actually assembling your own set.

Use the print freely and you will find set building a simple and enjoyable pastime. The

great thing about the full-size prints produced each week by AMATEUR WIRELESS is that they enable the beginner to get right down to the practical side of wireless without any great knowledge of the theory of the subject.

The basis of all our sets is a panel fixed at right angles to a wooden baseboard. The panel is usually of ebonite, though often this could be made of wood.

The blueprint, since it is printed as a flat sheet of paper, must of necessity turn the two-dimensional basis of the set into one dimension. The panel is therefore laid out in the same plane as the baseboard.

The fixing of the panel to baseboard often causes a little trouble to the beginner. Here is a simple hint. Place the panel up against the board in the position it will eventually be fixed and scribe a line along the panel with the baseboard as your "ruler." This will give you the right position for the fixing screws.

Drilling the panel is a simple job if you use the print as a template. Be careful when drilling the panel fixing holes, as these are rather near the edge and may cause the ebonite to split unless the final drilling is done gently.

For drilling you can use a breast drill with  $\frac{1}{8}$ -in. drills for the preliminary holes, enlarging where necessary with  $\frac{3}{8}$ -in. drills. If you cannot afford a breast drill you can quite easily make use of an ordinary brace.

For the baseboard fixing we

usually use round-headed black screws, either  $\frac{1}{2}$  in. or  $\frac{3}{8}$  in. long and of a fairly narrow gauge, say No. 4. Thicker screws will

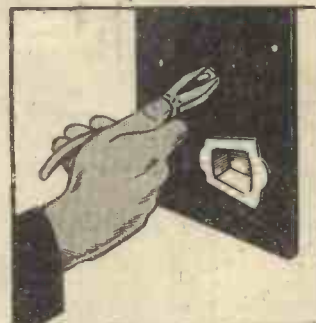

Use square-nosed pliers to tighten component terminals

tend to split the bakelite mouldings of the components.

Much of the difficulty of set construction was eliminated when soldering gave way to pressure contacts between the



Prick through the screw holes in the full-size blueprint when fixing the baseboard components

leads and the terminals of the components. Although we have proved by long experience that this simpler method of making contact is satisfactory it is essential to make really good contacts.

The best plan is to make each lead tight as you connect it under its component terminal, and not to wait until all the leads have been put in place before going round with the pliers. Square-nosed pliers should be gently but firmly applied to the terminals securing the ends of the leads.

These ends should be properly looped and not just nipped under the terminal by the straight ends of the wire. There is a right and a wrong way of doing these loops. The right way is to make the loops, with round-nosed pliers, so that when they are put under the terminal nuts they are closed up.

The wrong way is to put the loop on so that the wire is looping in an anti-clockwise direction, for then the tightening of the terminal nut will tend to unloop the wire instead of making it close up.

A use of the full-size print that is often overlooked is in the checking of the wiring. Cross off each of the wires on the print as you make the corresponding connections in your set. As the wires are all numbered this process enables you to leave the work and come back to it another time with the confident knowledge that no wire has been missed.

# PERCY W. HARRIS'S

# "BUILD AS YOU LEARN"

Start building the new three-valver in this new series of constructional articles by PERCY W. HARRIS. In this and the next few instalments you will learn how to assemble an efficient set with screen-grid, detector, and power valve circuit

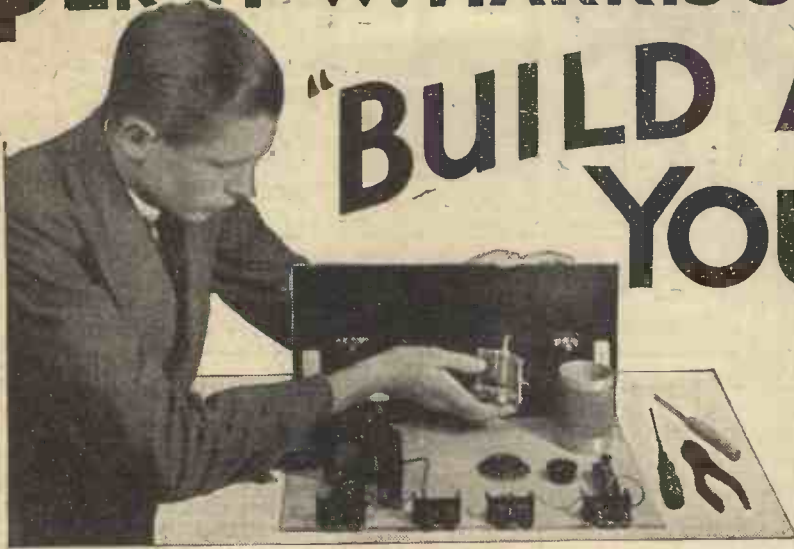

we have the advantage of a further tuned circuit to give selectivity. Of course we can use two tuned circuits before the detector to get this advantage of extra selectivity (I did so very successfully in the well-known "Mascot" receiver described in these pages).

### SCREEN-GRID ADVANTAGES

SO far in this series we have been through the elements of set design up to the point where we have completed a simple but very efficient detector and two low-frequency valve set. We have seen how the coil tunes, the effect on selectivity of various aerial tapings and adjustments of the compression condenser, and how reaction can be controlled both magnetically and by capacity variation.

We have been through a series of experiments teaching us about the detector and we know at least something about low-frequency stages, transformer and resistance coupling, and stability.

We now come to one of the most interesting subjects of all, the study of the screen-grid valve. We now know that one of the most important of the functions of a valve is to magnify the signals. In the set we have just finished, the incoming signals were tuned in by means of a coil and condenser and the voltages set up across this combination were applied straight to the grid and filament of the detector valve through a grid leak and condenser.

There was thus no magnification before the detector and only one tuned circuit. The magnification which we gave to the signals (and it was very considerable) occurred *after* detection when the signal had already become of the kind that will

affect telephones or loud-speaker. There are a number of important advantages in magnifying the signal

Indeed, a set made in this way and well designed throughout is more satisfactory and efficient both in selectivity and sensitivity than many of the poorly-designed sets using a screen-grid valve. However, if the design is good in both cases there are advantages in having a screen-grid valve in front of the detector, followed by only one low-frequency stage.

What is the screen-grid valve? The term is so generally used that it is well we should understand just what we are talking about. Any ordinary valve of reasonably good construction will magnify high-frequency currents just as it will low—it works irrespective of frequency.

A good deal of high-frequency magnification was done by ordinary three-electrode valves before the screen-grid valve was introduced, but unfortunately we could not get anything like the amount of magnification we wanted, owing to a certain peculiar defect.

We have seen in our reaction experiments how, after the signals were magnified in the detector valve, some of the energy was handed back to make up for the losses introduced by the first circuit, and remagnified, being again passed back, magnified once more and so on, till we built up a very big signal. If we passed back too much energy, the set would oscillate, as we found, and become

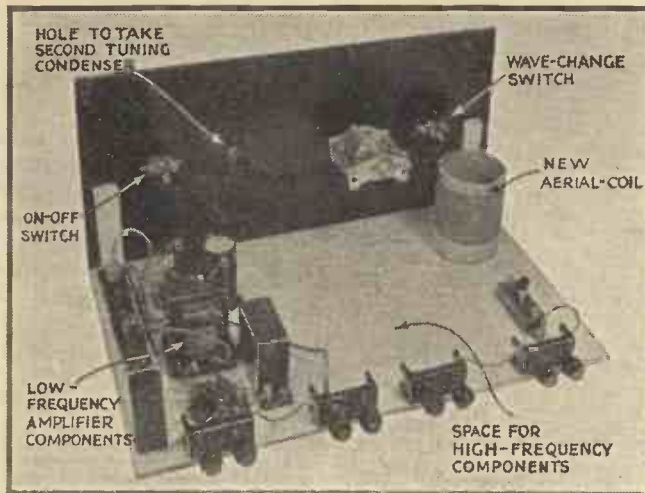

Getting the panel and baseboard ready for the new circuit. This week we leave you with the low-frequency parts all ready in position

before it is applied to the detector. For one, a detector works more efficiently on a strong than on a weak signal, and

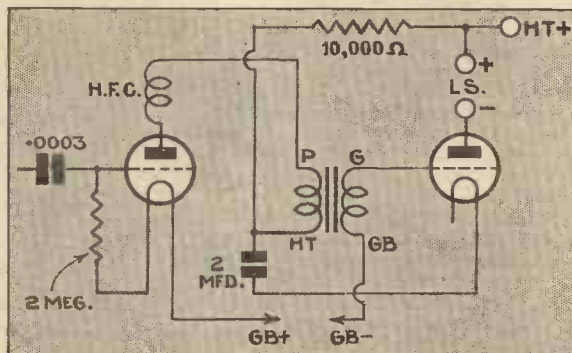

A theoretical diagram showing the connections of the low-frequency components in the new three-valve circuit

# THE SCREEN-GRID VALVE

unusable for reception, quite apart from the fact that in many cases it caused interference to our neighbours' reception.

## Oscillation

Now with the ordinary type of valve, no matter how carefully we keep the plate circuit away from the grid circuit in a high-frequency stage, and no matter how carefully we separate the coils, as soon as the magnification becomes really "worth-while" the small condenser formed by the plate of the valve and the wire mesh known as the grid, is quite big enough to hand back the magnified energy and cause oscillation. The effect is just as if we were to tie a small condenser between the plate and grid terminals of the valve holder, only in this case the condenser is formed inside the valve.

With a small amount of high-frequency magnification the feed-back is not enough to cause oscillation, but directly it becomes really important, the set becomes unstable. Prior to the advent of the screen-grid valve we were all using a scheme known as neutralis-

ation, which meant using another little condenser of about the same size as that formed inside the valve, to feed-back energy of equal strength and opposite direction so as to balance out or "neutralise" the capacity of the valve. In well-designed circuits this worked very well indeed but it had its own troubles.

Then several inventors set to work to overcome these difficulties and produced what is known as the "screened-grid" valve. Tucked away between the ordinary or controlling grid and the plate of the valve is a second grid which is connected to one of the high-tension tappings of the battery.

This grid serves two important purposes. By being made positive it helps to attract the electrons away from the filament towards the plate and being connected to earth through the high-tension battery (and often through a large condenser) it screens the plate from the grid and prevents the undesirable capacity effect feeding back unwanted energy. Being a mesh, it does not substantially hinder the flow of

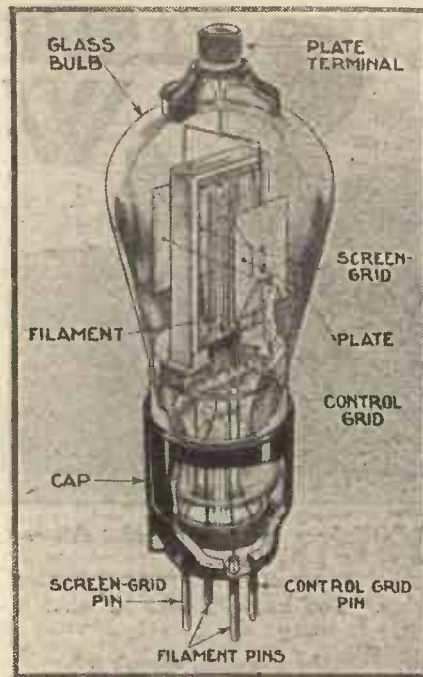

From this drawing you can see all the main features of a screen-grid type of valve, as used for high-frequency amplification

electrons from the filament to the plate in spite of the fact that it screens the capacity.

## Big Magnification

This is not really an article on valves, and I cannot go too deeply into the functioning of any one component, but I think I have told you enough to give you a general idea of what a screen-grid valve is and how it works. The great advantage, as I indicated, is that it enables us to get a big magnification of the signal before detection without the unpleasant feed-back effect which occurred before its introduction.

I promised that I would avoid as far as possible the necessity of purchasing parts we did not want and I intend to adhere to this throughout the course. As our first set has now served its purpose to illustrate the design, construction and working of detector and two low-frequency stage set, we will use the same baseboard, panel and components in our screen-grid experiments.

In the new few weeks I am going to show you how to build up a set consisting of a screen-grid valve, detector and one low-frequency stage and I hope to show you very many interesting things about the forms of coupling we must adopt. I do not wish to anticipate next week's lesson here, but I would like to show you how to begin the constructional work.

Take the set as it is, leave the panel in position but remove the reaction condenser from its hole and remove  
(Continued on page Six)

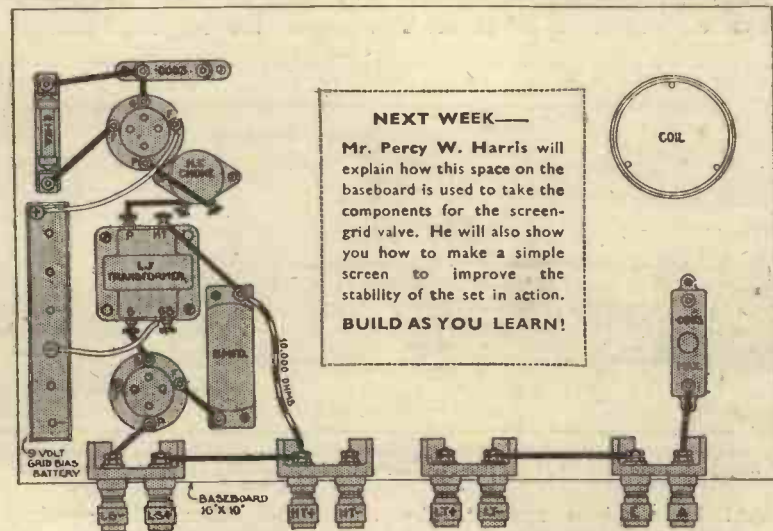
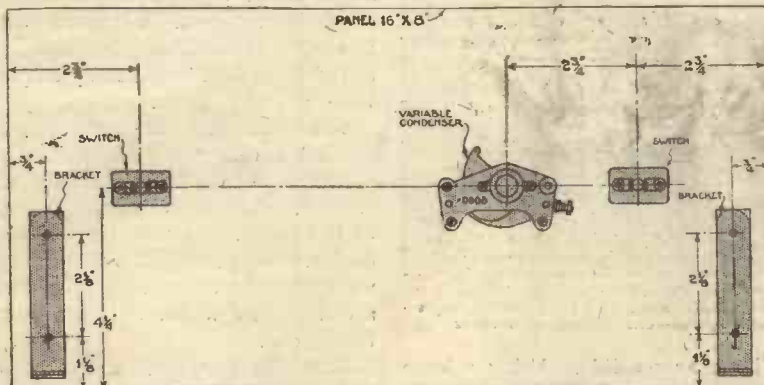

How the baseboard looks with the re-arrangement of the components. Note that the low-frequency parts fitted have been wired up as they do not in any way interfere with the rest of the layout to be described later

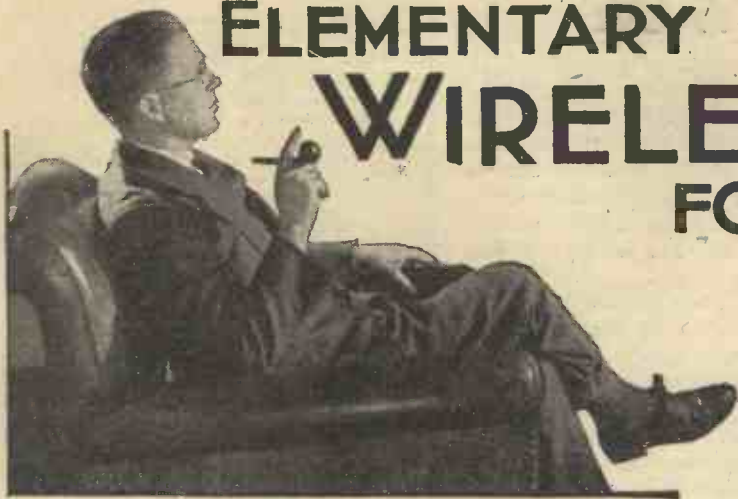

# ELEMENTARY WIRELESS COURSE FOR BEGINNERS

J. H. REYNER and the "A.W." staff tell you what reaction is and how it is introduced into a valve circuit

NEXT WEEK  
THE GANG CONDENSER

**YOU** have not told me what this reaction knob is for  
We will remedy that without further delay. You know, I take it, what it does?

**Increases the strength, doesn't it?**

That is the general effect. It also increases the sharpness of the tuning if it is used in the right way.

**What do you mean by "sharpness" of tuning?**

You know that when you are tuning to a station the signal strength can still be heard for a degree or two on either side of the actual tuning point. If this "spread" is small, so that a very small movement of the dial on either side reduces the strength practically to nothing, we say that the tuning is *sharp*. On the other hand, if the tuning point spreads over ten or twenty degrees on the dial, we say that the tuning is *flat*.

**But I thought you could only hear a station when you were tuned to the proper frequency?**

Broadly speaking, that is true, but the action is not a sudden one. If the voltages received on the aerial are vibrating a little slower or a little faster than the correct rate, they will be just a fraction of a second too late or too early to produce the maximum effect, so that the current produced will not be so strong.

Thus as we move the setting of the tuning condenser away from the actual tuning point, the strength of the oscillating current decreases very rapidly until finally there is practically no response at all.

So you see, there is no sudden burst of oscillation when the frequency is just right, and nothing at all if the frequency is wrong. The process is more or less gradual, and even if the circuit is slightly "mis-tuned" it is still possible to obtain appreciable currents, although these will not be anything like as strong as when the system is properly tuned to resonance.

**Then how far can we "mis-tune," as you call it?**

It depends upon the arrangement of the circuit. One factor is the inductance of the tuning coil, which should

be as large as possible. Using a large inductance automatically makes the circuit more selective. If the circuit is important. The wire in the coil obviously has some resistance, and the strength of the oscillating currents produced by any voltage picked up on the aerial is directly dependent upon this resistance. If the resistance is small the current is large and *vice versa*, so that if we want to make the greatest possible use of the small voltages picked up on the aerial, it is important to keep the circuit resistance small.

**How do we arrange that?**

By winding our coil in certain ways, which I will discuss another time, since it is really a separate subject. To make a coil with a really low resistance is an expensive business. Fortunately, there is a way of obtaining the same effect as reducing the resistance by employing what we call *reaction*.

You know that a varying voltage applied across the grid of the valve produces a variation in the anode current. Usually we pass this through a resistance, transformer or similar device. Suppose that before doing this we cause the current to pass through a coil of wire which we place near the tuning coil.

Now you saw last week that when two coils of wire are placed near together, the magnetic field of one

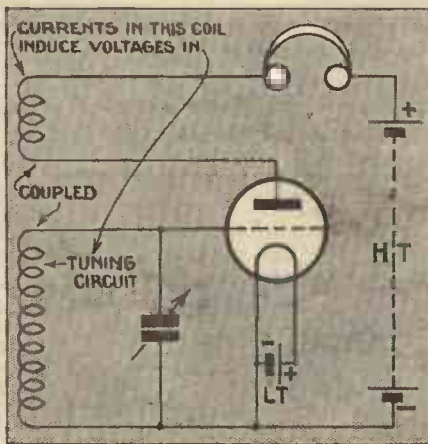

By now you should be able to follow this theoretical diagram, which shows a simple form of reaction applied to a valve

be as large as possible. Using a large inductance automatically makes the circuit more selective. If the circuit is

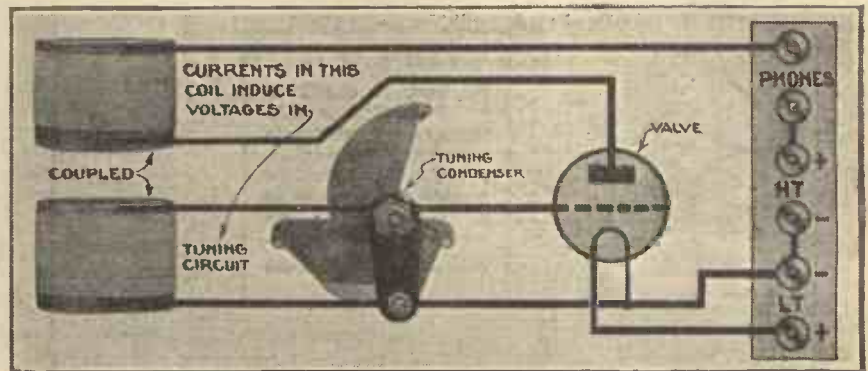

If you cannot yet understand theoretical diagrams, this simple pictorial layout of reaction will help you. Note that when the two coils are close together they are said to be coupled

mis-tuned by a given amount, the current falls off more rapidly than it would do with a small inductance.

The resistance of the circuit is very

affects the other. Consequently the varying anode current flowing through this *reaction coil*, as we term it, will induce voltages in the tuning coil,



# REACTION SIMPLY EXPLAINED

## Like a transformer?

It is a transformer, only we are dealing with high-frequency currents instead of low-frequency ones. The voltages induced in the tuning circuit can be arranged to be in the same direction as the voltages picked up by the aerial, so that the oscillating current is increased just as if we had reduced the resistance.

The effect is proportional to the existing current in the tuning circuit. Thus if the circuit is mis-tuned the current is reduced and the reaction effect is reduced. Consequently the current falls off on either side of the tuning point and signals rapidly die out. The strength of the current all the way is just a little more than before but is considerably more at the actual tuning point, so that we obtain a marked increase in strength by this means.

## Then can you make the current as large as you like?

No. In fact, we quickly reach a limit. If we feed back too much voltage from the anode circuit we cause such a large increase in the current in the tuning circuit that the system becomes uncontrollable. The oscillations continue irrespective of whether there is any signal being received on the aerial or not. We say that the circuit is in a state of continuous oscillation, and in fact we actually use this method to produce oscillations at the transmitting station.

For receiving purposes, however, we cannot use such a system because we require the oscillations to vary their strength in accordance with the speech modulation. So, you see, the reaction must be carefully controlled.

## How do you control reaction?

There are two principal methods. One is to vary the position of the reaction coil relative to the tuning coil. The other and more usual method is to split up the current in the anode circuit of the valve. One part we use in the ordinary way, while the other part is passed through the reaction circuit. We arrange to vary the strength of the current in this circuit by some suitable means.

For instance, we could insert a variable resistance in the circuit. If the resistance is made large, then very little current can flow in the reaction circuit and the reaction effect is therefore small. As we reduce the resistance, the reaction effect becomes greater and greater, and so we reach the point where the system becomes unstable and continuous oscillations result. This is usually called the *oscillation point*.

## Then this knob on my set is for controlling reaction?

Yes. It varies either the position of the coil or the current through the coil.

## How should it be used?

Having tuned in the station we bring up the strength by adjusting the reaction knob to the desired extent. If we increase it too far we get a whistling noise due to the interference between the oscillations generated continuously in our receiver and those being received from the transmitting station. Actually one often uses both the tuning and the reaction controls together in order to keep the receiving circuit in its most sensitive condition while we are actually tuning.

## Why do you do that?

Because the reaction not only increases the strength but improves the selectivity of the receiver. As I mentioned, the reaction effect is proportional to the current in the oscillation circuit, so that it has its greatest effect when the circuit is properly tuned to resonance, and only produces a small result when the circuit

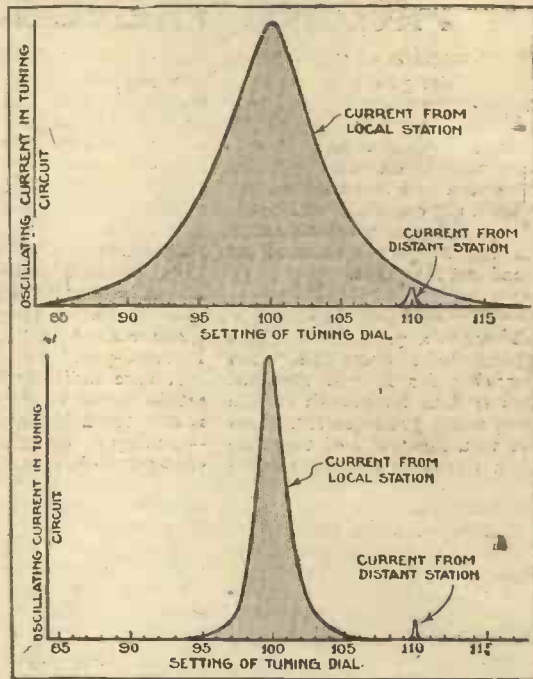

These queer-looking "mountains" are called resonance curves and they tell you in a simple way how the current energy from the broadcasting station affects the tuning dial of your set. The top curve is for an unselective tuning circuit, and the bottom curve is for a much more selectively tuned set. Note that whereas in the top curve the distant station comes within the setting of the local station, it is quite outside the curve below.

## Does that not make the tuning more difficult?

It makes it much sharper, which is what we require.

## I should have thought that would be a disadvantage

A flatly-tuned circuit is certainly easier to handle, but under modern conditions it is of little use. There are so many countries wanting broadcast stations in various centres that it is necessary to operate the various transmitters on frequencies very close to one another. Consequently if we want to select the required station and disregard the others, it is necessary to have a circuit which is very sharply tuned.

## If the circuit is flatly tuned do you hear two stations at once?

Yes; the effect is known as *interference*. It is particularly noticeable when there is a powerful local transmitter within ten or twenty miles. The strength of this station may be such that even when we are mis-tuned by 10 or 15 per cent. the resulting currents are still about as strong as the best that can be received from a station many hundreds of miles away. So you see, it is of the utmost necessity that the current should fall away very rapidly as the tuning condenser is moved off the tuning point.

Let me make the point a little clearer. We illustrate what we call a *resonance curve*. Along the bottom of this curve

(Continued on page Six)

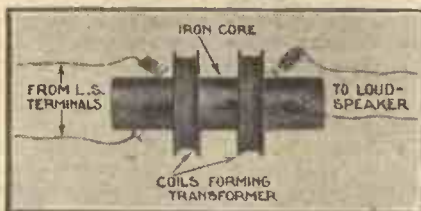

Here you see a simple example of the transformer. These coils and the iron core make a low-frequency transformer, while two tuning coils, as in the reaction circuit, make a high-frequency transformer

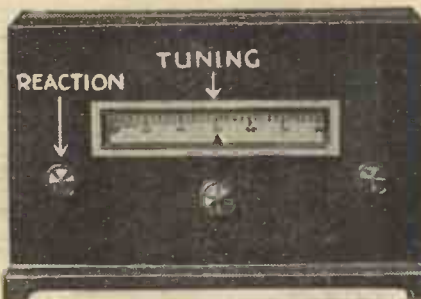

Just to remind you that every set has some sort of tuning arrangement. Here you see the degree divisions on the tuning dial. You should remember them when studying the resonance curves at the top of this page

is mis-tuned. Therefore the *relative current* when the circuit is properly tuned becomes very much greater.

# FINDING FRENCH BROADCASTING STATIONS

**P**ICKING out the French stations you hear on your set is quite easy if you listen carefully to their call signs. There are about twenty French transmitters on the medium waveband and two on the long.

With the exception of Russia, France is the only country that has two long-wave stations for broadcast reception.

### Golden Rule!

There is a golden rule which should be remembered when searching for French stations. This is that no French station gives really good quality. You can test the truth of this rule when you have definitely heard a number of French transmitters on your own set!

The two French stations on the long waveband are Radio Paris (1,725 metres) and Eiffel Tower (1,445 metres). The former is just above Daventry, National and Eiffel Tower just below.

Eiffel Tower is usually heard at very good strength, but with bad quality. Radio Paris broadcasts gramophone records in the morning from 7.40 a.m. until 8 o'clock, when the hour chimes are heard. Incidentally, this time signal is very accurate, a great help for the early morning!

The broadcasting system of

France is far behind the times. She has only one high-power station of the 60-kilowatt variety on the medium waveband, and two or three around 10 and 15 kilowatts.

One is Poste Parisien (328.2 metres), which will be found about half-way between London Regional and North National. This position will be easily understood from the diagram on this page. The call sign (phonetically) is "Ee-see Post Pa-ree-si-yen."

A sure indication that your set is tuned to Poste Parisien is that the neighbouring station—moving downwards—often causes interference. This other big station is the new German 60-kilowatt station at Breslau (325 metres).

The other Frenchman, of special importance to British listeners, is announced as Fécamp to British listeners and as Radio Normandie during French concerts.

Fécamp is easily found at the bottom of the medium waveband, well below London National. Do not mistake Trieste, a powerful Italian transmitter on 247.7 metres, for Fécamp. The English call sign is unmistakable and the French one is "Allo Ees-ee Rardio Nor-man-dee." The wavelength

is always moving up and down a little; at present it is 225.2 metres.

Fécamp's programmes on Sundays from the late afternoon till 3 a.m. on Monday

which has been a very popular station, is now almost completely swamped by the huge 120-kilowatt German giant, Leipsig. You may, with luck, manage to pick up his call sign, the familiar "Ee-see Rardio Too-loose."

Strasbourg and Bordeaux-Lafayette often give reasonable entertainment. Strasbourg on 345 metres is two channels below London Regional. A deep-toned gong is used as an interval signal and the call sign is "Allo Allo Ee-see Rardio Stras-boorg Pay-tay-tay."

### French Calls

Bordeaux-Lafayette will be found just about North National, the call sign being "Allo Ee-see Rardio Bor-doh Pay-tay-tay."

The call sign of most French stations is two "Hallo's," then "Ici—" (this is) followed by the name of the transmitting station. Reception of the less powerful stations depends on the selectivity of your set and on the prevailing conditions in the ether.

On this page is a diagram which shows the relative positions of many French stations on the medium waveband. Please note that the dial readings are not meant to be accurate and are only to be taken as a guide.

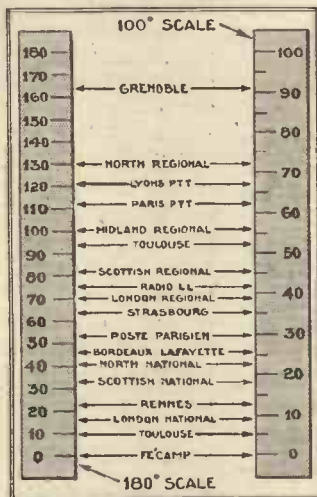

Showing the relative dial positions of the French stations. Use the home stations as a guide

mornings are arranged by the International Broadcasting Co., and are mainly of popular gramophone records.

The other French stations are not well heard. Toulouse,

## "BUILD AS YOU LEARN"

(Continued from page Three)

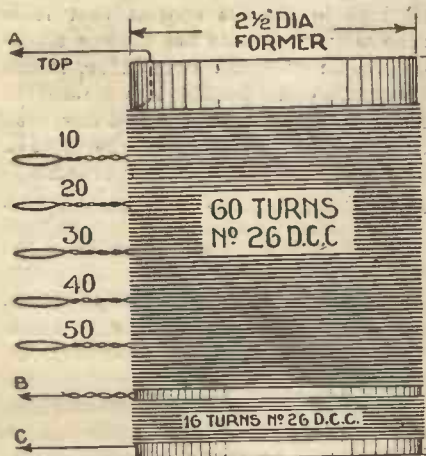

Winding details of the extra aerial coil needed for next week's three-valve set

everything from the baseboard with the exception of the compression condenser and the terminal blocks.

You will see from the drawings and photographs how I have re-arranged certain of the parts, and I suggest that you do this ready for the beginning of next

week's lesson. You will notice that the grid condenser and leak are connected to the grid terminal of the detector valve holder which is placed near the panel and in the plate circuit we have a high-frequency choke and the primary of the low-frequency transformer.

I am not at present incorporating reaction with this set as I want to show you the other effects first, but later we shall fix the reaction condenser to the same panel in a slightly different position and take the leads from the plate circuit as before.

De-coupling is just as important in this as any other set, and therefore we have put the 30,000-ohm resistance and the 2-microfarad condenser in circuit as before. The grid-bias plugs are joined to the grid-bias terminal of the low-frequency transformer and the negative terminal of one of the valve holders.

We shall need one or two new parts for next week's experiments which are as follows: a second .0005-microfarad vari-

able condenser, a piece of aluminium foil or copper foil about 12 in. by 18 in. (the size is not very important as long as it is as big as this, as we shall cut sundry pieces from it), a piece of wood about 10 in. by 8 in., one screen-grid valve, and a duplicate of our first coil without the long-wave or reaction winding just as it was described in the first lesson of the series.

## ELEMENTARY WIRELESS COURSE

(Continued from page Five)

are shown the dial settings of the tuning control. Along the vertical scale we represent the strength of the current, and you will see that at 100 divisions on the dial the strength of the current is shown as a maximum.

If we alter the setting of the tuning dial, the circuit is no longer correctly tuned to incoming signals and the current is reduced. You will see that the farther away we go from the actual tuning point the less is the current.

Suppose we are trying now to receive the signals from a different station which tunes in at 110 degrees. The current received from this station is also

shown on the figure, and it will be seen that the curve has the same general form, but the current is very much smaller owing to the greater distance from the transmitting station.

If the first station is not transmitting then we can receive this distant station quite easily by setting the dial at 110. If the first station is transmitting, however, you will see that with the dial at 110 the "backwash" of the local station is still stronger than the maximum strength we can possibly receive from the distant station. Therefore we shall not hear the distant station at all.

### How do you get over that?

With a simple set we could improve matters by using reaction. This would increase the strength of the distant station so that it could be heard, although there would still be a background of the local transmission. A better method is to use more than one circuit so that the signal has to undergo several selecting processes before it is finally applied to the detector. If with one circuit the strength with the condenser mistuned by 5 per cent. were reduced to one-third, then with two such circuits the strength would be reduced to one-ninth.

# THE A. B. C. OF GRAMO-RADIO

LAST week we mentioned, among explanations of wireless jargon, that gramophone apparatus for radio and gramophone record reproduction.

the pick-up lead to the filament take it to a negative socket in a bias battery as shown. The positive end of the bias battery is connected to the filament.

grid will get its bias through the pick-up winding without in any way affecting the action of the pick-up.

There is a gadget that will make a great deal of difference to your gramophone results—a volume control. If the full output of the pick-up is directly applied to the grid of the valve, even when the valve is well biased there may be some distortion due to the fact that the valve cannot handle more than a certain amount of voltage.

To regulate the pick-up output is the job of the potentiometer volume control. This consists of a high resistance winding of between 25,000 and 50,000 ohms, with a slider moving along it.

The two ends of the winding go to the two ends of the pick-up and we tap off the output of the

pick-up simply by moving the slider along the windings. The slider goes to the grid of the valve, instead of one end of the pick-up. Then one end, it matters not which, goes to the bias battery as before.

The potentiometer regulates the output of the pick-up in this way: as the slider moves towards the end of the winding connected to grid bias the voltage is reduced, and as the slider moves towards the other end of the winding the voltage increases.

Do not use a very low value of resistance for this volume control or the high notes will be cut down. Up to a point this may be an advantage in cutting down needle scratch, but quality suffers if this process is carried too far.

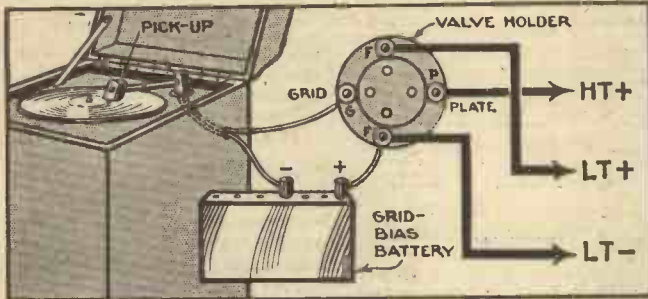

The gramophone pick-up is connected in the grid circuit of an amplifying valve, which has to be negatively biased as shown

Let us now go into this gramophone more fully. The first thing to learn is that the gramophone pick-up is the link between the mechanical vibrations set up by the needle travelling over the grooves of the record and the electrical energy passed on to the amplifying valve.

The vibrations of the needle cause minute currents to be developed in the pick-up coil and these are applied to a valve amplifier, emerging from the output valve as large low-frequency currents of the same nature as wireless signals after detection and amplification.

We have to connect the pick-up in the grid circuit of the first amplifying valve. What, then, is the grid circuit? It is the path between the grid of the valve and the negative side of the filament.

So if we connect one of the two pick-up leads to the grid and the other to the filament we shall have placed the pick-up in the grid circuit. Exactly—but there will be no negative bias applied to the amplifying valve, and that will mean distortion.

It is easy to intercept the pick-up connections and get our bias on the grid of the amplifying valve. Instead of taking

The pick-up will be in the grid circuit as before, and the

## HOW TO CHOOSE THE RIGHT LOUD-SPEAKER

TO-DAY the choice of a loud-speaker is very wide and many listeners wonder which is best for their sets. Although there are so many loud-speakers on the market, in chassis and cabinet form, the only big difference is between those called moving-coils and those called moving-irons.

You must remember that owing to great improvements in the moving-coil type it is now possible to use it with almost every sort of set. At one time this was not so, and only a very powerful set could be made to give sufficient volume from the moving-coil.

Small sets, by which we mean sets with only two or three valves, and using small power output valves, had to be used with the moving-iron type of loud-speaker.

The reason was, and to some extent still is, that the moving-iron loud-speaker, often referred to as a balanced-armature owing to the method of arranging the movement of the iron armature, is very sensitive to weak signals. It is not capable of bringing out the low notes like the moving-coil, but where the output is small these notes would in any case be weak.

Owing to their accentuation of the higher frequencies the moving-iron is very suitable for reception of speech. The moving-iron takes a lot of beating when we are considering clarity of speech.

With a normal two-valve set, using an LP2 type of power valve, that is a valve giving a total power output of about 150 milliwatts, the well-designed moving-iron with balanced-armature construction is probably still the most suitable.

set, and needs no more extras than a moving-iron loud-speaker.

Many moving-coils have a low resistance, which means that they must have an output transformer to "match up" with the power valve.

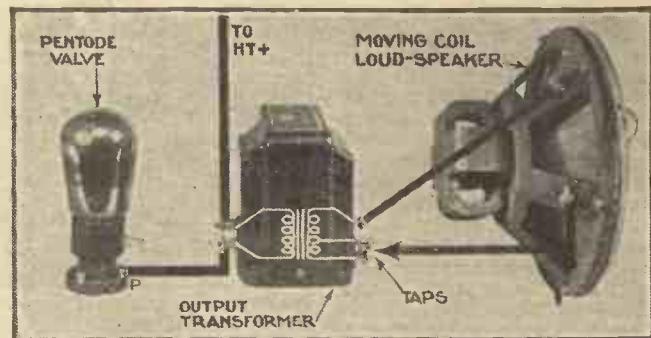

The secret of good quality is accurate matching of the set's power valve with the loud-speaker. This is most easily done with an output transformer, connected as shown above

For all other sets the new moving-coil types are to be preferred. Not only has the sensitivity been greatly improved, so that a large volume is provided from the normal output of a three-valver's power valve, but the frequency range is such that both high and low notes are reproduced with great realism.

There are now many moving-coil loud-speakers that have what are known as permanent magnets. This is instead of the energised type of magnet that necessitates the use of the electric-light mains.

The modern permanent-magnet moving-coil can be used with great success on a battery

Most power valves, especially the pentode type, have a much higher resistance than the moving-coil. To overcome this discrepancy we use an output transformer, which has a primary winding that matches the valve and a secondary winding that matches the loud-speaker. This means a step-down transformer.

Sometimes the loud-speaker has its own transformer. Many of the latest chassis have, and with these you can couple the set directly to the terminals on the transformer. Usually there are two or three alternative secondary terminals, so that you can experiment to get the best tone and volume.

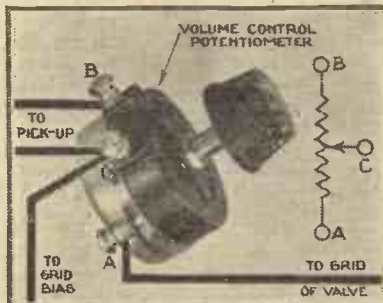

How a potentiometer is connected to a pick-up to control the amount of energy handed on to the amplifying valve

# A PAGE OF SELECTIVITY HINTS FOR BEGINNERS



DO you know what selectivity is? The word is often used by listeners when speaking of the tuning of their sets. We can broadly define selectivity as the ability of the set's

The following hints are offered to the beginner who is troubled with very unselective tuning. One or more of these simple hints will usually improve the aerial tuning, which is the circuit that is easiest for the amateur to modify without altering the internal wiring of the set

we may have too much wire. In the earth too high a resistance. Overcome both of these losses, or rather reduce their effect, and we shall be on the way to better aerial tuning. Your aerial wire may be 100 feet long. If so cut it down to 70 feet. This should be the total length, including the lead-in wire.

The length depends on your distance from the local station.

to one terminal of the condenser, and then connect the remaining terminal of the condenser to the aerial terminal of the set.

## THE CAPACITY DEPENDS ON YOUR AERIAL

Usually you will have an odd fixed condenser lying about the junk box of your keen amateur friend. The capacity can be anything from .0001 microfarad to .0003 microfarad. The smaller the capacity the sharper will be the tuning. The longer the aerial the smaller is the capacity needed to get this sharp tuning.

If the aerial is already short a capacity of .0002 microfarad ought to serve. If the aerial is very long nothing higher than .0001 microfarad is likely to give any improvement.

This insertion of a condenser in the aerial lead is all very well, but it does cut down the signal strength. The idea is to find the compromise between just sufficient selectivity to get the wanted station clear and just

stations can be tuned in clear of interference. The trap must be a low-loss tuning circuit, or in trapping the local it will also trap most of the wanted foreigners.

The simplest and probably the most effective trap we know is a tapped coil with a parallel tuning condenser. The aerial lead is taken to a tapping on a 60-turn coil, and one end of the coil is then taken to the aerial terminal of the set.

The local is tuned in on the set's circuit and then the dial of the trap condenser is slowly turned until at one spot the local will disappear or be greatly reduced in strength. The lower the aerial tap the sharper will be the tuning.

Another method of sharpening the aerial tuning is to add on another tuning coil and condenser, and to couple this extra circuit to the set by means of a small variable condenser. The advantage of this system is that sharper tuning is obtained over all the wave-band, and not, as with the trap, for just one wavelength.

## COUPLING CAPACITY

Almost any coil and condenser tuning circuit can be added on but care must be taken to use a suitable type of coupling condenser. One of the so-called neutralising condensers is recommended, that is a small air-spaced condenser with a very low minimum capacity, say 2 micro-microfarads.

The smaller you make this condenser the greater will be the selectivity, but this process must not be carried too far or the range of the set will be appreciably cut down.

## USING A VARIABLE CONDENSER

Now it is obvious that the amount of selectivity will not be the same for all stations received, since the strength of stations varies very greatly. What you need to do the job really well is a variable capacity. This is available in the so-called pre-set condensers, which are variable over sufficient capacity for this special job, though they would not be any use for tuning.

The wave-trap, though greatly over-rated in the past, still has its use in enabling a powerful local to be cut down in strength or cut right-out so that foreign



A wave trap is useful in cutting out a powerful local station, although you must remember it does not improve the general selectivity of the set

Another point to watch: the external tuned circuit must not interact with the tuning circuit in the set. You may find a small vertical metal screen an advantage,

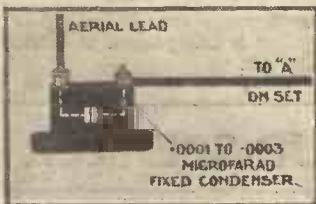

A small fixed condenser between the aerial lead and the aerial terminal of the set is sure to sharpen up the tuning

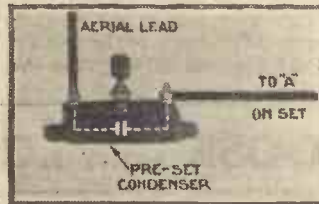

Here we use a pre-set type of condenser to obtain a variable coupling between the aerial and the aerial tuning circuit

tuning circuits to select a wanted station to the exclusion of all others, and particularly those stations on wavelengths adjacent to the wanted.

Your ability to get the station you want depends on the tuning circuits in the set. To get complete separation of stations under all conditions you must use several tuning circuits. One circuit, no matter how efficient or "sharply" it may tune, cannot cope completely with modern conditions.

It so happens that there are still in use many sets that have only one tuning circuit, and that is in the aerial and earth circuit. Such sets, though not able to give the separation wanted under all conditions, can, by careful alteration, be made to tune in the locals very nearly clear of foreigners, and to bring in some foreigners clear of the locals.

## SELECTIVITY NEEDS

As half a loaf is better than no bread at all we can heartily commend the beginner to the following hints for improving aerial tuning selectivity. Remember, though, that modern selectivity needs can be fully met only with a number of tuned circuits.

The first points of attack on flat tuning are the aerial and the earth. These are part of the aerial tuning and must be made as low-loss as possible. What are the losses? In the aerial

If you are within ten miles of a regional you may have to cut down to 50 feet or even less.

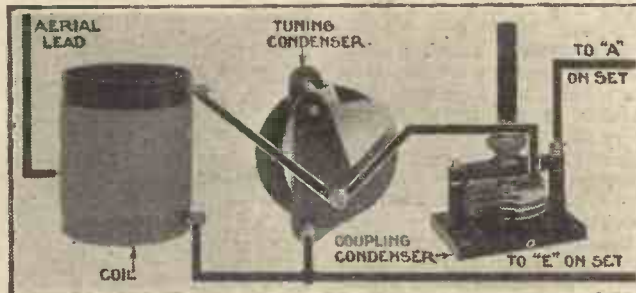

An external tuned circuit can easily be used with an existing set, as this diagram of connections shows. Note the coupling condenser is a neutralising type with very small minimum capacity

What about the earth? If this has a very long lead see that the wire used is of thick gauge—the stranded 7/22 aerial wire is very suitable. If the earth is a buried plate and has been down for more than a year dig it up and make a new one. If a water-pipe earth is used clean up the contact.

These simple measures may work a great improvement in your set's tuning and you may not have to try any of the other hints.

Perhaps you are not inclined to meddle with the aerial wire. You can achieve much the same effect of cutting down the length by using a small fixed condenser. Take off the lead from the aerial terminal of the set. Connect the aerial lead

sufficient strength to make reception worth while.