

HOW TO GET THE STATIONS YOU WANT

# Amateur Wireless

Every Thursday 3<sup>d</sup>

# Wireless

and  
Radiovision

Vol. XX. No. 516

Saturday, April 30, 1932

*Tips on*

HUIZEN

BRINGING IN

RADIO-PARIS

THE STATIONS

MOSCOW

VIENNA

TOULOUSE

KALUNDBORG

BARCELONA

BORDEAUX

THE HINTS  
AND TIPS  
ON PAGE 793

OPERATING  
SIMPLE SUPER  
ON PAGE 804



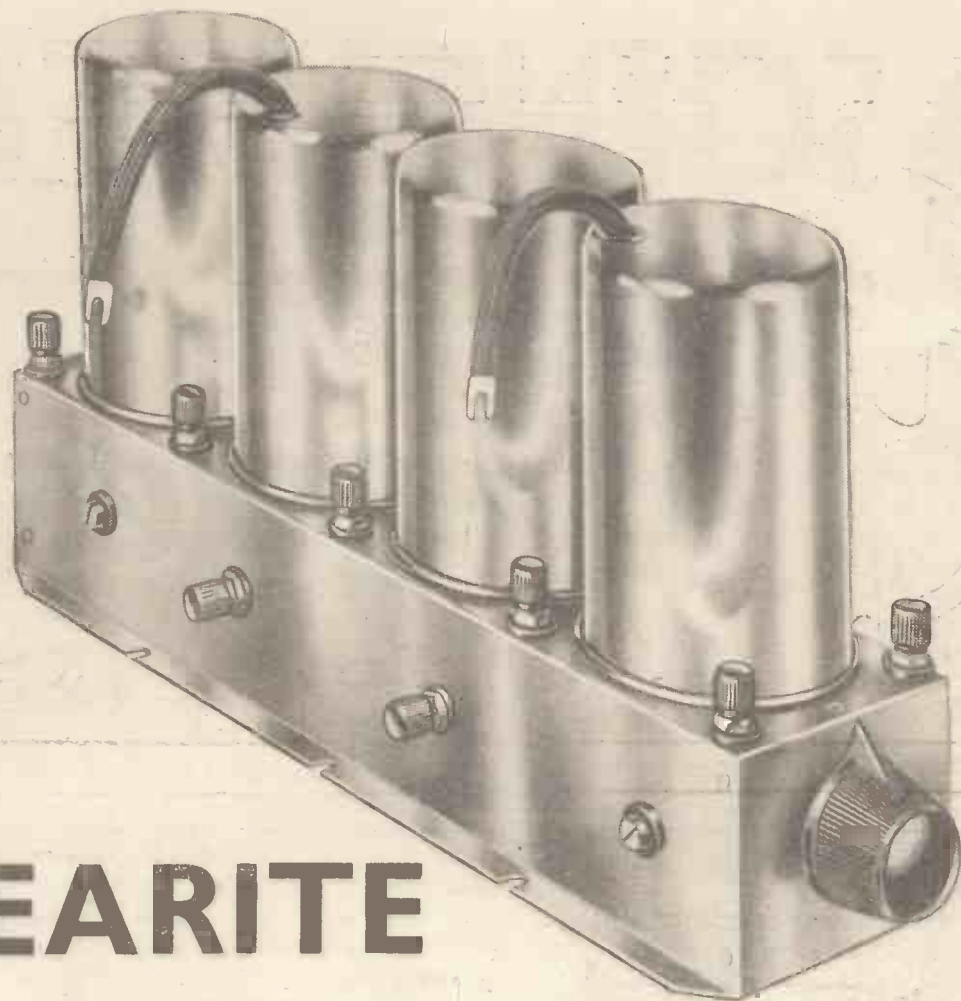

Patent applied for

# The WEARITE SUPER-HET COIL

THE Wearite Super-Het 4-Coil Unit, designed and constructed entirely by Wright & Weaire, Ltd., has virtually made the "Simple Super" possible. All problems of wiring and building are eliminated; it is the heart of the Set—and around this unit Mr. James has built the simplest and most efficient of all Super-Hets, the "Simple Super."

This Set will even surprise "Century Super" and "Super 60" users—those who know of the wonderful performance of these two receivers still have a thrill to come with the "Simple Super."

—which has made the "Simple Super" possible

**You will also need these Wearite parts:—**

* One Wearite O.T.1 super-het coil	...	...	...	Price
				10/6
* One Wearite O.T.2 super-het coil	...	...	...	10/6
Seven Wearite 4-pin valve holders (S.L.), each	...	...	...	1/3
One Wearite H.F. choke (H.F.S.)	...	...	...	6/6
One Wearite grid-leak holder (A.1)	...	...	...	6d.
One Wearite earth tube	...	...	...	3/6

\* Not needed if you have already built the "Century Super" or "Super 60."

Price of the complete four-coil chassis in copper, all coils critically tested and matched to laboratory standards, is

**58/6**

**WEARITE**

WRIGHT & WEAIRE LTD., 740 HIGH ROAD, TOTTENHAM, N.17 Phone: Tottenham 3847-8



# SCIENCE AHEAD

COMPONENTS THAT SYNCHRONIZE WITH LATEST DEVELOPMENTS in CIRCUIT DESIGNS of TO-DAY and the FUTURE



Efficiency at lowest cost is the dominating influence in circuit design to-day, hence, one finds, in all principal circuits for 1932 the specification of R.I. productions, because they are designed and built first and foremost for absolute efficiency and Reliability irrespective of price, yet they cost *no more than ordinary components.*

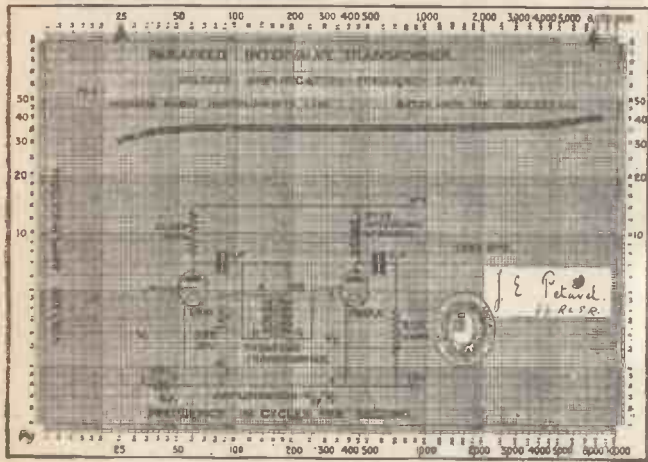

Amazing N.P.L. Curves 25 to 8,000 cycles.  
Primary Inductance 80 to 100 henries.

## The 'PARAFEED' L.F. TRANSFORMER

The "PARAFEED" Transformer is used by practically all designers of modern high efficiency circuits. For parallel-feed amplification "PARAFEED" possesses advantages not equalled by any similar transformer. The amazing N.P.L. curves published are proof positive before you buy, that "PARAFEED" will give the best results obtainable in the circuits in which it is used

Get a copy of the "PARAFEED" book—it is an education in amplification—ask your radio dealer or us for a copy.

Primary Inductance 80—100 henries. Primary D.C. Resistance 1,100 ohms. Secondary D.C. Resistance 2,800 ohms. Turns Ratio 1:3. Ratio of 1:4 obtainable by "auto-connection." List No. DY28

8/6

## The 'DUX' AUDIRAD

An Outstanding Radio Development for 1932  
A SUPER-CHOKER that deals with H.F.  
as well as L.F.

**WHAT AUDIRAD IS.** The Dux Audirad is a new form of choke dealing with low frequencies and high frequencies by means of a unique stopping device, which bars H.F. currents that would normally be passed by the self-capacity of an ordinary L.F. Choke, and cause hum or other H.F. interference.

It is recommended as an output choke by notable designers of high efficiency sets who use it because it is so absolutely consistent with modern circuit design.

**FOR MAINS UNITS AND SETS,** it is super-efficient for smoothing or output filtering in A.C. or D.C.

**FOR BATTERY SETS** it gives amazing output filter service, and ensures freedom from unwanted current fluctuations. Ask for the "Dux Audirad" leaflet, which gives full technical information and diagrams.

L.F. Inductance 25 henries. H.F. Inductance of H.F. Stopper.....10,000 micro-henries  
Maximum D.C. Current; 50 m.a. Overall dimensions: 2 ins. x 2½ ins. x 2½ ins.  
Weight; 15 ozs. List No. D.Y. 31.

8/9

**YOUR COPY OF THE LATEST R.I. CATALOGUE AWAITS  
YOU—ASK YOUR RADIO DEALER OR US FOR A COPY**



The Advertisement of R.I. Ltd., Croydon, Surrey, 'Phone: Thornton Heath 3211.

You will Help Yourself and Help Us By Mentioning "A.W." to Advertisers

# Sir HENRY J. WOOD says

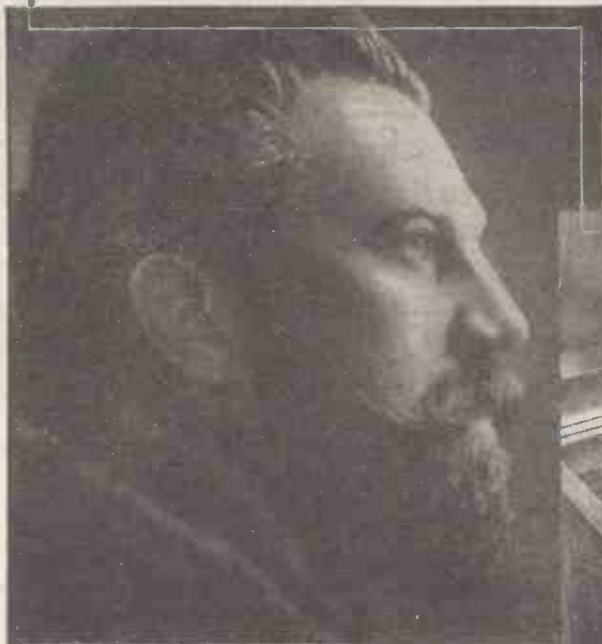

"Your latest Radio-Graphophone is a splendid instrument. Its standard represents the highest achievement in musical performance to-day, and I should like to see one IN EVERY HOME. Indeed, this is not an unreasonable wish, judging by its very modest price."

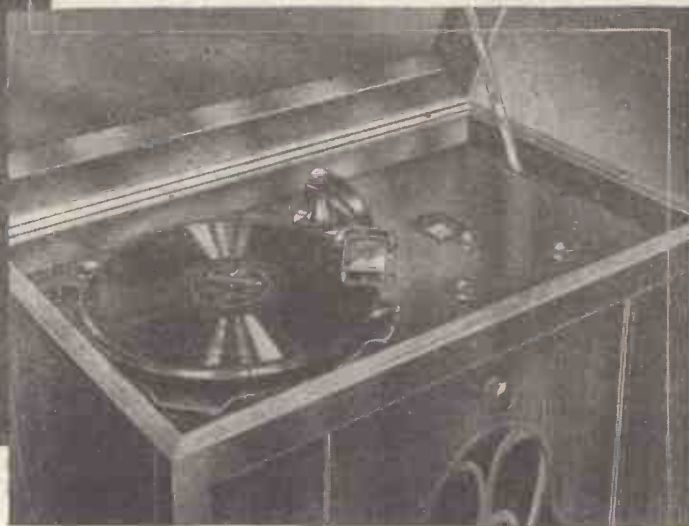

"In every home"  
—made possible by the

## Columbia RADIO-GRAPHOPHONE



The opinion of Sir Henry J. Wood is significant; this instrument indeed "represents the highest achievement in musical performance to-day." This is the greatest tribute yet paid to any radio-gramophone.

Never before has such a wealth of home entertainment been offered at such a low price. This instrument provides the pick of European music—some 40 radio programmes, powerful and distinct, from a set which incorporates two screen grid valves and band-pass tuning. And then—your own programme on the electric gramophone, chosen when you wish, music of superb fidelity, and tonal purity . . . "the highest achievement in musical performance to-day."

For 40 gns. (Model 603) you may obtain the outstanding radio-gramophone of the year possessed of remarkable power and selectivity. For only 7 gns. extra it may be had with the last word in convenience, an automatic record changer (Model 604).

Model 602  
**£2. 14s.**  
monthly  
*deposit £3.9.6 and  
12 payments of £2.14s.*  
**32 gns.**  
cash

**FREE CATALOGUE OR HOME TRIAL.**

(a)★ I should like to hear Model ..... playing in my home without cost or obligation to myself.

(b)★ I should like a Catalogue of Columbia Radio-Graphophones and/or Columbia Radio.

★ Cross out if not required.

NAME.....

ADDRESS.....

Cut this out and post it in an unsealed envelope bearing 1/2d. stamp to Columbia, 102B, Clerkenwell Road, London, E.C.1.

To Ensure Speedy Delivery, Mention "A.W." to Advertisers



**BRITAIN'S LEADING RADIO WEEKLY**  
**FOR CONSTRUCTOR, LISTENER & EXPERIMENTER**

**EDITOR:**  
**BERNARD E. JONES.**

**TECHNICAL EDITOR:**  
**J. H. REYNER. B.Sc. A.M.I.E.E.**

**RESEARCH CONSULTANT:**  
**W. JAMES.**

**ASSISTANT EDITOR:**  
**H. CORBISHLEY.**

**NEWS & GOSSIP OF THE WEEK**

**THE "PROMS"**

MAKE a note of the fact that the "Proms" start on Saturday, August 6, and continue for eight weeks. Sir Henry Wood is to be congratulated, as this is the thirty-eighth season under his conductorship. Incidentally it is the sixth season under the auspices of the B.B.C. and of course the concerts will be broadcast.

**TWO "PROMS" SEASONS?**

IN addition to the usual Proms season under Sir Henry Wood, in August, the B.B.C. is at present planning a Christmas Proms season. As many members of the Symphony Orchestra as possible are to be given a chance to work in these Prom concerts, so last year's personnel may be changed somewhat, so as to give everyone a fair chance.

**A MATTER OF ACOUSTICS**

HAVE you noticed the great improvement in the tone of the B.B.C. military-band broadcasts? The reason is that the band has been broadcasting from the special studio in Broadcasting House—the one used by Henry Hall during this transitional period. The new dance band will have a better chance to justify itself when the new special dance-music studio in Broadcasting House is brought into use in a few weeks' time.

**B.B.C. CONTROL CHANGES**

AT the end of this month the studios of Savoy Hill, linked with the Savoy Hill control room, will become an O.B. point during the general transition from Savoy Hill to Broadcasting House. The new Control Room at "B.H." will then take

over the whole of the remaining studio activities of Savoy Hill, all broadcasts being trunked via the new headquarters.

**ACTUALITY PROGRAMMES**

THE German liking for what might be termed actuality programmes, featuring real-life incidents, is well illustrated by the recent German broadcast of a play on the life of the late Commander Glen Kidston, whose life was certainly packed with thrills. The B.B.C. will not attempt to make use of this play, contending that it would cause unnecessary pain to relatives.

**THOSE TRAIN EFFECTS**

THE B.B.C. has been congratulated on the realism of its train effects, and listeners may be interested to know that very often a record is used featuring a tank engine puffing up and down Willesden Junction! All sorts of trains have been recorded for broadcasting, such as a German train and a goods train. Then there is the Effects Department's own train, but it is a sort of "ghost train"—you cannot ride in it!

**THE PROGRAMME EXCHANGES**

THE series of programme exchanges with America is proving popular, and further relays will be made next week on May 6, and on May 20 and June 3. The Post Office trans-atlantic telephone link is used, and an article in this issue explains just how it is done.

**BRITISH BUILT!**

RADIO EXCELSIOR, of Buenos Aires, has sent over to Chelmsford for a new 20-kilowatt station, including all the very latest gadgets—crystal control, low-power modulation and so on. The Marconi engineers are busy on it now and probably by the end of the year there will be a new station for you to log.

**WESTERN REGIONAL IS GROWING**

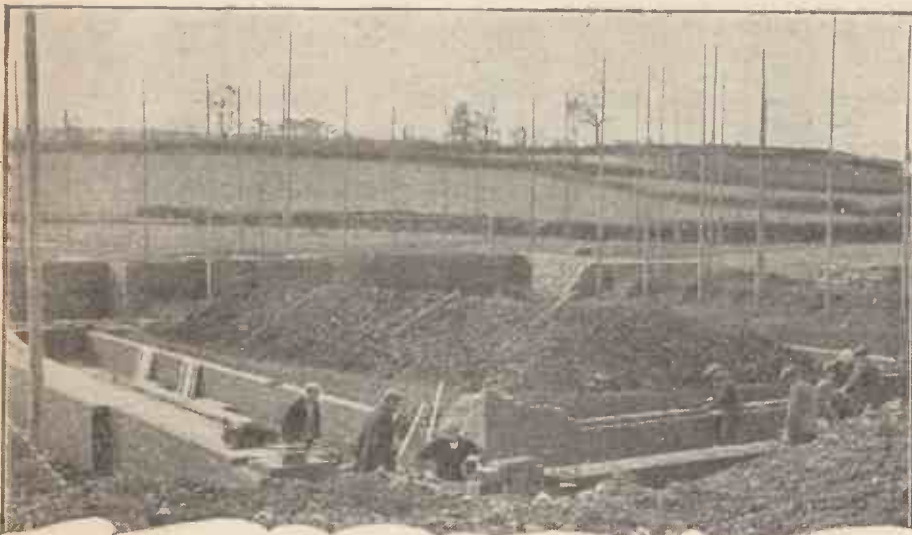

A busy scene at the site of the new Western Regional Station in Somerset. The foundations are rapidly taking shape

**NEXT WEEK: "THE HOME-LOVER'S BATTERY THREE"**

# NEWS & GOSSIP OF THE WEEK — Continued

## SCOTTISH REGIONAL

**PUBLIC** tests of the Scottish Regional station will begin on May 2. On Mondays, Wednesdays and Fridays, when there is no regional late dance music, the tests will be done from 11.15 p.m. until midnight. On Tuesdays, Thursdays and Saturdays the tests will be from 12.15 until 1 a.m. the following morning. Light music will be played.

## TAKING OVER

**ASSUMING** the public gets used to Scottish Regional in a reasonable time, it is expected that the new station will start taking over the Glasgow and relay service during the third week in May, and while Scottish Regional is sending out the late dance music, the existing stations will close down.

## ENGINEERING TESTS

**IN** Glasgow and Edinburgh, according to B.B.C. field-strength measurements, listeners are getting signals comparable in strength to those received in London from Brookmans Park. Reception in Dundee is satisfactory.

## CUP FINAL TO EMPIRE

**BLATTNERPHONE** records were taken of the last ten minutes of the running commentary on the Cup Final at Wembley, and of the subsequent summary of the game, for transmission on April 23 in the Empire news bulletins from G5SW. This is the first time an outstanding sporting event has been "bottled" for Empire consumption on the Blattnerphone, though

there will be much of this sort of thing when the new Empire stations at Daventry get going in the autumn.

## FROM FÉCAMP

**HAVE** you heard any of the "electrical transcriptions" from Fécamp on Sundays? For the last two or three weeks Colonial Radio Programmes have been on this popular French station with broadcasts of records made by eminent literary folk, as mentioned some time ago. Already John Buchan, Hugh Walpole, and J. B. Priestley have been heard, and it is hard to tell that these authors were not actually in the Fécamp studio.

## DR. BOULT FOR SCOTLAND

**DR. BOULT**, the B.B.C.'s Music Chief, has decided to go to Scotland to give personal auditions during the formation of the Scottish National Orchestra. The Doctor may be relied upon to find the best performers—without the regard to the accident of their birth or relationship!

## THE "HAZARD" SERIES

**FORMER** Zeppelin Commander, Captain Breithaupt, will take part in the new series of Saturday "Hazard" talks. An unusual test to which he was submitted has proved satisfactory. Breithaupt visited a Berlin studio and spoke into a microphone which was connected by trunk line to the General Post Office in London. Thence his voice was relayed to Savoy Hill so that B.B.C. officials might be able to judge whether his enun-

ciation was suitable. Captain Breithaupt took part in several raids over England.

## RADIO FLORENCE IS OPEN

**AFTER** the long preliminary tests on a small aerial, Radio Florence, the latest Italian station, is now working on just over 500 metres. It was given an official opening on the anniversary of the foundation of Rome. Radio Florence was held up for a long while because the main masts were destroyed in a gale before the transmitter itself was built.

## A VAUDEVILLE "SIGNATURE"

**MR. KNEALE KELLEY** has recently introduced into vaudeville programmes perhaps the shortest "signature tune" on record. At breakfast one day he thought that it was unreasonable to let listeners suppose that dance orchestras had a monopoly of signature tunes, and so he at once procured a blank sheet of music paper and jotted down the notes of the fanfare which now precedes the vaudeville programmes. He got in touch with the publishers of "I Pagliacci," and asked for permission to tack on to it some bars from the famous opera. The vaudeville signature tune bids fair to become as well known to listeners as the B.B.C. Dance Orchestra's "It's just the time for dancing" and "Here's to the next time."

## A NEW B.B.C. STUDIO

**A NEW** studio outside the B.B.C. premises has now come into use at Birmingham and will shortly bear the brunt of Midland studio transmissions, to enable the B.B.C. to proceed with the work of reconstructing the official premises in Broad Street, work which is long overdue. In their search for a temporary studio the Birmingham officials inspected several halls and finally a Birmingham firm offered the loan of a room which had been used for testing electrical apparatus. It was a properly padded and draped room, which had been prepared specially for the carrying out of delicate work, and was, therefore, eminently suited to broadcasting.

## READY FOR DROITWICH

**IN** addition it contained a small organ. The room is about 108 ft. long, 21 ft. wide, and 14 ft. high, and can accommodate approximately eighty. When the B.B.C. engineers are satisfied that broadcasts of every kind for which a studio is required can be carried out from this temporary studio, the studio at the Birmingham station will be dismantled and reconstructed in readiness for the more elaborate work that will be performed there when the Midland Regional transmitter is transferred from Daventry to Droitwich.

Professor H. A. Marquand, Professor of Industrial Relations at the University College, Cardiff, gives a West Regional talk entitled "South Wales Industry—A Programme of Regional Action," on May 13.

## B.B.C. GIANT ORCHESTRA RECORDS



The B.B.C. Orchestra recently paid a visit to the H.M.V. London studio centre and recorded in the big "concert hall" studio. Three microphones were used

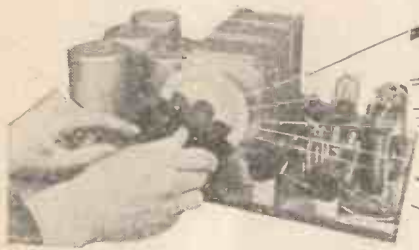

# TIPS ON BRINGING IN THE STATIONS

Here is a selection of useful practical tips on bringing in the stations you want to hear, whether at home or abroad. Compiled by the AMATEUR WIRELESS Technical Staff.

### Avoid Damping

MANY sets would bring in more of the stations if due attention were paid to the avoidance of excessive damping in the various tuning circuits. Just bear in mind these likely points:—

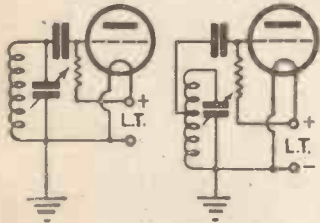

Excessive grid damping will make the tuning unselective. The grid condenser can be connected to a tap on the tuning coil, as shown

(1) Aerial damping, caused by connection of the aerial lead to the grid end of the tuning coil, instead of to a coil tap, or through a pre-set if the aerial is long.

(2) Detector damping, caused by grid current flowing through the tuning circuit or through a parallel circuit. This can be prevented by increasing the value of the grid leak, decreasing the positive bias on the detector grid, or connecting the grid condenser to a tap on the tuning coil instead of directly to the high-potential end.

(3) Close proximity of metal parts to the tuning coil, such as coil shields and large screens. If these are too near the tuning coil, signal energy will be absorbed, and tuning will be flattened.

### Daytime Reception

WHEN bringing in the stations during the daytime you will notice that the strength of the

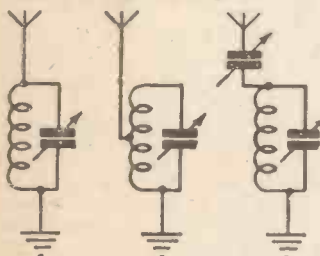

Alternative aerial connections. With a very short aerial the lead is connected direct to the top of the coil. With a longer aerial the lead must go to a coil tap. If there is no tap, connect the aerial lead through a pre-set condenser

foreigners is greatly reduced, but that what signal volume is obtained is constant. The same effect is at work in reducing the

strength as in eliminating the fading.

During the daytime there is very little reflection of the upward ray, so you have to rely on what arrives by the ground ray. Although not augmented by reflected ray, such signals as do manage to arrive over several hundreds of miles are constant because there is no adding or subtracting effect from the reflected ray.

Due to the very great power of modern stations it is now possible to bring in signals from the Continent even during daytime at good strength, as the ground ray sets up quite an appreciable field strength.

One point to note is that a foreign station tuned in at good strength during the day may fade more appreciably at night than a station that cannot be heard at all during the day. The worst fading seems to occur when the ground and reflected rays are about equal in strength.

In America some sets are fitted with automatic volume controls, whereby as the signal fades the amplification is increased to make up for the loss of volume. This idea involves an extra valve, so is not popular in this country.

### Before R.C. Coupling

IF you are using the resistance-capacity method of coupling your detector valve to the following

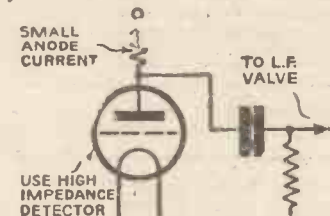

To achieve maximum sensitivity with a detector preceding resistance capacity coupling, use a high-impedance detector valve, and then the anode current will be small, and so the loss of voltage across the anode resistance will be reduced

valve use a high-impedance valve for the detector position. If the impedance is too low a large anode current will flow through the resistance in the anode circuit, and this will cause a large voltage drop, so that the sensitivity of the detector will be impaired owing to inadequate anode voltage.

### High-efficiency Coils

THERE is little point in fitting a high-efficiency coil in a directly connected aerial-tuning circuit,

as the losses in the aerial and earth system will entirely swamp any coil losses. But the efficiency of a good coil can be taken advantage of if the aerial damping is restricted, as by an aerial tap, or an aperiodic coil in the aerial circuit.

### That "Silent Point"

THERE are many thousands of detector sets still in use, with one or two stages of low-frequency amplification, and reaction for "boosting up" the strength of distant stations. But many owners of such sets do not correctly adjust reaction when bringing in the stations, with the result that distorted reproduction is produced, and interference caused to neighbouring sets.

The biggest crime is to tune in a foreigner on what is known as the "silent point" of reaction. This process comes about in this way: first of all, the reaction condenser is moved to the point where oscillation is produced, and, leaving this in such a condition, the tuning control is then operated until a SILENT POINT



The best test to determine whether you are tuned to the silent point of oscillation is to turn the dial each side of the tuning point. If there is a squeal you must reduce reaction

station's carrier wave is heterodyned.

On each side of the station's dial setting a squeal is produced, but at the exact point of tuning there is no squeal, though actually the set is then in a most unstable condition. The best test to avoid silent-point reception is to move the tuning dial slightly to each side of the point of tune whenever a station is logged.

### A Vertical Aerial

THOSE who are perplexed with selectivity troubles might like to try the effect of a vertical aerial wire, without any "roof." Such a wire can be suspended about a foot from the wall, and might come from a staple driven into the wall outside the top window, being led into the set in a downstairs room.

A total length of about 30 feet is usually possible with this type of aerial when erected in the

average home, and surprisingly good results can frequently be obtained. The signal pick-up depends a lot on the reduction of absorption effects, as from the near-by wall. Keep the down-coming wire as far away from the wall as possible.

With a vertical aerial of 30 feet you will probably have to dispense

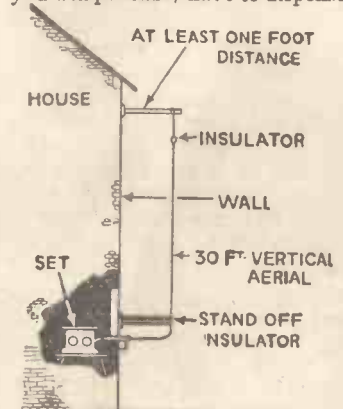

Why not try a short vertical aerial wire if you want really good selectivity? Note the points in erection illustrated by this sketch

with the aerial pre-set condenser, as its inclusion will probably reduce signal strength too greatly. But even without the pre-set the vertical wire is very selective. The usual wire can be used, that is, 7/22 stranded copper, or, if you prefer it, rubber-covered cable, say 5 millimetres, can be used.

On a good three-valver in London an aerial of the type described gives a selection of 15 medium-wave foreign stations, and there is no interference from Brookmans Park stations.

### "Ploppy" Reaction

POOR reaction action may be due to several causes, but as a rule it can be put right quite simply. Here are the most important points:—

- (1) Fit an anode by-pass condenser, between .0002 and .0005 microfarad.
- (2) Use a good high-frequency choke.
- (3) See that the reaction winding is not too large. A small winding and a large condenser are usually to be preferred.

### What Type of Condenser?

WE are often asked what is the best type of tuning condenser to use to make sure of bringing in the stations to the best advantage. If your aim is equal spacing of



HOW  
THE LAMP  
IS USED

## A NOVEL INSPECTION LAMP

a small dry battery instead of the accumulator. There is no need for a switch, as the circuit can be broken at will by simply unscrewing the lamp half a turn or so in its holder.

The necessary materials for making this inspection lamp cost very little, and they can be assembled in a few minutes. The lamp-holder used should be of the kind shown in Fig. 1, the side contact-screw A and the base B being removed. A washer may be slipped on to the bottom contact-screw C to fill up the gap caused

B.A. screw of suitable dimensions is passed through it from the inside. The head of the screw should either be countersunk, which may present some difficulty as it has to be done on the inside of the ring, or else rubbed down flat and smooth with a file, so that it will not chafe the finger when the ring is slipped on and off.

A small washer is slipped on to the stem of the B.A. screw, outside the ebonite ring, and the screw is then turned into the tapped hole in the side of the lamp-holder (i.e. the hole from which the contact-screw A was removed). Before driving the screw right home, however, the bared end of one of the flex leads is passed round it between the washer and the metal lamp-holder, with which it is intended

EVERY wireless enthusiast has probably, at some time or other, experienced the difficulty of making adjustments and alterations, or carrying out small repairs, in the dim interior of a wireless cabinet.

In the ordinary course of events, it is usually necessary to disconnect the aerial, earth, loud-speaker, and battery leads, and then slide the baseboard out of the cabinet, if one wants to get a really good light on the intricacies of the "works"!

The simple but extremely useful inspection lamp shown in the illustrations to this article puts an end to the difficulty. Consisting of a small lamp-holder mounted on a ring, intended to be slipped on to the finger, this handy little accessory enables you to throw a brilliant beam of light on to any intricate or "fiddling" job you are doing in a dim corner, and at the same time it leaves both hands free.

A pilot-lamp bulb of the low-consumption type, rated at the same voltage as the valves in the set, is screwed into the holder, and leads of twin flex a yard or so in length, with spade-terminals on their free ends, serve to connect up the lamp-holder to the terminals of the low-tension accumulator. If preferred, of course, the current for the lamp can be supplied from

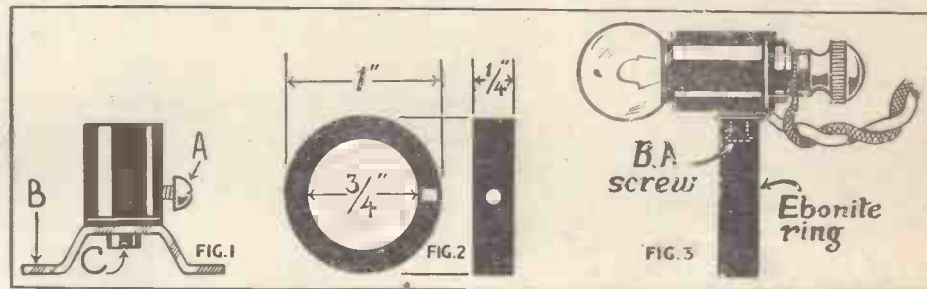

Features in the construction of the lamp. Fig. 1 shows the type of lamp-holder used, Fig. 2 the ebonite finger and Fig. 3 the complete lamp

by removing the base. Or, alternatively, the original screw may be discarded and a short piece of B.A. threaded rod with a nut or collar and terminal-head used instead, as shown in Fig. 3.

The finger-ring is made of ebonite. A suitable ring may be cut from a piece of ebonite tubing having a diameter of, say,  $\frac{3}{4}$  in. inside and 1 in. outside; it may be of any convenient breadth—say  $\frac{1}{4}$  in. A small hole is drilled through the ring at one point, as shown in Fig. 2, and a

to make contact. The B.A. screw thus serves to secure the ring to the lamp-holder and also to make one of the connections to the lamp. The remaining connection is made by clamping the bared end of the other flex lead under the head of the central contact-screw or terminal at the bottom of the lamp-holder. The arrangement of these simple connections should be perfectly clear on glancing at Fig. 3, which shows the finished inspection lamp all ready for use.

W. OLIVER.

### "TIPS ON BRINGING IN THE STATIONS" (continued from preceding page).

the stations around the dial, assuming, of course, that the stations are separated by equal frequency, the straight-line-frequency condenser is recommended.

The least suitable is the straight-line capacity, for this means a great crowding of stations at the bottom of the scale, and only a few stations at the top. In between come straight-line-wavelength and log-mid-line condensers which are probably the most generally used, especially in sets having two or three ganged tuned circuits.

One point to remember—the type of condenser does *not* affect the selectivity of a tuning circuit, so it is no use expecting to separate two stations on a straight-line-frequency condenser if they are causing mutual interference on another type of condenser.

#### Slow-motion Dials

FOR short-wave tuning a slow-motion dial is essential, but it is not always realised that the reaction condenser adjustment is just as critical—so fit an equally good slow-motion dial to the reaction condenser. Beware of back-lash in the movement, for a dial suffering from this defect is worse than a plain dial.

#### Band-pass Action

ALTHOUGH it is possible to obtain very good-quality selectivity from the band-pass system of tuning, this desirable effect is often missed through maladjustment of the two halves of the band-pass.

You can prove whether the correct action is being obtained by seeing how each station is tuned in. With the correct action

a station should spread at equal volume over an appreciable part of the dial, but should fall away sharply at each side of the spread limit.

The best way to adjust a band-pass is to set the tuning dial to about the centre of the scale, and then tackle the trimmers in turn. As each trimmer is adjusted the condenser dial should be rotated from side to side. It is useless to trim up a gang condenser at the bottom of the scale, for then it will be out of adjustment at the middle and top of the scale.

#### Improving Selectivity

SELECTIVITY is not only a question of tuned circuits—often the operation of a set can be conducted in such a way that the selectivity is greatly improved,

without altering the circuit in any way.

Take, for example, the three-valver fitted with a pre-detector volume control and reaction, in addition to the usual tuning control. Here is a way of improving selectivity. Reduce the overall amplification of the set by turning down the volume control (this *must* be a pre-detector control, remember) and then push reaction up to its safe limit.

You will find that reaction increases the amplification of the station you want more than it increases the amplification of the stations you do not want. Often two interfering stations can be entirely separated this way, when they would be causing serious interference with the reaction reduced and volume control turned up.



# MAKING A DYNATRON WAVEMETER

EVERY EXPERIMENTER SHOULD HAVE A HANDY LOCAL SOURCE OF RADIATION, SO THAT AT A MOMENT'S NOTICE A FAULTY SET CAN BE TESTED AND THE WAVELENGTH OF ANY RECEIVER CHECKED. THIS SIMPLE UNIT WILL DO THESE AND MANY OTHER JOBS FOR YOU



Only half-a-dozen components are required

THERE are many kinds of wavemeter, but if you really want something which is going to be of use to you in set testing as well as in accurate wavelength plotting, then you must have a heterodyne meter. One way of checking up wavelengths, by an absorption meter, consists in placing a coil and parallel condenser close to the tuning side of the set. This extra tuned circuit absorbs from the main circuit when the two are in tune, and if the dial of the wavemeter is calibrated, then wavelengths can be plotted with a reasonable degree of accuracy.

A much better way is to use a heterodyne wavemeter—a radiating source of locally generated oscillations. If you have a little unit, such as the one illustrated here, which is capable of oscillating at any normal frequency, and the dial calibrated, then you have only to stand it a few feet away from the set, switch on, and turn the set's dials until the oscillator's squeak is heard. The unit can be used as a handy source of signals for set testing, and it enables one to provide one's own test "transmissions" at any normal wavelength.

The construction of this dynatron-type

### COMPONENTS FOR WAVEMETER

- Baseboard, 6 in. by 8 in. (Camco, Peto-Scott, Readi-Rad).
- Panel, 6 in. by 7 in. (Becol, Peto-Scott, Readi-Rad, Dani-pad).
- .0005-mfd. variable slow-motion condenser (Lctus, Ormond, Formo).
- One 4-pin valve holder (Lissen, Benjamin, Wearite, Lotus, W.B., Telsen, Junit, Bulgin).
- Filament switch (Bulgin, Lissen, Readi-Rad, W.B., Junit, Lctus, Wearite, Benjamin).
- One plug-in coil holder (Bulgin, Lissen, Lotus).
- Two 1-mfd. fixed condensers, non-inductive (Dubilier, type 9200; T.C.C., Lissen, Telsen, Ferranti, Wilburn).
- Three wander plugs, marked H.T.—, H.T.+1, H.T.+2 (Belling-Lee, Clix, Eelex).
- Two spade terminals, marked L.T.—, L.T.— (Belling-Lee, Clix, Eelex).
- S.G. anode connector (Belling-Lee, Clix).
- Three yards thin flex (Lewcoflex).
- Connecting wire and sleeving (Lewcos, Jiffilix, Quick-wyre).

### ACCESSORIES

- Cabinet.
- Valves (Mazda 215SG, Mullard PM12, Marconi or Osram S22, Cossor 215SG, Six-Sixty 215SG, Lissen SC215, Eta BY6, Tungram S210, etc.).
- 120-volt H.T. battery (Lissen, Drydex, Pertrix, Ever-Ready, Oldham, Fuller).
- 2-volt accumulator (Lissen, Exide, Pertrix, Ever-Ready, C.A.V., Oldham, Fuller).
- Two plug-in coils (Nos. 50 and 150) (Lewcos, Lissen Atlas Tunewell).

of the characteristic dip in the curve of a 4-electrode valve, oscillates at the frequency determined by the plug-in coil and the condenser on the front panel. The unit is provided with flex connections for the L.T. supply to the screen-grid valve, and with two H.T. tapings.

The unit is not connected in any way to the set.

### The Circuit

The circuit shows how the wavemeter works. About 90-100 volts is applied to the screening grid and a much lower voltage, about 30-40, is applied to the anode. The tuned circuit is in the screen-grid valve anode output. Provided suitable voltage values are chosen, the valve will oscillate. It is advisable to follow the layout shown which makes for short connections, but any normal modifications will not affect the working, as each meter must be individually calibrated.

Most S.G. valves will oscillate in this manner, but the one first specified has very suitable characteristics.

The best method of calibration is to try out the meter in conjunction with a set capable of bringing in a dozen or so stations. Put a medium-size coil, about

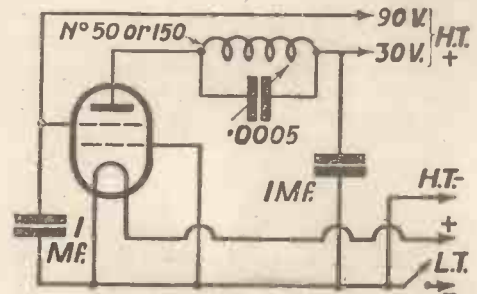

The connections can be followed from this circuit diagram

No. 50, into the holder on the baseboard of the unit, and by adjusting the voltage get it oscillating. When the unit is stood about 4 ft. away from the set and the set's tuning controls (with the receiver in a state of gentle oscillation) are slowly rotated, a squeal like a carrier-wave will be heard.

### How to Use the Meter

Tune the set to a known station with the reaction adjusted for good reception, and then rotate the wavemeter dial until the silent point of the locally generated carrier exactly coincides with the point of maximum tuning. You will then know that if the station's wavelength is, say, 300 metres, that particular setting of the oscillator dial is for the same wavelength. Ten or a dozen other stations should be matched up in the same way until you know what wavelengths are represented by the degrees on the wavemeter tuning scale.

A curve could be made showing the relationship between dial degrees and wavelength of frequency for the oscillator.

Assuming that you have calibrated the unit so that 20 degrees on the dial represents a wavelength of 250 metres. You want to find, say, where 250 metres will come on a new set. Simply set the oscillator dial to 20 degrees, stand it a short distance away from the set, switch on and with the receiver just oscillating, rotate the dials, until the oscillator squeal is heard. This gives you the exact tuning point.

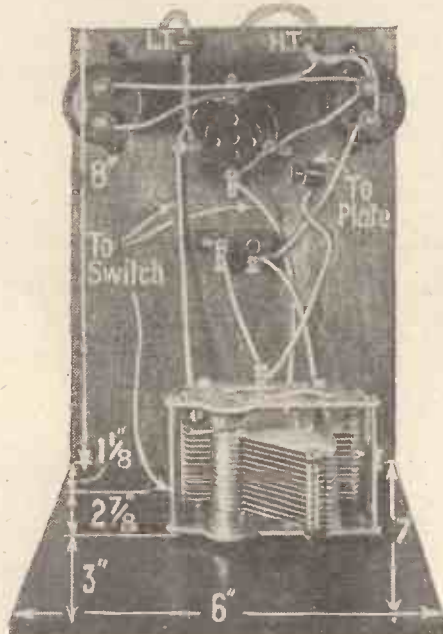

This plan view of the wavemeter gives all the necessary details of its construction

## SIMPLE TESTING FOR THE AMATEUR—II

# TRACING THE CAUSES OF WEAK RECEPTION

In this, the second article of a short series, our contributor "Hotspot" deals with the causes of weak reception, and shows you the most likely points to examine in the set

As explained last week, when the set goes wrong the best way to put it right is first to classify the fault under one of four headings, and then to look out for the simple causes before assuming that the trouble is very deep-seated or mysterious. And remember the other item of advice—substitute a suspected component for one you know is in good order.

Under our second heading, as mentioned last week, comes a type of trouble that can best be classified as weakness of reception. This may be further subdivided into reception weakness of all signals received, or weakness of distant stations.

If only the distant stations are weaker than usual you may be fairly sure that the trouble lies in the high-frequency side of the set, or if it is a set without any high-frequency valve the reaction and detector circuit must be suspected.

Local stations will still come in well even when the high-frequency side is inoperative or working badly, owing to the great initial strength of the signals. But distant signals will at once be reduced in volume if the pre-detector amplification is faulty. Probably a valve has lost its emission, or the battery voltage on the anode has been wrongly adjusted. For the present, my advice is to try a known good valve in place of the suspected "dud"

Now let us deal with the more common trouble under this heading—weakness of all signals received. The following tests cannot be claimed as exhaustive, but nine sets out of ten will probably come within their scope.

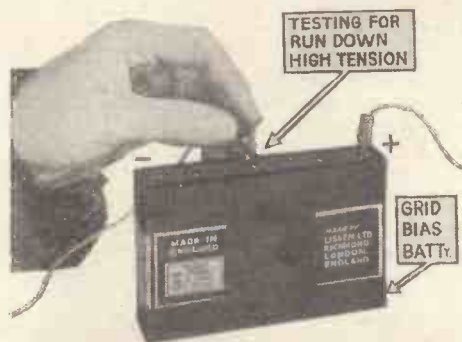

Reducing the grid bias voltage may give an increase in signal strength—if so, the high tension is probably running down

First of all, remember that no matter how perfectly the set may be working, it will not give good reception if the aerial and earth are faulty. Weak reception may easily be caused by a partial short-circuiting of the aerial to earth. In fact this is the first thing to look for. Examine the aerial wire from the remote point right up to the set.

Common aerial defects are broken

insulators, "perished" lead-in tubes, and severely oxidised wall-mounted earthing switches and lightning arrestors.

The aerial may be in good order, but

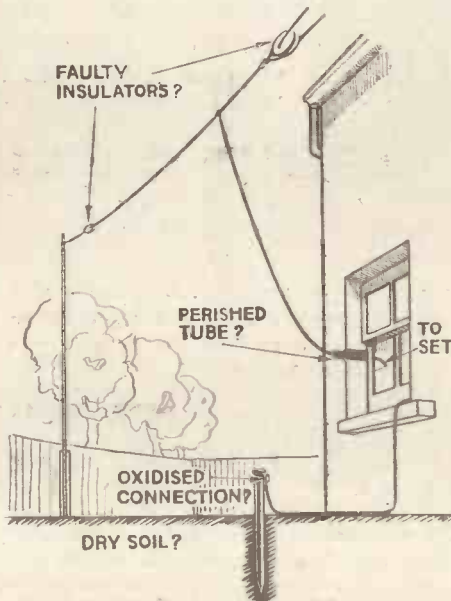

This pictorial diagram shows you the points to watch in locating a fault in the aerial and earth system—a fruitful source of weak reception

perhaps the earth has "gone dry"—a fault liable to develop now that the summer is coming along. The most vulnerable point of the earth is the connection between the earth lead and the plate or spike.

### Look to the Power Supply

If tests show that the aerial and earth system has not deteriorated—and remember you can finally prove this by trying out a friend's set on your aerial system—you must look at the power supply, which may be batteries or an eliminator. The high-tension battery is probably the most fruitful source of signal weakness, for most listeners are tempted to go on using the battery long after its voltage has fallen below the useful limit.

As already explained, tests of the battery voltage must be carried out while the set is in action, otherwise even a good meter will not show the true state of affairs. Here is a hint—if you have no meter handy—to see whether the high-tension supply is running down. Reduce the grid-bias voltages, and if this gives louder signals you may be almost sure that the valve is over biased, which will only occur when the anode voltage has severely fallen.

### The Valves

The next point of suspicion is naturally the valves. It is difficult to say how long

a valve should last, and I am not going to risk giving a definite figure, but certainly the modern valve should give not less than 1,000 hours use—possibly a great deal more.

At this stage I again advise you to try replacing each valve in turn with a known good valve. Another way is to try each of your valves in the set of a friend, and note whether a loss of volume results with any one valve.

Talking of valve life reminds me that if you are using an eliminator for the high-tension supply you must also suspect the valve rectifier after a year's use. The grid-bias or better still the meter test, while the set is in action, will prove this point.

If you are using a somewhat elaborate set the weakness of reception may easily be traced to mis-ganging of the tuning circuits. Note whether the weakness is evenly distributed over the tuning scale, or whether it is confined to one part of the scale. If the latter, look to the trimmer adjustments on the gang condenser.

With simple sets you might try the old trick of replacing the grid leak with any other that happens to be handy. Sometimes the most mysterious weakness and deadness in a set can be entirely cured by putting in a new grid leak.

While on the subject of tracing troubles by noting operating details, you can often narrow down a fault by seeing how much reaction is needed to produce oscillation. This applies more especially to simple sets. Thus if you find that much more reaction than usual is required



Sometimes one of the trimmers of a condenser may come out of adjustment, and this will cause reduction in signal strength over one part of the dial

to give oscillation you may safely assume that extra resistance has been introduced in the aerial tuning circuit, or that the detector valve has lost its emission.

HOTSPOT.

# 354V

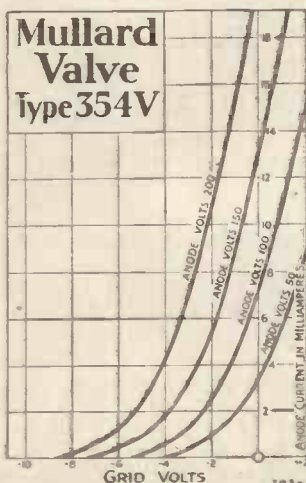

## TECHNICAL INFORMATION ABOUT A FAMOUS VALVE

The type number alone tells you quite a lot about the 354V. First of all, the symbols 4V mean that it is one of the Mullard series of indirectly heated A.C. mains valves, while the figures 3,5 indicate that its amplification factor is 35.

Your knowledge of radio technics will tell you that a 3-electrode valve having these characteristics should be an excellent general purpose valve—and that is just what the 354V is.

### FOR DETECTION.

Type 354V is pre-eminently the detector for use in A.C. all-mains receivers, and particularly for sets employing one or more high frequency amplifying stages where, operating under power grid conditions and, of course, zero grid bias, it will handle big input signals and, if followed by transformer coupling, fully load the average three-electrode or pentode output valve.

### FOR LOW FREQUENCY AMPLIFICATION.

As a low frequency amplifier, operated at an anode voltage of 150 to 200 volts and a grid bias of 3 to 4 volts, the 354V should be used as the first stage valve in gramophone amplifiers, in which position it will handle large "pick-up" voltages and give a high effective amplification.

The 354V now incorporates the new Mullard rigid-unit construction, and will be found perfectly free from microphonic trouble, even in large receivers, and radio-grams with powerful built-in speakers.

## REDUCED PRICE 13/6

The correct Mullard valves for the "Simple Super" described in this issue are:—

2-P.M.12., 1-P.M.IHL.,  
1-P.M.IDG., 1-P.M.2A.

OPERATING DATA.				CHARACTERISTICS.	
				(At anode Volts 100; Grid Volts Zero).	
Heater Voltage	...	...	4.0V	Anode Impedance	... 10,000 ohms
Heater Current	...	...	1.0A	Amplification Factor	... 35
Max. Anode Voltage	...	...	200V	Mutual Conductance	... 3.5mA/V

### AUTOMATIC BIAS.

If automatic bias is applied to the 354V, the biasing resistance should have a value of 1,000 ohms.

# Mullard

## THE MASTER VALVE

### MADE IN ENGLAND

Advt. The Mullard Wireless Service Co., Ltd., Mullard House, Charing Cross Road, London, W.C.2. ARK5

You will Help Yourself and Help Us by Mentioning "A.W." to Advertisers

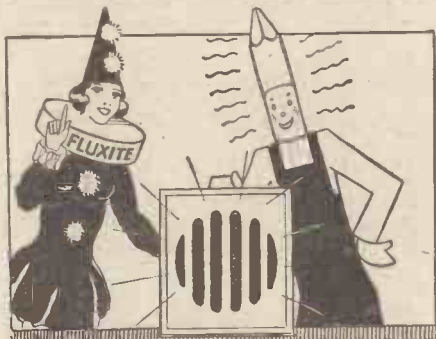

"We're Fluxite and Solder, The reliable pair, Famous for Soldering—Known everywhere! So don't dabble with Wireless And mess up your set, Let US join the connections—Then PERFECTION you'll get!"

See that Fluxite and Solder are always by you—in the house, garage, workshop—anywhere where simple, speedy, soldering is needed. They cost so little, but will make scores of everyday articles last years longer! For Pots, Pans, Silver, and Brassware; RADIO; odd jobs in the garage—there's always something useful for Fluxite and Solder to do.

All Hardware and Ironmongery Stores sell Fluxite in tins, 8d., 1/4 and 2/8. ANOTHER USE FOR FLUXITE Hardening Tools and Case Hardening. Ask for Leaflet on improved method.

NEW "JUNIOR" SIZE, 4d. per tin  
FLUXITE SOLDERING SET

Simple to use and lasts for years in constant use. Contains special "small-space" soldering iron, with non-heating metal handle; pocket blow-lamp, Fluxite, Solder, etc.; and full instructions.

COMPLETE, 7/6, or LAMP only, 2/6.

FLUXITE, LTD.  
(Dept. 326)

ROTHERHITHE, S.E.13

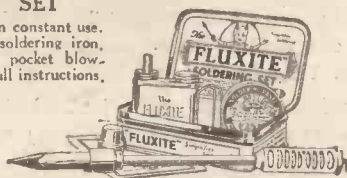

ALL MECHANICS WILL HAVE

# FLUXITE

IT SIMPLIFIES ALL SOLDERING



## CLEAN and SHARP as the Scissors' Clip

British Radiophone ganged condensers pick out the stations for you—making each one as sharp and clear as though no other existed. This is the kind of selectivity you want especially when it is accompanied by smooth steady action, no vestige of slipping and perfect ganging. Accuracy is guaranteed to within one half of one per cent—a supreme achievement.



NEW REDUCED PRICES  
2-Gang Condenser now 15/-  
Dustproof Metal Cover now 2/6  
3-Gang Condenser now 25/-  
Dustproof Metal Cover now 3/-  
4-Gang Condenser now 30/-  
Dustproof Metal Cover now 3/6  
Drum Drive ... 8/6  
Oxidised silver escutcheon and drive assembly complete with pilot lamp attachment, 5/-

# RADIOPHONE GANGED CONDENSERS

THE BRITISH RADIOPHONE LTD., Aldwych House, Aldwych, W.C.2

## "NEW RADIOS FOR OLD"

Save half your annual radio expense by joining the Radialaddin Club. One shilling per week means:—

1. Constant exchange of set, etc.
2. Second-hand sets at discount prices.
3. All sets sold with definite exchange values.
4. Hire-purchase without deposit.
5. Expert advice in all radio matters.
6. An opportunity of making a considerable annual income without expense.

Write for full particulars, enclosing 1½d. stamp.

Actual free exchange value of your present set by filling in the form on the right.

Please forward this ENQUIRY FORM (without obligation).

I am interested in purchasing the undermentioned Radio Receiver:

Make..... Model and List Price.....

Present Set: Make ..... \*Batteries or Mains.....

Date of Purchase..... Original Cost of Set.....

Balance of purchase price would be payable by me as follows:

Plan A. Whole of balance in cash.

Plan B. Whole of balance over (Six, Nine, Twelve\* months).

\* Delete unwanted words.

NAME, in Full (Block Letters).....

ADDRESS.....

## RADIALADDIN LTD.

THE LARGEST RADIO EXCHANGE DEALERS IN THE U.K. (Dept. A.W.), 47 Berners Street, London, W.1. Telephone: Museum 1821



British Made

THE RELIABLE BECOL EBONITE FORMER which has stood the TEST OF TIME and tested before despatch. Prices LOW.

EFFICIENCY COUNTS!!!

LOOK FOR TRADE-MARK. SOLE MAKERS

THE BRITISH EBONITE CO., LTD.  
HANWELL, W.7

HERE IT IS EXACTLY WHAT YOU REQUIRE FOR SHORT WAVES



## HOUSE YOUR RADIO-GRAM IN A CAMCO CABINET!

This is the Camco "Waverley" Radio-Gram Cabinet. It is beautifully finished in Oak and Mahogany, and is made in two models—Junior and Senior. Full provision is made for an electric or clockwork gramophone motor. From £5.10.0. Write for FREE copy of the 24-page Camco Radio-Cabinet Catalogue.

CARRINGTON MFG. CO., LTD.

Showrooms

24 Hatton Garden, London, E.C.1.

Phone: HOLborn 8202. Works: S. Croydon.

NAME.....

ADDRESS.....

..... A.W.33.

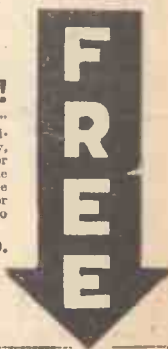

# REVOLUTIONARY New MoToR Unit

BRITISH MADE

Once again MoToR leads the loud-speaker field with a startling new discovery. Revolutionary in principle, radically new in the design of its patent "compensating" armature, the new S.40 MoToR Unit is nothing less than amazing in its combination of rich tonal quality and super sensitivity.

WITH  
PATENT  
COMPENSATING  
ARMATURE

**"YORK"**

A very attractive figured walnut cabinet, size 15 ins. x 14 ins. x 7 ins., fitted with the new S.40 Unit **55/-**



Every note, every instrument, every tap of the drum can be identified. It has been acclaimed by experts as the most outstanding and definite advance towards perfect tone quality since radio was first invented. You must hear it for yourself. Write for fully descriptive pamphlet to:—

S.  
40 32 1/2

AN AMAZING  
REVELATION  
IN  
SENSITIVITY  
AND TONE

TEKADE RADIO & ELECTRIC, LTD.  
147, FARRINGDON ROAD, LONDON, E.C.1  
Telephone: CLIFKENWELL 2468

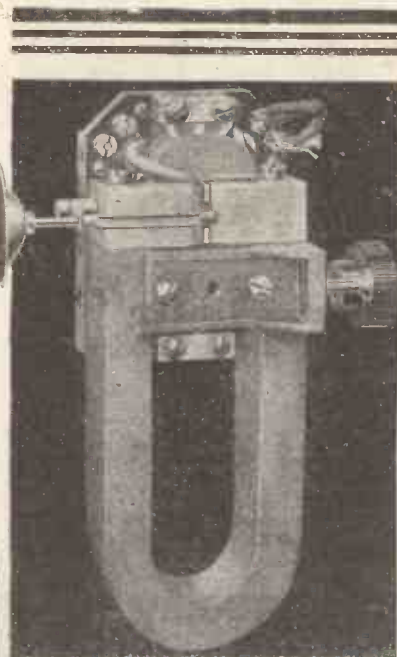

**USED  
UNIVERSALLY**  
The world's  
Standard for  
Eight Years—  
Still the Best

"B" Type. name.  
Non-rotating stem.  
Price 6/6 each.  
"R" Type.  
Rotating stem. Price  
2/6 each.

**BELLING-LEE  
TERMINALS**

Advert. of Belling & Lee, Ltd., Queensway, Ponders End, Middlesex.

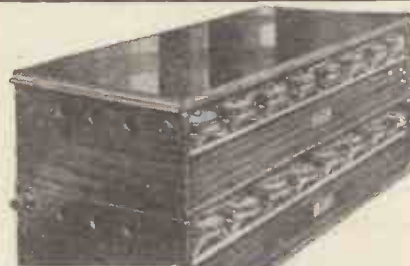

**INSTALL WATES  
STANDARD**

and end H.T. battery expense

THE continual drain on your pocket ends when you instal the "Standard" which is PERMANENT. Made on the famous Leclanché principle, ensuring an ideal silent H.T. supply—the "Standard" RECHARGES ITSELF when the set is shut down. No re-charging required: the eventual replacement being merely a matter of changing cartridges. Thousands of enthusiastic users. Write for

STANDARD BOOKLET SENT POST FREE

Any voltage A5 for 1-2 valves **28/3**  
108v., 3,000 m.a.

Any capacity D6 for 3-4 valves **34/9**  
108v., 6,000 m.a.

**5/-** Other capacities up to 24,000 m.a. Any voltage.  
DOWN Tray containers extra if required.

BRITISH MADE

STANDARD BATTERY CO., Department A.W.,  
184-8, Shaftesbury Avenue, LONDON, W.C.2

Advertisers Appreciate Mention of "A.W." with Your Order

"the best  
of two  
worlds" . . .

"first class radio  
programmes and  
good quality record  
reproduction"  
says "Amateur Wireless" . . .

"fine value for  
money" . . . . . A.W.23/4/32

**22 GNS**  
**OR 42/- DOWN**

and 11 monthly instalments of 43/6 each or 84/-  
down and 10 monthly payments of 42/-.

SPECIFICATION :

1. High Amplification Screened Grid Valve.
2. Steep Slope Detector Valve.
3. Power Pentode Valve handling 2 watts of undistorted power.
4. Valve Rectifier of ample output.
5. Super-sensitive British Moving-Coil Speaker, capable of handling the enormous power obtained by the instrument, with Speech Transformer accurately matched to impedance of Output Valve.
6. Collaro Electric Motor with fully automatic stop.
7. Beautifully finished figured walnut cabinet.

Write for FREE Colour Leaflet

**BRITISH MADE**

CLIMAX RADIO ELECTRIC LTD., Haverstock Works, Parkhill Road, Hampstead, London, N.W.3.

Telephone: Primrose 1171



**CLIMAX**

**ALL-ELECTRIC  
RADIO GRAMOPHONE**

With built-in moving-coil speaker

Mention of "Amateur Wireless" to Advertisers will Ensure Prompt Attention

# Oh Your Wireless!

## A QUEER CASE

**I** HAD a curious instance recently of really mysterious behaviour on the part of a set. When originally made up, it gave excellent results and was duly passed as being quite up to the mark. Three weeks later, without any alteration whatever having been made, it was tried again. On the second occasion its performances were quite hopeless. It was a little two-valver with a perfectly straightforward circuit in which the valves, condensers, resistances, transformer, and so on were all of the highest quality. Every one of these components was tested and all proved to be in excellent condition. The only remaining component was the tuner, which contained an aerial coil, a grid coil, and a reaction coil all on the same former. Ordinary tests showed that the windings were still continuous.

## THE CAUSE OF THE TROUBLE

**W**HAT, then, had happened? A new tuner was made up, and when it had been inserted the set immediately functioned finely. The explanation of the falling off during the three weeks mentioned is rather interesting. For the grid-coil wire of unknown make with red-dyed cotton insulation had been used. Some red dyes contain active chemicals which have a slow destructive effect upon the insulating properties of the cotton. Small high-frequency leakages were taking place across the coil, with the result that the set became a poor, feeble thing. The moral is always to buy wire of well-known make, but if you must buy cheap stuff the origin of which is unknown, see that the cotton covering is plain white.

## SOME INTERESTING VALVES

**I** SAW some very interesting valves of Continental manufacture the other day which seemed to have considerable possibilities. They are of the mains type and are made for both A.C. and D.C. supplies. The great point about them is that the heater is made to take the full mains voltage, the current consumption being 30 milliamperes for all types. This compares very favourably with other types of mains valves, particularly those intended for D.C. operation, since it works out on a 220-volt supply at only 6.6 watts per heater. About A.C. valves of this type, though, there is, unfortunately, one snag which appears to be quite insuperable. At first sight you think "What an excellent idea," you simply connect the heaters straight to the mains with nothing but a simple smoothing circuit. No need to fit an expensive transformer. And that is just where the snag is. By the regulations of the Institute of Electrical Engineers it is against all the rules to operate a wireless set from A.C. mains without an intervening transformer.

With D.C. mains, of course, nothing of the kind crops up, and I shall not be surprised to see the idea developed over here for D.C. valves.

## A USEFUL HINT

**I** FIND it very handy to have a small aerial-earth panel fixed to the wall quite close to the table on which my receiving set stands. Since the idea will probably fit in with your arrangements, I will tell you how it works out. The panel consists simply of an ebonite strip an inch in width by four inches in length, containing two standard sockets. It fits into a small neat box which is fixed to the wall on a level with the terminal strip of a receiving set standing on the table. The aerial lead-in goes to one socket and the earth wire to the other. Now the great point of this arrangement is that you have not the least trouble in connecting up or disconnecting any set that you want to use. The set has a pair of short leads—aerial and earth—each provided with a plug. Simply push the plugs into the sockets, turn over the aerial switch, and there you are.

When the feminine members of the household want to move your apparatus for cleaning purposes they don't go tearing your aerial and earth wires out by the roots. If they should pull the table out from the wall without first disconnecting the set, the plugs simply come out of their sockets. This little panel costs a matter of pence to make, but I can assure you that it is very well worth the trouble. Remember, though, to keep the aerial and earth sockets well apart and don't make the leads from the set of twin flex. They should be as short as possible and arranged well apart.

## GOOD ADVICE

**W**ITH these days of fool-proof valve-holders one is apt to become rather careless when inserting valves, since an accidental burn-out during the action of insertion of the valve is very rare. With the increasing use of sets having a metal chassis there would appear to be quite a real danger of burn-outs due to careless handling in the manner I have just described. The real moral, of course, is always to fit a fuse in the circuit, preferably of the gold film variety, as this blows so rapidly that there is no danger of damage to the valve filament, even if it is connected directly across the H.T. battery.

## MISSING THE POINT

**I**N a lay paper the other day I noticed a letter by a reader who asked why people bothered about foreign stations when the home programmes were so much better. There is not the faintest shadow of doubt that, taking them all round, the B.B.C.'s

programmes are by far the best and most attractive in the world to-day. But the trouble is that neither you nor I want to take them all round. There are times when I tune in the National station and find, say, some highbrow modern piece of music being rendered, whilst the Regional is giving a talk on how to make a smart blouse for half a crown, or something of that kind. I don't like the music and I feel no inward urgings to make a blouse. Round goes the tuning knob, and I sit and listen to tuneful stuff from Heilsberg or Toulouse, or Rome or Prague. Again, you and I are both apt to want entertainment from the wireless set at times when the B.B.C. is not providing it. It is a wet afternoon; there is nothing much to do; let's turn on the wireless. One station is giving a talk for schools; the other is silent. If we were tied to the home stations that would be that. But, thank goodness, we aren't.

## A GOOD TIP

**I** LIKE metallised valves very much indeed, and they certainly make a big difference to the selectivity of sensitive sets operated close to a high-powered broadcasting station. But there is one little fly in the ointment when it comes to the use of the metallised screen-grid valve. And here it is. The whole of the surface of the bulb is earthed; the lead attached to the terminal at the top is usually from 60 to 80 volts positive. Should you happen to forget this fact when changing a valve, you may obtain one of those little surprises that do come the way of the absent-minded wireless man every now and then. Let the screening-grid lead slip from your fingers for an instant so that it touches the metallised surface of the bulb, and you will see what I mean. Here is a tip which avoids the possibility of such accidents. It doesn't take more than a minute or two to carry out. If the domestic department cannot produce a tin of stove enamel, obtain one from any ironmonger. Just give the metallised coverings of your screen-grids a couple of coats—the stuff dries almost instantly—and you will make them quite safe without in any way impairing the screening qualities of the metal.

## A REACTION DIFFICULTY

**I** CAME across a most unpleasant fault the other day when testing out a hook-up. I had a perfectly simple dual-range coil consisting of a solenoid for the short-wave section and a bunched winding for the long waves, both sections being wound on the same former, as is usual, and the long-wave section being short-circuited when receiving on the broadcast band. I found that when I tuned in the circuit on the broadcast band it behaved quite normally and gave me the results I required, but that on the long waves the reaction control was quite hopeless. As the reaction condenser was

## On Your Wavelength! (continued)

increased, the circuit would suddenly start to oscillate with a click and this oscillation appeared to have no relation to the ordinary signal being received. Certainly it had no building-up effect, and did not produce any useful result at all.

The coil was of straightforward construction, and as I had made many coils of this type before, I could not quite see where I had made a mistake. However, I thought that there must be some trouble with the reaction winding, and I tried stripping turns until I had only about five turns left, but still this curious trouble persisted. I then wound a reaction winding on another former and slid this over the original former, so that I could locate it in various positions relative to the long- and short-wave section. This is a very useful trick when trying to find the best position for a reaction winding, or for a coupling winding generally, but in this case it had no effect, for wherever the coil was placed I got this unpleasant failure to oscillate properly.

### PARASITIC OSCILLATION

**T**HEREFORE, I came to the conclusion that the oscillation was what is known as a parasitic oscillation, namely, one which occurs at a frequency quite different from that being received. I tested with an oscillating wavemeter until I actually heterodyned the oscillation, and found that it was taking place at a frequency out of the broadcast band altogether. Why this should be so I could not see for some time until I realised that the only unusual thing about my circuit was that the grid of the valve was not connected to the top of the coil, but to a centre-tap on the short-wave section. I had tapped the grid down the coil a little in the hope of minimising the grid damping. This turned out to be the real reason for the trouble, for I found that on moving the tapping to the top of the coil, the circuit behaved in a perfectly normal manner, and this parasitic oscillation entirely disappeared.

This remedy did not please me very much because it was really dodging the whole issue, but it was some time before I was able

to find a real cure. This was to add a resistance of two or three hundred ohms in series with the reaction coil. This had no appreciable effect on the ordinary reaction, but was sufficient to damp out the parasitic oscillation completely.

### THE YOUNG VISITOR

**E**VEN small children are notorious for their powers of imitation, and as there is an obvious fascination about knobs which can be "twiddled" to produce all sorts of music, pater-familias generally takes care to see that the wireless set is located well out of reach of tiny fingers. But a young gentleman of my acquaintance—still on the right side of his fourth birthday—had an unexpected bit of luck the other day. He was taken to visit his grandparents, and feeling bored by a long spell of family gossip, managed to escape into another room. Here, with the help of a chair and a skilful bit of climbing, he succeeded in getting to close grips with the old folks' set, before anyone began to wonder what was keeping him so quiet. Luckily, he was discovered by his grandmother, and as no damage had apparently been done, was gently led back to his parents without any "tales" being told.

### THE SEQUEL

**H**OWEVER, that evening the performance of his hosts' wireless set fell decidedly below its usual level. Signal strength was but a feeble imitation of its normal output—and altogether it seemed far from well. I was invited in to put matters right. At first sight the symptoms pointed either to a dud H.T. battery or else to a run-down accumulator, but inquiries showed that one was practically new, and the other freshly charged. I was just about to settle down to give the set a thorough "vetting," when Grandmother confessed that she had caught her young visitor "twisting the knobs" that afternoon. This information didn't seem to throw much light on the situation, as the local station, although

pretty feeble, was coming in at the correct condenser setting. Suddenly I had an inspiration. The loud-speaker was standing close by, and a turn of the armature-control knob, at the back of the casing, solved the mystery. As he could get nothing out of the usual knobs, our young friend had spotted this extra one and given it a turn for luck—leaving the speaker half "strangled."

### DUSTING THE HEAVISIDE LAYER

**I** WONDER whether the widespread volcanic eruptions recently reported from the Andes will have any effect on wireless reception. I remember some twenty years or so ago, when Krakatoa "blew its head off" in the East Indies, we had a series of abnormal sunsets which lasted on and off for nearly three years afterwards. They were caused by immense quantities of fine volcanic dust, projected by the force of the volcanic explosions into the upper atmosphere, in some cases to a height of nearly twenty miles. I never heard, in those days, whether the extra "loading" of a region which is shared by the Heaviside layer actually resulted in any appreciable interference with long-distance wireless transmission. In theory I rather think it should, and shall be interested to see if any thing of the kind will follow the recent upheaval.

### A GOOD ONE

**O**NE lives and learns. I have before me a press cutting which states that German reporters are now carrying concealed microphones in their coats. It would appear that, armed with these (the microphones, I mean, not the coats), they seek interviews with famous men, who, thinking that there is no one to overhear, are indiscreet enough to give away their closest secrets. Subsequently, they are horrified on finding out that they have really been giving the show away to countless thousands of listeners. It is a good story; on the whole, a very good story. Being, though, of a somewhat sceptical nature, I am afraid that I swallow it with the proverbial grain of salt. THERMION

### PERSONALITIES IN THE WEEK'S PROGRAMMES





The programme exchanges between the B.B.C. and the Columbia Broadcasting System of America are now

# EXCHANGING PROGRAMMES WITH AMERICA

AT the invitation of the Post Office, I have seen the apparatus which is used to link up with the B.B.C. in connection with the American programme exchanges.

No doubt you have heard some of these B.B.C. programme "swops" with the Columbia Broadcasting System of America. The B.B.C. is sending some typically British programmes over to America by the transatlantic telephone, where they are broadcast over all stations of the Columbia System; and Columbia, on the other hand, is giving us programmes, again on the P.O. Radio Telephone, which are being broadcast over here. The whole series is being heard both by C.B.S. listeners and by us.

The B.B.C. has very little to do with the programme exchanges from the technical end, the British Post Office on this side, and the A.T.T. authorities on the American side, having arranged the radio link.

When we take the Columbia programmes they are received on the Post Office transatlantic telephone sets and given by land-line to the B.B.C. London Control Room at about the same volume as an ordinary outside broadcast.

## Four Wavelength Channels

The Post Office has several channels to New York, one being the well-known 5,000-metre Rugby wavelength. There are four short waves. The 16-metre gear is used during the day, the 22-metre gear at dusk and the 32-metre gear during the night. There is also a 44-metre channel. The Columbia programmes are transmitted at Rocky Point and picked up at the Post Office receiving point at Baldock in Hertfordshire. Super-hets are used, the apparatus being shown in one of the accompanying photographs.

"Simple Super" enthusiasts will be interested in the super-het arrangement used by the Post Office for short-wave reception. The feeder lines for the 16-, 22-, 30-, and 44-metre receivers come in to tuned stages on the panels. The right-hand bay is taken up with the preliminary tuning and first detectors for all wavelength channels. One type of intermediate frequency amplification is used for all wavelengths and the I.F. couplers are tuned to 300 kilocycles. There is a separate oscillator in each case.

## Prevention of Fading

A novelty is that in order to keep the volume constant, and to prevent programmes fading out during reception, there is an automatic volume regulator or, what the engineers call a "gain" control. There

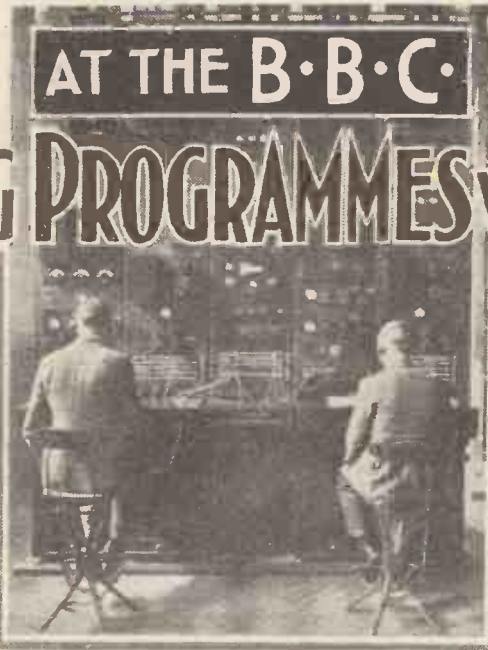

Post Office operators at the London terminal position, controlling the American relays

are three screen-grid valves in the I.F. stages and the gain control works back from the second detector, keeping the volume constant.

There are two L.F. panels in the Baldock receiver, each having four valves.

## Volume Control

These are the receivers, incidentally, which are used for the "muddled" secret transatlantic telephone service, but the side-band distorter apparatus is not used during the B.B.C. and Columbia programme exchanges as secrecy is of no importance and the very best quality is desired.

Baldock is connected by specially

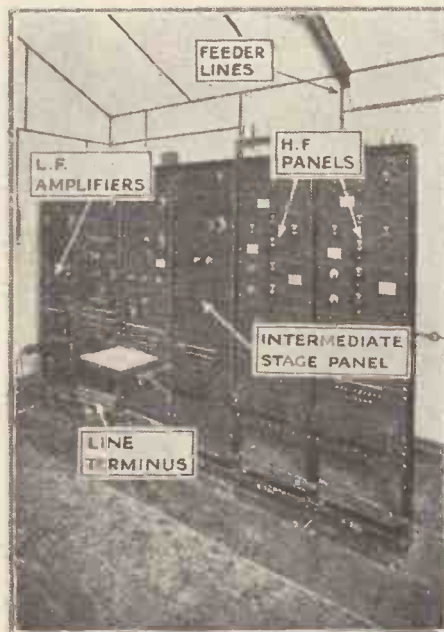

This lettered photograph shows the chief details of the short-wave super-heterodynes used at Baldock for receiving the American short-wave transmissions

in force. Our special Commissioner describes how these are done on the Post Office transatlantic telephone.

balanced lines with the London trunk exchange where, in a little room on the first floor, are the control panels for the whole system. During an important programme exchange, the programme is sent simultaneously over several wavelength channels and the operator at London has only to touch a key to select the best reception.

He has a manual gain control, very similar to the ordinary B.B.C. volume controls and he watches a meter which resembles the B.B.C. programme meter, described recently in AMATEUR WIRELESS. His panel connects up with the special line joining the London trunk exchange with the B.B.C. control room.

The greatest credit is due to the Post Office on account of the remarkable efficiency of the whole system. Getting through to New York is just as easy as phoning from a trunk exchange to the B.B.C.! At the touch of a key, one can speak from London to New York, Australia, South Africa, and, of course, to ships at sea.

It would be quite possible to relay a whole programme from, say, the *Leviathan*, when in mid-Atlantic! The Post Office has, during the last fortnight, installed a special panel which will make it even easier to change over from the ordinary commercial transatlantic telephone working to the rather special requirements of broadcasting. The panel also connects up with the chief towns all over the country, through trunk lines, so that "outside broadcasts" from practically any centre, can be taken by the Post Office and relayed to America, or, in fact, to any of the continents at present connected by the radio telephone service.

Padriac Gregory is to devote the fourth of his series of talks on "Our Old Popular Ballads" to "The Ballad in Modern Literature." This talk will be given on May 7.

Grieg's famous "Norwegian Dances" feature in a programme by the Midland Studio Orchestra on May 9.

Mr. W. Arthur Clarke conducts a concert by the Birmingham Military Band for Midland Regional listeners on May 10.

Cinema organ music continues to be one of the most popular items in the broadcast programmes, and arrangements have been made by the B.B.C. in Scotland for relays to be broadcast from another cinema—the Regal, Glasgow. The first programme will be heard on May 2 at twelve o'clock.

THE "Simple Super" has a wavelength tuning control, a combined wavelength and battery switch and a volume control.

To tune it you therefore turn the left-hand knob from the off position to the long or medium wavelengths, this switch being joined to the batteries and all coils. Then the aerial knob is turned to adjust the wavelength of the circuits, the volume control being used as desired.

Nothing could be easier than to use this set, as there are no critical adjustments to be made. There is no reaction, and so the tuning process is quite straightforward. The set does not radiate the locally generated oscillations. This is quite definite. Do not be afraid of using a large aerial. The set provides all the selectivity that is necessary, and a short aerial offers no advantages. Use a good earth, of course, if at all possible.

**Trimming the Set**

The trimming is, I suppose, the most interesting part of the work involved in preparing a set of this sort. I strongly advise you to purchase a cheap meter reading, say, 5 milliamperes. Connect this in the second detector circuit, that is, between H.T. +2 and the battery tapping of, say, 90 volts. The meter will read a current of between two and three milliamperes when no signal is being received.

When the set is tuned to a signal the

reading will be less, depending upon the strength. A good idea is to tune to a fairly strong signal and notice the reading of the meter. Then, when the volume control is adjusted to reduce the signal, the needle of the meter will move further across the scale, showing a bigger current. The current flowing through the detector circuit falls off when the signal is increased in strength.

**Gang on a Weak Signal**

This meter is of the greatest assistance in ganging the circuits as a change in the reading of the meter can be seen when the change in the strength cannot clearly be heard from the loud-speaker. The trimming procedure is exactly as described before, excepting that you watch the meter, listening as well, of course.

Always make the signal as weak as possible, consistent, naturally, with being able to hear and to see results. Gang as described before, testing at about 40 and 160 degrees. If you move the tuning condenser slightly about the correct point of tune you will see the needle fall and rise. The needle should move from the normal reading (no signal) to the lower reading and back again, as the set is tuned, without any suggestion of dipping in between.

# HOW TO GET WITH THE

This art operate structure



If, for example, the normal (no signal) reading is 3 milliamperes, the needle should move from 3 to, say, 2.5 and back to 3 as the tuning is varied through the signal. The ganging is not correct if the needle does not swing down and up again.

**Using a Meter**

When ganging, therefore, the object is to obtain the strongest signal as indicated

## GETS EVERY STATION

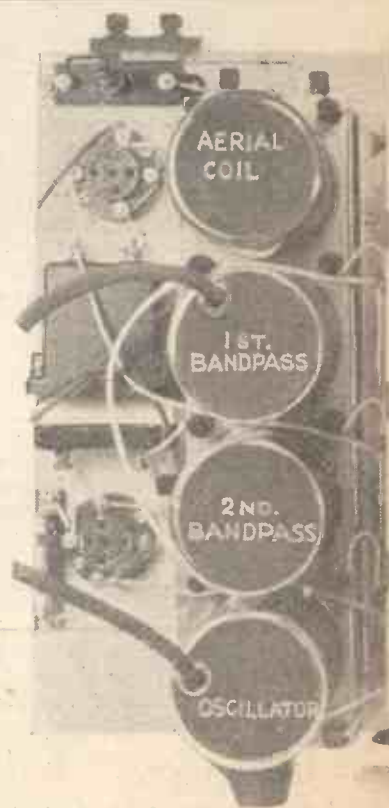

This lettered plan view will be of assistance which are given in

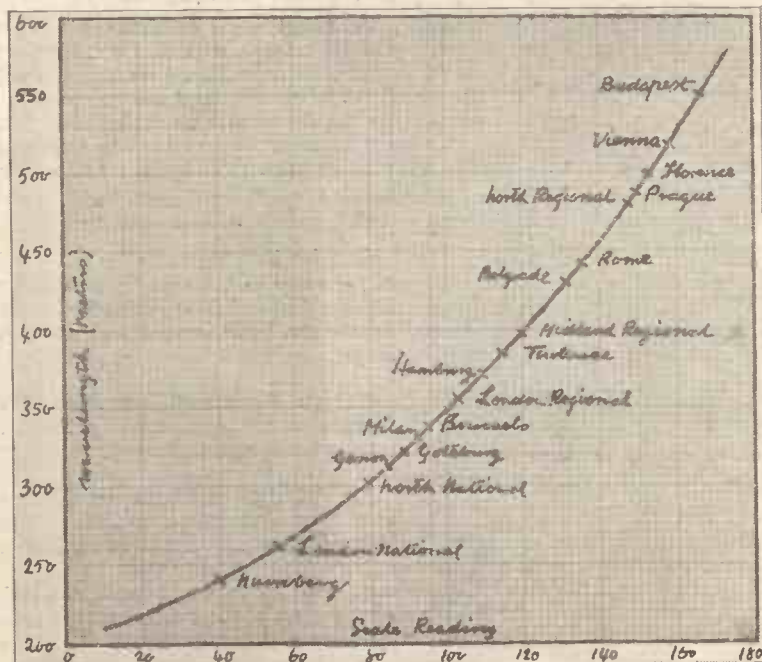

This is the tuning graph of the medium-wave stations and, providing the trimming of the oscillator is correct it will be the same for any "Simple Super"

# T THE STATIONS E "SIMPLE SUPER"

... by W. JAMES, describes how to trim and  
the "A.W." "Simple Super" of which full con-  
... details were given in the two preceding issues

strength, although perhaps you cannot hear it, is indicated by a reduction in the current flowing in the detector circuit.

You can test again on the long waves as a matter of interest, but you will find that the tuning is correct over both wave-ranges if it has been made correct over the medium waves. When testing you will have noted that the volume control may be moved back from the position giving maximum amplification without reducing the sound output from the loud-speaker, although the meter shows that the signals have been weakened. Do not over-load the detector, there-

fore, and always have back the control as far as possible.

The amount of the volume depends chiefly upon the size of the power valve, the high-tension and the loud-speaker, always assuming that the signals will fully load the valve. But a large power valve cannot be used unless the high-tension is available for it. A mains unit will often be used, and ordinary types will give satisfactory results.

### H. T. Supplies

There are three high-tension positive tapings. Tap H.T. +1 goes normally to about 120 volts and may be joined to H.T. +3 when a battery is used. When the voltage is over 120, take H.T. +3 to the maximum and H.T. +1 to about 120, with H.T. +2 to about 90.

This trimmer is across the band-pass filter coil, and it should be adjusted carefully in order to make the signal the strongest.

### Final Adjustments

Next adjust the second trimmer and finally the first. The setting of the first one depends upon the pre-set condenser of the aerial, so start with the pre-set condenser at the maximum capacity, that is, with the screw turned down.

Having got the best results from the local station, turn to about 40 degrees and find a fairly strong signal. If necessary make slight adjustments to the trimmers. Then go to about 160 degrees and test again. You may find that the aerial trimmer wants adjusting again. This is because the preset condenser has too large a capacity. Therefore reduce it a little by unscrewing the knob and test the tuning of the aerial circuit at about 40 and 160 degrees again.

### The Pre-Set

The pre-set condenser should be reduced to the point where the tuning is exact at both testing places. If you reduce the capacity of the pre-set condenser still further, nothing is gained and the signals are weakened. All that you must remember is that an increase in

## ON WORTH GETTING

AERIAL SECTION

1ST. BANDPASS

2ND. BANDPASS

OSCILLATOR SECTION



... in "trimming" the set, instructions for  
... the accompanying text

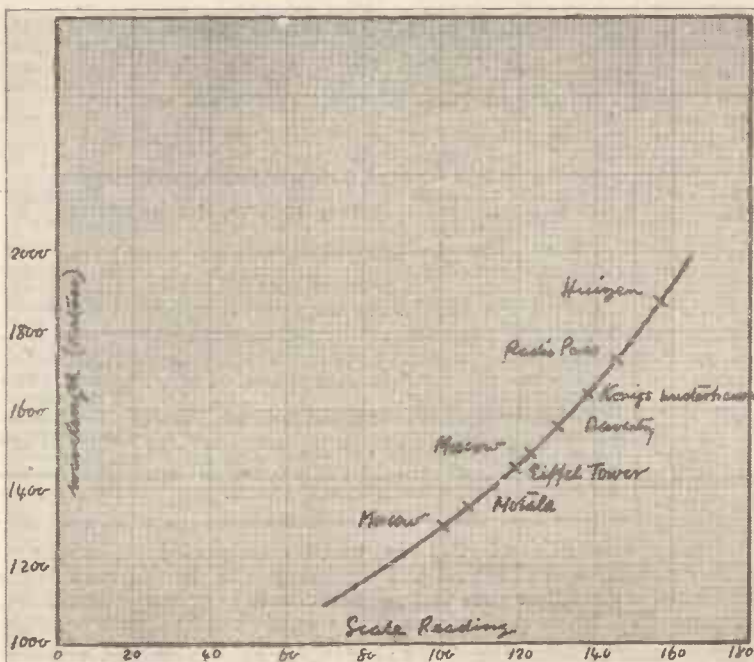

The graph for the long-wave stations. Both these graphs have been specially compiled by the designer, W. James

“How to Get the Stations with the ‘SIMPLE SUPER’” (Continued from preceding page)

The mains unit may have a fixed or power tap and two others, either fixed or adjustable. Take H.T.+3 to the fixed power tap and try H.T.+1 and H.T.+2 connected to the other output tappings. The best results may be obtained with H.T.+1 and H.T.+3 joined to the power tap, and this should be tried:

found by trial, starting off with the bias suggested by the makers.

The circuit of the set is one that is satisfactory with mains units. This is because transformer couplings are used and by-pass condensers are included.

use the maximum high tension that is needed for the best results, as it is poor economy to run the valve with a low value of high tension. It is true that the current is less when the high tension is low, but it is worth while using about 90 volts.



Trimming the “Simple Super” is a simple operation if the procedure described is followed

No difficulty is likely to arise with a mains unit, provided H.T.+1 can be supplied with current at not too high or too low a voltage. We found that 150 volts on H.T.+1 is satisfactory with some screen-grid valves and is too much for others. Hence it is necessary to try joining the H.T.+1 tap to all the output sockets provided on the mains unit.

When the voltage for H.T.+1 is either too high at the power socket or too low at other sockets, the best plan is to connect H.T.+1 through a resistance to the power socket. Try a value of 5,000 ohms, and it may be necessary to add a 2-microfarad condenser

A pentode output valve can be fitted if desired. The usual tone-correcting circuit should be used with it, including a resistance and a condenser of about 15,000 ohms and .01 microfarad. There is not

THE COMPONENTS REQUIRED FOR BUILDING THE “SIMPLE SUPER”

- Baseboard, 16 in. by 12½ in. (Camco, Peto-Scott, Readi-Rad).
- Four-gang .0005-mfd. variable condenser (J.B.).
- Four-coil super-hot unit (Wearite type GL32).
- Two super-hot coils (Wearite, one OT1 and one OT2).
- Seven 4-pin valve holders (Telsen, Lotus, Lissen, W.B., Goltone, Wearite, Junit, Igranic, Benjamin).
- One 1-mfd. fixed condenser (T.C.C., Lissen, Dubilier, Telsen, Goltone, Ferranti).
- Two 1-mfd. fixed condensers (Dubilier, Lissen, Telsen, T.C.C., Goltone, Ferranti).
- High-frequency choke (Peto-Scott, Lewcos, Lissen, Wearite, Goltone, Dubilier).
- Low-frequency transformer (Lissen Hypernik, Telsen, Lotus, Ferranti, Varley, Goltone, Lewcos, Igranic, R.I.).
- .0003-mfd. maximum pre-set condenser (Sovereign, Formo, Telsen, Igranic, R.I., Lissen, Polar, Goltone).
- Grid-leak holder (Readi-Rad, Lissen, Goltone, Bulgin, Telsen, Dubilier).
- Two 1-megohm grid leaks (Dubilier, Lissen, Telsen, Sovereign, Goltone).
- One .0003-, one .0005-, and one .0002-mfd. fixed condensers (Lissen, Telsen, T.C.C., Goltone, Dubilier, Sovereign, Formo, Ormond, Graham-Farish).

- One 15,000-ohm, one 30,000-ohm spaghetti resistances (Lewcos, Lissen, Telsen, Sovereign, Varley, Goltone, Graham-Farish).
  - Two terminal mounts (Sovereign, Junit, Belling-Lee).
  - Four terminals marked Aerial, Earth, L.S.+, L.S.— (Belling-Lee, Clix, Bulgin, Eelex).
  - Two spade terminals, marked L.T.+, L.T.— (Belling-Lee, Clix, Eelex).
  - Six wander plugs, marked G.B.+, G.B.—, H.T.—, H.T.+1, H.T.+2, and H.T.+3 (Belling-Lee, Clix, Eelex).
  - Connecting wire and sleeving (Lewcos, Jifilinx, Quickwyre).
  - Five yards thin flex (Lewcoflex).
  - 50,000-ohm potentiometer (Colvern).
- ACCESSORIES
- 120-volt H.T. battery (Lissen, Pertrix, Drydex, Fuller, Ever-Ready, C.A.V.).
  - Accumulator (Lissen, Pertrix, Drydex, Fuller, Ever-Ready, C.A.V.).
  - 9-volt grid bias battery (Lissen, Pertrix, Drydex, Fuller, Ever-Ready, C.A.V.).
  - Cabinet (Peto-Scott).
  - Loud-speaker (Ultra, Ormond, Lissen, R. & A., H.M.V., Tekade, Sovereign, Blue Spot, Goodman).

to the circuit: one side of this is taken to the earth terminal of the set and the other side of the condenser goes to the H.T.+1 tap, so that between this point and the mains unit is the fixed resistance.

It is necessary to adjust the grid bias to suit the power valve and the voltage of the high tension at the anode of the power valve. The best value is easily

much chance of high-frequency currents reaching the loud-speaker circuit, and the circuit is perfectly stable. Naturally the valves used affect the results, and it is a good plan to use those which are specified on this page.

In a set of this sort the valve used in the second detector stage is called upon to carry fairly strong inputs. Always

receive a large number of stations clearly and easily.

HOT FOOD!

THE basement of Broadcasting House will be one large cafeteria, capable of providing up to 200 hot lunches. The food will be under the control of an ex-Army caterer!



See how  
Mr James  
has used  
**LISSEN** for

**QUALITY OUTPUT  
in the Simple Super**

MR. JAMES is proud of the output of the "Simple Super." He has used components that were bound to give him quality—a Lissen Hypernik Transformer, with its fine response curve over all audible frequencies—Lissen Fixed Condensers and Grid Leaks, which are tested for silent working and absolutely unvarying values—Lissen Accumulator—and the original "Simple Super" draws its high tension from the extraordinary power output of the Improved Lissen Battery.

Build the "Simple Super" yourself with Lissen parts and get that fine tone and volume which Mr. James has planned to give you.

**THE LISSEN HYPERNIK TRANSFORMER**

Mr. James has used this transformer in the "Simple Super." *You cannot get such a good response curve—such fine quality of reproduction—from any other transformer at anything like this price.*

With a primary inductance of fully 100 henries, it yet operates perfectly when passing currents up to 5 m/A. or more. Its step-up ratio is 4 to 1, and a stage amplification of more than 100 is obtained.

PRICE **12/6**

**THE PARTS THAT PULL TOGETHER**

LISSEN LIMITED . WORPLE ROAD . ISLEWORTH . MIDDLESEX

Please Mention "A.W." When Corresponding with Advertisers

# Our Broadcast Critic

## TALKS ABOUT

### UNWANTED MUSIC



SOLOMON

THERE is a growing tendency in broadcast programmes to flavour everything with music. Nothing, in the estimation of the B.B.C., seems complete without it. More than once recently I have listened to productions which have been spoiled by dragging in songs where they were not wanted.

There was a good specimen this week—*Arrest in Africa*. It was described in the programme as a musical farce. It was hardly a farce in itself; it was the music that made it one. Perhaps that justified the title in a sense, but while listening to it I became interested in the plot. As soon as I did that someone asked someone else to sing a song, which was just what I did not want him to do.

Dragged-in music is superfluous in every sense of the term; it is a burden many plays cannot bear. I did not dislike the music as music; I simply questioned the need for it. The Noise Department, by the way, must have enjoyed itself; it imitated everything to perfection.

There has been another Funeraudeville. Deep crêpe and harrowing solemnity surrounded the Thursday night effort. Sir Nigel Playfair did not mean to be amusing, so he must be excused; in fact, his contribution was the only one that attracted me.

But tell me, am I *wrong* in supposing vaudevilles are primarily intended to amuse? If I am wrong, then we must look to the hyper-modern music broadcasts for our fun; we can generally extract some amusement out of them—at least I can.

I liked Frederique's voice very much. I discovered that she was singing in English, I heard *two words*; that is how I found out.

Reginald Tate gave a lecture on musical instruments; I think serious lectures in vaudeville are out of place unless illustrated.

I heard Ross and Sargent both times in their syncopated harmony. The term means nothing musically—harmony can never be syncopated. On the other

hand, diction can be distinct; theirs was. I have rarely heard words come through better.

The Hythe Male Voice Quartet are quite good enough to hear more than once. May they be asked again? They make good links in the vaudeville chain.

Eric Ross and Ida Williams in their cross-talk produced one or two guffaws from the studio audience but no more: I am sure they can produce better patter than that.

Strobl on the three-inch mouth-organ was very clever. A little of that sort of thing—unless one can see the performer—goes a very long way. Still, it was clever.

I want to say something to Jack and Claude Hulbert. Your best audience was in the studio; that was your own fault. You played to them far too much. You are so good and often so funny that you must not run risk of criticism of that kind. Listeners have every right to complain if they are not considered first. The studio audience did not pay anything to hear you; we paid .005d. out of our licence-money. Therefore we should have the preference.

The fourteenth conversation in the train was one of the best I have heard. It was carried out, to my way of thinking, in a manner absolutely true to the style of thing it represented. Also there were many truths spoken in it. I thoroughly enjoy this novel feature. I imagine it will have a long run.

#### PROGRAMME POINTERS

A word about the Epilogues. One Sunday, a week or two ago, "God be in my Head" was sung at the end. As the voices died away I began thinking about these Epilogues. My conclusion was that it is a mistake to have well-known hymns sung in any of them. I think the Psalm might always stand, because of the fascinating system of pointing. The hymn, I am convinced, is a mistake. The reason is, that there have been many hymns already sung in the broadcast services during the day. Those who listen to the Epilogues—and I am convinced that there are thousands who do—are likely, also, to have heard the services or else to have been to some place of worship. Therefore, I suggest that the concluding musical item be a short motet, a snatch from an oratorio, even a "verse" from some old-world contrapuntal evening service, such as Gibbons in F or Kelway in B minor. The perfect Epilogue cannot aim too high.

Solomon and Evelyn Scotney were really fine on the Friday night. Madame Scotney's voice is almost too much for an ordinary loud-speaker, but her insight into the songs she sings is always well worth studying. She should be regarded as a model by many an aspiring broadcaster.

Solomon is one of the few present-day pianists who can play Chopin. His handling of the *G Minor Ballade* must have pleased many whose tastes lie in that direction.

Very good series is *Here and Now* by Gerald Barry. Listen to him on a Friday evening; you will find he makes a singularly striking opposite number, so to speak, to Vernon Bartlett.

I listened to the second part of Mendelssohn's *Elijah*, relayed from the Town Hall, Lewes. I was not impressed with any of it, except, perhaps, Keith Falkener's singing of the part of Elijah. Even he could not have felt very comfortable with such an orchestra to accompany him. Why were there no trumpets? "Be Not Afraid" sounded appalling without them.

The performance of the choir was creditable when one realised that its membership was recruited from rural districts round Lewes, but I did not think it was quite good enough for broadcasting. That is my criticism, really; creditable enough for Lewes, but as a broadcast performance of such an oratorio hardly up to standard.

I heard the last part of the all-Welsh concert. Hearing the Funeraudeville prevented me from hearing the whole of it; I wished I had heard that instead of the other, for there was some very good choral singing.

The Wednesday night symphony concert had great moments. Sir Henry Wood made a deep impression on me in the slow movement of the Elgar symphony. I heard the first performance of that beautiful work in Manchester in 1908, but I do not think the tone of the strings in the Hallé Orchestra of those days was anything like that of the B.B.C. Orchestra now.

The Prokofiev concerto, played by the composer, was a disappointment to me; just as some really beautiful theme rose up, Prokofiev seemed to remember that he *must* be "modern." It was a concerto of surprises and disappointments.

WHITAKER-WILSON.



**MORE  
VOLUME**



**AND BETTER  
TONE**

**I**F you want many more stations, and all at fine, full loud-speaker volume, get a Lissen Detector Valve and a Lissen Power Pentode. Then you will have lively, responsive tuning—your set will bring in the foreigners like magic—and where before you got a whisper now you will hear a torrent of pure sound. Not only this, but you will get that typical brilliance of tone which “pentode output” gives—that “punch” which you have heard and admired from demonstration sets.

**THE LISSEN DETECTOR VALVE**  
The Lissen Detector Valve—H.L.210—liven up your tuning, gives you extra range, greater sensitivity. It passes a crisper, more powerful signal on to the L.F. stage of your receiver, and you get louder, clearer radio altogether when you use it. Ask for Lissen H.L.210.  
**PRICE**

**5<sup>5</sup>/<sub>6</sub>**

**LISSEN LIMITED**  
**WORPLE ROAD**  
**ISLEWORTH**  
**MIDDLESEX**

**LISSEN POWER PENTODE VALVE**  
The Lissen Power Pentode Valve—P.T.225—converts any set with one stage of L.F. amplification into a fine, full-volume “pentode-output” receiver. Use it instead of a power valve and at once you get an amazing step-up in volume. And it takes no more current than the power valve it replaces—its H.T. consumption is only 7 m/A. Ask for Lissen P.T.225.  
**PRICE**

**12<sup>5</sup>/<sub>6</sub>**

**LISSEN VALVES**

*A Brilliant British Best!*

## HOW LOUD SHOULD REPRODUCTION BE?

Percy W. Harris discusses an interesting point

IN conversation with an old friend whom I had the pleasure of entertaining recently I gathered that neither from books nor from conversation with experts had he been able to get a satisfactory reply to a question which had been bothering him for a long time. The real reason as usual was that he was not very clear on the question itself, but I gathered that this was roughly the idea. In order that the reproduction in his room might be perfectly natural just how loud should a signal be, and how much power would his output valve have to handle in order to prevent overloading?

The discussion was not finished even at midnight when he went home, but in talking the matter over the position became much clearer and I think he is now more or less satisfied. So much revolves around the point of what is "natural." There is also implied in his question the erroneous assumption that one strength will do for everything, which is manifestly *not* the case when we think about it. You might at first suppose that if the reproduction from the loud-speaker were made of the same strength as the

actual sound at the point where it is generated this should be perfectly natural (assuming, of course, a lack of distortion in the set). But look what an awful mess this would lead us into! Picture to yourself a man standing on the platform of the Albert Hall playing a cornet solo and then try to imagine the effect of a cornet being played at just that strength in an ordinary dining-room; think of a stirring appeal by Mr. Ramsay MacDonald at some public dinner being transferred at equal strength to a small living-room; worst of all, think of a dance band—no, don't think of that! When it comes to concert music most people, I imagine, like the strength of reproduction to be about what it would sound like from a good seat in a well designed concert hall. Speech in a news bulletin, talks lectures, and the like are best adjusted so that they sound as if the speaker were situated actually in the loud-speaker itself, but music is very difficult indeed to arrange.

### Effect and Direction

One of the great difficulties about musical reproduction is that human ears are very sensitive instruments, working both together so as to give not only the *effect* of the sound but also its *direction*. However faithful the reproduction of sound tones and intensity happens to be in our wireless receiver the fact remains that all the reproduced sound comes from *one point*, or, at least, from a small area which is that of the loud-speaker diaphragm. When you sit in a concert hall and listen to a well-balanced orchestra your ears can tell at once from which side of the platform comes the sound of any particular instrument, just as by using your two eyes you can judge the depth of a scene. It is impossible to get the same aural effect when all sound is coming from one point as when it comes from a number of different points spread over an area of, maybe twenty feet by ten.

Another problem is that of the *range of*

*intensity* of sound reproduced or reproducible. The microphone with its associated amplifying apparatus in the transmitter can handle a certain range of intensity without overloading and that range of intensity is known to the transmitting engineers, for which reason a controlling engineer has to be continually on watch with the volume control. I have not the latest B.B.C. figures by me at the moment, but I think I am correct in saying that the range of intensities heard in the concert hall is at least ten times as great as that accommodated in the transmitter, which means that the crashing finale which may so impress you in the concert hall itself has to be reduced considerably in intensity by the controlling engineer before it gets "on the air."

### Sensitivity and Intensity

Again, there is the great problem of the variation of *sensitivity* of the ear according to the *intensity* of the sound. I have mentioned this before, but it is worth referring to again. To put the matter simply we may say that if you successively strike the notes of a piano so as to give uniform output of sound from each note at one particular intensity and you then repeat the experiment so as to give a sound of four or five times the actual intensity of that previously given, although the increase of the strength of each note is the same it will not *sound* so to the ear. Thus if you magnify by means of a uniform amplifier the reproduction of a piano solo so as to make the strength about five or six times as great as normal, the low notes will seem to be over accentuated. Similarly over magnifying the human voice will make it sound deep and boomy.

Some moving-coil loud-speakers which are rather deficient in bass response only sound "natural" when signals are made very loud, due to the above reasons, and so the listener who runs his speaker with very loud signals to get a natural effect is combining speaker distortion and intensity distortion to balance one another!

### REACTION ON THE "MASCOT"

SOME "Mascot" users using valves other than those specified are finding trouble in getting sufficient reaction over the whole scale. Valves vary considerably in their reaction effects for which reason the choice of the detector valve is important, and should be made from the types named. Similarly even the correct valves will not oscillate if insufficient high tension is used, particularly as we are using a decoupling resistance in series with the 100,000 ohm. resistance which couples the two valves. Use at least 100 volts, preferably 120 volts with the "Mascot" and you will get all the reaction required.

A special vaudeville programme of street pavement artists will be broadcast from the London Regional on May 2.

Clapham and Dwyer are in the first musical comedy to be heard from the new B.B.C. headquarters, the dates of broadcasting being May 3 (National) and 4 (Regional).



A false time signal to help out the husband returning late from the office!



# Multi-point Filament Suspension Mica Bridge Mounting

—the two vital constructional features that make COSSOR Valves—

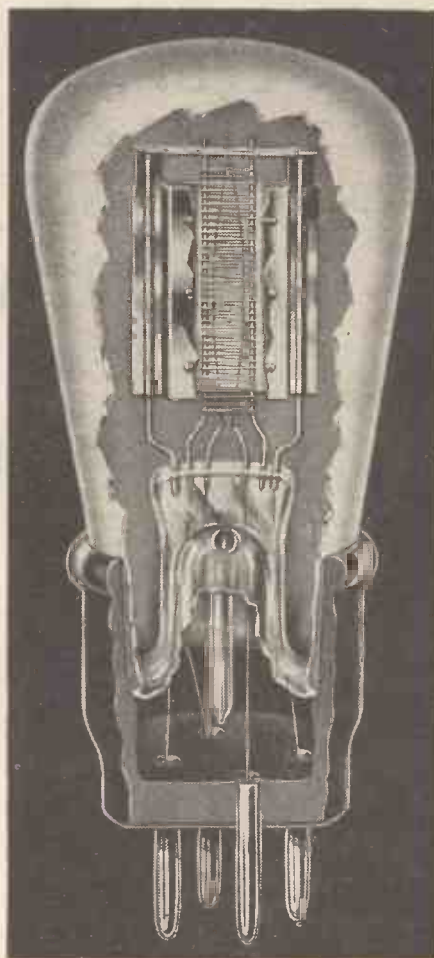

# NON- MICROPHONIC

**M**ICROPHONIC noises are definitely prevented in every Cossor Valve: Firstly by Cossor multi-point suspension—a system of construction which provides as many as four extra filament supports thereby eliminating all tendency to filament vibration. Secondly by Mica Bridge Mounting, the Cossor

constructional system under which all the elements are rigidly braced together in permanent alignment preventing individual movement, and vibration of the elements. Thus, no part of the valve structure vibrates. And since vibration is the cause of microphonic noises it follows that Cossor Valves are proof against this trouble.

A copy of the 72 page Cossor Wireless Book B11 will be sent you free on application to A. C. Cossor Ltd., Melody Dept., Highbury Grove, London, N.5.

Get one of the new Cossor Station Charts price 2d. Ask your dealer for a copy of this useful novelty or write to us enclosing 2d. stamp.

# COSSOR

ALL-BRITISH  
VALVES

A. C. Cossor Ltd., Highbury Grove, London, N.5. Depots at Birmingham, Bristol, Glasgow, Leeds, Liverpool, Manchester, Newcastle, Sheffield and Dublin. 63 ♡ 375

You will Help Yourself and Help Us By Mentioning "A.W." to Advertisers

## SETS OF DISTINCTION

# The MARCONIPHONE MODEL 42 THREE-VALVER

Makers: Marconiphone Co., Ltd. Price: 20 guineas

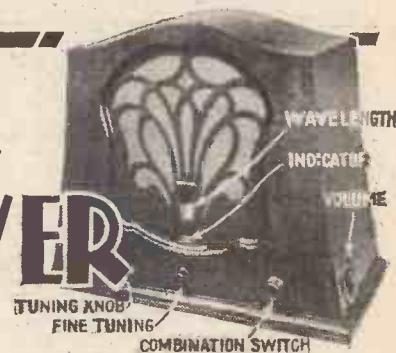

**T**HERE is something very satisfying about an all-electric console—you can put it into operation so easily, and, when the few preliminaries are over, such as adjusting the mains-voltage terminals on the input transformer and connecting up aerial and earth, the ether is at your command. Here, in the Marconiphone three-valver, you have an excellent example of the all-electric console idea. I have obtained delightful reproduction from a host of foreign stations, and with an ease of control that is, even now, all too rare.

### Attractive Features

The illustrations show the pleasant lines of the walnut cabinet, in which are contained all the essentials of worth-while radio, including a permanent-magnet moving-coil loud-speaker, a powerful three-valve band-pass chassis, and the equipment for obtaining the necessary power from the mains.

There is no panel in the ordinary sense, as the control knobs are fitted in a line along the front of the cabinet, with the volume-control knob, which works equally well on radio as on gramophone pick-up, let into the right-hand side of the cabinet. Just below the loud-speaker fret is the escutcheon of the tuning scale, and this is illuminated when the set is switched on, and well calibrated in medium and long wavelengths.

I think the most attractive feature of the control is the rotating-switch indication just below the tuning escutcheon, which shows you at a glance which circuit—medium, long, or gramophone—is in use. There is another position for this switch, and that is the mains "Off" position. A most ingenious arrangement that all non-technical set users must appreciate.

### Simple Operation

To put this set into action is just a matter of fitting the valves and plugging into the A.C. mains. I used my 205-volt supply, and, of course, the test aerial of 60 feet total length. By the way, the mains transformer is arranged so that all voltages between 95 and 260 volts can be used, by a simple system of plugs and sockets.

A fine batch of Marconi valves are used in this set, with an MS<sub>4</sub>B for the screen-grid stage, an MH<sub>4</sub> for the detector, and an MPT<sub>4</sub> for the pentode output—and there is a Uro valve rectifier.

I soon found how well these valves work together when I switched on the set, for without any fuss I tuned in a dozen stations at full strength. Then

I discovered there was a volume control on the side—I had been getting those stations with this control almost at minimum!

### Tuning Arrangements

The calibrated tuning scale is easy to read, and is a great help in finding the stations. I found this scale control rather deceptive at first, for unless you work the trimmer knob fitted below the scale, which controls the aerial tuning, you may get the impression that tuning is broad. Actually, the scale knob is uncritical—an advantage when locating

tive above the average in my opinion.

Quality is always a little difficult to define, but I am sure all who hear this set will agree that the bass note output is splendid, and that the top note cut-off has been skilfully balanced so that essential crispness has not been sacrificed.

While on the subject of quality, I might mention that the high-note response is sufficiently good to make heterodynes distinctly audible, though this nuisance is somewhat abated when the volume control is turned down.

The quality is well maintained when the volume control is turned to the "full-on" position, and under this condition the output is most impressive—showing just what can be done with a pentode working into a matched moving-coil loud-speaker. The pentode has an undistorted maximum power output of well over 1 watt, and this, taken in conjunction with the very great sensitivity of the permanent moving-coil, must account for the really amazing volume possible under "all out" conditions.

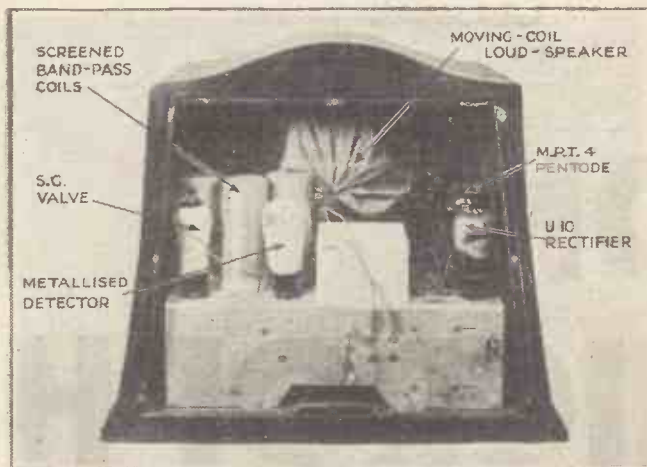

A rear view of the Marconiphone Three-valver: note the clean layout and ample spacing of components

stations. *But you get all the really sharp tuning you need by working the trimmer control.*

The band-pass tuning works on the capacity-coupling system, and gives good quality selectivity, by which I mean that stations are limited in dial spread without loss of high notes. I thought the performance was at its best at the top end of the scale, and this is an advantage, since most of the worth-while stations come in above 300 metres.

On the long waves I noticed a similar condition, Huizen at the very top of the wave-band being received at really fine strength and quality. Altogether seven stations were well logged on the long waves.

### Wide Range

Using the mains aerial plug instead of the usual aerial I got plenty of medium wavers at loud-speaker strength, such stations as Rome and Beromunster being more than loud enough. The set is sensi-

the full-bodied bass, which is entirely devoid of the box resonance we used to think was bass.

If you have a turntable I strongly recommend this set as a gramophone-record amplifier. All you have to do is to fix a pick-up and the volume control on the set controls the output. This is made possible by the inclusion of a ganged volume control, consisting of two potentiometers, one taking care of screen-grid volts and the other being across the pick-up sockets. Using a Marconiphone pick up I obtained first-class record reproduction, and I found the volume control convenient and effective.

You must make sure of a good earth with this set, although, as already mentioned, the aerial may be taken from the mains if nothing better can be fixed up. Even under the worst reception conditions this set can be relied upon to bring in a dozen or so stations.

SET TESTER.

# a battery for every need

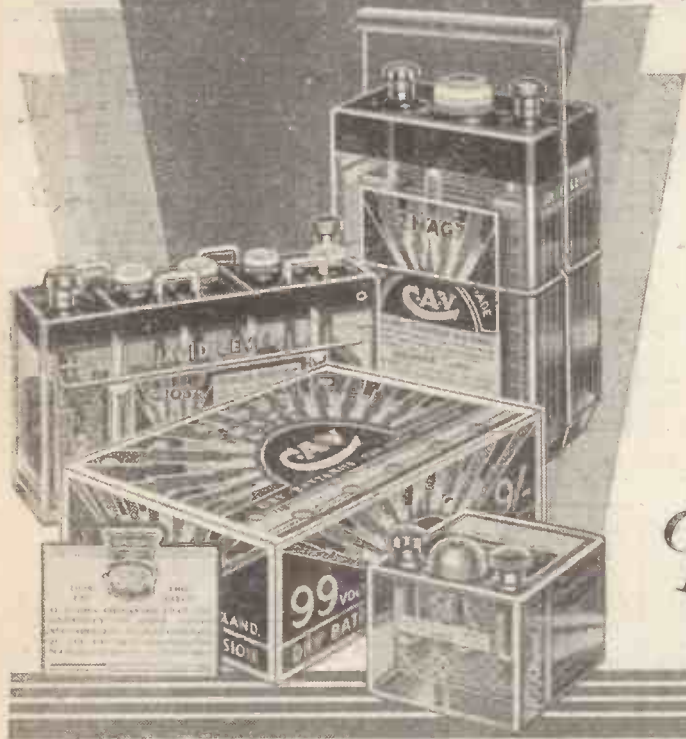

 Careful discrimination in the choice of a Battery should extend not only to the make but also to the capacity. Decide first on one of unquestionable reputation, such as the C.A.V., and then give consideration to the type that will give the longest life and the most complete satisfaction.

The benefit of our experience may be valuable to you. Send us details of your receiver and we will assist you in the choice of one best suited to your requirements.

Have you tried the C.A.V. H.T. Dry Battery yet?

Free

FREE. A USEFUL BOOK ON THE MAINTENANCE OF C.A.V. H.T. & L.T. ACCUMULATORS AND HOW THESE CAN BE CHARGED AT HOME FROM D.C. MAINS. A POST-CARD WILL BRING YOU A COPY. APPLY TO DEPT. CA

**C.A. Vandervell Ltd.**  
WELL STREET,  
BIRMINGHAM.

# INDISPENSABLE

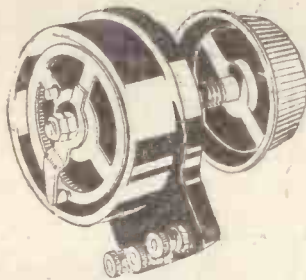

TO ALL MODERN CIRCUITS

To modern Sets, this component is indispensable in matters of volume and tonal control and this SOVEREIGN Volume Control is best of all for constructors. Sturdily built into a solid moulded bakelite former, its patented spring-diaphragm action ensures perfect contact all round with smooth dead silent action. 3 terminal connections make it suitable for all circuits. Supplied complete with bakelite dust-and-damp proof cover to protect the resistance and mechanism. The SOVEREIGN VOLUME CONTROL is non-inductive, of course, and is obtainable from all dealers.

Made in all standard values up to and including 2 megohms 4/6. Sovereign wire-wound volume controls (up to 50,000 ohms) as recommended for Simple Super 4/6.

SOVEREIGN PRODUCTS Ltd.  
52/54, ROSEBERY AV., E.C.1.



SIX-SIXTY VALVE SERVICE STATIONS GIVE STRAIGHT ADVICE WITHOUT OBLIGATION, ON ALL VALVE PROBLEMS.

Build your Sets (and Kits) with Six-Sixty Valves. S.S. Valve Service Stations everywhere will help you to get the best results from sets fitted with Six-Sixty Valves.

Better still, buy your components as well as your valves from your nearest Valve Station and make sure of their ability to help you fully with every item you incorporate.

Six-Sixty Valve Service Stations exist in most districts, and are being appointed rapidly in the remaining areas. Write to us for the address of that nearest you. Six-Sixty Radio Co. Ltd., Six-Sixty House, 17, 18, Rathbone Place, Oxford Street, W.1.

P.S. If your set has Six-Sixty Valves now, you know already how good they are. But whatever they may be, ask your local S.S. Valve Service Station to show you if the latest types will make it better.

Don't Forget to Say That You Saw it in "A.W."



# IN MY WIRELESS DEN

Weekly Hints —  
CONSTRUCTIONAL & THEORETICAL  
BY  
**W. JAMES**

## METAL SHIELDED WIRE

**S**YSTOFLEX having a covering of wire mesh is being used more and more for the purpose of shielding circuit wires. Suppose, for example, that you have to use a fairly long wire to the grid of a screen-grid valve and that it would run close to the anode circuit.

The stray coupling would in all probability be enough to produce instability and would certainly couple the anode and grid circuits to such an extent that the amplification to be obtained is greatly reduced. The shielded systoflex, when the covering is earthed, will effectually shield the circuit wire. Unfortunately, there is capacity between the shielding and the circuit wire.

This may be enough to upset matters. If a fine connecting wire is used, however, the capacity is the minimum and the circuit may usually be balanced as the trimming condensers have enough capacity to take care of a little extra circuit capacity.

It is necessary to use the shielded systoflex with caution or the results may well be spoilt. Remove the covering about an inch from the ends and bind the covering with fine wire to hold it in position. Then take the end to a convenient earthing point, such as low-tension negative or to the metal chassis when one is used.

## CONTROLLING THE STRENGTH

The problem of how best to control the volume is always with us. It is really

a matter of providing a means for varying the strength of the signals applied to the last valve, as it is not very good practice to adjust the strength of the output.

If we did this we should be wasting power in a resistance, besides which the quality is usually upset. Then again, a

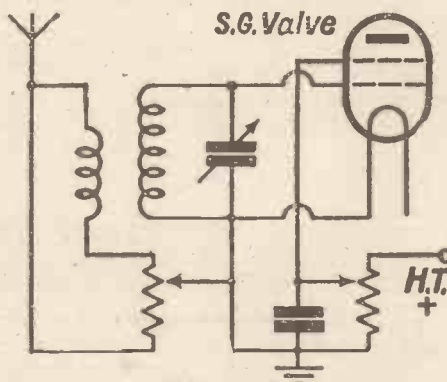

This is the volume control arrangement referred to in the accompanying paragraph

low-frequency control is not always desirable and so we are left with the high-frequency side. We can control two things here. One is the strength of the signal applied to the first valve and the other is the amplification provided by the high-frequency amplifier.

Two separate controls may be used or they can be joined through a spindle and so be worked by a single knob. The diagram shows a good combination. The two parts have previously been described and it is a simple matter to arrange an insulating bush to couple the two units.

One resistance is joined in the aerial circuit and the other to the screen grid of the first valve. The accompanying diagram shows that as the two contacts are moved towards the earth end (downwards) the input from the aerial circuit is reduced and so is the voltage to the screen of the valve. Therefore the input and the amplification are reduced.

Moving the contacts upwards increases the strength. Usual values are 10,000 ohms for the aerial portion and 50,000 ohms for the screen-grid part, a tapped aerial coil may be used.

## "NOISY" ACCUMULATORS

An accumulator which bubbles badly is usually in need of attention. In trying out a sensitive set I noticed slight noises and these vanished when another accumulator was fitted.

The first accumulator was rather old and the electrolyte turned out to be faulty. Another noise was traced to a poor earth connection which draws attention to the fact that earths are often left to take care of themselves.



## "World-wide Short-wave 3" Results

**S**IR,—Recently I completed my first month's tests with my "World-wide Short-wave 3" and should like to report the results.

Using 80 volts H.T. and an outside aerial of about 70 ft., I have logged—between February 27 and March 26—the following stations: Rome, Vatican HVJ, Moscow, Drummondville VE9DR (Canada), Chicago W9XF, Cincinnati W8XAL, Vienna Expt'l. VOR2, Chicago W9XAA, Bowmanville VE9GW (Canada), Bound Brook W3XAL, Saigon F3ICD, Rome, Pittsburgh East W8XK, Radio Col, Schenectady W2XAD.

I have also received six American transmitters, including W2XBJ, Riverhead, Long Island, and WA1XR.

I should like to take this opportunity of thanking you for the "World-wide Short-wave 3," which has proved very satisfactory and affords me many hours pleasure.

E. S. (Weymouth).

## Six-volt Valves and the "Simple Super"

**S**IR,—Will you please let me know whether the "Simple Super" would operate successfully with 6-volt valves.

E. B. (Barnes).

It is not possible to obtain a 6-volt bi-grid valve and it would, therefore, seem that 6-volt valves are out of the question for use with this receiver. If you are prepared to experiment, we would suggest you try a 6-volt screen-grid valve in place of the bi-grid. A 2-volt S.G. valve has been used in a similar

capacity in our experiments and has proved quite satisfactory.—Ed.

## Output Transformers

**S**IR,—In your issue of April 9 under the above title you give the formula for determining approximate output ratios for transformers for different types of power valve. Is there some inaccuracy in the formula given, as I am unable to arrive at a satisfactory solution to my calculations?

D. C. S. (Southampton).

Owing to an unfortunate oversight, the formula given was reversed. The formula should read:

1. For cone loud-speakers:

$$\text{Ratio} = \sqrt{\frac{\text{valve impedance} \times 2}{\text{speaker impedance}}}$$

2. For moving-coil speakers:

$$\text{Ratio} = \sqrt{\frac{\text{valve impedance} \times 2.5}{\text{speaker impedance}}}$$

In the above formula twice the valve impedance or, in the case of moving-coil speaker, two and a half times the valve impedance, is considered to be the approximate optimum load of the valve.—Ed.

(Continued on next page)

**Stage Gain Magnification with Parallel Feed**

SIR,—Recently you published a description of how to design amplifiers from the theoretical standpoint. You did not, however, explain how to determine the gain per stage of amplification when using parallel-fed transformers. Are there insurmountable difficulties relating to this particular form of coupling in regard to determining how much magnification is actually to be expected?

J. K. (Letchworth).

It is simple to determine, approximately, what stage gain is to be expected, provided that we assume certain figures used in the formula to be relatively and sufficiently correct for the values of the components which they are intended to represent. For instance, where a resistance is used in the anode circuit, the value of this resistance should be assumed to be constant at all audible frequencies. Again, the coupling condenser capacity should be assumed to have a negligible impedance to the audible frequencies to be dealt with by the amplifier. It is then only necessary to determine the impedance of the transformer primary at three different frequencies and to take the mean of these values. The formula to be used is then:

$$\text{Stage gain is equal to } \mu \left( \frac{A}{A+r} \right) n$$

Where  $\mu$  equals the magnification factor of the valve,  $A$  equals the mean impedance of the anode resistance and the primary of the transformer,  $r$  equals the A.C. resistance (impedance) of the valve, and  $n$  equals the step-up ratio of the transformer. Where an L.F. choke is used in the plate circuit of a valve instead of an anode resistance, its impedance at three different frequencies should be determined and the mean figure taken to represent  $A$  in the formula. The impedance is obtained by the formula  $2\pi fL$ ,  $f$  being the frequency in cycles per second and  $L$  the inductance in henries. As the choke or anode resistance impedance and the transformer primary impedance are virtually in parallel, the effective impedance value will be less than either individual impedance value. Parallel impedances are calculated in much the same way as parallel resistances.—Ed.

**Speaker Vibration**

SIR,—I was greatly interested in Theron's remarks in a recent issue on the question of reducing speaker vibration in a cabinet or on a baffle. I have been wrestling with the same problem for some time. Possibly my solution may be of general interest to your readers. My set is housed in the top compartment of a large cabinet, 3 ft. high. Mains unit and accumulators are on the bottom shelf and various oddments on the intervening one. A circle was cut in the side of the cabinet and the chassis of the speaker unit screwed to the inside. Considerable resonance and vibration caused various unpleasant noises.

Finally, I seccotined some plain rubber draught tubing on the flat round of the chassis, in such a way that the tube acted as a semi-pneumatic cushion when fixed in position again. By putting rubber washers on the screws and not driving them quite home I secured a perceptible resilience when the unit was pressed on. Now, with doors all closed, there is practically no vibration even on the panel itself, while the former objectionable resonance has disappeared.

W. C. B. (Wallasey).

**IMMEDIATE DELIVERY—C.O.D.—CASH or H.P.**  
**FOLLOW THE AUTHOR WITH A PILOT AUTHOR KIT**

**SPEAKERS**

**BLUE SPOT SPEAKER UNIT AND CHAS313, TYPE 100U.** Send 5/5 only  
Cash or C.O.D. £1/19/8.  
Balance in 7 monthly payments of 5/5.

**R & A "100" PERMANENT MAGNET MOVING-COIL SPEAKER.** Send 5/4 only  
Complete with multi-ratio input transformer. Cash Price £2/17/6.  
Balance in 11 monthly payments of 5/4.

**W.B. PERMANENT MAGNET MOVING-COIL SPEAKER P.M.4 with input transformer.** Send 5/9 only  
Cash Price £2/2/0.  
Balance in 7 monthly payments of 5/9.

**W.B. PERMANENT MAGNET MOVING-COIL SPEAKER P.M.3.** Send 4/10 only  
Complete with 3-ratio input transformer. Cash Price, £2/12/6.  
Balance in 11 monthly payments of 4/10.

**W.B. P.M.1 PERMANENT-MAGNET MOVING-COIL SPEAKER, complete with input transformer.** Send 11/- only  
Cash Price £6 0 0  
Balance in 11 monthly payments of 11/-.

**ULTRA IMP PERMANENT MAGNET MOVING-COIL SPEAKER, with input transformer.** Send 5/- only  
Cash Price £2/15/3.  
Balance in 11 monthly payments of 5/-.

**ELIMINATORS**

**ATLAS A.C. ELIMINATOR, TYPE A.C. 244.** Send 5/6 only  
Three tappings, S.G., detector, and power. Output, 120-volts at 20 m.a. Cash Price £2/19/3.  
Balance in 11 monthly payments of 5/3.

**ATLAS A.C. 290 super all-mains unit for H.T., L.T. and G.B.** Send 11/11 only  
Three tappings, two variable, one fixed; B.L. brickle charger for 2, 4 or 6 volts at 5 amp, and four G.D. tappings. Cash Price £5 10 0  
Balance in 11 monthly payments of 11/11.

**EKCO H.T. UNIT, Type A.G. 25.** Send 7/1 only  
Four multi-valve sets requiring up to 25 m/a. 3 tappings; S.G., detector and 120/150 volts. For A.C. Mains. Cash. Price £3/17/6.  
Balance in 11 monthly payments of 7/1.

**REGENTONE H.T. ELIMINATOR for D.C. Mains, Type W.I.F.** Send 4/4 only  
Tapped 60/70, S.G. and 110 v. at 12 m.a. Cash Price, £2/7/3.  
Balance in 11 monthly payments of 4/4.

**KIT SETS**

**FO4MO TRIPLE-WAVE 3.** Send 5/11 only  
Detector, I.F. and Power. Less Valves, but with chassis and switch-operated three-wave coil. Cash Price, £3/5/0.  
Balance in 11 monthly payments of 5/11.

**GOSBOR EMPIRE MELODY MAKER 234** Send 10/- only  
with valves and cabinet. Cash Price £6/8/6.  
Balance in 11 monthly payments of 11/10.

**GOSBOR ALL-ELECTRIC MELODY MAKER, TYPE 235** Send 17/4 only  
for A.C. mains, complete with valves and cabinet. Cash Price £9/9/6.  
Balance in 11 monthly payments of 17/4.

**GRAHAM FARISH AMAZING 3.** Send 6/- only  
Less valves and cabinet. Cash Price £1/18/6.  
Balance in 6 monthly payments of 6/-.

**IMMEDIATE DELIVERY MR. W. JAMES' SIMPLE SUPER KIT A**

Author's Kit less Valves and Cabinet CASH or C.O.D. **£8.8.0**

Or 12 monthly payments of 15/6. Specified Valves £3 8 9. Specified Peto-Scott Cabinet £1/1/-

**KIT B** Author's Kit with Valves; less Cabinet. CASH or C.O.D. **£11.17.0**  
Or 12 monthly payments of 21/9.

**KIT C** Author's Kit complete with Valves and Cabinet. CASH or C.O.D. **£12.18.0**  
Or 12 monthly payments of 23/8.

Any part supplied separately. See our previous full page Announcements.

**MASCOT PILOT AUTHOR'S KIT**

**KIT "A"** Author's Kit less Valves and Cabinet. Complete with a ready drilled panel to specification. CASH or C.O.D. **76/-**  
Or 12 monthly payments of 7/-.

Specified Valves £12/9.  
**KIT B** Author's Kit with Valves; but less Cabinet. CASH or C.O.D. **£4.18.9**  
Or 12 monthly payments of 9/-.

Specified Cabinet 19/5.  
**KIT C** Author's Kit complete with Valves and Cabinet. CASH or C.O.D. **£5.18.3**  
Or 12 monthly payments of 10/10.

**MASCOT PILOT ECONOMY KIT**

**KIT "A"** Pilot Economy Kit less Valves and Cabinet. Complete with a ready drilled panel to specification. CASH or C.O.D. **56/6**  
Or 12 monthly payments of 5/2.

1 Set of Specified Valves £12/9  
1 Peto-Scott Cabinet as specified by the Author 19/6  
**KIT B** Pilot Economy Kit with Valves, less Cabinet. CASH or C.O.D. **£3.19.3**  
Or 12 monthly payments of 7/3.

**KIT C** Pilot Economy Kit complete with Valves and Cabinet. CASH or C.O.D. **£4.18.9**  
Or 12 monthly payments of 9/-.

**HOME-LOVER'S ALL-ELECTRIC 3**

**KIT "A"** Author's Kit, less valves and Cabinet and Speaker Equipment. Panels and terminal strips ready drilled. Complete with a ready drilled panel to specification. CASH or C.O.D. **£6 10 0**  
Or 12 monthly payments of 11/11.

Set of Specified Valves £3,0/0  
**KIT B** Author's Kit with Valves less Cabinet and Speaker equipment. CASH or C.O.D. **£9.10.0**  
Or 12 monthly payments of 17/5.

Cabinet as Specified £17/0/0  
**KIT C** Author's Kit complete with Valves, Cabinet and Speaker equipment. CASH or C.O.D. **£11.5.0**  
Or 12 monthly payments of 20/8.

Any parts supplied separately. If order value over 10/- sent carriage paid. C.O.D. post charges paid.



77 CITY ROAD, LONDON, E.C.1. Telephone: Clerkenwell 9406-7-8.  
62 HIGH HOLBORN, LONDON, W.C.1. Telephone: Chancery 8266

To PETO-SCOTT CO. LTD. 77, CITY ROAD, LONDON, E.C.1  
Please send me C.O.D., CASH/H.P.

for which I enclose Cash/H.P. Deposit £      s.  
Name.....  
Address..... A.W. 30/3/32.

We supply everything Radio Cash or C.O.D. or H.P. Part Kits or miscellaneous components, etc., supplied on Easy Terms on orders of 50/- and over.

LET "A.W." SOLVE YOUR WIRELESS PROBLEMS.



A weekly review of new components and tests of apparatus conducted by J. H. Reyner, B.Sc., A.M.I.E.E.

### R.I. "MASCOT" COILS

THE R.I. dual-range coil, on which we are reporting this week, has been developed especially for use with the "Mascot."

This coil is neat and well made, being built up on a paxolin former approximately 2 inches in diameter. The medium-wave winding at one end is in the form of a solenoid, while the long-wave winding at the other end of the former is accommodated in a built-up slot and has a multi-layer construction.

On test we found the coil quite satisfactory, the wave ranges were correct and



One of a pair of R.I. matched coils for the "Mascot."

the coil behaved quite nicely. A high-frequency resistance test was also conducted on the coil with the following results. On the short waves the effective resistance was approximately 8 ohms at 400 metres, while at 1,600 metres the resistance was approximately 45 ohms. These figures are quite normal and indicate that the coil should give quite efficient service in use. For wave changing a two-point switch is required; this is not supplied with the coil.

Although this coil has been designed for use with the "Mascot" it is, of course, quite suitable for use in other types of receiver.

### GOOD FLEXIBLE CORD

THE question of the flexibles to be used for the external connections to the receiver or other apparatus is one which is rarely given much consideration, but good flexibles are just as important to the continued satisfactory operation of an installation as is any other component part.

The new type of dual-flexible conductor just placed on the market by Messrs. Ward & Goldstone, Ltd., known as the Akros flexible cord is an endeavour to produce a cord having an attractive finish which is, at the same time strong and of the best quality electrically.

The cord consists of two rubber-covered conductors spaced from one another and twisted round a central core composed of ten strands of a kind of woollen string, the whole being covered with red braiding.

The cord is suitable for use in all circumstances where a good and attractive flex is required. It is made in sizes from 14-36 and larger.

### PEAK HIGH-VOLTAGE CONDENSERS

WE were very interested to receive recently two samples of a new range of high-voltage condensers just placed on the market by Messrs. Wilburn & Co., under the name of Peak condensers.

The range includes condensers having capacities varying from .1 to 4 microfarads, the ratings being guaranteed to plus or minus 10 per cent. The condensers are tested to 1,500 volts D.C. and have a working voltage of 700 volts D.C., these values making them quite suitable for use in all normal circumstances.

The range also includes a .1-microfarad + .1-microfarad 1,000 volt A.C. test condenser, for use in obtaining an artificial earth point in A.C. eliminator circuits, and for preventing oscillation of the rectifier valve. The construction as far as can be seen is quite normal, the condensers being housed in metal cans, finished in a light-grey colour and arranged for baseboard mounting. Lugs or terminals for connec-

tion can be obtained, these protruding through the can at the top.

The samples tested consisted of a 4-microfarad and .1-microfarad + .1-microfarad condensers. The capacities were measured and the actual values obtained were 3.8 microfarads and .097 microfarad + .096 microfarad respectively, these values being well within the tolerance allowed. The insulation resistance was excellent, it being too high to obtain any reliable reading on our instruments. The condensers retail at prices ranging from 1s. 10d. to 6s. 9d. These prices are exceedingly low and the range should make a wide appeal.

### NEW WATMEL RESISTANCE

THE new Watmel three-terminal resistance is an interesting example of modern design and workmanship. It is intended for use in circumstances where a wire-wound resistance is not required. It has a maximum value of 500,000 ohms.

The construction is interesting. The resistance element is located around the inside of the rim of the cup-shaped bakelite case. Contact with the element is made with wire loops arranged equidistantly on a strip of pliable insulating material which is fitted into the case just inside the resistance element. This contact ring is forced against the element by means of a cone-shaped clamping arrangement which is bolted to the case. A moving arm then rotates over the edge of these loops, making contact at the required point and giving a smooth and easy action.

The actual maximum resistance value



A useful variable resistance, the Watmel

was 500,000 ohms, and no grading of the element has been employed. In use, the resistance was quite satisfactory, giving a silent and smooth control. The method of construction ensures a good contact with the resistance element and the component should give good and long service. It retails at a price of 4s. 6d., which is good value.

### WHAT READERS SAY ABOUT THE "MASCOT"

A selection of opinions of readers all over the country who have built the Percy Harris "Mascot," described in Nos. 509 and 510.

*I have made up your latest set, the "Mascot" . . . there is a station at every turn of the dial. Both the selectivity and sensitivity are amazing. I have nothing but praise for the "Mascot."*—L.S. (Newlyn, Penzance).

*It is a real pleasure to write about the best three-valve set I have ever constructed. My conditions are about as awkward as one can have. My aerial is screened by phone and telegraph wires, radio relay mains and lighting service cables. The "local" is Moorside Edge, sixteen miles away. Yet the "Mascot" is indifferent to all these trouble makers . . . it's a champion set.*—G.W.C. (Bacup, Lancs.).

*I think it is all you claim for it . . . thanking you for bringing out such a fine set.*—J.F.T. (London, W.14).

# Proof!

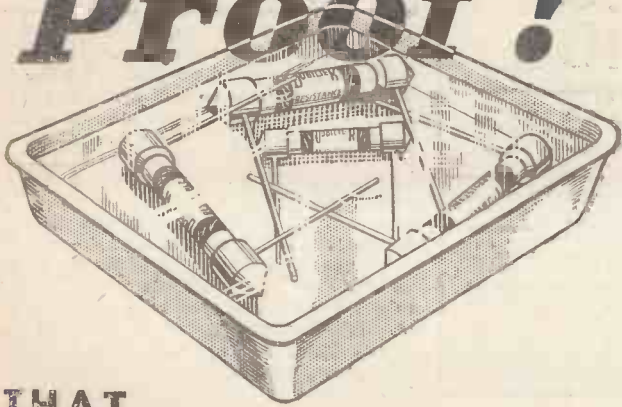

## THAT MOISTURE CANNOT HARM THEM!

Don't run risks of ruining the performance of your Receiver by using ordinary resistances which will set up crackling noises at the faintest suggestion of the presence of moisture . . . use Dubilier Metallized Resistances which cannot be harmed by moisture. Look at the test carried out above . . . that's proof! The Resistances functioned perfectly after having been completely immersed.

Dubilier Metallized Resistances are manufactured under a patent process and are worthy of that great reputation for reliability which goes with all products bearing the name Dubilier.

Whatever your Resistance requirements—ask for Dubilier.

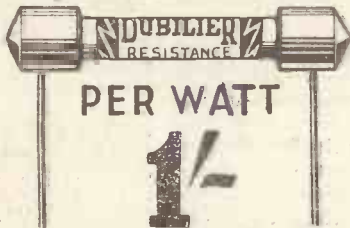
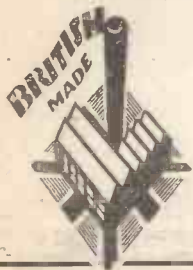

1 watt 1/-, 2 watt 2/-, 3 watt 3/-

# DUBILIER Metallized RESISTANCES

DUBILIER CONDENSER CO. (1925) LTD.  
Ducon Works, Victoria Road, North Acton, W.3

# NEW 'SQUARE PEAK' SUPER-HET COILS

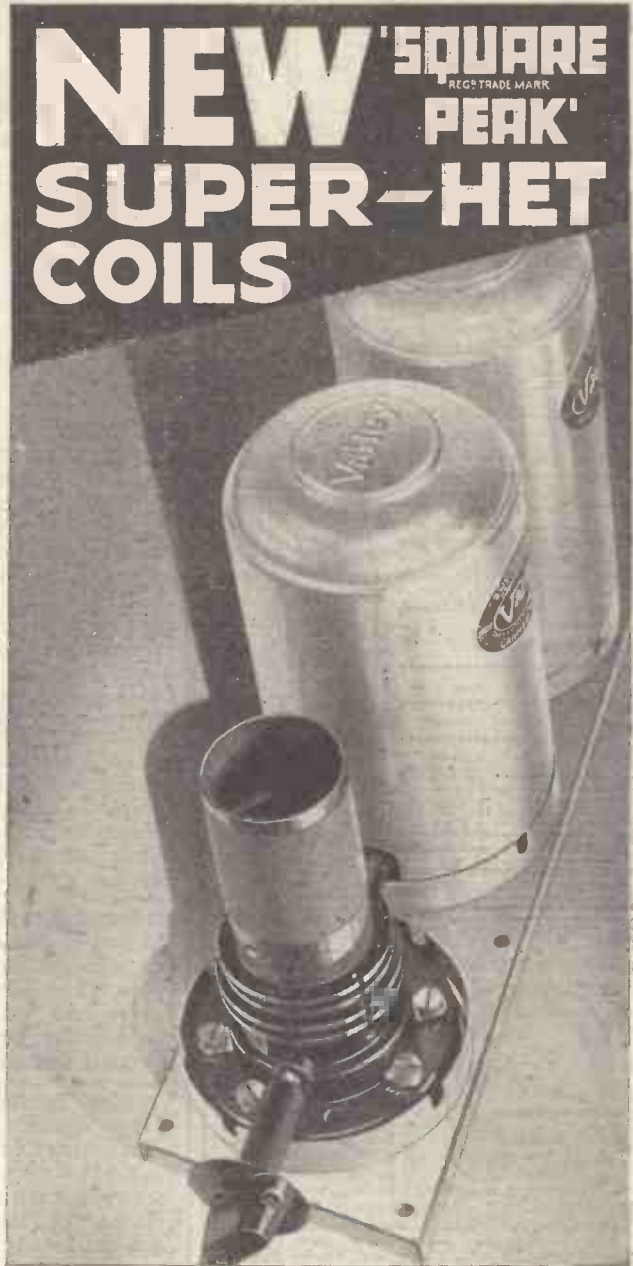

With these coils **single knob control is obtained** without using any "padding" condensers on the medium waves, and with only one additional fixed condenser on the long waves. The intermediate frequency is 110 k.c.

Supplied as a complete unit comprising single control aerial, intervalve and oscillator coils. List No. BP19, 3-gang unit on aluminium base-plate - - - 30/-

# Varley

(Proprietors: Oliver Pell Control Ltd)

Adet. of Oliver Pell Control Ltd, Kingsway House, 103, Kingsway, London, W.C.2

Mention of "Amateur Wireless" to Advertisers will Ensure Prompt Attention

# HEYBERD

MONARCH OF THE MAINS.

## Charge your own ACCUMULATORS at Home!

Save those recharging costs. Just install a Heyberd Trickle-charger, switch on to the mains, and charge your accumulators quicker, cheaper, and neater yourself. They last longer this way. Complete with Westinghouse Rectifier in neat steel case, charging 2, 4, and 6 volts at  $\frac{1}{2}$  ampere.

Price **35 $\frac{1}{2}$**

-----POST NOW-----

I enclose 3d. stamps for Lists, with diagrams, giving the full range of Heyberd Mains Kits, Transformers, Chargers, Chokes, Condensers, etc.

M.....

Address.....

..... A.W.30.

F. C. HEYBERD & CO.,  
10, Finsbury St., London, E.C.2  
One minute from Moorgate Uad. Sta.



## ELECTRADIX STERLING SNIPS

ANOTHER BIG SALE OF R.A.F. BARGAINS, TELEPHONES, &c.



—The cheapest tester is a pair of 2/9 Sullivan phones and a 6d. cell for any circuit, 8,000 ohms for DX., 4/6. Brown's A reed for short-wave sets, 1,500 ohms, 12/6; 120 ohms, 7/6. Western Elec., 2,000 ohms, 4/3 pair. House Phones, 6/3 each.

**MICROPHONES.**—Public Address W.E., £20; Broadcast No. 5, £3 5s.; Home Recorders, pedestal, 12/6; pendant, 6/6.

**LOUD SPEAKERS.**—Moving coil, 6v. for Battery Sets, 25/-; 220v. D.C., 35/-; 110v. A.C., 52/6; 200/250v. A.C., 55/-.

**2,000 METERS** of all ranges at cut prices.

**TRANSFORMERS.**—1,200 Intervolve Marconi-Ericsson square type list 12/6, great bargain, guar., 2/6 only; 5 amp. 3-1 power type, 4/9.

**MARCONI WAVE TRAPS,** 15/-; Wave-meters, 190/3,000 metres, 70/-; Igranit Unitun plug-in Coils, 2/-.

**PHOTO-CELLS**—for Home Talkies—British Talkie Pictures unmounted 15/-; American U.X.867 mounted, 25/-. The usual price of Photo-Cells is £4 10s.—£7 10s. each.

**MORSE KEYS.**—7/- and 6/6; Push type, 6d.; 5 amp. Tumbler, 6d.; Rocker on-off, 6d.; 3-way, 10d.; 5-way, 1/-; 8-way, 3/6.

**DYNAMOS, &c.**—H.T. Double-current Generators, 8 volts and 600 volts 80m/a, list £15, sale to clear, 22/6. Rotary Interruptor Motors for making A.C. off 6/12 volts, New Wilson, 15/-.

**RECORDERS.**—Fultograph Kits, 27/6; Recorder Kit, 19/6; Morse Inkers, £4 10s.

**USEFUL PARCELS.**—Experimenters' sundries from dismantled apparatus; Terminals, chokes, holders, switches, wire, condensers, coils and fittings made up in 7 lbs., 5/-, 10 lbs., 1/-, 1,000 other bargains in our Green Sale List.

**ELECTRADIX RADIOS**  
218 Upper Thames Street, E.C.4

Let "AMATEUR WIRELESS" solve your wireless problems

# Postcard Radio Literature

## GET THESE CATALOGUES FREE

Here "Observer" reviews the latest booklets and folders issued by well-known manufacturers. If you want copies of any or all of them FREE OF CHARGE, just send a postcard giving the index numbers of the catalogues required (shown at the end of each paragraph) to "Postcard Radio Literature," "AMATEUR WIRELESS," 58/61, Fetter Lane, E.C.4. "Observer" will see that you get on the literature you desire. Please write your name and address in block letters.

## A Rapid Valve Guide

I HAVE just received a pocket-size book produced by Mullard, which I strongly recommend to every valve user. In one section of it is a full catalogue of Mullard receiving valves, in another section are circuits and technical details of interest to every keen listener. Free copies of this handy book can be obtained through my Catalogue Service. **748**

## A Cheap "Three"

The Tower Royal Radio Co., have sent me details of the "New Three." This is a complete three-valver, selling with all accessories at only £5 10s. Details are obtainable free, through my Catalogue Service. **749**

## Reduced Eta Prices

Users of Eta valves should get the new catalogue giving reduced prices of many types. The catalogue gives performance curves and working instructions for all the popular types, battery and mains-operated and rectifiers. **750**

## Vernier Tuning

It is difficult to make accurate tuning adjustments without good slow-motion dials. If your present fittings are unsatisfactory, get details, through my Catalogue Service, of the Burndept Ethovernier dials marketed by Henry E. Taylor, Ltd. **751**

## Super-hot Coils

Varley have sent me a leaflet dealing with single-control super-hot coils, comprising an aerial coil, oscillator and three-gang unit. Copies of this should interest every super-hot user. **752**

OBSERVER.

On May 3 the Children's Hour will have a Zoo programme with Mr. Will Owen introducing the animals. The "studio" is to be in the Reptile House and microphones will be fixed in the Bird House, the Wolves' Den, the Lion House, the Monkey House, and the Mappin Terraces.

Speeches from the opening of the New Central Public Library at Lancaster will be relayed to North Regional listeners on May 4. The ceremony is to be performed by the Earl of Crawford and Balcarres. This library has been fitted up to accommodate listening groups.

## OUR LISTENING POST

By JAY COOTE

CURIOSLY enough, although generally speaking, atmospheric conditions have been fairly favourable recently, I have not at any time been able to pick up broadcasts from Madrid (EAJ 7)—at least, on and around its allotted wavelength. On the other hand, Moscow (Stalin) has been heard at almost any hour of the evening or night, and as the transmission is perfectly clear, I am inclined to believe that Madrid has moved to another wavelength—hitherto untraced.

I learn that Radio Luxembourg, the new 200-kilowatt (?) transmitter now being erected in the little Grand Duchy of that name, will shortly be ready for tests; they may be expected at any time. As was anticipated, a long wave has been chosen, namely, 1,250 metres, although 230 metres was the wavelength officially allotted as an exclusive channel to Luxembourg. To ascertain the value and range of the selected channel, experiments are being carried out with a low-power plant almost daily between 5.30 and 6.30 p.m. You may, therefore, hear a French call on that section of the condenser dial. Whether the station will be allowed to retain this particular wavelength is a questionable point, as it is likely to interfere with important aviation traffic services.

However, tests will be carried out for a period of three months, as the official opening of the transmitter is not due before July.

## The New Paris

The new Poste Parisien high-power station has now taken over the broadcast of the midday programmes and may be heard daily at great strength on about 327-328 metres. The evening entertainments are still transmitted by the original and weaker plant situated in Paris.

Have you noticed how well Radio Normandie (Fécamp) is now received throughout the British Isles? Although the station has not yet been authorised to boost up its energy to the limit of its ambition—it is certainly broadcasting at higher power than advertised—better results have been achieved since the aerial masts were raised to over 150 feet. Radio Normandie, in view of its position on the French coast is likely to become an important station to British listeners, and it intends to make the most of its sponsored entertainments to secure capital for the reconstruction of its plant.

## Italian Interval Signals

I notice that, although the Italian studios have retained their distinctive opening and interval signals, they have now added to them a gong. It is struck to indicate to listeners the end of an act of the studio broadcast of a play or the termination of any part of a symphony concert. When relays are carried out from theatres or public places of amusement, no such signal is needed, as the applause of the audience is a better substitute.

The considerable rise in power of the Leninograd, Moscow, and Warsaw transmissions is causing perturbation on the Continent, and by the end of the year we may log much heftier broadcasts emanating from Scandinavian countries. The Swedish authorities, to cope with this competition, have decided to increase the energy of Motala to 100 kilowatts. Reconstruction of the transmitter is to be taken in hand without delay in order to accomplish this conversion by the autumn. As you will, no doubt, have noticed, it is often easier to hear the programme from Stockholm direct, notwithstanding the close proximity of the Italian giant.

A special May Day concert has been arranged for Northern listeners on Sunday afternoon, May 1.



# YOUR TUNING GUIDE

Broadcasting Stations classified by country and in order of wavelengths. For the purpose of better comparison, the power indicated is that of the carrier wave.

Kilo-Metres	Station and Call Sign	Power (Kw.)	Kilo-Metres	Station and Call Sign	Power (Kw.)	Kilo-Metres	Station and Call Sign	Power (Kw.)
<b>GREAT BRITAIN</b>								
25.53	11,751 Chelmsford (G5SW)	10.0	327.4	926.4 Poste Parisien	35.0	240.2	1,249.2 Stavanger	0.5
242.3	1,238 Belfast	1.0	327.5	916 Grenoble (PTI)	2.0	364	824 Bergen	1.0
261.6	1,147 London Nat.	50.0	345.2	869 Strasbourg (PTT)	11.5	367.6	876 Frederikstad	0.7
288.5	1,040 Newcastle	1.2	369.4	822.4 Radio LL (Paris)	0.5	495.9	605 Trondheim	1.2
288.5	1,040 Swansea	0.12	384.4	779 Radio Toulouse	8.0	1,083	277 Oslo	00.0
288.5	1,040 Plymouth	0.12	450	666.7 Paris (PTT)	0.7	<b>POLAND</b>		
288.5	1,040 Edinburgh	0.3	406	644 Lyons (PTT)	1.5	244.2	1,400 Warsaw (2)	1.9
288.5	1,040 Dundee	0.12	1,445.7	207.5 Eiffel Tower	13.5	234.9	1,283 Lodz	2.2
288.5	1,040 Bournemouth	1.0	1,725	174 Radio Paris	75.0	312.8	959 Cracow	1.5
288.5	1,040 Aberdeen	1.0	292.2	1,292 Cassel	0.25	394.4	397 Poznan	1.9
301.5	995 North National	50.0	292.2	1,292 Kiel	0.25	380.7	788 Lvov	16.0
309.9	968 Cardiff	1.0	230.4	1,253 Nurnberg	2.0	409.8	732 Katowice	12.0
353.9	843 London Regional	50.0	245.0	1,220 Cassel	0.25	566.5	529.6 Wilno	16.0
376.4	797 Glasgow	1.0	253.1	1,185 Gleiwitz	5.0	1,411.8	212.5 Warsaw	120.0
398.9	752 Midland Regional	25.0	250.3	1,157 Leipzig	2.0	<b>PORTUGAL</b>		
480	625 North Regional	50.0	260.8	1,122 Bremen	0.2	241.0	1,241.8 Oporto	0.25
1,354.4	193 Daventry (Nat.)	30.0	276.5	1,085 Heilsberg	60.0	282.2	1,063 Lisbon (CTIAA)	2.0
<b>AUSTRIA</b>								
218.7	1,375 Salzburg	0.5	283	1,060 Magdeburg	0.5	also on 42.9 m. (Fri.)		
245.9	1,220 Linz	0.5	283	1,060 Berlin (E)	0.5	<b>ROMANIA</b>		
286.2	1,052 Innsbruck	0.5	283	1,060 Stettin	0.5	304	261 Bucharest	12.0
352.1	852 Graz	7.0	318.8	941 Dresden	0.25	<b>RUSSIA</b>		
453.2	666 Klagenfurt	15.0	325	923 Breslau	1.5	349	360 Leningrad RV70	10.0
517	587 Vienna	0.5	306.6	832 Muhlacker	00.0	358	338 Moscow (Exp.)	15.0
also testing on 1,237 m. from 7.0 p.m. (Mon., Wed., Sat.)								
<b>BELGIUM</b>								
206	1,456 Antwerp	0.25	372	806 Hamburg	1.5	368.1	315 Kharkov	10.0
210.2	1,429 Liege	0.15	389.6	770 Frankfurt	1.5	378	792.5 Moscow Regional	20.0
215.3	1,393 Chatelineau	0.2	419.9	716 Berlin	1.5	385	779 Stalingrad	10.0
215.0	1,394 Bruxelles	0.2	453.2	663 Danzig	0.5	389.0	770 Archangel	10.0
Conference 0.2								
216	1,389 Liege	0.1	472.4	635 Langenberg	00.0	424.3	707 Moscow-Stalin	100.0
221.4	1,355 Biiche	0.1	532.9	567 Munich	1.5	411	729.2 Pokrovsk-Volgo	20.0
240.8	1,245.8 Liege (Exp.)	0.1	559.7	536 Kaiserslautern	1.5	449.4	667.5 Odessa RV13	10.0
268.3	1,118.1 Liege (Cointe)	0.4	559.7	536 Augsburg	0.3	473.2	634 Sebastopol	10.0
283.0	1,058 Brussels (SBR)	0.5	556	530 Hanover	0.3	502.4	597 Nijni Novgorod	10.0
337.8	888 Brussels (No. 2)	15.0	509.3	527 Freiburg	0.25	720	416.6 Moscow (PTT)	20.0
500.3	589 Brussels (No. 1)	15.0	1,634.9	183.5 Norddeich	10.0	824.2	364 Sverdlovsk RV5	50.0
<b>BULGARIA</b>								
318.8	941 Sofia (Rodno Radio)	0.5	2,525	119.3 Konigswuster	75.0	849	353 Rostov (Don)	4.0
<b>CZECHO-SLOVAKIA</b>								
249.0	1,207.8 Prague (2)	5.0	2,900	103.5 hausen (press)	15.0	937.5	320 Kharkov (RV20)	25.0
263.8	1,177 Moravska-Ostrava	10.0	4,000	75 ditto	10.0	968	370 Alma-Ata	10.0
279.3	1,073 Bratislava	13.0	<b>HOLLAND</b>					
293	1,023 Kosice	2.5	293.1	1,023 Hilversum	8.5	also on 50 m. (6,000 Kcs.)		
341.7	878 Brunn (Brno)	32.0	1,071.4	280 Scheveningen-Haven	10.0	1,380	217.5 Novosibirsk	100.0
488.0	614 Prague	120.0	1,875	160 Huizen	8.5	1,482	203 Moscow	100.0
<b>DENMARK</b>								
281.2	1,067 Copenhagen	0.75	<b>HUNGARY</b>					
1,153	260 Kalundborg	7.5	210	1,129 Budapest (2)	3.0	202	1,115 Barcelona (EAJ15)	1.0
also on 31.51 m. (9,520 Kcs.)								
<b>ESTONIA</b>								
298.8	1,004 Tallinn	11.0	550	545 Budapest (1)	18.5	206.8	1,124.4 Valencia	20.0
453.2	663 Tartu	0.5	<b>ICELAND</b>					
<b>FINLAND</b>								
291	1,031 Viipuri	13.0	1,200	250 Reykjavik	16.0	348.8	860 Barcelona (EAJ1)	8.0
368.1	815 Helsinki	12.0	<b>IRISH FREE STATE</b>					
434.6	690 Pori	1.5	224.4	1,337 Cork (6CK)	1.2	411.5	815 Seville (EAJ5)	1.5
540	556 Tampere	1.0	413	725 Dublin (2RN)	1.2	427.4	703 Madrid (EAJ7)	2.0
1,796	167 Lahti	54.0	<b>ITALY</b>					
<b>FRANCE</b>								
219.0	1,364.1 Béziers	0.5	42.7	7,016 Rome (2RO)	15.0	456.6	557 San Sebastian (EAJ3)	0.6
222	1,351 Fécamp	5.0	247.7	1,211 Trieste	10.0	<b>SPAIN</b>		
230.7	1,267.3 Bordeaux-Sud-Ouest	2.0	273.2	1,098 Turin (Torino)	7.0	202	1,115 Barcelona (EAJ15)	1.0
245.9	1,220 Strasbourg 8GF	1.0	280	1,072 Bari	20.0	206.8	1,124.4 Valencia	20.0
251.1	1,205 Juan-les-Pins	0.5	312.2	961 Genoa (Genova)	10.0	348.8	860 Barcelona (EAJ1)	8.0
255.1	1,176 Toulouse (PTT)	1.0	318.8	941 Naples (Napoli)	1.5	368.1	315 Seville (EAJ5)	1.5
265.4	1,130 Lille (PTT)	1.3	331.5	905 Milan	7.0	411.5	729 Madrid (EAJ7)	2.0
271.5	1,105 Rennes	1.2	368.1	815 Bolzano	10.0	427.4	703 Madrid (EAJ7)	2.0
285.4	1,051 Montpellier	0.8	441	680 Rome (Roma)	50.0	456.6	557 San Sebastian (EAJ3)	0.6
286.8	1,046 Radio Lyons	10.0	500.8	599 Florence (Firenze)	20.0	<b>SWEDEN</b>		
294.7	1,017.7 Limoges (PTT)	0.5	523.7	570.7 Palermo	3.0	230.6	1,301 Malmö	1.25
304.9	984 Bordeaux (PTT)	13.0	<b>LATVIA</b>					
308.8	971.4 Radio Vitus	1.0	198.5	1,520 Riga (tests)	10.0	257	1,167 Hörby	10.0
also on 43.75 m. (6,865 Kcs.)								
315	050 Marseilles	1.6	525	572 Riga	13.0	305.8	981 Falun	0.5
<b>NORWAY</b>								
and 32.20 m. (9,300 Kcs.)								
<b>LITHUANIA</b>								
1,935 155 Kaunas								
<b>NORTH AFRICA</b>								
363.4 825.3 Algiers (PTT) 10.0								
410 221 Radio Maroc (Rabat) 6.0								
285.5 1,274 Kristiansand 0.5								

## COLVERSTAT VARIABLE RESISTANCES

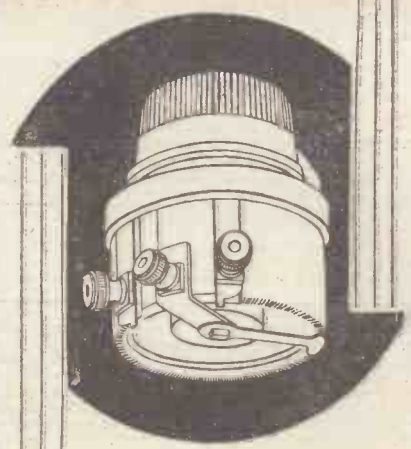

### Type S.T.10

Rating 10 watts.  
Values 500 to 50,000 ohms. 5/6

Specified for the "SIMPLE SUPER"

### Type S.T.5

Rating 5 watts.  
Values 250 to 25,000 ohms. 5/3

### Type M.T.

Rating 3 watts.  
Values 25 to 10,000 ohms. 4/6

Wire wound, smooth in movement, silent in action, constant in setting.  
For all voltage regulation and volume control.

**COLVERN LIMITED**  
MAWNEYS RD., ROMFORD  
ESSEX

### WHEN SUBMITTING QUERIES . . . .

Please write concisely, giving essential particulars. A Fee of One Shilling (postal order), a stamped addressed envelope, and the coupon on the last page must accompany all letters. The following points should be noted:  
Not more than two questions should be sent with any one letter.  
The designing of apparatus or receivers cannot be undertaken.  
Modifications of a straightforward nature can be made to blueprints, but we reserve to ourselves the right to determine the extent of an alteration to come within the scope of a query. Modifications

to proprietary receivers and designs published by contemporary journals cannot be undertaken.  
Readers' sets and components cannot be tested at this office. Readers desiring specific information upon any problem should not ask for it to be published in a forthcoming issue, as only queries of general interest are published and these only at our discretion. Queries cannot be answered by telephone or personally.  
Readers ordering blueprints and requiring technical information in addition, should address a separate letter to the Query Department and conform with the rules.

The first radio-drama from Broadcasting House is expected to be a revival of Rudolph de Cordova's *Dr. Abernethy*, one that was very well liked by listeners on the two occasions on which it was heard last year.

On May 3 the third of the six subscription orchestral concerts will take place in the concert studio of Scottish Broadcasting House. As in the two previous concerts in this series, the second part of the concert will be broadcast.

PREPAID ADVERTISEMENTS

Advertisements under this head are charged THREEPENCE PER WORD, minimum charge THREE SHILLINGS. DEPOSIT SYSTEM. As the publishers cannot accept responsibility for the bona fides of advertisers in this publication, they have introduced a system of deposit which it is recommended should be adopted by readers when dealing with persons with whom they are unacquainted. It is here explained.

Intending purchasers should forward to the Publishers the amount of the purchase money of the article advertised. This will be acknowledged to both the Depositor and the Vendor, whose names and addresses must necessarily be given. The deposit is retained until advice is received of the completion of the purchase, or of the article having been returned to and accepted by the Vendor. In addition to the amount of the deposit, a Fee of 6d. for sums of £1 and under, and 1s. for amounts in excess of £1, to cover postage, etc., must be remitted at the same time. In cases of persons not resident within the United Kingdom, double fees are charged.

The amount of the Deposit and Fee must be remitted by Postal Order or Registered Letter (Cheques cannot be accepted), addressed to, "AMATEUR WIRELESS," ADVERTISEMENT DEPARTMENT, 58/61 FETTER LANE, LONDON, E.C.4

TRANSFORMER STAMPINGS, Instrument Wire, etc. Cheap. Lists free.—Lumen Electric Company, 9 Scarisbrick Avenue, Litherland, Senforth, Lancs.

WIRELESS AS A CAREER.—Those already engaged in the radio industry and those who would like to obtain employment in this interesting profession should write for a copy of our booklet, sent post free without obligation.—Northern Counties Wireless School, 55-57 Guildhall Street, Preston.

ENGINEERS—IMPORTANT NOTICE.—The 19th edition of "Engineering Opportunities" is now ready for distribution. This is not merely a pamphlet, but a 200-page book of unique reference that you cannot well afford to miss. By reading it you will know us, our work, our aims, and how we can alter your entire outlook and earning power, whatever your age or experience. Among other things, the handbook shows the easiest way of preparing for B.Sc., A.M.I.Mech.E., I.E.E., G.P.O., etc. Exams., outlines Modern Home-Study Courses in all branches of Civil, Mech., Elec., Motor, Aero., Radio and "Talkie" Engineering, and explains the unique advantages of our Employment Department. "Engineering Opportunities" has shown the way to better things to over 120,000 of your fellows. Send for your copy to-day—Free and without obligation.—British Institute of Engineering Technology, 100 Shakespeare House, 20-31 Oxford Street, London W.1.

A.W. "SIMPLE SUPER" KITS.—Specified components, £6/5/- Kits for "Mascot 3," "S.T.-300" and "Cosmic 3" £2/4/- each. We quote keenest prices for anything wireless. Old sets taken in part exchange for 1932 models.—Servwell Wireless Supplies, 74 Gough Street, London, E.14.

"UNIVERSAL" RADIO BARGAINS.—R.C. Units, 1/3; 2-mid. Bakelite Condensers, 1/11. Double-reading Voltmeters, 2/11. Dario Valves, 3/11. Power, 4/11. Screen grid, 9/3. Telsen S.T.300 Coils, 7/11 pair. Triotron Power Units, 10/6. Triotron metallised S.G. Valves, 9/3. Ormond Units, small, 5/11; large, 8/11. Baseboard-mounting dual Coils with Switch, 3/11. Thousands of other bargains. All guaranteed, brand new, boxed. Lists free. Callers, book to Rye Lane Station.—"Universal," 20 Victoria Road, Peckham, S.E.15.

SHOPS TO LET in new buildings, centre of Loughborough; main thoroughfare. Attractive proposition to established firms.—Particulars, Echo Press Ltd., Loughborough.

ACCUMULATOR SERVICEMEN.—A Technical Engineering College Course in Battery Charging, studied at home, will guarantee you a successful business. Write for "Prospectus and Guide to Success" from W. S. Ibbetson, B.Sc., A.M.I.E.E., 16 Speenham Road, Stockwell, London, S.W. 9.

OSRAM MUSIC MAGNET THREE. List price £8 5s.; only 39/6.—227 High Road, Lee, S.E.13.

ALUMINIUM Sheet, for home constructors, 3/8 in., 1/8; 3/4 in., 3/- per square foot, carriage paid. Screens and Chassis supplied. Estimates free.—Minns, 19 Woodthorpe Road, King's Heath, Birmingham.

8d. ART COURSES.—"Water Colour Drawing"—"Caricature and Cartoon"—"Lettering"—"Figure Drawing"—"Sketching from Life"—8d. each, post paid.—A. M. Haynes, Imperial Chambers, Dale Street, Liverpool.

REGENTONE ELIMINATOR W4A, £7/10/-; practically new, accept £5.—Grant, 30 Gyppess Avenue, Whitton, Middlesex.

OAK CABINETS, beautifully finished, hinged lid, 14 in. by 7 in. by 10 in., 7/6; 16 in. by 7 in. or 8 in. and 18 in. by 7 in. by 10 in., 8/-; 21 in. by 7 in. 10 in., 9/9; baseboards, 9d. carriage paid. 18 in. by 7 in. by 10 in. "Permol" panel and baseboard, 14/6. Refunded unsatisfied. Other sizes to order, quick dispatch. Telsen 3 cabinet, 7/- Speaker cabinets from 9/-. Front fronts. Baffle boards. Trade supplied.—F. S. Gibson, maker, 99, Burnley Road Ainsdale, Lancs.

1932 SUPER SIXTY KIT, including valves, £5. Marconi-phone eliminator, 250 volts 60 milliamps, 4 variable tapplings, nearly new.—Manley, 30 Market Place, Chalfont-St. Peter, Bucks.

SIMPLE SUPER SPECIFIED KIT, £7; Mascot, 70/6; all kits supplied. Let us quote you.—Clifford Smith, 90 Boundary Road, Wallington, Surrey.

BANKRUPT BARGAINS.—List with 3-valve diagram free. Kits. Century Super, 76/-; Mascot, 45/-; Cosmic, 45/-; S.T.300, 45/-; Straight 3, with cabinet, 32/6. Graham Farish 3, 27/6. All smaller parts cheap. Eliminators, valves, speakers, etc. Second-hand to clear. J.B. chassal-mount, 2-gang, 11/-; Single, 5/6. Pair Varley I.F. coils, 10/-; Lewcos bandpass, 7/-; Part exchange.—Butlin, 143b Preston Road, Brighton.

H.T. ACCUMULATORS CORRECTLY CHARGED by Specialists, also complete H.T. and L.T. Htre Services. Express delivery over wide area.—Aneloy Radio, 36 Hindmans Road, East Dulwich. Phone: New Cross 4074. Charging Contractors to Camberwell Council and Official Oldham Service Station.

YOUR OLD COMPONENTS

are worth money. Sort out the spare radio parts you no longer require and advertise them in the "Miscellaneous Columns" of AMATEUR WIRELESS. You will be surprised how quickly they will be snapped up. Your announcement will cost you 5s. a word. Send your list of parts, together with your name, address and remittance to: "Small Advertisement" Department AMATEUR WIRELESS 58-61, Fetter Lane, London, E.C.

"Amateur Wireless and Radiovision." Price Threepence. Published on Thursdays and bearing the date of Saturday immediately following. Post free to any part of the world: 3 months, 4s. 6d.; 6 months, 8s. 9d.; 12 months, 17s. 6d. Postal Orders, Post Office Orders, or Cheques should be made payable to "Bernard Jones Publications, Ltd."

General Correspondence is to be brief and written on one side of the paper only. All sketches and drawings to be on separate sheets. Contributions are always welcome, will be promptly considered, and if used will be paid for. Communications should be addressed, according to their nature, to The Editor, The Advertisement Manager, or The Publisher, "Amateur Wireless," 58-61 Fetter Lane, London, E.C.4.



Make a Radiogram or Gramophone at quarter price. Order loose kits or sets and assemble them at home, making your own cabinet or box. Get for 3d. our new 64-page catalogue No. 222/1932 with scale drawings and instructions how to make cabinets, gramophones or radiograms, what parts to choose and the lowest prices to pay. We sell motors from 7/6, tone-arms, soundboxes, 1/2, pick-ups, horns, loud-speakers, radio kits, complete receiving sets, gramophones, radiograms and parts. Also accordions, violins and mandolines.—Established 1903.—The Regent Platings Co., A.W., 120 Old Street, London E.C.

Advertisement for Godwinex Non-Corroding Earth Tube. Features: A Good Set or a Good Earth. Godwinex Non-Corroding Earth Tube. Gives consistent round. Heavy lead out prevents corrosion. Perfect earth ton without Over 180 earthing. Earthing all the year coating inside and rosin and gives wire connection sq. ins. surface. J. DYSON & CO. LTD., 567 GODWIN ST BRADFORD, 2, COLEMAN ST LONDON E.C.2

EASY TERMS

WE supply all good quality Radio Receivers, Components and accessories on deferred terms. We carry adequate stocks and can give PROMPT DELIVERY. 12 EXIDE W.H. HIGH-TENSION ACCUMULATORS (120 volts 0.000 m/a). Large capacity type. Cash Price £3 15 0 Or 5/- with order and 10 monthly payments of 7/12. Carriage charged on all orders from Scotland. This is the best and cheapest form of High Tension supply where the electric light mains are not available. Send list of requirements, and quotations will be sent by return. Price list FREE on request.

LONDON RADIO SUPPLY CO., (ESTABLISHED 1925), 11, OAT LANE, NOBLE ST., LONDON, E.C.2 TELEPHONE: National 1977

Advertisement for Picketts Radio-Gram Cabinet. Famous Makers Offer £5 Radio-Gram CABINET for 65/- 7 DAYS' FREE TRIAL (OR 10/- MONTHLY). Polished Oak and Piano built! The acoustic tone brings a fine thrill! Makers to (Radio-Press, B.B.C., 3,000 clients) Other Models 35/- to £15. Photographs and List FREE. PICKETTS Piano-Tone Cabinets, (A.M.) Albion Road, Bexleyheath.

REPAIRS to Blue Spots 5/-, Loudspeakers, Head-phones and Transformers 4/- each. Mains and Eliminators quoted for. Prompt Service. 12 months' guarantee. Trade invited. Loud-speaker Repair Co., 2 SHIPKA ROAD, Balham, London

FULL-SIZE BLUEPRINTS

When ordering, please send Postal Order, NOT STAMPS:

Table listing various radio components and sets with prices. Includes sections for Crystal Set (6d.), One-Valve Set (1s.), Two-Valve Sets (1s. each), Three-Valve Sets (1s. each), and Four-Valve Sets (1s. 6d. each). Lists items like '20-shilling Two (D, Trans)', 'The Room-to-Room 2 (D, Trans)', 'Square Peak Three (SG, D, Trans)', etc.

Amateur Wireless INFORMATION BUREAU COUPON Available until Saturday MAY 7, 1932 FEE 1/-

**PIFCO**  
**ALL IN ONE**  
**RADIOMETER**

**TESTS EVERYTHING**

VALVE TESTS  
 COMPONENT TESTS  
 CIRCUIT TESTS  
 M.T. TEST • H.T. TEST  
 TOTAL DISCHARGE from BATTERY  
 10 WAMPS DISCHARGE ON ONE TAPPING

*The Sherlock Holmes of your Radio*

**12/6**

Solve any radio problem with the Pifco "All-in-One" Radiometer. This marvellous instrument will locate any fault in a few minutes. As essential to the radio user as

a stethoscope is to the doctor. Saves its first cost over and over again. Patented throughout the world, there is no other instrument like it. Simple to use and efficient.

Standard Model for Battery Receivers. Handsomely finished in octagonal bakelite case, complete with leads. Price **12/6**

De Luxe Model 125,000 ohms Resistance, for Electric Receivers, Mains Units, and Battery-operated Sets. In maroon bakelite case complete with cables. Price **£2.2.0**

Ask to see the "All-in-One" Radiometer at your radio or electrical dealer. Leaflet on request from Patentees:—Pifco Ltd., High Street, Manchester. © S.I.

# 2 VOLT MAZDA MASTERPIECES

## REDUCED PRICES

H.210	-	-	7/0
HL.210	-	-	7/0
*HL.2	-	-	7/0
*L.2	-	-	7/0
P.220	-	-	8/9
P.220A	-	-	12/0
P.240	-	-	12/0
PEN.230	-	-	17/6
PEN.220	-	-	17/6
PEN.220A	-	-	17/6
S.G.215	-	-	16/6
*S.215A	-	-	16/6
*S.215B	-	-	16/6

\* METALLISED



LOOK FOR  
"EDDY"  
IN YOUR  
DEALERS'  
WINDOW



Never in the history of 2-volt valves, has there been such an amazing range as this—so much evidence of brilliant engineering—so many valves with outstanding characteristics. Instance the Pen.220; a pentode valve which at once presents the solution to the output stage problem in portable sets, giving an extraordinary large output for a combined screen and anode current of under 5 m.A. It is a valve for which dry-battery users have long waited.

Being typical of all Mazda valves, it is outstanding in its efficiency. Mazda 2-volt valves, both metallised and clear bulb types, are sold by all good radio dealers. Mazda valves are 100 per cent. British made and designed by British engineers.

THE AMAZING

# MAZDA THE BRITISH VALVES

## MAZDA PEN. 220

### Characteristics:

Filament Voltage - 2.0 volts    Anode Current (Max) - 12 mA  
 Filament Current - 0.2 amps    Screen Voltage (Max) - 150 volts  
 Anode Voltage (Max) - 150 volts    Mutual Conductance - 2.5 mA/V  
 At  $E_a = 100$ ;  $E_s = 100$ ;  $E_g = 0$ .

PRICE 17/6

The Edison Swan Electric Co. Ltd.



155 Charing Cross Road, London, W.C.2

V135