

**OUR "HOT" SET**

**FULL-SIZE  
LAYOUT  
-PLAN-  
IN THIS ISSUE**

# Amateur Wireless

and  
Radiovision

Every  
Thursday

3<sup>d</sup>

Vol. XVIII. No. 463

Saturday, April 25, 1931

**The CENTURY  
SUPER**

THE WORLD'S  
BEST CONSTRUCTOR  
SET *by* W. JAMES



**EASILY GETS  
SCORES OF  
STATIONS,  
EVERY ONE  
CLEAR-CUT**

**Build This Super Set at Low Cost**

# RANGE THE WORLD



## with The

# LEWCOS

(Regd)

**T**HIS new LEWCOS achievement—the Super-het Coil Kit—which has a nine-kilocycle wave-band separation and consists of one Oscillator Coil, two I.F. Coils “with pigtails,” and one I.F. Coil without marks a new epoch in radio reception. The I.F. Transformers are accurately matched, thus giving a remarkable degree of efficiency.

This Kit, which is specified for the “Century Super,” can also be fitted with extraordinary ease in any set of similar design and the results will be truly astounding!

The small space available is completely inadequate to give even a short description of these wonderful new LEWCOS Coils, and you are invited to write for an illustrated explanatory leaflet.



## SUPER-HET COIL KIT

which is recommended  
for the  
“CENTURY SUPER”  
receiver described  
in this issue.

Price 50/-

BRITISH THROUGHOUT

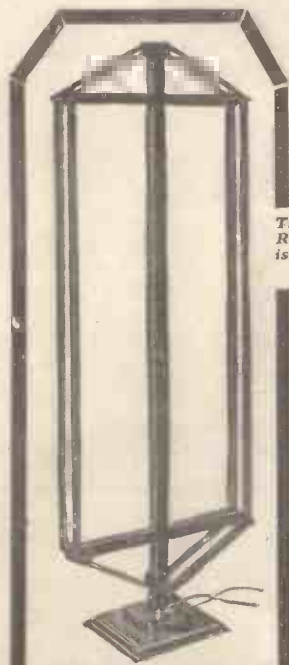

This is a photograph of the LEWCOS Dual Range Centre-Tapped Frame Aerial which is specified for the “Century Super.”

PRICE 32/6

Two LEWCOS “Spaghetti Resistances” of 1,000 ohms each

PRICE 9d. each  
are specified for the  
“Century Super”

A COMPLETE KIT OF PARTS FOR THE “CENTURY SUPER,” WHICH INCLUDES THE LEWCOS SUPER-HET COIL KIT AND THE FRAME AERIAL, CAN BE OBTAINED FROM

MESSRS. READY RADIO LIMITED  
AND THE  
H. & B. RADIO COMPANY

—See separate advertisements in this issue—



### LEWCOS RADIO PRODUCTS FOR BETTER RECEPTION

THE LONDON ELECTRIC WIRE COMPANY AND SMITHS LIMITED, CHURCH ROAD, LEYTON, LONDON, E.15

To Ensure Speedy Delivery, Mention “A.W.” to Advertisers.



for every MODERN CIRCUIT

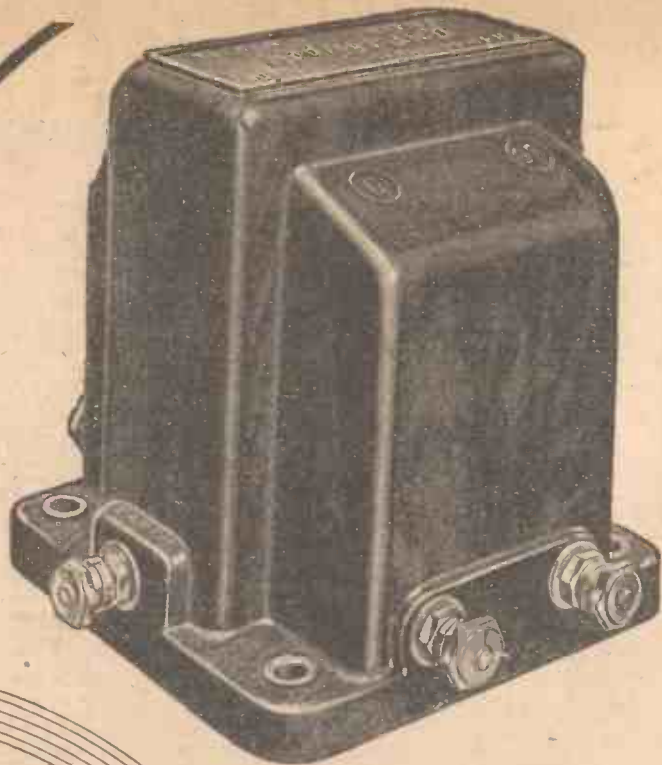

**TELSEN L.F. TRANSFORMERS**  
 "ACE" - Ratios 3-1 & 5-1 8/8  
 "RADIOGRAND" - 3-1 & 5-1 12/8  
 "RADIOGRAND" - Super Ratio 7-1 17/8



**Telsen H.F. Chokes.** Designed to cover the whole waveband range from 18 to 4,000 metres, extremely low self capacity, shrouded in genuine bakelite. Inductance, 150,000 microhenries; resistance, 400 ohms. Price 2/6 each.

Yet another tribute to TELSEN Components—The 'Century Super' designed by Mr. W. James and described in this issue specifies a TELSEN Transformer and TELSEN Four-Pin Valve holders . . . Radio enthusiasts—expert and amateur—make sure of as many fixed points of infallible efficiency as possible—they insist on TELSEN Components



**Telsen Grid Leaks.** Absolutely silent and non-microphonic, practically unbreakable, cannot be burnt out, and are unaffected by atmospheric changes. Not being wire wound, there are no capacity effects. Made in capacities: 1, 1, 1, 2, 3, 4, and 5 megohms. Price 1/- ea.



**TELSEN FIVE-PIN VALVE HOLDERS.** Price 1/3 each.



**TELSEN FOUR-PIN VALVE HOLDERS**  
 Price 1/- each.

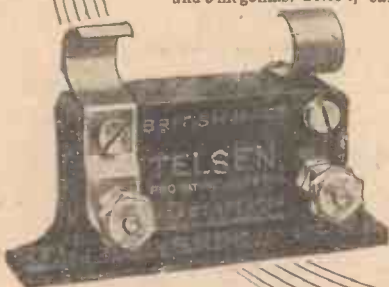

**Telsen Fixed (Mica) Condensers.** Shrouded in genuine bakelite, made in capacities up to .002 mfd. Pro. Pat. No. 20287/30. .0003 supplied complete with patent grid-leak clips to facilitate series or parallel connection. Can be mounted upright or flat. Tested on 500 volts. Price 1/- each.

**TELSEN**  
**COMPONENTS**

Adv. of Telsen Electric Co., Ltd., Birmingham

Please Mention "A.W." When Corresponding with Advertisers

CY8-RA

# MOTOR UNITS • CHASSIS • SPEAKERS



### Type S4. Isophon - MOTOR Super Power Unit

A 4-pole balanced armature Super Power Unit which represents the very highest achievement in Loud-speaker perfection. The quality of reproduction and wealth of volume are exceptional. High notes are brilliantly clear, and bass notes richly emphasised. The very powerful field-magnet has a pull of approximately 10 lb., making the unit sensitive to the slightest impulse, yet capable of handling an amazing top load power without rattle or distortion. Provided with alternative resistances to suit various output valves.

PRICE 27/6

### Type S5. Super Unit

An extremely efficient Unit, compact in size but generously large in power. Faithfulness and purity of reproduction are combined with a richness of tone which is equally prominent on both high and low notes. Handles an output up to 3 watts.

22/6



### 'MOTOR' Type 1 LOUD-SPEAKER 'DYNOLA'

A handsome cabinet speaker of highly polished walnut, fitted with the new Isophon-MOTOR Super Unit, Type S5. The modern fret design is backed with figured gold silk gauze, and the performance of this desirable Speaker is in keeping with its beautiful appearance. Size of Cabinet, 14 x 12 1/2 x 6 in.

45/-

The range of MOTOR Cabinet Speakers and Chassis caters for every individual need. If any difficulty in seeing and hearing them locally, send us the name of your nearest dealer.

Northern Distributors:

L. KREMNER LTD., 49a Shudehill, Manchester.  
HARDMAN & Co. Ltd., The Baum, Yorkshire St., Rochdale;  
61 Bridge St., Manchester; 25 Trinity St., Leeds; and 2a Leach Lane, St. Annes-on-Sea.

## TEKADE RADIO & ELECTRIC LTD.

29 Farringdon St., London, E.C.4. Telephone: Cent. 2482

Agent for Scotland: R. G. J. Nisbet, 132 Renfrew Street, Glasgow, C.2.

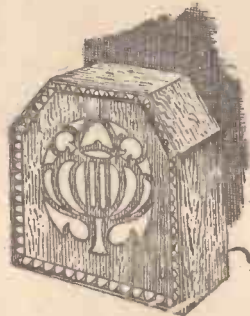

Everybody's  
calling for

*Player's  
Please*



### NOTICE

## BECOL LOW LOSS EBONITE FORMERS



ARE  
**RELIABLE**  
Tested before despatch  
PANELS, RODS,  
TUBES

12 SIZES

LOOK FOR TRADE-MARK BRITISH MADE

Sole Makers—

**THE BRITISH EBONITE CO., LTD.**  
HANWELL, LONDON, W.7

### THE "A.W." CONDENSER

THE WORLD'S FINEST  
DIFFERENTIAL CONDENSER

(used in building the best Sets) is now available at your dealers. To use any condenser but the A.W. is to be old-fashioned.

Prices :

.00015 - - 3/-  
.0003 - - 3/6  
.0005 - - 3/9

Your Dealer stocks A.W. Condensers

Sole Distributors :

**G. ROBINSON & SON, LTD.**

River Plate House, South Place, London, E.C.2

Telephone : Metropolitan 5886-7-8





# H & B GUARANTEED KITS

## The "CENTURY SUPER"

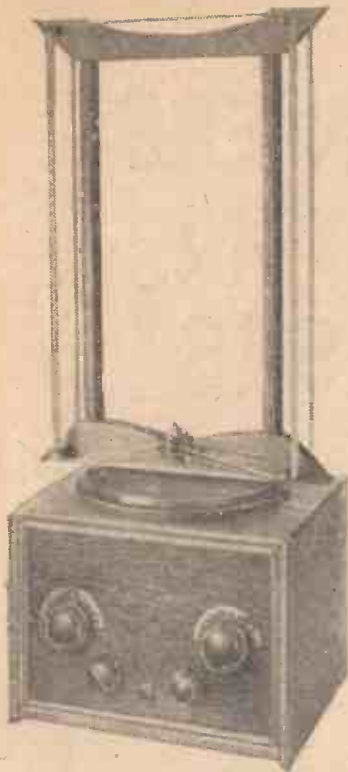

### H & B CABINET

In OAK with Polished Oak Panel and Baseboard - - **15/-**  
Hand Polished Mahogany £1.3.6

### H & B DUAL RANGE FRAME AERIAL

Complete with Turntable, Rubber flex, three plugs and three ebonite spacers **20/-**

### H & B DUAL RANGE FRAME AERIAL

fitted with **WAVE-CHANGE SWITCH**  
Complete as illustrated above. The switch gives immediate change-over without having to disconnect any leads - - - **25/6**

**TERMS:** Carriage Paid on all Cash Orders. C.O.D. charges paid on orders over £1.

**TRADE SUPPLIED**

### H & B GUARANTEED STANDARD KIT

	£	s.	d.
2 .0005 variable condensers with slow motion (J.B. "Tiny")	17	0	
1 50,000 ohm wire wound Potentiometer (Colvern)	5	6	
1 Three point shorting switch (W.B.)	1	3	
1 Set of 4 superhet coils (Lewcos or Wearite)	2	10	0
6 Valve holders (Telsen)	6	0	
1 Triple coil base (H. & B.)	2	0	
5 1 mfd. fixed condensers (Dubilier)	12	6	
2 .001 fixed condensers (T.C.C.)	3	8	
1 .0002 fixed condenser (Formo)	6		
1 Grid leak holder (Lissen)	6		
1 1 meg. grid leak (Telsen)	1	0	
1 L.F. transformer (Telsen "Ace")	8	6	
1 Terminal strip with three terminals for baseboard mounting (H. & B.)	8		
1 15,000 and one 20,000 Spaghetti resistance (Lewcos)	3	0	
1 Fuse holder and fuse (Bulgin)	1	3	
5 Yards of thin flex (Lewcos)	7		
6 Wander plugs, engraved (Belling Lee)	1	0	
2 Spade terminals, engraved (Belling Lee)	8		
Connecting wire and sleeving (H. & B.)	1	3	

CASH PRICE **£5-16-10**

### H & B GUARANTEED SPECIAL KIT

	£	s.	d.
2 Variable condensers .0005 with slow motion (Polar "Ideal")	1	5	0
1 Potentiometer, wire wound (Electrad)	6	0	
1 Three point shorting switch (W.B.)	1	3	
1 Set of 4 superheterodyne coils (Lewcos)	2	10	0
6 Valve holders (W.B.)	6	0	
1 Triple coil base (H. & B.)	2	0	
5 1 mfd. fixed condensers (Dubilier)	12	6	
2 .001 mfd. fixed condensers (T.C.C.)	3	8	
1 .0002 mfd. fixed condenser (Formo)	6		
1 Grid leak holder (Dubilier)	1	0	
1 1 meg. grid leak (Dubilier)	1	8	
1 L.F. transformer (Lewcos)	17	6	
1 Terminal strip with three terminals (H. & B.)	8		
1 15,000 Spaghetti resistance (Lewcos)	1	6	
1 20,000 Spaghetti resistance (Lewcos)	1	6	
1 Fuse holder and fuse (Bulgin)	1	3	
5 Yards of Lewcoflex	7		
6 Engraved wander plugs (Belling Lee)	1	0	
2 Spade ends (Belling Lee)	8		
Connecting wire and sleeving (H. & B.)	1	3	

CASH PRICE **£6-15-6**

MARVELLOUS VALUE. 100% EFFICIENCY. SIMPLE TO BUILD. ONLY TWO TUNING CONTROLS. NO OUT-DOOR AERIAL OR EARTH NEEDED. NUMEROUS STATIONS GUARANTEED WHEN USING THE H & B DUAL RANGE FRAME AERIAL.

To meet the request of many of our clients we quote for "Special" Kit as an alternative to our "Standard" Kit. Both are guaranteed.

#### RECOMMENDED ACCESSORIES

2 Siemens Double Capacity 60-volt H.T. Batteries	27/-
1 Siemens 9-volt Grid Bias Battery	1/6
1 Exide 2-volt 100 amp Accumulator	14/6
1 Ormond Loudspeaker in Cabinet	27/6
6 Mullard Valves (as specified)	£3 16 0

LEWCOS C/T Frame Aerials in Stock £1 - 12 - 6

SUPPLIES OF KITS ARE PACKED READY FOR IMMEDIATE DISPATCH. NO DELAY THE H. & B. WAY

## H & B RADIO CO.,

34, 36, 38 BEAK STREET, REGENT STREET, LONDON, W.1

Telephone: Gerrard 2834

You will Help Yourself and Help Us by Mentioning "A.W." to Advertisers

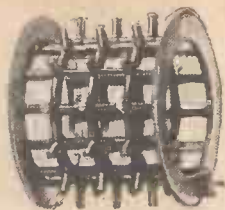

One of the unique moulded skeleton coil formers



The secondary coil, shewing the air-spaced sectionalised low capacity windings



Beautifully made and ready for the case.



The finished Product.

# IF TRANSFORMERS WERE SOLD IN GLASS CASES!

A smartly-finished transformer case may cover a multitude of sins, and form a hiding place for scrap metal, poor wire, cardboard, string and pitch. Such transformers sell on outward appearance, Press "boosting" and low price, but how can one expect even a moderately good performance?

If transformers were sold in glass cases! Even to see the internal structure of a Ferranti transformer, with its skeleton formers, its air spaced sectionalised windings, and unmistakable precision workmanship, is to realise that there are many reasons for its world-wide reputation and great superiority.

Meanwhile the curve is the measure of a transformer's performance, and a study of published curves will lead ultimately to the choice of a Ferranti—the transformer with a pedigree and unrivalled performance.

Ratio	Ratio	Ratio
AF3. 1 to 3½-25¢	AF4. 1 to 3½-17'6	AF5. 1 to 3½-30¢
AF6. 1 to 7-30¢	AF7. 1 to 1¾-30¢	AF8. 1 to 3½ 11'6

FERRANTI LTD.,  
 Head Office and Works:  
 Hollinwood, Lancashire.  
 London:  
 Eush House, Aldwych, W.C.2.

# FERRANTI





# By test -

## THE CHEAPEST AND LONGEST LASTING POWER FOR YOUR PORTABLE

If you own a Portable, you cannot do better—for your Portable or your pocket—than power it with the Ever Ready battery made specially for it. Not only is every Ever Ready Battery more powerful over a longer period than any ordinary battery; it is actually cheaper to use! The cost of Ever Ready power per hour has been established to the fraction of a penny by a series of experiments in the Ever Ready Laboratories.

The result of these tests has demonstrated beyond every possibility of doubt the fact that an Ever Ready battery in a Portable Set provides power at a lower cost than that of any other battery!

Start to-day to enjoy cheaper, longer lasting Ever Ready power in your Portable. Write for the free Ever Ready guide to purchasers of batteries. In it, you will find listed every kind of set, with the correct size and type of Ever Ready battery to power it most effectively and at the least possible cost. The list is free—from the address below, or from any Dealer.

THE EVER READY CO.,  
(Great Britain) Limited,  
HERCULES PLACE  
Holloway, London, N.7



THE BATTERY  
THAT GIVES  
UNWAVERING  
POWER . . .

Don't Forget to Say That You Saw it in "A.W."

Simple facts for  
Valve Users No. 2.

# Why Cossor Valves never vary in performance

**T**HE performance of a valve is largely determined by the spacing of its grid wires, the distances between the filament and the grid and between the grid and the anode. Any variation in these distances—will alter the characteristics of the valve.

The Cossor Insulated Bridge System of construction entirely eliminates the human element in assembly. These distances are automatically fixed by means of holes in the insulated bridge piece and by the use of precision instruments which space the upright supports with microscopic exactitude. Any variation is utterly impossible. The elements are locked in position in perfect alignment—there can be no individual movement even under the heaviest impact. Remember uniformity in manufacture means uniformity in results. For the finest performance, therefore, under all conditions, you will be wise to select Cossor Valves. There is a full range of types to choose from at every good Wireless Shop.

Over 50 types of Cossor Valves are available from any Wireless Shop to suit all 2, 4, and 6 volt Battery operated and A.C. Mains Receivers.

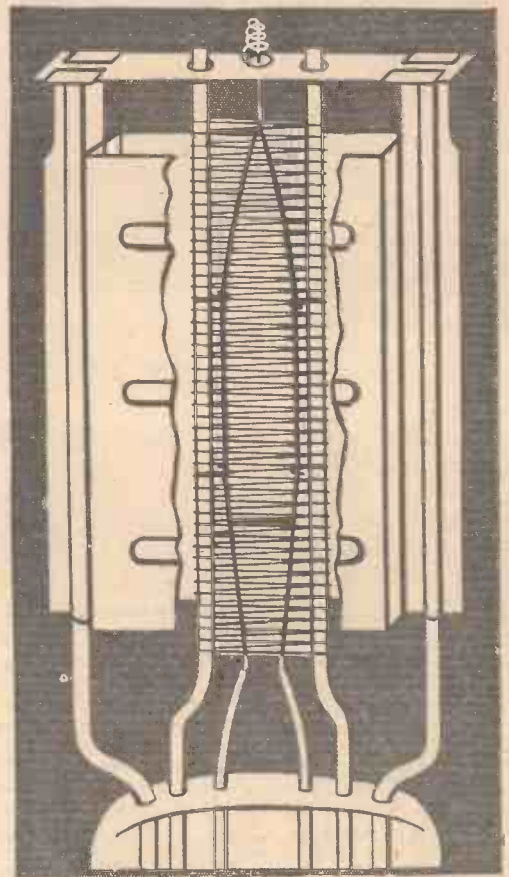

# COSSOR

A. C. Cossor Ltd., Highbury Grove, London, N.5

♥ 8226

*You Will Help Yourself and Help Us by Mentioning "A.W." to Advertisers*





# Amateur Wireless

and  
Radiovision



EDITOR:  
BERNARD E. JONES.

TECHNICAL EDITOR:  
J.H. REYNER, B.Sc., A.M.I.E.E.

RESEARCH CONSULTANT:  
W. JAMES.

ASSISTANT EDITOR:  
H. CORBISHLEY.

THE LEADING RADIO WEEKLY FOR THE  
CONSTRUCTOR, LISTENER & EXPERIMENTER.

## NEWS · & · GOSSIP · OF THE · WEEK

### HERE'S THE CENTURY!

WE have introduced the "Century Super" to you, and in this issue you will find full details of this very latest and best set: a "super" set, and, more technically speaking, a super-het. It is a hundred-station set which can bring in a hundred stations, all on the speaker, each quite clear of the others. No other type of set than a super-het can do this, and the "Century Super" is *guaranteed* to do it. Full-size constructional plans are included in this issue.

### PLAYS WITHOUT WORDS!

ONE of the Continental stations is making arrangements for the broad-

casting of radio plays where the action will rely entirely on sound effects—no words at all being spoken! This new departure in radio drama technique is being awaited with interest by broadcasting authorities all over the world. It's an idea that might be commended to the B.B.C. as an antidote to too much talk! Anyway, it would give "Effects" something to think about.

### ABOUT MOORSIDE EDGE

THE policy behind the North Regional station is already being discussed by the B.B.C. An official told our correspondent, "When the second wavelength is brought into operation the Regional wavelength will develop distinctively and

### PRINCIPAL CONTENTS

	PAGE
News and Gossip ... ..	659
Why You Should Build the "Century Super" ... ..	660
My Aims for North Regional Programmes ... ..	661
Power Valve Points ... ..	662
How to Receive America ... ..	663
Cheap Aids to Selectivity ... ..	664
On Your Wavelength ... ..	667
We Visit Moorside Edge ... ..	669
Without Fear or Favour ... ..	671
The "Century Super" ... ..	672
In My Wireless Den ... ..	676
The Kolster-Brandes A.C. Pup ... ..	680
We Test for You ... ..	678
Some Short-wave Hints ... ..	682
Readers' Ideas and Questions ... ..	684
Radiograms ... ..	688
Broadcast Telephony ... ..	689

## WHERE THE WAVES START



B. B.C. officials and some visitors discussing the North Regional Station inside the transmitter hall. One of the twin control desks is in the foreground, and the panels of one of the transmitters are at the right

in contrast to the transmission of the National wavelength. The North Region comprises the principal industrial centres of England, several of the largest ports and five universities. It has several famous orchestral societies and many choirs and bands. In general, the wealth of programme material which has already been drawn upon as a result of the grouping of the present eight local transmitters during the past two years and a half will find more adequate expression through the new high-power twin-wave transmitter." Let's hope this is good news for the North.

### THESE WOMEN'S HOURS

MISS ISHBEL MACDONALD opens the new session's morning broadcasts to women on May 4. Household affairs, jam-making, the canning of fruit at home, fruit and vegetable bottling, meals for special occasions and meals in the summer are among the topics which will be discussed during the session. Many other aspects of women's interests will be dealt with.

### IN IRELAND

SINCE John Watt was transferred from Belfast, the Ulster station has been without a regular producer. Now a new

**NEXT WEEK: MORE ABOUT THE AMAZING "CENTURY SUPER"**



## NEWS &amp; GOSSIP OF THE WEEK —Continued

permanent producer has been appointed to the B.B.C.'s Northern Ireland staff. He is Sam Bulloch, who is already very well-known as a producer and actor. Mr. Bulloch has a wide knowledge of the Irish drama and a reputation as a producer of Shakespeare. He will form the third of a brilliant triumvirate who have helped to place the Belfast station in the front rank for broadcast productions the first two being Tyrone Guthrie, now director of productions to the largest broadcasting system in Canada, and John Watt, now on the production staff at Savoy Hill.

THE SET YOU HAVE BEEN WAITING FOR—"THE CENTURY SUPER"

## ANOTHER "COMMAND" BROADCAST

IT is good news that a broadcast has been arranged of the Royal Command Performance at the London Palladium in aid of the Variety Artists' Benevolent Fund and Institution on May 11. The greater part of the programme will be relayed in the National programme and listeners will also hear the comments of the "Buggins family" (Mabel Constanduros and Michael Hogan) who will be watching a Command Performance for the first time.

## THESE O.B.'S

HOW long will it be before the quarrel dies down between the B.B.C. and various authorities at centres where sports outside broadcasts are made? The football people still have a notion that when a match is broadcast, the number of people who actually go to watch decreases. One would have thought that after the fair number of O.B.'s of this kind which have been made, all clubs would fall in line.

But apparently listeners must lose their football commentaries because the League blames the B.B.C. for reduced gate-money.

## THE FIGURES

THERE is no room for two opinions on this gate-money question. Nor is there any guesswork, for all the figures are given by the B.B.C. in the *Radio Times*. It is unnecessary for them to be given here, because they interest the B.B.C. and the F.A. more than listeners; but they do show the fallacy of stopping broadcast commentaries if and when the gate money drops.

## ANOTHER RIDGEWAY "FIND"

THE Ridgeway Parades are going from strength to strength, and when I dropped in at one of the rehearsals of a forthcoming Parade yesterday," (writes our B.B.C. Correspondent), "I learned that Ridgeway, having 'found' Babs Farren, has not yet stopped looking for new talent. He has recently discovered Beatrice Galleway, a radio 'star,' who sings and dances in the new radio performances.

## MIND THE SWANS!

AN Edinburgh man was listening in the other day when something went wrong with his set. He investigated, and found that the aerial had been damaged. Lying close by was an injured swan, which had evidently come to grief through striking the aerial.

## BOMBAY SHORT-WAVE TAKES NEW WAVELENGTH

SO successful has been the wavelength (31.28 metres) used by PCJ, the famous short-wave station, that several stations are endeavouring to get the use of wavelengths near it. Bombay has recently relinquished its wavelength of 49 metres and is now working on 31.1 metres. As regular short-wave listeners know, PCJ in Holland is always a reliable station, and owing to "skip" effect is often better in some parts than our own G5SW.



Here is an important link between Brookman's Park and the new Broadcasting House in Portland Place. Over 400 wires connecting the studios with the transmitter are covered by these conduits

## A TRAVELLING "MIKE"

IN Germany as in other countries, it is sometimes difficult to get prominent people before the microphone. To surmount this difficulty, the German broadcasting authorities send an interviewer with a microphone. Connection to the transmitter is made over the phone. Many interesting broadcasts have been made in this way.

## WHY YOU SHOULD BUILD THE "CENTURY SUPER"

WE could advance a multitude of reasons why a very great number of AMATEUR WIRELESS readers should build the "Century Super," but there are four outstanding reasons that occur to us in writing this foreword on W. James' new set, fully described and illustrated by the designer on pages 672 to 674.

Firstly, for such a remarkable performer, the "Century Super" is absurdly cheap. Complete with coils, frame aerial, and cabinet, but without valves, the "Century Super" costs less than £7 10s. We emphasise this low cost because we want to make it quite clear that a modern set—a multi-valver—can be designed and built at a price within the reach of the amateur set-builder.

Secondly, we should like to emphasise the extremely simple layout of the "Century Super," implying an ease of construction that will appeal to every reader. The use of valve holders for the coils greatly simplifies the baseboard layout and the special design of the coils obviates all complicated screening. Every reader can tackle with confidence the assembly of a "Century Super" from the instructions given in this and succeeding issues.

Thirdly, the operation of the "Century Super" is delightfully simple. In spite of the very high degree of selectivity, the rotation of the two tuning dials is certainly not critical. Nor do both dials have to be rotated simultaneously. First, the oscillator condenser dial

is turned a degree and then the frame condenser dial is likewise moved until the station on the adjacent frequency channel is heard.

There is an admirable control of volume, for a knob on the panel operates a potentiometer connected to the two screen-grid valves in such a way that it provides a wide adjustment in the sensitivity of these two valves. The adaptability of the tuning coils—they can be used on the ultra-short, medium, and long waves—greatly enlarges the appeal and scope of the set.

Fourthly, and this is really the most important reason of all, the performance of the "Century Super" is in a category by itself. No set so far described in this or any wireless journal can definitely log 100 stations with such certainty, with such volume, and with such ease of operation. It is an amazing aspect of the "Century Super" that when one has tuned out, say, the London Regional, the next station, namely, Muhlacker, is tuned in almost as loudly and, of course, quite clear of interference.

From our tests of the "Century Super," we know every reader who builds this set can be sure of at least fifty stations and we feel safe in saying that many enthusiastic readers will quickly compile a log of a century. We stress the fact that a high percentage of the stations actually logged on the "Century Super" are worth listening to. That is to say a good proportion of the stations logged in our tests of this set are programme alternatives to the local.



# MY AIMS *for* NORTH REGIONAL PROGRAMMES

MR. EDWARD LIVEING, the North Regional Director, explains his plans for the North Regional transmissions



An exclusive interview

"WILL you please give me a thumbnail sketch of your plans for making North Regional transmissions on 479 metres typical of the tastes and sentiments of your region?" That was my first question to Mr. Liveing, whose enthusiasm is unbounded and who is not dismayed by the great responsibilities that the starting up of Moorside Edge has entailed.

"First of all," said Mr. Liveing, "I think that by this development we have at last a real opportunity for the North to express itself in the programmes.

"Remember, too, that these programmes are to be put out on a wavelength and power that will ensure a very considerable radius of reception. In the Brookmans Park area a programme has been developed that is, one might say, an aesthetic contrast to the National programme. A somewhat similar condition applies to the Midland service. But in the North the B.B.C. will be able to bring out something more geographically distinctive in character. In other words a programme of truly regional interest."

### Programme Resources

I put another question. "We hear a good deal, Mr. Liveing, of the great and largely untapped programme resources of the North. Will you tell me more about these resources?"

"Well, for a start, we have many big universities in the region, such as Durham, Manchester, Leeds, Sheffield, and Liverpool. These and one or two prominent colleges provide that background of a northern culture and much programme matter can be drawn from them.

"Then we have the Hallé Orchestra, the Liverpool Philharmonic and the Leeds Symphony, three first-rate sources of orchestral broadcasting. And you must not overlook our choral societies. I have no wish to single out any one in particular, but I have in mind the West Riding group, notably the Sheffield Choral Union and the Huddersfield Choral Union, for whose excellent work we have to thank Sir Henry Coward, and the fine choral societies of Leeds.

"Perhaps you do not realise that these West Riding choral societies are very well known all over the continent of Europe. They have, in fact, been justifiably compared with the best Russian choral combinations.

"Brass bands are, of course, a strong feature of Northern music. As you know,

we have the Besses o' the Barn, the Irwell Springs and numerous other excellent bands to draw upon.

"You may take it also that the religious life of the region covered by Moorside Edge is very well developed. We can draw upon the Minster of York and the Cathedrals of Chester, Durham, Ripon, and Carlisle. Many other places of worship are also wired for broadcasting."

### Sports Broadcasts

I asked how the North would be represented in the sporting line.

"We shall do a good deal of commenting in connection with Lancashire and Yorkshire cricket during the coming season. The T.T. cycle race at the Isle of Man will be another fixture. Tennis tournaments may be the subject of broadcast commentaries, particularly those at Scarborough, Manchester and Liverpool."

When one recalls the resources of Blackpool, the Palace Theatre and the Tower Ballroom for examples, it is easy to see that North Regional will have no lack of "O.B." material. So much for the detailed programme aspects of my interview. We then talked of more general topics.

"When you are considering the development of the North Region as an area of broadcast individuality, please remember that within the area covered by Moorside Edge is a very considerable population. It may surprise your readers when I say that North of England covers a population one-and-a-half times that of Canada!"

### The Manchester Headquarters

Here Mr. Liveing sketched the distribution of the organisation for the North Regional wavelength. The heart of things is Broadcasting House, at Piccadilly, Man-

chester, but this central point is wired to sub-offices at Leeds and Newcastle. And, of course, cables go out from Broadcasting House, Manchester, to Moorside Edge and to London.

Although the low-power transmitters in some of the northern cities at present possessing them will not be needed when North Regional takes over the full twin programme service, these localities will, in the near future, provide far more broadcast material than has yet been possible. This point needs stressing, for the closing down of the low-power outlets actually means more programme representation for the new and old areas.

### Contrasting Programmes

I discussed with Mr. Liveing the question of Newcastle's wavelength. At present it is a National programme relay on 288 metres, but under the regional scheme it will be a source of regional radiation. Those in the Tyneside area who listened to the National programme from Newcastle will still be able to hear this programme either from the long-wave Daventry station or from Moorside Edge on 301 metres.

As Newcastle is on the border line of the service range of Moorside Edge, the Newcastle station will not be closed down, but may act as a miniature Moorside Edge, and probably it will transmit on the 479-metre North Regional wavelength. I understand that B.B.C. engineers are experimenting on these lines at the present time.

Before leaving Mr. Liveing, I asked him what relation the Regional programme on 479 metres, made up largely of Northern talent, would bear to the National programme on 301 metres, arranged at London.

"As far as possible our Regional programme, although reflecting the character of the region, will be built up quite definitely to contrast with the National programme. Of course, there will be some difficulties in dove-tailing the two programmes to provide this contrast, but after all, that is part of our job!"

On April 27 the Vienna station will broadcast a special concert in which Lotte Lehmann and Alfred Piccaver are taking part.

On May 8, France will celebrate the Joan of Arc fête at Orleans, and the official ceremony with the special musical broadcasts will be relayed to Paris PTT, Eiffel Tower, and other provincial transmitters.

**NEXT WEEK: FOR CENTURY SUPER BUILDERS—A LARGE SCALE CONSTRUCTOR'S GUIDE GIVING A WEALTH OF INFORMATION ON THIS NEW SET**



**THE HOW AND WHY OF RADIO**

**XXXIII—POWER VALVE POINTS**

*If you are a beginner in wireless, now is your chance to gain a clear conception of its theory and practice. In this series of articles, specially prepared for the beginner, no previous knowledge of wireless is assumed. It is intended to deal with every aspect of the subject and the whole series will endow the beginner with sufficient knowledge to enable him to derive the greatest possible interest from the fascinating hobby of wireless*

**M**OST beginners at wireless soon learn how great a bearing the power valve has upon the volume and quality of the reproduction from the loud-speaker. Probably few start off with a clear idea of the meaning of the various facts given on the slip of paper packed in the valve carton.



A typical power valve

We will take as an example the P2 power valve. Firstly, the filament voltage is stated to be 2 volts and the filament current .2 ampere. The amount of current that will flow through the filament at 2 volts depends entirely upon the resistance of the filament. The resistance of the filament will depend upon its thickness. The thicker the filament the more copious is the electron stream. So, for a power valve capable of considerable power output we must

obviously use a thick filament and this entails a fairly big filament current.

To increase the electron emission we not only thicken the filament but lengthen it. The longer the filament the greater the voltage dropped across its ends. For this reason a big power valve usually has a 6-volt filament.

One of the most important facts about a power valve is its impedance, that is to say its A.C. resistance. This is measured in ohms and varies from 5,000 to 1,000 ohms, according to the type of power valve. The impedance of the valve determines the value of the anode current at any particular anode voltage. That is to say, the flow of electrons from the filament to the anode is greater with a low-impedance valve than with a high-impedance valve. The greater the anode current the greater is the power output of the valve and for this reason large-power valves always have low impedances.

**Amplification Factor**

The amplification factor of a power valve is not of primary importance, except in sets needing some extra signal boosting at the output stage. By dividing the amplification factor by the impedance in ohms and multiplying the answer by 1,000 we obtain a figure known as the mutual conductance of the valve. For a given amplification factor it follows that the lower the impedance the greater will be the mutual

conductance. As this factor is the measure of the valve's efficiency we choose the valve with the lowest impedance for any given amplification factor requirement.

As a matter of fact, the mutual conductance of power valves is not so essential as in other types of valves. For with power valves the main function to be watched is the power-handling ability. Sometimes a big valve is rated by its watts dissipation. This is rather misleading, since it does not represent the power handed on to the loud-speaker. It is merely the equivalent in electrical energy of the heat radiated at the anode. This anode dissipation in watts can be found by multiplying the anode voltage by the anode current and dividing by 1,000.

The P2 valve just mentioned has an anode dissipation of about 2.6 watts, for its anode current is 17 milliamperes with 150 volts on the anode. Now the undistorted A.C. power output of this valve is about 300 milliwatts, or little more than one-tenth of the power represented by anode dissipation.

It is important to note that the maximum power output of the valve is obtained only with a certain loud-speaker impedance. With this valve it is 5,000 ohms. With most small power valves the impedance of the loud-speaker should be twice the A.C. resistance or impedance of the power valve. **HOTSPOT.**

**ALFRED HAS AN IDEA—**



**—BUT THE B.B.C. DON'T SETTLE ARGUMENTS**





An article of  
topical  
interest  
by  
KENNETH  
ULLYETT



# HOW TO RECEIVE AMERICA

*It is possible to receive American stations at this time of the year on the ordinary broadcast wavelengths and with a reasonably efficient set. This article gives a number of practical hints*

Between London and Heilsberg is a very popular transatlantic station, WPG, Atlantic City, which works on 272 metres. If you are lucky enough to have a wavemeter then you can spot his exact wavelength direct, but the readings for 261 and 272 metres should give an accurate enough guide of Atlantic-City's position on your tuning dial.

A little further up the dial is Aberdeen on 301 metres and Bordeaux on 304 metres. Just between them on 303 metres is WBZ, the Springfield, Mass., station.

Just on the other side of Bordeaux is the medium-waveband transmitter of KDKA which is, perhaps, better known on the short waveband. KDKA transmits here

safe in showing off to friends who doubt the efficiency of the average three- or four-valver to get direct American reception. There are several other stations, some of them using comparatively low power, which also come in well at this time of the year before the long summer nights set in.

You will find that in reception over these very long distances of 2,000 and 3,000 miles, transmitting power is not always an indication of good reception. It may be freak reception that some low-power American stations come in quite strongly but as they have been doing so for the past six or eight weeks, they are safe as occasional standbys.

There is no need to stay up very late,

ALTHOUGH there is a thrill in tuning in, say, Moscow or Madrid among the European stations, there is fascination which is almost indescribable in getting direct American reception. Whatever the fascination may be, it certainly does exist, and as conditions are particularly favourable for picking up a few transatlantic stations on the medium waveband, there is great fun in getting the American stations with really good purity, free, at times, from serious interference and at such a strength that they can be heard a few feet away from the speaker on any fairly efficient set.

A typical tuning dial showing relative positions of European and American stations

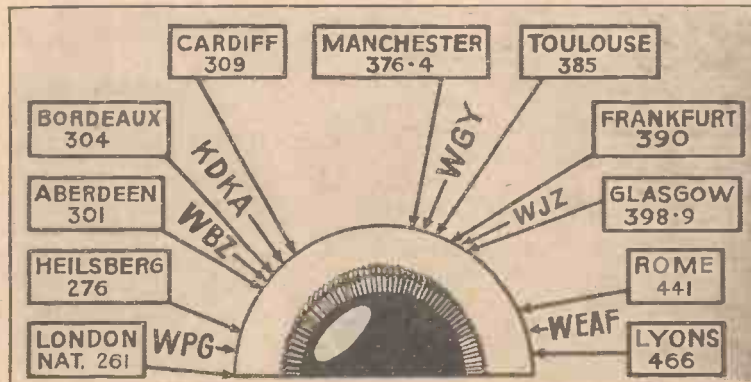

on 306 metres and he fits in on the dial exactly between Bordeaux and the 309 metres of Cardiff.

Then there is another jump to Manchester on 376.4 metres and Radio Toulouse on 385. Between these two landmarks on 380 metres is WGY, Schenectady, New York.

Further up the dial is Frankfurt on 390 metres, and a few degrees above is WJZ, Boundbrook, New Jersey. Glasgow is just above him on 398.9 metres. This station is coming in very well at the moment and Frankfurt serves as a fine guide to WJZ's position on the dial.

Up at the top end of the medium waveband is WEPF, New York, which works on 454 metres.

The best way to find him is to mark Rome's setting accurately on the dial during the early part of the evening (Rome is on 441 metres) and then later in the evening when you are out to get New York, you will find WEPF a few degrees above Rome's setting. Lyons on 466 metres is immediately above New York and this is another guide.

These stations I have mentioned, WPG, WBZ, KDKA, WGY, WJZ, and WEPF are my favourite American stations, all working on fairly high power and which I feel

in fact directly the local stations shut down you can start searching in order to get a rough idea of whether the Americans will come in. Within the last two weeks I have had KDKA at 11 o'clock at night.

Generally speaking though, you will not need to burn the midnight oil, even for the pleasure of American station reception, and judging by the strength with which they are coming in at present you have no need to do so. Use well-known European stations as dial-degree guides in the manner indicated.

## AT THE QUEEN'S HALL

THE best things at the B.B.C. Wagner concert on April 15 were Isolde's "Death Song" and the final scene from *The Twilight of the Gods*. Mme. Helene Wildbrunn was superb. Her voice is not powerful, but she used it to full advantage even in the loudest orchestral passages, and it is as true as anyone could desire. Mr. Albert Coates, who is a famous Wagner conductor, produced as brilliant performances of the Prelude to Act III of *The Mastersingers*, *The Ride of the Valkyries* and other well-known excerpts as I have heard.

L. R. J.



# CHEAP AIDS TO SELECTIVITY

ALAN HUNTER explains in this article how sets can be adapted to meet the B.B.C.'s recent wavelength changes

NOW that the B.B.C. wavelength changes are in effect, whereby Midland Regional transmits on 398.9 metres instead of the 479-metre wave, listeners to that station will be able to gauge the selectivity of their sets. I know many London listeners "poach" on the preserves of the Midland region, frequently tuning in to the Midland Regional station when it broadcasts a programme distinct from the London Regional.

That was a comparatively simple job when Midland Regional was on 479 metres, with a frequency difference of 216 kilocycles between the London and Midland stations on 356 and 479 metres respectively.

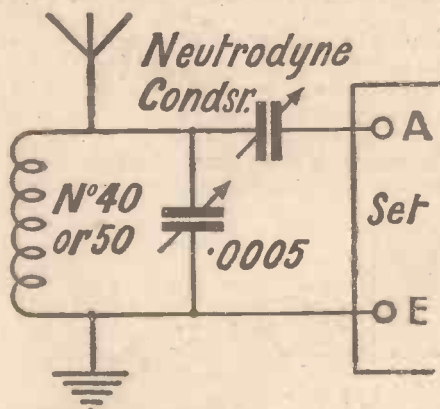

Fig. 1. Tuned circuit capacity-coupled to the aerial tuning circuit

Now the Midland Regional has given up its 479-metre wavelength to the Manchester station, as a preliminary move towards North Regional's regular service broadcasting. From reports received it appears that many London listeners to Midland transmissions and Midland listeners to London transmissions are finding their sets not selective enough to cope with the new order of things. No doubt many sets that could separate these two stations when they were 216 kilocycles apart are having difficulty now that the separation is only 90 kilocycles.

## The Demand for Selectivity

When North Regional is going regularly on 479 metres, and its alternative on 301 metres is introduced, there will indeed be a nation-wide cry for selectivity. Then the cry will be almost universal, since the changes already made and contemplated affect London, Midland and Manchester districts.

Foreseeing this dislocation, particularly in simple sets, the B.B.C. has prepared two pamphlets, one already available called "Receiving the North Regional Station," and another, shortly to be published, called "Selectivity."

Most of the suggested arrangements in the selectivity pamphlet appeal to me as likely to be of use to listeners with simple sets. One or two arrangements might well be tried by those London and Midland listeners who want to continue to poach on

each other's preserves without interference from the local regional station.

As sets used in regional broadcasting areas have to be able to separate the two alternative programmes, they must in any case have a measure of selectivity. Sets able by virtue of two or three valve stages to get a third station are those most likely to need alteration in London and Birmingham.

I quite realise that many listeners who have bought or made sets sufficiently selective to separate, say, the two London stations, must feel loth to make structural alterations.

But possibly the suggestion indicated by the circuit illustrated by Fig 1 will appeal to them. This consists of a separate tuned circuit capacity coupled to the existing aerial-tuning circuit of the set. The tuned circuit can comprise a No. 40 or No. 50 plug-in coil of the ordinary type, or, if the interference is severe, a No. 60 tapped-coil is preferable. The variable condenser is a standard .0005-microfarad type.

To couple this tuned circuit to the aerial tuning circuit of the set, a very small variable condenser, as extensively used in the old days for neutralised circuits, is recommended. The maximum capacity of this neutrodyne condenser is not so important a consideration as its minimum. A minimum of 2 micro-microfarads is specified. If the minimum is too high the circuit cannot be made selective.

## A Cheap Method

Those who do not want to go to the expense of buying a neutrodyne condenser before being assured of the circuit's use to them may care to act upon the B.B.C.'s recommendation. It is suggested that a coupling condenser be improvised from a short piece of good quality twin flexible wire, such as is used for electric-light connections.

A piece of flex about 6 inches long is needed. One of the wires forms one "plate" of the condenser and the other wire forms the second "plate." Of course, the free ends of the wire must be separated.

The operation of this extra tuned circuit in conjunction with the normal controls of the set is not very difficult after a little practice. First of all the variable condenser of the external tuned circuit should be set to its middle position and then the tuning control of the set turned until the required distant station is wanted. At this point the unwanted local station will probably cause some interference. By adjusting the condenser of the aerial circuit outside the set, the required programme will

probably be increased in strength and the local interference may disappear. If it does not, the small coupling condenser must be adjusted so that its capacity is reduced. If the flexible-wire condenser make-shift is used a turn or two should be uncoiled.

A readjustment of the coupling condenser has some effect upon the external tuning circuit and the set's tuning circuit, so both should be readjusted after any alteration to the coupling condenser's capacity.

Referring to Fig. 2, which is the B.B.C.'s "S"-type crystal circuit, readers will see

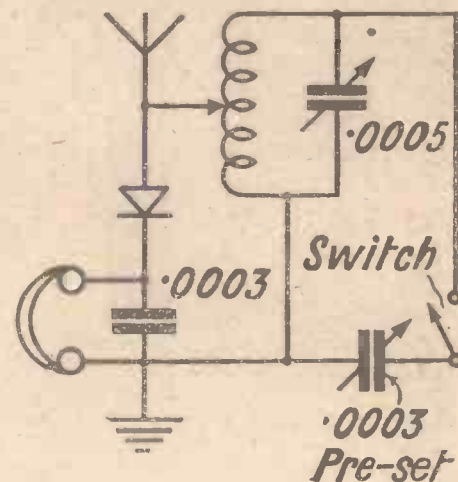

Fig. 2. A pre-set condenser and switch as an aid to selectivity

that the B.B.C. suggests a simple way of selecting one of two available regional programmes by the addition of a pre-set condenser and switch. This circuit is inherently selective, due to the fact that both aerial and crystal damping are reduced by connecting the aerial side of the crystal to a tap on the main tuning coil.

## Crystal-receiver Troubles

Many listeners still using crystal sets for head-phone reception are faced not only with the difficulty of separating the two regional programmes but of continually adjusting the controls in selecting one or the other. It is for such listeners that the addition of a switch and .0003- or .0005-microfarad pre-set condenser as a series arrangement in parallel with the main tuning condenser is suggested.

The short-wavelength regional station is tuned in on the main variable condenser with the switch open and then the switch is closed and the additional capacity needed for the long-wavelength Regional station is obtained by an adjustment of the pre-set condenser. Subsequently, the operator has only to close the switch for the long-wavelength station or to open it for the short-wavelength station.

Many other useful suggestions will be found in the B.B.C.'s selectivity pamphlet when it is published on the opening of the 301-metre North Regional alternative-programme station.

THE MOST UP-TO-DATE SET FOR 1931—  
"A. W's." NEW CENTURY SUPER



**The J.B. TINY No. 2**  
*will bring up your score*  
 in the "**CENTURY SUPER**"

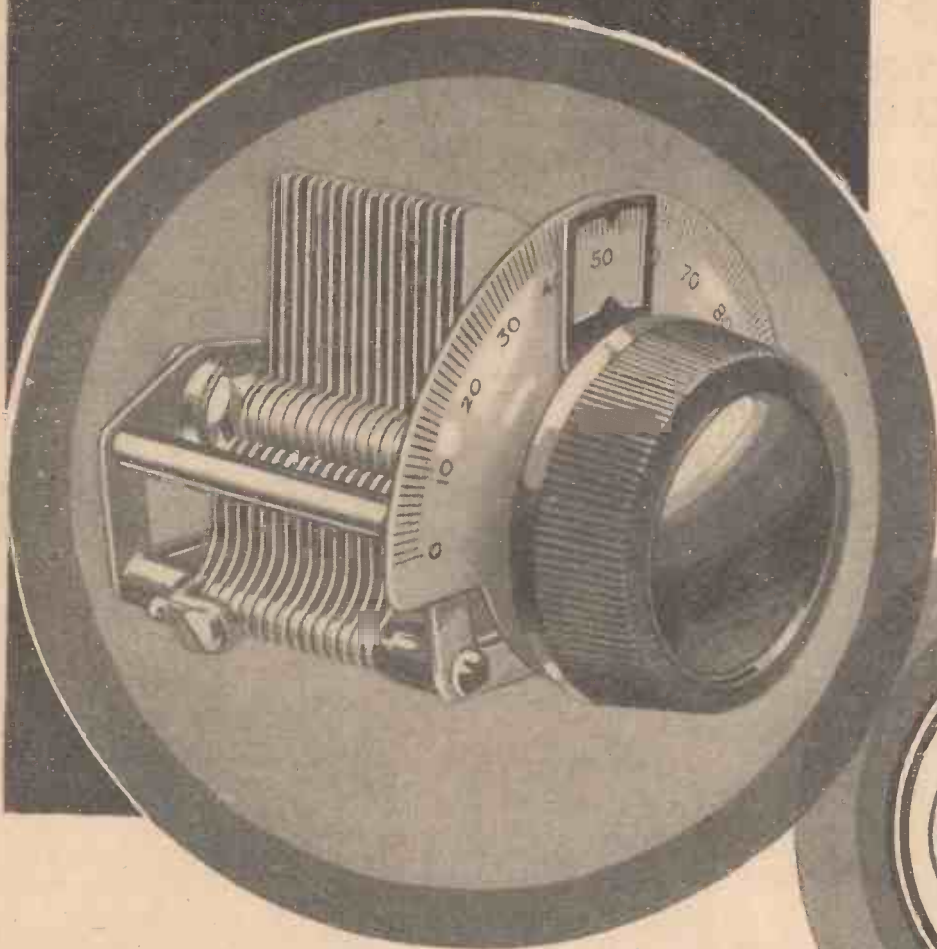

**USED AND  
 SPECIFIED  
 IN THE  
 CENTURY  
 SUPER**



For the wonderful "Century Super" the designers required a condenser that would separate the crowding stations easily and hold them when found—a compact slow-motion condenser, smooth in action and free from back-lash. **SO THEY USED AND SPECIFIED THE J.B. TINY No. 2, a typical example of J.B. precision.**

The neatness, lightness and rigidity of this J.B. Condenser make it particularly useful for portables, or wherever space is limited. The slow-motion mechanism (ratio 8-1) is housed in the bottom bearing, taking no extra space, and is controlled by a large knob. Super-hardened brass end plates and hard aluminium vanes give absolute rigidity and accuracy. One-hole fixing. Ball-bearing centre spindle. Pigtail to rotor. See this excellent Condenser at your dealers.

Price, complete with knob, pointer and scale. .0005 8/6.

*Immediate Deliveries.*

**PRECISION  
 INSTRUMENTS**

*Advertisement of Jackson Bros., 72 St. Thomas' Street, London, S.E.1*

*Telephone : Hop. 1837*

*To Ensure Speedy Delivery, Mention "A.W." to Advertisers*

# PILOT KIT PRODUCES SET

● “MODERN TO THE MINUTE . . . meets modern broadcasting conditions by giving knife-edge selectivity”

SAYS LT.-COMMANDER THE HON. J. M. KENWORTHY, R.N., M.P., IN HISTORIC LETTER.

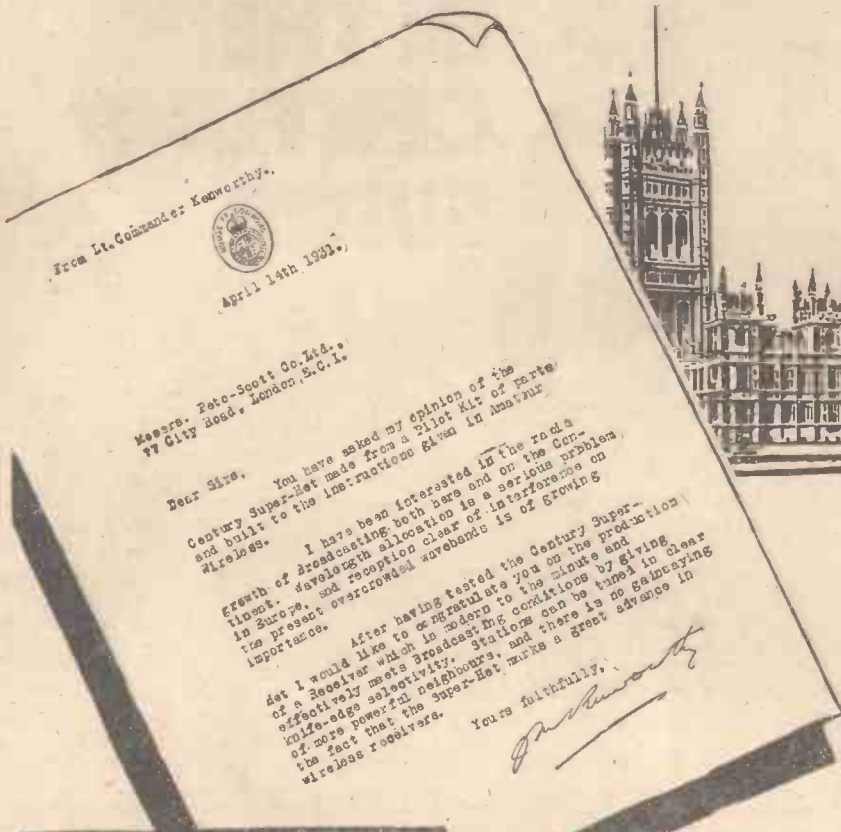

SEE PAGE  
**681**  
FOR FULL  
DETAILS AND  
PRICES OF  
THIS WON-  
DERFUL SET

*It is absolutely essential to build the Century Super-Het with a Pilot Kit of Parts to ensure the marvellous results with which Lt.-Commander Kenworthy is so enthusiastic in his letter reproduced by his kind permission in this announcement.*

*The finest version of the finest set for Home Constructors—better built with a Pilot Kit*  
**PETO-SCOTT CO. LTD.**

77 CITY ROAD, LONDON, E.C.1: Clerkenwell 9406; 62 HIGH HOLBORN, LONDON, W.C.1 Chancery 8266; MANCHESTER: 33 WHITELOW ROAD, CHORLTON-CUM-HARDY. Phone: Chorlton-cum-Hardy 2028; NEWCASTLE, STAFFS: 7 ALBANY ROAD. Phone: 67190

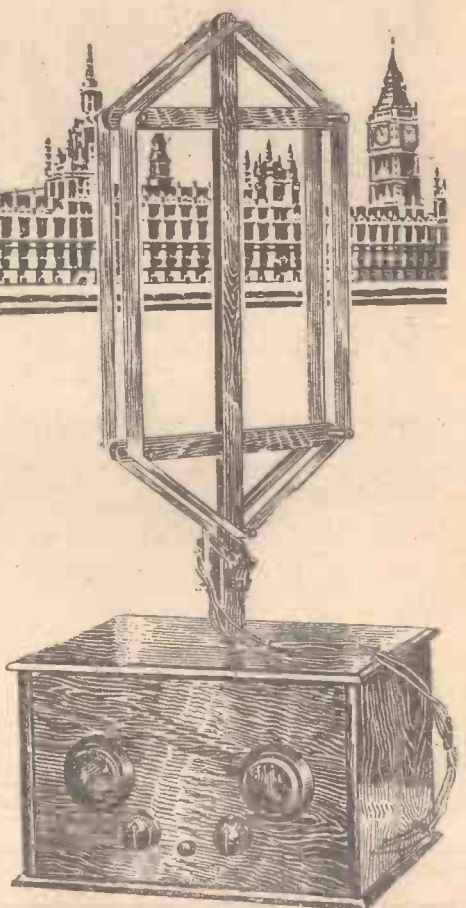

Mention of "Amateur Wireless" to Advertisers will Ensure Prompt Attention



# On Your Wavelength!

## HOW'S YOUR SHORT-WAVER?

MANY short-wave sets went out of commission last year when conditions became so appallingly bad. Since the beginning of this year things have looked up wonderfully, and reception is now very good indeed on most nights. A good part of the band just now is that between 25 and about 32 metres. This contains such excellent stations as W8XK, WGN and W2XAF, in addition to PCJ of Eindhoven, the German Zeesen, and the powerful LSW, which transmits from Buenos Aires with 20 kilowatts behind it. G5SW, our home short-waver, is also in this part of the band, though you will have to be a long way from Chelmsford to obtain good reception, owing to skip-distance effects. Higher up the band, too, stations have been coming in pretty well. On 48.86 metres, for example, the second W8XK (both of them relay KDKA) has been well heard of late, and I have reports of satisfactory reception from the Vatican station on just over 50 metres.

## QUITE SIMPLE

THOSE who have not previously tried their hands at short-wave reception need have no qualms about taking up this fascinating side of long-distance wireless as a hobby. The short-wave set of to-day is just about as simple to operate as the medium-wave receiver, and it certainly is an astonishing thing to use. There are still a good many people who believe that a short-wave set must be a highly complicated box of tricks which alters its tuning by several metres if the operator raises an eyebrow. Eight or nine years ago it was something of the kind. In those far-off days one friend of mine used to perform his fine tuning by moving from place to place in the room in which the set was. But things are very different now. Gone are the old extension handles and complicated controls. Fine tuning is easily accomplished by means of slow-motion dials or geared condensers and capacity effects simply don't exist with a well-designed short-waver. The screen-grid valve solved some of the most difficult problems in connection with short-wave reception.

## AN INTERESTING USE

TALKING of screen-grid valves, I wonder how many readers have tried them out as detectors working on the grid-leak-and-condenser principle? They can be used in this way with quite excellent results, for use can be made of quite a considerable amount of the big amplification available. Though the screen-grid valve has already played an enormous part in wireless, its use has been confined almost entirely to high-frequency amplification. I should not be at all surprised to see this valve developed in other directions, and it is quite possible that some enterprising maker will give us a pattern specially adapted for use as detector.

Another valve that we may possibly see is the high-frequency pentode. This valve

is used quite largely in America with very satisfactory results; in fact, the L.F. pentode that we have had for several years is only just making its appearance in the United States.

## BETTER B.A. UNITS

AS readers will know, I have always had an affection for the balanced-armature loud-speaker drive, and I wrote long ago that there was a big opportunity for all makers to get down to serious research work with a view to producing a really first-rate component of this type. Wonderful improvements have been made of late in B.A. units, and there are many nowadays which are capable of putting up a very good showing when compared with moving-coil loud-speakers. There still, though, remains, so my musical friends tell me, one shortcoming in the balanced-armature drive. It is a little apt to make one note run into another in passages where all should be absolutely clean cut and distinct. The reason is that the armature, the connecting rod, and the cone must all move together and that these parts have a comparatively big weight. As you know, anything heavy takes a big effort to set it in motion. Once you have got it going, a small amount of effort will keep it moving, but you have to work hard when you want to stop it again.

## BALANCED ARMATURES

IN the balanced armature loud-speaker the results of inertia are that there is a little lag in the response of the moving parts to a note played in the broadcasting studio, and that once they have got into movement they don't stop quite as quickly as they should. This results in a slight slurring of notes. The difficulty should not be insuperable, and I have no doubt that it will be satisfactorily tackled before long.

## A SPRING HINT

LET me remind you this spring of one unseen but very important part of your wireless receiving equipment. This is the earth plate, which lies snugly buried in that flower bed of yours. If you have not had a look at it for some time I should advise you to do so next time that you are feeling energetic. Some soils are very acid and exercise a rapid corrosive effect upon metals. Some years ago I buried a 7-lb. biscuit tin many feet down and enjoyed splendid reception owing to the excellent contact that it made. As time went on I noticed that I was becoming more and more dissatisfied with the performance of sets in my house and I couldn't think why friends were obtaining better results than I was. Then one fine day it occurred to me to have a look at the earth connection. On digging down I discovered that nothing remained of my beautiful tin but the beaded rim, to which the strands of the cabled wire had been soldered, and a few flakes of rusty iron. Since then I have always used a copper earth plate.

## MIXED VALVES

I FOUND a friend of mine in difficulty the other day. He is one of those enthusiasts who use 6-volt valves, for he says the performance is distinctly better than the 2-volt variety, and as he charges his own accumulator with a trickle charger, the extra accumulator size does not worry him at all. However, he read an article somewhere to the effect that 2-volt detector valves were rather better than the 6-volt equivalent. He thought that he would like to put this to the test, and he therefore put in a suitable resistance in the filament lead to the detector valve, and replaced his 6-volt valve with a 2-volt one, adjusting the resistance so that the voltage was correctly 2 volts on the filament of the valve.

Instead of finding that the results were appreciably better, he found that he could get no results at all. Something was obviously quite wrong, for he knew the valve was good, for he had checked it up on a valve emission tester. He then measured voltages all over the place, and found that everything seemed to be in order. In fact, if anything, the voltage on the detector valve was a little higher than before, but he assumed that this was all to the good.

## WHY IT WOULD NOT WORK

IT was therefore in a state of puzzlement that I found him when I happened to blow in. He explained to me what had happened and showed me the circuit he was using. "Of course," he said, "I have put a resistance in the filament lead to cut down the voltage on the detector valve, but that has not been shown in the diagram." Whereupon I asked him how he had inserted the resistance. He therefore inspected the set and drew in the filament resistance in its actual position. When this had been done the trouble became obvious. He was using an anode-bend detector biased about 3 volts negative. The bias battery was connected between L.T.— and the detector coil. He had, however, arranged his filament resistance in the negative leg of the filament, so that there was 4 volts drop between the negative of the valve filament and the negative L.T. This, of course, was adding itself to the bias, so that the valve was receiving 7 volts grid bias, which was altogether too much and rendered it quite inoperative. Changing the resistor over to the positive lead put everything in order and the set worked quite satisfactorily.

## CONDUCTOR OR INSULATOR?

ALTHOUGH the textbooks agree that ordinary water has an extremely high electrical resistance, one is constantly being warned of the danger of manipulating mains-driven appliances with wet hands. The bathroom, for instance, seems to be a particularly risky place for anything to go wrong with the insulation, as anyone who has ever happened to touch a "live" electric-light switch in that room with



## On Your Wavelength! (continued)

damp fingers will thoroughly agree. But I have always been a little hazy as to the precise reason why damp hands should increase the risk of getting a "shock" from the mains. Pure water certainly does not conduct electricity in the ordinary sense of the term, although a salt solution will, of course, convey a current by electrolytic action. I know I have plunged my hand into a jet of cooling water flowing from the anode of a high-power generating valve, and have felt only the merest tingle, although a few feet away the same jet was in direct contact with ten thousand volts. Yet, if you should happen to touch any "live" wire first with dry fingers and then with wet you will have no difficulty in feeling a difference. Mind you, I do not recommend the experiment!

### A.C. AND D.C.

**M**OST of us have at one time or other taken current from the old-fashioned hand-driven magneto-generator. Some people still use this kind of appliance as a cure for rheumatism and similar ailments. At all events, it is well known that the shock effect is much more pronounced if the electrodes are moistened, or if the hands are immersed in a bowl of water. The current is alternating and the increased "shock" is partly due to the high storage capacity of the water acting as the dielectric of a condenser, and partly to the fact that the "charging" current is continually being reversed. If the generated current were direct instead of alternating, one would feel a single pulse of current as the condenser system charged up, and no more. This helps to explain why contact with A.C. mains is usually more dangerous than with D.C. mains of the same voltage. Of course, if the voltage is sufficiently high the result will be the same in either case.

### GREAT NEWS!

**I** FIND difficulty in conveying my sense of jubilation at the news **AMATEUR WIRELESS** publishes this week. I refer, of course, to the "Century Super," designed and described by W. James. As regular readers know, I have long been preaching the super-het gospel. It is my conviction that this is the only practicable type of set for present-day broadcasting conditions.

The recent wavelength change involving the Midland Regional station has once more brought home the inadequacy of the tuning apparatus in the average three- or four-valver. Just above Midland Regional's new wavelength is the excellent Swiss station Söttens, but even its 60-kilowatt power does not save it from being absolutely wiped out by the Midland transmission.

A similar wipe-out affects Mühlacker, which can never be heard clear of London Regional by those living within thirty miles or so of Brookmans Park. One could cite many other examples, but they are all too well known by regular distant listeners.

Now, even if the "Century Super" were not remarkably cheap, were not absurdly easy to build, were not child's play to operate—actually it is all these, and then

some—the wonderful selectivity would alone commend itself to hundreds of enthusiasts. I have been privileged to try one of these sets, and I can tell you there is something positively uncanny in being able to hear Mühlacker and Söttens without a trace of London and Midland Regional stations respectively.

So completely does this "Century Super" fulfil every ultimate desire of the listener that the imagination stops short at anything better. Of course, detailed developments and improvements can be expected, but fundamentally I should say the "Century Super" cannot possibly be superseded for years.

## 115 STATIONS ON THE "CENTURY SUPER"

*As we go to press we have received an advance test report on the "Century Super" from J. Godchaux Abrahams ("Jay Coote," the well-known authority on European reception), and there is particular interest in the amazing results which he has obtained with this super set at a listening point on the south coast. He says: "It is far in advance of any radio receiver it has yet been my privilege to try. I thoroughly enjoyed myself . . . A LOG OF 115 STATIONS ALL TUNED IN THROUGH A LOUD-SPEAKER. In most instances the volume at which certain transmissions were received, even from low-power stations, called for a generous use of the potentiometer. With this receiver . . . YOU HAVE EUROPE AT YOUR ELBOW; you may run around the dials with the certainty of capturing any stations you set yourself out to bag. It will pick up almost any whisper on the ether . . . pulling in lesser-heard stations, such as Nice-Juan-les-Pins, Riga, Zagreb, Naples, Kosice, Reykjavik, and Istanbul. . . . You will find no difficulty in cleanly separating London Regional from Graz or Mühlacker and Warsaw from Eiffel Tower. . . . Personally, I could not wish for a better receiver." The full station log of 115 stations, including 8 Americans, will be given, with dial readings, in next week's issue.*

### DUMPING

**W**E are threatened with a dumping campaign by American manufacturers. Over in the States the position is very interesting. The number of wireless sets in use is about fourteen millions, and if you allow each of them a useful life of three years you will see that the number that can be absorbed annually is between four and five millions. Some of the big firms have an enormous output. A friend who visited one factory last autumn told me that they were turning out 5,000 complete sets—

**DESCRIBED ON PAGES  
672 TO 674—THE  
CENTURY SUPER—  
THE SET FOR YOU**

seven- or eight-valvers—every day. Now, wireless is much more seasonal in the United States than it is over here, since in the summer time atmospheric conditions in most parts of that country are so bad that listening is frequently impossible for considerable periods; at any rate, there is little pleasure in it. It follows that if the manufacturer has not sold the whole of his output during the winter he is left with large numbers of sets which must either be scrapped or sold at a break-up price in order to make way for the new models of the coming autumn. Since they are practically valueless, it pays him to dispose of them at almost any price. But it does not pay you or me to purchase them, for several very good reasons.

### WHERE THEY DON'T SCORE

**T**HE American set is designed entirely for reception on wavelengths between 200 and 550 metres, since there are no long-wave American stations. Some of the dumped sets will, no doubt, have long-wave adaptors; but anyone who has designed a wireless set knows that very special problems are introduced by long-wave reception and that in nine cases out of ten you cannot satisfactorily adapt a design intended for medium waves only. This refers particularly to super-heterodynes. Next, the American public is still going through something that we have grown out of. It demands a great thumping, booming, woofing bass, and doesn't care two hoots about the top notes so long as it gets the low ones. The manufacturers pander to this, with the result that all experts know what is meant by the phrase "typical American quality." Few American broadcasting stations have transmitters capable of sending out the programmes with the high quality that is the B.B.C.'s standard; still fewer types of American sets can reproduce these programmes faithfully. Again, do not be misled by the prevalent idea that the American set is vastly more selective than its British counterpart. It is not.

### ONE MORE POINT

**T**HERE is just one more point which is of very great importance. Any designer knows that his first business is to produce a set suitable for use with the valves that are generally available to his public. American sets are therefore designed for American valves, which are not by any means the same thing as British valves. The dumped sets will, no doubt, be provided with a British type of valve holder, and you can therefore stick our own valves into them. But the sets have not been made to work with these valves, and you cannot therefore expect them to be at their best. The American manufacturer is unfortunately aided in his dumping campaign by two financial factors. He has no import tariff to check him and, unlike our own makers, he has no patent royalties to pay. So long as the basic Marconi patents were in operation we could keep the foreigner out, but now that these have lapsed this weapon is no longer ours. **THERMION.**



*By a Member of the  
"Amateur Wireless"  
Staff invited by the  
B.B.C. to see the new  
North Regional station*

BECAUSE of the mist and drizzle, we did not see even the masts of Moorside Edge until our coach had almost reached the station building. The site is about as desolate and miserable as the writer has ever seen, but it was chosen because of its 1,100 feet elevation above sea-level. It is five miles from Huddersfield on the Oldham-Huddersfield road.

Undoubtedly, the masts are impressive. No government restriction was placed upon their height, so the three of them, supporting the two aerials, tower up to 500 feet, literally into the clouds. Each mast is a triangular section, of latticed steel construction. Unlike the Brookmans Park masts, those at Moorside Edge are elaborately stayed at seven points by triple steel stays, secured to massive concrete anchors. We were told that the weight of the steel work of each mast is 40 tons.

**An Ideal Site**

We were reminded that broadcasters have to contend with what is termed "mast shadow effect," resulting in uneven radiation from the aerials unless suitable precautions are taken. Each mast has, therefore, been insulated from earth at the base, by seven sets of porcelain insulators. As a matter of fact, at the time of the visit, experiments were in progress on the aerial masts and temporarily the two masts supporting the 479-metre aerials have been earthed. This has had no effect upon the east-to-west radiation, but has apparently improved radiation to the south-south-west.

As the day of our visit was typical for its mist and drizzle we can quite believe

*We  
Visit  
Moorside  
Edge*



that the Moorside Edge site, although fulfilling technical requirements, must be subject to very severe weather conditions. The erection and maintenance of aerials under such conditions is particularly difficult. The B.B.C. engineers have found it necessary to design the aerial system to withstand a wind velocity up to 100 miles per hour.

In the winter it is quite conceivable that ice forming on the aerial wire conductors would severely overload them and quite possibly break down the whole system. To guard against such a calamity the power station generators can be connected to the aerial wires and a heating current of several hundred amperes passed through them. With a power of 100 kilowatts enough heat can be generated in 20 minutes to melt the thickest ice formation.

In its main outlines the station building resembles Brookmans Park. But we noted the builders have favoured red brick instead of the Portland stone used at Brookmans Park. We have no intention of going into all the details of the elaborate gear seen in the main building, but it is interesting to record a general impression. Although the machinery is so massive and in-

volves so much elaborate installation and maintenance, its essential function is to supply anode current, filament current and grid-bias voltages to the transmitting valves.

**Big Figures**

Compared with the amateur's set-power requirements, the figures for the Moorside Edge transmitter are certainly gigantic. For example, the filament current of the water-cooled valves is 1,300 amperes, at a filament voltage of 20 volts. The anode current of the main power amplifier is 19 amperes and this is at 12,000 volts. Real high tension! Grid-bias voltages of 2,000, 500 and 250 volts are also needed. These supplies are obtained from D.C. generators and it is a point of considerable interest that no rectifying apparatus is needed. One of the surprising aspects of the modern transmitter such as Moorside Edge is the tremendous amount of water needed for cooling the engines and the valves. So important is this question of water supply that a special reservoir has been built outside the station. This has a capacity of 200,000 gallons and we were shown plant designed for treating this water to make it suitable for all the purposes required.

Undoubtedly, the most impressive part of the building is the main transmitter hall. The transmitting apparatus for each of the two stations is placed on each side of the room and the switchboard for controlling the various supplies is mounted along the end wall near the motor-generating room. In this way the wiring is kept short.

Much of the apparent elaboration of the gear we inspected is due to the precautions taken to avoid interruptions to the programme. As far as possible Moorside Edge has been designed so that every part of the circuit can be seen at work by the engineers.

**AT THE NORTH REGIONAL**



The Chief Engineer of the B.B.C. chats with Mr. Liveing, the North Regional Director (seated)

**Blank**



A Weekly Programme Criticism—By SYDNEY MOSELEY.

# Without Fear or Favour



## BACH

ALEXANDER AND MOSE

MISS KATHLEEN TOWERS knows the right way to make an appeal. In her five minutes' talk on behalf of the Women's Settlement, Canning Town, E., she opened in a human and arresting fashion, and did what few do—sustained the interest. I hope she did well.

Readers who trounce me for criticising Bach I will term Bach-biters. They are quite entitled to stick up for their famous composer. As it happens, I like Bach, too; but not his cantatas, which we have heard so often that we are thoroughly sick of them.

Harry Tate did better in his last broadcast. "Motoring" is out of date, but his latest stunt—in his office—is more suitable to broadcasting.

The Amateur Orchestra of London, conducted by Winn Reeves, has an influential following, but it deserves it, and its broadcast was quite a success, even though it put over a rather high-brow programme.

I like to say the nice thing about foreign visitors, but the Stuttgart Madrigal Society's programme of old German and Italian madrigals was not quite to my taste. Madrigal societies, like madrigals, are rather out of date.

Much of the "Hot Jazz Vaudeville" programme I could not understand. This quick-fire stuff is very smart, but what is the use of it if it is unintelligible?

I was glad that the *Murder at Savoy Hill* was not taken too seriously. This was the first time, too, that an advertisement was given to the Blattner process of recording broadcast. But the episode, on the whole, was rather feeble, although the idea had a possible germ in it.

Mr. A. P. L. Gordon's talks on "Business" are straight-forward and sensible, and created some interest.

I switched on Rome and—would you believe it?—it was *The Geisha* they were relaying. "Ching-ching Tinkabit," it sounded like. Rather difficult language to fit in, for, remember, the English lyrics were rather short and monosyllabic. Still,

it sounded particularly amusing to English ears.

*The House of the Arrow* was well produced, but the fault I found with it was in the foreign character. Even with an excellent set a foreign language is rather trying to listen to, and without the foreign detective I suppose the play would be like *Hamlet* without the Prince of Denmark.

Betty Harlowe spoke rather quickly when excited, and thus was rather unintelligible.

YOUR NEW SET MUST BE  
"THE CENTURY SUPER"

I didn't hear Leonard Merrick's little masterpiece, but I understand it was well produced by Lance Sieveking, which bears out what I told him some time ago; and that is to stick to well-known authors.

Alexander and Mose seem to be sports. Commenting indirectly on my having given their identities away, one said: "Look out! There's a journalist over there, and he will tell everybody who you are!"

By the way, the discovery of their iden-

## THE COMMENTARIES

"PLUGGING"

tities has not done them any harm. On the contrary, it has brought them even more to the notice of the public.

I liked the chief engineer's talk on broadcasting. There are no frills about him, but he knows his subject from A to Z—which is all that matters.

It was rather amusing to notice that in the first programme which was meant to be an alternative to Bach there were two songs from Bach, which took up most of the half-hour's concession.

If the B.B.C. meant this for a joke, we might forgive it. But it is incapable of joking and, goodness knows, the Sunday programmes are no joke to us.

That was a really good vaudeville programme in which there was Anona Winn, Flotsam and Jetsam, Annie Croft, and others.

Flotsam and Jetsam are getting a wee bit casual in their broadcasts, and I desire to warn them against it.

Cicely Courtneidge was extremely good; so were the Bayan Sisters.

Needless to add, Mabel Constanduros and Michael Hogan were a scream. I have always said that Mabel is at her best as "Grandmother," and, in fact, when I first heard her I thought the part was taken by somebody else.

This stunt might very well be repeated.

I listened to Lloyd George's speech when it was relayed from the dinner given by the Jewish Agency for Palestine. Politics apart, David still knows how to speak. Indeed, he was quite touching, although I suppose it was the agency that did the touching. And for a good cause, too.

I fear there is likely to be trouble and a big development with regard to the broadcast commentaries. But, at any rate, the B.B.C. makes the most of the few that it has at present.

In regard to my campaign against song plugging, I have been asked to say that proof that song plugging does go on has been forwarded to the B.B.C. I now await the sequel.



An Impression of Betty Davies



FOR a long time I have felt that sooner or later it would be necessary to break right away from the existing styles of sets in order to provide that selectivity, ease of operation, sensitivity, and good quality which we all desire.

I have taken part in the development of the modern ganged set, with its screen-grid valves, matched coils and condensers and heavy cost. Considering the results of the best of these, I concluded that they fell short of what was needed.

Selectivity was not good enough, that is, not startlingly good; the sets were not easy enough to make, not easy enough to gang up, and the first cost was too great.

**Low Cost and Super Results**

I had set out with a definite object: to produce a set which all the readers of AMATEUR WIRELESS could build easily, having a low cost, simple operation, and being economical in current, in order that the running costs should be low. I wanted the smallest possible chances of failure to occur in the building of the set and it, therefore, had to be so simple that any reader could build it.

Naturally time has had to be spent in the preparation of the set, so as to provide something which would justify the working out of the ideas.

Examination of the most lately developed circuits showed them to be out of reach of my readers. Who could gang four circuits? Look at the cost of the condensers and coils; the shielding necessary.

Part of the trouble has been that we think too much of the number of valves used. We are apt to pay too much attention to the valves. Actually a valve is cheaper than a transformer; cheaper than a coil. What matters all the time is the total cost considering the results.



A remarkable feature of the "Century Super" is the few components required which means that the total cost is about the same as a three-valver

# THE CENTURY

## A STATION FOR EACH DEGREE

### AN AMAZING SET Specially Designed for "A.W." by W. JAMES

And I discovered that for the cost of a good three-valve set I could produce a six-valve super-heterodyne, running costs not being appreciably greater either.

There is, of course, no comparison in the results. The selectivity of the super is much better; the set is extraordinarily sensitive, easy to operate, and gives good tone. In fact, this set, the "Century Super," I will be so bold as to state, is far more selective and gets more stations than any other published.

The "Century Super" is as simple and

straightforward as a set can possibly be. You think of a super set—it is that in more ways than one. It's as easy to build as a straight three—possibly easier. Look at the parts and the wiring and you will see that all this is true enough.

**Remarkable Selectivity**

This set represents a clean break away from the old obstacle of considering valves alone. Valves are cheaper than many other parts and you get far better results when each valve is given a small job to do. We

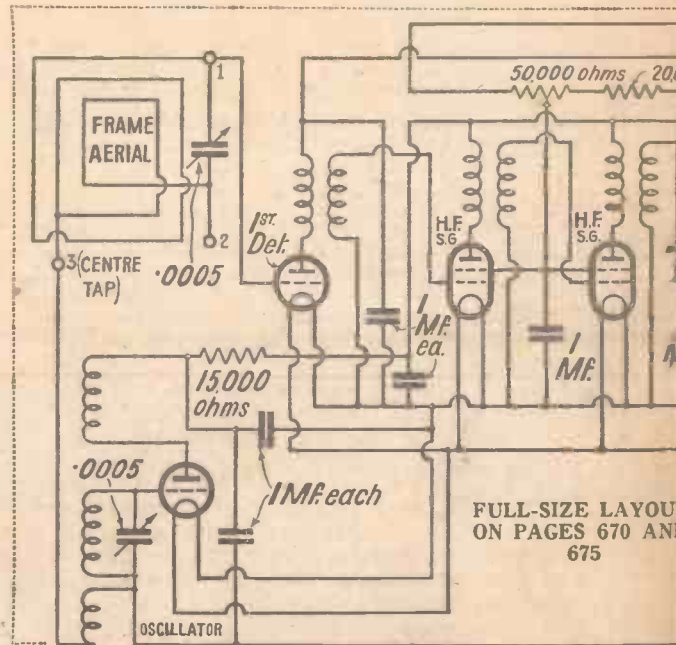

FULL-SIZE LAYOUT ON PAGES 670 AND 675



# CENTURY SUPER-

CHEAP TO BUILD & OPERATE



## SIX-VALVE RESULTS AT THREE-VALVE COST

On the baseboard we have, at the right-hand side looking at the back of the set, a small strip of ebonite or paxolin having three terminals. The frame aerial is connected to these terminals, the two outer ends, and the centre tapping. Near the centre of the set and towards the panel edge is a valve holder for the oscillator. Then there are various fixed condensers.

In front of them is a strip having three sets of valve sockets. The three special super-heterodyne coils are plugged into these sockets after the wiring has been completed.

To the right of this strip is a safety fuse, and to the left a low-frequency transformer. Towards the front are the five valve holders, grid leak, and by-pass condensers.

There is ample room everywhere, yet the set is so compact. You cannot go wrong if you follow the layout.

No terminal strips are used for the batteries or loud-speaker—the wires themselves are brought out and fitted with engraved connectors. The theoretical circuit and the explanatory diagram show the principles of the circuit. We have first an anode-bend detector. To this is connected the frame aerial and also the oscillator. Joined to the anode circuit of the first detector is a filter transformer.

### The Super-het Principle

This, in turn, is coupled to a screen-grid valve, which is also coupled by a transformer to a second screen-grid valve. Thus we have two stages of screen-grid high-frequency magnification and because the

have the result here in the "Century Super," with which over 100 stations have been received.

The local station is tuned in and out in less than a degree and only one hand is needed for tuning.

Can you make it? Of course you can. It was designed for the novice as well as the expert. And you will both get the same results. There are no tricks in tuning. On the front panel there is a tuning condenser (on the left) for tuning the frame aerial. That on the right tunes the oscillator.

In the centre is the on-off switch, and you have as well a volume control and a wavelength switch. The positions of these

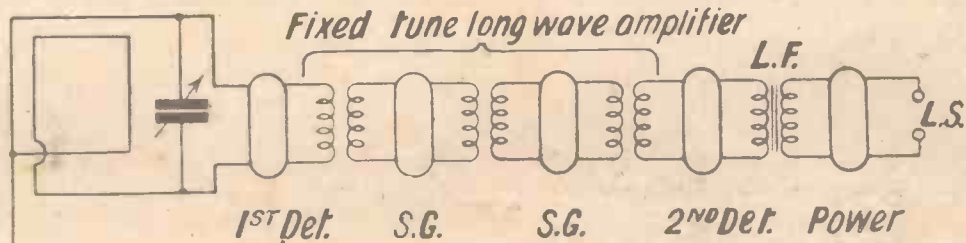

Six valves are used and this pictorial diagram shows their sequence. Below is a plan view of the "Century Super"

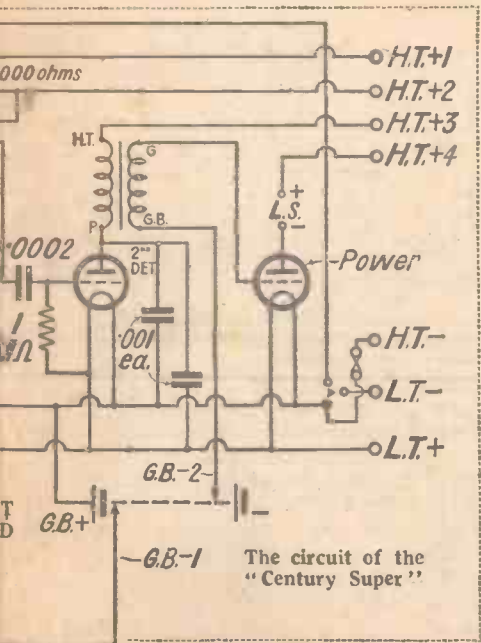

parts are given in the large diagram. It is easy enough to drill the panel and to fit these parts.

### Constructional Features

The wave-range switch, you will notice, is part of the oscillator unit, which is a completely shielded unit having contacts arranged with coloured tags and the switch spindle projecting from one end. The whole is fitted by tightening one nut.

Oscillator

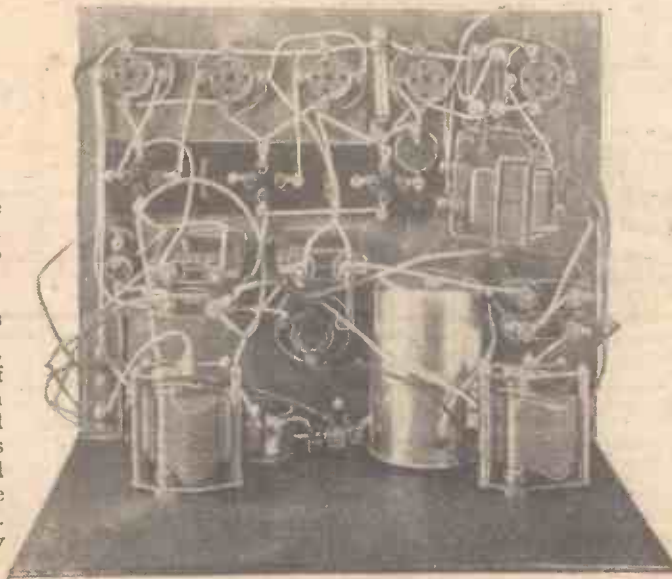



Amateur Wireless

# THE "CENTURY SUPER"

## THE WORLD'S FINEST CONSTRUCTOR SET

By W. JAMES

### FULL-SIZE LAYOUT and WIRING PLAN WITH LIST OF COMPONENTS

#### COMPONENTS REQUIRED for the "CENTURY SUPER"

Special cabinet and baseboard, and wooden panel (Camco, Peto-Scott, H. & B.).

Two .0005-mfd. variable condensers with slow-motion movement (J.B. "Tiny No. 2," Peto-Scott, Ormond, Read-Rad, Cyldon).

50,000-ohm wire-wound potentiometer (Colvern, Sovereign, Regentstat, Rotor).

Three-point shorting switch (Readi-Rad, Wearite, Bulgin, H.B., Benjamin, Lissen, Junit).

Set of super-heterodyne coils (Wearite, Lewcos).

Six valve holders (Telsen, Wearite, Lotus, Lissen, Benjamin, W.B., Clix).

Triple coil base (Peto-Scott).

Five 1-mfd. fixed condensers (Dubilier, T.C.C., Lissen).

Two .001-mfd. fixed condensers (T.C.C., Telsen, Dubilier, Lissen, Formo).

.0002-mfd. fixed condenser (Formo, T.C.C., Dubilier, Lissen, Read-Rad, Graham Farish).

Grid-leak holder (Readi-Rad, Wearite, Bulgin, Lissen, Dubilier, Formo).

1-meg. grid-leak (Lissen, Dubilier, Telsen, Graham-Farish).

Low-frequency transformer (Telsen "Ace," Lissen, Varley, Ferranti, Burton, Lewcos, R.I., Voltron).

Terminal strip with three small terminals for baseboard mounting (Peto-Scott).

15,000 and 20,000-ohm spaghetti resistances (Lewcos, Bulgin, Readi-Rad, Turner, Graham-Farish).

Fuse-holder and fuse (Bulgin, Readi-Rad).

Five yards of thin flex (Lewcos).

Eight wander plugs marked: H.T.—, H.T.+1, H.T.+2, H.T.+3, H.T.+4, G.B.—, G.B.—1, G.B.—2 (Belling-Lee, Clix, Eelex).

Two spade terminals marked: L.T.—, L.T.— (Belling-Lee, Clix, Eelex).

Connecting wire and sleeving (Jifilnx, Readi-Rad).

Frame aerial (Peto-Scott, Lewcos, Wearite).

#### ACCESSORIES

One cone speaker (B.T.H., Amplion, Mullard, Ormond, Blue-Spot).

One double capacity 120-volt H.T. battery (Ever-Ready, Pertrix, Drydex, Fuller).

One grid-bias battery, 9 volts (Ever-Ready, Pertrix, Drydex, Fuller).

One 2-volt accumulator (C.A.V., Exide, Pertrix).

Valves: One Mullard PMILF, one Mullard PM2, two Mullard PM1HF, two Mullard PM12.

Explanatory and Constructional Article on pages 672, 673 and 674

BASEBOARD  
12" X 9 3/4"

OSCILLATOR  
CONDENSER

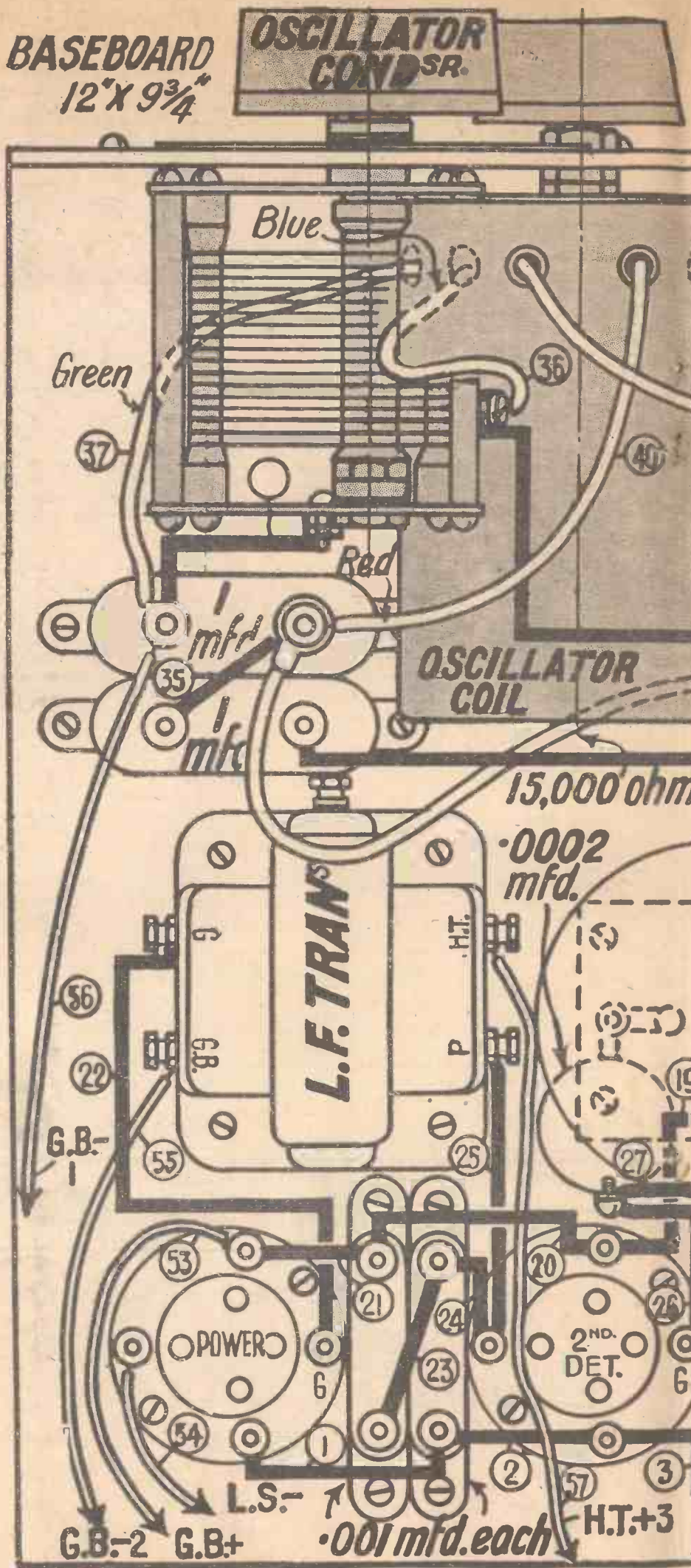



L.T. SWITCH

POT MTR.  
50000 ohms

AERIAL  
COND SR.

PANEL  
12"x8" (wood)

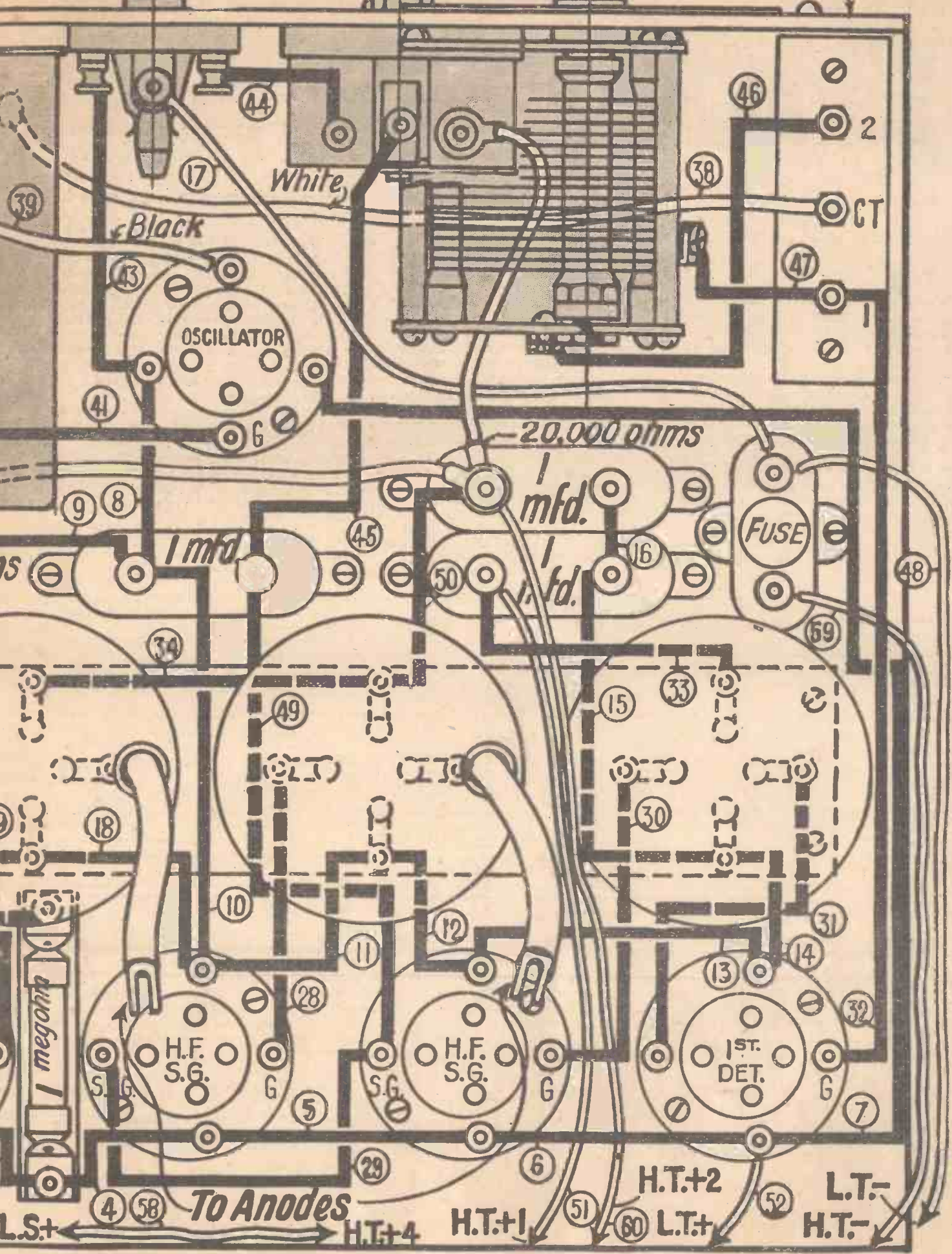



# W. JAMES' "CENTURY SUPER" (Continued from preceding page)

filter transformers are sharply tuned by the makers to a given frequency, the magnification is considerable and the selectivity is wonderful.

Complete stability is obtained, the different transformers or filters being completely shielded. After the second screen-grid valve comes the second detector. This has a grid condenser and leak joined to it in the usual way, but in its anode circuit are two fixed by-pass condensers; one goes from the anode to the positive side of the filament and the other from the anode to the negative side.

Following the detector is a transformer coupling to the power valve.

Now if you are not familiar with the working of a super-heterodyne receiver, you will be wondering what the oscillator is for and why two detectors are needed. First, let us suppose that the two screen-grid stages, with the three filter transformers, are tuned to 3,000 metres. We get good magnification and stability, and as the coils are all accurately matched at the factory, there is no tuning at all. You have, in effect, a long wavelength amplifier, tuned to one wavelength and followed by a detector and power valve. This accounts for the last four valves, the two screen-grid, leaky-grid detector, and power valve.

We are left with the first detector and the oscillator, and it is the function of these two valves to change the frequency of the signal tuned in, to make the frequency the same as that of the long-wavelength amplifier.

### Tuning

To do this we first tune in the signal desired by adjusting the condenser tuning the frame aerial. Say the signal has a wavelength of 300 metres or a frequency of 1,000,000 cycles. We tune the frame to 300 metres. Now the frequency of the long-

When the two circuits are properly tuned we have in the grid circuit of the first (anode-bend) detector the signals being received and the local oscillations.

In the anode circuit of the detector, however, we have a new signal, one of 3,000 metres or 100,000 cycles. This is magnified by the rest of the set in the usual way, is detected and applied to the power valve.

In the anode circuit of the first detector are other currents also, but these are by-passed by the first filter coil.

To tune the set, therefore, you merely adjust the frame-aerial circuit to the wavelength of the station desired and then tune the oscillator; when the tuning point is reached the station is heard.

If the volume is too great, you adjust the volume control, which alters the amount of the long-wave amplification. The control is a potentiometer connected to the screens of the two shielded valves.

There is no deliberate reaction in the set. When the volume control is placed near its maximum position the long wavelength amplifier will just oscillate. Reaction is not applied to any of the coils or the frame aerial.

It is necessary to adjust the two condensers only and then to regulate the

be connected to the set through three short flex leads and a plug or a switch may be provided on the frame itself to connect the medium wave in parallel with the long wave.

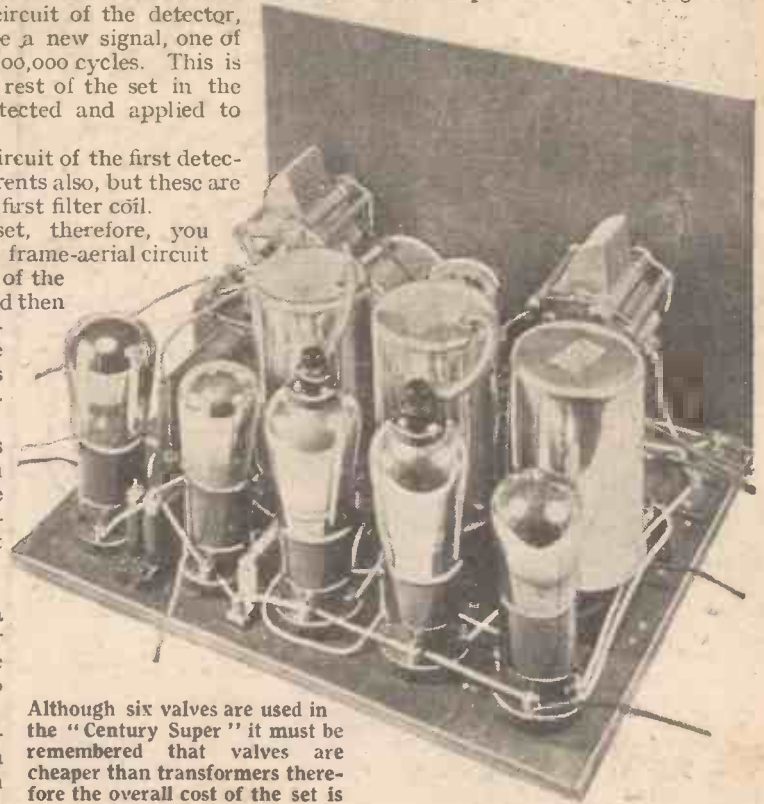

Although six valves are used in the "Century Super" it must be remembered that valves are cheaper than transformers therefore the overall cost of the set is comparatively small

A point to note is that the oscillator has three positions, for short, medium, and long waves. With the switch in the short-wave position stations from 19 metres up can be received with a suitable frame or tuning-coil, as I shall show later. When the switch is in its central position the oscillator is working on the medium waveband, from below 200 to about 600 metres.

With the switch in its third position the whole of the long-wavelength broadcast band is covered. Nothing could be simpler.

### No Shielding

In the construction you will have noticed there is no shielding at all. The coils themselves are properly shielded. Two of the coils have anode connecting wires coming out of their tops, while the third coil is plain. This plain coil connects the first detector with the first screen-grid valve. It is the first of the long-wave filter coils. The other two, which are identical and, therefore, may be changed about, are used for coupling the screen-grid valves and the second detector.

Owing to the short connecting wires and to the use of adequate by-pass condensers, the great magnification is obtained without further shielding and so the construction is as simple as one could wish.

The parts should be screwed down in the positions indicated in the layout diagram, and then it is as well to fit the panel to the baseboard to make sure that there is

*(Continued on 3rd col. of page 676)*

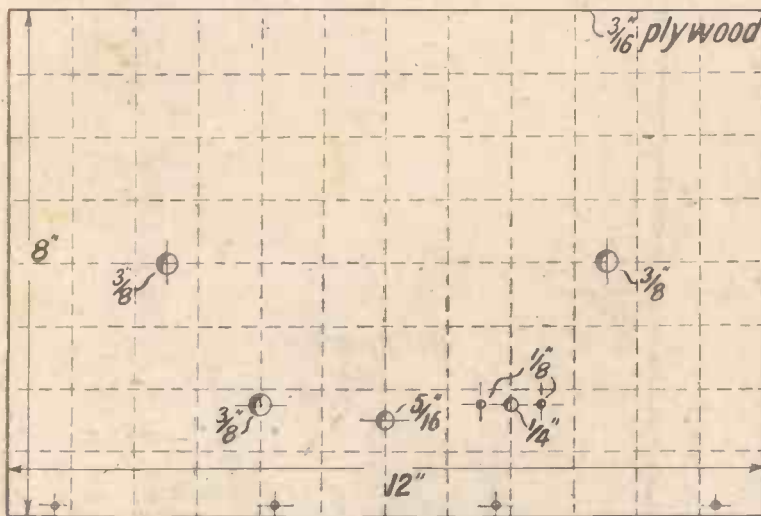

This dimensioned drawing of the panel shows the actual positions of the components which are shown shaded in the full-size layout and wiring diagram

wavelength amplifier we have assumed to be 100,000 cycles, corresponding to a wavelength of 3,000 metres. We must, therefore, tune the oscillator to a frequency which is 100,000 cycles above or below the frequency of the signal being received, that is, to 1,100,000 cycles or 900,000 cycles.

volume. One of the circuits, the oscillator, tunes more sharply than the other. This is an advantage. A station is held over a part of a degree only and there is no spreading at all.

The frame aerial has two windings, of stranded wire. They may be separate and



**Blank**

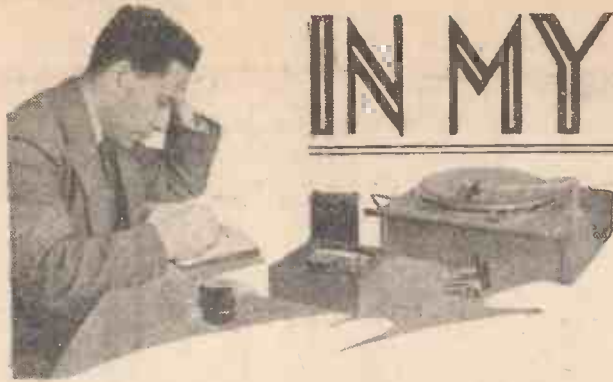

# IN MY WIRELESS DEN

WEEKLY TIPS—  
CONSTRUCTIONAL AND THEORETICAL

By W. JAMES.

## How to Gang

IT is not very difficult to gang a circuit, provided the coils are accurately matched.

My experience goes to show that failure to gang can generally be proved to be due to the coils not being suitable. Even when the coils themselves are accurately adjusted to a given value, it is possible for the user easily to destroy the matching by placing the coils in wrong positions.

Thus if you place one of the coils near a tuning condenser and the second coil is well removed from metal parts, the chances are that the inductance of the first coil is reduced by an amount sufficient to make ganging difficult.

The inductance of a coil is reduced when a piece of metal is placed in its field. It is possible that the reduction is not very much, but if the metal is placed near the coil the inductive value may well be reduced by several per cent.

You can easily try this in any set by noting the difference in the tuning point when a piece of metal is placed near the tuning coil. You will find that more capacity is needed to tune in a given station, thus showing that the piece of metal has had the effect of reducing the inductance of the coil.

## Watch Your Pre-sets

How long does a pre-set condenser maintain the value of capacity at which it was adjusted? This question is of some interest to those who have ganged circuits in which these condensers are used for trimming.

Some may stay fixed for a lengthy period, but I have met with cases where the capacity has altered within a few months. It depends upon how the trimming condenser is made. This point is worth noting. If you have a ganged set and the performance seems to be falling off, try adjusting the trimming condensers again. Perhaps one of them has changed since you last set it.

## New-type Speakers

Some of the new permanent-magnet type moving-coil speakers, selling in chassis-form for two or three pounds, are very good, considering their low cost.

I prefer the moving-coil type speaker to others, although there are many moving-iron patterns which give excellent results. A baffle must be used if the lower notes are to be reproduced, and this should be fairly large and not only two feet square. The low notes cannot be heard properly when the

baffle is of too small a size, and this is a mistake made by many amateurs.

## Transformer Couplings

Be careful how you use a low-frequency transformer having a "radio metal" core.

A transformer having a core of this high permeability metal usually works best with only a very small direct current passing through its primary.

If you connect it to a detector valve passing, say, 4 milliamperes, the effective inductance may be much lower than you expect and the results, taken as a whole, may not be good.

Probably the best way of using a transformer of this type, unless it is definitely

condenser, excellent bass amplification is to be obtained.

## Why Not Change the Tone?

I wonder how many amateurs have tried altering the tone of the reproduction in order to obtain the most pleasing results from the various items broadcast.

Some find that results are much improved by adding a fixed condenser to the output circuit. In one tone control that I have examined the user is able, by turning a knob, to connect four or five different condensers across the loud-speaker.

With the largest condenser connected the higher notes are, of course, greatly weakened, but some prefer to hear, say, a dance band this way. Others find that with a lower value the general results are better and there is no doubt but that when listening to distant stations the reception is often made a little more clear when the higher notes are weakened.

If you have a few fixed condensers you can easily try them across the loud-speaker, and you may well find an improvement results with a particular value. Loud-speakers and sets both vary a good deal in the manner in which the higher notes are handled, but values of .001, .002 microfarad and larger sizes are useful. One size is, though, rarely the best for all occasions.

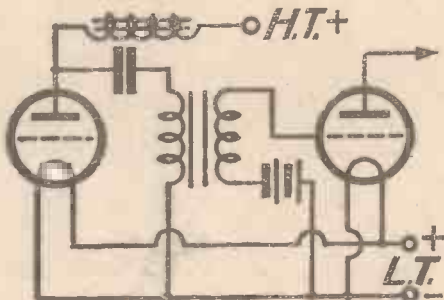
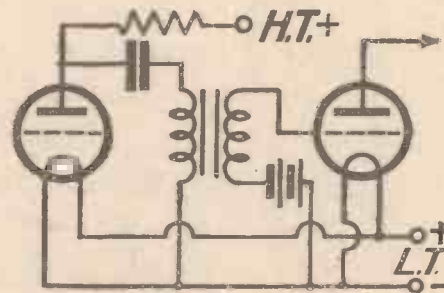

Here are two methods of by-pass feeding a transformer (above), resistance feed, and (below) choke feed

designed to work with a current of several milliamperes, is to use a resistance or choke feed, both of which are illustrated here.

With a resistance feed the voltage of the anode of the valve may be dangerously low, unless the high tension is fairly high, such as 150 volts or more. There is a fall in voltage across the resistance and with a battery of only 120 volts the results may suffer.

When a highly inductive choke is used, however, the drop in voltage is negligible, but the results are good. By properly proportioning the choke and the coupling

## "THE 'CENTURY SUPER' "

(Continued from page 674)

clearance—no parts touching. The grid condenser, you will notice, has one end fastened under a terminal and a small bolt and nut is fitted to the other end of the condenser. This is wired to the grid of the detector later on.

Be sure and tighten all valve-holder nuts before screwing them down. The valve-holder strip for the three filter coils is a great convenience, as it automatically spaces the coils by the right amount.

The metal covers of the filter coils, by the way, are connected to one side of the coils inside the covers and must, therefore, not be connected externally.

Batteries or a mains high-tension unit may be used. The set is not critical in any way and full details of the wiring and operation will be given in following issues. Meanwhile the construction can be proceeded with. Use only the recommended parts, as then you will be sure they will fit in the space available. You could use an ebonite panel instead of the wood if desired, but wood is quite satisfactory. Note also that the on-off switch has three points and not only two



# THE SET OF THE CENTURY

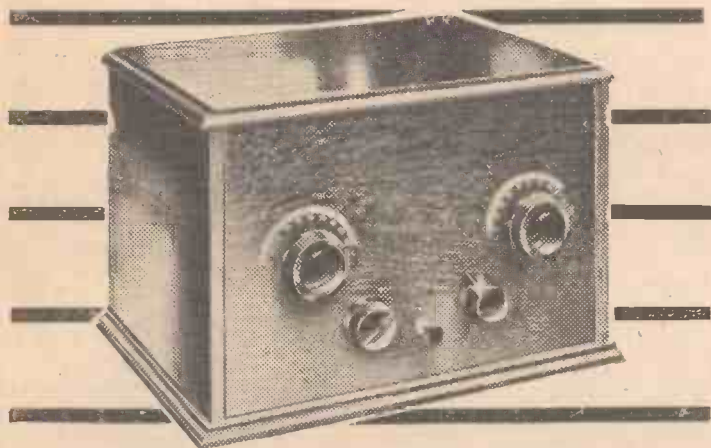

## COME AND HEAR IT

You are cordially invited to call for a free demonstration of the "Century Super" at our Showrooms at 159 Borough High St., London Bridge, S.E.1.

## SUPER DELIVERIES OF THIS SUPER SET

Ready Radio have made preparations for special high-speed deliveries of the "Century Super."

**NOW TURN TO PAGE 679**

## The Century Super gets 100 stations and gets them well

Just think of it! One hundred stations—all clearly separated. A fine choice of programmes from home and abroad, including America.

The "Century Super" is a thoroughly modern Super-het with none of the disadvantages of the old type of circuit. It gives truly remarkable selectivity, extreme range of reception, great volume, with excellent quality of tone and simplicity of control. It is the most modern of modern sets yet costs only £6 18 6 to build. If it is not convenient for you to send cash, post your order now and pay on delivery. Or you can order now and pay by easy monthly instalments.

Make sure of success by building your Century Super with a Ready Radio Kit.

### Ready Radio

159, BOROUGH HIGH STREET,  
LONDON BRIDGE, S.E.1.

Telephone: Hop 5555 (Private Exchange) Telegrams: READIRAD, SEDIST.

To Ensure Speedy Delivery, Mention "A.W." to Advertisers

# WE TEST FOR YOU

A weekly review of  
new components



and tests of  
apparatus.

Conducted by J. H. REYNER, B.Sc., A.M.I.E.E.

## The New Tannoy G.B.1 Unit

WE have tested this week a Tannoy mains unit suitable for A.C. supply. This is a combination unit supplying H.T., L.T., and grid bias, the latter being obtained in a somewhat unusual manner. The circuit which is used for feeding the trickle charge to the accumulator when the set is not in use is utilised during the working period for providing grid bias. This, therefore, enables an entirely separate source of grid bias supply to be obtained without any further cost or trouble, and moreover this grid bias is entirely independent of the H.T. supply.

The characteristics of the H.T. portion are of the usual order. We took one milliamp from the screen tap, 5 milliamps from the detector tap, and 15 milliamps from the power tap. Under these conditions the voltages were 70, 90, and 110 respectively.

On the trickle charge side we found that the unit charged a two-volt accumulator at .38 amp, while from the grid bias we were able to obtain 14, 6 and 2 volts. Each G.B. lead is fed through a series decoupling resistance with a condenser to earth, so that if an attempt is made to measure the voltage with an ordinary voltmeter, no reading is obtained. The

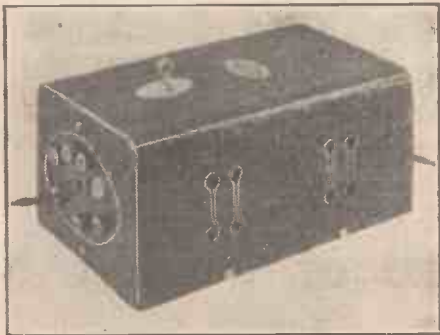

The new Tannoy type G.B.1 unit which gives H.T., grid bias and L.T. charging

voltage is delivered to the valves in a set quite satisfactorily, however, since the grid circuit takes no current if it is working correctly.

## Eta Valves

WE have already referred in these columns to the new Eta valves. We are reporting this week on a directly-heated A.C. power valve of considerable promise. As this valve is directly heated it can be used on battery sets if desired, where a 4-volt accumulator is available, the current consumption being 1.05 amps. This valve is designed to run at an anode voltage of 250, and has an amplification factor

of 3.5 with an impedance of 1,800 ohms. Our test gave values which were in agreement with these figures, the amplification factor being found to be 3.26 and the impedance 1,850.

This valve will handle a grid swing of 50 volts peak, under which conditions, with 250 volts on the anode, an undistorted output of 1,600 milliwatts can be obtained. We made a calculation on our own characteristics and found that this figure is quite correct, the optimum load being in the neighbourhood of 4,500 ohms. The valve, therefore, is worthy of particular attention, especially in view of the fact that its price is only 11s. 6d. Those readers who like to make their own calculations with regard to working conditions will be helped by the fact that the anode current-anode voltage characteristics of the valve are given, together with customary grid voltage-anode current curve.

The range of these valves is comprehensive, and we are unable from considerations of space to deal with each valve individually. We hope to report from time to time on some of the more interesting samples, but we recommend those who are looking for a good valve with a cheap price to apply for the complete list of these valves from Electrical Trading Association, Aldwych House, W.C.2.

## A New Peto-Scott Condenser

THE Peto-Scott variable condenser which we have tested this week is a pleasing job, both in appearance and handling. The condenser itself is provided with moulded bakelite end-plates, carrying at one end the combined bearing and one-hole fixing. The spindle is hollow and is provided with a concentric shaft which operates the slow-motion control through a train of disc drives, giving a double reduction resulting in a 16-1 motion. That is to say there are eight complete revolutions of the slow-motion knob in covering the 180 degrees. The slow-motion drive is very smooth, and indeed the condenser is one which can be rotated by placing a finger lightly on the outside of the slow-motion dial, and spinning it round. If one has any fine tuning to do this form of control is particularly convenient.

THE MOST UP-TO-DATE SET  
FOR RANGE, POWER, AND  
PURITY — "THE CENTURY  
SUPER"

The drive is such that if the main dial is turned round there is a tendency for the slow-motion dial to rotate sixteen times as fast. In other words the gearing is reversible, which is in some respects undesirable. However, by catching hold



A new Peto-Scott condenser fitted with a slow-motion device

of both knobs together, this effect may be avoided.

We measured the capacity in the laboratories and found that the maximum was .00045 microfarad, while the minimum was .000019. We should like to see the maximum slightly higher as this may somewhat restrict the tuning range at the upper end of the scale. On the whole, the condenser is an attractive proposition.

## A Novel Speaker Cone

ALTHOUGH the magnet unit is the crux of a good loud-speaker, the cone itself has a very marked effect on the results obtained, both as regards sensitivity and distortion by resonance. A light cone has an advantage as far as the reproduction of transients are concerned, since it rapidly takes up the motion of the armature. Rigidity is also a matter of supreme importance in obtaining a good response.

We have received for test two rather interesting 11-inch cones made by Messrs. British Electrical Development Association, Inc., of 15 Savoy Street, W.C.2. The material employed is a fine celluloid of exceptional lightness and rigidity, and it is therefore particularly suitable for loud-speaker use. Furthermore, this semi-transparent substance is attractive in appearance. One of the cones has a colour texture resembling marble, whilst the other has a woven texture of red, green and black.

Our expectations that this material would make an effective cone were realised on actual test. The reproduction of both speech and music was crisp and could be put up to the full strength on normal amplifiers without the slightest sign of dither.



# GET IT FROM READY RADIO

## THE CENTURY SUPER

### KIT A

(Less Valves and Cabinet, but including Wound Frame Aerial.)

£6 : 18 : 6

or 12 equal monthly instalments of 12/8

### KIT B

(Including Valves, Wound Frame Aerial, but less Cabinet.)

£10 : 14 : 6

or 12 equal monthly instalments of 19/8

### KIT C

(Including Valves, Cabinet and Wound Frame Aerial.)

£11 : 9 : 6

or 12 equal monthly instalments of 21/-

	£	s.	d.
1 Cabinet complete with wooden panel 12 in. by 6 in. and baseboard 12 in. by 10 in. ...	15	0	0
1 Frame aerial wound to specification ...	1	0	0
2 Jackson .0005 mfd. variable condensers, Tiny No. 2 ...	17	0	0
1 Colvern 50,000 ohm potentiometer ...	5	6	0
1 Readi Rad 3-point shorting switch ...	1	6	0
1 Set Wearite or Lewcos Super Heterodyne coils ...	2	10	0
6 Telsen 4-pin valve holders ...	6	0	0
1 Triple coil base ...	2	9	0
5 T.C.C. 1 mfd. fixed condensers ...	14	2	0
2 Telsen .001 mfd. fixed condensers ...	2	0	0
1 Formo .0002 mfd. "Mikadenser" ...	6	0	0
1 Readi Rad 1-megohm grid leak and holder ...	1	4	0
1 Telsen "Ace" L.F. transformer ...	8	6	0
1 Terminal strip fitted 3 6-B.A. terminals ...	6	0	0
1 Readi Rad 15,000 ohm. link resistance ...	1	3	0
1 Readi Rad 20,000 ohm. link resistance ...	1	3	0
1 Readi Rad fuse and holder ...	1	3	0
8 Belling Lee wander plugs ...	1	4	0
2 Spade terminals, red and black ...	3	0	0
1 Packet Readi Rad "Jifilinx" for wiring ...	2	6	0
6 Valves to specification, 2 S.G., 2 H.F., L.F. and Power ...	3	16	0
5 Yards thin flex, screws, etc. ...	11	0	0
<b>Total (including Valves, Cabinet and Wound Frame Aerial) ...</b>	<b>£11</b>	<b>9</b>	<b>6</b>

#### RECOMMENDED ACCESSORIES

	£	s.	d.
2 Fuller 60-volt "Super" capacity H.T. batteries ...	1	7	0
1 Fuller 9-volt grid bias battery ...	1	6	0
1 Fuller (S.W.X.9) 2-v. 40/80 amp. L.T. acu. ...	12	9	0
1 Celestion D.10 loudspeaker ...	3	0	0
or 1 Amplion cone loudspeaker A.C. 21 ...	1	19	6

Any Component can be supplied separately.

## IMMEDIATE DESPATCH ORDER FORM

To: Ready Radio (R.R. Ltd.), 159 Borough High St., London Bridge, S.E.1

**CASH ORDER.** Please despatch to me at once the goods specified for which I enclose payment in full of £ .....

**C.O.D. ORDER.** Please despatch to me at once the goods specified for which I will pay in full the sum of £ .....

**HIRE PURCHASE ORDER.** Please despatch my Hire Purchase order for the goods specified for which I enclose first deposit of £ .....

Cross out whichever does not apply.

Name .....

Address .....

KIT REQUIRED .....

Please Mention "A.W." When Corresponding with Advertisers

**ORDER NOW**  
**STRICTLY PRIVATE**  
**EASY PAYMENTS**

**ORDER NOW**  
**IT COSTS NO MORE**  
**PAY ON DELIVERY**

**IMMEDIATE**  
**DESPATCH**

Avoid delay and disappointment and the offer of unsatisfactory substitutes by ordering a complete kit of specified components from Ready Radio.

#### THE CENTURY SUPER

Completely assembled with valves, cabinet and wound frame aerial, ready for use and aerial tested.

Price ... .. **£14:10:0**

or 12 monthly payments of 26/6.

**WE PAY POSTAGE**

Inland orders post free or carriage paid. Overseas orders carefully packed for export and insured, all charges forward.

Buy all  
your radio from  
**Ready Radio**  
R.R.L.  
159, BOROUGH HIGH STREET,  
LONDON BRIDGE, S.E.1.  
Telephone Wop 5555 (Private Exchange)  
Telegrams READIRAD, SEDIST

## SETS OF DISTINCTION



# KOLSTER BRANDES

## A.C. PUP

Makers: KOLSTER-BRANDES LTD. Price: £8.10.0

SETS that are self-contained except for the aerial and earth, commonly known as consoles, are undoubtedly ousting all other types. Probably by next season we shall find the so-called table-cabinet set the exception rather than the rule. After all, the set maker who stops short at the mere set and leaves the set-buyer to choose a suitable loud-speaker for external connection, leaves rather a lot to chance so far as quality of reproduction is concerned.

Quite apart from this consideration, we must all appreciate the greater convenience of the console type of set as compared with the table-cabinet set needing external accessories.

It is a little unfortunate that the merits of the console type of set have so far had only a limited appeal owing to the fact that prices have been prohibitive so far as the ordinary listener is concerned. For this reason I welcome the Kolster Brandes A.C. Pup, which at £8 10s. needs only an aerial and earth to complete a very serviceable local-station installation.

### All Supplies from the Mains

Here is a two-valver working entirely from A.C. mains and reproducing on its self-contained loud-speaker full loud-speaker signals from stations within service range. The design and construction of this set follows Kolster Brandes traditions, in that there is no unnecessary waste of material. As the pictures show, the Kolster Brandes A.C. Pup is notable for its simplicity, both externally and internally.

This set is suitable for A.C. supplies of 100 to 120 volts (model KB252), and for 200 to 250 volts (model KB253), with periodicities between 40 and 60 cycles. As readers probably know, a battery version of the Pup has been on the market for some time and was reviewed in the October 11, 1930, issue of AMATEUR WIRELESS.

A good point about the mains operation is that the back of the cabinet cannot be removed without automatically breaking the electric supply. So if one wishes to inspect the interior, one can do so without the least danger of touching a live part. The mains transformer is fitted with three terminal screws, and before the set is put into operation it is necessary to connect the flexible lead to the appropriate terminal.

The two valves are arranged in the sequence of detector and power output. One has a choice of Mazda, Mullard, and Osram A.C. types. The set tested had a Mazda AC/HL detector, and a Mullard 104V output valve. In addition to these two valves, the set was supplied with a Philips 506K rectifying valve for the high-tension and grid-bias supply.

The arrangement of the controls can be seen from the picture. There are two knobs mounted on the top of the cabinet with 0-to-180 degree scales. The left-hand knob is the aerial-tuning control, and the right-hand knob is the reaction control. Mounted on the left-hand side of the cabinet is the aerial-earth terminal board, comprising four sockets providing two alternative aerial connections, an earth connection, and a wave-band switching device.

To receive long-wave signals between 1,000 and 2,000 metres the wave-range plug



With the exception of the aerial the Kolster Brandes A.C. Pup is entirely self-contained

is removed from the short-wave socket and the aerial inserted in one of the two aerial terminals at the top of the terminal board. For the medium-wave stations the flexible lead is plugged into the short-wave socket. With this connection the tuning range is approximately 210 to 530 metres, when the set is used with an average size of aerial.

From tests I can say that operation is easy and the control smooth in action. The very clear engraving of the two dials was a pleasing point noted during reception tests.

### Selectivity

The choice of aerial terminal A2 or A1 is determined by the distance of the local station and by the length of aerial connected to the set. I found that terminal A1 provided considerable volume from the local stations, but terminal A2 was utilised to bring in both Brookmans Park stations clear of mutual interference.

The London National came in at 30 degrees and spread to 20 and 42 degrees. This is quite a reasonable spread in view of the considerable volume of sound obtained at the maximum tuning point. London Regional, at 82 degrees, was quite clear of interference. It spread to 70 and 95 degrees.

Midland Regional was logged at good loud-speaker strength at 140 degrees. In view of the fact that these results were obtained on an indoor aerial of 50 feet total length, I feel justified in giving this set a pat on the back.

With a little care in manipulating the reaction dial, I obtained Brussels No. 1, Langenberg, the new Sottens station, Toulouse, Strasbourg, Bordeaux, Rome, and Heilsberg. These distant stations came in at fair loud-speaker strength, although some of them naturally suffered from local-station interference.

### Good Quality

Turning to the long waves, and using aerial terminal A1, I got Daventry at great strength at 50 degrees. I was surprised to hear Zeesen at 60 degrees, although it suffered from some interference from Daventry. Radio Paris was strong at 73 degrees, as was Eiffel Tower at 38 degrees. Using the other aerial terminal, I got 5XX at 80 degrees and Radio Paris quite clear of it.

During these tests I was able to listen critically to the quality of reproduction, which, for such an inexpensive set, is really pleasing. There is an accessible adjusting screw on the front of the cabinet for the loud-speaker. There was no chattering even at full volume on the local stations.

Provision is made for the connection of an external loud-speaker. Two connecting sockets are fitted at the right-hand side of the cabinet, and two plugs are supplied for connecting extension lines for the additional loud-speaker. SET TESTER.

### COSSOR ALL-ELECTRIC TWO-VALVER

In connection with last week's test report on this excellent two-valve set for A.C. mains, "Set Tester" asks us to state that the price of £7 10s. od. was incorrect. Actually the list price of this set, complete with valves is £11 10s. od. We greatly regret the error and we commend readers interested to write to A.C. Cossor Ltd. for further details.

### ELIMINATING NOISE

LOW-frequency noise in a mains-driven set can sometimes be cured by putting a choke coil, shunted by a condenser, in the plate circuit of the detector valve. Of course, the most thorough remedy is to decouple all the valves by inserting high-resistance shunts and condensers in the ordinary way. But as the detector valve is the most sensitive link in the chain of amplification, the trouble can sometimes be eliminated there. One of the windings of a discarded L.F. transformer will save the cost of buying a special choke coil for this purpose. B. A. R.



# 3 WAY PLAN FOR THE CENTURY SUPER-HET

**C.O.D**



**CASH**

PAY THE POSTMAN — it costs no more  
— WE PAY ALL CHARGES.  
ON ALL ORDERS OVER 10/-

Strict Privacy Guaranteed  
on all H.P. Orders

with order—Carriage Paid

**DELIVERY UP TO THE MINUTE!**



**KIT "A"**

Complete Kit less  
Cabinet, Valves and  
Frame aerial

**£5-6-6**

or 12 monthly  
payments of

**9/9**

As above with Frame Aerial

**£6-6-6**

or 12 monthly  
payments of

**11/7**

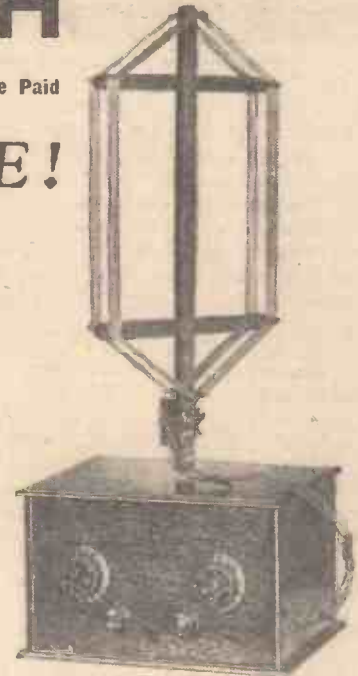

## CENTURY SUPER-HET Kit of parts as specified by A.W.

2 .0005 mfd. Variable Condensers with slow motion movement. Peto Scott	£	s.	d.
1 50,000 ohm wire wound potentiometer. Sovereign		4	6
1 Three point shorting switch. Ready Radio		1	6
1 Set of Super-heterodyne coils. Wearite or Lewcos	2	10	0
6 Valve holders. Telsen		6	0
1 Triple coil base. Peto Scott		2	9
5 1 mfd. Fixed condensers. Franklin	10	10	0
2 .001 mfd. Fixed condensers. Graham Farish		2	0
1 .0002 mfd Fixed condensers. Formo or Ormond		6	6
1 Grid leak holder		6	6
1 1 meg. Grid leak. Telsen		1	0
1 Low Frequency Transformer. Telsen "Ace"		8	6
2 Spaghetti resistances, 15,000 and 20,000 ohm. Keystone or Lewcos		3	0
1 Fuse holder and fuse. Ready Radio or Bulgin		1	3
8 Wander plugs marked H.T.—, H.T.+1, H.T.+2, H.T.+3, H.T.+4, G.B.—, G.B.—1, G.B.—2, Belling Lee		2	0
2 Spade Terminals L.T.—, L.T.— Peto-Scott.			3
Koneceterkit. Terminal strip with three small terminals for baseboard mounting, (Peto Scott)			
5 yards of thin flex, glazed connecting wire, fixing screws, bolts and nuts, etc.			

\* Fitted with J.B. "Tiny" Condensers 5/- extra

**KIT "A"** As above less valves, Cabinet and Frame Aerial. **£5.6.6**

or 12 monthly payments of 9/9.  
**KIT "A"** with Frame Aerial **£6-6-6**  
or 12 monthly payments of 11/7.

**KIT "B"** As above with valves but less Cabinet and Frame Aerial **£9-2-6**  
or 12 monthly payments of 16/9

**KIT "B"** with Frame Aerial **£10-2-6**  
or 12 monthly payments of 18/7.

**KIT "C"** Complete with Valves, Cabinet and Baseboard, Panel and Frame Aerial. **£10-17-6**  
or 12 monthly payments of £1-0-0.

## SPECIFIED ACCESSORIES

Handsome Polished Oak or Mahogany Cabinet with figured oak panel 12" x 8" ready drilled and 6 ply baseboard 12" x 10"	£	s.	d.
CENTURY SUPER FRAME AERIAL	1	0	0
2 REELS SPECIAL FRAME AERIAL WIRE	4	6	
Oak panel polished and drilled 12" x 8"	2	0	
6 ply baseboard	1	0	
Ebonite panel 12" x 8" x 3/8" drilled	4	6	
1 Green Triangle 120V. H.T. Battery, Drydex	18	6	
1 Grid Bias 9V Battery, Drydex	1	4	
1 20/40 Accumulator	9	6	
6 Mullard Valves, 1 P.M.1.L.F.: 2 P.M.1.H.F.: 1 P.M.2 : 2 P.M.12	3	16	0

ANY PARTS SUPPLIED SEPARATELY  
If value over 10/- sent C.O.D.

**FINISHED INSTRUMENT**

Fitted with Valves, Cabinet and Frame Aerial **£12.7.6**

Royalties **£1 10 0**

Or by 12 monthly payments of **£1 5 6**

NOTE : Batteries extra.

**FREE** with every Kit a Koneceterkit containing all screws, nuts, bolts, etc., terminal strips, 5 yds. flex and glazed connecting wire.

**FREE** to every purchaser of the CENTURY, a full sized diagram and copy of "Amateur Wireless" containing constructional details.

**FREE** CENTURY owners become entitled to free technical advice and assistance.

Customers ordering the £5.6.6 "Kit A" are supplied with matched knobs in mottled oak effect to tone with the polished oak panel.

**WE HAVE ADEQUATE STOCKS OF EVERYTHING FOR THE CENTURY SUPER-HET. ORDER NOW AND SAVE DELAY.**

## PETO-SCOTT CENTURY FRAME AERIAL

AS ILLUSTRATED, IN POLISHED OAK OR MAHOGANY **20/-**

Supplied with accurate fitting bearing bush, wave-change switch, three way leads and six spacers. Each strand of wire is enamelled and cotton covered overall which ensures maximum results. Correct centre-tapped. This is a new type frame aerial designed at the request of "A.W." by Peto-Scott himself. No substitute will do. Beware of imitations. You must have a Peto-Scott Century Frame Aerial to ensure proper results.

**CABINET.** Specification : Handsome Polished Oak, 12" x 8" x 10" deep. Fitted with figured oak panel polished and drilled, also 12" x 10" 6-ply baseboard. Oak or Mahogany. **15/-**

**EXPRESS ORDER FORM**

To PETO-SCOTT CO. LTD.

Please send me **C.O.D./CASH/H.P.**

\_\_\_\_\_

\_\_\_\_\_

\_\_\_\_\_

for which I enclose **Cash / H.P. Deposit**  
£ s. d.

Name \_\_\_\_\_

Address \_\_\_\_\_

\_\_\_\_\_

A.W. 25/4/31

# PETO-SCOTT CO. LTD.

77 CITY ROAD, LONDON, E.C.1: Clerkenwell 9406. 62 HIGH HOLBORN, LONDON, W.C.1  
Chancery 8266. MANCHESTER: 33 WHITELOW ROAD, CHORLTON-CUM-HARDY. Phone:  
Chorlton-cum-Hardy 2028. NEWCASTLE, STAFFS: 7 ALBANY ROAD. Phone: 67190.

Advertisers Appreciate Mention of "A.W." with Your Order



# SOME SHORT-WAVE HINTS

By J. H. REYNER, B.Sc., A.M.I.E.E.

THE idea that short waves are something mysterious, requiring a technique of their own, is rapidly disappearing. Reception from incredible distances can be carried out by those who have never before handled a short-wave set. On the transmission side the improvements which are being made in aerial design are gradually reducing the fading.

Broadcast reception in the old days used to be very much more fun than it is now. The reception of distant stations was then a matter of real skill. Some of this pleasure still can be found to-day by receiving on the ultra-short waves below 50 metres, because a certain delicacy of handling and ability in tuning is still necessary for best results.

## Short-wave Receivers

Now, a short-wave receiver is exactly the same as a broadcast receiver in its essential principles. The only differences are in the values of the components in the circuit to allow for the very much higher frequency currents which are being received. Due to this high frequency, it is not customary to use high-frequency amplification to any serious extent on these ultra-short wavelengths. One can design circuits for such amplifiers, and, in fact, I myself have made receivers embodying one stage of H.F. amplification, in which a definite step-up was obtainable. The amplification, however, is much less than on the broadcast band, and it is customary to use either a straight detector circuit or a super-heterodyne arrangement. I propose to deal more particularly with the simple detector in the present article.

## Frequency Separation

The diagram shows a simple short-wave circuit. It is similar to an ordinary detector circuit, but one or two precautions must be taken in order to obtain the best results. In the first place, a good slow-motion dial or condenser must be used. Tuning is very much sharper on these short waves, and a little thought shows the reason why. Telephony stations occupy something like 10 kilocycles in frequency, perhaps a little more, since we have side bands extending for 5,000 kilocycles on each side of the carrier wave. The medium waves (200 to 600 metres) extend from 500 to 1,500 kilocycles, and, therefore, on this basis we have room for one hundred stations.

Let us assume that the coil is now replaced with one having one hundredth of the original inductance. The capacity range of the condenser will remain substantially the same, so that our wavelength range will be 20 to 60 metres, corresponding to a frequency range of 5,000 to 15,000 kilocycles. In this band, therefore, we have room for 1,000 stations, i.e., ten times as much as on the broadcast band.

Consequently, tuning will be very much sharper, each station occupying only one tenth of the space normally occupied on a broadcast receiver, even by a distant

station. As a result, it is usual to reduce the wavelength range covered by the condenser. This is conveniently done by using a capacity of perhaps .0002 or .00025 maximum, which automatically reduces the frequency range, since the minimum remains approximately the same. We still cover this frequency range with the full hundred degrees of the dial, so there is proportionately more space for each station.

The next precaution is the use of a very good slow-motion dial, which must be absolutely free from backlash.

If a slow-motion condenser is used, care must be taken to employ a suitable type. For example, it is found that condensers in which steel balls are used in a brass housing are liable to give noises due to contact potentials which are set up between the two dissimilar metals. Some condenser manu-

facturers overcome this defect by using phosphor-bronze balls instead of steel balls in condensers specially intended for short-wave use.

It is sometimes found necessary to use, say, a 3- or 4-turn tuning coil with a 6- or 8-turn reaction coil. Otherwise the circuit cannot be made to oscillate. This, however, is not a satisfactory solution because the tune of the reaction circuit will be found to be higher than the minimum of the tuning circuit, and this being the case, oscillation will occur at the frequency of the reaction circuit, and not at the setting to which the tuning circuit is adjusted. Since in searching one always has to use the receiver towards the oscillation point, it will be seen that the reaction circuit takes control, and prevents the receiver from being tuned down to the correct wavelength.

## Reaction Effects

The only remedy is to find out why the circuit is requiring such a large reaction

Here is the circuit of the tuning and detector arrangements of a good short-waver. As explained in the accompanying article, the reaction coil is smaller than the grid coil. Note the H.F. by-pass condenser and the potentiometer bias arrangement with a 3-megohm leak. This simple detector stage will work with most low-frequency amplifiers, one or two valves being needed

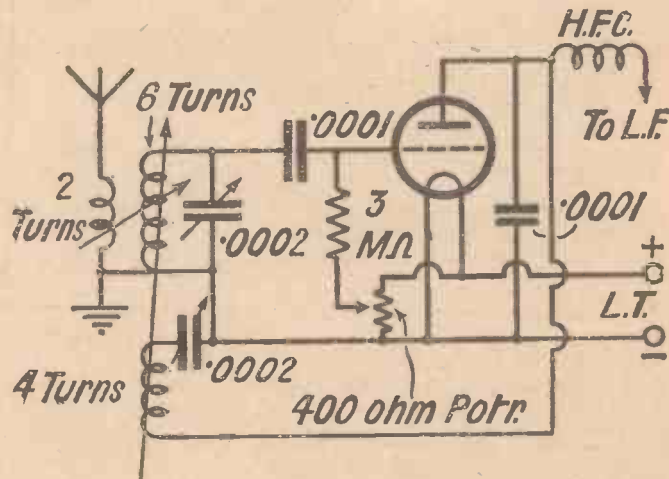

facturers overcome this defect by using phosphor-bronze balls instead of steel balls in condensers specially intended for short-wave use.

## Coils

We have seen that it is almost essential in short-wave reception to limit the frequency band covered in any one range. This means a number of interchangeable coils, going progressively lower in wavelength, each designed to cover a convenient band when tuned with, say, a .0002 condenser. In this connection reference may be made to a difficulty which is sometimes experienced when using plug-in coils. We have assumed that it is possible to obtain a minimum capacity of 50 micro-microfarads, and this with a maximum capacity of .0002 will give us about 2 to 1 in wavelength. It is often found, however, that a circuit will not tune down to the theoretical minimum value. The maximum value is in accordance with the calculations, but it appears to be impossible to tune below a certain value, however carefully the circuit is laid out.

The reason for this is usually that there is some other circuit coupled to the tuning circuit, which is itself tuned to a higher value than the minimum of the tuning circuit. The most common source of trouble

coil. This is usually due to bad layout. The leads between the condenser and the coil in the tuning circuit should be kept short, and relatively close together. About half an inch separation is quite sufficient. The leads from the tuning circuit, as a whole, to the valves may be several inches in length without causing any difficulty. See that the high-tension tapping has a condenser across it, and generally construct the circuit in accordance with the best principles of broadcast practice. If this is done it will be found that the circuit oscillates much more readily, and a smaller value of reaction coil can be used. Strictly speaking, the reaction coil should never be larger than the tuning coil, and should preferably be about half the size for the best results.

Another cause of this failure to tune may be found in the aerial circuit. Particularly if a long aerial is being used, there are resonant points obtained where the frequency being received corresponds to the natural frequency of the aerial or to the harmonics thereof. The remedy here is to change the aerial coil or to move it farther away from the tuning coil. Alternatively, a small series .0001 condenser may be connected to the aerial lead. In any case, the aerial coupling coil should not exceed about two turns.



# VALVES FOR D.C. MAINS

## THREE NEW AMAZING MAZDA VALVES



Mazda Engineers are again first in the field, this time with Valves specially designed for operation from D.C. Mains. The characteristics are approximately the same as those of the well-known Mazda A.C. Valves, and the efficiency of the Valves is equally good in all other respects.

Economical working is ensured by the very low current consumption, which is only half that of other mains valves.

These valves are fully described in an article in the "Wireless World," issued January 7th, 1931, giving full data and suitable circuits, a reprint of which will be gladly sent on application.

The three types at present available are:—

D.C./S.G. (25/-)

D.C./H.L. (15/-)

D.C./PEN. (17/6)

and are in stock at all good radio dealers.

**D.C./S.G.**

A.C. resistance 600,000 ohms. Amplification factor 1,200. Mutual conductance 2mA/volt. Max. anode voltage (Ea) 200. Screen, voltage (Es) 80. Filament volts 6. Filament current 0.5 amp.

**D.C./H.L.**

A.C. resistance, 12,000 ohms. Amplification factor 3.0. Mutual conductance 2.5 mA/volt. Maximum anode voltage (Ea) 200. Filament volts 6. Filament current 0.5 amp.

**D.C./PEN.**

Mutual conductance 2.5 mA/volt. Maximum anode potential 250. Maximum auxiliary grid volts 200. Filament volts 8. Filament current 0.5 amp.

# MAZDA

THE  
BRITISH  
VALVES



**THE EDISON SWAN ELECTRIC CO. LTD.**

*Incorporating the Wiring Supplies, Lighting Engineering and Radio Business of the British Thomson-Houston Co. Ltd.*

Radio Division

155 Charing Cross Road, London, W.C.2

Showrooms in all the Principal Towns

# EDISWAN

V 120

Don't Forget to Say That You Saw it in "A.W."



**"Free" Wireless Sets**

SIR,—In regard to the controversy prevailing in connection with the coupon gift schemes, I can frankly state that, as applied to gift cameras, the system has been very beneficial to the photographic industry as a whole. Enormous quantities of free cameras have been distributed which are useless without films, and the films are sold entirely through the recognised dealers.

The sale of films for these cameras has been very large indeed, and the profit to the retailer on these alone greatly exceeds any profit he would have made on the sale of the cameras. Further, developing and printing are required, and this service also is obtained through dealers, and already there is evidence that users of these free cameras are led to acquire better-class instruments to improve their results.

A. C. B. (Editor, *The Photographic Dealer*).

SIR,—In reference to the letter about gift scheme sets, I feel that your correspondent is taking a very narrow view of this matter. To our knowledge some

43,000 two-valve sets have been supplied under this scheme to the public without batteries or accumulators—which means that the latter must have been purchased through retailers, the H.T. batteries probably at a cost of 12s. each, grid-bias batteries at 3s. 6d. each, and accumulators at 14s. 6d. each. Wireless retailers are benefiting every week through the charging of the 43,000 accumulators. Moreover, as the range of a two-valve set is necessarily limited, the tendency is eventually to go to the local retailer for a three- or four-valve set which will bring in foreign stations.

If thought is given to the matter it will be realised that the majority of people who have obtained these goods from coupons would never have troubled with them if they had had to pay for them, and the coupon scheme, therefore, introduces an entirely new wireless public which must eventually benefit all sections of the industry, including the retailers.

If manufacturers refused to provide goods for the coupon schemes, what would be the result? The tobacco companies are well

supplied with capital, and it would be a small matter for them, as I have actually heard threatened, to start their own factories for the manufacture of gifts.

W. H. S. (Elm Mfg. Co., Ltd.).

**Linen-diaphragm Speakers**

SIR,—I have made up several linen-diaphragm loud-speakers, but in every case I have more or less deviated from printed instructions. I now wish to make up one of your designs, but would like to be advised on certain particular points before making a start. What, in your opinion, is the best dope to use and how should the dope be applied? If you can give me information on these points, I think I shall be able to improve upon my other attempts.

J. G. (Walsall).

Use collodion or one of the proprietary dopes. The linen should be doped before being stretched. The diaphragm centres should then be joined together and the stretching process should be begun whilst at the same time further coats of dope should be applied. Dope and stretch alternately until the diaphragm, when flicked with the finger, gives forth a

(Continued on page 686)



**MOVING COIL SPEAKER**

**1 DIAPHRAGM MATERIAL**  
A new material produced after exhaustive tests; a distinct advance on anything used before. Rigid centring allows for free parallelling.

**2 FIELD STRENGTH**  
9,000 lines per sq. cm. in the gap, giving extreme sensitivity coupled with ability to handle almost unlimited power. Permanent magnet requires no energising.

**3 CONSTRUCTION**  
Robust Diecast Aluminium housing makes this a most workman-like job, and every detail has the honest finish associated with all PARMEKO apparatus.

**4 OUTPUT TRANSFORMER**  
In special base; series-parallel change-over (no loss of efficiency) from 11:1 to 22:1 and from 2,000 to 8,000ohms primary impedance for pentodes, etc.

REAR OF BASE WITH OUTPUT TRANSFORMER

Prices: Speaker only £6:10:0 Output Transformer in base 30/-

Further details from

Ask your local dealer to demonstrate

**PARTRIDGE & MEE LTD.,**

25 Dover Street, Leicester, and 74 New Oxford Street, London  
Phone Leicester 22276 Phone Museum 5070



# SPECIFIED FOR THE "CENTURY SUPER"

## ADDITIONAL WEARITE COMPONENTS FOR THE "CENTURY SUPER"



**WEARITE DUAL-RANGE FRAME AERIAL**

Entirely new in design and embodying exclusive features which give extremely high efficiency. The windings are of Litzendraht wire, carefully wound at even tension throughout, in order to maintain the accuracy of spacing. The winding is centre-tapped and provided with the necessary three terminals for connection to set. The change from short to long waves is affected by means of a switch at the base: no other alterations to connections are necessary. The frame aerial swings through 180 degrees and is mounted on a polished mahogany base. It is of particular

ly handsome appearance.

PRICE **42/-**



**WEARITE THREE-POINT SHORTING SWITCH**

Push-pull action. Sound self-cleaning contact. With insulated spindle.

PRICE **1/6**

**WEARITE GRID-LEAK HOLDER**



Has new type contact spring clips. Fits any size grid leak.

PRICE **6d.**



**WEARITE FIVE-PIN VALVE HOLDER**

Robust construction. Sprung sockets ensure good contact. Fitted with terminals and soldering tags.

PRICE **1/3**

The Coils chosen by Mr. W. James for his "Century Super" are made specially by Wright & Weaire Ltd.

The outstanding performance of this receiver is only made possible by the use of Wearite SUPER-HET COILS.

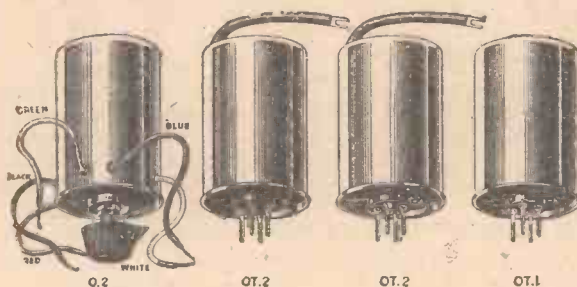

The Oscillator Coil is designed for panel mounting and is fitted with flexible connecting leads. The three long-wave coil units are fitted with standard valve pin bases so that they may be mounted in ordinary 4-pin valve holders.

Price of complete set of coils **50/-**

(Illustrated descriptive leaflet explaining the unique construction of these coils will be sent on request.)



**TRIPLE COIL BASE**

Base for above coils, complete with terminals and tags. Coil sockets are sprung similar to valve holders.

PRICE **2/9**

Send for Free Illustrated Lists

# WEARITE

## COMPONENTS

WRIGHT & WEAIRE LTD.

740, HIGH ROAD, TOTTENHAM, N.17

Telephone : Tottenham 3847-8-9

Don't Forget to Say That You Saw it in "A.W."

## "READERS' IDEAS AND QUESTIONS"

(Continued from page 684)

definite "ping." This is the best procedure to follow, but be very careful that the diaphragms do not split at the centres.—ED.

### Are Crystal Sets Dead?

SIR,—In a recent issue the question is asked, "Are Crystal Sets Dead?"

As far as I am concerned the answer is in the negative. I am the possessor of three sets, (1) screen grid, detector, low frequency; (2) detector and one low frequency; and (3) crystal. I use the valve sets for loud-speaker reception and for foreigners, but whenever I wish to listen in with 'phones to London I invariably use the crystal. While admitting that a cone speaker, driven by a super-power valve is superior for orchestral music, yet as far as speech is concerned I have never found the humble crystal set and 'phones surpassed.

Surely there is ample scope for research for improving the sensitivity of crystals and 'phones?

G. R. W. (London, N.4).

### "Stations Rolling In"

SIR,—I have just completed building the "1931 Ether Searcher," but I have not had time to give it a fair trial. The stations come rolling in one after another and I should say it is all that you claim it to be. I work it from the mains by adding an Ecko unit and it sounds O.K. I am working the set with a Blue Spot loud-speaker.

T. J. L. (Plymouth).

## OUR LISTENING POST

by JAY COOTE

SO far as my log is concerned, the number of Swiss stations has now been reduced to two, namely, Söttens and Beromuenster. From the former, nightly, you may get concerts from either Geneva or Lausanne; from the latter, entertainments from Berne, Zurich, or Basle. By now, Beromuenster may be working regularly and its wavelength is such that it is fairly clear from any interference, the only trouble now and again being caused by ship morse. Bear in mind that, as the question of languages has now been definitely settled, from this station in future we shall only hear German, from Söttens only French; and Berne has given up its bi-lingual announcements. The call at the moment is, "*Hier der, Deutsch-Schweizerische Landessender*" (National transmitter), and the interval signals differ according to the origin of the broadcast. Although the transmission is a powerful one, for some reason I have not been getting it at the same volume as that from Söttens. (Basle, by the way, has adopted a new interval signal; it consists of a very musical carillon of bells.)

Lahti of late has been a prominent station in my log, as towards 8 p.m. B.S.T. it invariably provides a full loud-speaker broadcast. It is useless to search for this station at a late hour, except on Saturdays, when dance music is relayed from the Restaurant Porssi at Helsinki. On ordinary weekdays you will hear the lady announcer wish you a cheerful "*God Natt!*" as soon as she has given out the Swedish and Finnish news bulletins at about 9.15 or 9.30 p.m. B.S.T.

You would do well to stand by for invigorated transmissions from Königswusterhausen, as I understand that work on the new 75-

kilowatt plant is completed and this station will come on the air shortly with its full power.

In the later evening hours have you picked up broadcasts by Vienna on a wavelength above 1,000 metres? Tests are being carried out to find a suitable site for the projected high-power station and in the meantime, after programme hours, experiments are being made on the long waves. Vienna, in imitation of its neighbours, intends to add a 75 to 120-kilowatt to its radio system.

Also, in the immediate vicinity of Riga on some evenings for an hour or so you may pick up tests by Genoa, which is doing its utmost to find a favourable position in the waveband. Wilno, with its 21 kilowatt, is too hefty a bed-fellow to be disregarded, and the Italian is seeking its own place in the sun.

As regards the Dutch studios, the official "quarterly farce" has been revived; Huizen is now Hilversum, and Hilversum has reverted to the character of Huizen and will remain so for another three months.

During the past fortnight, more favourable conditions having prevailed, I have been able to tune in at fair strength both Dublin and Cork, and have listened to some of the sponsored programmes. On Mondays, between 9.30 and 10.30 p.m., you might turn to Ireland, as in connection with these entertainments you will find interesting competitions. The inclusion of publicity puffs in these broadcasts has led some readers to believe that they had reached out to the United States!

Search no longer for Radio Catalana (Barcelona EAJ13), as the station has been dismantled; it is now in course of erection at Valencia, where, I understand, it will operate on the same wavelength in the distant future.

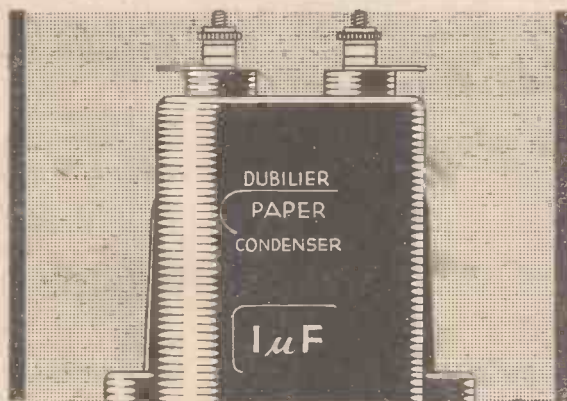

5 Dubilier  
1 Microfarad  
Condensers

Specified  
for the "A.W."  
Century Super

Dubilier Condensers were chosen for the "A.W." Century Super because of their obviously fine quality and reliability.

Follow the designer and be sure that you get Dubilier Condensers.

BRITISH MADE

**DUBILIER**  
CONDENSERS



# THE AMPLION POPULAR RANGE

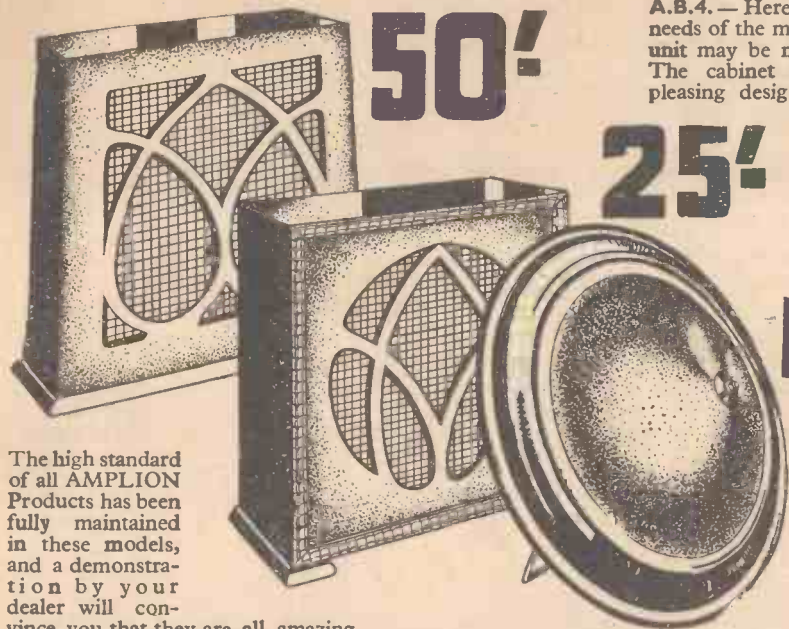

The high standard of all AMPLION Products has been fully maintained in these models, and a demonstration by your dealer will convince you that they are all amazing value for money. Ask for a folder illustrating all new AMPLION Speakers. Or write direct to:—  
Graham Amplion Ltd., 26 Savile Row, London, W.1.

**50"**

**25"**

**15"**

**A.B.4.**—Here is a speaker that in every way meets the needs of the most discriminating. The balanced armature unit may be matched to power valve or Pentode output. The cabinet is built on modern lines of particularly pleasing design. Price, Oak 50/-, Walnut 59/6

**A.C.6.**—A cabinet model of attractive appearance and really surprising tone. This speaker is fitted with a new and improved unit. The most outstanding speaker value of the year. Standard shaded Oak finish. Price 25/-.

**A.C.2A.**—Better even in performance and appearance than the famous Guinea-Cone, this 'popular' model is fitted with an entirely new unit mounted in an open cone, Standard finish black and silver, fitted for standing or hanging. Price 15/-.

**ASK YOUR DEALER FOR A DEMONSTRATION**

# AMPLION

## THIS IS THE DIAL

that will give you that ideal tuning. Firm, smooth, no slip! Praised and used by the Technical Press.

**"ASTRA"**  
FAST & SLOW MOTION  
DIAL

"Astra" dials have a geared action which is precision itself. There is no trace of backlash and action is noiseless and firm. Direct drive is obtained by simply switching up the lower knob. Fits any condenser spindle. Easily mounted. Various attractive finishes.

"Astra" "Popu'ar" 3" diam. 3/-  
"Astra" Type No. 1 3" diam. 3/6  
"Astra" Type No. 2 4" diam. 5/-

"Astra" are the only dials manufactured under Ormond licence



"ASTRA" POPULAR MODEL



"ASTRA" PRODUCTS ARE OBTAINABLE FROM ALL DEALERS

## MAKE YOURS A MAINS SET FOR LESS THAN £3

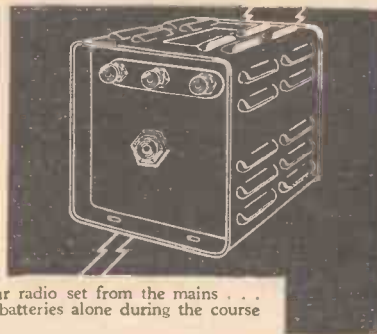

If your house is supplied with alternating current, as little as £2 15s. will enable you to run your radio set from the mains . . . less than you would spend on dry batteries alone during the course of a year.

As you know, a rectifier is necessary when employing alternating current to run a wireless set.

The H.T.5, priced at 15/-, is a particularly popular style.

Of the many types of rectifier obtainable, none can claim so many virtues as the "Westinghouse." It is all-metal . . . substantial . . . compact . . . never needs attention . . . and its life is so prolonged we haven't yet been able to determine its limit.

If you think of converting an existing battery-driven receiver to mains-driven, or building a new one, send for the booklet, "The All-Metal Way, 1931," which tells you all about the Westinghouse Metal Rectifiers, and also contains chapters on high-tension trickle-charging, low-tension trickle-charging, moving-coil loud-speakers, general principles and methods of rectification, smoothing, transformers for eliminators and the voltage doubler circuit, voltage dropping, etc. (Please enclose 3d. for your copy.)

## WESTINGHOUSE METAL RECTIFIERS

THE WESTINGHOUSE BRAKE & SAXBY SIGNAL CO., LTD.,  
82 York Rd., King's Cross, London, N.1. Phone: North 2415

Mention of "Amateur Wireless" to Advertisers will Ensure Prompt Attention





**BAGDAD ON THE SUBWAY**, John Watt's radio vision of New York, will be given a second presentation on May 5 (National) and 6 (Regional). The cast for this impression in sound of modern America will be composed mainly of Americans.

Two seaside programmes for National listeners are from Hastings, on April 26, when Julius Harrison conducts the Hastings Municipal Orchestra in the White Rock Pavilion, and on May 2, when the Society of Symphonic Players of Brighton and Hove plays in the Dome, Brighton.

The first of a series of talks entitled "Idle Thoughts," will be broadcast by Mr. Denis Mackail on May 1, as a continuation of Mr. Harold Nicolson's recent commentaries on "People and Things." Other speakers in the new series will include Lord Ponsonby, Captain Robert Hartman, Mr. Compton Mackenzie, and Mr. Harold Nicolson.

The National Orchestra of Wales gives a light orchestral concert on May 9, which will be relayed on the Daventry National and London Regional wavelengths.

A concert from the Royal Pump Room, Leamington Spa, will be broadcast to Midland listeners on May 2.

Mr. Joe Corrie, the miner dramatist, is also a poet, and he has just published a new book of verses entitled "The Road the Fiddler Went." He will broadcast a reading from these on April 28.

A relay station is shortly to be erected at Pietermaritzburg, Natal, as the reception of the Durban station is very poor in this town and district. This new station will take the Durban programmes; the wavelength has not yet been decided.

Midland listeners will be taken over to the Birmingham Children's Hospital during the Children's Hour on April 28 when the speeches on the occasion of the presentation of the Second Midland Radio Circle Cot to the Governors of the Hospital will be relayed. This will be the second cot which the Midland Radio Circle has presented to the Children's Hospital. The endowment for each cot is £1,000, all of which has been derived from Radio Circle subscriptions.

The Prime Minister, Mr. Ramsay MacDonald, will give an Empire Day broadcast from the National transmitters on May 23.

One of the most popular plays of the broadcast studio was *Dr. Abernethy—His Book*, which was first heard by listeners in February. It is to be repeated on May 18 (Regional) and May 20 (National) by request.

On April 30 a new play called *Runaway Matches*, by the Yorkshire dramatist, Edwin Lewis, will be broadcast from Newcastle. The play deals with Gretna Green.

A new revue by Graham Squiers entitled "Baa Baa, Moo Cow, Have you any Eggs?" will be broadcast from the Birmingham studios by a group of well-known revue artists on May 9.

The African Broadcasting Company is considering the erection of a new station to replace the present one, in addition to short-wave transmission stations proposed to Cape Town and at Durban.

The Federal Radio Commission recently granted licences to film "caravans" fitted with short-wave 50-watt transmitters to keep in touch with thousands of film actors, sometimes scattered over miles of desert terrain and broken country.

Which country has the highest proportion of listeners? Denmark reached a total of 429,333 radio receiving licences in 1930, including 9,400 free to the blind, cripples, and the chronic invalids. There are about 800,000 families in Denmark, and 53.7 per cent. of these have receiving sets, probably the highest percentage in the world.

## Now a BRITISH GENERAL OUTPUT TRANSFORMER

A sound component of typical BRITISH GENERAL workmanship, designed to give FIVE RATIOS, offering a wide choice of matchings to give perfect tonal quality. Definitely prevents possible damage to loud speaker due to excessive current supply. Full instructions for obtaining correct ratio for every type of speaker.



Excellent comment upon in Editorial columns *Amateur Wireless* April 18.

From all dealers or direct from the manufacturers

PRICE

**9/6**

BRITISH GENERAL  
MANUFACTURING  
Co. Ltd.

Brockley Works,  
London, S.E.4

Telephone: Lee Green 5055/6

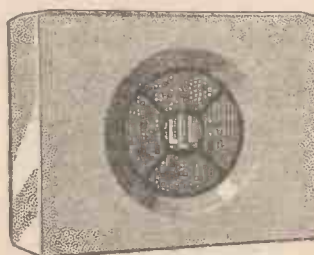

The **Lanchester**  
PERMANENT MAGNET  
MOVING COIL SPEAKERS  
(Patents Pending)

Sold direct to the public only, on 7 days' approval against cash with order or C.O.D.  
Write for details.

SENIOR MODEL **£4.4.0**

Complete in Cabinet

CHASSIS ONLY, **£2.18.0**

Full Musical Range

JUNIOR MODEL **£2.8.0**

Complete in Cabinet

CHASSIS ONLY, **£1.8.0**

Speech Perfect

**LANCHESTER'S LABORATORIES**  
TYSELEY ... LIMITED BIRMINGHAM

Your Name  
and  
Address

### USED IN MODERN SETS

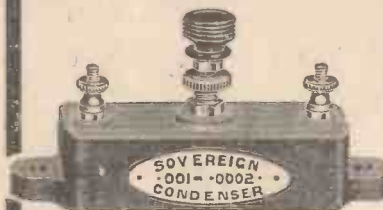

THE ever growing need for selectivity in receivers has resulted in a far greater use of COMPRESSION TYPE CONDENSERS, particularly SOVEREIGN. Accurate, sturdy and reliable in performance, these components too, are of Sovereign quality. Fit Sovereign to improve any circuit.

In Bakelite case with nickel-plated fittings. All values. **4/6** Each

Sovereign Components are specified again and again in "A.W." Circuits. Fit them wherever you can. If your dealer cannot supply write direct (also for list of full range) to

SOVEREIGN PRODUCTS LTD.  
52/54, Rosebery Avenue, London, E.C.1





# BROADCAST TELEPHONY

Broadcasting Stations classified by country and in order of wavelengths. For the purpose of better comparison, the power indicated is aerial energy.

Kilo-Metres	Station and Call Sign	Power (Kw.)	Kilo-Metres	Station and Call Sign	Power (Kw.)	Kilo-Metres	Station and Call Sign	Power (Kw.)
<b>GREAT BRITAIN</b>								
25.53	11,751 Chelmsford		287.1	1,045.1 Radio Lyons...	0.5	416	721 Radio Maroc (Rabat)	10.0
200	1,500 Leeds.....	0.16	294.6	1,043.1 Limoges (PTT)...	0.5	1,250	240 Tunis Kasbah...	0.0
242	1,238 Belfast.....	1.2	304.3	986 Bordeaux (PTT)...	35.0	<b>NORWAY</b>		
261.3	1,148 London Nat. ....	68.0	313.3	956.8 Natan-Vitus (Paris)	0.5	235.5	1,275 Kristiansand ...	0.5
288.5	1,040 Newcastle.....	1.2	317.3	945.4 Marseilles (PTT)...	1.5	240.6	1,247 Stavanger.....	0.5
288.5	1,040 Swansea.....	0.16	327.5	916 Grenoble (PTT)...	3.0	364	824 Bergen.....	1.0
288.5	1,040 Stoke-on-Trent ..	0.16	329.5	910.3 Poste Parisien... 1.2		365.1	821.7 Frederiksstad ...	0.7
288.5	1,040 Sheffield.....	0.16	345.2	869 Strasbourg (PTT)...	15.0	453.2	662 Porsgrund.....	1.5
288.5	1,040 Plymouth.....	0.16	370	810.5 Radio LL (Paris)...	0.5	493.3	668 Nidaros.....	1.2
288.5	1,040 Liverpool.....	0.16	385	779 Radio Toulouse...	8.0	580.3	517 Hamar.....	0.8
288.5	1,040 Hull.....	0.16	447	671 Paris (PTT) ...	2.0	1,071	280 Oslo.....	75.0
288.5	1,040 Edinburgh.....	0.4	466	644 Lyons (PTT) ...	2.3	<b>POLAND</b>		
288.5	1,040 Dundee.....	0.16	1,445.7	207.5 Eiffel Tower ...	15.0	214.2	1,400 Warsaw (2?) .....	14.0
288.5	1,040 Bournemouth ..	1.2	1,725	174 Radio Paris.....	17.0	234	1,283 Lodz.....	2.2
288.5	1,040 Bradford.....	0.16	<b>GERMANY</b>					
301	995 Aberdeen.....	1.2	31.38	9,560 Zeesen.....	15.0	312.8	959 Cracow.....	1.5
309.9	968 Cardiff.....	1.2	217	1,382 Königsberg.....	1.7	335	896 Poznan.....	1.9
356.3	842 London Reg. ....	70.0	219	1,309.7 Flensburg.....	0.6	368.1	815 Wilno.....	20.0
376.4	797 Glasgow.....	1.2	227	1,319 Cologne.....	1.7	381	788 Lvov.....	21.0
398.9	752 Midland Reg. ....	38.0	227	1,319 Münster.....	0.6	408	734 Katowice.....	16.0
479.2	626 Manchester (temp)	1.2	227	1,319 Aachen.....	0.3	1,411.8	212.5 Warsaw	158.0
479.2	626 North Regional testing	70.0	232.2	1,292 Kiel.....	0.31	<b>PORTUGAL</b>		
1,554.4	193 Daventry (Nat.)	35.0	239	1,250 Nürnberg.....	2.3	240	1,250 Oporto (Teatro Apollo)	0.25
<b>AUSTRIA</b>								
219	1,370 Salzburg.....	0.6	240.4	1,217.2 Cassel.....	0.3	234.7	1,053.6 Lisbon (CTIAA)	0.25
246	1,220 Linz.....	0.6	253.4	1,184.4 Gletwitz.....	5.6	<b>ROMANIA</b>		
288.9	1,050 Innsbruck.....	0.6	259.3	1,157 Leipzig.....	2.3	394	761 Bucharest.....	16.0
351.7	837 Graz.....	9.5	269.8	1,112 Bremen.....	0.3	427	702.5 Kharkov.....	4.0
453	666 Klagenfurt.....	0.6	276.5	1,083 Heilsberg.....	75.0	720	416.6 Moscow (PTT)...	20.0
517	581 Vienna.....	20.0	283.6	1,058 Magdeburg.....	0.6	800	375 Kiev.....	20.0
also testing on about 1,100 m.								
<b>BELGIUM</b>								
206	1,456 Antwerp.....	0.4	283.6	1,058 Serlin (E).....	0.6	834	364 Sverdlovsk.....	25.0
215.5	1,392 Chatelineau.....	0.25	283.6	1,058 Stettin.....	0.6	837.5	320 Kharkov (RV20)	25.0
216	1,391 Radio Conférence Brussels	0.25	318.8	941 Dresden.....	0.3	1,000	300 Leningrad.....	100.0
245.9	1,221.7 Schaarbeek.....	0.5	325	927 Breslau.....	1.7	1,060	283 Tiflis.....	15.0
338.2	887 Brussels (No. 2)	20.0	360	833 Mühlacker.....	75.0	1,103	272 Moscow Popoif... 40.0	
509	590 Brussels (No. 1)	20.0	372	806 Hamburg.....	1.7	1,200	250 Kharkov (RV4)	25.0
<b>BULGARIA</b>								
319	941 Sofia (Rodno Radio)	1.0	390	770 Frankfurt.....	1.7	1,304	230 Moscow (Trades Unions)	165.0
<b>CZECHO-SLOVAKIA</b>								
250	1,202 Cesky Brod.....	75.0	418	776 Berlin.....	1.7	1,380	217.5 Bakou.....	10.0
(testing shortly)								
263	1,139 Moravska-Ostrava	11.0	452.1	662 Danzig.....	0.2	1,481	202.5 Moscow (Kom)	20.0
279	1,076 Bratislava.....	14.0	473	635 Langenberg.....	17.0	<b>SPAIN</b>		
293	1,022 Kosice.....	2.5	583	563 Munich.....	1.7	253.5	1,188 Barcelona (EAJ15)	1.0
341.7	878 Brunn (Brno) ..	22.0	559.7	536 Kaiserslautern... 1.0		268	1,121 Valencia.....	8.0
487	617 Prague (Prahá)	5.5	559.7	536 Augsburg.....	0.3	349	860 Barcelona (EAJ1)	8.0
<b>DENMARK</b>								
281	1,067 Copenhagen.....	1.0	569	530 Hanover.....	0.3	368	815 Seville (EAJ15)...	1.5
1,153	260 Kalundborg.....	10.0	569	530 Freiburg.....	0.35	424	707 Madrid (EAJ7)...	2.0
<b>ESTONIA</b>								
296.1	1,013 Tallinn.....	0.7	1,035	283.5 Zeesen.....	35.0	453	662.2 San Sebastian (EAJ8)	0.0
463	648 Tartu.....	0.5	1,835	183.5 Norddeich.....	10.0	<b>SWEDEN</b>		
<b>FINLAND</b>								
221	1,355 Helsinki.....	15.0	<b>HOLLAND</b>					
291.5	1,029 Tampere.....	1.0	31.28	9,599 Eindhoven (PCJ)...	30.0	230.3	1,304 Malmö.....	0.75
291.5	1,029 Viipuri.....	15.0	299	1,004 Hilversum.....	8.5	257	1,166 Hörby.....	15.0
1,796	167 Lahti.....	54.0	299	1,004 Radio Idzarda (The Hague)	3.0	305.9	980.6 Falun.....	0.65
<b>FRANCE</b>								
219.3	1,368 Béziers.....	0.6	1,060	283 Scheveningen-Haven	5.0	322	932 Göteborg.....	15.0
222.9	1,346 Fécamp.....	1.0	1,875	160 Huizen.....	3.5	436	689 Stockholm.....	75.0
235.1	1,275 Nîmes.....	1.0	550	545 Budapest.....	23.0	542	554 Sundsvall.....	15.0
237.2	1,263 Bordeaux-Sud-Ouest	2.0	1,200	250 Reykjavik.....	21.0	770	389 Ostersund.....	0.75
249	1,205 Juan-les-Pins.....	0.5	<b>IRISH FREE STATE</b>					
256	1,172 Toulouse (PTT)...	1.0	224.4	1,337 Cork (IFS).....	1.5	1,220.5	244 Boden.....	0.75
265	1,130 Lille (PTT).....	15.0	413	725 Dublin (2RN)...	1.5	1,348	222.5 Motala.....	40.0
272	1,103 Rennes.....	1.2	<b>ITALY</b>					
285.4	1,051 Montpellier.....	2.0	25.4 and 80	Riga (3RO).....	9.0	244.1	1,229 Basle.....	0.65
<b>INDIA, AUSTRALIA, AND AFRICA</b>								
India, and Australia respectively. The London-Sydney circuit, for instance, covers a distance of over 9,000 miles. It is a significant fact that the Indo-European cable route—6,000 miles long—has recently been closed down owing to the superior efficiency and lower cost of the modern beam service.								

## Easy Terms FIRST IN 1924 FIRST IN 1931

**CENTURY SUPER HET KIT "A,"** less Valves, Cabinet and Frame. Cash Price £5 6s. 6d. **9/9** order

Balance in 11 monthly payments of 9/9

**CENTURY SUPER HET EXTRAS.** Consisting of Polished Oak Cabinet, Frame Aerial and 6 Mullard Valves. Cash Price £5 11s. 0d. **10/2** order

Balance in 11 monthly payments of 10/2

Note.—Further details on application.

**COSSOR EMPIRE MELODY MAKER KIT,** 1931 model, S.G., Detector and Power. Cash Price £8 17s. 6d. **10/-** order

Balance in 11 monthly payments of 12/9

**MULLARD 1931 ORGOLA FOUR-VALVE KIT,** two S.G. Detector and Pentode. Cash Price £13 12s. 6d. **32/6** order

Balance in 11 monthly payments of 24/-

**ULTRA MOVING COIL D.C. CHASSIS** with tapped input transformer for Pentode or Power Valves 200/250 volts. Cash Price £2 19s. 6d. **5/6** order

Balance in 11 monthly payments of 5/6

**EXIDE 120-VOLT W.H. TYPE ACCUMULATOR,** in crates. Cash Price £4 13s. **8/6** order

Balance in 11 monthly payments of 8/6

**LAMPLUGH OR FARRAND INDUCTOR SPEAKER** for perfect reproduction. Unit and Chassis complete, ready mounted. Cash Price £3 10s. **6/5** order

Balance in 11 monthly payments of 6/5

**BLUE SPOT MODEL 51R CABINET SPEAKER.** Cash Price £4 4s. **7/9** order

Balance in 11 monthly payments of 7/9

Every make of Radio Set or Accessory supplied on **EASY TERMS.** Send for our splendid 96-page Catalogue. It's free!

## New Times Sales Co

56 LUDGATE HILL, LONDON, E.C.4  
(Established 1924) Telephone: CENTRAL 2716

### DOES YOUR SWITCH SPINDLE TURN ROUND?

IF SO, YOUR SET "CRACKLES!"



By Fitting a "BUSCO" SWITCH your trouble is ended because there is no contact point to turn round, and when you "switch on" you have contact like a power switch. WHY NOT FIT ONE? They are as cheap as the inferior type but far superior in operation. From your local dealer, or

**BUSBY & CO., LTD. (Patentees)**  
Dept. A.W., PRICE ST., BIRMINGHAM

### MIKES FOR HOME RECORDING

Pulpit Pedestal, 12/6, Pedestal Broadcaster, as illustrated, 18/6, Microphones with handle, 15/-, powerful Public Address models 55/- and 65/-, Transformers 4/6, Couplers 15/-, Valve Amplifiers 55/-, for Band Repeater or Public Address work, Home Recorder for Gramo.



**ELECTRADIX RADIOS**  
218 Upper Thames Street, London, E.C.4  
CITY 0191.

## "WIRELESS MAGAZINE" THE BEST MONTHLY

### INTERNATIONAL RADIO

AT the end of last year more than 170 radio channels were in operation between the various countries of the world. The most important groups are those linking North and South America, and the radio services between Europe and America,

### WHEN SUBMITTING QUERIES

Please write concisely, giving essential particulars. A Fee of One Shilling (postal order), a stamped addressed envelope, and the coupon on the last page must accompany all letters. The following points should be noted.

Not more than two questions should be sent with any one letter.

The designing of apparatus or receivers cannot be undertaken.

Modifications of a straightforward nature can be made to blueprints, but we reserve to ourselves the right to determine the extent of an alteration to come within the scope of a query. Modifications

to proprietary receivers and designs published by contemporary journals cannot be undertaken.

Readers' sets and components cannot be tested at this office. Readers desiring specific information upon any problem should not ask for it to be published in a forthcoming issue, as only queries of general interest are published and these only at our discretion. Queries cannot be answered by telephone or personally.

Readers ordering blueprints and requiring technical information in addition, should address a separate letter to the Query Department and conform with the rules.

M. B.



# OPERATING THE "D.C. ETHER SEARCHER"

**B**UILDERS of the D.C. model of the "1931 Ether Searcher" should take advantage of these operating instructions, which also apply in several details to the battery-driven and alternating-current models of this popular set. As the mains operation of the D.C. version is automatic, there is practically nothing to go wrong, provided that the set and unit have been made and wired up correctly.

The outfit should work first time, and it remains only to get the best out of the set in the way of ganging the circuits correctly.

As mentioned last week, only the special D.C. mains valves can be used, these being the DC/SG for the H.F. stage, DC/HL for the detector and the DC/PEN in the last stage. These valves all take approximately 1/2 amp., the S.G. and H.L. valves being six-volters, and the pentode an eight-volt valve. The correct L.T. is provided by the unit.

There are five high-tension tappings, H.T. +1 being for the screening grid of the H.F. valve, H.T. +2 for the anode of the detector, H.T. +3 for the anode of the screen grid valve, H.T. +4 for the internal grid of the pentode and H.T. +5, the maximum tapping, for the anode of this valve. These five H.T. flex leads from the set should be connected to the appropriate terminals on the mains unit.

### Alternative Resistances

In the mains unit two resistances of 182 ohms were specified to be connected up in series for the heater supply to the valves. These values of resistance were suited to 200 volt D.C. mains. Intending constructors may possibly have different voltage mains, and the different resistances will be needed. Suitable resistances can be obtained from Messrs. Peto Scott Co., Ltd., 77 City Road, London, E.C.1.

Mains Voltage	Total Resistance
200 volts ..	364 ohms
210 volts ..	380 ohms
220 volts ..	400 ohms
230 volts ..	420 ohms
240 volts ..	440 ohms
250 volts ..	460 ohms
150 volts ..	260 ohms

Readers wishing to use 150-volt mains

must be prepared to experiment with the voltage limiting resistances in the anode feed circuits to the valves to suit this lower voltage. Mains voltages lower than 150 volts should not be used.

It is advisable to keep the mains unit fairly close to the set, so that these high-tension leads are short and direct. The three other flex leads are for the high-tension, negative, and for the low-tension supply.

The only variable control on the mains unit is for the screen of the S.G. valve, and the best position for the arm of the potentiometer must be found by trial. If there are no incorrect leads or faulty contacts in the set it should be possible to get results immediately on switching on and by swinging the dial round until one or other of the local stations is picked up.

You will find that the set will work only when the mains plug is inserted the right way round, but no harm will be done if the plug is accidentally inserted the wrong way round.

A good earth connection is advisable in the interests of satisfactory reception, and this helps also in cutting down mains noise. As with the battery and alternating-current models of the Searcher, correct ganging is very important in order to get good results. Obviously if one of the circuits is out of tune with the others, then there will be a loss of signal strength and the circuit will appear to be flatly tuned because the bandpass points will not be correct.

It is advisable to make use of the station log given with "A.W." No. 451. It is recommended that first all the trimmers should be rotated with a screwdriver in an anti-clockwise direction so that the spring blades are separated by about 1/4 in. Now it should be possible to tune in a local station at somewhere between 40 and 60 degrees on the dial. Reduce the dial reading by about five degrees and re-tune to the point of maximum volume by means of the trimmers. A distant station can now be tuned in and the trimmers slightly readjusted. Sometimes in making this preliminary adjustment it may be found necessary to reduce the dial reading by even more than five degrees in order

to reach the point of maximum tune.

When adjusting the ganging of a set which is to be used within the swamp area of a main station, then the trimming condenser of the main aerial tuning condenser (on the left looking from the front of the set) should be screwed in so that it will be necessary to have the aerial preset condenser on the panel at its minimum setting with the vanes apart.

You will find that this preset condenser on the panel is a very handy control of volume, of selectivity and of the ganging at the extreme ends of the condenser scale.

### The Preset Condenser

When tuning in stations near the top or bottom ends of the scale, try readjusting this preset condenser on the panel. Very probably a point will be found where there is a noticeable increase as readjustment of this brings the circuits back into tune. If a serious discrepancy is noticeable then probably the circuits are not correctly ganged and you should make another trial.

When using the set for gramophone working, simply plug the pick-up into the jack provided on the strip at the back of the set. Automatic negative bias is given by the 1,000-ohms resistance in series with the cathode of the detector valve.

It is advisable to have a volume control across the pick-up, because with some makes of pick-up comparatively large voltages are developed which may overload the first valve and cause distorted results with gramophone working, although the set may not even reach the overloading point with full volume on radio. It should be noted that the cabinet illustrated last week is a special Camco design made by the Carrington Manufacturing Co., Ltd.

"Amateur Wireless and Radiovision." Price Threepence. Published on Thursdays and bearing the date of Saturday immediately following. Post free to any part of the world: 3 months, 4s. 6d.; 6 months, 8s. 9d.; 12 months, 17s. 6d. Postal Orders, Post Office Orders, or Cheques should be made payable to "Bernard Jones Publications, Ltd."

General Correspondence is to be brief and written on one side of the paper only. All sketches and drawings to be on separate sheets.

Contributions are always welcome, will be promptly considered, and if used will be paid for.

Communications should be addressed, according to their nature, to The Editor, The Advertisement Manager, or The Publisher, "Amateur Wireless," 58-61 Fetter Lane, London, E.C.4.

For Super results in the "Century Super"

All British



6/9

OF ALL DEALERS

Ratio 5:1 & 3:1

DYNAPLUG

TRANSFORMER

A Voltron Product

Voltron Electric Ltd., Queensway, Ponders End, Mddx.

## "The Eliminator is Perfect—"

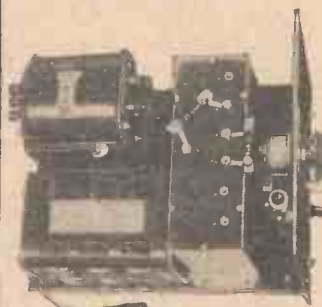

Not a surprising statement, for this unsolicited testimonial is but one of many hundreds received. When you buy a Model C

### HEYBERD MAINS KIT

you have the best of the British market. You do not purchase a glistening case with an interior of doubtful quality, for it is our wish that you examine every Hayberd Component and note its sterling characteristics. You have a safeguard against breakdown that only Hayberd can offer—a signed

### TWO YEARS GUARANTEE

Model C150  
150 volts @ 25 ma. Westinghouse Rectification. Assembled in Metal Case. Requires wiring up only. Point-to-Point diagram. Price - 76/-

Send 3d. stamps for List 947 showing how to build the Mains Unit best suited for your particular Receiver.

F. C. HEYBERD & CO., 10, Finsbury St., LONDON, E.C.2



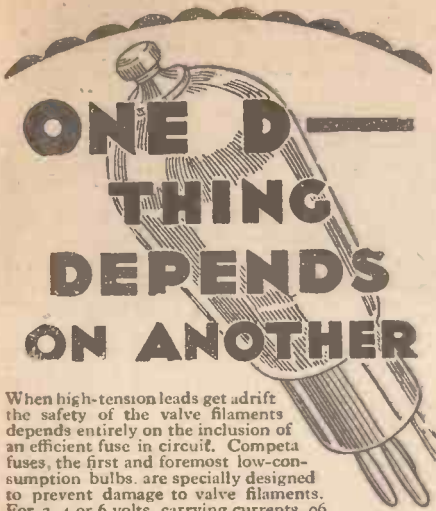

**ONE THING DEPENDS ON ANOTHER**

When high-tension leads get adrift the safety of the valve filaments depends entirely on the inclusion of an efficient fuse in circuit. Competa fuses, the first and foremost low-consumption bulbs, are specially designed to prevent damage to valve filaments. For 2, 4 or 6 volts, carrying currents .00, .1, .15, .2, .25, .3 amps.

Send 2d. for illustrated catalogue and manual, and ask for Competa Fuse Folder.

**A. F. BULGIN & CO., LTD.**  
9, 10, 11 Cursitor St., Chancery Lane, London, E.C.4  
Telephone: Holborn 1072 and 2072



**TUNEWELL**



**THE CLARION COIL**

TUNEWELL CLARION COILS AERIAL or ANODE 7/9. (6 pin base 2/-.)  
PANEL MOUNTING 10/6. (3 pt. switch 1/3).  
SHORT WAVES 3/11.

The splendid performance of the "Ultra Selective Straight 3" is largely due to the efficiency of this new Tunewell dual-range coil. It gives greatly increased range and selectivity to any straight 2- or 3-valve circuit. Enormously improved results with the Mullard Master 3, Favourite 3 or similar sets.

TUNEWELL ALL-BRITISH SPAGHETTI RESISTANCES, 10,000 and 15,000 ohms, 1/-, 20,000, 25,000 and 30,000 ohms, 1/4, 40,000, 50,000 and 60,000 ohms, 1/6.

Send for Lists

TURNER & CO., 54, Station Road, London, N.11.

**DX**

**THE STANDARD PLUG-IN COIL**

Sold everywhere from 1/-  
DX COILS Ltd, London, E.8

**Postcard Radio Literature**

**GET THESE CATALOGUES FREE**

Here "Observer" reviews the latest booklets and folders issued by well-known manufacturers. If you want copies of any or all of them FREE OF CHARGE, just send a postcard giving the index numbers of the catalogues required (shown at the end of each paragraph) to "Postcard Radio Literature," "AMATEUR WIRELESS," 58/61, Fetter Lane, E.C.4. "Observer" will see that you get all the literature you desire. Please write your name and address in block letters.

**The Squiregram**

HERE is a fine idea produced by Frederick Squire, Ltd., the loud-speaker people—a portable-type gramophone provided with a pick-up instead of the usual sound box and tone arm. You can connect this to practically any set to give radio-gramophone results. Two models are available and both have Cowey double-spring motors. A leaflet giving full details of this novel idea can be had free.

**230**

**From the Mains**

Tannoy Products have just sent me a leaflet which I am sure will interest everyone who wants a mains unit giving high-tension, low-tension, and an entirely independent grid-bias supply. The new G.B.I Tannoy unit does this in an excellent manner, and the leaflet gives details of its operation.

**231**

**A Colvern Book**

Here is another edition of the Colvern radio book, which gives details of all the ordinary types of coil and many special circuits. I have brought this to your attention before and I knew that it was going to be popular; so a new edition is not a surprise. If you have not a copy, then write at once.

**232**

**For Home Recorders**

In view of the great interest at present in gramophone home recording, I think you should write to Igranic for a free copy of the folder which gives details of the Pentrol microphone—fine for home recording and public-address work. A microphone control unit to match up with this is also made, and is described on the same leaflet.

**233**

**A Good Recommendation**

I see that Capt. Sir Malcolm Campbell has chosen a Pye portable set for his own personal use. You can get a fine illustrated folder, giving all the needed information on these Pye twin-triple portable sets, and I recommend this for your attention.

**234**

**Marconi Sets**

"Better Radio for Brighter Homes" is the slogan which Marconiphone is putting to good use, and a neat little folder with this title has just come to hand. It illustrates and describes all the popular low-price models of sets and speakers. You should have this.—OBSERVER.

**235**

HERE IT IS—

**The NEW Mains Unit**

(Prov. Patent No. 1642/31.)

TYPE G.B.1.

**H.T.**

150 v. at 15 m/a. or 120 v. at 20 m/a. (Also S.G. and DET. TAPPINGS)

**G.B.**

Three Tappings up to 12 v. Independent of H.T.

**L.T.**

2, 4 or 6 v. Trickie Charger.

Full wave WESTINGHOUSE RECTIFIERS

for

**9/2**

and 11 payments of 8/8 or

Cash Price **£4:15:0**

**TANNOY PRODUCTS**

The **only** mains unit for portables incorporating independent G.B.

Dalton St., West Norwood, S.E.27

**FACT!**  
If you drove a car with solid wheels and no springs even over modern roads it would soon shake to pieces. And if you put even a modern valve in a solid valve-holder with no springs vibration will soon play 'old Harry' with the heated filament and you will lose emission. That isn't fancy, it's a fact.  
Write for Catalogue No. 1142  
The BENJAMIN ELECTRIC LTD.  
Tariff Road, Tottenham, N.17.  
Tottenham (3)

**BENJAMIN**

**TAYLEX WET H.T. BATTERIES**  
New Prices: Jars 1/3. Sizes 1/2. Zincs 1 Od. Sample doz. 18 Volts complete with bands and electrolyte 4/1 post 9d. Sample unit 6d. Illus. booklet free. Bargain list free.  
AMPLIFIERS, 3s/-. 3 VALVE ALL-STATION SET £5.  
A. TAYLOR, 57, Studley Road, Stockwell, LONDON.



PREPAID ADVERTISEMENTS

Advertisements under this head are charged THREPPENCE PER WORD, minimum charge THREE SHILLINGS. DEPOSIT SYSTEM As the Publishers cannot accept responsibility for the bona fides of advertisers in this publication, they have introduced a system of deposit which it is recommended should be adopted by readers when dealing with persons with whom they are unacquainted. It is here explained. Intending purchasers should forward to the Publishers the amount of the purchase money of the article advertised. This will be acknowledged to both the Depositor and the Vendor, whose names and addresses must necessarily be given. The deposit is retained until advice is received of the completion of the purchase, or of the article having been returned to and accepted by the Vendor. In addition to the amount of the Deposit, a Fee of 6d. for sums of £1 and under, and 1s. for amounts in excess of £1, to cover postage, etc., must be remitted at the same time. In cases of persons not resident within the United Kingdom, double fees are charged.

The amount of the Deposit and Fee must be remitted by Postal Order or Registered Letter (Cheques cannot be accepted), addressed to

"AMATEUR WIRELESS" ADVERTISEMENT DEPARTMENT, 53/51 FETTER LANE, LONDON, E.C.4

PHOENIX THREE-VALVE kits complete with cabinet, £17/6. Ditto with valves, £2/15/-. Ditto with H.T. and I.T. batteries and speaker, £1/19/6. H.P. terms on kit: 5/2 deposit, 2/7 per week.—Phoenix, 314 High Road, Leo, S.E.13.

VERT WIRING CLIP. No soldering. Tested and approved "Amateur Wireless." Samples 3d. and stamped envelope. Half gross, 2/- (sufficient for three-valve set).—Green & Sons, Reddlyffe, Horley, Surrey.

PERSONS WANTED as manufacturing agents, new and interesting industry. Regular work supplied, cash paid weekly. Write E. 87, "Everlast" Leather Matting Co., Wellingborough.

ENGINEERS, CAN'T WE GET TOGETHER?—All we ask is the chance to prove that you can earn £300, £400, and even £1,000 per year and more. Other men are doing it and you can do the same. If you wish for something more than a "bread and butter" job, you owe it to yourself to investigate our service. Our new handbook, "Engineering Opportunities," contains, amongst other intensely interesting matter, details of B.Sc., A.M.I.C.E., A.M.I.Mech.E., A.M.I.E.E., A.M.I.A.E., A.M.I. Struct.E., M.R.San.L., L.I.B.O., F.S.I., G.P.O., C. & G., etc. Exams., outlines courses in all branches of Civil, Mechanical, Electrical, Motor, Wireless, Aeronautical, and Talkie Engineering, and explains the unique advantages of our Appointments Department. We alone guarantee "No pass—no fee." This is your opportunity. Send for our new handbook to-day. State subject or exam. of most interest (free and post free).—British Institute of Engineering Technology, 109 Shakespeare House, 29-31 Oxford Street, London.

RYCE'S.—Renowned Mains Transformer, type AB041, was used in the test model of "A.C. Amplifier," price 25/-, post free. Type AB1, output 300-0-300 volts, 80 m.a., 2.5-0-2.5 volts, 1.6 amp., 2-0-2 volts 3 amp., 2-0-2 volts 1 amp., price 27/6, post free, fully guaranteed. Write for test report.—Ryce's, Transformer Dept., Dawson Street, Bury, Lancs.

BEST QUALITY PORTABLE CASES, Suitcase, and Oak and Mahogany types, all made for Classic Radio (in liquidation). Hide, 12/6; 15 by 12 by 8, blue fabricoid, 7/6 to 17/6. Latter fitted fret frame, etc., wound, size, 16 by 13 1/2. Mullard Fixed Condensers, .001 to .006, .0002, .0004, .0005, 9d. each, 6/6 dozen, boxed.—G. A. Ryall, 182 Kennington Road, London, S.E.11.

CORRESPONDENCE COURSES OF INSTRUCTION IN WIRELESS.—Particulars from Correspondence Course Department of the R.M. College, 26-27 St. Mary Street, Cardiff.

CHARGE YOUR H.T. FROM YOUR L.T. AT HOME. Wonderful discovery. Fox's Recharger will trickle-charge H.T. accumulators. Ratio, 1 amp. Set can be on or off safely. Fitted 2 minutes. Guaranteed, 6/6 (diagram only, 1/6).—Fox, 188 Cambervell Grove, S.E.5.

A.C. H.T. ELIMINATORS, from 65/-, or 12 monthly payments of 6/- . A.C. H.T. Eliminator Kits from 43/- to 62/6; cash or monthly terms. Cabinet Speakers, 12/6 each, worth double. Cash or C.O.D.—Serwell Wireless Supplies (Dept. M.O.), 74 Gough Street, London, E.14.

ETHER SEARCHER KIT, unused. Cost £5 14s. 6d.; sell £4 4s.—Write 6 Hillfield Park, N.21.

SOLID OAK WIRELESS CABINETS, well polished 18 or 18 by 7 by 10 in., 6/6; 21 by 7 by 10 in., 7/- . C.W.O. Refunded if not satisfied. Baseboards, 6d. and 9d. Carriage, 1/6.—F. S. Gibson, 99 Burnley Road, Ainsdale.

LINEN SPEAKER KIT BARGAINS.—Weedon Universal Kits, including Chassis 21 in. square, with Weedon Self-centre Rod and Golden Tautening Dope, best linen and unit bracket, complete instructions. For Double, 9/-, or single, 7/6, post free, or C.O.D. Limited number.—Weedon and Co., 26a Lisle Street, London, W.C.2.

EXPERIMENTER'S SURPLUS, new and unboxed, Paillard induction motor, turntable, automatic stop, complete, 36/- B.T.H. pick-up and arm, 30/- . 30-henry 70 ma. choke, 6/6. A.C. accumulator charger, 14/- . Epoch speaker, £2. Also 1st Ether Searcher, sell separately. All brand new. Post free, C.O.D.—Ransome, 6 Cyprus Avenue, N.3.

FOR SALE.—Amplifiers, 4-valve (push-pull) with Ferranti Transformers, etc., 40/- or offer; 6-valve ditto, 50/-; 8-valve ditto, 60/- . Moving-coil Speakers, B.T.H. R.K. type, 100-110 volts, 60/- or offer. H.T. Eliminator by well-known firm, input 100-110 A.C., output 50-200 volts D.C., 60 ma., 40/- each or offer.—A. Oakley, 126 Pelham Road, Wimbledon, S.W.19.

A MAGNIFICENT SET.—The National and Regional Three, absolutely complete, including Tungram valves, 2-volt accumulator, 100-volt H.T. battery, B.T.H. 45-loud-speaker. Perfect reception from home and foreign stations. Guaranteed 12 months. Amazing value, £4, inclusive.—H. Panagakis, Radio Manufacturer, 91 Dale Street, Liverpool.

MARCONI MOVING-COIL SPEAKERS (less cones), 6 volt, 15/-; R.K., 200/240, 22/6. Igranio Eliminator Kits, 100/25 A.C., 40/-—Hillier, 22 Cork Street, W.1.

BANKRUPT BARGAINS.—List free with 3-valve diagram. Transformers, 2/9; Telsen Ace, 0/6; Radiogrand, 9/6. .0005 Variable, 2/6; Midget .0005, 2/- . Differentials, 2/6. P.W. Duals, 8/6; Bullphone Duals, 8/6. Spaghettilis, from 10d. H.F. Chokes, 1/6. Speaker Units: Trioiron, 9/6; Bullphone, 9/6. Also Motor, Undy, etc. 3-valve Kits, 35/-; 2-valve, 24/-, with cabinets. Good stock, all new.—Butlin, 143b Preston Road, Brighton.

AGENTS WANTED to sell well-known H.T. Units, etc. for cash or easy terms. Prices are very competitive and good commission is offered.—Brookman Rapid Radio Service, 105 Spencer Street, Birmingham. Wireless and Cycle Factors. Specialists in Radio Cabinet Work.

BARGAINS.—Shop-soiled and partly-used Components, Sets, Speaker, etc. All guaranteed perfect electrical condition. Supplied on seven days' approval against cash. Send list your requirements.—Bostock & Stonnill, 1 Westbourne Terrace, S.E.23.

NEW "PURATONE" PROCESS 2 VOLT DARK EMITTER H.F., L.F., VALVES 3/9 DET., R.C. VALVES 3/9 Power - 5/3 Super-Power 6/3 Screen-Grid 7/6 BRITISH MADE. FULLY GUARANTEED. RUBON LTD., 189 New King's Rd., London, S.W.6

REPAIRS to any make of L.F. Transformer, Headphones or Loud-speaker (except Bins Spot) dispatched in 48 Hours—TWELVE MONTHS' GUARANTEE with each repair. 4/- post free. Cash with order. Terms to Trade. TRANSFORMER REPAIR CO. Dept. S, 955 GARRATT LANE, LONDON, S.W.17

YOU CAN BUILD A £40 GRAMOPHONE WITH OUR SCALE DRAWINGS FOR 40/- Book of instructions 3d. Catalogue of Motors, Tonearms, Soundboxes, latest internal amplifiers, Gramophones and Cabinets Free. Cash or Terms. W. BURT, 185 High St., Deptford.

MAGNUM ALL THAT IS BEST IN RADIO COMPONENTS SETS ETC. BURNE-JONES & CO. LTD. 296, BORO' HIGH ST., LONDON S.W.1

KONDUCTITE [Prov. Patent 4817/31] METALLIC PAPER Konductite consists of a thin sheet of aluminium mounted on a comparatively stiff backing paper and has all the advantages of sheet metal. It is very easy to work with and infinitely superior to tin or copper foil. It is now specified in all leading circuits. For Covering Baseboards: Back of Panels: Linings of Cabinets and all Screening purposes In sheets measuring 30" x 20" 2/-. Postage and packing 6d. extra Free sample on receipt of stamped addressed envelope GRAMO-RADIO AMPLIFIERS LTD., 1a NEW LONDON ST., E.C.3 Phone: Royal 4300

You MUST have the "WIRELESS MAGAZINE" Every Month Price 1/-

FULL-SIZE BLUEPRINTS

When ordering, please send Postal Order, NOT STAMP.

CRYSTAL SET (6d.) B.B.C. Crystal Set .. .. . AW281 ONE-VALVE SETS (1s. each) One Ultra One .. .. . AW267 Regional Ultra-selective One .. .. . AW278 B.B.C. One .. .. . AW280 Hartley One .. .. . WM198

TWO-VALVE SETS (1s. each) Talisman Two (D, Trans) .. .. . AW194 No-battery A.C. Mains Two (D, Trans) .. .. . AW230 No-battery Gramo-radio 2 (D, Trans) .. .. . AW238 1930 Talisman 2 (D, Trans) .. .. . AW239 Searcher Two (D, Trans) .. .. . AW245 Arrow Two (D, Trans) .. .. . AW240 Forty-five-shilling Two (D, Trans) .. .. . AW250 Searcher Short-wave 2 (D, Trans) .. .. . AW259 Challenge Two (D, Trans) .. .. . AW261 Loftin-White Two (A.C. Mains) .. .. . AW263 Everybody's All-in 2 (D, Trans) .. .. . AW273 Twenty-Shilling Two (D, Trans) .. .. . AW274 Brookman's Two (D, Trans) .. .. . WM168 Gleaner Two (D, Trans) .. .. . WM201 Music Monitor (D, Trans) .. .. . WM208 Merlin Two (A.C. Set) .. .. . WM213 Five-Point Two (D, Trans) .. .. . WM220 Brookman's A.C. Two (D, Trans) .. .. . WM225 Aladdin Two (D, Trans) .. .. . WM231

THREE-VALVE SETS (1s. each) 1930 Clarion Three (SG, D, Trans) .. .. . AW223 Beginner's Regional Three (D, 2LF) .. .. . AW233 The "A.W." Exhibition 3 .. .. . AW247 Push-Pull "Two" (D, Push-Pull) .. .. . AW270 1931 Ether Searcher (SG, D, Trans) .. .. . AW271 1931 Ether Searcher (A.C. model) .. .. . AW276 Mains Unit .. .. . AW277 Ultra-Selective Straight Three (SG, D, Trans) .. .. . AW282 1931 Ether Searcher (D.C. model) .. .. . AW284 Mains Unit .. .. . AW285 Fanfare Three (D, 2 Trans) .. .. . WM187 Brookman's Three (SG, D, Trans) .. .. . WM161 Brookman's Push-Pull Three (SG, D, Trans) 1/6 .. .. . WM170 Inceptordyne (SG, D, Pentode) .. .. . WM179 Music Marshal (D, 2 Trans) .. .. . WM190 Concert Three (D, 2 Trans) .. .. . WM199 De-Luxe Three (D, RC, Trans) .. .. . WM200 Five-Point Three (SG, D, Trans) .. .. . WM214 Falcon Three (A.C. Set) .. .. . WM217 New Brookman's Three (SG, D, Trans) .. .. . WM218 Five-point Short-waver (D, RC, Trans) .. .. . WM223 Baffle-Board Three (D, RC, Trans) .. .. . WM226 Plug-in Coil Three (D, 2 Trans) .. .. . WM232 Regional Three (SG, D, Trans) .. .. . WM236 Gramo-radio A.C. Three (SG, D, Trans) .. .. . WM237

FOUR-VALVE SETS (1s. 6d. each) Horizon Four (SG, D, 2 Trans) .. .. . AW237 Challenge Radio Gramophone (SG, D, RC, Trans) .. .. . AW265 Lodestone Four (HF, D, RC, Trans) .. .. . WM193 Searcher's Four (SG, D, RC, Trans) .. .. . WM194 Regional Band-pass Four (SG, D, RC, Trans) .. .. . WM211 Five-Point Four (SG, D, RC, Trans) .. .. . WM216 Regional A.C. Four (SG, D, RC, Trans) .. .. . WM222 Supertone Four (SG, D, Push-pull) .. .. . WM227 Brookman's Three-Plus-One (SG, D, RC, Trans) .. .. . WM233

FIVE-VALVE SETS (1s. 6d. each) James Quality Five (2SG, D, RC, Trans) .. .. . AW227 Companion Portable (2HF, D, RC, Trans) .. .. . AW279 1930 Five (2HF, D, RC, Trans) .. .. . WM171 Radio-Record Five (SG, D, Trans-parallel) .. .. . WM188 Overseas Five (3SG, D, Trans) .. .. . WM191 Regional A.C. Five (3SG, D, Trans) .. .. . WM224

SIX-VALVE SETS (1s. 6d. each) Century Super (Super-het) .. .. . AW287 Hyperdyne Receiver .. .. . WM221 Super 60 (Super-het) .. .. . WM229

AMPLIFIERS (1s. each) "A.W." Gramophone Amplifier .. .. . AW205 Two-valve Amplifier .. .. . AW216 Simple Gramophone Amplifier .. .. . AW257 High Quality Amplifier for A.C. Mains .. .. . AW275 2-Watt Amplifier for A.C. Mains .. .. . AW283 Radio-Record Amplifier (DC Mains) .. .. . WM183 Selecto Amplifier (HF, Unit) .. .. . WM210

MISCELLANEOUS (1s. each) Simple Tester Unit (6d.) .. .. . AW246 "A.W." Improved Linen-diaphragm Speaker .. .. . AW248 Handy L.T. and G.B. Unit for A.C. Mains .. .. . AW254 Our H.T. Unit for A.C. Mains .. .. . AW262 Gramophone Tone Control .. .. . AW264 Short-wave Super-het Adaptor .. .. . AW268 H.T. Unit and Trickle Charger for D.C. Mains .. .. . AW272 Booster Speaker .. .. . AW286 "W.M." Standard A.C. Unit .. .. . WM214 "W.M." Standard D.C. Unit .. .. . WM215 Falcon A.C. Unit .. .. . WM219 Hyperdyne Short-wave Adaptor .. .. . WM228 Big H.T. Unit for A.C. Mains .. .. . WM230

PORTABLE SETS Continental Portable (SG, D, Trans) .. .. . AW241 1/6 Companion Portable (2HF, D, RC, Trans) .. .. . AW279 1/6 Pedlar Portable Two (D, Trans) .. .. . WM195 1/- Pedlar Portable Three (D, 2 Trans) .. .. . WM197 1/- Super 60 Portable (Super-het) .. .. . WM238

Copies of the "Wireless Magazine" and of "Amateur Wireless" containing descriptions of any of these sets can be obtained at 1s. 6d. and 2s. respectively, post free. Index letters "A.W." refer to "Amateur Wireless" sets and "W.M." to "Wireless Magazine."

Address letters: Amateur Wireless Blueprints Dept., 59-61 Fetter Lane London, E.C.4.

Amateur Wireless Available until Saturday MAY 2, 1931



# Cheaper Radio!

## Everlasting High Tension for a trifle over the cost of 2 120-Volt Batteries



### The Neatest & Cheapest A.C. Unit ever made

With alternating current electric lighting in the home it is now possible for you to banish your radio troubles and assure H.T. for your set for a lifetime at a little more than the cost of a year's supply of batteries—the secret is the "ATLAS" new Unit A.C. 244. A development of the famous "ATLAS" Olympia Winner—Model A.C. 188. It is no larger than a 60-volt battery, and no matter what your set is, from one to four valves, standard or portable, the facilities and output of A.C. 244 will be found more than satisfactory. Three variable tappings are provided—60/80 volts for screen grid valve, 90/100 volts for detector valve, and 120/150 volts for pentode or power valve. Output:—120 volts at 20 m/A or 150 volts at 15 m/A. It incorporates the Westinghouse Metal Rectifier and is complete with wander plugs and earth terminal, and fully guaranteed for 12 months.

**59/6**  
CASH PRICE

# "CLARKE'S" ATLAS

**MAINS H.T. UNIT—A.C. 244.**

Ask your dealer for a demonstration of this amazing unit and in case of difficulty write direct for Folder No. 56 to the makers:—

H. CLARKE & CO. (M/CR) LTD., ATLAS WORKS,  
OLD TRAFFORD, MANCHESTER  
LONDON OFFICE: 60 CHANDOS STREET, STRAND, W.C.2  
GLASGOW OFFICE: 24 OSWALD STREET

# Where others have failed



# The HYPERMU SUCCEEDS

Transformers come and go but the Hypermu is the perfect amplification unit continuing to maintain an impregnable position in the confidence of critical experimenters who have either employed it from the first because they rely on R.I. reputation for components of certain reliability, or because they have ultimately had to resort to the Hypermu to get the requisite overall amplification covering the widest field of audio frequencies—particularly with the modern highly selective circuits and powerful valves. Hypermu N.P.L. Curve is still by comparison best—get the technical leaflet from your dealer or write to us direct for a copy. Gives the most amazing amplification of all frequencies between 25 to 7,000 cycles. Primary inductance 85 henries. Rat. 0.4-1. Weight 13 ozs. Black bakelite case.

# 21/-

**SPECIAL NOTE** The Hypermu was mis-quoted as 17/6 in our advertisement of April 18th—it remains at 21/- and is best amongst transformers of any price.

R.I. Components are best and cost no more.

Get a copy of the New Edition of R.I. Catalogue.

Madrigal Works,  
Purley Way, Croydon

Telephone:  
Thornton Heath 3211



Advertisers Appreciate Mention of "A.W." with Your Order



# There is an 'Ekco' Unit for every type of set

## Battery Operated · Portable · Constructor Kits

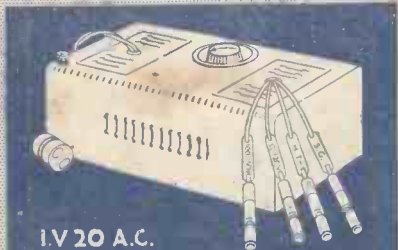

1V 20 A.C.

### H.T. UNITS

#### 10 MILLIAMPERES OUTPUT

Voltage tappings 60 and 120

D.C. Model 2F.10	--	..	..	£1 . 9 . 6
A.C. Model 2A.10	--	..	..	£3 . 10 . 0

All you have to do is done simply and quickly—3 minutes only. Fit a suitable "Ekco" Unit in place of your battery or accumulator, or both; then plug the "Ekco" adaptor into any light or power socket and switch on—that's all. "Ekco" Units last a life-time, but cost on an average only 2s. 6d. per 1,000 hours of use.

OBTAINABLE FROM ANY RADIO DEALER BY EASY PAYMENTS.

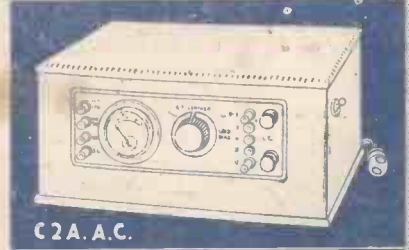

C2A A.C.

### ALL POWER UNITS

#### 20 MILLIAMPERES OUTPUT

H.T. Voltage tappings—S.G.; 60; 120/150  
L.T. .. .. —2 to 5 amp. max. at 2, 4, or 6 volts  
G.B. .. .. —5 tappings up to 12 volts

A.C. Model C2A	..	..	..	£10 . 17 . 6
----------------	----	----	----	--------------

*No alterations required to set, wiring or valves.*

#### 20 MILLIAMPERES OUTPUT

Voltage tappings S.G.; 60; 120/150

D.C. Model 3F.20	..	..	..	£1 . 17 . 6
A.C. Model 3F.20	..	..	..	£3 . 19 . 6

Model 1V.20 for all Portable Receivers.  
Voltage tappings S.G.; 0-120 variable; 120/150

D.C. Model £1 . 17 . 6	..	..	..	A.C. Model £3 . 19 . 6
------------------------	----	----	----	------------------------

#### FOR 1-5 VALVE SETS

#### SUPPLIES H.T., L.T. & G.B.

#### 60 MILLIAMPERES OUTPUT

H.T. Voltage tappings—S.G.; 0-120 var.; 120/150 Power  
L.T. .. .. —3 to 1 amp. max. at 2, 4, or 6 volts  
G.B. .. .. —7 tappings up to 21 volts

A.C. Model C1A	..	..	..	£17 . 15 . 0
----------------	----	----	----	--------------

*No alterations required to set, wiring or valves.*

#### 30 MILLIAMPERES OUTPUT

Voltage tappings S.G.; 0-120 var.; 120/150; 150/170

D.C. Model 1V.30	..	..	..	£2 . 19 . 6
A.C. Model 1V.30	..	..	..	£5 . 15 . 0

#### FOR MULTI-VALVE SETS

#### PORTABLE UNIT

#### 20 MILLIAMPERES OUTPUT

H.T. Voltage tappings ..—S.G.; 0-120 var.; 120/150  
L.T. (Trickle Charger) ..—25 amp. at 2, 4, or 6 volts  
A.C. Model C.P.1. .. .. £6 . 0 . 0  
*Fits quickly and snugly into any portable set. Supplies H.T. and keeps accumulator constantly charged.*

#### 60 MILLIAMPERES OUTPUT

Voltage tappings S.G.; 0-120 var.; 120/150; Power

D.C. Model 4T.60	..	..	..	£3 . 15 . 0
A.C. Model 4A.60	..	..	..	£8 . 10 . 0

#### FOR MULTI-VALVE SETS

#### FOR A.C. VALVES

#### 30 MILLIAMPERES OUTPUT

H.T. Voltage tappings—S.G.; 150  
L.T. (Raw A.C.) ..—4 volts from 2 to 4 amps. 6 volts from .25 to 1 amp.  
G.B. .. .. —5 tappings up to 15 volts  
A.C. Model ACV .. .. £6 . 0 . 0  
Control Unit for use with above .. .. £1 . 5 . 0  
*Can be fitted into any set to make it "All Electric."*

To: E. K. COLE, LTD., Dept. K.4.  
"Ekco" Works, Southend-on-Sea.

Please send me:

(a) Particulars of how I can electrify my present battery set or portable with an "Ekco" Unit

(b) Illustrated literature on "Ekco" Sets and Speakers with details of Easy Payments.  
*Strike out whichever is not required.*

Name .....

Address .....



#### OTHER UNITS

- Model T.500 Trickle Charger. Charges 2, 4, or 6 volt accumulator from A.C. Mains. £2 . 12 . 6.
- Model RA.20 Rectifier Unit. For D.C. Units used on A.C. Mains. £3 . 10 . 6.
- Model I.Tr. Isolating Transformer. For isolating speaker, etc., from set. 15s.

Woburn