

Amateur

# RADIO

For all two-way radio enthusiasts

Something for Nothing:  
A Scrounger's Notebook

Datasheet:  
The 555 Timer IC



On Test: the Kenwood TS-680S HF  
Mobile Transceiver

Home-made Printed Circuit Boards

MORSE REPORT

**SCANNERS**

**BEARCAT BY uniden**



UBC 175XL

RAYCOM ARE TRADE AND RETAIL DISTRIBUTORS FOR THIS SUPERB RANGE OF QUALITY SCANNERS. THE POPULAR UBC 100XL HAND HELD HAS SOLD IN THOUSANDS, BUT IS NOW COMPLEMENTED BY THE UBC 70XCL POCKET SIZED HANDHELD. ALSO THE NEW COST EFFECTIVE UBC 50XL HANDHELD. SEE THE NEW MODELS IN OUR SHOWROOMS OR SEND A S.A.E. FOR DETAILS. FROM £95.00 + carriage



UBC 100XL  
UBC 50XL  
UBC 70XL

**RAYCOM**

COMMUNICATIONS SYSTEMS LTD

TEL: 021-544 6767

**SUMMER SPECIAL OFFERS**

WHILE STOCKS LAST

Icom ICR7000 + Royal 1300.....	<b>£899.00</b>
Icom IC3200E 25W Dual Band Mobile.....	<b>£399.00</b>
BJ200 Mk2 Handheld AM/FM Scanner.....	<b>£199.50</b>
Sony ICF2001D SW Receiver plus Airbond.....	<b>£289.00</b>
Sony ICF7600DS Super SW Receiver.....	<b>£199.00</b>

**SCANNERS**

YAESU FRG9600 from the company who specialises in fitting extra options, as supplied to Government departments and professional bodies. We also upgrade existing models, please call for more details, prices, delivery and information

Yaesu FRG8600 Basic Model Improved 'S' Meter + Sens	<b>£465.00</b>
Yaesu FRG8600 RWC Mk2 60-950MHz 'N' Connector Fitted	<b>£495.00</b>
Yaesu FRG8600 RWC Mk3 HF 100kHz-950MHz plus Mk2 Spec	<b>£595.00</b>
Yaesu FRG9600 RWC Mk5 HF 50kHz-950MHz Active Mixer	<b>£625.00</b>
Yaesu PAL Video Unit for above	<b>£27.50</b>
Icom ICR7000 25M-2GHz superb quality professional Rx	<b>£859.00</b>
Icom ICR7000/AH7000 Receiver plus Matching Discone	<b>£937.50</b>
Kenwood RZ 1 New 500kHz-950MHz Wide and Narrow AM/FM POA	<b>£139.00</b>
Fox VHF-UHF Multi Function Mobile Scanner FM only	<b>£95.00</b>
Uniden-Bearcat UBC 50XL VHF-UHF 10ch H/held Scanner	<b>£179.00</b>
Uniden-Bearcat UBC 70XL VHF-UHF 20ch Miniature H/held Scanner	<b>£179.00</b>
Uniden-Bearcat UBC 100XL VHF-UHF Airband H/held Scanner	<b>£189.00</b>
Uniden-Bearcat UBC 175XL VHF-UHF Airband Desk-Top	<b>£175.00</b>
BJ200 Mk2 VHF-UHF Airband-Military Airband H/held	<b>£199.50</b>
ADR 2002 25-550, 800-1300MHz Desk-Top/Mobile AM/FM	<b>£469.00</b>
Sony Air 7 Top Quality VHF-Airband Handheld Scanner	<b>£245.00</b>
Package deal on above Mk3/5 FRG9600 c/w AH7000 discone, G5RV, PA4 AC PSU, complete receiving station HF-UHF including delivery UK mainland. Add £100.00 to above price.	

PACKAGE DEAL AVAILABLE ON ALL MAKES. IF IT'S GOOD, WE STOCK IT!

**A new concept in Amateur Radio . . . uniden 2830**

It's here at last! A beautifully-made processor-controlled full feature 10w (20w PEP) multimode transceiver with LCD readout and all functions necessary to work DX with Sporadic E and in the forthcoming sunspot maxima and also for transverting to the VHF and UHF bands. Work out the facts . . . how much is a Two Metre Multimode? How much is the Uniden 2830 Ten Metre Multimode and a 2 metre transverter? With the Uniden 2830 you can have two bands for the price of one, with 10 watts on each band and all modes including CW. \* S.A.E. for copy of Review.

**Features**

- \* All modes, AM/FM/USB/LSB/CW
- \* LCD readout of frequency/functions
- \* CW with Sidetone
- \* FM bandwidth compatible with VHF/UHF
- \* 10Watts continuously variable o/p AM and FM
- \* Scanning feature, up and down steps on mic.
- \* Selectable frequency steps, 10kHz, 1kHz, 100Hz.
- \* Ten metre band selectable in 500kHz steps
- \* Build-in VSWR meter and protection circuit
- \* Superb receiver sensitivity +3uV FM

Just TEN of the many reasons for choosing the UNIDEN 2830

THIS PRODUCT IS EXCLUSIVE TO RAYCOM, WE ARE THE U.K. DISTRIBUTOR. WHOLESALE ENQUIRIES WELCOME

**10 metre band amateur transceiver**



**£279.00**  
£10.00 post and packing

Matching transverters  
2M transverter £169.00  
6M transverter £189.00  
Package Deal: 2M + 2830 ..... **£399.00 Post £10**

**HANDHELDS**

\* = Extended Receiver coverage available, call for details

YAESU FT1727R/FNB4A 2.5W (5W) DUAL BANDER C/W CHRGR	<b>£395.00</b>
*YAESU FT23R FBA10 2.5W (5W) 2MTRS	<b>£229.00</b>
*YAESU FT73R/FNB10 2.5W (5W) 70CMS C/W CHARGER	<b>£259.00</b>
*ICOM MICRO 2E 2.5W 2MTR HANDHELD WITH CHARGER	<b>£209.00</b>
CTE1600 (SAME AS ICOM IC2E) C/W NICAD CHARGER	<b>£179.00</b>

Many other types of handheld stocked, please enquire

**SHORT WAVE RECEIVERS**

Yaesu FRG8800 Short Wave 100kHz-30MHz all Mode + Mem.	<b>£589.00</b>
Yaesu FRG8800 FRV8800 as above with VHF Conv. fitted	<b>£679.00</b>
Icom ICR-71 Top Grade Communications Receiver	<b>£799.00</b>
Sony PRO80 HF VHF Handheld Scanner c/w accessories	<b>£345.00</b>
Sony 2001D Short Wave/Airband Receiver	<b>£349.00</b>
Sony SW1 Micro Short Wave Receiver	<b>£249.00</b>

Many more makes and models in stock. PLEASE CALL FOR PRICES. DELIVERY COSTS and any advise or information, or send large SAE. (Insured post and packing £10.00. Carrier £12.50).

**YAESU FT 747GX**

**£649.00** including our FREE fitted MOD Board!

We improve the reciprocal mixing performance by up to 15dB which gives you receive performance of higher priced rigs! Only available from Raycom, buy it elsewhere if you want SECOND BEST! YAESU IS STILL BEST VALUE FOR MONEY!

ALL CURRENT YAESU AND ICOM HF RIGS STOCKED, CALL FOR A DEAL!

**MOBILES**

YAESU FT211RH 45W 2MTR MOBILE WITH FREE 1' 4 WAVE ANT	<b>£299.00</b>
YAESU FT212RH NEW 45W 2MTR MOBILE DVS FEATURE OPT.	<b>£349.00</b>
*ICOM IC28E 2MTR 25W MOBILE WITH FREE 5/8 ANTENNA	<b>£359.00</b>
Alnico Dual Band ALD-24E	<b>£445.00</b>
ICOM IC48E 70cm 25W	<b>£428.00</b>
ICOM IC3200 Dual Band 25W	<b>SPECIAL £399</b>

Compare our prices!  
Many other types and makes stocked, please enquire

**PORTABLES**

FT290RMK2 2.5W MULTIMODE STANDARD ACCESSORIES	<b>£399.00</b>
FT290RMK2 2.5 WATT M/M AS ABOVE C/W NICADS CHRGR	<b>£425.00</b>
FT290RMK2/FL2025 (STD) WITH 25W LINEAR AMPLIFIER	<b>£489.00</b>
FT690RMK2 6MTR 2.5W MULTIMODE STANDARD ACCES.	<b>£399.00</b>
FT690RMK2 6MTR 2.5W M/M AS ABOVE C/W NICADS CH	<b>£425.00</b>
FT790RMK2 NEW 70CM 2.5W MULTIMODE DUE OUT SOON	<b>£499.00</b>

**ANTENNAS & ACCESSORIES**

NOW AVAILABLE AT RAYCOM: CUSHCRAFT, BUTTERNUT, HY-GAIN ANTENNAS, JAYBEAM, TONNA, MET, HAM-M ROTATORS, Call for full details, prices, availability and delivery costs.

ICOM AH7000 SUPER 250-1300MHz DISCONE	<b>£79.50</b>
G5RV HALF SIZE HF ANTENNA ready to use	<b>£16.50</b>
G5RV FULL SIZE HF ANTENNA ready to use	<b>£18.50</b>
GBKW-TYPE 7 1MHz TRAP DIPOLE KIT SO239	<b>£24.50</b>
GBKW-TYPE as above for use with 75 OHM	<b>£23.50</b>
GBKW-TYPE 2X 7 1 TRAPS ONLY. LESS CABLE	<b>£9.95</b>
RAYCOM AIRBAND-VHF SIX ELEMENT DISCONE	<b>£12.50</b>
RAYCOM DISCONE VHF 60-600MHz 8E SO239	<b>£29.50</b>
SUN KG209 SE2M 5/8 MOBILE TILT-OVER 259	<b>£14.50</b>
RAYCOM CAST GLITTERMOUNT C/W SO239/COAX	<b>£8.50</b>
GAMMA TWIN 2 METRE SLIM JIM KIT inc. instr.	<b>£14.50</b>
RAYCOM/RWC HB9CV 2 METRE 2E MINI BEAM	<b>£12.50</b>
RAYCOM/RWC HB9CV 70CM 2E MINI BEAM	<b>£8.95</b>

The above popular products POST FREE. (UK mainland only)

**ROYAL 1300 WIDEBAND DISCONE**

Following the huge success and popularity of the 25-1300MHz, wideband discone antenna - Icom AH 7000 & Welz - Diamond D109 with transmit facilities on VHF-UHF amateur bands, Raycom decided to persuade a UK manufacturer to make a "BRITISH COPY!" at a very competitive price!



COMPLETE WITH PROFESSIONAL CABLE & CONNECTORS AT ONLY £59.50 P&P £5.

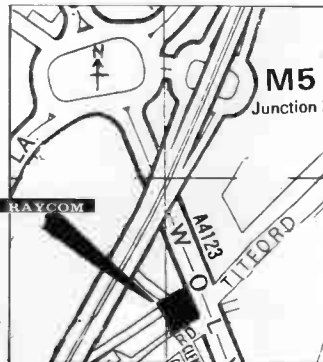

CALL IN, EASY TO GET TO, EASY PARKING

Opening hours 9am-5.30pm 6 days, late nights Thursday & Friday till 7pm. We stay open later!

**ORDERING INFORMATION**

ALL PRODUCTS WE ADVERTISE ARE NORMAL STOCK ITEMS. OUR NEW MAIL ORDER DEPARTMENT CAN NOW DESPATCH MANY ITEMS SAME DAY, BUT PLEASE ALLOW UP TO 14 DAYS. DELIVERY TIME IS SUBJECT TO CARRIAGE METHOD. IF ORDERING BY MAIL PLEASE INCLUDE CARRIAGE AND STATE YOUR DAYTIME TELEPHONE NUMBER. ALL PRODUCTS OVER £75.00 CARRIAGE FREE. PLEASE ALLOW TIME FOR PERSONAL CHEQUES TO CLEAR. PLEASE CALL BEFORE ORDERING AND FOR MORE INFORMATION

PLEASE TEL: 021 544 6767

**RAYCOM COMMUNICATIONS SYSTEMS LTD.**  
INTERNATIONAL HOUSE, 963 WOLVERHAMPTON ROAD  
OLDBURY WEST MIDLANDS B69 4RJ  
Telephone 021 544 6767. Fax 544 7124. Telex 336483 Identi-G

**RAYCOM gives you MORE PURCHASING POWER!**



FOR FAST SERVICE PHONE IN YOUR ORDER WITH ANY MAJOR CREDIT CARD OR IN MOST CASES WE CAN OFFER YOU INSTANT CREDIT OF UP TO £1,000.00 (SUBJECT TO STATUS). RAYCOM ARE LICENSED CREDIT BROKERS. APR 29.8% SUBJECT TO VARIATION. FREE CREDIT ON CERTAIN PRODUCTS AT M.R.P. PRICES. 50% DEPOSIT AND SIX MONTHLY PAYMENTS. PLEASE TELEPHONE FOR MORE DETAILS AND APPLICATION FORMS.

NEW INFOLINE 0836 282228 available 5-9pm (weekdays only)



FOR THE BEST IN AMATEUR RADIO

THROUGH YOUR CONTINUOUS AND VALUED CUSTOM, RAY WITHERS COMMUNICATIONS LTD. HAS MOVED AND EXPANDED TO ENABLE US TO OFFER YOU EVEN BETTER SERVICE AND PRICES - STILL WITH THE RAYCOM GUARANTEE, BEST EQUIPMENT, BEST SERVICE, BEST PRICES, BEST BACK-UP, AND PLENTY OF PARKING FACILITIES AND EASIER TO GET TO! WE NOW BOAST THE BEST CENTRAL FACILITIES IN THE COUNTRY. WHY NOT POP ALONG AND SEE THE LATEST TRANSCEIVERS, SHORTWAVE/SCANNING RECEIVERS AND ACCESSORIES? MOST OTHER PRODUCTS ADVERTISED IN THIS MAGAZINE ARE AVAILABLE AT RAYCOM, AND DON'T FORGET OUR EXCLUSIVE PRODUCTS AND MODIFICATIONS!

# Amateur RADIO

**Editorial:**

Iain Mackenzie  
Penny Phillips

**Advertisement  
Manager:**

Marian Vidler

**Advertisement Executive**  
Maria Smith**Subscriptions:**  
01-684 9542**Publisher:**  
Peter Williams

**On sale:**  
Last Thursday of the  
month preceding cover  
date

**Next issue:**  
Cover date October, on  
sale 29th September 1988

**Published by:**  
Amateur Radio  
Magazines,  
Sovereign House,  
Brentwood, Essex.  
CM14 4SE, England  
(0277) 219876

**Printed:** In England

**ISSN:** 0264-2557

**News Trade Sales by:**  
S M Distribution,  
6 Leigham Court Road,  
Streatham, London.  
SW16 2PG  
Tel: 01-677 8111

**Front cover:**  
Kenwood TS-680SHF  
Mobile Transceiver

Whilst every care is taken when accepting advertisements we cannot accept responsibility for unsatisfactory transactions. We will, however, thoroughly investigate any complaints. The views expressed by contributors are not necessarily those of the publishers. Every care is also taken to ensure that the contents of *Amateur Radio* are accurate, we assume no responsibility for any effect from errors or omissions.

© Copyright 1988  
Amateur Radio Magazines

**6 Straight & Level**

The latest news, comments and developments on the amateur radio scene

**8 Home-made Printed Circuit Boards**

John Goodier shows how simple it is to produce high quality PCBs at home, using easy, straightforward techniques

**12 DX Diary**

Don Field, G3XTT, with this month's DX news

**15 Angus McKenzie Tests . . .**  
. . . the Kenwood TS-680S HF  
Mobile Transceiver**19 The RSGB Data  
Symposium**

Don Field reports

**20 The Dipole Aerial**

Dipole aerials are the most widely used of all in amateur radio communication and yet most operators only have a basic understanding of their application and characteristics. In a three part series starting this month, Ken Williams aims to put this right

**24 Second-hand**

Hugh Allison, G3XSE, helps more enthusiasts with rig repairs

**28 Short Wave Listener**

This month, Trevor Morgan, GW4OXB, looks at propagation, special event stations and reports on the latest award winners

**30 The Ten Tec Argosy II  
Transceiver**

A user review by Ian Poole, G3YWX

**33 Project Book**

Martin Williams shows how to construct a simple filter

**34 Mostly Morse**

Peter Wood relates his experiences of learning Morse

**36 Datasheet**

Ian Poole, G3YWX, looks at the 555 timer IC

**39 Morse Report**

Tony Smith, G4FA1, with his bimonthly look at the world of dots and dashes

**40 On the Beam**

Glen Ross, G8MWR, with the latest news on VHF, UHF and microwaves

**41 Coming Next Month****42 50MHz**

Ken Ellis, G5KW, with the latest developments on 6m

**44 The APT160 Antenna**

Richard Q Marris, G2BZQ, constructs a small, simple, low-cost 160m transmitting/receiving antenna

## SERVICES

**37 Newsagent Order Form****38 Subscription Order Form****45 Free Classified Ads****50 Advertisers Index****50 Advertising Rates and  
Information**



PHONE  
0474 60521

# P.M. COMPONENTS LTD

SELECTION HOUSE,  
SPRINGHEAD ENTERPRISE PARK, SPRINGHEAD ROAD,  
GRAVESEND, KENT DA11 8HD

TELEX  
966371  
TOS PM

## INTEGRATED CIRCUITS

AN103	2.80	LA4430	2.50	AL1397Q	1.10	TA7609P	3.95	TCA760	2.50	10A4050	2.90
AN124	2.50	LA4461	3.05	SN7474	1.80	TA7511AP	2.95	TCAR00	2.50	10A4600	2.90
AN216	2.50	LC7120	3.25	TA7629	2.50	TA7629	2.50	TCAR00	0.95	TDA4600	2.90
AN236	1.95	LC7130	3.80	SN76023N	3.95	TAA310A	3.50	TCA830S	1.95	TEA1003	1.35
AN239	2.50	LC7132	6.50	SN76110N	0.89	TAA320A	3.50	TCAR00	2.50	UPC41C	3.50
AN240	2.80	LM323K	4.85	SN76501N	1.25	TAA350A	1.95	TCA940	1.85	UPC566H	2.98
AN247	2.50	LM324N	0.95	SN76131N	1.30	TAA550B	1.95	TD4440	2.20	BA157	0.30
AN260	1.95	LM3800N	2.50	SN76222D	1.00	TAA570	1.95	TD1001	2.95	BA244	0.75
AN262	2.05	LM3808N	1.80	SN76227N	1.08	TAA621	3.95	TD1003A	3.95	BA301	0.75
AN264	2.80	LM388T	2.85	SN76228N	2.95	TAA661B	1.95	UPC10001H	1.95	BA302	0.85
AN271	3.95	LM390N	2.50	SN76533N	1.95	TAA700	1.70	TD10006A	2.80	BA318	2.98
AN301	2.95	LM1011	1.15	SN76550N	1.18	TAA930	3.95	TD10100	2.15	BA328	2.95
AN303	3.50	M5155L	2.98	SN76560N	0.90	TAA120AS/B/C	1.00	TD10105	2.25	BA521	1.75
AN313	2.95	M51513L	2.30	STK011	7.95	TAA120AS/B/C	1.00	TD10135	2.50	BA521	1.75
AN315	2.25	M51521L	1.80	STK014	7.95	SA/SB/T/U	1.00	TD10137	1.95	BAW62	0.19
AN316	2.95	MB3705	1.80	STK015	5.95	TBA395	1.50	TD10144	2.15	BAX13	0.04
AN331	2.95	MB3712	2.80	STK016	7.95	TBA396	0.78	TD11170	1.95	BAX16	0.12
AN342	2.95	MB3756	2.90	STK025	11.95	TBA440N	1.55	TD11180	2.15	BA2157	0.30
AN362L	2.50	MC1307P	1.00	STK032	7.95	TBA480Q	1.28	TD1270Q	1.98	BA244	0.75
AN612	2.15	MC1310P	1.95	STK078	11.95	TBA510	2.50	TD1270Q	1.98	BA301	0.75
AN6362	3.95	MC1327	1.70	STK085	8.95	TBA510Q	2.50	TD13127	3.90	BA302	0.85
AN7140	3.50	MC1327Q	0.98	STK415	7.95	TBA520	1.10	TD20002	1.95	BA313	0.78
AN7145	3.95	MC1357	2.80	STK435	7.95	TBA520Q	1.10	TD20003	2.95	BA318	2.98
AN7150	2.95	MC1358	2.35	STK437	7.95	TBA530	1.10	TD20010	1.98	BA328	2.95
AN7151	2.50	MC1495	3.00	STK439	7.95	TBA540	1.28	TD20020	2.95	BA521	1.75
BA521	3.95	MC1496	1.75	STK461	11.80	TBA540Q	1.38	TD21250	3.95	BAW62	0.19
CA1352E	1.75	MC3401L	2.80	STK0015	7.95	TBA550Q	1.98	TD2150	2.95	BAX13	0.04
CA3096	0.46	MC3431E	2.78	STK0029	7.95	TBA560Q	1.48	TD2151	1.98	BAX16	0.12
CA3123E	1.95	MC4106P	2.95	STK0039	7.95	TBA570	1.00	TD2251	1.95	BY208	0.40
CA3131EM	2.50	MC4158BP	1.80	TA7061AP	1.80	TBA651R	2.50	TD2520	3.95	BY208-000	0.33
CA3140T	1.18	ML231B	1.75	TA7072	2.85	TBA673	1.98	TD2532	1.95	BY209	0.30
ET6106	2.50	ML232B	2.80	TA7108P	1.80	TBA720A	2.48	TD2540	1.95	BY223	0.90
HA1137W	1.95	TA7120P	1.65	TA7120P	1.65	TBA750	1.98	TD2541	2.15	BY298-400	0.22
HA1156W	1.90	TA7120P	1.80	TA7120P	1.80	TBA750Q	2.95	TD2550	2.15	BY299-500	0.22
HA1306	1.80	TA7130P	1.90	TA7130P	1.90	TBA800	0.89	TD2551	2.15	BYX10	0.20
HA1322	1.95	TA7137P	1.60	TA7137P	1.60	TBA810AS	2.95	TD2582	2.98	BYX25-600	1.28
HA1339A	2.95	TA7176P	1.50	TA7176P	1.50	TBA810P	1.65	TD2583	2.95		
HA1366W	2.75	TA7176P	1.50	TA7176P	1.50	TBA820M	0.78	TD2600	0.80		
HA1377	3.50	TA7193P	3.95	TA7193P	3.95	TBA820Q	1.48	TD2611A	1.95		
HA1406	1.95	TA7203	2.95	TA7203	2.95	TBA890	2.50	TD2621	1.95		
HA1551	2.95	TA7204P	2.18	TA7204P	2.18	TBA920	1.85	TD2680A	2.75		
HA1201	0.95	TA7222AP	1.80	TA7222AP	1.80	TBA950/2X	2.35	TD2690	4.48		
HA1230	1.95	TA7227P	4.25	TA7227P	4.25	TA7204P	2.18	TD2690	4.48		
LA3201	0.95	TA7228P	1.95	TA7228P	1.95	TA7310P	1.80	TD2690	4.48		
LA4140	2.95	TA7310P	1.80	TA7310P	1.80	TA7313AP	2.95	TD2690	4.48		
LA4031P	1.95	TA7313AP	2.95	TA7313AP	2.95	TA7314P	2.95	TD2690	4.48		
LA4400	3.80	TA7321P	2.25	TA7321P	2.25	TCAR00	2.50	TD2690	4.48		
LA4420	3.80	TCAR00	2.50	TCAR00	2.50						
LA4422	2.50										

## SEMICONDUCTORS

AAV12	0.28	BC182IB	0.10	BD237	0.40	BF493	0.35	MRF453	17.80	TV106	1.50
AC126	0.48	BC183	0.10	BD242	0.85	BF595	0.23	MRF454	26.50	TV106/2	1.50
AC127	0.20	BC183L	0.09	BD246	0.75	BF597	0.25	MRF455	17.50	ZRF0112	16.50
AC128	0.28	BC184LB	0.09	BD376	0.32	BFR39	0.23	MRF475	2.95	2N1100	6.50
AC128K	0.32	BC204	0.25	BD379	0.45	BFR40	0.23	MRF477	14.95	2N1308	1.35
AC141	0.28	BC207B	0.10	BD410	0.65	BFR81	0.25	OC16W	2.50	2N1711	0.20
AC141K	0.34	BC208B	0.10	BD414	0.65	BFR88	0.30	OC23	9.50	2N2219	0.38
AC142K	0.45	BC212	0.09	BD434	0.45	BFR90	0.45	OC25	1.50	2N2626	0.95
AC176	0.22	BC212L	0.09	BD437	0.75	BFR91	1.75	OC28	1.80	2N2905	0.40
AC176K	0.31	BC213	0.09	BD438	0.75	BFR92	1.75	OC28	1.80	2N3053	0.40
AC187	0.25	BC213L	0.09	BD510	0.95	BFT43	0.35	OC29	4.50	2N3054	0.50
AC187K	0.28	BC214	0.09	BD518	0.78	BFW10	0.55	OC32	8.50	2N3055	0.52
AC188	0.25	BC214C	0.09	BD520	0.65	BFW11	0.75	OC42	1.50	2N2702	0.12
AC188K	0.37	BC214L	0.09	BD534	0.45	BFW16A	1.15	OC44	1.25	2N3703	0.12
AD142	0.50	BC237B	0.15	BD535	0.45	BFW61	0.60	OC45	1.00	2N3704	0.12
AD143	0.50	BC238	0.15	BD538	0.45	BFW62	0.60	OC47	1.00	2N3705	0.20
AD149	2.70	BC239	0.15	BD575	0.95	BFX29	0.30	OC71	0.75	2N3706	0.20
AD161	0.50	BC251A	0.18	BD587	0.95	BFX84	0.26	OC72	2.50	2N3708	0.12
AD162	0.50	BC252A	0.18	BD588	0.95	BFX85	0.32	OC75	1.50	2N3733	0.95
AF106	0.50	BC258	0.28	BD597	0.95	BFX86	0.30	OC81	1.00	2N3773	2.75
AF114	1.95	BC258A	0.39	BD695	1.80	BFX88	0.25	OC84	1.50	2N3792	1.35
AF121	0.65	BC300	0.30	BD698	1.80	BFY18	1.38	OC139	12.50	2N4427	1.95
AF124	0.65	BC300L	0.30	BD701	1.25	BFY30	0.32	OC171	4.50	2N4444	1.18
AF125	0.35	BC301	0.30	BD702	1.25	BFY31	0.32	OC200	4.50	2N5294	0.42
AF126	0.65	BC303	0.26	BD707	0.90	BFY90	0.77	OC201	5.50	2N5298	0.42
AF127	0.65	BC307B	0.09	BDX32	1.50	BLY48	1.78	OC205	10.00	2N5298	0.42
AF139	0.40	BC327	0.10	BDX33B	1.65	BR100	0.48	R2008B	1.45	2N5485	0.48
AF150	0.60	BC328	0.10	BF115	0.35	BR101	0.48	R2009	2.50	2N5496	0.65
AF176	1.95	BC337	0.10	BF119	0.85	BR103	0.85	R2010B	1.45	2SA329	0.98
AF229	0.45	BC340	0.09	BF120	0.39	BR303	0.85	R2202	0.88	2SA715	0.58
AFU06	0.95	BC347A	0.13	BF127	0.39	BR444B	1.18	R2203	0.88	2SC496	0.80
AY102	2.95	BC461	0.35	BF177	0.38	BR499	0.48	R2540	2.48	2SC578	0.75
BC107A	0.11	BC478	0.20	BF160	0.27	BSW64	0.95	RCA16029	0.85	2SC784	0.75
BC107B	0.11	BC527	0.20	BF173	0.22	BSX60	1.25	RCA16039	0.85	2SC785	0.75
BC108	0.10	BC548	0.10	BF158	0.22	BT100A/02	0.85	RCA16181	0.85	2SC789	0.65
BC108B	0.12	BC548L	0.10	BF178	0.28	BT106	0.45	RCA16334	0.85	2SC931D	1.95
BC109	0.10	BC549A	0.10	BF179	0.34	BT110	1.60	RCA16335	0.85	2SC937	1.95
BC109B	0.12	BC550	0.14	BF180	0.29	BT115	1.20	RCA16372	0.85	2SC937L	1.95
BC109C	0.12	BC557	0.08	BF181	0.29	BT120	1.20	S2060D	0.95	2SC1036	4.80
BC114A	0.09	BC558	0.10	BF182	0.29	BT120	1.20	SKE5F	1.45	2SC1096	4.80
BC115	0.55	BC639/10	0.30	BF183	0.29	DJ105	1.95	T6021V	0.45	2SC1124	0.95
BC116A	0.55	BCY33A	19.50	BF184	0.35	BU108	1.60	T6027V	0.45	2SC1162	0.95
BC116A	0.50	BD115	0.30	BF185	0.28	BU124	1.25	T6029V	0.45	2SC1172Y	2.15
BC117	0.19	BD124P	0.59	BF194	0.11	BU125	1.25	T6036V	0.85	2SC1173	1.15
BC119	0.24	BD132	0.42	BF195	0.11	BU126	1.90	T9002V	0.55	2SC1364	0.80
BC125	0.25	BD133	0.40	BF197	0.11	BU204	1.55	T9011V	0.75	2SC1413A	2.80
BC139BC	0.02	BD133	0.40	BF198	0.16	BU205	1.30	T9015V	0.80	2SC1428	0.90
BC140	0.31	BD135	0.30	BF199	0.14	BU208	1.39	T9034V	2.15	2SC1449	0.90
BC141	0.25	BD136	0.30	BF200	0.40	BU208A	1.52	T9038V	3.95	2SC1528	1.95
BC142	0.21	BD137	0.32	BF201	0.20	BU208D	1.80	THY15/80	2.25	2SC1945	3.75
BC143	0.24	BD138	0.30	BF241	0.15	BU326	1.20	THY15/85	2.25	2SC1953	0.95
BC147B	0.12	BD139	0.32	BF245	0.30	BU326S	1.50	TIP25	0.40	2SC1957	0.80
BC148A	0.09	BD140	0.30	BF256L	0.38	BU407	1.24	TIP29C	0.42	2SC1969	2.90
BC148B	0.09	BD144	1.10	BF257	0.28	BU408	1.40	TIP47	0.50	2SC1985	1.90
BC149	0.09	BD15									



PHONE

0474 60521  
0474 60521  
FAX NO.0474 333 762

**P.M. COMPONENTS LTD**  
**SELECTRON HOUSE**  
**SPRINGHEAD ENTERPRISE PARK, SPRINGHEAD ROAD**  
**GRAVESEND, KENT DA11 8HD**

**TELEX**  
**966371**  
**TOS PM**

**A SELECTION FROM OUR**

**STOCK OF BRANDED VALVES (Contd)**

Table listing various valve types (DL35, DL6, DL7, etc.) and their prices. Includes a 'Selection' section for Mullard and other brands.

Table listing various valve types (DM5B, OM6, ORP30, etc.) and their prices.

Table listing various valve types (VR105/30, VR150/30, etc.) and their prices.

Table listing various valve types (30PL13, 30PL14, etc.) and their prices.

**OVER 4 MILLION VALVES IN STOCK**  
**4,000 + Different Types**  
Please enquire for types not listed  
Specially selected and matched valves  
available on request  
**CALLERS WELCOME**  
**OPEN MON-THUR 9AM-5.30PM**  
**FRI 9AM-5.00PM**  
**"24-HOUR ANSWERPHONE SERVICE"**  
**ACCESS & BARCLAYCARD**  
**PHONE ORDERS P&P £1**  
**UK ORDERS P&P £1**  
**PLEASE ADD 15% VAT**  
**EXPORT ORDERS WELCOME**  
**CARRIAGE AT COST**  
**PLEASE SEND YOUR**  
**ENQUIRIES FOR SPECIAL**  
**QUOTATIONS FOR LARGE**  
**REQUIREMENTS.**



### POPULAR BAKERS DOZEN PACKS (still available)

All packs are £1 each, if you order 12 then you are entitled to another free. Please state which one you want. Note the figure on the extreme left of the pack ref number and the next figure is the quantity of items in the pack, finally a short description.

- BD1 5 13A junction boxes for adding extra points to your ring main circuit.
- BD2 5 13A spurs provide a fused outlet to a ring main where devices such as a clock must not be switched off.
- BD7 4 In flex switches with neon on/off lights, saves leaving things switched on.
- BD9 2 6V 1A mains transformers upright mounting with fixed clamps.
- BD11 1 6 1/2in speaker cabinet ideal for extensions, takes our speaker. Ref BD137.
- BD13 12 30 watt reed switches, it's surprising what you can make with these burglar alarms, secret switches, relay, etc., etc.
- BD22 2 25 watt loudspeaker two unit crossovers.
- BD29 1 B.D.A.C. stereo unit is wonderful value.
- BD30 2 Nicad constant current chargers adapt to charge almost any nicad battery.
- BD32 2 Humidity switches, as the air becomes damper the membrane stretches and operates a microswitch.
- BD34 48 2 meter length of connecting wire all colour coded.
- BD42 5 13A rocker switch three tags so on/off, or change over with centre off.
- BD45 1 24hr time switch, ex-Electricity Board, automatically adjust for lengthening and shortening day. original cost £40 each.
- BD49 10 Neon valves, with series resistor, these make good night lights.
- BD56 1 Mini uniselector, one use is for an electric jigsaw puzzle, we give circuit diagram for this. One pulse into motor, moves switch through one pole.
- BD59 2 Flat solenoids - you could make your multi-tester read AC amps with this.
- BD67 1 Suck or blow operated pressure switch, or it can be operated by any low pressure variation such as water level in water tanks.
- BD91 2 Mains operated motors with gearbox. Final speed 16 rpm, 2 watt rated.
- BD103A 1 6V 750mA power supply, nicely cased with mains input and 6V output leads.
- BD120 2 Stripper boards, each contains a 400V 2A bridge rectifier and 14 other diodes and rectifiers as well as dozens of condensers, etc.
- BD122 10m Twin screened flex with white pvc cover.
- BD128 10 Very fine drills for pcb boards etc. Normal cost about 80p each.
- BD132 2 Plastic boxes approx 3in cube with square hole through top so ideal for interrupted beam switch.
- BD134 10 Motors for model aeroplanes, spin to start so needs no switch.
- BD139 6 Microphone inserts - magnetic 400 ohm also act as speakers.
- BD148 4 Reed relay kits, you get 16 reed switches and 4 coil sets with notes on making c/o relays and other gadgets.
- BD149 6 Safety cover for 13A sockets - prevent those inquisitive little fingers getting nasty shocks.
- BD180 6 Neon indicators in panel mounting holders with lens.
- BD193 6 5 amp 3 pin flush mounting sockets make a low cost disco panel.
- BD196 1 in flex simmerstat - keeps your soldering iron etc. always at the ready.
- BD199 1 Mains solenoid, very powerful, has 1in pull or could push it modified.
- BD200 8 Keyboard switches - made for computers but have many other applications.
- BD210 4 Transistors type 2N3055, probably the most useful power transistor.
- BD211 1 Electric clock, mains operated, put this in a box and you need never be late.
- BD221 5 12V alarms, make a noise about as loud as a car horn. Slightly soiled but OK.
- BD242 2 6in x 4in speakers, 4 ohm made from Radiomobile so very good quality.
- BD246 2 Tacho generators, generate one volt per 100 revs.
- BD252 1 Panostat, controls output of boiling ring from simmer up boil.
- BD259 50 Leads with push-on 1/4in tags - a must for hook-ups - mains connections etc.
- BD263 2 Oblong push switches for bell or chimes, these can mains up to 5 amps so could be foot switch if fitted into patress.
- BD268 1 Mini 1 watt amp for record player. Will also change speed of record player motor.
- BD275 1 Guitar mic - clip-on type suits most amps.
- BD283 3 Mild steel boxes approx 3in x 3in x 1in deep - standard electrical.
- BD293 50 Mixed silicon diodes.
- BD296 3 Car plugs with lead, fit into lighter socket.
- BD305 1 Tubular dynamic mic with optional table rest.

Most other packs still available and you can choose any as your free one.

### 5A BATTERY CHARGER KIT

All parts, including case, Only £5 plus £1 postage

### OVER 400 GIFTS YOU CAN CHOOSE FROM

There is a total of over 400 packs in our Baker's Dozen range and you become entitled to a free gift with each dozen packs.

A classified list of these packs and our latest "News Letter" will be enclosed with your goods, and you will automatically receive our next news letter.



### F.O.D. BARGAIN

3 1/2in Floppy Disc Drive, made by the Chicon Company of Japan. Beautifully made and probably the most compact device of its kind as it weighs only 600g and measures only 104mm wide, 162mm deep and has a height of only 32mm. Other features are 80 track, high precision head positioning, single push loading and eject direct drive brushless motor. Shugart compatible interface, standard connections interchangeable with most other 3 1/2 and 5 1/4 drives. Brand new with copy of maker's manual. Offered this month at £28.50 post and VAT included.

**CASE** Adaptable for 3 1/2" FDD, has room for power supply components. Price only £4 includes circuit of PSU. Our Ref 4P7

**POWER SUPPLY FOR FDD** 5V and 12V voltage regulated outputs, complete kit of parts will fit into case 4P7 price £8 or with case £11. Our ref 11P2

### 9" MONITOR

Ideal to work with computer or video camera uses Philips black and white tube ref M24/306W. Which tube is implosion and X-ray radiation protected. VDU is brand new and has a time base and EHT circuitry. Requires only a 16V dc supply to set it going. It's made up in a lacquered metal framework but has open sides so should be cased. Offered at a lot less than some firms are asking for the tube alone, only £16 plus £5 post.

### CASE FOR 9" MONITOR

We have arranged with a metal worker to make cases for the 9" Monitor. Delivery promised for the end of May and the price £12 plus £2 post. The case will be made from coated sheet steel, overall size approx 10in x 10in x 7in high which will give ample space for the Power Supply and external controls if you fit them.

### PROBLEM SOLVED!

We have obtained from the manufacturers of the 9" Monitor, the TTL converter which makes it composite input suitable to work with any computer. We have had the printed circuit board made and have all the components and can supply this converter in kit form price £6. Our ref. 6P4

### AN ALLADIN'S CAVE

We have opened another shop in Hove, the address is number 12 Boundary Road which is between Hove and Portside fairly close to the seafront. When you want to see before you buy and when you want to browse around the special bargains available, this is where you should make for as the Portland Road shop in future will be just mail order. You can of course collect from Portland Road but you should bring in an order complete with reference numbers so that the stores can attend to it easily.

### MINI MDNO AMP on p.c.b. size 4" x 2" (app.)

Fitted volume control and a hole for a tone control should you require it. The amplifier has three transistors and we estimate the output to be 3W rms. More technical data will be included with the amp. Brand new, perfect condition, offered at the very low price of £1.15 each, or £13 for 12.



### THIS MONTH'S SNIP

**ACORN COMPUTER DATA RECORDER (CASSETTE)** This is a mono data recorder with switchable motor control intended for use with the Acorn Electron or BBC computers but also functions with almost any other computer and can be used for normal record and play-back of music and speech.

Six key controls give "PAUSE", "STOP" and "EJECT"; "CUE/FAST FORWARD"; "REWIND/REWIND" and "RECORD", fast forward and rewind (100 seconds for C60). Also tape counter with reset button. Input signal range 5mV to 500mV. Input impedance 40k ohm. Can be battery operated but is supplied with a mains adaptor. Brand new still in manufacturer's wrapping £8. Order Ref. 8P18 add £2 postage.

### VENNER TIME SWITCH

Mains operated with 20 amp switch, one on and one off per 24 hrs. repeats daily automatically correcting for the lengthening or shortening day. An expensive time switch but you can have it for only £2.95 without case, metal case - £2.95, adaptor kit to convert this into a normal 24hr time switch but with the added advantage of up to 12 on/off per 24hrs. This makes an ideal controller for the immersion heater. Price of the adaptor kit is £2.30.



Ex-Electricity Board. Guaranteed 12 months.

### AKAI RV-UM300 MIDI-RACK

is a really excellent piece of furniture, ideal to hold your computer or audio equipment. Has three shelves in the upper section and a hinged glass fronted lower section. Height approximately 3ft, width 13 1/2in, depth 14in, on castors, dark walnut veneer finish. £15 plus £8 for Securicor delivery. Order Ref. 15P11.

### MULLARD UNILEX AMPLIFIERS

We are probably the only firm in the country with these now in stock. Although only four watts per channel, these give superb reproduction. We now offer the 4 Mullard modules - i.e. Mains power unit (EP9002) Pre-amp module (EP9001) and two amplifier modules (EP9000) all for £6.00 plus £2 postage. For prices of modules bought separately see TWO POUNDERS.

### 25A ELECTRICAL PROGRAMMER

Learn in your sleep. Have radio playing and kettle boiling as you wake - switch on lights to warn off intruders - have a warm house to come home to. You can do all these and more. By a famous maker with 25 amp on/off switch. A beautiful unit at £2.50.



### POWERFUL IDNISER

Generates approx. 10 times more IONS than the E71 and similar circuits. Will refresh your home, office, workshop etc. Makes you feel better and work harder - a complete mains operated kit, case included. £11.50 + £3 P&P

### J & N BULL ELECTRICAL

Dept AR, 250 PORTLAND ROAD, HOVE

BRIGHTON, SUSSEX BN3 5QT

MAIL ORDER TERMS: Cash, PO or cheque with order. Orders under £20 add £1.50 service charge. Monthly account orders accepted from schools and public companies. Access and B/card orders accepted. Brighton (0273) 734648 or 203500

### NEW ITEMS

Some of the many items described in our current list which you will receive with your parcel

**POWERFUL 12V MOTOR** was intended for Sinclair Electric Car rating approx. 1/2 HP. Price £15 plus £2 post  
**3 INCH FDD Hitachi** ref. HFD 3055XA. Ideal replacement or second drive in most computers, especially Amstrad 6128, etc. Price £30 plus £3 post.

**SOLAR POWERED NI-CAD CHARGER** 4 Ni Cad batteries AA (HP77) charged in eight hours or two in only 4 hours (It is a complete, boxed ready to use unit. Price £6. Our ref. 6P3

**50V 20A TRANSFORMER** 'C' Core construction so quite easy to adapt for other outputs. Tapped mains input. Only £25 but very heavy so please add £5 if not collecting. Order Ref. 25P4

**FREE POWER!** Can be yours if you use our solar cells. Sturdily made modules with new system bubble magnifiers to concentrate the light and so eliminate the need for actual sunshine. They work just as well in bright light. Voltage input is 45, you join in series to get desired voltage and in parallel for more amps. Module A gives 100mA, Price £1. Our ref. BD631. Module C gives 400mA, Price £2. Our ref. 2P199. Module D gives 700mA, Price £3. Our ref. 3P42

**SWITCH AC LOADS WITH YOUR COMPUTER** This is easy and reliable if you use our solid state relay. This has no moving parts, has high input resistance and acts as a noise barrier and provides 4kW isolation between logic terminals. The turn on voltage is not critical, anything between 3 and 30V, internal resistance is about 1K ohm. AC loads up to 10A can be switched. Price is £2 each. Ref. 2P183

**METAL PROJECT BOX** Ideal size for battery charger, power supply etc. Sprayed grey, size 8in x 4 1/4in x 4in high, ends are louvred for ventilation other sides are flat and undrilled. Order Ref. 2P191. Price £2. Our ref. 3P41

**BIG SMOOTHING CAPACITOR** Sprague powerlytic 39,000uF at 50V. £3. Our ref. 3P41

**4-CORE FLEX CABLE** Cores separately insulated and grey PVC covered overall. Each copper core size 7/0 2mm. Ideal for long telephone runs or similar applications even at mains voltage 20 metres £2. Our ref. 2P196 or 100 metres coil £8. Order ref. 8P19

**TWIN GANG TUNING CAPACITOR** Each section is 0005uF with trimmers and good length 1/4in spindle. Old but unuse3d and in very good condition. £1 each. Our ref. BD630

**13A PLUGS** Good British make complete with fuse, parcel of 5 for £2. Order ref. 2P185

**13A ADAPTERS** Takes 2 13A plugs, packet of 3 for £2. Order ref. 2P187

**20V-0-20V** Mains transformers 2 1/2 amp (100 watt) loading, tapped primary, 200-245 upright mountings £4. Order ref. 4P24

**BENCH ISOLATION TRANSFORMERS** 250 watt 230V in and out with plenty of tappings to give exact volts. £5 plus £2. Order ref. 5P5

**BURGLAR ALARM BELL** 6" gong OK for outside use if protected from rain. 12V battery operated. Price £8. Ref. 8P2

**24 HOUR TIME SWITCH** 16A changeover contacts, up to 6 on/off per day. Nicely cased, intended for wall mounting. Price £8. Ref. 8P6

**CAPACITOR BARGAIN** axial ended, 4700uF at 25V. Jap made, normally 50p each, you get 4 for £1. Our ref. 613

**CLEANING FLUID** Extra good quality. Intended for video and tape heads. Regular price £1.50 per spray can. Our price 2 cans for £1. Ref. BD604

**PIEZO ELECTRIC FAN** An unusual fan, more like the one used by Madame Butterfly than the conventional type, it does not rotate. The air movement is caused by two vibrating arms. It is American made, mains operated, very economical and causes no interference, so is ideal for computer and instrument cooling. Price is only £1 each. Ref. BD605

**SPRING LOADED TEST PRODS** Heavy duty, made by the famous Bulgin company very good quality. Price 4 for £1. Ref. BD599

**CURLY LEAD** Four core, standard replacement for telephone handset, extends to nearly 2 metres. Price £1 each. Ref. BD599

**TELEPHONE BELLS** These will work off our standard mains through a transformer, but to sound exactly like a telephone, they then must be fed with 25Hz 50V. So with these bells we give a circuit for a suitable power supply. Price 2 bells for £1. Ref. BD600

**ASTEC P.S.U.** Switch mode type. Input set for +230V. Output 3.5 amps at +5V, 1.5 amps at +12V, and 3 amps at +5V. Should be OK for floppy disc drives. Regular price £30. Our price only £10. Ref. 10T34. Brand new and unused.

**APPLIANCE THERMOSTATS** Spindle adjust type suitable for convector heaters or similar. Price 2 for £1. Ref. BD582

**3-CORE FLEX BARGAIN No. 1** Core size 5mm so ideal for long extension leads carrying up to 5 amps or short leads up to 10 amps. 15mm for £2. ref. 2P189

**3-CORE FLEX BARGAIN No. 2** Core size 1.25mm so suitable for long extension leads carrying up to 13 amps, or short leads up to 25A. 10m for £2. Ref. 2P190

**CASE WITH 13A PRONGS** To go into 13A socket, nice size and suitable for plenty of projects such as battery trickle charger, speed controller, time switch, night light, noise suppressor, dimmers etc. Price 2 for £1. Ref. BD565

**ALPHA-NUMERIC KEYBOARD** This keyboard has 73 keys giving trouble free life and no contact bounce. The keys are arranged in two groups, the main area is a DOWERTY array and on the right is a 15 key number pad. Board size is approx. 13" x 4" brand new but offered at only a fraction of its cost, namely £3. plus £1 post. Ref. 3P27

**TELEPHONE EXTENSIONS** It is now legal for you to undertake the wiring of telephone extensions. For this we can supply 4-core telephone cable, 100m coil £8.50. Extension BT sockets £2.95. Packet of 50 plastic headed staples £2. Dual adaptor for taking two appliances from one socket £3.95. Leads with BT plug for changing old phones, 3 for £2

**WIRE BARGAIN** 500 metres 0.7mm solid copper tinned and pvc covered. Only £3 plus £1 post. Ref. 3P31 that's well under 1p per metre, and this wire is ideal for push on connections

**INTERRUPTED BEAM KIT** This kit enables you to make a switch that will trigger when a steady beam of infra-red or ordinary light is broken. Main components relay, photo transistor, resistors and caps, etc. Circuit diagram but no case. Price £2. Ref. 2P15

**3-30V VARIABLE VOLTAGE POWER SUPPLY UNIT** with 1 amp DC output. Intended for use on the bench for experimenters, students, inventors, service engineers etc. This is probably the most important piece of equipment you can own (after a multi range test meter). It gives a variable output from 3-30 volts and has an automatic short circuit and overload protection, which operates at 1.1 amp approximately. Other features are very low ripple output, a typical ripple is 3mV pk-pk, 1mV rms. Mounted in a metal fronted plastic case, this has a voltmeter on the front panel in addition to the output control knob and the output terminals. Price for complete kit with full instructions is £15. Ref. 15P7

**TRANSMITTER SURVEILLANCE (BUG)** Tiny, easily hidden, but which will enable conversation to be picked up with FM radio. Can be housed in a matchbox, all electronic parts and circuit. Price £2. Ref. 2P52

# LEVEL

## NEW AMATEUR RADIO LICENCE

A new amateur radio licence will be introduced from the beginning of next year. This follows a major review of the licence by DTI. This was necessary because licences were becoming increasingly difficult to interpret due to rapidly changing technology, and many recent relaxations in policy towards amateur radio needed to be incorporated in the licence document.

Changes resulting from the review include:

- a new format making the licence more attractive and easier to read;
- licensees receiving a yearly Validation Document to indicate renewal and validity of the licence;
- conformity with the requirements of the European Conference of Postal and Telecommunications Administrations (CEPT). Recommendation T/R 61-01 will enable UK amateurs to operate their UK licence in a growing number of European countries. From 1st January 1989, amateurs from many European countries will be able to operate in the UK;
- maritime mobile operation no longer requiring a separate licence;
- relaxation of restrictions on RAYNET (Radio Amateur Emergency Network) operation and message handling;
- operation using digital communications (which includes packet radio operation). Mailbox/bulletin board operation will need a separate authority available through the RSGB;
- operation under the supervision of the licensee, by anyone who has passed the Radio Amateurs' Examination;
- unattended operation of beacons and low power devices;
- simplification of identification requirements;
- log keeping on magnetic disc or tape;
- opening of 1.850-2.000MHz band for radioteletype.

An information sheet (Amateur Radio Information Sheet No 7) giving further

information on the new licence may be obtained from DTI Radiocommunications Division, Waterloo Bridge House, Waterloo Road, London SE1 8UA.

## MINI DIGITAL MULTIMETER

The PAN1005 offers an accuracy of 0.5% in a pocket-sized digital multimeter format.

It has a 3½ digit LCD display with autozero, polarity and low battery indicator. Range selection is by way of six push buttons that provide dc voltage measurement of up to 1000V dc and up to 750 ac. Resistance is measured in four ranges from 2k ohms up to 2m ohms.

The PAN1005 measures 130 x 75 x 28mm and weighs 195gm. It is powered by a 9V battery and is supplied with a test label set and full instructions.

For further information, contact: *Jean Newman, Electronic & Computer Workshop Ltd. Tel: (0376) 517413*

## WORKSHOP AMATEUR RADIO SOCIETY

Here is an update of events concerning the Workshop Amateur Radio Society:

- Official Club Meeting. 13 September - Talk: Photography on the Cheap with Colin, G4RUD. 27 September - Talk: Simple Transceiver for Top Band with Peter, G4BVV. 11 October - Junk Sale. 25 October - Annual General Meeting. 8 November - Call my Bluff (Maltby visit Workshop). 25 November - Call my Bluff (Workshop visit Maltby). 6 December - Video night. 17 December - Annual Dinner and Dance. 20 December - A Night on the Air.

For further information, contact: *Mrs G Gee, 100 Plantation Hill, Workshop, Notts. Tel: Workshop 486614*

## CIRKIT CATALOGUE

The Summer 1988 edition of the Cirkit constructors' catalogue is now available, featuring many new products for the electronic constructor in its

184 pages.

Being shown for the first time among the 3,000 lines, are a low cost 10MHz oscilloscope, the Easiwire fast circuit prototyping system, an automatic NiCad charger-cycler, two new models of hand-held scanning receivers, a 2-5000MHz RF power meter, and the 'Rolls Royce' of digital multimeters - the AVO M2000 series.

The new products are complemented by additions to Cirkit's components range, with enlarged selections of NiCad batteries, mains connectors, Scart connectors, dc fans, RFI filters, high current chokes, ABS and 19in rack cases, rocker switches, tip cleaners and cyno adhesive.

A special attraction for the first 500 constructors to send in an order over £50 (excluding VAT) is a free digital travel alarm with date, hours, minutes and seconds display. Cirkit is also running its popular competition, with one of the new 10MHz oscilloscopes as the first prize. Prizes for runners-up are auto-ranging multimeters and electronic toolkits.

For further information, contact: *Cirkit Distribution Ltd, Port Lane, Broxbourne, Herts. Tel: (0992) 444111*

## CONTACT GROUP

Amateur radio enthusiast, Subhash Haridas, would like to hear from other enthusiasts interested in forming a contact group. For more details write to Mr Haridas, 14 Springbank Road, Chesterfield, Derbyshire.

## SPECIAL EVENT

Two members of Radio Link will be operating the Special Event Station of GBIRLD, from the outside broadcast caravan at Derby City Hospital, on the Amateur Band of 2m VHF on the following dates:

17 September 1988, Saturday 1000 to 1600 hours.

18 September 1988, Sunday 1000 to 1600 hours.

Representatives of local organisations will be visiting

# All the latest news, views, comment and developments on the amateur radio scene

the Event. Each person will receive a Special QSL Card; via the RSGB mailing service. This year will be the second Event operated by *Radio Link*; last year's contacts/reports were received from amateur radio people in: Fakenham, Southport, Norwich, Denby, Chapel St Leonards, Birmingham, Doncaster, Wrexham.

They intend to operate a GB75 prefix in December 1988, to celebrate the 75th Anniversary of the RSGB and help other amateur radio people collect points for the GB75 Award issued by the RSGB.

For further information, contact: *John Huddestone, 208 Wilmot Ave, Chaddesdon, Derby DE2 6PL. Tel: Derby 676822*

## NEW ANTENNAS

Walters and Stanton Electronics announce the introduction of two new aerials that will be of particular interest to the airband enthusiast.

The 125M antenna is designed for mobile operation, with a magnetic base, 4m of low loss coax cable and a PL259 plug. The aerial itself is a quarter wave centred on 125MHz, incorporating a spring base section. The bandwidth is sufficient to provide complete coverage of the VHF airband. The combination of spring base and flexible whip makes this antenna suitable mobile operation.

The GP-150 is an airband base station antenna with 3dB of gain over a quarter wave. Constructed of heat treated aluminium, it has excellent bandwidth and low angle of signal acceptance for DX performance. The antenna is supplied complete with radials and mast mounting brackets. Base impedance is 50 ohms and the antenna is fitted with an SO239 socket and weather protective sleeve.

For further details contact: *Walters and Stanton Electronics, 18-20 Main Rd, Hockley, Essex. Tel: (0702) 206835*

## PATTERN GENERATORS

The Philips PM 5514 and PM 5514V colour pattern generators are suitable for TV, monitor and video troubleshooting.

The PM 5514 is intended for monochrome and colour TV testing. The PM 5514V, on the other hand, with its CVBS and RGB outputs, will meet the requirements of the video equipment, computer and CCTV monitor markets.

They both offer a choice of over 70 colour patterns and combinations, together with simple and secure microprocessor-controlled operation. Test patterns are selected by 12 push-buttons on the display panel.

As well as a selection of colour patterns and combinations, the PM 5514 offers an RF carrier in two frequency ranges of 175-270MHz and 525-810MHz. The one in use is clearly indicated by the LED display. Sound modulation is provided with a choice of internal and external modulation modes and a switchable carrier signal.

An additional rear-panel CVBS output for the SS14V caters for SYNC and sub-carrier signals to meet the needs of colour monitors and other video requirements, but this is only available as a factory-fitted optional extra. Both units cover the PAL, B, G, I and D TV standards; also NTSC M standard, but with the SS14V only.

For further information, contact: *Instrumex (UK), Dorcan House, Meadfield Road, Langley, Slough SL3 8AL.*

## FREQUENCY DOUBLER

The new Triangle model PD-29 frequency doubler has a low conversion loss of 10dB (typical) for an input from 2 to 4GHz, rising to 12dB from 4 to 9GHz.

The PD-29 suppresses third order harmonics to better than 25dB and isolates from fundamental frequencies to 25dB. The doubler accepts an input bandwidth from 2 to 9GHz, giving an output from 4 to 18GHz. Input VSWR is 1.5:1

with a maximum of only 2.0:1.

Rated input power is 200mW up to 25°C and 10mW at 85°C. The operating temperature range is from -54 to +85°C

For further information contact: *Stan Cohen, Director, Anglia Microwaves Limited. Tel: (0277) 630000*

## RAE AND MORSE

Courses in the above commence in the week of 26th September at the West Bristol Adult Education Area, Stoke Lodge, Shirehampton Road, Stoke Bishop, Bristol.

The RAE class will meet on Wednesdays, 7-9pm, and will lead to the C&G examination in May 1989. The Morse class will meet on Mondays, 7-9pm.

The tutor for both courses will be B E Carr, G4UHQ. The fee for each course is £36.60. Reduced fees are possible for certain groups of students.

For further details tel: (0272) 683112.

## WINE RUN

On the 15th September the Great English Wine Run will be passing through Kent on its way to France. The aim of this is to transport English wine from London to Paris in the most individual and enjoyable way possible, while raising money for the NSPCC.

An amateur radio station will be set up at one of the local vineyards and will stay in contact with the team vehicle as it travels to Paris. It will also communicate on a global basis.

Please support this worthwhile event. Further details from: *Greg McKenzie, tel (0304) 240612.*

## COMMS SOFTWARE

TALK2PLC is a new program from Klippon MicroSystems which enables users of Toshiba EX200B, EX250 and EX500 PLCs to test the operation of serial line communications when the Toshiba computer-link module is incorporated into these particular units.

Designed to run on IBM

PC/XT/ATs or compatibles, the program uses one serial port (either port 1 or 2) to communicate with the PLC which is primarily intended for use as a commissioning and testing aid. It allows an engineer, using a PC, to fully test the serial line facilities of the PLC by reading and writing the system's I/O, counters, timers and registers; displaying the status of the program running within the PLC and starting and stopping the PLC program when required. The user is provided with on-line guidance with respect to entering necessary data in order to build up commands to the PLC.

The engineer can specify, using TALK2PLC, the communications parameters (baud rate and station address) for the link to the PLC which allows the program to be run without altering the PLC set-up.

All enquiries are displayed on screen in a comprehensible format. TALK2PLC is supplied on a single 5¼in floppy disc, complete with an operations manual.

For further details, contact: *Lynn Thomas, Klippon MicroSystems, DPTS House, Cramptons Road, Sevenoaks, Kent TN14 5DZ. Tel: 0732 460066*

## RSGB HF CONVENTION

The RSGB HF Convention takes place on Sunday, 25th September at the Belfry Hotel, Milton Common, Oxford. Admission is £3 and the doors open at 9.30am.

Attractions include a car boot sale, RSGB bookstall, HF demonstration station, 1.8MHz get-together, worked All Britain stand, RNARS QRQ CW Tests, G-QRP Club stand, constructors' advice booth and many others. There is also a full lecture programme starting at 10.30am.

Light lunches and snacks will be available at the hotel for a modest charge. Tickets should be purchased from reception on arrival.



# Home-made Printed Circuit Boards

by John Goodier

## Introduction

Most electronic projects that appear in *Amateur Radio* and other constructional magazines usually use printed circuit boards (PCBs) to mount most of the components. Over the years, many different types of board have been produced to enable constructors to wire together electronic components to form a working circuit. The most famous of these is Veroboard, in which a laminated board is pierced with holes, with a copper strip running parallel, down or across the board. The idea is to mount the components through the holes and use the copper strips to form the electrical connections between each component.

There is no doubt that Veroboard works very well and is an excellent medium between point to point wiring and a proper printed circuit board. Veroboard can be cut to any size, the

tracks can be cut as required and it is excellent for prototypes and simple projects. The main disadvantage with this type of board is that mistakes are easily made and most people who use it usually build straight onto it from the circuit diagram, not a job for the inexperienced constructor. The best way to construct an electronic project is onto a proper printed circuit board, these have the advantage that the connections are already made via copper tracks which link together all the components in the circuit.

Most home constructors are put off building a project unless the PCB is available commercially and many feel it is beyond their capabilities to produce a simple home-made printed circuit board. I have seen and read many articles which describe various ways to produce a finished board. These range from simply

painting the pattern onto the board then etching it, to using photo resist coated boards and ultra violet exposure units to copy the pattern onto the copper. The ultra violet method is an excellent and quick way of making very high quality boards but as far as home constructors go, it is a little expensive with a UV unit costing in excess of £120.

The aim of this article is to show how simple and easy it is to produce high quality printed circuit boards at home, using easy and straight-forward techniques. I have used this method to produce all the boards described in my articles and have found it quick, easy and convenient. A printed circuit board can usually be produced in an afternoon including etching and drilling.

## Getting started

We are going to make the PCB to the

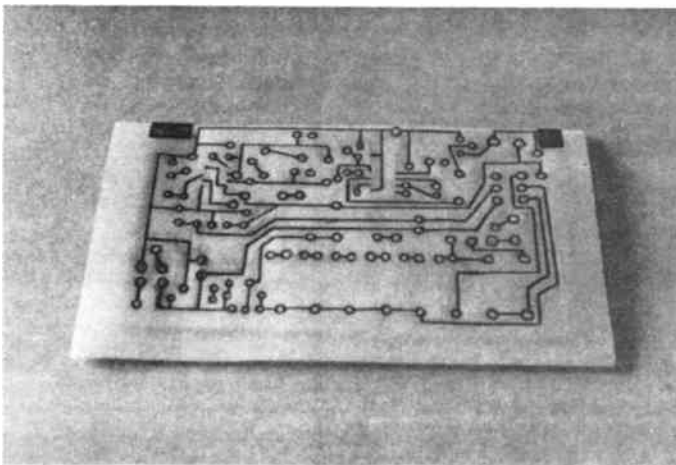

**Fig 1:** The tracing of the PCB pattern fixed to the copper clad board

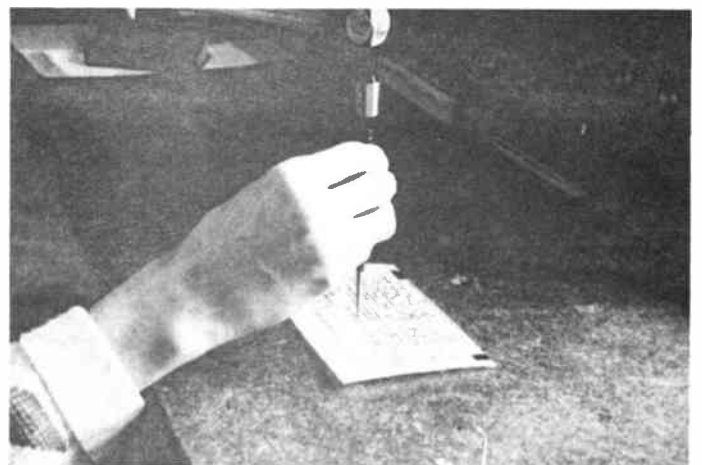

**Fig 2:** Mark the position of a few pads then draw them in with a PCB pen

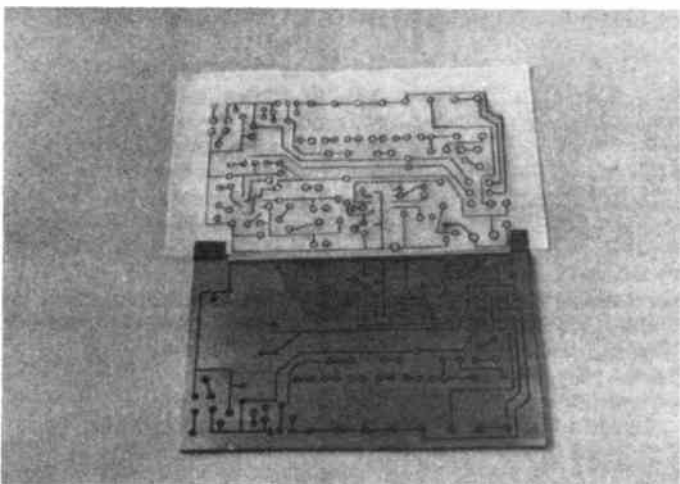

**Fig 3:** On the board, a small part of the track has already been drawn in

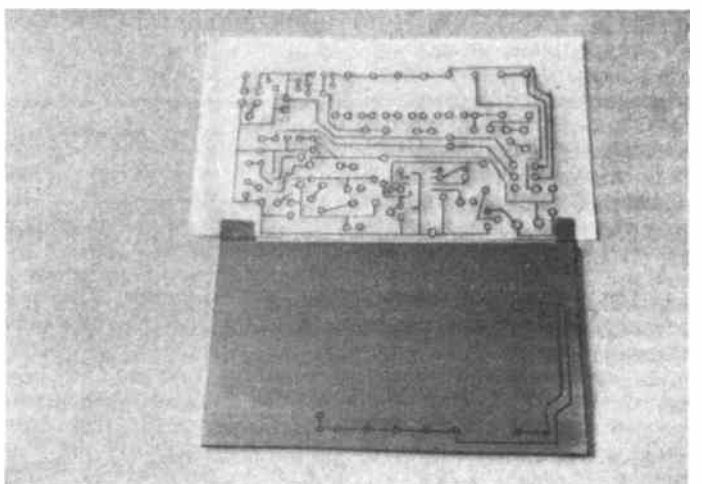

**Fig 4:** Most of the board has been drawn in, now complete the whole board

Fast Ni-Cad Charger we have built. The construction project on this will be in next month's issue of *Amateur Radio*. I have deliberately chosen this board because it is fairly complex and will give a good example of the type of board that can be produced using this method. First cut a piece of copper clad board to the correct size, in our case this is 130 x 80mm. There are two types of printed circuit board available. The first is made from a laminated paxolin material and this can be purchased very cheaply from rallies etc, this is the type I have used. The second type and by far the best, is a glass-fibre coated board. The advantage of this is that the pattern can be seen from the top side making it easier to locate components and trace connections. The other advantage is that it does not crack or split when drilled and it gives the top side of the board a much more professional finish.

First make a tracing of the pattern, you can hold the tracing paper in place with either paper clips or a small piece of sticky tape at the top corners. Where a hole is to be drilled, mark with a pencil dot, you must mark the positions of any ICs. Pre-set resistor or relays as accurately as possible. When you have finished the tracing, double check you have not missed any pad or connection and when you are happy it can be fixed in place on the copper side of the PCB. Before doing this, clean the copper with wire wool and wash the board in hot, soapy water. The tracing can be adhered

with sticky tape (*figure 1*).

Once the tracing is in place, it may be lifted like a flap so you can gain access to the copper side of the board. Now the PCB pattern can be put onto the copper. To do this a PCB etch resistant pen is needed. The best one is a Staedtler Lumocolor 318 Permanent which can be purchased from Maplin Electronics or any good stationery shop. It must be noted that the Lumocolor 318 Permanent is not classed as a PCB pen but as a normal water-resistant pen, fortunately it works brilliantly and is totally acid resistant. A number of different water resistant pens are available, but these may not work as well as the Lumocolor 318.

#### Laying down the pattern

The next job is to mark the position of the first few printed circuit board pads that are to be joined; I usually start at the bottom of the board and work my way inwards. To mark the position of each hole to be drilled, I use a scribe or sharp pointed instrument. With the tracing flat on the board, place the scribe on the pencil dot, and gently tap it with a small hammer. This will make an indent on the copper board and clearly mark each drilling position (*figure 2*). As you can see (*figure 3*), I have marked a number of pads, then, having used the tracing as a guide, carefully joined them using a ruler to produce straight lines.

Progressively work around the board, marking each pad and then joining it with

its neighbour; use the tracing to check the position of each pad and line. *figure 4* shows a large majority of the board completed and *figure 5* shows the finished board.

Be careful when drawing the IC pads, ensuring two are not joined together. Note that some legs of the IC are not used and these have not been drawn. Once the board has been completed, bring down the tracing and check you have not missed any pads or connections. I would advise you to spend some time doing this, as a missed connection will mean a non-working project.

When you are happy with your work, remove the tracing and begin to thicken the lines using the pen (*figure 6*). The board is now ready for etching. If you are preparing a board with large areas of copper to be covered, it is a good idea to use a PCB pen to draw the outline and then use enamelled paint to cover the larger areas.

#### Etching

The solution used for etching is ferric chloride which can be purchased either as a fluid or crystal format. This type of acid is not particularly strong, so if some accidentally splashes on your hand you will not be left with a smouldering stump, but it does stain clothing and will irritate skin so if you come into contact with it, wash off with cold water. Follow the instructions supplied with the acid. I have only used the crystal type and as an example, I usually mix-up half the bag -

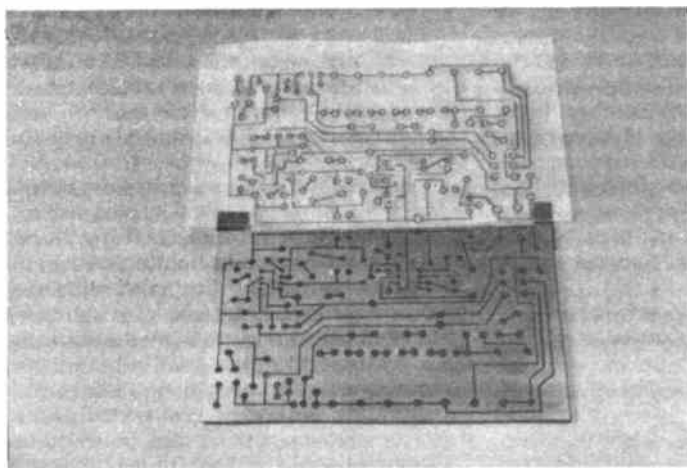

**Fig 5:** the pattern has now been drawn in, check that everything has been finished

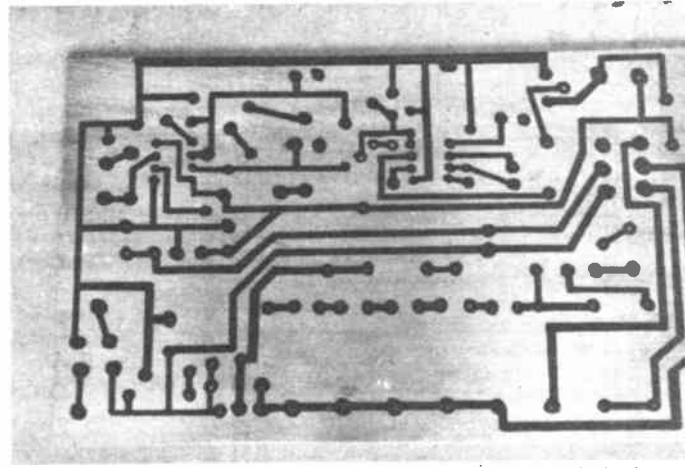

**Fig 6:** thicken up the lines as shown and when ready, etch the board

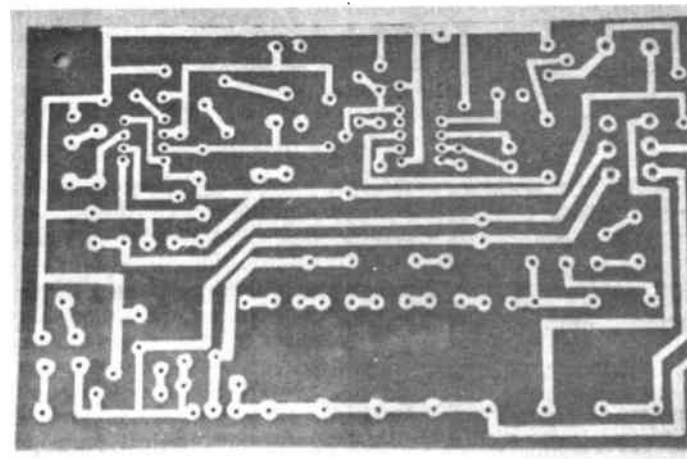

**Fig 7:** the etched and drilled PCB

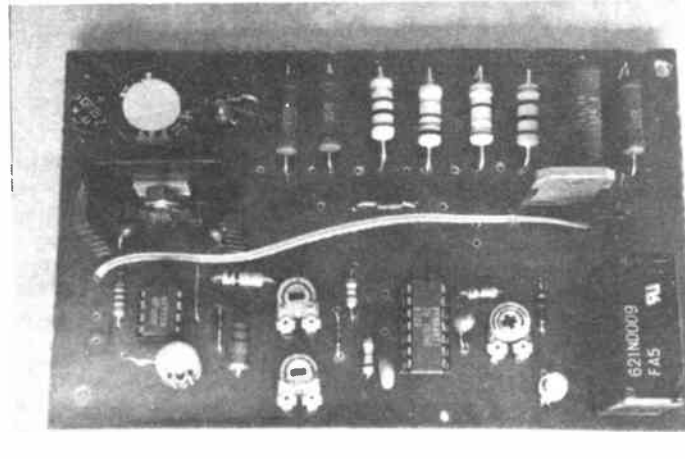

**Fig 8:** the completed PCB with all the components in place

this amount will etch many boards.

The rate of etching will depend on a number of factors, including the temperature of the solution. I normally warm the acid in the microwave oven until it is quite hot and then put it in a plastic bucket with the board. The acid works from the edge inwards, so it's a good idea to apply more ink to the tracks on the edge of the board than those towards the centre. Etching time can be greatly decreased by swilling the acid around over the PCB. By using new acid, at a fairly warm temperature, etching can take as little as ten minutes but this time period can rise to thirty or forty minutes if old acid is used. You will know when the acid is working as the uncovered copper starts to turn pink and slowly dissolves. Leave the board in the solution until all traces of copper have disappeared.

When you have etched the board, store the acid in a plastic container for later use and wash the PCB under running water to remove any traces of the acid. The board must now be cleaned to remove the PCB ink and reveal the copper pattern, it can then be washed. Etch resist remover for cleaning off PCB ink is available from Maplin Electronics. I always use wire wool for this and find it works very well, leaving the copper track free from grease and ink.

#### Drilling

A number of small high-speed PCB drills are available for this purpose,

ranging from £7 to £15 for a 250V ac model (the cheaper models usually run from 12V dc). As I do not own one I always use a hand drill. You will also need to purchase a number of high speed metric drill bits ranging from 0.8mm to 6mm. Usually, a 1 to 1.5mm drill bit is sufficient in size for mounting most electronic components. It is useful to have a large range of these drills to hand as larger components such as transistors or relays etc, need much larger mounting holes than standard size components, such as resistors. These drills are not cheap so take extra care when using them, as they tend to break easily.

All the drilling positions should already be marked on the board so it is just a matter of drilling each pad in turn. If you have used a paxolin board, then use a backing material underneath to help prevent the drill tearing the paxolin when it emerges on the other side. When you have finished drilling the board use a polishing block or a piece of wire wool to remove the burr around the holes. After washing in hot water, your home-made printed circuit board is ready for use. Figure 7 shows the etched and drilled PCB.

Figure 8 shows the completed circuit board for the Fast Ni-Cad Charger. Try and be neat when mounting components and always check you have mounted electrolytic capacitors, diodes and transistors the correct way round. If possible, use IC sockets for integrated

circuits. Always ensure that your solder joints are shiny and bright, if they look a dull dry colour then re-solder the joint. Many home constructional projects fail to work due to bad solder joints, misplaced components or mistakes in the final wiring.

#### Conclusion

If you follow the steps given above then you should be able to make many of the printed circuit boards featured in *Amateur Radio* and many other electronic magazines. This method of producing boards gets better with practice and you will find that you can produce a finished board very quickly. Of course, when the complexity of some printed circuit boards are beyond this method of production, it must be hoped that a commercially made board is available.

If you have never made a PCB before, here is a good chance to have a go and see how easy and simple it is. As I have already stated, try to use the Staedtler Lumocolor 318 or another type of permanent pen instead of the normal PCB pen.

#### Items required

Copper clad printed circuit board, Maplin HX01B  
Staedtler Lumocolor 318 Permanent pen, Maplin HX02C  
Ferric Chloride crystals, Maplin XX12N  
See text for other items.

PROFESSIONALLY DESIGNED EQUIPMENT

**FOR AMATEURS**

**R. N. Electronics**  
6 & 4m transverters

**NEW**  
Additions to our range

- 144/50MHz Transverter  
25w pep £179 + £4 p&p
- 28/50MHz Transverter  
25w pep £199 + £4 p&p
- 144/70MHz Transverter  
25w pep £239 + £4 p&p
- 144/70MHz Transverter  
10w pep £199 + £4 p&p
- 28/70MHz Transverter  
10w pep £199 + £4 p&p
- 7dB Attenuator  
£22 + p&p
- Switched 10m Receive Converter 2m IF. Ideal for crossband £45 + £2 p&p
- Receive Converters, 2m, 4m, 6m, 10m with 2m or 10m IF  
£39 + £2 p&p

**ALL PRICES INCLUDE VAT**

**MADE IN ENGLAND**

MARKET LEADERS IN 6 METRE TRANSVERTERS

**ANNOUNCING**

**A NEW DIMENSION IN 2m F.M. MOBILES**

**NAVICO**



★ 2 models  
★ British design  
★ 5w or 25w  
★ Dual VFO  
★ Full repeater operation

**ONLY £247.25**  
incl VAT + £4 p&p

★ Full scanning version

**£299.00**  
incl VAT + £4 p&p

**AVAILABLE FIRST AT THE LEICESTER RALLY**

From: **R. N. Electronics**

**37 Long Ridings Avenue,**  
**Hutton, Brentwood,**  
**Essex CM13 1EE**

**FOR DETAILS**  
**(0277) 214406**

## TX-3 RTTY/CW/ASCII TRANSCEIVE

The high performance, low cost system

Split-screen, type-ahead operation, 24 memories, clock, review store, callsign capture, RTTY auto CR/LF, CW software filtering and much more. Needs interface or TU. **BBC-B and Master, CBM64** tape £20, disc £22. **Spectrum** tape £35, +3 disc £37 inc adapter board (needs interface/TU also). For **VIC20** we have our RTTY/CW transceive program. Tape £20.

## RX-4 RTTY/CW/SSTV/AMTOR RECEIVE

This is still a best-selling program and it's easy to see why. Superb performance on all 4 modes, switch modes at a keypress to catch all the action. Text and picture store with dump to screen, printer or tape/disc. An essential piece of software for the SWL. Needs interface. **BBC-B and Master, CBM64** tape £25, disc £27. **VIC20** tape £25. **Spectrum** tape £40, +3 disc £42 inc adapter board (needs interface also). The SPECTRUM software-only version (input to EAR socket) is still available, tape £25, +3 disc £27.

## TIF1 INTERFACE

Perfect for TX-3 and RX-4, RTTY and CW Fitters, computer noise isolation for excellent reception. Transmit outputs for MIC, PTT and KEY. Kit £20 (assembled PCB + cables, connectors) or ready-made £40, boxed. State rig. Available only with TX-3 or RX-4 software.

ALSO MORSE TUTOR £6, LOGBOOK £8, RAE MATHS £9 for BBC and CBM64 (disc £2 extra), SPECTRUM, ELECTRON, VIC20

Prices include VAT and p&p, 1st Class inland, airmail overseas, normally by return. Eire, CI, BFPO deduct 13%.

## Technical Software (AR)

Fron, Upper Llandwrog, Caernarfon LL54 7RF

Tel 0286 881886



## THE HANGEAR PMX PRESELECTOR

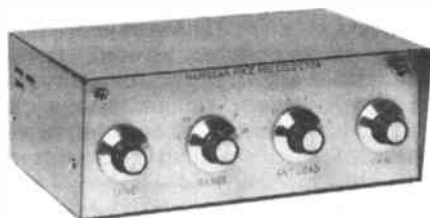

Introducing our new HF band preselector and antenna tuning unit combined, covering 1.7 to 34 MHz completely. The ATU section allows endless experiments with various lengths and types of antenna and offers correct matching of these antennas to your receiver.

The pre-amp section has a gain of 20 DBS which can be controlled down to zero gain, then on down to minus 15 DBS, allowing a boost just where the RX might need it or an attenuation where the band dictates.

The PMX can also be supplied with a built-in calibrator, having outputs at 1 MHz, 100 KHz and 10 KHz, with harmonics of these throughout the HF spectrum.

Casework is all metal with brushed aluminium engraved panel.

We can also supply a projects case matching the PMX, a close fitting, wrap-over style in aluminium. The top is blue, front and back shiny aluminium, sizes 8" x 5" x 3", plus a matching brushed front panel to accept engraving or stick-on lettering to give that professional finish.

### Prices are:

Unpowered PMX .....	£69.00
Mains powered PMX.....	£78.00
Mains powered PMX with calibrator .....	£97.00
Projects case .....	£12.00
Brushed front panel.....	£3.00

All prices include UK postage

Send for 4-page information on this PMX series

## HANGEAR ELECTRONICS

125 Wroxham Road, Norwich NR7 8AD

Tel: Norwich (0603) 405611



"TOWERS OVER THE WORLD"

ANOTHER **Western** WINNER!

THE ORIGINAL (but now copied!)

## 30ft ULTIMAST

The 'ULTIMATE IN DESIGN FROM A COMPANY SUPPLYING TOWERS OVER 330ft HIGH

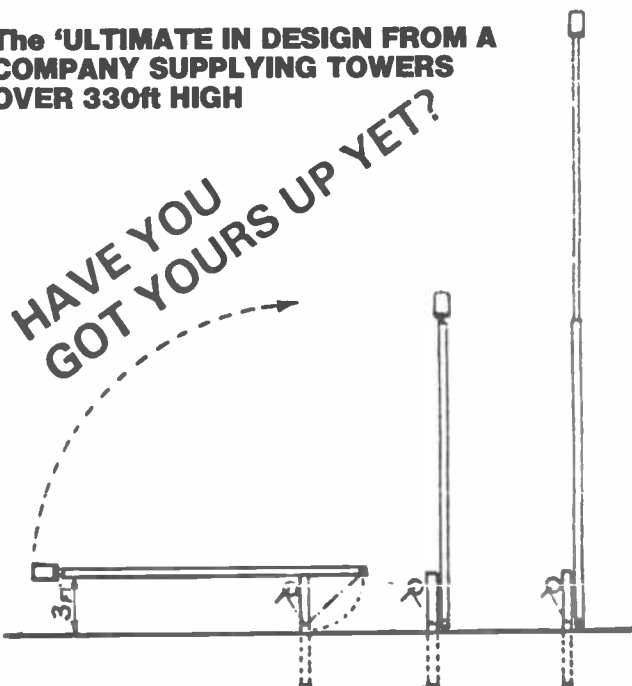

HAVE YOU GOT YOURS UP YET?

The UM-1 ULTIMAST is a tubular steel two-section mast which is telescopic and tilt-over. Constructed of two steel tubes - the lower square section and the upper round section, hot-dip galvanised to BS729. The ULTIMAST telescopes up to 30ft (9m) and down to 15ft (4.5m). Secured to a square tubular base post, the mast can be tilted over to only 3ft (1m) above ground for ease of access to antennas. Two head units allow clamping of rotor or "2" (50mm dia stub (UHD-1), or a caged head unit (UHD-2) instead of the standard base post a detachable base, DB-1, is available to facilitate easy removal.

- ☆ Slim and unobtrusive
- ☆ One-winch operation
- ☆ Simple ground fixing
- ☆ Self-supporting
- ☆ For HF and VHF antennas

Send 3x18p stamps for leaflet

PRICES (CARR/VAT INC) UM-1, £328.90, UHD-1 £115.50, UHD-2, £37.95, DB-1, £28.75. Scotland, Devon, Cornwall and Anglesey add £20 carr. extra.

## DX "PENETRATOR"

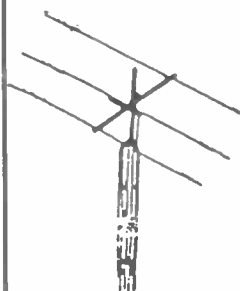

Cat No	WESTERN ANTENNAS (carriage paid)	Price
1075 DX 7/2	7MHz 2 ele Yagi Gamma matched 20' boom	£437.00
1076 DX 7/3	7MHz 2 ele Yagi Gamma matched 40' boom	£603.75
1077 DX 51	Rotary dipole for 26, 24, 21, 18 and 14MHz	£155.25
1080 DX 6V	10.80m Multi band vertical plus 30m	£138.00
1081 DX 31	Dipole 10/15/20m 2Kw p.e.p.	£115.00
1082 DX 32	2 element 10/15/20m 2Kw p.e.p.	£202.40
1083 DX 33	3 element 10/15/20m 2Kw p.e.p.	£297.85
1084 DX 34	4 element 10/15/20m 2Kw p.e.p.	£361.00
1085 DX 31/32	Conversion Kit	£30.65
1086 DX 32/33	Conversion Kit	£36.60
1087 DX 33/34	Conversion Kit	£36.60
1089 DX 103	3 element 10m Yagi	£120.75
1090 DX 105	5 element 10m Yagi	£161.00
1093 DX 4K	Converts DX 31/2/3/4 to 40m dipole	£126.50
1094 DX 27/1	Rotary dipole for 27MHz CB	£40.25
1095 DX 27/3	3 ele Beam for 27MHz Gamma matched	£120.75
1096 DX 240	2 ele quad 2, 10, 15 & 20m	£338.00
1097 DX 260	2 ele quad 2, 10, 15, 16 & 20m	£341.55
1099 DX 7/14	2 ele 40m/6 ele on 20m. 50' boom	£1006.25

Mail order only to: Western Electronics (UK) Ltd  
P.O.B. 378, Llandudno LL30 3RS

# DX DIARY

News for HF operators compiled by Don Field G3XTT

After all the anticipation, the Lynx DX Group expedition to North Yemen turned out to be a non-event. The DX press has carried lots of different reasons why this should be. In reality it looks as though the licence itself was not a major problem. Getting visas should not have been difficult either – plenty of people are able to travel to North Yemen. The most likely culprits, and this has happened in other countries too, are the military authorities out there who are unlikely to be sympathetic to a bunch of foreigners carrying out radio transmissions. The Spaniards are saying they will keep trying, perhaps for an operation around Christmas, but don't hold your breath.

Having said all this, July produced a flurry of excitement elsewhere (quite apart from the Wimbledon finals!) with a last minute announcement of a joint Finnish/Soviet DXpedition to Malyj Vysotskij Island. Ever heard of it? No? I'm not surprised. Malyj Vysotskij is uninhabited, about one mile long, and lies in the Bay of Vyborg in the Baltic Sea. Its significance in amateur radio terms is that it is leased to Finland, but separated from that country by Russian territory and, on this basis, the ARRL decreed in 1970 that, should it ever be activated, it would count as a new country. So it was that 4J1FS appeared on the air on 7th July and netted 14,000 contacts in 96 hours of operation. UK amateurs reported QSOs on 10, 15, 20 and 40m.

Despite all the excitement, I would be very surprised if the ARRL were to count Malyj Vysotskij as a new country. The DXCC rules have changed significantly in the last 18 years, particularly in respect of land leased to other countries. The reason for this is that the rules as they stood at that time could quite easily have been interpreted to allow embassies,

foreign military bases, and a host of other oddities such as the Kennedy Memorial Site at Runnymede (given to the Americans in perpetuity) to count as 'countries'. This would obviously have been a nonsense. Anyway, we shall have to wait and see. If it all comes to nothing, at least your 4J1FS QSLs will count towards the Islands on the Air awards.

## What is a QSO?

A couple of months back I said that the new DXCC rules make it clear that no signal reports need be exchanged in order to have a valid QSO. This may have seemed surprising, but some information which has since come to light in one of the US bulletins provides more background to the thinking at the ARRL. Basically, the ARRL are saying that a QSO has taken place when information has been passed which was previously unknown. This could be just an exchange of call-signs. However, if the call-signs are already known (for example because it is a sked QSO or because a net MC has passed the calls across) then some further information should be passed. This could be a signal report, but names or, indeed, pretty well anything else would do.

Certainly more and more contest organisers are now dropping the requirement for an exchange of signal report (which generally tends to be '59') and replacing it with something more meaningful and harder to guess such as QTH locator, zone number, or whatever.

## Computerised DX Edge

Many moons ago I recommended the DX Edge in this column as an invaluable aid to LF DXers. Its plastic overlays, on a map of the world, show areas of the world in daylight and darkness at any time of the day for any month of the year. This information is

necessary when predicting LF openings, and especially grey line propagation.

Recently I have had the opportunity to evaluate the Super DX Edge, also made and supplied by Xantek, which is available to run on the IBM and Commodore computers. This program displays a map of the world on the screen and plots the terminator (the boundary between day and night) for whatever date and time you want. You can also run it in real time, watching the terminator move as the computer updates it at regular intervals. The display is attractive if you have a colour monitor, although it would be difficult to read off a sunset or sunrise time with any precision.

## Other features

The Super DX Edge also has a number of other useful features. It will calculate MUFs (Maximum Usable Frequency) between two specified locations for whatever sunspot or solar flux number you enter, great circle distances between any two locations, and beam headings. For these various calculations you can specify the locations exactly by entering latitude and longitude or, alternatively, it has its own look-up table and you can simply enter the prefixes or country names.

The Super DX Edge is simple to use, being completely menu-driven, and comes with a reasonably comprehensive instruction booklet for when you get stuck. All in all an interesting and useful addition to the shack, though I am not convinced that it is worth the \$34.95 price tag (plus \$4 p&p outside the USA). There are cheaper, although less high-tech, ways of having all this information to hand. The Super DX Edge is available from The DX Edge, PO Box 834, Madison Square Station, New York, NY 10159, USA.

## DX news

Conditions during July were rather patchy, with some good days on the higher bands allowing stations like T31JS and ZK3RVC to be worked on 15 metres, but many days when 15 and 10 barely opened up at all.

Now that we are going into September, propagation should really start to look up, and the major contests should prove to be very fruitful. Already a number of groups have announced their plans for the CQWW SSB Contest in October. N1GL will put in a single-operator effort from Aruba; there will be a major multi-multi operation under the call sign PJ1B; W8KKF and W6CDR hope to be on from Grenada; OH2BH and friends will sign CR9BZ from Madeira in a multi-multi operation, and WB4FLB hopes to be active from Macao. Also see some of the items below. No doubt there will be many more announcements nearer the time.

This month and next look like being quite productive for anyone chasing USSR oblasts. Look for UA9ZZ/U-18V and UA0X during September, and UZ9OWB/UH8W during October. In addition to these, EK0AKA, EK0AKR and EK0AKW should be active from various Russian offshore islands until 5th September.

Look out for T32BE from 15th-21st September and VK9YG from October 18th to November 1st. The first of these will be operated by WC5P, the latter by Steve, G4JVG, who will be holidaying on Cocos-Keeling Island and is another who plans a contest effort in the CQWW SSB. G3ZMP will sign /5N6 for the next two years. All Hungarian amateurs now have access to topband, and class B and C licence holders can also now use 30m. ZD8AE has been very active, especially in the evenings on 15 metres. He was due back in

the UK from 4th August until 2nd September, but expect lots more activity during the autumn.

Looking further ahead, VK2AU expects to operate from both Western and US Samoa during December and January. Ross, WB6GFJ, who was in the UK recently for the RSGB 75th anniversary binge, told me his pearl import business will take him back to Tahiti in March and April, from where he will use his FO0FB callsign. VP8BRT has been very active from the South Orkney Islands, making a point of looking for UK contacts and now expects to be there until June 1989. Despite recent problems in Thailand regarding amateur radio licensing, two operators at HSOB have gained permission to put the station on the air daily between 1000 and 1400GMT until the end of the year.

VRGHJ recently became the 5th YL operator on Pitcairn Island; not bad when the total population is only about 45! If you still need Pitcairn, VR6KB is active almost every day on 14146 around 0630GMT, and Tom, VR6TC, is often about 5kHz lower at the same time. Bear in mind when you QSL direct to Pitcairn that boats call only rarely, so it can take anything up to a year to get a reply.

KD7P is now in Guam and hopes to get some big antennas up shortly. He will be there for two years, signing KD7P/KH2. OH1RY and OH2BAZ's Pacific itinerary has them starting in Tahiti in mid-October, followed by South Cooks, Fiji, Wallis Island, New Hebrides, Tonga, Fiji again and, finally, Niue. For the CQWW SSB contest OH1RY will be on from YJ8 and OH2BAZ will be on from A35. C9MKT, operated by SM7DZZ, showed up in July and claims to have authority to operate for 2-3 days each month, which would make this the first legitimate operation from Mozambique for some years. Look out for him on both SSB and CW.

#### Prefix news

The 4J1 prefix used by the Malj Vysotskij expedition was unusual, of course. As well as this, other forthcoming prefixes include 6K42. The station 6K42SO (Seoul Olympics) will be active from Korea from mid-September. 6K88-KOG, 6K88A and 6K88SOG should also be active. You should also take note that

visitors to the USA now sign W1/home call, or whatever call area they are in. The exceptions are Canadian visitors who continue to sign home call/W1. So much for logic and common sense!

Nearer to home, IU4BU will be active again from 10-15th September, and 4N9A from Palagruza Island from 1st-5th September. PY5FB/PP8 is now active from the Amazonas region of Brazil and will be there for 2-3 years. Wes hopes to sign ZZ8WHL in major contests and is trying for the permanent callsign PP8WHL. 8J7XPO and 8J8XPO are located at either end of the Seikan Tunnel and will be QRV until 18th September. XL3IG will be on the air from 30th September until 2nd October to celebrate the 50th anniversary of the Blue Water Bridge between Ontario and Michigan.

#### Contests

Don't forget the SSB leg of the EU DX-Contest on 10th and 11th September. I can help with a copy of the rules if required, but not with official log sheets (can any reader supply me with one?). See below for a couple of forthcoming RTTY contests. And, above all, start getting your station in shape for the CQWW SSB and CW contests on the last full weekends of October and November respectively. Meanwhile, why not try your hand at the Scandinavian Activity contests? The CW leg is on 17th and 18th September, and the SSB leg the following weekend. Scandinavian amateurs are generally excellent operators, and there are lots of nice awards to be gained for working stations from that part of the world.

The VK/ZL/Oceania Contests take place in October, the SSB leg on 1st and 2nd October, and the CW leg the following weekend. These run for 24 hours from 1000GMT on the Saturday, and are a good opportunity to work into the Antipodes, especially on the lower bands. To complete the picture, I should also mention the LZ DX CW contest on 4th September.

#### RTTY

The Second Annual CQ World-wide RTTY DX Contest on 24th and 25th September will have particular appeal for datacomms enthusiasts. The full rules appeared in the June issue of CQ Magazine

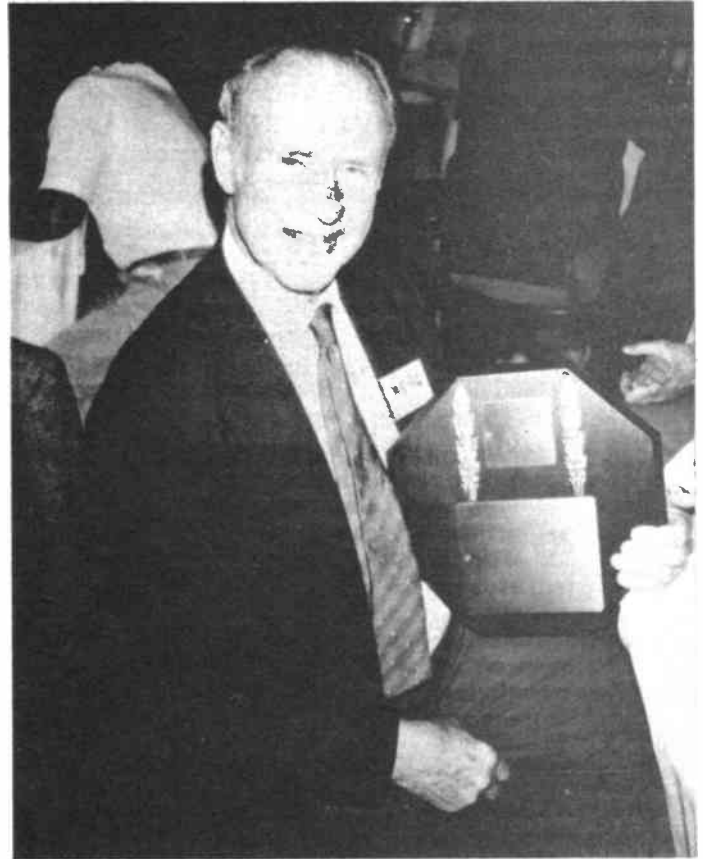

W615Q, elected this year to the CQ Hall of Fame

and I can provide a photocopy if required. Single operators are allowed up to 30 hours of operation in the 48 hour contest period. Exchange RST and CQ zone number (the UK is in zone 14). Contacts can be made on Baudot, ASCII, AMTOR or packet, but only one contact is allowed per band with any one station. Points are scored for each QSO, with a multiplier for countries, states, provinces and zones. There are single and multi-band categories.

In the first of these contests, held last year, there were seven entries from the UK, with top honours going to G4SKA who made 142,725 points from 323 contacts. The other UK entrants were G4PKP, G0ATX, G4UZN, GW0ANA, G0AGH and G4JLU.

The only snag with the CQWW RTTY Contest is the clash of dates with the RSGB HF Convention, where I hope to meet lots of DX Diary readers. The lecture programme this year includes W0AIH on 'Building a Contest Super Station' and F6EXV on the KH5/T32 expedition earlier this year. G3OSS, G4RLE and the G-QRP Club are also scheduled to speak, so it looks like being an excellent occasion all round. If you need further information, please contact me.

While on the subject of

RTTY contests, the RTTY leg of the European DX-Contest (organised by the German DARC) takes place on 12th and 13th November, starting at 1200GMT on the Saturday and running for 36 hours. The rules are much the same as for the CW and SSB legs, with extra points gained for 'QTC' traffic but, unlike the other two legs, contacts within Europe count for points in the RTTY event.

If you are chasing RTTY DXCC, do remember that contacts on all data modes (Baudot, ASCII, Packet and AMTOR) are valid. Some stations already have well over 200 countries confirmed on RTTY, so the activity is obviously coming on apace. Finally, congratulations to Fred, G4BWP, who becomes only the fourth UK DXer to gain the 5-band Worked All Zones award, and to Ian, G4GIR, who has also submitted his cards so should become number five. Congratulations also to Hazel, G4YLO, this year's winner of the Bermuda contest.

This month is rather special for me, as I was licensed in September 1968. Even after so long there is still plenty of DX which I need, so don't expect it all to find its way into your logbooks overnight. Nevertheless, the true blue DXer lives in hope. 73 de Don.

# STAN WILLETTS

DEPT 0, 37 HIGH STREET, WEST BROMWICH, WEST MIDLANDS B70 6PB

Tel: 021 553 0186 / 559 1437



⏏ **GRUNDIG INFRA-RED REMOTE-CONTROL VIF-K1**  
(13 function) consists of transmitter TPV355 & Receiver VIF-E1 (suitable for use with GRUNDIG 2x4 Super & Stereo Videos), brand new & boxed complete with battery £4.99 P&P 52p. FIF-E1 Receiver 10 for £9.99 P&P £3.50.

## VIDEO HEAD CLEANERS

brand new with full instructions £1.99 VHS or Beta P&P 75p.

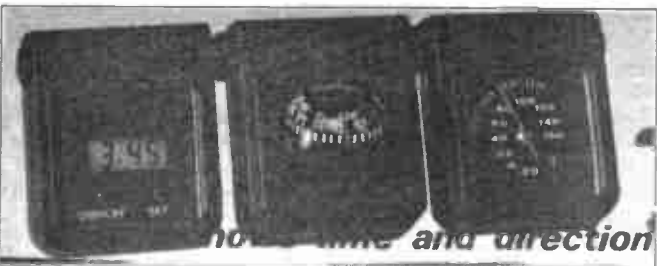
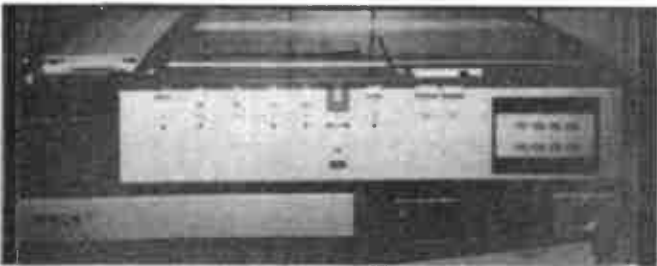

## ⏏ 'REDIFFUSION' TRANSLATOR No847038

8-way 'Preatmat' - TV Tuning of band 1-111 7 UHF with AFC. Mains power supply 240v, in cabinet 14x7½x3½ inches. The Translator may be used directly or modified to convert wired TV to normal use with monitor (1V P-P), TV sound tuner, (Hi-Fi), with any VCR. These units are guaranteed in perfect working order and A1 condition £4.99 P&P £3 Circuit & Modification instructions £1 extra.

## ⏏ VIDEO RECORDER (BETA) SONY & SANYO

C5 & C7 etc, perfect working order £39. VHS £79. Faulty machines from £15 all types.

## V2000 VIDI TAPES 'MEMEREX'

brand new VCC360 £6.99 VCC480 £7.99 P&P £1.

## 'VIDEOLAB' VHS E180

Video tapes PREMIUM QUALITY which we recommend & guarantee one for one exchange £1.99 P&P £1.

## ⏏ THERMOETER, COMPASS & CLOCK,

(detachable) brand new £1.99 P&P 75p.

## CB CONVERTER

40 channel, work in conjunction with A/M 12 volt Car Radio brand new & boxed £2.50 P&P £1.

## GRUNDIG 2x4

Video Heads complete in head assembly £29 P&P £4. Power Pack £24 P&P £4. Pannels £5.99 each. DFT, Servo, Video, Croma-Steriton, Meter Boad, Modulator & Tuner P&P £1.

## ⏏ ELECTRONIC AUDIO CASSETTE DEMAGATISER,

electronic circuit LED indicator, (degausses one second brand new £7.99

**PLEASE NOTE WE ARE  
INTERESTED IN  
PURCHASING ALL TYPES  
OF EQUIPMENT.**

# ANGUS MCKENZIE

## TESTS



## THE KENWOOD TS-680S HF MOBILE TRANSCEIVER

In March this year I reviewed the Kenwood TS-140S, and pointed out that the model TS-680S would be coming later in the year. I have now had the opportunity of putting this model through its paces, and the inclusion of the 50MHz band is such an obvious asset that I cannot help but feel surprised that almost all other HF transceivers have omitted a 50MHz facility. Only the Yaesu FT-767 might be considered comparable, although the VHF bands are in the form of modules which can be added. This rig's predecessor, the TS-670S, only included a Tx capability on some HF bands as well as 50MHz, and was at the time very over-priced.

The TS-680S gives a Tx capability on all amateur bands from 1.8 to 28MHz at 100W PEP on CW, SSB, AM and FM. The same modes are available on the 50MHz band, but at 10W PEP, the RF input and output being carried on the same socket as is used for HF. As a receiver, the coverage is very wide indeed, from 50kHz to 35MHz, and 45 to 60MHz. This allows the rig to become an ideal IF strip for driving UHF and microwave transverters. The only sacrifice that I could find with the TS-680S as compared with the TS-140S is that the latter's vox circuitry is omitted so as to give space to the 50MHz circuitry. However, semi and full break in keying is still provided and Kenwood can supply an optional extra 'vox box', which can provide external vox control if this is essential.

### The marketing philosophy

For some odd reason, Kenwood originally planned this model for the Japanese market only, with the TS-140S regarded as the export model. However, the moment that amateurs from coun-

tries in Europe having a 50MHz allocation, heard of the 680S, Kenwood received so many requests that the TS-680S was eventually released in Europe. Considering that it only costs around £120 more than the 140S, I think that it is highly likely that sales of the 680 will outnumber those of the 140.

I can't really decide whether to look on this rig as an HF one with the 50MHz band as a bonus, or as a 50MHz 10W rig with HF capability thrown in, or possibly as a rig in which the 50MHz band is introduced as an extension to HF rather than a VHF one. Each reader will have his own way of looking at it, but I'm sure everyone will agree that including the 50MHz band is a very good idea. Perhaps the pity is that the 50MHz PA is only capable of 10W PEP, rather than, say, 25W, which would be just right for driving an average Yagi to the fully licensed ERP for the UK, or for driving a single stage, high power, solid state PA to around 160W PEP, which is a useful power to have on the band, using a linear such as a Luna, Mirage or BNOS model.

### Facilities

In the March 1988 issue of *Amateur Radio* I described all the facilities of the TS-140S in great detail, so in order to save space, may I please refer readers to that issue. However, for the benefit of those who don't have a copy I will give a short précis of some of the points mentioned. The tuning knob rotates at the rate of 10kHz per rev on CW and SSB, and 50kHz per rev on AM and FM. A very linear 10Hz stepping rate is provided for CW and SSB, and this makes for far smoother tuning than does a 25Hz rate, for example. Under normal transceiving conditions, the up and down band

change buttons select just the amateur bands, and 500kHz steps are provided on the 28 and 50MHz bands. If the Rx 'only 1MHz' button is depressed, then the band buttons change frequency in 1MHz steps, jumping from 35 to 45MHz or 60MHz to 50kHz. If you tune the rig quite quickly, the tuning rate increases quite noticeably, but there is one more superb ergonomic point for tuning which is that the memory channel switch changes the tuned frequency in 10kHz steps as it is rotated in the VFO mode. This is not only very convenient for FM channelling on the 28 and 50MHz bands, but it makes for a very quick QSY on the other bands as well.

Of the 30 memories provided, numbers 20 to 30 have a very special facility, for you can insert the beginning and end of a band so that the memory acts as a band VFO allowing you to keep within a pre-determined segment. In addition to frequency, the memories can also retain mode. There are two normal VFOs which can also provide for split operation. The three mode buttons each cycle between two modes, LSB and USB, CW wide or narrow, and AM or FM. You have an immediate reminder of the mode selected by an appropriate letter sent in Morse. Other front panel facilities include RIT with 10 or 20Hz steps, a choice of two noise blankers, a series of faders for operating Tx power out, mic gain, Rx RF gain and noise blanking level. Buttons select dial lock, VFO/memories, VFO A or B, and A=B, memory into VFO, scan, memory write, RIT on/off, general coverage or transceive, mox Tx/Rx, speech processor on/off, meter ALC or power output, Rx input attenuator (20dB), AGC fast/slow and finally RF pre-amp on/off. The last



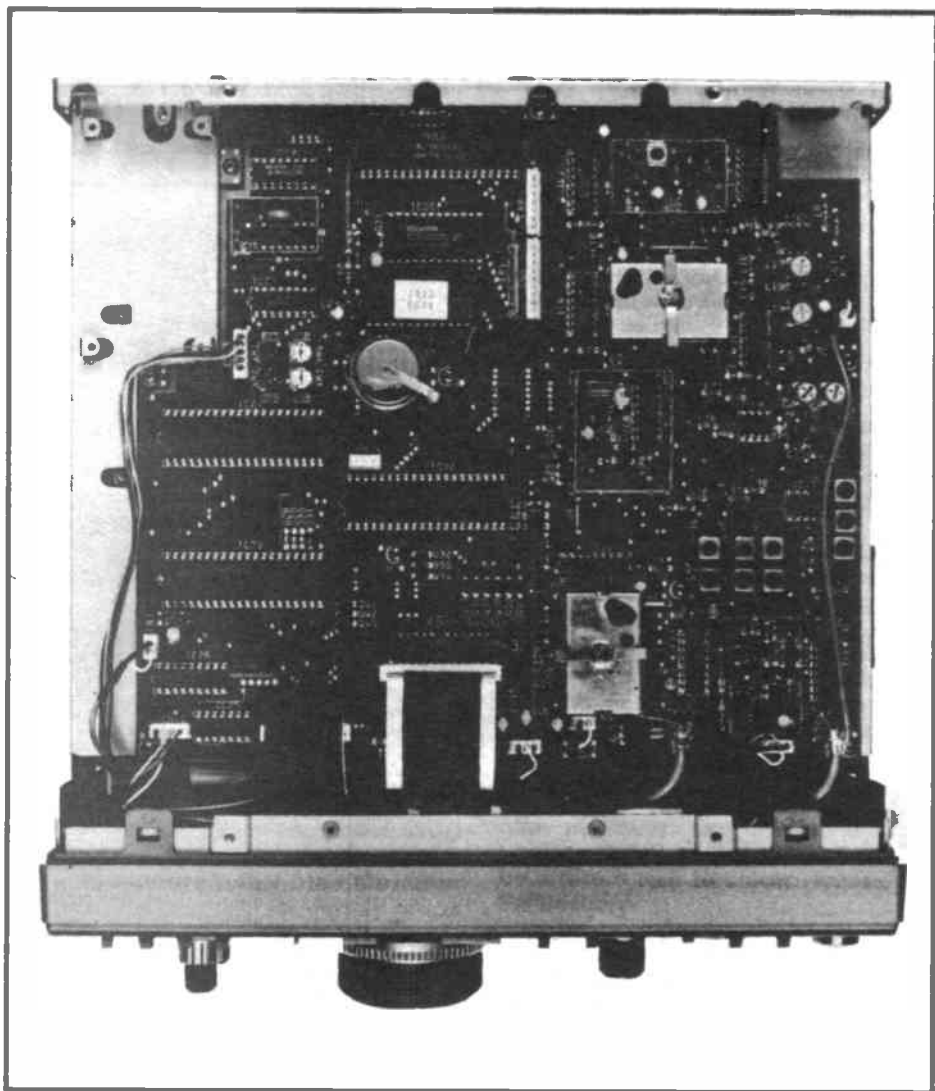

facility replaces the vox one on the TS-140S, and operates from 21.5 to 35MHz and 45 to 60MHz only.

The rear panel of the TS-680S is virtually identical to that of the TS-140S, other than that the vox pre-sets are omitted. There is only one antenna socket, and I feel this may be a disadvantage.

#### Subjective tests

I was very impressed indeed with what I can only describe as the phenomenally good sensitivity of this rig on the 28 and 50MHz bands. Having previously become used to the TS-140S, I at first found the 50MHz sensitivity only just adequate, and perhaps slightly disappointing, but then I realised that the vox button became an RF pre-amp switch in the 680S, whereupon the Rx gain shot up, and I immediately started hearing DX signals which I previously could hardly detect. The RF pre-amp was obviously a very good one indeed.

The TS-680S behaved virtually identically to the TS-140S, but there seemed to be slightly less mush around on the LF bands near strong signals. I was very struck by the superb audio quality from the best 50MHz stations, and there was a very marked contrast between the best and poorest 50MHz black boxes! I was particularly pleased that I obtained some very good reports of the transmitted

quality from this rig, both on SSB and FM.

I particularly liked the tuning ergonomics, and I found myself using the 10kHz steps of the memory rotary switch quite frequently on the 50MHz band when jumping from beacon section to either the 50.11 or 50.2MHz band sections. It was easy to QSY 30kHz up or down on the band, so don't underestimate the usefulness of this facility.

I will précis here some of the remarks I made about the TS-140S, which is virtually identical in operation, and add some appropriate remarks for the 680S. The front panel is very well designed, and uncluttered, and so finding one's way around it was much easier than usual. The miniature slider faders for power output, mic gain etc, although satisfactory, felt just slightly flimsy, and I wonder how long they would last if used a lot. The narrow CW filter was not fitted to the review sample, but is available at around £54. Another narrow one, made for the more expensive rigs is better, but costs £112 odd, which is a lot to pay for an accessory for this rig.

The receiver's dynamic range seemed to be very good on all frequencies, especially if the RF pre-amp was switched out. The inclusion of an attenuator is very helpful on the LF bands. You may very well find the extended Rx coverage up to 35MHz very useful indeed if you are using the

equipment with transverters, having added some appropriate modifications for this. It would allow you to tune up to 439MHz on 70cm, or 1303MHz on 23cm, for example. Similarly, as the Rx tunes down to 45MHz and up to 60MHz, you could get extended Rx coverage from DIY transverters for VHF, UHF and microwave if you were to use the 50MHz band as an IF.

Some very useful second functions are available which can set parameters for some facilities. You can pre-select 10 or 20Hz steps for RIT, thus giving QSY ranges of  $\pm 1.25$  or 2.5kHz. You can select 500kHz or 1MHz band changing when in the general coverage mode. The main frequency display can be set to give 10Hz or 100Hz resolution. When the set is tuning across medium wave, you can pre-select 9 or 10kHz steps, and I would strongly advise you to select 9kHz for Europe. Programme scan hold can be switched on or off, and finally you can switch the various pip alarms and Morse code identifiers on or off as it suits you.

The two noise blankers seemed to work very well, and will be found particularly useful on 50MHz, the noise blanking threshold fader allowing a very wide adjustment range. The fast and slow AGC speeds seemed to be well compromised, and both weak and very strong signals were well accommodated.

Although this rig would normally only be peaking at around 17A or so on Tx when delivering 100W PEP, under certain circumstances an initially high transient current can cause a problem to some power supplies if they are the type that shut down completely when there is a momentary overload. Lowe Electronics can put in a modification to the ALC line to remove very high transient currents, but you will have to ask for this mod if you want it.

Although it is not possible to feed transverters in the normal way from this rig, there are two separate ways of tackling the problem if you don't want to go to the expense of paying £150 to £200 for a very expensive Lowe Electronics' modification. This was developed for the TS-440S, and takes about one and a half days to put in!

The first method is to cut down the output PEP power by adding an external ALC control unit. You can make this yourself quite simply, with circuit details and instructions available free of charge from Lowe Electronics. This allows you to set the transmit power down to 500mW peak quite reliably unless you accidentally touch the controls on the ALC unit. This could be used with a 28 or 50MHz IF of course, as appropriate.

A much more satisfactory method is to modify the feed circuit to the PA by adding a relay which would divert the drive to a transverter drive output whilst biasing the PA off. Another miniature relay could be used to switch the receiver input to a separate input from the transverter on Rx. This could make the 680S a very useful rig for driving transverters. But unless you really know what you are doing, I would not advise you to DIY.

I had a very long discussion with two notable Japanese amateurs over the

period of the RSGB 75th anniversary celebrations, and it seems that there is quite a major distinction in Japan between rigs designed for mobile use and base stations. They seemed to be very surprised indeed when I told them that probably nine out of ten UK amateurs who purchase HF mobile rigs buy them primarily for base station use, as they are less expensive. Perhaps Japanese manufacturers are not fully aware of this point, which is why some interfacing facilities such as transverter connections, and linear relay switching over are omitted from so many 'mobile' rigs. However, the various auxiliary multi-pin sockets do provide more than the usual facilities, which include linear control.

#### Laboratory tests: the receive section

The performance on the HF bands is almost identical to that of the TS-140S, although the sensitivity on 21 and 28MHz is about 1dB inferior. However, with the RF pre-amp switched on, the 28MHz sensitivity becomes quite exceptional, and about the best that I have yet measured on an all-band HF rig. On 50MHz, with the RF pre-amp on, the sensitivity was again superb. The only rig which just marginally bettered the TS-680S was the Icom IC-575, but this rig only covers 28 and 50MHz, gives 10W PEP output, and costs slightly more anyway.

The front-end RF input intercept point on the HF bands measured very well, and on 50MHz it was very satisfactory, although not in the same class as the IC-575, which was quite outstanding. The reciprocal mixing measurements showed that this rig was in the same class as the TS-440S, 940S (without Lowe modifications) and R5000 models, and was better than the TS-140S sample tested. However, the IC-575 was quite a lot better. I would describe the reciprocal mixing performance as adequate but not particularly good close in, although easily good enough further out.

I noted a very slight blocking problem if there were interfering signals rather close to the wanted one. This was due to a rather wide first IF filter. The performance, however, is fairly typical in this respect, and quite a few rigs are noticeably worse. SSB selectivity was quite well optimised and is around 4kHz bandwidth for -60dB whilst maintaining a reasonable bandwidth for -6dB. FM selectivity was adequate for 20kHz spacing, but completely unsatisfactory for 10kHz channelling on 28MHz. The performance for 12.5kHz channelling (if you wished to transvert to 144MHz, for example) would be adequate. AM selectivity was quite reasonable for short wave listening purposes, and allowed an acceptable amount of HF to get through, whilst cutting very steeply indeed above 3kHz of audio. Thus the overall RF bandwidth is just over 6kHz for 6dB down.

We noted some 28dB difference between S1 and S9 on the S meter, and readings above S9 were quite logarithmic. We noted that the S meter had a usable range of 19dB between S1 and S9 on FM, which is better than average.

## Kenwood TS-680S Laboratory Test Results

Please also refer to TS-140S results in March 1988 issue of Amateur Radio.

RF sensitivity SSB, level for 12dB sinad  
50.2MHz -127dBm (0.1uV) pre amp in  
-123dBm (0.16uV) pre amp out

Results same 50 to 52MHz

RF sensitivity FM, level for 12dB sinad  
50 to 52MHz -123dBm (0.16uV) pre amp in

RF sensitivity SSB, level for 12dB sinad  
28.55MHz -127dBm (0.1uV) pre amp in  
-22.5dBm (0.17uV) pre amp out

RF input intercept point, 100/200kHz spacings  
50.2MHz -9dBm pre amp in  
-3dBm pre amp out

28.55MHz -2.5dBm pre amp in  
+11dBm pre amp out

Reciprocal mixing ratios at 28.55MHz noise floor/disturbing signal level

5kHz	76dB
10kHz	83dB
20kHz	91dB
50kHz	102dB
100kHz	112dB

S meter SSB pre amp in

S1	-119dBm
S3	-113
S5	-108
S7	-101
S9	-91
S9 + 20	-69
S9 + 40	-50
S9 + 60	-34

SSB selectivity bandwidth

3dB	1.9kHz
6dB	2.4
40dB	3.4
60dB	4.0

FM selectivity

±12.5kHz	22dB average
±20kHz	53.5dB average
±25kHz	74dB average

SSB product detector distortion for 1kHz beat 1.2%

FM distortion

5kHz	3.8%
3kHz	3.5%
1kHz	1.6%

Maximum audio output for 10% THD

8 ohms	2W
4 ohms	3W

Frequency accuracy at 28.55MHz  
50.2MHz 10Hz  
100Hz

#### Transmitter measurements

Typical max power  
HF 100W PEP  
50MHz band 10W PEP

Dimensions (WxHxD) with projections 281 x 107 x 305mm  
Weight 6.1kg

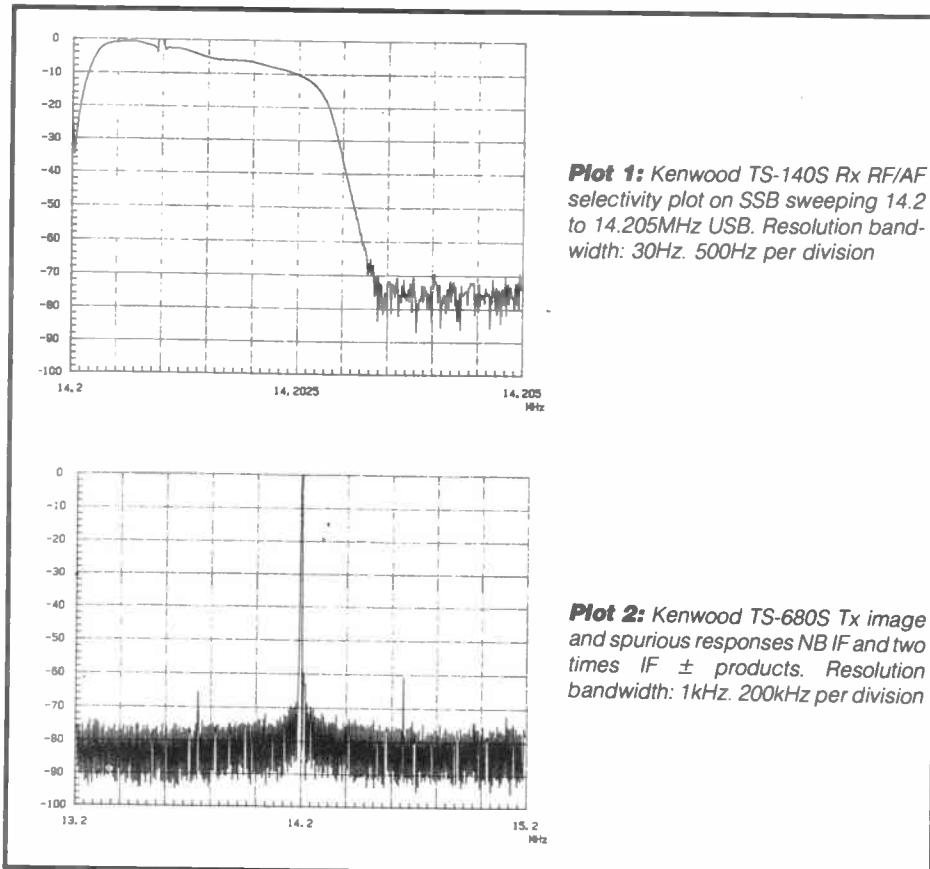

Audio distortion on SSB was quite low and slightly better than on the TS-140S, possibly because of the slightly lower synthesizer noise background. FM distortion was adequate, but not particularly good. The FM audio response, as received, showed a steep bass cut below 400Hz, and quite a rapid roll-off above 3kHz. On SSB, there was a certain amount of audio tailoring above 2kHz before the IF filter edge was reached, and I would have preferred it flatter here.

The maximum audio power output was just slightly less than most other mobile rigs, but the increase from 2W to 3W from 8 ohms to 4 ohms loading is quite useful.

The received frequency accuracy was astonishingly good, and at the moment of measurement near the beginning of the test, it was actually only 10Hz out at 28MHz! After a very considerable time (several hours) the received error on 50MHz was only 100Hz, and I consider

this very good indeed. I was able to leave the rig receiving or transmitting on the same frequency for very long periods without any appreciable drift. In setting the rig at various offsets, we noted that the linearity of the 10Hz steps was particularly good.

The filters used in this rig are the same as in the TS-140S, and so I am repeating the RF/AF SSB selectivity plot for readers' convenience (plot 1).

#### Transmitter section

In addition to checking the performance of the rig on 50.2MHz, we also checked for the spurious found on the TS-140S when the rig was used on 14MHz. I was a little critical about these in the TS-140S review, but the levels of the various products of the final frequency ± multiples of IF were far lower on the 680S, suggesting that the original TS-140S sample was somewhat below stan-

dard. Plot 2 shows the TS-680S performance at 14MHz, which is acceptable.

Looking at the two tone intermodulation performance on 50.2MHz on Tx, you can see that the IM products are quite a lot lower than usual for 50MHz rigs, and this is a credit to Kenwood. Tests at lower levels were very satisfactory. The SSB transmitted passbands were more accurately aligned than they had been on the TS-140S, and both carrier and alternate sideband rejections were satisfactory. The frequency accuracy was excellent. Please refer to the TS-140S review for detailed measurements at HF.

#### Conclusions

It is clear to me that whilst the TS-140S is good value for money, the TS-680S is even better (costing £985 inc VAT) and I can give it a good recommendation for purchase. If you must have a vox control on SSB, then you can buy the optional external unit. I feel very strongly indeed that HF rigs should incorporate 50MHz as a matter of course, and this rig certainly shows the way forward, but I do regret that the output power on 50MHz is only 10W, although of course the rig gives 100W on HF. The actual specifications show it to give 0.5dB less output on HF than the TS-140S, and I assume that this is to allow for the 50MHz PA being around the same area as the HF PA. However, it seems strange that Kenwood should have marginally lowered the specified maximum output power which seems relatively unimportant.

I very much enjoyed using this rig, and it offered so much more than the Yaesu FT-747 which I reviewed last month. I suggest that this rig has just about the right amount of bells and whistles on it to be useful, without giving the impression of having too much!

Very many thanks to Fiona for helping with all the tests, and to Lowe Electronics at Matlock for loaning me an official Kenwood sample, which was well worth waiting for. I cannot help but feel that it is sometimes better to wait a few months after a model has been introduced in Japan to allow the production line to get all the bugs out. I foresee that this will be a very good seller for Kenwood, but don't forget that Icom have announced a budget rig for release later this year, or early next year.

**Start training now for the following courses. Send for our brochure – without obligation or Telephone us on**

REF: AR

**06267 79398**



**NAME**.....

**Telecoms Tech  
271 C & G**

.....

**Radio Amateur  
Licence C & G**

.....

**Micro-processor**

.....

**Introduction to  
Television**

**Radio & Telecommunications Correspondence School  
12 Moor View Drive, Teignmouth, Devon TQ14 9UN**

## G4ZPY PADDLE KEYS

Britain's leading High Quality Hand Built Morse Key Manufacturer

PUMP (Straight) KEY	Brass £26.00 & £30	Nickel £31 & £35
SINGLE PADDLE KEY	Brass Std £42.00	Deluxe £44.50
Nickel on Brass	Std £47.00	Deluxe £49.50
TWIN PADDLE KEY	Brass Std £48.00	Deluxe £50.50
Nickel on Brass	Std £53.00	Deluxe £55.50

60. VARIATIONS OF THESE KEYS ARE AVAILABLE. Some to Order.

IAMBIC ELECTRONIC KEYS (with Auto Inter-Character Spacing) £40.00  
 1K PEP BALUNS 3.5-30 Megs £15.00  
 10-70 Megs £16.50, P&P UK: – KEYS £3.00  
 IAMBICS AND BALUNS £2.00

SAE for further details to

**41 Mill Dam Lane, Burscough, Ormskirk, Lancs L40 7TG  
or Phone: 0704 894299**

# THE RSGB DATA SYMPOSIUM

by Don Field

The first RSGB Data Symposium was held at the end of July as one of the RSGB's 75th Anniversary attractions and was attended by just over 100 RTTY and packet enthusiasts. The venue was held at the historic Harrow School. Unfortunately, the acoustics turned out to be dreadful, not being helped by the PA system which insisted on picking up one of the local radio stations. The large number of stairs was also a problem for the few disabled attendees.

Having said this, the symposium programme turned out to be a fascinating cross-section of the 'light and heavy'. The former category included a presentation on the history of telegraphy by G8EXV and G3GJW, with an illustrated talk on teleprinter 'art' by VK3KAF/G1XPB.

Representatives from Eire, France, Germany, the United States and Belgium, spoke about the development of packet radio in their respective countries. The contrast is considerable. Eire has only about fifty active packet operators, three network nodes, and a very liberal licensing regime. Conversely, Germany has very high levels of packet activity, a multitude of network nodes and some of the same problems of licensing that we face here in the UK.

The 'heavy' part of the programme consisted of a number of technical lectures about various aspects of packet and AMTOR, together with three presentations from professional users of data communications; BT on data over mobile radio, British Rail on radio block signalling and John Coll of X-On who spoke about electronic conferencing and data transmission over the *Teletext* network.

It was interesting to contrast these professional presentations with those from the amateur contingent. Amateur packet radio has made enormous strides in a few short years, with very high levels of activity in many parts of the world. Messages can be forwarded almost anywhere, using a variety of wavebands,

networking protocols and media. Perhaps the most advanced medium is the satellite-borne repeater. G0/K8KA gave a fascinating insight into the way satellite mailbox facilities are rapidly becoming available to even modestly equipped stations.

However, in many ways packet radio has failed to live up to the initial hype. Where it was once possible to have 'real time' contacts over long distances using intermediate digi-repeaters or level 3 network nodes, the high level of usage has led to increasing congestion; at least in or near the most populated areas. This has resulted in most people sticking to local QSOs of messaging via their local mailbox.

Mike Dennison, Chairman of the RSGB's packet working group, spoke about how delays in legislating for packet activity have prevented the use of 70cm for mailbox and network node access, while 2m simply does not have enough channels to cater for the demand. The new licence will clear up some of the anomalies regarding packet use from our own station but licensing of unmanned mailboxes and repeaters, at least on bands other than 2m, is likely to be a very slow process indeed.

What the future could hold, if the technical and legislative problems can be overcome, almost defies the imagination. We could have 'real time' access to distant specialist mailboxes and news services, with our personal mail delivered automatically to our home computer terminals.

We could have a rapid call set-up to any other user on the international network, with low congestion, highly 'user-friendly' interfaces, the ability to send a digitised voice, text or image, and much more. G3VPF spoke about how some of this might evolve from present technology. G3RUH showed his newly-developed 9600 baud modem, which is designed to work with conventional radios and will do much to increase network throughput.

G6KVH spoke about the TCP/IP networking protocols which are technically very advanced, but while the TCP/IP and OSI factions have been battling it out, NET/ROM, a quick and dirty protocol in comparison, has come in and stolen the show.

Clearly, it is all very well to plan for a sophisticated network, but at the end of the day it must serve the average amateur who has limited funds and expertise. In this context, G1DIL's talk on 'Mailboxes, who needs them?' was very relevant. Mailboxes are a great step forward in the amateur world but they are also major contributors to network congestion. In addition, the WORLI mailbox software is already showing its limitations, compared to the kind of software that many amateurs are currently using in their professional lives.

There was the inevitable debate about HF packet. G3XDV presented a paper by G3PLX, the 'father' of AMTOR, on how AMTOR could be used for HF links in a global network in preference to packet. G4LPQ/A4XZL gave another slant to this when he described his successes with HF packet when stationed in Oman. The debate continues.

Interest in packet radio is increasing rapidly in the UK, mainly because of the availability of TNCs at affordable prices.

'Why', as one of the speakers asked, 'do we persevere with this new mode at all when we could pick up a microphone and talk to somebody via the local speech repeater?' But then he went on, 'if all we wanted to do was communicate, we would simply pick up the telephone'. The fun of packet radio is being involved in something which is new and developing rapidly, with lots of promise for the future. Fortunately for those of you who were not at the Data Symposium, the proceedings will be available in printed form.

Taken overall, the event was worthwhile, despite hiccoughs in the logistics and a packed programme of topics which received only very superficial coverage.

## L F HANNEY

77 Lower Bristol Road, Bath, Avon  
TEL: 0225 24811

Your electronic component  
specialist for Avon,  
Wilts & Somerset

Closed Thursdays

## MAKE YOUR INTERESTS PAY!

More than 8 million students throughout the world have found it worth their while! An ICS home-study course can help you get a better job, make more money and have more fun out of life! ICS has over 90 years experience in home-study courses and is the largest correspondence school in the world. You learn at your own pace, when and where you want under the guidance of expert 'personal' tutors. Find out how we can help YOU. Post or phone today for your **FREE INFORMATION PACK** on the course of your choice.

Electronics	Radio, Audio and TV Servicing
Basic Electronic Engineering (City & Guilds)	Radio Amateur Licence Exam (City & Guilds)
Electrical Engineering	Car Mechanics
Electrical Contracting/Installation	Computer Programming
	GCSE and 'A' level subjects

Course of Interest: \_\_\_\_\_  
Name: \_\_\_\_\_

ICS Address: \_\_\_\_\_ P. Code \_\_\_\_\_  
International Correspondence Schools Dept EF598, 312/314 High  
Street, Salford, Surrey SM1 1PR. Tel: 01-643 9568 or 041-221 2926 (24 hrs)

# THE DIPOLE AERIAL

## Part 1

By Ken Williams

Dipole aerials, in one form or another, are undoubtedly the most widely used of all, in amateur radio communication. Yet, despite the fact that they adorn the vast majority of amateur stations, most operators have only a rudimentary knowledge of their operation and characteristics.

The elementary dipole forms the basis for many aerial computations, however, under such circumstances the theory assumes that the phase and amplitude of the RF is constant throughout its length, a condition only realised in aerials shorter than a tenth of a wavelength.

Larger aerials are assumed to comprise a large number of infinitesimal dipoles of varying space position; polarisation; current magnitude and phase, corresponding to the distribution of these parameters in the aerial being represented. Field intensity equations are then developed by integrating or otherwise summing the field vectors of the many elementary dipoles.

Such mathematical techniques, however, are not necessary for the average radio amateur who is interested only in installing the best possible aerial, taking account of his location, facilities and finances.

### The half wave dipole

When the word 'dipole' is mentioned almost every amateur immediately thinks of the half wave dipole. Perhaps therefore, this is the appropriate place to start.

When we were learning radio theory, we were all taught that a half wave dipole has a radiation resistance of 73 ohms, radiates a polar diagram shaped somewhat like a doughnut with the nulls off the ends and has a current maximum at the centre. To a degree this is true, but it is not the whole story, for this only applies in free space.

As soon as the aerial is manufactured

**Fig 1:** The doughnut-shaped radiation pattern of a half wave dipole in free space

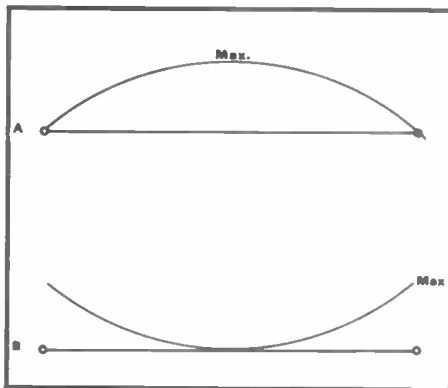
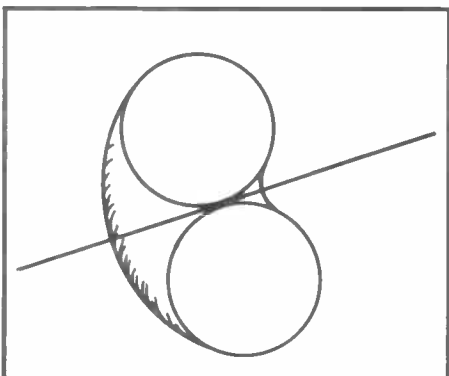
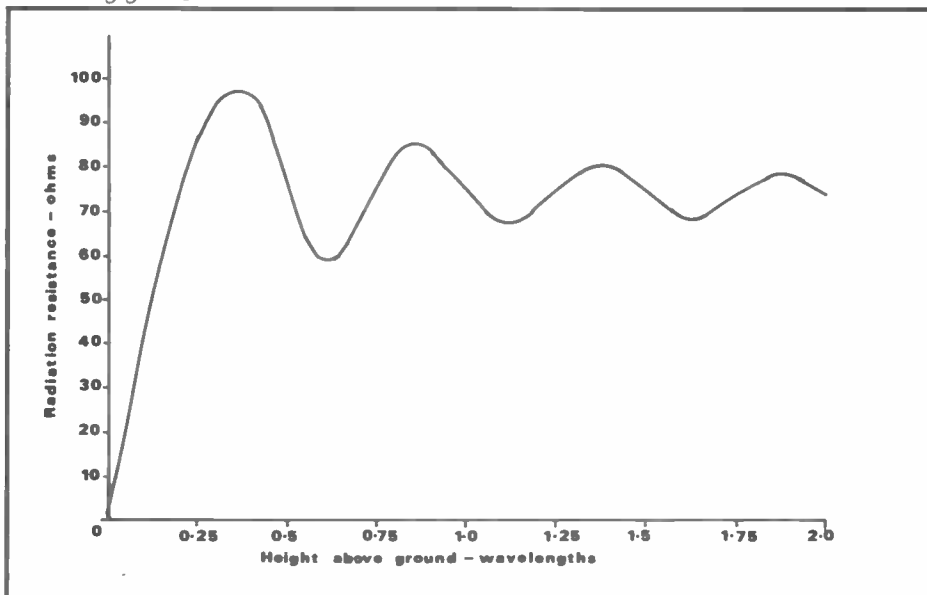

**Fig 2:** A current and B voltage distribution on a half wavelength aerial

of practical materials and brought into the proximity of the earth, other factors take over. Firstly, the aerial must be less than half a wavelength long, the radiation resistance may be anything from a few ohms to a hundred and the vertical polar diagram may indicate any number of lobes, although the horizontal pattern will stay substantially the same.

The electrical length of an aerial (or any other wire for that matter) is not the same as its physical length for it also exhibits properties of inductance and capacity. The passage of the wave is, therefore, slowed down while passing through the wire. The electrical length is determined by the time which the wave takes for a specified phenomenon. So the length of an electrical half wavelength is determined by the distance which the wave travels in the time it

**Fig 3:** Variation in radiation resistance of a horizontal  $\frac{1}{2}$  dipole with height above perfectly conducting ground



takes to rise from zero to a maximum and back to zero again. As a result of the slowing of the wave, due to inductance and capacitance, its length will be in the order of 5% less than a physical half wave.

In practical aerials, the presence of nearby objects, such as the ground, houses and trees, can also affect the length necessary for resonance. The lengths quoted in books and articles in magazines should, therefore, be considered only as a guide, with the final length being determined by experiment.

The radiation resistance of a dipole is usually quoted as 73 ohms. In the practical situation, however, the value may vary considerably from this figure. The reason for this lies in the fact that the ground beneath the aerial acts as a reflector. RF power radiated downwards by the aerial is reflected by the ground back towards the aerial, inducing further RF current in the aerial. If this induced current is in phase with that already there, then the two will combine. The higher current present will therefore result in a lower effective radiation resistance. If the induced current is out of phase with that existing, the two will subtract, resulting in higher radiation resistance.

This effect decreases with increasing height of the aerial and is negligible at aerial heights of ten wavelengths and above. So, although this is of major importance to the HF operator, particularly those working on the lower bands, it can be safely ignored on VHF. It also indicates one of the difficulties which may arise if an HF aerial is tuned at low level and then raised to operating height.

The other effect, which is caused by ground reflection, is the development of the vertical polar diagram into a series of lobes.

The dipole aerial radiates a signal at all angles broadside to the wire. Some of this, as we have seen in the previous paragraph, is reflected from the ground back to the aerial and influences the radiation resistance. All signals, however, which are radiated at angles

below horizontal will impinge on the ground and be reflected.

In similar manner to the reflections in a mirror which we learnt in optics at school, the angle of reflection is equal to the angle of the incident wave. So, a wave radiated from the aerial at an angle, say, of fifteen degrees below the horizontal will hit the ground and be reflected at a similar angle.

This reflected signal will then combine in space with the wave directly radiated from the aerial at the same angle. The reflected wave will, however, by virtue of travelling initially downwards and being reflected, have travelled a greater distance and will be of different phase to the directly radiated signal. Depending on this phase difference, the two waves will either add or subtract.

The strength of the reflected wave is such as to cause almost complete cancellation of the signal at certain angles of elevation. So the vertical radiated pattern breaks into a series of lobes, the number of which depends on the additional distance which the reflected wave has to travel, ie due to the height of the aerial above ground.

The number of lobes developed is equal to the height of the aerial above ground in complete half waves. If the aerial is between a complete number of half waves (eg  $\frac{3}{4}$  wavelength) in height, an additional lobe will be radiated vertically.

It is usually considered that the best lobe angle for DX working is between ten and fifteen degrees. If a horizontal dipole aerial is erected at a height in excess of one wavelength, then the lowest lobe of the vertical radiation pattern will be at, or below, this figure.

It may be of interest that Instrument Landing System (ILS), the radio aid which aircraft use for approach and landing, uses this principle to define the vertical approach path. In this, the required path is delineated by the boundary between the lobe patterns of two aerials at different heights.

As the lobe angle is determined by ground reflection (if the aerial is located on the side of a hill) the lobe angle will be lowered in the downhill direction and raised in the opposite.

A further factor which affects the performance of an aerial is the ratio of its length to diameter. This can vary widely, for example, a top band half wave dipole of 18swg ( $\frac{1}{8}$ in diameter) wire would have a ratio in the order of 25000:1 while a 2m dipole constructed of  $\frac{1}{2}$ in tubing would only be about 80:1.

Although the greater the length to diameter ratio, the higher the radiation resistance, the overall effect is very small and can safely be ignored. Far greater is the effect on the 'Q' of the aerial, for the greater the length to diameter ratio, the higher the 'Q'. As an aerial is effectively a tuned circuit, the greater the 'Q' the more narrow the bandwidth.

The effect that most VHF aerials exhibit a low VSWR across the whole band, while that of HF aerials can vary widely within a few hundred kHz is due to this characteristic.

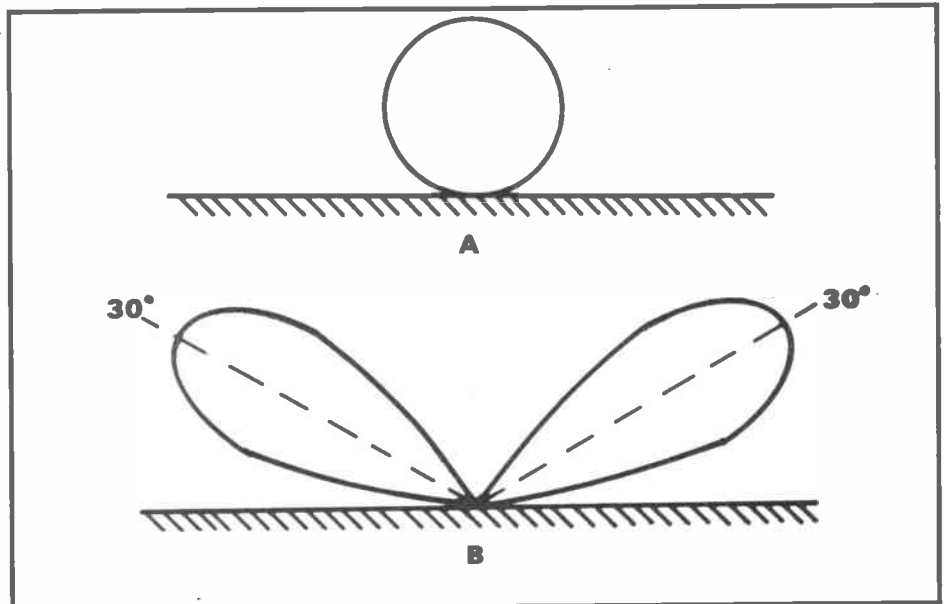
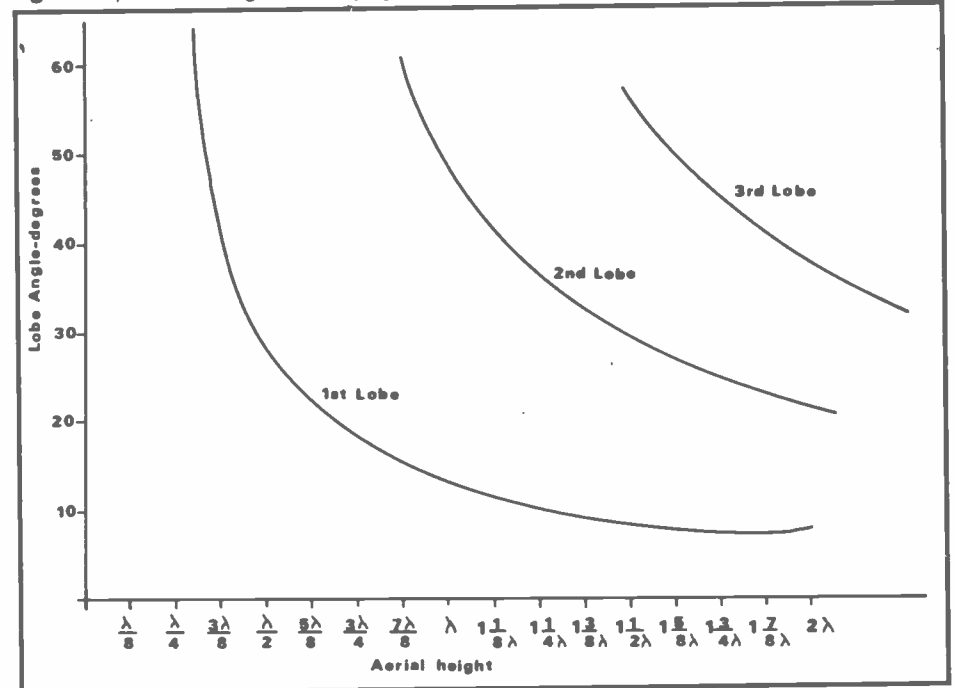

Fig 4: Vertical polar diagram for a horizontal half wave aerial A  $\frac{1}{8}$  high B  $\frac{1}{2}$  high

Fig 5: Graph of lobe angles for varying height of a horizontal dipole



### The folded dipole

Earlier in this article, we saw how signal reflection from the ground could seriously affect the radiation resistance of a dipole. Similarly, when a dipole is brought into close proximity to other aerial elements, the effect is even more dramatic. In a close spaced beam, common on HF, the radiation resistance may drop to a few ohms.

There are several methods of overcoming this problem and still provide a reasonable match to the feeder system, one of the most common being to use a folded dipole element which provides a useful increase in feed impedance.

The increase in impedance results from the fact that the aerial current divides between the two wires comprising the aerial. If these wires are identical, then the current distribution will be equal and half the current will flow in each wire. As the power remains the same and equals  $I^2 R$ , then by halving the

current, the resistance will be increased by a factor of four.

If, however, the two conductors comprising the folded dipole are not identical, the current distribution will not be equal and the impedance will be increased by some other factor which will be dependent on the relative diameters of the elements and their spacing.

By varying relative diameters and spacing, it is possible to arrange an impedance step-up ratio between 2:1 and 16:1.

Therefore, by using a folded dipole comprising two different diameter elements, it is possible to arrange the wide variation of impedance step-up ratio necessary to match almost any beam driven element to any feeder impedance.

There are other advantages, however, in using a folded dipole which can recommend it even when not being used in a beam.

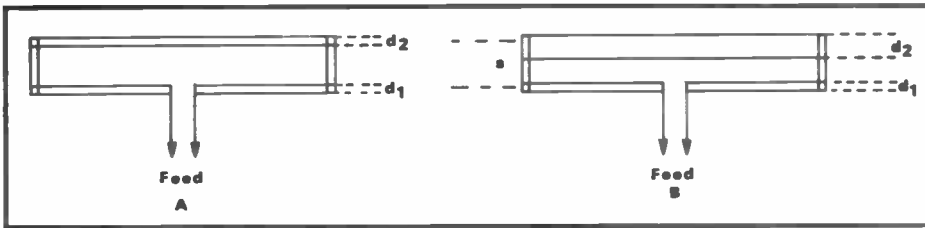

**Fig 6:** Folded dipoles. In **A** the conductors are of equal diameter and give a 4:1 impedance step-up. In **B** the conductors are of unequal diameter and, depending on the relative diameters and spacing, step-up ratios from 2:1 to 16:1 are possible

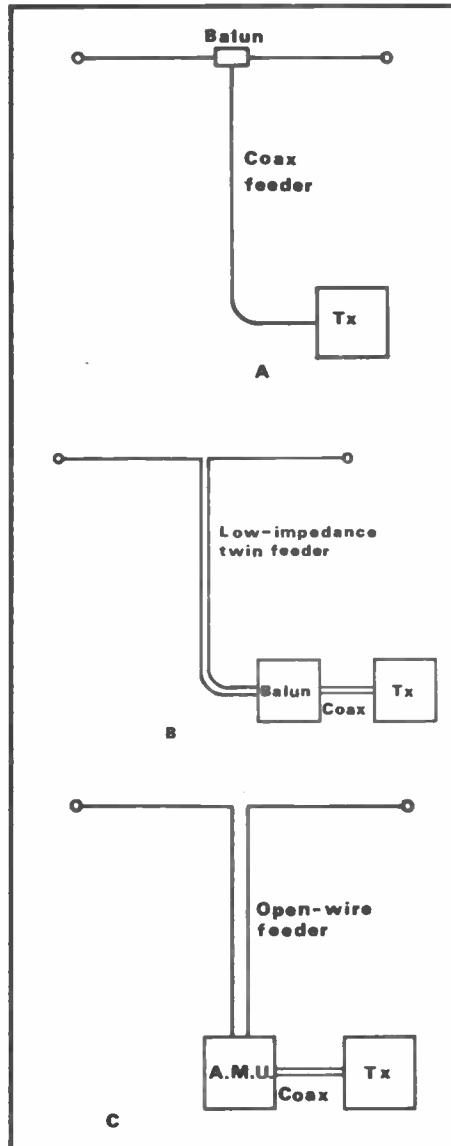

**Fig 7:** Three ways of feeding a half wave dipole. It should be noted that an aerial matching unit (AMU) would almost certainly be required in addition in **A** and **B** if a solid state PA is being used

The folded dipole has almost twice the bandwidth of its single wire counterpart, which can be a considerable advantage to HF operators who use both the CW and telephony ends of the bands. It also has lower losses and directly matches 300 ohm feeder which is lighter, cheaper and more efficient than coaxial cable, particularly when a long feeder run is necessary.

#### Feeding the dipole

The feed impedance of a centre fed half wave dipole is normally considered

to be about 70 ohms, but as we have seen, it may vary considerably from this.

On VHF, aerial systems are normally single band and suitable arrangements are made to ensure that the system matches either 50 or 75 ohm standard feeder.

On HF, however, except for beam aeriels, specific matching systems are rarely incorporated, the only concession being that the aerial length is adjusted to give the best match on the frequencies most commonly used.

By far the most common feed arrangement is to use a balun at the aerial feed point in conjunction with coaxial feeder. This arrangement has much to commend it for it is convenient, no more of an eyesore for the neighbours than necessary and couples very well with the unbalanced output universal on equipment today. It is not, however, either the cheapest or the most efficient means of feeding an aerial.

The dipole is essentially a balanced system, so for optimum results a balance to unbalance transformer (balun) is desirable to match to unbalanced feeder. The weight of this, coupled with that of the feeder, especially when half-inch such as UR67 is used, can add considerably to the tension necessary to minimise aerial sag.

In contrast, low impedance twin is far

lighter and the balun can be located next to the rig inside the shack. Losses on balanced twin are also considerably lower than even the best coaxial cable.

If an aerial matching unit is to be used, the balanced twin feeder need not be 70 ohms, for if wide spacing is used, the feeder will act as a matching transformer, converting the 70 ohms at the aerial feed point to some different impedance at the equipment. This is then matched to the output impedance of the transmitter by the action of the aerial matching unit.

An interesting point is that if the open wire feeder is an exact number of half waves long at the operating frequency, then the impedance at the equipment end will be the same as at the aerial.

Open wire line is not, to my knowledge, available in your local emporium. This is no disadvantage for it can be easily made at home. The only necessity is to provide sufficient spacers made of Perspex, plastic, or other convenient non-conducting material, to keep the two conductors, each of about 18swg wire, a reasonably constant two or three inches apart.

The actual impedance of the line is not critical as the impedance transformation to the transmitter will be made by the aerial matching unit. The author has made satisfactory balanced line using the spools from 120 photographic film as spacers.

In his book *HF Antennas for all Locations*, G6XN refers to his use of 150 yards of home-made open wire feeder from his shack to his aerial which has a loss of only 1.6dB at 14MHz. This is about half the loss of an equivalent length of UR67 while costing virtually nothing for the materials, most of which could be found in the station junk box.

The use of open wire line and aerial matching unit also gives the great advantage that the aerial will operate on

**Fig 8:** Home-made open wire feeder. Almost any insulating material may be used. Thickness need only be sufficient to make the spreader stiff. 2-3ft spacing of spreaders should be sufficient

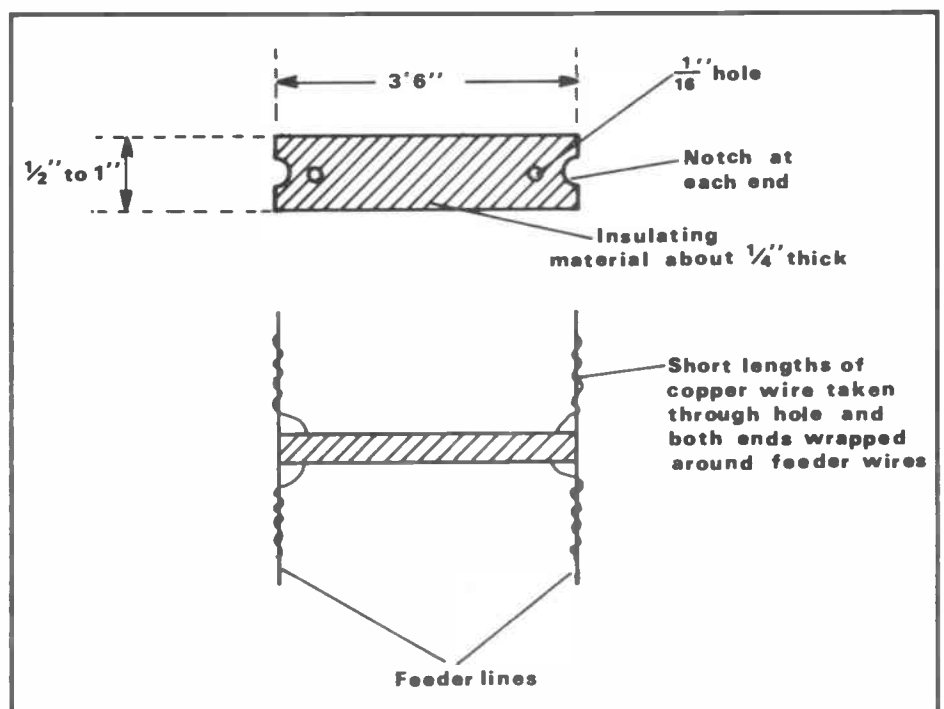

almost any band. I will be going more deeply into this in a later article.

Whichever type of feeder is used, it will be within the strong RF field radiated by the aerial and if it runs closer to one side of the aerial than the other, particularly if twin feeder is in use, RF pick-up will unbalance the system. Feeders should, therefore, be led away at right angles from the aerial to ground level or for a distance of at least a quarter of a wavelength if this is not possible.

### Voltage Standing Wave Ratio

If the load (ie aerial) does not present a perfect match to the transmission line (ie feeder), it will not absorb all the power supplied and some will be reflected back down the line. This will combine with the 'forward' power, either adding or subtracting according to their relative phases.

This will cause a standing wave pattern to be set up along the line. The measure of the depth of standing wave is the comparison of the amplitudes of the peaks and troughs of this pattern and is known as the Standing Wave Ratio. This may also be shown to represent the ratio of the aerial to feeder impedances.

Power losses on feeders are due to three main reasons: resistance of the conductors, dielectric losses, and feeder radiation.

If the feeder is short (in terms of wavelengths), ohmic resistance and dielectric losses will be small. So on HF a much higher SWR can be tolerated than on VHF.

On the HF bands, ratios of up to 3:1 would cause negligible loss but on VHF this would be intolerable for even the shortest feeders are several wavelengths long.

With valve power amplifiers incorporating a PI network output, the effect of any moderate VSWR can be matched, but the development of transistor power amplifiers with fixed impedance output for HF has, however, removed this facility. For these, if connected to a feeder with poor SWR, the consequences could be serious, if not fatal.

With the valve equipment, the PI output circuit acts as an efficient impedance matching network, but the transistor output circuit is a broadband transformer converting the very low output impedance of the output transistors to the 50 ohms output impedance.

Now, as the SWR represents a ratio of impedances, if the transmitter 'sees' an SWR of 3:1, it could mean that the impedance presented is 150 ohms. This higher impedance reflects back through the broadband transformer, and the output transistors 'see' a much higher load than normal, which would limit output.

Equally, however, a 3:1 SWR could mean that the load presented was only 17 ohms. Under such circumstances the output transistors would be looking into a load only one third of normal. As the PA collector impedance is very low, it tends to act as a constant voltage source and supply extra power into the load.

In a similar circumstance, a valve PA

would saturate and self-limit its output, but transistors do not have this property and power would increase until either the required power was being supplied to the load or, more likely, they self-destruct due to excessive current.

Even a fuse in circuit could not prevent this, for the action of the fuse is far slower than that of the output transistors.

I have often heard less experienced amateurs say that their aerial had a high SWR but they had 'tuned it out' with the aerial matching unit. This is not possible. What they have achieved is to use the AMU to match the impedance presented by the feeder to the 50 ohms required by the transmitter. As the SWR meter is on the transmitter side of the AMU, the SWR has apparently been 'tuned out'. In such circumstances the transmitter is quite safely looking into 50 ohms, but the SWR on the feeder system will still be present.

### Vertical, sloping and inverted VEE dipoles

All discussion so far has considered that the dipoles are horizontal. There is no necessity that this should be so and in certain circumstances there are definite advantages if this is not.

All comment regarding horizontal dipoles also applies equally to sloping and vertical dipoles, the only major difference being the radiation pattern.

The horizontal polar diagram of a horizontal dipole shows maxima broadside to, and minima in line with the aerial. If the aerial is tilted, the radiation tends to move towards the direction of the lower end and when the angle reaches 45 degrees, the majority is in that direction.

As the aerial tends towards vertical, the horizontal pattern gradually becomes omnidirectional but the vertical pattern undergoes the most change, developing a main lobe parallel to the ground. Ground losses rapidly attenuate the lower part of this lobe but even then the main radiation is at around 10 degrees – ideal for DX working.

The popularity of inverted VEE aerial is undoubtedly due to its convenience of erection, but it also has two advantages over its horizontal counterpart. The lowering of the ends tends to make the nulls in the radiation pattern less obtrusive, while the angle of the wire encourages a certain amount of low angle vertical polarisation.

In my next article I shall look at forms of multi- and broad band dipoles.

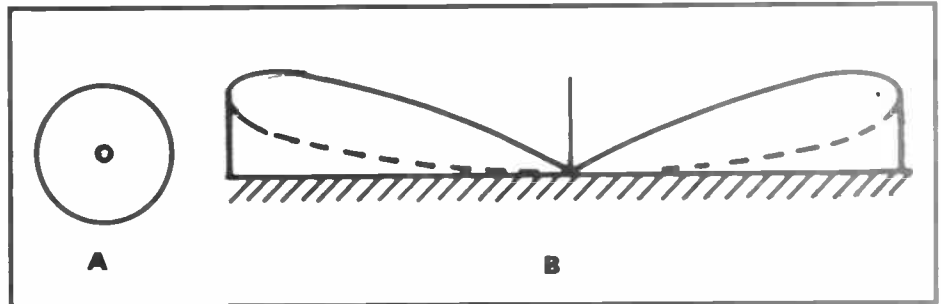

Fig 9: A Horizontal and B vertical polar diagrams of a vertical half wave dipole. In B the lobe is parallel to the ground but absorption of the lower part of the lobe results in an effective lobe angle of about 8-10°. The height of the centre of the aerial is  $\frac{1}{4}\lambda$ .

Fig 10: The heart-shaped radiation pattern developed by a sloping half wave dipole

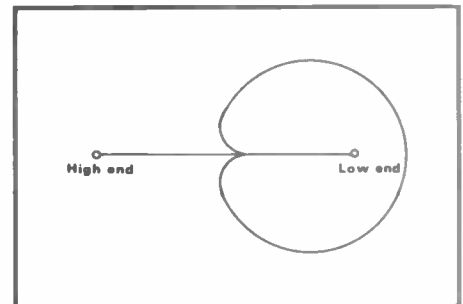
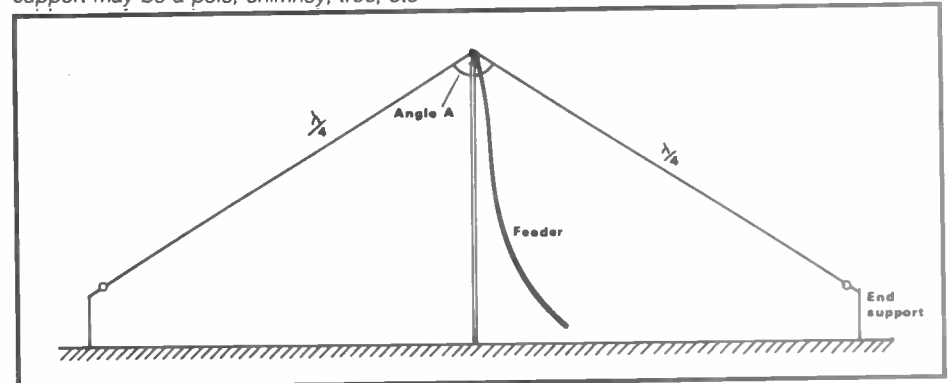

Fig 11: The inverted VEE dipole. The included angle A should be more than 90°. The end supports are for safety as high voltages exist at the dipole ends; 8-10ft should be adequate. The centre support may be a pole, chimney, tree, etc





# SECOND-HAND

by HUGH ALLISON G3XSE

## Eddystone S750

In comes an example of the above receiver, clearly not working despite looking like the day it was born. After a careful look at the mains lead – it is rubber and a bit prone to cracking – I plugged it in. No lights inside the rectifier bottle, plus a lack of pinky-blue glow in the stabiliser, led me to the awe-inspiring conclusion that there was not going to be much HT about. Out with the rectifier, it looked OK on the avo. Switched it back on with the bottle out and in with the avo probes down the valve base. Reset trip on avo (I'd left it on ohms) and all looked OK. I then noticed a thin green growth on the valve pins. Out with the scotchbright and after a gentle rub over, bottle back in and all was well.

A couple of days later, a super version of the above receiver (well, it had an 'S' meter fitted) resided on the work-bench. Lots of noise but no receiving going on. A quick wave of the scope probe at the fixed bits of the three gang variable tuning capacitor revealed no local oscillator. Upended the set and wandered round the general area of the oscillator valve. All volts were present and correct, and it was lighting up. Pulled out valve prior to getting someone to give it a medical on the valve tester (that machine and I have agreed to avoid each other) when I noticed a green growth on the valve pins...

Incidentally, a lot of Eddystone stuff used what were called, I think, B8A based valves. These are eight pins all in a circle, not one pin missing like your average B9A. Valve pin location was done by a pip in the glass on the side. This locates in a slot in the base and there is a tongue in the slot to keep the valve in. The tongue tends to rust up and thus not move. You pull the valve out and the tongue doesn't budge. Something has to give, and it's the pip. It breaks off and in goes the air. Bitter experience has taught me to exercise the tongue a few times before whipping out B8A based valves.

## Variable capacitors

Another problem that seems to have become virtually an epidemic is hardening grease in the variable capacitors. The stuff gets harder and harder, and consequentially more effort is required on the tuning knob, until, more than likely, the dial cord snaps. The cure is to wash out the old grease and lightly oil. Sounds easy? Unfortunately the variable capacitor is either structural and it seems unwise to remove it for fear of damaging something else, or the bloody thing was the first bit in on the production line and everything else was built on top of it.

It's worth trying to wash the old stuff out with a solvent, IPA, meths or

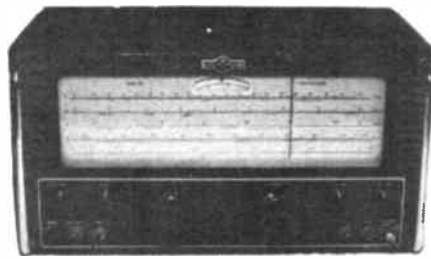

The Eddystone S750

such like. Otherwise, after the solvent has evaporated, try heating up the shaft with a soldering iron and then briskly rotate it several times with a pair of pliers. In with a drop of oil whilst still warm and it should be as smooth as a baby's... Don't put the iron through the dial cord!

## Servicing Things

I've often advised touching the centre tap of the volume pot as *move one* when presented with a 'dead' set. Speaker 'buzz' indicates that all is well in the audio section and that you have some form of volts about and the speaker is OK. If we are repairing your average tunable HF receiver then *move two* as briefly outlined above, is to wave a scope probe at the fixed bits of the variable capacitor which moves when you twiddle the main tuning knob. You should find on one of the gangs, loads of wobble. A valve set should have several volts running at the required tuning frequency (plus or minus the frequency of the IF). The frequency and amplitude of the wobbling is irrelevant; the frequency of oscillation is going to be upset by the capacity of the probe anyway. The object of the exercise is to see some action. For the second that it costs you, I tend to give the tuning knob a spin, checking that the frequency varies a bit. I've uncovered 'dead' sets that have had important components of their gear trains missing by doing this, plus the odd set where the moving vanes of the capacitor are not earthed.

If you do find variable oscillation, then the local oscillator is functioning properly and can be declared innocent. It is a reasonable bet that in non-stabilised valve sets the lower HT rail for the IF/RF stages is present and correct. If you cannot find any trace of oscillation then you are now on your way to fixing the set. It could well be the active device, be it valve, transistor or IC. Have a good look across the device to see if it has volts across it. If there are no volts; whip him out and look again. Volts now? Then the device is suspect. If volts are still not present, start searching, as it is probably the short circuit capacitors to the deck or an open circuit resistor in series.

In multi-ganged variable capacitors there really is no standard as to which one is the oscillator section, it could be the first, second or third (or more, depending on the circuit). One thing is for sure though; one section should have some sort of oscillation on it.

Incidentally, if you do not have a scope, it should be possible to listen for the local oscillator on a general coverage set. Tune to the frequency of the 'dead' set (plus or minus the IF) and try to find a blank carrier. Have a practice with two good sets.

## Elvaston Castle

This was a brilliant rally, having a well attended flea market and a large bring and buy section. I can thoroughly recommend this event to everyone.

One trader had a truly great new idea. He made an enclosure out of several vans and filled the middle with all sorts of interesting bits and pieces.

Admission was £3.00 and as you went in you were given a large plastic bag to carry whatever you wanted. Judging by the enthusiasm of those I met, the plastic bag idea was extremely popular. I came across one young lad who was systematically buying one of everything as he was trying to get his own junk box started!

## Timid

One afternoon, there was a timid knock on my front door. It was a young listener who was close to tears. He had bought a Telequipment scope at a local rally which didn't work. Really, what did he expect?

However, onto the workbench with it and off with the cover. He had previously run it up with the covers off and assured me that the valves all lit up. What he had failed to notice was that one of the valves was definitely white where it should have been silver. This was due to the valve's vacuum being contaminated with air. The valve was an ECC88 and although I didn't have any, I did have plenty of E88CCs which would do.

After fixing the standard faults, the resistor between the two HT smoothing capacitors is always an open circuit and the astig 1M $\Omega$  pot being likewise, he left with a smile on his face. The moral is that although a valve lights up it can still have air in it.

## Advance OS3000 scopes

These scopes seem to be appearing in vast quantities at rallies, often sold as seen at bargain prices. I have picked them up for £25 a pair, duff, and seen them for £50 or £100 each as workers.

There is obviously a great saving to be had here when buying a duff one but they are not easy to repair and if you are not

## SECOND-HAND

mega confident, I would advise you to buy a worker. The problems always seem to be in the EHT section. The EHT generator is a pair of BFY50s in a transformer coupled multivibrator. I am a big fan of stuffing in whatever is to hand when it comes to replacing transistors but do learn from my bitter experience, in this scope, BFY50s seem essential.

Unfortunately, the BFY50s being duff is not the end of your troubles. They have probably failed because of something else not working. One of the capacitors in the voltage multiplier is a fair bet and, joy of joys, the multiplier is encapsulated in some smelly 'gunge' which has to be dug out. Whoopie!

If it's not the multiplier, it might be the EHT transformer. Try running up the multivibrator on a separate low voltage supply with the transformer (secondary) disconnected. If it takes over 50mA at 5V and is oscillating, then the transformer is arcing over (you can often hear it). One other point to look out for is the heat shrink type sleeving used on the high voltage wires within the EHT generator, they can become conductive with moderately disastrous results.

Although I have now repaired over thirty of these scopes (all EHT troubles), one had me in tears of frustration recently. In sheer desperation I pulled every component off the EHT board and

tested it before replacing them. The 1Ω over current sensing resistor had gone high to about 2Ω and was causing the current trip bit to activate. I wasted a whole day on that one.

If you buy an OS3000 which is working, or repair a duff one, you should end up with an apart-from-EHT reliable, all solid state scope. The trace is acceptably bright even on top 'speed' and ×10. We have dual channels, twin timebase, delayed etc with all the more advanced tricks like bright up. Worth considering.

### Talking of repairing scopes

I always like to get something up on the tube face as soon as possible when repairing a scope. Very often, you get something up and it's working. The trick here is to turn off the timebase and, if appropriate, switch the trigger select to line.

Line triggering on simple scopes only use a handful of components and should ensure that the thing isn't blanked off waiting for a trigger. Locate the X and Y plates, these are very often the four separate pins halfway down the tube on the side. Now connect an avo across each pair and twiddle the appropriate shift (X or Y) until the avo reads 0V. *Be careful, sometimes the plates can be at a high voltage above or below the chassis.* You now know that there should be a dot

in the middle when you get the thing going. If it is not possible to get 0V on the avo then you have probably found the fault, one plate is hard on or off and thus the trace is biased off the screen. This is often a short circuit device in a transistor scope or an open circuit load resistor in a valve one. If the latter, take care, as the resistor is often non-inductive. *Don't replace with a wire wound!*

### Help

A reader bought a 'sold as not working' Blazetone FM200 rig at a rally. This is a 2m rig built very much like a CB set; one big PCB with no logical layout. The bad news for him came in two stages. First, the previous owner had removed the synthesizer chip. Second, the importer appears to have gone bankrupt. It's a rig I would never come across but my guess is that the missing chip might be a Suwa Seiko NIS7264B, based on the 11.52MHz rock with 16 pins and addresses only all down one side.

If you have a Blazetone, I would appreciate it if you could confirm the guess by whipping off a cover and having a look. If anyone knows a source for the chip I'd also be grateful. Apparently, it was used in many early CB sets, such as the Kraco KCB4003 and KLB4088, Pace 8340 and Surveyor 2630. So if you have a 'dead' one of these, please let us know.

## M & B RADIO (LEEDS)

THE NORTH'S LEADING USED TEST-EQUIPMENT DEALER

### SPECTRUM ANALYSERS

HP 8444A Tracking Generator OSGOP	£1,200
HP 8558B 1 to 1500 MHz 1B2 Frame	£4,750
HP 1411 8554L 8552A 1250MHz	£2,950
Tektronix 491 1.5 to 40 GHz	£1,000

### OSCILLOSCOPES

Quantity of Cossor CDU150 Compact Solid State Oscilloscopes, Dual Beam 35MHz with delayed time base with probes. Each one tested and checked for calibration	£175
HP1741A 100MHz storage	£800
HP108A Dual Beam 50MHz	£275
Philips PM3267 100MHz	£700
Telegquipment D83 50MHz D/T	£325
Telegquipment D75 50MHz	£250
Telegquipment D54 15MHz	£140
Telegquipment D67 25MHz D/B	£185
Telegquipment D61	£150
Textronix 442 30MHz	£325
Textronix 465 100MHz	£650
Textronix RMS29 Waveform Monitor	£185
System Video Pal Vector Scope	£600
HP 1B2 Main Frame	£350

### SIGNAL GENERATORS

Marconi TF2015/1 TF2171 Sync 10 to 520MHz	£675
Marconi TF2016 TF2173 Sync 10Hz to 120MHz	£475
Marconi TF1066/B 10-470MHz AM FM	£175
Marconi TF144/H 10Hz 72MHz	£75
Marconi TF1064B/5 68-470MHz	£100
Philips PM5234 100KHz-110MHz	£375
Marconi TF2333 Transmission Test Set	£350
Feedback FG600 Function Generator	£80
Lyons PG73N B Polar Generator	£85
HP202C LF Oscillator	£95
HP 8620A Sweep Generator 1.2 to 12GHz	£3,000
HP3311A Function Generator	£175
HP333A Distortion Analyser	£350
Marconi TF2330A Wave Analyser	£300
Levell TG200B RC Oscillator	£40
HP654A Test Oscillator	£495
Fliuke 6160A Freq Synthesizer	£275
Texscan WB11 500MHz Sweeper	£475
Radford LD02 DMS2 The Pair	£235
Marconi TF2012 400 to 520MHz	£175
Tektronix 184 Time Mark Generator	£175

### GENERAL TEST EQUIPMENT

HP 1600A 1607A Logic Analyser	£550
HP 1600A Logic Analyser	£350
Gould LA500 50MHz Logic Analyser	£750
Goult G200 Biomation Logic Analyser	£200
HP 1601A Logic Analyser Plug in	£375
HP 8170A Logic Pattern Generator	£1,250
Data Lab DLGOS Transient Recorder	£150
Marconi TF2300 Mod Meter	£200
Marconi TF2300B Mod Meter	£400
Marconi TF2700 LCR Bridge	£150
Radiometer MM2 LCR Bridge	£175
Marconi TF1313A 1° LCR Bridge	£200
Marconi TF1245/1246 Q Meter	£195
Brd Terminal 6254 100MW 30-500MHz	£75
Marconi TF2501 RF Power Meter	£135
Marconi TF6460-6420 Head	£450
HP141A Storage Main Frames Good Tubes	£120
Ferroglyph RTS2 Audio Test Set	£250
Kerco Bipolar PSU 20V.220V. 20A.20	£200
HP3400A RMS Voltmeter	£325
HP400EL Voltmeter	£200
HP3403C True RMS Voltmeter	£650
Racal Dana 9915M	£200
Racal Dana 9917A	£235
Racal Dana 9916	£225
HP 5381A 80MHz Counter	£175
HP 5300A 5304 Counter	£195
Schlumberger 7201 Locators 2 Pods	New
Schlumberger 4980 ATT	£250
Brandenburg Alpha 30Kv PSU	£150
HP8052 Sound Level Meter	£100
Marconi TF1026 Freq Meter 500/1000MHz	£15
Racal RA17 Communications Receivers	£145
500 Kcs to 30MHz Checked & Tested	£375
Eddystone EC958	£375
Eddystone UHF 9905	£175

Tektronix 7603 Main Frames in stock with various plug ins. Phone for quote

### SPECIAL OFFERS

60/40 Solder BS441 22swg 18swg 1 2Kg	£5 50
AVOB Multimeter Tested	£55
Farnell E30 Bench PSU 0-30v 5A CL	£25
Revox A77HS Tape Recorders Stereo	£250
Bradley CT471 Electronic Meters to 1GHz	£25

ALL PRICES PLUS VAT AND CARRIAGE

**86 Bishopgate Street, Leeds LS1 4BB.**

**Tel: 0532 435649**

## RADIO AMATEURS EXAM? PASS FIRST TIME!

**Before you enrol check the benefits of RRC'S unique Home Tuition Service**

RRC has helped thousands of students to success in their examinations with this unique system of postal tuition, one which guides you, step-by-step, to qualify in the shortest possible time. Only The Rapid Results College offers you all these advantages:

- |   |  |
|---|--|
| <input type="checkbox"/> A qualified personal tutor             | <input type="checkbox"/> Free advice before you enrol                    |
| <input type="checkbox"/> Study material prepared by specialists | <input type="checkbox"/> Telephone Helpline                              |
| <input type="checkbox"/> Completely self-contained courses      | <input type="checkbox"/> Free 'How to Study' Guide                       |
| <input type="checkbox"/> Handy pocket-sized booklets            | <input type="checkbox"/> Instalment Plan                                 |
| <input type="checkbox"/> Personal study programme               | <input type="checkbox"/> Free Postage on course material                 |
| <input type="checkbox"/> Regular marked tests                   | <input type="checkbox"/> Worldwide Airmail Service                       |
| <input type="checkbox"/> Courses regularly updated              | <input type="checkbox"/> Extra tuition free if you don't pass first time |
| <input type="checkbox"/> 48 hour despatch                       |  |

### POST COUPON TODAY FOR FREE RADIO AMATEURS PROSPECTUS

Please send me my prospectus as quickly as possible.

Mr/Mrs/Miss/Ms \_\_\_\_\_

Address \_\_\_\_\_

Postcode \_\_\_\_\_



**The Rapid Results College**

Dept JS21 Tuition House, London SW19 4DS FREE ADVICE: 01 947 7272 (9am-5pm)  
PROSPECTUS: 01 946 1102 (24 hour Revocall Service quoting Dept No above)



# ICOM

# DUAL



## NEW! IC-32E Dual Band VHF/UHF FM handportable

### Features:

- Full cross band duplex operation.
- 20 Dual band memories.
- Scanning.
- Compatible with ICOM accessories.
- 5 Watt output with IC-BP7 nicad.
- Small size.
- Power saver circuit.

When are ICOM going to produce a dual band handportable? This has been the most asked question about new ICOM products for a long time. The IC-32E is the answer.

This exciting new handportable offers full cross-band duplex operation, and with a built-in duplexer allows single antenna operation. 3 Watt output is standard but with the BP7 high power nicad pack or external 13.8v, 5 Watts can be achieved on both bands. The IC-32E comes packed with features, such as the 20 memory channels which can store both a VHF and UHF frequency in one memory and also simplex duplex condition, offset direction and frequency.

There is a choice of five scanning functions, full programmed memory, memory band and priority. The die-cast frame gives a solid construction featuring rubber gaskets for splashproof operation. The IC-32E is supplied with VHF/UHF a dual band antenna, BP3 battery pack and wall charger.

**Icom (UK) Ltd.**

Dept AR , Sea Street, Herne Bay, Kent CT6 8LD. Tel: 0227 363859. 24 Hour.

Count on us!

# BAND.

## NEW! IC-3210E Dual Band FM Mobile



If you are newly licensed or just undecided about which band to operate first, then the new ICOM IC-3210 is just the answer. This dual band FM transceiver is ideally suited for the mobile operator. Transmit on one frequency and receive on the other and you're operating full duplex. It's just like talking on the telephone.

The simple and well laid-out front panel ensures quick and easy operation of all its many functions. A great convenience when driving. Optional accessories available are the UT40 tone squelch board, HS15 + SB mobile microphone and switch box, SP8 external speaker and PS45 AC power supply.

### Features:

- Full crossband duplex.
- 20 double-spaced memory channels.
- Built-in duplexer.
- 2 call channels.
- 4 priority watch functions.
- Programmed, memory and selected band memory scan.
- Variable LCD backlight intensity.
- Tone squelch and pocket beep functions (optional).
- 25 watts output.

**Helpline:** Telephone us free-of-charge on 0800 521145, Mon-Fri 09.00-13.00 and 14.00-17.30. This service is strictly for obtaining information about or ordering Icom equipment. We regret this cannot be used by dealers or for repair enquiries and parts orders, thank you.

**Datapost:** Despatch on same day whenever possible.

**Access & Barclaycard:** Telephone orders taken by our mail order dept, instant credit & interest-free H.P.



# SHORT WAVE LISTENER

TREVOR MORGAN GW40XB

In a recent letter, a reader asked why, when listening to a QSO in progress, he could hear one station quite clearly while the other station, although geographically closer to him, could not be heard at all. Of course, the second station could be using a beam aerial aimed away from the listener, or the stations could be using split frequency. This is where two VFOs are used by each station, tuned to enable the stations to transmit on one frequency and receive on another. Just to complicate matters, the frequencies can also be on different bands, which is known as crossband working.

However, nature has a part to play in this one way traffic and it would take far more room than we have here to explain it all. The subject is called propagation, a word bandied about on the air quite frequently so you have probably heard about it even if you don't know what it means.

The Oxford dictionary defines propagate as to '...extend the action or operation of, transmit, convey in some direction'. So, how are radio waves extended or conveyed? Well, we obviously don't want to get bogged down in technical jargon or masses of equations, so let's put it simply.

Firstly, above the earth are layers of particles of matter. Depending on the action of the sun, these particles become charged and reflect radio waves. When there is no solar activity, these layers allow radio waves to pass into space. There are four layers of particles known as the D, E, F1 and F2 layers and each affects radio waves of different frequencies.

Let's say a signal leaves a station using a G5RV aerial. The signal travels up to the ionosphere and, coming into contact with the layers, is reflected back to earth. The distance between the transmitting station and the receiving station is known generally as the skip distance. If the

transmitting station then changes aeriels to a triband vertical, the signal, being of low angle radiation, takes a different path and travels further than that from the G5RV (see Figure 1).

Now, our reader could live near station 'A' which would put him in the range of ground waves (direct contact) from the G5RV, but, when the station changed to the vertical and the signal went up at a high angle, our friend wouldn't hear him. However, the return signals from station 'B' would pass over him from a G5RV but he would hear the signals from a vertical. Get it? So, the poor bloke hasn't got a deaf receiver, just bad luck!

Propagation has other tricks up its sleeve. Ground waves are affected by what is known as sporadic E which occurs when layers of ionised 'clouds' are formed in the higher atmosphere, and signals from 28MHz upwards can be diverted from their normal course and travel great distances. There are other conditions that cause variations in radio wave propagation, but these are best covered in specialised articles. Suffice to say, that there is much to be learned about the subject and interested listeners are encouraged to seek more knowledge!

## RSGB anniversary

The Radio Society of Great Britain celebrated its 75th Anniversary this year and many of you have logged the special GB75 stations that have been around...and there are more still to come!

On 15th, 16th and 17th July a special rally was held at the NEC in Birmingham. It was officially opened by HRH Prince Philip, who is patron of the Society. At the invitation of the Society, I had the pleasure of being at the opening. During Prince Philip's speech, he welcomed the encouragement of young people into the hobby, something I have tried to do through this column.

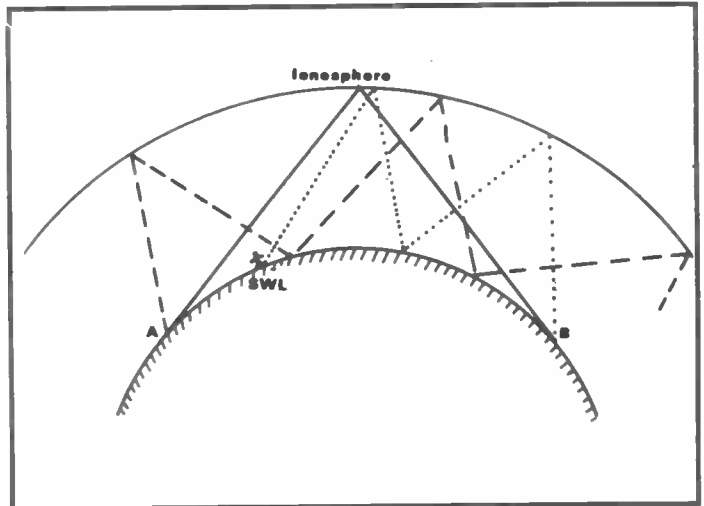

The rally itself was pretty well attended but, being split over three days, did not attract the large crowds one is used to seeing at weekend or one day events. There was plenty to see and there were quite a few receivers around, but with price tags like £89 for a Codar CR70A and £110 for an ancient Eddystone, it's no wonder youngsters think the hobby is expensive.

There has been a move by the manufacturers towards simple transceivers offering the basics for the licensed types. It would be nice to see a good quality receiver produced without the fancy lights and frills. Perhaps for something less than £1,000? At least, Sony are trying, but are they miniaturising too much? What do you think?

Personally, I had a very enjoyable weekend and was able to chat to some of the dealers who advertise in *Amrad* and get some of the latest information. It was also a pleasure to meet many readers of this column and writers of other columns in our magazine, George Dobbs, Don Field and Glen Ross, and chat about the hobby in general.

## Award winners

So, to our readers, and in particular, those who regularly search the bands for prefixes, and countries for our awards.

Firstly, to Peter Cardwell of Sheffield, who approached me at the NEC with a few sheets of computer paper containing his lists for the European, USSR, North American and South American Continental Awards. It was only after I shook his hand that he presented me with a massive file containing his log sheets for the 2000 prefixes necessary for the Premier Award! I'm not going to forget that in a hurry, mate! I'm not going to list the lot here, but there was a lot of choice stuff in the lists. Very well done, Peter!

It's nice to see Mike Ribton of Maidstone back in with the hunters again and I received his claim for the Silver Prefix award this time. AA200, CI8, CQ8, ED1, EX0, FV8, FJ0, H22, KB5CGA/HR2, IY8, J45, KC-200, TW6, TV7, VO7, WA200, YT22, ZF2 and 9Y4 featured in the lists. Mike has been hard at it with the soldering iron of late, making a filter for the Rx and also dabbling with a magnetic loop antenna. The loop seems to work fine and tunes nicely on 80, 40 and 20. He's taken the original design a stage further and has a smaller loop inside the big one at right angles to it. They are in the loft and operated remotely using a control box and 6V motors.

Steve Wilson G4ZGY, is an American, at present stationed in Lakenheath with the

USAF. Despite his duties, Steve found enough spare time to log some 500 prefixes for his Bronze and Silver awards. Among the loggings were 3A2, 5B4, 5H3, 6W6, 6Y5, 8P9, AA4, AB5, BV2, CJ1, DU7, FZ5, HH2, KC9, KZ2, T77, TV6, VK8, YB0, YT4 and ZP5. He is using the TS-430 for reception with a homebrew dipole cut for 20m which is usable on all bands via an ATU.

Darrell Jacobs of Reading is still in there, gnawing away like a mouse at a pantry door! His latest offerings being for the Bronze Prefix award for 10m only. Some nice stuff here, with 5S2, CO7, OD5, KV4, HZ2, TZ6, VP2, ZY5, J28 (QSO in French!), ZY1, 5W7, 9K2, CP1000SMG and CE45LN. A couple of nice QRP catches were LU6DHY (18W) and PP7BNY (8W). He also claimed the South American Continental award, also for 10m, and the European Continental.

Darrell now has a 71ft wire up, running north to south-south-west – put up with the aid of a brick! It proved itself during the All Asia Japan Contest when it pulled in YC4, TF3, JA2, LS1, YB8, JA3, YB0, HC2, D44, JA9, JH4, A3 and JA8, all on 20m, between getting those in for the 10m award.

Philip Davies of Market Drayton is also no stranger to the column and submitted his claim for the USSR Continental award. Phil has mentioned a number of contests he has logged, but one of the most interesting was the CQWW which was notable for weird band conditions and few openings to the States.

Top band offered OK6DX, 80m found FV8NDX, FJ0A and FY5ER; 40m found IY8UN and TW5E; 20m found H22H (Cyprus), 5U7 (Niger) and J45JG (Greece); 15m found SY0DX and TX0A (French Guyana); and 10m found ZP5, LR1V and LS1E (Argentina), PY5, PP2ZDD, CX4, CE3, CE4 and VP8!

By the Sunday, propagation was even weirder with AT0T (India), YM2KC (Turkey), loads of Africans, 5U7, 9L1, 5H3, C53, S0, TZ2, 9J0A and 5H1HK all on 10m. Twenty was also good to Africa with J28, EL2 and an unusual CS9CU in Madeira, and was also pulling in LS8E and YW5A from South America. And so ended the contest in a solar storm!

This just repeats what I said earlier about nature controlling propagation. Thanks for the reports, Phil.

Joan Slater RS90400, of Matlock, has been tuning 10m as well but says she's heard better and commented that all the signs are of an upward trend. North and South America are coming in well and some nice African states are being heard but nothing unusual to note. QRM levels have been high, but 15m has yielded a few nice ones with YV5DEI, J88AQ, CE6DFY, KL7Y, VE7DGE, YC0JWY and YC5ODQ.

### Special event stations

I had a very interesting letter from Roy Clayton G4SSH, of Scarborough, regarding the Scarborough Special Events Group. This group aims to publicise major events in the area by operating special event stations.

Their most recent event was the 50th Anniversary of the setting up of the world speed record for a steam train by the locomotive *Mallard*. The station, GB75MAL, was very successful and special attention was given to SWLs, giving full QSL information.

In his letter, Roy made some observations regarding SWL reports that are worth mentioning here:

1. SWLs should double check the date/time/frequency. Some cards were received giving the day of the week only, BST for the time and USB for the mode (in fact, the station was only on LSB).
2. More than one report gave a SINPO report. The correct amateur report code is RST (readability, strength and, for CW, tone).
3. Always mention a specific station being worked by the event, preferably a couple.
4. Always print your name. Some signatures are unreadable.
5. Save money by using second class stamps. Cards take a few days to sort anyway so another day isn't going to matter.
6. Always send a stamped addressed envelope. The costs of special event stations are met by the operators.
7. Comments on the station and its operation are appreciated by the operators.

These comments match my own feelings and, having operated from many such stations myself, I reinforce the last item. After a heavy weekend struggling with the crowds on 80m and the DX on 20m, it's nice to hear that someone out there actually enjoyed hearing the station.



Incidentally, be honest with your reports *please!* Multiple 59 reports might look fine in the log but don't tell the operators anything about conditions or how well the signals were being received.

A month or so ago, I heard station K1MAN on 14275. The station was run by the International Amateur Radio Network and the programme contained much of interest to listeners including propagation reports, advice on aerials, radio interference and other matters. I sent a report to the station and received a very interesting reply.

The primary purpose of the IARN is to handle emergency, medical, health and welfare traffic. The secondary goal is to provide the radio public with services which enhance the radio operators' knowledge and use of the radio spectrum. Included in the programme is the 'Westlink Report', the 'RP Report', IARN interviews, editorials, SWL reports and other news relating to the use or development of the radio spectrum.

The basis and outline of the Network is typically American and very professionally organised. Teams of helpers, including surgeons, paramedics and liaison staff are on standby. During the San Salvador earthquakes last year, they organised the donation of over 600 pints of blood by radio hams and other volunteers, and the shipment of \$200,000 worth of medical equipment and supplies to the capital. More recently, they were able to help CBS to get information from Russia following the Chernobyl disaster.

In only two years, the IARN has grown to over 600 members in forty countries. Its headquarters are based in the middle of Great Pond, Maine, under the control of Glenn

Baxter K1MAN, and his team.

The station can be heard on 3.975, 14.275 and 28.475 at 1400, 1800, 2200, 0100 and 0500GMT (April to September, one hour earlier). The programme consists of 45 minutes of amateur programming followed by IARN co-ordinated nets.

Derby and District ARS announced the results of its 144-145MHz contest which was held in March. Full details are available from the DDARS (G3ERD, QTHR). The winner of the full legal power section was G6HKM and the 30W maximum section was won by G1NUS/P.

### Rallies

We have three rallies to mention this month. The South Bristol ARC has its rally on September 18th. The venue is the Brunel Great Train Shed at Temple Meads station. Something for the railway buffs here, I reckon. I will be at this one with the ILA stand so pop over for a chat. Further details from G4WUB.

The Telford ARRAG will be holding its annual rally on September 4th at the Telford Exhibition Centre. Always a good rally, so well worth the trip. Details from G8ARS.

The Scottish Amateur Radio Convention will be held at the Aberdeen Exhibition Centre. The area is the size of a football pitch so there should be plenty of room! The date is September 17th, so make a note in the diary.

It has always struck me that there are, perhaps, too many local club rallies during the year. Don't get me wrong, the clubs do an excellent job and rallies are, generally, well attended. But, and it's only a thought, wouldn't it be even better to have regional rallies, where the resources of a number of clubs could be pooled to put on really good two day events at first class venues?

# The Ten Tec Argosy II Transceiver



## A User Report by Ian Poole G3YWX

Ten Tec is a company which has built up a very good reputation over the years. This is particularly true of their QRP equipment where many of their older designs are sought out by enthusiasts today.

Another company which has developed and maintained a good reputation over the years is KW Communications. Some years ago, the two companies linked up to market Ten Tec equipment in the UK, where the Japanese seem to have totally dominated the market. Initially, transceivers like the Argonaut and Omni-D were offered but now they have been superseded by the Century 22, Argosy II and the Corsair II. As well as all these there is the latest addition to the range which is the Paragon. Unlike many of the Japanese products, these transceivers appear to have been designed by concentrating on the basic performance and not on unnecessary frills and gadgets which seem to have become a part of amateur radio these days.

Of the range of transceivers from Ten Tec and KW, the Argosy II falls approximately in the middle of the range. It is an HF transceiver offering both SSB and CW with an output up to 50W. There is also a low power position which makes it ideal for QRP enthusiasts.

Originally, the transceiver was successfully launched about seven years ago, however it only had an analogue readout. Now the upgraded version, Argosy II, includes a digital readout together with some modifications.

### The specification

The Argosy offers a fairly straightforward specification. There are no unnecessary bells and whistles to make it more difficult to use, adding to the chance of it going wrong. However, there is still quite a lot of circuitry inside it. This is borne out by the number of semi-conductors. In total there are 48 transistors, 4 FETs, 18 ICs (including a processor to drive the display) and 58 diodes of which 4 are PIN diodes.

The transceiver covers most of the HF

bands. The actual ranges are: 3.5-4.0; 7.0-7.5; 10.0-10.5; 14.0-14.5; 21.0-21.5; 28.0-28.5; 28.5-29.0; 29.0-29.5 and 29.5-30.0. On each of these ranges there is a slight overrun of approximately 40kHz allowing signals just outside those ranges to be heard.

The frequency readout is by means of four 3in LED displays. These give an indication of the frequency down to 100Hz but do not show the MHz, as this is assumed from the band switch. This frequency meter is accurate to  $\pm 100$ Hz which is quite sufficient for normal sideband or CW operation.

The power requirements are 12 to 14V dc. On receive the current drawn is around 500mA but this rises to 9 amps when running full power on transmit.

The construction makes the unit fairly robust. The chassis is made of steel and has a moulded front panel. The top and bottom covers, together with the rear panel, are all made of aluminium. The use of aluminium panels and covers as well as the moulded front panel, all help to keep the weight down to eight pounds. It is also quite compact measuring 4in x 9.5in x 12in (HWD) and with its colour scheme it looks very attractive.

Another important factor is the frequency stability. Being of American origin, this is quoted in  $^{\circ}$ F as 20Hz charge for a  $1^{\circ}$ F charge after a 30 minute warm up. Whilst looking at the VFO it is worth noting that it is in fact a permeability tuned oscillator which has a very low phase noise, unlike most synthesizer controlled rigs. This is of particular advantage when searching out weak signals on bands where there are strong signals.

### Transmitter

On the transmit side, the Argosy can deliver 40-50W of RF on all bands for a dc input of 100W, provided that the PA is correctly loaded into 50 ohms. It can also maintain a duty cycle of 100% for up to 20 minutes. Although this is unlikely to be performed under normal amateur use, it does prove the heatsinking and conservative rating of the output stage. This is very reassuring, as it all adds to the

reliability of the transceiver.

On CW there is full break-in. This is achieved by using PIN diode transmit receive switching. As a result, there are no annoying relay noises in the background. It also means that the switching is virtually instantaneous—a fact which is not always so on other transceivers. Often when VOX circuits are pressed into service to give some form of break-in, there is a short delay before the relay switches over. This can sometimes noticeably affect the first dot or dash.

For use on CW there is a sidetone which can be adjusted by setting two preset potentiometers accessed through the side of the top panel. By using these two controls, both the level and pitch of the tone can be adjusted. Sideband transmit receive switching is accomplished by using the PTT on the microphone. Also of interest, is that the microphone input presents a high impedance and will be suitable for most microphones.

### The receiver

In terms of the receiver, it is quite sensitive. The specification quotes a sensitivity of 0.3V for a 10dB S+N/N ratio and this is more than adequate for HF operation.

The audio output is quite reasonable, giving 1W into 8 ohms. Normally, an internal speaker mounted on the bottom cover is used but it is possible to use an external one if this is required.

The selectivity of the receiver is obviously important. This is governed by the crystal filter. Normally, a 4 pole filter giving a 2.5kHz bandwidth and a 2.7:1 shape factor is fitted. However, it is possible to purchase an 8 pole filter which gives a worthwhile improvement. As this filter is also used in generating the transmitted signal, it will also give an improvement on transmit as well. There is also provision for an extra crystal filter for CW which can be switched in from the front panel. In addition, there is an audio filter. Although this was originally an option it is now fitted as standard by KW Communications. It has two positions.

The first gives a 450Hz bandwidth (at -10dB) whilst the second is for use under worse conditions and gives a bandwidth of 150Hz. In addition to all of this there is a notch filter which is capable of giving 50dB rejection between 200Hz and 3.5kHz.

### Options and extras

From the outset, it was Ten Tec's aim to provide a basic transceiver at a competitive price with various optional extras, to be purchased with the rig, or at a later date. All of them are easy to fit, usually just involving plug-in assemblies.

The crystal filters which have already been mentioned are probably the most important. The existing 4 pole filter, whilst adequate for some applications, does show its limitations when there is a lot of QRM about. Two replacement filters are available. One has a bandwidth of 1.8kHz whilst the other is 2.4kHz. Both of these filters are 8 pole varieties and have a much better shape factor than the standard 4 pole filter. One further advantage of fitting the improved filter is that it is used not only in the receive path, but also as part of the sideband generator. This means that it will also improve the transmitted signal as well.

A CW crystal filter is another option. Again there is a choice of two. Both are 8 pole filters, but one has a 250Hz bandwidth, whilst the other has a 500Hz bandwidth. The choice is very much a matter of personal preference but either would give a great improvement in trying to copy CW under adverse conditions.

Replacement or installation of both of these filters is very easy. It is simply a matter of unplugging the old filter in the case of the sideband filter and plugging in the new one. The positions are well marked on the board, so this should not create any problems.

There is also a companion power supply for the Argosy. It gives the full 9 amps required by the set and incorporates both overvoltage and overcurrent protection. The overcurrent protection is of particular importance as it not only protects the PSU itself but also the set. This is because badly matched aerials can cause the PA transistors to draw too much current. If this happens, the current trip in the supply prevents damage occurring to them.

In view of this, if the Argosy is used from a different supply, or from a battery, a circuit breaker can be utilised. The manufacturers recommend their 10 amp breaker, because the current limit on a different power supply is unlikely to be set exactly right and a battery will obviously have no limit at all!

A noise blanker is another option. This operates at the intermediate frequency of 9MHz. Normally, the IF noise blankers are much better than the AF ones which seem to have little or no effect.

### Front panel

Although the front panel may appear to be fairly small from its measurements, it did not give an impression of being cramped whilst it was operated. In fact, all the controls are neatly arranged and with adequate access. Only the push

button switches appeared to be small and even these are well spaced so that there is no possibility of operating two at the same time.

The panel is dominated by the main tuning dial with its digital readout. The dial itself is on a slow motion drive so that it gives about 18kHz per revolution whilst its calibrated skirt gives 100kHz.

At the top left hand side of the panel is the mode switch. This has four positions: sideband reverse, sideband normal, CW and lock. The correct sideband for the band in use is chosen by the way the VFO is mixed with its crystal oscillator and then with the sideband signal.

The normal and reverse sidebands are chosen by placing the carrier at one side of the crystal filter. The carrier position is also changed in the CW position. This means that there is a small discrepancy between the actual frequency and the digital readout in the sideband reverse and CW positions. It is 750Hz on CW and 3kHz on sideband reverse, however, it is quite small and should not cause any real problems.

Below the mode switch are the FWD/REV power switches for use with the meter on transmit, the Noise Breaker and Display on/off. Although the display may be required all the time for fixed station use, it can be advantageous to save the 300mA used by the display if batteries are being used.

Underneath the switches are the microphone and headphone jacks. Both of these are standard 1/4in jack sockets. The headphone output is taken directly from the speaker output, so it may be advisable to fit a small attenuator if low impedance phones are to be used.

Near the meter is the ALC LED which

lights up when full power is reached. This enables the drive to be adjusted correctly. Insufficient drive will obviously result in low output, whilst too much can cause distortion on SSB or destroy the keying characteristics on CW.

At the bottom of the panel are four more controls. The first is labelled 'Offset' and is for incremental receiver tuning and gives just over 3kHz swing each way. Next to it is the notch control. The setting was rather critical if the unwanted signal was to be notched out, however, with a little practice, it becomes very useful. Below these controls are the drive and AF output.

Finally, at the bottom of this side of the panel are the various selectivity controls. The first is the xtal in/out switch for the CW crystal filter. If no filter is fitted, turning the switch on will remove the signals. The other two switches are used to select the AF filter and its bandwidth.

### Rear panel

The rear panel is dominated by the PA heatsink which is in the centre. Either side of this are various sockets, terminals and controls.

The High/Low power switch is located at the top left hand side of the panel (looking from the back). Even though it is not on the front panel, it is still reasonably accessible. In the high power position the full 40 to 50W is attainable, however, in the low power position the power is limited to 5W. This is accomplished by switching the setting of the ALC so that the power is limited to 5W whilst still using the main power amplifier.

Underneath this switch is the antenna corrector. This is a standard 50 ohm

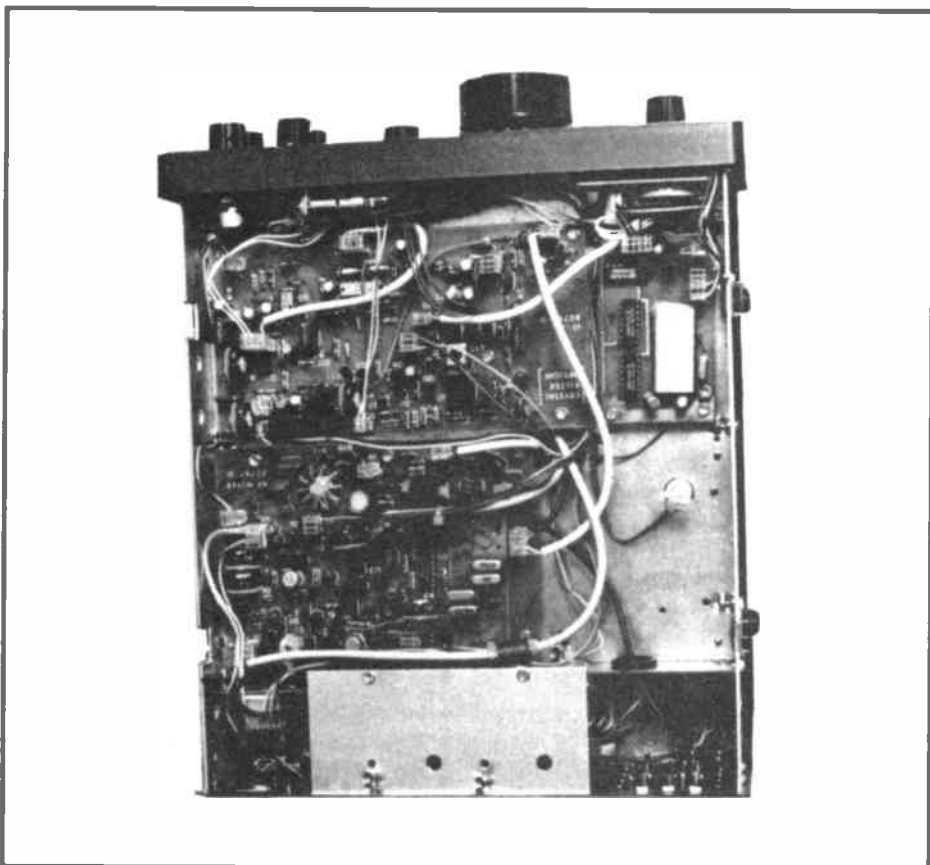

Interior view of the Ten Tec Argosy II



SO239. As with all transistor PAs, it is necessary to present a good match at the output. Accordingly, it is a very wise precaution to use an ATU to ensure that the aerial system is properly matched. Not only will this ensure that the system is operating at maximum efficiency, but it will also prevent the output transistors from drawing too much current.

On the top right hand side of the panel are six phono sockets. Two of them provide a source of 12V to supply external units like keyers or speech processors, whilst a third is the key socket. The three remaining ones are spares which may be used for any enhancements or modifications.

At the bottom of the panel is the grounding terminal and power connector. This connector not only carries the power into the Argosy, but it also carries the live side of the mains if the companion PSU is used. This is done so that the AF Power control can be used to switch the unit on and off.

### Inside

By simply removing four screws, the top panel can be taken off. A further four screws allow the bottom panel to be removed just as easily. A little care has to be taken as the speaker and its associated leads are attached to the bottom cover.

Once the covers are removed most of the boards are in view and easy to get at. Only the PA and filter boards are located right at the back of the unit because of the heatsink and screening. The VFO is housed in a separately screened box, but even this is easy to reveal if necessary.

The standard of construction seems to be quite acceptable. The components appeared to be of a good quality which should mean that the rig should give trouble-free service.

### On the bands

When using any new piece of equipment first impressions count for a lot. In the case of the Argosy it felt very easy to use. The uncluttered panel was a definite advantage and all the controls were quite accessible. The only point which did feel a little odd at first, was the absence of an RF gain control. This was only because most HF receivers and transceivers seem to have one. Certainly, the operation of the rig did not seem to suffer because of the lack of it. In any case, it would only have added another control.

Another point which very quickly came to light was the superb break-in (QSK) facility on CW. Having no relays, the rig jumps in and out of transmit with no problems at all. In fact, it is possible to listen between dots (and dashes) at whatever speed you want. It is obvious that a lot of work has been put into the design of the break-in circuitry and there is no doubt that it has paid off.

When using sideband the transmit/receive circuitry is good as well. Changing from receive to transmit and vice versa, there is not a big 'plop' as the circuits change over. This gave a very nice feel to the rig.

The reports of audio quality on trans-

mit were very favourable. However, as there is no processing, apart from the ALC, a good speech processor could be considered at a later date. In fact, tests with a Datong ASP showed that an appreciable amount of gain could be achieved.

The heatsinking on the transmitter appeared to be very good. Even after extended periods of operation on both CW and sideband, the rig appeared to run quite cool.

The receiver performed well. The bandspread on the tuning was just about right. It was nice and easy to tune-in sideband and CW stations, whilst it did not take too long to tune from one end of the band to another.

With the original 4 pole filter in place the selectivity was fair. However, this was only to be expected, and the 8 pole filter was good. In the wider of the two positions it could be used on sideband in some circumstances. Whilst using the narrow position, CW signals could be pulled out of the QRM quite easily.

While tuning around the bands, some spurious signals (internally generated) were noted. The worst one is actually mentioned in the Argosy specification and it occurs at 28.980MHz at about S5. However, it can be overcome by tuning to the bottom end of the 29.0 to 29.5MHz band. All the other spurious signals were below S1 on the meter and would not have caused problems under normal operating conditions.

The stability of the rig was good. Although having a variable frequency oscillator and not a synthesizer, some drift has to be expected. Even so, this would not be noticed if the rig was given a quarter of an hour or so to stabilise. Measurements indicated that it drifted by only 200Hz in the first fifteen minutes. After this, it reduced quite considerably and was certainly not noticeable during normal operations.

The Argosy has done well operating on the bands. Contacts have been made all over the globe on SSB and CW using only poor wire aerials at very modest heights. Despite this, reports of 59 or 599 have frequently been obtained from the States. Furthermore, the audio quality has been commented on very favourably from many sources.

### Servicing and repairs

Ease of service and maintenance is one point which is very important. Although Ten Tec equipment appears to be reliable, from the reports I have heard, there may be a time when re-alignment or repair is necessary.

This can either be done at home, or it can be sent back to KW Communication's service department at Chatham. If the home approach is adopted, then the manual will obviously be very important. In fact, the one supplied with the Argosy was generally very good. It gave a description of the rig, operating instructions and then the service or maintenance details. A block diagram of the whole unit is given and this is followed by circuit diagrams and descriptions of each board. It also gives the set up procedures if re-alignment is ever required. This means that someone with access to the right equipment should be able to maintain the rig without any real difficulty.

In addition, if any components do fail it should be possible to obtain them from a number of sources. This is better than having to rely on just a single importer who may not stock spares after a few years. Having said this, KW still stock many spares for their old valve designs and will undoubtedly stock spares for Ten Tec equipment for many years.

Failing the DIY approach, KW are able to service them. In the past, my experience with them has been very good. Not only have they given friendly help over the telephone, but reports of their customer and repair service have been very good. This is one factor which should be borne in mind when buying any piece of equipment.

### Summary

The Argosy is a very nice piece of equipment. It is easy to use and has many features which would make it appeal to the serious radio amateur. It currently costs just under £600, although the price does vary according to the exchange rate. The power supply is also available at just over £100 and extra crystal filters are about £50.

My thanks go to KW Communications for their help in answering questions and for supplying the Argosy itself.

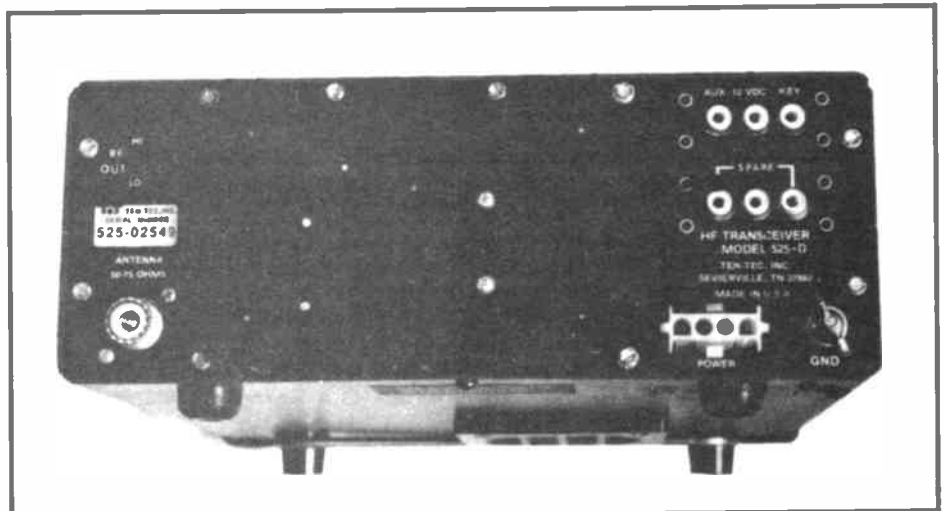

Rear panel

# PROJECT

# BOOK

by Martin Williams

In various issues over the last year I have described filters for audio frequency use and also RF types for use at 144 and 432MHz. There has been a high response to these articles and most people have said they have not become involved with filters, mainly because the maths is a little off putting. It has become obvious that simply built designs using kitchen table techniques that work, are in great demand.

### 1296 filter

This is a band where a good filter really provides useful improvements in performance. There are two main reasons for this. Firstly, most people use a pre-amp for this band and most of these have very little selectivity. Due to this, out of band signals are also amplified and sent to the receive converter where, if they are strong enough, they develop cross-mod problems or, at best, have unwanted signals breaking through.

The second reason is due to excessive bandwidth in the receive converter, so it is possible to hear the noise produced by the pre-amp at the image frequency. If the selectivity is tightened up, the background noise can be reduced by half, with a consequent improvement in weak signal performance. So, less noise, less spurious responses, equals better performance.

### Construction

Filters for the lower frequencies, are normally of the quarter wave type but on 1296 this would involve somewhat miniaturised construction. An alterna-

tive, is the half wave type, with elements twice the length of the quarter wave unit. This is the type shown in the mechanical drawings.

The filter is built on the lid of a small diecast box (about 4x1x1in). The sockets may be N or BNC types, according to your system requirements and are mounted close to the ends of the lid. Fit a solder tag to both fixing bolts at the outer edges of the sockets.

### Capacitor

The tuning capacitor is mounted centrally between the two sockets and is a DIY job. You will need a trimmer with a tubular body with an adjustment screw running into it; the value is unimportant. Break the ceramic or glass body away from the trimmer so that you are left with the mounting and tuning screw. Next, carefully solder a 2BA washer to the end of the screw ensuring it is at right angles to the screw. File away any excess solder to leave a flat surface.

### The line

More ingenuity is called for here. The line can be made from a piece of welding rod or perhaps a length of 6BA threaded rod, or some similar material. Whatever you use, ensure it will take solder. It should be formed into the shape shown in the diagram, with the legs made to such a length as to position the rod into the centre of the box when the unit is assembled.

Solder the legs to the solder tags and make sure the tag fitting bolts are securely tightened. At the centre point

file a flat surface and solder on a 2BA washer to make the other plate of the tuning capacitor. To ensure these are positioned opposite each other and are parallel, place a small piece of non-solderable material between them and resolder both washers while they are under slight pressure. Finally, make connections from the two centre pins of the sockets to the line using tinned copper wire. The diagrams should make all this clear.

### Use

Fit the lid to the box and screw the fixing screws down tightly. Connect the unit in the aerial lead to the converter or transverter and tune to the strong signal in the part of the band you normally use. Now adjust the tuning screw for the best S meter reading to finish the job. If built well, the insertion loss will be about 0.2dB. The unit has been tested with 10W

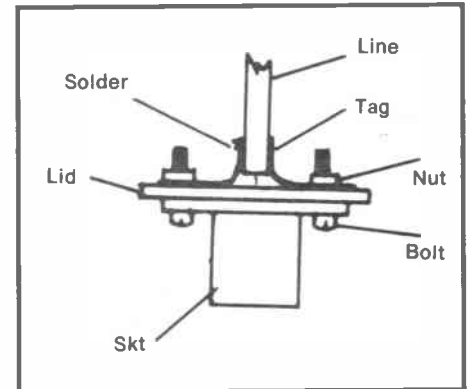

Detail of line mounting

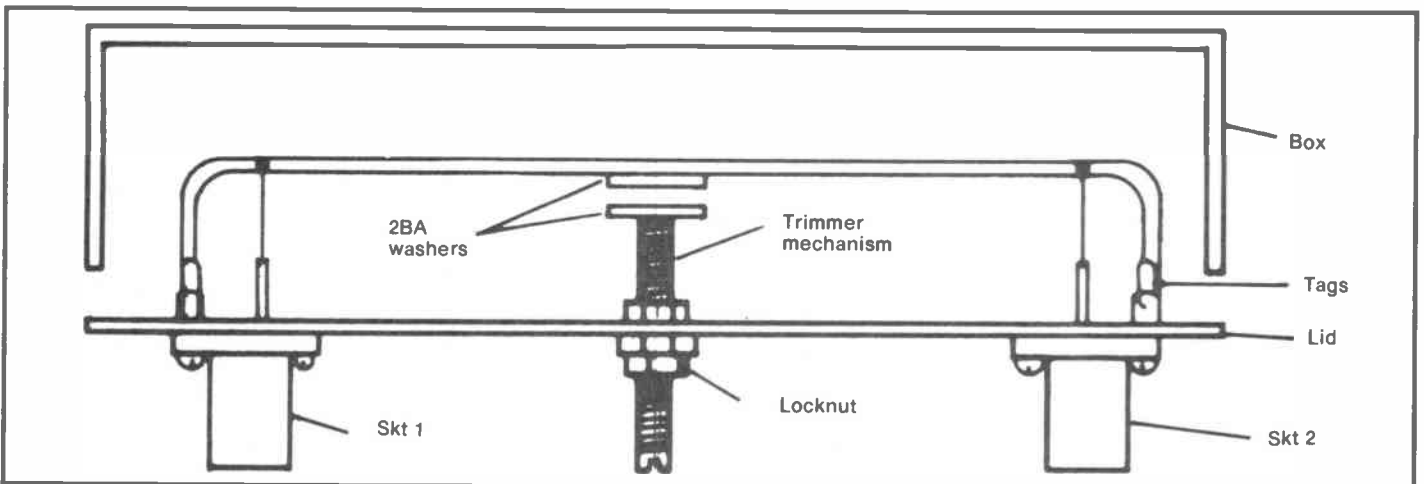

# MOSTLY MORSE

by Peter Wood

Stories about people taking the Morse exam are legendary. Sometimes they are offered by way of encouragement; sometimes they are told to tantalize and taunt those lesser mortals yet to cross the Rubicon. These tales often feature aloof, austere examiners whilst others tell of kindly, avuncular characters, keen to create conditions which enable candidates to give their best. To the person considering or on the point of taking their Morse exam, these stories are no help at all.

Like many other forms of human activity, the process of learning Morse is an individual one. There are, however, some common themes and knowing about them can reduce the feeling of isolation in 'getting there'. Few of us can resist the temptation to offer advice. What follows is not so much advice, more an account of a journey through the process, incorporating the advice and experience of others along the way.

I was delighted and surprised to pass the Radio Amateur's Exam in May 1986. Although I applied for a 'B' Licence immediately, it had always been my ambition to take the Morse exam and 'work the world'.

## The Basics

My first step was to buy a copy of the Radio Society of Great Britain's booklet *The Morse Code for Radio Amateurs*. This sets out a systematic approach to learning first the alphabet and then figures, with test passages for practice and working up speed. I also booked in for a 20 week course of Morse classes at my local radio club, the Southdown Amateur Radio Society at Hailsham, starting in the Autumn.

The Morse Code Examination is now conducted by the RSGB in various test centres throughout the country. On application, they will send you details of your nearest centre with test dates and the deadlines for making an application, normally one month ahead. There is a test fee.

A pass in the exam requires that an operator achieve a speed of twelve words a minute. Thirty-six words of plain language are sent in three minutes by the examiner, during which time a maximum of four receiving errors are permitted by the candidate. This is followed by ten groups of five figures sent in one and a half minutes, in which two receiving errors are permitted.

Then it's your turn to send the plain language at the required speed. You are permitted four corrections but no uncorrected errors. Similarly with the figures, there must be no uncorrected errors, although two corrections are allowed. No punctuation is required and if you pass the exam, the pass is valid for life.

Before the Morse classes began, I bought a computer Morse Tutor program for use with my Spectrum Plus. It provided the opportunity to program and listen to variable speed Morse, although personally I found it a bit soulless!

## Sorting the dits from the dahs

Let me say that I had never tried to learn Morse before. However, I discovered that I had two unexpected advantages. Firstly, I had spent seven years in a church choir as a lad and secondly, I was living just half an hour from my office base. So what you ask? Well, having a bit of a musical ear, or more importantly, a sense of rhythm, seemed to help. I still experienced the classic problems of being unable to establish a rhythm for certain characters, notably the letter 'C' and the number '3'. A good tip was to associate the rhythm of a character with a well known phrase; 'God Save the Queen' translates very nicely into the letter 'Q' (dah-dah-dit-dah). You won't need to do this for all letters as many are easy to absorb. You can invent your own phrases to deal with the more troublesome ones. Certain rhythms stick in our minds for different reasons. I can recall how, as a boy, the ticking of top gear on my bike's 3-speed Sturmey Archer gears sounded like a passage from a Beethoven symphony, frequently played by my father on his gramophone!

So how did living half an hour from my office help? It gave me the opportunity to listen to Morse on a comparatively uninterrupted basis for up to an hour a day. First I hired the radio club's Datong Morse Tutor. This generates random Morse characters and numbers at varying speeds and spacings. Later, it can be used as an oscillator in conjunction with a Morse key when you are reasonably competent at copying. Others warned that I should not become too dependent on this machine as I might find difficulty in adapting to the human stuff.

I took to recording the Morse lessons on a portable cassette player and playing the tapes in the car. One such lesson came with me on a rapid trip to Scotland and back. My classmates were surprised to learn the following week that they accompanied me over Shap Fell the previous weekend!

Useful too, were practice tapes made by a fellow amateur and another produced professionally, starting from around 6 words per minute to beyond test speed (with in one case a 'fun' piece of 16wpm!). Listening to Morse this way over eight months was a great 'boon' and is available to those who travel to work by bus or train using the ubiquitous personal stereo cassette player!

Heeding the advice I was given, I

waited before buying a Morse key until I had hauled in all the characters and my speed of receiving had begun to rise, albeit slowly. I built an oscillator kit for practice purposes. Circuit diagrams for these abound but I built the CM Howes ST2 Side Tone or Practice Oscillator kit.

If anything, I think I took up sending a bit late in the day. There was little or no sending practice in my Morse classes and I realised that sending numbers was my weakness, although I could receive them without difficulty. It is a very individual matter as to when you should start each stage of learning Morse and it is by no means a smooth process.

It was suggested that I should listen to Morse over the air at an early stage. This I did mainly on 80m but found much of it buried in noise, too fast or frankly some of it pretty ropy stuff! The situation improved after I built two filters and realised what life could be like on 80m!

The first Morse I copied satisfactorily over the air was 'OK Buenos Noches' which I cut out from my notepad and attached to my Morse booklet as a keepsake. This happened some three months after I had begun studying and I was still hoping to sit the spring exam. At about the same time, I sent my first Morse over the air on 2m. It was as nerve-racking as my first contact, not many months previously. The recipients of my efforts coughed politely and suggested that I had some polishing up to do! This kind of feedback was both painful and valuable. In the early stages, it is extremely difficult to judge fairly the standard of your own Morse.

## Practice makes perfect?

It was helpful to listen to the regular weekly slow Morse put out on behalf of the RSGB. I listened on 2m - three quarters of an hour of intensive but enjoyable work with the opportunity to call in and report one's progress.

To give fresh impetus to my practice, I decided to book my test. This left me with three months to work up my speed; the period I had underestimated in my original calculations about when I might sit the exam.

I realised at this stage that I had constructed a variety of ways of learning Morse. Different methods suited me at different stages. Facing my classmates in the early days without having done *some* practice seemed unthinkable. I was encouraged by my progress there. Possibly to the annoyance of others I found that I was actually enjoying Morse!

There were the inevitable periods I had been warned about when I seemed to be making no progress at all despite the daily listening sessions in the car. Replaying earlier tapes of the Morse classes, enabled me to gauge my progress and scorn with satisfaction my earlier and much slower speeds!

A curious thing was beginning to happen to me. Although I had consciously been translating adverts, car numbers and sign boards into Morse, I was finding it was happening without my trying! Reading papers at work would often give rise to a string of unpremeditated Morse in my head!

I rattled away on the key at home but as the exam approached I needed another shove. It was then that I had the good fortune to link up with John, G1UQS, in Eastbourne. He was also keen to sit his exam and we met on the air several times a week for the remainder of the time I had available.

There was always the risk that our own poor copying or sending would be interpreted as the other man's problem. Occasionally, experienced operators would join us and offer helpful criticism. Between us, John and I developed an entire repertoire of excuses for poor operating, for example, a knock at the door, car interference, children calling from their beds for a drink, fatigue. You name it, we had the excuse!

I would not particularly recommend Morse practice into the early hours or for long periods but I knew I had to keep going. On the odd day I missed for some reason, I always returned to Morse refreshed, which underlined other advice I'd had about taking periods off if long learning plateaux were encountered.

The test date drew nearer. My tendency to 'nerves' on the air was not, I was alarmed to find, diminishing very much. Practising alone, my Morse began to sound competent and speedy (well I thought so!) but over the air I could be tense and jittery. I battled and John suffered, endeavouring to lift the real-'dits' from the unintentional ones. I tried different gap settings on the key, different chair and key heights and breathing deeply. Practice was the real key if you'll pardon the pun!

### Examination Day

The day of the exam arrived. I had decided not to practise the previous day reckoning on my 'keep fresh' theory. I want to bed reasonably early and had a fairly leisurely start to the morning. My children drew me a couple of cartoon characters and insisted that I take them with me for good luck. As I left the house, I accidentally kicked the milk bottles off the step, shattering one. Was this an omen?

I took my VHF transceiver in the car with me and listened to others making their way to the rally at *HMS Mercury* in Hampshire. They were going to have fun whereas I was going to the Horsham Test Centre! Three members of the local radio club called up to wish me good luck, which was most thoughtful and encouraging. During the journey, a storm broke overhead; was this another omen?

Part of my strategy had included telling the world and his aunt that I was taking the exam. How could I fail and face them all afterwards? I even mentioned it during a local radio interview the previous week, on an item about the 20th anniversary of the Southdown Amateur Radio Society!

Having found the Test Centre in good time from directions sent by the RSGB, I took a walk up the High Street. I bought a Sunday newspaper for something to read and wondered how I would feel in an hour's time when it was all over. Right now, the priority was to find a toilet, so I

walked briskly back to the Centre!

The welcome was friendly but low key. Some 29 candidates were due to pass through the Test Centre during the day until 2030 that evening. The pass rate for the Centre was pinned on the wall. I wasn't too sure how I felt about that!

Eventually, three of us were called in together to sit the receiving part of the exam. The two examiners invited us to make ourselves comfortable, sign a form and confirm our identities. I used a passport for this but other legal documents carrying your name, photograph and signature, are equally acceptable, the idea being to minimise opportunities for people to recruit an understudy!

There was a short period of practice to help us tune our ears (headphones were on offer). First, there was the plain text and then the numbers; again after a brief break and further practice. One of my fantasies was that the 12wpm I had always been told I was listening to was secretly faster than necessary, so that on the day I would find the real speed much easier. As it was, it seemed very comfortable. Apart from one letter, I felt confident about the way things were going. At the end we all signed our test papers. I was then asked to stay behind to do the sending part of the exam.

For reasons that are not entirely rational, I didn't take my own Morse key, which is an option open to all candidates. I rather like experimenting with other keys and somehow I thought this would help. As there was a choice of keys, I picked the friendliest looking one! I sent a practice piece of fairly fluent text and announced that I was ready.

Half way through, I began to get the 'shakes'. Things got so bad that I had to stop and explain my problem. The examiners were most sympathetic and I was eventually offered a much larger, more substantial key, which was adjusted for a larger gap. The clatter from this key almost drowned out the sound of the oscillator and despite the circumstances, the situation struck me as rather funny at the time!

I eventually completed the characters and tried to relax. I thought how near and yet how far I was from those coveted HF bands. This made me feel even more shaky as I practised a sequence of numbers. One of the examiners invited me to continue, but by this time I was rapidly deteriorating into a jibbering heap. My arm seemed uncontrollable and I started to become rather despondent. At last I finished and, after some polite conversation I left the room. I spoke briefly to another candidate who had attended the same Morse classes but my mind was so numb that I wished him good luck and left the Test Centre.

As I drove home I was convinced I had blown it. I cursed myself for at least half an hour and couldn't bring myself to switch on the radio that had given me so much enjoyment for nearly a year. At home, I shared my depression with my family and later in the afternoon we visited some friends, one of whom is a licensed amateur. The advice he gave helped to put the experience into some sort of perspective.

### Had I passed or failed?

In the week that followed, I was inclined to be less hard on myself, but no less pessimistic about the outcome. I told everyone that I had messed it up and postponed thoughts of HF. I began to plan my strategy for retaking the exam as soon as possible, just to prove that I could do it. I went to the radio club one evening and with just a touch of drama, I reeled off the clearest and most satisfactory Morse so far!

During the week two cruel tricks were played on me.

First came a letter from the RSGB. It turned out to be a membership renewal notice! Another official letter from the Radio Amateur Licensing Unit (had they heard?) notified me that my 'B' licence was due for renewal. How could they do this to me? I sent off the money, confident that I would not be applying for an 'A' licence in the near future.

Then *the* letter arrived. Ironically, I was practising some early morning Morse when it dropped on the mat. I opened the letter to see which sort of application form had been enclosed – one for an 'A' licence or one to resit the Morse exam? To my utter astonishment, it was a form to apply for the full licence. It could still be a mistake so I looked at the Pass/Fail sheet. I had passed! The report showed that I had only made one error in receiving text and none in the figures. There had been one recorded error in my sending of text and two in the numbers section. Only two? My delight was mixed with disbelief. I re-checked the letter. Yes, I had really passed!

On the way to work, I called upon 2m to my Morse Mate, John, to give him the news. His congratulations helped reinforce the fact that I had actually passed the exam. During the day, I told a few others who seemed just as pleased. Ordinary mortals thought I was just in an extra-good mood, although fellow amateurs knew why I was so ecstatic. Was it all really 'just a hobby'?

### Satisfaction

My first two years of amateur radio have been full of 'firsts' of one kind or another and there are undoubtedly more to come. How they will compare with receiving the results of the RAE and the Morse exam I can only guess. The satisfaction from these two events alone has been enormous.

I owe my success to the encouragement, generosity and advice of a number of radio amateurs, not least to my Morse tutor, Dave, G0DMT and John, G1UQS, whose particular forbearance during live Morse practice over the air was greatly appreciated. My thanks are also due to my long-suffering family who were so encouraging when I thought I had failed. I'd like to think I'll maintain my interest in Morse. When sent well, it's an eminently satisfying method of communication.

Morse most certainly isn't a 'doddle' but I hope that my experience shows what can be achieved in months rather than years, as some of the more gloomy raconteurs will have you believe. Good Luck!

# DATA SHEET

by Ian Poole G3YWX

The 555 timer IC has been around for some time. Even so it is still widely used as a cheap and very versatile chip capable of being built into many amateur projects. It can be used in a variety of ways, as a timer, delay or oscillator. This versatility has made the 555 one of the industry standards which will be used well into the future by hobbyists and professionals alike.

## About the IC

The 555 comes in a number of packages. The basic IC is available in either an 8 pin DIL or TO5 package with the pin configurations shown in *Figure 1*. Alternatively, there is a dual version of the IC, the 556, which comes in a 14 pin DIL package.

Inside the IC there are a flip flop, two comparators for the trigger and threshold circuits, and an output stage which can sink or source a hefty 200mA. However, beware when this stage switches state from high to low or vice versa. It can take a large surge of current which can easily put some sizeable spikes into the voltage rail. If they are not suppressed these spikes could upset other nearby ICs. In view of this a 0.1µF and a 1µF in parallel are recommended to decouple the supply as a cure or a preventive measure.

The IC basically generates a time delay once it has been triggered. By using different circuit configurations it can be set up to operate as either a monostable or an astable.

## Monostable operation

As a monostable the IC functions as a 'one shot' device. Once it is triggered the output changes state for a period of time governed by the charging rate of a resistor capacitor network. Then it returns to its 'normal' state until it is triggered again.

The circuit for using a 555 as a monostable is shown in *Figure 2*. Its operation is fairly straightforward. Initially, the capacitor  $C_1$  is held discharged by the internal circuitry. Once a negative going pulse is applied to the trigger the internal flip flop changes state allowing the capacitor to charge and the output to change from low to high. Then the capacitor starts to charge up through the resistor  $R_1$ . This continues until the capacitor voltage reaches two thirds of the rail voltage. When this point is reached the flip flop switches over and the IC reverts to its initial state.

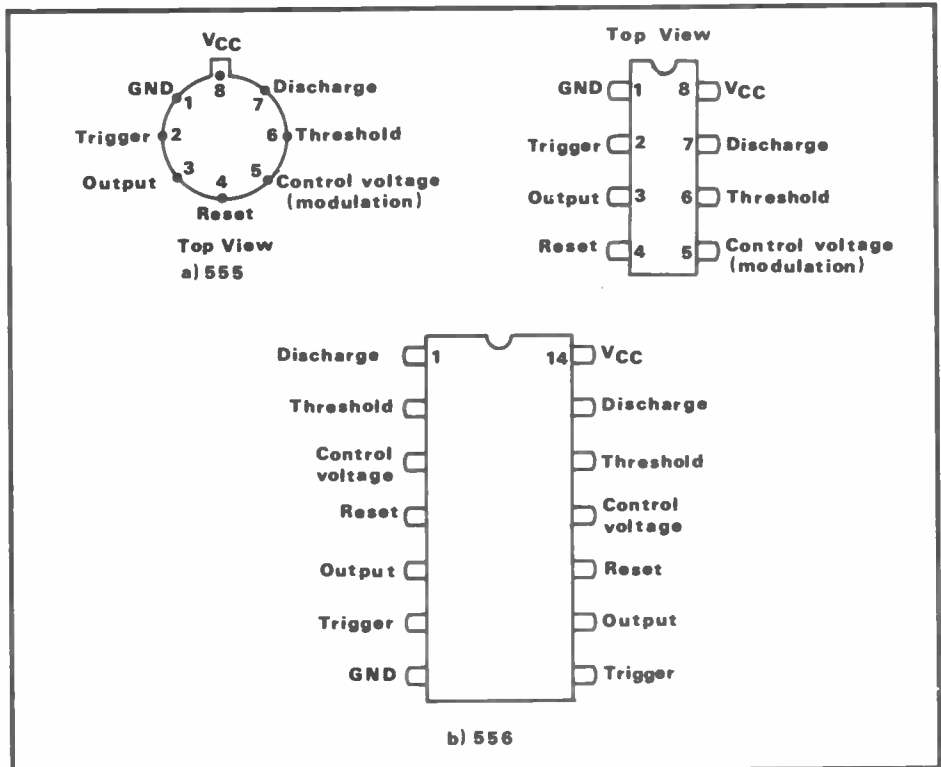

Fig 1: Pin connections for the 555 and 556

As the charge rate of the capacitor and the switch over point of the flip flop are both directly proportional to the supply voltage it is found that the actual timing is independent of it. In fact, the time period for which the IC output is high can be simply worked out from the equation:  $t = 1.1 R_1 C_1$

Once the IC has been triggered it is found that the trigger has no effect until the IC reverts to its initial state. However, it can be reset. If the reset function is not being used it is worth connecting the reset input to the supply pin on the IC. In this way the 555 can be prevented from being reset by any stray pulse which may be picked up. This should be done whether the IC is set up as a monostable or an astable.

## Astable operation

While the IC is often used as a monostable it can also be turned into an astable by rearranging the circuitry a little. This is done by setting up the circuit so it re-triggers itself as shown in *Figure 3*.

In this mode the trigger is taken to the threshold input so the circuit re-triggers when the capacitor voltage reaches a set

level. The capacitor charge and discharge rates are obviously determined by the value of the capacitor  $C_1$ . In addition to this  $R_2$  governs the discharge as pin 7 of the IC is switched to 0V during the discharge part of the cycle. During the charge part of the cycle,  $R_1$  and  $R_2$  govern the rate of charge as current is taken from the supply via these two resistors. As a result, the values of these resistors affect not only the frequency of oscillation but also the duty cycle. It is a simple matter to calculate the duty cycle as the formula is  $D = R_2 / (R_1 + 2R_2)$ . Unfortunately with the circuit set up in this configuration you can't obtain a 50% duty cycle. This problem can be overcome in a number of ways. One is to place a diode across  $R_2$  so the capacitor only charges up through  $R_1$ .

With the circuit set up as in *Figure 3* the capacitor voltage will charge and discharge between one third and two thirds of the supply voltage. Again this means that the frequency of operation will be independent of the supply voltage. The frequency can be calculated by:

$$f = \frac{1.44}{(R_1 + 2R_2)}$$







## Tony Smith G4FAI takes his bimonthly look at the world of dots and dashes

### The wind of change?

Like everyone else, I know that QSLs with USSR stations must go via Box 88, Moscow. Imagine my surprise, therefore, when a UB5 recently sent 'QSL DIRECT' to me. Thinking it was a mistake, I replied 'QSL VIA BURO?'

Back he came with 'NO. QSL DIRECT, MY ADDRESS IS... PSE UR ADDRESS?' I sent my card straight away expecting that if I got one back at all it would be via Box 88. Amazingly, and by return, I received direct, a QSL, a calendar, two postcards and a car windscreen sticker, the latter, of course, in Russian.

I thought the late RAEM was the only one ever allowed to QSL direct. Is this the new order of things? Has anyone else had the same experience?

### FISTS Anniversary

The FISTS CW Club, one year old in September, is now a member of the European CW Association, with around 300 members, and growing daily. It will celebrate its anniversary with a Straight Key Week from 0001 Sunday, 4th September to 2359 Saturday, 10th September. Non-members may participate. Just use a straight key and work as many FISTS members as you can.

You can use contacts made during the week to qualify for the FISTS Century Award. Score 100 points from contacts with FISTS members as follows: UK or EU members = 1 point. Members outside Europe = 2 points. FISTS club station G0IPX or G0IPX/A = 3 points. Send logs, signed by two independent operators (QSLs not required), showing date, band, call and membership numbers of FISTS members worked, to George Longden G3ZQS, 119 Cemetery Road, Darwen, Lancs BB3 2LZ. Cost to non members £1.

### 'Phone-sked'

This is a service for beginners to CW who are nervous about making their first call on the air. A list of operators in the UK and Eire, with their telephone numbers is available from G3ZQS on receipt of an SAE. A newcomer can

telephone one of these operators to arrange a first QSO and be sure of sympathy, understanding and help during those first few never-to-be-forgotten minutes on the air. You need not be a member of FISTS to use this facility.

### Second RSGB straight key day

Following last year's success, this event is to be repeated on 8th October 1988, from 0800 to 2100, between 3515 and 3555kHz. It is hoped that use of 80m at these times will ensure good propagation around the UK.

It is simply a day of straight key operation—ordinary QSOs with the usual exchanges, plus information about the key being used. Afterwards write to Colin Turner G3VTT, Hurley, Weaving Street, Maidstone, Kent ME14 5JJ, with nominations for the best FIST heard. Please include comments about the event, photographs of the key used and/or the operator using it, plus notes on the key's history if known.

For the benefit of participants from last year, Colin reports that 'Boris', the straight key from behind the Iron Curtain has been retired. He will be replaced in this year's event by his friend 'Emil' from Czechoslovakia. 'Want to hear him?', asks Colin, 'See you on 8th October!'

### Intruder alert

As most of us know, band-plans divide amateur bands into sections set aside for use by each mode. In some parts of the world, including the USA, observance of these divisions is mandatory. In others, including the UK, the band-plan is advisory, although its observance is supported by all national societies who are members of the International Amateur Radio Union.

It is undoubtedly in the interests of individual amateurs to observe these band-plans, ensuring peaceful co-existence with users of other modes, respecting each other's right to use the bands within sensible, internationally agreed limits. Our 40m band, for instance, is fairly straightforward: 7.00 to 7.04kHz is

allocated for CW, 7.04 to 7.10 for CW and phone, and at the boundary point  $\pm 7.04$ , 5kHz is allocated for RTTY, jointly with the other modes. RTTY has always been most popular on 80 and 20m but with the advent of AMTOR, coupled with improvements in the current sunspot cycle, activity is apparently increasing on other bands, including 40m.

Within the CW only section of 40m there is an internationally observed QRP frequency, 7.030kHz, on and around which, low-power operation takes place.

The G-QRP Club recently became aware of an application to be submitted to the RSGB/DTI for a special callsign for an automatic AMTOR transmitter to operate, with formal approval, on 7.030 or 7.031kHz. This would not only be within the CW section of the band-plan, but right on top of a well-established centre of QRP operation.

It appears from correspondence held by the QRP Club, that downward pressure from SSB operators higher up, has made AMTOR operation difficult in the recommended RTTY section of the band. AMTOR operators have decided to move further down and operate in the CW section.

### Protests

The G-QRP Club has protested strongly to the RSGB and to the IARU Region 1 at the unacceptable proposed intrusion. The European CW Association, of which the Club is a member, has also protested and has alerted all member societies across Europe. Undoubtedly, the RSGB and the IARU will not be parties to any contravention of an agreed IARU band-plan but any future pressure will surely change the band-plans to accommodate new or expanding modes.

In true amateur spirit, negotiation and compromise will be necessary but not only from the CW side! CW operators generally confine themselves to the 'CW only' sections, leaving the shared sections to others. They have been pushed down to the bottom part of each band over the years, with ever increasing pressure from above. Now there is nowhere else to go except over the edge!

### Raise your voices

High technology may be the 'in' thing, but we all have our stake in amateur radio. If a good number of us still want to continue in the time-honoured way then we need to raise our voices to make sure we can.

That is why the AMTOR matter is so important. CW organisations, perhaps for the first time, have banded together, to remind the hierarchy of amateur radio that Morse operating is still alive and has every intention of remaining so; equal in status with all the other modes.

Individuals have also protested, and continue to do so, but if you are a dedicated operator, join a dedicated CW organisation, preferably one which is a member of the European CW Association. I hope I am wrong, but I suspect that you will not read about this matter in the pages of *Radio Communication!*





## News and comment from Glen Ross G8MWR

An interesting letter has arrived from Brian, G14KIS in Antrim. He reports that at 2305GMT on 15th July he had a 2m contact with EA8BML in IL27GX on a frequency of 144.3MHz. This was then followed at 23.35GMT with a contact with EA8BML who was located in the same square. The contact lasted for half an hour until 0055GMT on the 16th. During the contact the signal strengths of both stations varied from around S3 to S9+10, the contact was, of course, on SSB.

### A new record?

Subject to confirmation of all the details it looks as if this is probably a new Region 1 tropospheric record. The distance works out at 3056km and would comfortably beat the existing 3025km held by GD8EXI also for a contact into EA8. Another interesting point about the contact is that none of the stations involved is in the 'mega' league. EA8BML used an FT480R driving a 60W linear amplifier. This was fed to a 17 element Tonna at 9 metres above ground level. The receive side was helped by a low noise pre-amp. At the other end of the path G14KIS used an FT290R driving a 100W linear. The aerial system was a bit larger than most people use, being an array of four 9 element yagis, 18 metres above ground. Here, also, the receive side was helped along with a low noise pre-amp. As well as possibly being a new distance record it is also believed to be the first G1 to EA8 contact.

### Advantages

The path to EA8 as a record maker is possible because, as you will see if you look at a map, it is for all practical purposes completely over water right up to and through the Irish Sea. The path has been steadily extended from the Devon/Cornwall peninsula up to the Isle of Man and now even further into Northern Ireland. It would appear to be only a matter of time before a station located in South Western Scotland extends the record even further. Per-

haps for many years to come the Brits can keep a stranglehold on this record. It should also be possible to do the same thing on 70cm with really good equipment.

### The awards

This is the time of the year when the awards scene cools down somewhat. This month is no exception and we only have one new one to report. That goes to G6BFP near Slough. He claims a 144 Bronze with a best contact to DU3UH at 580km. The award was gained using an FT726R driving a 100W linear, the whole lot being connected to a 4 element quad at 20ft above ground. If you want information on the awards, send an SAE to the address at the end of the column.

### More records

VK6TCF sends a cutting from the Australian magazine *Amateur Radio* from which we get reports of new DX records on the 1.3, 2.3 and 3.4GHz bands. These records were set by VK6WG and VK5QR and the distance is 1885km. On March 18th VK6WG AND VK3ZBJ, who is located in Melbourne made contact on 23cm, the distance being over 2500km. VK6WG was running 50W to a 1.2m dish. These contacts were followed on March 22nd by a 23cm FM contact between VK6AOM in Western Australia and VK3ZBJ in Victoria. Five and seven reports were exchanged over this path across the Great Australian Bight.

### Get the picture?

Our mole has been at work again and reports the fact that G8OZP managed to get ATV signals running on 437GHz. This is a wavelength of about 635 nanometres and is probably the highest frequency ever used by amateurs. Pictures were P5 over a distance of 43cm with a strange patterning effect, the cause of which is not known. What is certain is that by the time you read this the distance will have been increased. For the technically curious the transmitter ran 2mW from a

helium neon laser and the receiver used a diode array followed by some 60dB of gain. Anyone want to go for something even higher?

### More wallpaper

I have been asked to bring to the attention of the certificate chasing fraternity, the Solent Fortifications Award. The basis of this one is to contact stations operating in various forts and castles, and to assist you there will be many special stations laid on. Awards are available on VHF and UHF bands and to even things up a bit, the number of contacts required depends to a certain extent on your distance from the Isle of Wight. This may seem strange but all will be revealed if you send an 8 x 10in SAE to Mr V Harris, 72 Elmore Avenue, Lee on the Solent, Gosport PO13 9ES.

If you want to make a quick start the stations to look out for will use call signs in the GB0, GB1, GB2 and GB6 series followed by the two letters 'CD' for coastal defences and a third letter which will indicate where they are located. The basic VHF certificate requires contact with seven of the fortifications. It sounds as though it could be fun.

### A question

Our 6m allocation is held on the basis that we do not interfere with Continental Band 1 TV reception. To this end we have both power and aerial restrictions; why? For something like forty years we have been throwing multi-kilowatts of power at them from our own Band 1 system in the South East of the country. All of these stations were well sited with very efficient aerial arrays mounted at several hundred feet above ground, to say nothing of the height above sea level. You could probably see into PA and ON land from some of them on a clear day. Several of the television transmitters also had the advantage of a virtual sea path all the way to the Continent. Now add to this similar stations in Denmark, Norway and Sweden.

The total power runs into tens of megawatts and yet this did not seem to cause any undue problems in Holland and Belgium. For that matter most of these Scandinavian stations are still up and running and still causing no problems. So what chance have our low power amateur stations got of causing any hassle over there? That's right; virtually none.

We know the RSGB had to go along with this sort of thinking (and rightly so) to get us on the band but is there, perhaps, a sneaking suspicion that some government official decided he was going to defend his own little kingdom to the bitter end? After all, if we had got blanket approval with no restrictions then there would be no need for someone to 'keep an eye on the situation, old man' and bang goes an official, three typists, a tea boy and probably a mountain of paperwork.

### Action replay

Yet another 23cm ATV repeater comes on stream. This one is GB3RT which is located at Rugby, the actual locator

## ON THE BEAM

being IO92JH. Both input and output are on FM and the frequencies involved are 1249MHz input and 1318.5MHz output. You need a standard 625 line signal and there are facilities for a 6MHz sound carrier. The unit is well sited and runs 25W output.

### Expeditions

ON1CAK and ON1CDQ were operating from Andorra until the end of July using the callsign C30EAB. They were reported to have been running around 150W to a pair of 11 element yagis. Another nice one you might have heard was GM0MHZ who was operating from Shetland until the end of July. Operation was from near Sullom in HU37 square. You may also have had time to look for GB2XS and GB0LCS who were both active from XS square until the end of July. Amplifiers rated at 200W and 13 element yagis should have put out a potent signal. Yet more activity may be found by listening for EI5CZB on 144.325 SSB and EI2FN on 144.075 CW as they work their way round several Irish counties including Longford, Sligo, Mayo, Leitrim and Roscommon. 180W to a 12 element on 2 or a 9 element on 70cm should put good signals into our shores.

### Monster array

W5UN reported on the 14MHz VHF net,

which you really ought to be keeping a listening watch on, that he has just added another 16 long yagis to his 2m array. He now has 48 of them on the stacking frame making a total of over 800 elements. Makes your average 9 elements look a bit sick!

### Mind-boggling

Even that monster array pales into insignificance when compared to the aerial used by KP4I for his moonbounce attempts. This is no less a device than the huge radio telescope aerial at Arecibo. This dish was made by recontouring a natural depression in the ground to give a dish with a surface area of 20 acres. As a further mind-boggling thought the surface is accurate to within  $\frac{1}{8}$ in over the entire dish. It does have one major disadvantage though; it cannot be turned or tilted so can only be used when the earth is pointing the right way.

### Beacon news

First news of the Gibraltar beacon; this is now set up on 50.035MHz and has an output of 35W. The aerial is originally a 5 element yagi but this may well change to an omni-directional array so as to give world-wide coverage as conditions steadily improve. The callsign to look for is ZB2VHF. A little further up the band is the Icelandic beacon TF3SIX which runs

50W on 50.057MHz. To the South you may find GJ4HXJ on Jersey. The frequency is 50.0655MHz and it is currently running 10W to a Halo aerial. In time the callsign will change to GB3IOJ.

### Oscar 13

The new bird was successfully sent aloft from French Guyana at 1119.43UCT on Wednesday 15th June. A few hours later reports started to arrive from South Africa saying that the beacon signal on 145.812MHz was being well received. Some four hours later the beacon was heard in the UK as the satellite came over the horizon at about 100 degrees east of us.

Until such time as the go ahead is given by AmSat it is essential that you make no use of the transponder. This is because vital tests need to be completed and if they are not, then precious weeks could be lost.

I hope next month to give a complete run down on the various facilities it carries and how you can make best use of them.

### Close down

It is always interesting to get your letters and comments. The address is 81 Ringwood Highway, Coventry CV2 2GT, or on prestel using MBX 20361-6941.

**NEXT MONTH**

# Amateur RADIO

Don't miss the October issue on sale 29th September



Ken Michaelson reviews the Icom IC-U4E UHF H/H FM Tx.

■ Angus McKenzie tests the PXO2 Pulse Generator and Marker Unit; and the new Low Loss Coaxial Cable from Westlake.

Ken Michaelson

ALL THE REGULARS:

DX DIARY

PROJECT BOOK

SECOND-HAND

ON THE BEAM

FREE CLASSIFIED ADS

# 50MHz

by Ken Ellis G5KW

By the time this is in print the 1988 E's season will be over, but the results and records will be an historic memory for the future. It is now time to prepare for the next phase – the TE path, during which openings occur between Northern Europe and Central Africa, with occasional extensions to the fringe area. In my columns last year I gave some details of the propagation modes, and results to expect during this interesting form of propagation, but for the benefit of new readers it will not be amiss to repeat some of the basic information.

## History of TEP

We have to go back over 40 years to the start of TEP. During the run-up to Cycle 18, from 1946 onwards, a form of long distance propagation was experienced around 50MHz between stations equidistant and at right angles to the geomagnetic equator. This could not at that time be explained. In America during 1947, XE1KE began working Argentinian stations on 50MHz. During the afternoon and early evening he had over 50 contacts with LU and OA4. The LUs also worked TG9JW, CE1AH and PY2QK.

At this time I was operating as MD5KW in the Suez Canal Zone of Egypt, and had the time and facilities to conduct monitoring of the 5 and 6m bands. I had been receiving TV and commercial signals from the south. ZS1T and ZS1P had been receiving the Alexandra Palace TV on Band 1. In 1946 I installed a beacon at my QTH running continuously and beaming north and south at 30 minute intervals. The beacon was received in the spring and autumn of 1946 in Europe and South Africa. A listening watch was kept on 28100 for reports, but no contacts were made until October and November 1947.

On 15th October there was a 50 minute opening to South Africa and I had two-way 50MHz QSOs with VQ2PL and ZS1P. On the 17th further QSOs took place with the same stations; this was the first time that I experienced the 'flutter' type of fading which later became characteristic of one form of TEP. Flutter fading was experienced by the South African stations from around 1800 during the remainder of November 1947.

During the next decade little was heard in this country of 50MHz TEP due to Band 1 TV, but some interesting experiments were being carried out by F9BG, G4LX (who had been granted a special 50MHz permit), ZC4IP, ZC4WR, ZE2JV, ZS6PW and others. These were reported in a long article by R G Cracknell, ZE2JV (now G2AHU) in *QST* November 1959. Ray kindly lent me a copy

of the article, and I am able to make brief extracts of some of the salient information.

'During the years since the end of World War II, increasing use of the 50MHz band by amateurs in areas adjacent to the tropics has revealed radio propagation conditions in the VHF region, up to at least 80MHz that could not be explained by conventional theories. In general the TE path is between areas on either side of the geomagnetic equator, and 1500 to 2500 miles away from it. It is effective during the hours of darkness and on frequencies up to 1.5 times the observed MUF for F layer propagation.

'Optimum propagation conditions occur at the time of the spring and autumn equinox; between points on the same longitude located about 2000 miles from the geomagnetic equator. The TE mode may be usable between locations where the direct line between the two stations cuts the geomagnetic equator at an angle as low as 45 degrees, and beyond the limits mentioned above, but moving away from the most favourable spots causes both the reliability and the MUF to drop off. The quality of the modulation on a TE propagated signal is often distorted by a characteristic "flutter fading". A few watts of RF in a vertical quarter wave aerial may induce a signal of one mV or more in a similar aerial 4000 miles away in the opposite TE zone.

'TEP is by no means limited to the hours of darkness. At the peak of solar activity 50MHz daytime signals were weak and infrequent at Salisbury, but in 1959, probably due to decreased ionisation at the lower levels, signals from the Mediterranean area have been received at ZE2JV very regularly, and at great strength at frequencies up to 56MHz throughout the day.'

I have prepared an approximate diagram based on the original one in *QST* which was based on the few reports available at that time ( *Figure 1*). These details are subject to amendment in the light of more recent observations.

Examination of *Figure 1* shows that the geomagnetic equator traverses Central Africa in a convex arc, approximately five hundred miles north of Victoria Falls, at its widest point across the continent. It has a radius of approximately 2000 miles. The effect of this curvature is to give places in Southern Africa lying within the TE belt, an abnormally large zone into which the TE propagation is concentrated and in which interference and noise can be received.

During the International Geophysical Year, Gordon Spencer G4LX, Newcastle, had a special 50MHz permit for experiments, and made valuable contributions to tests from this country. His observations showed that ZE2JV signals were received in Newcastle frequently for two brief periods; 1700-1715 usually showing

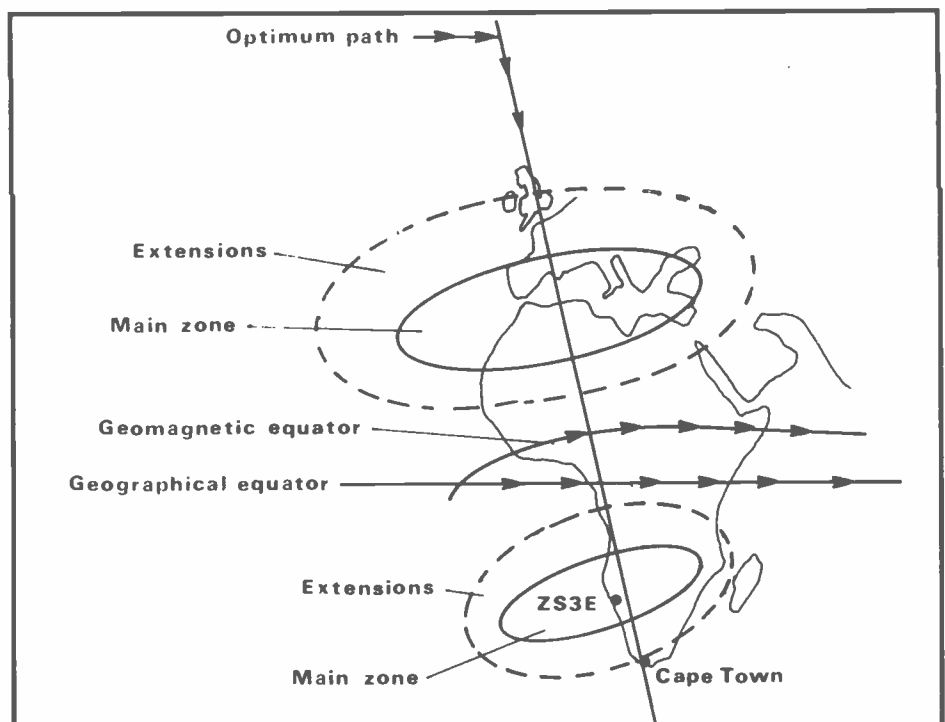

Fig 1: Diagram showing the geomagnetic equator

a 'clean' signal and 1900-1930 showing flutter which is characteristic of TE propagation (local time in Southern Rhodesia was GMT+2 hours).

It would appear that Newcastle is situated near the northern limit of TE, but due to the few observers at that time we may have to revise this, and that Cape Town is near the southern limit.

### Seasonal effects

The position of the sun affects TEP. There tends to be more frequent and longer extensions to the south in the southern summer, and to the north in the northern summer. These are most noticeable a month or so each side of the respective solstice.

During the propagation study I made of 50MHz in the Isles of Scilly during the peak of Cycle 21, I was mainly concerned with Fs. See the June 1987 issue of *Amateur Radio*. In 1981 I arrived at IOS in late September towards the end of the TE season, but still managed a few interesting crossband contacts.

### TEP prospects for Cycle 22

With the general release of the 50MHz band to Class A and B licensees after the close down of Band 1 TV in the UK, an upsurge of interest on 50MHz was expected. As we were at the trough of the cycle with low MUF and little F2 propagation, no major openings have taken place to date. With the high solar flux sunspot count and rising MUF that we have been getting over the last few months, it is reasonable to expect TEP openings during the autumn or next spring. Stations in the southern TE area are already preparing for this, and will be transmitting and listening on 50.110 and monitoring on 28.885 during suitable periods. On August 1st a Solar Flux was monitored on 187. At 2100 G4UPS received the ZD8VHF Beacon for over an hour. CT0WW was also heard and both beacons were received over a wide area of the UK. Is this an early start to the TEP

season?

During TEP openings, the operating frequency may be up to 1½ times the actual F2 frequency at the time. Therefore, if the MUF rises above 35MHz, by checking known transmissions from the south, the WWV and Radio Australia's information on solar data, an indication of possible openings for TEP can be made. It is then time to look on 28.885 for South African stations.

### Grid locator squares

The system of Grid Locator Squares now in general use internationally (with a few exceptions), is based on 1° Longitude and 2° Latitude squares sub-divided into 600 divisions for precise indication of QRA.

The old QRA locator system which was very popular in the past, is still being used, but it is fast dying out. In IARU Region One, most countries include in the rules for VHF contests the use of Grid Locator Squares as mandatory. The American ARRL Awards for contacts on VHF (using Grid Locator Squares) have given a new interest for QSL card chasers, particularly on the 50MHz band.

During the recent openings with the USA, a number of G stations who made a transatlantic contact were pleasantly surprised to receive their QSO and QSL by airmail within a few days. This included an IRC coupon from the other side requesting QSL card replies.

The RSGB has recently announced a plan for certificates to be awarded for 'Squares worked'. To enable G stations to locate their own 'Grid locator square'.

### The North South path

Taking an imaginary line from the UK, passing through the geomagnetic equator to Cape Town at right angles is the optimum path, with conditions falling off as we move east or west. The 'line' passes through Windhoek (Namibia) and the QTH of ZS3E and ZS3AT. We are more likely to have contacts with these two

stations than with the stations to the east, as they will be out of the optimum area (except under exceptional conditions). Botswana is another probable area to be considered as it is nearer to the optimum path than Pretoria.

### From the mailbag

Mike Devereaux, G3SED, reported on 9th July that the PJ0M DXpedition to Saba Island in the Caribbean worked GM3 POI/A at 2145 and G3SED at 2150. Both contacts were new to both GM and G. The opening only lasted 5 minutes with each station. No other QSOs have occurred to date, although G4GLT was heard at 2155 that evening.

I was alerted to the possibility of an opening by careful monitoring of 28MHz which had opened to W4, T12, HP2 and 6Y5. The signals were very weak, due to the unexpected late openings. Propagation was probably enhanced by the F2 layer, due to high solar flux activity and low A index.

TF3JP has applied for a licence to use 6m now that a beacon has been established in Iceland. He is confident of obtaining one shortly. June and July have produced excellent conditions on 50MHz with openings to the USA on the 6th and 25th June, as well as the 4th, 5th, 9th and 10th July.

### Southern Africa 6m Award

Hal Lund, ZS6WB, reports that the Southern Africa 6m Award is available to amateur radio stations in any country except the Republic of South Africa. Applicants must present proof of having completed two-way, 6m contacts with stations in at least ten different grid squares on the African mainland south of the equator. All contacts must have been made after 1st January 1986. ZS3E is in JG89, ZS3AT and JG87. Applications for the award should be sent to: VHF Awards Committee, Pretoria Branch, SARL PO Box 1259, Pretoria 0001, Republic of South Africa.

### G5KW on 28.885 African stations on 50MHz

28 September 1981	1735	ZS3E	sent	52	received	53	Very clear signals
4 October 1981	1645	ZS6LN	sent	52	received	52	Very clear signals
5 October 1981	1607-1612	ZS6LN	sent	52	received	52	Very clear signals
9 October 1981	1630	ZS6LN	sent	339	received	53	Weak and fluttery
15 October 1981	1735-1925	ZS3E	sent	57	received	55	Very clear signals
10 October 1981	1237	ZS6XJ	sent	45	received	52	Very clear signals
10 October 1981	1257	ZS6XJ	sent	539	received	57	Very clear signals
10 October 1981	1530	ZS3E	sent	529	received	55	Very clear signals
10 October 1981	1530	ZS6BUF	sent	529	received	57	
18 October 1981	1120	ZS6BT	sent	579	received	57	
23 October 1981	1535	ZS6LN	sent	579	received	56	
28 October 1981	1200-1245 Heard Cape Town beacon 329 Clear signals						

# The APT160 Antenna

by Richard Q Marris

The APT160 is a small, simple, low cost and effective experimental 160 metre band transmitting/receiving antenna. Though specifically designed for use in a flat, it can easily be adapted for use in any confined space; indoors or outdoors or, part in/part out. It can easily be weatherised, for outdoor use, with marine varnish or similar. Use a conventional 10-80 metre Transmatch ATU and the APT160 can be used on the higher HF bands.

The antenna (Figure 1) consists of a horizontal length of wire placed diagonally across the room, from corner to corner, and about 8in below the ceiling. The Tx end drops down to the simple ATU and the far end, to a multi-turn vertical component L2.

The maximum RF voltage occurs at the bottom end of L2 and, therefore, the maximum current (ie radiation) occurs in the section consisting of the wire and the upper two-thirds of L2; the ATU being grounded to a metal water pipe. The electrical length is approximately 0.28 wave length. The Tx power used (input) does not exceed 10W input (CW) in accordance with GB 160 metre band licence regulations.

## Construction and operating

On the prototype the wire section consists of 18ft slung diagonally across the room, supported by nylon fishing line. A 4ft long section drops down to the ATU, near the Tx/Rx, and a further 12in drops down to L2, terminating in a crocodile clip, so L2 can be removed and stored when not in use. White PVC covered 7/0.2mm (o/d 1.2mm) wire flex is used. L2 is wound on a 6ft long length of white 3/4in bore (7/8in outside diameter) plastic waste pipe, obtained from a local DIY shop. Onto this, starting at the top, are close wound 73m/242ft of wire (Figure 2). Again 7/0.2mm (o/d 1.2mm) of white PVC flex is used.

The base, for L2, consists of a stout piece of thick wood with a length of 3/4in diameter wood dowel inserted, and glued, in the centre. It will probably be necessary to rub down the dowel before fixing, so it slips into the bore hole of the plastic tube. When in use, L2 is just pushed over the dowel on the base. The simple, L-match variation ATU, is built into a small metal box. It is necessary to put a suitable low loss socket in the box top, to accept the end of the antenna. A terminal is also required, connected directly to the metal of the box, for the ground connection. A 15ft length of stout wire flex is taken from the ATU and clipped to a metal waterpipe, which was the only grounding available and works well.

In the ATU, C1 is a good quality 350pF air-spaced Rx type variable capacitor, though a 500pF would suffice. Series

capacitor C2/C2 consists of two 350pF (1kV) disc ceramic capacitors, wired in parallel, giving 700pF.

L1, in the ATU (Figure 2), is wound on a 3in length of 1 1/4in outside diameter plastic tubing. It consists of forty-nine turns of 20 gauge enamel copper wire, close wound. Tap 1 is fifteen turns from the end and Tap 2 is twenty turns. This means the whole coil can be used, or fifteen turns shorted out using Tap 1 (or twenty turns using Tap 2). In practice, Tap 1 was used with a shorting link soldered to coil end, as shown in Fig 2.

A short length of 50 ohm RG58 coaxial cable is taken to the Tx/Rx with suitable coaxial plugs/sockets.

The APT160 is simple to 'tune up' with a little practice. Line up the Tx into a dummy load, at about 1830kHz, and substitute the ATU/Antenna combina-

tion. On 'receive' adjust C1 for maximum signal to get an approximate setting. Then on 'transmit' readjust C1 slightly, as required. Using a neon bulb, it can be ascertained that maximum RF voltage appears at the bottom part of L2. Indoors, a field strength meter device is difficult to use because of reflections from surrounding objects. Apart from the usual harmonic measurements TV1 can be checked with a TV (with whip antenna) under the antenna!

Should loading difficulties occur, due to different format or grounding, for example, then try the other taps on L1 (ie Tap 2 and end of L1). In case of extreme difficulty, which might occur with radical change of layout, then the L1 winding should be experimented with. It is also essential to keep the antenna as far away as possible from the walls, ceiling and metal objects.

The APT160 can give worthwhile results for the flat dweller - and why not? After all, quite remarkable results have been achieved with a 6 to 8ft long mobile whip grounded to the car metalwork. It is, of course, unlikely to compete with a massive outdoor antenna, but will give acceptable results using low power.

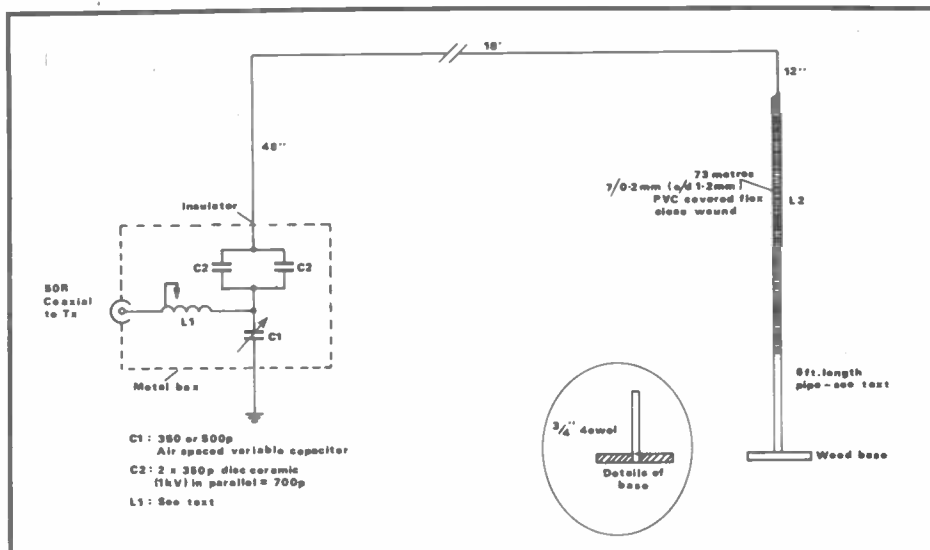
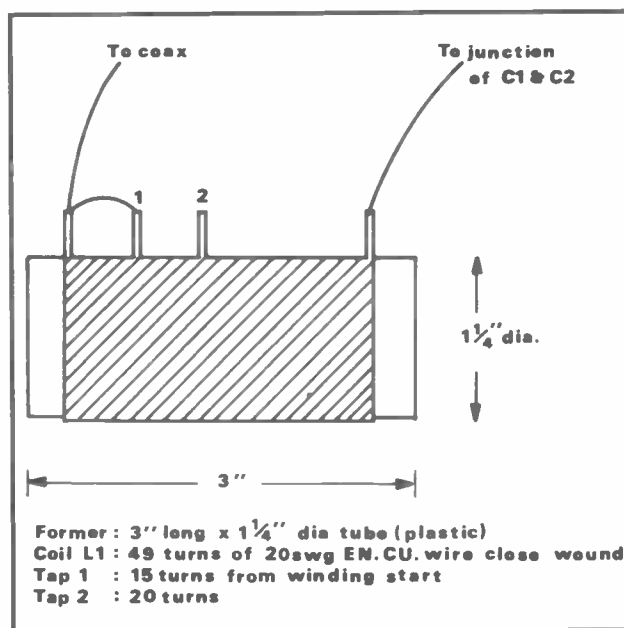

Fig 1 (above): Detail of the APT160

Fig 2: (left): Detail of the ATU inductance L1



# FREE CLASSIFIED ADS

## FREE CLASSIFIED ADS CAN WORK FOR YOU

We are pleased to be able to offer you the opportunity to sell your unwanted equipment or advertise your 'wants'.

Simply complete the order form at the end of these ads. Feel free to use an extra sheet of paper if there is not enough space. We will accept ads not on our order form.

Send to: **Amateur Radio Classified Ads**, Sovereign House, Brentwood, Essex CM14 4SE.

## DEADLINE AND CONDITIONS

Advertisements will be published in the first available issue on a first come first served basis. We reserve the right to edit or exclude any ad. Trade advertisements are not accepted.

## FOR SALE

■ Uniden CR20-21, amateur and broadcast bands, boxed with manual plus PSU, excellent condition and in working order. Tel: (0743) 246948  
■ Datong D70 Morse tutor, plus Hi-mound HK708, boxed, manual and connection, excellent condition, £40. Tel: (0743) 246948  
■ Trio TS830S HF transceiver, de luxe tuning knob, only used on RX. Complete with handbook, £500. Dave, GW1JPF. Tel: (0654) 710030  
■ Belcom LS102L, 26 to 30MHz, in excellent condition with manual, £160 ono. Tel: (0661) 34959  
■ Polaroid Polavision movie outfit, CW zoom lens camera and replay monitor, as new, in original box. Swap for UHF scanner or HF receiver, WHY? Tel: 01-906 4206  
■ Ham multimode 2m LSB, USB, AM/FM with super low, Breml 200W amp power supply. G-com 5 amp, £130. Also Zetagi B300P, £95. Excalibur transceiver, LSB, AM/FM, USB, £85. Strictly cash. Tel: (061) 927 7325  
■ Pye Continental VHF FM mobile radio telephone, could be converted to 2m, needs crystals, six selectable channels, plus service manual. All offers to include postage, can be collected. Also several radio magazines, including USA. Send an SAE for lists. All letters answered. Michael Hudson, 71 Knight Avenue, Canterbury, Kent CT2 8PY  
■ Spectrum receive pre-amplifier RP10S, factory built and tested, unused, £20. Tel: (0743) 246948  
■ 70cm 100W linear amp, MML 432/100, excellent condition, £250 ono. VHS/VCR Telefunken VR520 with Band I (50MHz DX/TV) plus Band III, UHF ch 21-68 up, converts Band I and III to ch 36, will record all Bands I and III and VHF. Very good indicator for 2m Es openings, excellent condition, £150 ono. 23cm linear amp 800mW in, 6W out, £35. Tel: (0924) 278699  
■ Sony portable video outfit, SLF1UB recorder, TTF1UB tuner and timer, HVC3000P camera, 3 NiCad packs, vgc, £800 ono. Tokyo Hi-Power Micro 70cm, 3 channel 200mW handle. Xtal RB10 and 432.800MHz, 2 sets NiCads, £80 ono. Also, Scooper MR110, 10 channel mobile scanner, fitted 2m xtals, £25 ono. G0CCU. Tel: Bristol 721744 anytime  
■ Tentec 22 with magnetic circuit breaker, plus crystal marker, electronic keyer and manual, as new, £245. Also, Hamgear super pre-selector and ATU, £25. Tel: Jeff (0484) 645923  
■ Icom 720A transceiver with general coverage, excellent condition, £495. FT757GX Yaesu transceiver, as new, £550. FP757 power supply, £65. RN Electronics 6m 25W transverter, unused, £135. LA1000, no tune, HF all band linear amp, 1.2kW, very compact, ideal DXpeditions, little used, £450. Tel: (0534) 54186 after 6pm  
■ HF5 vertical antenna, also HF5R matching radial kit, both items bought new 3 months ago, never used, £130 ono. Tel: Mid Calder 880345 anytime  
■ Bearcat UBC17XL 16 channel Rx, vgc, £135 ovno. Peter, G3JX. Tel: (0908) 642398  
■ President Jackson, brand new, boxed. Suitable for conversion, £200 ono. Tel: Kevin (0224) 684004  
■ Realistic Pro 2004 scanner, as new, £250. Tel: (0256) 53896  
■ TS520S, ext. VFO, workshop manual, spare tubes, Shure 404C mic, all as new, showroom condition, reluctant sale, £400 ovno. Cobra 148GTL 15m SSB rig, £75 ono. Also working AR88D receiver, needs slight attention, £50 ono. Buyer to collect. Trio R1000 receiver, £200. All items available separately. Will consider p/ex for all items except TS520S. D Burt, 14 Mulberry Close, Eastbourne BN22 0TU  
■ Colour Genie computer RTTY/CW, split screen, type ahead. Tunicator, B/W TV, tapes, tape recorder, hardly used, handbooks, £110 or over. Tel: (0473) 49139, ask for Noel  
■ Sanyo RPM6900 LCD digital clock/radio,

pocketable, AM/FM, LED tuning, case, £119. Sanyo TV, 5in mono portable, mains/battery, £20. Toshiba KT-V580 Walkman radio/cassette recorder, auto reverse, endless loop, FM/AM, stereo recording, Dolby, stereo mic, case, £40. Sony ICR4800 6 band, MW/SW breadspan, pocketable, LED tuning indicator and case, £25. Hitachi WM20 short wave transverter, 13-90m, 9 ban, all pushbuttons, for car radio or base use, £20. Mercedes compact MW/FM stereo, 4 short wave bands, 2.3-28MHz, LED tuning, case, £20. Royce cordless telephone, charger-base and handset, £30. Aiwa HR-501 2 band stereo/radio headphones, £15. BSR 8 track stereo deck, £6. G4IF QTHR. Tel: 01-722 7040  
■ Lattice tower, aluminium, very lightweight, four sections, to make 22ft tower, wall mounting, ideal for side of garage etc. Would easily make 30ft with stub mast, transportable by car, buyer collects, bargain, £40 no offers. Tel: Cambridge 845093  
■ Phillips N4504 tape deck, 3 head, 3 motor, 3 speed concept, 5 tapes, service manual, as new, £45. Carriage extra. Write to: S Smyth, 67 East Princes Street, Helensburgh G84 7DG, Scotland  
■ Icom 202E SSB transceiver for 2m, vgc, complete with mic, manual, shoulder strap, £100. NEC 2m FM transceiver, complete with manual, mic, £80. US Signal Corps frequency meter, BC-221-B, complete with original headphones, PSU and manual, £35. Will sell separately or will swap the lot for 2m multimode, FT290R, IC290A etc. Tel: Jason (0427) 2006 after 4pm weekdays, any time weekends  
■ ERA micro reader Rx for CW/RTTY, plus Morse tutor, 6-18wpm, £85. Wood & Douglas 70cm Tx/Rx 10W boards, built, set up and tested, requires case, £105. MML 432/50 linear and pre-amp, £100. MML 144/100 linear and pre-amp, £105. Itchen LCR bridge, £12. YC355D f/counter to 200MHz, £65. Maplin notch filter, £12. All vgc. G8ESC QTHR. Tel: (0274) 497438  
■ HRO P/P, 4 coils, £50. HQ170 Rx, ham bands plus 6m and 4m, good condition, £130. 888A ham bands, £70. Trio MC60 desk mic, new, £45. Kenwood R820 Rx, as new, extra frequencies, boxed, leads, £500. Goodmans 40-40 amp, £25. Trio deck KD1033, £20. Amstrad FM tuner, £10. Leak Mod 20 valve amp and control, £25. Armstrong tuner amp, £75. Tel: (0908) 313507  
■ Tele-quiptment S32 service scope and manual, £20. Wayne Korr auto balance, universal bridge type B641, with service maintenance manual and operating manual, with all leads, £50. APT regulated power supply, type TCV0550, 0-50V, £10. Tel: (0235) 816947  
■ Uniace 100, 40 ch, FM, CB radio plus Breml antenna matcher and TVI filter, Rama SWR meter and extension speaker, legal Breml homebase antenna. All boxed in excellent condition, will sell complete for £70, ono (half new price). Buyer collects or pays postage. Ian. Tel: (0359) 70527 after 6pm  
■ Radio amateur exam: complete set of course lessons, invaluable back-up to evening class instruction, £15 including postage. Tel: 051-336 7505  
■ Scanner SX200N, 26-88MHz, 108-180MHz, 380-512MHz coverage, AM/FM modes, 16 memories, 2 speed scan, vgc, mains adapter, £100. Tel: (0742) 649752  
■ Yaesu 207R 2m hand-held. NC1A ac charger. PA2 car adapter/charger, £110. GEC messenger, 10W mobile, modified to 2m. R5, S20, S21, S22, S23 fitted. Rx needs attn, £25. Heathkit HO10E monitor scope, (not wkg, handbook, offers? Tel: Chelmsford (0245) 256416  
■ Yaesu FT301S HF trans, 10W 160m to 10m CW filter, mic etc, boxed, vgc, £295 ono. Tokyo hi-power HT106 6m SSB, CW trans, mic etc, boxed, as new, unwanted gift, £260 ono. Tel: (0305) 813202  
■ Tandata TD1100 viewdata terminal, connect to

Prestel, RSGB and other computer databases using 1200/75 baud. Self-contained unit connects directly to standard TV (can be modified for RGB) incorporating keyboard, centronics printer port, cassette port (to record and play back data off line). Autostore and autodial of six telephone numbers, instruction book and aerial lead. Good working condition, demo freely available, £120 ono. Tel: Blackpool (0253) 823522 after 6pm  
■ Sony 6800W short wave receiver, 31 bands, 1 FM band, 1 MW band and 29 short wave bands. Digital and analogue readout, USB/LSB CW and filter, great performance, £150. Tel: (061) 483 4583 after 6pm  
■ Yaesu FT726 2m 70cm sat CW filter. G0GBN. Tel: (051) 327 2425  
■ Yaesu FT690 50MHz multimode, £230. Ham International Viking, covering 10m band, £30. Tet Tri-band, 3-element beam, £140. Realistic 40 ch hand-held with NiCads, mic etc, £60. All equipment in clean condition with boxes. Tel: John G4YMZ, Preston 726378 or 30336  
■ Yaesu FRG7700 gen cov Rx with FRT7700 ATU, and FRV7700 VHF converter, 118/150MHz, vgc, £300, complete with manuals and FF5 filter. A Chandler. Tel: 01-570 6115  
■ Yaesu FT290R muTek front-end, NiCads, charger and carrying case. Excellent condition, £275. Tel: Tony G4TKJ, 01-720 4640  
■ Sony ICF SW1S multiband receiver, complete with active antenna, stereo earphone, mains adapter and carry case. Latest model, mint condition. Cost £250, accept £190. Tel: Doncaster (0302) 69548  
■ ICR70 gen cov Rx with AD270 active antenna, ICR70 cover, 0kHz-30MHz, digital display, dual/VFO PBT RIT notch filter, RF gain, squelch, dual/AGC. N blanker monitor, pre-att mode AM/SSB/CW RTTY, FM, AD270 cover, 0-30MHz. Like new, £550 ono. M Yaseen, 49 Gaythorne Road, West Bowling, Bradford 5, Yorkshire BD5 7ES  
■ Trio TR2300 2m FM transceiver with matching VB2300 10W power amplifier. Carrying case, MB2 mobile bracket, NiCads, microphone, charger, manuals, £140. Sentinel 2m linear, 10W in, 40W out, RF sensing, switchable pre-amp, £45. Ken Ballance G3KNB. Tel: Stafford 44964  
■ Yaesu 757GX transceiver 500 29.999 all modes. Perfect working order, offers over £300. Tel: (0732) 885207  
■ FT-757GX all mode transceiver with general coverage receive, plus matching FP-757HD heavy duty power supply. Two years old, little used, good condition. Original cost over £1,000. Bargain at only £550. Tel: Bristol (0272) 844133 after 6pm  
■ Sony ICF2001D, 10 months old, as new. Also AN1 active antenna plus many extras. Genuine reason for sale, £320 ono. For more details tel: David Rowan (0633) 853583  
■ Standard C8900 2m FM 10W, mint condition with manual and box, £125. Yaesu FTV707, no module, as new, £45. KW2000B, vgc, new valves, £220. Tel: Coventry 450476  
■ Morse Tutor disc for BBC micro, five programs on one disc, 40/80 track with user manual. Learn by ear, practise using random letters, figures, words. Morse key can also be used. Cost £49.95 when new, only £10. Tel: (0366) 388615  
■ Trio VSWR meter, 5W 200A 1.8 thru 150MHz, box opened, never used, coupler included, a bargain at £75. Tel: (0436) 5489  
■ 4m. Three Nolton Sabre transceivers, xtal on 70.300 AM. Manual, magnetic mount, ¼ wave whip, £110. G8SIG. Tel: (0606) 554178  
■ Kenwood TS830S, complete with external VFO120. Excellent condition, only 2 years old, all manuals and original packaging, £750 ovno. Buyer to inspect and collect. Nigel G0CQZ QTHR. Tel: (0993) 772595 evenings/weekends  
■ Yaesu FT107M mains or dc, good cond, 100W,

# FREE CLASSIFIED ADS

superb receiver, £400 ono. Tel: Frank, (0268) 680596

■ Trio 2500 H/H inc case, charger, spare NiCads pack, no toneburst, £120 or p/ex with cash for Icom 290 or Trio 9130 or any 10 to 25W multimode. G7AQX. Tel: (0705) 528162 Portsmouth

■ Yaesu 757GX FC107 ATU, matching PSU, 3-ele beam for 6, 10, 15, 20m plus rotator, £950 the lot. G0GCW. Tel: (0484) 541475 or 536384

■ TS940S fitted internal ATU, mint, £1,700. Save £750 on list. MC60A desk mic pre-amp, up/down, £60. SP940 speaker, 3 filters, 2 inputs, £62. All matching. VS1 voice synthesizer, £23. Manuals, original cartons. G4IOF QTHR. Tel: 01-722 7040

■ CR100 service manual, £10. Selection back issues *Amateur Radio*, *R&EW*, *Radcom*, etc. SAE list. R1155 T1154 full manual, £10. Mr Small, 10 Sibleys Rise, South Heath, Bucks HP16 9QQ

■ Epson PX-9 lap-held 64K computer. Ideal portable/mobile packet terminal. CP/M 2.2 OS, BASIC, word processor (portable Wordstar), spreadsheet (portable calc), diary/appointments (scheduler). Terminal, file-transfer and utility programs. All software on ROMs. Built-in micro-cassette for data storage. Superb condition with all manuals, in original packing, £150 or may haggle. Peter G0FRQ not QTHR. Tel: (0535) 56557 West Yorkshire

■ Eddystone EC10 0.5-30MHz in 5 bands, solid state Rx, complete with Eddystone power pack or batteries, headphones and manual, vgc, £45. Thermion 13.8V dc 20A linear PSU, overvolts/current protection, twin meters, air cooled, £35. 13.8V dc 15A linear PSU, £15. 24V 20A transformer, £6. Heathkit 0-300V ac/dc voltmeter, bench type with large scale ideal mains monitor, £5. Heathkit field strength meter with adj sensitivity, £5. Racal (army) headphones with pads, £5. Racal variable Tx, sidetone/practice Morse oscillator with tape rec o/p, £5. Advance 'Advac' wideband VVM with manual, £10. 4 marine quality ceramic ribbed AE insulators, £3 the lot. Box of assorted Tx/Rx components, transformers, tuning conds, hi-volts, caps etc, £5 the lot. G4FZG QTHR. Tel: (0242) 580329

■ G-Whip, base section, f/glass extension, 80m, 40m, coils, top whip, £28. HQ 170A Rx, plus 6m, 4m, good condx, £130. 888A, £70. HRO, 4 coils, p/p, £50. Trio MC60 desk mic, as new, £45. Trio KD1033 r/deck, £20. Goodman 40-40A, £25. Amstrad tuner, £10. Leak stereo, 20A and vol tone control unit, £25. Armstrong tuner/amp and SP25 deck, all in oak cases, £75. Wants GPO/Telecom screwdrivers, nut drivers etc. Tel: Milton Keynes (0908) 313507

■ SSV system with robot interfacier and decoder, TS430S vic comms ATU BNOS power supply, 13.8V, 25A, plus 40/50A and Cobra without driver or fimal. Tel: Rodney, (0689) 58825

■ Daiwa CN-500 SWR meter. Crossed needle, 1.8-60MHz, 20W, £15. Tel: (0926) 498388

■ Exchange FT-250/FP-250, 240W PEP, matching power supply, with speaker, mic, manual, mint, reliable, 80-10m HF rig by Sommerkamp, for either Sony CRF-330K, 320 or CRF-1 Rx or sell. Tel: (061) 743 1570

■ FC757AX auto ATU, as new, £240 ono. G3KNA QTHR. Tel: (0274) 873122

■ Two 11m multimode rigs for conversion to 10. Stalker 9 and Ham Mason, both 80 channels. Stalker is vgc with excellent SSB audio, £90 or will accept 2m rig with cash adjustment. Ham is fair condition, £75 ono. Might consider scanner. Tel: Taunton (0823) 45593

■ FT790, bought Dec 1986, hardly used, two small scratch marks on sides of cover, otherwise immaculate, £275 ono. GM4DGT QTHR. Tel: (0259) 217385

■ Major 588, AM/FM/USB/LSB board fitted for FCC freq, good condition, £75. Also have Major 360, non-working, ideal spares or repair, £25. Both radios for £90. Both will convert to 10m. Also Raytheon radio, believed marine, 5 channels plus PA, needs new valve, £25. Tel: Stalham (0692) 82075 daytime only. Please ask for Ian

■ Ham International Conc 3, £130 ono. CTE International TR45, 27.205-6.600MHz, with Tipo 45 ant, £100 ono. Zetagi TM1000 SWR pwr meter, £30. Ranger AR3300 26-30MHz, mint cond, £280. Tel: (0298) 78268 Derbyshire

■ Uniden Bearcat miniature H/H scanner, 70XLT, 20 memory channels, VHF/UHF, 10 band coverage, absolutely mint condition and boxed, cost £199,

sell for £130. Tel: (0382) 502966

■ FT703R plus extras, £160. Standard C8800 2m mobile, £165. Daiwa LA2065R GasFet linear amp, 65W for 10W in, £90. Microwave Modules pre-amp, £25. Nevada TC35 amp, 10m amp, 4W in, 25/30 out, £15. Morse oscillator, £5. Two-way ant switch, £5. Power echo mic, £15. Two comm speakers, £4 each. NATO 2000, 10m, £180. T R Green G0JEJ. Tel: (048 93) 4960

■ TS180S HF Tx, WARC bands, 100W, in vgc, £450. TR9000 and PSU PS20. Both mint, hardly used, £325. MML 144/50S linear AGN, mint, not 12 months old, hardly used, £70. 8-el yagi 2m, £35. Collinear 2m, £25. Tel: (0270) 257578

■ HQ-1 beam for 20-15-10 metres, complete with Hirschmann rotator, £110. Tel: (0443) 683912

■ Yaesu FT767GX transceiver, including hand mic and 3 modules. Twelves months old, as new, £900. Tel: (058086) 370

■ Racal RA17L, good condition, with full manual and instructions, £150. Tel: Noel G0JFY, (0203) 491245

■ Yaesu FT77 100W HF mobile with FM, scan mic, FC700 ATU. Both boxed, excellent condition, £450 or swap for IC720A. Tel: (0375) 679377 after 6pm

■ C11 rotary transformer, £25. Mains PSU30, £65. Tel: Bob, St Austell 61842

■ Superstar 2000 with 40 extra channels, 25.965 to 28.005, offers, £145. Ranger AR3500 scanning in 100Hz, 1,000, 10,000 increments, split frequency operation, LSB/USB, FM/AM/CW 8W, 25W. Tel: (0283) 221870

■ Redifon ACU9 ATU, in good condition, £50. Grandstand CB, home base, in good order, £100 or will exchange for anything to do with radio. One roller coaster, two variable capacitors, 180pF, £5 each, or what have you? Mr Spencer. Tel: (0522) 792640

■ Kenwood TM401A 70cm mobile Tx/Rx, complete with mobile mount, in vgc, £240. Also 3 x ½ collinear for 70cm, three months old, £30. C S Beynon, Barry, S Glamorgan. Tel: (04468) 261

■ Due to a bereavement I have to sell urgently my FT767 with 2m module and manipulator key, £1,300 ono. C767 (1 month old). Tel: Chas, 01-240 1277 days, 01-987 2296 after 7pm

■ Icom IC-751 HF general coverage Tx/Rx, 250Hz CW filters, RC-10 frequency controller, £895 ono. Philips CD304 CD player (infra-red remote control), £135 ono. Bruce G4WVX QTHR. Tel: (06286) 64415

■ HF5 vertical HF aerial, £40. SM10 SWR power meter, £10. Amiga 500 computer, stereo colour monitor and additional disc drive, loads of software, all as new, £575. Tel: Peter G4HAK, (0273) 517933 Newhaven, Sussex

■ AEA/ICS CPI 'computer patch' RTTY unit, variable speeds, filters, tuning indicator, super unit, as new, £80. SSB (German) L5M24 mixer/oscillator/Tx unit, 2m IF, 24cm (1268-1270MHz) out. Two xtal positions can be re-txaled for anywhere within 23/24cm and retuned, £100. Tel: Paul B4XHF QTHR, (0293) 515201

■ Comm receiver, Trio 9R-59DS, 0-30MHz, plus speaker and Mizuho ATU, 2m converter with power supply handbook, lot £135, includes Securicor or exchange airband or 2m, or scanner. Tel: Steele. Little Cherrington 202 after 8pm, Oxfordshire

■ Racal Rx, RA217 with manuals, good condition, prefer buyer inspects and collects. Reasonable offers please. Terylene rope 4mm dia, 525m drum. VHF/UHF power meters c/w dummy load. Marconi TF1020A and TF1152A, good condition. Various attenuators VHF and MF. Collectors' items as follows: USA valve testers, valve voltmeters, C/R bridge, WWI Wheatstone bridge, transformers, chokes, meters, valves etc. Also WWII and post-war military radio items (no sets). Lists available. John King G4VJK QTHR. Tel: (0298) 783556

■ RTTY unit, G3LIV and all leads for BBC micro, plus disc of ham radio programs, 80TKS only. Will work with other micros, £35. Seagate ST-225 20MHz hard disc, never been used, brand new, will suit IBM or compt, £150. Tel: (061) 427 5931

■ Yaesu FL2100Z linear, two brand new valves, plus one spare, £650 ono. Sommerkamp TS208 45W FM Tx, 144 to 148MHz, £115 ono. Lightweight tower in 3 x 10ft sections, plus crown unit, £50 ono. G4OFR QTHR. Tel: (0752) 880784 Plymouth

■ TS830S, £675. Marine Rx 1.6-4MHz, AM/SSB,

H/B, £10. AOR2001, £275. Panasonic midi unit, twin tapes, record deck etc, £80. Sharpe G5757 portable stereo cassette recorder, auto-search etc, £35. All vgc with full manuals and packing, all ono. Tel: John (0284) 701531 days, (0379) 83596 evenings

■ Icom 1200E 230cm, 10W transceiver (mobile/base), complete with original packing, mint, £460. Wood & Douglas GD1F 107ub 10GHz WBFM board, unused and professionally made 'penny' feed, £75. Kenwood HC10 digital world clock, new, £55. Solfan 10GHz heads (aligned), £8. Tel: Paul G4XHF (0293) 515201

## WANTED

■ Trio TM221E. Tel: John, (0284) 701531 days, (0379) 83596 evenings

■ 7700 with airband frequency. Also Pro 2004. Tel: (0283) 221870

■ Daiwa SR-9 VHF receiver (marine band version) with or without crystals. Fair price paid if reasonable condition. All letters answered. Nick Plumb, Flat 48, Fobbing Farm Close, Nether Mayne, Baisildon, Essex SS16 5NL

■ KW Vespa Mk2 power supply. Good price paid for a vgc unit. Beattie, 44 Collins Road, Helensburgh, Dunbartonshire. Tel: (0436) 5489

■ ATU KW or Drake, also linear WHY? Tel: Coventry 450476

■ Wanted, any ham international Tx/Rx, ham multimode mkl/II, preferably must be in fully working order and in good condition, cash waiting, don't hesitate to call. Tel: Gary, (0504) 46313 after 6pm

■ Audio output transformer to match pair of KT66 valves in push-pull 10KΩ A-A to 4/8Ω speaker. Also same to match pair EL84's. Tel: Andrew, (0423) 69280 after 7pm

■ FT707, TS120/130 type of HF transceiver req'd, good condition, preferably with digital display or WHY. Fair price paid for right equipment. Tel: G0DUE, (0274) 678149

■ I need amp bits! Anything considered, Trans, caps, HT supplies. Needed quickly, fans, small but meaty enough to run a 4CX250 amp circuit of 4m amp, using a 4XC250 valve. HF Tx valves and circuits, any ideas? Spectrum 128K +2 PSU joysticks, I/F software, £75 ono. Also need 70cm 12m 'Wessies', FM only, converted or not, req'd now. Tel: Simon, (0505) 29363

■ Thandar SC110A scope, Larsholt MPU FM tuner, mod 6096, timer counter, model TC321 by Gould. Kenwood audio lab scope, model 6060, Ferguson video 3V23 with remote control. 16in TV, ITT remote control. Exchange for HF transceiver, not Yaesu and receiver. Write to: Rick Jackson 156 Runley Road, Luton, Beds LU1 1UA

■ Exchange: Superstar 360 low-loss to high-high on AM/FM, USB, LSB, for SX200N scanner or Revco scanner RS2000E. Tel: 021-788 8447

■ Marconi TF1064 signal generator. Also, early (pre-1925) wireless valves. Mr Holmes. Tel: 01-977 8938P

■ Military power supply for wireless set, 38 AFV, power supply for Phillips PCR comms receiver. Both must be original, but condition not important. Also required cheap, WW2 military radio equipment. Handbook or circuit information for Panasonic WVP100 camera. Mark. Tel: (04862) 71094 evenings, or (0483) 898072 days

■ I require the following books in good condition please. Will pay well for right ones. *Solid State Circuits Guidebook* by Brice Ward, *Amplifiers* by N H Crowhurst, *Amplifiers* by H L York, *The Use of AF Transformers* by N H Crowhurst, *High Quality Sound Repro* by J Moir, *Loud/Spk* by G A Briggs, *Audio Measurements* by N H Crowhurst. Also any old audio mags and books. Write to: Michael Rose, 63 Rectory Road, London N16 7PP

■ Racal RA17L receiver. Must be in good condition and appearance. Tel: (0730) 62049

■ SSB, Tx/Rx, 2m, in working order, looks unimportant, must be cheap. G10BE QTHR. Tel: (0268) 768610

■ Eddystone receivers: Models 940 and 880/2, must be in mint condition. Good price paid, will collect. L Rogers. Tel: (07356) 2476

■ Station accessories for Yaesu FT901. Please write stating price and condition to Richard Wilcockson G1VPE, 10 Apple Tree Road, Stanfree, Bolsover, Chesterfield, Derbs

■ Eddystone S640 manual, circuit diagram or

## FREE CLASSIFIED ADS

photocopy wanted by ancient radio enthusiast. Derek Wilson. Tel: (0548) 550392

■ Service manual, circuit diagrams, or any information for ITT M5 Star radio telephone (3 ch UHF/FM). Also any conversion information for 70cm (old magazine articles etc), for ITT M5. Tel: Andy G6REG (0604) 48551

■ FRG7 receiver wanted. W J Marles. Tel: Bingham (Notts) 38906

■ Two-element 10m band yagi antenna, aerial must be strong and well made, ie TET HB10 F2T or G2BAR model, even HB9CV will do. Good price paid. Maurice Hughes. Tel: Mid Calder 880345 any time

■ TA124 interface, converts Ferguson Tx10 to video/audio use. Also Peritel interface, converts Tx100 to video/audio use. Exchanges only for 3cm Tx/Rx. Write to: J Brown, 45 Marlborough Avenue, Falmouth TR11 4HS

■ Codar 250/S AC/PV, as used with AT5 Tx. Also old ARRL handbooks. Please send details of condition and prices to: Richard Marris, 35 Kingswood House, Farnham Road, Slough, Berks SL2 1DA

■ Circuit diagram for Pye type PCR2 communications receiver. Mr Lawrence. Tel: (0702) 64877

■ Novus Model 650 electronic calculator, LED display, on sale in UK in 1974 for about £10. Has six digits and uses a PP3 9V battery. Must be marked Novus 650. Wanted to replace one of sentimental value, stolen from office. Please write with price, or would anyone sell me an inexpensive LED (not LCD) pocket electronic calculator? David Knight, 2 The Croft, Putnoe, Bedford

■ PCR3 ex-army receiver. Not working condition considered, provided mechanically sound and original components, especially in RF/mixer, if amplifiers are present and intact. Also, good short wave receivers, valve type or silicon transistors, civilian or ex-military types, in good working order with circuit diagram/handbook. Would consider not working ones if in reasonably repairable condition, or for spares. Write to: Mr Ö S Ekinoglu, 83 Denton Road, Newcastle-on-Tyne NE15 7HB

■ Exchange Canon A1 camera fitted with Canon 35/70 zoom lens ERC. Also Vivitar zoom flash type 2500. All as new, for Yaesu FT290R multi-mode with NiCads and charger, must be in similar condition. Tel: Mr J Horton, Rotherham 893772

■ One or two radio spares 0-30V, 0-0.1A voltage, regulator modules, code 306-998. Must be fully serviceable, preferably unused. Tel: Dick Guntrip, Mullion (0326) 240798 evenings/weekends

■ Heathkit Mohican or GR78, working or not. Manual required for same. Money waiting can collect. John G4LEX, Harrogate. Tel: (0423) 67390

### FREE CLASSIFIED ADS FREE CLASSIFIED ADS CAN WORK FOR YOU

We are pleased to be able to offer readers the opportunity to sell your unwanted equipment or advertise your 'wants'.

Simply complete the order form at the end of these ads - feel free to use an extra sheet of paper if there is not enough space. We will accept ads not on our order form. Send to **Amateur Radio, Classified Ads**, Sovereign House, Brentwood, Essex CM14 4SE.

■ Authentic tuning meter for an AR88 communication receiver. Tel: (0546) 2475

■ Sony ICF 2001D preferably with active antenna. Direct swap for Rolex, Oyster, Chronometer, Perpetual, Explorer. Write to Mr K Miller, 15 The Rise, Green Lane, Whitby, Yorks YO22 4ES

■ Wanted urgently - can't take the silence any more! Does anyone local-ish have a cheap HF Rx for sale, working or not? I have recently moved to the west country, all my HF gear is 200 miles way. Until I can get my lonely AR88 down here, I need something to keep me sane! Anything considered,

not looking for collectors item, cheaper the better! Tel: (0392) 74202 after 5pm. Ask for Andy

■ Grundig professional 3400, or 1400 model receiver for good cash price. Would also consider Sony shortwave receivers CRF320, CRF330, ICF6800, or Panasonic RF8000/RF9000, Icom, ICR70/ICR71E. Tel: Oakley (02302) 2438

■ Heathkit RA-1, including manual. Must be sensibly priced for invalid SWL. Also need manual for Heathkit RG-1, to buy or borrow for copying. Tel: Anthony Wiseman, (0204) 693878

■ Redifon R1007 receiver, must be in good condition, price and details to: John Brook, The Clock Tower, Pidgeon House Farm, Church Norton, Selsey, West Sussex PO20 9DS. Tel: (0243) 606682

■ R109, ex-WD, Rx, 6V unmodified. Your price paid plus carriage. Also ex-WD aerial vari-ometer ATU (19 set type) your price + carriage paid. Tel: Peter (0287) 34397 daytime

■ Racal RA17 receiver in good clean working order with service manual, £150 offered. Will collect if in East Anglia. Tel: Mr Brown, Horringer 441 (Suffolk)

■ Kenwood system base BO-9A in mint condition, for 9130, 9500. Tel: (0446) 710938 after 6pm

■ 'Galaxy' MESA 9000ST radio receiver with BFO and stereo. Pre-sets must be in new condition. Telephone any time, (0472) 358896

■ Medium/heavy duty rotator, exchange for Canon 518SV 8mm zoom cine camera, plus standard Eumig sound projector, both superb condition. Tel: G7AGD, (094881) 302

■ Commtron NATO CB radio, must be in good condition and working. Serious offers only please. Tel: Peter D Darke, (0702) 353247, evenings/weekends

■ Circuit diagrams for FDK multi 750X, Icom IC202 and also Mizuho SB2X. Photocopy of any of the above would be appreciated. All expenses paid. Tel: Barry 91VZW, (0254) 581949 after 5pm

■ KW Vespa mkII power supply. I need a good working unit, above average price paid for a vgc unit. Tel: (0436) 5489

## FREE CLASSIFIED AD FORM

Ad Form removed



# Amateur RADIO SMALL ADS

## IAN FISHER COMMUNICATIONS OF STANHOPE

**CB Works, The Market Shop, Market  
Place, Stanhope, County Durham**  
☎ (0388) 528464

Main Distributors of 27MHz CB radios and the  
NEW CEPT models including UNIDEN and DNT.  
Including U.K. and CEPT walkie talkies.

Large stocks of coaxial cable, plugs, sockets and  
adaptors.

Stockists of the new UNIDEN 28/30 Multimode  
Transmitter receiver

All available via mail order. Retail/Wholesale

OPEN: MON-SAT 10.30am-6.00pm  
SUN 2.30 - 4.30

RING FOR DETAILS (0388) 528464

## ETESON ELECTRONICS



158 Lower Green,  
Poulton-le-Fylde, Blackpool  
Tel: (0253) 885107

Open 9.30am - 12.30, 1.30 - 5.30. Closed Wed & Sun.  
Electronic Component Specialists.

A wide range of electronic components. IC's, capacitors,  
transistors, resistors, plugs and sockets etc.

## ALAN HOOKER ELECTONICS



42 Nethernall Road  
Doncaster



Tel: 0302 25690

Large stocks of electronic  
components

## WORKSHOP SERVICE MANUALS

Any Colour/Mono TV, Amateur Radio,  
Military Surplus, Music System, Vintage  
Valve Wireless etc, etc..... **£5.00 plus LSAE**  
Any Video Recorder ..... **£10.00 plus LSAE**

**FREE** Catalogue Unique Repair and Data  
Guides for LSAE.

**MAURITRON (AR)**  
8 Cherry Tree Road, Chinnor  
Oxon OX9 4QY

## Selectronic

The UK's leading suppliers of  
934MHz personal radio equipment

**203 High Street  
Canvey Island, Essex,**  
Tel: **0268 691481**  
(Open Mon-Sat 9-5.30)

Amateur radio equipment also in stock

**TO ADVERTISE IN THIS  
SPACE CALL MARIA ON  
0277 219876**

## JAPANESE Ic's (PART OF OUR RANGE)

AN7178 £2.95, BA5406 £2.20, HA1377 £2.20, HA1382 £2.50, HA1394 £2.95,  
HA1397 £2.75, HA1398 £2.75, HA13001 £2.95, LA4480 £1.80, LA4481 £1.80,  
LA4507 £4.25, LC7137 £4.50, M51517 £2.80, MB3705 £1.80, MB3712 £1.50,  
MB3722 £3.50, MB3730 £2.50, MB3731 £3.50, STK463 £7.50, STK463 £8.40,  
TA7205AP £1.00, TA7222AP £1.30, TA7240 £2.95, TA7241 £2.95, TA7270  
£2.75, TA7271 £2.75, TA7274 £2.95, TA7280 £3.50, TA7281 £2.95, TA7282  
£3.00, TA7283 £3.00, TA7288 £3.00, TA7611 £1.20, UIC576 £1.00, UIC1156

Form removed

**VALUABLE SPACE FOR SALE!**

Telephone the advertising department on: **0277 219876** for details

**USED AMATEUR EQUIPMENT?**

I buy, sell and exchange

For the deal you've been looking for, phone Dave, G4TNY, anytime on Hornchurch (040 24) 57722 or (0836) 201530 9am-7pm Mon-Sat or send SAE

**G4TNY Amateur Radio**  
132 Albany Road, Hornchurch, Essex RM12 4AG

**BRENT ELECTRONICS & COMMS**

49 Seaview Street, Cleethorpes  
South Humberside DN35 8EU  
Tel: 0472 690383

Pye M296 UHF mobiles.....POA  
Pye A200 linear amp, 148/174MHz ..... **£35 each**

Airlight 62 headset EM mic.... **£35**  
X-Band 20 inch dish and feed  
EL/AZ mount inc motor drives and syncros..... **£50**

Solid State indicator units ex. "Red Steer" radar ..... **£65**

Helical antennas BNC fitting, 2 metres..... **£5.50 each**

All + 15% VAT  
Cheque with order - carriage included

★ **PSSS....** ★

**ALL THE SUPER BARGAINS ARE ON PAGE 14 OF THIS MAGAZINE!!**

★ ★

**THE SCIENTIFIC WIRE COMPANY**  
811 Forest Road, London E17. Telephone 01-631 1888

**ENAMELLED COPPER WIRE**

SWG	1lb	5oz	4oz	2oz
8 to 34	3.63	2.09	1.10	0.68
35 to 39	3.82	2.31	1.27	0.83
40 to 43	6.00	3.20	2.25	1.61
44 to 47	8.67	5.80	3.49	2.75
48	15.96	9.58	6.38	3.69

**SILVER PLATED COPPER WIRE**

14 to 30	9.09	5.20	2.93	1.97
----------	------	------	------	------

**TINNED COPPER WIRE**

14 to 30	3.97	2.41	1.39	0.94
----------	------	------	------	------

Fluxcore

Please add 15% VAT. Orders under £3 add 50p. SAE for list of copper and resistance wire. Dealer enquiries welcome.

**SOUTH WALES**

**ELECTRO DISPOSALS**

2000 sq ft of surplus equipment and components

**UNIT 31, LONLAS WORKSHOPS SKEWEN, NEATH**  
Tel: 0792 818451

**QUARTZ CRYSTALS and FILTERS**

Large numbers of standard frequencies in stock for amateur, CB, professional and industrial applications.

Stock crystals **£5.00 each** (inc VAT and UK post). Any frequency or type made to order from **£6.50**.

Phone or SAE for lists.

**GOLLEDGE ELECTRONICS**  
Merriott, Somerset TA16 5NS.  
Tel: (0460) 73718.

**MRZ MICROWAVE MOBIL ANTENNA**

DESK DC SUPPLY AND BASE FOR ICOM PORTABLES

ICOM-BUSINESS/AMATEUR/MARINE/AIR UK AND EXPORT

**MRZ COMMUNICATIONS LTD**  
NEWCASTLE UNDER LYME

TEL: (0782) 619658  
7 DAY SERVICE

**CRYSTALS** 32.768KHz, 1MHz, 2MHz, £2.35625, 3.579645, 4.00, 4.433614, 4.433619, 4.435672, 4.5, 4.49152, 5.00888, 8.4672, 9.26375, 10.240, 10.245, 10.60445, 15.00, 26.540, 26.690, 26.995, 27.045, 27.095, 27.125, 27.33625, 35.002 @ £1 ea. ALUMINUM PPK 118.500, 119.500, 119.500, 119.850, 119.900, 119.100, 119.350, 119.450, 119.500, 119.650, 119.700, 119.800, 119.850, 120.00, 120.200, 120.300, 120.400, 120.55, 121.00, 121.20, 121.40, 121.75, 121.90, 123.75, 124.00, 125.85, 127.55, 127.75, 128.15, 128.75, 129.55, 20MTR RDK 145.025, 145.05, 145.075, 145.10, 146.125, 145.15, 145.175, 145.20, 145.225, 145.25, 145.275, 145.45, 145.50, 145.55, 145.575, 145.75, 145.80, 145.825, 145.850, 156.0, 156.30, 156.375, 156.50, 156.60, 156.80, 70CMBB 433.000, 433.05, 433.10, 433.15, 433.20, 433.25, 433.30, 433.35, 433.40, 433.45, 433.50, 434.00, 434.65, 434.70, 434.75, 434.85, 434.90, 434.950, £2.00. SAE TO:

**ELECTROKITS**  
18 Kings Road, Sutton Coldfield W Mids B73 5AB

**ON OFFER: IBM 5110 Mainframe. Printer + Diskette. BBC computer with side ram + Disc Drive. New range of 39 Element 23/24cm aerials £60.00. 23/24cm valve cavity amplifiers. Single valve amplifier £110.00 Two valve £200.00 complete with base. BIAS circuit + blower. 432MHz dual range converters. 70cm + Satellite 2 metre IF £40.00**

**MICROMAX R.F. SYSTEMS.**  
TEL 0902 343746. ALL ITEMS + P&P

**VHF ACTION RECEIVERS**

Specialist hand-compact VHF monitor receivers for lo/mid/hf band detection + 10/11m.

Hear Ham's, Aircraft, Public-Service, Marine, Local 2-Way and much more!  
All 53-176MHz signals, +28-30 Mc Hf (11m version also), Squelch, VFO facilities etc. International Series, Special Price: **£29.50** inc p&p.  
Prompt dispatch from:

**TAYLOR RADIO**  
8 Emmerson Street, Crook, Co Durham DL15 8NF. Tel: 0388 763323

**TAR COMMUNICATIONS**

For all Aerials & Lashing equipment. We are famous for the G5 RB antenna and the 5, 7 & 12 element ZL.

For Retail or Mailorder contact:

**TAR COMMUNICATIONS**  
King William St, Stourbridge, W Midlands DY8 4EY  
0384 390944  
NEW GM AERIALS NOW AVAILABLE

**NEXT ISSUE OF**

*Amateur*  
**RADIO**

On Sale Thursday  
29th September

Please mention  
**Amateur Radio**  
when replying  
to any  
advertisements

DISPLAY AD RATES		series rates for consecutive insertions			
depth mm x width mm	ad space	1 issue	3 issues	6 issues	12 issues
61 x 90	1/8 page	£96.00	£62.00	£59.00	£53.00
126 x 90 or 61 x 186	1/4 page	£115.00	£110.00	£105.00	£92.00
126 x 186 or 263 x 90	1/2 page	£225.00	£210.00	£200.00	£180.00
263 x 186	1 page	£430.00	£405.00	£385.00	£345.00
263 x 394	double page	£830.00	£780.00	£740.00	£660.00

COLOUR AD RATES		colour rates exclude cost of separations	series rates for consecutive insertions		
depth mm x width mm	ad space	1 issue	3 issues	6 issues	12 issues
126 x 186 or 263 x 90	1/2 page	£305.00	£290.00	£275.00	£245.00
263 x 186	1 page	£590.00	£550.00	£530.00	£470.00
263 x 394	double page	£1,130.00	£1,070.00	£1,010.00	£900.00

SPECIAL POSITIONS	Covers: Bleed: Facing Matter:	Outside back cover 20% extra, inside covers 10% extra 10% extra [Bleed area = 307 x 220] 15% extra
-------------------	-------------------------------------	--

DEADLINES		*Dates affected by public holidays			
issue	colour & mono proof ad	mono no proof & small ad	mono artwork	on sale thurs	
Sep 88	26 Jul 88	3 Aug 88	5 Aug 88	25 Aug 88	
Oct 88	1 Sep 88	7 Sep 88	9 Sep 88	29 Sep 88	
Nov 88	29 Sep 88	5 Oct 88	7 Oct 88	27 Oct 88	
Dec 88	27 Oct 88	2 Nov 88	4 Nov 88	24 Nov 88	

CONDITIONS & INFORMATION			
<p><b>SERIES RATES</b> Series rates also apply when larger or additional space to that initially booked is taken. An ad of at least the minimum space must appear in consecutive issues to qualify for series rates. Previous copy will automatically be repeated if no further copy is received. A "hold ad" is acceptable for maintaining your series rate contract. This will automatically be inserted if no further copy is received. Display Ad and Small Ad series rate contracts are not interchangeable.</p>	<p>If series rate contract is cancelled, the advertiser will be liable to pay the unearned series discount already taken.</p> <p><b>COPY</b> Except for County Guides copy may be changed monthly. No additional charges for typesetting or illustrations (except for colour separations). For illustrations just send photograph or artwork. Colour Ad rates do not include the cost of separations. Printed - web offset.</p>	<p><b>PAYMENT</b> Above rates exclude VAT. All single insertion ads are accepted on a pre-payment basis only, unless an account is held. Accounts will be opened for series rate advertisers subject to satisfactory credit references. Accounts are strictly net and must be settled by the publication date. Overseas payments by International Money Order or credit card.</p> <p><b>FOR FURTHER INFORMATION CONTACT</b> Amateur Radio, Sovereign House, Brentwood, Essex CM14 4SE. (0277) 219676</p>	<p>Commission to approved advertising agencies is 10%.</p> <p><b>CONDITIONS</b> 10% discount if advertising in both Amateur Radio and Radio &amp; Electronics World. A voucher copy will be sent to Display and Colour advertisers only. Ads accepted subject to our standard conditions, available on request.</p>

# ADVERTISERS INDEX

Brian Price Electronic Instruments.....	37	ICS International .....	19
J Bull .....	51	G4ZPY Puddlekey .....	18
P M Components.....	4	M & B Radio .....	25
P M Components.....	5	Radio & Telecomm Corres School .....	18
R N Electronics.....	10	Rapid Results College .....	25
Hamgear Elec .....	11	Stan Willets .....	14
L F Hanney .....	19	Technical Software .....	11
Harrison Elect.....	37	Waters & Stanton .....	52
Icom .....	26	Weston Elec .....	11
Icom .....	27	R Withers .....	2

- ★ 2m/70cm
- ★ 25 Watts output
- ★ Full duplex operation
- ★ 21 Memories
- ★ 2 Call channels
- ★ Priority channel
- ★ Dual VFO's
- ★ 12.5 & 25kHz steps
- ★ Memory Scan
- ★ Programme Scan
- ★ Memory Skip

**£449 inc vat**

**ALD-24E**

## ALINCO DUAL BANDER



This transceiver could transform your operating habits! It contains completely separate 2m and 70cms transceivers, permitting full duplex operation. To the un-initiated, this means you can transmit on 2m whilst receiving on 70cms, or vice versa. The built-in duplexer means a single antenna socket with a full 25 watts output on both bands. Measuring only 5.5"x2"x6.5" it is the ideal mobile rig. Its comprehensive memory and scanning facilities provide rapid access to both

simplex and repeater channels on 2m & 70cms. Using the dual VFO's you can instantly switch between 2m & 70cm and the single knob tuning provides simple and quick frequency selection. The large LCD readout incorporates an S-meter and is back lighted. If you are looking for a completely self contained 2m & 70cm station, then look no further. At this price it has to be a bargain. For further details of this amazing transceiver, send today for the full colour brochure.

## OUR FAMOUS FREQUENCY MANUALS!

### UK LISTENERS CONFIDENTIAL FREQUENCY LIST 5th EDITION

This publication has now sold well over 3500 copies since it was advertised only a few months ago. Now the recent updated version is selling even better. No self respecting listener should be without a copy. If you enjoy exploring the short wave bands then this publication will add to your enjoyment. It covers the hf spectrum from 2 to 30 MHz and gives details of transmissions outside the amateur bands. Specially designed for the UK and European listener it sets out in a very easy way a comprehensive list of hundreds of interesting transmissions that will keep you occupied for days on end! Only a fraction of the cost of other similar publications it contains details of Marine, Air, Military, Embassy, Press and News agencies. Many listings have time schedules included together with comprehensive RTTY details. It tells you the frequencies used by civil and military aircraft whilst flying the Atlantic, when and where to pick up the press bulletins, long distance marine traffic etc and much more. Send today for your copy of this worthwhile publication.

**NEW 1988 EDITION £6.95 p&p 90p**

### 4th EDITION VHF-UHF AIRBAND FREQUENCY LIST

This frequency manual is without doubt the most comprehensive list of VHF/UHF aircraft listings available in the UK. Of vital importance to the airband enthusiast or indeed any keen VHF/UHF listener it sets out in a very easy to follow manner full details of a whole host of stations. Every known UK airfield frequencies, etc. Included are Civil, RAF, USAF, MOD, Naval fields on both VHF and UHF bands. There are also air to air frequencies, the Red Arrows frequency, and much more. Send today for your copy and find out just how much you have been missing!

**£5.95 p&p 90p**

### THE COMPLETE UHF-VHF FREQUENCY GUIDE 26-2000 MHz

**New 1988 Edition.** Many listeners have asked for a guide to the wide VHF/UHF spectrum and to meet this request we have recently published this frequency manual. It covers the range 26 to 2000 MHz and has been specially prepared for the UK listener. Anybody who has used a scanning receiver will know that the wide frequency range involved means that it is difficult to know exactly where to listen. This guide takes all the guessing out of monitoring. It lists all the services throughout the spectrum together with both simplex and duplex frequency splits. If you've spent your hard earned money on a scanning receiver or are considering buying one you'll find that this publication contains a wealth of information that has previously remained un-published!

**£5.95 p&p 75p**

### HF OCEANIC AIRBAND COMMUNICATIONS 1988 EDITION.

Prepared in response to many requests for more information about the air traffic on the hf bands this little guide sets out to explain to the beginner how the hf band works in relation to air traffic. It contains full details of the world aircraft frequency bands in the range 2 to 23 MHz together with control frequencies and those commonly used for Oceanic control. Also included are many VOLMET frequencies, the Search and Rescue frequencies used by RAF helicopters and Nimrods, the Hf RT network, London Company frequencies, European control centres etc. An ideal companion for the hf airband listener. Send today for your copy.

**£3.50 p&p 70p**

**WATERS  
& STANTON  
ELECTRONICS**

18-20 MAIN ROAD, HOCKLEY, ESSEX - 12 NORTH STREET, HORNCHEURCH, ESSEX.  
MAIL ORDER TO: 18-20 MAIN ROAD, HOCKLEY, ESSEX TEL: (0702) 206835

