

Amateur

# RADIO

For all two-way radio enthusiasts

**Construction:  
Build a Battery Tester**

**Design Practical  
Single-Layer RF Chokes**



**On Test: 144/433MHz duplexers,  
Revex power/SWR meters and the  
Microwave Modules 6m transverter**

# NEVADA

## HIGH QUALITY BRITISH MADE PRODUCTS

### TM1000 1KW All Band ATU

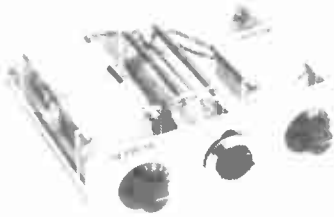

Our unique wide band roller coaster enables effortless matching of GSRV, LW, Vertical and Coax fed antennas with this unit.

Standard model ..... £148  
 For balanced feed ..... £165  
 Fitted with 2 Kw Balun  
 TM1000 Kit complete ..... £129  
 (Add £5 carriage for all versions)

### BUILD YOUR OWN HIGH POWER ATU WITH OUR RANGE OF ATU COMPONENTS

Roller Coaster 1KW 30uH	£24.00	£1 p.p
250 pF Var. Capacitor 1KW (4mm air gap)	£19.95	£1 p.p
250 - 250 pF Ganged Variable 1Kw (4mm air gap)	£28.00	£2 p.p
TC48 Turns counter for RC26	£12.95	£1 p.p
Case (Pre-drilled for above)	£28.86	£3 p.p

### U.H.F. REMOTE ANTENNA SWITCH

(For masthead mounting)

Freq: DC - 1.2 Ghz

Power: 300W P.E.P.

Insertion Loss: 0.19 dB at 900 Mhz

Connectors: Green Par 'N' Type

**£49.95**

ALLOWS SELECTION OF 2 ANTENNAS FROM 1 COAX FEEDER

### H.F. REMOTE ANTENNA SWITCH

(For masthead mounting)

Now you can switch between two HF Antennas on one coax feeder.

Freq: DC - 185 Mhz

RF Power: 1KW P.E.P.

Insertion Loss: 0.15 dB at 144 Mhz

Connectors: SO239

**£39.95**

### 50 Mhz LINEAR AMPLIFIER

WITH HARMONIC FILTER

#### SPECIFICATIONS

Supply: 13 V DC

Input Power: 2.5 Watts

Output Power: 15 Watts

Freq: 50-52 Mhz

Power Gain: Approx 8dB

**£29.95**

+ £1 p+p

### 29Mhz FM R.F. POWER AMPLIFIER

WITH HARMONIC FILTER

#### SPECIFICATIONS

Supply: 13 V DC

Input Power: 1-4 Watts

Output Power: 25-30 Watts

ONE YEAR GUARANTEE

**£24.95**

+ £1 p+p

## THE UK'S SCANNER SPECIALISTS

### BLACK JAGUAR MkII POCKET SCANNER



Two bands covered AM FM  
 Long wave AM (1600-1700 kHz)  
 Frequency range  
 29.54MHz - 118.74MHz  
 406-512MHz  
 906-912MHz

**£235**

### Bearcat 100 XL

Hand held scanner with 100 channels

Memory scan covering 118-174MHz 406-512MHz

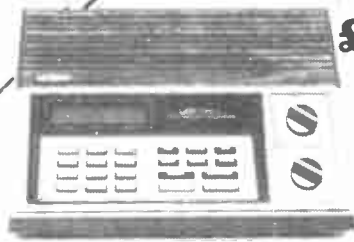

**£189.99**

### Bearcat 175 XL BASE

Base station scanner for use in stations with 1200 covering 29.54MHz

118-174MHz 406-512MHz

NEW LOW PRICE

**£179.99**

### Bearcat 50 XL

A super NEW Pocket scanner with 50 channels and covers 118-174MHz 406-512MHz

**£99.99**



### Bearcat 800 XLT

40 Channel Base Scanner

Covers 29.54MHz 118-174MHz

406-512MHz 906-912MHz

Complete with 1200 Antenna

**£257**

### 70 XLT

#### Bearcat

Pocket size scanner with 70 memory scan

covering 66-88 Mhz

118-174MHz 406-512MHz

Complete with 1200 Antenna and carrying case

**£179.99**

### NEW Bearcat 580 XLT



Base or mobile scanner

100 Memory channels covers

29-54MHz 118-174MHz 406-512MHz

Requires 12V DC supply

**£225**

**HOTLINE (0705) 662145**

USE YOUR CREDIT CARD FOR IMMEDIATE DESPATCH

UK IMPORTERS

## NEVADA COMMUNICATIONS

189 LONDON ROAD, NORTH END, PORTSMOUTH, PO2 9AE

Tel: (0705) 662145 FAX: (0705) 690626 TELEX: 869107 TELCOM G

# ANGUS MCKENZIE

---

# TESTS

---

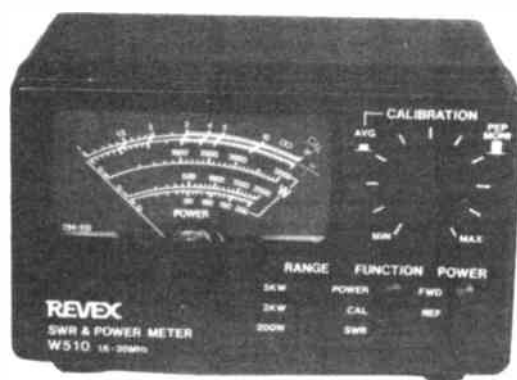

---

## REVEX W510, W520, W510

---

### Power/SWR meters

---

In the August 1986 edition of this magazine I gave a good recommendation to the Daiwa model NS660P power meter which covered HF and VHF bands, and also UHF/microwave with optional heads. Very recently Waters and Stanton announced a new range of Revex power/SWR meters. All the meters are in-line types, and are claimed to be capable of reading PEP on all modes as well as normal average power. They can all read reverse power, but require FSD forward calibration before switching to SWR to obtain an SWR reading.

#### The W510 HF power/SWR meter

The W510 has switched power ranges of 200, 2000 and 5000W – the last range is almost mind-boggling, but possibly appropriate for some overseas stations! Next to the three position range switch is the power, calibrate and SWR switch, and finally there is a forward or reverse power switch. The meter itself is oblong, measuring 65 by 30mm, the scaling being fairly small but easy to read. Although the instrument is a passive type, an alleged PEP facility is provided when the SWR CAL knob is pulled out. This facility was extremely disappointing (see later).

The meter is only suitable for measuring powers between 1.8 and 30MHz, and note that the most sensitive range is 200W, so low power levels cannot be read at all easily. Transceiver and antenna connections are on SO239 sockets at the back of the instrument.

#### The W520 HF/VHF power/SWR meter

Almost identical in appearance to the W510 is the W520, which offers power ranges of 2W, 20W and 200W for full scale deflection. All other switches on the meter are identical to those on the 510,

and the only other difference is that the frequency range is extended to 150MHz, the in and out connections again being SO239s on the rear. The PEP facility was again considered to be very poor.

#### The W570 power/SWR meter

The front panel and switching facilities on this model are identical to those on the other two models, but this meter also includes a detachable directional coupler fitted with N type sockets. This allows it to be put in line with a coaxial feeder up to 1 metre away from the back panel. Fixed SO239s are provided on the back and are interconnected with the HF/VHF internal coupler. The external one can also be screwed on to the back panel. A row of vertically mounted push buttons select four different frequency ranges, only the lowest one selecting the SO239s and internal coupler. These ranges are 1.6 to 160MHz, 400 to 525MHz, 700 to 1100MHz and 1240 to 1300MHz. The power ranges are 5, 20 and 200W FSD.

#### Power limitations

Whereas the W510 is not suitable for use at 144MHz (it actually indicated 350W when I put through 150W carrier for a few seconds!), the W520 and 570 models were both suitable for VHF. However, although the two latter instruments are scaled at 200W FSD on the highest power range and can read this power perfectly well, the instructions make it very clear that you are limited to no more than 100W continuous throughput on modes such as FM and RTTY between 1.6 and 60MHz. More seriously, there is only 70W continuous throughput from 60 to 160MHz. On the W570 from 400 to 1300MHz a sensible throughput continuous power of 150W is allowed.

It is quite obvious that the directional coupler used for the SO239 socket connections is not really man enough for a lot of applications that this equipment could be used for, eg 100 to 150W FM continuous RF. Even 160W FM leaving the shack is perfectly legal if you have at least 2dB cable loss. I regularly use a Mirage linear at 160W output on 145MHz when controlling an FM net from an omnidirectional discone antenna. The high omni ERP is used so that I can cover all the home counties reasonably well for my RAIBC net. Both these meters will of course read up to 200W for short periods.

#### Ergonomics

All the meters are extremely well ergonomically designed, and I liked the lever switches very much. It is so convenient to be able to pull out the rotary knob for reading PEP, but it would be even better if the PEP readings were useful!

In the case of the W570, it was quite simple to take the external coupler off the back panel for remote use. However, I had continual trouble with the frequency range buttons, for only the slightest touch either released the one that was in or pushed the wrong one in. You would have to be extremely careful to make sure that you pushed in the correct one. One odd point was that the SO239s for the lowest frequencies were mounted at the top of the back panel, but the N sockets on the coupler were at the bottom when the coupler was used on the back of the instrument, despite the fact that the buttons were HF at the bottom and microwave at the top!

#### Overall power accuracy

We checked power on several HF

bands from low to high frequency, and at various levels. In general the accuracy of all three meters was excellent, usually within 5% of the values obtained from a carefully calibrated Marconi 2382 analyser and Racal 9303 microprocessor controlled wattmeter. The W510 did under-read 7% on 28MHz at the 100W level, but this is only around 0.3dB! However, on the 2kW range, quite a marked under-read of 12% was noted when I sent 1kW through it for a few seconds.

The W520 meter was within 5% at low and high power levels when the appropriate range was selected.

On the W570, 145MHz readings were very accurate at medium and high power levels, but the instrument did under-read by up to 10% at low levels (around 2W). The same meter gave readings which were within 10% of other equipment on 70cms and 23cms after very careful calibration.

Reflected power readings were checked against forward ones, and very similar readings were noted, this test being applied to all three meters.

#### SWR accuracy

In general SWR readings tended to be on the optimistic side on all three meters, but accuracy always seemed better on high rather than low power. Readings were at least as accurate as other meters checked, and are certainly an excellent guide, since minimum indicated SWR did correspond to 50 ohms.

The 520 and 570 required less than 3W forward power to obtain FSD readings, but accuracy was better when at least 20W was used. The W510 required nearly 10W to obtain FSD on the calibrate

position, but once again higher through-put powers were required to get acceptably accurate readings.

We placed a Bird 4410 through line wattmeter between the transmitter and both the 520 and 570 in turn, in order to check whether the SO239 sockets were good enough to avoid any noticeable effect on the system SWR on 144MHz. We could not detect any significant return power at all, the Bird meter needle only just coming off the bottom stop on the 1W range when we were sending quite high power. Incidentally, no significant power losses were noticed through any of the power meters in the test.

#### Peak envelope power indications

I have been using quite an old Hanson FS710H on the HF bands for many years for reading PEP and automatic SWR, the instrument being placed immediately before my Icom AT500 automatic ATU. I have checked it against my Bird PEP meter, and it has always performed very well, even a short tut over the mic or a single 'dit' on the key giving a full reading. Just occasionally it might overshoot 5% or so.

I placed the W570 in line with it, initially to gain an idea of approximate accuracy on the HF bands as compared with my Hanson (which I do not use as an actual lab standard!). When I pulled out the knob for reading PEP on the Revex meter, we were horrified to see that when the Hanson was peaking 110W PEP on 3.75MHz, the Revex meter read between 10W and 25W. I tried various HF bands, and could only get higher readings with pretty hard processing switched on which gave a maximum of 50W, against the Hanson's 110W or so, other than when I whistled or made a

continuous sound, which is not what a PEP meter is all about.

I then switched on my Kenwood panoramic adaptor/station monitor, which has a simple two tone/single tone audio output source, and fed this into my TS940S, which was used for all the HF tests. Single tone readings on the Revex were just what I expected, but two tone readings read around 12% low. Even on the average position the two tone reading was 18% down, whereas it should have been reading at a much lower level on average power as opposed to peak envelope power.

#### Conclusions

I can recommend purchase of any of the three instruments reviewed, if you do not need a meter which is capable of indicating peak envelope power on speech etc. They are all very compact and easy to use, and accuracy was very adequate for amateur use. However, you will have to look elsewhere if you want a PEP meter. The best bet would probably be the Daiwa twin needle PEP meter at £115 from Lowe Electronics or their agents. Revex is, apparently, a companion company to Welz, which has now merged with Diamond, the precise details of Japanese companies' comings and goings being almost indescribably complex. The Revex W510 costs £79, the W520 is £59.95, and the W570 £119, all prices including VAT.

I would like to thank Jeff Stanton of Waters and Stanton Ltd for kindly loaning the review samples, and for very helpfully discussing the PEP reading problem, which he acknowledges. Also very many thanks to Fiona for helping me with all the measurements and the word processing.

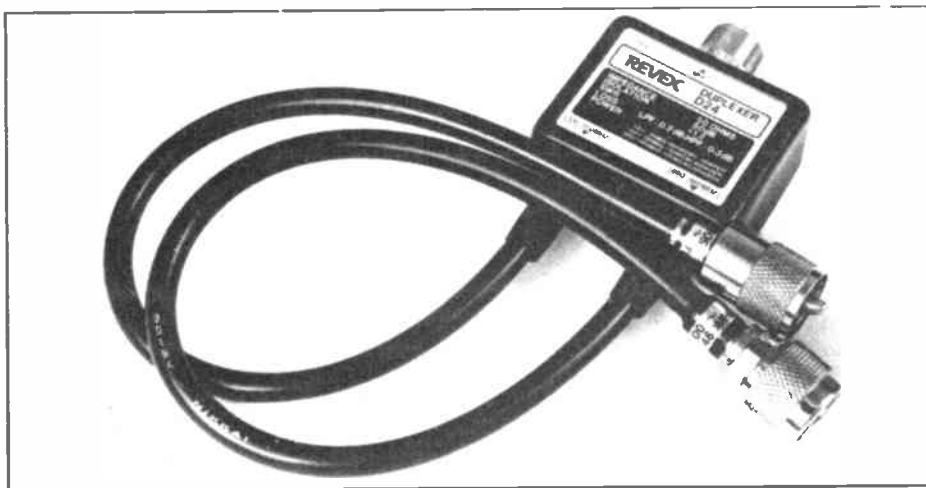

## REVEX D24 and MALDOL HS780

### VHF/UHF duplexers

There are several dual band collinear antennas available for 2m and 70cm FM, and I reviewed two new Hokushin

models last month. However, I only know of three rigs that produce both bands on the same output socket; the Icom

IC3200E mobile, the Yaesu FT727 and the recent Standard dual-bander, the last two rigs both being hand-helds.

Many fixed and mobile dual-banders have been released, the best known of these being Yaesu's FT726 and 736 base stations and FT2700 mobile; Kenwood's TS770 and 780, and TW4000 and 4100 are all typical examples. All the rigs having separate outputs for VHF and UHF invariably seem to use an SO239 for 2m and an N type for 70cms.

All the dedicated 70cm rigs that I can think of released in the last few years also have N type sockets for the antenna connection, so it is logical that any duplexers made to combine the outputs of 2m and 70cm rigs should have an N type plug on the 70cm connection and a PL259 for the 2m one.

I acquired my first duplexing unit in 1983 with the MA4000 Kenwood mobile dual-band antenna, for use with the TW4000 mobile rig. The duplexer seemed to work very satisfactorily, and I have never had any problem with it. However, this model is only rated at 50W FM and so is only suitable for use with barefoot rigs, as are some of the earlier dual-band antennas, which I learned to my cost. I

can well remember blowing up my dual-band base station collinear by absent-mindedly putting 100W through it for a very long over, and then wondering why everyone had gone quiet!

I therefore thought it would be a good idea to have a look at exactly how good some of these duplexers are, and whether one can reasonably trust them, especially if you want to transmit through them on one band whilst receiving on the other. I have used both the TW4000 and 4100 as test-beds, the latter being used for duplex tests.

### Input and output connections

Whereas the original Kenwood MA4000 duplexer (from Lowe Electronics) and the Revex model D24 (available from Waters and Stanton), had an N type plug for 70cms with a PL259 for 2m, the antenna socket on the duplexer was always an SO239 unfortunately, a type of socket that should be avoided on all 433MHz equipment.

For some very odd reason, the Maldol Model HS780 (from Lowe Electronics) is very confusingly fitted with PL259s for both VHF and UHF connections. I can see absolutely no reason for this at all, since for many years I have not come across a 70cm rig with an SO239 antenna socket.

You have to bear in mind what these duplexers actually have to do. They have to pass RF from the transmitter through the appropriate port of the device to the antenna output. If one port is passing Tx power, there should be next to no leakage through to the other port, which will be feeding a receiver. Whether or not the receiver is actually live, there has to be extremely good isolation between the ports to avoid any risk of damage to the circuitry. Furthermore, if the equipment is being used in the duplex mode, any breakthrough from Tx should not materially desensitize the receiver on the other band.

There will obviously be problems at or near harmonics, and there might also be a few spurious frequencies noted. The actual level difference at the duplexer's antenna socket between the transmitted signal and the receiver noise floor is of the order of 178dB or so. One therefore has to consider the remnant noise floor at the third harmonic of the transmitter over the entire band, as well as the harmonic level itself.

For good duplex operation the transmitter performance has to be good in this area, but the lower frequency input port must also have excellent lowpass filtering. Similarly, the higher frequency port must have excellent highpass filtering to give good rejection of the lower frequency fundamentals.

Some rigs have rather broad-banded Rx input stages, whereas others have reasonably good bandpass characteristics between the antenna change over relay and the first Rx amplification stage. A duplexer that might be good enough for one rig or combination of rigs might be inadequate for another.

**Plot 2** Revex/Welz D24 duplexer 145MHz port response throughput to antenna socket lowpass filtering. Resolution bandwidth: 1000kHz. 40MHz per division

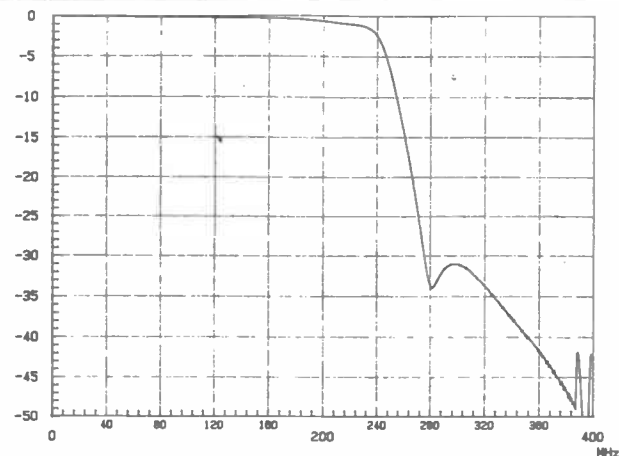

**Plot 1** Kenwood MA4000 duplexer Tx through response via 144MHz port, 50 ohm loading. Resolution bandwidth: 100kHz. 40MHz per division

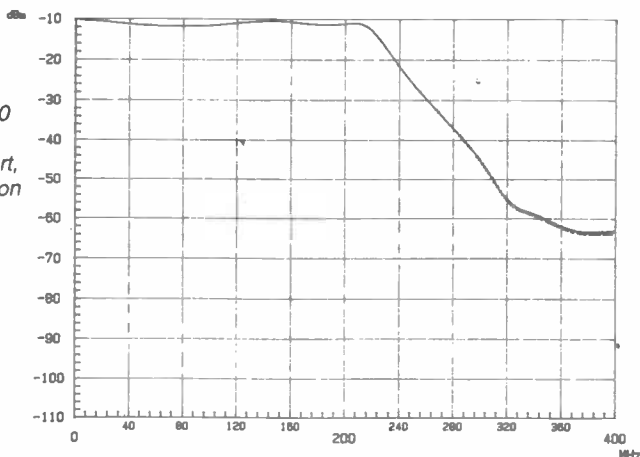

### Through losses

The three duplexers were all measured in the same way for through loss from the relevant input port to the output socket, with the alternate port loaded with 50 ohms. In each case, the test source was a Marconi 2019 signal generator, with a microprocessor-controlled Racal type 9303 RF Level and Power meter. All losses are relative to a straight through connection, bypassing the duplexer and any necessary adaptors.

On 145MHz, the original Kenwood duplexer had the highest loss (0.3dB), but even this loss is considered to be minimal. The Maldol HS780 gave a loss of 0.25dB, whilst the best was the Revex D24 at only 0.2dB. Considering that this included two PL259/SO239 junctions, the losses within the duplexer are very low indeed. On 433MHz the losses were somewhat greater, the highest loss being noted on the Maldol at 0.5dB, whereas the others were close to 0.4dB – a little more significant, although the difference is very marginal.

### Port Isolation

For this test we used a 50 ohm dummy load on the antenna socket, and measured the breakthrough from one port to the other at the appropriate frequency. 145MHz breakthrough to the UHF port (loaded 50 ohms) was poorest on the Maldol at around -49dB, but was superb at below -70dB on the Kenwood model. The Revex was very satisfactory at just below -60dB.

To put this into perspective: if the Maldol had 100W on 145MHz passing through it, then there would be around 1mW going into the receiver input on UHF which could cause blocking on some rigs. 100W would be too much for the original Kenwood model, but the Revex would produce just less than 100µW, which would probably be satisfactory for most rigs.

How about the other way round? The Maldol gave -53dB of 433MHz through to the 145MHz port, but the Kenwood was only marginally better at -53dB. The Revex was far superior at -64dB. In my experience, 145MHz stages tend to be more robust than UHF ones, so you would probably not have trouble with any of the duplexers when transmitting on UHF.

I then decided to see what would happen if there was a bad mismatch on the antenna. I thought the worst possible case would be an open circuit, and this degraded the breakthrough in either direction by up to 6dB or so. A slight SWR hardly had any effect on the figure. The units did not seem to introduce any SWR problems on either of the bands.

### VHF/UHF crossover

To give an idea of the crossover performance, a brief perusal of Plot 1 of the original Kenwood duplexer from 145MHz input to the antenna socket shows a very good lowpass filter action. A plot of the UHF throughput is more or less the inverse of the VHF response. The Revex duplexer gave surprisingly



## RAYCOM GIVES YOU MORE PURCHASING POWER



FOR FAST SERVICE PHONE IN YOUR ORDER WITH ANY MAJOR CREDIT CARD OR IN MOST CASES WE CAN OFFER YOU INSTANT CREDIT OF UP TO £1,000.00 (SUBJECT TO STATUS). RAYCOM ARE LICENCED CREDIT BROKERS, APR 29.8% SUBJECT TO VARIATION. FREE CREDIT ON CERTAIN PRODUCTS AT LIST PRICES. 50% DEPOSIT AND SIX MONTHLY PAYMENTS. PLEASE TELEPHONE FOR MORE DETAILS AND APPLICATION FORMS.



## ORDERING INFORMATION

ALL PRODUCTS WE ADVERTISE ARE NORMAL STOCK ITEMS. OUR NEW MAIL ORDER DEPARTMENT CAN NOW DESPATCH MANY LINES SAME DAY. BUT PLEASE ALLOW UP TO 14 DAYS. DELIVERY TIME IS SUBJECT TO CARRIAGE METHOD. IF ORDERING MY MAIL PLEASE INCLUDE CARRIAGE AND STATE YOUR DAYTIME TELEPHONE NUMBER. ALL PRODUCTS OVER £750.00 CARRIAGE FREE. PLEASE ALLOW TIEM FOR PERSONAL CHEQUES TO CLEAR. PLEASE CALL **BEFORE ORDERING** AND FOR MORE DETAILS.

Telephone 021-544 6767

NEW HELPLINE 0836 282228 (until 9pm Daily)

THROUGH YOUR CONTINUOUS AND VALUED CUSTOM, RAY WITHERS COMMUNICATIONS LTD HAS MOVED AND EXPANDED TO ENABLE US TO OFFER YOU EVEN BETTER SERVICE AND PRICES - STILL WITH THE RAYCOM GUARANTEE, BEST EQUIPMENT, BEST SERVICE, BEST PRICES, BEST BACK-UP, PLENTY OF PARKING FACILITIES AND EASIER TO GET TO! WE NOW BOAST THE BEST CENTRAL FACILITIES IN THE COUNTRY. WHY NOT POP ALONG AND SEE THE LATEST TRANSCEIVERS, SHORTWAVE/SCANNING RECEIVERS AND ACCESSORIES? MOST OTHER PRODUCTS ADVERTISED IN THIS MAGAZINE ARE AVAILABLE AT RAYCOM, AND DON'T FORGET OUR EXCLUSIVE PRODUCTS AND MODIFICATIONS!

## uniden A new concept in amateur radio . . . UNIDEN 2830 10mtr band amateur transceivers

It's here at last! A beautifully made processor controlled full feature 10w (20w PEP) multimode transceiver with LCD readout and all functions necessary to work DX with Sparadic E and in the forthcoming sunspot maxima and also for transverting to the VHF and UHF bands! Work out the facts . . . how much is a Two Meter multimode? How much is the Uniden 2830 Ten Meter multimode and a 2 mtr transverter? With the Uniden 2830 you can have two bands for the price of one, with 10 watts on each band and all modes including CW.

### FEATURES:

- \* All modes, AM/FM/USB/LSB/CW
- \* LCD Readout of frequency/functions
- \* CW with Sidetone
- \* FM bandwidth compatible with VHF/UHF
- \* 10 Watts continuously variable o/p AM and FM
- \* Scanning feature, up and down steps on Mic
- \* Selectable frequency steps, 10Khz, 1Khz, 100Khz
- \* Ten meter band selectable in 500Khz steps
- \* Built-in VSWR Meter and protection circuit
- \* Superb receiver sensitivity <.3 uV FM

Just ten of the many reasons for choosing the Uniden 2830  
\* A range of VHF-UHF of matching transverters available, please enquire for models currently in stock  
\* This product is exclusive to Raycom



10/2 MTR Version  
Out Soon @ £399.00

## ANTENNAS & ACCESSORIES

NOW AVAILABLE AT RAYCOM: CUSHCRAFT, BUTTERNUT, HY-GAIN ANTENNAS, JAYBEAM, TONNA, MET, HAM-M ROTATORS. Call for full details, prices, availability and delivery costs.

ICOM AH7000 SUPER 25-1300MHz DISCONE	£70.50
G5RV HALF SIZE HF ANTENNA ready to use	£16.50
G5RV FULL SIZE HF ANTENNA ready to use	£18.50
C8KW-TYPE 7 1MHz TRAP DIPOLE KIT SO239	£24.50
G8KW-TYPE as above for use with 75 OHM	£23.50
G8KW-TYPE 2x7.1 TRAPS ONLY, LmSS CABLE	£9.95
RAYCOM AIRBAND-VHF SIX ELEMENT DISCONE	£12.50
RAYCOM DISCONE VHF 60-600MHz 8E 50239	£20.50
SUN KG205 2M 5/8 MOBILE TILT-OVER 259	£14.50
RAYCOM CAST GUTTER MOUNT C/W SO239/COAX	£9.50
GAMMA TWIN 2 METRE SLIM JIM KIT inc instr	£14.50
RAYCOM/RWC HB9CV 2 METRE 2E MINI BEAM	£12.50
RAYCOM/RWC HB9CV 70CM 2E MINI BEAM	£8.95

The above popular products POST FREE (UK mainland only)

## SCANNERS

### BEARCAT by uniden



UBC 175XL



UBC 100XL

RAYCOM ARE TRADE AND RETAIL DISTRIBUTORS FOR THIS SUPERB RANGE OF QUALITY SCANNERS. THE POPULAR UBC 100XL HANDHELD HAS SOLD IN THOUSANDS, BUT IS NOW COMPLIMENTED BY THE UBC 70XL POCKET SIZED HANDHELD. ALSO THE NEW COST EFFECTIVE UBC 50XL HANDHELD. SEE THE NEW MODELS IN OUR SHOWROOMS OR SEND A SAE FOR DETAILS.  
FROM £99.50

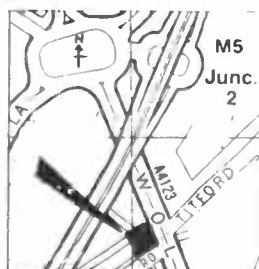

## SCANNERS

YAESU FRG9600 from the company who specialises in fitting extra options, as supplied to Government departments and professional bodies. We also upgrade existing models, please call for more details, prices, delivery and information.

Yaesu FRG9600 Basic Model Improved 'S' Meter + Sens	£465
Yaesu FRG9600/RWC Mk 2 60-950MHz 'N' Connector Fitted	£495
Yaesu FRG9600/RWC Mk 3 HF 100KHz-950MHz plus Mk 2 Spec	£595
Yaesu FRG9600/RWC Mk 5 HF 50KHz-950MHz Active Mixer	£525
Package deal on above Mk 3/5 FRG9600 c/w AH7000 discone, G5RV PA4 AC PSU, complete receiving station HF-UHF including delivery UK mainland. Add £100 to above price.	
Icom ICR7000 25M-2GHz superb quality professional Rx	£850
Icom ICR7000/AH7000 Receiver plus Matching Discone	£937.50
KENWOOD RZ1 New 500KHz-950MHz Mobile	
Wide & Narrow AM/FM	POA
Fox VHF-UHF Multi Function Mobile Scanner FM only	£139
UNIDEN BEARCAT UBC 50XL VHF-UHF 10ch H/held Scanner	£95
UNIDEN BEARCAT UBC 70XL VHF-UHF 20ch Miniature H/held	£179
Uniden-Bearcat UBC 100XL VHF-UHF-Airband H/held Scanner	£189
Uniden-Bearcat UBC 175XL VHF-UHF-Airband Desk-Top	£175
BJ200 Mk 2 VHF-UHF-Airband-Military Airband H/held	£220
AOR 2002 25-550, 800-1300MHz Desk-Top/Mobile AM/FM	£469
Sony Air 7 Top Quality VHF-UHF-Airband Handheld Scanner	£245

### SHORT WAVE RECEIVERS

Yaesu FRG8800 Short Wave 100KHz-30MHz all Mode + Mem	£589
Yaesu FRG8800/FRV8800 as above with VHF Conv fitted	£679
Icom ICR-71 Top Grade Communications Receiver	£799
Sony PRO80 HF/VHF Handheld Scanner c/w accessories	£345
Sony 2001D Short Wave/Airband DE1 IIFX RX with ANI kit	£395

Many more makes and models in stock. PLEASE CALL FOR PRICES, DELIVERY COSTS and any advise or information, or send large SAE (Insured post and packing £10.00. Carrier £12.50).

**SONY** - RAYCOM now appointed official Sony dealers, full range of both professional and domestic models available to order. Worth waiting for!

## HANDHELDS

\* Extended Receiver coverage available, call for details

YAESU FT272R/FNB4A 2.5W (5W) DUAL BANDER C/W CHRGR	£395.00
*YAESU FT23R/FNB10 2.5W (5W) 2 MTRS C/W CHARGER	£249.00
*YAESU FT73R/FNB10 2.5W (5W) 70CMS C/W CHARGER	£259.00
*ICOM MICRO 2E 5W 2 MTR HANDHELD WITH CHARGER	£209
CTE1600 (SAME AS ICOM IC2E) C/W NICAD CHARGER	£179.00

Many other types of handheld stocked, please enquire

## PORTABLES

FT290RMK2 2.5W MULTIMODES STANDARD ACCESSORIES	£399
FT290RMK2 2.5W WATT M/M AS ABOVE C/W NICADS CHRGR	£425
FT290RM2/DL2025 (STD) WITH 25W LINEAR AMPLIFIER	£489.00
FT690RMK2 6MTR 2.5W MULTIMODE STANDARD ACCES	£399.00
FT690RMK2 6MTR 2.5W M/M AS ABOVE C/W NICADS CH.	£425.00
FT790VK2 NEW 70CM 2.5W MULTIMODE DUE OUT SOON	£499

## MOBILES

YAESU FT211RH 45W 2MTR MOBILE WITH FREE 1/4 WAVE ANT	£299
YAESU FT212RH NEW 45W 2MTR MOBILE DVS FEATURE OPT	£349
*ICOM IC28E 2MTR 25W MOBILE WITH FREE 5/8 ANTENNA	£359
ALINCO Dual Bander ALD-24E	£445.00
ICOM IC-48E 70cm 25W	£429.00
ICOM IC-3200 Dual Band 25W	£499.00

Many other types of makes stocked, please enquire

Opening hours 9am-5.30pm 6 days, late nights Thursday & Friday till 7pm



## RAYCOM COMMUNICATIONS SYSTEMS LTD

INTERNATIONAL HOUSE, 963 WOLVERHAMPTON ROAD, OLDBURY, WEST MIDLANDS B69 4RJ  
Telephone: 021-544 6767. Fax: 021-7124. Telex: 336483 Ident-G

low losses on all the HF and VHF bands on the 145MHz port (*Plot 2*) and so you will be able to use it if you wish to duplex HF or 50MHz, for example, with 433MHz.

#### Combining and splitting

Many amateurs are strictly limited in the number of coaxial cables available to them between the shack and the antenna farm. A typical example of a problem situation is when an amateur lives on the ground floor of a block of flats, and is allowed roof mounted antennas provided there is only one coaxial cable running up to the roof. There is no reason why two rigs should not be duplexed to one low loss co-ax, but split again up at roof height to separate antennas for 145 and 432MHz bands. The losses within the duplexers can be virtually ignored when

you consider the advantages.

There is, however, another advantage in using one of these duplexers with separate rigs. A rig driving an antenna on the roof on one band, whilst another fairly close antenna is feeding a separate receiver on another band, is likely to produce higher breakthrough levels than the duplexing of the two rigs into one cable. This is because of the low and highpass filtering actions of these duplexers. You can of course improve breakthrough between separately fed antennas by careful positioning, or by the use of appropriate bandpass filters.

#### Conclusions

Bearing in mind all the above considerations and measurements, I have no hesitation in recommending the Revex

R24 as being the safest duplex with comparatively low through losses. It is very well made and is supplied with an amazing specification, which will probably make you think of many other applications. The LF port is rated to be used from 1.6 to 30MHz at up to 1kW PEP, or 400 CW, and from 140 to 150MHz throughput power is specified as 400W PEP or 150W CW.

Through loss is claimed to be 0.2dB from 1.6 to 150MHz, and 0.3dB between 400 and 460MHz. On 433MHz, the power rating is 250W PEP or 100W CW. The SWR is claimed to be better than 1.2:1. No power specification is given for the 50 and 70MHz bands.

The Revex (made by Welz) is available at £26.95 including VAT, from Waters and Stanton Ltd, Hockley, Essex.

## The Microwave Modules MMT50/28S 6m Transverter

I have had to wait over two years to obtain a sample of this transverter for review because the manufacturers explained they could not keep up with demand, and therefore could not spare one for review! I am consequently indebted to Lowe Electronics for lending me this review sample, which they had purchased.

Very many years ago Microwave Modules Ltd made many transverters for 70, 144, 432 and even 1296MHz, and most of these have been reviewed either in this magazine or in my RSGB book, *The Buyer's Guide to Amateur Radio*. The best of the bunch was quite definitely the newer 144MHz transverter for direct connection to a 28MHz transceiver. This was quite a good model, but its RF input intercept point was not good enough for today's traffic on the 144MHz band, although I understand that improvements were made in later production samples. In 1985 the new muTek transverter proved to be very much superior to the Microwave Modules one, but now that muTek have ceased trading, the only competition is from the excellent SSB Products one.

#### The MMT50/28S

Competition for this fairly new design of 6m transverter is rather more limited, and I have so far only met with an R N Electronics model which requires 144MHz as an IF for 50MHz RF, and I have also tried a Yaesu 50MHz transverter intended for use with some earlier transceivers, which did work fairly well.

The MMT50/28S requires a drive level on 28MHz from about 20 $\mu$ W to a maximum of 750mW for full output to be reached. All the input and output sockets are SO239s and, as is usual with their products, MM have one socket for transceiving on 28MHz whilst a second

gives an independent receive signal for use with a separate Rx input. The normal 50MHz output socket is also usually wired for transmit and receive, but a second socket is mounted so, by changing the internal leads around, a user can arrange to have a separate Rx input.

Although the transmit section has an ALC loop around it, which can accommodate up to 20dB gain reduction, there is also an IF input drive potentiometer. This is adjustable by screwdriver through a small hole in the back panel, which allows for the very wide input drive range. There is also a switch to select a pre-amplifier for the input drive, or direct feed into the mixer input circuitry. The switch and preset thus allow this model to cope with the very low levels now given by recent models from Yaesu and Icom, with peak drive levels well below 1mW, as well as many older models giving 100mW or even more.

#### Power requirements

The usual 270° five pin DIN socket is mounted on the back panel for 13V dc connections and external PTT for Tx. The transverter also has RF vox sensing, with a user variable hold time giving a variation from almost instantaneous fallback to around two seconds hold. This control is on the front panel, and gave a very good range of adjustment.

The only other controls on the front panel are a 13V dc on/off switch and a sideways acting switch which selects the 6m band section 50-52MHz or 52-54MHz, using an IF from 28-30MHz. A row of LEDs is provided to give an approximate idea of Tx power output, the top one coming on at around 10W.

The unit is housed in a metal case, finished in black with a grey front panel and fitted with handles. The dc on/off and Tx LEDs provide useful indications.

The rig requires up to 4A on Tx if your



# Amateur RADIO

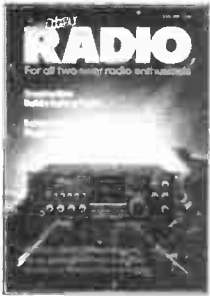

**Editorial:**  
Lisbeth Stedman  
Bob Farmer

**Advertisement  
Manager:**  
Marian Vidler

**Subscriptions:**  
01-760 0409

**Accounts:**  
Clare Brinkman

**Publisher:**  
Peter Williams

**On sale:**  
Last Thursday of the  
month preceding cover  
date

**Next issue:**  
Cover date July 1988, on  
sale 30th June 1988

**Published by:**  
Amateur Radio  
Magazines, Sovereign  
House, Brentwood,  
Essex CM14 4SE,  
England  
(0277) 219876

**Printed:** In England

**ISSN:** 0264-2557

**News Trade Sales by:**  
S M Distribution,  
6 Leigham Court,  
Streatham,  
London. SW16 2PG  
Tel: 01-677 8111

**Front cover:**  
The Icom IC781 HF  
transceiver

Whilst every care is taken when accepting advertisements we cannot accept responsibility for unsatisfactory transactions. We will, however, thoroughly investigate any complaints. The views expressed by contributors are not necessarily those of the publishers. Every care is also taken to ensure that the contents of *Amateur Radio* are accurate, we assume no responsibility for any effect from errors or omissions.

© Copyright 1988  
Amateur Radio Magazines

## 6 Straight and Level

All the latest news, comments and developments on the amateur radio scene

## 8 DX Diary

Don Field G3XTT with this month's DX news

## 10 Power Supplies for Beginners

John and Steven Goodier conclude their beginner's guide to PSUs by dealing with undervoltage and overvoltage protection

## 17 Angus McKenzie Tests

G3OSS looks at Revex power/SWR meters, Revex D24 and Maldol HS780 VHF/UHF duplexers and the Microwave Modules MMT50/28S 6m transverter

## 24 A Beginner's Guide to Packet BBS Operation

Now that you're expert on power supplies you can tell everybody on your LAN - Joe Kasser gives you an insight into how it works in the States

## 29 Project Book

Did you know the 741 has a few tricks up its sleeve? Martyn Williams guides you through the prestidigitation

## 32 Practical Single-layer RF Chokes

A straightforward guide to designing RF chokes by Ray Fautley

## 34 Battery Tester

For those of you who haven't built a power supply, B B Walters describes a useful gadget to make sure your batteries still have life in them

## 36 Second-hand Receivers for under £50

Built a battery tester or power

supply? Perhaps you'll want to economise on your receiver budget by taking Hugh Allison's advice

## 39 Sandown 1988

A review of the RSGB's National VHF Convention by Fiona McKenzie

## 40 Short Wave Listener

Trevor Morgan has had an interesting letter on the subject of awards

## 42 Coming Next Month

More informative articles

## 44 Bits to Build

George Dobbs begins a short series which describes how to build a modular direct conversion receiver for the amateur HF bands from 160m to 20m

## 46 50 MHz

A propagation study from the Scilly Isles courtesy of Ken Ellis

## 48 On the Beam

No short cuts to success but Glen Ross tells of two new 150km paths

## 50 Second-hand

Hugh Allison's backwards transformers have caused a spate of dead sets

## 53 Free Classified Ads

They speak for themselves

## SERVICES

**43 Newsagents Order Form**

**55 Free Classified Ad Form**

**58 Back Issues Order Form**

**58 Advertisers Index**

**58 Advertising Rates and  
Information**







# STRAIGHT &

# LEVEL

## Shielded coil forms

Cirkit have introduced a comprehensive range of shielded coil forms, manufactured by Micrometals of California. The assemblies include both an adjustable threaded core and a fixed cup to close the magnetic path.

Iron powder cores are offered as standard, but ferrite cores are available for applications which need higher inductance at lower frequencies. Winding forms vary from series to series, with impregnated paper tube, polyester tube and nylon bobbins available. Shielding cans for electromagnetic shielding are made of copper with tin plating to ensure performance.

A thermoset plastic that will not deform at elevated temperatures is used for the plastic moulded bases; all pins are copper tin plated.

For further information, contact: *Cirkit Distribution Ltd, Park Lane, Broxbourne, Hertfordshire EN10 7NQ. Tel: (0992) 444111.*

## Digital multimeter

With the introduction of the Siemens B1010, Instrumex is now offering a digital multimeter which is specially designed to be of use to power and plant maintenance engineer.

The hand-held B1010 covers all the measurements that maintenance engineers are likely to need. Minimum and maximum values are clearly presented on the 3½-digit liquid crystal display. Temperature, phase sequence, diode and continuity test as well as features such as standard parameters of current, voltage and resistance are included.

Readings are given from 200mV-1000V and from 20mA-10A on dc and from 200mV-750V and 10mA-30A on ac. Both are with 100µV and 10µA maximum resolutions. Resistance readings from 10mΩ to 2MΩ and temperature readings from -20 to +1200°C can also be made.

The B1010 gives phase sequence indication - ie, the direction of phase rotation of

three phase supplies and measurement of the phase to phase voltage. Maximum and minimum value storage allows both unattended measurement and the retention of extreme values for later evaluation.

This overload-proof multimeter has large easy-to-use controls and display, making it a good choice for difficult situations. It is powered by 6 x 1.5V batteries, and is supplied as standard with rugged case, safety jacks and safety test leads.

For further information please contact: *Instrumex, Dorcan House, Meadfield Road, Langley, Berkshire SL3 8AL. Tel: (0753) 44878.*

## Instrumentation catalogue

STC Instrument Services has produced a massive 320-page catalogue covering equipment ranging from computers and UPSs to oscilloscopes. Also included are speech design products from over sixty-five leading suppliers.

The 20-section publication now features a new area dedicated to training. This encompasses the Global Specialties CDA-1 powered proto-board; the HP1 advanced logic designer and PB503 protoboard, as well as the MTP-80 microcomputer fundamentals program.

Speech Design's audio card, Rifa's PKC dc/dc converters and the Global Specialties 2005D function generator are also among the new products which are highlighted.

Details of the STC test house facilities and information about on-site exhibitions are also provided.

For further details, contact: *STC Instrument Services, Dewar House, Central Road, Harlow, Essex CM20 2TA. Tel: (0279) 641641.*

## Display module range

STC Mercator has launched a new 'super-slim' range of dot character display modules.

The CU-SCPB series includes devices measuring just 176 x 44 x 28mm featuring

an 8-bit bidirectional parallel data bus and user definable programmable fonts. Working from a 5V supply, power usage is 300mA for the 5-font 2 x 20 version and 750mA for the 2-font 2 x 40 device.

In the same series is a compact 1 x 20 unit costing less than £40 and measuring 150 x 32 x 24mm. This has an 8-bit parallel and serial input (1200BPS) and a command base 8-step dimming function. Other features include a user-programmable font; a unidirectional data bus and a 5V, 100mA (typical) power requirement.

For further information, contact: *STC Mercator, South Denes, Great Yarmouth, Norfolk NR30 3PX. Tel: (0493) 844911.*

## PCB package

At CADCAM '88 Number One Systems launched a printed circuit board design and schematic draughting package entitled *Easy PC*.

Continuing their quest for affordable CAD, *Easy PC* was developed to make professional computer-aided printed circuit design available to the tightest of budgets.

The company is firmly convinced that users of the system will recoup the cost of *Easy PC* many times over in time savings, perhaps even with their first design.

Number One Systems are not trying to vie with the 'big boys' who provide full auto-routing, connectivity lists and schematic capture, but do intend to shake up the low cost market where auto-routing algorithms can still leave the user to do the tricky tracks, and where a comprehensive range of layout features, drawing functions and speed are of more practical value than the frills.

*Easy PC* is exceptionally fast - zooms, pans and red-raws are done at considerable speed, on a single key-press.

For further information contact: *Number One Systems Ltd, Harding Way, Somersham Road, St Ives, Huntingdon, Cambridgeshire PE17 4WR.*

## Icom IC781

The Icom IC781, pictured on the cover, is something new in the realm of amateur radio. With a built-in spectrum scope, twin passband tuning and DDS (Direct Digital Synthesizer), it is a truly unique rig.

Naturally, all bands and all modes are included – SSB, CW, RTTY, AM and FM. The IC781 has a 105dB dynamic range and 150W output power. Impressed? You should see the rest of the facilities.

We could quote the manufacturer's specifications – the information provided in the leaflet is an indication of the quality of this machine. Suffice it to say that we prefer to let our own Angus McKenzie do the talking for us – he intends to review this remarkable HF rig in a future edition.

Since Angus is enthusiastic about the possibility of reviewing the 781, you may wish to know more. Remember, though, that your local Icom dealer probably won't have one in stock. At £4,500 including VAT, you can understand why.

Nevertheless, a rig which transmits on amateur bands from 160m to six metres has to be a cut above the rest. And the receiver is a quadruple conversion superhet on SSB, CW, RTTY and AM, and a triple conversion on FM! Enough said... Angus's review follows shortly.

## Royal visit

Those who wish to attend the RSGB's 75th anniversary National Convention in Birmingham will be pleased to hear that the hobby will have the royal seal of approval.

HRH Prince Philip will be opening the Convention on Friday, July 15th – let's hope that the weather reflects the warm welcome which such a distinguished visitor is bound to attract.

## Shetland expedition

John Kelley G0HMZ writes to tell us that he is going to be operational as GM0HMZ/P from Shetland during the period July 19th-29th.

He will be active on 144MHz, 3.5MHz, 14MHz and possibly 29/28MHz, depending on conditions.

The QTH will be near Sulom in (NGR) HU37 square. John doesn't know the locator square at present, but all relevant info will be included

on the special QSL cards which will be issued.

John says that cards can be sent to him via the bureau or QTHR. He is going to use a Trio TR9000 for two metres and an FT707 for HF. Skeds can be arranged in advance if desired. He intends to be on-air each weekday on 3.640MHz ±QRM, from 0530 to 0630GMT, and skeds can be arranged then.

## Here comes summer

There's plenty afoot in Coventry this month, as Coventry ARS get into the swing of summer. June 3rd is the club's usual night on the air with Morse tuition, as is June 17th.

June 10th brings a 2 metre DFing Contest. Now, where did I put that rig?

The club's allowing plenty of opportunities for frantic searching this month, with a treasure hunt and barbecue on Sunday, June 19th. Sounds like great fun, and anyone who's worried about the burgers can run a metal detector casually over them without looking too out of place...

CARS is going places on June 24th. Where? Who knows? The visit has yet to be arranged. Perhaps it's a magical mystery tour, though we hadn't noticed any yellow submarines parked around the streets of Coventry. Maybe our sleuths aren't looking hard enough.

CARS meets every Friday at 8pm in Baden Powell House, 121 St Nicholas Street, Radford, Coventry. Visitors are welcome and anyone wishing to join the club should contact Jon G4HHT on (0203) 610408.

## Tripe and nonsense

Incidentally, a Blunt Northerner rang the Ed the other day. 'Your magazine?' he said. 'It's rubbish. And I didn't like any of it except Angus McKenzie.' Well, the Ed asked politely, exactly what would he like to see? 'Interesting things.' Perhaps, then, he'd like to write something more interesting for himself? 'Not\*\*\*\*likely! I don't pay for summats and write it too.'

With a few more rude words the gent rang off. Now, we really like to know what you want in the mag, don't we? (Though preferably not exclusively in four-letter words). So if you feel that your favourite subject isn't covered enough,

or even too much (!), please write. That's the only way we find out what you want in the mag, and the only way we can make it the best mag on the market.

Please don't phone the Ed just yet, though. She's still recovering...

## Promising stuff

I wonder what it is about summer that makes people rush off to inaccessible Scottish islands and transmit from them? Even the Girl Guides are doing it.

In fact, there's an International Girl Guide Camp at Aikerness, Evie, Orkney between July 2nd and 8th, and they are setting up a special event station.

Operating with the callsign GB2ACO they will be about on HF SSB on 80, 40, 20 and possibly 15 metres, mostly in the evenings when the girls are in the camp. There will be a special QSL card and for WABers, the square is HY32.

More information can be obtained from Anne GM6WPA or Bill GM3IBU, QTHR.

## Searching story

The Midland ARS, celebrating the finding of a new club house, is taking up looking for things in earnest.

June 21st brings a midsummer treasure hunt by G4OMP and G0GPZ, and since the club is now situated in Birmingham's Jewellery Quarter, the seekers might not have to go far to strike gold!

The club meets several times a week, holding Morse classes on Wednesdays, a night on the air on Thursdays and computer groups on the second Tuesday and last Monday in the month. No wonder they wear club houses out so quickly!

MARS meets at 7.30pm in Unit 16, 60 Regent Place, Birmingham, and everyone is welcome.

## Tx talk

Blackwood and District ARS are not holding a meeting at half term – they meet in a college, so the doors are closed to them out of term.

They will be making up for lost time later in the month, though. June 10th brings a technical description of the FT101ZD by Ross Clare GW3NWS. Since this rig is one of the commonest around, this should be a most useful talk.

On June 17th, Robert Morgan, who is a member of Islwyn Borough Council's Planning Department, will be talking to the club about how to obtain planning permission. Just think, Blackwood could be full of 100ft towers by the autumn!

The club meets at 7pm on Fridays in Oakdale community centre. For further information, contact Brian Matthews GW6YYR on (0495) 243858 or Terry John GW4XCU on (0495) 222573.

## The train now standing

Those of you who don't work cheek-by-jowl with a model railway magazine probably won't have seen the Mallard recently (or even a reasonable facsimile thereof).

The record-breaking steam loco is not forgotten though – Scarborough Special Events Group is commemorating the 50th anniversary of the train's 126mph run by holding Special Event Stations on July 3rd and 9th.

Using the callsign GB75MAL, the group will be around on 3725/7055kHz and 2m FM.

The Mallard will also be around – on those days it will run from London to Scarborough.

Special QSL cards will be issued to commemorate this very special event, and a very beautiful train. Enquiries should be directed to Roy Clayton G4SSH, QTHR.

## World Radio TV Handbook

It's here! The book the clubs get together to buy – the 1988 edition is out. This is a comprehensive list of current world radio frequencies.

Feature articles this year include details of how Cuba is monitored, how IRCs are used, the work of the BBC Monitoring Service and clandestine stations. Not to mention the receiver review which includes the ubiquitous ICF7600D and Grundig Yachtboy as well as the more serious Kenwood R5000 and Lowe HF125.

What else is there to say? The book's general usefulness has made it a popular – in fact, a standard – text. It's well worth spending those saved pennies on.

*Billboard Publications, £17.95. ISBN 902285 13*

# DX DIARY

News for HF operators compiled by Don Field G3XTT

The big news this month is that EA9IE and Martti OH2BH announced at the Visalia DX Convention in April that they had permission to operate as 4W0EA from the Yemen in the last week of June. They plan to go there with the Lynx DX Group who, of course, are the team responsible for last year's SORASD operation. If anyone can pull off a coup of this sort it must be Martti, who is one of the few to have operated from Albania in the past, so let's keep our fingers crossed!

There were rumours that the RL8PYL Club would be active from Vietnam as 3W8YL during the CQ-M contest in May. UA9YE is also reported to have said that ten Soviet operators had licences in hand for a Vietnam operation during the October CQWW Contest. And *DX News Sheet* has received a letter from UL7PAE of the RL8PYL Club to the effect that they hope for a Vietnam operation during the 1989 CQWW Contest, and possibly this year as well, which seems to go some way to confirming the various rumours. Again, we can but hope.

## Kingman Reef et al

The days of hoping for KH5 are now over. As I write this the Kingman Reef operation is in full swing, signing K9AJ/KH5K. They have been workable in the early morning on 20 metres, and there was also an excellent evening opening to the UK on 15 metres late the first evening. Perhaps most surprisingly of all, on at least one morning they were an excellent signal on 40 metres CW.

The manners and operating behaviour of the Europeans have, unfortunately, been as bad as ever and I dwelt on this topic at length last time. However, there has been plenty of opportunity to make a QSO and, in the end, if we fail to make it then we have only ourselves to blame.

I'm pleased to say that quite a lot of recently licensed UK operators managed a QSO, and special thanks are due to Paul F6EXV, the only European operator on the DXpedition. Paul made a point of looking specifically for European contacts, despite frequent rude comments from US stations who felt that, having put up most of the money, they should get priority.

What I do find rather a pity is that many of the stations getting through in the first couple of days were the well-known 'big boys', most of whom I'm sure already had this one credited to their DXCC score. It would be nice if they gave some of the newcomers a chance first, but I suppose that is wishful thinking.

Certainly it looked at one stage as if the operation might be short-lived, when a storm blew up and the group had to close down operations (Kingman Reef is barely above sea level, just a few hundred metres long and a few metres wide). Fortunately, they were able to resume activity about 12 hours later and went on to make many more QSOs. Given that so little of Kingman Reef remains above water, there must be a serious doubt as to whether any future operations will take place. Hopefully Paul F6EXV will be at the RSGB HF Convention in September to give us the full story.

The KH1, Baker and Howland Island, operation also took place during April. This one was more difficult for the European operators to crack, apparently due in part to the DXpedition operators not knowing when to look for Europe. There is even one report from New Zealand of them calling 'CQ Europe' on 80 metres at 1000GMT. Not surprisingly, they didn't get any takers! Nevertheless, the operation amassed almost

30,000 contacts in all. DJ6SI also turned up in April from yet another rare location. This time it was Benin, where Baldur and Hans DK9KK operated as TY9SI, making many people happy.

There was plenty of other DX to be had in April, and I won't go into detail. Probably the most noteworthy point is that once again 10 metres was showing remarkable signs of life, with strong signals at times even from Hawaii. Since the new sunspot cycle started in September 1986, the sunspot count has increased at a faster rate than in any previous cycle. The only one which came close was Cycle 19 which peaked in the late 1950s, with a sunspot count of over 200. A good omen? If the count really did get that high, even 6 metres would exhibit ionospheric propagation. We can only wait and see.

I was also pleased to see a report during April that JY1 had appeared briefly on 10 and 20 metres. In case this doesn't ring any bells, JY1 is none other than King Hussein of Jordan. He was very active in the early 70s, but affairs of state seem to have kept him very busy in recent years and he rarely manages to get on to the amateur bands. He also holds a UK call and has occasionally shown up on two metres when over here, much to the surprise of those who work him!

## Iran

As I have mentioned before, there have been a number of EP stations active on the bands recently. According to *DX News Sheet* these stations are tolerated by the authorities but official licensing will not be re-introduced until hostilities between Iran and Iraq cease. In the meantime, QSLs from these stations are not acceptable for DXCC.

## DXCC

Talking about DXCC, the

start date for the new 10-metre single-band DXCC award is July 1st. Applications will be accepted by the ARRL up to two weeks in advance of this date. Of the applications to hand on July 1st, the station with the highest total will receive certificate number 1, the next highest number 2, and so on. If two stations have the same total, they will both receive a DXCC certificate with the same number.

The new application form must be used (send two units of postage, or in other words about 1 dollar, to: DXCC Application Forms, ARRL HQ, 225 Main St, Newington, CT 06111, USA. Contacts after November 15th 1945 will count. The same procedure will apply for the new single-band 40 and 80 metre awards, but the start date for the 80 metre award will be November 1st and the 40 metre award will not start until May 1st 1989.

Interestingly, the ARRL has now defined in more detail what it expects to find on a QSL card for it to be acceptable for DXCC awards purposes. There is still no requirement for a signal report, but the confirmation (normally a QSL card, but any written confirmation is OK) must include the callsigns of both stations, the country, mode, date and time of QSO, and the frequency band. In my own collection I have a number of cards carrying the callsign but without the country explicitly stated. It remains to be seen how stringently the ARRL will apply these criteria.

## Forthcoming DX

As soon as you have this column in your hands, start looking for ZY0TR and other ZY0T callsigns. This will be a Brazilian group who are due to operate from Trindade from June 1st-7th. The operators will include PY1BVY and PS7KM and the group will pay particular attention to CW

and RTTY, with CW activity 15kHz above the band edges. QSLs, and donations towards the cost of the operation, go to Karl Mesquita Leits PS7KM, Caixa Postal 385, 59001-Natal, Brazil.

A couple of the US bulletins report that N4NW (currently active as 9Q5NW) has permission to operate from TN, probably as TN4NW. Tom planned to visit the Congo on as many weekends as he could manage, travelling there by boat along with Duncan 9Q5DA on a Friday evening and returning about midday on Sunday. Each trip was expected to cost about \$150 per day, so any donations with your QSL would be most appreciated.

If you still need Aruba then look out for P40P from June 15th-22nd. N1CIX will be the operator and his announced frequencies cover CW and SSB on 80 to 10 metres, including the WARC bands.

#### News in brief

JX8KY (LA8KY) should be back on Jan Mayen by now and will be there until late September. At the time of writing there was talk of an operation from Revilla Gigedo in May or June, but no definite announcements. A group of Japanese amateurs were due to operate from Micronesia from May 27th until June 5th, taking in the CQ WPX CW Contest. The callsigns were expected to be KC6DX, KC6MS and KC6AB. QSL to JA7AGO.

A group of Americans were due on from St Pierre and Miquelon from May 26th-29th, and FROEH expected to be operational from Juan de Nova during May and then from Glorioso Island from June 22nd until July 31st. Finally, Bing VK2BCH was due to leave on May 8th for a three month Pacific tour taking in 5W, ZK3 and ZK1. He will only accept direct QSLs, to his Australian address.

#### Solomon Islands

Apparently, from May 1st there has been a tightening of licence conditions in the Solomon Islands so that only those operators who have passed a CW test will be allowed to operate on HF. This will reduce the number of H4 stations active on the HF bands to just five. However, to celebrate the 10th anniversary of independ-

ence, the special station H44X will be active from June until August. A special QSL card will be available from H44SI, Box 418, Honiara.

#### Prefixes

Stations in Swaziland now use the strange prefix 3DAO, rather than 3D6. Don't ask me why! Stations in St Kitts are due to start using the V45 prefix rather than the usual V47, to celebrate the 5th anniversary of independence. FV6PAX will be active until 30th June for the 44th anniversary of D-Day. TQ6JUN will be active until June 13th.

#### Yasme

As always, Lloyd and Iris Colvin were on tour this last winter. They operated as XE2GKG, 9N5QL, W6KG/4S7 and YB0QL. They were also able to visit Bangladesh, Bhutan and Burma, but could not obtain licences in any of these countries. At best they got a promise that amateur radio licensing might be reconsidered sometime in the future.

Lloyd and Iris will be at home in California until October; they then hope to resume their travels once again. Neither of them is getting any younger, but their continuing efforts and travels on behalf of amateur radio put many a younger DXer to shame.

#### IOTA

On the Islands on the Air front, nine members of the International Police Association will sign TX9IPA from the Iles St Marcouf between June 3rd and 11th. K5MK and others expect to activate the Ship group of islands in a limited operation on June 25/26th, and intend to make a full-scale effort on October 22nd/23rd. TV6HOE will be active from the Hoedic Islands (IOTA EU48) from June 3rd-6th.

#### RTTY

I have noticed a number of interesting stations recently on RTTY including such DX as ZD7, ZD8, C5, 3C1, C0, 9J and V4. If, like me, you are the proud owner of a multimode terminal unit then it is well worth firing it up on RTTY or Amtor.

Most activity seems to be on 20 metres, though 15 metres carries quite a lot of RTTY traffic when it is open.

#### DXNS Silver Jubilee Award

In the final analysis, the 6 month *DX News Sheet* challenge was won by Hazel G4YLO who worked 268 countries, 192 zones (on five bands) and 98 countries on Top Band.

Hazel completed her Top Band DXCC just a couple of days after the competition ended. This was a remarkable achievement, especially as Hazel had only two weeks holiday from work during the 6 month period. Congratulations are due to Hazel and a salutary reminder to the rest of us about what can be achieved on the HF bands, given enough determination. Now perhaps Hazel's OM, Tim G4STH, will be able to get his hands on the rig again!

#### Oblast guide

Geoff Watts, who already publishes several useful lists, has now introduced a *USSR Oblast Guide*. This includes a full list of oblasts, information on how to identify the oblast in which a station is located, outline maps and much more in its thirteen pages.

It can be obtained for £1, from Geoff Watts, 62 Belmore Rd, Norwich, Norfolk NR7 0PU. Overseas readers should take note that the dollar price of all Geoff Watts' publications has now increased to \$3.

While on the subject of USSR oblasts, it appears that a number of the restrictions which have applied to USSR amateurs are in the process

of being lifted. Unconfirmed reports suggest that USSR amateurs may now work Israeli stations, may have photos and their address on their QSLs, and that full address information will be published in callbooks and may be passed over the air. In addition the power limit has been raised from 200 watts to a kilowatt, and packet radio is permitted for the first time. If these reports prove to be accurate, this is very welcome news indeed.

#### Contests

Don't forget the CQ-M Contest on May 14th/15th (details were given last month) and the CQ WPX CW Contest on May 28th/29th (rules are as for the SSB leg, see my March column).

#### Congratulations

Finally, congratulations are due to Al Slater G3FXB, who was inducted to the CQ Contest Hall of Fame during the Visalia DX Convention, and also to Jim Thurber K9KQ, who has become the first North American station to qualify for the Worked All Britain Diamond Award. Al G3FXB has been a leading contestant for many, many years and is also known for the major role he plays in FOC, the First Class Operators Club. A well-deserved honour indeed.

That's it for this month. As always, please take the time to send me your news, shack photos, etc. 73 de Don.

Don Field brings  
more Dx News  
next month.

Enquiries can be  
directed to our  
editorial office  
on page 3

# POWER SUPPLIES FOR BEGINNERS Part 2

By Steven and John Goodier, G4KUB and G4KUC

## Part 2 – the construction of a power supply

The layout of the supply is not too critical. It can be built on a small piece of Veroboard instead of a PCB. The best way to make the PCB is to buy one of the many printed circuit pens which are now available. The pattern is very simple and can be copied onto a 75 × 45mm copper-clad board; see *Figure 7a* (May issue) for the foil pattern. Thicken all the lines, especially around the rectifiers and smoothing capacitors, then etch the board in ferric chloride solution. Next, drill all the holes, clean the copper side of the board with wire wool and wash it in hot, soapy water. You are now ready to solder into place all the components.

### Starting construction

Start by soldering into place the four rectifier diodes. Make sure you fit each diode the correct way round and double check them with the PCB overlay. Fit

the smoothing capacitors, again double check that you have fitted them the correct way round. The case of each electrolytic capacitor is marked with a positive and negative symbol, so make sure they correspond with the symbols on the overlay. If you are using a single axial capacitor then solder it in place as shown in *Figure 7b* (May issue); this fits where the three single-ended capacitors would normally go and an extra solder pad has been provided on the board to take its extra length. Next, solder into place C2 and C3. C2 can be fitted either way round, but C3 is electrolytic so make sure it is fitted correctly.

If you are planning to use the regulator at its normal fixed voltage output, it's just a simple matter of leaving out R1 and fitting two wire links in place of R2 and R3. If you wish to increase the output voltage of the circuit then refer to *Table*

3. Listed are a number of fixed resistor values for R2 and R3 and the resulting output voltage. *Table 3* also shows a list of resistors for use with a 470R pre-set resistor. Using a pre-set resistor for R3 will enable you to adjust the output voltage much more accurately.

### Experimentation

The adjustment of the output voltage would be a lot more accurate if the value of the pre-set resistor were reduced to about 100R, but then you would need to experiment with the value of the fixed resistor. You can't fit R3 and a pre-set resistor to the board at the same time: you either fit one or the other; the choice is up to you. If you wish to use the zener diode circuit shown in *Figure 6b* (May issue) then increase the value of R1 to 4k7, replace R2 with a wire link and fit the zener diode in place of R3.

### Fitting the regulator

The next step is to fit the regulator itself. *Figure 13* shows a number of different voltage regulators' leadouts; if you look at the 78 series, you can clearly identify the three different legs. Don't forget that when drawing high current, the regulator will get quite hot and will need bolting to a heatsink of some type. If you look through the component catalogues, you will find a variety of different types of heatsink; make sure you choose one that will provide adequate cooling.

### Insulation

Most people bolt this type of regulator to the back of the instrument case and use short flying leads to the regulator board. If you are going to use the regulator at its normal fixed voltage and the instrument case is at zero volts, ie earthed, then there is no need to insulate the metal back of the regulator from any of the metal. If you have decided to use one of the modifications to increase the output voltage then the regulator *must* be insulated from any metal parts of the

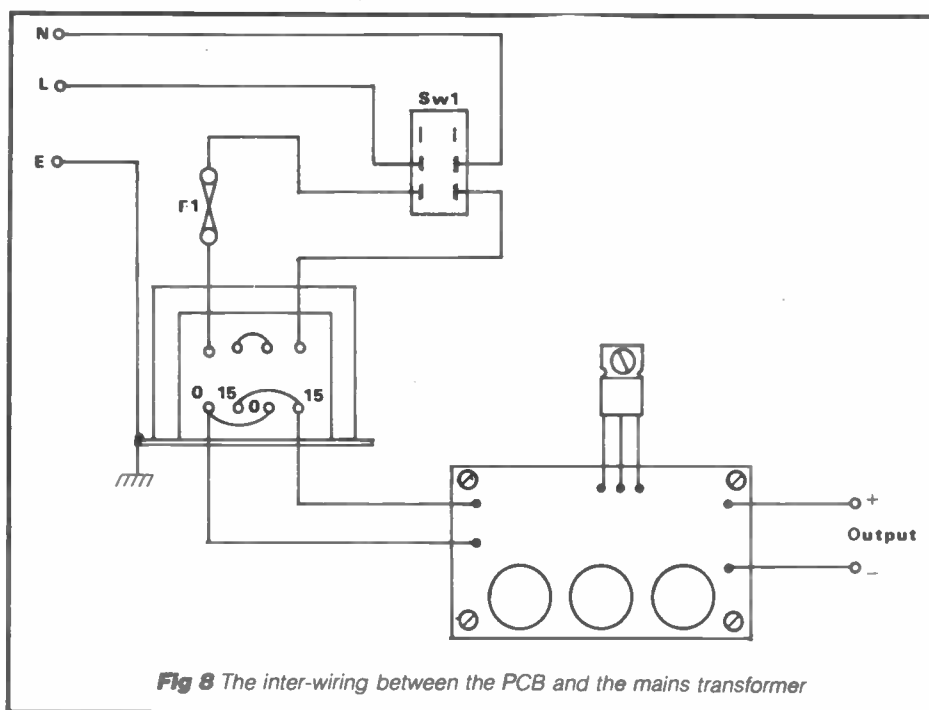

**Fig 8** The inter-wiring between the PCB and the mains transformer

# POWER SUPPLIES

case. The only way to do this is by using a TO66 mounting kit (about 7p from Maplin Electronics). If you don't insulate the regulator, the modification for increased output voltage will not work.

## NB

Figure 8 shows the inter-wiring between the PCB, mains transformer and mains input. Please note that there is a 1A quick-blow fuse F1 in line with the live input. The mains plug must also be fitted with a fuse of about 3A, purely for safety reasons.

Remember that fuses blow before anything else does. First, the live and neutral are wired to a double-pole switch – the mains on/off switch for the power supply. The earth can be bolted to a convenient point on the chassis. In Figure 8 I have used one of the bolts holding the mains transformer in place. If you are using a metal box to house your power supply, you *must* earth it.

The type of transformer shown has a secondary winding of 15-0-15-0 wired in parallel. Remember that the secondary voltage and current rating of the transformer depend on the final output you wish your PSU to supply. A list of suitable transformers for standard output voltages is shown in Table 4.

## Variable regulators

All the devices we have looked at so far have been fixed voltage regulators which can be made variable over a limited range. To cover a much larger voltage swing, it is far better to use a variable three-terminal voltage regulator such as the L200 or the very famous UA723. We have decided to concentrate on the LM317 series, for which a brief list of specifications is given in Table 4. A much more detailed list can be found on page 401 of the current Maplin Electronics catalogue.

## Built-in limiting

The LM317 series regulators are completely variable from about 1.2 to 37V and can provide output currents of between 100mA and 5A. All the devices have in-built current limiting and can withstand a direct short circuit on the output. Figure 9 shows the circuit diagram of a typical 1.2 to 25V PSU. The data supplied in Table 2 shows the maximum input voltage for the LM317 is 40V, so I have used unregulated supply line of about 35V to avoid damaging the regulator. In the prototype, I used the LM317MP, rated at only 500mA output, so I chose a transformer with secondary windings rated at 12-0-12-0, 0.6A. These are wired in series to produce an unregulated supply of about 35V across C1 (see Figure 9).

## Modifications

The LM317 needs only two resistors and three capacitors to get it up and running. The basic circuit can be modified in a number of different ways; the most common one is to wire a capacitor across the variable resistor

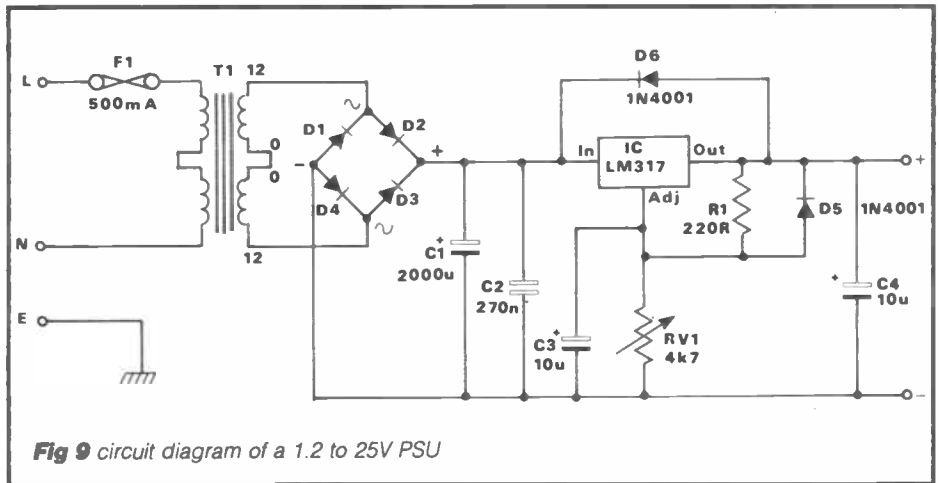

Fig 9 circuit diagram of a 1.2 to 25V PSU

VR1. This increases the ripple rejection from 65dB up to 80dB. Diodes D5 and D6 are added to protect the regulator from any short circuit on either its input or output.

## Similar circuit

Figure 10 shows a similar regulator circuit to that of Figure 9, but in this design there are a few changes to the voltage selection part. In this version, the output voltage can either be set by one or two fixed resistors or by a fixed resistor and a low value pre-set resistor. A list of resistors and output voltages is shown in Table 6, and it is only a matter of choosing the correct values for the output voltage you require. Both of these basic circuits should work with all the LM317 regulators, so it is up to you to choose. All you have to do is make sure

that the transformer, rectifiers and smoothing capacitors are rated accordingly.

## Building a variable supply

Construction of the variable power supply unit is very similar to that of the fixed voltage types already described. The unit is built on a single PCB, about 70 × 45mm in size, or on a piece of Veroboard. The PCB pattern is shown in Figure 11a and the component overlay is shown in Figure 11b. The board has been designed to take both versions of the supply, so make sure you use the right components list.

Start by soldering into place the rectifier diodes, then all the capacitors and, finally, solder D5 and D6 into place. Make sure that the diodes and electrolytic capacitors are the correct

Table 2

LM317 Variable Regulator Specifications				
Type	Output Voltage	Output Current	Input Voltage	Ripple Rejection
LM317LZ	1.2 – 37V	100mA	3 – 40V	80dB
LM317MP	1.2 – 37V	500mA	3 – 40V	80dB
LM317T	1.2 – 37V	1.5A	3 – 40V	80dB
LM388K	1.2 – 32V	5A	3 – 35V	75dB

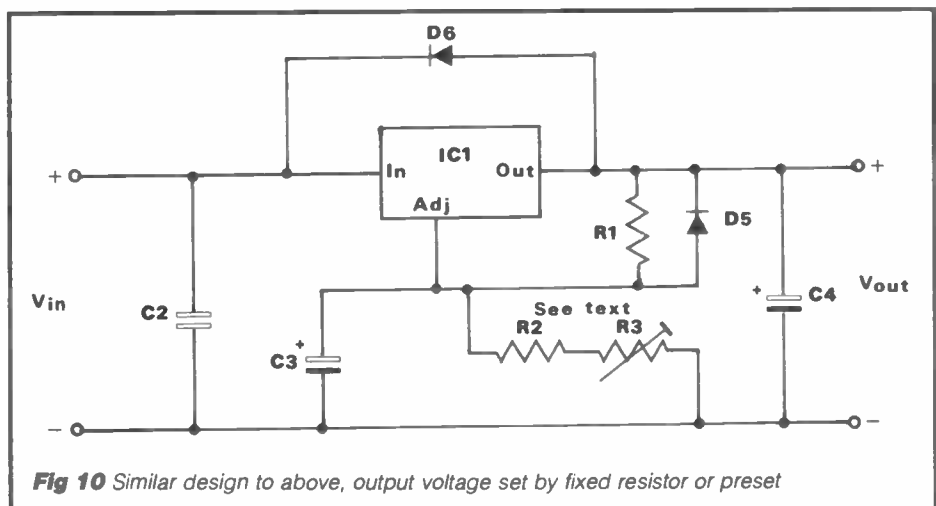

Fig 10 Similar design to above, output voltage set by fixed resistor or preset



# POWER SUPPLIES

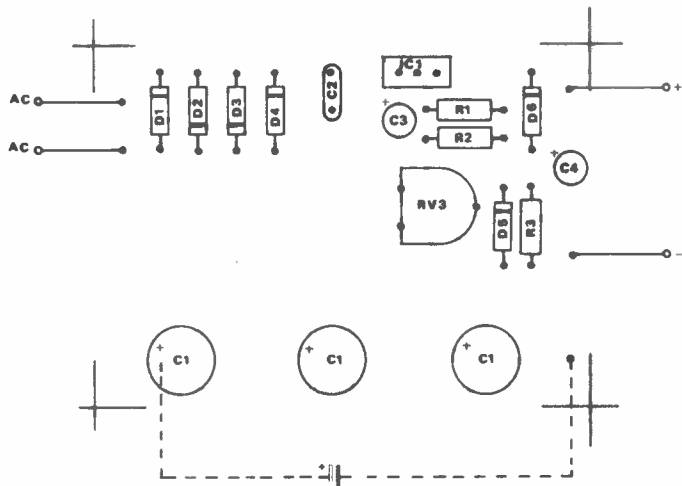

Fig 11 PCB foil and component overlay. Board is 70 x 45mm

way round. If you are making the variable supply (Figure 9), leave out R3 and make R2 a wire link. VR1 is mounted off the board and is wired as shown in Figure 12.

## Resistor values

If you are building the type of supply in Figure 10, it is now that you will have to decide the values of R2 and R3 (see Table 6). R3 can be either a fixed-value resistor or a low-value pre-set potentiometer of about 470R. The idea of the design is first to 'prop' up the voltage with R2 then to use R3 as a fine adjustment which gives more control over the final output voltage. The component overlay shown in Figure 11b shows two R3s mounted on the board; one is the pre-set potentiometer and the other is a fixed resistor. Don't use both components; choose one or the other to suit your requirements.

## Insulation

As before, this type of regulator needs to be bolted to a heatsink to help keep it cool when drawing a lot of current. The metal part of the case is also connected to the output of the regulator so this type of device *must* be insulated from the chassis. Use a good quality TO66 mounting kit and double check that there is no short to earth with an ohmmeter. Keep all wires to and from the regulator as short as possible and use a good quality cable. Refer to Figure 13 for lead out information.

## Thicken the tracks

If you plan to use the 5A version of the LM317, I suggest you use the PCB layout and thicken the tracks to help handle the extra current. The rectifier diodes must also be up-rated to 3 or 5A types and the value of the smoothing capacitors must be increased to between 7,000 and 10,000 $\mu$ F. There is no way of mounting this size of capacitor onto the PCB, so I suggest you leave out the on-board smoothing capacitors and replace them with a single can-style electrolytic. This is bolted to the case and you can then use extension wires between the capacitor and PCB, as shown in the outline in Figure 12.

## Final wiring

Final wiring for the supply is shown in Figure 12. The secondary of the transformer is wired in series to provide 24V output, which I then used as the basis of a 1.2 to 25V variable PSU. The type of transformer used will very much depend on the output voltage and current you require from your supply (see Table 4 for suggestions). Any of the transformers listed in Table 4 can be used with the LM317 series, but remember to keep the unregulated supply at least 3V above the desired output and make sure that the transformer can supply the expected output current of your supply.

## Should work

Though I said that both the circuits described should work with all LM317

Table 3

78xx Output Voltages			
Device	Output Voltage	R2	R3
7805	5V	link	link
7805	6V	100R	22R
7805	7.5V	220R	13R
7805	9V	390R	link
7805	10V	560R	link
7805	5 - 9.7V	link	470R pot
7805	7.6 - 11.9V	220R	470R pot
7805	9.1 - 13.8V	470R	470R pot
7812	12V	link	link
7812	13.8V	47R	39R
7812	15V	180R	link
7812	12 - 21V	link	470R pot
7815	15V	link	link
7815	17V	100R	13R
7815	20V	220R	39R
7815	15 - 25V	link	470R pot

Output voltages  $\pm 200\text{mV}$

Table 4

Common Mains Transformers			
Regulator Type	Transformer Sec Voltage	Transformer Sec Current	VA
78L05	9 (S)	0.6A	6
78L12	15 (P)	0.2A	6
78L15	15 (P)	0.2A	6
7805	9 (S)	2.2A	20
7812	15 (P)	1.6A	50
7815	15 (P)	1.6A	50

(P) = Secondaries connected in parallel  
(S) = Secondaries connected in series

# POWER SUPPLIES

regulators, I must admit that I have only had a chance to try the 500mA version myself. I hope in the near future to build a small 13.8V, 5A PSU using an LM338K regulator. It is interesting to note that Verospeed are now selling a 3A version of the regulator, known as the UA350KC, which will deliver 1.2 to 33V output and will allow peak currents of up to 6A for short periods. I have no other information about this device but, for £2.52, it's well worth a try.

## Overvoltage protection

It's not common to add overvoltage protection to the simple PSUs we have been looking at, nevertheless the circuits are interesting. If a short circuit appears between the smoothing capacitors and the output of the regulator, all the unregulated supply will appear at the output terminals of the power supply. The result could be disastrous for voltage-sensitive equipment connected to the supply.

The job of an overvoltage protection

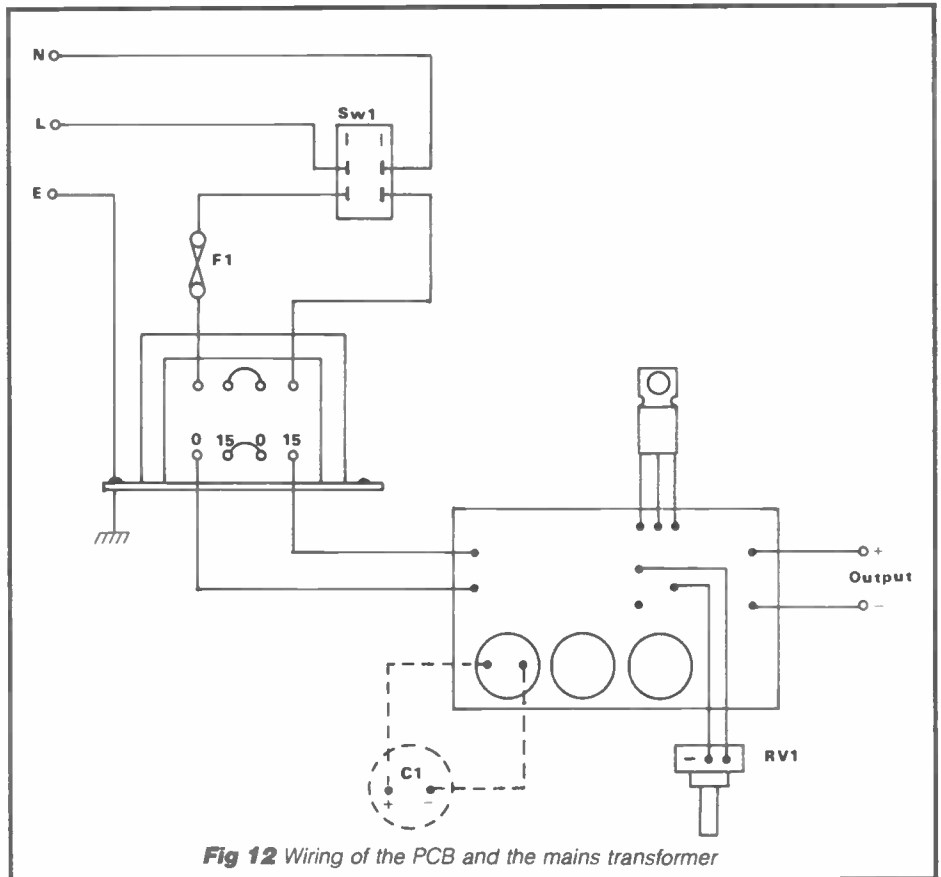

Fig 12 Wiring of the PCB and the mains transformer

system is to monitor the output of a power supply unit. If the output voltage goes over a pre-set level, it automatically switches off the supply. In most systems this means blowing a fuse in the output, thus removing the supply voltage to the equipment. In other systems, when an overvoltage condition is detected, the mains power supply is disconnected and the smoothing capacitors are quickly

discharged to earth, thus removing the output voltage to the equipment. The whole process takes less than half a second.

## Over-voltage protection

Figure 14 shows a simple overvoltage protection circuit which could be added to most PSUs. The zener diode ZD1 sets the voltage at which the circuit trips. If

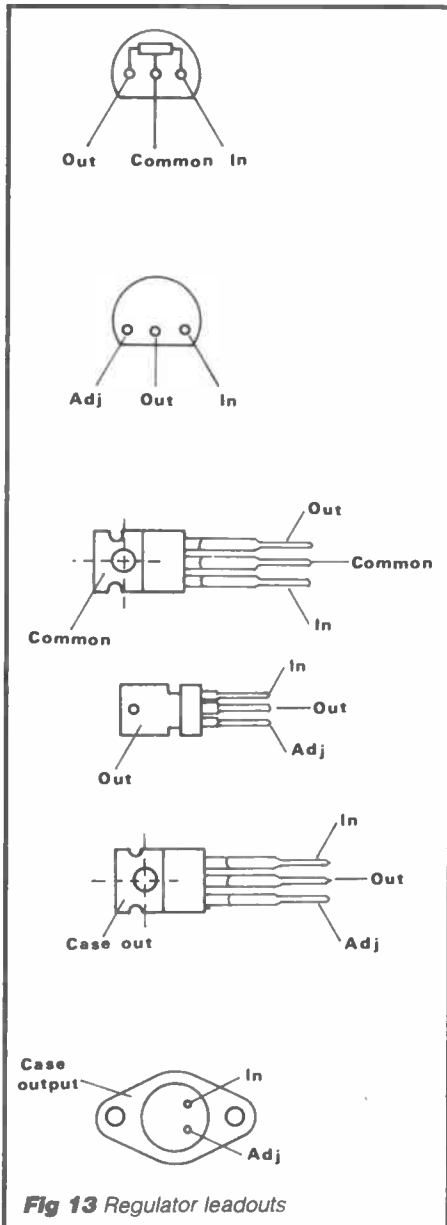

Fig 13 Regulator leadouts

Table 5

## Components List 78xx Board

### Resistors

R1 1k or 4k7 (see text)  
R2, R3 (see Table 2 and text)

### Capacitors

C1 2x 1000µF 35V wkg (see text)  
C2 270nF  
C3 10µF tant 25V wkg

### Semiconductors

D1, D2, D3, D4 1N4001 (see text)  
IC1 78xx regulator to suit design (see text)

### Miscellaneous

Mains transformer to suit design (see Table 3 and text)  
500mA or 1A mains fuse plus holder  
Double-pole mains switch  
TO66 mounting kit  
PCB, wire, nuts, bolts, etc

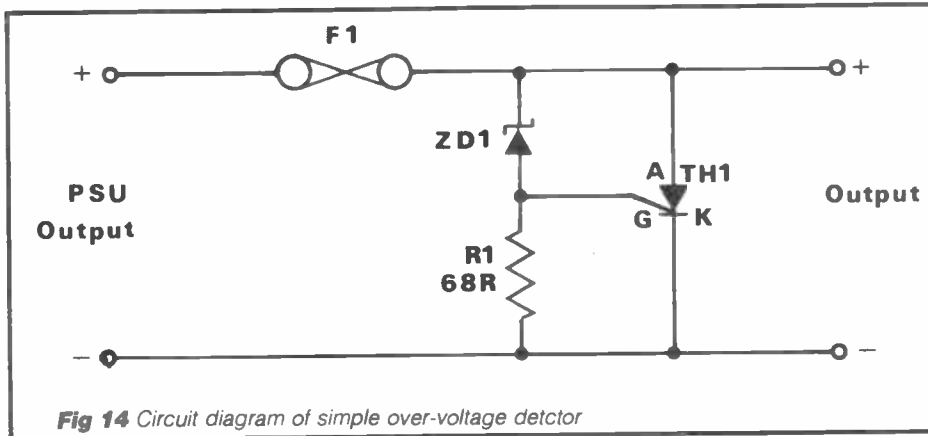

Fig 14 Circuit diagram of simple over-voltage detector

the fuse. If the fuse is rated at 5A, choose a thyristor of 7A or more.

### Crowbar protector

Figure 15 shows a more sophisticated overvoltage detector, based around the very popular MC3423 crowbar protector IC. In this circuit, some of the output voltage of the supply is fed via the resistor network R1, VR1 and R2 back to pin 2 of the IC. The setting of VR1 determines the firing voltage. As soon as the firing voltage is exceeded, pin 8 goes high and can be used to fire a thyristor or trigger some other form of warning. A circuit of the type in Figure 14 could still be used, but with ZD1 and R1 removed and the gate of the thyristor connected to R4.

### False tripping

It must be said that a very simple overvoltage detector, such as that shown in Figure 14, is sometimes prone to false tripping. Voltage spikes on the output line can sometimes trip the circuit and blow the fuse. This can be very annoying. Fitting high-speed suppressors to the output will help with this problem. To help with false tripping, the MC3423 has a programmable delay feature which uses C2 to determine the minimum overvoltage duration required to trip the overvoltage protector. A 100nF capacitor will give a delay of about 1ms. If we change the value to 0.01μF, the delay will be about 0.1ms.

### Undervoltage protection

You might want to add an undervoltage detector to your PSU. This type of circuit will monitor the output of the supply and detect any drop in its voltage. Any sudden drop in output voltage of a regulated supply could mean either the PSU or the equipment it supplies has developed a fault. This type of circuit is also useful for detecting a short circuit on the output as any short circuit will produce a sudden drop in voltage. When the detector has been triggered, its output can then be used to switch off the supply.

### Effective detector

Figure 16 shows the circuit diagram of a simple but very effective undervoltage detector. The unit is built around a very inexpensive 741 op amp. A reference voltage is generated via R1 and ZD1, this is then applied to pin 3 of the IC. The zener diode ZD1 sets the trip level – 12V in the circuit shown. The power supply output is sampled at pin 2 via R2. When this voltage falls below the reference voltage, pin 6 goes high; this, along with other circuitry, can then be used to switch off the supply. C1 has been added to hold the output low just after switch on, while the power supply reaches its normal operating voltage.

### Further information

We hope that this article has given some useful and practical information about simple low-current power supply

you want a trip setting of 15V, then use a 15V zener. The large thyristor TH1 is connected across the supply lines. It has three connections and it works rather like a diode, the main difference being that no voltage will flow from anode to cathode until the gate of the thyristor has been triggered.

As soon as the zener voltage is

reached, the gate of the thyristor, which is connected to the junction of ZD1 and R1, goes high. This triggers the thyristor into action and the whole of the output voltage is dumped to earth, blowing the fuse F1 and disconnecting the output voltage. When choosing the thyristor, you must check that it is capable of handling all the current needed to blow

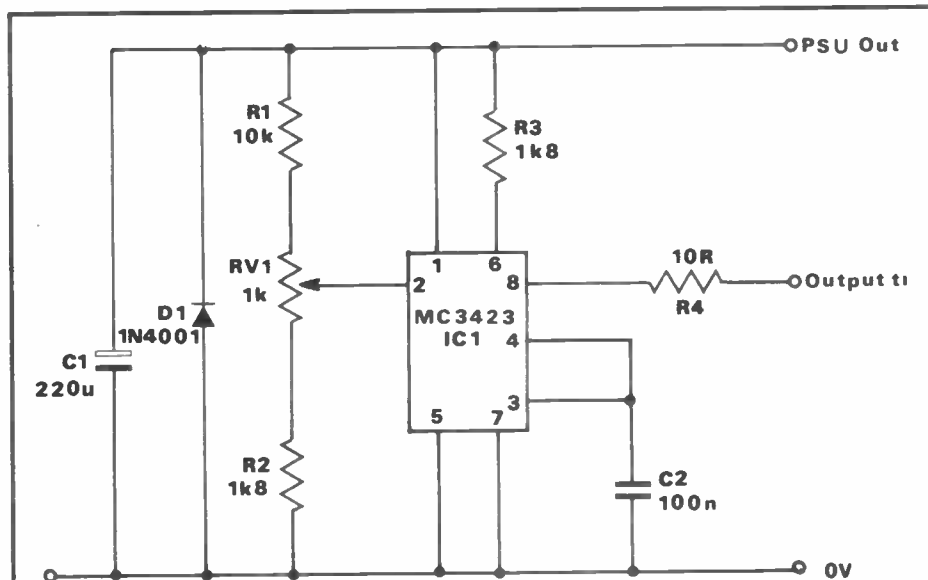

Fig 15 Over-voltage detector using the MC3423

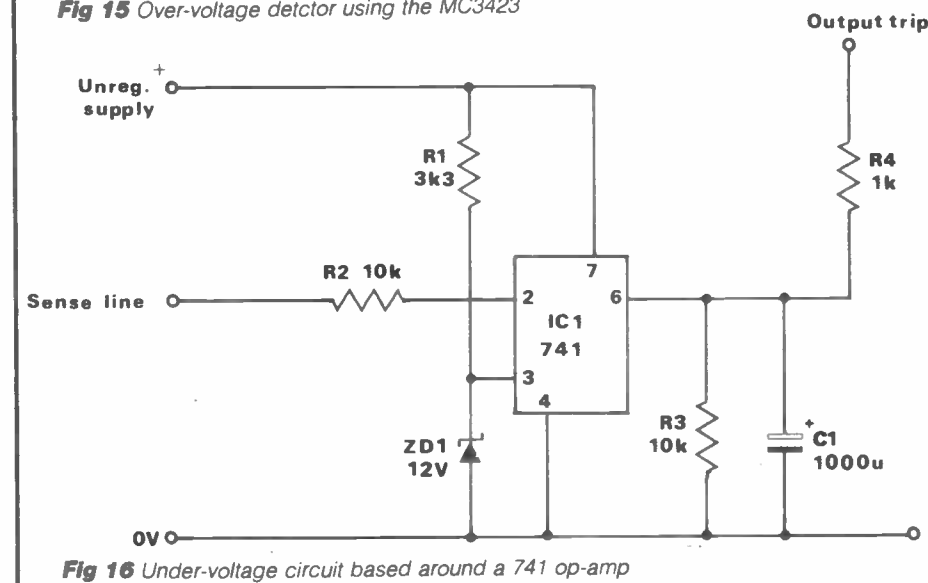

Fig 16 Under-voltage circuit based around a 741 op-amp

# POWER SUPPLIES

units. We have tried wherever we can to be practical, concentrating as much as possible on circuits and designs which the amateur can use in his or her own projects. This is the reason why we have only dealt with designs which produce a positive output and units which are easy and cheap to build. There is no doubt that we have aimed this article at the beginner, but we hope that the more experienced constructor can make some use of the designs.

## Further articles

You might be interested in a couple of articles concerning high current power supply units which have appeared in *Amateur Radio*. The first, 'Fixed Voltage High Current Supplies', by Roger Alban GW3SPA, appeared in August 1986 and dealt with the design and construction of a 10 to 12A, 13.8V PSU. There is plenty of information in the article about transformers, rectifiers, regulators, pass transistors, current limiting and overvoltage protection.

## Suggested reading

The other article, 'A Complete 13.8V, 20A PSU', appeared in the September 1987 issue of *Amateur Radio*. This design dealt with the full construction of a PSU suitable for all types of amateur radio equipment. The article clearly shows the use of both undervoltage and overvoltage detector circuits which, if triggered, will completely shut the supply down and disconnect the mains power supply. Part 2 of the design, which appeared in the following month's issue, gives details of how to fit both voltage and current meters to any type of power supply.

## LM317 Output Voltages

Output Voltage	R2	R3
3V	100R	220R
5V	link	680R
7.5V	390R	680R
9V	470R	1k
10.5V	100R	1k5
13.8V	link	2k2
15V	220R	2k2
17V	560R	2k2
20V	560R	2k7
25V	220R	3k7
1.7 - 4V	link	470R pot
4 - 6.5V	390R	470R pot
7.5 - 10V	1k	470R pot
9.8 - 12.8V	1k5	470R pot
11.5 - 14.5V	1k8	470R pot
13.8 - 16.5V	2k2	470R pot
17 - 20V	2k8	470R pot
20.2 - 23V	3k3	470R pot
24 - 27V	3k9	470R pot
1.8 - 25V	link	4k7 pot

Output voltages  $\pm 200\text{mV}$

Table 6

Part 1 of this article appeared in last month's issue of *Amateur Radio*

Table 7

## Components List LM317 Design

### Resistors

R1	220R
R2, R3	(see text and Table 5)
VR1	4k7

### Capacitors

C1	2x 1000 $\mu\text{F}$ 35V wkg (see text)
C2	270nF
C3	10 $\mu\text{F}$ tant 35V wkg
C4	10 $\mu\text{F}$ tant 35V wkg

### Semiconductors

D1, D2, D3, D4	1N4001 (see text)
D5, D6	1N4001
IC1	LM317 regulator (see text)

### Miscellaneous

Mains transformer to suit design (see Table 3 and text)  
 500mA or 1A mains fuse plus holder  
 Double-pole main switch  
 TO66 mounting kit  
 PCB, wire, nuts, bolts, etc

To obtain copies of the articles mentioned above, contact our Back Issues Department at the editorial address on page 3

particular model gives the full rated output from the PA, but this review sample unfortunately did not draw more than 2.6A, and the maximum power output was considerably below the manufacturer's claims. However, obviously the output could be turned up by altering the ALC threshold levels, but I certainly did not want to disturb these as I was perfectly satisfied with 14W PEP.

## Subjective tests

I connected up this transverter to my Kenwood TS940S, and connected my normal 5-element Tonna 50MHz antenna to it. On listening around the band, and with all our computers turned off, I was just a little surprised that there were fewer little birdies than usual. Band noise seemed to be less crackly too,

although there was stacks of gain in the transverter – if anything, 6dB or so too much.

After quite a lot of listening, I unplugged the antenna and noted only an almost imperceptible change of noise, which implied that the transverter was slightly deaf. I did have contacts on it and the transmission quality was good, according to reports received. I was most surprised to find that when I tuned onto GB3NHQ for absolutely zero beat, my 940S frequency readout was exactly 28.050MHz on SSB. Perhaps this was a slight coincidence, as the readout was to 10Hz resolution, but it was at least a very good sign.

I found that the RF vox sensing was not sensitive enough unless I turned on the processor and set the thresholds and

drive levels very carefully, so as to limit the 940S drive and yet have plenty of audio on board. The TS940S typically gives between 5 and 20mW peak output on the transverter drive socket, and we therefore used the lower sensitivity switched position on the transverter, as suggested in the instruction manual. I therefore strongly recommend the use of wired-in PTT, which you will certainly need in any case if your rig is one of the very low output ones, from the transverter drive socket.

I did not note any drift at all over quite an extended period, and the only birdies I detected were those that came down the antenna. The transverter, incidentally, was very easy to interface and the instructions were very clear.

## Laboratory tests

One of the most important measurements on a transverter is that of its overall noise figure, and in the case of this review sample I was dismayed to find that it was of the order of 13 to 14dB. When combined with a TS940S, the system sensitivity was  $-113\text{dBm}$  input RF for 12dB sinad, equivalent to  $0.5\mu\text{V}$  EMF/2.

I fully realise that sensitivity does not have to be very good, to the extent that it must be on 144MHz and above, but this is sufficiently poor for many weak stations to be far more difficult to copy than they should be, unless you live in a very noisy environment.

Despite this, the RF input intercept point measured  $+11\text{dBm}$ , an astonishingly good figure which is actually 1dB better than specification. For this reason, and the fact that the overall gain was marginally higher than spec rather than greatly reduced, I considered that it was not reasonable to suspect a blown front end device! In any case, we had been particularly careful in all the tests, and checked intercept point and gain before and after all the other subjective and objective tests.

The local oscillator seems to be very quiet indeed, and was not only incredibly accurately set at 22MHz, with an error of no more than 30Hz even after some hours of Rx and Tx, but on switch-on was only 20Hz out. This is the best accuracy I have yet noted in a transverter frequency change, and certainly one of the very lowest frequency drifts.

Not only does the antenna input signal pass through a very good five-pole lowpass filter, shared with Tx, but immediately prior to the parallel JFETs, operated in common base mode, there is a three-pole highpass filter. The output from the pre-amp feeds through a 50MHz bandpass filter switched between Rx and Tx circuitry.

The mixer consists of two balanced JFETs with broadband transformers on input, output and local oscillator ports to obtain the best intermodulation performance. The 28MHz IF output passes through a bandpass filter to a bipolar large signal amplifier, which feeds the output circuit.

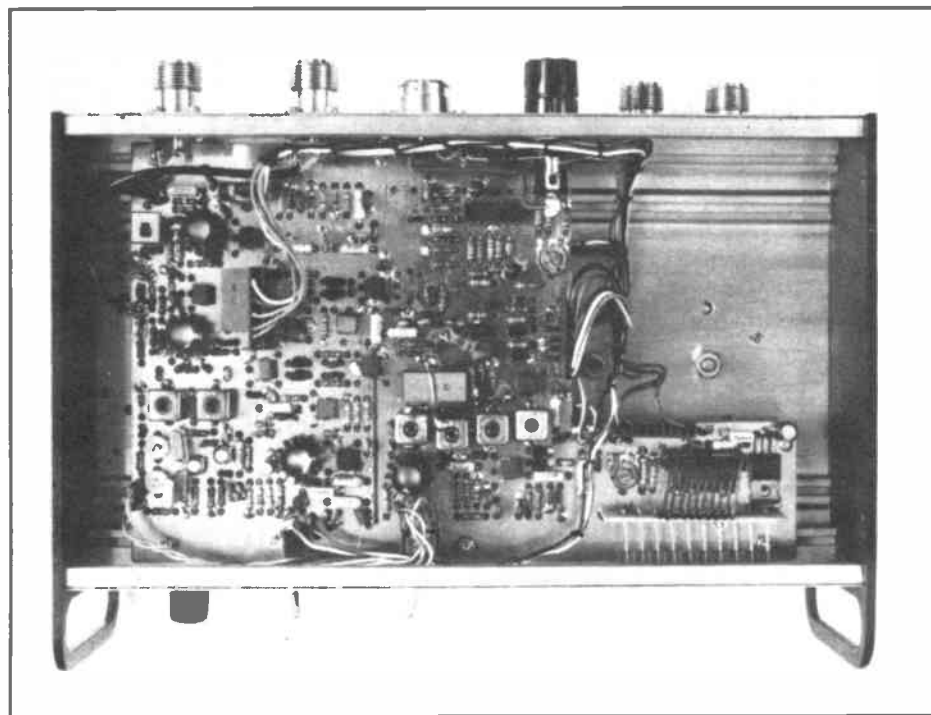

The local oscillator is Colpitts type, using a fundamental 22 or 24MHz crystal, these being switchable on the front panel. The output is very well buffered and filtered, and after splitting into two, feeds the transmit and receive mixers at levels of around 25mW each.

We checked the bandpass responses of both the 50/52MHz and 52/54MHz positions, and *Plot 1* shows the excellent response given by the system from input to output, referred to input frequency. The maximum gain was at the top end of the band section, and the overall system gain was around 22dB, some 3.5dB higher than specification. I would personally have preferred a somewhat lower overall gain of around 15dB as a better compromise.

We had a good look around for various breakthroughs and image responses, and in general these were at quite low levels, although the 22MHz LO breakthrough on the output was at the rather high level of around 6.5mV, which might cause a problem to a few receivers.

LO harmonics on the output were also noted; 44MHz at 4mV, 66MHz at 2.8mV, and 88MHz at 1.8mV. These should not be a problem, but are commented on in case there might be a reaction between them and a local oscillator or intermediate frequency of the transceiver used.

An output image of 39dB below the main signal was noted at 72.2MHz from an input of 50.2MHz. This should not be a problem. The input image of 6.2MHz produced an output of 28.2MHz at 50dB below the input level, and this might need watching if you are very close to a short wave transmitting station using the band 6 to 8MHz. A 72.2MHz input signal, mixing with the second harmonic of the local oscillator, produced an output some 69dB below the normal transverter gain at the nominal frequencies. This is a good rejection, and was measured because some earlier transverters did have some rather annoying spurious responses.

I checked a rather esoteric product by sending in 59.8MHz, which produced a signal at 28.2MHz at only 32dB lower than the normal through gain. This could well be a problem if you live near any high-end Band 1 transmitters in the 58 to 60MHz region. Some earlier Microwave Modules transverters did produce spurious receptions from Band II FM radio stations, but I checked this by sending in a strong 94.2MHz signal. Here, the rejection was superb at better than 82dB, the limit of measurement, no actual products being detected on the spectrum analyser.

### Transmitting section

The input drive signal passes through the 28MHz IF relay to the RF pre-amp bypass switch, which selects drives above or below a nominal 5mW level, allowing an input pre-amp to be bypassed as required. A preset pot can then be used to give a fine adjustment to the input gain. There is an ALC loop from the

**Plot 1**  
Microwave Modules MMT50/28S Rx bandpass RF input -60dBm, LO at 22MHz. Resolution bandwidth: 30kHz. 1MHz per division

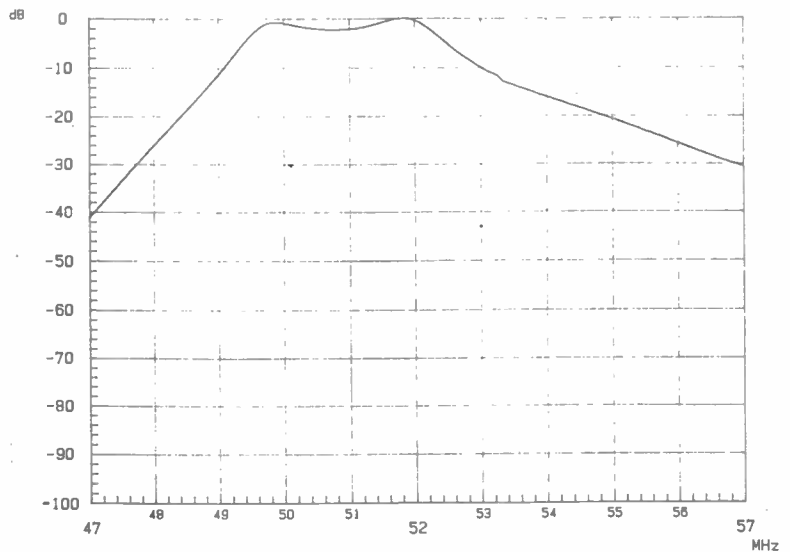

**Plot 2**  
MMT50/28S TVTR two-tone Tx test 14WPEP output tones 1kHz apart. Resolution bandwidth: 100Hz. 2kHz per division

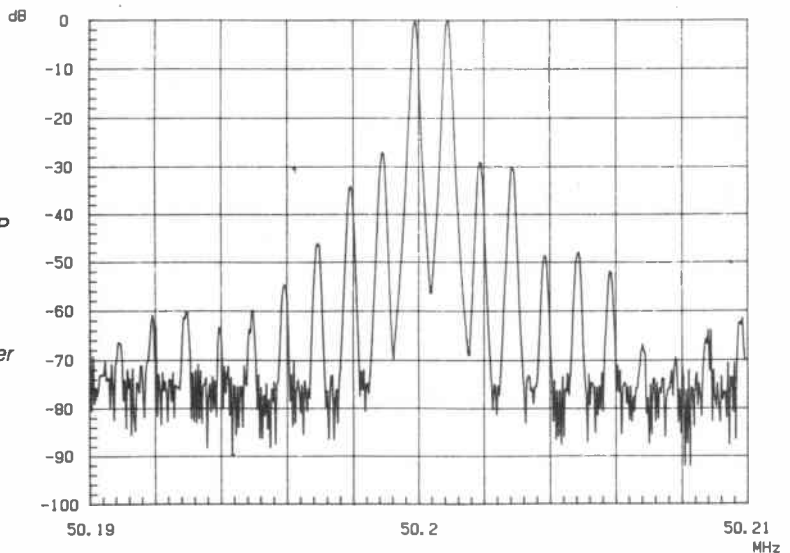

**Plot 3**  
MMT50/28S TVTR two-tone test 5WPEP. Resolution bandwidth: 100Hz. 2kHz per division

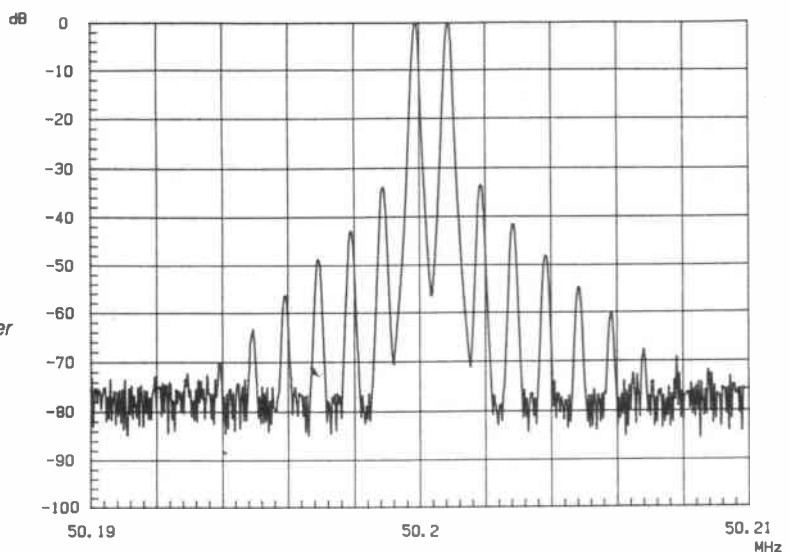

50MHz RF output back to the input which has about 20dB gain reduction capability, the detected dc voltage from the output also being used to operate a row of power indicators on the front panel.

With the input drive switch selecting the maximum gain position (you have to take the left side cheek off, and you will find it easier to slide the top cover away too, and then switch the selector towards the back) and with the drive preset flat out, sensitivity was astonishingly high; only 5mV being required for 1W output and 18mV for 10W, with ALC giving 1.5dB compression here. When the input was raised by 20dB, the maximum saturated output at 50.2MHz was only 13W. The frequency was slowly increased right up to 52MHz, and the power output stayed absolutely constant all the way.

The switched input attenuation allows one to bypass the input pre-amp. It puts in 20.5dB gain loss, so even feeding straight into the mixer will only require a maximum drive of 180mV or so (just below 1mW). This is excellent.

We had a long look at maximum output power and achieved, under normal test conditions, between 11 and 12W going just slightly into ALC, with the equipment driven with the input switch in the bypass position. We did note 14W PEP as a maximum, using two tones spaced 1kHz apart, *Plot 2* showing the performance at 2kHz per division in order to display several higher order distortion products.

The performance is good, although the higher order products did not fall down as rapidly as they ought to. The cause is probably insufficient standing current. I would have much preferred a 10W PEP specification with lower products, and thus a much cleaner transmission. Even so, it performs better than many Japanese black boxes. 10W PEP gave a very similar, but slightly better plot. However, one taken at 12W PEP, using RF sensing and not PTT, and only just above the onset of Tx, gave a plot which was noticeably worse than *Plot 2*, which was odd. *Plot 3* shows the performance at 5W PEP, which is a lot better and as good as one needs for this power. We also took a 1W PEP plot, which was superb.

With input selector on maximum sensitivity, the vox sensing circuits pulled the rig over to transmit on 90mV, just over 100µW. On lower sensitivity between 7 and 20mV were required for vox sensing, the fine gain preset slightly loading down the vox sensed levels when at maximum input gain. I would have liked about another 10dB sensitivity in the vox sensing circuits, but this is not too important since you will get far better results if you use PTT override.

The maximum Tx transversion frequency error noted was only 29Hz, and this was after two hours of continuous Tx, the last half hour being at around the 10W level. This is an absolutely superb performance. We had a good look at RF harmonics from a 12W carrier, and the important and dangerous second harmonic was way down at -80dBc. Third was at -58dBc, 4th at -75dBc and 5th at -69dBc. This shows excellent lowpass filtering.

We then looked for spurious frequencies and noted just four, in addition to the main output signal on 50.2MHz, which was set for full output. 44MHz came through (second harmonic of LO), at -58dBc, but this rose to -52dBc if the RF drive was switched off. A spurious at 46.8MHz was noted at -54dBc. At around 53.6MHz we noted one at -45dBc, and at 56.4MHz, one at -57dBc.

You will have some fun working out how these frequencies are derived. I worked them out in bed, but promptly forgot how I got the answers by the time I wrote this! How about submitting a computer program for the magazine for printing out all possible strange products? We did not note any 22MHz local oscillator breakthrough on the output.

The maximum current drawn on the single carrier tests was marginally over 2.6A, a long way short of the 4A specified, and I have to assume that the ALC line and power LEDs had been incorrectly set by the manufacturer. Some 1.5dB less maximum output than specified was thus given, although the distortion products were very close to, or slightly better than, spec. However, the transverter did not come up to spec as far as spurious responses are concerned.

## Conclusions

I was very pleased indeed to see that this transverter gave such a good performance in so many parameters, and while the limited transmitter output power was almost certainly due to a factory alignment error, the only area of concern was the input sensitivity which was very poor indeed. Perhaps there was a component fault, but not only did this seem unlikely, because all other measurements were normal, or superb, but there was not time to send the rig back to the manufacturers and wait for it to be returned.

The ergonomics were excellent, and you really should not find it difficult to connect this up to your transceiver, provided you don't do anything crazy. I remember hearing about one chap who connected his transverter output socket to the rig's input drive, quite correctly, but the receive line was connected to the main transceiver's SO239 antenna socket. After a short period of excellent reception, the amateur concerned pressed his PTT and...poof! The Rx IF stage did not like 100W going into it backwards. MuTek told me that the same amateur did it three times to the same rig.

The transverter is quite well presented, and I can very warmly recommend purchase if you can be assured that the receive section's input sensitivity is up to spec, this being specified as 3.8dB noise figure, and not around 14dB as measured.

You should be able to hear a very marked change in background noise when you plug the receiving aerial in and out of the rig, and I would advise you to reject the transverter if there is no audible background noise difference when you do this, assuming that the transverter's own output noise at 28MHz more than overcomes your main transceiver's own input noise.

Very many thanks indeed to Lowe Electronics for loaning me the review sample, and to Fiona for helping with all the tests. At the moment the transverter is quite reasonably priced at £295 including VAT.

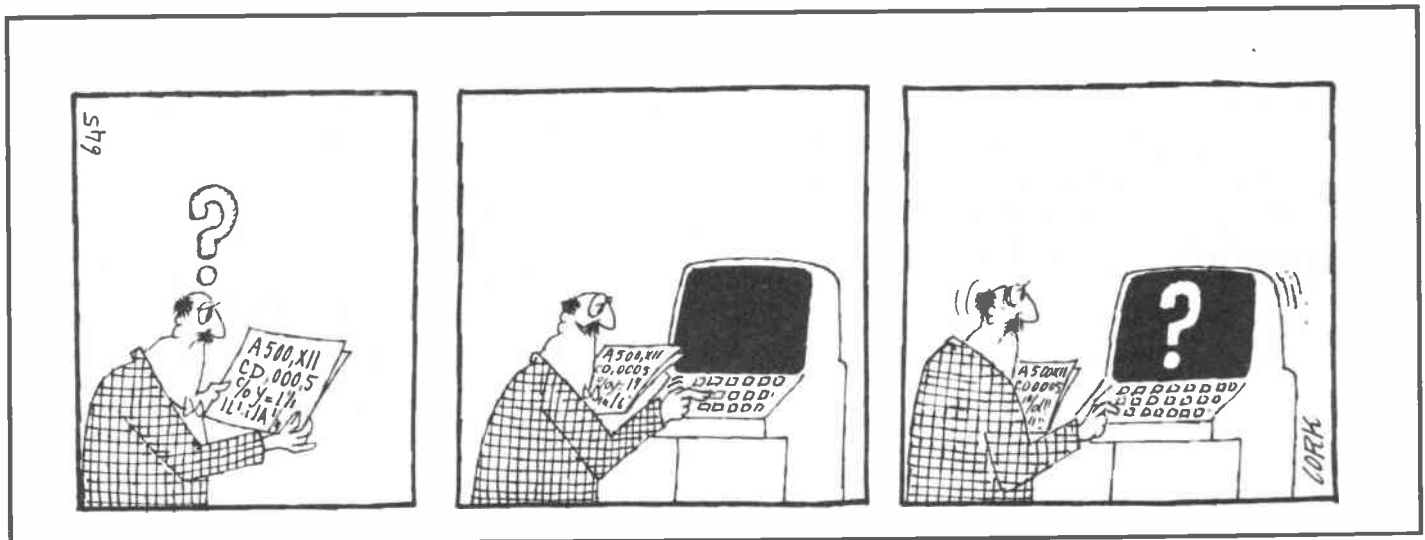

# A BEGINNER'S GUIDE TO PACKET BBS OPERATION

by Joe Kasser

If you have packet radio equipment and haven't made the acquaintance of your local Packet Bulletin Board System (PBBS), you are missing out on most of what packet radio has to offer. Packet has brought amateur radio into the information age, and the PBBS is where that information is.

Your local PBBS has a wealth of features to offer. Not only does it allow you to leave messages for other people on your Local Area Network (LAN), but it also gives you access to bulletins, documents and programs. If you have never used a PBBS, you are in for a surprise. This article tells you all about the features within the PBBS.

The vast majority of PBBSs in common use around the world today use software written by WA7MBL or by W0RLI/VE3GYQ or are compatible with them. They are very similar in appearance and in their command structure when you connect to them. There are, however, some differences in the features that they offer and in the commands that you use to control them. These will be discussed in further detail in the article.

## How to connect to the PBBS

You connect to the PBBS in the same way as you connect to any other packet station. If you are using a minimal software setup, that means that you have to type 'CBBSCALL' where BBSCALL is the call of the PBBS. If you are using YAPP, PK232COM or LAN-LINK you use the Alternate C character to tell the program that you want to initiate a connect; it will ask you to enter the call of the PBBS and then go on to try to establish the connect. Note that if the PBBS is using an SSID, such as '-1', you must use the whole call including the SSID. For example, if the PBBS that you wish to access is N8BMA-1 then you must issue the connect request to N8BMA-1 not N8BMA. The TNC will then issue a connect request to the PBBS station.

## Connected to the PBBS

When the connect goes through, you will see the normal TNC message  
\*\*\* CONNECTED to BBSCALL  
followed by the 'sign on' or 'welcome' message unique to that PBBS. This initial message tells you something about the PBBS itself. Some typical PBBS sign on messages are shown in Figure 1 (right).  
WA2PVV signed on identifying the version of the software that the PBBS is running, and then indicated that I had unread mail posted, told me who the mail was from and what it was about, and then prompted me for a command.  
VE3CKU gave me a little more

[W0RLI 4.22]

You have new mail:

Msg#	TR	Size	To	From	@ BBS	Date	Title
374	PN	205	G3ZCZ	W1IDH		0215/2028	QSL

WA2PVV BBS>

Hello joe, Welcome to the VE3CKU MailBox from Ron in SARNIA

Last logged at 0428 on 880215.

Type H for help, L to list new messages.

You have new mail:

Msg#	TR	Size	To	From	@ BBS	Date/Time	Title
997	N	5	G3ZCZ	W9TNN		0218/0232	test
996	PN	595	G3ZCZ	AF4K	NM8X	0218/0224	HF PACKET HOW?

G3ZCZ de VE3CKU: at 0255Z on 880218 B, C, D, H, I, J, K, L, M, N, P, R, S, T, U, V, W, ?

[GYQ-CBBS4.4-\$]

Hello joe,

Welcome to the KE8X MailBox in Trenton, MI

--\*\* Dedicated to Traffic and ARRL Bulletins \*\*--

Last logged at 0423UTC on 880218, 115 active msgs, 3468 to 3480 are NEW.

Type H for help, L to list new messages, W for additional files.

G3ZCZ de KE8X: at 1946Z on 880218 ?, B, C, D, H, I, J, K, L, M, N, P, R, S, T, U, V, W >

Hello ?-Name, Welcome to the WD4ELJ Gateway in Lynchburg, Va.

Type T to talk to Nick, If no answer, Please leave message.

Type H for help.

\*\*\* N (name) to enter your name.

\*\*\* NH (call) to enter your home BBS.

G3ZCZ de WD4ELJ: at 1534 local on 880218 B, C, D, H, J, K, M, N, R, S, T, U, W, >

[MBL-\$]

NA2B PBBS - Massena, N.Y.

Multiport System: 145.01, 14.107, 7.093MHz

H = help for more details.

NNY-Net: NA2B BBS (B, H, KM, RM, S, T) >

LOCAL USER PORT 145.05 - WA8OOH - WELCOME TO THE PTG PBBS

Hello joe, Welcome to the Packet Technical Group PBBS.

From Ron in Livonia MI. Last logged at 0046 on 871004.

Type H for help, L to list new messages, NE for expert prompt.

Locals please use WA8OOH on 145.05MHz or N8BMA-1 on 220.52MHz.

You have new mail!:

Msg#	TR	Size	To	From	@ BBS	Date	Title
553	N	184	G3ZCZ	WB8WKA		1003/1445	address
547	N	883	G3ZCZ	WB8COX		1002/2337	reply ... pk232com

G3ZCZ de WA8OOH: at 0142Z on 871004 ?, B, C, D, H, I, J, K, L, M, N, P, R, S, T, U, V, W >

145.01 BBS forwarding only. Please use WA8OOH on 145.05 or N8BMA-1 on 220

[GYQ-CBBS4.4-\$]



information. It reminded me of the last time I had logged in to it, and gave me a little bit of information about how to use data, before telling me about my messages.

KE8X told me a little bit about itself as part of its sign on message. It also told me something about the messages on the system.

When I logged into the WD4ELJ PBBS for the first time, it didn't know my name, so it called me '?-Name'. It also gave me some information about itself and prompted me to give it my name and 'home BBS' (more about that later).

NA2B's sign on message was somewhat different. It told me the frequencies that it was active on before giving me the prompt message.

WA8OOH has two sign on messages depending on which frequency I connected to it. The local user port on 145.05 gives a friendly welcome message, the other port on 145.01 tells why it is there and requests that you use an alternate channel if you are not a BBS. Notice that the BBS identification was only shown on the 145.01 port.

Each of the sign on messages have things in common, but they are arranged differently. The SYStem OPerator (SYSOP) has the ability to customise almost all the messages that the PBBS will send to you, as you will see during the remainder of this article.

### Connected, but what next?

At this point we are connected to a PBBS and it is waiting for us to give it a command to do something. Each command that it expects consists of one or two letters. Each command may or may not be followed by a qualifier. When you send a command followed by a qualifier, there should be a single space character between the command and the qualifier.

For the purposes of the article, commands will be shown enclosed in single quotes (''). You should not type the single quotes when working a PBBS. Each command should also be followed by a carriage return (enter).

### Telling it your name

You will have noticed from the sign on messages that the PBBS likes to address you by name. I suppose that it wants to be friendly, and in the American manner addresses you by your first name. The command you use to tell it your name is the letter 'N' followed by your name. For example, I usually use

```
'N Joe'
```

to tell it my name.

When you tell it your name it will send you a reply message confirming that it has received your name and stored it away somewhere. Typical responses to the 'N' command are shown in *Figure 2*.

WD4ELJ is using the W0RLI PBBS software, because that is the only one that asks for the 'home BBS' and sometimes for your Zip code (nb – in Britain, this would be a postcode). The home PBBS is entered (as prompted) by means of the 'NH' command, as in

```
'NH N4QQ'
```

if your home BBS is N4QQ.

N8FIS PBBS, on the other hand, is

```
*** Done.
*** NH (call) to enter your home BBS.
G3ZCZ de WD4ELJ: at 1535 local on 880218 B, C, D, H, J, K, M, N, R, S, T, U, W, >

*** Done.
G3ZCZ de WD4ELJ: at 1536 local on 880218 B, C, D, H, J, K, M, N, R, S, T, U, W, >

64 Msgs. – Next, New User – >
*** Your NAME is entered as: Joe
64 Msgs. – Next, Joe – >

Oh, Hello Joe
WA3PXX BBS (B, D, H, I, J, K, L, N, R, S, T, U, V, W, X, Y, ?) >

*** Ok Joe it's done, what next?
*** Please use the NH command to enter the call of your local BBS.
G3ZCZ de AK3P: at 2019z on 880306 B, D, G, H, I, J, K, L, N, P, R, S, T, U, W >

Welcome to the ARINC Radio Club BBS, Joe
W3ZH BBS (B, D, H, I, J, K, L, N, R, S, T, U, V, W, X, Y, ?) >
```

**Fig 2**

running the WA7MBL software, and not only does it confirm my name when I enter it, as shown in *Figure 2*, (above) but continues to use it each time it prompts me for a command.

### Getting information about the PBBS

If you want to know something about the PBBS, namely who the operator is, or what equipment is being used, you use the 'I' (Information) command. This command is a single letter on a line by itself. Typical responses received on-the-air from NM8X, WA2PVV, WA8ERQ, VE3CKU and WD4ELJ are shown in *Figure 3* (overleaf). The response from WA2PVV means that the SYSOP has not placed any information about the system in the file that is transmitted to you when you send the Information command. WD4ELJ has left the standard text (that the software came supplied with) in place, and has not yet edited the file to include a description of his system.

### The command prompt line

The PBBS will always signal or prompt you when it is ready for you to send it a command. These prompt messages can be customised by each SYSOP, and may take many forms. Each PBBS has two kinds of prompt, the short (expert) prompt and the long (novice) prompt. You can toggle from one to the other using the 'eXpert toggle' command. The command on a WA7MBL PBBS is 'X' and 'NE' on a W0RLI PBBS. Some examples of both types of prompt messages are shown in *Figure 4*.

### Changing the prompt line

Once you are somewhat familiar with PBBS operation you should switch to the 'Expert' message. You use the 'X' command on a WA7MBL PBBS or the 'NE' command on a W0RLI/VE3GYQ PBBS to toggle from one message mode to another. In either case, the PBBS remembers what you commanded, and will give you the same form of message next time you log on.

When you change to the expert user status you may get a message like 'You have been changed to an Expert User'

followed by the (new) short prompt message.

### Listing the messages and bulletins

Once logged into the PBBS, you use the 'L' command to get a list of the messages on the system. Use of the basic 'L' command will get you a list of all the 'readable' messages posted on the system since you last logged in. If this is your first time, it may get you a list of every message on the system or it may get you a response telling you that there aren't any messages posted. *Figure 5* shows some typical message listings. You can only read public messages or private ones addressed to you.

The first column shows you the message number. The second one tells you what the type and status of the message is. The third column tells you how big the message is. The remaining ones tell you who sent the message to whom, when and what it is about.

The message number is the key to reading the message. You *must* refer to all messages by their number. The type of message is indicated by the two letters in the second column. The two PBBS software packages differ somewhat in their use of designator letters.

The first column tells you what kind of message it is, these are referenced by letters as shown below.

A ARRL bulletin.

B other type of Bulletin.

F <special message type, not killed after Forwarding.

P Personal/Private message.

T Traffic message.

The second column tells you something about the status of the message, also referenced by letters as shown below.

F The bulletin has been Forwarded.

H a message that has been Held.

N <Message has Not been

NM8X is operating WORLI/VE3GYQ PBB version 4.3 on a WYSE 80386 computer with 2048k Ram and a 44 Mbyte hard drive.

This system is a general purpose packet radio server node. It supports message store and forward, file upload/download, and also information about all stations heard or connected. This mail and file server is part of the ON1E/ON1W, ON1S/ON1N and ALLMI/SEMICH networking system.

Normal PBBS operating time is 24 hours a day. The PBBS is accessible by manual-keyboard users via a maximum four-digipeater link on 145.03 and on 145.09.

Mail-only ports are not used but forwarding is done on 145.09 and local users are also urged to use 145.09 whenever possible to ease the load on 03 and allow that frequency to be used for point to point communications.

TNC's in service on all ports are Kantronics KPC-2s and radio's on both 2 meter ports are Kenwood TM-2570s.

Antennas are an AEA Isopol at 95ft on 03 and an AEA Isopol at 60ft on 09.

For further information, leave a message to NM8X, N8HTG, NT8V or VE3CK (Sysops) on this PBBS.

Have Fun DE:

NM8X	Jim	519-542-8529
N8HTG	Lee	313-987-6821
NT8V	Roy	313-987-6821
VE3CKU	Ron	519-336-1112

G3ZCZ de NM8X: at 1335z on 880217 B, C, D, H, I, J, K, L, M, N, P, R, S, T, U, V, W, ? >

\*\*\* File not found: /mb/bbs/info. mb

WA2PVV BBS>

This PBBS is a three port system that provides store and forward message handling, forward and reverse automatic mail forwarding, as well as ASCII and binary file storage, retrieval and transfer.

Normal PBBS operating hours are 24hrs daily. The PBBS is accessible by local manual-keyboard users via a maximum five-digipeater link on 145.010MHz maximum of eight-digipeaters on 145.05.

TNC's in use are MFJ's 1274 on HF and 1270 and PK 80 on VHF rigs on VHF both Azden 3000 running 10 watts to a Mirage b 1016 amp, ant is a Ringo at 65 ft. RIG on HF is a Kenwood 530S running 200 watts pep to a Wilson Vertical at 40 ft

This system is open to all.

ENJOY THE SYSTEM

73

DICK

Mid-Net BBS>

This system is a general purpose packet radio server node. It supports message store and forward, file upload/download, GateWay linking between the radios, and information about stations heard or connected.

\*\*\* Put a nice description of your station here \*\*\*

G3ZCZ de WD4ELJ: at 1539 local on 880218 B, C, D, H, J, K, M, N, R, S, T, U, W, >

VE3CKU is operating WORLI's version 4.30 BBS, on an XT Clone with a 20MB hard drive, and two COM ports. VE3CKU is part of the ON1W/ON1E/ON1N/ALLMI/SEMICH Networks.

VE3CKU-BBS has two ports, the 2-meter port on 145.090 consists of a Kenwood TR-7200A, putting 10 watts into a mobile whip at 95ft. The 220.520MHz port consists of a Kenwood TM-3530, a 75ft feedline up to the VE3SUR repeater cabinet in the rooftop radio room, then a Mirage C3012 amplifier/preamplifier puts out 100 watts to a 7 element beam at 140ft. The beam is fixed/aimed at Detroit. Both TNCs are Kantronics KPC-2s, and the radios are equipped with time-out timers. Both ports are operated 24 hours a day, and up to 4 digipeaters may be used for access. Primarily VE3CKU-BBS is for automatic mail forwarding and distribution of bulletins, etc, on the network. Users are encouraged to check into NM8X-9/NM8X-3/or NM8X-2, to receive full BBS services, download files, and real mail.

HAVE FUN! de Ron VE3CKU	Remote Sysop's
	Jim — NM8X
	Lee — N8HTG
	Roy — NT8V

G3ZCZ de VE3CKU: at 0255z on 880218 B, C, D, H, I, J, K, L, M, N, P, R, S, T, U, V, W, ? >

Fig 3

read/forwarded.

O Old message.

Y Yes, message has been read.

\$ Message has been forwarded.

The Size column tells you how many characters are in the message. This will give you an idea of how long it will take to read it, or how much space you will need on a disk if you want to capture it and save it.

The next three columns tell you who the message is to, who sent it, and if it is to someone on a different PBBS, which PBBS the destination station is expected to read the message on. The software in the WORLI and WA7MBL PBBS put the source station and destination PBBS in different positions in the listing. It should, however, be easy to figure out which is which.

There is a category of messages called bulletins. These are general interest messages and are sent to many PBBSs along a route or distribution chain. For example a bulletin may originate at the ARRL and be posted at W1AW. It may then go from PBBS to PBBS until it gets to Detroit, or to Florida. These bulletins usually show up as messages to 'ALL' along distribution routes which show up on the BBS column in the form of NEOH (North East Ohio), RT5N (RouTe 5 Northbound), SEMICH (South East Michigan) and ON1W (Ontario, Westbound).

The 'L' command has some qualifiers to let you control which of the messages are listed on your screen. If you follow the 'L' command by a number it means that you want a list of messages with message numbers equal to or greater than the number you sent. For example if you send 'L 200', you will get a list of all readable messages with numbers greater than 200 as well as message number 200. This means that the listing of messages shown for GB3HQ in Figure 5 could have been obtained by the command 'L 1028'. (Just to confuse you, it could also have been obtained if the message posted when you last connected to GB3HQ had been message number 1027). On WA7MBL PBBS you can also get a listing of messages between a range of numbers. For example the command 'L 1028 1032' will get you a list of anything readable with message numbers between 1028 and 1032.

'LM' (List Mine) will get you a list of messages associated with your callsign. On a WORLI PBBS you will get a list of all messages that you have sent and are still posted, and all incoming messages to your callsign posted on the PBBS which you have not yet read. On a WA7MBL PBBS you will get a list of all INCOMING messages even if you have read them. This is a good feature because it will remind you that old messages are still posted and to delete them.

The 'LN' (List New) command on a WA7MBL PBBS will give you a list of the New or unread messages. 'LT' (List Traffic) will get you a list of the NTS traffic messages posted. 'LL' (List Last) is followed by a number. For example, to read the last 100 messages posted you'd send 'LL 100'.

You can get a listing of messages posted to a different PBBS or to a routing list by using the 'L@' command. For example:

'L @ ON1W'

would get you a listing of all bulletins posted along the ON1W route.

You can also get a listing of messages posted to or from a particular callsign by using the 'L>' and 'L<' commands. Note the way the arrow is pointing. 'L> CALL' will get you a listing of messages to a callsign, and 'L< CALL' will get you a listing of messages from the callsign.

### Reading messages

Having listed the messages you probably want to read a few of them. To read a message you send the 'R' command followed by the message number. The command 'R 1040' will get you the contents of message number 1040. The WA7MBL PBBS software allows you to ask for up to six messages at a time. So for example you could send the command

'R 1027 1234 1345 1029'

to read four different messages.

If you have a number of messages posted, you can ask for them all using the 'RM' (Read Mine) command. On a W0RLI PBBS the 'RM' command will get you the contents of any unread messages. To do the same job on a WA7MBL PBBS you'd have to use the 'RN' (Read New) command. On a WA7MBL PBBS the 'RM' command will get you the contents of all messages posted to you on the PBBS.

A typical message is shown in *Figure 6*. The first line of the message is the same as you'd see if you asked for a listing of messages. It's message number 9 on the NM8X PBBS. This is a bulletin that has been forwarded along the ON1W distribution route. It was first posted as a message on a PBBS by NF6K, and was received at NM8X on the 30th of January at 0535.

The subject of the message is the same as the item shown in the last column of a list. The path that the message took to reach NM8X is then shown in reverse order. Thus NM8X got it from VE3GYQ, who got it from VE3EUI and so on. Finally you get to see the text of the message.

The 'R' command shows the message headers in their condensed or short form version. The W0RLI PBBS lets you see the full headers if you use the 'RH' command. The WA7MBL PBBS also allows you to get a display of the full headers in the message path routing, using the 'V' (Verbose) command. You may also use 'VM' and 'VN'. *Figure 6b* shows the expanded path routing which not only shows you which PBBSs the messages came through, but also gives you date/time data for each section of the link as well as usually telling you the message number each PBBS assigned to the message, as well as something about the PBBS itself.

### Sending messages

To send or post a message you use the 'S' command. The PBBS allows you to post different types of messages. You may send personal/private or public messages. Personal messages can only

```
G3ZCZ de NM8X: at 0459z on 880216 B, C, D, H, I, J, K, L, M, N, P, R, S, T, U, V, W, ? >
G3ZCZ de VE3CKU: at 0438z on 880218 B, C, D, H, I, J, K, L, M, N, P, R, S, T, U, V, W, ? >
```

```
N4QQ BBS (B, H, KM, RM, S, T) >
NNY-Net: NA2B BBS (B, H, KM, RM, S, T, T) >
Mid-Net WA8ERQ BBS>
WA2PVV BBS>
N4QQ BBS>
1138, 24 msgs>
Mid-Net BBS>
64 Msgs. - Next, Joe ->
WA8YWH BBS>
Select option B, H, J, K, L, N, R, S, X >
>
```

Fig 4

Fig 5

Msg#	TR	Size	To	From	@ BBS	Date	Title
362	F	1123	N2CEH	KM2H	N2EZG	0215/1207	220 WRAP
358	FH	905	ALL	N1API	RT5N	2115/0629	Need 2 Meter AMP Help
354	H	662	ALL	W1ETH		0214/1655	Corrected Apple HELPI!
348	FN	2176	ALL	WB2HBZ	WA8TWH	0214/1453	Moulder Co, CO War on Amateurs
327	FN	1290	ALL	N2GBT	RT5N	0214/0638	BLIND AUCTION COMING UP
326	FN	1281	ALL	WA2MOE	RT5N	0214/0637	ARRL £16 Western Sahara
325	FN	8578	ALL	WB2HBZ	RT5N	0214/0633	Sweden Calling DX 1977 2-0 .
324	FN	3772	ALL	WB2HBZ	RT5N	0214/0630	Another PC Virus-Part 2
323	FN	8016	ALL	WB2HBZ	RT5N	0214/0627	Another PC Virus-Part 1
315	FN	2377	ALL	WB2HBZ	RT5N	0213/1942	Boulder Co, CO War on Amateurs

WA2PVV BBS>

Msg#	TS	Size	TO	@ BBS	From	Date	Subject
1084	N	41	G3OUF		G4MTPM	17-Aug	hi
1082	N	204	ALL		G1UWS	17-Aug	SWOP ATARI ST
1073	N	187	G8KXW		G3PAQ	16-Aug	Welcome
1072	N	43	G4LZK		G4FEC	16-Aug	HELLO TED
1068	N	466	ALL		G1BFV	16-Aug	Radio Database
1067	N	138	ALL		G1SLS	16-Aug	REF PK232 DRIVER BBC/MASTER
1054	\$	770	ALL		G1HUL	16-Aug	**** SCOUTING USERS GROUP ****
1051	N	304	G3UEG		G3AAJ	15-Aug	New FO-12 Mailbox commands
1042	AS	4201	ALL		G3RWL	15-Aug	warning
1041	AS	1282	ALL		G3RWL	15-Aug	DON'T use Oscar-10
1028	BS	138	SYSOPS		GB3RA	15-Aug	G1AWD BBS IS NOW GB3RA!!

GB3HQ BBS>

Msg#	TS	Size	TO	@BBS	From	Date	Subject
480	BN	5819	ALL	@NEOH	K3RC	18-Feb	Exam sites in Ohio
479	EB	6013	ALL	@NEOH	KA4BCD	18-Feb	W5YI Report 2-15-88 3 of 3
476	AF	2344	ALL	@NEOH	W8PH	18-Feb	OHIO SECTION BULLETIN NR 7
475	FF	5428	ALL	@NEOH	KA4BCD	18-Feb	W5YI Report 2-15-88 1 of 3
474	FF	6580	ALL	@NEOH	KA4BCD	18-Feb	W5YI Report 2-15-88 2 of 3
473	FF	6083	ALL	@NEOH	KA4BCD	18-Feb	W5YI Report 2-15-88 3 of 3
470	BN	878	ALL	@WA8YWH	WB2VPH	18-Feb	MIDI interface for IBM/Commodore
469	BN	1231	ALL	@WA8YWH	WB2VPH	18-Feb	WinterFest!!!!
468	N	1135	ALL	@WA8YWH	WB2VPH	18-Feb	Luking 4 Azden PCS2800
467	N	1198	ALL	@WA8TWH	WB2VPH	18-Feb	GE 4EG21A11
468	BN	1455	ALL	@WA8YWH	WB2VPH	18-Feb	Ka Node Owners
456	FN	1944	ALL	@WA8YWH	WB2VPH	18-Feb	Portable C-64
464	FN	3670	ALL	@WA8YWH	WB2VPH	18-Feb	Contester's Diet

WA8YWH BBS>

normally be read by the person they have been sent to. Public messages may be read by anyone. You can send NTS traffic, you can post bulletins, and best of all you can even send messages to someone on another LAN, even if that person is out of state or even across the country.

To send a message you just use the command 'SCALL' where 'CALL' is the callsign of the station you are sending the message to. If you are sending the message to someone on another PBBS you'd use the command 'SCALL@PBBS'. If it were a private message you'd use 'SPCALL'. For example if you wanted to send me a comment on this article you'd use the command

'S G3ZCZ @ N4QQ'.

This command tells the PBBS that the message is going to G3ZCZ, who usually checks into the N4QQ PBBS for his messages. When the PBBS receives the command it will send you a reply asking you for the subject of the message. This is the part that describes the contents (a summary) and also shows up in the header and in the listing of messages (the 'L' command).

The request for the subject may take different forms. Typical off-the-air examples are  
'Enter title for message:',  
'Enter Subject for Msg £ 15382:',  
'Message Subject (City, State or Country if not local):',  
and 'Sj:'.

Enter the subject of the message but keep it short (it has got to fit in that column in the listing). When the computer has accepted the subject, it will ask you to enter the message. The request may take the form of  
'Enter message, Z (CTL-Z) or /EX to end, it will be message 781'

or  
'Send message. Use CTRL-Z or /EX to end:'  
or even just plain  
'Msg:'.

At this point you enter the text of the message. When you have completed the message, enter a 'control Z' character (depress the control key and the 'Z' key at the same time) and then depress the 'Enter' key. After a few moments the computer will confirm reception and storage of the message by giving you the regular prompt message.

If you are sending a message to someone at another PBBS and you think that the PBBS SYSOP won't know how to route the message, put the routing information in the subject of the message. For example, if you were sending a message to G3ZCZ @ N8BMA the subject would be 'short description (Detroit MI)' which would tell the SYSOP and any others along the way, that the message is going to Detroit in Michigan.

In the examples shown above you may have noticed that the PBBS gives you the message number for you to refer back to it later. To send NTS traffic, type 'ST NTSxx', where 'xx' is the two letter state abbreviation. Thus NTS traffic to Michigan would be 'NTSMI' and traffic to Alaska would be sent to 'NTSAK'. You can also use the first three digits of the

Msg £9 Type: F Stat: F To: ALL @ON1W From: NF6K Date: 30-Jan/05

Subject: AEA PK-232 modifications

Path: VE3GYQ!VE3EUK!VE3KOI!W2ICZ!KA2VTY!N2EPO!KC3BQ!N2EZG!N1BCK!  
N2AYY!WB2HBZ-1!WB2QJA

AEA has announced modifications to the PK232 to improve performance. These modifications are as follows

Install a .047µF capacitor in series with R79. This will improve performance on VHF packet with some Icom and Kenwood transceivers

Change the value of R35 to 39KΩ. This modification will improve performance by 6kB on CW making the sensitivity twice as sensitive

These modifications will turn an already outstanding TNC into the best thing the world has seen since sliced bread. 73 and GL DE Steve, KF7K

G3ZCZ de NM8X: at 0514z on 880216 B, C, D, H, I, J, K, L, M, N, P, R, S, T, U, V, W, ?, >

Fig 6a

Path: VE3GYQ!VE3EUK!VE3KOI!W2ICZ!KA2VTY!N2EPO!KC3BQ!N2EZG!N1BCK!  
N2AYY!WB2HBZ-1!WB2QJA

R: 870127/0407z @: VE3GYQ London, ON £: 4920 O: NF6K

R: 870128/2232z @: VE3EUK Kitchener ON £: 218 O: NF6K F: 145.01/145.09

R: 870128/0421z @: VE3KOI Milton, ON £:469 O: NF6K F: 145.01/145.03

R: 870127/1015z @: W2ICZ Buffalo NY £:172 O: NF6K F: HF/145.01

R: 870127/0827z @: KA2VTY Elba, NY £:198 O: NF6K G: FN03 F: 145.01/59 P: 716

R-870127/0124e @: N2EPO Churchville, NY £: 538 O: NF6K G: FN13 F: 145.01 P:716

R: 870127/0531z @: KC3BQ Skaneateles, NY £: 5265 O: NF6K P: 315 F: 145.01/03

R: 870127/0312z @N2EZG Alpine, NY £: 1032 O: NF6K G: FN12 P: 607 F: 145.01/07

At N1BCK: 66 From NF6K Rcvd 870126/2013, Sent 870127/0317

R: 870126/0717z @: N2AYY Glens Falls NY £: 3163 O: NF6K

R: 870124/1619z S: 870126/0715z WB2HBZ-1, Kinnelon, NJ 184 < NF6K (1201)

At WB2QJA: 758 From NF6K Rcvd 870124/0937, Sent 870124/1120

Fig 6b

zip code of the destination area, such as 'NTS209'.

To send a bulletin to everybody on a routing list or to everyone at your local PBBS you have to use the 'SB' command. Thus

'SB ALL'

would post a bulletin to everyone on the PBBS. If you want to post the bulletin so that it is distributed along a routing list, you'd put the routing list as the destination PBBS such as

'SB ALL @ ON1W'.

Routing lists take the form of RT2S, ON1W, SEMICH and ALLOH. If you want to know more about routing lists, post a message to your local SYSOP asking which ones the PBBS is linked to.

### Killing messages

Now that you can see which messages are posted, read and send them, you also have to learn how to kill or delete some. Once you have read your messages, delete them from the PBBS. The 'K' (Kill) command is used to kill messages. If you want to kill all incoming messages at once, use the 'KM' command. If you do so, *make sure you know exactly which messages are there*. Depending on the PBBS software it's very easy to delete messages *before* reading them! It is far better, but longer, to selectively delete each message. You delete a single message using the command 'K number'

where number is the number of the message to be deleted. For example to delete message 234 you'd type the command

'K 234'.

### Files

The PBBS allows you to upload and download text or ASCII files. Files are usually stored in sub-directories. The 'W' command is used to see what sub-directories are available on the PBBS. This command performs the same function, but the information presented to you by the PBBS is different on an RLI to an MBL.

Part Two will  
appear in  
the July issue  
of Amateur  
Radio

# PROJECT

# BOOK

by Martyn Williams

Two items that are often pressed into service in amateur construction projects are the BC108 and the 741 integrated circuit. Both have an impressive range of work which they will undertake, but the 741 has a few tricks up its sleeve that are perhaps not so generally used. Its use as a high gain amplifier and in filter circuits is well known, but it is not generally realised that it can also be used as a comparator device.

If the PSU output voltage changes, the 741 provides an output which is used to control the voltage regulator in order to regain the required PSU output voltage.

instance the station PSU. One of the inputs is held at a constant voltage by the zener diode, which is fed by R1.

The other input is supplied with a voltage which can be preset by RV1. These two inputs may be taken to either of the 741 input pins, depending on whether you want the light to come on if the voltage is above or below the required level.

## Alternatives

The 741 is provided with two inputs, and a change of voltage on one of the pins will provide an increase in the output voltage. If the voltage on the other pin is increased, the output voltage will decrease. Both of these conditions of use require the unused pin to be held at a reference voltage.

## Comparisons

From the above description it can be seen that the 741 is acting as a comparator device. It 'looks' at the two inputs and provides a computed output. What happens if the two inputs are identical?

In this case, the output will be set to one half of the supply voltages to the 741. As well as providing a varying output voltage, the 741 can be made to act as a switch which will go from full positive to full negative output with only a minute change in the input voltage.

## Control

The output of the comparator is taken to the base of the BC107, which is used as a switch to control the output. In the diagram this is shown driving an LED indicator, but it would drive a small relay which could control external circuitry.

Setting up is very simple: assuming that you are using an LED indicator, connect the unit to a variable voltage supply and set the voltage to the point at which you want the LED to come on. Now adjust RV1 until the lamp lights. If you wish to reverse the action, transpose the wires to the inputs and reset RV1.

## Normal Use

This is the normal method of use in a regulated power supply, where one pin is held at a constant voltage and the other is fed with a sample taken from the output voltage.

## Indicator

This 'flip flop' action is used in *Figure 1*, which is a simple circuit in which the LED only comes on when the supply voltage varies from a predetermined level.

How does the circuit work? The 741 takes its supply voltages from the voltage line we wish to monitor, for

## Construction

There is nothing tricky about building this simple unit and it can be easily constructed on a small bit of Veroboard. The uses of the circuit are limited only by your imagination. If you disconnect the top of RV1 from the power supply lines then any low voltage which you wish to monitor can be connected straight across RV1 and the preset adjusted as already described.

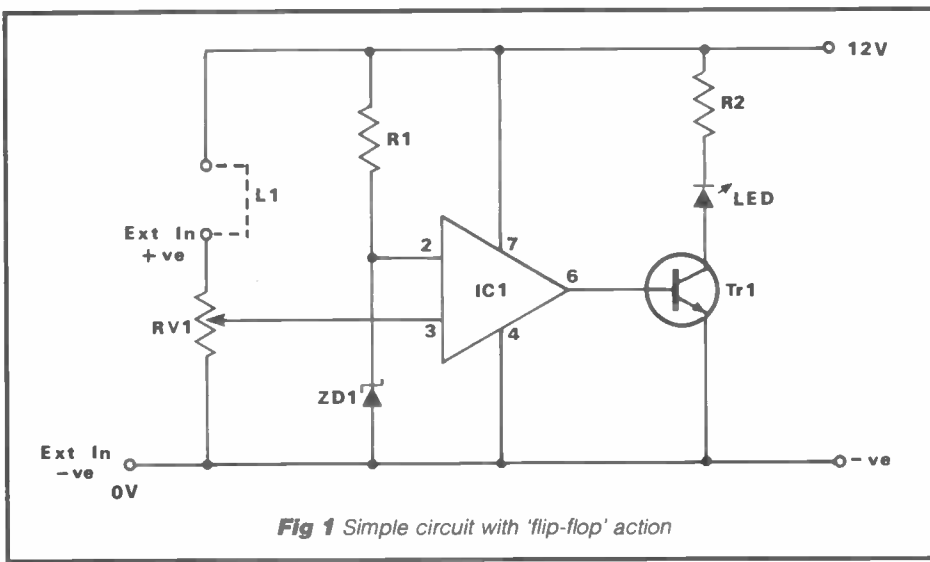

Fig 1 Simple circuit with 'flip-flop' action

COMPONENTS	
R1	1kΩ .25 watt
R2	1.2k .25 watt
RV1	5kΩ preset
ZD1	4.7V zener diode
IC1	741
TR1	BC107
L1	Instal link to monitor supply voltage lines

# ICOM

## NEW! IC-228E 2 Meter FM Transceiver



Actual  
size

### Features:

- Multicolour Liquid Crystal Display.
- 25 Watt output.
- 20 Memory channels.
- Scanning.
- Call and priority function.
- Compact size.
- HM15 microphone supplied.

Take a close look at this easy to use and compact VHF Mobile Transceiver. It's unique orange, red and green LCD highlights the numbers and letters for easy viewing. With a 25 watt output from a custom designed power module and a extra large heatsink, this transceiver does not get too hot under your dashboard.

Each of the 20 memory channels can store frequency, offset and direction, in fact all the information to work simplex or a repeater. The memory scan function will scan the memory channels and with the skip

function miss those you choose. The program scan will scan all frequencies between two programmable limits. The call channel ensures that your favourite frequency is within easy reach, and with the priority watch the call channel or memory channels can be monitored every five seconds.

This transceiver provides you with so many features, its small compact size and simple front panel design make it a superb mobile transceiver. See the IC-228E or the IC-228H 45 watt high power version at your local ICOM dealer.

**Icom (UK) Ltd.**

Dept AR , Sea Street, Herne Bay, Kent CT6 8LD. Tel: 0227 363859. 24 Hour.

# Count on us!

## NEW! IC-32E Dual Band VHF/UHF FM handportable

### Features:

- Full cross band duplex operation.
- 5 Watt output with IC-BP7 nicad.
- 20 Dual band memories. • Small size.
- Scanning. • Power saver circuit.
- Compatible with ICOM accessories.

When are ICOM going to produce a dual band handportable? This has been the most asked question about new ICOM products for a long time. The IC-32E is the answer.

This exciting new handportable offers full crossband duplex operation, and with a built in duplexer allows single antenna operation. 3 Watt output is standard but with the BP7 high power nicad pack or external 13.8v, 5 Watts can be achieved on both bands. The IC-32E comes packed with features, such as the 20 memory channels which can store both a VHF and UHF frequency in one memory and also simplex duplex condition, offset direction and frequency.

There is a choice of five scanning functions, full programmed memory, memory band and priority. The die-cast frame gives a solid construction featuring rubber gaskets for splash-proof operation. The IC-32E is supplied with VHF/UHF a dual band antenna, BP3 battery pack and wall charger. OK, when are ICOM going to produce a new dual band mobile with full cross band duplex? The IC-3210E will be the answer.

## NEW! IC-2GE 2 Meter FM handportable

### Features:

- Rugged and compact. • High power option.
- Power saver circuit.
- 20 memories. • Scanning.
- Compatible with ICOM accessories.

What's new on 2? ICOM's latest 144MHz FM handportable. The ICOM IC-2GE fulfils the most important criteria for a handheld transceiver, it is small, rugged and easy to operate.

The 3 Watt RF output is a compromise on battery life against power output, but for those who require extra punch, the set can deliver 7 Watts when used with the BP7 or external 13.8v DC. On receive the power saver circuit reduces current drain automatically, but can be overridden for pocket operation.

The 20 memory channels can store all your favourite simplex and repeater frequencies, and with the programmed scan and memory scan functions, there is no need to manually search for activity. The IC-2GE utilises most existing ICOM handheld accessories plus a new line of carrying cases. If you are expecting to be outdoors this summer or looking for your first handportable transceiver, the ICOM IC-2GE will take a lot of beating.



**Helpline:** Telephone us free-of-charge on 0800 521 145, Mon-Fri 09.00-13.00 and 14.00-17.30. This service is strictly for obtaining information about or ordering Icom equipment. We regret this cannot be used by dealers or for repair enquiries and parts orders, thank you.

**Datapost:** Despatch on same day whenever possible.

**Access & Barclaycard:** Telephone orders taken by our mail order dept, instant credit & interest-free H.P.



# PRACTICAL SINGLE-LAYER RF CHOKES

by Ray Fautley G3ASG, C Eng, MIERE

We will start with a couple of questions before considering how to design RF chokes:

*What are RF chokes?*

RF chokes are simply inductors, or coils.

*What are they used for?*

They are used to supply dc with as small a voltage drop as possible to circuits where a high impedance is required between dc supplies and ac circuits.

An ideal RF choke would be a short circuit at zero frequency, or dc, and an open circuit at all frequencies where it is required to operate. Strangely enough, an RF choke operates over nearly all of its frequency range not as an inductor, but as a capacitor! Hopefully, this will not deter the reader from continuing because he thinks that the author is a nut! A bit of theory is unfortunately necessary here to explain this apparent paradox.

At very low frequencies the impedance of the choke will be an inductive reactance which will increase in value as the frequency increases. However, all components have some, even though the amount is often small, stray capacitance between their terminations and so our simple inductor is really a coil in parallel with a capacitor, which at some frequency will exhibit parallel resonance. This frequency is where the value of the inductive reactance of the choke is numerically equal to the value of the capacitive reactance of the stray parallel capacitance. At this frequency,  $f_{res}$ , the impedance of the parallel combination will be a high value of resistance alone. Above this frequency the impedance will be a capacitive reactance.

So, if the inductance is made high enough for  $f_{res}$  to be well below the lowest operating frequency, the choke will behave as a very small capacitance over the required working band. At lower frequencies, below the required operational band and down to  $f_{res}$ , the equivalent capacitance will be even less and below resonance it will become negative (ie an inductance). Thus, the stray capacitance will be neutralised to some extent. Only at frequencies lower than  $f_{res}$  will the impedance start to fall as, being inductive, the reactance will fall as the frequency is reduced.

Over a very wide frequency range from just below resonance,  $f_{res}$  upwards, the RF choke behaves as a very high impedance whilst carrying dc with very little voltage drop. This is dependent only on the dc resistance of the wire.

Let us state what we require from an RF choke: an inductance high enough to put  $f_{res}$  near the lowest operating frequency whilst keeping self capacitance as low as possible. The dc resistance should also

be as low as possible. From the above information let us construct a table of the characteristics of RF chokes.

In the table we mention the *danger area* for the choke. What's this all about? This hasn't been mentioned before, but it's a very important part of the whole theory of RF chokes. It's the part where many designs go wrong, causing at the very least holes in the response of receiver amplifiers and, at worst, complete burn-out of the choke in a high power transmitting amplifier.

We know that a series circuit of inductance and capacitance provides a very low resistance at its resonant frequency. Now, from the theory we discussed earlier, we know that the whole component can be considered as a parallel tuned circuit at  $f_{res}$ . But consider point P in Figure 1, close to one end of the choke. At a certain frequency,  $f_1$ , the larger part of the choke would have its own resonant frequency and would therefore be capacitive at frequencies above  $f_1$ .

The smaller part of the choke would also have its own resonant frequency, say  $f_2$ . This would be at a much higher frequency than  $f_1$  because both the inductance and capacitance of the smaller part would be much smaller. At a frequency  $f_x$ , somewhere between  $f_1$  and  $f_2$ , the larger part would act like a capacitance and the smaller part as an inductance. If we have a capacitance in series with an inductance then, inevitably, there will be a frequency where the

two opposite sign reactances are numerically equal – that is, we have a series resonant circuit.

This is exactly the opposite to our ideal, for at that frequency the choke will behave as if it were a very low value of resistance – nearly a dead short, in fact. Any signal applied to the choke at that frequency will be nearly short-circuited, resulting in power being dissipated in the small value of resistance of the choke rather than being passed to the following circuit or load.

How can we avoid short circuits yet still use an RF choke to cover a wide bandwidth? We can't avoid all series resonances, but we can make them appear *outside* the band we want.

How do we find out where such unwanted responses of the choke are to be found? This problem is covered in the design procedure (step 11 onwards).

## Design procedure for RF chokes

1 State the lowest frequency at which the choke is to be used:

$f_{low}$  in MHz

2 State the highest frequency at which the choke is to be used:

$f_{high}$  in MHz

3 Determine a suitable parallel resonant frequency empirically from:

$f_{res} = 0.8 (f_{low})$

4 Using a ratio of length to radius of about 12 to 20 for the choke winding,

FREQUENCY	IMPEDANCE
Zero or dc	The dc resistance of wire
Below $f_{res}$	Inductive reactance rising with frequency
Just below $f_{res}$	High inductive reactance, neutralising stray capacitive reactance
$f_{res}$	Very high resistance (where $X_L$ equals $X_C$ of stray capacitance)
Just above $f_{res}$	High capacitive reactance
Above $f_{res}$	High capacitive reactance falling with frequency
Above about $2 (f_{res})$	Falling at series resonances to very low values – <i>danger area for choke</i>

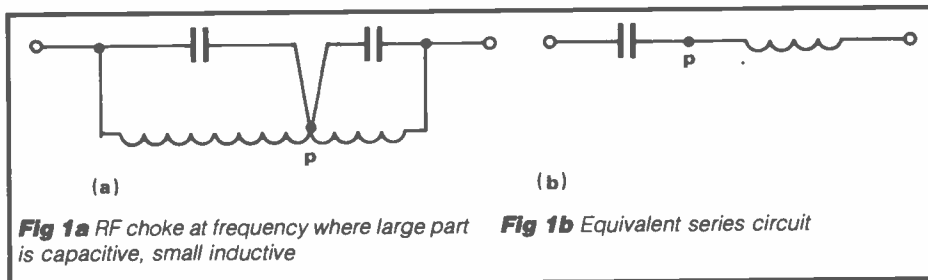

Fig 1a RF choke at frequency where large part is capacitive, small inductive

Fig 1b Equivalent series circuit



# RF CHOKES

depending on size of former available at the time, state the preferred length and radius of the choke, both in inches (or both in mm). The coil former should be glass fibre, ceramic etc, low loss at frequencies in use and around  $3\frac{3}{16}$  inch (or 5mm) radius.

**5** Approximate the self capacitance of the choke from:

$$C_s = 0.3a + 1.4r$$

or

$$C_s = 0.0118a + 0.055r$$

$C_s$  is in pF, self capacitance.  $a$  is the length in inches or the length in mm,  $r$  is the radius in inches or the radius in mm.

Both  $a$  and  $r$  must be both in inches or both in mm.

**6** Determine the inductance necessary to obtain  $f_{res}$  from:

$$\frac{L = 25330}{(f_{res})^2 \times C_s}$$

$L$  is in  $\mu H$

$f_{res}$  is in MHz

$C_s$  is in pF

**7** Determine the number of turns required on a single layer solenoid to provide the value of inductance calculated in step 6:

$$N = \sqrt{\frac{L(9r + 10a)}{r}}$$

$r$  is in inches

$a$  is in inches

$$N = \sqrt{\frac{L[(0.354r) + (0.3937a)]}{0.03937r}}$$

$r$  is in mm

$a$  is in mm

$N$  is the number of turns on coil

$L$  is in  $\mu H$

**8** From the number of turns and the coil length find the thickness of wire which will just fill the coil length:

$$d = \frac{a}{N}$$

$d$  is the wire diameter

$a$  is the length of coil

$N$  is the number of turns

where  $a$  and  $d$  are both in inches or both in mm.

$$\text{and so } \frac{a}{r} = \frac{3}{0.25} = 12$$

**9** Determine the nearest standard wire gauge (SWG) wire having a diameter just below the value of  $d$  in step 8. This will be the thickest wire usable for the winding length available. Consult SWG copper wire tables for the size required, and check that the current rating is suitable.

The current rating in the table is usually stated for 1200A per square inch, which is a conservative rating for transformer windings. For open single layer coils this figure may safely be doubled. If even after doubling the current rating it is still too low, the choke should be redesigned using a longer coil (if the coil radius is to remain the same) so that thicker wire can be used.

**10** Wind the RF choke to the above design.

**11** Set a dip oscillator to a frequency just below  $f_{LOW}$ .

**12** Bring the dip oscillator into proximity with the choke so that the oscillator coil and the choke are mutually coupled.

**13** Slowly increase the frequency of the dip oscillator up to  $f_{HIGH}$ , watching carefully for any signs of resonance caused by absorption of power from the oscillator. This will be indicated by a sudden dip in the oscillator meter reading.

**14** Record the frequency of any resonances between  $f_{LOW}$  and  $f_{HIGH}$ .

**15** Now temporarily solder a very short piece of wire across the ends of the choke, thus short-circuiting it.

**16** Repeat steps 11 to 14 above.

**17** Any resonances found in step 16 are series resonance frequencies, and the choke will act very nearly as a dead short instead of the high impedance we set out to make. If the resonances occur in any unwanted bands (for example, in between amateur bands where no RF power would be generated in a transmitter) they can possibly be ignored, as long as they are not too close to wanted

frequencies. Try to get the lowest frequency series resonance at least 20% above  $f_{HIGH}$ .

**18** If the lowest series frequency resonance (which is usually the most troublesome one) occurs just below  $f_{HIGH}$ , remove a few turns from the choke (or just one turn if there are only about ten turns on the coil).

**19** Repeat steps 11 to 17. If there are now no series resonances within the required band  $f_{LOW}$  to  $f_{HIGH}$ , the RF choke is ready for use.

**20** If a dangerous resonance is still found within the required band of operation, take a couple more turns off the choke.

**21** Repeat steps 11 to 17.

**22** If it is found that the series resonance can't be moved far enough outside the wanted band without losing too much inductance, redesign the choke using a larger ratio of length to radius (step 4).

Why should we test the choke with a short circuit across it (see step 15)? The answer is that because a series tuned circuit becomes a very low value of resistance (in fact very nearly a dead short) at its resonant frequency, further shorting of the choke with a piece of wire will have very little effect on its impedance. For how can you short out a short circuit?

By testing the RF choke for resonances whilst it is shorted, as in step 15, we can very easily find the danger areas.

One interesting point about using the choke (an inductor) as a small capacitor over its operational frequency range is that it behaves then just as an extra bit of stray capacitance as far as the rest of the stage in which it is used is concerned. It can therefore be taken care of, together with all the other strays, when designing any following receiver tuned circuits or transmitter  $\pi$  tank circuits.

Now for a practical example. An RF choke is required for the anode circuit of a valve RF power amplifier covering all amateur bands between 14 and 29.7MHz. Such a stage is shown in Figure 2.

Following the design procedure:

**1**  $f_{LOW} = 14.0\text{MHz}$

**2**  $f_{HIGH} = 29.7\text{MHz}$

**3**  $f_{RES} = 11.2\text{MHz}$

**4** length,  $a = 3$  inches  
radius,  $r = 0.25$  inches

**5**  $C_s = 0.3(3) + 1.4(0.25) = 1.25\text{pF}$

**6**  $\frac{L = 25330}{(11.2)^2 \times 1.25} = 161.5\mu H$

**7**  $N = \sqrt{\frac{161.5 [(9 \times 0.25) + (10 \times 3)]}{0.25}} = 289$  turns

**8**  $d = \frac{3}{289} = 0.01$  inches

**9** 34SWG is 0.0092 inches diameter

**10** Wind the RF choke

That completes the design. However, the detailed testing procedure from **11** onwards must be followed to ensure that the choke has adequate impedance over the band of operation.

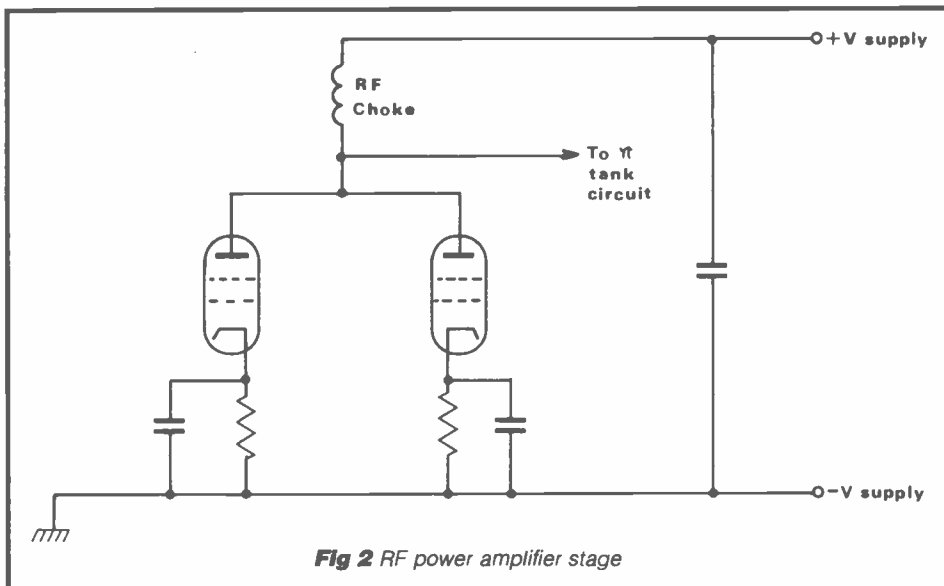

Fig 2 RF power amplifier stage

# BATTERY

# TESTER

A useful constructional project for the shack

by B B Walters

During my years as a radio technician I have often heard the comment: 'I have batteries and a charger, but never know the condition of them'. This battery tester fits the bill for most batteries used on amateur hand-sets.

When placed on battery terminals this tester takes a load of approximately 50mA. The press button takes approximately 1A load on a 12V battery.

The actual values do not matter, as usually the condition indicated is of primary importance.

### How it works

R1 is a load device taking approximately 50mA from the battery. The voltage drop is monitored through R3, R4 and D1.

D1 is a zener diode which gives the minimum voltage suitable for the battery in use. Thus, the meter starts to monitor from approximately 7 to 15V, depending on VR5 adjustment. Because of the meter sensitivity, a small voltage change produces a large meter movement.

R2 simulates the transmit current used by your rig. Check the handbook for this information and use the formula to find R2:

$$R_2 = \frac{F}{I}$$

This equals the 12V battery used divided by a 1A Tx current, which equals a 12Ω resistor.

Note that if held on test load too long, the paint will burn off the resistor.

The meter was purchased at a local rally for 50p and encribed as shown in Figure 2. Any value from 50μA to 500μA has been used in past projects.

### Components List

R1	270Ω 2W
R2	12Ω 5W
R3, 4	150Ω 0.5W
VR5	50kΩ
D1	6.8V zener 400mW

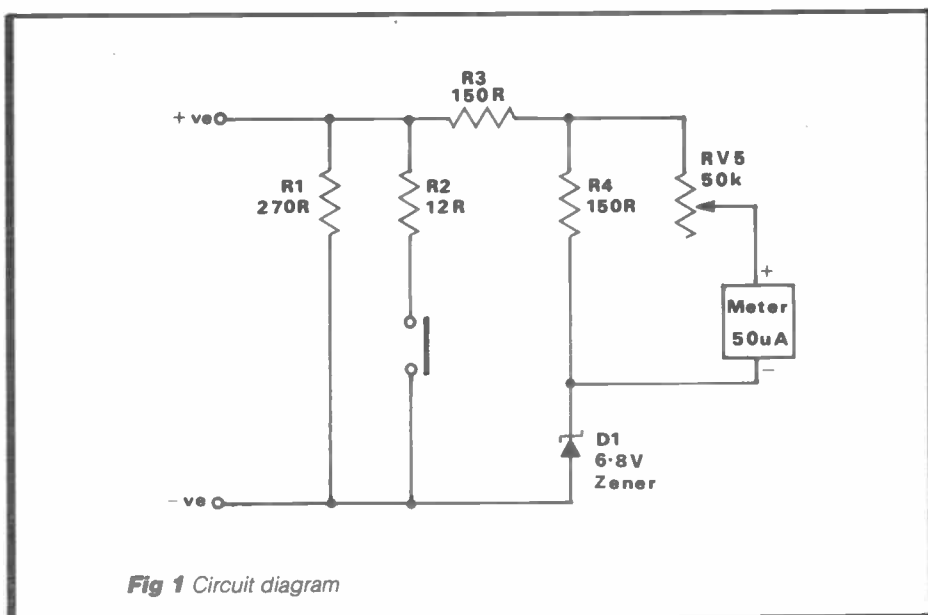

Fig 1 Circuit diagram

### Battery checks

*Meter position 3* (coloured green). This equates to a well-charged battery.

*Meter position 2* (coloured white). This indicates a good battery which requires charging.

*Meter position 1* (coloured red). This means that the battery is in poor condition; try charging it.

### Results

At this point you should press the button for 3 seconds. A small movement in the green section indicates that the battery is OK. If it drops from 3 to 2, it is a good battery but it requires charging. A drop from 2 to 1 means that you should try charging the battery as it is at the end of its life. If it drops from red to 0, the battery is unserviceable.

The D1 value depends on your battery. If it's a 6V working try a 3.9V zener. If it's a 9V working try a 5.6V zener.

### Check your handbook

The R1 value could be the current of your receiver on standby – again, check your handbook and use the formula

previously mentioned to find R1. For example, using a 9V battery and 20mA on standby,

$$R_1 = \frac{E}{R} = \frac{9}{20 \times 10^{-3}} = \frac{9}{20} \times 1000 = 450\Omega$$

VR5 can be set to 75% of meter movement when a fully charged new battery is checked.

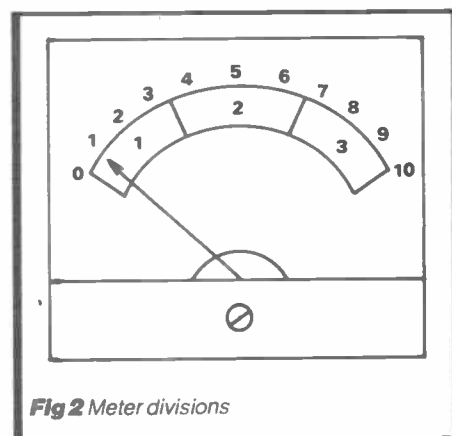

Fig 2 Meter divisions

## Matmos Ltd

1 Church Street, Cuckfield, West Sussex RH17 5JZ  
Tel: (0444) 414484/454377

## Computer Appreciation

30/31 Northgate, Canterbury, Kent CT1 1BL  
Tel: (0227) 470512

**TA/ROYAL OFFICE MASTER 2000 DAISY WHEEL PRINTERS.** Our purchase of nearly 2000 of these printers direct from West Germany enables us to offer them at enormous savings!

Features include:

- \* 20 cps operation
- \* Full **DIABLO 630** and IBM compatibility
- \* **CENTRONICS** compatible parallel interface
- \* 132 column with variable pitch capability including micro proportional spacing
- \* Subscripts, superscripts, bold type, underline etc.
- \* Manufactured to highest standards (rigid steel chassis etc) in West Germany by Europe's largest typewriter manufacturer

- \* 6 month full guarantee
- \* Ribbon & typewheel included

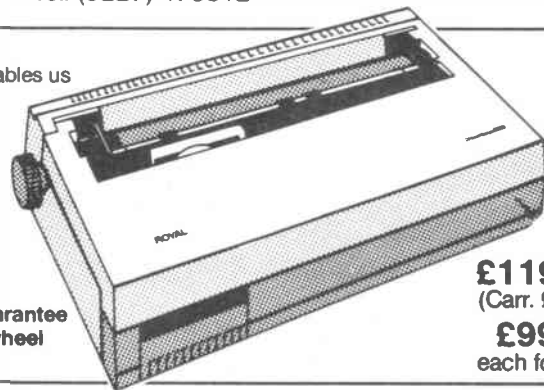

**£119.50**  
(Carr. £5.00)  
**£99.50**  
each for 5 +

**PANASONIC Model JU-363 3 1/2" Disc Drives.** Shugart interface, 1/2 height, 1 megabyte double sided double-density 80 track, low component. Will interface to just about anything. (A quantity discount of at least 20% is available for 10 + off).



**£59.50**  
(Carr. £3.00)

**ITT SCRIBE III PROCESSING SYSTEM.** Professional system originally selling at around £6000 without printer. Colour leaflet available.

**SOFTWARE INCLUDES** — DATABASE \* AUTOMATIC LETTER WRITING \* HELP FILES \* BASIC \* PROGRAMMABLE COMMANDS \* MATHS/ACCOUNTS FUNCTIONS \* FULL EDITING  
**HARDWARE INCLUDES** — 128k SCREEN/WORKSTATION \* DUAL DSDD SHUGART 5 1/4" DISC DRIVES

**£290.00**

**DUPLEX Model M100 Monochrome Monitors.** With 12" high resolution green screen & composite video input. Equivalent to other models such as ZENITH & PHILIPS.

**£39.50**  
(Carr. £5.00)

**PLESSEY Model T24 V22/V22 bis 1200/2400 Baud MODEM.** Compact automatic modem featuring the latest technology & the highest data rate over the ordinary phone system. Features:

- \* Software available for IBM PC & compatibles & MATMOS PC
- \* High speed PRESTEL compatibility
- \* Auto call & auto answer
- \* New low price

**Now**  
**£169.00**  
(Carr. £5.00)

**VICTOR SpeedPac 286 IBM PC ACCELERATOR.** Half-wide 80286 accelerator card for IBM PC or PCXT, VICTOR VPC, and compatibles. Features 8KB cache memory & 7.2mhz 80286 processor. Offers AT/Personal Systems 2 performance for a fraction of the cost. Runs up to 7.5 times faster.

**£139.00**

**Please note:**

We have only a few 3" HITACHI SSDD drives left at **£24.95**. Cases now available for 3" drives at **£4.99** (single) and **£7.99** (dual). VAT and carriage must be added to all items. New TRANSDATA 307 originate/answer acoustic couplers available at **£14.95**.

## Siskin Electronics

The RF Data Communication Specialists

### PACKET and More!!



#### Pac-Comm

TNC-220 Dual port (HF/VHF) very popular	£149.00
PC-110 PC card! Single port, inc software	£159.00
PC-120 PC card! Dual port, inc software	£179.00
TINT-2 Single port VHF TNC. Great Value	£109.95
Micro-2. Low power (40mA), high spec	£159.00
DR-200. Dual port digipeater	£169.00

#### AFA

PK-57 Single port TNC with 'HOSTMODE'	£149.50
PK-50 Commercial specification TNC	£465.00
PK-432 Packet/Ascii/CW/Amtor/RTTY/WEFAX and NAVTEX!	£269.95

#### ICS

FAX-1 Receive weather maps from any SSB receiver to a suitable printer	£279.95
--	---------

#### Kantronics

KPC-2 VHF/HF TNC, WEFAX and PBBS inc	£159.00
KPC-4 Dual port TNC, gateway command	£298.00
KAM Packet/CW/RTTY/Ascii/Amtor/WEFAX. KA/NODE and PBBS inc	£265.00
MD24 2400 baud modem for KAM or KPC-4. Great value at only	£59.00

#### Accessories

RS-232 Lead for most computers	£9.95
HR-125 HF Receiver, ideal for FAX as well as RTTY/AMTOR etc	£375.00

#### Software

Please contact us to discuss your software needs. We can supply a wide range of both public domain and specialist software to get the most from your TNC

PO Box 32. Hythe, Southampton,  
SO4 6WQ. England  
FAX: 04893-5081

Orders and Information  
Phone: 0703-849962



# Second-Hand Receivers

## for under £50

By Hugh Allison G3XSE

One of the most frequent types of letter I receive is along the lines of 'I'm unemployed, retired, broke, stingy, a beginner and want to know what I can get in the way of an HF receiver/HF transmitter/two metre rig for under £50'. This article is the first in a projected long term series of three and, hopefully, covers the receiver requirement. The next two will cover HF Tx's and two metre boxes.

HF receivers fall into two camps: amateur bands only and general coverage. Your scribe was sent, willingly, to a rally with a full wallet to purchase examples of what your average punter could buy, play with them and report back.

### General points

You may think that the following reports dwell too much on the 10 metre (28MHz) band. There are two reasons for this. Firstly, it is an interesting band in its own right and, secondly, it is an often used IF for converters. Its performance here will determine how well you will receive, say, two metres when your new wonder-box is strung on the end of a converter. 28 to 30MHz is as high as the set will receive, so this will give an indication of the stability of the set at lower frequencies and its sensitivity.

If sensitivity measurements in microvolts confuse and bemuse you, then just think that your average CB set has about one microvolt sensitivity for 20dB quietening. As a very rough guide, a station you can just hear on your CB set will be inaudible on a 5 microvolt general coverage set. Do not sneer at this; there is a lot to listen to on even a moderately deaf receiver. There is no point in having a really sensitive receiver if it is unstable and wobbles about all over the place. You pay your money and take your choice, although, hopefully, after reading this you may be in the position to make an informed choice.

### Minimitter MR44/II

The MR44/II looks about as attractive as a dead rat. However, do bear in mind that occasionally good things come in ugly packages. If you can live with the extremely dated looks you can pick up a

really decent receiver here for between £25 and £35. If I tell you that here we have a dual conversion amateur bands receiver with built-in 'Q' multiplier and crystal filter (admittedly there are only two crystals, but it sounds good) you will expect a reasonable performer. Then add a built-in RF stage and you will appreciate that quite acceptable results, even by modern day standards, are available from this electrically well-designed box of tricks.

For those who are unfamiliar with such devices, a 'Q' multiplier is best considered as follows. An ordinary coil will have a bandwidth of something like 12dB/octave. In layman's terms, that is wide. A single coil crystal set will often pull in several stations at once due to the poor bandwidth characteristics of that one coil.

Your average superhet, of course, has coils all over the place. Add a crystal filter and you can get the bandwidth down to, say 2.7kHz for SSB reception. This is great for SSB, but not very useful for CW (Morse) because on 14MHz you can have 27 (or more!) people having conversations on the key within that sort of bandwidth. Put that lot through a 2.7kHz filter and you have a mess. However, switch in the 'Q' multiplier and 100Hz bandwidths can be achieved, which should help you sort them out.

What happens is that there is a coil arranged within the 'Q' multiplier which is *just about* to oscillate via a valve or transistor. This, of course, produces positive feedback. The nearer you adjust this towards oscillation, the sharper the circuit becomes. Unfortunately, you have to couple this coil into your IF stage and a strong signal can sometimes 'tip' the 'Q' multiplier into oscillation. With practice, though, this is a useful addition to an older set.

Right, back to the set. We bought the review sample for £3.50 at a rally, not working. It took longer to take the covers off than it did to find the fault, which was a dead decoupling capacitor in the RF stage. For the less adventurous, there was another example available for £20. This was covered in dust and brown nicotine goo but, we were informed, worked. By the way, we are talking 'old' amateur bands only: 80-10. There is a built-in mute for transmit but no speaker.

On the test bench the higher than normal first IF gave a good 55dB down for second channel rejection at 30MHz. Sensitivity was of the order of a microvolt for a 10dB signal with noise to noise at all bands up to (and including) 14MHz, but we plummeted to 5 microvolts on 28MHz. Very stable with no drift at all on any band.

One final point, don't lean, push or pull

Minimitter MR44/II

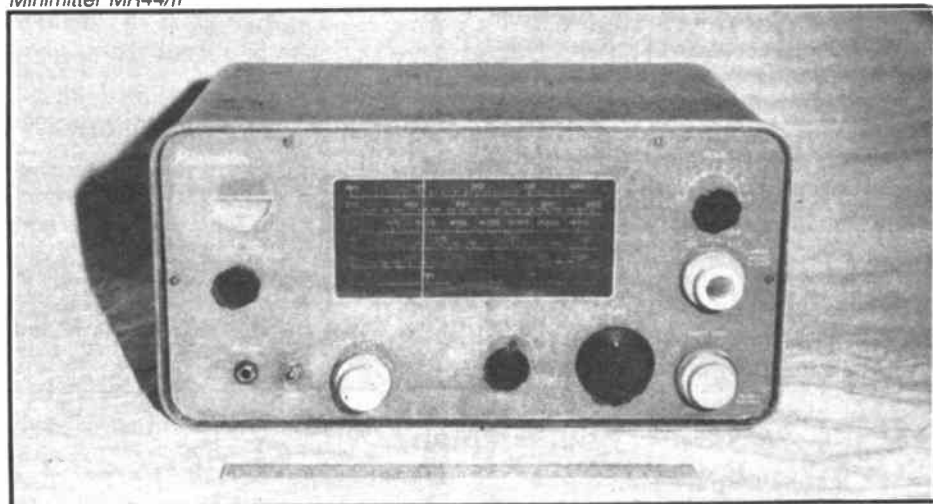

## SECOND-HAND RECEIVERS

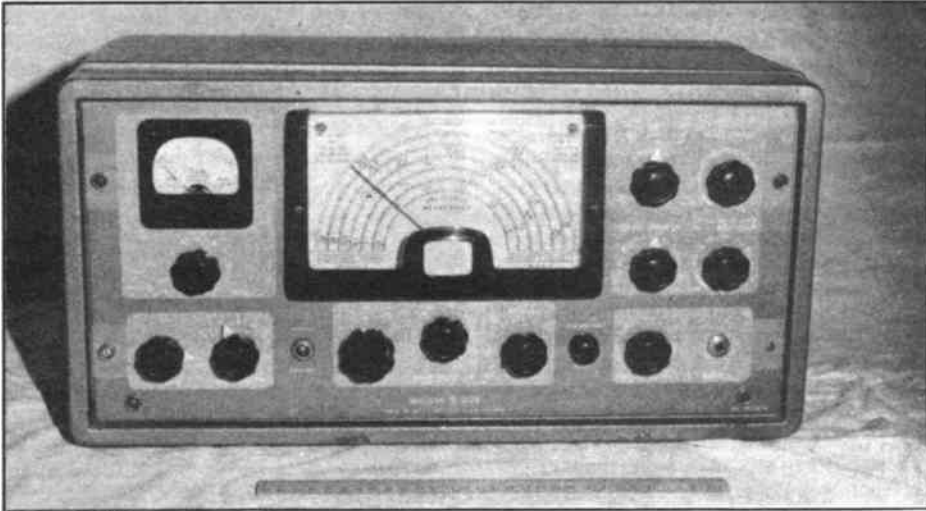

*Geloso G209*

on the front panel. It's thin plastic and very brittle.

Not exactly a state-of-the-art receiver but, all in all, a real bargain and well worth considering. Be prepared for your friends to die laughing at its looks, though!

### **Geloso G209**

The G209 is also dated, but it has, in my opinion, aged gracefully and looks super. It is big and very heavy, about 30lbs, but that is about all I can find to say against it.

In its heyday Geloso had a well respected name for stability and this set is no exception. Try as I could, it didn't drift, with not even a 'boing' when whacked. Excellent and very solidly built.

Again, this set is a dual conversion model. The conversion crystal from first to second IF is switchable to invert the sidebands; you can leave the BFO alone when going from an LSB signal to a USB one by just flicking the switch. There is a built-in mute system for transmit.

On the test bench sensitivity was again about a microvolt for 10dB signal to noise up to, and including, 14MHz. 21MHz was two microvolts and 28MHz was four. Second channel rejection was again 55dB at 28MHz.

Top Band was not fitted as standard to G209 receivers. About half the examples that I have seen, however, have been modified to cover it. I think that there must have been an article on this published at some point as all the modifications seem identical. The lid can be lifted off easily to reveal a rotary switch mounted on top of the RF section. Throw this switch and, with the radio set to 80 metres, you receive Top Band.

A lovely aspect of this receiver is the accuracy of the tuning dial. It is big, clear and easy to read. You can set it to receive with confidence to within a couple of kilohertz – not bad considering the vintage. Again, the old amateur bands only – or 160m if modified.

The fact that the performance is so similar to the Minimitter MR44/II, illustrates just how much styling counts in the

price. G209s are always around £50, give or take a fiver. It looks like a real mean machine and has a performance to match. Well worth considering.

### **Lafayette HE30**

There are two warnings I must give about the HE30. One is obvious: the dial markings are prone to falling off, so you might get nude tuning scales.

The second is more serious: many of these receivers are 110 volts only. This is not too serious if your example is sold to you with an auto-transformer or step-down transformer, which are often built in, but, without this, if you naively plug a 110 volt into the 240 volt British mains the front panel bulbs will glow bright and the valves will pop. You have been warned, though it must be admitted that 240 volt sets do exist.

There is a built in Q multiplier and a whole host of other knobs to twiddle on this general coverage receiver. Sensitivity is good – a microvolt all the way to 28MHz – but this set is not too stable. It drifts a bit, 5kHz to 10kHz an hour, and there is not much evidence that it will ever stop. This is only on the top range, however, and is at its worst on 28MHz. Frequency setting is a bit hit and miss so,

*Lafayette HE30*



if I was to be nice about it, I could say that the HE30 might be of use to the AM short wave listener who just wants to tune around or for amateur listening up to 14MHz. If I decided to be rude I might say for sadists only on 28MHz CW, especially with the band wide open and the Q multiplier switched in.

A price of £40 will buy you one, but £50 is too much. If the dial markings have peeled off then £20 to £25 is about right, if you must.

### **Eddystone EC10**

The one thing you are not going to do with an EC10 is lose money on it. A grubby worker, with battery power only will be around £35. A full collection of power trays (one mains, one battery) in a mint condition model will be £50. If you look after it you will always be able to sell it again and get your dough back. Keep it for a few years and you might even make a small profit on it. The EC10 Mk 2 might be a tenner up on these prices, and non-workers about a third of the above.

What do you get for your money with this general coverage receiver? For a start, not much sensitivity on 21 and 28MHz. For example, tests showed 7 microvolts for 10dB signal noise at 28MHz, and about 2.5 on 14MHz. Selectivity is not enhanced by crystal filters, etc so is about 9kHz at the 3dB points. There is, however, an audio filter for CW work and it rings nicely. It is difficult to get any meaningful measurements for this, but I'd guess it is a few hundred cycles wide, dependent upon input signal level.

I like this filter but must admit that I am biased; as a kid I spent happy days with an EC10 on CW and got quite used to it.

Stability is good up to and including 14MHz, even when using batteries which are on their way out (they would not even manage a glow out of the dial lights). This was a bit of a struggle on ten CW, but shows that it can be done. SSB reception on ten is marginal; you certainly need a steady hand (not much bandwidth).

Dial setting accuracy is debatable. I would certainly not like to use an EC10 to find someone on, say, 21.210MHz

## SECOND-HAND RECEIVERS

because you can't be that precise. What you can do is find the relevant amateur band quite easily then tune around it. A crystal calibrator might be a good accessory.

Another problem is second channel rejection. On 28MHz with only a 455kHz IF you cannot expect much. In actual fact, you are going to get 20 to 30dB (I measured 3 sets), so CBers might appear on the 10 metre band when they are operating quite legitimately on another frequency.

It is unfortunate that the above gives a bad image of the EC10. What you are getting for your money is your first 'real' short wave set. It looks nice, can work well and, as a bonus, seems to be increasing a fiver in value every other year; what more could you ask for? There is nothing to stop you trying a decent preselector ahead of the set to breathe life into it on 10m.

Please don't let the following put you off buying one either. Faults that commonly occur in the EC10 are as follows. Firstly, the audio filter button fails to lock in. This is simply cured by a bit of phosphor bronze spring finger-soldered on in the appropriate spot to compensate for the old spring's failure. Secondly, there is the dreaded AF type transistor collector to screen growth. What happens is that moisture seeps in through the tin/lead seal and the collector 'grows' until it shorts to the screen. These transistors have 4 leads: emitter, base, screen and collector. To cure this fault, cut the screen lead off. I'd say that 50% of the dead EC10s I see suffer from this.

Problems caused by people are diverse, though by far the best way to break an EC10 is to play with the cores. If you take the wrong tool to the IF core it will crack. Even if you use the correct tool it is likely that the centre of the coil former will turn as well as the core, thus snapping off the leadout wires. Be extremely careful. Even better - *leave the cores alone.*

Another receiver which is just a little unusual is the EC10 A/2. This was made

for coastguard and marine use, and has a fixed 2182kHz position for distress use as well as the more usual tuning ranges. When I was a boy I took my Morse test at a coastguard station (it was nothing to do with the RSGB in those days). Afterwards (having been told that they couldn't tell me if I had passed but they would say that I hadn't failed), I was taken on a guided tour of the station. In a console was an EC10 A/2 as a back-up receiver to the main Atlanta. Imagine my surprise to see that selfsame set in a pile of junk at the RTTY Convention at Sandown Park 20 years later, with the coastguard station name still engraved in it! For £8 it became a restoration project and is now a treasured possession.

The EC10 features a built-in speaker but no transmit muting. With its classic Eddystone styling, its looks are timeless. Well worth having for general short wave hacking around. The battery powered models will last for ages provided you lay off the dial light button.

### Yaesu FR50

The FR50 is absolutely 100% reliable. If you leave it alone it will work forever. If it is kept in a damp room (like a shed or garage), unused and unloved for a couple of years the bandchange switch will be intermittent, but after a few swings from one end to the other it will cure itself. Apart from that, it is a very well behaved set. The problems in every one that I have ever repaired have been due to their owners 'improving' them.

The FR50 is a classic valve amateur bands only set. It covers over 80 to 10, old bands only. It has a 5 to 5.5MHz (ish) VFO and all that. It's dead stable, good enough for CW on 10. Sensitivity is good, though it needs a pre-amp on 10 for serious work. There's good image rejection, 55dB plus on 10. What more can I say?

One thing that may tempt you towards a FR50 is the thought of a FL50, which is the matching Tx, and with which it will transceive (there's single knob tuning of both). Don't be tempted. FL50s on their own are as rare as million pound pools



Yaesu FR50

winners. Incidentally, the FL50 is a bit of a mains transformer eater.

A FR50/FL50 combo is going to cost £100 to £150. The receiver alone is going to cost you £50, and maybe a little haggling. The top price seen for one selling last year was £65 - that was for a mint condition one, still in its box and with a handbook.

New bands *can* be added. If you are desperate, change the mix crystal for the nearest band fitted. The preselector has a good swing and will often tune to your chosen new band without tweaking the RF coil cores.

This is an excellent receiver for amateur bands only use. It's easy to set precisely to frequency, give or take a kHz or so. It would team up nicely with, say, a homebrew CW Tx to make a reasonable first station. It looks good, works well and holds its price. Couple that with its reliability and you could well have a good buy on your hands here for £50.

### Heathkit GR64

Note the 'kit' bit in Heathkit. Someone has built whatever it is you are thinking of buying, and he could be worse at building things than you are. More importantly, he might be worse at building things than I am. You might be buying a whole heap of damaged components held together with loads of dry joints, or one lovingly built by a retired engineer who devoted a year of his life to crafting the item before you. You just don't know from the outside.

A mate of mine bought a DX40U transmitter where someone had twisted the wires together and flicked solder over the joints, and I once (knowingly, it was embarrassingly cheap) bought a HW8 where someone had mis-read the handbook and assembled the circuit board on the wrong side of the chassis. 'Heathkit', in your mind, should equate to 'get the covers off and have a look'. There is no other way to find out what you are buying. Look for dull 'dry' joints, loose components, burnt cable looms, etc.

The good news is the handbook. Heathkit handbooks are fabulous - even I can understand them. There are good clear circuit diagrams, excellent layouts, clear, well written circuit descriptions and fault finding sections. It's also true to say that Heathkit use good quality, generously rated components. It's the builder that might have been the only

Eddystone EC10



## SECOND-HAND RECEIVERS



Heathkit GR64

weak link in the chain, so check this out.

Right, on to the GR64. There's a nice cabinet; it looks good. Performance-wise it's like trying to mow a football pitch with nail scissors. Give a GR64 a whack when you've finally got it to resolve a SSB signal on 28MHz, and you will be lucky if it is still tuning the same amateur band when you've finished. A desire to resolve SSB above 14MHz plus a GR64 gives you muscles on your fingers due to all the exercise they will get following the station about. The thing

has pretensions of being useful in the amateur shack, having a Tx mute switch, but don't be fooled.

We are talking about valves, in a badly vented cabinet (hence the drift), no RF stage, a 455kHz IF and no measurable image rejection at all on 28. What it manages to receive up there comes in twice. Personally, if there was only a GR64 in the shack I'd go out for a walk. It may be of use to a broadcast bands short wave listener who doesn't want to find a particular frequency. You don't see many

as main receivers in licenced amateur shacks!

Price-wise I've paid a quid for a nice looking example that had been so highly modified by its owner that it no longer worked; I've seen comedians ask (but not get) £45 for one. £25 is the going average but really I wouldn't advise it.

Oh, I nearly forgot. The speaker is built in. Tune in a signal and, say, someone talks on the wild waves you are receiving. To convert this to sound, the speaker moves. This vibrates the local oscillator components, which causes the frequency to shift, which causes the speaker to move, etc. The result is an 800Hz howl when you tune in a station and turn up the audio wick. I've come across this in 18 out of 22 of these sets that I have bought/serviced/repaid/told their owner to get rid of. You can cure this by using an external speaker, or by selling the set.

**Next month Hugh Allison looks at six more second-hand receivers for under £50.**

# SANDOWN 1988

by Fiona McKenzie

The RSGB's National VHF Convention took place at Sandown Park Racecourse on Sunday, May 1st. Opinion was divided about whether the early rain was an advantage or not for attendance figures. I don't have the final tally, but I heard that 2000 went in the first two hours.

The convention was formally opened by the RSGB President, Sir Richard Davies G2XM, whose first visit to Sandown it was. He said that it was a great honour to welcome everyone, and hoped that the Convention would be a great success. Mentioning the 75th anniversary convention at the NEC Birmingham, in July, he said that this was not just an occasion for self-congratulation, but an opportunity to focus the campaign to attract the new licencees, particularly the young, on whom the future of the hobby depends. Frequency allocations above 30MHz, he said, must be well used in order to ensure that we keep the frequencies, while the use of new bands will relieve pressure on 2m.

Sir Richard then presented eleven trophies which have been competed for over the past year. Recipients included The Hillbillies, with both the Surrey Trophy and the Mitchell Milling Trophy, the Parallel Lines Group with the VHF Manager's Trophy and the VHF Contests Committee Cup, The South of Scotland VHF/UHF Contest Group with the Tartan

Trophy, Bob Treacher RS32525 with the Hansen Trophy and Dale Harvey G3XBY, with the Telford Trophy - this last being a replica of the Telford Iron Bridge.

The lecture streams were well attended, and included 'Trends in Tropo' by Ray Flavell G3LTP, 'Measurements for the Amateur Station' by Peter Ghadwick G3RZP, a Morse Test forum, Angus McKenzie G3OSS, on, Breakthrough Problems from 144MHz Band Usage, and Mike Dennison G3XDV, on packet working.

The trade stands attracted attention throughout the day; getting around only becoming easier after lunch when the lectures started. The equipment measuring service, run for the RSGB by Marconi

*The RSGB President, Sir Richard Davies G2XM (left) with Shelagh Chambers, RAIBC treasurer, and Angus McKenzie G3OSS, RAIBC chairman and RSGB council member at the VHF Convention*



# SHORT WAVE LISTENER

## TREVOR MORGAN GW40XB

Yet another busy month has flown past and there are definite signs of the bands improving, with fifteen and ten metres showing great progress towards their DX potential.

Kurt Brauer of Altstaetten in Switzerland mentioned some very nice DX captured on fifteen from JA7AS/QRP and JR8XGL/QRP working 3 watts both ways! He also mentioned 9J2AL with ZL2UW and VS6VT running 3 watts. David is QRV at the weekends on 21060, as is LA4RA. Feng BV2DA is also around on 21001 to 21005 from 0800 to 1000 UTC, so keep your ears open. Incidentally, Kurt's station includes the NRD525 and the Sony ICF2001D, which he finds excellent, but he will be at the sharp end of the DX around now from Thailand, so listen out for HS2AMX.

Geoff Hughes of Dover has been getting into the DX as well and mentioned ZL4RN, TG5TP, AP6TV, VX3EZU, VK1YE and HP1XHT. Geoff writes of the Dutch amateur radio society station on 3602. Amateur radio news is broadcast at 1830 in Dutch and at 1845 in English, while at 1900 they transmit practice Morse. The callsign is PI4AA, so listen out for them.

### DX directory

I had a very interesting letter from Ted Melinosky K1BV, telling me about the *K1BV DX Awards Directory*. This is a comprehensive listing of over 800 awards available from over seventy countries worldwide.

The contents of the directory include rules for over 800 awards, listings from nearly

100 DXCC countries, club member lists for specialised awards and full identification of those awards available to SWLs.

In addition to the awards details, the directory includes a special section with hints for the beginner, including a description of terms used, details on QSLing and the effective use of bureaux.

At the moment it is available only from Ted at 525 Foster Street (suite 500), South Windsor, Connecticut, 06074-2936, USA, but I hope to be able to make some copies available here. The cost from Ted is \$16.95 for airmail delivery.

### Strange waves

A little query popped up the other day while I was working K2DXE on twenty metres CW. John gave me a 569 report, so I wasn't really surprised to encounter Bill VE3AR immediately afterwards with a 579 report. What did surprise me a bit was to immediately get a call from Jaco LU7AMU, who also gave me 579, and Oscar PZ1AV with 579 too! Now that might be expected with a vertical or long wire aerial, but I was using the AQ6-20 minibeam which, since the recent gales, has been stuck in a north-easterly direction! Just to crown it, I worked over a dozen Europeans with SSTV on 14230 and was complimented on the strong signal! Funny things, radio waves.

I've often mentioned rallies, and how you can pick up a bargain. Well, John Markey of Lydney certainly did so at a recent rally when he spied what appeared to be a couple

of useful loudspeakers half hidden under a counter. On asking the price, the reply was a wry look and 'give us a quid'.

Having parted with the necessary coin, he gathered up his purchase and went off, only to find, on later examination, that he was now the proud owner of a Sony TC133 stereo tape recorder...with attached speakers and two mikes!

### Lots a letters

Just one small point to make regarding mail. If you want a reply...please send a first class stamp. Between January 1st and March 27th, I received 253 letters. Although the majority were from ILA members, it gives you an idea of the problem of postage costs this end if I don't get stamps. *Please* do not send envelopes, as they are frequently too small.

A reminder from our friend Marc Domen ONL6945 about the UBA Listeners Contest. The idea is to log as many countries as possible on the 160, 80, 40, 20, 15 and 10 metre bands during 1988. The contest is always well supported but there were only *five* UK listeners in the frame last year, and I feel we should offer more of a challenge to the other countries. Our boys did well, however, and congratulations to BRS28198, BRS88825, and to BRS52868, BRS84869 and G1VDW for getting in there and having a go.

The categories are: Phone (single op), CW (single op), RTTY, AMTOR, ASCII (single op), SSTV, FAX (single op) and all mode (club or multi

op). The full rules are available from me.

With the bands on the upward trend, it's no surprise to be receiving plenty of award claims. After last month's excellent offering, I thought we would be in for a bit of a respite, but here we are again.

### Awards

First to Malcolm Element G0EBD, of Shrewsbury, with a claim for the Gold Prefix award. Using the TS930 with a G5RV and a five band vertical, Malcolm logged 3A2, 3Y2, 4S7/P, 4V5, 5B4, 5L2, 5T5, 6W7, 8P9, 9V1, 9Y4, A92, AP2, BV6, BY1, DD2, FY5, HH7, HV3, JQ6, KK9/VP2, KN4/PJ7, PP5, PQ1, PZ2, T27, TT8, VQ1, VX3, XX9, YB4, ZP3, ZY5 and ZZ5 amongst the thousand-odd. Well done, Malcolm!

Darrell Jacobs ILA152 of Mortimer, has settled in his new QTH nicely and found time to chase them on fifteen for the North American Continental award. The ARRL contest helped no end, and his (*still*) temporary end-fed wire in the bedroom is working well.

### Oops

Darrell mentioned the slip I made about the Continental awards. Listeners can claim an award for their own continent, but their own country must not be included. Sorry about that!

Heinz Tank DE7TXL, of Berlin, put in a trio of claims for Bronze Prefix, Broadcast Monitor and USSR Continental awards. Amongst the prefixes were AP2, A61, CU8, CX6, J28, KL7, PP7 and PZ1. Heinz uses the Panasonic DR49 and is interested in the broadcast side of listening as well as amateur, which keeps him fully occupied.

Obviously, the DR49 is working well as these claims were swiftly followed by further ones for Asia, North America and the Medium Wave DXers award. Heinz is also a keen 27MHz FM operator and enjoys a good chat to fellow listeners on that mode.

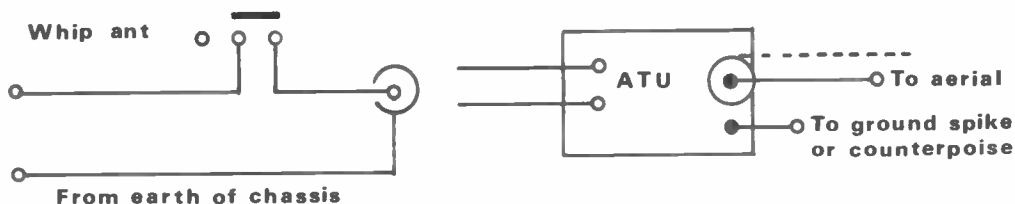

Fig 1 Aerial tuners are much more effective if earthed



He hopes to be operating from around Alicante in June, so keep an ear open for 'Pelikano'.

Derek Taylor of Preston gets into the lists again with claims for South American Continental and the Medium Wave DXers awards. Derek is a member of the Medium Wave Circle, so the latter was right up his street.

He mentions some nice first loggings in his claim, including Radio Taino (Cuba), Action Radio (Guyana), Radio Favoritas (Maracaibo) and Radio JBC (Jamaica), although his favourites were Radio SCM (Canal Zone) and Radio Santa Rosa (Peru).

When you consider that Derek only uses the Sony ICF2001D and a 50ft loop antenna, it goes to show just what can be heard if you've a mind to. The medium waves are not just full of the 'top twenty'.

Marc Domen of Antwerp has just celebrated receiving his 1000th prefix confirmation. As you may remember, Marc was awarded his Gold *Amateur Radio* Prefix award a couple of months ago, but it was the icing on the cake to get all of those QSL cards just to prove the point.

On the DXCC front, he has 246 countries confirmed now with 32 on 1.8MHz, 113 on 3.5MHz, 119 on 7MHz, 205 on 14MHz, 181 on 21MHz and 124 on 28MHz and over 50 awards decorating the shack!

Terry Lincoln is still hard on the trail and worked hard to get the Silver Prefix award. Amongst the list were CU6, HH7, AE8, YV1, ZL3, 5B4, VK9, ZS1, 4N7, VK8 and CE2. Terry uses the FRG8800 with an FRT7700 tuning an end-fed wire antenna.

Martyn Whyte of Edinburgh finally got Rosemary off the receiver and managed to get some listening done. It was fruitful too, with claims being submitted for the Continental awards for Africa, Oceania, Asia and the USSR. They obviously don't buy wallpaper up there any more!

Tony Blackburn RS87156, of Stratford upon Avon, has now installed the Icom 735 with a muTek 2m converter and CapCo ATU. He is very struck by the performance of the new line-up. Some of the best DX heard so far, in just over a month of use, is EX0CR, S0RASD, HZ1BA, VP5KEL, HK0HEU, J6LB, OA4LH,

9X2AA, DU7RLC, EP2SA, 6W6JX, SU1ER, 5V7SA, J28EV, FM5CL, AP2SQ, XE1HON, 5H1HK, 5N9GM, VU2ZAP, HL5FJJ, ZD7CW...and on it goes!

An interesting point is that, while listening to a QSO between VU2ZAP and UR2RMC, the Russian said that, sometime in the near future, some USSR stations would be allowed to QSL direct. Apparently, one station has already been given a PO Box number. This is very good news and takes 'glasnost' another step in the right direction.

### Stamps galore

The news comes as no surprise to yours truly, however, as my son Glyn has been exchanging stamps with a couple of Russians for some time by direct mail. Apparently Vasilii, one of his penpals, says that he has a licence to exchange mail and the quantity of mail is restricted. It should be pointed out that Vasilii can be heard on the stamp programme on Radio Kiev!

Funnily enough, just as I was writing this piece the mail arrived and the first letter in the pile was from Boris Chuis-tov UB5-067-67, in Yalta, who is the first Soviet listener to join the ILA...he also has a box number.

Meanwhile, down among the elephant grass and hippos, Stan Porter of Malawi, while still slaving over a hot receiver to get the Premier prefix award (for 2000 prefixes), managed to find time to gather enough to claim the South African and Oceania continental awards.

Stan is hoping to be in the UK again this year and will, no doubt, be looking up a couple more listeners. On the way over he'll be hoping to get his apartment in the Algarve ready for retirement.

A piece of sad news has filtered through from Matty Bell of Redcar. Frank Brown G0FLR has passed away. Frank was an early supporter of the International Listeners Association and an enthusiastic member of the Redcar Amateur Radio Society. He was always ready to help newcomers to the hobby and made many friends on 27MHz as well as amateur radio. He will be missed, and our belated condolences are passed to his family.

I have received an interesting letter from Ivan Chidwick of Wakefield that could be of particular interest to flat dwellers. Ivan lives in a ground floor flat without any outside space for aerials and he was beginning to despair of ever being able to log the DX. A friend loaned him the Datong AD270 Active Antenna, and first results were encouraging, but he decided to experiment.

He has a 1.5m base-loaded whip for use with 27MHz FM, and wondered if he could couple this with the AD270 for HF reception. In true Heath Robinson tradition, he connected the co-ax downlead of the whip to the AD270 in place of the supplied dipole. The result? Fantastic, says Ivan, with 5/9 signals from all over the place...amateur and broadcast. Trying RTTY, he received excellent copy from Brazzaville on 10.137 using the RX4 receive program. SSTV has also been very successful with some excellent pictures being received. It just goes to show that it doesn't matter how daft it sounds...try it!

Those of you interested in SSTV must have been having a field day (or week) over the Easter period with the IVCA contest on almost non-stop. I've been having a 'dabble' in that mode myself for the past few months, and was pleased to receive some good reports on my signals from readers - thank you! Even the humble ZX81 is capable of handling SSTV signals and a couple of reports included printouts from the old ZX printers, which were perfectly readable. The same goes for RTTY and Morse, so it is well worth considering one of the older computers if you want a cheap way of getting into data reception.

It's a different kettle of fish if you are interested in computers as technical improvements over the past couple of years have made many computers obsolete almost before they have come onto the market. If you are simply interested in using them for radio reception, it is well worth the small investment in a discontinued model, particularly the Sinclairs, which have a mass of software.

The original Spectrum with the spongy keyboard, although not the computer enthusiast's favourite

machine, can give you good service, can still be upgraded with the better keyboard if you wish and there are plenty of spare parts available unlike a lot of the less well known marques.

Some people have said they are unreliable, but the most common problem is caused by removing an interface from the output port while the computer is still switched on... that little error will cost about £15 to put right, so don't do it! My two 128Ks take a real bashing and have given no problems.

If there's something that always got on my wick when listening, it was when that exotic DX station stated that QSLs were via his manager and then went QRT before I had got the details. Of course, *RadCom* (the RSGB bulletin) gives details of some managers, but I didn't realise the extent of this method of QSLing until I received the W6GO/K6HHD *QSL Manager List* from Brian Russell, G1WBI. The listing takes up sixteen A4 sides which, in the small typeface used, is one hell of a lot of managers... over 5,000, in fact!

### Pirate radio

The printout also includes some other useful information for those wishing to QSL directly. For instance, did you know TJ1AP was an Italian Catholic Mission? The call was believed to be pirated on CW, and IK8DYD denied being the QSL manager. However, one reader reckons he had a QSL direct from the Cameroon! If you would like more information (and there are plans afoot to issue it on computer disk) drop a line to Brian, QTHR.

As a matter of interest (well, it is to me) I should be operating CW from a boat on the river Thames during the last two weeks of June so, if you hear me, reports would be most welcome. The rig will be the Heathkit HW9 with an end-fed into the matching ATU.

This month also heralds the annual rally at Longleat House on the 26th, and the ILA will have a stand. So, if you want to pop over for a chat, you will be most welcome.

Last month we had a look at what the amateur bands are, and some of their individual features. However some receivers, particularly the

older ones, have a distinct reduction in sensitivity and image rejection when it comes to the higher frequencies. One answer to this problem is to use a preselector between the aerial and the receiver (some receivers have one built in, eg the Sony ICF6700W). One that has been giving good results is the Hamgear ATU/preselector which I reviewed here some months ago. A number of readers have commented on the improvement.

Many portable receivers have built in aerials of the telescopic whip type and these are often very effective, depending on the location of the receiver, and the receiver itself is tuned to match that aerial.

You can, in fact, retract the aerial and clip on a wire to lead from this to an Aerial Tuning Unit, but a better idea is to install a decoupling switch such as a double pole changeover toggle. That will isolate the telescopic aerial and link a simple socket, which should be earthed to the chassis of the receiver.

This way, you will be able to use either the telescopic aerial or an external one. The ATU should be able to take care of the mismatch between the aerial and the impedance of the input.

You will usually find there is plenty of room to put the switch and socket at the rear of the receiver. I have done this modification to even pocket portables with airband frequencies, to couple them up to my base station discone, with an excellent improvement in reception. The sockets I use are chassis mounting phono sockets, the switches I use are the sub-miniature changeover variety.

**Trial and error**

Remember also that aerial tuners are much more effective if earthed. Even dipoles work better if tuned against ground, as many doubters have found out.

The type of aerial you use is a matter of trial and error, and a roll of plastic covered copper wire is a basic requirement for every listener's shack - for obvious

reasons. If you can get to a local rally, do so, and wander round the surplus stalls. You should be able to get a whole 100m reel of suitable wire for less than a fiver, and I rarely come away from a rally without one.

The most basic aerial, the end-fed random wire, can give astonishingly good results (remember Darrell Jacobs' results last month with 15ft of wire in the bedroom?). Naturally, the longer the wire and the higher you can get it, the better. A nearby tree is useful but, in some locations, the local telephone engineers can be very obliging and will not object to you putting a screw-eye into a nearby telegraph pole to hook up to. Usually, if the aerial is going over a public right of way this is not allowed, as the local planning office may object (due to third party claims if it drops on someone).

A neighbour may let you run a wire to his house or line post (it helps if you stick a big egg insulator on... this puts his mind at rest).

Remember that aerials, although designed in straight lines, do not *have* to be so in practice, and successful operating and listening has been done by yours truly using aerials with so many dog legs in they resembled wire puzzles! Whatever the design, it pays to experiment.

An interesting point is mentioned in the QRP magazine *Sprat*, where one QRP operator writes that, just for the hell of it, he tagged a feeder onto his central heating radiator, and tuned it with his Z match against a four foot counterpoise on the earth terminal of the ATU. The result was 20 countries worked in three continents in five days on only 3 watts output - including UA9 and UA7 on 28MHz and a W8 on 21MHz! Well done G3ROO!

So, with that experiment in mind, do try the unusual. Remember, if you've a mind to do it, you'll find a way. They say necessity is the mother of invention... is that why we British have some of the best inventors in the world? Good listening!



Amateur  
**RADIO**

**all the regulars...**

DX Diary  
On the Beam  
Secondhand  
SWL  
Straight and Level  
Your letters and  
features covering  
the whole of  
Amateur Radio

■ **RADIO WAVE PROPAGATION**

Alan Malcher enlightens you about sporadic-E and tropospheric ducting

■ **REALISTIC PRO-38/BEARCAT BC 50XL**

Are the two sets identical? Peter Rouse had to look closely

■ **OUT OF THE JUNK BOX**

Richard Marris still hasn't thrown anything away but he has built a couple of transmitters

**JULY ISSUE ON SALE JUNE 30**

# ICS

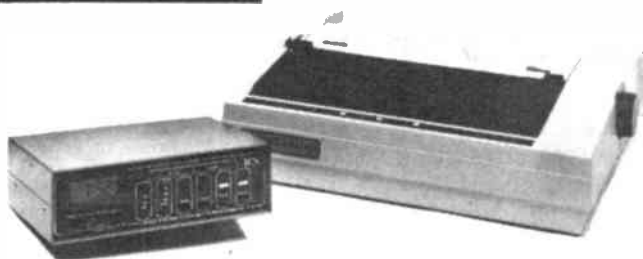

**Incredible value at ONLY £399.95 inc VAT**  
Carriage and packing (Securicor) £12.50

Send large SAE for details, print sample and product review. Printer and FAX-1 available separately if required

## WEATHER FAX/RTTY/NAVTEX: COMPLETE RECEIVE SYSTEM

Operates with any HF SSB Receiver.  
Easy to use. No computer knowledge needed.  
Fully automatic operation. Built in timer and tuning indicator

Gives superbly detailed weather maps, satellite cloud cover printouts, printed weather forecasts, navigation warnings and news bulletins from around the globe

Includes FAX-1 demodulator, mains power unit, Epson compatible printer, paper, ribbon and all connecting cables. **Nothing more to buy.** Just connects to receiver loudspeaker output

Hundreds of FAX-1s already in use world wide by professional and amateur weather forecasters, yachtsmen, aviators and enthusiasts. British designed and manufactured

## ICS Electronics Ltd

PO Box 2, Arundel,  
West Sussex. BN18 0NX

Telephone: 024 365 590. Facsimile: 024 365 575

12 months parts and labour warranty, Price includes VAT at 15%

VISA



## TX-3 RTTY/CW/ASCII TRANSCEIVE

The high performance, low cost system

Split-screen, type-ahead operation, receive screen unwrap, 24 large memories, clock, review store, call sign capture, RTTY auto CR/LF, CW software filtering and much more. Needs interface or TU. **BBC-B and Master, CBM64** tape £20, disc £22. **Spectrum** tape £35, +3 disc £37 inc adapter board (needs interface/TU also). For **VIC20** we have our RTTY/CW transceive program. Tape £20.

## RX-4 RTTY/CW/SSTV/AMTOR RECEIVE

This is still a best-selling program and it's easy to see why. Superb performance on all 4 modes, switch modes at a keypress to catch all the action. Text and picture store with dump to screen, printer or tape/disc. An essential piece of software for trawling the bands. Needs interface. **BBC-B and Master, CBM64** tape £25, disc £27. **VIC20** tape £25. **Spectrum** tape £40, +3 disc £42 inc adapter board (needs interface also). The Spectrum software-only version (input to EAR socket) is still available, tape £25, +3 disc £27.

## TIF1 INTERFACE

Perfect for TX-3 and RX-4, it has 2-stage filters and computer noise reduction for excellent reception. Transmit outputs for MIC, PTT and KEY. Kit £20 (assembled PCB + cables, connectors) or ready-made £40, boxed with all connections. State rig for transceive. Interface available only with TX-3 or RX-4 software.

MORSE TUTOR, LOGBOOK, LOCATOR, RAE MATHS programs also available for BBC-B, Master, CBM64, Spectrum, VIC20.

Prices include VAT and p&p. 1st Class inland, airmail overseas, normally by return. Eire, CI, BFPO deduct 13%.

## Technical Software (RE)

Fron, Upper Llandwrog, Caernarfon LL54 7RF

Tel 0286 881886



**Amateur Radio**  
— the monthly magazine for all two-way radio enthusiasts

Don't take a chance on being able to get your copy

## AVOID DISAPPOINTMENT

Place a regular order with your newsagent

Should you have any difficulties obtaining a copy, phone (0277) 219876 or write to Circulation Department, **Amateur Radio**, Sovereign House, Brentwood, Essex, CM14 4SE.



## NEWSAGENT ORDER FORM

To (name of newsagent) .....

Please order a copy of *Amateur Radio* for me every month

NAME .....

ADDRESS .....

.....

.....

..... POSTCODE .....

Newtrade distributors: SM Distribution, 16-18 Trinity Gardens, London SW9 8DX. (Tel: 01-274 8611)

# BITS TO BUILD

## THE JANDEK RECEIVER – Part 1

Even for a jaded old constructor like me, little can beat the satisfaction of building a receiver. Other projects may bleep, swing meter needles, flash lights or perform all manner of electronic functions, but the excitement of hearing the first signals on a homebuilt receiver still remains, however many previous receiver projects have been completed. No one can claim to be a radio constructor until they have built a receiver.

A good starting point for the receiver constructor is to attempt a direct conversion circuit. Many people decry them as over-simplistic but, for what is invested in the circuitry, the results can be surprising. I know many amateur radio stations which only use direct conversion receivers. Like most multistage electronic projects, the direct conversion receiver divides into a number of functional modules.

A typical direct conversion block diagram is shown in *Figure 1 (a)*. The signal is selected via a tuned circuit front end, from which it goes to a product detector. The product detector mixes the incoming signal with a tuned variable frequency oscillator (VFO). The VFO tunes the desired band and the difference between the input frequency and the VFO frequency produces the required audio signal. The low level audio signal requires amplification and filtering.

Unlike a superhet receiver, most of the selectivity and sensitivity of a direct conversion receiver is derived at the audio stages. Audio preamplification and filtering is usually followed by final amplification to an adequate listening level.

That rather cursory account of the workings of a direct conversion receiver is best supported by further reading for those readers not familiar with the principles of radio reception. But it does show how the receiver can be divided into sections. For the less experienced constructor, the modular approach to building a project is helpful, in that the whole project can be considered, built and even tested in small, discrete units.

Recently I discovered yet another new company which had entered the radio kit business. The company, Jandek, has produced a modular direct conversion receiver which can be adapted for use on any amateur HF band from 160m to 20m. Jandek sell the direct conversion receiver in modules which may be combined to produce the total receiver.

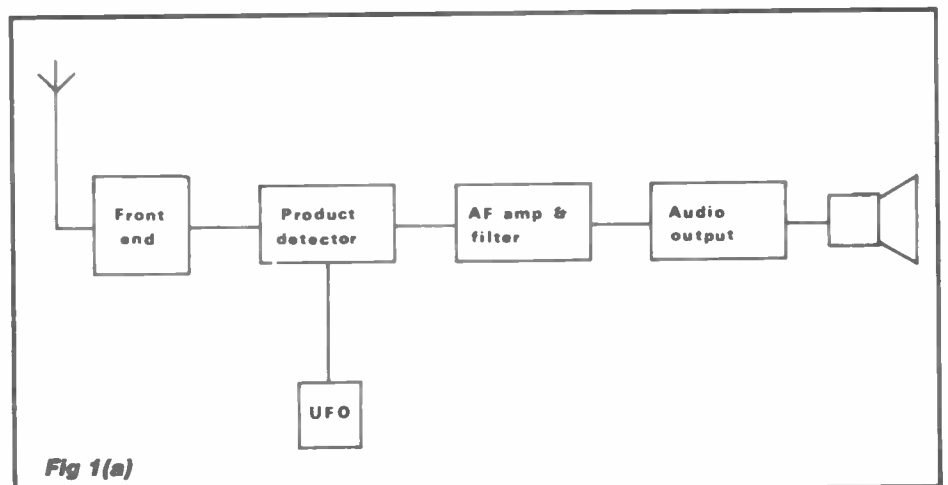
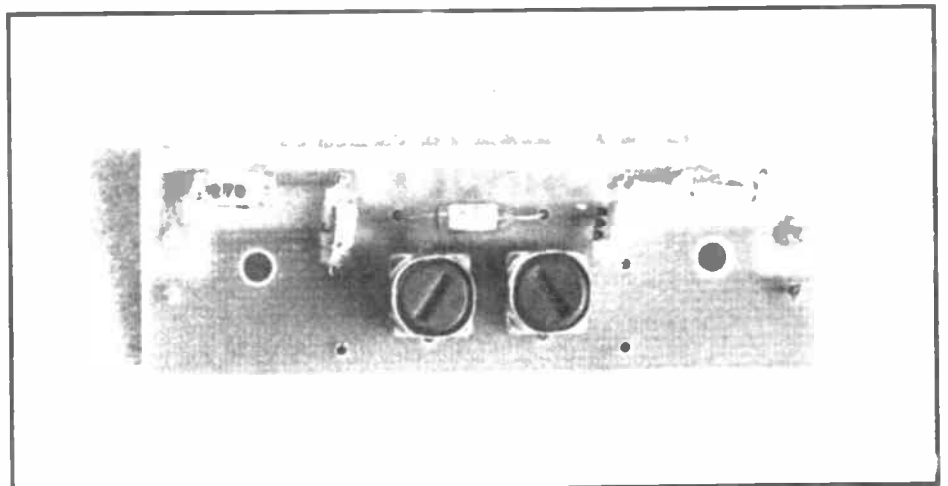
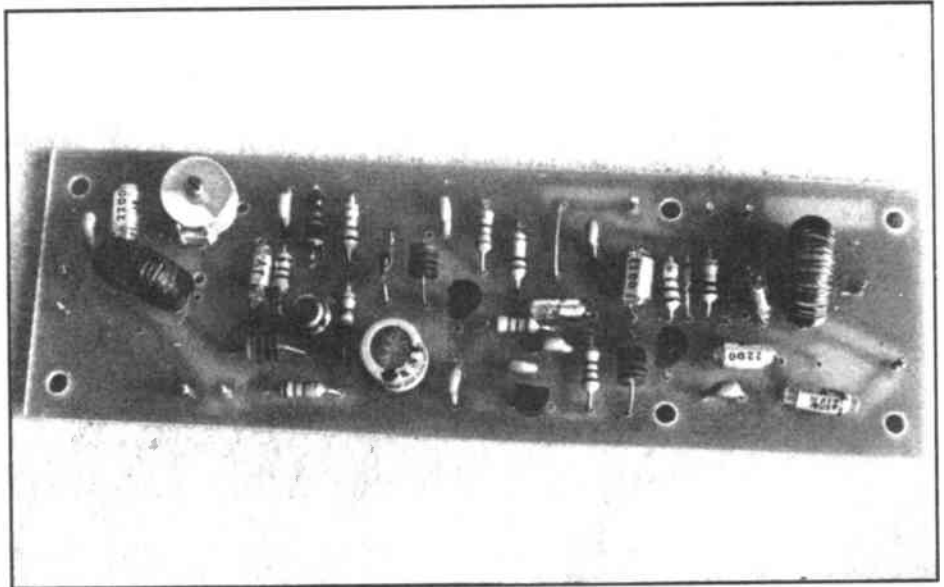

**Fig 1(a)**

## BITS TO BUILD

This gives not only the option of choice of band and filtering, but also choice of mixing their modules with other favourite circuits.

On inspection, I found that their circuitry, though conventional, used reliable and good performance techniques, capable of producing an above average receiver. The components are all good quality and the documentation is adequate enough even for the beginner to tackle any of their modules. The prices of the small kits are very reasonable for what is supplied and would represent money well spent for the would-be receiver builder.

What follows is my description of the use of the Jandek receive module kits to build a 160m (1.8 - 2.0MHz) receiver. I chose the 160m option because many amateurs seem to lack equipment for this band. The same would apply for the modules if built on any band up to 20m (14MHz). Here I describe the JD004 (VFO) (product detector), JD001 (audio amplifier) and the JD007 (front end) modules.

These can form a direct conversion receiver (see Figure 1 (b)), although additional amplification is really required between the product detector and the audio amplifier. This may be provided by the JD002C (CW) or JD002S (SSB) active filters, which will be described in Part 2 of this article.

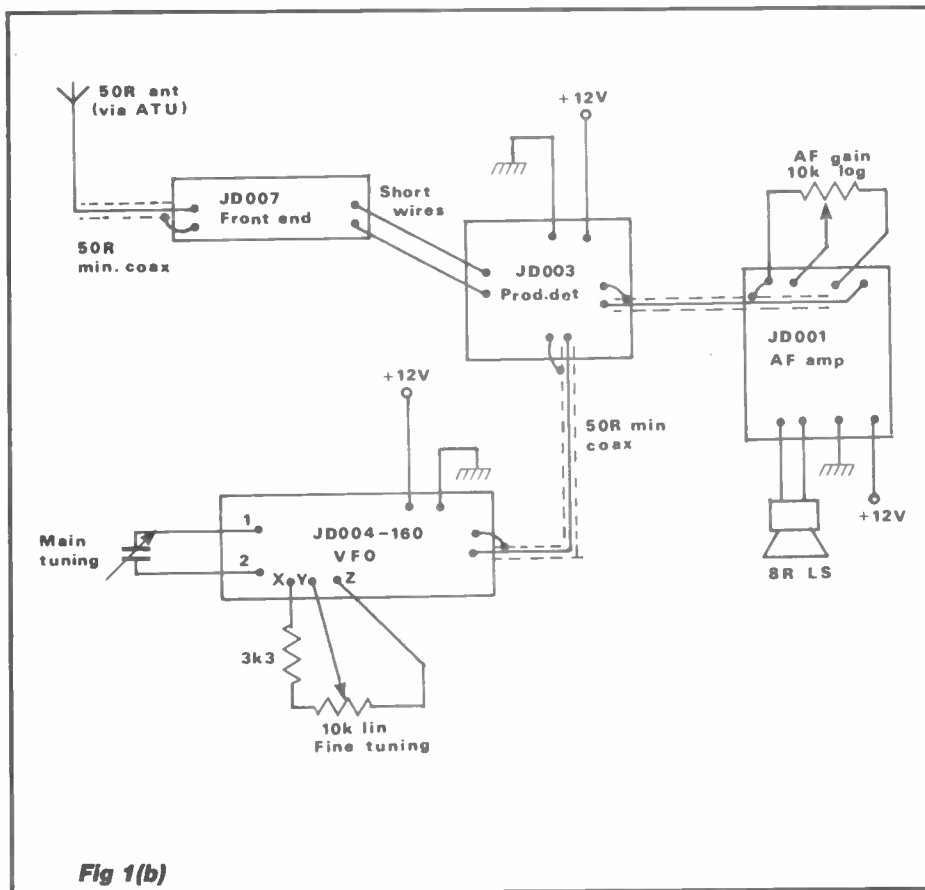

Fig 1(b)

## R. N. Electronics

Professionally designed equipment for Amateurs

### 6 METRE Linear TRANSVERTER

Reviewed in  
February issue

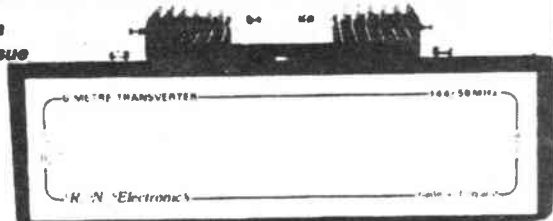

Allows any popular 2 Metre Transceiver (up to 3W) to be used on 6 Metres any mode (ssb, FM, CW, Packet etc.)

- \*Low harmonic output\*
- \*DC or RF switching\*
- \*Low noise BF981 front end\*

Boxed versions supplied with either PL259 or BNC plug to 2 metre transceiver

- 25W pep o/p complete boxed transverter **£172 +4.00 p&p**
- 2W pep o/p complete boxed transverter **£135 +4.00 p&p**
- 2W pep o/p assembled and tested P.C.B. **£105 +2.00 p&p**
- 25W pep o/p add on P.C.B. **£47 +2.00 p&p**
- 25W PA for use with FT690 etc. with 2-3W drive including switching and low pass filter **£75 +4.00 p&p**
- 7dB Switched 10W Attenuator **£22 +2.00 p&p**
- ★ 4 meter transverter (145MHz I.F.) **£243 +£4 p&p**

**ALL PRICES INCLUDE VAT**

**37 Long Ridings Ave Hutton Brentwood  
Essex CM13 1EE. Tel: 0277 214406**



## TRAINEE RADIO OFFICERS

Are you looking for a secure shore-based job which offers a rewarding career in the forefront of modern Telecommunications technology... then consider joining GCHQ as a Trainee Radio Officer.

Training involves a 32 week residential course, plus 6 weeks extra if you cannot touch type! After which you will be appointed RADIO OFFICER and undertake a variety of specialist duties covering the whole of the spectrum from DC to light.

**We offer you: Job Security · Good Career prospects · Opportunities for Overseas Service · Attractive Salaries · and much more.**

To be eligible you must hold or hope to obtain an MRGC or HNC in a Telecommunications subject with an ability to read Morse at 20 wpm.

(City and Guilds 7777 at advanced level incorporating morse transcription would be advantageous). Anyone with a PMG, MPT or 2 years relevant radio operating experience is also eligible.

The Civil Service is an equal opportunity employer.  
**Salaries:** Starting pay for trainees is age pointed to 21 years. For those aged 21 or over entry will be at £7,162. After training an RO will start at £10,684 rising by 5 annual increments to £15,753 inclusive of shift and weekend working allowance.

Write or telephone for an application form to -



THE RECRUITMENT OFFICE, GCHQ, ROOM A/1108  
PRIORS ROAD, CHELTENHAM, GLOS GL52 5AJ  
OR TELEPHONE (0242) 232912/3

# 50MHz

by Ken Ellis G5KW

The month under review has provided some interesting solar conditions, with a sharp upward trend in the solar cycle. Ten solar flares were recorded of various magnitude; with severe storms on the 4th and 5th of April. As is usual with these events, a general 'blackout' occurred on all frequencies – sometimes for several days – but just before the fadeout a short period of enhanced propagation occurs with real DX conditions. This is particularly noticeable on six metres. Generally there is a repeat of these conditions 27 days later.

We are now starting the main sporadic E season, followed by the F2 period when international DX conditions prevail. As promised last month I have included some details of the propagation study I made from the Isles of Scilly during the peak years of Cycle 21. The full report appeared in the *Short Wave Magazine*, issues May, June and July 1982, but the basic information is repeated here as a useful guide to those who did not see the original articles. Although we do not expect to see major F2 openings until the autumn of 1989 and later, the enhanced conditions mentioned earlier could bring some surprising DX openings with inter-continental openings. Dedicated monitoring of the beacons listed last month could pay dividends.

## F2 propagation

In my column for May last year I gave basic information about F2 propagation. From the NBS and other prediction charts the highest MUF is stated to occur north and south of the Magnetic Equator in the 20 degree latitudes, with a gradual and progressive decrease as the latitudes become higher north or south. A distance of about 2500 miles is generally accepted as the maximum distance for single hop F2 layer propagation on the east-west path. This is based on the 'Control point theory' which assumes a point about 1200 miles from either end along the Great Circle path between the two stations under consideration.

A difference of opinion exists as to whether multi-hop or a type of 'wave guide' effect is responsible for the greater distances covered during sunspot peaks and other abnormal conditions. The fact that signals are heard at greater distances than 2500 miles tends to support the 'wave guide' theory, but we still have a lot to learn and the similarity to HF propagation, with skip distances lengthening as the MUF gets higher, must be considered. Times have been averaged along the route from VELAVX to the far west of USA with no evidence of a major skip between; but this is not conclusive.

## The effect of latitude

During Sunspot Cycle 18 (1947), when I was operating from the Suez Canal Zone of Egypt as MD5KW, tests with G5BY, G6DH, W1HDQ and others produced some interesting data.

According to the prediction charts, at latitudes between 50 and 60 degrees North, there is an average downward gradient in the MUF of 0.8MHz per degree; G5BY's MUF to the USA should be 1.6MHz higher than that of G6DH (G6DH's QTH was at Clacton and G5BY was at Bolt Tail, S Devon).

Working with the MUF at a bare 50MHz this was amply borne out in practice: when, at G6DH, W1HDQ was only weakly received it was generally found that G5BY had a good opening for an hour or so. The fact that G5BY was nearer to W1HDQ by over 200 miles was important, as the nearest station from North America was over 3000 miles away. In the other direction, G5BY also scored. During the course of many tests with MD5KW, on a number of occasions G5BY would report MD5KW S9+ when the signal was inaudible at G6DH, even though the MUF was above 50MHz in that direction. In these instances G6DH was too close to MD5KW – the distance is 2100 miles. PA0UN had, on a number of occasions, been unable to receive MD5KW, who was 1950 miles from him when G5BY was receiving him OK. On 9th November, 1947 when MD5KW made his first two-way 6/6 QSO with UK (G6DH) the signals were S9 at both stations. West Country and Channel Isles stations have a distinct advantage over stations to the North and East.

## Scilly Isles propagation study

		VELAVX	OTHER VE	W1	W2	W3	W5	W9	W4	W0	W5	W7	W6	CENTRAL AMERICA	OTHER DX
1979	GMT	1200	1300	1300	1300	1400	1400	1500	1500	1600	1600	1700			
	OCT	3	3	3	3	3	1	-	1	-	-	-	-	1	
	NOV	27	14	14	12	2	4	2	3	-	3	1	-	4	
	DEC	22	10	7	4	1	8	5	8	3	4	1	-	6	
		52	27	24	19	6	13	7	12	3	7	2	-	11	
1980	JAN	6	4	3	5	-	1	-	-	-	-	-	-	1	
	OCT	4	1	2	2	1	-	-	2	-	-	-	-	4	VK6DX 0950 27 NOV
	NOV	16	10	9	3	-	6	-	5	-	1	1	3	-	
	DEC	13	3	8	3	4	2	-	1	-	-	1	-	-	
		39	18	22	13	5	9	-	8	-	1	2	3	5	
1981	JAN	10	-	6	2	-	1	-	-	-	-	-	-	-	
	OCT	5	1	6	5	1	-	-	1	-	-	-	-	3	V54RE 1107 20 NOV
	NOV	18	16	12	13	12	7	5	6	6	2	-	4	14	
	DEC	14	7	14	14	12	9	6	10	9	7	8	5	4	
		47	24	38	34	25	17	11	17	15	9	8	9	21	
TOTAL	138	69	84	66	36	39	18	37	18	17	12	12	37		

## G5KW and cycle 21

During the Autumn of 1979, while operating from a chalet at Culverstone, Kent about 600 feet ASL, I experienced a similar frustrating experience that had happened to stations in the eastern area during Cycle 18.

The nearest station to G5KW successfully working West Coast W stations was G3FX3 in Sussex, so a decision was made to go as far west as possible. With the assistance of Mike Goody G3RPC I managed to get permission to operate from the Garrison Fort at the South East tip of St Mary's. This is an excellent site, free from traffic and other forms of man-made interference, with a clear take-off in all directions. Incidentally, anyone planning to operate from the Crown property in Isles of Scilly should apply in advance to Colonel Robinson, Land Agent, Duchy of Cornwall Office, St Mary's, IOS. Caravans are not allowed on the IOS, so get in touch with me if you propose visiting there and I can help with advice. It was soon clear that a wise decision had been made, and that some interesting results were likely, as an almost daily crossband QSO was made with VELAVX at St Johns, Newfoundland, approximately 2500 miles – the optimum distance to the west for F2 propagation.

Figure 1 shows, in block diagram form, crossband QSOs with the various North American stations during the peak years of Cycle 21, and will be an indication of 'what to expect' during the current cycle. The highest Solar Flux numbers for Cycle 21 occurred around November 9th/10th 1979, 324/325, and was considered to be the peak of the cycle.

**From the mailbag**

Ted G4UPS received a telephone call from Helsinki saying their talks with their PTT are going well and that they hope to be on six metres by June of this year. Old timer Bill G2AWT of Croydon feels strongly about the QRM around 50.200 by the crossband fraternity and suggests that the area around 50.2500 should be used. G4JCC tried some time ago but, with little success.

From John GW3MHW (who heads the official UK countries worked on six) writes, 'The aurora of 4th April will be long remembered as an outstanding event.

I first became aware of it at 1720 GMT, it lasted until 1942 GMT. DX contacts included LA6HL at 1736 and EI7EH at 1935'. Tim G4VXE confirms that he hopes to be operating from Gibraltar from 31st May on six and four metres. Main

frequencies 50.165, and 70.165.

Ted G4UPS reports an opening on six to ZS6 on 8th April when Solar flux 125 Aindex 12. 'At 1323Z started getting TV birdies on six from South - not very strong. At 1422Z ZS60B on 28885 reported that he was copying my keyer on 50.110 at 419 - a two-way proved unsuccessful. At 1449Z I heard ZS60B calling EA4CGN on 50.110 with no characteristic TEP flutter, but a good beefy signal 57 on SSB. Unfortunately he was not listening on 50.110 but to EA4CGN on 28885. That same day the ZS6 boys worked later with 9H1 on six metres.'

Mike ZD8MB has had a very successful season during the TEP openings this spring with many two-way QSOs to the Med area; CT: EA: TR8DX: ZD7; PY: HC: J88 and FM. Quite an impressive list, and a forecast of things to come when the Sporadic E and F2 conditions are in operation. By the time this appears in print the E's season should have started.

From Hatsuo JA1VOK we hear that Singapore has issued a special permission to Singapore Amateur Radio Transmitting Society (SARTS) on 50.125 spot with 10dbw out power between 3rd and 12th of June for a propagation research. The callsign will be 9V1VS and a split QSO is proposed by 50.110 call/50.125 (QSL via JA1UT).

The well-known DXpedition operator W6JKV is reported to be going to ARUBA Netherland Antilles from 9th-17th June to operate from PJ6 during the VHF contests.

**Getting the record straight**

I'm afraid that once again I have to report some incorrect information from a source who should be more particular about reporting: French amateurs have not yet got permission to operate on six metres. Eric F9LT says that any operation is illegal at present, and amateurs contacting French amateurs direct on six metres are infringing the terms of their licence. Be warned. Permission will not be granted for some time yet. Belgium has not given permission for six metre operation, and I understand that no negotiations are currently taking place. Belgium was one of the main protesters about six metre permits being granted to British amateurs, and is not likely to change its attitude at present! Before embarking on DXpedition make sure you have *written* permission to operate from the country you propose visiting and operating from.

That about sums it up for this month, but please send in reports or telephone me at the home QTH: Ken Ellis G5KW, 18 Joyes Road, Folkestone, Kent CT19 6NX. Tel: (0303) 53267.

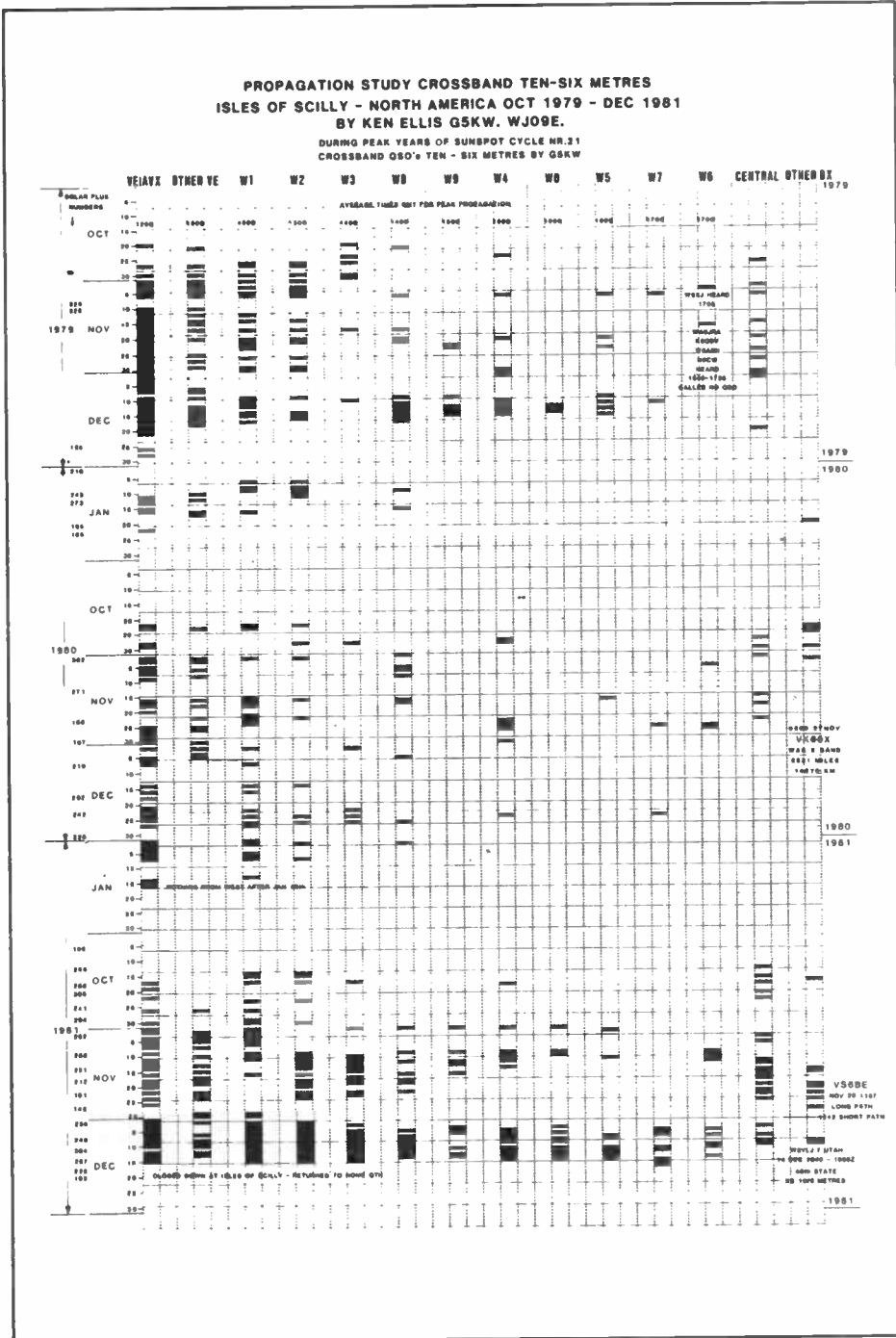



## News and comment from Glen Ross G8MWR

As promised in last month's issue the first job this month is to get up to date with the recently issued certificates. Before making a start on that let me first clarify a few points. I do not keep records of your claimed contacts for any particular award because your copy log is returned to you with the certificate. When you are ready to claim a higher grade, simply send in the log which I returned to you together with the extra details that are required to get the upgrade. This saves me a lot of time and you a lot of writing. Also, please remember that the certificates come free but please include a stamp for the return postage.

### All aurora

As you know the certificates can be endorsed in any way you request, within reason. The first endorsement for a Silver 144MHz award with all the contacts made by aurora has been issued to Bill GM6RGN, of Haroldswick in Shetland. This is to add to the Bronze that he already holds; just the Gold to get and he has made a clean sweep.

Being in the far North certainly helps on this mode and Harold mentions a large event on the 2nd January when he worked more than fifty stations including lots of SM and OZ. To really make his day, he found Y21NB 1050kms away in JO53RO for a new country. Another person to get both Bronze and Silver with the aurora only endorsement is Chris GM1KHU, from Insch in Aberdeenshire.

### Starting early

A claim from Paul Beastall G1WBZ, from Nottingham, for Bronze, Silver and Gold awards for two metres also got a special endorsement as the youngest applicant to get a clean sweep. Paul is just fifteen years old. His award proves that you do not need high power or a superb site to do well. He runs thirty watts to a nine element aerial at thirty feet above ground, and the QTH is only 250 feet above sea level. A poor take-off to the North means difficulty working

into Scotland and he has actually worked more OK stations than GMs. From Leeds, Peter G0HTG claims a two meter Bronze. All contacts were made on SSB and the best DX was HB9RSO at 920kms.

### The book

Patrick G1HEW, located at Sheffield, weighs in with a two metre Gold award, the longest distance being to SP5KVW at the 1508kms mark. He also asks for details of awards that are available from other organisations. There are literally hundreds of them and details were provided in a book that was published by the RSGB a few years ago and, as far as I know, is still available from them.

For your interest I will detail just some of the awards that I have information about. Some of the most attractive certificates are available from VERON, the Dutch equivalent of the RSGB. The three main ones are the VHF-6, UHF-6 and SHF-6. All of these require confirmation of a minimum of six countries, and you can then apply for stickers which are available for upgrading to the fifty country mark. I wonder who will be the first to get one of those on two metres?

### Quantity discount

The PACC-VHF/UHF/SHF awards require contacts with 100 Dutch stations on two metres, seventy cms or twenty-three cms respectively, which should be fairly easy to get if you live in the south east part of the country. If you are really into punishment you could try for the PAMC award but this one needs contacts with one thousand Dutch stations to qualify.

There is also the 23x23 for contacts with twenty-three stations on twenty-three cms, the 13x13 for thirteen stations on thirteen cms and the 9x9; I leave you to work that one out. You can keep collecting certificates right up to the bands until you get to the 3x3 for working three Dutch stations on 10GHz; and that takes some doing. You do not send QSL cards but you must have your application signed as correct by two other amateurs.

They work on the same idea that we do; if you cheat you only cheat yourself.

To get full details and application forms for all these awards the man to write to is J Lourens, Keerweer 13, 6862 CD Oosterbeek, Netherlands.

### RSGB awards

The society offers a fair number of awards for the VHF operator. These are based on various criteria such as distance, number of squares, counties or countries worked. The design of the older ones has what can best be described as old world charm but the newer ones are much more colourful.

Some of them are a simple once and for all award but many of them can be upgraded by applying for stickers as you pass the various goal posts. They are available for all bands from four metres up until you arrive at the award for working at least 150kms on 10GHz. Details of all these can be obtained from the RSGB VHF award manager G5UM who is QTHR.

### Yet more

The WAB organisation runs an award scheme and, being exceptionally helpful, also organises contests and expeditions to help you qualify for them. Details of these are available from Bob Nash G4GEE who is also QTHR. From Germany comes the DIG award program and this contains several certificates of interest to the VHF operator. All the certificates are issued by different operators and this can make life a little difficult when you come to claim the awards. I have included the most recent details of the award managers which are available to me.

The WGLC certificate is for working at least ten large German towns on two metres. A large town is defined as having a population of more than 1,000,000 and details are available from H Schutte, Box 810660, Hanover. The DIPLOM-77 requires contacts with at least seven countries, details from DC6JC. The One Million award is a complicated job, the score for which is arrived at by adding up all the postcode figures of the stations you contact; somewhat on the lines of the Birmingham postcode award. Further details of this one are available from DC6XT.

### Exotic stuff

If you are into collecting prefixes then you will want details of the EU-PX award. To qualify for this one you need to get contacts with at least 100 different prefixes. For details contact DJ8VC. For those of you who are looking for something really unusual to collect, how about going for the IAPA award. This one requires getting contacts into cities with international airports. Details on what is defined as an international airport and other matters are available from DJ8JS. The top of the range awards are the DIG-Plaque and DIG-Trophy. These are large wall mounted brass plaques with the lettering done in blue and red; all very smart. Details of these are obtainable from DL9XW. All the callsigns listed are QTHR.



# ON THE BEAM

## Go Stateside

Our USA cousins have gone overboard for what they call the grid squares; in our terms the Maidenhead locator system. The ARRL is well known for its DXCC awards for the HF bands, but it has recently instituted a VHF version, the VUCC. The starting levels are: 50MHz needs 100 squares; 144 needs 100; 432 needs 50 and 1296 requires 25.

For the UHF man the requirements are 2.3GHz – 10 squares with the 3.4, 5.7 and 10GHz bands all requiring five squares. Each award can be improved in increments of 25 squares on 50 and 144; 10 on 432 and 5 on 1296.

For the higher bands, the endorsements are available in increments of five squares. Whoever decided on the increment for upgrading the 10GHz award must have been living in cloud cuckoo land, and he is certainly no microwave operator. Bearing in mind that all contacts must be obtained from the same site, then on 10GHz even five squares takes some getting and ten squares is, with present technology, completely out of court.

If you want to claim any of these awards remember that all contacts must have been made since January 1st 1983. You do not have to apply to the States for details of these awards as G8VR (QTHR) is the local representative for the ARRL in these matters.

## More wallpaper

From Mildenhall, Steve G4ZGY claims for 144 Bronze and Silver awards. Another special endorsement, this time for the first YL CW only award goes to Angie G0HGA, from Stevenage. She did it the hard way, running QRP at ten watts or less. A real CW addict, she has over a thousand CW contacts in the log since April 1987.

Arnold G6FFN! from Oadby in Leicestershire goes for a 144 Bronze award, with the 500kms plus part provided by G0EAE in the Scilly Isles. I think this is the first time a British station has been given as the DX qualifier. The last special endorsement to mention is a 24GHz certificate to Dave G0DJA of Birmingham for a 44km contact. This is the highest frequency certificate yet issued; who will be the first to get one for 47GHz?

## A new path

There are very few paths available in Great Britain which will allow the microwave man to get the coveted 150km RSGB award, so it comes as a pleasant surprise to get news of two new ones, especially as they are both well placed geographically to fill in large gaps in path availability. The two well known paths are from Wun Fach to Axe Edge and the Prescally Mountains near Swansea into Exmoor.

Paul G6MEN reports working a 153km

path to Ray G3NKL on Fairsnape, the exact locators being 1082GN and 1083QW.

## GM to EI

News has arrived of what is believed to be the first GM to EI contact on three centimetres, after a very determined effort by Dave GM3WIL. He has been trying paths into Northern Ireland with G18JGX, who operates from Angews Hill. Their best effort had been a 141km contact to a site located at NS-531-502. Dave thought that a hill to the north-east of Glasgow might be a possible site from which to get the extra distance, but did not much fancy the extended climb it would take to get up there.

Calculations showed that the distance would actually work out at 173km so the climb was undertaken. At first the signals were very weak but by careful alignment of the dishes and a lot of perseverance they eventually made 5 and 9 full duplex copy.

This GM to EI path is believed to be the second longest path worked in the UK and is certainly so of Scotland.

## The final

The past month has brought a lot of interesting news from you; please keep it coming to 81 Ringwood Highway, Coventry. If you are on Prestel try 203616941. Good hunting.

# TMR 7602 Also known as

SPECIFICATIONS & FEATURES TATUNG (AMBASSADOR 2020) (Realistic DX440)

- \* Two Bandwidths 6/2-7KHz
  - \* Large digital frequency display
  - \* Correct "Makers" Power supply £10 optional extra
  - \* Full AM/FM frequency range 150-29999kHz plus FM 87.5-108MHz, mono/stereo.
  - \* Five Tuning Functions:
    - Direct press button frequency input Auto scanning, manual scanning
    - Memory recall and manual tuning knob
  - \* Built-in clock and alarm. Radio turns on automatically at preset time & frequency.
  - \* Fourteen memories
    - Nine memory channels for your favourite station frequencies.
    - Last setting of mode & waveband stored in 5 memories.
  - \* Direct press-button access to all 12 shortwave broadcast bands.
  - \* Two power sources – battery or AC mains adaptor.
  - \* General coverage of all AM bands in LW/MW/SW (dedicated broadcast band coverage on all versions). Plus of course the FM band for quality Sound broadcasts in headphone stereo.
  - \* SLEEP Function turns the radio On or Off after an adjustable time of 10-90 minutes.
  - \* Separate BASS & TREBLE controls for maximum listening pleasure.
  - \* External antenna jack for better reception.
  - \* Adjustable RF GAIN control to prevent overloading when listening close to other strong stations or if there is interference.
  - \* BFO control (beat frequency oscillator) enables reception of SSB/USB/LSB (single side band) and CW (Morse Code) transmissions.
  - \* Illuminated display to facilitate night-time use.
  - \* Designed for both portable and desk top use.
  - \* Five dot LED signal strength indicator.
  - \* Dimensions: 29.2cm x 16.0cm (11.5in x 6.3in x 2.36in).
  - \* Output: — 1200mW (10% THD).
- \* Weight: — 1.7kg (3.75lbs) without batteries.  
\* Wide/narrow filter switch.

RADIO NEDERLANDS "MEDIA NETWORK" REVIEW GAVE THIS RADIO 3 STARS

Nothing leaves our shop until checked and tested in all Modes and all functions  
\* We are a man and wife business team (a team at home too!) \*

DETAILED CATALOGUE £1 ■ S.A.E. ALL CORRESPONDANCE

★ DX440 ★  
★ SANGEAN ATS803A ★  
★ EEB2020 ★ MATSUI UEH/ ★

Sony ICF7600DS **£164** post paid  
Full range of Sony radios

**Panasonic portables,**  
Grundig 'Satellites', models 650 & 400

**Vega Selena 215 Mk II**  
Complete with long range aerial & earpiece **£39.95** £3 P&P

**Goodmans 'Diplomat' £39.95**  
10 waveband pocket miracle  
L/M/stereo VHF/seven shortwaves

Good range of handheld  
scanners Air/PSB/Marine

**FREE WRTH (recent)**

**£2 please for our handling**

charge with **ANY** radio purchase.

# JOHNSONS SHORTWAVE RADIO

43 FRIAR ST, WORCESTER WR1 2NA 0905-25740

As I said 'We're just a couple of amateurs!' but remember 'professionals built the Titanic' – the ark was built by amateurs.

# SECOND-HAND

BY HUGH ALLISON G3XSE

Some time ago I wrote about using transformers 'backwards' to get yourself out of trouble. For instance, I showed how a 6.3 volt heater transformer can be connected across a heater (ie 6.3 to 6.3) to give a HT type voltage out of the 'mains' winding on the one used backwards.

Since then, the postbag has bulged with letters from people with dead sets, be they Tx, Rx or transceivers, all suffering from unwell mains transformers. The first move, obviously, has got to be the probably forlorn attempt to get a replacement from the manufacturer and/or agent of the dead box. If we are discussing a mega-old set, their present day importers are worth a try. It's also worth looking in old magazines to see who used to sell them. Incidentally, manufacturers who send back letters saying 'we no longer support spares on this product' might well note that I get covering letters along the lines of 'I ain't buying anything else from them in future'. A good spares backup helps ensure customer loyalty.

Right. Burnt-out transformer and no spares. You can try local transformer winding shops. You might be lucky, but I don't hold out much hope. The problem is that yours is probably on a (nowadays) non-standard former, so it will have to be stripped down and re-built. It also requires a competent transformer engineer to do this - he has to count off the turns, measure the gauge of wire, see what insulation was used etc.

## Over a ton

Sure, it is possible to buy a new transformer of some sort for a fiver or so, but you have to buy a popular one which can be banged out by the thousand using relatively inexperienced labour. Get a 'one off' on a former that doesn't fit the firm's machines and £100 plus soon becomes a reasonable charge. Well, not reasonable to you or I, but justifiable. If anyone knows of any shops that have recently done rewinds at a reasonable rate, please write in and let us all know.

Right. Duff set, no spares, no local rewind facility, or a rewind cost well beyond the value of your beloved wonderbox. All is not lost. Whip out the transformer and fire it up with mains. See what comes out, but be careful, very careful. There's probably volts all over the place. A transformer with a shorted turn heats up quickly, like in 10 seconds or so. My first move is thus to fire it up for just a few seconds. Then, see if it feels warm - after turning it off, obviously. Sure, an ac ammeter in series will show you the energising current - normally less than 100mA for a good transformer of amateur transceiver sizes. If there is over half an amp there you've got a

shorted turn. This is a lot of mucking about though, just see if it overheats.

On the subject of burn-outs, you will often be pleasantly surprised to find that an externally well-charred example that has produced alarming amounts of smoke and stunk the house out for weeks may only be duff on one winding. The trick is to now squeeze in another transformer that will provide the volts previously obtained from that one duff winding, after re-fitting the remains of the original. A moment's thought will make you realise that the old transformer is now understressed, 'cos the new transformer is doing the business for one winding.

## Bad practice

Suppose the mains winding is a gonner? Well it's bad practice to stuff 110 volts up an American/UK set with a half-gone mains winding, 'cos you are not generating the required flux, etc. Bad practice indeed. Mind you, I've got away with it occasionally.

What I have done, in desperation, is to stuff high voltage ac up a similar winding. Take, for example, a rig with a 350-0-350 volt winding with the mains winding a gonner and about a million other windings. Get a substantial 350-0-350 out transformer and stuff it up the same flavour windings on the dead 'un and insulate liberally. This is another great bodge.

## Burnt to a crisp

OK - last but not least we deal with a real flame out, with nothing left of the original. There are no spares, you don't even know what the damn thing used to give. Doubtless there were a billion windings of all sorts of voltages. See what you have on each winding - colours can sometimes help identify pairs of centre-tapped windings. See where they go - normally they only go to heaters or to a rectifier.

The output of a rectifier normally goes to an electrolytic capacitor; see what volts working it was and ask yourself if three quarters of its rated dc voltage would seem reasonable for what it was doing. The rectifier 'twixt winding and capacitor can be looked up and its voltage and current ratings will give a clue as to what the transformer was producing before you had to call in the fire brigade.

Once you have a fair idea of what you want, see if you can get one similar, or similarish. Maybe two. Be creative. If it won't go in the box any longer, well, have an external power supply. It's better than having a full rubbish bin. In sheer desperation I once - no, I'd better not tell you - oh, all right, but keep it to yourself.

I once needed a 350 volt rail, a -50 volt

rail and 6.3 volts. I got a 350 volt transformer with another 50 volt winding. There was no 6.3, and no room for another transformer to light the 6.3 volt heaters. Who unwired all the heaters, nine in parallel, connected them up in series and stuffed them across the 50 volt winding? Are you impressed, or are you appalled? It's still working though, and that is the name of the game.

## By the way

Incidentally, we have made sure we have removed the cause of the original burn out, haven't we? Very often the transformer has burnt out 'cos a rectifier has gone a short or similar (except with FL50s, they eat mains transformers for no good reason). There's no point in fitting a replacement and then setting fire to it.

On the subject of being creative, HT volts to the PA can be hard to generate, especially at the peak currents required. Although a 350-0-350 can provide the best part of a kilovolt if you go across the outsides, even this may not be enough to generate the urge you used to have previously. Well, you've always wanted to try QRP haven't you? Lower volts equals lower watts, it's true. On the other hand, the PA bottles are going to last longer plus, at least, the rig functions again. Take care that the grid two volts are lower than the anode volts, or grid two might get delusions of grandeur and try to be an anode.

## Yaesu FT207

This was a very early synthesised two metre FM hand-portable. Would you believe it has an LED frequency read-out? The only other hand-portable I can recall that was blessed with a current-eating LED display was the dreaded Palmasizer (bring your own spare battery).

The FT207 was not mega-sensitive, about a microvolt for 20dB seems the going rate. As it comes it tunes up (and down) in 12.5kHz steps, with the .5 not being displayed. The display is very reminiscent of the early LED watch display by the way, ie small.

We are talking either keyboard entry or up/down push buttons. If you are on transmit and hit the keyboard you can send out the telephone dial tones.

The transmitter features a really weird output transistor, like, crazy man. It looks like a half-height T05 transistor and is of standard looking leadouts, only it isn't. Instead of EBC we have CBE, with collector by the little tag that normally signifies emitter. The emitter is the case. Whoopee! You have been warned.

*Faults:* The on/off switch on the volume control seems prone to growing a few crystals over itself - probably encouraged by the battery terminals which are

## SECOND-HAND

adjacent. This causes the micro to go into funny modes. You get letters up on the normally number-only display, for example. To cure this, scrape a screwdriver blade over the moving bit of the switch and the fixed post that it hits when making.

No modulation, but toneburst and keyboard tones when on transmit equals the mike (which is an electrofet type) having shed the outer connection of its co-ax at the main PCB end. This is very common if the covers are removed more than a couple of times.

### Popping the PA transistor

The transmitter is keen on popping its PA transistor if run into a dodgy aerial or no aerial at all. They are obtainable, at a price, or you can bodge in a 2N4427 or BLY33 if you can take a bit of a reduction in O/P. 2N3553's will not work here for some reason. Beware the oddball leadouts—see above—I prefer to see what pin has what on it when I'm fitting the thing. The one with nothing is the emitter, the one with +12V is the collector and the one with a volt or two of RF has got to be the base. This may seem like repetition, but wait 'til you are faced with one—the leadout throws me every time.

Value? Well, one with NiCads, charger and speaker/mike sells for £125. A ton should fairly easily get you a bare one, £85 if you are very lucky.

### Talking of leadouts

At Gillingham I bought a Heathkit HW202 FM xtal-controlled 2 metre FM wonderbox. The previous owner had displayed amazing honesty and was selling it as working, except that there was no squelch.

Later that day, I got it onto the bench. It was obvious that the 'noise amplifier' transistor had been changed, due to the bright solder. In with the 'scope, I found 100mV of noise on the base, nought on the collector. I took out the transistor, whilst noting that the screen printing was showing the leadout to be BCE. Due to the intense and determined re-forming of the transistor leadouts I figured that it must be EBC (it can be done, I do it often enough myself).

After waving the Avo at the removed transistor it became obvious why the squelch didn't work. The removed transistor was the required unusual leadout and he had re-formed it back to the more usual type! Beware transistors with 'L' at the end of their type number. It might indicate an oddball leadout. Similarly, stud mounted diodes and zeners with an 'R' in their part number may not be what you are expecting.

### The Rainham rally

The Gillingham/Rainham rally is held on a Saturday. It's smallish, two rooms in a community centre, but absolutely packed with bargains. Last year it was good and I assumed it was a fluke, but this year was excellent. The bring and buy is only one tenth the size of, say, Longleat, but it provides just as many goodies. Some of the stands are taken by amateurs (rather than dealers) and provide a good selection of toot. Well worth a visit, this one has now gone on my 'to be visited at all costs' list.

### Venus SS2

This is a slow scan television. For those not in the know, slow scan is a means whereby a television picture can be transmitted over a speech link, ie if you can talk to them you can send them a picture. Due to the limited bandwidth of an audio channel the pictures take several seconds to form. It is thus obvious that some form of storage is required, and here techniques split into two camps, long persistence tubes or digital storage.

### A modest price

Historically, long persistence was the first technique used. Lots of war surplus junk used this type of tube in radar equipment and there used to be loads of them about, literally at pennies each. Nowadays a second-hand tube, with its scan coils (if they are not electrostatic, which most are) plus its focusing gubbins, can cost you £5 to £7. It never ceases to amaze me how good a picture you can get on a long persistence tube, albeit in a slightly darkened room.

In more recent times the digital

storage brigade have gained ground. This is, obviously, due to the declining price of the chips. You can either use a dedicated machine, often called a scan converter, (homebrew or bought, such as the Drae system) or use a program on your home computer. There are some excellent ones about, particularly for the Spectrum. The major drawback is the barrage of RF noise the computer chucks out, drowning the received signal.

### Neat and tidy

The Venus is a long persistence tube type of machine. It really does trigger very well and can produce startlingly good results, even on 20 metres with all its attendant QRM. Its unique 'accuscan' feature lets you look at the incoming signal in a scope type display, and really helps you to tune in 'spot on' to the incoming signal. It is nicely packaged in one neat mains-powered box, with no messy leads, tape recorders, home computer and television cluttering up the shack, just a single cable from the speaker and the one extra box.

### Homebrew

The normal SSTV set-up in my shack is a home made scan converter loosely based on the excellent *RadCom* design of a few years ago. I've always been more than happy with that, but I was equally pleased to play with a Venus when one recently came my way.

Price-wise, the Venus is dropping. A few years ago a second-hand one (that's all that's available nowadays, by the way) would set you back £90-ish. The price seems to have now levelled out at about the fifty to sixty quid mark, dependent on condition.

### No trouble at all

Faults are uncommon, totally random failures point to a good design with no weak areas. I seem to have repaired one a year, and they are no trouble to work on. The handbook contains a good clear easy to use circuit diagram plus full supporting block diagram. This is a good bit of kit that can add a new dimension to your enjoyment of the hobby at a modest price.

## G4ZPY PADDLE KEYS

Britain's leading High Quality Hand Built Morse Key Manufacturer

PUMP (Straight) KEY	Brass £26.00 & £30	Nickel £31 & £35
SINGLE PADDLE KEY	Brass Std £42.00	Deluxe £44.50
Nickel or Brass	Std £47.00	Deluxe £49.50
TWIN PADDLE KEY	Brass Std £48.00	Deluxe £50.50
Nickel of Brass	Std £53.00	Deluxe £55.40

60. VARIATIONS OF THESE KEYS ARE AVAILABLE. Some to Order.

IAMBIC ELECTRONIC KEYER (with Auto Inter-Character Spacing) £40.00  
1K PEP BALUNS 3.5-30 Megs £15.00  
10-70 Megs £16.50, P&P UK: - KEYS £3.00  
IAMBICS AND BALUNS £2.00

SAE for further details to

41 Mill Dam Lane, Burscough, Ormskirk, Lancs L40 7TG  
or Phone: 0704 894299

## MAKE YOUR INTERESTS PAY!

More than 8 million students throughout the world have found it worth their while! An ICS home-study course can help you get a better job, make more money and have more fun out of life! ICS has over 90 years experience in home-study courses and is the largest correspondence school in the world. You learn at your own pace, when and where you want under the guidance of expert 'personal' tutors. Find out how we can help YOU. Post or phone today for your **FREE INFORMATION PACK** on the course of your choice.

Electronics	Radio, Audio and TV Servicing
Basic Electronic Engineering (City & Guilds)	Radio Amateur Licence Exam (City & Guilds)
Electrical Engineering	Car Mechanics
Electrical Contracting/Installation	Computer Programming
	GCSE and 'A' level subjects

Course of Interest:

Name: \_\_\_\_\_

**ICS**

Address: \_\_\_\_\_ P Code \_\_\_\_\_  
International Correspondence Schools Dept EF568, 312/314 High Street, Sutton, Surrey SM1 1PR. Tel: 01-643 9568 or 041-221 2926 (24 hrs)

## Universal Semiconductor Devices Ltd

UNIT 4, SPRINGFIELD ROAD,  
CHESHAM, BUCKS HP5 1PW

TEL: 0494 791298; FAX 0494 791296; TLX 837707 usdo g



WE OFFER ONE OF THE LARGEST RANGES OF SEMICONDUCTORS AT HIGHLY ECONOMICAL PRICES. THE FOLLOWING SEMICONDUCTOR TYPES ARE AVAILABLE FROM STOCK. IF WE DON'T STOCK WHAT YOU NEED THEN WE CAN GET IT FAST FROM OUR FACILITIES IN WEST GERMANY AND USA UPON REQUEST

### TRANSISTORS -

BIPOLARS - GERMANIUM AND SILICON  
SMALL SIGNAL  
POWER  
DARLINGTONS - ALL SHAPES AND SIZES  
VHF/UHF DEVICES - ALL SHAPES AND SIZES

### FETS - POWER MOSFETS UNIJUNCTIONS

DIODES - GERMANIUM AND SILICON  
RECTIFIERS AND BRIDGES  
OPTO-ELECTRONIC DEVICES  
LEDS OF ALL SHAPES AND SIZES

### THYRISTORS AND TRIACS - ALL

SHAPES  
SIZES  
RATINGS

### INTEGRATED CIRCUITS

CONSUMER - DIGITAL/ANALOGUE  
MICROPROCESSORS AND PERIPHERALS  
IC SOCKETS

JAPANESE COMPONENTS - VAST RANGE OF DISCRETES AND CONSUMER IC'S  
CATALOGUE - PLEASE SEND £1 CHEQUE, POSTAL ORDER OR STAMPS FOR OUR 1988  
CATALOGUE. SUPPLIED FREE OF CHARGE TO COMPANIES WHEN REQUESTED ON AN  
OFFICIAL LETTERHEAD

SPECIAL DISCOUNTS AND PAYMENT TERMS ARE AVAILABLE TO OEM'S, SCHOOLS,  
COLLEGES, UNIVERSITIES, GOVERNMENT INSTITUTIONS, COMPUTER FIRMS,  
ELECTRONIC REPAIR FIRMS AND DISTRIBUTORS

PLEASE ENQUIRE FOR QUANTITY DISCOUNTS

WE WELCOME TELEPHONE, TELEFAX AND TELEX ENQUIRIES

WE  
SUPPLY  
SEMI  
CONDUCTORS  
FOR  
SATELLITE  
TV

## ASTRID +

Access UoSAT OSCAR 9 & 11 Scientific Satellites with your BBC B upwards or Spectrum 48K upwards computers. (Others via RS232 serial port).

A complete Satellite Receiving System including all cables, aerial, display software etc.

All for only £156+VAT, direct from the designers.

Send for full details to:

**SRW Communications Ltd**  
**ASTRID House, The Green**  
**Swinton, MALTON, N Yorks YO17 0SN**  
**or Telephone Malton (0653) 697513**

**TO ADVERTISE IN  
AMATEUR RADIO  
TELEPHONE MARIA OR  
MARIAN ON  
0277-219876  
FOR DETAILS**

# C. M. HOWES COMMUNICATIONS

**Eydon, Daventry,  
Northants NN11 6PT  
(mail order only)  
Phone: 0327 60178**

## NEW! 2M and 6M CONVERTER KITS

If you have a receiver that covers the 20M amateur band, you can use it to monitor the 2 and 6 Meter bands by adding the new **HOWES CV220** and **CV620** frequency converter kits to your station. Suitable for use with our popular **DcRx20** receiver kit, these new converters can also be used with any general coverage communications receiver (no modifications to the receiver are involved, they simply connect externally to the antenna socket).

An excellent constructional project could combine these two new kits, together with one of our **DcRx20** SSB/CW receiver kits. This will give a great little monitor receiver covering three of the DX chasers most favoured bands. A really cost effective way of enjoying the 'weak signal mode' DX on 2-and 6 meters, together with the most popular HF DX band.

**CV220 or CV620 kit: £17.50 Assembled PCB module: £23.90**

## HOWES FINISHED EQUIPMENT RANGE

**HC266 to 6M transverter.** 10W RF output with ALC, VSWR protection and very low harmonics. Case specially manufactured to high standards by computer controlled machine tools. 1 to 5W drive level standard, 5 to 10W drive available as a no cost option. Operators handbook includes block and schematic diagrams. **HC246** 4M output version is available at **£179.90** including post and VAT and normally available off the shelf from us, and from selected retailers.

### HOWES KIT RANGE includes:

		Assembled KIT	PCB
<b>DcRx20,</b>	<b>DcRx40, DcRx80, DcRx160</b> SSB/CW Receivers	£15.60	£21.50
<b>CTX40,</b>	<b>CTX80</b> QRP CW Transmitters for 40 and 80CM	£13.80	£19.90
<b>MTX 20</b>	10W CW TX for 20M	£22.90	£29.90
<b>CVF20</b>	<b>CVF40, CVF80</b> VFOs for above transmitters	£10.40	£16.90
<b>HC220,</b>	<b>HC280</b> 2M to HF transverters, 10W output	£52.50	£83.50
<b>CSL4</b>	Dual bandwidth SSB/CW filter for DcRx	£9.90	£15.90
<b>ASL5</b>	Dual bandwidth filter for 'black boxes'	£14.90	£22.50
<b>TRF3</b>	Shortwave Broadcast receiver	£14.80	£20.20
<b>CTU30</b>	HF bands ATU for receiving or 30W TX	£27.90	£33.90
<b>SWB30</b>	SWR/Relative power indicator, 160 to 2M	£12.50	£17.30
<b>CM2</b>	Quality microphone with VOGAD	£11.90	£15.90
<b>AP3</b>	Automatic Speech Processor	£15.90	£22.80
<b>ST2</b>	Sine-wave side-tone/practice oscillator	£8.80	£13.50
<b>XM1</b>	Crystal Calibrator with 8 marker intervals	£16.80	£21.90

All HOWES KITS include a high quality glass-fibre PCB with screen printed parts locations, full instructions and all board mounted components. Tuning capacitors to suit our receivers and VFOs (except 160M) are available at £1.50 extra (DcRx needs two, TRF3 and CVF need one).

A copy of our free catalogue and information sheets on any products you are interested in available for an SAE.

Please add £1.00p P&P for kit orders.

UK delivery is normally within 7 days.

**73 from Dave G4KQH,**  
**Technical Manager.**



**HELPING TO BUILD YOUR STATION**

# FREE CLASSIFIED ADS

## FREE CLASSIFIED ADS CAN WORK FOR YOU

We are pleased to be able to offer you the opportunity to sell your unwanted equipment or advertise your 'wants'.

Simply complete the order form at the end of these ads. Feel free to use an extra sheet of paper if there is not enough space. We will accept ads not on our order form.

Send to: **Amateur Radio Classified Ads**, Sovereign House, Brentwood, Essex CM14 4SE.

## DEADLINE AND CONDITIONS

Advertisements will be published in the first available issue on a first come first served basis. We reserve the right to edit or exclude any ad. Trade advertisements are not accepted.

## FOR SALE

■ FT77 HF tcvr, unmarked FM unit, 100W output never used mobile, also matching FC700 ATU, £550 ono. SEM Tranzmatch 160/10MHz, £75. Also Spectrum 6mtr tvtr, 10MHz drive, £50 ono. 14-ele Parabeam 2mtr ant, and 8-ele yagi beam 2mtr, £45 and £25, both first class. M L Brown, Barncroft, Croft Road, East Ogwell, Devon TQ12 6BA. Tel: Newton Abbot 56159

■ Yaesu FTDX401, working but low on receive and Tx. Think just an IF down. You sus it, bargain £70 ono incl hi-z base microphone. Realistic pocket-tv LCD television with mains adapter, as new, cost £110 will accept £50, no offers, not much bigger than packet of fags! Mick GOEIG, 8 Railway Street, Leyland, Lancashire. Tel: Leyland 424878 after 6pm

■ Hammarlund SP-600. Rag Otterstad, Vejdammen 5, DK-2840 Holte, Denmark

■ Cossor single beam oscilloscope radio TV specialisation, simple basic, easy maintenance equipment, also diatonic audio amplifier, 15 to 20 watts clearance, sale any reasonable offer, buyer must move. Evenings after 8pm. Tel: (01) 436 3806

■ Realistic Pro 2021 AM/FM monitor receiver, with aerial, some co-ax, also external aerial, excellent condition, £200 ono. Tel: (0772) 454405

■ Complete Wood and Douglas 70cms synthesised transcvr kit consisting of 70FM05T4, 70FM05R5, 70FM10, 70VC05, 70SY25B, SSR1, MPA2, SSR1, plus pre-amp, mic, case, fitted switch, all boards built, meter etc. With comprehensive construction details, illness reason for sale, £65 ono. Mr N Porter, 23 Calder Crt, Surbiton. Tel: 01-390 2650

■ Realistic Pro 2004 UHF VHF programmable scanner, covers 25-520MHz and 760-1300MHz. 300 memories, host of other features, only two weeks old, completely as new, boxed, one year guarantee, cost £349. Will accept £280 or will swap for Sony ICF2001D or similar, but must be in brand new condition and in similar price range. Stewart Anson, 15 Wallbrae Road, South Carbrain, Cumbernauld, Glasgow, Scotland. Tel: (02367) 28715

■ Communications receiver, Rees Mace marine, 60kHz to 32MHz, mains PSU, super condition, £45. T1154 Lancaster Tx and R1155 receiver, receiver working fine with AC PSU. Tx untested but complete with valves, 813, £150. 10 mtr FM Tx/Rx ex lcl CB, £30. 2 mtr transverter to suit above 10 mtr rig, Meon PCB with amp, 2 watt o/p, 12 volt, £40 or £60 the pair. 80 mtr CW transceiver, CM Howe PCBs, with sidetone and audio filter, boxed, 12 volt, £50. Atari 800XL computer, with cassette and disc drive, with several disc programs, £170. Contact Ben. Tel: (0562) 743253

■ Hallicrafters - FPM300 Tx, the famous Safari, 10-80m, all modes, 125W, fixed, station or mobile (12V). Mic, manual, spare final/driver valves (others all solid state), pi-output. Nice efficient, compact rig, PSU and speaker all in. Suit starter at low cost. Accept £200 collected. Also RCA AR88D, v clean, good DXer, spare valves, £60. Tel: (061) 430 3127

■ Yaesu FRG7700 gen cov Rx plus FRT7700 ATU. Also FRV7700 118/150MHz VHF converter (A), £300. Tel: Shrewsbury 63535 after 6pm

■ Trio Kenwood TS430S with two SSB filters and an AM and CW filter plus FM board. Just been serviced, with mic, £790. Tel: Rodney, (0689) 58825

■ Yaesu FP757-HD PSU, absolute mint condition, £120 ono. Wideband dummy load 3.5MHz-500MHz model T200, mint condition, £25 ono. Monacor FS1-40 SWR and power meter, £15. Tel: Dave (0507) 801514

■ ICR70 gen cov Rx with FM 12V dc conv with box, etc, mint, £425. G4FQF QTHR. Tel: Romford (0708) 47998

■ Drake R4C notch filter, passband audio mod fitted, good condition, £300. Slow scan monitor, £35. Trio filters YG455CN, £40. YG88C, £28. YF88H

Fox Tango 2.1, £20 for TS820. L Huntley G4LW, 118 Bradford Road, Trowbridge, Wilts BA14 9AR. Tel: Trowbridge 3166

■ Want to get QRV on RTTY? I have a Commodore Vic 20, technical software interface and RTTY/CW Tx/Rx programme, ready to go RTTY station, bargain at £55. Also have fully expanded Cobra 148 GTL DX, vgc, ideal for 10 metres or even six. Adrian (G7AMN). Tel: Carlisle (0228) 41309

■ Legal CB Amstrad 901, complete with Mag-mount aerial for mobile use and SWR meter. Excellent condition, with manual and original box. Have magazine review, £40 ono. Dave Heath, 49A Parkland Road, Wood Green, London N22 6SU. Tel: 01-881 0824

■ Cybernet Delta 1 934MHz rig with Crestbyte preamp, £280. Bnos 2m linear amp L144-10-100, £120. Mike. Tel: (0799) 27155

■ Technical software RX-4 receive program and TIF1 interface for use with Spectrum computer to decode RTTY/CW/SSTV/Amtor. Cost £65 new, accept £40. Technical software, RAE maths teaching program for use with Spectrum computer, excellent program, £5. Tel: Ian, (0359) 70527 after 6pm

■ Sinclair ZX81 and ZX80, also BBC interface with docs. Zx port for 80 and 81 docs. 2 mains adaptors for 80 81. 4 comp to TV leads, 2 comp to cassette player leads, 2 16K RAM packs. Manuals for 80 81 games programs book. Also Zx printer manual but no printer! Will separate, offers? Tel: (0766) 85298 after 6pm

■ Yaesu FT726R. Fitted 2 metres. Purchased 9.2.88 boxed, operators manual, workshop manual, mint cond, save £100 on last price, £600. No offers. Reason for sale, going HF only. Tel: Gravesend (0474) 328163

■ CB radio, Cobra 148 GTL DX, AM, FM, LSB, USB, brand new with circuit diagram, £170, no offers. Tel: (207) 2326 or (207) 0706 Elstree

■ Superstar 360 FM multimode converted to 10m band by Spectrum. Mint cond, £150. Wood and Douglas 2m 25W linear, £20. Mark McIntyre, 36 Beechgrove Park, Belfast BT6 0NR, N Ireland. Tel: 795783

■ Yaesu FT709 handie trncvr, fitted with 12 volt NiCad pack, also desk charger and spkr mic, mobile mount, etc, all in mint cond and boxed, still under guarantee, £225 ono. Tel: (061) 480 1933 anytime

■ Spectrum 3 joystick etc, also Pye marine band receiver, working but requires xtals, would like to exchange these items for anything radio related, these items are mint condition. Tel: (0266) 45527

■ Yaesu VHF converter, FRV 7700 model C, in excellent condition, would exchange for GDO or WHY. C R Smallwood, 35 Dakin Ave, Fairfield, Buxton, Derbyshire SK17 7EE. Tel: (0298) 77007

■ Yaesu FRG7 receiver, fitted with Lee Electronics digital frequency display module, little used, so excellent condition, £120. Brewer. Tel: Bracknell (0344) 487 989

■ G3LIV RTTY unit. Includes normal and reverse shift, plus 170Hz and 425Hz shift for amateur and commercial RTTY. Fully boxed, with all leads to plug into BBC micro, will also work on other computer systems such as Spectrum, Amstrads, etc. Comes with disc of amateur programs for BBC micro, £45. Tel: (061) 427 5931, ask for John or Steve

■ BBC B issue 7. c/w 40TDD ATPL ROM, RAM board, G3LIV RTTY computer interface and ROM, Forth ROM and manual replay ROM, mono 12in monitor, £300 ono. Tel: (0532) 778689

■ Icom IC2E, with spare battery pack ICBP3 and dc converter ICDC1 plus battery charger, BC25E and speaker mic, £160. Bencher lambic key, unused, £30, buyer collects. Tom G4MMY QTHR. Tel: Wakefield 270525

■ FDK750E 2m FM CW SSB transceiver. 1 watt, 10 watt output, mobile mount, £230. Peter G0ISU. Tel:

E/Rudham 8951 evenings, weekends only

■ Swift HIP4 regulated power supply. Outputs 6V, 7.5V, 9V, 12V dc, 1 amp, 2 amp surge, new in boxes, 4 off at £12 each. Swift 300mA regulated power supplies. Outputs of 6V, 7.5V, 9V dc (small plug type with adaptors), £5 each, new in boxes. Swift FM wireless intercom FMX3 3 channel, ch1 150kHz, ch2 170kHz, ch3 190kHz, £25 per pack, again new in boxes. Swift RXP4 radio paging system, base plus 2 pagers, £85. Base with 4 pagers, £100 (good 5 miles radius with 27 megs silver rod), again new in boxes. Yaesu FRG7700 exc cond, £280. Daiwa 2m handie, £70, good cond. Sapphire X4000 CB, £25. Toshiba CD player model no XRJ9, £85 exc cond, all items collected or plus postage. Tel: Frank, (041) 445 2155 anytime

■ Trio SSB/CW 2m rig, TR7010, 10W output, £85. Home/b VFO also available, £25. AEA Morse RTTY ASCII reader, very good condition, £80. Tower, very heavy, two sections 20/15ft free standing. R Pearson, West 38 Portsfield Ave, Fareham, Hants PO16 8LW. Tel: (0705) 371183

■ Pye pocketphones, one Tx, one Rx, for conversion to 70cms (no batteries), £6.50 a pair inc postage. Tel: (0702) 512814 ask for Mick

■ Yaesu FT757GX Mk1 FP757HD and FC757AT, only 9 months old so as new condition, still boxed, £1200, may try an offer. J Gallimore. Tel: Hereford (0432) 355441 (office hours)

■ Antenna, 5 band vertical, Welz CP5, separate traps, as new, £95. Tel: (0487) 823779 after 6pm

■ Tektronix 2246 100MHz oscilloscope, four channels, four probes, smart cursors, front cover, manuals inc service. superb instrument - suit professional. 1 year old, £1600 ono. D Carne, Flat 2, Emsleigh House, Victoria Park Road, Exeter, Devon EX2 4NT. Tel: (0392) 217642 day, (0392) 37469 evening

■ Drake complete station - T4XB, R4C, HS4 speaker and power supply, all filters fitted. Works transceive mode. covers usual bands, plus extra 15 bands. Condition as new, original packing, the best equipment available, going mobile. Give away at £475. Tel: G3WPN, (0531) 4851 Hereford

■ Two Tektronix oscilloscopes, 545B with dual time base and 1A1 vert amp, £90. 533A single time base with CA vert amp, £70. John. Tel: 01-458 9888

■ Yaesu FT757GX transceiver, FC757 auto ATU, FP757HD heavy duty power supply. All boxed and as new, £925 the three. Tel: 01-514 5998 anytime

■ SSB electronics (German) LSM, 24cm (1268-1270MHz) lo/mixer unit, 2m IF, 500mW out for Oscar phase III etc, £130. ICS/AEA CPI, 'computer patch' RTTY TU plus 'BBC' driver ROM, £80. NEC 12in green screen (composite input) monitor, perfect, £40. Jaybeam D15/15 1296MHz yagi (new), £33. Paul G4XHF. Tel: (0293) 515201

■ Realistic Pro-2004, 300 channel programmable scanner, covers 25 to 520MHz and 760 to 1300MHz in 5, 12.5, 50kHz steps, with modes of wide FM and narrow FM and AM. Also Icom AH-7000 super wideband omnidirectional aerial, covering 25 to 1300MHz, complete with 15m of cable. All in mint condition, will accept £290 the lot. Mark Matthews, 55 Kingsbridge Road, Southall, Middlesex. Tel: 01-571 1609 after 6pm weekends

■ Marko Excalibur Mk II multimode gold Jumbo homebase. Super condition, AM, FM, USB, LSB with kHz shift. Also UK CB and FCC CEPT CB EPROM board fitted. Can easily have 10m lo-lo and hi-lo fitted. This is a super transceiver, recently valued at over £275. Will accept £250 ovno, buyer collects as it is very heavy. Will consider amateur radios Rx or Rx/Tx part exchange. Write to Ian, 101 Sherrin Way, Withywood, Bristol BS13 8RP

■ Grundig Satellit 300, computer controlled tuning, 30 memories plus manual tuning frequency counter, timer start, as new, boxed, £70. Flat 2, 19 Chesham Road, Brighton, Sussex BW2 1NB

■ Impoverished student needs cash. FT DX401,

# FREE CLASSIFIED ADS

£165. SWR/pwr meter, 2kW HF/VHF, £20. ARE microreader with Morse tone, £75, or £250 the lot. Please write, giving your phone number, to Gareth G1LVN, 21 Regent Park Terrace, Hyde Park, Leeds, West Yorks LS6 2AX (sorry no phone)

■ Yaesu FT620B, 6m base rig, USB, LSB, AM and CW. Mains or 13V input. Mint cond and very rare. Open to offers, or exchange for 2m base rig, or WHY? Philip. Tel: 01-405 6079, 9am to 5pm weekdays only

■ Super Star 2000-5+40, the set you have been looking for, £165. Ranger 3500 FM, AM, USB, LSB, CW, 26-30MHz in steps of 100Hz, 1kHz, 10kHz, 100kHz, 1MHz. 8 watts and 30 watts output, scans all frequencies, £380. Taking up another hobby. Wanted: Realistic Pro-2004 or equivalent, and FRG7700 with airband or equivalent. Tel: (0283) 221870

■ FT290R car mount, NiCad charger, mag-mount aerial, new log book, £275. Tel: (0926) 311580

■ Complete SWL station, FRG7700 pre-amp ATU, all call books, WRTH, h/held Uniden scanner, all items exc cond, £380, buyer collects. Or exchange for mint condition complete 934MHz station. Tel: Dave Howes (0634) 404096

■ Yaesu FL2100Z linear amp with manual and box, £525. Wanted: FC102, KW109 or other high power ATU. GOCEL QTHR. Tel: Kevin. (0202) 42828

■ Trio R2000 communications receiver with VC10 VHF converter, immaculate, £200. Realistic Pro-2008 programmable FM scanning rcvr, immac, £50. Realistic DX-200 5-band comms rcvr, immac, £40. Hira HH880 AM/FM/air/CB radio, £6. Tel: Northallerton (0609) 70704

■ Spectrum 48K computer with VTX5000 modem for micronet, complete with PSU, boxed, £60 ono. Will exchange for 2m or 70cm mobile linear amp in good condition, or 70cm SWR/pwr meter. Have a Jupiter Ace computer - Forth language with manual - offers. Tel: 01-359 2276 after 6pm

■ Two 2 amp variac transformers, £10 each. Two Norman 100 watt, 100 volt line, tapped distribution audio transformers, £5 each. Pair of Tinsley precision switched resistor decades, comprising nine ranges 0.1 to 1000 ohms, one per cent accuracy, £10 pair. All in excellent condition, carriage and packing inclusive. JH Pepper G3JHL, Turlington, Salisbury Road, Shootash, Romsey, Hants. Tel: (0794) 512283 evenings or weekends

■ 2kW HF linear. SB220 in immaculate condition, 2 3-500Z tubes giving in excess of 1kW out on 10 through 80 metres. Variable power output control and other latest mods incorporated. This amp has worked 303 countries and won the Bermuda Contest 1987. Complete with manual, control cable etc. Very clean output, £750. Reason for sale? In a moment of madness, have just bought another 2kW amp at twice the price. Ian G4LJF. Tel: Wokingham (0734) 780022

■ Converters, hardly used. MMC144/28, £15; MMC432/28, £15. STE Ario Rx module, 28 to 30MHz, AM/FM/SSB/CW, ideal tunable IF, £25. QVO5-25 (807) new, boxed, £3. 5B/254M new, unboxed, £7. Heath VHF SWR/pwr meter HM2102, £10. All plus postage. Tel: Barbon (046836) 276 (Cumbria)

■ Yaesu FT101ZD, 6 band HF rig, USB/LSB/CW/AM, good condition, spare PA valves, mic, fan, manual. Only used for receive, ideal first rig or club rig, £365. Also Yaesu FRG7000 HF Rx, 250kHz to 30MHz, SSB/CW/AM, digital display, digital clock/timer, two antenna inputs, fine tune etc, good condition with manual, £185. Buyer invited to inspect and collect. Please write to Pete G1SFS, 23 Chestnut Walk, Bishopsworth, Bristol 3, Avon BS13 7RJ

■ FDK multi 700A/E 2m FM tcvr with regulated PSU, mic, mobile mount, as new, £125. Codar AT5 Tx mains regulated PSU, good cond, £40. Both items ex-silent key, carriage at cost. Don MacLennan G3KGM QTHR. Tel: 01-300 0767

■ Mizuho Sky Coupler KX2, unwanted gift, offers or WHY? Tel: Peter. (0553) 841119

■ Rolex Oyster, perpetual chronometer, 26 jewels, Explorer I stainless steel, one year old. Cost £681, accept £400. Would take Sony receiver, Pro-80 with converter, or 2001D with active antennas in part exchange, or WHY? Ken Miller, 15 The Rise, Green Lane, Whitby, Yorks YO22 4ES

■ Clear out, vintage radios. HMV148, Derwent, Cossor 363, Cossor 72, GEC BC5060, Gecophone folded horn. Eddystone 840, Avo valve characteris-

tic meter, crystal sets, many other items. Also very rare National Portable c1928, £55. Tel: Dean 22776 or 542329, ask for Ken

■ RTTY ST5MC terminal unit with 45/50 speed converter, normal and reverse, plus Creed 444 with tape perf and reader built in, paper rolls and ink spools. Both in perfect condition, will deliver within 50 mile radius of Lincoln or pay petrol. Both items, £50. T R Cooling. Tel: Lincoln (0522) 595051

■ Long persistence CRT, ex-SSTV unit, ideal for very low freq scope. Green trace, 3FP7, complete with base, £5 plus postage. 5 Green Courts, Winterton-on-Sea, Great Yarmouth, Norfolk

■ Have Yaesu MK1 desk mic, would swap for good paddle key, eg Bencher etc. Wanted, mains transformer for Heathkit SB610 monitorscope. Paul G0ILO. Tel: Canterbury (0227) 455052

■ NRD515 communications rcvr, complete with 600Hz CW filter, box and manual, £675 ono. Excellent cond, genuine reason for sale - YL to XYL conversion! Transport or delivery can be arranged, viewing at any time. Colin Peake G4UDN. Tel: (0773) 873580

■ One pre-1987 Communicators citizens band transceiver. Can be modified to 10 metres transceiver or CB model N1-440DX, £20. Wood. Tel: (05427) 378

■ Drae Morse tutor, £35. AOR2001 scanner, 25-550MHz, £225. Both as new, with instructions and boxed. G6HMF. Tel: Bedford (0234) 782435 evenings

■ Yaesu FT102 HF trans, WARC, c/w filter, vgc, boxed etc, £550 ono. Trio Kenwood TS530S HF trans, c/w filter box etc, vgc, £475 ono. Tel: Weymouth (0305) 813202

■ Scanning receiver, Regency MX500, 25MHz to 550MHz, very little used, complete with manual and antenna, in original box and packing, £225. Tel: (0276) 63128 (Camberley)

■ Psion organiser, model XP, 32K RAM. Datapak 64K, Datapak 32K, mains power unit, £160 the lot. Icom world clock, GC5, £25. All items as new, boxed, with manuals. Carriage extra or buyer collects. Mr Kenwood. Tel: 01-570 5603

■ AR2002 communications rcvr, continuous coverage, 25-550, 800-1300MHz. This set is as new, own box, power supply mod to 13A plug. NFM/WFM/AM, scan and search modes, auto or manual, £320 ono. Tel: (0772) 683098 any time (Preston)

■ Cobra 148GTL/DX, converted to 10 metres, handbook and instructions, £170. Weltz SP15M and AC38M matching network, 200W to 2.5W, £60. 9-ele Tonna, 70MHz with co-ax, £30 ono. G0IMI QTHR (G6NWX). Tel: (0602) 293745 (Notts)

■ Practical Wireless and Spanish radio mags, very low prices. Exchange or buy schemes, from antennas or linear amps for 10 metres original, or from any mag. Please write with info. IRCs welcome. Write to Jorge, Box 859VA, 46080, Valencia, Spain

■ Discone antenna 25MHz to 1300MHz, used one week, in original pack, £62. Tel: Gorseinon (0792) 891458

■ Sony ICF6800W multi-band receiver, FM/MW 29SW, SSB/CW, vgc, £170. Tel: 01-620 1335 work, 01-794 0843 home

■ MM 144/28R tvtr, 25W out, 6 months old, £150. Drae Morse tutor, £35. BBC Master compact professional system, colour monitor, 3 1/2in + 5 1/4in d/drives, NLQ printer and lots more, £550. Would consider exchange of above plus full FT757 line-up for TS930, TS940 etc, with ATU, mic etc. Try me! Ian G0IHK. Tel: (0491) 36720, South Oxon

■ Jaybeam TB3 triband beam, KR400 rotator, plus 40ft tilt-over mast. Swap for large 2m valve linear. Free transport within 20 mile radius. John G4ZPL, 104 Stamford Road, Kettering, Northants NN16 8LW. Tel: (0536) 521790

■ Yaesu FRG7700 HF receiver with FRV7700 converter (B-type), FRA7700 active antenna and memory module fitted (along with 12V dc socket), plus service manual, £280. Tel: (0273) 503458 after 6pm, ask for David

■ FT101E for sale, or swap for FP757HD PSU or FC757AT, or £250 cash. David. Tel: (0603) 413129 after 6pm

■ Hamgear PMX preselector, mint condition plus literature. Gives good results with only very short indoor wire. Now have long high external aerial, so PMX is surplus to requirements, sell for £39.

Gordon. Tel: Doncaster 532021 any time

■ Yaesu FT23R handie, mint condition, with 12V dc adapter and homebrew fast charger, £190. Realistic Pro-31 hand-held FM scanner, 60-512MHz, with NiCads, £100. Tristar 747 multimode transceiver, xtalled for 10 metres, 14W output, exc cond, £80. BNOS 144MHz lowpass filter, SO239 sockets, £12. Homebrew RTTY TU with software for IBM or Amstrad PC, professional appearance, £30. Mobile whips, various, 20m to 2m, from £6. You collect. G4ILO, QTHR. Tel: Colchester (0206) 210878

■ Rascal RA17L, good condx, cabinet fitted. Redifon R551A synth HF Rx, needs attention, £70 ono. GEC RC410 synth marine Rx, superb condx, needs attention, offers. Rees-Mace marine Rx, 60kHz, 32MHz, good condx with PSU, £75. HRO, coils, PSU, £40. Storno VHF gear 600, Viscounts, Pye base station lot, £20. Bendix TA12 Tx. TCS12 Tx. Class D w/meter. All items heavy. Inspect, collect. Cain, 18 Oaky Balks, Alnwick, Northumberland. Tel: (0665) 602487

■ KW Vespa MK2, recently overhauled by KW. Exc condition, mic and key, KW201 Rx, both £240. HF5 vertical, £35; DL600 dummy load, mint, £35; SW200A VSWR meter plus coupling, mint condition, very little use, bargain, £75 ono. Marconi AD108D aircraft rcvr, covers LF/HF bands, £15. All items boxed. Prefer sell all in one package. Beattie. Tel: (0436) 5489

■ Sony ICF2001D, excellent cond, £245 ovno. Tel: Uxbridge (0895) 51838 evenings, 01-572 0313 daytime

■ Trio TH21E 2m mini hand-held, excellent cond, £145, or poss exchange for quality 10 metre gear. Jon. Tel: (0249) 712009, Wiltshire

■ Going QRT. All items mint. Trio TR2400 VHF hand-held (spare NiCads, dc/dc etc). Kenwood SW100 VHF/UHF SWR meter, Yaesu FT101ZD MkII (fan, CW filter etc). Yaesu FC107 ATU, Yaesu SP107 speaker, new G5RV antenna, base mic (TW232 DX). Most items boxed. Also loads of Commodore 128 and 64 hardware/software, including Geos 128, Superscript 128, Superbase 128, new modem. Cheap/offers. Tel: (08482) 314

■ Yaesu 480R 2m multimode, complete with box and manual, mobile bracket, in mint condition, £300 ovno. Also 10-element 2m beam, never been used, still in box, £20. Tel: (0623) 552912

■ Pan International receiver, solid state, full coverage, 12 bands SW/VHF/UHF freq-readout, with BFO, for SB, CW and RTTY, as new, in box with manual and circuit diagrams, cost £380, sell for £250. Also Global ATU 1000, cost £69, sell £25 with above. Also ZX Spectrum + computer with printer, data processor, and 12in green screen monitor, over £100 software with Morse and RTTY program, all new and boxed, £180. Tel: (061) 748 5140

■ Sony ICF7600D Rx, 150K-30MHz, brand new, still in wrapper and boxed, £140. Heath HW9 de luxe QRP CW Tx, 80-10m, inc new bands. Full QSK, beautifully built, perfect working order (except needs alignment on 10m Tx). Includes Yaesu FL110 100W linear amp, giving instant QRO, cost £380, sell both for £280 inc leads and handbooks. Excellent QRP/QRO station. Buyer to pay carriage. Steve GM4GTU QTHR. Tel: (0224) 743039 or (0903) 776570

■ Robot 800 terminal Tx/Rx RTTY assc CW/SSW, also 2mtrs/70cm MM transverter and transverter for FT290 to HF, 14MHz-30MHz. Exchange for large 2m linear or WHY? GM4ZOA. Tel: (031) 447 3905 after 6pm

■ FRG8800 with FRT6800 ATU and FRV8800 conv, £375. Pro-32 or Black Jaguar portable scanner accepted p/x, buyer collects. Bill Batley. Tel: (0924) 471226

■ Sommerkamp/Yaesu FL200B HF transmitter, 240W PEP input, built-in PSU, £95 ono. Wanted: HF linear amp. Tel: (061) 439 4226

■ FT277ZD (101) dc/dc converter, CW filter, fan, mic, mint cond, £500. FT290R 2mtr multimode, mint cond, NiCads, charger, case, rubber duck, £275. Will deal for Argosy QRP transceiver. Tel: (061) 301 3750 (Manchester)

■ Kenpro KT400 (similar to IC4E) 70cm hand-held, c/w charger, NiCads, helical, £160. 70cm power amp, 1W in, 10W out, £30. Pye pocketphones (PF2UB), suitable for conversion to 70cm, one good, one for spares, c/w speaker mic, NiCads, antenna and conversion details, inc diagrams, set-up procedures etc, £40. Chris G1DEY. Tel: 01-888 8903 after 6pm

# FREE CLASSIFIED ADS

■ Yaesu FT460R 2m all-mode transceiver, £270; Trio TR8400 70cm FM transceiver, £180; digital LCD multimeter, autorange, £30. Jaybeam 8XY/2m crossed yagi, 2m aerial, £20; R107T ex-WD general coverage receiver, £30. Portable mast, ex-WD with kit of tools etc, £20; heavy duty lowpass filter, £15; AVO industrial test set, as seen, £15, plus other misc ham gear. Dexter. Tel: Nottingham (0602) 271405 or 605056

■ AOR2002, as new, boxed, manual, PSU plus Revcone discone antenna, £350 or exchange with cash adjustment for 2m base station. SMC RF speech processor SP4, mint, £30. JEP terminal unit for CW, RTTY etc, with manual, plus Morse reader PRO for Spectrum, £20. Tel: Guildford (0483) 233991

■ Pre-war wireless components, Drake R4C, CW filter, Lafayette HE80 Rx, CW filter for FR101 Rx. Wanted: Eddystone 940 Rx, must be in near mint condition; de Luxe tuning knob for Trio 820 series. Mr Wright, 54 Queen Mary Avenue, Basingstoke, Hants RG21 2PE. Tel: (0256) 468649

■ Scanner listener requires someone from the Angus or Kincardineshire area to swap frequencies with. Please write to Tom, PO Box 4, Montrose, Angus

■ Certain trader service sheets, between numbers 1 and 573 on valve radios. Also old QSL cards, postcards etc relating to radios, radio stations and amateurs. Please contact Tom Valentine, 38 Grampian View, Montrose, Angus DD10 95X. Tel: (0674) 76503

■ Mullard BGY36, 35 or 32 module, price and source of supply. Critchley G6NUK, 16 Finch Mill Avenue, Shevington Vale, Wigan WN6 9DF

■ Scrapped CB multimode, Ham series Concord, Tri Star, Cobra etc, no mods please, and with original VCO block, any condition. Tel: Peter (0639) 820356

■ Icom ICR7000 25 to 2000 scanner. Yaesu FRG9600. Datong active antenna. HF and VHF converters, Rx4 RTTY/CW/SSTV/Amtor/receive programs or Morse/RTTY reader/decoder. Pocom or other makes. Reference books also required. Tel: (0283) 68439

■ Still seeking a KDK2025 2 metre FM mobile transceiver. A fair price offered for a good condition example. Particulars to J H Lepper, Turlington, Salisbury Road, Shootash, Romsey, Hants SO51 6GA. Tel: (0794) 512283 evenings/weekends

■ RAC AR88 LF manual or data, can you help please? John Reid, 1 Bolton Court, New Skelton, Saltburn, Cleveland TS12 2YE. Tel: Guisborough (0287) 50948

■ Bug keys, any semi-automatic mechanical speed keys by Vibroplex, McElroy, Bunnell, Speed-X, Lionel, Eddystone etc. Any age, any condition, scrap or mint. American J-37 or J-38 lightweight hand keys. G3TSS. Tel: (043) 471 3125

■ Novus model 650 electronic calculator - the type with LED display, on sale in 1974. It has six digits and uses a PP3 battery and must be marked Novus 650. Wanted to replace one of sentimental value which was stolen from my place of work. Please write with price wanted to David Knight, 2 The Croft, Putnoe, Bedford.

■ CB hand-held, must be 40 channel, 4 watts. Swap valve general coverage receiver featuring 55MHz to 30MHz continuous in four bands with six bandspreads, BFO, Q-multiplier, AVC, ANL and more. Other CB items sought, WHY? Twigs, mobile mounts, mics etc bought at right prices. Davidson. Tel: (0453) 860827 (Dursley, nr Bristol/Gloucester)

■ Two, possibly three, VHF/UHF portable transceivers, must be c/w crystals, battery packs, aerials etc, range between 100 yards and four miles. Anything considered - no toys please. Will collect or cover your postage. Money no object. Tel: (0276) 23455, ask for Steven

■ 934MHz transceiver, Reftec or similar for portable use. Also suitable mobile 934MHz aerial and small beam for 934MHz use. Reasonable prices please. Can collect within 100 miles of Cardiff, or will pay all delivery charges in advance. Martin Williams. Tel: (0443) 411954 any time

■ Required urgently, base insulator suitable for mounting a 100ft guyed tower. Also Talurit, or similar, hydraulic wire rope splicing press and ferrules, suitable for splicing 4mm and 6mm wire rope guys. Can collect. Jones G3RRN QTHR. Tel: Lincoln (0522) 751557

■ 2m mobile rig or 2m portable, also SWR meter. Tel: (0922) 22994

■ Exchange Sommerkamp FT767 DX (FT207) plus mic, owner's and workshop manuals, 4 spare crystals, plus parts for 160m for IC271E or TR9130 or TR751E, also Shimizu SS105S 10W, 5 band HF rig with modified TL120, 200W PEP linear, plus 48K Spectrum ZX microdrive, ZX interface one, plus leads, boxed - for 50MHz multimode, 25 amp PSU or Belcom LS102 plus 25 amp PSU, also Tau SPC3000D. G4XPP QTHR.

■ Ham International Hercules, 40ch FM CB homebase and Jumbo II or III. Must be in mint condition, cash waiting for the right gear. No other homebase CB radios considered. Martin Williams. Tel: (0443) 411954 any time

■ AMTOR software for Amstrad 464 on disc or tape, or address to obtain. Will refund costs/postage. T Craig VK6PQ, 76 Hume Road, Thornlie, 6108, Western Australia

### WANTED

■ Early Eddystone receivers, components and literature. Top prices paid, and collection anywhere in the UK arranged by keen collector. Tel: (021) 556 3324 any time except weekends

■ Tandy Realistic Pro-22 hand-held xtal scanner. Tel: (0207) 544342 after 6pm, evenings/weekends

■ Information please. Does anyone know where I can get two 16swg aluminium chassis (for valve amplifiers) made up to requirements? F Cosgrove, 59 Fenton Road, Bournemouth BH6 5BS. Tel: (0202) 432973

■ Valve transmitter, CW/SSB - no junk, (local location please). Would want to see before buying. Tel: Basildon (0268) 282373

■ R109 6V Rx, pref unmodified. Your price paid plus carriage. Also ex-army type aerial, variometer (19 set type) as above. Your price paid plus carriage. Peter. Tel: (0287) 34397 daytime

■ Exchange Trio R600 gen cov Rx + Black Jaguar hand-held scanner, both items as new, for Yaesu FRG9600 or Realistic Pro-2004. Must be in good condn. Tel: Langley Mill (0773) 761459

## FREE CLASSIFIED AD FORM

Send to: Amateur Radio Classified Ads · Sovereign House · Brentwood · Essex CM14 4SE

**Classification:** (tick appropriate box) If you want to insert ads under more than one classification use separate sheets for second and subsequent ads

For Sale .....  Wanted.....

**USE BLOCK CAPITALS** (One word per box)

To avoid mistakes please write clearly and punctuate your ad

Name/Address									
Postcode/Telephone									

**USE SEPARATE SHEET FOR MORE WORDS**

**Ensure that you have included your name and address, and/or telephone number**

**CONDITIONS:** Ads will be published in the first available issue on a first come first served basis. We reserve the right to edit or exclude any ad. Trade advertisements are not accepted

# Amateur RADIO SMALL ADS

## JAYCEE ELECTRONICS LTD

JOHN GM30PW

20 Woodside Way, Glenrothes,  
Fife KY7 5DP

Tel: 0592 756962

Open: Tues-Sat 9-5

Quality secondhand equipment in stock. Full range of TRIO goodies. Jaybeam - Microwave Modules - LAR.



## IAN FISHER COMMUNICATIONS OF STANHOPE

CB Works, The Market Shop, Market  
Place, Stanhope, County Durham  
☎ (0388) 528464

Main Distributors of 27MHz CB radios and the NEW CEPT models including ATRON and DNT.

Including U.K. and CEPT walkie talkies.

Large stocks of coaxial cable, plugs, sockets and adaptors.

All available via mail order. Retail/Wholesale

OPEN: MON-SAT 10.30am-6.00pm

SUN 2.30 - 4.30

RING FOR DETAILS

(0388) 528464

24v ni-cad battery contains twenty XD type cells, used condition, some cells may be faulty ..... £12.00  
Spring tension gauges, set of 3. 0-4 ounce, 0-16 ounce, 0-6lb..... £8.00  
Ex Vulcan bomber hitch and roll assembly, contains gears, shafts, bearings etc

£15.00

Range and bearing-marker unit, contains bevel gears, servos, shafts etc..... £15.00

Radar drive unit, contains 2 ex 24v motors, gears, components etc..... £15.00

Eddystone type 770R VHF receiver, 19-155 MHz..... £120.00

Type R210 receiver 2-15 MHz, complete with plug and headphones..... £55.00

ITT UHF TX-RX base station..... £40.00

ITT 149 MHz VHF transmitter..... £40.00

Collins R390A receiver, poor condition

£150.00 Ring for details

Readyphone 100 watt, LIN, amplifier, complete with ATU..... £75.00

Prices include postage and packing

### A C ELECTRONIC SERVICE

17 APPLETON GROVE, LEEDS LS9 9EN  
TELEPHONE: 0532 496048

### AGRIMOTORS

MERTON CB AND RADIO CENTRE  
MERTON GARAGE AND POST OFFICE, MERTON.  
Nr OAKHAMPTON, DEVON EX20 3DZ

OPEN 6 DAYS 9-6 LUNCH 1-2pm  
EARLY CLOSING THURSDAY 1.00pm  
(SUNDAYS BY APPOINTMENT)

SPECIALIST IN 934 MHz

SUPPLIERS OF ALL 27MHz AND 934 MHz EQUIPMENT  
AMATEUR ACCESSORIES CATERED FOR  
08053 200

### QUARTZ CRYSTALS and FILTERS

Large numbers of standard frequencies in stock for amateur, CB, professional and industrial applications.

Stock crystals £5.00 each (inc VAT and UK post). Any frequency or type made to order from £6.50.

Phone or SAE for lists.

### GOLLEDGE ELECTRONICS

Merriott, Somerst TA16 5NS.  
Tel: (0460) 73718.

### ALAN HOOKER ELECTRONICS



42 Nethemall Road  
Doncaster



Tel: 0302 25690

Large stocks of electronic components

## ETESON ELECTRONICS



15B Lower Green,  
Poulton-le-Fyde, Blackpool  
Tel: (0253) 885107

Open 9.30am - 12.30, 1.30 - 5.30. Closed Wed & Sun.  
Electronic Component Specialists.

A wide range of electronic components, IC's, capacitors, transistors, resistors, plugs and sockets etc.

### USED AMATEUR EQUIPMENT?

I buy, sell and exchange

For the deal you've been looking for, phone Dave, G4TNY, anytime on Hornchurch (040 24) 57722 or (0836) 201530  
9am-7pm Mon-Sat or send SAE

G4TNY Amateur Radio

132 Albany Road, Hornchurch, Essex RM12 4AQ

### SMC/TMP ELECTRONICS



Unit 27 Pinfold Workshops  
Pinfold Lane,  
Buckley, Chord



Tel: 0244 548883

For all your amateur equipment and accessories. Open Tues, Wed, Fri 10am-5pm, Saturday 10am-4pm. Other days by appointment

# Amateur RADIO

This method of advertising is available in multiples of a single column centimetres — (minimum 2cms). Copy can be changed every month.

### RATES

per single column centimetre:

1 insertion £7.00, 3 — £6.60, 6 — £6.30, 12 — £5.60.

# SMALL ADS

## AMATEUR RADIO SMALL AD ORDER FORM

TO: Amateur Radio · Sovereign House  
Brentwood · Essex CM14 4SE · England · (0277) 219876

PLEASE RESERVE.....centimetres by.....columns

FOR A PERIOD OF 1 issue..... 3 issues..... 6 issues..... 12 issues.....

COPY enclosed..... to follow.....

PAYMENT ENCLOSED: (Add 15%VAT)....

£ —

Cheques should be made payable to Amateur Radio. Overseas payments by International Money Order and Credit Card

CHARGE TO MY ACCOUNT..... CREDIT CARD EXPIRY DATE  /

COMPANY .....

ADDRESS .....

SIGNATURE ..... TELEPHONE.....

C P I



**VALUABLE SPACE FOR SALE!**

Telephone the advertising department on: **0277 219876** for details

**JAPANESE IC's (PART OF OUR RANGE)**  
 AN7178 £2 95, BA5406 £2 20, HA1377 £2 20, HA1392 £2 50, HA1394 £2 95, HA1397 £2 75, HA1398 £2 75, HA13001 £2 95, LA4460 £1 80, LA4461 £1 80, LA4507 £4 25, LC7137 £4 50, M51517 £2 80, MB3705 £1 80, MB3712 £1 50, MB3722 £3 50, MB3730 £2 50, MB3731 £3 50, STK461 £7 50, STK463 £8 40, TA7205AP £1 00, TA7222AP £1 30, TA7240 £2 95, TA7241 £2 95, TA7270 £2 75, TA7271 £2 75, TA7274 £2 95, TA7280 £3 50, TA7281 £2 95, TA7282 £2 95, TA7283 £2 95, TA7288 £2 95, TA7611 £3 20, UPC575 £1 00, UPC1156 £2 95, UPC1181 £1 10, UPC1182 £1 10, UPC1185 £2 50, UPC1186 £2 75, UPC1230 £2 50, UPC1263 £2 50, UP1277 £2 75, UPC1278 £2 75, UPC1365 £3 60, UPC1394 £1 95.  
 ADD 60p POST AND PACKING AND THEN ADD 15% VAT TO TOTAL  
**T POWELL, 16 PADDINGTON GREEN LONDON W2 1LG**  
 OPEN MON-FRI 10AM-5PM, SAT 9AM-12 NOON.  
 TELEPHONE: 01 723 9246  
 ACCESS/VISA. TELEPHONE ORDERS ACCEPTED OVER £5.00

★ **PSSS....** ★

**ALL THE SUPER BARGAINS ARE ON THE INSIDE-FRONT COVER OF THIS MAGAZINE!!**

★ ★

**MRZ COMMUNICATIONS LTD**  
**NEWCASTLE UNDER LYME**  
**DESK DC SUPPLY AND BASE FOR ICOM PORTABLES**  
**ICOM-BUSINESS/AMATEUR/MARINE/AIR**

**YAESU - AMATEUR UK AND EXPORT**

**ICOM**

**TEL: (0782) 619658**  
**7 DAY SERVICE**

**Selectronic**

The UK's leading suppliers of 934MHz personal radio equipment

**203 High Street**  
**Canvey Island, Essex,**  
**Tel: 0268 691481**  
 (Open Mon-Sat 9-5.30)

Amateur radio equipment also in stock

**Booth Holdings Bath**

**GOLF CLUBLANE SALT FORD BRISTOL**  
**Tel: 02217 2402**  
 Open Tues-Sat 9am-9pm  
 Closed Monday  
**SEE YOU ALL AT LONGLEAT**

**PROFESSIONAL GRADE VHF-FM BROADCAST EQUIPMENT**

The Galaxy range offers superb specifications at an economic price. We offer a special range of high quality transmitters, power amplifiers, stereo encoders, UHF repeater links, compressors, antennas. Powers 10w to 1kw. Built to high specifications at an economic price. Meets IBA & Full Broadcast specifications.

Phone now for prices and delivery:  
**Cyberscan International**  
**3 Eastcote View, Pinner, Middx HA5 1AT. Tel: 01-866 3300**

**NORTH WALES AMATEUR RADIO MART**

AMATEUR RADIO - CB RADIO - MARINE RADIO - PMR

**25 ABBEY STREET RHYL**

Open Monday-Saturday: 11am-5.30pm  
 All repairs and accessories available ex stock. Mail Order welcome

**Tel: 0745-51579**

**Thought Factory**

**Turn your photographs into Q.S.L cards.**

**From only £44**  
 From ordinary snapshots or professional photographs.

<b>£44</b> for 250	<b>£69</b> for 1,000
<b>£55</b> for 500	<b>£98</b> for 2,000

Prices are PLUS V A T  
 Please send **1st. class stamp** for **FREE Promotional Pack,**  
 Colour Brochure, Samples & Price List

Thought Factory,  
 40-42 Hastings Rd Ind Development,  
 Leicester LE5 0HL  
 (Dept AR)

**Thought Factory**

**TEST EQUIPMENT**

HP 864f0B .5-512mhz ..... **£3,550**  
 HP 1720 scope 200mhz ..... **£750**  
 HP 1725A scope 275mhz ..... **£1,975**  
 Marconi Counter 2437 ..... **£350**  
 Solartron RMS voltmeter ..... **£125**  
 Multi-meter PSM37 ..... **£85**  
 HP 3437A system voltmeter ..... **£1,500**  
 HP 3438A digital Multi-meter ..... **£850**  
 Fluke 8800A digital Multi-meter ..... **£120**  
 Marconi Apollo HF receiver **£450**  
 Video system portable Sony camera HVC 4000P with JVC VHS/C compact recorder/player ..... **£500**  
 Airlight 62 headset & boom mic ..... **£45**  
 Bone Dome Mk 3C, new ..... **(POA)**  
 770U receiver ..... **£165**

**Telephone: 0472 690383**

**2 METRE COLLINEAR UVRAL X2<sup>5</sup>/8over 5/8**

An omni directional antenna giving low angle radiation. The ideal base station vertical. Ruggedly constructed for long life

**Technical Specification**

Gain	- 6 dB
Impedance	- 50 Ohms
Max Power	- 100 Watts
Length	- 3.14 metres
SWR 144 to 146Mhz	- Less than 1.5
Wind Loading	- 4.6 Kgf at 100mph
Weight	- 1.2 Kgs
Mounting Diameter	- 25mm
Termination	- Free 'N' Socket

N Plug extra, costs **£3.93**

Send cheque or postal order for **£29.95** plus **£2.60** postage to:

**BUCKLEYS (UVRAL) LTD**  
 Beta Works, Range Road  
 Hythe, Kent CT21 6HG  
 Tel: (0303) 60127/60128  
 Various Frequencies Available

**NEXT ISSUE OF**

**Amateur RADIO**

**On Sale Thursday 30th June**

DISPLAY AD RATES		series rates for consecutive insertions			
depth mm x width mm	ad space	1 issue	3 issues	6 issues	12 issues
61 x 90	1/8 page	£66.00	£62.00	£59.00	£53.00
128 x 90 or 61 x 186	1/4 page	£115.00	£110.00	£105.00	£92.00
128 x 186 or 263 x 90	1/2 page	£225.00	£210.00	£200.00	£180.00
263 x 186	1 page	£430.00	£405.00	£385.00	£345.00
263 x 394	double page	£830.00	£780.00	£740.00	£660.00

COLOUR AD RATES		series rates for consecutive insertions			
depth mm x width mm	ad space	1 issue	3 issues	6 issues	12 issues
128 x 186 or 263 x 90	1/2 page	£305.00	£290.00	£275.00	£245.00
263 x 186	1 page	£590.00	£550.00	£530.00	£470.00
263 x 394	double page	£1,130.00	£1,070.00	£1,010.00	£900.00

SPECIAL POSITIONS	Covers:	Outside back cover 20% extra, inside covers 10% extra
	Bleed:	10% extra [Bleed area = 307 x 220]
	Facing Matter:	15% extra

DEADLINES		*Dates affected by public holidays			
issue	colour & mono proof ad	mono no proof & small ad	mono artwork	on sale there	
Aug 88	30 Jun 88	6 Jul 88	8 Jul 88	28 Jul 88	
Sep 88	28 Jul 88	3 Aug 88	5 Aug 88	25 Aug 88	
Oct 88	1 Sep 88	7 Sep 88	9 Sep 88	29 Sep 88	
Nov 88	29 Sep 88	5 Oct 88	7 Oct 88	27 Oct 88	

CONDITIONS & INFORMATION	
<p><b>SERIES RATES</b> Series rates also apply when larger or additional space to that initially booked is taken. An ad of at least the minimum space must appear in consecutive issues to qualify for series rates. Previous copy will automatically be repeated if no further copy is received. A 'hold ad' is acceptable for maintaining your series rate contract. This will automatically be inserted if no further copy is received. Display Ad and Small Ad series rate contracts are not interchangeable.</p>	<p>If series rate contract is cancelled, the advertiser will be liable to pay the unearned series discount already taken.</p> <p><b>COPY</b> Except for County Guides copy may be changed monthly. No additional charges for typesetting or illustrations (except for colour separations). For illustrations just send photograph or artwork. Colour Ad rates do not include the cost of separations. Printed - web offset.</p>
<p><b>PAYMENT</b> Above rates exclude VAT All single insertion ads are accepted on a pre-payment basis only, unless an account is held. Accounts will be opened for series rate advertisers subject to satisfactory credit references. Accounts are strictly net and must be settled by the publication date. Overseas payments by International Money Order or credit card.</p> <p><b>FOR FURTHER INFORMATION CONTACT</b> Amateur Radio, Sovereign House, Brentwood, Essex CM14 4SE. (0277) 219876</p>	<p>Commission to approved advertising agencies is 10%.</p> <p><b>CONDITIONS</b> 10% discount if advertising in both Amateur Radio and Radio &amp; Electronics World. A voucher copy will be sent to Display and Colour advertisers only. Ads accepted subject to our standard conditions, available on request.</p>

## AMATEUR RADIO BACK ISSUES SERVICE

**TO:** Back Issues Department • Amateur Radio  
• Sovereign House • Brentwood • Essex • CM14 4SE

NAME .....

ADDRESS .....

.....

.....

POSTCODE .....

---

**PLEASE SUPPLY:** (state month and year of issue/s required) **NOTE:**  
Only issues from August 1986 are available

..... at £1.45 each

**PAYMENT ENCLOSED:** £ -

Cheques should be made payable to **Amateur Radio** Overseas payment by International Money Order or credit card

**CREDIT CARD PAYMENT:**    EXPIRY DATE

..... / .....

SIGNATURE .....

.....

.....

## ADVERTISERS INDEX

J Bull.....	59
SRW Communications.....	52
P M Components .....	4,5
Computer Appreciation .....	35
ICS Electronics .....	43
R N Electronics .....	45
G C H Q .....	45
C M Howes .....	52
ICOM .....	30,31
ICS International .....	51
Johnsons Shortwave.....	49
G4ZPY Paddley Keys.....	51
Siskin Electronics .....	35
Technical Software .....	43
Telecomms.....	16
Universal Semi-Conductors.....	52
Waters and Staton .....	60
R Withers .....	2



## POPULAR BAKERS DOZEN PACKS (still available)

All packs are £1 each, if you order 12 then you are entitled to another free. Please state which one you want. Note the figure on the extreme left of the pack ref number and the next figure is the quantity of items in the pack, finally a short description.

- BD1 5 13A junction boxes for adding extra points to your ring main circuit.
  - BD2 5 13A spurs provide a fused outlet to a ring main where devices such as a clock must not be switched off.
  - BD7 4 In flex switches with neon on/off lights, saves leaving things switched on.
  - BD9 2 6V 1A mains transformers upright mounting with fixed clamps.
  - BD11 1 6 1/2in speaker cabinet ideal for extensions, takes our speaker. Ref BD137.
  - BD13 12 30 watt reed switches, it's surprising what you can make with these—burglar alarms, secret switches, relay, etc., etc.
  - BD22 2 25 watt loudspeaker two unit crossovers.
  - BD29 1 B.D.A.C. stereo unit is wonderful value.
  - BD30 2 Nicad constant current chargers adapt to charge almost any nicad battery.
  - BD32 2 Humidity switches, as the air becomes damper the membrane stretches and operates a microswitch.
  - BD34 48 2 meter length of connecting wire all colour coded.
  - BD42 5 13A rocker switch three tags so on/off, or change over with centre off.
  - BD45 1 24hr time switch, ex-Electricity Board, automatically adjust for lengthening and shortening day, original cost £40 each.
  - BD49 10 Neon valves, with series resistor, these make good night lights.
  - BD56 1 Mini uniselector, one use is for an electric jigsaw puzzle, we give circuit diagram for this. One pulse into motor, moves switch through one pole.
  - BD59 2 Flat solenoids—you could make your multi-tester read AC amps with this.
  - BD67 1 Suck or blow operated pressure switch, or it can be operated by any low pressure variation such as water level in water tanks.
  - BD91 2 Mains operated motors with gearbox. Final speed 16 rpm, 2 watt rated.
  - BD103A 1 6V 750mA power supply, nicely cased with mains input and 6V output leads.
  - BD120 2 Stripper boards, each contains a 400V 2A bridge rectifier and 14 other diodes and rectifiers as well as dozens of condensers, etc.
  - BD122 10m Twin screened flex with white pvc cover.
  - BD128 10 Very fine drills for pcb boards etc. Normal cost about 80p each.
  - BD132 2 Plastic boxes approx 3in cube with square hole through top so ideal for interrupted beam switch.
  - BD134 10 Motors for model aeroplanes, spin to start so needs no switch.
  - BD139 6 Microphone inserts—magnetic 400 ohm also act as speakers.
  - BD148 4 Reed relay kits, you get 16 reed switches and 4 coil sets with notes on making c/o relays and other gadgets.
  - BD149 6 Safety cover for 13A sockets—prevent those inquisitive little fingers getting nasty shocks.
  - BD180 6 Neon indicators in panel mounting holders with lens.
  - BD193 6 5 amp 3 pin flush mounting sockets make a low cost disco panel.
  - BD196 1 In flex simmerstat—keeps your soldering iron etc. always at the ready.
  - BD199 1 Mains solenoid, very powerful, has 1in pull or could push if modified.
  - BD200 8 Keyboard switches—made for computers but have many other applications.
  - BD210 4 Transistors type 2N3055, probably the most useful power transistor.
  - BD211 1 Electric clock, mains operated, put this in a box and you need never be late.
  - BD221 5 12V alarms, make a noise about as loud as a car horn. Slightly soiled but OK.
  - BD242 2 6in x 4in speakers, 4 ohm made from Radiomobile so very good quality.
  - BD246 2 Tacho generators, generate one volt per 100 revs.
  - BD252 1 Panostat, controls output of boiling ring from simmer up boil.
  - BD259 50 Leads with push-on 1/4in tags—a must for hook-ups—mains connections etc.
  - BD263 2 Oblong push switches for bell or chimes, these can mains up to 5 amps so could be foot switch if fitted into pattress.
  - BD268 1 Mini 1 watt amp for record player. Will also change speed of record player motor.
  - BD275 1 Guitar mic—clip-on type suits most amps.
  - BD283 3 Mild steel boxes approx 3in x 3in x 1in deep—standard electrical.
  - BD293 50 Mixed silicon diodes.
  - BD296 3 Car plugs with lead, fit into lighter socket.
  - BD305 1 Tubular dynamic mic with optional table rest.
- Most other packs still available and you can choose any as your free one.

## 5A BATTERY CHARGER KIT

All parts, including case, Only £5 plus £1 postage

## OVER 400 GIFTS YOU CAN CHOOSE FROM

There is a total of over 400 packs in our Baker's Dozen range and you become entitled to a free gift with each dozen packs.

A classified list of these packs and our latest "News Letter" will be enclosed with your goods, and you will automatically receive our next news letter.



## THIS MONTH'S SNIP

3 1/2in Floppy Disc Drive, made by the Chinton Company of Japan. Beautifully made and probably the most compact device of its kind as it weighs only 600g and measures only 104mm wide, 162mm deep and has a height of only 32mm. Other features are high precision head positioning—single push loading and eject—direct drive brushless motor—Shugart compatible interface—standard connections—interchangeable with most other 3 1/2 and 5 1/4 drives. Brand new with copy of maker's manual. Offered this month at £28.50 post and VAT included.

**CASE**—adaptable for 3" or 3 1/2" FDD, has room for power supply components. Price only £4 includes circuit of PSU. Our Ref 4P8

**POWER SUPPLY FOR FDD**—5V and 12V voltage regulated outputs, complete kit of parts will fit into case 4P8 price £8 or with case £11.

### MULLARD UNILEX AMPLIFIERS

We are probably the only firm in the country with these now in stock. Although only four watts per channel, these give superb reproduction. We now offer the 4 Mullard models—i.e. Mains power unit (EP9002) Pre-amp module (EP9001) and two amplifier modules (EP9000) all for £6.00 plus £2 postage. For prices of modules bought separately see TWO POUNDERS.

### 25A ELECTRICAL PROGRAMMER

Learn in your sleep. Have radio playing and kettle boiling as you wake—switch on lights to warn off intruders—have a warm house to come home to. You can do all these and more. By a famous maker with 25 amp on/off switch. A beautiful unit at £2.50.

### MINI MONO AMP

on p.c.b. size 4" x 2" (app.) Fitted volume control and a hole for a tone control should you require it. The amplifier has three transistors and we estimate the output to be 3W rms. More technical data will be included with the amp. Brand new, perfect condition, offered at the very low price of £1.15 each, or £13 for 12.

### LIGHT BOX

This when completed measures approximately 15" x 14". The light source is the Philips fluorescent 'W' tube. Above the light a sheet of fibreglass and through this should be sufficient light to enable you to follow the circuit on fibreglass PCBs. Price for the complete kit, that is the box, choke, starter, tube and switch, and fibreglass is £5 plus £2 post. Order ref. 5P69.



Ex-Electricity Board Guaranteed 12 months.

### FANS & BLOWERS

4" x 4" Muffin equipment cooling fan 115V £2.00  
4" x 4" Muffin equipment cooling fan 230/240V £5.00  
9" Extractor or blower 115V supplied with 230 to 115V adaptor £9.50+£2 post.  
All above are ex-computers but guaranteed for 12 months.  
10" x 3" Tangential blower. New, very quiet—supplied with 230 to 115V adaptor to use in two series to give long blow £2.00+£1.50 post or £4.00+£2.00 post for two.

### 9" MONITOR

Ideal to work with computer or video camera uses Philips black and white tube ref M24/306W. Which tube is implosion and X-ray radiation protected. VDU is brand new and has a time base and EHT circuitry. Requires only a 16V dc supply to set it going. It's made up in a lacquered metal framework but has open sides so should be cased. The VDU comes complete with circuit diagram and has been line tested and has our six months guarantee. Offered at a lot less than some firms are asking for the tube alone, only £16 plus £5 post.

### 12 volt MOTOR BY SMITHS

Made for use in cars, etc. these are very powerful and easily reversible. Size 3 1/2" long by 3" dia. They have a good length of 1/4" spindle. 1/10hp £3.45  
1/8hp £5.75 1/6hp £7.50

### TELEPHONE LEAD

3 mtrs long terminating one end with new BT flat plug and the other end with 4 correctly colour coded wires to fit to phone or appliance. Replaces the lead on old phone making it suitable for new BT socket. Price £1 ref. BD552 or 3 for £2 ref. 2P154

### COMPACT FLOPPY DISC DRIVE EME-101

The EME-101 drives a 3" disc of the new standard which despite its small size provides a capacity of 500k per disc, which is equivalent to the 3 1/2" and 5 1/4" discs. We supply the Operators Manual and other information showing how to use this with popular computers: BBC, Spectrum, Amstrad etc. All at a special snip price of £27.50 including post and VAT. Data available separately £2, refundable if you purchase the drive

### POWERFUL IONISER

Generates approx. 10 times more IONS than the ETI and similar circuits. Will refresh your home, office, workroom etc. Makes you feel better and work harder—a complete mains operated kit, case included. £11.50+£3 P&P

## J & N BULL ELECTRICAL

Dept AR, 250 PORTLAND ROAD, HOVE BRIGHTON, SUSSEX BN3 5QT

MAIL ORDER TERMS: Cash, PO or cheque with order. Orders under £20 add £1 service charge. Monthly account orders accepted from schools and public companies. Access and B/card orders accepted. Brighton (0273) 734648 or 702500

## NEW ITEMS

Some of the many items described in our current list which you will receive with your parcel

**13A PLUGS** Good British make complete with fuse, parcel of 5 for £2. Order ref. 2P155.

**13A ADAPTERS** Takes 2 13A plugs, good British make, packet of 5 for £2. Order ref. 2P187.

**20V 4-20V Mains transformers** 2 1/2 amp (100 watt) loading, tapped primary, 200-245 upright mountings 4. Order ref. 4P24.

**BENCH ISOLATION TRANSFORMERS** 250 watt 230V in and out with plenty of tappings to give exact volts. £5 plus £2. Order ref. 5P5.

**POWERFUL 12V MOTOR**—was intended for Sinclair car, rating approx 1/2hp. Price £15. Ref. 15P8.

**BURGLAR ALARM BELL**—6" gong OK for outside use if protected from rain. Mains or 12V battery operated, state which required. Price £8. Ref. 8P2.

**24 HR TIME SWITCH**—16A changeover contacts, up to 6 on/offs per day. Nicely cased, intended for wall mounting. Price £8. Ref. 8P6.

**CAPACITOR BARGAIN**—axial ended, 4700µF at 25V. Jap made, normally 50p each, you get 4 for £1. Our ref. 613.

**AGAIN AVAILABLE**—12" mini fluorescent tubes. Price £1 each. Ref. BD314.

**POWER PACK OR AMPLIFIER CASE**—Size approx 10" x 8 1/4" x 4 3/4" plated steel—with ample perforations for cooling. Front panel has on/off switch and EEC mains inlet plug with built-in RF filter—undoubtedly a very fine case which would cost at least £50 from regular sources. Our price is £5 each and £2 post. Ref. 5P111.

**MINIATURE BCD THUMB WHEEL SWITCH**—Matt black edge switch engraved white on black gold plated, make before break contacts. Size approx 25mm high, 8mm wide, 20mm deep, made by the famous Cherry Company and designed for easy stacking. Price £1 each. Ref. BD601.

**EDGE METER**—Miniature, whole size approx 37mm x 13mm 100µs f.s.d, centre zero scaled 0 to -10 and 0 to +10. Price £1 each. Ref. BD602.

**CLEANING FLUID**—Extra good quality—intended for video and tape heads. Regular price £1.50 per spray can. Our price 2 cans for £1. Ref. BD604.

**PIEZO ELECTRIC FAN**—An unusual fan, more like the one used by Madame Butterfly than the conventional type, it does not rotate. The air movement is caused by two vibrating arms. It is American made, mains operated, very economical and causes no interference, so is ideal for computer and instrument cooling. Price is only £1 each. Ref. BD605.

**SPRING LOADED TEST PRODS** Heavy duty, made by the famous Bulgur car spring very good quality. Price 4 for £1. Ref. BD599.

**TELEPHONE BELLS**—These will work off our standard mains through a transformer, but to sound exactly like a telephone, they then must be fed with 25Hz 50V. So with these bells we give a circuit for a suitable power supply. Price 2 bells for £1. Ref. BD600.

**ULTRA SENSITIVE POCKET MULTIMETER**—4k ohms per volt—11 ranges—carry one of these and so be always ready to test ac/dc volts to 1000 DC millamps and have an ohms range for circuit testing. Will earn its cost in no time. Price only £7. Ref. 7P2.

**BLOW YOUR ROOF OFF!**—40 watt speaker systems—new type you must not hide! They have golden cones and golden surrounds and look really "bootful". 12" woofer, Midrange and tweeter and comes with a crossover at a special introductory price of £49 carriage paid. Two sets for £95 carriage paid. 140w Woofer only £35 carriage paid.

**ASTEC P.S.U.**—Switch mode type. Input set for +230V. Output 3.5 amps at +5V, 1.5 amps at +12V, and 3 amps at +5V. Should be OK for floppy disc drives. Regular price £30. Our price only £10. Ref. 10134. Brand new and unused.

**APPLIANCE THERMOSTATS**—Spindle adjust type suitable for convector heaters or similar. Price 2 for £1. Ref. BD582.

**COMPOSITE VIDEO INPUT UNIT**—For our 9" monitor with notes on suppression of fly back lines and improving "hold" makes our monitor ideal for use with any computer or camera. Kit contains p.c.b. and all components. Price £4. Ref. 4P23.

**3-CORE FLEX BARGAIN No. 1**—Core size 5mm so ideal for long extension leads carrying up to 5 amps or short leads up to 10 amps. 15mm for £2. Ref. 2P189.

**3-CORE FLEX BARGAIN No. 2**—Core size 1.25mm so suitable for long extension leads carrying up to 13 amps, or short leads up to 25A. 10m for £2. Ref. 2P190.

**NOVEL NIGHT LIGHT**—Plugs into a 13A socket. Gives out a surprising amount of light, certainly enough to navigate along passages at night or to keep a nervous child happy, very low consumption, probably not enough to move the meter. Price £1. Ref. BD563.

**CASE WITH 13A PRONGS**—To go into 13A socket, nice size and suitable for plenty of projects such as battery trickle charger, speed controller, time switch, night light, noise suppressor, dimmers etc. Price—2 for £1. Ref. BD565.

**SPEAKER EXTENSION CABLE**—Twin 0.7mm conductors so you can have long runs with minimum sound loss and for telephone extensions or burglar alarms, bells, intercoms etc. 250m coil only £3 plus £1 post. Ref. 3P28.

**ALPHA-NUMERIC KEYBOARD**—This keyboard has 73 keys with contactless capacitance switches giving trouble free life and no contact bounce. The keys are arranged in two groups, the main area field is a QWERTY array and on the right is a 15 key number pad, board size is approx. 13" x 4"—brand new but offered at only a fraction of its cost, namely £3, plus £1 post. Ref. 3P27.

**TELEPHONE EXTENSIONS**—It is now legal for you to undertake the wiring of telephone extensions. For this we can supply 4-core telephone cable, 100m coil £8.50. Extension BT sockets £2.95. Packet of 50 plastic headed staples £2. Dual adaptor for taking two appliances from one socket £3.95. Leads with BT plug for changing old phones, 3 for £2.

**MODULAR SWITCH**—Panel mounting highest quality and ideal where extra special front panel appearance is required, can be illuminated if required (d.p.d. and latching. Price 2 for £1. Ref. BD607).

**WIRE BARGAIN**—500 metres 0.7mm solid copper tinned and p.v.c. covered. Only £3 plus £1 post. Ref. 3P31—that's well under 1p per metre, and this wire is ideal for push on connections.

**INTERRUPTED BEAM KIT**—This kit enables you to make a switch that will trigger when a steady beam of infra-red or ordinary light is broken. Main components—relay, photo transistor, resistors and caps, etc. Circuit diagram but no case. Price £2. Ref. 2P15.

**3-30V VARIABLE VOLTAGE POWER SUPPLY UNIT**—with 1 amp DC output. Intended for use on the bench for experimenters, students, inventors, service engineers etc. This is probably the most important piece of equipment you can own (after a multi range test meter). It gives a variable output from 3-30 volts and has an automatic short circuit and overload protection, which operates at 1.1 amp approximately. Other features are very low ripple output, a typical ripple is 3mV pk-pk, 1mV rms. Mounted in a metal fronted plastic case, this has a voltmeter on the front panel in addition to the output control knob and the output terminals. Price for complete kit with full instructions is £15. Ref. 15P7.

**TRANSMITTER SURVEILLANCE (BUG)**—Tiny, easily hidden, but which will enable conversation to be picked up with FM radio. Can be housed in a matchbox, all electronic parts and circuit. Price £2. Ref. 2P52.

- ★ 2m/70cm
- ★ 25 Watts output
- ★ Full duplex operation
- ★ 21 Memories
- ★ 2 Call channels
- ★ Priority channel
- ★ Dual VFO's
- ★ 12.5 & 25kHz steps
- ★ Memory Scan
- ★ Programme Scan
- ★ Memory Skip

**£449 inc vat**

**ALD-24E**

## ALINCO DUAL BANDER



This transceiver could transform your operating habits! It contains completely separate 2m and 70cms transceivers, permitting full duplex operation. To the un-initiated, this means you can transmit on 2m whilst receiving on 70cms, or vice versa. The built-in duplexer means a single antenna socket with a full 25 watts output on both bands. Measuring only 5.5"x2"x6.5" it is the ideal mobile rig. Its comprehensive memory and scanning facilities provide rapid access to both

simplex and repeater channels on 2m & 70cms. Using the dual VFO's you can instantly switch between 2m & 70cm and the single knob tuning provides simple and quick frequency selection. The large LCD readout incorporates an S-meter and is back lighted. If you are looking for a completely self contained 2m & 70cm station, then look no further. At this price it has to be a bargain. For further details of this amazing transceiver, send today for the full colour brochure.

## OUR FAMOUS FREQUENCY MANUALS!

### UK LISTENERS CONFIDENTIAL FREQUENCY LIST 5th EDITION

This publication has now sold well over 3500 copies since it was advertised only a few months ago. Now the recent updated version is selling even better. No self respecting listener should be without a copy. If you enjoy exploring the short wave bands then this publication will add to your enjoyment. It covers the hf spectrum from 2 to 30 MHz and gives details of transmissions outside the amateur bands. Specially designed for the UK and European listener it sets out in a very easy way a comprehensive list of hundreds of interesting transmissions that will keep you occupied for days on end! Only a fraction of the cost of other similar publications it contains details of Marine, Air, Military, Embassy, Press and News agencies. Many listings have time schedules included together with comprehensive RTTY details. It tells you the frequencies used by civil and military aircraft whilst flying the Atlantic, when and where to pick up the press bulletins, long distance marine traffic etc and much more. Send today for your copy of this worthwhile publication.

**NEW 1988 EDITION £6.95 p&p 90p**

### 4th EDITION VHF-UHF AIRBAND FREQUENCY LIST

This frequency manual is without doubt the most comprehensive list of VHF/UHF aircraft listings available in the UK. Of vital importance to the airband enthusiast or indeed any keen VHF/UHF listener it sets out in a very easy to follow manner full details of a whole host of stations. Every known UK airfield frequencies, etc. Included are Civil, RAF, USAF, MOD, Naval fields on both VHF and UHF bands. There are also air to air frequencies, the Red Arrows frequency, and much more. Send today for your copy and find out just how much you have been missing!

**£5.95 p&p 90p**

### THE COMPLETE UHF-VHF FREQUENCY GUIDE 26-2000 mHz

**New 1988 Edition.** Many listeners have asked for a guide to the wide VHF/UHF spectrum and to meet this request we have recently published this frequency manual. It covers the range 26 to 2000 mHz and has been specially prepared for the UK listener. Anybody who has used a scanning receiver will know that the wide frequency range involved means that it is difficult to know exactly where to listen. This guide takes all the guessing out of monitoring. It lists all the services throughout the spectrum together with both simplex and duplex frequency splits. If you've spent your hard earned money on a scanning receiver or are considering buying one you'll find that this publication contains a wealth of information that has previously remained un-published!

**£5.95 p&p 75p**

### HF OCEANIC AIRBAND COMMUNICATIONS 1988 EDITION.

Prepared in response to many requests for more information about the air traffic on the hf bands this little guide sets out to explain to the beginner how the hf band works in relation to air traffic. It contains full details of the world aircraft frequency bands in the range 2 to 23 MHz together with control frequencies and those commonly used for Oceanic control. Also included are many VOLMET frequencies, the Search and Rescue frequencies used by RAF helicopters and Nimrods, the HF RT network, London Company frequencies, European control centres etc. An ideal companion for the hf airband listener. Send today for your copy.

**£3.50 p&p 70p**

**WATERS  
& STANTON  
ELECTRONICS**

18-20 MAIN ROAD, HOCKLEY, ESSEX - 12 NORTH STREET, HORNCURCH, ESSEX.  
MAIL ORDER TO: 18-20 MAIN ROAD, HOCKLEY, ESSEX TEL: (0702) 206835

