

# Amateur RADIO

For all two-way radio enthusiasts

The history  
of the superhet

10m conversions  
– Cobra update

TVI and all that

On test: Icom IC12E 23cm  
FM hand-held transceiver



ICOM IC28E REVIEWED

# R. WITHERS COMMUNICATIONS LTD

Manufacturers, importers and suppliers of world famous communications products  
 584 HAGLEY ROAD WEST OLDBURY, WARLEY, BIRMINGHAM B68 0BS  
 021-421 8201/2/3. CELLNET 0860 323056. PRESTEL MBX 214218216 FAX 0215614074



Amateur Radio. Business Radio. Radio Telephones. Sales. Service Accessories and antenna systems.



YAESU



THE TECHNICALLY ORIENTATED  
 RADIO COMMUNICATIONS  
 SPECIALISTS.

## RWC AUTUMN SALE

This is our first ever Shop Sale in over Five years trading in the Amateur Radio Field (about time too!) All stock offered is new and has full warranty. Some units are Ex-Demonstration and may have slightly marked Boxes. We need to clear some stock to make way for our new range of scanning receivers and other products. Pssss, Keep in touch for latest news.

**Important Note** Due to current exchange rates the price of all imported equipment is subject to change, and rarely do prices come down (you noticed!) we anticipate a price increase on ICOM, YAESU and KENWOOD/TRIO of between 5-20% imminently. This added to copy dates of between 1 and 3 months before the magazines appear on sale means that you normally have up to a three month old price list! we hold our prices on existing stocks and usually get **NO WARNING** from our suppliers when prices go up. Consequently we often have to make a sale at the OLD PRICE or lose a good customer. Well, if you want a Bargain here are some offers you cannot refuse, **DONT SAY WE DIDN'T WARN YOU, we will never again be able to make you the following offers!**

Sorry Bernie and Brenda, Harvey and Peter, we are having a SALE!  
 (prior to opening our Fast food Take-away maybe!)

All goods are offered on a first-come first-served basis. Please check stock levels before ordering.  
**Please add post and packing of £5.00 minimum on transceivers and £2.50 on accessories. Datapost/Next day delivery extra. Please telephone for more details. PART EXCHANGE WELCOME, FULL CREDIT FACILITIES ARRANGED AND INTEREST FREE FINANCE ON SELECTED ITEMS. (SUBJECT TO STATUS)**

### ONLY LIMITED STOCKS AVAILABLE

#### ICOM

IC271H 100W MULTIMODE BASE STATION  
 IC3200E 25W DUAL BAND MOBILE  
 IC28E NEW 25W 138-174 MOBILE  
 IC745E 100W HF TRANSCEIVER

#### CURRENT RETAIL

£1,029.00  
 £556.00  
 £359.00  
 £989.00

#### RWC SALE PRICE

£799.00  
 £499.00  
 £325.00  
 £799.00

#### TRIO/KENWOOD

TS711E 25W 2MTR BASE STATION  
 TR9130 25W 2MTR MOBILE  
 TM411A/E 25W UHF DCS MOBILE

£770.00  
 £544.73  
 £466.00

£699.00  
 £519.00  
 £349.00

#### YAESU MUSEN

FT290R 2.5W 2MTR M/MODE (inc Nicads)  
 FT690R 2.5W 6MTR MULTIMODE  
 FT790R 1W UHF MULTIMODE  
 FT2700RH 25W DUAL BAND FM MOBILE  
 FT270RH 45W FM MOBILE  
 FT726/2MTR MULTIMODE BAS STATION

£369.00  
 £399.00  
 £469.00  
 £399.00  
 £399.00  
 £869.00

£349.00  
 £299.00  
 £399.00  
 £369.00  
 £339.00  
 £825.00

#### BARGAIN BASEMENT

DNT M40FM modified 10FM 6W TRX  
 DNT M40FM as above with RPT. SHIFT  
 DNT M40FM CB/27/81 4W unmodified  
 RAYCOM 7000 VSWR METER 1.6-160MHz  
 G-COMM REGULATED PSU 3-5A AC240V  
 G-COMM REGULATED PSU 5-7A AC240V  
 WODEN UNIVERSAL NICAD CHARGER

£49.50  
 £59.50  
 £39.00  
 £19.50  
 £19.60  
 £29.50  
 £8.99

£45.00  
 £55.00  
 £30.00  
 £12.50  
 £17.50  
 £25.00  
 £3.75

**MANY OTHER ODDMENTS AVAILABLE IN SMALL QUANTITIES,  
 PLEASE CALL INTO OUR HAGLEY ROAD BRANCH AND HAVE A LOOK**

We are only one minute away along the A456 from junction 3.M5 towards Birmingham, first shop on the left next to the Texaco Station. Full demonstration facilities, all major brands in stock + the latest scanning receivers and antennas. We have something of interest for everybody! SWLs licenced amateurs, all radio enthusiasts and even plumbers!

Morning and afternoon tea and coffee served in mugs!

Please send £1.00 for our latest Raycom Catalogue which has all current prices and information of major brands and our own products (refundable) or send a large SAE for our FREE famous Bi-Weekly used list and any other information or colour leaflets (which are available for major products).

**RWC for the latest in RADIO TECHNOLOGY**

Tel: 021 421 8201 (24hr answerphone)

Telex: 334303 G TXAGWM



# Amateur RADIO



**Editor:**  
Anita Ley  
**Assistant Editor:**  
Jane Berry  
**Advertisement  
Manager:**  
Marian Vidler  
**Subscriptions:**  
01-760 0409  
**Accounts:**  
Clare Brinkman  
**Publisher:**  
Peter Williams  
**On sale:** Last  
Thursday of the  
month preceding  
cover date  
**Next issue:** Cover  
date November 1986  
on sale 30 October  
1986  
**Published by:**  
Amateur Radio  
Magazines,  
Sovereign House,  
Brentwood, Essex  
CM14 4SE, England  
(0277) 219876  
**Printed:** In England  
**ISSN:** 0264-2557  
**News Trade Sales by:**  
Argus Press Sales &  
Distribution Ltd, 12-18  
Paul Street, London  
EC2A 4JS.  
01-247 8233

**Front cover:** Icom ICI2E (p21)  
Photo by Jay Moss-Powell  
G6XIB

Whilst every care is taken when accepting advertisements we cannot accept responsibility for unsatisfactory transactions. We will, however, thoroughly investigate any complaints. The views expressed by contributors are not necessarily those of the publishers. Every care is also taken to ensure that the contents of *Amateur Radio* are accurate, we assume no responsibility for any effect from errors or omissions.

© Copyright 1986  
Amateur Radio Magazines

## 6 Straight and Level

All the latest news, comment and developments on the amateur radio scene

## 16 DX Diary

Don Field G3XTT with this month's DX news

## 18 The History of the Superhet

The development of the superhet took many years to come together. Ian Poole explains the origins of the idea

## 21 Angus McKenzie Tests

This month G3OSS reviews the new Icom IC28E 2m mobile, the Icom ICI2E 23cm hand-held and a useful little SWR/power meter from Diawa

## 28 SWL

Trevor Morgan GW4OXB tries to define DX and congratulates a few more successful applicants for the Prefix Awards

## 30 TVI and all that

... insult the family name, despoil a father's daughter, but never stop people from watching television!

## 34 CB Conversions – Cobra Update

If you thought Roger Alban's series Cobra conversions left a few questions unanswered, you may well find the solutions here

## 40 The KW204 revisited

Ian Poole G3YWX takes a nostalgic look at the last transmitter to emerge from the KW stable

## 43 Invisible and Disguised Antennas

A few ideas on how to hide an aerial from the noisiest of neighbours

## 46 Visiting ARRL HQ

Jim Smith VK9NS popped in to view the mechanics of amateur radio administration in America

## 48 On the Beam

Glen Ross G8MWR with all the latest news from VHF, UHF and microwaves

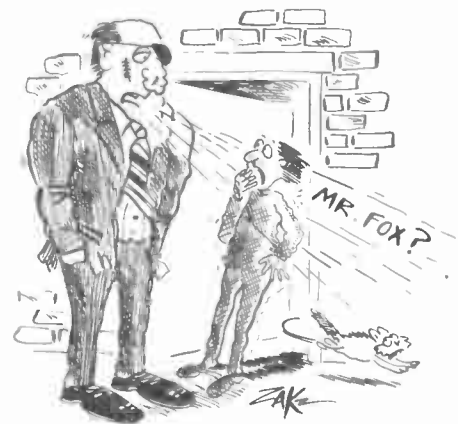

## 49 Coming Next Month

What's in store for you

## 50 Secondhand

Hugh Allison G3XSE never runs out of ideas when he's suffering from an itchy soldering iron. This month he raided an aircraft rally!

## 53 Free Classified Ads

The market for buying and selling

## SERVICES

39 Newsagents order form

42 Radio and Electronics World  
subscription order form

51 Subscription order form

58 Advertisers Index

58 Advertising rates and information

We regret to inform readers that due to constantly rising production costs, and to enable us to maintain the high standard of content in *Amateur Radio*, the price of the magazine will be £1.35 from this issue.



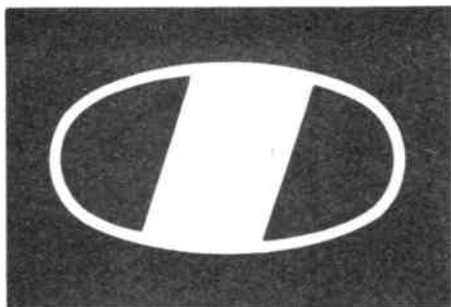

# ICOM

## Total coverage.. 100kHz to 2GHz!



### IC-R7000.

**The R71E now has a team-mate – the IC-R7000. With these matching receivers it is now possible to tune from 100kHz-2GHz.\***

The IC-R7000 covers Aircraft, Marine, FM Broadcast Amateur Radio, Television and weather satellite bands. The IC-R7000 incorporates FM wide/FM narrow, AM, USB and LSB modes of operation with six tuning speeds - 0.1, 1.0, 5, 10, 12.5 and 25kHz. \*Frequency coverage 25-1000MHz and 1025-2000MHz (25-1000MHz and 1260-1300MHz guaranteed specification). With the IC-R7000 you have normal tuning capability with the front panel tuning knob or for quick tuning of a desired frequency by using the front panel key-pad. A total of 99 memory channels are available for storage of received frequencies and operating mode. Memory channels can be called up by pressing the memory switch then rotating the memory channel knob or by direct keyboard entry.

**These receivers are available separately but together would make a superb listening station for the shortwave listener or licensed amateur.**

A sophisticated scanning system provides instant access to specific frequency ranges. By depressing the Auto M switch, the IC-R7000 automatically memorises frequencies that are in use whilst in the scan mode and can be recalled later. The scanning speed is adjustable and the scanning system includes memory selected frequency ranges or priority channels. All functions including memory channel readout are clearly shown on a dual colour fluorescent display with dimmer switch. Other features include dial-lock, noise blanker, S-meter and attenuator.

Options include RC12 infra red controller, EX310 voice synthesizer, SP3 and SP7 external loudspeakers, HP1 headphones and the ICOM AH 7000 super wideband discone antenna.

The IC-R71E is a general coverage receiver 100kHz-30MHz featuring direct keyboard frequency entry and infra-red remote controller (optional), SSB, AM, CW, RTTY and FM (optional) modes of operation. With 32 programmable memory channels, twin VFOs, scanning systems, selectable AGC, noise blanker, pass band tuning and a deep notch filter. Keyboard frequencies can be selected by pushing the digit keys in sequence of frequency. The frequency is altered without changing the main tuning control. Options include EX257 FM unit, RC11 infra-red controller, CK70 D.C. adaptor for 12 volt operation, CW filter options and a high stability crystal filter, SP3 and SP7 external loudspeakers, EX310 voice synthesizer, HP1 headphones.



### IC-R71E.

**Computer Control** These receivers can be connected to a computer terminal via a suitable interface: JT602 Serial Interface for IC-R7000, JT603 Parallel Interface for IC-R71E (IC-R7000). The ICOM IC-R71E requires the IC-FX09 interface connector.



Thalet ICOM Thalet ICOM Thalet ICOM Thalet ICOM Thalet ICOM Thalet ICOM Thalet ICOM Thalet ICOM Thalet ICOM





# STRAIGHT &

# LEVEL

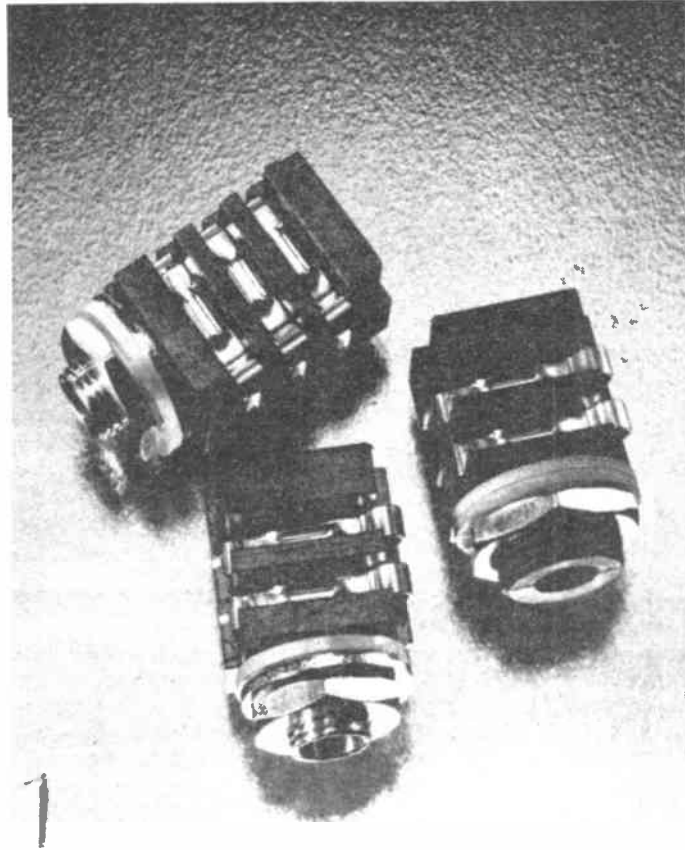

### JACK SOCKET

A UK-manufactured miniature jack socket specifically designed for PCB mounting is now available from Rendar.

This new design, manufactured for all audio and intercomms applications, uses gold-flashed phosphor bronze spring contacts for good solderability and corrosion-resistance. Contacts feature a generous curve at the fixed end for enhanced

spring life.

These 3.5mm sockets, provided with break switching, are available in 2 and 3-pole versions, and are compatible with Rendar's 2 and 3-pole miniature jack plugs. Body material is tough glass-filled nylon.

For further information contact: *Rendar Ltd, Durban Road, South Bersted, Bognor Regis, West Sussex PO22 9RL. Tel: (0243) 825811.*

### BEARCAT RXs

R Withers Communications has announced the availability of a new range of Bearcat scanning receivers, now manufactured by Uniden. RWC is the main distributor of this equipment for the Midlands area.

Three new models are available, one being the DX1000 digital short wave receiver. This is a synthesized keyboard/VFO short wave Rx, 10kHz to 30MHz all-mode, with three selectivity filters

fitted as standard.

Powered from a 12-13.8V dc source with an internal battery compartment for portable operation, the receiver comes with a small telescopic antenna and a long wire antenna. It costs £329 including VAT.

The BC100XL hand-held VHF/UHF receiver is an upgraded version of the Bearcat 100, incorporating a new search mode scanning facility. It has an FM sensitivity of better than  $.4\mu\text{V}$  for 12dB

sinad and air band sensitivity is better than  $.8\mu\text{V}$ . The frequency range is 66-88MHz, 108-136MHz air band, 136-174MHz FM and 360-512MHz UHF, with 16 memories.

The 100XL is supplied with nicads and a wall charger/ac supply. It retails at £219.50 including VAT.

The BC175XL desk-top VHF/UHF scanning receiver operates from 12-13.8V dc for portable and mobile operation and has a 240V ac adapter. The frequency range is the same as the 100XL and the performance specification is quoted at  $.3\mu\text{V}$  FM for 12dB sinad.

The unit is supplied with an adjustable telescopic antenna and an auto-squelch circuit is incorporated. It retails at £209.50 including VAT.

More details are available from: *R Withers Communications Ltd, 584 Hagley Road West, Oldbury, Warley, Birmingham B68 0BS. Tel: (021 421) 8201/2/3.*

### MULTIPURPOSE SOLDER

Multicore Solders Limited have developed a unique, fast acting flux-cored solder which is suitable for all electrical and electronic work, as well as for most types of metal. The flux in the solder wire is entirely non corrosive.

Recently this has been sold for specialised industrial use, but it is now available in a consumer pack, and is a 60/40 alloy, 1.2mm diameter 5-core solder wire.

This solder product should be of particular interest to handymen and service engineers, for in future they will only need one type of solder to effect most soldering work.

The new MX100 solder is available from most electrical and hardware stores at a retail price of £1.99 including VAT.

Details are available from: *Bib Solder Division, Bib Audio/Video Products Ltd, Kelsey House, Wood Lane End, Hemel Hempstead, Herts HP2 4RQ. Tel: (0442) 61291.*

# All the latest news, views, comment and developments on the amateur radio scene

## ANTEL ANTENNAS

The Swedish company Antel has launched three series of antennas intended for mobile telephone systems.

The antennas are manufactured without internal cables and this, according to the manufacturers, results in low losses and improved reliability.

The three series of products have differing properties. The BCD range consists of omnidirectional antennas, while the BCR and LPD ranges are directional. The directional antennas provide for separate feeds to the dipoles, giving effective control of the vertical radiation pattern.

The antennas are intended for use in the 800-960MHz band. The BCD and BCR types are split into two frequency bands, 800-900MHz and 870-970MHz. Bandwidth is 100MHz. The LPD antennas have a bandwidth of 170MHz.

The absence of internal cables offers several advantages. Cable losses and the risks resulting from humidity and contact problems disappear, thus further improving reliability.

The use of various forms of reflector, in conjunction with an omnidirectional antenna, type BCD, allows wider opportunities for design of the radiation pattern to suit specific requirements.

In the case of the LPD series, radiation patterns giving 120°, 90° and 60° sectors are available. Gain is between 5dBd and 15dBd, depending on design. The BCD type gives a gain of 7 or 10dBd while the BCR is available for 14 or 17dBd gain. The antennas give 5% null fill-up in the vertical plane and a lobe tilt of 1.25%.

For details contact: *Antel AB, Bagargatan, S-384 00 Blomstermåla, Sweden. Tel: 46 499 22710.*

## THE OCTOPUS

The Octopus offers an extra pair of hands for all types of assembly, fixing and intricate work.

This new work holder system is now available from Electronic and Computer Workshop Ltd.

It consists of a base block secured to a work surface using a clamp mechanism and four five-inch long flexible 'Stayput' wires fitted with crocodile clip work clamps. These can be angled precisely to give infinitely variable positioning of the work for accurate soldering and glueing.

The standard Octopus kit is provided complete with a handy tool wallet. Also available is the Octopus Super kit, which provides two additional arms, one terminated in a high quality magnifying glass

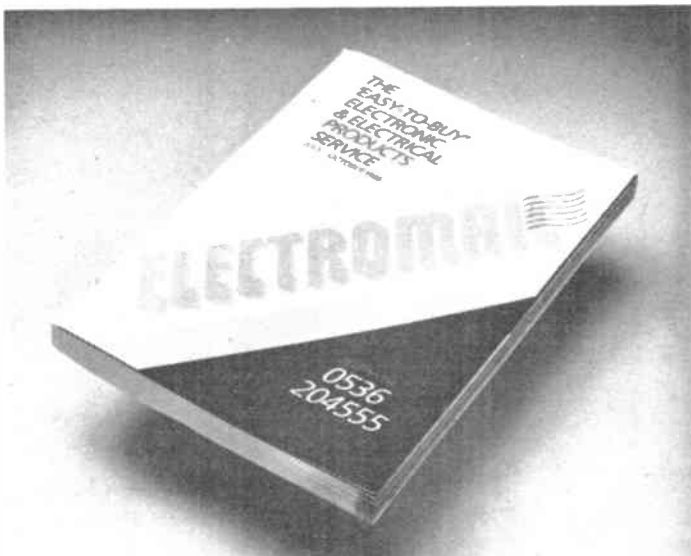

## ELECTROMAIL

RS Components, a leading industrial distributor of electronic and electrical components and supporting instruments, tools and hardware, has announced the launch of Electromail - an easy-to-buy distribution catalogue.

Electromail offers the full RS range of over 12,500 products, from capacitors to cabinets and from batteries to

books. The 688-page catalogue gives complete price, product and ordering information together with photographs and detailed descriptions. Payment is by cheque or credit card and fast despatch can be expected.

To receive a copy of the catalogue send £2.50 to: *Electromail, PO Box 33, Corby, Northants NN17 9EL. Tel: (0536) 204555.*

for miniature work and the other with a very useful magnetic holder.

ECW offers the standard Octopus at a price of £7.45 including VAT and P&P and the Octopus Super Kit is

offered at £9.99.

For further information contact: *Electronic and Computer Workshop Ltd, 171 Broomfield Rd, Chelmsford, Essex CM1 1RY. Tel: (0245) 262149.*

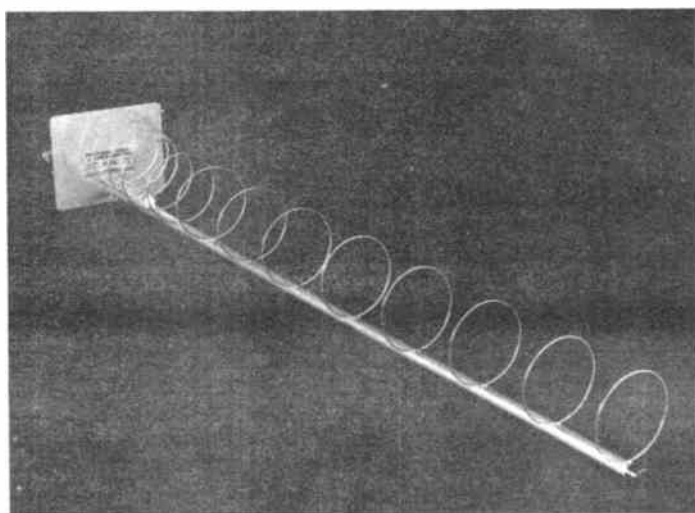

## WIDEBAND BEAM

Telecomms recently released a 'unique' wideband beam for cellular radio use with a gain of over 18dBi and a frequency coverage of 855-955MHz.

The Nevada TC12LW has been developed to enable users access to the UK cellular system from outside the cells, in areas such as Wales or in the English Channel, for example.

Initial trials have shown that the beam can increase the range of the cellular system dramatically and a sample has already been purchased by British Telecom for evalua-

tion. The cost of the beam is £65.00 + VAT.

Also newly available from Telecomms is a new range of Japanese 50 ohm ultra low loss cable.

The cable is double screened with a white outer jacket. H100 has become a popular low loss co-ax here in the UK but has the disadvantage of being very rigid - the Japanese cables have much greater flexibility and lower losses.

For further details contact: *Telecomms, 189 London Road, North End, Portsmouth, Hampshire PO2 9AE. Tel: (0705) 698113.*



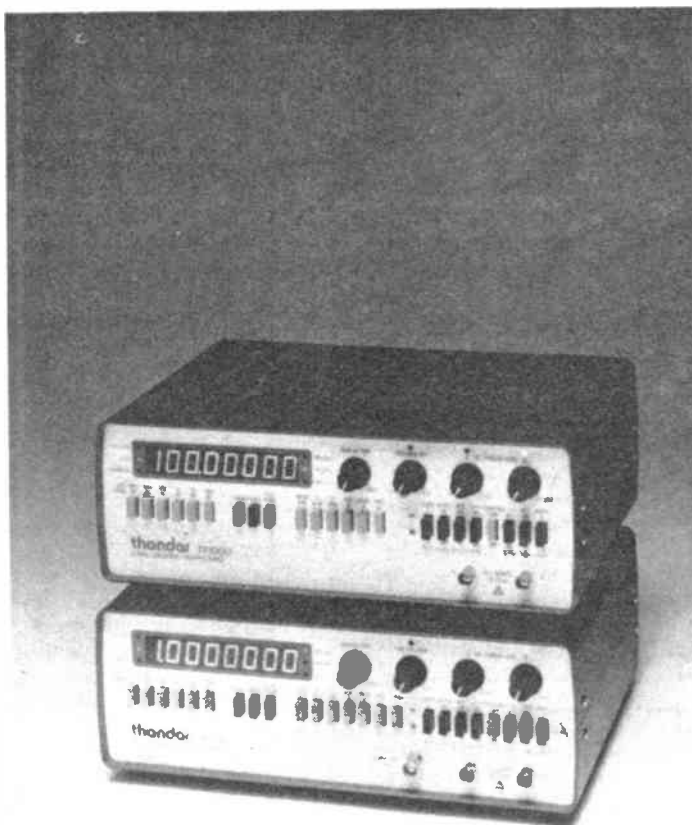

## COUNTER TIMERS

Thandar have introduced two new counter timers. Designated the TF1000 and TF1100 respectively, they offer the following specifications.

The TF1000 is a 100MHz universal counter timer with frequency, period, period average, time interval, time interval average, frequency ratio and totalise measurement modes.

Both inputs (A and B) have dc to 100MHz bandwidth, ac or dc coupling, slope selection and a  $\times 1/\times 10$  attenuator. Channel A also has an HF filter. Both channels have trigger level controls with 3-state trigger indicators.

A trigger hold-off control is provided for time interval measurements and a display timer control allows display times between 100mS and infinity (hold). There is an 8-digit 0.56 inch red LED display with six additional annunciators for external standard, gate, overflow, MHz/ $\mu$ S kHz/mS and secs.

Mounted on the rear panel are an internal/external clock switch and socket, low frequency monitors for channels

A and B for probe calibration, and dc trigger level outputs for A and B. There is also a monitor output for indication of start and stop points when in time interval mode; the output has 3 states when trigger hold-off is selected.

The TF1100 has an extra input (C) to allow frequency measurements to 1GHz. Both models have a high stability timebase option based upon a fast warm-up ovened crystal.

More information is available from: *Thandar Electronics Ltd, London Road, St Ives, Huntingdon, Cambs PE17 4HJ. Tel: (0480) 64646.*

## 250MHz OSCILLOSCOPE

A 250MHz oscilloscope designed to give the maximum degree of measurement flexibility but which remains simple to use has been introduced by Solartron Instruments. The 5228 Compact Oscilloscope makes use of clear function keys to simplify operator procedures while providing storage for two complete oscilloscope configurations, which can be recalled at any time even after the instrument has been

switched off.

The 5228 has a bandwidth of 250MHz together with a wide choice of independent, clearly identified trigger modes for each timebase.

The oscilloscope's input impedance is 50 ohms or 1 megohm for channels A and B, which can be selected from the front panel controls, and 10M or 100M according to the probe used. The vertical axis provides for simultaneous display of channels A and B, the algebraic sum of  $A \pm B$ , and channel C.

A high luminosity spot CRT gives easy, simultaneous display of any type of signal. All sweep combinations are possible, including the 'mixed' and 'alternative' modes.

A built-in multimeter with automatic range selection and LED display is incorporated in the 5228, for measurement of time interval, offset amplitude and input voltage values. A selectable filter enables the vertical amplifier bandwidth to be reduced to 20MHz.

A third input (channel C) has two sensitivity positions: one is 100mV/div and the other is 1V/div.

For details contact: *Solartron Instruments, Victoria Road, Farnborough, Hants GU14 7PW. Tel: (0252) 544433.*

## SIGNAL GENERATOR

New from Farnell Instruments is the PSG1000 synthesized signal generator, a compact, lightweight, fully portable instrument for use in the frequency range 10kHz-1GHz.

Designed to operate from an external 12V dc supply or any standard ac mains supply, the unit measures only 145 x 330 x 405mm, weighs a mere

8.6kg and is ideal for field or bench use. Full +13dBm (1Vpd) output is available from 10kHz to 1GHz and an integral modulation synthesizer (10Hz to 10kHz) is provided. The instrument can also sweep carrier frequency/level and modulation frequency/level between set limits. Employing micro-processor control to provide advanced technical performance, the entire frequency range of the PSG1000 is achieved by direct RF synthesis, with a resolution of 10Hz up to 128MHz and 100Hz from 128MHz to 1GHz.

Controls are of the sealed tactile membrane type. This results in increased reliability, prevents the ingress of dust or moisture and reduces RF leakage. The front panel includes high visibility semi-alphanumeric LED displays of output frequency, output level, modulation rate and modulation level. An automatic sinad facility is included which provides a quick method of measuring receiver sensitivity.

AM, FM and PM modulation are available and other features include facilities for external modulation, external reference frequency, reverse power protection to 50W, patented RF screening techniques and 100 non-volatile memories for front panel set-ups or user defined modulation tones.

In addition to manual data entry and updating, the PSG1000 is programmable via the standard IEEE488 bus or Hewlett-Packard interface loop (HPIL).

More information can be obtained from: *Farnell Instruments Ltd, Sandbeck Way, Wetherby, West Yorkshire LS22 4DH. Tel: (0937) 61961.*

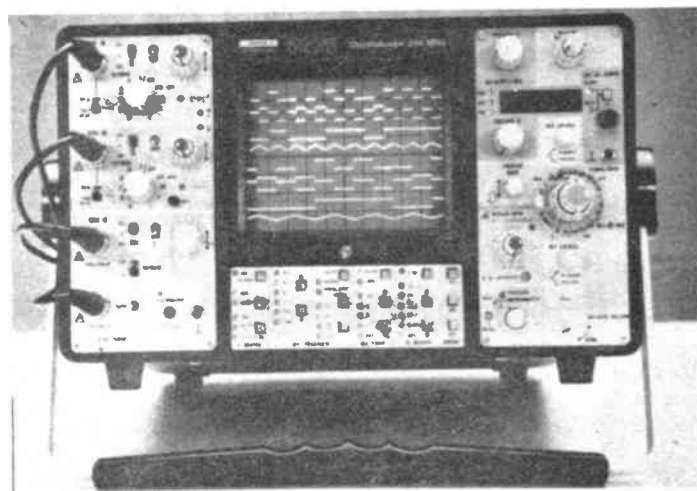



## LOGIC ANALYSER

Fieldtech Heathrow has introduced the Meguro MLA-3300 16-channel logic analyser, a compact, lightweight instrument with a 100nS maximum resolution (at 10MHz). The liquid crystal display gives the analyser very low power dissipation in logic circuits, allowing battery-powered operation. The analyser is designed to measure timing, state and signature and can be used in many applications from hardware to software.

The instrument may be powered from mains voltage, a 5-8V dc line in or by its internal nicad battery. In addition to the 16-channel data input there is an external

clock input, external trigger input and a clock qualifier input. The MLA-3300 provides a 256-bit/channel acquisition memory and a 256-bit/channel reference memory, allowing comparative acquisition. Both memories have a storage back-up facility allowing detailed analysis at a later time if required. Power trigger functions including words, glitch detection and clock delay send all assigned data into memory: glitch detection speed is at least 15nS.

Further information is available from: *Fieldtech Heathrow Ltd, Huntavia House, 420 Bath Road, Longford, Middlesex UB7 0LL. Tel: (01) 897 6446.*

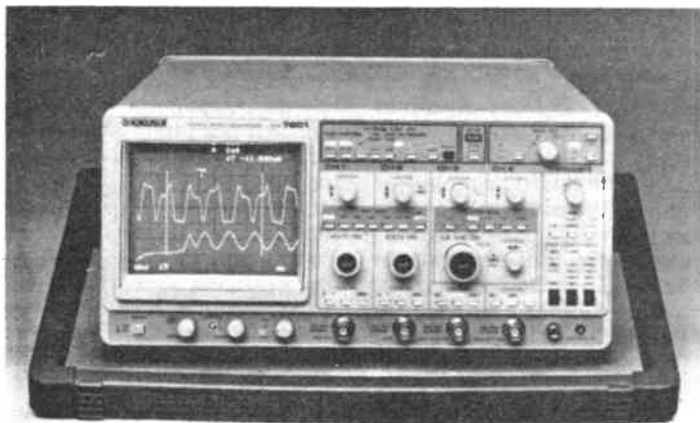
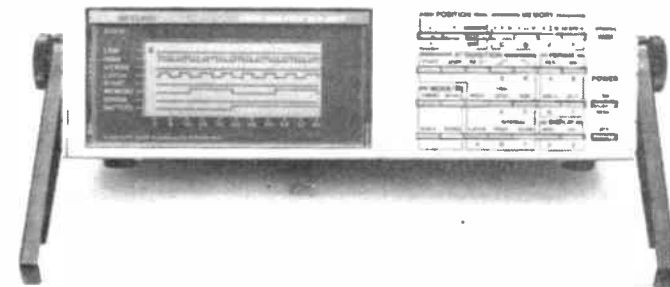

## HIGH SPEC SCOPE

Telonic Instruments Ltd, the UK distributor for Kikusui, have announced the availability of a new high specification CRT read-out oscilloscope range.

The COM 7000 series consists of 6 models with real-time bandwidths of up to 200MHz, all with CRT read-out, built-in DVM and frequency counter. Three of the six new instruments also incorporate digital storage.

The top of the range is the COM 7201, a 200MHz real-time bandwidth instrument with 50MHz clock rate digital storage capability and GPIB compatibility. In real-time mode the COM 7201 has 4 inputs, all with a 200MHz bandwidth. Channels 1 and 2 have selectable input impedances of 1 megohm or 50 ohms and have a sensitivity range from 1mV/div to 5V/div. Channels 3 and 4 have sensitivities of 0.1V/div or 0.5V/div.

Timebase speeds cover 1 nanosec/div to 0.5 sec/div on

both A and B timebases. The timebases can be operated in A only, alternate, B only or B triggered modes. The variable delay time range is 100 nanosecs to 5 seconds. Two separate trigger circuits provide for internal or external trigger capability.

In its digital storage mode the COM 7201 has 50MHz clock rate 8-bit A to D converters. Single-shot sinusoidal events up to 20MHz can be stored by using the sinusoidal interpolation facility. Repetitive signals up to 100MHz can be stored by using the repeat function (equivalent to sampling). A magnification function allows the stored waveform to be magnified by up to 100 times centred on the trigger point.

Telonic will be displaying the COM 7000 range at the International Test and Measurement Exhibition, Olympia, London, from 23-25 September. Also on show will be Kikusui's new FFT analyser, synthesizer func-

tion generator and various logic analysers and conventional scopes.

For more information contact: *Telonic Instruments Ltd, Boyn Valley Road, Maidenhead, Berks SL6 4EG. Tel: (0628) 73933.*

## BENCH POWER SUPPLIES

A new range of programmable bench power supplies, the LB series, has been introduced by Farnell Instruments Limited. The LB series can be controlled locally by means of 10-turn potentiometers or remotely by means of the integral IEEE488 interface. Providing a 0-30V dc output at 2A (LB30-2) or 4A (LB30-4), the units can operate in a constant current or constant voltage mode.

Output of the LB30-2 is monitored by a large analogue meter which is switched to read either voltage or current. The LB30-4 has separate analogue voltage and current meters. Remote sensing of the load voltage is provided on both models to ensure optimum performance when supplying distant loads.

Separate switching of mains input and dc output is provided and LED indicators, housed within the respective switch bezels, illuminate to show mains power on or when the unit is in current limit. The provision of a separate output on/off switch enables the supply to be adjusted in-circuit and left on standby prior to supplying the load.

Both models have ac mains input and dc output fuse protection, and electronic current limiting. Units may be connected in series or parallel to obtain increased voltage or current.

Also available from Farnell Instruments is the LS30-10

autoranging bench power supply, which utilises switch mode techniques to provide dc power up to 60 watts over a wide range of voltage and current combinations. The unit is small and lightweight and will rack or stack with a variety of instruments.

The output is adjustable from near zero to maximum volts and from near zero to maximum amps by the 10-turn front panel controls. Separate digital panel meters indicate voltage and current settings, and the autoranging characteristic of the LS30-10 is shown graphically on the front panel to aid the selection of suitable voltage and current combinations.

To enable the operator to monitor operating status, the power supply is provided with LED indication of 'output enabled' and 'CV' or 'CI' operation.

More information is available from: *Farnell Instruments Ltd, Sandbeck Way, Wetherby, West Yorkshire. LS224 DH. Tel: (0937) 61961.*

## DISTRIBUTION AGREEMENT

A F Bulgin and Company plc has taken a step in boosting its penetration of the power supplies market by signing a distribution agreement with Powerline Electronics Ltd, the UK's leading power supplies distributor.

Bulgin's Power Conversion Division, which recently doubled its design, test and production facilities at Barking, is systematically expanding its broad range of linear and dc/dc converter products, all of which are now stocked by Powerline.

For further information contact: *A F Bulgin and Co plc, Bypass Road, Barking, Essex IG11 0AZ. Tel: 01-594 5588.*

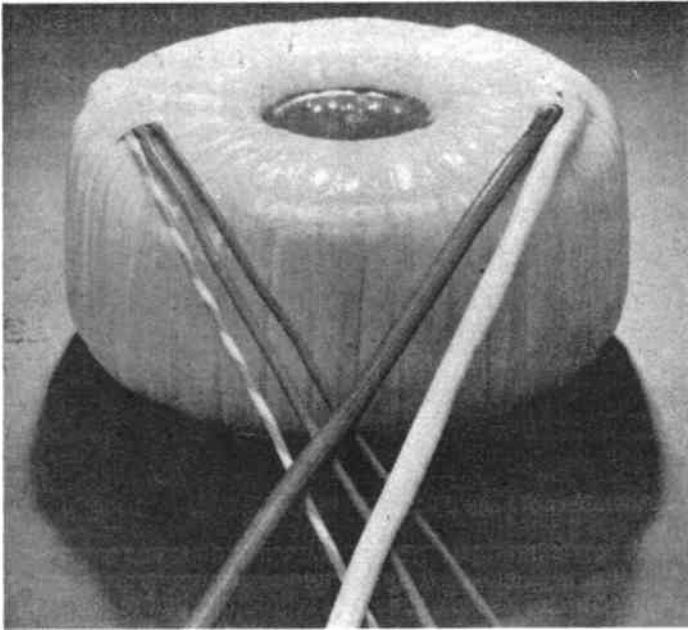

## POWER TRANSFORMERS

Toroid Technology Ltd are introducing a new range of UK designed and manufactured toroidal power transformers with applications in electronic and electrical equipment.

This high quality professional range consists of five power ratings from 15VA to 130VA, 48-60Hz: maximum ambient operating temperature is 55°C. These products are designed for applications requiring low magnetic field

and low temperature rise. They incorporate a copper foil screen between primary and secondary.

Terminations are heat resistant PVC stranded wires and mounting arrangement is by single screw fixing into the base of the transformer. Physical size is between 63 x 31 and 114 x 41mm.

Further details are available from: *Toroid Technology, 175a Brigstock Road, Thornton Heath, Surrey CR4 7JP. Tel: (01) 689 8002.*

## TRIP-PROBE

Providing a versatile method of testing many types of connection, circuits and components, a three-function oscilloscope probe set, the Tri-Probe, with x1, x10 and reference base-line setting options, is now available from Electronic and Computer Workshop Ltd. With the probe, a user can easily display signals from virtually any type of terminal or signal path.

Supplied complete with retracting hook, insulating tip, BNC adaptor, IC tip and trimmer tool, The Tri-Probe (model 307) is a highly adaptable probe concept for all oscilloscopes. Designed by Crotech Ltd, Tri-Probe offers a bandwidth from dc to 100MHz in the x10 mode and from dc to 1MHz in the x1 mode. The working voltage is 600V.

The reference mode earths the probe tip via a built-in 9.0Megohm resistor, and the oscilloscope input is also

earthed. The three modes are selected by a miniature switch located in the probe head.

ECW offers the Tri-Probe set at £14.95 including VAT and post/packing.

For further information contact: *Electronic and Computer Workshop Ltd, 171 Broomfield Rd, Chelmsford, Essex CM1 1RY. Tel: (0245) 262149.*

## MICROWAVE TESTING

The testing of the dynamic performance of microwave radio systems can now be carried out accurately and efficiently in the laboratory, due to the introduction of a new type of RF path simulator.

The simulator is placed in the antenna circuits of the transmitter and receiver and offers a good indication of performance in the presence of a wide range of atmospheric effects.

Manufactured by Arra Inc and available in the UK from

Anglia Microwaves Ltd, the simulators can be supplied in a range of types for analogue, digital and single sideband radio systems. The simulation is provided by a bi-directional substitution network, allowing operators to simulate atmospheric attenuation. This is an effective method for characterising such parameters as radio signal to noise performance and bit-error rates.

The simulators give a realistic and consistent testing method, greatly improving the validity of bench testing and gives a fast test capability for many types of production and development work.

This simulation method utilises precision, continuously-variable attenuators, replacing the more common directional couplers and step-attenuators used in earlier path simulation set-ups. It allows high dynamic measurements to be performed and also for multiple path and multiple signal level testing. The system does not have to be reconfigured for different paths and levels since the simulators can handle a wide dynamic range. Therefore, testing time is reduced and the tests themselves simplified.

For further information contact: *Anglia Microwaves Ltd, Radford Business Centre, Radford Way, Billericay, Essex CM12 0BZ. Tel: (02774) 58955.*

## FREQUENCY STANDARD

An ultra-miniature (3 cubic inch), high stability, low ageing rate frequency standard, the Piezo model 2850038, is now available from Anglia Microwaves Ltd.

Offered in frequencies of

10.0MHz and 10.23MHz, the model 2850038 has an SSB phase noise figure of better than  $-153\text{dBc/Hz}$  at 10kHz and an ageing rate guaranteed at  $5 \times 10^{-10}$  /day at time of shipment. Frequency stability is  $\pm 1 \times 10^{-8}$ . The sinewave output has a harmonic content of less than  $-25\text{dB}$  and spurious output of less than  $-100\text{dB}$ .

Operating over a temperature range from  $-40$  to  $+70^\circ\text{C}$ , the 2850038 requires a supply voltage of  $+15\text{V dc}$  ( $\pm 5\%$ ) and draws  $1.5\text{W}$  of power during normal operation.

For further information contact: *Anglia Microwaves Ltd, Radford Business Centre, Radford Way, Billericay, Essex CM12 0BZ. Tel: (02774) 58955.*

## PCB FILTERS

Roxburgh Suppressors have introduced custom design PCB filters in the PC 103/105/110 range in addition to the standard products. These low cost PCB mounting filters protect digital circuits from mains-borne interference.

Three standard variants are rated at 3, 5 and 10A, and units are available with 2200pF 'Y' rated capacitors to comply with European earth leakage requirements.

Other options include different combinations of capacitors and values to suit customer needs.

All units can be potted in ABS boxes for environmental and mechanical protection, or assembled on PC boards.

More information is available from: *Roxburgh Suppressors Ltd, Haywood Way, Ivyhouse Lane, Hastings, East Sussex TN35 4PL. Tel: (0424) 442160.*

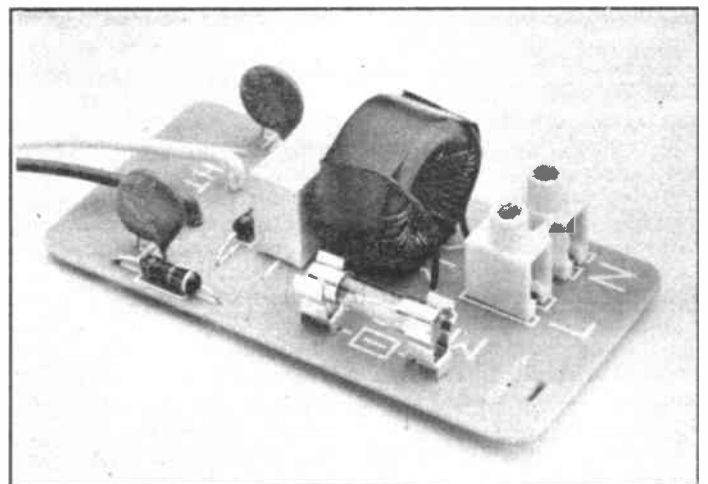



## CLUB NEWS

### GB4PRS anniversary

The Poole Radio Amateur Society will be running a special event station on Sunday, 16 November from the Brownsea Room, Haven Hotel, Sandbanks, Poole, Dorset.

The station is being set up as part of the society's tenth anniversary celebrations, and will be operating mainly on 80m (SSB and CW) and other HF bands, according to conditions, as well as 2m (SSB and FM), using the callsign GB4PRS.

The station will be operational from 09.00GMT until 20.00GMT and will be in WAB square SZ08. The locator is IO90AQ (ZK21g).

Some local traders have also been invited to exhibit. Anyone interested in amateur radio will be very welcome to

come along. Visitors coming from the Isle of Purbeck should note that, because of its annual maintenance programme, the Sandbanks to Shell Bay ferry will *not* be operating.

The Haven Hotel was used by Marconi for some of his early tests. His first land station was at Alum Bay on the Isle of Wight, which was used in conjunction with another at Madeira House, Bournemouth, to carry out experiments with small vessels cruising off the Needles. From 30 September 1898, Marconi moved the Madeira House station to the Haven Hotel, Sandbanks, which remained a Marconi station until 1926.

Special QSL cards will be available. More details may be obtained from Dave G0EQV on Poole (0202) 674802.

### Repeater news

The South-West Hertfordshire UHF Group's 433MHz FM repeater, GB3HR (RB14), is now 10 years old.

Although no longer operational from the original site at Bushey Heath, near Watford, the present site near Stanmore gives a much improved coverage in most directions, and the installation of a better aerial system in February 1986 further improved the service.

Reliability over the last 10 years has been very satisfactory with only one component failure and a feeder cable fault at the Stanmore site. The Bushey Heath site suffered from several electricity mains failures, but so far the supply at Stanmore has been excellent, except for the day that the EEB removed the fuses and meter by mistake!

Plans for the future of HR include a complete standby

repeater station, a new duplexer for single aerial working and a protected mains electricity supply.

The group also operates a 10GHz beacon station, GB3SWH, on 10.3680GHz. Facilities are provided for both narrow and wideband reception. This station, located at Bushey Heath, is horizontally polarized and gives an almost omnidirectional coverage. Several long distance reception reports have been received by the beacon keeper, Trevor Groves G4KUJ, but many more would be gratefully received to build up a better picture of the paths that exist from the site. The present transmitter was built by Les Sharrock G3BNL.

GB3BH, a 23cm FM beacon/repeater, Tx 1297.0MHz, Rx 1291.0MHz, is due to be operational from Bushey Heath during 1986.

### Satellites

Readers interested in DBS and ATV may be interested in attending a lecture on these subjects on 9 October. The Southgate ARC is the host, and the venue will be the Holy Trinity Church Hall (Upper), Green Lanes, Winchmore Hill, London N21 at 7.45pm.

The meeting on the 23rd of the month will be informal.

For further information phone Dave Elson G4YLL on (0992) 30051.

### Open day at SMC

To celebrate the move to new premises, South Midlands Communications has organised an open day on Sunday 21 September from 10.00am to 5.00pm.

Radio amateurs will be able to try the new FT767GX 100 watt amateur bands transceiver, the FL7000 matching 500 watt (with ATU) linear and, hopefully, the new FT290 MkII and the FT727 dual band hand-held.

In addition to SMC's bargains, amateurs are invited to bring along their own bargains to a free car boot sale in SMC's car park (over 100 spaces).

For this special day SMC will be giving 10% discount of all stock items for cash or credit card sales (except towers) and 5% on free finance purchases.

For those unable to travel to Chandlers Ford on the 21st, SMC are allowing the same 10% discount at all their branches on Saturday 20 September (1 day only).

Amateur radio is a thirsty

business, so SMC have arranged for beer and soft drinks to be available on site and free drinks are available until the quota expires. Food will also be available.

Does your radio work correctly? Sure? Bring it to SMC's 'Diagnostic Bar' and have it checked. Such vital signs of illness as poor sensitivity, low output power and over deviation can be checked on all equipment operating between 1.8MHz - 440MHz.

Bring the family with you! After a visit to SMC you could travel to Marwell Zoological Park or beautiful Broadlands, discount tickets for which are available from SMC. A full list of local attractions will be displayed on the day.

G4SMC will operate talk-in on S22 although Chandlers Ford, which is just off the A33 at the Eastleigh turn off, will be signposted on the day.

Last, but not least, a raffle will be held in which you can win a Yaesu FT290. Tickets will be sold at the event (20 pence each).

### Intruder Watch

In the latest edition of the Irish Radio Transmitters Society's Yearbook a form was published to encourage members to submit reports of intrusion heard on amateur bands.

Now the IRTS plans to recruit volunteers to monitor the bands. These monitors will be provided with a pad of forms and a booklet giving guidelines on the types and modes of transmission to look for. Any SWL or licensed amateur will be welcome to take part.

All reports will be collated by the IRTS and submitted to the Region 1 Intruder Watch, who will report to the IARU. The IARU will in turn put pressure on the ITU to have the intruders removed. The IRTS believes that this action will help preserve amateur allocations on the HF bands.

More information on the scheme is available from PO Box 462, Dublin 9.

### QRP demo

The Borehamwood and Elstree Amateur Radio Society meets on the second Monday of each month at the Organ Hall Community Centre, Bairstowe Close, Borehamwood, Herts.

The October meeting will consist of a QRP demonstration and lecture by G3JPJ. A tour of the BBC Brookmans Park Station is also being arranged.

Enquiries about this should go to Tony King G0DDJ on 01-207 3809 (after 7.00pm) and general information is available from Ivor Rosenberg, 11 Parkside Drive, Edgware, Middlesex.

### Surplus to requirements

The Wimbledon and District Amateur Radio Society has a surplus equipment sale scheduled for 31 October. The venue is St Andrews Church Hall, Herbert Road, Wimbledon SW19, and the event begins at 7.30pm.

All enquiries should go to the WDARS's secretary, George Cripps, 115 Bushey Road, Raynes Park, London SW20 8DG. Tel: 01-540 2180.

### Mobile rally

The Carmarthen Amateur Radio Society is holding a mobile rally on 12 October at St Peters Civic Hall, Nott Square, Carmarthen, Dyfed. Doors open at 10.30am and admission is £1.00.

More information is available from B Dowling GW3GUE on (0267) 83460.

### Get on down

Friday night is club night for the Mid Lanark Amateur Radio Society. Meetings commence at 7.30pm at the Wrangholm Hall, Jerviston Street, New Stevenson, Motherwell.

Regular lectures are held, and details of these are available from David Williams GM1SSA, 32/34 Carfin Street, New Stevenson, Motherwell ML1 4UQ. Tel: Holytown 732403.

## Radio Newcastle

BBC Radio Newcastle will be inviting the public to view their new studios during an open day on Sunday 12 October.

The purpose-built broadcasting centre at Fenham, near the City Centre, has been on the air since 25 May, and next year BBC Television will move in when the TV studios are completed.

As an added attraction the Tyneside Amateur Radio Society will operate a special event station from the News

room with the callsign GB2FBC.

This will be the second time Tyneside ARS has run a special event station for Radio Newcastle. In 1982 when the BBC was celebrating 60 years of public broadcasting in Newcastle (originally from 5N0), Tyneside ARS operated GB5NO at the site of the first broadcast for one week. During this time they had a QSO on two metres with G4MHW, a staff presenter for BBC, and this was broadcast over the air.

## Let's get together

The Northern Amateur Radio Confederation exists to promote self-help and co-operation between member clubs, ie to help organise lists of speakers, inter-club quizzes and other activities, provide a communication channel between clubs, and circulate lists of stolen equipment.

The confederation also runs special event stations and has set up a local award,

born out of one such special event (details can be obtained from G4WCE QTHR).

Although the NARC aims to be self-financing (from awards, etc) a donation of £10.00 per club is requested; this may be refunded later, finances permitting.

Further information is available from Peter Kirsop G4WCE, 5 Planetree Road, Hale, Cheshire WA15 9JJ.

## Spenn Valley

The Spenn Valley Amateur Radio Society (G3SVC) was formed in 1946 and is thus celebrating its fortieth anniversary this year, and the society's schedule is packed with events.

On 2nd October there will be an evening devoted to the members, with 5 minute talks presented by them on various aspects of the hobby. This will be followed on the 16th by a lecture entitled 'Sea Cadet Corps Communications', by Hugh O'Connor G4SCC.

The club endeavours to maintain a varied programme

of events, and therefore includes subjects other than radio.

These will include talks on bee-keeping and rifle shooting later this year, and possibly the more alcoholic version of home-brewing!

Formal meetings are held on the first and third Thursdays of the month at 8.00pm. The venue is the Old Bank Working Men's Club in Mirfield, West Yorkshire.

Further details can be obtained from the secretary, Ian Jones G4MLW, at 54 Milton Road, Heckmondwike, West Yorkshire.

## Emergency planning

The Verulam Amateur Radio Club meets at the RAF Headquarters, New Kent Road, off Marlborough Road, St Albans on the second and fourth Tuesdays in each month.

On Tuesday 11 November an 'activity evening' is scheduled and on 25 November there will be a talk by the County Emergency Planning Officer for Hertfordshire on the role of the amateur in emergency planning. All visitors will be welcome. Both meetings will commence at 7.30 for 8.00pm.

For further information

contact Gerry Wimpenny G4OBH, 30 Faircross Way, St Albans. Tel: (0727) 52003.

## WARS moves

The Worksop Amateur Radio Society has a new club house: The Woodhouse Inn, Woodend, Rhodesia, Worksop, Notts.

Meetings will continue to be held each Tuesday evening at 7.30pm as usual, and further information about club activities and events is available from Mrs C S Gee G4ZUN (Honourary Secretary), 100 Plantation Hill, Worksop, Nottingham. Tel: (0909) 486614.

## Busy bees

The October schedule of the Fareham and District Amateur Radio Club is as follows: 1 October - natter night; 8 October - Packet Radio by Tony G4CJO; 15 October - natter night; and 22 October - a lecture (further details to be announced).

The club meets every Wednesday at 7.30pm, although a Morse class is held at 7.00pm.

All enquiries should go to the secretary, A S Chester G3CCB at 'Deva Wood', 44 The Ridgeway, Down End, Fareham, Hants PO16 8RE. Tel: (0329) 288139.

## North Bristol ARC

The North Bristol Amateur Radio Club has a very busy schedule of events planned this month.

On 3 October Microwave Modules will present a talk on the latest equipment available, whilst on the 10th there will be a lecture on satellite communications.

A VHF activity night is planned for 17 October, followed on the 31st by a video show on the Radio Society of Great Britain.

All meetings will take place at 7.00pm at the Self Help Enterprise, 7 Braemar Crescent, Northville, Bristol.

## Celebrations

Following the success of its special event station GB4WAB, held in April to commemorate its fiftieth anniversary, the Cannock Chase Amateur Radio Society plans to continue the celebrations with a similar event.

During October, the club will operate the special event station GB6SW, based on the club callsign G6SW, which was the first HF call in the

Cannock Chase area. Operation will be on most bands and will be supplemented by GB1GCC and GB8GCC.

QSL cards will be sent for all contacts and the Cannock Chase Award will run for this event.

The cost of the award is £1.00 and more details can be obtained from B 'Robinson G0FEC at 68 Langholm Drive, Heath Hayes, Cannock, Staff WS12 5EZ.

## ANDY TIPPS by DeeJay

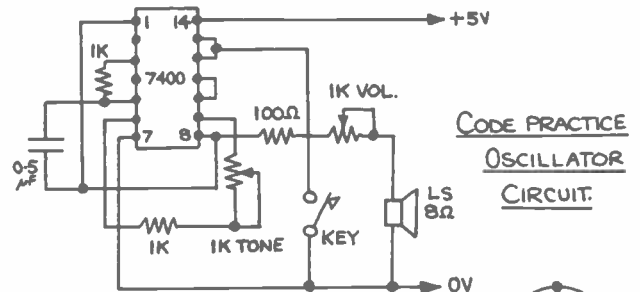

CODE PRACTICE  
OSCILLATOR  
CIRCUIT.



ANDY SAYS:-

"HERE'S A SIMPLE AUDIO OSCILLATOR BASED ON A SINGLE 7400 I.C. IT'S IDEAL FOR ASPIRING CLASS A LICENSEES, SO PLUG YOUR KEY IN AND PRACTICE SENDING! THE 5 VOLT SUPPLY CAN BE OBTAINED FROM A 9 VOLT SOURCE VIA A 7805 REGULATOR."





# Bored with a humdrum existence? Tired with a tedious life?

Fancy straying from the straight and narrow or even crossing to the wrong side of the tracks? Yes, we thought as much . . .

So what's the solution? Where's the sparkling new package to break the dreary mould? Why it's here! . . .  
**4x4 Magazine!**

**4x4** has all that's best in off-road and four-wheel-drive action. Lacking only a mushroom cloud in terms of spectacle, it's guaranteed to excite and entertain, but beware! . . . This magazine contains explicit material which some readers, especially those of a frail disposition, may find disturbing. You have been warned!



**Place a regular order with your newsagent or take out a subscription**

**ON SALE AT YOUR NEWSAGENTS 2nd THURSDAY EVERY MONTH**

## 4x4 SUBSCRIPTION ORDER FORM

**TO:** Subscription Department · 4x4 · 1 Clarendon Road · Croydon · Surrey · CR0 3SJ

**PLEASE SUPPLY:** (tick box) for 12 issues, all rates include P & P

**Inland** £15.20  **World-Surface** £16.45  **Europe-Air** £22.55  **World-Air** £29.30

**PAYMENT ENCLOSED:**

£ —

**CREDIT CARD PAYMENT**

Cheques should be made payable to 4x4 Magazines. Overseas payment by International Money Order or credit card.

NAME  ADDRESS

Postcode  AR10

PHONE  
0474 60521



# P.M. COMPONENTS LTD

(SELECTRON HOUSE, SPRINGHEAD ENTERPRISE PARK  
GRAVESEND, KENT DA11 8HD)

TELEX  
966371  
TOS PM

## INTEGRATED CIRCUITS

AN124 2.50	MC1351P 1.50	STK437 7.95
AN214Q 2.80	MC1357 2.35	STK439 7.95
AN239 2.50	MC1358 1.58	STK461 11.50
AN240P 2.50	MC14518PC 1.50	TA7061A 1.50
AN254 2.50	MC14518PC 1.50	TA7108P 1.50
AN612 2.15	MC1495 3.00	TA7120P 1.65
AN362L 2.50	MC1496 1.25	TA7129P 2.50
AN7140 3.80	MC145106P 1.50	TA7130P 1.50
AN7145 3.50		TA7137P 1.00
AN7150 3.50	MC1723 0.50	TA7176AP 2.95
BA521 3.35	MC3301 2.80	TA7193P 3.95
CA1352E 1.75	ML2318L 1.78	TA7203 2.95
CA3086 0.46	ML2328 2.50	TA7204P 2.15
CA3123E 1.95	MSM5807 8.75	TA7205AP 1.15
CA3140T 1.15	PL132A 5.75	TA7222AP 1.80
ET1610 2.50	SAAS00A 3.50	TA7310P 1.80
HA1139A 2.95	SA1102S 7.25	TA7313AP 2.95
HA1366W 2.75	SAS560S 1.75	TA7314P 2.95
HA1377 3.80	SAS570S 1.78	TA7137P 1.00
HA1550 2.95	SAS580 2.85	TA7314P 2.95
LA1230 1.95	SA/SB/TT/ 1.00	TA7321P 2.95
LA4102 2.95	SL901B 7.95	TA7595C 2.95
LA4031P 1.95	SL917B 6.65	TA7611AP 2.95
LA4420 2.95	SL1310 1.80	TAA310A 1.95
LA4400 4.15	SL1327 1.10	TAA320A 1.95
LA4422 2.50	SL1327G 1.10	TAA350A 1.95
LA4461 3.95	SN76033N 3.95	TAA461B 1.95
LC7120 3.25	SN76033N 3.95	TAA700 1.70
LC7130 5.50	SN76110N 0.85	TBA120AS/B- 1.00
LC7131 5.50	SN76115N 1.25	TBA395 1.50
LM1011 3.15	SN76131N 1.30	TBA396 0.75
LM324N 0.45	SN76226D 1.00	TBA400 1.25
LM3808N 1.50	SN76227N 1.05	TBA510 2.50
LM3838T 2.95	SN76533N 1.85	TBA510Q 2.50
LM390N 3.50	SN76570N 1.00	TBA520 1.10
MS1513L 2.30	SN76650N 1.15	TBA530 1.10
MS1521L 2.95	SN76660N 0.90	TBA530Q 1.10
MB3712 2.00	STK014 7.95	TBA540 1.25
MB3756 2.50	STK015 8.95	TBA540D 1.35
MC1307P 1.00	STK023 11.95	TBA550C 1.95
MC1310P 1.95	STK078 11.95	TBA560Q 1.45
MC1327 0.95	STK415 7.95	TBA570 1.00
MC1349P 1.20	STK433 5.95	TBA651R 2.50
MC1350P 0.95		

TDA2581 2.45	TDA2582 2.95	TDA2583 2.95
TDA2584 2.95	TDA2600 6.50	TDA2610 2.50
TDA2611 1.95	TDA2612 3.50	TDA2613 1.95
TDA2614 1.95	TDA2615 1.95	TDA2616 1.95
TDA2617 1.95	TDA2618 1.95	TDA2619 1.95
TDA2620 3.50	TDA2621 2.45	TDA2622 2.45
TDA2623 2.45	TDA2624 2.45	TDA2625 2.45
TDA2626 2.45	TDA2627 2.45	TDA2628 2.45
TDA2629 2.45	TDA2630 2.45	TDA2631 2.45
TDA2632 2.45	TDA2633 2.45	TDA2634 2.45
TDA2635 2.45	TDA2636 2.45	TDA2637 2.45
TDA2638 2.45	TDA2639 2.45	TDA2640 2.45
TDA2641 2.45	TDA2642 2.45	TDA2643 2.45
TDA2644 2.45	TDA2645 2.45	TDA2646 2.45
TDA2647 2.45	TDA2648 2.45	TDA2649 2.45
TDA2650 2.45	TDA2651 2.45	TDA2652 2.45
TDA2653 2.45	TDA2654 2.45	TDA2655 2.45
TDA2656 2.45	TDA2657 2.45	TDA2658 2.45
TDA2659 2.45	TDA2660 2.45	TDA2661 2.45
TDA2662 2.45	TDA2663 2.45	TDA2664 2.45
TDA2665 2.45	TDA2666 2.45	TDA2667 2.45
TDA2668 2.45	TDA2669 2.45	TDA2670 2.45
TDA2671 2.45	TDA2672 2.45	TDA2673 2.45
TDA2674 2.45	TDA2675 2.45	TDA2676 2.45
TDA2677 2.45	TDA2678 2.45	TDA2679 2.45
TDA2680 2.45	TDA2681 2.45	TDA2682 2.45
TDA2683 2.45	TDA2684 2.45	TDA2685 2.45
TDA2686 2.45	TDA2687 2.45	TDA2688 2.45
TDA2689 2.45	TDA2690 2.45	TDA2691 2.45
TDA2692 2.45	TDA2693 2.45	TDA2694 2.45
TDA2695 2.45	TDA2696 2.45	TDA2697 2.45
TDA2698 2.45	TDA2699 2.45	TDA2700 2.45
TDA2701 2.45	TDA2702 2.45	TDA2703 2.45
TDA2704 2.45	TDA2705 2.45	TDA2706 2.45
TDA2707 2.45	TDA2708 2.45	TDA2709 2.45
TDA2710 2.45	TDA2711 2.45	TDA2712 2.45
TDA2713 2.45	TDA2714 2.45	TDA2715 2.45
TDA2716 2.45	TDA2717 2.45	TDA2718 2.45
TDA2719 2.45	TDA2720 2.45	TDA2721 2.45
TDA2722 2.45	TDA2723 2.45	TDA2724 2.45
TDA2725 2.45	TDA2726 2.45	TDA2727 2.45
TDA2728 2.45	TDA2729 2.45	TDA2730 2.45
TDA2731 2.45	TDA2732 2.45	TDA2733 2.45
TDA2734 2.45	TDA2735 2.45	TDA2736 2.45
TDA2737 2.45	TDA2738 2.45	TDA2739 2.45
TDA2740 2.45	TDA2741 2.45	TDA2742 2.45
TDA2743 2.45	TDA2744 2.45	TDA2745 2.45
TDA2746 2.45	TDA2747 2.45	TDA2748 2.45
TDA2749 2.45	TDA2750 2.45	TDA2751 2.45
TDA2752 2.45	TDA2753 2.45	TDA2754 2.45
TDA2755 2.45	TDA2756 2.45	TDA2757 2.45
TDA2758 2.45	TDA2759 2.45	TDA2760 2.45
TDA2761 2.45	TDA2762 2.45	TDA2763 2.45
TDA2764 2.45	TDA2765 2.45	TDA2766 2.45
TDA2767 2.45	TDA2768 2.45	TDA2769 2.45
TDA2770 2.45	TDA2771 2.45	TDA2772 2.45
TDA2773 2.45	TDA2774 2.45	TDA2775 2.45
TDA2776 2.45	TDA2777 2.45	TDA2778 2.45
TDA2779 2.45	TDA2780 2.45	TDA2781 2.45
TDA2782 2.45	TDA2783 2.45	TDA2784 2.45
TDA2785 2.45	TDA2786 2.45	TDA2787 2.45
TDA2788 2.45	TDA2789 2.45	TDA2790 2.45
TDA2791 2.45	TDA2792 2.45	TDA2793 2.45
TDA2794 2.45	TDA2795 2.45	TDA2796 2.45
TDA2797 2.45	TDA2798 2.45	TDA2799 2.45
TDA2800 2.45	TDA2801 2.45	TDA2802 2.45
TDA2803 2.45	TDA2804 2.45	TDA2805 2.45
TDA2806 2.45	TDA2807 2.45	TDA2808 2.45
TDA2809 2.45	TDA2810 2.45	TDA2811 2.45
TDA2812 2.45	TDA2813 2.45	TDA2814 2.45
TDA2815 2.45	TDA2816 2.45	TDA2817 2.45
TDA2818 2.45	TDA2819 2.45	TDA2820 2.45
TDA2821 2.45	TDA2822 2.45	TDA2823 2.45
TDA2824 2.45	TDA2825 2.45	TDA2826 2.45
TDA2827 2.45	TDA2828 2.45	TDA2829 2.45
TDA2830 2.45	TDA2831 2.45	TDA2832 2.45
TDA2833 2.45	TDA2834 2.45	TDA2835 2.45
TDA2836 2.45	TDA2837 2.45	TDA2838 2.45
TDA2839 2.45	TDA2840 2.45	TDA2841 2.45
TDA2842 2.45	TDA2843 2.45	TDA2844 2.45
TDA2845 2.45	TDA2846 2.45	TDA2847 2.45
TDA2848 2.45	TDA2849 2.45	TDA2850 2.45
TDA2851 2.45	TDA2852 2.45	TDA2853 2.45
TDA2854 2.45	TDA2855 2.45	TDA2856 2.45
TDA2857 2.45	TDA2858 2.45	TDA2859 2.45
TDA2860 2.45	TDA2861 2.45	TDA2862 2.45
TDA2863 2.45	TDA2864 2.45	TDA2865 2.45
TDA2866 2.45	TDA2867 2.45	TDA2868 2.45
TDA2869 2.45	TDA2870 2.45	TDA2871 2.45
TDA2872 2.45	TDA2873 2.45	TDA2874 2.45
TDA2875 2.45	TDA2876 2.45	TDA2877 2.45
TDA2878 2.45	TDA2879 2.45	TDA2880 2.45
TDA2881 2.45	TDA2882 2.45	TDA2883 2.45
TDA2884 2.45	TDA2885 2.45	TDA2886 2.45
TDA2887 2.45	TDA2888 2.45	TDA2889 2.45
TDA2890 2.45	TDA2891 2.45	TDA2892 2.45
TDA2893 2.45	TDA2894 2.45	TDA2895 2.45
TDA2896 2.45	TDA2897 2.45	TDA2898 2.45
TDA2899 2.45	TDA2900 2.45	TDA2901 2.45
TDA2902 2.45	TDA2903 2.45	TDA2904 2.45
TDA2905 2.45	TDA2906 2.45	TDA2907 2.45
TDA2908 2.45	TDA2909 2.45	TDA2910 2.45
TDA2911 2.45	TDA2912 2.45	TDA2913 2.45
TDA2914 2.45	TDA2915 2.45	TDA2916 2.45
TDA2917 2.45	TDA2918 2.45	TDA2919 2.45
TDA2920 2.45	TDA2921 2.45	TDA2922 2.45
TDA2923 2.45	TDA2924 2.45	TDA2925 2.45
TDA2926 2.45	TDA2927 2.45	TDA2928 2.45
TDA2929 2.45	TDA2930 2.45	TDA2931 2.45
TDA2932 2.45	TDA2933 2.45	TDA2934 2.45
TDA2935 2.45	TDA2936 2.45	TDA2937 2.45
TDA2938 2.45	TDA2939 2.45	TDA2940 2.45
TDA2941 2.45	TDA2942 2.45	TDA2943 2.45
TDA2944 2.45	TDA2945 2.45	TDA2946 2.45
TDA2947 2.45	TDA2948 2.45	TDA2949 2.45
TDA2950 2.45	TDA2951 2.45	TDA2952 2.45
TDA2953 2.45	TDA2954 2.45	TDA2955 2.45
TDA2956 2.45	TDA2957 2.45	TDA2958 2.45
TDA2959 2.45	TDA2960 2.45	TDA2961 2.45
TDA2962 2.45	TDA2963 2.45	TDA2964 2.45
TDA2965 2.45	TDA2966 2.45	TDA2967 2.45
TDA2968 2.45	TDA2969 2.45	TDA2970 2.45
TDA2971 2.45	TDA2972 2.45	TDA2973 2.45
TDA2974 2.45	TDA2975 2.45	TDA2976 2.45
TDA2977 2.45	TDA2978 2.45	TDA2979 2.45
TDA2980 2.45	TDA2981 2.45	TDA2982 2.45
TDA2983 2.45	TDA2984 2.45	TDA2985 2.45
TDA2986 2.45	TDA2987 2.45	TDA2988 2.45
TDA2989 2.45	TDA2990 2.45	TDA2991 2.45
TDA2992 2.45	TDA2993 2.45	TDA2994 2.45
TDA2995 2.45	TDA2996 2.45	TDA2997 2.45
TDA2998 2.45	TDA2999 2.45	TDA3000 2.45

## NEW BRANDED CATHODE RAY TUBES - Please allow additional £3 per tube for carriage

A1865-20 65.00	D14-173GR 55.00	M19-103W 86.00	M50-120GV 65.00
AW36 11 25.00	D14-181GH/98 55.00	M23-110GH 55.00	M50-120L 65.00
CME822W 19.00	D14-181GM 55.00	M23-112GM 55.00	M61-120W 75.00
CME822GH 25.00	D14-181GMS0 59.00	M23-112GW 55.00	S6B 45.00
CME1428GH 45.00	D14-181GMS5 59.00	M23-112KA 55.00	SE4-D/P-7 45.00
CME1428W 39.00	D14-200BE 89.00	M23-112L 55.00	SE42BP31AL 55.00
CME1431GH 39.00	D14-200GA 59.00	M24-120GM 59.00	SE42BP31 55.00
CME1431W 39.00	D14-210GH 75.00	M24-120W 59.00	T93T 65.00
CME202GH 45.00	D14-270GH/50 75.00	M24-120W/AR 59.00	T948H 65.00
CME2024W 45.00	D14-310W 110.00	M28-12GH 55.00	V4150L 55.00
CME3128W 45.00	D14-320GH/82 85.00	M28-13L 49.00	V5004GR 59.00
CME3132GH 45.00	D14-340KA 45.00	M28-13L 49.00	V5004LD 59.00
CME3155W 45.00	D16-100GH 45.00	M28-13GR 55.00	V6001GH 65.00
CRE1400 25.00	D16-100GH/65 69.00	M28-13GH 55.00	V6002GH 59.00
CV429 89.00	D16-100GH/97 69.00	M31-101GH 55.00	V60034W 59.00
CV1450 35.00	D16-100GH/79 69.00	M31-182GR 55.00	V604CL 59.00
CV1526 19.00	D16-160GH 69.00	M31-182GV 65.00	V6052GR 65.00
CV2191 19.00	D21-10GH 65.00	M31-184GH 65.00	V6059P31 55.00
CV2193 15.00	DB7 36 35.00	M31-184P31 65.00	V6064CL 55.00
CV5119 85.00	DB7 36 35.00	M31-186W 69.00	V6069GH 55.00
CV5320 85.00	DG7 5 55.00	M31-190GH 55.00	V6070P31 49.00
CVX388 85.00	DG7 32 45.00	M31-190GR 55.00	V7030 65.00
D9-110GH 39.50	DG3 91 55.00	M31-190LA 55.00	V7031 59.00
D10-210GH 45.00	DHT 91 45.00	M31-191GV 55.00	V7032 59.00
D10-210GH/68B 35.00	DP7 5 35.00	M31-220W 59.00	V7033 59.00
D10-230GH 35.00	DP7 6 35.00	M31-271P31 65.00	V7035A 49.00
D10-230GH/90 35.00	DN13 78 35.00	M31-271P31 65.00	V7037GH 45.00
D13-30GH 49.50	F16-101GM 75.00	M31-271W 65.00	V8004GR 65.00



PHONE  
0474 60521  
3 LINES

**P.M. COMPONENTS LTD**  
**SELECTOR HOUSE**  
**SPRINGHEAD ENTERPRISE PARK, SPRINGHEAD ROAD**  
**GRAVESEND, KENT DA11 8HD**



TELEX  
966371  
TOS PM

**A SELECTION FROM OUR STOCK OF BRANDED VALVES**

A1714 24.50	EB91 0.80	EL95 1.75	M8163 5.80	U50 2.00	2C39A 29.50	6AK6 2.50	6GK5 1.50	12BH7A 2.50	404A 10.95
A1998 11.50	EB91 0.80	EL153 12.15	M8190 4.50	U82 3.00	2C39BA 29.50	6AL5 0.60	6GK6 1.95	12BL6 1.75	425A5 8.00
A2087 11.50	EBF80 0.85	EL183E 3.50	M8195 6.50	U191 0.70	2C40 37.00	6AM4 3.25	6GM6 0.95	12BY7A 2.75	431U 4.50
A2134 14.95	EBF83 0.85	EL183P 3.50	M8196 5.50	U192 1.00	2C42 29.50	6AM5 6.00	6GK7 2.15	12CA5 1.95	572B 65.00
A2253 6.80	EBF85 0.95	EL500 1.40	M8204 5.50	U193 0.65	2C51 0.75	6AM6 1.50	6GV7 2.50	12CX6 1.20	563E 1.50
A226 29.50	EBF89 0.70	EL504 5.20	M8224 2.00	U251 1.00	2C5V 1.50	6AN5 2.65	6GW8 0.80	12D06B 3.50	6158 3.20
A2599 37.50	EBL1 2.50	EL519 8.95	M8225 3.50	U801 0.75	2B7 1.50	6AN8A 2.65	6H1 9.50	12DWA4 3.50	6328 14.50
A2792 27.50	EBL21 2.00	EL802 3.65	ME1401 29.50	UABC80 0.65	2D21 1.50	6AQ5 2.15	6H3N 1.10	12DW7 2.50	6386 14.50
A2900 11.50	EC52 0.75	EL821 8.50	ME1402 29.50	UAF42 1.00	2D21W 2.50	6AQ8 0.85	6HE 1.95	12E1 17.95	6883B 9.95
A3042 24.00	EC70 1.75	EL822 12.95	ME1501 14.00	UCB41 0.60	2E22GY 45.00	6AR5 5.95	6HB7 0.95	12E14 38.00	6973 5.95
A3283 24.00	EC80 9.50	EM1 9.00	ML4 3.50	UCB81 1.80	2E26 7.95	6AR8 3.95	6HF5 5.50	12HG7A 4.50	705A 8.00
AC/THI 4.00	EC86 1.00	EM4 9.00	MHL06 4.00	UCB85 0.60	2E42 93.00	6AS5 1.50	6HF8 2.50	12JG7 3.50	715C 45.00
ACT22 99.78	EC88 1.00	EM80 0.70	ML4 3.50	UCF80 1.00	2K25Ray 27.50	6AS6 2.50	6H56 4.95	12K5 1.95	725A 275.00
AC/S2PEN	EC90 1.10	EM84 1.85	MU14 3.50	UCF81 1.20	2K26 95.00	6AT6 0.75	6H58 1.95	12K7G 1.50	7527 89.50
8.50	EC91 5.50	EM85 3.95	N37 12.50	UCF82 1.20	2K26 250.00	6AT8 1.75	6J4 2.15	12K8 1.95	7703 395.00
AH221 39.00	EC92 1.95	EM87 2.50	N78 9.85	UCF83 1.00	2K56 250.00	6AU4 2.00	6J4W 3.15	12S2ATG 1.95	8251 14.50
AH238 39.00	EC93 3.50	EM89 1.50	OC2 2.50	UCF84 1.00	3A107B 9.00	6AU6 0.95	6J5 2.50	12S2GT 4.75	805 39.00
AL6 6.00	EC95 7.00	EN91 1.50	OC2 2.50	UCF85 1.00	3A107B 12.00	6AV6 0.75	6J5 2.50	12S7 1.95	807 1.95
AN1 14.00	EC97 1.10	EN92 4.50	OC2 2.50	UCF86 1.00	3A109B 11.00	6AZ8 5.95	6J6 2.05	12S7 1.95	810 85.00
AR12 0.70	EC99 1.10	ESU150 14.95	OC2 2.50	UCF87 1.00	3A110B 12.00	6AZ8 5.95	6J6 2.05	12S7 1.95	811A 15.00
ARP34 1.25	EC99 1.10	ESU150 14.95	OC2 2.50	UCF88 1.00	3A111B 11.00	6B2 2.80	6J6 2.05	12S7 1.95	813 23.50
ARP35 2.00	EC99 1.10	ESU150 14.95	OC2 2.50	UCF89 1.00	3A112B 11.00	6B2 2.80	6J6 2.05	12S7 1.95	829B 14.50
AZ1 4.00	EC99 1.10	ESU150 14.95	OC2 2.50	UCF90 1.00	3A113B 11.00	6B2 2.80	6J6 2.05	12S7 1.95	832A 14.50
BL63 2.00	EC99 1.10	ESU150 14.95	OC2 2.50	UCF91 1.00	3A114B 11.00	6B2 2.80	6J6 2.05	12S7 1.95	833A 95.00
BS450 67.00	EC99 1.10	ESU150 14.95	OC2 2.50	UCF92 1.00	3A115B 11.00	6B2 2.80	6J6 2.05	12S7 1.95	833A 95.00
BS810 58.00	EC99 1.10	ESU150 14.95	OC2 2.50	UCF93 1.00	3A116B 11.00	6B2 2.80	6J6 2.05	12S7 1.95	833A 95.00
BS814 58.00	EC99 1.10	ESU150 14.95	OC2 2.50	UCF94 1.00	3A117B 11.00	6B2 2.80	6J6 2.05	12S7 1.95	833A 95.00
CIK 19.00	EC99 1.10	ESU150 14.95	OC2 2.50	UCF95 1.00	3A118B 11.00	6B2 2.80	6J6 2.05	12S7 1.95	833A 95.00
CSJA 39.50	EC99 1.10	ESU150 14.95	OC2 2.50	UCF96 1.00	3A119B 11.00	6B2 2.80	6J6 2.05	12S7 1.95	833A 95.00
CSA 9.00	EC99 1.10	ESU150 14.95	OC2 2.50	UCF97 1.00	3A120B 11.00	6B2 2.80	6J6 2.05	12S7 1.95	833A 95.00
C1112G 70.00	EC99 1.10	ESU150 14.95	OC2 2.50	UCF98 1.00	3A121B 11.00	6B2 2.80	6J6 2.05	12S7 1.95	833A 95.00
C1108 65.00	EC99 1.10	ESU150 14.95	OC2 2.50	UCF99 1.00	3A122B 11.00	6B2 2.80	6J6 2.05	12S7 1.95	833A 95.00
C1134 32.00	EC99 1.10	ESU150 14.95	OC2 2.50	UCF100 1.00	3A123B 11.00	6B2 2.80	6J6 2.05	12S7 1.95	833A 95.00
C1148A 116.00	EC99 1.10	ESU150 14.95	OC2 2.50	UCF101 1.00	3A124B 11.00	6B2 2.80	6J6 2.05	12S7 1.95	833A 95.00
C1150A	EC99 1.10	ESU150 14.95	OC2 2.50	UCF102 1.00	3A125B 11.00	6B2 2.80	6J6 2.05	12S7 1.95	833A 95.00
133.00	EC99 1.10	ESU150 14.95	OC2 2.50	UCF103 1.00	3A126B 11.00	6B2 2.80	6J6 2.05	12S7 1.95	833A 95.00
C1534 32.00	EC99 1.10	ESU150 14.95	OC2 2.50	UCF104 1.00	3A127B 11.00	6B2 2.80	6J6 2.05	12S7 1.95	833A 95.00
CCA 2.60	EC99 1.10	ESU150 14.95	OC2 2.50	UCF105 1.00	3A128B 11.00	6B2 2.80	6J6 2.05	12S7 1.95	833A 95.00
CCV 0.90	EC99 1.10	ESU150 14.95	OC2 2.50	UCF106 1.00	3A129B 11.00	6B2 2.80	6J6 2.05	12S7 1.95	833A 95.00
CL3 2.00	EC99 1.10	ESU150 14.95	OC2 2.50	UCF107 1.00	3A130B 11.00	6B2 2.80	6J6 2.05	12S7 1.95	833A 95.00
C3 Nos Prices on request	EC99 1.10	ESU150 14.95	OC2 2.50	UCF108 1.00	3A131B 11.00	6B2 2.80	6J6 2.05	12S7 1.95	833A 95.00
D3a 29.50	EC99 1.10	ESU150 14.95	OC2 2.50	UCF109 1.00	3A132B 11.00	6B2 2.80	6J6 2.05	12S7 1.95	833A 95.00
D83 1.20	EC99 1.10	ESU150 14.95	OC2 2.50	UCF110 1.00	3A133B 11.00	6B2 2.80	6J6 2.05	12S7 1.95	833A 95.00
DA41 22.50	EC99 1.10	ESU150 14.95	OC2 2.50	UCF111 1.00	3A134B 11.00	6B2 2.80	6J6 2.05	12S7 1.95	833A 95.00
DA42 17.50	EC99 1.10	ESU150 14.95	OC2 2.50	UCF112 1.00	3A135B 11.00	6B2 2.80	6J6 2.05	12S7 1.95	833A 95.00
DA90 4.80	EC99 1.10	ESU150 14.95	OC2 2.50	UCF113 1.00	3A136B 11.00	6B2 2.80	6J6 2.05	12S7 1.95	833A 95.00
DA100 125.00	EC99 1.10	ESU150 14.95	OC2 2.50	UCF114 1.00	3A137B 11.00	6B2 2.80	6J6 2.05	12S7 1.95	833A 95.00
DAF91 0.45	EC99 1.10	ESU150 14.95	OC2 2.50	UCF115 1.00	3A138B 11.00	6B2 2.80	6J6 2.05	12S7 1.95	833A 95.00
DAF91 0.70	EC99 1.10	ESU150 14.95	OC2 2.50	UCF116 1.00	3A139B 11.00	6B2 2.80	6J6 2.05	12S7 1.95	833A 95.00
DAF96 1.00	EC99 1.10	ESU150 14.95	OC2 2.50	UCF117 1.00	3A140B 11.00	6B2 2.80	6J6 2.05	12S7 1.95	833A 95.00
DC70 1.75	EC99 1.10	ESU150 14.95	OC2 2.50	UCF118 1.00	3A141B 11.00	6B2 2.80	6J6 2.05	12S7 1.95	833A 95.00
DC90 1.20	EC99 1.10	ESU150 14.95	OC2 2.50	UCF119 1.00	3A142B 11.00	6B2 2.80	6J6 2.05	12S7 1.95	833A 95.00
DCX4-1000	EC99 1.10	ESU150 14.95	OC2 2.50	UCF120 1.00	3A143B 11.00	6B2 2.80	6J6 2.05	12S7 1.95	833A 95.00
12.00	EC99 1.10	ESU150 14.95	OC2 2.50	UCF121 1.00	3A144B 11.00	6B2 2.80	6J6 2.05	12S7 1.95	833A 95.00
DCX4-5000	EC99 1.10	ESU150 14.95	OC2 2.50	UCF122 1.00	3A145B 11.00	6B2 2.80	6J6 2.05	12S7 1.95	833A 95.00
25.00	EC99 1.10	ESU150 14.95	OC2 2.50	UCF123 1.00	3A146B 11.00	6B2 2.80	6J6 2.05	12S7 1.95	833A 95.00
DET16 28.50	EC99 1.10	ESU150 14.95	OC2 2.50	UCF124 1.00	3A147B 11.00	6B2 2.80	6J6 2.05	12S7 1.95	833A 95.00
DET18 28.50	EC99 1.10	ESU150 14.95	OC2 2.50	UCF125 1.00	3A148B 11.00	6B2 2.80	6J6 2.05	12S7 1.95	833A 95.00
DET23 35.00	EC99 1.10	ESU150 14.95	OC2 2.50	UCF126 1.00	3A149B 11.00	6B2 2.80	6J6 2.05	12S7 1.95	833A 95.00
DET24 39.00	EC99 1.10	ESU150 14.95	OC2 2.50	UCF127 1.00	3A150B 11.00	6B2 2.80	6J6 2.05	12S7 1.95	833A 95.00
DET25 22.00	EC99 1.10	ESU150 14.95	OC2 2.50	UCF128 1.00	3A151B 11.00	6B2 2.80	6J6 2.05	12S7 1.95	833A 95.00
DF91 0.80	EC99 1.10	ESU150 14.95	OC2 2.50	UCF129 1.00	3A152B 11.00	6B2 2.80	6J6 2.05	12S7 1.95	833A 95.00
DF92 0.80	EC99 1.10	ESU150 14.95	OC2 2.50	UCF130 1.00	3A153B 11.00	6B2 2.80	6J6 2.05	12S7 1.95	833A 95.00
DF96 0.75	EC99 1.10	ESU150 14.95	OC2 2.50	UCF131 1.00	3A154B 11.00	6B2 2.80	6J6 2.05	12S7 1.95	833A 95.00
DF97 1.00	EC99 1.10	ESU150 14.95	OC2 2.50	UCF132 1.00	3A155B 11.00	6B2 2.80	6J6 2.05	12S7 1.95	833A 95.00
DH63 1.20	EC99 1.10	ESU150 14.95	OC2 2.50	UCF133 1.00	3A156B 11.00	6B2 2.80	6J6 2.05	12S7 1.95	833A 95.00
DH77 0.90	EC99 1.10	ESU150 14.95	OC2 2.50	UCF134 1.00	3A157B 11.00	6B2 2.80	6J6 2.05	12S7 1.95	833A 95.00
DH79 0.50	EC99 1.10	ESU150 14.95	OC2 2.50	UCF135 1.00	3A158B 11.00	6B2 2.80	6J6 2.05	12S7 1.95	833A 95.00
DH149 0.90	EC99 1.10	ESU150 14.95	OC2 2.50	UCF136 1.00	3A159B 11.00	6B2 2.80	6J6 2.05	12S7 1.95	833A 95.00
DK91 0.90	EC99 1.10	ESU150 14.95	OC2 2.50	UCF137 1.00	3A160B 11.00	6B2 2.80	6J6 2.05	12S7 1.95	833A 95.00
DK92 1.20	EC99 1.10	ESU150 14.95	OC2 2.50	UCF138 1.00	3A161B 11.00	6B2 2.80	6J6 2.05	12S7 1.95	833A 95.00
DL35 2.50	EC99 1.10	ESU150 14.95	OC2 2.50	UCF139 1.00	3A162B 11.00	6B2 2.80	6J6 2.05	12S7 1.95	833A 95.00
DL53 1.00	EC99 1.10	ESU150 14.95	OC2 2.50	UCF140 1.00	3A163B 11.00	6B2 2.80	6J6 2.05	12S7 1.95	833A 95.00
DL70 2.50	EC99 1.10	ESU150 14.95	OC2 2.50	UCF141 1.00	3A164B 11.00	6B2 2.80	6J6 2.05	12S7 1.95	833A 95.00
DL73 2.50	EC99 1.10	ESU150 14.95	OC2 2.50	UCF142 1.00	3A165B 11.00	6B2 2.80	6J6 2.05	12S7 1.95	833A 95.00
DL91 1.80	EC99 1.10	ESU150 14.95	OC2 2.50	UCF143 1.00	3A166B 11.00	6B2 2.80	6J6 2.05	12S7 1.95	833A 95.00
DL92 0.95	EC99 1.10	ESU150 14.95	OC2 2.50	UCF144 1.00	3A167B 11.00				





# DX DIARY

News for HF operators compiled by Don Field G3XTT

What is DX? To the Class B licensee, recently arrived on the HF bands, everything is DX compared to what he has been used to, with exotic calls from different countries and continents conjuring up visions of sun-soaked vistas or wild forests. To the old-timer, high on the DXCC Honour Roll, DX might just be the two or three contacts he needs in order to have worked every so-called 'country' there is.

For the real enthusiast, though, DX is an ever changing scene, bringing new delights at every turn of the tuning control. A new prefix, a rare oblast, an old friend to renew acquaintance with. When one peak has been scaled another is sought. A new band, a new mode, or make a fresh start on the ladder, perhaps with QRP this time.

## Restless energy

Our American cousins seem to be able to find this kind of restless energy, causing them to build ever bigger antennas, sink their cash into ever more real estate on which to build their dream station, or go off on expeditions to exotic places to sample the delights of the pile-up from the sharp end.

Very few British amateurs seem to exude this enthusiasm. Perhaps it is our retiring nature, or perhaps our other halves are less accommodating. Often interest wanes once even quite modest goals are achieved. Some manage to stand out from the pack, however. Read, for instance, Steve

Lowe's account in last month's issue of a contest operation from Montserrat. But consider that the same few regulars seem to appear time and again at the head of the contest results or at the top of league tables of countries, prefixes, zones and all the rest.

Having said all this, I am encouraged by the number of recently licensed G0s who I have heard in the 20 metre pile-ups for Operation Raleigh activities or in some of the regular 20 metre DX nets. Is it too much to hope that some of you will stay the course and go on to higher things? Otherwise HF amateur radio in the UK will continue to be dominated by the old-timers (like yours truly!) and will lose its verve and its momentum.

## QSL bureaux

Changing tack slightly, one major aspect of DXing for many is to achieve a collection of interesting QSL cards, both for awards purposes and as a memento of the QSO. Some awards do not require you to have QSL cards, only a certified log extract. I have never understood this. You may believe you worked a rare station but, in the heat of the pile-up, he may not have been working you at all or may have missed your report to him. The only way you can know for certain is when the QSL card arrives.

The cheapest way to collect QSL cards is to use the bureau system and, contrary to popular myth, this can be surprisingly fast. However, one point to bear in mind is

that there are still a number of countries without QSL bureaux. These are listed in the table. You may be surprised at how many there are, and it just might explain why you failed to receive some of those rare cards you were after.

## Always ask

With these countries the best way is to ask the operator concerned how you should go about getting his QSL card. He may ask you to send the card direct, or he may tell you that he has a QSL manager to whom the card should be sent. If you do QSL direct, it is usually best not to mention amateur radio on the envelope.

The local postmen in some of these countries soon get to know that such envelopes tend to contain IRCs or dollar bills, and so these items fail to reach their final destination. It is also sensible not to use commemorative stamps because, again, these can be a temptation to those who handle the envelope along its route.

Incidentally, the latest supplement to the *International Callbook* contains the addresses of many USSR amateurs, something which hasn't happened in the past, so this may be an indication that restrictions are being eased over there. Finally, while on the subject of the USSR and QSLs, *DX News Sheet* reports that VK6NE, who runs the Australian bureau, recently received a 1.875kg package of QSLs from the Russian bureau. Of these, 1.075kg were from SWLs!

## Around the bands

While my own log is relatively empty of late (yes, I'm afraid I took another holiday!), there have continued to be 20 metre openings to the Pacific, enabling many UK stations to work the GB0SWR gang from each of their stops (VR6, 5W, A3, 3D2) as mentioned above. BY (China) continues to be very active, with new call signs appearing at regular intervals. The HS0C operation by the Japanese group was worked by many people, and I heard at least 6 UK stations get through on 80 metres CW. Baldur DJ6SI put in an appearance from Kenya as 5Z5EXP, giving many a new prefix. 9M8GH has been active daily on 20 metres SSB around 1600GMT. VS6CT/KP2 was worked on several bands and also put in a brief appearance from one of the other Caribbean islands.

On the negative side, a group of Italians who announced that they would be on from Mt Athos had to pull out at the last minute when the Greek authorities withdrew permission. However, there are rumours that this attempt may finally have spurred the Greeks themselves to put on an expedition. Keep an ear to the bands this month.

## Upcoming DX

ZD9BV hopes to operate from Gough Island, commencing on 6 October. Krishna 9N1MC is now quite active from Nepal and is asking for UK amateur radio publications in order to encourage more interest in amateur



radio in that country. His address is Krishna Khatri, Ministry of Communications, Katmandu, Nepal.

A group of Dutch amateurs, together with one Englishman, will operate from Luxembourg on all bands from 9-13 October. VQ9GB is reported to be especially active at weekends from 1600GMT on 14200kHz. OH1RY is planning a Pacific trip to take in Fiji from 19-22 October, Tuvalu from 22-29 October, Tonga from 29 October to 5 November, and Western Samoa from 5-9 November. Ron ZL1AMO is rumoured to be planning another jaunt some time this autumn, also taking in Fiji and Western Samoa as well as VK9X, Christmas Island.

Another rumour is that VQ9ZZ and N4GNR will activate Spratly Island and Kingman Reef later in the year. Fingers crossed, though I would regard this with suspicion. A group of Argentinian amateurs hope to sign AZ1D from Trinidad Island (not the island of Trinidad) from 20-25 October. Check 3510, 7005, 14020, 21020, 28020, 3690, 7090, 14200 and 28600kHz. And, of course, don't forget GM3YOR/4S7. This has slipped back a week, so the dates are now 21 October to 5 November.

### CQ world-wide

Details are starting to come in of the expeditions which will be mounted for the CQ World-wide DX Contests at the end of October and November (SSB leg on 25/26 October, CW leg on 29/30 November). In the October event HL9CW and others will operate /KH0 from the Marianas and NQ41 will be putting in a single operator multiband effort as 8R1Z from Guyana.

In the November event JA5DQH will operate from VS6DO's station in Hong Kong, and three Californian amateurs will operate from the Turks and Caicos islands as VP5X. Finally, the radio-equipped villas on Montserrat used by G4JVG and others (see his article last month) have been booked for both legs of the contest.

### Other contests

There are other, lesser, contests due to take place during October. The VK/ZL/Oceania SSB Contest

takes place over the weekend of 4/5 October and the CW leg is a week later. The latter coincides on the Sunday with the RSGB 21/28MHz SSB Contest. A couple of US QSO parties also take place during that weekend: the Pennsylvania event on 11/12 October and the Illinois event on 12/13 October. The Cayman Island Pirates Week runs from 25 October to 1 November, an opportunity to catch up with some of the locals on this island paradise.

### Jubilee Award

*DX News Sheet* carries details of the LZ60 Jubilee Award, issued free by the Bulgarian Federation of Radio Amateurs to commemorate the 60th anniversary of the foundation of the first amateur club station in Bulgaria. The award is available to amateurs and SWLs around the world who have made/heard the requisite number of contacts during the period 15 July to 31 December 1986.

A total of 60 points is required and may be gained as follows: 6 points for a contact with an LZ6 station, 1 point for each contact with an LZ1 or LZ2 station. Each LZ station may be counted only once. LZ6 is a special prefix authorised for this period and, by late August, some 39 LZ6 callsigns were in use. Applications, consisting of a log extract certified by a national awards manager or two licensed amateurs, should be sent to BFRA, PO Box 830, 1000 Sofia, Bulgaria. No charge is mentioned in connection with this award.

### DXCC

A recent issue of the American *CQ Magazine* carried an interesting item about the history of the DXCC Award and the countries list. This was prompted by recent attempts in the USA to restart DXCC from scratch and put all amateurs back on an equal footing.

The DXCC Award actually came into being as long ago as 1937, and *QST* magazine in November of that year listed the first holders of the award. Even before this there had been attempts to define a countries' list so that DXers could compare their achievements and could arrive at contest scores. In 1935 an American columnist stated

that, in his view, every discrete geographical or political entity should count as a separate 'country'. Amazingly, in retrospect, he felt that, on this basis, amateurs should be able to draw up their own lists of countries and that these lists would be identical!

By the time the DXCC Award was introduced, though, the ARRL had published a world map showing some 250 or so countries. A year later an amended list had been issued which separated the Cayman Islands from Jamaica, and added a number of new countries by way of the Channel Islands, Wales, Scotland and the Isle of Man, Curacao, Trinidad and Tobago, Turks and Caicos, French India, Jan Mayen, Jarvis Island, Kuwait, South West Africa, and several of the Russian republics plus Franz Josef Land. At the same time the Bismark Archipelago was deleted from the list. It was this revised list which formed the basis of the DXCC Award and which remains remarkably unchanged after nearly 50 years.

### Some changes

Some minor changes were made to the list in 1939. Things then became quiet during the war years. The DXCC programme as we now know it was started after the war, with some minor provisions being made for those who had obtained the pre-war award. The post-war countries list was published in 1947, and if you get a DXCC application form from the ARRL you will see that it lists all additions and deletions from that time, with credit being given for deleted countries.

Newcomers may not realise that the RSGB countries list differed from the DXCC list until, if my memory serves me right, some time in the early 1970s. For instance, the RSGB regarded the Channel Islands as a single country, whereas DXCC had for many years given separate credit for Jersey and Guernsey (again, you may not realise that the prefix for all the Channel Islands at that time was GC, rather than GJ and GU. Some national societies still go their own way. *CQ Magazine*, in scoring the CQ World-wide Contests, recognises the ARRL list plus those European countries which are on

the German WAE list, specifically the Shetland Islands and the Karelo-Finnish Republic (UN1).

A lot of fuss about nothing? Maybe, but the countries list is one of the hottest topics of conversation among DXers. Any changes are hotly contested, and at this very moment there are heated discussions about the Pribilof Islands, the Vienna International Centre, and Aruba. As to whether DXCC will be restarted from scratch, we will have to wait and see. If you are a newcomer you may well be in favour, to put you on an equal footing with the rest. But will you still be as keen in 20 years time when the then new-licences request yet another restart and all your efforts are as nothing?

With that thought I will close for another month. Any comments on the above or other HF-related issues will be welcome as always.

### Countries with no QSL Bureau

A5	Bhutan
A6	UAE
A7	Qatar
BV	Taiwan
C9	Mozambique
D6	Comoros
ET	Ethiopia
HZ	Saudi Arabia
J5	Guinea-Bissau
KC4	US Antarctica
KC6	Belau
KC6	Micronesia
KH1	Baker & Howland
KH3	Johnston Is
KH5	Palmyra and Jarvis
KH7	Kure Is
KH9	Wake Is
KP1	Navassa Is
KP5	Desecheo
T2	Tuvalu
T3	Kiribati
T5	Somalia
TJ	Cameroon
TL	Central African Republic.
TN	Congo
TT	Chad
TY	Benin
TZ	Mali
V4	St Kitts
VP2E	Anguilla
VR6	Pitcairn
XT	Burkino Faso
XU	Kampuchea
XV	Vietnam
XW	Laos
XX	Macao
XZ	Burma
YA	Afghanistan
ZA	Albania
ZD7	St Helena
ZD9	Tristan da Cunha
ZK2	Niue
ZK3	Tokelau
3C	Equatorial Guinea
3V	Tunisia
3X	Guinea
4W	North Yemen
5A	Libya
5H	Tanzania
5R	Malagasy Republic
5U	Niger
5X	Uganda
7O	Yemen People's Democratic Republic
7Q	Malawi
8Q	Maldiv Islands
9G	Ghana
9N	Nepal
9U	Burundi

# Ian Poole G3YWX investigates

## The **HISTORY** of the **SUPERHET**

The superhet principle is used almost universally in all types of receiver today. Transistor portables, communications receivers, radar systems and equipment for space travel communications all use the superhet principle to obtain the required performance.

Today's communications receivers are highly selective, sensitive and very stable – all attributes which are made possible by the superhet principle. Today, high performance receivers are taken for granted, but in the early days of wireless, sensitivity, selectivity and stability were not easy to achieve, especially with the components which were available then. The development of the idea of the superhet took several years as people discovered the different effects which could finally be brought together to produce the superhet. Even when it had been developed there were some disadvantages, which meant that it took many years before the superhet became firmly established as the most popular concept to use for receiver design.

### Early discoveries

Before the basic concept of the superheterodyne receiver was evolved, a large number of other ideas had to be discovered and developed. Later these ideas were to be put together to form the principle of the superhet receiver.

One of these early discoveries was made by an American engineer called Fessenden. His idea was to transmit a

signal which would produce the required output in the receiver headphones. Although this might appear very simple, it should be remembered that at this time Morse was used exclusively and the signals were heard as a set of clicks which were not easy to decipher.

One way in which Fessenden suggested that his idea could be realised was to transmit two signals which were close together in frequency. When the combined signal was detected in the receiver an audio tone would be produced which would be much easier to decipher. This very basic idea was patented in 1901 and was the first recorded proposal in which beat frequencies were used in wireless.

### Revised and improved

Later on Fessenden revised and improved his initial concept. Instead of transmitting two signals from the transmitter, he put forward the idea of transmitting one and generating the other locally within the receiver. Using this idea, the operator could then control the beat note to give the best output. Fessenden called this oscillator a heterodyne oscillator from the Greek words *heteros* and *dynamis*, meaning external force.

Surprisingly enough, this idea was not developed any further for some years. This was mainly due to the limitations of the technology available at the time, which meant that this system was even less sensitive than others of that period.

However, over the years other advancements were made which allowed the heterodyne receivers to improve their sensitivity. Improvements were such that during some American Naval tests in 1913 the heterodyne receiver was shown to offer better sensitivity than other systems. One of the reasons for this was undoubtedly that the heterodyne receiver gave out an audio tone, whereas the others gave outputs in which it was difficult to distinguish between the wanted signal and atmospheric noise.

### New discoveries

There were, of course, many other discoveries which were to contribute to the development of the superhet in other areas of wireless technology. One of these was the thermionic valve. The first discovery in this field was made by Dr J A Fleming of University College, London. In his laboratory in the university buildings, just off Gower Street in central London, he developed his diode valve. This discovery was soon followed in America by the inclusion of a third electrode to form a triode valve, which was capable of amplifying signals.

Then, in 1913, the laboratories at Telefunken managed to produce the first valve oscillator. This was a major step forward because the previous units which had been used to produce continuous signals were both cumbersome and expensive. Therefore, the advent of valve oscillators meant that it was considerably easier to generate radio frequency signals for transmitters and receivers.

Further advances using valves followed very rapidly. One of these came at the end of 1913, when Captain H V Round produced a receiver called the autodyne. In this receiver one valve was used to perform the functions of oscillator and mixer. This type of development was particularly useful because valve circuits were still very large and expensive. Unfortunately it did have some drawbacks, the main one being that it proved difficult to make the valve operate at audio and at RF simultaneously.

In spite of the many difficulties which were encountered, progress was being made which paved the way for the development of the superhet itself.

### The first superhets

With the development of the valve and the heterodyne principle the way was now open for the discovery of the superhet itself. As it happened a further ingredient was added to encourage its discovery – the First World War. With the onset of war, the value of wireless communication was quickly appreciated and more development was started.

Investigations were made into the selective reception of weak signals of what were then very high frequencies, between 500kHz and 3MHz. Initial ideas for designing amplifiers at these frequencies ran into severe problems, mainly because of the valves which were available. The high interelectrode capacitance of these valves gave rise to instability whilst keeping their gain low.

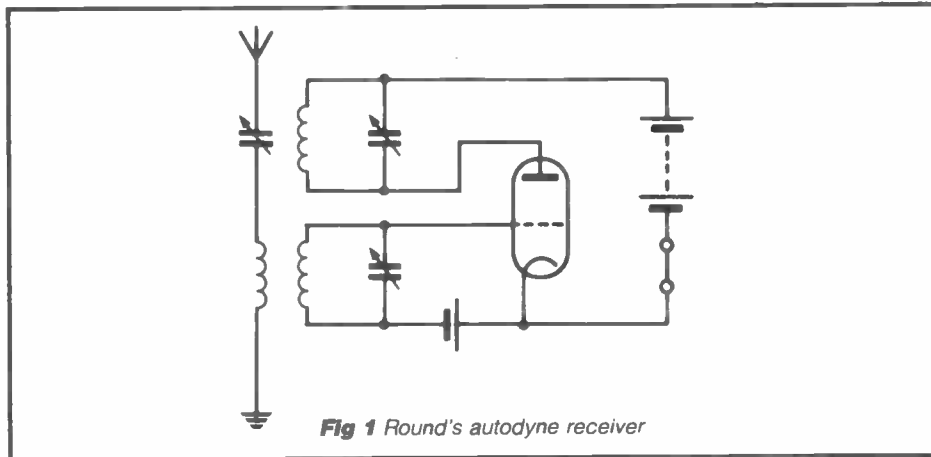

Fig 1 Round's autodyne receiver



# SUPERHET

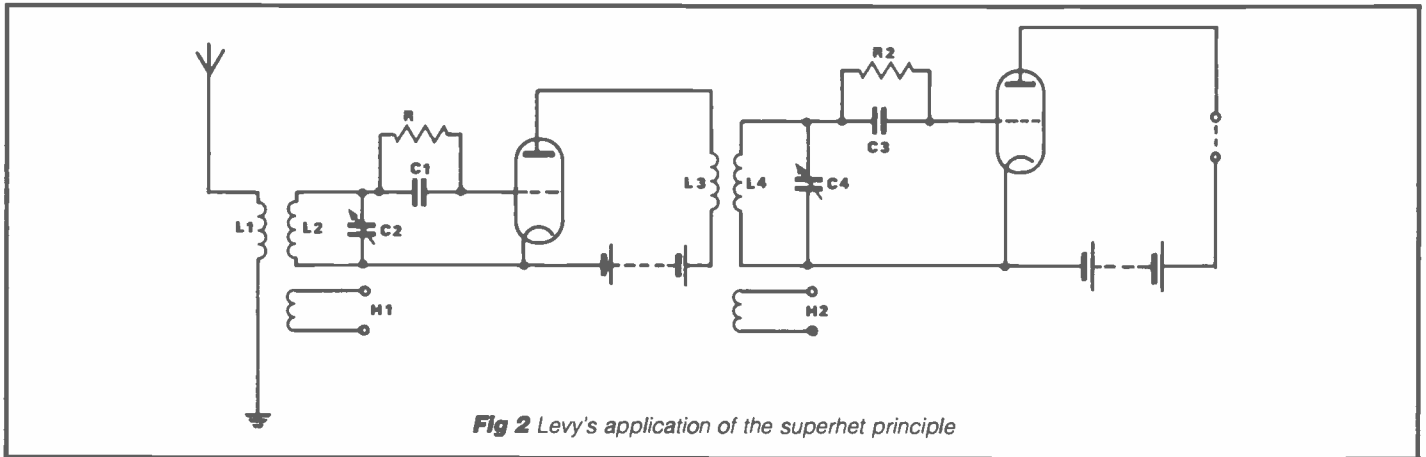

Fig 2 Levy's application of the superhet principle

Although many attempts were made to build amplifiers at these frequencies and some level of success was achieved, it was obvious that a new approach had to be sought.

## Lucien Levy

The first person to do this was a French engineer named Lucien Levy. He was primarily looking at ways of improving the selectivity of receivers and developed the idea of converting the signals to a frequency where they could be more easily separated from one another. He did this by superimposing or mixing the wanted signal with another locally produced one to give what was called an ultra-acoustical beat. Having achieved this, the signal could be amplified and tuned more easily. After this the signal was converted to audio by the use of a second heterodyne.

The advantages of this system were enormous. The 'ultra-acoustical' beats could be separated more easily and Levy even claimed that this new idea would completely remove atmospheric interference! The other main advantage was that the idea overcame the instability problems associated with the multistage tuned amplifiers of the day because it enabled amplification at a much lower frequency. Levy filed the patent for his idea in August 1917.

Although Levy had very nearly discovered the idea of the superhet as we know it today, he still retained the idea of variable tuning at the intermediate frequency. This presented problems in ensuring that all the stages were tuned to the same frequency.

The next development was to finalise the idea of the superhet in the form it is known today. An American named Armstrong is credited with actually inventing it and he filed his patent at the end of December in 1918. His design used a fixed intermediate frequency and this enabled him to use more stages of amplification. In his patent Armstrong claimed that his new idea gave higher gain because the signal amplification was performed at a lower frequency, where valves were more stable and capable of producing the necessary gain. He also said that his system was more selective because of the lower

frequency involved, and because several stages could be used.

In fact, Armstrong produced an eight valve superhet consisting of a first detector or mixer, a heterodyne oscillator, three stages of IF amplification, a second detector and two stages of audio amplification. Although this was a very early design, it was still capable of giving good results which were certainly much better than those obtained with any other receivers at the time.

Armstrong is always credited with having invented the superhet, but work into this idea was also carried out elsewhere. In fact, a German named Schottky had patented the idea about six months before Armstrong.

## After the war

After the war had ended in 1918 the rate of development of new ideas slowed considerably. In spite of this, the performance of valves continued to improve and they became more stable and able to provide more gain at higher frequencies. As a result, some of the advantages of the superhet were eroded as it became easier to construct high gain RF amplifiers. In addition, there were only a few high power stations on the air and the need for selectivity was less. Then there were other practical reasons, like the fact that the filament of each valve consumed about three quarters of an amp. As this current had to be supplied by batteries, designers attempted to minimise the number of valves which

were used and only incorporate valves giving gain. This meant that the oscillator stage in a superhet was considered an unnecessary luxury, making this approach look less attractive.

Very little was heard of the superhet in Europe until some short wave transatlantic tests were carried out. Some initial tests in February 1920 had not been successful and because of this the ARRL decided to send a representative named Paul Godley to Britain for the next series of tests to be conducted. He set up his station at Ardrossan in Scotland in the winter of 1921. Using his 9 valve Armstrong Superhet with an IF of 100kHz and a beverage aerial, he was the first person to hear and identify an American station - 1BCG in New York. Later on during these tests he heard several other American stations, although this time other British stations, including 2KW, using simple TRF receivers managed to hear some Americans as well.

Despite this success, the superhet still remained unpopular although some development still continued. New ideas were tried and names like harmonic heterodyne, tropodyne and infradyne appeared, describing variations on the basic superhet theme.

## Production receivers

It was chiefly in the USA that the superhet first found favour to any degree. There was a rapid growth in the number of high powered broadcast stations. With this arose the need for a

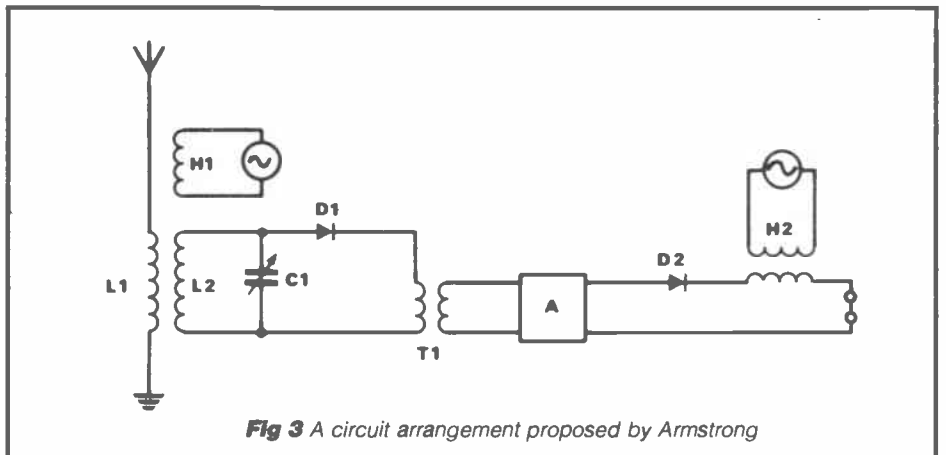

Fig 3 A circuit arrangement proposed by Armstrong

## SUPERHET

degree of selectivity that the existing TRF (tuned radio frequency) receivers were unable to give.

Unfortunately, the superhet was still far from ideal, as it suffered from a number of disadvantages which had to be overcome before it could be widely produced. The first one was the very poor image performance which these sets possessed. This was caused by the fact that the standard intermediate frequency was only 50kHz. It had been chosen because it enabled the IF amplifier to be more stable, selective and have a higher degree of gain. However, as the performance of valves improved it was possible to use a frequency of 180kHz. This enabled great improvements to be made in reducing the problems caused by image signals.

Another development in valves also helped. New valves with 'dull emitters' were produced and these only consumed about a quarter of the filament current of the previous ones. This meant that sets could be made smaller, and they were less costly.

### Other problems

There were other problems which had to be overcome. One of these was that sets required two tuning controls: one for the RF tuning and the other for the local oscillator. This made the sets more

difficult to use, and accordingly less easy to sell. The problem was overcome by devising a dual gang variable condenser (or capacitor) which would enable both circuits to be tuned by the same control. Although this may seem an obvious solution now, problems like these were more difficult to overcome in these early days of wireless pioneering.

In spite of all these improvements, interest in the superhet remained low in Europe. There were considerably less broadcast stations on the air and three-valve designs, using one valve for the RF stage, one for the detector and a third for the audio, remained popular.

### Reduced cost

As time passed more high power broadcast stations came on the air, particularly in the early 1930s, and the need for better receivers was felt more in Europe. As well as this, the better manufacturing techniques and ideas pioneered in the USA meant that the cost of superhet sets were lower and more could be sold. It was only by about 1934 that the superhet made its presence felt in the market place. More circuits were seen in 1934 and a design in *Wireless World* created a lot of interest.

Developments continued throughout the late 1930s and sets giving higher quality and incorporating many new

features, such as automatic gain control, were seen. All of these developments were vital as they would be needed to improve communication in the war which was about to begin in 1939. As a result of the war, many receiver designs appeared which are still seen today. Receivers like the AR88, HRO, 19 set and so on were produced and they can still give a good account of themselves.

### Recent developments

Since the 1940s the design of superhets has advanced in many ways. Amateur band receivers have been designed with two conversions: the first one higher in frequency to give better image rejection, and the second one at a lower frequency to give the required selectivity. There have also been high performance designs using a crystal controlled first conversion and an unswitched VFO for the second conversion to give high degrees of stability. Then, of course, designs have changed to use phase locked loop synthesizers, giving new levels of versatility and stability. However, beneath all this the basic concept of the superhet has remained the same, and all today's high performance, state of the art receivers can trace their origins back to the early work done by people such as Levy, Armstrong and Schottky.

## The Archer Z80 SBC

The SDS ARCHER – The Z80 based single board computer chosen by professionals and OEM users.

- ★ Top quality board with 4 parallel and 2 serial ports, counter-timers, power-fail interrupt, watchdog timer, EPROM & battery backed RAM.
- ★ **OPTIONS:** on board power supply, smart case, ROMable BASIC, Debug Monitor, wide range of I/O & memory extension cards.

from £185 + VAT.

## The Bowman 68000 SBC

The SDS BOWMAN – The 68000 based single board computer for advanced high speed applications.

- ★ Extended double Eurocard with 2 parallel & 2 serial ports, battery backed CMOS RAM, EPROM, 2 counter-timers, watchdog timer, powerfail interrupt, & an optional zero wait state half megabyte D-RAM.
- ★ Extended width versions with on board power supply and case.

from £295 + VAT.

## Sherwood Data Systems Ltd

Sherwood House, The Avenue, Farnham Common, Slough SL2 3JX. Tel. 02814-5067

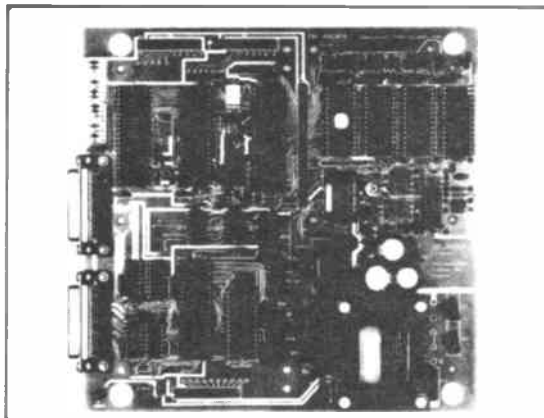



# ANGUS MCKENZIE

## TESTS

The IC28E is Icom's latest FM mobile for 2m. It is surprisingly small, yet capable of delivering well over 25W into an antenna. The rig comes complete with a mobile mounting bracket, measures only 140mm W x 50mm H x 148.5mm D (including projections) and weighs just under 1kg. The mic supplied is an HM15 electret hand mic with PTT, toneburst and up and down buttons. There is a switch on the back which will turn off the up and down actuating circuits, which can be quite useful.

The rig itself covers the entire band, 144 to 146MHz in 12.5 or 25kHz steps, but on receive it offers channelised coverage from 138 to 174MHz, thus covering some quite interesting frequencies. The normal Rx filter fitted at 455kHz is for 25kHz channelling, and is an E type with around 15kHz bandwidth. You would need to change this to a G type if you wanted a 12.5kHz channelling capability, these filters having between 8 and 10kHz bandwidths, depending on the make.

All Icom FM mobile rigs are normally fitted with 15kHz bandwidth filters, but Thanet can fit the narrower ones to special order at additional cost, the G filter costing around £20 including a fitting charge. The built-in speaker is underneath the rig, but you may find it much better to use an external mobile speaker for improved readability, as the quality from the internal speaker is limited.

### Front panel facilities

The tuning knob clicks round in 12.5 or 25kHz steps, selected by pressing a 'set' button and then clicking the VFO one step, which toggles between the two channellings. On pressing set again you return to normal operation with the selected channelling. This set button also allows you to select the required repeater offset, an additional button cycling between simplex, minus or plus repeater shifts. There are 21 memories into which one can store frequency and repeater shift.

A call button allows one to access memory 21 instantly. Additional buttons select memory write, VFO or memory recall rocker, 1MHz up/down rocker (also changes memory channels in memory mode) and tone squelch/digital squelch (functioning with optional accessories, not normally for the UK market). Two rotaries are provided for audio Rx gain with incorporated on/off push switch and squelch, the latter giving reverse repeater operation when pushed in (spring-loaded). A power switch selects full power or low power operation. The mic socket has the standard Icom 8-pin configuration, and includes a screw locking collar ring.

The digital frequency display is a black

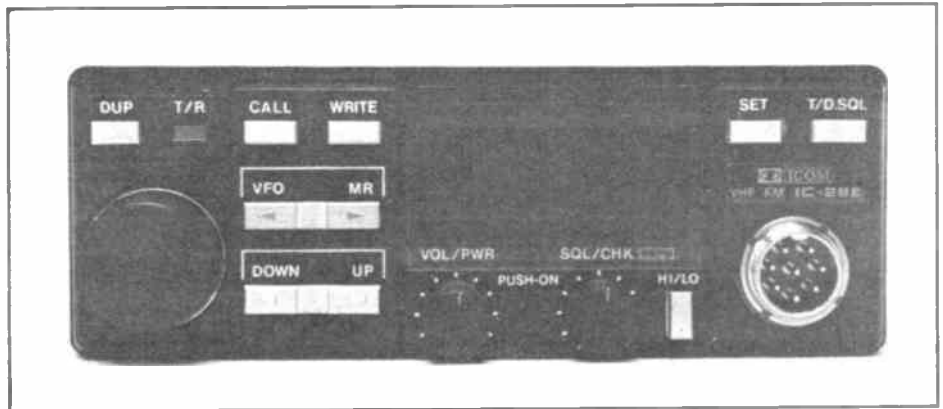

## ICOM IC28E

### 144MHz FM mobile transceiver

LCD on a green lit background, and is easy to read. The display gives comprehensive status indications, including S-meter and low/high power, etc. I have found some Icom rigs rather cluttered on the front panel, but this time it seems much more obvious and easier to operate at a glance, although you will have to resort to the instruction book to sort out some of the second functions operated by the set switch.

### Rear panel

The 13.8V dc interconnection is on a short flying lead fitted with a plug and socket, an extension lead being provided which is fused in both positive and negative and is of more than ample length (2.65m). The antenna connection is again on a flying lead, at the end of which is a good quality SO239 socket encased in a waterproofing shield. The

only other rear panel connection is a 3.5mm jack socket for an external speaker.

There is a heatsink on the back but unfortunately no fan is fitted, and it has to be said here that the back gets extremely hot in operation, especially after a long over. Although there was no failure on the review sample, and I have not heard of any problems that others have had with the rig, I am rather concerned about this overheating, and you will obviously have to seriously consider providing excellent ventilation behind and under the rig in a mobile installation.

### Subjective trials

The rig has the usual scanning facility, which is operated by the up/down buttons on the mic. When scanning is engaged either in the VFO or memory mode the rig searches for a channel in

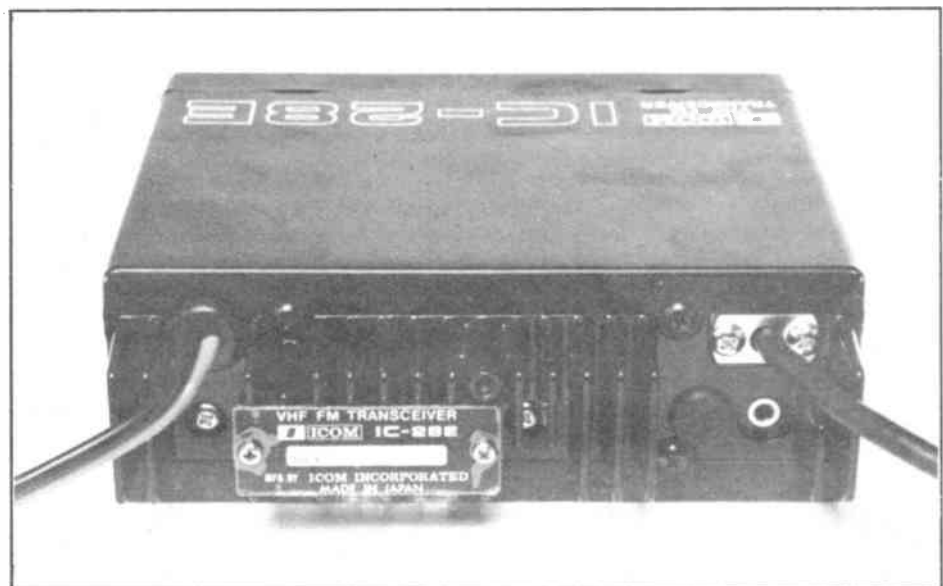

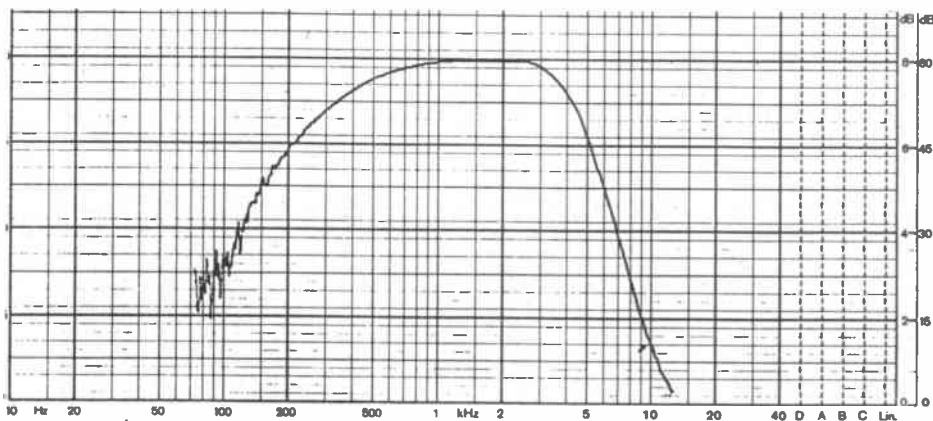

IC28E Tx response into 750µS de-emphasis

## Icom IC28E Laboratory Results

### Receiver tests

Rx sensitivity RF level for 12dB sinad

138MHz	-119dBm
143.6MHz	-123.8dBm
144.025MHz	-122.7dBm
144.950MHz	-122.4dBm
145.975MHz	-121.8dBm
174MHz	-109.7dBm

Quieting at 12dB sinad point -13.8dB

RF input intercept point 50/100kHz spacing -4.8dBm  
100/200kHz spacing -3.9dBm

### Selectivity

12.5kHz channels	+10.8dB average
25kHz channels	+69.7dB average

### S-meter

S1	-108dBm
S5	-104dBm
S9	-101dBm
S9+	-100dBm
S9++	-99dBm

Capture ratio 4.6dB

3dB limiting point -126.7dBm

### Discriminator distortion

1kHz deviation	0.5%
3kHz deviation	1.3%
5kHz deviation	3.1%

### Audio output power for 10% THD

8 ohms	2.9 watts
4 ohms	4.9 watts

Squelched Rx current drain at 13.8V 340mA

### Transmitter tests

RF output power, high/low	30/4.9 watts
Max deviation	6.1kHz
Typical speech deviation	5kHz
Toneburst deviation	4.6kHz
Toneburst frequency	1750Hz within 0.1Hz
Carrier frequency accuracy	+820Hz
Repeater shift	Within 10Hz
Harmonics	Below -60dBc
RF spuri	Below -70dBc

Signal to noise ratio ref full mod better than 44dB

Current drain on Tx at 13.8V  
High 5.3 amps  
Low 2.43 amps

use, and it stops when you press PTT or one of the other buttons. If you do not hold the scan at this point, scanning recommences after about 12 seconds, or 2.5 seconds after a carrier has dropped.

There is a skip facility for use on memory scan, which allows you to skip over any number of the memory channels. To obtain the skip function, you switch the rig to the memory mode, dial in the memory channel required by using the VFO knob or the up and down buttons, then press set to enable skip. Pressing set again removes the skip command.

I found in general operation that the ergonomics were very good, and the facilities provided are just about at the maximum of what one normally needs. Fortunately, the bevy of dual function buttons provided on some earlier Icoms have been avoided, so the IC28E is much less confusing. The RF sensitivity is adequate enough, but not as good as some of its competition, and whilst the front-end is almost bomb proof, the selectivity is rather wide and not suitable for coping with 12.5kHz channelled stations if there are QSOs on adjacent channels. Received audio quality was limited on the built-in speaker, but was excellent on an external one, the transmitted quality also being liked.

I quite liked the repeater offset button, which cycles between simplex and offsets, and all the other front panel facilities were easy to use, the MHz up/down and memory or VFO switches being rocker ones which are easier to use than some alternatives.

### Laboratory tests

The receiver's RF sensitivity was in no way outstanding and it was actually just adequate at the FM end, although it improved at the bottom of the band where you would not be using the rig anyway. Between 144 and 146MHz, a helical filter is switched in to the front-end to give good rejection of out of band signals, but this clearly affected the sensitivity slightly. Mark Capstick had a good look at sensitivity across the entire range from 138 to 174MHz, and optimum sensitivity was at around 143.5MHz. It was actually quite good at this point, being around 2dB more sensitive than it had been 2MHz higher.

One could easily optimise the sensitivity where it is desired by tweaking the antenna input circuit, but I feel that Icom should have done this more accurately themselves at the factory. Down at 138MHz, however, sensitivity was poor but usable, whilst at 174MHz it was extremely poor, around 14dB less sensitive than at 143.5MHz. The broadband receive facility is a bonus, but at least it can be optimised to become quite good in the middle of the band.

The front-end intercept point measured extremely well, so you are not likely to get any intermodulation problems with this rig unless you are very close to several strong stations off channel, perhaps in the same car park,



for example! The local oscillator seemed very clean, and the selectivity excellent for 25kHz channelling, but not even adequate for 12.5kHz separations. The S-meter is a simple LCD bar graph and gave a range of only 7dB between S1 and S9, the next indication coming on with an increase of only 1dB above S9. It seems that most received signals will be below S1 or above S9! I suppose one might say that this S-meter serves to indicate the presence of a signal which you can hear anyway!

The FM detector distortion was at a fairly low level up to 3kHz deviation, whilst at 5kHz it increased to just over 3%. Plenty of power was available into an external 8 ohm speaker load, and nearly 5W could be driven on peaks into a 4 ohm speaker, which means that much more power is available than usual.

The received frequency response, measured using a 750 $\mu$ S pre-emphasised source, showed quite a steep bass roll-off below 400Hz, which is just about right in the context of mobile operation. This should certainly avoid any boominess in speech reproduction in the car, and add to the general clarity. At the treble end the response is fairly flat up to around 3kHz and, somewhat surprisingly, 5kHz is only 11dB down, which I consider too extended. Under normal circumstances this will allow quite good speech intelligibility, but on a very crowded band, and when 12.5kHz channelling is in use, you may note rather more interference than usual at the HF audio end.

The receiver was very well set up in terms of received frequency accuracy, and no improvement in apparent sensitivity was noted when we swung the generator off frequency either side of the nominal one. Weak signals were reproduced quite cleanly, but the signal to noise ratio at the 12dB sinad sensitivity point was only marginally better, showing that there was very little distortion subjectively in the sinad audio measurement.

### The transmitting section

The rig gave a healthy 30W output when driven from a 13.8V supply, slightly more power being available at the HF end. Just under 5W was available on the low power position, which should normally be used to avoid heating up the rig too much and to give improved channel occupancy potential in any area.

We checked for second and third RF harmonics, and these were well below -60dB and not detectable. We did not note any spurious at up to  $\pm 50$ MHz from the transmitted carrier above -70dB, which is excellent. On Tx, the VCO runs at final frequency and is a FET oscillator, with varicap modulation. In a frequency sweep test, carried out at 20dB above standard deviation, we noted a maximum of 6.1kHz deviation at the low frequency of 360Hz. Normal speech deviation peaked around 5kHz, whilst the tone-burst deviated 4.6kHz and its frequency accuracy was within 0.1Hz!

The RF frequency accuracy was 820Hz

*Icom IC28E FM received audio response (750 $\mu$ S pre-emphasis)*

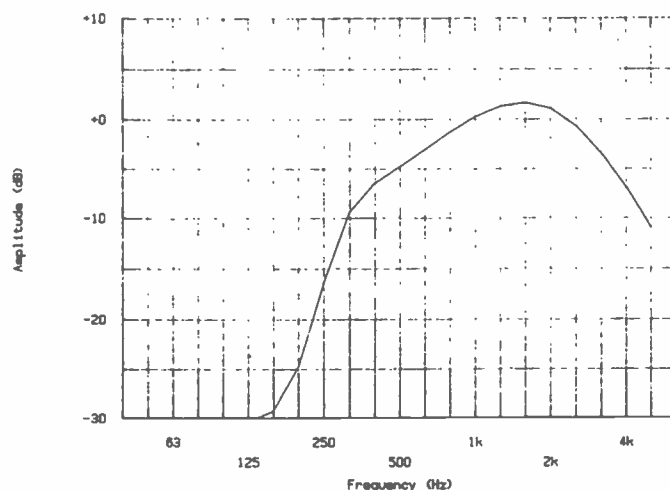

out, which is adequate, and the repeater shift was extremely accurate. We checked the potential transmitted signal to noise ratio by noting the transmitted deviation with the mic connected, and with everybody in the lab being as quiet as mice, and achieved an excellent 44dB transmitted dynamic range.

We checked the transmitted response from the mic input socket to the carrier with a deviation meter having 750 $\mu$ S de-emphasis switched in. The response was flat from 1kHz to 2.5kHz and below 1kHz response rolled off gently down to 500Hz (-2dB), whilst at LF it attenuated more rapidly, but certainly not steeply. At HF, the response was only 1dB down at 3.2kHz, whilst at 5kHz it was only 9dB down. I feel this response is excessively wide and there will certainly be a tendency to splatter at HF into an adjacent 12.5kHz channel, so you may need to add some additional HF roll-off if you choose to reset the deviation down to 3kHz or so and install a narrower filter for 12.5kHz channelling.

At high power the rig takes 5.3A, but this reduces to 2.4A on low power. The

receiver takes 340mA when squelched, which shows reasonable current economy for a mobile rig, but don't leave it on over the weekend in the garage!

### Conclusions

This is an amazingly compact high power rig, and although I am a little worried about its heating up problem, I feel that I can safely recommend it. Its audio quality on transmit and receive is good, and the ergonomics seem a lot better than on some earlier Icom mobiles. You will be able to put the rig in places where much of the competition will not fit, but don't forget to have good ventilation around it.

The rig costs £325 including VAT, and this includes mic and mobile bracket. The IC28H is a high power version, rated at 45W output and selling at £358 including VAT. This has a larger heatsink on the back, and presumably also gets very hot as it does not have a fan either.

Many thanks to Thanet Electronics for the loan of the review sample, and to Mark Capstick G4RCD for helping in all the measurements.

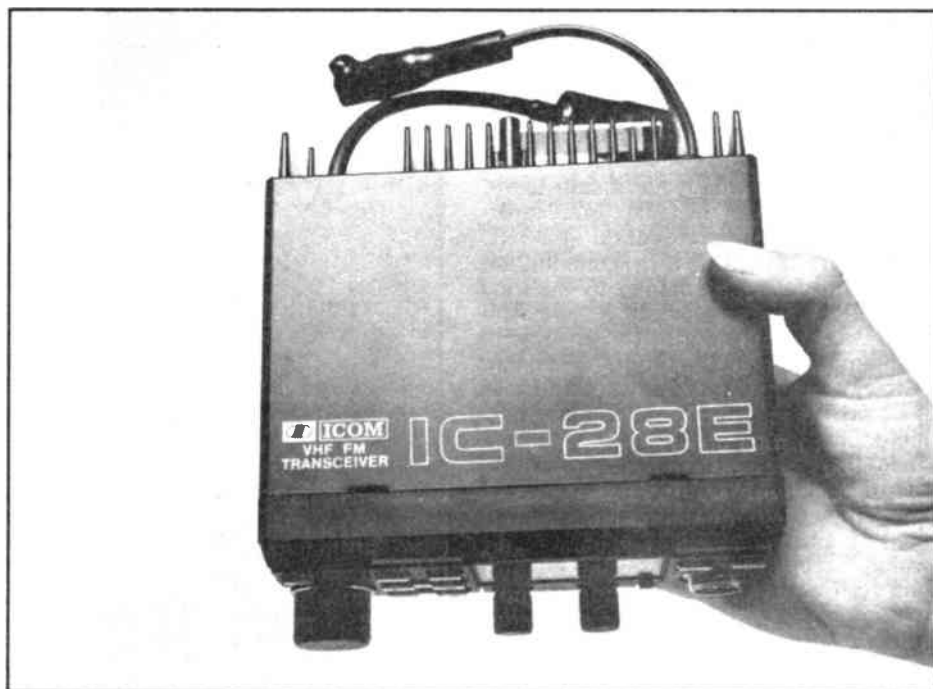



## ICOM IC12E

### 23cm FM hand-held

Before Icom released this new hand-held, there were only two other FM only rigs available for the 23cm band, the Icom IC120 mobile rig and the Trio TR50 portable. Both were extremely expensive and thus not really viable. The new IC12E is styled virtually identically to the IC02E and IC04E models, but, interestingly, the whip connection is a TNC instead of a BNC. This is very similar, but the spring lock is replaced by a screw thread, thus resembling an N type. The whip would appear to be a 5/8" with matching built into the plug. A BP3 nicad battery and charger is also supplied with the rig, the total cost being £395 including VAT.

On the top panel is the audio volume on/off rotary, by the side of which, concentrically mounted, are the squelch control and a centre indented rotary which can be switched either to alter Tx and Rx frequencies up to  $\pm 7$ kHz, or to become an RIT with the same maximum offset. Three miniature push-buttons select low or high power (typically 100mW and 900mW respectively), VXO or

RIT, and illumination on/off.

Also on the top panel are miniature sockets for connecting an external microphone and headset, and 13.8V dc input. The battery includes a charging socket on the rear and the battery slides off from the bottom of the rig to reveal the internal battery contacts.

The 4 x 4 matrix pad on the front has the same labelling as the IC02E. It allows one direct access to any frequency in 12.5, 25, 37.5, 50 or 62.5kHz channels between 1260 and 1299.9875MHz. You can select your own required repeater shift and the present UK one is 6MHz negative on Tx, although as yet there are only two or three repeaters actually functioning. Ten memories allow you to store frequency and repeater offset if required. You can go up and down channels quite easily, and direct access to a priority channel is included.

#### Subjective trials

Having satisfied myself that the rig was functioning by working G4RCD around my own home location, we jointly worked G3JXN in Ealing, who was able to follow us everywhere in the house with signals of at least 5/9, even when we were only running 100mW. G3JXN is around 10 miles away and has an excellent 23cm station, but even so I was surprised at his reports, even with the rig at ground level.

We came to the conclusion that the IC12E was capable of being received just as well as an equivalent power from a 70cm hand-held, and whilst there was much more flutter when I was walking around, there were far more reflections, and thus a better coverage, when obstacles obstructed the path.

Both the transmitted and received quality were up to the standard of the lower frequency models, and I suspect that the overall transmitted quality is actually better than that of the other versions, as one can use somewhat higher deviation, which permits a better

signal to noise ratio with an appropriate wide receive filter.

We only carried out brief tests, but we noted that the transmitted frequency error was about 2.5kHz. Adequate, but a little disappointing, although one can, of course, offset this by using the VXO control. We never managed to achieve the claimed 1W output, even using our standard Racal power meter with a high quality TNC to N type adaptor, but I don't suppose anyone will worry about the maximum output being only 0.5dB below spec. The toneburst deviation was set at 3.6kHz. Peak speech deviation managed to reach 7.4kHz when I roared like a bull at it, but under normal conditions it peaked around 5kHz. The repeater shift was very accurate, once you had set the VXO on the receiver.

The rig appeared surprisingly sensitive, but I was not able to measure it. However, the importers checked one out at around  $0.2\mu\text{V}$  ( $-121\text{dBm}$ ) for 12dB sinad, which is only 3dB inferior to the better 70cm handi-talkies.

#### Conclusions

Although this is quite an expensive rig, it is certainly viable if you want a degree of privacy for special purposes, and when there are more 23cm repeaters around it could be a very useful rig indeed. A pair of them could be invaluable for Raynet use, but as I have suggested for the other 23cm FM rigs, it has perhaps been introduced a little early, so I do not expect that it will sell all that well.

I can recommend purchase if you want a hand-held on this band, but FM stations on the band are few and far between, although most stations using SSB and CW can at least receive FM. The rig is beautifully made internally and seems to be of modular construction.

Many thanks to Thanet for the loan of the review sample, and to Mark G4RCD for helping with the trials.

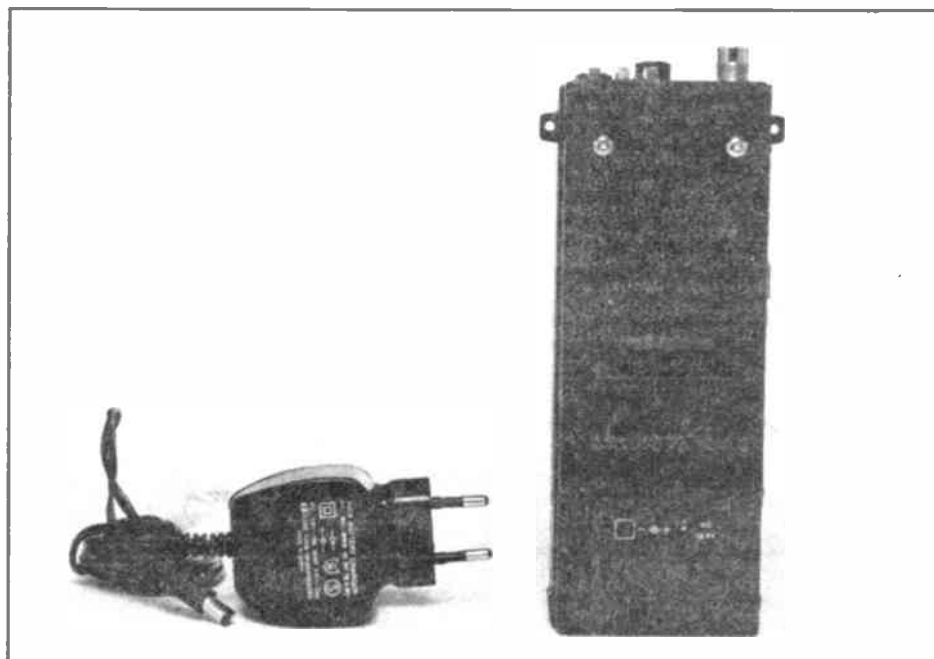



## G3OSS TESTS

This is rather a dinky little power meter, designed to measure power between 900 and 1300MHz and with full scale deflection ranges of 5 and 20W. The meter itself is Daiwa's twin needle type, which allows you to read forward and reverse power simultaneously, whilst the crossing point of the two needles is scaled in SWR.

The meter is very small, measuring 75mm W x 75mm H x 46mm D. There is an input for illuminating the meter which requires a voltage not exceeding 16V dc, 13.8V being ideal.

### Power selection

A slide switch at the rear can select either dc volts (FSD 16V dc) or reverse power. A DIN socket on the back is the receptacle for a 5 pin DIN plug on a 450mm lead, which interconnects with the measurement head. This head is in a metal box fitted with N type sockets for RF input and output, and has two spade type lugs for screwing it down. A U-bolt and accessories are supplied to allow the measurement head to be mounted at masthead, in which case you will have to extend the interconnection cable down to the shack.

### Brief trials

I tried the meter in the feed to a 934MHz antenna, driving it with a Delta 1. The power readings seemed quite sensible, with the SWR indication being extremely close to that given by a Bird throughline wattmeter. The meter was extremely easy to use, and most convenient to read. The forward power scales have FSDs of 5 and 20W, whilst reverse power is scaled at 1.6 and 6W respectively. The SWR indications under the needle crossing points indicate from 1:1 to 5:1, followed by an infinity:1 indication. I also used the meter for measuring low power on 1296MHz, and again it performed very well.



## DAIWA NS448 SWR/power meter

### A useful little meter for 934 and 1296MHz

### Brief laboratory tests

For the power checks on 934MHz, the full output of the Delta 1 was connected through the meter to a calibrated 20dB attenuator and thence to a Racal 9303 power meter. We also tried the SSB Products PM1300A Termlaine power meter, using both 500MHz and 1.3GHz ranges. The Daiwa meter read 4.5W, whilst the PM1300A read 5W on the 500MHz range and 4.5W on the 1.3GHz range. The Racal 9303 read 5.5W after careful calibration of the attenuator. The real power would probably have been

around 5W, and thus the Daiwa would appear to be under-reading by around 10% , which is surprisingly accurate at this high frequency, these readings applying to the 5W range. On the 20W range the Daiwa read about 4.8W, which is even closer.

We then checked the accuracy of the reverse power reading by feeding the transmitter through the measurement head in the reverse direction. The reading on the 6W range was 4W, which is a 20% under-read.

We checked the SWR reading by loading the meter with a resistive load giving approximately 1.7:1 SWR. The Daiwa meter read this as approximately 1.65:1, but there were insufficient graduations on the scale to note it any more accurately, so we interpolated the measurement between the scale indications of 1.5:1 and 1.7:1.

We then drove the meter from an SSB Products 1296MHz transverter, loading the meter with the same 20dB attenuator and again terminating with the Racal digital power meter. When the Daiwa was indicating 8.5W, the Racal was reading 7.8W, so this time the Daiwa over-read by just under 10%. At a 2W level, with the Daiwa set to the 5W range, the Racal also indicated 2W, which shows excellent accuracy. With 5W on the low range, the Racal indicated 4.8W; astonishingly close.

We had just one temporary hiccup. At first we thought the reverse power was not reading at all, but then we remembered the switch on the rear which I had previously left to read dc V! It is easy enough to forget this, so I mention it as a reminder.

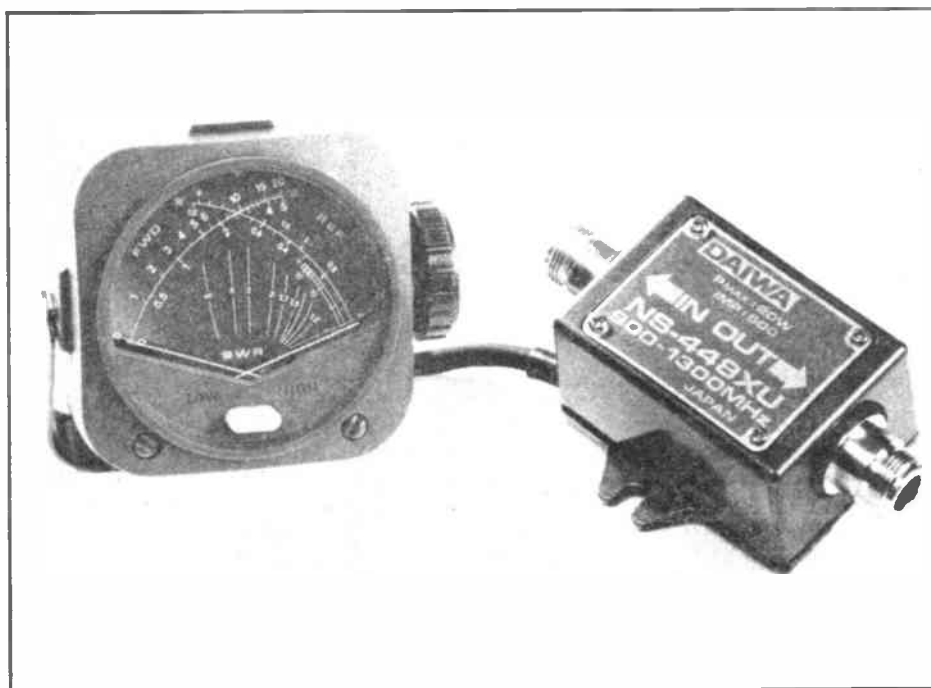

# ICOM AH7000

## Super wideband omnidirectional antenna

### Conclusions

This is a most useful little meter, and it is most convenient that you can place the measurement head up by the antenna. However, it is a pity that it did not have a much higher power range of, say, 100W, which would have been much more useful. I particularly recommend the meter for use on the 934MHz band, with 10W 23cm rigs such as the Icom IC1271E and also SSB Products transverters. Considering the excellent construction and the inclusion of a remote head with N type sockets, the price of £75 including VAT seems quite reasonable.

Thanks to Lowe Electronics for loaning the review sample, and to Mark G4RCD, for assisting with the measurements.

This new antenna from Icom is primarily intended as an accessory for the new Icom ICR7000 general coverage VHF/UHF receiver, but it is also very suitable as a general purpose omnidirectional transmitting antenna for the 50, 144, 432, 934 and 1296MHz bands. The antenna is designed to receive frequencies from 25MHz to 1300MHz and, by modifying the discone type design principle to include a vertical section above the disc, Icom claim an improved match for transmitting.

There are eight elements hanging down at 45° from the horizontal. These are evenly spaced around the centre stem to form the cone part of the antenna, each element measuring 820mm. The eight horizontal elements, each 280mm long, spread out from the centre hub like the spokes of a wheel. Coming up from the central hub is a based loaded vertical whip with a total length of 915mm. This vertical section has been added to improve the match at the LF end and, although I cannot confirm it, I suspect that it is acting as a loaded quarter wave ground plane on 6m, with the plane itself represented by the elements that are hanging down.

### Connections

The cone section is directly connected to the earth and the outer of the support tube, whilst the coaxial inner feeds the hub, which is directly connected to the horizontal elements, and the base of the vertical loading coil. Just below the hub is an N type female socket, and a 600mm hollow tube comes down from the hub so that the N socket is well waterproofed once the tube has been bolted on. The coaxial feed line thus has to be screwed onto the end socket before the tube is bolted on.

Icom supply a 14.5 metre co-ax lead with the antenna, and a loss curve up to 400MHz is shown in the accompanying plot. The plot shows that the cable loss is almost one half that of URM43, but certainly it is not as good as UR67. If you wish to use the antenna up to 1.3GHz I would most certainly recommend Pope H100, but you will have to be very careful when putting on an N plug, as it is rather difficult to fit it to H100. Special wide

entry N plugs are available to special order, but are difficult to obtain.

I have tried quite a few discones over the years, including the Hokushin GDX-2, which covers 50 to 500MHz, and its smaller companion which covers from around 400MHz to just over 1GHz. Between 50 and 150MHz I found very little to choose between the Icom and the GDX-2, but the Icom antenna seemed to be far superior at UHF and just above 1GHz.

It is very much better made than the GDX-2 and is much easier to assemble, especially as the hanging down elements are in one piece, rather than two hanging down for each element in the case of the GDX-2. I have also found over the years that odd bits have fallen off the GDX-2; these have to be replaced every now and again when a friend with climbing experience comes round!

My family informs me that the AH-7000 looks a lot more acceptable against a skyline, and it is quite a good deal smaller with thinner elements.

### Power specification

The antenna is intended to match into 50 ohms, and the specification allows it to take up to 200W of power on all the amateur bands in its range. The SWR is claimed to be better than 2:1, but brief measurements on 144 and 432MHz show it to be a lot better than this. Using the cable supplied, there was almost no visible reflected power on the Bird throughline wattmeter used, so the effective SWR at the end of the co-ax must be substantially better than 1.2:1.

Although the antenna is claimed to be satisfactory for transmitting on the 6m band, I should remind readers that the

DTI do not permit the use of vertically polarised transmitting antennas as yet, and I have not tried transmitting with it on the 70MHz band. However, it receives very well on both 50 and 70MHz.

I compared signal strengths received from the antenna over a very broad range of frequencies with those from my GDX-2, allowing for co-ax losses, and I was quite surprised that the AH-7000 was so good, as it was smaller. When slowly pumping up a mast to a maximum of 10m above ground level, we noted a very substantial increase in received signal strengths, especially when the height was increased above 5m. A final increase from 7 to 10m above ground level improved average strengths by around 4 or 5dB, although this did depend quite strongly on the direction of the signals and thus the amount of obscuration by hills on the horizon. I therefore strongly recommend that you install the aerial as high up as possible, height gain becoming even more important than fairly fine differences between reasonable co-ax cables.

The antenna costs £75 and weighs 1kg. It is available from Icom dealers. However, it is also made for Icom by Diamond, and Waters and Stanton can supply this version. It is fitted with an SO239 socket and with a similar cable terminated with PL259s, and this version costs £69.

### Recommendations

I would recommend the Icom version with N sockets above the Diamond one, which might be more lossy at UHF, and note that this antenna is one third the weight of the GDX-2 and has much less wind loading.

Icom AH7000 supplied cable: loss 0 to 400MHz. Resolution bandwidth: 1000kHz. 40MHz per division

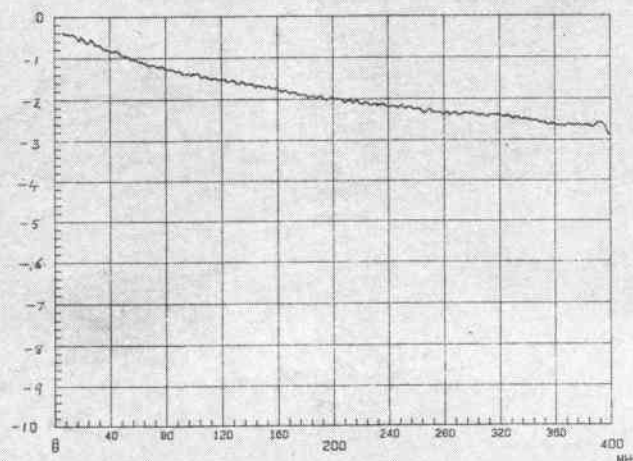



# JUST PUBLISHED

3rd EDITION OF

## U.K. LISTENERS CONFIDENTIAL FREQUENCY LIST

**50% LARGER, SMARTLY BOUND  
with semi-stiff cover.**

**Completely revised:- Now includes lots more  
information on MILITARY, CIVIL, AIR,  
MARITIME, PRESS BULLETINS, RTTY etc.**

**£5.95 + p.p 75p**

**4 PUBLICATIONS  
YOU SHOULDN'T BE WITHOUT!**

### UK LISTENERS CONFIDENTIAL FREQUENCY LIST NEW EDITION

This publication has now sold well over 2500 copies since it was advertised only a few months ago. Now the recent updated version is selling even better. No self respecting listener should be without a copy. If you enjoy exploring the short wave bands then this publication will add to your enjoyment. It covers the hf spectrum from 2 to 30 MHz and gives details of transmissions outside the amateur bands. Specially designed for the UK and European listener it sets out in a very easy way a comprehensive list of hundreds of interesting transmissions that will keep you occupied for days on end! Only a fraction of the cost of other similar publications it contains details of Marine, Air, Military, Embassy, Press and News agencies. Many listings have time schedules included together with comprehensive RTTY details. It tells you the frequencies used by civil and military aircraft whilst flying the Atlantic, when and where to pick up the press bulletins, long distance marine traffic etc and much more. Send today for your copy of this worthwhile publication.

**£5.95 p&p 75p**

### THE COMPLETE UHF-VHF FREQUENCY GUIDE 26-2000 MHz

Many listeners have asked for a guide to the wide VHF/UHF spectrum and to meet this request we have recently published this frequency manual. It covers the range 26 to 2000 MHz and has been specially prepared for the UK listener. Anybody who has used a scanning receiver will know that the wide frequency range involved means that it is difficult to know exactly where to listen. This guide takes all the guessing out of monitoring. It lists all the services throughout the spectrum together with both simplex and duplex frequency splits. If you've spent your hard earned money on a scanning receiver or are considering buying one you'll find that this publication contains a wealth of information that has previously remained un-published!

**£4.95 p&p 40p**

### VHF-UHF AIRBAND FREQUENCY LIST

This frequency manual is without doubt the most comprehensive list of VHF/UHF aircraft listings available in the UK. Of vital importance to the airband enthusiast or indeed any keen VHF/UHF listener it sets out in a very easy to follow manner full details of a whole host of stations. Every known UK airfield quencies, etc. Included are Civil, RAF, USAF, MOD, Naval fields on both VHF and UHF bands. There are also air to air frequencies, the Red Arrows frequency, and much more. Send today for your copy and find out just how much you have been missing!

**£3.95 p&p 40p**

### HF OCEANIC AIRBAND RADIO SUPPLEMENT NEW SECOND ADD.

Prepared in response to many requests for more information about the air traffic on the hf bands this little guide sets out to explain to the beginner how the hf band works in relation to air traffic. It contains full details of the world aircraft frequency bands in the range 2 to 23 MHz together with control frequencies and those commonly used for Oceanic control. Also included are many VOLMET frequencies, the Search and Rescue frequencies used by RAF helicopters and Nimrods, the Hf RT network, London Company frequencis, European control centres etc. An ideal companion for the hf airband listener. Send today for your copy.

**£2.95 p&p 35p**

**WATERS  
& STANTON  
ELECTRONICS**

18-20 MAIN ROAD, HOCKLEY, ESSEX - 12 NORTH STREET, HORNCHURCH, ESSEX.  
MAIL ORDER TO: 18-20 MAIN ROAD, HOCKLEY, ESSEX TEL: (0702) 206835



# SHORT WAVE LISTENER

TREVOR MORGAN GW40XB

This time of the year usually heralds the start of the RAE classes being held throughout the country. Over the past few weeks I have been very pleased to hear that many of our readers passed the May examinations and are now proudly displaying their new call signs.

Some of those who passed the examinations echoed the sentiment that their time spent as short wave listeners had stood them in good stead during the test. May I wish all of you who plan to sit the exam in May the best of luck during the coming months of study and hope that you will be successful!

## Congratulations

Our sincere congratulations to Peter Wood of Crowborough for his credit in part one and pass in part two. Peter has taken up his old hobby of gliding this year so there's no doubt that, one way or another, he will be 'on air' in the future. Frank Brown RS88134, of Redcar, also has his results in and is now chasing the dots and dashes. With the QTH needing a spot of paint, he's having to squeeze the practice in while wielding the paintbrush with his other hand!

Len Willford, of Plymouth, is first in the mailbag section this month. By the time this is published Len will have installed a nice new Trio R2000. He has got one of those gardens that were not designed for aerials (maybe there should be a ham or a listener in architects' offices!) and is puzzling over the old problem of getting 130ft of copper wire into a 30ft garden without decapitating the cat!

## Prefix hunter

Frank Garraway, of Keynsham, is still hunting for his second 250 prefixes, but his receiver has had to go to the doctor with internal problems. Frank mentioned that he used to be at the local university and occasionally gets hold of 'obsolete' gear

from this source. However, he is at a loss to find a use for a 10kW amplifier that saw duty driving a speaker coil in earthquake experiments! I don't think the Department of Trade and Industry would take kindly to earthquakes on HF, but maybe someone will come up with something.

## No doubts

Peter Reed, of Bristol, is quite new to listening, with a Sony ICF2001 receiver which he bought secondhand. Although his first letter expressed doubts about it, subsequent letters have cast these aside and he is really enjoying himself. His purchase of a Spectrum and hopes of getting into RTTY and other mechanical modes show his enthusiasm, and we wish him well in his new hobby.

Like many newcomers, Peter finds the terminology a bit strange and isn't sure what is meant by DXing or what to do about aerials. For the beginner to the hobby, there's nowt wrong with a length of copper wire strung up as high as possible and fed straight into the receiver.

## Experimentation

As experience is gained, the addition of a small antenna tuning unit (see the July issue) can be simply and cheaply made and will stand you in good stead while you experiment with wires in every possible position and configuration. This is part of the enjoyment of the hobby, and a part which never ceases to capture the imagination. Your location, soil conditions, available space and height will all have an effect on how well any given design will perform. The quad loop at your mate's house up the road may work well there, but it may not be so good at your place.

My own QTH is located only just above sea level, between two hills, and is surrounded by buildings and structures. The forty-foot mast takes the centre of any dipoles up over the surrounding roof-tops.

Over the past fifteen years at this location all types of wire aerials have been tried, from end-feds to windoms, from dipoles to delta loops. At the moment there is a G5RV with the centre up at forty feet, one end at thirty feet and the other end sloping down with an 'elbow' at ten feet and terminating at only four feet above ground level. Nevertheless, my first log-book under licence, using the barefoot TS130V with ten watts output, notes my third QSO on phone as being with VK7GK in Tasmania!

Among the early loggings of that period are PY2TE1, KC2EL, W1BS, W3FXF, ZS6TJ, PY2BC and (my favourite) VP8ANT, which proved that even in a difficult location some good DX could be found and worked.

## What is DX?

On the subject of DXing, just what is DX? It is generally accepted as working or hearing stations over long distances and comes from the telegraphic abbreviations, where an X is used as the main part of a long word, eg Tx = transmit (ter) or Rx = receive (er), etc. However, with many stations operating up to legal power limits and using high gain multi-element antennas, there are few places inaccessible nowadays and modern receivers are so sensitive that the average listener should be able to log most areas in reasonable time.

## Desirability

So, what DX is left? I have always maintained that DX should really stand for 'desirability', as although logging Australia or the Philippines may be the best in distance terms, any operator from, say, Andorra, Mayotte or Sealand (yes, the principality) would be sure of creating a pile-up because of the desirability of getting the call sign into one's log for the first time.

Likewise, receiving the average US station is nothing

unusual, but digging out an operator from the noise to find that he is using two watts from Connecticut can most certainly be regarded as DX in my book.

Another form of DX is neatly described by Howard Dove, of Barry, who was 'idling' his way around the bands when he came across signals from the 'Virgin Challenger' on her record making trip across the Atlantic. Now, if I had *that* in my log or on tape, I would be a very happy DXer indeed!

## Twiddling the knobs

In the days when I was a 'Wolf Cub', the only contact I had with radio was twiddling the knobs of my Dad's 'ultra all band' accumulator powered wireless (we used to pick up Radio Australia on a Woolworths' Wonder Wire in those days!). Nowadays, the Radio Scouting Group have things a bit easier and Scouts world-wide will be using today's technology during the annual Jamboree on the Air. JOTA takes place over the weekend of 18/19 October and is the time when the Scouts use radio to 'shake hands' with their brothers. There's no contest or hassle, just friendly chat between the Scouts, and a good time is had by all.

During this period, to encourage regular listeners and younger Scouts, I will be promoting the White Fang Fellowship JOTA Award again, the idea being to log as many Scout stations as possible.

All participants receive a certificate and the senders of the three best logs will receive engraved plaques.

## Raising money

Logs should show time, frequency and details of the station. There is an entry fee of 50p or 2 IRCs (UK) or 4 IRCs (abroad) which is donated to charity. Last year we raised over £52 for Ethiopia. This year we'll be helping 'Children in Need'. Please send your logs to me by 1 December at 1 Jersey Street, Hafod,



Swansea SA1 2HF.

Our award hunters are still in full swing, despite some really dreadful conditions. Chris Gibbs RS47426, of Camberley, claimed Bronze and Silver for mixed modes. Chris had a bit of a problem with his computer disc system but managed to print out his claims, with 3A2, 3B8, 3X4, 5B4, 5N22, 5T5, C21, HK3, J87, KE6/KH0, XT2, YC5, ZP5 and ZY2 among those listed. He hopes to be claiming Gold before too long.

#### Pen-pals

Mike Newell G1HGD, of Kenilworth, is still on the hunt and claimed his Silver using his Realistic DX100L with its telescopic whip antenna to get most of his second 250, as his Hallicrafters SX140 has taken early retirement. Mike is on 2m and 70cm and also busy writing to pen-pals in the USA, which he found through the American *CQ Magazine*. Now Mike is ploughing on for the Gold award so is sure to be busy for a month or so.

Ken Burnell RS88456, of Milton Keynes, also went for 'mixed doubles' with Bronze and Silver, using his Yaesu FRG7700 set-up with a 65ft end-fed. ZC4, ZP5, 9J2, 5B4, 8R1, 4N3, 8P9, YB5, HH5, VP2, VP9 and VK5 fell into the net and he is also on route for the Gold award.

Ken is trying to decide whether to go for a computer or a Morse/RTTY reader. Depends on what you want from it, Ken. If you only intend receiving the mechanical modes a dedicated unit is probably as good a buy as any, but the computer can be used for many other things including the radio programs that are on the market. Don't be overawed by computers, however, as often many of the things you think could be done on it can be done just as well with pen and paper!

#### A bit confused

Roy Westmeckett G4MRW, of Fareham, put in his first claim for Bronze, including A4X, A35/MM (in the Red Sea), C31, HK4, JY3, PY5, CN9, CY6 and LU2 to start the ball rolling, but was a bit confused over the definition of callsign prefixes.

To clarify, the prefix of a callsign is an indication of the location. Each country is allocated a series in which it issues its licences. In the UK

the series is GAA/GZZ in the range from 1-0. The best guide available is Geoff Watts' *Prefix-Country-Zone Lists*, which are available for £1 from 62 Belmore Road, Norwich NR7 0PU.

Trevor Newstead RS88952 of Morecambe, also got his claim in for the Bronze, with AP2, CX4, J28, VP2, ZC4, 3A2, 5H3, 8P6 and 9Y4 coming into the net put out by the FRG8800 and 20m dipole.

Philip Le Brun of Cheltenham claimed his Silver, offering A22, AP2, BY2, C30, HK6, HL1, VP2, VP8, YT7 and 7S2. Philip uses the Yaesu FRG7 and a 132ft end-fed and is now studying hard for the RAE while searching the secondhand market for a reasonable buy for the proposed shack... nothing like optimism to get the adrenalin going, Philip.

#### Really determined

Determination is the watchword with Angela Sitton RS88639. She not only claimed her Silver award for mixed band all SSB but followed it almost immediately with a Silver for single band SSB on twenty metres! A2M, A71, BV2, CY2, HK4, PP4, VK5, YZ7, XA5, 2A4 and 6F3 were among the offerings, and she is now threatening me with further claims.

Angela's old car finally bit the dust and it's a toss-up whether the readies go on a new one or a better receiver... terrible, these decisions! An entry into the RSGB Listener Contest achieved over 24,000 points, which was a fine first effort and bodes well for when the new receiver arrives.

Ron Harvey, of Weston Super Mare, has been getting to grips with the RX4 program which I reviewed recently. His ventures into the world of slow-scan television have brought in good copy from Spain, Switzerland, Italy and others, including one hilarious signal which he sent me a copy of (but couldn't possibly be printed in a 'family' magazine) that defies description! Yes, there are even pirates on SSTV!

#### Play-time

Aside from SSTV, Ron has been playing with aerials and now has a window for 14 plus another end-fed for the same band, a couple of revamped CB aerials and an old VHF TV

aerial, all of which he's trying to tune to frequencies they weren't meant for.

Meanwhile, down there in Dunedin, New Zealand, Tom Millar ZL4BL has been using the Spectrum for FAX reception. To date, he has received weather maps from Japan, Canada, Europe as well as Australia and New Zealand. He finds it almost essential to have memory facilities on the receiver, especially when scanning.

It seems that conditions, radio wise, are not much better in ZL than they are here but his National RF-B600L is being put to good use, with the G5RV and a six-band trap vertical doing the honours on the antenna front.

For those who have never come across this mode, FAX or facsimile is a means of transmitting graphic information. It is used extensively in the transmission of weather information. Basically, the original information is converted into electrical signals which can be transmitted via cable or radio to a receiver, which reproduces copy exactly like the original.

The old facsimile machines used either electrolytic or photosensitive paper and were usually obtained from office equipment disposal channels in the same way as teletype (RTTY) machines. They need converting for amateur use but this is, apparently, not a difficult job. However, FAX programs are becoming available for the home computer owner which should bring a new area for the keen listener (watcher?) to explore.

#### My home town

I had the pleasure of visiting my home town, London, in July for the Radio Fair at Wembley. Armed with my folding table and display of Awards, I made my way there by train and tube, getting there just in time to set up ready for the opening. Unfortunately, someone had forgotten to tell the organisers that, firstly, it was the RSGB National Field Day and, secondly, Rod Stewart was holding a concert in the nearby arena! Now, I've got nothing against Rod, but when he's holding a concert the traffic problems are enormous and many radio enthusiasts must have been put off by the local news reports on

traffic hold-ups. Whatever the reason, attendance was disappointing!

However, all the usual distributors were there and there was a good selection of new items to see. Funny enough, last month's comment about Longleat being short of secondhand equipment applied here also... there was very little to be seen.

During the weekend, I was very pleased to meet a number of readers including Don Pye, Uma Patel, Peter Wood, Keith Stone, Chris Gibbs and Tim Armitage, who kept an eye open for the ILA sign. I also had a visit from a dozen or so Radio Scouting lads led by Bill Livens G2CKB and Terry Lockyer. These meetings made the trip worthwhile and I thank all of you for your support!

#### Chinese puzzle

So, how many of you can speak Chinese? Funny question? Not if you are one of the many listeners who have been mentioned on Lily Liu's Mailbag Time! Lily is the young lady who reads listeners' letters on Radio Free China, Taiwan. Very often I hear names of correspondents to these pages. One of the regular items on the programme is 'Let's Speak Chinese' and a book is offered to interested listeners. Taiwan is easily heard on 15345 and 17890 at 2200 every evening.

Radio Australia broadcasts to the USA between 0000hrs and 0700hrs around 15395. It is not easy to log but is worth listening for. RA has not QSLd for a while though. Austrian Radio in English can be heard on 15320 at 1230 and has some interesting DX information during broadcasts. United Arab Emirates broadcasts in English at 1330 on 17775 with a good DX programme. Radio Canada International broadcasts at 2000 and 2300 on 11710 and 17875 and has interesting programmes on listening and DXing. Switzerland International has been logged at 1530 on 15260 with mailbag and listener information.

So, that's it for another month. Thank you for all your letters and information and I look forward to next month's column. Meanwhile, I hope the bands clean up so that you can enjoy a good month's listening. Cheers for now!

'Marie?' I said, staring out of the bedroom window at 6.30 on a warm September morning.

'Wassamarra?' came the sleepy response from the four poster bed.

Choosing my words very carefully, I asked 'What colour was our front lawn when we went to bed last night?' Stooping low to pick up the slipper which had just ricocheted off my head, I repeated the question.

'Why?' demanded the XYL, showing signs of life at last.

'Because it's blue now,' I replied warily. There was still the other slipper. 'Blue?'

'Yup.'

'BLOOOO?' yelled Marie, diving across the bed to the window. She stood there, staring mesmerised at the royal blue front lawn, repeating over and over to herself 'It's blue!'

This was the opening gambit in a war of attrition. The subject of the war was television interference, often abbreviated to 'I'll kill the swine'. Never in my life have I seen a simple technical problem escalate so quickly into a bloody war of nerves. Run over someone's dog, insult the family name, despoil a father's daughter, bend somebody's car, but never, *never* stop people from watching television. Anyway, I'm getting a bit in front of myself, so let's start at the beginning.

It was mid-summer. A calm, settled period of good WX had the JAs, VKs and ZLs wall to wall late every evening all week. There I was, night after night, banging away on the key knocking off DX after DX station. If I coughed in my shack, someone in Japan said the Japanese equivalent of 'ouch'. I was just about to deliver the *coup de grace* to yet another VK when I heard a knock on the front door.

'It's for you dearest,' I called downstairs, ever the helping husband. I continued thumping the paddles whilst cocking one ear to the front door.

'Excuse me, Mrs, I've been having

some trouble with my television lately, and my friend who knows about these things...'

I let out a deep groan of misery. In my experience, 'friends who know about these things' invariably: a) don't, and b) cause the maximum amount of trouble trying to prove that they do.

The voice at the front door continued '...and he says that a CBer is causing it. I noticed that your husband has a lot of aerials in the garden, and I was wondering whether he was a CBer?'

'Yes he is', said the XYL, which produced teeth gnashing sounds from the upstairs shack.

The wife then pointed her voice at the stairs, cupped a hand to her delicate rosebud mouth and bellowed: 'Kevin? You're wiping out *all* the televisions again!' Again? Oh no, what had she done? First rule of dealing with a TVI complaint: *never admit to anything*.

Reluctantly I left the shack to sort out the voice at the front door. As I arrived at the foot of the stairs, he invited himself into the hall. He stood there, hands gripping his lapels, rocking back and forth on his heels. He was dead certain he had his man. He explained his trouble, then pointed a wagging finger at me and told me that causing interference to someone's telly was a criminal offence, adding emphasis to each syllable by stabbing his wagging digit into my chest.

'Are you a teacher by any chance?' I enquired lightly. He confirmed.

'Ah,' I said. Using words of one syllable, I then went on to explain that, firstly, the fact that he had paid for a TV licence did not guarantee him perfect viewing rights, or me a term in prison for infringing them. And, in any case, it was yet to be proved that I was responsible.

This seemed to take some of the wind out of his sails. I agreed, purely as a goodwill gesture on behalf of the amateur radio movement, to conduct some tests on his behalf at his house. Before we left I told him that I was just nipping upstairs to switch everything off.

# TW1

## The lengths people will go

Back in the shack, I hastily tuned my rig to an empty frequency, then jammed an ashtray against the dah paddle of my keyer so that my rig was sending out an endless stream of Morse dahs.

We walked over to his house, about 60 yards across the green from mine. Standing sentry duty at his garden gate was a horse, cunningly disguised as a Great Dane. It woofed. I fell over. It dived over the gate and landed astride my prostrate and easily damaged body. The dog shoved its menacing face into mine, tilting its head from side to side as if in indecision. Finally, it decided, then batted my head from side to side with its huge, wet tongue.

'Down, Pickwick,' commanded my complaining neighbour. I groaned; obviously a teacher's dog. We entered his house, and there in a corner of the room a 26-inch technoflashy colour television set was doing its nut.

'See! I told you, Fiona.' The complaining neighbour was hopping from foot to foot in excitement.

'See what, George?' answered Fiona, somewhat puzzled.

'I told you it was that idiot...oh, er, sorry...that chap at number 14,' concluded George, triumphantly.

'But George, dear, the idiot from number 14 is here with us, so how can it be his fault?'

I ignored the second 'idiot' because I was watching George's face closely. A look of complete astonishment washed over it.

'I take it that you're not a teacher, Fiona?' I enquired, innocently.

Edging carefully past the dog, I left them to it, returned to MDQ Castle and carried on working the DX.

The next morning Fiona came over to see me, asking for help. Not wanting to shirk my amateur radio responsibilities (and because I fancied her a little), I agreed to help. I started them off with some simple home-made, high-pass jobs. They failed. Unfortunately, George had taken my willingness to help as an admission of guilt. The fact that he was right didn't make it any easier for me.

Next, I tried some ferrite ring jobs, but yet again these failed. George was becoming a real pain now. His 'friend who knows about these things' had been slipping him information about Dirty Trix Inc's (Department of Trade and Industry) Radio Interference Department. George kept slipping in the odd threat about sending in 'The Firm'. Having had no previous dealings with these semi-

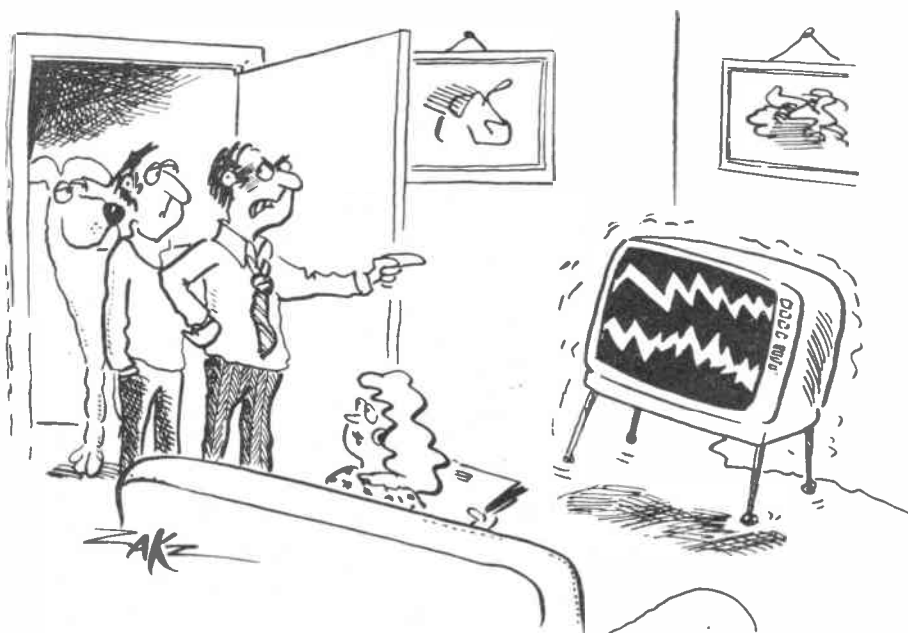



and all that!

to – Kevin Fox reports

mythical men, I renewed my efforts to find a cure. I was 99% certain that it wasn't my equipment that was faulty, but... well, can one ever be sure?

I knew that time was running out. I was spending so much time in their house, my wife thought that I was having an affair. Then I finally cracked it.

I made a pair of Faraday loops and connected them to the set. 'This will work,' I assured them, 'but there is a slight problem with this type of filter.'

'And what's that?' said pompous George, smugly.

'A 165dB drop in received signal level,' I answered, switching on the TV set. The screen lit up, and *viola!* No interference. Trouble was, there wasn't much picture either. I have been thrown out of better houses.

It was at this time that little niggling things began to happen. You know what I mean, small things like the hinges of the garden gate being sawn through, so that when I opened it it fell off and broke my foot. Or two ton of Redi-Mix concrete appearing outside the garage door, doggy poo left in strategically vital places, and three feet of co-ax missing from the centre of my feeder system. Of course, it wasn't all one way.

By chance, I discovered that Pickwick, George's Great Dane, was particularly partial to chocolate. I wandered over to his gate, and nonchalantly fed 9 bars of Ex-Lax to him (the dog, not George). We were all awakened next morning by a frantic, sorrowful howling, and I was just in time to see Pickwick fly out of their house sporting a perfect imprint of a size 9 boot on his cherry-red doggy bottom.

The next morning I awoke to find my pristine, crown green bowling standard front lawn a particularly attractive royal blue colour. I was very impressed with George's ingenuity, but as usual, it was the women who saved the day.

Fiona and Marie had a meeting and demanded that the problem was passed over to the proper authorities. Being a firm believer in the old Arabian maxim 'put your trust in Allah (but tie up your camel)', I began making my station ready for THE VISIT.

I sat in my shack night after night, trying hard to think of all the people I had worked in the past four years. Failing miserably, I invented a few to fill in the blank spaces.

Then one day I saw a yellow Bedford van with dark windows parked outside my house. A cold panic swept over my body, turning my knees to jelly.

Shoulders drooping, I traipsed off and opened the door. In front of my eyes was a navel. My eyes travelled north from the navel, and my head tilted back.

Quickly, I took in the deep scarlet duelling scar on his right cheek, the cauliflowered right ear and the teeth marks on the end of his nose. I saw the swelling of his stomach, and traced the path northwards until, with a thunderous roar, the words exploded into my face.

'MR FOX?'

Getting back up on my feet, I fought down an insane urge to say that he was out/had emigrated/was dead. I nodded meekly and produced a sickly smile.

'Can I come in?' It wasn't really a question. I idly speculated on whether anybody had ever been fool enough to deny him anything. Stooping down, and turning his body sideways, he edged into the front hallway. I considered asking to see his ID card, but looking up at that black eye-patch convinced me that he was genuine.

'As you know, one of your neighbours has sent in a complaint. I'm here to sort things out.'

His voice reminded me of finger-nails scraping down a blackboard. I began to write my hands together.

'Step this way,' I pleaded with him, then, as a brilliant afterthought, added, 'sir.'

He entered my bedroom/shack. That one good eye scanned the room and equipment like a radar scanner. He took in the rig, looked at me and smirked.

'Well, well, well. Haven't seen one of these for years,' he chortled to himself. 'Let's start with the log-book, then.'

'You haven't written in the test you did on 30 October 1983 at a quarter past two,' he said, lifting his eye up from the book to bore into me. I was absolutely flabbergasted. He looked at my horrified face.

'Well, never mind. I'll turn a blind eye to it this time,' he concluded, absolutely deadpan. Again he stared at me, daring me to laugh. I struggled furiously, and was just about to make it when he burst into gales of pealing laughter.

'Ho, ho, ho! Hee, hee, hee! Oh yes, jolly good show,' I enthused.

'All right, laddie, don't go over the top,' he commanded.

Suddenly, he whipped out a walkie-talkie.

'Yoo ready over there, Bert?' he bellowed into the radio.

'What?' responded Bert.

'Fifty!' replied my man.

'Fifty what?'

'Yes.'

'What?'

'I jus' told you,' said my man, losing patience.

'OK,' agreed Bert.

I had explained that the trouble only happened when I was CW on twenty metres, so my man asked me to fire up the rig and send a test signal. I complied, and again their walkie-talkies were busy. My man seemed satisfied. He turned to me and said 'Well, it's definitely your signal that's knocking his telly. What have you tried so far?' I explained which filters I had already tried, and he seemed pleased with me.

'Far too many amateurs simply ignore the problem and send for us. At least you have tried to do something for yourself,' he explained.

I felt a warm glow. I was well chuffed. He then left to go over to George's house, warning me that Bert would come over to me to witness some more tests.

'What's your name, then?' asked Bert.

'Kevin,' I answered.

'Right, Keith. Let's have some SSB on two metres, then.'

'Name's Kevin,' I corrected.

'Good.'

'No. Kevin,' I riposted, merrily.

'God!'

'OK,' I said, waiting for him to supply a rig and mic.

'Well, wotcher waitin' for?' said Bert, truculently. I looked at him wonderingly. Was this a wind-up?

'I'm sorry, I don't have any two metre equipment,' I said.

Bert looked at me in a funny way, shrugged his shoulders and said 'Well,

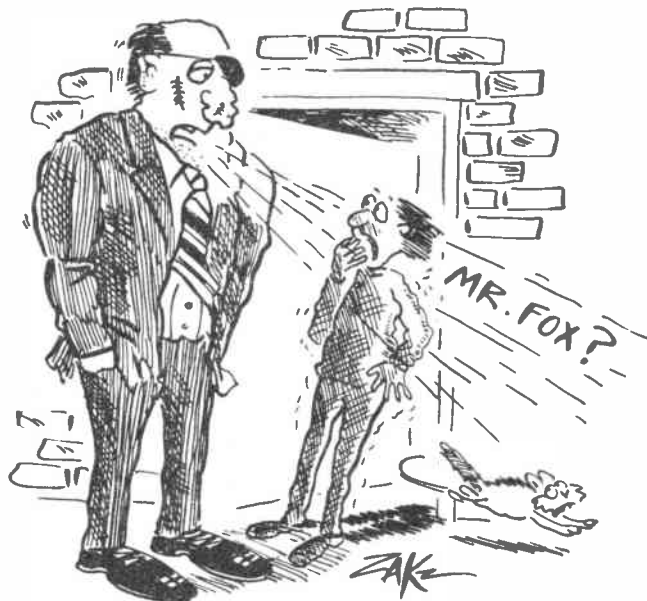

# TVI AND ALL THAT

put something out will you?'

I sent CQ test a few times around the base end of twenty.

'OK,' said my man, 'your stuff checks out all right. He's got a telly that's well known for this problem. I want you to stay off twenty metres altogether for the next twenty-eight days to give him a chance to get it fixed. You can go back on twenty after that.'

This sounded fine to me; I had been expecting to be totally shut down for a month. So we had some tea, and I told them about my experiences when trying to sort out the TVI. They had a good laugh and we parted the best of friends.

So, I forgot all about twenty metres. Then, one night three months later, being fed up with the usual stuff on eighty, I decided that I would give twenty a visit. Looking in my log-book, I was surprised that it had been three months since I was asked to cease activities on the band. A tweak of the rig, and away I went, joyously to battle. Before the echoes of my CQ had vanished, there was a furious pounding on the front door. My wife being out, I was forced to answer. On the other side of the door was a red-faced George.

He spluttered 'You...you...you criminal! You cad! You bouncer...you...you!'

I looked all around me, but decided that it must be me he was referring to. There wasn't anyone else around.

'Yes, George?' I asked, politely.

'Don't you George me,' he said. I played with his appalling English in my head.

'You don't happen to teach English do you, George?'

'How dare you...of all the... Right! Right!' Poor George. He was near bursting with righteous indignation.

'You were told! You were told never to transmit ever again. They came here, two official representatives of the Government, and they told you that you must never use your radio again.' There was no chance of reasoning with him. No point in explaining what was really said. I was suddenly heartily sick of the whole business. I told him to phone the DTI RIS and ask them what they had said. Leaving him raving on the doorstep, I shut the door and returned to the airwaves.

The very next day, there came a hesitant knock on the front door. I answered it, and was confronted by a TV service engineer.

'Nice day,' he opined. 'I drew the short straw to sort out yon fellow's telly. Would you mind co-operating in some tests please?' Now here was a fellow I could easily grow to like. I assured him of my full co-operation, and he went to work. Well, the poor lad tried everything. At every failure, George berated him intolerably. Finally, in desperation, he fetched George a new TV set. At last!

George was TVI free. I congratulated the TV chappie and invited him in for a cuppa.

'I told him to steer away from that model of TV,' said the TV chappie. 'We've had nothing but trouble with that model and we were packing the last one up to return it to the maker. He came in and wanted to buy it. I tried my best. I explained what could happen, but my boss shut me up and flogged him it. He even gave him a ten per cent discount for cash.' I made sympathetic noises in the right places. The young TV chappie left, and everything was once more as it should be. George was watching TV. I was back on twenty and working the DX.

About two months later, George was sitting in his garden listening to the cerebral delights of Radio Three on his Ghetto Blaster. He rolled a languid finger along, in time with the music. Across the other side of the green a customised Ford Escort pulled up outside a neighbour's house. Suddenly, Beethoven was rudely interrupted by 'Breaker 14, breaker 14, this here's Zippy. Any breaker for a copy?'

I was just in time to see George destroying his portable radio cassette machine with a sledge hammer. His face was contorted, and he was screaming 'No...no...not again. Oh God! Why me, why me?' You had to be a heartless bugger to laugh. Me? I was in hysterics.

## BECOME A RADIO AMATEUR

**Train now for the Radio Amateur Licence examination. No previous knowledge needed, only a few hours per week of home study for 3 to 6 months. Post coupon now for details.**

British National Radio & Electronics School, PO Box 7, Teignmouth, Devon, TQ14 0HS.



FREE brochure without obligation from:-

**British National Radio & Electronics School**  
PO Box 7, TEIGNMOUTH, DEVON, TQ14 0HS

Name .....

Address .....

AM7M

BLOCK CAPS PLEASE

**REG WARD & CO LTD**  
1 Western Parade  
Axminster Devon EX13 5NY

**South Wests  
Largest Amateur  
Radio Dealer**

Official Agents Yaesu, Trio, Icom, FDK  
:Complete range stocked:  
:Full demonstration facilities:  
:Mail/Phone orders on all items:  
:Barclaycard, Access, Instant Credit:

APPROVED  
**TRIO**  
DEALER

Ancillary equipment: Adonis, AKD, AOR, Benchor, BNOS, CAP.CO, Datong, Diawa, Drae, Hansen, Hinound, JIL, Kemprow, Microwave Modules, Mutek, SEM, Snare, TAU Tolcyo Hypower, Tono, Toyo, Welz, Wood & Douglas  
Aerials by: G Whip, Hygain, Jaybean, Mini Products, Rexco, TET, Tonna

New complete range Wood & Douglas Kits  
TAU Tuner SPC 3000



Cables, plugs, sockets, insulators, etc.

Opening hours: Tues-Sat 9.-5.30 (lunch 1-2) Closed Mondays

Tel: Axminster (0297) 34918

## SANDPIPER COMMUNICATIONS

AERIALS (STAINLESS STEEL ELEMENTS)

	£20.00	P&P
145mgs/2mtr		
2 x 7/8 Collinear	£20.00	3.00
3 x 5/8 Collinear	£20.00	4.00
6 El Yagi	£14.00	4.00
10 El Yagi	£20.00	4.00
12 El Yagi	£28.00	4.00
6 El Yagi Crossed	£23.00	4.00
10 El Yagi Crossed	£28.00	4.00
<b>435mgs/70cm</b>		
4 F/Glass Collinear	£25.00	2.00
17 Element	£18.00	4.00
Double Delta	£35.00	4.00
8 Turn Helical	£35.00	4.00
<b>1296/23cm &amp; 934/32cm</b>		
Mobile Collinear	£25.00	2.00
Base Collinear	£39.95	2.00
20 Turn Helical	£33.00	4.00
Para Delta	£45.00	5.00
6ft 6in Parabolic Dish	£95.00	9.00

**DIY Versions**  
Available in most models Also 4mtr & 6mtr PMR Weather Satellite/s  
70cm TV, 24cm TV and all one/off frequencies.

**Power Splitters**  
2 mtr  
70cm  
23/32cm

2 way & 4 way  
Lots more available.

FIBRE GLASS MASTS/TUBES  
3/8in to 1 3/4in e.g. 1 1/2in dia - £5 per mtr.

**SAE FOR FULL LISTS**  
**PENTWYN HSE. PENYARD,**  
**LLWYDCOE, ABERDARE, MID. GLAM.**  
Tel: 0685 - 870425  
Delivery Cash/P.O Return Cheque 7 Days



# UP YOUR FUNDAMENTAL

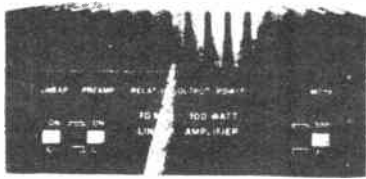

- ★ LOW NOISE SWITCHABLE PRE-AMP
- ★ SWITCHABLE LINEAR AMPLIFIER
- ★ RF OR HARD-WIRED SWITCHING
- ★ SWITCHABLE HANG-TIME
- ★ 'BARGRAPH LED' POWER METER
- ★ CONTINUOUSLY RATED

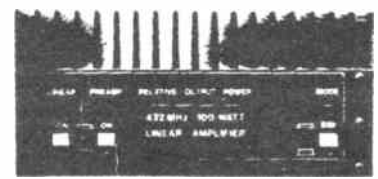

WITH ONE OF THE NEW VHF LINEAR AMPLIFIERS FROM B.N.O.S. ELECTRONICS

★ SEE US AT THE LEICESTER SHOW ★

## 4M

Frequency Range 70 to 72 MHz  
 Output Power 100W +/-0.5dB  
 Power Requirements 13.8V DC, 14A +/-15%  
 Pre-amp Gain 12dB Typical  
 RX Noise Factor Better than 1.5dB

LPM70-10-100 ..... 195.00



- POSTAGE FREE
- SECURICOR DELIVERY AVAILABLE AT £5 PER ORDER
- DEALERS LOCALLY AND THROUGHOUT EUROPE

## 2M



LP144-3-50 ..... 125.00  
 LP144-10-50 ..... 125.00

## 6M

Frequency Range 50 to 54MHz  
 Output Power 100W +/-0.5dB  
 Power Requirements 13.8V DC, 14A +/-15%  
 Pre-amp Gain 12dB typical  
 RX Noise Factor Better than 1.5dB

LPM50-10-100 ..... 195.00  
 LP50-3-50 ..... 135.00  
 (Just Released)  
 LP50-10-50 ..... 135.00

### B.N.O.S

ELECTRONICS

LIMITED

B.N.O.S. ELECTRONICS LTD, DEPT AR  
 MILL LANE, STEBBING,  
 GT DUNMOW, ESSEX CM6 3SL  
 TEL: (037186) 681 TLX: 817763

# SCOPES

Repaired and recalibrated. All makes - all models. Nationwide collection and delivery. Copies of handbooks and spares for most popular models including golden oldies.

Phone  
**Mendascope Ltd 069-172 597**

Amateur Radio smart blue binders, each holding up to 12 issues keeping them in prime condition

# BINDERS!

Only  
**£4.75**  
 inc p&p

Overseas readers please add 30p  
 Please allow 28 days for delivery

Send your orders to  
 Edwardschild Ltd, 28 Shenfield Cres  
 Brentwood, Essex CM15 8BN



## THE START OF SOMETHING NEW

If you are leaving College and planning a career in modern communications or if your present job lacks interest and challenge - why not join us in GCHQ?  
 We are recruiting

### RADIO OFFICERS

who are after initial training will become members of an organisation that is in the forefront of communications technology. Government Communications Headquarters can offer you a satisfying and rewarding career in the wide field of communications. Training involves a 32 week course (38 weeks if you come straight from Nautical College) which will fit you for appointment to RADIO OFFICER.

Not only will you find the work as an RO extremely interesting but there are also good prospects for promotion opportunities for overseas travel and a good salary. Add to this the security of working for an important Government Department and you could really have the start of something new.

The basic requirement for the job is 2 years radio operating experience or hold a PMG, MPT or MRGC or be about to obtain a MRGC. Registered disabled people are welcome to apply.

Salaries start at **£5,817** at age 19 to **£6,920** at age 25 and over during training and then **£7,954** at 19 to **£10,162** at 25 and over as a Radio Officer. Increments then follow annually to **£13,777** inclusive of shift and weekend working allowances.

For full details and application form phone 0242 32912/3 or write to:



The Recruitment Office A/1108  
 Priors Road  
 CHELTENHAM  
 Glos GL52 5AJ

(2906)

# 10m CONVERSIONS COBRA UPDATE

by  
**Roger Alban  
GW3SPA**

Following the series of articles entitled *Cobra Conversion*, which appeared in *Amateur Radio* in February, March and April of this year, a number of readers telephoned me to enquire why their Superstar 360 or Cobra 148GTL did not conform to the circuit configuration described in these articles. I decided to go on a spending spree to find an explanation and purchased six secondhand sets, which comprised one President Grant, three Superstars and two Cobra 148GTL rigs.

The circuit configuration of each set revealed a most interesting story about the development of the various design stages, culminating in the design using the Motorola MC145106 PLL chip, as described previously. However, a number of aspects are common between the designs of the Cobra and Superstar models. For one thing, the layout of the controls on the front panel is very similar. Also the design of the transmitter and receiver circuitry is the same.

## Early development

During the mid-seventies a 120 channel multimode transceiver was designed and named the Cobra 148GTL. Although this set did not comply with the FCC specification in America, it proved to be very popular with illegal CB users. However, there were problems which confronted the set manufacturer. The PLL chip used was of the very early type and the programmable divide-by-N divider prevented the set from operating over 120 channels with only one down-mixer crystal.

In fact, the earlier Cobra model required a separate down-mixer crystal for each band of 40 channels. This in turn represented a higher manufacturing cost, which was reflected in the purchase price. In an attempt to reduce the manufacturing cost, an update in the design was attempted using the same primitive PLL chip, but this time using binary addition which resulted in the use of only two down-mixer crystals.

This design was sold in a set called the President Grant. However, this unit never really took off with the CB user. The owners of the Cobra 148GTL model had become used to the versatile facilities provided by the coarse and fine tune control, which had the ability to vary both the transmit and receive frequency 5kHz either side of the channel frequency. On the President Grant model, the designer had provided a clarifier which only varied the receive frequency a couple of kHz either side of the channel frequency. I doubt that the manufacturer easily forgot the lessons learnt by this particular modification.

When Motorola produced the now familiar MC145106 PLL chip, the designers of the Cobra model got to work on an update in the design. They kept the original design of the transmit and receive sections of the Cobra 148GTL, with the exception of the PLL circuitry. They scrapped the early type of PLL chip and replaced it with the Motorola MC145106 chip. They even kept the original design for the VCO circuitry. The designers were then able to scrap two of

the three separate down-mixer crystal oscillators and adjust the binary address produced by the channel switch to cover 120 channels by using binary addition.

The Motorola chip was described in my earlier article, and has proved to be a very versatile PLL chip. The dynamic range of the programmable divider was fully exploited in the new design. However, one thing was not surprising: because of the success of the old style 148GTL the manufacturer installed the new design PCB inside the old case, so as not to upset the CB fraternity. Cobra had successfully reduced their manufacturing cost with the newly designed PLL circuitry.

Towards the end of the late 1970s, when CB sales in America flattened out, the new design was inserted into another case the same size as the 148GTL, fitted with the same control layout on the front panel, and the set was renamed the Superstar 360.

How confusing! No wonder I was misled to believe that the Motorola PLL chip existed in all models of Cobra 148GTL and Superstar 360. The question remaining to be answered is how do we modify the other designs of PLL circuitry to get the set operating on the amateur ten metre band?

## MB8719 PLL chip

First of all we must look closely at the characteristics of the MB8719 PLL chip which was used by Cobra in the earlier designs. The  $F_{in}$  of the chip is capable of accepting a maximum frequency input of only a couple of MHz. The programmable divider is equipped with only six program lines.

However, there is an unusual feature here. When program line  $P_6$  is kept at logic level 1, the maximum binary value of the other program lines will be  $P_0 + P_1 + P_2 + P_3 + P_4 + P_5 + P_6$ , which equals a maximum value of 127. When program line  $P_6$  is at logic level 0, then the new binary value will be  $P_0 + P_1 + P_2 + P_3 + P_4 + P_5 + 128$ , which equals 191. When program line  $P_6$  is at logic level 0, 128 is added to the binary value of the program lines  $P_0$  through to  $P_5$ . This technique will be used in the President Grant.

The block schematic diagram of the early Cobra is shown in *Figure 1*. It can be seen that the design uses a 10.24MHz reference crystal whose frequency is divided in the reference divider of the PLL chip to obtain a reference frequency of 10kHz, which is injected into one input of the phase comparator. The output of the phase comparator is fed via a low-pass filter to the VCO. The output of the VCO is fed directly to the receiver first mixer and to the input of the transmitter mixer.

The block schematic diagram compares with the design described in my earlier article. However, there is a difference in the design which has occurred because of the limitations of the programmable divider of the PLL chip. For example, on channel 40 on the highband, the transmit frequency in the unconverted set will be 27.855MHz. The VCO will be operating at a frequency of 27.855MHz minus 10.695MHz, which



equals 17.16MHz. The frequency of the down-mixer crystal oscillator must be such that the value of  $F_{in}$  will be 1.23MHz.

This is the required frequency chosen by the set designer to cater for the shortcomings of using the MB8719 PLL chip. Therefore, the frequency of the down-mixer crystal oscillator will be the frequency of the VCO, 17.16MHz, minus the frequency of  $F_{in}$ , 1.23MHz, which will give a frequency of 15.930MHz.

On channel 1 in the highband, the transmit frequency will be 27.415MHz. The VCO will be operating at a frequency of 27.415MHz minus 10.695MHz, which gives 16.72MHz. Here, again, the set designer requires the frequency of  $F_{in}$  to be 0.790MHz on channel 1. The calculated frequency of the down-mixer crystal oscillator will be 16.72MHz minus 0.790MHz, which gives 15.93MHz, the same calculated frequency as for channel 40 on the highband. The corresponding crystal frequencies for the midband will be 15.48MHz, and 15.03MHz for the lowband.

The type of crystal oscillator used requires satisfactory oscillation of the down-mixer crystal, to add a value of 2.5kHz to the calculated value of the crystal frequencies. Therefore, you will probably find that the actual crystal frequencies used in the unconverted design will be 15.9325MHz, 15.4825MHz and 15.0325MHz respectively.

Please note that the set designer has rearranged the bands of operating frequencies so that on some sets channel 40 in the highband will be operating on a frequency of 28.305MHz, which is inside the CW section of the amateur ten metre band. The corresponding crystal frequency used in the set will be 16.3825MHz. Therefore, you will probably find that the three down-mixer crystal values will be 16.3825MHz, 15.9325MHz and 15.4825MHz, which can sometimes make life confusing!

### Ten metre mod

The location of the down-mixer crystals and the associated tuning cores for the three crystal oscillators is shown in *Figure 2*. To change the operating frequency of the set we will need to change the frequency of the down-mixer crystals. Let us assume that we wish to have the set operating on a frequency of 29.70MHz on channel 40 on the highband. This in turn will correspond to my standard convention of having channel 30 in the highband operating on the FM calling frequency of 29.60MHz.

On channel 40 on the highband the VCO will need to operate on a frequency of 29.70MHz minus 10.695MHz, which gives a frequency of 19.005MHz. As previously mentioned, the operating frequency of  $F_{in}$  must remain at 1.23MHz on channel 40 if the loop is to remain in lock. The new frequency of the down-mixer crystal oscillator will be 19.005MHz minus 1.23MHz, which gives a frequency of 17.775MHz. Don't forget, you will need to add 2.5kHz to this frequency to arrive at the actual frequency value of the crystal, which will be 17.7775MHz.

When calculating the values of the down-mixer crystals to obtain sequential

frequency operation between the low, mid, and highbands, note that the channel switch produces a binary code which produces a non-sequential frequency relationship with channel number which is required by the FCC specification.

If you examine *Table 5* on page 40 of the March 1986 issue of *Amateur Radio*, you will observe that channel 40 in the highband is operating on a frequency of 29.70MHz, and channel 1 in the highband will be operating on a frequency of 29.26MHz. Therefore, it would be wise to have channel 40 on the midband operating on a frequency of 29.25MHz.

The corresponding frequency for the down-mixer crystal oscillator will be 29.25MHz minus 10.695MHz, which gives the VCO an operating frequency of 18.555MHz. Remember that the operating frequency of  $F_{in}$  must be 1.23MHz. Therefore, the operating frequency of the down-mixer crystal oscillator will be 18.555MHz minus 1.23MHz, which gives an oscillating frequency of 17.325MHz. Remember to add 2.5kHz to this value to obtain the required frequency for the crystal, which will be 17.3275MHz.

### Repeat the exercise

The same exercise must be performed when calculating the value of the crystal required for the lowband. If channel 40 on the midband is operating on a frequency of 29.25MHz, channel 1 will be operating on a frequency of 28.81MHz. Therefore, it would be wise to have channel 40 on the lowband operating on a frequency of 28.80MHz. The corresponding value of the down-mixer crystal will be the 16.8775MHz. Try the calculation for yourself.

The resulting operating frequency for channel 1 on the lowband will be 28.36MHz. The new operating frequency allocation is shown in *Table 1*. The disadvantage of using the technique of changing the down-mixer crystals to bring the set to operate on ten metres is that you retain the odd jumps and skips in frequency required by the FCC specification. Also, it would be difficult to include a repeater shift facility. However, an EPROM could be inserted between the channel switch and the program lines of the PLL chip to provide a repeater shift and sequential frequency movement to correspond to the channel selected. Due to the limitations of the divide-by-N number selectable by the MB8719 PLL chip, however, it would be necessary to retain the three down-mixer crystals.

If you do decide to add an EPROM to the conversion modification you will need to know that the program logic input voltage levels conform to CMOS technology. That is, a logic level 1 requires approximately +8 volts. In the past, I have used an Intel 2716 EPROM, which conforms to TTL logic voltage levels of +5 volts for logic level 1. Therefore, it will be necessary to use 7407 non-inverting open collector buffer gates between the output data lines of the 2716 EPROM and the program lines of the PLL chip.

The circuit configuration of the

EPROM memory is shown in *Figure 7* on page 41 of the March 1986 issue. It will be necessary to remove the interconnecting wires to the band switch, as they will not be required in this particular application. I have not bothered with this additional modification, and the reader has been left to calculate the address and data required to be entered into the EPROM.

The new down-mixer crystals should operate in the fundamental mode. When ordering these three down-mixing crystals, ensure that the manufacturer is asked to supply a crystal that will operate with about 30pF of capacitance in parallel, supplied in an HC 18u holder so that it can be soldered directly onto the PCB of the set.

### President Grant

In an attempt to reduce the manufacturing cost of the set, the designers developed an update which continued to use the MB8719 PLL chip but which only

**Table 1** New frequency allocation

Channel	Low	Mid	High
1	28.36	28.81	29.26
2	28.37	28.82	29.27
3	28.38	28.83	29.28
4	28.40	28.85	29.30
5	28.41	28.86	29.31
6	28.42	28.87	29.32
7	28.43	28.88	29.33
8	28.45	28.90	29.35
9	28.46	28.91	29.36
10	28.47	28.92	29.37
11	28.48	28.93	29.38
12	28.50	28.95	29.40
13	28.51	28.96	29.41
14	28.52	28.97	29.42
15	28.53	28.98	29.43
16	28.55	29.00	29.45
17	28.56	29.01	29.46
18	28.57	29.02	29.47
19	28.58	29.03	29.48
20	28.60	29.05	29.50
21	28.61	29.06	29.51
22	28.62	29.07	29.52
23	28.65	29.10	29.55
24	28.63	29.08	29.53
25	28.64	29.09	29.54
26	28.66	29.11	29.56
27	28.67	29.12	29.57
28	28.68	29.13	29.58
29	28.69	29.14	29.59
30	28.70	29.15	29.60
31	28.71	29.16	29.61
32	28.72	29.17	29.62
33	28.73	29.18	29.63
34	28.74	29.19	29.64
35	28.75	29.20	29.65
36	28.76	29.21	29.66
37	28.77	29.22	29.67
38	28.78	29.23	29.68
39	28.79	29.24	29.69
40	28.80	29.25	29.70

required two down-mixer crystal oscillators. This new design was housed in a larger metal box and was called the President Grant. The designers had managed to adjust the channel switch logic codes by using a technique called binary addition.

Two binary adder CMOS 14008 chips were connected between the logic output of the channel switch and the input to the program lines of the phase locked loop chip.

### Channel switch codes

On the lowband the channel switch code is allowed to pass through the binary adder circuitry unaffected. A separate down-mixer crystal oscillator operating on a frequency of 15.00MHz is used on the lowband. On the highband a single 15.45MHz down-mixer crystal oscillator is used for both the mid and highbands.

The channel switch codes on the midband remain unaffected by the binary adder circuitry. However, on the highband the binary adder circuitry adds a binary value of 45 to the channel switch code to shift the operating frequency of the set from the midband to the highband without altering the value of the down-mixer crystal oscillator.

Band/channel	P <sub>0</sub>	P <sub>1</sub>	P <sub>2</sub>	P <sub>3</sub>	P <sub>4</sub>	P <sub>5</sub>	P <sub>6</sub>	P <sub>7</sub>	Binary	F <sub>in</sub> MHz	Tx freq MHz
High 40	1	1	0	1	0	1	0	0	171	1.71	27.855
High 1	1	1	1	1	1	1	1	1	127	1.27	27.415
Mid 40	0	1	1	1	1	1	1	1	126	1.26	27.405
Mid 1	0	1	0	0	1	0	1	1	82	0.82	26.985
Low 40	0	1	1	1	1	1	1	1	126	1.26	26.955
Low 1	0	1	0	0	1	0	1	1	82	0.82	26.515

**Table 2** Relationship between logic code, binary value, F<sub>in</sub> and operating frequency for the early Cobra design

To cleverly manipulate the divide-by-N number of the programmable divider to obtain the coverage of 120 channels using only two down-mixer crystals, the designers had to choose different values of N compared with the earlier Cobra design.

Table 2 shows the relationship between the logic codes, binary values, F<sub>in</sub> and the operating frequencies for channels 1 and 40 on the low, mid and

highbands. For example, in the Cobra design the value of F<sub>in</sub> for channel 1 was 0.790MHz and 1.230MHz for channel 40.

The designers of the President Grant had to change the value of F<sub>in</sub> to 0.82MHz for channel 1 and 1.26MHz for channel 40 on the low and midbands. However, on the highband they had to use a value of F<sub>in</sub> which is different to accommodate the use of only two down-mixer crystals. On the highband the frequency of F<sub>in</sub> on channel 1 is 1.27MHz and 1.71MHz for channel 40. Remember that on the highband a binary value of 45 has been added to the channel switch code, which in turn will modify the value of F<sub>in</sub>. It is worth noting from Table 2 that on channel 40 on the highband, program line P<sub>6</sub> has been altered by the binary adder circuitry to be at logic level 0, which adds 128 to 64 to produce the required binary value of 171.

### The metre modification

Let us assume, as before, that we require the set to operate on 29.6MHz on channel 40 on the highband. The block schematic diagram of the set is similar to that shown in Figure 1, with the exception that we are now using different values of N in the programmable divider. Therefore, for the set to operate on a frequency of 29.6MHz on channel 40 in the highband, the VCO will be operating on a frequency of 19.005MHz, the same frequency as for the Cobra design.

For the loop to remain locked, the value of F<sub>in</sub> must be 1.71MHz. Therefore, the down-mixer crystal oscillator must be operating at a frequency of 19.005MHz minus 1.71MHz, which equals 17.295MHz. Don't forget that we must add 2.5kHz to the down-mixer crystal oscillator operating frequency to arrive at the required frequency for the crystal, which will be 17.2975MHz.

The operating frequency on channel 1 on the highband will be 29.26MHz. Remember that in this particular design of set we retain the same down-mixer crystal oscillator frequency for the midband as for the highband. Therefore, what will be the operating frequency of the set using the 17.2975MHz crystal on channel 40 on the midband? From Table 2, the value of F<sub>in</sub> on channel 40 on the midband will be 1.26MHz. The VCO

will be operating at a frequency of 17.295MHz plus 1.26MHz, which equals 18.555MHz. The transmit frequency of the set will be 18.555MHz plus 10.695MHz, which equals 29.25MHz. The corresponding operating frequency on channel 1 on the midband will be 28.81MHz. On the lowband the set design requires a different down-mixer crystal to be used.

If the operating frequency on channel 1 on the lowband is 28.81MHz, it would be desirable to have the operating frequency of channel 40 on the lowband at 10kHz lower, operating on 28.80MHz. The VCO will be operating on a frequency of 28.80MHz minus 10.695MHz, which equals 18.105MHz. On channel 40 on the lowband, the designers required F<sub>in</sub> to be 1.26MHz for the loop to be locked. Therefore, the operating frequency of the down-mixer crystal oscillator will be 18.105MHz minus 1.26MHz, which equals 16.845MHz. Remember to add 2.5kHz to the operating frequency of the down-mixer crystal oscillator to obtain the required crystal frequency of 16.8475MHz.

### Ordering crystals

When ordering crystals, the specification for the crystal will be the same as for the Cobra design, with the exception of the operating frequency. This crystal modification to have the set up and running on the amateur ten metre band does not overcome the odd jumps in frequency that occur as a result of the FCC specification. The modification will not provide the facility of repeater shift. If you do require the options of sequential frequency stepping with the channel selected and repeater shift, then you will have to insert an EPROM between the channel switch logic output lines and the A inputs to the binary adder circuitry.

The 14008 binary adder integrated circuits conform to CMOS technology, and therefore 7407 non-inverting open collector buffers will have to be used between the output of the data lines of the EPROM and the A input lines to the binary adder circuitry. Alternatively, the binary adder integrated circuits can be dispensed with altogether and the outputs from the non-inverting open collector buffers connected directly to the program lines of the PLL chip. The

**Fig 1** Block schematic diagram of early Cobra design

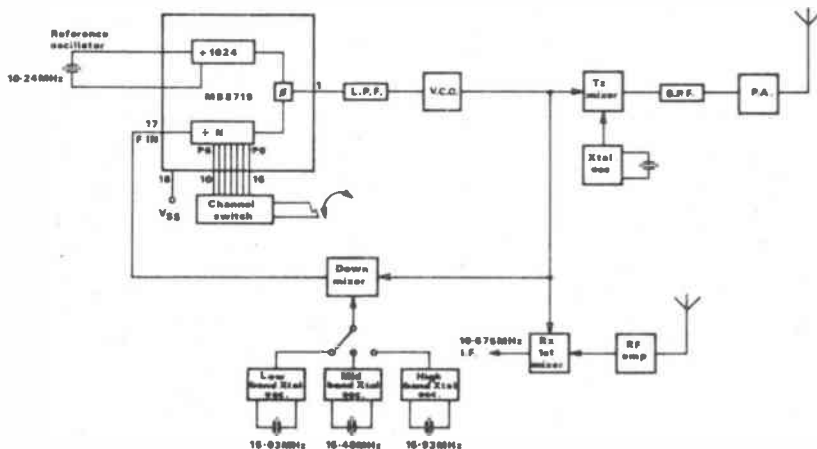

**Fig 2** Location of band crystals and associated tuning cores

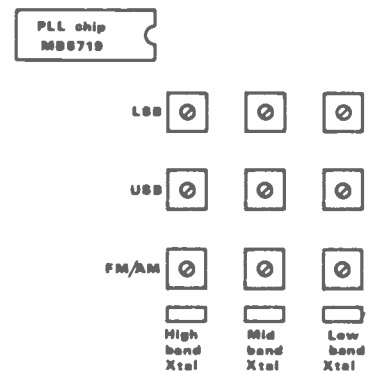



circuit configuration shown in *Figure 7* on page 41 of the March 1986 issue would suffice, except that the band switch part of the circuitry will not be required.

I have not bothered with this additional modification and the reader has been left to calculate the data required to be inserted into the EPROM. One remaining point worth mentioning concerning the President Grant design is associated with the logic value on the B input lines to the binary adder circuitry.

Earlier I mentioned that the binary adder circuitry added a binary value of 45 to the channel switch codes on the highband. Well, this is not strictly true. The channel switch used in the President Grant design is the same as the channel switch used in the Cobra design, and therefore produces the same binary code output. The channel switch binary code is required to be different in the President Grant design on all three bands.

For example, the divide-by-N number for channel 1 in the Cobra design is 79, 82 on the lowband and 127 on the highband for the President Grant design. Therefore, a binary value of 3 is added to the channel switch code on the low and midbands. On the highband a binary value of 48 is added to the channel switch code by the binary adder circuitry. The location of the down-mixer crystals is shown in *Figure 3*. The function of the down-mixer tuning cores is similar to that shown in *Figure 2*, with the exception that only two crystals are used.

### Superstar 360

In my earlier article, the contents of the EPROM were arranged to work in conjunction with the original down-mixer crystal oscillator, tuned to operate on a frequency of 14.995MHz. This was designed so that the existing 15.0025MHz crystal could be pulled down in frequency by the tuning cores in the collector of the crystal oscillator transistor. The oscillator would then operate at a frequency 5kHz lower.

A number of readers have written to me expressing difficulty with the stability of the down-mixer crystal oscillator. On some occasions the oscillator failed to oscillate when the supply was applied to the set. This can often be corrected by

rotating the mode switch on the front panel, which alters the value of inductance in the collector of the crystal oscillator transistor. The crystal oscillator in my set would refuse to oscillate only if the supply was gradually increased to full voltage. The only solution to this problem is to change the down-mixer crystal for a 14.9975MHz crystal. The 2.5kHz correction factor has been added to the value of the crystal frequency.

From the feedback received from a number of readers, it would therefore appear that the 15.0025MHz crystal does not like to be pulled 5kHz down in frequency. Other readers have discovered that their version of the later design of Cobra or Superstar, which use the Motorola MC145106 PLL chip, contains a 15.450MHz crystal instead of the 15.0025MHz crystal. Again, the solution to this problem is to change the down-mixer crystal for a 14.9975MHz crystal. When ordering the crystal, the specification is the same as that previously given for the Cobra design. The crystal oscillator operates in its fundamental mode and is *not* a third overtone crystal oscillator, as mentioned on page 38 of the February edition of *Amateur Radio*.

Some readers have expressed difficulty in tuning the VCO to obtain a stable locked condition over 120 channels. To successfully tune the VCO it will be necessary to monitor the dc voltage, which is applied to the capacitance diode forming part of the VCO tuned circuit. This can be achieved by soldering a small length of wire to the PCB track marked dc test point in *Figure 4*. Connect an oscilloscope with the Y amplifier switched to dc, 1 volt per division, to this test point. With the set switched to channel 20 on the midband, locate and adjust the tuning core of L18. This is the VCO tuning coil and can be found next to the 10.24MHz reference crystal.

By adjusting the core of L18 you should observe the voltage at the test point vary from 8 volts down to zero volts. Adjust the tuning core of L18 to obtain a voltage reading of approximately 5.5 volts. Now adjust the channel select switch and band switch to examine between channel 1 on the lowband and channel 40 on

the highband, and ensure that the test voltage does not reach zero or 8 volts. In fact, the voltage should track the channel and band selected.

If you find that the test voltage does not remain stable for a given combination of channel and band selected, this will probably be due to a low level of signal being fed to  $F_{in}$  on the PLL chip. This problem can be overcome by tuning L17, which is the low frequency output tuned circuit of the down-mixer, for maximum signal level of  $F_{in}$  on the appropriate pin on the PLL chip when on channel 20 on the midband. The loop should now be locked and remain locked over the entire 120 channels.

### Transmitter tuning

A small number of readers have been concerned about the purity of the transmitted signal. One reader in particular suffered chronic breakthrough on his two metre set, which was located alongside his ten metre set. The probable cause of this problem is that the bandpass filter, comprising L52 and L53, has not been adjusted correctly.

I suggested in my earlier article that the tuning cores of L52 and L53 should be adjusted for maximum power output on either channel 19 or 20 on the midband. Tuning the bandpass filter in this manner can cause, if you are not very careful, the bandpass filter to be tuned wider in bandwidth than is intended. The experience I gained by modifying and tuning six sets shows that a different approach is necessary.

Initially, adjust L52 and L53 to obtain maximum power on channel 20 on the midband. Next, tune L52 for maximum power output on channel 1 on the lowband. Now tune L53 for maximum output power on channel 40 on the highband. Repeat this tuning exercise until no further adjustment is required. The bandpass filter will now be correctly tuned.

Next, adjust L44 located near the RF power transistor for maximum output power, with the set tuned to channel 20 on the midband. The transmitter should now be fully tuned. If you do happen to experience difficulty when tuning L44 for maximum output power, you may find it necessary to replace C195, a 560pF

**Fig 3** The location of band crystals and associated tuning cores

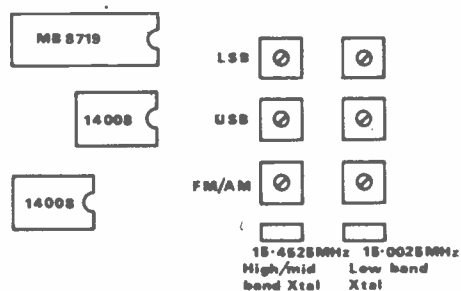

**Fig 4** Location of dc test point for PLL loop

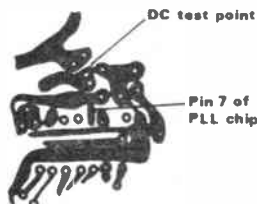

**Fig 5** Modification to the winding of L7

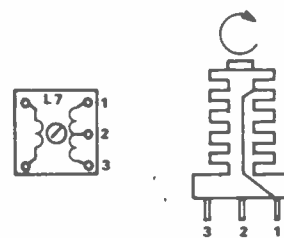

capacitor, for a 470pF capacitor. If it is your intention to run the set into a linear amplifier, it would be wise to insert a 50 ohm low-pass filter between the set and the linear amplifier.

Some models of the Cobra, President Grant and Superstar are manufactured with a modified power amplifier which is capable of supplying aerial power in excess of 10 watts. Most small CB linear amplifiers which are capable of being tuned onto the ten metre band are designed to give maximum power with an input power of only 4 watts. Therefore, it would be wise to ensure that the set is operating on a power output of only 4 watts.

The voltage supplied to the power amplifier of the set is fed via a power PNP transistor which on AM provides the amplitude modulation. On FM the voltage on the base of this transistor controls the voltage and hence the output power of the power amplifier. The voltage on the base of the PNP transistor can be adjusted by varying VR13, which is a preset potentiometer soldered to the main PCB and is located towards the back right-hand side of the PCB. With this preset you should be able to adjust the output power down to 4 watts on FM.

#### Receiver tuning

A small number of readers have complained that their receiver seems a bit deaf compared with other ten metre rigs. The probable cause of this problem is that the receiver front-end has not

been tuned successfully. In part III of my previous article I suggested that if you could not obtain the use of a suitable signal generator, the receiver front-end could be tuned from an off-air signal generated by another radio amateur.

Firstly, let me say that there is no real substitute for the use of a good quality signal generator. Beg or borrow a good one. I am currently attempting, with little success, to convince my local club to invest in test equipment that can be used by the members, instead of spending vast sums of money buying the latest all-singing microprocessor controlled rig when the existing rig is more than adequate.

Tune the signal generator to 29.10MHz. Set the FM deviation to about 1.5kHz with a modulating signal of approximately 1,000Hz. Inject 100mV of signal into the aerial socket of the set when tuned to channel 23 on the midband. The mode switch should be in the FM position. Adjust L7, L8 and L9 to obtain maximum reading on the signal strength S-meter located on the front panel. If you find that you are unable to adjust L7 to obtain maximum signal strength reading then you will need to remove the coil from the PCB and one turn from the tapped winding.

Figure 5 shows the coil former facing the tapped winding on pins 1, 2 and 3. Unsolder the wire connected to terminal 1 and remove one turn. Resolder the wire back onto the terminal and the coil former back onto the PCB. L7 should now

be able to be tuned to give you the maximum indicated signal on the S-meter.

If you are using a signal generator, it is worth adjusting L54 to obtain a maximum S-meter reading. This tuned circuit adjusts the mixer injection level for the receiver first mixer stage. The receiver will now be fully tuned and the set ready for use on the ten metre amateur band. With 100mV being injected into the set, the S-meter should be reading S9. If this is not the case, then you will need to adjust VR1 to obtain an S9 reading on the S-meter.

#### Conclusions

The additional information given in this article should assist the vast majority of readers who have experienced problems with the modification. My modified Superstar 360 has worked very well from day one, and the signal reports received would indicate that the set is performing well.

Recently an opening occurred on ten metres and a number of DX stations were worked on FM and SSB using only 4 watts into a quarter-wave vertical antenna. The remaining five sets that I purchased were sold earlier this year at the Swansea Mobile Rally. Early reports received from West Wales indicate that the recipients of the sets are pleased with their performance on ten metres. I wish you the best of luck with your set conversion and look forward to working you on ten metres.

**NOW OPEN**

**THE HAM SHOP**

#### Stockists of:

Equipment, New & S/Hand  
Antennae VHF/HF  
Accessories  
Components  
Tools  
Cable  
Hi Fi

#### TRADE/RETAIL

Also, we are official stockists of Revox specialist Hi Fi & Studio equipment for the home enthusiast/professional. "Once bought rarely sold". Equipment for the discerning. Call us for appointment and demonstration.

**GIPDY  
(PETER)**  
Tel 0905-  
29136

**THE HAM SHOP.  
WESTBURY HOUSE  
RAINBOW HILL  
WORCESTER**

#### THE NEW TX-3

#### RTTY/CW/ASCII TRANSCIVE PROGRAM

This program has so many features that it is impossible to do it justice in this space so please write or phone for full details. Some of them are:

Split-screen, type-ahead operation, receive screen unwrap, 24 large memories, real-time clock, review store output to screen & printer, callsign capture, memories, review store and current status can be saved/loaded. Auto CR/LF on RTTY. Software filtering on CW.

**You don't need an expensive terminal unit** to operate it, either. Our **NEW TIF1 INTERFACE** gives great results with its RTTY and CW filters.

TX-3 available for **BBC-B** now, other versions coming. Tape £20, disc £22 (state 40/80 track). If you already have our RTTY/CW transceive program, return it with your order for a £10 discount. TIF1 kit (assembled and tested PCB, User port connector, cables) £15. Boxed with all connections for 1 rig £25, 2 rigs £28 state rig(s).

#### For the listener we have the

#### RX-4 MULTIMODE RECEIVE PROGRAM

Lots of features and performance for receiving **RTTY, CW, SSTV, AMTOR. Spectrum** needs no hardware, **BBC-B, CBM64, VIC20** us TIF1 or a T U on RTTY or CW. Tape £25, disc £27 (not Spectrum, BBC state 40/80 track). Again, write or phone for more information on the best-selling program. Prices include VAT and p&p, 1st Class inland, airmail overseas, normally by return. Eire, CI, BFPO deduct 13%



**technical software (AR)**

**Fron, Upper Llandwrog, Caernarfon LL54  
7RF. Tel: 0286 881886**



# KW TEN – TEC CORSAIR II

NO FRILLS, "GIMMICKS", OR UNUSED FACILITIES – FOR THE SERIOUS PHONE/CW OPERATOR WHO WANTS THE LOWEST NOISE, CLEANEST AND MOST SELECTIVE AMATEUR hf TRANSCEIVER ON THE WORLD MARKET.

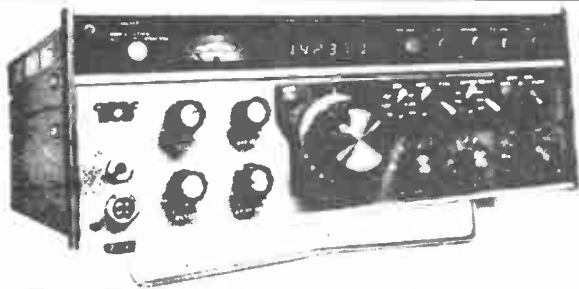

Other KW-TEN TEC winners  
The ARGOSY II phone/cw transceiver. The CENTURY 22 cw only transceiver. The original KW TRAP DIPOLE and TRAPS, 8 ATU's, KW BALUN, and ANTENNAS  
*WRITE OR PHONE FOR DETAILS*

## KW TEN – TEC LIMITED

Vanguard Works, Jenkins Dale, Chatham, Kent, ME4 5RT  
Telephone. 0634 – 815173.

**Amateur Radio**  
– the monthly magazine for all two-way radio enthusiasts

Don't take a chance on being able to get your copy

### AVOID DISAPPOINTMENT

Place a regular order with your newsagent

Should you have any difficulties obtaining a copy, phone (0277) 219876 or write to Circulation Department, *Amateur Radio*, Sovereign House, Brentwood, Essex, CM14 4SE.

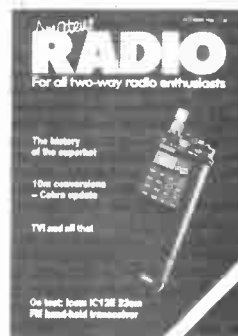

### NEWSAGENT ORDER FORM

To (name of newsagent).....  
Please order a copy of *Amateur Radio* for me every month  
NAME.....  
ADDRESS.....  
.....  
POSTCODE.....  
Newtrade distributors: Argus Press Sales & Distribution Ltd, 12-18 Paul Street, London EC2A 4JS. (Tel: 01-247 8233)



**TUNE INTO TONY & HELEN AT LEICESTER STAND 26 AND SEE OUR NEW RANGE OF PRODUCTS INCLUDING:**

Aerial tuning units for amateur & commercial use. Baluns 1:4 and 4:1 **£15.50**

1kw fully encapsulated. The G40GP clip-on aerial kit **£5.30**

PLUS Make-a-Cap large air-spaced capacitors from **£12.00**

**SPC-300D**  
Handling Capability  
1Kw P.E.P.  
**ONLY £225.00 INC VAT**

**SPC-3000D**  
Handling Capability  
3Kw P.E.P.  
**ONLY £325.00 INC VAT**



**OUR RETAIL OUTLETS:**  
Amcomm/ARE & all branches of SMC Ltd R Withers Communications A J H Electronics Reg Ward & Co Ltd Radioshack Ltd, Arrow Electronics + G W Morse Keys

If you want an ATU which will be used for as long as you're licensed – remember the CAPCO motto:

*"Stay tuned forever with a CAP CO ATU – once bought – never replaced"*

**63 Hallcroft, Birch Green, Skelmersdale, Lancs WN8 6QB 0695 27948 (24hrs)**

- ★ Both units have a unique Cap. Co. built-in lightning protection circuit. No need to unplug aerials
- ★ Unique Cap-Co modular composite robust structure
- ★ Tunes continuous 1 to 30 MHz with no gaps
- ★ Will tune a piece of wire or a logaperiodic
- ★ Unique switching for A.T.U. or bypass position
- ★ Choice of three aerial input sockets
- ★ Built-in 4 to 1 balun for balanced or unbalanced feeder input
- ★ Featured in the latest book from Angus McKenzie (MBE G3OSS) "The Buyers Guide to Amateur Radio"

# THE KW204 REVISITED

A  
transmitter  
review



by  
Ian Poole  
G3YWX

KW is a name which has long associations with amateur radio. Over many years KW has produced several notable pieces of equipment, with names such as Vanguard, Viceroy and Valiant bringing back memories for many amateurs. Then, of course, the famous KW2000 must be mentioned, because even now it is still very popular on the secondhand market.

The last transmitter to come out of the KW stable, before the company was taken over by Decca, was the KW204. This piece of equipment reflected the expertise gained over many years by the KW design team, and it still performs well over ten years later.

The KW204 is an all valve HF transmitter covering all the bands of the day from Top Band to ten metres. The VFO functions over 500kHz and this means that each band is fully covered without having to change the bandswitch. The obvious exception is ten metres, for which there are four positions.

The transmitter is designed primarily as an SSB and CW transmitter, running 180 watts PEP input or 100 watts output on sideband and 150 watts input on CW. It is also possible to run AM but with a reduced input of 75 watts. The power

level is automatically reduced on Top Band to a maximum output of 40 watts PEP, and this can be easily reduced to conform with the UK licence conditions.

The 204 is housed in one of the standard KW G-line cases, which gives it a pleasant yet professional look. It measures approximately 13 x 13 x 6 inches and weighs about 27lbs, so it won't dominate the operating table. However, it is a bit larger than a modern transceiver of about the same power, but that is only to be expected.

Taking a closer look at the transmitter reveals that it has few of the frills that are so prevalent on today's equipment. However, it does have a good basic specification, which makes it worth investigating when a transmitter is needed and only limited funds are available.

## The circuit

The transmitter circuit design is fairly straightforward. It generates the single sideband signal at 455kHz and then mixes the signal up to a variable IF using the VFO. Then the signal is mixed again with the output from a crystal oscillator to bring it to its final frequency, where it is amplified first by a driver and then by the final power amplifier. Although the line-up may sound very standard, the results produced by the transmitter always bring favourable reports on quality and therefore it is worth taking a closer look to see how this is achieved.

It is best to start at the audio stages. The microphone amplifier consists of two triodes, each of which is half of a double triode valve. The first one acts as a voltage amplifier with a high input impedance and the second one is used in a cathode follower configuration to drive the balance modulator.

There is one further triode used in the audio section. This is used as an audio sidetone oscillator for CW to enable an accompanying receiver to monitor the Morse being sent. In fact this output was specifically intended for when the KW204 is used with its companion receiver, the KW202.

The carrier oscillator is fairly standard and employs two crystals which are switched to give the appropriate side-

band. Then the output from this oscillator is fed into a double diode balanced mixer together with the audio to generate the double sideband. This double sideband is then amplified and passed into a mechanical filter where the unwanted sideband is removed.

The basic single sideband signal has now been generated and the remaining stages put the signal into the right frequency and then amplify it.

The first link in this chain is the VFO. This uses a 6u8 triode-pentode valve. The triode section acts as the oscillator and its output is then buffered by the pentode. As the oscillator runs between 2.2 and 2.7MHz it is quite stable; the specification quotes 200Hz per hour after warm up.

The oscillator has a calibration control on the front panel and the frequency is trimmed by applying a variable bias to a varicap diode in the oscillator. The oscillator frequency is also altered very slightly when changing between upper and lower sideband. This is necessary to compensate for the change in carrier oscillator frequency so that the output carrier frequency remains constant whichever sideband is selected.

## Balanced mixer

The output from the VFO is mixed with the 455kHz single sideband in a balanced mixer consisting of a 12AT7. The output from this stage lies between 2.655 and 3.155MHz and it is passed through a bandpass filter to remove any unwanted mixer products.

Again the signal is mixed, but this time with the output from a switched crystal oscillator. This brings the signal to its required frequency where it has to be amplified before it is fed to the aerial.

First the signal is amplified by the driver, which is based around a 6CH6 or EL821. Unfortunately this valve is rather expensive to get hold of, so if you see one cheap it is worth snapping it up!

The PA is a robust design employing two 6146Bs. These valves can take far more of a hammering than the line driver valves which were popular at about the time the KW204 was designed. Although the 6146Bs should give a long life they are becoming more expensive. Again, if

## Front Panel Controls

### Controls:

- Carrier insertion.
- PA current/RF volt meter switch
- Cal set
- Pre-selector
- PA tune
- Net-receive-send
- VOX on-off
- Main tuning
- Off - LSB - USB - CW - tune
- Mic gain
- PA load
- Bandswitch

### Connectors:

- Mic input (stereo jack)
- Key (mono jack)

### Indicator:

- Meter - indicates RF volts on antenna output or PA cathode current



any pairs of these valves from a reputable manufacturer are seen cheaply, then they are worth picking up.

The transmitter employs an ALC (Automatic Level Control) circuit to avoid overloading the PA, which would cause splatter and could damage the valves. This is accomplished by deriving detected audio from the grids of the PA valves and applying a control voltage with a fast attack and slow decay to the 455kHz amplifier.

Finally, the power supply, which is a fairly standard design but generates a variety of voltages for the various circuits. The EHT supply for the PA develops 850 volts, whilst the standard HT line runs at 260 volts. In addition there is a negative 90 volt bias supply. All of these are smoothed, but in fact none of them are regulated, with the exception of a 150 volt supply derived from the HT line for the carrier oscillator and VFO. Then, of course, there is the heater supply which, apart from supplying the valves, is rectified to provide the necessary voltages for the relays and the optional add-on VOX circuit.

### The front

The front panel is neat and uncluttered. All the controls are adequately spaced so that people with the standard British finger (or bigger) should have no difficulty in using them.

Although the operation of most of the controls is quite self-explanatory, it is still worth describing some features.

The first one is the tuning control as it has its position right in the middle of the front panel. The actual control itself is dual speed, having two concentric knobs; the outer one which is nearer the front panel gives fast tuning, whereas the centre one gives slow tuning.

The dial is easy to read, being back-lit by two small lights. It was found that the calibration linearity was good: when it was calibrated using the small calibrator control to the right of the dial its accuracy was good enough.

The other front panel control with a slow motion drive was the preselector control for tuning the PA driver stage. The addition of this slow motion control made tuning very much easier.

The transmit/receive control is effected either by using the net receive/send control or the PTT line on the microphone. In practice, it was found much easier to use the microphone PTT on sideband and the front panel switch on CW. Incidentally, when using the PTT line to control the transmitter it is worth remembering to switch the net control to receive, otherwise not a lot happens! Obviously if a VOX unit is fitted this can be used to switch the transmitter to transmit, but the VOX switch on the front panel must be on.

### Back panel

The back of the transmitter has only a few connections. The most obvious of these are the two SO239 sockets for the aerial and connection to the receiver.

## Specification

Emission	Single sideband suppressed carrier Single sideband with carrier CW			
Frequency bands	1.8-2.3 14.0-14.5 28.5-29.0	3.5-4.0 21.0-21.5 29.0-29.5	7.0-7.5 28.0-28.5 29.5-30.0	MHz
VFO stability	Better than 200Hz after 30 minute warm up and with constant input voltage			
Power requirements	117V or 234V $\pm$ 5% ac 45-65Hz			
Power consumption	Approximately 320 watts on transmit			
Cabinet dimensions	Height	15.8cm	6.25in	
	Width	35.2cm	13.875in	
	Depth	33.6cm	13.25in	
Weight	27lbs, approximately 12kg			
Carrier suppression	-50dB relative to maximum output			
Unwanted sideband	-45dB relative to maximum output			
Second harmonic	-40dB from output signal			
Third order distortion	-30dB from output signal			
Mic input	High impedance			
Audio response	300-2500Hz $\pm$ 6dB			
RF output impedance	52 ohms			
Output power	10-80 metres 160 metres	100 watts 40 watts	PEP nominal PEP nominal	(both into 52 ohms)

Looking at the back of the transmitter, the one furthest to the left is for the antenna and the other one is for the receiver. Unfortunately they are not marked, and if they were to be connected incorrectly nasty things might happen to the receiver front-end, so take care.

### Possible problem

The connector to the right of the two RF ones is used to link the transmitter controls to an accompanying receiver and linear. It carries the various switching lines so that the receiver can be muted and the linear switched during transmit. As the KW204 was designed for use with the KW202 receiver and KW1000 linear, these lines match the required levels and there is a standard interconnecting cable to interface to the KW202. However, if different receivers and linears are to be used there is little difficulty in selecting the correct control lines. The main problem is likely to be in obtaining the correct type of mating connector, as it uses a 12-pin 'octal' type not normally stocked by dealers.

The next connection to the right is for use with a VOX unit. This is an add-on extra which is mounted on the back of the case just above the cut-out for the connectors. The cable which comes out of the VOX unit then plugs directly into this socket.

The only other connections through the back panel are the mains lead, mains fuse and earth connection, all of which are self-explanatory.

### Inside

The transmitter has been designed to give easy access. On the top there is a hinged lid which opens to reveal the top of the chassis. Using this there is sufficient access to be able to change all the valves except for the ones in the PA. As well as this most of the coil adjusters are accessible so that it is possible to perform a lot of the alignment.

Access to the underside of the chassis is also quite easy - remove the two screws from the top of the cover, and the screws which hold the bottom of the

### Valve complement

V1	12AX7	Mic amp/ tone osc
V2	12AT7	Audio cathode follower/carrier osc
V3	EF183	455kHz amp
V4	12AT7	1st mixer
V5	12AT7	2nd mixer
V6	6CH6	Driver
V7	6146	PA
V8	6146	PA
V9	6 $\mu$ 8	VFO
V10	6AM6	HF crystal oscillator
V11	0A2	Voltage stabiliser

cover to the chassis and keep the feet on. This leaves the cover free to slide off the chassis revealing the underside of the transmitter.

Underneath the chassis the layout is neat, and even though most of the individual circuit sections have screens between them there is still adequate access to all of the components. As there is space underneath the chassis as well as on top, there should be sufficient room in many areas to mount add-on extras, especially if they consist of a few components or small Vero or printed circuit boards.

The top of the PA compartment is the only section which is not immediately accessible once the chassis has been removed. It is enclosed in a screen which not only reduces the RF levels but also acts as a safety screen to prevent the valve anode top caps from being accidentally touched. This is particularly necessary as they carry the full 850V EHT.

### The book of words

The manual is comprehensive and far more useful than the operator's guides which are often provided with the new boxes these days. Not only does it give a specification and operating instructions, but it also includes a full circuit description, servicing instructions, tables of voltages and layout diagrams. Finally, the circuit diagram is included

and even though it has been reduced to fit on A2 paper, it is still reasonably legible.

### On the air

Operating the 204 was a pleasure. It was easy to use, easy to tune-up and capable of taking a reasonable amount of punishment without objecting. However, it should be said that because it is a transmitter and not a transceiver it does need to be netted onto the receiver frequency before calling. This may be annoying to someone who is more accustomed to using a transceiver, but it does not take long to net it onto the right frequency so this should not prove to be a big problem.

Once on the air it proved its pedigree. The reports which were received on single sideband were all very favourable. The audio was consistently reported to be very good. In fact this may have led to the transmitter's ability to get through some pile-ups, because a legible signal can often be superior to a loud signal. However, it was found that a speech processor was an advantage on occasions. If one is to be used then it is worth using a good quality audio processor or an RF one so that the audio quality is not unduly impaired.

CW produced equally good results. Reports were received saying that the signal was very clean and free from any

sign of chirp or key clicks. Again, this can help to get through pile-ups, or just make the signal easier to read and more pleasant to listen to, especially when sending rapidly.

While drift is no longer a problem on modern transceivers because of the use of frequency synthesizers, many older radios have free running VFOs which can sometimes drift. Despite the fact that the KW204 has a VFO and uses valves, which can make the problem worse because of the heat generated, the drift was found to be quite acceptable after warm up.

### Summary

The KW204 is a 'no frills' transmitter designed for good all-round performance. Although it is a valve design, this does not mean that it has an inferior performance to a solid-state one. In fact the main difficulty with valves is replacements, which should not prove too much of a problem, with the possible exception of the 6CH6/EL821, but even this is available at a price. If servicing is required, this can usually be done without too much difficulty or test equipment. However, it is still possible to get KW to service them if necessary. In view of all of these factors the 204 represents excellent value for money, and if a well maintained model is bought it should give years of trouble free service.

## THE PERFECT COMPLEMENT TO AMATEUR RADIO

Packed with construction projects and the latest technology plus pages of readers' classified ads



Take out a POST-FREE (UK) sub while offer lasts

- Delivery to your door by publication date each month
- Inflation proof – price guaranteed for 12 months

### On sale NOW at your newsagent and at equipment dealers

#### RADIO & ELECTRONICS WORLD SUBSCRIPTION ORDER FORM

To: Subscription Department • Radio & Electronics World • 1 Clarendon Road • Croydon • Surrey • CR0 3SJ. Tel: 01-760 0409

PLEASE SUPPLY: (tick box) for 12 issues, all rates include P & P

Inland	World-Surface	Europe-Air	World-Air
£15.60..... <input type="checkbox"/>	£17.40..... <input type="checkbox"/>	£21.50..... <input type="checkbox"/>	£28.45..... <input type="checkbox"/>

NAME.....  
 ADDRESS.....  
 .....  
 .....Postcode.....

Cheques should be made payable to Radio & Electronics World. Overseas payment by International Money Order, or credit card.

PAYMENT ENCLOSED: £ —

CREDIT CARD PAYMENT  VISA

.....

Signature .....



# INVISIBLE AND DISGUISED ANTENNAS

by D V Pritchard G4GVO

Many amateurs find restrictions imposed on the erection of antennas for HF operation, especially those living on modern estates where the presence of a mast, not to mention a beam on top of it, is either forbidden or frowned upon. Others, for a number of reasons, may not wish to advertise the presence of an amateur station in the neighbourhood.

For enthusiasts such as these, who find their activities curtailed because of their environment, I offer the following ideas as basic patterns for further exploration.

Some of these suggestions result from a visit to a friend who has recently moved to a modern estate. He found himself surrounded by those curious individuals who shriek at the enormity of a thirty foot mast at the bottom of the garden, yet remain unperturbed and even impressed at the presence of a dinghy with a forty foot mast in the driveway.

A further study of neighbourhood psychology revealed that the presence of two or even three TV antennas singled out the occupants as people of affluence and this was therefore acceptable, while the addition of an FM antenna and even a CB whip elevated them even more in their estimation.

## Secret operations . . .

It goes without saying that where secrecy has to be maintained for as long as possible, the erection of an invisible or a disguised antenna must be undertaken under the guise of the usual activities you might be expected to carry out in the garden or on the house. If you are an ardent do-it-yourself expert, no-one will raise an eyebrow if you put up a ladder to inspect the gutters or to paint the gable.

Even the erection of a TV antenna and mast on the side of the house will lead to little more than admiration for your skill and energy.

It is all a question of what your neighbours are accustomed to.

A simple but effective antenna for all bands is the 132 foot end-fed wire which, if fed via a simple L-match tuning unit and employing a good earth, is capable of 2dB gain on 21MHz and 3.5dB gain on 28MHz, reference dipole. Its performance on 160, 80 and 40 metres is outstanding, while 20 metre operation also brings excellent results. A tuning unit for the antenna is shown in *Figure 9*.

The problem of erecting such a length in a modern garden of 60 feet or less is overcome by end-loading, in this example by winding the surplus wire on a former and using a short aluminium mast as a form of capacity for the coil to work against.

## Effective disguises

*Figure 1* shows how the 132 foot length can be effectively disguised. The TV antenna mast on the rear wall of the house is fitted top and bottom with plastic bushes with rounded internal edges to allow the wire to move up and down easily. Number 24 enamel is suitable for the antenna, although a thinner size can be used if breakages can be tolerated.

An additional refinement is to camouflage the wire against the skyline by colouring it a light blue-grey, and a quick way of doing this is to calculate the length from the masthead to the end of the garden, coil up this section loosely and spray it with the appropriate aerosol colour.

If you have a garden chalet or shed at the end of the garden, another TV antenna on a shorter mast should attract little attention.

As shown in *Figure 2*, the mast is doctored by the inclusion of the end-loading coil. Bear in mind that the length of this mast and the windings on the coil must be included in the 132 feet, the bottom part of the mast being the capacity against which the coil works.

A 10 or 12 foot mast is ideal and is cut

about 2 feet from the antenna end. A 2 foot length of plastic water-pipe is inserted as shown and bolted in position, the bolts also serving as anchoring points for the ends of the coil. The first 3 or 4 turns, incidentally, should be introduced gradually so that the standing wave starts from the end and not somewhere in the middle of the inductance.

On completion, the coil is covered with a strip cut from an old inner tube or similar material and taped neatly in position. If the mast is given a coat of suitable grey paint (not aluminium) the coil can be completely disguised.

At the house end the wire is inserted at the top of the mast before erection, after which it is dressed away to the shack via a window or other convenient point of entry, colouring it to match the background if required. The far end takes a turn or two round one of the TV antenna elements and is connected by a crocodile clip or other suitable method.

As mentioned earlier, even thinner wire may be used (which will defy the keenest vision) and if it parts, it is a simple matter to join a new length and gently pull it through the house mast.

If you have no garden chalet, it is perfectly easy to make up a coil and disguise it on a stake or pole by the fence and run a few feet of wire down its length.

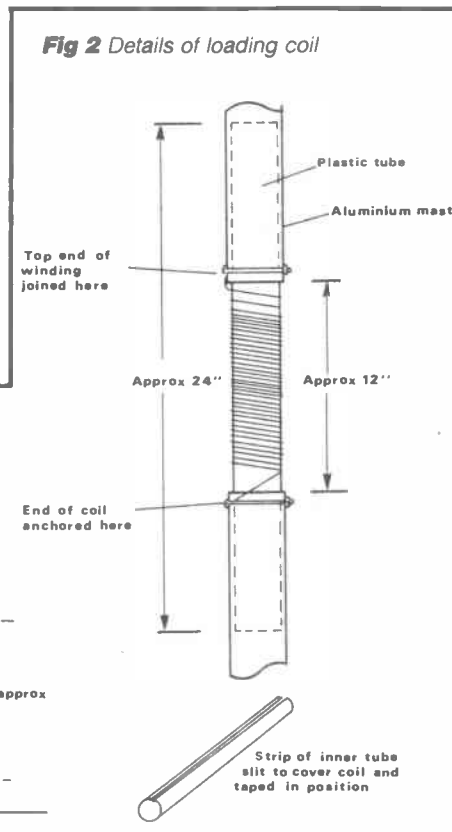
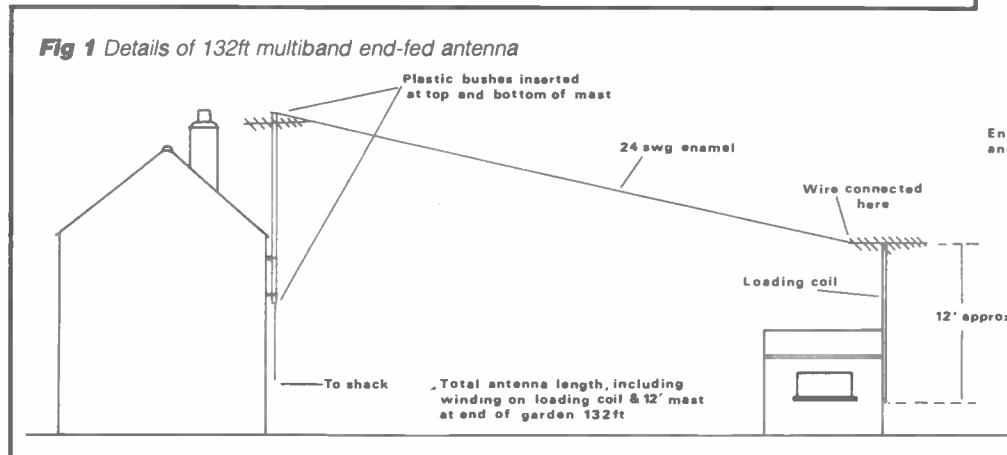

# DISGUISED ANTENNAS

**Fig 3** Details of invisible G5RV erection

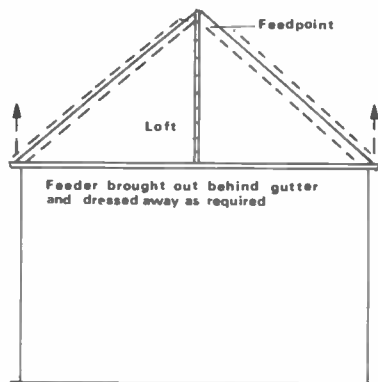
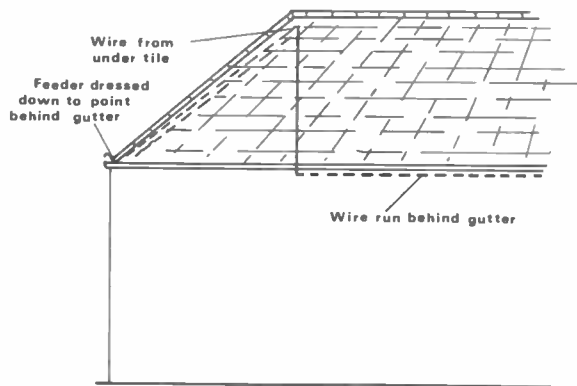

**Fig 4** How wires are fed under tiles and feedpoint details of G5RV

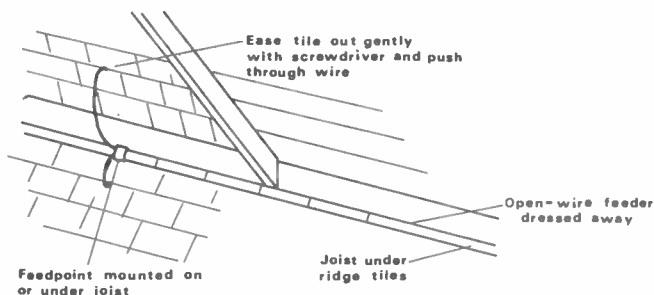

**Fig 5** Layout of heightened G5RV or other form of dipole or loop antenna

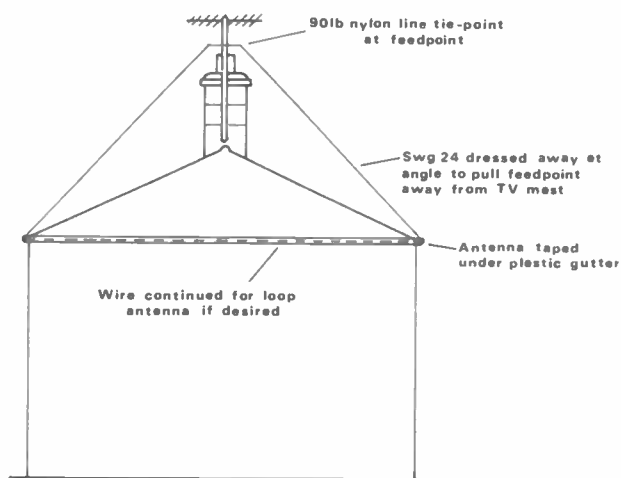

The installation will work just as well. As with any end-fed wire, the use of a good earth and, if possible, radials is mandatory if TVI is to be overcome, and this point cannot be over-emphasised.

## Plastic gutter technology

The use of plastic guttering on modern dwellings is a boon to the amateur, as it not only makes an effective insulated support but allows for absolute invisibility. Indeed, a full-size G5RV can be installed if the total gutter length is 102 feet or more.

Admittedly, the average gutter height is only around 17 feet, but even this permits good results to be obtained, although tuned feeders and a balanced ATU are obligatory since the usual length of 300 ohm ribbon feeder into 75 ohm co-ax or twin feeder is too long.

If a convenient mid-point is available, the tuned feeder may often be run down the wall and camouflaged to match the background. Two-inch plastic spacers are all that is required, and it may be possible to hide these behind a down-pipe.

A more sophisticated method, however, is shown in *Figure 3* and may even be used in a bungalow to good effect. The feedpoint is made in the loft as shown, and the feeders led away along a joist. Calculate the distance from the ridge to the gutters, measure 51 feet of number 24 enamel for both legs of the antenna and, leaving enough wire free to cover the measured distance, coil the rest into a neat flattened winding with a dab or two of tape to keep it in order.

Inside the loft a tile is gently raised with a screwdriver (not a difficult job) and the coil is allowed to drop down towards the gutter. Armed with a plastic bucket and a trowel, surreptitiously retrieve the coil, unwind it in the bucket, and pass the wire under the brackets as you proceed. A dab of suitably coloured tape will keep it taut and secure the ends.

If you want a neat camouflaged job, give the wire lengths between the tiles and gutters an occasional smear of the appropriate colour beforehand. On rooftops an occasional smear is more effective than coating the entire length.

Open-wire feeder with a balanced ATU is the most efficient way of feeding the antenna, as this provides complete coverage of all bands and allows an SWR of 1:1 to be achieved quite easily. On Top Band the feeders are strapped to turn the array into a Marconi T type antenna.

As 15 feet of the top section of the feeder radiates on 80 metres, it is advisable to dress the feeder down to a point where it can be brought out of the wall behind the gutter. If no convenient down-pipe is nearby behind which it may be hidden, it should run parallel down the wall, about an inch away from it, supported by a few insulated stand-offs. A length of suitable plastic channelling to cover it should be sufficient.

The only real problem of course is a snow-laden roof, but then you can't have everything and at least you have a full-



# DISGUISED ANTENNAS

size G5RV which is virtually invisible!

Additional height can, of course, be achieved if the presence of thin wire is tolerable. Figure 5 shows how this is attained by attaching the feed-point to within a foot or so of the TV mast with 90lb nylon fishing line.

While no claim for complete invisibility can be made, colouring of the exposed wires will at least render them unobtrusive.

## Gables and garages

Where 20, 15 or 10 metre operation is favoured and few opportunities exist elsewhere on the site, if your house has gables these may often serve as a suitable location, as shown in Figure 6.

Very often these protrude from the wall for a foot or so, and it is a simple job to drill a hole at one side of the joist within the loft for the feeder. Erection merely requires a few screw-hooks to support the wire. If the fascia is wide, it is often possible to erect a nest of dipoles and, if size permits, loops may even be incorporated by running camouflaged wires across at the base.

A flat-roofed garage by the side of the house sometimes offers possibilities for a nest of loops, as shown in Figure 7, and again the use of thin camouflaged wire does not constitute an eyesore.

## Foul pipe fooling

A plastic foul pipe, while serving a fundamental purpose elsewhere, offers other useful functions where your neighbours' bowels of mercy are constricted (*Ouch!-Ed*). Its average height of 17 feet and its proximity to the gutter are admirable features which shout 'ground-plane!' as soon as you look at them, and this form of antenna for 20, 15 and 10 metres often flushes out the DX...

Figure 8 shows how the antenna may be constructed. As the top of the pipe is a foot or so above the edge of the roof, this provides ample clearance (no pun intended) for the elements. These too are made from number 24 enamel and camouflaged in the usual way, the lengths required being:

20 metre band - 16 foot, 6 inches

15 metre band - 11 feet

10 metre band - 8 foot, 2 inches

A feedpoint is made very simply by joining the ends, together with the radials, to a 'birds nest' cage of metal or plastic which is still a common feature at the top of foul pipes.

The element wires are cut slightly longer than required but the actual radiating lengths are marked with a tiny dab of paint for identification. Calculate the distance between the top of the pipe and the roof in relation to the element lengths, but allow a foot or so for their entrance under a tile and subsequent fixing to screw-eyes in the joists in the loft.

Installation is carried out as described for the invisible G5RV. The elements are fanned out about a foot apart, so the choosing of the tiles to be raised is a simple matter. Once again, the wire is

Fig 6 Gable antenna

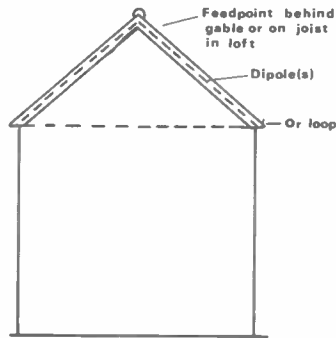

Fig 7 Garage loop(s)

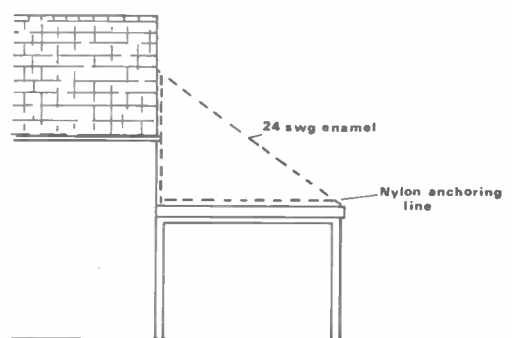

Fig 8 Details of foul pipe groundplane antenna

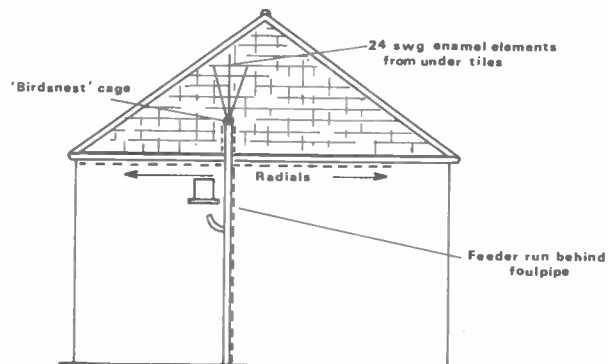
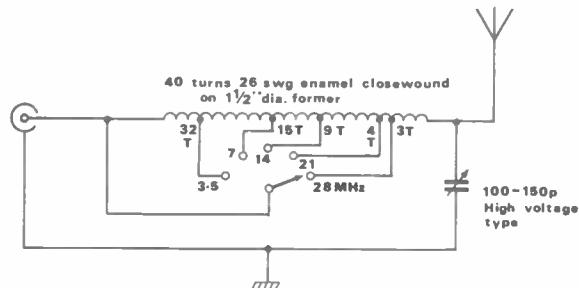

Fig 9 Circuit of L-match tuner for the multiband antenna



made into a flattened coil, leaving sufficient free wire for it to reach the gutter, whereupon it can later be retrieved.

A pair of multiple radials is quite adequate for a groundplane, and these are made from 3-core cable which is run behind the gutter and taped down as required. Approximately two feet of each radial will be dressed up the pipe, but if fairly thin cable of the appropriate colour is used, camouflage is an easy matter.

Ideally, soldered connections are best. However, a 'chocolate box' connector block will serve quite well and is easily concealed.

The radials are cut to the following lengths:

20 metre band - 16 foot, 8 inches

15 metre band - 11 foot, 2 inches

10 metre band - 8 foot, 4 inches

and, although they should be placed at a

45° angle for 50 ohms impedance, very little mismatch will occur at 90°. The element ends within the loft may be made off to convenient joists, as mentioned earlier. The 50 ohm co-ax feeder is run down behind the foul pipe to ground level if desired, where its subsequent routing to the shack can be easily hidden from prying eyes.

## Conclusion

As mentioned earlier, the ideas presented here are in basic form only, but may furnish inspiration for development in a number of ways, according to the circumstances. No claim to originality for the use of thin wire is made, neither is the concept of disguise and camouflage a novel one. However, I firmly believe that if this is taken into account, much more can be achieved than might otherwise be the case. Have fun!

# A VISIT TO ARRL HEADQUARTERS

by Jim Smith VK9NS

The idea of visiting the ARRL Headquarters was first broached at the Dayton Hamvention by Don Search, Communications Manager in charge of administering the ARRL DXCC programme.

My wife, Kirsti, and I were scheduled to visit George K20N in White Plains NY. Hartford didn't seem to be all that far away from K20N, so the idea was considered and in due course became a reality.

Over the VHF repeater system around the NY Connecticut area arrangements were made for the visit. Kirsti and I would make our own way to Danbury (about half way between White Plains and Hartford), and Paul KB2BE would then pick us up and drive us the remaining leg to the ARRL.

Spring had arrived with a vengeance and the countryside was glorious. The road systems are just superb and before we knew it we were pulling into the ARRL HQ. There was ample evidence of amateur radio, with several imposing antennas around. The immediate entrance to the two-storied building has a large area with a reception desk and several large glass cabinets. My attention was soon caught by the wonderful collection of old goodies. Coils, capacitors, Morse keys and various other items were in evidence: a record of the radio activities of yesterday.

Next to the reception desk a large selection of league publications was on display, and an immediate feeling of wanting to buy the latest *ARRL Handbook*, *Antenna Handbook* and so on was quickly curbed. Such is the weight allowance restriction of long distance air travel.

Before long Don Search was showing us around and without exception people were very friendly. Many of the staff in the various departments had callsigns, and many knew or had worked Kirsti or myself. There was quite a bit of interest in Norfolk Island.

## QSL bureau

One of the offices visited was the QSL bureau and Don was quick to dig out the VK9 cards; there were many for Kirsti and myself. We had to firmly decline the idea of saving ARRL a bit of postage. A couple of kilos of QSL cards were the last thing we needed to take on board! The system is well set up, though, and of course they deal in QSL cards by the thousand. They are there by the bucketful and no sooner is one lot sorted than another batch is with the incoming mail.

We were soon in the office where artwork was being prepared for an ARRL publication. The wall carried many

examples of previous work. Front covers for the *ARRL Radio Handbook* were among some of the covers featured.

We stopped and met John W1XX (*Operating News*) and Chas K8CH (one of the technical editors). All carried that distinctive QSL card, which most of us have received from time to time: 'One of the *ARRL Headquarters Gang*'.

In the laboratory area I was interested in the wide range of equipment and the well-equipped bench areas. Before a project is committed to a full blown technical article in *QST*, it is built and tested here to ensure (as far as possible) that it can be constructed with confidence by Mr or Mrs Average Ham.

## W1AW

Later, we made our way over to the separate building which houses the headquarters station, W1AW. Many of you will have heard of this station, and may have worked it or copied the bulletins over the years. Like all dedicated stations, it is very impressive. Excellent antenna systems make sure that the best possible signal is radiated. Station layout is such that various areas and operating positions take care of the different modes and bands. Separate amplifiers for each band avoids continual band switching.

It was inconvenient to operate the station whilst we were there, as a TV interview was being conducted. However, we now understand why W1AW is usually heard if there is any propagation at all. These days, unfortunately, we miss the bulletins on 21MHz due to lack of sunspots.

## DXCC desk

Finally, it was time to get over to the DXCC desk. As an avid DXer and the holder of several DXCC certificates from various call areas, I was very taken by the idea of seeing for myself what happened in this area.

Don Search W3AZD has been administering the ARRL DXCC programme for several years now. It is not exactly an easy task as sometimes the politics of the DXCC list are daunting. Why doesn't VO1CO/S2 count, or how about the 1Z9 stations, aren't they in Burma? These are questions that must be dealt with.

Don gets a lot of flak, mainly as he is very active at the various DX gatherings, always in a sort of forum situation as the disgruntled DXer tries to nail Don with his or her theory on why something should count. Of course, it is a mistake to blame Don; he implements policy and does not make the decision on whether something should count or not. There

have been many changes made in the DXCC scene over the years. However, despite those who are always knocking the system, none have come up with anything approaching the status or integrity of the ARRL DXCC Award.

The DXCC programme is on-going, and continually being measured and monitored to give the best to a sometimes very complicated picture. Many disputed areas have finally been resolved. A stronger stand has been taken on requiring proof that licence and permission (where required) is valid. There have been a number of grey areas in the past.

In discussion with Don about incidents involving bogus cards, etc, he says he does not consider the problem to be a large one. There is a great deal of expertise within the DXCC area and cards are scrutinised. Of course, this does not mean that every card is checked under a microscope. Under such a system the whole programme would come to a grinding halt within a week. Even today there is often a back-log and sometimes some delay in getting that certificate into the ARRL mail-room to be sent to the new DXCC holder. However, you can be sure that your request will be processed as quickly as possible.

## Real DXers

In addition, there are those who, for reasons best known to themselves, decide that obtaining 100 countries is just a start and go on to better things. These are the people I call DXers. In these cases it is a question of pulling out the original application and adding the latest batch of cards to the total. I know the system works, as some years ago I needed a copy of my original claim for G3HSR. I had the copy within a few weeks and also a duplicate copy of my DXCC certificate.

It is my opinion that within amateur radio nothing gives a ham a bigger thrill than working outside his own immediate area. Make it a different country and that is something else again. Of course hundreds of amateurs have no real interest in DXCC. Nevertheless, judging by the hundreds of thousands of QSL cards that go the rounds via QSL bureaux etc, a great many radio amateurs do, and seek cards as reminders of various QSOs.

In order to become involved in DXCC one must at least make some sort of effort to work 100 countries. It can be done, of course, during periods of high activity - like one of the CQ WW contests, or perhaps during a DXpedition.

The *ARRL DXCC Country List* is used as a guideline for the chase. Many



complain about the fact that a certain reef may count as a country and so on. However, the criteria for the list avoids the use of the word 'country' and talks about 'entities' or 'areas' and the conditions for DXCC status.

### Application for DXCC

Application for DXCC can be made to the ARRL using the correct form, which obviously makes it easier to check the claim. The forms are readily obtainable from ARRL. The minimum number of cards required is 100, but the application form wisely has space for 105 cards. This is a sensible move since quite frequently a card may not be acceptable for DXCC. The reasons for this are varied but a couple of examples are:

1. No documentation received for the operation;
2. Altered or amended QSL card submitted.

The first example is easily understood, but you may get the impression from the second statement that you are being called a cheat. Of course this is not the case. Hundreds of cards are submitted in good faith, although they have been altered in some way. A very typical example would be where the person writing the card makes a small error and corrects it. Another example would be where the card comes back with your call incorrect, and there may be a tendency to change the call. *Don't do it.* Send the card back for replacement. Another example would be no mode – you know you worked him on CW, the report on the card indicates CW, but no mode has been checked. Again, avoid the temptation to alter the card; find another or return the card for correction.

The rule is clear, and to avoid deliberate attempts to cheat no exceptions are made. So check cards carefully and submit only QSLs which you are satisfied reflect all the information required about the QSO under DXCC rules.

### Traumatic

Mailing can be a traumatic experience, especially if you have a couple of hundred hard earned QSL cards. They may well have cost countless hours and much expense to obtain. Registered airmail *there and back* is the only way to ensure their safe return. Why send your cards one way registered airmail and not include sufficient postage to have them returned the same way? One cannot expect ARRL to foot the postage bill for your QSL cards.

Wrap the cards securely and be assured that they will come back from ARRL packed better than when you sent them. Make sure that you have completed the DXCC application form, and, most important, make sure your writing is legible. One example I saw was really quite amazing and it took a bit of time to decipher it all.

On arrival at the ARRL mail-room contents are checked and any money or cheques extracted. The mail is cleared on a regular basis and your bundle of cards quickly finds its way into the DXCC area. Again, the mail item is booked into

the system and will have to wait its turn amongst the other bundles.

Whilst I was there a largish bundle was being checked several times; cards and totals did not agree with country totals being claimed. Finally, Don sat down with the offending bundle and noticed that although there was a card from Hawaii KH6, the applicant had not written it on the list.

Next a further and slower check was carried out, remembering that certain cards are not allowed, eg S2BTF, except for such and such a period, and that there were no altered cards or obvious forgeries.

Of course, one can hardly expect DXCC to spot a deliberate forgery where the card has been printed as an exact copy of the usual card stock. Yes, sad to say, there have been a few examples of that sort of thing.

Finally, the totals agreed and a DXer was getting nearer to that new total or his first certificate or whatever. File information would now be arranged to allow future applications to be made. This is how one gets comments like: 'KH3 already claimed, see your KJ6BZ card submitted previously'.

The end result is the mail-room once again and the DXCC certificate is soon on its way, securely packed in a strong cardboard tube. There are very few complaints about damaged certificates. Also, as mentioned previously, all QSL cards have been repacked in a strong cardboard box with details of your final total, cards not accepted (if any) and the reasons, a sticker for your original DXCC certificate if you are updating, and, of course, your DXCC badge.

Many of the cards in Don's collection, displayed in the DXCC area, took me back many years: the XV8, XZ2, 4W1, all no longer available on the bands. I wondered how often I had claimed DXCC, and was just a bit surprised at the total.

The ARRL DXCC certificate has always had a special meaning for me. The usual prompt and courteous service seems to continue. I thoroughly enjoyed my visit and extend my thanks to Don for a very pleasant couple of hours.

My advice to all you budding DXers out there is to get your cards sorted out and get them in the mail. Once you have that DXCC certificate on the wall you know you have a valid country score.

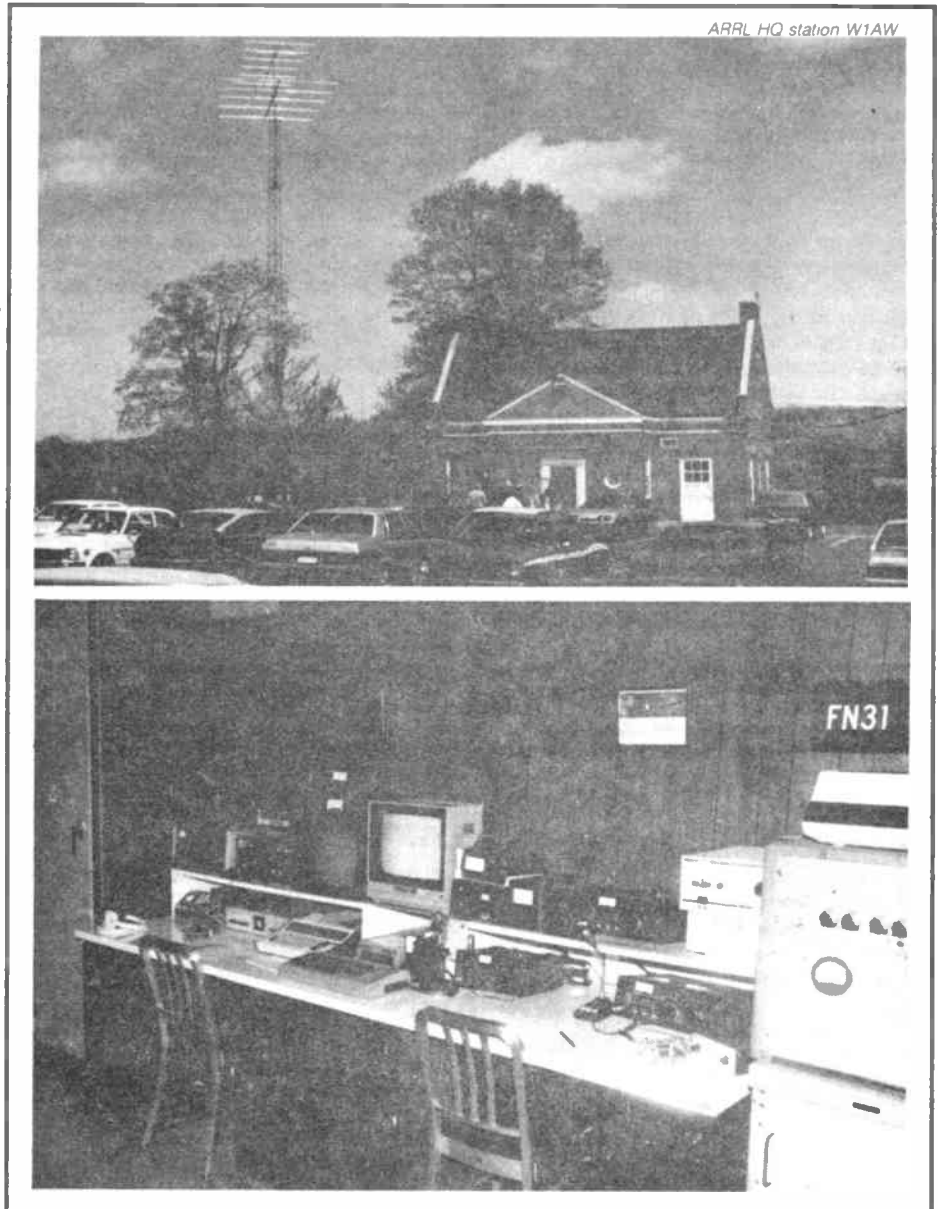

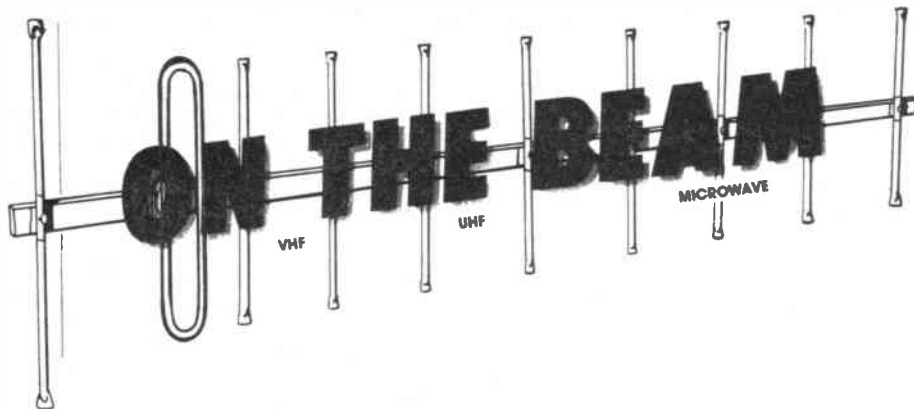

## News and comment from Glen Ross G8MWR

One of the problems with the Radio Amateurs Examination (RAE) is that it tells you, hopefully, all the technical things that you ought to know to become a good amateur, but in most respects it does not tell you how to use the information so that you also become a well liked operator. Believe me, there is a difference!

### Overdrive

One of the points that it falls down badly on is the correct care and feeding of linear amplifiers. We all know, I hope, that transistor 'linear' amps are seldom truly linear.

If you do not believe me then have another look at any of G3OSS's reviews printed in the August issue of the magazine, and note his general comments on how poor nearly all of them are if driven to more than about half the manufacturer's claimed output.

You could claim that the figures that Angus gives are too technical for you to understand, so let us put it into very simple terms. If the system is truly linear, when you double the input drive the output should also double. It rarely does, however.

### So what?

'All very interesting,' you may say, 'but as long as I get my 100 watts, or whatever, I am not too concerned.'

Well you should be, because otherwise you cannot be certain that you are going to be included in our list of best liked operators.

Let us look a little deeper into what is going to happen when you try and get that last watt of output. Perhaps the easiest way to do this is to compare our linear to something we all know about, the home hi-fi unit.

Now this is also a linear amplifier, and provided that we keep the volume control within sensible limits we get clean sound and very little distortion. What happens if we push the volume (in radio frequency terms the drive level) up hard?

### Distortion

We all know the answer to that one: we get some rather grotty reproduction because we are overdriving the linear output amplifiers in the hi-fi set, and we are now hearing all the distortion products that they are generating. What you may not know is that you are also hearing a lot of spurious responses that were not in the input signal, but have been produced in the amplifier because it is now non-linear, and that these can be generated well beyond the frequencies that you can actually hear. Does this sound to you like a possible cause of all the splatter that you are getting from the guy across town? And is it perhaps the answer to all the splatter he claims to be getting from you?

### Who's to blame?

Well, the original manufacturers are to a small degree guilty, but remember that you only want to spend a reasonable amount of money on your gear and therefore they have to design to an acceptable selling price. Could it be that you are the culprit? You will not like admitting to it, but this is usually the truth of the matter. Perhaps we should be fair and consider the possibility that your SWR bridge is not responding correctly when set to read power output. 'Can't be that,' you say, 'I just paid £100 for it.' Sadly, it may still have its limitations.

### Power meter

The snag is that, being a mechanical device, it will not respond instantly to sudden changes in power, which is what SSB is. It does a fine job on FM, where it has time to settle down, but it just cannot keep up with the ever changing SSB power levels. So, what does it do? Simple. It tends to average out the peak readings. What you have to do is turn up the gain, or yell into the microphone, to get the magic 100 watts showing on the meter. This is where the trouble really sets in, because that 100 watt rating on your linear is PEP (peak envelope power) when using SSB and not an average.

### Splatter

This is where we came in with the hi-fi system. You have in effect gone into overdrive, and now the linear has gone into overload and is producing distortion products. Some of those, in the audio case, were beyond your hearing range, but those produced by the linear are well within 'audibility', as far as your receiver is concerned, and simply appear as splatter up and down the band from the actual transmitted frequency.

### Other causes

Before you start throwing things at the other guy, bear a couple of points in mind. First, the RF stages in your receiver are not completely linear either and a very strong input signal can generate those nasties in your front end. This is more likely to be a problem if you are also using a pre-amp, so make a check by turning the pre-amp off and then swinging the beam away from the 'offending' station to reduce the signal to, say, around S5. If the problem disappears it was most likely due to receiver overload and mud should not be thrown. One other point to bear in mind is that the noise limiter in most receivers is simply a diode gate in series with the signal path, and that diodes are about as non-linear as you can get (hence the common use of them as mixers). Switch the noise limiter off and see if the splatter goes away. If after you have done these checks the splatter is still there, reach for the pile of bricks and start throwing.

### A clean signal

What do you do to make sure those bricks are not coming your way? Start by running the rig on FM and make a note of the power meter reading, then switch to SSB and talk the power up until the meter reads no more than about half the previous level. This does not mean that you are getting less output, you are simply making allowances for the inertia in the meter movement not being able to keep up with those envelope peaks.

To prove this point, simply whistle into the microphone and you will find the output will go up to the usual FM level. Talking it up any further may appear to give you more power, but it does not actually do so. What your meter is now reading is the power in your correct transmission *plus* all the power in those horrible sproggies that you are producing all over the band.

### Power supply

If your power supply voltage sags on speech peaks you are also in trouble; you must use a well regulated supply. Putting a voltmeter across the supply line will not check this for you because, just like the power meter, the voltmeter has an inertia problem. The only real way to do it is to use an oscilloscope across the output of the supply. If you are using a commercially built supply with a good name you should not have to worry about this problem because, presumably, the manufacturers have checked it out for you. Don't you wish the RAE had explained all that to you?



## Distressed mole

Our mole is in trouble with the RSGB! They used up nearly a whole page in *RadCom* to tell members that the mole had said we were going to lose 70cm. They even got a statement from the DTI, actually mentioning *Amateur Radio* and the 'fact' that we said you were going to lose the band, to back them up. The RSGB then said that the mole had got the information from the pages of some daily newspaper which had misquoted a Hansard report, and complained bitterly about moles who had not got the sense to use the telephone to check the facts!

## Get it right

I did not say that we were going to lose the band. What I did say was that the top end of the band was likely to disappear, or at least be filled with a new government system. I also said, and I quote, 'there is nothing firm to go on', which is hardly the same as saying we are losing the band. I said that it came from 'usually well informed sources'.

It did! For, amongst other sources, it came from the pages of *Defence Electronics*, and you do not get a better informed source than that. They reported that the USA has agreed a budget of more than a billion pounds for the modernisation and extension of the 'Pave Paws' high power radar system. Now, the first thing to bear in mind about this is that it is a very high

power system and that it is broadband. In fact, it operates over the range of 420 to 450MHz, and that includes the whole of our amateur band. The second point is that they talk of an extension to a system which already covers the whole of continental USA. So where are they going to extend to?

## Extensions

Perhaps the RSGB can help us here; I refer you to paragraph five of their item. In discussing the equipment at Fylingdales they say: 'The Ministry of Defence is currently modernising it. . .the MOD is reluctant to give much detail about the new equipment. . .published information suggests a phased array radar akin to the American 'Pave Paws' system'. So they do know about the threat after all. Perhaps they just did not understand the implications or have not been involved in any discussions with the authorities as to how it might affect our use of the band. Could it mean that the American extension of Pave Paws is going to be into Europe? It looks that way.

## No threat?

Don't you believe it! Having lived and worked in the States, I have seen at first hand just what this stuff is capable of doing and, to put it bluntly, it can make the band unusable. If you work on 23cm you will be aware of the problems

generated by such things as the radar system at Heathrow and other sites. Believe me, these are toys compared to Pave Paws, and this will be running on 70cm – a much more heavily used band. It also has implications for our European neighbours. Could this be why some of them have suffered severe restrictions on radiated power recently? Perhaps the Pave Paws people don't want too much interference on the screens or data processing gear.

## Final thoughts

Perhaps the RSGB will come clean on the fact that they were aware of a threat from Pave Paws. Perhaps they will give equal prominence in *RadCom* to a withdrawal of a slur on the accuracy of statements made in this column. They might even admit that at no time did I say we were going to lose the band. Perhaps they will start reading something other than *RadCom*, the *Guardian* and the *Financial Times*. Perhaps, as they advised our mole to do, they will learn how to pick up a telephone and find out where the facts came from before they rush into print. Somehow I doubt it.

## QRT

That's it for another month. Please keep your comments and news coming to me at 81 Ringwood Highway, Coventry or use Prestel 203616941.

**NEXT MONTH**

Amateur  
**RADIO**

### all the regulars. . .

DX Diary  
On the Beam  
Secondhand  
SWL  
Straight and Level  
Your letters and  
features covering  
the whole of  
Amateur Radio

### ■ ANGUS MCKENZIE TESTS

On test this month are the Yaesu FL7000 solid-state linear and a new pocket DMM from AB European Marketing

### ■ PORTABLE ATU FOR 80m

A simple and straightforward project from L B Uphill

### ■ PSU FROM THE JUNKBOX

Ian Poole presents an easily built power supply for the cheap and cheerful brigade

**DON'T MISS THE OCTOBER ISSUE**  
On sale 30 October

# SECONDHAND EQUIPMENT GUIDE

by Hugh Allison G3XSE

I'll bet most readers haven't heard of the Cranfield Rally, as the event in question is an aircraft rally. Attracting thousands of aircraft, including autogyros, microlights, helicopters and conventional fixed wing aeroplanes, this 3-day event is thought to be the biggest of its kind in Europe.

Fine, you may say, but what has this to do with secondhand amateur radio equipment? Well, there are quite a few clubs/groups/individuals in the country that collect and/or restore old aircraft radios, etc.

At the above 'do' there were traders selling valve ground to air and air to ground communications equipment, navigational aids such as marker, VOR and NDB receivers – some of which were quite recent examples – alongside more conventional aircraft rally junk like pedals, hinges, fairings, etc. Most of the radio stuff was being ignored by the punters present, yet there was gear that normally goes quickly at radio rallies, such as 1155s, RA1s (not the Heathkit sort, but the variety fitted in Spitfires) just lying around at a fiver a time.

One explanation may be that most of the visitors, like your scribe, fly in. Your average visitor is thus restricted by both weight and size as to what he can take home. Although I was not too badly held back, having gone there with my wife and son in an AA5 Grumann Cheetah, which is a four-seater, I still had to curtail the buying to an extent. In the end, on day two I went back in the car.

As an aside, the bargains I bought when I flew there just put me inside the top of the weight and balance envelope of the plane. Taking off from Cranfield was no problem, with its vast expanses of concrete runway, but I was unprepared for the landing back home. The extra weight meant more momentum to stop, and the far hedge came up frighteningly quickly after landing! To sum up, the Cranfield Popular Flying Association Rally could be a good day out for you. It is usually held on the first weekend of July.

## Frequency counters

I've had a few enquiries from readers regarding cheap counters. One that has featured in several letters over the past few months is the Yaesu YC355D. This machine is an odd mixture of good and bad, the bad being that it is a 5 digit display. Let us suppose we wish to set a rig up to transmit on S21, 145.525MHz. A 5 digit display gives 145.52, which isn't too handy. To allow for this you can shift the display over, so that it will display

5.5250. Inconvenient and niggly I think.

The good news is that the counter really does exceed its specifications. It has a front panel switch that routes the input via a prescaler for high frequency work. The switch is marked 35MHz in one position, ie frequencies up to 35MHz, the other position is marked 30 to 200MHz. In this position all the examples of the YC355D that I have played with will do about 350MHz at about 10mV sensitivity and will go on to 450MHz at about 50mV.

Above 450MHz no amount of extra surge up the input hole will get any action, but it is rare to find a 200MHz counter that is still accurate and of use on seventy centimetres. Please don't go out and buy one of these counters for use on seventy, but if you own one and have never thought of using it that high you could be in for a pleasant surprise. The counter has a very bright, easy to read display even in strong sunlight.

## A bit odd

A further oddity of the machine is that it can be powered from either mains or 12 volts, both supplies going in via the same four-pin mini Jones type plug. On 12 volts the counter takes a moderately greedy one and a half amps, but the real aggro is that people will mix up the two leads, or buy it with only one lead and try and fire the beast up with the wrong volts. Twelve volts dc up the mains lead causes no damage, but 240V ac up the 12V lead is spectacular and worth watching, provided it isn't yours! There is a small switch on the back marked ac in one position and dc in the other.

Your scribe bought an example of a YC355D at the Cranfield Rally for six quid. It had the 12 volt lead plugged into it (it sports standard red/black twin lead, as per most mobile rigs) but the non-counter end had a mains plug on it! The power selection switch was in the ac position and the seller, an aviation trader, said it didn't work. I must have been born lucky, since it had not been tried with mains up it on the dc position and 12V up the lead and flicking the power switch over brought action.

If you are in any doubt about running one on the mains that you have not used before, try 12V dc up the lead first. If this does not work, remove the top cover and check (with an AVO) that your mains leads, live and neutral, connect up to the white leads on the inside of the Jones plug. The price for a working model, secondhand, will be about £35/40.

I have seen a lot of Anadex CF700s at rallies this year. This is magnificent,

capable of exceeding its 1GHz limitation by, typically, 350MHz. Well worth the £60 that it seems to be selling for, this 8 digit machine is very well built and, if you are looking for a decent counter, is worth considering. I must admit I was a bit put off it since I didn't recognise the name, but am delighted with the example I bought. That one also came from Cranfield for six quid. It was sold as a non-worker, but worked perfectly from switch on!

The only other counter available secondhand in any quantity is the Microwave Modules one in the mini die-cast box (sometimes with a matching prescaler in another, similar box). Like all MM gear, boringly reliable and I've never seen one fail to work. They fetch about £35 without prescaler, £50 with. A bit overpriced in my humble opinion, though they work well.

## HF QRP rigs

There is a lot of interest in low power HF operation these days, a lot of it stirred up over the past five years or so by that amateur licensed man of the cloth, the Reverend Dobbs. This has led to a massive upsurge in demand for ready built rigs, and prices have rocketed. Five years ago the humble HW7 Heathkit QRP rig could be bought for ten to fifteen quid, and good cheap fun it was too. Today the prices are obscene, and I felt ill at Longleat when an amateur, old enough and licensed long enough to know better, shelled out £75 for an HW8.

There is one solution, however, for the aspiring Class A guy who wants either cheap HF CW contacts or is genuinely interested in QRP (or both): the Ten-Tec PM2 (or 2A, with CW sidetone fitted). These little 12 volt powered boxes have changed hands for £15 to £25 for as long as I can remember, the price being dependent more on the accessories that accompany them, like headphones, power leads, handbook and ATUs, than the condition of the rig. The VFO scale is calibrated for 80, 40 and 15 metres, but beware, 15 was an option. Check that this is fitted if it is important to you.

I have bought a few with very dead PA transistors, but a 2N4427, BLY33 or 2N3866 will all provide a cure at a reasonable price. A fiver a go seems to be the going rate for a dead one, and invariably it is only that the PA has short circuited, so don't be put off.

In use, the VFO is stable and SSB signals can be resolved with ease should you care to listen further up the band, though you can only work these on CW of





# THE WORLD OF

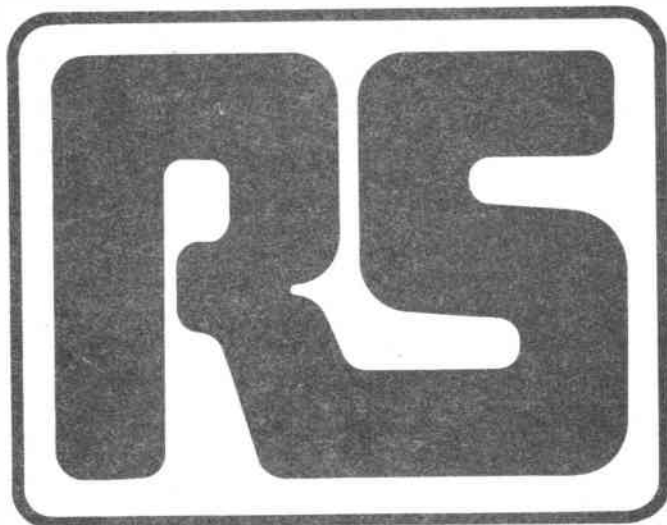

# FOR ONLY £2.50

## ELECTROMAIL - A BRAND NEW WAY TO BUY RS PRODUCTS.

- Over 12,000 products from a single source.
- The quality range - proven by industry.
- Excellent stock availability.
- 24 hour ordering.
- 688 page catalogue.

Write or phone today for your copy of the new Electromail catalogue.

It's an invaluable technical reference packed with photographs and detailed descriptions of the complete product range.

Send £2.50 or, if phoning, quote your Access/Visa number.

The Electromail service is only available to UK customers.

# ELECTROMAIL

Dept. 700, PO Box 33, Corby, Northants. NN17 9EL

TELEPHONE:

# 0536 204555

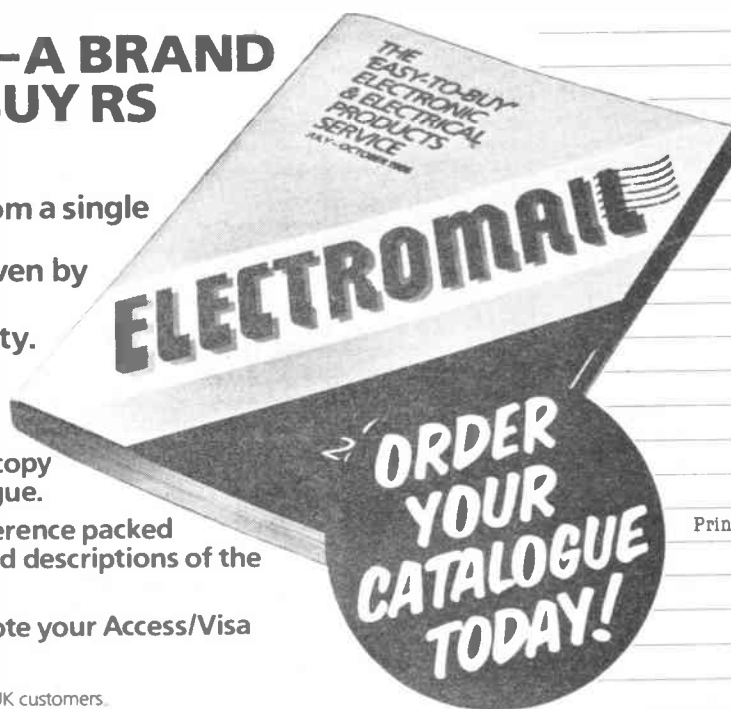

Batteries
Cables and accessories
Conduit and trunking systems
Connectors
Control and switchgear
Drafting aids
Emergency/safety lighting
Enclosures and accessories
Fasteners
Fuses & circuit breakers
Instruments
Integrated circuits
Optoelectronics/indicators
Power supplies
Printed circuit boards & fabrication
Relays, solenoids and sensors
Resistors and capacitors
Security & safety products
Semiconductors
Service aids
Soldering and desoldering
Speakers & microphones
Suppressors & filters
Switches
Technical books and videos
Timers, counters, controllers
Tools & production aids
Transformers and wound components
Wiring accessories
Workshop equipment



# FREE CLASSIFIED ADS

## FREE CLASSIFIED ADS CAN WORK FOR YOU

We are pleased to be able to offer you the opportunity to sell your unwanted equipment advertise your 'wants'.

Simply complete the order form at the end of these ads, feel free to use an extra sheet of paper if there is not enough space. We will accept ads not on our order form.

Send to: **Amateur Radio Classified Ads**, Sovereign House, Brentwood, Essex CM14 4SE.

## DEADLINE AND CONDITIONS

Advertisements will be published in the first available issue on a first come first served basis. We reserve the right to edit or exclude any ad. Trade advertisements are not accepted.

## FOR SALE

■ FRG9600 all mode scanning receiver, modified 60-950MHz, no gaps, £350 ovno. FDK ATC720 hand-held airband receiver, 118-136MHz, 720 synthesized channels, £125 ovno. FDK RX40 hand-held VHF monitor receiver, 141-180MHz, 15,600 synthesized channels, £100. Signal R517 hand-held airband receiver, full tuning of airband, 118-136MHz plus 3 crystal controlled channels anywhere in airband. Price includes several crystals, £50 ovno. Mr K L Phillips, 3 Linden Court, Frithville Gardens, London W12 7JJ. Tel: 01-743 0811

■ Advance mainframe dual trace storage oscilloscope, type OS2200 with OS2006 and OS2007 plugins, including instruction manual, not working, requires new transformer, hence very low price, £75 ovno. AVO transistor and diode tester, type TT537 with instruction manual, £20. Dot matrix computer printer, ENM paper, width up to 15 inches, traction drive, excellent print quality, price includes several new ribbons, £50 ovno. Mr K L Phillips, 3 Linden Court, Frithville Gardens, London W12 7JJ. Tel: 01-743 0811

■ Wavemeter, BC221T, mains. Codar PR40, joystick aerial, Transworld radio, pre-amp, 25-32MHz, 12 volts dc. Weller heat control soldering iron, USA, 250 volts ac and number of test meters. WHY or offers, all letters answered. Chubb, 32 Kelvedon Road, Fulham, London SW6 5BW

■ MML432-50 plus pre-amp, new, £115. SEM 10 x 2 mtr linear, plus pre-amp, £110. Pair, £200 or exch for 2 mtr valve linear. Mike. Tel: Epsom 42476

■ Silent key sale. AR88D, £40 ono. TE18 grid dip meter, offers. Buyer collects. G2PU, 39 London Road, Harston, Cambridge CB2 5QQ

■ Signal R-537 aircraft Rx, tunable from 118 to 136MHz, pocket size with soft case and mobile ant adaptor. Ideal for use at airports, airshows etc. Excellent condition, £45. Mr R Williams, 25 Peghouse Rise, Stroud, Glos GL5 1RU. Tel: Stroud (04536) 6171

■ KW E Z-match, £40. Two metre crystals for R3 and S18, 12 and 15MHz series, suitable FT202R etc, £4 for both pairs. GW4GNY. Tel: (0936) 75441 evenings and weekends

■ Racal RA17L triple conversion comm receiver, c/w manual, vgc, £200 ono. Will swap for 2 metre 100W solid-state linear, good condition. R A Nicklin, 10 Heol Dewi Sant, Penllergaer, Nr Swansea SA4 1BD. Tel: (0792) 894282

■ Eddystone EA12 receiver, £140 cash, buyer to inspect and collect, mint condition. Genuine buyers only please. Hopkins, Reigate. Tel: 48812 (Surrey)

■ Yaesu transverter, FTV107R, fitted 2 metres, manuals, leads etc, as new condition, £130. Heathkit SB610 monitor scope, manuals etc, £85. Would exchange for FV901DM VFO with slight cash adjustment. Both items as new condition. Mr C Compton G1CHV, No 6 Bungalow, Common Road, Wrangle, Boston, Lincs PE22 9BY. Tel: Boston 870227 any time

■ BNOS 70cm linear, LPM432-1-50, four months old, ideal for use with 790R etc, perfect condition, £150 including carriage. Tel: (0670) 824788 after 5pm

■ Tokyo HL1K, one kilowatt HF linear, all bands inc WARC, boxed as new, £650. Also Tokyo 2kW ATU to match, all bands, £200. HQ1 mini beam, £50. 17-element tonna, £15. Crossed nine element tonna, £15. KR400 rotator, £100. Yaesu RSM700 HF portable antenna, £100 (would accept good camera equipment in part exchange). B G Havenhand, 11 The Coppice, Booker HP12 4SA. Tel: (0494) 29890

■ Kenwood TS940S transceiver, fitted with auto ATU, as new, boxed, £1,400. Trio SP940 speaker, £40. Yaesu FT107R transverter, fitted 144MHz and 70cm modules, to suit TS940S, £400. Spare 107R mainframe, £40. Alinco 25 amp power supply, 13.8V,

new, boxed, £70. MC60A microphone, boxed, £45. Transformer for 50 amp power supply unit, £20. Would p/ex for good camera equipment. Dr B G Havenhand, 11 The Coppice, Booker HP12 4SA. Tel: (0494) 29890

■ FL2100Z linear, as new, all bands, mint cond, £285. 40ft West Tower f/s, 2½ years old, £230. Yaesu 225RD, immac cond, muTek front-end board, original packing, £285. New QTH forces sale. Tel: 01-890 9733 after 6pm or weekends

■ Icom ICR70, as new, re-checked by Thanet and FM board fitted, excellent receiver, £450. Carriage paid or exchange for scanner AR2002, must be in first class condition. Tel: (0282) 51416 for any details

■ CWR610 RTTY, CW reader, vgc, £60. FT3015 HF trans, 160m-10m, £250. 2500 portable with charger, £125. 2300 portable synth with charger, £90. 14-ele junior boomer, £20. SWR 200B block, £20. All good condition. Tel: Epping 75129

■ R107 9-valve receiver, CW/RT 17.5MHz to 1.2MHz, variable bandwidth, BFO, ac mains, gwo, with complete data, £35. Also PCR2 less PSU, £20. Tel: Brighton (0273) 737076

■ Yaesu FRG7700M (yes, the one with memories and fine tuner) with FRT7700 ATU, 60kHz-30MHz, 5 separate filters; AM wide/medium/narrow NBFM/LSB/USB/CW. Superb receiver, as new condition, handbooks, original packing, £285. Ken Ballance G3KNB, 18 Rumbleford Way, Parkside, Stafford ST16 1TW. Tel: Stafford (0785) 44964

■ Shack clearance frees the following items: fully fused and metered high power PSU in instrument case, large selection of valves (from Acorns to Eimac QRO), two small CRTs, about a dozen mains transformers (LT, HT and EHT), variac - about 200 watts rating, numerous meters ( $\mu$ A, mA, V and kV), many quartz crystals (from 4 to 7.5MHz), microphones, headphones, lots of resistors, pots and capacitors. Telephone G4CK at any time on Northampton 61553 for written details, and bear in mind that he is looking for a modern transmitter/receiver for the HF bands

■ Ferguson Dolby tape recorder, offers around £30 ovno. Tel: (0283) 221870

■ Trio HF911 linear amplifier, 2kW, SSB, CW, recent overhaul, new PA valves, £350. FT101E, excellent condition, one owner, £350. Both in original packing with manuals. Trio 2200 portable-mobile 144MHz FM Tx/Rx, with Trio 30G VFO manuals. Geo MacLauchlan, 16 Well Park, Ter, Bonnybridge FK4 1DE. Tel: (0324) 813349

■ Trio TR3500 UHF FM transceiver, virtually new, only used on a few occasions, hence reason for sale. Perfect synthesized hand-held for portable use, £200 ono. Swap for some form of mobile rig, or other equipment considered. Simon Jones. Tel: Burton-on-Trent (0283) 66935 after 6pm

■ Icom IC290A, high quality 2m multi-mode. Full 144-148MHz Tx/Rx. Boxed, c/w, boxed accs, vgc, £425. Hitachi, TV/cassette/radio combination, £40 ono. Tel: (0799) 24049 (Essex)

■ Stalker ST9F DX, AM, FM, USB, LSB, lo, hi bands, 360 channels in all. Suit mod to ten metres? Anyway, vgc and all for £85 ono. Tel: Swaffham (0760) 24274, evenings only please

■ 934MHz Reftec mobile radio, Nevada mobile gutter mount, PA7E, Nevada base collinear. Will sell together, £120 ono. Tel: Chris (0634) 43886 after 6.30pm or weekends

■ Yaesu FRG7 comms receiver, no mods, recently realigned, complete with manual, box, two books and aerial wire. Only used for 6 months, £115 ovno. Tel: Philip. Cheltenham (0242) 571279, or write to 22 Russet Road, Cheltenham, Glos GL5 7LW

■ Sky coupler ATU, 0-30MHz, £20. SR9 2 metre Rx, £20. Eddystone 770R Rx, 19-165MHz, heavy, buyer collects, £60. Tel: Roger Bradford 670329

■ Sony ICF2001D synthesized receiver, air, AM, FM, brand new, in box with AN1 active antenna,

must sell, bargain. Tel: 01-767 7736

■ HF ? Full station for sale, all as new condition. FT77 FM, FC700, FP700, also brand new 40-80m antenna, £550. Antenna only for £15. Sorry will not split. Tel: (0207) 508629 (North East)

■ Yaesu FT101E, mint, G3LLL FM unit, fan, workshop manual, speech processor, new PA valves, £400 ovno. Will p/ex for FT290R. Tel: G1ULV. (0209) 714342 after 6pm

■ Yaesu FT77, FP700, FC7700 ATU and FTV707 transv, mainframe, all in excellent cond, Top Band and FM fitted, £650 ovno. Will split if sensible offer. Wanted: Yaesu FT101ZD FM Mk III plus ATU. G4YMC. Tel: (091) 2674861

■ Yaesu FT230R 2m FM, 3W and 25W output, mint condition, hardly used, in original box with manual and mobile bracket, scanning and memory channels, £170. Buyer collects or postage extra. Tel: (051) 644 9122, after 8pm (Merseyside area)

■ Yaesu FT707 HF transceiver, also Yaesu RSL 20 mtr centre loaded ant with gutter mount. Both in excellent condition, £250. Tel: John (0946) 4361 after 6pm

■ Yaesu FT290R, muTek pre-amp fitted, case and YH1 head-set, £265. Also Trio TM201A with mobile mount and speaker, £240. Tel: Derby (0332) 515840

■ Icom R71E communication receiver, brand new, including VHF unit, voice synthesizer, remote controller, external speaker, headphones, world clock, in maker's carton, must sell, bargain. Tel: 01-767 7736

■ Yaesu 209RH, NC18C charger, speaker mic, good condition, £175. Mr W M Edwards GW1SBO. Tel: (0970) 3111 ext 3162, between 9am-5pm

■ Collins 390/A, £275. Marconi Atalanta, £65. HRO PSU, coils, £45. Dancomm VHF marine, 55 channels, as new, £225. Collectors' items: R1155, WS19, BC342, BC348, BC221, RF245, R2A-ARR3, CR300, type 2 Morse trainer, GRC9, SAE for full list. Wanted for TCS12 installation: PSU, key, mic, cables etc. Cain, 18 Oaky Balks, Alnwick, Northumberland NE66 2QE

■ 934MHz Reftec, £175. AR86D general purpose communications receiver with instruction manual, parts list, circuit diagram, £90 or would consider exchange for scanner UHF/VHF receiver. 1kW transformer, 240 volts ac in, 29 volts dc out, hardly been used, £20. Pack of blank licensed radio amateur QSL cards, approx 200, £2.75. Pack of ISW listener cards, approx 200 with free envelopes, £3. Post paid. Tel: Mike. (0704) 892088 (Burscough, Lancs)

■ Yaesu 225RD, muTek FE board immac cond, £325. Yaesu FL2100Z linear, new bands, mint cond, £285. West Tower F/S 45ft, 2 years old, £220. New QTH forces sale on all above equip. Tel: 01-890 4666 after 6pm or weekends only

■ Welz SP380 power/SWR meter, 1.8-500MHz, 20/200W ranges, dual sensors, SO239 connectors. Boxed, complete, with instructions, £40. Microwave Modules MMT70/144 four metre transverter, 10 watts output, £55. Tonna 144MHz, 9 ele yagi, 50 ohms, £8. Steve G4ASL QTHR. Tel: 01-668 3386

■ Jaybeam 2m 10 el long yagi, 4.4m boom length, 11.0dBd gain, £15 + post. Wanted: AR40 rotator for spares (must work), control box must have separate direction/start rotation button. Mark, G4RGB QTHR. Or Phone Medway (0634) 30822, anytime

■ 100 watt linear amplifier, freq range 26-30MHz, £25. Ideal for 10 metres. Roger K-bleep, £3. VTX 5000 modem for ZX Spectrum, as new, £35. Slow scan television transmit and receive program for ZX Spectrum, £5. Heatsink compound 20ml tube, £1. Paul. Tel: (0386) 388615

■ Yaesu FRG7000 HF receiver, digital readout, £165 ono. Commtel NPR 934MHz Tx/Rx, vgc, £275 (cost £495), one year old. Home base 934 collinear, £40. Mobile 934 collinear, £25. Tel: Tony (0945) 581372

# FREE CLASSIFIED ADS

■ Klystron and PSU, 8 to 10.5GHz, 25mW, mech tuning, £20. Coaxial switches, dc to 1GHz, 10W, DPDT, BNC sockets, 24V coil, £5 each. Wanted: Murphy Radio memorabilia; adverts, brochures, catalogues, handbooks, instructions, sales-aids, etc. Alan Williams G3KSU QTHR. Tel: Ryde (0983) 65551

■ TAU SPC3000 super transmatch ATU with the 10 metre conversion and the 1-6 reduction drives-also with 4.1 balun. I would swap the TAU for a Drake. Rodney. Tel: Farnborough, Kent 58825

■ Service manual for Cobra 148GTL DX, £5.00, includes p&p. Also rig bracket for 148GTL, £3.00, includes p&p. John Higgins, 30 Underwood Road, Portishead, Bristol, Avon BS20 8PJ. Tel: (0272) 845351

■ Yaesu FT301 transceiver, solid-state, digital 160-10m, AM, SSB, CW, FSK, speech processor, noise blanker, notch filter, all filters fitted, marker, frequency standard RIT on Rx/Tx, VOX, MOX, variable AGC, £350 ono. Spectrum Plus computer, unused, unwanted gift, £70. Tel: St Albans 39333

■ 1983 Yaesu FT101ZD FM, 9 bands, fan, one of the last, YD84A base mic, FC902 ATU, SP901 speaker, 11m xtals available, £575 ovno. Icom 210 FM base station, £130 ono. Harvard H407 27MHz home base, £45. Sigma TV, £20. HyGain 14AVQ, £50. Tel: (0621) 772418

■ Valve list: send me your priced lists of any quantity of unused boxed valves and I will try to put you in touch with readers who send me an SAE stating their valve requirements. No charges. C T Brown, 8 The Elms, Horringer, Bury St Edmunds, Suffolk IP29 5SE

■ Bargain - Yaesu FT One, HF general coverage transceiver. All extras fitted, commercial model, complete with manuals, scan mike, all filters, FM, non-volatile memory. Original packing, excellent condition. Buyer to inspect and collect. Phone for price and details. Tel: (0792) 475629 (Wales)

■ Barlow-Wadley Xtal-controlled portable general coverage receiver. 0.5-30MHz in 1MHz bands, AM and SSB, very good reception using in-built telescopic antenna. Also has VHF FM broadcast band. Excellent condition, £95 ono. Tel: Alan, Basildon (0268) 45573, after 6pm

■ Yaesu FRG7 general coverage Rx, £80. Sony ICF2001D, bought November, surplus to requirements, bargain at £180 for quick sale. Tel: 01-888 6007, evenings

■ Yaesu FRG7700 with memory. Also Yaesu FRV7700, good condition, £300 ovno. Tel: Whaley Bridge (06633) 3401

■ Rascal RA-17 rcvr with SSB adaptor, handbook, G5RV full wave dipole aerial, £185. Shack clearance: valves, speakers, co-ax, copper wire, transfmrs, books, mags, pots, lots of odds and ends, reel to reel tape, old AR77, £50 the lot (buyer collects). Mr R Robbins. Tel: Lymington (Hants) 22979

■ Ten 1/2in recording tapes, approx 40 mins, £2 each plus £2 p&p. Sony camera/wiper, Sony camera-mixer/fader complete with sync pulse gen. Two b/w cameras, all working ok, £220 the lot. Buyer collects. Dave G4JBU. Tel: (021 501) 2962 day, (021 552) 7560 evening

■ Spectrum 48K with Saga keyboard, interface 1, microdrive, cartridges, £95. Alphacom printer and paper, £20. Kaga 12in green screen monitor, £25. Lots of software, mainly business/utility/graphics and books. SAE for list. Tel: Dyer, Warwick (0926) 491848, evenings

■ Admiralty ex-navy general coverage HF communications receiver, type B40D, 0.64MHz-30.5MHz, near mint condition and good working order, £70 ono. Weight approx 100lbs so buyer collects. Would consider exchange for T1154 transmitter. Tel: (0380) 830428 (Wilts)

■ Icom IC290E 2m multimode, scanning mike, gc, £270. Stalker IX, AM, SSB, 80 chann CB, 20 watt on SSB, ideal for conversion to 10m, £45. Tel: (0226) 716477

■ Hard to find multimode President Madison, modified to new CEPT CB frequencies 1987. 200 plus channels. What offers? Give your telephone number. Edward, PO Box 8, Mirfield, West Yorks WF14 0XA

■ DX200 receiver, good condition, instruction manual, 0-15 30MHz AM, SSB, CW, CB, £50. Robuk three-speed reel to reel tape recorder, working, requires attention, record playback head, £25 ono.

Buyer collects both items, will separate. Hudson, 49 Radstock Road, Stretford, Manchester M320AJ. Tel: (061 862) 6987

■ Trio TR9130, mint condition, only three months old, boxed. Exchange for mint FT77 and 2m transverter or FT707 and transverter, or FT707 and FP707 PSU, may consider other HF rig plus transverter or heavy duty PSU. Write to Bob, PO Box 73, Luton, Beds LU1 5QD. Tel: Luton (0582) 36961, office hours, ask for Bob

■ Trio TS830S HF transceiver, mic, full service manual, boxed, £650. Trio TR2600E HT transceiver, two PB26 nicads, BC2 charger, 6 AA battery pack, SMC30 speaker/mike, leather case, belt clip shoulder strap c/w ground plane, standard plus US Larsen antenna, £280. AEA PK80 AX25 Packet TNC, £170. ICS AMT2, Amtor/RTTY/-CW/ASCII, TU, £170. Datong PC-1 general coverage converter, £90. Kenwood MC60 desk mic c/w pre-amp, K/pip tone, £40. 13.8V dc PSU (9A int, 7A cont), £40. Lowe FX-1 wavemeter 0.7-250MHz, £20. Himound Morse key with marble base, £15. Twin SWR/pwr meter 3.5-150MHz, £10. All equip exc cond, prices ono. Inspection/demonstration welcome. Dave. Tel: Tadley (07356) 5185

■ Icom R70 Rx, £450 ono. AVO Mark seven, for spares, £10. Mr J P Wright, 12 Norn Hill, Basingstoke, Hants RG21 2HD. Tel: Basingstoke 488649

■ VCR2000, needs setting up electronically, new head unit, workshop manual provided. Looks tatty, eight hour tapes provided, £40. FT707 CW filter, 250Hz, unused, £15. May swap VCR for cheap scope. Also have Marshall 4 x 12 speaker cabinet, vgc, £100. Paul. Tel: Hoddesdon (0992) 442794

■ AOR2002 scanner, 25-550, 800-1300, PSU, whip ant, as new, £350. Sony 2001D, air, FM, general coverage, preselector, £225. Both cover the entire spectrum, together £550. Ferrograph reel to reel, 3 heads, 3 motors, 3-speed stereo output, series 6 stereo, £50. Wanted: B40D, must be in newish condition, no scrap iron. Write: 31 Anerley Park, Penge SE20. No callers.

■ Yaesu FT7B 50W trscvr, with YC7B digital read-out, boxed, with manual, £300. MM linear amp, type MML144/25, £40. Quantity of 5 inch and 7 inch reel audio tapes, with library boxes. Heath audio watt meter, AW1U, £25. Heath transistor checker, IT18, £30. Heath solid-state voltmeter, IM17, £25. Uphill, 12 Rushley Mount, Hest Bank, Lancaster. Tel: Hest Bank 822125

■ Yaesu FT757GX transceiver complete with Amtech 300 ATU, Drae three-way antenna switch, BNOS PSU plus G5RV half-size wire antenna. All in mint condition, only used SWL. Manufacturer's guarantee until 13/11/86, £625. Tel: (0582) 606046, Dunstable

■ FT209RH, £195. Icom 251E, £425. Astatic D104 mike, £25. Yaesu SP102 speaker, £25. Hanson power/SWR meter, £20. Wood & Douglas 2m and 70cms pre-amp, £20. Regency HX2000E scanner, £95. Alinco 25W linear, £20. All items vgc. G4TGN QTHR. Tel: 01-897 3794

■ Yaesu FT290, very little used, with nicads, charger and carrying case, £260, no offers. Trio R600 receiver with ATU, also little used, £250, no offers. Tel: (061) 480 6950 after 5pm

■ KW2000A trans, good working order, complete with PSU and manual. Consider exchange for Yaesu HF rig with cash difference. G10WX QTHR. Tel: Leeds 863362

■ World-wide countries check list. Book covering 160m through to 23cms, plus satellites, HF, VHF, UHF sections. Contains over 390 prefixes, fully detailed index and much more, £1.50. A Goodier, 35 Rose Lane, Marple, Nr Stockport, Cheshire SK6 6DS

■ Swan 350 HF, SSB, CW rig, 80m to 10m, 180 watts output, with matching mains PSU, Yaesu mic, new pair of 6146B PA valves fitted, £220. Belcom Lincor 2, 144MHz SSB rig, receive pre-amp fitted, 8 watts RF output, mobile mount, £80. Les Barnes G0FAJ, 29 Overlands Road, Wyke Regis, Weymouth, Dorset. Tel: Weymouth (0305) 789022

■ Exchange unused and still boxed VHS video recorder, remote control, cost £349, for HF transceiver. Mr R Barritt, 39 Stanley Street, Runcorn, Cheshire WA7 1RN

■ Cheap gear! CT436 Hartley double beam scope, 10MHz bandwidth, with manual, £35. Grid dip

meter, model TE15, 400kHz-280MHz, with manual, £10. Leak point one valve pre-amp, £2. Valve FM preset tuner free! Casio PT30 keyboard, £35. Solid state modules, 2m to 28MHz converter, £4. Tel: Horsham (0403) 57030, Sussex

■ Yaesu FT290 with muTek board, nicads, charger, boxed with manuals, £250. 6m multi 5W with 3 ele beam, £150. 20A PSU, £50. Yaesu FR50, good ham band Rx, plus VHF conv, £85. SSB filter for Yaesu, £15. HF linear IL1000, £275. Com-in 64, RTTY, CW, SSTV prog, RSGB books, VHF man, HF ants (Moxon), test equipment, all as new, offers, WHY. Martyn Bolt G4SUI. Tel: (0924) 495916

■ Rx, 150kHz-30MHz, in 31 bands. 87.5 to 108MHz, AM/SSB/CW/FM, boxed with manual, 5 months old, £160 ono. C P France, 16 Epping Drive, Melton Mowbray, Leics LE13 1UH. Tel: (0664) 62842

■ Grundig portable transceiver, FM, LW, MW, SW, 5.8 to 18MHz, ac or battery, mint cond. Want good working ATU in exchange. H C Bach, 52 Tudor Close, Belsize Avenue, London NW3 4AG. Tel: 01-794 9790

■ R537 airband radio with seven various crystals and leather case. Frequency range 118 to 136MHz, excellent condition, £80. Mr Cribbens, 4 Woodville Road, Ramsgate, Kent CT12 6DU. Tel: Thanet (0843) 586636 after 6pm

■ SMC 12.8V 25/35 amp, stabilised, PSU, £65. Trio VB2200 1/10 watt 2m linear, £14.50. TEC TE-15 tradiper GDO, £24.50. Twin paddle key on heavy marble base, £14.50. Dragon 32K data recorder, joysticks, 23 games, 3 books, £50. Morse keys, £1.50 and £1 each. Heathkit HW8 and matching PSU, £85. Tel: (0562) 886272

■ Prop pitch motor. Bendix radio compass 5 inch face mounted in cabinet with Celson, also two spare Celsons. Will turn two full size HF beams. Offers. Richard, Common Crest, Drapary Common, Glensford, Suffolk. Tel: (0787) 280259

■ 70cm linear amp, Microwave. Modules MML432/30, 1 or 3 watts input gives 30 watts output, very good condition, perfect working order, £110 ono. Buyer collects. Tel: Phil G6YAL QTHR, Alfreton 835546 (evenings)

■ Two QY03-20A unused valves, £16 the pair. Active audio filter (AP-M1), switch either notch or bandpass, plugs into h/phone socket of receiver, ideal CW listening when rig's IF is too wide to separate adjacent signals, £15. Tel: (0904) 792208 weekends only, G4XIV not QTHR

■ TV, Vega 6 inch mono UHF, VHF. Ideal for continental caravanning or DXing. Battery, mains, £50. Tel: (0283) 221870

■ KDK two metre FM transceiver, model FM2030, 5/25 watts output, vgc, original carton and accessories, £120 ono. Two metre 3/4 whip antenna, complete with mag mount, £15. Tel: (0492) 33082 Colwyn Bay, N Wales

## WANTED

■ FAS1-4R remote aerial switch required to fit into FC102 ATU. GM4HKW, J W Henderson, 1 Rossiabank Crescent, Westmuir, Kirriemuir, Angus DD8 5LB. Tel: (0575) 73455

■ 45ft telescopic mast or higher required. G4ZMH, Gerald Robinson, 32 Dam Road, Barton-on-Humber, South Humberside

■ Swap Grundig portable 220, FM, LW, MW, SW, 5.9 to 18MHz ac or battery, mint cond, manual plus Ricoh camera, 35mm, model 500G, semi-automatic. Wanted: first class ATU. H C Bach, 52 Tudor Close, Belsize Avenue, London NW3 4AG. Tel: 01-794 9790

■ Old type CW only transmitter, LG300 or similar if serviceable. Service manual for B40 receiver. N V Clarke, Sandy's Hill, Haddington, East Lothian, Scotland EH41 3SB. Tel: (062 082) 5510

■ SP230, AT230, YG455C, MC50, HS5. Also require 2m, 4m and 6m converters or transverters. P Smith, 3 Raven Avenue, Tibshelf, Derbyshire DE5 5NR

■ Help - can anyone help? Wanted: YC7B digital display unit for FT7B, poor eyesight. Tel: (0538) 757225

■ Drake R4B, R4C, DSR2, Collins 75A-4 or FR101 digital etc. Eric Rutter, 4 Crompton Avenue, Blackpool, Lancs FY4 3LQ. Tel: Blackpool 64680

■ Can anyone sell me an Akai model 1700 reel to reel stereo tape recorder, for spares? I am unable to get any help from Akai as this is a very old model. Would you kindly write to me (Bob) and let me know the price. I am an old age pensioner and want to get my Akai going as I cannot afford another reel



## FREE CLASSIFIED ADS

to reel. R A Boughton, 6 Southmead Close, Folkestone, Kent CT19 5LH. Tel: (0303) 76230

■ Elderly disabled RAIBC member wishes to purchase a multi-mode CB home base transceiver in good working order. Ham International Jumbo, Excelsior Marco or President range. Must have AM, FM, USB and LSB frequencies. I will pay your price up to max of £130 plus postage. All letters answered. Mr R P Boyle, 134 South Seton Park, Port Seton, East Lothian EH32 0BN

■ 20X50 Mark Scheffel binoculars, Toshiba stereo music centre, matching speakers, 48K Spectrum power supply, interface, base unit word processor, copy tape, lots of software, joystick, cassette recorder. Exchange for transceiver, scanning receiver or WHY? Tel: Oxford 772370 or drop me a line at 57 Windrush Tower, Cowley, Oxford OX4 5HY

■ Optional extras for HF rig urgently wanted: Icom IC740, FM unit and crystal marker boards, any condx, even home-brew if reasonable, your price. High working voltage capacitors for VHF linear amplifier (2500V). Doug Mellor G8WPD, QTHR. Tel: (0298) 79481 (Derbyshire)

■ SEM Z-match 80m to 10m ATU, with or without easy tune. YC7B digital readout for FT7B HF transceiver. Icom IC202S. Les Barnes G0FAJ, 29 Overlands Road, Wyke Regis, Weymouth, Dorset DT4 9HS. Tel: Weymouth (0305) 789022

■ National company Malden receivers in good condition, plus manuals for NC100A, NC33 receivers. Copies of manuals for Scarab Systems MPTU-1 terminal unit, interface SP-RTTY-3 for Spectrum. Details on how to use Futaba LCDs: 6-LT-062, 7-LT-02, 5-LT-03. *Radio & Electronics World* Jan 1982. All expenses paid. Tel: St Albans 39333

■ Trio 130V/S or Yaesu 707 transceiver plus accessories. Tel: (0562) 886272

■ FT101ZD, 101E, 101B. Valves: T160L, 572B, 6146B. Richard, Common Crest, Drapary Common, Glemsford, Suffolk CO10 7PQ. Tel: (0787) 280259

■ Manual and/or circuit diagram for Ham Int Multimode 3. All costs paid. Ron, 16 PO Box 99,

Musselburgh EH21 8ER, Scotland

■ Tuner for Dynatron record reproducer, HFC1 series. Mr Leigh, 31 Tewkesbury Road, Birmingham B20 3DX

■ Stop! Look! Have you a Burndep 470 UHF handheld that doesn't work? If so, send it to me. Ring me and tell me how much it is. Also wanted: Marconi or Racal millivolt meter. Tel: (0302) 835280 and leave a message on the robot

■ FV901DM VFO unit in gwo. Exchange Yaesu FTV107R transverter in gwo, fitted with two metre manuals, leads, etc. Also have Heathkit SB610 monitor scope in gwo, manuals, leads, etc. Take your pick, or take both with cash adjustment. Both items as new. Mr C Compton G1CHV, No 6 Bungalow, Common Road, Wrangle, Boston, Lincs PE22 9BY. Tel: Boston 870227, any time

■ Valve receivers: Collins 51J, R338, R390A/B2, BC312, BC342, BC348, BC779, BRT400. Hammarlund: Super Pro, SP400, SP600. Hallicrafters: S27, SX28, S36, S42. RCA: AR77, AR88. Early National: HRO, HRO-50, HRO-60 etc, in clean condition only. Early hi-fi: Tannoy and dual concentric speaker units, Lowther, Garrard 301, Thorens TD124 Mk II, Ortofon, SME, Decca, Quad, Valve amplifiers, Western Electric audio equipment, EMT etc. John Baker. Tel: 01-833 3008 (Kings Cross)

■ Heathkit AR2000 Mk2 FM/AM tuner amplifier in kit form or made-up state. The FM tuner needs to be in factory aligned condition. Also required: Marconi CR300 communications Rx: circa 1936/37, Pilot all-wave table model or radiogram, working or non-working. Have got, for part exchange or sale: 2 Tektronics scopes, type 545B with type CA plug-in units, both with valves, also with spare set and workshop manuals. One working at £35, the other requires repair to EHT, £20 ono. Tel: (0526) 20520

■ Icom scanning mike (HM10), Mirage B1016 instruction booklet - reimburse expenses for a photocopy, 70cm QRO amplifier, 40/50 watt 144MHz amp (switchable) with or without pre-amp (which must be switchable if fitted). Tel: G14OMK QTHR. Tel: (0232) 702528

■ Quartz crystals. Help me with my vintage rig restoration project. I am rebuilding my 1949 Tx and need some ¼ inch pin-spacing crystals (10X/QCC, Bliley, STC, etc) for 3.5, 7 and 10MHz, £1 each offered for active examples. Cash by return. Send to G3GGL, Livery House, Sandbourne Drive, Bewdley, Worcs. Tel: (0299) 403372

■ *A Guide to Amateur Radio*, by Pat Hawker G3VA, 18th edition only. Trowell G2HKU. Tel: (0795) 873100

■ FT107, FT707 (QRO version) must be perfect condx. Seller must be local to Kent. Tel: Mark (0634) 30822 (G4RGB)

■ Transverter, serial no FTV650, for use with FLDX400 HF Tx. Tel: (0782) 612868, ask for Allan

■ Trio/Kenwood R-820 receiver, with CW filter if possible. Good price paid for model in first class condition. Tel: (04536) 3994

■ Hallicrafters CR50 Rx. Also Ham Int multimode 2. Parts: squelch and volume knobs. Also front fascia panel. John Higgins, 30 Underwood Road, Portishead, Bristol, Avon BS20 8PJ. Tel: (0272) 845351

■ Exchange 48K ZX Spectrum with interface one and microdrive, all leads, books and boxed, for either Belcom LS10ZL or Sommerkamp TS788DX or SPC300 ATU or HD, PSU 30-40 amp, or 70cm multimode, portable or mobile. J D Bolton G4XPP, 10 Bowness Road, Coniston Park Estate, Timperley, Cheshire WA15 7YA

■ Have Thanet Electronics brass keyer, also Kenpro practice oscillator. Both brand new. Would exchange for SWL antenna tuner in sound condition. Reason for sale explained. Tel: Thanet (0843) 45561

■ SP230, YG455C, AT230, MC50. Fair price paid for equip in good cond. P Smith, 3 Raven Avenue, Tibshelf, Derbyshire DE5 5NR

■ VFO suitable FT75 (EV50B etc) not too expensive please, OAP. David, c/o Davis, 1 Milovaig Ave, Glasgow G23 5HY

■ Pye PF2UB or similar for 70cm. Must be complete and working. Channels immaterial, top price paid. Will collect. Tel: Reading (0734) 668532

## FREE CLASSIFIED AD FORM

Ad Form removed

# Amateur RADIO SMALL ADS

## NORTH WALES AMATEUR RADIO MART

AMATEUR RADIO - CB RADIO - MARINE  
RADIO - PMR  
**25 ABBEY STREET**  
RHVL

Open Monday-Saturday: 11am-5.30pm  
All repairs and accessories available ex  
stock Mail order welcome  
Tel: 0745-51579



## A KELLY ELECTRONIC AND COMMUNICATION EQUIPMENT

**3 STOKE RD, ASTON FIELDS,  
BROMSGROVE, WORCS B60 3EG**  
Telephone (0527) 71165

**BEST PRICES EVER ON ALINCO  
MOBILES & HANDHELD**

We will sell your equipment on  
commission basis.

Part exchange trade in?

3 month warranty on all second hand  
equipment sold

Please ask for the best deal to suit you.

We also stock Microwave Modules  
DRAE, Tal Aerials, RSGB publications,  
Mutek, Starmaster keys

**MANY SPECIAL OFFERS - RING FOR DETAILS**

Open 6 Days a Week. Evenings by

Appointment

24 hr Answerphone



## IAN FISHER COMMUNICATIONS OF STANHOPE

**CB Works, Bondisle Way, Stanhope,  
Bishop Auckland Co Durham DL13 QTY**  
(0388) 528464

Main Distributors of 27MHz CB radios and the  
NEW DELTA 1 series 2 model transceiver with  
the latest cybernet board. Also the NEW  
Nevada range of 934MHz aerials to suit, also  
934MHz pre-amplifiers and VSWR meters and  
GREENPAR BNC and 'N' type plugs.

Large stocks of coaxial cable, plugs, sockets  
and adaptors.  
All available via mail order.

OPEN: MON-SAT 10.30am-6.00pm  
RING FOR DETAILS  
(0388) 528464

## USED AMATEUR EQUIPMENT?



**I Buy, Sell & Exchange!**

SELLING? I pay the  
BEST POSSIBLE PRICES for your Clean  
Used Equipment! BUYING? I have the  
BEST SELECTION  
of top Quality Used  
Equipment Available!

For the Deal You've been Looking for, Phone Dave, G4TNY  
ANYTIME ON HORNCHURCH (04024) 57722 or Send SAE

**G4TNY AMATEUR RADIO**

132 Albany Road, Hornchurch, Essex RM12 4AQ

## D.P. HOBBS (Norwich) Ltd

13 St Benedicts Street, Norwich Tel: 615786



Open Mon-Sat 9-5.30  
Closed Thurs 1.00pm  
Stockists of:



YAESU, FDK, ICOM, JAYBEAM  
& Electronic Component Specialists

## SERVICE MANUALS

For most Makes, Models Age of electronic equipment  
Amateur Radio Test equipment Audio Television Video Vintage  
Military etc Thousands Stocked SAE enquiries

**MAURITRON TECHNICAL SERVICES**

Dept AR, 8 Cherry Tree Road, Chinnor, Oxon OX9 4QY.

## JAYCEE ELECTRONICS

JOHN GM30PW

20 Woodside Way, Glenrothes,  
Fife KY7 5DP

Tel: 0592 756962

Open: Tues-Sat 9-5



Amateur

SMALL



# NEXT ISSUE ON SALE

Amateur

# RADIO

Thursday 30th  
October

## HEATHERLITE MOBILE MICROPHONES

You've probably seen one and heard one, they're well tried and tested. Lightweight and inconspicuous, good audio quality, ease of operation, worn around the collar or over the head. Control box with mic gain control, scan buttons, LED indicator on transmit, made individually and plugged to suit your rig.

with plug and scan buttons

£25.00

with plug without scan buttons

£23.00

with plug and extra amplifier for 8

pin Icom rigs eg IC 255 etc .. £23.00

Mic band and coax, no control box, circuit to make your own box

£7.00

Post & Packing £1.50 per order

Cheques to:

**HEATHER RODMELL**

**G8SAV QTHR:**

**Tel: (0401) 50921**

## SPECIALIST VHF RECEIVERS. . .

Pocket-Sized with 26-30/54-176MHz for ALL the action - Public-Service activity, Aircraft, Marine, Ham-Radio, CB, Business, Surveillance, Utilities & More! Even VHF TV Sound & FM Radio. 'THE ENTIRE LISTENING POST' professionally engineered with integral VFO, Squelch & Volume facility. INCREDIBLE OFFER @ ONLY £29.50 POST PAID, CWO/COD WELCOME from:

**D TAYLOR (Dept AR9), 8 EMMERSON STREET, CROOK, CO DURHAM DL15 8NF.**  
**Tel: 0388 763323**

## SP ELECTRONICS

48 Limby Road  
Huckhall, Nottingham  
Tel: (0602) 640377

Open Monday-Saturday  
8.30-5.30

## AGRIMOTORS

MERTON CB AND RADIO CENTRE  
MERTON GARAGE AND POST OFFICE, MERTON.  
Nr OAKHAMPTON, DEVON EX20 3DZ

OPEN 6 DAYS 9-6 LUNCH 1-2pm  
(SUNDAYS BY APPOINTMENT)

SPECIALIST IN 934 MHz

SUPPLIERS OF ALL 27MHz AND 934 MHz EQUIPMENT  
AMATEUR ACCESSORIES CATERED FOR  
08053 200

## 12 VOLT 12AH POWER PACK

Portable. Battery operated.

for Video lights, TV, Portable Radio Equipment.  
Black case with handle and DIN socket contains two unspillable, rechargeable batteries.

Size: 12 1/2" long x 3 1/4" wide x 6 1/2" high

SPECIAL PRICE £29.80 (P&P £3.50)

CHARGER £7.00 (P&P £1.50)

**APS BATTERIES LIMITED**

001 Unit A East Cross Centre

Waterden Road Stratford

London E15 2HN

Tel: 01-383 8793

CWO  
SAE for leaflet

## DW ELECTRONICS G3 XCF

Amateur Radio Supplies

71 Victoria Rd, Widnes

Tel: 061-420 2889



Open Mon-Sat 9.30-6 (closed all day Thurs)

We supply YAESU, ICOM, Tonna, Jaybeam,

Microwave Modules, Datongs etc

# XXX

## ADULT VIDEO CLUB

OUR GIRLS WILL GIVE YOU  
THE INTIMATE DETAILS. NOW RING

**0924 262122** (24 HRS)

OR WRITE: AVC, PO BOX 12,

BATLEY, W YORKSHIRE

## BEAM VIDEO

Throughout the house on Channel 36.  
Price £10.50 + P&P 50p. Phone for leaflet:

**Electronic Mailorder A**

62 Bridge Street, Ramsbottom

Lancs BLO 9AG

Tel: 070682-3036 (24hrs)



## G4 DXX

### Video Electronics

For Icom, Dray, Wells, DAIWA, Datong, N934 MHz  
equipment, logbooks,  
rotators, cable, etc.

OPEN 9-5pm, Closed Wednesdays

141 Lancaster Road, Morecombe, Lancashire LA4 5JQ

Phone: (0524) 418873

## JAPANESE Ic's (PART OF OUR RANGE)

AN301 £3.50, AN7140 £2.20, AN7145 £1.95, AN7146 £2.20, BA532 £1.60,  
BA536 £2.40, HA1377 £2.20, HA1398 £2.75, HA13001 £2.95, LA4460 £1.80,  
LA4461 £1.80, LA4507 £4.25, LC7137 £2.75, M51515 £2.50, M51517 £2.80,  
MB3705 £1.80, MB3712 £1.50, MB3722 £3.50, MB3730 £2.50, MB3731 £3.50,  
MB3756 £2.60, MB8719 £3.85, STK461 £7.50, STK463 £8.40, TA7205AP  
£1.00, TA7222AP £1.30, TA7229 £3.25, TA7240 £2.95, TA7607 £2.95, TA7614  
£2.75, TA7628 £2.95, TA7640 £1.75, UPC575 £1.00, UPC1001 £2.20,  
UPC1031 £1.95, UPC1158 95p, UPC1181 £1.10, UPC1182 £1.10, UPC1185  
£2.50, UPC1186 £2.75, UPC1230 £2.50, UPC1277 £2.75, UPC1365 £3.60,  
ADD 60p POST AND PACKING AND THEN ADD 15% VAT TO TOTAL  
**T POWELL 16 PADDINGTON GREEN LONDON W2 1LG**  
**OPEN MON-FRI 10AM-5PM, SAT 9AM-12 NOON.**  
**TELEPHONE: 01 723 9246**  
ACCESS/VISA. TELEPHONE ORDERS ACCEPTED OVER £5.00



## ELECTRO SUPPLIES

NORTHERN COMPONENT SPECIALISTS

Test Equipment, Computers, Peripherals

SEND FOR CATALOGUE Trade Enquiries Welcome

45 LOWER HILLGATE,  
STOCKPORT, CHESHIRE.  
061 477 9272

also at SHAWCLOUGH ROAD,  
WATERFOOT,  
ROSENDALE B84 9JZ.  
0706 215556

## RF DEVICES AT ROCK BOTTOM PRICES!

Nobody beats us!

Over 30,000 RF devices at low prices

### REPLACEMENT RF TRANSISTORS

MRF454 HF/SSB 80W	£18.20
MFR450 HF/SSB 50W	£11.60
MRF238 VHF/FM 25W	£12.80
MRF475 HF/SSB 20W	£2.99
2SC1969 HF/SSB 18W	£2.50
2SC2043/1307 HF 16W	£2.00
2SC1947 VHF 3.5W	£7.60
2SC1946A VHF 32W	£14.30

### REPLACEMENT RF POWER MODULES

M57704/SAU3 UHF 15W	£36.00
M57712/SAV7 VHF/FM 25W	£39.00
M57713/SAV8 VHF/SSB 15W	£39.00
M57716/SAU4 UHF/SSB 15W	£49.00
M57719 VHF/PMR 15W	£29.00
M57727 VHF/SSB 38W	£45.00
M57749/SAU11 934/FM 7W	£29.00

Send £1.00 p&p and SAE for full list  
All prices inc. VAT

Many Ic's and other types in stock

**RAYCOM LTD**  
DEPT AR 584 HAGLEY RD WEST  
QUINTON BIRMINGHAM

B68 OBS

021 421 8201-3

(24hr answer phone)

## GROSVENOR SOFTWARE (G3BMK)

AX25 Packet Radio

Dragon 32/64 and Tandy Color

A breakthrough in Packet Radio - AX25 stand-alone  
software in ROM cartridge, plus a built VHF 1200 Baud  
modem for just £99!

Full AX25 implementation with up to 6 simultaneous  
connections, optional beacon, and digipeater  
operation. HF kit available soon. Send an SAE for full  
details of this and RTTY CW SSTV and AMTOR.

2 Beacon Close, Seaford,

East Sussex BN25 2JZ

Tel: (0323) 893378

VALUABLE  
SPACE FOR  
SALE!

Telephone  
the advertising  
department on:  
**0277 219876**  
for details

# ADVERTISERS INDEX

B N O S.....	33	K W Ten-Tec .....	39
B N R E S.....	32		
J Bull .....	59	Mendascope .....	33
Capco .....	39	Sandpiper .....	32
P M Components.....	14,15	Sherwood Data .....	20
Edwardschild .....	33	Technical Software .....	38
Electromail.....	52	Telecoms .....	60
G C H Q.....	33		
The Ham Shop .....	38	Reg Ward .....	32
Icom .....	4,5	Waters & Stanton .....	27
		R Withers .....	2

## Amateur RADIO

## ADVERTISING RATES & INFORMATION

DISPLAY AD RATES		series rates for consecutive insertions			
depth mm x width mm	ad space	1 issue	3 issues	6 issues	12 issues
61 x 90	1/8 page	£66.00	£62.00	£59.00	£53.00
128 x 90 or 61 x 186	1/4 page	£115.00	£110.00	£105.00	£92.00
128 x 186 or 263 x 90	1/2 page	£225.00	£210.00	£200.00	£180.00
263 x 186	1 page	£430.00	£405.00	£385.00	£345.00
263 x 394	double page	£850.00	£760.00	£740.00	£660.00

COLOUR AD RATES		series rates for consecutive insertions			
depth mm x width mm	ad space	1 issue	3 issues	6 issues	12 issues
128 x 186 or 263 x 90	1/2 page	£305.00	£290.00	£275.00	£245.00
263 x 186	1 page	£590.00	£550.00	£530.00	£470.00
263 x 394	double page	£1130.00	£1070.00	£1010.00	£900.00

SPECIAL POSITIONS	Covers	Outside back cover 20% extra, inside covers 10% extra
	Bleed	10% extra [Bleed area = 307 x 220]
	Facing Matter	15% extra

DEADLINES		*Dates affected by public holidays			
issue	colour & mono proof ad	mono no proof & small ad	mono artwork	on sale thurs	
Sep 86	31 Jul 86	6 Aug 86	8 Aug 86	28 Aug 86	
Oct 86	28 Aug 86	3 Sep 86	5 Sep 86	25 Sep 86	
Nov 86	2 Oct 86	8 Oct 86	10 Oct 86	30 Oct 86	
Dec 86	30 Oct 86	5 Nov 86	7 Nov 86	27 Nov 86	

CONDITIONS & INFORMATION	
<p><b>SERIES RATES</b> Series rates also apply when larger or additional space to that initially booked is taken.</p> <p>An ad of at least the minimum space must appear in consecutive issues to qualify for series rates</p> <p>Previous copy will automatically be repeated if no further copy is received.</p> <p>A 'hold ad' is acceptable for maintaining your series rate contract. This will automatically be inserted if no further copy is received.</p> <p>Display Ad and Small Ad series rate contracts are not interchangeable.</p>	<p>If series rate contract is cancelled, the advertiser will be liable to pay the unearned series discount already taken.</p> <p><b>COPY</b> Except for County Guides copy may be changed monthly.</p> <p>No additional charges for typesetting or illustrations (except for colour separations)</p> <p>For illustrations just send photograph or artwork</p> <p>Colour Ad rates do not include the cost of separations. Printed - webb-offset</p>
<p>Above rates exclude VAT</p> <p><b>PAYMENT</b> All single insertion ads are accepted on a pre-payment basis only, unless an account is held. Accounts will be opened for series rate advertisers subject to satisfactory credit references.</p> <p>Accounts are strictly net and must be settled by the publication date.</p> <p>Overseas payments by International Money Order.</p> <p><b>FOR FURTHER INFORMATION CONTACT</b> Amateur Radio, Sovereign House, Brentwood, Essex CM14 4SE (0277) 219876</p>	<p>Commission to approved advertising agencies is 10%</p> <p><b>CONDITIONS</b> 10% discount if advertising in both Amateur Radio and Radio &amp; Electronics World.</p> <p>A voucher copy will be sent to Display and Colour advertisers only.</p> <p>Ads accepted subject to our standard conditions, available on request.</p>





### £1 BAKERS DOZEN PACKS

Price per pack is £1.00. \* Order 12 you may choose another free. Items marked (sh) are not new but guaranteed ok.

1. 5-13 amp ring main junction boxes
2. 5-13 amp ring main spur boxes
3. surface mounting switches suitably insulated for mains voltage
4. electrical switches intermediate type, will also replace 1 or 2 way switches, white flush mounting
7. 4- in flex line switches with neon
9. 2- mains transformers with 6V 1A secondaries
10. 2- mains transformers with 12V 1A secondaries
11. 1- extension speaker cabinet for 6 1/2" speaker
13. 12- glass reed switches
17. 2- ultra transmitters and 2 receivers with circuit
19. 2- light dependent resistors
25. 4- wire switches - Sp 2 way, Ap 3 way, Zp 6 way, 2p 5 way, 1p 12 way small on/off fitting and good length spindle your choice
28. 1- 8 digit counter mains voltage
30. 2- Nicad battery chargers
31. 1- lay switch with key
33. 2- aerosol cans of 100% Lubricant
34. 96- 1 metre lengths colour-coded connecting wire
39. 1- long and medium wave tuner kit
41. 8- rocker switch 10 amp mains SPST
45. 1- 24 hour time switch mains operated (s.h.)
48. 2- 6V operated reed switch relays
49. 10- neon valves - mains glow night lights
50. 2- 12V DC or 24V AC, 3 CO relays
51. 1- 12V 2 CO miniature relay very sensitive
52. 1- 12V 4 CO miniature relay
53. 2- mains operated relays 2 x 8 amp changeover (s.h.)
54. 10- rows of 32 gold plated IC sockets (total 320 sockets)
55. 1- locking mechanism with 2 keys
56. 1- miniature unselector with circuit for electric jigsaw puzzle
60. 5- ferrite rods 4" x 5/16" diameter aerials
61. 4- ferrite slab aerials with 1/2 & 1/4 wave coils
63. 1- Mullard thyristor trigger module
64. 10- assorted lenses | spindles
65. 5- different thermostats, mainly bi-metal types
66. 1- magnetic brake - stops rotation instantly
67. 1- low pressure 3 line switch can be mouth operated
69. 2- 25 watt pots 8 ohm
70. 2- 25 watt pots 1000 ohm
71. 4- wire wound pots - 10, 33, 50 and 100 ohm your choice
72. 1- 1250 watt dimmer Ultra ref SE20
73. 1- time reminder adjustable 1-60 mins clockwork
81. 2- 30A panel mounting spark fuses
85. 1- mains shaded pole motor 3" stack - 3 shaft
89. 1- mains motor with gear box 1/8 rpm
91. 2- mains motors with gear box 1/8 rpm
96. 1- thermostat for fridge
98. 1- motorised stud switch (s.h.)
101. 1- 2 1/2 hours delay switch
103. 1- mains power supply unit - 6V DC
104. 1- mains power supply unit - 4.5V DC
105. 5- pin fan fan and panel socket
107. 1- 5" speaker size radio cabinet with handle
110. 10- slider type volume controls
111. 2- musical boxes (least keys)
112. 1- heating pad 20W mains
113. 1- FM front end with tuning condenser and data
114. 1- 1W amplifier Mullard 1172
115. 1- wall mounting thermostat 24V
118. 1- teak effect extension 5" speaker cabinet
120. 2- p.s. boards with 20W mains and 17 other recs
121. 4- push push switches for table lamps etc.
122. 10- mtrs twin screened flex w/c.p.c. outer
123. 100- staples for thin flex
124. 25- clear plastic lenses 1/2" diameter
127. 4- pilot bulb lamp meters on type
128. 10- very fine drills for pcbs etc.
129. 4- extra thin screw drivers for instruments
132. 2- plastic boxes with windows, ideal for interrupted beam switch
134. 10- model aircraft motor - require no on/off switch, just span to start
136. 2- car radio speakers 5" x 7" mains made for Radiomobile
137. 1- 6 1/2" 4 ohm 10 watt speaker and 3" tweeter
142. 10- 4 BA spanners 1 end open, other and closed
145. 2- 4 lead relay kits 3V coil normally open or c/o if magnets added
146. 20- pilot bulbs 6.5V 3A Philips
147. 1- secret switch kit with data
149. 4- socket covers (protect inquisitive little fingers) for twin 13A
152. 1- air or gas shut off valve - clockwork operated
153. 1- air or gas shut off valve - thermostat operated
154. 1- 12V drip proof relay - ideal for car jobs
155. 3- warning push button switches with knobs
156. 5- 12 way connector blocks 2A 250V
158. 3- 12 way connector blocks 25A 250V
162. 1- 13A fused and switched spur for surface mounting or can be removed from box for flush mounting
- 3- 13A socket good British make but brown
169. 4- short wave air spaced trimmers 2.30f
171. 1- shocking coil air spaced trimmer - have fun with this
172. 10- 12V 6W bulbs Philips m.e.s.
178. 3- oblong amber indicators with leupolds 12V
180. 6- round amber indicators with neon 240V
181. 100- p.v.c. grommets | hole size
182. 1- short wave tuning condenser 50 pf with 1/2" spindle
184. 1- three gang tuning condenser each section 500 pf with trimmers and good length 1/2" spindle
186. 1- plastic box sloping metal front, 18 x 95mm depth 45mm
- 2- double pole 2D amp 250V flush mounting switch - white
191. 6- B.C. lamp holder adaptors white
193. 8- 5 amp 3 pin flush sockets brown
195. 5- B.C. lampholders brown bakelite threaded iron
196. 1- flex armrest for electric blanket soldering iron etc.
197. 2- thermostats, spindle setting - adjustable range for ovens etc
199. 1- mains operated solenoid with plunger 1" travel
200. 1- 10 digit switch pad for telephones etc.
201. 8- computer keyboard switches with knobs, pcb or vero mounting
202. 10- mtrs 80 ohm, standard type on/off white
216. 1- electric clock mains driven, always right time - not ceased
218. 1- stereo pre-amp Mullard EP9001
232. 1- 12V solenoids small with plunger
236. 1- mains transformer 5V 1 amp secondary C core construction
241. 1- car door speaker (very flat) 6 1/2" 15 ohm made for Radiomobile
243. 2- speakers 6" x 4" 4 ohm 5 watt made for Radiomobile
244. 2- speakers 6" x 4" 16 ohm 5 watt made for Radiomobile
245. 4- standard size pots - mag with dp switch
249. 1- 13A switched socket on double plate with fused spur for water heater
266. 2- mains transformers 9V 1A secondary split primary so it also for 115V
267. 1- mains transformers 15V 1A secondary p.c.b. mounting
289. 50 3.5V torch bulbs
290. 3 7" rail to rail tape spools
291. 1 tan turns 3 watt pot | spindle 100 ohm
292. 5 two plate brown bakelite ceiling roses
293. 50 silicon diodes mixed unmarked
294. 50 Germanium transistors mixed and unmarked
295. 10 round potentiometer 2 1/2" spindle
296. 3 car cigar lighter socket plugs
297. 1 cover for 24hr time switch ref BD45
298. 2 15 amp round pin plugs brown bakelite
300. 1 mains solenoid with plunger compact type
301. 10 ceramic magnets Mullard 1" x 3/8" x 5/16"
303. 1 12 pole 3 way ceramic wave charge switch
304. 1 stereo amp 1 watt per channel
305. 1 tubular dynamic microphone with desk rest
306. 1 module, speaker & battery to make musical card
307. 5 thermal fuse 15 amp wocds metal
308. 1 T.V. turret tuner (black & white T.V.)
309. 12 adaptable legended knobs 1/2" spindle
310. 2 oven thermostats
311. 1 Clare Elliot sealed relay 12V
312. 1 pressure pad switch 4" x 18 (Trigger Meet)
313. 5 sub miniature micro switches
314. 1 12" B watt min fluorescent tube white
315. 1 6" 4 watt min fluorescent tube white
316. 1 round pin kettle plug with moulded on lead

### MULLARD UNILEX AMPLIFIERS

We are probably the only firm in the country with these now in stock. Although only four watts per channel, these give superb reproduction. We now offer the 4 Mullard modules - i.e. Mains power unit (EP9002) Pre amp module (EP9001) and two amplifier modules (EP9000) all for £6.00 plus £2 postage. For prices of modules bought separately see TWO POUNDERS.

### CAR STARTER/CHARGER KIT

Flat Battery! Don't worry you will start your car in a few minutes with this unit - 250 watt transformer 20 amp rectifiers, case and all parts with data £16.50 or without case £18.00 post paid.



Ex-Electricity Board. Guaranteed 12 months.

### VENER TIME SWITCH

Mains operated with 20 amp switch, one on and one off per 24 hrs. repeats daily automatically correcting for the lengthening or shortening day. An expensive time switch but you can have it for only £2.95 without case, metal case - £2.95, adaptor kit to convert this into a normal 24hr. time switch but with the added advantage of up to 12 on/off per 24hrs. This makes an ideal controller for the immersion heater. Price of adaptor kit is £2.30.

### SOUND TO LIGHT UNIT

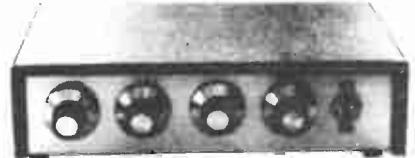

Complete kit of parts of a three channel sound to light unit, controlling over 2000 watts of lighting. Use this at home if you wish but it is plenty rugged enough for disco work. The unit is housed in an attractive two tone metal case and has controls for each channel, and a master on/off. The audio input and output are by 1/2" sockets and three panel mounting fuse holders provide thyristor protection. A four pin plug and socket facilitate ease of connecting lamps. Special price is £14.98 in kit form.

### 12 volt MOTOR BY SMITHS

Made for use in cars, etc. these are very powerful and easily reversible. Size 3 1/2" long by 3" dia. They have a good length of 1/2" spindle - 1/10 hp £3.45 1/8 hp £5.75. 1/6 hp £7.50

### 25A ELECTRICAL PROGRAMMER

Leaving in your sleep. Have radio playing and kettle boiling as you wake - switch on lights to ward off intruders - have a warm house to come home to. You can do all these and more. By a famous maker with 25 amp on/off switch. A beautiful unit at £2.50.

### THIS MONTH'S SNIP

is a Prestel Unit, brand new and complete except for some ICs, also we understand tested, so should work OK directly the missing chips are fitted. Supplied complete with handbook and keypad at only £5. It's a bargain that should not be missed, even if you don't want to use it for its original purpose, it has wonderful spares value: you will have a long low case, ideal if you plan to make something which has a lot of controls, such a case could easily cost you £5. You will have a modern; more and more telephone/computer operations are being performed and this modern could set you going. Price £5 plus £1 post.

### GOODS ARE ON APPROVAL

these notes are often hastily written and technical information sheets are seldom available about the items we have to describe, also advertisements sometimes go to press without our having a chance to correct any mistakes, however, everything we sell is supplied on the understanding that if it is not suitable for your project you may return it within 7 days for credit. If there was a definite error of description in our copy then we will pay postage. If not, then you pay the postage. Note this offer applies to kits, but only if construction is not started.

### FANS & BLOWERS

Woods extractors  
5" £5 + £1.25 post. 6" £6 + £1.50 post  
4" x 4" Muffin extractor cooling fan 115V £2.00  
4" x 4" Muffin extractor cooling fan 230/240V £5.95  
5" Planair extractor £5.50  
9" Extractor or blower 115V supplied with 230 to 115V adaptor £9.50 + £2 post.  
All above are ex computers but guaranteed 12 months.  
10" x 3" Tangential Blower. New. Very quiet - supplied with 230 to 115V adaptor on two in series to give low blow £2.00 + £1.50 post or £4.00 + £2.00 post for two.

### IONISER KIT

Refresh your home, office, shop, work room, etc. with a negative ION generator. Makes you feel better and work harder - a complete mains operated kit, case included. £11.95 plus £2.00 post.

### TELEPHONE BITS

Master socket (has surge arrester - ringing condenser etc) and takes B.T. plug ..... £3.95  
Extension socket ..... £2.95  
Dual adaptors (2 from one socket) ..... £3.95  
Cord terminating with B.T. plug 3 metres ..... £2.95  
Kit for converting old entry terminal box to new B.T. master socket, complete with 4 core cable, cable clips and 2 BT extension sockets ..... £11.50

### MINI MONO AMP

on p.c.b. size 4" x 2" (app.)  
Fitted volume control and a hole for a tone control should you require it. The amplifier has three transistors and we estimate the output to be 3W rms. More technical data will be included with the amp. Brand new, perfect condition, offered at the very low price of £1.15 each, or 13 for £12.00

## J & N BULL ELECTRICAL

Dept. AR, 128 PORTLAND ROAD, HOVE, BRIGHTON, SUSSEX BN3 5QL

MAIL ORDER TERMS: Cash, P.O. or cheque with order. Orders under £20 add £1 service charge. Monthly account orders accepted from schools and public companies. Access & B/card orders accepted. Brighton 0273 734648. Bulk orders: write for quote.

## OVER 400 GIFTS YOU CAN CHOOSE FROM

There is a total of over 400 gifts in our Baker's dozen range and you become entitled to a free gift with each dozen packs you spend on these packs. A classified list of these packs and our latest 'News Letter' will be enclosed with your goods, and you will automatically receive our next news letters.

### TWO POUNDERS\*

- 2P2 - Wall mounting thermostat, high precision with mercury switch and thermometer
- 2P3 - Variable and reversible 8-12V psu for model control
- 2P4 - 24 volt psu with separate channels for stereo made for Mullard UNILEX
- 2P6 - 100W mains to 115V auto-transformer with voltage tappings
- 2P6 - Mains motor with gear box and variable speed selector. Series wound so suitable for further speed control
- 2P9 - Time and set switch. Board, glass fronted and with knobs. Controls up to 15 amps. Ideal to program electric heaters
- 2P10 - 12 volt 5 amp mains transformer - low volt winding on separate bobbin and easy to remove to convert to lower voltages for higher currents
- 2P11 - Power amp module Mullard Unilex EP9000 (note stereo pre-amp module Unilex 9001 is B0218)
- 2P12 - Disk or Tape precision motor - has balanced rotor and is reversible 230v mains operated 1500 rpm
- 2P14 - Mug Stop kit - when thrown emits piercing squeak
- 2P15 - Interrupted Beam kit for burglar alarms, counters, etc.
- 2P17 - 2 rev pr mins mains driven motor with gear box, ideal to operate mirror ball
- 2P18 - Liquid/gas shut off valve mains solenoid operated
- 2P19 - Disco switch-motor drives 6 or more 10 amp change over micro switches supplied ready for mains operation
- 2P20 - 20 metres extension lead, 2 core - ideal most Black and Decker garden tools etc.
- 2P21 - 10 watt amplifier, Mullard module reference 1173
- 2P22 - Motor driven switch 20 secs on or off after push
- 2P26 - Counter resettable mains operated 3 digit
- 2P27 - Goodmans Speaker 6 inch round Bohm 12 watt
- 2P28 - Drill Pump - always useful couples to any make portable drill
- 2P31 - 4 metres 98 way interconnecting wire easy to strip
- 2P32 - Hot Wire amp meter - 4 1/2 round surface mounting 0-10A - old but working and definitely a bit of history
- 2P34 - Solenoid Air Valve mains operated
- 2P35 - Battery charger kit comprising mains transformer, full wave rectifier and meter, suitable for charging 6v or 12v
- 2P38 - 200 R.P.M. Guard Mains Motor 1" stack quite powerful, definitely large enough to drive a rotating aerial or a tumbler for polishing stones etc.
- 2P43 - Small type blower or extractor fan, motor inset so very compact, 230V
- 2P46 - Our famous drill control kit complete and with prepared case
- 2P49 - Fire Alarm break glass switch in heavy cast case
- 2P51 - Stereo Headphone amplifier, with pre-amp
- 2P55 - Mains motor, extra powerful has 14" stack and good length of spindle
- 2P62 - 1 pair Goodmans 15 ohm speakers for Unilex
- 2P63 - 1 5Kv 20 mA mains transformer ex-equipment
- 2P64 - 1 five bladed fan 6 1/2" with mains motor
- 2P66 - 1 2Kw tangential heater 115v easily convertible for 230V
- 2P67 - 1 12v-0-12v 2 amp mains transformer
- 2P68 - 1 15v-0-15v 2 amp mains transformer
- 2P69 - 1 250v-0-250v 80 mA & 86.3v 5A mains transformer + 50p post
- 2P70 - 1 5H.I. tape motor two speed and reversible
- 2P72 - 1 115v Muffin fan 4" x 4" socket (s.h.)
- 2P75 - 1 2 hour timer, plugs into 13A socket
- 2P78 - 1 aux tweeter partner to 5P28 speaker
- 2P82 - 9v-0-9v 2 amp mains transformer
- 2P84 - Modem board with press keys for telephone radiator
- 2P85 - 20v-0-20v 1/2 A Mains transformer
- 2P88 - Sangamo 24 hr time switch 20 amp (s.h.)
- 2P89 - 120 min. time switch with knob
- 2P90 - 90 min. time switch with edgewise engraved controller
- 2P92 - Bailey & Macky pressure switch 15 p.s.i.
- 2P94 - Telephone handset for EE home telephone circuit

### £5 POUNDERS\*

- 1. 12 volt submersible pump complete with a tap which when brought over the basin switches on the pump and when pushed back switches off, an ideal caravan unit.
- 2. Sound to light kit complete in case suitable for up to 750 watts.
- 3. Silent sentinel ultra sonic transmitter and receive kit, complete.
- 5. 250 watt isolating transformer to make your service bench safe, has voltage adj. taps, also as it has a 115V tapping it can be used to safely operate American or other 115V equipment which is often only insulated to 115V. Please add £3 postage if you can't collect as this is a heavy item.
- 6. 12V alarm bell with heavy 6" gong, suitable for outside if protected from direct rainfall. Ex GPO but in perfect order and guaranteed.
- 12. Equipment cooling fan - mini snail type mains operated.
- 13. Ring pong ball blower - or for any job that requires a powerful stream of air - ex computer. Collect or add £21 post.

- 5P15 - Unselector 5 pole, 25 way 50 volt coil
- 5P18 - motor driven water pump as fitted to many washing machines
- 5P20 - 2 kits, matchbox size, surveillance transmitter and FM receiver
- 5P23 - miniature (appr. 2 1/2" wide) tangential blow heater, 1.2hw
- 5P24 - 1/2 hp motor, ex computer, 230V, mains operation 1450rpm. If not collect add £3 post
- 5P25 - special effects lighting switch. Up to 8 channels of lamps can be on or off for varying time periods
- 5P26 - Audax woofer 8" Bohm 35 watt
- 5P27 - cartridge player 12V, has high quality stereo amplifier
- 5P28 - gear pump, mains motor driven with inlet and outlet pipe connectors
- 5P32 - large mains operated push or pull solenoid. Heavy so add £1.50 post
- 5P34 - 24V 5A toroidal mains transformer
- 5P35 - modem board from telephone auto dialler, complete with keypad and all ICs
- 5P37 - 24 hour time switch, 2 on/off and clockwork reserve, ex Elec. Board loading up to 50A. Add £1 post
- 5P41 - 5" extractor fan, very quiet runner (s.h.), gntd 12 mths.
- 5P51 - 200 watt auto transformer, toroidal wound and encapsulated 230-115V
- 5P58 - Arstrand AM/FM stereo tuner with connection diagram

LIGHT CHASER KIT motor driven switch bank with connection diagram, used in connection with 4 sets of xmas lights makes a very eye catching display for home, shop or disco, only £5 ref 5P58.

VALVE PRE AMP described in the Aug E.T.I. it's a very interesting circuit if you intend trying it, we can supply many of the parts mains transformer 250-0-250 + 6.3V our ref 2P69 + £1 post B9A valve bases 4 for £1 BD95 Double tag strips 3 lengths £2 2P100 Toggle switches dot and 4p 4 way rotary switch BD394 1 meg single gang pot 4 for £1 BD391 100 + 100pf 320V electrolytic 2 for £1 BD392 4uf 300V 4 for £1 BD393



# TELECOMMS

DISTRIBUTORS OF AMATEUR AND PERSONAL RADIO EQUIPMENT.

SEND £1 FOR OUR FULL CATALOGUE AND RECEIVE A £2 VOUCHER



## 93.4 MHz PERSONAL RADIO



- CYBERNET DELTA 20 Channel TCVR W/Scan & Memory £355
- NEVADA HRA 900 N/Head G a As F.E.T. Amp £139.95
- NEVADA HRA 934L in line Pre amplifier £125
- NEVADA TC12L 12 EL. Loop QUAD 18 dB £39
- NEVADA HPS 900 SWR/PWR Meter £89.95
- NEVADA PA7-E Base Colinear 7 dB £66
- NEVADA HAS-1 N Type Co-axial Switch £59.95
- NEVADA P593A Power Divider (for 2 ants) £24.50
- SEND FOR OUR FULL 93.4MHz CATALOGUE ..... £1

## RF AMPLIFIERS

All amplifiers except broadband models are tuned for 29.6MHz centre freq. Should you require a lower freq. i.e. 28.5MHz please state when ordering. Export models available for 26-30MHz.

### MOBILE AMPLIFIERS

**C.T.E. MOD 767**  
76 Watts FM  
INPUT:- 05-10 Watts  
SWITCHABLE:- Class AB Class C  
SUPPLY:- 13.8 Volt  
REMOTE CONTROL FACILITY



- CTE MOD 737 50W FM AM/SSB/CW £37.69
- CTE MOD 767 80W FM AM/SSB/CW £43.00
- CTE MOD 757 150W FM Broadband £99.98
- ZETAGI B35 25W FM 26-30MHz £22.23
- ZETAGI B150 70W FM 26-30MHz £47.87
- ZETAGI B300 150W FM (2-30MHz) £108.42
- NEVADA TC35 30W FM 26-30MHz £23.75

### MAINS OPERATED AMPLIFIERS

- CTE DC9 Solid State 150W FM (Broadband) £14.50
- ZETAGI BV 131 150W FM (Valve) (26-30MHz) £99.12
- ZETAGI B132 150W FM Solid State (Broadband) £99.12

## 2 MTR EQUIPMENT

### 2 MTR HANDHELD NEW MOD. C.T.E. CT1600

A superbly sensitive new handheld covering 142-149MHz  
● Repeater shift  
● High/low power 1.5/0.5 Watt  
● Thumbwheel selector



### VHF MOBILE AMPLIFIERS

- CTE B110 144MHz 110 Watt W/Pre Amp £169
- CTE B42 144MHz 40 Watt £59.68
- ZETAGI L405435 144MHz 45 Watt £65.10

### C.T.E. B42 MOBILE AMP

40 Watt output  
10 Watt input



### ALINCO 2 MTR PRODUCTS

- ALR-206E 25 Watt FM Mobile £295
- SPECIAL OFFER ALM-203E H/held with 30 Watt Amp £249

## POWER SUPPLIES

### F911 10 AMP MAX. 13.8V DC

- CTE F1820 20 Amp Supply £99.98
- CTE F911 10 Amp Supply £49.47
- ZETAGI 12105 12 Amp Supply £89.70
- ZETAGI 12101 10 Amp Supply £68.83
- ZETAGI 12201 25 Amp Supply £107.73
- ZETAGI 12205 25 Amp W/Meters £123.92
- ZETAGI 12405 40 Amp W/Meters £199.95

### CTE FD 1350 1.3 GHz FREQ. COUNTER

For the technically minded this counter is ideal for both 27MHz and 93.4MHz use  
12 Volts Operation  
High Resolution

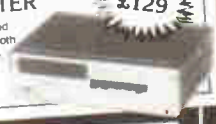

## 29 MHz BIASER ANTENNAS

### NEVADA TC52 1/2 WAVE

This top class British made half wave uses high grade aluminium and a low loss coil handling up to 1 kW  
WIND RESISTANCE: 75 MPH  
GAIN:- 2.5 dB  
FREQ:- 28-30MHz

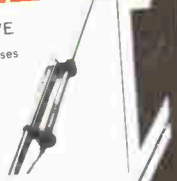

### NEVADA TC58 5/8 WAVE

British made using high grade aluminium and a low loss coil complete with small radials this antenna is our most popular amongst the 29MHz fraternity  
POWER:- 1kW  
GAIN:- 35 dB  
FREQ:- 28-30MHz  
LENGTH:- 66 MTRS



### SALIUT 3/4 WAVE

Using a unique base hoop this antenna offers exceptional ground wave coverage on 10 FM  
POWER:- 2kW  
GAIN:- 45 dB  
FREQ:- 28-30MHz  
LENGTH:- 91 MTRS

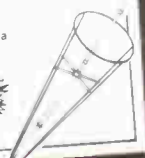

## NEVADA

### HIGH QUALITY BRITISH MADE 29MHz FM PRODUCTS

#### NEVADA TC35 RF POWER AMPLIFIER

INPUT:- 1.4 Watts FM  
OUTPUT:- 25 30 Watts FM  
SUPPLY:- 13.8V DC  
FREQ:- 26-30MHz



A switchable RF power amplifier with polarity protection and correctly matched input stage centred on 29MHz

#### NEVADA TC27 RX RECEIVER PRE-AMP FOR 26-30MHz

A superior low noise pre-amplifier for 29MHz FM operation  
Variable gain -6dB to +18dB suitable for use with transceivers up to 25 Watts output



#### NEVADA TC27 RXM MOBILE PRE-AMPLIFIER FOR 29MHz FM

An F.E.T. low noise pre-amplifier with variable gain. Designed to improve reception on even the best transceiver  
GAIN:- -6 to +20dB

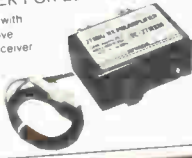

### NEVADA TM27 ANTENNA MATCHER

Ideal for both home and mobile use this matcher really works allowing full coverage of the 10 MTR band and handling 100 Watts



### TC2 2 WAY ANTENNA SWITCH

A robust unit with unique double screening handling up to 200 Watts and exceptionally low insertion loss  
FREQ:- 1-100MHz



### NEVADA PLP 1 LOW PASS TVI FILTER

Ensures your transceiver has clean output cutting off just over 30MHz  
Low cost. peace of mind



### NEVADA PSDL PROFESSIONAL DUMMY LOAD

FREQ:- DC to 3GHz  
A must for the HF, VHF and UHF operator! This dummy load at last offers wide freq. coverage at an affordable price



# TELECOMMS

HOTLINE 0705 662145  
TELEX 869107 TELCOM G

189 LONDON ROAD, PORTSMOUTH, HANTS, PO2 9AE,

USE YOUR CREDIT CARD (AMERICAN EXPRESS, ACCESS OR VISA) FOR IMMEDIATE DESPATCH.